

**Digital Enhanced Cordless Telecommunications (DECT);
Common Interface (CI); Test Case Library (TCL);
Part 6: Test Suite Structure (TSS) and Test Purposes (TP) -
Network (NWK) layer - Portable radio Termination (PT)**



Reference

REN/DECT-040131-6 (4lpi011c.PDF)

Keywords

DECT, terminal, testing, TSS&TP, network

ETSI

Postal address

F-06921 Sophia Antipolis Cedex - FRANCE

Office address

650 Route des Lucioles - Sophia Antipolis
Valbonne - FRANCE
Tel.: +33 4 92 94 42 00 Fax: +33 4 93 65 47 16
Siret N° 348 623 562 00017 - NAF 742 C
Association à but non lucratif enregistrée à la
Sous-Préfecture de Grasse (06) N° 7803/88

Internet

secretariat@etsi.fr
Individual copies of this ETSI deliverable
can be downloaded from
<http://www.etsi.org>
If you find errors in the present document, send your
comment to: editor@etsi.fr

Copyright Notification

No part may be reproduced except as authorized by written permission.
The copyright and the foregoing restriction extend to reproduction in all media.

© European Telecommunications Standards Institute 1999.
All rights reserved.

Contents

Intellectual Property Rights	5
Foreword	5
1 Scope	6
2 References	6
3 Definitions and abbreviations	7
3.1 DECT definitions	7
3.2 Abbreviations	7
4 Test Suite Structure (TSS)	9
4.1 TSS overview	9
4.2 Test groups	10
4.2.1 Protocol groups	10
4.2.1.1 Call Control (CC)	10
4.2.1.2 Mobility Management (MM)	10
4.2.1.3 Lower layer Management Entity (ME)	10
4.2.1.4 Link Control (LC)	10
4.2.1.5 Call Independent Supplementary Services (CISS)	10
4.2.1.6 Connection Oriented Message Services (COMS)	10
4.2.1.7 Connectionless Message Services (CLMS)	10
4.2.2 Main test groups	10
4.2.2.1 Basic InTerconnection tests (IT)	10
4.2.2.2 Capability tests (CA)	10
4.2.2.3 Valid Behaviour tests (BV)	10
4.2.2.4 Invalid Behaviour tests (BI)	11
4.2.2.5 InOpportune Behaviour tests (BO)	11
4.2.2.6 Timer expiry and counter mismatch tests (TI)	11
5 Test Purposes (TPs)	11
5.1 Introduction	11
5.1.1 TP definition conventions	11
5.1.2 References	11
5.1.3 TP naming conventions	12
5.2 CC test purposes	12
5.2.1 CC/IT test purposes	13
5.2.2 CC/CA test purposes	13
5.2.3 CC/BV test purposes	13
5.2.3.1 CC/BV/OC test purposes	13
5.2.3.2 CC/BV/IC test purposes	14
5.2.3.3 CC/BV/CI test purposes	15
5.2.3.4 CC/BV/CR test purposes	17
5.2.3.5 CC/BV/SC test purposes	18
5.2.3.6 CC/BV/PM test purposes	18
5.2.3.7 CC/BV/RS test purposes	18
5.2.3.8 CC/BV/HP test purposes	19
5.2.4 CC/BO test purposes	22
5.2.5 CC/BI test purposes	23
5.2.6 CC/TI test purposes	23
5.3 MM test purposes	24
5.3.1 MM/IT test purposes	24
5.3.2 MM/CA test purposes	24
5.3.3 MM/BV test purposes	24
5.3.3.1 MM/BV/ID test purposes	24
5.3.3.2 MM/BV/AU test purposes	25
5.3.3.3 MM/BV/LO test purposes	27
5.3.3.4 MM/BV/AR test purposes	29

5.3.3.5	MM/BV/KA test purposes	30
5.3.3.6	MM/BV/PR test purposes	30
5.3.3.7	MM/BV/CH test purposes.....	31
5.3.4	MM/BO test purposes.....	32
5.3.5	MM/BI test purposes	32
5.3.6	MM/TI test purposes.....	32
5.4	ME test purposes	33
5.4.1	ME/BV test purposes.....	33
5.4.2	ME/BO test purposes.....	34
5.5	LC test purposes	35
5.5.1	LC/BV test purposes	35
5.5.1.1	LC/BV/LE test purposes	35
5.5.1.2	LC/BV/LR test purposes	35
5.5.1.3	LC/BV/LS test purposes.....	36
5.5.1.4	LC/BV/LL test purposes	36
5.5.2	LC/BI test purposes	36
5.5.3	LC/TI test purposes.....	37
5.6	IS test purposes.....	37
5.6A	IS/BV test purposes	37
5.7	MO test purposes.....	38
5.8	CL test purposes	38
5.9	CL/BV test purposes	38
	Bibliography	39
	History	40

Intellectual Property Rights

IPRs essential or potentially essential to the present document may have been declared to ETSI. The information pertaining to these essential IPRs, if any, is publicly available for **ETSI members and non-members**, and can be found in SR 000 314: "*Intellectual Property Rights (IPRs); Essential, or potentially Essential, IPRs notified to ETSI in respect of ETSI standards*", which is available **free of charge** from the ETSI Secretariat. Latest updates are available on the ETSI Web server (<http://www.etsi.org/ipr>).

Pursuant to the ETSI IPR Policy, no investigation, including IPR searches, has been carried out by ETSI. No guarantee can be given as to the existence of other IPRs not referenced in SR 000 314 (or the updates on the ETSI Web server) which are, or may be, or may become, essential to the present document.

Foreword

This European Standard (Telecommunications series) has been produced by ETSI Project Digital Enhanced Cordless Telecommunications (DECT), and is now submitted for the Voting phase of the ETSI standards Two-step Approval Procedure.

The present document is part 6 of a multi-part EN covering the Common Interface (CI) Test Case Library (TCL), as identified below:

- Part 1: "Test Suite Structure (TSS) and Test Purposes (TP) for Medium Access Control (MAC) layer";
- Part 2: "Abstract Test Suite (ATS) for Medium Access Control (MAC) layer - Portable radio Termination (PT)";
- Part 3: "Abstract Test Suite (ATS) for Medium Access Control (MAC) layer - Fixed radio Termination (FT)";
- Part 4: "Test Suite Structure (TSS) and Test Purposes (TP) - Data Link Control (DLC) layer";
- Part 5: "Abstract Test Suite (ATS) - Data Link Control (DLC) layer";
- Part 6: "Test Suite Structure (TSS) and Test Purposes (TP) - Network (NWK) layer - Portable radio Termination (PT)";**
- Part 7: "Abstract Test Suite (ATS) for Network (NWK) layer - Portable radio Termination (PT)";
- Part 8: "Test Suite Structure (TSS) and Test Purposes (TP) - Network (NWK) layer - Fixed radio Termination (FT)";
- Part 9: "Abstract Test Suite (ATS) for Network (NWK) layer - Fixed radio Termination (FT)".

Proposed national transposition dates	
Date of latest announcement of this EN (doa):	3 months after ETSI publication
Date of latest publication of new National Standard or endorsement of this EN (dop/e):	6 months after doa
Date of withdrawal of any conflicting National Standard (dow):	6 months after doa

1 Scope

The present document contains the test specification for the Digital Enhanced Cordless Telecommunications (DECT) (EN 300 175 parts 1 to 8 [1] to [8]).

The objective of this test specification is to provide a basis for approval tests for DECT equipment giving a high probability of air interface inter-operability between different manufacturer's DECT equipment. This test specification defines the Test Suite Structure (TSS) and Test Purposes (TP) for testing of the Network (NWK) layer at the Portable radio Termination (PT).

The ISO standard for the methodology of conformance testing (ISO/IEC 9646-1 [12]) as well as the ETSI rules for conformance testing (ETS 300 406 [9]) are used as a basis for the test methodology.

Test specifications for the Physical layer (PHL) are provided in other DECT standards.

2 References

The following documents contain provisions which, through reference in this text, constitute provisions of the present document.

- References are either specific (identified by date of publication, edition number, version number, etc.) or non-specific.
- For a specific reference, subsequent revisions do not apply.
- For a non-specific reference, the latest version applies.
- A non-specific reference to an ETS shall also be taken to refer to later versions published as an EN with the same number.

- [1] EN 300 175-1: "Digital Enhanced Cordless Telecommunications (DECT); Common Interface (CI); Part 1: Overview".
- [2] EN 300 175-2: "Digital Enhanced Cordless Telecommunications (DECT); Common Interface (CI); Part 2: Physical Layer (PHL)".
- [3] EN 300 175-3: "Digital Enhanced Cordless Telecommunications (DECT); Common Interface (CI); Part 3: Medium Access Control (MAC) layer".
- [4] EN 300 175-4: "Digital Enhanced Cordless Telecommunications (DECT); Common Interface (CI); Part 4: Data Link Control (DLC) layer".
- [5] EN 300 175-5: "Digital Enhanced Cordless Telecommunications (DECT); Common Interface (CI); Part 5: Network (NWK) layer".
- [6] EN 300 175-6: "Digital Enhanced Cordless Telecommunications (DECT); Common Interface (CI); Part 6: Identities and addressing".
- [7] EN 300 175-7: "Digital Enhanced Cordless Telecommunications (DECT); Common Interface (CI); Part 7: Security features".
- [8] EN 300 175-8: "Digital Enhanced Cordless Telecommunications (DECT); Common Interface (CI); Part 8: Speech coding and transmission".
- [9] ETS 300 406: "Methods for Testing and Specification (MTS); Protocol and profile conformance testing specifications; Standardization methodology".
- [10] EN 300 444: "Digital Enhanced Cordless Telecommunications (DECT); Generic Access Profile (GAP)".
- [11] EN 300 824: "Digital Enhanced Cordless Telecommunications (DECT), Cordless Terminal Mobility (CTM); CTM Access Profile (CAP)".

- [12] ISO/IEC 9646-1: "Information technology; Open Systems Interconnection; Conformance testing methodology and framework; Part 1: General concepts".
- [13] ISO/IEC 9646-2: "Information technology; Open Systems Interconnection; Conformance testing methodology and framework; Part 2: Abstract Test Suite Specification".

3 Definitions and abbreviations

3.1 DECT definitions

For the purposes of the present document, the terms and definitions given in ISO/IEC 9646-1 [12], ISO/IEC 9646-2 [13], EN 300 175-1 [1], EN 300 175-5 [5], EN 300 175-6 [6] and EN 300 175-7 [7] apply.

3.2 Abbreviations

For the purposes of the present document, the following abbreviations apply:

AC	Authentication Code
AR	Access Rights
AU	Authentication
BI	Invalid Behaviour
BO	Inopportune Behaviour
BV	Valid Behaviour
CA	Capability
CC	Call Control
CH	Ciphering
CI	Call Information
CISS	Call Independent Supplementary Services
CLMS	Connectionless Message Services
COMS	Connection Oriented Message Services
CR	Call Release
DECT	Digital Enhanced Cordless Telecommunications
FT	Fixed radio Termination
HP	Handover Procedure
IC	Incoming Call
ID	Identification
IPUI	International Portable User Identity
IUT	Implementation Under Test
KA	Key Allocation
LC	Link Control
LE	connection oriented Link Establishment
LL	connectionless Link control
LO	Location
LR	connection oriented Link Release
LS	connection oriented Link Suspend and resume
ME	Management Entity
MM	Mobility Management
MO	Connection Oriented Message Services
NWK	Network layer
OC	Outgoing Call
PARK	Portable Access Rights Key
PDU	Protocol Data Unit
PHL	Physical layer
PICS	Protocol Implementation Conformance Statement
PIXIT	Protocol Implementation Extra Information for Testing
PM	Packet Mode
PR	Parameter Retrieval

PT	Portable radio Termination
RS	Call Related Supplementary Services
SC	Service Change
TP	Test Purpose
TSS	Test Suite Structure
UAK	User Authentication Key

4 Test Suite Structure (TSS)

4.1 TSS overview

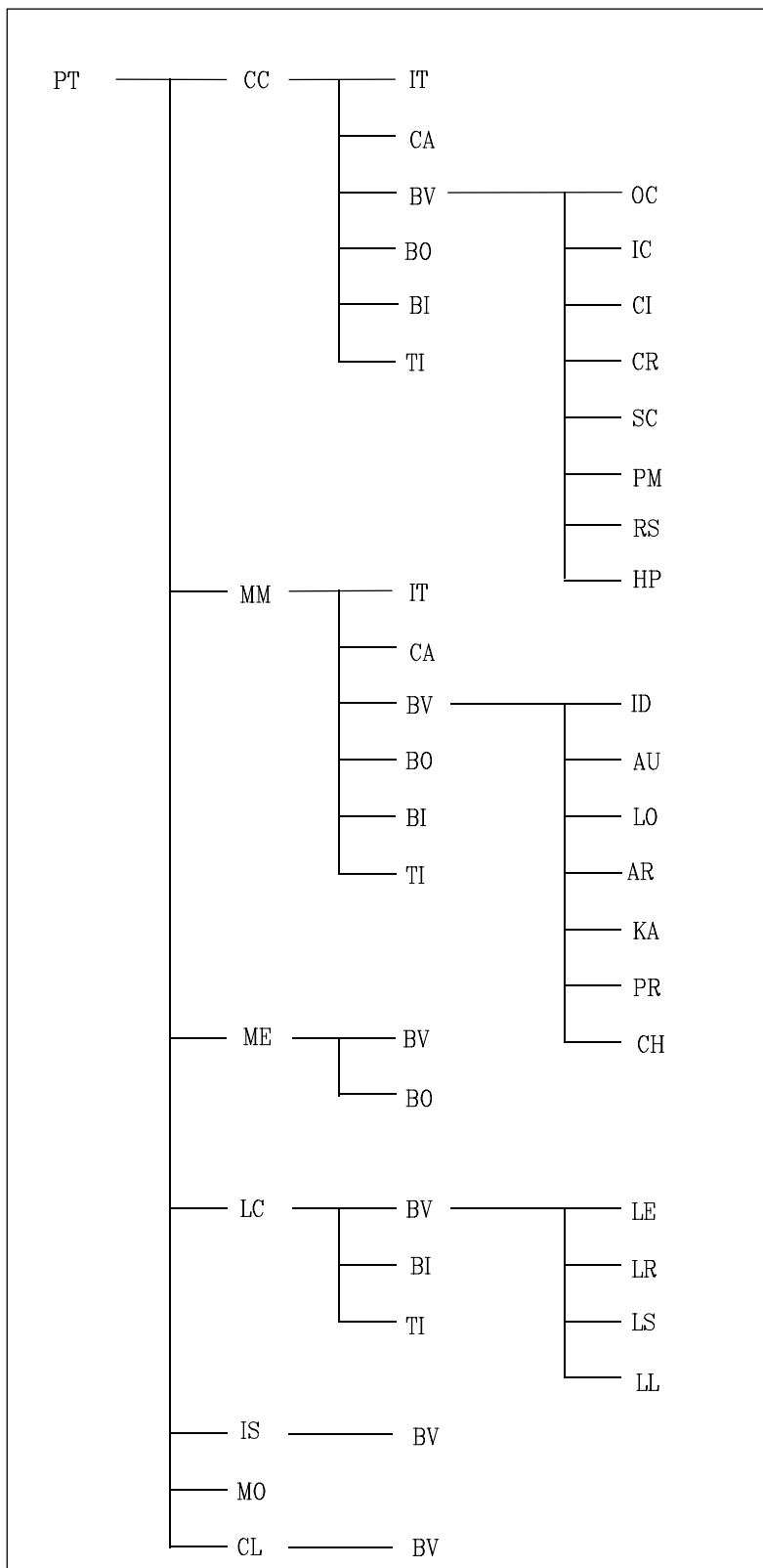

Figure 1: TSS

4.2 Test groups

4.2.1 Protocol groups

4.2.1.1 Call Control (CC)

Reference: EN 300 175-5 [5], subclause 5.2, clause 9 and subclause 15.7.

4.2.1.2 Mobility Management (MM)

Reference: EN 300 175-5 [5], subclause 5.6 and clause 13.

4.2.1.3 Lower layer Management Entity (ME)

Reference: EN 300 175-5 [5], clause 15.

4.2.1.4 Link Control (LC)

Reference: EN 300 175-5 [5], subclause 5.7 and clause 14.

4.2.1.5 Call Independent Supplementary Services (CISS)

Reference: EN 300 175-5 [5], subclauses 5.3 and 10.4.2.2.

4.2.1.6 Connection Oriented Message Services (COMS)

Reference: EN 300 175-5 [5], subclause 5.4 and clause 11.

4.2.1.7 Connectionless Message Services (CLMS)

Reference: EN 300 175-5 [5], subclause 5.5 and clause 12.

4.2.2 Main test groups

4.2.2.1 Basic InTerconnection tests (IT)

IT tests provide limited testing of an Implementation Under Test (IUT) in order to establish that there is sufficient conformance for possible interconnection without trying to perform thorough testing. In particular, only those test cases will be executed which will assure the sufficient interconnection between the IUT of the NWK layer and the test system exists, so that the rest of the test cases can then be put into execution.

4.2.2.2 Capability tests (CA)

CA tests provide limited testing that the observable capabilities of the IUT are in accordance with the static conformance requirements and the additional capabilities claimed in the Protocol Implementation Conformance Statement / Protocol Implementation Extra Information for Testing (PICS / PIXIT). In particular, this test group can be regarded as a set of spot checks for all the capabilities of the IUT stated in the PICS / PIXIT. Scope of the test group is the observable capabilities of the IUT with respect to NWK layer connection, call control, and the mobility management.

4.2.2.3 Valid Behaviour tests (BV)

BV group tests an IUT in response to valid behaviour of the test system. "Valid" means that a test event is syntactically and contextually correct. All test cases in the valid behaviour group are intended to verify as thoroughly as possible the various functions of the protocol.

4.2.2.4 Invalid Behaviour tests (BI)

BI group is intended to verify that the IUT is able to react properly in case an invalid protocol data unit (message) occurring. Invalid Protocol Data Unit (PDU) here means syntactically or semantically invalid test events generated by the test system. A syntactically or semantically invalid test event regardless of the current state is not allowed.

4.2.2.5 InOpportune Behaviour tests (BO)

BO test group is intended to verify that the IUT is able to react properly in case an inopportune test event occurring. Such an event is syntactically correct, but occurs when it is not allowed.

4.2.2.6 Timer expiry and counter mismatch tests (TI)

Different timers and counters are defined to supervise the various state transitions. This test subgroup is intended to verify that the IUT is reacting properly to an expiry of one of the timers or counters mismatch.

5 Test Purposes (TPs)

Each test case is allocated directly under a defined TP.

5.1 Introduction

5.1.1 TP definition conventions

The TPs are defined following particular rules as shown in table 1.

Table 1: TP definition rules

TP Id according to the TP naming conventions	Reference Initial condition Stimulus Expected behaviour
TP Id:	The TP Id is a unique identifier it shall be specified according to the TP naming conventions defined in the subclause below.
Reference:	The reference should contain the references of the subject to be validated by the actual TP (specification reference, clause, paragraph).
Condition:	The condition defines in which initial state the IUT has to be to apply the actual TP.
Stimulus:	The stimulus defines the test event to which the TP is related.
Expected behaviour:	Definition of the events that are expected from the IUT to conform to the base specification.

5.1.2 References

Subclause 5.1.2 defines the use of references given in the TPs. The structure provides the interrelationship with:

- the source EN giving the clause / subclause reference; and
- the profile EN giving the clause / subclause reference.

5.1.3 TP naming conventions

The identifier of the TP is built according to table 2.

Table 2: TP naming convention

TP<rt>/<fm>/<x>/<s>/<nn>		
<rt> = type of radio termination	PT	Portable radio Termination
<fm> = functional module	CC MM ME LC IS MO CL	Call Control Mobility Management Lower Layer Management Entity Link Control Entity Call Independent Supplementary Services Connection Oriented Message Service Connectionless Message Service
x = Type of testing	IT CA BV BO BI TI	Basic Interconnection Tests Capability Tests Valid Behaviour Tests Inopportune Behaviour Tests Invalid Behaviour Tests Timer expiry and counter mismatch tests
s = test subgroup	OC IC CI CR SC PM RS HP ID AU LO AR KA PR CH LE LR LS LL	Outgoing Call establishment Incoming Call establishment Call Information Call Release Service Change Packet Mode Call Related Supplementary services Handover Procedure Identification Authentication Location Access Rights Key Allocation Parameter Retrieval Ciphering Connection oriented Link Establishment Connection oriented Link Release Connection oriented Link Suspend and resume ConnectionLess Link Control
<nn> = sequential number	(01-99)	Test Purpose Number

5.2 CC test purposes

Test group objectives:

To check the behaviour of the CC module of the IUT.

Subgroups:

- IT;
- CA;
- BV;
- BO;
- BI;
- TI;
- HP.

5.2.1 CC/IT test purposes

There are no test purposes defined for this group in the present document.

5.2.2 CC/CA test purposes

There are no test purposes defined for this group in the present document.

5.2.3 CC/BV test purposes

Subgroups:

- OC;
- IC;
- CI;
- CR;
- SC;
- PM;
- RS.

5.2.3.1 CC/BV/OC test purposes

Test subgroup objectives:

To check the IUT's behaviours to setup an outgoing call.

Test purposes:

TP/PT/CC/BV/OC-01	EN 300 175-5 [5], subclause 9.1 - subclause 9.2 - subclause 9.3.1 EN 300 444 [10], subclause 8.1, figure 1 Initial state: T-00 Verify that the IUT is able to perform a CC-state transition from the T-00 state to T-10 state via T-01, T-02, T-03 and T-04 for an outgoing normal call set-up using piece-wise method to transfer dialling information in state T-02.
TP/PT/CC/BV/OC-02	EN 300 175-5 [5], subclause 9.1 - subclause 9.2 - subclause 9.3.1 EN 300 444 [10], subclause 8.1, figure 2 Initial state: T-00 Verify that the IUT is able to perform a CC-state transition from the T-00 state to T-10 state via T-01 for an outgoing normal call set-up using piece-wise method to transfer dialling information in state T-10.
TP/PT/CC/BV/OC-03	EN 300 175-5 [5], subclause 9.1 - subclause 9.2 - subclause 9.3.1 EN 300 444 [10], subclause 8.1, figure 3 Initial state: T-00 Verify that the IUT is able to perform a CC-state transition from the T-00 state to T-10 state via T-01 and T-02 for an outgoing normal call set-up using piece-wise method to transfer dialling information in states T-02 and T-10.
TP/PT/CC/BV/OC-04	EN 300 175-5 [5], subclause 9.3.1.4 - subclause 9.3.1.5, EN 300 444 [10], subclause 8.3, figure 9, table 11 Initial state: T-01 Verify that the IUT is able to connect the U-plane on receipt of the {CC-SETUP-ACK} message with the information element <<PROGRESS INDICATOR>> containing "in-band information or appropriate pattern now available".
TP/PT/CC/BV/OC-06 Previously existing TCL test DECT/T (98) 17, page 6	CAP feature N.2 EN 300 824 [11], subclause 9.2, table 9 - subclause 14.6 Initial state: T-00 LT simulates one FT the IUT has no subscription to. The LT shall transmit the extended higher layer capabilities bit a40 set to 1 prior to IUT locking. IUT may be or may be not locked. Verify that the IUT is able, prior to subscription, to perform a CC-state transition from the T-00 state to T-10 state for an outgoing emergency call set-up.
TP/PT/CC/BV/OC-07 Previously existing TCL test DECT/T (98) 17, page 6	CAP feature N.2 EN 300 824 [11], subclause 9.2, table 10 Initial state: T-00 The LT shall transmit the extended higher layer capabilities bit a40 set to 1 prior to IUT locking. Verify that the IUT is able, when it has subscription record in FT, to perform a CC-state transition from the T-00 state to T-10 state for an outgoing emergency call set-up.
TP/PT/CC/BV/OC-50 TP/PT/CC/BV/OC-06a DECT/T (98) 17, page 6	CAP feature N.2 EN 300 824 [11], subclause 9.2, table 9 - subclause 14.6 Initial state: T-00 LT simulates one FT the IUT has no subscription to. The LT shall transmit the extended higher layer capabilities bit a40 set to 0 prior to IUT locking. Verify that the IUT does not initiate, prior to subscription, emergency call set-up.

5.2.3.2 CC/BV/IC test purposes

Test subgroup objectives:

To check the IUT's behaviours to setup an incoming call.

Test purposes:

TP/PT/CC/BV/IC-01	EN 300 175-5 [5], subclause 9.1 - subclause 9.2 - subclause 9.3.2 EN 300 444 [10], subclause 8.11, figure 28 Initial state: T-00 Verify that the IUT is able to process an incoming call via the states T-06, T-07 and -08 to the state T-10, on receipt of the information element <<SIGNAL>> in the {C-INFO} message
TP/PT/CC/BV/IC-02	EN 300 175-5 [5], subclause 9.1 - subclause 9.2 - subclause 9.3.2 EN 300 444 [10], subclause 8.11, figure 29 Initial state: T-00 Verify that the IUT is able to process an incoming call via the states T-06, T-07 and -08 to the state T-10. The information element <<SIGNAL>> is in the {CC-SETUP} message.
TP/PT/CC/BV/IC-03	EN 300 175-5 [5], subclause 9.3.2.4 EN 300 444 [10], subclause 8.12 Initial state: T-00 Verify that the IUT in case of incoming call, is able to connect the U-plane on receipt of the {CC-SETUP} message with the information element <<PROGRESS INDICATOR>> containing "in-band information or appropriate pattern now available".
TP/PT/CC/BV/IC-04	EN 300 175-5 [5], subclause 9.3.2.4 EN 300 444 [10], subclause 8.14 Initial state: T-00 Verify that the IUT in case of incoming call, is able to connect the U-plane on receipt of a {CC-INFO} message with the information element <<PROGRESS INDICATOR>> containing "in-band information or appropriate pattern now available".

5.2.3.3 CC/BV/CI test purposes

Test subgroup objectives:

To check the IUT's behaviours for information transfer.

Test purposes:

TP/PT/CC/BV/CI-01	EN 300 175-5 [5], subclause 9.3.1.5 EN 300 444 [10], subclause 8.13 Initial state: T-06 Verify that the IUT is able to alert the user of an incoming call, when the information element <<SIGNAL>> is present in the {CC-SETUP} message.
TP/PT/CC/BV/CI-02	EN 300 175-5 [5], subclause 9.3.1.5 EN 300 444 [10], subclause 8.10, table 20 Initial state: T-02 Verify that the IUT, after the user has invoked pulse (decadic) dialling, sends a {CC-INFO} message with a <<MULTI-KEYPAD>> information element containing keypad-info '12H' (goto pulse). (feature N.23 in EN 300 444 [10])
TP/PT/CC/BV/CI-03	EN 300 175-5 [5], subclause 9.3.1.5 EN 300 444 [10], subclause 8.10, table 20 Initial state: T-10 Verify that the IUT, after the user has invoked pulse (decadic) dialling, sends a {CC-INFO} message with a <<MULTI-KEYPAD>> information element containing keypad-info '12H' (goto pulse). (feature N.23 in EN 300 444 [10])
TP/PT/CC/BV/CI-04	EN 300 175-5 [5], subclause 9.3.1.5 EN 300 444 [10], subclause 8.10, table 20 Initial state: T-02 Verify that the IUT, after the user has invoked dialling pause, sends a {CC-INFO} message with a <<MULTI-KEYPAD>> information element containing keypad-info '05H' (dialling pause). (feature N.7 in EN 300 444 [10])
TP/PT/CC/BV/CI-05	EN 300 175-5 [5], subclause 9.3.1.5 EN 300 444 [10], subclause 8.10, table 20 Initial state: T-10 Verify that the IUT, after the user has invoked dialling pause, sends a {CC-INFO} message with a <<MULTI-KEYPAD>> information element containing keypad-info '05H' (dialling pause). (feature N.7 in EN 300 444 [10])
TP/PT/CC/BV/CI-06	EN 300 175-5 [5], subclause 9.3.1.5 EN 300 444 [10], subclause 8.10, table 20 Initial state: T-02 Verify that the IUT, after the user has invoked DTMF dialling with defined tone length, sends a {CC-INFO} message with a <<MULTI-KEYPAD>> information element containing keypad-info '14H' (goto DTMF, defined tone length). (feature N.6 in EN 300 444 [10])
TP/PT/CC/BV/CI-07	EN 300 175-5 [5], subclause 9.3.1.5 EN 300 444 [10], subclause 8.10, table 20 Initial state: T-10 Verify that the IUT, after the user has invoked DTMF dialling with defined tone length, sends a {CC-INFO} message with a <<MULTI-KEYPAD>> information element containing keypad-info '14H' (goto DTMF, defined tone length). (feature N.6 in EN 300 444 [10])
TP/PT/CC/BV/CI-08	EN 300 175-5 [5], subclause 9.3.1.5 EN 300 444 [10], subclause 8.10, table 20 Initial state: T-02 Verify that the IUT, after the user has invoked DTMF dialling with defined tone length, sends a {CC-INFO} message with a <<MULTI-KEYPAD>> information element containing keypad-info '16H' (goto DTMF, infinite tone length). (feature N.22 in EN 300 444 [10])
TP/PT/CC/BV/CI-09	EN 300 175-5 [5], subclause 9.3.1.5 EN 300 444 [10], subclause 8.10, table 20 Initial state: T-10 Verify that the IUT, after the user has invoked DTMF dialling with defined tone length, sends a {CC-INFO} message with a <<MULTI-KEYPAD>> information element containing keypad-info '16H' (goto DTMF, infinite tone length). (feature N.22 in EN 300 444 [10])

TP/PT/CC/BV/CI-10	<p>EN 300 175-5 [5], subclause 9.3.1.5 EN 300 444 [10], subclause 8.10, table 20 Initial state: T-02 Verify that the IUT, after the user has invoked the sending of the basic digits (0-9, star, hash mark), sends one or more {CC-INFO} messages with <<MULTI-KEYPAD>> information elements containing the basic digits. (feature N.4 in EN 300 444 [10])</p>
TP/PT/CC/BV/CI-11	<p>EN 300 175-5 [5], subclause 9.3.1.5 EN 300 444 [10], subclause 8.18, table 30, table 31 Initial state: T-00 Verify that the IUT, after the user has invoked an internal call, performs one of the possible internal call setups, as described in EN 300 444 [10], subclause 8.18, table 30 and 31. PT can either send internal call specification in the CC-SETUP PDU, or in the CC-INFO PDU later on</p>
TP/PT/CC/BV/CI-12 Existing validated GAP test DECT/T (98) 17, page 7	<p>GAP/CAP feature N.3 EN 300 444 [10], subclause 8.16, table 27 EN 300 824 [11], subclause 9.3, table 11 Initial state: T-10 Verify that the IUT, on reception of <<MULTI_DISPLAY>> information elements, containing standard characters in {CC-INFO} messages, is able to show these characters on the display.</p>
TP/PT/CC/BV/CI-13 Existing validated GAP test DECT/T (98) 17, page 7	<p>GAP/CAP feature N.3 EN 300 444 [10], subclause 8.16, table 27 EN 300 824 [11], subclause 9.3, table 11 Initial state: T-10 Verify that the IUT, on reception of <<MULTI_DISPLAY>> information elements, containing control characters in {CC-INFO} messages, is able to understand and react upon these characters.</p>
TP/PT/CC/BV/CI-14	<p>EN 300 175-5 [5], subclause 9.3.1.5 EN 300 444 [10], subclause 8.10, table 20 Initial state: T-10 Verify that the IUT, after invocation of 'register recall', is able to activate the feature register recall in a {CC-INFO} message.</p>

5.2.3.4 CC/BV/CR test purposes

Test subgroup objectives:

To check the IUT's behaviour to release an outgoing and incoming call.

Test purposes:

TP/PT/CC/BV/CR-01	EN 300 175-5 [5], subclause 9.5.1 EN 300 444 [10], subclause 8.3.2.4 Initial state: T-02 Verify that the IUT is able to process a FT initiated normal release.
TP/PT/CC/BV/CR-02	EN 300 175-5 [5], subclause 9.5.1 EN 300 444 [10], subclause 8.7 Initial state: T-03 Verify that the IUT is able to process a FT initiated normal release.
TP/PT/CC/BV/CR-03	EN 300 175-5 [5], subclause 9.5.1 EN 300 444 [10], subclause 8.7 Initial state: T-04 Verify that the IUT is able to process a FT initiated normal release.
TP/PT/CC/BV/CR-04	EN 300 175-5 [5], subclause 9.5.1 EN 300 444 [10], subclause 8.7 Initial state: T-08 Verify that the IUT is able to process a FT initiated normal release.
TP/PT/CC/BV/CR-05	EN 300 175-5 [5], subclause 9.5.1 EN 300 444 [10], subclause 8.7 Initial state: T-10 Verify that the IUT is able to process a FT initiated normal release.
TP/PT/CC/BV/CR-06	EN 300 175-5 [5], subclause 9.5.1 EN 300 444 [10], subclause 8.7 Initial state: T-10 Verify that the IUT is able to process an IUT initiated normal release.
TP/PT/CC/BV/CR-07	EN 300 175-5 [5], subclause 9.5.2 EN 300 444 [10], subclause 8.2.2.3 Initial state: T-01 Verify that the IUT is able to process a FT initiated abnormal release.
TP/PT/CC/BV/CR-08	EN 300 175-5 [5], subclause 9.5.2 EN 300 444 [10], subclause 8.3.2.2 Initial state: T-02 Verify that the IUT is able to process a FT initiated abnormal release.
TP/PT/CC/BV/CR-09	EN 300 175-5 [5], subclause 9.5.2 EN 300 444 [10], subclause 8.8 Initial state: T-10 Verify that the IUT is able to process a FT initiated abnormal release.
TP/PT/CC/BV/CR-10	EN 300 175-5 [5], subclause 14.2.7 EN 300 444 [10], subclause 8.9 Initial state: T-10 Verify that the IUT is able to process a FT initiated partial release.
TP/PT/CC/BV/CR-11	EN 300 175-5 [5], subclause 14.2.7 EN 300 444 [10], subclause 8.9 Initial state: T-10 Verify that the IUT is able to process an IUT initiated partial release.

5.2.3.5 CC/BV/SC test purposes

There are no test purposes defined for this group in the present document.

5.2.3.6 CC/BV/PM test purposes

There are no test purposes defined for this group in the present document.

5.2.3.7 CC/BV/RS test purposes

Test subgroup objectives:

To check the IUT's behaviour during any call related procedures.

Test purposes:

TP/PT/CC/BV/RS-01 Existing validated GAP test DECT/T (98) 17, page 3	EN 300 444 [10], subclause 8.12, table 21 EN 300 824 [11], subclause 7.7, table 3 Initial state: T-00 Verify that the IUT shows the calling party number correctly on receipt of calling party number indication before accepting a call. (feature N.30 in EN 300 444 [10])
--	--

5.2.3.8 CC/BV/HP test purposes

Test subgroup objectives:

To check the IUT's behaviour during external handover.

Test purposes:

<p>TP/PT/CC/BV/HP-50 CAP/PT/NWK/01.1 DECT/T (98) 17, page 3</p>	<p>CAP feature N.1 (Handover candidate indication) EN 300 824 [11], subclause 9.1.1.1 Initial state: T-00 Verify that the IUT is able to perform the external handover call setup procedure. The external handover information will have been provided to the IUT in <<Ext h/o indicator>> and <<network parameter>> information elements in a CC-SETUP-ACK message during establishment of the outgoing call.</p>
<p>TP/PT/CC/BV/HP-51 CAP/PT/NWK/01.2 DECT/T (98) 17, page 3</p>	<p>CAP feature N.1 (Handover candidate indication) EN 300 824 [11], subclause 9.1.1.1 Initial state: T-00 Verify that the IUT is able to perform the external handover call setup procedure. The external handover information will have been provided to the IUT in <<Ext h/o indicator>> and <<network parameter>> information elements in a CC-INFO message during establishment of the outgoing call.</p>
<p>TP/PT/CC/BV/HP-52 CAP/PT/NWK/01.3 DECT/T (98) 17, page 3</p>	<p>CAP feature N.1 (Handover candidate indication) EN 300 824 [11], subclause 9.1.1.1 Initial state: T-00 Verify that the IUT is able to perform the external handover call setup procedure. The external handover information will have been provided to the IUT in <<Ext h/o indicator>> and <<network parameter>> information elements in a CC-CONNECT message during establishment of the outgoing call.</p>
<p>TP/PT/CC/BV/HP-53 CAP/PT/NWK/02.1 DECT/T (98) 17, page 3</p>	<p>CAP feature N.1 (Handover candidate indication) EN 300 824 [11], subclause 9.1.1.1 Initial state: T-00 Verify that the IUT is able to perform the external handover call setup procedure. The external handover information will have been provided to the IUT in <<Ext h/o indicator>> and <<network parameter>> information elements in a CC-SETUP message during establishment of the incoming call.</p>
<p>TP/PT/CC/BV/HP-54 CAP/PT/NWK/02.2 DECT/T (98) 17, page 4</p>	<p>CAP feature N.1 (Handover candidate indication) EN 300 824 [11], subclause 9.1.1.1 Initial state: T-00 Verify that the IUT is able to perform the external handover call setup procedure. The external handover information will have been provided to the IUT in <<Ext h/o indicator>> and <<network parameter>> information elements in a CC-INFO message during establishment of the incoming call.</p>
<p>TP/PT/CC/BV/HP-55 CAP/PT/NWK/03 DECT/T (98) 17, page 4</p>	<p>CAP feature N.1 (Handover candidate retrieval) EN 300 824 [11], subclause 9.1.1.2, table 6 Initial state: T-10 Verify that the IUT requests external handover parameters any time during an incoming call if the <<Ext h/o indicator>> information element provided during call setup had the OID value set to "1". Verify that the IUT is subsequently able to successfully complete the external handover call setup procedure.</p>
<p>TP/PT/CC/BV/HP-56 CAP/PT/NWK/04 DECT/T (98) 17, page 4</p>	<p>CAP feature N.1 (Handover reference retrieval) EN 300 824 [11], subclause 9.1.3.2 Initial state: T-10 Verify that the IUT applies the handover reference retrieval procedure as soon as possible after establishment of an incoming call (only in CC active) where the <<network parameter>> information element was not supplied. Verify that the IUT is subsequently able to successfully complete the external handover call setup procedure.</p>
<p>TP/PT/CC/BV/HP-57 CAP/PT/NWK/04.2 DECT/T (98) 17, page 4</p>	<p>CAP feature N.1 (Failure of the PP handover reference retrieval attempt) EN 300 824 [11], subclause 9.1.3.2.1 Initial state: T-10 Verify that the IUT starts the handover reference retrieval procedure as soon as possible after establishment of an incoming call (only in CC active) where the <<network parameter>> information element was not supplied. Verify that the IUT consider the handover reference retrieval procedure as failed upon receipt of a MM_INFO_REJECT and that after such failure the IUT does not attempt to carry out the external handover call setup procedure.</p>
<p>TP/PT/CC/BV/HP-58 CAP/PT/NWK/04.4 DECT/T (98) 17, page 4</p>	<p>CAP feature N.1 (Failure of the PP handover reference retrieval attempt) EN 300 824 [11], subclause 9.1.3.2.1 Initial state: T-10 Verify that the IUT starts the handover reference retrieval procedure as soon as possible after establishment of an incoming call (only in CC active) where the <<network parameter>> information element was not supplied. Verify that the IUT consider the Handover reference retrieval procedure as failed upon expiry of <MM_info.1> and that after such failure the IUT does not attempt to carry out the external handover call setup procedure.</p>

TP/PT/CC/BV/HP-59 CAP/PT/NWK/05 DECT/T (98) 17, page 4	CAP feature N.1 (Handover candidate call setup) EN 300 824 [11], subclause 9.1.4, table 8 Initial state: T-10 Verify that the IUT is able to perform the external handover call setup procedure and successfully establishes the U-plane on the new connection.
TP/PT/CC/BV/HP-60 CAP/PT/NWK/06 DECT/T (98) 17, page 4	CAP feature N.1 (Handover call setup - abnormal link release) EN 300 824 [11], subclause 9.1.4.2.1 Initial state: T-10 Verify that the IUT is able to complete the external handover call setup procedure successfully when an abnormal link release occurs on the FP-1 link.
TP/PT/CC/BV/HP-61 CAP/PT/NWK/07 DECT/T (98) 17, page 5	CAP feature N.1 (Handover call setup N400) EN 300 175-5 [5], subclause 15.7.4.5 EN 300 824 [11], subclause 9.1.4 Initial state: T-10 Verify that, during the external handover call setup procedure, after call setup is complete on FP-2, the IUT releases the FP-1 link using a {CC-RELEASE} message containing a <<release reason>> indicating "external handover release" if timer N400 expires.
TP/PT/CC/BV/HP-62 CAP/PT/NWK/07.2 DECT/T (98) 17, page 5	CAP feature N.1 (Handover call setup - normal call release on FP-2 leg) EN 300 824 [11], subclause 9.1.4.2.2 Initial state: T-10 Verify that, after handover has been accepted and the user releases the call, call release procedure as defined in EN 300 444 subclause 8.7 is used with regard to FP-2.
TP/PT/CC/BV/HP-63 CAP/PT/NWK/07.3 DECT/T (98) 17, page 5	CAP feature N.1 (Handover call setup - normal call release on FP-2 leg) EN 300 824 [11], subclause 9.1.4.2.2 Initial state: T-10 Verify that, after handover has been accepted and the network releases the call, call release procedure as defined in EN 300 444 subclause 8.7 is used with regard to FP-2.
TP/PT/CC/BV/HP-64 CAP/PT/NWK/07.4 DECT/T (98) 17, page 5	CAP feature N.1 (Handover call setup - abnormal link release on FP-2 leg) EN 300 824 [11], subclause 9.1.4.2.3 Initial state: T-10 Verify that, upon receipt of a link release indication (FP-2) before the handover request to FP-2 has been confirmed, the PT remain connected to FP-1.
TP/PT/CC/BV/HP-65 CAP/PT/NWK/08 DECT/T (98) 17, page 5	CAP feature N.1 (Handover ciphering PT initiated) EN 300 824 [11], subclause 9.1.5.1 Initial state: T-10 Verify that after performing the external handover call setup procedure on a ciphered connection, the IUT initiates and successfully performs the PT initiated ciphering procedure on the new connection.
TP/PT/CC/BV/HP-66 CAP/PT/NWK/09 DECT/T (98) 17, page 5	CAP feature N.1 (Handover ciphering FT initiated) EN 300 824 [11], subclause 9.1.5.2 Initial state: T-10 Verify that after performing the external handover call setup procedure, the IUT successfully performs the FT initiated ciphering procedure on the new connection when the {CIPHER-REQUEST} is sent before the first call is released.
TP/PT/CC/BV/HP-67 CAP/PT/NWK/10 DECT/T (98) 17, page 5	CAP feature N.1 (Handover ciphering PT initiated fails) EN 300 175-5 [5], subclause 15.7.6 EN 300 824 [11], subclause 9.1.5.1 Initial state: T-10 Verify that after performing the external handover call setup procedure, and initiating the PT initiated ciphering procedure on the new connection, the IUT releases the link on FP-2 if PT initiated ciphering fails.
TP/PT/CC/BV/HP-68 CAP/PT/NWK/11 DECT/T (98) 17, page 6	CAP feature N.1 (Handover ciphering FT initiated fails) EN 300 175-5 [5], subclause 15.7.6 EN 300 824 [11], subclause 9.1.5.2 Initial state: T-10 Verify that after performing the external handover call setup procedure, and initiating the FT initiated ciphering procedure on the new connection, the IUT releases the link on FP-2 if FT initiated ciphering fails.
TP/PT/CC/BV/HP-69 CAP/PT/NWK/12 DECT/T (98) 17, page 6	CAP feature N.1 (Location registration after external handover) EN 300 824 [11], subclause 14.2 Initial state: T-10 Verify that after performing the external handover call setup procedure to an FP in a different location area, the IUT immediately performs the location registration procedure on the new connection.

TP/PT/CC/BV/HP-70 CAP/PT/NWK/14 DECT/T (98) 17, page 6	CAP feature N.1 (N500 timer and N501 counter) EN 300 824 [11], subclause 14.5 Initial state: T-10 Verify that after N501 consecutive unsuccessful external handover attempts, the IUT waits at least N500 seconds before initiating a new external handover attempt.
TP/PT/CC/BV/HP-71 CAP/PT/NWK/20 DECT/T (98) 17, page 10	CAP feature N.1 (External handover setup) EN 300 824 [11], subclause 9.1.1.1, table 7 - subclause 9.1.4 Initial state: T-00 Verify the IUT is able to perform the external handover call setup procedure if the <<Ext h/o indicator>> information element provided during call setup indicated multiframe, multiframe number and PSCN synchronization in the SYNC field.
TP/PT/CC/BV/HP-72 CAP/PT/NWK/21 DECT/T (98) 17, page 10	CAP feature N.1 (External handover setup) EN 300 824 [11], subclause 9.1.1.1, table 7 - subclause 9.1.4 Initial state: T-00 Verify the IUT is able to perform the external handover call setup procedure if the <<Ext h/o indicator>> information element provided during call setup indicated multiframe and PSCN synchronization in the SYNC field.
TP/PT/CC/BV/HP-73 CAP/PT/NWK/22 DECT/T (98) 17, page 10	CAP feature N.1 (External handover setup) EN 300 824 [11], subclause 9.1.1.1, table 7 - subclause 9.1.4 Initial state: T-00 For those IUTs that support the feature, verify the IUT is able to perform the external handover call setup procedure if the <<Ext h/o indicator>> information element provided during call setup indicated multiframe synchronization in the SYNC field.
TP/PT/CC/BV/HP-74 CAP/PT/NWK/23 DECT/T (98) 17, page 10	CAP feature N.1 (External handover setup) EN 300 824 [11], subclause 9.1.1.1, table 7 - subclause 9.1.4 Initial state: T-00 For those IUTs that support the feature, verify the IUT is able to perform the external handover call setup procedure if the <<Ext h/o indicator>> information element provided during call setup indicated no synchronization in the SYNC field.
TP/PT/CC/BV/HP-75 CAP/PT/NWK/13 DECT/T (98) 17, page 6	CAP feature N.1 (N500 timer) EN 300 824 [11], subclause 14.5 Initial state: T-10 Verify that after performing a successful external handover call setup procedure, the IUT will not attempt to perform another external handover call setup until timer N500 has expired.

5.2.4 CC/BO test purposes

Test group objectives:

To check the CC of the IUT in response to the messages that are syntactically correct but not allowed to occur in some states of the CC procedures.

Test purposes:

TP/PT/CC/BO-01	EN 300 175-5 [5] subclause 17.4.1 EN 300 444 [10], subclause 6.9.4 Initial state: T-03 Verify that the IUT ignores the unexpected message {CC-CALL-PROC}. The {CC-CALL-PROC} message occurs in an unexpected state.
TP/PT/CC/BO-02	EN 300 175-5 [5] subclause 17.4.1 EN 300 444 [10], subclause 8.7.2.1, figure 21 Initial state: T-19 Verify that the IUT is able to react correctly on a release collision, in the sense that on the reception of a {CC-RELEASE} message in state F-19, no {CC-RELEASE-COM} message is sent back, and the call is cleared.
TP/PT/CC/BO-50 CAP/FT/NWK/07.1 DECT/T (98) 17 p.14	CAP feature N.1 (Handover candidate call setup) EN 300 824 [11], subclause 9.1.4 Initial state: different from T-10 Verify that the IUT does not perform the external handover call setup procedure towards FP-2 if the associated call in FP-1 is not in state "ACTIVE".

5.2.5 CC/BI test purposes

Test group objectives:

To check the CC module of the IUT in response to invalid messages.

Test purposes:

TP/PT/CC/BI-01	EN 300 175-5 [5], subclause 17.6.1 EN 300 444 [10], subclause 6.9.4 Initial state: T-00 Verify that the IUT sends a {CC-RELEASE-COM} message, on receipt of a {CC-SETUP} message with a mandatory information element missing. The mandatory information element that is missing, is 'basic service'.
TP/PT/CC/BI-02	EN 300 175-5 [5] subclause 17.6.2 EN 300 444 [10], subclause 6.9.4 Initial state: T-00 Verify that the IUT on receipt of a {CC-SETUP} message containing a mandatory information element with invalid contents returns a {CC-RELEASE-COM} message. The mandatory information element 'portable_id' has invalid contents
TP/PT/CC/BI-03	EN 300 175-5 [5] subclause 17.4.1 EN 300 444 [10], subclause 6.9.4 Initial state: T-10 Verify that the IUT ignores an unrecognized message, when it is constructed as a {CC-SETUP} with one bit wrong in the <<message type>>.

5.2.6 CC/TI test purposes

Test group objectives:

To check the IUT's properly reacting to an expiry of one of the timers.

Test purposes:

TP/PT/CC/TI-01	EN 300 175-5 [5], subclause 9.5.1 EN 300 444 [10], subclause 8.7.2.3 Initial state: T-19 Verify that the IUT, after having started timer P-<CC.02>, sends a {CC-RELEASE-COM} message when the timer expires after the defined time. The {CC-RELEASE-COM} message should arrive within the allowed margin time of $\pm 5\%$.
TP/PT/CC/TI-02	EN 300 175-5 [5], subclause 9.3.2.1 EN 300 444 [10], subclause 8.2.2.1 Initial state: T-01 Verify that the IUT, after having started timer P-<CC.03>, sends a {CC-RELEASE-COM} message when the timer expires after the defined time. The {CC-RELEASE-COM} message should arrive within the allowed margin time of $\pm 5\%$.
TP/PT/CC/TI-03	EN 300 175-5 [5], subclause 9.3.2.1 EN 300 444 [10], subclause 8.2.1.1 Initial state: T-01 Verify that the IUT is able to restart timer P-<CC.03>. on receipt of a {CC-NOTIFY} message, sent by the FT.
TP/PT/CC/TI-04	EN 300 175-5 [5], subclause 9.3.2.8 EN 300 444 [10], subclause 8.15.2.3 Initial state: T-08 Verify that the IUT, after having started timer P-<CC.05>, releases the call using the normal procedure when the timer expires after the defined time. The {CC-RELEASE} message should arrive within the allowed margin time of $\pm 5\%$.

5.3 MM test purposes

Test group objectives:

To check the behaviour of the MM module of the IUT. The initial states are not fixed. The manufacturer has to decide in which state the test case is to be done.

Subgroups:

- IT;
- CA;
- BV;
- BO;
- BI;
- TI.

5.3.1 MM/IT test purposes

There are no test purposes defined for this group in the present document.

5.3.2 MM/CA test purposes

There are no test purposes defined for this group in the present document.

5.3.3 MM/BV test purposes

Subgroups:

- ID;
- AU;
- LO;
- AR;
- KA;
- PR;
- CH.

5.3.3.1 MM/BV/ID test purposes

Test subgroup objectives:

To check the IUT's behaviours of identity request procedure.

Test purposes:

TP/PT/MM/BV/ID-01	<p>EN 300 175-5 [5], subclause 13.2.1 EN 300 444 [10], subclause 8.19, figure 43 Initial state: T-00 Verify that the IUT, on receipt of an {IDENTITY-REQUEST} message specifying the International Portable User Identity (IPUI), returns an {IDENTITY-REPLY} message with the IPUI.</p>
TP/PT/MM/BV/ID-02	<p>EN 300 175-5 [5], subclause 13.2.1 EN 300 444 [10], subclause 8.19.2.1 Initial state: T-00 Verify that the IUT, on receipt of an {IDENTITY-REQUEST} message specifying an unavailable identity type, returns an {IDENTITY-REPLY} message without identity information elements thereby indicating reject.</p>
TP/PT/MM/BV/ID-03	<p>EN 300 175-5 [5], subclause 13.2.1 Initial state: T-00 Verify that the IUT, on receipt of an {IDENTITY-REQUEST} message specifying a portable identity with IPUI type for which it has stored more than one identity, returns an {IDENTITY-REPLY} message with all available portable id's with IPUI type. In order for the IUT to receive more than one portable_id, a second access rights request will have to be done, assigning a second portabis id.</p>
TP/PT/MM/BV/ID-04	<p>EN 300 175-5 [5], subclause 13.2.1 Initial state: T-00 Verify that the IUT, on receipt of an {IDENTITY-REQUEST} message specifying a fixed identity with Portable Access Rights Key (PARK) type for which it has stored more than one identity, returns an {IDENTITY-REPLY} message with all available fixed id's with PARK type. In order for the IUT to receive more than one fixed_id, a second access rights request will have to be done, assigning a second fixed-id.</p>
TP/PT/MM/BV/ID-08	<p>EN 300 175-5 [5], subclause 13.2.1 EN 300 444 [10], subclause 8.19, figure 43 Initial state: T-00 Verify that the IUT, on receipt of an {IDENTITY-REQUEST} message specifying the PARK, returns an {IDENTITY-REPLY} message with the PARK.</p>

5.3.3.2 MM/BV/AU test purposes

Test subgroup objectives:

To check the IUT's valid behaviours of the authentication procedure.

Test purposes:

TP/PT/MM/BV/AU-01	<p>EN 300 175-5 [5], subclause 13.3.1 EN 300 444 [10], subclause 8.21 Initial state: T-00 Verify that the IUT is able to operate the basic authentication of PT procedure. (IUT has not stored ZAP value and service class information.) Authentication will be based on a User Authentication Key (UAK), so a precondition to this test will be that the UAK is assigned. A DCK will not be stored by the PT. It is assumed that the IUT will reply to the authentication request automatically, without any user intervention needed.</p>
TP/PT/MM/BV/AU-02	<p>EN 300 175-5 [5], subclause 13.3.1 EN 300 444 [10], subclause 8.21.2.1 Initial state: T-00 Verify that the IUT, on receipt of an {AUTH-REQUEST} message containing unacceptable algorithm, returns an {AUTH-REJECT} message. Authentication will be based on UAK, so a precondition to this test will be that the UAK is assigned.</p>
TP/PT/MM/BV/AU-03	<p>EN 300 175-5 [5], subclause 13.3.1 EN 300 444 [10], subclause 8.23 Initial state: T-00 Verify that the IUT, when it has stored ZAP value, includes the <<ZAP field>> in the {AUTH-REPLY} message during the authentication of PT procedure. Authentication will be based on UAK, so a precondition to this test will be that the UAK is assigned</p>
TP/PT/MM/BV/AU-04	<p>EN 300 175-5 [5], subclause 13.3.1 EN 300 444 [10], subclause 8.23 Initial state: T-00 Verify that the IUT increments the ZAP field during an authentication of PT procedure. The IUT may or may not authenticate the FT before incrementing the ZAP value. Authentication will be based on UAK, so a precondition to this test will be that the UAK is assigned.</p>
TP/PT/MM/BV/AU-05	<p>EN 300 175-5 [5], subclause 13.3.1 EN 300 444 [10], subclause 8.23 Initial state: T-00 Verify that the IUT, if it supports authentication of FT as part of the increment ZAP procedure, does not increment the ZAP value if the FT authentication fails. Authentication will be based on UAK, so a precondition to this test will be that the UAK is assigned.</p>
TP/PT/MM/BV/AU-06	<p>EN 300 175-5 [5], subclause 13.8 - subclause 7.7.24 EN 300 444 [10], subclause 8.24 Initial state: T-00 Verify that the IUT, receiving an {AUTH-REQ} message containing an <<AUTH-TYPE>> information element, containing UPC bit = 1 (store DCK), stores the DCK and that the DCK can be used again in a successive FT initiated ciphering procedure. Authentication will be based on UAK, so a precondition to this test will be that the UAK is assigned. The test purpose will be checked by switching on ciphering, and afterwards requesting an identity (IPUI) of the IUT. If no response is received on this identity request, LT and IUT are probably ciphering with a different DCK.</p>
TP/PT/MM/BV/AU-07	<p>EN 300 175-5 [5], subclause 13.3.2 EN 300 444 [10], subclause 8.22 Initial state: T-00 Verify that the IUT is able to operate the basic authentication of user procedure.</p>
TP/PT/MM/BV/AU-08	<p>EN 300 175-5 [5], subclause 13.3.3 EN 300 444 [10], subclause 8.20 Initial state: specified in PIXIT Verify that the IUT, after invoking the basic authentication of FT procedure, is able to operate the procedure. Authentication will be based on UAK, so a precondition to this test will be that the UAK is assigned.</p>

TP/PT/MM/BV/AU-09	<p>EN 300 175-5 [5], subclause 13.3.1 EN 300 444 [10], subclause 8.23 Initial state: T-00 Verify that the IUT, when it has stored service class information, includes the <<Service class>> information elements in the {AUTH-REPLY} message during the authentication of PT procedure. Authentication will be based on UAK, so a precondition to this test will be that the UAK is assigned.</p>
-------------------	--

5.3.3.3 MM/BV/LO test purposes

Test subgroup objectives:

To check the IUT's valid behaviours of the location procedure.

Test purposes:

TP/PT/MM/BV/LO-01	<p>EN 300 175-5 [5], subclause 13.4.1 EN 300 444 [10], subclause 8.25 Initial state: T-00 Verify that the IUT, if the a44 and a38 bits in the FT broadcasted "higher layer capabilities" were set to "1", is capable to operate the basic location registration procedure after it performed the obtain access rights procedure. (FT does not perform TPUI assignment). See note</p>
TP/PT/MM/BV/LO-02	<p>EN 300 175-5 [5], subclause 13.4.1 EN 300 444 [10], subclause 8.25 Initial state: T-00. Verify that the IUT, if the a44 and a38 bits in the FT broadcasted "higher layer capabilities" were set to "1", is capable to operate the basic location registration procedure after it performed the obtain access rights procedure. (FT does perform TPUI assignment). See note</p>
TP/PT/MM/BV/LO-03	<p>EN 300 175-5 [5], subclause 13.4.1 EN 300 444 [10], subclause 8.25 Initial state: T-00. Verify that the IUT, if the a44 bit in the FT broadcasted "higher layer capabilities" was set to "1" but a38 is set to "0", does not initiate location registration procedure after it performed the obtain access rights procedure. See note</p>
TP/PT/MM/BV/LO-04	<p>EN 300 175-5 [5], subclause 13.4.1 EN 300 444 [10], subclause 8.25 Initial state: T-00 Verify that the IUT, if the a38 bit in the FT broadcasted "higher layer capabilities" was set to "1" and if location area changes not during a CC call, is able to operate location registration procedure. (FT does not perform TPUI assignment). See note</p>
TP/PT/MM/BV/LO-05	<p>EN 300 175-5 [5], subclause 13.4.1 EN 300 444 [10], subclause 8.25 Initial state: T-00. Verify that the IUT, if the a38 bit in the FT broadcasted "higher layer capabilities" was set to "1", after power-off and power-on and after locking to the FT to which it has access rights, will initiate location registration procedure. See note</p>
TP/PT/MM/BV/LO-06	<p>EN 300 175-5 [5], subclause 13.4.1 EN 300 444 [10], subclause 8.25 Initial state: T-00 Verify that the IUT, during a location registration procedure on receipt of a {LOCATE-ACCEPT} message specifying an unacceptable TPUI, will reject the assignment.</p>
TP/PT/MM/BV/LO-07	<p>EN 300 175-5 [5], subclause 13.4.1 EN 300 444 [10], subclause 8.25 Initial state: T-00 Verify that the IUT, entering a new location area, deletes the individual assigned TPUI, before performing the location registration procedure. This shall be done by verifying that the IUT does not return the deleted TPUI in the identity request procedure.</p>

TP/PT/MM/BV/LO-08	EN 300 175-5 [5], subclause 13.7 EN 300 444 [10], subclause 8.26 Initial state: T-00 Verify that the IUT, as part of the parameter retrieval procedure on receipt of a location update request, will start location registration procedure within reasonable time, when in the broadcast attributes bit a38 was set to "1".
TP/PT/MM/BV/LO-09	EN 300 175-5 [5], subclause 13.7 EN 300 444 [10], subclause 8.26 Initial state: T-00 Verify that the IUT, as part of the parameter retrieval procedure on receipt of a location update request, will start location registration procedure within reasonable time, even when in the broadcast attributes bit a38 was set to "0".
TP/PT/MM/BV/LO-10 CAP/PT/NWK/21a DECT/T (98) 17, page 11	GAP/CAP feature M.13 EN 300 175-3 [3], subclause 11.3.2 EN 300 175-6 [6], subclause 5.6 Initial state: T-00 Verify that the IUT can correctly perform location registration and a following outgoing call when it uses SARI as the means to lock to the LT.
TP/PT/MM/BV/LO-50 CAP/PT/NWK/16 DECT/T (98) 17, page 8	CAP feature N.5 EN 300 824 [11], subclause 9.5 - subclause 14.4 Initial state: T-00 Verify that the IUT transmits a valid DETACH message to the LT upon power down when the LT is broadcasting a PARI which is not an ARI A.
TP/PT/MM/BV/LO-51 CAP/PT/NWK/16.1 DECT/T (98) 17, page 8	CAP feature N.5 EN 300 824 [11], subclause 9.5, table 12 - subclause 14.4 Initial state: T-00 The LT simulates 2 base stations(FP_1 and FP_2) with different RFPs. The IUT has subscription to both and is locked to FP_1. Verify that the IUT, when it is locked to the LT(FP_1), transmits a valid DETACH message towards the LT(FP_1) upon changing the active subscription to the subscription with FP_2. The DETACH shall be sent before initiation of location registration to the FP_2.
TP/PT/MM/BV/LO-52 CAP/PT/NWK/17 DECT/T (98) 17, page 8	CAP feature N.6 EN 300 824 [11], subclause 9.6, table 13 - subclause 14.2 Initial state: T-00 Verify that the IUT periodically repeats the location procedure immediately after the expiry of the time period defined by the <<DURATION>> information element in the LOCATE-ACCEPT message. "Defined time limit 1" is indicated by the LT.
TP/PT/MM/BV/LO-53 CAP/PT/NWK/17a DECT/T (98) 17, page 8	CAP feature N.6 EN 300 824 [11], subclause 9.6, table 13 - subclause 14.2 Initial state: T-00 Verify that the IUT periodically repeats the location procedure immediately after the expiry of the time period defined by the <<DURATION>> information element in the LOCATE-ACCEPT message. "Defined time limit 2" is indicated by the LT.
TP/PT/MM/BV/LO-54 CAP/PT/NWK/17b DECT/T (98) 17, page 8	CAP feature N.6 EN 300 824 [11], subclause 9.6, table 13 - subclause 14.2 Initial state: T-00 Verify that the IUT does not repeat the location procedure when the time period defined by the <<DURATION>> information element in the LOCATE-ACCEPT message indicates "Infinite".
TP/PT/MM/BV/LO-55 CAP/PT/NWK/17.1 DECT/T (98) 17, page 8	CAP feature N.6 EN 300 824 [11], subclause 9.6, table 13 - subclause 14.2 Initial state: T-00 Verify that the IUT repeats the location procedure immediately after the expiry of the time period defined by the <<DURATION>> information element in the LOCATE-REJECT message. "Defined time limit 1" is indicated by the LT.
TP/PT/MM/BV/LO-56 CAP/PT/NWK/17f DECT/T (98) 17, page 9	CAP feature N.6 EN 300 824 [11], subclause 9.6 - subclause 14.2 Initial state: T-00 Verify that the IUT will initiate location registration procedure after it locks to the LT(FP) if IUT loses lock and cannot lock again within the time period defined by the <<DURATION>> information element in the LOCATE-ACCEPT message. "Temporary user limit 1" is indicated by the LT.
TP/PT/MM/BV/LO-57 CAP/PT/NWK/17g DECT/T (98) 17, page 9	CAP feature N.6 EN 300 824 [11], subclause 9.6 - subclause 14.2 Initial state: T-00 Verify that the IUT will initiate location registration procedure after it locks to the LT(FP) if IUT loses lock and cannot lock again within the time period defined by the <<DURATION>> information element in the LOCATE-ACCEPT message. "Temporary user limit 2" is indicated by the LT.

TP/PT/MM/BV/LO-58 CAP/PT/NWK/17h DECT/T (98) 17, page 9	CAP feature N.6 EN 300 824 [11], subclause 9.6 - subclause 14.2 Initial state: T-00 Verify that the IUT will not initiate location registration procedure after it locks to the LT(FP) if IUT loses lock and cannot lock again within some time when the <<DURATION>> information element in the LOCATE-ACCEPT message indicated. "No limits".
TP/PT/MM/BV/LO-59 CAP/PT/NWK/17i DECT/T (98) 17, page 9	CAP feature N.6 EN 300 175-6 [6], subclause 6.3.1 EN 300 824 [11], subclause 9.6, table 13 Initial state: T-00 Verify that the IUT deletes the TPUI if the IUT leaves the locked state with that LT (fails to receive the PARI) for more than T603 seconds when the <<DURATION>> information element in the LOCATE-ACCEPT message received during the last successful location registration indicated "Temporary user limit 2".
TP/PT/MM/BV/LO-60 CAP/PT/NWK/18 DECT/T (98) 17, page 9	CAP feature N.6 EN 300 824 [11], subclause 9.6, table 14 Initial state: T-00 Verify that when the IUT receives no response to {LOCATE-REQUEST}, it makes a new location registration attempt after at least time N700 and before time N700 + N800.
TP/PT/MM/BV/LO-61 CAP/PT/NWK/20a DECT/T (98) 17, page 11	CAP feature M.1 EN 300 824 [11], subclause 11.3 Initial state: T-00 Verify that the IUT can correctly perform location registration and a following outgoing call when it uses TARI as the means to lock to the LT.
NOTE:	The phrase 'bit a38 was set to 1' means: the bit a38 had the value of 1 during the time the PT locked to the IUT.

5.3.3.4 MM/BV/AR test purposes

Test subgroup objectives:

To check the IUT's valid behaviours of the access rights procedure.

Test purposes:

TP/PT/MM/BV/AR-01	EN 300 175-5 [5], subclause 13.5.1 EN 300 444 [10], subclause 8.27, figure 53 Initial state: No access rights Verify that the IUT, after invocation, if the a44 bit in the FT broadcasted "higher layer capabilities" is set to "1" is able to perform the basic operation of the obtain access rights procedure. (PT has only Authentication Code (AC))
TP/PT/MM/BV/AR-03	EN 300 175-5 [5], subclause 13.5.1 EN 300 444 [10], subclause 8.27 Initial state: T-00 Verify that the IUT, after invocation, if the a44 bit in the FT broadcasted "higher layer capabilities" is set to "0" does not initiate obtain access rights procedure after it has locked to the FT.
TP/PT/MM/BV/AR-05	EN 300 175-5 [5], subclause 13.5.2 EN 300 444 [10], subclause 8.28, figure 55 Initial state: T-00 Verify that the IUT, is able to perform the basic operation of the FT initiated terminate access rights procedure. (IUT may or may not authenticate the FT before performing the procedure.)
TP/PT/MM/BV/AR-06	EN 300 175-5 [5], subclause 13.5.2 EN 300 444 [10], subclause 8.28.2.1, figure 56 Initial state: T-00 Verify that the IUT, if requested by the FT to terminate the access rights, will first try to authenticate the FT and if this procedure fails, rejects the access rights terminate procedure.
TP/PT/MM/BV/AR-09	EN 300 175-5 [5], subclause 13.5.1 EN 300 444 [10], subclause 8.28, figure 55 Initial state: T-00 Verify that the IUT, on receipt of the {ACCESS-RIGHTS-ACCEPT} message containing the information element <<ZAP-FIELD>>, will store this information.

TP/PT/MM/BV/AR-10	EN 300 175-5 [5], subclause 13.5.1 EN 300 444 [10], subclause 8.28, figure 55 Initial state: T-00 Verify that the IUT, on receipt of the {ACCESS-RIGHTS-ACCEPT} message containing the information element <<SERVICE-CLASS>>, will store this information.
TP/PT/MM/BV/AR-50 CAP/PT/NWK/19 DECT/T (98) 17, page 9	CAP feature N.7 EN 300 824 [11], subclause 9.8, table 18 Initial state: T-00 Verify that the IUT correctly performs the procedure of on-air modification of user parameters and that after this procedure the IUT stores the new parameters correctly.
TP/PT/MM/BV/AR-51 CAP/PT/NWK/19a DECT/T (98) 17, page 10	CAP feature N.7 EN 300 824 [11], subclause 9.8 Initial state: T-00 Verify that the IUT will not initiate the obtain access rights procedure in response to access rights modify suggest if the FT authentication procedure fails.
TP/PT/MM/BV/AR-52 CAP/PT/NWK/19b DECT/T (98) 17, page 10	CAP feature N.7 EN 300 824 [11], subclause 9.8 Initial state: T-00 Verify that the IUT will not modify the current access rights parameters if the obtain access rights procedure in response to access rights modify suggest fails due to link failure.
TP/PT/MM/BV/AR-53 CAP/PT/NWK/19c DECT/T (98) 17, page 10	CAP feature N.7 EN 300 824 [11], subclause 9.8 Initial state: T-00 Verify that the IUT will not modify the current access rights parameters if the obtain access rights procedure in response to access rights modify suggest fails due to no answer from the LT(FT).

5.3.3.5 MM/BV/KA test purposes

Test subgroup objectives:

To check the IUT's valid behaviour of the key allocation procedure.

Test purposes:

TP/PT/MM/BV/KA-01	EN 300 175-5 [5], subclause 13.6 EN 300 444 [10], subclause 8.29, figure 57 Initial state: T-00 Verify that the IUT is able to operate the basic key allocation procedure.
TP/PT/MM/BV/KA-02	EN 300 175-5 [5], subclause 13.6 EN 300 444 [10], subclause 8.29.2.3, figure 58 Initial state: T-00 Verify that the IUT is able to send an {AUTH_REJECT} message as a response to the key allocation procedure when the <<Allocation type>> information element is not acceptable.
TP/PT/MM/BV/KA-03	EN 300 175-5 [5], subclause 13.6 EN 300 444 [10], subclause 8.29.2.5, figure 60 Initial state: T-00 Verify that after failure of the authentication of FT as part of the key allocation procedure, the PT retains the AC and does not convert it into a User Authentication Key (UAK).

5.3.3.6 MM/BV/PR test purposes

Test subgroup objectives:

To check the IUT's valid behaviour of the parameter retrieval procedure.

Test purpose:

TP/PT/MM/BV/PR-01	EN 300 175-5 [5], subclause 13.7 Initial state: specified in PIXIT Verify that the IUT, after invocation, is able to operate the basic operation of the PT initiated parameter retrieval procedure.
-------------------	---

5.3.3.7 MM/BV/CH test purposes

Test subgroup objectives:

To check the IUT's valid behaviour of the ciphering procedure.

Test purposes:

TP/PT/MM/BV/CH-01	EN 300 175-5 [5], subclause 13.8 EN 300 444 [10], subclause 8.31, figure 63 Initial state: specified in PIXIT Verify that the IUT, being in unciphered mode, is able to operate the basic PT initiated cipher-switching procedure requesting "cipher-on".
TP/PT/MM/BV/CH-02	EN 300 175-5 [5], subclause 13.8 EN 300 444 [10], subclause 8.31, figure 63 Initial state: specified in PIXIT Verify that the IUT, being in ciphered mode, is able to operate the basic PT initiated cipher-switching procedure requesting "cipher-off".
TP/PT/MM/BV/CH-03	EN 300 175-5 [5], subclause 13.8 EN 300 444 [10], subclause 8.30, figure 61 Initial state: T-00 Verify that the IUT, being in unciphered mode, is able to operate the basic FT initiated cipher-switching procedure requesting "cipher-on".
TP/PT/MM/BV/CH-04	EN 300 175-5 [5], subclause 13.8 EN 300 444 [10], subclause 8.30, figure 61 Initial state: specified in PIXIT Verify that the IUT, being in ciphered mode, is able to operate the basic FT initiated cipher-switching procedure requesting "cipher-off".
TP/PT/MM/BV/CH-05	EN 300 175-5 [5], subclause 13.8 EN 300 444 [10], subclause 8.30, figure 61 Initial state: T-00 Verify that the IUT, being in unciphered mode, on receipt of a {CIPHER-REQUEST} message containing unacceptable algorithm or key and requesting "cipher-on", will reject the request.
TP/FT/MM/BV/CH-08	EN 300 175-7 [7], subclause 6.4.7 EN 300 444 [10], subclause 10.15 Initial state: specified in PIXIT Check that the IUT releases the basic connection when it cannot conclude the procedure to switch from clear mode to encrypt mode (PT initiated cipher-switching).
TP/PT/MM/BV/CH-09	EN 300 175-7 [7], subclause 6.4.7 EN 300 444 [10], subclause 10.15 Initial state: specified in PIXIT Check that the IUT, for a duplex bearer, correctly initiates and completes an intercell bearer handover procedure using basic set-up when encryption is enabled (PT initiated cipher-switching).
TP/PT/MM/BV/CH-10	EN 300 175-7 [7], subclause 6.4.6 EN 300 444 [10], subclause 10.14 Initial state: specified in PIXIT Check that the IUT, for a duplex bearer, correctly initiates and completes an intracell bearer handover procedure using basic set-up when encryption is enabled (PT initiated cipher-switching).
TP/PT/MM/BV/CH-11	EN 300 175-7 [7], subclause 6.4.6 EN 300 444 [10], subclause 10.14 Initial state: specified in PIXIT Check that the IUT releases the basic connection when it cannot conclude the procedure to switch from encrypt mode to clear mode (PT initiated cipher off procedure).
TP/PT/MM/BV/CH-12	EN 300 175-7 [7], subclause 6.4.6 EN 300 444 [10], subclause 10.14 Initial state: T-00 Check that the IUT releases the basic connection when it cannot conclude the procedure to switch from clear mode to encrypt mode (FT initiated cipher-switching).
TP/PT/MM/BV/CH-13	EN 300 175-7 [7], subclause 6.4.6 EN 300 444 [10], subclause 10.14 Initial state: T-00 Check that the IUT, for a duplex bearer, correctly initiates and completes an intercell bearer handover procedure using basic set-up when encryption is enabled (FT initiated cipher-switching).

TP/PT/MM/BV/CH-14	EN 300 175-7 [7], subclause 6.4.7 EN 300 444 [10], subclause 10.15 Initial state: T-00 Check that the IUT, for a duplex bearer, correctly initiates and completes an intracell bearer handover procedure using basic set-up when encryption is enabled (FT initiated cipher-switching).
TP/PT/MM/BV/CH-15	EN 300 175-7 [7], subclause 6.4.6 EN 300 444 [10], subclause 10.14 Initial state: specified in PIXIT Check that the IUT releases the basic connection when it cannot conclude the procedure to switch from encrypt mode to clear mode (FT initiated cipher off procedure).

5.3.4 MM/BO test purposes

Test group objectives:

To check the MM of the IUT in response to the messages that are syntactically correct but not allowed to occur in some phase of the MM procedures.

Test purpose:

TP/PT/MM/BO-01	EN 300 175-5 [5], subclause 17.4.4 EN 300 444 [10], subclause 6.9.4 Initial state: T-00 Verify that the IUT ignores the unexpected message {ACCESS-RIGHTS-ACCEPT} after the IUT has initiated the location registration procedure.
----------------	--

5.3.5 MM/BI test purposes

Test group objectives:

To check the MM module of the IUT in response to invalid messages.

Test purposes:

TP/PT/MM/BI-01	EN 300 175-5 [5], subclause 17.4.4 EN 300 444 [10], subclause 6.9.4 Initial state: T-00 Verify that the IUT ignores an invalid message with an unrecognized message type.
TP/PT/MM/BI-02	EN 300 175-5 [5], subclause 17.6.4 EN 300 444 [10], subclause 6.9.4 Initial state: T-00 Verify that the IUT's response to a {CIPHER-REQUEST} message with invalid <<cipher info>> information element is the sending of a {CIPHER-REJECT} message.
TP/PT/MM/BI-03	EN 300 175-5 [5], subclause 17.6.4 EN 300 444 [10], subclause 6.9.4 Initial state: T-00 Verify that the IUT, on receipt of an {AUTHENT-REQUEST} message without <<rand>> information element, sends back an {AUTH-REJECT} message.
TP/PT/MM/BI-04	EN 300 175-5 [5], subclause 17.6.4 EN 300 444 [10], subclause 6.9.4 Initial state: No access rights Verify that the IUT, during a PT-initiated Obtain access rights procedure ignores an {ACCESS-RIGHTS-ACC} message containing a <<portable-id>> information element with invalid content.

5.3.6 MM/TI test purposes

Test group objectives:

To check the IUT's properly reacting to an expiry of one of the timers.

Test purposes:

TP/PT/MM/TI-01	EN 300 175-5 [5], subclause 13.3.3 EN 300 444 [10], subclause 8.29.2.2 Initial state: T-00 Verify that the IUT, when the timer P-<MM_auth.1> as part of the key allocation procedure expires after the defined time ($\pm 5\%$), aborts the procedure and thus allows the same priority procedure identity request of PT to proceed.
TP/PT/MM/TI-02	EN 300 175-5 [5], subclause 13.3.3 EN 300 444 [10], subclause 8.20.1.1 Initial state: T-00 Verify that the IUT is capable of completing the FT Authentication procedure at a point in time 10 % before expiry of the timer P-<MM_auth.1>.
TP/PT/MM/TI-03	EN 300 175-5 [5], subclause 13.4.1 EN 300 444 [10], subclause 8.25.2.2 Initial state: T-00 Verify that the IUT is capable of completing the Location Registration procedure at a point in time 10 % before expiry of the timer P-<MM_locate.1>.
TP/PT/MM/TI-04	EN 300 175-5 [5], subclause 13.5.1 EN 300 444 [10], subclause 8.27.2.2 Initial state: T-00 Verify that the IUT is capable of obtaining Access Rights at a point in time 10 % before expiry of the timer P-<MM_access.1>.
TP/PT/MM/TI-05	EN 300 175-5 [5], subclause 13.8 EN 300 444 [10], subclause 8.31.2.2 Initial state: T-00 Verify that the IUT is capable of completing the PT Initiated Ciphering procedure at a point in time 10 % before expiry of the timer P-<MM_cipher.2>.

5.4 ME test purposes

Subgroups:

- BV;
- BO.

5.4.1 ME/BV test purposes

Test group objectives:

To check priority scheme in the MM entity and interleaving operation of MM entity and CC entity of the IUT.

Test purposes:

TP/PT/ME/BV-01	EN 300 175-5 [5], subclause 15.5 EN 300 444 [10], subclause 6.9.6 Initial state: T-00 Verify that the IUT is able to operate the authentication of PT procedure before answering to the {CC-SETUP} message.
TP/PT/ME/BV-02	EN 300 175-5 [5], subclause 15.5 EN 300 444 [10], subclause 8.26 Initial state: specified in PIXIT Verify that the IUT, if interrupted by the parameter retrieval procedure indicating "locate suggest" during the PT initiated cipher switching procedure, finishes the ciphering procedure before initiating the location registration.
TP/PT/ME/BV-03	EN 300 175-5 [5], subclause 15.5 EN 300 444 [10], subclause 6.9.6 Initial state: No access rights Verify that the IUT is able to perform authentication of the user request, when it interrupts an obtain access rights procedure.

TP/PT/ME/BV-04	EN 300 175-5 [5], subclause 15.5 EN 300 444 [10], subclause 6.9.6 Initial state: No access rights Verify that the IUT is able to perform authentication of PT request, when it interrupts an obtain access rights procedure.
TP/PT/ME/BV-05	EN 300 175-5 [5], subclause 15.5 EN 300 444 [10], subclause 6.9.6 Initial state: T-00 Verify that the IUT is able to operate the authentication of PT procedure performed in parallel with an outgoing call establishment.
TP/PT/ME/BV-06	EN 300 175-5 [5], subclause 15.5 EN 300 444 [10], subclause 6.9.6 Initial state: T-00 Verify that the IUT is able to perform the FT initiated cipher-switching procedure in parallel with an outgoing call establishment.
TP/PT/ME/BV-07	EN 300 175-5 [5], subclause 15.5 EN 300 444 [10], subclause 6.9.6 - subclause 8.30 Initial state: T-00 Verify that the IUT is able to perform the FT initiated cipher-switching procedure, before reception of a {CC_SETUP_ACK} message during an outgoing call establishment.
TP/PT/ME/BV-09	EN 300 175-5 [5], subclause 13.8 - subclause 7.7.24 EN 300 444 [10], subclause 8.24 Initial state: T-00 Verify that the IUT is able to operate correctly the procedure for storing the DCK started in cipher mode. The IUT shall store the DCK, but not use it for the current ciphering session.
TP/PT/ME/BV-10	EN 300 175-5 [5], subclause 13.4.1 EN 300 444 [10], subclause 8.25 Initial state: T-10 Verify that the IUT, if the a38 bit in the FT broadcasted "higher layer capabilities" was set to "1" and if location area changes during a CC call, will initiate location registration procedure before or after entering the T-00 state. (FT does not perform TPUI assignment.)
TP/PT/ME/BV-11	EN 300 175-5 [5], subclause 15.5 EN 300 444 [10], subclause 6.9.6 Initial state: T-00 Verify that the IUT is able to operate the terminate access rights procedure before answering to the {CC-SETUP} message.
TP/PT/ME/BV-12	EN 300 175-5 [5], subclause 14.2.7 EN 300 444 [10], subclause 8.34 Initial state: T-10 Verify that the IUT, when the link fails during an active call, will clear the call.
TP/PT/ME/BV-13	EN 300 175-5 [5], subclause 13.5.1 EN 300 444 [10], subclause 8.27 Initial state: No access rights Verify that the IUT, after invocation, if the a44 bit in the FT broadcasted "higher layer capabilities" is set to "1", is able to accept key allocation procedure interrupting obtaining access rights procedure and to continue normal operation.

5.4.2 ME/BO test purposes

Test group objectives:

To check priority scheme in the MM entity and interleaving operation of MM entity and CC entity of the IUT in response to the messages that are syntactically correct but not allowed to occur at certain phase.

Test purpose:

TP/PT/ME/BO-01	EN 300 175-5 [5], subclause 17.4.4 - subclause 15.5 EN 300 444 [10], subclause 6.9.6 - subclause 13.1 Initial state: T-00 Verify that the IUT, if it receives during a FT authentication procedure an {AUTH-REQUEST} message as an attempt from the FT to initiate the authentication of PT procedure, will ignore the interrupting procedure.
----------------	--

5.5 LC test purposes

Test group objectives:

To verify the behaviour of the LC entity of the IUT.

Subgroups:

- BV;
- BI;
- TI.

5.5.1 LC/BV test purposes

Subgroups:

- LE;
- LR;
- LS;
- LL.

5.5.1.1 LC/BV/LE test purposes

Test subgroup objectives:

To check the IUT's behaviour of establishing connection oriented link procedure.

Test purposes:

TP/PT/LC/BV/LE-01	EN 300 175-5 [5], subclause 14.2.2 EN 300 444 [10], subclause 8.3.3 Initial state: T-00 Verify that the IUT, when no link to the FT exists, on receipt of a higher layer message is able to operate a direct link establishment procedure.
TP/PT/LC/BV/LE-02	EN 300 175-5 [5], subclause 14.2.3 EN 300 444 [10], subclause 8.32, figure 65 Initial state: T-00 Verify that the IUT is able to respond to indirect (paged) FT-initiated link establishment request which uses a short address request paging and contains correct identity.

5.5.1.2 LC/BV/LR test purposes

Test subgroup objectives:

To check the IUT's valid behaviour of connection oriented link release procedures.

Test purposes:

TP/PT/LC/BV/LR-01	EN 300 175-5 [5], subclause 14.2.7 EN 300 444 [10], subclause 8.36 Initial state: T-00 Verify that the IUT is able to perform a normal release after a MM procedure has been accomplished, and no other entities are using the link.
TP/PT/LC/BV/LR-02	EN 300 175-5 [5], subclause 14.2.7 EN 300 444 [10], subclause 8.36 Initial state: T-07 Verify that the IUT is able to perform a normal release after a CC procedure has been accomplished, and no other entities are using the link.
TP/PT/LC/BV/LR-03	EN 300 175-5 [5], subclause 14.2.7 EN 300 444 [10], subclause 8.36 Initial state: T-07 Verify that the IUT, after a CC requested partial release has been agreed, is able to maintain the link for a specified time, and no other entities are using the link.

5.5.1.3 LC/BV/LS test purposes

Test subgroup objectives:

To check the IUT's valid behaviour of connection oriented link suspend and resume procedures.

Test purposes:

There are no test purposes defined for this group in the present document.

5.5.1.4 LC/BV/LL test purposes

Test subgroup objectives:

To check the IUT's valid behaviour of connectionless link control procedures.

Test purposes:

There are no test purposes defined for this group in the present document.

5.5.2 LC/BI test purposes

Test group objectives:

To check the LC entity of the IUT in response to invalid messages.

Test purposes:

TP/PT/LC/BI-01	EN 300 175-5 [5] subclause 17.1 EN 300 444 [10], subclause 6.9.4 Initial state: T-00 Verify that the IUT ignores a message containing a protocol discriminator value that indicates a service that is not supported by the IUT.
TP/PT/LC/BI-03	EN 300 175-5 [5], subclause 17.3.1 EN 300 444 [10], subclause 6.9.4 Initial state: T-00 Verify that the IUT ignores an {IDENTITY-REQUEST} message containing illegal transaction identifier.

5.5.3 LC/TI test purposes

Test group objectives:

To check the IUT's properly reacting to an expiry of one of the timers.

Test purposes:

TP/PT/LC/TI-02	EN 300 175-5 [5], subclause 14.2.7 EN 300 444 [10], subclause 8.36 Initial state: T-00 Verify that the IUT, after termination of an MM procedure, maintains the link for a period of <LCE.02>. The link shall be released in the period (<LCE_02> - 1 000) to 10 500 ms.
----------------	--

5.6 IS test purposes

Subgroups:

- BV.

5.6A IS/BV test purposes

Test group objectives:

To verify the behaviour of the CISS entity of the IUT.

Test purposes:

TP/PT/IS/BV-01	EN 300 175-5 [5], subclause 14.2.1 - subclause 14.2.3 Initial state: T-00 Test the IUT's capability to operating of a CISS outgoing call containing a <<Feature Activate>> information element.
TP/PT/IS/BV-02	EN 300 175-5 [5], subclause 14.2.1 - subclause 14.2.3 Initial state: T-00 Test the IUT's capability of operating a CISS outgoing call containing a <<KEYPAD>> information element.
TP/PT/IS/BV-03	EN 300 175-5 [5], subclause 14.2.1 - subclause 14.2.3 Initial state: T-00 Test the IUT's capability of operating a CISS outgoing call containing a <<Facility>> information element.
TP/PT/IS/BV-04	EN 300 175-5 [5], subclause 14.2.1 - subclause 14.2.3 Initial state: T-00 Test the IUT's capability of operating a CISS incoming call containing <<Facility>> information element.
TP/PT/IS/BV-50 CAP/PT/NWK/15 DECT/T (98) 17, page 7	CAP feature N.4 EN 300 824 [11], subclause 9.7 - subclause 9.7.1, table 16 Initial state: T-00 Verify that the IUT as part of a Message waiting indication procedure, on reception of a {FACILITY} message containing a <<FACILITY>> information element specifying "numberOfMessages" equal to 127 and 'basicService' equal to "speech (1)" provides a suitable indication to the user that a speech message is waiting.
TP/PT/IS/BV-51 CAP/PT/NWK/15a DECT/T (98) 17, page 7	CAP feature N.4 EN 300 824 [11], subclause 9.7 - subclause 9.7.1, table 16 Initial state: T-00 Verify that the IUT as part of a Message waiting indication procedure, on reception of a {FACILITY} message containing a <<FACILITY>> information element specifying "numberOfMessages" equal to 127 and 'basicService' equal to "teletex (33)" provides a suitable indication to the user that a teletex message is waiting.

TP/PT/IS/BV-52 CAP/PT/NWK/15b DECT/T (98) 17, page 7	CAP feature N.4 EN 300 824 [11], subclause 9.7 - subclause 9.7.1, table 16 Initial state: T-00 Verify that the IUT as part of a Message waiting indication procedure, on reception of a {FACILITY} message containing a <<FACILITY>> information element specifying "numberOfMessages" equal to 127 and 'basicService' equal to "allServices (0)" provides a suitable indication to the user that a message is waiting.
TP/PT/IS/BV-53 CAP/PT/NWK/15.1 DECT/T (98) 17, page 7	CAP feature N.4 EN 300 824 [11], subclause 9.7 - subclause 14.9 Initial state: T-00 Verify that the IUT, starting from a state where there is an indication to the user that a message is waiting, deactivates the indication when the IUT is switched off and on.
TP/PT/IS/BV-54 CAP/PT/NWK/15.2 DECT/T (98) 17, page 7	CAP feature N.4 EN 300 824 [11], subclause 9.7 - subclause 14.9 Initial state: T-00 Verify that the IUT, starting from a state where there is an indication to the user that a message is waiting, deactivates the indication after receipt of FACILITY messages containing MWIndicate for each basic service specifying a zero numberOfMessages.
TP/PT/IS/BV-55 CAP/PT/NWK/15.3 DECT/T (98) 17, page 8	CAP feature N.4 EN 300 824 [11], subclause 9.7 - subclause 14.9 Initial state: T-00 Verify that the IUT, after receiving the following sequence of FACILITY messages maintains the message waiting indication for unknown messages: Message 1: MWIndicate{basicService=unknown,numberOfMessages=1} Message 2: MWIndicate{basicService=speech,numberOfMessages=1} Message 3: MWIndicate{basicService=speech,numberOfMessages=0}.
TP/PT/IS/BV-56 CAP/PT/NWK/15l DECT/T (98) 17, page 8	CAP feature N.4 EN 300 824 [11], subclause 14.9 Initial state: T-00 Verify that the IUT will delete the Message waiting information upon changing of subscription (the active IPUI/PARK pair).

5.7 MO test purposes

There are no test purposes defined for this group in the present document.

5.8 CL test purposes

Subgroups:

- BV.

5.9 CL/BV test purposes

Test group objectives:

To verify the behaviour of the CLMS entity of the IUT.

Test purposes:

TP/PT/CL/BV-01	EN 300 175-5 [5], subclause 14.2.1 - subclause 14.2.3 Initial state: T-00 Test the IUT's capability of processing a CLMS-FIXED message sent by the FT.
TP/PT/CL/BV-02	EN 300 175-5 [5], subclause 14.2.1 - subclause 14.2.3 Initial state: T-00 Test the IUT's capability to send a CLMS-VARIABLE.
TP/PT/CL/BV-03	EN 300 175-5 [5], subclause 14.2.1 - subclause 14.2.3 Initial state: T-00 Test the IUT's capability to process a CLMS-VARIABLE message.

Bibliography

The following material, though not specifically referenced in the body of the present document (or not publicly available), gives supporting information.

- Directive 98/13/EC of the European Parliament and of the Council of 12 February 1998 relating to telecommunications terminal equipment and satellite earth station equipment, including the mutual recognition of their conformity.
- EWOS/ETSI Project Team No 5: "Project Report and Technical Report. OSI Conformance Testing Methodology and Procedures in Europe".
- ETR 015: "Digital Enhanced Cordless Telecommunications (DECT); Reference document".
- ETR 022: "Advanced Testing Methods (ATM); Vocabulary of terms used in communications protocols conformance testing".
- ETR 041: "Transmission and Multiplexing (TM); Digital Enhanced Cordless Telecommunications (DECT); Transmission aspects 3,1 kHz telephony Interworking with other networks".
- ETR 042: "Digital Enhanced Cordless Telecommunications (DECT); A Guide to DECT features that influence the traffic capacity and the maintenance of high radio link transmission quality, including the results of simulations".
- ETR 043: "Digital Enhanced Cordless Telecommunications (DECT); Common interface; Services and Facilities requirements specification".
- ETR 056: "Digital Enhanced Cordless Telecommunications (DECT); System description document".
- ETR 141: "Methods for Testing and Specification (MTS); Protocol and profile conformance testing specifications; The Tree and Tabular Combined Notation (TTCN) style guide".
- TBR 6: "Digital Enhanced Cordless Telecommunications (DECT); General terminal attachment requirements".
- TBR 10: "Digital Enhanced Cordless Telecommunications (DECT); General terminal attachment requirements; Telephony applications".
- TBR 22: "Radio Equipment and Systems (RES); Attachment requirements for terminal equipment for Digital Enhanced Cordless Telecommunications (DECT) Generic Access Profile (GAP) applications".
- CEPT Recommendation T/SGT SF2 (89) 6/0: "Draft Recommendation T/SF Services and Facilities of Digital Enhanced Cordless Telecommunications".

History

Document history		
Edition 1	August 1996	Publication as ETS 300 497-6
Edition 2	February 1998	Publication as ETS 300 497-6
V0.3.0	August 1998	Public Enquiry PE 9852: 1998-08-28 to 1998-12-25
V0.3.2	June 1999	Vote V 9934: 1999-06-07 to 1999-08-20