

Final draft **ETSI EN 300 444** V1.4.0 (2001-05)

European Standard (Telecommunications series)

**Digital Enhanced Cordless Telecommunications (DECT);
Generic Access Profile (GAP)**



ReferenceREN/DECT-A0195

Keywordsaccess, DECT, generic, profile, radio,
synchronization**ETSI**

650 Route des Lucioles
F-06921 Sophia Antipolis Cedex - FRANCE

Tel.: +33 4 92 94 42 00 Fax: +33 4 93 65 47 16

Siret N° 348 623 562 00017 - NAF 742 C
Association à but non lucratif enregistrée à la
Sous-Préfecture de Grasse (06) N° 7803/88

Important notice

Individual copies of the present document can be downloaded from:

<http://www.etsi.org>

The present document may be made available in more than one electronic version or in print. In any case of existing or perceived difference in contents between such versions, the reference version is the Portable Document Format (PDF). In case of dispute, the reference shall be the printing on ETSI printers of the PDF version kept on a specific network drive within ETSI Secretariat.

Users of the present document should be aware that the document may be subject to revision or change of status. Information on the current status of this and other ETSI documents is available at <http://www.etsi.org/tb/status/>

If you find errors in the present document, send your comment to:
editor@etsi.fr

Copyright Notification

No part may be reproduced except as authorized by written permission.
The copyright and the foregoing restriction extend to reproduction in all media.

© European Telecommunications Standards Institute 2001.
All rights reserved.

Contents

Intellectual Property Rights	9
Foreword	9
1 Scope.....	10
2 References	10
3 Definitions, symbols and abbreviations	11
3.1 Definitions	11
3.2 Symbols	13
3.3 Abbreviations.....	13
4 Feature definitions	15
4.1 Network (NWK) features.....	15
4.2 Application features	16
5 Service definitions	16
5.1 DLC service definitions.....	16
5.2 MAC service definitions.....	17
6 Inter-operability requirements	18
6.1 General	18
6.2 NWK features	19
6.3 DLC services.....	20
6.4 MAC services	20
6.5 Physical layer (PHL) services	20
6.6 Application features	21
6.7 NWK feature to procedure mapping.....	21
6.8 Service to procedure mapping.....	23
6.8.1 DLC service to procedure mapping	23
6.8.2 MAC service to procedure mapping	24
6.8.3 Application feature to procedure mapping	25
6.9 General requirements.....	25
6.9.1 NWK layer message contents	25
6.9.2 Transaction identifier	25
6.9.3 Length of a NWK layer message	25
6.9.4 Handling of error and exception conditions.....	25
6.9.5 GAP default setup attributes	26
6.9.6 Coexistence of MM and CC procedures.....	26
6.9.7 Coding rules for information elements.....	26
7 Procedure description	26
8 NWK layer procedures	27
8.1 Summary of outgoing call messages, normal cases.....	27
8.2 Outgoing call request.....	28
8.2.1 Associated procedures.....	29
8.2.1.1 Timer P-<CC.03> management.....	29
8.2.2 Exceptional cases	30
8.2.2.1 Timer P-<CC.03> expiry	30
8.2.2.2 PT releases the outgoing call request.....	30
8.2.2.3 FT rejects the outgoing call request	31
8.3 Overlap sending	31
8.3.1 Associated procedure	32
8.3.1.1 Timer F-<CC.01> management.....	32
8.3.2 Exceptional cases	32
8.3.2.1 PT releases the outgoing call request.....	32
8.3.2.2 FT rejects the outgoing call request	32
8.3.2.3 Timer F-<CC.01> expiry	33

8.3.2.4	FT releases the outgoing call request.....	33
8.4	Outgoing call proceeding.....	34
8.4.1	Exceptional cases.....	34
8.4.1.1	PT releases the outgoing call request.....	34
8.4.1.2	FT releases the outgoing call request.....	35
8.5	Outgoing call confirmation.....	35
8.5.1	Exceptional cases.....	35
8.5.1.1	PT releases the outgoing call request.....	35
8.5.1.2	FT releases the outgoing call request.....	36
8.6	Outgoing call connection.....	36
8.7	Normal call release.....	37
8.7.1	Associated procedures.....	38
8.7.1.1	Timer P-<CC.02> management.....	38
8.7.1.2	Timer F-<CC.02> management.....	38
8.7.2	Exceptional cases.....	38
8.7.2.1	Release collisions.....	38
8.7.2.2	Timer F-<CC.02> expiry.....	39
8.7.2.3	Timer P-<CC.02> expiry.....	39
8.8	Abnormal call release.....	40
8.9	Partial release.....	40
8.10	Sending keypad information.....	41
8.11	Summary of incoming call related messages, normal cases.....	42
8.12	Incoming call request.....	43
8.12.1	Associated procedure.....	44
8.12.1.1	Timer F-<CC.03> management.....	44
8.12.2	Exceptional cases.....	45
8.12.2.1	FT releases the incoming call request.....	45
8.12.2.2	PT rejects the incoming call request.....	45
8.12.2.3	Timer F-<CC.03> expiry.....	46
8.12.3	Collective and group ringing.....	46
8.13	Incoming call confirmation.....	46
8.13.1	Exceptional cases.....	47
8.13.1.1	FT releases the incoming call transaction.....	47
8.13.1.2	PT releases the incoming call transaction.....	47
8.14	PT alerting.....	47
8.15	Incoming call connection.....	48
8.15.1	Associated procedure.....	49
8.15.1.1	Timer P-<CC.05> management.....	49
8.15.2	Exceptional cases.....	49
8.15.2.1	FT releases the incoming call transaction.....	49
8.15.2.2	PT releases the incoming call transaction.....	49
8.15.2.3	Timer P-<CC.05> expiry.....	50
8.16	Display.....	50
8.17	Terminal capability indication.....	51
8.18	Internal call setup.....	52
8.19	Internal call keypad.....	52
8.20	Service call setup.....	52
8.21	Service call keypad.....	53
8.22	Identification of PP.....	53
8.22.1	Associated procedure.....	54
8.22.1.1	Timer F-<MM_ident.2> management.....	54
8.22.2	Exceptional cases.....	54
8.22.2.1	Identity not existing in the PT.....	54
8.22.2.2	Timer F-<MM_ident.2> expiry.....	54
8.23	Authentication of FT.....	55
8.23.1	Associated procedure.....	55
8.23.1.1	Timer P-<MM_auth.1> management.....	55
8.23.2	Exceptional cases.....	56
8.23.2.1	Authentication algorithm/key not supported.....	56
8.23.2.2	Authentication challenge RES has wrong value.....	56
8.23.2.3	Timer P-<MM_auth.1> expiry.....	56
8.24	Authentication of PP.....	56

8.24.1	Associated procedure	58
8.24.1.1	Timer F-<MM_auth.1> management	58
8.24.2	Exceptional cases	58
8.24.2.1	Authentication algorithm/key not supported	58
8.24.2.2	Timer F-<MM_auth.1> expiry	58
8.25	Authentication of user	58
8.25.1	Associated procedure	59
8.25.1.1	Timer F-<MM_auth.2> management	59
8.25.2	Exceptional cases	59
8.25.2.1	Authentication algorithm/key not supported	59
8.25.2.2	Timer F-<MM_auth.2> expiry	59
8.26	Incrementing the ZAP value	59
8.27	Storing the DCK.....	60
8.28	Location registration.....	60
8.28.1	Associated procedures.....	62
8.28.1.1	Timer P-<MM_locate.1> management.....	62
8.28.1.2	Timer F-<MM_ident.1> management	62
8.28.2	Exceptional cases	62
8.28.2.1	FT rejects the location registration procedure	62
8.28.2.2	Failure of location registration procedure	63
8.28.2.3	PT rejects the identity assignment	63
8.28.2.4	Timer F-<MM_identity.1> expiry	63
8.29	Location update.....	63
8.30	Obtaining access rights.....	64
8.30.1	Associated procedure	66
8.30.1.1	Timer P-<MM_access.1> management	66
8.30.2	Exceptional cases	66
8.30.2.1	FT rejects the access rights.....	66
8.30.2.2	Timer P-<MM_access.1> expiry.....	67
8.31	FT terminating access rights	67
8.31.1	Associated procedure	68
8.31.1.1	Timer F-<MM_access.2> management	68
8.31.2	Exceptional cases	68
8.31.2.1	PT rejects the termination request	68
8.31.2.2	Timer F-<MM_access.2> expiry.....	68
8.32	Key allocation	69
8.32.1	Associated procedures.....	70
8.32.1.1	Timer F-<MM_key.1> management	70
8.32.1.2	Timer P-<MM_auth.1> management	70
8.32.2	Exceptional cases	70
8.32.2.1	Timer F-<MM_key.1> expiry	70
8.32.2.2	Timer P-<MM_auth.1> expiry	70
8.32.2.3	Allocation-type element is unacceptable.....	71
8.32.2.4	Authentication of PT fails	71
8.32.2.5	Authentication of FT fails	71
8.33	Cipher-switching initiated by FT.....	72
8.33.1	Associated procedure	72
8.33.1.1	Timer F-<MM_cipher.1> management	72
8.33.2	Exceptional cases	73
8.33.2.1	PT rejects the cipher request	73
8.33.2.2	Timer F-<MM_cipher.1> expiry	73
8.34	Cipher-switching initiated by PT.....	73
8.34.1	Associated procedure	74
8.34.1.1	Timer P-<MM_cipher.2> management	74
8.34.2	Exceptional cases	75
8.34.2.1	FT rejects the cipher request	75
8.34.2.2	Timer P-<MM_cipher.2> expiry	75
8.35	Indirect FT initiated link establishment	75
8.35.1	Associated procedure	76
8.35.1.1	Timer F-<LCE.03> management.....	76
8.35.2	Exceptional cases	77
8.35.2.1	The IPUI received in the {LCE-PAGE-RESPONSE} does not match	77

8.35.2.2	Timer <LCE.03> expiry.....	77
8.35.2.3	Release from the higher entity.....	78
8.36	Direct PT initiated link establishment	78
8.36.1	Exceptional case	79
8.36.1.1	Link establishment failure.....	79
8.37	Link release "normal"	79
8.37.1	Associated procedure	81
8.37.1.1	Timer <LCE.01> management.....	81
8.37.2	Exceptional cases.....	81
8.37.2.1	Timer <LCE.01> expiry.....	81
8.37.2.2	Outstanding data has been discarded	81
8.38	Link release "abnormal"	82
8.39	Link release "maintain"	82
8.39.1	Associated procedure	82
8.39.1.1	Timer <LCE.02> management.....	82
8.40	Enhanced FT initiated U- plane connection.....	82
9	DLC layer procedures	83
9.1	Class A link establishment.....	83
9.1.1	Associated procedures.....	85
9.1.1.1	Timer P<DL.07> management.....	85
9.1.1.2	Re-transmission counter management	85
9.1.1.3	Multiple frame operation variables management.....	85
9.1.1.4	Lower Layer Management Entity (LLME) establishment of a MAC connection.....	85
9.1.2	Exceptional cases.....	86
9.1.2.1	Timer P<DL.07> expiry.....	86
9.1.2.2	Receipt of a request for link release.....	87
9.1.2.3	Receipt of an indication for a connection release	87
9.2	Class A Acknowledged Information transfer.....	87
9.2.1	Acknowledgement with an I_frame	87
9.2.2	Acknowledgement with a RR_frame	88
9.2.3	Class A acknowledged information transfer with segment reassemble.....	89
9.2.4	Associated procedures.....	89
9.2.4.1	Timer <DL.04> management.....	89
9.2.4.2	Re-transmission counter management	89
9.2.4.3	Multiple frame operation variables management.....	89
9.2.5	Exceptional cases.....	90
9.2.5.1	Timer <DL.04> expiry.....	90
9.2.5.2	Receipt of a request for link release.....	90
9.2.5.3	Receipt of an indication for a connection release	90
9.2.5.4	DLC wants to make a connection handover.....	90
9.3	Class A link release	90
9.3.1	Associated procedures.....	91
9.3.1.1	LLME U-plane release.....	91
9.3.1.2	LLME release a MAC connection.....	91
9.4	Class A link re-establishment.....	91
9.5	C _s channel fragmentation and recombination	91
9.6	Normal broadcast	91
9.7	Class A basic connection handover	92
9.7.1	Voluntary handover.....	93
9.7.2	Associated procedure	93
9.7.2.1	LLME connection handover management	93
9.7.3	Exceptional case	93
9.7.3.1	Receipt of a request for link release.....	93
9.8	Encryption switching.....	93
9.8.1	Associated procedure	94
9.8.1.1	Providing Encryption key to the MAC layer.....	94
9.8.2	Exceptional cases.....	94
9.8.2.1	Encryption fails	94
9.8.2.2	Connection handover of ciphered connections.....	94
9.9	U-plane class 0/min delay.....	94
9.9.1	Associated procedure	94

9.9.1.1	LLME U-plane establishment	94
9.10	FUI frame operation.....	94
10	MAC layer procedures	95
10.1	General	95
10.2	Downlink broadcast.....	95
10.2.1	N _T message.....	96
10.2.2	Q _T - static system information	96
10.2.3	Q _T - FP capabilities	96
10.2.4	Q _T - SARI list contents	97
10.3	Paging broadcast	97
10.3.1	Short page, normal/extended paging.....	97
10.3.2	Zero page normal/extended paging.....	98
10.3.3	Blind slot information	98
10.3.4	Bearer handover information.....	99
10.4	Setup of basic connection, basic bearer setup (A-field).....	99
10.4.1	M _T message	99
10.4.2	Associated procedures.....	100
10.4.2.1	Timer T200 management.....	100
10.4.2.2	Counter N200 management.....	100
10.4.3	Exceptional cases	100
10.4.3.1	Bearer setup attempt fails N200+1 times	100
10.4.3.2	Timer T200 expiry.....	101
10.5	Connection/bearer release.....	101
10.5.1	M _T message	101
10.6	Bearer handover request	102
10.6.1	M _T message.....	102
10.7	Connection handover request.....	102
10.7.1	M _T message	102
10.8	C _S channel data	103
10.9	Q2 bit setting.....	103
10.10	RFPI handshake	103
10.11	Antenna diversity	103
10.12	Sliding collision	103
10.13	Encryption process - initialization and synchronization	103
10.14	Encryption mode control	104
10.14.1	M _T message	104
10.15	Handover encryption process	104
10.16	Extended frequency allocation	104
11	PHL layer requirements	104
11.1	General	104
11.2	Minimum Normal Transmit Power (NTP).....	105
11.3	Radio receiver sensitivity.....	105
11.4	Z-field.....	105
11.5	Sliding collision detection.....	105
11.6	Physical channel availability.....	105
11.7	Synchronization window	105
12	Requirements regarding the speech transmission.....	105
12.1	General	105
12.2	User controlled volume control.....	105
13	Management procedures	106
13.1	Management of MM procedures	106
13.2	Location registration initiation	106
13.3	Assigned individual TPUI management	106
13.4	PMID management.....	106
13.5	DCK management.....	107
13.6	Broadcast attributes management.....	107
13.7	Storage of subscription related data.....	107
14	Application procedures	108
14.1	Subscription control	108

14.2	AC to bitstring mapping	108
14.3	Manual entry of the PARK	108
Annex A (informative):	PP locking procedure for on-air subscription.....	110
Annex B (informative):	Tones, progress indicator and U-plane connection.....	112
B.1	General.....	112
B.2	Connection of U-plane and provision of tones	112
B.3	Provision of tones before connection of the U-plane.....	112
B.4	Provision of tones and <<Progress indicator>> information element	112
B.5	Summary	113
Annex C (normative):	Synchronization requirements for fixed parts	114
Annex D (informative):	Bibliography.....	115
History	116

Intellectual Property Rights

IPRs essential or potentially essential to the present document may have been declared to ETSI. The information pertaining to these essential IPRs, if any, is publicly available for **ETSI members and non-members**, and can be found in ETSI SR 000 314: "*Intellectual Property Rights (IPRs); Essential, or potentially Essential, IPRs notified to ETSI in respect of ETSI standards*", which is available from the ETSI Secretariat. Latest updates are available on the ETSI Web server (<http://www.etsi.org/ipr>).

Pursuant to the ETSI IPR Policy, no investigation, including IPR searches, has been carried out by ETSI. No guarantee can be given as to the existence of other IPRs not referenced in ETSI SR 000 314 (or the updates on the ETSI Web server) which are, or may be, or may become, essential to the present document.

Foreword

This European Standard (Telecommunications series) has been produced by ETSI Project Digital Enhanced Cordless Telecommunications (DECT), and is now submitted for the ETSI standards One-step Approval Procedure.

The present document is based on EN 300 175, parts 1 [1] to 8 [8]. General attachment requirements and speech attachment requirements are based on EN 301 406 [11] (replacing TBR 006) and EN 300 176-2 [10] (previously covered by TBR 010).

The present document has been developed in accordance to the rules of documenting a profile specification as described in ISO/IEC 9646-6 [12].

Proposed national transposition dates	
Date of latest announcement of this EN (doa):	3 months after ETSI publication
Date of latest publication of new National Standard or endorsement of this EN (dop/e):	6 months after doa
Date of withdrawal of any conflicting National Standard (dow):	6 months after doa

1 Scope

The present document specifies that set of technical requirements for Digital Enhanced Cordless Telecommunications (DECT) Fixed Part (FP) and DECT Portable Part (PP) necessary for the support of the Generic Access Profile (GAP).

The GAP is applicable to all DECT Portable radio Terminations (PT) and Fixed radio Terminations (FT) which under the scope of EN 300 176-2 [10] (i.e. 3,1 kHz telephony teleservice) and specifies the minimum functionality that is supported by all other 3,1 kHz voice profiles.

The objective of the present document is to ensure the Air Interface (AI) inter-operability of DECT equipment capable of 3,1 kHz telephony applications, in such a way that any DECT PT conforming to the procedures described in the present document is inter-operable with any DECT FT conforming to the procedures described in the present document.

The profile consists of the minimum mandatory requirements that allow a 3,1 kHz teleservice connection to be established, maintained and released between a FT and a PT with the appropriate access rights, irrespective of whether the FP provides residential, business or public access services.

In addition, the present document defines the features, services, procedures etc. for both the FT and the PT, which are provision mandatory either in the PT or in the FT, as well as some elements that are provision optional but still process mandatory.

Mobility Management (MM) procedures at the DECT AI to support incoming calls and outgoing calls are included.

Inter-working between the FT and the attached network is outside the scope of the present document.

2 References

The following documents contain provisions which, through reference in this text, constitute provisions of the present document.

- References are either specific (identified by date of publication, edition number, version number, etc.) or non-specific.
- For a specific reference, subsequent revisions do not apply.
- For a non-specific reference, the latest version applies.

- [1] ETSI EN 300 175-1: "Digital Enhanced Cordless Telecommunications (DECT); Common Interface (CI); Part 1: Overview".
- [2] ETSI EN 300 175-2: "Digital Enhanced Cordless Telecommunications (DECT); Common Interface (CI); Part 2: Physical layer (PHL)".
- [3] ETSI EN 300 175-3: "Digital Enhanced Cordless Telecommunications (DECT); Common Interface (CI); Part 3: Medium Access Control (MAC) layer".
- [4] ETSI EN 300 175-4: "Digital Enhanced Cordless Telecommunications (DECT); Common Interface (CI); Part 4: Data Link Control (DLC) layer".
- [5] ETSI EN 300 175-5: "Digital Enhanced Cordless Telecommunications (DECT); Common Interface (CI); Part 5: Network (NWK) layer".
- [6] ETSI EN 300 175-6: "Digital Enhanced Cordless Telecommunications (DECT); Common Interface (CI); Part 6: Identities and addressing".
- [7] ETSI EN 300 175-7: "Digital Enhanced Cordless Telecommunications (DECT); Common Interface (CI); Part 7: Security features".
- [8] ETSI EN 300 175-8: "Digital Enhanced Cordless Telecommunications (DECT); Common Interface (CI); Part 8: Speech coding and transmission".

- [9] ETSI EN 300 176-1: "Digital Enhanced Cordless Telecommunications (DECT); Approval test specification; Part 1: Radio".
- [10] ETSI EN 300 176-2: "Digital Enhanced Cordless Telecommunications (DECT); Approval test specification; Part 2: Speech".
- [11] ETSI EN 301 406: "Digital Enhanced Cordless Telecommunications (DECT); Harmonized EN for Digital Enhanced Cordless Telecommunications (DECT) covering essential requirements under article 3.2 of the R&TTE Directive; Generic radio".
- [12] ISO/IEC 9646-6: "Information technology - Open Systems Interconnection - Conformance testing methodology and framework - Part 6: Protocol profile test specification".
- [13] ISO/IEC 9646-7: "Information technology - Open Systems Interconnection - Conformance testing methodology and framework - Part 7: Implementation conformance statements".
- [14] ISO/IEC 8073 (1997): "Information technology - Open Systems Interconnection - Protocol for providing the connection-mode transport service".

3 Definitions, symbols and abbreviations

3.1 Definitions

For the purposes of the present document, the following terms and definitions apply:

attach: process whereby a PP within the coverage area of a FP to which it has access rights, notifies this FP that it is operative

The reverse process is detach, which reports the PP as inoperative.

NOTE 1: An operative PP is assumed to be ready to receive calls.

authentication: process whereby a DECT subscriber is positively verified to be a legitimate user of a particular FP

NOTE 2: Authentication is generally performed at call setup, but may also be done at any other time (e.g. during a call).

bearer service: type of telecommunication service that provides a defined capability for the transmission of signals between user-network interfaces

NOTE 3: The DECT user-network interface corresponds to the top of the Network (NWK) layer (layer 3).

C-plane: control plane of the DECT protocol stacks, which contains all of the internal DECT protocol control, but may also include some external user information

NOTE 4: The C-plane stack always contains protocol entities up to and including the NWK layer.

call: all of the NWK layer processes involved in one NWK layer peer-to-peer association

NOTE 5: Call may sometimes be used to refer to processes of all layers, since lower layer processes are implicitly required.

DECT network: network that uses the DECT AI to interconnect a local network to one or more portable applications
The logical boundaries of the DECT network are defined to be at the top of the DECT NWK layer.

NOTE 6: A DECT network is a logical grouping that contains one or more FTs plus their associated PT. The boundaries of the DECT network are not physical boundaries.

Fixed Part (DECT Fixed Part) (FP): physical grouping that contains all of the elements in the DECT network between the local network and the DECT AI

NOTE 7: A DECT FP contains the logical elements of at least one FT, plus additional implementation specific elements.

Fixed radio Termination (FT): logical group of functions that contains all of the DECT processes and procedures on the fixed side of the DECT AI

NOTE 8: A FT only includes elements that are defined in the DECT Common Interface (CI) standard. This includes radio transmission elements together with a selection of layer 2 and layer 3 elements.

geographically unique identity: This term relates to FP identities, PARIs and RFPIs. It indicates that two systems with the same PARI, or respectively two RFPs with the same RFPI, cannot be reached or listened to at the same geographical position.

NOTE 9: For PARI and RFPI, see abbreviations.

global network: telecommunication network capable of offering a long distance telecommunication service

NOTE 10: The term does not include legal or regulatory aspects, nor does it indicate if the network is a public or a private network.

globally unique identity: identity is unique within DECT (without geographical or other restrictions)

handover: process of switching a call in progress from one physical channel to another physical channel

NOTE 11: There are two physical forms of handover, intra-cell handover and inter-cell handover.

incoming call: call received at a PP

inter-cell handover: switching of a call in progress from one cell to another cell

internal handover: handover processes that are completely internal to one FT
Internal handover reconnects the call at the lower layers, while maintaining the call at the NWK layer

NOTE 12: The lower layer reconnection can either be at the Data Link Control (DLC) layer (connection handover) or at the Medium Access Control (MAC) layer (bearer handover).

inter-operability: capability of FPs and PPs, that enable a PP to obtain access to teleservices in more than one Location Area (LA) and/or from more than one operator (more than one service provider)

inter-operator roaming: roaming between FP coverage areas of different operators (different service providers)

Interworking Unit (IWU): unit that is used to interconnect sub networks

NOTE 13: The IWU will contain the interworking functions necessary to support the required sub-network interworking.

intra-cell handover: switching of a call in progress from one physical channel of one cell to another physical channel of the same cell

intra-operator roaming: roaming between different FP coverage areas of the same operator (same service provider)

Local Network (LNW): telecommunication network capable of offering local telecommunication services

NOTE 14: The term does not include legal or regulatory aspects, nor does it indicate if the network is a public network or a private network.

locally unique identity: unique identity within one FP or LA, depending on application

Location Area (LA): domain in which a PP may receive (and/or make) calls as a result of a single location registration

location registration: process whereby the position of a DECT PT is determined to the level of one LA, and this position is updated in one or more databases

NOTE 15: These databases are not included within a DECT FT.

MAC connection (connection): association between one source MAC Multiple Bearer Control (MBC) entity and one destination MAC MBC entity
This provides a set of related MAC services (a set of logical channels), and it can involve one or more underlying MAC bearers.

outgoing call: call originating from a PP

Portable Application (PA): logical grouping that contains all the elements that lie beyond the DECT network boundary on the portable side

NOTE 16: The functions contained in the PA may be physically distributed, but any such distribution is invisible to the DECT network.

Portable Part (DECT Portable Part) (PP): physical grouping that contains all elements between the user and the DECT AI

PP is a generic term that may describe one or several physical pieces.

NOTE 17: A DECT PP is logically divided into one PT plus one or more PAs.

Portable radio Termination (PT): logical group of functions that contains all of the DECT processes and procedures on the portable side of the DECT AI

NOTE 18: A PT only includes elements that are defined in the DECT CI standard. This includes radio transmission elements (layer 1) together with a selection of layer 2 and layer 3 elements.

Radio Fixed Part (RFP): one physical sub-group of a FP that contains all the radio end points (one or more) that are connected to a single system of antennas

registration: ambiguous term that should always be qualified. See either location registration or subscription registration

roaming: movement of a PP from one FP coverage area to another FP coverage area, where the capabilities of the FPs enable the PP to make or receive calls in both areas

NOTE 19: Roaming requires the relevant FPs and PP to be inter-operable.

RS: value used to establish authentication session keys

subscription registration: infrequent process whereby a subscriber obtains access rights to one or more FPs

NOTE 20: Subscription registration is usually required before a user can make or receive calls.

3.2 Symbols

For the purposes of the present document, the following symbols apply:

M	mandatory to support (provision mandatory, process mandatory)
O	optional to support (provision optional, process mandatory)
I	out-of-scope (provision optional, process optional) not subject for testing
C	conditional to support (process mandatory)
N/A	not applicable (in the given context the specification makes it impossible to use this capability)

Provision mandatory, process mandatory means that the indicated feature service or procedure shall be implemented as described in the present document, and may be subject to testing.

Provision optional, process mandatory means that the indicated feature, service or procedure may be implemented, and if implemented, the feature, service or procedure shall be implemented as described in the present document, and may be subject to testing.

NOTE: The used notation is based on the notation proposed in ISO/IEC 9646-7 [13].

3.3 Abbreviations

For the purposes of the present document, the following abbreviations apply:

AC	Authentication Code
AI	Air Interface
ARC	Access Rights Class
ARD	Access Rights Details

ARI	Access Rights Identity
BCD	Binary Coded Decimal
CC	Call Control
CI	Common Interface
CISS	Call Independent Supplementary Service
CLMS	Connectionless Message Service
DCK	Derived Cipher Key
DECT	Digital Enhanced Cordless Telecommunications
DLC	Data Link Control
DLEI	Data Link Endpoint Identifier
DSAA	DECT Standard Authentication Algorithm
DSCA	DECT Standard Cipher Algorithm
DTMF	Dual Tone Multi-Frequency
FLEN	Frame LENgth
FP	Fixed Part
FT	Fixed radio Termination
GAP	Generic Access Profile
IPEI	International Portable Equipment Identity
IPUI	International Portable User Identity
IUT	Implementation Under Test
IWU	Interworking Unit
KS	PP authentication Session Key
KS'	FP authentication Session Key
LA	Location Area
LAL	Location Area Level
LCE	Link Control Entity
LLME	Lower Layer Management Entity
LLN	Logical Link Number
LNW	Local NetWork
LSB	Least Significant Bit
LSIG	Link SIGNature
MAC	Medium Access Control
MBC	Multiple Bearer Control
ME	Management Entity
MM	Mobility Management
MSB	Most Significant Bit
NLF	New Link Flag
NTP	Normal Transmit Power
NWK	NetWorK
P	Public (environment)
PA	Portable Application
PARI	Primary Access Rights Identity
PARK	Portable access rights key
PHL	PHysical Layer
PLI	Park Length Indicator
PMID	Portable part MAC Identity
PP	Portable Part
PSN	Portable equipment Serial Number
PT	Portable radio Termination
PUN	Portable User Number
PUT	Portable User Type
RAND	RANDom challenge issued by a FP
R/B	RESidential/Business (environment)
RES	RESponse calculated by a PP
RFP	Radio Fixed Part
RFPI	Radio Fixed Part Identity
RLR _H	Receiving Loudness Rating of the Handset
RPN	Radio fixed Part Number
SAP	Service Access Point
SAPI	Service Access Point Identifier
SARI	Secondary Access Rights Identity
SS	Supplementary Services

TARI	Tertiary Access Rights Identity
TBC	Traffic Bearer Control
TCL	Telephone Coupling Loss
TPUI	Temporary Portable User Identity
TRUP	TRansparent UnProtected service
UAK	User Authentication Key
UPI	User Personal Identification

4 Feature definitions

For the purposes of the present document the feature definitions in the following clauses apply.

The number given in square brackets after the name of a feature is the item number used in the tables of the present document.

4.1 Network (NWK) features

outgoing call [N.1]: call initiated at a DECT PP

off-hook [N.2]: ability to indicate the action of going off-hook, e.g. to start call setup or accept a call

on-hook (FULL Release) [N.3]: ability to indicate the action of going on-hook (e.g. to terminate a call) and fully release the radio resource

dialled digits (basic) [N.4]: capability to dial digits 0 to 9, *, #

register recall [N.5]: ability of the PP to request the invocation of the supplementary service "register recall" over the DECT interface and the ability of the FP to transmit the request to the local network
Register recall means to seize a register (with dial tone) to permit input of further digits or other action.

go to DTMF signalling (defined tone length) [N.6]: go to DTMF signalling with defined tone length

pause (dialling pause) [N.7]: ability to generate or indicate a dialling pause, e.g. to await further dial tone

incoming call [N.8]: call received at a DECT PP

authentication of PP [N.9]: process by which the identity of a DECT PP is checked by the FP

authentication of user [N.10]: process by which the identity of a user of a DECT PP is checked by the FP. The User Personal Identification (UPI), a personal identification of 0 to 8 digits, manually entered by the user, is used for user authentication

location registration [N.11]: facility whereby a PP can be registered with a FP or a cluster of FPs such that incoming calls, radio pages or messages may be routed to it

on-air key allocation [N.12]: capability to transform Authentication Code (AC) into User Authentication Key (UAK) using the key allocation procedure

identification of PP [N.13]: ability for the FP to request and PP to provide specific identification parameters

service class indication/assignment [N.14]: assignment by the FP to PP of the service class and indication to the FP by the PP of the contents of its service class

alerting [N.15]: activates or deactivates alerting at the PP using any appropriate indication

ZAP [N.16]: ability first to assign and then to re-program the account data held in the PP so that access rights may be suspended subject to the conditions set by the service provider being met, coupled with the ability to re-program the account data again to reinstate access rights once these conditions have been met
One ZAP field shall be provided per account field. The PP has the right to authenticate the FP prior to the execution of ZAP suspend.

encryption activation FT initiated [N.17]: activation of the encryption process requested by FT

subscription registration procedure on-air [N.18]: standardized procedure for loading subscription registration data into a PP in real time over the air-interface

link control [N.19]: ability to request, accept, maintain and release a data link for the purposes of a NWK layer procedure

terminate access rights FT initiated [N.20]: ability of the FP to delete a subscription in the PP

partial release [N.21]: ability to release an established or in progress Call Control (CC) call whilst retaining the radio resource for the purpose of accessing further services

go to DTMF (infinite tone length) [N.22]: go to DTMF signalling, indicating infinite DTMF tone duration

go to pulse [N.23]: go to pulse (decadic) signalling

signalling of display characters [N.24]: transmission to the PP of characters to be displayed on the user's PP display (if provided)

display control characters [N.25]: characters sent to the PP to control the user's display in the PP (if provided) Such characters include cursor control, clear screen, home, flash, inverse video etc.

authentication of FT [N.26]: process by which the identity of a FP is checked by the PP

encryption activation PT initiated [N.27]: activation of the encryption process suggested by PT
The real time start of ciphering is done in the MAC layer and is always initiated by the PT.

encryption deactivation FT initiated [N.28]: deactivation of the encryption process requested by FT
The real time stop of ciphering is done in the MAC layer and is always initiated by the PT.

encryption deactivation PT initiated [N.29]: deactivation of the encryption process suggested by PT
The real time stop of ciphering is done in the MAC layer and is always initiated by the PT.

Calling Line Identification Presentation (CLIP) [N.30]: ability to provide the calling party number to the called party before accepting the call

internal call [N.31]: call between 2 users that does not make use of the local network resources
This is typically useful in residential environments.

service call [N.32]: call initiated by a DECT PT for entering of FT related service and adjustment procedures in a transparent way
After having sent the service call indication, the PT behaves according to the rules of a normal call.

Enhanced U- plane connection [N.33]: ability of the FT to initiate connection of the U- plane during call establishment or release e.g. to facilitate the provision of in band tones or announcements

4.2 Application features

AC to bitstring mapping [A.1]: mapping of the AC into a bitstring

multiple subscription registration [A.2]: ability of PP to store more than one subscription

manual entry of the Portable Access Rights Key (PARK) [A.3]: ability of the PP to accept a manual entry of the PARK for ensuring attachment to the right FP in a physical area covered by many providers

5 Service definitions

For the purposes of the present document the following service definitions apply.

5.1 DLC service definitions

LAPC class A service and Lc [D.1]: single frame acknowledged C-plane data link service providing a single data link between one FT and one PT

The higher layer information is segmented (if necessary) and transmitted in numbered frames. The Lc provides frame delimiting, transparency and frame synchronization.

C_s channel fragmentation and recombination [D.2]: Lc service providing channel dependant fragmentation (by means of dividing a LAPC data unit into more than one service data units for delivery to the MAC layer C_s logical channel) and recombination (by means of joining several service units received from the MAC layer C_s logical channel into a LAPC data unit)

broadcast Lb service [D.3]: simplex point-to-multipoint transmission using simple fixed length DLC frames providing a restricted broadcast service in direction FP to PP(s)

intra-cell voluntary connection handover [D.4]: internal handover process provided and initiated by the DLC layer (e.g. as a result of continued poor quality of service from the MAC layer), whereby one set of DLC entities (C-plane and U-plane) can re-route data from one MAC connection to a second new MAC connection in the domain of the same cell, while maintaining the service provided to the NWK layer

intercell voluntary connection handover [D.5]: internal handover process provided and initiated by the DLC layer (e.g. as a result of continued poor quality of service from the MAC layer), whereby one set of DLC entities (C-plane and U-plane) can re-route data from one MAC connection to a second new MAC connection not in the domain of the same cell, while maintaining the service provided to the NWK layer

encryption activation [D.6]: transporting the NWK layer encryption request and the cipher key to the MAC layer, thereby enabling the encryption process in the MAC layer

LU1 TRansparent UnProtected service (TRUP) class 0/min_delay [D.7]: transparent unprotected service introducing minimum delay between the higher layers and the MAC layer
May be used for speech and non-speech applications. Speech transmission shall only use the class 0/min_delay operation over a single bearer MAC connection. Data integrity is not guaranteed. No error protection is applied, and octets may be lost, erroneous or duplicated. The continuous higher layer data is fragmented for delivery to the I_N logical channel in the transmission direction, and recombined from the I_N logical channel in the receiving direction.

FU1 [D.8]: offers a defined fixed length frame structure and buffering functions for transmission of U-plane data to the MAC layer (at the transmit side) or accept of data from the MAC layer (at the receiving side) on demand and with minimum delay. Used for speech but may be used for more general data purposes

encryption deactivation [D.9]: transporting the NWK layer encryption deactivation request to the MAC layer, thereby disabling the encryption process in the MAC layer

5.2 MAC service definitions

general [M.1]: set of basic requirements regarding data formats, multiplexing, CRC usage, scanning and locking, which are prerequisites to communication between peer MAC entities

continuous broadcast [M.2]: simplex service from FT to PT whereby the FT maintains at least one bearer with continuous transmissions

The PT can use the information carried in this bearer to lock to the FT and to obtain knowledge about the FT.

paging broadcast [M.3]: service whereby the identities of specific PTs can be broadcast by the FT. This service is normally used by the FT to request a specific PT to set up a link to the FT

basic connection [M.4]: service providing connection between FT and PT consisting of one full slot duplex bearer supporting the In_minimum_delay data service (i.e. speech)

Only one basic connection may exist between a FT and particular PT (except during connection handover). The service includes the means for setting-up and releasing the required bearer(s).

C_s higher layer signalling [M.5]: low rate connection oriented data service with ARQ using the C_s channel to transfer higher layer signalling data

quality control [M.6]: provides means for monitoring and controlling the radio link quality

encryption activation [M.7]: service providing means for enabling the encryption whereby on demand all higher layer data (including speech) is transferred across the AI in an encrypted form
Always initiated by the PT.

extended frequency allocation [M.8]: service which allows a FT to support frequencies in addition to the standard DECT frequencies

bearer handover - intra-cell [M.9]: internal MAC process whereby data transfer (C channel and I channel) is switched from one duplex bearer to another in the domain of the same cell while maintaining the service to the DLC layer

bearer handover - inter-cell [M.10]: internal MAC process whereby data transfer (C channel and I channel) is switched from one duplex bearer to another not in the domain of the same cell while maintaining the service to the DLC layer

connection handover - intra-cell [M.11]: in the MAC layer, it is the process enabling setting up a new basic connection in the domain of the same cell to support connection handover at the DLC layer

connection handover - inter-cell [M.12]: in the MAC layer, it is the process enabling setting up a new basic connection not in the domain of the same cell to support connection handover at the DLC layer

Secondary Access Rights Identity (SARI) support [M.13]: ability to support, in addition to the primary Access Rights Identity (ARI), secondary ARIs that the FT broadcasts less frequently than PARIs
These may be used to reflect an inter-operators agreement allowing a portable to access more than one operator or services through FT.

encryption deactivation [M.14]: service providing means for disabling the encryption whereby on demand the process of transmitting higher layer data (including speech) across the AI in encrypted form is to be cancelled (a connection release automatically disables ciphering)

6 Inter-operability requirements

6.1 General

The tables listed in this clause define all the protocol elements i.e. features, services, and procedures which are mandatory, optional, or conditional under the provision of another protocol element, or outside the scope of the present document, or in some context not applicable according to the status column designation as defined in clause 3.3 for the GAP FP and PP. All optional elements shall be process mandatory according to the procedures described in the present document.

Protocol elements defined as mandatory, optional or conditional in this clause are further defined in clauses 8, 9, 10, 11, 12, 13 and 14 in detail, either explicitly and/or as references to the DECT base standard EN 300 175, parts 2 [2] to 8 [8], EN 300 176-1 [9] and EN 300 176-2 [10].

NOTE: Annexes A and B are informative and may be used as additional information, but do not mandate requirements.

The requirements of EN 301 406 [11] and EN 300 176-2 [10] shall be met by all equipment conforming to the present document.

6.2 NWK features

Table 1: NWK features status

Feature supported					
Item no.	Name of feature	Reference	PT	Status	
				R/B	P
N.1	Outgoing call	4.1	M	M	M
N.2	Off hook	4.1	M	M	M
N.3	On hook (full release)	4.1	M	M	M
N.4	Dialled digits (basic)	4.1	M	M	M
N.5	Register recall (note 4 and note 5)	4.1	M	O	O
N.6	Go to DTMF signalling (defined tone length) (note 1)	4.1	M	O	M
N.7	Pause (dialling pause) (note 3)	4.1	M	O	O
N.8	Incoming call	4.1	M	M	M
N.9	Authentication of PP	4.1	M	O	M
N.10	Authentication of user (note 2)	4.1	M	O	O
N.11	Location registration	4.1	M	O	M
N.12	On air key allocation (note 2)	4.1	M	O	O
N.13	Identification of PP	4.1	M	O	O
N.14	Service class indication/assignment	4.1	M	O	M
N.15	Alerting	4.1	M	M	M
N.16	ZAP (note 2)	4.1	M	O	O
N.17	Encryption activation FT initiated	4.1	M	O	M
N.18	Subscription registration procedure on-air	4.1	M	M	M
N.19	Link control	4.1	M	M	M
N.20	Terminate access rights FT initiated (note 2)	4.1	M	O	O
N.21	Partial release	4.1	O	O	O
N.22	Go to DTMF (infinite tone length)	4.1	O	O	O
N.23	Go to Pulse	4.1	O	O	O
N.24	Signalling of display characters	4.1	O	O	O
N.25	Display control characters	4.1	O	O	O
N.26	Authentication of FT	4.1	O	O	O
N.27	Encryption activation PT initiated	4.1	O	O	O
N.28	Encryption deactivation FT initiated	4.1	O	O	O
N.29	Encryption deactivation PT initiated	4.1	O	O	O
N.30	Calling Line Identification Presentation (CLIP)	4.1	O	O	O
N.31	Internal call	4.1	O	O	O
N.32	Service call	4.1	O	O	O
N.33	Enhanced U- plane connection	4.1	O	O	O
NOTE 1: The PT is only required to be able to send the <<MULTI-KEYPAD>> information element containing the DECT standard 8-bit character (EN 300 175-5 [5], annex D) codings "Go to DTMF", defined tone length and the FT is required to be able to understand it in the public environment.					
NOTE 2: This feature is required to be supported in the PT to guarantee the same level of security among all the handsets that operates in a system. The invocation of the feature is however optional to the operator.					
NOTE 3: The PT is required to be able to send the <<MULTI-KEYPAD>> information element containing the DECT standard 8-bit character (EN 300 175-5 [5], annex D) codings "Dialling Pause". This guarantees automatic access to secondary or alternative networks.					
NOTE 4: This feature uses keypad code 15 hex.					
NOTE 5: The FT is not mandated to receive and understand the register recall DECT character. However, if a FT supports it there may be no corresponding action that the FT can take with the local network as a result of this function.					

6.3 DLC services

Table 2: DLC services status

Service supported					
Item no.	Name of service	Reference	PT	Status	
				R/B	P
D.1	LAPC class A service and Lc	5.1	M	M	M
D.2	C _s channel fragmentation and recombination	5.1	M	M	M
D.3	Broadcast Lb service	5.1	M	M	M
D.4	Intra-cell voluntary connection handover	5.1	M	C201	C201
D.5	Intercell voluntary connection handover (note)	5.1	M	O	O
D.6	Encryption activation	5.1	M	C203	M
D.7	LU1 TRUP Class 0/min_delay	5.1	M	M	M
D.8	FU1	5.1	M	M	M
D.9	Encryption deactivation	5.1	C202	C202	C202

NOTE: The PT is required to be able to support handover between RFPs. The invocation of the feature is however optional to the operator.

C201: IF service M.9 THEN O ELSE M;

C202: IF feature N.29 OR N.28 THEN M ELSE I;

C203: IF feature N.17 OR N.27 THEN M ELSE I.

6.4 MAC services

Table 3: MAC services status

Service supported					
Item no.	Name of service	Reference	PT	Status	
				R/B	P
M.1	General	5.2	M	M	M
M.2	Continuous broadcast	5.2	M	M	M
M.3	Paging broadcast	5.2	M	M	M
M.4	Basic connections	5.2	M	M	M
M.5	C _s higher layer signalling	5.2	M	M	M
M.6	Quality control	5.2	M	M	M
M.7	Encryption activation	5.2	M	C304	M
M.8	Extended frequency allocation (note)	5.2	M	O	O
M.9	Bearer Handover, intra-cell	5.2	M	C301	C301
M.10	Bearer Handover, inter-cell	5.2	M	O	O
M.11	Connection Handover, intra-cell	5.2	M	C302	C302
M.12	Connection Handover, inter-cell	5.2	M	O	O
M.13	SARI support	5.2	M	O	O
M.14	Encryption deactivation	5.2	C303	C303	C303

NOTE: Handsets not supporting these extra frequencies need only adapt scanning to allow continued use of the standard DECT frequencies.

C301: IF service M.11 THEN O ELSE M;

C302: IF service M.9 THEN O ELSE M;

C303: IF feature N.29 OR N.28 THEN M ELSE I;

C304: IF feature N.17 OR N.27 THEN M ELSE I.

6.5 Physical layer (PHL) services

See PHL requirements, clause 11.

6.6 Application features

Table 4: Application features status

Feature supported					
Item no.	Name of feature	Reference	PT	Status	
				FT	
				R/B	P
A.1	AC_bitstring_mapping	4.2	M	C401	M
A.2	Multiple subscription registration	4.2	M	N/A	N/A
A.3	Manual entry of the PARK	4.2	O	N/A	N/A

C401: IF feature N.9 OR N.10 OR N.12 OR N.26 THEN M ELSE N/A.

6.7 NWK feature to procedure mapping

Table 5: NWK feature to procedure mapping

Feature/Procedure mapping					
Feature	Procedure	Reference	PT	Status	
				FT	
				R/B	P
N.1 Outgoing call		4.1	M	M	M
	Outgoing call request	8.2	M	M	M
	Overlap sending	8.3	M	O	O
	Outgoing call proceeding	8.4	M	O	O
	Outgoing call confirmation	8.5	M	O	O
	Outgoing call connection	8.6	M	M	M
	Sending keypad information	8.10	M	M	M
N.2 Off Hook		4.1	M	M	M
	Outgoing call request	8.2	M	M	M
	Incoming call connection	8.15	M	M	M
N.3 On Hook (full release)		4.1	M	M	M
	Normal call release	8.7	M	M	M
	Abnormal call release	8.8	M	M	M
N.4 Dialed digits (basic)		4.1	M	M	M
	Sending keypad information	8.10	M	M	M
N.5 Register recall		4.1	M	O	O
	Sending keypad information	8.10	M	M	M
N.6 Go to DTMF signalling (defined tone length)		4.1	M	O	M
	Sending keypad information	8.10	M	M	M
		4.1	M	O	O
N.7 Pause (dialling pause)		8.10	M	M	M
	Sending keypad information	8.10	M	M	M
N.8 Incoming call		4.1	M	M	M
	Incoming call request	8.12	M	M	M
	Incoming call confirmation	8.13	M	M	M
	PT alerting	8.14	M	M	M
	Incoming call connection	8.15	M	M	M
N.9 Authentication of the PP		4.1	M	O	M
	Authentication of PT	8.24	M	M	M
N10 Authentication of the user		4.1	M	O	O
	Authentication of user	8.25	M	M	M
N.11 Location registration		4.1	M	O	M
	Location registration	8.28	M	M	M
	Location update	8.29	M	O	O
N.12 On air key allocation		4.1	M	O	O
	Key allocation	8.32	M	M	M
N.13 Identification of PP		4.1	M	O	O
	Identification of PT	8.22	M	M	M

Feature/Procedure mapping					
Feature	Procedure	Reference	PT	Status	
				R/B	P
N.14 Service class indication/assignment		4.1	M	O	M
	Obtaining access rights	8.30	M	M	M
	Authentication of PT	8.24	M	M	M
N.15 Alerting		4.1	M	M	M
	PT alerting	8.14	M	M	M
N.16 ZAP		4.1	M	O	O
	Obtaining access rights	8.30	M	M	M
	Incrementing the ZAP value	8.26	M	M	M
	Authentication of FT	8.23	O	M	M
N.17 Encryption activation FT initiated		4.1	M	O	M
	Cipher-switching initiated by FT	8.33	M	M	M
	Storing the Derived Cipher Key (DCK)	8.27	M	M	M
N.18 Subscription registration user procedure on-air		4.1	M	M	M
	Obtaining access rights	8.30	M	M	M
N.19 Link control		4.1	M	M	M
	Indirect FT initiated link establishment	8.35	M	M	M
	Direct PT initiated link establishment	8.36	M	M	M
	Link release "normal"	8.37	M	M	M
	Link release "abnormal"	8.38	M	M	M
	Link release "maintain"	8.39	M	M	M
N.20 Terminate access rights FT initiated		4.1	M	O	O
	FT terminating access rights	8.31	M	M	M
	Authentication of FT	8.23	O	M	M
N.21 Partial release		4.1	O	O	O
	Partial release	8.9	M	M	M
N.22 Go to DTMF (infinite tone length)		4.1	O	O	O
	Sending keypad information	8.10	M	M	M
N.23 Go to Pulse		4.1	O	O	O
	Sending keypad information	8.10	M	M	M
N.24 Signalling of display characters		4.1	O	O	O
	Display	8.16	M	M	M
	Terminal capability indication	8.17	M	M	M
N.25 Display control characters		4.1	O	O	O
	Display	8.16	M	M	M
	Terminal capability indication	8.17	M	M	M
N.26 Authentication of FT		4.1	O	O	O
	Authentication of FT	8.23	M	M	M
N.27 Encryption activation PT initiated		4.1	O	O	O
	Cipher-switching initiated by PT	8.34	M	M	M
	Storing the DCK	8.27	M	M	M
N.28 Encryption deactivation FT initiated		4.1	O	O	O
	Cipher-switching initiated by FT	8.33	M	M	M
N.29 Encryption deactivation PT initiated		4.1	O	O	O
	Cipher-switching initiated by PT	8.34	M	M	M
N.30 Calling Line Identification Presentation (CLIP)		4.1	O	O	O
	Incoming call request	8.12	M	M	M
N.31 Internal call		4.1	O	O	O
	Internal call setup	8.18	M	M	M
	Internal call keypad	8.19	M	O	O

Feature/Procedure mapping					
Feature	Procedure	Reference	PT	Status	
				R/B	P
N.32 Service call		4.1	O	O	O
	Service call setup	8.20	M	M	M
	Service call keypad	8.21	M	O	O
N.33 Enhanced U- plane connection		4.1	O	O	O
	Enhanced FT initiated U- plane connection	8.40	M	M	M

6.8 Service to procedure mapping

6.8.1 DLC service to procedure mapping

Table 6: DLC service to procedure mapping

Service/Procedure mapping					
Service	Procedure	Reference	PT	Status	
				R/B	P
D.1 LAPC class A service and Lc		5.1	M	M	M
	Class A link establishment	9.1	M	M	M
	Class A acknowledged information transfer	9.2	M	M	M
	Class A link release	9.3	M	M	M
	Class A link re-establishment	9.4	M	M	M
D.2 C _S channel fragmentation and recombination		5.1	M	M	M
	C _S channel fragmentation and recombination	9.5	M	M	M
D.3 Broadcast Lb service		5.1	M	M	M
	Normal broadcast	9.6	M	M	M
D.4 Intra-cell voluntary connection handover		5.1	M	C601	C601
	Class A basic connection handover	9.7	M	M	M
D.5 Inter-cell voluntary connection handover		5.1	M	O	O
	Class A basic connection handover	9.7	M	M	M
D.6 Encryption activation		5.1	M	C603	M
	Encryption switching	9.8	M	M	M
D.7 LU1 TRUP Class 0/min_delay		5.1	M	M	M
	U-plane Class 0/min delay	9.9	M	M	M
D.8 FU1		5.1	M	M	M
	FU1 frame operation	9.10	M	M	M
D.9 Encryption deactivation		5.1	C602	C602	C602
	Encryption switching	9.8	M	M	M

C601: IF service M.9 THEN O ELSE M;

C602: IF feature N.29 OR N.28 THEN M ELSE I;

C603: IF feature N.17 OR N.27 THEN M ELSE I.

6.8.2 MAC service to procedure mapping

Table 7: MAC service to procedure mapping

Service/Procedure mapping					
Service	Procedure	Reference	PT	Status	
				R/B	P
M.1 General		5.2	M	M	M
	General	10.1	M	M	M
M.2 Continuous broadcast		5.2	M	M	M
	Downlink broadcast	10.2	M	M	M
M.3 Paging broadcast		5.2	M	M	M
	Paging broadcast	10.3	M	M	M
M.4 Basic connections		5.2	M	M	M
	Setup of basic connection, basic bearer setup (A-field)	10.4	M	M	M
	Connection/bearer release	10.5	M	M	M
M.5 C _s higher layer signalling		5.2	M	M	M
	C _s channel data	10.8	M	M	M
	Q2 bit setting	10.9	M	M	M
M.6 Quality control		5.2	M	M	M
	RFPI handshake	10.10	M	M	M
	Antenna diversity	10.11	M	O	O
	Sliding collision detection	10.12	O	M	M
M.7 Encryption activation		5.2	M	C704	M
	Encryption process - initialization and synchronization	10.13	M	M	M
	Encryption mode control	10.14	M	M	M
	Handover encryption process	10.15	M	M	M
M.8 Extended frequency allocation		5.2	M	O	O
	Extended frequency allocation	10.16	M	M	M
M.9 Bearer handover, intra-cell		5.2	M	C701	C701
	Bearer handover request	10.6	M	M	M
M.10 Bearer handover, inter-cell		5.2	M	O	O
	Bearer handover request	10.6	M	M	M
M.11 Connection handover, intra-cell		5.2	M	C702	C702
	Connection handover request	10.7	M	M	M
M.12 Connection handover, inter-cell		5.2	M	O	O
	Connection handover request	10.7	M	M	M
M.13 SARI support		5.2	M	O	O
	Downlink broadcast	10.2	M	M	M
M.14 Encryption deactivation		5.2	C703	C703	C703
	Encryption mode control	10.14	M	M	M

C701: IF service M.11 THEN O ELSE M;
 C702: IF service M.9 THEN O ELSE M;
 C703: IF feature N.29 OR N.28 THEN M ELSE I;
 C704: IF feature N.17 OR N.27 THEN M ELSE I.

6.8.3 Application feature to procedure mapping

Table 8: Application feature to procedure mapping

Feature/Procedure mapping					
Feature	Procedure	Reference	PT	Status	
				R/B	P
A.1 AC to bitstring mapping		4.2	M	C801	M
	AC to bitstring mapping	14.2	M	M	M
A.2 Multiple subscription registration		4.2	M	N/A	N/A
	Subscription control	14.1	M	N/A	N/A
A.3 Manual entry of the PARK		4.2	O	N/A	N/A
	Manual entry of the PARK	14.3	M	N/A	N/A

C801: IF feature N.9 OR N.10 OR N.12 OR N.26 THEN M ELSE N/A.

6.9 General requirements

6.9.1 NWK layer message contents

All reserved single bits shall be set to 0.

6.9.2 Transaction identifier

The transaction identifier value for a CC call shall always get assigned the lowest available free number.

6.9.3 Length of a NWK layer message

PP and the FP shall be capable of receiving and processing NWK layer messages of at least 63 octets long. All mandatory information elements as defined in the present document shall be included in the first 63 octets.

This requires only one DLC segment to be supported as mandatory. The DLC shall convey the first segment of a layer 3 message to the NWK layer. Additional segments of a layer 3 message may be discarded by the receiving side, (see clause 9.2.3).

6.9.4 Handling of error and exception conditions

If a MM message, requesting initiation of a MM procedure, is received in a CC state where the receiving entity is not required to support it and does not support it, this message shall be ignored.

Whenever an unexpected CC message, except {CC-RELEASE} or {CC-RELEASE-COM}, or an unrecognized message is received in any CC state, the message shall be ignored.

When a message other than {CC-SETUP}, {CC-RELEASE} or {CC-RELEASE-COM} is received which has one or more mandatory information elements missing or with invalid content, the normal release procedure as described in clause 8.7 shall be invoked.

EN 300 175-5 [5], clause 17.6.4 shall also apply to mandatory information elements in MM messages with a length exceeding the allowed maximum value.

The usage of a reserved value in an information element field shall not by itself constitute an error. The receiver of such a value shall process the value if it understands it or shall ignore it otherwise.

In all other cases the rules and order of precedence specified in EN 300 175-5 [5], clause 17, shall be obeyed.

6.9.5 GAP default setup attributes

The <<IWU-ATTRIBUTES>> and <<CALL-ATTRIBUTES>> information elements are not required to be understood by a "GAP" equipment. The values, as stated in EN 300 175-5 [5], annex E shall be considered as default. The value "1" of the field <Network layer attributes> in <<CALL-ATTRIBUTES>> shall be interpreted as indicating "Generic Access Profile (GAP)".

6.9.6 Coexistence of MM and CC procedures

The following table describes whether an MM procedure is supported in any CC state or whether a restriction applies. The restriction has been made in order to limit the complexity of the receiving side so that it is not mandated to understand MM messages in all CC states for the purpose of achieving inter-operability.

Table 9: Support of MM procedures in CC states

Procedure	Mandatory support in CC state
Identification of PT	All states
Authentication of FT	All states
Authentication of PT	All states
Authentication of user	All states
Location registration	All states
Location update	All states
Obtaining access rights	T(F)-00
FT terminating access rights	F(T)-00, T-01, T-10
Key allocation	F(T)-00
Cipher-switching initiated by FT	All states
Cipher switching initiated by PT	All states

The CC and MM entities may work independently one from the other. If a FT decides to perform a MM procedure prior to proceeding with a PT initiated CC procedure, the FT has the rights to restart the CC timers in the PT to prevent the CC state machine from waiting on a response delayed because of the MM procedure execution. For this purpose the FT may send a {CC-NOTIFY} message. The support of this message is mandatory for the PT and optional for the FT. The {CC-NOTIFY} shall include the <<TIMER-RESTART>> information element.

6.9.7 Coding rules for information elements

For mandatory information elements, at least the first octet within any octet group shall be present. It is not permitted to use the information element field <Length of Contents> to omit an octet group. However, if explicitly stated a mandatory information element may contain zero length contents.

7 Procedure description

The following clauses define the process mandatory procedures which are in the scope of the GAP. Each procedure (if appropriate) is divided into three parts:

- normal (i.e. successful) case(s). This part defines the functions and respective protocol element values in normal operation;
- associated procedure(s). This is an integral part of the actual procedure (if defined in the present document), i.e. if a procedure is being declared to be supported, the respective entity shall also support the associated procedures, e.g. timer management, in the clause following the description of the normal case;
- exceptional case(s). This is an integral part of the actual procedure (if defined in the present document), i.e. if a procedure is being declared to be supported, the respective entity shall also support the exception handling defined in the clause following the description of the normal case.

All protocol elements listed in the following clauses are process mandatory, i.e. the FT and PT depending on their role in the procedure shall send or shall receive and process the relevant protocol elements as listed in the respective tables if not explicitly stated as being optional.

The primitives used in procedure descriptions are defined only for the purpose of describing layer-to-layer interactions. The primitives are defined as an abstract list of parameters, and their concrete realization may vary between implementations. No formal testing of primitives is intended. The primitive definitions have no normative significance.

8 NWK layer procedures

This clause specifies the NWK layer procedures, messages and information elements required in the GAP.

This profile does not prevent any PT or FT from transmitting or receiving and processing any other NWK layer message or information element not specified in the profile. A PT or FT receiving an unsupported NWK layer message or information element, which it does not recognize, shall ignore it, as specified in EN 300 175-5 [5], clause 17.

8.1 Summary of outgoing call messages, normal cases

Figures 1 to 4 show a summary of possible sequences of outgoing call related messages.

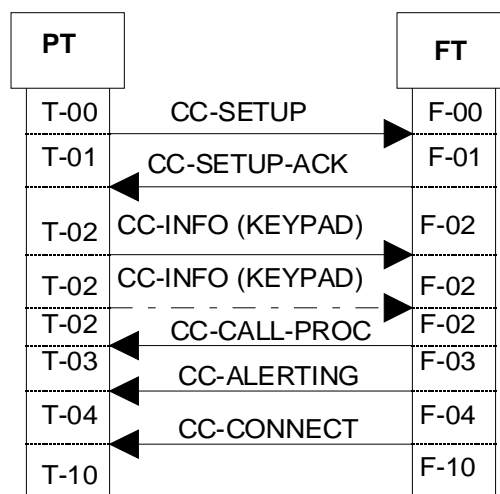

Figure 1

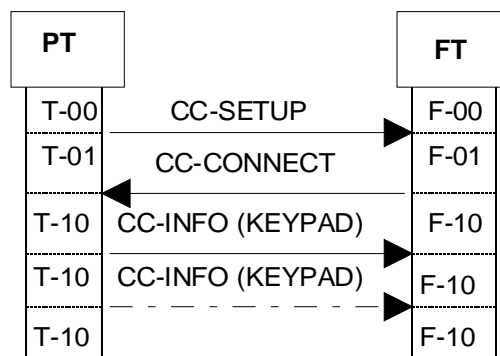

Figure 2

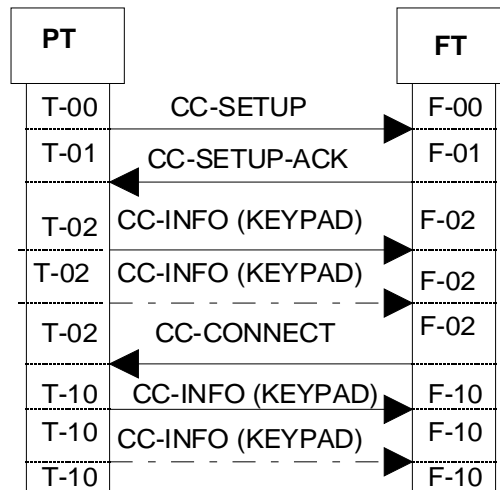

Figure 3

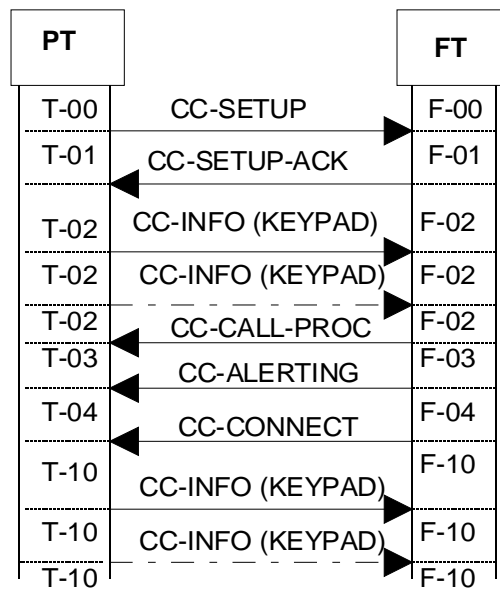

Figure 4

8.2 Outgoing call request

The procedure shall be performed as defined in EN 300 175-5 [5], clauses 9.3.1, 9.3.1.1 and 9.3.1.2. Figure 5 and table 10 together with the associated clauses define the mandatory requirements with regard to the present document.

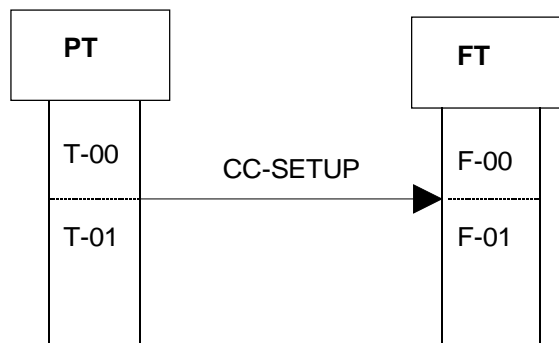

Figure 5: Outgoing call request

Table 10: Values used within the {CC-SETUP} message

Information element	Field within the information element	Standard values within the field/information element	Normative action/comment
<<Portable identity>>			
	<Type>	0	International Portable User Identity (IPI)
	<PUT>	All	Area dependent
	<PUN>	All	Area dependent
<<Fixed Identity>>			Shall always include the whole PARK including the non-significant bits.
	<Type>	32	PARK
	<Length of identity value>	All	PARK Length Indicator (PLI)+1
	<ARC+ARD>	All	Area dependent
<<Basic service>>			
	<Call class>	8	Normal call setup
		9	Optional, relates to feature internal call [N.31]. For the associated procedure (see clause 8.18)
		11	Optional, relates to feature service call [N.32]. For the associated procedure (see clause 8.20)
	<Basic service>	0	

8.2.1 Associated procedures

8.2.1.1 Timer P-<CC.03> management

<CC.03> CC setup timer;

Value Refer to EN 300 175-5 [5], annex A;

Start A {CC-SETUP} message has been sent;

Stop An indication for release or reject from the IWU or for link release from the DLC layer is received. A {CC-SETUP-ACK}, {CC-CONNECT} or {CC-RELEASE-COM} message is received;

Restart FT may restart it at any time by sending a {CC-NOTIFY} message (see clause 6.9.6).

8.2.2 Exceptional cases

8.2.2.1 Timer P-<CC.03> expiry

The abnormal call release procedure shall be used, (see clause 8.8).

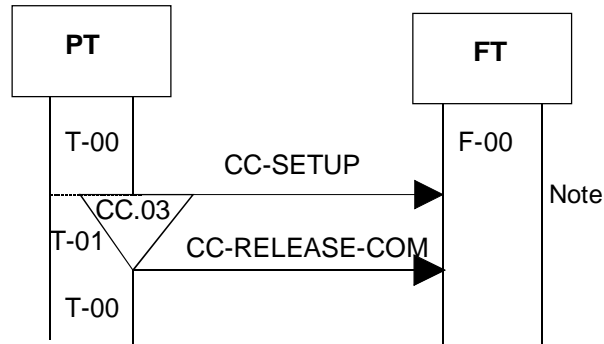

NOTE: FT may not be answering because of some FT problems or because the {CC-SETUP} message has been lost or corrupted. The same result will occur if the eventual FT answer has been lost or corrupted.

Figure 6: Timer P<CC.03> expiry

For the values used within the {CC-SETUP} see table 10. For the contents of {CC-RELEASE-COM} message, see table 17.

8.2.2.2 PT releases the outgoing call request

The normal call release procedure shall be used, (see clause 8.7).

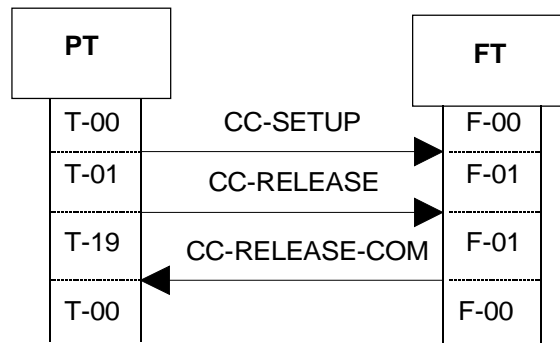
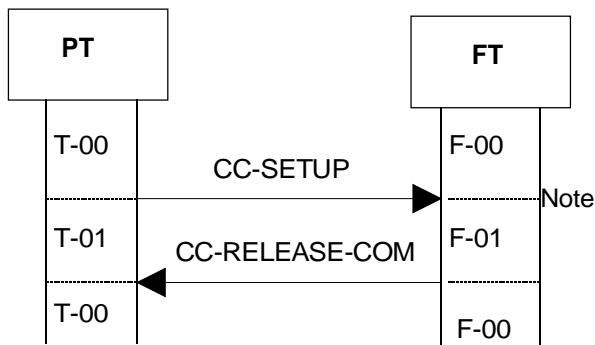

Figure 7: PT releases the outgoing call request

For the values used within {CC-SETUP} see table 10. For the contents of {CC-RELEASE} and {CC-RELEASE-COM} messages, see tables 15 and 16.

8.2.2.3 FT rejects the outgoing call request

The abnormal call release procedure shall be used, (see clause 8.8).



NOTE: Either F-CC or the F-IWU may reject the call.

Figure 8: FT rejects the outgoing call request

For the contents of {CC-RELEASE-COM} see table 17.

The contents of an unacceptable {CC-SETUP} is outside the scope of the present document.

8.3 Overlap sending

The procedure shall be performed as defined in EN 300 175-5 [5], clauses 9.3.1.5 and 9.3.1.4. The following text together with the associated clauses define the mandatory requirements with regard to the present document.

Both PT and FT shall support piecewise dialling using the <<MULTI-KEYPAD>> information element.

NOTE: A single <<MULTI-KEYPAD>> information element may contain the complete dialling information.

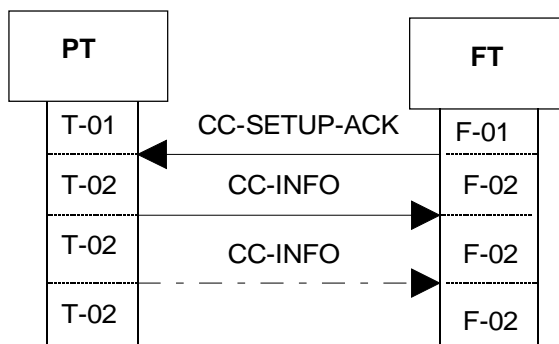

Figure 9: Overlap sending

Table 11: Values used within the {CC-SETUP-ACK} message

Information element	Field within the information element	Standard values within the field/information element	Normative action/comment
<<Progress indicator>>			
	<Progress description>	8H	"In band information or appropriate pattern now available". Inclusion of this information element is optional, but if it is present, PT shall connect the U-plane

For the values used in {CC-INFO} see table 20.

8.3.1 Associated procedure

8.3.1.1 Timer F-<CC.01> management

<CC.01> Overlap sending timer;

Value: Refer to EN 300 175-5 [5], annex A;

Start: A {CC-SETUP-ACK} has been sent;

Stop: As soon as FT leaves "Overlap Sending" state;

Restart: A {CC-INFO} message has been received.

8.3.2 Exceptional cases

8.3.2.1 PT releases the outgoing call request

The normal call release procedure shall be used, (see clause 8.7).

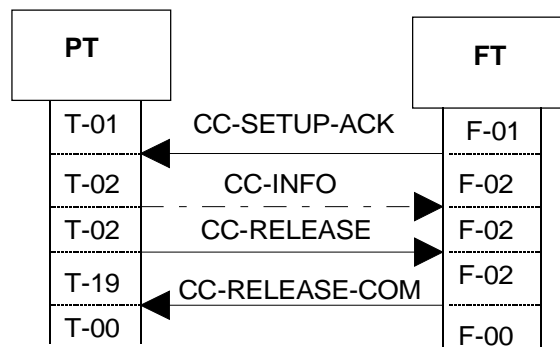
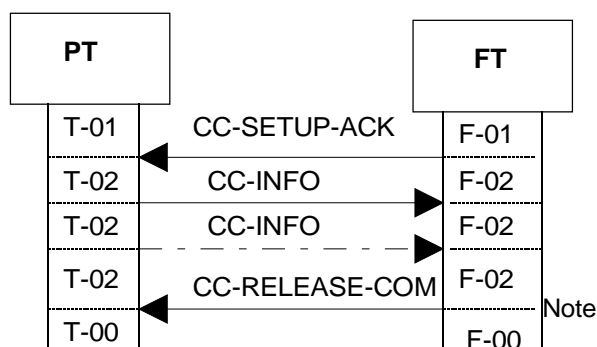

Figure 10: PT release the outgoing call request

For the values used within the {CC-SETUP-ACK} see table 11. For the contents of {CC-RELEASE} and {CC-RELEASE-COM} messages, see tables 15 and 16.

8.3.2.2 FT rejects the outgoing call request

The abnormal release procedure shall be used, (see clause 8.8).



NOTE: Either F-CC or F-IWU may reject the call.

Figure 11: FT rejects the outgoing call request

For the contents of {CC-SETUP-ACK} see table 11.

The contents of an unacceptable {CC-INFO} message is outside the scope of the present document.

For the contents of {CC-RELEASE-COM} see table 17.

8.3.2.3 Timer F-<CC.01> expiry

The normal release procedure shall be used, (see clause 8.7).

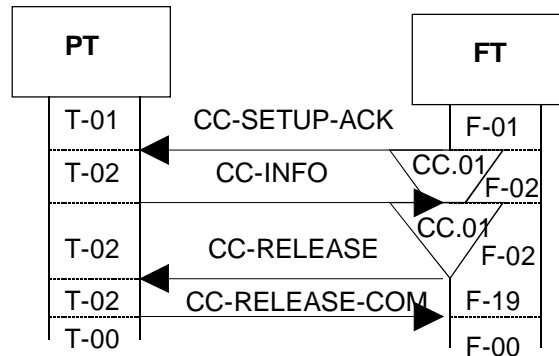

Figure 12: Timer F<CC.01> expiry

For the values used within the {CC-SETUP-ACK} see table 11. For {CC-INFO} (if any has been sent) see table 20. For the contents of {CC-RELEASE} and {CC-RELEASE-COM} messages, see tables 15 and 16.

8.3.2.4 FT releases the outgoing call request

The normal release procedure shall be used, (see clause 8.7).

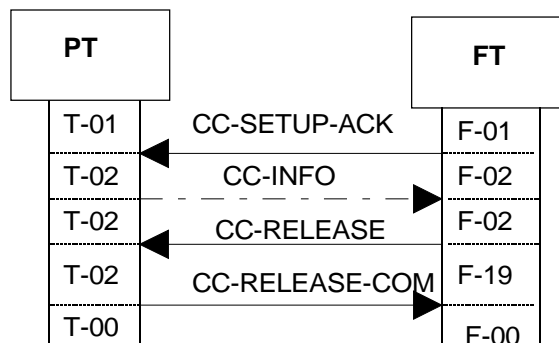

Figure 13: FT releases the outgoing call request

For the values used within the {CC-SETUP-ACK} see table 11. For {CC-INFO} (if any has been sent) see table 20. For the contents of {CC-RELEASE} and {CC-RELEASE-COM} messages, see tables 15 and 16.

8.4 Outgoing call proceeding

The procedure shall be performed as defined in clauses 9.3.1.6 and 9.3.1.4 of EN 300 175-5 [5]. Figure 14 and table 12 together with the associated clauses define the mandatory requirements with regard to the present document.

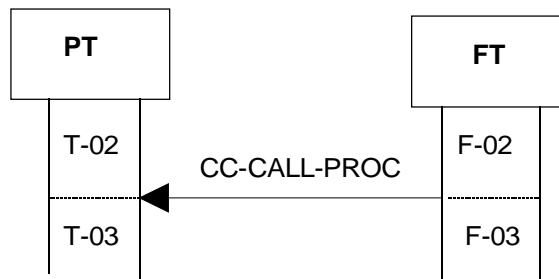

Figure 14: Outgoing call proceeding

Table 12: Values used within the {CC-CALL-PROC} message

Information element	Field within the information element	Standard values within the field/information element	Normative action/comment
<<Progress indicator>>			
	<Progress description>	8H	"In band information or appropriate pattern now available". Inclusion of this information element is optional, but if it is present, PT shall connect the U-plane

8.4.1 Exceptional cases

8.4.1.1 PT releases the outgoing call request

The normal release procedure shall be used, (see clause 8.7).

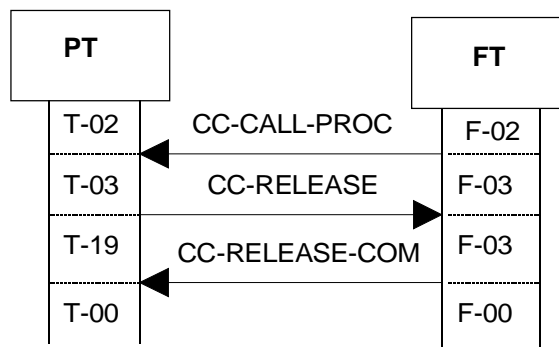

Figure 15: PT releases the outgoing call request

For the values used within the {CC-CALL-PROC} see clause 8.4, table 12. For the contents of {CC-RELEASE} and {CC-RELEASE-COM} messages, see clause 8.7, tables 15 and 16.

8.4.1.2 FT releases the outgoing call request

The normal release procedure shall be used, (see clause 8.7).

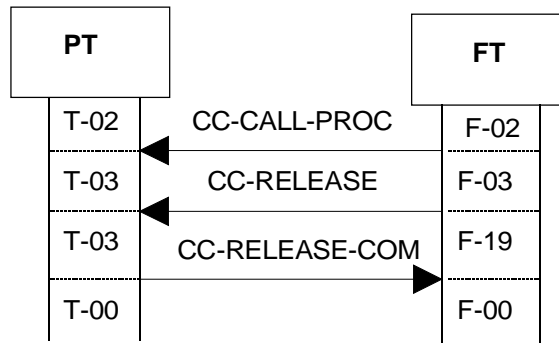

Figure 16: FT releases the outgoing call request

For the values used within the {CC-CALL-PROC} see clause 8.4, table 12. For the contents of {CC-RELEASE} and {CC-RELEASE-COM} messages, see clause 8.7, tables 15 and 16.

8.5 Outgoing call confirmation

The procedure shall be performed as defined in clauses 9.3.1.7 and 9.3.1.4 of EN 300 175-5 [5]. Figure 17 and table 13 together with the associated clauses define the mandatory requirements with regard to the present document.

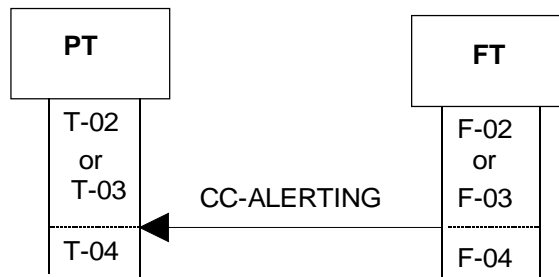

Figure 17: Outgoing call confirmation

Table 13: Values used within the {CC-ALERTING} message

Information element	Field within the information element	Standard values within the field/information element	Normative action/comment
<<Progress indicator>>			
	<Progress description>	8H	"In band information or appropriate pattern now available". Inclusion of this information element is optional, but if it is present, PT shall connect the U-plane

8.5.1 Exceptional cases

8.5.1.1 PT releases the outgoing call request

The normal release procedure shall be used, (see clause 8.7).

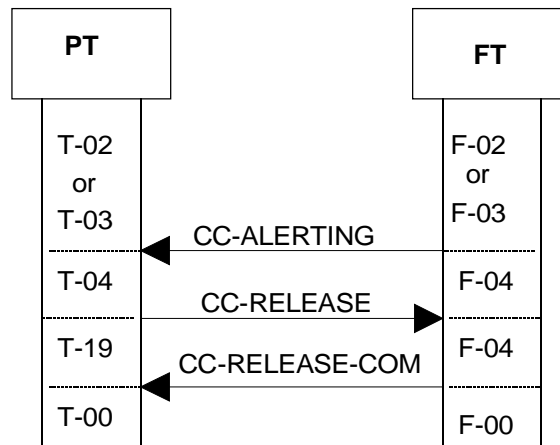

Figure 18: PT releases the outgoing call request

For the values used within the {CC-ALERTING} see table 13. For the contents of {CC-RELEASE} and {CC-RELEASE-COM} messages, see tables 15 and 16.

8.5.1.2 FT releases the outgoing call request

The normal release procedure shall be used, (see clause 8.7).

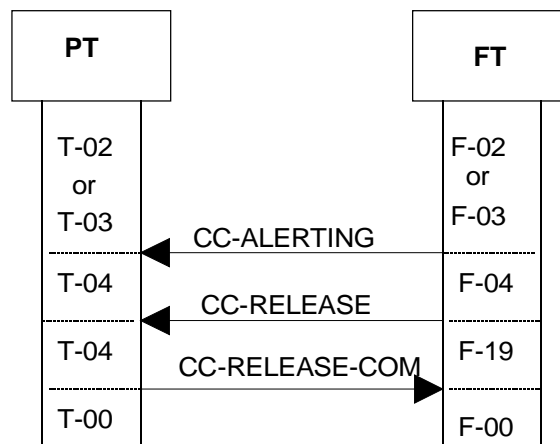

Figure 19: FT releases the outgoing call request

For the values used within the {CC-ALERTING} see table 13. For the contents of {CC-RELEASE} and {CC-RELEASE-COM} messages, see tables 15 and 16.

8.6 Outgoing call connection

The procedure shall be performed as defined in EN 300 175-5 [5], clauses 9.3.1.8 and 9.3.1.4. The following text together with the associated clauses define the mandatory requirements with regard to the present document.

Before sending the {CC-CONNECT} message the FT shall connect the U-plane. On receipt of {CC-CONNECT} message the PT shall connect the U-plane.

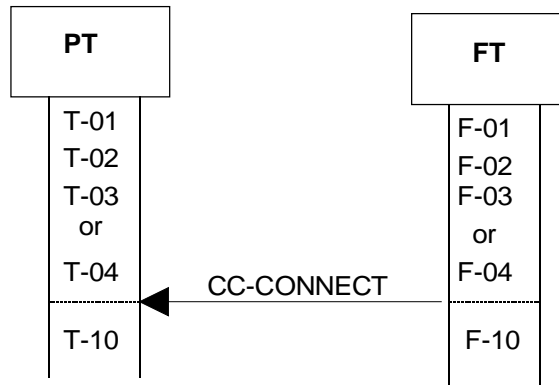

Figure 20: Outgoing call connection

Table 14: Values used within the {CC-CONNECT} message

Information element	Field within the information element	Standard values within the field/information element	Normative action/comment
			All optional

8.7 Normal call release

The procedure shall be performed as defined in EN 300 175-5 [5], clauses 9.5.1 and 9.5.3. Figures 21 and 22, and table 15 together with the associated clauses define the mandatory requirements with regard to the present document.

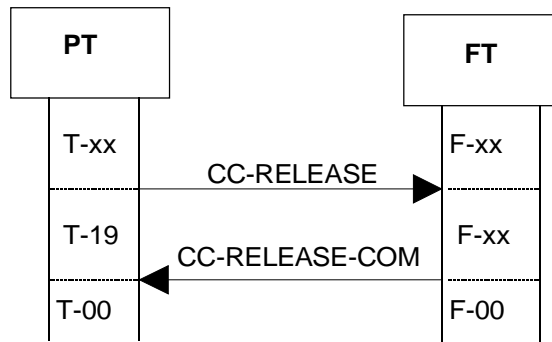

Figure 21: Normal call release, PT initiated

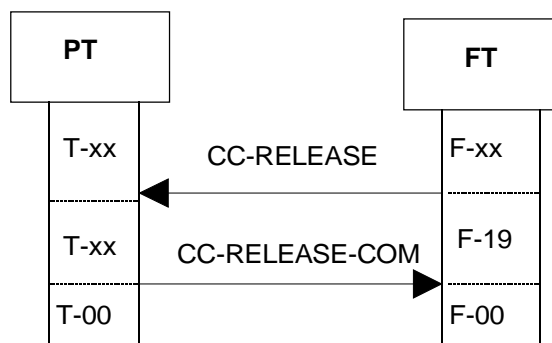

Figure 22: Normal call release, FT initiated

The PT is allowed to initiate this procedure in any state except T-00, T-06 and T-19.

The FT is allowed to initiate this procedure in any state except F-00, F-01 and F-19.

Table 15: Values used within the {CC-RELEASE} message

Information element	Field within the information element	Standard values within the field/information element	Normative action/comment
			All optional

Table 16: Values used within the {CC-RELEASE-COM} message

Information element	Field within the information element	Standard values within the field/information element	Normative action/comment
			All optional

8.7.1 Associated procedures

8.7.1.1 Timer P-<CC.02> management

<CC.02>: CC release timer;

Value: Refer to EN 300 175-5 [5], annex A;

Start: A {CC-RELEASE} message has been sent;

Stop: An indication for link release from the DLC layer is received. A {CC-RELEASE-COM} or a {CC-RELEASE} message is received;

Restart: FT may restart it at any time by sending a {CC-NOTIFY} message, (see clause 6.9.6).

8.7.1.2 Timer F-<CC.02> management

<CC.02>: CC release timer;

Value: Refer to EN 300 175-5 [5], annex A;

Start: A {CC-RELEASE} message has been sent;

Stop: An indication for link release from the DLC layer is received. A {CC-RELEASE-COM} or a {CC-RELEASE} message is received.

8.7.2 Exceptional cases

8.7.2.1 Release collisions

A release collision occurs when both sides send {CC-RELEASE} at the same time or a {CC-RELEASE} message has been received when the receiver is in "RELEASE PENDING" state due to loss of the first sent {CC-RELEASE} message.

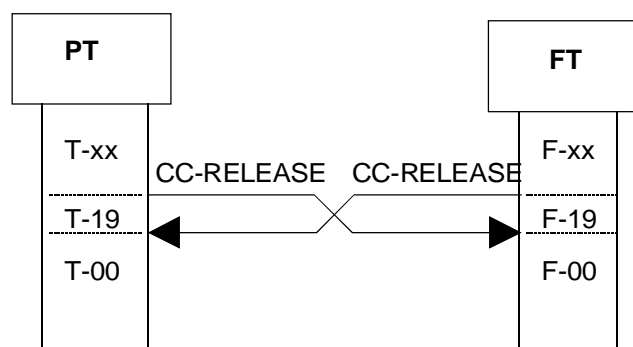

Figure 23: Both sides send {CC-RELEASE}

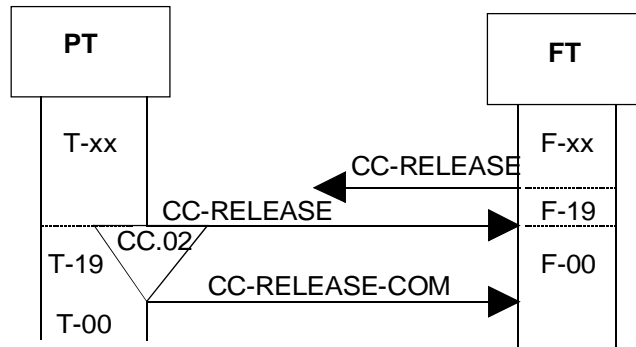
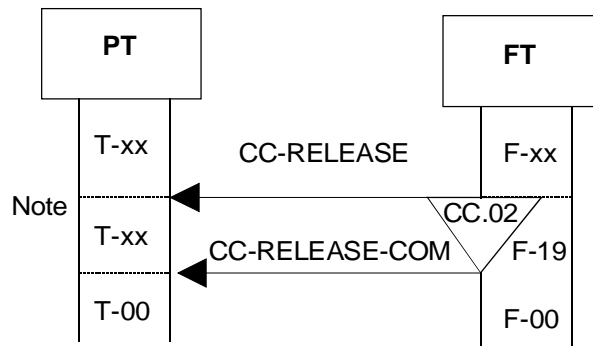

Figure 24: The {CC-RELEASE} sent by the FT has been lost

For the values used within the {CC-RELEASE} and {CC-RELEASE-COM} see tables 15 and 16.

8.7.2.2 Timer F-<CC.02> expiry



NOTE: PT may not be answering because of some PT problems or the {CC-RELEASE} sent by the FT or the eventual {CC-RELEASE-COM} message sent by the PT has been lost or corrupted.

Figure 25: Timer F<CC.02> expiry

For the values used within the {CC-RELEASE} and {CC-RELEASE-COM} messages, see tables 15 and 16.

8.7.2.3 Timer P-<CC.02> expiry

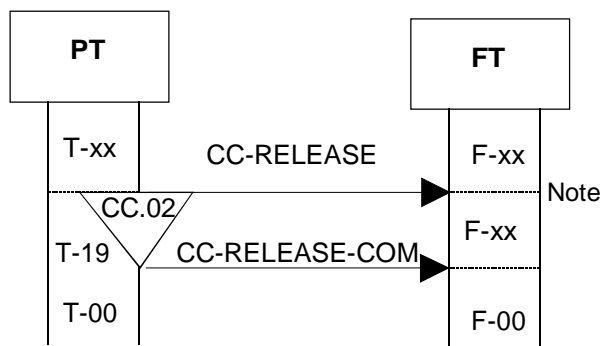

NOTE: FT may not be answering because of some FT problems or the {CC-RELEASE} sent by the PT or the eventual {CC-RELEASE-COM} message sent by the FT has been lost or corrupted.

Figure 26: Timer P<CC.02> expiry

For the values used within the {CC-RELEASE} and {CC-RELEASE-COM} messages, see tables 15 and 16.

8.8 Abnormal call release

The procedure shall be performed as defined in EN 300 175-5 [5], clause 9.5.2. The following text together with the associated clauses define the mandatory requirements with regard to the present document.

The abnormal release is indicated by the unexpected receipt of a {CC-RELEASE-COM} message without a prior transmission of a {CC-RELEASE} message.

In state T19 {CC-RELEASE-COM} may also be sent without expiry of <CC.02>

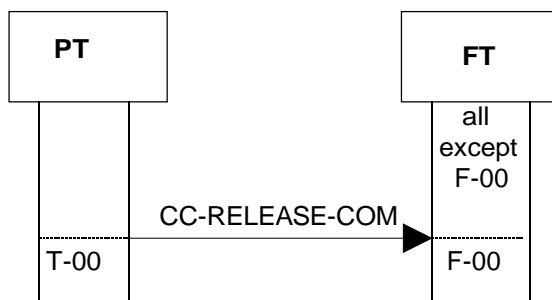

Figure 27: Abnormal call release, PT initiated

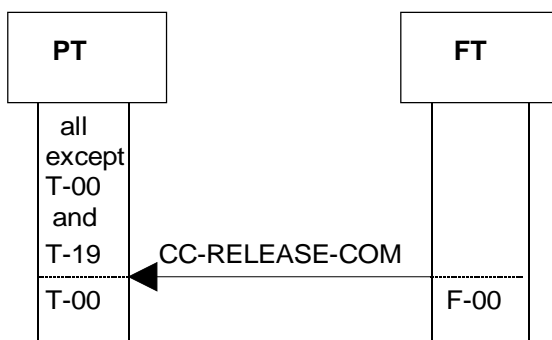

Figure 28: Abnormal call release, FT initiated

Table 17: Values used within the {CC-RELEASE-COM} message

Information element	Field within the information element	Standard values within the field/information element	Normative action/comment
			All optional

8.9 Partial release

The procedure shall be performed as defined in EN 300 175-5 [5], clause 14.2.7. The following text together with the associated clauses define the mandatory requirements with regard to the present document.

If a "partial release" has been indicated in the <<Release reason>> information element in the {CC-RELEASE} message (implying that a follow-on call activities are expected), both the requesting and the requested CC (if the requested CC supports the feature N.21 as well) shall request a delayed link release from the Link Control Entity (LCE). In this event the link shall be retained for a few seconds (timer <LCE.02>) as it is described in clause 8.39.

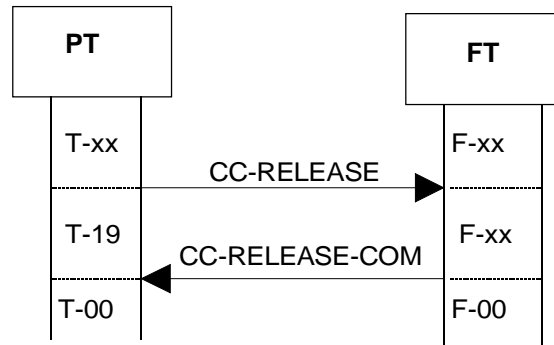

Figure 29: Partial release, PT initiated

Table 18: Values used within the {CC-RELEASE} message

Information element	Field within the information element	Standard values within the field/information element	Normative action/comment
<<Release reason>>	<Release reason code>	0EH	Partial release

Table 19: Values used within the {CC-RELEASE-COM} message

Information element	Field within the information element	Standard values within the field/information element	Normative action/comment
<<Release reason>>	<Release reason code>	0EH	Always shall be included if the "partial release" has been requested, (see table 18), and if the requested side supports feature N.21

The case when the FT initiates this procedure differs only in the notation.

8.10 Sending keypad information

The procedure shall be performed as defined in EN 300 175-5 [5], clauses 10.2, 9.3.1.5 and 9.4. The following text together with the associated clauses define the mandatory requirements with regard to the present document.

The PT shall be capable of sending keypad information which shall be included in the <<MULTI-KEYPAD>> information element in one or several {CC-INFO} messages. The PT and the FT are mandated to be able to perform this procedure in states T-02 and T-10.

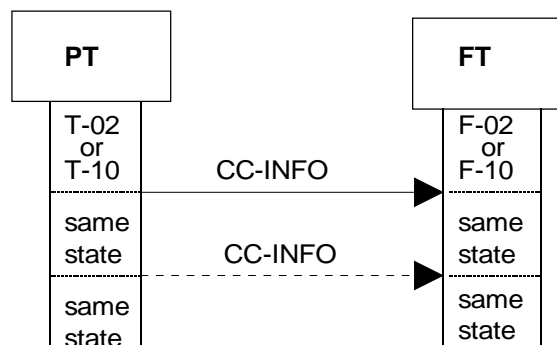

Figure 30: Sending keypad information

Table 20: Values used within the {CC-INFO} message

Information element	Field within the information element	Standard values within the field/information element	Normative action/comment
<<Multi keypad>>			
	<Keypad information>	05H	Relate to feature pause (dialling pause) [N.7]
		12H	Go to pulse. The support of this code is mandatory only if feature [N.23] is implemented
		14H	Relate to feature go to DTMF signalling (defined tone length) [N.6]
		15H	Relate to feature register recall [N.5]
		16H	Go to DTMF signalling (infinite tone length). The support of this code is mandatory only if feature [N.22] is implemented
		17H	Relates to feature internal call [N.31]. For the related procedure (see clause 8.19)
		18H	Relates to feature service call [N.32]. For the related procedure (see clause 8.21)
		23H, 2AH, 30H - 39H	#, *, 0 - 9. Relate to feature dialled digits (basic) [N.4] and outgoing call [N.1]

8.11 Summary of incoming call related messages, normal cases

Figures 31 and 32 show a summary of possible sequences of incoming call related messages.

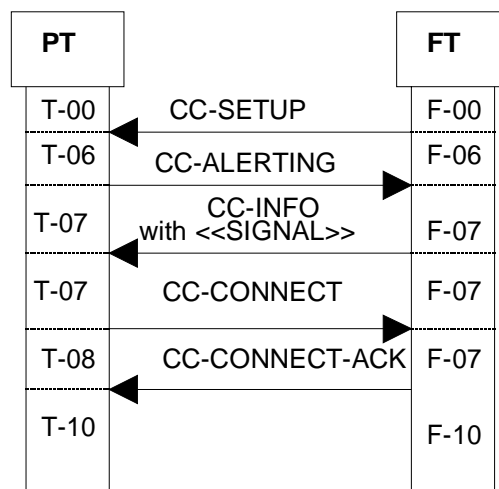

Figure 31

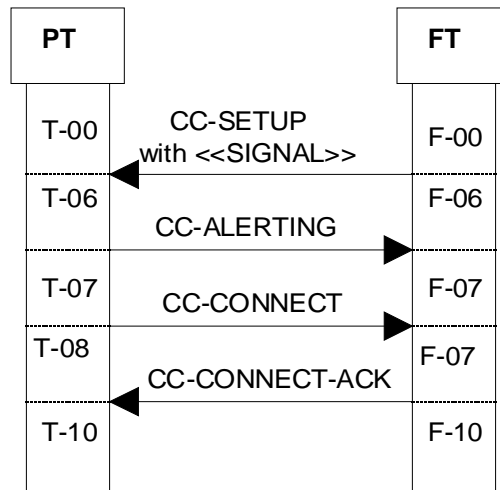

Figure 32

8.12 Incoming call request

The procedure shall be performed as defined in EN 300 175-5 [5], clauses 9.3.2, 9.3.2.1 and 9.3.2.2. Figure 33 and table 21 together with the associated clauses define the mandatory requirements with regard to the present document.

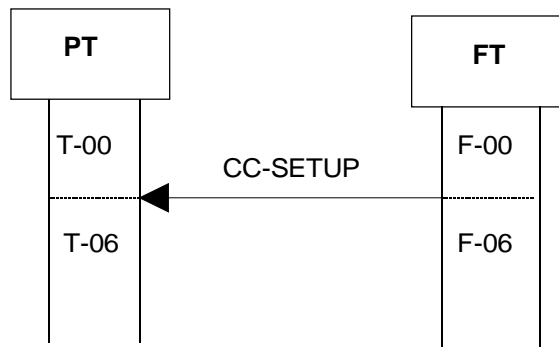

Figure 33: Incoming call request

Table 21: Values used within the {CC-SETUP} message

Information element	Field within the information element	Standard values within the field/information element	Normative action/comment
<<Portable identity>>			
	<Type>	0	IPUI
	<PUT>	All	Area dependent
	<PUN>	All	Area dependent
<<Fixed Identity>>			Shall always include the whole PARK including the non-significant bits
	<Type>	32	PARK
	<Length of identity value>	All	PLI+1
	<ARC+ARD>	All	Area dependent
<<Basic service>>			
	<Call class>	8	
	<Basic service>	0	
<<Signal>>			Relates to procedure PT alerting, (see clause 8.14)
	<Signal value>	40H - 47H, 48H, 4FH	
<<Calling party number>>			The support of this information element is only mandatory if feature [N.30] is implemented
	<Number type>	All	
	<Numbering plan id>	All	
	<Presentation indicator>	All	
	<Screening indicator>	All	
	<Calling party address>	All	

8.12.1 Associated procedure

8.12.1.1 Timer F-<CC.03> management

<CC.03>: CC setup timer;

Value: Refer to EN 300 175-5 [5], annex A;

Start: A {CC-SETUP} message has been sent;

Stop: An indication for release from the IWU or for link release from the DLC layer is received. A {CC-ALERTING} or {CC-RELEASE-COM} message is received.

8.12.2 Exceptional cases

8.12.2.1 FT releases the incoming call request

The normal release procedure shall be used, (see clause 8.7).

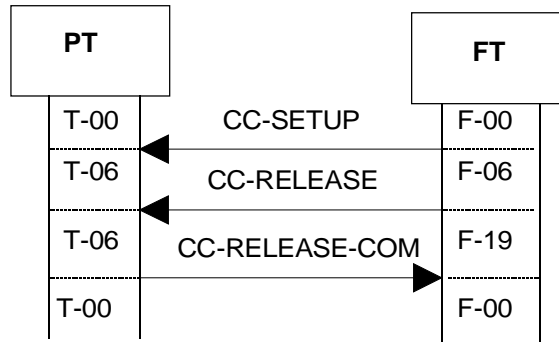
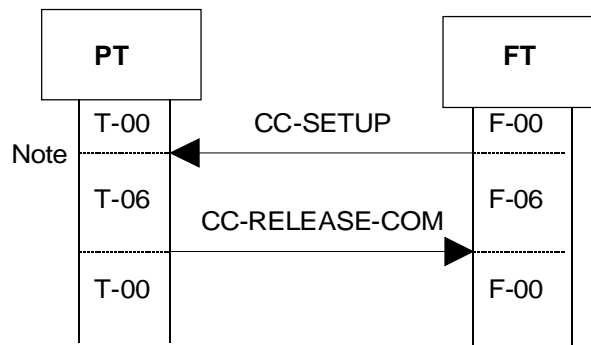

Figure 34: FT releases the incoming call request

For the values used within the {CC-SETUP} see table 21. For the contents of {CC-RELEASE} and {CC-RELEASE-COM} messages, see tables 15 and 16.

8.12.2.2 PT rejects the incoming call request

The abnormal release procedure shall be used, (see clause 8.8).



NOTE: Either PT-CC or PT-IWU may reject the call.

Figure 35: PT rejects the incoming call request

For the values used within the {CC-SETUP} see table 21. For the contents of {CC-RELEASE-COM} message see table 17.

8.12.2.3 Timer F-<CC.03> expiry

The abnormal release procedure shall be used, (see clause 8.8).

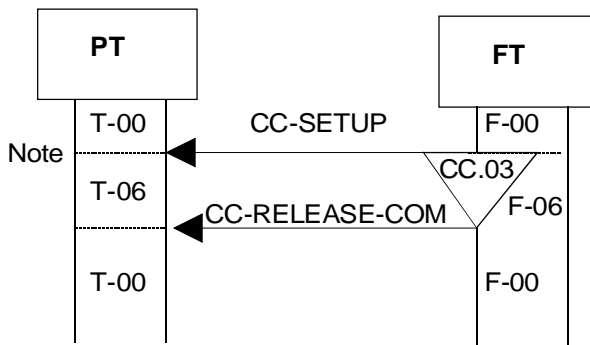

NOTE: PT may not be answering because of some PT problems or because the {CC-SETUP} message has been lost or corrupted. The same result will occur if the eventual answer from the PT has been lost or corrupted.

Figure 36: Timer F<CC.03> expiry

For the values used within the {CC-SETUP} see table 21. For the contents of {CC-RELEASE-COM} see table 17.

8.12.3 Collective and group ringing

GAP equipment, which supports additionally to its GAP features collective and group ringing shall follow the procedures as specified in EN 300 175-5 [5], clause 14.4.

A PP that has already established a call, should interpret a collective or group ringing request as an unexpected message and shall not initiate ringing.

Similarly, when a PP receives a call setup request during collective or group ringing, should stop ringing and allow the call setup to proceed.

8.13 Incoming call confirmation

The procedure shall be performed as defined in EN 300 175-5 [5], clause 9.3.2.7. Figure 37 and table 22 together with the associated clauses define the mandatory requirements with regard to the present document.

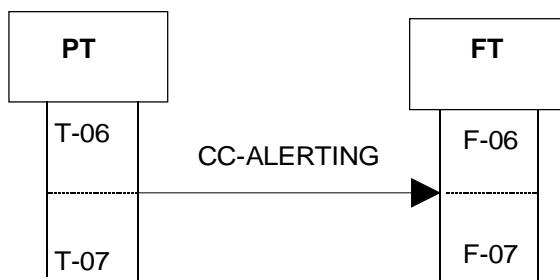

Figure 37: Incoming call confirmation

Table 22: Values used within the {CC-ALERTING} message

Information element	Field within the information element	Standard values within the field/information element	Normative action/comment
			All optional

8.13.1 Exceptional cases

8.13.1.1 FT releases the incoming call transaction

The normal release procedure shall be used, (see clause 8.7).

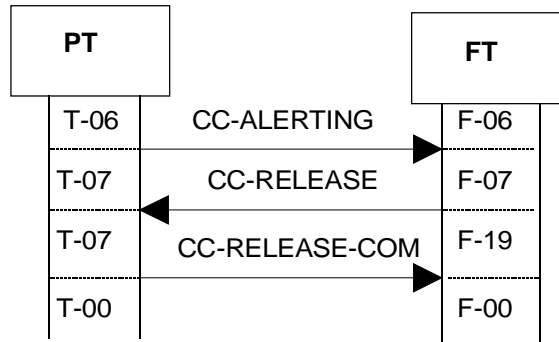

Figure 38: FT releases the incoming call transaction

For the values used within the {CC-ALERTING} see table 22. For the contents of {CC-RELEASE} and {CC-RELEASE-COM} messages, see tables 15 and 16.

8.13.1.2 PT releases the incoming call transaction

The normal release procedure shall be used, (see clause 8.7).

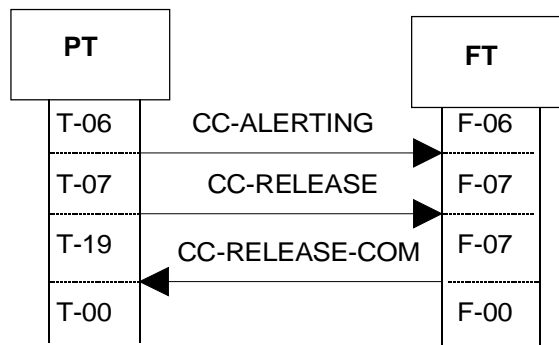

Figure 39: PT release the incoming call transaction

For the values used within the {CC-ALERTING} see table 22. For the contents of {CC-RELEASE} and {CC-RELEASE-COM} messages, see tables 15 and 16.

8.14 PT alerting

The procedure shall be performed as defined in EN 300 175-5 [5], clause 9.3.2.7. The following text together with the associated clauses define the mandatory requirements with regard to the present document.

PT alerting may be initiated either by including the <<SIGNAL>> information element in the {CC-SETUP} message or in a {CC-INFO} message in state F-07. FT is required to support one of the methods, PT is required to support both.

For PT alerting through the {CC-SETUP} see table 21, with the following additions:

Table 23: Values added within the {CC-SETUP} message

Information element	Field within the information element	Standard values within the field/information element	Normative action/comment
<<Signal>>			
	<Signal value>	40H - 47H, 48H, 4FH	40H - internal, 41H - external

For PT alerting through {CC-INFO} in state F(T)-07 consider the following.

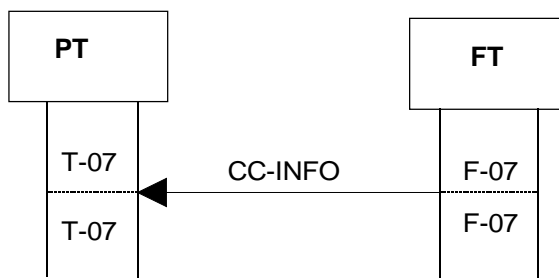

Figure 40: PT alerting in F-07

Table 24: Values used within the {CC-INFO} message

Information element	Field within the information element	Standard values within the field/information element	Normative action/comment
<<Signal>>			
	<Signal value>	40H - 47H, 48H, 4FH	40H - internal, 41H - external

8.15 Incoming call connection

The procedure shall be performed as defined in EN 300 175-5 [5], clause 9.3.2.8. The following text together with the associated clauses define the mandatory requirements with regard to the present document.

When the PT leaves the T-07 it shall stop alerting.

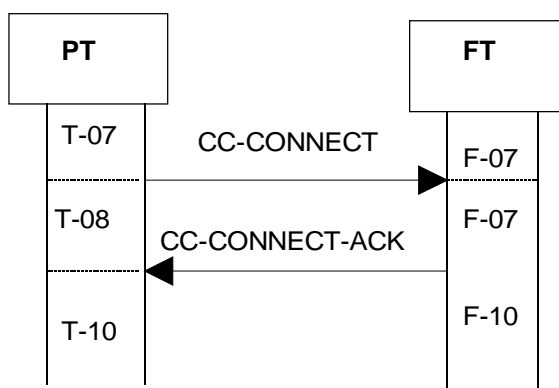

Figure 41: Incoming call connection

Table 25: Values used within the {CC-CONNECT} message

Information element	Field within the information element	Standard values within the field/information element	Normative action/comment
			All optional

Table 26: Values used within the {CC-CONNECT-ACK} message

Information element	Field within the information element	Standard values within the field/information element	Normative action/comment
			All optional

8.15.1 Associated procedure

8.15.1.1 Timer P-<CC.05> management

<CC.05>: CC connect timer;

Value: Refer to EN 300 175-5 [5], annex A;

Start: A {CC-CONNECT} message has been sent;

Stop: An indication for release from the IWU or for link release from the DLC layer is received. A {CC-CONNECT-ACK} or {CC-RELEASE} message is received;

Restart: FT may restart it at any time by sending a {CC-NOTIFY} message, (see clause 6.9.6).

8.15.2 Exceptional cases

8.15.2.1 FT releases the incoming call transaction

The normal release procedure shall be used, (see clause 8.7).

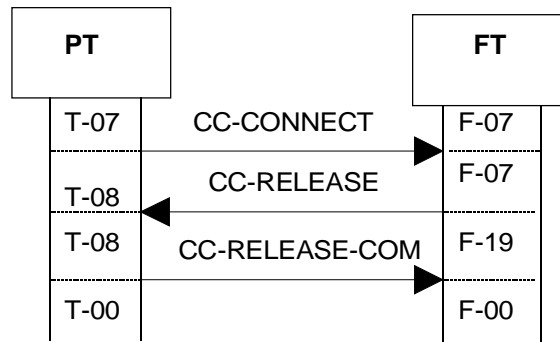

Figure 42: FT releases the incoming call transaction

For the values used within the {CC-CONNECT} see table 25. For the contents of {CC-RELEASE} and {CC-RELEASE-COM} messages, see tables 15 and 16.

8.15.2.2 PT releases the incoming call transaction

The normal release procedure shall be used, (see clause 8.7).

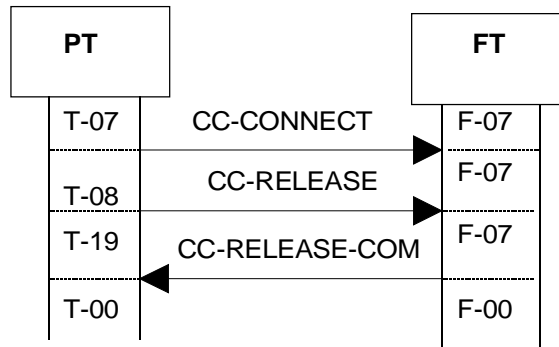
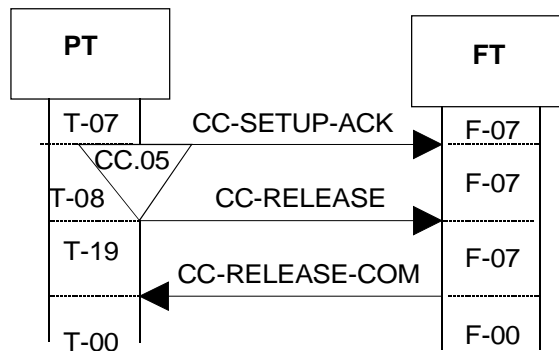

Figure 43: PT releases the incoming call transaction

For the values used within the {CC-CONNECT} see table 25. For the contents of {CC-RELEASE} and {CC-RELEASE-COM} messages, see tables 15 and 16.

8.15.2.3 Timer P-<CC.05> expiry

The normal release procedure shall be used, (see clause 8.7).



NOTE: FT may not be answering because of some FT problems or because the {CC-CONNECT} message has been lost or corrupted. The same result will occur if the eventual answer from FT has been lost or corrupted.

Figure 44: Timer P<CC.05> expiry

For the values used within the {CC-CONNECT} see table 25. For the contents of {CC-RELEASE} and {CC-RELEASE-COM} messages, see tables 15 and 16.

8.16 Display

The procedure shall be performed as defined in EN 300 175-5 [5], clauses 10.2 and D.2.2. The following text together with the associated clauses define the mandatory requirements with regard to the present document.

A <<DISPLAY>> information element may be included in any CC messages in the FT =>PT direction except in {CC-NOTIFY} and {IWU-INFORMATION}, (see EN 300 175-5 [5], clause 6.3.2).

Table 27: Values used within the <<DISPLAY>> information element in any message that includes it

Information element	Field within the information element	Standard values within the field/information element	Normative action/comment
<<Multi display>>			
	<Display information>	0CH, 20H, 23H, 2AH, 30H - 39H	DECT standard characters = standard IA5 characters. The support of these codes is only mandatory if feature [N.24] is implemented. For the actual supported values see <<Terminal capability>> information element, clause 8.17
		08H - 0BH, 0DH	DECT control characters. The support of these codes is only mandatory if feature [N.25] is implemented. For the actual supported values see <<Terminal capability>> information element, clause 8.17

8.17 Terminal capability indication

The PP shall be able to send the <<Terminal capability>> information element and the FP shall be able to receive it at least in {ACCESS-RIGHTS-REQUEST} and when location registration is supported in the {LOCATE-REQUEST}. The following text together with the associated clauses define the mandatory requirements with regard to the present document.

Table 28: Values used within the <<TERMINAL CAPABILITY>> information element

Information element	Field within the information element	Standard values within the field/information element	Normative action/comment
<<Terminal capability>>			
	<Tone capability>	All	
	<Display capability>	All	If PT supports feature [N.24] it shall indicate in this field value which is equal to or higher than 2
	<Profile indicator_1>	"xxxxx1x"B	GAP and/or PAP supported
	<Control codes>	All	If PT supports feature [N.25] it shall indicate in this field value which is equal to or higher than 2

The capabilities in table 29 shall be assumed as default if the following fields in the <<TERMINAL CAPABILITY>> information element are not present.

Table 29: Values assumed as terminal capabilities

Information element	Field within the information element	Standard values within the field/information element	Normative action/comment
<<Terminal capability>>			
	<Echo parameters>	1	Minimum Telephone Coupling Loss (TCL) (>34 dB)
	<N-REJ>	1	No noise rejection
	<A-VOL>	1	No PP adaptive volume control
	<Slot type capability>	8	Full slot

No echoing of characters is allowed in the FT and therefore the PT would be responsible for displaying dialled digits (see figure 45). All display information from the FT would be assumed to be additional information that the PT shall display in addition. The PT shall logically separate display information originating at the FT and PT. This could be achieved, for example, by one physical display and two logical displays or two physical displays and two logical displays. The key point is that display characters from the PT and FT shall not be simultaneously interleaved/mixed on the same physical display.

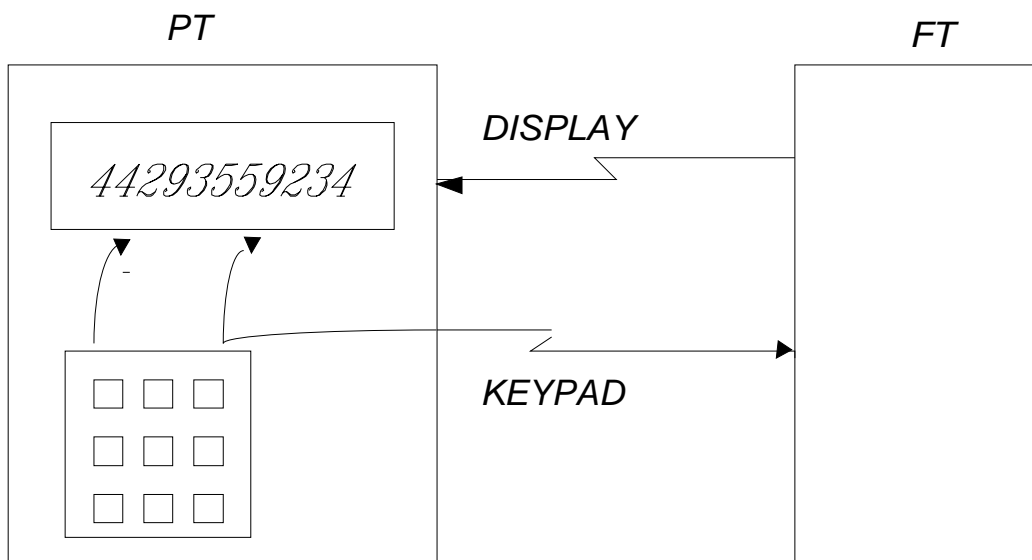

Figure 45: Terminal display

8.18 Internal call setup

The following text together with the associated clauses define the mandatory requirements with regard to the present document.

For the initiation of this procedure the outgoing call request procedure shall be used, (see clause 8.2) with the following replacement to the {CC-SETUP} message.

Table 30: Values used within the {CC-SETUP} message for internal call

Information element	Field within the information element	Standard values within the field/information element	Normative action/comment
<<Basic service>>	<Call class>	9	Internal call

8.19 Internal call keypad

The following text together with the associated clauses define the mandatory requirements with regard to the present document.

For the initiation of this procedure the sending keypad information procedure shall be used, (see clause 8.10) with the following replacement to the {CC-INFO} message.

Table 31: Values used within the {CC-INFO} message for internal call

Information element	Field within the information element	Standard values within the field/information element	Normative action/comment
<<Multi keypad>>	<Keypad information>	17H	Internal call

8.20 Service call setup

The following text together with the associated clauses define the mandatory requirements with regard to the present document.

For the initiation of this procedure the outgoing call request procedure shall be used, (see clause 8.2) with the following replacement to the {CC-SETUP} message.

Table 32: Values used within the {CC-SETUP} message for service call

Information element	Field within the information element	Standard values within the field/information element	Normative action/comment
<<Basic service>>	<Call class>	11	Service call.

8.21 Service call keypad

The following text together with the associated clauses define the mandatory requirements with regard to the present document.

For the initiation of this procedure the sending keypad information procedure shall be used, (see clause 8.10) with the following replacement to the {CC-INFO} message.

Table 33: Values used within the {CC-INFO} message for service call

Information element	Field within the information element	Standard values within the field/information element	Normative action/comment
<<Multi keypad>>	<Keypad information>	18H	Service call

8.22 Identification of PP

The procedure relates to feature Identification of PT [N.13] and shall be performed as defined in EN 300 175-5 [5], clause 13.2.1. Figure 46, and tables 34 and 35, together with the associated clauses define the mandatory requirements with regard to the present document.

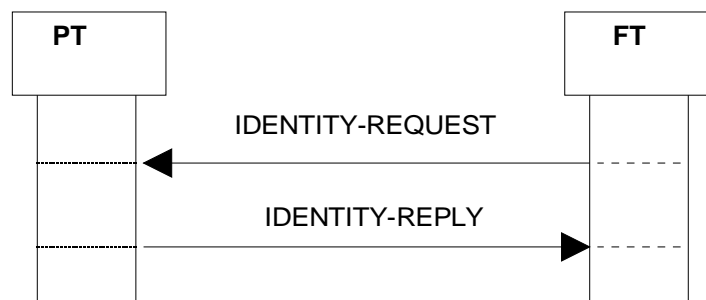
**Figure 46: Identification of PT****Table 34: Values used within the {IDENTITY-REQUEST} message**

Information element	Field within the information element	Standard values within the field/information element	Normative action/comment
<<Identity-type>>			
	<Identity-group>	0, 4	Portable identity, Fixed identity
	<Type>	0, 16, 32	Codings for identity-group = 0 IPUI, IPEI, TPUI required
		0, 1, 32	Codings for identity-group = 4 PARI, PARI plus RPN, PARK required

If an identity request is made for a Temporary Portable User Identity (TPUI), this implies a request for the assigned TPUI, but not the default TPUI.

Table 35: Values used within the {IDENTITY-REPLY} message

Information element	Field within the information element	Standard values within the field/information element	Normative action/comment
<<Portable-identity>>			The inclusion of this information element depends on what type identity has been requested in the {IDENTITY REQUEST}. This identity relates to the active IPUI/PARK pair
	<Type>	0, 16, 32	
	<Identity-value>	all PUT values, all PUN values	For <Type> = 0 The parameter depends upon subscription records
		all EMC values, all PSN values	For <Type> = 16 The parameter depends upon subscription records
		TPUI type: 0-B, all TPUI values	For <Type> = 32 The parameter depends upon subscription records
<<Fixed-identity>>			The inclusion of this information element depends on what type identity has been requested in the {IDENTITY REQUEST}. This identity relates to the active IPUI/PARK pair
	<Type>	0, 1, 32	
	<Length indicator>	All	Depending on the type
	<ARC+ARD (+RPN)>	All	Radio fixed Part Number (RPN) is needed only for type 1

The PARI or PARI + RPN sent in the {IDENTITY-REPLY} message shall be taken from the RFP to which the PT is currently locked.

8.22.1 Associated procedure

8.22.1.1 Timer F-<MM_ident.2> management

<MM_ident.2> Identification timer;

Value: Refer to EN 300 175-5 [5], annex A;

Start: An {IDENTITY-REQUEST} message is sent or an interrupting higher priority transaction is completed;

Stop: An indication for link release from the DLC layer is received. An {IDENTITY-REPLY} message is received or an interrupting higher priority transaction begins.

8.22.2 Exceptional cases

8.22.2.1 Identity not existing in the PT

This procedure is equivalent to the identification of PT procedure successful case defined in clause 8.22 except that the {IDENTITY-REPLY} message shall be sent without the identity information elements that have been requested but do not exist.

8.22.2.2 Timer F-<MM_ident.2> expiry

The timer F-<MM_ident.2> shall not be restarted by the FT. If a re-transmission of the {IDENTITY-REQUEST} message (and restarting of the timer F-<MM_ident.2>) is needed, it may be initiated by the interworking unit/application layer.

8.23 Authentication of FT

The procedure relates to features ZAP [N.16] and Terminate access rights FT initiated [N.20], as well as to feature Authentication of FT [N.26] and shall be performed as defined in EN 300 175-5 [5], clause 13.3.3. Figure 47, and tables 36 and 37, together with the associated clauses define the mandatory requirements with regard to the present document.

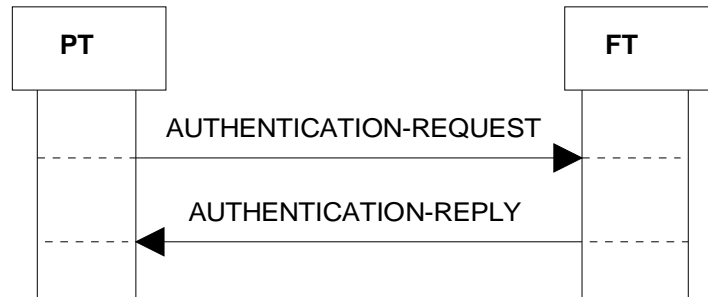

Figure 47: Authentication of FT

Table 36: Values used within the {AUTHENTICATION-REQUEST} message

Information element	Field within the information element	Standard values within the field/information element	Normative action/comment
<<Auth-type>>			
	<Auth algorithm id>	1	DSAA.
	<Auth key type>	1	UAK
		4	AC. Length shall always be 32 bits
	<Auth Key number>	8	Always IPUI/PARK pair (= subscription)
	<INC>	0	Ignore
	<TXC>	0	Ignore
	<UPC>	0	Ignore
	<Cipher key number>	0	Ignore
<<RAND>>			
	<RAND Field>	All	DSAA length

Table 37: Values used within the {AUTHENTICATION-REPLY} message

Information element	Field within the information element	Standard values within the field/information element	Normative action/comment
<<RES>>	<RES Field>	All	DSAA length
<<RS>>	<RS Field>	All	DSAA length

8.23.1 Associated procedure

8.23.1.1 Timer P-<MM_auth.1> management

<MM_auth.1> Authentication timer;

Value: Refer to EN 300 175-5 [5], annex A;

Start: An {AUTHENTICATION-REQUEST} message is sent;

Stop: An indication for link release from the DLC is received. An {AUTHENTICATION-REPLY} or {AUTHENTICATION-REJECT} message is received.

8.23.2 Exceptional cases

8.23.2.1 Authentication algorithm/key not supported

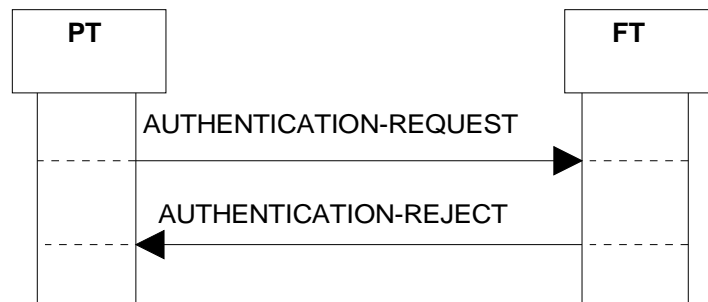

Figure 48: Authentication algorithm/key not supported by the FT

Table 38: Values used within the {AUTHENTICATION-REJECT} message

Information element	Field within the information element	Standard values within the field/information element	Normative action/comment
			All optional

The <<reject reason>> information element need not be sent by the FT and need not be understood by the PT.

In case the PT has made attempt with non DSAA algorithm indicated the PT shall re-attempt to authenticate the FT with DSAA.

8.23.2.2 Authentication challenge RES has wrong value

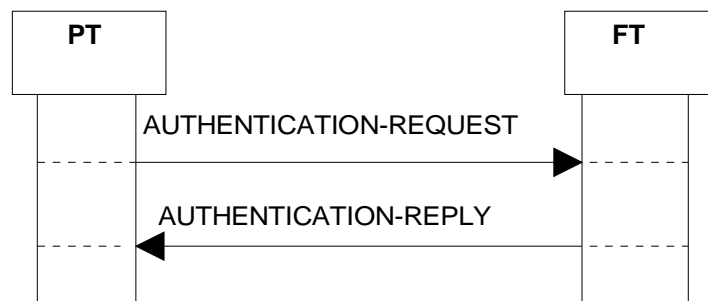

NOTE: If the received RES value in the {AUTHENTICATION REPLY} message is not equal to XRES1 further actions taken by the PT depend on the PP application.

Figure 49: Authentication challenge RES has wrong value

8.23.2.3 Timer P-<MM_auth.1> expiry

The timer P-<MM_auth.1> shall not be restarted by the PT. The inter-working unit/application layer may start the procedure again if necessary by sending the relevant primitive.

8.24 Authentication of PP

The procedure relates to the feature Authentication of PP [N.9] and shall be performed as defined in EN 300 175-5 [5], clause 13.3.1. Figure 50, and tables 39 and 40, together with the associated clauses define the mandatory requirements with regard to the present document.

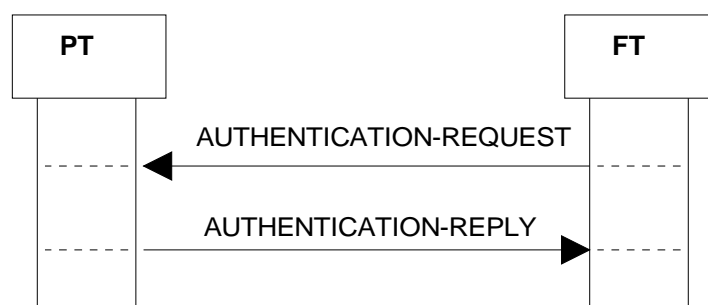

Figure 50: Authentication of PT

Table 39: Values used within the {AUTHENTICATION-REQUEST} message

Information element	Field within the information element	Standard values within the field/information element	Normative action/comment
<<Auth-type>>			
	<Auth algorithm id>	1	DSAA
	<Auth key type>	1	UAK
		4	AC. Length shall always be 32 bits
	<Auth key number>	8	Always IPUI/PARK pair (= subscription)
	<INC>	0	Value 1 used in incrementing the ZAP value procedure, (see clause 8.26)
	<TXC>	0	
	<UPC>	0	Value 1 used in storing the DCK procedure, (see clause 8.27)
	<Cipher key number>	0	Value 8 used in storing the DCK procedure, (see clause 8.27)
<<RAND>>			
	<RAND Field>	All	DSAA length
<<RS>>			
	<RS Field>	All	DSAA length

Table 40: Values used within the {AUTHENTICATION-REPLY} message

Information element	Field within the information element	Standard values within the field/information element	Normative action/comment
<<RES>>			
	<RES Field>	All	DSAA length. RES = XRES1
<<ZAP field>>			
	<Contents field>	0-15	M if stored else O. Associated to feature [N.16]
<<Service class>>			
	<Service class field>	1-6	M if stored else O. Associated to feature [N.14]

If the <UPC> field is set the PT shall store the new cipher key (even if ciphering is currently active) but the new key shall not be used until the next initiation of a ciphering procedure.

8.24.1 Associated procedure

8.24.1.1 Timer F-<MM_auth.1> management

<MM_auth.1> Authentication timer;

Value: Refer to EN 300 175-5 [5], annex A;

Start: An {AUTHENTICATION-REQUEST} message is sent or an interrupting higher priority transaction is completed;

Stop: An indication for link release from the DLC is received. An {AUTHENTICATION-REPLY} or {AUTHENTICATION-REJECT} message is received or an interrupting higher priority transaction begins.

8.24.2 Exceptional cases

8.24.2.1 Authentication algorithm/key not supported



Figure 51: Authentication algorithm/key not supported by the PT

For the contents of the {AUTHENTICATION-REJECT} message see table 38.

The <<reject reason>> information element need not be sent by the PT and need not be understood by the FT.

In case the FT has made attempt with non DSAA algorithm indicated, the FT shall re-attempt to authenticate the PT with DSAA.

8.24.2.2 Timer F-<MM_auth.1> expiry

The timer F-<MM_auth.1> shall not be restarted by the FT. The interworking unit/application layer may start the procedure again if necessary by sending the relevant primitive.

8.25 Authentication of user

The procedure relates to the feature Authentication of user [N.10] and shall be performed as defined in EN 300 175-5 [5], clause 13.3.2. The following text together with the associated clauses define the mandatory requirements with regard to the present document.

This procedure is equivalent to the authentication of PT procedure defined in clause 8.24 with the following replacement to the {AUTHENTICATION-REQUEST} message:

Table 41: Additional coding to <<Auth Type>> for user authentication

Information element	Field within the information element	Standard values within the field/information element	Normative action/comment
<<Auth type>>			
	<Auth key type>	3	UPI

The UPI shall be mapped to a bitstring in the following way:

- UPI shall always have a length of 32 bits;
- each decimal digit entered by the user, is translated into one semi-octet (BCD coded). The PT shall be capable to accept any UPI between 0 and 8 decimal digits (limits included);
- the resulting string of semi-octets is padded with a number of leading "all ones " semi octets to achieve a total of 8 semi octets;
- the result is a bitstring of 32 bits.

EXAMPLE: A value of "091" (3 decimal digits entered via keypad) is translated into a bitstring UPI of the following value:

"1111 1111 1111 1111 1111 0000 1001 0001".

8.25.1 Associated procedure

8.25.1.1 Timer F-<MM_auth.2> management

<MM_auth.2>: Authentication of user timer;

Value: Refer to EN 300 175-5 [5], annex A;

Start: An {AUTHENTICATION-REQUEST} message is sent or an interrupting higher priority transaction is completed;

Stop: An indication for link release from the DLC is received. An {AUTHENTICATION-REPLY} or {AUTHENTICATION-REJECT} message is received or an interrupting higher priority transaction begins.

8.25.2 Exceptional cases

8.25.2.1 Authentication algorithm/key not supported

This procedure is equivalent to the procedure defined in clause 8.24.2.1.

8.25.2.2 Timer F-<MM_auth.2> expiry

The timer F-<MM_auth.2> shall not be restarted by the FT. If a re-transmission of the {AUTHENTICATE-REQUEST} message (and restarting of the timer <MM_auth.2>) is needed, it may be initiated by the interworking unit/application layer.

8.26 Incrementing the ZAP value

The procedure relates to the feature ZAP [N.16] and shall be performed as defined in EN 300 175-5 [5], clause 13.3.3. The following text together with the associated clauses define the mandatory requirements with regard to the present document.

This procedure is equivalent to the authentication of PT procedure defined in clause 8.24 with the following additions/replacements.

The procedure may consist of two nested MM transactions:

- one authentication of PT indicating "ZAP increment"; and
- authentication of the FT with its own independent transaction identifier.

Before incrementing the ZAP, PT may authenticate the FT and if this authentication fails, the PT shall not increment the ZAP field. The support of authentication of FT transaction in incrementing the ZAP value procedure is optional for the PT and mandatory for the FT.

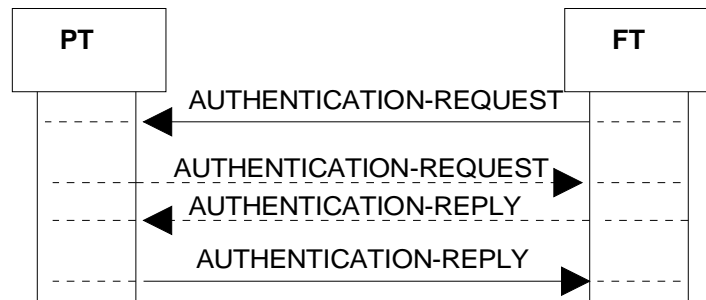

Figure 52: ZAP increment

Table 42: Replacement to {AUTHENTICATION-REQUEST} for incrementing the ZAP value

Information element	Field within the information element	Standard values within the field/information element	Normative action/comment
<<Auth-type>>			
	<INC bit coding>	1	Increment

For the contents of {AUTHENTICATION-REQUEST} sent by PT and {AUTHENTICATE REPLY} sent by FT see tables 36 and 37.

For the contents of {AUTHENTICATION-REPLY} sent by the PT see table 40.

8.27 Storing the DCK

This procedure relates to the feature encryption activation FT initiated [N.17] as well as to feature encryption activation PT initiated [N.27] and is equivalent to the authentication of PT procedure defined in clause 8.24 with the replacement in table 43 to the {AUTHENTICATION-REQUEST} message.

Table 43: Replacement to {AUTHENTICATION-REQUEST} for storing the DCK

Information element	Field within the information element	Standard values within the field/information element	Normative action/comment
<<Auth-type>>			
	<UPC>	1	Store the new DCK
	<Cipher key number>	8	

8.28 Location registration

The procedure relates to the feature location registration [N.11] and shall be performed as defined in EN 300 175-5 [5], clause 13.4.1. The following text together with the associated clauses define the mandatory requirements with regard to the present document.

The location registration procedure consists of only one MM transaction regardless of whether an attempt for TPUI assignment has been made or has not.

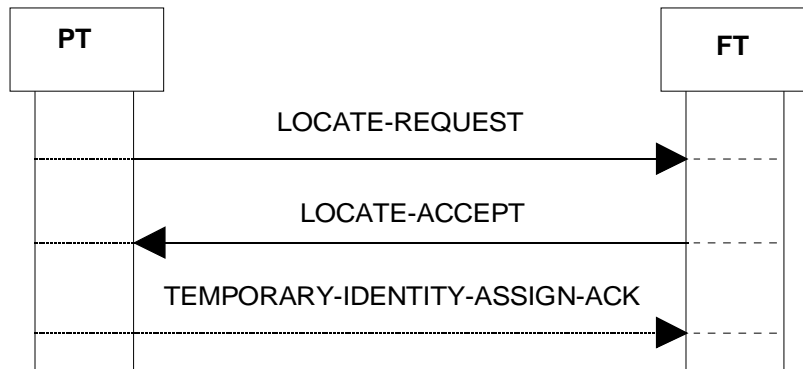

Figure 53: Location registration

Table 44: Values used within the {LOCATE-REQUEST} message

Information element	Field within the information element	Standard values within the field/information element	Normative action/comment
<<Portable-identity>>			
	<Type>	0	IPUI
	<PUT>	All	Depends upon subscription records
<<Fixed-identity>>			This information element shall contain the old PARI+RPN. (see table 104)
	<Type>	1	
	<ARC>	All	
<<Location-area>>	<ARD+RPN>	All	
			This information element shall contain the old Location Area Level (LAL) (see table 104)
	<LI-type>	1	
<<Terminal capability>>	<LAL>	All	
			(see clause 8.17)
	<Tone capability>	All	
	<Display capability>	All	
	<Profile indicator_1>	"xxxxx1x"B	GAP and/or PAP supported
	<Control codes>	All	

Table 45: Values used within the {LOCATE-ACCEPT} message

Information element	Field within the information element	Standard values within the field/information element	Normative action/comment
<<Portable-identity>>			Always mandatory. FT may use zero length contents if it does not wish to assign a TPUI. In this case PT maintains its current assigned TPUI if present or shall use default TPUI otherwise
	<Type>	32	TPUI
	<Length of id value>	20	
	<Identity-value>	Values in EN 300 175-6 [6] clause 6.3.1 are allowed	Only assigned individual TPUIs are allowed
<<Location-area>>			
	<LI-type>	1	
	<LAL>	0-39	Even if default LAL

Table 46: Values used within the {TEMPORARY-IDENTITY-ASSIGN-ACK} message

Information element	Field within the information element	Standard values within the field/information element	Normative action/comment
			All optional

Upon reception of the {LOCATE-ACCEPT} message the PP shall store the PARI and the RPN derived from the RFPI. See clause 13.7 (storage of subscription related data).

If a zero length contents of <<Portable identity>> information element is received by the PP, it shall not respond with a {TEMPORARY-IDENTITY-ASSIGN-ACK} message to the FP. If TPUI is to be assigned a {TEMPORARY-IDENTITY-ASSIGN-ACK} message shall follow.

8.28.1 Associated procedures

8.28.1.1 Timer P-<MM_locate.1> management

<MM_locate.1>: Location timer;

Value: Refer to EN 300 175-5 [5], annex A;

Start: {LOCATE-REQUEST} message is sent or an interrupting higher priority transaction is completed;

Stop: An indication for link release from the DLC is received. {LOCATE-ACCEPT} or {LOCATE-REJECT} message is received or interrupting higher priority transaction begins.

8.28.1.2 Timer F-<MM_ident.1> management

<MM_ident.1>: TPUI assignment timer;

Value: Refer to EN 300 175-5 [5], annex A;

Start: {LOCATE-ACCEPT} message assigning a TPUI is sent or an interrupting higher priority transaction is completed;

Stop: An indication for link release from the DLC is received. A {TEMPORARY-IDENTITY-ASSIGN-ACK} or a {TEMPORARY-IDENTITY-ASSIGN-REJECT} message is received, or, interrupting higher priority transaction begins.

8.28.2 Exceptional cases

8.28.2.1 FT rejects the location registration procedure

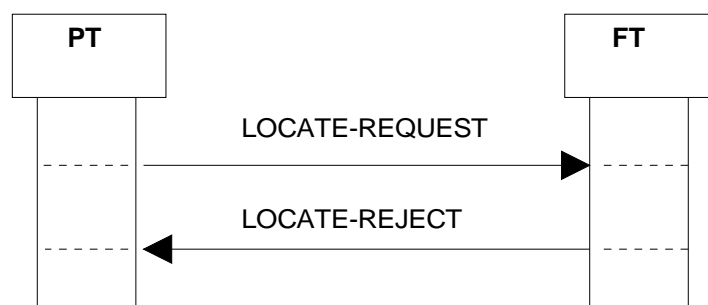

Figure 54: Location registration not supported by the FT

Upon receipt of a {LOCATE-REJECT} message the PP shall maintain the existing LAL value.

Table 47: Values used within the {LOCATE-REJECT} message

Information element	Field within the information element	Standard values within the field/information element	Normative action/comment
			All optional

The <<Reject reason>> information element need not be sent by the FT and need not be understood by the PT. In this case the PT should not initiate a location registration procedure until the conditions for location registration initiation are met as defined in clause 13.2.

8.28.2.2 Failure of location registration procedure

Upon expiry of <MM_locate.1> or indication for link released is received from the DLC layer, PT shall consider the procedure as failed. The PP shall maintain the existing LAL value. PT shall not re-transmit the {LOCATE-REQUEST} message and shall not restart the timer <MM_locate.1> as part of the same procedure. The P-IWU should initiate a new location registration procedure.

8.28.2.3 PT rejects the identity assignment

PT shall be capable of storing an individual assigned TPUI. If the FT performs identity assignment and PT does not have the capability of storing the TPUI (excluding an assigned individual TPUI) or there is an error in the {LOCATE-ACCEPT} message, the PT shall send back a {TEMPORARY-IDENTITY-ASSIGN-REJECT} message.

NOTE: For the requirements in regard to FT sending the {LOCATE-ACCEPT} message, the requirements as stated in table 46, clause 8.28 apply.

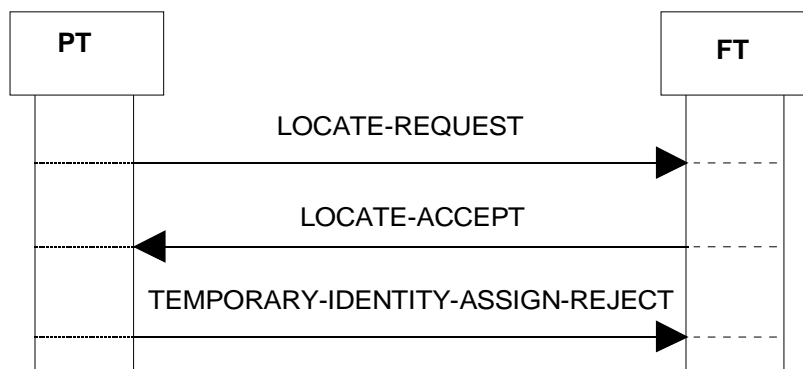
**Figure 55: Rejection of identity assignment****Table 48: Values used within the {TEMPORARY-IDENTITY-ASSIGN-REJECT} message**

Information element	Field within the information element	Standard values within the field/information element	Normative action/comment
			All optional

8.28.2.4 Timer F-<MM_identity.1> expiry

If timer F-<MM_identity.1> expires the FT shall consider the TPUI assignment as failed.

8.29 Location update

The procedure relates to the feature Location registration [N.11] and shall be performed with regard to clause 13.4.3 of EN 300 175-5 [5]. The following text together with the associated clauses define the mandatory requirements with regard to the present document.

Location update consists of two procedures (the location update procedure and the location registration procedure) each having its own transaction. It may be described as FT suggesting location registration and PT performing location registration.

The FT shall send two consecutive {MM-INFO-SUGGEST} messages, each contains an <<INFO-TYPE>> information element with only the parameter type "locate suggest"; the <ext> parameter associated to this parameter type shall be set to 0 in the first {MM-INFO-SUGGEST} and to 1 in the second {MM-INFO-SUGGEST}.

Upon receipt of the {MM-INFO-SUGGEST} message the PT shall check the parameter type. If the parameter type "locate suggest" is indicated in the <<INFO-TYPE>> information element, the PT shall ignore bit 8 and the PT shall initiate the location registration procedure as described in clause 8.28.

Even if the bit a38, see clause 13.6, table 103, is not set to "1" the PT shall initiate location registration procedure on request of location update procedure. In the situation where the {MM-INFO-SUGGEST} sent by the FT interrupts a priority level 3 PT-initiated transaction the PT shall complete the interrupted one before initiating the location registration.

In the situation when the {MM-INFO-SUGGEST} interrupts a Location Registration procedure, the {MM-INFO-SUGGEST} shall be ignored.

NOTE: A PT implementation should take care that during the time the interrupting MM-INFO-SUGGEST message is processed a possible arriving LOCATE-ACCEPT or LOCATE-REJECT message does not get lost.

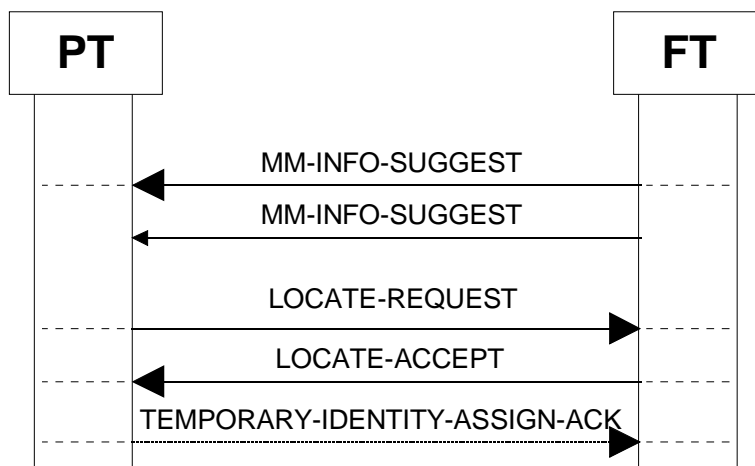

NOTE 1: The {LOCATE-REQUEST} message may be received by the FT before the second {MM-INFO-SUGGEST} message is sent by the FT.

NOTE 2: The requirement of sending two MM-INFO-SUGGEST instead of one has been introduced for backward compatibility with existing DECT equipment.

Figure 56: Location update

Table 49: Values used within the {MM-INFO-SUGGEST} message

Information element	Field within the information element	Standard values within the field/IE	Normative action/comment
<<Info-type>>			
	<Length of Contents >	1	
	<ext>	0/1	The first {MM-INFO-SUGGEST} message shall be sent using value 0, the second using value 1
	<Parameter type>	0	Locate suggest

8.30 Obtaining access rights

The procedure relates to the features Subscription registration user procedure on-air [N.18], Service class indication/assignment [N.14], and, ZAP [N.16] and shall be performed as defined in EN 300 175-5 [5], clause 13.5.1.

The following text together with the associated clauses define the mandatory requirements with regard to the present document.

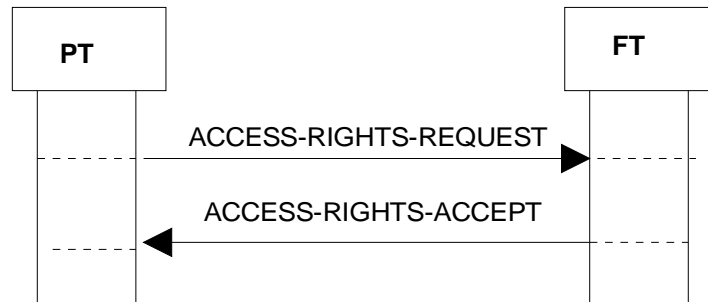

Figure 57: Obtain access rights

Table 50: Values used within the {ACCESS-RIGHTS-REQUEST} message

Information element	Field within the information element	Standard values within the field/information element	Normative action/comment
<<Portable-identity>>			Default IPUI if not yet assigned
	<Type>	0	IPUI
	<PUT>	All	Depends upon subscription records
	<PUN>	All	Depends upon subscription records
<<Auth-type>>			
	<Auth-algorithm-id>	1	DSAA
	<Auth key type>	1, 4	The PT shall set the value to 4 (AC) only if it does not have a UAK. If the PT sends value 1 (UAK), the FT assumes that the PT has a UAK. If FT has only AC for this PT, the FT shall assume that the AC-value has not been entered by the PP user. The FP shall not accept the access rights request
	<Auth key number>	8	The keys are associated to IPUI/PARK pair (= subscription)
	<INC>	0	Ignore
	<TXC>	0	Ignore
	<UPC>	0	Ignore
	<Cipher key number>	0	Ignore
<<Terminal capability>>			(see clause 8.17)
	<Tone capability>	All	
	<Display capability>	All	
	<Profile indicator_1>	"xxxxx1x"B	GAP and/or PAP supported
	<Control codes>	All	

Table 51: Values used within the {ACCESS-RIGHTS-ACCEPT} message

Information element	Field within the information element	Standard values within the field/information element	Normative action/comment
<<Portable-identity>>			
	<Type>	0	IPIU. All ARI equipment classes other than Class A equipment, shall never send IPIU type N
	<PUT>	All	Depends upon subscription records
	<PUN>	All	Depends upon subscription records
<<Fixed identity>>			Depends upon subscription records. Shall always include the whole PARK including the non-significant bits
	<Type >	32	PARK
	<Length of identity value>	All	PLI+1
	<ARC+ARD>	All	
<<Zap field>>			Relates to feature [N.16]
	<Contents-field>	All	
<<Service-class>>			Relates to feature [N.14]
	<Service-class-field>	All	

8.30.1 Associated procedure

8.30.1.1 Timer P-<MM_access.1> management

<MM_access.1>: Access rights timer;

Value: Refer to EN 300 175-5 [5], annex A;

Start: An {ACCESS-RIGHTS-REQUEST} message is sent or an interrupting higher priority transaction is completed;

Stop: An indication for link release from the DLC is received. An {ACCESS-RIGHTS-ACCEPT} or {ACCESS-RIGHTS-REJECT} message is received or an interrupting higher priority transaction begins.

8.30.2 Exceptional cases

8.30.2.1 FT rejects the access rights

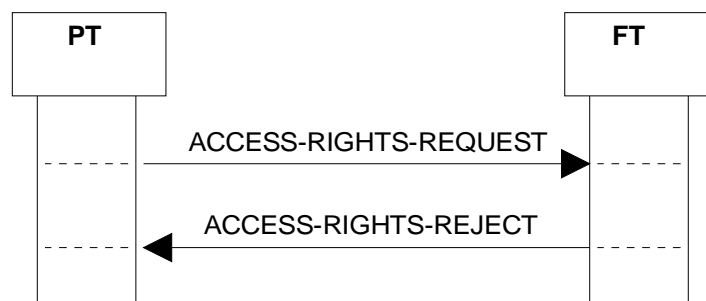
**Figure 58: FT rejects access rights request****Table 52: Values used within the {ACCESS-RIGHTS-REJECT} message**

Information element	Field within the information element	Standard values within the field/information element	Normative action/comment
			All optional

No actions are required by the portable.

If the PT has requested access rights identifying non DECT authentication or/and cipher algorithm, the PT shall initiate a new access rights request with DSAA or/and DCA.

8.30.2.2 Timer P-<MM_access.1> expiry

Upon expiry of P-<MM_access.1> PT shall consider the procedure as failed. PT shall not re-transmit the {ACCESS-RIGHTS-REQUEST} message and shall not restart the timer P-<MM_access.1> as part of the same procedure. The interworking unit/application layer may start the procedure again if necessary by sending the relevant primitive.

8.31 FT terminating access rights

The procedure relates to the feature FT terminate access rights [N.20] and shall be performed as defined in EN 300 175-5 [5], clause 13.5.2. The following text together with the associated clauses define the mandatory requirements with regard to the present document.

The procedure consists of two nested MM transactions: one FT terminating access rights and other authentication of the FT with its own independent transaction identifier. Before terminating the access rights, PT may authenticate the FT and if this authentication fails, the PT shall not terminate the access rights. The support of authentication of FT transaction in FT terminating access rights procedure is optional for the PT and mandatory for the FT.

An FP may request termination of a subscription assigned to an IPUI/PARK pair which has not been used for the establishment of the current link however it is optional for the PP to accept it.

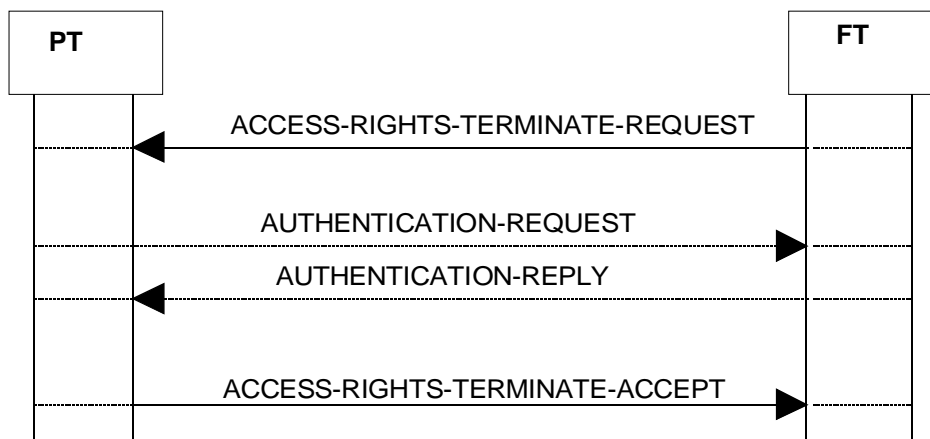

Figure 59: Termination of access rights

Table 53: Values used within the {ACCESS-RIGHTS-TERMINATE-REQUEST} message

Information element	Field within the information element	Standard values within the field/information element	Normative action/comment
<<Portable-identity>>			
	<Type>	0	IPUI
	<PUT>	All	Depends upon subscription records
	<PUN>	All	Depends upon subscription records
<<Fixed identity>>			Depends upon subscription records. This procedure is only allowed for IPUI/PARK pair, therefore, <<Fixed-id>> shall always be included
	<Type>	32	PARK
	<length of identity value>	All	PLI+1
	<ARC+ARD>	All	

For the values used within the {AUTHENTICATE-REQUEST} and {AUTHENTICATE-REPLY} see tables 36 and 37.

Table 54: Values used within the {ACCESS-RIGHTS-TERMINATE-ACCEPT} message

Information element	Field within the information element	Standard values within the field/information element	Normative action/comment
			No information elements

The reception of {ACCESS-RIGHTS-TERMINATE-ACCEPT} indicates to the FT that the PT has deleted the subscription data associated to the received IPUI/PARK.

8.31.1 Associated procedure

8.31.1.1 Timer F-<MM_access.2> management

<MM_access.2> Access rights termination timer;

Value: Refer to EN 300 175-5 [5], annex A;

Start: An {ACCESS-RIGHTS-TERMINATE-REQUEST} message is sent or an interrupting higher priority transaction is completed;

Stop: An indication for link release from the DLC is received.
An {ACCESS-RIGHTS-TERMINATE-ACCEPT} or {ACCESS-RIGHTS-TERMINATE-REJECT} message is received or an interrupting higher priority transaction begins.

8.31.2 Exceptional cases

8.31.2.1 PT rejects the termination request

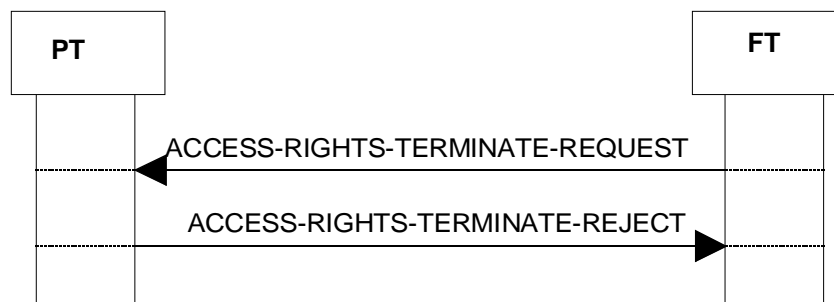

Figure 60: PT rejects

Table 55: Standard values used within the {ACCESS-RIGHTS-TERMINATE-REJECT} message

Information element	Field within the information element	Standard values within the field/information element	Normative action/comment
			All optional

8.31.2.2 Timer F-<MM_access.2> expiry

Upon expiry of F-<MM_access.2> FT shall consider the procedure as failed. FT shall not re-transmit the {ACCESS-RIGHTS-TERMINATE-REQUEST} message. and shall not restart the timer F-<MM_access.2> as part of the same procedure. However, the interworking unit/application layer may start the procedure again if necessary by sending the relevant primitive.

8.32 Key allocation

The procedure relates to the feature On air key allocation [N.12] and shall be performed as defined in EN 300 175-5 [5], clause 13.6. The following text together with the associated clauses define the mandatory requirements with regard to the present document.

The PT shall support the key allocation procedure prior to the completion of the obtaining access rights procedure even if the IPUI/PARK pair may not have been provided yet.

The key allocation procedure consists of only one MM transaction.

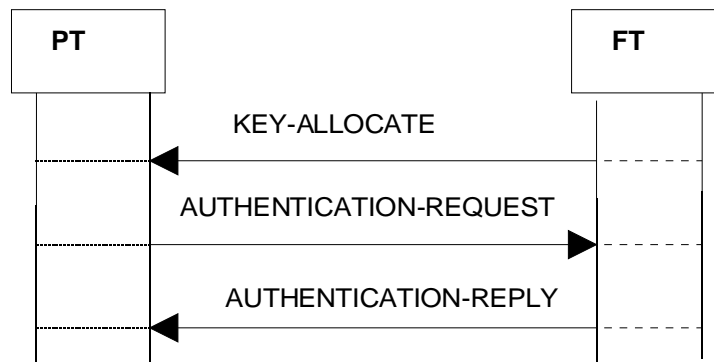

Figure 61: Key allocation

Table 56: Values used within the {KEY-ALLOCATE} message

Information element	Field within the information element	Standard values within the field/information element	Normative action/comment
<<Alloc-type>>			
	<Auth-algorithm-id>	1	DSAA
	<UAK number>	8	Keys relate to IPUI/PARK pair, if available
	<AC number>	8	Keys relate to IPUI/PARK pair, if available
<<RAND>>			
	<RAND Field>	All	DSAA length.RAND_F
<<RS>>			
	<RS Field>	All	DSAA length

Table 57: Values used within the {AUTHENTICATION-REQUEST} message

Information element	Field within the information element	Standard values within the field/information element	Normative action/comment
<<Auth-type>>			
	<Auth-algorithm-id>	1	DSAA
	<Auth key type>	4	AC, Length shall always be 32 bits
	<Auth key number>	8	Key relates to IPUI/PARK pair
	<INC>	0	Ignore
	<TXC>	0	Ignore
	<UPC>	0	Ignore
	<Cipher key number>	0	Ignore
<<RAND>>			
	<RAND Field>	All	DSAA length. RAND_P
<<RES>>			
	<RES Field>	All	DSAA length. RES1

The value RES1 is computed by the PT from RAND_F and RS. FT possesses the value XRES1 which is the result from the same computation. The authentication of PT is considered as successful if RES1 = XRES1.

Table 58: Values used within the {AUTHENTICATION-REPLY} message

Information element	Field within the information element	Standard values within the field/information element	Normative action/comment
<<RES>>	<RES Field>	All	DSAA length. RES2

The value RES2 is computed by the FT from RAND_P and RS. The FP authentication Session Key (KS') value, an intermediate result from this computing, shall be stored at FT as a new UAK under number 8. The FT marks the new UAK with "unconfirmed status" and shall retain both the AC and the UAK until the PT has been successfully authenticate using the UAK, then the AC shall be erased and the "unconfirmed status" marking shall be removed from the UAK.

The PT possesses the value XRES2 which is the result from the same computation. The authentication of FT is considered as successful if RES2 = XRES2. Then the PP authentication Session Key (KS) value, an intermediate result from the computing of XRES2 at PT, is stored at PT as a new UAK under number 8. The AC used for the UAK derivation shall be erased.

8.32.1 Associated procedures

8.32.1.1 Timer F-<MM_key.1> management

<MM_key.1>: Key allocation timer;

Value: Refer to EN 300 175-5 [5], annex A;

Start: An {KEY-ALLOCATE} message is sent or an interrupting higher priority transaction is completed;

Stop: An indication for link release from the DLC is received. An {AUTHENTICATION-REQUEST}, or {AUTHENTICATION-REJECT} message is received.

8.32.1.2 Timer P-<MM_auth.1> management

<MM_auth.1>: Authentication timer;

Value: Refer to EN 300 175-5 [5], annex A;

Start: An {AUTHENTICATION-REQUEST} message is sent or an interrupting higher priority transaction is completed;

Stop: An indication for link release from the DLC is received. An {AUTHENTICATION-REPLY} or {AUTHENTICATION-REJECT} message is received or an interrupting higher priority transaction begins.

8.32.2 Exceptional cases

8.32.2.1 Timer F-<MM_key.1> expiry

Upon expiry of F-<MM_key.1> FT shall consider the procedure as failed. FT shall not re-transmit the {KEY-ALLOCATE} message and shall not restart the timer F-<MM_key.1> as part of the same procedure. However, the interworking unit/application layer may start the procedure again if necessary by sending the relevant primitive.

8.32.2.2 Timer P-<MM_auth.1> expiry

Upon expiry of P-<MM_auth.1> PT shall consider the procedure as failed and shall abort it.

8.32.2.3 Allocation-type element is unacceptable

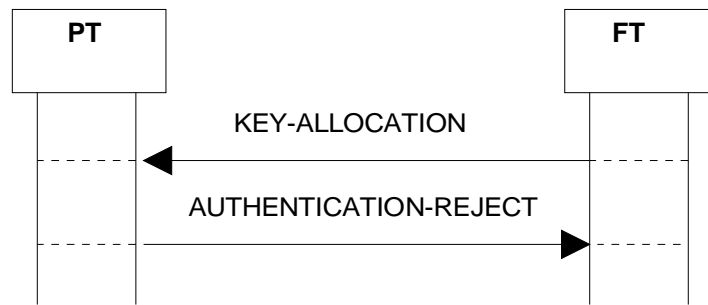

Figure 62: Allocation-type unacceptable for PT

Table 59: Standard values used within the {AUTHENTICATION-REJECT} message

Information element	Field within the information element	Standard values within the field/information element	Normative action/comment
			All optional

8.32.2.4 Authentication of PT fails

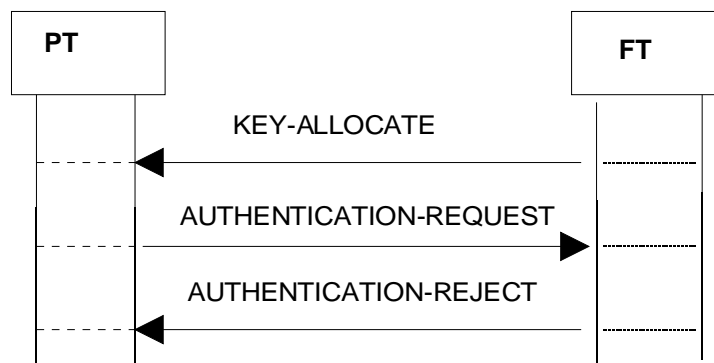

Figure 63: Authentication of PT fails

Table 60: Standard values used within the {AUTHENTICATION-REJECT} message

Information element	Field within the information element	Standard values within the field/information element	Comments	Normative actions
			All optional	

8.32.2.5 Authentication of FT fails

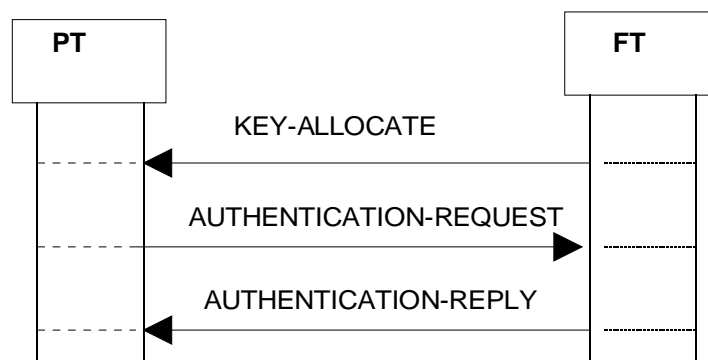

Figure 64: Authentication of FT fails

If the Authentication of FT fails, as XRES2<>RES2, the KS shall be not stored, and the PT shall retain the AC. At the same time the FT has stored KS' as an eventual UAK with status "Unconfirmed", and the FT shall try to use this key in a future Authentication of PT procedure. In that case the PT shall reject because "authentication key not available" and the FT shall delete this UAK.

8.33 Cipher-switching initiated by FT

This procedure relates to the feature Encryption activation FT initiated [N.17] as well as to feature Encryption deactivation FT initiated [N.28] and shall be performed as defined in EN 300 175-5 [5], clauses 13.8 and EN 300 175-7 [7], clause 6.5.3. Figure 65 and table 61 together with the associated clauses define the mandatory requirements with regard to the present document.



Figure 65: Cipher - switching initiated by FT

Table 61: Values used within the {CIPHER-REQUEST} message

Information element	Field within the information element	Standard values within the field/information element	Normative action/comment
<<Cipher-info>>			
	<Y/N>	0	Disable ciphering. The support of this value is only mandatory if the procedure is used for feature [N.28]
		1	Enable ciphering
	<Cipher-algorithm-id>	1	DECT standard cipher algorithm 1
	<Cipher key type>	9	DCK
	<Cipher key number>	8	Always IPUI/PARK pair (= subscription)

The {CIPHER-REQUEST} shall be sent before the transfer of any C-plane data intended to be encrypted (e.g. dialled number).

The DCK shall be produced and stored in advance using the storing the DCK procedure (see clause 8.27). In order for the encryption mechanism to be activated at the MAC layer the NWK layer shall provide the encryption key by sending a DL_ENC_KEY-req primitive to the DLC layer any time the encryption activation is requested. A new DCK may be produced and stored during the time a call is ciphered; this DCK shall not affect the current encryption mode.

Upon receipt, the <<Cipher-info>> shall be examined by the receiver. It is defined to be acceptable if the Y/N bit is consistent with the current cipher mode, the algorithm can be implemented, and the cipher key is available. Once this is accepted, Encryption activation/deactivation DLC and MAC services shall be invoked and ciphering shall be enabled/disabled at the MAC layer.

8.33.1 Associated procedure

8.33.1.1 Timer F-<MM_cipher.1> management

<MM_cipher.1>: Cipher-switching timer;

Value: Refer to EN 300 175-5 [5], annex A;

Start: An {CIPHER-REQUEST} message is sent;

Stop: An indication for link release from the DLC is received. An {CIPHER-REJECT} message or an indication from DLC layer for Y/N ciphering is received or an interrupting higher priority transaction begins.

8.33.2 Exceptional cases

8.33.2.1 PT rejects the cipher request

Possible reasons a cipher request to be rejected: Required Cipher algorithm is not supported; Required cipher key is not supported or is not available.

The FT should not release the call on reception of a CIPHER-REJECT message.

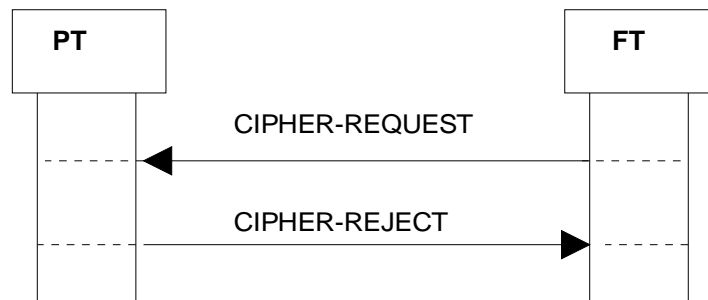

Figure 66: PT rejects the cipher request

Table 62: Standard values used within the {CIPHER-REJECT} message

Information element	Field within the information element	Standard values within the field/information element	Comments	Normative actions
			All optional	
Actions by the FT/PT: If a non-DECT cipher algorithm was requested and the ciphering has been rejected a new attempt shall be made requesting this time the DECT Standard Cipher Algorithm (DSCA).				

8.33.2.2 Timer F-<MM_cipher.1> expiry

Inconsistency of the Y/N bit with the current cipher mode is one of the possible reasons that shall not trigger an answer from the PT.

Upon expiry of F-<MM_cipher.1> the FT shall consider the procedure as failed. The FT shall not re-transmit the {CIPHER-REQUEST} message and shall not restart the timer F-<MM_cipher.1> as part of the same procedure. However, the interworking unit/application layer may start the procedure again if necessary by sending the relevant primitive.

The FT should not release the call on Timer F-<MM_cipher.1> expiry.

8.34 Cipher-switching initiated by PT

The procedure relates to the feature Encryption activation PT initiated [N.27] and Encryption deactivation PT initiated [N.29] and shall be performed as defined in EN 300 175-5 [5], clause 13.8 and EN 300 175-7 [7], clause 6.5.3. The following text together with the associated clauses define the mandatory requirements with regard to the present document.

The cipher-switching initiated by PT procedure consists of only one MM transaction.

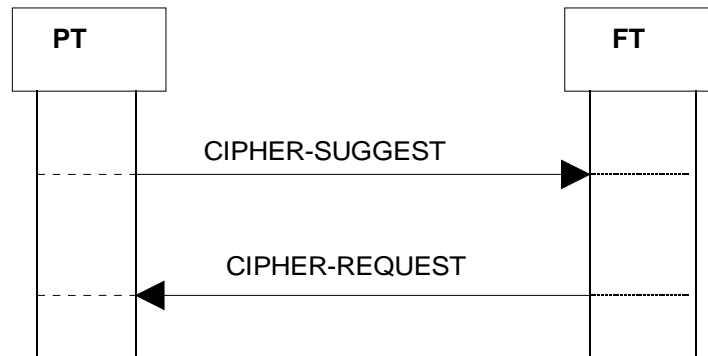

Figure 67: Ciphering, PT initiated

Table 63: Values used within the {CIPHER-SUGGEST} message

Information element	Field within the information element	Standard values within the field/information element	Normative action/comment
<<Cipher-info>>			
	<Y/N>	0	Disable ciphering. Relates to feature [N.29]
		1	Enable ciphering. Relates to feature [N.27]
	<Cipher-algorithm-id>	1	DSCA
	<Cipher key type>	9	DCK
	<Cipher key number>	8	Always IPUI/PARK pair (= Subscription)

Table 64: Values used within the {CIPHER-REQUEST} message

Information element	Field within the information element	Standard values within the field/information element	Normative action/comment
<<Cipher-info>>			
	<Y/N>	0	Disable ciphering. Relates to feature [N.29]
		1	Enable ciphering. Relates to feature [N.27]
	<Cipher-algorithm-id>	1	DSCA
	<Cipher key type>	9	DCK
	<Cipher key number>	8	Always IPUI/PARK pair (= Subscription)

The DCK shall be produced and stored in advance using the storing the DCK procedure (see clause 8.27). In order for the encryption mechanism to be activated at the MAC layer, the NWK layer shall provide the encryption key by sending a DL_ENC_KEY-req primitive to the DLC layer any time the encryption activation is requested. A new DCK may be produced and stored during the time a call is ciphered; this DCK shall not affect the current encryption mode.

Upon receipt, the <<Cipher-info>> shall be examined by the receiver. It is defined to be acceptable if the Y/N bit is consistent with the current cipher mode, the algorithm can be implemented and the cipher key is available. Once this is accepted the FT shall start the FT initiated cipher switching procedure, (see clause 8.33 and the associated clauses).

8.34.1 Associated procedure

8.34.1.1 Timer P-<MM_cipher.2> management

<MM_cipher.1>: Cipher-switching timer;

Value: Refer to EN 300 175-5 [5], annex A;

Start: A {CIPHER-SUGGEST} message is sent;

Stop: An indication for link release from the DLC is received. A {CIPHER-REJECT} or {CIPHER-REQUEST} message is received.

8.34.2 Exceptional cases

8.34.2.1 FT rejects the cipher request

Possible reasons a cipher request is rejected: required cipher algorithm is not supported; required cipher key is not supported or is not available.

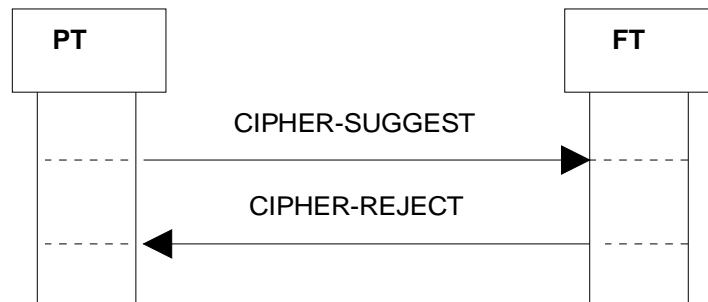

Figure 68: FT rejects the cipher requests

Table 65: Standard values used within the {CIPHER-REJECT} message

Information element	Field within the information element	Standard values within the field/information element	Comments	Normative actions
			All optional	
Actions by the FT/PT: If a non-DECT cipher algorithm was requested and the ciphering has been rejected a new attempt shall be made requesting this time the DSCA.				

8.34.2.2 Timer P-<MM_cipher.2> expiry

Inconsistency of the Y/N bit with the current cipher mode is one of the possible reasons that shall not trigger an answer from the FT.

Upon expiry of P-<MM_cipher.2> the PT shall consider the procedure as failed. The PT shall not re-transmit the {CIPHER-SUGGEST} message and shall not re-start the timer P-<MM_cipher.2> as part of the same procedure. However, the inter-working unit/application layer may start the procedure again if necessary by sending the relevant primitive.

8.35 Indirect FT initiated link establishment

The procedure shall be performed as defined in EN 300 175-5 [5], clauses 14.2.1 and 14.2.3. The following text together with the associated clauses define the mandatory requirements with regard to the present document.

FT and PT shall only support short format for the {LCE-REQUEST-PAGE} message. When the FT request for a link establishment is successfully received by the intended PT, the PT shall initiate direct PT link establishment (see clause 8.36).

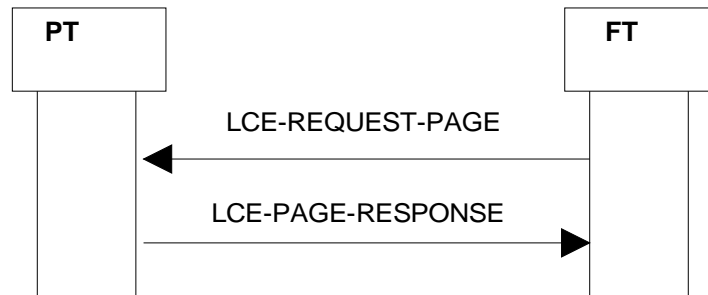

Figure 69: Indirect FT initiated link establishment

Table 66: Values used within the {LCE-REQUEST-PAGE} message

Information element	Field within the information element	Standard values within the field/information element	Normative action/comment
<<LCE Header>>			
	<W>	All	
	<LCE-header>	0,4	Indicates the U-plane services (MAC) required. The "0" value shall be used when only C-plane is required (e.g. MM procedures). The PT shall support a follow on call on the same link even if value "0" was used during initial paging
<<Short address>>			
	<TPUI Address>	All	The lowest 16 bits from the actual TPUI value

Table 67: Values used within {LCE-PAGE-RESPONSE} message

Information element	Field within the information element	Standard values within the field/information element	Normative action/comment
<<Portable identity>>			Depends upon subscription records
	<Type>	0	IPUI
	<PUT>	All	
	<PUN>	All	
<<Fixed identity>>			Parameters depend upon subscription records
	<Type>	32	PARK
	<Length of identity value>	All	PLI+1
	<ARC+ARD>	All	

8.35.1 Associated procedure

8.35.1.1 Timer F-<LCE.03> management

There shall be separate instances of a <LCE.03> timer corresponding to each IPUI identity that has been paged with {LCE-REQUEST-PAGE} message.

<LCE.03>: {LCE-REQUEST-PAGE} message re submission timer;

Value: Refer to EN 300 175-5 [5], annex A;

Start: A {LCE-REQUEST-PAGE} message is sent;

Stop: A {LCE-PAGE-RESPONSE} message with a matching IPUI or a release from the higher entity is received.

8.35.2 Exceptional cases

8.35.2.1 The IPUi received in the {LCE-PAGE-RESPONSE} does not match

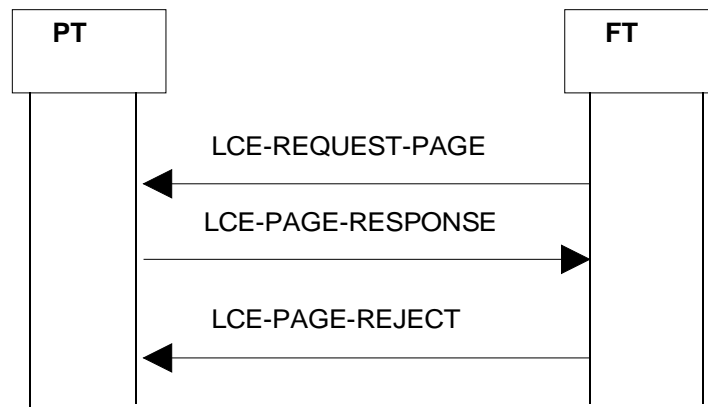

Figure 70: The IPUi received in the {LCE-PAGE-RESPONSE} does not match

Table 68: Values used within the short format {LCE-PAGE-REJECT} message

Information element	Field within the information element	Standard values within the field/information element	Normative action/comment
<<Portable identity>>			It shall be the full IPUi of the PT that is rejected
	<Type>	IPUI	
	<PUT>	All	
	<PUN>	All	

The unwanted link shall immediately be released using the Link release "normal" procedure (see clause 8.37).

The {LCE-PAGE-REJECT} message shall be sent by a DL_DATA-req primitive via the S-Service Access Point (SAP) (SAP Identifier (SAPI) = "0") using the same Data Link Endpoint Identifier (DLEI) as indicated by the DL_ESTABLISH-ind carrying the {LCE-PAGE-RESPONSE}. This FT reply shall also use the same transaction value as used by the PT in the {LCE-PAGE-RESPONSE} message.

8.35.2.2 Timer <LCE.03> expiry

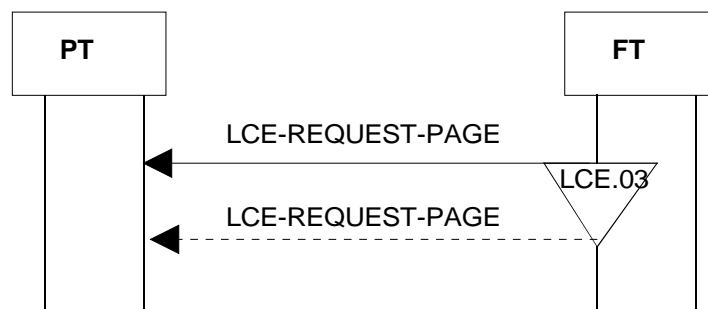

Figure 71: Timer <LCE.03> expiry

If timer <LCE.03> expires before the wanted link is established, the LCE may resubmit the {LCE-REQUEST-PAGE} message; in this case the link shall remain in the "ESTABLISH-PENDING" state. Resubmitted messages shall only be issued at a lower priority than other outstanding B-format messages. A message may be resubmitted a maximum of N300 times, before it is discarded.

NOTE: N300 is an application specific value. Recommended value for voice applications is three (3).

8.35.2.3 Release from the higher entity

If the higher entity indicates that the link resources are no longer required the LCE shall immediately delete the outstanding IPUI and stop the corresponding timer <LCE.03>.

8.36 Direct PT initiated link establishment

The procedure shall be performed as defined in EN 300 175-5 [5], clauses 14.2.1 and 14.2.2. The following text together with the associated clauses define the mandatory requirements with regard to the present document.

Direct PT initiated link establishment shall occur when the first service requested is detected by the LCE in the PT. In this procedure there shall be no peer-to-peer NWK layers message exchange except if the procedure is used in an indirect FT link establishment procedure. In the latter case a {LCE-PAGE-RESPONSE} message shall be sent.

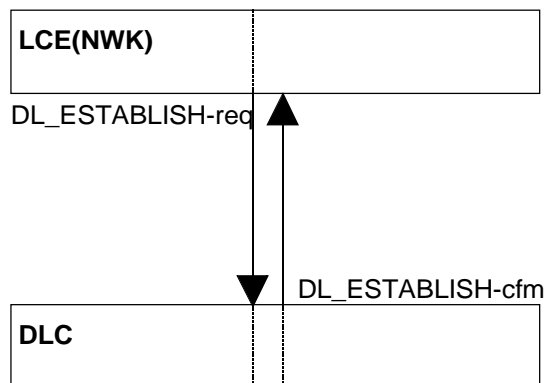

Figure 72: Direct PT initiated link establishment, initiating side

Table 69: Values used within the DL_ESTABLISH-req primitive

Parameter	Information within the parameter	Normative action/comment
<<DLEI>>	Data Link Endpoint Identifier	(see EN 300 175-4 [4], clause 7.3.6)
<<Establish mode>>	Class A operation	
<<Message unit length>>	The length of the higher layer information	Included only when the parameter <<Message unit>> follows
<<Message unit>>	Higher layer information	The PT shall use the <<Message unit>> parameter to carry the {LCE-PAGE-RESPONSE} message when the procedure is used as a part of an indirect FT initiated link establishment (see clause 8.35) otherwise it shall be empty

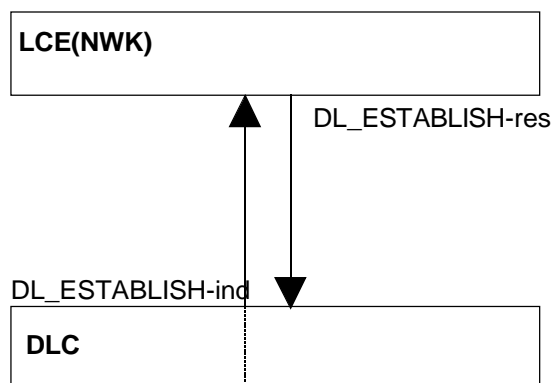

Figure 73: Direct PT initiated link establishment, receiving side

Table 70: Values used within the DL_ESTABLISH-ind primitive

Parameter	Information within the parameter	Normative action/comment
<<DLEI>>	Data Link Endpoint Identifier	(see EN 300 175-4 [4], clause 7.3.6)
<<Establish mode>>	Class A operation	
<<Message unit length>>	The length of the higher layer information	Included only when the parameter <<Message unit>> follows
<<Message unit>>	Higher layer information	The PT shall use the <<Message unit>> parameter to carry the {LCE-PAGE-RESPONSE} message when the procedure is used as a part of an indirect FT initiated link establishment (see clause 8.35) otherwise it shall be empty

8.36.1 Exceptional case

8.36.1.1 Link establishment failure

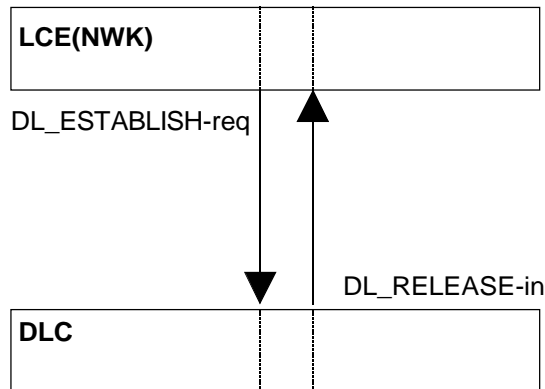
**Figure 74: Direct PT initiated link establishment failure****Table 71: Values used within the DL_RELEASE-ind primitive**

Parameter	Information within the parameter	Normative action/comment
<<DLEI>>	Data Link Endpoint Identifier	(see EN 300 175-4 [4], clause 7.3.6)
<<Release mode>>	Abnormal	
Actions by the FT/PT: The LCE shall inform all higher entities requesting the use of the link that the link establishment has failed and shall enter "LINK-RELEASED" state.		

8.37 Link release "normal"

The procedure shall be performed as defined in EN 300 175-5 [5], clause 14.2.7. The following text together with the associated clauses define the mandatory requirements with regard to the present document.

In this procedure there is no peer-to-peer NWK layer message exchange, only NWK (LCE) to DLC layer information exchange thereby invoking services from the lower layers.

The "normal" release allows the DLC to complete transmission of any outstanding messages before releasing the link.

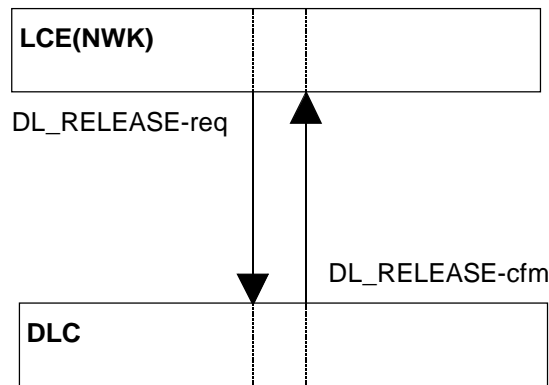

Figure 75: Link release "normal", initiating side

Table 72: Values used within the DL_RELEASE-req primitive

Parameter	Information within the parameter	Normative action/comment
<<DLEI>>		
	Data Link Endpoint Identifier	(see EN 300 175-4 [4], clause 7.3.6)
<<Release mode>>		
	Normal	

Table 73: Values used within the DL_RELEASE-cfm primitive

Parameter	Information within the parameter	Normative action/comment
<<DLEI>>		
	Data Link Endpoint Identifier	(see EN 300 175-4 [4], clause 7.3.6)
<<Release mode>>		
	Normal	

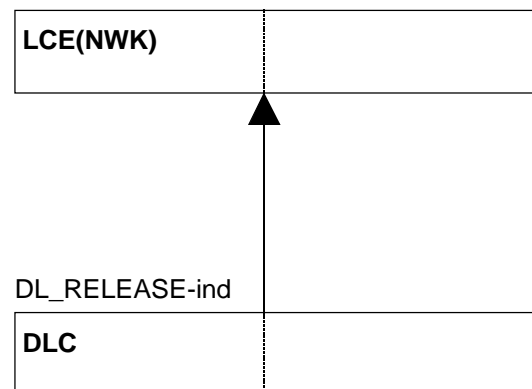

Figure 76: Link release "normal", receiving side

Table 74: Values used within the DL_RELEASE-ind primitive

Parameter	Information within the parameter	Normative action/comment
<<DLEI>>		
	Data Link Endpoint Identifier	(see EN 300 175-4 [4], clause 7.3.6)
<<Release mode>>		
	Normal or Abnormal	
Actions by the FT/PT: The LCE shall inform all higher entities using the link that the link has been released and shall enter "LINK-RELEASED" state.		

8.37.1 Associated procedure

8.37.1.1 Timer <LCE.01> management

<LCE.01>: Link release timer;

Value: Refer to EN 300 175-5 [5], annex A;

Start: A DL_RELEASE-req primitive is sent;

Stop: A DL_RELEASE-cfm primitive is received.

8.37.2 Exceptional cases

8.37.2.1 Timer <LCE.01> expiry

If the <LCE.01> expires before a DL_RELEASE-cfm is received (e.g. the transmission of outstanding data needs more time) a new request for link release shall immediately be issued this time indicating release mode as "abnormal".

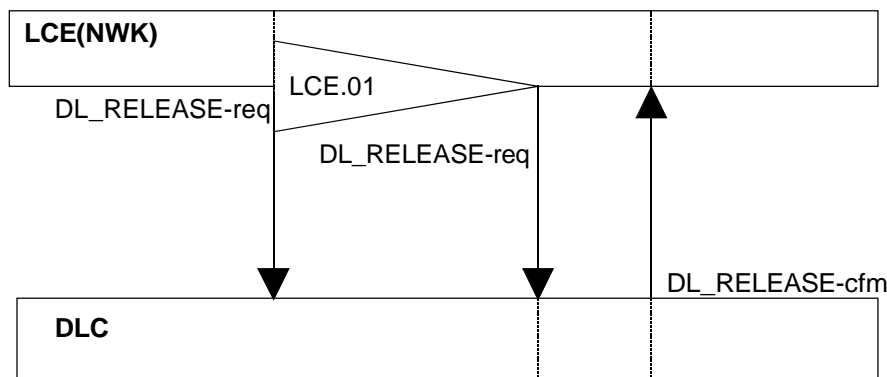

Figure 77: Timer <LCE.01> expiry

Table 75: Values used within the DL_RELEASE-req primitive

Parameter	Information within the parameter	Normative action/comment
<<DLEI>>		
	Data Link Endpoint Identifier	(see EN 300 175-4 [4], clause 7.3.6)
<<Release mode>>		
	Abnormal	

Table 76: Values used within the DL_RELEASE-cfm primitive

Parameter	Information within the parameter	Normative action/comment
<<DLEI>>		
	Data Link Endpoint Identifier	(see EN 300 175-4 [4], clause 7.3.6)
<<Release mode>>		
	Normal or Abnormal	

8.37.2.2 Outstanding data has been discarded

Even if the requested release mode was "normal" the DL_RELEASE-cfm primitive may indicate "abnormal" release mode (e.g. if any DL_DATA-req or I-frames were discarded or were unacknowledged because of time-out or other problems at the lower layers).

The primitive's exchange is the same as in link release "normal", except the information that is to be carried back in the DL_RELEASE-cfm primitive.

Table 77: Values used within the DL_RELEASE-cfm primitive

Parameter	Information within the parameter	Normative action/comment
<<DLEI>>		
	Data Link Endpoint Identifier	(see EN 300 175-4 [4], clause 7.3.6)
<<Release mode>>		
	Abnormal	

8.38 Link release "abnormal"

The procedure shall be performed as defined in EN 300 175-5 [5], clause 14.2. The following text defines the mandatory requirements with regard to the present document.

The "abnormal" release requires the DLC to release immediately the link without completing the transmission of any outstanding data.

The procedure description differs from the link release "normal" procedure description (see clause 8.37) only in the release mode identification which here shall be set to "Abnormal". Clauses 8.37.1 and 8.37.2 are not relevant to link release "abnormal" procedure.

8.39 Link release "maintain"

The procedure shall be performed as defined in EN 300 175-5 [5], clause 14.2.7. The following text together with the associated clauses define the mandatory requirements with regard to the present document.

Every higher entity shall provide an explicit notification to the LCE when it ceases to use a link. This notification shall indicate if the entity requires the link to be maintained. If the higher entity requires the link to be maintained then it shall indicate release reason "partial release" and the LCE shall start timer <LCE.02> (even if the timer is already running).

If the higher entity does not require the link to be maintained and no other higher entities are using it and no LCE timers are running then the LCE shall release the link.

On expiry of timer <LCE.02> when no higher entities are using the link and no other LCE timers are running the LCE shall release the link immediately using the "abnormal" release procedure (see clause 8.38). No action shall be taken on expiry of timer <LCE.02> if any higher layer entity is still using the link or any other LCE timer is running.

The MM (except after a location registration procedure with TPUI assignment or after an obtaining access rights procedure), Call Independent Supplementary Service (CISS) and Connection Less Message Service (CLMS) shall always indicate that the link shall be maintained using partial release. If CC wants to maintain the link it shall first initiate partial release procedure (see clause 8.9) the support of this procedure is optional.

8.39.1 Associated procedure

8.39.1.1 Timer <LCE.02> management

<LCE.02>: Link maintain timer;

Value: Refer to EN 300 175-5 [5], annex A;

Start: A higher entity indicates partial release to the LCE;

Stop: An indication for link release from the DLC layer has been received.

8.40 Enhanced FT initiated U- plane connection

The procedure shall be performed as defined in clauses 9.3.1.4 and 9.3.2.4 of EN 300 175-5 [5]. Figure 78 and table 78 together with the associated clauses define the mandatory requirements with regard to the present document.

The PT shall support the call connection procedures defined in this clause in the following call states: T02, T03, T04 (outgoing call), T07, T08 (incoming call), T19 (call release).

The call connection procedures apply the <<Progress Indicator>> within the {CC-INFO} message as follows:

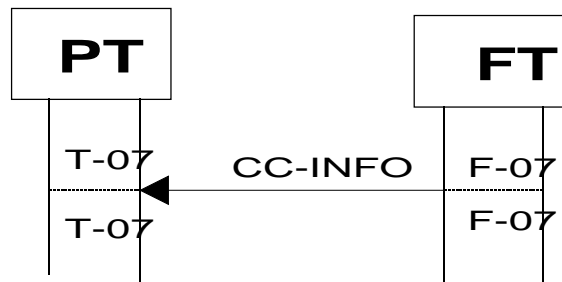

Figure 78: Call connection example, in F-07

Table 78: Values used within the {CC-INFO} message

Information element	Field within the information element	Standard values within the field/IE	Normative action/comment
<<Progress indicator>>			
	<Progress description>	8H	In band information or appropriate pattern now available The PT shall connect the U-plane

9 DLC layer procedures

9.1 Class A link establishment

The procedure shall be performed as defined in EN 300 175-4 [4], clause 9.2.3.1. The following text together with the associated clauses define the mandatory requirements with regard to the present document.

If, class B acknowledged transfer is requested but not supported (B acknowledged transfer is not required to be supported for GAP) by the receiving side, the I_frame requesting class B operation shall be treated as though it was a class A frame, see EN 300 175-4 [4], clause 9.2.4.3.1 b).

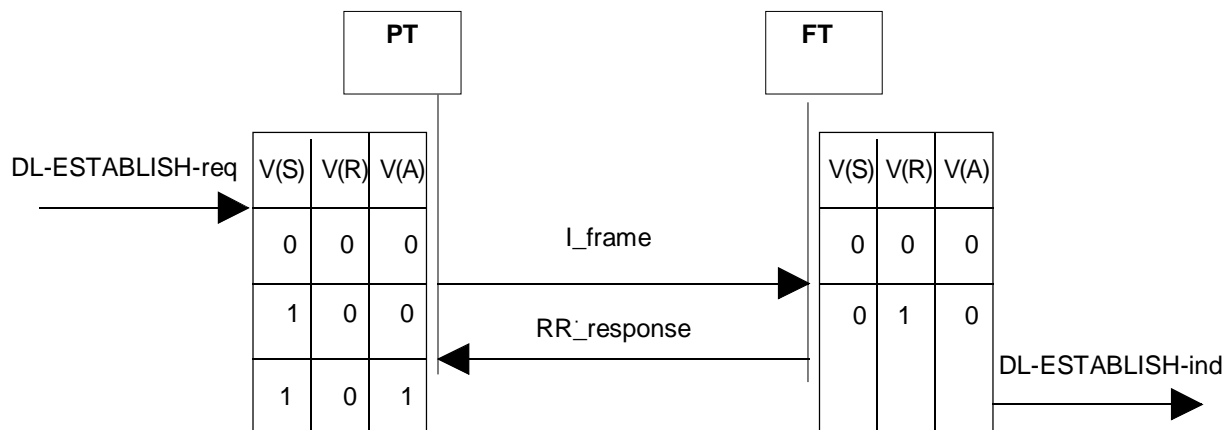

Figure 79: Class A link establishment

Table 79: Values used within the I-frame

Field	Parameter within the field	Standard values within the field/parameter	Normative action/comment
<<Address-field>>			
	<NLF>	1	New link
	<LLN>	1	Class A operation
	<SAPI>	0	Connection oriented
	<C/R>	0	PT command
	<RES>	1	
<<Control-field>>			
	<N(R)>	0	N(R)=V(R)
	<P>	0	Ignore
	<N(S)>	0	N(S)=V(S)
<<Length-indicator-field>>			
		0	No higher layer information
		1..63	Higher layer info length
	<M>	All	
	<N>	1	No extended length field. If "0" the frame may be discarded
<<Information field>>		All appropriate	Higher layer information. If field indicates "0" shall be omitted. This field shall be used to carry the {LCE-PAGE-RESPONSE} message in case of FT initiated indirect link establishment
<<Fill field>>		11110000B	Ignore. 0 to 4 such octets may be included in case for the C _S logical channel, as the Frame Length (FLEN) mod 5 = 0. If indicates "0", no <Fill field> is required
<<Checksum field1>>		All	The contents shall be calculated using two elements: LSI _G see EN 300 175-4 [4] clause 10.3.1; underlying checksum calculation based on ISO/IEC 8073 [14]
<<Checksum field2>>		All	See above

Table 80: Values used within the {RR-Frame} S-format message

Field	Parameter within the field	Standard values within the field/parameter	Normative action/comment
<<Address-field>>			
	<NLF>	1	New link
	<LLN>	1	Class A operation
	<SAPI>	0	Connection oriented
	<C/R>	0	FT response
	<RES>	1	
<<Control-field>>			
	<N(R)>	1	N(R) = V(R)
	<P/F>	0	Ignore
	<SS>	0	
	<***>	1	constant
<<Length-indicator-field>>			
		0	No higher layer information
	<M>	0	
	<N>	1	No extended length field. If "0" the frame may be discarded
<<Checksum field1>>		All	
<<Checksum field2>>		All	

9.1.1 Associated procedures

9.1.1.1 Timer P<DL.07> management

<DL.07>: Class A establishment timer;

Value: Refer to EN 300 175-4 [4], annex A;

Start: A Class A link establishment I_frame is transmitted;

Stop: On receipt of: a Class A errorless RR_response with the New Link Flag (NLF) bit set to "1"; a DL_RELEASE-req primitive indicating "abnormal"; a MAC_DIS-ind primitive.

9.1.1.2 Re-transmission counter management

Refer to EN 300 175-4 [4], clauses 9.2.3.1 and 9.2.3.6.

Each LAPC entity shall maintain an internal Re-transmission count variable determining the maximum number of re-transmissions of an I_frame. The default value shall be 3.

For Class A operations the Re-transmission counter shall be reset any time a new I_frame has been sent.

9.1.1.3 Multiple frame operation variables management

Refer to EN 300 175-4 [4], clause 7.5.2.

For the DLC layer acknowledged transfer to be performed the V(S), V(A), and V(R) operation variables together with their appropriate management shall be supported.

The allowed values of all state variables for a given class of operation shall always be defined by the modulus operation. For Class A operation, the modulus equals 2.

9.1.1.4 Lower Layer Management Entity (LLME) establishment of a MAC connection

The procedure shall be performed as defined in EN 300 175-4 [4], clause 10.2 and EN 300 175-3 [3], clause 8.1.1. The following text together with the associated clauses define the mandatory requirements with regard to the present document.

For a link to be established a suitable MAC connection is needed. If such one does not exist the LLME shall request it.

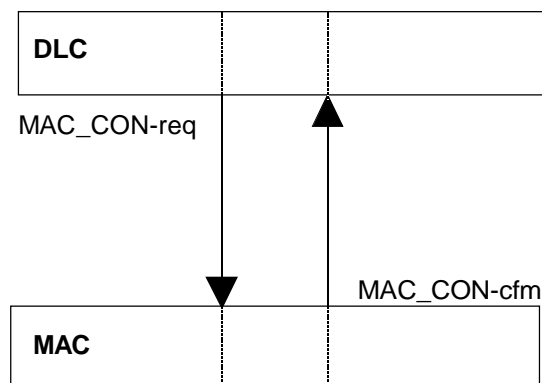

Figure 80: Establishment of a MAC connection initiating side

Table 81: Values used within the MAC_CON-req primitive

Parameter	Information within the parameter	Normative action/comment
<<MCEI>>	MAC Connection Endpoint Identifier	Refer to EN 300 175-4 [4], clause 10.2.4.4
<<PMID>>	Portable part MAC Identity (PMID)	(see clause 13.4)
<<CHO flag>>	Y/N	Y - if the connection is required for Connection handover
<<Old MCEI>>	All relevant	Only needed for Connection handover and Basic type connections
<<Cf required>>	No	
<<Slot type>>	full slot	
<<Service type>>	In_minimum_delay or C-channel only	
<<connection type>>	basic	

Table 82: Values used within the MAC_CON-cfm primitive

Parameter	Information within the parameter	Normative action/comment
<<MCEI>>	MAC Connection Endpoint Identifier	Refer to EN 300 175-4 [4], clause 10.2.4.4
<<Connection type>>	Basic	The type of the established connection

The receiving side shall be informed about the action that has taken place in case it was successful by a MAC_CON-ind primitive.

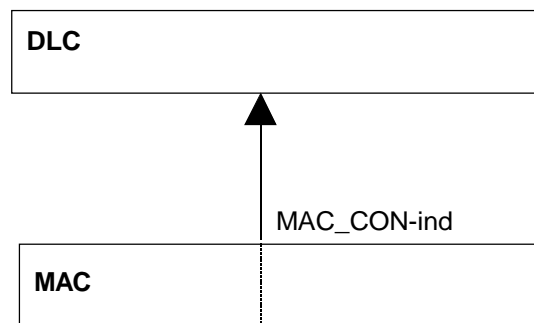
**Figure 81: Establishment of a MAC connection receiving side****Table 83: Values used within the MAC_CON-ind primitive**

Parameter	Information within the parameter	Normative action/comment
<<MCEI>>	MAC Connection Endpoint Identifier	Refer to EN 300 175-4 [4], clause 10.2.4.4
<<PMID>>	PMID	(see clause 13.4)
<<CHO flag>>	Y/N	Y - if the connection is required for Connection handover
<<Cf required>>	No	
<<Slot type>>	full slot	
<<Service type>>	In_minimum_delay or C-channel only	
<<connection type>>	basic	

9.1.2 Exceptional cases

9.1.2.1 Timer P<DL.07> expiry

If a RR response is received with the NLF bit set to "0" or containing errors the LAPC entity shall discard it. If the peer finds errors in the I_frame, response shall not be generated. In both cases timer P<DL.07> shall expire. An action shall be taken according to EN 300 175-4 [4], clause 9.2.3.1.

9.1.2.2 Receipt of a request for link release

If DL_RELEASE-req primitive is received timer P<DL.07> shall be stopped. Class A link release procedure shall be performed (see clause 9.3).

9.1.2.3 Receipt of an indication for a connection release

Timer P<DL.07> shall be stopped, all outstanding data shall be discarded, and, the NWK layer shall be informed for the MAC failure by DL_RELEASE-ind primitive.

9.2 Class A Acknowledged Information transfer

The procedure shall be performed as defined in EN 300 175-4 [4], clauses 9.2.3.2, 9.2.3.3, 9.2.3.4, 9.2.3.5, and 9.2.3.6. The following text together with the associated clauses define the mandatory requirements with regard to the present document.

The following cases, depending on the frame which confirms the reception of the frame-request, shall be supported:

- acknowledgement with an I_frame;
- acknowledgement with an RR_frame.

9.2.1 Acknowledgement with an I_frame

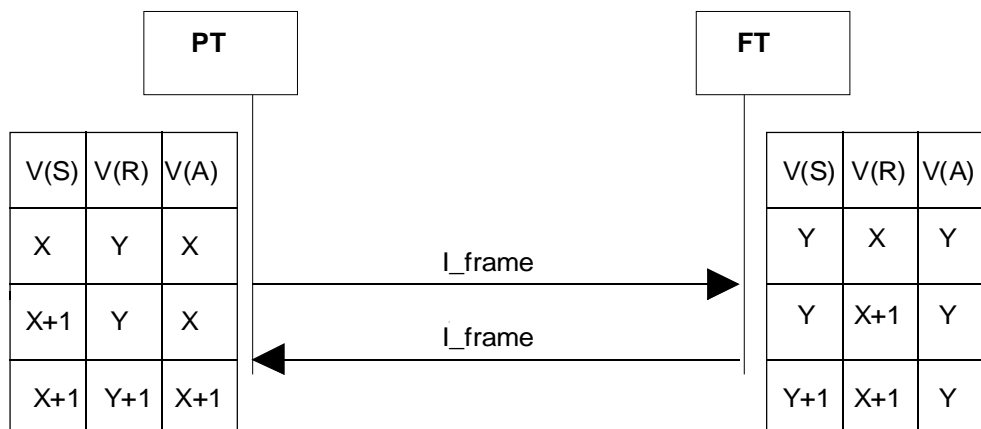

NOTE 1: During the calculation of the variable's values the assumptions have been made that the I_frame sent by PT is not used for acknowledgement of previous received I_frames and, both frames are not re-transmission.

NOTE 2: A Class A acknowledged information transfer procedure is considered as successful for the Initiator when in case N(S) is sent and N(R) is received the next equation is valid: $(N(S)+1) \bmod 2 = N(R)$.

NOTE 3: The I_frame sent by the FT is assumed to be acknowledged as well. (not indicated in the figure).

NOTE 4: The case when FT initiates differs only in the notations.

Figure 82: Class A acknowledge information transfer by I_frame, PT initiated

Table 84: Values used within the I-Frame sent by the PT(FT)

Field	Parameter within the field	Standard values within the field/parameter	Normative action/comment
<<Address-field>>			
	<NLF>	0	
	<LLN>	1	Class A operation
	<SAPI>	0	Connection oriented
	<C/R>	0	From PT
		1	From FT
	<RES>	1	
<<Control-field>>			
	<N(R)>	=V(R)	In I_frame transmitter
	<P>	0	Ignore
	<N(S)>	=V(S)	In I_frame transmitter
<<Length-indicator-field>>			
		1..63	Higher layer info length
	<M>	All	
	<N>	1	No extended length field. If "0" the frame may be discarded
<<Information field>>		All relevant	Higher layer information
<<Fill field>>		11110000B	Ignore. 0 to 4 such octets may be included in case for the C _S logical channel
<<Checksum field1>>		All	
<<Checksum field2>>		All	

9.2.2 Acknowledgement with a RR_frame

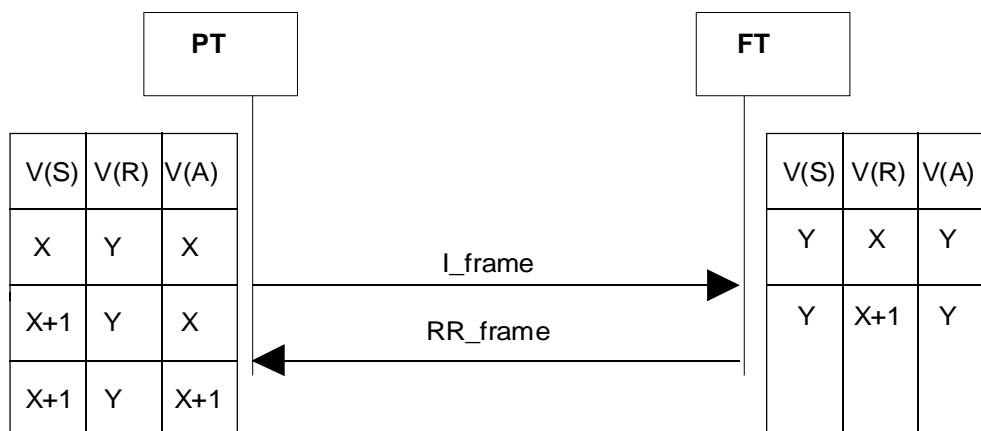

NOTE 1: During the calculation of the variable's values an assumption has been made that the I_frame sent by PT is not used for acknowledgement of previous received I_frames and is not a re-transmission.

NOTE 2: A Class A acknowledged information transfer procedure is considered as successful for the Initiator when in case N(S) is sent and N(R) is received the next equation is valid: $(N(S)+1) \bmod 2 = N(R)$.

NOTE 3: The case when FT initiates differs only in the notations.

Figure 83: Class A acknowledge information transfer by RR_frame

The values used within the {I-Frame} shall be the same as in the case Acknowledgement with an I_frame, (see table 84).

Table 85: Values used within the {RR-Frame} S-format message

Field	Parameter within the field	Standard values within the field/parameter	Normative action/comment
<<Address-field>>			
	<NLF>	0	
	<LLN>	1	Class A operation
	<SAPI>	0	Connection oriented
	<C/R>	0	From FT
		1	From PT
	<RES>	1	
<<Control-field>>			
	<N(R)>	= V(R)	In RR-frame transmitter
	<P/F>	0	Ignore
	<SS>	0	
	<***>	1	Constant
<<Length-indicator-field>>			
		0	No higher layer information
	<M>	0	
	<N>	1	No extended length field. If "0" the frame may be discarded
<<Checksum field1>>		All	
<<Checksum field2>>		All	

9.2.3 Class A acknowledged information transfer with segment reassemble

As the required length of a NWK layer message to be supported is 63 octets (see clause 6.9.3) the segmentation of NWK layer messages in the DLC layer is not required to be supported for implementations complying with GAP.

If an implementation supporting longer messages wants to access a GAP implementation which does not support segmentation, the last shall act as follows:

- acknowledge the receipt of each error free, in sequence segment;
- do not store any segment after the first;
- deliver to its own NWK layer only the first segment.

9.2.4 Associated procedures

9.2.4.1 Timer <DL.04> management

DL.04>: Re transmission timer;

Value: Refer to EN 300 175-4 [4], annex A;

Start: A I_frame is transmitted;

Stop: On receipt of: an acknowledgement for that frame; a DL_RELEASE-req primitive indicating "abnormal"; a MAC_DIS-ind primitive.

9.2.4.2 Re-transmission counter management

Refer to clause 9.1.1.2.

9.2.4.3 Multiple frame operation variables management

Refer to clause 9.1.1.3.

9.2.5 Exceptional cases

9.2.5.1 Timer <DL.04> expiry

Refer to EN 300 175-4 [4], clause 9.2.3.6.

An errored or erroneous I-frame shall be discarded and therefore shall not generate peer response.

An errored or erroneous frame-acknowledgement shall be discarded and timer <DL.04> shall not be stopped.

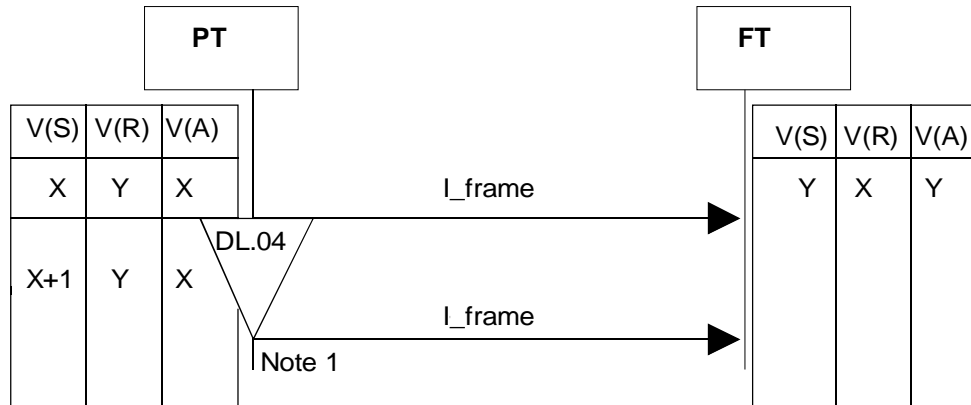

NOTE 1: The I_frame is re-transmitted only if $N250 < \text{max.value}$.

NOTE 2: During the calculation of the variable's values an assumption has been made that the I_frames sent are not used for acknowledgement of previous received I_frames and the first one is not a re-transmission.

NOTE 3: The case when FT initiates differs only in the notations.

NOTE 4: The contents of the retransmitted frame shall be exactly the same as the first one.

Figure 84: Timer <DL.04> expiry

The values used within the {I-Frame} shall be the same as in the case acknowledgement with an I_frame, (see table 84).

9.2.5.2 Receipt of a request for link release

On receipt of a DL_RELEASE-req after an I-frame has been transmitted timer <DL.04> shall be stopped and class A link release procedure (see clause 9.3) shall be performed.

9.2.5.3 Receipt of an indication for a connection release

On receipt of an indication from the MAC layer for a release meaning either a bearer release started by the MAC layer or a bearer release resulting from a link release initiated by the peer, the timer <DL.04> shall be stopped and class A Link release procedure (see clause 9.3) shall be performed.

9.2.5.4 DLC wants to make a connection handover

See class A basic connection handover procedure given in clause 9.7.

9.3 Class A link release

The procedure shall be performed as defined in EN 300 175-4 [4], clauses 9.2.3.7, 9.2.7.1.2, 10.2.2, and 10.4.1, EN 300 175-3 [3], clause 8.1.6, and EN 300 175-5 [5], clause 17.9. The following text together with the associated clauses define the mandatory requirements with regard to the present document.

The procedure for Class A link release is initiated on receipt of a DL_RELEASE-req primitive (see clauses 8.37 and 8.38) or a MAC_DIS-ind primitive.

On receipt of a MAC_DIS-ind primitive DLC shall release the link.

A link release procedure is qualified as "normal" if no outstanding I-frames or outstanding DL_DATA-req primitives have been discarded before the link has been released.

Even if in the DL_RELEASE-req primitive a "normal" link release has been requested, the DLC layer might be unable to process all outstanding data. If any outstanding I-frames or DL_DATA-req primitives were or have to be discarded the release is qualified as "abnormal" and the resulting "abnormal" release mode shall be indicated in the DL_RELEASE-cfm and DL_RELEASE-ind primitives respectively.

9.3.1 Associated procedures

9.3.1.1 LLME U-plane release

The procedure shall be performed as defined in EN 300 175-4 [4], clause 10.4.2.

9.3.1.2 LLME release a MAC connection

The procedure shall be performed as defined in of EN 300 175-4 [4], clause 10.2 and EN 300 175-3 [3], clause 8.1.6.

9.4 Class A link re-establishment

The procedure shall be performed as defined in of EN 300 175-4 [4], clause 9.2.3.8 and EN 300 175-5 [5], clause 17.8. The following text together with the associated clauses define the mandatory requirements with regard to the present document.

A class A link may be re-established at any time using the procedure for class A link establishment, (see clause 9.1). All outstanding DL_DATA primitives and I-frames shall be discarded, and all link variables shall be reset.

Alternatively an implementation is permitted to release the link after receipt of an I-frame with NLF flag set to "1".

A link shall not be re-established whilst in the "RELEASE-PENDING" state, see EN 300 175-5 [5], clause 14.2.7.

9.5 C_S channel fragmentation and recombination

The procedure shall be performed as defined in EN 300 175-4 [4], clauses 6.1.2, 6.1.3, 6.1.4, 6.1.4.2 and 10.2.5. The following text together with the associated clauses define the mandatory requirements with regard to the present document.

The complete frame shall be fragmented into 5 octet fragments.

9.6 Normal broadcast

The procedure shall be performed as defined in EN 300 175-4 [4], clauses 6.2.1, 8.3.3.1, 9.4.1.1 and 9.4.1.2 and EN 300 175-3 [3], clause 8.2.1. The following text together with the associated clauses define the mandatory requirements with regard to the present document.

Only short frame format (frame length = 3) is required to be supported.

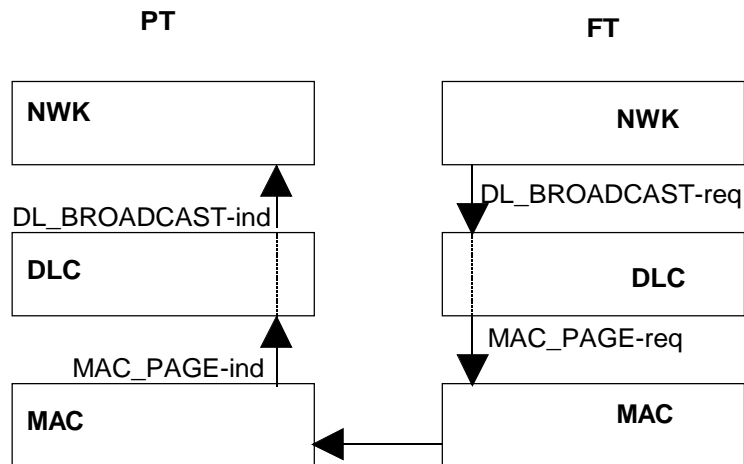

Figure 85: Normal broadcast

Table 86: Information used within the DL_BROADCAST-req primitive

Parameter	Information within the parameter	Normative action/comment
<<Cluster address list>>	All cluster/an integer	
<<Message unit length>>	3 octets	Only short frame format is required to be supported
<<Message unit>>	From the NWK layer	

Table 87: Information used within the MAC_PAGE-req primitive

Parameter	Information within the parameter	Normative action/comment
<<cluster ID>>	All clusters/an integer	
<<page type>>	Normal	"fast" is not required to be supported
<<length of page field>>	0 or 20	
<<SDU>>	The data from the <<Message unit>> received in the DL_BROADCAST-req primitive	

Table 88: Information used within the MAC_PAGE-ind primitive

Parameter	Information within the parameter	Normative action/comment
<<length of page field>>	20	
<<SDU>>		

Table 89: Information used within the DL_BROADCAST-ind primitive

Parameter	Information within the parameter	Normative action/comment
<<Message unit length>>	3 octets	
<< Message unit>>	The data from the <<SDU>> from the MAC_PAGE-ind primitive	

9.7 Class A basic connection handover

The procedure shall be performed as defined in EN 300 175-4 [4], clauses 9.2.7.3, 9.2.7.3.1, 9.2.7.3.3, 10.5 and 9.2.7.1.2. The following clauses define the mandatory requirements with regard to the present document.

9.7.1 Voluntary handover

As a result of continued poor quality of service from the MAC layer, the LLME in the PT shall inform the PT LAPC entity, the LAPC entity shall enter the Handover pending condition, timer <DL.05> is not needed to be started, a new MAC connection shall be requested to be established.

The establishment of a new MAC connection shall be achieved by the LLME connection setup procedure (see clause 9.1.1.4). If a new MAC connection is successfully established the LAPC entity shall leave the Handover pending condition, and one of the two MAC connections shall be released by the PT using the LLME MAC connection release procedure (see clause 9.3.1.2).

This implies that in case of unsuccessful handover the associated links shall not be released since the connection is still operational (even with bad quality).

NOTE: The involuntary handover is not required to be supported by an implementation complying with GAP. Any time an unexpected upward MAC_DIS-ind primitive is received, the receiver of this primitive may assume that the connection and the far side of the link have been released.

9.7.2 Associated procedure

9.7.2.1 LLME connection handover management

The procedure shall be performed as defined in EN 300 175-4 [4], clause 10.5. The following text together with the associated clauses define the mandatory requirements with regard to the present document.

Timer <DL.06> shall be started either after the connection handover is successfully completed or immediately after N251 successive "unsuccessful" connection handover attempts.

It shall be stopped upon an initiation of a link release "abnormal" (see clause 8.38) or release indication from MAC layer (see clause 9.3).

As long as <DL.06> is running, no connection handover attempts shall be initiated.

9.7.3 Exceptional case

9.7.3.1 Receipt of a request for link release

If while in the connection handover pending condition a link release request has been received from the own NWK layer the handover pending condition shall be cleared and class A link release procedure (see clause 9.3) shall be performed.

The associated connection and the connection for which establishment is in progress shall also be released using the LLME release of the MAC connection procedures (see clause 9.3.1.2).

9.8 Encryption switching

The procedure shall be performed as defined in EN 300 175-4 [4], clause 10.6, EN 300 175-7 [7], clauses 6.5.3 and 6.4.6 and EN 300 175-3 [3], clause 6.2.3. The following text together with the associated clauses define the mandatory requirements with regard to the present document.

The procedure for encryption deactivation is not required to be supported since a new connection is always established in clear mode. Therefore any connection or link release implies encryption deactivation.

The encryption deactivation is mandatory only if service [D.9] is supported.

9.8.1 Associated procedure

9.8.1.1 Providing Encryption key to the MAC layer

On receipt of the DCK in a DL_ENC_KEY-req primitive the DLC shall transmit it to the MAC layer.

A record shall be kept for the active (the one used for the current encryption) DCK for use in case of connection handover.

9.8.2 Exceptional cases

9.8.2.1 Encryption fails

An encryption attempt which fails means the desired "Crypted" mode is not achieved. If the MAC fails to switch from clear to encrypted mode the connection is released and the DLC layer is informed by a MAC_DIS-ind primitive. At the peer side this indication shall arrive as a result of the connection release.

9.8.2.2 Connection handover of ciphered connections

During a connection handover the new connection shall always be established in clear (encryption disabled). If the status of the old connection was "Crypted" then the LLME at the PT side shall command the DLC layer to enable ciphering on the new connection as soon as it is established by issuing a MAC_ENC_Key-req primitive to the MAC layer (to provide the cipher key) followed by a MAC_ENC_EKS-req primitive with the flag set to "Go Crypted".

NOTE: If during the time that data has been crypted a new DCK has been produced and stored when a connection handover of ciphered connection is performed the new key is not available at the DLC layer. Therefore the ciphering is performed using the old DCK.

Notification of successful encryption of the new connection shall be indicated by receipt of a MAC_ENC_EKS-cfm at the initiating side and a MAC_ENC_EKS-ind at the peer side. In this event no indication shall be issued to the NWK layer.

If the encryption of the new connection fails, the connection is released and the DLC layer is informed using the MAC_DIS-ind primitive. No indication with a MAC_ENC_EKS-ind or a MAC_ENC_EKS-cfm primitive shall be provided.

9.9 U-plane class 0/min delay

The procedure shall be performed as defined in EN 300 175-4 [4], clauses 11.2, 14.2.3.1 and 14.3.2.

9.9.1 Associated procedure

9.9.1.1 LLME U-plane establishment

The procedure shall be performed as defined in EN 300 175-4 [4], clause 10.4.1. The following text together with the associated clauses define the mandatory requirements with regard to the present document.

On demand from the NWK layer for the connection of the U-plane (see the NWK layer procedures in clauses 8.3, 8.4, 8.5, 8.6, and 8.15) the LLME shall establish a suitable DLC entity and shall associate the DLC entity to the MAC connection already available for the C-plane. The NWK layer entity shall be informed by the LLME of the success of the procedure.

9.10 FU1 frame operation

The procedure shall be performed as defined in EN 300 175-4 [4], clauses 12.1 and 12.2. The following text together with the associated clauses define the mandatory requirements with regard to the present document.

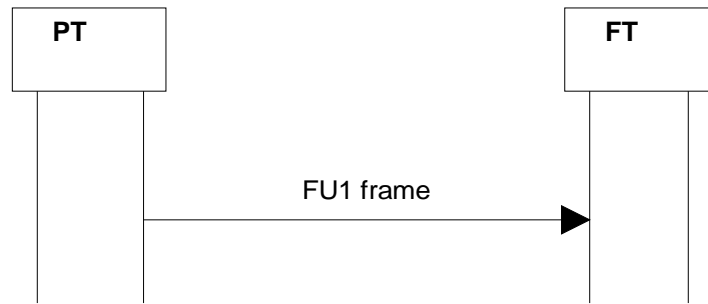

NOTE: The case when FT initiates differs only in the notations.

Figure 86: Sending a FU1 frame

The length of a FU1 frame $k = 40$ octets (full slot).

One complete frame shall be submitted to/from MAC layer included in a MAC_CO_DATA-req(ind) primitive.

10 MAC layer procedures

10.1 General

The FT and PT shall support In_minimum_delay service as defined in EN 300 175-3 [3], clause 10.8.3.1.

The FT and PT shall support frame format as follows:

- full slot mode defined in EN 300 175-3 [3], clause 4.2.2;
- D-field mapping shall support the D-00 and D32 as defined in EN 300 175-3 [3], clause 6.2.1.1.

The FT and PT shall support A-field mapping A-MAP.

The FT and PT shall understand all A field tail identifications (a0, a1 and a2) in the header field as defined in EN 300 175-3 [3], clauses 6.2.1.2 and 7.1.2.

The FT and PT shall support the following B-field field identifications (a4, a5 and a6) as defined in EN 300 175-3 [3], clause 7.1.4:

- U-type: In, "000"B;
- no B-field, "111" B (shall only be used for dummy bearers).

The FT and PT shall support T-MUX as defined in EN 300 175-3 [3], clause 6.2.2.1.

The FT and PT shall support B-field multiplex E/U MUX type U32a.

The FT and PT shall support scrambling as defined in EN 300 175-3 [3], clause 6.2.4.

The FT and PT shall provide R-CRC generation and checking as defined in EN 300 175-3 [3], clause 6.2.5.2. The FT and PT shall provide X-CRC generation and checking as defined in EN 300 175-3 [3], clauses 6.2.5.3 and 6.2.5.4.

The PT shall support the normal duty cycle idle_locked mode as defined in EN 300 175-3 [3], clauses 11.3 and 4.3.1.

The FT and PT shall support primary scan procedure as defined in EN 300 175-3 [3], clause 11.8.

10.2 Downlink broadcast

The procedure shall be performed as defined in EN 300 175-3 [3], clause 9.1.1.

10.2.1 N_T message

The FT shall be capable of sending and the PT shall be capable of receiving and processing the N_T message as defined in EN 300 175-3 [3], clause 7.2.2.

Table 90: Values used within N_T message

MAC message/broadcast element	Field within the message/broadcast element	Standard values within the MAC message	Normative action/comment
<<RFPI>>			
	<E-bit>	0	No SARI.
		1	SARI available. Relates to service SARI support [M.13].
	<PARI>	All	
	<RPN>	All	

10.2.2 Q_T - static system information

The FT shall be capable of sending and the PT shall be capable of receiving and processing the Q_T message as defined in EN 300 175-3 [3], clause 7.2.3.2.

Table 91: Values used within static system info

MAC message	Field within the message	Standard values within the MAC message	Normative action/comment
<<Static system info>>			
	<Qh>	0	
	<NR>	0	PT shall support all values in order to gain lock. Asymmetric connections are not required to be supported by the PT
	<SN>	0 - 11	PT shall support all values
	<SP>	0	PT shall support all values in order to gain lock. Half slot connections are not required to be supported by the PT
	<ESC>	0	PT may ignore and assume the value to be 0
	<Txs>	0	PT may ignore and assume the value to be 0
	<Ext-car>	0, 1	PT shall support all values in order to keep in synchronization with the primary scan
	<RF-car>	1 - 1 023	The PT shall not use carriers which are not supported
	<SPR>	0	PT may ignore
	<CN>	0 - 9	PT shall support all values
	<SPR>	0	PT may ignore
	<PSCN>	0 - N	PT shall support values 0 - 9

10.2.3 Q_T - FP capabilities

If the bit a33 in higher layer capabilities (see table 103) is set to value "1", the PT may assume the values as indicated in table 92 to be set to value "1". The FT shall set the respective values to "1".

Table 92: Values used within FP capabilities

MAC message	Field within the message	Standard values within the MAC message	Normative action/comment
<<FP capabilities>>			
	<Qh>	3	
	<a17>	1	Full slot
	<a23>	1	Basic A-field setup
	<a27>	1	In minimum delay

Higher layer information: the management entity in the FP supplies the MAC layer with a 16-bit SDU via the Management Entity (ME) SAP. At the PT the MAC layer passes the 16 bits out through the ME SAP to the management entity.

For the setting of the higher layer information bits see clause 13.6.

10.2.4 Q_T - SARI list contents

The FT may send and the PT shall be capable of receiving and processing (if broadcast by the FT) the Q_T message as defined in EN 300 175-3 [3], clause 7.2.3.6, and EN 300 175-6 [6], clauses 5.5, 5.5.1, 5.5.3 and 5.5.4.

This is relevant if the N_T message indicates SARI support.

Table 93: Values used within SARI list contents

MAC message	Field within the message	Standard values within the MAC message	Normative action/comment
<<SARI list contents>>			
	<Qh>	5	
	<SARI list length>	All	
	<TARIs yes/no>	All	The PP may ignore it if Tertiary Access Rights Identity (TARI) request is not supported (support of TARI is not required in GAP)
	<Black yes/no>	All	The PP shall be able of distinguishing ARI from black ARI even if TARI is not supported
	<ARI or black-ARI>	All	

10.3 Paging broadcast

The procedure shall be performed as defined in EN 300 175-3 [3], clause 9.1.3.

10.3.1 Short page, normal/extended paging

The following fields as defined in EN 300 175-3 [3], clause 7.2.4 shall be supported by the PT and the FT.

Table 94: Values used within short page message

MAC message	Field within the message	Standard values within the MAC message	Normative action/comment
<<Short page message>>			
	<Extend flag>	0, 1	PT shall support all values. Optional for the FT to support value 1
	<B _s SDU length indication>	1	PT and FT shall support short page messages
	<20 bits of BS channel data>	All	Higher layer information
	<Information type>	1, 2, 5 and 9	The PT shall support values 1, 2, 5, and 9. FT shall support value 1 (see clause 10.3.3) if blind slot information available. The FT shall support value 9 (see clause 10.3.4) if bearer handover information available. Other values need not be supported by FT or PT
	<MAC layer information>	Corresponding information	Information type defined in the previous field

10.3.2 Zero page normal/extended paging

The following fields as defined in EN 300 175-3 [3], clause 7.2.4 in the zero page message shall be supported by the PT and the FT.

Table 95: Values used within zero page message

MAC message	Field within the message	Standard values within the MAC message	Normative action/comment
<<Zero page message>>			
	<Extend flag>	0, 1	PT shall support all values. Optional for the FT to support value 1
	<B _s SDU length indication>	0	PT shall support zero length page messages. The FT shall support if "Blind slot information" included
	< 20 least significant bits of RFPI>	All	May be ignored by PT
	<Information type>	1, 2, 5 and 9	The PT shall support values 1, 2, 5 and 9. FT shall support value 1 (see clause 10.3.3) if blind slot information available. The FT shall support value 9 (see clause 10.3.4) if bearer handover information available. Other values need not be supported by FT or PT
	<MAC layer information>	Corresponding information	Information type defined in the previous field

10.3.3 Blind slot information

It is mandatory for RFP's that have blind slots, due to non-duplex bearer operation on that slot (i.e. those RFP's that have technological limitations such as a slow synthesizer), to periodically announce these blind slots (at least every 10 s). In the event the RFP announces blind slot information, such information may also include all blind slots due to an active bearer as well.

Not available (blind) slot means that the FP recommends the PP not to attempt a setup on this slot.

If the PP receives blind slot information, it is mandatory for that PP to use it in the process of channel selection. The PP does not have to wait for the blind slot information before making the channel selection.

10.3.4 Bearer handover information

It is mandatory for FTs not supporting bearer handover within the whole FT to periodically send the bearer handover information (at least every 10 s).

It is mandatory for PT to support the following values of field "Info type" (bits a36 to a39) for "Bearer handover information" (value "9" of <Information type> in the P_t message, see tables 94 and 95): "0000", "0001", "0010" and "0011".

10.4 Setup of basic connection, basic bearer setup (A-field)

The procedure shall be performed as defined in EN 300 175-3 [3], clauses 10.2.4.2 and 10.5.1.1.

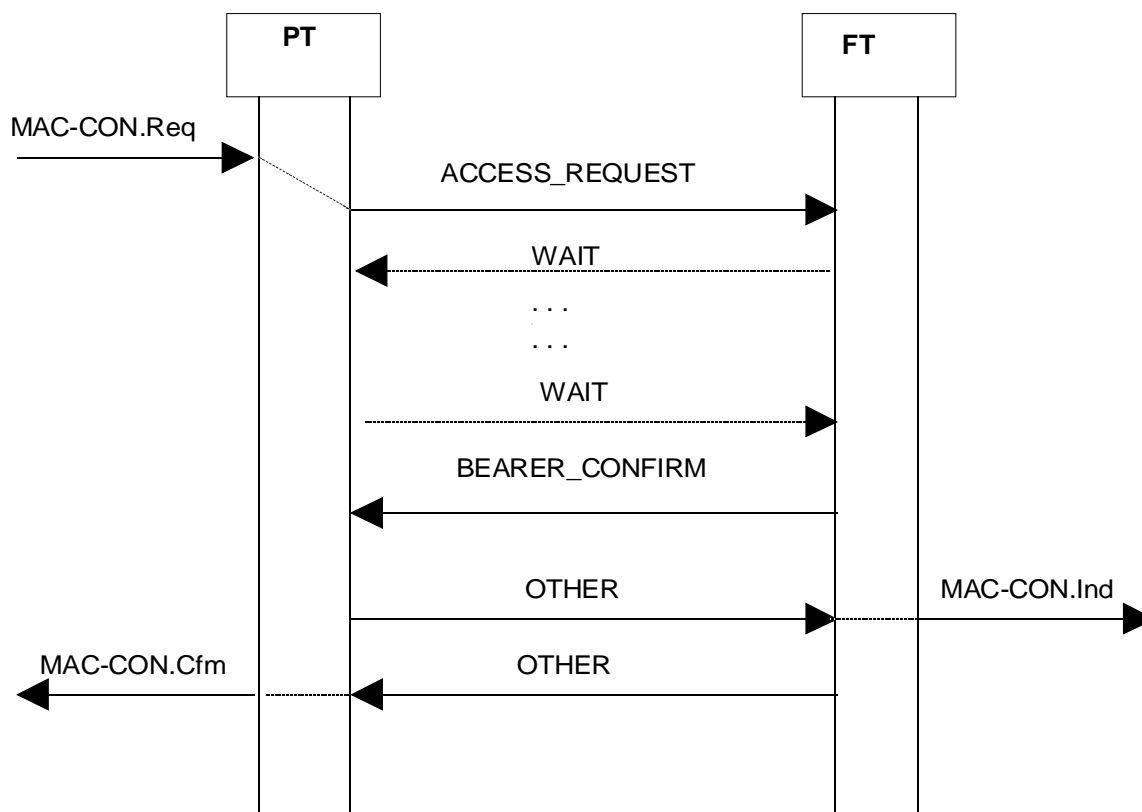

Figure 87: Setup of basic connection and bearer

10.4.1 M_T message

The following fields as defined in EN 300 175-3 [3], clause 7.2.5.2 of in the MAC control (M_T) message shall be supported by the PT and the FT.

Table 96: Values used within M_T message

MAC message	Field within the message	Standard values within the MAC message	Normative action/comment
<<M _T message>>			
	<M _T header>	0	"Basic connection control"
	<Command>	0	"Access_request"
		4	"Bearer_confirm"
		5	"Wait"
	<FMID>	All	
	<PMID>	All	(see clause 13.4)

10.4.2 Associated procedures

10.4.2.1 Timer T200 management

T200: Connection setup timer;

Value: Refer to EN 300 175-3 [3], annex A;

Start: At the creation of a MBC;

Stop: The TBC reports "bearer_established" or on request for MAC connection release.

10.4.2.2 Counter N200 management

N200: Max. number bearer setup re attempts during connection setup;

Value: Refer to EN 300 175-3 [3], annex A;

Start: ACCESS_REQUEST is sent;

Change: A new ACCESS_REQUEST within the same connection setup attempt is sent;

Clear: The TBC reports "bearer_established" or on request for MAC connection release.

10.4.3 Exceptional cases

10.4.3.1 Bearer setup attempt fails N200+1 times

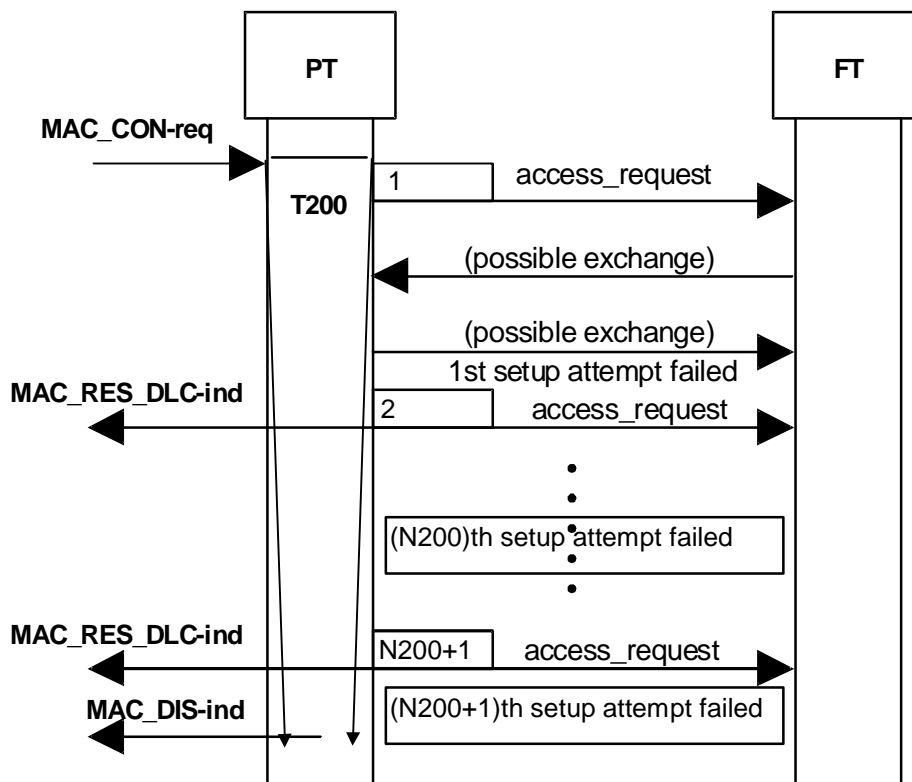

Figure 88: Bearer setup attempt fails N200+1 times

10.4.3.2 Timer T200 expiry

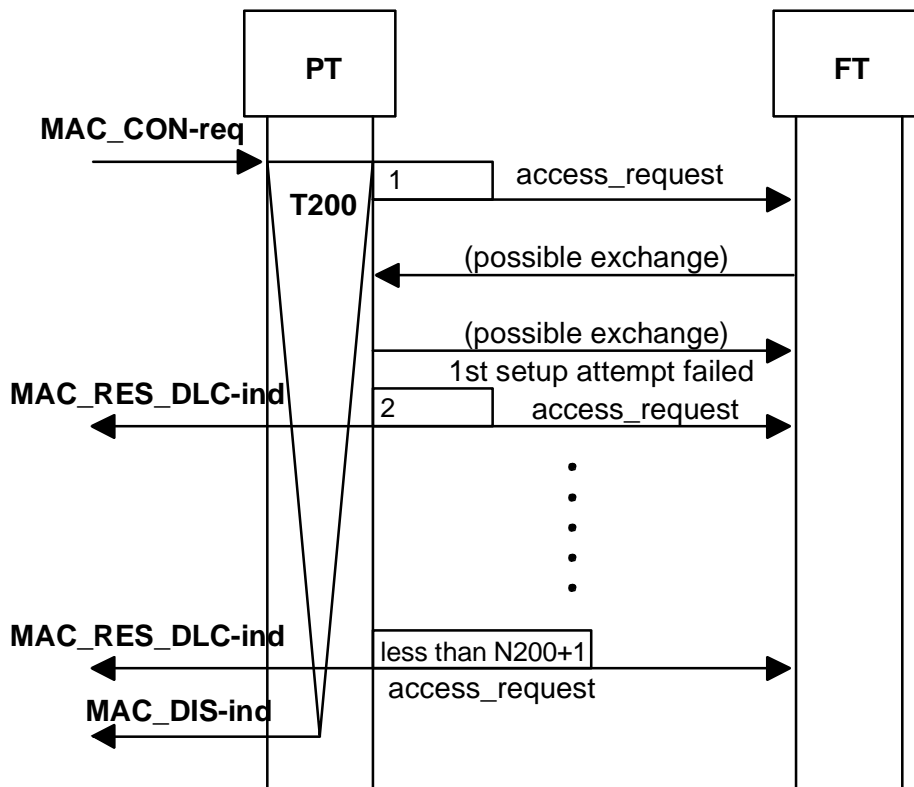

Figure 89: Timer T200 expiry

10.5 Connection/bearer release

The procedure shall be performed as defined in EN 300 175-3 [3], clauses 10.4 and 10.7.2.1.

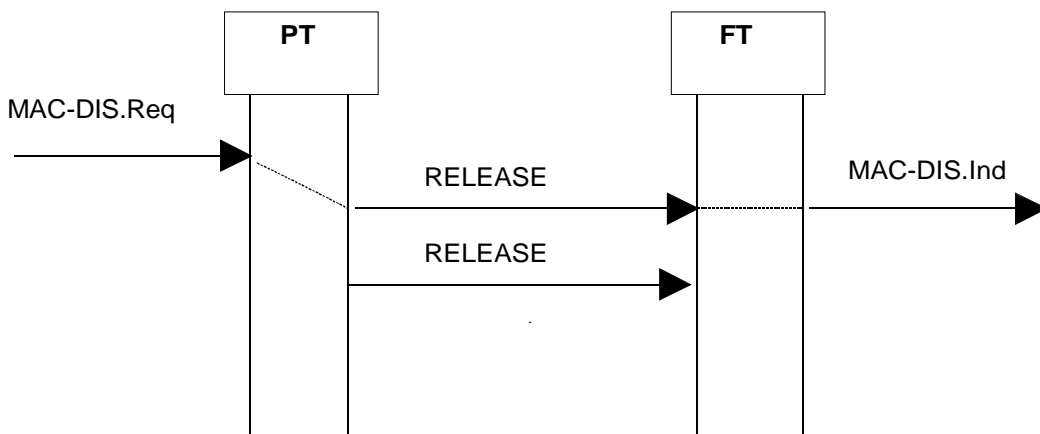

Figure 90: Bearer release

10.5.1 M_T message

The following fields as defined in EN 300 175-3 [3], clause 7.2.5.2 in the MAC control (M_T) message shall be supported by the PT and the FT.

Table 97: Values used within M_T message

MAC message	Field within the message	Standard values within the MAC message	Normative action/comment
<< M_T message>>			
	< M_T header>	0	Basic connection control
	<Command>	15	Release
	<FMID>	All	
	<PMID>	All	(see clause 13.4)

10.6 Bearer handover request

The procedure shall be performed as defined in EN 300 175-3 [3], clauses 10.6.2 and 10.5.1.1.

The procedure is equivalent for intra- and inter-cell handover.

The FT should not release the old bearer within 10 ms after the establishment of the new bearer.

10.6.1 M_T message

The following fields as defined in EN 300 175-3 [3], clause 7.2.5.2 in the MAC control (M_T) message shall be supported by the PT and the FT.

Table 98: Values used within M_T message

MAC message	Field within the message	Standard values within the MAC message	Normative action/comment
<< M_T message>>			
	< M_T header>	0	"Basic connection control"
	<Command>	1	"Bearer_handover_request"
		4	"Bearer_confirm"
		5	"Wait"
	<FMID>	All	
	<PMID>	All	(see clause 13.4)

10.7 Connection handover request

The procedure shall be performed as defined in EN 300 175-3 [3], clauses 10.2.4.2 and 10.5.1.1.

The procedure is equivalent for intra- and inter-cell handover.

10.7.1 M_T message

The following fields as defined in EN 300 175-3 [3], clause 7.2.5.2 in the MAC control (M_T) message shall be supported by the PT and the FT.

Table 99: Values used within M_T message

MAC message	Field within the message	Standard values within the MAC message	Normative action/comment
<<M _T message>>			
	<M _T header>	0	"Basic connection control"
	<Command>	2	"Connection_handover_request". PT shall capable to send. FT shall be capable to process
		4	"Bearer_confirm"
		5	"Wait"
	<FMID>	All	
	<PMID>	All	(see clause 13.4)

10.8 C_S channel data

The procedure shall be performed as defined in EN 300 175-3 [3], clause 10.8.1.1.

10.9 Q2 bit setting

The procedure shall be performed for C_S channel as defined in EN 300 175-3 [3], clause 10.8.1.3.1.

10.10 RFPI handshake

The procedure shall be performed as defined in EN 300 175-3 [3], clause 11.5.1. The FT shall ignore the received E-bit.

10.11 Antenna diversity

The procedure shall be performed as defined in EN 300 175-3 [3], clause 10.8.1.3. The PT shall send and set Q1 bit accordingly. The FT may use the Q1 bit information to perform locally antenna diversity procedure.

10.12 Sliding collision

The procedure shall be performed as defined in EN 300 175-3 [3], clause 10.8.1.3. The FT shall send and set Q1 bit accordingly when Q2 is set to "1". The PT may use the Q1 bit information to detect a sliding collision situation and act accordingly.

10.13 Encryption process - initialization and synchronization

The procedure shall use DSCA and shall be performed as defined in EN 300 175-7 [7], clauses 6.4.4 and 6.4.5 of Encryption shall be applied for the logical C_S and I_N channels.

The FT shall (if encryption is provided by the FT) support broadcast of multiframe number as defined in EN 300 175-3 [3], clauses 7.2.3.7 and 9.1.1. The multiframe shall be synchronized between the RFPs in the whole FP area.

Table 100: Values used within Q_T multiframe number message

MAC message	Field within the message	Standard values within the MAC message	Normative action/comment
<<multiframe number>>			
	<Q header>	6	
	<spare>	111100001111B	
	<multi frame number>	All	The number of the multiframe, modulo 2 ²⁴

10.14 Encryption mode control

The procedure shall be performed as defined in EN 300 175-7 [7], clause 6.4.6.

10.14.1 M_T message

The following fields as defined in EN 300 175-3 [3], clause 7.2.5.7 in the MAC control (M_T) message shall be supported by the PT and the FT.

Table 101: Values used within M_T message

MAC message	Field within the message	Standard values within the MAC message	Normative action/comment
<< M_T message>>			
	< M_T header>	5	Encryption control.
	<Command>	0	Start Encryption Request
		1	Start Encryption Confirm
		2	Start Encryption Grant
		4	Stop Encryption Request. The support of this code is mandatory only if service [M.14] is implemented
		5	Stop Encryption Confirm. The support of this code is mandatory only if service [M.14] is implemented
		6	Stop Encryption Grant. The support of this code is mandatory only if service [M.14] is implemented

10.15 Handover encryption process

The procedure shall be performed as defined in EN 300 175-7 [7], clause 6.4.7.

10.16 Extended frequency allocation

This procedure shall be performed as defined in EN 300 175-3 [3], clauses 7.2.3.3 and 7.2.3.2.7.

Table 102: Values used within extended RF carrier information message

MAC message	Field within the message	Standard values within the MAC message	Normative action/comment
<<Extended RF carrier information>>			
	<Q header>	2	
	<RF carriers>	All	
	<RF band>	All	
	<Spare>	0	
	<Number of RF carriers>	All	

11 PHL layer requirements

11.1 General

As specified in EN 300 175-2 [2], and EN 301 406 [11] (replacing TBR 0006).

To carry the speech information, full slots shall be used.

11.2 Minimum Normal Transmit Power (NTP)

The nominal NTP shall be greater than 80 mW per simultaneously active transmitter as shown by the test verdict criteria and declaration of EN 300 176-1 [9], clause 10.2.3.

11.3 Radio receiver sensitivity

The radio receiver sensitivity shall be -86 dBm, or better.

11.4 Z-field

The Z-field shall be transmitted by RFPs and PTs.

11.5 Sliding collision detection

PT and FT shall be able to detect sliding collision on received packets.

Minimum criteria for sliding collision are defined as S- or Z-field failure. Early sliding collision detection may be supported by other means e.g. signal strength measurements in the guard band.

The Z-field is defined to have failed if the received X- and Z-fields are not identical.

S-field failure is defined with some tolerance in order not to restrict the physical implementation of the word synchronization detector.

S-field failure may be indicated if there are 1 or more bit errors in bits s12 to s31 (errors in bits s0 to s11 shall be ignored). In all cases, S-field failure shall be indicated if 3 or more bit errors occur in bits s16 to s31.

11.6 Physical channel availability

A FP shall be able to receive and transmit on all DECT frequencies f0 to f9 and at least half of the slot pairs 0 to 11.

A PP shall be able to receive and transmit on all DECT frequencies f0 to f9, and shall be able to lock on any slot number 0 to 11, and receive and transmit at least on every slot pair that is not directly neighboured to the slot the PP is locked to, or to a slot on which a traffic bearer is active at the PP.

11.7 Synchronization window

Related to its reference timer, the PP synchronization window shall be at least ± 4 bits for bearers to the RFP to which the reference timer is synchronized, and at least ± 10 bits for other bearers.

12 Requirements regarding the speech transmission

12.1 General

The applicable requirements specified in EN 300 175-8 [8] and EN 300 176-2 [10] (previously covered by TBR 010) shall be applied.

12.2 User controlled volume control

A user-controlled volume control shall be provided in all GAP PP equipment, except where that equipment incorporates an adaptive volume control in the PP.

When adjusting the volume control from nominal to maximum setting, the decrease in RLR_H shall not be less than 6 dB.

13 Management procedures

13.1 Management of MM procedures

The procedure shall be performed as defined in EN 300 175-5 [5], clause 15.5. The following text together with the associated clauses define the mandatory requirements with regard to the present document.

A MM procedure may consist of one or more transactions. Each transaction is owned by a single instance of a MM entity. Each instance of a MM entity may own only a single transaction. The priority level relates to the transaction, and not to the procedure.

13.2 Location registration initiation

The initiation of the location registration procedure (PT initiated) is dependent of the value of call attribute a38 broadcasted by the FT i.e. if set to "1" the PT shall initiate the location registration procedure in the following cases:

- upon change of LA; latest immediately after entering the CC null state (T-00);
- upon power-up and after the first lock to a system which the PT has access rights to.

Location registration shall be performed regardless if the system has been accessed via a PARI or SARI.

If call attribute a38 set to "0", the PT shall not initiate the location registration procedure except upon receipt of "Locate suggest" in the parameter retrieval procedure initiated by the FT.

The FT may initiate and the PT may receive incoming calls without a location registration procedure. The initiation of the location registration procedure as defined in clause 8.28 is always mandatory in the PT except when bit a38 in the broadcast attributes, see table 103, is set to 0.

Location registration shall be initiated immediately after a successful access rights procedure.

13.3 Assigned individual TPUI management

Only one individual assigned TPUI shall be stored per subscription i.e. any new assignments of an individual assigned TPUI overwrites an existing individual assigned TPUI.

The PT shall always delete the old individual assigned TPUI immediately when entering a new LA prior the initiation of location registration procedure. The PT shall always delete the old individual assigned TPUI immediately when entering a new LA even if the location registration is not being performed i.e. the broadcast attribute a38 is set to value "0", see table 103.

The default TPUI shall be derived from the allocated IPUI. If no IPUI has been allocated, the TPUI shall be derived from IPUI N, i.e. the International Portable Equipment Identity (IPEI).

The LCE-PAGE-REJECT message shall not be used to delete an assigned TPUI.

NOTE: To avoid ambiguities of assigned TPUIs/PMIDs, assigned TPUIs should be unique within the entire FP rather than within LAs, see EN 300 175-6 [6], clause 6.3.1, note 2.

13.4 PMID management

If the PP has a valid assigned individual TPUI, the PMID shall be this TPUI.

If the PP has not a valid assigned individual TPUI, the PMID shall be the arbitrary PMID. It may be derived from the IPUI used for the MAC connection setup.

Within a link establishment procedure, the assigned PMID is recalculated for every connection setup attempt (during the connection setup procedure the assigned PMID shall not change); the arbitrary PMID is recalculated for every new bearer setup attempt.

The PT shall not update its PMID until the current DLC link is released even if a connection or bearer handover has taken place or the individual assigned TPUI has changed, e.g. due to change of the LA.

13.5 DCK management

The FT is responsible for initiating and storage of a DCK, (see clause 8.27) for the relevant procedure, and shall take into consideration that the PT may not have a DCK or may not have a valid DCK when entering a LA (or "SARI" area).

13.6 Broadcast attributes management

RFPs belonging to the same LA shall broadcast the same values of higher layer attributes (see EN 300 175-5 [5], annex F) at any given time.

The GAP PP shall be capable to read and interpret at least the following broadcast attributes codings during locking procedure. In the locked state the PP may assume them as static.

Table 103: Broadcast attributes interpretation by the Implementation Under Test (IUT) PP

BIT Number	Attribute	Value	Note
a32	ADPCM/G.721 Voice service	All	
a33	GAP and/or PAP basic speech	All	
a36	Standard authentication required	All	
a37	Standard ciphering supported	All	
a38	Location registration supported	All	See location update procedure, clause 8.29 as an exception
a40	Non-static FP	All	A FP which is mounted on a moving vehicle
a44	Access Rights requests supported	All	The FP can toggle this bit to enable or disable on air subscription, (see annex A)
a46	Connection handover supported	All	

13.7 Storage of subscription related data

The data as defined in table 104 shall be stored in the PP non-volatile memory as part of normal power-down routine of the PT. Removal of the battery whilst the PP is powered is not considered as a normal power-down. The PP shall be capable to retrieve the data upon power on and associate it to the subscription.

Table 104: Storage of identities/data

Item	Identity/Data	Normative comment
1	IPUI	Given at subscription
2	PARK	Given at subscription. PARK shall be the complete PARK, including non-significant bits
3	PLI	Given at subscription
4	LAL	Last received value
5	ARI	Last received value. Implementations are not mandated to store PARI bits that are not covered by LAL
6	RPN	Last received value. Implementations are not mandated to store PARI bits that are not covered by LAL
7	UAK/AC	UAK and AC shall not co-exist within one subscription
8	ZAP field	
9	<Service class> field	

The data as defined in table 105 shall be deleted in the PP upon power-down.

Table 105: Storage of identities/data

Item	Identity/Data	Normative comment
1	TPUI	Default TPUI shall be used upon power on
2	DCK	Last value told to store. Last received value in regard to the active IPUI/PARK pair

14 Application procedures

14.1 Subscription control

The PP shall be capable of accepting a new subscription for the active IPUI and PARK pair, in order to change the access rights (i.e. overwriting the active subscription).

The active IPUI/PARK pair is the stored IPUI/PARK value that the PT is using to seek to get locked or is locked to.

The PT shall be capable of storing at least two subscriptions i.e. 2 pairs of IPUI and PARK and associated subscription data.

14.2 AC to bitstring mapping

The mapping of AC shall be done as follows:

- the AC shall always have a length of 32 bits;
- each decimal digit entered by the user, is translated into one semi-octet (BCD coded). The PT shall be capable to accept any AC between 0 and 8 decimal digits (limits included);
- the resulting string of semi-octets is padded with a number of leading "all ones " semi octets to achieve a total of 8 semi octets;
- the result is a bitstring of 32 bits.

EXAMPLE: A value of "091" (3 decimal digits entered via keypad) is translated into a bitstring AC of the following value:

"1111 1111 1111 1111 1111 0000 1001 0001".

MSB: AC[31] LSB: AC[0]

NOTE: With regard to EN 300 175-7 [7], clause 4.5.2, AC[0] is defined as the least significant Bit (LSB) as defined above.

14.3 Manual entry of the PARK

In order to allow proper inter-operation of GAP equipment it may be necessary to enter an initial PARK into a PP to allow it to correctly identify a FP to which to subscription register (e.g. in the telepoint or business environment the same physical area may be covered by different providers).

If manual entry of the PARK into the PP is provided, the key sequence shall be as follows:

!!LLP_____PC#

where:

!! is a manufacturer specific enabling key sequence;

LL is a two digit decimal representation of the PARK length;

P_____P is up to 12 octal digit representation of the PARK;

C is a check digit;

is the terminating digit.

The length indication specifies the number of bits in the PARK. The first digit is the most significant digit of the number, between 01 and 36.

The P_____P field is variable length, and the number of octal digits in this field shall be sufficient to define the number of bits indicated in LL; any unused bits shall be ignored by the PP. The first digit represents the most significant three bits of the PARK.

The check digit is calculated as the sum of each digit in the input stream multiplied by its position in the input stream, modulo 11; if the result is 10, this is represented by the digit "*".

EXAMPLE: PARK length is 13 bits; PARK is 101 110 010 001 1

MSB													LSB
1	0	1	1	1	0	0	1	0	0	0	1	1	

Figure 91

This is padded out to 15 bits, with two 0's, 101110010001100, which is 56 214 in octal;

Check is calculated as:

$$1 \times 1 + 2 \times 3 + 3 \times 5 + 4 \times 6 + 5 \times 2 + 6 \times 1 + 7 \times 4 = 1 + 6 + 15 + 24 + 10 + 6 + 28 = 90$$

90 modulo 11 = 2, hence C = 2.

Thus the input key sequence is:

!	!	L	L	P	P	P	P	P	C	#
!	!	1	3	5	6	2	1	4	2	#

Figure 92

Annex A (informative): PP locking procedure for on-air subscription

This annex describes the locking procedure for PP on-air subscription:

- 1) invoke "subscription mode" manually;
- 2) listen and wait for the "FP capability" Q_T message, read a44 "access rights supported" bit;
- 3) if bit a44 = 1 then try the subscription registration procedure;
- 4) if bit a44 = 0 then lock out and search for another FP;
- 5) leave subscription mode after finishing the subscription procedure. The PP may terminate this mode by means of e.g. a timer after some period of time;
- 6) the PP does not have to check if bit a44 goes off after having "seen" a44 on because the PP presumes the Q_T -info as static (see clause 13.6).

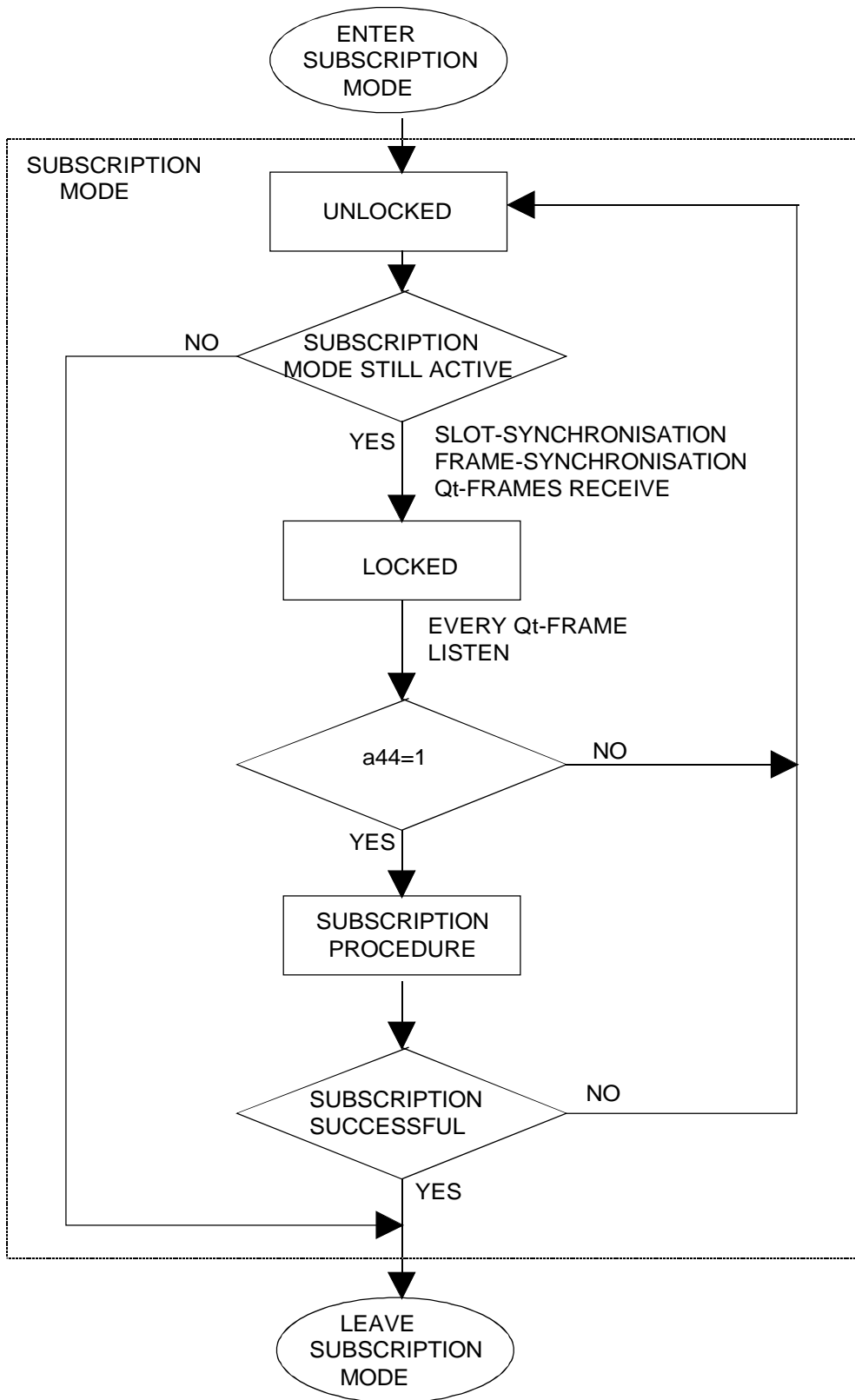

Figure A.1: PP "subscription mode" for MAC layer

Annex B (informative): Tones, progress indicator and U-plane connection

B.1 General

In order to prevent a possible misbehaviour upon receiving the <<Progress indicator>> information element, the connection of the U-plane, and the provision of tones to the GAP PP user, a GAP implementation manufacturer should consider that:

- there may be calls (external) leaving the FP (only the calling side belongs to the particular FP);
- there may be calls (internal) that do not leave the FP (calls between portables within the same FP);
- there may be a GAP FP without local tone provision;
- there may be a GAP PP without local tone provision;
- there may be a Local Network (LNW) without provision of in-band tones.

B.2 Connection of U-plane and provision of tones

A GAP PP will connect the U-plane either:

- Case A: upon receipt of the appropriate message that placed the PT in active state, (see clauses 8.6 or 8.15); or
- Case B: upon receipt of the <<Progress indicator>> information element indicating "In-band information or appropriate pattern now available" in an appropriate message beforehand, (see clauses 8.3, 8.4 and 8.5).

When connection of the U-plane is the result of case B a PP may assume that the FP or the LNW provide a suitable in-band tone and may therefore not switch local tone (if provided) to the user.

B.3 Provision of tones before connection of the U-plane

For an outgoing call, in the case when a PP enters state T-02 (Overlap sending) and no dialling digit has been entered or available in the local dialling buffer, and the PP has not received the appropriate <<Progress indicator>> information element, that PP may indicate to its user that he should start to dial (invitation for dial) by providing local tones or another appropriate indication (e.g. by buzzer, display, etc.).

B.4 Provision of tones and <<Progress indicator>> information element

In the case where a LNW provides in-band tones a GAP FP may use this tones for calls that leaves the FP. The FP should indicate the provision of these in-band tones to the PP by transmitting the <<Progress indicator>> information element indicating "In-band information or appropriate pattern now available" in an appropriate message. This should imply that the FP has knowledge about the tone provision situation of the LNW. The PP should accept these in-band tones.

In the case where the LNW does not provide in-band tones or the FP has no knowledge about the tone provision situation of the LNW, the FP itself may supply in-band tones for calls that leave and that do not leave the FP indicating the provision of this tones by transmitting the <<Progress indicator>> information element indicating "In-band information or appropriate pattern now available" in an appropriate message. The PP should accept these in-band tones.

A GAP FP may be designed without local tone generator, therefore no in-band tones can be provided to the PP user. Such FP, if it has no knowledge about the tone provision situation of the LNW, should not transmit the <<Progress indicator>> information element indicating "In-band information or appropriate pattern now available".

B.5 Summary

Table B.1

	FP with local tone generator		FP without local tone generator	
	LNW provides in-band tones; FP knows	LNW does not provide in-band tones or FP does not know	LNW provides in-band tones; FP knows	LNW does not provide in-band tones or FP does not know
PP has a local tone generator; internal call	Use of FP local tone generator; convey <<Progress indicator>> to PP	Use of FP local tone generator; convey <<Progress indicator>> to PP	Use of PP local tone generator; do not convey <<Progress indicator>> to PP	Use of PP local tone generator; do not convey <<Progress indicator>> to PP
PP has a local tone generator; external call	Convey in-band tones from LNW; convey <<Progress indicator>> to PP	Use of FP local tone generator; convey <<Progress indicator>> to PP	Convey in-band tones from LNW; convey <<Progress indicator>> to PP	Use of PP local tone generator; do not convey <<Progress indicator>> to PP
PP has not a local tone generator; internal call	Use of FP local tone generator; convey <<Progress indicator>> to PP	Use of FP local tone generator; convey <<Progress indicator>> to PP	No tones available for the PP user; use other means to invite for dialling (e.g. display, buzzer, etc.)	No tones available for the PP user; use other means to invite for dialling (e.g. display, buzzer, etc.)
PP has not a local tone generator; external call	Convey in-band tones from LNW; convey <<Progress indicator>> to PP	Use of FP local tone generator; convey <<Progress indicator>> to PP	Convey in-band tones from LNW; convey <<Progress indicator>> to PP	No tones available for the PP user; use other means to invite for dialling (e.g. display, buzzer, etc.)

Annex C (normative): Synchronization requirements for fixed parts

Public systems shall provide intersystem synchronization and shall have either Global Positioning System (GPS) synchronization and a Class 1 or Class 2 synchronization output port or a complete Class 1 or Class 2 synchronization port (input and output). This will allow absolute time synchronization via GPS or wired mutual synchronization if an operator requires local synchronization between fixed parts.

Annex D (informative): Bibliography

- ETSI TBR 006: "Digital Enhanced Cordless Telecommunications (DECT); General terminal attachment requirements".
- ETSI TBR 010: "Digital Enhanced Cordless Telecommunications (DECT); General Terminal Attachment Requirements; Telephony Applications".

History

Document history		
Edition 1	December 1995	Publication as ETS 300 444
V1.2.2	August 1997	Publication
V1.3.3	May 1999	Publication
V1.4.0	May 2001	One-step Approval Procedure OAP 20010921: 2001-05-23 to 2001-09-21