

# ETSI EN 300 417-9-1 V1.1.1 (2001-09)

---

*European Standard (Telecommunications series)*

**Transmission and Multiplexing (TM);  
Generic requirements of transport functionality of equipment;  
Part 9: Synchronous Digital Hierarchy (SDH)  
concatenated path layer functions;  
Sub-part 1: Requirements**

---



---

**Reference**

DEN/TM-01015-9-1

---

**Keywords**

SDH, transmission

**ETSI**

---

650 Route des Lucioles  
F-06921 Sophia Antipolis Cedex - FRANCE

Tel.: +33 4 92 94 42 00 Fax: +33 4 93 65 47 16

Siret N° 348 623 562 00017 - NAF 742 C  
Association à but non lucratif enregistrée à la  
Sous-Préfecture de Grasse (06) N° 7803/88

---

**Important notice**

Individual copies of the present document can be downloaded from:

<http://www.etsi.org>

The present document may be made available in more than one electronic version or in print. In any case of existing or perceived difference in contents between such versions, the reference version is the Portable Document Format (PDF). In case of dispute, the reference shall be the printing on ETSI printers of the PDF version kept on a specific network drive within ETSI Secretariat.

Users of the present document should be aware that the document may be subject to revision or change of status. Information on the current status of this and other ETSI documents is available at

<http://portal.etsi.org/tb/status/status.asp>

If you find errors in the present document, send your comment to:

[editor@etsi.fr](mailto:editor@etsi.fr)

---

**Copyright Notification**

No part may be reproduced except as authorized by written permission.  
The copyright and the foregoing restriction extend to reproduction in all media.

© European Telecommunications Standards Institute 2001.  
All rights reserved.

# Contents

Intellectual Property Rights .....	7
Foreword.....	7
1 Scope .....	8
2 References .....	8
3 Definitions, symbols and abbreviations .....	8
3.1 Definitions .....	8
3.2 Symbols.....	9
3.3 Abbreviations .....	9
4 Generic Processes.....	9
4.1 Layer network interworking function.....	9
4.2 Virtual concatenation multiframe alignment .....	9
5 Concatenated VC-4 path layer functions.....	10
5.1 Atomic functions overview .....	10
5.2 Layer information.....	11
5.2.1 VC-4-X layer access point.....	11
5.2.2 VC-4-X layer connection point.....	12
5.2.3 VC-4-Xc layer connection point.....	12
5.2.4 VC-4-Xv layer connection point.....	13
5.2.5 VC-4-XP layer access point.....	14
5.2.6 VC-4-XP layer connection point .....	15
5.3 VC-4-Xc Layer Connection Function S4-Xc_C.....	15
5.3.1 SNC protection .....	15
5.4 VC-4-Xc Layer Trail Termination Functions S4-Xc_TT.....	15
5.4.1 VC-4-Xc Layer Trail Termination Source Function S4-Xc_TT_So.....	15
5.4.2 VC-4-Xc Layer Trail Termination Sink Function S4-Xc_TT_So .....	16
5.5 VC-4-Xc Layer Monitoring Functions .....	16
5.5.1 VC-4-Xc Non-intrusive Monitoring Function S4-Xcm_TT_Sk.....	16
5.5.2 VC-4-Xc Supervisory Unequipped Termination Source Function S4-Xcs_TT_So .....	16
5.5.3 VC-4-Xc Supervisory Unequipped Termination Sink Function S4-Xcs_TT_Sk.....	16
5.6 VC-4-Xc Tandem Connection Sublayer Functions.....	16
5.6.1 VC-4-Xc Tandem Connection Trail Termination Source Function S4-XcD_TT_So.....	16
5.6.2 VC-4-Xc Tandem Connection Trail Termination Sink Function S4-XcD_TT_Sk .....	17
5.6.3 VC-4-Xc Tandem Connection Non-intrusive Monitoring Trail Termination Sink Function S4-XcDm_TT_Sk.....	17
5.6.4 VC-4-Xc Tandem Connection to VC-4-Xc Adaptation Source Function S4-XcD/S4-Xc_A_So .....	17
5.6.5 VC-4-Xc Tandem Connection to VC-4-Xc Adaptation Sink Function S4-XcD/S4-Xc_A_Sk .....	17
5.7 VC-4-Xv Layer Trail Termination Functions S4-Xc_TT.....	17
5.7.1 VC-4-Xv/VC-4-X Adaptation Source Function S4-Xv/S4-X_A_So .....	17
5.7.2 VC-4-Xv/VC-4-X Adaptation Sink Function S4-Xv/S4-X_A_Sk .....	17
5.7.3 VC-4-Xv Layer Trail Termination Source Function S4-Xv_TT_So.....	18
5.7.4 VC-4-Xv Layer Trail Termination Sink Function S4-Xv_TT_Sk.....	18
5.8 Interworking Functions .....	18
5.8.1 VC-4-Xc to VC-4-Xv Interworking Function S4-Xc>S4-Xv_I.....	18
5.8.2 VC-4-Xv to VC-4-Xc Interworking Function S4-Xv>S4-Xc_I.....	18
5.9 VC-4-X Layer Adaptation Functions .....	18
5.9.1 VC-4-X to P0s Adaptation Source Function S4-X/P0s_A_So .....	18
5.9.2 VC-4-X to P0s Adaptation Sink Function S4-X/P0s_A_Sk .....	18
5.9.3 VC-4-X to HDLC Adaptation Source Function S4-X/HDLC_A_So .....	18
5.9.4 VC-4-X to HDLC Adaptation Sink Function S4-X/HDLC_A_Sk.....	18
5.9.5 VC-4-X to Avp Adaptation Source Function S4-X/Avp_A_So .....	18
5.9.6 VC-4-X to Avp Adaptation Sink Function S4-X/Avp_A_Sk.....	18
5.9.7 VC-4-X to TSS1 Adaptation Source Function S4-X/TSS1_A_So .....	19
5.9.8 VC-4-X to TSS1 Adaptation Sink Function S4-X/TSS1_A_Sk.....	19

5.10	VC-4-X Layer Trail Protection Functions.....	19
5.10.1	VC-4-X Trail Protection Connection Functions S4-XP_C.....	19
5.10.1.1	VC-4-X Layer 1+1 uni-directional Protection Connection Function S4-XP1+1u_C.....	19
5.10.1.2	VC-4-X Layer 1+1 bi-directional Protection Connection Function S4-XP1+1b_C.....	19
5.10.2	VC-4 Layer Trail Protection Trail Termination Functions.....	19
5.10.2.1	VC-4-X Protection Trail Termination Source S4-XP_TT_So.....	19
5.10.2.2	VC-4-X Protection Trail Termination Sink S4-XP_TT_Sk.....	19
5.10.3	VC-4 Layer Linear Trail Protection Adaptation Functions.....	20
5.10.3.1	VC-4-X trail to VC-4-X trail Protection Layer Adaptation Source S4-X/S4-XP_A_So.....	20
5.10.3.2	VC-4-X trail to VC-4-X trail Protection Layer Adaptation Sink S4-X/S4-XP_A_Sk.....	20
5.11	VC-4-X layer clock adaptation source (S4-X-LC_A_So).....	20
6	Concatenated VC-3 path layer functions.....	21
6.1	Atomic functions overview.....	21
6.2	Layer information.....	22
6.2.1	VC-3-X layer access point.....	22
6.2.2	VC-3-X layer connection point.....	23
6.2.3	VC-3-Xv layer connection point.....	23
6.2.4	VC-3-XP layer access point.....	24
6.2.5	VC-3XP layer connection point.....	25
6.3	VC-3-Xv Layer Trail Termination Functions S3-Xc_TT.....	25
6.3.1	VC-3-Xv/VC-3-X Adaptation Source Function S3-Xv/S3-X_A_So.....	25
6.3.2	VC-3-Xv/VC-3-X Adaptation Sink Function S3-Xv/S3-X_A_Sk.....	25
6.3.3	VC-3-Xv Layer Trail Termination Source Function S3-Xv_TT_So.....	25
6.3.4	VC-3-Xv Layer Trail Termination Sink Function S3-Xv_TT_Sk.....	25
6.4	VC-3-x Layer Adaptation Functions.....	26
6.4.1	VC-3-x to P0s Adaptation Source Function S3-x/P0s_A_So.....	26
6.4.2	VC-3-x to P0s Adaptation Sink Function S3-x/P0s_A_Sk.....	26
6.4.3	VC-3-x to HDLC Adaptation Source Function S3-x/HDLC_A_So.....	26
6.4.4	VC-3-x to HDLC Adaptation Sink Function S3-x/HDLC_A_Sk.....	26
6.4.5	VC-3-x to Avp Adaptation Source Function S3-x/Avp_A_So.....	26
6.4.6	VC-3-x to Avp Adaptation Sink Function S3-x/Avp_A_Sk.....	26
6.4.7	VC-3-x to TSS3 Adaptation Source Function S3-x/TSS3_A_So.....	26
6.4.8	VC-3-x to TSS3 Adaptation Sink Function S3-x/TSS3_A_Sk.....	26
6.5	VC-3-X Layer Trail Protection Functions.....	27
6.5.1	VC-3-X Trail Protection Connection Functions S3-XP_C.....	27
6.5.1.1	VC-3-X Layer 1+1 uni-directional Protection Connection Function S3-XP1+1u_C.....	27
6.5.1.2	VC-3-X Layer 1+1 bi-directional Protection Connection Function S3-XP1+1b_C.....	27
6.5.2	VC-3 Layer Trail Protection Trail Termination Functions.....	27
6.5.2.1	VC-3-X Protection Trail Termination Source S3-XP_TT_So.....	27
6.5.2.2	VC-3-X Protection Trail Termination Sink S3-XP_TT_Sk.....	27
6.5.3	VC-3 Layer Linear Trail Protection Adaptation Functions.....	27
6.5.3.1	VC-3-X trail to VC-3-X trail Protection Layer Adaptation Source S3-X/S3-XP_A_So.....	27
6.5.3.2	VC-3-X trail to VC-3-X trail Protection Layer Adaptation Sink S3-X/S3-XP_A_Sk.....	28
6.6	VC-3-X layer clock adaptation source (S3-X-LC_A_So).....	28
7	Concatenated VC-2 path layer functions.....	29
7.1	Atomic functions overview.....	29
7.2	Layer information.....	30
7.2.1	VC-2-X layer access point.....	30
7.2.2	VC-2-X layer connection point.....	31
7.2.3	VC-2-Xv layer connection point.....	31
7.2.4	VC-2-XP layer access point.....	32
7.2.5	VC-2XP layer connection point.....	33
7.3	VC-2-Xv Layer Trail Termination Functions S2-Xc_TT.....	33
7.3.1	VC-2-Xv/VC-2-X Adaptation Source Function S2-Xv/S2-X_A_So.....	33
7.3.2	VC-2-Xv/VC-2-X Adaptation Sink Function S2-Xv/S2-X_A_Sk.....	33
7.3.3	VC-2-Xv Layer Trail Termination Source Function S2-Xv_TT_So.....	33
7.3.4	VC-2-Xv Layer Trail Termination Sink Function S2-Xv_TT_Sk.....	33
7.4	VC-2-x Layer Adaptation Functions.....	33
7.4.1	VC-2-X to HDLC Adaptation Source Function S2-X/HDLC_A_So.....	33
7.4.2	VC-2-X to HDLC Adaptation Sink Function S2-X/HDLC_A_Sk.....	33

7.4.3	VC-2-X to Avp Adaptation Source Function S2-X/Avp_A_So .....	34
7.4.4	VC-2-X to Avp Adaptation Sink Function S2-X/Avp_A_Sk .....	34
7.4.5	VC-2-X to TSS4 Adaptation Source Function S2-X/TSS4_A_So .....	34
7.4.6	VC-2-X to TSS4 Adaptation Sink Function S2-X/TSS4_A_Sk .....	34
7.5	VC-2-X Layer Trail Protection Functions .....	34
7.5.1	VC-2-X Trail Protection Connection Functions S2-XP_C .....	34
7.5.1.1	VC-2-X Layer 1+1 uni-directional Protection Connection Function S2-XP1+1u_C .....	34
7.5.1.2	VC-2-X Layer 1+1 bi-directional Protection Connection Function S2-XP1+1b_C .....	34
7.5.2	VC-2 Layer Trail Protection Trail Termination Functions .....	34
7.5.2.1	VC-2-X Protection Trail Termination Source S2-XP_TT_So .....	34
7.5.2.2	VC-2-X Protection Trail Termination Sink S2-XP_TT_Sk .....	35
7.5.3	VC-2 Layer Linear Trail Protection Adaptation Functions .....	35
7.5.3.1	VC-2-X trail to VC-2-X trail Protection Layer Adaptation Source S2-X/S2-XP_A_So .....	35
7.5.3.2	VC-2-X trail to VC-2-X trail Protection Layer Adaptation Sink S2-X/S2-XP_A_Sk .....	35
7.6	VC-2-X layer clock adaptation source (S2-X-LC_A_So) .....	35
8	Concatenated VC-12 path layer functions .....	36
8.1	Atomic functions overview .....	36
8.2	Layer information .....	37
8.2.1	VC-12-X layer access point .....	37
8.2.2	VC-12-X layer connection point .....	38
8.2.3	VC-12-Xv layer connection point .....	38
8.2.4	VC-12-XP layer access point .....	39
8.2.5	VC-12XP layer connection point .....	40
8.3	VC-12-Xv Layer Trail Termination Functions S12-Xc_TT .....	40
8.3.1	VC-12-Xv/VC-12-X Adaptation Source Function S12-Xv/S12-X_A_So .....	40
8.3.2	VC-12-Xv/VC-12-X Adaptation Sink Function S12-Xv/S12-X_A_Sk .....	40
8.3.3	VC-12-Xv Layer Trail Termination Source Function S12-Xv_TT_So .....	40
8.3.4	VC-12-Xv Layer Trail Termination Sink Function S12-Xv_TT_Sk .....	40
8.4	VC-12-x Layer Adaptation Functions .....	40
8.4.1	VC-12-X to HDLC Adaptation Source Function S12-X/HDLC_A_So .....	40
8.4.2	VC-12-X to HDLC Adaptation Sink Function S12-X/HDLC_A_Sk .....	40
8.4.3	VC-12-X to Avp Adaptation Source Function S12-X/Avp_A_So .....	41
8.4.4	VC-12-X to Avp Adaptation Sink Function S12-X/Avp_A_Sk .....	41
8.4.5	VC-12-X to TSS4 Adaptation Source Function S12-X/TSS4_A_So .....	41
8.4.6	VC-12-X to TSS4 Adaptation Sink Function S12-X/TSS4_A_Sk .....	41
8.5	VC-12-X Layer Trail Protection Functions .....	41
8.5.1	VC-12-X Trail Protection Connection Functions S12-XP_C .....	41
8.5.1.1	VC-12-X Layer 1+1 uni-directional Protection Connection Function S12-XP1+1u_C .....	41
8.5.1.2	VC-12-X Layer 1+1 bi-directional Protection Connection Function S12-XP1+1b_C .....	41
8.5.2	VC-12 Layer Trail Protection Trail Termination Functions .....	41
8.5.2.1	VC-12-X Protection Trail Termination Source S12-XP_TT_So .....	41
8.5.2.2	VC-12-X Protection Trail Termination Sink S12-XP_TT_Sk .....	42
8.5.3	VC-12 Layer Linear Trail Protection Adaptation Functions .....	42
8.5.3.1	VC-12-X trail to VC-12-X trail Protection Layer Adaptation Source S12-X/S12-XP_A_So .....	42
8.5.3.2	VC-12-X trail to VC-12-X trail Protection Layer Adaptation Sink S12-X/S12-XP_A_Sk .....	42
8.6	VC-12-X layer clock adaptation source (S12-X-LC_A_So) .....	42
<b>Annex A (informative):</b>	<b>Concatenated VC-11 path layer functions .....</b>	<b>44</b>
A.1	Atomic functions overview .....	44
A.2	Layer information .....	45
A.2.1	VC-11-X layer access point .....	45
A.2.2	VC-11-X layer connection point .....	46
A.2.3	VC-11-Xv layer connection point .....	46
A.2.4	VC-11-XP layer access point .....	47
A.2.5	VC-11XP layer connection point .....	48
A.3	VC-11-Xv Layer Trail Termination Functions S11-Xc_TT .....	48
A.3.1	VC-11-Xv/VC-11-X Adaptation Source Function S11-Xv/S11-X_A_So .....	48
A.3.2	VC-11-Xv/VC-11-X Adaptation Sink Function S11-Xv/S11-X_A_Sk .....	48
A.3.3	VC-11-Xv Layer Trail Termination Source Function S11-Xv_TT_So .....	48

A.3.4	VC-11-Xv Layer Trail Termination Sink Function S11-Xv_TT_Sk .....	48
A.4	VC-11-x Layer Adaptation Functions .....	49
A.4.1	VC-11-X to HDLC Adaptation Source Function S11-X/HDLC_A_So .....	49
A.4.2	VC-11-X to HDLC Adaptation Sink Function S11-X/HDLC_A_Sk .....	49
A.4.3	VC-11-X to Avp Adaptation Source Function S11-X/Avp_A_So .....	49
A.4.4	VC-11-X to Avp Adaptation Sink Function S11-X/Avp_A_Sk .....	49
A.4.5	VC-11-X to TSS4 Adaptation Source Function S11-X/TSS4_A_So .....	49
A.4.6	VC-11-X to TSS4 Adaptation Sink Function S11-X/TSS4_A_Sk .....	49
A.5	VC-11-X Layer Trail Protection Functions .....	50
A.5.1	VC-11-X Trail Protection Connection Functions S11-XP_C .....	50
A.5.1.1	VC-11-X Layer 1+1 uni-directional Protection Connection Function S11-XP1+1u_C .....	50
A.5.1.2	VC-11-X Layer 1+1 bi-directional Protection Connection Function S11-XP1+1b_C .....	50
A.5.2	VC-11 Layer Trail Protection Trail Termination Functions .....	50
A.5.2.1	VC-11-X Protection Trail Termination Source S11-XP_TT_So .....	50
A.5.2.2	VC-11-X Protection Trail Termination Sink S11-XP_TT_Sk .....	50
A.5.3	VC-11 Layer Linear Trail Protection Adaptation Functions .....	50
A.5.3.1	VC-11-X trail to VC-11-X trail Protection Layer Adaptation Source S11-X/S11-XP_A_So .....	50
A.5.3.2	VC-11-X trail to VC-11-X trail Protection Layer Adaptation Sink S11-X/S11-XP_A_Sk .....	51
A.6	VC-11-X layer clock adaptation source (S11-X-LC_A_So) .....	51
	History .....	52

---

## Intellectual Property Rights

IPRs essential or potentially essential to the present document may have been declared to ETSI. The information pertaining to these essential IPRs, if any, is publicly available for **ETSI members and non-members**, and can be found in ETSI SR 000 314: "*Intellectual Property Rights (IPRs); Essential, or potentially Essential, IPRs notified to ETSI in respect of ETSI standards*", which is available from the ETSI Secretariat. Latest updates are available on the ETSI Web server (<http://www.etsi.org/legal/home.htm>).

Pursuant to the ETSI IPR Policy, no investigation, including IPR searches, has been carried out by ETSI. No guarantee can be given as to the existence of other IPRs not referenced in ETSI SR 000 314 (or the updates on the ETSI Web server) which are, or may be, or may become, essential to the present document.

---

## Foreword

This European Standard (Telecommunications series) has been produced by ETSI Technical Committee Transmission and Multiplexing (TM).

The present document is part of a library of functional blocks for the functional description of the European Transmission Hierarchy.

The present document is part 9, sub-part 1 of a multi-part deliverable covering the generic requirements of transport functionality of equipment, as identified below:

- Part 1: "Generic processes and performance";
- Part 2: "Synchronous Digital Hierarchy (SDH) and Plesiochronous Digital Hierarchy (PDH) physical section layer functions";
- Part 3: "Synchronous Transport Module-N (STM-N) regenerator and multiplex section layer functions";
- Part 4: "Synchronous Digital Hierarchy (SDH) path layer functions";
- Part 5: "Plesiochronous Digital Hierarchy (PDH) path layer functions";
- Part 6: "Synchronization layer functions";
- Part 7: "Equipment management and auxiliary layer functions";
- Part 9: "Synchronous Digital Hierarchy (SDH) concatenated path layer functions";**
- Sub-part 1: "Requirements".**

<b>National transposition dates</b>	
Date of adoption of this EN:	21 September 2001
Date of latest announcement of this EN (doa):	31 December 2001
Date of latest publication of new National Standard or endorsement of this EN (dop/e):	30 June 2002
Date of withdrawal of any conflicting National Standard (dow):	30 June 2002

---

# 1 Scope

The present document specifies requirements of transport functionality of equipment, which processes SDH concatenated path layers. The functionality is described by a set of functional building blocks and a set of rules by which they are combined. The generic description method and generic functionality is described in EN 300 417-1-1 [1] and ITU-T Recommendation G.806 [2].

For equipment which is compliant with the present document the processing of SDH concatenated path layers with in the equipment shall be describable as an interconnection of a subset of the functional blocks contained within the present document.

---

# 2 References

The following documents contain provisions which, through reference in this text, constitute provisions of the present document.

- References are either specific (identified by date of publication and/or edition number or version number) or non-specific.
- For a specific reference, subsequent revisions do not apply.
- For a non-specific reference, the latest version applies.

- [1] ETSI EN 300 417-1-1: "Transmission and Multiplexing (TM); Generic requirements of transport functionality of equipment; Part 1-1: Generic processes and performance".
- [2] ITU-T Recommendation G.806 (2000): "Characteristics of Transport Equipment - Description Methodology and Generic Functionality".
- [3] ETSI EN 300 417-4-1: "Transmission and Multiplexing (TM); Generic requirements of transport functionality of equipment; Part 4-1: Synchronous Digital Hierarchy (SDH) path layer functions".
- [4] ITU-T Recommendation G.783 (2000): "Characteristics of synchronous digital hierarchy (SDH) equipment functional blocks".
- [5] ETSI EN 300 147: "Transmission and Multiplexing (TM); Synchronous Digital Hierarchy (SDH); Multiplexing structure".
- [6] ETSI EN 301 163-2-1: "Transmission and Multiplexing (TM); Generic requirements of Asynchronous Transfer Mode (ATM) transport functionality within equipment; Part 2-1: Functional model for the transfer and layer management plane".

---

# 3 Definitions, symbols and abbreviations

## 3.1 Definitions

For the purposes of the present document, the following terms and definitions apply:

**concatenation:** procedure whereby a multiplicity of Virtual Containers is associated one with another with the result that their combined capacity can be used as a single container across which bit sequence integrity is maintained  
Two versions exists:

- Contiguous concatenation;
- Virtual concatenation.



## 3.2 Symbols

For the purposes of the present document, the following symbols apply:

c	contiguous concatenation
v	virtual concatenation

## 3.3 Abbreviations

For the purposes of the present document, the following abbreviations apply:

<u>I</u>	Interworking Function
S4-X	Concatenated VC-4 path layer
S4-Xc	Contiguous concatenated VC-4 path layer
S4-Xv	Virtual concatenated VC-4 path layer
S3-X	Concatenated VC-3 path layer
S3-Xv	Virtual concatenated VC-3 path layer
S2-X	Concatenated VC-2 path layer
S2-Xv	Virtual concatenated VC-2 path layer
S12-X	Concatenated VC-12 path layer
S12-Xv	Virtual concatenated VC-12 path layer
S11-X	Concatenated VC-11 path layer
S11-Xv	Virtual concatenated VC-11 path layer

---

# 4 Generic Processes

## 4.1 Layer network interworking function

Refer to ITU-T Recommendation G.806 [2], clause 5.6.4 "Layer network interworking function".

## 4.2 Virtual concatenation multiframe alignment

Refer to ITU-T Recommendation G.783 [4], clause 8.2.5 "Virtual concatenation multiframe alignment".



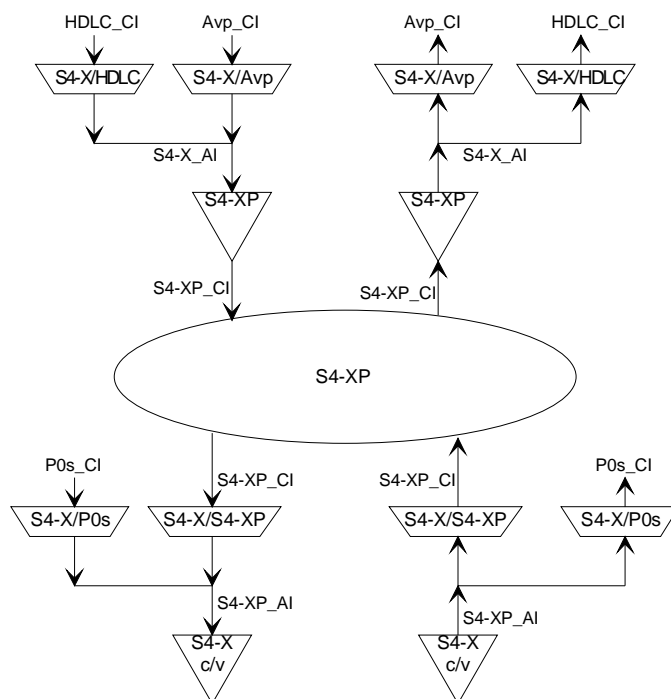

Figure 2: Concatenated VC-4 Layer Trail Protection atomic functions

## 5.2 Layer information

### 5.2.1 VC-4-X layer access point

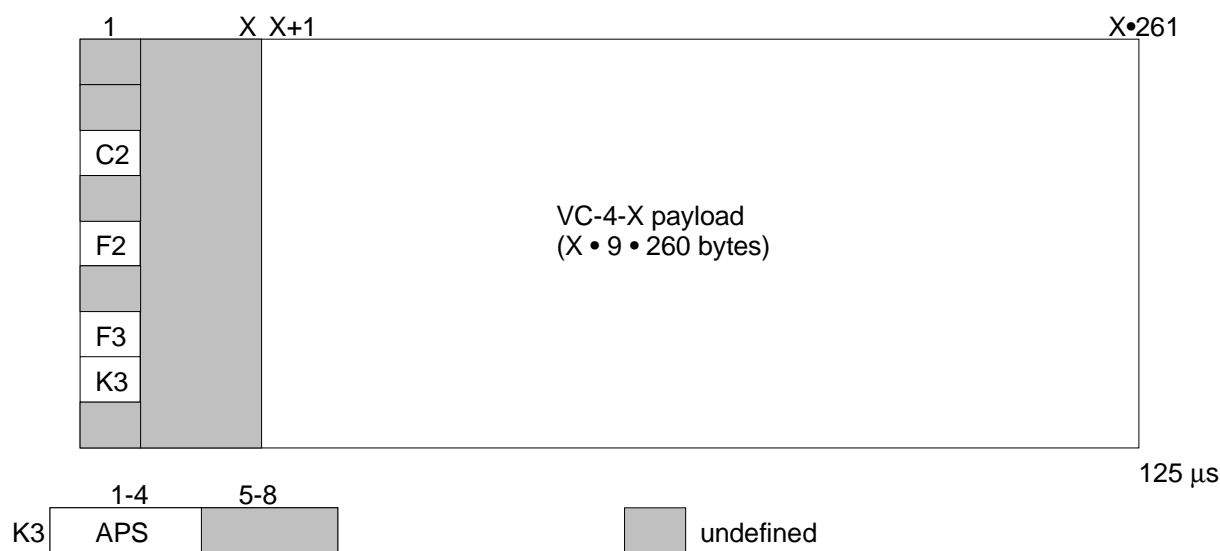

Figure 3: S4-X\_AI\_D

The VC-4-X AI (S4-x\_AI\_D) at this point is octet structured with a 125 μs frame. It represents adapted client layer information comprising  $X \cdot 2\,340$  bytes of client layer information, the signal label byte C2, and the 2 path user channel bytes F2/3 as defined in EN 300 147 [5]. For the case the signal has passed the trail protection sublayer, S4\_AI has defined APS bits (1 to 4) in byte K3.

NOTE 1: The APS signal has not been defined; a multiframed APS signal might be required.

NOTE 2: Bits 1 to 4 of byte K3 will be undefined when the signal S4-X\_AI has not been processed in a trail protection connection function S4-XP\_C.

NOTE 3: Bytes F2 and F3 will be undefined when the adaptation functions sourcing these bytes are not present in the network element.

A VC-4-X comprises one of the following payloads:

- an ATM  $X \cdot 149\,760$  kbit/s cell stream signal;
- a PPP  $X \cdot 149\,760$  kbit/s cell stream signal;
- a Test Signal Structure (TSS1).

## 5.2.2 VC-4-X layer connection point

A VC-4 concatenated trail can be transported via contiguous concatenated VC-4 (VC-4-Xc) or virtual concatenated VC-4 (VC-4-Xv) connections.

If the concatenated VC-4-X trail is supported by a contiguous concatenated VC-4-Xc connection, the only allowed values for X are 4 and 16. If the concatenated VC-4-X trail is supported by a virtual concatenated VC-4-Xv connection all values for  $X \geq 1$  are allowed.

## 5.2.3 VC-4-Xc layer connection point

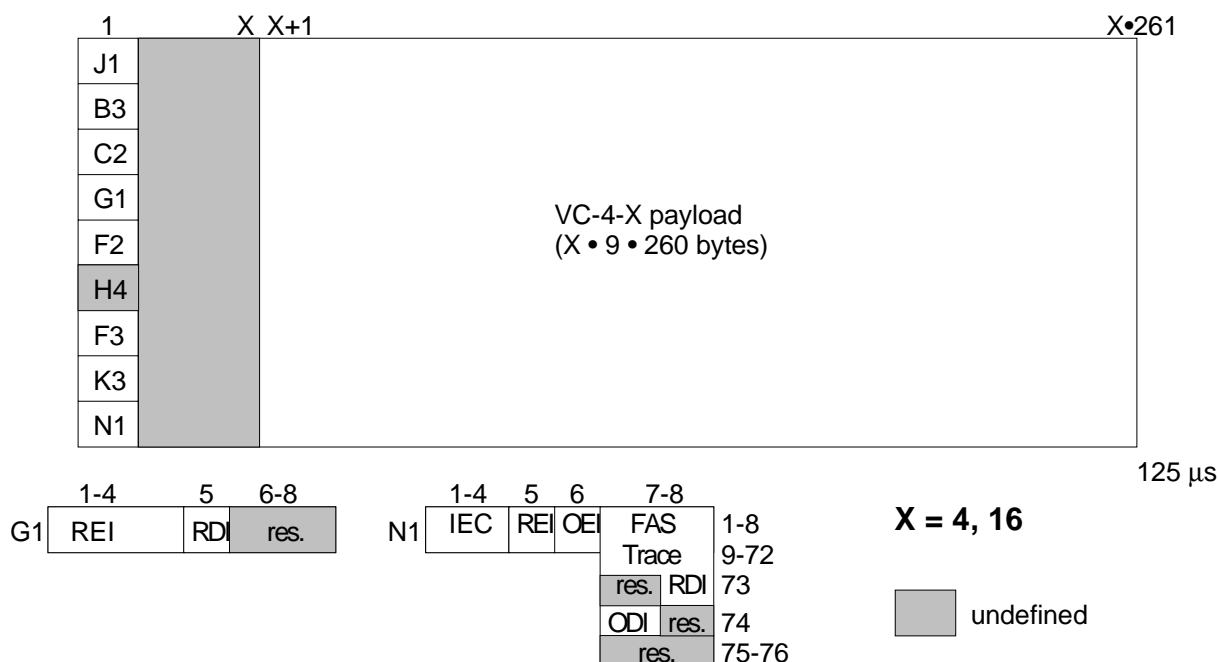
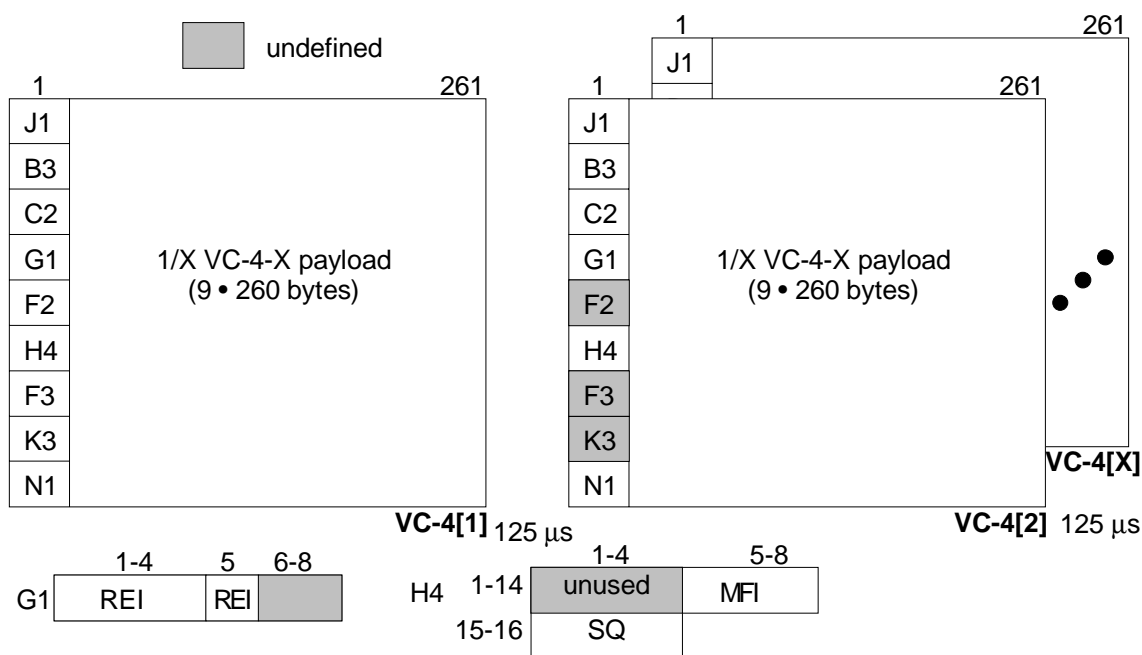

**Figure 4: S4-Xc\_CI\_D**

The CI of a VC-4-Xc (S4-Xc\_CI\_D) signal is octet structured with a 125  $\mu$ s frame. Its format is characterized as S4-X\_AI plus the VC-4 trail termination overhead in the J1, B3, and G1 locations as defined in EN 300 147 [5]

NOTE: H4 is not used in VC-4-Xc

### 5.2.4 VC-4-Xv layer connection point



**Figure 5: S4-Xv\_CI\_D**

The CI of a VC-4-Xv (S4-Xv\_CI\_D) consists of X times S4\_CI as defined in EN 300 417-1-1 [1]. The H4 byte is generated as defined in EN 300 147 [5].

The mapping of S4-X\_AI to S4-Xv\_CI is performed as shown in figure 6.

NOTE: F2, F3 and K3 of VC-4[2...X] are undefined.

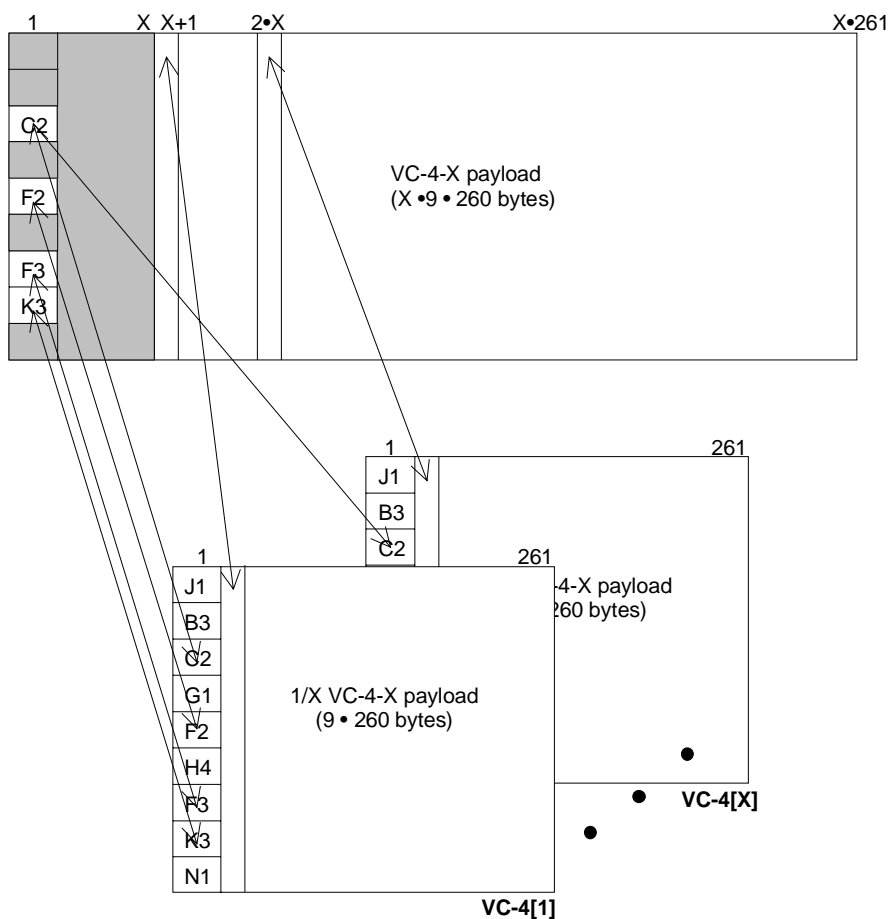

Figure 6: S4-X\_AI\_D to S4-Xv\_CI\_D mapping

### 5.2.5 VC-4-XP layer access point

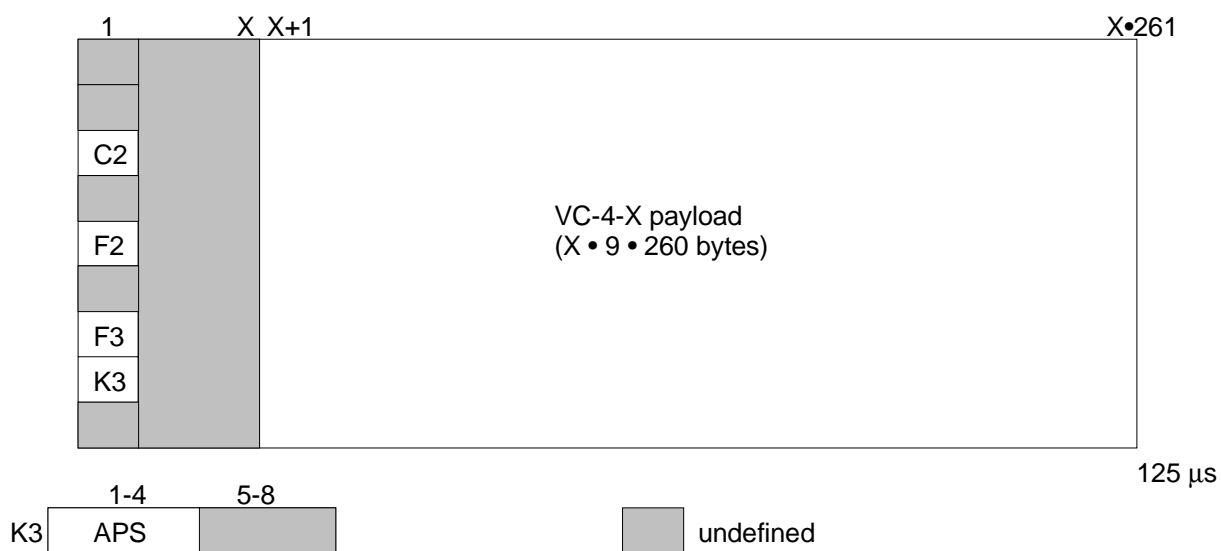
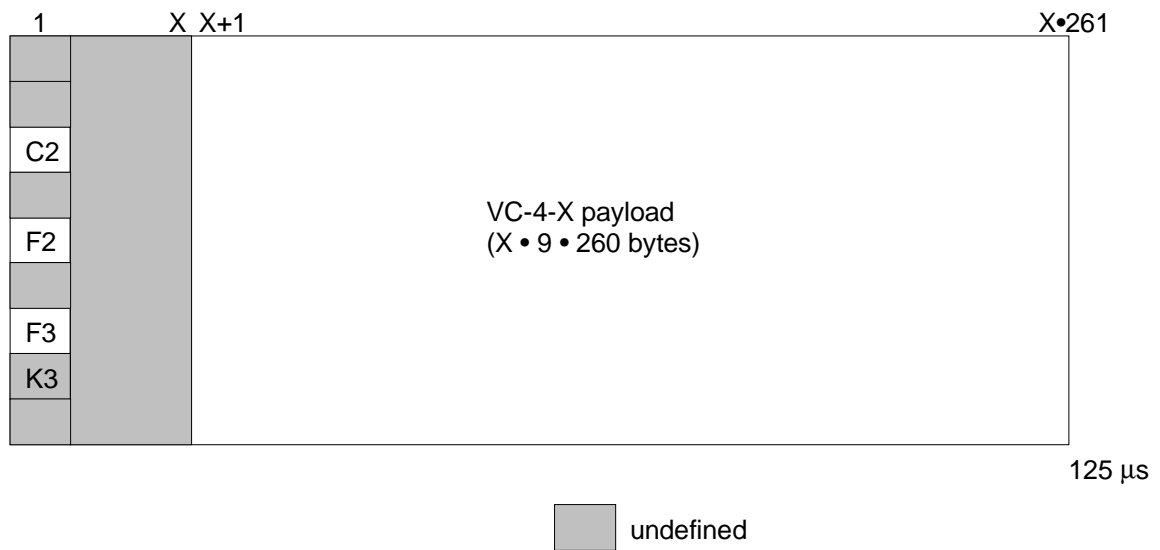

Figure 7: S4-XP\_AI\_D

The S4-XP AI is identical to the S4-X AI with defined APS information if the protection scheme uses it.

## 5.2.6 VC-4-XP layer connection point



**Figure 8: S4-XP\_CI\_D**

The S4-XP CI is identical to the S4-X AI, with undefined APS information.

NOTE: The presence/absence of F2/F3 depends on the location of the S4-X/P0s\_A function.

## 5.3 VC-4-Xc Layer Connection Function S4-Xc\_C

Refer to EN 300 417-4-1 [3], clause 4.1 "VC-4 Layer Connection Function S4\_C" with:

- S4 => S4-Xc;
- VC-4 => VC-4-Xc.

### 5.3.1 SNC protection

Refer to EN 300 417-4-1 [3], clause 4.1.1 "SNC protection" with:

- S4 => S4-Xc;
- VC-4 => VC-4-Xc.

## 5.4 VC-4-Xc Layer Trail Termination Functions S4-Xc\_TT

### 5.4.1 VC-4-Xc Layer Trail Termination Source Function S4-Xc\_TT\_So

Refer to EN 300 417-4-1 [3], clause 4.2.1 "VC-4 Layer Trail Termination Source S4\_TT\_So" with:

- S4 => S4-Xc;
- VC-4 => VC-4-Xc.

## 5.4.2 VC-4-Xc Layer Trail Termination Sink Function S4-Xc\_TT\_So

Refer to EN 300 417-4-1 [3], clause 4.2.2 "VC-4 Layer Trail Termination Sink S4\_TT\_Sk" with:

- S4 => S4-Xc;
- VC-4 => VC-4-Xc.

## 5.5 VC-4-Xc Layer Monitoring Functions

### 5.5.1 VC-4-Xc Non-intrusive Monitoring Function S4-Xcm\_TT\_Sk

Refer to EN 300 417-4-1 [3], clause 4.4.1 "VC-4 Layer Non-intrusive Monitoring Function S4m\_TT\_Sk" with:

- S4 => S4-Xc;
- VC-4 => VC-4-Xc.

### 5.5.2 VC-4-Xc Supervisory Unequipped Termination Source Function S4-Xcs\_TT\_So

Refer to EN 300 417-4-1 [3], clause 4.4.2 "VC-4 Layer Supervisory-Unequipped Termination Source S4s\_TT\_So" with:

- S4 => S4-Xc;
- VC-4 => VC-4-Xc.

### 5.5.3 VC-4-Xc Supervisory Unequipped Termination Sink Function S4-Xcs\_TT\_Sk

Refer to EN 300 417-4-1 [3], clause 4.4.3 "VC-4 Layer Supervisory-Unequipped Termination Sink S4s\_TT\_Sk" and with:

- S4 => S4-Xc;
- VC-4 => VC-4-Xc.

## 5.6 VC-4-Xc Tandem Connection Sublayer Functions

### 5.6.1 VC-4-Xc Tandem Connection Trail Termination Source Function S4-XcD\_TT\_So

Refer to EN 300 417-4-1 [3], clause 4.6.1 "VC-4 Tandem Connection Trail Termination Source function (S4D\_TT\_So)" with:

- S4 => S4-Xc;
- VC-4 => VC-4-Xc.



## 5.6.2 VC-4-Xc Tandem Connection Trail Termination Sink Function S4-XcD\_TT\_Sk

Refer to EN 300 417-4-1 [3], clause 4.6.2 "VC-4 Tandem Connection Trail Termination Sink function (S4D\_TT\_Sk)" with:

- S4 => S4-Xc;
- VC-4 => VC-4-Xc.

## 5.6.3 VC-4-Xc Tandem Connection Non-intrusive Monitoring Trail Termination Sink Function S4-XcDm\_TT\_Sk

Refer to EN 300 417-4-1 [3], clause 4.6.5 "VC-4 Tandem Connection Non-intrusive Monitoring Trail Termination Sink function (S4Dm\_TT\_Sk)" with:

- S4 => S4-Xc;
- VC-4 => VC-4-Xc.

## 5.6.4 VC-4-Xc Tandem Connection to VC-4-Xc Adaptation Source Function S4-XcD/S4-Xc\_A\_So

Refer to EN 300 417-4-1 [3], clause 4.6.3 "VC-4 Tandem Connection to VC-4 Adaptation Source function (S4D/S4\_A\_So)" with:

- S4 => S4-Xc;
- VC-4 => VC-4-Xc.

## 5.6.5 VC-4-Xc Tandem Connection to VC-4-Xc Adaptation Sink Function S4-XcD/S4-Xc\_A\_Sk

Refer to EN 300 417-4-1 [3], clause 4.6.4 "VC-4 Tandem Connection to VC-4 Adaptation Sink function (S4D/S4\_A\_Sk)" with:

- S4 => S4-Xc;
- VC-4 => VC-4-Xc.

## 5.7 VC-4-Xv Layer Trail Termination Functions S4-Xc\_TT

Refer to ITU-T Recommendation G.783 [4], clause 12.5.1.1 "VC-n-Xv Layer Trail Termination Function Sn-Xv\_TT" with n = 4.

### 5.7.1 VC-4-Xv/VC-4-X Adaptation Source Function S4-Xv/S4-X\_A\_So

Refer to ITU-T Recommendation G.783 [4], clause 12.5.1.1.1 "VC-n-Xv/VC-n-X Adaptation Source Function Sn-Xv/Sn-X\_A\_So" with n = 4.

### 5.7.2 VC-4-Xv/VC-4-X Adaptation Sink Function S4-Xv/S4-X\_A\_Sk

Refer to ITU-T Recommendation G.783 [4], clause 12.5.1.1.2 "VC-n-Xv/VC-n-X Adaptation Sink Function Sn-Xv/Sn-X\_A\_Sk" with n = 4.

### 5.7.3 VC-4-Xv Layer Trail Termination Source Function S4-Xv\_TT\_So

Refer to ITU-T Recommendation G.783 [4], clause 12.5.1.1.3 "VC-n-Xv/VC-n-X Adaptation Source Function Sn-Xv/Sn-X\_A\_So" with n = 4.

### 5.7.4 VC-4-Xv Layer Trail Termination Sink Function S4-Xv\_TT\_Sk

Refer to ITU-T Recommendation G.783 [4], clause 12.5.1.1.4 "VC-n-Xv/VC-n-X Adaptation Sink Function Sn-Xv/Sn-X\_A\_Sk" with n = 4.

## 5.8 Interworking Functions

### 5.8.1 VC-4-Xc to VC-4-Xv Interworking Function S4-Xc>S4-Xv\_I

Refer to ITU-T Recommendation G.783 [4], clause 12.5.2.1 "VC-4-Xc to VC-4-Xv Interworking Function S4-Xc>S4-Xv\_I"

### 5.8.2 VC-4-Xv to VC-4-Xc Interworking Function S4-Xv>S4-Xc\_I

Refer to ITU-T Recommendation G.783 [4], clause 12.5.2.2 "VC-4-Xv to VC-4-Xc Interworking Function S4-Xv>S4-Xc\_I"

## 5.9 VC-4-X Layer Adaptation Functions

### 5.9.1 VC-4-X to P0s Adaptation Source Function S4-X/P0s\_A\_So

Refer to EN 300 417-4-1 [3], clause 4.3.7 "VC-4 Layer to P0s Layer Adaptation Source S4/P0s\_A\_So" with:

- S4 => S4-Xc;
- VC-4 => VC-4-Xc.

### 5.9.2 VC-4-X to P0s Adaptation Sink Function S4-X/P0s\_A\_Sk

Refer to EN 300 417-4-1 [3], clause 4.3.8 "VC-4 Layer to P0s Layer Adaptation Sink S4/P0s\_A\_Sk" with:

- S4 => S4-Xc;
- VC-4 => VC-4-Xc.

### 5.9.3 VC-4-X to HDLC Adaptation Source Function S4-X/HDLC\_A\_So

For further study.

### 5.9.4 VC-4-X to HDLC Adaptation Sink Function S4-X/HDLC\_A\_Sk

For further study.

### 5.9.5 VC-4-X to Avp Adaptation Source Function S4-X/Avp\_A\_So

The specification of this function is addressed in EN 301 163-2-1 [6].

### 5.9.6 VC-4-X to Avp Adaptation Sink Function S4-X/Avp\_A\_Sk

The specification of this function is addressed in EN 301 163-2-1 [6].

### 5.9.7 VC-4-X to TSS1 Adaptation Source Function S4-X/TSS1\_A\_So

Refer to EN 300 417-4-1 [3], clause 4.3.11 "VC-4 Layer to TSS1 Adaptation Source S4/TSS1\_A\_So" with:

- S4 => S4-Xc;
- VC-4 => VC-4-Xc.

### 5.9.8 VC-4-X to TSS1 Adaptation Sink Function S4-X/TSS1\_A\_Sk

Refer to EN 300 417-4-1 [3], clause 4.3.12 "VC-4 Layer to TSS1 Adaptation Sink S4/TSS1\_A\_Sk" with:

- S4 => S4-Xc;
- VC-4 => VC-4-Xc.

## 5.10 VC-4-X Layer Trail Protection Functions

### 5.10.1 VC-4-X Trail Protection Connection Functions S4-XP\_C

#### 5.10.1.1 VC-4-X Layer 1+1 uni-directional Protection Connection Function S4-XP1+1u\_C

Refer to EN 300 417-4-1 [3], clause 4.5.1.1 "VC-4 Layer 1+1 uni-directional Protection Connection Function S4P1+1u\_C " with:

- S4 => S4-Xc;
- VC-4 => VC-4-Xc.

#### 5.10.1.2 VC-4-X Layer 1+1 bi-directional Protection Connection Function S4-XP1+1b\_C

Refer to EN 300 417-4-1 [3], clause 4.5.1.2 "VC-4 Layer 1+1 bi-directional Protection Connection Function S4P1+1b\_C " with:

- S4 => S4-Xc;
- VC-4 => VC-4-Xc.

### 5.10.2 VC-4 Layer Trail Protection Trail Termination Functions

#### 5.10.2.1 VC-4-X Protection Trail Termination Source S4-XP\_TT\_So

Refer to EN 300 417-4-1 [3], clause 4.5.2.1 "VC-4 Protection Trail Termination Source S4P\_TT\_So" with:

- S4 => S4-Xc;
- VC-4 => VC-4-Xc.

#### 5.10.2.2 VC-4-X Protection Trail Termination Sink S4-XP\_TT\_Sk

Refer to EN 300 417-4-1 [3], clause 4.5.2.2 "VC-4 Protection Trail Termination Sink S4P\_TT\_Sk" with:

- S4 => S4-Xc;
- VC-4 => VC-4-Xc.

### 5.10.3 VC-4 Layer Linear Trail Protection Adaptation Functions

#### 5.10.3.1 VC-4-X trail to VC-4-X trail Protection Layer Adaptation Source S4-X/S4-XP\_A\_So

Refer to EN 300 417-4-1 [3], clause 4.5.3.1 "VC-4 trail to VC-4 trail Protection Layer Adaptation Source S4/S4P\_A\_So" with:

- S4 => S4-Xc;
- VC-4 => VC-4-Xc.

#### 5.10.3.2 VC-4-X trail to VC-4-X trail Protection Layer Adaptation Sink S4-X/S4-XP\_A\_Sk

Refer to EN 300 417-4-1 [3], clause 4.5.3.2 "VC-4 trail to VC-4 trail Protection Layer Adaptation Sink S4/S4P\_A\_Sk" with:

- S4 => S4-Xc;
- VC-4 => VC-4-Xc.

### 5.11 VC-4-X layer clock adaptation source (S4-X-LC\_A\_So)

**Symbol and interfaces:**

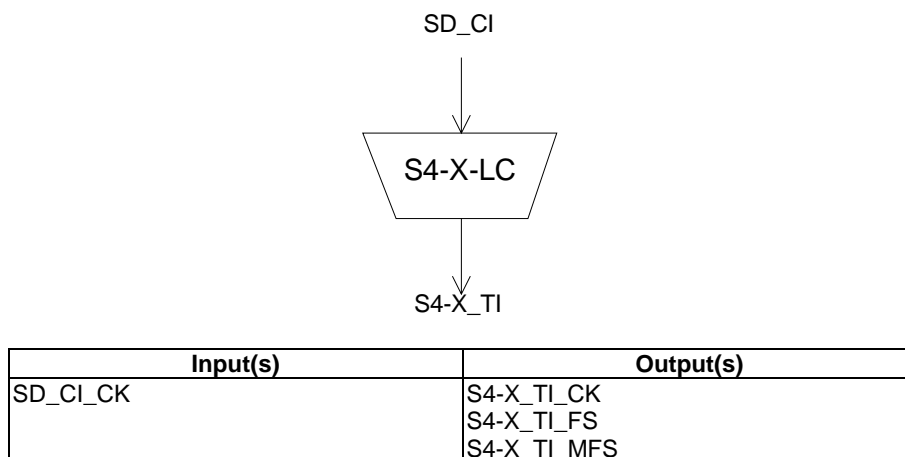

**Figure 9: S4-X-LC\_A\_So symbol and in/output signals**

**Processes:**

This function performs the VC-4-X clock and frame start signal generation locked to the network element clock signal SD\_CI\_CK, to time the adaptation source and connection functions in this layer.

**Clock generation:** The function shall generate the clock (bit) reference signal S4-X\_TI\_CK for the VC-4-X signal. The S4-X\_TI\_CK frequency shall be  $X \bullet 150\,336$  kHz locked to the input signal SD\_CI\_CK.

**Jitter limiter:** For Further study.

**Frame Start signal generation:** The function shall generate the frame start reference signal S4-X\_TI\_FS for the VC-4-X signal. The S4-X\_TI\_FS signal shall be active once per  $X \bullet 18\,792$  clock cycle and the multiframe reference S4-X\_TI\_MFS shall be active once every 4 096 frames.

<b>Defects:</b>	None.
<b>Consequent Actions:</b>	None.
<b>Defect Correlations:</b>	None.
<b>Performance Monitoring:</b>	None.

## 6 Concatenated VC-3 path layer functions

### 6.1 Atomic functions overview

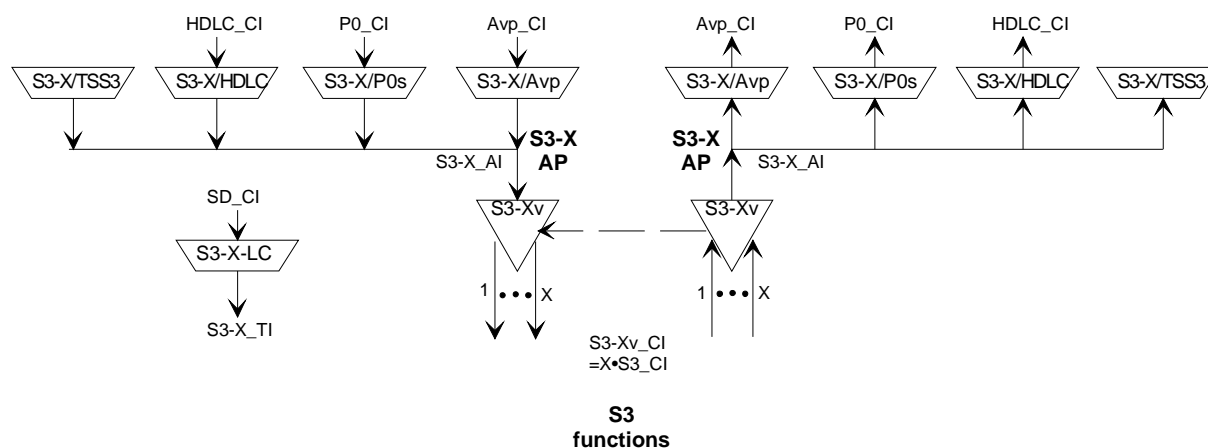

**Figure 10: Concatenated VC-3 path layer atomic functions**

Figure 10 shows the set of atomic functions for the concatenated VC-3 path layer. Figure 11 shows the additional functions for the concatenated VC-3 layer trail protection. It should be noted that the S3-X/P0s\_A function can be absent, or connected before or after the protection functions S3-XP\_C. When connected before S3-XP\_C the transport of the user channel signal is not protected, otherwise it is protected.

Figures 10 and 11 show that more than one adaptation function exists in the S3-X layer that can be connected to one S3-X access point. For such cases, a subset of these adaptation source functions is allowed to be activated together, but only one adaptation source function may have access to a specific timeslot. Access to the same timeslot by other adaptation source functions shall be denied. In contradiction with the source direction, adaptation sink functions may be activated all together. This may cause faults to be detected and reported. To prevent this an adaptation sink function can be deactivated.

**NOTE:** If one adaptation function only is connected to the AP, it will be activated. If one or more other functions are connected to the same AP accessing the same timeslot, one out of the set of functions will be active.

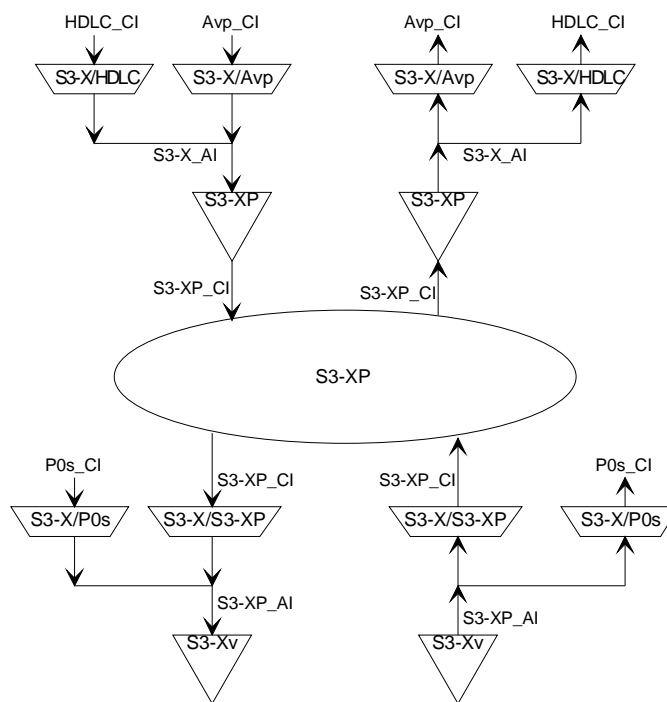

Figure 11: Concatenated VC-3 Layer Trail Protection atomic functions

## 6.2 Layer information

### 6.2.1 VC-3-X layer access point

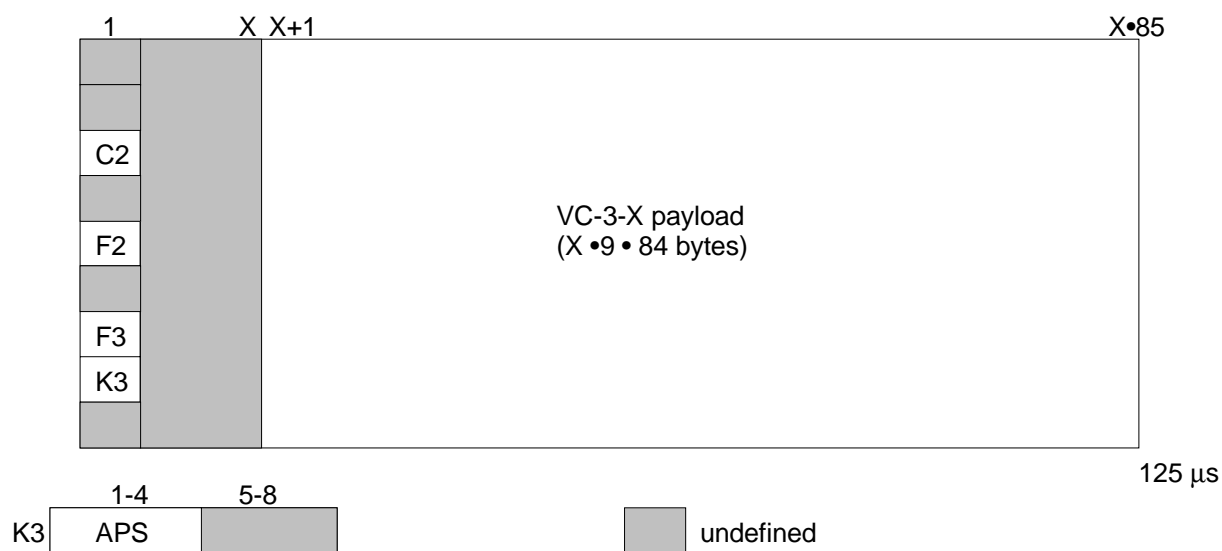

Figure 12: S3-X\_AI\_D

The VC-3-X AI (S3-X\_AI\_D) at this point is octet structured with an 125 μs frame. It represents adapted client layer information comprising  $X \cdot 756$  bytes of client layer information, the signal label byte C2, and the 2 path user channel bytes F2/3 as defined in EN 300 147 [5]. For the case the signal has passed the trail protection sublayer, S3\_AI has defined APS bits (1 to 4) in byte K3.

NOTE 1: The APS signal has not been defined; a multiframed APS signal might be required.

NOTE 2: Bits 1 to 4 of byte K3 will be undefined when the signal S3-X\_AI has not been processed in a trail protection connection function S3-XP\_C.

NOTE 3: Bytes F2 and F3 will be undefined when the adaptation functions sourcing these bytes are not present in the network element.

A VC-3-X comprises one of the following payloads:

- an ATM X • 48 384 kbit/s cell stream signal;
- an PPP X • 48 384 kbit/s cell stream signal;
- a Test Signal Structure (TSS3).

## 6.2.2 VC-3-X layer connection point

A VC-3 concatenated trail is transported via virtual concatenated VC-3 (VC-3-Xv) connections.

For a virtual concatenated VC-3-Xv connection all values for X ≥ 1 are allowed.

## 6.2.3 VC-3-Xv layer connection point

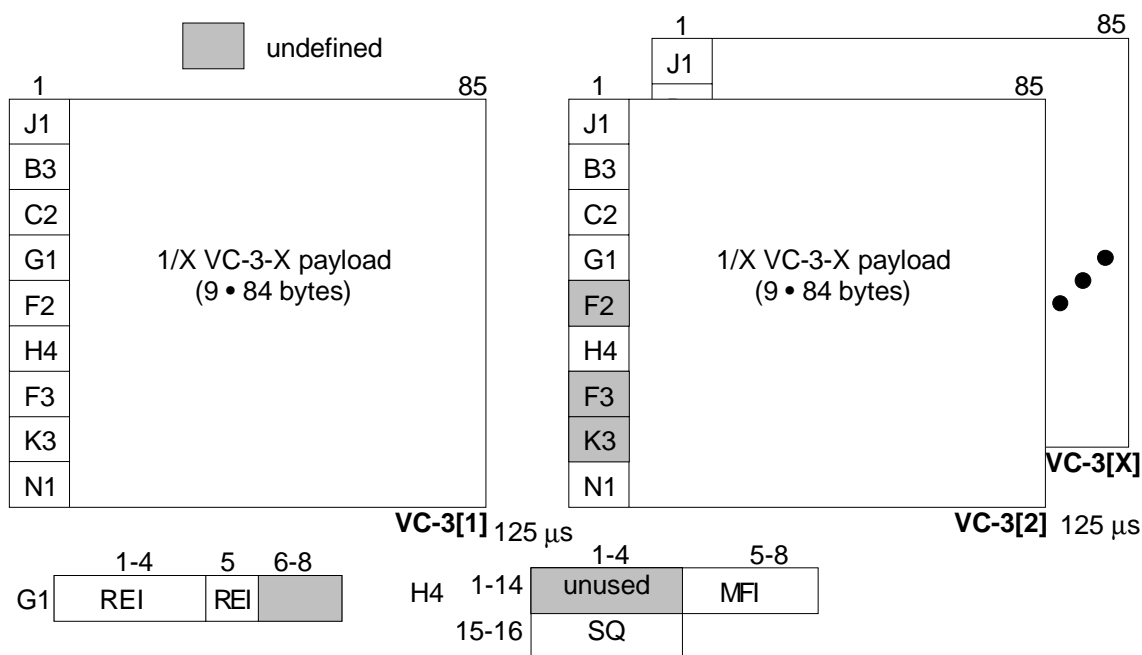

Figure 13: S3-Xv\_CI\_D

The CI of a VC-3-Xv (S3-Xv\_CI\_D) consists of X times S3\_CI as defined in EN 300 417-1-1 [1]. The H4 byte is generated as defined in EN 300 147 [5].

The mapping of S3-X\_AI to S3-Xv\_CI is performed as shown in figure 14.

NOTE: F2, F3 and K3 of VC-3[2...X] are undefined.

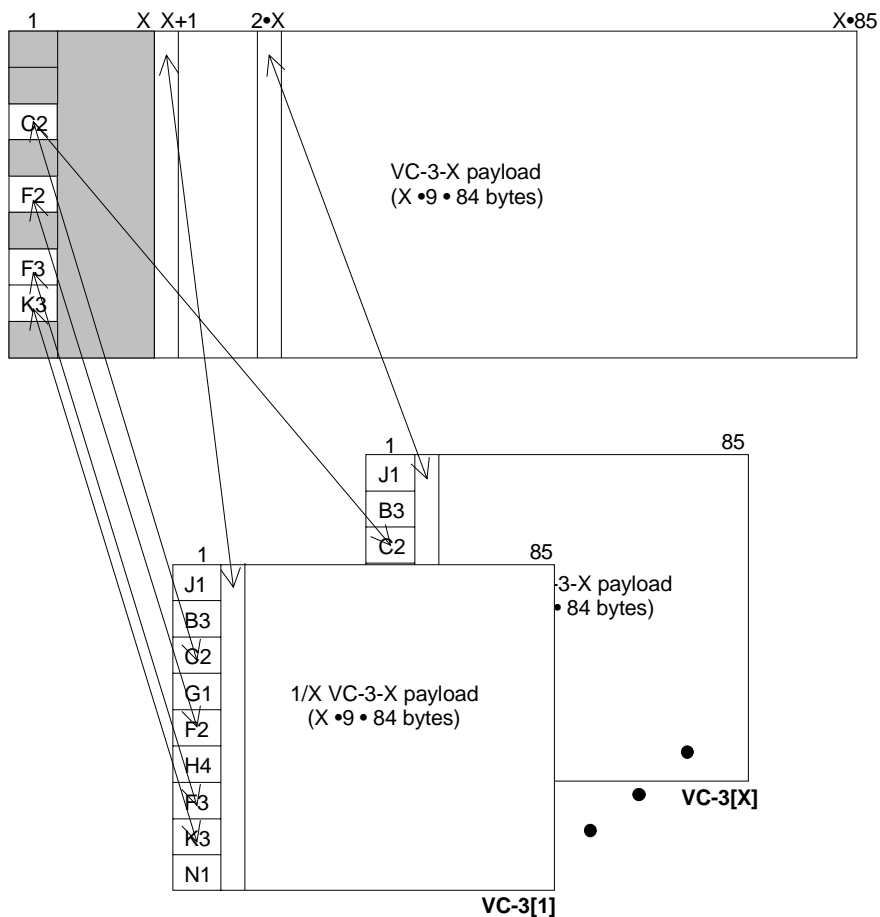

Figure 14: S3-X\_AI\_D to S3-Xv\_CI\_D mapping

### 6.2.4 VC-3-XP layer access point

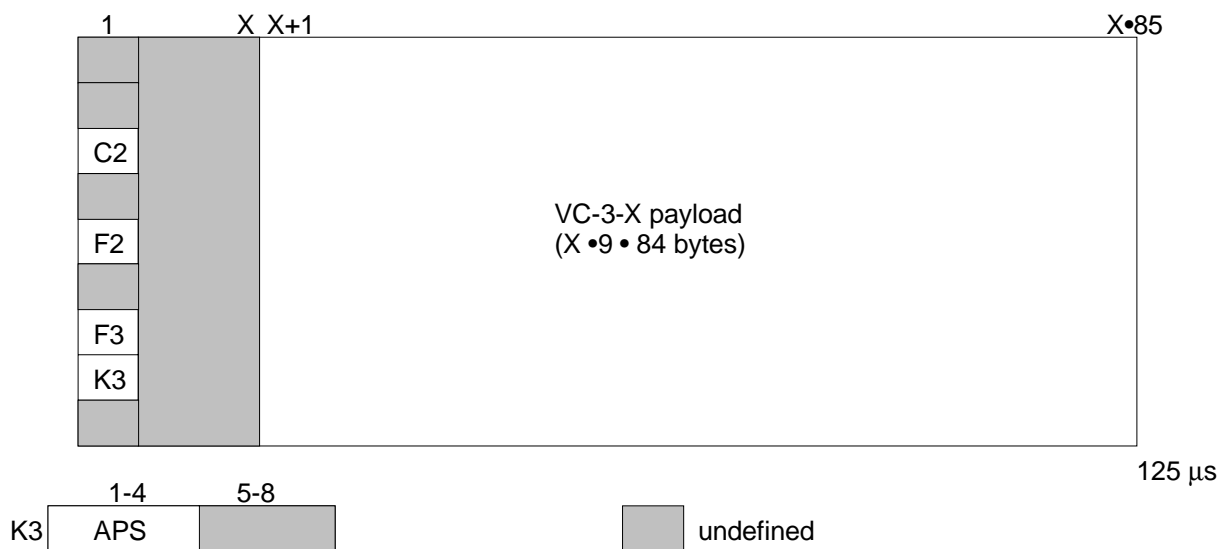
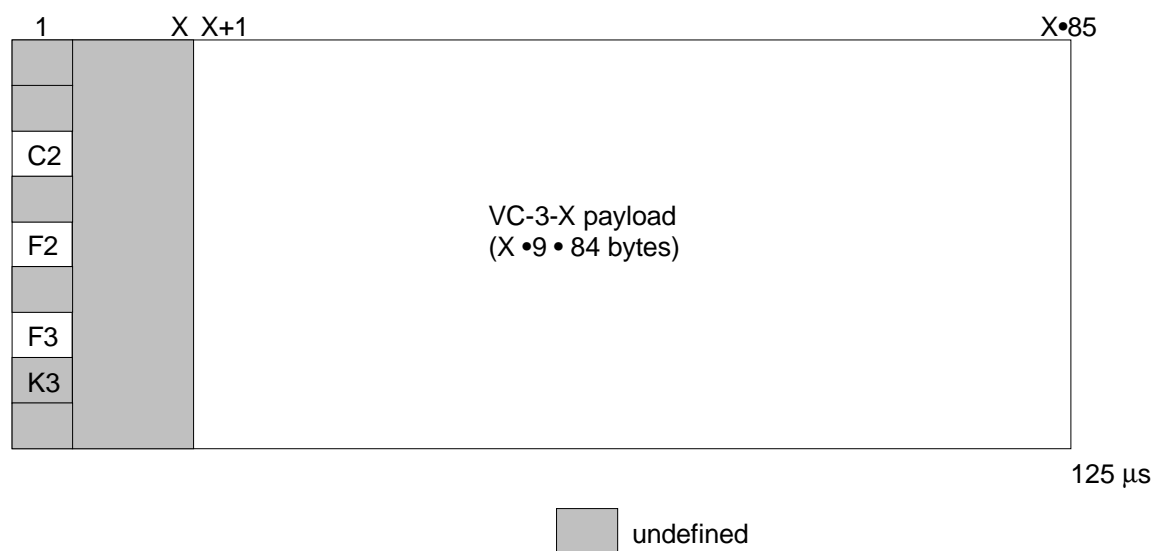

Figure 15: S3-XP\_AI\_D

The S3-XP AI is identical to the S3-X AI with defined APS information if the protection scheme uses it.



## 6.2.5 VC-3XP layer connection point



**Figure 16: S3-XP\_CI\_D**

The S3-XP CI is identical to the S3-X AI, with undefined APS information.

NOTE: The presence/absence of F2/F3 depends on the location of the S3-X/P0s\_A function.

## 6.3 VC-3-Xv Layer Trail Termination Functions S3-Xc\_TT

Refer to ITU-T Recommendation G.783 [4], clause 12.5.1.1 "VC-n-Xv Layer Trail Termination Function Sn-Xv\_TT" with n = 3.

### 6.3.1 VC-3-Xv/VC-3-X Adaptation Source Function S3-Xv/S3-X\_A\_So

Refer to ITU-T Recommendation G.783 [4], clause 12.5.1.1.1 "VC-n-Xv/VC-n-X Adaptation Source Function Sn-Xv/Sn-X\_A\_So" with n = 4.

### 6.3.2 VC-3-Xv/VC-3-X Adaptation Sink Function S3-Xv/S3-X\_A\_Sk

Refer to ITU-T Recommendation G.783 [4], clause 12.5.1.1.2 "VC-n-Xv/VC-n-X Adaptation Sink Function Sn-Xv/Sn-X\_A\_Sk" with n = 3.

### 6.3.3 VC-3-Xv Layer Trail Termination Source Function S3-Xv\_TT\_So

Refer to ITU-T Recommendation G.783 [4], clause 12.5.1.1.3 "VC-n-Xv/VC-n-X Adaptation Source Function Sn-Xv/Sn-X\_A\_So" with n = 3.

### 6.3.4 VC-3-Xv Layer Trail Termination Sink Function S3-Xv\_TT\_Sk

Refer to ITU-T Recommendation G.783 [4], clause 12.5.1.1.4 "VC-n-Xv/VC-n-X Adaptation Sink Function Sn-Xv/Sn-X\_A\_Sk" with n = 3.

## 6.4 VC-3-x Layer Adaptation Functions

### 6.4.1 VC-3-x to P0s Adaptation Source Function S3-x/P0s\_A\_So

Refer to EN 300 417-4-1 [3], clause 5.3.5 "VC-3 Layer to P0s Layer Adaptation Source S3/P0s\_A\_So" with:

- S3 => S3-xc;
- VC-3 => VC-3-xc.

### 6.4.2 VC-3-x to P0s Adaptation Sink Function S3-x/P0s\_A\_Sk

Refer to EN 300 417-4-1 [3], clause 5.3.6 "VC-3 Layer to P0s Layer Adaptation Sink S3/P0s\_A\_Sk" with:

- S3 => S3-xc;
- VC-3 => VC-3-xc.

### 6.4.3 VC-3-x to HDLC Adaptation Source Function S3-x/HDLC\_A\_So

For further study.

### 6.4.4 VC-3-x to HDLC Adaptation Sink Function S3-x/HDLC\_A\_Sk

For further study.

### 6.4.5 VC-3-x to Avp Adaptation Source Function S3-x/Avp\_A\_So

The specification of this function is addressed in EN 301 163-2-1 [6].

### 6.4.6 VC-3-x to Avp Adaptation Sink Function S3-x/Avp\_A\_Sk

The specification of this function is addressed in EN 301 163-2-1 [6].

### 6.4.7 VC-3-x to TSS3 Adaptation Source Function S3-x/TSS3\_A\_So

Refer to EN 300 417-4-1 [3], clause 5.3.7 "VC-3 Layer to TSS3 Adaptation Source S3/TSS3\_A\_So" with:

- S3 => S3-xc;
- VC-3 => VC-3-xc.

### 6.4.8 VC-3-x to TSS3 Adaptation Sink Function S3-x/TSS3\_A\_Sk

Refer to EN 300 417-4-1 [3], clause 5.3.8 "VC-3 Layer to TSS3 Adaptation Sink S3/TSS3\_A\_Sk" with:

- S3 => S3-xc;
- VC-3 => VC-3-xc.

## 6.5 VC-3-X Layer Trail Protection Functions

### 6.5.1 VC-3-X Trail Protection Connection Functions S3-XP\_C

#### 6.5.1.1 VC-3-X Layer 1+1 uni-directional Protection Connection Function S3-XP1+1u\_C

Refer to EN 300 417-4-1 [3], clause 5.5.1.1 "VC-3 Layer 1+1 uni-directional Protection Connection Function S3P1+1u\_C" with:

- S3 => S3-Xc;
- VC-3 => VC-3-Xc.

#### 6.5.1.2 VC-3-X Layer 1+1 bi-directional Protection Connection Function S3-XP1+1b\_C

Refer to EN 300 417-4-1 [3], clause 5.5.1.2 "VC-3 Layer 1+1 bi-directional Protection Connection Function S3P1+1b\_C" with:

- S3 => S3-Xc;
- VC-3 => VC-3-Xc.

### 6.5.2 VC-3 Layer Trail Protection Trail Termination Functions

#### 6.5.2.1 VC-3-X Protection Trail Termination Source S3-XP\_TT\_So

Refer to EN 300 417-4-1 [3], clause 5.5.2.1 "VC-3 Protection Trail Termination Source S3P\_TT\_So" with:

- S3 => S3-Xc;
- VC-3 => VC-3-Xc.

#### 6.5.2.2 VC-3-X Protection Trail Termination Sink S3-XP\_TT\_Sk

Refer to EN 300 417-4-1 [3], clause 5.5.2.2 "VC-3 Protection Trail Termination Sink S3P\_TT\_Sk" with:

- S3 => S3-Xc;
- VC-3 => VC-3-Xc.

### 6.5.3 VC-3 Layer Linear Trail Protection Adaptation Functions

#### 6.5.3.1 VC-3-X trail to VC-3-X trail Protection Layer Adaptation Source S3-X/S3-XP\_A\_So

Refer to EN 300 417-4-1 [3], clause 5.5.3.1 "VC-3 trail to VC-3 trail Protection Layer Adaptation Source S3/S3P\_A\_So" with:

- S3 => S3-Xc;
- VC-3 => VC-3-Xc.

### 6.5.3.2 VC-3-X trail to VC-3-X trail Protection Layer Adaptation Sink S3-X/S3-XP\_A\_Sk

Refer to EN 300 417-4-1 [3], clause 5.5.3.2 "VC-3 trail to VC-3 trail Protection Layer Adaptation Sink S3/S3P\_A\_Sk" with:

- S3 => S3-Xc;
- VC-3 => VC-3-Xc.

## 6.6 VC-3-X layer clock adaptation source (S3-X-LC\_A\_So)

**Symbol and interfaces:**

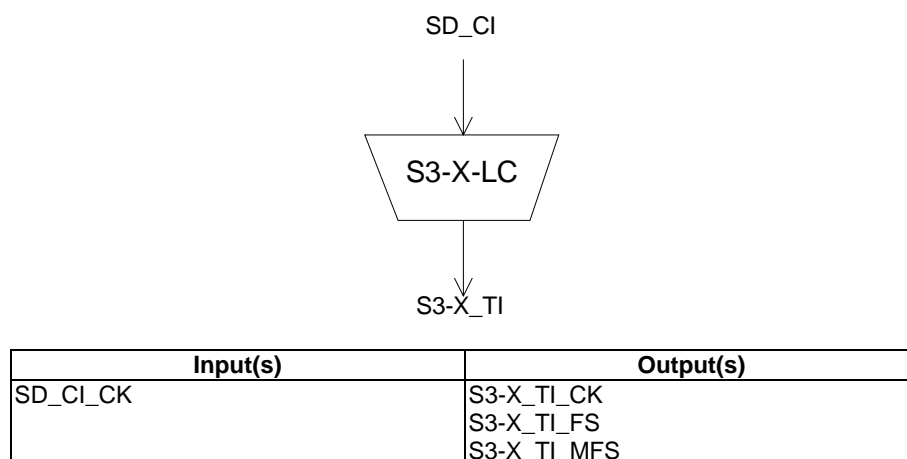

**Figure 17: S3-X-LC\_A\_So symbol and in/output signals**

**Processes:**

This function performs the VC-3-X clock and frame start signal generation locked to the network element clock signal SD\_CI\_CK, to time the adaptation source and connection functions in this layer.

**Clock generation:** The function shall generate the clock (bit) reference signal S3-X\_TI\_CK for the VC-3-X signal. The S3-X\_TI\_CK frequency shall be  $X \bullet 48\,960$  kHz locked to the input signal SD\_CI\_CK.

**Jitter limiter:** For Further study.

**Frame Start signal generation:** The function shall generate the frame start reference signal S3-X\_TI\_FS for the VC-3-X signal. The S3-X\_TI\_FS signal shall be active once per  $X \bullet 6\,120$  clock cycle and the multiframe reference S3-X\_TI\_MFS shall be active once every 4 096 frames.

**Defects:** None.

**Consequent Actions:** None.

**Defect Correlations:** None.

**Performance Monitoring:** None.

## 7 Concatenated VC-2 path layer functions

### 7.1 Atomic functions overview

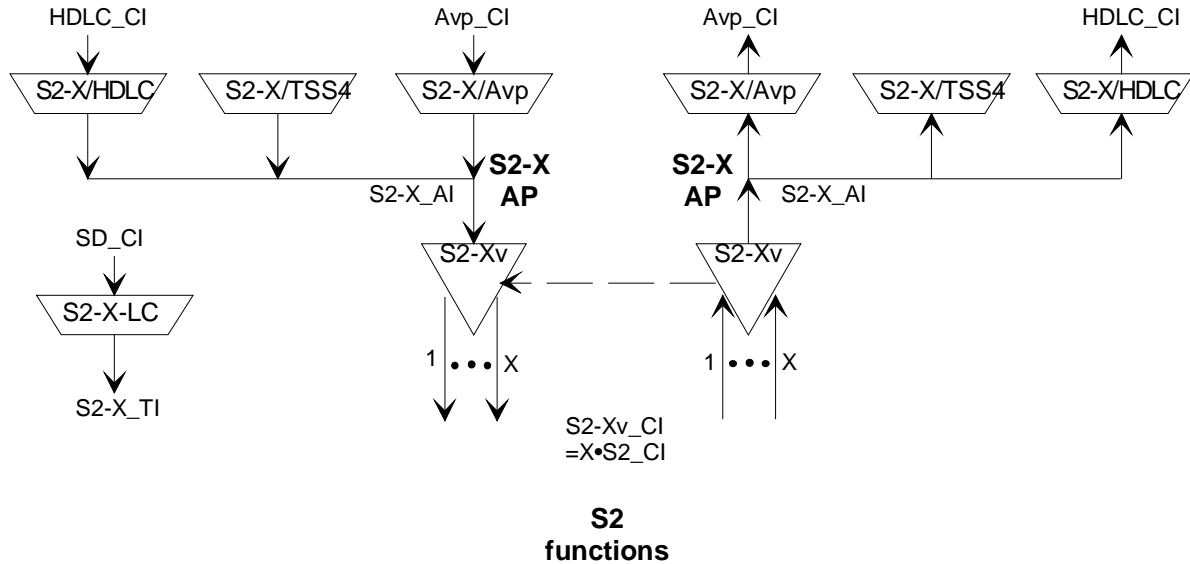

**Figure 18: Concatenated VC-2 path layer atomic functions**

Figure 18 shows the set of atomic functions for the concatenated VC-2 path layer. Figure 19 shows the additional functions for the concatenated VC-2 layer trail protection.

Figures 18 and 19 show that more than one adaptation function exists in the S2-X layer that can be connected to one S2-X access point. For such cases, a subset of these adaptation source functions is allowed to be activated together, but only one adaptation source function may have access to a specific timeslot. Access to the same timeslot by other adaptation source functions shall be denied. In contradiction with the source direction, adaptation sink functions may be activated all together. This may cause faults to be detected and reported. To prevent this an adaptation sink function can be deactivated.

**NOTE:** If one adaptation function only is connected to the AP, it will be activated. If one or more other functions are connected to the same AP accessing the same timeslot, one out of the set of functions will be active.

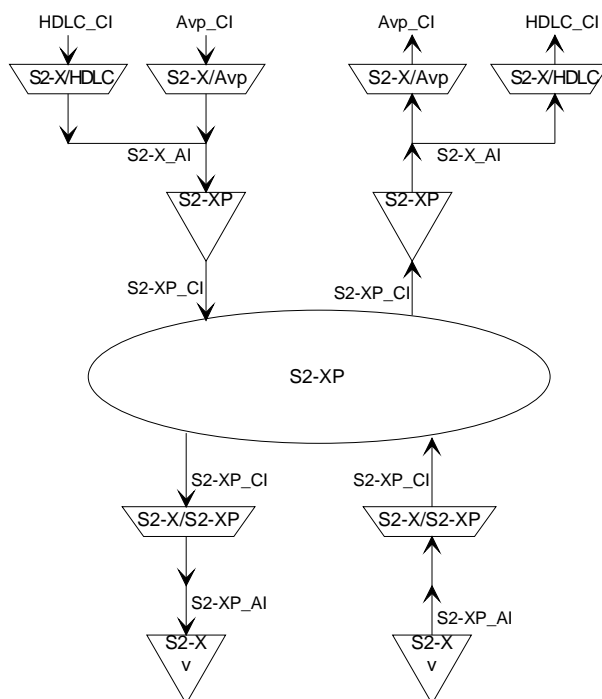

Figure 19: Concatenated VC-2 Layer Trail Protection atomic functions

## 7.2 Layer information

### 7.2.1 VC-2-X layer access point

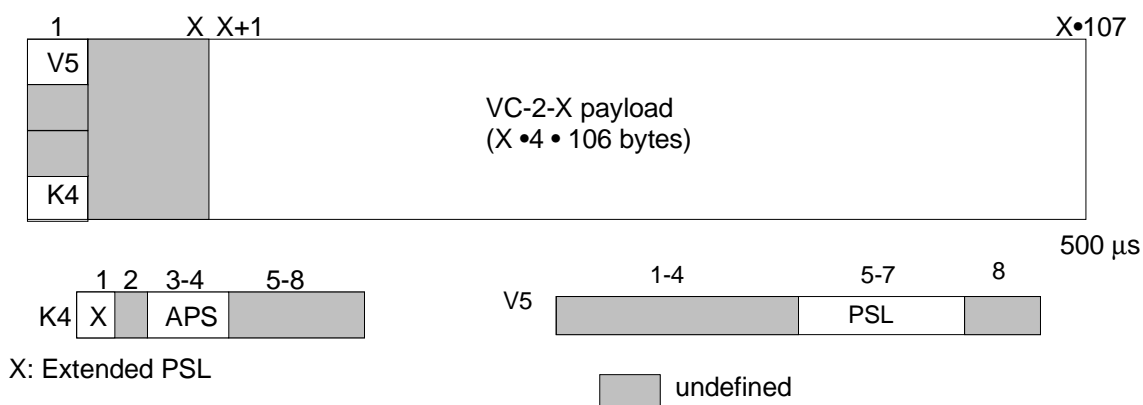

Figure 20: S2-X\_AI\_D

The VC-2-X AI (S2-X\_AI\_D) at this point is octet structured with an 500  $\mu$ s frame. It represents adapted client layer information comprising  $X \cdot 424$  bytes of client layer information, the signal label in bits 5-7 of the V5 byte as defined in EN 300 147 [5]. For the case the signal has passed the trail protection sublayer, S2\_AI has defined APS bits (3 to 4) in byte K4.

NOTE 1: The APS signal has not been defined; a multiframed APS signal might be required.

NOTE 2: Bits 3 to 4 of byte K4 will be undefined when the signal S2-X\_AI has not been processed in a trail protection connection function S2-XP\_C.

A VC-2-X comprises one of the following payloads:

- an ATM X • 6 784 kbit/s cell stream signal;
- an PPP X • 6 784 kbit/s cell stream signal;
- a Test Signal Structure (TSS4).

### 7.2.2 VC-2-X layer connection point

A VC-2 concatenated trail is transported via virtual concatenated VC-2 (VC-2-Xv) connections.

For a virtual concatenated VC-2-Xv connection all values for X ≥ 1 are allowed.

### 7.2.3 VC-2-Xv layer connection point

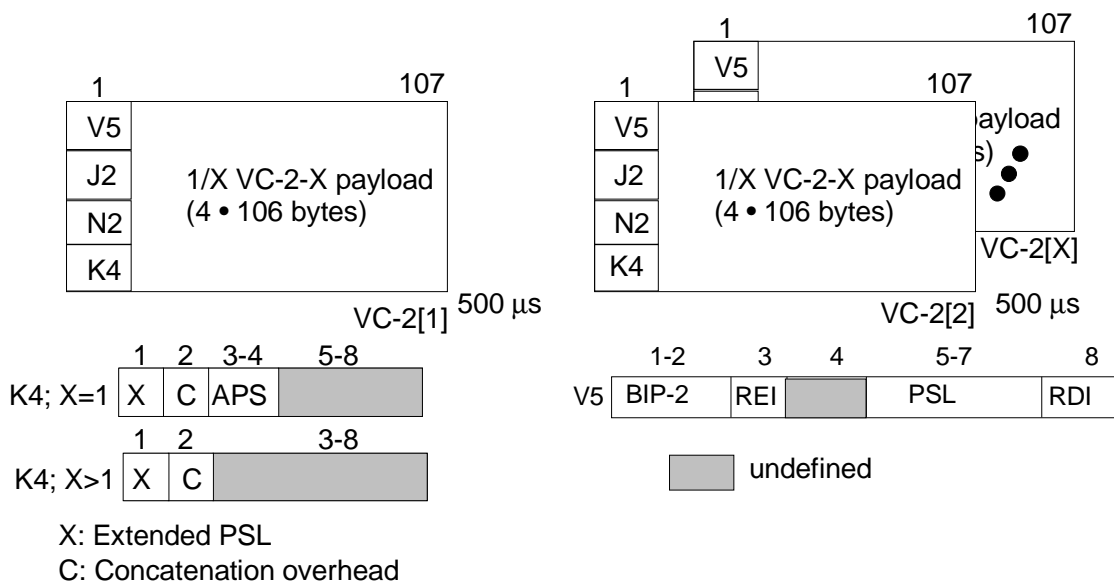

**Figure 21: S2-Xv\_CI\_D**

The CI of a VC-2-Xv (S2-Xv\_CI\_D) consists of X times S2\_CI as defined in EN 300 417-1-1 [1]. The H4 byte is generated as defined in EN 300 147 [5].

The mapping of S2-X\_AI to S2-Xv\_CI is performed as shown in figure 22.

NOTE: K4, bits 3-4 (APS) of VC-2[2...X] are undefined.

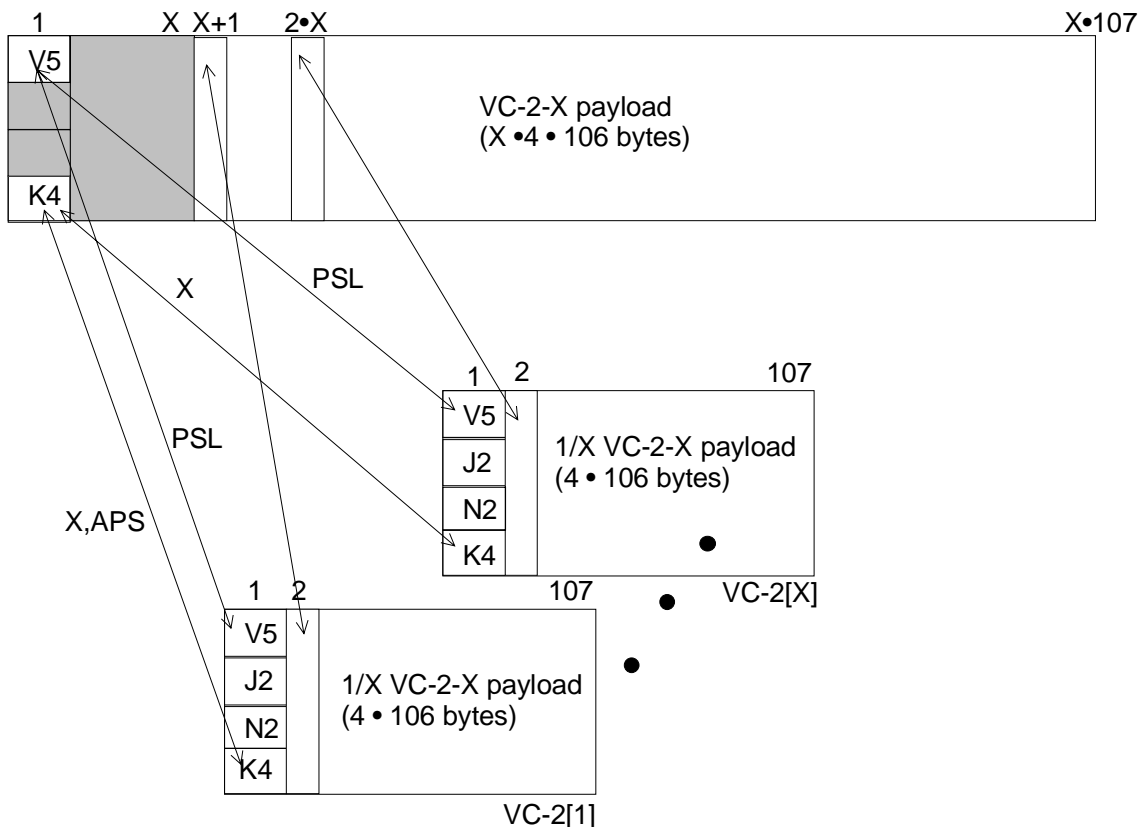

Figure 22: S2-X\_AI\_D to S2-Xv\_CI\_D mapping

7.2.4 VC-2-XP layer access point

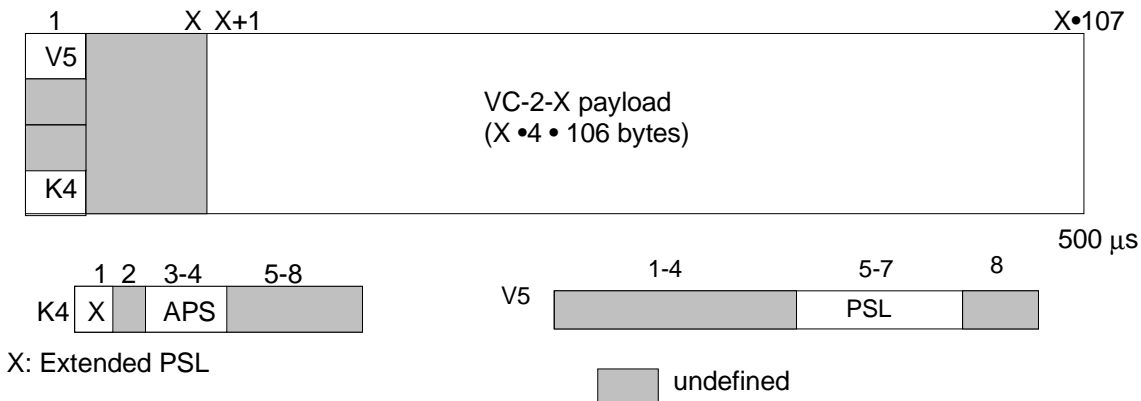
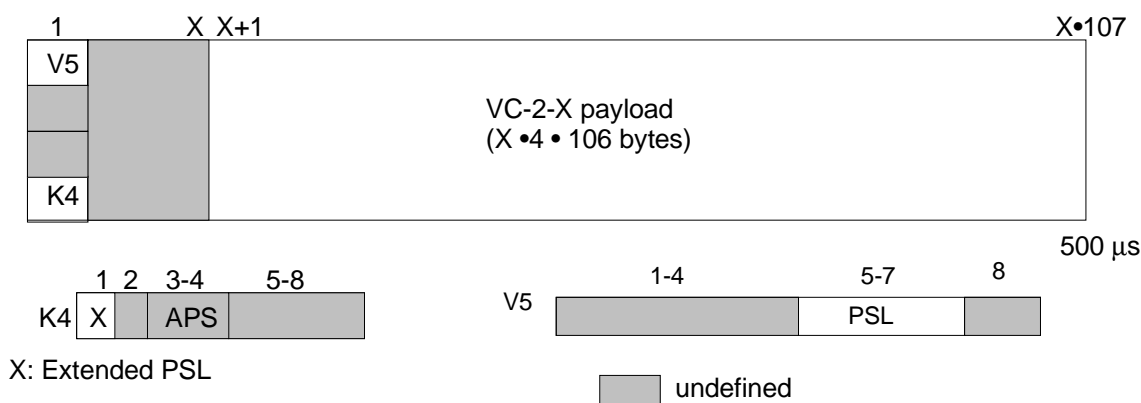

Figure 23: S2-XP\_AI\_D

The S2-XP AI is identical to the S2-X AI with defined APS information if the protection scheme uses it.



## 7.2.5 VC-2XP layer connection point



**Figure 24: S2-XP\_CI\_D**

The S2-XP CI is identical to the S2-X AI, with undefined APS information.

## 7.3 VC-2-Xv Layer Trail Termination Functions S2-Xc\_TT

Refer to ITU-T Recommendation G.783 [4], clause 13.5.1.1 "VC-m-Xv Layer Trail Termination Function Sm-Xv\_TT" with  $m = 2$ .

### 7.3.1 VC-2-Xv/VC-2-X Adaptation Source Function S2-Xv/S2-X\_A\_So

Refer to ITU-T Recommendation G.783 [4], clause 13.5.1.1.1 "VC-m-Xv/VC-m-X Adaptation Source Function Sm-Xv/Sm-X\_A\_So" with  $m = 2$ .

### 7.3.2 VC-2-Xv/VC-2-X Adaptation Sink Function S2-Xv/S2-X\_A\_Sk

Refer to ITU-T Recommendation G.783 [4], clause 13.5.1.1.2 "VC-m-Xv/VC-m-X Adaptation Sink Function Sm-Xv/Sm-X\_A\_Sk" with  $m = 2$ .

### 7.3.3 VC-2-Xv Layer Trail Termination Source Function S2-Xv\_TT\_So

Refer to ITU-T Recommendation G.783 [4], clause 13.5.1.1.3 "VC-m-Xv/VC-m-X Adaptation Source Function Sm-Xv/Sm-X\_A\_So" with  $m = 2$ .

### 7.3.4 VC-2-Xv Layer Trail Termination Sink Function S2-Xv\_TT\_Sk

Refer to ITU-T Recommendation G.783 [4], clause 13.5.1.1.4 "VC-m-Xv/VC-m-X Adaptation Sink Function Sm-Xv/Sm-X\_A\_Sk" with  $m = 2$ .

## 7.4 VC-2-x Layer Adaptation Functions

### 7.4.1 VC-2-X to HDLC Adaptation Source Function S2-X/HDLC\_A\_So

For further study.

### 7.4.2 VC-2-X to HDLC Adaptation Sink Function S2-X/HDLC\_A\_Sk

For further study.

### 7.4.3 VC-2-X to Avp Adaptation Source Function S2-X/Avp\_A\_So

For further study.

### 7.4.4 VC-2-X to Avp Adaptation Sink Function S2-X/Avp\_A\_Sk

For further study.

### 7.4.5 VC-2-X to TSS4 Adaptation Source Function S2-X/TSS4\_A\_So

Refer to EN 300 417-4-1 [3], clause 6.3.1 "VC-2 Layer to TSS4 Adaptation Source S2/TSS4\_A\_So" with:

- S2 => S2-Xc;
- VC-2 => VC-2-Xc.

### 7.4.6 VC-2-X to TSS4 Adaptation Sink Function S2-X/TSS4\_A\_Sk

Refer to EN 300 417-4-1 [3], clause 6.3.2 "VC-2 Layer to TSS4 Adaptation Sink S3/TSS4\_A\_Sk" with:

- S2 => S2-Xc;
- VC-2 => VC-2-Xc.

## 7.5 VC-2-X Layer Trail Protection Functions

### 7.5.1 VC-2-X Trail Protection Connection Functions S2-XP\_C

#### 7.5.1.1 VC-2-X Layer 1+1 uni-directional Protection Connection Function S2-XP1+1u\_C

Refer to EN 300 417-4-1 [3], clause 6.5.1.1 "VC-2 Layer 1+1 uni-directional Protection Connection Function S2P1+1u\_C" with:

- S2 => S2-Xc;
- VC-2 => VC-2-Xc.

#### 7.5.1.2 VC-2-X Layer 1+1 bi-directional Protection Connection Function S2-XP1+1b\_C

Refer to EN 300 417-4-1 [3], clause 6.5.1.2 "VC-2 Layer 1+1 bi-directional Protection Connection Function S2P1+1b\_C" with:

- S2 => S2-Xc;
- VC-2 => VC-2-Xc.

### 7.5.2 VC-2 Layer Trail Protection Trail Termination Functions

#### 7.5.2.1 VC-2-X Protection Trail Termination Source S2-XP\_TT\_So

Refer to EN 300 417-4-1 [3], clause 6.5.2.1 "VC-2 Protection Trail Termination Source S2P\_TT\_So" with:

- S2 => S2-Xc;
- VC-2 => VC-2-Xc.

### 7.5.2.2 VC-2-X Protection Trail Termination Sink S2-XP\_TT\_Sk

Refer to EN 300 417-4-1 [3], clause 6.5.2.2 "VC-2 Protection Trail Termination Sink S2P\_TT\_Sk" with:

- S2 => S2-Xc;
- VC-2 => VC-2-Xc.

### 7.5.3 VC-2 Layer Linear Trail Protection Adaptation Functions

#### 7.5.3.1 VC-2-X trail to VC-2-X trail Protection Layer Adaptation Source S2-X/S2-XP\_A\_So

Refer to EN 300 417-4-1 [3], clause 6.5.3.1 "VC-2 trail to VC-2 trail Protection Layer Adaptation Source S2/S2P\_A\_So" with:

- S2 => S2-Xc;
- VC-2 => VC-2-Xc.

#### 7.5.3.2 VC-2-X trail to VC-2-X trail Protection Layer Adaptation Sink S2-X/S2-XP\_A\_Sk

Refer to EN 300 417-4-1 [3], clause 6.5.3.2 "VC-2 trail to VC-2 trail Protection Layer Adaptation Sink S2/S2P\_A\_Sk" with:

- S2 => S2-Xc;
- VC-2 => VC-2-Xc.

## 7.6 VC-2-X layer clock adaptation source (S2-X-LC\_A\_So)

**Symbol and interfaces:**

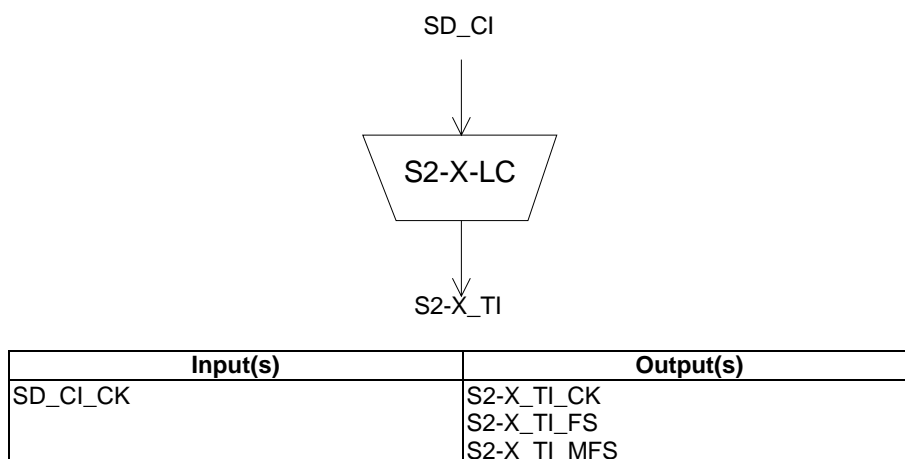

**Figure 25: S2-X-LC\_A\_So symbol and in/ output signals**

**Processes:**

This function performs the VC-2-X clock and frame start signal generation locked to the network element clock signal SD\_CI\_CK, to time the adaptation source and connection functions in this layer.

**Clock generation:** The function shall generate the clock (bit) reference signal S2-X\_TI\_CK for the VC-2-X signal. The S2-X\_TI\_CK frequency shall be  $X \cdot 6\,848$  kHz locked to the input signal SD\_CI\_CK.

**Jitter limiter:** For Further study.

Frame Start signal generation: The function shall generate the frame start reference signal S2-X\_TI\_FS for the VC-2-X signal. The S2-X\_TI\_FS signal shall be active once per  $X \cdot 3424$  clock cycle and the multiframe reference S2-X\_TI\_MFS shall be active once every 1 024 frames.

<b>Defects:</b>	None.
<b>Consequent Actions:</b>	None.
<b>Defect Correlations:</b>	None.
<b>Performance Monitoring:</b>	None.

## 8 Concatenated VC-12 path layer functions

### 8.1 Atomic functions overview

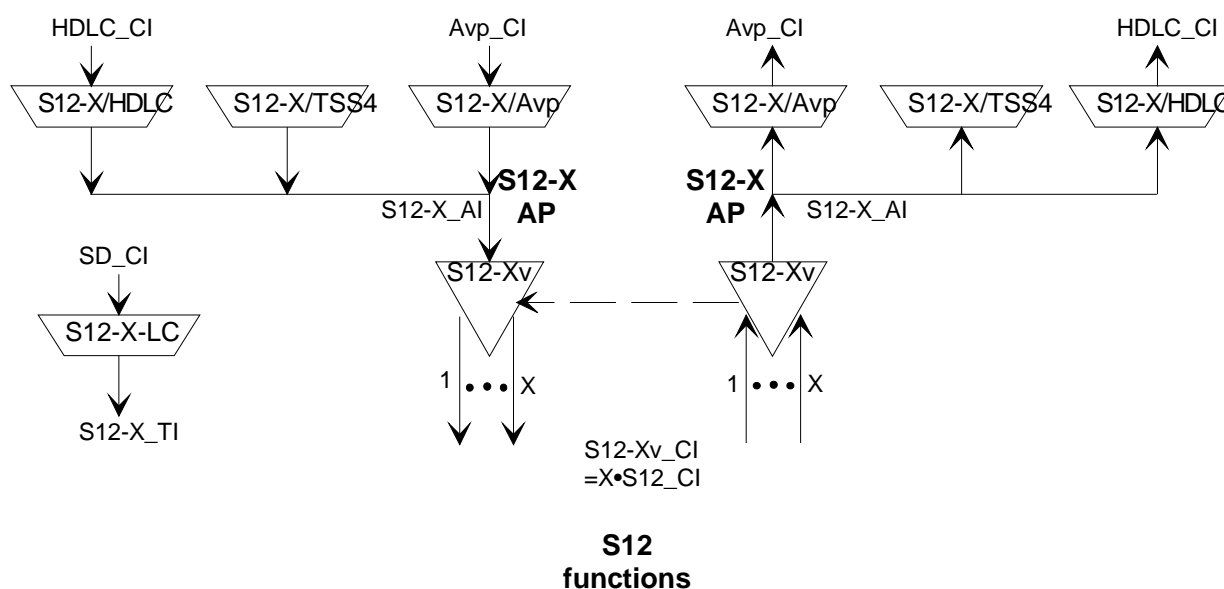

**Figure 26: Concatenated VC-12 path layer atomic functions**

Figure 26 shows the set of atomic functions for the concatenated VC-12 path layer. Figure 27 shows the additional functions for the concatenated VC-12 layer trail protection.

Figures 26 and 27 show that more than one adaptation function exists in the S12-X layer that can be connected to one S12-X access point. For such cases, a subset of these adaptation source functions is allowed to be activated together, but only one adaptation source function may have access to a specific timeslot. Access to the same timeslot by other adaptation source functions shall be denied. In contradiction with the source direction, adaptation sink functions may be activated all together. This may cause faults to be detected and reported. To prevent this an adaptation sink function can be deactivated.

**NOTE:** If one adaptation function only is connected to the AP, it will be activated. If one or more other functions are connected to the same AP accessing the same timeslot, one out of the set of functions will be active.

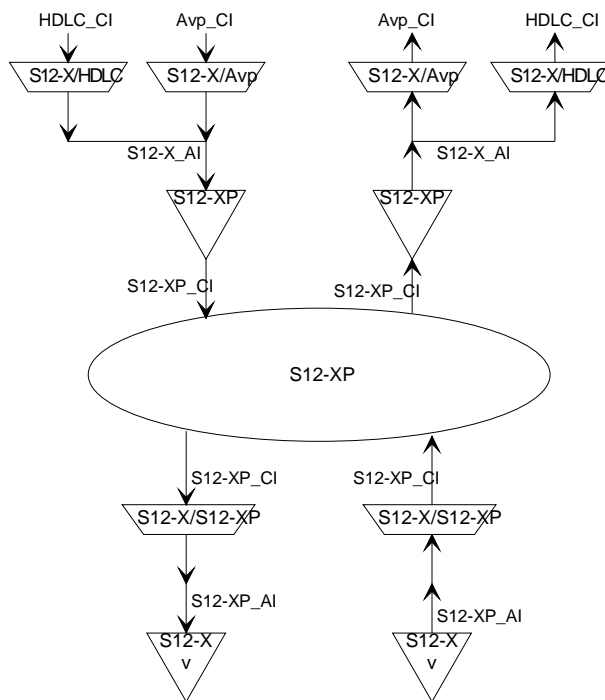

Figure 27: Concatenated VC-12 Layer Trail Protection atomic functions

## 8.2 Layer information

### 8.2.1 VC-12-X layer access point

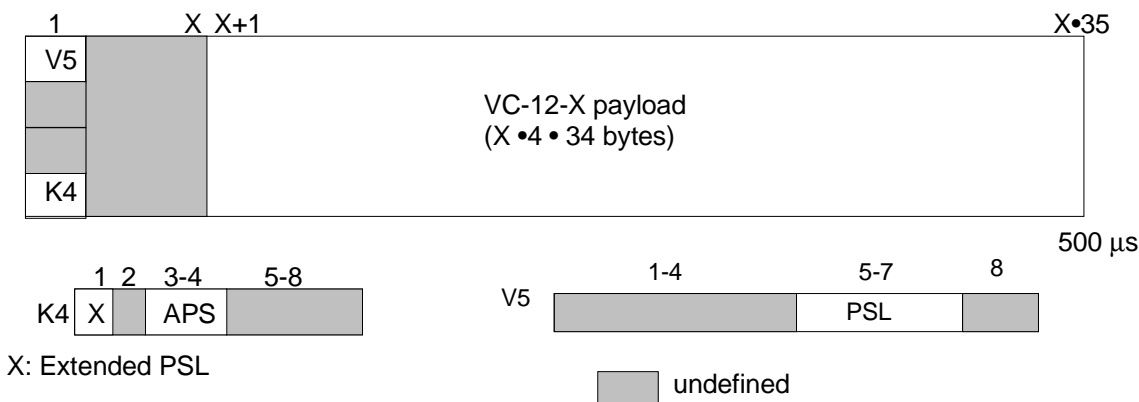

Figure 28: S12-X\_AI\_D

The VC-12-X AI (S12-X\_AI\_D) at this point is octet structured with an 500 μs frame. It represents adapted client layer information comprising  $X \cdot 424$  bytes of client layer information, the signal label in bits 5-7 of the V5 byte as defined in EN 300 147 [5]. For the case the signal has passed the trail protection sublayer, S12\_AI has defined APS bits (3 to 4) in byte K4.

NOTE 1: The APS signal has not been defined; a multiframed APS signal might be required.

NOTE 2: Bits 3 to 4 of byte K4 will be undefined when the signal S12-X\_AI has not been processed in a trail protection connection function S12-XP\_C.



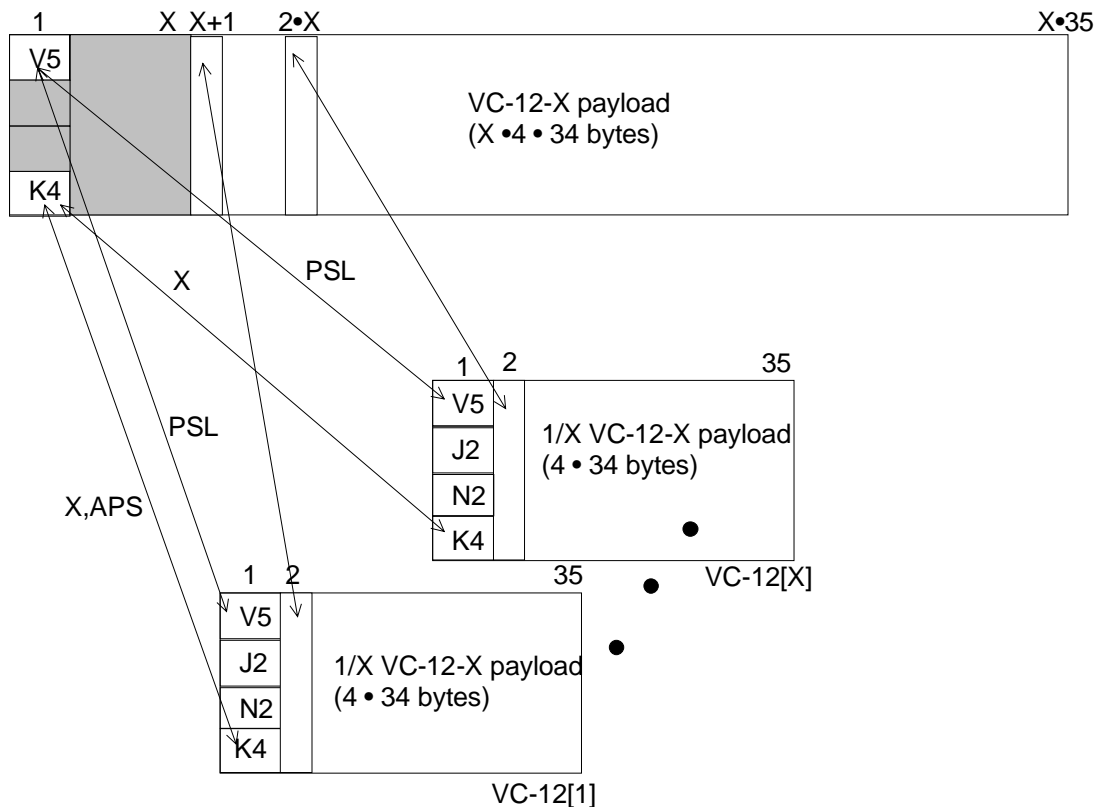

Figure 30: S12-X\_AI\_D to S12-Xv\_CI\_D mapping

### 8.2.4 VC-12-XP layer access point

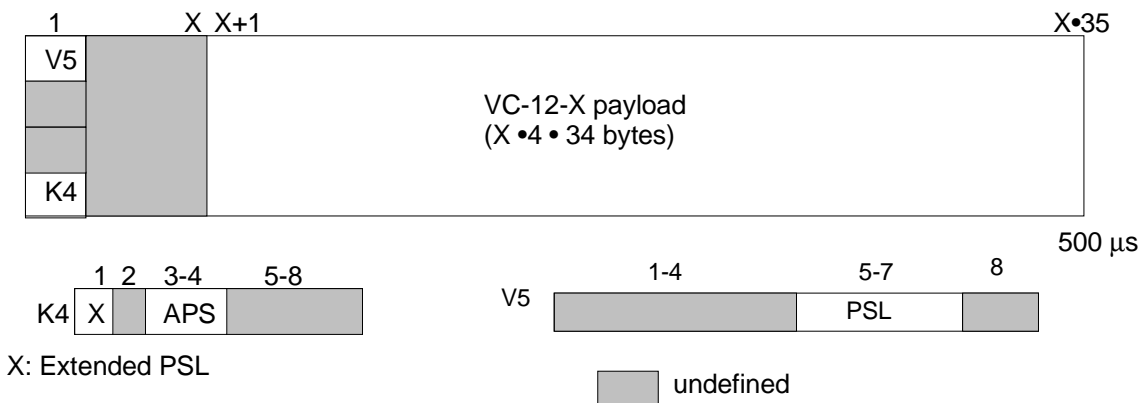
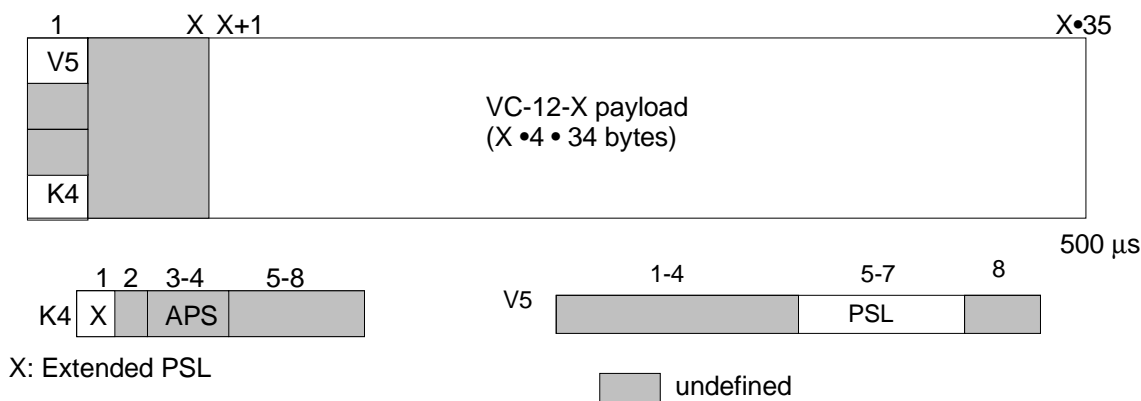

Figure 31: S12-XP\_AI\_D

The S12-XP AI is identical to the S12-X AI with defined APS information if the protection scheme uses it.

## 8.2.5 VC-12XP layer connection point



**Figure 32: S12-XP\_CI\_D**

The S12-XP CI is identical to the S12-X AI, with undefined APS information.

## 8.3 VC-12-Xv Layer Trail Termination Functions S12-Xc\_TT

Refer to ITU-T Recommendation G.783 [4], clause 13.5.1.1 "VC-m-Xv Layer Trail Termination Function Sm-Xv\_TT" with m = 12.

### 8.3.1 VC-12-Xv/VC-12-X Adaptation Source Function S12-Xv/S12-X\_A\_So

Refer to ITU-T Recommendation G.783 [4], clause 13.5.1.1.1 "VC-m-Xv/VC-m-X Adaptation Source Function Sm-Xv/Sm-X\_A\_So" with m = 12.

### 8.3.2 VC-12-Xv/VC-12-X Adaptation Sink Function S12-Xv/S12-X\_A\_Sk

Refer to ITU-T Recommendation G.783 [4], clause 13.5.1.1.2 "VC-m-Xv/VC-m-X Adaptation Sink Function Sm-Xv/Sm-X\_A\_Sk" with m = 12.

### 8.3.3 VC-12-Xv Layer Trail Termination Source Function S12-Xv\_TT\_So

Refer to ITU-T Recommendation G.783 [4], clause 13.5.1.1.3 "VC-m-Xv/VC-m-X Adaptation Source Function Sm-Xv/Sm-X\_A\_So" with m = 12.

### 8.3.4 VC-12-Xv Layer Trail Termination Sink Function S12-Xv\_TT\_Sk

Refer to ITU-T Recommendation G.783 [4], clause 13.5.1.1.4 "VC-m-Xv/VC-m-X Adaptation Sink Function Sm-Xv/Sm-X\_A\_Sk" with m = 12.

## 8.4 VC-12-x Layer Adaptation Functions

### 8.4.1 VC-12-X to HDLC Adaptation Source Function S12-X/HDLC\_A\_So

For further study.

### 8.4.2 VC-12-X to HDLC Adaptation Sink Function S12-X/HDLC\_A\_Sk

For further study.



### 8.4.3 VC-12-X to Avp Adaptation Source Function S12-X/Avp\_A\_So

For further study.

### 8.4.4 VC-12-X to Avp Adaptation Sink Function S12-X/Avp\_A\_Sk

For further study.

### 8.4.5 VC-12-X to TSS4 Adaptation Source Function S12-X/TSS4\_A\_So

Refer to EN 300 417-4-1 [3], clause 7.3.7 "VC-12 Layer to TSS4 Adaptation Source S12/TSS4\_A\_So" with:

- S12 => S12-Xc;
- VC-12 => VC-12-Xc.

### 8.4.6 VC-12-X to TSS4 Adaptation Sink Function S12-X/TSS4\_A\_Sk

Refer to EN 300 417-4-1 [3], clause 7.3.8 "VC-12 Layer to TSS4 Adaptation Sink S3/TSS4\_A\_Sk" with:

- S12 => S12-Xc;
- VC-12 => VC-12-Xc.

## 8.5 VC-12-X Layer Trail Protection Functions

### 8.5.1 VC-12-X Trail Protection Connection Functions S12-XP\_C

#### 8.5.1.1 VC-12-X Layer 1+1 uni-directional Protection Connection Function S12-XP1+1u\_C

Refer to EN 300 417-4-1 [3], clause 7.5.1.1 "VC-12 Layer 1+1 uni-directional Protection Connection Function S12P1+1u\_C" with:

- S12 => S12-Xc;
- VC-12 => VC-12-Xc.

#### 8.5.1.2 VC-12-X Layer 1+1 bi-directional Protection Connection Function S12-XP1+1b\_C

Refer to EN 300 417-4-1 [3], clause 7.5.1.2 "VC-12 Layer 1+1 bi-directional Protection Connection Function S12P1+1b\_C" with:

- S12 => S12-Xc;
- VC-12 => VC-12-Xc.

### 8.5.2 VC-12 Layer Trail Protection Trail Termination Functions

#### 8.5.2.1 VC-12-X Protection Trail Termination Source S12-XP\_TT\_So

Refer to EN 300 417-4-1 [3], clause 7.5.2.1 "VC-12 Protection Trail Termination Source S12P\_TT\_So" with:

- S12 => S12-Xc;
- VC-12 => VC-12-Xc.

### 8.5.2.2 VC-12-X Protection Trail Termination Sink S12-XP\_TT\_Sk

Refer to EN 300 417-4-1 [3], clause 7.5.2.2 "VC-12 Protection Trail Termination Sink S12P\_TT\_Sk" with:

- S12 => S12-Xc;
- VC-12 => VC-12-Xc.

### 8.5.3 VC-12 Layer Linear Trail Protection Adaptation Functions

#### 8.5.3.1 VC-12-X trail to VC-12-X trail Protection Layer Adaptation Source S12-X/S12-XP\_A\_So

Refer to EN 300 417-4-1 [3], clause 7.5.3.1 "VC-12 trail to VC-12 trail Protection Layer Adaptation Source S12/S12P\_A\_So" with:

- S12 => S12-Xc;
- VC-12 => VC-12-Xc.

#### 8.5.3.2 VC-12-X trail to VC-12-X trail Protection Layer Adaptation Sink S12-X/S12-XP\_A\_Sk

Refer to EN 300 417-4-1 [3], clause 7.5.3.2 "VC-12 trail to VC-12 trail Protection Layer Adaptation Sink S12/S12P\_A\_Sk" with:

- S12 => S12-Xc;
- VC-12 => VC-12-Xc.

## 8.6 VC-12-X layer clock adaptation source (S12-X-LC\_A\_So)

**Symbol and interfaces:**

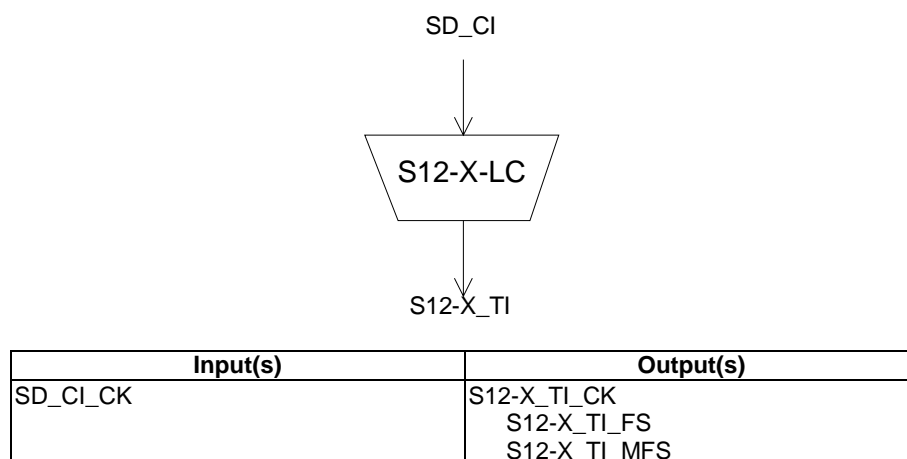

**Figure 33: S12-X-LC\_A\_So symbol and in/output signals**

**Processes:**

This function performs the VC-12-X clock and frame start signal generation locked to the network element clock signal SD\_CI\_CK, to time the adaptation source and connection functions in this layer.

**Clock generation:** The function shall generate the clock (bit) reference signal S12-X\_TI\_CK for the VC-12-X signal. The S12-X\_TI\_CK frequency shall be  $X \cdot 2\,240$  kHz locked to the input signal SD\_CI\_CK.

**Jitter limiter:** For Further study.

Frame Start signal generation: The function shall generate the frame start reference signal S12-X\_TI\_FS for the VC-12-X signal. The S12-X\_TI\_FS signal shall be active once per  $X \cdot 1\,120$  clock cycle and the multiframe reference S12-X\_TI\_MFS shall be active once every 1 024 frames.

**Defects:** None.

**Consequent Actions:** None.

**Defect Correlations:** None.

**Performance Monitoring:** None.

## Annex A (informative): Concatenated VC-11 path layer functions

### A.1 Atomic functions overview

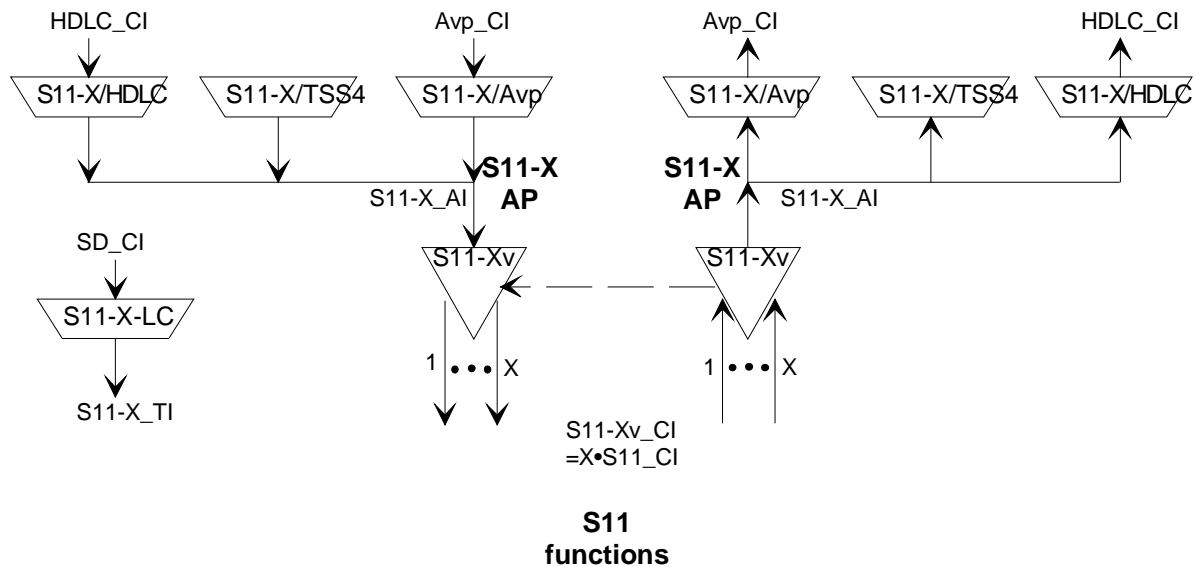

**Figure A.1: Concatenated VC-11 path layer atomic functions**

Figure A.1 shows the set of atomic functions for the concatenated VC-11 path layer. Figure A.2 shows the additional functions for the concatenated VC-11 layer trail protection.

Figures A.1 and A.2 show that more than one adaptation function exists in the S11-X layer that can be connected to one S11-X access point. For such cases, a subset of these adaptation source functions is allowed to be activated together, but only one adaptation source function may have access to a specific timeslot. Access to the same timeslot by other adaptation source functions shall be denied. In contradiction with the source direction, adaptation sink functions may be activated all together. This may cause faults to be detected and reported. To prevent this an adaptation sink function can be deactivated.

**NOTE:** If one adaptation function only is connected to the AP, it will be activated. If one or more other functions are connected to the same AP accessing the same timeslot, one out of the set of functions will be active.

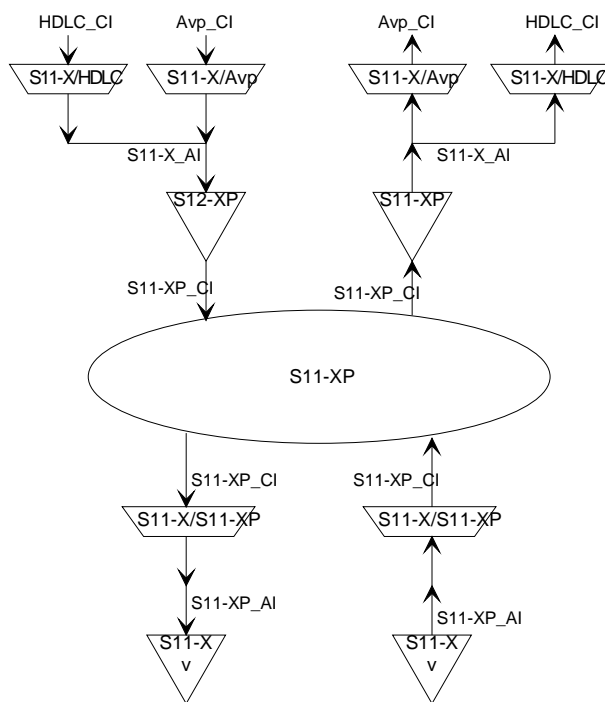

Figure A.2: Concatenated VC-11 Layer Trail Protection atomic functions

## A.2 Layer information

### A.2.1 VC-11-X layer access point

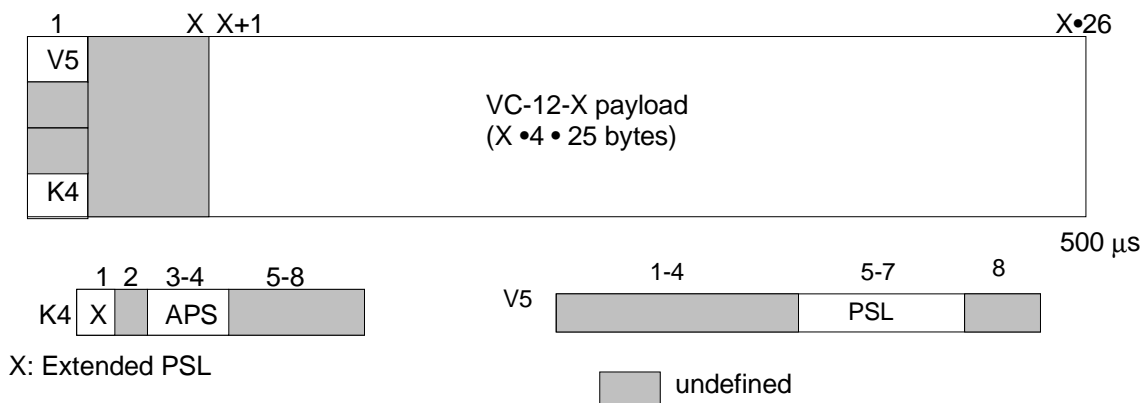

Figure A.3: S11-X\_AI\_D

The VC-11-X AI (S11-X\_AI\_D) at this point is octet structured with an 500 μs frame. It represents adapted client layer information comprising  $X \cdot 424$  bytes of client layer information, the signal label in bits 5-7 of the V5 byte as defined in EN 300 147 [5]. For the case the signal has passed the trail protection sublayer, S11\_AI has defined APS bits (3 to 4) in byte K4.

NOTE 1: The APS signal has not been defined; a multiframed APS signal might be required.

NOTE 2: Bits 3 to 4 of byte K4 will be undefined when the signal S11-X\_AI has not been processed in a trail protection connection function S11-XP\_C.

A VC-11-X comprises one of the following payloads:

- an ATM X • 1 600 kbit/s cell stream signal;
- an PPP X • 1 600 kbit/s cell stream signal;
- a Test Signal Structure (TSS4).

### A.2.2 VC-11-X layer connection point

A VC-11 concatenated trail is transported via virtual concatenated VC-11 (VC-11-Xv) connections.

For a virtual concatenated VC-11-Xv connection all values for X ≥ 1 are allowed.

### A.2.3 VC-11-Xv layer connection point

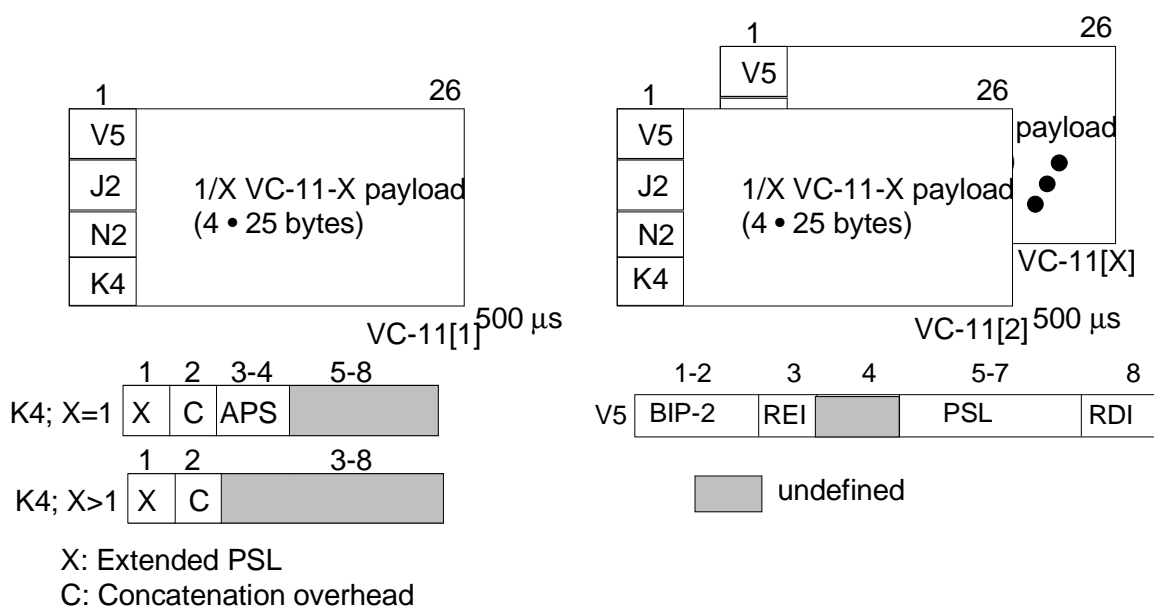

**Figure A.4: S11-Xv\_CI\_D**

The CI of a VC-11-Xv (S11-Xv\_CI\_D) consists of X times S11\_CI as defined in EN 300 417-1-1 [1]. The H4 byte is generated as defined in EN 300 147 [5].

The mapping of S11-X\_AI to S11-Xv\_CI is performed as shown in figure A.5.

NOTE: K4, bits 3-4 (APS) of VC-11[2...X] are undefined.

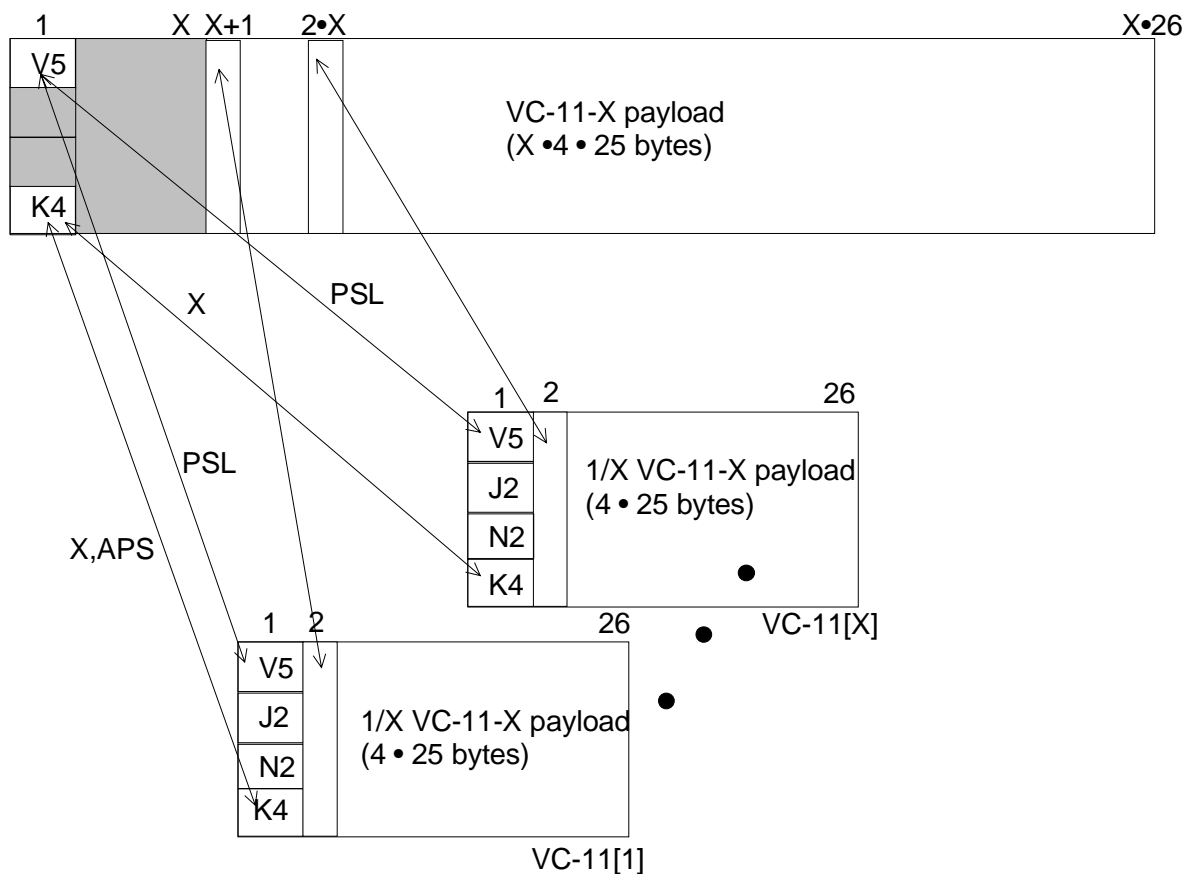

Figure A.5: S11-X\_AI\_D to S11-Xv\_CI\_D mapping

### A.2.4 VC-11-XP layer access point

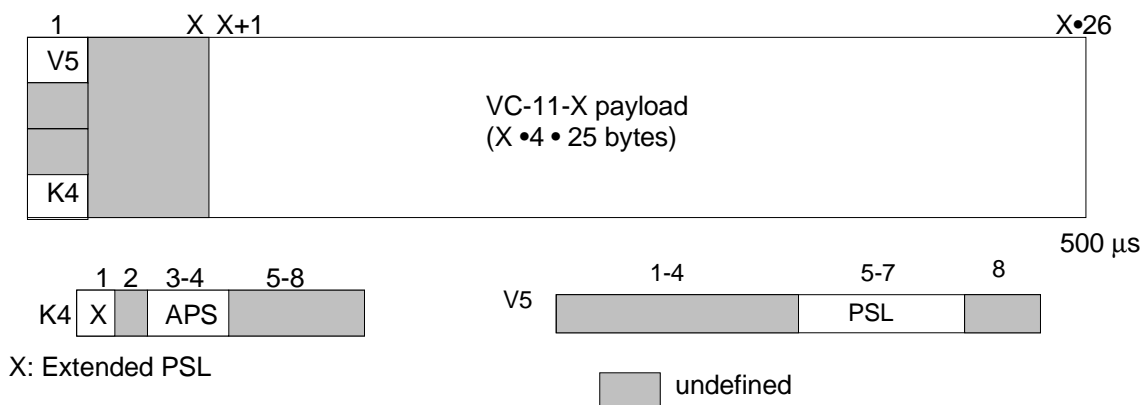
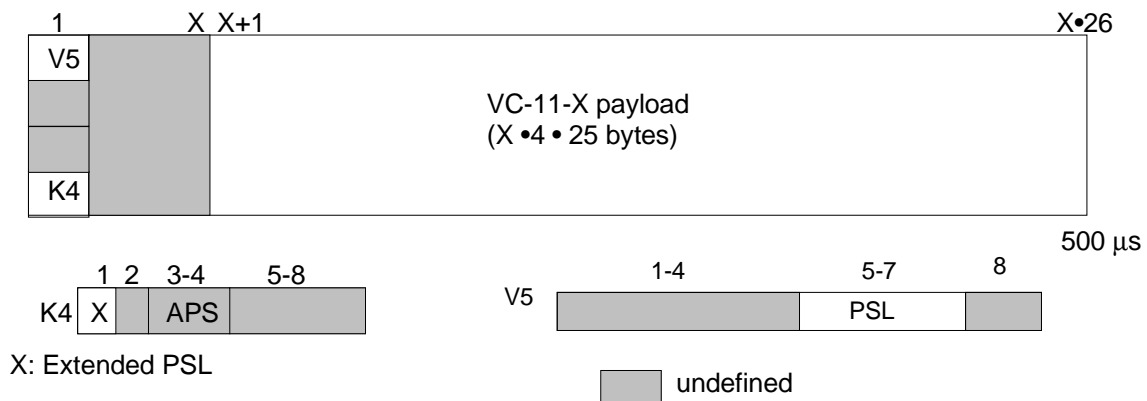

Figure A.6: S11-XP\_AI\_D

The S11-XP AI is identical to the S11-X AI with defined APS information if the protection scheme uses it.

## A.2.5 VC-11XP layer connection point



**Figure A.7: S11-XP\_CI\_D**

The S11-XP CI is identical to the S11-X AI, with undefined APS information.

---

## A.3 VC-11-Xv Layer Trail Termination Functions S11-Xc\_TT

Refer to ITU-T Recommendation G.783 [4], clause 13.5.1.1 "VC-m-Xv Layer Trail Termination Function Sm-Xv\_TT" with m = 11.

### A.3.1 VC-11-Xv/VC-11-X Adaptation Source Function S11-Xv/S11-X\_A\_So

Refer to ITU-T Recommendation G.783 [4], clause 13.5.1.1.1 "VC-m-Xv/VC-m-X Adaptation Source Function Sm-Xv/Sm-X\_A\_So" with m = 11.

### A.3.2 VC-11-Xv/VC-11-X Adaptation Sink Function S11-Xv/S11-X\_A\_Sk

Refer to ITU-T Recommendation G.783 [4], clause 13.5.1.1.2 "VC-m-Xv/VC-m-X Adaptation Sink Function Sm-Xv/Sm-X\_A\_Sk" with m = 11.

### A.3.3 VC-11-Xv Layer Trail Termination Source Function S11-Xv\_TT\_So

Refer to ITU-T Recommendation G.783 [4], clause 13.5.1.1.3 "VC-m-Xv/VC-m-X Adaptation Source Function Sm-Xv/Sm-X\_A\_So" with m = 11.

### A.3.4 VC-11-Xv Layer Trail Termination Sink Function S11-Xv\_TT\_Sk

Refer to ITU-T Recommendation G.783 [4], clause 13.5.1.1.4 "VC-m-Xv/VC-m-X Adaptation Sink Function Sm-Xv/Sm-X\_A\_Sk" with m = 11.



---

## A.4 VC-11-x Layer Adaptation Functions

### A.4.1 VC-11-X to HDLC Adaptation Source Function S11-X/HDLC\_A\_So

For further study.

### A.4.2 VC-11-X to HDLC Adaptation Sink Function S11-X/HDLC\_A\_Sk

For further study.

### A.4.3 VC-11-X to Avp Adaptation Source Function S11-X/Avp\_A\_So

For further study.

### A.4.4 VC-11-X to Avp Adaptation Sink Function S11-X/Avp\_A\_Sk

For further study.

### A.4.5 VC-11-X to TSS4 Adaptation Source Function S11-X/TSS4\_A\_So

Refer to EN 300 417-4-1 [3], clause F.3.3 "VC-11 Layer to TSS4 Adaptation Source S11/TSS4\_A\_So" with:

- S11 => S11-Xc;
- VC-11 => VC-11-Xc.

### A.4.6 VC-11-X to TSS4 Adaptation Sink Function S11-X/TSS4\_A\_Sk

Refer to EN 300 417-4-1 [3], clause F.3.4 "VC-11 Layer to TSS4 Adaptation Sink S3/TSS4\_A\_Sk" with:

- S11 => S11-Xc;
- VC-11 => VC-11-Xc.

---

## A.5 VC-11-X Layer Trail Protection Functions

### A.5.1 VC-11-X Trail Protection Connection Functions S11-XP\_C

#### A.5.1.1 VC-11-X Layer 1+1 uni-directional Protection Connection Function S11-XP1+1u\_C

Refer to EN 300 417-4-1 [3], clause F.5.1.1 "VC-11 Layer 1+1 uni-directional Protection Connection Function S11P1+1u\_C" with:

- S11 => S11-Xc;
- VC-11 => VC-11-Xc.

#### A.5.1.2 VC-11-X Layer 1+1 bi-directional Protection Connection Function S11-XP1+1b\_C

Refer to EN 300 417-4-1 [3], clause F.5.1.2 "VC-11 Layer 1+1 bi-directional Protection Connection Function S11P1+1b\_C" with:

- S11 => S11-Xc;
- VC-11 => VC-11-Xc.

### A.5.2 VC-11 Layer Trail Protection Trail Termination Functions

#### A.5.2.1 VC-11-X Protection Trail Termination Source S11-XP\_TT\_So

Refer to EN 300 417-4-1 [3], clause F.5.2.1 "VC-11 Protection Trail Termination Source S11P\_TT\_So" with:

- S11 => S11-Xc;
- VC-11 => VC-11-Xc.

#### A.5.2.2 VC-11-X Protection Trail Termination Sink S11-XP\_TT\_Sk

Refer to EN 300 417-4-1 [3], clause F.5.2.2 "VC-11 Protection Trail Termination Sink S11P\_TT\_Sk" with:

- S11 => S11-Xc;
- VC-11 => VC-11-Xc.

### A.5.3 VC-11 Layer Linear Trail Protection Adaptation Functions

#### A.5.3.1 VC-11-X trail to VC-11-X trail Protection Layer Adaptation Source S11-X/S11-XP\_A\_So

Refer to EN 300 417-4-1 [3], clause F.5.3.1 "VC-11 trail to VC-11 trail Protection Layer Adaptation Source S11/S11P\_A\_So" with:

- S11 => S11-Xc;
- VC-11 => VC-11-Xc.

### A.5.3.2 VC-11-X trail to VC-11-X trail Protection Layer Adaptation Sink S11-X/S11-XP\_A\_Sk

Refer to EN 300 417-4-1 [3], clause F.5.3.2 "VC-11 trail to VC-11 trail Protection Layer Adaptation Sink S11/S11P\_A\_Sk" with:

- S11 => S11-Xc;
- VC-11 => VC-11-Xc.

## A.6 VC-11-X layer clock adaptation source (S11-X-LC\_A\_So)

**Symbol and interfaces:**

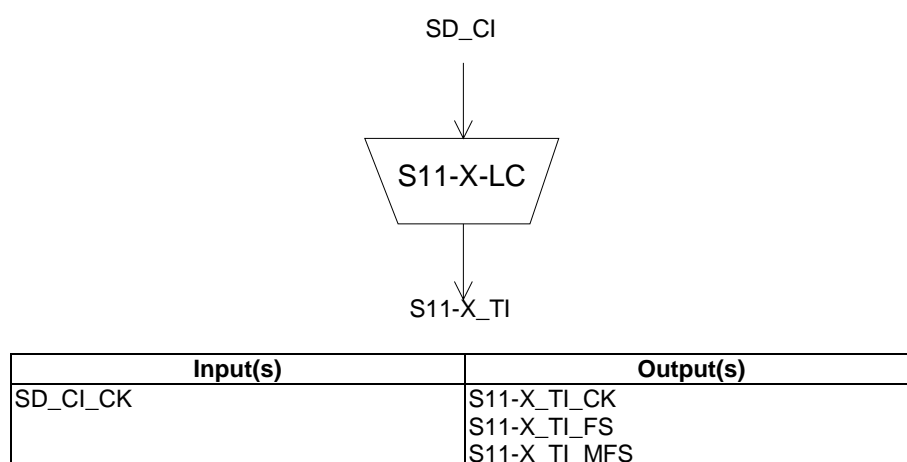

**Figure A.8: S11-X-LC\_A\_So symbol and in/output signals**

**Processes:**

This function performs the VC-11-X clock and frame start signal generation locked to the network element clock signal SD\_CI\_CK, to time the adaptation source and connection functions in this layer.

**Clock generation:** The function shall generate the clock (bit) reference signal S11-X\_TI\_CK for the VC-11-X signal. The S11-X\_TI\_CK frequency shall be  $X \cdot 1\,664$  kHz locked to the input signal SD\_CI\_CK.

**Jitter limiter:** For Further study.

**Frame Start signal generation:** The function shall generate the frame start reference signal S11-X\_TI\_FS for the VC-11-X signal. The S11-X\_TI\_FS signal shall be active once per  $X \cdot 832$  clock cycle and the multiframe reference S11-X\_TI\_MFS shall be active once every 1 024 frames.

**Defects:** None.

**Consequent Actions:** None.

**Defect Correlations:** None.

**Performance Monitoring:** None.

---

## History

<b>Document history</b>		
V1.1.1	May 2001	One-step Approval Procedure OAP 20010921: 2001-05-23 to 2001-09-21
V1.1.1	September 2001	Publication