

EN 300 417-3-1 V1.1.2 (1998-11)

European Standard (Telecommunications series)

**Transmission and Multiplexing (TM);
Generic requirements of transport functionality of equipment;
Part 3-1: Synchronous Transport Module-N (STM-N)
regenerator and multiplex section layer functions**



Reference

REN/TM-01015-3-1 (3v0r9idc.PDF)

Keywords

Transmission, SDH, interface

ETSI

Postal address

F-06921 Sophia Antipolis Cedex - FRANCE

Office address

650 Route des Lucioles - Sophia Antipolis
Valbonne - FRANCE
Tel.: +33 4 92 94 42 00 Fax: +33 4 93 65 47 16
Siret N° 348 623 562 00017 - NAF 742 C
Association à but non lucratif enregistrée à la
Sous-Préfecture de Grasse (06) N° 7803/88

Internet

secretariat@etsi.fr
<http://www.etsi.org>

Copyright Notification

No part may be reproduced except as authorized by written permission.
The copyright and the foregoing restriction extend to reproduction in all media.

© European Telecommunications Standards Institute 1998.
All rights reserved.

Contents

| | |
|--|----|
| Intellectual Property Rights..... | 7 |
| Foreword | 7 |
| 1 Scope..... | 9 |
| 2 References..... | 9 |
| 3 Definitions, abbreviations and symbols..... | 10 |
| 3.1 Definitions | 10 |
| 3.2 Abbreviations..... | 10 |
| 3.3 Symbols and Diagrammatic Conventions | 12 |
| 3.4 Introduction..... | 12 |
| 4 STM-1 Regenerator Section Layer Functions | 13 |
| 4.1 STM-1 Regenerator Section Connection functions..... | 14 |
| 4.2 STM-1 Regenerator Section Trail Termination functions..... | 14 |
| 4.2.1 STM-1 Regenerator Section Trail Termination Source RS1_TT_So..... | 14 |
| 4.2.2 STM-1 Regenerator Section Trail Termination Sink RS1_TT_Sk | 16 |
| 4.3 STM-1 Regenerator Section Adaptation functions | 18 |
| 4.3.1 STM-1 Regenerator Section to Multiplex Section Adaptation Source RS1/MS1_A_So | 18 |
| 4.3.2 STM-1 Regenerator Section to Multiplex Section Adaptation Sink RS1/MS1_A_Sk | 19 |
| 4.3.3 STM-1 Regenerator Section to DCC Adaptation Source RS1/DCC_A_So | 20 |
| 4.3.4 STM-1 Regenerator Section to DCC Adaptation Sink RS1/DCC_A_Sk..... | 21 |
| 4.3.5 STM-1 Regenerator Section to P0s Adaptation Source RS1/P0s_A_So/N..... | 22 |
| 4.3.6 STM-1 Regenerator Section to P0s Adaptation Sink RS1/P0s_A_Sk/N..... | 23 |
| 4.3.7 STM-1 Regenerator Section to V0x Adaptation Source RS1/V0x_A_So..... | 24 |
| 4.3.8 STM-1 Regenerator Section to V0x Adaptation Sink RS1/V0x_A_Sk | 25 |
| 5 STM-1 Multiplex Section Layer Functions | 26 |
| 5.1 STM-1 Multiplex Section Connection functions | 28 |
| 5.2 STM-1 Multiplex Section Trail Termination functions | 28 |
| 5.2.1 STM-1 Multiplex Section Trail Termination Source MS1_TT_So | 28 |
| 5.2.2 STM-1 Multiplex Section Trail Termination Sink MS1_TT_Sk | 29 |
| 5.3 STM-1 Multiplex Section Adaptation functions | 32 |
| 5.3.1 STM-1 Multiplex Section to S4 Layer Adaptation Source MS1/S4_A_So..... | 32 |
| 5.3.2 STM-1 Multiplex Section to S4 Layer Adaptation Sink MS1/S4_A_Sk | 35 |
| 5.3.3 STM-1 Multiplex Section to DCC Adaptation Source MS1/DCC_A_So..... | 37 |
| 5.3.4 STM-1 Multiplex Section to DCC Adaptation Sink MS1/DCC_A_Sk..... | 37 |
| 5.3.5 STM-1 Multiplex Section to P0s Adaptation Source MS1/P0s_A_So..... | 38 |
| 5.3.6 STM-1 Multiplex Section to P0s Adaptation Sink MS1/P0s_A_Sk | 40 |
| 5.3.7 STM-1 Multiplex Section to Synchronization Distribution Adaptation Source MS1/SD_A_So | 41 |
| 5.3.8 STM-1 Multiplex Section to Synchronization Distribution Adaptation Sink MS1/SD_A_Sk | 41 |
| 5.3.9 STM-1 Multiplex Section Layer Clock Adaptation Source MS1-LC_A_So | 41 |
| 5.4 STM-1 Multiplex Section Layer Monitoring Functions..... | 41 |
| 5.5 STM-1 Multiplex Section Linear Trail Protection Functions | 41 |
| 5.5.1 STM-1 Multiplex Section Linear Trail Protection Connection Functions | 41 |
| 5.5.1.1 STM-1 Multiplex Section 1+1 Linear Trail Protection Connection MS1P1+1_C | 41 |
| 5.5.1.2 STM-1 Multiplex Section 1:n Linear Trail Protection Connection MS1P1:n_C..... | 44 |
| 5.5.2 STM-1 Multiplex Section Linear Trail Protection Trail Termination Functions | 46 |
| 5.5.2.1 Multiplex Section Protection Trail Termination Source MS1P_TT_So..... | 46 |
| 5.5.2.2 Multiplex Section Protection Trail Termination Sink MS1P_TT_Sk..... | 47 |
| 5.5.3 STM-1 Multiplex Section Linear Trail Protection Adaptation Functions | 48 |
| 5.5.3.1 STM-1 Multiplex Section to STM-1 Multiplex Section Protection Layer Adaptation Source MS1/MS1P_A_So | 48 |
| 5.5.3.2 STM-1 Multiplex Section to STM-1 Multiplex Section Protection Layer Adaptation Sink MS1/MS1P_A_Sk | 49 |

| | | |
|---------|--|-----|
| 6 | STM-4 Regenerator Section Layer Functions | 50 |
| 6.1 | STM-4 Regenerator Section Connection functions..... | 51 |
| 6.2 | STM-4 Regenerator Section Trail Termination functions..... | 51 |
| 6.2.1 | STM-4 Regenerator Section Trail Termination Source RS4_TT_So..... | 51 |
| 6.2.2 | STM-4 Regenerator Section Trail Termination Sink RS4_TT_Sk | 54 |
| 6.3 | STM-4 Regenerator Section Adaptation functions | 56 |
| 6.3.1 | STM-4 Regenerator Section to Multiplex Section Adaptation Source RS4/MS4_A_So | 56 |
| 6.3.2 | STM-4 Regenerator Section to Multiplex Section Adaptation Sink RS4/MS4_A_Sk | 57 |
| 6.3.3 | STM-4 Regenerator Section to DCC Adaptation Source RS4/DCC_A_So | 58 |
| 6.3.4 | STM-4 Regenerator Section to DCC Adaptation Sink RS4/DCC_A_Sk | 59 |
| 6.3.5 | STM-4 Regenerator Section to P0s Adaptation Source RS4/P0s_A_So/N..... | 60 |
| 6.3.6 | STM-4 Regenerator Section to P0s Adaptation Sink RS4/P0s_A_Sk/N..... | 61 |
| 6.3.7 | STM-4 Regenerator Section to V0x Adaptation Source RS4/V0x_A_So..... | 62 |
| 6.3.8 | STM-4 Regenerator Section to V0x Adaptation Sink RS4/V0x_A_Sk | 63 |
| 7 | STM-4 Multiplex Section Layer Functions | 64 |
| 7.1 | STM-4 Multiplex Section Connection functions | 66 |
| 7.2 | STM-4 Multiplex Section Trail Termination functions | 67 |
| 7.2.1 | STM-4 Multiplex Section Trail Termination Source MS4_TT_So | 67 |
| 7.2.2 | STM-4 Multiplex Section Trail Termination Sink MS4_TT_Sk | 69 |
| 7.3 | STM-4 Multiplex Section Adaptation functions | 72 |
| 7.3.1 | STM-4 Multiplex Section to S4 Layer Adaptation Source MS4/S4_A_So/N..... | 72 |
| 7.3.2 | STM-4 Multiplex Section to S4 Layer Adaptation Sink MS4/S4_A_Sk/N | 75 |
| 7.3.3 | STM-4 Multiplex Section to S4-4c Layer Adaptation Source MS4/S4-4c_A_So | 77 |
| 7.3.4 | STM-4 Multiplex Section to S4-4c Layer Adaptation Sink MS4/S4-4c_A_Sk | 80 |
| 7.3.5 | STM-4 Multiplex Section to DCC Adaptation Source MS4/DCC_A_So | 82 |
| 7.3.6 | STM-4 Multiplex Section to DCC Adaptation Sink MS4/DCC_A_Sk..... | 83 |
| 7.3.7 | STM-4 Multiplex Section to P0s Adaptation Source MS4/P0s_A_So..... | 84 |
| 7.3.8 | STM-4 Multiplex Section to P0s Adaptation Sink MS4/P0s_A_Sk | 85 |
| 7.3.9 | STM-4 Multiplex Section to Synchronization Distribution Adaptation Source MS4/SD_A_So | 86 |
| 7.3.10 | STM-4 Multiplex Section to Synchronization Distribution Adaptation Sink MS4/SD_A_Sk | 86 |
| 7.3.11 | STM-4 Multiplex Section Layer Clock Adaptation Source MS4-LC_A_So | 86 |
| 7.4 | STM-4 Multiplex Section Layer Monitoring Functions..... | 86 |
| 7.5 | STM-4 Multiplex Section Linear Trail Protection Functions | 86 |
| 7.5.1 | STM-4 Multiplex Section Linear Trail Protection Connection Functions | 86 |
| 7.5.1.1 | STM-4 Multiplex Section 1+1 Linear Trail Protection Connection MS4P1+1_C | 86 |
| 7.5.1.2 | STM-4 Multiplex Section 1:n Linear Trail Protection Connection MS4P1:n_C..... | 89 |
| 7.5.2 | STM-4 Multiplex Section Linear Trail Protection Trail Termination Functions | 91 |
| 7.5.2.1 | Multiplex Section Protection Trail Termination Source MS4P_TT_So..... | 91 |
| 7.5.2.2 | Multiplex Section Protection Trail Termination Sink MS4P_TT_Sk..... | 92 |
| 7.5.3 | STM-4 Multiplex Section Linear Trail Protection Adaptation Functions | 93 |
| 7.5.3.1 | STM-4 Multiplex Section to STM-4 Multiplex Section Protection Layer Adaptation Source MS4/MS4P_A_So | 93 |
| 7.5.3.2 | STM-4 Multiplex Section to STM-4 Multiplex Section Protection Layer Adaptation Sink MS4/MS4P_A_Sk | 94 |
| 8 | STM-16 Regenerator Section Layer Functions | 95 |
| 8.1 | STM-16 Regenerator Section Connection functions..... | 96 |
| 8.2 | STM-16 Regenerator Section Trail Termination functions..... | 96 |
| 8.2.1 | STM-16 Regenerator Section Trail Termination Source RS16_TT_So..... | 96 |
| 8.2.2 | STM-16 Regenerator Section Trail Termination Sink RS16_TT_Sk | 99 |
| 8.3 | STM-16 Regenerator Section Adaptation functions | 101 |
| 8.3.1 | STM-16 Regenerator Section to Multiplex Section Adaptation Source RS16/MS16_A_So | 101 |
| 8.3.2 | STM-16 Regenerator Section to Multiplex Section Adaptation Sink RS16/MS16_A_Sk..... | 102 |
| 8.3.3 | STM-16 Regenerator Section to DCC Adaptation Source RS16/DCC_A_So | 103 |
| 8.3.4 | STM-16 Regenerator Section to DCC Adaptation Sink RS16/DCC_A_Sk..... | 104 |
| 8.3.5 | STM-16 Regenerator Section to P0s Adaptation Source RS16/P0s_A_So/N..... | 105 |
| 8.3.6 | STM-16 Regenerator Section to P0s Adaptation Sink RS16/P0s_A_Sk/N..... | 106 |
| 8.3.7 | STM-16 Regenerator Section to V0x Adaptation Source RS16/V0x_A_So..... | 107 |
| 8.3.8 | STM-16 Regenerator Section to V0x Adaptation Sink RS16/V0x_A_Sk | 108 |

| | | |
|---------|---|-----|
| 9 | STM-16 Multiplex Section Layer Functions | 109 |
| 9.1 | STM-16 Multiplex Section Connection functions | 114 |
| 9.2 | STM-16 Multiplex Section Trail Termination functions | 114 |
| 9.2.1 | STM-16 Multiplex Section Trail Termination Source MS16_TT_So | 114 |
| 9.2.2 | STM-16 Multiplex Section Trail Termination Sink MS16_TT_Sk | 116 |
| 9.3 | STM-16 Multiplex Section Adaptation functions | 118 |
| 9.3.1 | STM-16 Multiplex Section to S4 Layer Adaptation Source MS16/S4_A_So/N..... | 118 |
| 9.3.2 | STM-16 Multiplex Section to S4 Layer Adaptation Sink MS16/S4_A_Sk/N | 121 |
| 9.3.3 | STM-16 Multiplex Section to S4-4c Layer Adaptation Source MS16/S4-4c_A_So/N..... | 123 |
| 9.3.4 | STM-16 Multiplex Section to S4-4c Layer Adaptation Sink MS16/S4-4c_A_Sk/N | 126 |
| 9.3.5 | STM-16 Multiplex Section to DCC Adaptation Source MS16/DCC_A_So..... | 128 |
| 9.3.6 | STM-16 Multiplex Section to DCC Adaptation Sink MS16/DCC_A_Sk..... | 129 |
| 9.3.7 | STM-16 Multiplex Section to P0s Adaptation Source MS16/P0s_A_So..... | 130 |
| 9.3.8 | STM-16 Multiplex Section to P0s Adaptation Sink MS16/P0s_A_Sk | 131 |
| 9.3.9 | STM-16 Multiplex Section to Synchronization Distribution Adaptation Source MS16/SD_A_So | 132 |
| 9.3.10 | STM-16 Multiplex Section to Synchronization Distribution Adaptation Sink MS16/SD_A_Sk..... | 132 |
| 9.3.11 | STM-16 Multiplex Section Layer Clock Adaptation Source MS16-LC_A_So | 132 |
| 9.4 | STM-16 Multiplex Section Layer Monitoring Functions..... | 132 |
| 9.5 | STM-16 Multiplex Section Linear Trail Protection Functions | 132 |
| 9.5.1 | STM-16 Multiplex Section Linear Trail Protection Connection Functions | 132 |
| 9.5.1.1 | STM-16 Multiplex Section 1+1 Linear Trail Protection Connection MS16P1+1_C | 132 |
| 9.5.1.2 | STM-16 Multiplex Section 1:n Linear Trail Protection Connection MS16P1:n_C..... | 135 |
| 9.5.2 | STM-16 Multiplex Section Linear Trail Protection Trail Termination Functions | 137 |
| 9.5.2.1 | Multiplex Section Protection Trail Termination Source MS16P_TT_So..... | 137 |
| 9.5.2.2 | Multiplex Section Protection Trail Termination Sink MS16P_TT_Sk..... | 138 |
| 9.5.3 | STM-16 Multiplex Section Linear Trail Protection Adaptation Functions | 139 |
| 9.5.3.1 | STM-16 Multiplex Section to STM-16 Multiplex Section Protection Layer Adaptation Source MS16/MS16P_A_So | 139 |
| 9.5.3.2 | STM-16 Multiplex Section to STM-16 Multiplex Section Protection Layer Adaptation Sink MS16/MS16P_A_Sk | 140 |
| 9.6 | STM-16 Multiplex Section 2 Fibre Shared Protection Ring Functions | 141 |
| 9.6.1 | STM-16 Multiplex Section 2 Fibre Shared Protection Ring Connection MS16P2fsh_C..... | 141 |
| 9.6.2 | STM-16 Multiplex Section 2 Fibre Shared Protection Ring Trail Termination Functions | 145 |
| 9.6.2.1 | STM-16 Multiplex Section 2 Fibre Shared Protection Ring Trail Termination Source MS16P2fsh_TT_So..... | 145 |
| 9.6.2.2 | STM-16 Multiplex Section 2 Fibre Shared Protection Ring Trail Termination Sink MS16P2fsh_TT_Sk..... | 146 |
| 9.6.3 | STM-16 Multiplex Section 2 Fibre Shared Protection Ring Adaptation Functions | 147 |
| 9.6.3.1 | STM-16 Multiplex Section to STM-16 Multiplex Section 2 Fibre Shared Protection Ring Adaptation Source MS16/MS16P2fsh_A_So..... | 147 |
| 9.6.3.2 | STM-16 Multiplex Section to STM-16 Multiplex Section 2 Fibre Shared Protection Ring Adaptation Sink MS16/MS16P2fsh_A_Sk..... | 148 |
| 9.7 | STM-16 Multiplex Section 4 Fibre Shared Protection Ring Functions | 149 |
| 9.7.1 | STM-16 Multiplex Section 4 Fibre Shared Protection Ring Connection MS16P4fsh_C..... | 149 |
| 9.7.2 | STM-16 Multiplex Section 4 Fibre Shared Protection Ring Trail Termination Functions | 149 |
| 9.7.2.1 | STM-16 Multiplex Section 4 Fibre Shared Protection Ring Trail Termination Source MS16P4fsh_TT_So..... | 149 |
| 9.7.2.2 | STM-16 Multiplex Section 4 Fibre Shared Protection Ring Trail Termination Sink MS16P4fsh_TT_Sk..... | 149 |
| 9.7.3 | STM-16 Multiplex Section 4 Fibre Shared Protection Ring Adaptation Functions | 149 |
| 9.7.3.1 | STM-16 Multiplex Section to STM-16 Multiplex Section 4 Fibre Shared Protection Ring Adaptation Source MS16/MS16P4fsh_A_So..... | 149 |
| 9.7.3.2 | STM-16 Multiplex Section to STM-16 Multiplex Section 4 Fibre Shared Protection Ring Adaptation Sink MS16/MS16P4fsh_A_Sk..... | 149 |

| | | |
|--|---|------------|
| 10 | STM-64 Regenerator Section layer functions..... | 149 |
| 11 | STM-64 Multiplex Section layer functions | 149 |
| Annex A (normative): Generic specification of linear protection switching operation | | 150 |
| A.1 | Protection process overview | 151 |
| A.2 | External switch commands definition..... | 152 |
| A.3 | Conditions of working and protection trail / connections..... | 153 |
| A.4 | States within protection process | 153 |
| A.5 | Numbering of working, protection, normal, extra traffic, null signals | 154 |
| A.6 | Priority of request types (conditions, external commands, states) | 155 |
| A.7 | APS signal definition | 156 |
| A.7.1 | APS signal fields..... | 156 |
| A.7.2 | STM-N MS-APS..... | 157 |
| A.7.3 | STM-N VC-APS..... | 158 |
| A.8 | Switch performance: switching and holdoff times | 158 |
| A.9 | Subprocesses | 158 |
| Annex B (informative): STM-16 regenerator functional model (example) | | 166 |
| Annex C (informative): AU-4-Xc numbering scheme & pointer allocation | | 167 |
| Annex D (informative): MS protection examples..... | | 171 |
| | Bibliography | 173 |
| | History | 174 |

Intellectual Property Rights

IPRs essential or potentially essential to the present document may have been declared to ETSI. The information pertaining to these essential IPRs, if any, is publicly available for **ETSI members and non-members**, and can be found in SR 000 314: "*Intellectual Property Rights (IPRs); Essential, or potentially Essential, IPRs notified to ETSI in respect of ETSI standards*", which is available **free of charge** from the ETSI Secretariat. Latest updates are available on the ETSI Web server (<http://www.etsi.org/ipr>).

Pursuant to the ETSI IPR Policy, no investigation, including IPR searches, has been carried out by ETSI. No guarantee can be given as to the existence of other IPRs not referenced in SR 000 314 (or the updates on the ETSI Web server) which are, or may be, or may become, essential to the present document.

Foreword

This European Standard (Telecommunications series) has been produced by ETSI Technical Committee Transmission and Multiplexing (TM).

The present document is one of a family of documents that has been produced in order to provide inter-vendor and inter-operator compatibility of Synchronous Digital Hierarchy (SDH) equipment.

The present document is part 3-1 of a multi-part EN covering the Generic requirements of transport functionality of equipment, as identified below:

Part 1-1: "Generic processes and performance".

Part 1-2: "General information about Implementation Conformance Statement (ICS) proforma".

Part 1-3 "Generic processes and performance; Abstract Test Suite (ATS)".

Part 2-1: "Synchronous Digital Hierarchy (SDH) and Plesiochronous Digital Hierarchy (PDH) physical section layer functions".

Part 2-2: "Synchronous Digital Hierarchy (SDH) and Plesiochronous Digital Hierarchy (PDH) physical section layer functions; Implementation Conformance Statement (ICS) proforma specification".

Part 2-3: "Synchronous Digital Hierarchy (SDH) and Plesiochronous Digital Hierarchy (PDH) physical section layer functions; Abstract Test Suite (ATS)".

Part 3-1: "Synchronous Transport Module-N (STM-N) regenerator and multiplex section layer functions".

Part 3-2: "Synchronous Transport Module-N (STM-N) regenerator and multiplex section layer functions; Implementation Conformance Statement (ICS) proforma specification".

Part 3-3: "Synchronous Transport Module-N (STM-N) regenerator and multiplex section layer functions; Abstract Test Suite (ATS)".

Part 4-1: "Synchronous Digital Hierarchy (SDH) path layer functions".

Part 4-2: "Synchronous Digital Hierarchy (SDH) path layer functions; Implementation Conformance Statement (ICS) proforma specification".

Part 4-3: "Synchronous Digital Hierarchy (SDH) path layer functions; Abstract Test Suite (ATS)".

Part 5-1: "Plesiochronous Digital Hierarchy (PDH) path layer functions".

Part 5-2: "Plesiochronous Digital Hierarchy (PDH) path layer functions; Implementation Conformance Statement (ICS) proforma specification".

Part 5-3: "Plesiochronous Digital Hierarchy (PDH) path layer functions; Abstract Test Suite (ATS)".

Part 6-1: "Synchronization layer functions".

Part 6-2: "Synchronization layer functions; Implementation Conformance Statement (ICS) proforma specification".

Part 6-3: "Synchronization layer functions; Abstract Test Suite (ATS)".

Part 7-1: "Auxiliary layer functions".

Part 7-2: "Auxiliary layer functions; Implementation Conformance Statement (ICS) proforma specification".

Part 7-3: "Auxiliary layer functions; Abstract Test Suite (ATS)".

Parts 2 to 7 specify the layers and their atomic functions.

NOTE 1: The present document does not currently address configuration management.

NOTE 2: The SDH radio equipment functional blocks are addressed by ETSI WG TM4.

Various of the above parts have previously been published as parts of ETS 300 417.

They have been converted to parts of EN 300 417 without technical changes, but some editorial changes have been necessary (e.g. references). In particular:

- Parts 2-1 and 3-2 have been modified to take account of editorial errors present in edition 1.
- Part 1-1 has had its title change of to align with other parts published at a later date.

Also note that in the meantime parts 8-1, 8-2 and 8-3 have been stopped.

| Transposition dates | |
|--|-------------------|
| Date of adoption of this EN: | 4 April 1997 |
| Date of latest announcement of this EN (doa): | 30 September 1997 |
| Date of latest publication of new National Standard or endorsement of this EN (dop/e): | 31 March 1998 |
| Date of withdrawal of any conflicting National Standard (dow): | 31 March 1998 |

1 Scope

The present document specifies a library of basic building blocks and a set of rules by which they are combined in order to describe transport functionality of equipment. The library comprises the functional building blocks needed to completely specify the generic functional structure of the European Transmission Hierarchies. Equipment which is compliant with the present document needs to be describable as an interconnection of a subset of these functional blocks contained within the present document. The interconnections of these blocks need to obey the combination rules given. The generic functionality is described in EN 300 417-1-1 [3].

2 References

The following documents contain provisions which, through reference in this text, constitute provisions of the present document.

- References are either specific (identified by date of publication, edition number, version number, etc.) or non-specific.
- For a specific reference, subsequent revisions do not apply.
- For a non-specific reference, the latest version applies.
- A non-specific reference to an ETS shall also be taken to refer to later versions published as an EN with the same number.

- [1] ETS 300 147: "Transmission and Multiplexing (TM); Synchronous Digital Hierarchy (SDH); Multiplexing structure".
- [2] ETS 300 166 (1993): "Transmission and Multiplexing (TM); Physical and electrical characteristics of hierarchical digital interfaces for equipment using the 2 048 kbit/s - based plesiochronous or synchronous digital hierarchies".
- [3] EN 300 417-1-1: "Transmission and Multiplexing (TM); Generic requirements of transport functionality of equipment; Part 1-1: Generic processes and performance".
- [4] EN 300 417-4-1: "Transmission and Multiplexing (TM); Generic requirements of transport functionality of equipment; Part 4-1: Synchronous Digital Hierarchy (SDH) path layer functions".
- [5] EN 300 417-6-1: "Transmission and Multiplexing (TM); Generic requirements of transport functionality of equipment; Part 6-1: Synchronization distribution layer functions".
- [6] ETS 300 746: "Transmission and Multiplexing (TM); Synchronous Digital Hierarchy (SDH); Network protection schemes; Automatic Protection Switch (APS) protocols and operation".
- [7] ITU-T Recommendation G.783: "Characteristics of synchronous digital hierarchy (SDH) equipment functional blocks".

3 Definitions, abbreviations and symbols

3.1 Definitions

The functional definitions are described in EN 300 417-1-1 [3].

3.2 Abbreviations

For the purposes of the present document, the following abbreviations apply:

| | |
|--------|--|
| A | Adaptation function |
| AcTI | Accepted Trace Identifier |
| ADM | Add-Drop Multiplexer |
| AI | Adapted Information |
| AIS | Alarm Indication Signal |
| AP | Access Point |
| APId | Access Point Identifier |
| APS | Automatic Protection Switch |
| AU | Administrative Unit |
| AUG | Administrative Unit Group |
| AU-n | Administrative Unit, level n |
| BER | Bit Error Ratio |
| BIP | Bit Interleaved Parity |
| BIP-N | Bit Interleaved Parity, width N |
| C | Connection function |
| CI | Characteristic Information |
| CK | ClocK |
| CM | Connection Matrix |
| CP | Connection Point |
| CS | Clock Source |
| D | Data |
| DCC | Data Communications Channel |
| DEC | DECrement |
| DEG | DEGraded |
| DEGTHR | DEGraded THReshold |
| EBC | Errored Block Count |
| ECC | Embedded Communications Channel |
| ECC(x) | Embedded Communications Channel, layer x |
| EDC | Error Detection Code |
| EDCV | Error Detection Code Violation |
| EMF | Equipment Management Function |
| EQ | EQUIPMENT |
| ES | Electrical Section |
| ES | Errored Second |
| ExTI | Expected Trace Identifier |
| F_B | Far-end Block |
| FAS | Frame Alignment Signal |
| FOP | Failure Of Protocol |
| FS | Frame Start signal |
| HO | Higher Order |
| HOVC | Higher Order Virtual Container |
| HP | Higher order Path |
| ID | IDentifier |
| IF | In Frame state |
| INC | INCrement |
| INV | INValid |
| LC | Link Connection |
| LO | Lower Order |

| | |
|--------|--|
| LOA | Loss Of Alignment; generic for LOF, LOM, LOP |
| LOF | Loss Of Frame |
| LOP | Loss Of Pointer |
| LOS | Loss Of Signal |
| LOVC | Lower Order Virtual Container |
| MC | Matrix Connection |
| MCF | Message Communications Function |
| MDT | Mean Down Time |
| mei | maintenance event information |
| MI | Management Information |
| MO | Managed Object |
| MON | MONitored |
| MP | Management Point |
| MS | Multiplex Section |
| MS1 | STM-1 Multiplex Section |
| MS16 | STM-16 Multiplex Section |
| MS4 | STM-4 Multiplex Section |
| MSB | Most Significant Bit |
| MSOH | Multiplex Section OverHead |
| MSP | Multiplex Section Protection |
| MSPG | Multiplex Section Protection Group |
| NC | Not Connected |
| N_B | Near-end Block |
| NC | Network Connection |
| NDF | New Data Flag |
| NE | Network Element |
| NMON | Not MONitored |
| NNI | Network Node Interface |
| NU | National Use (bits, bytes) |
| NUx | National Use, bit rate order x |
| OAM | Operation, Administration and Maintenance |
| OFS | Out of Frame Second |
| OOF | Out Of Frame state |
| OS | Optical Section |
| OSI(x) | Open Systems Interconnection, layer x |
| OW | Order Wire |
| P | Protection |
| P_A | Protection Adaptation |
| P_C | Protection Connection |
| P_TT | Protection Trail Termination |
| PDH | Plesiochronous Digital Hierarchy |
| PJE | Pointer Justification Event |
| PM | Performance Monitoring |
| Pn | Plesiochronous signal, level n |
| POH | Path OverHead |
| PRC | Primary Reference Clock |
| PS | Protection Switching |
| PSC | Protection Switch Count |
| PTR | PoinTeR |
| QOS | Quality Of Service |
| RDI | Remote Defect Indication |
| REI | Remote Error Indication |
| RI | Remote Information |
| RP | Remote Point |
| RS | Regenerator Section |
| RS1 | STM-1 Regenerator Section |
| RS16 | STM-16 Regenerator Section |
| RS4 | STM-4 Regenerator Section |
| RSOH | Regenerator Section OverHead |
| RxTI | Received Trace Identifier |

| | |
|--------|---|
| S4 | VC-4 path layer |
| SASE | Stand-Alone Synchronization Equipment |
| SD | Synchronization Distribution layer, Signal Degrade |
| SDH | Synchronous Digital Hierarchy |
| SEC | SDH Equipment Clock |
| SF | Signal Fail |
| Sk | Sink |
| SNC | Sub-Network Connection |
| SNC/I | Inherently monitored Sub-Network Connection protection |
| SNC/N | Non-intrusively monitored Sub-Network Connection protection |
| SNC/S | Sublayer monitored Sub-Network Connection protection |
| So | Source |
| SOH | Section OverHead |
| SPRING | Shared Protection RING |
| SR | Selected Reference |
| SSD | Server Signal Degrade |
| SSF | Server Signal Fail |
| SSM | Synchronization Status Message |
| SSU | Synchronization Supply Unit |
| STM | Synchronous Transport Module |
| STM-N | Synchronous Transport Module, level N |
| TCP | Termination Connection Point |
| TI | Timing Information |
| TIM | Trace Identifier Mismatch |
| TM | Transmission_Medium |
| TMN | Telecommunications Management Network |
| TP | Timing Point |
| TPmode | Termination Point mode |
| TS | Time Slot |
| TSD | Trail Signal Degrade |
| TSF | Trail Signal Fail |
| TT | Trail Termination function |
| TTI | Trail Trace Identifier |
| TTs | Trail Termination supervisory function |
| TxTI | Transmitted Trace Identifier |
| UNEQ | UNEQuipped |
| UNI | User Network Interface |
| USR | USeR channels |
| V0 | 64 kbit/s contradirectional data layer |
| VC | Virtual Container |
| VC-n | Virtual Container, level-n |
| W | Working |

3.3 Symbols and Diagrammatic Conventions

The symbols and diagrammatic conventions are described in EN 300 417-1-1 [3].

3.4 Introduction

The atomic functions defining the regenerator and multiplex section layers are described below (clause 4 onwards).

4 STM-1 Regenerator Section Layer Functions

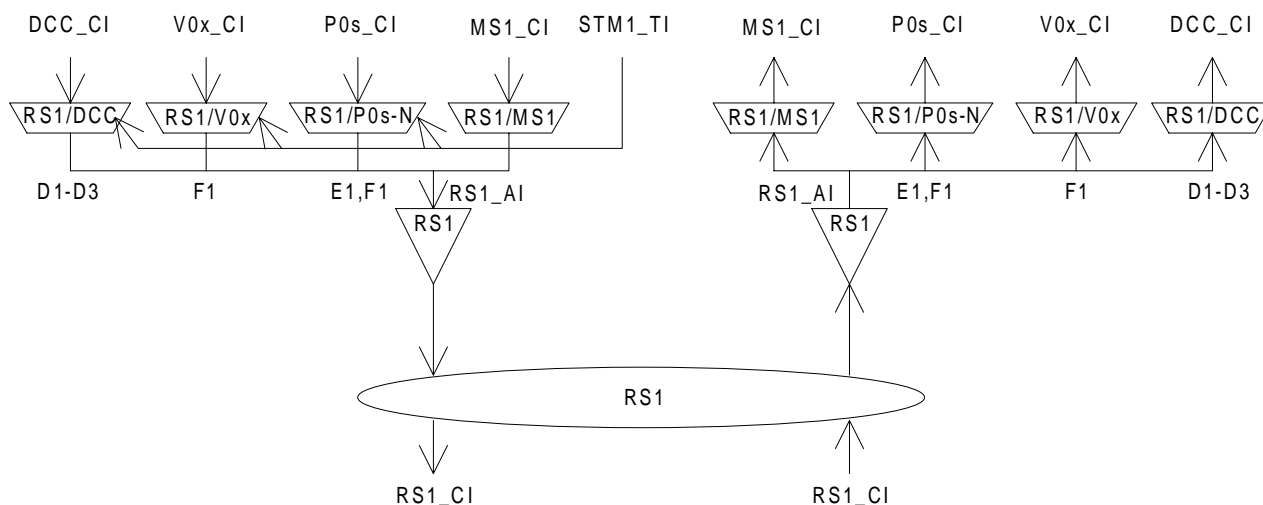

Figure 1: STM-1 Regenerator Section atomic functions

RS1 Layer CP

The CI at this point is an octet structured, 125 μ s framed data stream with co-directional timing. It is the entire STM-1 signal as defined in ETS 300 147 [1]. Figure 2 depicts only bytes handled in the RS1 layer.

NOTE 1: The unmarked bytes [2, 6], [3, 6], [3, 8], [3, 9] in rows 2,3 (figure 2) are reserved for future international standardization. Currently, they are undefined.

NOTE 2: The unmarked bytes [2, 2], [2, 3], [2, 5], [3, 2], [3, 3], [3, 5] in rows 2,3 (figure 2) are reserved for media specific usage (e.g. radio sections). In optical and electrical section applications they are undefined.

NOTE 3: The bytes for National Use (NU) in rows 1,2 (figure 2) are reserved for operator specific usage. Their processing is not within the province of the present document. If NU bytes [1, 8] and [1, 9] are unused, care should be taken in selecting the binary content of the bytes which are excluded from the scrambling process of the STM-N signal to ensure that long sequences of "1"s or "0"s do not occur.

| | 1 | 2 | 3 | 4 | 5 | 6 | 7 | 8 | 9 | 10 | | 270 |
|---|----|----|----|----|----|----|----|----|----|----|------|-----|
| 1 | A1 | A1 | A1 | A2 | A2 | A2 | J0 | NU | NU | | | |
| 2 | B1 | | | E1 | | | F1 | NU | NU | | | |
| 3 | D1 | | | D2 | | | D3 | | | | | |
| 4 | | | | | | | | | | | | |
| 5 | | | | | | | | | | | | |
| 6 | | | | | | | | | | | | |
| 7 | | | | | | | | | | | | |
| 8 | | | | | | | | | | | | |
| 9 | | | | | | | | | | | | |

Figure 2: RS1_CI_D signal

RS1 Layer AP

The AI at this point is octet structured and 125 μ s framed with co-directional timing and represents the combination of adapted information from the MS1 layer (2 403 bytes per frame), the management communication DCC layer (3 bytes per frame if supported), the OW layer (1 byte per frame if supported) and the user channel F1 (1 byte per frame if supported). The location of these four components in the frame is defined in ETS 300 147 [1] and depicted in figure 3.

NOTE 4: Bytes E1, F1 and D1-D3 will be undefined when the adaptation functions sourcing these bytes are not present in the network element.

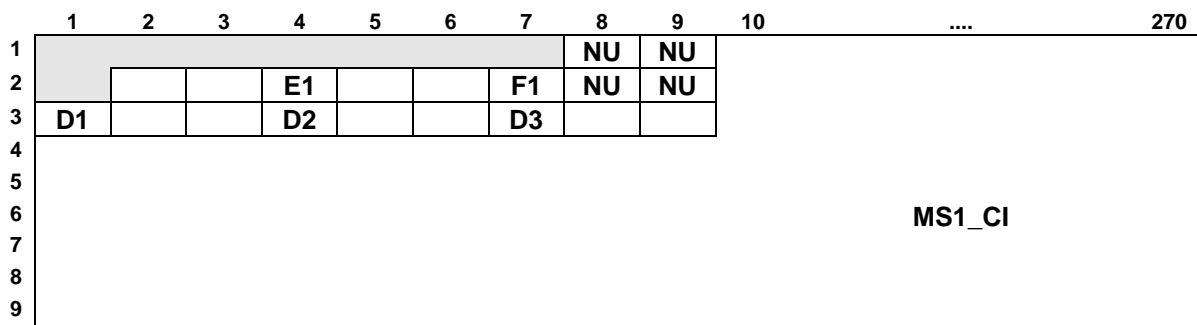

Figure 3: RS1_AI_D signal

4.1 STM-1 Regenerator Section Connection functions

For further study.

4.2 STM-1 Regenerator Section Trail Termination functions

4.2.1 STM-1 Regenerator Section Trail Termination Source RS1_TT_So

Symbol:

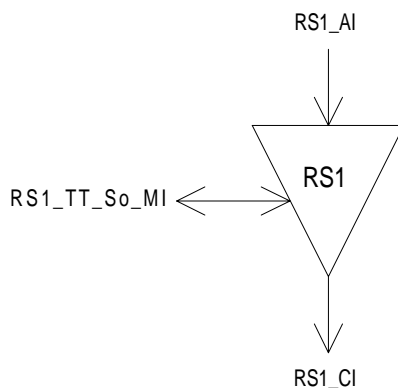

Figure 4: RS1_TT_So symbol

Interfaces:

Table 1: RS1_TT_So input and output signals

| Input(s) | Output(s) |
|---|-----------------------|
| RS1_AI_D RS1_AI_CK RS1_AI_FS RS1_TT_So_MI_TxTI | RS1_CI_D RS1_CI_CK |

Processes:

The function builds the STM-1 signal by adding the frame alignment information, bytes A1A2, the STM Section Trace Identifier (STI) byte J0, computing the parity and inserting the B1 byte.

J0: In this byte the function shall insert the Transmitted Trail Trace Identifier TxTI. Its format is described in EN 300 417-1-1 [3], subclause 7.1.

B1: The function shall calculate a Bit Interleaved Parity 8 (BIP-8) code using even parity. The BIP-8 shall be calculated over all bits of the previous STM-1 frame after scrambling and is placed in byte position B1 of the current STM-1 frame before scrambling (figure 5).

A1A2: The function shall insert the STM-1 frame alignment signal A1A1A1A2A2A2 into the regenerator section overhead as defined in ETS 300 147 [1].

Scrambler: This function provides scrambling of the RS1_CI. The operation of the scrambler shall be functionally identical to that of a frame synchronous scrambler of sequence length 127 operating at the line rate. The generating polynomial shall be $1 + X^6 + X^7$. The scrambler shall be reset to "1111 1111" on the most significant bit (MSB) of the byte [1, 10] following the last byte of the STM-1 SOH in the first row. This bit and all subsequent bits to be scrambled shall be modulo 2 added to the output of the X^7 position of the scrambler. The scrambler shall run continuously throughout the remaining STM-1 frame.

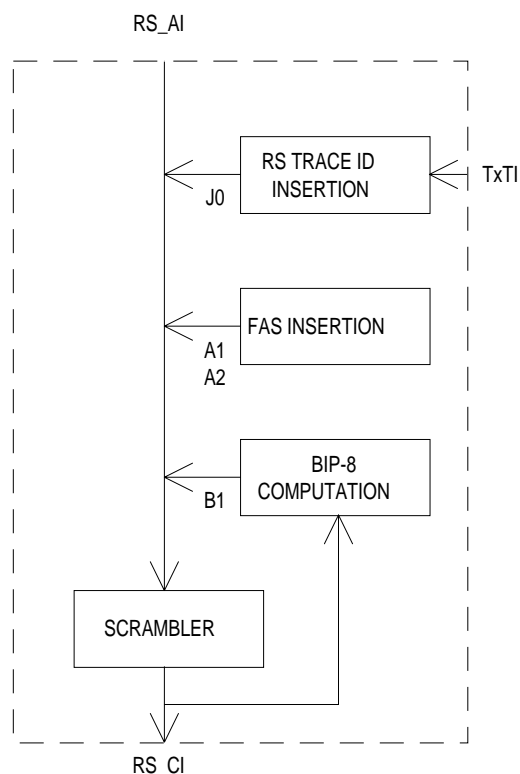

Figure 5: Some processes within RS1_TT_So

Defects: None.

Consequent Actions: None.

Defect Correlations: None.

Performance Monitoring: None.

4.2.2 STM-1 Regenerator Section Trail Termination Sink RS1_TT_Sk

Symbol:

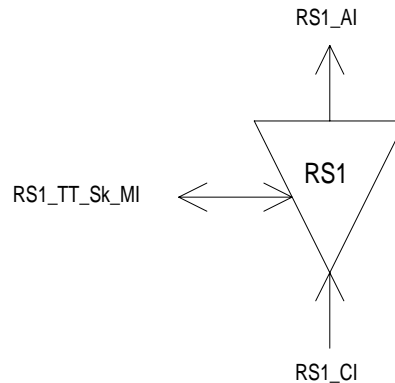

Figure 6: RS1_TT_Sk symbol

Interfaces:

Table 2: RS1_TT_Sk input and output signals

| Input(s) | Output(s) |
|-----------------------|---------------------|
| RS1_CI_D | RS1_AI_D |
| RS1_CI_CK | RS1_AI_CK |
| RS1_CI_FS | RS1_AI_FS |
| RS1_CI_SSF | RS1_AI_TSF |
| RS1_TT_Sk_MI_ExtI | RS1_TT_Sk_MI_AcTI |
| RS1_TT_Sk_MI_TPmode | RS1_TT_Sk_MI_cTIM |
| RS1_TT_Sk_MI_TIMdis | RS1_TT_Sk_MI_pN_EBC |
| RS1_TT_Sk_MI_ExtImode | RS1_TT_Sk_MI_pN_DS |
| RS1_TT_Sk_MI_1second | |

Processes:

This function monitors the STM-1 signal for RS errors, and recovers the RS trail termination status. It extracts the payload independent overhead bytes (J0, B1) from the RS1 layer Characteristic Information:

Descrambling: The function shall descramble the incoming STM-1 signal. The operation of the descrambler shall be functionally identical to that of a scrambler in OS1/RS1_A_So.

B1: Even bit parity is computed for each bit n of every byte of the preceding scrambled STM-1 frame and compared with bit n of B1 recovered from the current frame ($n = 1$ to 8 inclusive) (figure 7). A difference between the computed and recovered B1 values is taken as evidence of one or more errors (nN_B) in the computation block.

J0: The Received Trail Trace Identifier RxTI shall be recovered from the J0 byte and shall be made available as AcTI for network management purposes. The application and acceptance and mismatch detection process shall be performed as specified in EN 300 417-1-1 [3], subclauses 7.1 and 8.2.1.3.

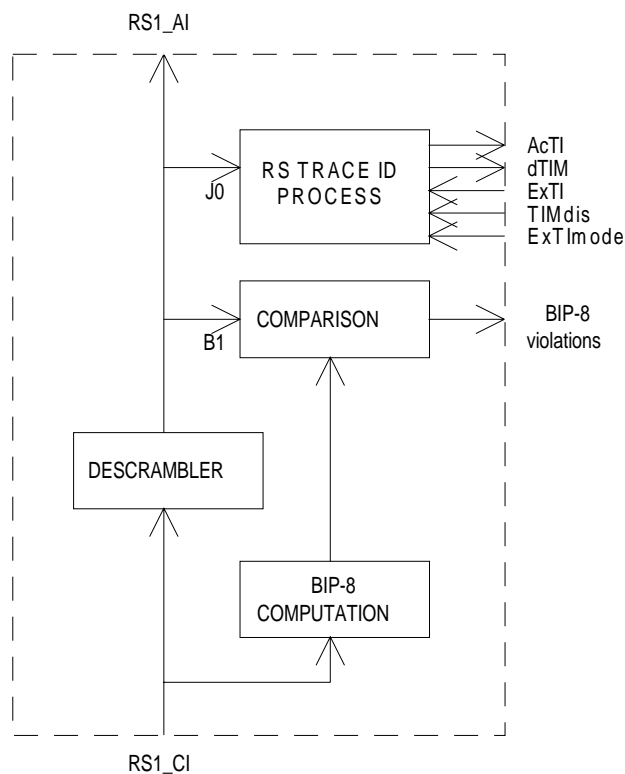

Figure 7: Some processes within RS1_TT_Sk

Defects:

The function shall detect for dTIM defect according the specification in EN 300 417-1-1 [3], subclause 8.2.1.

Consequent Actions:

aAIS ← CI_SSF or dTIM.

aTSF ← CI_SSF or dTIM.

On declaration of aAIS the function shall output an all-ONEs (AIS) signal within 250 μ s; on clearing of aAIS the function shall output normal data within 250 μ s.

NOTE 1: The term "CI_SSF" has been added to the conditions for aAIS while the descrambler function has been moved from the e.g. OS1/RS1_A_Sk to this function. Consequently, an all-ONEs (AIS) pattern inserted in the mentioned adaptation function would be descrambled in this function. A "refreshment" of all-ONEs is required.

NOTE 2: The insertion of AIS - especially due to detection of dTIM - will cause the RS-DCC channel to be "squashed" too, so that control of the NE via this channel is lost. If control is via this channel only, there is a risk of a dead-lock situation if dTIM is caused by a misprovisioning of ExTI.

Defect Correlations:

cTIM ← MON and dTIM.

Performance Monitoring:

For further study.

4.3 STM-1 Regenerator Section Adaptation functions

4.3.1 STM-1 Regenerator Section to Multiplex Section Adaptation Source RS1/MS1_A_So

Symbol:

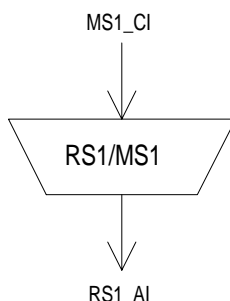

Figure 8: RS1/MS1_A_So symbol

Interfaces:

Table 3: RS1/MS1_A_So input and output signals

| Input(s) | Output(s) |
|------------|-----------|
| MS1_CI_D | RS1_AI_D |
| MS1_CI_CK | RS1_AI_CK |
| MS1_CI_FS | RS1_AI_FS |
| MS1_CI_SSF | |

Processes:

The function multiplexes the MS1_CI data (2 403 bytes / frame) into the STM-1 byte locations defined in ETS 300 147 [1] and depicted in figure 2.

NOTE 1: There might be cases in which the network element knows that the timing reference for a particular STM-1 interface can not be maintained within $\pm 4,6$ ppm. For such cases MS-AIS can be generated. This is network element specific and outside the scope of the present document.

Defects: None.

Consequent Actions:

aAIS ← CI_SSF.

On declaration of aAIS the function shall output all ONEs signal within 250 μ s; on clearing of aAIS the function shall output normal data within 250 μ s. The frequency of the all ONEs signal shall be within 155 520 kHz \pm 20 ppm.

NOTE 2: If CI_SSF is not connected (when RS1/MS1_A_So is connected to a MS1_TT_So), SSF is assumed to be false.

Defect Correlations: None.

Performance Monitoring: None.

4.3.2 STM-1 Regenerator Section to Multiplex Section Adaptation Sink RS1/MS1_A_Sk

Symbol:

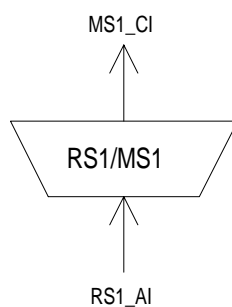

Figure 9: RS1/MS1_A_Sk symbol

Interfaces:

Table 4: RS1/MS1_A_Sk input and output signals

| Input(s) | Output(s) |
|------------|------------|
| RS1_AI_D | MS1_CI_D |
| RS1_AI_CK | MS1_CI_CK |
| RS1_AI_FS | MS1_CI_FS |
| RS1_AI_TSF | MS1_CI_SSF |

Processes:

The function separates MS1_CI data from RS1_AI as depicted in figure 2.

Defects: None.

Consequent Actions:

aSSF ← AI_TSF.

Defect Correlations: None.

Performance Monitoring: None.

4.3.3 STM-1 Regenerator Section to DCC Adaptation Source RS1/DCC_A_So

Symbol:

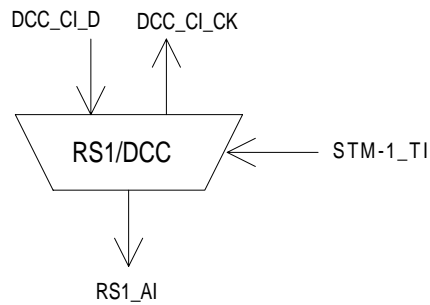

Figure 10: RS1/DCC_A_So symbol

Interfaces:

Table 5: RS1/DCC_A_So input and output signals

| Input(s) | Output(s) |
|--------------------------------------|-----------------------|
| DCC_CI_D STM1_TI_CK STM1_TI_FS | RS1_AI_D DCC_CI_CK |

Processes:

The function multiplexes the DCC CI data (192 kbit/s) into the byte locations D1, D2 and D3 as defined in ETS 300 147 [1] and depicted in figure 3.

NOTE: DCC transmission can be "disabled" when the matrix connection in the connected DCC_C function is removed.

Defects: None.

Consequent Actions: None.

Defect Correlations: None.

Performance Monitoring: None.

4.3.4 STM-1 Regenerator Section to DCC Adaptation Sink RS1/DCC_A_Sk

Symbol:

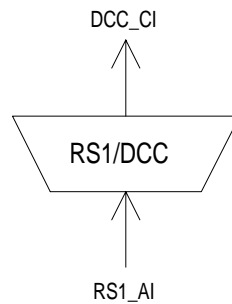

Figure 11: RS1/DCC_A_Sk symbol

Interfaces:

Table 6: RS1/DCC_A_Sk input and output signals

| Input(s) | Output(s) |
|------------|------------|
| RS1_AI_D | DCC_CI_D |
| RS1_AI_CK | DCC_CI_CK |
| RS1_AI_FS | DCC_CI_SSF |
| RS1_AI_TSF | |

Processes:

The function separates DCC data from RS Overhead as defined in ETS 300 147 [1] and depicted in figure 3.

NOTE: DCC processing can be "disabled" when the matrix connection in the connected DCC_C function is removed.

Defects: None.

Consequent Actions:

aSSF ← AI_TSF.

Defect Correlations: None.

Performance Monitoring: None.

4.3.5 STM-1 Regenerator Section to P0s Adaptation Source RS1/P0s_A_So/N

Symbol:

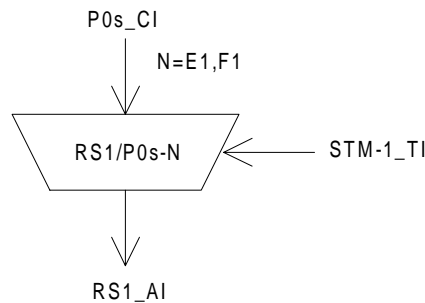

Figure 12: RS1/P0s_A_So symbol

Interfaces:

Table 7: RS1/P0s_A_So input and output signals

| Input(s) | Output(s) |
|--|-----------|
| P0s_CI_D P0s_CI_CK P0s_CI_FS STM1_TI_CK STM1_TI_FS | RS1_AI_D |

Processes:

This function provides the multiplexing of a 64 kbit/s orderwire or user channel information stream into the RS1_AI using slip buffering. It takes P0s_CI, a 64 kbit/s signal as defined in ETS 300 166 [2], as an octet structured bit-stream with a synchronous bit rate of 64 kbit/s, present at its input and inserts it into the RSOH byte E1 or F1 as defined in ETS 300 147 [1] and depicted in figure 3.

NOTE: Any frequency deviation between the 64 kbit/s signal and the associated STM-1 signal leads to octet slips.

Frequency justification and bitrate adaptation: The function shall provide an elastic store (slip buffer) process. The data signal shall be written into the store under control of the associated input clock. The data shall be read out of the store under control of the STM-1 clock, frame position (STM1_TI), and justification decisions.

Each justification decision results in a corresponding negative / positive justification action. Upon a positive justification (slip) action, the reading of one 64 kbit/s octet (8 bits) shall be cancelled once. Upon a negative justification (slip) action, the same 64 kbit/s octet (8 bits) shall be read out a second time.

The elastic store (slip buffer) shall accommodate at least 18 μ s of wander without introducing errors.

64 kbit/s timeslot: The adaptation source function has access to a specific 64 kbit/s channel of the RS access point. The specific 64 kbit/s channel is defined by the parameter N (N = E1, F1).

Defects: None.

Consequent Actions: None.

Defect Correlations: None.

Performance Monitoring: None.

4.3.6 STM-1 Regenerator Section to P0s Adaptation Sink RS1/P0s_A_Sk/N

Symbol:

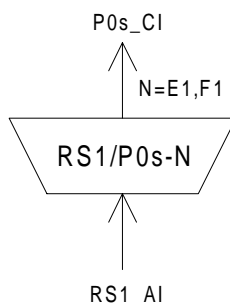

Figure 13: RS1/P0s_A_Sk symbol

Interfaces:

Table 8: RS1/P0s_A_Sk input and output signals

| Input(s) | Output(s) |
|------------|------------|
| RS1_AI_D | P0s_CI_D |
| RS1_AI_CK | P0s_CI_CK |
| RS1_AI_FS | P0s_CI_FS |
| RS1_AI_TSF | P0s_CI_SSF |

Processes:

The function separates P0s data from RS Overhead byte E1 or F1 as defined in ETS 300 147 [1] and depicted in figure 3.

Data latching and smoothing process: The function shall provide a data latching and smoothing function. Each 8-bit octet received shall be written and latched into a data store under the control of the STM-1 signal clock. The eight data bits shall then be read out of the store using a nominal 64 kHz clock which may be derived directly from the incoming STM-1 signal clock (e.g. 155 520 kHz divided by a factor of 2 430).

64 kbit/s timeslot: The adaptation sink function has access to a specific 64 kbit/s of the RS access point. The specific 64 kbit/s is defined by the parameter N (N = E1, F1).

Defects: None.

Consequent Actions:

aSSF ← AI_TSF.

aAIS ← AI_TSF.

On declaration of aAIS the function shall output an all-ONES (AIS) signal - complying to the frequency limits for this signal (a bit rate in range 64 kbit/s ± 100 ppm) - within 1 ms; on clearing of aAIS the function shall output normal data within 1 ms.

Defect Correlations: None.

Performance Monitoring: None.

4.3.7 STM-1 Regenerator Section to V0x Adaptation Source RS1/V0x_A_So

Symbol:

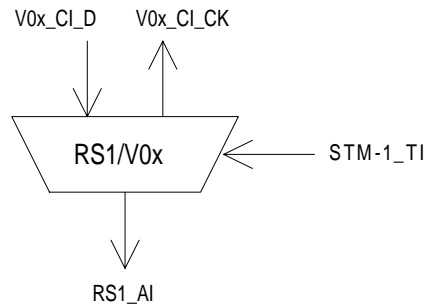

Figure 14: RS1/V0x_A_So symbol

Interfaces:

Table 9: RS1/V0x_A_So input and output signals

| Input(s) | Output(s) |
|--------------------------------------|-----------------------|
| V0x_CI_D STM1_TI_CK STM1_TI_FS | RS1_AI_D V0x_CI_CK |

Processes: None.

This function shall multiplex the V0x_CI data (64 kbit/s) into the byte location F1 as defined in ETS 300 147 [1] and depicted in figure 3.

Defects: None.

Consequent Actions: None.

Defect Correlations: None.

Performance Monitoring: None.

4.3.8 STM-1 Regenerator Section to V0x Adaptation Sink RS1/V0x_A_Sk

Symbol:

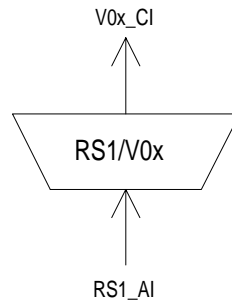

Figure 15: RS1/V0x_A_Sk symbol

Interfaces:

Table 10: RS1/V0x_A_Sk input and output signals

| Input(s) | Output(s) |
|--|-------------------------------------|
| RS1_AI_D RS1_AI_CK RS1_AI_FS RS1_AI_TSF | V0x_CI_D V0x_CI_CK V0x_CI_SSF |

Processes:

This function separates user channel data from RS Overhead (byte F1) as defined in ETS 300 147 [1] and depicted in figure 3.

Defects: None.

Consequent Actions:

aSSF ← AI_TSF.

aAIS ← AI_TSF.

On declaration of aAIS the function shall output an all-ONES (AIS) signal within 1 ms; on clearing of aAIS the function shall output normal data within 1 ms.

Defect Correlations: None.

Performance Monitoring: None.

5 STM-1 Multiplex Section Layer Functions

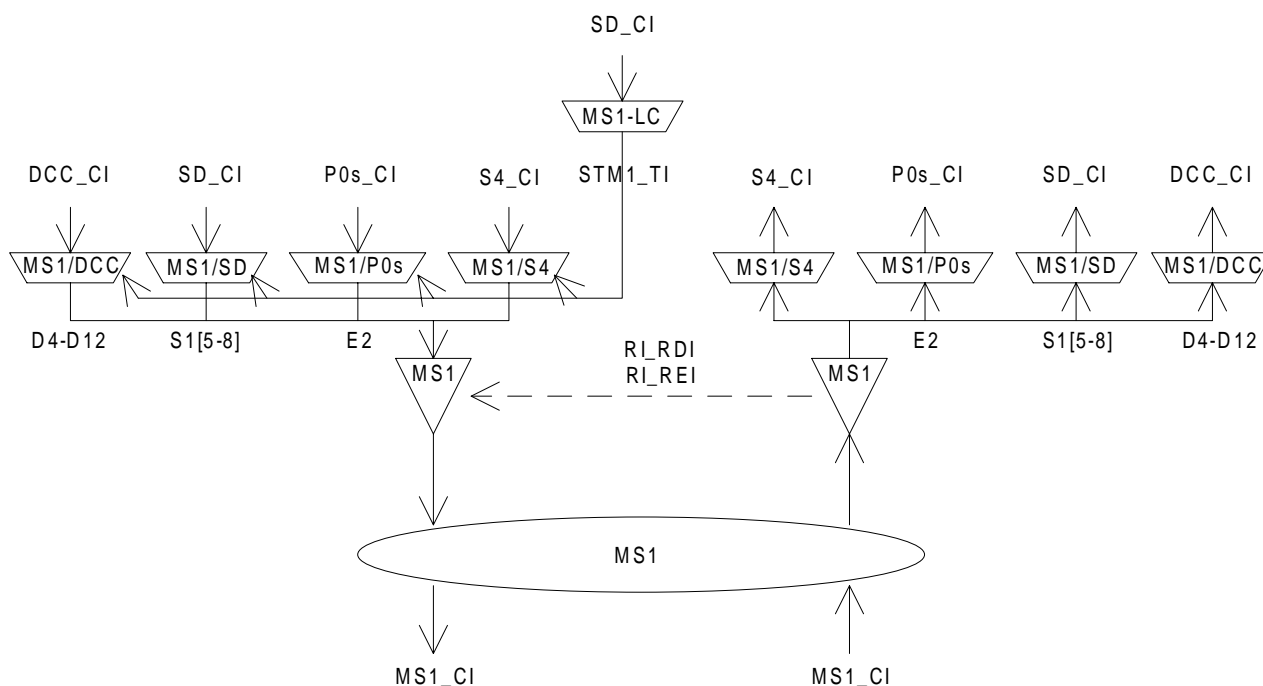

Figure 16: STM-1 Multiplex Section atomic functions

MS1 Layer CP

The CI at this point is octet structured and 125 μs framed with co-directional timing. Its format is characterized as the MS1_AI with an additional MS Trail Termination overhead in the three B2 bytes, byte M1, and bits 6-8 of the K2 byte in the frame locations defined in ETS 300 147 [1] and depicted in figure 17.

NOTE 1: The unmarked bytes in rows 5, 6, 7, 8 and 9 (see figure 17) are reserved for future international standardization. Currently, they are undefined.

NOTE 2: The bytes for National Use (NU) in row 9 (see figure 17) are reserved for operator specific usage. Their processing is not within the province of the present document.

| | | | | | | | | | | | | | | |
|---|-----|-----|-----|-----|-----|-----|-----|----|----|---|------|-----|--|--|
| | 1 | 2 | 3 | 4 | 5 | 6 | 7 | 8 | 9 | 10 | | 270 | | |
| 1 | | | | | | | | | | AU4 payload capacity (261 × 9 bytes) | | | | |
| 2 | | | | | | | | | | | | | | |
| 3 | | | | | | | | | | | | | | |
| 4 | H1 | "Y" | "Y" | H2 | "1" | "1" | H3 | H3 | H3 | | | | | |
| 5 | B2 | B2 | B2 | K1 | | | K2 | | | | | | | |
| 6 | D4 | | | D5 | | | D6 | | | | | | | |
| 7 | D7 | | | D8 | | | D9 | | | | | | | |
| 8 | D10 | | | D11 | | | D12 | | | | | | | |
| 9 | S1 | | | | | M1 | E2 | NU | NU | | | | | |

Figure 17: MS1_CI_D

MS1 Layer AP

The AI at this point is octet structured and 125 μs framed with co-directional timing. It represents the combination of information adapted from the VC-4 layer (150 336 kbit/s), the management communications DCC layer (576 kbit/s), the OW layer (64 kbit/s if supported), the AU-4 pointer (3 bytes per frame), the APS signalling channel (13 or 16 bits per frame if supported, see note 3), and the Synchronization Status Message (SSM) channel (4 bits per frame if supported). The location of these five components in the frame is defined in ETS 300 147 [1] and depicted in figure 18.

NOTE 3: 13 bits APS channel for the case of linear MS protection. 16 bits APS channel for the case of MS SPRING protection

NOTE 4: Bytes E2 and D4-D12 will be undefined when the adaptation functions sourcing these bytes are not present in the network element.

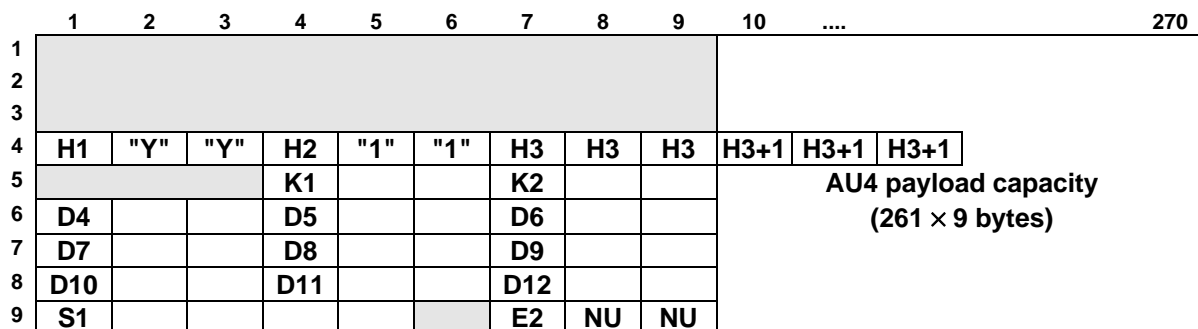

Figure 18: MS1_AI_D

NOTE 5: The allocation of definitions and associated processing of unused MS OH bytes might change due to their future application.

Figure 19 shows the MS trail protection specific sublayer atomic functions (MS1/MS1P_A, MS1P_C, MS1P_TT) within the MS1 layer. Note that the DCC (D4-D12), OW (E2), and SSM (S1[5-8]) signals can be accessible before (unprotected) and after (protected) the MS1P_C function. The choice is outside the scope of the present document.

NOTE 6: Equipment may provide MS protection and bi-directional services such as DCC and OW in the MS layer. Where a link uses this provision both ends of the link shall be configured to operate these services in the same mode (i.e. either protected or unprotected).

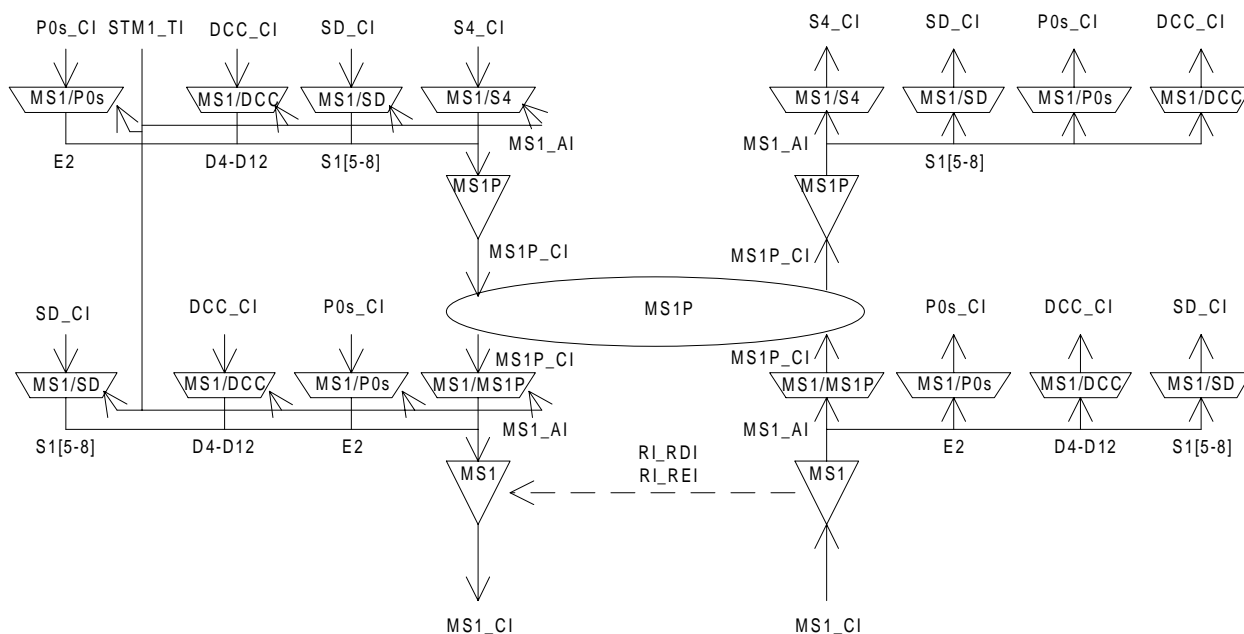

Figure 19: STM-1 Multiplex Section Linear Trail Protection Functions

MS1P Sublayer CP

The CI at this point is octet structured and 125 μs framed with co-directional timing. Its format is equivalent to the MS1_AI and depicted in figure 20.

NOTE 7: Bytes S1, E2 and D4-D12 will be undefined when the adaptation functions sourcing these bytes are not present in the network element or are unprotected (see above).

| | | | | | | | | | | | | | | | |
|---|-----|-----|-----|-----|-----|-----|-----|----|----|---|------|-----|--|--|--|
| | 1 | 2 | 3 | 4 | 5 | 6 | 7 | 8 | 9 | 10 | | 270 | | | |
| 1 | | | | | | | | | | AU4 payload capacity (261 × 9 bytes) | | | | | |
| 2 | | | | | | | | | | | | | | | |
| 3 | | | | | | | | | | | | | | | |
| 4 | H1 | "Y" | "Y" | H2 | "1" | "1" | H3 | H3 | H3 | | | | | | |
| 5 | | | | K1 | | | K2* | | | | | | | | |
| 6 | D4 | | | D5 | | | D6 | | | | | | | | |
| 7 | D7 | | | D8 | | | D9 | | | | | | | | |
| 8 | D10 | | | D11 | | | D12 | | | | | | | | |
| 9 | S1 | | | | | | E2 | NU | NU | | | | | | |

NOTE 8: K2* represents bits 1 to 5 of K2.

Figure 20: MS1P_CI_D

5.1 STM-1 Multiplex Section Connection functions

For further study.

5.2 STM-1 Multiplex Section Trail Termination functions

5.2.1 STM-1 Multiplex Section Trail Termination Source MS1_TT_So

Symbol:

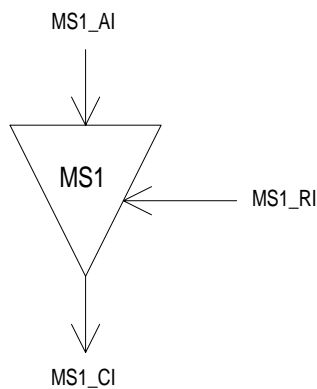

Figure 21: MS1_TT_So symbol

Interfaces:**Table 11: MS1_TT_So input and output signals**

| Input(s) | Output(s) |
|--|------------------------------------|
| MS1_AI_D MS1_AI_CK MS1_AI_FS MS1_RI_REI MS1_RI_RDI | MS1_CI_D MS1_CI_CK MS1_CI_FS |

Processes:

This function adds error monitoring capabilities and remote maintenance information signals to the MS1_AI.

M1: The function shall insert the value of MS1_RI_REI into the REI (Remote Error Indication) - to convey the count of interleaved bit blocks that have been detected in error by the BIP-24 process in the companion MS1_TT_Sk - in the range of "0000 0000" (0) to "0001 1000" (24).

K2[6-8]: These bits represents the defect status of the associated MS1_TT_Sk. The RDI indication shall be set to "110" on activation of MS1_RI_RDI within 250 µs, determined by the associated MS1_TT_Sk function, and set to "000" within 250 µs on the clearing of MS1_RI_RDI.

B2: The function shall calculate a Bit Interleaved Parity 24 (BIP-24) code using even parity. The BIP-24 shall be calculated over all bits, except those in the RSOH bytes, of the previous STM-1 frame and placed in three B2 bytes of the current STM-1 frame.

NOTE: The BIP-24 procedure is described in ETS 300 147 [1].

Defects: None.

Consequent Actions: None.

Defect Correlations: None.

Performance Monitoring: None.

5.2.2 STM-1 Multiplex Section Trail Termination Sink MS1_TT_Sk

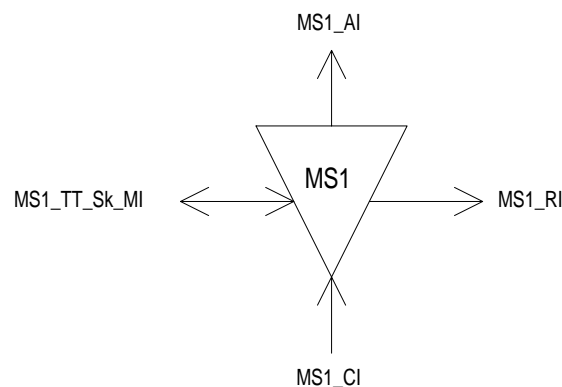
Symbol:**Figure 22: MS1_TT_Sk symbol**

Interfaces:**Table 12: MS1_TT_Sk input and output signals**

| Input(s) | Output(s) |
|---------------------------|---------------------|
| MS1_CI_D | MS1_AI_D |
| MS1_CI_CK | MS1_AI_CK |
| MS1_CI_FS | MS1_AI_FS |
| MS1_CI_SSF | MS1_AI_TSF |
| MS1_TT_Sk_MI_DEGTHR | MS1_AI_TSD |
| MS1_TT_Sk_MI_DEGM | MS1_TT_Sk_MI_cAIS |
| MS1_TT_Sk_MI_1second | MS1_TT_Sk_MI_cDEG |
| MS1_TT_Sk_MI_TPmode | MS1_TT_Sk_MI_cRDI |
| MS1_TT_Sk_MI_SSF_Reported | MS1_TT_Sk_MI_cSSF |
| MS1_TT_Sk_MI_AIS_Reported | MS1_TT_Sk_MI_pN_EBC |
| MS1_TT_Sk_MI_RDI_Reported | MS1_TT_Sk_MI_pF_EBC |
| | MS1_TT_Sk_MI_pN_DS |
| | MS1_TT_Sk_MI_pF_DS |
| | MS1_RI_REI |
| | MS1_RI_RDI |

Processes:

This function monitors error performance of associated MS1 including the far end receiver.

B2: The BIP-24 shall be calculated over all bits, except of those in the RSOH bytes, of the previous STM-1 frame and compared with the three error monitoring bytes B2 recovered from the MSOH of the current STM-1 frame. A difference between the computed and recovered B2 values is taken as evidence of one or more errors (nN_B) in the computation block.

M1: The REI information carried in these bits shall be extracted to enable single ended maintenance of a bi-directional trail (section). The REI (nF_B) is used to monitor the error performance of the other direction of transmission. The application process is described in EN 300 417-1-1 [3], subclause 7.4.2 (REI).

The function shall interpret the value of the byte (for interworking with old equipment generating a 7 bit code) as shown in table 13.

Table 13: STM-1 M1 interpretation

| M1[2-8] code, bits 234 5678 | code interpretation [#BIP violations], (nF_B) |
|--------------------------------|--|
| 000 0000 | 0 |
| 000 0001 | 1 |
| 000 0010 | 2 |
| 000 0011 | 3 |
| ⋮ | ⋮ |
| 001 1000 | 24 |
| 001 1001 | 0 |
| 001 1010 | 0 |
| ⋮ | ⋮ |
| 111 1111 | 0 |

NOTE: Bit 1 of byte M1 is ignored.

NOTE: In case of interworking with old equipment not supporting MS-REI, the information extracted from M1 is not relevant.

K2[6-8] - RDI: The RDI information carried in these bits shall be extracted to enable single ended maintenance of a bi-directional trail (section). The RDI provides information as to the status of the remote receiver. A "110" indicates a Remote Defect Indication state, while other patterns indicate the normal state. The application process is described in EN 300 417-1-1 [3], subclauses 7.4.11 and 8.2.

K2[6-8] - AIS: The MS-AIS information carried in these bits shall be extracted.

Defects:

The function shall detect for dDEG and dRDI defects according the specification in EN 300 417-1-1 [3], subclause 8.2.1.

dAIS: If at least x consecutive frames contain the "111" pattern in bits 6, 7 and 8 of the K2 byte a dAIS defect shall be detected. dAIS shall be cleared if in at least x consecutive frames any pattern other than the "111" is detected in bits 6, 7 and 8 of byte K2. The x is in range 3 to 5.

Consequent Actions:

aAIS ← dAIS.
 aRDI ← dAIS.
 aREI ← #EDCV.
 aTSF ← dAIS.
 aTSD ← dDEG.

On declaration of aAIS the function shall output an all-ONES signal within 250 μ s; on clearing of aAIS the function shall output normal data within 250 μ s.

Defect Correlations:

cAIS ← MON and dAIS and (not CI_SSF) and AIS_Reported.
 cDEG ← MON and dDEG.
 cRDI ← MON and dRDI and RDI_Reported.
 cSSF ← MON and dAIS and SSF_Reported.

Performance monitoring:

The performance monitoring process shall be performed as specified in EN 300 417-1-1 [3], subclause 8.2.4 through 8.2.7.

pN_DS ← aTSF or dEQ.
 pF_DS ← dRDI.
 pN_EBC ← Σ nN_B.
 pF_EBC ← Σ nF_B.

5.3 STM-1 Multiplex Section Adaptation functions

5.3.1 STM-1 Multiplex Section to S4 Layer Adaptation Source MS1/S4_A_So

Symbol:

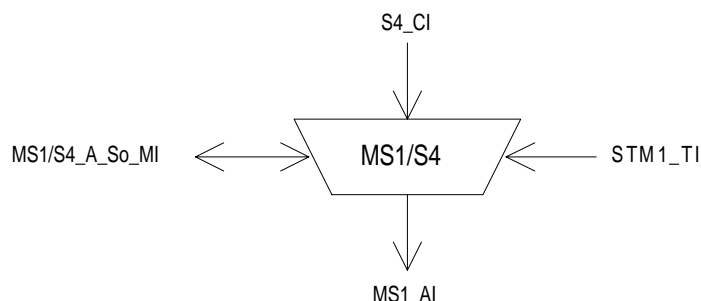

Figure 23: MS1/S4_A_So symbol

Interfaces:

Table 14: MS1/S4_A_So input and output signals

| Input(s) | Output(s) |
|------------|----------------------|
| S4_CI_D | MS1_AI_D |
| S4_CI_CK | MS1_AI_CK |
| S4_CI_FS | MS1_AI_FS |
| S4_CI_SSF | |
| STM1_TI_CK | MS1/S4_A_So_MI_pPJE+ |
| STM1_TI_FS | MS1/S4_A_So_MI_pPJE- |

Processes:

This function provides frequency justification and bitrate adaptation for a VC-4 signal, represented by a nominally $(261 \times 9 \times 64) = 150\,336$ kbit/s information stream and the related frame phase with a frequency accuracy within $\pm 4,6$ ppm, to be multiplexed into a STM-1 signal.

NOTE 1: Degraded performance may be observed when interworking with SONET equipment having a ± 20 ppm network element clock source.

The frame phase of the VC-4 is coded in the related AU-4 pointer. Frequency justification, if required, is performed by pointer adjustments. The accuracy of this coding process is specified below. See EN 300 417-4-1 [4], annex A.

Frequency justification and bitrate adaptation: The function shall provide for an elastic store (buffer) process. The data and frame start signals shall be written into the buffer under control of the associated input clock. The data and frame start signals shall be read out of the buffer under control of the STM-1 clock, frame position, and justification decision.

The justification decisions determine the phase error introduced by the MS1/S4_A_So function. The amount of this phase error can be measured at the physical interfaces by monitoring the AU-4 pointer actions. An example is given in EN 300 417-4-1 [4], clause A.2.

Each justification decision results in a corresponding negative / positive justification action. Upon a positive justification action, the reading of 24 data bits shall be cancelled once and no data written at the three positions H3+1. Upon a negative justification action, an extra 24 data bits shall be read out once into the three positions H3.

NOTE 2: A requirement for maximum introduced phase error cannot be defined until a reference path is defined from which the requirements for network elements can be deduced. Such a requirement would also limit excessive phase error caused by pointer processors under fixed frequency offset conditions.

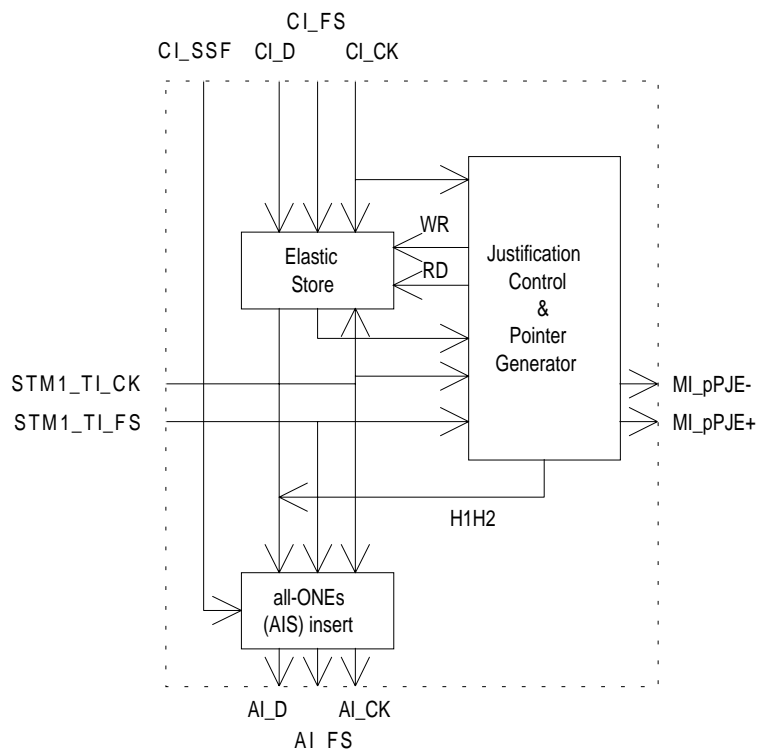

Figure 24: Main processes within MS1/S4_A_So

Buffer size: For further study.

Behaviour at recovery from defect condition: The incoming frequency (S4_CI_CLK) of a passing through VC-4 may exceed its limits during a STM1dLOS condition. As a consequence, the buffer (elastic store) fill is not reliable any more. Due to all-ONEs (AIS) insertion after the pointer generator this reliability is not important for the operation of the network element. However, it shall be prevented to generate excessive pointer adjustments when recovering from the defect condition.

NOTE 3: The definition of excessive pointer adjustments is for further study.

The AU-4 pointer is carried in 2 bytes of payload specific OH (H1, H2) in each STM-1 frame. The AU-4 pointer is aligned in the STM-1 payload in fixed position relative to the STM-1 frame. The AU-4 pointer points to the begin of the VC-4 frame within the STM-1. The format of the AU-4 pointer and its location in the frame are defined in ETS 300 147 [1].

H1H2 - Pointer generation: The function shall generate the AU-4 pointer as is described in EN 300 417-1-1 [3], annex A: Pointer Generation. It shall insert the pointer in the appropriate H1, H2 positions with the SS field set to 10 to indicate AU-4.

YY1*1* - Fixed stuff insertion: The function shall insert fixed stuff codes $Y = 1001ss11$ in bytes [4, 2], [4, 3] and code "1" = 11111111 in bytes [4, 5], [4, 6]. Bits ss are undefined.

Defects: None.

Consequent Actions:

aAIS ← CI_SSF.

On declaration of aAIS the function shall output an all-ONEs signal within 250 µs; on clearing of aAIS the function shall output normal data within 250 µs.

NOTE 4: If CI_SSF is not connected (when MS1/S4_A_So is connected to a S4_TT_So), CI_SSF is assumed to be false.

Defect Correlations: None.

Performance Monitoring:

Every second the number of generated pointer increments within that second shall be counted as the pPJE+. Every second the number of generated pointer decrements within that second shall be counted as the pPJE-.

NOTE 5: This is applicable for a passing through VC-4 only. A locally generated VC-4 may have a fixed frame phase; pointer justifications will not occur.

5.3.2 STM-1 Multiplex Section to S4 Layer Adaptation Sink MS1/S4_A_Sk

Symbol:

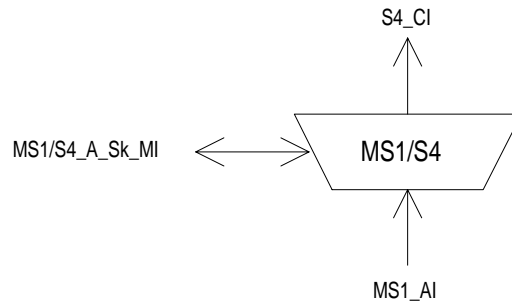

Figure 25: MS1/S4_A_Sk symbol

Interfaces:

Table 15: MS1/S4_A_Sk input and output signals

| Input(s) | Output(s) |
|-----------------------------|---------------------|
| MS1_AI_D | S4_CI_D |
| MS1_AI_CK | S4_CI_CK |
| MS1_AI_FS | S4_CI_FS |
| MS1_AI_TSF | S4_CI_SSF |
| MS1/S4_A_Sk_MI_AIS_Reported | MS1/S4_A_Sk_MI_cAIS |
| | MS1/S4_A_Sk_MI_cLOP |

Processes:

This function recovers the VC-4 data with frame phase information from the STM-1 as defined in ETS 300 147 [1].

H1H2 - AU-4 pointer interpretation: An AU-4 pointer consists of 2 bytes, [4, 1] and [4, 4]. The function shall perform AU-4 pointer interpretation according to annex B of EN 300 417-1-1 [3] to recover the VC-4 frame phase within the STM-1. The process shall maintain its current phase on detection of an invalid pointer and searches in parallel for a new phase.

YY1*1*: The bytes [4, 2], [4, 3], [4, 5], [4, 6] contain fixed stuff, of a specified value, ignored by the AU-4 pointer interpreter.

Defects:

dAIS: The dAIS defect shall be detected if the pointer interpreter is in the AIS_state (see EN 300 417-1-1 [3], annex B). The dAIS defect shall be cleared if the pointer interpreter is not in the AIS_state.

dLOP: The dLOP defect shall be detected if the pointer interpreter is in the LOP_state (see EN 300 417-1-1 [3], annex B). The dLOP defect shall be cleared if the pointer interpreter is not in the LOP_state.

Consequent Actions:

aAIS ← dAIS or dLOP.

aSSF ← dAIS or dLOP.

On declaration of aAIS the function shall output an all-ONES (AIS) signal within 250 µs; on clearing of aAIS the function shall output the recovered data within 250 µs.

Defect Correlations:

cAIS ← dAIS and (not AI_TSF) and AIS_Reported.

cLOP ← dLOP.

Performance Monitors: None.

5.3.3 STM-1 Multiplex Section to DCC Adaptation Source MS1/DCC_A_So

Symbol:

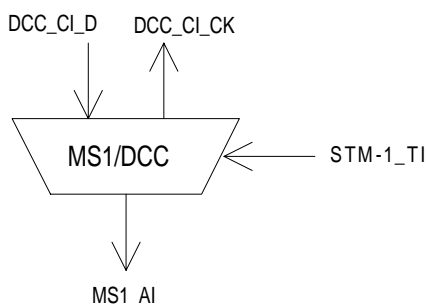

Figure 26: MS1/DCC_A_So symbol

Interfaces:

Table 16: MS1/DCC_A_So input and output signals

| Input(s) | Output(s) |
|--------------------------------------|-----------------------|
| DCC_CI_D STM1_TI_CK STM1_TI_FS | MS1_AI_D DCC_CI_CK |

Processes:

The function multiplexes the DCC CI data (576 kbit/s) into the byte locations D4 to D12 as defined in ETS 300 147 [1] and depicted in figure 18.

NOTE: DCC transmission can be "disabled" when the matrix connection in the connected DCC_C function is removed.

Defects: None.

Consequent Actions: None.

Defect Correlations: None.

Performance Monitoring: None.

5.3.4 STM-1 Multiplex Section to DCC Adaptation Sink MS1/DCC_A_Sk

Symbol:

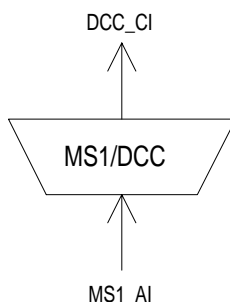

Figure 27: MS1/DCC_A_Sk symbol

Interfaces:

Table 17: MS1/DCC_A_Sk input and output signals

| Input(s) | Output(s) |
|--|-------------------------------------|
| MS1_AI_D MS1_AI_CK MS1_AI_FS MS1_AI_TSF | DCC_CI_D DCC_CI_CK DCC_CI_SSF |

Processes:

The function separates DCC data from MS Overhead as defined in ETS 300 147 [1] and depicted in figure 18.

NOTE: DCC processing can be "disabled" when the matrix connection in the connected DCC_C function is removed.

Defects: None.

Consequent Actions:

aSSF ← AI_TSF.

Defect Correlations: None.

Performance Monitoring: None.

5.3.5 STM-1 Multiplex Section to P0s Adaptation Source MS1/P0s_A_So

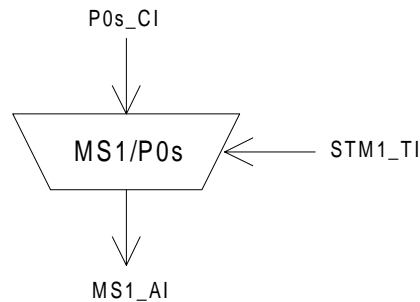
Symbol:**Figure 28: MS1/P0s_A_So symbol****Interfaces:****Table 18: MS1/P0s_A_So input and output signals**

| Input(s) | Output(s) |
|--|-----------|
| P0s_CI_D P0s_CI_CK P0s_CI_FS STM1_TI_CK STM1_TI_FS | MS1_AI_D |

Processes:

This function provides the multiplexing of a 64 kbit/s orderwire information stream into the MS1_AI using slip buffering. It takes P0s_CI, defined in ETS 300 166 [2] as an octet structured bit-stream with a synchronous bit rate of 64 kbit/s, present at its input and inserts it into the MSOH byte E2 as defined in ETS 300 147 [1] and depicted in figure 18.

NOTE: Any frequency deviation between the 64 kbit/s signal and the associated STM-1 signal leads to octet slips.

Frequency justification and bitrate adaptation: The function shall provide for an elastic store (slip buffer) process. The data signal shall be written into the store under control of the associated input clock. The data shall be read out of the store under control of the STM-1 clock, frame position and justification decisions.

Each justification decision results in a corresponding negative / positive justification action. Upon a positive justification (slip) action, the reading of one 64 kbit/s octet (8 bits) shall be cancelled once. Upon a negative justification (slip) action, the same 64 kbit/s octet (8 bits) shall be read out a second time.

Buffer size: The elastic store (slip buffer) shall accommodate at least 18 μ s of wander without introducing errors.

Defects: None.

Consequent Actions: None.

Defect Correlations: None.

Performance Monitoring: None.

5.3.6 STM-1 Multiplex Section to P0s Adaptation Sink MS1/P0s_A_Sk

Symbol:

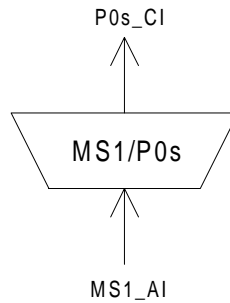

Figure 29: MS1/P0s_A_Sk symbol

Interfaces:

Table 19: MS1/P0s_A_Sk input and output signals

| Input(s) | Output(s) |
|------------|------------|
| MS1_AI_D | P0s_CI_D |
| MS1_AI_CK | P0s_CI_CK |
| MS1_AI_FS | P0s_CI_FS |
| MS1_AI_TSF | P0s_CI_SSF |

Processes:

The function separates P0s data from MS Overhead byte E2 as defined in ETS 300 147 [1] and depicted in figure 18.

Data latching and smoothing process: The function shall provide a data latching and smoothing function. Each 8-bit octet received shall be written and latched into a data store under the control of the STM-1 signal clock. The eight data bits shall then be read out of the store using a nominal 64 kHz clock which may be derived directly from the incoming STM-1 signal clock (e.g. 155 520 kHz divided by a factor of 2 430).

Defects: None.

Consequent Actions:

aSSF ← AI_TSF.

aAIS ← AI_TSF.

On declaration of aAIS the function shall output an all-ONEs (AIS) signal - complying to the frequency limits for this signal (a bit rate in range 64 kbit/s ± 100 ppm) - within 1 ms; on clearing of aAIS the function shall output normal data within 1 ms.

Defect Correlations: None.

Performance Monitoring: None.

5.3.7 STM-1 Multiplex Section to Synchronization Distribution Adaptation Source MS1/SD_A_So

See EN 300 417-6-1 [5].

5.3.8 STM-1 Multiplex Section to Synchronization Distribution Adaptation Sink MS1/SD_A_Sk

See EN 300 417-6-1 [5].

5.3.9 STM-1 Multiplex Section Layer Clock Adaptation Source MS1-LC_A_So

See EN 300 417-6-1 [5].

5.4 STM-1 Multiplex Section Layer Monitoring Functions

For further study.

5.5 STM-1 Multiplex Section Linear Trail Protection Functions

5.5.1 STM-1 Multiplex Section Linear Trail Protection Connection Functions

5.5.1.1 STM-1 Multiplex Section 1+1 Linear Trail Protection Connection MS1P1+1_C

Symbol:

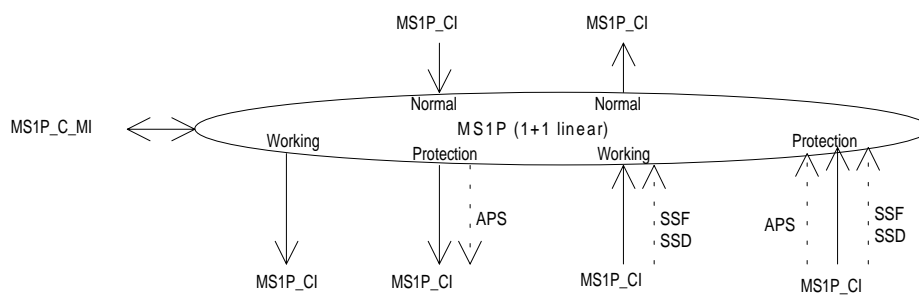

Figure 30: MS1P1+1_C symbol

Interfaces:**Table 20: MS1P1+1_C input and output signals**

| Input(s) | Output(s) |
|---|--|
| For connection points W and P: MS1P_CI_D MS1P_CI_CK MS1P_CI_FS MS1P_CI_SSF MS1P_CI_SSD | For connection points W and P: MS1P_CI_D MS1P_CI_CK MS1P_CI_FS |
| For connection points N: MS1P_CI_D MS1P_CI_CK MS1P_CI_FS | For connection points N: MS1P_CI_D MS1P_CI_CK MS1P_CI_FS MS1P_CI_SSF |
| Per function: MS1P_CI_APS | Per function: MS1P_CI_APS |
| MS1P_C_MI_SWtype MS1P_C_MI_OPERtype MS1P_C_MI_WTRTime MS1P_C_MI_EXTCMD | MS1P_C_MI_cFOP MS1P_C_MI_pPSC MS1P_C_MI_pPSD |
| NOTE: Protection status reporting signals are for further study. | |

Processes:

The function performs the STM-1 linear multiplex section protection process for 1 + 1 protection architectures; see EN 300 417-1-1 [3], subclause 9.2. It performs the bridge and selector functionality as presented in figure 48 of EN 300 417-1-1 [3]. In the sink direction, the signal output at the normal #1 reference point can be the signal received via either the associated working #1 section or the protection section; this is determined by the SF, SD conditions (relayed via CI_SSF, CI_SSD signals), the external commands and the information relayed via the APS signal. In the source direction, the working outputs are connected to the associated normal inputs. The protection output connected to the normal #1 input.

Provided no protection switching action is activated / required the following changes to (the configuration of) a connection shall be possible without disturbing the CI passing the connection:

- change between switching types;
- change between operation types;
- change of WTR time.

MS Protection Operation: The MS trail protection process shall operate as specified in annex A, according the following characteristics.

Table 21

| | |
|----------------------------------|--|
| Architecture: | 1 + 1 |
| Switching type: | uni-directional or bi-directional |
| Operation type: | revertive or non-revertive |
| APS channel: | 13 bits, K1[1-8] and K2[1-5] |
| Wait-To-Restore time: | in the order of 0-12 minutes |
| Switching time: | ≤ 50 ms |
| Hold-off time: | not applicable |
| Signal switch conditions: | SF, SD |
| External commands: | (revertive operation) LO, FSw-#1, MSw-#1, CLR, EXER-#1 (non-revertive operation) LO or FSw, FSw-#i, MSw, MSw-#i, CLR, EXER-#i |
| SFpriority, SDpriority: | high |

Defects: None.

Consequent Actions: None.

Defect Correlations:

cFOP ← (see annex A).

Performance Monitoring:

pPSC ← (see annex A).

pPSD ← (see annex A).

5.5.1.2 STM-1 Multiplex Section 1:n Linear Trail Protection Connection MS1P1:n_C

Symbol:

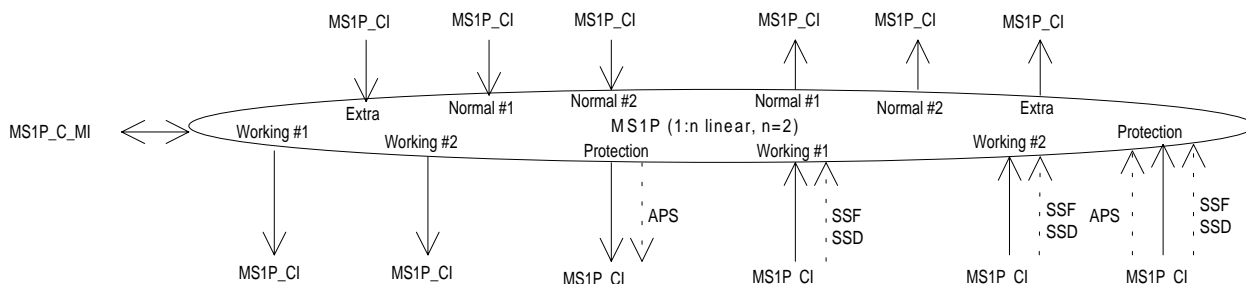

Figure 31: MS1P1:n_C symbol

Interfaces:

Table 22: MS1P1:n_C input and output signals

| Input(s) | Output(s) |
|---|--|
| For connection points W and P: MS1P_CI_D MS1P_CI_CK MS1P_CI_FS MS1P_CI_SSF MS1P_CI_SSD MS1P_C_MI_SFpriority MS1P_C_MI_SDpriority | For connection points W and P: MS1P_CI_D MS1P_CI_CK MS1P_CI_FS |
| For connection points N and E: MS1P_CI_D MS1P_CI_CK MS1P_CI_FS | For connection points N and E: MS1P_CI_D MS1P_CI_CK MS1P_CI_FS MS1P_CI_SSF |
| Per function: MS1P_CI_APS | Per function: MS1P_CI_APS |
| MS1P_C_MI_SWtype MS1P_C_MI_EXTRAttraffic MS1P_C_MI_WTRTime MS1P_C_MI_EXTCMD | MS1P_C_MI_cFOP MS1P_C_MI_pPSC MS1P_C_MI_pPSD |
| NOTE: Protection status reporting signals are for further study. | |

Processes:

The function performs the STM-1 linear multiplex section protection process for 1:n protection architectures; see EN 300 417-1-1 [3], subclause 9.2. It performs the bridge and selector functionality as presented in figure 47 of EN 300 417-1-1 [3]. In the sink direction, the signal output at the normal #i reference point can be the signal received via either the associated working #i section or the protection section; this is determined by the SF, SD conditions (relayed via CI_SSF, CI_SSD signals), the external commands and the information relayed via the APS signal. In the source direction, the working outputs are connected to the associated normal inputs. The protection output is unsourced (no input connected), connected to the extra traffic input, or connected to any normal input.

Provided no protection switching action is activated / required the following changes to (the configuration of) a connection shall be possible without disturbing the CI passing the connection:

- change between switching types;
- change of WTR time.

MS Protection Operation: The MS trail protection process shall operate as specified in annex A, according to the following characteristics.

Table 23

| | |
|----------------------------------|-----------------------------------|
| Architecture: | 1:n ($n \leq 14$) |
| Switching type: | uni-directional or bi-directional |
| Operation type: | revertive |
| APS channel: | 13 bits, K1 [1-8] and K2 [1-5] |
| Wait-To-Restore time: | in the order of 0-12 minutes |
| Switching time: | ≤ 50 ms |
| Hold-off time: | not applicable |
| Signal switch conditions: | SF, SD |
| External commands: | LO, FSw-#, MSw-#, CLR, EXER |

Defects: None.

Consequent Actions:

For the case where neither the extra traffic nor a normal signal input is to be connected to the protection section output, the null signal shall be connected to the protection output. The null signal is either one of the normal signals, an all-ONES, or a test signal.

For the case of a protection switch, the extra traffic output (if applicable) is disconnected from the protection input, set to all-ONES (AIS) and aSSF is activated.

Defect Correlations:

cFOP ← (see annex A).

Performance Monitoring:

pPSC ← (see annex A).

pPSD ← (see annex A).

5.5.2 STM-1 Multiplex Section Linear Trail Protection Trail Termination Functions

5.5.2.1 Multiplex Section Protection Trail Termination Source MS1P_TT_So

Symbol:

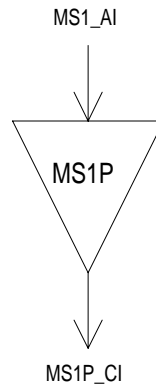

Figure 32: MS1P_TT_So symbol

Interfaces:

Table 24: MS1P_TT_So input and output signals

| Input(s) | Output(s) |
|-----------|------------|
| MS1_AI_D | MS1P_CI_D |
| MS1_AI_CK | MS1P_CI_CK |
| MS1_AI_FS | MS1P_CI_FS |

Processes:

No information processing is required in the MS1P_TT_So, the MS1_AI at its output being identical to the MS1P_CI at its input.

Defects: None.

Consequent Actions: None

Defect Correlations: None.

Performance Monitoring: None.

5.5.2.2 Multiplex Section Protection Trail Termination Sink MS1P_TT_Sk

Symbol:

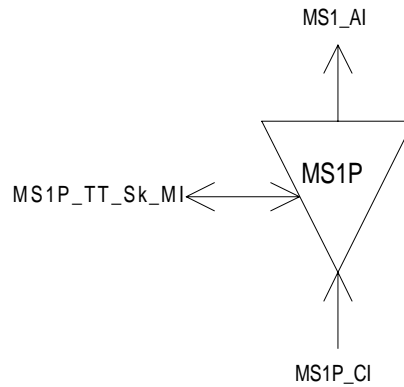

Figure 33: MS1P_TT_Sk symbol

Interfaces:

Table 25: MS1P_TT_Sk input and output signals

| Input(s) | Output(s) |
|----------------------------|--------------------|
| MS1P_CI_D | MS1_AI_D |
| MS1P_CI_CK | MS1_AI_CK |
| MS1P_CI_FS | MS1_AI_FS |
| MS1P_CI_SSF | MS1_AI_TSF |
| MS1P_TT_Sk_MI_SSF_Reported | MS1P_TT_Sk_MI_cSSF |

Processes:

The MS1P_TT_Sk function reports, as part of the MS1 layer, the state of the protected MS1 trail. In case all connections are unavailable the MS1P_TT_Sk reports the signal fail condition of the protected trail.

Defects: None.

Consequent Actions:

aTSF ← CI_SSF.

Defect Correlations:

cSSF ← CI_SSF and SSF_Reported.

Performance Monitoring: None.

5.5.3 STM-1 Multiplex Section Linear Trail Protection Adaptation Functions

5.5.3.1 STM-1 Multiplex Section to STM-1 Multiplex Section Protection Layer Adaptation Source MS1/MS1P_A_So

Symbol:

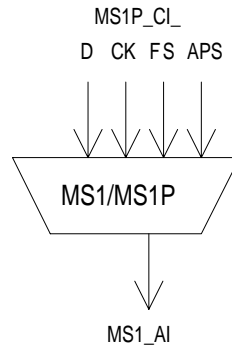

Figure 34: MS1/MS1P_A_So symbol

Interfaces:

Table 26: MS1/MS1P_A_So input and output signals

| Input(s) | Output(s) |
|-------------|-----------|
| MS1P_CI_D | MS1_AI_D |
| MS1P_CI_CK | MS1_AI_CK |
| MS1P_CI_FS | MS1_AI_FS |
| MS1P_CI_APS | |

Processes:

The function shall multiplex the MS1 APS signal and MS1 data signal onto the MS1 access point.

Defects: None.

Consequent actions: None.

Defect Correlations: None.

Performance Monitoring: None.

5.5.3.2 STM-1 Multiplex Section to STM-1 Multiplex Section Protection Layer Adaptation Sink MS1/MS1P_A_Sk

Symbol:

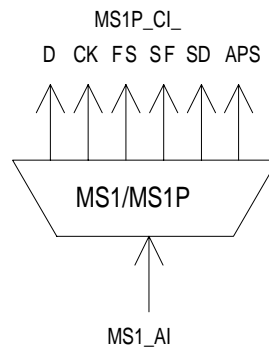

Figure 35: MS1/MS1P_A_Sk symbol

Interfaces:

Table 27: MS1/MS1P_A_Sk input and output signals

| Input(s) | Output(s) |
|------------|--|
| MS1_AI_D | MS1P_CI_D |
| MS1_AI_CK | MS1P_CI_CK |
| MS1_AI_FS | MS1P_CI_FS |
| MS1_AI_TSF | MS1P_CI_SSF |
| MS1_AI_TSD | MS1P_CI_SSD |
| | MS1P_CI_APS (for Protection signal only) |

Processes:

The function shall extract and output the MS1P_CI_D signal from the MS1_AI_D signal.

K1[1-8]K2[1-5]: The function shall extract the 13 APS bits K1[1-8] and K2[1-5] from the MS1_AI_D signal. A new value shall be accepted when the value is identical for three consecutive frames. This value shall be output via MS1P_CI_APS. This process is required only for the protection section.

Defects: None.

Consequent actions:

aSSF ← AI_TSF.

aSSD ← AI_TSD.

Defect Correlations: None.

Performance Monitoring: None.

6 STM-4 Regenerator Section Layer Functions

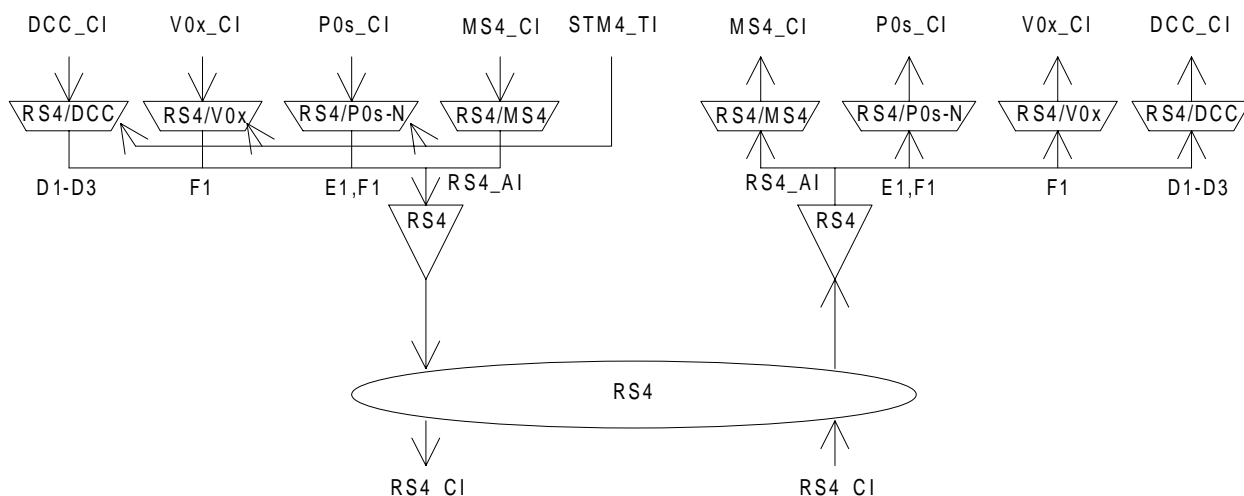

Figure 36: STM-4 Regenerator Section atomic functions

RS4 Layer CP

The CI at this point is an octet structured, 125 μs framed data stream with co-directional timing. It is the entire STM-4 signal as defined in ETS 300 147 [1]. Figure 37 depicts only bytes handled in the RS4 layer.

NOTE 1: The unmarked bytes [2, 2] to [2, 12], [2, 14] to [2, 24], [3, 2] to [3, 12], [3, 14] to [3, 24], and [3, 26] to [3, 36] in rows 2 and 3 (see figure 37) are reserved for future international standardization. Currently, they are undefined.

NOTE 2: The bytes for National Use (NU) in rows 1,2 (see figure 37) are reserved for operator specific usage. Their processing is not within the province of the present document. If NU bytes [1, 29] to [1, 36] are unused, care should be taken in selecting the binary content of the bytes which are excluded from the scrambling process of the STM-N signal to ensure that long sequences of "1"s or "0"s do not occur.

NOTE 3: The bytes Z0 [1, 26] to [1, 28] are reserved for future international standardization. Currently, they are undefined Care should be taken in selecting the binary content of these bytes which are excluded from the scrambling process of the STM-N signal to ensure that long sequences of "1"s or "0"s do not occur.

| | | | | | | | | | | | | | | | | | | | | | | | | | | | | | | | | | | | | | | |
|---|----|----|----|----|----|----|----|----|----|----|----|----|----|----|----|----|----|----|----|----|----|----|----|----|----|----|----|----|----|----|----|----|----|----|----|----|----|------|
| | 1 | 2 | 3 | 4 | 5 | 6 | 7 | 8 | 9 | 10 | 11 | 12 | 13 | 14 | 15 | 16 | 17 | 18 | 19 | 20 | 21 | 22 | 23 | 24 | 25 | 26 | 27 | 28 | 29 | 30 | 31 | 32 | 33 | 34 | 35 | 36 | 37 | 1080 |
| 1 | A1 | A1 | A1 | A1 | A1 | A1 | A1 | A1 | A1 | A1 | A1 | A1 | A2 | A2 | A2 | A2 | A2 | A2 | A2 | A2 | A2 | A2 | A2 | A2 | A2 | J0 | Z0 | Z0 | Z0 | NU | NU | NU | NU | NU | NU | NU | NU | NU |
| 2 | B1 | | | | | | | | | | | | E1 | | | | | | | | | | | | | F1 | NU | NU | NU | NU | NU | NU | NU | NU | NU | NU | NU | NU |
| 3 | D1 | | | | | | | | | | | | D2 | | | | | | | | | | | | | D3 | | | | | | | | | | | | |
| 4 | | | | | | | | | | | | | | | | | | | | | | | | | | | | | | | | | | | | | | |
| 5 | | | | | | | | | | | | | | | | | | | | | | | | | | | | | | | | | | | | | | |
| 6 | | | | | | | | | | | | | | | | | | | | | | | | | | | | | | | | | | | | | | |
| 7 | | | | | | | | | | | | | | | | | | | | | | | | | | | | | | | | | | | | | | |
| 8 | | | | | | | | | | | | | | | | | | | | | | | | | | | | | | | | | | | | | | |
| 9 | | | | | | | | | | | | | | | | | | | | | | | | | | | | | | | | | | | | | | |

Figure 37: RS4_CI_D signal

RS4 Layer AP

The AI at this point is octet structured and 125 μs framed with co-directional timing and represents the combination of adapted information from the MS4 layer (9 612 bytes per frame), the management communication DCC layer (3 bytes per frame if supported), the OW layer (1 byte per frame if supported) and the user channel F1 (1 byte per frame if supported). The location of these four components in the frame is defined in ETS 300 147 [1] and depicted in figure 38.

NOTE 4: Bytes E1, F1 and D1-D3 will be undefined when the adaptation functions sourcing these bytes are not present in the network element.

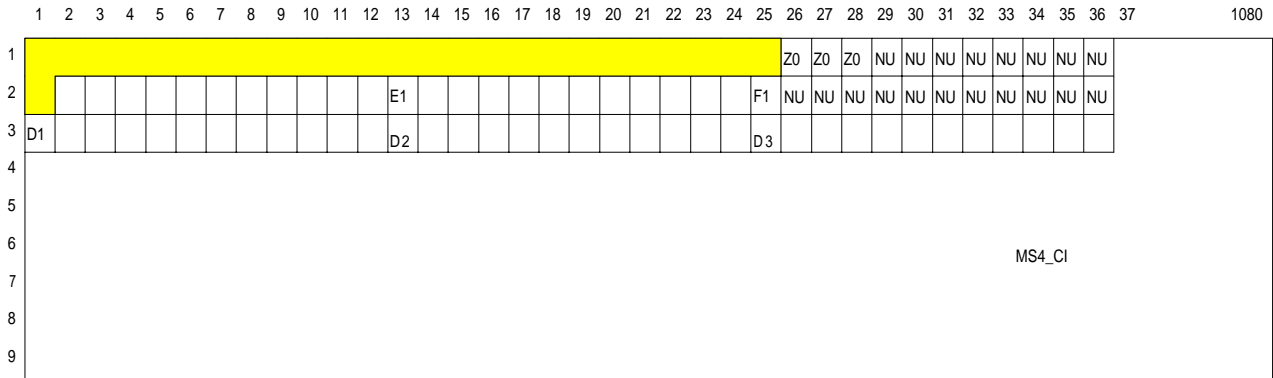

Figure 38: RS4_AI_D signal

6.1 STM-4 Regenerator Section Connection functions

For further study.

6.2 STM-4 Regenerator Section Trail Termination functions

6.2.1 STM-4 Regenerator Section Trail Termination Source RS4_TT_So

Symbol:

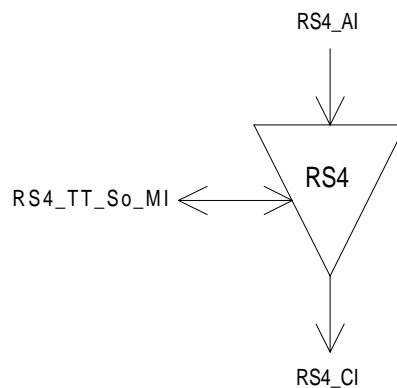

Figure 39: RS4_TT_So symbol

Interfaces:**Table 28: RS4_TT_So input and output signals**

| Input(s) | Output(s) |
|---|-----------------------|
| RS4_AI_D RS4_AI_CK RS4_AI_FS RS4_TT_So_MI_TxTI | RS4_CI_D RS4_CI_CK |

Processes:

The function builds the STM-4 signal by adding the frame alignment information, bytes A1A2, the STM Section Trace Identifier (STI) byte J0, computing the parity and inserting the B1 byte.

J0: In this byte the function shall insert the Transmitted Trail Trace Identifier TxTI. Its format is described in EN 300 417-1-1 [3], subclause 7.1.

B1: The function shall calculate a Bit Interleaved Parity 8 (BIP-8) code using even parity. The BIP-8 shall be calculated over all bits of the previous STM-4 frame after scrambling and is placed in byte position B1 of the current STM-4 frame before scrambling (see figure 40).

A1A2: The function shall insert the STM-4 frame alignment signal A1...A1A2...A2 into the regenerator section overhead as defined in ETS 300 147 [1] and depicted in figure 37.

Scrambler: This function provides scrambling of the RS4_CI. The operation of the scrambler shall be functionally identical to that of a frame synchronous scrambler of sequence length 127 operating at the line rate. The generating polynomial shall be $1 + X^6 + X^7$. The scrambler shall be reset to "1111 1111" on the most significant bit (MSB) of the byte [1, 37] following the last byte of the STM-4 SOH in the first row. This bit and all subsequent bits to be scrambled shall be modulo 2 added to the output of the X^7 position of the scrambler. The scrambler shall run continuously throughout the remaining STM-4 frame.

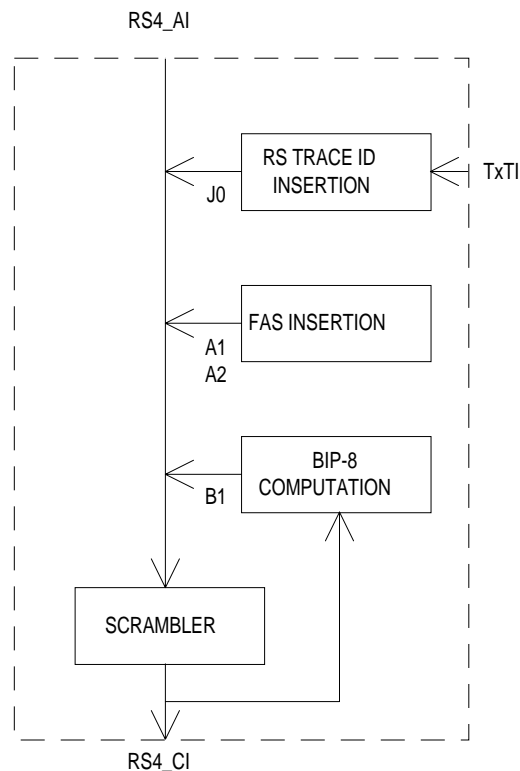
**Figure 40: Some processes within RS4_TT_So**

Defects: None.

Consequent Actions: None.

Defect Correlations: None.

Performance Monitoring: None.

6.2.2 STM-4 Regenerator Section Trail Termination Sink RS4_TT_Sk

Symbol:

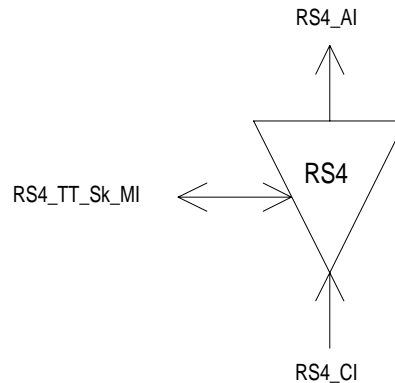

Figure 41: RS4_TT_Sk symbol

Interfaces:

Table 29: RS4_TT_Sk input and output signals

| Input(s) | Output(s) |
|-----------------------|---------------------|
| RS4_CI_D | RS4_AI_D |
| RS4_CI_CK | RS4_AI_CK |
| RS4_CI_FS | RS4_AI_FS |
| RS4_CI_SSF | RS4_AI_TSF |
| RS4_TT_Sk_MI_ExtI | RS4_TT_Sk_MI_AcTI |
| RS4_TT_Sk_MI_TPmode | RS4_TT_Sk_MI_cTIM |
| RS4_TT_Sk_MI_TIMdis | RS4_TT_Sk_MI_pN_EBC |
| RS4_TT_Sk_MI_ExtImode | RS4_TT_Sk_MI_pN_DS |
| RS4_TT_Sk_MI_1second | |

Processes:

This function monitors the STM-4 signal for RS errors, and recovers the RS trail termination status. It extracts the payload independent overhead bytes (J0, B1) from the RS4 layer Characteristic Information:

Descrambling: The function shall descramble the incoming STM-4 signal. The operation of the descrambler shall be functionally identical to that of a scrambler in OS4/RS4_A_So.

B1: Even bit parity is computed for each bit n of every byte of the preceding scrambled STM-4 frame and compared with bit n of B1 recovered from the current frame ($n = 1$ to 8 inclusive) (see figure 42). A difference between the computed and recovered B1 values is taken as evidence of one or more errors (nN_B) in the computation block.

J0: The Received Trail Trace Identifier RxTI shall be recovered from the J0 byte and shall be made available as AcTI for network management purposes. The application and acceptance and mismatch detection process shall be performed as specified in EN 300 417-1-1 [3], subclauses 7.1 and 8.2.1.3.

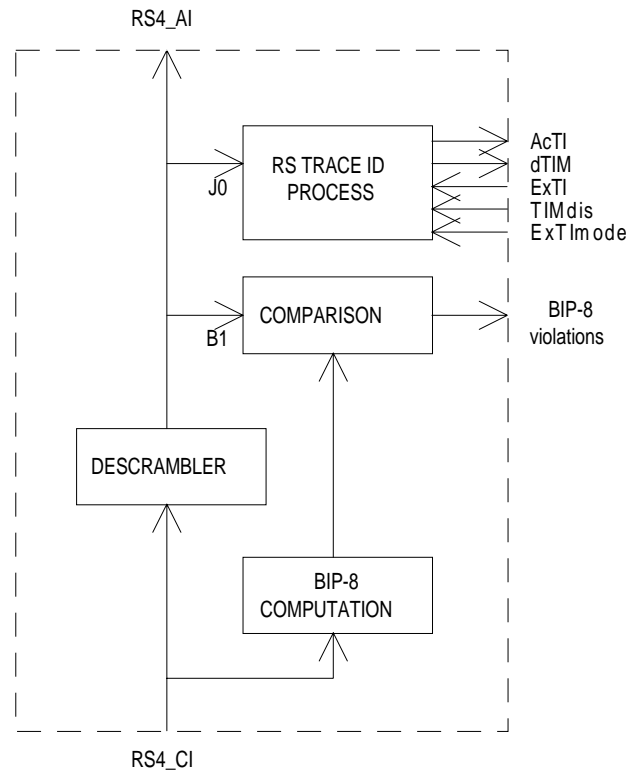

Figure 42: Some processes within RS4_TT_Sk

Defects:

The function shall detect for dTIM defects according the specification in EN 300 417-1-1 [3], subclause 8.2.1.

Consequent Actions:

aAIS ← CI_SSF or dTIM.

aTSF ← CI_SSF or dTIM.

On declaration of aAIS the function shall output an all-ONEs (AIS) signal within 250 µs; on clearing of aAIS the function shall output normal data within 250 µs.

NOTE 1: The term "CI_SSF" has been added to the conditions for aAIS while the descrambler function has been moved from the e.g. OS4/RS4_A_Sk to this function. Consequently, an all-ONEs (AIS) pattern inserted in the mentioned adaptation function would be descrambled in this function. A "refreshment" of all-ONEs is required.

NOTE 2: The insertion of AIS - especially due to detection of dTIM - will cause the RS-DCC channel to be "squashed" too, so that control of the NE via this channel is lost. If control is via this channel only, there is a risk of a dead-lock situation if dTIM is caused by a misprovisioning of ExTI.

Defect Correlations:

cTIM ← MON and dTIM.

Performance Monitoring:

For further study.

6.3 STM-4 Regenerator Section Adaptation functions

6.3.1 STM-4 Regenerator Section to Multiplex Section Adaptation Source RS4/MS4_A_So

Symbol:

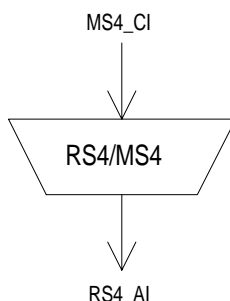

Figure 43: RS4/MS4_A_So symbol

Interfaces:

Table 30: RS4/MS4_A_So input and output signals

| Input(s) | Output(s) |
|--|------------------------------------|
| MS4_CI_D MS4_CI_CK MS4_CI_FS MS4_CI_SSF | RS4_AI_D RS4_AI_CK RS4_AI_FS |

Processes:

The function multiplexes the MS4_CI data (9 612 bytes / frame) into the STM-4 byte locations defined in ETS 300 147 [1] and depicted in figure 37.

NOTE 1: There might be cases in which the network element knows that the timing reference for a particular STM-4 interface can not be maintained within $\pm 4,6$ ppm. For such cases MS-AIS can be generated. This is network element specific and outside the scope of the present document.

Defects: None.

Consequent Actions:

aAIS ← CI_SSF.

On declaration of aAIS the function shall output all ONEs signal within 250 μ s; on clearing of aAIS the function shall output normal data within 250 μ s. The frequency of the all ONEs signal shall be within 622,080 kHz \pm 20 ppm.

NOTE 2: If CI_SSF is not connected (when RS4/MS4_A_So is connected to a MS4_TT_So), SSF is assumed to be false.

Defect Correlations: None.

Performance Monitoring: None.

6.3.2 STM-4 Regenerator Section to Multiplex Section Adaptation Sink RS4/MS4_A_Sk

Symbol:

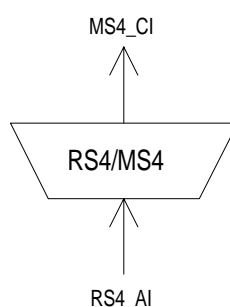

Figure 44: RS4/MS4_A_Sk symbol

Interfaces:

Table 31: RS4/MS4_A_Sk input and output signals

| Input(s) | Output(s) |
|------------|------------|
| RS4_AI_D | MS4_CI_D |
| RS4_AI_CK | MS4_CI_CK |
| RS4_AI_FS | MS4_CI_FS |
| RS4_AI_TSF | MS4_CI_SSF |

Processes:

The function separates MS4_CI data from RS4_AI as depicted in figure 37.

Defects: None.

Consequent Actions:

aSSF ← AI_TSF.

Defect Correlations: None.

Performance Monitoring: None.

6.3.3 STM-4 Regenerator Section to DCC Adaptation Source RS4/DCC_A_So

Symbol:

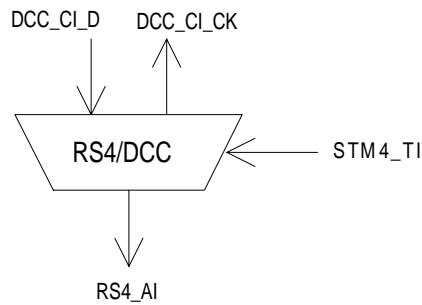

Figure 45: RS4/DCC_A_So symbol

Interfaces:

Table 32: RS4/DCC_A_So input and output signals

| Input(s) | Output(s) |
|--------------------------------------|-----------------------|
| DCC_CI_D STM4_TI_CK STM4_TI_FS | RS4_AI_D DCC_CI_CK |

Processes:

The function multiplexes the DCC CI data (192 kbit/s) into the byte locations D1, D2 and D3 as defined in ETS 300 147 [1] and depicted in figure 38.

NOTE: DCC transmission can be "disabled" when the matrix connection in the connected DCC_C function is removed.

Defects: None.

Consequent Actions: None.

Defect Correlations: None.

Performance Monitoring: None.

6.3.4 STM-4 Regenerator Section to DCC Adaptation Sink RS4/DCC_A_Sk

Symbol:

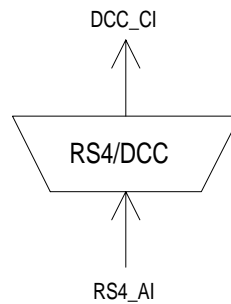

Figure 46: RS4/DCC_A_Sk symbol

Interfaces:

Table 33: RS4/DCC_A_Sk input and output signals

| Input(s) | Output(s) |
|------------|------------|
| RS4_AI_D | DCC_CI_D |
| RS4_AI_CK | DCC_CI_CK |
| RS4_AI_FS | DCC_CI_SSF |
| RS4_AI_TSF | |

Processes:

The function separates DCC data from RS Overhead as defined in ETS 300 147 [1] and depicted in figure 38.

NOTE: DCC processing can be "disabled" when the matrix connection in the connected DCC_C function is removed.

Defects: None.

Consequent Actions:

aSSF ← AI_TSF.

Defect Correlations: None.

Performance Monitoring: None.

6.3.5 STM-4 Regenerator Section to P0s Adaptation Source RS4/P0s_A_So/N

Symbol:

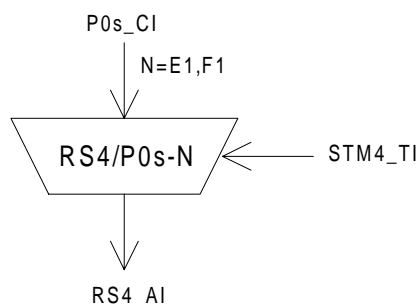

Figure 47: RS4/P0s_A_So symbol

Interfaces:

Table 34: RS4/P0s_A_So input and output signals

| Input(s) | Output(s) |
|--|-----------|
| P0s_CI_D P0s_CI_CK P0s_CI_FS STM4_TI_CK STM4_TI_FS | RS4_AI_D |

Processes:

This function provides the multiplexing of a 64 kbit/s orderwire or user channel information stream into the RS4_AI using slip buffering. It takes P0s_CI, defined in ETS 300 166 [2] as an octet structured bit-stream with a synchronous bit rate of 64 kbit/s, present at its input and inserts it into the RSOH byte E1 or F1 as defined in ETS 300 147 [1] and depicted in figure 38.

NOTE: Any frequency deviation between the 64 kbit/s signal and the associated STM-4 signal leads to octet slips.

Frequency justification and bitrate adaptation: The function shall provide an elastic store (slip buffer) process. The data signal shall be written into the store under control of the associated input clock. The data shall be read out of the store under control of the STM-4 clock, frame position (STM4_TI), and justification decisions.

Each justification decision results in a corresponding negative / positive justification action. Upon a positive justification action, the reading of one 64 kbit/s octet (8 bits) shall be cancelled once. Upon a negative justification action, the same 64 kbit/s octet (8 bits) shall be read out a second time.

Buffer size: The elastic store (slip buffer) shall accommodate at least 18 μ s of wander without introducing errors.

64 kbit/s timeslot: The adaptation source function has access to a specific 64 kbit/s channel of the RS access point. The specific 64 kbit/s channel is defined by the parameter N (N = E1, F1).

Defects: None.

Consequent Actions: None.

Defect Correlations: None.

Performance Monitoring: None.

6.3.6 STM-4 Regenerator Section to P0s Adaptation Sink RS4/P0s_A_Sk/N

Symbol:

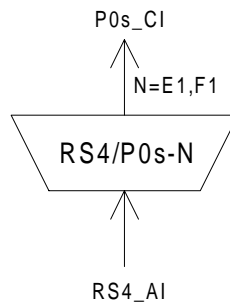

Figure 48: RS4/P0s_A_Sk symbol

Interfaces:

Table 35: RS4/P0s_A_Sk input and output signals

| Input(s) | Output(s) |
|------------|--------------|
| RS4_AI_D | P0s_CI_Sk_D |
| RS4_AI_CK | P0s_CI_Sk_CK |
| RS4_AI_FS | P0s_CI_FS |
| RS4_AI_TSF | P0s_CI_SSF |

Processes:

The function separates P0s data from RS Overhead byte E1 or F1 as defined in ETS 300 147 [1] and depicted in figure 38.

Data latching and smoothing process: The function shall provide a data latching and smoothing function. Each 8-bit octet received shall be written and latched into a data store under the control of the STM-4 signal clock. The eight data bits shall then be read out of the store using a nominal 64 kHz clock which may be derived directly from the incoming STM-4 signal clock (e.g. 622 080 kHz divided by a factor of 9 720).

64 kbit/s timeslot: The adaptation sink function has access to a specific 64 kbit/s of the RS access point. The specific 64 kbit/s is defined by the parameter N (N = E1, F1).

Defects: None.

Consequent Actions:

aSSF ← AI_TSF.

aAIS ← AI_TSF.

On declaration of aAIS the function shall output an all-ONES (AIS) signal - complying to the frequency limits for this signal (a bit rate in range 64 kbit/s ± 100 ppm) - within 1 ms; on clearing of aAIS the function shall output normal data within 1 ms.

Defect Correlations: None.

Performance Monitoring: None.

6.3.7 STM-4 Regenerator Section to V0x Adaptation Source RS4/V0x_A_So

Symbol:

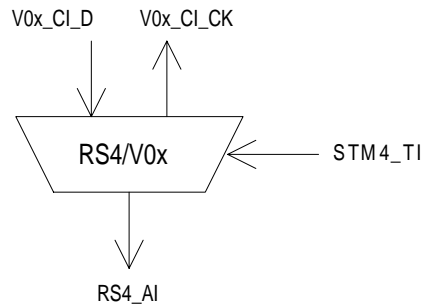

Figure 49: RS4/V0x_A_So symbol

Interfaces:

Table 36: RS4/V0x_A_So input and output signals

| Input(s) | Output(s) |
|--------------------------------------|-----------------------|
| V0x_CI_D STM4_TI_CK STM4_TI_FS | RS4_AI_D V0x_CI_CK |

Processes: None.

This function shall multiplex the V0x_CI data (64 kbit/s) into the byte location F1 as defined in ETS 300 147 [1] and depicted in figure 38.

Defects: None.

Consequent Actions: None.

Defect Correlations: None.

Performance Monitoring: None.

6.3.8 STM-4 Regenerator Section to V0x Adaptation Sink RS4/V0x_A_Sk

Symbol:

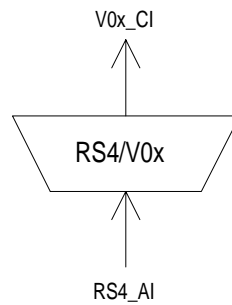

Figure 50: RS4/V0x_A_Sk symbol

Interfaces:

Table 37: RS4/V0x_A_Sk input and output signals

| Input(s) | Output(s) |
|--|-------------------------------------|
| RS4_AI_D RS4_AI_CK RS4_AI_FS RS4_AI_TSF | V0x_CI_D V0x_CI_CK V0x_CI_SSF |

Processes:

This function separates user channel data from RS Overhead (byte F1) as defined in ETS 300 147 [1] and depicted in figure 38.

Defects: None.

Consequent Actions:

aSSF ← AI_TSF.

aAIS ← AI_TSF.

On declaration of aAIS the function shall output an all-ONES (AIS) signal within 1 ms; on clearing of aAIS the function shall output normal data within 1 ms.

Defect Correlations: None.

Performance Monitoring: None.

7 STM-4 Multiplex Section Layer Functions

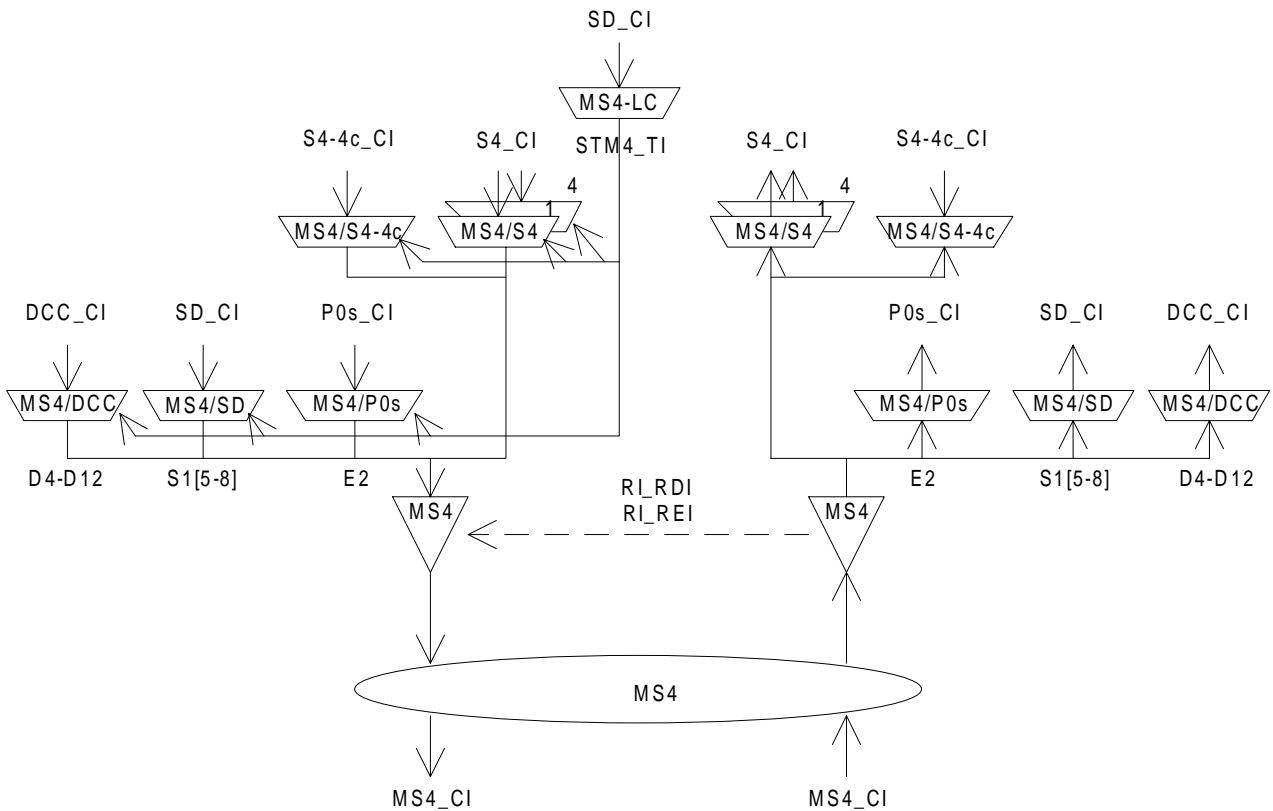

Figure 51: STM-4 Multiplex Section atomic functions

MS4 Layer CP

The CI at this point is octet structured and 125 μs framed with co-directional timing. Its format is characterized as the MS4_AI with an additional MS Trail Termination overhead in the twelve B2 bytes, byte M1, and bits 6-8 of the K2 byte in the frame locations defined in ETS 300 147 [1] and depicted in figure 52.

NOTE 1: The unmarked bytes in rows 5, 6, 7, 8, 9 (see figure 52) are reserved for future international standardization. Currently, they are undefined.

NOTE 2: The bytes for National Use (NU) in row 9 (see figure 52) are reserved for operator specific usage. Their processing is not within the province of the present document.

| | | | | | | | | | | | | | | | | | | | | | | | | | | | | | | | | | | | | | | | | | | | | | | | | | | | |
|---|-----|----|----|----|----|----|----|----|----|----|----|----|----|-----|----|----|----|-----|-----|-----|-----|-----|-----|-----|-----|----|-----|----|----|----|----|----|----|----|----|----|--------------------------------------|--|--|--|--|--|--|--|--|--|--|--|----|----|----|
| 1 | 2 | 3 | 4 | 5 | 6 | 7 | 8 | 9 | 10 | 11 | 12 | 13 | 14 | 15 | 16 | 17 | 18 | 19 | 20 | 21 | 22 | 23 | 24 | 25 | 26 | 27 | 28 | 29 | 30 | 31 | 32 | 33 | 34 | 35 | 36 | 37 | 1080 | | | | | | | | | | | | | | |
| 1 | | | | | | | | | | | | | | | | | | | | | | | | | | | | | | | | | | | | | STM-4 payload (4 x 261 x 9 bytes) | | | | | | | | | | | | | | |
| 2 | | | | | | | | | | | | | | | | | | | | | | | | | | | | | | | | | | | | | | | | | | | | | | | | | | | |
| 3 | | | | | | | | | | | | | | | | | | | | | | | | | | | | | | | | | | | | | | | | | | | | | | | | | | | |
| 4 | H1 | H1 | H1 | H1 | Y | Y | Y | Y | Y | Y | Y | Y | Y | H2 | H2 | H2 | H2 | '1' | '1' | '1' | '1' | '1' | '1' | '1' | '1' | H3 | H3 | H3 | H3 | H3 | H3 | H3 | H3 | H3 | H3 | H3 | | | | | | | | | | | | | H3 | | |
| 5 | B2 | B2 | B2 | B2 | B2 | B2 | B2 | B2 | B2 | B2 | B2 | B2 | B2 | K1 | | | | | | | | | | | | | K2 | | | | | | | | | | | | | | | | | | | | | | | | |
| 6 | D4 | | | | | | | | | | | | | D5 | | | | | | | | | | | | | D6 | | | | | | | | | | | | | | | | | | | | | | | | |
| 7 | D7 | | | | | | | | | | | | | D8 | | | | | | | | | | | | | D9 | | | | | | | | | | | | | | | | | | | | | | | | |
| 8 | D10 | | | | | | | | | | | | | D11 | | | | | | | | | | | | | D12 | | | | | | | | | | | | | | | | | | | | | | | | |
| 9 | S1 | | | | | | | | | | | | | | M1 | | | | | | | | | | | | E2 | NU | NU | NU | NU | NU | NU | NU | NU | NU | | | | | | | | | | | | | NU | NU | NU |

Figure 52: MS4_CI_D

7.2 STM-4 Multiplex Section Trail Termination functions

7.2.1 STM-4 Multiplex Section Trail Termination Source MS4_TT_So

Symbol:

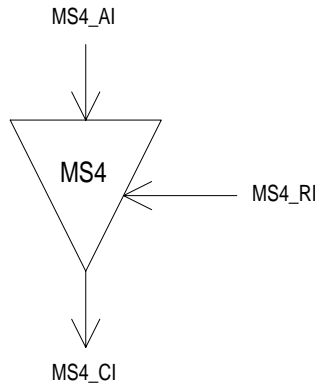

Figure 56: MS4_TT_So symbol

Interfaces:

Table 38: MS4_TT_So input and output signals

| Input(s) | Output(s) |
|------------|-----------|
| MS4_AI_D | MS4_CI_D |
| MS4_AI_CK | MS4_CI_CK |
| MS4_AI_FS | MS4_CI_FS |
| MS4_RI_REI | |
| MS4_RI_RDI | |

Processes:

This function adds error monitoring capabilities and remote maintenance information signals to the MS4_AI.

M1: The function shall insert the value of MS4_RI_REI into the REI (Remote Error Indication) - to convey the count of interleaved bit blocks that have been detected in error by the BIP-96 process in the companion MS4_TT_Sk - in the range of "0000 0000" (0) to "0110 0000" (96).

K2[6-8]: These bits represents the defect status of the associated MS4_TT_Sk. The RDI indication shall be set to "110" on activation of MS4_RI_RDI within 250 μ s, determined by the associated MS4_TT_Sk function, and passed through transparently (except for incoming codes "111" and "110") within 250 μ s on the MS4_RI_RDI removal. If MS4_RI_RDI is inactive an incoming codes "111" or "110" shall be replaced by code "000".

NOTE 1: K2[6-8] can not be set to "000" on clearing of RI_RDI; MS SPRING APS extends into those bits. The bits shall be passed transparently in this case. With linear MS protection or without protection it shall be guaranteed that neither code "111" nor "110" will be output.

B2: The function shall calculate a Bit Interleaved Parity 96 (BIP-96) code using even parity. The BIP-96 shall be calculated over all bits, except those in the RSOH bytes, of the previous STM-4 frame and placed in twelve B2 bytes of the current STM-4 frame.

NOTE 2: The BIP-96 procedure is described in ETS 300 147 [1].

Defects: None.

Consequent Actions: None.

Defect Correlations: None.

Performance Monitoring: None.

7.2.2 STM-4 Multiplex Section Trail Termination Sink MS4_TT_Sk

Symbol:

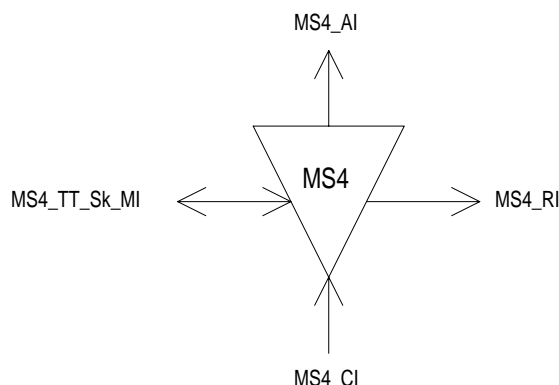

Figure 57: MS4_TT_Sk symbol

Interfaces:

Table 39: MS4_TT_Sk input and output signals

| Input(s) | Output(s) |
|---------------------------|---------------------|
| MS4_CI_D | MS4_AI_D |
| MS4_CI_CK | MS4_AI_CK |
| MS4_CI_FS | MS4_AI_FS |
| MS4_CI_SSF | MS4_AI_TSF |
| MS4_TT_Sk_MI_DEGTHR | MS4_AI_TSD |
| MS4_TT_Sk_MI_DEGM | MS4_TT_Sk_MI_cAIS |
| MS4_TT_Sk_MI_1second | MS4_TT_Sk_MI_cDEG |
| MS4_TT_Sk_MI_TPmode | MS4_TT_Sk_MI_cRDI |
| MS4_TT_Sk_MI_SSF_Reported | MS4_TT_Sk_MI_cSSF |
| MS4_TT_Sk_MI_AIS_Reported | MS4_TT_Sk_MI_pN_EBC |
| MS4_TT_Sk_MI_RDI_Reported | MS4_TT_Sk_MI_pF_EBC |
| | MS4_TT_Sk_MI_pN_DS |
| | MS4_TT_Sk_MI_pF_DS |
| | MS4_RI_REI |
| | MS4_RI_RDI |

Processes:

This function monitors error performance of associated MS4 including the far end receiver.

B2: The BIP-96 shall be calculated over all bits, except of those in the RSOH bytes, of the previous STM-4 frame and compared with the three error monitoring bytes B2 recovered from the MSOH of the current STM-4 frame. A difference between the computed and recovered B2 values is taken as evidence of one or more errors (nN_B) in the computation block.

M1: The REI information carried in these bits shall be extracted to enable single ended maintenance of a bi-directional trail (section). The REI is used to monitor the error performance of the other direction of transmission. The application process is described in EN 300 417-1-1 [3], subclause 7.4.2 (REI).

The function shall interpret the value in the byte (to allow interworking with old equipment generating a 7 bit code), as shown in table 40.

Table 40: STM-4 M1 interpretation

| M1[2-8] code, bits 234 5678 | code interpretation [#BIP violations], (nF_B) |
|-----------------------------------|--|
| 000 0000 | 0 |
| 000 0001 | 1 |
| 000 0010 | 2 |
| 000 0011 | 3 |
| 000 0100 | 4 |
| 000 0101 | 5 |
| ⋮ | ⋮ |
| 110 0000 | 96 |
| 110 0001 | 0 |
| 110 0010 | 0 |
| ⋮ | ⋮ |
| 111 1111 | 0 |
| NOTE: Bit 1 of byte M1 is ignored | |

NOTE: In case of interworking with old equipment not supporting MS-REI, the information extracted from M1 is not relevant.

K2[6-8] - RDI: The RDI information carried in these bits shall be extracted to enable single ended maintenance of a bi-directional trail (section). The RDI provides information as to the status of the remote receiver. A "110" indicates a Remote Defect Indication state, while other patterns indicate the normal state. The application process is described in EN 300 417-1-1 [3], subclauses 7.4.11 and 8.2.

K2[6-8] - AIS: The MS-AIS information carried in these bits shall be extracted.

Defects:

The function shall detect for dDEG and dRDI defects according the specification in EN 300 417-1-1 [3], subclause 8.2.1.

dAIS: If at least x consecutive frames contain the "111" pattern in bits 6, 7 and 8 of the K2 byte a dAIS defect shall be detected. dAIS shall be cleared if in at least x consecutive frames any pattern other than the "111" is detected in bits 6, 7 and 8 of byte K2. The x shall be in range 3 to 5.

Consequent Actions:

aAIS ← dAIS.
aRDI ← dAIS.
aREI ← #EDCV.
aTSF ← dAIS.
aTSD ← dDEG.

On declaration of aAIS the function shall output an all-ONES signal within 250 μs; on clearing of aAIS the function shall output normal data within 250 μs.

Defect Correlations:

cAIS ← MON and dAIS and (not CI_SSF) and AIS_Reported.
cDEG ← MON and dDEG.
cRDI ← MON and dRDI and RDI_Reported.
cSSF ← MON and dAIS and SSF_Reported.

Performance monitoring:

The performance monitoring process shall be performed as specified in EN 300 417-1-1 [3], subclause 8.2.4 through 8.2.7.

$pN_DS \leftarrow aT_{SF} \text{ or } dEQ.$

$pF_DS \leftarrow dRDI.$

$pN_EBC \leftarrow \Sigma nN_B.$

$pF_EBC \leftarrow \Sigma nF_B.$

7.3 STM-4 Multiplex Section Adaptation functions

7.3.1 STM-4 Multiplex Section to S4 Layer Adaptation Source MS4/S4_A_So/N

Symbol:

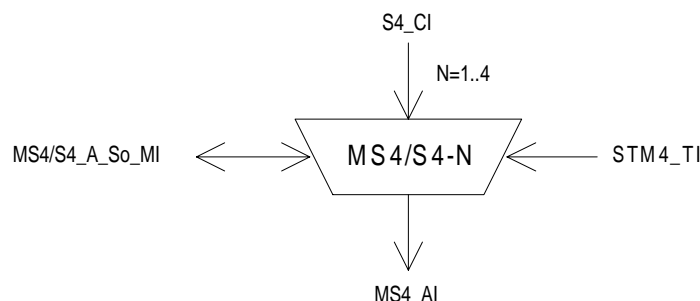

Figure 58: MS4/S4_A_So symbol

Interfaces:

Table 41: MS4/S4_A_So input and output signals

| Input(s) | Output(s) |
|-----------------------|----------------------|
| S4_CI_D | MS4_AI_D |
| S4_CI_CK | MS4_AI_CK |
| S4_CI_FS | MS4_AI_FS |
| S4_CI_SSF | |
| STM4_TI_CK | MS4/S4_A_So_MI_pPJE+ |
| STM4_TI_FS | MS4/S4_A_So_MI_pPJE- |
| MS4/S4_A_So_MI_Active | |

Processes:

This function provides frequency justification and bitrate adaptation for a VC-4 signal, represented by a nominally $(261 \times 9 \times 64) = 150\,336$ kbit/s information stream and the related frame phase with a frequency accuracy within $\pm 4,6$ ppm, to be multiplexed into a STM-4 signal at the AU tributary location indicated by N. The function can be activated / deactivated when multiple payload adaptation functions are connected to the access point.

NOTE 1: Degraded performance may be observed when interworking with SONET equipment having a ± 20 ppm network element clock source.

The frame phase of the VC-4 is coded in the related AU-4 pointer. Frequency justification, if required, is performed by pointer adjustments. The accuracy of this coding process is specified below. See EN 300 417-4-1 [4], annex A.

Frequency justification and bitrate adaptation: The function shall provide for an elastic store (buffer) process. The data and frame start signals shall be written into the buffer under control of the associated input clock. The data and frame start signals shall be read out of the buffer under control of the STM-4 clock, frame position, and justification decision.

The justification decisions determine the phase error introduced by the MS4/S4_A_So function. The amount of this phase error can be measured at the physical interfaces by monitoring the AU-4 pointer actions. An example is given in EN 300 417-4-1 [4], clause A.2.

Each justification decision results in a corresponding negative / positive justification action. Upon a positive justification action, the reading of 24 data bits shall be cancelled once and no data written at the three positions H3+1. Upon a negative justification action, an extra 24 data bits shall be read out once into the three positions H3.

NOTE 2: A requirement for maximum introduced phase error cannot be defined until a reference path is defined from which the requirements for network elements can be deduced. Such a requirement would also limit excessive phase error caused by pointer processors under fixed frequency offset conditions.

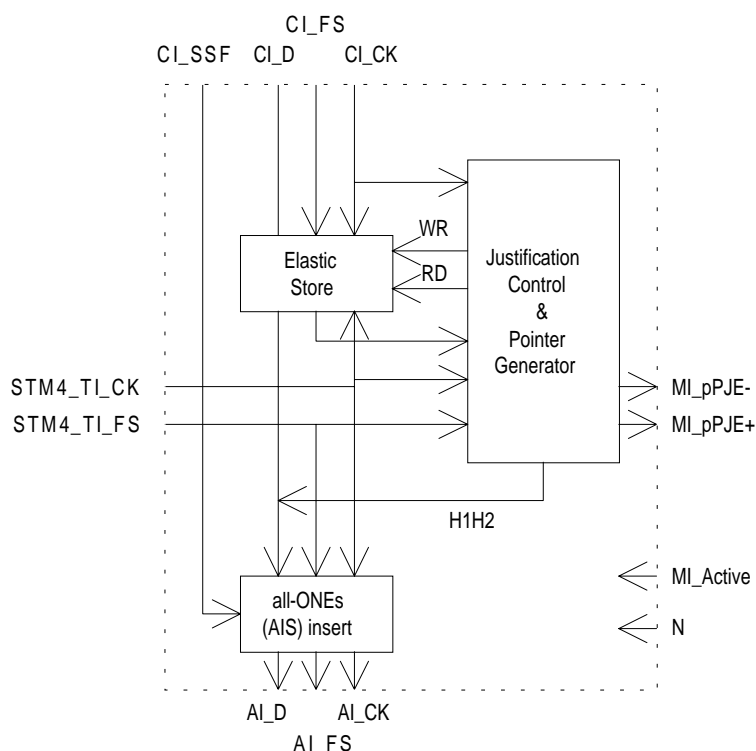

Figure 59: Main processes within MS4/S4_A_So

Buffer size: For further study.

Behaviour at recovery from defect condition: The incoming frequency (S4_CI_CK) of a passing through VC-4 may exceed its limits during a STM4dLOS condition. As a consequence, the buffer (elastic store) fill is not reliable any more. Due to all-ONEs (AIS) insertion after the pointer generator this reliability is not important for the operation of the network element. However, it shall be prevented to generate excessive pointer adjustments when recovering from the defect condition.

NOTE 3: The definition of excessive pointer adjustments is for further study.

The AU-4 pointer is carried in 2 bytes of payload specific OH (H1, H2) in each STM-4 frame. The AU-4 pointer is aligned in the STM-4 payload in fixed position relative to the STM-4 frame. The AU-4 pointer points to the begin of the VC-4 frame within the STM-4. The format of the AU-4 pointer and its location in the frame are defined in ETS 300 147 [1].

H1H2 - Pointer generation: The function shall generate the AU-4 pointer as is described in EN 300 417-1-1 [3], annex A: Pointer Generation. It shall insert the pointer in the appropriate H1, H2 positions with the SS field set to 10 to indicate AU-4.

YY1*1* - Fixed stuff insertion: The function shall insert fixed stuff codes $Y = 1001ss11$ in bytes $[4, 4+N]$ and $[4, 8+N]$ and code "1" = 11111111 in bytes $[4, 16+N]$ and $[4, 20+N]$. Bits ss are undefined.

AU-4 timeslot: The adaptation source function has access to a specific AU-4 of the MS4 access point. The AU-4 is defined by the parameter N ($N = 1..4$).

Activation: The function shall access the access point when it is activated (MI_Active is true). Otherwise, it shall not access the access point.

Defects: None.

Consequent Actions:

aAIS ← CI_SSF.

On declaration of aAIS the function shall output an all-ONEs signal within 250 µs; on clearing of aAIS the function shall output normal data within 250 µs.

NOTE 4: If CI_SSF is not connected (when MS4/S4_A_So is connected to a S4_TT_So), CI_SSF is assumed to be false.

Defect Correlations: None.

Performance Monitoring:

Every second the number of generated pointer increments within that second shall be counted as the pPJE+. Every second the number of generated pointer decrements within that second shall be counted as the pPJE-.

NOTE 5: This is applicable for a passing through VC-4 only. A locally generated VC-4 may have a fixed frame phase; pointer justifications will not occur.

7.3.2 STM-4 Multiplex Section to S4 Layer Adaptation Sink MS4/S4_A_Sk/N

Symbol:

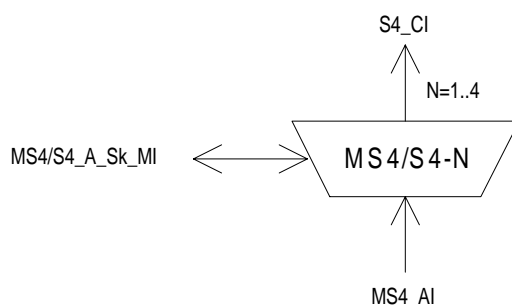

Figure 60: MS4/S4_A_Sk symbol

Interfaces:

Table 42: MS4/S4_A_Sk input and output signals

| Input(s) | Output(s) |
|-----------------------------|---------------------|
| MS4_AI_D | S4_CI_D |
| MS4_AI_CK | S4_CI_CK |
| MS4_AI_FS | S4_CI_FS |
| MS4_AI_TSF | S4_CI_SSF |
| MS4/S4_A_Sk_MI_Active | MS4/S4_A_Sk_MI_cAIS |
| MS4/S4_A_Sk_MI_AIS_Reported | MS4/S4_A_Sk_MI_cLOP |

Processes:

This function recovers the VC-4 data with frame phase information from the STM-4 as defined in ETS 300 147 [1]. The VC-4 is extracted from the AU tributary location indicated by N. The function can be activated / deactivated when multiple payload adaptation functions are connected to the access point.

H1H2 - AU-4 pointer interpretation: An AU-4 pointer consists of 2 bytes, [4, N] and [4, 12+N]. The function shall perform AU-4 pointer interpretation according to annex B of EN 300 417-1-1 [3] to recover the VC-4 frame phase within the STM-4. The process shall maintain its current phase on detection of an invalid pointer and searches in parallel for a new phase.

YY1*1*: The bytes [4, 4+N], [4, 8+N], [4, 16+N], and [4, 20+N] contain fixed stuff, of a specified value, ignored by the AU-4 pointer interpreter.

AU-4 timeslot: The adaptation sink function has access to a specific AU-4 of the MS4 access point. The AU-4 is defined by the parameter N (N = 1..4).

Activation: The function shall perform the operation specified above when it is activated (MI_Active is true). Otherwise, it shall transmit the all-ONES signal at its output (CI_D) and not report its status via its management point.

Defects:

dAIS: The dAIS defect shall be detected if the pointer interpreter is in the AIS_state (see EN 300 417-1-1 [3], annex B). The dAIS defect shall be cleared if the pointer interpreter is not in the AIS_state.

dLOP: The dLOP defect shall be detected if the pointer interpreter is in the LOP_state (see EN 300 417-1-1 [3], annex B). The dLOP defect shall be cleared if the pointer interpreter is not in the LOP_state.

Consequent Actions:

aAIS ← dAIS or dLOP.

aSSF ← dAIS or dLOP.

On declaration of aAIS the function shall output an all-ONEs (AIS) signal within 250 µs; on clearing of aAIS the function shall output the recovered data within 250 µs.

Defect Correlations:

cAIS ← dAIS and (not AI_TSF) and AIS_Reported.

cLOP ← dLOP.

Performance Monitoring: None.

7.3.3 STM-4 Multiplex Section to S4-4c Layer Adaptation Source MS4/S4-4c_A_So

Symbol:

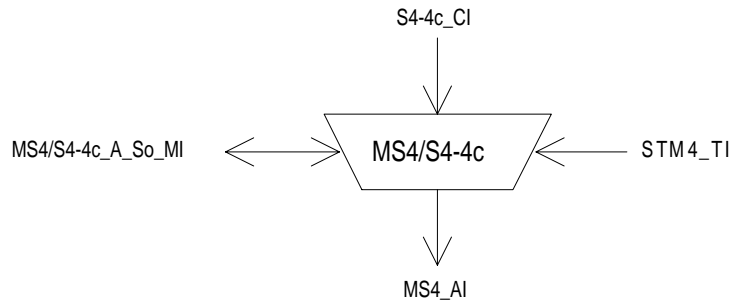

Figure 61: MS4/S4-4c_A_So symbol

Interfaces:

Table 43: MS4/S4-4c_A_So input and output signals

| Input(s) | Output(s) |
|--------------------------|-------------------------|
| S4-4c_CI_D | MS4_AI_D |
| S4-4c_CI_CK | MS4_AI_CK |
| S4-4c_CI_FS | MS4_AI_FS |
| S4-4c_CI_SSF | |
| STM4_TI_CK | MS4/S4-4c_A_So_MI_pPJE+ |
| STM4_TI_FS | MS4/S4-4c_A_So_MI_pPJE- |
| MS4/S4-4c_A_So_MI_Active | |

Processes:

This function provides frequency justification and bitrate adaptation for a VC-4-4c signal, represented by a nominally $(4 \times 261 \times 9 \times 64) = 601\,344$ kbit/s information stream and the related frame phase with a frequency accuracy within $\pm 4,6$ ppm, to be multiplexed into a STM-4 signal. The function can be activated / deactivated when multiple payload adaptation functions are connected to the access point.

NOTE 1: Degraded performance may be observed when interworking with SONET equipment having a ± 20 ppm network element clock source.

The frame phase of the VC-4-4c is coded in the related AU-4-4c pointer. Frequency justification, if required, is performed by pointer adjustments. The accuracy of this coding process is specified below. See EN 300 417-4-1 [4], annex A.

Frequency justification and bitrate adaptation: The function shall provide for an elastic store (buffer) process. The data and frame start signals shall be written into the buffer under control of the associated input clock. The data and frame start signals shall be read out of the buffer under control of the STM-4 clock, frame position, and justification decision.

The justification decisions determine the phase error introduced by the MS4/S4-4c_A_So function. The amount of this phase error can be measured at the physical interfaces by monitoring the AU-4-4c pointer actions. An example is given in EN 300 417-4-1 [4], clause A.2.

Each justification decision results in a corresponding negative / positive justification action. Upon a positive justification action, the reading of 96 data bits shall be cancelled once and no data written at the twelve positions H3+1. Upon a negative justification action, an extra 96 data bits shall be read out once into the twelve positions H3.

NOTE 2: A requirement for maximum introduced phase error cannot be defined until a reference path is defined from which the requirements for network elements can be deduced. Such a requirement would also limit excessive phase error caused by pointer processors under fixed frequency offset conditions.

Buffer size: For further study.

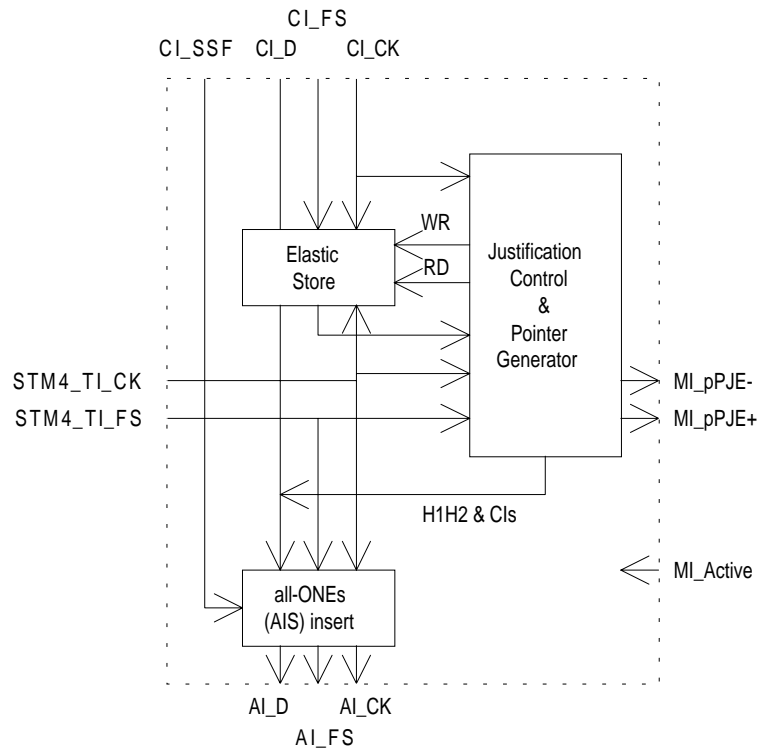

Figure 62: Main processes within MS4/S4-4c_A_So

Behaviour at recovery from defect condition: The incoming frequency (S4-4c_CI_CLK) of a passing through VC-4-4c may exceed its limits during a STM4dLOS condition. As a consequence, the buffer (elastic store) fill is not reliable any more. Due to all-ONEs (AIS) insertion after the pointer generator this reliability is not important for the operation of the network element. However, it shall be prevent to generate excessive pointer adjustments when recovering from the defect condition.

NOTE 3: The definition of excessive pointer adjustments is for further study.

The AU-4-4c pointer is carried in 2 + 6 bytes of payload specific OH in each STM-4 frame. The AU-4-4c pointer is aligned in the STM-4 payload in fixed position relative to the STM-4 frame. The AU-4-4c pointer points to the begin of the VC-4-4c frame within the STM-4. The format of the AU-4-4c pointer and its location in the frame are defined in ETS 300 147 [1].

H1H1H1H1H2H2H2H2 - Pointer generation: The function shall generate the AU-4-4c pointer as is described in EN 300 417-1-1 [3], annex A: Pointer Generation. It shall insert the pointer in the H1 [4, 1], H2 [4, 13] positions with the SS field set to 10 to indicate AU-3/AU-4/AU-4-4c. It shall insert the concatenation indicator in the other pointer locations H1 [4, 2] to [4, 4], H2 [4, 14] to [4, 16]. The concatenation indicator is defined as 1001ss11 11111111, with ss being undefined bits.

YYYYYYYY1*1*1*1*1*1*1*1* - Fixed stuff insertion: The function shall insert fixed stuff codes Y = 1001ss11 in bytes [4, 5] to [4, 12] and code "1" = 11111111 in bytes [4, 17] to [4, 24]. Bits ss are undefined.

Activation: The function shall access the access point when it is activated (MI_Active is true). Otherwise, it shall not access the access point.

Defects: None.

Consequent Actions:

aAIS ← CI_SSF.

On declaration of aAIS the function shall output an all-ONEs signal within 250 µs; on clearing of aAIS the function shall output normal data within 250 µs.

NOTE 4: If CI_SSF is not connected (when MS4/S4-4c_A_So is connected to a S4-4c_TT_So), CI_SSF is assumed to be false.

Defect Correlations: None.

Performance Monitoring:

Every second the number of generated pointer increments within that second shall be counted as the pPJE+. Every second, the number of generated pointer decrements within that second shall be counted as the pPJE-.

NOTE 5: This is applicable for a passing through VC-4-4c only. A locally generated VC-4-4c may have a fixed frame phase; pointer justifications will not occur.

7.3.4 STM-4 Multiplex Section to S4-4c Layer Adaptation Sink MS4/S4-4c_A_Sk

Symbol:

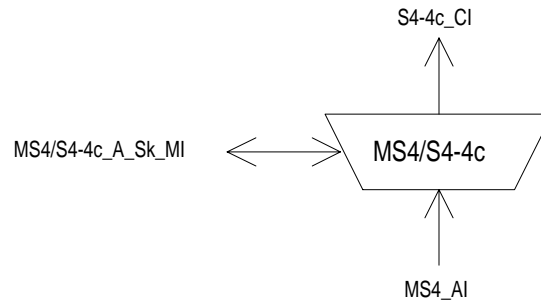

Figure 63: MS4/S4-4c_A_Sk symbol

Interfaces:

Table 44: MS4/S4-4c_A_Sk input and output signals

| Input(s) | Output(s) |
|--------------------------------|------------------------|
| MS4_AI_D | S4-4c_CI_D |
| MS4_AI_CK | S4-4c_CI_CK |
| MS4_AI_FS | S4-4c_CI_FS |
| MS4_AI_TSF | S4-4c_CI_SSF |
| MS4/S4-4c_A_Sk_MI_Active | MS4/S4-4c_A_Sk_MI_cAIS |
| MS4/S4-4c_A_Sk_MI_AIS_Reported | MS4/S4-4c_A_Sk_MI_cLOP |

Processes:

This function recovers the VC-4-4c data with frame phase information from the STM-4 as defined in ETS 300 147 [1]. The function can be activated / deactivated when multiple payload adaptation functions are connected to the access point.

H1H2 - AU-4-4c pointer interpretation: An AU-4-4c pointer consists of 4 x 2 bytes, [4, 1]/[4, 13], [4, 2]/[4, 14], [4, 3]/[4, 15], and [4, 4]/[4, 16]. The last three pairs of pointer bytes contain the concatenation indication. The function shall perform AU-4-4c pointer interpretation according to annex B of EN 300 417-1-1 [3] to recover the VC-4-4c frame phase within the STM-4. The process shall maintain its current phase on detection of an invalid pointer and searches in parallel for a new phase.

YY1*1*: The bytes [4, 5] to [4, 12] and [4, 17] to [4, 24] contain fixed stuff, of a specified value, ignored by the AU-4-4c pointer interpreter.

Activation: The function shall perform the operation specified above when it is activated (MI_Active is true). Otherwise, it shall transmit the all-ONEs signal at its output (CI_D) and not report its status via its management point.

Defects:

dAIS: The dAIS defect shall be detected if the pointer interpreter is in the AISX_state (see EN 300 417-1-1 [3], annex B). The dAIS defect shall be cleared if the pointer interpreter is not in the AISX_state.

dLOP: The dLOP defect shall be detected if the pointer interpreter is in the LOPX_state (see EN 300 417-1-1 [3], annex B). The dLOP defect shall be cleared if the pointer interpreter is not in the LOPX_state.

Consequent Actions:

aAIS ← dAIS or dLOP.

aSSF ← dAIS or dLOP.

On declaration of aAIS the function shall output an all-ONEs (AIS) signal within 250 µs; on clearing of aAIS the function shall output the recovered data within 250 µs.

Defect Correlations:

cAIS ← dAIS and (not aTSF) and AIS_Reported.

cLOP ← dLOP.

Performance Monitoring: None.

7.3.5 STM-4 Multiplex Section to DCC Adaptation Source MS4/DCC_A_So

Symbol:

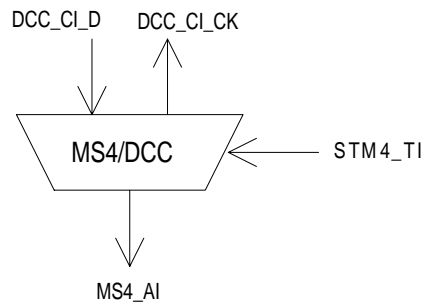

Figure 64: MS4/DCC_A_So symbol

Interfaces:

Table 45: MS4/DCC_A_So input and output signals

| Input(s) | Output(s) |
|--------------------------------------|-----------------------|
| DCC_CI_D STM4_TI_CK STM4_TI_FS | MS4_AI_D DCC_CI_CK |

Processes:

The function multiplexes the DCC CI data (576 kbit/s) into the byte locations D4 to D12 as defined in ETS 300 147 [1] and depicted in figure 53.

NOTE: DCC transmission can be "disabled" when the matrix connection in the connected DCC_C function is removed.

Defects: None.

Consequent Actions: None.

Defect Correlations: None.

Performance Monitoring: None.

7.3.6 STM-4 Multiplex Section to DCC Adaptation Sink MS4/DCC_A_Sk

Symbol:

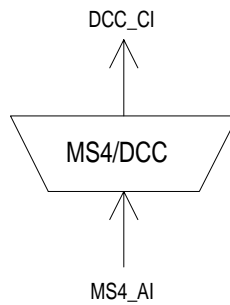

Figure 65: MS4/DCC_A_Sk symbol

Interfaces:

Table 46: MS4/DCC_A_Sk input and output signals

| Input(s) | Output(s) |
|--|-------------------------------------|
| MS4_AI_D MS4_AI_CK MS4_AI_FS MS4_AI_TSF | DCC_CI_D DCC_CI_CK DCC_CI_SSF |

Processes:

The function separates DCC data from MS Overhead as defined in ETS 300 147 [1] and depicted in figure 53.

NOTE: DCC processing can be "disabled" when the matrix connection in the connected DCC_C function is removed.

Defects: None.

Consequent Actions:

aSSF ← AI_TSF.

Defect Correlations: None.

Performance Monitoring: None.

7.3.7 STM-4 Multiplex Section to P0s Adaptation Source MS4/P0s_A_So

Symbol:

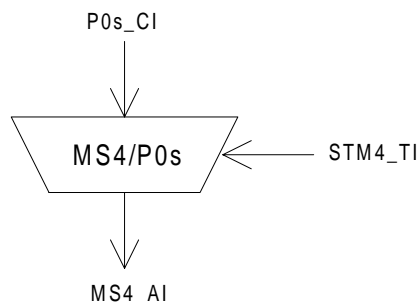

Figure 66: MS4/P0s_A_So symbol

Interfaces:

Table 47: MS4/P0s_A_So input and output signals

| Input(s) | Output(s) |
|--|-----------------|
| P0s_CI_D P0s_CI_CK P0s_CI_FS STM4_TI_CK STM4_TI_FS | MS4/P0s_AI_So_D |

Processes:

This function provides the multiplexing of a 64 kbit/s orderwire information stream into the MS4_AI using slip buffering. It takes P0s_CI, defined in ETS 300 166 [2] as an octet structured bit-stream with a synchronous bit rate of 64 kbit/s, present at its input and inserts it into the MSOH byte E2 as defined in ETS 300 147 [1] and depicted in figure 53.

NOTE: Any frequency deviation between the 64 kbit/s signal and the associated STM-4 signal leads to octet slips.

Frequency justification and bitrate adaptation: The function shall provide for an elastic store (slip buffer) process. The data signal shall be written into the store under control of the associated input clock. The data shall be read out of the store under control of the STM-4 clock, frame position, and justification decisions.

Each justification decision results in a corresponding negative / positive justification action. Upon a positive justification (slip) action, the reading of one 64 kbit/s octet (8 bits) shall be cancelled once. Upon a negative justification (slip) action, the same 64 kbit/s octet (8 bits) shall be read out a second time.

Buffer size: The elastic store (slip buffer) shall accommodate at least 18 μ s of wander without introducing errors.

Defects: None.

Consequent Actions: None.

Defect Correlations: None.

Performance Monitoring: None.

7.3.8 STM-4 Multiplex Section to P0s Adaptation Sink MS4/P0s_A_Sk

Symbol:

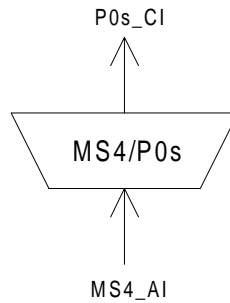

Figure 67: MS4/P0s_A_Sk symbol

Interfaces:

Table 48: MS4/P0s_A_Sk input and output signals

| Input(s) | Output(s) |
|------------|--------------|
| MS4_AI_D | P0s_CI_Sk_D |
| MS4_AI_CK | P0s_CI_Sk_CK |
| MS4_AI_FS | P0s_CI_FS |
| MS4_AI_TSF | P0s_CI_SSF |

Processes:

The function separates P0s data from MS Overhead byte E2 as defined in ETS 300 147 [1] and depicted in figure 53.

Data latching and smoothing process: The function shall provide a data latching and smoothing function. Each 8-bit octet received shall be written and latched into a data store under the control of the STM-4 signal clock. The eight data bits shall then be read out of the store using a nominal 64 kHz clock which may be derived directly from the incoming STM-4 signal clock (e.g. 622 080 kHz divided by a factor of 9 720).

Defects: None.

Consequent Actions:

aSSF ← AI_TSF.

aAIS ← AI_TSF.

On declaration of aAIS the function shall output an all-ONEs (AIS) signal - complying to the frequency limits for this signal (a bit rate in range 64 kbit/s ± 100 ppm) - within 1 ms; on clearing of aAIS the function shall output normal data within 1 ms.

Defect Correlations: None.

Performance Monitoring: None.

7.3.9 STM-4 Multiplex Section to Synchronization Distribution Adaptation Source MS4/SD_A_So

See EN 300 417-6-1 [5].

7.3.10 STM-4 Multiplex Section to Synchronization Distribution Adaptation Sink MS4/SD_A_Sk

See EN 300 417-6-1 [5].

7.3.11 STM-4 Multiplex Section Layer Clock Adaptation Source MS4-LC_A_So

See EN 300 417-6-1 [5].

7.4 STM-4 Multiplex Section Layer Monitoring Functions

For further study.

7.5 STM-4 Multiplex Section Linear Trail Protection Functions

7.5.1 STM-4 Multiplex Section Linear Trail Protection Connection Functions

7.5.1.1 STM-4 Multiplex Section 1+1 Linear Trail Protection Connection MS4P1+1_C

Symbol:

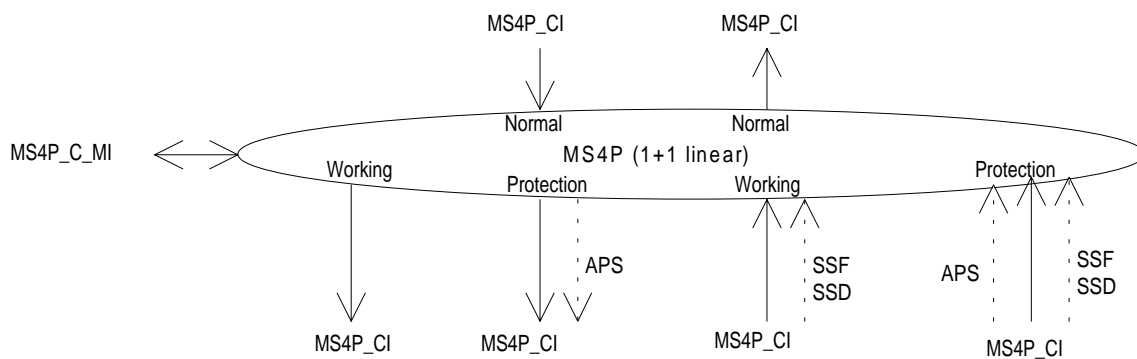

Figure 68: MS4P1+1_C symbol

Interfaces:**Table 49: MS4P1+1_C input and output signals**

| Input(s) | Output(s) |
|---|--|
| For connection points W and P: MS4P_CI_D MS4P_CI_CK MS4P_CI_FS MS4P_CI_SSF MS4P_CI_SSD | For connection points W and P: MS4P_CI_D MS4P_CI_CK MS4P_CI_FS MS4P_CI_SSF |
| For connection points N: MS4P_CI_D MS4P_CI_CK MS4P_CI_FS | For connection points N: MS4P_CI_D MS4P_CI_CK MS4P_CI_FS MS4P_CI_SSF |
| Per function: MS4P_CI_APS | Per function: MS4P_CI_APS |
| MS4P_C_MI_SWtype MS4P_C_MI_OPERtype MS4P_C_MI_WTRTime MS4P_C_MI_EXTCMD | MS4P_C_MI_cFOP MS4P_C_MI_pPSC MS4P_C_MI_pPSD |
| NOTE: Protection status reporting signals are for further study. | |

Processes:

The function performs the STM-4 linear multiplex section protection process for 1 + 1 protection architectures; see EN 300 417-1-1 [3], subclause 9.2. It performs the bridge and selector functionality as presented in figure 48 of EN 300 417-1-1 [3]. In the sink direction, the signal output at the normal #1 reference point can be the signal received via either the associated working #1 section or the protection section; this is determined by the SF, SD conditions (relayed via CI_SSF, CI_SSD signals), the external commands and the information relayed via the APS signal. In the source direction, the working outputs are connected to the associated normal inputs. The protection output is connected to the normal #1 input.

Provided no protection switching action is activated / required, the following changes to (the configuration of) a connection shall be possible without disturbing the CI passing the connection:

- change between switching types;
- change between operation types;
- change of WTR time.

MS Protection Operation: The MS trail protection process shall operate as specified in annex A, according the following characteristics:

Table 50

| | |
|----------------------------------|--|
| Architecture: | 1 + 1 |
| Switching type: | uni-directional or bi-directional |
| Operation type: | revertive or non-revertive |
| APS channel: | 13 bits, K1[1-8] and K2[1-5] |
| Wait-To-Restore time: | in the order of 0-12 minutes |
| Switching time: | ≤ 50 ms |
| Hold-off time: | not applicable |
| Signal switch conditions: | SF, SD |
| External commands: | (revertive operation) LO, FSw-#1, MSw-#1, CLR, EXER-#1 (non-revertive operation) LO or FSw, FSw-#i, MSw, MSw-#i, CLR, EXER-#1 |
| SFpriority, SDpriority: | high |

Defects: None.

Consequent Actions: None.

Defect Correlations:

cFOP ← (see annex A).

Performance Monitoring:

pPSC ← (see annex A).

pPSD ← (see annex A).

Table 52

| | |
|----------------------------------|-----------------------------------|
| Architecture: | 1:n ($n \leq 14$) |
| Switching type: | uni-directional or bi-directional |
| Operation type: | revertive |
| APS channel: | 13 bits, K1[1-8] and K2[1-5] |
| Wait-To-Restore time: | in the order of 0-12 minutes |
| Switching time: | ≤ 50 ms |
| Hold-off time: | not applicable |
| Signal switch conditions: | SF, SD |
| External commands: | LO, FSw-#, MSw-#, CLR, EXER |

Defects: None.

Consequent Actions:

For the case where neither the extra traffic nor a normal signal input is to be connected to the protection section output, the null signal shall be connected to the protection output. The null signal is either one of the normal signals, an all-ONES, or a test signal.

For the case of a protection switch, the extra traffic output (if applicable) is disconnected from the protection input, set to all-ONES (AIS) and aSSF is activated.

Defect Correlations:

cFOP ← (see annex A).

Performance Monitoring:

pPSC ← (see annex A).

pPSD ← (see annex A).

7.5.2 STM-4 Multiplex Section Linear Trail Protection Trail Termination Functions

7.5.2.1 Multiplex Section Protection Trail Termination Source MS4P_TT_So

Symbol:

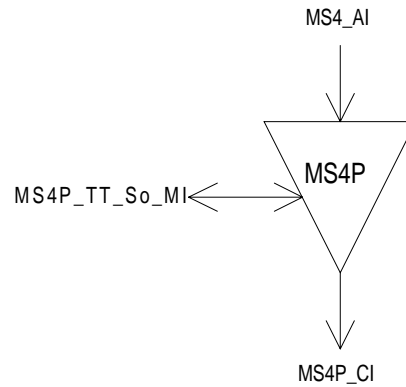

Figure 70: MS4P_TT_So symbol

Interfaces:

Table 53: MS4P_TT_So input and output signals

| Input(s) | Output(s) |
|-----------|------------|
| MS4_AI_D | MS4P_CI_D |
| MS4_AI_CK | MS4P_CI_CK |
| MS4_AI_FS | MS4P_CI_FS |

Processes:

No information processing is required in the MS4P_TT_So, the MS4_AI at its output being identical to the MS4P_CI at its input.

Defects: None.

Consequent Actions: None

Defect Correlations: None.

Performance Monitoring: None.

7.5.2.2 Multiplex Section Protection Trail Termination Sink MS4P_TT_Sk

Symbol:

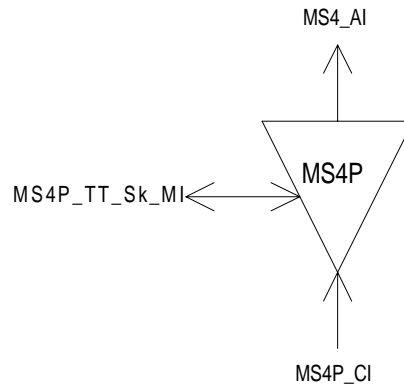

Figure 71: MS4P_TT_Sk symbol

Interfaces:

Table 54: MS4P_TT_Sk input and output signals

| Input(s) | Output(s) |
|----------------------------|--------------------|
| MS4P_CI_D | MS4_AI_D |
| MS4P_CI_CK | MS4_AI_CK |
| MS4P_CI_FS | MS4_AI_FS |
| MS4P_CI_SSF | MS4_AI_TSF |
| MS4P_TT_Sk_MI_SSF_Reported | MS4P_TT_Sk_MI_cSSF |

Processes:

The MS4P_TT_Sk function reports, as part of the MS4 layer, the state of the protected MS4 trail. In case all connections are unavailable the MS4P_TT_Sk reports the signal fail condition of the protected trail.

Defects: None.

Consequent Actions:

aTSF ← CI_SSF.

Defect Correlations: None.

cSSF ← CI_SSF and SSF_Reported.

Performance Monitoring: None.

7.5.3 STM-4 Multiplex Section Linear Trail Protection Adaptation Functions

7.5.3.1 STM-4 Multiplex Section to STM-4 Multiplex Section Protection Layer Adaptation Source MS4/MS4P_A_So

Symbol:

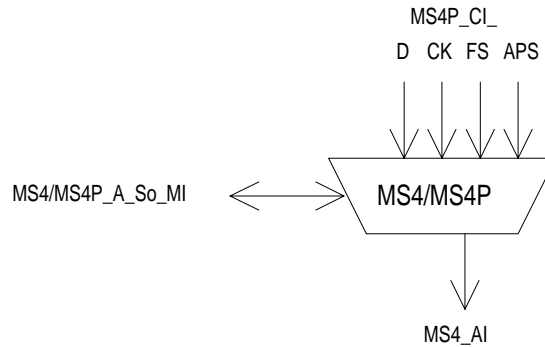

Figure 72: MS4/MS4P_A_So symbol

Interfaces:

Table 55: MS4/MS4P_A_So input and output signals

| Input(s) | Output(s) |
|-------------|-----------|
| MS4P_CI_D | MS4_AI_D |
| MS4P_CI_CK | MS4_AI_CK |
| MS4P_CI_FS | MS4_AI_FS |
| MS4P_CI_APS | |

Processes:

The function shall multiplex the MS4 APS signal and MS4 data signal onto the MS4 access point.

Defects: None.

Consequent actions: None.

Defect Correlations: None.

Performance Monitoring: None.

7.5.3.2 STM-4 Multiplex Section to STM-4 Multiplex Section Protection Layer Adaptation Sink MS4/MS4P_A_Sk

Symbol:

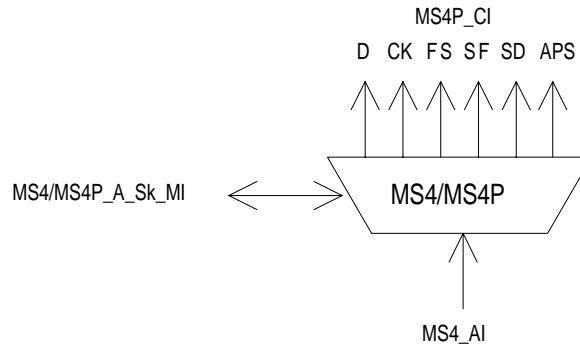

Figure 73: MS4/MS4P_A_Sk symbol

Interfaces:

Table 56: MS4/MS4P_A_Sk input and output signals

| Input(s) | Output(s) |
|------------|--|
| MS4_AI_D | MS4P_CI_D |
| MS4_AI_CK | MS4P_CI_CK |
| MS4_AI_FS | MS4P_CI_FS |
| MS4_AI_TSF | MS4P_CI_SSF |
| MS4_AI_TSD | MS4P_CI_SSD |
| | MS4P_CI_APS (for Protection signal only) |

Processes:

The function shall extract and output the MS4P_CI_D signal from the MS4_AI_D signal.

K1[1-8]K2[1-5]: The function shall extract the 13 APS bits K1[1-8] and K2[1-5] from the MS4_AI_D signal. A new value shall be accepted when the value is identical for three consecutive frames. This value shall be output via MS4P_CI_APS. This process is required only for the protection section.

Defects: None.

Consequent actions:

aSSF ← AI_TSF.

aSSD ← AI_TSD.

Defect Correlations: None.

Performance Monitoring: None.

8 STM-16 Regenerator Section Layer Functions

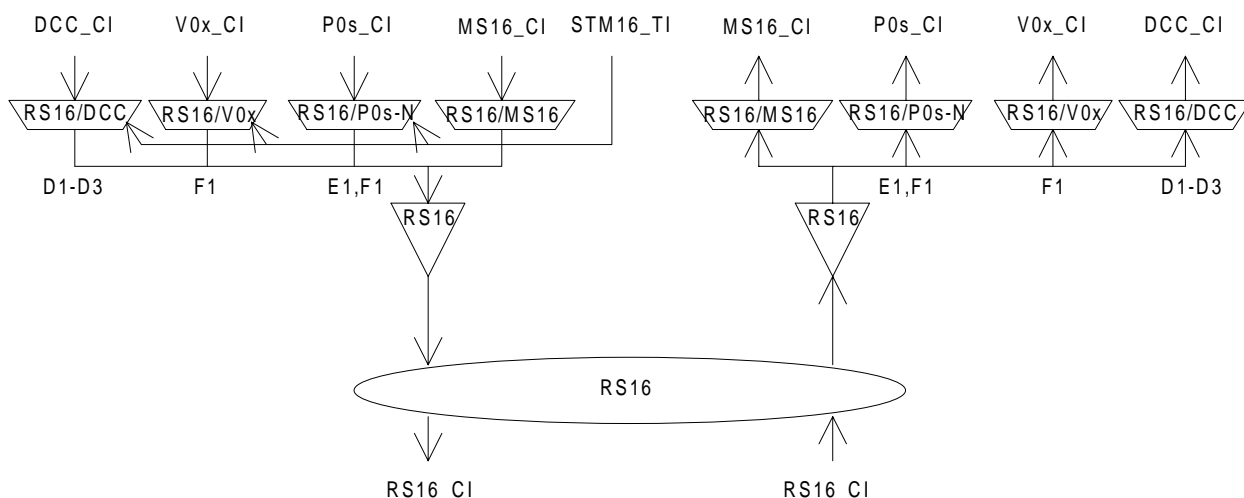

Figure 74: STM-16 Regenerator Section atomic functions

RS16 Layer CP

The CI at this point is an octet structured, 125 μs framed data stream with co-directional timing. It is the entire STM-16 signal as defined in ETS 300 147 [1]. The figure 75 depicts only bytes handled in the RS16 layer.

NOTE 1: The unmarked bytes [2, 2] to [2, 48], [2, 50] to [2, 96], [3, 2] to [3, 48], [3, 50] to [3, 96], and [3, 98] to [3, 144] in rows 2,3 (figure 75) are reserved for future international standardization. Currently, they are undefined.

NOTE 2: The bytes for National Use (NU) in rows 1,2 (figure 75) are reserved for operator specific usage. Their processing is not within the province of the present document. If NU bytes [1, 113] to [1, 144] are unused, care should be taken in selecting the binary content of the bytes which are excluded from the scrambling process of the STM-N signal to ensure that long sequences of "1"s or "0"s do not occur.

NOTE 3: The bytes Z0 [1, 98] to [1, 112] are reserved for future international standardization. Currently, they are undefined. Care should be taken in selecting the binary content of these bytes which are excluded from the scrambling process of the STM-N signal to ensure that long sequences of "1"s or "0"s do not occur.

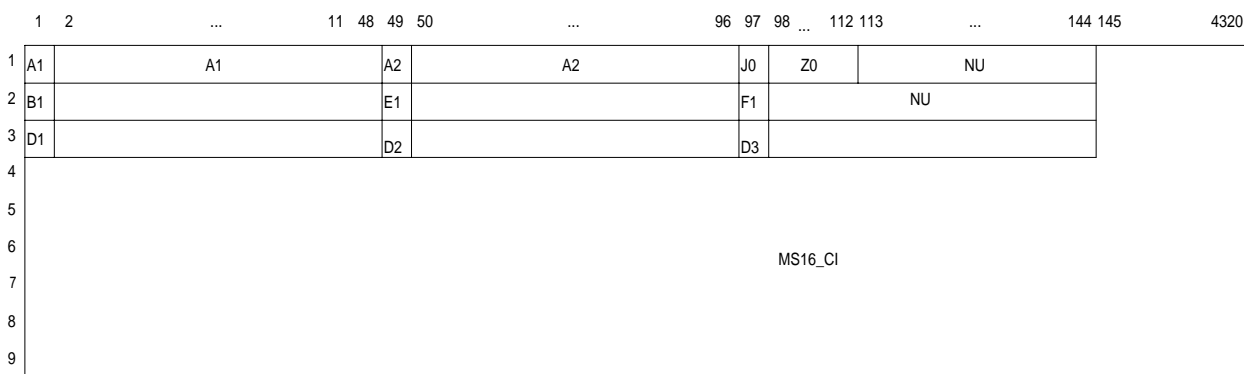

Figure 75: RS16_CI_D signal

RS16 Layer AP

The AI at this point is octet structured and 125 μs framed with co-directional timing and represents the combination of adapted information from the MS16 layer (38 448 bytes per frame), the management communication DCC layer (3 bytes per frame if supported), the OW layer (1 byte per frame if supported) and the user channel F1 (1 byte per frame if supported). The location of these four components in the frame is defined in ETS 300 147 [1] and depicted in figure 76.

NOTE 4: Bytes E1, F1 and D1-D3 will be undefined when the adaptation functions sourcing these bytes are not present in the network element.

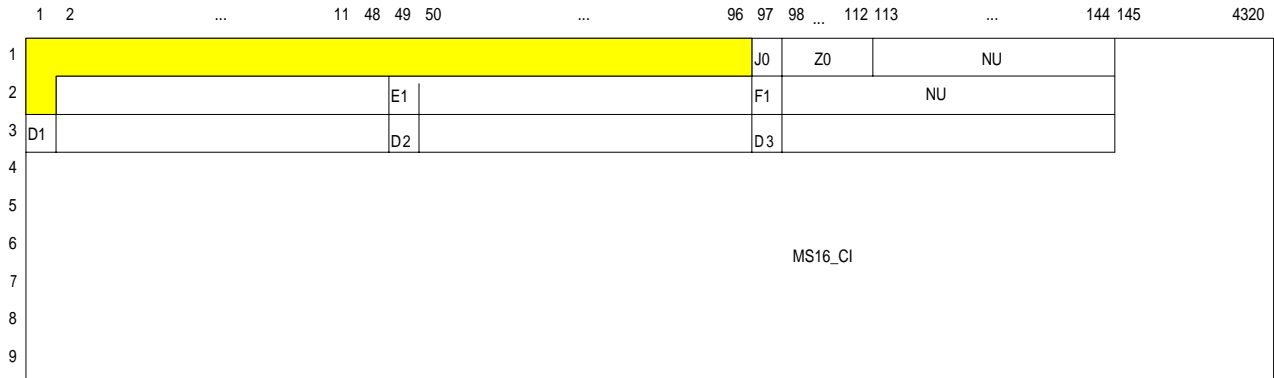

Figure 76: RS16_AI_D signal

8.1 STM-16 Regenerator Section Connection functions

For further study.

8.2 STM-16 Regenerator Section Trail Termination functions

8.2.1 STM-16 Regenerator Section Trail Termination Source RS16_TT_So

Symbol:

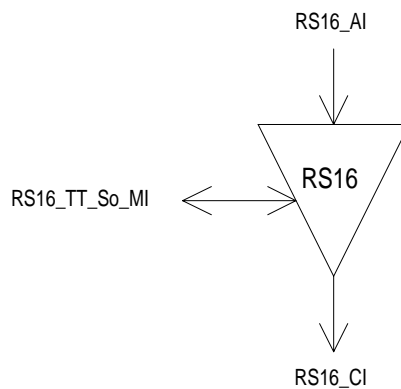

Figure 77: RS16_TT_So symbol

Interfaces:**Table 57: RS16_TT_So input and output signals**

| Input(s) | Output(s) |
|---|-------------------------|
| RS16_AI_D RS16_AI_CK RS16_AI_FS RS16_TT_So_MI_TxTI | RS16_CI_D RS16_CI_CK |

Processes:

The function builds the STM-16 signal by adding the frame alignment information, bytes A1A2, the STM Section Trace Identifier (STI) byte J0, computing the parity and inserting the B1 byte.

J0: In this byte the function shall insert the Transmitted Trail Trace Identifier TxTI. Its format is described in EN 300 417-1-1 [3], subclause 7.1.

B1: The function shall calculate a Bit Interleaved Parity 8 (BIP-8) code using even parity. The BIP-8 shall be calculated over all bits of the previous STM-16 frame after scrambling and is placed in byte position B1 of the current STM-16 frame before scrambling (figure 78).

A1A2: The function shall insert the STM-16 frame alignment signal A1...A1A2...A2 into the regenerator section overhead as defined in ETS 300 147 [1] and depicted in figure 75.

Scrambler: This function provides scrambling of the RS16_CI. The operation of the scrambler shall be functionally identical to that of a frame synchronous scrambler of sequence length 127 operating at the line rate. The generating polynomial shall be $1 + X^6 + X^7$. The scrambler shall be reset to "1111 1111" on the most significant bit (MSB) of the byte [1, 145] following the last byte of the STM-16 SOH in the first row. This bit and all subsequent bits to be scrambled shall be modulo 2 added to the output of the X^7 position of the scrambler. The scrambler shall run continuously throughout the remaining STM-16 frame.

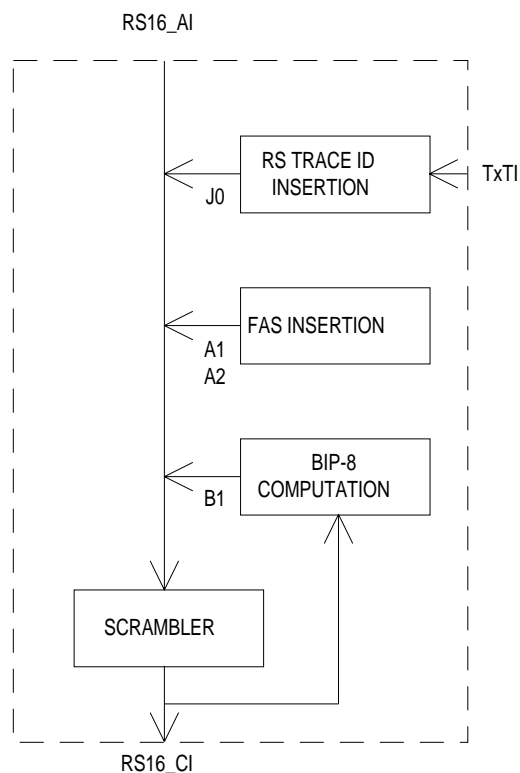
**Figure 78: Some processes within RS16_TT_So**

Defects: None.

Consequent Actions: None.

Defect Correlations: None.

Performance Monitoring: None.

8.2.2 STM-16 Regenerator Section Trail Termination Sink RS16_TT_Sk

Symbol:

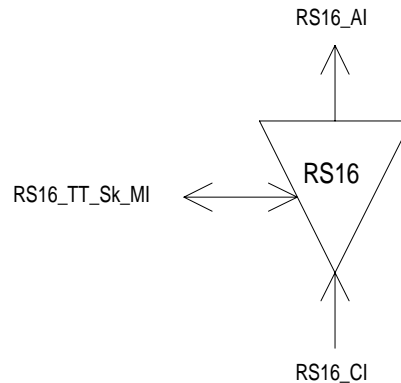

Figure 79: RS16_TT_Sk symbol

Interfaces:

Table 58: RS16_TT_Sk input and output signals

| Input(s) | Output(s) |
|------------------------|----------------------|
| RS16_CI_D | RS16_AI_D |
| RS16_CI_CK | RS16_AI_CK |
| RS16_CI_FS | RS16_AI_FS |
| RS16_CI_SSF | RS16_AI_TSF |
| RS16_TT_Sk_MI_ExtI | RS16_TT_Sk_MI_AcTI |
| RS16_TT_Sk_MI_TPmode | RS16_TT_Sk_MI_cTIM |
| RS16_TT_Sk_MI_TIMdis | RS16_TT_Sk_MI_pN_EBC |
| RS16_TT_Sk_MI_ExtImode | RS16_TT_Sk_MI_pN_DS |
| RS16_TT_Sk_MI_1second | |

Processes:

This function monitors the STM-16 signal for RS errors, and recovers the RS trail termination status. It extracts the payload independent overhead bytes (J0, B1) from the RS16 layer Characteristic Information:

Descrambling: The function shall descramble the incoming STM-16 signal. The operation of the descrambler shall be functionally identical to that of a scrambler in OS16/RS16_A_So.

B1: Even bit parity is computed for each bit n of every byte of the preceding scrambled STM-16 frame and compared with bit n of B1 recovered from the current frame ($n = 1$ to 8 inclusive) (figure 80). A difference between the computed and recovered B1 values is taken as evidence of one or more errors (nN_B) in the computation block.

J0: The Received Trail Trace Identifier RxTI shall be recovered from the J0 byte and shall be made available as AcTI for network management purposes. The application and acceptance and mismatch detection process shall be performed as specified in EN 300 417-1-1 [3], subclauses 7.1, and 8.2.1.3.

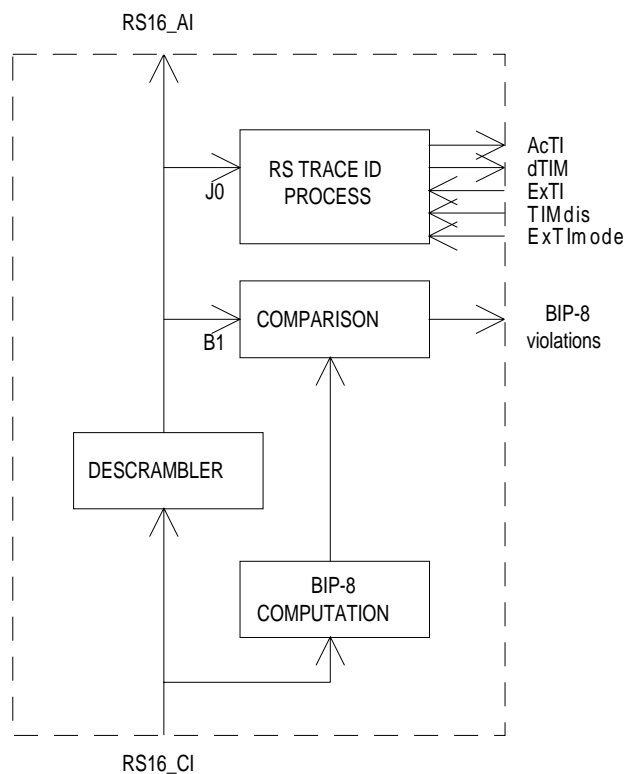

Figure 80: Some processes within RS16_TT_Sk

Defects:

The function shall detect for dTIM defects according the specification in EN 300 417-1-1 [3], subclause 8.2.1.

Consequent Actions:

aAIS ← CI_SSF or dTIM.

aTSF ← CI_SSF or dTIM.

On declaration of aAIS the function shall output an all-ONEs (AIS) signal within 250 µs; on clearing of aAIS the function shall output normal data within 250 µs.

NOTE 1: The term "CI_SSF" has been added to the conditions for aAIS while the descrambler function has been moved from the e.g. OS16/RS16_A_Sk to this function. Consequently, an all-ONEs (AIS) pattern inserted in the mentioned adaptation function would be descrambled in this function. A "refreshment" of all-ONEs is required.

NOTE 2: The insertion of AIS - especially due to detection of dTIM - will cause the RS-DCC channel to be "squashed" too, so that control of the NE via this channel is lost. If control is via this channel only, there is a risk of a dead-lock situation if dTIM is caused by a misprovisioning of ExTI.

Defect Correlations:

cTIM ← MON and dTIM.

Performance Monitoring:

For further study.

8.3 STM-16 Regenerator Section Adaptation functions

8.3.1 STM-16 Regenerator Section to Multiplex Section Adaptation Source RS16/MS16_A_So

Symbol:

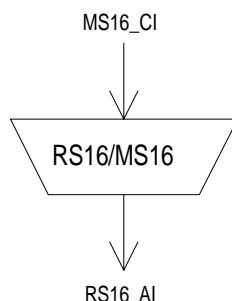

Figure 81: RS16/MS16_A_So symbol

Interfaces:

Table 59: RS16/MS16_A_So input and output signals

| Input(s) | Output(s) |
|--|---------------------------------------|
| MS16_CI_D MS16_CI_CK STM16_CI_FS STM16_CI_SSF | RS16_AI_D RS16_AI_CK RS16_AI_FS |

Processes:

The function multiplexes the MS16_CI data (38 448 bytes / frame) into the STM-16 byte locations defined in ETS 300 147 [1] and depicted in figure 75.

NOTE 1: There might be cases in which the network element knows that the timing reference for a particular STM-16 interface can not be maintained within $\pm 4,6$ ppm. For such cases MS-AIS can be generated. This is network element specific and outside the scope of the present document.

Defects: None.

Consequent Actions:

aAIS ← CI_SSF.

On declaration of aAIS the function shall output an all-ONEs signal within 250 μ s; on clearing of aAIS the function shall output normal data within 250 μ s. The frequency of the all ONEs signal shall be within 2 488,320 kHz \pm 20 ppm.

NOTE 2: If CI_SSF is not connected (when RS16/MS16_A_So is connected to a MS16_TT_So), SSF is assumed to be false.

Defect Correlations: None.

Performance Monitoring: None.

8.3.2 STM-16 Regenerator Section to Multiplex Section Adaptation Sink RS16/MS16_A_Sk

Symbol:

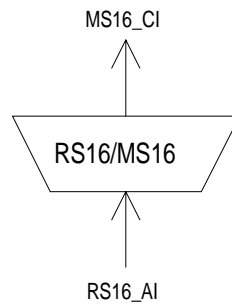

Figure 82: RS16/MS16_A_Sk symbol

Interfaces:

Table 60: RS16/MS16_A_Sk input and output signals

| Input(s) | Output(s) |
|-------------|-------------|
| RS16_AI_D | MS16_CI_D |
| RS16_AI_CK | MS16_CI_CK |
| RS16_AI_FS | MS16_CI_FS |
| RS16_AI_TSF | MS16_CI_SSF |

Processes:

The function separates MS16_CI data from RS16_AI as depicted in figure 75.

Defects: None.

Consequent Actions:

aSSF ← AI_TSF.

Defect Correlations: None.

Performance Monitoring: None.

8.3.3 STM-16 Regenerator Section to DCC Adaptation Source RS16/DCC_A_So

Symbol:

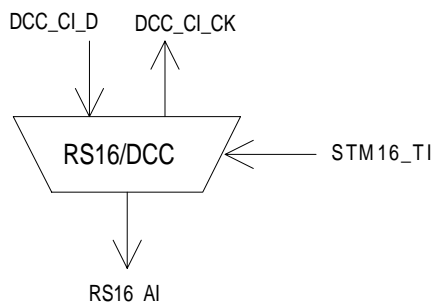

Figure 83: RS16/DCC_A_So symbol

Interfaces:

Table 61: RS16/DCC_A_So input and output signals

| Input(s) | Output(s) |
|--|------------------------|
| DCC_CI_D STM16_TI_CK STM16_TI_FS | RS16_AI_D DCC_CI_CK |

Processes:

The function multiplexes the DCC CI data (192 kbit/s) into the byte locations D1, D2 and D3 as defined in ETS 300 147 [1] and depicted in figure 76.

NOTE: DCC transmission can be "disabled" when the matrix connection in the connected DCC_C function is removed.

Defects: None.

Consequent Actions: None.

Defect Correlations: None.

Performance Monitoring: None.

8.3.4 STM-16 Regenerator Section to DCC Adaptation Sink RS16/DCC_A_Sk

Symbol:

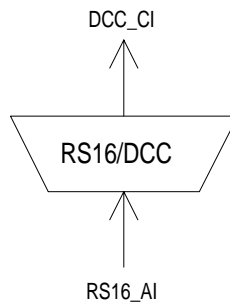

Figure 84: RS16/DCC_A_Sk symbol

Interfaces:

Table 62: RS16/DCC_A_Sk input and output signals

| Input(s) | Output(s) |
|-------------|------------|
| RS16_AI_D | DCC_CI_D |
| RS16_AI_CK | DCC_CI_CK |
| RS16_AI_FS | DCC_CI_SSF |
| RS16_AI_TSF | |

Processes:

The function separates DCC data from RS Overhead as defined in ETS 300 147 [1] and depicted in figure 76.

NOTE: DCC transmission can be "disabled" when the matrix connection in the connected DCC_C function is removed.

Defects: None.

Consequent Actions:

aSSF ← AI_TSF.

Defect Correlations: None.

Performance Monitoring: None.

8.3.5 STM-16 Regenerator Section to P0s Adaptation Source RS16/P0s_A_So/N

Symbol:

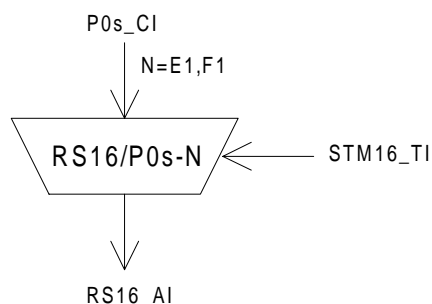

Figure 85: RS16/P0s_A_So symbol

Interfaces:

Table 63: RS16/P0s_A_So input and output signals

| Input(s) | Output(s) |
|--|-----------|
| P0s_CI_D P0s_CI_CK P0s_CI_FS MS16_TI_CK MS16_TI_FS | RS16_AI_D |

Processes:

This function provides the multiplexing of a 64 kbit/s orderwire or user channel information stream into the RS16_AI using slip buffering. It takes P0s_CI, defined in ETS 300 166 [2] as an octet structured bit-stream with a synchronous bit rate of 64 kbit/s, present at its input and inserts it into the RSOH byte E1 or F1 as defined in ETS 300 147 [1] and depicted in figure 76.

NOTE: Any frequency deviation between the 64 kbit/s signal and the associated STM-16 signal leads to octet slips.

Frequency justification and bitrate adaptation: The function shall provide an elastic store (slip buffer) process. The data signal shall be written into the store under control of the associated input clock. The data shall be read out of the store under control of the STM-16 clock, frame position (STM16_TI), and justification decisions.

Each justification decision results in a corresponding negative / positive justification action. Upon a positive justification action, the reading of one 64 kbit/s octet (8 bits) shall be cancelled once. Upon a negative justification action, the same 64 kbit/s octet (8 bits) shall be read out a second time.

Buffer size: The elastic store (slip buffer) shall accommodate at least 18 μ s of wander without introducing errors.

64 kbit/s timeslot: The adaptation source function has access to a specific 64 kbit/s channel of the RS access point. The specific 64 kbit/s channel is defined by the parameter N (N = E1, F1).

Defects: None.

Consequent Actions: None.

Defect Correlations: None.

Performance Monitoring: None.

8.3.6 STM-16 Regenerator Section to P0s Adaptation Sink RS16/P0s_A_Sk/N

Symbol:

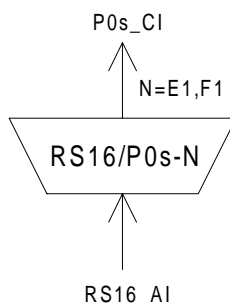

Figure 86: RS16/P0s_A_Sk symbol

Interfaces:

Table 64: RS16/P0s_A_Sk input and output signals

| Input(s) | Output(s) |
|-------------|--------------|
| RS16_AI_D | P0s_CI_Sk_D |
| RS16_AI_CK | P0s_CI_Sk_CK |
| RS16_AI_FS | P0s_CI_FS |
| RS16_AI_TSF | P0s_CI_SSF |

Processes:

The function separates P0s data from RS Overhead byte E1 or F1 as defined in ETS 300 147 [1] and depicted in figure 76.

Data latching and smoothing process: The function shall provide a data latching and smoothing function. Each 8-bit octet received shall be written and latched into a data store under the control of the STM-16 signal clock. The eight data bits shall then be read out of the store using a nominal 64 kHz clock which may be derived directly from the incoming STM-16 signal clock (e.g. 2 488 320 kHz divided by a factor of 38 880).

64 kbit/s timeslot: The adaptation sink function has access to a specific 64 kbit/s of the RS access point. The specific 64 kbit/s is defined by the parameter N (N = E1, F1).

Defects: None.

Consequent Actions:

aSSF ← AI_TSF.

aAIS ← AI_TSF.

On declaration of aAIS the function shall output an all-ONEs (AIS) signal - complying to the frequency limits for this signal (a bit rate in range 64 kbit/s ± 100 ppm) - within 1 ms; on clearing of aAIS the function shall output normal data within 1 ms.

Defect Correlations: None.

Performance Monitoring: None.

8.3.7 STM-16 Regenerator Section to V0x Adaptation Source RS16/V0x_A_So

Symbol:

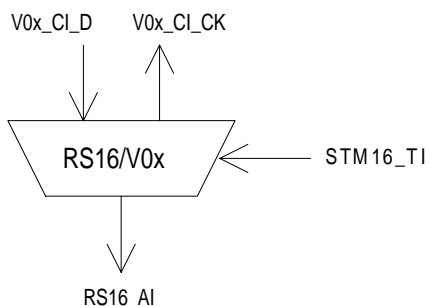

Figure 87: RS16/V0x_A_So symbol

Interfaces:

Table 65: RS16/V0x_A_So input and output signals

| Input(s) | Output(s) |
|--|------------------------|
| V0x_CI_D STM16_TI_CK STM16_TI_FS | RS16_AI_D V0x_CI_CK |

Processes: None.

This function multiplexes the V0x_CI data (64 kbit/s) into the byte location F1 as defined in ETS 300 147 [1] and depicted in figure 76.

The user channel byte F1 shall be added to the 125 μ s frame.

Defects: None.

Consequent Actions: None.

Defect Correlations: None.

Performance Monitoring: None.

8.3.8 STM-16 Regenerator Section to V0x Adaptation Sink RS16/V0x_A_Sk

Symbol:

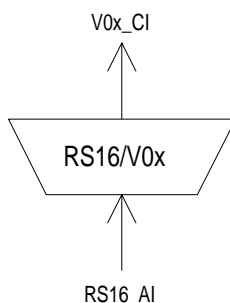

Figure 88: RS16/V0x_A_Sk symbol

Interfaces:

Table 66: RS16/V0x_A_Sk input and output signals

| Input(s) | Output(s) |
|--|-------------------------------------|
| RS16_AI_D RS16_AI_CK RS16_AI_FS RS16_AI_TSF | V0x_CI_D V0x_CI_CK V0x_CI_SSF |

Processes:

This function separates user channel data from RS Overhead (byte F1) as defined in ETS 300 147 [1] and depicted in figure 76.

Defects: None.

Consequent Actions:

aSSF ← AI_TSF.

aAIS ← AI_TSF.

On declaration of aAIS the function shall output an all-ONEs (AIS) signal within 1 ms; on clearing of aAIS the function shall output normal data within 1 ms.

Defect Correlations: None.

Performance Monitoring: None.

9 STM-16 Multiplex Section Layer Functions

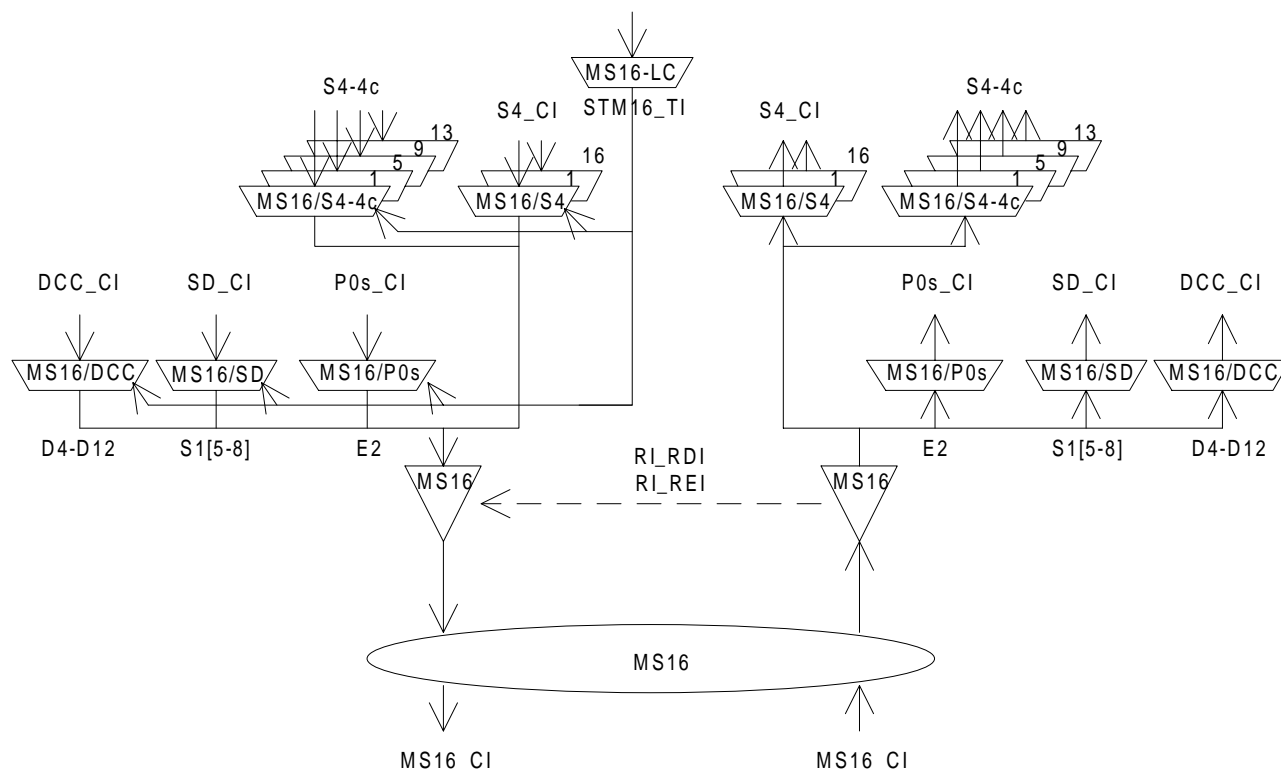

Figure 89: STM-16 Multiplex Section atomic functions

NOTE 1: The modelling of the MS16 to VC-4 and VC-4-4c layer adaptation functionality requires a further enhancement making it similar to the VC-4 to lower order VC layer adaptation functionality. This is for further study.

MS16 Layer CP

The CI at this point is octet structured and 125 μ s framed with co-directional timing. Its format is characterized as the MS16_AI with an additional MS Trail Termination overhead in the forty eight B2 bytes, byte M1, and bits 6-8 of the K2 byte in the frame locations defined in ETS 300 147 [1] and depicted in figure 90.

NOTE 2: The unmarked bytes in rows 5, 6, 7, 8, 9 (figure 90) are reserved for future international standardization. Currently, they are undefined.

NOTE 3: The bytes for National Use (NU) in row 9 (figure 90) are reserved for operator specific usage. Their processing is not within the province of the present document.

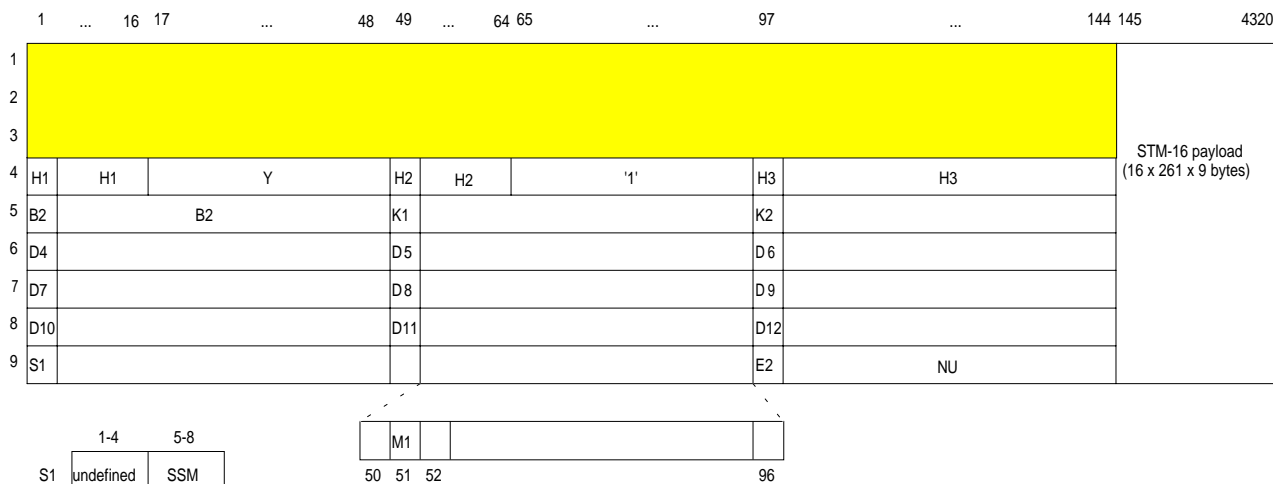

Figure 90: MS16_CI_D

MS16 Layer AP

The AI at this point is octet structured and 125 μs framed with co-directional timing. It represents the combination of information adapted from the VC-4 layer (150 336 kbit/s), the management communications DCC layer (576 kbit/s), the OW layer (64 kbit/s if supported), the AU-4 pointer (3 bytes per frame), the APS signalling channel (13 or 16 bits per frame if supported, see note 4), and the SMS channel (4 bits per frame if supported). The location of these five components in the frame is defined in ETS 300 147 [1] and depicted in figure 91.

NOTE 4: 13 bits APS channel for the case of linear MS protection. 16 bits APS channel for the case of MS SPRING protection.

NOTE 5: Bytes E2 and D4-D12 will be undefined when the adaptation functions sourcing these bytes are not present in the network element.

The composition of the payload transported by an STM-16 will be determined by the client layer application. Typical compositions of the payload include:

- four VC-4-4c of 601 344 kbit/s;
- sixteen VC-4s of 150 336 kbit/s;
- combinations of VC-4s and VC-4-4cs up to the maximum of 16 VC-4 equivalents;
- eight [two] working VC-4s [VC-4-4cs] and eight [two] protection VC-4s [VC-4-4cs] (in MS16 SPRING application).

Figure 89 shows that more than one adaptation source function exists in the MS16 layer that can be connected to one MS16 access point. For such case, a subset of these adaptation source functions is allowed to be activated together, but only one adaptation source function may have access to a specific AU timeslot. Access to the same AU timeslot by other adaptation source functions shall be denied. In contradiction with the source direction, adaptation sink functions may be activated all together. This may cause faults (e.g. cLOP) to be detected and reported. To prevent this an adaptation sink function can be deactivated.

NOTE 6: If one adaptation function only is connected to the AP, it will be activated. If one or more other functions are connected to the same AP accessing the same AU timeslot, one out of the set of functions will be active.

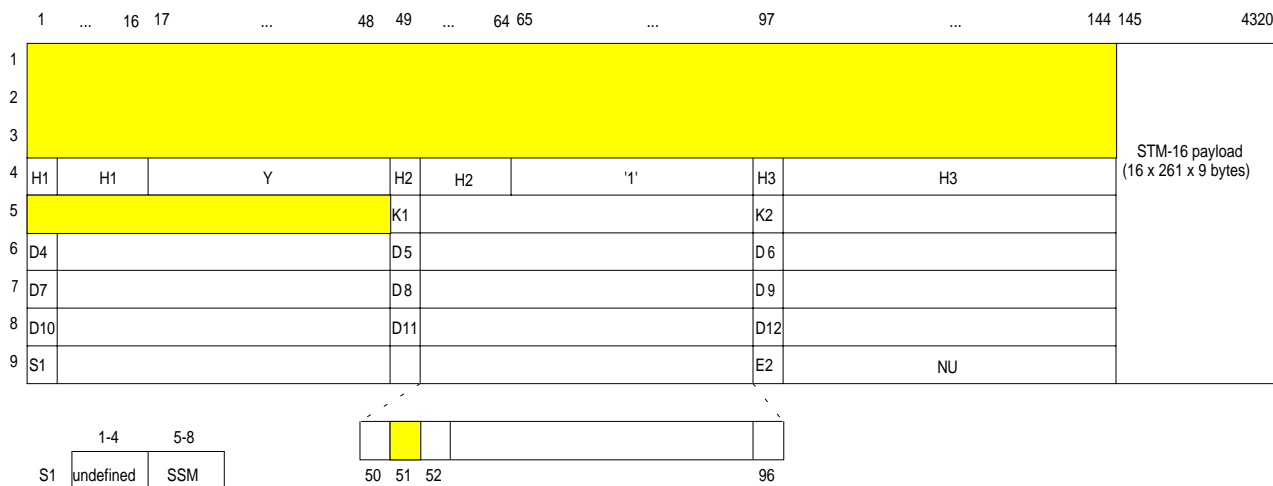

Figure 91: MS16_AI_D

Figure 92 shows the MS trail protection specific sublayer atomic functions (MS16/MS16P_A, MS16P_C, MS16P_TT) within the MS16 layer. Note that the DCC (D4-D12), OW (E2), and SSM (S1[5-8]) signals can be accessible before (unprotected) and after (protected) the MS16P_C function. The choice is outside the scope of the present document.

NOTE 7: Equipment may provide MS protection and bi-directional services such as DCC and OW in the MS layer. Where a link uses this provision both ends of the link shall be configured to operate these services in the same mode (i.e. either protected or unprotected).

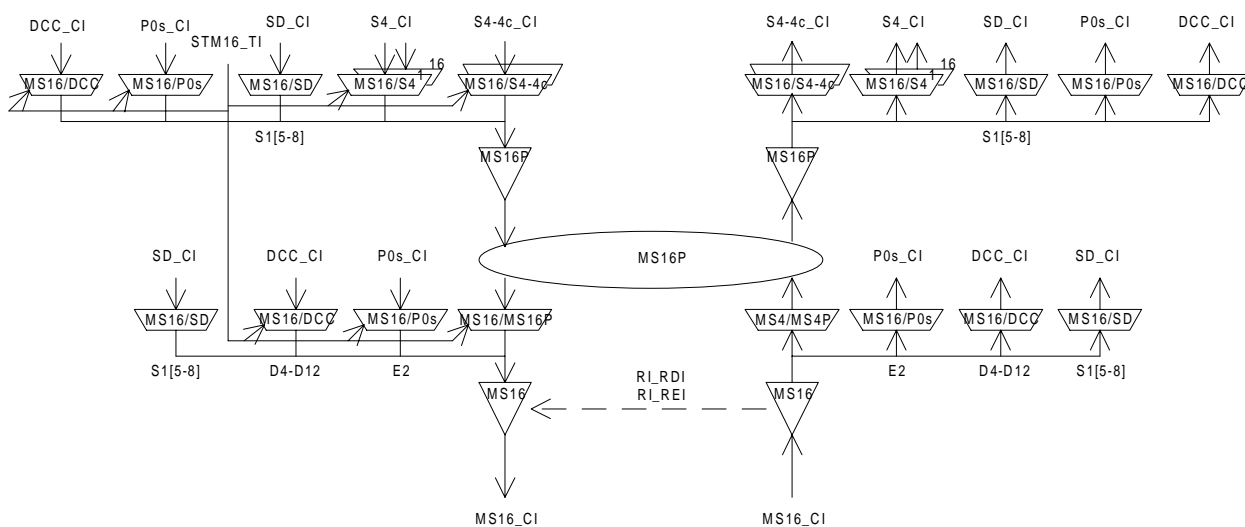

Figure 92: STM-16 Multiplex Section Linear Trail Protection Functions

MS16P Sublayer CP

The CI at this point is octet structured and 125 μs framed with co-directional timing. Its format is equivalent to the MS4_AI and depicted in figure 93.

NOTE 8: Bytes S1, E2 and D4-D12 will be undefined when the adaptation functions sourcing these bytes are not present in the network element or are unprotected (see above).

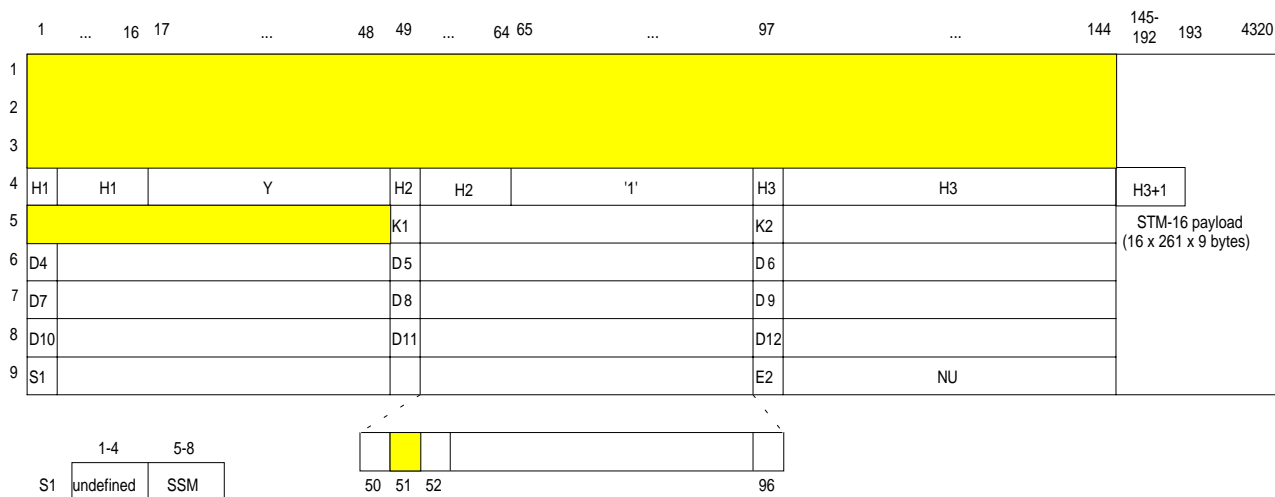

Figure 93: MS16P_CI_D

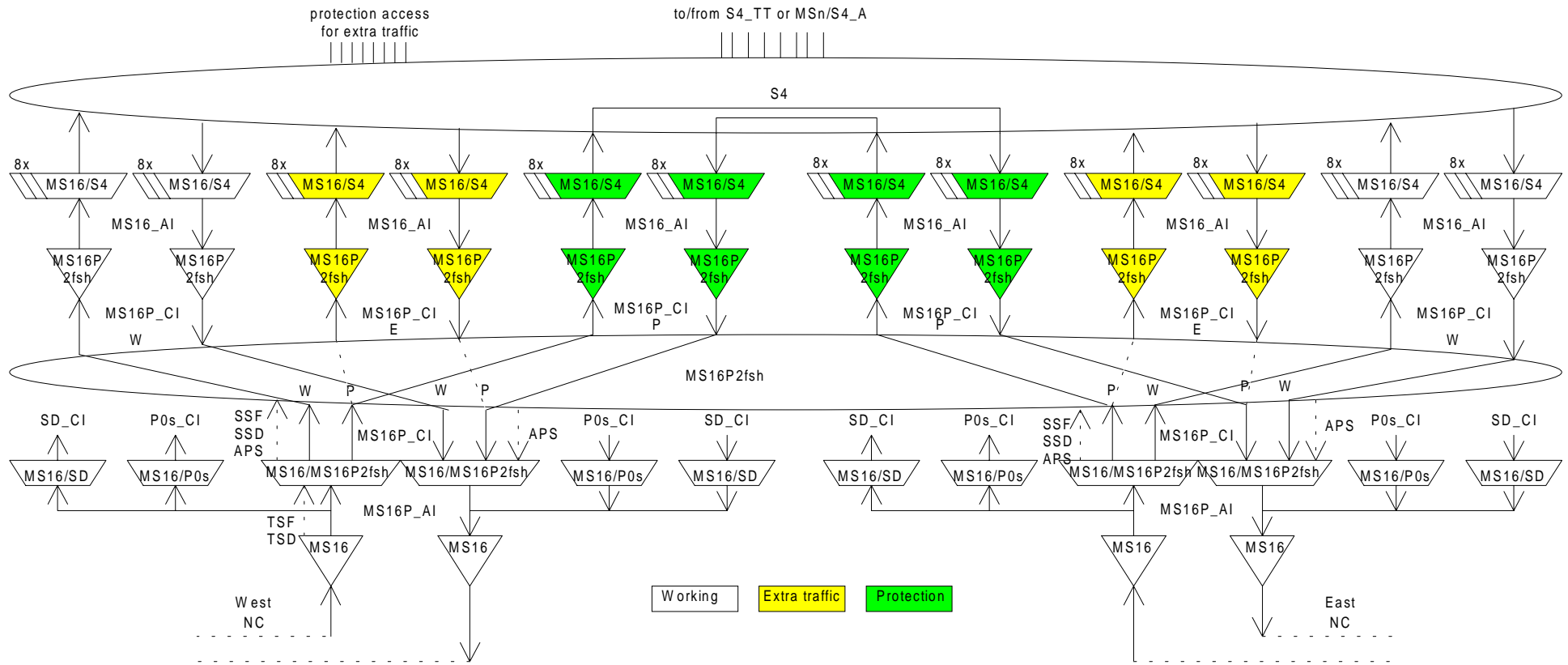

Figure 94: STM-16 Multiplex Section 2 fibre Shared Protection Ring model (working: AU-4 #1 to AU-4 #8, protection: AU-4 #9 to AU-4 #16)

9.1 STM-16 Multiplex Section Connection functions

For further study.

9.2 STM-16 Multiplex Section Trail Termination functions

9.2.1 STM-16 Multiplex Section Trail Termination Source MS16_TT_So

Symbol:

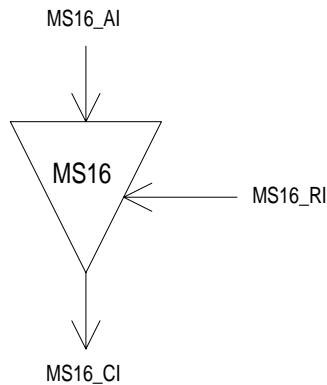

Figure 95: MS16_TT_So symbol

Interfaces:

Table 67: MS16_TT_So input and output signals

| Input(s) | Output(s) |
|---|---------------------------------------|
| MS16_AI_D MS16_AI_CK MS16_AI_FS MS16_RI_REI MS16_RI_RDI | MS16_CI_D MS16_CI_CK MS16_CI_FS |

Processes:

This function adds error monitoring capabilities and remote maintenance information signals to the MS16_AI.

M1: The function shall insert the value of MS16_RI_REI into the REI (Remote Error Indication) - to convey the count of interleaved bit blocks that have been detected in error by the BIP-384 process in the companion MS16_TT_Sk - in the range of "0000 0000" (0) to "1111 1111" (255) where the value conveyed is truncated at 255.

K2[6-8]: These bits represents the defect status of the associated MS16_TT_Sk. The RDI indication shall be set to "110" on activation of MS16_RI_RDI within 250 μ s, determined by the associated MS16_TT_Sk function, and passed through transparently (except for incoming codes "111" and "110") within 250 μ s on the MS16_RI_RDI removal. If MS16_RI_RDI is inactive an incoming code "111" or "110" shall be replaced by code "000".

NOTE 1: K2[6-8] can not be set to "000" on clearing of RI_RDI; MS SPRING APS extends into those bits. The bits shall be passed transparently in this case. With linear MS protection or without protection it shall be guaranteed that neither code "111" nor "110" will be output.

B2: The function shall calculate a Bit Interleaved Parity 384 (BIP-384) code using even parity. The BIP-384 shall be calculated over all bits, except those in the RSOH bytes, of the previous STM-16 frame and placed in forty-eight B2 bytes of the current STM-16 frame.

NOTE 2: The BIP-384 procedure is described in ETS 300 147 [1].

Defects: None.

Consequent Actions: None.

Defect Correlations: None.

Performance Monitoring: None.

9.2.2 STM-16 Multiplex Section Trail Termination Sink MS16_TT_Sk

Symbol:

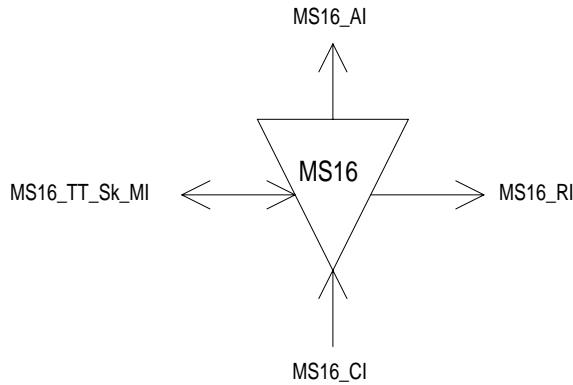

Figure 96: MS16_TT_Sk symbol

Interfaces:

Table 68: MS16_TT_Sk input and output signals

| Input(s) | Output(s) |
|----------------------------|----------------------|
| MS16_CI_D | MS16_AI_D |
| MS16_CI_CK | MS16_AI_CK |
| MS16_CI_FS | MS16_AI_FS |
| MS16_CI_SSF | MS16_AI_TSF |
| MS16_TT_Sk_MI_DEGTHR | MS16_AI_TSD |
| MS16_TT_Sk_MI_DEGM | MS16_TT_Sk_MI_cAIS |
| MS16_TT_Sk_MI_1second | MS16_TT_Sk_MI_cDEG |
| MS16_TT_Sk_MI_TPmode | MS16_TT_Sk_MI_cRDI |
| MS16_TT_Sk_MI_SSF_Reported | MS16_TT_Sk_MI_cSSF |
| MS16_TT_Sk_MI_AIS_Reported | MS16_TT_Sk_MI_pN_EBC |
| MS16_TT_Sk_MI_RDI_Reported | MS16_TT_Sk_MI_pF_EBC |
| | MS16_TT_Sk_MI_pN_DS |
| | MS16_TT_Sk_MI_pF_DS |
| | MS16_RI_REI |
| | MS16_RI_RDI |

Processes:

This function monitors error performance of associated MS16 including the far end receiver.

B2: The BIP-384 shall be calculated over all bits, except of those in the RSOH bytes, of the previous STM-16 frame and compared with the three error monitoring bytes B2 recovered from the MSOH of the current STM-16 frame. A difference between the computed and recovered B2 values is taken as evidence of one or more errors (nN_B) in the computation block.

M1: The REI information carried in these bits shall be extracted to enable single ended maintenance of a bi-directional trail (section). The REI is used to monitor the error performance of the other direction of transmission. The application process is described in EN 300 417-1-1 [3], subclause 7.4.2 (REI).

The function shall interpret the value in the byte as shown in table 69.

Table 69: STM-16 M1 interpretation

| M1[2-8] code, bits 1234 5678 | code interpretation [#BIP violations], (nF_B) |
|---------------------------------|--|
| 0000 0000 | 0 |
| 0000 0001 | 1 |
| 0000 0010 | 2 |
| 0000 0011 | 3 |
| 0000 0100 | 4 |
| ⋮ | ⋮ |
| 1111 1111 | 255 |

NOTE: In case of interworking with old equipment not supporting MS-REI, the information extracted from M1 is not relevant.

K2[6-8] - RDI: The RDI information carried in these bits shall be extracted to enable single ended maintenance of a bi-directional trail (section). The RDI provides information as to the status of the remote receiver. A "110" indicates a Remote Defect Indication state, while other patterns indicate the normal state. The application process is described in EN 300 417-1-1 [3], subclauses 7.4.11 and 8.2.

K2[6-8] - AIS: The MS-AIS information carried in these bits shall be extracted.

Defects:

The function shall detect for dDEG and dRDI defects according the specification in EN 300 417-1-1 [3], subclause 8.2.1.

dAIS: If at least x consecutive frames contain the "111" pattern in bits 6, 7 and 8 of the K2 byte a dAIS defect shall be detected. dAIS shall be cleared if in at least x consecutive frames any pattern other than the "111" is detected in bits 6, 7 and 8 of byte K2. The x shall be in range 3 to 5.

Consequent Actions:

aAIS ← dAIS.
aRDI ← dAIS.
aREI ← #EDCV.
aTSF ← dAIS.
aTSD ← dDEG.

On declaration of aAIS the function shall output an all-ONES signal within 250 μ s; on clearing of aAIS the function shall output normal data within 250 μ s.

Defect Correlations:

cAIS ← MON and dAIS and (not CI_SSF) and AIS_Reported.
cDEG ← MON and dDEG.
cRDI ← MON and dRDI and RDI_Reported.
cSSF ← MON and dAIS and SSF_Reported.

Performance monitoring:

The performance monitoring process shall be performed as specified in EN 300 417-1-1 [3], subclause 8.2.4 through 8.2.7.

pN_DS ← aTSF or dEQ.
pF_DS ← dRDI.
pN_EBC ← Σ nN_B.
pF_EBC ← Σ nF_B.

9.3 STM-16 Multiplex Section Adaptation functions

9.3.1 STM-16 Multiplex Section to S4 Layer Adaptation Source MS16/S4_A_So/N

Symbol:

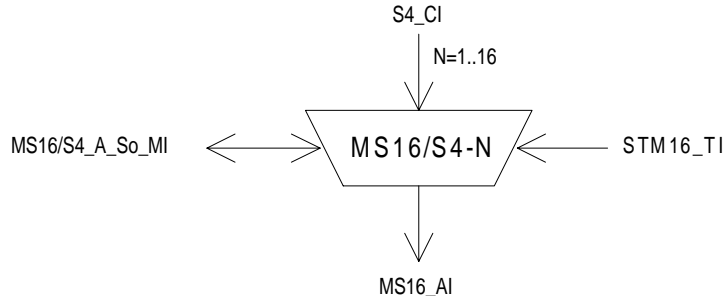

Figure 97: MS16/S4_A_So symbol

Interfaces:

Table 70: MS16/S4_A_So input and output signals

| Input(s) | Output(s) |
|------------------------|-----------------------|
| S4_CI_D | MS16_AI_D |
| S4_CI_CK | MS16_AI_CK |
| S4_CI_FS | MS16_AI_FS |
| S4_CI_SSF | |
| STM16_TI_CK | MS16/S4_A_So_MI_pPJE+ |
| STM16_TI_FS | MS16/S4_A_So_MI_pPJE- |
| MS16/S4_A_So_MI_Active | |

Processes:

This function provides frequency justification and bitrate adaptation for a VC-4 signal, represented by a nominally $(261 \times 9 \times 64) = 150\,336$ kbit/s information stream and the related frame phase with a frequency accuracy within $\pm 4,6$ ppm, to be multiplexed into a STM-16 signal at the AU tributary location indicated by N. The function can be activated / deactivated when multiple payload adaptation functions are connected to the access point.

NOTE 1: Degraded performance may be observed when interworking with SONET equipment having a ± 20 ppm network element clock source.

The frame phase of the VC-4 is coded in the related AU-4 pointer. Frequency justification, if required, is performed by pointer adjustments. The accuracy of this coding process is specified below. See EN 300 417-4-1 [4], annex A.

Frequency justification and bitrate adaptation: The function shall provide for an elastic store (buffer) process. The data and frame start signals shall be written into the buffer under control of the associated input clock. The data and frame start signals shall be read out of the buffer under control of the STM-16 clock, frame position, and justification decision.

The justification decisions determine the phase error introduced by the MS16/S4_A_So function. The amount of this phase error can be measured at the physical interfaces by monitoring the AU-4 pointer actions. An example is given in EN 300 417-4-1 [4], annex A.2.

Each justification decision results in a corresponding negative / positive justification action. Upon a positive justification action, the reading of 24 data bits shall be cancelled once and no data written at the three positions H3+1. Upon a negative justification action, an extra 24 data bits shall be read out once into the three positions H3.

NOTE 2: A requirement for maximum introduced phase error cannot be defined until a reference path is defined from which the requirements for network elements can be deduced. Such a requirement would also limit excessive phase error caused by pointer processors under fixed frequency offset conditions.

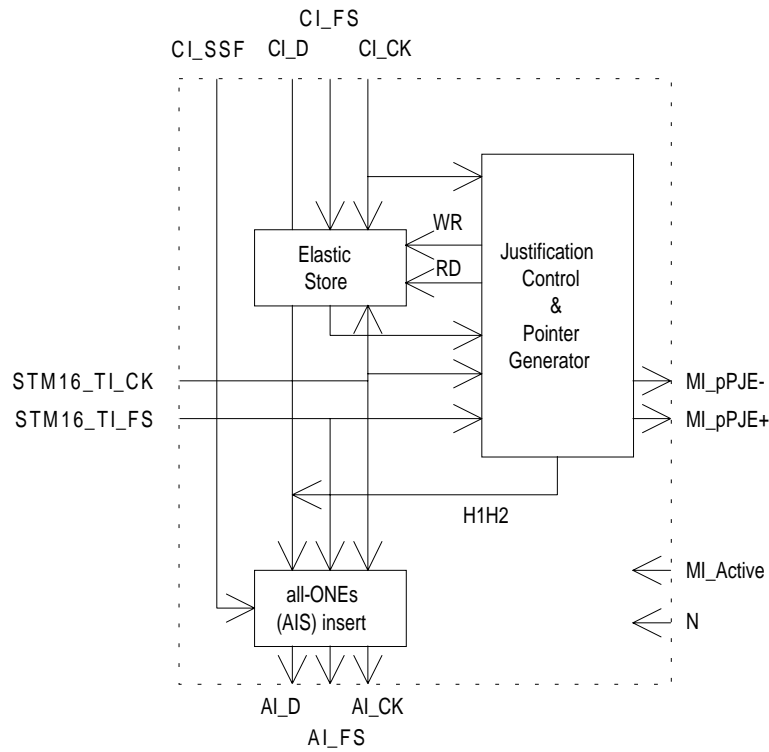

Figure 98: Main processes within MS16/S4_A_So

Buffer size: For further study.

Behaviour at recovery from defect condition: The incoming frequency (S4_CI_CK) of a passing through VC-4 may exceed its limits during a STM16dLOS condition. As a consequence, the buffer (elastic store) fill is not reliable any more. Due to all-ONEs (AIS) insertion after the pointer generator this reliability is not important for the operation of the network element. However, it shall be prevent to generate excessive pointer adjustments when recovering from the defect condition.

NOTE 3: The definition of excessive pointer adjustments is for further study.

The AU-4 pointer is carried in 2 bytes of payload specific OH (H1, H2) in each STM-16 frame. The AU-4 pointer is aligned in the STM-16 payload in fixed position relative to the STM-16 frame. The AU-4 pointer points to the begin of the VC-4 frame within the STM-16. The format of the AU-4 pointer and its location in the frame are defined in ETS 300 147 [1].

H1H2 - Pointer generation: The function shall generate the AU-4 pointer as is described in EN 300 417-1-1 [3], annex A: Pointer Generation. It shall insert the pointer in the appropriate H1, H2 positions with the SS field set to 10 to indicate AU-4.

YY1*1* - Fixed stuff insertion: The function shall insert fixed stuff codes Y = 1001ss11 in bytes [4, 16+N] and [4, 32+N] and code "1" = 11111111 in bytes [4, 64+N] and [4, 80+N]. Bits ss are undefined.

AU-4 timeslot: The adaptation source function has access to a specific AU-4 of the MS16 access point. The AU-4 is defined by the parameter N (N = 1..16).

Activation: The function shall access the access point when it is activated (MI_Active is true). Otherwise, it shall not access the access point.

Defects: None.

Consequent Actions:

aAIS ← CI_SSF.

On declaration of aAIS the function shall output an all-ONEs signal within 250 µs; on clearing of aAIS the function shall output normal data within 250 µs.

NOTE 4: if CI_SSF is not connected (when MS16/S4_A_So is connected to a S4_TT_So), CI_SSF is assumed to be false.

Defect Correlations: None.

Performance Monitoring:

Every second the number of generated pointer increments within that second shall be counted as the pPJE+. Every second the number of generated pointer decrements within that second shall be counted as the pPJE-.

NOTE 5: This is applicable for a passing through VC-4 only. A locally generated VC-4 will have a fixed frame phase; pointer justifications will not occur.

9.3.2 STM-16 Multiplex Section to S4 Layer Adaptation Sink MS16/S4_A_Sk/N

Symbol:

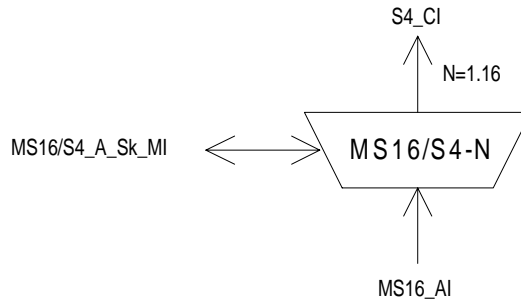

Figure 99: MS16/S4_A_Sk symbol

Interfaces:

Table 71: MS16/S4_A_Sk input and output signals

| Input(s) | Output(s) |
|------------------------------|----------------------|
| MS16_AI_D | S4_CI_D |
| MS16_AI_CK | S4_CI_CK |
| MS16_AI_FS | S4_CI_FS |
| MS16_AI_TSF | S4_CI_SSF |
| MS16/S4_A_Sk_MI_Active | MS16/S4_A_Sk_MI_cAIS |
| MS16/S4_A_Sk_MI_AIS_Reported | MS16/S4_A_Sk_MI_cLOP |

Processes:

This function recovers the VC-4 data with frame phase information from the STM-16 as defined in ETS 300 147 [1]. The VC-4 is extracted from the AU tributary location indicated by N. The function can be activated / deactivated when multiple payload adaptation functions are connected to the access point.

H1H2 - AU-4 pointer interpretation: An AU-4 pointer consists of 2 bytes, [4, N] and [4, 48+N]. The function shall perform AU-4 pointer interpretation according to annex B of EN 300 417-1-1 [3] to recover the VC-4 frame phase within the STM-16. The process shall maintain its current phase on detection of an invalid pointer and searches in parallel for a new phase.

YY1*1*: The bytes [4, 16+N], [4, 32+N], [4, 64+N], and [4, 80+N] contain fixed stuff, of a specified value, ignored by the AU-4 pointer interpreter.

AU-4 timeslot: The adaptation sink function has access to a specific AU-4 of the MS16 access point. The AU-4 is defined by the parameter N (N = 1..16).

Activation: The function shall perform the operation specified above when it is activated (MI_Active is true). Otherwise, it shall transmit the all-ONES signal at its output (CI_D) and not report its status via its management point.

Defects:

dAIS: The dAIS defect shall be detected if the pointer interpreter is in the AIS_state (see EN 300 417-1-1 [3], annex B). The dAIS defect shall be cleared if the pointer interpreter is not in the AIS_state.

dLOP: The dLOP defect shall be detected if the pointer interpreter is in the LOP_state (see EN 300 417-1-1 [3], annex B). The dLOP defect shall be cleared if the pointer interpreter is not in the LOP_state.

Consequent Actions:

aAIS ← dAIS or dLOP.

aSSF ← dAIS or dLOP.

On declaration of aAIS the function shall output an all-ONEs (AIS) signal within 250 μs; on clearing of aAIS the function shall output the recovered data within 250 μs.

Defect Correlations:

cAIS ← dAIS and (not AI_TSF) and AIS_Reported..

cLOP ← dLOP.

Performance Monitoring: None.

9.3.3 STM-16 Multiplex Section to S4-4c Layer Adaptation Source MS16/S4-4c_A_So/N

Symbol:

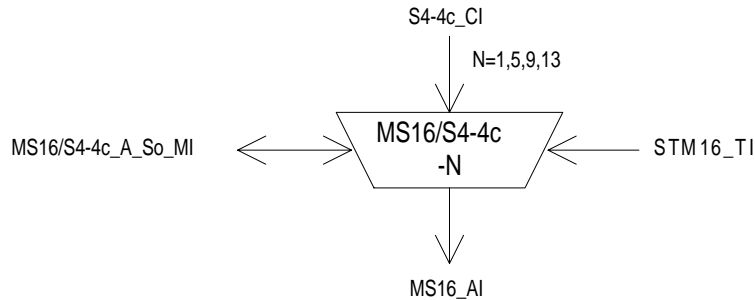

Figure 100: MS4/S4-4c_A_So symbol

Interfaces:

Table 72: MS16/S4-4c_A_So input and output signals

| Input(s) | Output(s) |
|---------------------------|--------------------------|
| S4-4c_CI_D | MS16_AI_D |
| S4-4c_CI_CK | MS16_AI_CK |
| S4-4c_CI_FS | MS16_AI_FS |
| S4-4c_CI_SSF | |
| STM16_TI_CK | MS16/S4-4c_A_So_MI_pPJE+ |
| STM16_TI_FS | MS16/S4-4c_A_So_MI_pPJE- |
| MS16/S4-4c_A_So_MI_Active | |

Processes:

This function provides frequency justification and bitrate adaptation for a VC-4-4c signal, represented by a nominally $(4 \times 261 \times 9 \times 64) = 601\,344$ kbit/s information stream and the related frame phase with a frequency accuracy within $\pm 4,6$ ppm, to be multiplexed into a STM-16 signal at the AU-4-4c tributary location indicated by "N". The function can be activated / deactivated when multiple payload adaptation functions are connected to the access point.

NOTE 1: Degraded performance may be observed when interworking with SONET equipment having a ± 20 ppm network element clock source.

The frame phase of the VC-4-4c is coded in the related AU-4-4c pointer. Frequency justification, if required, is performed by pointer adjustments. The accuracy of this coding process is specified below. See EN 300 417-4-1 [4], annex A.

Frequency justification and bitrate adaptation: The function shall provide for an elastic store (buffer) process. The data and frame start signals shall be written into the buffer under control of the associated input clock. The data and frame start signals shall be read out of the buffer under control of the STM-16 clock, frame position, and justification decision.

The justification decisions determine the phase error introduced by the MS16/S4-4c_A_So function. The amount of this phase error can be measured at the physical interfaces by monitoring the AU-4-4c pointer actions. An example is given in EN 30 417-4-1 [4], subclause A.2.

Each justification decision results in a corresponding negative / positive justification action. Upon a positive justification action, the reading of 96 data bits shall be cancelled once and no data written at the twelve positions H3+1. Upon a negative justification action, an extra 96 data bits shall be read out once into the twelve positions H3.

NOTE 2: A requirement for maximum introduced phase error cannot be defined until a reference path is defined from which the requirements for network elements can be deduced. Such a requirement would also limit excessive phase error caused by pointer processors under fixed frequency offset conditions.

Buffer size: For further study.

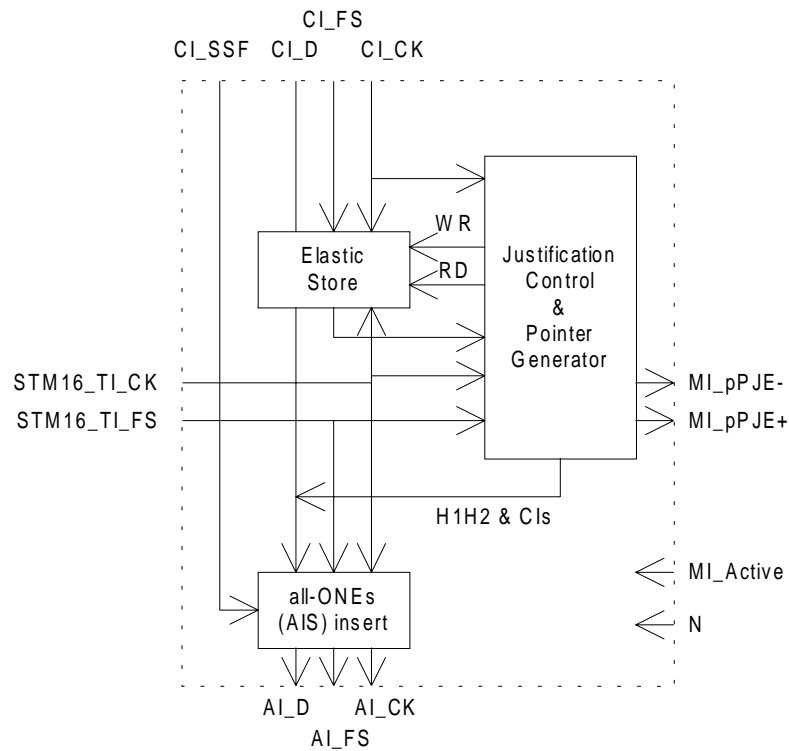

Figure 101: Main processes within MS16/S4-4c_A_So

Behaviour at recovery from defect condition: The incoming frequency (S4-4c_CI_CLK) of a passing through VC-4-4c may exceed its limits during a STM16dLOS condition. As a consequence, the buffer (elastic store) fill is not reliable any more. Due to all-ONEs (AIS) insertion after the pointer generator this reliability is not important for the operation of the network element. However, it shall be prevent to generate excessive pointer adjustments when recovering from the defect condition.

NOTE 3: The definition of excessive pointer adjustments is for further study.

The AU-4-4c pointer is carried in 2 + 6 bytes of payload specific OH in each STM-16 frame. The AU-4-4c pointer is aligned in the STM-16 payload in fixed position relative to the STM-16 frame. The AU-4-4c pointer points to the begin of the VC-4-4c frame within the STM-16. The format of the AU-4-4c pointer and its location in the frame are defined in ETS 300 147 [1].

H1H1H1H1H2H2H2H2 - Pointer generation: The function shall generate the AU-4-4c pointer as is described in EN 300 417-1-1 [3], annex A: Pointer Generation. It shall insert the pointer in the H1 [4, N], H2 [4, 48+N] positions with the SS field set to 10 to indicate AU-3/AU-4/AU-4-4c. It shall insert the concatenation indicator in the other pointer locations H1 [4, 1+N] to [4, 3+N], H2 [4, 49+N] to [4, 51+N]. The concatenation indicator is defined as 1001ss11 11111111, with ss being undefined.

YYYYYYYY1*1*1*1*1*1*1* - Fixed stuff insertion: The function shall insert fixed stuff codes Y = 1001ss11 in bytes [4, 16+N] to [4, 19+N] and [4, 32+N] to [4, 35+N] and code "1" = 11111111 in bytes [4, 64+N] to [4, 67+N] and [4, 80+N] to [4, 83+N]. Bits ss are undefined.

AU-4-4c timeslots: The adaptation source function has access to a specific AU-4-4c of the MS16 access point. The AU-4-4c is defined by the parameter N (N = 1,5,9,13).

Activation: The function shall access the access point when it is activated (MI_Active is true). Otherwise, it shall not access the access point.

Defects: None.

Consequent Actions:

aAIS ← CI_SSF.

On declaration of aAIS the function shall output an all-ONEs signal within 250 µs; on clearing of aAIS the function shall output normal data within 250 µs.

NOTE 4: If CI_SSF is not connected (when MS16/S4-4c_A_So is connected to a S4-4c_TT_So), CI_SSF is assumed to be false.

Defect Correlations: None.

Performance Monitoring:

Every second the number of generated pointer increments within that second shall be counted as the pPJE+. Every second the number of generated pointer decrements within that second shall be counted as the pPJE-.

NOTE 5: This is applicable for a passing through VC-4-4c only. A locally generated VC-4-4c may have a fixed frame phase; pointer justifications will not occur.

9.3.4 STM-16 Multiplex Section to S4-4c Layer Adaptation Sink MS16/S4-4c_A_Sk/N

Symbol:

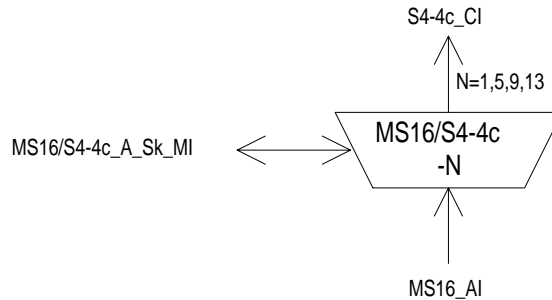

Figure 102: MS16/S4-4c_A_Sk symbol

Interfaces:

Table 73: MS16/S4-4c_A_Sk input and output signals

| Input(s) | Output(s) |
|---------------------------------|-------------------------|
| MS16_AI_D | S4-4c_CI_D |
| MS16_AI_CK | S4-4c_CI_CK |
| MS16_AI_FS | S4-4c_CI_FS |
| MS16_AI_TSF | S4-4c_CI_SSF |
| MS16/S4-4c_A_Sk_MI_Active | MS16/S4-4c_A_Sk_MI_cAIS |
| MS16/S4-4c_A_Sk_MI_AIS_Reported | MS16/S4-4c_A_Sk_MI_cLOP |

Processes:

This function recovers the VC-4-4c data with frame phase information from the STM-16 as defined in ETS 300 147 [1]. The VC-4-4c is extracted from tributary location indicated by "N". The function can be activated / deactivated when multiple payload adaptation functions are connected to the access point.

H1 H1H1H1H2H2H2H2 - *AU-4-4c pointer interpretation*: The function shall perform AU-4-4c pointer interpretation according to annex B of EN 300 417-1-1 [3] to recover the VC-4-4c frame phase within the STM-16. The process shall maintain its current phase on detection of an invalid pointer and searches in parallel for a new phase.

YYYYYYYYY1*1*1*1*1*1*1*: An AU-4-4c pointer consists of 2 bytes, [4, N] and [4, 48+N]. There will be 3 concatenation indicators, each 2 bytes long, in [4, 1+N]/[4, 49+N], [4, 2+N]/[4, 50+N], and [4, 3+N]/[4, 51+N]. The bytes [4, 16+N] to [4, 19+N], [4, 32+N] to [4, 35+N], [4, 64+N] to [4, 67+N] and [4, 80+N] to [4, 83+N] contain fixed stuff, of a specified value, ignored by the AU-4-4c pointer interpreter.

AU-4-4c timeslots: The adaptation source function has access to a specific AU-4-4c of the MS16 access point. The AU-4-4c is defined by the parameter N (N = 1,5,9,13).

Activation: The function shall perform the operation specified above when it is activated (MI_Active is true). Otherwise, it shall transmit the all-ONES signal at its output (CI_D) and not report its status via its management point.

Defects:

dAIS: The dAIS defect shall be detected if the pointer interpreter is in the AISX_state (see EN 300 417-1-1 [3], annex B). The dAIS defect shall be cleared if the pointer interpreter is not in the AISX_state.

dLOP: The dLOP defect shall be detected if the pointer interpreter is in the LOPX_state (see EN 300 417-1-1 [3], annex B). The dLOP defect shall be cleared if the pointer interpreter is not in the LOPX_state.

Consequent Actions:

aAIS ← dAIS or dLOP.

aSSF ← dAIS or dLOP.

On declaration of aAIS the function shall output an all-ONEs (AIS) signal within 250 µs; on clearing of aAIS the function shall output the recovered data within 250 µs.

Defect Correlations:

cAIS ← dAIS and (not aTSF) and AIS_Reported.

cLOP ← dLOP.

Performance Monitoring: None.

9.3.5 STM-16 Multiplex Section to DCC Adaptation Source MS16/DCC_A_So

Symbol:

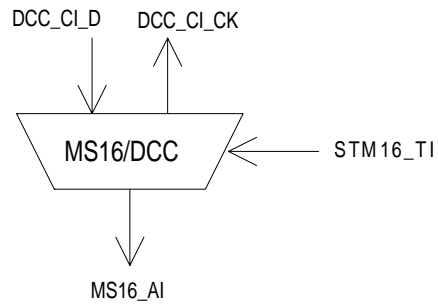

Figure 103: MS16/DCC_A_So symbol

Interfaces:

Table 74: MS16/DCC_A_So input and output signals

| Input(s) | Output(s) |
|--|------------------------|
| DCC_CI_D STM16_TI_CK STM16_TI_FS | MS16_AI_D DCC_CI_CK |

Processes:

The function multiplexes the DCC CI data (576 kbit/s) into the byte locations D4 to D12 as defined in ETS 300 147 [1] and depicted in figure 91.

NOTE: DCC transmission can be "disabled" when the matrix connection in the connected DCC_C function is removed.

Defects: None.

Consequent Actions: None.

Defect Correlations: None.

Performance Monitoring: None.

9.3.6 STM-16 Multiplex Section to DCC Adaptation Sink MS16/DCC_A_Sk

Symbol:

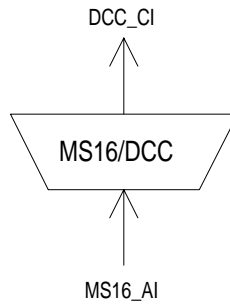

Figure 104: MS16/DCC_A_Sk symbol

Interfaces:

Table 75: MS16/DCC_A_Sk input and output signals

| Input(s) | Output(s) |
|--|-------------------------------------|
| MS16_AI_D MS16_AI_CK MS16_AI_FS MS16_AI_TSF | DCC_CI_D DCC_CI_CK DCC_CI_SSF |

Processes:

The function separates DCC data from MS Overhead as defined in ETS 300 147 [1] and depicted in figure 91.

NOTE: DCC processing can be "disabled" when the matrix connection in the connected DCC_C function is removed.

Defects: None.

Consequent Actions:

aSSF ← AI_TSF.

Defect Correlations: None.

Performance Monitoring: None.

9.3.7 STM-16 Multiplex Section to P0s Adaptation Source MS16/P0s_A_So

Symbol:

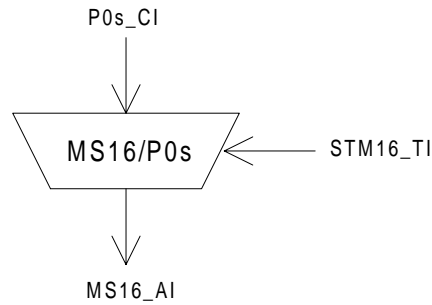

Figure 105: MS16/P0s_A_So symbol

Interfaces:

Table 76: MS16/P0s_A_So input and output signals

| Input(s) | Output(s) |
|--|------------------|
| P0s_CI_D P0s_CI_CK P0s_CI_FS STM16_TI_CK STM16_TI_FS | MS16/P0s_AI_So_D |

Processes:

This function provides the multiplexing of a 64 kbit/s orderwire information stream into the MS16_AI using slip buffering. It takes P0s_CI, defined in ETS 300 166 [2] as an octet structured bit-stream with a synchronous bit rate of 64 kbit/s, present at its input and inserts it into the MSOH byte E2 as defined in ETS 300 147 [1] and depicted in figure 91.

NOTE: Any frequency deviation between the 64 kbit/s signal and the associated STM-16 signal leads to octet slips.

Frequency justification and bitrate adaptation: The function shall provide for an elastic store (slip buffer) process. The data signal shall be written into the store under control of the associated input clock. The data shall be read out of the store under control of the STM-16 clock, frame position, and justification decisions.

Each justification decision results in a corresponding negative / positive justification action. Upon a positive justification (slip) action, the reading of one 64 kbit/s octet (8 bits) shall be cancelled once. Upon a negative justification (slip) action, the same 64 kbit/s octet (8 bits) shall be read out a second time.

Buffer size: The elastic store (slip buffer) shall accommodate at least 18 μ s of wander without introducing errors.

Defects: None.

Consequent Actions: None.

Defect Correlations: None.

Performance Monitoring: None.

9.3.8 STM-16 Multiplex Section to P0s Adaptation Sink MS16/P0s_A_Sk

Symbol:

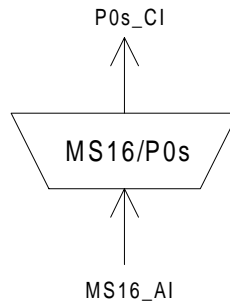

Figure 106: MS16/P0s_A_Sk symbol

Interfaces:

Table 77: MS16/P0s_A_Sk input and output signals

| Input(s) | Output(s) |
|-------------|--------------|
| MS16_AI_D | P0s_CI_Sk_D |
| MS16_AI_CK | P0s_CI_Sk_CK |
| MS16_AI_FS | P0s_CI_FS |
| MS16_AI_TSF | P0s_CI_SSF |

Processes:

The function separates P0s data from MS Overhead byte E2 as defined in ETS 300 147 [1] and depicted in figure 91.

Data latching and smoothing process: The function shall provide a data latching and smoothing function. Each 8-bit octet received shall be written and latched into a data store under the control of the STM-16 signal clock. The eight data bits shall then be read out of the store using a nominal 64 kHz clock which may be derived directly from the incoming STM-16 signal clock (e.g. 2 488 320 kHz divided by a factor of 38 880).

Defects: None.

Consequent Actions:

aSSF ← AI_TSF.

aAIS ← AI_TSF.

On declaration of aAIS the function shall output an all-ONEs (AIS) signal - complying to the frequency limits for this signal (a bit rate in range 64 kbit/s \pm 100 ppm) - within 1 ms; on clearing of aAIS the function shall output normal data within 1 ms.

Defect Correlations: None.

Performance Monitoring: None.

9.3.9 STM-16 Multiplex Section to Synchronization Distribution Adaptation Source MS16/SD_A_So

See EN 300 417-6-1 [5].

9.3.10 STM-16 Multiplex Section to Synchronization Distribution Adaptation Sink MS16/SD_A_Sk

See EN 300 417-6-1 [5].

9.3.11 STM-16 Multiplex Section Layer Clock Adaptation Source MS16-LC_A_So

See EN 300 417-6-1 [5].

9.4 STM-16 Multiplex Section Layer Monitoring Functions

For further study.

9.5 STM-16 Multiplex Section Linear Trail Protection Functions

9.5.1 STM-16 Multiplex Section Linear Trail Protection Connection Functions

9.5.1.1 STM-16 Multiplex Section 1+1 Linear Trail Protection Connection MS16P1+1_C

Symbol:

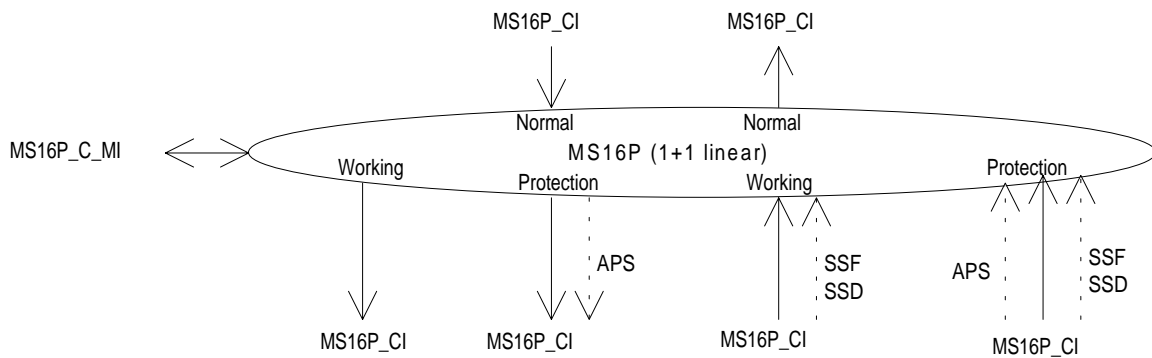

Figure 107: MS16P1+1_C symbol

Interfaces:**Table 78: MS16P1+1_C input and output signals**

| Input(s) | Output(s) |
|--|--|
| For connection points W and P: MS16P_CI_D MS16P_CI_CK MS16P_CI_FS MS16P_CI_SSF MS16P_CI_SSD | For connection points W and P: MS16P_CI_D MS16P_CI_CK MS16P_CI_FS MS16P_CI_SSF |
| For connection points N: MS16P_CI_D MS16P_CI_CK MS16P_CI_FS | For connection points N: MS16P_CI_D MS16P_CI_CK MS16P_CI_FS MS16P_CI_SSF |
| Per function: MS16P_CI_APS | Per function: MS16P_CI_APS |
| MS16P_C_MI_SWtype MS16P_C_MI_OPERtype MS16P_C_MI_WTRTime MS16P_C_MI_EXTCMD | MS16P_C_MI_cFOP MS16P_C_MI_pPSC MS16P_C_MI_pPSD |
| NOTE: Protection status reporting signals are for further study. | |

Processes:

The function performs the STM-16 linear multiplex section protection process for 1 + 1 protection architectures; see EN 300 417-1-1 [3], subclause 9.2. It performs the bridge and selector functionality as presented in figure 48 of EN 300 417-1-1 [3]. In the sink direction, the signal output at the normal #1 reference point can be the signal received via either the associated working #1 section or the protection section; this is determined by the SF, SD conditions (relayed via CI_SSF, CI_SSD signals), the external commands and the information relayed via the APS signal. In the source direction, the working outputs are connected to the associated normal inputs. The protection output is unsourced (no input connected) or connected to any normal input.

Provided no protection switching action is activated / required the following changes to (the configuration of) a connection shall be possible without disturbing the CI passing the connection:

- change between switching types;
- change between operation types;
- change of WTR time.

MS Protection Operation: The MS trail protection process shall operate as specified in annex A, according the following characteristics.

Table 79

| | |
|----------------------------------|--|
| Architecture: | 1 + 1 |
| Switching type: | uni-directional or bi-directional |
| Operation type: | revertive or non-revertive |
| APS channel: | 13 bits, K1[1-8] and K2[1-5] |
| Wait-To-Restore time: | in the order of 0-12 minutes |
| Switching time: | ≤ 50 ms |
| Hold-off time: | not applicable |
| Signal switch conditions: | SF, SD |
| External commands: | (revertive operation) LO, FSw-#1, MSw-#1, CLR, EXER-#1 (non-revertive operation) LO or FSw, FSw-#i, MSw, MSw-#i, CLR, EXER-#1 |
| SFpriority, SDpriority: | high |

Defects: None.

Consequent Actions: None.

Defect Correlations: None.

cFOP ← (see annex A).

Performance Monitoring:

pPSC ← (see annex A).

pPSD ← (see annex A).

9.5.1.2 STM-16 Multiplex Section 1:n Linear Trail Protection Connection MS16P1:n_C

Symbol:

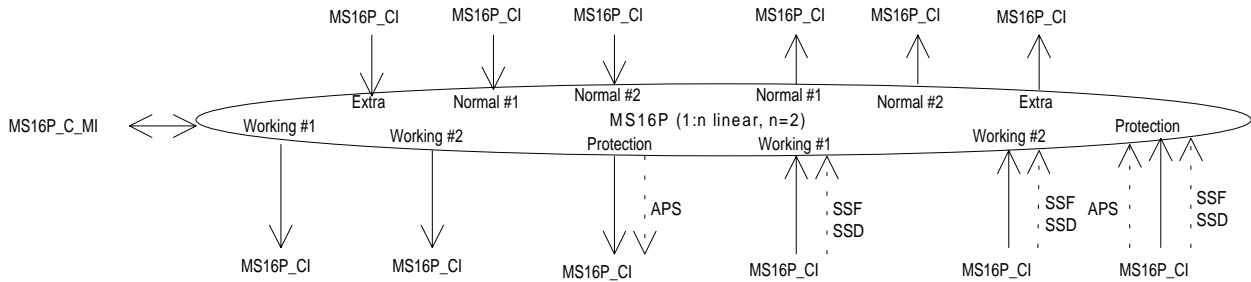

Figure 108: MS16P1:n_C symbol(s)

Interfaces:

Table 80: MS16P1:n_C input and output signals

| Input(s) | Output(s) |
|--|--|
| For connection points W and P: MS16P_CI_D MS16P_CI_CK MS16P_CI_FS MS16P_CI_SSF MS16P_CI_SSD MS16P_MI_SFpriority MS16P_MI_SDpriority | For connection points W and P: MS16P_CI_D MS16P_CI_CK MS16P_CI_FS MS16P_CI_SSF |
| For connection points N and E: MS16P_CI_D MS16P_CI_CK MS16P_CI_FS | For connection points N and E: MS16P_CI_D MS16P_CI_CK MS16P_CI_FS MS16P_CI_SSF |
| Per function: MS16P_CI_APS | Per function: MS16P_CI_APS |
| MS16P_C_MI_SWtype MS16P_C_MI_EXTRAttraffic MS16P_C_MI_WTRTime MS16P_C_MI_EXTCMD | MS16P_C_MI_cFOP MS16P_C_MI_pPSC MS16P_C_MI_pPSD |
| NOTE: Protection status reporting signals are for further study. | |

Processes:

The function performs the STM-16 linear multiplex section protection process for 1:n protection architectures; see EN 300 417-1-1 [3], subclause 9.2. It performs the bridge and selector functionality as presented in figure 47 of EN 300 417-1-1 [3]. In the sink direction, the signal output at the normal #i reference point can be the signal received via either the associated working #i section or the protection section; this is determined by the SF, SD conditions (relayed via CI_SSF, CI_SSD signals), the external commands and the information relayed via the APS signal. In the source direction, the working outputs are connected to the associated normal inputs. The protection output is unsourced (no input connected), connected to the extra traffic input, or connected to any normal input.

Provided no protection switching action is activated / required the following changes to (the configuration of) a connection shall be possible without disturbing the CI passing the connection:

- change between switching types;
- change of WTR time.

MS Protection Operation: The MS trail protection process shall operate as specified in annex A, according the following characteristics.

Table 81

| | |
|----------------------------------|-----------------------------------|
| Architecture: | 1:n ($n \leq 14$) |
| Switching type: | uni-directional or bi-directional |
| Operation type: | revertive |
| APS channel: | 13 bits, K1[1-8] and K2[1-5] |
| Wait-To-Restore time: | in the order of 0-12 minutes |
| Switching time: | ≤ 50 ms |
| Hold-off time: | not applicable |
| Signal switch conditions: | SF, SD |
| External commands: | LO, FSw-#, MSw-#, CLR, EXER |

Defects: None.

Consequent Actions:

For the case where neither the extra traffic nor a normal signal input is to be connected to the protection section output, the null signal shall be connected to the protection output. The null signal is either one of the normal signals, an all-ONES, or a test signal.

For the case of a protection switch, the extra traffic output (if applicable) is disconnected from the protection input, set to all-ONES (AIS) and aSSF is activated.

Defect Correlations:

cFOP ← (see annex A).

Performance Monitoring:

pPSC ← (see annex A).

pPSD ← (see annex A).

9.5.2 STM-16 Multiplex Section Linear Trail Protection Trail Termination Functions

9.5.2.1 Multiplex Section Protection Trail Termination Source MS16P_TT_So

Symbol:

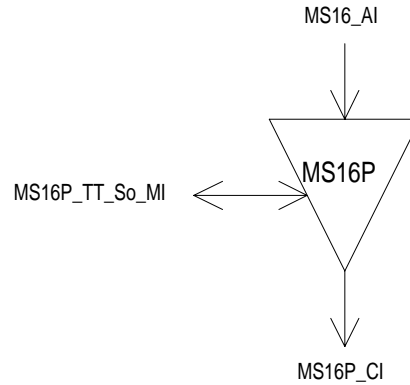

Figure 109: MS16P_TT_So symbol

Interfaces:

Table 82: MS16P_TT_So input and output signals

| Input(s) | Output(s) |
|------------|-------------|
| MS16_AI_D | MS16P_CI_D |
| MS16_AI_CK | MS16P_CI_CK |
| MS16_AI_FS | MS16P_CI_FS |

Processes:

No information processing is required in the MS16P_TT_So, the MS16_AI at its output being identical to the MS16P_CI at its input.

Defects: None.

Consequent Actions: None

Defect Correlations: None.

Performance Monitoring: None.

9.5.2.2 Multiplex Section Protection Trail Termination Sink MS16P_TT_Sk

Symbol:

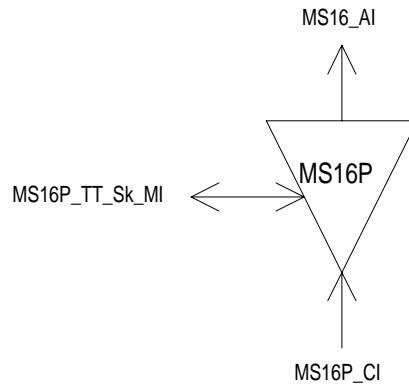

Figure 110: MS16P_TT_Sk symbol

Interfaces:

Table 83: MS16P_TT_Sk input and output signals

| Input(s) | Output(s) |
|-----------------------------|---------------------|
| MS16P_CI_D | MS16_AI_D |
| MS16P_CI_CK | MS16_AI_CK |
| MS16P_CI_FS | MS16_AI_FS |
| MS16P_CI_SSF | MS16_AI_TSF |
| MS16P_TT_Sk_MI_SSF_Reported | MS16P_TT_Sk_MI_cSSF |

Processes:

The MS16P_TT_Sk function reports, as part of the MS16 layer, the state of the protected MS16 trail. In case all connections are unavailable the MS16P_TT_Sk reports the signal fail condition of the protected trail.

Defects: None.

Consequent Actions:

aTSF ← CI_SSF.

Defect Correlations: None.

cSSF ← CI_SSF and SSF_Reported.

Performance Monitoring: None.

9.5.3 STM-16 Multiplex Section Linear Trail Protection Adaptation Functions

9.5.3.1 STM-16 Multiplex Section to STM-16 Multiplex Section Protection Layer Adaptation Source MS16/MS16P_A_So

Symbol:

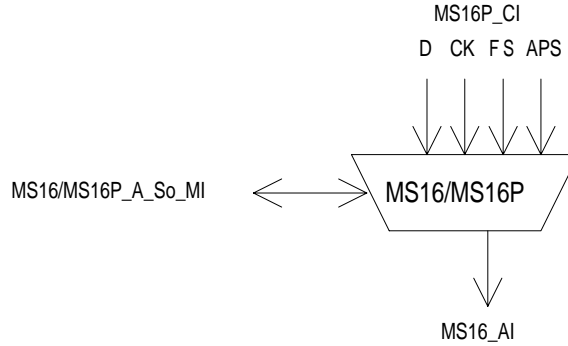

Figure 111: MS16/MS16P_A_So symbol

Interfaces:

Table 84: MS16/MS16P_A_So input and output signals

| Input(s) | Output(s) |
|--------------|------------|
| MS16P_CI_D | MS16_AI_D |
| MS16P_CI_CK | MS16_AI_CK |
| MS16P_CI_FS | MS16_AI_FS |
| MS16P_CI_APS | |

Processes:

The function shall multiplex the MS16 APS signal and MS16 data signal onto the MS16 access point.

Defects: None.

Consequent actions: None.

Defect Correlations: None.

Performance Monitoring: None.

9.5.3.2 STM-16 Multiplex Section to STM-16 Multiplex Section Protection Layer Adaptation Sink MS16/MS16P_A_Sk

Symbol:

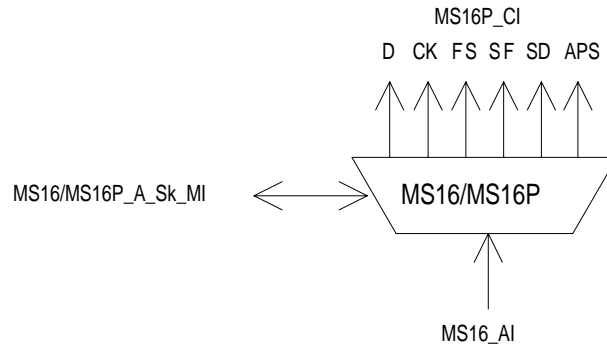

Figure 112: MS16/MS16P_A_Sk symbol

Interfaces:

Table 85: MS16/MS16P_A_Sk input and output signals

| Input(s) | Output(s) |
|-------------|---|
| MS16_AI_D | MS16P_CI_D |
| MS16_AI_CK | MS16P_CI_CK |
| MS16_AI_FS | MS16P_CI_FS |
| MS16_AI_TSF | MS16P_CI_SSF |
| MS16_AI_TSD | MS16P_CI_SSD |
| | MS16P_CI_APS (for Protection signal only) |

Processes:

The function shall extract and output the MS16P_CI_D signal from the MS16_AI_D signal.

K1[1-8], K2[1-5]: The function shall extract the 13 APS bits K1[1-8] and K2[1-5] from the MS16_AI_D signal. A new value shall be accepted when the value is identical for three consecutive frames. This value shall be output via MS16P_CI_APS. This process is required only for the protection section.

Defects: None.

Consequent actions:

aSSF ← AI_TSF.

aSSD ← AI_TSD.

Defect Correlations: None.

Performance Monitoring: None.

Processes:

The function is able to route (bridge and select) the Working and Protection group signals between its connection points (inputs / outputs) as specified in ETS 300 746 [6], multiplex section 2 fibre shared protection ring operation.

NOTE 1: The functional model is a maximum model; the extra traffic related inputs and outputs may not be present in an actual equipment.

Possible Matrix Connections that can be supported are:

- Ww_A ↔ Ww_B
 - Pw_A ↔ Pw_B
 - Pw_A ↔ Ew_B
 - Pw_A ↔ We_B
 - Pw_A [TSx] ← all-ONEs (AIS)
 - Pw_A [TSx] ← unequipped HOVC
 - APSw ↔ APSe (APS pass through) *legend:*
 - APSw sourced
 - APSe sourced
- We_A ↔ We_B.
Pe_A ↔ Pe_B.
Pe_A ↔ Ee_B.
Pe_A ↔ Ww_B.
Pe_A [TSx] ← all-ONEs (AIS).
Pe_A [TSx] ← unequipped HOVC.
Xy_Z -X = Working, Protection, Extra traffic.
y = west, east.
Z = A, B;
TSx - AU-4 TimeSlot #x (x = 1..16).

Table 87: MS16P2fsh_C traffic matrix connections

| traffic matrix connections | | | OUTPUTS | | | | | | | | | |
|----------------------------|---|----|---------|----|----|----|----|----|----|----|----|----|
| | | | A | | | | B | | | | | |
| | | | Ww | Pw | We | Pe | Ww | Ew | Pw | We | Ee | Pe |
| I | A | Ww | | | | | X | | | | | |
| N | | Pw | | | | | | X | X | X | | |
| P | | We | | | | | | | | X | | |
| U | | Pe | | | | | X | | | | X | X |
| T | B | Ww | X | | | X | | | | | | |
| S | | Ew | | X | | | | | | | | |
| | | Pw | | X | | | | | | | | |
| | | We | | X | X | | | | | | | |
| | | Ee | | | | X | | | | | | |
| | | Pe | | | | X | | | | | | |

In the sink direction (figure 113, from A to B), the signal output at the West [East] Working B MS16P2fsh connection point can be the signal received via either the associated West Working A capacity or the East Protection capacity; this is determined by the SF, SD conditions (relayed via CI_SSF, CI_SSD signals), the external commands and the information relayed via the APS signal.

In the source direction, the working A outputs are connected to the associated working B inputs. The protection A outputs are connected to a local unequipped VC generator, extra traffic input, or one of the working inputs at B as shown in figures 114 to 117.

NOTE 2: ETS 300 746 [6] states that protection AUs when not in use (for extra traffic or working traffic) shall be source by VC unequipped signals. This shall be performed in this MS16P2fsh_C functions as ETS 300 746 [6] also shows that the S4_C (S4-4c_C) functions have permanent matrix connections for the protection timeslot capacity. The protection is a MS layer protection scheme and should not impact client layers. In the functional model, the MS16 layer knows the HO VC path multiplex structure, and is able to control HO VC unequipped signal insertion.

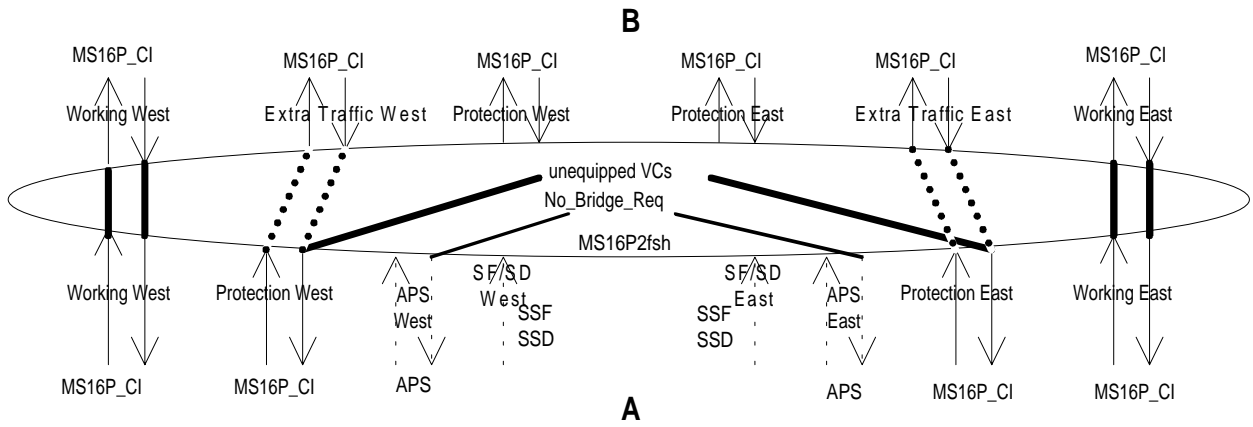

Figure 114: Matrix connections in a network element within a ring without a fault; dotted lines represent the case of extra traffic support

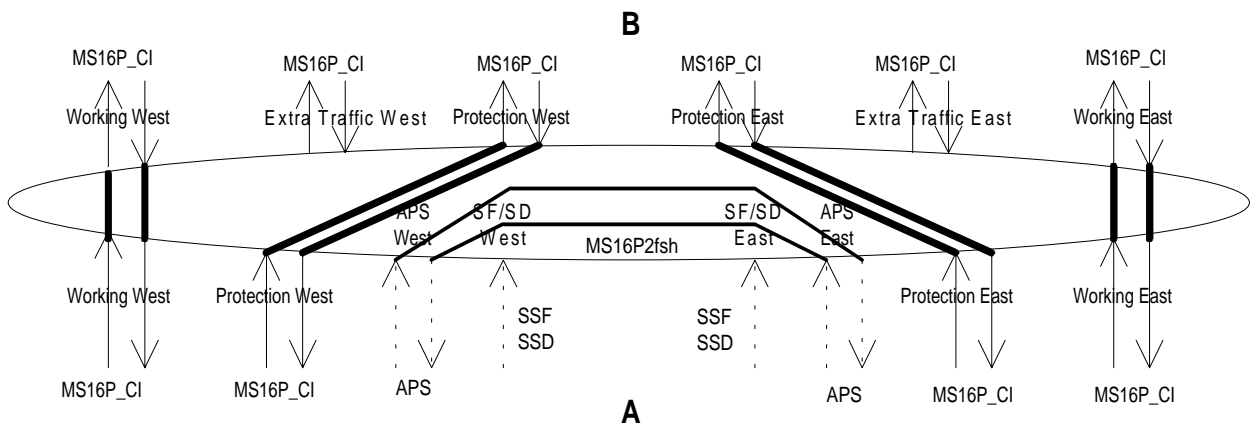

Figure 115: Matrix connections in a network element not adjacent to a fault

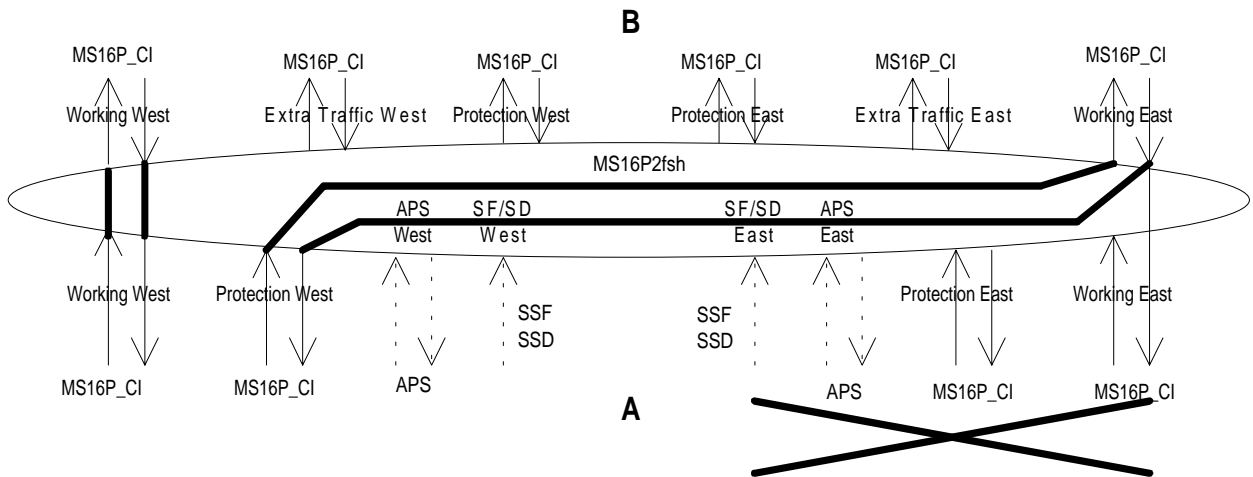

Figure 116: Matrix connections in a network element adjacent to a fault on its East side

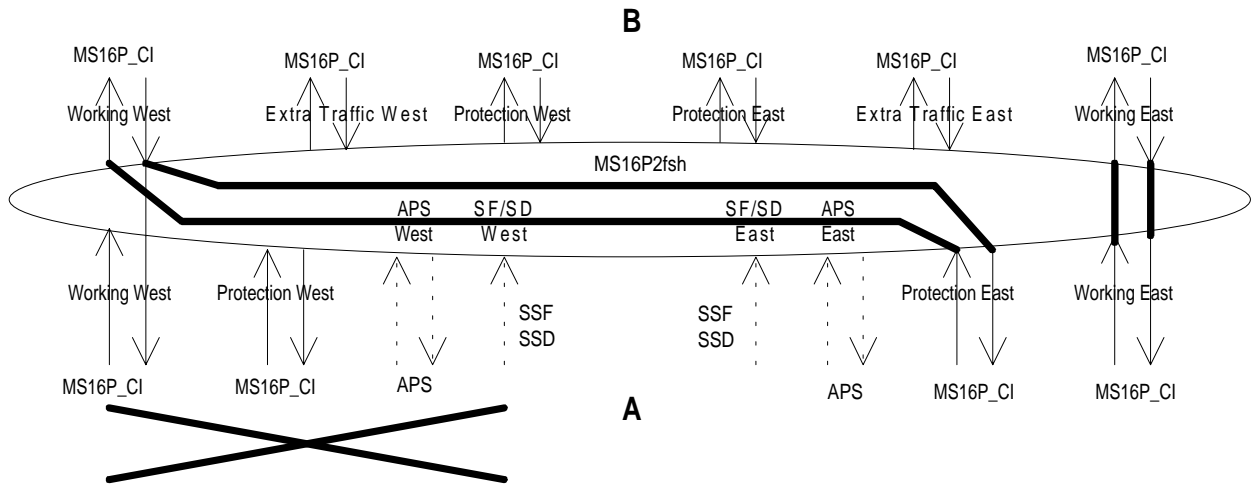

Figure 117: Matrix connections in a network element adjacent to a fault on its west side

MS Protection Operation: The 2 fibre MS shared protection ring trail protection process shall operate as specified in ETS 300 746 [6].

Defects:

For further study.

Consequent Actions:

The function shall generate a VC-4 [VC-4-4c] unequipped signal (plus valid AU-4 [AU-4-4c] pointer) for each protection timeslot when the protection timeslot is not in use.

The function shall insert all-ONEs (AIS) (squelching) for an AU-4 [AU-4-4c] within protection timeslots that would otherwise be misconnected.

Defect Correlations:

For further study.

Performance Monitoring:

For further study.

9.6.2 STM-16 Multiplex Section 2 Fibre Shared Protection Ring Trail Termination Functions

9.6.2.1 STM-16 Multiplex Section 2 Fibre Shared Protection Ring Trail Termination Source MS16P2fsh_TT_So

Symbol:

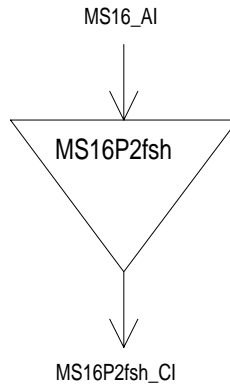

Figure 118: MS16P2fsh_TT_So symbol

Interfaces:

Table 88: MS16P2fsh_TT_So input and output signals

| Input(s) | Output(s) |
|-----------------|-----------------|
| MS16P2fsh_AI_D | MS16P2fsh_CI_D |
| MS16P2fsh_AI_CK | MS16P2fsh_CI_CK |
| MS16P2fsh_AI_FS | MS16P2fsh_CI_FS |

Processes:

No information processing is required in the MS16P2fsh_TT_So, the MS16_AI at its output being identical to the MS16P2fsh_CI at its input.

Defects: None.

Consequent Actions: None

Defect Correlations: None.

Performance Monitoring: None.

9.6.2.2 STM-16 Multiplex Section 2 Fibre Shared Protection Ring Trail Termination Sink MS16P2fsh_TT_Sk

Symbol:

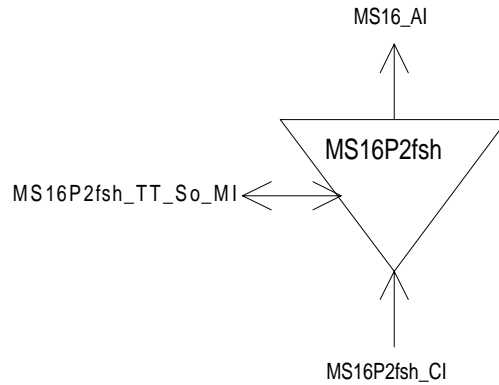

Figure 119: MS16P2fsh_TT_Sk symbol

Interfaces:

Table 89: MS16P2fsh_TT_Sk input and output signals

| Input(s) | Output(s) |
|---------------------------------|-------------------------|
| MS16P2fsh_CI_D | MS16_AI_D |
| MS16P2fsh_CI_CK | MS16_AI_CK |
| MS16P2fsh_CI_FS | MS16_AI_FS |
| MS16P2fsh_CI_SSF | MS16_AI_TSF |
| MS16P2fsh_TT_Sk_MI_SSF_Reported | MS16P2fsh_TT_Sk_MI_cSSF |

Processes:

The MS16P2fsh_TT_Sk function reports, as part of the MS16 layer, the state of the protected MS16 trail. In case all connections are unavailable the MS16P2fsh_TT_Sk reports the signal fail condition of the protected trail. This is applicable only for the working capacity.

Defects: None.

Consequent Actions:

aTSF ← CI_SSF.

Defect Correlations:

cSSF ← CI_SSF and SSF_Reported.

Performance Monitoring: None.

9.6.3 STM-16 Multiplex Section 2 Fibre Shared Protection Ring Adaptation Functions

9.6.3.1 STM-16 Multiplex Section to STM-16 Multiplex Section 2 Fibre Shared Protection Ring Adaptation Source MS16/MS16P2fsh_A_So

Symbol:

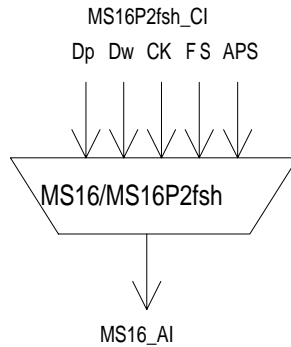

Figure 120: MS16/MS16P2fsh_A_So symbol

Interfaces:

Table 90: MS16/MS16P2fsh_A_So input and output signals

| Input(s) | Output(s) |
|------------------|------------|
| MS16P2fsh_CI_Dw | MS16_AI_D |
| MS16P2fsh_CI_Dp | MS16_AI_CK |
| MS16P2fsh_CI_CK | MS16_AI_FS |
| MS16P2fsh_CI_FS | |
| MS16P2fsh_CI_APS | |

Processes:

The function shall multiplex two groups of signals (CI_Dw, CI_Dp) into the MS16 payload (16 AU-4 timeslots). The working group signal shall be multiplexed into AU-4 timeslots 1 to 8 and the protection group signal shall be multiplexed into AU-4 timeslots 9 to 16.

The function shall map the MS16 2 fibre shared protection ring APS signal into bytes K1 and K2.

Defects: None.

Consequent actions: None.

Defect Correlations: None.

Performance Monitoring: None.

9.6.3.2 STM-16 Multiplex Section to STM-16 Multiplex Section 2 Fibre Shared Protection Ring Adaptation Sink MS16/MS16P2fsh_A_Sk

Symbol:

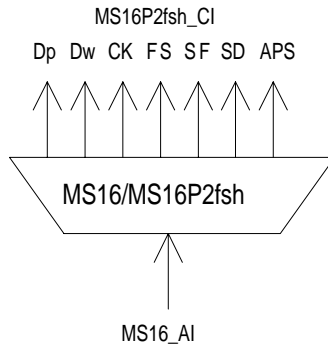

Figure 121: MS16/MS16P2fsh_A_Sk symbol

Interfaces:

Table 91: MS16/MS16P2fsh_A_Sk input and output signals

| Input(s) | Output(s) |
|-------------|------------------|
| MS16_AI_D | MS16P2fsh_CI_Dw |
| MS16_AI_CK | MS16P2fsh_CI_Dp |
| MS16_AI_FS | MS16P2fsh_CI_CK |
| MS16_AI_TSF | MS16P2fsh_CI_FS |
| MS16_AI_TSD | MS16P2fsh_CI_SSF |
| | MS16P2fsh_CI_SSD |
| | MS16P2fsh_CI_APS |

Processes:

The function shall split the MS16 payload (i.e. 16 AU-4 timeslots) into two groups; the working group contains AU-4 timeslots 1 to 8 and the protection group contains AU-4 timeslots 9 to 16. The working group shall be output at MS16P2fsh_CI_Dw and the protection group at MS16P2fsh_CI_Dp.

K1K2: The function shall extract the 16 APS bits K1[1-8] and K2[1-8] from the MS16_AI_D signal. A new value shall be accepted when the value is identical for three consecutive frames. This value shall be output via MS16P2fsh_CI_APS.

Defects: None.

Consequent actions:

aSSF ← AI_TSF.

aSSD ← AI_TSD.

Defect Correlations: None.

Performance Monitoring: None.

9.7 STM-16 Multiplex Section 4 Fibre Shared Protection Ring Functions

For further study.

9.7.1 STM-16 Multiplex Section 4 Fibre Shared Protection Ring Connection MS16P4fsh_C

For further study.

9.7.2 STM-16 Multiplex Section 4 Fibre Shared Protection Ring Trail Termination Functions

9.7.2.1 STM-16 Multiplex Section 4 Fibre Shared Protection Ring Trail Termination Source MS16P4fsh_TT_So

For further study.

9.7.2.2 STM-16 Multiplex Section 4 Fibre Shared Protection Ring Trail Termination Sink MS16P4fsh_TT_Sk

For further study.

9.7.3 STM-16 Multiplex Section 4 Fibre Shared Protection Ring Adaptation Functions

9.7.3.1 STM-16 Multiplex Section to STM-16 Multiplex Section 4 Fibre Shared Protection Ring Adaptation Source MS16/MS16P4fsh_A_So

For further study.

9.7.3.2 STM-16 Multiplex Section to STM-16 Multiplex Section 4 Fibre Shared Protection Ring Adaptation Sink MS16/MS16P4fsh_A_Sk

For further study.

10 STM-64 Regenerator Section layer functions

For further study.

11 STM-64 Multiplex Section layer functions

For further study.

Annex A (normative): Generic specification of linear protection switching operation

NOTE 1: The text in this annex is a reworked copy of annex A of ITU-T Recommendation G.783 [7] and presents an attempt to formalize the protection process specification to remove ambiguities present in ITU-T Recommendation G.783 [7].

The protection process described in this annex supports linear trail protection (see EN 300 417-1-1 [3], subclause 9.3.1) as well as linear connection (subnetwork, network) protection (see EN 300 417-1-1 [3], subclauses 9.4.1 and 9.4.2) in the combinations as listed in table A.1. This protection process controls the bridge and selector functionality (EN 300 417-1-1 [3], subclause 9.2, figures 47 to 49).

Table A.1: Supported linear protection process combinations

| Protection type | Architecture type | Switching type | Operation type | APS signal | Extra traffic |
|-----------------|-------------------|-----------------|----------------|------------|---------------|
| MS-n trail | 1 + 1 | uni-directional | non-revertive | no (note) | no |
| MS-n trail | 1 + 1 | uni-directional | revertive | no (note) | no |
| MS-n trail | 1 + 1 | bi-directional | non-revertive | yes | no |
| MS-n trail | 1 + 1 | bi-directional | revertive | yes | no |
| MS-n trail | 1:n (n ≤ 14) | uni-directional | revertive | yes | no |
| MS-n trail | 1:n (n ≤ 14) | bi-directional | revertive | yes | no |
| MS-n trail | 1:n (n ≤ 14) | bi-directional | revertive | yes | yes |
| VC-m SNC/I | 1 + 1 | uni-directional | non-revertive | no | no |
| VC-m SNC/I | 1 + 1 | uni-directional | revertive | no | no |
| VC-m SNC/N | 1 + 1 | uni-directional | non-revertive | no | no |
| VC-m SNC/N | 1 + 1 | uni-directional | revertive | no | no |
| VC-m SNC/S | 1 + 1 | uni-directional | non-revertive | no | no |
| VC-m SNC/S | 1 + 1 | uni-directional | revertive | no | no |
| VC-m trail | 1 + 1 | uni-directional | non-revertive | no | no |
| VC-m trail | 1 + 1 | bi-directional | revertive | no | no |
| VC-m trail | 1 + 1 | bi-directional | non-revertive | yes | no |
| VC-m trail | 1 + 1 | bi-directional | revertive | yes | no |

NOTE: ITU-T Recommendation G.783 [7] specifies the use of the APS in these cases, without taking any action on the information.

NOTE 2: Bi-directional switched 1 + 1 VC-m trail protection requires the definition and bit allocation of the VC-APS signal.

The remainder of this annex is organized as follows:

- protection process overview;
- external commands definition;
- conditions of protected trail / connection signals;
- states within protection process;
- numbering of working, protection, normal, extra traffic and null signals;
- numbering and priority of external commands, trail / connection signal conditions, and states;
- Automatic Protection Switch (APS) signal definition;
- specification of subprocesses within protection process.

A.1 Protection process overview

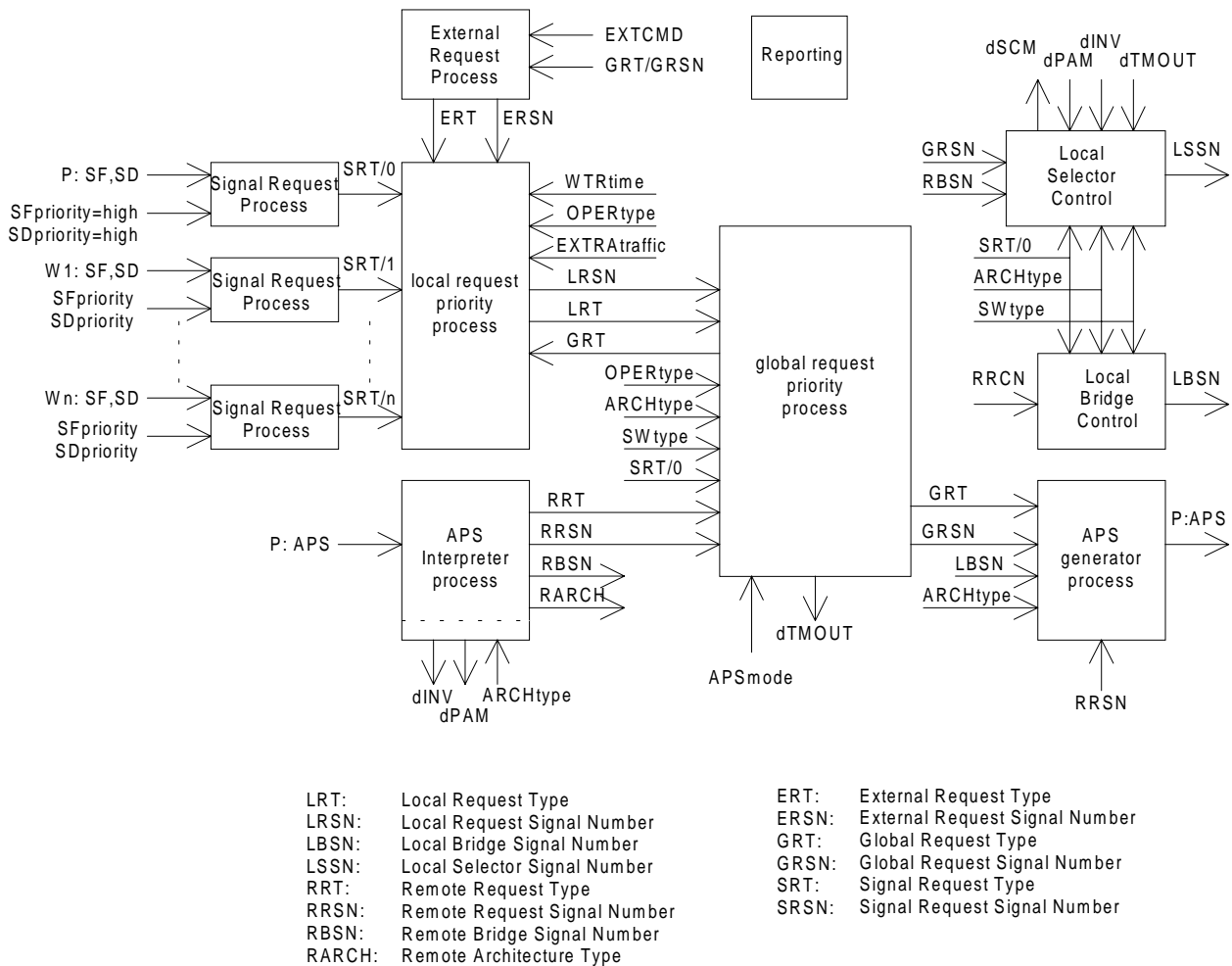

Figure A.1: Subprocesses within generic linear trail / connection protection processes

Linear protection processes can be characterized by the following (super)set of subprocesses (figure A.1):

| | |
|--------------------------------|--|
| Signal Request | converts SF and SD signals of a working / protection trail / connection signal into a (signal) request type and trail / connection number; |
| External Request | converts the external commands into an (external) request type and signal number; |
| Local Request Priority | determines the highest priority local request; |
| APS Interpretation | converts the APS signal into a (remote) request type, request signal number, bridged signal number, and architecture type (if applicable); |
| Global Request Priority | determines the highest global request type comparing local and remote (if applicable) requests; |
| Local Bridge Control | determines which of the normal / extra traffic signals is bridged to the protection trail / connection; |
| Local Selector Control | determines which of the normal / extra traffic signals is connected to / extracted from the protection trail / connection; |
| APS Generation | converts the global request type, global request signal number, local bridged signal number, and local architecture into the APS signal; |
| Reporting | reports the status (local, remote) of the protection process; remote status if APS signal is supported. |

A specific protection application is characterized by the following parameter set:

Table A.2

| Parameter | Value options |
|--|--|
| Architecture type (ARCHtype) | 1 + 1, 1:n |
| Switching type (SWtype) | uni-directional, bi-directional |
| Operation type (OPERtype) | revertive, non-revertive |
| APS signal (APSmode) | true, false |
| Wait-To-Restore time (WTRtime) | in the order of 0-12 minutes |
| Switching time | ≤50 ms |
| Hold-off time (HOtime) | 0 to 10 seconds in steps of the order of 100 ms |
| Protection type (PROTtype) | SNC/I, SNC/N, SNC/S, trail |
| Signal switch conditions: | SF = SSF (SNC/I) SF = TSF (SNC/N, SNC/S, trail), SD = TSD (SNC/N, SNC/S, trail) |
| External commands (EXTCMD) | LO-#0, FSw-#i, MSw-#i, EXER-#i, CLR |
| Extra traffic (EXTRAtraffic) | true, false |
| Priority of SF and SD (SFpriority, SDpriority) | low, high |

A.2 External switch commands definition

A switch command issues an appropriate external request. Only one switch request can be issued per protection group. Switch commands are listed below in the descending order of priority and the functionality of each is described.

NOTE 1: The addition of the Lockout for Working #i command is for further study.

The function shall generate an automatic response confirming that the request was executed, or stating that the request was denied for a particular reason.

- 1) **Clear (CLR):** Clears all switch commands listed below.
- 2) **Lockout of protection (LO):** Request to deny all normal signals (and the extra traffic signal, if applicable) access to the protection trail / connection.

NOTE 2: Request is honoured unless an equal priority switch command is in effect. If the request is denied, it is released and forgotten.

- 3) **Forced switch #i (FSw-#i):** Request to switch normal signal #i ($1 \leq i \leq n$, $n \leq n_{\max}$) to the protection trail / connection, or request to switch extra traffic signal # $n_{\max} + 1$ to the protection trail / connection, or (for the case of 1 + 1 non-revertive systems) request (FSw-#0) to switch normal signal to working trail / connection.

NOTE 3: Request is honoured unless an equal or higher priority switch command is in effect or (for the case an APS signal is in use) SF condition exists on the protection trail / connection. If the request is denied, it is released and forgotten.

NOTE 4: For 1 + 1 non-revertive systems, "forced switch no normal signal (FSw-#0)" transfers the normal signal from protection to the working trail / connection, unless an equal or higher priority request is in effect. Since forced switch has higher priority than SF or SD on the working trail / connection, this command will be carried out regardless of the condition of the working trail / connection.

NOTE 5: For 1: n architectures, "forced switch to extra traffic (FSw-# $n_{\max} + 1$)" forces the extra traffic signal to the protection trail / connection and prevents normal signals to be transported over protection.

- 4) **Manual switch #i (MSw-#i):** Request to switch normal signal #i ($1 \leq i \leq n$, $n \leq n_{\max}$) to the protection trail / connection, or (for the case of 1 + 1 non-revertive systems) request (MSw-#0) to switch normal signal to working trail / connection.

NOTE 6: Request is honoured unless a defect condition exists on other trail / connections (including the protection trail / connection) or an equal or higher priority switch command is in effect. If the request is denied, it is released and forgotten.

NOTE 7: For 1 + 1 non-revertive systems, "manual switch no normal signal (MSw-#0)" transfers the normal signal back from protection to the working trail / connection, unless an equal or higher priority request is in effect. Since manual switch has lower priority than SF or SD on a working trail / connection, this command will be carried out only if the working trail / connection is not in SF or SD condition.

- 5) **Exercise #i (EXER-#i):** Request for an exercise to check responses on APS bytes for normal signal #i ($1 \leq i \leq n$, $n \leq n_{\max}$). The switch is not actually completed, i.e. the selector is released by an exercise request on either the sent or the received and acknowledged K1 byte.

NOTE 8: Request is honoured unless the protection signal is in use.

The following table presents alternative user interface external command strings for the case of 1 + 1 protection architectures. Note that the generic names will be used in the present document.

Table A.3

| Generic | Alternative for 1 + 1 revertive | Alternative for 1 + 1 non-revertive | Result |
|---------|---------------------------------|-------------------------------------|--|
| LO (#0) | LO | - | normal signal connected to working trail / connection |
| Fsw-#0 | - | Fsw-(to)-W | normal signal connected to working trail / connection |
| Fsw-#1 | Fsw-(to)-P | Fsw-(to)-P | normal signal connected to protection trail / connection |
| MSw-#0 | - | MSw-(to)-W | normal signal connected to working trail / connection |
| MSw-#1 | MSw-(to)-P | MSw-(to)-P | normal signal connected to protection trail / connection |

A.3 Conditions of working and protection trail / connections

Working and protection trail / connection (signals) have a condition associated with them: fault free, signal fail, signal degrade. The condition is communicated with the protection process by means of the SF and SD signals within the characteristic or adapted information of the working / protection trail / connection signal.

A.4 States within protection process

The protection process has a number of so called states associated with it: no request, do not revert, reverse request, and wait to restore. A description of the effect of the states is presented below:

Wait to restore (WTR): In the revertive mode of operation, the normal signal will be restored (i.e. the signal on the protection trail / connection will be switched back to the working trail / connection) when the working trail / connection has recovered from the fault.

To prevent frequent operation of the selector due to an intermittent fault, a failed working trail / connection shall become fault-free. After the failed trail / connection meets this criterion, (and no other externally initiated commands are present) a fixed period of time will elapse before it is used again by the normal signal. During this WTR state, switching will not occur.

An SF or SD condition will override the WTR. After the WTR period is completed, a No Request state will be entered. Switching will then occur from the protection trail / connection to the working trail / connection.

Reverse request: For the case of bi-directional switching, a reverse request is returned for exerciser and all other requests of higher priority. This clearly identifies which end originated the switch request.

If the head end had also originated an identical request (not yet confirmed by a reverse request) for the same signal, then both ends would continue transmitting (in the APS signals) the identical request type (RT) and signal number (RSN) and perform the requested switch action.

In uni-directional switching, reverse request is never indicated.

Both wait-to-restore and do not revert requests in the RT fields of the transmitted APS signal are normally acknowledged by a reverse request in the RT field of the received APS signal. However, no request is acknowledged by another no request received.

Do not revert: In the non-revertive mode of operation, assuming the normal signal is on protection when the working trail / connection is repaired or a switch command is released, the tail end maintains the selection and issues LRT/LRSN = DNR/1 (do not revert for normal signal 1).

For the case of bi-directional switching, the head end also maintains the selection and continues indicating reverse request. The do not revert is removed when pre-empted by a defect condition or an external request.

No request: This state represents the inactive state of the request processes (signal, external, local, remote, and global request processes). None of the trail / connection signal conditions is active, none of the external commands is active, and none of the states described above is active.

A.5 Numbering of working, protection, normal, extra traffic, null signals

The protection trail / connection shall be referred to as number "0". The working trails / connections are numbered "1", "2", etc. The assignment of these numbers to physical entities in a network element is equipment specific and not within the scope of the present document.

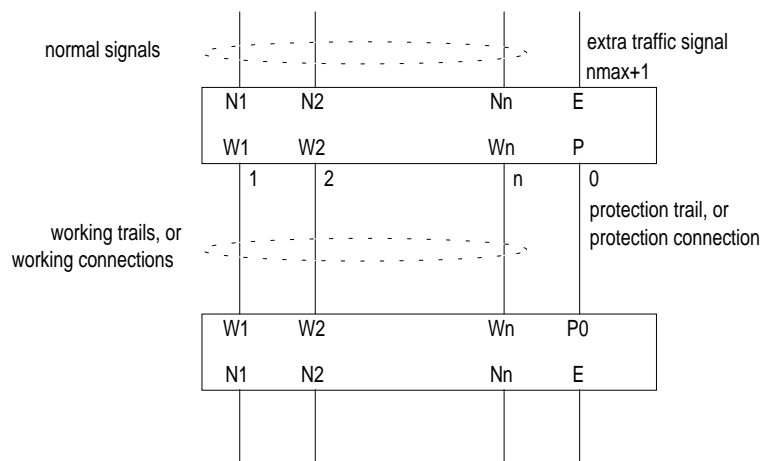

Figure A.2: Definitions of working trail / connection, protection trail connection, normal and extra traffic signal

The normal signals shall be numbered (equivalent to the working trails / connections) "1", "2", etc. In 1:n ($n = 1, 2, 3, \dots, n_{\max}$) protection architectures normal signal #i shall be transported over working trail / connection #i or over the protection trail / connection. For the case of section layer protection, the assignment of these numbers to physical entities in a network element is equipment specific and not within the scope of the present document. For the case of path layer protection, the assignment of these numbers to physical entities in a network element shall be provisionable via configuration management.

NOTE: The value of n_{\max} is protection application dependent.

The extra traffic signal (supported in 1:n architectures only) shall be referred to as number $n_{\max} + 1$. The extra traffic signal shall be transported over the protection trail / connection when this one is not transporting a normal signal and the protection trail / connection is not "locked out".

The null signal, present in 1:n architectures only, shall be referred to as number "0". When none of the normal signals nor an extra traffic signal is transported over the protection trail / connection, the null signal shall be transported. This can be any signal (e.g. one of the normal signals, a test signal, an all-ONEs signal).

A.6 Priority of request types (conditions, external commands, states)

A request can be a local or remote:

- 1) condition (SF and SD) associated with a working or protection trail / connection. A condition has high or low priority;

NOTE 1: A condition has an associated priority (high or low) only in case of multiplex section protection. In MSP 1:n architecture, the priority associated to the protection section is fixed high (SFpriority=high, SDpriority=high) and the priorities associated to the working sections are provisionable from the EMF (SFpriority=MI_SFpriority, SDpriority=MI_SDpriority). In MSP 1+1 architecture, the priority associated to both working and protection sections is fixed high (SFpriority=high, SDpriority=high).

For interworking with equipment generating conditions with low priority instead of the (above specified) fixed high priorities, the receiving equipment will accept those conditions with associated low priority and react on those according the priority list in table A.2.

NOTE 2: VC-m SNC and trail protections have no priority associated to SF and SD conditions. In order to simplify the content of this annex, it is considered that, for these protection types, SF is equivalent to SF-H and SD to SD-H.

- 2) state (wait-to-restore, do not revert, no request, reverse request) of the protection process;
- 3) external request (lockout of protection trail / connection, forced or manual switch of normal / extra traffic signal, exercise).

The basic priorities of the requests shall be as specified by table A.4. In addition, a SF-H or SF-L condition of the protection trail / connection has priority over FSw when an APS signal is supported.

NOTE 3: Requests are selected from the table, depending on the protection switching arrangements; i.e. in any particular case, only a subset of the requests may be required.

Table A.4: Request Type (RT) priority

| Request Type with APS | Request Type without APS | Priority |
|--|--------------------------|----------|
| LO | LO | highest |
| <i>SF-H, SF-L on protection trail / connection</i> | | |
| FSw | FSw | |
| SF-H | SF-H | |
| SF-L | SF-L | |
| SD-H | SD-H | |
| SD-L | SD-L | |
| MSw | MSw | |
| WTR | WTR | |
| EXER | EXER | |
| RR | RR | |
| DNR | DNR | |
| NR | NR | |
| INV | - | lowest |

A.7 APS signal definition

A.7.1 APS signal fields

An automatic protection switch (APS) signal performs the communication function between the protection processes at the two ends of the protection span. For a linear protection application the following information will be passed:

- Request Type (RT);
- Request Signal Number (RSN);
- Local Bridged Signal Number (LBSN);
- local ARCHitecture type (ARCH) (application dependent).

RT: 4 bits indicate the type of request, as listed in table A.5.

Table A.5: Request Type mapping into APS signal

| RT | code in RT field [MSB-LSB] |
|------|-------------------------------|
| NR | 0000 |
| DNR | 0001 |
| RR | 0010 |
| EXER | 0100 |
| WTR | 0110 |
| MSw | 1000 |
| SD-L | 1010 |
| SD-H | 1011 |
| SF-L | 1100 |
| SF-H | 1101 |
| Fsw | 1110 |
| LO | 1111 |

RSN: M bits indicate the number of the signal (normal, extra, trail, connection) for which the request is issued, as shown in table A.6. The coding in the RSN field of the APS signal is binary.

NOTE: M is application dependent.

Table A.6: Request signal number

| Signal number | Refers to requesting switch action for |
|-----------------|--|
| 0 | Null signal or protection trail / connection signal depending on associated Request Type (RT): - Conditions (SF, SD) and associated priority apply to the protection trail / connection signal. - External commands (LO-#0, FSw-#0, MSw-#0) apply to the protection trail / connection. - States (NR-#0, RR-#0, WTR-#0, DNR-#0) for further study. |
| 1 to n_{\max} | Normal signal or working trail / connection signal depending on associated Request Type (RT): - Conditions (SF, SD) and associated priority apply to the corresponding working trail signals. - External commands (FSw-#i, MSw-#i, EXER-#i) apply to the corresponding normal signals. - States (NR-#i, RR-#i, WTR-#i, DNR-#i) for further study. For 1 + 1, only normal signal / working trail / connection signal 1 is applicable. |
| $n_{\max} + 1$ | Extra traffic signal: - Conditions (SF, SD) are not applicable. - External commands (FSw-#M, MSw-#M, EXER-#M) apply to the extra traffic signal. - States (NR-#M) for further study. Exists only when provisioned in a 1:n architecture. |

LBSN: M bits (M is application dependent) indicate the number of the signal (null, normal, or extra) that is bridged to the protection trail, as shown in table A.7. The coding in the LBSN field of the APS signal is binary.

Table A.7: Local bridged signal number

| Signal number | Indication of |
|--|------------------------------------|
| 0 | Null signal. |
| 1 to n_{\max} | Normal signal. (see note 1) |
| $n_{\max} + 1$ | Extra traffic signal. (see note 2) |
| NOTE 1: For 1 + 1, only normal signal 1 is applicable. | |
| NOTE 2: Exists only in a 1:n architecture. | |

ARCH: 1 bit indicates the type of the architecture as shown in table A.8:

Table A.8: architecture type

| ARCH | Architecture type |
|------|-------------------|
| 0 | 1 + 1 |
| 1 | 1:n |

A.7.2 STM-N MS-APS

The APS signal for 1 + 1 and 1:n linear STM-N MS protection consists of 13 bits organized in 4 groups as depicted in figure A.3. See ETS 300 707 [5].

| K1 | | | | | | | | K2 | | | | |
|--------------|---|---|---|-----------------------|---|---|---|-----------------------------|---|---|---|------|
| 1 | 2 | 3 | 4 | 5 | 6 | 7 | 8 | 1 | 2 | 3 | 4 | 5 |
| request type | | | | request signal number | | | | local bridged signal number | | | | arch |

Figure A.3: STM-N MS-APS definition

A.7.3 STM-N VC-APS

VC APS definition and bit allocation is for further study.

Figure A.4: VC APS definition (to be defined)

A.8 Switch performance: switching and holdoff times

For automatically initiated conditions (i.e. SF and SD), the protection switch completion time shall be less than 50 ms. Protection switch completion time excludes the detection time necessary to initiate the protection switch, and hold-off time. It includes the transmission transfer delay time when bi-directional and 1:n uni-directional switching is selected.

NOTE 1: The allocation of the maximum protection switching completion time is currently under study in ITU-T.

NOTE 2: When bi-directional and 1:n uni-directional switching is required, the transfer delay time may limit the length of the protected trail / connection. This is due to the transfer delay of protection information that is to be communicated between the two ends via the APS signals. Alternatively, the protection switch time for such a case could be defined as a value with 3 components: a fixed (basic) value, the length of the protection trail / connection, and the number of network elements and their processing level (e.g. AU only, AU and TU). This is for further study.

Hold-off times are useful to stagger protection switching activation between various transport layers or within the same transport layer. It shall be possible to provision for each protection group (see EN 300 417-1-1 [3], subclause 9.2.1) whether or not a holdoff timer is enabled. The objective is that the holdoff time should be selectable per protection group on an individual basis. As a minimum, a single holdoff time per layer shall be supported, applicable for all protection groups within that layer. The defect condition should be continuously monitored for the full duration of the hold-off time before switching occurs. The hold-off time should therefore be provisionable from 0 to 10 seconds in steps of 100 ms.

NOTE 3: The specification of the operation of a holdoff timer within the protection switch process is for further study.

The service interruption due to the switching on an external command (CLR, LO, FSw, MSw) shall be limited to the switch-over time.

A.9 Subprocesses

This subclause specifies in a more or less formal manner the operation of the subprocesses within the protection process.

NOTE 1: SDL specification for the following pseudo code is for further study.

NOTE 2: The addition of a Lockout of Working #i command is for further study.

NOTE 3: The addition of a holdoff timer is for further study.

Signal request (type & signal number) processes

This process shall transfer the input SF and SD signals from a trail / connection (either protection (#0), or working #1, .. , or working #n) into a Signal Request Type (SRT) and Signal Request Signal Number (SRSN):

- The SRSN shall be "0" (zero) for the protection trail / connection and "i" ($1 \leq i \leq n$) for working trail / connection #i.

- The SRT shall be generated based on the inputs SF, SD, SFpriority, SDpriority, as follows:

```

if (SF==true)
then   if (SFpriority==high)
       then SRT= SF-H
       else SRT=SF-L
       fi
else   if (SD==true)
       then if (SDpriority==high)
            then SRT=SD-H
            else SRT=SD-L
            fi
       else SRT= NR
       fi
fi

```

External request (type & signal number) process

This process shall transfer the external commands (EXTCMD) into an External Request Type (ERT) and External Request Signal Number (ERSN):

- The ERSN shall be "0" (zero) if no normal signal is indicated, "i" ($1 \leq i \leq n_{\max}$) for normal signal #i, and " $n_{\max}+1$ " for the extra traffic signal.
- The ERT/ERN shall be generated as follows:

```

do on external command reception
start 2,5 s Completion Timer (CTimer)
if (EXTCMD==clear)
then  ERT=NR
      ERSN=0
else  if (EXTCMD==lockout of protection)
      then  ERT=LO
            ERSN=0
      else  if (EXTCMD==forced switch-#i)
            then  ERT=FSw
                  ERSN=#i
            else  if (EXTCMD==manual switch-#i)
                  then  ERT=MSw
                        ERSN=#i
            else  if (EXTCMD==exercise-#i)
                  then  ERT=EXER
                        ERSN=#i
            fi
      fi
fi
fi
fi
wait until CTimer is expired
then  {check if FSw request is denied, then release external (FSw) request}
      if (ERT==FSw) and not [ ((GRT==FSw) or (GRT==RR)) and (GRSN==ERSN) ]
      then  ERT=NR
            ERSN=0
      fi
      {check if LO request is denied, then release external (LO) request}
      if (ERT==LO) and not [ ((GRT==LO) or (GRT==RR)) and (GRSN==ERSN) ]
      then  ERT=NR
            ERSN=0

```

```

    { check if MSw request is denied, then release external (MSw) request }
    if (ERT==MSw) and not [ ((GRT==MSw) or (GRT==RR)) and (GRSN==ERSN) ]
    then  ERT=NR
         ERSN=0
    fi
    { check if EXER request is denied, then release external (EXER) request }
    if (ERT==EXER) and not [ ((GRT==EXER) or (GRT==RR)) and (GRSN==ERSN) ]
    then  ERT=NR
         ERSN=0
    fi
  tiaw
od

```

NOTE 4: The above clearing of external requests is continuously active after expiry of 2,5 seconds timer. If the external command was acknowledged initially, but is overruled later on, the external command is dropped consequently.

Local request (type & signal number) priority process

This process shall determine the highest priority local request. It shall evaluate the status of the protection and working input signals (SRT/SRSN #0 to SRT/SRSN #n), the external command (ERT/ERSN), and protection parameters OPERtype and EXTRAtraffic by a three step priority logic:

- 1) The highest priority local request shall be determined over the set of SRT/0, SRT/1, ..., SRT/n, ERT inputs based on the descending order of request type priorities in table 91.
- 2) If there is at least one SRT that is higher than the ERT, and if two or more trails / connections (working / protection) have the same highest request type (SRT), the trail / connection with the lowest number shall take priority, unless the priority of the highest SRT is identical to the current LRT.

NOTE 5: The protection trail / connection has the highest priority due to its number (#0).

NOTE 6: When normal signal number B is already transported via the protection trail / connection, it will not be replaced by normal signal number A ($A < B$) if both working trail / connection A and working trail / connection B have the same defect condition with the same priority (i.e. $SRT/A == SRT/B$ is e.g. SF-H).

- 3) If highest priority request (SRT, ERT) detected under 1. and 2. is no-request (NR), the LRT depends on the history of the protection process, the operation type, and the presence of an extra traffic signal.

The following pseudo code describes this 3 step process:

```

if ((LRT==WTR) and (ERT==EXER))
then  { exercise command is of lower priority then wait-to-restore state }
      LRTnew=NR
      LRSNnew=0
      LRsource=signal
else
      LRTnew = ERT          { initialize process }
      LRSNnew=ERSN
      LRsource=external
fi
for i==0 to n
do  { find highest priority local request active }
   if (LRTnew < SRT/i)
   then  LRTnew=SRT/i
        LRSNnew=i
        LRsource=signal
   fi
od
if (LRTnew==NR)
then  { No-Request case }
     if (OPERtype==non-revertive)
     then  { non-revertive case }
          if (LRSN==1)
          then LRT= DNR
          { check if do not revert needs to be generated }
     fi
fi

```



```

else LRT=NR
fi
else {revertive case}
if ( ((LRT==SF) or (LRT==SD) or (LRT==WTR)) and (WTRtimer > 0) )
then {previous request was a SF or SD, or a WTR running}
    LRT=WTR
else {previous request was no-request}
    LRT=NR
    if (EXTRAtraffic==true)
    then {extra traffic supported}
        LRSN=nmax+1
    else {extra traffic not supported}
        LRSN=0
    fi
fi
fi
else {Request case}
if (LRsource==external)
then {external local request has highest priority}
    LRT=LRTnew
    LRSN=LRSNnew
else {a signal has highest local request priority}
if (LRTnew≠LRT)
then {new request not equal to existing local request}
    LRT=LRTnew
    LRSN=LRSNnew
else {new request equal to existing local request}
if (SRT/LRSN≠LRTnew)
then {existing local request source has changed request}
    LRSN=LRSNnew
fi
fi
fi
fi

```

In revertive mode of operation a wait-to-restore timer (WTRtimer) shall be supported. The wait-to-restore period (WTRtime) shall be provisionable in the order of 0 - 12 minutes, in steps of Y seconds. The timer shall be set to the provisioned value when the SF or SD defect condition is active (LRT=SF or LRT=SD). The timer shall be started when the last defect condition (SF, SD) clears; i.e. when all SRTs indicate No Request (NR). The WTR timer shall count down to zero. The WTR timer shall be reset to zero (deactivates earlier) if the Global Request Type (GRT) no longer indicates wait-to-restore, i.e. when any request of higher priority pre-empts this state.

The value of Y is for further study.

APS interpretation process

This process shall translate the accepted APS signal into the signals Remote Request Type (RRT), Remote Request Signal Number (RRSN), Remote Bridged Signal Number (RBSN) and Remote Architecture type (RARCH), as follows:

- RRT as specified in table A.9;
- RRSN = AcRSN;
- RBSN = AcLBSN;
- RARCH = AcARCH.

NOTE 7: AcRSN and AcLBSN can be out of range due to a fault or bit errors. For such case an invalid defect will be detected.

Table A.9: Remote Request Type (RRT) interpretation from APS signal

| AcRT | RRT |
|------|---------|
| 0000 | NR |
| 0001 | DNR |
| 0010 | RR |
| 0011 | invalid |
| 0100 | EXER |
| 0101 | invalid |
| 0110 | WTR |
| 0111 | invalid |
| 1000 | MSw |
| 1001 | invalid |
| 1010 | SD-L |
| 1011 | SD-H |
| 1100 | SF-L |
| 1101 | SF-H |
| 1110 | FSw |
| 1111 | LO |

Defects:

If the received APS Architecture (RARCH) value differs from the local architecture type (ARCHtype) for a period of 50 ms, a Protection Architecture Mismatch defect (dPAM) shall be detected. The defect shall be cleared when there is a match again.

If the request type bits (RT) in the APS signal indicate an invalid request code, or the RSN or LBSN indicate a non-existing trail / connection / normal signal number, an invalid command defect (dINV) shall be detected when the condition exist for 50 ms. The defect shall be cleared when the RT indicate a valid code and the RSN or LBSN indicate an existing signal number. Neither shall be considered remote requests for a locally locked out normal signal.

Global request priority process

The local request (LRT,LRSN) and the remote request (RRT,RRSN) shall be compared to decide which has priority. The priority shall be determined according to the descending order of priorities in table A.4. Note that a received reverse request shall not be considered in the comparison.

The result, Global Request Type (GRT) and Global Request Signal Number (GRSN) shall be determined as follows:

```

if ((SWtype==bi-directional) and (SRT/0≠SF) and (RRT≠RR) and
    [(RRT>LRT) or
     ((RRT==LRT) and (RRT>NR) and (GRT==RR)) or
     ((RRT==LRT) and (RRT>NR) and (GRT≠RR) and (RRSN<LRSN))])
then      {bi-directional switching, no SF on protection trail / connection, no reverse request, and either "remote
           request overrules local request" or "remote request equals local request and was already accepted" or
           "remote request equals local request and remote signal number is lower than local signal number"}
    GRT=RR
    GRSN=RRSN
else      {uni-directional switching or SF on protection trail / connection or reverse request received or local request
           overrules remote request or local and remote requests are equal and local signal number is less or equal
           remote signal number}
    GRT=LRT
    GRSN=LRSN
fi

```

NOTE 8: See clause A.4.

Defects:

If a head end response on a tail end request does not comply to the protocol (i.e. "not ((RRT==RR and RRSN==GRSN) or RRT≥LRT)") within a period of 50 ms, an acknowledge timeout defect (dTMOUT) shall be detected. The defect shall be cleared when the head-end response complies again or if the protection trail / connection is in SF condition.

Bridge control process

This process controls which of the normal / extra traffic signals is bridged to the protection trail / connection. Its operation shall be as follows:

```

if (ARCHtype==1+1)
then
    LBSN=1      {1+1 architecture}
    {normal #1 signal permanent bridged}
else
    {1:n architecture}
    if [ (SRT/0≠SF) and (not (dPAM or dSCM or dTMOUT or dINV)) ]
    then
        {no SF on protection and no failure of protocol}
        LBSN=RRSN
    else
        {SF on protection or failure of protocol}
        if (SWtype==bi-directional)
        then LBSN=0
        fi
    fi
fi

```

NOTE 9: When the protection trail / connection is not in use, null signal is indicated on both RSN and LBSN fields in the APS signal. Any normal signal may be bridged to the protection trail / connection at the head end. The tail end shall not assume or require any specific signal.

Selector control process

This process controls which of the normal / extra traffic signals is connected to / extracted from the protection trail / connection. Its operation shall be as follows:

```

if ( (ARCHtype==1+1) and (SWtype==uni-directional) )
then
    if [ (SRT/0≠SF) or (APSmode==false) ]
    then LSSN=LRSN
    else LSSN=0      {release the selector due to SF on protection when an APS channel is in use}
    fi
else
    {1+1 bi-directional switching or 1:n uni- & bi-directional switching}
    if [(GRSN==RBSN) and (SRT/0≠SF) and (not (dPAM or dSCM or dINV or dTMOUT))]
    then
        LSSN=GRSN
    else
        LSSN=0 {release the selector due to protection SF or failure of protocol}
    fi
fi

```

NOTE 10: In 1 + 1 architecture in uni-directional switching, each end operates independently of the other end, and APS signal is not needed to co-ordinate switch action. However, for the case an APS is supported it is still used to inform the other end of the local action.

NOTE 11: Selectors can be temporarily released when normal signal #i gets replaced by normal signal #j, due to temporary signal number mismatch on GRSN (RSN in transmitted APS signal) and RBSN (LBSN in received APS signal).

NOTE 12: The operation of 1 + 1 bi-directional switching is optimized for a network in which 1 : n protection switching is widely used and which is therefore based on compatibility with a 1 : n arrangement. Since the bridge is permanent, i.e. normal signal number 1 is always bridged, normal signal 1 is indicated on the LBSN field in the transmitted APS signal, unless the RSN field in the received APS signal indicates null signal (0). Switching is completed when both ends select the signal, and may take less time because LBSN indication does not depend on a bridging action.

NOTE 13: When the switch is no longer required, e.g. the failed working trail / connection has recovered from the fault and Wait-to-restore has expired, the tail end indicates No Request for Null Channel on the APS fields RT and RSN. This releases the selector due to signal number mismatch. The head end then releases the bridge and replies with the same indication on its RT and RSN fields and Null signal indication on LBSN. The selector at the head end is also released due to mismatch. Receiving Null signal on RSN causes the tail end to release the bridge. Since the LBSN fields now indicate Null Channel which matches the Null Channel on the RSN bytes, the selectors remain released without any mismatch indicated, and restoration is completed.

Defects:

If a mismatch between RBSN and GRSN persists for 50 ms, a Selector Control Mismatch defect (dSCM) shall be detected. The dSCM shall be cleared when RBSN is identical to GRSN or if the protection trail / connection is in SF condition.

Consequent Actions:

The selector shall be released if one or more of the four defects dPAM, dSCM, dTMOUT, dINV is active.

APS generation process

This process shall translate the signals Global Request Type (GRT), Global Request Signal Number (GRSN), Local Bridged Signal Number (LBSN) and local Architecture type (ARCHtype) into a transmitted APS signal, as follows:

- TxRT as specified in table A.10
- TxRSN = GRSN
- if ((RRSN==0)
 - then TxLBSN = 0
 - else TxLBSN = LBSN
- fi
- if (ARCHtype==1+1)
 - then TxARCH = 0
 - else TxARCH = 1
- fi

Table A.10: Global Request Type (GRT) mapping into APS signal

| GRT | TxRT |
|------|------|
| NR | 0000 |
| DNR | 0001 |
| RR | 0010 |
| EXER | 0100 |
| WTR | 0110 |
| MSw | 1000 |
| SD-L | 1010 |
| SD-H | 1011 |
| SF-L | 1100 |
| SF-H | 1101 |
| Fsw | 1110 |
| LO | 1111 |

Reporting

The issue of reporting is for further study. However, initial thoughts on this topic are given below:

The function reports the active external request, active local request, active remote request (if APS supported), reason of denial of an external command, and the condition (SF, SD) of the working and protection trails / connections.

The condition of the working and protection trails / connections is reported to present a complete set of information to allow unambiguous interpretation of the status of the protection entity and reaction on external commands.

MI_SignalStatus/i ← SRT/i

Defect Correlations:

cFOP ← (dSCM or dPAM or dTMOUT or dINV) and (not CI_SSF).

Performance Monitoring:

Every second the number of Protection Switch actions within that second shall be reported as pPSC (Protection Switch Count).

For the case of revertive operation, every second that the normal signal #i is not selected from the working trail / connection #i shall be reported as a pPSD/i, $i \geq 1$, (Protection Switch Duration for working trail / connection #i). Every second that a normal signal is selected from the protection trail / connection shall be reported as a pPSD/0.

Annex B (informative): STM-16 regenerator functional model (example)

Figure B.1 presents the combination of atomic functions that represent the transport part of a STM-16 regenerator network element. In this example, a DCC, orderwire and user channel are supported; the physical section atomic functions of the orderwire (E0) and user channel (E0 or V11) are not shown.

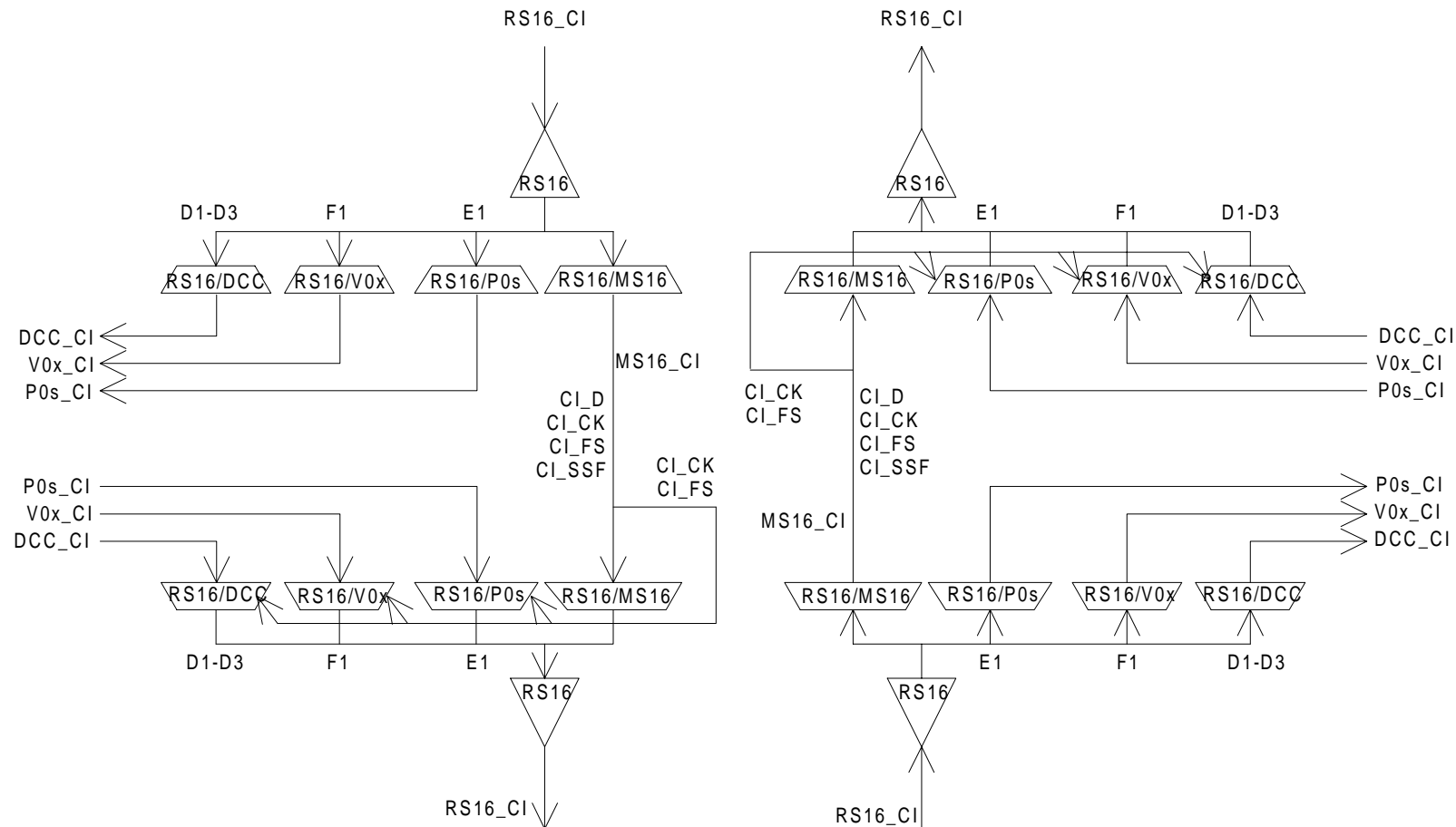

Figure B.1: STM-16 regenerator model (supporting DCC, OW, USR)

Annex C (informative): AU-4-Xc numbering scheme & pointer allocation

The following figures depict the AU-4 and AU-4-4c numbering scheme within an STM-16 signal.

The AU-4-4c will be numbered by means of the first AU-4 timeslot number that is occupied by the AU-4-4c: AU-4-4c/z, with $z = 1, 5, 9, 13$. Each AU-4-4c is bound to a quadrant within the STM-16 AU structure as indicated in the range of values of "z".

NOTE 1: Future extensions to this AU-4-4c allocation scheme (i.e. $z = 2, 3, 4, 6, 7$, etc.) are for further study.

Figures C.1 to C.3 show a small part of the STM-16 frame; figure C.1 in a parallel format (16 x 155,520 MHz) and figures C.2 and C.3 in a serial format. Each block represents a byte. A byte is identified in the figures by (x,y), with x is the "155,520 Mbit/s" number ($x = 1..16$) and y is the number of the "AU-3" byte within an AU-4 ($y = 1..3$).

NOTE 2: Transmission in parallel format is from top to bottom and from left to right.

Figure C.1 shows AU byte allocation for AU-4 and AU-4-4c. The most right column shows the capacity allocation for the case of an STM-16 MS SPRING protection ring.

NOTE 3: The working capacity (i.e. 1,2 Gbit/s) can be provisioned. For the case extra traffic is not supported, the protection capacity can not be provisioned. Protection capacity, when used to recover from a defect condition in the ring, shall automatically adapt to the AU multiplex structure that is received, as the provisioned working AU multiplex structure between any two nodes in the ring can be different, but will be transported via the same protection capacity (during a defect condition).

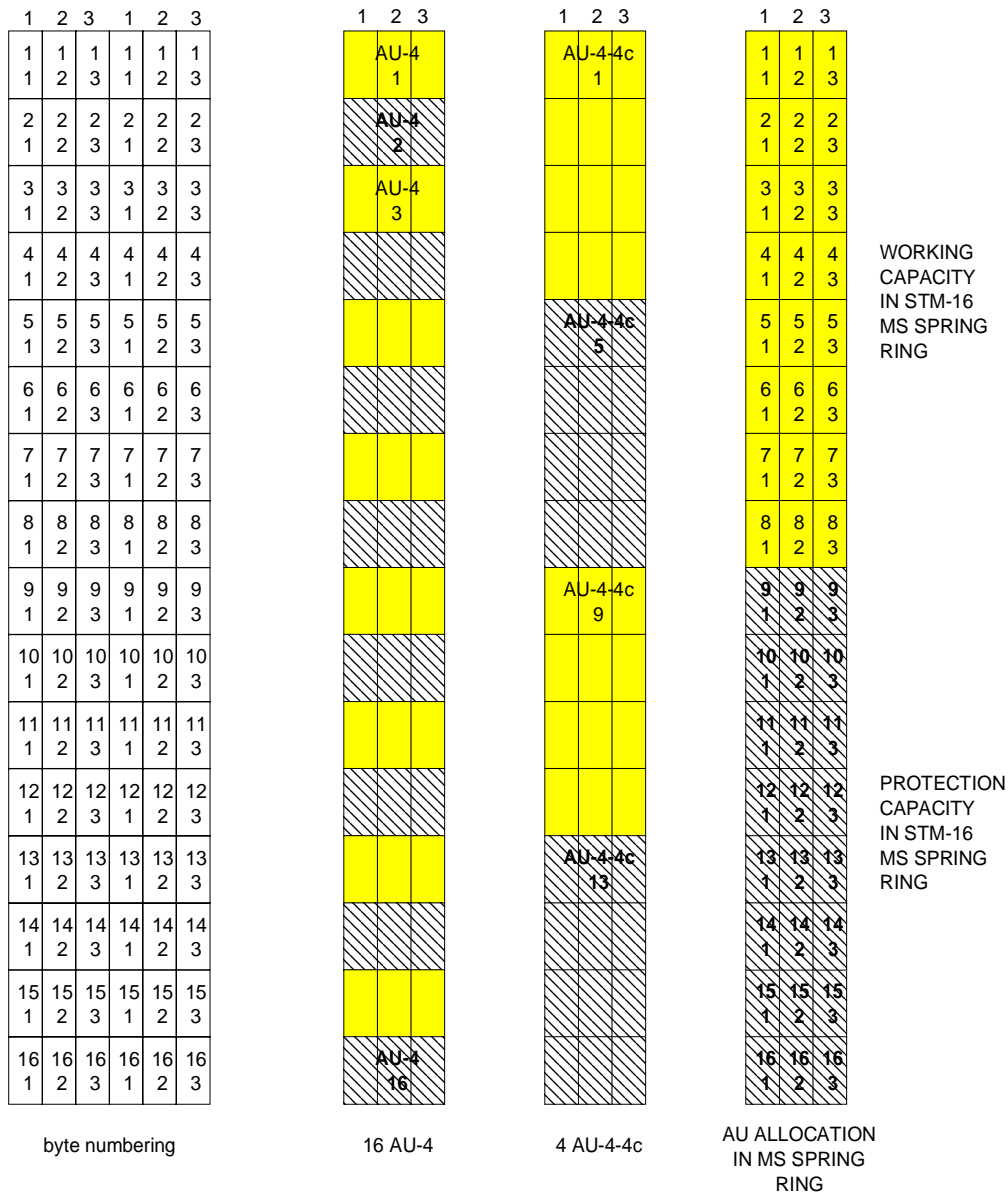

Figure C.1: AU bandwidth allocation in STM-16 and AU multiplex structures (in parallel format)

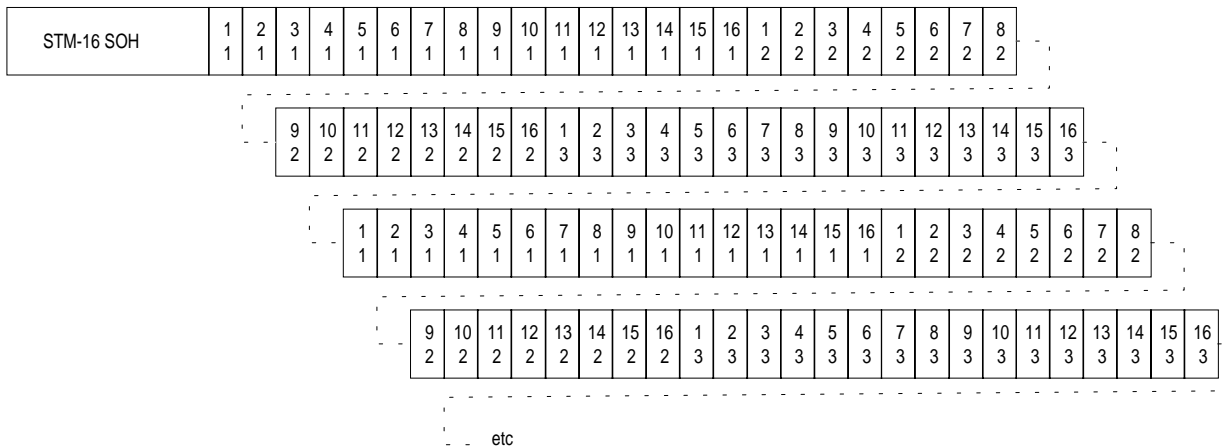

Figure C.2: AU bandwidth allocation in STM-16 (in serial format)

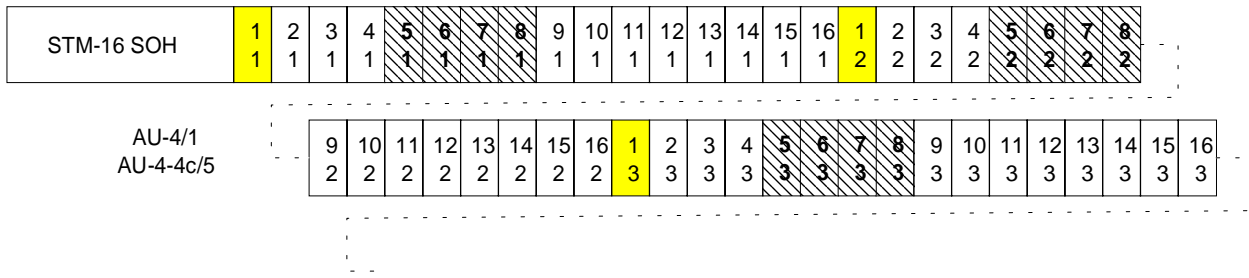

Figure C.3: Example of AU multiplex structure with an AU-4/1 and an AU-4-4c/5 (in serial format)

Figures C.4 and C.5 show the pointers, justification opportunity bytes (H3), and some payload bytes (P) of one AU-4 and one AU-4-4c.

STM-16 - ROW 4

| | 1 | 2 | 3 | 1 | 2 | 3 | 1 | 2 | 3 | 1 | 2 | 3 |
|-----------|----|----|----|----|----|----|----|----|----|----|----|----|
| AU-4/1 | H1 | Y | Y | H2 | 1* | 1* | H3 | H3 | H3 | P | P | P |
| | 2 | 2 | 2 | 2 | 2 | 2 | 2 | 2 | 2 | 2 | 2 | 2 |
| | 1 | 2 | 3 | 1 | 2 | 3 | 1 | 2 | 3 | 1 | 2 | 3 |
| | 3 | 3 | 3 | 3 | 3 | 3 | 3 | 3 | 3 | 3 | 3 | 3 |
| | 1 | 2 | 3 | 1 | 2 | 3 | 1 | 2 | 3 | 1 | 2 | 3 |
| | 4 | 4 | 4 | 4 | 4 | 4 | 4 | 4 | 4 | 4 | 4 | 4 |
| | 1 | 2 | 3 | 1 | 2 | 3 | 1 | 2 | 3 | 1 | 2 | 3 |
| | H1 | Y | Y | H2 | 1* | 1* | H3 | H3 | H3 | P | P | P |
| | Y | Y | Y | 1* | 1* | 1* | H3 | H3 | H3 | P | P | P |
| AU-4-4c/5 | Y | Y | Y | 1* | 1* | 1* | H3 | H3 | H3 | P | P | P |
| | Y | Y | Y | 1* | 1* | 1* | H3 | H3 | H3 | P | P | P |
| | 9 | 9 | 9 | 9 | 9 | 9 | 9 | 9 | 9 | 9 | 9 | 9 |
| | 1 | 2 | 3 | 1 | 2 | 3 | 1 | 2 | 3 | 1 | 2 | 3 |
| | 10 | 10 | 10 | 10 | 10 | 10 | 10 | 10 | 10 | 10 | 10 | 10 |
| | 1 | 2 | 3 | 1 | 2 | 3 | 1 | 2 | 3 | 1 | 2 | 3 |
| | 11 | 11 | 11 | 11 | 11 | 11 | 11 | 11 | 11 | 11 | 11 | 11 |
| | 1 | 2 | 3 | 1 | 2 | 3 | 1 | 2 | 3 | 1 | 2 | 3 |
| | 12 | 12 | 12 | 12 | 12 | 12 | 12 | 12 | 12 | 12 | 12 | 12 |
| | 1 | 2 | 3 | 1 | 2 | 3 | 1 | 2 | 3 | 1 | 2 | 3 |
| | 13 | 13 | 13 | 13 | 13 | 13 | 13 | 13 | 13 | 13 | 13 | 13 |
| | 1 | 2 | 3 | 1 | 2 | 3 | 1 | 2 | 3 | 1 | 2 | 3 |
| | 14 | 14 | 14 | 14 | 14 | 14 | 14 | 14 | 14 | 14 | 14 | 14 |
| | 1 | 2 | 3 | 1 | 2 | 3 | 1 | 2 | 3 | 1 | 2 | 3 |
| | 15 | 15 | 15 | 15 | 15 | 15 | 15 | 15 | 15 | 15 | 15 | 15 |
| | 1 | 2 | 3 | 1 | 2 | 3 | 1 | 2 | 3 | 1 | 2 | 3 |
| | 16 | 16 | 16 | 16 | 16 | 16 | 16 | 16 | 16 | 16 | 16 | 16 |
| | 1 | 2 | 3 | 1 | 2 | 3 | 1 | 2 | 3 | 1 | 2 | 3 |

Figure C.4: Example of AU multiplex structure with an AU-4 and an two AU-4-4c (in parallel format)

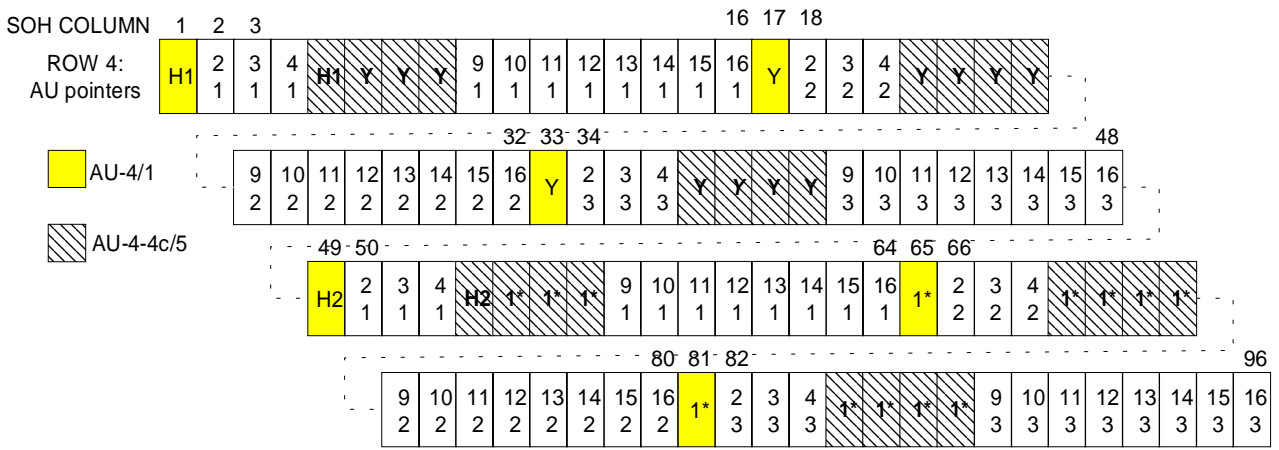
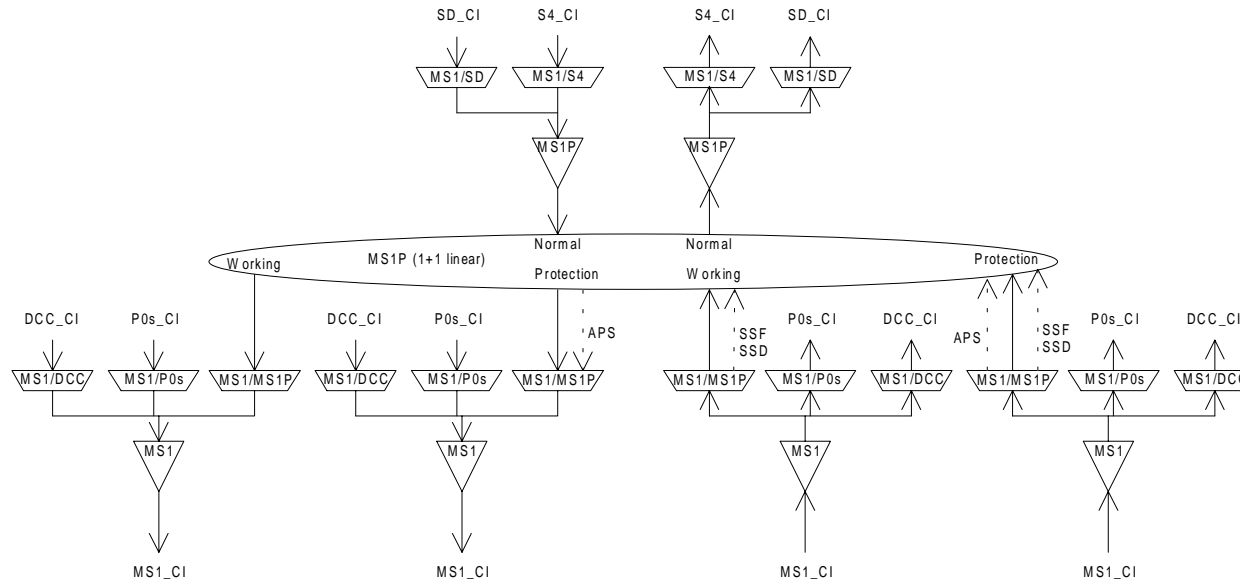

Figure C.5: AU pointers in STM-16 supporting AU examples in figure C.4 (in serial format)

Annex D (informative): MS protection examples



**Figure D.1: 1+1 STM-1 Multiplex Section Linear Trail Protection model
(unprotected DCC, OW, protected SSM)**

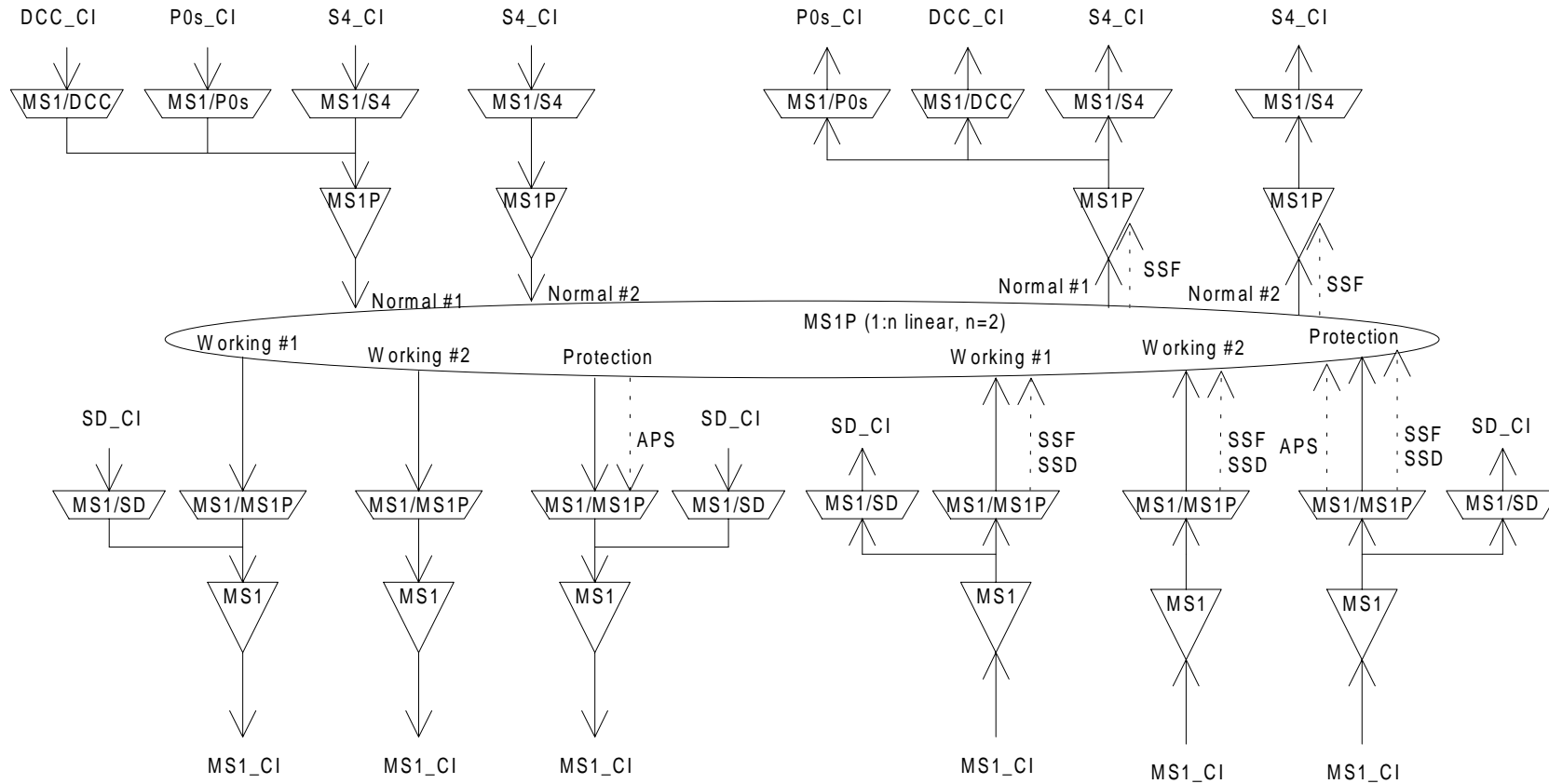

Figure D.2: 1:n STM-1 Multiplex Section Linear Trail Protection model (Working / Normal #1 supports (protected) OW,DCC and (unprotected) SSM: Working /Normal #2 does not support OW,DCC,SSM)

Bibliography

- TS 101 009 (V.1.1): "Transmission and Multiplexing (TM); Synchronous Digital Hierarchy (SDH); Network protection schemes; Types and characteristics".
- ITU-T Recommendation G.707 (1996): "Network Node Interface for the Synchronous digital hierarchy (SDH)".

History

| Document history | | |
|-------------------------|---------------|---|
| Edition 1 | June 1997 | Publication as ETS 300 417-3-1 |
| V1.1.2 | November 1998 | Publication (Converted to EN 300 417-3-1) |
| | | |
| | | |
| | | |