

# ETSI EN 300 401 V2.2.1 (2026-06)



EUROPEAN STANDARD

**Radio Broadcasting Systems;  
Digital Audio Broadcasting (DAB) to mobile,  
portable and fixed receivers**



---

**Reference**

REN/JTC-DAB-114

---

**Keywords**

audio, broadcasting, DAB, data, digital, terrestrial

**ETSI**

650 Route des Lucioles  
F-06921 Sophia Antipolis Cedex - FRANCE

---

Tel.: +33 4 92 94 42 00 Fax: +33 4 93 65 47 16

Siret N° 348 623 562 00017 - APE 7112B  
Association à but non lucratif enregistrée à la  
Sous-Préfecture de Grasse (06) N° w061004871

---

**Important notice**

The present document can be downloaded from the  
[ETSI Search & Browse Standards](#) application.

The present document may be made available in electronic versions and/or in print. The content of any electronic and/or print versions of the present document shall not be modified without the prior written authorization of ETSI. In case of any existing or perceived difference in contents between such versions and/or in print, the prevailing version of an ETSI deliverable is the one made publicly available in PDF format on [ETSI deliver](#) repository.

Users should be aware that the present document may be revised or have its status changed, this information is available in the [Milestones listing](#).

If you find errors in the present document, please send your comments to the relevant service listed under [Committee Support Staff](#).

If you find a security vulnerability in the present document, please report it through our [Coordinated Vulnerability Disclosure \(CVD\)](#) program.

---

**Notice of disclaimer & limitation of liability**

The information provided in the present deliverable is directed solely to professionals who have the appropriate degree of experience to understand and interpret its content in accordance with generally accepted engineering or other professional standard and applicable regulations.

No recommendation as to products and services or vendors is made or should be implied.  
In no event shall ETSI be held liable for loss of profits or any other incidental or consequential damages.

Any software contained in this deliverable is provided "AS IS" with no warranties, express or implied, including but not limited to, the warranties of merchantability, fitness for a particular purpose and non-infringement of intellectual property rights and ETSI shall not be held liable in any event for any damages whatsoever (including, without limitation, damages for loss of profits, business interruption, loss of information, or any other pecuniary loss) arising out of or related to the use of or inability to use the software.

---

**Copyright Notification**

No part may be reproduced or utilized in any form or by any means, electronic or mechanical, including photocopying and microfilm except as authorized by written permission of ETSI.

The content of the PDF version shall not be modified without the written authorization of ETSI.

The copyright and the foregoing restriction extend to reproduction in all media.

© ETSI 2026.  
© European Broadcasting Union 2026.  
All rights reserved.

# Contents

Intellectual Property Rights .....	7
Foreword.....	7
Modal verbs terminology.....	8
1 Scope .....	9
2 References .....	9
2.1 Normative references .....	9
2.2 Informative references.....	10
3 Definition of terms, symbols, abbreviations and conventions.....	10
3.1 Terms.....	10
3.2 Symbols.....	13
3.2.0 General.....	13
3.2.1 Arithmetic operators .....	13
3.2.2 Logical and set operators .....	13
3.2.3 Functions .....	13
3.2.4 Constants .....	13
3.3 Abbreviations .....	13
3.4 Conventions.....	15
4 Basic DAB system description.....	15
4.0 General .....	15
4.1 Transport mechanisms.....	17
4.2 Multiplex Configuration Information (MCI).....	19
4.3 Audio coding.....	19
4.4 Service Information (SI).....	19
4.5 Conditional Access (CA).....	19
4.6 Energy dispersal .....	19
4.7 Convolutional coding .....	19
4.8 Time interleaving .....	20
4.9 Common Interleaved Frame (CIF).....	20
4.10 DAB transmission signal.....	20
4.11 Radio frequency parameters .....	20
5 Transport mechanisms.....	20
5.1 Introduction .....	20
5.2 Fast Information Channel (FIC) .....	22
5.2.1 Fast Information Block (FIB) .....	22
5.2.2 Fast Information Group (FIG) .....	23
5.2.2.0 Introduction.....	23
5.2.2.1 MCI and SI: FIG type 0 data field.....	24
5.2.2.2 Labels: FIG type 1 data field.....	25
5.2.2.3 Extended labels: FIG type 2 data field .....	26
5.2.2.3.1 FIG type 2.....	26
5.2.2.3.2 Structure of the extended label data field .....	27
5.2.2.3.3 Segmentation .....	28
5.2.2.3.4 Receiver considerations.....	28
5.2.2.4 CA: FIG type 6 data field.....	28
5.2.2.5 Summary of available FIGs.....	29
5.3 Main Service Channel (MSC) .....	30
5.3.0 General.....	30
5.3.1 Stream mode .....	30
5.3.2 Packet mode - network level.....	30
5.3.2.0 Introduction.....	30
5.3.2.1 Packet header .....	31
5.3.2.2 Packet data field .....	31
5.3.2.3 Packet CRC .....	32
5.3.3 Packet mode - data group level.....	32

5.3.3.0	Introduction .....	32
5.3.3.1	MSC data group header .....	33
5.3.3.2	Session header .....	33
5.3.3.3	MSC data group data field .....	34
5.3.3.4	MSC data group CRC .....	34
5.3.4	Interrelation of network and transport level in packet mode .....	34
5.3.5	FEC for MSC packet mode .....	35
5.3.5.0	Introduction .....	35
5.3.5.1	FEC frame .....	36
5.3.5.2	Transport of RS data .....	36
5.3.5.3	Receiver considerations .....	38
6	<b>Multiplex Configuration Information (MCI)</b> .....	38
6.1	Introduction .....	38
6.2	Sub-channel organization .....	40
6.2.0	General .....	40
6.2.1	Basic sub-channel organization .....	40
6.2.2	FEC sub-channel organization .....	44
6.3	Service organization .....	44
6.3.0	General .....	44
6.3.1	Basic service and service component definition .....	45
6.3.2	Service component in packet mode with or without Conditional Access .....	46
6.3.3	Service component with Conditional Access in stream mode .....	47
6.3.4	Void .....	48
6.3.5	Service component global definition .....	48
6.3.6	User application information .....	49
6.3.7	Locating service components .....	51
6.3.7.1	Service component identification .....	51
6.3.7.2	Stream audio service components .....	51
6.3.7.3	Stream data service components .....	51
6.3.7.4	Packet data service components .....	52
6.4	Ensemble and configuration information .....	52
6.4.1	Ensemble information .....	52
6.4.2	Configuration information .....	53
6.5	Multiplex reconfiguration .....	54
7	<b>Audio coding</b> .....	54
7.1	Introduction .....	54
7.2	Void .....	55
7.3	Void .....	55
7.4	Programme Associated Data (PAD) .....	55
7.4.0	Introduction .....	55
7.4.1	Coding of F-PAD .....	55
7.4.2	Structure of X-PAD .....	57
7.4.2.0	General .....	57
7.4.2.1	Short X-PAD .....	58
7.4.2.2	Variable size X-PAD .....	58
7.4.3	Application types .....	59
7.4.4	Contents indicator .....	60
7.4.4.1	Contents indicator in short X-PAD .....	60
7.4.4.2	Contents indicator in variable size X-PAD .....	60
7.4.5	Applications in X-PAD .....	61
7.4.5.0	Introduction .....	61
7.4.5.1	MSC data groups in X-PAD .....	61
7.4.5.1.0	Introduction .....	61
7.4.5.1.1	X-PAD data group for data group length indicator .....	61
7.4.5.1.2	X-PAD data group for MSC data group .....	62
7.4.5.1.3	Transport of MSC data groups in short X-PAD .....	62
7.4.5.1.4	Transport of MSC data groups in variable-sized X-PAD .....	62
7.4.5.2	Dynamic label .....	62
8	<b>Service Information</b> .....	65
8.1	Service Information (SI) .....	65

8.1.1	Introduction.....	65
8.1.2	Service component language .....	67
8.1.3	Time and country identifier .....	68
8.1.3.1	Date and time (d&t) .....	68
8.1.3.2	Country, LTO and International table .....	69
8.1.4	Service Component Information.....	70
8.1.5	Programme Type .....	72
8.1.6	Announcements .....	73
8.1.6.0	General .....	73
8.1.6.1	Announcement support .....	73
8.1.6.2	Announcement switching.....	74
8.1.6.3	OE Announcement support.....	75
8.1.6.4	OE Announcement switching.....	76
8.1.7	EWS information .....	77
8.1.8	Frequency Information .....	80
8.1.9	Void.....	84
8.1.10	OE Services .....	84
8.1.11	Void.....	85
8.1.12	Void.....	85
8.1.13	Ensemble label.....	85
8.1.14	Service label.....	85
8.1.14.1	Programme service label .....	85
8.1.14.2	Data service label .....	86
8.1.14.3	Service component label .....	86
8.1.14.4	X-PAD user application label .....	87
8.1.15	Service linking information .....	87
9	Conditional Access (CA).....	90
10	Energy dispersal .....	90
10.1	General procedure .....	90
10.2	Energy dispersal as applied in the Fast Information Channel .....	90
10.3	Energy dispersal as applied in the Main Service Channel.....	91
11	Convolutional coding .....	91
11.0	Introduction .....	91
11.1	Convolutional code.....	91
11.1.1	Mother code .....	91
11.1.2	Puncturing procedure.....	92
11.2	Coding in the Fast Information Channel .....	94
11.2.1	Transmission mode I.....	94
11.3	Coding in the Main Service Channel.....	94
11.3.0	Introduction.....	94
11.3.1	Unequal Error Protection (UEP) coding .....	94
11.3.2	Equal Error Protection (EEP) coding.....	97
11.3.3	Future error protection coding .....	98
12	Time interleaving .....	99
13	Common Interleaved Frame .....	105
14	DAB transmission signal.....	105
14.1	General principles.....	105
14.2	Structure of the main signal.....	106
14.3	Synchronization channel .....	109
14.3.0	Introduction.....	109
14.3.1	Null symbol .....	109
14.3.2	Phase reference symbol .....	109
14.3.3	Time reference .....	110
14.4	Block partitioning and association of blocks to OFDM symbols .....	110
14.4.0	Introduction.....	110
14.4.1	Block partitioning and association of blocks to OFDM symbols in the Fast Information Channel.....	111
14.4.1.1	Transmission mode I.....	111
14.4.2	Block partitioning and association of blocks to OFDM symbols in the Main Service Channel .....	112

14.4.2.1	Transmission mode I .....	112
14.5	QPSK symbol mapper .....	113
14.6	Frequency interleaving .....	113
14.6.0	Introduction.....	113
14.6.1	Transmission mode I.....	114
14.7	Differential modulation .....	114
14.8	Transmitter Identification Information signal .....	115
14.8.0	Introduction.....	115
14.8.1	Transmission mode I.....	116
15	Radio frequency characteristics.....	118
15.1	Use of the transmission mode.....	118
15.2	Time characteristics.....	118
15.3	Spectrum characteristics .....	119
15.4	Spectrum mask .....	120
15.5	Permitted values of the central frequency .....	120
<b>Annex A (normative): DAB location coding .....</b>		<b>121</b>
A.1	Introduction .....	121
A.2	Coordinates.....	121
A.3	Division into zones.....	121
A.4	Division of the banded zones .....	123
A.5	Division of the polar zones.....	124
<b>Annex B:</b>	<b>Void .....</b>	<b>127</b>
<b>Annex C:</b>	<b>Void .....</b>	<b>128</b>
<b>Annex D (informative):</b>	<b>Multiplex reconfiguration .....</b>	<b>129</b>
<b>Annex E (normative):</b>	<b>Calculation of the CRC word .....</b>	<b>131</b>
History .....		132

---

# Intellectual Property Rights

## Essential patents

IPRs essential or potentially essential to normative deliverables may have been declared to ETSI. The declarations pertaining to these essential IPRs, if any, are publicly available for **ETSI members and non-members**, and can be found in ETSI SR 000 314: "*Intellectual Property Rights (IPRs); Essential, or potentially Essential, IPRs notified to ETSI in respect of ETSI standards*", which is available from the ETSI Secretariat. Latest updates are available on the [ETSI IPR online database](#).

Pursuant to the ETSI Directives including the ETSI IPR Policy, no investigation regarding the essentiality of IPRs, including IPR searches, has been carried out by ETSI. No guarantee can be given as to the existence of other IPRs not referenced in ETSI SR 000 314 (or the updates on the ETSI Web server) which are, or may be, or may become, essential to the present document.

## Trademarks

The present document may include trademarks and/or tradenames which are asserted and/or registered by their owners. ETSI claims no ownership of these except for any which are indicated as being the property of ETSI, and conveys no right to use or reproduce any trademark and/or tradename. Mention of those trademarks in the present document does not constitute an endorsement by ETSI of products, services or organizations associated with those trademarks.

**DECT™**, **PLUGTESTS™**, **UMTS™** and the ETSI logo are trademarks of ETSI registered for the benefit of its Members. **3GPP™**, **LTE™** and **5G™** logo are trademarks of ETSI registered for the benefit of its Members and of the 3GPP Organizational Partners. **oneM2M™** logo is a trademark of ETSI registered for the benefit of its Members and of the oneM2M Partners. **GSM®** and the GSM logo are trademarks registered and owned by the GSM Association.

---

# Foreword

This European Standard (EN) has been produced by Joint Technical Committee (JTC) Broadcast of the European Broadcasting Union (EBU), Comité Européen de Normalisation ELECTrotechnique (CENELEC) and the European Telecommunications Standards Institute (ETSI).

NOTE 1: The EBU/ETSI JTC Broadcast was established in 1990 to co-ordinate the drafting of standards in the specific field of broadcasting and related fields. Since 1995 the JTC Broadcast became a tripartite body by including in the Memorandum of Understanding also CENELEC, which is responsible for the standardization of radio and television receivers. The EBU is a professional association of broadcasting organizations whose work includes the co-ordination of its members' activities in the technical, legal, programme-making and programme-exchange domains. The EBU has active members in about 60 countries in the European broadcasting area; its headquarters is in Geneva.

European Broadcasting Union  
CH-1218 GRAND SACONNEX (Geneva)  
Switzerland  
Tel: +41 22 717 21 11  
Fax: +41 22 717 24 81

The Eureka Project 147 was established in 1987, with funding from the European Commission, to develop a system for the broadcasting of audio and data to fixed, portable or mobile receivers. Their work resulted in the publication of European Standard, ETSI ETS 300 401 [i.1], for DAB® (see note) which now has worldwide acceptance.

NOTE 2: DAB® is a registered trademark owned by one of the Eureka Project 147 partners.

The DAB® family of standards is supported by World DAB®, an organization with members drawn from broadcasting organizations and telecommunication providers together with companies from the professional and consumer electronics industry.

With respect to the previous version of ETSI EN 300 401 [i.2] published in January 2017, the present document contains several refinements to the DAB system. These refinements were performed and agreed by the WorldDAB Forum and include the following areas:

- inclusion of new and revised FIGs;
- provision of signalling for indication of services with public prominence;
- addition of the DAB location coding system.

### National transposition dates

Date of adoption of this EN:	28 May 2026
Date of latest announcement of this EN (doa):	31 August 2026
Date of latest publication of new National Standard or endorsement of this EN (dop/e):	28 February 2027
Date of withdrawal of any conflicting National Standard (dow):	28 February 2027

---

## Modal verbs terminology

In the present document "**shall**", "**shall not**", "**should**", "**should not**", "**may**", "**need not**", "**will**", "**will not**", "**can**" and "**cannot**" are to be interpreted as described in clause 3.2 of the [ETSI Drafting Rules](#) (Verbal forms for the expression of provisions).

"**must**" and "**must not**" are **NOT** allowed in ETSI deliverables except when used in direct citation.

---

# 1 Scope

The present document establishes a broadcasting standard for the Digital Audio Broadcasting (DAB) system designed for delivery of high-quality digital audio and video programmes and data services for mobile, portable and fixed reception from terrestrial transmitters in the Very High Frequency (VHF) frequency bands as well as for distribution through cable networks. The DAB system is designed to provide spectrum and power efficient techniques in terrestrial transmitter network planning, known as the Single Frequency Network (SFN) and the gap-filling technique. The DAB system meets the required sharing criteria with other radiocommunication services.

The present document defines the DAB transmission signal. It includes the coding algorithms for multiplexing of audio and video programmes and data services, channel coding and modulation. Provision is also made for transmission of additional data services which may be programme related or not, within the limit of the total system capacity. The present document provides information on the system configuration which includes information about the ensembles, services, service components and linking of them.

The present document describes the nominal characteristics of the emitted DAB signal. The aspects related to the receiver design are outside the scope of the present document.

---

## 2 References

### 2.1 Normative references

References are either specific (identified by date of publication and/or edition number or version number) or non-specific. For specific references, only the cited version applies. For non-specific references, the latest version of the referenced document (including any amendments) applies.

Referenced documents which are not found to be publicly available in the expected location might be found in the [ETSI docbox](#).

NOTE: While any hyperlinks included in this clause were valid at the time of publication, ETSI cannot guarantee their long-term validity.

The following referenced documents are necessary for the application of the present document.

- [1] [ETSI TS 103 466](#): "Digital Audio Broadcasting (DAB); DAB audio coding (MPEG Layer II)".
- [2] [ETSI TS 102 563](#): "Digital Audio Broadcasting (DAB); Transport of Advanced Audio Coding (AAC) audio".
- [3] [ETSI TS 101 756](#): "Digital Audio Broadcasting (DAB); Registered Tables".
- [4] [ETSI TS 102 367](#): "Digital Audio Broadcasting (DAB); Conditional access".
- [5] [ETSI TS 103 176](#): "Digital Audio Broadcasting (DAB); Rules of implementation; Service information features".
- [6] [ETSI EN 301 234](#): "Digital Audio Broadcasting (DAB); Multimedia Object Transfer (MOT) protocol".
- [7] [ETSI TS 102 980](#): "Digital Audio Broadcasting (DAB); Dynamic Label Plus (DL Plus); Application specification".
- [8] [ETSI ES 201 980](#): "Digital Radio Mondiale (DRM); System Specification".
- [9] [ETSI TS 102 386](#): "Digital Radio Mondiale (DRM); AM signalling system (AMSS)".
- [10] [IEC 62106](#): "Radio data system (RDS) - VHF/FM sound broadcasting in the frequency range from 64,0 MHz to 108,0 MHz".

- [11] [Recommendation ITU-T X.25](#): "Interface between Data Terminal Equipment (DTE) and Data Circuit-terminating Equipment (DCE) for terminals operating in the packet mode and connected to public data networks by dedicated circuit".
- [12] [ETSI TS 104 089](#): "Digital Audio Broadcasting (DAB); Emergency Warning System (EWS); Definition and rules of behaviour".

## 2.2 Informative references

References are either specific (identified by date of publication and/or edition number or version number) or non-specific. For specific references, only the cited version applies. For non-specific references, the latest version of the referenced document (including any amendments) applies.

NOTE: While any hyperlinks included in this clause were valid at the time of publication, ETSI cannot guarantee their long-term validity.

The following referenced documents may be useful in implementing an ETSI deliverable or add to the reader's understanding, but are not required for conformance to the present document.

- [i.1] ETSI ETS 300 401 (edition 1) (1995): "Radio Broadcasting Systems; Digital Audio Broadcasting (DAB) to mobile, portable and fixed receivers".
- [i.2] ETSI EN 300 401 (V2.1.1) (2017): "Radio Broadcasting Systems; Digital Audio Broadcasting (DAB) to mobile, portable and fixed receivers".

---

## 3 Definition of terms, symbols, abbreviations and conventions

### 3.1 Terms

For the purposes of the present document, the following terms apply:

**Access Control System (ACS):** particular set of rules for managing entitlement checking and conditional access messages

**announcement cluster:** group of services which share the same announcement interruption privileges

**Capacity Unit (CU):** smallest addressable unit (64 bits) of the Common Interleaved Frame (CIF)

**Change Event Indication (CEI):** set of FIG fields with particular values to indicate a change of database content for certain service information features

**Common Interleaved Frame (CIF):** serial digital output from the main service multiplexer which is contained in the Main Service Channel part of the transmission frame

**Conditional Access (CA):** mechanism by which the user access to service components can be restricted

**convolutional coding:** coding procedure which generates redundancy in the transmitted data stream in order to provide ruggedness against transmission distortions

**DAB transmission signal:** transmitted radio frequency signal

**database key:** set of FIG fields that sub-divide a database for certain service information features

**data service:** service which comprises a non-audio primary service component and optionally additional secondary service components

**energy dispersal:** operation involving deterministic selective complementing of bits in the logical frame, intended to reduce the possibility that systematic patterns result in unwanted regularity in the transmitted signal

**ensemble:** transmitted signal, comprising a set of regularly and closely-spaced orthogonal carriers

NOTE: The ensemble is the entity which is received and processed. In general, it contains programme and data services.

**Ensemble Identifier (EId):** unique 16-bit code, allocated to an ensemble and intended to allow unambiguous world-wide identification of that ensemble

**Equal Error Protection (EEP):** error protection procedure which ensures a constant protection of the bit stream

**Extended Programme Associated Data (X-PAD):** extended part of the PAD carried towards the end of the DAB audio frame, immediately before the Scale Factor Cyclic Redundancy Check (CRC)

NOTE: Its length is variable.

**Fast Information Block (FIB):** data burst of 256 bits

**Fast Information Channel (FIC):** part of the transmission frame, comprising the Fast Information Blocks, which contains the multiplex configuration information together with optional service Information and data service components

**Fast Information Group (FIG):** package of data used for one feature in the Fast Information Channel. Eight different types are available to provide a classification of the features

**Fixed Programme Associated Data (F-PAD):** fixed part of the PAD contained in the last two bytes of the DAB audio frame

**logical frame:** data burst, contributing to the contents of a sub-channel, during a time interval of 24 ms

EXAMPLE: Data bursts at the output of an audio encoder, a Conditional Access scrambler and a convolutional encoder are referred to as logical frames. The number of bits contained in a specific logical frame depends on the stage in the encoding process and the bit rate associated with the sub-channel.

**logical frame count:** value of the CIF counter corresponding to the first CIF which carries data from the logical frame

**Main Service Channel (MSC):** channel which occupies the major part of the transmission frame and which carries all the digital audio service components, together with possible supporting and additional data service components

**MSC data group:** package of data used for one user application in the Main Service Channel

NOTE: MSC data groups are transported in a series of one or more packets or X-PAD data sub-fields.

**Multiplex Configuration Information (MCI):** information defining the configuration of the multiplex

NOTE: It contains the current (and in the case of an imminent reconfiguration, the forthcoming) details about the services, service components and sub-channels and the linking between these entities. It is carried in the FIC in order that a receiver may interpret this information in advance of the service components carried in the Main Service Channel. It also includes identification of the ensemble itself.

**N:** transform length of Fast Fourier Transform (FFT)

**null symbol:** first Orthogonal Frequency Division Multiplex (OFDM) symbol of the transmission frame

**OFDM symbol:** transmitted signal for that portion of time when the modulating phase state is held constant on each of the equi-spaced, equal amplitude carriers in the ensemble

NOTE: Each carrier is four-phase differentially modulated from one symbol to another, giving a gross bit rate of two bits per carrier per symbol.

**packet mode:** mode of data transmission in which data are carried in addressable blocks called packets

NOTE: Packets are used to convey MSC data groups within a sub-channel.

**primary service component:** first and mandatory component of a service

NOTE: It can be used as a default selection in the receiver.

**programme:** time-slice of a programme service, corresponding to an entry in a programme schedule

**Programme Associated Data (PAD):** information which is related to the audio data in terms of contents and synchronization

**programme item:** time-slice of a programme, for example, a piece of music or a news report

**programme service:** service which comprises an audio primary service component and optionally additional secondary service components

**protection level:** level specifying the degree of protection, provided by the convolutional coding, against transmission errors

**protection profile:** scheme of convolutional coding applied

**Reserved for future addition (Rfa):** bits that do not change the meaning of other parts of an information entity and so are not evaluated by receivers

NOTE: Rfa bits are always set to zero. If a new requirement is determined and specified in the future, Rfa bits may be replaced by fields with definite functions, but this will have no effect on any existing parts of the information entity.

**Reserved for future use (Rfu):** bits that change the meaning of other parts of an information entity and so are evaluated by receivers

NOTE: Rfu bits are always set to zero. If a new requirement is determined and specified in the future, Rfu bits may be replaced by fields with definite functions, and associated parts of the information entity may also change meaning.

**secondary service component:** service component that is additional to the primary service component

**service:** user-selectable output which can be either a programme service or a data service

**service component:** part of a service which carries either audio (including PAD) or data

**Service Identifier (Sid):** 16-bit or 32-bit code used to identify a particular service

**Service Information (SI):** auxiliary information about services, such as service labels and programme type codes

**service label:** alphanumeric characters associated with a particular service and intended for display in a receiver

**Single Frequency Network (SFN):** network of DAB transmitters sharing the same radio frequency to achieve a large area coverage

**stream mode:** mode of data transmission within the Main Service Channel in which data are carried transparently from source to destination

**sub-channel:** part of the Main Service Channel which is individually convolutionally encoded and comprises an integral number of Capacity Units per Common Interleaved Frame

**synchronization channel:** part of the transmission frame providing a phase reference

**transmission frame:** actual transmitted frame, conveying the Synchronization Channel, the Fast Information Channel and the Main Service Channel

**transmission mode:** specific set of transmission parameters (e.g. number of carriers, OFDM symbol duration)

**Unequal Error Protection (UEP):** error protection procedure which allows the bit error characteristics to be matched with the bit error sensitivity of the different parts of the bit stream

**User Application (UA):** data application defined in a separate standard

**X-PAD data group:** package of data used for one user application in the Extended Programme Associated Data (X-PAD)

## 3.2 Symbols

### 3.2.0 General

For the purposes of the present document, the following symbols apply.

#### 3.2.1 Arithmetic operators

$\wedge$	Power
/	Integer division with truncation of the result toward zero; for example, $7/4$ and $-7/-4$ are truncated to 1 and $-7/4$ and $7/-4$ are truncated to -1
$Q(a/b)$	$Q(a/b)$ is the quotient part of the division of a by b (a and b positive integers)
$R(a/b)$	$R(a/b)$ is the remainder of the division of a by b
$\text{mod}(a,b)$ (b positive integer)	$\text{mod}(a,b) = \begin{cases} R(a/b) & \text{if } a \text{ is a positive integer} \\ R((b-R(-a/b))/b) & \text{if } a \text{ is a negative integer} \end{cases}$
$(\text{mod } p)$	Modulo p operation

#### 3.2.2 Logical and set operators

$\max [,\dots,]$	The maximum value in the argument list
$\min [,\dots,]$	The minimum value in the argument list
$\oplus$	Exclusive or
$\cap$	Set intersection
$\cup$	Set union
$\setminus$	Set exclusion: $\{-3, -2, \dots, 3\} \setminus \{0\}$ is the set of integers $\{-3, -2, -1, 1, 2, 3\}$

#### 3.2.3 Functions

$\sin$	Sine
$\cos$	Cosine
$\exp$	Exponential
$e^{(\cdot)}$	Exponential function
$\sqrt{\quad}$	Square root
$\log_{10}$	Logarithm to base 10
$j$	Imaginary unit, $j^2 = -1$
$\text{Rect}$	$\text{Rect}(x) = \begin{cases} 1 & \text{if } 0 \leq x < 1 \\ 0 & \text{elsewhere} \end{cases}$
$\delta$	Kronecker symbol $\delta(i,j) = \begin{cases} 1 & \text{if } i = j \\ 0 & \text{if } i \neq j \end{cases}$

#### 3.2.4 Constants

$\pi$	3,14159265359...
e	2,71828182846...

## 3.3 Abbreviations

For the purposes of the present document, the following abbreviations apply:

A/D	Audio/Data
ACS	Access Control System
AM	Amplitude Modulation
AMSS	Amplitude Modulation Signalling System
AppTy	Application Type
ASCTy	Audio Service Component Type
ASu	Announcement Support flags
ASw	Announcement Switching flags

AU	Access Unit
C/N	Current/Next
CA	Conditional Access
CAId	Conditional Access Identifier
CAOrg	Conditional Access Organization
CEI	Change Event Indication
CI	Contents Indicator
CIF	Common Interleaved Frame
CRC	Cyclic Redundancy Check
CU	Capacity Unit
d&t	date and time
DAB	Digital Audio Broadcasting
DFT	Discrete Fourier Transform
DG	Data Group
DL	Dynamic Label
D-QPSK	Differential QPSK
DRC	Dynamic Range Control
DRM	Digital Radio Mondiale
DSCTy	Data Service Component Type
EBU	European Broadcasting Union
ECC	Extended Country Code
EEP	Equal Error Protection
EId	Ensemble Identifier
ETS	European Telecommunication Standard
EWS	Emergency Warning System
FEC	Forward Error Correction
FFT	Fast Fourier Transform
FI	Frequency Information
FIB	Fast Information Block
FIC	Fast Information Channel
FIG	Fast Information Group
FM	Frequency Modulation
F-PAD	Fixed Programme Associated Data
IEC	International Electrotechnical Commission
ILS	International Linkage Set indicator
LA	Linkage Actuator
LSb	Least Significant bit
LSI	Leap Second Indicator
LSN	Linkage Set Number
LTO	Local Time Offset
MainId	Main Identifier of a transmitter
MCI	Multiplex Configuration Information
MJD	Modified Julian Date
MOT	Multimedia Object Transfer
MPEG	Moving Pictures Expert Group
MSb	Most Significant bit
MSC	Main Service Channel
MUX	MULTipleXer
OE	Other Ensemble
OFDM	Orthogonal Frequency Division Multiplex
P/D	Programme/Data service flag
P/S	Primary/Secondary
PAD	Programme Associated Data
PI	Programme Identification code (RDS)
PRBS	Pseudo-Random Binary Sequence
PTy	Programme Type
QPSK	Quadrature Phase Shift Keying
R&M	Range and Modulation
RDS	Radio Data System
Rfa	Reserved for future addition
Rfu	Reserved for future use
RS	Reed-Solomon

S/D	Static/Dynamic
SC	Service Component
SCId	Service Component Identifier
SCIdS	Service Component Identifier within the Service
SFN	Single Frequency Network
SI	Service Information
SId	Service Identifier
SIV	Service Information Version
SPI	Service and Programme Information
SubChId	Sub-Channel Identifier
SubId	Sub-Identifier of a transmitter
TII	Transmitter Identification Information
TMIId	Transport Mechanism Identifier
TPEG	Transport Protocol Expert Group
TTI	Traffic and Travel Information
UA	User Application
UEP	Unequal Error Protection
UTC	Co-ordinated Universal Time
UTF	Unicode Transformation Format
VHF	Very High Frequency
X-PAD	eXtended Programme Associated Data

## 3.4 Conventions

Unless otherwise stated, the following notation, regarding the order of bits within each step of processing is used:

- in figures, the bit shown in the left hand position is considered to be first;
- in tables, the bit shown in the left hand position is considered to be first;
- in byte fields, the Most Significant bit (MSb) is considered to be first and denoted by the higher number. For example, the MSb of a single byte is denoted "b<sub>7</sub>" and the Least Significant bit (LSb) is denoted "b<sub>0</sub>";
- in vectors (mathematical expressions), the bit with the lowest index is considered to be first.

NOTE: Due to time-interleaving, this order of bits is not the true transmission order.

---

# 4 Basic DAB system description

## 4.0 General

The DAB system is a rugged, yet highly spectrum- and power-efficient sound, video and data broadcasting system. It uses industry standard audio and video encoding techniques to remove redundancy from the source signals, it then applies closely controlled redundancy to the signal to be transmitted to provide strong error protection. The transmitted information is spread in both the frequency and time domains so that the defects of channel distortions and fades can be eliminated from the recovered signal in the receiver, even when working in conditions of severe multi-path propagation, whether stationary or mobile. Efficient spectrum utilization is achieved by interleaving multiple programme signals and, additionally, by a special feature of frequency re-use, which permits broadcasting networks to be extended, virtually without limit, by operating additional transmitters carrying the same multiplexes on the same radiated frequency. The latter feature is known as the Single Frequency Network (SFN). This can also employ the gap filling technique. In this case, a gap filler transmitter receives and re-transmits the signal on the same frequency without demodulation and remodulation. This provides coverage of shadowed areas (including tunnels), which can arise within the overall coverage area provided by the main broadcast network transmitters. Nevertheless, the relatively low co-channel protection ratio of the DAB system also permits adjacent local coverage areas to be planned, on a continuously extending basis, with as few as four different frequency blocks.

The DAB system provides a signal which carries a multiplex of several digital services simultaneously. The system bandwidth is about 1,5 MHz, providing a total transport bit rate capacity of just over 2,4 Mbit/s in a complete "ensemble". Depending on the requirements of the broadcaster (transmitter coverage, reception quality), the amount of error protection provided is adjustable for each service independently, with a coding overhead ranging from about 33 % to 300 % (200 % for audio). Accordingly, the available bit rate for broadcast services ranges between about 1,7 Mbit/s and 0,6 Mbit/s. The services can contain audio, video or data, and the data may or may not be related to an audio programme. The number and bit rate of each individual service is flexible and receivers may be able to decode several service components or services simultaneously. The actual content of the flexible multiplex is described by the so-called Multiplex Configuration Information (MCI). This is transported in a specific reserved part of the multiplex known as the Fast Information Channel (FIC), because it does not suffer the inherent delay of time interleaving which is applied to the Main Service Channel (MSC). In addition, the FIC carries information on the services themselves and the links between the services.

In particular, the following principal features have been specified:

- Audio bit rates from 8 kbit/s to 384 kbit/s. This enables the multiplex to be configured to provide typically 10 to 20 audio programmes.
- Programme Associated Data (PAD), embedded in the audio bit stream, for data which is directly linked to the audio programme.
- Data services, whereby each service can be a separately defined stream or can be divided further by means of a packet structure.
- Service Information (SI) for service selection, information and control functions of the receiver.

A simplified conceptual block diagram of the DAB system is shown in figures 1 and 2; figure 1 shows a conceptual transmitter drive in which each service signal is coded individually at source level and then error protected and time interleaved. Then it is multiplexed into the Main Service Channel (MSC), with other similarly processed service signals, according to a pre-determined, but changeable, services configuration. The multiplexer output is frequency interleaved and combined with multiplex control and service information which travel in a Fast Information Channel (FIC) in order to avoid the delay of time-interleaving. Finally, very rugged synchronization symbols are added before applying Orthogonal Frequency Division Multiplexing (OFDM) and differential QPSK modulation onto a large number of carriers to form the DAB signal.

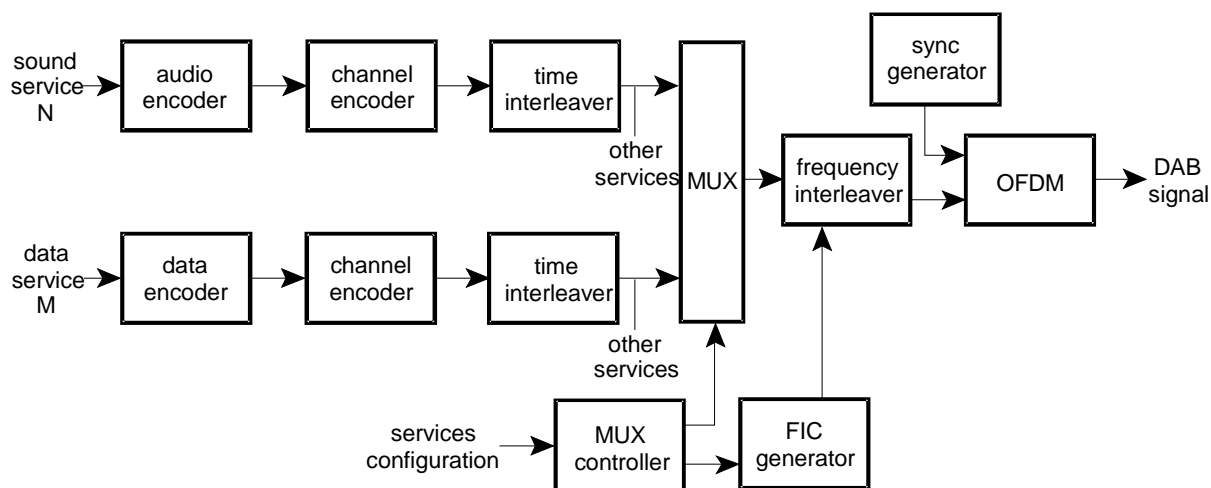

**Figure 1: Conceptual block diagram of the DAB system transmitter drive**

Figure 2 shows a conceptual receiver, in which the received signal is selected, down-converted and quadrature demodulated before applying it to an analogue-to-digital converter pair. Thereafter, the receiver performs the transmitter operations of figure 1 in reverse order, having selected the wanted DAB ensemble and acquired synchronization. Thus selection is done in the analogue tuner, which performs the tuning and filtering functions.

The digitized output of the converter is first fed to the Discrete Fourier Transform (DFT) stage and differentially demodulated. This is followed by time and frequency de-interleaving processes, and error correction to output the original coded service data. That data is further processed in an audio decoder, producing the left and right audio signals, or in a data decoder as appropriate. The decoding of more than one service component from the same ensemble, e.g. an audio programme in parallel with a data service, is practicable and provides interesting possibilities for new receiver features. The system controller is connected to the user interface and processes the user commands, in accordance with the information contained in the FIC.

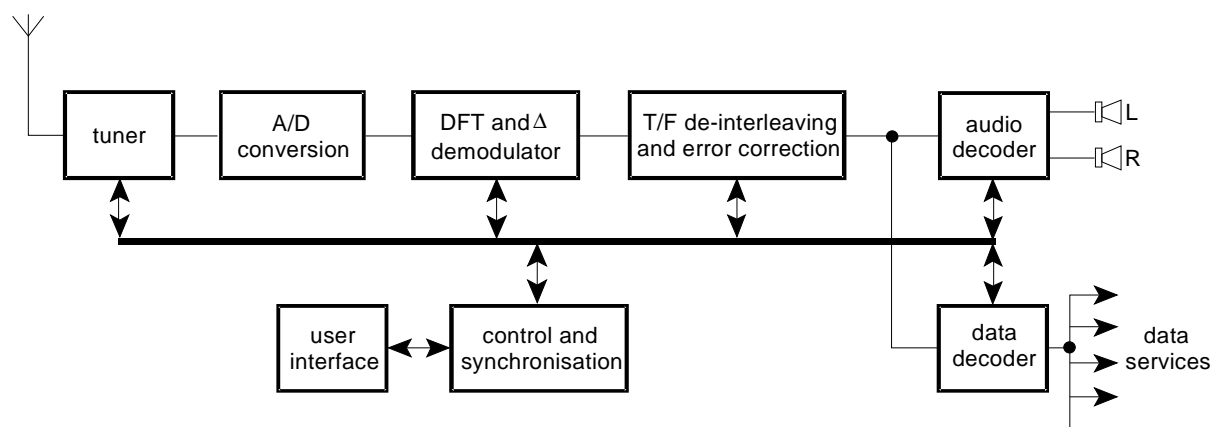

**Figure 2: Conceptual block diagram of the DAB system receiver**

The complete conceptual block diagram of the emission part of the DAB system is given in figure 3. Each block is labelled in order to indicate the function it performs.

The present document gives the description of the individual blocks in terms of their input/output transfer functions, as appropriate. The sequence of clauses in the present document generally follows the information flow in the left-to-right direction. The functions of the DAB system related to general transport mechanisms and multiplex control are given in clauses 5 and 6, respectively. Clause 7 describes a main function of the DAB system, i.e. audio coding. This is followed by the description of the available service information features, in clause 8. Clauses 10 to 15 give the description of the transmission-related functions, as shown in figure 3.

## 4.1 Transport mechanisms

General transport mechanisms used in the DAB system for transmission of digital audio programme and data services are described in clause 5.

The primary function of the FIC, which is made up of Fast Information Blocks (FIB), is to carry control information necessary to interpret the configuration of the MSC. The essential part of this control information is the Multiplex Configuration Information (MCI), which contains information on the multiplex structure and, when necessary, its reconfiguration. Other types of information which can be included in the FIC represent the Service Information (SI) and the Conditional Access (CA) management information. In order to allow a rapid and safe response to the MCI, the FIC is transmitted without time interleaving, but with a high level of protection against transmission errors.

The MSC is made up of a sequence of Common Interleaved Frames (CIF). A CIF is a data field of 55 296 bits, transmitted every 24 ms. The smallest addressable unit of the CIF is the Capacity Unit (CU), the size of which is 64 bits. Integral number of CUs are grouped together to constitute the basic transport unit of the MSC, called a sub-channel. The MSC constitutes therefore a multiplex of sub-channels.

For Service Components (SCs) in the MSC, two different transport modes are defined, the stream mode and the packet mode.

The stream mode provides a transparent transmission from source to destination at a fixed bit rate in a given sub-channel.

The packet mode is defined for the purpose of conveying several data service components into a single sub-channel. Each sub-channel may carry one or more service components.

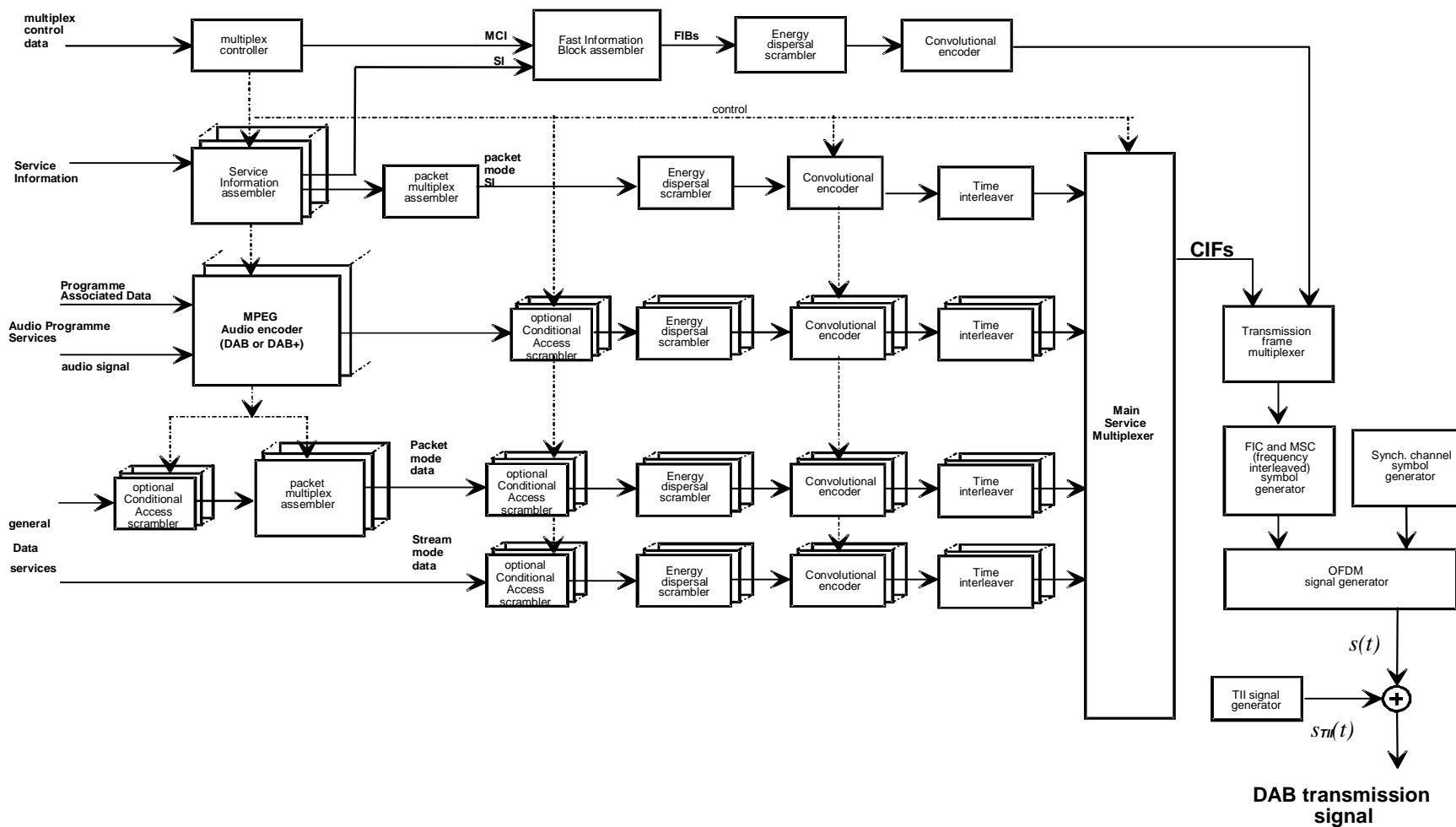

Figure 3: Conceptual DAB emission block diagram

## 4.2 Multiplex Configuration Information (MCI)

The Multiplex Configuration Information (MCI) of the system is described in clause 6.

The MCI is carried in the FIC. The MCI basically describes how the DAB multiplex is organized. Specifically, it provides the following information:

- a) defines the sub-channel organization;
- b) lists the services available in the ensemble;
- c) establishes links between services and service components;
- d) establishes links between sub-channels and service components;
- e) manages the multiplex reconfiguration.

## 4.3 Audio coding

The DAB system is primarily used to distribute radio services. The original system specified MPEG Audio Layer II, suitably formatted for DAB transmission. This audio coding has been largely superseded by HE-AACv2 audio coding. The original MPEG Audio Layer II encoding is specified in ETSI TS 103 466 [1], whereas the HE-AACv2 encoding is specified in ETSI TS 102 563 [2].

Each DAB audio frame or DAB+ audio AU contains a number of bytes which may be used to carry the Programme Associated Data (PAD), i.e. the information that is related to the audio in terms of contents and synchronization. The PAD contains two bytes of Fixed PAD (F-PAD), and an optional extension called the Extended PAD (X-PAD).

## 4.4 Service Information (SI)

In addition to the MCI, which describes the makeup of the DAB ensemble, various types of service information can be provided which provide additional system features to enhance the user experience. These features are described in clause 8. Key features include the labels which allow users to readily identify the content they want, and the date and time information which allows for the synchronization of additional elements and data services, such as SlideShow, Service and Programme Information, etc. Helper information, such as service linking, frequency information, etc., allow receivers to automatically provide alternatives to the tuned programme as the receiver moves around.

## 4.5 Conditional Access (CA)

General provisions for Conditional Access (CA) are given in ETSI TS 102 367 [4].

The purpose of CA is to permit the service and/or service components to be made incomprehensible to unauthorized users.

The MCI includes the appropriate parameters to indicate whether service components are scrambled or not, and how to find the parameters necessary for descrambling.

## 4.6 Energy dispersal

Clause 10 describes the energy dispersal of the DAB signal. The purpose is to avoid the transmission of signal patterns which might result in an unwanted regularity in the transmitted signal.

## 4.7 Convolutional coding

The process of convolutional coding is applied at the output of each energy dispersal scrambler. The convolutional coding process described in clause 11 consists of generating redundancy as part of the error protection mechanism required to combat adverse propagation conditions.

The convolutional coding parameters depend on the type of service carried, the net bit rate, and the desired level of error protection. Two error protection procedures are available: Unequal Error Protection (UEP) and Equal Error Protection (EEP). The former is primarily designed for audio but can be used for data. The latter can be used for audio as well as for data.

## 4.8 Time interleaving

The process of time interleaving described in clause 12 is applied at the output of each convolutional encoder contributing to the sub-channels in the MSC. It is not applied to the FIC.

## 4.9 Common Interleaved Frame (CIF)

Clause 13 describes how the convolutionally-encoded and time-interleaved logical frames constituting the sub-channels, are combined into a structure called the Common Interleaved Frame (CIF). A CIF consists of 55 296 bits, grouped into 864 Capacity Units (CU) and is transmitted every 24 ms. The configuration of the CIF is signalled by the Multiplex Configuration Information (MCI) carried in the FIC.

## 4.10 DAB transmission signal

The description of the DAB transmission signal in the temporal domain is given in clause 14. The transmitted signal has a frame structure of 96 ms duration (Transmission mode I). It consists of consecutive Orthogonal Frequency Division Multiplex (OFDM) symbols. The OFDM symbols are generated from the output of the multiplexer which combines the CIFs and the convolutionally encoded FIBs. Their generation involves the processes of Differential Quadrature Phase Shift Keying (D-QPSK), frequency interleaving, and D-QPSK symbols frequency multiplexing (OFDM generator).

The transmission frame consists of a sequence of three groups of OFDM symbols: synchronization channel symbols, Fast Information Channel symbols and Main Service Channel symbols. The synchronization channel symbols comprise the null symbol and the phase reference symbol.

The null symbols are also used to allow a limited number of OFDM carriers to convey the Transmitter Identification Information (TII).

## 4.11 Radio frequency parameters

Clause 15 specifies the permitted values of the central frequency of the DAB ensemble and indicates the frequency limits under which DAB transmission is designed to operate. Elements on time and spectrum characteristics of the emitted signal are also given.

---

# 5 Transport mechanisms

## 5.1 Introduction

The DAB system is designed to carry several digital audio signals together with data signals. Audio and data signals are considered to be service components which can be grouped together to form services (see clause 6). This clause describes the main transport mechanisms available in the DAB multiplex.

The DAB transmission system combines three channels (see also clause 14.1):

- 1) **Main Service Channel (MSC):** used to carry audio and data service components. The MSC is a time-interleaved (see clause 12) data channel divided into a number of sub-channels which are individually convolutionally coded, with equal or unequal error protection (see clause 11.3). Each sub-channel may carry one or more service components. The organization of the sub-channels and service components is called the multiplex configuration.

- 2) **Fast Information Channel (FIC):** used for rapid access of information by a receiver. In particular it is used to send the Multiplex Configuration Information (MCI) (see clause 6) and Service Information (see clause 8). The FIC is a non-time-interleaved data channel with fixed equal error protection (see clause 11.2).
- 3) **Synchronization channel:** used internally within the transmission system for basic demodulator functions, such as transmission frame synchronization, automatic frequency control, channel state estimation, and transmitter identification. The synchronization channel is described in clause 14.3 and no further details are given here.

Each channel supplies data from different sources and these data are provided to form a transmission frame (see also figure 3). A more detailed description is given in clause 14.2.

The structure of the transmission frame is shown in figure 4. The FIC consists of a sequence of Fast Information Blocks (FIBs) and the MSC consists of a sequence of Common Interleaved Frames (CIFs).

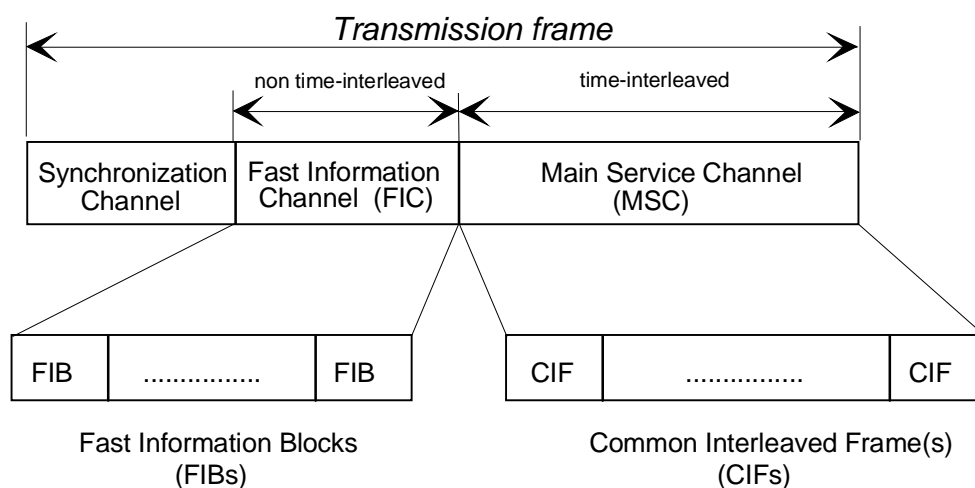

**Figure 4: Transmission frame structure**

Table 1 gives the transmission frame duration and the number of FIBs and CIFs which are associated with each transmission frame.

**Table 1: General transport characteristics of the transmission frame**

Transmission mode	Duration of transmission frame	Number of FIBs per transmission frame	Number of CIFs per transmission frame
I	96 ms	12	4

Figure 5 shows how the FIBs and CIFs are allocated in the mode I transmission frame and the relationship between the various parts.

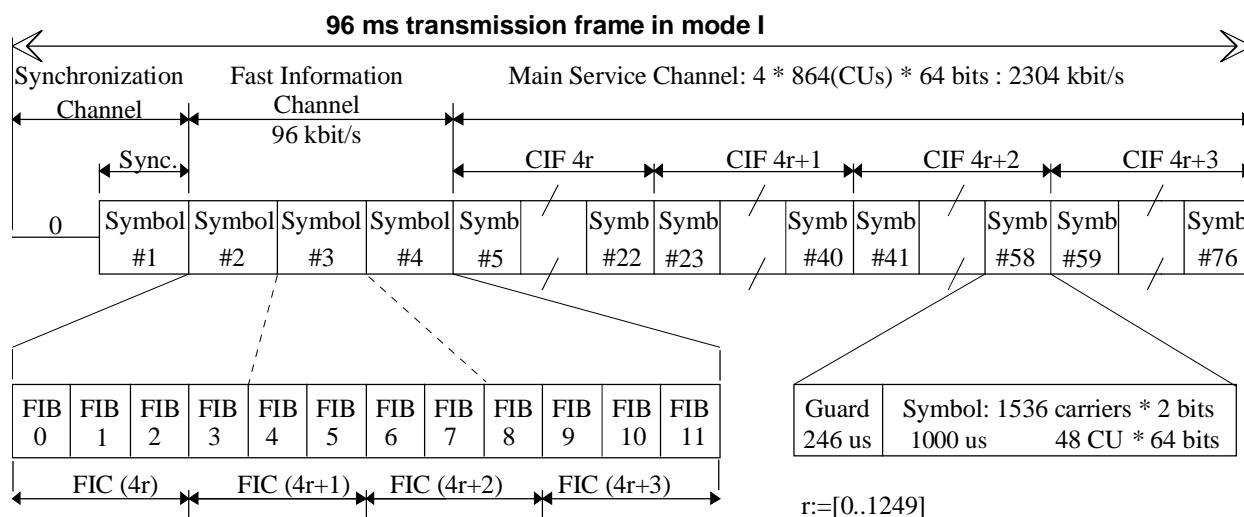

**Figure 5: Structure of Transmission mode I**

In transmission mode I there are 12 FIBs and 4 CIFs per transmission frame of 96 ms. The 12 FIBs of the three FIC symbols are divided into four groups that are each assigned to one CIF. This assignment is performed as shown in figure 5. The information contained in the first three FIBs in the frame refers to the first CIF, the information contained in the fourth, fifth and sixth FIBs refers to the second CIF, etc.

The following clauses describe the formation of the FIC and MSC.

## 5.2 Fast Information Channel (FIC)

### 5.2.1 Fast Information Block (FIB)

The general structure of the FIB is shown in figure 6, for a case when the useful data does not occupy the whole of a FIB data field. The FIB contains 256 bits and comprises an FIB data field and a CRC.

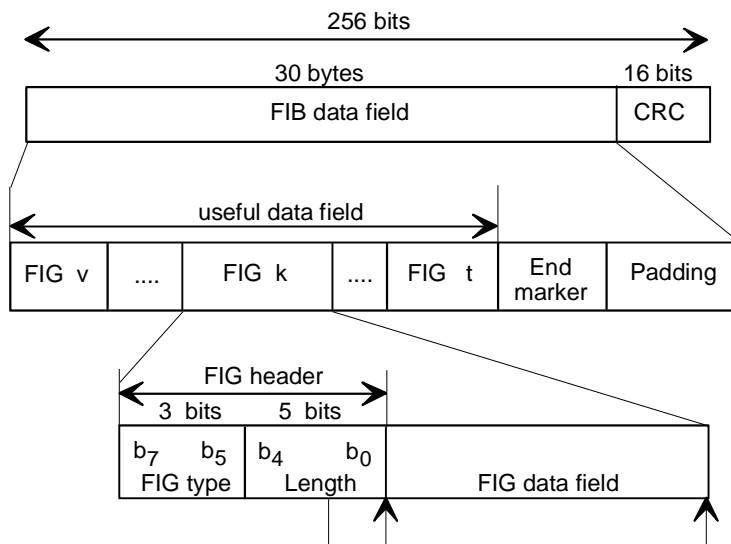

**Figure 6: Structure of the FIB**

**FIB data field:** the FIB data field shall be organized in bytes allocated to useful data, an end marker and padding in the following way:

- the useful data occupy the whole 30 bytes of the FIB data field. In this case, there shall be no end marker and no padding bytes;

- the useful data occupy 29 bytes of the FIB data field. In this case, there shall be an end marker but no padding bytes;
- the useful data occupy less than 29 bytes. In this case, there shall be both an end marker and padding bytes;
- there is no useful data. In this case, the FIB data field shall begin with an end marker and the rest of the FIB data field contains padding bytes.

The FIB data field is described as follows:

- **Useful data field:** this contains one or more Fast Information Groups (FIGs) (see clause 5.2.2).
- **End marker:** is a special FIG and shall have a FIG header field (111 11111) and no FIG data field.
- **Padding:** this field shall contain the bytes required to complete the FIB data field. The padding byte field shall contain all zeroes.
- **CRC:** a 16-bit Cyclic Redundancy Check word is calculated on the FIB data field and shall be generated according to the procedure defined in annex E. The generation shall be based on the polynomial

$$G(x) = x^{16} + x^{12} + x^5 + 1 \text{ (Recommendation ITU-T X.25 [11])}$$

At the beginning of each CRC word calculation, all shift register stage contents shall be initialized to "1". The CRC word shall be complemented (1's complement) prior to transmission.

## 5.2.2 Fast Information Group (FIG)

### 5.2.2.0 Introduction

The FIG shall comprise the FIG header and the FIG data field (see figure 6). The following definitions apply:

**FIG header:** shall contain the FIG type and the length:

- **FIG type:** this 3-bit field shall indicate the type of data contained in the FIG data field. The assignment of FIG types is given in table 2.

**Table 2: List of FIG types**

FIG type number	FIG type	FIG application
0	000	MCI and part of the SI
1	001	Labels, etc. (part of the SI)
2	010	Labels, etc. (part of the SI)
3	011	Reserved
4	100	Reserved
5	101	Reserved
6	110	Conditional Access (CA)
7	111	Reserved (except for Length 31)

- **Length:** this 5-bit field shall represent the length in bytes of the FIG data field and is expressed as an unsigned binary number (MSb first) in the range 1 to 29. Values 0, 30 and 31 shall be reserved for future use of the FIG data field except for 31 ("11111") when used with FIG type 7 ("111") which is used for the end marker.

**FIG data field:** this field is described in clauses 5.2.2.1 to 5.2.2.4, 6.2 to 6.4 and clause 8.

Generally, FIGs may be arranged in any order except where stated (see clause 6.4). FIGs shall not be split between FIBs. FIG types 0, 1, 2 and 6 are defined in clauses 5.2.2.1 to 5.2.2.4.

Each FIG type and extension is assigned a repetition rate and the transmission system should be designed to meet these rates. However, there may be some operational circumstances in which the specified rates cannot be met, either temporarily or continuously: a poorer user experience should be expected in this case. Efficient packing of FIGs into FIBs will help to reduce the occurrence of missed repetition rates.

Not all FIG types and extensions are defined. Those that are not defined are reserved for future definition. Receivers shall ignore FIGs that they do not recognize - the length field in the FIG header allows the receiver to find the next FIG in the FIB. If any parsing error occurs in processing a FIG, the rest of the FIG shall be ignored and parsing continues with the next FIG.

Some fields in the FIGs are designated as either "Reserved for future addition" (Rfa) or "Reserved for future use" (Rfu) which are set to zero for the currently defined features. The Rfa bits may be ignored by receivers, but the Rfu bits shall be evaluated to ensure that they are set to zero: if an Rfu bit is received as a one it indicates that a new feature has been implemented.

### 5.2.2.1 MCI and SI: FIG type 0 data field

The FIG type 0 is used to signal the current and future multiplex configuration, a multiplex reconfiguration, time and date and other basic Service Information. The structure of the FIG type 0 data field is shown in figure 7.

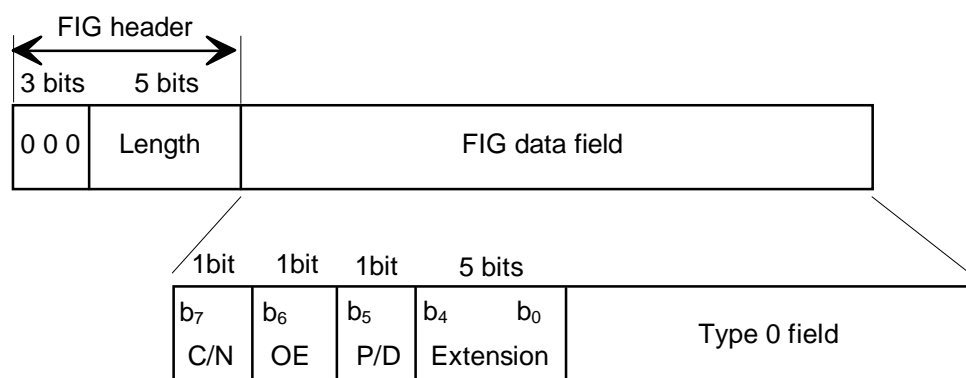

Figure 7: Structure of the FIG type 0 data field

The following definitions apply:

**Current/Next (C/N):** this 1-bit flag shall indicate one of two situations, according to the Extension, as follows:

- a) MCI - the type 0 field applies to the current or the next version of the multiplex configuration, as follows:
  - 0: current configuration;
  - 1: next configuration.
- b) SIV - the type 0 field carries information for a database. The database may be large and require more than one FIG to transport. The C/N flag indicates the Service Information Version (SIV). Certain Extensions divide the database into smaller portions each addressed by use of a database key. When the database is defined, the C/N flag is used to indicate the first FIG carrying data for the database or subsequent FIGs. Any change to the contents of the database is signalled by sending a Change Event Indication (CEI) which is a FIG with certain parameters set to particular values.

When the database is being defined, the C/N flag is used as follows:

- 0: start of database;
- 1: continuation of database.

When a change to the database needs to be signalled, using the CEI, or a control function needs to be signalled, the C/N flag is used as follows:

- 0: change event;
- 1: control function.

The database key and CEI are defined individually for each Extension.

For those Extensions which do not use this flag, the bit b<sub>7</sub> shall be reserved for future use of the type 0 field. This Reserved for future use (Rfu) bit shall be set to zero for the currently specified extension field and type 0 field.

**Other Ensemble (OE):** this 1-bit flag shall indicate, according to the Extension, whether the information is related to this or another ensemble, as follows:

0: this ensemble;

1: other ensemble (or FM or AM or DRM service).

For those Extensions which do not use this flag, the bit  $b_6$  shall be reserved for future use of the type 0 field. This Rfu bit shall be set to zero for the currently specified Extension field and type 0 field.

**P/D:** this 1-bit flag shall indicate, according to the Extension, whether the Service Identifiers (SIDs) are in the 16-bit or 32-bit format, as follows:

0: 16-bit SID, used for programme services;

1: 32-bit SID, used for data services.

When the P/D flag is not used, the Service Identifier (SID) takes the 16-bit format.

FIG 0/15 has a special definition of the P/D flag, see clause 8.1.7.

For those Extensions which do not use this flag, the bit  $b_5$  shall be reserved for future use of the type 0 field. This Rfu bit shall be set to zero for the currently specified extension field and type 0 field.

NOTE: 16-bit and 32-bit Service Identifiers may not be mixed in the same type 0 field.

**Extension:** this 5-bit field, expressed as an unsigned binary number, identifies one of 32 interpretations of the FIG type 0 field (see clauses 6.2, 6.3, 6.4 and 8.1). Those extensions, which are not defined, are reserved for future use.

The use of the C/N, OE and P/D flags for each Extension is specified for each type 0 FIG and summarized in clause 5.2.2.5.

### 5.2.2.2 Labels: FIG type 1 data field

The FIG type 1 is used to signal labels for display. The structure of the FIG type 1 data field is shown in figure 8.

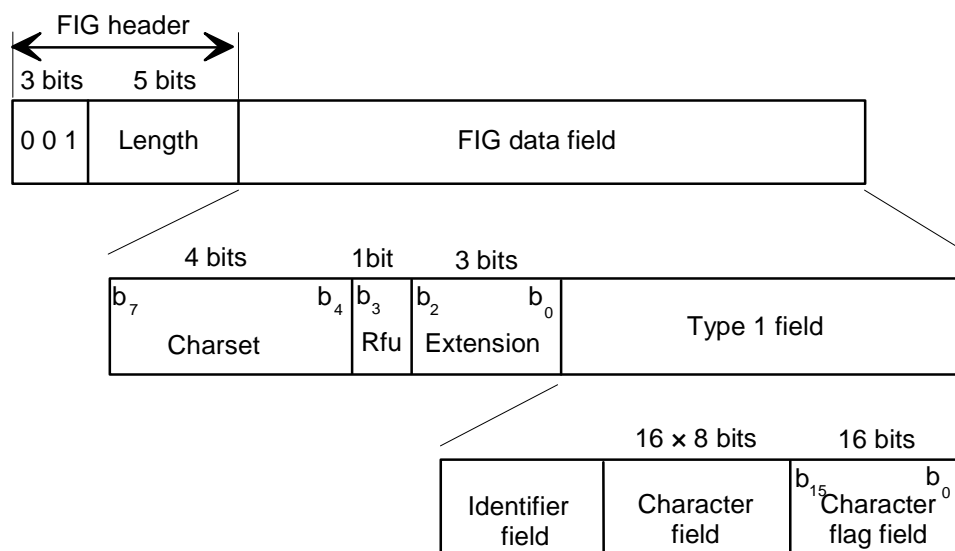

**Figure 8: Structure of the FIG type 1 data field**

The following definitions apply:

**Charset:** this 4-bit field shall identify a character set to qualify the character information contained in the FIG type 1 field. This field shall be set to 0000 - Complete EBU Latin based repertoire. The interpretation of this field by receivers shall be as defined in ETSI TS 101 756 [3], table 1.

**Rfu:** this 1-bit flag shall be reserved for future use. The Rfu bit is set to zero for the currently specified extension field and FIG type 1 field.

**Extension:** this 3-bit field, expressed as an unsigned binary number, shall identify one of 8 interpretations of the FIG type 1 field (see clause 8.1). Those extensions, which are not defined, are reserved for future use.

**Identifier field:** this field is defined individually for each extension of the FIG type 1 field (see clause 8.1).

**Character field:** this 16-byte field shall define the label. It shall be coded as a string of up to 16 characters, which are chosen from the character set signalled by the Charset field in the first byte of the FIG type 1 data field. The characters are coded from byte 15 to byte 0. The first character starts at byte 15. Bytes at the end of the character field that are not required to carry the label shall be filled with 0x00.

**Character flag field:** this 16-bit flag field shall indicate which of the characters of the character field are to be displayed in an abbreviated form of the label, as follows:

$b_i$ : ( $i = 0, \dots, 15$ );

0: not to be displayed in abbreviated label;

1: to be displayed in abbreviated label.

Not more than 8 of the  $b_i$  may be set to "1".

If the character field contains fewer than 16 characters, the unused bits in the character flag field (having no corresponding character) shall be set to zero.

### 5.2.2.3 Extended labels: FIG type 2 data field

#### 5.2.2.3.1 FIG type 2

The FIG type 2 is used to signal extended labels of up to 16 characters and up to 32 bytes in length, using either UTF-8 or UTF-16 encoding. The encoding scheme that provides the lowest byte length should be chosen. The structure of the FIG type 2 data field is shown in figure 9.

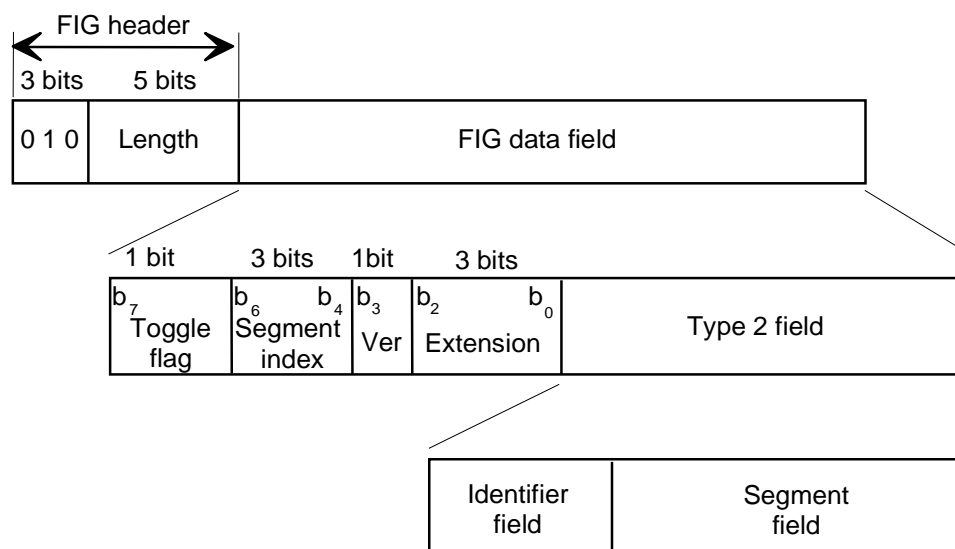

**Figure 9: Structure of the FIG type 2 data field**

The following definitions apply:

**Toggle flag:** this bit shall be maintained in the same state for all segments of the same label. When a label is changed, this bit shall be inverted with respect to its previous state. When a label is repeated then this bit shall remain unchanged.

**Segment index:** this 3-bit field, expressed as an unsigned binary number in the range 0 to 1, shall define the index of the segment field carried in the FIG type 2 field.

**Ver:** this 1-bit flag shall indicate the version of the Type 2 field. It shall be set to 1. The interpretation of this field by receivers shall be as follows:

0: Version 1 (deprecated);

1: Version 2.

**Extension:** this 3-bit field, expressed as an unsigned binary number, shall identify one of 8 interpretations of the FIG type 2 field (see clause 8.1). Those extensions, which are not defined, are reserved for future use.

**Identifier field:** this field is defined individually for each extension of the FIG type 2 field (see clause 8.1).

**Segment field:** this variable length field carries one segment of the extended label data field (see clause 5.2.2.3.3).

### 5.2.2.3.2 Structure of the extended label data field

The structure of the extended label data field is shown in figure 10.

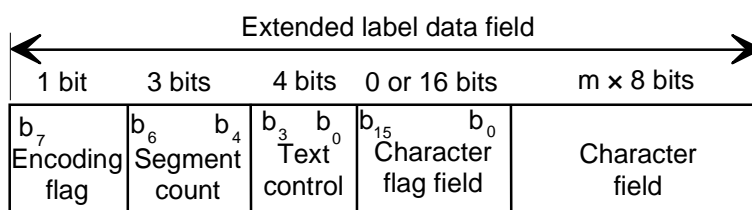

**Figure 10: Structure of the extended label data field**

The following definitions apply:

**Encoding flag:** this 1-bit flag shall define the character encoding as follows:

0: UTF-8 character encoding is used (1 to 4 bytes per character);

1: UTF-16 character encoding is used (2 bytes per character, big endian byte order, Basic Multilingual Plane only).

**Segment count:** this 3-bit field, expressed as an unsigned binary number in the range 0 to 1, shall define the total number of segments minus 1 used to carry the extended label data field.

**Text control:** this 4-bit field shall indicate the presentation complexity of the label. It shall be coded as follows:

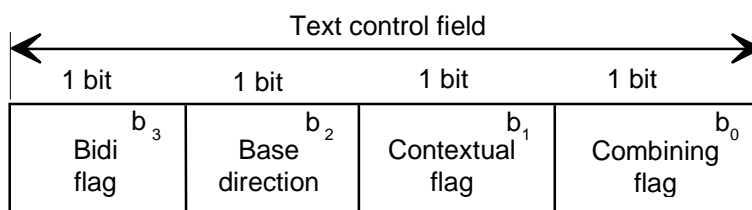

**Figure 10a: Structure of the text control field**

**Bidi flag:** this 1-bit flag shall indicate whether the label contains bidirectional text (excluding numerals) as follows:

0: bidirectional text is not present;

1: bidirectional text is present.

**Base direction:** this 1-bit flag shall define the Unicode base direction of the label as follows:

0: left-to-right (LTR);

1: right-to-left (RTL).

**Contextual flag:** this 1-bit flag shall indicate whether contextual characters are used in the label as follows:

0: contextual characters are not present (presentation characters only);

1: contextual characters are present.

**Combining flag:** this 1-bit flag shall indicate whether combining characters are used in the label as follows:

0: combining characters are not present;

1: combining characters are present.

**Character flag field:** this 16-bit flag field shall **only be present when Ver = 0** and shall indicate which of the characters of the character field are to be displayed in an abbreviated form of the label, as follows:

$b_i$ : ( $i = 0, \dots, 15$ );

0: not to be displayed in abbreviated label;

1: to be displayed in abbreviated label.

Not more than 8 of the  $b_i$  may be set to "1".

If the character field contains fewer than 16 characters, the unused bits in the character flag field (having no corresponding character) shall be set to zero.

**Character field:** this variable length field shall define the label. It shall be coded as a string of up to 16 characters, which are encoded according to the Encoding flag. The first byte is part of the first character.

#### 5.2.2.3.3 Segmentation

The label may be carried in one or two FIGs: in the latter case segmentation is used. The segments are recombined in the receiver to form the complete label using the segment index. The total number of segments used to transport the label is signalled using the segment count field. The length of each segment is determined from the FIG type 2 header field.

The first byte of the FIG type 2 extended label data field shall be transported in the first (or only) segment with corresponding Segment index field equal to 0. The second segment (if needed) shall be carried in a following FIG type 2 data field with the same Extension and Identifier fields and the Segment index field equal to 1.

#### 5.2.2.3.4 Receiver considerations

Receivers shall check the **Ver** flag. They are only required to decode the FIG type 2 label when the **Ver** flag is set to 1.

#### 5.2.2.4 CA: FIG type 6 data field

The FIG type 6 is used to send Conditional Access related parameters. The structure of the FIG type 6 data field is defined in ETSI TS 102 367 [4].

## 5.2.2.5 Summary of available FIGs

Table 3: Summary of type 0 FIGs

FIG type/ext	Clause	Description	MCI/SI	Type 0 flags		
				C/N	OE	P/D
FIG 0/0	6.4.1	Ensemble information	MCI	Rfu	Rfu	Rfu
FIG 0/1	6.2.1	Sub-channel organization	MCI	MCI	Rfu	Rfu
FIG 0/2	6.3.1	Service organization	MCI	MCI	Rfu	P/D
FIG 0/3	6.3.2	Service component in packet mode	MCI	MCI	Rfu	Rfu
FIG 0/4	6.3.3	Service component with CA in stream mode	MCI	MCI	Rfu	Rfu
FIG 0/5	8.1.2	Service component language	SI	Rfu	Rfu	Rfu
FIG 0/6	8.1.15	Service linking information	SI	SIV	Rfu	P/D
FIG 0/7	6.4.2	Configuration information	MCI	MCI	Rfu	Rfu
FIG 0/8	6.3.5	Service component global definition	MCI	MCI	Rfu	P/D
FIG 0/9	8.1.3.2	Country, LTO & International table	SI	Rfu	Rfu	Rfu
FIG 0/10	8.1.3.1	Date & time	SI	Rfu	Rfu	Rfu
FIG 0/11		-				
FIG 0/12		-				
FIG 0/13	6.3.6	User Application information	MCI	MCI	Rfu	P/D
FIG 0/14	6.2.2	FEC sub-channel organization	MCI	MCI	Rfu	Rfu
FIG 0/15	8.1.7	EWS information	SI	SIV	OE	(note)
FIG 0/16		-				
FIG 0/17	8.1.5	Programme Type (PTy)	SI	Rfu	Rfu	Rfu
FIG 0/18	8.1.6.1	Announcement support	SI	Rfu	Rfu	Rfu
FIG 0/19	8.1.6.2	Announcement switching	SI	Rfu	Rfu	Rfu
FIG 0/20	8.1.4	Service component information	SI	Rfu	Rfu	P/D
FIG 0/21	8.1.8	Frequency Information (FI)	SI	SIV	OE	Rfu
FIG 0/22		-				
FIG 0/23		-				
FIG 0/24	8.1.10	OE services	SI	SIV	OE	P/D
FIG 0/25	8.1.6.3	OE Announcement support	SI	Rfu	Rfu	Rfu
FIG 0/26	8.1.6.4	OE Announcement switching	SI	Rfu	Rfu	Rfu
FIG 0/27		-				
FIG 0/28		-				
FIG 0/29		-				
FIG 0/30		-				
FIG 0/31		-				

NOTE: The P/D flag has a special definition for FIG 0/15.

Table 4: Summary of label FIGs

FIG type/ext	Clause	Description
FIG 1/0, 2/0	8.1.13	Ensemble label
FIG 1/1, 2/1	8.1.14.1	Programme service label
FIG 1/2, 2/2		-
FIG 1/3, 2/3		-
FIG 1/4, 2/4	8.1.14.3	Service component label
FIG 1/5, 2/5	8.1.14.2	Data service label
FIG 1/6, 2/6	8.1.14.4	X-PAD User Application label
FIG 1/7, 2/7		-

Table 5: Summary of other FIGs

FIG type/ext	Clause	Description
FIG 3/x		-
FIG 4/x		-
FIG 5/x		-
FIG 6/x	9	CA (see ETSI TS 102 367 [4])
FIG 7/x	5.2.2.0	In-house/end marker

## 5.3 Main Service Channel (MSC)

### 5.3.0 General

The MSC is made up of Common Interleaved Frames (CIFs). The CIF contains 55 296 bits. The smallest addressable unit of the CIF is the Capacity Unit (CU), comprising 64 bits. Therefore, the CIF contains 864 CUs, which shall be identified by the CU addresses 0 to 863. The bit structure of the CIF is described in clause 13.

The MSC is divided into sub-channels. Each sub-channel shall occupy an integral number of consecutive CUs and is individually convolutionally encoded. Each CU may only be used for one sub-channel. A service component is a part of a service which carries either audio or general data. The DAB service structure is explained in clause 6.1.

The data, carried in the MSC, shall be divided at source into regular 24 ms bursts corresponding to the sub-channel data capacity of each CIF. Each burst of data constitutes a logical frame. Each logical frame is associated with a corresponding CIF. Succeeding CIFs are identified by the value of the CIF counter, which is signalled in the MCI (see clause 6.4).

The logical frame count is a notional count which shall be defined as the value of the CIF counter corresponding to the first CIF which carries data from the logical frame.

There are two transport modes in the MSC: one is called the stream mode and the other the packet mode.

### 5.3.1 Stream mode

The stream mode allows a service application to accept and deliver data transparently from source to destination. At any one time, the data rate of the application shall be fixed in multiples of 8 kbit/s. The application shall either supply information on demand, or include a method of handling data asynchronously at a lower rate. Data shall be divided into logical frames.

### 5.3.2 Packet mode - network level

#### 5.3.2.0 Introduction

The packet mode allows different data service components to be carried within the same sub-channel. The permissible data rates for the sub-channel shall be multiples of 8 kbit/s. Data may be carried in data groups (see clause 5.3.3) or transported using packets alone. The value of the DG flag (see clause 6.3.2) indicates which mode is used. The sub-channel may have additional Forward Error Correction applied to further mitigate against transmission errors (see clause 5.3.5).

A packet shall be identified by an address. Packets with different addresses may be sent in any order in a sub-channel. However, the sequence of packets with the same address shall be maintained.

Packets shall have a fixed length and four standard packet length types are allowed (see table 6). It is permissible to mix packet types of several lengths in a sub-channel provided that there is an integral number of packets per logical frame. Padding packets shall be used, if necessary to adjust the data rate to the required multiple of 8 kbit/s.

The links between the service component and the packet address are given in the MCI (see clause 6.3.2).

A packet shall consist of a Packet header, a Packet data field and a Packet CRC (see figure 11).

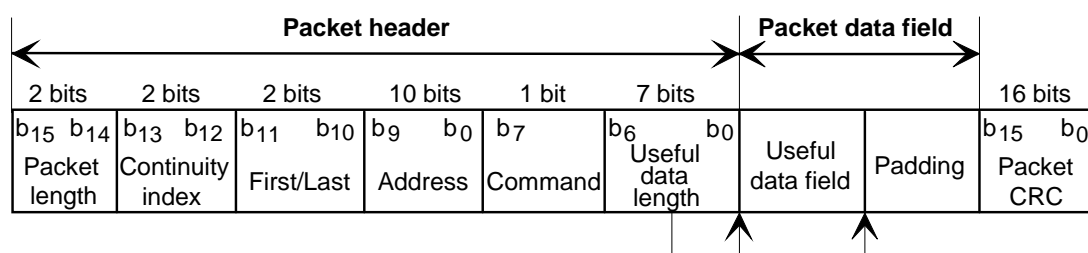

Figure 11: Packet structure

### 5.3.2.1 Packet header

The packet header has a length of 3 bytes and it shall comprise the following parameters:

- **Packet length:** four different packet data field lengths are allowed, see table 6.

**Table 6: Packet length**

Packet length b <sub>15</sub> b <sub>14</sub>		Packet length (in bytes)	Packet data field length (in bytes)
0	0	24	19
0	1	48	43
1	0	72	67
1	1	96	91

- **Continuity index:** this 2-bit, modulo-4 counter shall be incremented by one for each successive packet in a series having the same address. It provides the link between successive packets, carrying the same service component, regardless of length.
- **First/Last:** these two flags shall be used to identify particular packets which form a succession of packets, carrying data groups of the same service component (see clause 5.3.3). For service components that are transported without data groups, the flags shall be set to 0. When data groups are used, the flags shall be assigned as in table 7.

**Table 7: First/Last flags for packet mode**

First	b <sub>11</sub>	Last	b <sub>10</sub>	The packet is the:
0		0		intermediate packet of a series
0		1		last packet of a series
1		0		first packet of a series
1		1		the one and only packet

- **Address:** this 10-bit field shall identify packets carrying a particular service component within a sub-channel. Address 0 shall be used for padding packets and shall not be assigned to any service component. Up to 1 023 service components may be carried simultaneously in a sub-channel.
- **Command:** this 1-bit flag shall indicate whether the packet is used for general data or for special commands.

EXAMPLE: In conjunction with conditional access, see ETSI TS 102 367 [4]) as follows:

0: data packet;

1: command packet.

- **Useful data length:** this 7-bit field, coded as an unsigned binary number (in the inclusive range 0 to 91), shall represent the length in bytes of the associated useful data field.

### 5.3.2.2 Packet data field

This field contains the useful data field and padding.

**Useful data field:** this field shall contain the useful service component data.

**Padding:** this field shall comprise the bytes required to complete the packet data field according to the number of bytes given in table 6. The padding byte field shall contain all zeroes.

### 5.3.2.3 Packet CRC

The packet CRC shall be a 16-bit CRC word calculated on the packet header and the packet data field. It shall be generated according to the procedure defined in annex E. The generation shall be based on the polynomial

$$G(x) = x^{16} + x^{12} + x^5 + 1 \text{ (Recommendation ITU-T X.25 [11])}$$

At the beginning of each CRC word calculation, all shift register stage contents shall be initialized to "1". The CRC word shall be complemented (1's complement) prior to transmission.

## 5.3.3 Packet mode - data group level

### 5.3.3.0 Introduction

Service component data content can be structured into MSC data groups for transport in one or more packets. An MSC data group shall contain a data group header, an optional session header, a data group data field and a data group CRC. The structure of the MSC data group is shown in figure 12.

NOTE: MSC data groups can also be used to transport data in the PAD part of an MSC stream audio sub-channel.

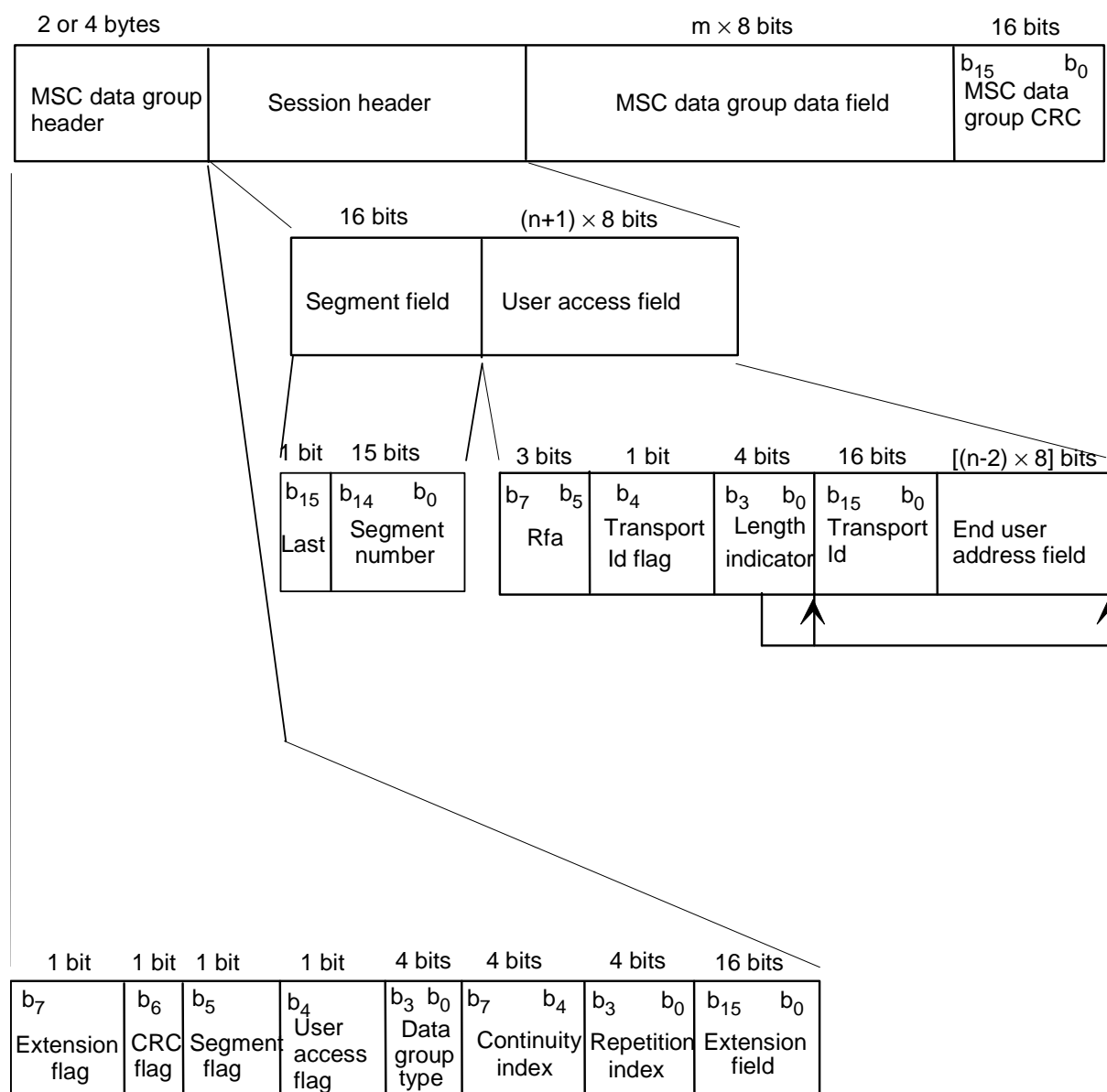

Figure 12: Structure of the MSC data group

### 5.3.3.1 MSC data group header

The following definitions apply:

- **Extension flag:** this 1-bit flag shall indicate whether the extension field is present, or not, as follows:
  - 0: no extension;
  - 1: extension.
- **CRC flag:** this 1-bit flag shall indicate whether there is a CRC at the end of the MSC data group as follows:
  - 0: no data group CRC (legacy support only);
  - 1: data group CRC present.

Transmission systems shall always set the CRC flag = 1. Previous versions of the present document permitted the data group CRC to be optional; for a transitional period these transmissions may remain on-air and so receivers shall check the value of the CRC flag.

- **Segment flag:** this 1-bit flag shall indicate whether the segment field is present, or not, as follows:
  - 0: no segment field;
  - 1: segment field present.
- **User access flag:** this 1-bit flag shall indicate whether the user access field is present, or not, as follows:
  - 0: no user access field;
  - 1: user access field present.
- **Data group type:** this 4-bit field shall define the type of data carried in the data group data field. The following types are defined for use by all data service components:
  - $b_3 - b_0$
  - 0 0 0 0 : General data;
  - 0 0 0 1 : CA messages (see ETSI TS 102 367 [4]).

The remaining types are dependent upon the value of the DSCTy and defined by the relevant document (see clause 6.3.1).

- **Continuity index:** the binary value of this 4-bit field shall be incremented each time a MSC data group of a particular type, with a content different from that of the immediately preceding data group of the same type, is transmitted.
- **Repetition index:** the binary value of this 4-bit field shall signal the remaining number of repetitions of a MSC data group with the same data content, occurring in successive MSC data groups of the same type. Exceptionally, the code "1111" shall be used to signal that the repetition continues for an undefined period.
- **Extension field:** this 16-bit field shall be used to carry information for CA on data group level (see ETSI TS 102 367 [4]). For other Data group types, the Extension field is reserved for future additions to the Data group header.

### 5.3.3.2 Session header

- **Last:** this 1-bit flag shall indicate whether the segment number field is the last or whether there are more to be transmitted, as follows:
  - 0: more segments to follow;
  - 1: last segment.

- **Segment number:** this 15-bit field, coded as an unsigned binary number (in the range 0 to 32 767), shall indicate the segment number.

NOTE: The first segment is numbered 0 and the segment number is incremented by one at each new segment.

- User access field:
  - **Rfa (Reserved for future addition):** this 3-bit field shall be reserved for future additions.
  - **Transport Id flag:** this 1-bit flag shall indicate whether the Transport Id field is present, or not, as follows:
    - 0: no Transport Id field;
    - 1: Transport Id field present.
  - **Length indicator:** this 4-bit field, coded as an unsigned binary number (in the range 0 to 15), shall indicate the length *n* in bytes of the Transport Id and End user address fields.
  - **Transport Id (Identifier):** this 16-bit field shall uniquely identify one data object (file and header information) from a stream of such objects. It may be used to indicate the object to which the information carried in the data group belongs or relates.
  - **End user address field:** this field shall indicate the address of the end user.

### 5.3.3.3 MSC data group data field

The data group data field shall contain an integral number of bytes, with a maximum of 8 191 bytes.

### 5.3.3.4 MSC data group CRC

The data group CRC shall be a 16-bit CRC word calculated on the data group header, the session header and the data group data field and generated according to the procedure defined in annex E. The generation shall be based on the polynomial  $G(x) = x^{16} + x^{12} + x^5 + 1$  (Recommendation ITU-T X.25 [11]).

At the beginning of each CRC word calculation, all shift register stage contents shall be initialized to "1". The CRC word shall be complemented (1's complement) prior to transmission.

## 5.3.4 Interrelation of network and transport level in packet mode

The information associated with one MSC data group shall be transmitted in one or more packets, sharing the same address. All packets may contain padding bytes. Figure 13 shows the situation when a MSC data group is spread across several packets, sharing the same address *j*. The settings of the First/Last flags are given.

The data field of the first packet shall begin with the data group header. The data field of the last packet shall end with the data group CRC, if any, and padding bytes, if necessary.

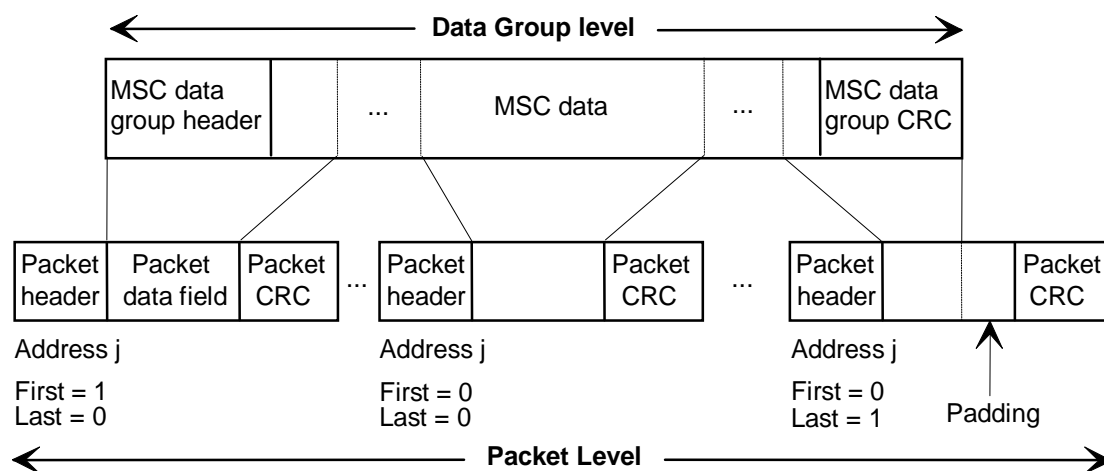

Figure 13: Relationship between a MSC data group and a sequence of packets

### 5.3.5 FEC for MSC packet mode

#### 5.3.5.0 Introduction

Forward Error Correction, in the form of Reed Solomon (RS) outer error protection and outer interleaving, shall be applied to sub-channels carrying service components in packet mode in order to further increase the error robustness of DAB data delivery.

The additional error protection is applied in such a way that legacy receivers not equipped with FEC decoders can still recover the packets for the service components, albeit with significantly reduced performance. This is accomplished by creating an FEC frame comprising the unaltered packets and additional RS data calculated over those packets as illustrated in figure 14.

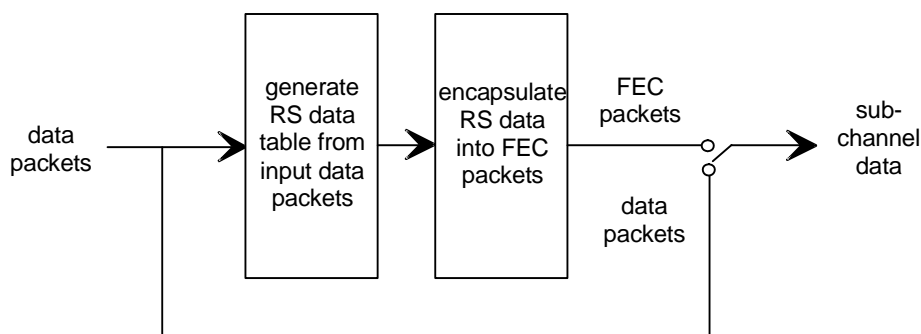

Figure 14: Conceptual diagram of the FEC frame generator combining outer coder and outer interleaver

The input to the functional block is a sequence of packets from a packet multiplexer. This sequence is referred to as the Application Data Packet Set. The Application Data Packet Set may consist of any combination of packet lengths, in any order, which in total comprise exactly 2 256 bytes.

The output of the functional block is the Application Data Packet Set in its original packet order, followed by nine 24-byte FEC packets. The FEC packets contain the RS parity data calculated from the preceding Packet Set. A new Packet Set follows immediately after the nine FEC packets.

The FEC scheme protects all packets in the sub-channel irrespective of their packet address.

A receive terminal shall apply the reverse process, using the FEC packets to correct any transmission errors in the packets.

The FEC scheme in use is signalled using FIG 0/14 (see clause 6.2).

### 5.3.5.1 FEC frame

Figure 15 shows the structure of the FEC frame. The frame has the dimensions of 204 columns by 12 rows and consists of an Application Data Table of 188 columns by 12 rows (i.e. 2 256 bytes) and an RS Data Table of 16 columns by 12 rows (i.e. 192 bytes).

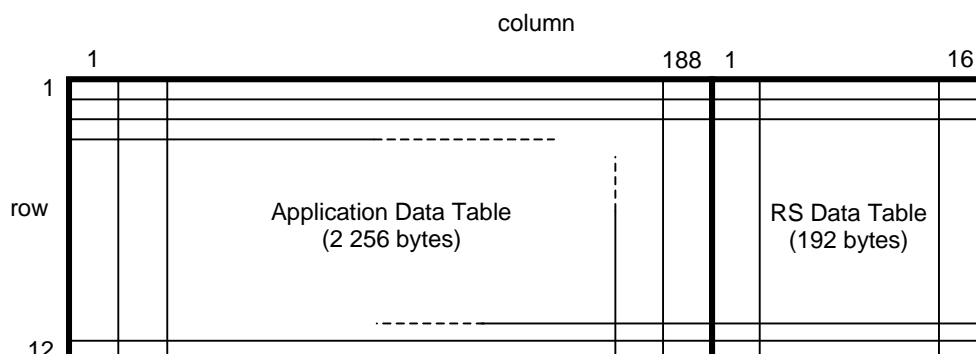

**Figure 15: Structure of FEC frame**

Packets (as defined in clause 5.3.2) are fed into the Application Data Table column by column starting with the first byte of the first packet going into row 1, column 1 and moving downwards row by row and to the right, column by column. Since there are 12 rows, each 24 byte, 48 byte, 72 byte or 96 byte packet exactly fills 2 columns, 4 columns, 6 columns or 8 columns.

The packet multiplexer shall generate sequences of packets that produce an Application Data Packet Set that completely fills the Application Data Table (i.e. a total of 2 256 bytes).

NOTE 1: Some of the packets may be padding packets.

The RS Data Table is filled by calculating the Reed-Solomon codeword from each row of data. The code used is the Reed-Solomon RS (204,188, t = 8) shortened code (see note 2), derived from the original systematic RS (255,239, t = 8) code.

NOTE 2: The Reed-Solomon codeword has length 204 bytes, dimension 188 bytes and allows up to 8 random erroneous bytes in a received word of 204 bytes to be corrected.

- Code Generator Polynomial:  $g(x) = (x+\lambda^0)(x+\lambda^1)(x+\lambda^2)\dots(x+\lambda^{15})$ , where  $\lambda = 02_{\text{HEX}}$ .
- Field Generator Polynomial:  $p(x) = x^8 + x^4 + x^3 + x^2 + 1$ .

The shortened Reed-Solomon code may be implemented by adding 51 bytes, all set to zero, before the information bytes (i.e. one row of the Application Data Table) at the input of an RS (255,239, t = 8) encoder. After the RS coding procedure these null bytes shall be discarded, leading to a RS codeword of N = 204 bytes.

For each row number, M, the following applies:

In the generated shortened RS code word for row M, the first byte is taken from column 1 row M of the Application Data Table, the second byte from column 2 row M, etc., up to column 188 (inclusive). Similarly, the first calculated RS parity byte, i.e. the 189<sup>th</sup> byte of the shortened codeword, is inserted in column 1 row M of the RS Data Table, the 190<sup>th</sup> byte of the codeword in column 2 row M, etc., up to column 16 (inclusive) of the RS Data Table. The RS code shortening zeroes can be assumed to be in column - 50, row M to column 0 row M if needed. The end result is that a complete row is identical to the corresponding RS codeword.

### 5.3.5.2 Transport of RS data

The RS Data Table is transported within nine consecutive FEC packets. The set of FEC packets is transmitted immediately following the Application Data Packet Set used to form the Application Data Table. The structure of the FEC packets is shown in figure 16.

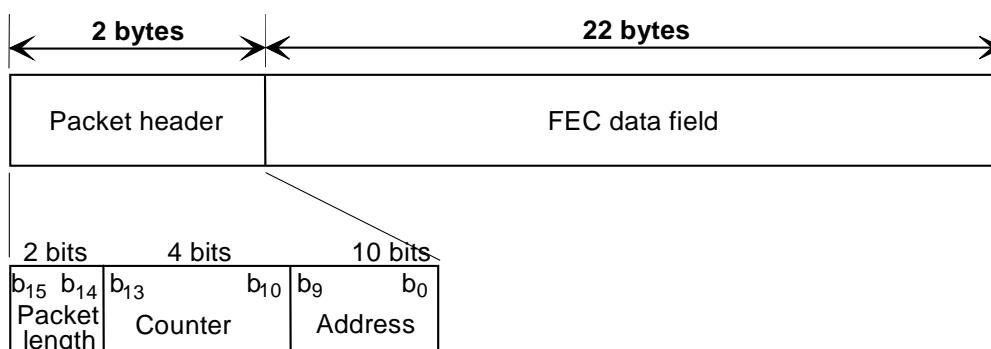

**Figure 16: Structure of FEC packet**

The packet header has a length of 2 bytes and it shall comprise the following parameters:

- **Packet length:** this 2-bit field shall take the value "00" indicating a 24-byte packet length (see table 6);
- **Counter:** this 4-bit counter, taking the values 0 to 8, shall be incremented by one for each successive FEC packet in a set;
- **Address:** this 10-bit field shall take the binary value "111111110" (1 022).

NOTE: The Packet length and Address parameters occupy the same bit positions in an FEC packet and a packet (see clause 5.3.2) permitting receivers without FEC decoding capability to process (discard) FEC packets.

The 192 bytes of the RS Data Table are transported in the FEC data field of a set of nine consecutive 24-byte FEC packets. The first FEC packet of a set has the Counter field set to 0. Each byte of data in the RS Data Table is mapped into successive FEC data fields, starting with the data byte in row 1, column 1 and working downwards, row by row, and to the right, column by column, until all the data has been mapped. When all the RS data has been mapped, there remain 6 unused bytes at the end of the FEC data field of the ninth FEC packet. These bytes shall be filled with zeros.

The complete set of FEC packets used to transport the RS data is shown in figure 17.

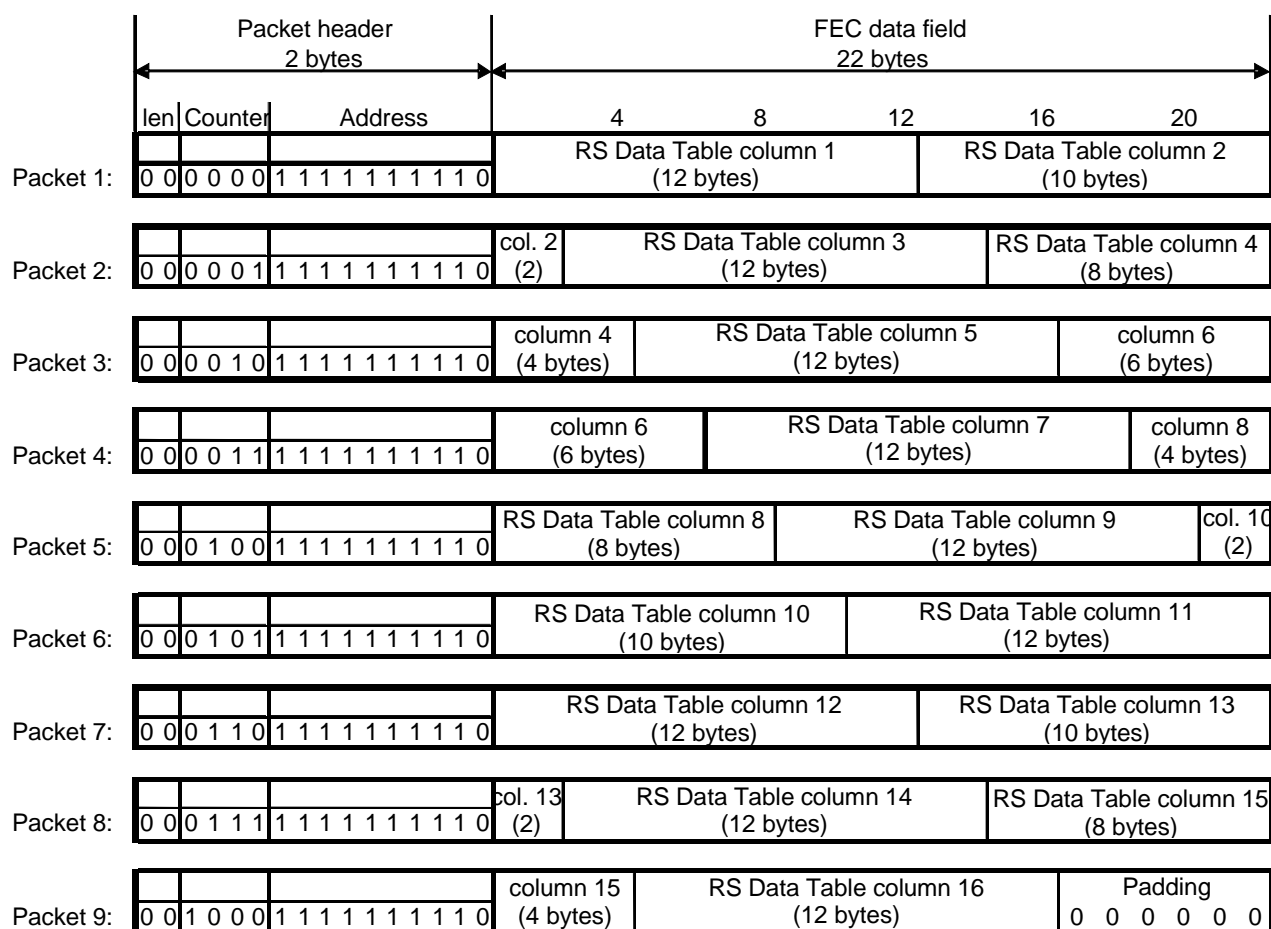

Figure 17: Complete FEC packet set

### 5.3.5.3 Receiver considerations

The FEC scheme creates a block of data totalling 2 472 bytes, 2 256 bytes from the Application Data Table (the set of packets containing service components) and 216 bytes comprising the RS Data Table transported as nine 24-byte FEC packets. The entire data block needs to be received and the FEC frame remapped before error correction can take place. The data block may take several logical frames to receive, depending on the data rate of the sub-channel.

A receiver may use the packet CRC to determine if individual packets have been received correctly, and if so, use those packets immediately. The CRC may also be used to inform the FEC decoder about which packets are likely to have errors and which are likely to be error free. More intelligent receivers may use a combination of these techniques to further improve the error-correcting ability of the outer FEC.

## 6 Multiplex Configuration Information (MCI)

### 6.1 Introduction

The principal methods of user access to the service components carried in the Multiplex are described in ETSI TS 103 176 [5]. Several services may be accessible within one ensemble, and each service contains one or more service components. However, dedicated DAB data terminals may search for and select the User Application(s) they are able to process automatically or after user selection.

The essential service component of a service is called the primary service component. Normally this would carry the audio (programme service component), but data service components can be primary as well. All other service components are optional and are called secondary service components.

An example of a service structure is shown in figure 18. In this example, the DAB ensemble is recognized by the associated ensemble label ("DAB Ensemble") and carries several services which can be accessed directly by the user, others might be processed in the background. Five of these services are described.

The first service (identified by the service label "Radio One") is a programme service with only a primary service component. This component carries audio and PAD containing a SlideShow and artist and title tag information. Most services on air at present simply consist of only a primary service component.

The second service (identified by the service label "Radio Two") comprises two service components. In this case, there is both a primary and a secondary programme service component. The secondary service component needs a component label ("Two Plus") for presentation in service lists. The primary service component carries additional dynamic label with news headline tags as PAD.

The third service (identified by the service label "Radio X") comprises two service components: a primary programme service component and a secondary data component which is used for an XML based information service. The primary service component carries a SlideShow as PAD.

The fourth service (identified by the service label "SPI") consists of only a primary service component carrying Service and Programme Information (SPI) for the whole ensemble.

The fifth service (identified by the service label "TPEG") consists of only a primary service component carrying Traffic and Travel Information (TTI) via Transport Protocol Expert Group (TPEG).

The primary components of the services "SPI" and "TPEG" share the same sub-channel.

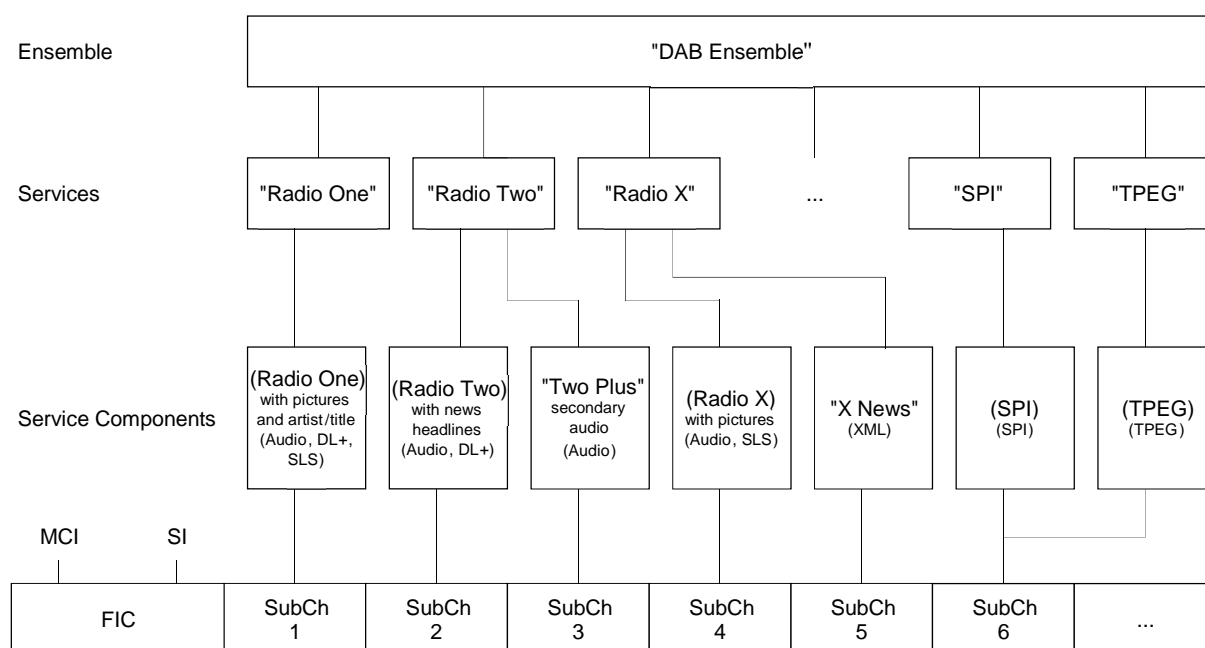

**Figure 18: An example of the DAB service structure**

The organization of the sub-channels, services and service components in an ensemble is managed by the MCI. The MCI serves five principal functions:

- to define the organization of the sub-channels in terms of their position and size in the CIF and their error protection;
- to list the services available in the ensemble;
- to establish the links between service and service components;
- to establish the links between service components and sub-channels;
- to signal a multiplex reconfiguration.

The details of coding the MCI in the FIC are described in clauses 6.2 to 6.4. The dynamic reconfiguration of the multiplex is described in clause 6.5.

The MCI is coded in FIG type 0 (see clause 5.2.2.1) using Extensions 0, 1, 2, 3, 4, 7, 8, 13 and 14. The C/N flag is used in Extensions 1, 2, 3, 4, 7, 8, 13 and 14 to distinguish between the current and the next configuration.

FIG 0/0 and FIG 0/7 have a defined location in the FIC (see clause 6.4).

The complete MCI for one configuration shall normally be signalled in a 96ms period; the exceptions are that the FIG 0/8 for primary service components containing data applications and for data secondary service components, and the FIG 0/13 may be signalled at a slower rate but not less frequently than once per second. When the slower rate is used, the FIG 0/8 and FIG 0/13 for the same service component should be signalled in the FIBs corresponding to the same CIF.

During the six second period of the reconfiguration, the MCI that describes the next configuration (see clause 6.5) shall be signalled within two consecutive 96ms periods, and during this period the complete current configuration need only be signalled once. For the MCI signalled at the slower rate, that is FIG 0/8 and FIG 0/13 for data applications, both the current and the next configuration shall be signalled within the one second repetition period.

## 6.2 Sub-channel organization

### 6.2.0 General

The sub-channel organization defines the position and size of the sub-channels in the CIF and the error protection employed. It is coded in Extensions 1 and 14 of FIG type 0. Up to 64 sub-channels may be addressed in a multiplex using a sub-channel Identifier which takes values 0 to 63. The values are not related to the sub-channel position in the MSC. The basic sub-channel organization information is coded in FIG 0/1 (see clause 6.2.1). Sub-channels used for carrying packet mode service components shall apply additional error protection (see clause 5.3.5) which is signalled using FIG 0/14 (see clause 6.2.2).

### 6.2.1 Basic sub-channel organization

The Extension 1 of FIG type 0 (FIG 0/1) defines the basic sub-channel organization. Each sub-channel is described explicitly by its start address (in the range 0 to 863 CUs) and (either explicitly or implicitly) by the size of the sub-channel and the error coding protection mechanism employed. The structure is shown in figure 19.

The FIG type 0 flags (see clause 5.2.2.1) are used as follows: C/N flag - MCI; OE flag - Rfu; P/D flag - Rfu.

Two forms of signalling the sub-channel size and error protection are used. The first is a shorter form which is used for service components employing the Unequal Error Protection (UEP) profiles given in clause 11.3.1. In this case, the UEP index is signalled explicitly and the sub-channel size can be implicitly derived from it. The second form requires the sub-channel size and error protection to be signalled explicitly. In this case, eight options for defining these parameters are allowed; only the first two are defined and are used for Equal Error Protection (EEP) according to clause 11.3.2.

UEP profiles shall be used for DAB audio at bit-rates indicated in table 8 (see also clause 11.3.1). EEP profiles shall be used for DAB+ audio and for data (see also clause 11.3.2); in addition, EEP profiles are used for DAB audio bit-rates of 8 kbit/s, 16 kbit/s, 24 kbit/s, 40 kbit/s and 144 kbit/s.

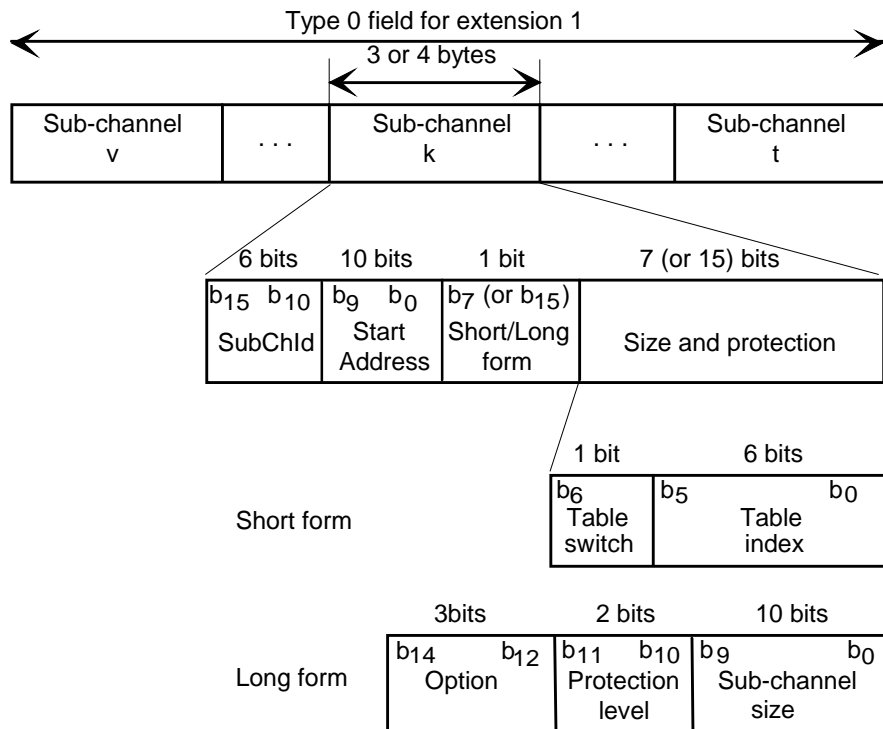

**Figure 19: Structure of the sub-channel organization field**

The following definitions apply:

**SubChId (Sub-channel Identifier):** this 6-bit field, coded as an unsigned binary number, shall identify a sub-channel.

**Start Address:** this 10-bit field, coded as an unsigned binary number (in the range 0 to 863), shall address the first Capacity Unit (CU) of the sub-channel.

**Short/Long form:** this 1-bit flag shall indicate whether the short or the long form of the size and protection field is used, as follows:

0: short form;

1: long form.

**Table 8: Sub-channel size for service components as a function of the sub-channel bit rate and the protection level (short-form application)**

Index	Sub-channel size (CU)	Protection level	Bit rate (kbit/s)	Index	Sub-channel size (CU)	Protection level	Bit rate (kbit/s)
0	16	5	32	33	64	5	128
1	21	4	32	34	84	4	128
2	24	3	32	35	96	3	128
3	29	2	32	36	116	2	128
4	35	1	32	37	140	1	128
5	24	5	48	38	80	5	160
6	29	4	48	39	104	4	160
7	35	3	48	40	116	3	160
8	42	2	48	41	140	2	160
9	52	1	48	42	168	1	160
10	29	5	56	43	96	5	192
11	35	4	56	44	116	4	192
12	42	3	56	45	140	3	192
13	52	2	56	46	168	2	192
	x			47	208	1	192
14	32	5	64	48	116	5	224
15	42	4	64	49	140	4	224
16	48	3	64	50	168	3	224
17	58	2	64	51	208	2	224
18	70	1	64	52	232	1	224
19	40	5	80	53	128	5	256
20	52	4	80	54	168	4	256
21	58	3	80	55	192	3	256
22	70	2	80	56	232	2	256
23	84	1	80	57	280	1	256
24	48	5	96	58	160	5	320
25	58	4	96	59	208	4	320
26	70	3	96		x		
27	84	2	96	60	280	2	320
28	104	1	96		x		
29	58	5	112	61	192	5	384
30	70	4	112		x		
31	84	3	112	62	280	3	384
32	104	2	112		x		
	x			63	416	1	384

- **Short form:**

- **Table switch:** this 1-bit flag shall indicate whether table 8 is signalled or there is some other use of the table index field, as follows:

0: table 8;

1: reserved for future use of the table index field.

- **Table index:** this 6-bit field, coded as an unsigned binary number, contains an index which shall identify one of the 64 options available for the sub-channel size and protection level. For table 8, the net data rate associated with each index is given. Six of the possible combinations of protection level and rate are not provided and are indicated by an "x".

- **Long form:**

- **Option:** this 3-bit field shall indicate the option used for the long form coding. Two options (000 and 001) are defined to provide Equal Error Protection as defined in clause 11.3.2. The remaining options are reserved for future use.

In the case of option 000, the following parameters are defined (see clause 11.3.2):

- **Protection level:** this 2-bit field shall indicate the protection level as follows:

00: protection level 1-A;

01: protection level 2-A;

10: protection level 3-A;

11: protection level 4-A.

The associated convolutional coding rate is given in table 9.

**Table 9: Sub-channel size for data at different coding rates, as a function of the data rate 8 n kbit/s (where n is an integer  $\geq 1$ )**

Protection level	1-A	2-A	3-A	4-A
Convolutional coding rate	1/4	3/8	1/2	3/4
Sub-channel size (CUs)	12 n	8 n	6 n	4 n

- **Sub-channel size:** this 10-bit field, coded as an unsigned binary number (in the range 1 to 864), shall define the number of Capacity Units occupied by the sub-channel. Table 9 shows the number of CUs required for all permissible data rates, in multiples of 8 kbit/s, for the four protection levels defined.

In the case of option 001, the following parameters are defined (see clause 11.3.2):

- **Protection level:** this 2-bit field shall indicate the protection level as follows:

00: protection level 1-B;

01: protection level 2-B;

10: protection level 3-B;

11: protection level 4-B.

The associated convolutional coding rate is given in table 10.

- **Sub-channel size:** this 10-bit field, coded as an unsigned binary number (in the range 1 to 864), shall define the number of Capacity Units occupied by the sub-channel. Table 10 shows the number of CUs required for all permissible data rates, in multiples of 32 kbit/s, for the four protection levels defined.

**Table 10: Sub-channel size for data at different coding rates, as a function of the data rate 32 n kbit/s (where n is an integer  $\geq 1$ )**

Protection level	1-B	2-B	3-B	4-B
Convolutional coding rate	4/9	4/7	4/6	4/5
Sub-channel size (CUs)	27 n	21 n	18 n	15 n

## 6.2.2 FEC sub-channel organization

The Extension 14 of FIG type 0 (FIG 0/14) defines the additional Forward Error Correcting scheme applied to sub-channels carrying packet mode service components. The structure is shown in figure 20.

The FIG type 0 flags (see clause 5.2.2.1) are used as follows: C/N flag - MCI; OE flag - Rfu; P/D flag - Rfu.

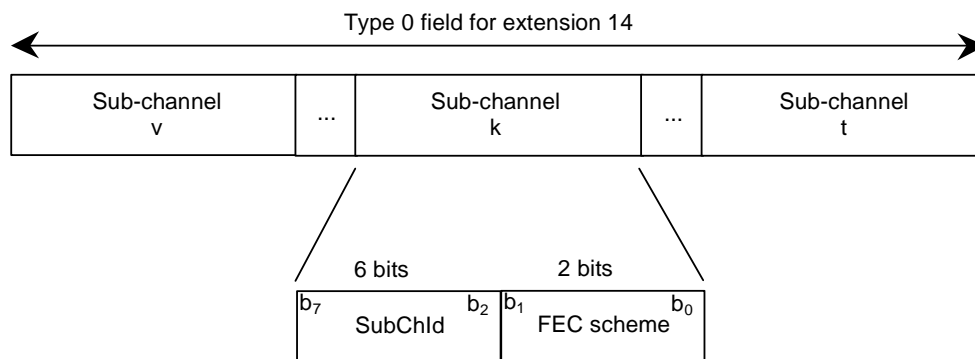

**Figure 20: Structure of the FEC sub-channel organization field**

The following definitions apply:

**SubChId (Sub-channel Identifier):** this 6-bit field, coded as an unsigned binary number, shall identify a sub-channel.

**FEC Scheme:** this 2-bit field shall indicate the Forward Error Correction scheme in use, as follows:

$b_1 - b_0$ ;

- 0 0: no FEC scheme applied (legacy support only);
- 0 1: FEC scheme applied according to clause 5.3.5;
- 1 0: reserved for future definition;
- 1 1: reserved for future definition.

Multiplexes shall signal FIG 0/14 for all sub-channels carrying packet mode service components to indicate which FEC scheme is applied.

## 6.3 Service organization

### 6.3.0 General

The service organization defines the services and service components carried in the ensemble. It is coded in the Extensions 2, 3, 4, 8 and 13 of FIG type 0. Each service shall be identified by a Service Identifier (SIId) which, when used in conjunction with an Extended Country Code (ECC), is unique world-wide. A service consists of a primary service component and optionally additional secondary service components. Each service component shall be uniquely identified by the combination of the SIId and the Service Component Identifier within the Service (SCIdS).

The basic service organization information is coded in FIG 0/2. Service components carried in Packet mode require additional signalling using FIG 0/3. When service components are scrambled (see ETSI TS 102 367 [4]), the Conditional Access Organization (CAOrg) field is signalled in FIG 0/3 for data in packet mode, and in FIG 0/4 for data carried in the stream mode. FIG 0/8 provides information to uniquely identify service components globally and to link the service component to the service component label and user application information. FIG 0/13 is used to signal the User Application for data applications carried in stream mode, packet mode, or the PAD of an audio service component.

### 6.3.1 Basic service and service component definition

The Extension 2 of FIG type 0 (FIG 0/2) defines the basic service organization. All the service descriptions applying to a service shall be contained within one field (service k) carried in a single FIG. Figure 21 shows the structure.

The FIG type 0 flags (see clause 5.2.2.1) are used as follows: C/N flag - MCI; OE flag - Rfu; P/D flag - P/D.

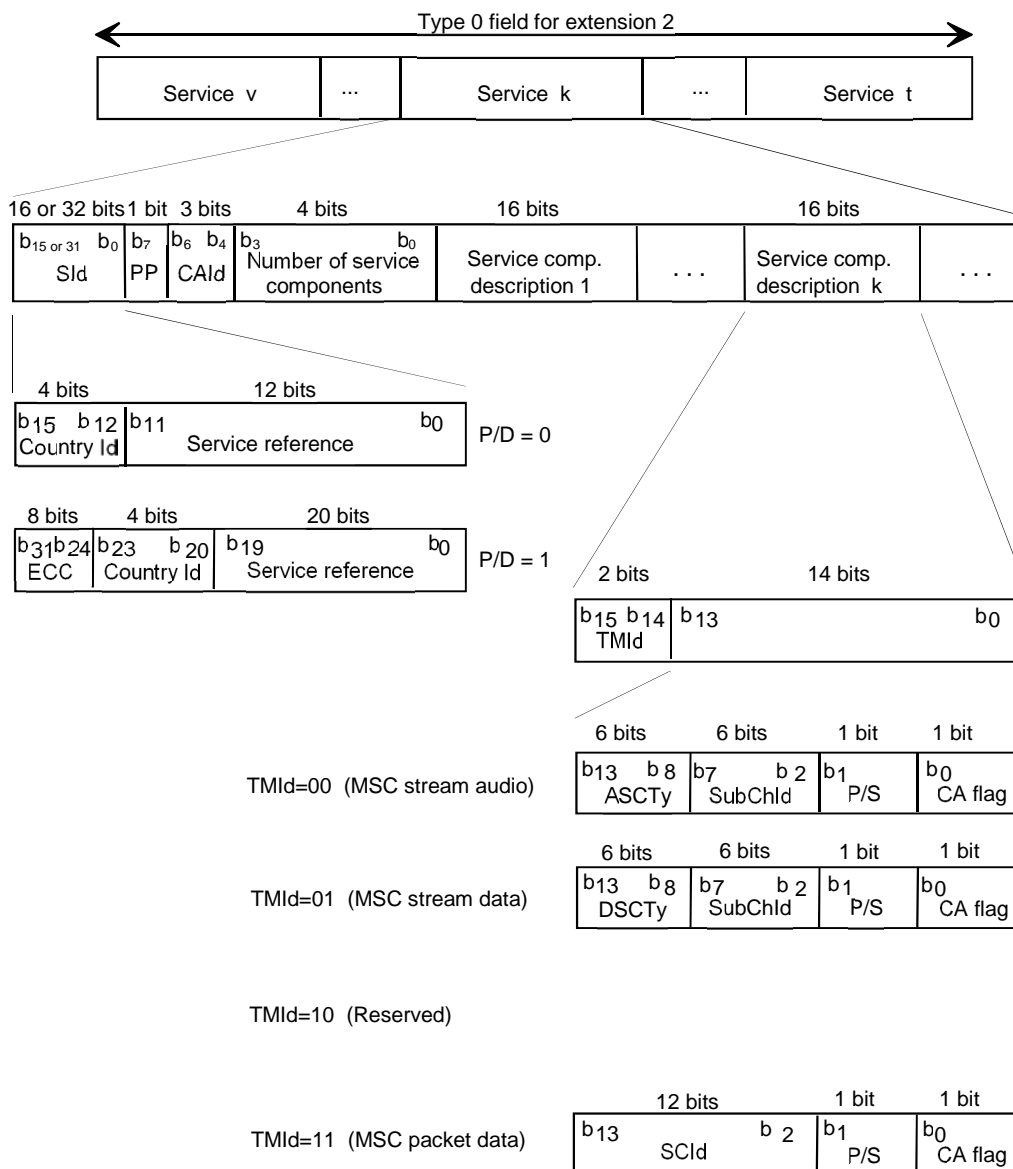

**Figure 21: Structure of the service organization field**

The following definitions apply:

**SId (Service Identifier):** this 16-bit or 32-bit field shall identify the service. The length of the SId shall be signalled by the P/D flag, see clause 5.2.2.1.

**Service Identifier description:**

- **Country Id (Identification):** this 4-bit field shall be as defined in ETSI TS 101 756 [3], tables 3 to 7.
- **Service reference:** this field shall indicate the number of the service.
- **ECC (Extended Country Code):** this 8-bit field shall be as defined in ETSI TS 101 756 [3], tables 3 to 7.

**PP (Public Prominence):** this 1-bit flag shall indicate whether the service has been designated to be of public prominence, or not, as follows:

0: not designated;

1: designated as a service of public prominence by the appropriate media regulator.

**CAId (Conditional Access Identifier):** this 3-bit field shall identify the Access Control System (ACS) used for the service. The definition is given in ETSI TS 102 367 [4]. A non-CA capable DAB receiver shall not interpret this field. If no ACS is used for the service, CAId is set to zero.

**Number of service components:** this 4-bit field, coded as an unsigned binary number, shall indicate the number of service components (maximum 12 for 16-bit SIDs and maximum 11 for 32-bit SIDs), associated with the service. Each component shall be coded, according to the transport mechanism used.

#### Service component description:

- **TMId (Transport Mechanism Identifier):** this 2-bit field shall indicate the transport mechanism used, as follows:

$b_{15} - b_{14}$ :

0 0: MSC - Stream mode - audio;

0 1: MSC - Stream mode - data;

1 0: Reserved;

1 1: MSC - Packet mode - data.

- **ASCTy (Audio Service Component Type):** this 6-bit field shall indicate the type of the audio service component. The interpretation of this field shall be as defined in ETSI TS 101 756 [3], table 2a.
- **SubChId (Sub-channel Identifier):** this 6-bit field shall identify the sub-channel in which the service component is carried.
- **P/S (Primary/Secondary):** this 1-bit flag shall indicate whether the service component is the primary one, as follows:

0: not primary (secondary);

1: primary.

- **CA flag:** this 1-bit field flag shall indicate whether access control applies to the service component, as follows:

0: no access control or access control applies only to a part of the service component;

1: access control applies to the whole of the service component.

Every DAB receiver shall check the "CA flag". A non-CA capable DAB receiver shall not try to decode the service component if the "CA flag" is set to 1.

- **DSCTy (Data Service Component Type):** this 6-bit field shall indicate the transport protocol used by the data service component. The interpretation of this field shall be as defined in ETSI TS 101 756 [3], table 2b.
- **SCId (Service Component Identifier):** this 12-bit field shall uniquely identify the service component within the ensemble.

### 6.3.2 Service component in packet mode with or without Conditional Access

The Extension 3 of FIG type 0 (FIG 0/3) gives additional information about the service component description in packet mode. Figure 22 shows the structure.

The FIG type 0 flags (see clause 5.2.2.1) are used as follows: C/N flag - MCI; OE flag - Rfu; P/D flag - Rfu.

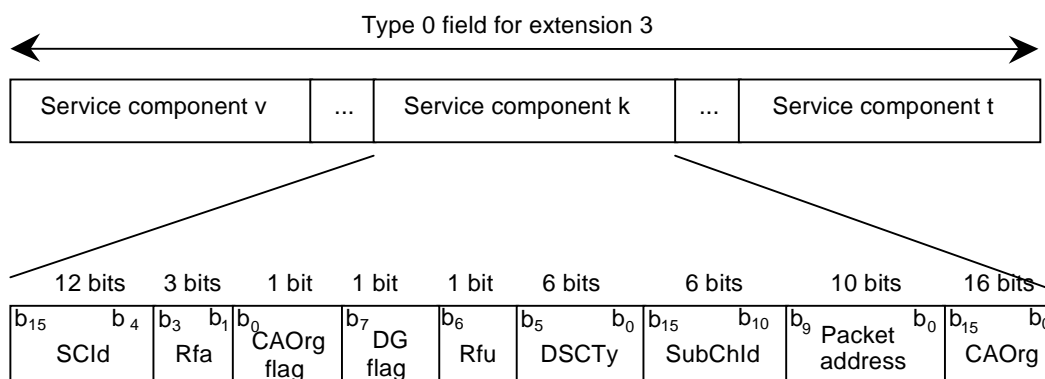

**Figure 22: Structure of the service component field in packet mode**

The following definitions apply:

**SCId (Service Component Identifier):** see clause 6.3.1.

**Rfa:** this 3-bit field shall be reserved for future additions. The bits shall be set to zero until they are defined.

**CAOrg flag:** this 1-bit flag shall indicate whether the Conditional Access Organization (CAOrg) field is present, or not, as follows:

0: CAOrg field absent;

1: CAOrg field present.

**DG flag:** this 1-bit flag shall indicate whether data groups are used to transport the service component as follows:

0: data groups are used to transport the service component;

1: data groups are not used to transport the service component.

**Rfu:** this 1-bit field shall be reserved for future use of the DSCTy field. The Rfu bit shall be set to zero for the currently specified definition of this field.

**DSCTy (Data Service Component Type):** see clause 6.3.1.

**SubChId (Sub-channel Identifier):** see clause 6.3.1.

**Packet address:** this 10-bit field shall define the address of the packet in which the service component is carried.

**CAOrg (Conditional Access Organization):** this 16-bit field shall contain information about the applied Conditional Access Systems and mode (see ETSI TS 102 367 [4]).

### 6.3.3 Service component with Conditional Access in stream mode

The Extension 4 of FIG type 0 (FIG 0/4) gives additional information about the service component description for components with CA and carried in Stream mode. Figure 23 shows the structure.

The FIG type 0 flags (see clause 5.2.2.1) are used as follows: C/N flag - MCI; OE flag - Rfu; P/D flag - Rfu.

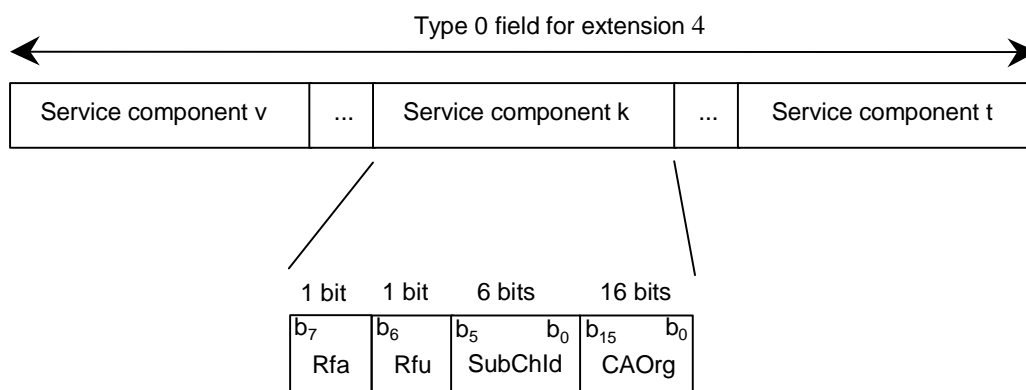

**Figure 23: Structure of the service component field in Stream mode**

The following definitions apply:

**Rfa:** this 1-bit field shall be reserved for future additions. The bit shall be set to zero until it is defined.

**Rfu:** this 1-bit field shall be reserved for future use of the SubChId field. The Rfu bit shall be set to zero for the currently specified definition of this field.

**SubChId (Sub-channel Identifier):** see clause 6.3.1.

**CAOrg (Conditional Access Organization):** see clause 6.3.2.

## 6.3.4 Void

## 6.3.5 Service component global definition

The Extension 8 of FIG type 0 (FIG 0/8) provides information to uniquely identify service components globally (in combination with the SId and ECC) and to link the service component to the service component label, X-PAD user application label and user application information. Figure 24 shows the structure. FIG 0/8 shall be signalled for all secondary service components, and for all primary service components which carry data applications signalled with FIG 0/13 (including PAD).

The FIG type 0 flags (see clause 5.2.2.1) are used as follows: C/N flag - MCI; OE flag - Rfu; P/D flag - P/D.

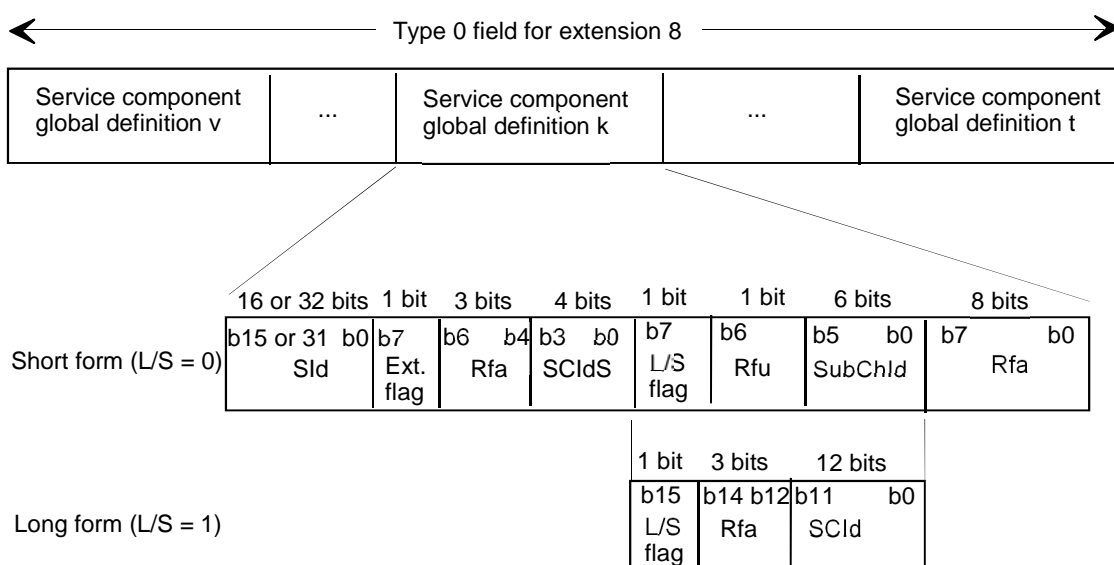

**Figure 24: Structure of the service component global definition field**

The following definitions apply:

**SIId (Service Identifier):** this 16-bit or 32-bit field shall identify the service. The length of the SIId shall be signalled by the P/D flag, see clause 5.2.2.1.

**Ext. (Extension) flag:** this 1-bit flag shall indicate whether or not the 8-bit Rfa field is present, as follows:

0: Rfa field absent;

1: Rfa field present.

**Rfa:** this 3-bit field shall be reserved for future additions. The bits shall be set to zero until they are defined.

**SCIdS (Service Component Identifier within the Service):** this 4-bit field shall identify the service component within the service. The primary service component shall use the value 0. Each secondary service component of the service shall use a different SCIdS value other than 0.

**L/S flag:** this 1-bit flag shall indicate whether the service component identifier takes the short or the long form, as follows:

0: short form;

1: long form.

**Short form:**

- **Rfu:** this 1-bit field shall be reserved for future use of the SubChId field. The Rfu bit shall be set to zero for the currently specified definition of this field.
- **SubChId (Sub-channel Identifier):** this 6-bit field shall identify the sub-channel in which the service component is carried.

**Long form:**

- **Rfa:** this 3-bit field shall be reserved for future additions. The bits shall be set to zero until they are defined.
- **SCId:** this 12-bit field shall identify the service component (see clause 6.3.1).

**Rfa:** this 8-bit field shall be reserved for future additions. The bits shall be set to zero until they are defined.

## 6.3.6 User application information

The Extension 13 of FIG type 0 (FIG 0/13) provides information to allow data applications to be associated with the correct user application decoder by the receiver. Figure 25 shows the structure. It allocates User Application information to a service component, and also allows a limited amount of application specific information to be signalled.

The FIG type 0 flags (see clause 5.2.2.1) are used as follows: C/N flag - MCI; OE flag - Rfu; P/D flag - P/D.

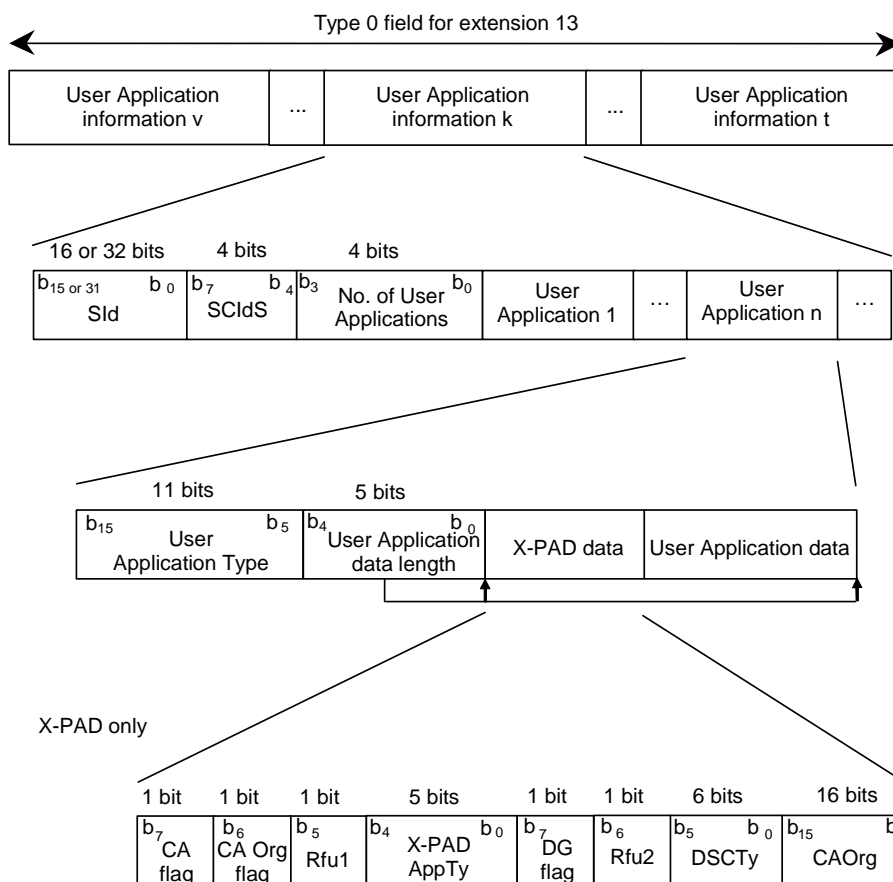

**Figure 25: Structure of the user application information field**

The following definitions apply:

**SId (Service Identifier):** this 16-bit or 32-bit field shall identify the service (see clause 6.3.1) and the length of the SId shall be signalled by the P/D flag (see clause 5.2.2.1).

**SCIdS (Service Component Identifier within the Service):** this 4-bit field shall identify the service component within the service. The combination of the SId and the SCIdS provides a globally valid identifier for a service component.

**Number of user applications:** this 4-bit field, expressed as an unsigned binary number, shall indicate the number of user applications (in the range 1 to 6) contained in the subsequent list.

**User Application Type:** this 11-bit field identifies the user application that shall be used to decode the data in the channel identified by SId and SCIdS. The interpretation of this field shall be as defined in ETSI TS 101 756 [3], table 16.

**User Application data length:** this 5-bit field, expressed as an unsigned binary number (in the range 0 to 23), indicates the length in bytes of the X-PAD data field (when present) and User Application data field that follows.

**X-PAD data:** this field is only present for applications carried in the X-PAD of an audio service component.

- **CA flag:** this 1-bit field shall indicate whether access control applies to the user application, or not, as follows:
  - 0: no access control or access control applies only to a part of the user application;
  - 1: access control applies to the whole of the user application.
- Every DAB receiver shall check the "CA flag". A non-CA capable DAB receiver shall not try to decode the user application if the "CA flag" is set to 1.

- **CAOrg flag:** this 1-bit field shall indicate whether the Conditional Access Organization (CAOrg) field is present, or not, as follows:
  - 0: CAOrg field absent;
  - 1: CAOrg field present.
- **Rfu1:** this 1-bit field shall be reserved for future use of the associated X-PAD application type. This bit shall be set to zero for the currently specified definition of the associated field.
- **X-PAD Application Type:** this 5-bit field shall specify the lowest numbered application type used to transport this user application (see clause 7.4.3).
- **DG flag:** this 1-bit flag shall indicate whether MSC data groups are used to transport the user application as follows:
  - 0: MSC data groups are used to transport the user application;
  - 1: MSC data groups are not used to transport the user application.
- **Rfu2:** this 1-bit field shall be reserved for future use of the DSCTy field. The Rfu bit shall be set to zero for the currently specified definition of this field.
- **DSCTy (Data Service Component Type):** see clause 6.3.1.
- **CAOrg (Conditional Access Organization):** this 16-bit field shall contain information about the Conditional Access Systems and mode (see ETSI TS 102 367 [4]).

**User Application data:** these 8-bit fields may be used to signal application specific information. The interpretation of these fields is determined by the user application identified by the User Application Type.

## 6.3.7 Locating service components

### 6.3.7.1 Service component identification

All service components are identified by the combination of Service Identifier (SI<sub>d</sub>) and Service Component Identifier within Service (SCID<sub>S</sub>). The primary service component of any service has the SCID<sub>S</sub> = 0. The SCID<sub>S</sub> of a stream audio or data service component is found by matching the SubChId between FIG 0/2 and FIG 0/8. The SCID<sub>S</sub> of a packet data service component is found by matching the SCID between FIG 0/2 and FIG 0/8.

A service may consist of any combination of service components using any transport mechanism (see clause 6.3.1). When the primary service component is a stream audio service component, the service is a programme service with a 16-bit SI<sub>d</sub>; when the primary service component is a stream data service component or packet data service component, the service is a data service with a 32-bit SI<sub>d</sub>.

Receivers shall be prepared to present content from secondary service components according to their capabilities, e.g. a SlideShow may be carried in a secondary packet data service component instead of X-PAD.

### 6.3.7.2 Stream audio service components

For stream audio service components, programme content is located from the FIG 0/2 information: the SubChId of the audio stream is provided and the ASCTy identifies the audio encoding method (either DAB audio or DAB+ audio).

Audio service components may also carry data applications in X-PAD. FIG 0/8 is provided for all such audio service components, primary or secondary, and the SCID<sub>S</sub> provides the link to the User Application information signalled in FIG 0/13. The FIG 0/13 provides the X-PAD AppTy to allow the correct part of the X-PAD to be sent to the application decoder, which is identified by the UATy. The transport protocol is indicated with the DSCTy and DG flag.

### 6.3.7.3 Stream data service components

For stream data service components the DSCTy is given in service component field of the FIG 0/2. The SCID<sub>S</sub> from FIG 0/8 provides the link to the User Application information signalled in FIG 0/13.

### 6.3.7.4 Packet data service components

For packet data service components, FIG 0/2 provides a Service Component Id (SCId) that is used to resolve SubChId, DSCTy and Packet address from FIG 0/3. The SCIdS provides the link to the related User Application information signalled in FIG 0/13.

## 6.4 Ensemble and configuration information

### 6.4.1 Ensemble information

The ensemble information contains control mechanisms which are common to all services contained in the ensemble. It is used to signal the identity of the ensemble and to provide an alarm flag. Two change flags and the CIF counter (24 ms increments) permit the management of multiplex reconfigurations. The ensemble information is coded in Extension 0 of FIG type 0 (FIG 0/0) as shown in figure 26.

The FIG type 0 flags (see clause 5.2.2.1) are used as follows: C/N flag - Rfu; OE flag - Rfu; P/D flag - Rfu.

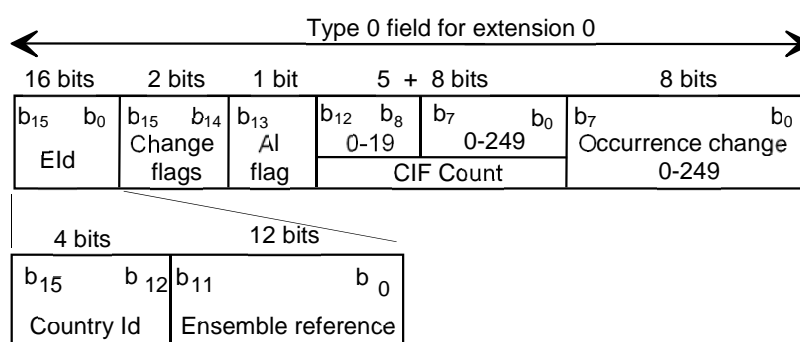

**Figure 26: Structure of the ensemble information field**

The following definitions apply:

**EId (Ensemble Identifier):** a unique 16-bit code, shall be allocated to the ensemble and allows unambiguous identification of the ensemble when associated with the Ensemble ECC (see clause 8.1.3).

- **Country Id (Country Identification):** see clause 6.3.1.
- **Ensemble reference:** this 12-bit field shall indicate the number of the Ensemble allocated for use within a national area.

NOTE 1: The EId is used as a reference by certain SI features. Changes to the EId will require reacquisition of MCI and SI and will cause interruption to audio presentation.

**Change flags:** this 2-bit field shall be used to indicate whether there is to be a change to the multiplex configuration, as follows:

b<sub>15</sub> - b<sub>14</sub>:

- |   |   |  |
|---|---|--|
| 0 | 0 | no change, no occurrence change field present;                                   |
| 0 | 1 | next sub-channel organization only signalled (legacy support only);              |
| 1 | 0 | next service organization only signalled (legacy support only);                  |
| 1 | 1 | complete next MCI (sub-channel organization and service organization) signalled. |

Transmission systems shall only indicate either Change flags = 0 0 or 1 1.

NOTE 2: Previous versions of the present document permitted Change flags = 0 1 or 1 0 which allowed only a part of the next configuration to be signalled. For a transitional period these transmissions may remain on-air and so receivers should also recognize reconfigurations signalled using these settings of the Change flags.

**AI flag (Alarm flag):** this 1-bit flag shall be used to signal that the ensemble supports the provision of alarm announcements, as follows:

0: alarm announcements shall not interrupt any service;

1: alarm announcements shall interrupt all services.

Alarm announcements require careful management, since when support is enabled using the AI flag, the alarm announcements signalled with FIG 0/19 or FIG 0/26 shall interrupt all services carried in the ensemble (see clause 8.1.6).

**CIF count:** this modulo-5 000 binary counter shall be arranged in two parts and is incremented by one at each successive CIF. The higher part is a modulo-20 counter (0 to 19) and the lower part is a modulo-250 counter (0 to 249).

**Occurrence change:** this 8-bit field shall indicate the value of the lower part of the CIF counter from which the new configuration applies.

In any 96 ms period, the FIG 0/0 shall be transmitted in a fixed time position. In transmission mode I, this shall be the first FIB (of the three) associated with the first CIF (of the four) in the transmission frame (see clause 5.1). The FIG 0/0 shall be the first FIG in the FIB.

## 6.4.2 Configuration information

The configuration information provides information about the currently tuned ensemble configuration to enable receivers to rapidly check already stored MCI.

The configuration information is coded in Extension 7 of FIG type 0 (FIG 0/7) as shown in figure 27.

The FIG type 0 flags (see clause 5.2.2.1) are used as follows: C/N flag - MCI; OE flag - Rfu; P/D flag - Rfu.

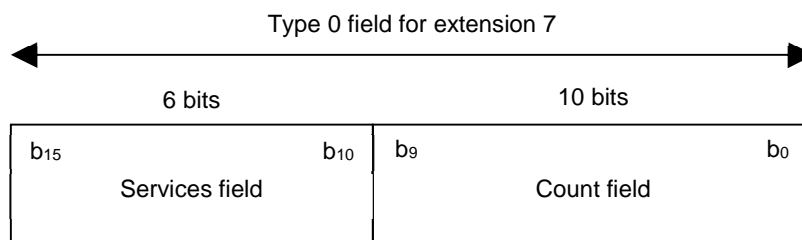

**Figure 27: Structure of the configuration information field**

The following definitions apply:

**Services:** this 6-bit field, coded as an unsigned binary number, contains the total number of services in the configuration.

**Count:** this modulo-1 024 binary counter increments by one for every multiplex reconfiguration.

The FIG 0/7 shall be transmitted in the same FIB as the FIG 0/0 and shall be the second FIG in the FIB.

A receiver can use the Services field to determine if the complete MCI has been received. This is especially useful under weak signal conditions when FIBs with erroneous CRCs are detected.

A receiver can use the Count field to verify if the configuration of an already known ensemble remains unchanged - if the received Count matches the stored Count then the configuration is the same. This can be used to speed up use cases like background scanning. The rest of the MCI need not be collected to judge if the stored configuration is still valid.

## 6.5 Multiplex reconfiguration

The ensemble information (see clause 6.4) provides the required mechanisms for signalling a change to the multiplex configuration whilst maintaining continuity of services. Such a multiplex reconfiguration is achieved by sending the complete MCI of the future multiplex configuration in advance as well as the MCI for the current configuration. Accordingly, every MCI message includes a C/N flag signalling whether its information applies to the current or to the next multiplex configuration (see clause 5.2.2).

Service continuity requires the signalling of the exact instant of time from which a multiplex reconfiguration is to be effective. Broadcasters should be aware that some multiplex re configurations are harder to achieve seamlessly than others. Service continuity in stream mode means that no interrupts occur to data integrity due to multiplex re configuration: in the case of audio this means that no impairment will be heard in ideal reception conditions. For packet mode, service continuity means that no packet is missed (in ideal reception conditions).

The time boundary between two CIFs provides the timing reference for a reconfiguration. Every CIF is addressable by the value of the CIF counter. A forthcoming multiplex re configuration is announced by setting the Change flags in FIG 0/0 to "11": this also indicates that the occurrence change field, which comprises the lower part of the CIF count, is present to signal the instant of the multiplex reconfiguration. A multiplex reconfiguration should be signalled from six seconds in advance, although a shorter period is permissible. The earliest CIF of which the lower part CIF count equals to the value signalled as occurrence change will be the first CIF to which the next configuration applies. A multiplex configuration shall remain stable for at least six seconds (250 CIFs).

A multiplex reconfiguration requires a careful co-ordination of the factors which affect the definition of the sub-channels. These factors include the bit rate and convolutional encoding/decoding. For audio streams, the instant of the reconfiguration should be coordinated with the audio super-framing; DAB audio service components coded at 24 kHz occupy two CIFs and DAB+ audio service components occupy five CIFs. The timing of changes made to any of these factors can only be made in terms of logical frames. However the logical frame count is related to the CIF count (see clause 5.3) and this provides the link for co-ordinating these activities.

In general, whenever a multiplex reconfiguration occurs at a given CIF count  $n$  (i.e. the new configuration is valid from this time), then each of the actions related to the sub-channels affected by this reconfiguration shall be changed at the logical frame with the corresponding logical frame count. There is only one exception to this rule: if the number of CUs allocated to a sub-channel decreases at the CIF count  $n$ , then all the corresponding changes made in that sub-channel, at the logical frame level, shall occur at CIF count  $(n - 15)$  which is fifteen 24 ms bursts in advance. This is a consequence of the time interleaving process, described in clause 12.

Service Information for services and service components being introduced at a reconfiguration may be signalled prior to the instance of the reconfiguration.

Additional information related to multiplex reconfiguration is given in annex D.

## 7 Audio coding

### 7.1 Introduction

Two audio coding methods are available: the original MPEG layer II encoding, "DAB audio", and the more recent MPEG 4 HE-AACv2 encoding, "DAB+ audio". It is recommended that DAB+ audio should be used in preference to DAB audio. Both methods provide a range of bit rates and audio modes and allow the addition of Programme Associated Data (PAD).

For DAB audio coding, two sampling rates are permitted, 48 kHz and 24 kHz. Each audio frame contains samples for 24 ms or 48 ms respectively and each frame has a constant size. The audio frames are carried in one or two DAB logical frames, respectively. Details are specified in ETSI TS 103 466 [1].

For DAB+ audio coding, the 960-transform shall be used with core sampling rates of 48 kHz, 32 kHz, 24 kHz and 16 kHz. Each Audio Frame (AU) contains samples for 20 ms, 30 ms, 40 ms or 60 ms respectively. In order to provide a similar architectural model to DAB audio, and simple synchronization, AUs are built into audio super frames of 120 ms which are then carried in five DAB logical frames. In order to provide additional error control, Reed Solomon coding and virtual interleaving is applied. Details are specified in ETSI TS 102 563 [2].

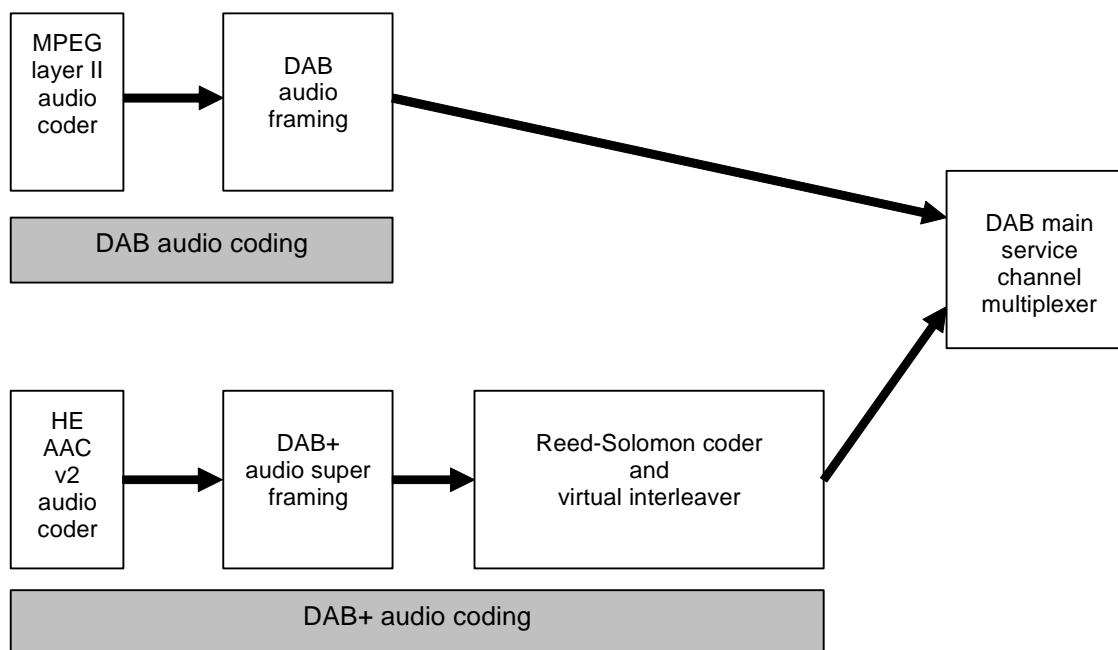

**Figure 28: Conceptual diagram of audio coding schemes**

## 7.2 Void

## 7.3 Void

## 7.4 Programme Associated Data (PAD)

### 7.4.0 Introduction

Each DAB audio frame or DAB+ audio AU contains a number of bytes which may carry Programme Associated Data (PAD). PAD is information which is synchronous to the audio and its contents may be intimately related to the audio. The PAD bytes in successive audio frames or AUs constitute the PAD channel.

The use of PAD is optional.

The PAD consists of two parts - the fixed PAD (F-PAD) and the extended PAD (X-PAD). The structure of these elements is the same for both audio coding methods, but their placement is dependent on the audio coding method.

### 7.4.1 Coding of F-PAD

Figure 29 shows the structure of the F-PAD field. The information in Byte L-1 is carried time-multiplexed in one-byte groups that are individually identified by their "F-PAD type". The information carried in Byte L-1 shall be valid for all following audio frames, until it is replaced by new information.

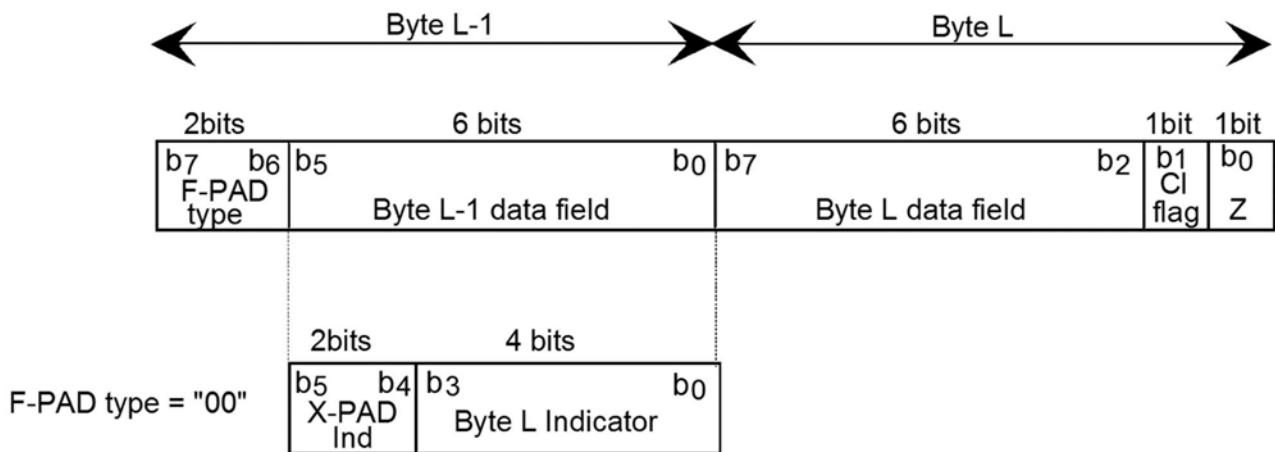

Figure 29: Structure of the F-PAD field

The following definitions apply for Byte L-1:

**F-PAD type:** this 2-bit field shall indicate the content of the Byte L-1 data field. The values "01", "10" and "11" are reserved for future use of the Byte L-1 data field.

**F-PAD type "00":**

- **X-PAD Ind (X-PAD Indicator):** this 2-bit field shall indicate the presence and length of the X-PAD field, as follows:

$b_5 - b_4$ ;

0 0: no X-PAD;

0 1: short X-PAD;

1 0: variable size X-PAD;

1 1: reserved for future use.

- **Byte L Indicator:** this 4-bit field shall indicate the data content of the Byte L data field, as follows:

$b_3 - b_0$ ;

0 0 0 0: In-house information, or no information;

0 0 0 1: DRC (Dynamic Range Control) data for DAB audio (see ETSI TS 103 466 [1]).

The remaining values are reserved for future use of the Byte L data field.

The coding of the in-house information is not subject to standardization.

NOTE: DRC data for DAB+ audio is carried inside the AU (see ETSI TS 102 563 [2]).

The following definitions apply for Byte L:

**Byte L data field:** the contents of this 6-bit field depend on the Byte L indicator. The in-house information is not subject to standardization.

**CI (Contents Indicator) flag:** this 1-bit flag shall signal whether the X-PAD field in the current DAB audio frame includes at least one contents indicator, as follows:

0: no contents indicator;

1: contents indicator(s) present.

**Z:** this bit shall be set to zero for synchronization purposes in serial communication links.

## 7.4.2 Structure of X-PAD

### 7.4.2.0 General

The X-PAD field contains at least one X-PAD data sub-field, and possibly a number of contents indicators. A contents indicator signals the application type for the data carried in the associated X-PAD data sub-field, and in the case of variable size X-PAD, the length of the sub-field. The user application information in FIG 0/13 indicates the application type(s) used to carry the user application data. The contents indicators may be omitted under certain conditions. Further details on the allowed number of X-PAD data sub-fields and the use of contents indicators are specified in clauses 7.4.2.1, 7.4.2.2 and 7.4.4.

Data carried in the X-PAD field are defined in logical order. Before transmission, the order of the bytes within each X-PAD field shall be reversed. The reversed order applies only to the byte sequence; the bit order within each byte shall not be reversed; MSb shall be transmitted first. This means that the application data is "transmitted before" the contents indicator(s), and that the contents indicator(s) are carried last.

Application data usually requires more than one X-PAD sub-field to be used to transport it. The application data can therefore be structured into X-PAD data groups, which are defined in clause 7.4.5, or sent as a simple byte stream.

Figures 30 and 31 illustrate two examples of how application data, structured into X-PAD data groups, are transported in the X-PAD channel. In the first example the X-PAD data group extends over a number of X-PAD fields (i.e. a number of DAB audio frames or DAB+ audio AUs), and in the second example three X-PAD data groups are carried in one X-PAD field (i.e. one DAB audio frame or DAB+ audio AU). The first example concerns short X-PAD, but similar situations are also possible for variable-sized X-PAD (see clauses 7.4.2.1 and 7.4.2.2). The second example concerns variable-size X-PAD only (see clause 7.4.2.2).

The X-PAD indicator (X-PAD Ind, transported in the F-PAD channel) signals whether no X-PAD, short X-PAD or variable size X-PAD is used. The CI flag signals whether the X-PAD field contains one or more Contents Indicators (CI) or only application data.

In the first example (figure 30) a single contents indicator is required to indicate the beginning of the X-PAD data group. In the second example (figure 31), three contents indicators are required, one for each data sub-field. In addition, a fourth contents indicator, CI 4, is used to terminate the contents indicator list (see clause 7.4.3).

NOTE: In figures 30 and 31 the logical order of the information is depicted (the transmission order within each DAB audio frame or DAB+ audio AU is reversed, as described above).

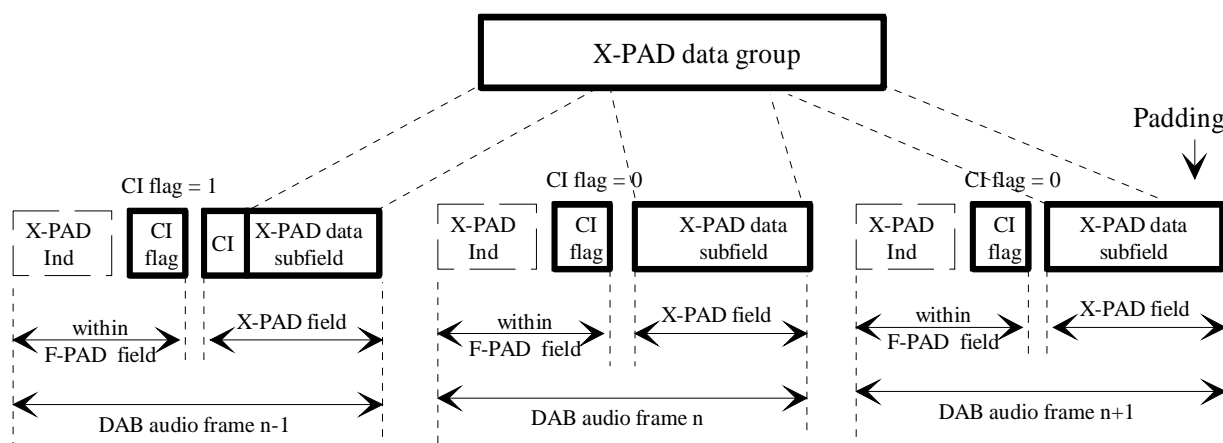
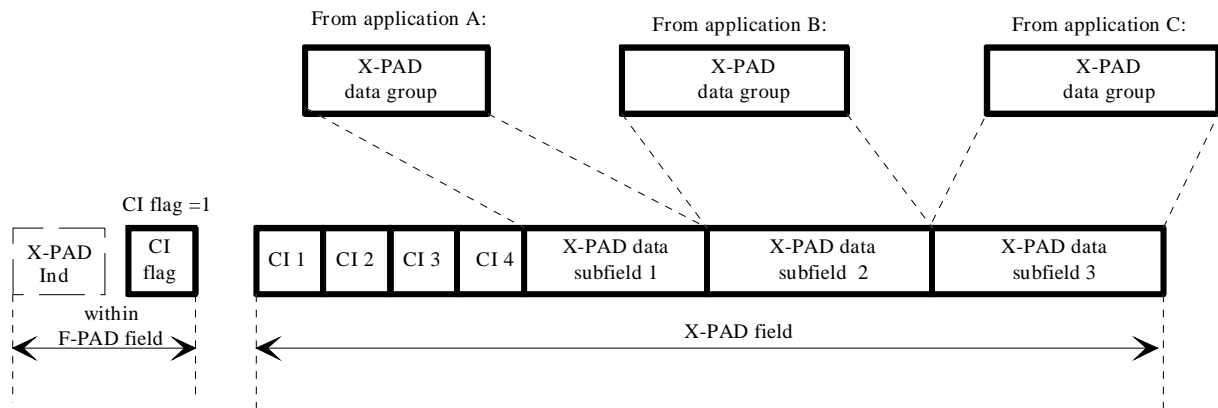

Figure 30: An X-PAD data group extending over three consecutive X-PAD fields



**Figure 31: Three X-PAD data groups carried in one X-PAD field**

When the X-PAD data group structure is applied, an X-PAD data sub-field may either contain a complete X-PAD data group or a part of a data group. An X-PAD data group may be interrupted by an X-PAD data group for a different user application (or the dynamic label), and resumed later. In this way a time-critical user application can be transported punctually, even if another application requires many X-PAD fields to transport one X-PAD data group.

#### 7.4.2.1 Short X-PAD

The length of the X-PAD field shall be 4 bytes. Each X-PAD field shall comprise either one contents indicator and one X-PAD data sub-field of 3 bytes, or one X-PAD data sub-field of 4 bytes. The contents indicator shall signal the application type.

A contents indicator is required for the following two situations:

- when the X-PAD data sub-field contains the start of an X-PAD data group;
- when the X-PAD data sub-field contains data from an X-PAD data group or byte stream that has been interrupted and now is being resumed.

The contents indicator may be omitted if the X-PAD data sub-field (4 bytes long) contains a continuation of the X-PAD data group or the byte stream carried in the previous DAB audio frame or DAB+ audio AU that contains an X-PAD field (i.e. data for the same user application).

If the final part of an X-PAD data group does not entirely fill the X-PAD data sub-field in which it is transported, padding bits shall be used to fill the X-PAD sub-field. Padding bits shall be set to zero.

The contents indicator flag, transported in the F-PAD field, shall signal for each DAB audio frame or DAB+ audio AU, whether the X-PAD field contains a contents indicator or not.

#### 7.4.2.2 Variable size X-PAD

The length of the X-PAD field may vary from one DAB audio frame or DAB+ audio AU to the next.

The contents indicators shall, when present, be assembled in a contents indicator list in the beginning (logical meaning) of the X-PAD field. Each X-PAD field shall comprise either one X-PAD data sub-field or a number of X-PAD data sub-fields, together with a contents indicator list.

Each contents indicator shall signal the application type for the data in the associated X-PAD data sub-field and the length of the sub-field. The total length of the X-PAD field may therefore be derived from the contents indicators.

The maximum number of data sub-fields within one X-PAD field is four. When more than one data sub-field is included there shall be a contents indicator associated with each sub-field. The order of the contents indicators within the list shall be the same as the order of the X-PAD data sub-fields, i.e. the first contents indicator is associated to the first X-PAD data sub-field, the second contents indicator to the second X-PAD data sub-field, etc.

The contents indicators are 1 byte long. The contents indicator list shall comprise up to 4 bytes, thereby allowing up to four X-PAD data sub-fields within one X-PAD field.

If the contents indicator list is shorter than four bytes, an end marker, consisting of a contents indicator of application type 0, shall be used to terminate the list, see clause 7.4.3.

A contents indicator list shall be included whenever any of the following situations apply:

- when there is more than one X-PAD data sub-field in the X-PAD field;
- when an X-PAD data sub-field contains the start of an X-PAD data group;
- at intervals allowing quick synchronization of terminals when an X-PAD data sub-field contains data from a byte stream;
- when an X-PAD data sub-field contains data from an X-PAD data group or a byte stream that has been interrupted and is now being resumed;
- when the capacity of the X-PAD channel is changed;
- when there is only one X-PAD data sub-field which does not fill the X-PAD field.

The contents indicator list may be omitted if both of the following conditions apply:

- the length of the X-PAD field is the same as in the previous DAB audio frame or DAB+ audio AU that contains an X-PAD field;
- the X-PAD field comprises a single data sub-field containing a continuation of the X-PAD data group or the byte stream carried in the last (logical meaning) X-PAD data sub-field of the previous DAB audio frame or DAB+ audio AU that contains an X-PAD field (i.e. data for the same user application).

If the final part of an X-PAD data group does not entirely fill the X-PAD data sub-field in which it is transported, padding bits shall be used to fill the X-PAD sub-field. Padding bits shall be set to zero.

The contents indicator flag, transported in the F-PAD field, shall signal for each DAB frame, whether the X-PAD field contains contents indicators or not.

### 7.4.3 Application types

There are a maximum of 31 application types available.

For applications that may generate long X-PAD data groups, two application types are defined: one is used to indicate the start of an X-PAD data group and the other is used to indicate the continuation of a data group after an interruption. Byte streams require just one X-PAD application type.

Application type 0 shall be used as the end marker. The end marker shall be used for two purposes:

- 1) to terminate the contents indicator list when, for the variable size X-PAD, there is a contents indicator list shorter than four bytes;
- 2) to signal that the X-PAD field contains no data.

Application type 1 shall be used for the data group length indicator (see clause 7.4.5.1).

Application types 2 and 3 shall be used for the dynamic label (see clause 7.4.5.2).

Application types 12 to 15 should be used for an MOT-based user application to provide compatibility with early receiver implementations. They shall not be used for other user applications.

Application type 31 shall not be used.

All other application types (4 to 11 inclusive and 16 to 30 inclusive) shall be used as identifiers for the user application data transported in the X-PAD. The correspondence between the application types used and the user application is signalled by FIG 0/13. Table 11 summarizes the use of the application types.

Table 11: X-PAD Application types

Application type	Description
0	End marker
1	Data group length indicator
2	Dynamic label segment, start of X-PAD data group
3	Dynamic label segment, continuation of X-PAD data group
4 to 11	User defined
12	MOT, start of X-PAD data group, see ETSI EN 301 234 [6]
13	MOT, continuation of X-PAD data group, see ETSI EN 301 234 [6]
14	MOT, start of CA messages, see ETSI EN 301 234 [6]
15	MOT, continuation of CA messages, see ETSI EN 301 234 [6]
16 to 30	User defined
31	Not used

The user defined application types shall be used as follows:

- If the user application uses a byte stream, then one application type is used by the user application.
- If the user application uses the X-PAD data group structure, then two consecutive application types are used (start and continuation).
- If the user application applies conditional access, then one (CA as byte stream) or two (CA as X-PAD data group structure) additional and consecutive application types are used.

## 7.4.4 Contents indicator

### 7.4.4.1 Contents indicator in short X-PAD

The coding of the contents indicator in the case of short X-PAD is shown in figure 32.

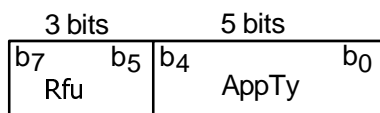

Figure 32: Contents indicator for short X-PAD

The following definitions apply:

**Rfu:** this 3-bit field is reserved for future use. The bits shall be set to zero until they are defined.

**AppTy (Application Type):** this 5-bit field shall specify an application type. Application types shall be coded as unsigned binary numbers.

### 7.4.4.2 Contents indicator in variable size X-PAD

The coding of the contents indicator in the case of variable size X-PAD is shown in figure 33.

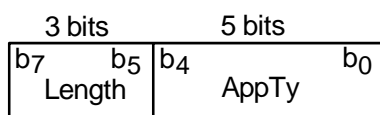

Figure 33: Contents indicator for variable size X-PAD

The following definitions apply:

**Length:** this 3-bit field shall indicate the length of the associated X-PAD data sub-field (in the current DAB audio frame or DAB+ audio AU), as follows:

$$b_7 - b_5;$$

0 0 0: 4 bytes;  
 0 0 1: 6 bytes;  
 0 1 0: 8 bytes;  
 0 1 1: 12 bytes;  
 1 0 0: 16 bytes;  
 1 0 1: 24 bytes;  
 1 1 0: 32 bytes;  
 1 1 1: 48 bytes.

**AppTy (Application Type):** this 5-bit field shall specify an application type. Application types shall be coded as unsigned binary numbers.

## 7.4.5 Applications in X-PAD

### 7.4.5.0 Introduction

This clause contains the coding details for the X-PAD data groups used to carry MSC data groups and the dynamic label segments. A Cyclic Redundancy Check is used for error detection.

The CRC shall be generated according to the procedure defined in annex E. The generation shall be based on the polynomial:

$$G(x) = x^{16} + x^{12} + x^5 + 1$$

The CRC word shall be complemented (1s complement) prior to transmission. At the beginning of each CRC word calculation, all register stages shall be initialized to "1".

One or more padding bytes which shall be set to zero may be included after the CRC to fill up the X-PAD data sub-field carrying the last part of the X-PAD data group.

### 7.4.5.1 MSC data groups in X-PAD

#### 7.4.5.1.0 Introduction

User applications may use the X-PAD to transport MSC data groups. In this case two X-PAD data groups are used to carry one MSC data group. The first X-PAD data group is used to signal the length of the following MSC data group, and the second X-PAD data group is used to transport the MSC data group itself.

#### 7.4.5.1.1 X-PAD data group for data group length indicator

The X-PAD data group for data group length indicator signals the length of the following MSC data group and is indicated by application type 1. Figure 34 shows the structure of the X-PAD data group for the data group length indicator.

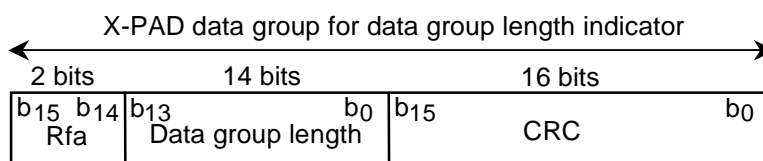

**Figure 34: Structure of the X-PAD data group for the data group length indicator**

**Rfa:** This 2-bit field shall be reserved for future additions. The bits shall be set to zero until they are defined.

**Data group length:** This 14-bit field shall indicate the length of the following X-PAD data group (MSC Data Group) in bytes. It is coded as an unsigned binary number. The Data group length covers the data group header, the session header, the data group data field and the optional CRC, if present. The structure of the MSC data group is shown in figure 12.

**CRC (Cyclic Redundancy Check):** This CRC shall be calculated on the Rfa and the Data group length field.

#### 7.4.5.1.2 X-PAD data group for MSC data group

The X-PAD data group for MSC data group carries one complete MSC data group. Figure 35 shows the structure of the X-PAD data group for MSC data group.

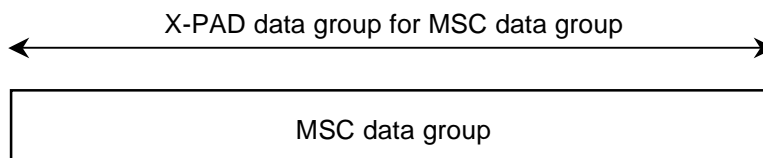

**Figure 35: Structure of the X-PAD data group for MSC data group**

**MSC data group:** This field contains a complete MSC data group.

#### 7.4.5.1.3 Transport of MSC data groups in short X-PAD

In the case of short X-PAD, audio frame  $n$  shall contain a contents indicator carrying application type 1 and the first three bytes of the X-PAD data group for data group length indicator. Audio frame  $n+1$  shall contain the final byte of the X-PAD data group for data group length indicator and three bytes of padding. Audio frame  $n+2$  shall contain a contents indicator carrying the appropriate "Start of X-PAD data group" application type and the first three bytes of the X-PAD data group for MSC data group application data. Subsequent audio frames shall continue according to the general rules (i.e. data applications may be interrupted by other data applications and resumed later).

#### 7.4.5.1.4 Transport of MSC data groups in variable-sized X-PAD

In the case of variable-sized X-PAD, contents indicators shall be used to signal application type 1 and then the appropriate "Start of X-PAD data group" application type for two consecutive X-PAD data sub-fields. The X-PAD data sub-field containing the X-PAD data group for data group length indicator and the X-PAD data sub-field containing the start of the following X-PAD data group containing the MSC data group shall not be interrupted by another X-PAD sub-field. This is to ensure the close and unique link between the data group length indicator and the X-PAD data group (MSC data group) it is referring to.

#### 7.4.5.2 Dynamic label

The dynamic label feature provides short textual messages which are associated with audio programme content for display on receivers. The messages can have any length up to a maximum of 128 bytes; depending on the character set used, the message can have up to 128 characters. Segmentation is provided in order to transport the messages; each segment carries up to 16 bytes of character data. The same segmentation is also used for transporting commands which control the way the character data is used; each segment then carries up to 16 bytes of command data.

Basic message presentation can be indicated by the use of control characters, although different display sizes and formats will affect the way these control characters are used. A "headline" part of a dynamic label can be indicated by the "end-of-headline" control character and the headline can be presented differently from the remainder of the label. The "preferred line break" control character is used to indicate a position where a line break would structure the text in a particular way. The "preferred word break" control character is used to indicate an appropriate position to break a long word if necessary.

Alternate presentation may be achieved through the use of dynamic label commands. These commands relate to the message that precedes them. The complete dynamic label message shall be transmitted before any commands that relate to it are transmitted.

The dynamic label may comprise up to 8 segments, each consisting of up to 16 bytes of either character data or command data. Each segment is carried in one X-PAD data group. Figure 36 shows the structure of the X-PAD data group for the Dynamic label segment.

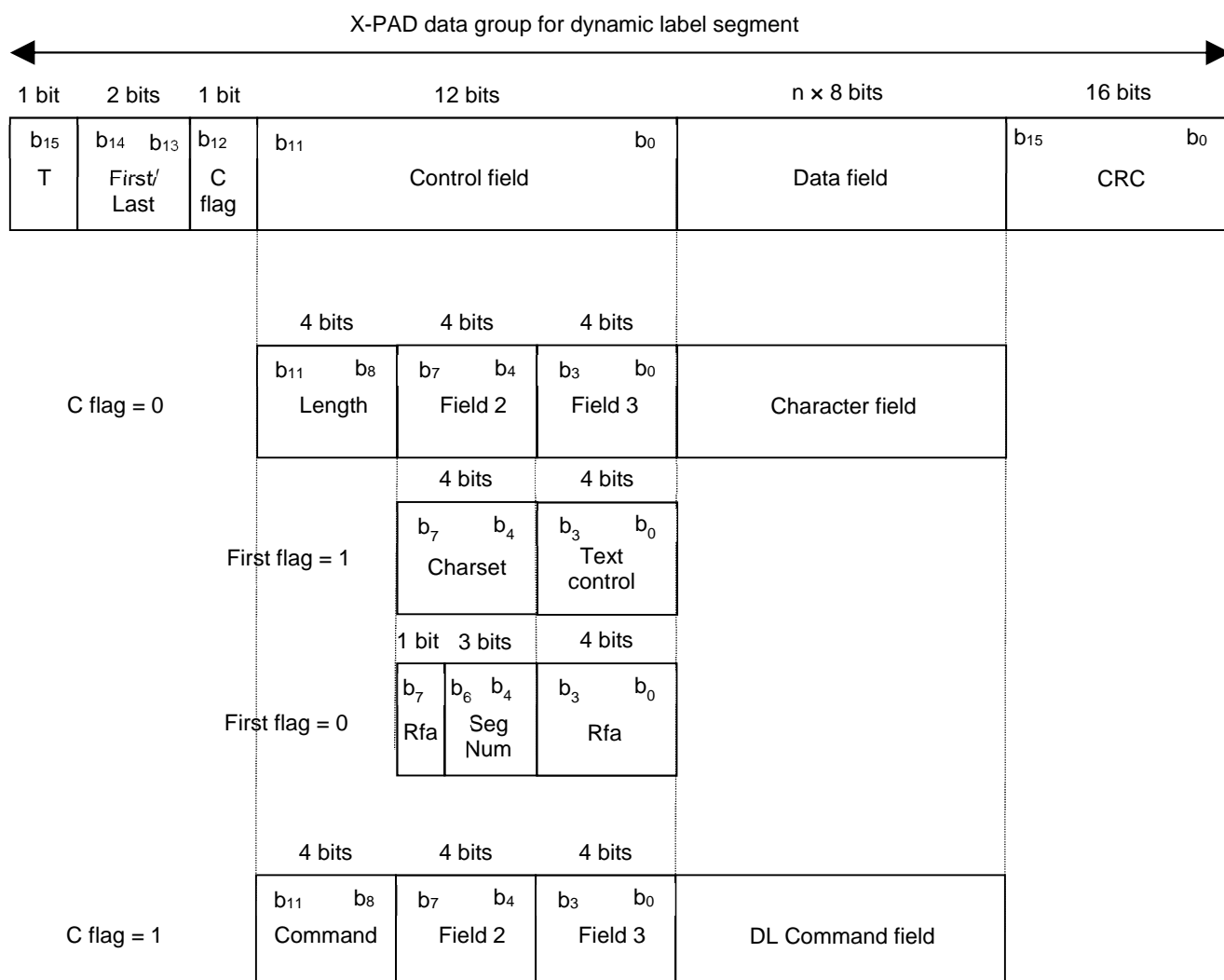

**Figure 36: Structure of the X-PAD data group for each dynamic label segment**

The following definitions apply:

**T (Toggle bit):** this bit shall indicate whether the dynamic label message or dynamic label command has changed or is repeated. The Toggle bit shall be considered separately for the dynamic label message (C flag = 0) and the dynamic label command (C flag = 1).

- **C flag = 0:** The Toggle bit shall be maintained in the same state for all character data segments from the same dynamic label message. When a different dynamic label message is sent, this bit shall be inverted with respect to its state for the previous dynamic label message. If a dynamic label message is a repeat of the previously sent dynamic label message, then this bit shall maintain its state.
- **C flag = 1:** The Toggle bit shall be maintained in the same state for all X-PAD data groups from the same dynamic label command. When a different dynamic label command is sent, either a changed command or a command that corresponds to a new dynamic label message, this bit shall be inverted with respect to its state for the previous dynamic label command. If a dynamic label command is a repeat of the previously sent dynamic label command, then this bit shall maintain its state.

**First/Last:** these flags shall be used to identify particular segments which form a succession of segments in a dynamic label message or command. The flags shall be assigned as follows:

First b <sub>14</sub>	Last b <sub>13</sub>	The segment is:
0	0	: an intermediate segment;
0	1	: the last segment;
1	0	: the first segment;
1	1	: the one and only segment.

**C (Command) flag:** this 1-bit flag shall signal whether the Control and Data fields contain message related information or command related information, as follows:

- 0: Control field and Data field contain message related information;
- 1: Control field and Data field contain command related information.

When the **C(Command) flag = 0** (message related information):

**Control field:** this 12-bit field shall contain:

- **Length:** this 4-bit field, expressed as an unsigned binary number, shall specify the number of bytes in the Character field minus 1.
- **Field 2:** this 4-bit field shall contain either a character set identifier or a segment number, depending on the value of the First flag (b<sub>14</sub>).
  - **First flag = "1":**
    - **Charset:** see clause 5.2.2.2.
  - **First flag = "0":**
    - **Rfa:** this 1-bit field is reserved for future additions. The bit shall be set to zero until it is defined.
    - **SegNum (Segment Number):** this 3-bit field, expressed as an unsigned binary number, shall specify the sequence number of the current segment minus 1. (The second segment of a label corresponds to SegNum=1, the third segment to SegNum=2, etc.) The value 0 is reserved for future use.
- **Field 3:** this 4-bit field shall contain either the text control field or is reserved, depending on the value of the First flag (b<sub>14</sub>).
  - **First flag = "1":**
    - **Text control:** see clause 5.2.2.3.2.
  - **First flag = "0":**
    - **Rfa:** this 4-bit field is reserved for future additions. The bits shall be set to zero until they are defined.

**Data field:** this  $n \times 8$  bit field shall contain:

- **Character field:** this field shall define the payload of the dynamic label segment. It shall be coded as a string of characters (maximum 16) which are chosen from the character set signalled by Charset field. If the last character of a Dynamic label segment is a multibyte character and not all bytes fit into the character field it is permitted to continue the character in the next Dynamic label segment. The first character starts with the first byte of the first dynamic label segment.

When **C(Command) flag = 1** (command related information):

**Control field:** this 12-bit field shall contain:

- **Command:** this 4-bit field shall contain a command, as follows (all other codes are reserved for future use):
  - $b_{11} - b_8$
  - 0 0 0 1: clear display command - immediately remove the dynamic label message from the display and do not redisplay the corresponding dynamic label;
  - 0 0 1 0: DL Plus command, see ETSI TS 102 980 [7].

When the **Command** field = **0 0 0 1** (clear display command):

- **Field 2:** this 4-bit field shall contain:
  - **Rfa:** reserved for future additions. The bits shall be set to zero until they are defined.
- **Field 3:** this 4-bit field shall contain:
  - **Rfa:** reserved for future additions. The bits shall be set to zero until they are defined.

**Data field:** this  $n \times 8$  bit field shall be omitted.

When the **Command** field = **0 0 1 0** (DL Plus command), Field 2, Field 3 and the DL Command field shall be used as specified in ETSI TS 102 980[7].

**CRC (Cyclic Redundancy Check):** this CRC shall be calculated on the preceding fields.

## 8 Service Information

### 8.1 Service Information (SI)

#### 8.1.1 Introduction

Service information is carried in the Fast Information Channel (FIC) as a series of Fast Information Groups (FIGs) carried in Fast Information Blocks (FIBs), see clause 5.2. Different FIGs are used for different service information, and several different FIGs may be needed to implement a particular service information feature, such as service linking or announcements. The FIC also carries Multiplex Configuration Information (MCI), see clause 6.

Service information essentially fits into two categories: unique information and list information.

For the unique information category FIGs, whatever information is carried replaces that already known to the receiver. The type 0 FIGs in the unique information category are as follows:

- FIG 0/5 - service component language, clause 8.1.2;
- FIG 0/9 - Country, LTO and International table, clause 8.1.3.2;
- FIG 0/10 - Date and Time, clause 8.1.3.1;
- FIG 0/17 - Programme Type, clause 8.1.5;
- FIG 0/18 - Announcement support, clause 8.1.6.1;
- FIG 0/19 - Announcement switching, clause 8.1.6.2;
- FIG 0/20 - Service component information, clause 8.1.4;
- FIG 0/25 - OE Announcement support, clause 8.1.6.3;

- FIG 0/26 - OE announcement switching, clause 8.1.6.4.

The type 1 and 2 FIGs, which define the various labels, are also in the unique information category. They shall be signalled for all services and service components that require selection by a user.

For the list information category FIGs, there are a variable number of items in each list, and there may be more than one list of that type of information. DAB handles the transfer of this kind of information from ensemble provider to receiver by use of FIGs using a database mechanism. The type 0 FIGs in the list information category are as follows:

- FIG 0/6 - service linking information, clause 8.1.15;
- FIG 0/15 - EWS information, clause 8.1.7;
- FIG 0/21 - Frequency Information, clause 8.1.8;
- FIG 0/24 - OE Services, clause 8.1.10.

The total set of information for each FIG is called a database, but since it may carry information from different service providers, it is divided into smaller portions to allow better management. Each portion of the database is addressed by the use of a database key so that it may be updated independently of the rest of the information. The database key is defined for each FIG and the information addressed by the database key is called a database entry.

The information carried by FIGs using the database mechanism is generally very stable, often relating to a transmitter network configuration. Since it is unknown when any particular receiver will tune to a DAB ensemble, the information needs to be transmitted cyclically. Each FIG using the database mechanism has a long form for carrying database entries and a short form for signalling that changes are to be made to a particular database entry.

Each database entry may require many FIGs to completely signal all of the information. The first FIG carrying information for a particular database entry is signalled with the C/N flag in the FIG type 0 header field (see clause 5.2.2.1) as the "start of database" entry; all subsequent FIGs needed to complete the database entry are signalled as "continuation of database" entries.

Over time, database entries will need to be changed, and this is done by means of the short form of the FIG - the Change Event Indication (CEI), which is defined separately for each FIG. The CEI mechanism works by sending a burst of short form FIGs to alert receivers of imminent changes. The short form is transmitted once per second for five seconds. When a database entry is changed, it is generally useful to send the new information for that entry more quickly than the overall repetition cycle for that database.

The FIG type 0 header field also contains the Other Ensembles (OE) and Programme/Data (P/D) flags. The OE flag is used to indicate if the information carried is for a service in the tuned ensemble or another ensemble. The P/D flag is used to indicate if the information is for a programme (audio) service or a data service, except for FIG 0/15, which has a special definition. It is not possible to mix start of database with continuation of database, tuned ensemble and other ensemble information, or audio service and data service information within a single FIG since the three header flags apply to all the information in the FIG.

Most FIGs are assigned a single repetition rate, but for database FIGs where long and short form FIGs are used, different repetition rates are assigned. Common repetition rates are as follows:

- ten times per second;
- once per second;
- once per ten seconds;
- complete database in two minutes.

The general process for signalling a database entry definition (or redefinition) is as follows:

- The CEI is signalled at least once per second for a period of five seconds. CEI is defined as the short form FIG with the C/N flag set to 0 and the database key defining which part of the database is being changed.
- The database definition begins using the long form FIG. The C/N flag is set to 0 for the start of the database definition and if more FIGs are required to complete the database entry, these are sent with C/N set to 1. The complete database entry for each key should generally be transmitted within 10 seconds.

The general process for maintaining the database is to cycle through all the database entries every two minutes to allow newly tuned in receivers to acquire the information.

For each FIG, the specific repetition rates to be used for each signalling situation are defined in the clauses describing the FIG.

The coding of these features in the Fast Information Channel (FIC) is given by reference to their FIG type and Extension (see clause 5.2).

## 8.1.2 Service component language

The service component language feature is used to signal a language associated with a service component; the spoken language of an audio component or the language of the content of a data component. This information can be used for user selection or display. The feature is encoded in Extension 5 of FIG type 0 (FIG 0/5). Figure 37 shows the structure of the service component language field which is part of the Type 0 field (see also figure 7).

The FIG type 0 flags (see clause 5.2.2.1) are used as follows: C/N flag - Rfu; OE flag - Rfu; P/D flag - Rfu.

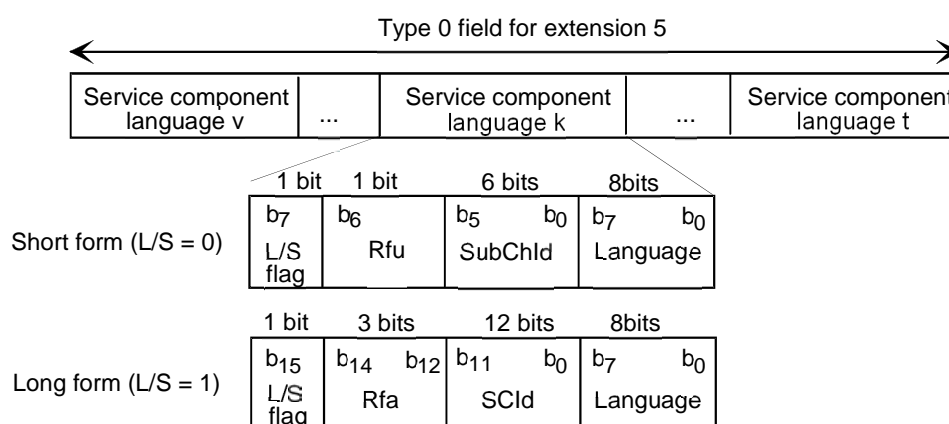

**Figure 37: Structure of the service component language field**

The following definitions apply:

**L/S flag:** this 1-bit flag shall indicate whether the service component identifier takes the short or the long form, as follows:

- 0: short form;
- 1: long form.

### Short form:

- **Rfu:** this 1-bit field shall be reserved for future use of the SubChId field. The Rfu bit shall be set to zero for the currently specified definition of this field;
- **SubChId (Sub-channel Identifier):** this 6-bit field shall identify the sub-channel in which the service component is carried;
- **Language:** this 8-bit field shall indicate the language of the audio or data service component. It shall be coded according to ETSI TS 101 756 [3], tables 9 and 10.

### Long form:

- **Rfa:** this 3-bit field shall be reserved for future additions. The bits shall be set to zero until they are defined;
- **SCId:** this 12-bit field shall identify the service component (see clause 6.3.1);
- **Language:** see above.

The FIG 0/5 has a repetition rate of once per second.

## 8.1.3 Time and country identifier

### 8.1.3.1 Date and time (d&t)

The date and time feature is used to signal a location-independent timing reference in UTC format. This feature is encoded in Extension 10 of FIG type 0 (FIG 0/10). Figure 38 shows the structure of the date and time field which is part of the Type 0 field (see also figure 7). The time reference shall be defined by the synchronization channel (see clause 14.3.3).

The FIG type 0 flags (see clause 5.2.2.1) are used as follows: C/N flag - Rfu; OE flag - Rfu; P/D flag - Rfu.

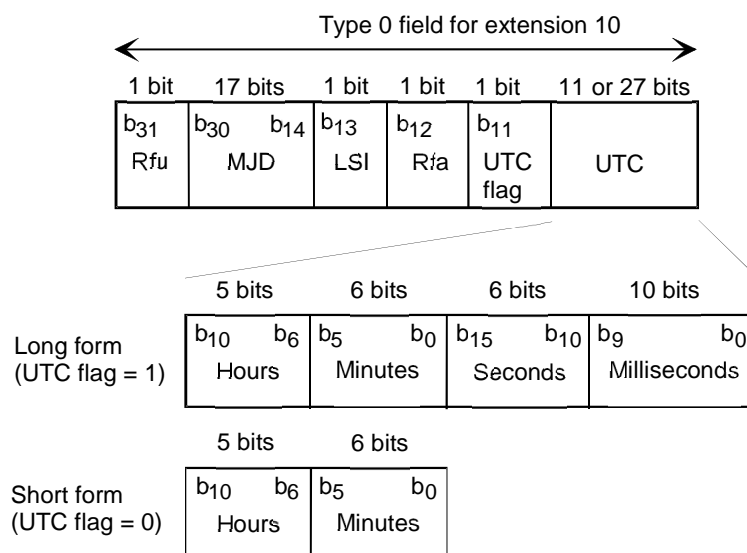

**Figure 38: Structure of the date and time field**

The following definitions apply:

**Rfu:** this 1-bit field shall be reserved for future use of the remainder of the Type 0 field for extension 10. The bit shall be set to zero for the currently specified definition of this field.

**MJD (Modified Julian Date):** this 17-bit binary number shall define the current date according to the Modified Julian coding strategy. This number increments daily at 0000 Co-ordinated Universal Time (UTC) and extends over the range 0 to 99 999, where MJD 0 is 1858-11-17. As an example, MJD 58 000 corresponds to 2017-09-04.

**LSI (Leap Second Indicator):** this 1-bit flag shall be set to "1" for the period of one hour before the occurrence of a leap second.

**Rfa:** this 1-bit field shall be reserved for future additions. The bit shall be set to zero until it is defined.

**UTC flag:** this 1-bit field shall indicate whether the UTC (see below) takes the short form or the long form, as follows:

0: UTC short form (legacy support only);

1: UTC long form.

Transmission systems shall always set the UTC flag = 1.

**NOTE:** Previous versions of the present document permitted the UTC flag = 0; for a transitional period these transmissions may remain on-air and so receivers should check the value of the UTC flag.

**UTC (Co-ordinated Universal Time):** two forms are available depending upon the state of the UTC flag. They shall be defined as follows:

- **long form:** this 27-bit field shall contain four sub-fields, coded as unsigned binary numbers. The first sub-field is a 5-bit field which shall define the hours; the second sub-field is a 6-bit field which shall define the minutes; the third sub-field is a 6-bit field which shall define the seconds and the fourth sub-field is a 10-bit field which shall define the milliseconds.
- **short form:** this 11-bit field contains two sub-fields, coded as unsigned binary numbers. The first sub-field is a 5-bit field which shall define the hours and the second sub-field is a 6-bit field which shall define the minutes; this coding is provided only for support of legacy transmission equipment.

The FIG 0/10 has a repetition rate of once per second.

### 8.1.3.2 Country, LTO and International table

The Country, LTO and International table feature defines the local time offset, the International Table and the Extended Country Code (ECC) for programme services (the ECC is already part of the data service SID field). The feature is encoded in Extension 9 of FIG type 0 (FIG 0/9). Figure 39 shows the structure of the country, LTO and international table field which is part of the Type 0 field (see also figure 7).

The FIG type 0 flags (see clause 5.2.2.1) are used as follows: C/N flag - Rfu; OE flag - Rfu; P/D flag - Rfu.

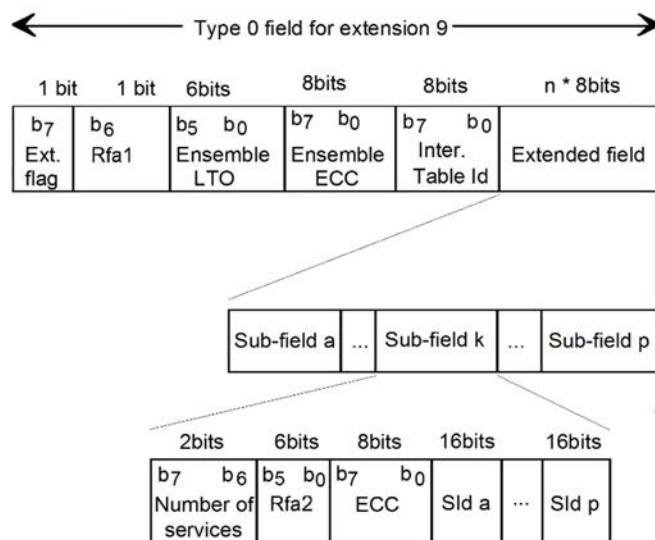

**Figure 39: Structure of the country field**

The following definitions apply:

**Ext. (Extension) flag:** this 1-bit flag shall indicate whether the Extended field is present or not, as follows:

- 0: extended field absent;
- 1: extended field present.

**Rfa1:** this 1-bit field shall be reserved for future additions. The bit shall be set to zero until it is defined.

**Ensemble LTO (Local Time Offset):** this 6-bit field shall give the Local Time Offset (LTO) for the ensemble. It is expressed in multiples of half hours in the range -15,5 hours to +15,5 hours. Bit  $b_5$  shall give the sense of the LTO, as follows:

- 0: positive offset;
- 1: negative offset.

**Ensemble ECC (Extended Country Code):** this 8-bit field shall make the Ensemble Id unique worldwide. The ECC shall be as defined in ETSI TS 101 756 [3], tables 3 to 7.

**Inter. (International) Table Id:** this 8-bit field shall be used to select an international table. The interpretation of this field shall be as defined in ETSI TS 101 756 [3], table 11.

**Extended field:** this  $n \times 8$ -bit field shall contain one or more sub-fields, which define those services for which their ECC differs from that of the ensemble. The maximum length of the extended field is 25 bytes. The following definitions apply to each sub-field:

- **Number of services:** this 2-bit field, expressed as an unsigned binary number, shall indicate the number of services (in the range 0 to 3) contained in the subsequent SId list;
- **Rfa2:** this 6-bit field shall be reserved for future additions. These bits shall be set to zero until they are defined;
- **ECC (Extended Country Code):** this 8-bit field shall be coded in the same way as the Ensemble ECC;
- **SId (Service Identification):** this 16-bit field shall identify the service, see clause 6.3.1.

The FIG 0/9 has a repetition rate of once per second.

## 8.1.4 Service Component Information

The Service Component Information (SCI) feature is used to signal information about services and service components to assist in the construction of a service list. The feature is encoded in Extension 20 of FIG type 0 (FIG 0/20). Figure 40 shows the structure of the Service Component Information field which is part of the Type 0 field (see also figure 7).

The use of the Service Component Information feature is described in detail in ETSI TS 103 176 [5].

The FIG type 0 flags (see clause 5.2.2.1) are used as follows: C/N flag - Rfu; OE flag - Rfu; P/D flag - P/D.

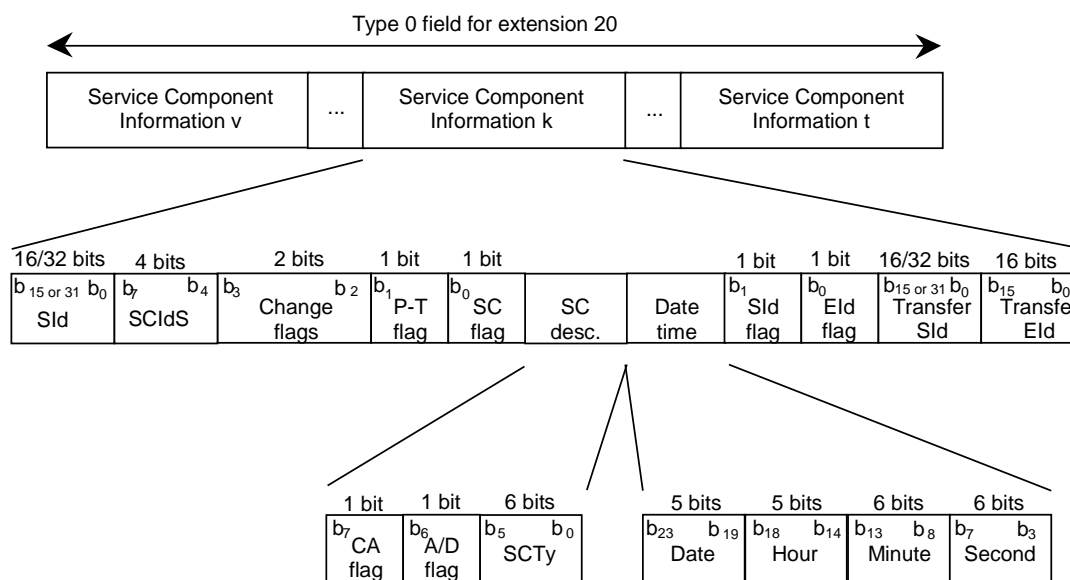

**Figure 40: Structure of Service Component Information field**

The following definitions apply:

**SId (Service Identifier):** this 16-bit or 32-bit field shall identify the service (see clause 6.3.1). The length of the SId shall be signalled by the P/D flag, see clause 5.2.2.1.

**SCIdS (Service Component Identifier within the Service):** this 4-bit field shall identify the service component within the service.

**Change flags:** this 2-bit field shall indicate future changes to a service element, as follows:

- 0 0: the service will remain in the ensemble with a new SId or will be moved to or from another ensemble;
- 0 1: the service element will be added to the ensemble;
- 1 0: the service element will be removed from the ensemble;
- 1 1: the service element will be removed from all ensembles.

**P-T (Part-time) flag:** this 1-bit flag shall indicate whether the service element is on-air or off-air continuously or cycles through on-air and off-air periods, as follows:

- 0: the service element is on-air or off-air continuously (i.e. 24 hours/day);
- 1: the service element cycles on-air and off-air (i.e. part-time).

**SC (Service Component) flag:** this 1-bit flag shall indicate the presence of the SC description field, as follows:

- 0: SC description field is absent;
- 1: SC description field is present.

**SC (Service Component) description:** the presence of this field is indicated by the SC flag. When present it contains the following:

- **CA flag:** this 1-bit field flag shall indicate whether access control applies to the service component, as follows:
  - 0: no access control or access control applies only to a part of the service component;
  - 1: access control applies to the whole of the service component.
- **A/D flag:** this 1-bit flag shall indicate whether the SCTy field carries the ASCTy or DSCTy, as follows:
  - 0 : ASCTy;
  - 1 : DSCTy.
- **SCTy (Service Component Type):** this 6-bit field shall carry either the ASCTy or DSCTy of the service component in accordance with the A/D flag.

**Date-time:** this field contains the following:

- **Date:** this 5-bit field shall carry the lower 5 bits of the MJD for the day on which the service component change occurs and which shall be no more than 28 days ahead of the current date.

NOTE 1: The Date field refers to the earliest future event - there may be an implied carry bit in the MJD - unless the Hour, Minute and Second fields carry the special value.

- **Hour:** this 5-bit field shall define the hour in UTC at which the service component change occurs in the range 0 to 23, or the special value 31.
- **Minute:** this 6-bit field shall define the minute in UTC at which the service component change occurs in the range 0 to 59, or the special value 63.
- **Second:** this 6-bit field shall define the second in UTC at which the service component change occurs in the range 0 to 59, or the special value 63.

NOTE 2: When the Hour, Minute and Second fields carry the special value, the Date field has no meaning.

NOTE 3: The precise instant of any change is signalled by the reconfiguration instant in FIG 0/0 (see clause 6.3.5).

**SId flag:** this 1-bit field shall indicate the presence of the Transfer SId field as follows:

- 0: Transfer SId field is absent;
- 1: Transfer SId field is present.

**EId flag:** this 1-bit field shall indicate the presence of the Transfer EId field as follows:

0: Transfer EId field is absent;

1: Transfer EId field is present.

**Transfer SId:** this 16-bit or 32-bit field, when present, shall contain the SId of the re-directed service. The length of the Transfer SId field shall be signalled by the P/D flag, see clause 5.2.2.1.

NOTE 4: The ECC of the Transfer SId is identical to the ECC of the SId.

**Transfer EId:** this 16-bit field, when present, shall contain the EId of the ensemble that contains the re-directed service.

NOTE 5: The ECC of the Transfer EId is identical to the ECC of the tuned ensemble.

FIG 0/20 shall be signalled at a repetition rate of once per second.

## 8.1.5 Programme Type

The Programme Type (PTy) feature allows programme contents to be categorized according to their intended audience.

The Programme Type feature is encoded in Extension 17 of FIG type 0 (FIG 0/17). The Programme Type code applies to all the audio components of the service. Figure 41 shows the structure of Programme Type field which is part of the Type 0 field (see also figure 7).

The FIG type 0 flags (see clause 5.2.2.1) are used as follows: C/N flag - Rfu; OE flag - Rfu; P/D flag - Rfu.

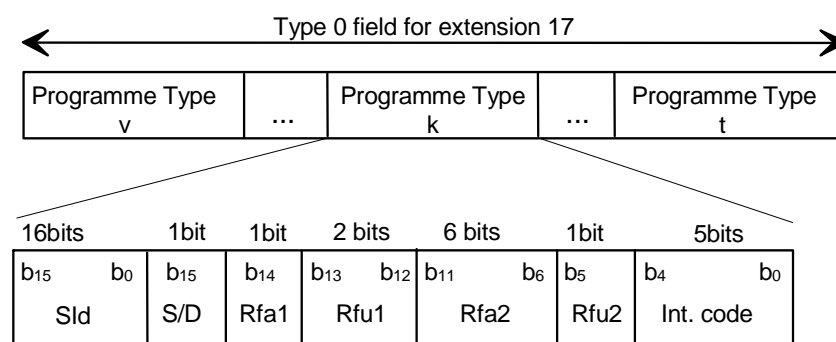

**Figure 41: Structure of the Programme Type field**

The following definitions apply:

**SId (Service Identifier):** this 16-bit field shall identify the service (see clause 6.3.1).

**S/D (Static/Dynamic):** this 1-bit flag shall indicate that the Programme Type code signalled in the programme type field, represents the current programme contents, as follows:

0: Programme Type code may not represent the current programme contents;

1: Programme Type code represents the current programme contents.

NOTE: When the S/D flag is set to 0 it indicates that the programme type does not change within a programme as the content changes for individual items but indicates the overall genre of the programme. When the S/D flag is set to 1 it indicates that the programme type does follow the various items within a programme.

At any one time, the PTy shall be either Static or Dynamic; there shall be only one PTy per service.

**Rfa1:** this 1-bit field shall be reserved for future additions. The bit shall be set to zero until it is defined.

**Rfu1:** this 2-bit field shall be reserved for future use. The bits shall be set to zero until they are defined.

**Rfa2:** this 6-bit field shall be reserved for future additions. The bits shall be set to zero until they are defined.

**Rfu2:** this 1-bit field shall be reserved for extending the international code field range. The bit shall be set to zero for the currently specified international code field.

**Int. (International) code:** this 5-bit field shall specify the basic Programme Type (PTy) category. This code is chosen from an international table (see clause 8.1.3.2).

The FIG 0/17 has a repetition rate of once per second.

## 8.1.6 Announcements

### 8.1.6.0 General

The Announcement feature allows a listener to be temporarily re-directed from the currently selected audio service component to another audio service component that provides a (largely) spoken message in the form of a short announcement. Different types of announcement can be signalled.

Each service explicitly permits interruption from announcements by using the announcement support information: if no support information is provided for a service it cannot be interrupted, unless overridden by the ensemble-wide permission for alarm announcements. Alarm announcements are a special kind of announcement which are enabled and disabled in the tuned ensemble by setting the AI flag in the FIG 0/0 (see clause 6.4.1).

The permissions for non-alarm announcements carried in the tuned ensemble are signalled with the announcement support feature (FIG 0/18) and those for announcements carried in other ensembles are signalled with the OE announcement support feature (FIG 0/25). The interruption mechanism depends on various selection (filter) criteria:

- which sources are permitted to interrupt the selected audio service;
- which types of announcement are permitted to interrupt the selected audio service;
- which types of announcement the user has selected to be active (alarm announcements are always active).

When an announcement is active within the tuned ensemble, announcement switching information (FIG 0/19) is provided to identify the target of the announcement, the type of the announcement, and the location of the audio service component. In the case of an alarm announcement, the switching information shall only be provided when alarm announcements are enabled with the AI flag in the FIG 0/0, and receivers shall ignore any received announcement switching information for alarm announcements when they are not enabled.

When an announcement is active in another ensemble (and which provides the announcements for services in the tuned ensemble with OE announcement support), OE announcement switching information (FIG 0/26) is signalled in the tuned ensemble to alert the receiver to the start of the announcement. In the case of an alarm announcement, the switching information shall only be provided when alarm announcements are enabled with the AI flag in the FIG 0/0, and receivers shall ignore any received announcement switching information for alarm announcements when they are not enabled.

After an announcement, the originally selected service component shall be reselected automatically.

The use of the Announcements feature is described in detail in ETSI TS 103 176 [5].

#### 8.1.6.1 Announcement support

The announcement support feature is encoded in Extension 18 of FIG type 0 (FIG 0/18). Figure 42 shows the structure of announcement support field which is part of the Type 0 field (see also figure 7). FIG 0/18 signals the permissions for services carried in the tuned ensemble to be interrupted by announcements carried in the tuned ensemble.

The FIG type 0 flags (see clause 5.2.2.1) are used as follows: C/N flag - Rfu; OE flag - Rfu; P/D flag - Rfu.

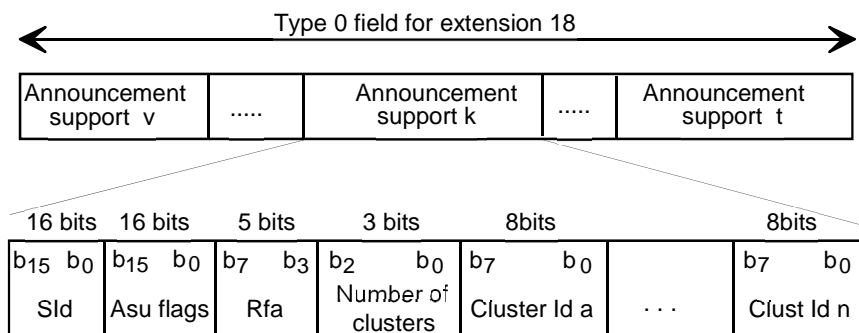

**Figure 42: Structure of announcement support field**

The following definitions apply:

**SId (Service Identifier):** this 16-bit field shall identify the service (see clause 6.3.1).

**ASu (Announcement support) flags:** this 16-bit flag field shall specify the type(s) of announcements by which it is possible to interrupt the reception of the service from another service component in the same ensemble. The interpretation of this field shall be as defined in ETSI TS 101 756 [3], table 14.

- The flags shall be coded as follows:
  - $b_0$  shall be set to "0";
  - $b_i$  ( $i = 1$  to 15);
    - 0: Announcement type shall not interrupt the service;
    - 1: Announcement type may interrupt the service.

**NOTE:** The  $b_0$  is set to "0" because ensemble-wide support for alarm announcements is provided by the AI flag in FIG 0/0.

**Rfa:** this 5-bit field shall be reserved for future additions. The bits shall be set to zero until they are defined.

**Number of clusters:** this 3-bit field, coded as an unsigned binary number, shall specify the number of the following Cluster Ids (maximum 7).

**Cluster Id:** this 8-bit field shall identify the announcement cluster for which the announcement is intended. The Cluster Id identifies a group of services in the tuned ensemble which share the same announcement interruption privileges. Cluster Id = "0000 0000" and Cluster Id = "1111 1111" are pre-defined (see clause 8.1.6.2) and shall not be signalled in the announcement support field.

The FIG 0/18 has a repetition rate of once per second.

### 8.1.6.2 Announcement switching

The announcement switching description is encoded in Extension 19 of FIG type 0 (FIG 0/19). Figure 43 shows the structure of the announcement switching field which is part of the Type 0 field (see also figure 7). FIG 0/19 signals the properties of an announcement that is carried in the tuned ensemble.

The FIG type 0 flags (see clause 5.2.2.1) are used as follows: C/N flag - Rfu; OE flag - Rfu; P/D flag - Rfu.

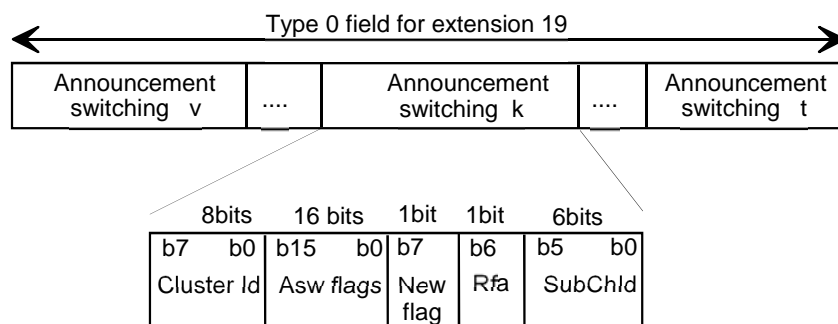

**Figure 43: Structure of announcement switching field**

The following definitions apply:

**Cluster Id:** this 8-bit field shall identify the announcement cluster, for which the announcement is intended. Cluster Id = "0000 0000" shall not be used. Cluster Id = "1111 1111" shall be used exclusively for all Alarm announcements.

**ASw (Announcement switching) flags:** this 16-bit field shall specify the announcement types which apply to the announcement. The individual bits indicate whether or not a particular announcement type is signalled. The interpretation of the flags shall be as defined in ETSI TS 101 756 [3], table 14. The flags shall be coded as follows:

$b_i$  ( $i = 0$  to 15);

0: Announcement type not valid: the audio does not include information concerning this announcement type;

1: Announcement type valid: the audio includes information concerning this announcement type.

**New flag:** this 1-bit flag shall indicate whether the announcement is newly introduced, as follows:

0: ongoing announcement;

1: newly introduced announcement.

**Rfa:** this 1-bit field shall be reserved for future additions. The bit shall be set to zero until it is defined.

**SubChId:** this 6-bit field shall identify the sub-channel which contains the audio service component carrying the announcement.

At the start of an announcement, FIG 0/19 shall be signalled with a repetition rate of ten times per second for the first five seconds and then at a rate of once per second for the duration of the announcement. At the end of the announcement, the FIG 0/19 shall be signalled with the Asw flags set to all zero with a repetition rate of ten times per second for two seconds.

### 8.1.6.3 OE Announcement support

The OE announcement support feature is encoded in Extension 25 of FIG type 0 (FIG 0/25). Figure 44 shows the structure of the OE announcement support field which is part of the Type 0 field (see also figure 7). FIG 0/25 signals the permissions for services carried in the tuned ensemble to be interrupted by announcements carried in other ensembles.

The FIG type 0 flags (see clause 5.2.2.1) are used as follows: C/N flag - Rfu; OE flag - Rfu; P/D flag - Rfu.

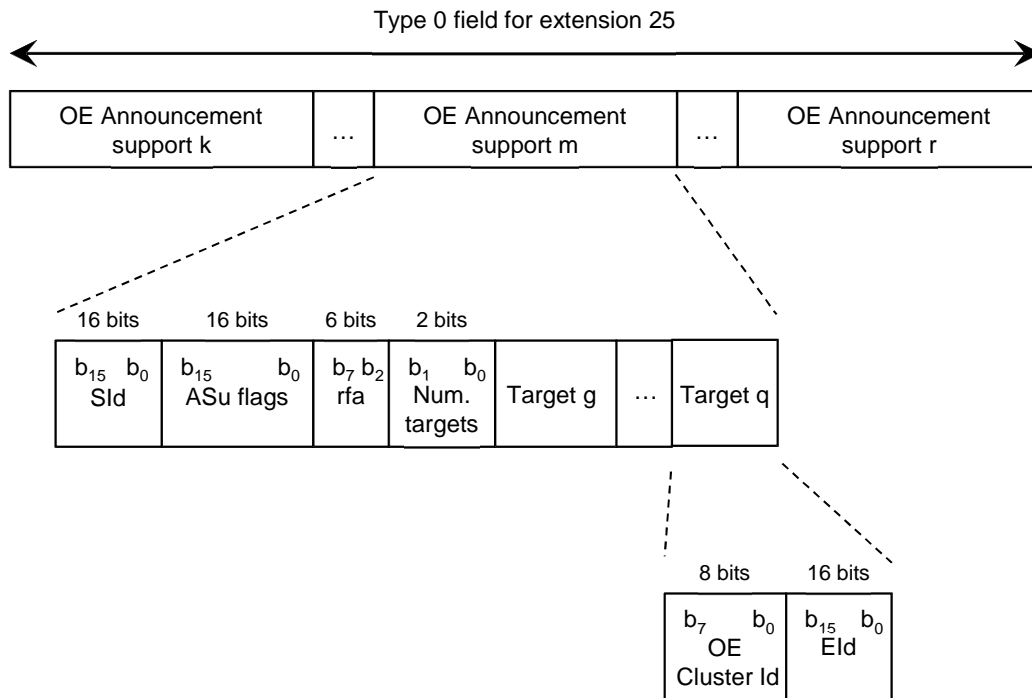

**Figure 44: Structure of other ensembles announcement support field**

The following definitions apply:

**SId (Service Identifier):** this 16-bit field shall identify the service (see clause 6.3.1).

**ASu (Announcement support) flags:** see clause 8.1.6.1.

**Rfa:** this 6-bit field shall be reserved for future additions. The bits shall be set to zero until they are defined.

**Num. targets:** this 2-bit field, expressed as an unsigned binary number, shall indicate the number of Targets - 1 (i.e. 1 to 4 targets).

**Target:** this field shall identify a permitted target for the announcement.

- **OE Cluster Id:** this 8-bit field shall identify the announcement cluster for which the announcement is directed in the current ensemble. The OE Cluster Id identifies a group of services in the tuned ensemble which share the same announcement interruption privileges. OE Cluster Id = "1111 1111" is pre-defined (see clause 8.1.6.4) and shall not be signalled in the OE announcement support field.
- **EId (Ensemble Identifier):** this 16-bit field shall identify the ensemble that carries the announcement service component. The coding details are given in clause 6.4.

The FIG 0/25 has a repetition rate of once per second.

#### 8.1.6.4 OE Announcement switching

The OE announcement switching description is encoded in Extension 26 of FIG type 0 (FIG 0/26). Figure 45 shows the structure of the OE announcement switching field which is part of the Type 0 field (see also figure 7). FIG 0/26 signals the properties of an announcement that is carried in another ensemble.

The FIG type 0 flags (see clause 5.2.2.1) are used as follows: C/N flag - Rfu; OE flag - Rfu; P/D flag - Rfu.

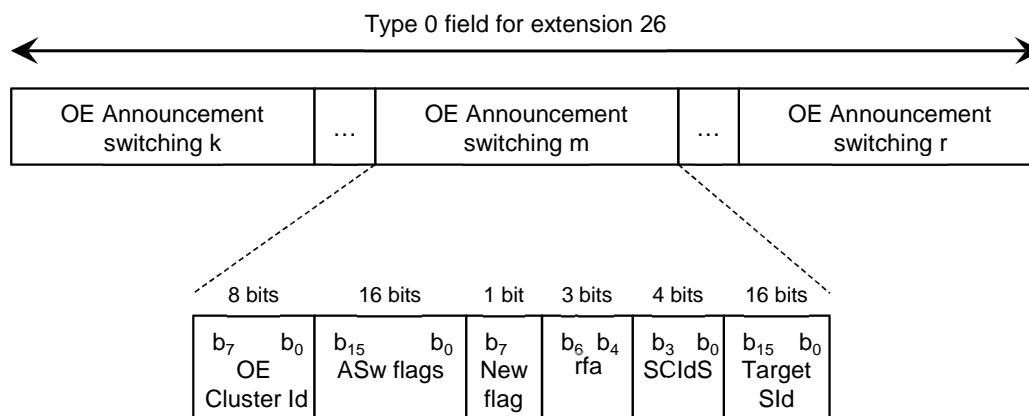

**Figure 45: Structure of announcement switching field**

The following definitions apply:

**OE Cluster Id:** this 8-bit field shall identify the OE announcement cluster, in the tuned ensemble, to which the announcement is intended. OE Cluster Id = "1111 1111" shall be used exclusively for all Alarm announcements.

**ASw (Announcement switching) flags:** see clause 8.1.6.2.

**New flag:** see clause 8.1.6.2.

**Rfa:** this 3bit field shall be reserved for future additions. The bits shall be set to zero until defined.

**SCIdS (Service Component Identifier within the Service):** this 4-bit field shall identify the service component within the service that carries the announcement in the other ensemble (see clause 6.3.5). When an alarm announcement is being signalled, the SCIdS field shall be set to "0".

**Target Sid (Service Identifier):** this 16-bit field shall identify the service that carries the announcement in the other ensemble (see clause 6.3.1). When an alarm announcement is being signalled, the Sid field shall carry the Ensemble Id (EId) of the ensemble making the alarm announcement.

NOTE: If alarm announcements are made on several other ensembles then several FIG 0/26 groups will occur.

At the start of an announcement, FIG 0/26 shall be signalled with a repetition rate of ten times per second for the first five seconds and then at a rate of once per second for the duration of the announcement. At the end of the announcement, the FIG 0/26 shall be signalled with the ASw flags set to all zero with a repetition rate of ten times per second for two seconds.

## 8.1.7 EWS information

The EWS information description is encoded in Extension 15 of FIG type 0 (FIG 0/15). Figure 45a shows the structure of the EWS information field which is part of the Type 0 field (see also figure 7). FIG 0/15 signals participation of an ensemble in an EWS, and the status and localization for EWS audio alerts that are carried in the tuned ensemble or in another ensemble. The alert area, when smaller than the complete ensemble coverage area, is defined by the use of location codes (see annex A). In order to allow complex alert areas to be signalled, a set of FIG 0/15s can be signalled: the set comprises between one and four FIG 0/15 instances. One or more alerts may be signalled concurrently: in this case there will be a set of one to four FIG 0/15s for each alert; the complete collection of FIG 0/15s that describe the current alert information is known as an alert group.

The use of the EWS Information feature is described in detail in ETSI TS 104 089 [12].

The FIG type 0 flags (see clause 5.2.2.1) are used as follows: C/N flag - SIV; OE flag - OE; P/D flag - special definition.

The P/D flag is used to ensure synchronization between the transmission equipment and receiving equipment that operates a sleep mode. It shall be set as follows:

0: Process

1: Discard

This feature shall use the SIV signalling (see clause 5.2.2.1). The database shall be divided by use of a database key. Changes to the database shall not be signalled using the CEI mechanism, because an alert database only exists during the alert.

A special form of FIG 0/15 is used as a heartbeat indicator (control function, C/N flag is set to 1) to identify that the ensemble is part of an EWS and will carry alert information when alerts are active. The heartbeat form has an empty type 0 field and is identified by the length field of the FIG type 0 header being equal to 1. The OE flag shall be set to 0. The heartbeat form of FIG 0/15 shall not be transmitted when alerts are signalled.

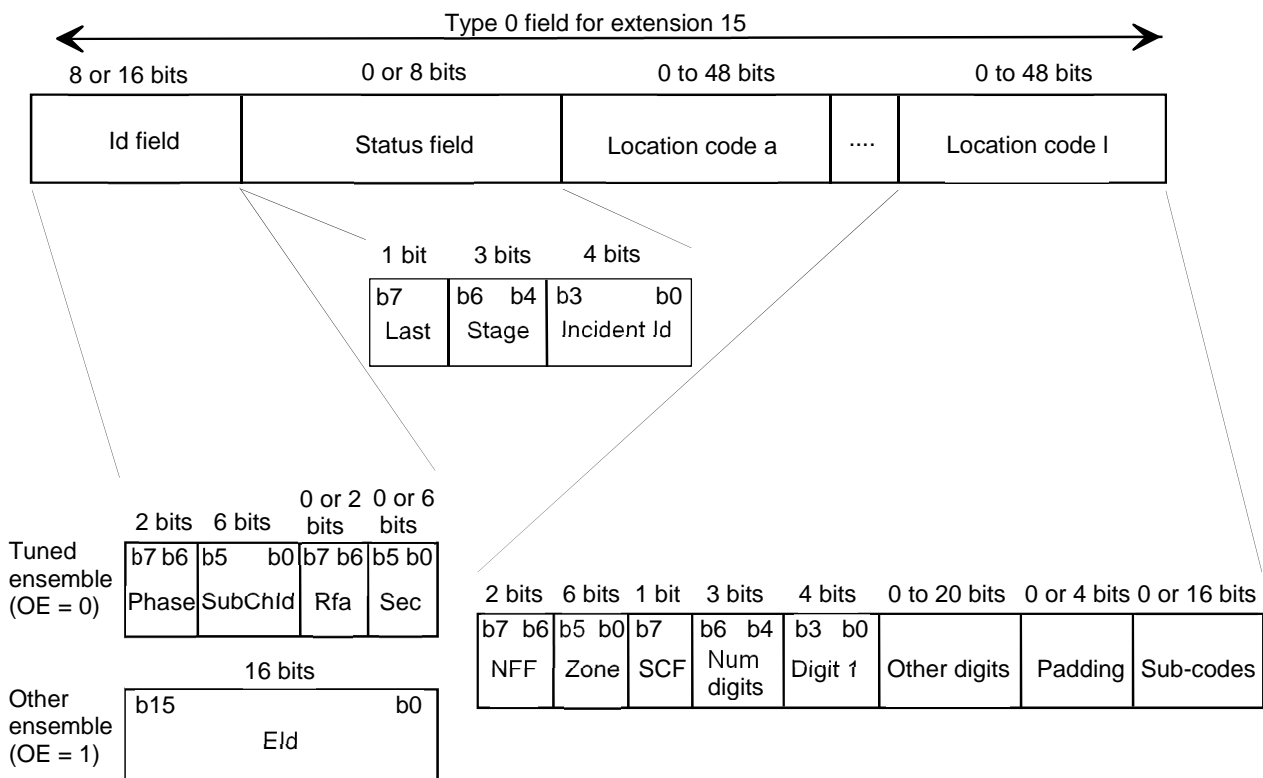

Figure 45a: Structure of EWS information field

The following definitions apply:

**Id field:** this 8- or 16-bit field shall contain the identity of the alert audio service component or the ensemble that carries the alert audio service component. The OE flag in the FIG type 0 header field (see clause 5.2.2.1) shall determine if the service component is in the tuned ensemble or another ensemble. The following definitions apply:

- **Phase:** this 2-bit field shall indicate the phase of the tuned ensemble alert, as follows:

0 0: Pre-trigger;

0 1: Trigger;

1 0: Sustain;

1 1: End.

- **SubChId:** this 6-bit field shall identify the sub-channel which contains the audio service component carrying the audio alert.

- **Rfa:** this 2-bit field shall only be present when the Phase field = Pre-trigger. The bits are reserved for future addition and shall be set to 0.
- **Sec:** this 6-bit field, coded as an unsigned binary integer, shall only be present when the Phase field = Pre-trigger and shall contain the seconds count corresponding to the start of the Trigger phase.
- **EId (Ensemble Identifier):** this 16-bit field shall identify the other ensemble that carries the audio alert.

**Status field:** this 8-bit field, when present, shall provide information about the alert. The following definitions apply:

- **Last:** this 1-bit flag shall indicate if this is the last FIG 0/15 to be signalled in this alert group as follows:
  - 0: not the last FIG 0/15 of the alert group
  - 1: the last FIG 0/15 of the alert group
- **Stage:** this 3-bit field shall indicate the stage of the EWS alert, as follows:
  - 0 0 0: Level 1 Start
  - 0 0 1: Level 1 Update
  - 0 1 0: Level 1 Repeat
  - 0 1 1: Level 1 Critical
  - 1 0 0: Level 2 Start
  - 1 0 1: Level 2 Update
  - 1 1 0: Level 2 Repeat
  - 1 1 1: Test
- **Incident Identifier (IId):** this 4-bit field, coded as an unsigned binary integer, shall identify an incident that is composed of a series of audio alerts. The value is assigned by the ensemble that carries the audio alert and shall be maintained through the various stages of an incident.

**Location code:** these  $n \times 8$ -bit fields define the geographic area that the EWS alert applies to. The areas specified are additive. If no location codes are provided then the alert is relevant to the entire ensemble coverage area. The number of location codes carried is not specified, but location codes fill the rest of the FIG 0/15 specified by the length field of the FIG 0/15 header. The following definitions apply:

- **NFF:** this 2-bit field, expressed as an unsigned binary number in the range 0 to 3, shall indicate the number of FIG 0/15s for this alert set which follow in order to signal the complete alert area.

NOTE 1: NFF is not part of the location code, it is provided for determining the integrity of the complete alert area.

NOTE 2: When the C/N flag in the type 0 header is set to 0, (NFF + 1) indicates the total number of FIG 0/15s in the alert set.

- **Zone:** this 6-bit field, expressed as an unsigned binary number, shall identify the global zone as defined in annex A.
- **SCF:** this 1-bit flag shall indicate whether the Sub-codes field is present or not, as follows:
  - 0: Sub-codes field is absent: the location code contains a single spherical rectangle.
  - 1: Sub-codes field is present: the location code contains 2 to 15 spherical rectangles.
- **Num digits:** this 3-bit field, expressed as an unsigned binary number, shall indicate the number of digits, in the range 0 to 5, contained in the subsequent Other digits field.

NOTE 3: When SCF=1, the smallest spherical rectangles are sub-coded and Num digits is in the range 0 to 4.

- **Digit 1:** this 4-bit field shall specify the most significant digit of the location code (see annex A). The special value 0 may be used for the polar zones to indicate the entire zone.

- **Other digits:** this 0- to 20-bit field shall only be present when the Other digits field is greater than 0. It shall contain all the remaining digits of the location code when SCF = 0 and all but the least significant digit of the remaining digits when SCF = 1.

NOTE 4: When SCF=1, the smallest spherical rectangles are sub-coded and so there are a maximum of 4 other digits.

- **Padding:** this 4-bit field shall only be present when Num digits is an odd number. All bits shall be set to 0.
- **Sub-codes:** this 16-bit flag field shall only be present when the SCF flag is set to 1. It shall specify between 2 and 15 spherical rectangles that are the sub-areas of the area specified by the zone and coded digits. The definition of the sub-areas is given in annex A. The use of sub-codes permits efficient coding of a more precisely defined area to be specified. The flags shall be coded as follows:

$b_i$  ( $i = 0$  to 15)

0: sub-area  $i$  is not part of alert area

1: sub-area  $i$  is part of alert area

NOTE 5: For 1 spherical rectangle, the coding efficiency is greater by including the least significant digit in the Other digits field; for 16 spherical rectangles, the sub-coding is not required as all sub-areas are part of the alert area.

The database key comprises the **OE** flag (see clause 5.2.2.1) and the **Id field**.

There is no Change Event Indication (CEI).

When no alert is signalled, the heartbeat form of FIG 0/15 shall be used to indicate that the ensemble is part of the EWS.

NOTE 6: If multiple EWS alerts are active concurrently, the capacity of the FIC for all other features could be reduced. Receivers may expect that the nominal repetition rates of FIG 0/15 and of other FIGs may be affected.

## 8.1.8 Frequency Information

The Frequency Information feature is assigned to providing radio Frequency Information (FI). The feature is encoded in Extension 21 of FIG type 0 (FIG 0/21). Figure 46 shows the structure of the FI field which is part of the Type 0 field (see also figure 7).

The FIG type 0 flags (see clause 5.2.2.1) are used as follows: C/N flag - SIV; OE flag - OE; P/D flag - Rfu.

When the FI applies to the tuned ensemble, or to a Primary service component from the tuned ensemble carried via FM with RDS, AM with AMSS or DRM, the OE flag shall be set to "0".

When the FI applies to other ensembles, or to services not in the tuned ensemble carried via FM with RDS, AM with AMSS or DRM, the OE flag shall be set to "1".

This feature shall use the SIV signalling (see clause 5.2.2.1). The database shall be divided by use of a database key. Changes to the database shall be signalled using the CEI.

Frequency information forms part of the signalling used for service following and OE announcements, which is described in detail in ETSI TS 103 176 [5].



- **R&M (Range & Modulation):** this 4-bit field shall define the range and modulation parameters which affect the structure of the alternative frequencies list. Unused entries are reserved for future use of the Frequency list field. The coding is as follows:

$b_7 - b_4$ ;

0 0 0 0: DAB ensemble;

0 1 1 0: DRM;

1 0 0 0: FM with RDS;

1 1 1 0: AMSS.

- **Continuity flag:** this 1-bit flag shall depend on the R&M field, as follows:
  - If R&M = "0000" the continuity flag shall signal that:
    - 0: continuous output not expected;
    - 1: continuous output possible.
  - If R&M = "0110", "1000" or "1110" the continuity flag shall indicate whether, or not, there is an appropriate time delay on the audio signal of an alternative service source on DRM/FM/AM to compensate the decoding time delay of DAB:
    - 0: no compensating time delay on DRM/FM/AM audio signal;
    - 1: compensating time delay on DRM/FM/AM audio signal.
  - For R&M = "0110", "1000" and "1110", the Continuity flag is only valid for OE = "0". For OE = "1", the bit  $b_3$  is reserved for future addition.
- **Length of Freq. (frequency) list:** this 3-bit field, expressed as an unsigned binary number, shall represent the length in bytes of the following Frequency list field;
- **Freq. (frequency) list:**

The structure of the frequencies list depends on R&M:

- **R&M = 0000:**
  - **Control field:** this 5-bit field shall be used to qualify the immediately following Freq (Frequency) a field. The following functions are defined (the remainder shall be reserved for future use of the Freq a field):
    - $b_{23} - b_{19}$ ;
    - 0 0 0 0 0: geographically adjacent area, no transmission mode signalled;
    - 0 0 0 1 0: geographically adjacent area, transmission mode I;
    - 0 0 0 0 1: not geographically adjacent area, no transmission mode signalled;
    - 0 0 0 1 1: not geographically adjacent area, transmission mode I.
  - **Freq (Frequency) a:** this 19-bit field, coded as an unsigned binary number, shall represent the carrier frequency associated with the alternative service source or other service.

The centre carrier frequency of the other ensemble is given by (in this expression, the decimal equivalent of freq a is used):

$$0 \text{ Hz} + (\text{Freq a} \times 16 \text{ kHz}).$$

The following values of the carrier frequency are defined:

b <sub>18</sub>	b <sub>0</sub>	Decimal	
0 0 0 0 0 0 0 0 0 0 0 0 0 0 0 0 0 0		0	: Not to be used;
0 0 0 0 0 0 0 0 0 0 0 0 0 0 0 0 0 1		1	: 16 kHz;
0 0 0 0 0 0 0 0 0 0 0 0 0 0 0 0 1 0		2	: 32 kHz;
" " " " " "			
1 1 1 1 1 1 1 1 1 1 1 1 1 1 1 1 1 1		524 287	: 8 388 592 kHz.

- **R&M = 0110:**

- **Id field 2:** this 8-bit field represents the DRM Service Identifier (most significant byte) (see ETSI ES 201 980 [8]).
- **Freq (Frequency) c:** this 16-bit field, consists of the following fields:
  - **multiplier:** this 1-bit field shall indicate the frequency multiplier as follows:
    - 0: 1 kHz (the Freq c field can indicate from 0 to 32 767 kHz in 1 kHz steps; indicated transmission has robustness mode A, B, C or D).
    - 1: 10 kHz (the Freq c field can indicate from 0 to 327 670 kHz in 10 kHz steps; indicated transmission has robustness mode E).
  - **frequency:** this 15-bit field, coded as an unsigned binary number, shall represent the reference frequency associated with the other service in multiples of 1 or 10 kHz, depending on the value of the multiplier field.

The following values of the reference frequency are defined:

b <sub>14</sub>	b <sub>0</sub>	Decimal	: multiplier = 0	: multiplier = 1
0 0 0 0 0 0 0 0 0 0 0 0 0 0 0 0		0	: Not to be used;	: Not to be used;
0 0 0 0 0 0 0 0 0 0 0 0 0 0 0 1		1	: 1 kHz;	: 10 kHz;
0 0 0 0 0 0 0 0 0 0 0 0 0 0 1 0		2	: 2 kHz;	: 20 kHz;
" " " " " "				
1 1 1 1 1 1 1 1 1 1 1 1 1 1 1 1		32 767	: 32 767 kHz.	: 327 670 kHz.

- **R&M = 1000:**

- **Freq (Frequency) b:** this 8-bit field, coded as an unsigned binary number, shall represent the carrier frequency associated with the other service:
- The carrier frequency of the FM transmission is given by (in this expression, the decimal equivalent of freq b is used):

$$87,5 \text{ MHz} + (\text{Freq b} \times 100 \text{ kHz}).$$

The following values of the carrier frequency are defined (other values shall be reserved for future use):

b <sub>7</sub>	b <sub>0</sub>	Decimal	
0 0 0 0 0 0 0 0		0	: Not to be used;
0 0 0 0 0 0 0 1		1	: 87,6 MHz;
0 0 0 0 0 0 1 0		2	: 87,7 MHz;
" " " "			
1 1 0 0 1 1 0 0		204	: 107,9 MHz.

- **R&M = 1110:**

- **Id field 2:** this 8-bit field represents the AMSS Service Identifier (most significant byte) (see ETSI TS 102 386 [9]).

- **Freq (Frequency) c:** this 16-bit field, consists of the following fields:
  - **Rfu:** this 1 bit field shall be reserved for future use of the frequency field and shall be set to zero until defined.
  - **frequency:** this 15-bit field, coded as an unsigned binary number, shall represent the centre frequency associated with the other service in kHz.

The following values of the reference frequency are defined:

b <sub>14</sub>	b <sub>0</sub>	Decimal	
0 0 0 0 0 0 0 0 0 0 0 0 0 0 0 0		0	: Not to be used;
0 0 0 0 0 0 0 0 0 0 0 0 0 0 0 1		1	: 1 kHz;
0 0 0 0 0 0 0 0 0 0 0 0 0 0 1 0		2	: 2 kHz;
" " " "			
1 1 1 1 1 1 1 1 1 1 1 1 1 1 1 1		32 767	: 32 767 kHz.

The database key comprises the **OE** and **P/D** flags (see clause 5.2.2.1) and the **Rfa**, **Id field**, and **R&M** fields.

The Change Event Indication (CEI) is signalled by the **Length of Freq list** field = 0.

The repetition rates for FIG 0/21 are provided in ETSI TS 103 176 [5].

## 8.1.9 Void

## 8.1.10 OE Services

The OE Services feature is used to identify the services currently carried in other DAB ensembles. The feature is encoded in Extension 24 of FIG type 0 (FIG 0/24). Figure 47 shows the structure of the other ensembles services field which is part of the Type 0 field (see also figure 7).

The FIG type 0 flags (see clause 5.2.2.1) are used as follows: C/N flag - SIV; OE flag - OE; P/D flag - P/D.

If the service is carried in the tuned ensemble the OE flag shall be set to "0" If the service is not carried in the tuned ensemble the OE flag shall be set to "1".

This feature shall use the SIV signalling (see clause 5.2.2.1). The database shall be divided by use of a database key. Changes to the database shall be signalled using the CEI.

OE Services forms part of the signalling used for service following, which is described in detail in ETSI TS 103 176 [5].

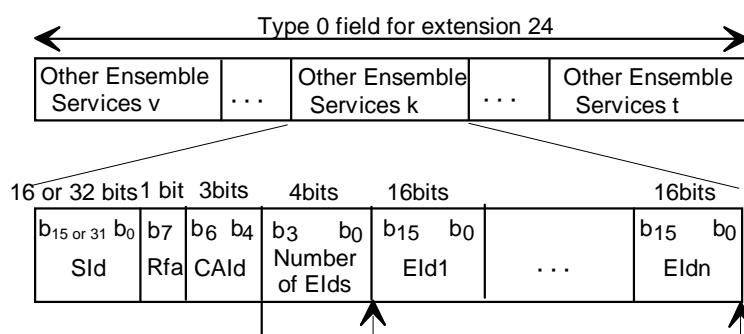

**Figure 47: Structure of the other ensembles services field**

The following definitions apply:

**SId (Service Identifier):** this 16-bit or 32-bit field shall identify a service. The coding details are given in clause 6.3.1.

**Rfa:** this 1-bit field shall be reserved for future additions. The bit shall be set to zero until it is defined.

**CAId (Conditional Access Identifier):** this 3-bit field shall identify the Access Control System (ACS) used for the service. The definition is given in ETSI TS 102 367 [4]. A non-CA capable DAB receiver shall not interpret this field. If no ACS is used for the service, CAId is set to zero.

**Number of EIds:** this 4-bit field, expressed as an unsigned binary number, shall indicate the number of EIds (maximum 12 for 16-bit SIDs and maximum 11 for 32-bit SIDs) contained in the subsequent list.

**EId (Ensemble identifier):** this 16-bit code shall identify the ensemble. The coding details are given in clause 6.4.

The database key comprises the **OE** and **P/D** flags (see clause 5.2.2.1) and the **SId** field.

The Change Event Indication (CEI) is signalled by the **Number of EIds** field = 0.

The repetition rates for FIG 0/24 are provided in ETSI TS 103 176 [5].

### 8.1.11 Void

### 8.1.12 Void

### 8.1.13 Ensemble label

The ensemble label feature is used to identify the ensemble in a textual format. The feature is encoded in Extension 0 of the FIG type 1 (FIG 1/0) and FIG type 2 (FIG 2/0). Figure 48 shows the structure of the Identifier field for the ensemble label which is part of the Type 1 field (see also figure 8) or part of the Type 2 field (see also figure 9).

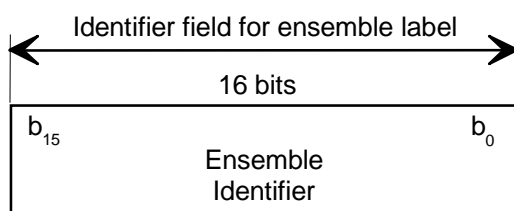

**Figure 48: Structure of the Identifier field for the ensemble label**

The following definitions apply:

**Ensemble Identifier (EId):** this 16-bit field shall identify the ensemble. The coding details are given in clause 6.4.

The ensemble label has a repetition rate of once per second.

### 8.1.14 Service label

#### 8.1.14.1 Programme service label

The programme service label feature is encoded in Extension 1 of the FIG type 1 (FIG 1/1) and FIG type 2 (FIG 2/1). Figure 49 shows the structure of the Identifier field for the service label which is part of the Type 1 field (see also figure 8) or part of the Type 2 field (see also figure 9).

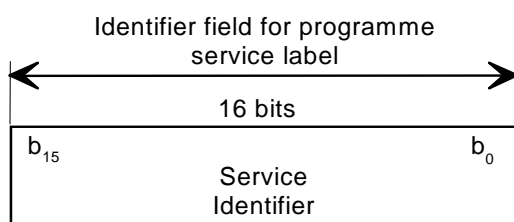

**Figure 49: Structure of the Identifier field for the service label**

The following definitions apply:

**Service Identifier (SIId):** this 16-bit field shall identify the service (see clause 6.3.1).

The programme service label has a repetition rate of once per second.

### 8.1.14.2 Data service label

The data service label feature is encoded in Extension 5 of the FIG type 1 (FIG 1/5) and FIG type 2 (FIG 2/5). Figure 50 shows the structure of the Identifier field for the service label which is part of the Type 1 field (see also figure 8) or part of the Type 2 field (see also figure 9).

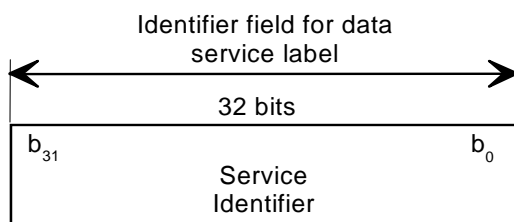

**Figure 50: Structure of the Identifier field for the data service label**

The following definitions apply:

**Service Identifier (SIId):** this 32-bit field shall identify the service (see clause 6.3.1).

The data service label has a repetition rate of once per second.

### 8.1.14.3 Service component label

The service component label feature is encoded in Extension 4 of FIG type 1 (FIG 1/4) and FIG type 2 (FIG 2/4). Figure 51 shows the structure of the Identifier field for the service component label which is part of the Type 1 field (see also figure 8) or part of the Type 2 field (see also figure 9). The service component label shall not be signalled for primary service components; the primary service component is identified by the programme service label or data service label.

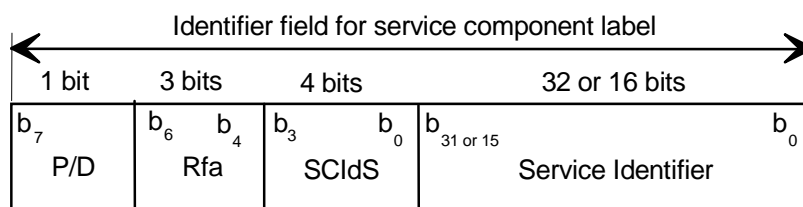

**Figure 51: Structure of the Identifier field for the service component label**

The following definitions apply:

**P/D:** this 1-bit flag shall indicate whether the Service Identifier (SIId) field is used for Programme services or Data services, as follows:

0: 16-bit SIId, used for Programme services;

1: 32-bit SIId, used for Data services.

**Rfa:** this 3-bit field shall be reserved for future additions. The bits shall be set to zero until they are defined.

**SCIdS (Service Component Identifier within the Service):** this 4-bit field shall identify the service component within the service.

**NOTE:** The service component label is not used for the primary component, so the value 0 is reserved for future use.

**Service Identifier (SIId):** this 16-bit or 32-bit field shall identify the service. The length of the SIId shall be signalled by the P/D flag, see clause 5.2.2.1.

The service component label has a repetition rate of once per second.

#### 8.1.14.4 X-PAD user application label

The X-PAD user application label feature is encoded in Extension 6 of FIG type 1 (FIG 1/6) and FIG type 2 (FIG 2/6). Figure 52 shows the structure of the Identifier field for the X-PAD user application label which is part of the Type 1 field (see also figure 8) or part of the Type 2 field (see also figure 9).

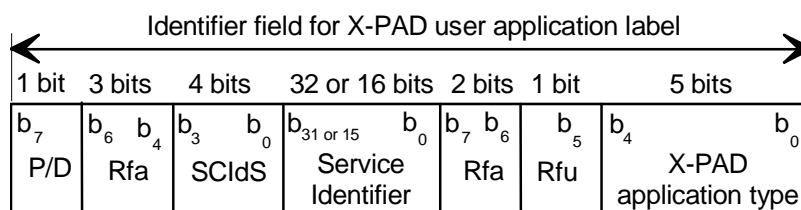

**Figure 52: Structure of the Identifier field for the X-PAD user application label**

The following definitions apply:

**P/D:** this 1-bit flag shall indicate whether the Service Identifier (SIId) field is used for Programme services or Data services, as follows:

0: 16-bit SIId, used for Programme services;

1: 32-bit SIId, used for Data services.

**Rfa:** this 3-bit field shall be reserved for future additions. The bits shall be set to zero until they are defined.

**SCIdS (Service Component Identifier within the Service):** this 4-bit field shall identify the service component within the service.

**Service Identifier (SIId):** this 16-bit or 32-bit field shall identify the service. The length of the SIId shall be signalled by the P/D flag, see clause 5.2.2.1.

**Rfa:** this 2-bit field shall be reserved for future additions. The bits shall be set to zero until they are defined.

**Rfu:** this 1-bit field shall be reserved for future use of the associated X-PAD application type. The Rfu bits shall be set to zero for the currently specified definition of this associated field.

**X-PAD Application Type:** this 5-bit field shall specify the application type (see clause 7.4.3).

The X-PAD user application label has a repetition rate of once per second.

#### 8.1.15 Service linking information

The Service linking information feature provides service linking information for use when services carry the same primary service component (hard link) or when the primary service components are related (soft link). The feature is encoded in extension 6 of FIG type 0 (FIG 0/6). Figure 53 shows the structure of the service linking field which is part of the Type 0 field (see also figure 7).

The FIG type 0 flags (see clause 5.2.2.1) are used as follows: C/N flag - SIV; OE flag - Rfu; P/D flag - P/D.

This feature shall use the SIV signalling (see clause 5.2.2.1). The database shall be divided by use of a database key. Changes to the database shall be signalled using the CEI. The first service in the list of services in each part of the database, as divided by the database key, shall be a service carried in the ensemble. This service is called the key service.

Service linking information forms part of the signalling used for service following, which is described in detail in ETSI TS 103 176 [5].

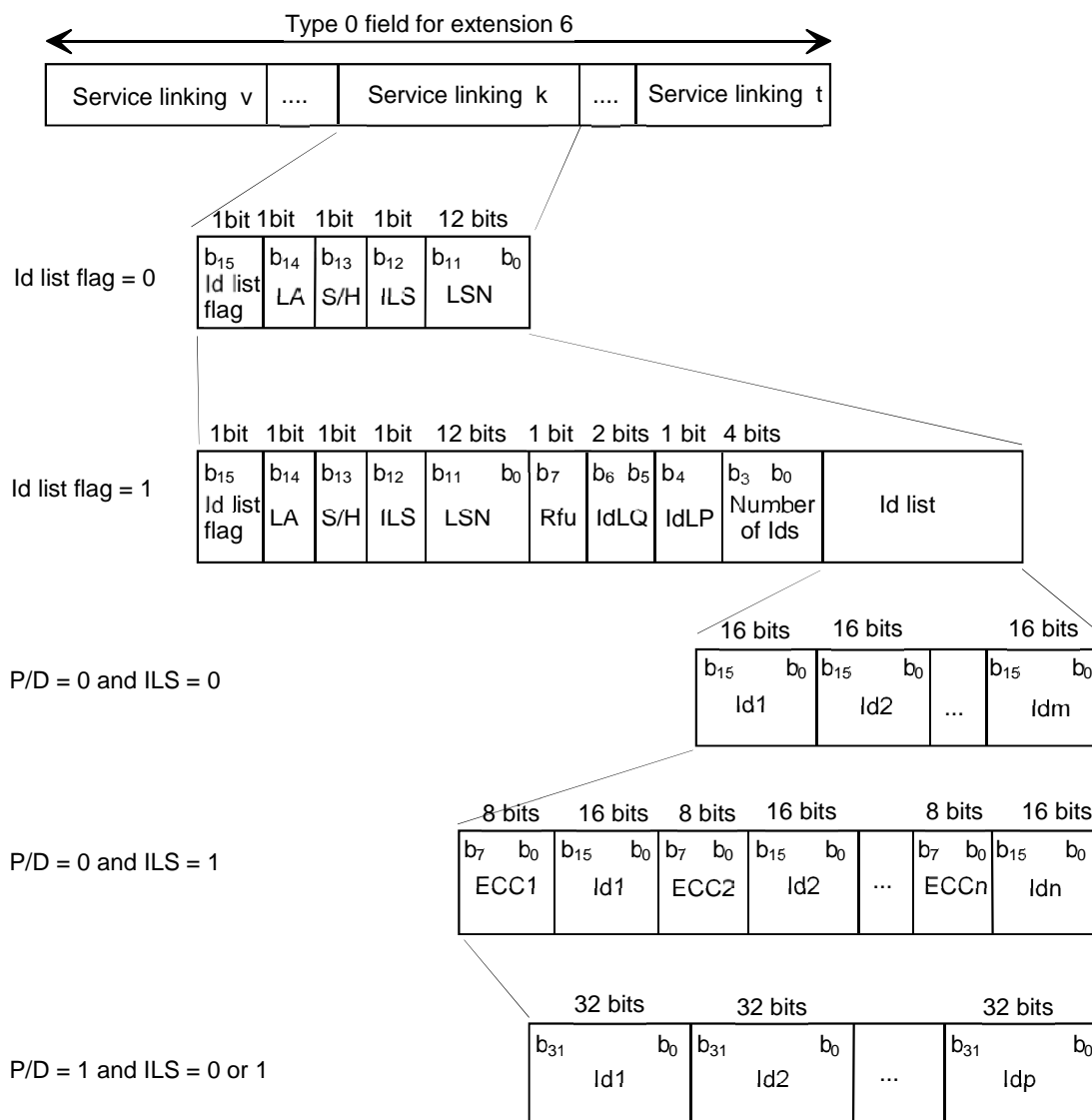

**Figure 53: Structure of the Service linking field**

The following definitions apply:

**Id (Identifier) list flag:** this 1-bit flag shall indicate whether the Id list, together with the preceding byte, is present or not, as follows:

0: Id list and the preceding byte absent;

1: Id list and the preceding byte present.

**LA (Linkage Actuator):** this 1-bit flag shall indicate whether the link is active or inactive (potential), as follows:

0: potential future link or de-activated link;

1: active link.

**S/H (Soft/Hard):** this 1-bit flag shall indicate whether the link is soft or hard, as follows:

0: Soft link (related services);

1: Hard link (services carrying the same primary service component).

**ILS (International linkage set indicator):** this 1-bit flag shall indicate whether the link affects only one country (national) or several countries (international), as follows:

0: national link;

1: international link (or DRM or AMSS).

NOTE: If a linkage set includes services broadcast using DRM or AMSS, then the link will always be an international link, even if all linked services are intended for national use.

**LSN (Linkage Set Number):** this 12-bit field represents a number which shall be common to all Services linked together as a set. The use of LSN = "0000 0000 0000" is reserved.

**Rfu:** this 1-bit field shall be reserved for future use of the IdLQ, the IdLP, the Number of Ids and the Id list fields. The Rfu bit shall be set to zero for the currently specified definition of the associated fields.

**IdLQ (Identifier List Qualifier):** this 2-bit field shall indicate how the identifiers, contained in the Id list, except for the key service, are qualified, as follows:

$b_6 - b_5$ ;

0 0 : each Id represents a DAB SId (see clause 6.3.1);

0 1 : each Id represents an RDS PI-code (see IEC 62106 [10]);

1 0 : reserved for future use;

1 1 : each Id represents all or part of a DRM Service Identifier (see ETSI ES 201 980 [8]) or all or part of an AMSS Service Identifier (see ETSI TS 102 386 [9]).

**IdLP (Identifier List Preference level):** this 1-bit field shall indicate the preference level of the identifiers in the **Id list**, as follows:

0: the identifiers in the **Id list** have a normal preference level;

1: the identifiers in the **Id list** have a low preference level.

**Number of Ids:** this 4-bit field expressed as an unsigned binary number, shall specify the number of identifiers in the Id list (maximum 12 when P/D = 0 and ILS = 0, maximum 8 when P/D = 0 and ILS = 1 and maximum 6 when P/D = 1).

The identifier for the key service, which shall always be a DAB SId of a service carried in the ensemble, is the first identifier in the Id list at the start of the database; this is when the version number of the type 0 field is set to "0" (see clause 5.2.2.1).

**Id list (P/D = "0"):**

- **Id (Identifier of Service):** this 16-bit field shall identify the programme service, depending on the IdLQ field (except for the key service). When the IdLQ = "11", the Id field shall carry the two least significant bytes of the DRM Service Identifier or AMSS Service Identifier.
- **ECC (Extended Country Code):** when the IdLQ = "00" or "01", this 8-bit field shall carry the ECC (see clause 8.1.3) of the programme service. When the IdLQ = "11", this 8-bit field shall carry the most significant byte of the DRM Service Identifier or AMSS Service Identifier.

**Id list (P/D = "1"):**

- **Id (Identifier of Service):** this 32-bit field shall identify the data service, depending on the IdLQ field (except for the key service). When the IdLQ = "11", the most significant byte shall be set to zero and the three least significant bytes shall carry the DRM Service Identifier.

All linkage set definitions shall include a service carried in the ensemble; therefore the OE flag (see clause 5.2.2.1) is reserved for future use and shall be set to "0".

The database key comprises the **OE** and **P/D** flags (see clause 5.2.2.1) and the **S/H**, **ILS**, and **LSN** fields.

The Change Event Indication (CEI) is signalled by the **Id List flag** = 0.

The repetition rates for FIG 0/6 are provided in ETSI TS 103 176 [5].

## 9 Conditional Access (CA)

The Conditional Access system used in the DAB system is specified in ETSI TS 102 367 [4].

## 10 Energy dispersal

### 10.1 General procedure

In order to ensure appropriate energy dispersal in the transmitted signal, the individual inputs of the energy dispersal scramblers shown in figure 3 shall be scrambled by a modulo-2 addition with a Pseudo-Random Binary Sequence (PRBS), prior to convolutional encoding.

The PRBS shall be defined as the output of the feedback shift register of figure 54. It shall use a polynomial of degree 9, defined by:

$$P(X) = X^9 + X^5 + 1$$

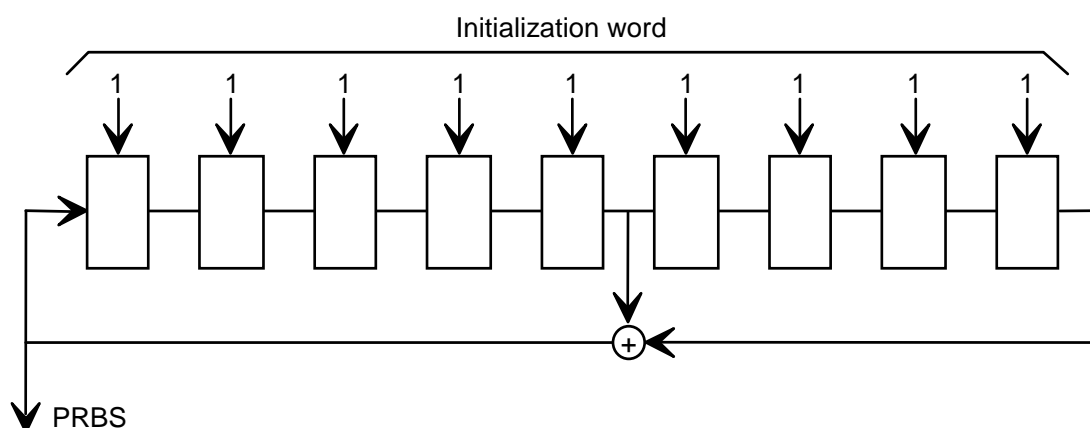

Figure 54: PRBS generator

The initialization word shall be applied in such a way that the first bit of the PRBS is obtained when the outputs of all shift register stages are set to value "1". The first 16 bits of the PRBS are given in table 12.

Table 12: First 16 bits of the PRBS

bit index	0	1	2	3	4	5	6	7	8	9	10	11	12	13	14	15
bit value	0	0	0	0	0	1	1	1	1	0	1	1	1	1	1	0

### 10.2 Energy dispersal as applied in the Fast Information Channel

The FIBs defined in clause 5.2.1 shall be processed by the energy dispersal scrambler as follows.

#### Transmission mode I

The 3 FIBs corresponding to one CIF shall be grouped together at the output of the Fast Information Block assembler to form a 768-bit vector. This vector shall be a juxtaposition of the 3 FIBs, the first bit of this vector being the first bit of the first FIB.

This vector shall be scrambled with the PRBS, the first bit of the vector being added modulo 2 to the PRBS bit of index 0.

## 10.3 Energy dispersal as applied in the Main Service Channel

The content of each logical frame (see clause 5.3.1) at the output of the SI packet multiplex assembler, and at the output of each CA scrambler, as shown in figure 3, shall be scrambled in such a way that the first bit of each logical frame associated with a given sub-channel shall be added modulo 2 to the PRBS bit of index 0.

# 11 Convolutional coding

## 11.0 Introduction

The channel encoding process is based on punctured convolutional coding, which allows both equal and Unequal Error Protection (UEP), matched to bit error sensitivity characteristics.

This process is applied to the output of each energy dispersal scrambler. The output of a scrambler is denoted as a vector  $(a_i)_{i=0}^{I-1}$  of  $I$  bits during any given logical frame.

Clause 11.1 defines the general encoding procedure. Clauses 11.2 and 11.3 define the particular application of the encoding procedure in the FIC and in the MSC.

## 11.1 Convolutional code

### 11.1.1 Mother code

The channel coding is based on a convolutional code with constraint length 7. The mother convolutional encoder generates from the vector  $(a_i)_{i=0}^{I-1}$  a codeword  $\{(x_{0,i}, x_{1,i}, x_{2,i}, x_{3,i})\}_{i=0}^{I+5}$ . This codeword shall be defined by:

$$x_{0,i} = a_i \oplus a_{i-2} \oplus a_{i-3} \oplus a_{i-5} \oplus a_{i-6};$$

$$x_{1,i} = a_i \oplus a_{i-1} \oplus a_{i-2} \oplus a_{i-3} \oplus a_{i-6};$$

$$x_{2,i} = a_i \oplus a_{i-1} \oplus a_{i-4} \oplus a_{i-6};$$

$$x_{3,i} = a_i \oplus a_{i-2} \oplus a_{i-3} \oplus a_{i-5} \oplus a_{i-6};$$

for  $i = 0, 1, 2, \dots, I+5$ .

When  $i$  does not belong to the set  $\{0, 1, 2, \dots, I-1\}$ ,  $a_i$  shall be equal to zero by definition.

The encoding can be achieved using the convolutional encoder presented in figure 55.

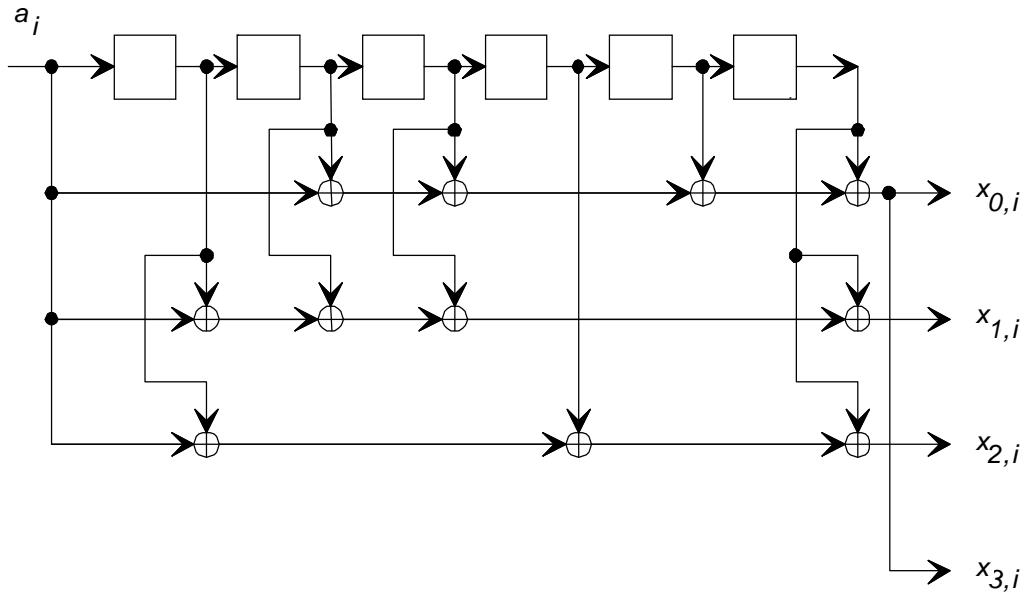

**Figure 55: Convolutional encoder**

The octal forms of the generator polynomials are 133, 171, 145 and 133, respectively.

The vector  $(\mathbf{a}_{-6}, \mathbf{a}_{-5}, \mathbf{a}_{-4}, \mathbf{a}_{-3}, \mathbf{a}_{-2}, \mathbf{a}_{-1})$  corresponds to the all-zero initial state of the shift register and the vector  $(\mathbf{a}_I, \mathbf{a}_{I+1}, \mathbf{a}_{I+2}, \mathbf{a}_{I+3}, \mathbf{a}_{I+4}, \mathbf{a}_{I+5})$  corresponds to the all-zero final state of the shift register.

Each codeword  $\{(x_{0,i}, x_{1,i}, x_{2,i}, x_{3,i})\}_{i=0}^{I+5}$  is ordered as a serial mother codeword  $\mathbf{U}$  with:

$$(u_0, u_1, u_2, \dots, u_{4I-1});$$

and

$$u_i = x_{R\binom{i}{4}, Q\binom{i}{4}} \text{ for } i = 0, 1, 2, \dots, 4I + 23.$$

The functions R and Q, denoting the remainder and the quotient of a division, respectively, are defined in clause 3.3.

### 11.1.2 Puncturing procedure

Punctured convolutional coding shall be applied; some predefined codebits generated by the mother code are not transmitted.

The first  $4I$  bits  $(\mathbf{u}_0, \mathbf{u}_1, \mathbf{u}_2, \dots, \mathbf{u}_{4I-1})$  of the serial mother codeword  $\mathbf{U}$  shall be split into consecutive blocks of 128 bits.

Each block shall be divided into four consecutive sub-blocks of 32 bits. All sub-blocks belonging to the same block shall be punctured using the same rule, given by the value of the puncturing index  $PI$ .

Each index  $PI$  corresponds to a puncturing vector  $\mathbf{V}_{PI}$ , denoted by:

$$\mathbf{V}_{PI} = (\mathbf{v}_{PI,0}, \mathbf{v}_{PI,1}, \dots, \mathbf{v}_{PI,i}, \dots, \mathbf{v}_{PI,31}).$$

The  $(i + 1)^{th}$  bit ( $i = 0, 1, 2, \dots, 31$ ) in each sub-block is processed according to the value of the element  $v_{PI,i}$  of the puncturing vector  $\mathbf{V}_{PI}$ , in the following way:

- for  $v_{PI,i} = 0$ , the corresponding bit shall be taken out of the sub-block and shall not be transmitted;
- for  $v_{PI,i} = 1$ , the corresponding bit shall be retained in the sub-block and shall be transmitted.

The values of the puncturing vectors are given in table 13.

In table 13, the value of the code rate (equal to  $\frac{8}{8+PI}$ ) is also indicated.

**Table 13: Puncturing vectors**

	$(V_{PI,0}, \dots, \dots, V_{PI,3})$
PI=1: code rate: 8/9	1100 1000 1000 1000 1000 1000 1000 1000
PI=2: code rate: 8/10	1100 1000 1000 1000 1100 1000 1000 1000
PI=3: code rate: 8/11	1100 1000 1100 1000 1100 1000 1000 1000
PI=4: code rate: 8/12	1100 1000 1100 1000 1100 1000 1100 1000
PI=5: code rate: 8/13	1100 1100 1100 1000 1100 1000 1100 1000
PI=6: code rate: 8/14	1100 1100 1100 1000 1100 1100 1100 1000
PI=7: code rate: 8/15	1100 1100 1100 1100 1100 1100 1100 1000
PI=8: code rate: 8/16	1100 1100 1100 1100 1100 1100 1100 1100
PI=9: code rate: 8/17	1110 1100 1100 1100 1100 1100 1100 1100
PI=10: code rate: 8/18	1110 1100 1100 1100 1110 1100 1100 1100
PI=11: code rate: 8/19	1110 1100 1110 1100 1110 1100 1100 1100
PI=12: code rate: 8/20	1110 1100 1110 1100 1110 1100 1110 1100
PI=13: code rate: 8/21	1110 1110 1110 1100 1110 1100 1110 1100
PI=14: code rate: 8/22	1110 1110 1110 1100 1110 1110 1110 1100
PI=15: code rate: 8/23	1110 1110 1110 1110 1110 1110 1110 1100
PI=16: code rate: 8/24	1110 1110 1110 1110 1110 1110 1110 1110
PI=17: code rate: 8/25	1111 1110 1110 1110 1110 1110 1110 1110
PI=18: code rate: 8/26	1111 1110 1110 1110 1111 1110 1110 1110
PI=19: code rate: 8/27	1111 1110 1111 1110 1111 1110 1110 1110
PI=20: code rate: 8/28	1111 1110 1111 1110 1111 1110 1111 1110
PI=21: code rate: 8/29	1111 1111 1111 1110 1111 1110 1111 1110
PI=22: code rate: 8/30	1111 1111 1111 1110 1111 1111 1111 1110
PI=23: code rate: 8/31	1111 1111 1111 1111 1111 1111 1111 1110
PI=24: code rate: 8/32	1111 1111 1111 1111 1111 1111 1111 1111

The last 24 bits of the serial mother codeword,  $(\mathbf{u}_{4I}, \mathbf{u}_{4I+1}, \mathbf{u}_{4I+2}, \dots, \mathbf{u}_{4I+23})$ , shall be punctured using the puncturing vector given by:

$$\mathbf{V}_T = (1100 1100 1100 1100 1100 1100).$$

The resulting 12 bits are called tail bits.

The four punctured sub-blocks originating from each 128-bit block shall then be grouped together into a block of length  $4(8+PI)$  bits. All these blocks shall then be grouped together and the tail bits shall be appended to the last block. The order of the sub-blocks and blocks shall be retained.

The resulting word is called a punctured codeword.

To ensure a word length of a multiple of 64 bits at the output of the encoding process, it shall be necessary for certain puncturing schemes to append "zero value" padding bits at the end of the punctured codeword, as specified in the following clauses.

The resulting word is called a convolutional codeword.

## 11.2 Coding in the Fast Information Channel

### 11.2.1 Transmission mode I

Each 768-bit vector  $(\mathbf{a}_i)_{i=0}^{767}$  at the output of the energy dispersal scrambler (see clause 10.2) shall be processed as defined in clause 11.1.1.

The first  $4I = 3\ 072$  bits of the serial mother codeword  $U$  shall be split into 24 consecutive blocks of 128 bits, as defined in clause 11.1.2.

The first 21 blocks shall be punctured as defined in clause 11.1.2, according to the puncturing index  $PI = 16$ .

The remaining 3 blocks shall be punctured as defined in clause 11.1.2, according to the puncturing index  $PI = 15$ .

This corresponds to a code rate of approximately 1/3.

Finally, the last 24 bits of the serial mother codeword shall be punctured as defined in clause 11.1.2. No padding bits shall be added.

The resulting convolutional codeword is denoted  $(b_i)^{2\ 303}$ .

## 11.3 Coding in the Main Service Channel

### 11.3.0 Introduction

In this clause the details of the puncturing procedure are specified in terms of protection profiles and protection levels. A protection profile associates the various blocks of a mother codeword with a collection of puncturing indices. For each of the allowed values of the sub-channel bit rate a number of permissible protection profiles are defined. The set of protection profiles allows for audio and data broadcasting over radio frequency channels or cable networks with a level of protection suited to the requirements of the transmission channel.

Each protection profile is associated with a protection level indicating the relative level of protection provided. Protection level 1 indicates the highest level of protection within each set of profiles. The protection levels defined in clauses 11.3.1 and 11.3.2 (set A and set B) are independent of each other.

### 11.3.1 Unequal Error Protection (UEP) coding

Each logical frame at the output of the energy dispersal scrambler (according to clause 10.3) corresponding to the processing of a UEP coded service component, consists of a  $I$ -bit vector  $(\mathbf{a}_i)_{i=0}^{I-1}$ , where  $I$  is a function of the sub-channel bit rate.

Each vector  $(\mathbf{a}_i)_{i=0}^{I-1}$  shall be processed as defined in clause 11.1.1. The first  $4I$  bits of the serial mother codeword  $U$  are split into  $L$  consecutive blocks of 128 bits, as defined in clause 11.1.2.

The value of  $L$  for each possible sub-channel bit rate shall comply with table 14.

**Table 14: Correspondence between the sub-channel bit rates and the parameters  $I$  and  $L$** 

Subchannel bit rate (kbit/s)	$I$	$L$
32	768	24
48	1 152	36
56	1 344	42
64	1 536	48
80	1 920	60
96	2 304	72
112	2 688	84
128	3 072	96
160	3 840	120
192	4 608	144
224	5 376	168
256	6 144	192
320	7 680	240
384	9 216	288

The first  $L_1$  blocks shall be punctured as defined in clause 11.1.2, according to the puncturing index  $PI_1$ .

The next  $L_2$  blocks shall be punctured as defined in clause 11.1.2, according to the puncturing index  $PI_2$ .

The next  $L_3$  blocks shall be punctured as defined in clause 11.1.2, according to the puncturing index  $PI_3$ .

The remaining  $L_4$  blocks shall be punctured as defined in clause 11.1.2, according to the puncturing index  $PI_4$ .

Finally the last 24 bits of the serial mother codeword shall be punctured as described in clause 11.1.2.

Each quadruple  $(L_1, L_2, L_3, L_4)$  associated to a quadruple  $(PI_1, PI_2, PI_3, PI_4)$ , defines a protection profile.

Five protection levels  $P$  ( $P = 1, 2, 3, 4, 5$ ) are defined.

The permissible protection profiles are specified as a function of the sub-channel bit rate and the protection level  $P$  in table 15 (see also table 8). To ensure a word length of a multiple of 64 bits at the output of the encoding process, a certain number of "zero value" padding bits shall be appended at the end of the punctured codeword for certain protection profiles, as specified in table 15.

The resulting convolutional codeword for a given logical frame is denoted  $(b_i)_{i=0}^{M-1}$ .

**Table 15: UEP coded service component protection profiles**

Sub-channel bit rate (kbit/s)	$P$	$L_1$	$L_2$	$L_3$	$L_4$	$PI_1$	$PI_2$	$PI_3$	$PI_4$	number of padding bits
32	5	3	4	17	0	5	3	2	-	0
32	4	3	3	18	0	11	6	5	-	0
32	3	3	4	14	3	15	9	6	8	0
32	2	3	4	14	3	22	13	8	13	0
32	1	3	5	13	3	24	17	12	17	4
48	5	4	3	26	3	5	4	2	3	0
48	4	3	4	26	3	9	6	4	6	0
48	3	3	4	26	3	15	10	6	9	4
48	2	3	4	26	3	24	14	8	15	0
48	1	3	5	25	3	24	18	13	18	0
56	5	6	10	23	3	5	4	2	3	0
56	4	6	10	23	3	9	6	4	5	0
56	3	6	12	21	3	16	7	6	9	0
56	2	6	10	23	3	23	13	8	13	8
64	5	6	9	31	2	5	3	2	3	0
64	4	6	9	33	0	11	6	5	-	0
64	3	6	12	27	3	16	8	6	9	0
64	2	6	10	29	3	23	13	8	13	8
64	1	6	11	28	3	24	18	12	18	4

Sub-channel bit rate (kbit/s)	$P$	$L_1$	$L_2$	$L_3$	$L_4$	$PI_1$	$PI_2$	$PI_3$	$PI_4$	number of padding bits
80	5	6	10	41	3	6	3	2	3	0
80	4	6	10	41	3	11	6	5	6	0
80	3	6	11	40	3	16	8	6	7	0
80	2	6	10	41	3	23	13	8	13	8
80	1	6	10	41	3	24	17	12	18	4
96	5	7	9	53	3	5	4	2	4	0
96	4	7	10	52	3	9	6	4	6	0
96	3	6	12	51	3	16	9	6	10	4
96	2	6	10	53	3	22	12	9	12	0
96	1	6	13	50	3	24	18	13	19	0
112	5	14	17	50	3	5	4	2	5	0
112	4	11	21	49	3	9	6	4	8	0
112	3	11	23	47	3	16	8	6	9	0
112	2	11	21	49	3	23	12	9	14	4
128	5	12	19	62	3	5	3	2	4	0
128	4	11	21	61	3	11	6	5	7	0
128	3	11	22	60	3	16	9	6	10	4
128	2	11	21	61	3	22	12	9	14	0
128	1	11	20	62	3	24	17	13	19	8
160	5	11	19	87	3	5	4	2	4	0
160	4	11	23	83	3	11	6	5	9	0
160	3	11	24	82	3	16	8	6	11	0
160	2	11	21	85	3	22	11	9	13	0
160	1	11	22	84	3	24	18	12	19	0
192	5	11	20	110	3	6	4	2	5	0
192	4	11	22	108	3	10	6	4	9	0
192	3	11	24	106	3	16	10	6	11	0
192	2	11	20	110	3	22	13	9	13	8
192	1	11	21	109	3	24	20	13	24	0
224	5	12	22	131	3	8	6	2	6	4
224	4	12	26	127	3	12	8	4	11	0
224	3	11	20	134	3	16	10	7	9	0
224	2	11	22	132	3	24	16	10	15	0
224	1	11	24	130	3	24	20	12	20	4
256	5	11	24	154	3	6	5	2	5	0
256	4	11	24	154	3	12	9	5	10	4
256	3	11	27	151	3	16	10	7	10	0
256	2	11	22	156	3	24	14	10	13	8
256	1	11	26	152	3	24	19	14	18	4
320	5	11	26	200	3	8	5	2	6	4
320	4	11	25	201	3	13	9	5	10	8
320	2	11	26	200	3	24	17	9	17	0
384	5	11	27	247	3	8	6	2	7	0
384	3	11	24	250	3	16	9	7	10	4
384	1	12	28	245	3	24	20	14	23	8

Table 16 gives the approximate value of the resulting average code rate as a function of the sub-channel bit rate and the protection level  $P$ . In this table, the options denoted by X are not provided.

**Table 16: Average code rate as a function of the sub-channel bit rate and the protection level  $P$** 

$P$					
Sub-channel bit rate (kbit/s)	1	2	3	4	5
32	0,34	0,41	0,50	0,57	0,75
48	0,35	0,43	0,51	0,62	0,75
56	X	0,40	0,50	0,60	0,72
64	0,34	0,41	0,50	0,57	0,75
80	0,36	0,43	0,52	0,58	0,75
96	0,35	0,43	0,51	0,62	0,75
112	X	0,40	0,50	0,60	0,72
128	0,34	0,41	0,50	0,57	0,75
160	0,36	0,43	0,52	0,58	0,75
192	0,35	0,43	0,51	0,62	0,75
224	0,36	0,40	0,50	0,60	0,72
256	0,34	0,41	0,50	0,57	0,75
320	X	0,43	X	0,58	0,75
384	0,35	X	0,51	X	0,75

### 11.3.2 Equal Error Protection (EEP) coding

Each logical frame at the output of the energy dispersal scrambler (according to clause 10.3), corresponding to the processing of one or more data service components (Packet mode), or a single service component (Stream mode), consists of  $I$ -bit vector  $(\mathbf{a}_i)_{i=0}^{I-1}$ , where  $I$  is a function of the bit rate.

Each vector  $(\mathbf{a}_i)_{i=0}^{I-1}$  shall be processed as defined in clause 11.1.1. The first  $4I$  bits of the serial mother codeword  $U$  are split into  $L$  consecutive blocks of 128 bits, as defined in clause 11.1.2.

The first  $L_1$  blocks shall be punctured as defined in clause 11.1.2, according to the puncturing index  $PI_1$ .

The remaining  $L_2$  blocks shall be punctured as defined in clause 11.1.2, according to the puncturing index  $PI_2$ .

Finally, the last 24 bits of the serial mother codeword shall be punctured as defined in clause 11.1.2. No padding bits shall be added.

Each pair  $(L_1, L_2)$  associated to a pair  $(PI_1, PI_2)$  defines a protection profile.

The resulting convolutional codeword for a given logical frame is denoted  $(\mathbf{b}_i)_{i=0}^{M-1}$ .

#### Bit rates in multiples of 8 kbit/s

Four protection levels are defined for bit rates in multiples of 8 kbit/s (see clauses 5.3.1 and 5.3.2). These four protection levels  $P$  ( $P = 1, 2, 3, 4$ ), correspond to the code rates  $1/4, 3/8, 1/2$  and  $3/4$  respectively.

The value of  $L$  for each possible bit rate shall comply with table 17.

**Table 17: Correspondence between the possible bit rates and the parameters  $I$  and  $L$** 

Sub-channel bit rate (kbit/s)	$I$	$L$
8	192	6
:	:	:
:	:	:
8n	192n	6n
:	:	:
:	:	:
1 728	41 472	1 296

The permissible protection profiles (set A) are specified as a function of the bit rate, and the protection level  $P$ , in table 18.

**Table 18: Equal error protection profiles (set A)**

Sub-channel bit rate (kbit/s)	$P$	$L_1$	$L_2$	$PI_1$	$PI_2$
$8n$	4-A	$4n-3$	$2n+3$	3	2
$8n$	3-A	$6n-3$	3	8	7
8	2-A	5	1	13	12
$8n$ ( $n>1$ )		$2n-3$	$4n+3$	14	13
$8n$	1-A	$6n-3$	3	24	23

**Bit rates in multiples of 32 kbit/s**

Four protection levels are defined for bit rates in multiples of 32 kbit/s (see clauses 5.3.1. and 5.3.2.). These four protection levels  $P$  ( $P = 1, 2, 3, 4$ ), correspond to the code rates  $4/9, 4/7, 2/3$  and  $4/5$  respectively.

The value of  $L$  for each possible bit rate shall comply with table 19.

**Table 19: Correspondence between the possible bit rates and the parameters  $I$  and  $L$** 

Sub-channel bit rate (kbit/s)	$I$	$L$
32	768	24
:	:	:
:	:	:
$32n$	$768n$	$24n$
:	:	:
:	:	:
1 824	43 776	1 368

The permissible protection profiles (set B) are specified as a function of the bit rate, and the protection level  $P$ , in table 20.

**Table 20: Equal error protection profiles (set B)**

Sub-channel bit rate (kbit/s)	$P$	$L_1$	$L_2$	$PI_1$	$PI_2$
$32n$	4-B	$24n-3$	3	2	1
$32n$	3-B	$24n-3$	3	4	3
$32n$	2-B	$24n-3$	3	6	5
$32n$	1-B	$24n-3$	3	10	9

**11.3.3 Future error protection coding**

There is provision for new error protection coding schemes, as indicated in clause 6.2. This may be required for new applications different from those defined in clauses 7 and 8. However, the encoding procedures specified in clause 11.1 shall apply.

## 12 Time interleaving

Time interleaving shall be applied to the output of each convolutional encoder for all sub-channels of the Main Service Channel (MSC). It shall not be applied to the FIC.

The output of each individual convolutional encoder is a sequence of convolutional codewords denoted  $(\mathbf{B}_r)_{r=-\infty}^{\infty}$  where  $r$  is defined as the time index ranging from  $-\infty$  to  $+\infty$ , whose value taken modulo 5 000 ( $\text{mod}(r, 5\,000)$ ) is equal to the logical frame count of the corresponding logical frame. The time index is introduced for the purpose of describing system properties over several logical frames independently of the absolute time. It is notionally related to the logical frame count in such a way that they are aligned at  $r$  equals 0.

The convolutional codeword  $\mathbf{B}_r$  is denoted as a vector:

$$\mathbf{B}_r = (b_{r,0}, b_{r,1}, \dots, b_{r,i_r}, \dots, b_{r,M_r-1})$$

of length  $M_r$  consisting of bits  $b_{r,i_r}$ .

The length  $M_r$  of these vectors depends on the index  $r$ , because it may change from one logical frame to the next, if a multiplex reconfiguration occurs.

However, due to the limitation on the minimum time between two successive multiplex reconfigurations (see clause 6), the value of  $M_r$  is not allowed to change more than once during a period of 250 logical frames.

The output of the interleaver is denoted as a sequence  $(\mathbf{C}_r)_{r=-\infty}^{\infty}$  of vectors,

$$\mathbf{C}_r = (c_{r,0}, c_{r,1}, \dots, c_{r,i_r}, \dots, c_{r,N_r-1})$$

of length  $N_r$  consisting of bits  $c_{r,i_r}$ . The sequence of vectors constitutes the content of a sub-channel.

As long as the multiplex configuration remains stable, the length of the vector  $\mathbf{C}_r$  shall be equal to the length of the vector  $\mathbf{B}_r$ , i.e.  $N_r = M_r$ . During a time period of 15 logical frames after a multiplex reconfiguration event, the length  $N_r$  may be larger than  $M_r$  for some sub-channels. The relation between  $N_r$  and  $M_r$  is defined later in this clause.

The time interleaving shall be performed according to the following relation:

$$c_{r,i_r} = \begin{cases} b_{r',i_r} & \text{if } i_r \leq M_{r'} - 1 \\ 0 & \text{if not} \end{cases}$$

for  $i_r = 0, 1, 2, \dots, N_r - 1$  and all integers  $r$ .

The relationship between the indices  $r'$ ,  $r$  and  $i_r$  is specified in table 21, where  $r'$  is given as a function of  $r$  for each of the possible values of  $i_r$  modulo 16.

Table 21: Relationship between the indices  $r'$ ,  $r$  and  $i_r$ 

$R(i_r/16)$	$r'(r, i_r)$
0	$r$
1	$r-8$
2	$r-4$
3	$r-12$
4	$r-2$
5	$r-10$
6	$r-6$
7	$r-14$
8	$r-1$
9	$r-9$
10	$r-5$
11	$r-13$
12	$r-3$
13	$r-11$
14	$r-7$
15	$r-15$

The following shall apply for the relationship between the values of  $M_r$  and  $N_r$ .

- a) If  $M_r$  has been constant over the last 16 frames, i.e.:

$$M_r = M_{r-1} = \dots = M_{r-15};$$

then

$$N_r = M_r.$$

- b) If  $M_r$  has increased during this period, i.e.:

$$M_r > M_{r-15};$$

then

$$N_r = M_r.$$

- c) If  $M_r$  has decreased over the last 16 frames, i.e.:

$$M_r < M_{r-15};$$

then

$$N_r = M_{r-15}.$$

NOTE: There is a one-to-one correspondence between  $M_r$  and  $N_r$  which may be expressed by the following two equivalent equations:

$$N_r = \max(M_r, M_{r-15});$$

or equivalently

$$M_r = \min(N_r, N_{r+15}).$$

The time interleaving rule is illustrated by the three following examples:

**EXAMPLE 1:** Time interleaving of a data service component with a bit rate of 8 kbit/s protected by protection level 4.

It is supposed that no multiplex reconfiguration occurs.

The convolutional codeword  $\mathbf{B}_r$  is:

$$\mathbf{B}_r = (b_{r,0}, b_{r,1}, \dots, b_{r,i_r}, \dots, b_{r,255}).$$

In this example,  $M_r = N_r = 256$  for all values of  $r$ .

Figure 56 illustrates the time interleaving rule.

**EXAMPLE 2:** Time interleaving of a data service component with a bit rate of 8 kbit/s protected by protection level 4, and reconfigured to a data service component with a bit rate of 8 kbit/s protected by protection level 3.

The convolutional codeword  $\mathbf{B}_r$  is:

$$\mathbf{B}_r = \begin{cases} (b_{r,0}, b_{r,1}, \dots, b_{r,i_r}, \dots, b_{r,255}) & \text{for } r \leq r_0 - 1 \\ (b_{r,0}, b_{r,1}, \dots, b_{r,i_r}, \dots, b_{r,383}) & \text{for } r \geq r_0 \end{cases}$$

$$\text{In this example, } M_r = \begin{cases} 256 & \text{for } r \leq r_0 - 1 \\ 384 & \text{for } r \geq r_0 \end{cases}$$

The value of  $N_r$  is given by:

$$N_r = \begin{cases} 256 & \text{for } r \leq r_0 - 1 \\ 384 & \text{for } r \geq r_0 \end{cases}$$

Figure 57 illustrates the time interleaving rule.

**EXAMPLE 3:** Time interleaving of a data service component with a bit rate of 8 kbit/s protected by protection level 3, and reconfigured to a data service component with a bit rate of 8 kbit/s protected by protection level 4.

The convolutional codeword  $\mathbf{B}_r$  is:

$$\mathbf{B}_r = \begin{cases} (b_{r,0}, b_{r,1}, \dots, b_{r,i_r}, \dots, b_{r,383}) & \text{for } r \leq r_0 - 1 \\ (b_{r,0}, b_{r,1}, \dots, b_{r,i_r}, \dots, b_{r,255}) & \text{for } r \geq r_0 \end{cases}$$

$$\text{In this example, } M_r = \begin{cases} 384 & \text{for } r \leq r_0 - 1 \\ 256 & \text{for } r \geq r_0 \end{cases}$$

The value of  $N_r$  is given by:

$$N_r = \begin{cases} 384 & \text{for } r \leq r_0 + 14 \\ 256 & \text{for } r \geq r_0 + 15 \end{cases}$$

Figure 58 illustrates the time interleaving rule.

Time interleaver input		Time interleaver output															time →
r-1	r	r	r+1	r+2	r+3	r+4	r+5	r+6	r+7	r+8	r+9	r+10	r+11	r+12	r+13	r+14	r+15
·	$a_{r-1,0}$	$a_{r,0}$	$a_{r,0}$	....	....	....	....	....	....	....	....	....	....	....	....	....	....
·	$a_{r-1,1}$	$a_{r,1}$	$a_{r-8,1}$	$a_{r-7,1}$	$a_{r-6,1}$	$a_{r-5,1}$	$a_{r-4,1}$	$a_{r-3,1}$	$a_{r-2,1}$	$a_{r-1,1}$	$a_{r,1}$	....	....	....	....	....	....
·	$a_{r-1,2}$	$a_{r,2}$	$a_{r-4,2}$	$a_{r-3,2}$	$a_{r-2,2}$	$a_{r-1,2}$	$a_{r,2}$	....	....	....	....	....	....	....	....	....	....
·	$a_{r-1,3}$	$a_{r,3}$	$a_{r-12,3}$	$a_{r-11,3}$	$a_{r-10,3}$	$a_{r-9,3}$	$a_{r-8,3}$	$a_{r-7,3}$	$a_{r-6,3}$	$a_{r-5,3}$	$a_{r-4,3}$	$a_{r-3,3}$	$a_{r-2,3}$	$a_{r-1,3}$	$a_{r,3}$	....	....
·	$a_{r-1,4}$	$a_{r,4}$	$a_{r-2,4}$	$a_{r-1,4}$	$a_{r,4}$	....	....	....	....	....	....	....	....	....	....	....	....
·	$a_{r-1,5}$	$a_{r,5}$	$a_{r-10,5}$	$a_{r-9,5}$	$a_{r-8,5}$	$a_{r-7,5}$	$a_{r-6,5}$	$a_{r-5,5}$	$a_{r-4,5}$	$a_{r-3,5}$	$a_{r-2,5}$	$a_{r-1,5}$	$a_{r,5}$	....	....	....	....
·	$a_{r-1,6}$	$a_{r,6}$	$a_{r-6,6}$	$a_{r-5,6}$	$a_{r-4,6}$	$a_{r-3,6}$	$a_{r-2,6}$	$a_{r-1,6}$	$a_{r,6}$	....	....	....	....	....	....	....	....
·	$a_{r-1,7}$	$a_{r,7}$	$a_{r-14,7}$	$a_{r-13,7}$	$a_{r-12,7}$	$a_{r-11,7}$	$a_{r-10,7}$	$a_{r-9,7}$	$a_{r-8,7}$	$a_{r-7,7}$	$a_{r-6,7}$	$a_{r-5,7}$	$a_{r-4,7}$	$a_{r-3,7}$	$a_{r-2,7}$	$a_{r-1,7}$	$a_{r,7}$
·	$a_{r-1,8}$	$a_{r,8}$	$a_{r-1,8}$	$a_{r,8}$	....	....	....	....	....	....	....	....	....	....	....	....	....
·	$a_{r-1,9}$	$a_{r,9}$	$a_{r-9,9}$	$a_{r-8,9}$	$a_{r-7,9}$	$a_{r-6,9}$	$a_{r-5,9}$	$a_{r-4,9}$	$a_{r-3,9}$	$a_{r-2,9}$	$a_{r-1,9}$	$a_{r,9}$	....	....	....	....	....
·	$a_{r-1,10}$	$a_{r,10}$	$a_{r-5,10}$	$a_{r-4,10}$	$a_{r-3,10}$	$a_{r-2,10}$	$a_{r-1,10}$	$a_{r,10}$	....	....	....	....	....	....	....	....	....
·	$a_{r-1,11}$	$a_{r,11}$	$a_{r-13,11}$	$a_{r-12,11}$	$a_{r-11,11}$	$a_{r-10,11}$	$a_{r-9,11}$	$a_{r-8,11}$	$a_{r-7,11}$	$a_{r-6,11}$	$a_{r-5,11}$	$a_{r-4,11}$	$a_{r-3,11}$	$a_{r-2,11}$	$a_{r-1,11}$	$a_{r,11}$	....
·	$a_{r-1,12}$	$a_{r,12}$	$a_{r-3,12}$	$a_{r-2,12}$	$a_{r-1,12}$	$a_{r,12}$	....	....	....	....	....	....	....	....	....	....	....
·	$a_{r-1,13}$	$a_{r,13}$	$a_{r-11,13}$	$a_{r-10,13}$	$a_{r-9,13}$	$a_{r-8,13}$	$a_{r-7,13}$	$a_{r-6,13}$	$a_{r-5,13}$	$a_{r-4,13}$	$a_{r-3,13}$	$a_{r-2,13}$	$a_{r-1,13}$	$a_{r,13}$	....	....	....
·	$a_{r-1,14}$	$a_{r,14}$	$a_{r-7,14}$	$a_{r-6,14}$	$a_{r-5,14}$	$a_{r-4,14}$	$a_{r-3,14}$	$a_{r-2,14}$	$a_{r-1,14}$	$a_{r,14}$	....	....	....	....	....	....	....
·	$a_{r-1,15}$	$a_{r,15}$	$a_{r-15,15}$	$a_{r-14,15}$	$a_{r-13,15}$	$a_{r-12,15}$	$a_{r-11,15}$	$a_{r-10,15}$	$a_{r-9,15}$	$a_{r-8,15}$	$a_{r-7,15}$	$a_{r-6,15}$	$a_{r-5,15}$	$a_{r-4,15}$	$a_{r-3,15}$	$a_{r-2,15}$	$a_{r-1,15}$
·	$a_{r-1,16}$	$a_{r,16}$	$a_{r,16}$	....	....	....	....	....	....	....	....	....	....	....	....	....	....
·	$a_{r-1,17}$	$a_{r,17}$	$a_{r-8,17}$	$a_{r-7,17}$	$a_{r-6,17}$	$a_{r-5,17}$	$a_{r-4,17}$	$a_{r-3,17}$	$a_{r-2,17}$	$a_{r-1,17}$	$a_{r,17}$	....	....	....	....	....	....
·	$a_{r-1,18}$	$a_{r,18}$	$a_{r-4,18}$	$a_{r-3,18}$	$a_{r-2,18}$	$a_{r-1,18}$	$a_{r,18}$	....	....	....	....	....	....	....	....	....	....
·	....	....	....	....	....	....	....	....	....	....	....	....	....	....	....	....	....
·	....	....	....	....	....	....	....	....	....	....	....	....	....	....	....	....	....
·	....	....	....	....	....	....	....	....	....	....	....	....	....	....	....	....	....
·	$a_{r-1,255}$	$a_{r,255}$	$a_{r-15,255}$	$a_{r-14,255}$	$a_{r-13,255}$	$a_{r-12,255}$	$a_{r-11,255}$	$a_{r-10,255}$	$a_{r-9,255}$	$a_{r-8,255}$	$a_{r-7,255}$	$a_{r-6,255}$	$a_{r-5,255}$	$a_{r-4,255}$	$a_{r-3,255}$	$a_{r-2,255}$	$a_{r-1,255}$
·																	

Figure 56: Illustration of time interleaving for example 1

Time interleaver input													time →							
$r_{0-3}$	$r_{0-2}$	$r_{0-1}$	$r_0$	$r_{0+1}$	$r_{0+2}$	$r_{0+3}$	$r_{0+4}$	$r_{0+5}$	$r_{0+6}$	$r_{0+7}$	$r_{0+8}$	$r_{0+9}$	$r_{0+10}$	$r_{0+11}$	$r_{0+12}$	$r_{0+13}$	$r_{0+14}$	$r_{0+15}$	$r_{0+16}$	
....	....	$a_{r_{0-1},0}$	$a_{r_0,0}$	....	....	....	....	....	....	....	....	....	....	....	....	....	....	....	....	
....	....	$a_{r_{0-1},1}$	$a_{r_0,1}$	....	....	....	....	....	....	....	....	....	....	....	....	....	....	....	....	
....	....	....	....	....	....	....	....	....	....	....	....	....	....	....	....	....	....	....	....	
....	....	$a_{r_{0-1},255}$	$a_{r_0,255}$	....	....	....	....	....	....	....	....	....	....	....	....	....	....	....	....	
				....	....	....	....	....	....	....	....	....	....	....	....	....	....	....	....	
				$a_{r_0,383}$	....	....	....	....	....	....	....	....	....	....	....	....	....	....	....	....
Time interleaver output																				
....	....	$a_{r_{0-1},0}$	$a_{r_0,0}$	....	....	....	....	....	....	....	....	....	....	....	....	....	....	$a_{r_{0+14},0}$	$a_{r_{0+15},0}$	....
....	....	$a_{r_{0-9},1}$	$a_{r_{0-8},1}$	....	....	....	....	....	....	....	....	....	....	....	....	....	....	$a_{r_{0+6},1}$	$a_{r_{0+7},1}$	....
....	....	....	....	....	....	....	....	....	....	....	....	....	....	....	....	....	....	....	....	....
....	....	$a_{r_{0-16},255}$	$a_{r_{0-15},255}$	....	....	....	....	....	....	....	....	....	....	....	....	....	....	$a_{r_{0-1},255}$	$a_{r_0,255}$	....
				$a_{r_0,256}$	$a_{r_{0+1},256}$	....	....	....	....	....	....	....	....	....	....	....	....	$a_{r_{0+14},256}$	$a_{r_{0+15},256}$	....
				0	0	....	....	....	....	....	....	....	....	....	....	....	....	....	....	$a_{r_{0+6},257}$
				....	....	....	....	....	....	....	....	....	....	....	....	....	....	....	....	....
				0	0	....	....	....	....	....	....	....	....	....	....	....	....	....	....	$a_{r_0,263}$
				0	$a_{r_0,264}$	....	....	....	....	....	....	....	....	....	....	....	....	$a_{r_{0+13},264}$	$a_{r_{0+14},264}$	....
				0	0	....	....	....	....	....	....	....	....	....	....	....	....	....	....	$a_{r_{0+5},265}$
				....	....	....	....	....	....	....	....	....	....	....	....	....	....	....	....	....
				0	0	....	....	....	....	....	....	....	....	....	....	....	....	....	....	0
				$a_{r_0,272}$	$a_{r_{0+1},272}$	....	....	....	....	....	....	....	....	....	....	....	....	$a_{r_{0+14},272}$	$a_{r_{0+15},272}$	....
				....	....	....	....	....	....	....	....	....	....	....	....	....	....	....	....	....
				0	$a_{r_0,376}$	....	....	....	....	....	....	....	....	....	....	....	....	$a_{r_{0+13},376}$	$a_{r_{0+14},376}$	....
				0	0	....	....	....	....	....	....	....	....	....	....	....	....	....	....	$a_{r_{0+5},377}$
				....	....	....	....	....	....	....	....	....	....	....	....	....	....	....	....	....
				0	0	....	....	....	....	....	....	....	....	....	....	....	....	....	....	$a_{r_{0+7},382}$
				0	0	....	....	....	....	....	....	....	....	....	....	....	....	0	$a_{r_0,383}$	....

Figure 57: Illustration of time interleaving for example 2

Time interleaver input										time →									
$r_{0-3}$	$r_{0-2}$	$r_{0-1}$	$r_0$	$r_{0+1}$	$r_{0+2}$	$r_{0+3}$	$r_{0+4}$	$r_{0+5}$	$r_{0+6}$	$r_{0+7}$	$r_{0+8}$	$r_{0+9}$	$r_{0+10}$	$r_{0+11}$	$r_{0+12}$	$r_{0+13}$	$r_{0+14}$	$r_{0+15}$	$r_{0+16}$
....	....	$a_{r_{0-1},0}$	$a_{r_0,0}$	....	....	....	....	....	....	....	....	....	....	....	....	....	....	....	....
....	....	$a_{r_{0-1},1}$	$a_{r_0,1}$	....	....	....	....	....	....	....	....	....	....	....	....	....	....	....	....
....	....	....	....	....	....	....	....	....	....	....	....	....	....	....	....	....	....	....	....
....	....	$a_{r_{0-1},255}$	$a_{r_0,255}$	....	....	....	....	....	....	....	....	....	....	....	....	....	....	....	....
....	....	....																	
....	....	$a_{r_{0-1},383}$																	
Time interleaver output																			
....	....	$a_{r_{0-1},0}$	$a_{r_0,0}$	....	....	....	....	....	....	....	....	....	....	....	....	$a_{r_{0+13},0}$	$a_{r_{0+14},0}$	$a_{r_{0+15},0}$	....
....	....	$a_{r_{0-9},1}$	$a_{r_{0-8},1}$	....	....	....	....	....	....	....	....	....	....	....	....	$a_{r_{0+5},1}$	$a_{r_{0+6},1}$	$a_{r_{0+7},1}$	....
....	....	....	....	....	....	....	....	....	....	....	....	....	....	....	....	....	....	....	....
....	....	$a_{r_{0-16},255}$	$a_{r_{0-15},255}$	....	....	....	....	....	....	....	....	....	....	....	....	$a_{r_{0-2},255}$	$a_{r_{0-1},255}$	$a_{r_0,255}$	....
....	....	$a_{r_{0-1},256}$	0	....	....	....	....	....	....	....	....	....	....	....	....	0	0		
....	....	$a_{r_{0-9},257}$	$a_{r_{0-8},257}$	....	....	....	....	....	....	....	....	....	....	....	....	0	0		
....	....	....	....	....	....	....	....	....	....	....	....	....	....	....	....	....	....		
....	....	$a_{r_{0-15},263}$	$a_{r_{0-14},263}$	....	....	....	....	....	....	....	....	....	....	....	....	$a_{r_{0-1},263}$	0		
....	....	$a_{r_{0-2},264}$	$a_{r_{0-1},264}$	....	....	....	....	....	....	....	....	....	....	....	....	0	0		
....	....	....	....	....	....	....	....	....	....	....	....	....	....	....	....	....	....		
....	....	....	....	....	....	....	....	....	....	....	....	....	....	....	....	....	....		
....	....	$a_{r_{0-16},271}$	$a_{r_{0-15},271}$	....	....	....	....	....	....	....	....	....	....	....	....	$a_{r_{0-2},271}$	$a_{r_{0-1},271}$		
....	....	$a_{r_{0-1},272}$	0	....	....	....	....	....	....	....	....	....	....	....	....	0	0		
....	....	$a_{r_{0-9},273}$	$a_{r_{0-8},273}$	....	....	....	....	....	....	....	....	....	....	....	....	0	0		
....	....	....	....	....	....	....	....	....	....	....	....	....	....	....	....	....	....		
....	....	....	....	....	....	....	....	....	....	....	....	....	....	....	....	0	0		
....	....	....	....	....	....	....	....	....	....	....	....	....	....	....	....	0	0		
....	....	$a_{r_{0-16},383}$	$a_{r_{0-15},383}$	....	....	....	....	....	....	....	....	....	....	....	....	$a_{r_{0-2},383}$	$a_{r_{0-1},383}$		

Figure 58: Illustration of time interleaving for example 3

## 13 Common Interleaved Frame

This clause specifies the bit structure of the Common Interleaved Frame (CIF). Each vector  $C_r$  at the output of a time interleaver (specified in clause 12) contains a multiple of 64 bits, and therefore, every sub-channel occupies an integral number of CUs in the CIF.

Using the notation of clause 12, the required number of CUs for a sub-channel during the CIF of time index  $r$ , is equal to  $N_r/64$ .

The vectors  $C_r$  for the various sub-channels shall be multiplexed in such a way that every sub-channel shall occupy an integral number of consecutive CUs.

The address of the CU assigned to the first bit of a vector  $C_r$  is called the start address.

The CIF bits shall be assigned consecutively so that the first bit of each vector  $C_r$  at the output of a time interleaver shall be assigned to the first bit of the CU of start address, and the last bit of each vector  $C_r$  shall be assigned to the last bit of the last CU assigned to that sub-channel.

If the set of sub-channels do not fill the whole CIF, all unassigned CUs shall be filled with padding bits. The value of the padding bits shall be defined as follows:

If the  $(i+1)^{\text{th}}$  bit of the CIF belongs to a CU containing padding bits, it shall take the value of the  $(i+1)^{\text{th}}$  bit of the PRBS defined in clause 10.

These rules are illustrated in figure 59.

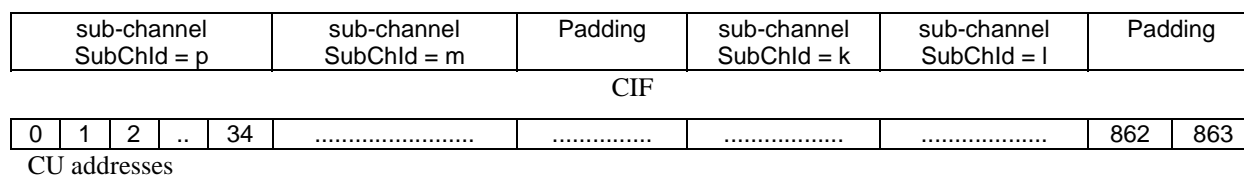

**Figure 59: Example of a CIF structure**

The  $(i+1)^{\text{th}}$  bit of the CIF of index  $r$  shall be denoted by  $d_{r,i}$  ( $i=0, 1, 2, \dots, 55\ 295$ ).

The index  $r$  taken modulo 5 000 ( $\text{mod}(r, 5\ 000)$ ) is equal to the CIF count defined in clause 5.3.

The structure of the CIF is signalled by the MCI, as defined in clause 6.2.

## 14 DAB transmission signal

### 14.1 General principles

The transmitted signal is built up around a transmission frame structure corresponding to the juxtaposition in time of the synchronization channel, the FIC and the MSC (see also clause 5.1).

The transmission frame duration is denoted by  $T_F$ .

The structure of the transmission frame is shown in figure 60.

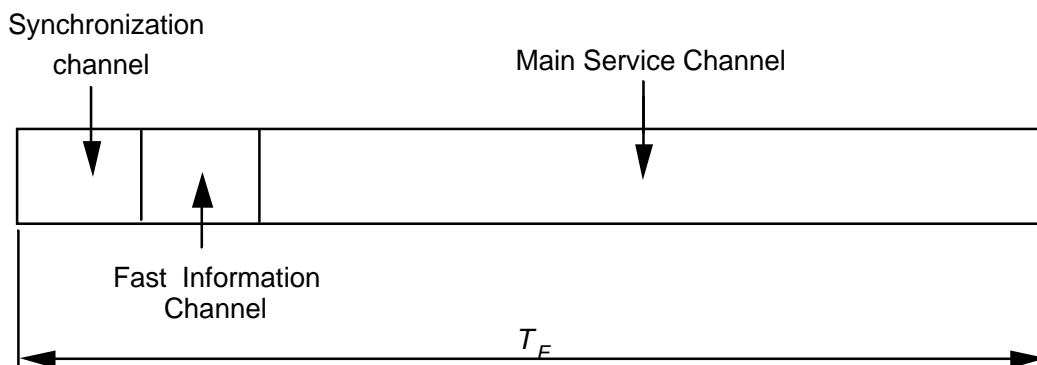

**Figure 60: Transmission frame structure**

Each transmission frame is divided into a sequence of OFDM symbols, each symbol consisting of a number of carriers. The DAB transmission signal is defined as the sum of two signals; the main signal  $s(t)$  and an optional signal  $s_{TII}(t)$  as illustrated in figure 3. Clause 14.2 defines the main signal. The clauses 14.3 to 14.7 specify the content of the synchronization channel as well as the processing applied to the convolutionally encoded FIBs and the CIFs in order to generate the main signal  $s(t)$ . Clause 14.8 specifies the generation of the signal  $s_{TII}(t)$ .

## 14.2 Structure of the main signal

Each transmission frame shall consist of consecutive OFDM symbols. The number of OFDM symbols in a transmission frame is dependent on the transmission mode. The synchronization channel in any transmission mode shall occupy the first two OFDM symbols of each transmission frame.

The first OFDM symbol of the transmission frame shall be the Null symbol of duration  $T_{NULL}$ . The remaining part of the transmission frame shall be a juxtaposition of OFDM symbols of duration  $T_S$ .

Each of these OFDM symbols shall consist of a set of equally-spaced carriers, with a carrier spacing equal to  $1/T_U$ . The main signal  $s(t)$  shall be defined using the following formula:

$$s(t) = \operatorname{Re} \left\{ e^{2j\pi f_c t} \sum_{m=-\infty}^{+\infty} \sum_{l=0}^L \sum_{k=-K/2}^{K/2} z_{m,l,k} \cdot g_{k,l}(t - mT_F - T_{NULL} - (l-1)T_S) \right\}$$

with

$$g_{k,l}(t) = \begin{cases} 0 & \text{for } l = 0 \\ e^{2j\pi k(t-\Delta)/T_U} \cdot \operatorname{Rect}(t/T_S) & \text{for } l = 1, 2, \dots, L \end{cases}$$

and  $T_S = T_U + \Delta$ .

The various parameters and variables are defined as follows:

- $L$  is the number of OFDM symbols per transmission frame (the Null symbol being excluded);
- $K$  is the number of transmitted carriers;
- $T_F$  is the transmission frame duration;
- $T_{NULL}$  is the Null symbol duration;
- $T_S$  is the duration of OFDM symbols of indices  $l = 1, 2, 3, \dots, L$ ;
- $T_U$  is the inverse of the carrier spacing;
- $\Delta$  is the duration of the time interval called guard interval;

$z_{m,l,k}$  is the complex D-QPSK symbol associated to carrier  $k$  of OFDM symbol  $l$  during transmission frame  $m$ . Its values are defined in the following clauses. For  $k = 0$ ,  $z_{m,l,k} = 0$ , so that the central carrier is not transmitted;

$f_c$  is the central frequency of the signal. The possible values of  $f_c$  are given in clause 15.

These parameters are specified in table 22 for transmission mode I. The values of the various time-related parameters are given in multiples of the elementary period  $T = 1/2\ 048\ 000$  seconds, and approximately in milliseconds or microseconds.

**Table 22: Definition of the parameters for transmission mode I**

Parameter	Transmission mode I
$L$	76
$K$	1 536
$T_F$	196 608 T 96 ms
$T_{NULL}$	2 656 T ~1,297 ms
$T_S$	2 552 T ~1,246 ms
$T_U$	2 048 T 1 ms
$\Delta$	504 T ~246 $\mu$ s

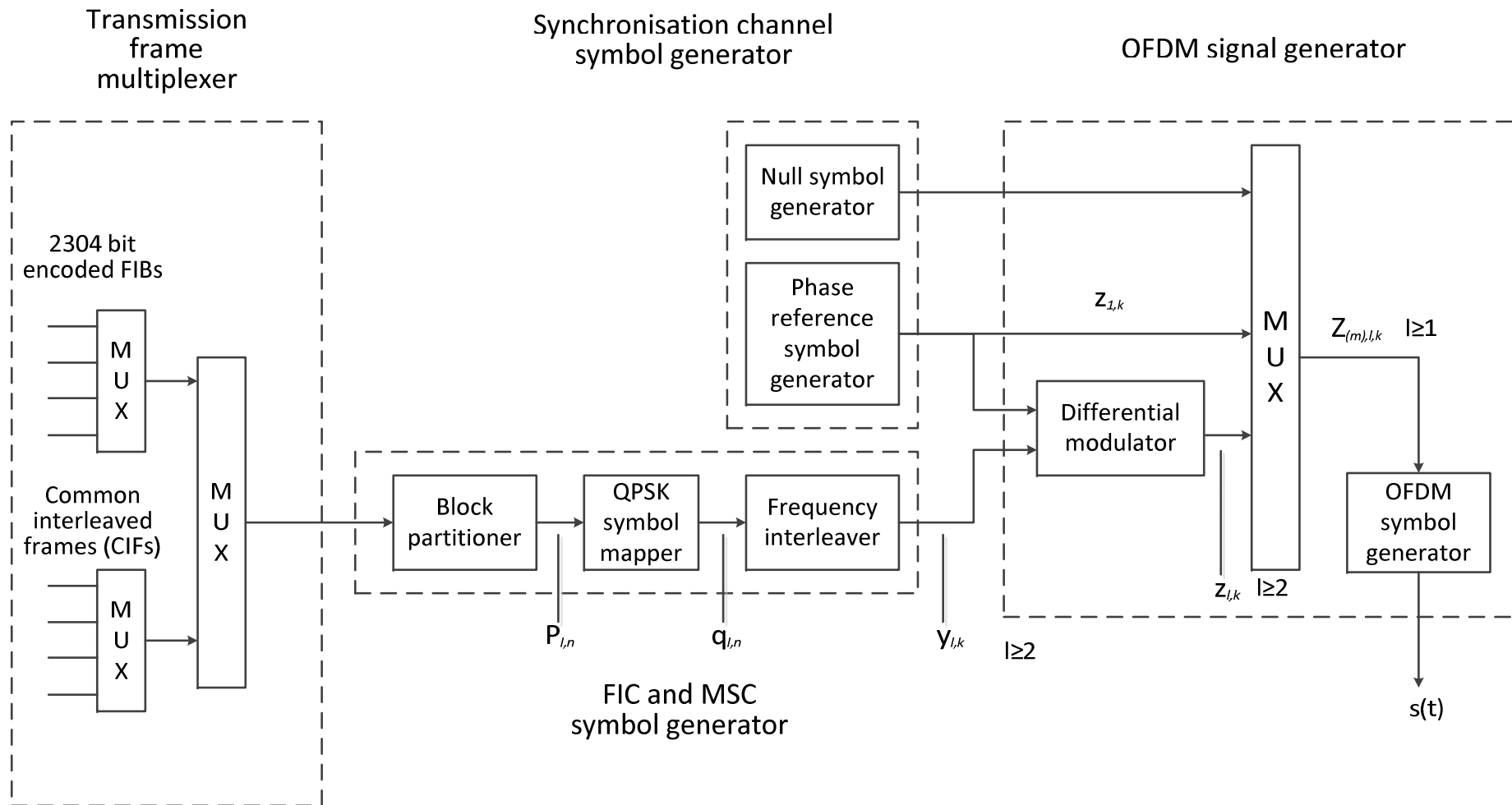

Figure 61: Conceptual block diagram of the generation of the main signal

Clauses 14.4 to 14.7 describe the generation of the complex D-QPSK symbols  $z_{m, l, k}$  constituting a transmission frame. Since the same processing is applied for every transmission frame, the index  $m$  will be suppressed when appropriate.

The generation of the main signal  $s(t)$  is described in the conceptual block diagram of figure 61.

## 14.3 Synchronization channel

### 14.3.0 Introduction

This clause specifies the characteristics of the synchronization channel which consists of the first two OFDM symbols of each transmission frame. This channel may also be used for carrying optional Transmitter Identification Information (TII) (see clause 14.8), by adding to the null symbol defined in clause 14.2, the TII signal.

### 14.3.1 Null symbol

As previously described, the first OFDM symbol of the transmission frame is the null symbol. During the time interval  $[0, T_{NULL}]$ , the main signal  $s(t)$  shall be equal to 0.

### 14.3.2 Phase reference symbol

The second OFDM symbol of the transmission frame is the phase reference symbol. It constitutes the reference for the differential modulation for the next OFDM symbol. The phase reference symbol is defined by the values of  $z_{l, k}$  for  $l = 1$ :

$$z_{1,k} = \begin{cases} e^{j\phi_k} & \text{for } -\frac{K}{2} \leq k < 0 \text{ and } 0 < k \leq \frac{K}{2} \\ 0 & \text{for } k = 0 \end{cases}$$

The values of  $\phi_k$  shall be obtained from the following formula:

$$\phi_k = \frac{\pi}{2} (h_{i, k-k'} + n)$$

The indices  $i$ ,  $k'$  and the parameter  $n$  are specified as functions of the carrier index  $k$  for transmission mode I in table 23.

The values of the parameter  $h_{i, j}$  as a function of its indices  $i$  and  $j$ , are specified in table 24.

Table 23: Relation between the indices  $i$ ,  $k'$  and  $n$  and the carrier index  $k$  for transmission mode I

$k$ in the range of		$k'$	$i$	$n$	$k$ in the range of		$k'$	$i$	$n$
min	max				min	max			
-768	-737	-768	0	1	1	32	1	0	3
-736	-705	-736	1	2	33	64	33	3	1
-704	-673	-704	2	0	65	96	65	2	1
-672	-641	-672	3	1	97	128	97	1	1
-640	-609	-640	0	3	129	160	129	0	2
-608	-577	-608	1	2	161	192	161	3	2
-576	-545	-576	2	2	193	224	193	2	1
-544	-513	-544	3	3	225	256	225	1	0
-512	-481	-512	0	2	257	288	257	0	2
-480	-449	-480	1	1	289	320	289	3	2
-448	-417	-448	2	2	321	352	321	2	3
-416	-385	-416	3	3	353	384	353	1	3
-384	-353	-384	0	1	385	416	385	0	0
-352	-321	-352	1	2	417	448	417	3	2
-320	-289	-320	2	3	449	480	449	2	1
-288	-257	-288	3	3	481	512	481	1	3
-256	-225	-256	0	2	513	544	513	0	3
-224	-193	-224	1	2	545	576	545	3	3
-192	-161	-192	2	2	577	608	577	2	3
-160	-129	-160	3	1	609	640	609	1	0
-128	-97	-128	0	1	641	672	641	0	3
-96	-65	-96	1	3	673	704	673	3	0
-64	-33	-64	2	1	705	736	705	2	1
-32	-1	-32	3	2	737	768	737	1	1

Table 24: Time-Frequency-Phase parameter  $h$  values

$j$	0	1	2	3	4	5	6	7	8	9	10	11	12	13	14	15
$h_{0,j}$	0	2	0	0	0	0	1	1	2	0	0	0	2	2	1	1
$h_{1,j}$	0	3	2	3	0	1	3	0	2	1	2	3	2	3	3	0
$h_{2,j}$	0	0	0	2	0	2	1	3	2	2	0	2	2	0	1	3
$h_{3,j}$	0	1	2	1	0	3	3	2	2	3	2	1	2	1	3	2

$j$	16	17	18	19	20	21	22	23	24	25	26	27	28	29	30	31
$h_{0,j}$	0	2	0	0	0	0	1	1	2	0	0	0	2	2	1	1
$h_{1,j}$	0	3	2	3	0	1	3	0	2	1	2	3	2	3	3	0
$h_{2,j}$	0	0	0	2	0	2	1	3	2	2	0	2	2	0	1	3
$h_{3,j}$	0	1	2	1	0	3	3	2	2	3	2	1	2	1	3	2

### 14.3.3 Time reference

The synchronization channel shall serve as the reference for the time information carried in the FIC (see clause 8.1.3). The time information carried in the FIC shall be taken to be the time of transmission of the start of the null symbol in the transmission frame carrying the time information.

## 14.4 Block partitioning and association of blocks to OFDM symbols

### 14.4.0 Introduction

This clause defines the process applied to the sequence of convolutionally encoded FIBs and to the sequence of CIFs, to constitute the blocks of data which will be associated to OFDM symbols.

## 14.4.1 Block partitioning and association of blocks to OFDM symbols in the Fast Information Channel

### 14.4.1.1 Transmission mode I

In transmission mode I, four groups of convolutionally encoded FIBs shall be transmitted within each transmission frame, as indicated in clause 5.1.

Four convolutional codewords, defined in clause 11.2.1 corresponding to four consecutive groups of FIBs shall be multiplexed to form a vector, which shall then be divided into three blocks to be transmitted on three OFDM symbols.

The bits  $b_i$  of the convolutional codeword  $(b_i)_{i=0}^{2303}$  defined in clause 11.2.1 will, in this clause, be indexed by the time index  $r$ , and will be denoted  $b_{r,i}$ . The index  $r$  is defined in such a way that its value modulo 5000 ( $\text{mod}(r, 5000)$ ) is equal to the CIF count defined in clause 5.3. This relationship follows from the association of FIBs to CIFs, see clause 5.1.

The multiplexing of four consecutive convolutional codewords into one vector  $\mathbf{B}'$  is defined by the following relation:

$$b'_{i'} = b_{r,i}$$

and

$$i' = i + 2304 \cdot \text{mod}(r, 4) \quad \text{for } i = 0,1,2, \dots, 2303 \text{ and for any value of } r.$$

where:

$b'_{i'}$  denotes the  $(i'+1)^{\text{th}}$  bit of the vector  $\mathbf{B}'$ ;

$b_{r,i}$  denotes the  $(i+1)^{\text{th}}$  bit of the  $(r+1)^{\text{th}}$  convolutional codeword.

This means that the arrangement of convolutionally encoded FIBs in a transmission frame shall be such that convolutionally encoded FIBs of CIF counts 0, 1, 2 and 3 are transmitted in the same transmission frame, those of CIF counts 4, 5, 6 and 7 in the next transmission frame, and so on.

The vector  $(b'_{i'})_{i'=0}^{9215}$  shall be divided into three consecutive blocks  $\mathbf{P}_l$ , each block containing the bits to be transmitted in the OFDM symbol of index  $l = 2, 3, 4$  respectively.

Each block  $\mathbf{P}_l$  is a vector  $(p_{l,n})_{n=0}^{3071}$ , the bits  $p_{l,n}$  being defined by:

$$p_{l,n} = b_i$$

and

$$\begin{aligned} l &= \text{Q}(i'/3072) + 2 & i' &= 0,1,2, \dots, 9215 \\ n &= \text{R}(i'/3072) & i' &= 0,1,2, \dots, 9215 \end{aligned}$$

The principle of this block partitioning is shown in figure 62, for  $r = 0, 1, 2$  and 3.

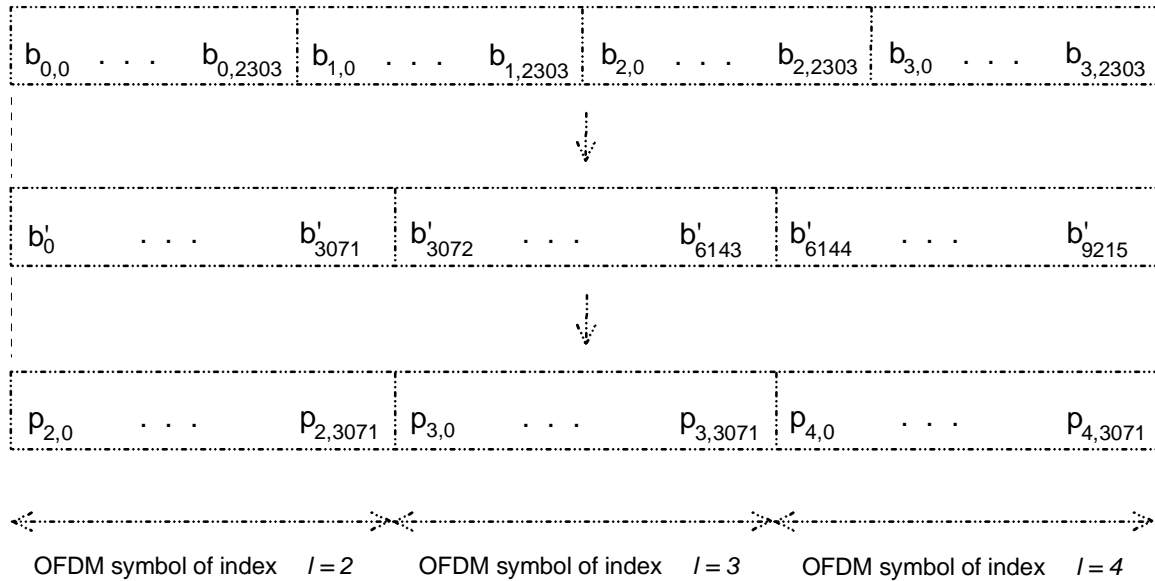

**Figure 62: Block partitioning in the FIC for transmission mode I**

## 14.4.2 Block partitioning and association of blocks to OFDM symbols in the Main Service Channel

### 14.4.2.1 Transmission mode I

In transmission mode I, four CIFs shall be transmitted within each transmission frame as indicated in clause 5.1.

Four consecutive CIFs defined in clause 13 shall be multiplexed to form a vector, which shall then be divided into 72 blocks to be transmitted on 72 OFDM symbols.

The multiplexing of four consecutive CIFs into one vector  $D'$  is defined by the following relation:

$$d'_{i'} = d_{r,i}$$

and

$$i' = i + 55296 \cdot \text{mod}(r, 4) \quad \text{for } i = 0, 1, 2, \dots, 55295 \quad \text{and for any value of } r.$$

where:

$d'_{i'}$  denotes the  $(i'+1)^{\text{th}}$  bit of the vector  $D'$ ;

$d_{r,i}$  denotes the  $(i+1)^{\text{th}}$  bit of the  $(r+1)^{\text{th}}$  CIF.

As defined in clause 13, the index  $r$  taken modulo 5000 ( $\text{mod}(r, 5000)$ ) is equal to the CIF count defined in clause 5.3.

This means that the arrangement of CIFs in a transmission frame shall be such that CIFs of CIF count 0, 1, 2 and 3 are transmitted in the same transmission frame, those of CIF count 4, 5, 6 and 7 in the next transmission frame, and so on.

The vector  $(d'_{i'})_{i'=0}^{221183}$  shall be divided into 72 consecutive blocks  $P_l$ , each block containing the bits to be transmitted in the OFDM symbol of index  $l = 5, 6, 7, \dots, 76$  respectively.

Each block  $P_l$  is a vector  $(p_{l,n})_{n=0}^{3071}$ , the bits  $p_{l,n}$  being defined by:

$$p_{l,n} = d'_{i'}$$

and

$$\begin{aligned} l &= Q(i'/3072) + 5 & i' &= 0,1,2, \dots, 221183 \\ n &= R(i'/3072) & i' &= 0,1,2, \dots, 221183 \end{aligned}$$

The principle of this block partitioning is shown in figure 63, for  $r = 0, 1, 2$  and  $3$ .

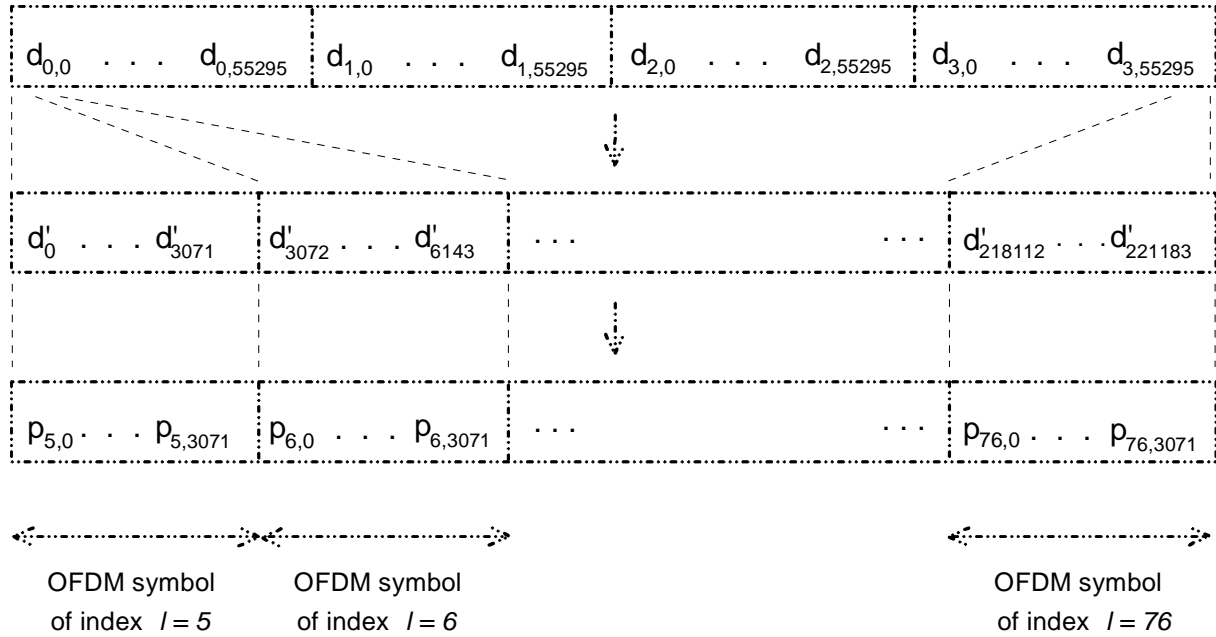

**Figure 63: Block partitioning in the MSC for transmission mode I**

## 14.5 QPSK symbol mapper

For any of the OFDM symbols of index  $l = 2, 3, 4, \dots, L$ , the  $2K$ -bit vector  $(p_{l,n})_{n=0}^{2K-1}$ , whose elements  $p_{l,n}$  are defined in clauses 14.4.1 and 14.4.2, shall be mapped on the  $K$  complex QPSK symbols  $q_{l,n}$  according to the following relation:

$$q_{l,n} = \frac{1}{\sqrt{2}} [(1 - 2p_{l,n}) + j(1 - 2p_{l,n+K})] \quad \text{for } n = 0, 1, 2, \dots, K - 1.$$

## 14.6 Frequency interleaving

### 14.6.0 Introduction

This clause defines the correspondence between the index  $n$  of the QPSK symbols  $q_{l,n}$  and the carrier index  $k$  ( $-K/2 \leq k < 0$  and  $0 < k \leq K/2$ ).

The QPSK symbols shall be re-ordered according to the following relation:

$$y_{l,k} = q_{l,n} \text{ for } l = 2, 3, 4, \dots, L$$

with  $k = F(n)$ , where  $F$  is a function defined in clause 14.6.1.

### 14.6.1 Transmission mode I

Let  $\Pi(i)$  be a permutation in the set of integers  $i = 0, 1, 2, \dots, 2047$  obtained from the following congruential relation:

$$\Pi(i) = 13 \Pi(i-1) + 511 \pmod{2048} \text{ and } \Pi(0) = 0;$$

for  $i = 1, 2, \dots, 2047$ .

$\Pi(i)$  defines a permutation of the ordered set  $(0, 1, 2, \dots, 2047)$ , resulting in the set:

$$A = \{\Pi(0), \Pi(1), \Pi(2), \dots, \Pi(2047)\}.$$

Let  $D$  be the set  $D = \{d_0, d_1, d_2, \dots, d_{1535}\}$ , containing 1536 elements and defined as being the subset of  $A$  with the same element ordering, comprising all the elements of  $A$  higher than or equal to 256 and lower than or equal to 1792, excluding 1024. Thus, if  $\Pi(i)$  is the  $(n+1)$ th element of  $A$  in the range  $[256, 1792]$  excluding 1024,  $d_n = \Pi(i)$ .

The correspondence between the index  $n \in \{0, 1, 2, \dots, 1535\}$  of the QPSK symbol  $q_{l, n}$  and the frequency index

$$k \in \{-768, -767, -766, \dots, 768\} \setminus \{0\},$$

shall be given by:

$$k = F(n) = d_n - 1024.$$

The function  $F$  is a one-to-one mapping between the sets  $\{0, 1, 2, \dots, 1535\}$  and  $\{-768, -767, -766, \dots, 768\} \setminus \{0\}$ .

The interleaving rule is illustrated in table 25.

**Table 25: Frequency interleaving for transmission mode I**

i	$\Pi(i)$	$d_n$	n	k
0	0			
1	511	511	0	-513
2	1 010	1 010	1	-14
3	1 353	1 353	2	329
4	1 716	1 716	3	692
5	291	291	4	-733
6	198			
7	1 037	1 037	5	13
8	1 704	1 704	6	680
9	135			
10	218			
11	1 297	1 297	7	273
12	988	988	8	-36
13	1 076	1 067	9	43
14	46			
15	1 109	1 109	10	85
16	592	592	11	-432
17	15			
18	706	706	12	-318
:	:	:		
2 044	1 676	1 676	1 533	652
2 045	1 819			
2 046	1 630	1 630	1 534	606
2 047	1 221	1 221	1 535	197

## 14.7 Differential modulation

Differential modulation shall be applied to the QPSK symbols on each carrier. The differential modulation is defined by the following rule:

$$\begin{aligned}
 z_{l,k} &= z_{l-1,k} \cdot y_{l,k} \\
 \text{for } l &= 2, 3, 4, \dots, L \\
 \text{and } -\frac{K}{2} &\leq k \leq \frac{K}{2}
 \end{aligned}$$

This means that each carrier is modulated using a  $\pi/4$ -shift D-QPSK. All together, they form the main signal defined in clause 14.2.

As indicated in clause 14.2, the generation of the complex D-QPSK symbols  $z_{m,l,k}$  does not depend on the transmission frame index  $m$ , which appears on the formula defining the main signal  $s(t)$ .

The main signal  $s(t)$  is therefore defined for all values of  $t$ . It is generated from the D-QPSK symbols  $z_{m,l,k}$  by the OFDM symbol generator of figure 61.

## 14.8 Transmitter Identification Information signal

### 14.8.0 Introduction

The TII is conveyed in the synchronization channel. It provides unambiguous identification of each transmitter in a DAB network. The implementation of TII is optional.

The coverage area of an SFN may be very large and network monitoring is enhanced by use of the TII. The TII signal enables receivers (usually monitoring receivers) to distinguish the individual transmitters of a network. Every transmitter sends a unique TII signal during the Null symbol of the transmission frame, thus violating the general rules of SFN transmission that requires all transmitters of the network to send identical signals. The potential interference problem is solved by defining TII signals in such a way that only a subset of the OFDM carriers are used by any transmitter. Assignment of TII signals to transmitters is performed so that adjacent transmitters use different carriers. This allocation follows the rules of conventional network planning.

The identifier comprises two parts; a main- and a sub-identifier for every transmitter in the SFN. From analysis of the Null symbol a receiver can derive the identifiers of those transmitters which are currently received.

Every transmitter switches on specific carrier pairs during the Null Symbol. Using carrier pairs instead of single carriers facilitates the determination of the geographical position of a receiver. In order to allow the receiver to perform channel state analysis, the TII signal is only transmitted in every other frame. The synchronization is aligned with the CIF counter.

The structure of the TII signal is based on a block of 384 carriers in transmission mode I. This block of carriers is organized as 24 "combs" of carrier pairs, each comb comprising 8 carrier pairs, and the structure is repeated four times in the frequency domain, to match the 1 536 available carriers. The 24 combs, which correspond to the set of possible SubIds of the transmissions, allow the conventional network planning of the TII signal inside the SFN. The allocation of SubId to a transmitter determines which of the combs of carriers it will transmit.

The TII signal for a given transmitter may only use 4 out of the 8 pairs. Since the number of combinations of 4 from a set of 8 is 70, this results in 70 unique "patterns" of carrier pairs per comb, which correspond to the set of possible MainIds of the transmissions. The allocation of MainId to a transmitter determines which of the patterns (i.e. which 4 out of the 8 carrier pairs in the comb) it will transmit.

In Transmission mode I, the TII structure is repeated 4 times in the frequency domain, so every transmitter uses four times four pairs of carriers, or 32 carriers in total. The ratio of carriers in a TII symbol to a normal DAB symbol is 1:48, so that the signal power in a TII symbol is 16 dB below the signal power of the other symbols. Therefore, coarse receiver synchronization from the null symbol containing TII is still possible.

The TII signal shall fill the null symbol of each transmission frame comprising the CIFs of CIF count 0, 1, 2, 3 modulo 8 (transmission mode I).

The TII signal consists of a certain number of pairs of adjacent carriers of an OFDM symbol; the actual selection of those carriers present in the TII symbol identifies the transmitter.

The selection of the carriers is defined by assigning two numbers to each transmitter; the pattern number  $p$  and the comb number  $c$ . These numbers are the Main Identifier and Sub-Identifier of a transmitter, respectively.

The TII signal  $s_{TII}(t)$  associated with a given transmitter shall be:

$$s_{TII}(t) = \text{Re}\left\{e^{2j\pi f_c t} \sum_{m=-\infty}^{+\infty} \sum_{k=-K/2}^{K/2} z_{m,0,k} \cdot g_{TII,k}(t - mT_F)\right\}$$

where:

$$g_{TII,k}(t) = e^{2\pi j k (t - T_{NULL} + T_U) / T_U} \cdot \text{Rect}(t / T_{NULL})$$

The parameters  $T_U$ ,  $T_{NULL}$  and  $f_c$  are defined in clause 14.2;  $z_{m,0,k}$  is the complex number associated to carrier  $k$  of the null symbol. It is equal to zero during the transmission frame  $m$  when the TII signal is not transmitted. Its values, for the transmission frame  $m$  where the TII signal is transmitted, shall be derived from the values of  $p$  and  $c$ .

The following relation is defined:

$$z_{m,0,k} = A_{c,p}(k) \cdot e^{j\varphi_k} + A_{c,p}(k-1) \cdot e^{j\varphi_{k-1}}$$

The values of  $\varphi_k$  are defined in clause 14.3.2. The values of  $A_{c,p}(k)$  are specified in clause 14.8.1.

### 14.8.1 Transmission mode I

The following formulae shall apply:

**Transmission mode I:**

$$A_{c,p}(k) = \begin{cases} \sum_{b=0}^7 \delta(k, -768 + 2c + 48b) \cdot a_b(p) & \text{for } -768 \leq k < -384 \\ \sum_{b=0}^7 \delta(k, -384 + 2c + 48b) \cdot a_b(p) & \text{for } -384 \leq k < 0 \\ \sum_{b=0}^7 \delta(k, 1 + 2c + 48b) \cdot a_b(p) & \text{for } 0 < k \leq 384 \\ \sum_{b=0}^7 \delta(k, 385 + 2c + 48b) \cdot a_b(p) & \text{for } 384 < k \leq 768 \end{cases}$$

and  $A_{c,p}(0) = A_{c,p}(-769) = 0$ .

This formula shall apply for  $0 \leq c \leq 23$ .

$a_b(p)$  is defined in table 26.  $\delta$  is the Kronecker symbol defined in clause 3.3.

Table 26: TII pattern for transmission mode I

<b>p</b>	$a_b(p)$ <b>b=0,1,2,3,4,5,6,7</b>	<b>p</b>	$a_b(p)$ <b>b=0,1,2,3,4,5,6,7</b>	<b>p</b>	$a_b(p)$ <b>b=0,1,2,3,4,5,6,7</b>
0	0 0 0 0 1 1 1 1	24	0 1 0 1 1 1 0 0	48	1 0 1 0 1 0 0 1
1	0 0 0 1 0 1 1 1	25	0 1 1 0 0 0 1 1	49	1 0 1 0 1 0 1 0
2	0 0 0 1 1 0 1 1	26	0 1 1 0 0 1 0 1	50	1 0 1 0 1 1 0 0
3	0 0 0 1 1 1 0 1	27	0 1 1 0 0 1 1 0	51	1 0 1 1 0 0 0 1
4	0 0 0 1 1 1 1 0	28	0 1 1 0 1 0 0 1	52	1 0 1 1 0 0 1 0
5	0 0 1 0 0 1 1 1	29	0 1 1 0 1 0 1 0	53	1 0 1 1 0 1 0 0
6	0 0 1 0 1 0 1 1	30	0 1 1 0 1 1 0 0	54	1 0 1 1 1 0 0 0
7	0 0 1 0 1 1 0 1	31	0 1 1 1 0 0 0 1	55	1 1 0 0 0 0 1 1
8	0 0 1 0 1 1 1 0	32	0 1 1 1 0 0 1 0	56	1 1 0 0 0 1 0 1
9	0 0 1 1 0 0 1 1	33	0 1 1 1 0 1 0 0	57	1 1 0 0 0 1 1 0
10	0 0 1 1 0 1 0 1	34	0 1 1 1 1 0 0 0	58	1 1 0 0 1 0 0 1
11	0 0 1 1 0 1 1 0	35	1 0 0 0 0 1 1 1	59	1 1 0 0 1 0 1 0
12	0 0 1 1 1 0 0 1	36	1 0 0 0 1 0 1 1	60	1 1 0 0 1 1 0 0
13	0 0 1 1 1 0 1 0	37	1 0 0 0 1 1 0 1	61	1 1 0 1 0 0 0 1
14	0 0 1 1 1 1 0 0	38	1 0 0 0 1 1 1 0	62	1 1 0 1 0 0 1 0
15	0 1 0 0 0 1 1 1	39	1 0 0 1 0 0 1 1	63	1 1 0 1 0 1 0 0
16	0 1 0 0 1 0 1 1	40	1 0 0 1 0 1 0 1	64	1 1 0 1 1 0 0 0
17	0 1 0 0 1 1 0 1	41	1 0 0 1 0 1 1 0	65	1 1 1 0 0 0 0 1
18	0 1 0 0 1 1 1 0	42	1 0 0 1 1 0 0 1	66	1 1 1 0 0 0 1 0
19	0 1 0 1 0 0 1 1	43	1 0 0 1 1 0 1 0	67	1 1 1 0 0 1 0 0
20	0 1 0 1 0 1 0 1	44	1 0 0 1 1 1 0 0	68	1 1 1 0 1 0 0 0
21	0 1 0 1 0 1 1 0	45	1 0 1 0 0 0 1 1	69	1 1 1 1 0 0 0 0
22	0 1 0 1 1 0 0 1	46	1 0 1 0 0 1 0 1		
23	0 1 0 1 1 0 1 0	47	1 0 1 0 0 1 1 0		

Figure 64 illustrates the result of this procedure in transmission mode I for  $c = 1$  and  $p = 11$ .

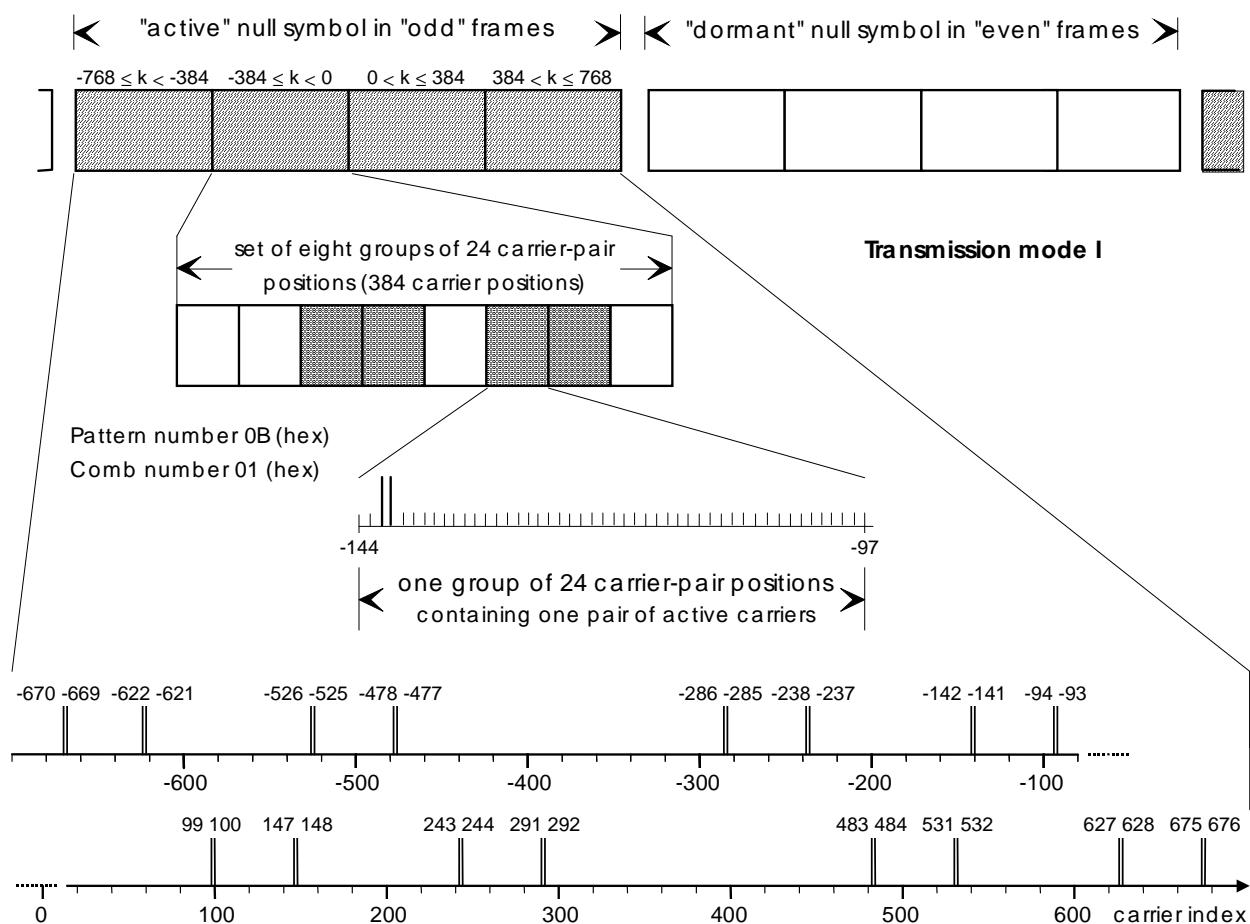

Figure 64: Example of TII signal in transmission mode I

## 15 Radio frequency characteristics

### 15.1 Use of the transmission mode

Transmission mode I is intended to be used for terrestrial Single Frequency Networks (SFN) and local-area broadcasting in Bands I, II and III. It may also be used for cable distribution.

### 15.2 Time characteristics

The DAB transmission signal consists of a succession of consecutive transmission frames of 96 ms duration for transmission mode I.

The synchronization channel occupies the first 5 208 elementary periods (approximately 2,543 ms) for transmission mode I. The elementary period is  $1/2\,048\,000$  s (see clause 14.2).

The modulated OFDM symbols, corresponding to the FIC and the MSC, occupy the remaining portion of the transmission frame. These are approximately 93,457 ms for transmission mode I.

The synchronization channel conveys a fixed pattern as defined in clause 14.

The modulated OFDM symbols, as a sum of equally-spaced orthogonal carriers with independent phases, exhibit a Gaussian-like amplitude distribution.

## 15.3 Spectrum characteristics

The synchronization channel, repeated at the transmission frame rate, constitutes a fixed pattern described in clause 14, during which the transmitted signal is the juxtaposition of equally-spaced orthogonal carriers, with fixed amplitudes and phases.

The modulated OFDM symbols constitutes a juxtaposition of equally-spaced orthogonal carriers, with constant amplitude and time varying independent phases, resulting from the modulation procedure described in clause 14.

The power spectral density  $P_k(f)$  of each carrier at frequency  $f_k = f_c + k/T_u$ .

( $-K/2 \leq k < 0$  and  $0 < k \leq K/2$ ) is defined by the following expression:

$$P_k(f) = \left[ \frac{\sin \pi(f-f_k)T_s}{\pi(f-f_k)T_s} \right]^2$$

The overall power spectral density of the modulated symbols is the sum of the power spectral densities of all the carriers. Because the OFDM symbol duration is larger than the inverse of the carrier spacing, the main lobe of the power spectral density of each carrier is narrower than twice the carrier spacing. The theoretical DAB transmission signal spectrum is illustrated in figure 65 for transmission mode I.

The level of the signal at frequencies outside the nominal 1,536 MHz bandwidth can be reduced by applying an appropriate filtering. The degree of suppression required of the side lobes shown in figure 65 will depend on the network configuration chosen and frequency co-ordination criteria with other transmissions.

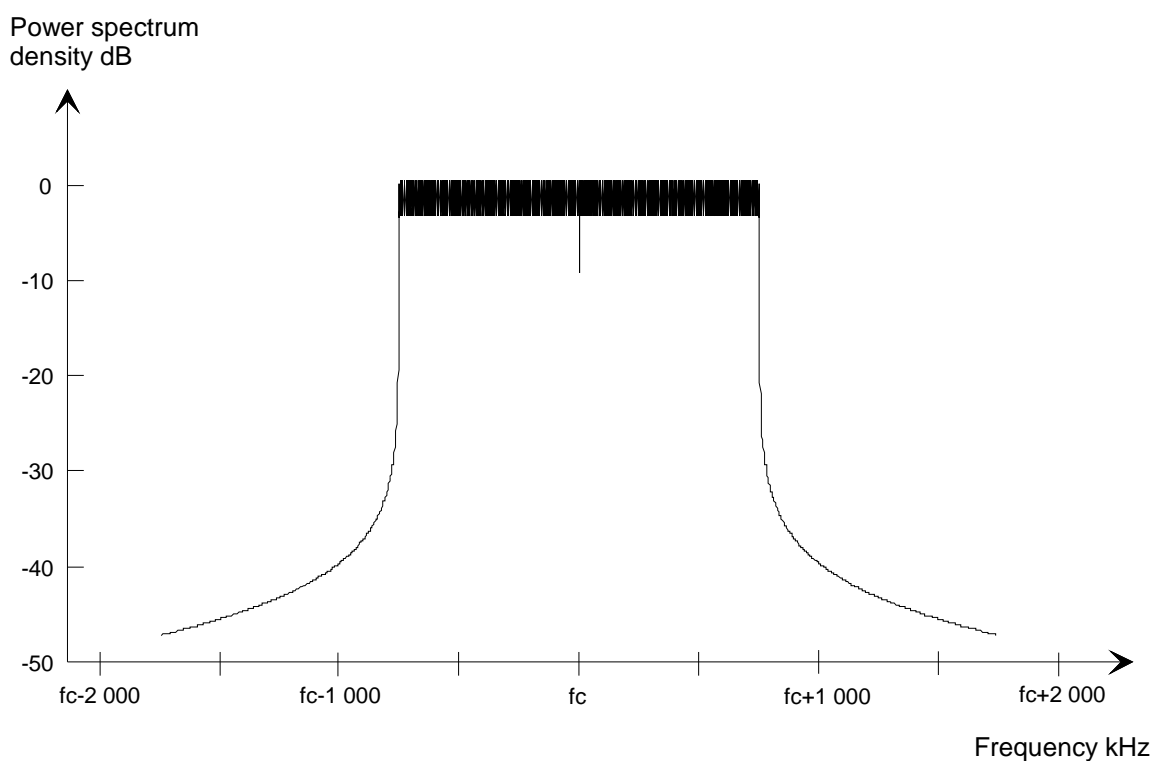

**Figure 65: Theoretical DAB transmission signal spectrum for transmission mode I**

## 15.4 Spectrum mask

The out-of-band radiated signal spectrum in any 4 kHz band shall be constrained by one of the masks defined in figure 66.

The solid line mask shall apply to VHF transmitters in critical areas for adjacent channel interference. The dotted line mask shall apply to VHF transmitters in other circumstances.

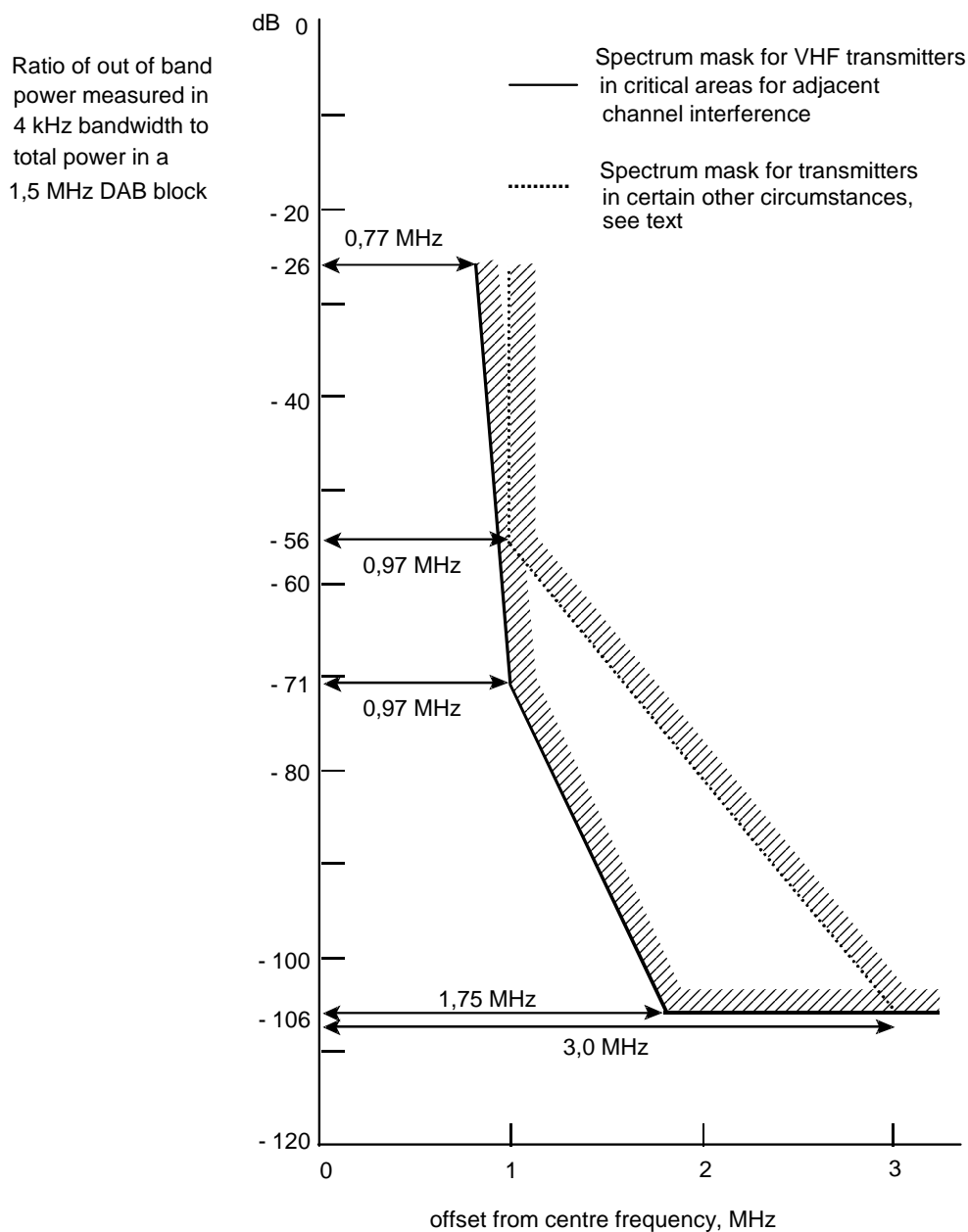

Figure 66: Out-of-band spectrum mask for DAB transmission signal (all transmission modes)

## 15.5 Permitted values of the central frequency

The nominal central frequency  $f_c$  shall be an exact multiple of 16 kHz.

---

# Annex A (normative): DAB location coding

## A.1 Introduction

Incidents and activities will rarely affect the same area as the coverage area of a particular DAB ensemble, and in many cases DAB ensembles have overlapping coverage areas. DAB location coding is applicable to any place on earth and uses a hierarchy of spherical rectangles (that is, rectangles defined in terms of polar coordinates). Each location code has a variable length with the first level of the code identifying the largest area, with each subsequent level identifying a sub-division of the previous level. The longer the code, the finer the spatial resolution. By providing a set of location codes, any arbitrary area may be described.

A location code consists of a top-level zone using 6-bits and up to six sub-division levels, each using 4-bits, to form location codes with a maximum length of 30 bits and a minimum length of 10 bits (zone plus one sub-division). The maximum spatial resolution of the scheme is 977 m north-south. In the east-west direction, the spatial resolution is 978 m at the equator and 302 m at 72° latitude. This level of precision is appropriate for a broadcast system. Each digit removed from the end of the location code reduces the spatial resolution by factor four, and increases the area described by a factor of 16.

---

## A.2 Coordinates

In WGS84, the latitude is 0° at the equator, 90° at the north pole and -90° at the south pole, and the longitude is given as the position east of the Greenwich meridian, with 0° at the meridian and increasing positively eastwards to 180° and negatively westwards to -180°.

To make calculations simpler for determining the location code, the WGS84 coordinates are translated using a simple mapping to use positive numbers only.

The WGS84 latitude is translated to the Southerly Extent (SE) by subtracting the WGS84 latitude from 90°; thus the north pole becomes 0°, the equator 90° and the south pole 180°.

The WGS84 longitude is translated to the Easterly Extent (EE) by adding 360° to negative values only; thus, for example, -10° becomes 350°.

---

## A.3 Division into zones

The top level of the hierarchy is a zone. There are 42 zones, as shown in figure A.1:

- 40 banded zones, which are spherical rectangles  $36^\circ \times 36^\circ$ ; and
- 2 polar zones, also  $36^\circ \times 36^\circ$ , which extend 18° from the poles.

The vast majority of the populated area of the globe is contained within the banded zones, that is between 72°N and 72°S from the equator.

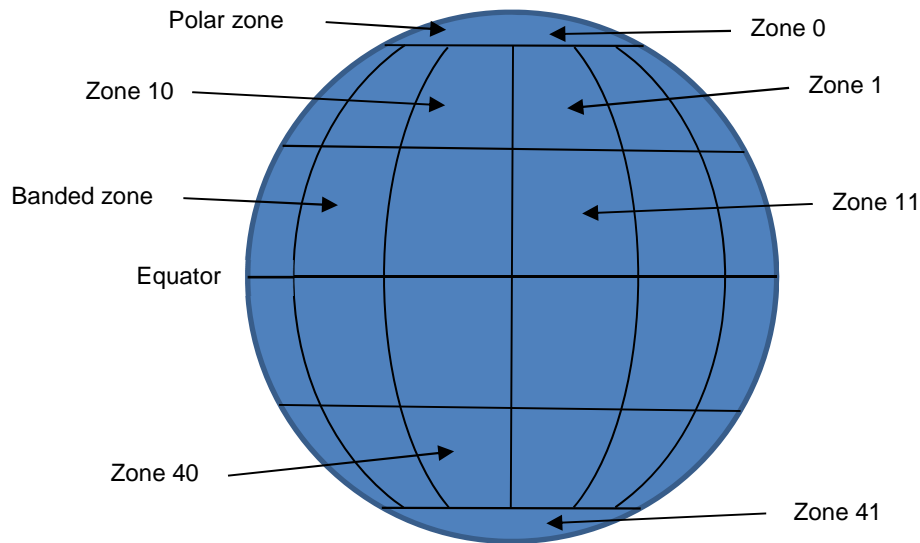

**Figure A.1: Representation of the zones**

The north polar zone is zone 0; the south polar zone is zone 41. The banded zones are numbered 1 to 40, in four rows of 10 zones, moving southwards and eastwards.

The identity of the zone may be determined from the SE and EE values as follows:

case ( $SE < 18$ )	zone = 0;
case ( $18 \leq SE < 162$ )	zone = $10 \times \text{int}((SE - 18)/36) + \text{int}(EE/36) + 1$ ;
case ( $SE \geq 162$ )	zone = 41;

where int indicates that only the integer part of the result is used.

Zone 1 therefore comprises the area contained within WGS84 coordinates from (36, 0) to (72, 36); zone 2 from (36, 36) to (72, 72); ... ; zone 10 from (36, -36) to (72, 0); zone 11 from (0, 0) to (36, 36); and so on to zone 40 from (-72, -36) to (-36, 0). This is shown in figure A.2.

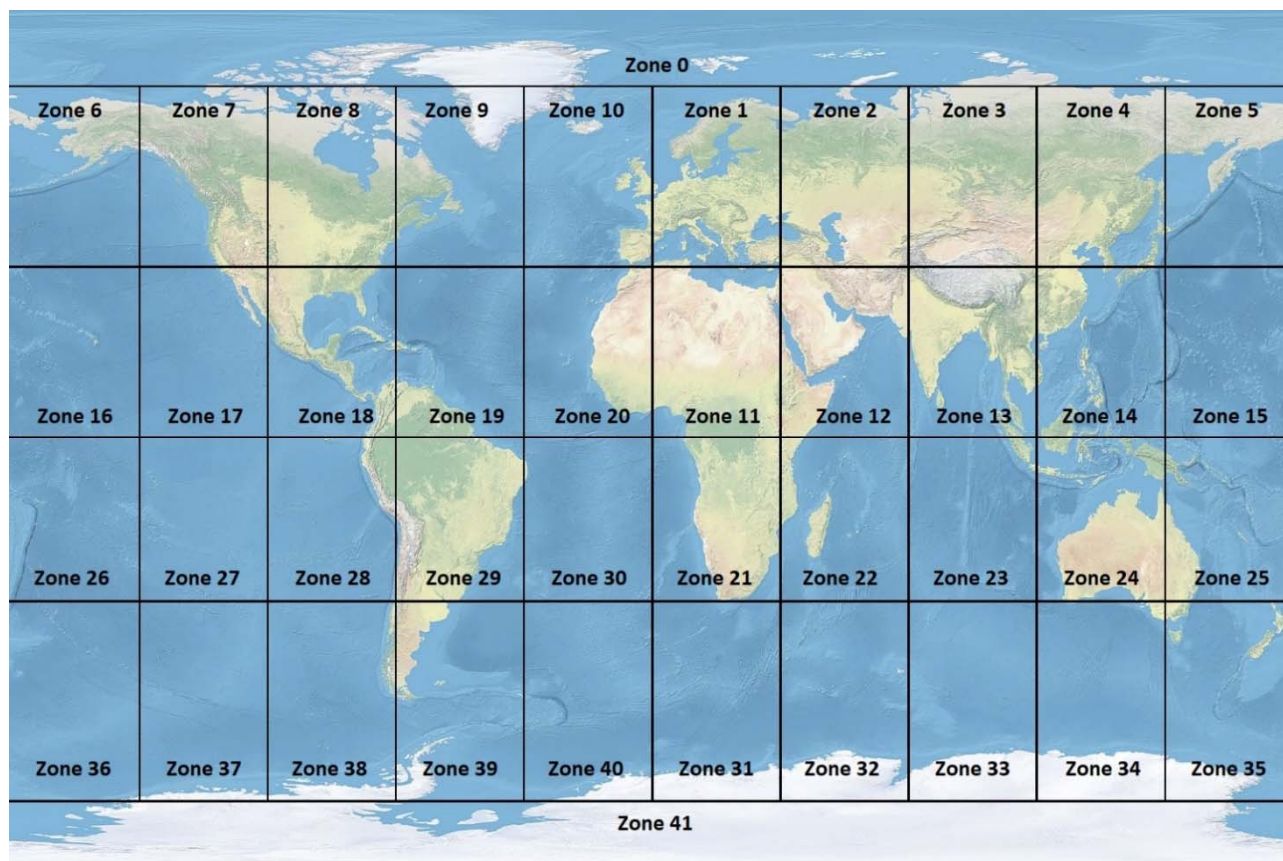

**Figure A.2: Position of the zones (variant of the Mercator projection)**

The polar zones have a radius of  $18^\circ$ , approximately 2 000 km. The zones bordering the equator are approximately 4 000 km north-south; 4 000 km at the equator, and 3 200 km at  $36^\circ$  from the equator, east-west. The zones adjoining the polar zones are also approximately 4 000 km north-south; 3 200 km at  $36^\circ$  from the equator, and 1 250 km at  $72^\circ$  from the equator, east-west.

## A.4 Division of the banded zones

The first division of the banded zones, and all subsequent divisions, are performed as follows.

The area is divided into 16 sub-areas of equal polar co-ordinate dimensions in a  $4 \times 4$  pattern, as shown in figure A.3. Each sub-area is numbered to identify its position, beginning at the north-west corner and moving eastwards and southwards.

**NOTE:** Using a 4-bit integer to identify a sub-area, the left-most (most significant) 2 bits count north-south and the right-most (least significant) 2 bits count west-east.

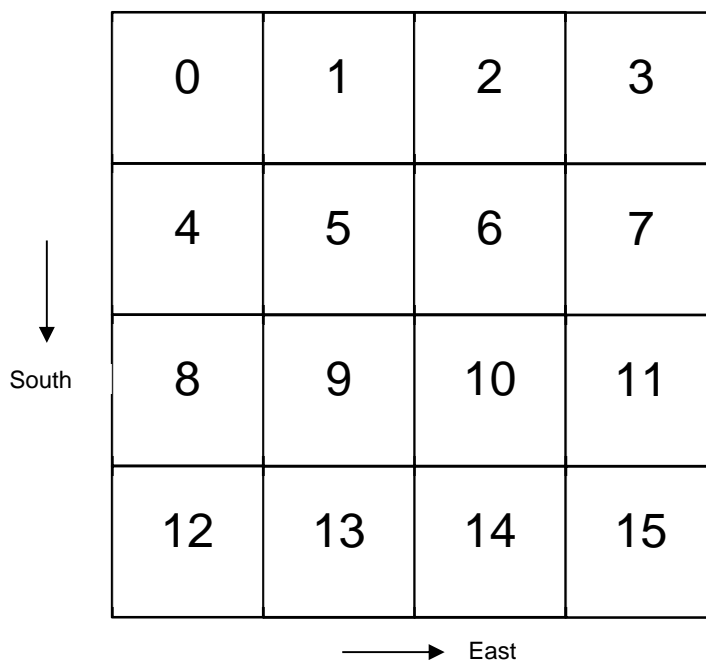

**Figure A.3: Division of spherical rectangles**

For any point on the earth's surface within the banded zones, the digits for the location code are calculated as follows:

Southerly Code (SC) =  $\text{int}(\text{frac}((\text{SE} - 18)/36) \times 2^{12})$  expressed as a 12-bit integer

Easterly Code (EC) =  $\text{int}(\text{frac}(\text{EE}/36) \times 2^{12})$  expressed as a 12-bit integer

where int indicates that only the integer part of the result is used and frac indicates that only the fractional part of the result is used.

The Combined Code (CC) is then formed by interleaving the SC and EC, 2-bits at a time, to produce a 24-bit integer, the most significant 2-bits are from the SC, the next 2-bits from the EC, and so on. That is, the digits representing a sub-area at each level of the 24-bit integer are formed by combining piecewise 2-bits from the SC and 2-bits from the EC.

**EXAMPLE:** BBC Broadcasting House in London is located at WGS84 (51,5187412, -0,1434571)

First, the coordinates are translated:

$$\text{SE} = 90 - 51,5187412 = 38,4812588$$

$$\text{EE} = -0,1434571 + 360 = 359,8565429$$

Second, the zone number is calculated:

$$\text{Zone} = 10 \times \text{int}((38,4812588 - 18)/36) + \text{int}(359,8565429/36) + 1 = 10$$

Third, the digits are calculated:

$$\text{SC} = \text{int}(\text{frac}((38,4812588 - 18)/36) \times 4\,096) = 2\,330 = 91A_{16} = 10\,01\,00\,01\,10\,10_2$$

$$\text{EC} = \text{int}(\text{frac}(359,8565429/36) \times 4\,096) = 4\,079 = \text{FEF}_{16} = 11\,11\,11\,10\,11\,11_2$$

$$\text{CC} = 1011\,0111\,0011\,0110\,1011\,1011_2 = \text{B736BB}_{16}$$

The location code for BBC Broadcasting House is thus Z10:B736BB.

## A.5 Division of the polar zones

The polar zones have a special coding for their first digit, because the area of a polar zone is circular. The first division of the polar zones is shown in figure A.4. Each sub-area is numbered to identify its position.

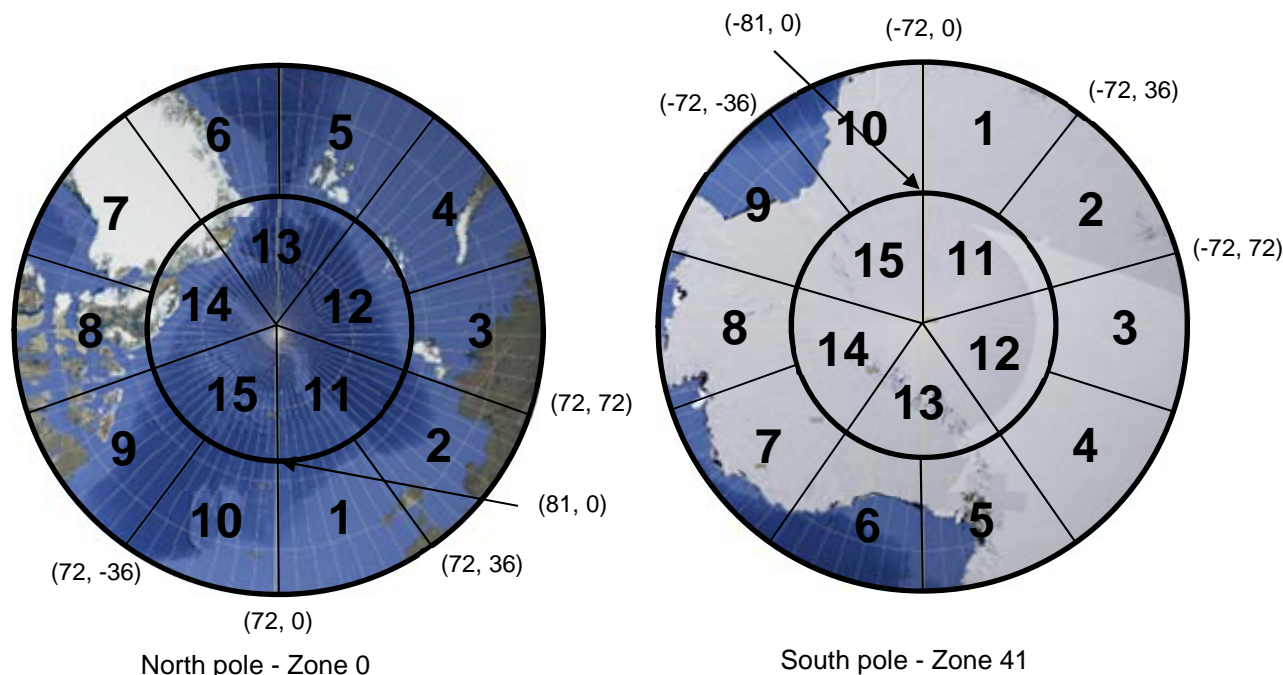

**Figure A.4: First division of polar zones (WGS84 co-ordinates)**

Subsequent digits are divided in the same way as for the banded zones (see figure A.3).

For any point on the earth's surface within the north polar zone, the digits for the location code are calculated as follows:

```

if (SE < 9) then {
    Digit 1 = int(EE/72) + 11
    Southerly Code (SC) = int(SE/9 × 210) expressed as a 10-bit integer
    Easterly Code (EC) = int(frac(EE/72) × 210) expressed as a 10-bit integer}
else {
    Digit 1 = int(EE/36) + 1
    Southerly Code (SC) = int(frac((SE - 9)/9) × 210) expressed as a 10-bit integer
    Easterly Code (EC) = int(frac(EE/36) × 210) expressed as a 10-bit integer};

```

the Combined Code (CC) is then formed by concatenating Digit 1 (most significant) with the result of interleaving the SC and EC, 2-bits at a time, to produce a 20-bit integer, the most significant 2-bits are from the SC, the next 2-bits from the EC, and so on.

For any point on the earth's surface within the south polar zone, the digits for the location code are calculated as follows:

```

if (SE < 171) then {
    Digit 1 = int(EE/36) + 1
    Southerly Code (SC) = int(frac((SE - 162)/9) × 210) expressed as a 10-bit integer
    Easterly Code (EC) = int(frac(EE/36) × 210) expressed as a 10-bit integer}
else {
    Digit 1 = int(EE/72) + 11
    Southerly Code (SC) = int(frac((SE - 171)/9) × 210) expressed as a 10-bit integer
    Easterly Code (EC) = int(frac(EE/72) × 210) expressed as a 10-bit integer};

```

the Combined Code (CC) is then formed by concatenating Digit 1 (most significant) with the result of interleaving the SC and EC, 2-bits at a time, to produce a 20-bit integer, the most significant 2-bits are from the SC, the next 2-bits from the EC, and so on.

**NOTE:** In the polar zones, the linear dimension of the edge of spherical rectangles that touch the pole is 0.

EXAMPLE: Svalbard Museum in Longyearbyen is located at WGS84 (78,222609, 15,651605)  
 First, the coordinates are translated:  
 $SE = 90 - 78,222609 = 11,777391$   
 $EE = 15,651605$   
 Second, the zone number is calculated:  
 $Zone = 0$   
 Third, the digits are calculated:  
 $Digit\ 1 = \text{int}(15,651605/36) + 1 = 1$   
 $SC = \text{int}(\text{frac}((11,777391 - 9)/9) \times 1\ 024) = 316 = 13C_{16} = 01\ 00\ 11\ 11\ 00_2$   
 $EC = \text{int}(\text{frac}(15,651605/36) \times 1\ 024) = 445 = 1BD_{16} = 01\ 10\ 11\ 11\ 01_2$   
 $CC = 0001\ 0101\ 0010\ 1111\ 1111\ 0001_2 = 152FF_{16}$   
 The location code for Svalbard Museum is thus Z0:152FF1

---

Annex B:  
Void

---

Annex C:  
Void

## Annex D (informative): Multiplex reconfiguration

The data associated with each Logical frame is spread over 16 CIFs as a result of the time interleaving process. This has to be taken into account, when the multiplex is reconfigured.

A CU may only be allocated to one sub-channel at a time. Consequently, when the data rate of a sub-channel is changed at the input of the time interleaver, the allocation of CUs to the sub-channel is affected in the following way:

- when the data bit rate is increased, the additional CUs need to be allocated immediately, because some of the bits have zero delay through the time interleaver. During the following 15 CIF periods, only half, on average, of the newly allocated CUs are filled with valid data. The remaining portion contains zero value padding bits;
- when the data bit rate is decreased, the original number of CUs needs to remain allocated to the original sub-channel for another 15 CIF periods, because some of the bits are delayed by 15 CIF periods in the time interleaver. During this period, only half, on average, of the CUs, to be released following the recombination process, are filled with valid data. The remaining portion contains zero value padding bits.

The combination of time interleaving and de-interleaving results in a constant delay of 15 CIF periods. Therefore, every change of bit rate at the input of the time interleaver should be followed by an equivalent change at the output of the de-interleaver 15 CIF periods later.

A multiplex reconfiguration is signalled as an event occurring at a given time instant. For sub-channels affected by the reconfiguration, the changes of bit rate at the inputs of the time interleavers have to be co-ordinated. The instant of the reconfiguration, signalled by the occurrence change, defines the CIF count from which the reallocation of CUs is effective.

As an illustration of the rules, defined in clause 6.5, for co-ordinating the changes in the bit rate and the instant of reconfiguration, the following examples are given. In all cases, it is assumed that the multiplex reconfiguration occurs between CIFs of time index  $r_o-1$  and  $r_o$ . Only a change of error protection profile in the convolutional encoders is considered in these examples:

- a) **change in sub-channel position only:** the convolutional encoder is not affected;
- b) **new sub-channel defined:** if a new sub-channel appears at  $r = r_o$  (which did not exist at  $r = r_o-1$ ) then the convolutional encoder uses the corresponding Protection profile for  $r \geq r_o$ ;
- c) **sub-channel removed:** if a sub-channel disappears at  $r = r_o$  (which did exist at  $r = r_o-1$ ) then the convolutional encoder ceases encoding at  $r = r_o-15$ ;
- d) **sub-channel capacity increased:** if a sub-channel increases its number of CUs between CIF of time index  $r = r_o-1$  and  $r = r_o$ , then the convolutional encoder uses the new Protection profile for  $r \geq r_o$ ;
- e) **sub-channel capacity decreased:** if a sub-channel decreases its number of CUs between CIF of time index  $r = r_o-1$  and  $r = r_o$ , then the convolutional encoder uses the new Protection profile for  $r \geq r_o-15$ ;
- f) **change in protection profile:** if the Protection profile changes between  $r = r_o-1$  and  $r = r_o$ , but the number of CUs remains unchanged, then the convolutional encoder uses the new Protection profile for  $r \geq r_o$ .

As a further illustration, figure D.1 shows how two sub-channels exchange capacity during two multiplex reconfigurations (cases d) and e) above) At the first reconfiguration, sub-channel 1 increases from 4 CUs to 6 CUs and sub-channel 2 decreases from 6 CUs to 4 CUs. The second reconfiguration restores the original situation.

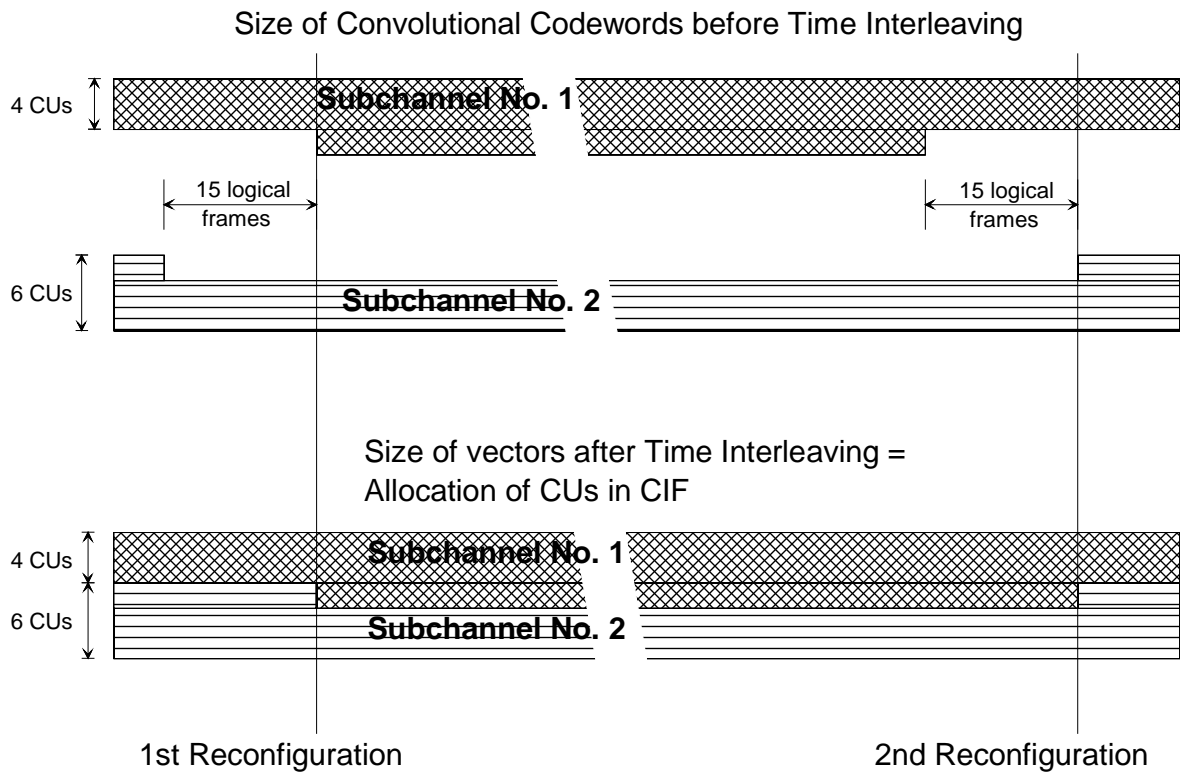

Figure D.1: Example of multiplex reconfiguration

## Annex E (normative): Calculation of the CRC word

The implementation of Cyclic Redundancy Check codes (CRC-codes) for audio and data transmission allows the detection of transmission errors at the receiver side. For this purpose CRC words shall be included in the transmitted data. These CRC words shall be defined by the result of the procedure described in this annex.

A CRC code is defined by a polynomial of degree  $n$ :

$$G(x) = x^n + g_{n-1}x^{n-1} + \dots + g_2x^2 + g_1x + 1$$

with  $n \geq 1$

and  $g_i \in \{0,1\}$ ,  $i = 1 \dots n - 1$

The CRC calculation may be performed by means of a shift register containing  $n$  register stages, equivalent to the degree of the polynomial (see figure E.1). The stages are denoted by  $b_0 \dots b_{n-1}$ , where  $b_0$  corresponds to 1,  $b_1$  to  $x$ ,  $b_2$  to  $x^2$ , ...,  $b_{n-1}$  to  $x^{n-1}$ . The shift register is tapped by inserting XORs at the input of those stages, where the corresponding coefficients  $g_i$  of the polynomial are "1".

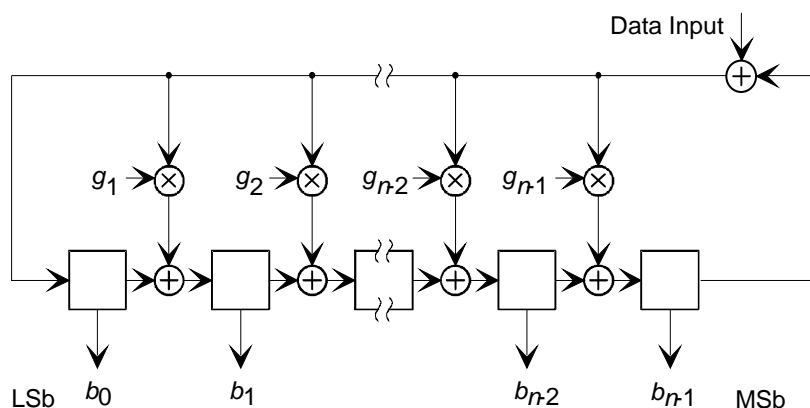

**Figure E.1: General CRC block diagram**

At the beginning of the CRC calculation, all register stage contents are initialized as specified in the respective clauses, either to all ones or to all zeros. After applying the first bit of the data block (MSb first) to the input, the shift clock causes the register to shift its content by one stage towards the MSb stage ( $b_{n-1}$ ), while loading the tapped stages with the result of the appropriate XOR operations. The procedure is then repeated for each data bit. Following the shift after applying the last bit (LSb) of the data block to the input, the shift register contains the CRC word which is then read out. Data and CRC word are transmitted with MSb first.

The CRC codes used in the DAB system shall be based on the following polynomials:

$$G(x) = x^{16} + x^{12} + x^5 + 1;$$

$$G(x) = x^{16} + x^{15} + x^2 + 1;$$

$$G(x) = x^8 + x^4 + x^3 + x^2 + 1.$$

The assignment of the polynomials to the respective applications are given in clauses 5.2.1, 5.3.2.3 and 5.3.3.3. These clauses also indicate the size and the content of the associated data blocks, the initialization of the shift register and a possible inversion (1's complement) of the CRC word prior to transmission.

## History

<b>Version</b>	<b>Date</b>	<b>Status</b>
Edition 1	February 1995	Publication as ETSI ETS 300 401
Edition 2	May 1997	Publication as ETSI ETS 300 401
V1.3.2	September 2000	Publication
V1.3.3	May 2001	Publication
V1.4.1	June 2006	Publication
V2.1.1	January 2017	Publication
V2.2.1	February 2026	ENAP process AP 20260528: 2026-02-27 to 2026-05-28
V2.2.1	June 2026	Publication