

# ETSI EN 300 392-12-16 V1.4.1 (2026-07)



**EUROPEAN STANDARD**

**Terrestrial Trunked Radio (TETRA);  
Voice plus Data (V+D);  
Part 12: Supplementary services stage 3;  
Sub-part 16: Pre-emptive Priority Call (PPC)**

---

**Reference**REN/TCCE-03278

---

---

**Keywords**data, radio, speech, stage 3,  
supplementary service, TETRA, V+D

---

**ETSI**650 Route des Lucioles  
F-06921 Sophia Antipolis Cedex - FRANCE

---

Tel.: +33 4 92 94 42 00 Fax: +33 4 93 65 47 16

Siret N° 348 623 562 00017 - APE 7112B  
Association à but non lucratif enregistrée à la  
Sous-Préfecture de Grasse (06) N° w061004871

---

**Important notice**

---

The present document can be downloaded from the  
[ETSI Search & Browse Standards](#) application.

The present document may be made available in electronic versions and/or in print. The content of any electronic and/or print versions of the present document shall not be modified without the prior written authorization of ETSI. In case of any existing or perceived difference in contents between such versions and/or in print, the prevailing version of an ETSI deliverable is the one made publicly available in PDF format on [ETSI deliver](#) repository.

Users should be aware that the present document may be revised or have its status changed,  
this information is available in the [Milestones listing](#).

If you find errors in the present document, please send your comments to  
the relevant service listed under [Committee Support Staff](#).

If you find a security vulnerability in the present document, please report it through our  
[Coordinated Vulnerability Disclosure \(CVD\)](#) program.

---

**Notice of disclaimer & limitation of liability**

---

The information provided in the present deliverable is directed solely to professionals who have the appropriate degree of experience to understand and interpret its content in accordance with generally accepted engineering or other professional standard and applicable regulations.

No recommendation as to products and services or vendors is made or should be implied.  
In no event shall ETSI be held liable for loss of profits or any other incidental or consequential damages.

Any software contained in this deliverable is provided "AS IS" with no warranties, express or implied, including but not limited to, the warranties of merchantability, fitness for a particular purpose and non-infringement of intellectual property rights and ETSI shall not be held liable in any event for any damages whatsoever (including, without limitation, damages for loss of profits, business interruption, loss of information, or any other pecuniary loss) arising out of or related to the use of or inability to use the software.

---

**Copyright Notification**

---

No part of this document may be reproduced in any form, by any means and in any media, without the prior written authorization of ETSI and except as expressly permitted below.

By way of exception and when the document is a normative deliverable (European Standard (EN), Technical Specification (TS), Group Specification (GS) or ETSI Standard (ES)), ETSI authorizes to reproduce and incorporate into products, services and technical documentation only those extracts (e.g. templates) that are strictly necessary for the technical implementation of the normative deliverable, to ensure compliance with the latter. Nothing in this notice shall be construed as limiting any mandatory exceptions to copyright provided by applicable law.

© ETSI 2026.  
All rights reserved.

# Contents

Intellectual Property Rights .....	6
Foreword.....	6
Modal verbs terminology.....	8
1 Scope .....	9
2 References .....	9
2.1 Normative references .....	9
2.2 Informative references.....	10
3 Definition of terms, symbols and abbreviations.....	10
3.1 Terms.....	10
3.2 Symbols.....	11
3.3 Abbreviations .....	11
4 SS-PPC service primitives.....	11
4.1 General .....	11
4.2 SS-PPC services offered over the TNSS-SAP.....	12
4.2.0 General.....	12
4.2.1 DEFINE request.....	12
4.2.2 DEFINE confirm .....	13
4.2.3 ASSIGN indication.....	13
4.2.4 ASSIGN response.....	13
4.2.5 INTERROGATE request.....	14
4.2.6 INTERROGATE confirm.....	14
4.2.7 REMOVE indication.....	14
4.2.8 REMOVE response.....	15
4.2.9 WITHDRAW request .....	15
4.2.10 WITHDRAW confirm .....	15
4.2.11 IMPENDING-PRE-EMPTION indication .....	15
4.2.12 USER-PRE-EMPTED indication .....	16
4.3 SS-PPC services offered over the TNCC-SAP.....	16
4.3.0 General.....	16
4.3.1 PRIORITY1 request - SS-PPC invocation.....	16
4.3.2 PRIORITY2 confirm/indication - SS-PPC operation .....	16
4.3.3 PRE-EMPTION .....	16
4.4 Parameter descriptions .....	16
5 SS-PPC protocol description .....	19
5.1 General .....	19
5.2 SS-PPC protocol states .....	19
5.2.0 General.....	19
5.2.1 Protocol states of FE1 .....	19
5.2.2 Protocol states of CCA to which FE1 is collocated .....	19
5.2.2.1 State IDLE.....	19
5.2.2.2 MO-CALL-SETUP .....	19
5.2.3 Protocol states of FE21 .....	20
5.2.3.0 General .....	20
5.2.3.1 State IDLE.....	20
5.2.4 Protocol states of CC to which FE21 is collocated.....	20
5.2.4.0 General .....	20
5.2.4.1 State ANY-STATE .....	20
5.2.4.2 State PARTIES-PRE-EMPTED.....	21
5.2.4.3 State SETUP-STARTED .....	21
5.2.5 Protocol states of FE3 .....	22
5.2.6 Protocol states of visited SwMI FE25.....	22
5.2.7 Protocol states of CC to which FE25 is collocated.....	22
5.2.7.0 General .....	22
5.2.7.1 State ANY-STATE .....	22

5.2.7.2	State PARTIES-PRE-EMPTED.....	23
5.2.7.3	State SETUP-STARTED .....	23
5.2.8	Protocol states of FE5 .....	23
5.2.9	Protocol states of CCA to which FE5 is collocated .....	24
5.2.9.1	ANY STATE.....	24
5.2.9.2	MT-CALL-SETUP .....	24
5.2.10	Protocol states of FE8 .....	24
5.2.11	Protocol states of CCA to which FE8 is collocated .....	25
5.3	SS-PPC signalling procedures.....	25
5.3.0	General.....	25
5.3.1	Procedures for FE1 .....	25
5.3.2	Procedures for FE21 .....	25
5.3.2.1	Definition in FE21 .....	25
5.3.2.2	Distribution in FE21 .....	25
5.3.2.3	Interrogation in FE21 .....	26
5.3.3	Procedures for CC to which FE21 is collocated .....	26
5.3.3.1	Verify priority in CC to which FE21 is collocated.....	26
5.3.4	Procedures for FE3 .....	27
5.3.4.1	Verification in FE3.....	27
5.3.5	Procedures for visited SwMI FE25.....	27
5.4	PDU descriptions.....	27
5.4.0	General.....	27
5.4.1	ASSIGN PDU .....	28
5.4.2	ASSIGN ACK PDU.....	28
5.4.3	DEFINE PDU .....	29
5.4.4	DEFINE ACK PDU.....	29
5.4.5	INTERROGATE PDU .....	29
5.4.6	INTERROGATE-ACK PDU.....	30
5.4.7	REMOVE PDU .....	30
5.4.8	REMOVE ACK PDU .....	30
5.4.9	WITHDRAW PDU.....	31
5.4.10	WITHDRAW ACK PDU .....	31
5.4.11	Pre-emption.....	31
5.4.11.1	D-RELEASE PDU .....	31
5.4.12	Priority 1 and Priority 2 .....	31
5.4.12.1	D-CONNECT PDU.....	31
5.4.12.2	D-SETUP PDU .....	31
5.4.12.3	U-SETUP PDU .....	32
5.4.13	IMPENDING-PRE-EMPTION PDU .....	32
5.4.14	USER-PRE-EMPTED PDU .....	32
5.5	Information element coding .....	32
5.5.0	General.....	32
5.5.1	Basic service(s).....	32
5.5.2	Number of pre-empted parties .....	33
5.5.3	Number of SS-PPC definitions .....	33
5.5.4	PPC PDU type .....	34
5.5.5	Pre-empted party.....	34
5.5.6	Range type .....	35
5.5.7	Result for definition.....	35
5.5.8	Result for interrogation.....	35
5.5.9	Result for withdrawal.....	36
5.5.10	SS-PPC assignment .....	36
5.5.11	SS-PPC definition.....	36
5.5.12	SS-PPC priority, Call priority and Non group member SS-PPC priority .....	37
5.5.13	Subscriber extension present.....	37
5.5.14	Subscriber identity .....	37
5.5.15	Time to pre-emption .....	38
6	SS-PPC FE behaviour .....	38
6.0	General .....	38
6.1	Behaviour of FE1 (SS entity of user A) .....	39
6.1.1	Service interaction for FE1 .....	39

6.1.2	Process description for FE1 .....	40
6.2	Behaviour of CCA to which FE1 is collocated .....	41
6.2.1	Service interaction for CCA to which FE1 is collocated .....	41
6.2.2	Process description for CCA to which FE1 is collocated .....	42
6.3	Behaviour of FE21 .....	43
6.3.1	Service interaction for FE21 .....	43
6.3.2	Process description for FE21 .....	44
6.4	Behaviour of CC to which FE21 is collocated .....	45
6.4.1	Service interaction for CC to which FE21 is collocated .....	45
6.4.2	Process description for CC to which FE21 is collocated .....	46
6.5	Behaviour of FE3 (SS entity of authorized user).....	49
6.5.1	Service interaction for FE3 .....	49
6.5.2	Process description for FE3 .....	50
6.6	Behaviour of visited SwMI FE25 .....	51
6.6.1	Service interaction for FE25 .....	51
6.6.2	Process description for visited SwMI FE25.....	52
6.7	Behaviour of CC to which FE25 is collocated .....	53
6.8	Behaviour of FE5 .....	54
6.8.1	Service interaction for FE5 .....	54
6.8.2	Process description for FE5 .....	55
6.9	Behaviour of CCA to which FE5 is collocated .....	56
6.9.0	General.....	56
6.9.1	Service interaction for CCA to which FE5 is collocated .....	56
6.9.2	Process description for CCA collocated to FE5.....	57
6.10	Behaviour of FE8 .....	59
6.10.1	Service interaction for FE8 .....	59
6.10.2	Process description for FE8 .....	60
6.11	Behaviour of CCA to which FE8 is collocated .....	61
6.11.1	Service interaction for CCA to which FE8 is collocated .....	61
6.11.2	Process description for CCA collocated to FE8.....	62
6.12	Inter-working considerations.....	62
<b>Annex A (informative):</b>	<b>Mapping of SS-PPC priorities received from the user application to priorities in basic service PDUs (for the MS) .....</b>	<b>63</b>
<b>Annex B (informative):</b>	<b>Bibliography .....</b>	<b>64</b>
<b>Annex C (informative):</b>	<b>Change requests .....</b>	<b>65</b>
History .....		66

# Intellectual Property Rights

## Essential patents

IPRs essential or potentially essential to normative deliverables (European Standard (EN), Technical Specification (TS), Group Specification (GS) or ETSI Standard (ES)) may have been declared to ETSI. The declarations pertaining to these essential IPRs, if any, are publicly available for **ETSI members and non-members**, and can be found in ETSI SR 000 314: "*Intellectual Property Rights (IPRs); Essential, or potentially Essential, IPRs notified to ETSI in respect of ETSI standards*", which is available from the ETSI Secretariat. Latest updates are available on the [ETSI IPR online database](#).

Pursuant to the ETSI Directives including the ETSI IPR Policy, no investigation regarding the essentiality of IPRs, including IPR searches, has been carried out by ETSI. No guarantee can be given as to the existence of other IPRs not referenced in ETSI SR 000 314 (or the updates on the ETSI Web server) which are, or may be, or may become, essential to the present document.

## Trademarks

The present document may include trademarks and/or tradenames which are asserted and/or registered by their owners. ETSI claims no ownership of these except for any which are indicated as being the property of ETSI, and conveys no right to use or reproduce any trademark and/or tradename. Mention of those trademarks in the present document does not constitute an endorsement by ETSI of products, services or organizations associated with those trademarks.

**DECT™**, **PLUGTESTS™**, **UMTS™** and the ETSI logo are trademarks of ETSI registered for the benefit of its Members. **3GPP™**, **LTE™** and **5G™** logo are trademarks of ETSI registered for the benefit of its Members and of the 3GPP Organizational Partners. **oneM2M™** logo is a trademark of ETSI registered for the benefit of its Members and of the oneM2M Partners. **GSM®** and the GSM logo are trademarks registered and owned by the GSM Association.

# Foreword

This European Standard (EN) has been produced by ETSI Technical Committee TETRA and Critical Communications Evolution (TCCE).

National transposition dates	
Date of adoption of this EN:	3 July 2026
Date of latest announcement of this EN (doa):	31 October 2026
Date of latest publication of new National Standard or endorsement of this EN (dop/e):	30 April 2027
Date of withdrawal of any conflicting National Standard (dow):	30 April 2027

The present document is part 12, sub-part 16 of a multi-part deliverable covering Terrestrial Trunked Radio (TETRA); Voice plus Data (V+D), as identified below:

- Part 1: "General network design";
- Part 2: "Air Interface (AI)";
- Part 3: "Interworking at the Inter-System Interface (ISI)";
- Part 4: "Gateways basic operation";
- Part 5: "Peripheral Equipment Interface (PEI)";
- Part 7: "Security";

Part 9: "General requirements for supplementary services";

Part 10: "Supplementary services stage 1";

Part 11: "Supplementary services stage 2";

**Part 12: "Supplementary services stage 3";**

Sub-part 1: "Call Identification (CI)";

Sub-part 2: "Call Report (CR)";

Sub-part 3: "Talking Party Identification (TPI)";

Sub-part 4: "Call Forwarding (CF)";

Sub-part 5: "List Search Call (LSC)";

Sub-part 6: "Call Authorized by Dispatcher (CAD)";

Sub-part 7: "Short Number Addressing (SNA)";

Sub-part 8: "Area Selection (AS)";

Sub-part 9: "Access Priority (AP)";

Sub-part 10: "Priority Call (PC)";

Sub-part 11: "Call Waiting (CW)";

Sub-part 12: "Call Hold (HOLD)";

Sub-part 13: "Call Completion to Busy Subscriber (CCBS)";

Sub-part 14: "Late Entry (LE)";

**Sub-part 16: "Pre-emptive Priority Call (PPC)";**

Sub-part 17: "Include Call (IC)";

Sub-part 18: "Barring of Outgoing Calls (BOC)";

Sub-part 19: "Barring of Incoming Calls (BIC)";

Sub-part 20: "Discreet Listening (DL)";

Sub-part 21: "Ambience Listening (AL)";

Sub-part 22: "Dynamic Group Number Assignment (DGNA)";

Sub-part 23: "Call Completion on No Reply (CCNR)";

Sub-part 24: "Call Retention (CRT)";

Part 13: "SDL model of the Air Interface (AI)";

Part 14: "Protocol Implementation Conformance Statement (PICS) proforma specification";

Part 15: "TETRA frequency bands, duplex spacings and channel numbering";

Part 16: "Network Performance Metrics";

Part 17: "TETRA V+D and DMO specifications";

Part 18: "Air interface optimized applications";

Part 19: "Interworking between TETRA and Broadband systems".

NOTE 1: Part 3, sub-parts 6 and 7 (Speech format implementation), part 4, sub-part 3 (Data networks gateway), part 10, sub-part 15 (Transfer of control), part 13 (SDL) and part 14 (PICS) of this multi-part deliverable are in status "historical" and are not maintained.

NOTE 2: Some parts are also published as Technical Specifications such as ETSI TS 100 392-2 and those may be the latest version of the document.

---

## Modal verbs terminology

In the present document "**shall**", "**shall not**", "**should**", "**should not**", "**may**", "**need not**", "**will**", "**will not**", "**can**" and "**cannot**" are to be interpreted as described in clause 3.2 of the [ETSI Drafting Rules](#) (Verbal forms for the expression of provisions).

"**must**" and "**must not**" are **NOT** allowed in ETSI deliverables except when used in direct citation.

---

# 1 Scope

The present document defines the stage 3 specifications of the Supplementary Service Pre-emptive Priority Call (SS-PPC) for the Terrestrial Trunked Radio (TETRA).

SS-PPC enables a user to have preferential access to the network resources in a TETRA system in times of congestion including pre-emption of calls. SS-PPC is applicable for pre-emptive priorities including the emergency priority. SS-PPC includes the capability to pre-empt resources needed for higher priority calls and the capability to pre-empt users from ongoing calls in order to move them to higher priority calls. SS-PPC specifies the definition, activation, deactivation and interrogation for the usage of pre-emptive call priorities in the TETRA system. The Switching and Management Infrastructure (SwMI) applies the SS-PPC priorities when it allocates the resources for calls. The SS-PPC operations are defined for the SwMI and for the Mobile Station (MS).

SS-PPC is defined to subscribers of one TETRA system, but the subscribers may be located in several TETRA systems and the information flows may be delivered over the Inter System Interface (ISI). SS-PPC is invoked for calls within one TETRA system or for calls that extend over ISI to several TETRA systems.

Man-Machine Interface (MMI) and charging principles are outside the scope of the present document.

Supplementary Service stage 3 specification is preceded by the stage 1 and the stage 2 specifications of the service. Stage 1 describes the functional capabilities from the user's point of view. Stage 2 defines the functional behaviour in terms of Functional Entities (FEs) and information flows. Stage 3 gives a precise description of the supplementary service from the implementation point of view. It defines the protocol for the service and the encoding rules for the information flows. It defines the processes for the FEs and their behaviour. The described protocols and behaviour apply to the SwMI, for the MS and may be applied over the ISI between TETRA systems. Aspects relating to all supplementary services are detailed in ETSI EN 300 392-9 [3].

---

## 2 References

### 2.1 Normative references

References are either specific (identified by date of publication and/or edition number or version number) or non-specific. For specific references, only the cited version applies. For non-specific references, the latest version of the referenced document (including any amendments) applies.

Referenced documents which are not found to be publicly available in the expected location might be found in the [ETSI docbox](#).

NOTE 1: While any hyperlinks included in this clause were valid at the time of publication, ETSI cannot guarantee their long-term validity.

NOTE 2: Note that for the TETRA standards, the reference is always to a European Standard (ETSI EN 300 xxx) if such has been published, but the latest version of that standard can be either an EN or a Technical Specification (ETSI TS 100 xxx), even if this is not visible in the reference list.

The following referenced documents are necessary for the application of the present document.

- [1] [ETSI EN 300 392-2](#): "Terrestrial Trunked Radio (TETRA); Voice plus Data (V+D); Part 2: Air Interface (AI)".
- [2] [ETSI EN 300 392-1 \(V1.2.1\)](#): "Terrestrial Trunked Radio (TETRA); Voice plus Data (V+D); Part 1: General network design".
- [3] [ETSI EN 300 392-9](#): "Terrestrial Trunked Radio (TETRA); Voice plus Data (V+D); Part 9: General requirements for supplementary services".
- [4] [ETSI EN 300 392-3-1](#): "Terrestrial Trunked Radio (TETRA); Voice plus Data (V+D); Part 3: Interworking at the Inter-System Interface (ISI); Sub-part 1: General design".
- [5] [Recommendation ITU-T Z.100](#): "Specification and Description Language - Overview of SDL-2010".

- [6] [ETSI EN 300 392-12-10](#): "Terrestrial Trunked Radio (TETRA); Voice plus Data (V+D); Part 12: Supplementary services stage 3; Sub-part 10: Priority Call (PC)".

## 2.2 Informative references

References are either specific (identified by date of publication and/or edition number or version number) or non-specific. For specific references, only the cited version applies. For non-specific references, the latest version of the referenced document (including any amendments) applies.

NOTE 1: While any hyperlinks included in this clause were valid at the time of publication, ETSI cannot guarantee their long-term validity.

NOTE 2: Note that for the TETRA standards, the reference is always to a European Standard (ETSI EN 300 xxx) if such has been published, but the latest version of that standard can be either an EN or a Technical Specification (ETSI TS 100 xxx), even if this is not visible in the reference list.

The following referenced documents may be useful in implementing an ETSI deliverable or add to the reader's understanding, but are not required for conformance to the present document.

Not applicable.

---

## 3 Definition of terms, symbols and abbreviations

### 3.1 Terms

For the purposes of the present document, the following terms apply:

**authorized user:** user who is authorized to define, activate, deactivate and interrogate SS-PPC

**Call Control Agent (CCA):** Call Control sub-entity for Supplementary Service Pre-emptive Priority Call in Circuit Mode Control Entity in Mobile Station

**emergency priority:** highest pre-emptive priority level

**Functional Entity (FE):** functional characteristics of the SS sub-entity within an MS or a SwMI related to an SS-PPC action, e.g. definition or invocation

**SS-PPC call:** basic service (call) to which the defined SS-PPC priority is applied

**SS-PPC invocation:** sending of priority request to infrastructure

NOTE: The SS-PPC invocation is done with the basic service invocation request.

**SS-PPC operation:** usage of SS-PPC priority for and in a basic service set-up

**SS-PPC pre-emption:** exclusion of one or more parties from an ongoing basic service due an SS-PPC operation for another basic service

NOTE: The pre-emption may be done due to the lack of resources or due to the need to join a called party to a higher priority pre-emptive call.

**SS-PPC priority:** any pre-emptive priority invoked and operated for an SS-PPC call

**user A:** calling party, the party that invokes or generates invocation of SS-PPC

**user B:** called party in a call in which SS-PPC is operated

**user C:** pre-empted user, a user that is involved in a call, which is pre-empted due to lack of resources for a SS-PPC

NOTE: There may be one, two or more pre-empted users due to a pre-empted call.

**user D:** remaining user or users in a call from which a user or users have been pre-empted

**visited SwMI:** TETRA system of which the Mobile Network Identity (MNI) is not equal to the MNI of the user

## 3.2 Symbols

Void.

## 3.3 Abbreviations

For the purposes of the present document, the following abbreviations apply:

CC	Call Control sub-entity for SS-PPC in CMCE in SwMI
CCA	Call Control Agent
CMCE	Circuit Mode Control Entity
FE	Functional Entity
GTSI	Group TETRA Subscriber Identity
ISI	Inter System Interface
ITSI	Individual TETRA Subscriber Identity
LS	Line connected Station
MCC	Mobile Country Code
MNC	Mobile Network Code
MNI	Mobile Network Identity
MO	Mobile station Originating
MS	Mobile Station
MT	Mobile station Terminating
PDU	Protocol Data Unit
SS	Supplementary Service sub-entity within CMCE
SSI	Short Subscriber Identity
SS-PC	Supplementary Service Priority Call
SS-PPC	Supplementary Service Pre-emptive Priority Call
SwMI	Switching and Management Infrastructure
TETRA	TERrestrial TRunked RAdio
TNCC-SAP	TETRA Network layer Call Control Service Access Point
TNSS-SAP	TETRA Network layer Supplementary Service Service Access Point
TSI	TETRA Subscriber Identity

---

## 4 SS-PPC service primitives

### 4.1 General

This clause describes the SS-PPC services offered by Supplementary Service (SS) and call control sub entities of CMCE of the TETRA voice plus data layer 3 service boundary in the MS. The SS-PPC services shall be offered at the Supplementary Service Service Access Point (TNSS-SAP) and the Call Control Service Access Point (TNCC-SAP). The SS-PPC services described in this clause shall be applicable for the MS.

**NOTE:** The SS-PPC services within the SwMI are outside the scope of the present document.

The SS-PPC services specified in the present document shall complement the Supplementary services and Call control services specified in ETSI EN 300 392-2 [1], clauses 12 and 11 respectively and the Supplementary Services general design standard ETSI EN 300 392-9 [3]. The SS-PPC services shall act as sub-services within the general supplementary services and call control services.

SS-PPC shall be an optional supplementary service for TETRA voice plus data layer 3. If SS-PPC is supported, this clause shall specify the services and their availability.

## 4.2 SS-PPC services offered over the TNSS-SAP

### 4.2.0 General

When the optional SS-PPC definition, user definition, activation, deactivation, interrogation, impending pre-emption indication and pre-empted party indication are supported, they shall be provided at TNSS-SAP.

NOTE: As the present document only deals with the SS-PPC all the service primitives have been shown without a TNSS-PPC-prefix e.g. the TNSS-PPC-ASSIGN request is shortened into an ASSIGN request.

The SS-PPC primitives for the user A (FE1) at the MS TNSS-SAP shall be:

- a) INTERROGATE request;
- b) INTERROGATE indication;
- c) ASSIGN indication;
- d) ASSIGN response.

The SS-PPC primitives for the authorized user (FE3) at the MS TNSS-SAP shall be:

- a) DEFINE request;
- b) DEFINE indication;
- c) INTERROGATE request;
- d) INTERROGATE indication.

The SS-PPC primitives for the pre-empted called user (FE5) at the MS TNSS-SAP shall be:

- a) IMPENDING-PRE-EMPTION indication.

The SS-PPC primitives for the pre-empted user (FE8) at the MS TNSS-SAP shall be:

- a) IMPENDING-PRE-EMPTION indication.

The SS-PPC primitives for the user (FE9) remaining in a call after pre-emption at the MS TNSS-SAP shall be:

- a) USER-PRE-EMPTED indication.

The activation and deactivation shall be done with the DEFINE request; the acknowledgement for activation and deactivation shall be done with DEFINE indication.

The information contained in the following primitive description tables correspond to the following key:

- Remark: comment;
- C: conditional;
- O: optional;
- M: mandatory.

### 4.2.1 DEFINE request

Optional DEFINE request primitive may be offered from the user application to FE3 over TNSS-SAP. The primitive shall contain the SS-PPC information parameters listed in table 1.

The subscriber identity parameter(s) shall indicate the subscriber identities on which the following definition shall be made.

**Table 1: DEFINE request contents**

Parameter	Request	Remark
Subscriber identity	M	Repeatable
Activated/deactivated	M	Note 1
Basic service	M	Repeatable
SS-PPC priority	M	Repeatable
Delivered to user A(s)	M	
Acknowledgement from user A(s)	C	Note 2
NOTE 1: Shall be used to indicate whether or not this PDU is used to activate a new PPC value or to deactivate an existing PPC value. When a PPC value is de-activated, a pre-programmed default value may then apply.		
NOTE 2: Conditional on the information element "Delivered to user A(s)".		

## 4.2.2 DEFINE confirm

If DEFINE request primitive is supported, then DEFINE confirm primitive shall be offered from FE3 to the user application over TNSS-SAP as an acknowledgement to a previously made definition request. The primitive shall contain the SS-PPC information parameters listed in table 2.

The Result for definition parameter shall indicate the result for all listed subscriber numbers and all basic service types.

NOTE 1: If the acknowledgements are different for different subscriber identities, FE3 may deliver several DEFINE confirm primitives to the user application.

NOTE 2: If the result for definition/activation/deactivation is "accepted, but some values changed by SwMI", the interrogation can be used to interrogate the values.

**Table 2: DEFINE confirm contents**

Parameter	Indication	Remark
Subscriber identity	M	Repeatable
Activated/deactivated	M	
Result for definition	M	

## 4.2.3 ASSIGN indication

Optional ASSIGN indication primitive may be offered from FE1 to the user application over TNSS-SAP. The primitive shall contain the SS-PPC information parameters listed in table 3.

FE1 shall only consider definitions made to a group number of which the subscriber is a member.

**Table 3: ASSIGN indication contents**

Parameter	Indication	Remark
Subscriber identity	M	
Activated/deactivated	M	
Basic service	M	Repeatable
SS-PPC priority	M	Repeatable
Acknowledgement from user A(s)	M	Note
NOTE: Parameter shall indicate if FE1 shall acknowledge the reception of the definition.		

## 4.2.4 ASSIGN response

If ASSIGN indication primitive is supported, then ASSIGN response primitive shall be offered from the user application to FE1 over TNSS-SAP as an acknowledgement to a previously received ASSIGN request, if acknowledgement was requested. The primitive shall contain the SS-PPC information parameters listed in table 4.

**Table 4: ASSIGN response contents**

Parameter	Response	Remark
Subscriber identity	M	
Activated/deactivated	M	
Basic service	M	
SS-PPC priority	M	
Result for definition	M	

## 4.2.5 INTERROGATE request

Optional INTERROGATE request primitive may be offered from the user application to FE1 or FE3 over TNSS-SAP and it shall be used to interrogate SS-PPC definitions. INTERROGATE request primitive shall contain the SS-PPC information parameters listed in table 5.

**Table 5: INTERROGATE request contents**

Parameter	Request	Remark
Subscriber identity	M	Repeatable

## 4.2.6 INTERROGATE confirm

If INTERROGATE request primitive is supported, then INTERROGATE confirm primitive shall be offered from FE1 or FE3 to the user application over TNSS-SAP as a response to a previously sent interrogation request. INTERROGATE confirm primitive shall contain the SS-PPC information parameters listed in table 6.

If the Subscriber identity parameter is repeated, the definition(s) shall be valid for all given numbers. The delivered to user A(s) and acknowledgement from user A(s) parameters shall indicate if these have been requested with the last successful definition request. The result for interrogation shall indicate, if the definition has been distributed to user A(s) and if user A(s) have acknowledged the distribution.

NOTE: If definitions/responses are different for different subscriber identity parameters FE3 may send several INTERROGATE confirm primitives to the user application.

**Table 6: INTERROGATE confirm contents**

Parameter	Indication	Remark
Subscriber identity	M	Repeatable
Result for interrogation	M	
Activated/deactivated	C	Note
Basic service	C	Repeatable
SS-PPC priority	C	Repeatable
Delivered to user A(s)	C	MS/LS-subscribers, note
Acknowledgement from user A(s)	C	Note
NOTE:	The parameter shall appear only if the "Result for interrogation" has the value "accepted", "accepted, but request to user A(s) pending in the SwMI" or "accepted, but user A(s) could not accept the request/user A(s) was not reached".	

## 4.2.7 REMOVE indication

Optional REMOVE indication primitive may be offered from FE1 to the user application over TNSS-SAP. This primitive shall be used to withdraw the SS-PPC service from a subscriber. The primitive shall contain the SS-PPC information parameters listed in table 7.

**Table 7: REMOVE indication contents**

Parameter	Indication	Remark
Subscriber identity	M	
Acknowledgement from user A(s)	M	Note
NOTE: Parameter shall indicate if FE1 shall acknowledge the reception of the removal.		

## 4.2.8 REMOVE response

If REMOVE indication parameter is supported, then REMOVE response primitive shall be offered from the user application to FE1 over TNSS-SAP as an acknowledgement to a previously received REMOVE request, if acknowledgement was requested. The primitive shall contain the SS-PPC information parameters listed in table 8.

**Table 8: REMOVE response contents**

Parameter	Response	Remark
Subscriber identity	M	
Result for withdrawal	M	

## 4.2.9 WITHDRAW request

Optional WITHDRAW request primitive may be offered from the user application to FE3 over TNSS-SAP and it shall be used to withdraw the PPC service from a subscriber. WITHDRAW request primitive shall contain the SS-PPC information parameters listed in table 9.

**Table 9: WITHDRAW request contents**

Parameter	Request	Remark
Subscriber identity	M	Repeatable
Delivery to user A(s)	M	MS/LS-subscribers
Acknowledgement from user A(s)	M	

## 4.2.10 WITHDRAW confirm

If WITHDRAW request primitive is supported, then WITHDRAW confirm primitive shall be offered from FE3 to the user application over TNSS-SAP as an acknowledgement to a previously received WITHDRAW request. The primitive shall contain the SS-PPC information parameters listed in table 10.

NOTE: If the acknowledgements are different for different subscriber identities, FE3 may deliver several WITHDRAW confirm primitives to the user application.

**Table 10: WITHDRAW confirm contents**

Parameter	Indication	Remark
Subscriber identity	M	Repeatable
Result for withdrawal	M	

## 4.2.11 IMPENDING-PRE-EMPTION indication

Optional IMPENDING-PRE-EMPTION indication may be offered from FE8 or FE5 to the user application to inform of a forthcoming pre-emption. IMPENDING-PRE-EMPTION indication primitive shall contain the SS-PPC information parameters listed in table 11.

**Table 11: IMPENDING-PRE-EMPTION indication contents**

Parameter	Indication	Remark
Impending pre-emption	M	
Time to pre-emption	O	(In seconds)

## 4.2.12 USER-PRE-EMPTED indication

Optional USER-PRE-EMPTED indication may be offered from FE9 to the user application to inform that one or more parties have been pre-empted from the ongoing call. USER-PRE-EMPTED indication primitive shall contain the SS-PPC information parameters listed in table 12.

**Table 12: USER-PRE-EMPTED indication contents**

Parameter	Indication	Remark
Subscribers pre-empted	M	
Subscriber identity	O	Pre-empted party

## 4.3 SS-PPC services offered over the TNCC-SAP

### 4.3.0 General

When the SS-PPC invocation, operation and pre-emption are supported they shall be provided at TNCC-SAP.

### 4.3.1 PRIORITY1 request - SS-PPC invocation

PRIORITY1 shall act as the invocation of SS-PPC and the invoked SS-PPC priority shall be included within the TNCC-SETUP request primitive offered over the TNCC-SAP.

The service user, e.g. user A, invokes SS-PPC by requesting a certain SS-PPC priority with a call invocation. The user application may verify that the priority is within the allowed range for a pre-emptive priority value and if not, change it, before passing the priority to CC. The user application shall pass the invoked Call priority within TNCC-SETUP to CC.

### 4.3.2 PRIORITY2 confirm/indication - SS-PPC operation

PRIORITY2 shall act as the operation of SS-PPC and the SwMI shall send the applied SS-PPC priority to user A and user B(s). The CC within user A and B(s) shall include the received SS-PPC priority to the TNCC-SETUP confirm and indication primitives and offer them over TNCC-SAP to the user application. The user application may indicate the SS-PPC priority to the service user.

**NOTE:** If the TNCC-SETUP indication is sent to a party that is already engaged in a call, a separate TNCC-RELEASE indication is not sent. The user application is responsible for releasing the lower priority call within the MS, if the MS joins an SS-PPC call when it is already engaged in another call.

### 4.3.3 PRE-EMPTION

The pre-emption shall be indicated to the pre-empted party (FE8 or FE5) by existing basic call release sequence with the disconnect cause "Pre-emptive use of resource" ("9").

## 4.4 Parameter descriptions

- Acknowledgement from user A(s) =
  - Acknowledgement requested from user A(s);
  - Acknowledgement not requested from user A(s).

- Activated/Deactivated =
  - Activated;
  - Deactivated.
- Basic service =
  - all applicable basic services (circuit mode speech and circuit mode data);
  - circuit mode speech;
  - circuit mode data.

**Table 13: Void**

- Delivered to user A(s) =
  - delivered;
  - not delivered.
- Impending pre-emption indication =
  - impending pre-emption.
- Result for definition =
  - accepted by SwMI/MS;
  - accepted but some priority values changed by SwMI;
  - user A could not accept the request/user A was not reached;
  - request failed for any reason;
  - user not authorized;
  - unknown TETRA identity;
  - parameters not valid;
  - insufficient information.

NOTE 1: Accepted by SwMI is applicable for DEFINE confirm; accepted by MS is applicable for ASSIGN response.

NOTE 2: User A can be referring to several user As.

- Result for interrogation =
  - accepted;
  - accepted but request pending in SwMI to user A(s);
  - accepted but user A(s) could not accept the request/user A(s) was not reached;
  - SS-PPC not defined for the given identity;
  - request failed for any reason;
  - user not authorized;
  - unknown TETRA identity;
  - parameters not valid.

- Result for withdrawal =
  - accepted by SwMI/MS;
  - user A was not reachable;
  - request failed for any reason;
  - user not authorized;
  - unknown TETRA identity;
  - parameters not valid;
  - insufficient information.

NOTE 3: "Accepted by SwMI" is applicable for WITHDRAW confirm; "accepted by MS" is applicable for REMOVE response.

NOTE 4: User A can be referring to several user As.

- SS-PPC priority =
  - pre-emptive priority 1;
  - pre-emptive priority 2;
  - pre-emptive priority 3;
  - pre-emptive priority 4 (Emergency).

NOTE 5: Readers are warned that supplementary service SS-PC ETSI EN 300 392-12-10 [6] defines SS-PC priority values 1 to 11 and the air interface uses the same information element to carry both the SS-PC and the SS-PPC values as range 1 to 15, the SS-PPC values being mapped to values 12 to 15.

- Subscriber number =

TETRA Subscriber Identity (TSI) = Short Subscriber Identity (SSI) + Mobile Country Code (MCC) + Mobile Network Code (MNC), see ETSI EN 300 392-1 [2], clause 7.
- Subscribers pre-empted =
  - subscriber identity given;
  - subscriber identity not given.
- Time to pre-emption =
  - 0 second;
  - 1 second;
  - 2 seconds;
  - 3 seconds;
  - 4 seconds;
  - 5 seconds;
  - 6 seconds;
  - 7 seconds;
  - 8 seconds;
  - 9 seconds;

- 10 seconds.

---

## 5 SS-PPC protocol description

### 5.1 General

This clause defines with clause 6 the layer 3 SS-PPC specific CMCE air interface protocol for the MS. SS-PPC protocol defines the SS-PPC specific protocol for Supplementary Service sub-entity and call control sub-entity within CMCE. The SS-PPC specification shall be normative for the MS.

The protocol in this clause shall complement the CMCE protocol described in ETSI EN 300 392-2 [1], clause 14, clause 14.5.5 excluded, with the SS-PPC specific protocol actions.

### 5.2 SS-PPC protocol states

#### 5.2.0 General

The normal SS-PPC protocol states are described in the present document.

#### 5.2.1 Protocol states of FE1

The capability to receive, save and acknowledge SS-PPC definitions and interrogation request shall be an optional feature within an MS. The state definitions given for the reception and acknowledgement of SS-PPC definitions and interrogation in this clause shall apply only, if the feature is supported.

State IDLE shall be the normal state of FE1. In the state IDLE FE1 shall:

- upon reception of an SS-PPC definition request indicating activation from the SwMI, FE1 shall pass the request to the user application;
- upon reception of an SS-PPC definition request indicating deactivation from the SwMI, FE1 shall pass the request to the user application;
- upon reception of an SS-PPC definition acknowledgement from the user application, FE1 shall send it to the SwMI;
- upon reception of an SS-PPC interrogation request from the user application, FE1 shall send it to the SwMI;
- upon reception of an SS-PPC interrogation response from the SwMI, FE1 shall pass it to the user application.

#### 5.2.2 Protocol states of CCA to which FE1 is collocated

##### 5.2.2.1 State IDLE

CCA to which FE1 is collocated shall be able to receive call invocation requests including the SS-PPC invocation (call priority) from the user application. The requested priority shall be sent to the SwMI with the call invocation request.

##### 5.2.2.2 MO-CALL-SETUP

Upon reception of the call set-up confirmation, CCA should give the priority to the user application.

NOTE: It is possible that the SwMI has changed the SS-PPC priority.

## 5.2.3 Protocol states of FE21

### 5.2.3.0 General

The capability to receive, save and acknowledge SS-PPC definitions and interrogation request shall be an optional feature within FE21. The state definitions given for the reception and acknowledgement of SS-PPC definitions and interrogation in this clause shall apply only, if the feature is supported.

### 5.2.3.1 State IDLE

State IDLE shall be the normal state of FE21. In the state IDLE FE21 shall:

- upon reception of an SS-PPC definition request indicating SS-PPC activation, FE21 shall save the SS-PPC definition in the SwMI, if the request is valid and authorized, FE21 shall acknowledge the SS-PPC definition request to FE3;
- if FE21 was requested to send the SS-PPC definitions to FE1(s), FE21 should send the definitions to FE1s;
- upon reception of an SS-PPC definition request indicating SS-PPC deactivation, the SS-PPC definition for the indicated subscriber identity (ies) shall be removed. A default SS-PPC value may then apply for the subscriber identity (ies);
- upon reception of an SS-PPC withdrawal request, the SS-PPC service for the indicated subscriber identity (ies) shall be withdrawn, FE21 should send the response to FE3 that the service has been withdrawn;
- upon reception of an SS-PPC interrogation request from FE1 or FE3, FE21 should send the response to the request to FE1 or FE3 respectively.

FE21 shall apply the SS-PPC definition-activation and define-deactivation from the moment it is made.

## 5.2.4 Protocol states of CC to which FE21 is collocated

### 5.2.4.0 General

The protocol states of CC to which FE21 is collocated shall carry the following tasks:

- start the call set-up;
- pre-empt resources for the call, if needed;
- pre-empt subscriber(s) for the SS-PPC group call, if needed;
- pre-empt subscriber(s) for the SS-PPC individual call, if needed, when FE21 and FE25 are collocated;
- set-up the SS-PPC call.

For these actions the corresponding states shall be: ANY-STATE, PARTIES-PRE-EMPTED and SETUP-STARTED.

The SETUP-STARTED corresponds to normal continuation of the call set-up.

### 5.2.4.1 State ANY-STATE

The protocol described for "ANY-STATE" shall refer to any state in which a call set-up request shall be received and the call set-up started.

The functional tasks for the state ANY-STATE shall be:

- upon reception of an SS-PPC call invocation, CC shall accept or reject the request;
- if the request is accepted, CC should verify the SS-PPC priority;

- CC shall determine if the pre-emption is needed due to lack of resources, and if the pre-emption is needed, CC shall:
  - determine which call FE21 should pre-empt;
  - optionally, send the impending pre-emption indication to FE8(s);
  - pre-empt the resources and send D-RELEASE with the pre-emption indication to FE8;

NOTE: If FE21 does not disconnect the call on behalf of the pre-empted party or parties when SS-PPC pre-emption takes place, the applied mechanisms are outside the scope of the present document.

- if one or two parties of a group call is pre-empted, FE21 may inform other parties of the call about the pre-emption;
- CC shall start the set-up procedure for the SS-PPC and send D-SETUP with the SS-PPC priority to the called party (parties):
  - if called user pre-emption is needed, CC may send the optional impending pre-emption indication to FE5(s);
- CC shall move to the SETUP-STARTED state; or, to the PARTIES-PRE-EMPTED state, if CC needs to pre-empt subscribers for the call.

#### 5.2.4.2 State PARTIES-PRE-EMPTED

If the pre-emption is needed in order to join a subscriber to the SS-PPC call, CC shall in the state PARTIES-PRE-EMPTED:

- If the SS-PPC call is an individual call:
  - Upon reception of the acceptance of the incoming call from CCA to which FE5 is collocated, CC shall continue the call set-up.
 

If the previous call is an individual call, CC shall ensure that this call is cleared. If the previous call is a group call, CC may indicate to the members of the call, that a party has left the call. This is done by sending the USER-PRE-EMPTED indication.
  - Upon reception of the rejection of the incoming call (U-DISCONNECT) from CCA to which FE5 is collocated, CC shall clear the call and indicate the rejection to the calling party.
- If the SS-PPC call is a group call:
  - If the previous call is an individual call, upon reception of U-DISCONNECT to the previous individual call, CC shall clear the individual call, indicate that to the other party of the call and respond with D-RELEASE to FE5.

NOTE 1: U-DISCONNECT and D-RELEASE may be sent in the traffic channel of the SS-PPC call in order to ascertain that the called party does not move back to control channel and join another call.

- If the previous call is a group call, CC may indicate to the members of the call, that a party has left the call. This is done by sending the USER-PRE-EMPTED indication.

NOTE 2: Before sending the USER-PRE-EMPTED indication, CC may poll the called subscriber in the previous call to find out, if he has left from the call. The polling is done with the poll request and poll response information elements in the D-INFO and U-INFO PDUs respectively.

NOTE 3: A TETRA system can clear the entire group call, if one or more subscribers are pre-empted from the call.

#### 5.2.4.3 State SETUP-STARTED

CC shall complete the call set-up as described in ETSI EN 300 392-2 [1], clause 14. In addition, CC shall send the SS-PPC priority within D-CONNECT to FE1.

## 5.2.5 Protocol states of FE3

State IDLE shall be the normal state of FE3. In the state IDLE FE3 shall:

- upon reception of an SS-PPC definition-activation, definition-deactivation or interrogation request from the user application, FE3 shall send it to the SwMI;
- upon reception of an SS-PPC definition-activation, definition-deactivation or interrogation responses from the SwMI, FE3 shall pass it to the user application;
- upon reception of an SS-PPC withdrawal request, from the user application, FE3 shall send it to the SwMI;
- upon reception of an SS-PPC withdrawal responses from the SwMI, FE3 shall pass it to the user application.

## 5.2.6 Protocol states of visited SwMI FE25

The capability to receive and acknowledge SS-PPC definitions and interrogation request shall be an optional feature within FE25. The state definitions given for the reception and acknowledgement of SS-PPC definitions and interrogation in this clause shall apply only, if the feature is supported.

IDLE should be the normal state of the visited SwMI FE25, refer ETSI EN 300 392-9 [3]. In this state:

- upon reception of an SS-PPC definition-activation, definition-deactivation and interrogation request or response from FE3, FE25 should deliver it to FE21, the home SwMI;
- upon reception of an SS-PPC definition-activation, definition-deactivation and interrogation request or response from the home SwMI FE21, FE25 should deliver it to FE3 located in visited SwMI.

## 5.2.7 Protocol states of CC to which FE25 is collocated

### 5.2.7.0 General

The protocol states of CC to which FE25 is collocated shall carry the following tasks:

- pre-empt resources for the call, if needed;
- pre-empt subscriber for the SS-PPC individual call, if needed;
- pre-empt subscriber for the SS-PPC group call, if needed;
- set-up the SS-PPC call when requested by FE21.

For these actions the corresponding states shall be: ANY-STATE, PARTIES-PRE-EMPTED and SETUP-STARTED.

The SETUP-STARTED corresponds to normal continuation of the call set-up.

### 5.2.7.1 State ANY-STATE

The protocol described for "ANY-STATE" shall refer to any state in which a call set-up indication shall be received from FE21 and the call set-up started.

The functional tasks for the state ANY-STATE shall be:

- upon reception of an SS-PPC call indication, CC shall determine, if the pre-emption is needed due to lack of resources. If the pre-emption is needed, CC shall:
  - determine which call FE25 should pre-empt;
  - optionally, send the impending pre-emption indication to FE8(s);
  - pre-empt the resources and send D-RELEASE with the pre-emption indication to FE8;

NOTE: If FE25 does not disconnect the call on behalf of the pre-empted party or parties when SS-PPC pre-emption takes place, the applied mechanisms are outside the scope of the present document.

- if one or two parties of a group call is pre-empted, FE25 may inform other parties of the call about the pre-emption;
- CC shall send D-SETUP with the SS-PPC priority to the called party (parties):
  - if the SS-PPC call is an individual call and called user pre-emption is needed, CC may send the optional impending pre-emption indication to FE5;
  - the optional feature impending pre-emption shall only be used to pre-empt the called user(s) to a PPC group call when the controlling SwMI, FE21, has requested impending pre-emption;
- CC shall move to the SETUP-STARTED state; or to the PARTIES-PRE-EMPTED state, if CC needs to pre-empt subscribers for the call.

### 5.2.7.2 State PARTIES-PRE-EMPTED

If the pre-emption is needed in order to join a subscriber to the SS-PPC call, CC shall in the state PARTIES-PRE-EMPTED:

- If the SS-PPC call is an individual call:
  - If the previous call is an individual call, CC shall ensure that the call is cleared. If the previous call is a group call, CC may indicate to the members of the call, that a party has left the call. This is done by sending the USER-PRE-EMPTED indication.
- If the SS-PPC call is a group call:
  - If the previous call is an individual call, upon reception of U-DISCONNECT to the previous individual call, CC shall clear the individual call, indicate that to the other party of the call and respond with D-RELEASE to FE5.

NOTE 1: U-DISCONNECT and D-RELEASE may be sent in the traffic channel of the SS-PPC call in order to ascertain that the called party does not move back to control channel and join another call.

- If the previous call is a group call, CC may indicate to the members of the call, that a party has left the call. This is done by sending the USER-PRE-EMPTED indication.

NOTE 2: A TETRA system can clear the entire group call, if one or more subscribers are pre-empted from the call.

### 5.2.7.3 State SETUP-STARTED

CC shall complete the call set-up as described in ETSI EN 300 392-2 [1], clause 14.

## 5.2.8 Protocol states of FE5

The capability to receive an impending pre-emption indication shall be an optional feature within FE5. The state definitions given for the reception of the impending pre-emption in this clause shall apply only, if the feature is supported.

IDLE shall be the normal state of FE5. In this state:

- upon reception of an impending pre-emption indication, FE5 shall pass it to the user application.

NOTE: The impending pre-emption and pre-empted party indication are processed by the SS process that has a fixed relationship with the corresponding Call control entity. See ETSI EN 300 392-2 [1], clause 14.2.4.2 for more information about SS processes within SS sub-entity.

## 5.2.9 Protocol states of CCA to which FE5 is collocated

### 5.2.9.1 ANY STATE

The protocol described for "ANY STATE" shall refer to any state in which a call set-up request shall be received and the call set-up started.

The functional tasks for the state ANY STATE shall be: Upon reception of an incoming basic service invocation with SS-PPC operation from the SwMI, CCA shall indicate the SS-PPC priority to the user application.

### 5.2.9.2 MT-CALL-SETUP

The functional tasks for the state MT-CALL-SETUP shall be:

- If the SS-PPC call is an individual call CCA shall:
  - Upon reception of the acceptance of the incoming call from the user application CCA shall send the response to CC to which FE21 is collocated. CCA shall continue the call set-up within the MS.
 

If the called party was engaged in an ongoing call, the SS-PPC SETUP shall also serve as disconnection to the previous call, if the user application accepted the SS-PPC call and the previous call is an individual call. CCA shall clear the previous call within the MS and may send a U-DISCONNECT to the SwMI for the previous call.
- NOTE: U-DISCONNECT and D-RELEASE may be sent in the traffic channel of the SS-PPC call in order to ascertain that the called party does not move back to control channel and join another call.
  - Upon reception of the rejection of the incoming call from the user application, CCA shall send U-DISCONNECT to CC to which FE21 is collocated and clear the SS-PPC call within it. CCA behaviour for the previous call, if any, shall not be affected.
- If the SS-PPC call is a group call CCA shall:
  - Upon reception of the acceptance of the incoming call from the user application CCA shall move to the new call and set-up the call within the MS.
 

If the called party was engaged in an individual call, the CCA shall after moving to the SS-PPC call, send U-DISCONNECT to CC to which the terminating SwMI is collocated to indicate that it has left the call. CCA shall receive the D-RELEASE from CC to which the terminating SwMI is collocated as a response. CCA shall clear the previous call within the MS.

If the called party was engaged in a group call, the SS-PPC SETUP shall also serve as disconnection to the previous call, if the user application accepted the SS-PPC call and CCA shall clear the previous call within the MS.
  - Upon reception of the rejection of the incoming call from the user application, CCA shall clear the SS-PPC call set-up within it. CCA behaviour for the previous call, if any, shall not be affected.
- When CCA joins a new higher priority call, when it is engaged in another call, CCA shall release the lower priority call within it.

## 5.2.10 Protocol states of FE8

The capability to receive an impending pre-emption indication shall be an optional feature within FE8. The state definitions given for the reception of the impending pre-emption in this clause shall apply only, if the feature is supported.

IDLE shall be the normal state of FE8. In this state FE8 shall, upon reception of an impending pre-emption indication, pass it to the user application.

## 5.2.11 Protocol states of CCA to which FE8 is collocated

The functional tasks of CCA to which FE8 is collocated shall be applicable to any state where a call is ongoing (set-up has started and the call has not been cleared) and which is described in ETSI EN 300 392-2 [1], clause 14. The tasks for CCA to which FE8 is collocated shall be, upon reception of a pre-emption indication within a D-RELEASE CCA, to which FE8 is collocated, shall indicate it to the user application. FE8 shall disconnect the call as instructed by FE21/FE25 by any of the methods described in ETSI EN 300 392-2 [1], clause 14.

NOTE: The impending pre-emption indication is processed by the SS processes that have a fixed relationship with the corresponding call control entity. See ETSI EN 300 392-2 [1], clause 14.2.4.2 for more information about SS processes within SS sub-entity.

## 5.3 SS-PPC signalling procedures

### 5.3.0 General

The normal SS-PPC procedures are described in the present document.

#### 5.3.1 Procedures for FE1

Upon reception of SS-PPC interrogation request from the user application, FE1 shall send the request to FE21.

FE1 shall construct the INTERROGATE PDU for the served user according to the user's request. The user shall interrogate the defined priority values of:

- one subscriber or group number;
- a list of group numbers.

NOTE: The served user may only interrogate its own priority or the priorities of affiliated talk groups.

#### 5.3.2 Procedures for FE21

##### 5.3.2.1 Definition in FE21

Upon reception of SS-PPC definition request, FE21 if supported shall:

- verify that the request is authorized;

NOTE 1: Only FE3 is allowed to define SS-PPC.

- verify that the parameters are in the correct range;
- the parameters in the DEFINE PDU shall be used in the following way:
  - either continue to carry out the request and acknowledge it to FE3, or rejects it and send a rejection to FE3.

NOTE 2: If a definition is requested for a subscriber number range or a list of subscriber numbers, the "Result for definition" can be different for different subscriber.

##### 5.3.2.2 Distribution in FE21

FE21 makes the definition to the SwMI, locates the FE1(s) and the definition request(s) to FE1(s).

FE21 shall construct the SS-PPC assign (ASSIGN) Protocol Data Unit (PDU) for user A according to the authorized user's request when this service is supported. FE21 may, however, change the priority values if authorized user has defined values he is not allowed to define. The assignment shall be made to:

- one subscriber or group number;

- a list of group numbers for a subscriber;
- a range of group numbers for a subscriber.

The priority may be defined to have different values for different basic services.

User A (FE1s) may acknowledge the definition request with ASSIGN-ACK, if requested.

### 5.3.2.3 Interrogation in FE21

FE21 shall fetch the interrogated data in order to send it to FE3 or FE1 when this service is supported.

FE21 shall construct the SS-PPC interrogation (INTERROGATE) information elements for authorized user or served user (user A) according to the user's request. The authorized user may interrogate the defined priority value for:

- one subscriber or group number;
- a list of subscriber or group numbers;
- a range of subscriber or group numbers.

The served user (user A) may interrogate the defined priority value for:

- its own subscriber number;
- one group number;
- a list of group numbers;
- a range of group numbers.

NOTE: The served user may only interrogate its own priority or the priorities of affiliated talk groups.

The SS-PPC priority may be defined to have different values for different basic services. All defined values should be included in the INTERROGATE-ACK.

If the user has interrogated the SS-PPC for a subscriber number range or list, and if any of the parameters listed in the present document are different for any of these numbers, FE21 should send separate INTERROGATE-ACK flows to FE3 or FE1:

- result for interrogation;
- number of basic service definitions;
- number of basic services;
- basic services;
- priority for the basic service(s).

## 5.3.3 Procedures for CC to which FE21 is collocated

### 5.3.3.1 Verify priority in CC to which FE21 is collocated

CC to which FE21 is collocated should receive call invocation requests including the priority from user A. CC should check the priority and if it finds it valid, should set-up the call using the requested priority.

The SS-PPC definition should be applied in the following way, if SS-PPC is defined and if the user A invokes SS-PPC with the service request:

- the SS-PPC definition for user A should be applicable, when user A invokes an individual call;
- the SS-PPC definition for a group ID should be applicable, when user A invokes a group call to the defined group identity and user A is a member of the called group;

- optionally, a separate SS-PPC definition for a group ID may be applicable, when user A invokes a group call to the defined group identity and user A is **not** a member of the called group. If a separate SS-PPC definition for non-group members is not supported, the SS-PPC definition used for group members may be used instead.

FE21 should not change an emergency priority. FE21 can change the requested call priority, if:

- the requested priority was not authorized;
- as an operator option, FE21 may always change the requested priority, e.g. due to congestion.

If the SS-PPC call extends to several TETRA systems, FE25 in the terminating SwMI shall not change the SS-PPC priority, however, it needs not to use this priority for resource allocation of the SS-PPC call.

## 5.3.4 Procedures for FE3

### 5.3.4.1 Verification in FE3

Upon reception of SS-PPC definition or interrogation request from the user application, FE3 shall send the request to FE21.

FE3 shall construct the DEFINE PDU according to the user's request. The definition shall be made to:

- one subscriber or group number;
- a list of subscriber or group numbers;
- a range of subscriber or group numbers.

The authorized user shall define different priority values for different basic services, if needed.

FE3 shall construct the INTERROGATE PDU for authorized user according to the user's request. The user shall interrogate the defined priority values of:

- one subscriber or group number;
- a list of subscriber or group numbers;
- a range of subscriber or group numbers.

## 5.3.5 Procedures for visited SwMI FE25

Refer ETSI EN 300 392-9 [3] and ETSI EN 300 392-3-1 [4].

## 5.4 PDU descriptions

### 5.4.0 General

The SS-FACILITY and Call priority information element shall be used to convey the supplementary service information to and from the MS and over the ISI. SS-FACILITY information element shall be transported in any call control PDU or in a D/U-FACILITY PDU. The Call priority information element used for circuit mode basic service operation and invocation shall be conveyed in U/D-SETUP and D-CONNECT PDU. The information element coding used for SS-PPC is in accordance with the general rules specified in ETSI EN 300 392-2 [1], clause 14.

The information element coding for SS-PPC is detailed in the following clauses.

The information contained in the following primitive description tables correspond to the following key:

- Length: length of the information element in bits;
- Type: information element type (1, 2 or 3) described in ETSI EN 300 392-2 [1], clause 14;
- C/O/M: conditional/optional/mandatory;

- Remark: comment.

### 5.4.1 ASSIGN PDU

The ASSIGN PDU shall be used by the SwMI to assign PPC values to an affected user or to one of the affected user's groups.

A PPC value can be assigned per basic service or for all basic services per ASSIGN PDU.

The ASSIGN PDU shall contain the SS-PPC information elements listed in table 14.

**Table 14: Definition of ASSIGN PDU**

Information element	Length	Type	C/O/M	Value	Remark
SS-Type	6	1	M		ETSI EN 300 392-9 [3]
PPC PDU type	5	1	M		ASSIGN
Activated/Deactivated	1	1	M	0	Activated
Note 1				1	Deactivated
Number of SS-PPC definitions	2	1	M		
SS-PPC assignment	variable		C		Repeatable, note 2
Acknowledgement from user A(s)	1	1	M	0	Acknowledgement requested
				1	Acknowledgement not requested
NOTE 1: Shall be used to indicate whether or not this PDU is used to activate a new PPC value or to deactivate an existing PPC value. When a PPC value is de-activated, a pre-programmed default value may then apply.					
NOTE 2: Information element shall be repeated as many times as indicated in the number of SS-PPC definitions information element.					

### 5.4.2 ASSIGN ACK PDU

The ASSIGN ACK PDU shall be used to acknowledge an assign PPC request, if acknowledgement was requested in the ASSIGN PDU.

An ASSIGN ACK PDU may be sent for each assigned PPC value. If more than one assigned PPC value exists in the ASSIGN ACK PDU, then the indicated Result shall apply for all the values.

The ASSIGN ACK PDU shall contain the SS-PPC information elements listed in table 15.

**Table 15: Definition of ASSIGN ACK PDU**

Information element	Length	Type	C/O/M	Value	Remark
SS-Type	6	1	M		ETSI EN 300 392-9 [3]
PPC PDU type	5	1	M		ASSIGN ACK
Activated/Deactivated	1	1	M	0	Activated
				1	Deactivated
Number of SS-PPC definitions	2	1	M		
SS-PPC assignment			C		Note
Result of definition	3	1	M		
NOTE: Information element shall be repeated as many times as indicated in the Number of SS-PPC definitions information element.					

### 5.4.3 DEFINE PDU

The DEFINE PDU shall be used to define either PPC values for individual identities or PPC values for group identities by an authorized user, FE3.

DEFINE PDU shall contain the SS-PPC information elements listed in table 16.

**Table 16: Definition of DEFINE PDU**

Information element	Length	Type	C/O/M	Value	Remark
SS-Type	6	1	M		ETSI EN 300 392-9 [3]
PPC PDU type	5	1	M		DEFINE
Range type	4	1	M		Note 1
Subscriber identity	Variable		C		Repeatable (see note 2)
Activated/Deactivated	1	1	M	0	Activated
Note 3				1	Deactivated
Number of SS-PPC definitions	2	1	M		
SS-PPC definition	Variable		C		Note 4
Delivered to user A(s)	1	1	M	0	To be delivered
				1	Not to be delivered
Acknowledgement from user A(s)	1	1	M	0	Acknowledgement requested
				1	Acknowledgement not requested
NOTE 1: The Range type value, "no element", shall not be applicable for this PDU.					
NOTE 2: Information element shall appear as many times as indicated in the "Range type" information element.					
NOTE 3: Shall be used to indicate whether or not this PDU is used to activate a new PPC value or to deactivate an existing PPC value. When a PPC value is de-activated, a pre-programmed default value may then apply.					
NOTE 4: Information element shall be repeated as many times as indicated in the number of SS-PPC definitions information element.					

### 5.4.4 DEFINE ACK PDU

DEFINE ACK PDU shall contain the SS-PPC information elements listed in table 17.

NOTE: If the result is different for different subscriber identities, FE21 sends several DEFINE ACKs to FE3.

**Table 17: Definition of DEFINE ACK PDU**

Information Element	Length	Type	C/O/M	Value	Remark
SS-Type	6	1	M		ETSI EN 300 392-9 [3]
PPC PDU Type	5	1	M		DEFINE ACK
Range type	4	1	M		
Subscriber identity	Variable		C		Repeatable, note
Activated/Deactivated	1	1	M	0	Activated
				1	Deactivated
Result for definition	3	1	M		
NOTE: Information element shall be conditional and appear as many times as indicated in the "Range type" information element.					

### 5.4.5 INTERROGATE PDU

INTERROGATE PDU shall contain the SS-PPC information elements listed in table 18.

**Table 18: Definition of INTERROGATE PDU**

Information element	Length	Type	C/O/M	Value	Remark
SS-Type	6	1	M		ETSI EN 300 392-9 [3]
PPC PDU type	5	1	M	0011 <sub>2</sub>	Interrogation
Range type	4	1	M		
Subscriber identity	Variable		C		Repeatable, see note
NOTE: Information element shall be conditional and appear as many times as indicated in the range type information element.					

## 5.4.6 INTERROGATE-ACK PDU

INTERROGATE-ACK PDU shall contain the SS-PPC information elements listed in table 19.

NOTE: If definitions/responses are different for different subscriber identity information elements, FE21 sends several INTERROGATE-ACKs to FE1/FE3.

**Table 19: Definition of INTERROGATE-ACK PDU**

Information element	Length	Type	C/O/M	Value	Remark
SS-Type	6	1	M		ETSI EN 300 392-9 [3]
PPC PDU type	5	1	M	0011 <sub>2</sub>	Interrogation
Range type	4	1	M		
Subscriber identity	Variable		C		Repeatable, see note 1
Result for interrogation	3	1	M		
Activated/Deactivated, note 2	1		C	0	Activated
				1	Deactivated
Number of SS-PPC definitions	2		C		See note 2
SS-PPC definition			C		See note 3
Delivered to user A(s), note 2	1		C	0	Delivered
				1	Not delivered
Acknowledgement from user A(s)	1		C	0	Acknowledgement requested
Note 2				1	Acknowledgement not requested
NOTE 1: Information element shall be conditional and appear as many times as indicated in the range type information element.					
NOTE 2: Information element shall be conditional on the value of result for interrogation. The information element shall be present if the value is accepted; accepted, but request pending in SwMI to user A(s); accepted, but user A(s) could not accept the request/user A(s) not reached					
NOTE 3: Information element shall be repeated as many times as indicated in the Number of SS-PPC definitions information element.					

## 5.4.7 REMOVE PDU

The REMOVE PDU shall be used by the SwMI to withdraw the SS-PPC feature for affected users.

REMOVE PDU shall contain the SS-PPC information elements listed in table 20.

**Table 20: Definition of REMOVE PDU**

Information element	Length	Type	C/O/M	Value	Remark
SS-Type	6	1	M		ETSI EN 300 392-9 [3]
PPC PDU type	5	1	M		REMOVE
Acknowledgement from user A(s)	1	1	M	0	Acknowledgement requested
				1	Acknowledgement not requested

## 5.4.8 REMOVE ACK PDU

REMOVE ACK PDU shall contain the SS-PPC information elements listed in table 21.

**Table 21: Definition of REMOVE ACK PDU**

Information element	Length	Type	C/O/M	Value	Remark
SS-Type	6	1	M		ETSI EN 300 392-9 [3]
PPC PDU Type	5	1	M		REMOVE ACK
Result for withdrawal	3	1	M		

## 5.4.9 WITHDRAW PDU

The WITHDRAW PDU shall be used to withdraw the SS-PPC feature for individual identities or for group identities by an authorized user, FE3.

WITHDRAW PDU shall contain the SS-PPC information elements listed in table 22.

**Table 22: Definition of WITHDRAW PDU**

Information element	Length	Type	C/O/M	Value	Remark
SS-Type	6	1	M		ETSI EN 300 392-9 [3]
PPC PDU type	5	1	M		WITHDRAW
Range type	4	1	M		Note 1
Subscriber identity	Variable		C		Repeatable, see note 2
Delivery to user A(s)	1	1	M	0	To be delivered
				1	Not to be delivered
Acknowledgement from user A(s)	1	1	M	0	Acknowledgement requested
				1	Acknowledgement not requested
NOTE 1: The range type value, "no element", shall not be applicable for this PDU.					
NOTE 2: Information element shall appear as many times as indicated in the "Range type" information element.					

## 5.4.10 WITHDRAW ACK PDU

WITHDRAW ACK PDU shall contain the SS-PPC information elements listed in table 23.

NOTE: If the result is different for different subscriber identities, FE21 sends several WITHDRAW ACKs to FE3.

**Table 23: Definition of WITHDRAW ACK PDU**

Information element	Length	Type	C/O/M	Value	Remark
SS-Type	6	1	M		ETSI EN 300 392-9 [3]
PPC PDU Type	5	1	M		WITHDRAW ACK
Range type	4	1	M		
Subscriber identity	Variable		C		Repeatable, note
Result for withdrawal	3	1	M		
NOTE: Information element shall be conditional and appear as many times as indicated in the "Range type" information element.					

## 5.4.11 Pre-emption

### 5.4.11.1 D-RELEASE PDU

D-RELEASE PDU shall contain the information elements defined in ETSI EN 300 392-2 [1], clause 14. The disconnection cause shall be set as "Pre-emptive use of resources".

## 5.4.12 Priority 1 and Priority 2

### 5.4.12.1 D-CONNECT PDU

D-CONNECT PDU shall contain the information elements defined in ETSI EN 300 392-2 [1], clause 14. The Call priority information element coding is described in clause 5.5.12.

### 5.4.12.2 D-SETUP PDU

D-SETUP PDU shall contain the information elements defined in ETSI EN 300 392-2 [1], clause 14. The Call priority information element coding is described in clause 5.5.12.

### 5.4.12.3 U-SETUP PDU

U-SETUP PDU shall contain the information elements defined in ETSI EN 300 392-2 [1], clause 14. The Call priority information element coding is described in clause 5.5.12.

### 5.4.13 IMPENDING-PRE-EMPTION PDU

IMPENDING-PRE-EMPTION PDU shall contain the SS-PPC information elements listed in table 24.

**Table 24: Definition of IMPENDING-PRE-EMPTION PDU**

Information element	Length	Type	C/O/M	Value	Remark
SS-Type	6	1	M		ETSI EN 300 392-9 [3]
PPC PDU type	5	1	M	0110 <sub>2</sub>	IMPENDING-PRE-EMPTION
Time to pre-emption	4	2	O		

### 5.4.14 USER-PRE-EMPTED PDU

USER-PRE-EMPTED PDU shall contain the SS-PPC information elements listed in table 25.

**Table 25: Definition of USER-PRE-EMPTED PDU**

Information Element	Length	Type	C/O/M	Value	Remark
SS-Type	6	1	M		ETSI EN 300 392-9 [3]
PPC PDU type	5	1	M	0110 <sub>2</sub>	USER-PRE-EMPTED
Number of pre-empted parties	5	1	M		Subscriber identity given
Pre-empted party	Variable		C		Note
NOTE: The information element shall be present as many times as the Number of pre-empted parties information element indicates.					

## 5.5 Information element coding

### 5.5.0 General

This clause shall specify the information element coding for the information elements within the PDUs defined in clause 5.4.

### 5.5.1 Basic service(s)

Basic service(s) shall indicate the basic service(s) to which the SS-PPC priority values are defined. Basic service information element is described in table 26.

All applicable basic services shall comprise of circuit mode speech and circuit mode data basic service.

**Table 26: Basic service contents**

Information element	Length	Value	Remarks
Basic service(s)	2	00 <sub>2</sub>	All applicable basic services
		01 <sub>2</sub>	Circuit mode speech
		10 <sub>2</sub>	Circuit mode data
		11 <sub>2</sub>	Reserved

## 5.5.2 Number of pre-empted parties

The Number of pre-empted parties information element shall indicate the number of pre-empted party identities listen in the USER-PRE-EMPTED PDU. Number of pre-empted parties information element is described in table 27.

**Table 27: Number of pre-empted parties contents**

Information element	Length	Value	Remarks
Number of pre-empted parties	5	00000 <sub>2</sub>	No pre-empted party identities
		00001 <sub>2</sub>	1 pre-empted party identities
		00010 <sub>2</sub>	2 pre-empted party identities
		..	
		11110 <sub>2</sub>	30 pre-empted party identities
		11111 <sub>2</sub>	31 pre-empted party identities

## 5.5.3 Number of SS-PPC definitions

The number of SS-PPC definitions information element shall indicate how many basic service and SS-PPC priority information elements shall follow in the PDU. Number of SS-PPC definition information element is described in table 28.

**Table 28: Number of SS-PPC definitions contents**

Information Element	Length	Value	Remarks
Number of SS-PPC definitions	2	00 <sub>2</sub>	Reserved
		01 <sub>2</sub>	1
		10 <sub>2</sub>	2
		11 <sub>2</sub>	Reserved

## 5.5.4 PPC PDU type

The PPC PDU type information element shall indicate the type of the action as described in table 29.

**Table 29: PPC PDU type contents**

Information element	Length	Value	Remark
PPC PDU type	5	0000 <sub>2</sub>	Defined in ETSI EN 300 392-9 [3]
		00001 <sub>2</sub>	Defined in ETSI EN 300 392-9 [3]
		00010 <sub>2</sub>	Defined in ETSI EN 300 392-9 [3]
		00011 <sub>2</sub>	Defined in ETSI EN 300 392-9 [3]
		00100 <sub>2</sub>	Defined in ETSI EN 300 392-9 [3]
		00101 <sub>2</sub>	DEFINE
		00110 <sub>2</sub>	DEFINE ACK
		00111 <sub>2</sub>	ASSIGN
		01000 <sub>2</sub>	ASSIGN ACK
		01001 <sub>2</sub>	WITHDRAW
		01010 <sub>2</sub>	WITHDRAW ACK
		01011 <sub>2</sub>	REMOVE
		01100 <sub>2</sub>	REMOVE ACK
		01101 <sub>2</sub>	INTERROGATE
		01110 <sub>2</sub>	INTERROGATE ACK
		01111 <sub>2</sub>	IMPENDING-PRE-EMPTION
		10000 <sub>2</sub>	USER-PRE-EMPTED
10001 <sub>2</sub>	Reserved		
Etc.	Etc.		
11111 <sub>2</sub>	Reserved		

## 5.5.5 Pre-empted party

The pre-empted party information element identifies the party that has been pre-empted. Either the TETRA identity or external subscriber number may be given. The pre-empted party information element shall be coded for the air interface as presented in table 30 and for Inter System Interface as presented in table 30A.

**Table 30: Pre-empted party information element contents for the air interface**

Information element	Length	Type	C/O/M	Value	Remark
Subscriber identity	Variable	2	O		See note 1
External subscriber number	Variable	2	O		See notes 1 and 2
NOTE 1: The present document does not define what the subscriber identity information element identifies, if both it and the External subscriber number information elements are present.					
NOTE 2: The external subscriber number shall be encoded as defined in ETSI EN 300 392-9 [3], clause 8.4.3, table 20. The value of the number of external subscriber number digits information element in it should not be set to "0" as the information element external subscriber number is already optional.					

**Table 30A: Pre-empted party information element contents for the Inter System Interface**

Information element	Length	Type	C/O/M	Value	Remark
Subscriber identity	Variable	2	O		See note 1
External subscriber number	Variable	2	O		See notes 1 and 2
External number parameter	9		O		See note 3
NOTE 1: The present document does not define what the subscriber identity information element identifies, if both it and the external subscriber number information elements are present.					
NOTE 2: The external subscriber number shall be encoded as defined in ETSI EN 300 392-9 [3], clause 8.4.3, table 20. The value of the number of external subscriber number digits information element in it should not be set to "0" as the information element external subscriber number is already optional.					
NOTE 3: This information element shall not be present if the external subscriber number is not present.					

## 5.5.6 Range type

The Range type information element shall indicate how many subscriber identity information elements shall follow in the PDU and how the information elements shall be interpreted, i.e. single identity, list of identities or a range of identities. The generic definition of the information element range type in ETSI EN 300 392-9 [3] applies, with the restriction that due to the way that information element is used in the present document, its value shall never be equal to 0.

In case of range, first and last information element of the range shall be given and the definition shall be requested to all subscriber numbers within the range including the first and last information element of the range.

## 5.5.7 Result for definition

Result for definition shall indicate whether the previously made definition request was successful or unsuccessful. Result for definition information element is described in table 31.

**Table 31: Result for definition contents**

Information Element	Length	Value	Remark
Result for definition	3	000 <sub>2</sub>	Accepted by SwMI or Accepted by MS, see note
		001 <sub>2</sub>	Accepted but SS-PPC priority values changed, see note
		010 <sub>2</sub>	Users A(s) could not accept the request/ users A(s) was not reached, see note
		011 <sub>2</sub>	Request failed for any reason
		100 <sub>2</sub>	User not authorized, see note
		101 <sub>2</sub>	Unknown TETRA identity
		110 <sub>2</sub>	Parameters not valid
		111 <sub>2</sub>	Insufficient information
NOTE: The following definition results only apply for the SwMI: - "accepted by SwMI", "accepted but SS-PPC priority values changed", "user A(s) was not reachable" and "user not authorized".			

## 5.5.8 Result for interrogation

Result for interrogation shall indicate whether the previously made interrogation request was successful or unsuccessful. Result for interrogation information element is described in table 32.

**Table 32: Result for interrogation contents**

Information element	Length	Value	Remark
Result for interrogation	3	000 <sub>2</sub>	Accepted
		001 <sub>2</sub>	Accepted, but one or more affected users could not accept the request/accepted, but one or more affected users where not reached
		010 <sub>2</sub>	SS-PPC not defined for the given identity
		011 <sub>2</sub>	Request failed for any reason
		100 <sub>2</sub>	User not authorized
		101 <sub>2</sub>	Unknown TETRA identity
		110 <sub>2</sub>	Parameters not valid
		111 <sub>2</sub>	Reserved

## 5.5.9 Result for withdrawal

Result for withdrawal shall indicate whether the withdrawal request was successful or unsuccessful. Result for withdrawal information element is described in table 33.

**Table 33: Result for withdrawal contents**

Information element	Length	Value	Remark
Result for withdrawal	3	000 <sub>2</sub>	Accepted by SwMI or Accepted by MS, see note
		001 <sub>2</sub>	Reserved
		010 <sub>2</sub>	User A(s) was not reachable, see note
		011 <sub>2</sub>	Request failed for any reason
		100 <sub>2</sub>	User not authorized, see note
		101 <sub>2</sub>	Unknown TETRA identity
		110 <sub>2</sub>	Parameters not valid
		111 <sub>2</sub>	Insufficient information
NOTE: The following definition results only apply for the SwMI: - "accepted by SwMI", "user A(s) was not reachable" and "user not authorized".			

## 5.5.10 SS-PPC assignment

This information element is used to assign a SS-PPC value for the indicated basic service.

**Table 34: SS-PPC assignment contents**

Information element	Length	Type	C/O/M	Remark
Basic service	2	1	M	
SS-PPC priority value	4	1	M	

## 5.5.11 SS-PPC definition

This information element is used to define a SS-PPC value or to delete a defined SS-PPC value for the indicated basic service.

**Table 35: SS-PPC definition contents**

Information element	Length	Type	C/O/M	Remark
Basic service	2	1	M	
SS-PPC priority value	4	1	M	
Non group member SS-PPC priority	4	2	O	See note
NOTE: The "Non group member SS-PPC priority" information element will not be assigned to affected users. Only the SwMI will store this information element.				

## 5.5.12 SS-PPC priority, Call priority and Non group member SS-PPC priority

Definition of SS-PPC values for the call priority and SS-PPC priority information element.

SS-PPC priority values are described in table 36.

**Table 36: SS-PPC priority value contents**

Information element	Length	Value	Remarks
SS-PPC priority value	4	0000 <sub>2</sub>	0, see note 1
		0001 <sub>2</sub>	1, see note 2
		Etc.	Etc.
		1011 <sub>2</sub>	11, see note 2
		1100 <sub>2</sub>	Pre-emptive priority 1, see note 3
		1101 <sub>2</sub>	Pre-emptive priority 2, see note 3
		1110 <sub>2</sub>	Pre-emptive priority 3, see note 4
		1111 <sub>2</sub>	Pre-emptive priority 4 (Emergency), see note 4
NOTE 1: Value 0 corresponds to undefined priority value.			
NOTE 2: Priority values from 1 to 11 are defined in ETSI EN 300 392-12-10 [6], SS-PC stage 3.			
NOTE 3: Will result in resources being pre-empted, application issue as to whether called user(s) is pre-empted.			
NOTE 4: Will result in both resources and the called user(s) being pre-empted.			

## 5.5.13 Subscriber extension present

The subscriber extension present information element shall indicate whether the MNI part of the TSI address of the subscriber is present in the PDU. The information element shall be as defined in table 37.

**Table 37: Subscriber extension information element contents**

Information element	Length	Value	Remark
Subscriber extension present	1	0	No group extension present
		1	Subscriber extension present

## 5.5.14 Subscriber identity

The Subscriber identity information element shall define a TSI. The subscriber identity information element is described in table 38.

**Table 38: Subscriber identity contents**

Information element	Length	Type	C/O/M	Remark
Short subscriber identity, SSI	24	1	M	See ETSI EN 300 392-1 [2], clause 7
Subscriber extension present	1	1	M	
Mobile Network Identity, MNI	24		C	See ETSI EN 300 392-1 [2], clause 7

## 5.5.15 Time to pre-emption

Time to pre-emption information element shall indicate the time remaining to the forthcoming pre-emption of resources or called user. Time to pre-emption information element is described in table 39.

**Table 39: Time to pre-emption contents**

Information element	Length	Value	Remark
Time to pre-emption	4	0000 <sub>2</sub>	0 second
		0001 <sub>2</sub>	1 second
		0010 <sub>2</sub>	2 seconds
		0011 <sub>2</sub>	3 seconds
		0100 <sub>2</sub>	4 seconds
		0101 <sub>2</sub>	5 seconds
		0110 <sub>2</sub>	6 seconds
		0111 <sub>2</sub>	7 seconds
		1000 <sub>2</sub>	8 seconds
		1001 <sub>2</sub>	9 seconds
		1010 <sub>2</sub>	10 seconds
		1011 <sub>2</sub>	Reserved
		Etc.	Etc.
1111 <sub>2</sub>	Reserved		

---

## 6 SS-PPC FE behaviour

### 6.0 General

The figures contained in this clause are intended to illustrate typical SS-PPC specific FE behaviour in terms of information flows sent and received.

**NOTE:** The intention of the figures in this clause is to describe the functionality of SS-PPC and the call related information flows are not complete, e.g. all the call set-up or call release primitives and PDUs are not included in the figures.

The behaviour of each FE is shown using the (Functional) Specification and Description Language defined in Recommendation ITU-T Z.100 [5]. Notice, however, that due to simplicity there are deviations from syntactical rules.

The convention used in figures 1 and 2 is that output signals to the left represent information flows towards the user and output signals to the right represent information flows towards the SwMI part of the PPC function. Input signals from the left represent information from the user and input signals from the right represent information flows from the central part of the SwMI.

FE1 refers to a block and FE\_1 refers to a process in figures 1 and 2.

## 6.1 Behaviour of FE1 (SS entity of user A)

### 6.1.1 Service interaction for FE1

Service interaction for FE1 is shown in figure 1.

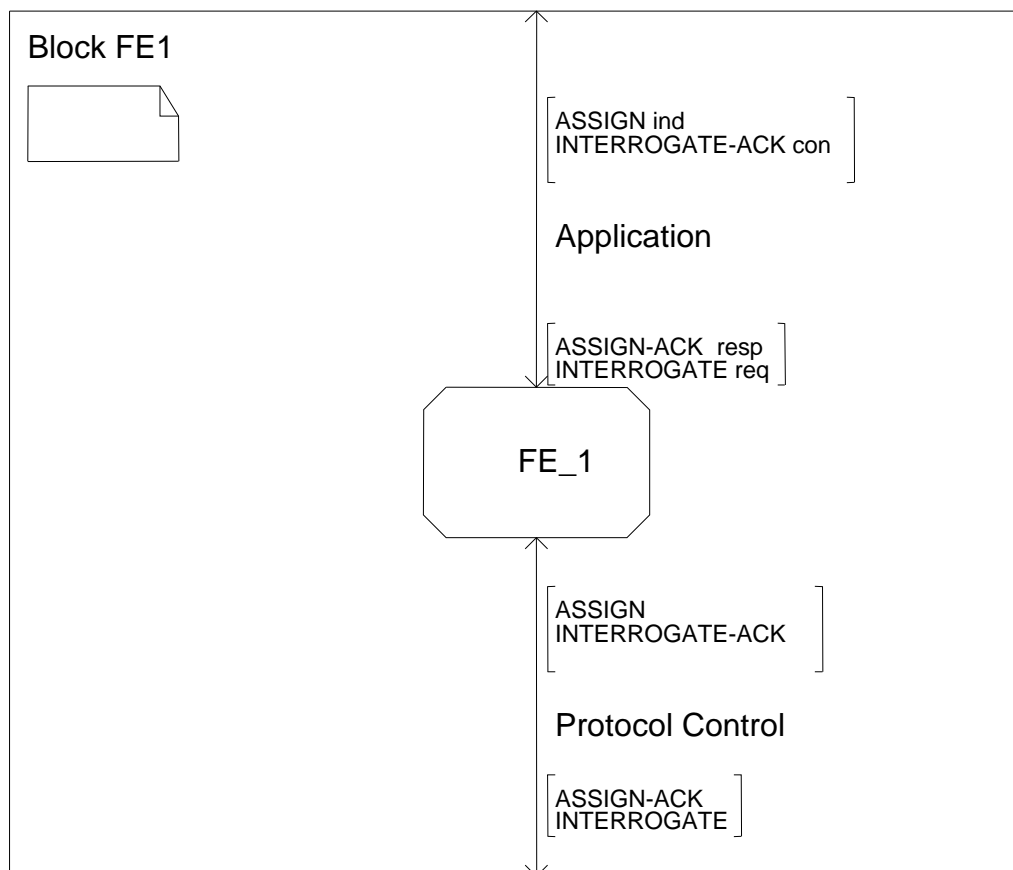

**Figure 1: Service interaction for FE1**

## 6.1.2 Process description for FE1

Process description of FE1 is shown in figure 2.

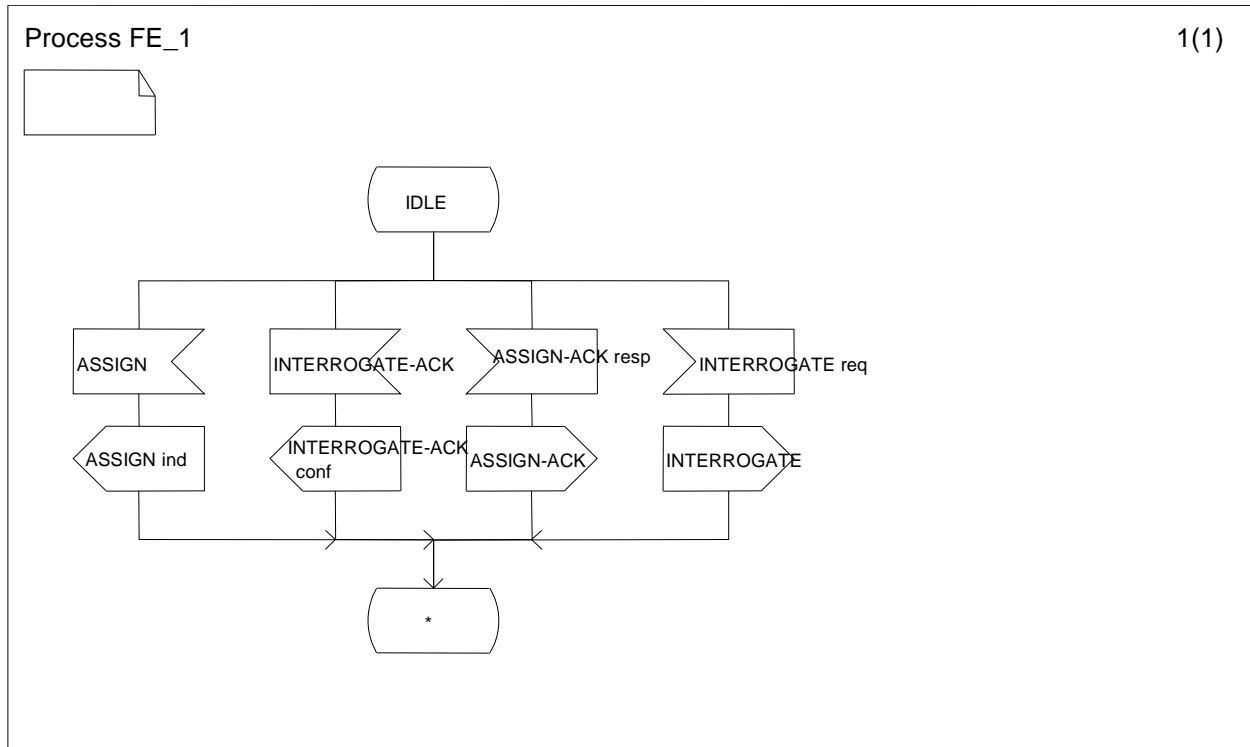
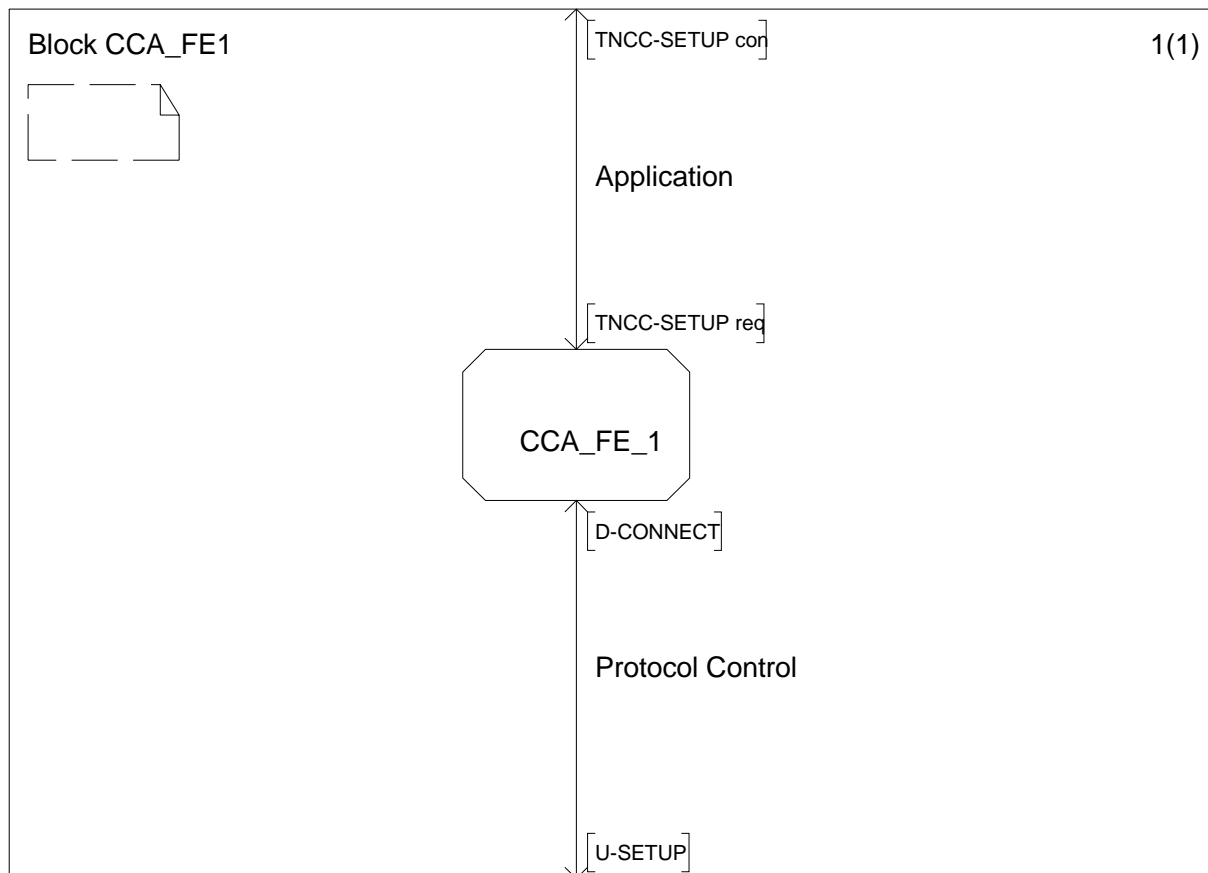

**Figure 2: Process description for FE1**

## 6.2 Behaviour of CCA to which FE1 is collocated

### 6.2.1 Service interaction for CCA to which FE1 is collocated

Service interaction for CCA to which FE1 is collocated is shown in figure 3.



**Figure 3: Service interaction for CCA to which FE1 is collocated**

## 6.2.2 Process description for CCA to which FE1 is collocated

Process description for CCA to which FE1 is collocated is shown in figure 4.

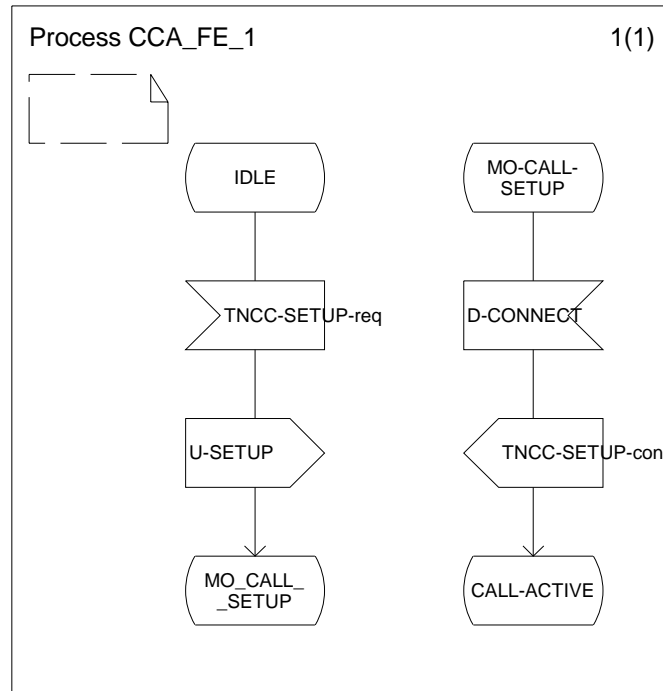

Figure 4: Process description for CCA to which FE1 is collocated

## 6.3 Behaviour of FE21

### 6.3.1 Service interaction for FE21

Service interaction for FE21 is shown in figure 5.

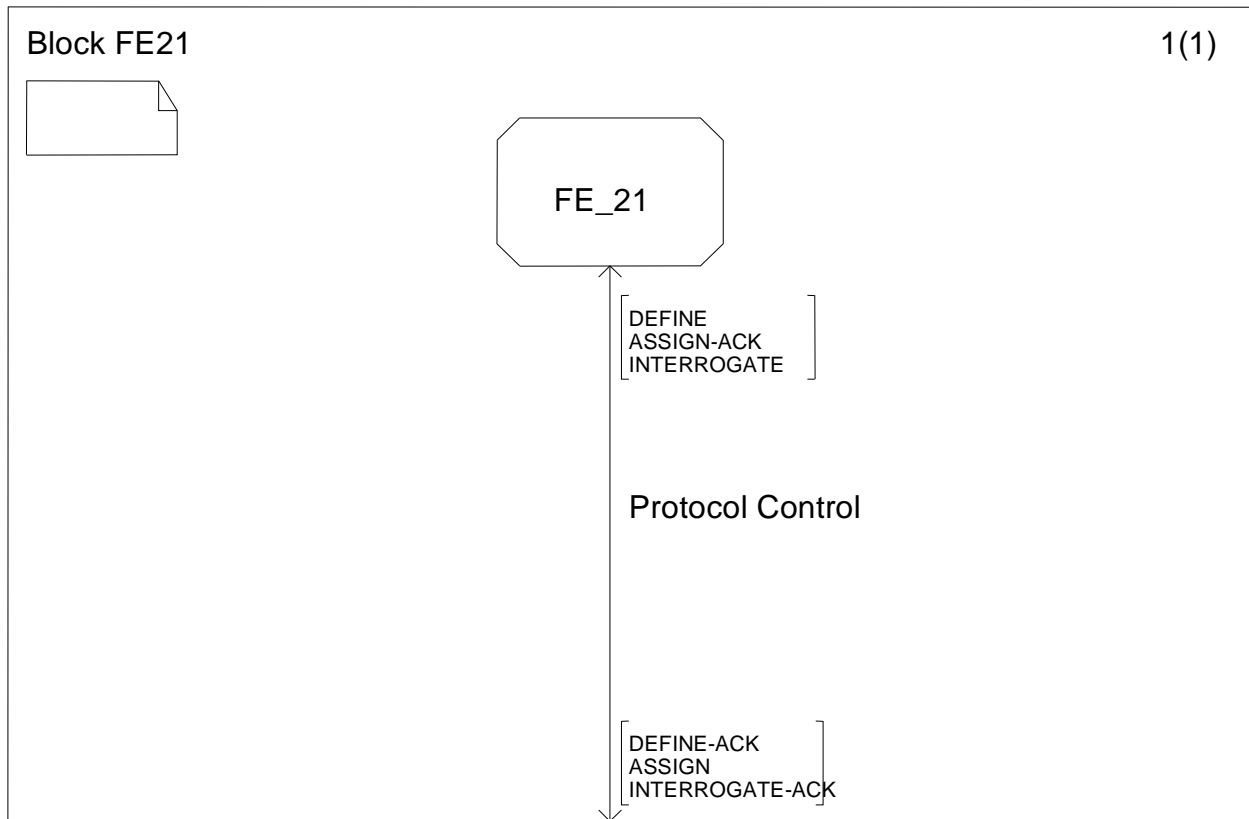

Figure 5: Service interaction for FE21

### 6.3.2 Process description for FE21

Process descriptions for FE21 state IDLE is shown in figure 6.

Process <<Block FE21>> FE\_21

1(2)

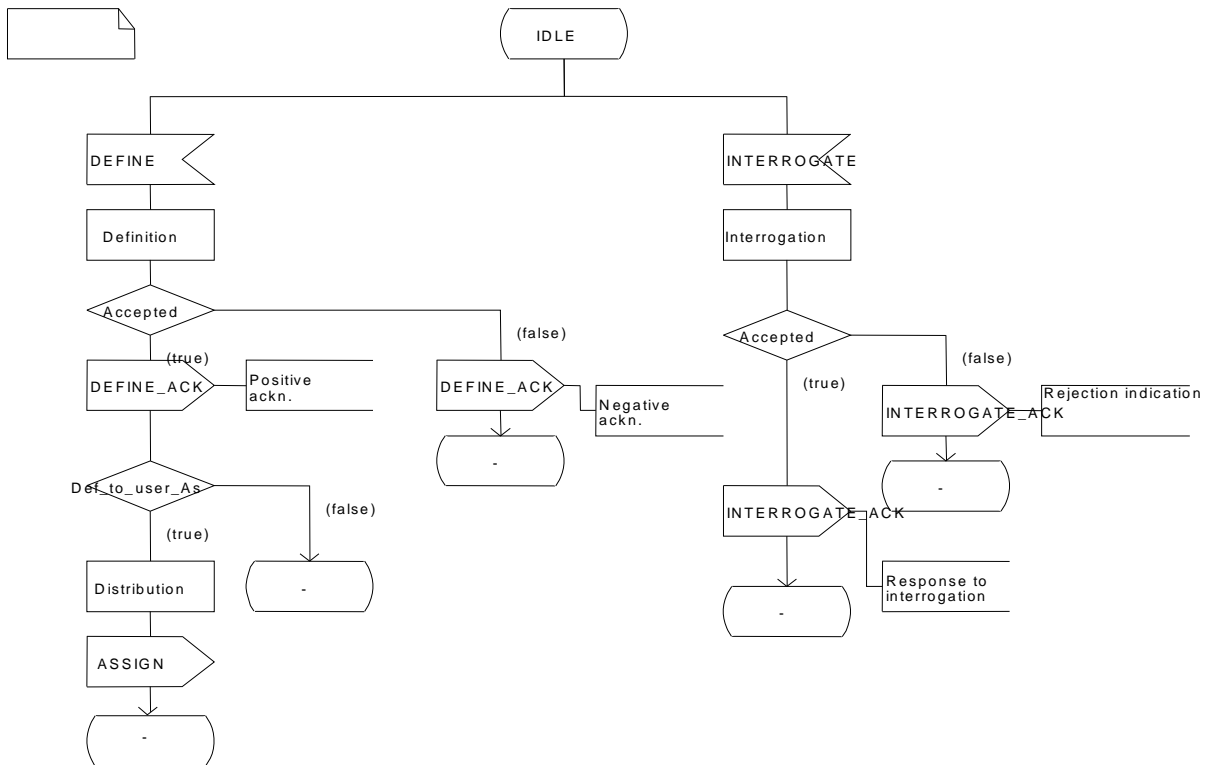

Figure 6: Process description for FE21 state IDLE

## 6.4 Behaviour of CC to which FE21 is collocated

### 6.4.1 Service interaction for CC to which FE21 is collocated

Service interaction for CC to which FE21 is collocated is shown in figure 7.

Block CC\_FE21

1(1)

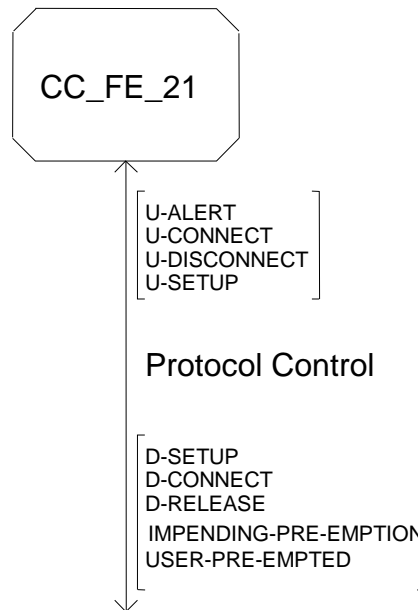

**Figure 7: Service interaction for CC to which FE21 is collocated**

### 6.4.2 Process description for CC to which FE21 is collocated

Process description for CC to which FE21 is collocated is shown in figures 8, 9 and 10.

Process CC\_FE\_21



1(3)

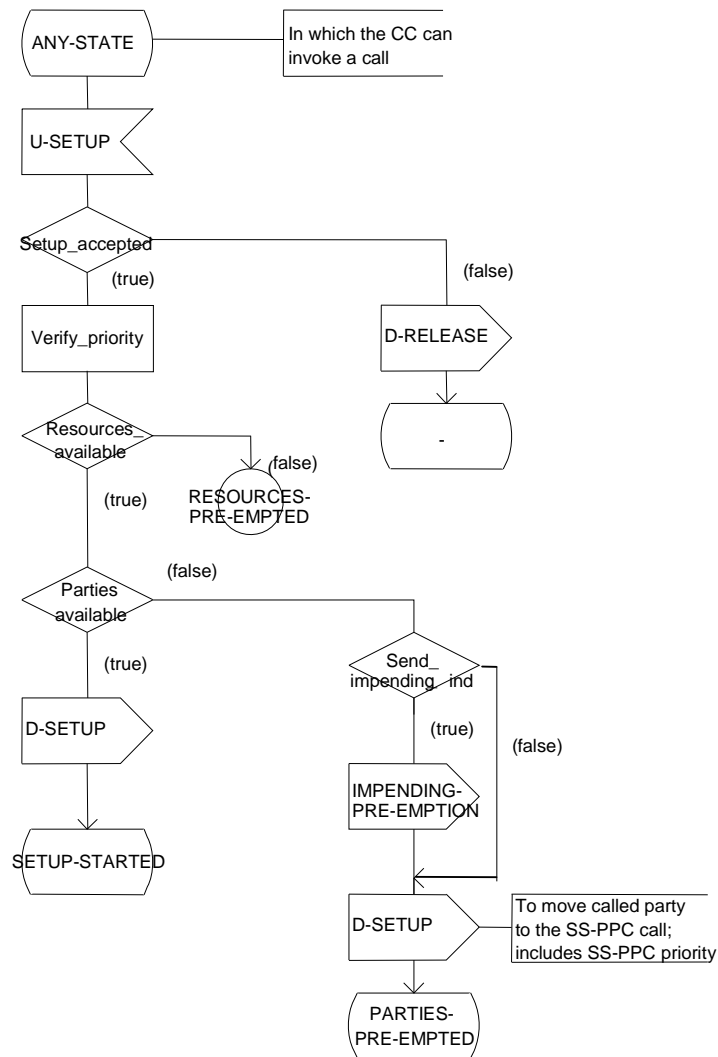

Figure 8: Process description for CC to which FE21 is collocated

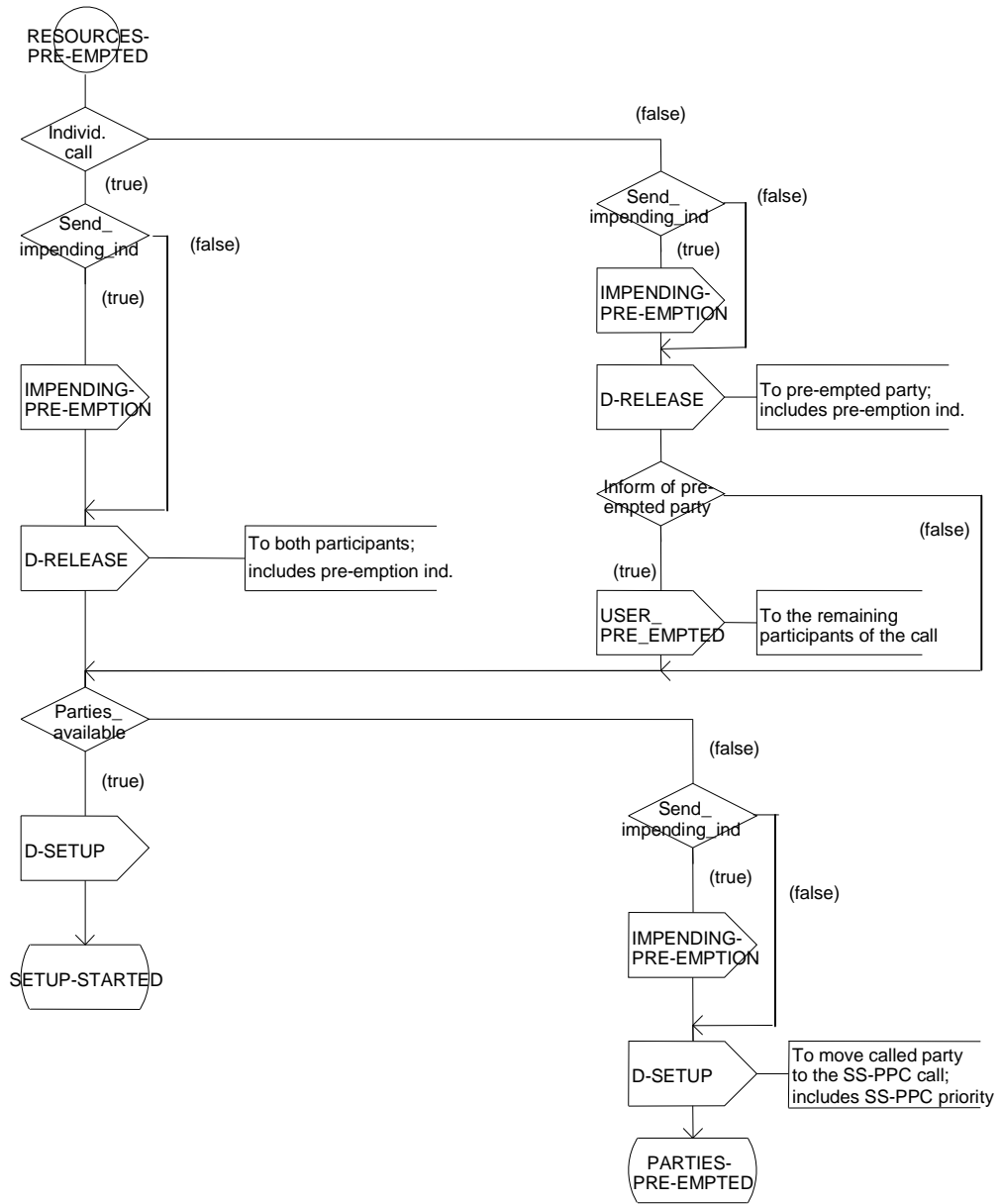

Figure 9: Process description for CC to which FE21 is collocated

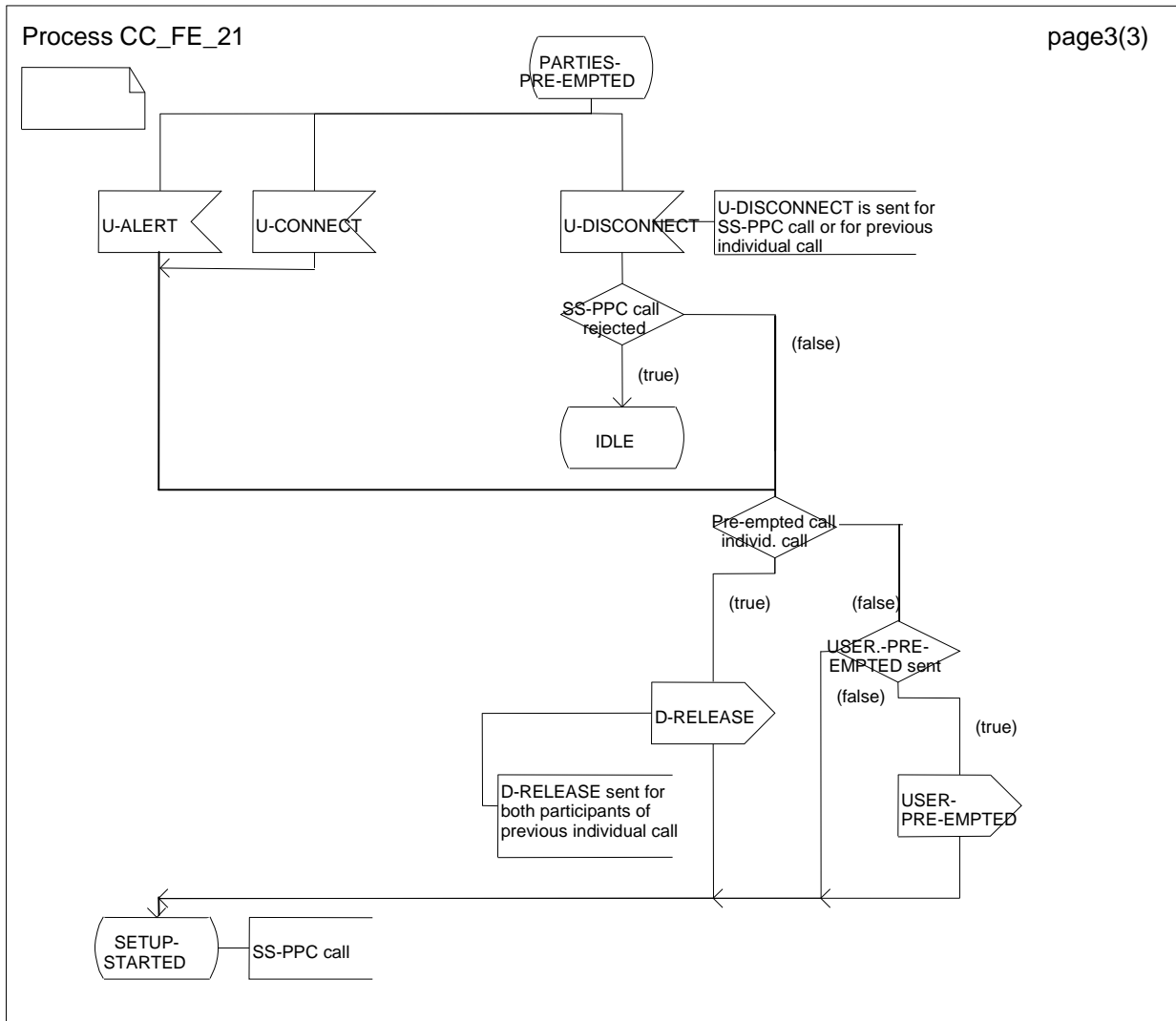
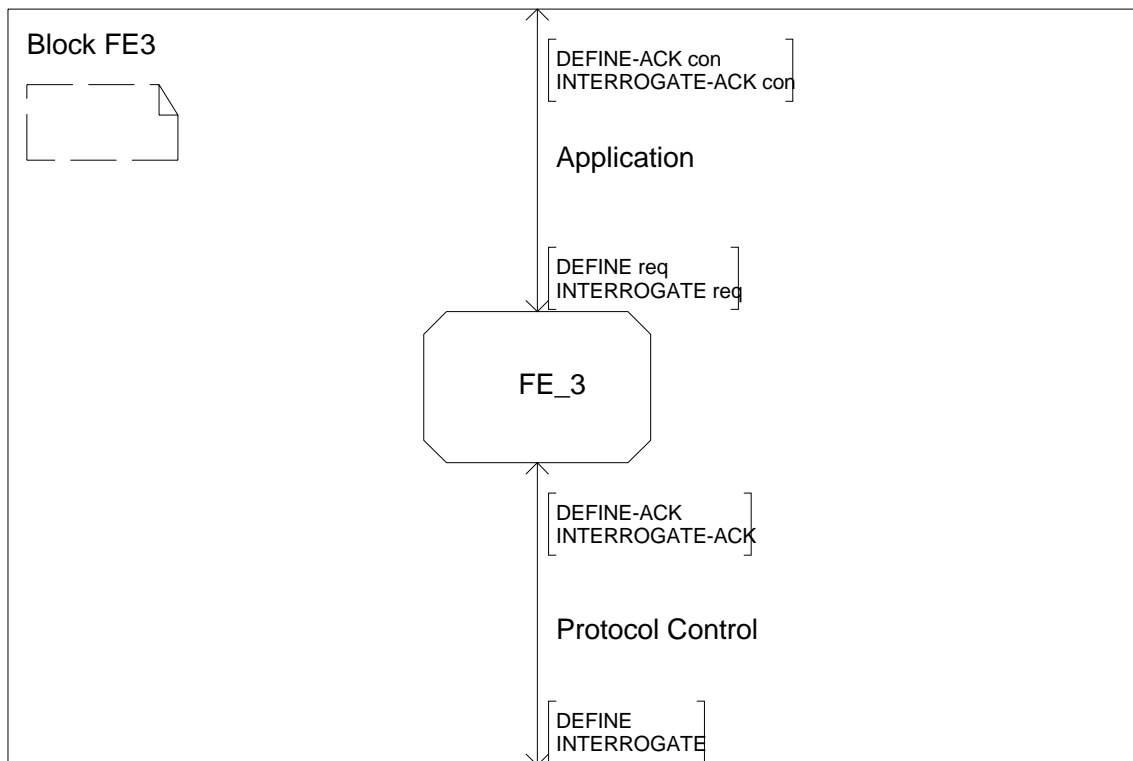

Figure 10: Process description for CC to which FE21 is collocated

## 6.5 Behaviour of FE3 (SS entity of authorized user)

### 6.5.1 Service interaction for FE3

Service interaction for FE3 is shown in figure 11.



**Figure 11: Service interaction for FE3**

## 6.5.2 Process description for FE3

Process description of FE3 is shown in figure 12.

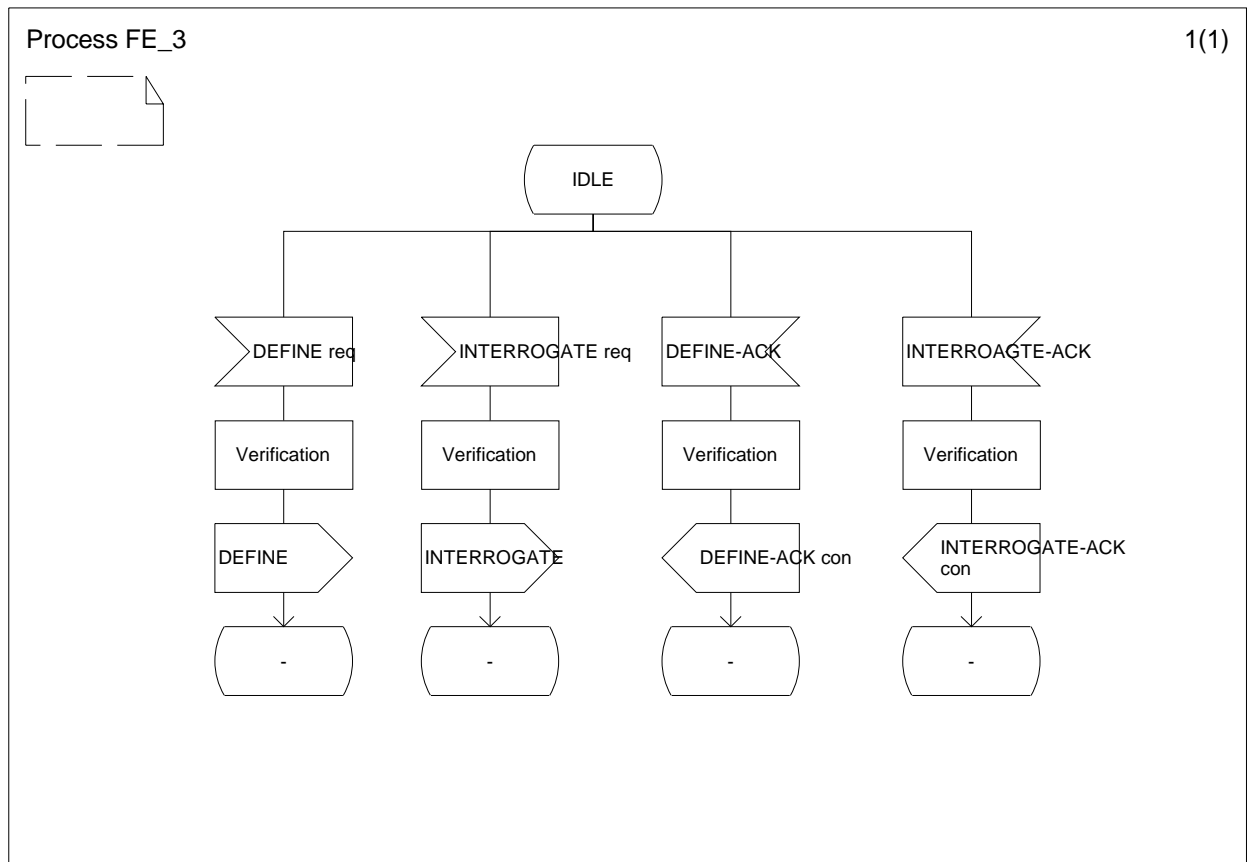
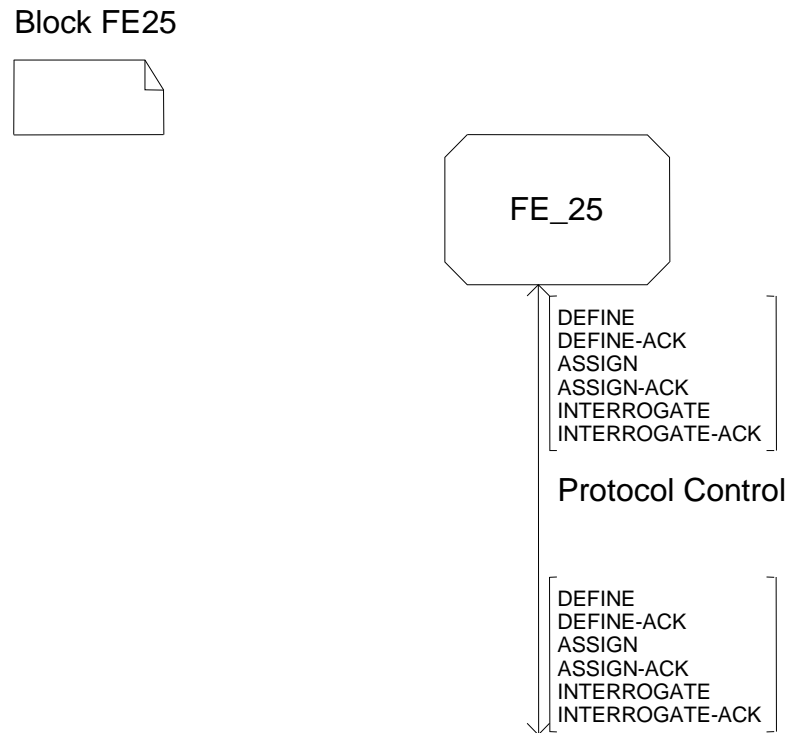

Figure 12: Process description for FE3

## 6.6 Behaviour of visited SwMI FE25

### 6.6.1 Service interaction for FE25

Service interaction for FE25 is shown in figure 13.



**Figure 13: Service interaction for visited SwMI FE25**

## 6.6.2 Process description for visited SwMI FE25

Process description for FE25 is shown in figure 14.

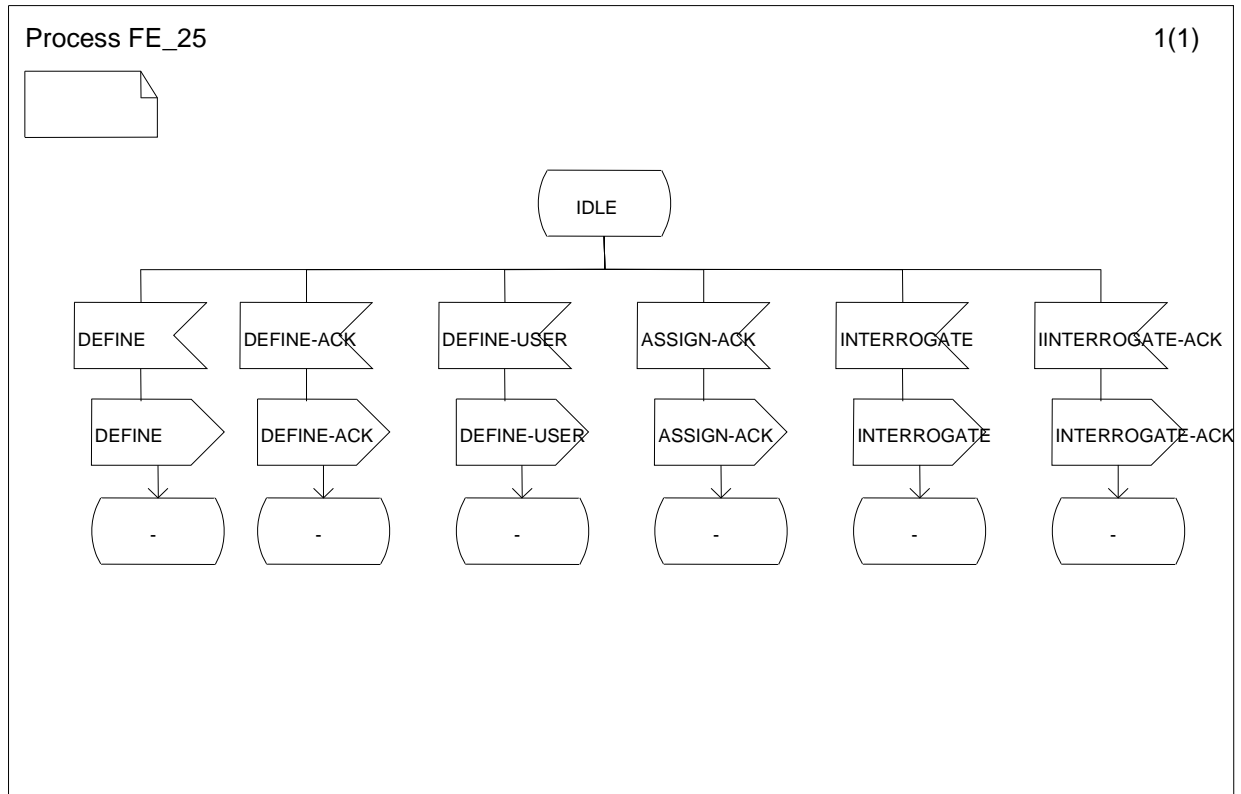

**Figure 14: Process description for FE25**

## 6.7 Behaviour of CC to which FE25 is collocated

Service interaction for CC to which FE25 is collocated is shown in figure 15.

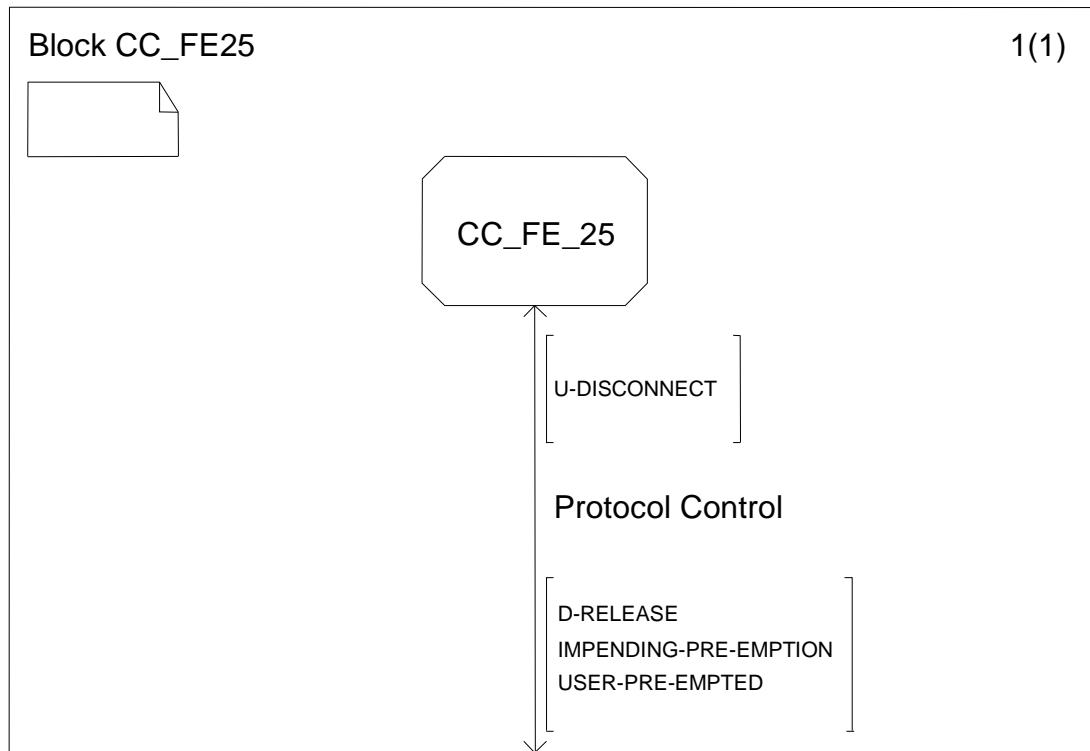
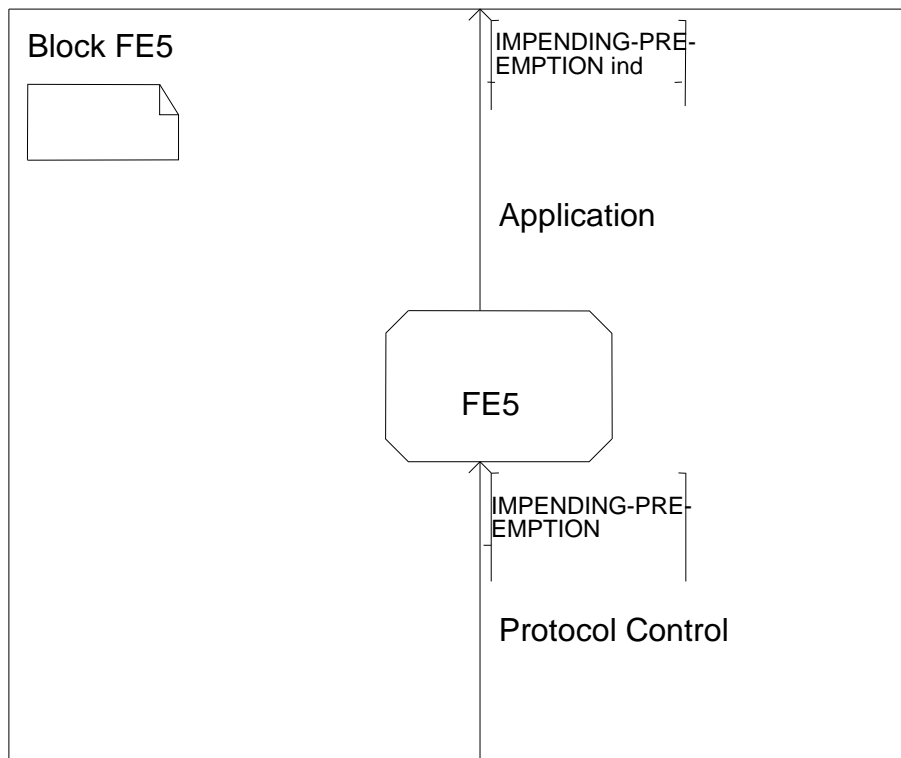

**Figure 15: Service interaction for CC to which FE25 is collocated**

## 6.8 Behaviour of FE5

### 6.8.1 Service interaction for FE5

Service interaction for FE5 is shown in figure 16.



**Figure 16: Service interaction for FE5**

## 6.8.2 Process description for FE5

Process description for FE5 is shown in figure 17.

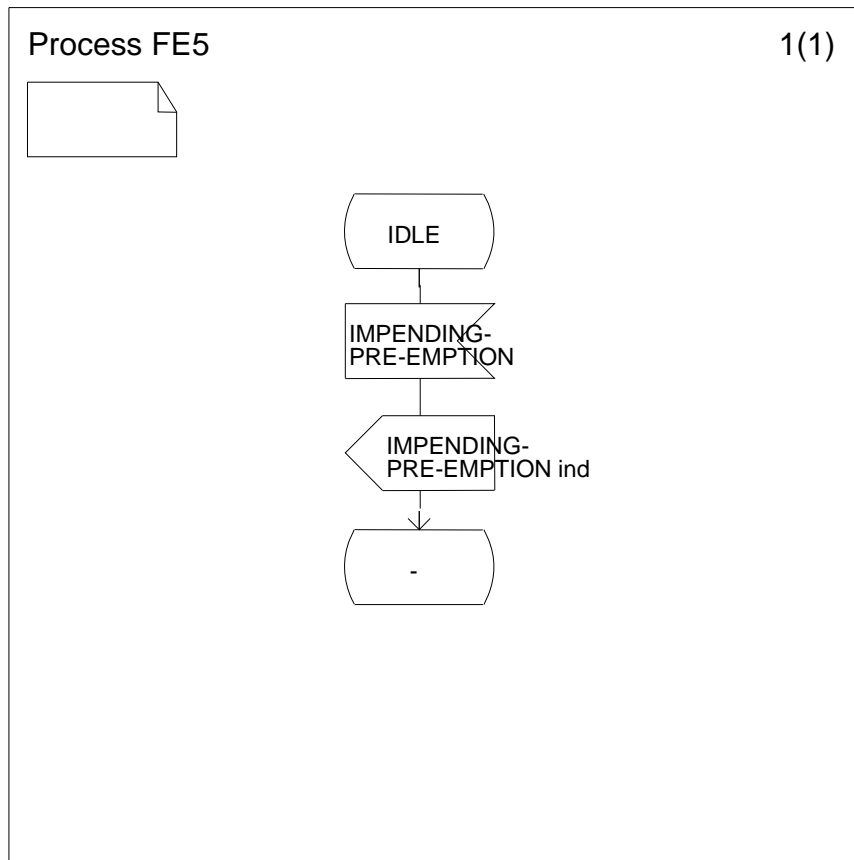

Figure 17: Process description for FE5

## 6.9 Behaviour of CCA to which FE5 is collocated

### 6.9.0 General

The disconnection of the possibly existing call within CCA collocated to FE5 is not shown in figures 18 and 20. However, upon reception of a higher priority SS-PPC call, the lower priority call should be released within CCA.

### 6.9.1 Service interaction for CCA to which FE5 is collocated

Service interaction for CCA to which FE5 is collocated is shown in figure 18.

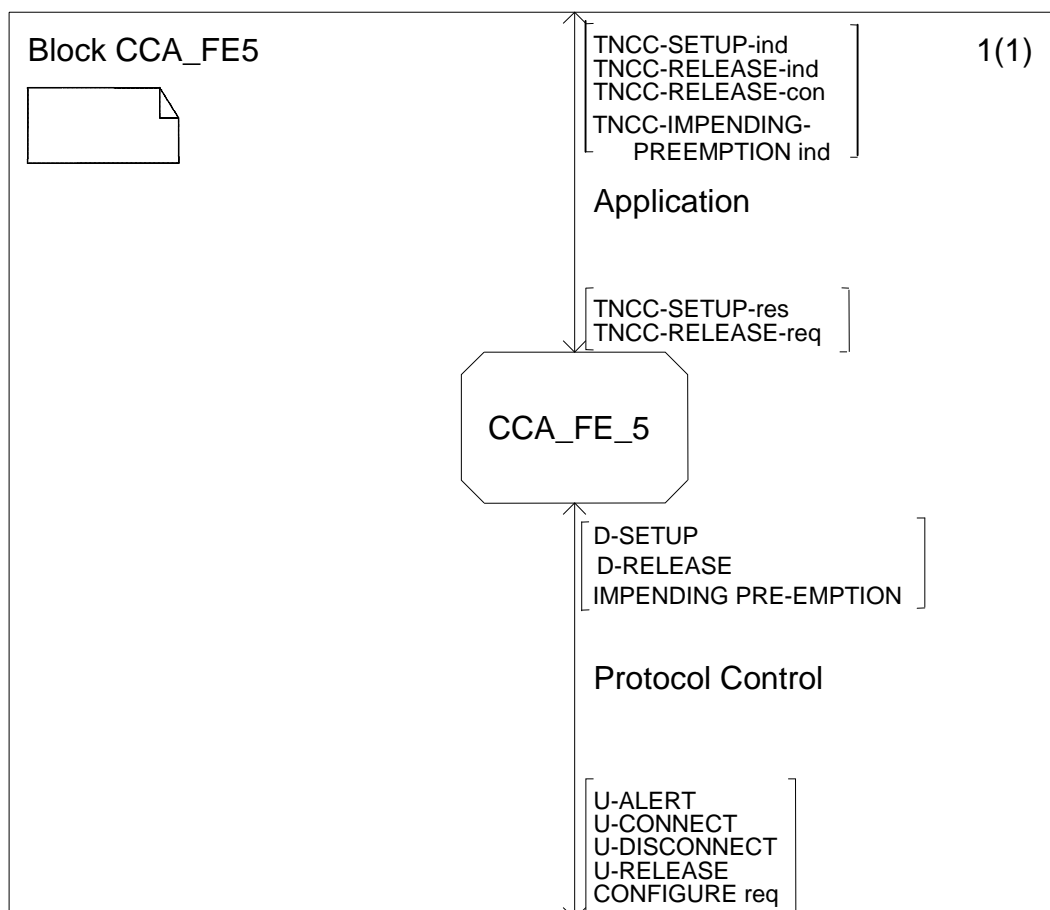
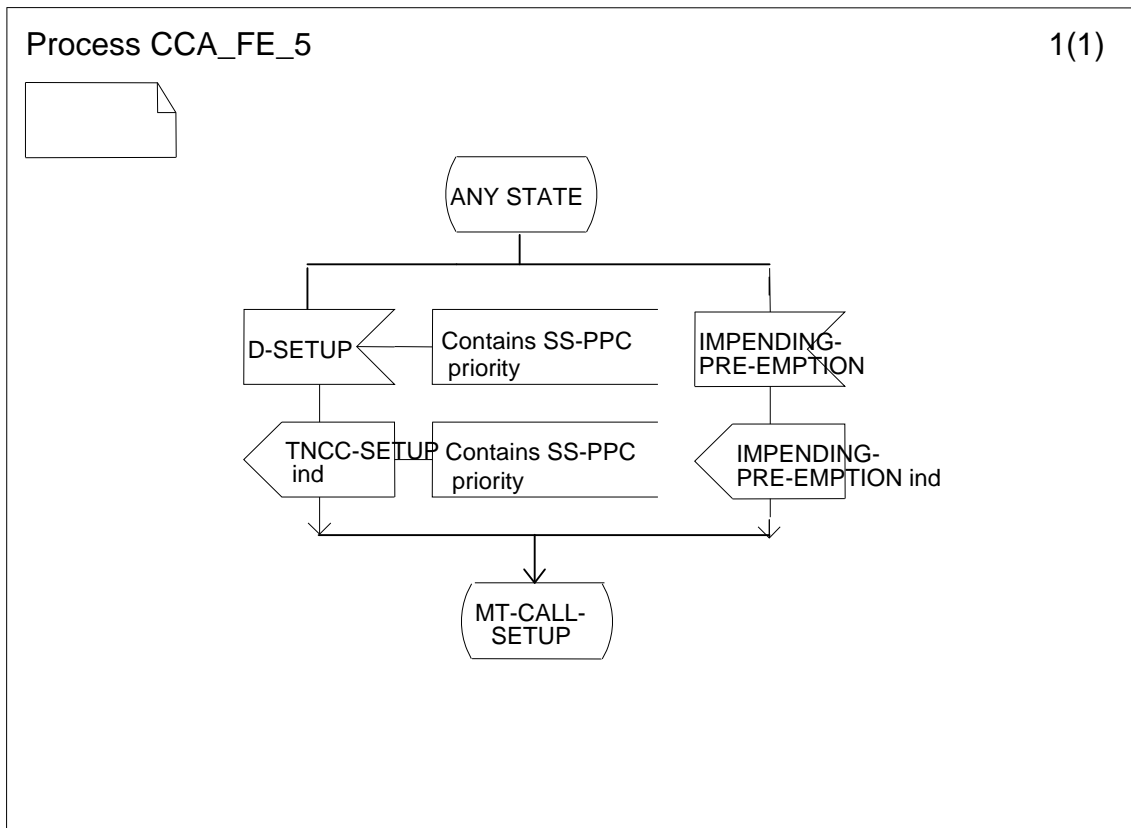

Figure 18: Service interaction for CCA to which FE5 is collocated

## 6.9.2 Process description for CCA collocated to FE5

Process description for CCA collocated to FE5 is shown in figures 19 and 20.



**Figure 19: Process description of ANY STATE for CCA collocated to FE5**

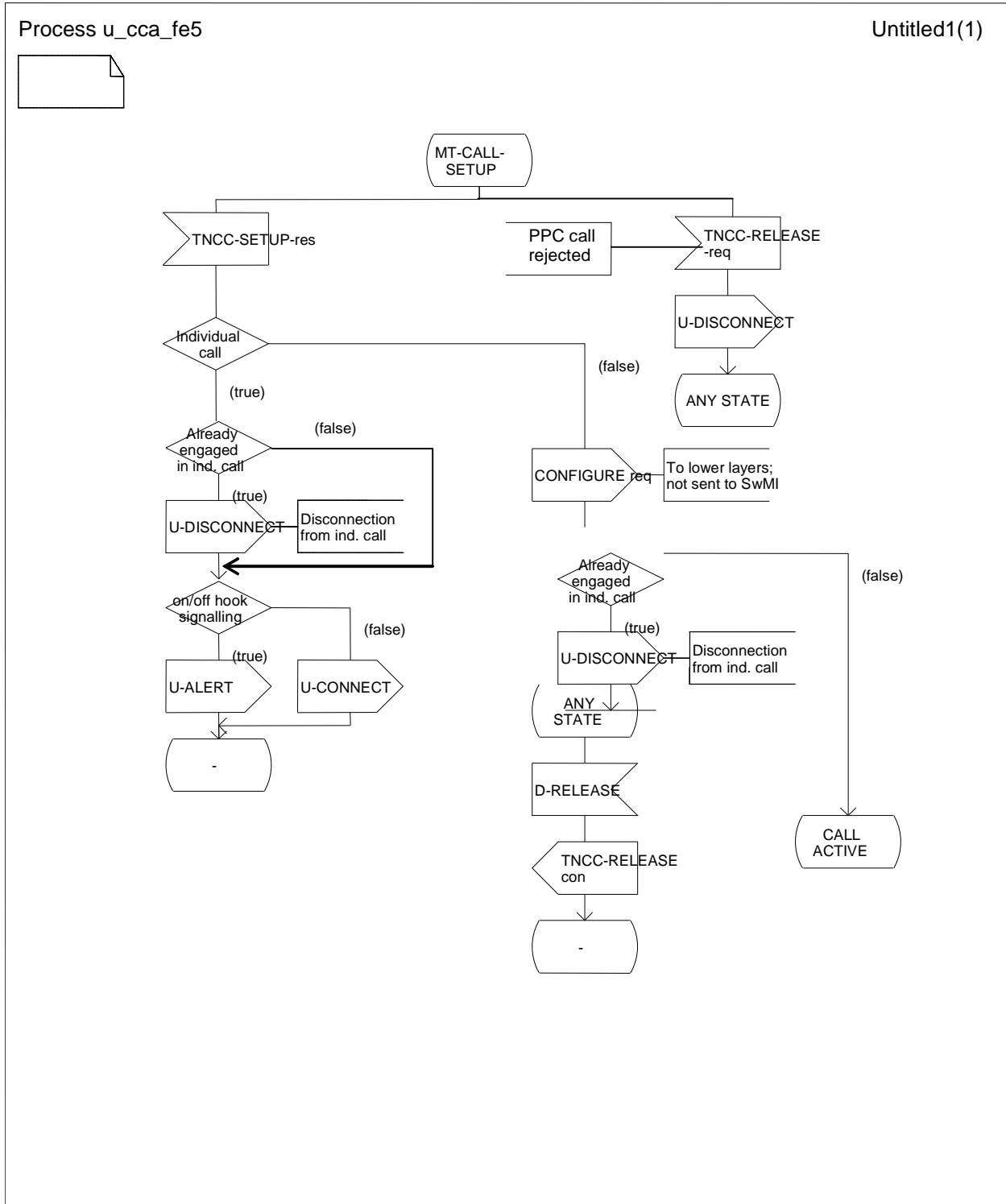

Figure 20: Process description of states MT-CALL-SETUP, CALL-ACTIVE and IDLE for CCA to which FE5 is collocated

## 6.10 Behaviour of FE8

### 6.10.1 Service interaction for FE8

Service interaction for FE8 is shown in figure 21.

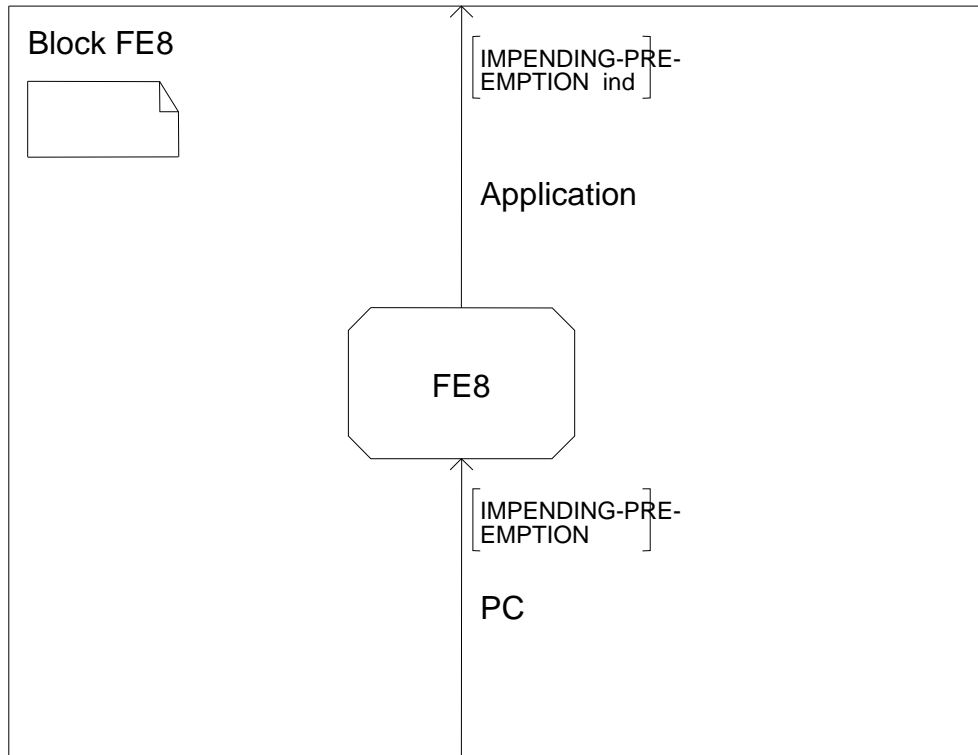
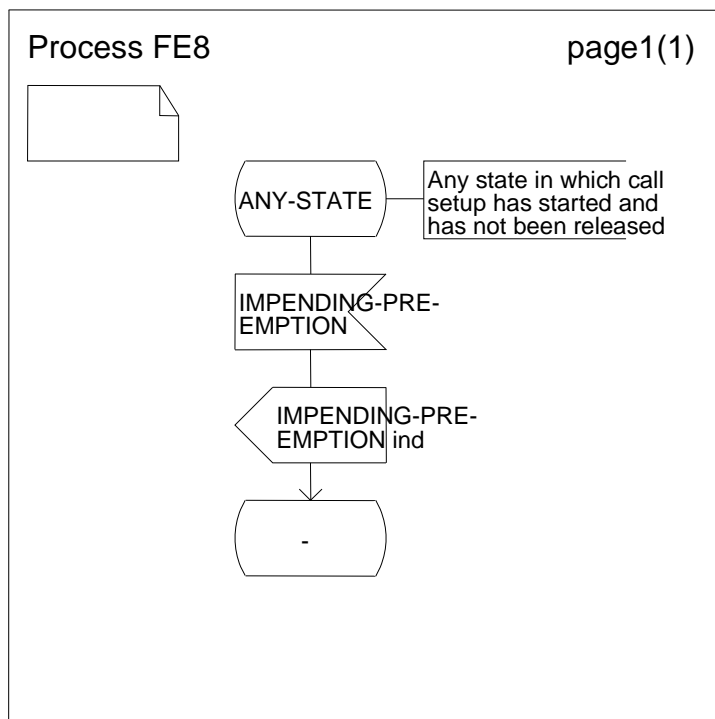

Figure 21: Service interaction for FE8

## 6.10.2 Process description for FE8

Process description for FE8 is shown in figure 22.

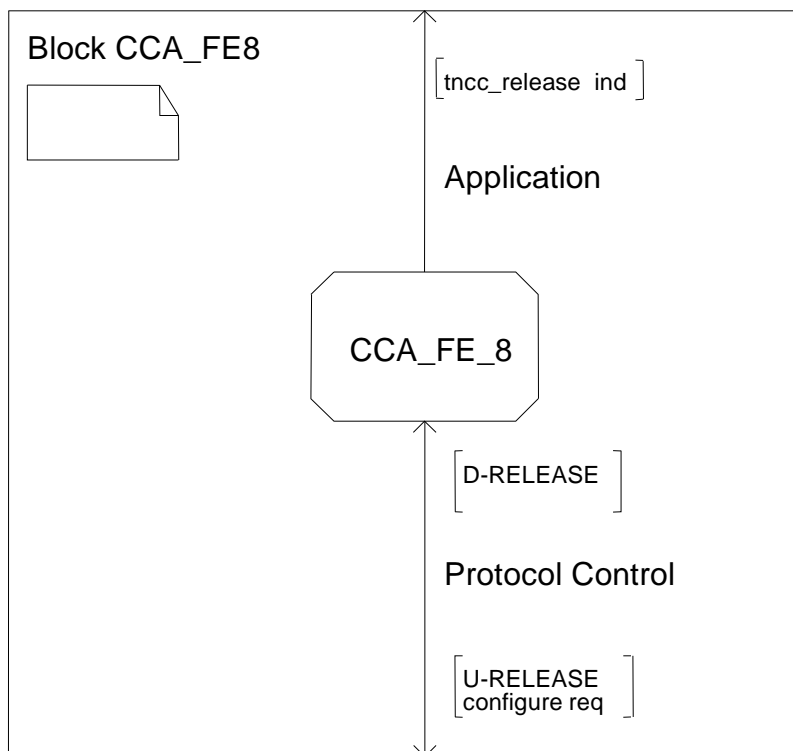

**Figure 22: Process description for FE8**

## 6.11 Behaviour of CCA to which FE8 is collocated

### 6.11.1 Service interaction for CCA to which FE8 is collocated

Service interaction for CCA to which FE8 is collocated is shown in figure 23.



**Figure 23: Service interaction for CCA to which FE8 is collocated**

## 6.11.2 Process description for CCA collocated to FE8

Process description for CCA collocated to FE8 is shown in figure 24.

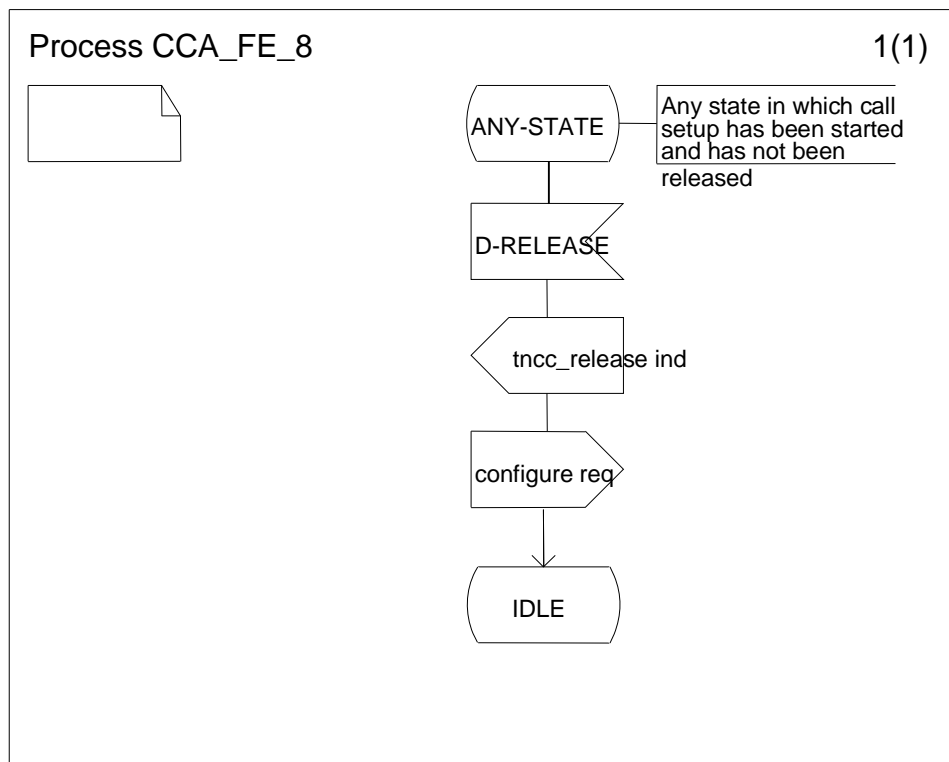

Figure 24: Process description for CCA collocated to FE8

## 6.12 Inter-working considerations

In order to enable the SS-PPC to extend to several TETRA systems over the ISI the FE2s in different TETRA systems shall be able to send and receive SS information flows over the ISI.

---

## Annex A (informative): Mapping of SS-PPC priorities received from the user application to priorities in basic service PDUs (for the MS)

The capability to save SS-PPC definitions in the MS is an optional feature within the MS and the recommendations given in the present document are applicable only for user A (calling party), if this optional feature is supported in the MS of user A.

FE1 should pass the SS-PPC definition requests to the user application in the MS. The user application should save the definition in the database in the MS. The user application should always accept the definition if the definition is made to the Individual TETRA Subscriber Identity (ITSI) related to the MS or to Group TETRA Subscriber Identity (GTSI), if the subscriber is member of the group. The user application should acknowledge the SS-PPC definition request, if an acknowledgement request was included in the definition request.

When the SS-PPC service is invoked to a call, the user application should give the correct SS-PPC priority value to layer 3. If defined, the SS-PPC definition should be applied in the following way:

- the SS-PPC definition for user A is applicable, when user A invokes an individual call;
- the SS-PPC definition for a group is applicable, when user A invokes a group call to the defined group identity and if user A is a member of the group.

The user application should allow the user to only request values that are allowed for the user. If the user is requesting a value that is not allowed for the user, the user application should replace the value with a correct value and indicate this to the user or bar the basic service request. However, if the service user requests emergency priority, the user application should always allow the value.

When CC receives the call priority value from the user application, it should not need to check the value. The Call Control sub-entity within layer 3 should include the priority into the Call priority parameter within SETUP PDU.

The SwMI sends the SS-PPC priority in the downlink messages to FE1 and FE5(s). FE1 and FE5 should pass the operated SS-PPC priority to the user application.

**NOTE:** As the operated SS-PPC priority can be different from the invoked SS-PPC priority, FE1 should pass the priority to the user application.

The user application should then accept the received priority and act upon it.

---

## Annex B (informative): Bibliography

- ETSI EN 300 392-11-16: "Terrestrial Trunked Radio (TETRA); Voice plus Data (V+D); Part 11: Supplementary services stage 2; Sub-part 16: Pre-emptive Priority Call (PPC)".

## Annex C (informative): Change requests

The present document contains changes since ETSI ETS 300 392-12-16 Ed.1 as presented in table C.1.

**Table C.1: Change requests**

No	CR vers.	Standard Version	Clauses affected	Title
001	APP	Ed. 1	4.4, 5.5.12	Emergency call user pre-emption
002	APP	Ed. 1	Many	Various editorial improvements
003	APP	Ed. 1	5.5.5	Information elements presence un-clearly defined in Pre-empted party information element
004	APP	Ed. 1	4.2.9, 5.4.9	WITHDRAW PDU encoding
005	APP	Ed. 1	4.2.1 to 4.2.12	Mandatory / optional definitions
006	10	1.2.1	5.4.12.1, 5.4.12.2 and 5.4.12.3	Correction of reference to Call priority element ( <i>WG3 approved 21.3.2022</i> )

---

## History

<b>Version</b>	<b>Date</b>	<b>Status</b>
Edition 1	September 2000	Publication as ETSI ETS 300 392-12-16 (Historical)
V1.2.1	September 2004	Publication
V1.3.1	July 2022	Publication as ETSI TS 100 392-12-16
V1.4.0	March 2026	ENAP process <span style="float: right;">AP 20260628: 2026-03-30 to 2026-06-29</span>
V1.4.1	July 2026	Publication