

**Terrestrial Trunked Radio (TETRA);
Voice plus Data (V+D);
Part 11: Supplementary services stage 2;
Sub-part 18: Barring of Outgoing Calls (BOC)**



Reference

DEN/TETRA-03A-11-18

Keywords

TETRA, supplementary service

ETSI

650 Route des Lucioles
F-06921 Sophia Antipolis Cedex - FRANCE

Tel.: +33 4 92 94 42 00 Fax: +33 4 93 65 47 16

Siret N° 348 623 562 00017 - NAF 742 C
Association à but non lucratif enregistrée à la
Sous-Préfecture de Grasse (06) N° 7803/88

Important notice

Individual copies of the present document can be downloaded from:

<http://www.etsi.org>

The present document may be made available in more than one electronic version or in print. In any case of existing or perceived difference in contents between such versions, the reference version is the Portable Document Format (PDF). In case of dispute, the reference shall be the printing on ETSI printers of the PDF version kept on a specific network drive within ETSI Secretariat.

Users of the present document should be aware that the document may be subject to revision or change of status. Information on the current status of this and other ETSI documents is available at <http://www.etsi.org/tb/status/>

If you find errors in the present document, send your comment to:
editor@etsi.fr

Copyright Notification

No part may be reproduced except as authorized by written permission.
The copyright and the foregoing restriction extend to reproduction in all media.

© European Telecommunications Standards Institute 2001.
All rights reserved.

Contents

Intellectual Property Rights	4
Foreword	4
1 Scope.....	5
2 References	5
3 Definitions and abbreviations	6
3.1 Definitions	6
3.2 Abbreviations.....	6
4 SS-BOC stage 2 specification	6
4.1 Functional model.....	6
4.1.1 Functional model description.....	6
4.1.2 Description of FEs	7
4.1.2.1 Affected user's FE, FE1	7
4.1.2.2 SS-BOC FE in the SwMI, FE2.....	8
4.1.2.3 Authorized user's FE, FE3.....	8
4.1.2.4 SS-BOC FE2 in visited SwMI.....	8
4.1.2.5 Called party's FE, FE5	8
4.2 Relationship with a basic and packet data service	9
4.3 Definition of information flows	9
4.3.1 Definition	9
4.3.1.1 DEFINE	10
4.3.1.2 DEFINE and DEFINE EXTERNAL ACK	11
4.3.1.3 DEFINE USER	11
4.3.1.4 DEFINE USER ACK.....	12
4.3.2 Interrogation	12
4.3.2.1 INTERROGATE	12
4.3.2.2 INTERROGATE ACK.....	13
4.3.3 Operation.....	14
4.3.3.1 CALL BARRED	14
4.4 Service primitives.....	15
4.5 Information flow sequences	15
4.5.1 Definition	16
4.5.2 Definition over ISI.....	16
4.5.3 Interrogation	17
4.5.4 Interrogation over ISI.....	18
4.5.5 Operation.....	18
4.5.6 Operation over ISI.....	18
4.6 FE actions	19
4.6.1 FE actions of FE1	19
4.6.2 FE actions of FE2	19
4.6.3 FE actions of FE3	19
4.6.4 FE actions of visited SwMI FE2	19
4.6.5 FE actions of FE5	20
4.7 Allocation of FEs to physical equipment.....	20
4.8 Inter-working considerations	20
4.8.1 General requirements	20
4.8.2 Management and operation	20
4.8.3 Migration.....	21
Annex A (informative): Bibliography.....	22
History	23

Intellectual Property Rights

IPRs essential or potentially essential to the present document may have been declared to ETSI. The information pertaining to these essential IPRs, if any, is publicly available for **ETSI members and non-members**, and can be found in ETSI SR 000 314: *"Intellectual Property Rights (IPRs); Essential, or potentially Essential, IPRs notified to ETSI in respect of ETSI standards"*, which is available from the ETSI Secretariat. Latest updates are available on the ETSI Web server (<http://www.etsi.org/ipr>).

Pursuant to the ETSI IPR Policy, no investigation, including IPR searches, has been carried out by ETSI. No guarantee can be given as to the existence of other IPRs not referenced in ETSI SR 000 314 (or the updates on the ETSI Web server) which are, or may be, or may become, essential to the present document.

Foreword

This European Standard (Telecommunications series) has been produced by ETSI Project Terrestrial Trunked Radio (TETRA), and is now submitted for the Vote phase of the ETSI standards Two-step Approval Procedure.

The present document had been submitted to Public Enquiry as ETS 300 392-11-18. During the processing for Vote it was converted into an EN.

The present document is part 11, sub-part 18 of a multi-part deliverable covering Voice plus Data (V+D), as identified below:

- Part 1: "General network design";
- Part 2: "Air Interface (AI)";
- Part 3: "Interworking at the Inter-System Interface (ISI)";
- Part 4: "Gateways basic operation";
- Part 5: "Peripheral Equipment Interface (PEI)";
- Part 6: "Line connected Station (LS)";
- Part 7: "Security";
- Part 9: "General requirements for supplementary services";
- Part 10: "Supplementary services stage 1";
- Part 11: "Supplementary services stage 2";**
- Part 12: "Supplementary services stage 3";
- Part 13: "SDL model of the Air Interface (AI)";
- Part 14: "Protocol Implementation Conformance Statement (PICS) proforma specification";
- TS 100 392-15: "TETRA frequency bands, duplex spacings and channel numbering".

Proposed national transposition dates	
Date of latest announcement of this EN (doa):	3 months after ETSI publication
Date of latest publication of new National Standard or endorsement of this EN (dop/e):	6 months after doa
Date of withdrawal of any conflicting National Standard (dow):	6 months after doa

1 Scope

The present document defines the stage 2 specification of the Supplementary Service Barring of Outgoing Calls (SS-BOC) for the Terrestrial Trunked Radio (TETRA) as provided by European operators.

SS-BOC enables barring restriction for outgoing calls to be set. SS-BOC specifies the definition, interrogation and operation of the supplementary service. The Switching and Management Infrastructure (SwMI) applies the SS-BOC definitions when the restricted user requests an outgoing service.

The SS-BOC actions are defined for the SwMI, for the Mobile Station (MS) and for the Line Station (LS). The SS-BOC information flows may be delivered over the Inter-System Interface (ISI). SS-BOC may also be invoked for services, e.g. calls, within one TETRA system or for services that extend over the ISI to several TETRA systems.

Man-Machine Interface (MMI) and charging principles are outside the scope of the present document.

Stage 2 describes the functional capabilities of the Supplementary Service introduced in stage 1 description. Stage 2 identifies the functional capabilities for the management and operation of the service in the SwMI, in the MS and in the LS. Stage 2 describes also the information flows exchanged between these entities and the flows sent over the ISI.

NOTE: The stage 2 description is followed by the stage 3 description, which specifies the encoding rules for the information flows and process behaviour for the different entities in the SwMI, in the MS and in the LS.

Aspects relating to all supplementary services are detailed in EN 300 392-9 [6].

2 References

The following documents contain provisions which, through reference in this text, constitute provisions of the present document.

- References are either specific (identified by date of publication and/or edition number or version number) or non-specific.
- For a specific reference, subsequent revisions do not apply.
- For a non-specific reference, the latest version applies.

- [1] ETSI EN 300 392-2: "Terrestrial Trunked Radio (TETRA); Voice plus Data (V+D); Part 2: Air Interface (AI)".
- [2] ETSI EN 300 392-12-18: "Terrestrial Trunked Radio (TETRA); Voice plus Data (V+D); Part 12: Supplementary services stage 3; Sub-part 18: Barring of Outgoing Calls (BOC)".
- [3] ETSI EN 300 392-11-19: "Terrestrial Trunked Radio (TETRA); Voice plus Data (V+D); Part 11: Supplementary services stage 2; Sub-part 19: Barring of Incoming Calls (BIC)".
- [4] ETSI ETS 300 392-10-1: "Terrestrial Trunked Radio (TETRA); Voice plus Data (V+D); Part 10: Supplementary services stage 1; Sub-part 1: Call identification".
- [5] ETSI ETS 300 392-10-6: "Terrestrial Trunked Radio (TETRA); Voice plus Data (V+D); Part 10: Supplementary services stage 1; Sub-part 6: Call Authorized by Dispatcher (CAD)".
- [6] ETSI EN 300 392-9: "Terrestrial Trunked Radio (TETRA); Voice plus Data (V+D); Part 9: General requirements for supplementary services".

3 Definitions and abbreviations

3.1 Definitions

For the purposes of the present document, the following terms and definitions apply:

affected user: user who has outgoing calls barred

authorized user: user who is permitted to bar outgoing calls on affected user's behalf

packet data service: packet mode data service, see EN 300 392-2, clause 28

3.2 Abbreviations

For the purposes of the present document, the following abbreviations apply:

CC	Call Control functional entity
CCA	Call Control functional entity Agent
FE	Functional Entity
ISI	Inter-System Interface
LS	Line Station
MS	Mobile Station
SDL	(Functional) Specification and Description Language
SS-BOC	Supplementary Service Barring of Outgoing Calls
SwMI	Switching and Management Infrastructure
TETRA	Terrestrial Trunked Radio
V+D	Voice plus Data

4 SS-BOC stage 2 specification

4.1 Functional model

4.1.1 Functional model description

The functional model shall comprise the following Functional Entities (FEs):

FE1 affected user's (calling party's) FE for SS-BOC in MS/LS;

FE2 SS-BOC FE in SwMIs;

FE3 authorized party's FE for SS-BOC in MS/LS;

FE5 called party's FE for SS-BOC in MS/LS;

CC call control functional entity in SwMI;

CCA call control functional entity agent in MS/LS.

NOTE: CC/CCA refers to any basic service sub-entity or packet mode data service entity, which shall be used in conjunction with SS-BIC.

The following relationships shall exist between these FEs:

- ra between FE1 and FE2;
- rb between FE2s in different SwMI;
- rc between FE2 and FE3;
- rd between FE2s in different SwMI;
- re between FE2 and visited SwMI FE2;
- rf between FE2 and visited SwMI FE2;
- rg between FE2 and FE5.

Figures 1 and 2 show these FEs and their relationships. Figure 1 gives the functional model for the management part and figure 2 gives the functional model for the operational part.

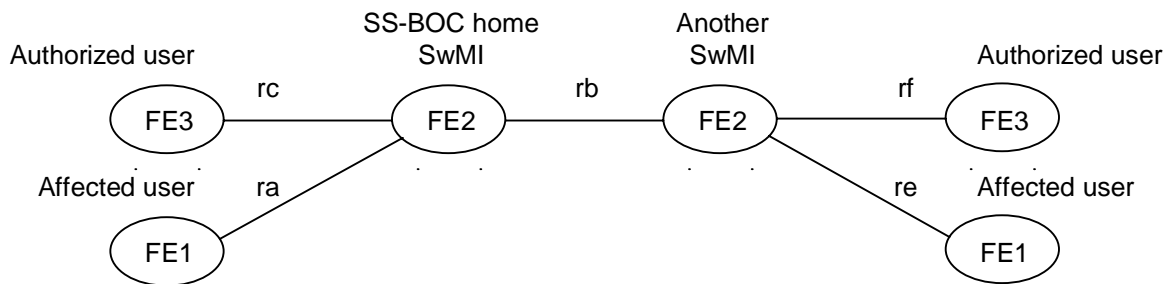
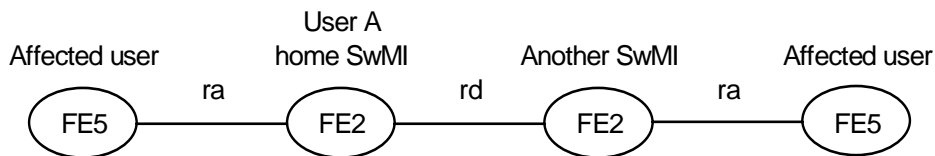

Figure 1: Functional model for the management part



NOTE: Called party FE5 does not receive any indication of the barred service.

Figure 2: Functional model for the operational part

4.1.2 Description of FEs

4.1.2.1 Affected user's FE, FE1

The functional tasks of FE1 shall be the following:

- upon reception of an SS-BOC definition indication from the SwMI, if FE1 supports the information procedure, FE1 shall inform the user application;
- upon reception of an SS-BOC interrogation request from the user application, FE1 shall send the interrogation request to the SwMI;
- upon reception of an SS-BOC interrogation response from the SwMI, FE1 shall inform the user application;
- upon reception of a barring indication from the SwMI, FE1 shall inform the user application of the barring of the basic or packet data service.

4.1.2.2 SS-BOC FE in the SwMI, FE2

The functional tasks of FE2 shall be the following in the home system of the affected user:

- upon reception of an SS-BOC definition request from FE3, FE2 shall save the definition in the SwMI and acknowledge the request to FE3. FE2 shall send the SS-BOC definition indication(s) to FE1(s), if requested by FE3 in the definition request;
- upon reception of an SS-BOC interrogation request from FE1 or FE3, FE2 shall send the interrogation response to FE1 or FE3 respectively;
- upon reception of an outgoing basic or packet data service request from FE1, for which the SS-BOC restrictions apply, FE2 shall bar the request and inform FE1 about the barring.

The functional tasks of FE2 shall be the following in the visited system of the affected user:

- upon reception of an SS-BOC interrogation request from FE1 or FE3, FE2 shall send the interrogation response to FE1 or FE3 respectively, if the visited system knows the SS-BOC definition;
- upon reception of an outgoing basic or packet data service request from FE1, for which the SS-BOC restrictions apply, FE2 shall bar the request and inform FE1 about the barring, if the visited system knows the SS-BOC definition;
- upon reception of an outgoing basic or packet data service request from FE1, FE2 may send the service request to the home system and bar the call, if indicated by the home system. FE2 shall inform FE1 about the barring of the service.

4.1.2.3 Authorized user's FE, FE3

The functional tasks of FE3 shall be the following:

- upon reception of an SS-BOC definition request from the user application, FE3 shall send the request to the SwMI;
- upon reception of an SS-BOC definition acknowledgement from the SwMI, FE3 shall inform the user application of the acknowledgement;
- upon reception of an SS-BOC interrogation request from the user application, FE3 shall send the request to the SwMI;
- upon reception of an SS-BOC interrogation response from the SwMI, FE3 shall inform the user application of the response.

4.1.2.4 SS-BOC FE2 in visited SwMI

The visited SwMI FE2 shall have as its functional tasks the following tasks, refer EN 300 392-9 [6]:

- upon reception of an SS-BOC information flow over the ISI from home SwMI FE2 to FE1 or to FE3, the visited SwMI FE2 shall transport the flow to FE1 or to FE3 respectively;
- upon reception of an SS-BOC information flow from FE1 or FE3 to home SwMI FE2, the visited SwMI FE2 shall transport the flow over the ISI to home SwMI FE2.

4.1.2.5 Called party's FE, FE5

FE5 does not have any actions related to SS-BOC. The FE is only presented to clarify the service behaviour.

4.2 Relationship with a basic and packet data service

FE2 shall be collocated to CC in the SwMI.

FE1 shall be collocated to CCA.

The relationship with basic and packet data service is shown in figure 3.

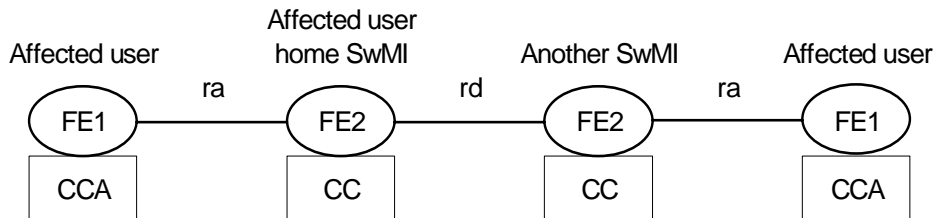

NOTE: FE5 does not receive any indication of the barred service.

Figure 3: Relationships with FEs and CCs/CCAs

4.3 Definition of information flows

In the tables listing the service elements in information flows, the column header "Type" indicates which of the service elements are Mandatory (M), Conditional (C) or Optional (O). If type is conditional, the conditions are stated.

The listed service elements shall specify whether the information of each element is included in the flow.

NOTE: It is possible that there is not a one-to-one mapping between a service element and Protocol Data Unit (PDU) or primitive elements described in EN 300 392-12-18 [2].

4.3.1 Definition

The authorized user shall be able to define barring restrictions on affected user's behalf. The SS-BOC definitions shall restrict outgoing services.

One restricted identity shall refer to an individual subscriber identity.

NOTE 1: Supplementary Service Barring of Incoming Calls (SS-BIC) is used to set restrictions for group identities, see EN 300 392-11-19 [3].

The authorized user shall only be allowed to define SS-BOC for subscriber identities which home system is the same as the authorized user's home system.

One definition request shall be made to restrict:

- one subscriber identity;
- a range of subscriber identities; or
- a list of subscriber identities.

The different barring restrictions shall comprise of one or more of the following:

- all or certain outgoing services outside closed user groups;
- all or certain outgoing services types;
- restricted destination addresses for outgoing services.

The definition may contain exceptions to the barred destination addresses.

The authorized user may request the SwMI to send the SS-BOC definition to the affected user for information.

The SS-BOC definition made for an individual subscriber should be sent over the ISI as part of the mobility management functions, when the subscriber migrates to the system.

NOTE 2: It is possible that a TETRA system is not able to receive the SS-BOC definitions over the ISI.

NOTE 3: It is possible that a TETRA system uses other mechanisms to determine the outgoing service restrictions for migrated subscribers within the system. These mechanisms are outside the scope of the present document.

4.3.1.1 DEFINE

The DEFINE and DEFINE EXTERNAL information flows shall be applied for the relationship rc and it shall be sent from FE3 to FE2. The flow shall also be applicable for the relationship rf and rb and it shall be sent from FE3 to home SwMI FE2 via visited SwMI FE2, if FE3 is in visited system.

If any of the given restrictions apply, the basic service is barred.

FE3 shall send the request to define SS-BOC to the SwMI for the given subscriber identity or identities.

The contents of the information flows are shown in table 1.

Table 1: DEFINE and DEFINE EXTERNAL information flow contents

Element	Type
Affected user identity(ies)	M, note 1
Outgoing services outside closed user groups restricted	C, note 2
Restricted outgoing service types	C, notes 2 and 3
Restricted destination address list	C, notes 2 and 4
Exceptions to restricted destination address list	O, note 5
Definition sent to affected user(s)	M, note 6
Acknowledgement from affected users	M, note 7
NOTE 1: The element specifies the TETRA Subscriber Identity(ies) on which behalf the SS-BOC definition is made. One subscriber identity, a range or set of subscriber identities are given.	
NOTE 2: At least one of the following elements shall be given in the definition request: <ul style="list-style-type: none"> - outgoing services outside closed user group restricted; - restricted outgoing services; - restricted destination address list. 	
NOTE 3: The element indicates the restricted service types.	
NOTE 4: The element is a list of restricted destination addresses for outgoing services. A restricted address comprises of a variable-length digit string. The destination address of a requested service, which starts with the restricted digit string, shall be barred.	
NOTE 5: The element is a list of exceptions to the restricted destination addresses for outgoing services. A restricted address comprises of a variable-length digit string. If the digit string for exception destination address is longer than the restricted destination address, the exception destination address overrides and the requested service is allowed.	
NOTE 6: The element indicates if the SS-BOC definition indication is sent to affected user(s) for information.	
NOTE 7: The element indicates if the affected user(s) is requested to acknowledge the reception of the definition indication.	

4.3.1.2 DEFINE and DEFINE EXTERNAL ACK

The DEFINE and DEFINE EXTERNAL ACK information flows shall be applied for the relationship rc and shall be sent from FE2 to FE3. The flow shall also be applicable for the relationship rb and rf and it shall be sent from home SwMI FE2 to FE3 via visited SwMI FE2, if FE3 is in visited system.

FE2 shall send the flow to acknowledge the SS-BOC definition request.

NOTE: The Definition result element does not give information whether the affected users have been successfully informed; the interrogation is used to request this, if needed.

The contents of the information flow are shown in table 2.

Table 2: DEFINE and DEFINE EXTERNAL ACK information flow contents

Element	Type
Affected user identity(ies)	M
Definition result	M, note
NOTE: This element indicates the definition result: - defined; - not defined and the applicable error code.	

4.3.1.3 DEFINE USER

The DEFINE USER information flow shall be applied for the relationship ra and shall be sent from FE2 to FE1. The flow shall also be applicable for the relationship rb and re and it shall be sent from home SwMI FE2 to FE1 via visited SwMI FE2, if FE1 is in visited system.

FE2 shall send the flow to inform affected user(s) of the SS-BOC definition. FE2 shall send the information flow, if requested by the authorized user, see table 1 Definition sent to affected user(s).

The contents of the information flow are shown in table 3.

Table 3: DEFINE USER information flow contents

Element	Type
Outgoing services outside closed user group restricted	C, note 1
Restricted outgoing service types	C, notes 2 and 3
Restricted destination address list	C, notes 2 and 3
Exceptions to restricted destination address list	O, note 4
Acknowledgement from affected user	M, note 5
NOTE 1: At least one of the following elements shall be given in the definition indication: - outgoing services outside closed user group restricted; - restricted outgoing service types; - restricted destination address list.	
NOTE 2: The element indicates the restricted basic and packet data service types.	
NOTE 3: The element is a list of restricted destination addresses for outgoing services. A restricted address comprises of a variable-length digit string. The destination address of a requested service, which starts with the restricted digit string, shall be barred.	
NOTE 4: The element is a list of exceptions to the restricted destination addresses for outgoing services. A restricted address comprises of a variable-length digit string. If the digit string for exception destination address is longer than the restricted destination address, the exception destination address overrides and the requested service is allowed.	
NOTE 5: The element indicates if the affected user(s) is requested to acknowledge the reception of the definition indication.	

4.3.1.4 DEFINE USER ACK

The DEFINE USER ACK information flow shall be applied for the relationship ra and shall be sent from FE1 to FE2. The flow shall also be applicable for the relationship re and rb and it shall be sent from FE1 to home SwMI FE2 via visited SwMI FE2, if FE1 is in visited system.

FE1 shall send the flow to acknowledge the reception of the SS-BOC definition indication, if the acknowledgement was requested, see table 3 Acknowledgement from affected user(s).

The contents of the information flow are shown in table 4.

Table 4: DEFINE USER ACK information flow contents

Element	Type
Distribution result	M, note
NOTE: This element indicates the definition indication result:	
- successfully received;	
- unsuccessfully received and the applicable error code.	

4.3.2 Interrogation

Authorized user may interrogate the SS-BOC definitions saved in the SwMI. Affected user may be authorized to interrogate his own SS-BOC definitions.

If SS-BOC is interrogated in the home system of the affected user, the home system shall give the response to the interrogation request.

If SS-BOC is interrogated in a system that is a visited system in relation to the affected user, the visited system shall give the response to the interrogation request, if it has the SS-BOC definition. If a visited system does not have the SS-BOC definition or if it is otherwise not able to provide the response to the interrogation, the visited system shall send the interrogation request to the home system, which shall return the response to the visited system.

NOTE: Normally, the visited system has the SS-BOC definition, if the affected user has migrated to the visited system.

4.3.2.1 INTERROGATE

The INTERROGATE information flow shall be applied for:

- the relationship ra and shall be sent from FE1 to FE2;
- the relationship rc and sent from FE3 to FE2;
- the relationship re and rb and it may be sent from FE1 to home SwMI FE2 via visited SwMI FE2, if FE1 is in visited system;
- the relationship rf and rb and it may be sent from FE3 to home SwMI FE2 via visited SwMI FE2, if FE3 is in visited system.

FE1 or FE3 shall send the flow to interrogate the SS-BOC definition.

The contents of the information flow are shown in table 5.

Table 5: INTERROGATE information flow contents

Element	Type
Affected user identity(ies)	M, note
NOTE: The element specifies the TETRA subscriber identity(ies) against which SS-BOC have been interrogated.	

4.3.2.2 INTERROGATE ACK

The INTERROGATE ACK information flow shall be applied for:

- the relationship ra and shall be sent from FE2 to FE1;
- the relationship rc and sent from FE2 to FE3;
- the relationship rb and re and it may be sent from home SwMI FE2 to FE1 via visited SwMI FE2, if FE1 is in visited system;
- the relationship rb and rf and it may be sent from home SwMI FE2 to FE3 via visited SwMI FE2, if FE3 is in visited system.

FE2 shall send the information flow as a response to the SS-BOC interrogation.

The contents of the information flow are shown in table 6.

Table 6: INTERROGATE ACK information flow contents

Element	Type
Affected user identity(ies)	M, note 1
Interrogation result	M, note 2
Outgoing services outside closed user group restricted	O, note 3
Restricted outgoing service types	O, note 3
Restricted destination address list	O, note 4
Exceptions to restricted destination address list	O, note 5
Delivery status to affected user(s)	O, note 6
<p>NOTE 1: The element specifies the TETRA subscriber identity(ies) against which the SS-BOC interrogation is made. One subscriber identity, a range or set of subscriber identities are given.</p> <p>NOTE 2: This element indicates the interrogation result, for example:</p> <ul style="list-style-type: none"> - SS-BOC defined for the given Affected user identity(ies); - SS-BOC not defined for the given Affected user identity(ies); - interrogation rejected and the error code. <p>The optional parameters in the INTERROGATE ACK are only used if the Interrogation result indicates that the definition has been made to the SwMI.</p> <p>NOTE 3: The element indicates the restricted basic and packet data service types.</p> <p>NOTE 4: The element is a list of restricted destination addresses for outgoing services. A restricted address comprises of a variable-length digit string. A service requested by subscriber, which address starts with the restricted digit string, shall be barred.</p> <p>NOTE 5: The element is a list of exceptions to the restricted destination addresses for outgoing services. A restricted address comprises of a variable-length digit string. If the digit string for exception destination address is longer than the restricted destination address, the exception destination address overrides and the requested service is allowed.</p> <p>NOTE 6: If the element is present, it indicates that the SS-BOC definition has been sent to affected user(s) for information. If the restricted identity is a group, the affected users are the members of the group.</p>	

4.3.3 Operation

The SS-BOC service operation occurs when FE2 bars an outgoing service requested by the affected user.

The SS-BOC operation shall bar services requested by the affected user, if the requested service is in accordance with any of the restrictions in the SS-BOC definition of the affected user:

- if calls requested to outside a closed user group are restricted and the called party is outside the given user group;
- if the called party address is restricted; or
- if the requested service type, e.g. circuit mode speech call, is restricted.

NOTE 1: Supplementary Service Call Diversion (SS-CD), ETS 300 392-10-1 [4], does not have any impact on the SS-BOC. In other words, if the SS-BOC restrictions of the affected user apply to any basic service, the basic service is barred, even if the called party has diversion activated. The SS-BOC restrictions apply also, if the affected user is the called party and he has his basic services diverted.

NOTE 2: Supplementary Service Call Authorized by Dispatcher (SS-CAD), ETS 300 392-10-6 [5], may be used to enable a dispatcher to allow a barred basic service to proceed.

If the SS-BOC definition is applicable to a service request, FE2 shall bar the request within the system:

- in the home system of the affected user;
- in a visited system, if the SS-BOC definition is transported to the visited system.

NOTE 3: The visited system should have the SS-BOC definition for an individual subscriber, if the subscriber has migrated to that system.

FE2 in the home system of the restricted identity shall bar the request, if FE2 in visited system sends the service request to FE2 in the home system. FE2 in visited system cannot bar the call, if:

- FE1 is located in a system to which the SS-BOC definitions have not been transported; or
- the system where FE1 is located does not support SS-BOC.

4.3.3.1 CALL BARRED

The CALL BARRED information flow shall be applied for the relationship ra and shall be sent from FE2 to FE1. The flow shall also be applied for the relationship rd and ra and it may be sent from FE2 to FE1 via another FE2.

FE2 shall send the information flow to FE1 to indicate that the service request has been rejected due to SS-BOC.

The contents of the information flow are shown in table 7.

Table 7: CALL BARRED information flow contents

Element	Type
Rejection reason (SS-BOC invoked)	M

NOTE: Also NOTIFICATION information flow can be used, refer to EN 300 392-9 [6].

4.4 Service primitives

This clause lists SS-BOC service primitives used to invoke or being a result of information flow sequences. The SS-BOC service primitives are defined in EN 300 392-12-18 [2], clause 4.3 and the basic call service primitives are defined in EN 300 392-2 [1], clause 11.

The SS-BOC service primitives for the affected user (FE1) at the MS/LS TNSS-SAP may be:

- CALL BARRED indication;
- DEFINE USER indication;
- DEFINE EXTERNAL USER indication;
- INTERROGATE request;
- INTERROGATE indication; and
- NOTIFICATION indicator.

The SS-BOC service primitives for the authorized user (FE3) at the MS/LS TNSS-SAP shall be:

- DEFINE request;
- DEFINE indication;
- DEFINE EXTERNAL request;
- DEFINE EXTERNAL indication;
- INTERROGATE request; and
- INTERROGATE indication.

4.5 Information flow sequences

Signalling procedures shall be provided in support of the information flow sequences showed below. In addition, signalling procedures shall be provided to cover other sequences arising from error situations, interactions with basic call, interactions with other supplementary services, different topologies, etc.

In the figures, the SS-BOC information flows are represented by solid arrows and basic call information flows are represented by broken arrows. An ellipse embracing two information flows indicates that the two information flows occur together. Within a column representing the SS-BOC functional entity, the numbers refer to functional entity actions listed in clause 4.5.

No timers are used in the figures.

NOTE: The information flow sequences are examples and they may not cover all possible variations of the service.

4.5.1 Definition

Figure 4 shows the information flow sequence for the SS-BOC definition within the home SwMI.

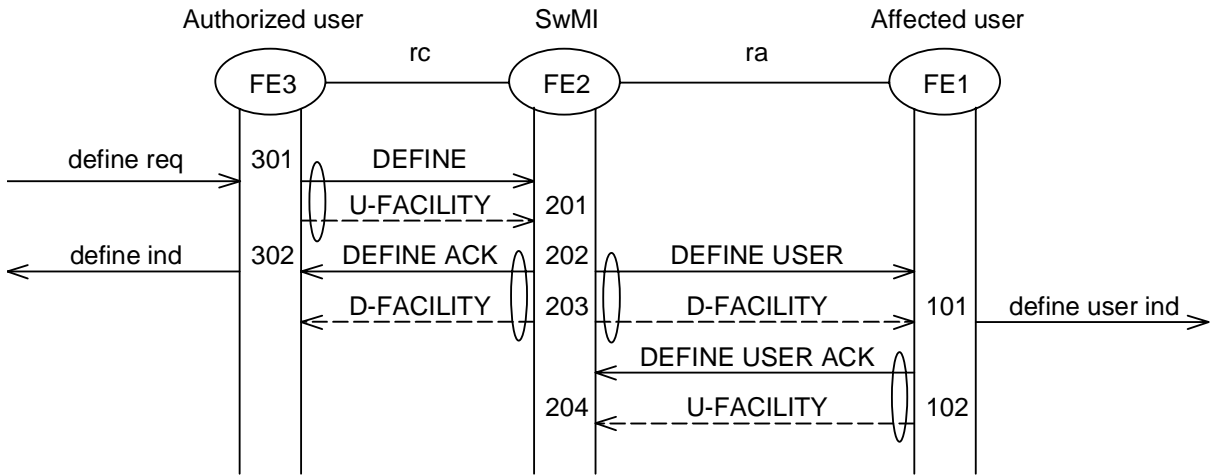

NOTE 1: The sending of DEFINE USER and DEFINE USER ACK in stage 3 is optional.
 NOTE 2: The same information flow figure applies to DEFINE EXTERNAL, DEFINE EXTERNAL USER, DEFINE ACK and DEFINE USER ACK.

Figure 4: Definition of SS-BOC

4.5.2 Definition over ISI

Figures 5 and 6 show the information flow sequence for the SS-BOC definition requested over the ISI.

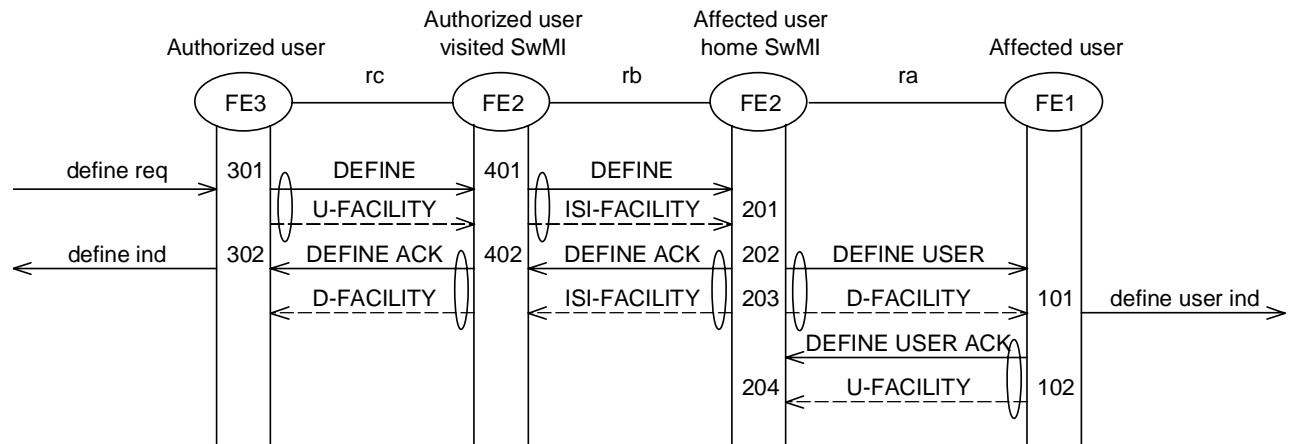

NOTE 1: The sending of DEFINE USER and DEFINE USER ACK is optional.
 NOTE 2: The same information flow figure applies to DEFINE EXTERNAL, DEFINE EXTERNAL USER, DEFINE ACK and DEFINE USER ACK.

Figure 5: Definition of SS-BOC over the ISI, authorized user in a visited SwMI

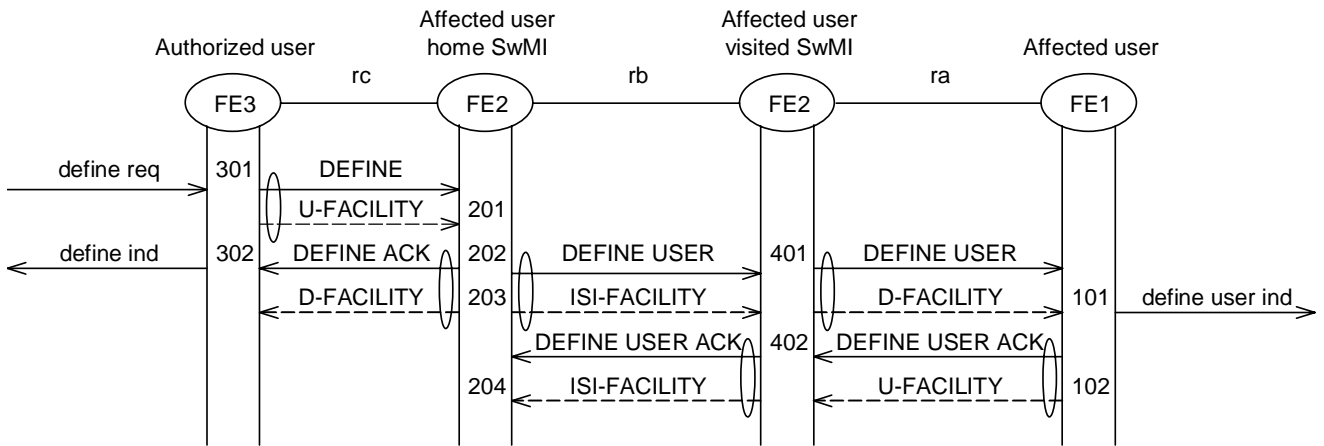

NOTE 1: The sending of DEFINE USER and DEFINE USER ACK is optional.

NOTE 2: The same information flow figure applies to DEFINE EXTERNAL; DEFINE EXTERNAL USER, DEFINE ACK and DEFINE USER ACK.

Figure 6: Definition of SS-BOC over the ISI, affected user in a visited SwMI

4.5.3 Interrogation

Figure 7 shows the information flow sequence for the SS-BOC interrogation within the home system. Figure 7 should also be applicable for visited system to which the SS-BOC definition has been transported.

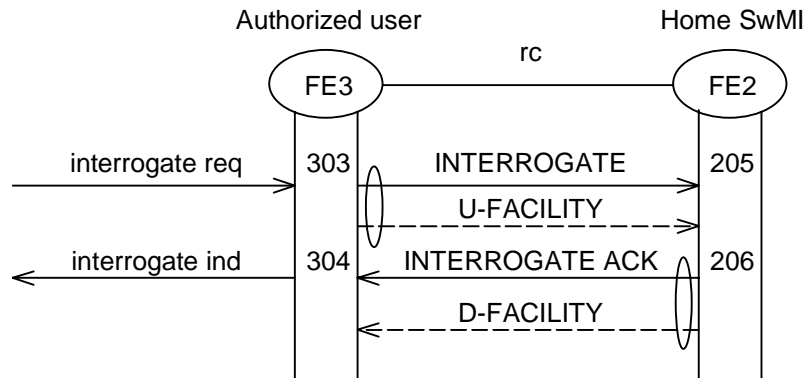

NOTE: Affected user may also interrogate SS-BOC.

Figure 7: Interrogation of SS-BOC

4.5.4 Interrogation over ISI

Figure 8 shows the information flow sequence for the SS-BOC interrogation over the ISI.

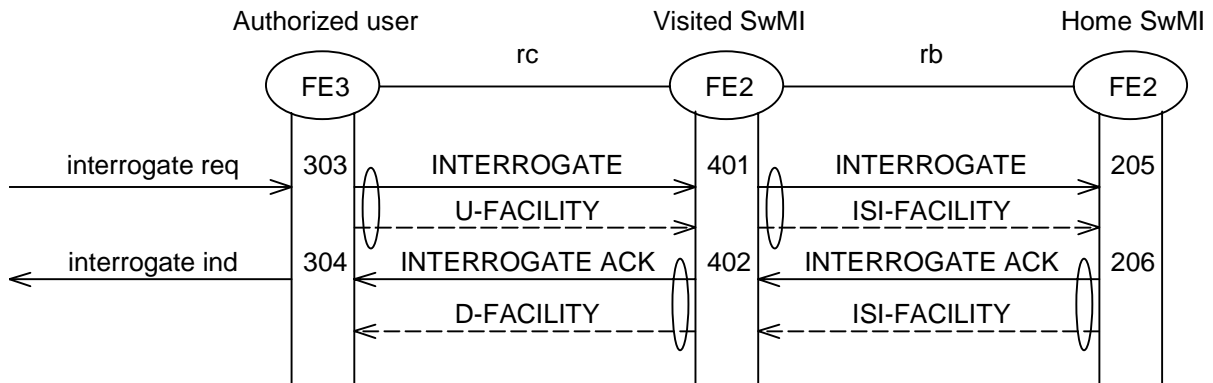

NOTE: Affected user may also interrogate SS-BOC over the ISI.

Figure 8: Interrogation of SS-BOC over the ISI

4.5.5 Operation

Figure 9 shows the information flow sequence for the SS-BOC operation within one SwMI. The SwMI shall be the home SwMI or a visited SwMI to which the SS-BOC definition has been transported.

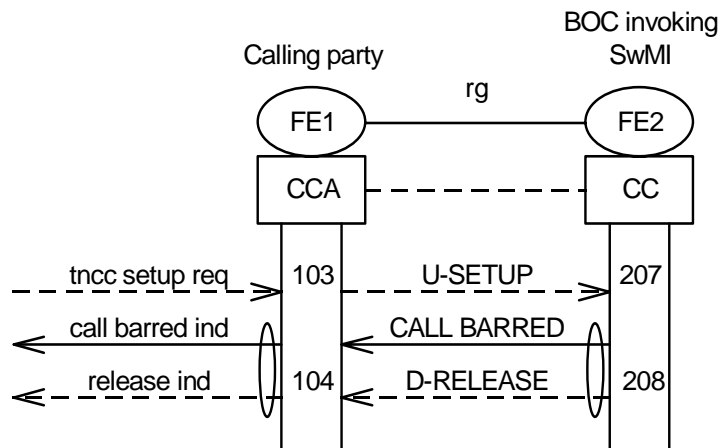

Figure 9: Operation of SS-BOC

4.5.6 Operation over ISI

Not applicable as the barring is operated in the originating SwMI.

4.6 FE actions

4.6.1 FE actions of FE1

- 101 Upon reception of the SS-BOC definition indication, FE1 shall inform the user of the indication.
- 102 FE1 shall acknowledge the SS-BOC definition indication to FE2, if the acknowledgement was requested in the indication.
- 103 When FE1 receives a call invocation request from the user, FE1 shall send it to FE2.
- 104 Upon reception of call invocation rejection due to SS-BOC, FE1 shall indicate the rejection reason to the user.

4.6.2 FE actions of FE2

- 201 Upon reception of the SS-BOC definition request, FE2 shall verify that the request is authorized and parameters valid. If FE2 accepts the definition, FE2 shall save the definition into the SwMI.
- 202 FE2 shall acknowledge the definition request to FE3.
- 203 FE2 shall send the SS-BOC definition indication to FE1, if FE2 accepted the SS-BOC definition request and if FE3 requested the sending in the definition request.
- 204 Upon reception of the SS-BOC definition indication acknowledgement from FE1, FE2 shall record the acknowledgement.
- 205 Upon reception of the SS-BOC interrogation request, FE2 shall verify that the request is authorized and parameters valid.
- 206 FE2 shall send the interrogation response to FE3.
- 207 Upon reception of a service request, FE2 shall bar the request if in accordance with the SS-BOC restriction.
- 208 FE2 shall indicate the barring to FE1.
- 209 If the service request is not barred in the visited system, the request may be sent to the home system.
- 210 Upon reception of the barring indication from home system, FE2 shall bar the call.

4.6.3 FE actions of FE3

- 301 Upon reception of the SS-BOC definition request from the user, FE3 shall send the request to FE2.
- 302 Upon reception of an acknowledgement to a SS-BOC definition request from FE2, FE3 shall indicate the acknowledgement to the user.
- 303 Upon reception of the SS-BOC interrogation request from the user, FE3 shall send the request to FE2.
- 304 Upon reception of a response to a SS-BOC interrogation request from FE2, FE3 shall indicate the response to the user.

4.6.4 FE actions of visited SwMI FE2

- 401 When the visited SwMI FE2 receives an SS-BOC information flow from FE3, it shall send the flow to FE2 in the FE3's home system.
- 402 When the visited SwMI FE2 receives an SS-BOC information flow from FE2 in FE3's home system, it shall send the flow to FE3.

Refer EN 300 392-9 [6] for further details.

4.6.5 FE actions of FE5

No actions for FE5.

4.7 Allocation of FEs to physical equipment

The allocation of FEs to physical equipment is described in table 8. Other means of SS-BOC management are optional and outside the scope of the present document.

Table 8: Allocation of FEs to Physical Equipment (PE)

Equipment/Function	SS-BOC Management	SS-BOC Operation
SwMI	FE3/FE2 (Optional, note 1)	FE2 (Mandatory)
MS/LS	FE3 (Optional, note 1),	FE1 (Optional, note 2)
NOTE 1: Support of the SS-BOC management is optional. If supported the FE is mandatory.		
NOTE 2: The SS-BOC shall operate even is the calling entity does not support FE1 functional entity.		

4.8 Inter-working considerations

4.8.1 General requirements

The SS-BOC may extend to several TETRA networks. The requirements for the inter-working over the ISI are:

- deliver and receive the SS-BOC definition information over the ISI;
- deliver and receive the SS-BOC interrogation information over the ISI (optional);
- barring of requested services within the system based on the SS-BOC definitions received over the ISI;
- barring of services in the home system and indicating this to the visited SwMI over the ISI;
- barring of services in the visited system when indicated by the home SwMI over the ISI;
- the capability to support the generic supplementary service functions over the ISI, refer EN 300 392-9 [6].

4.8.2 Management and operation

The SS-BOC may extend to several TETRA networks. The requirements for the management part from the SwMI, in which the authorized user and/or user A can be located, are to deliver and receive SS BOC definition information over the ISI and to the user(s) located in system 2. Refer to clause 4.2.3 for information flow examples.

The requirements for the operational part of SS-BOC include the capability to support the functions of FE2 in call set-up.

4.8.3 Migration

Upon individual user migration the home SwMI may send user related SS-BOC profile to the visited SwMI and the visited SwMI may response with a modified temporary profile, refer to ETS 300 392-3-5.

Profile contains the same information as the DEFINE/DEFINE EXTERNAL information flow.

Figure 10 shows SS-BOC information exchange during migration.

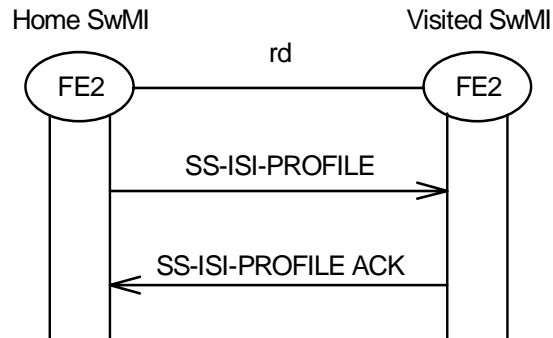

Figure 10: SS-BOC information exchange during migration

Annex A (informative): Bibliography

- ETSI ETS 300 392-3-5: "Terrestrial Trunked Radio (TETRA); Voice plus Data (V+D); Part 3: Interworking at the Inter-System Interface (ISI); Sub-part 5: Additional Network Feature for Mobility Management (ANF-ISIMM)".
- ETSI ETS 300 392-10-18: "Terrestrial Trunked Radio (TETRA); Voice plus Data (V+D); Part 10: Supplementary services stage 1; Sub-part 18: Barring of outgoing calls".

History

Document history		
Edition 1	October 1996	Public Enquiry PE 116: 1996-10-21 to 1997-02-14
		Converted from ETS to EN between Public Enquiry and Vote
V1.1.1	June 2001	Vote V 20010803: 2001-06-04 to 2001-08-03