

ETSI EN 300 392-11-17 V1.1.2 (2002-01)

European Standard (Telecommunications series)

**Terrestrial Trunked Radio (TETRA);
Voice plus Data (V+D);
Part 11: Supplementary services stage 2;
Sub-part 17: Include Call (IC)**



Reference

DEN/TETRA-03A-11-17

Keywordsdata, radio, speech, stage 2, supplementary
service, TETRA, V+D**ETSI**

650 Route des Lucioles
F-06921 Sophia Antipolis Cedex - FRANCE

Tel.: +33 4 92 94 42 00 Fax: +33 4 93 65 47 16

Siret N° 348 623 562 00017 - NAF 742 C
Association à but non lucratif enregistrée à la
Sous-Préfecture de Grasse (06) N° 7803/88

Important notice

Individual copies of the present document can be downloaded from:

<http://www.etsi.org>

The present document may be made available in more than one electronic version or in print. In any case of existing or perceived difference in contents between such versions, the reference version is the Portable Document Format (PDF). In case of dispute, the reference shall be the printing on ETSI printers of the PDF version kept on a specific network drive within ETSI Secretariat.

Users of the present document should be aware that the document may be subject to revision or change of status. Information on the current status of this and other ETSI documents is available at

<http://portal.etsi.org/tb/status/status.asp>

If you find errors in the present document, send your comment to:

editor@etsi.fr

Copyright Notification

No part may be reproduced except as authorized by written permission.
The copyright and the foregoing restriction extend to reproduction in all media.

© European Telecommunications Standards Institute 2002.
All rights reserved.

Contents

Intellectual Property Rights	4
Foreword.....	4
1 Scope	5
2 References	5
3 Definitions and abbreviations.....	6
3.1 Definitions	6
3.2 Abbreviations	6
4 Functional model.....	7
4.1 Functional model description	7
4.2 Description of functional entities	8
4.2.1 Served user functional entity, FE1	8
4.2.2 Served user SwMI functional entity, FE21	8
4.2.3 Group controlling SwMI functional entity, FE22	8
4.2.4 Other party SwMI functional entity, FE23	8
4.2.5 Affected user SwMI functional entity, FE25	8
4.2.6 Other party functional entity, FE3	8
4.2.7 Affected user functional entity, FE5	9
4.3 Relationship of functional model to basic call functional model	9
5 Information flows	10
5.1 Definition of information flows.....	10
5.1.1 BASIC CALL FAIL	10
5.1.2 CANCEL	10
5.1.3 INFORM.....	10
5.1.4 INVOKE.....	10
5.1.5 NOT SUBSCRIBED.....	11
5.1.6 NOT SUPPORTED	11
5.2 Relationship of information flows to basic individual call information flows	11
5.3 Service primitives.....	11
5.4 Examples of information flow sequences.....	12
5.4.1 Successful invocation and operation.....	12
5.4.2 Unsuccessful invocation	13
5.4.2.1 SS-IC not subscribed to.....	13
5.4.2.2 SS-IC failure due to basic call failure	13
5.4.2.3 SS-IC not supported	14
5.4.3 SS-IC cancellation	14
5.5 FE actions	15
5.5.1 Functional Entity actions of FE1	15
5.5.2 Functional Entity actions of FE21	15
5.5.3 Functional Entity Actions of FE23	15
5.5.4 Functional Entity actions of FE25	16
5.5.5 Functional Entity actions of FE3	16
5.5.6 Functional Entity actions of FE5	16
6 Allocation of functional entities to physical equipment.....	16
7 Interworking considerations	17
History	18

Intellectual Property Rights

IPRs essential or potentially essential to the present document may have been declared to ETSI. The information pertaining to these essential IPRs, if any, is publicly available for **ETSI members and non-members**, and can be found in ETSI SR 000 314: "*Intellectual Property Rights (IPRs); Essential, or potentially Essential, IPRs notified to ETSI in respect of ETSI standards*", which is available from the ETSI Secretariat. Latest updates are available on the ETSI Web server (<http://webapp.etsi.org/IPR/home.asp>).

Pursuant to the ETSI IPR Policy, no investigation, including IPR searches, has been carried out by ETSI. No guarantee can be given as to the existence of other IPRs not referenced in ETSI SR 000 314 (or the updates on the ETSI Web server) which are, or may be, or may become, essential to the present document.

Foreword

This European Standard (Telecommunications series) has been produced by ETSI Project Terrestrial Trunked Radio (TETRA).

The present document is part 11, sub-part 17 of a multi-part deliverable covering Voice plus Data (V+D), as identified below:

- Part 1: "General network design";
- Part 2: "Air Interface (AI)";
- Part 3: "Interworking at the Inter-System Interface (ISI)";
- Part 4: "Gateways basic operation";
- Part 5: "Peripheral Equipment Interface (PEI)";
- Part 7: "Security";
- Part 9: "General requirements for supplementary services";
- Part 10: "Supplementary services stage 1";
- Part 11: "Supplementary services stage 2";**
- Part 12: "Supplementary services stage 3";
- Part 13: "SDL model of the Air Interface (AI)";
- Part 14: "Protocol Implementation Conformance Statement (PICS) proforma specification";
- Part 15: "TETRA frequency bands, duplex spacings and channel numbering";
- Part 16: "Network Performance Metrics";
- Part 17: "TETRA V+D and DMO Release 1.1 specifications".

National transposition dates	
Date of adoption of this EN:	11 January 2002
Date of latest announcement of this EN (doa):	30 April 2002
Date of latest publication of new National Standard or endorsement of this EN (dop/e):	31 October 2002
Date of withdrawal of any conflicting National Standard (dow):	31 October 2002

1 Scope

The present document specifies the stage 2 description of the Supplementary Service Include Call (SS-IC) for the Terrestrial Trunked Radio (TETRA).

SS-IC enables a served user, while already participating in an active call (original call) to include new participant(s) into a group call together with the participant(s) in the original call.

Man-Machine Interface (MMI) and charging principles are outside of the scope of the present document.

Supplementary service specifications are produced in three stages according to the method defined in ITU-T Recommendation I.130 [1]. The stage 2 description identifies the functional capabilities and the information flows needed to support the supplementary service as specified in its stage 1 description (see ETS 300 392-10-17 [7]). The stage 2 description is followed by the stage 3 description, which specifies the protocols at the air interface and at the various Inter-System Interfaces (ISI) to support the service.

The present document is applicable to TETRA Voice plus Data terminal equipment and networks.

2 References

The following documents contain provisions which, through reference in this text, constitute provisions of the present document.

- References are either specific (identified by date of publication and/or edition number or version number) or non-specific.
- For a specific reference, subsequent revisions do not apply.
- For a non-specific reference, the latest version applies.

- [1] ITU-T Recommendation I.130 (1988): "Method for the characterization of telecommunication services supported by an ISDN and network capabilities of an ISDN".
- [2] ETSI EN 300 392-2: "Terrestrial Trunked Radio (TETRA); Voice plus Data (V+D); Part 2: Air Interface (AI)".
- [3] ETSI EN 300 392-3-2: "Terrestrial Trunked Radio (TETRA); Voice plus Data (V+D); Part 3: Interworking at the Inter-System Interface (ISI); Sub-part 2: Additional Network Feature Individual Call (ANF-ISIIC)".
- [4] ETSI ETS 300 392-3-3: "Terrestrial Trunked Radio (TETRA); Voice plus Data (V+D); Part 3: Interworking at the Inter-System Interface (ISI); Sub-part 3: Additional Network Feature Group Call (ANF-ISIGC)".
- [5] ETSI ETS 300 392-3-5: "Terrestrial Trunked Radio (TETRA); Voice plus Data (V+D); Part 3: Interworking at the Inter-System Interface (ISI); Sub-part 5: Additional Network Feature for Mobility Management (ANF-ISIMM)".
- [6] ETSI EN 300 392-9: "Terrestrial Trunked Radio (TETRA); Voice plus Data (V+D); Part 9: General requirements for supplementary services".
- [7] ETSI ETS 300 392-10-17: "Terrestrial Trunked Radio (TETRA); Voice plus Data (V+D); Part 10: Supplementary services stage 1; Sub-part 17: Include call".
- [8] ETSI EN 300 392-12-17: "Terrestrial Trunked Radio (TETRA); Voice plus Data (V+D); Part 12: Supplementary services stage 3; Sub-part 17: Include Call (IC)".
- [9] ISO/IEC 11574: "Information technology - Telecommunications and information exchange between systems - Private Integrated Services Network - Circuit-mode 64 kbit/s bearer services - Service description, functional capabilities and information flows".

3 Definitions and abbreviations

3.1 Definitions

For the purposes of the present document, the following terms and definitions apply:

affected user: user or users included in the original call

NOTE: The original call may be either a group call or an individual call but the resulting call is a group call.

affected user SwMI: any SwMI where an affected user is currently registered

another user: any other than server user in the original call to which new users will be included

another user SwMI: any SwMI where another user is currently registered

original call: the call already established in which the served user participates and which will be included in a group call together with new participant added by the served user

In addition, the terms and definitions of EN 300 392-9 [6] apply with the following modifications:

served user: user already participating in a call and who invokes the SS-IC supplementary service

served user SwMI: SwMI where the served user is currently registered

NOTE: The served user SwMI will be the group controlling SwMI of the resulting group call.

3.2 Abbreviations

For the purposes of the present document, the following abbreviations apply:

ANF-ISIMM	Additional Network Feature - Inter-System Interface Mobility Management
ANF-ISIGC	Additional Network Feature - Inter-System Interface Group Call
ANF-ISIIC	Additional Network Feature - Inter-System Interface Individual Call
CC	Basic Service Call Control functional entity
CCA	Basic Service Call Control functional entity agent

NOTE: CC and CCA are applied as defined in ISO/IEC 11574 [9].

IC	Include Call
FE	Functional Entity
ISI	Inter-System Interface
LS	Line Station
MS	Mobile Station
SDL	Specification and Description Language
SS	Supplementary Service

NOTE: The abbreviation SS is only used when referring to a specific supplementary service (e.g. SS-IC).

SwMI	Switching and Management Infrastructure
------	---

4 Functional model

4.1 Functional model description

The functional model shall comprise the following Functional Entities (FEs):

FE1	Served user functional entity;
FE2	Generic combination of FE21, FE22, FE23 and FE25;
FE21	Served user SwMI individual call FE;
FE22	Group controlling SwMI FE;
FE23	Another party SwMI in the original call;
FE25	Affected user SwMI FE;
FE3	Another party in the original call;
FE5	Affected user FE (included user).

The following relationships shall exist:

ra	between FE1 and FE21/FE22;
rb	between FE23/FE25 and FE3;
rc	between FE25/FE23 and FE5/FE3;
rd	between FE21/FE22 and FE23/FE25;
re	between FE21/FE25 and FE25/FE23.

Figure 1 shows these FEs and relationships. Figure 2 shows simplified FE model and relationships.

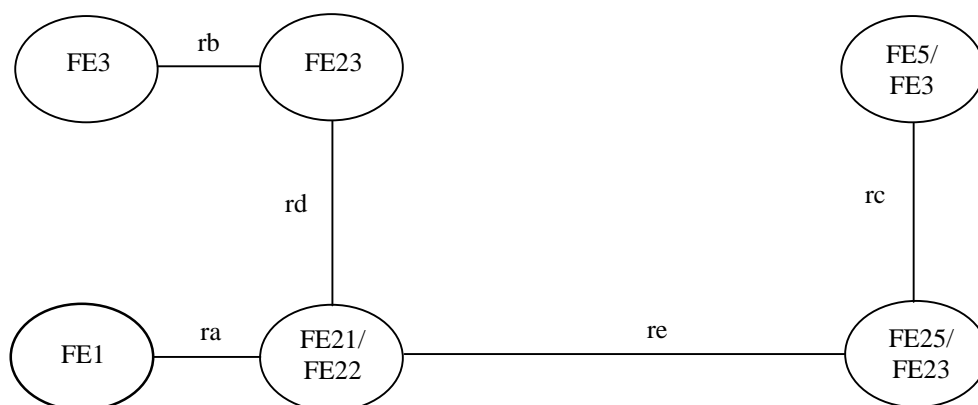

NOTE: Functional entity FE2 is a combination of FE21, FE22 and FE25

Figure 1: Functional model for the basic operational part of SS-IC

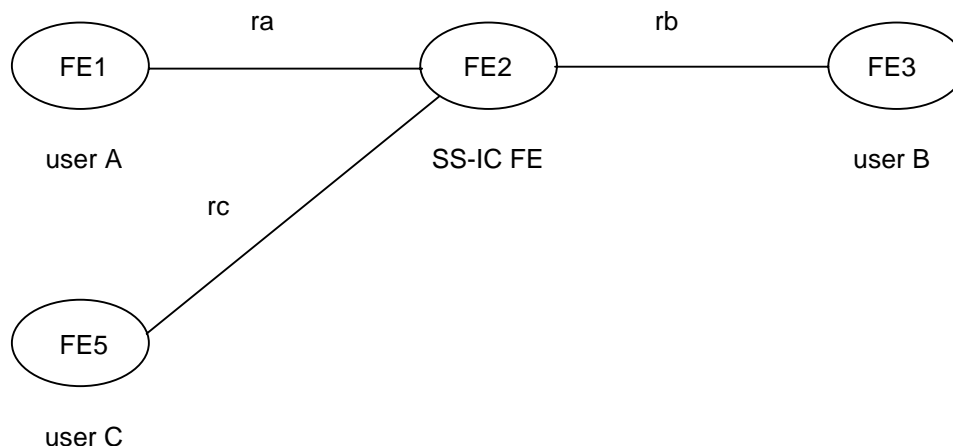

Figure 2: Functional model for the basic operation in a single SwMI

4.2 Description of functional entities

4.2.1 Served user functional entity, FE1

FE1 is the functional entity which serves the served user for the invocation of SS-IC.

4.2.2 Served user SwMI functional entity, FE21

When it receives a SS-IC invocation from FE1, FE21 checks whether SS-IC has been subscribed and, if yes, sets a second call to the included party FE5 and requests FE22 to include the original call and the second call (into a group call).

4.2.3 Group controlling SwMI functional entity, FE22

When informed by FE21 that SS-IC has been invoked FE22 includes all participants in the original call and the second call into a single group call.

4.2.4 Other party SwMI functional entity, FE23

FE23 receives from FE22 the information that SS-IC has been operated for the call and passes it to the other party FE3 entity and modifies the call into a group call, when necessary.

4.2.5 Affected user SwMI functional entity, FE25

FE25 may receive from FE21 information that SS-IC has been invoked (by the served user) for an individual user inclusion for FE5 availability checking. In that case during SS-IC operation FE25 receives from FE22 a call modification into a group call and passes it to the affected user entity FE5. FE25 may also receive from FE21 information that SS-IC has been invoked for a group inclusion. In both cases the FE25 performs call set-up to FE5 and informs that the call is an include call. After the inclusion FE25 ceases to exist and FE23 is invoked for the call to serve for any new SS-IC functions.

4.2.6 Other party functional entity, FE3

FE3 is the functional entity which serves the other party in the original call to inform him that new participants are included into the current call.

4.2.7 Affected user functional entity, FE5

FE5 is the functional entity which serves the affected user to inform him that the call contains more participants than the calling user or the group identity implies (as a result of SS-IC operation). Once the SS-IC operation is completed FE5 ceases to exist and the FE3 serves the other party for any new SS-IC actions.

4.3 Relationship of functional model to basic call functional model

Although no formal model has been defined for basic individual call, that model can be readily derived from the PISN model for basic call, in ISO/IEC 11574 [9].

FE1 shall be collocated with the two-served user CCAs, in the original call and the second call.

FE21 shall be collocated with the CC functional entities in the served user SwMI for the original call and the second call.

FE22 shall be collocated with the CC functional entity in the group controlling SwMI for the group call resulting from SS-IC operation.

FE23 shall be collocated with the CC functional entity in the other party SwMI for the call in which that user participates (the original call). In the specific case where the affected user participates in both the original call and the second call, FE23 shall be collocated with the CC functional entities for each of these calls.

FE3 shall be collocated with the CCA of the other party for the original call in which that user participates. In the specific case where the other party participates in both the original call and the second call, FE3 shall be collocated with the CCAs for each of these calls.

FE25 shall be collocated with the CC functional entity in the affected user SwMI for the call in which that user participates (the original call or the second call). In the specific case where the affected user participates in both the original call and the second call, FE25 shall be collocated with the CC functional entities for each of these calls.

FE5 shall be collocated with the CCA of the affected user for the call in which that user participates. In the specific case where the affected user participates in both the original call and the second call, FE5 shall be collocated with the CCAs for each of these calls.

NOTE: Obviously the specific case where the affected user participates in both the original call and the second call cannot happen when both of these calls are individual calls.

Figure 3 shows relationship between SS-IC and the basic calls.

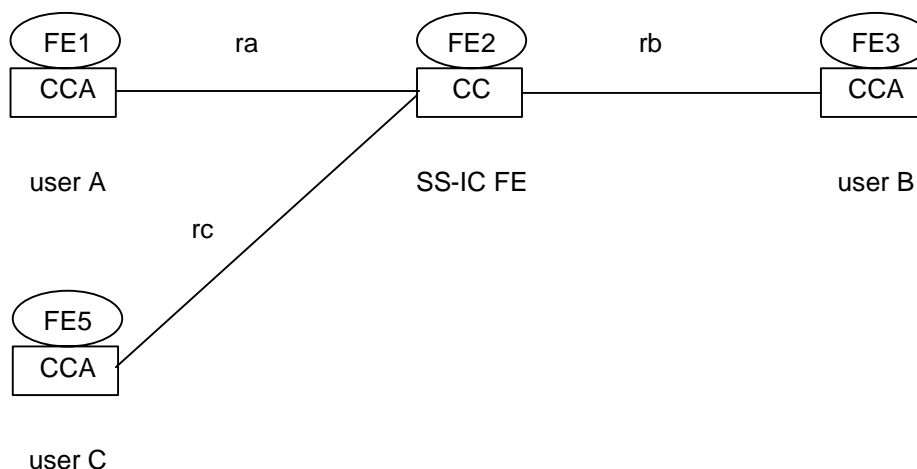

Figure 3: Relationship between models for SS-IC and basic call

5 Information flows

5.1 Definition of information flows

In the tables listing the information elements in information flows, the column headed "Type" indicates which of these elements is Mandatory (M), which are Optional (O) and which are Conditional (C).

5.1.1 BASIC CALL FAIL

BASIC CALL FAIL is an unconfirmed information flow across relationships ra from FE2 (FE21/FE22/FE23/FE25) to FE1 to inform served user about the SS-IC operation failure.

Table 1 defines the contents of the BASIC CALL FAIL information flow.

Table 1: Contents of BASIC CALL FAIL

Element	Type
Invocation failure cause	M
Disconnect cause	M

5.1.2 CANCEL

CANCEL is an unconfirmed information flow across relationships rb and rc from FE1 to FE2 to cancel SS-IC operation before the affected user is included to the call as defined in table 2.

Table 2: Contents of CANCEL

Element	Type
Cancelled to-be included party	M

5.1.3 INFORM

INFORM is an unconfirmed information flow across relationships rb and rc from FE2 (FE21/FE22/FE23/FE25) to FE 3 and FE5 to inform another and affected users about the SS-IC operation. There are no elements in the INFORM information flow.

5.1.4 INVOKE

INVOKE is an unconfirmed information flow across relationship ra from FE1 to FE2 to invoke SS-IC.

Table 3 defines the contents of the INVOKE information flow.

Table 3: Contents of INVOKE

Element	Type
New participant(s)	M

5.1.5 NOT SUBSCRIBED

NOT SUBSCRIBED is an unconfirmed information flow across relationship ra from FE2 (FE21/FE22) to FE1 to inform the served user who has invoked SS-IC that that invocation has failed because the supplementary service has not been subscribed for that user.

NOTE: The above statement implies that there is a FE21 (FE22) functional entity. Otherwise, this means that the originating SwMI does not support SS-IC and by definition there is no information flow NOT SUBSCRIBED. In such a case, the served user who has invoked SS-IC may nevertheless be informed about the invocation failure by some generic failure reports of the air interface protocol (see clause 5.4.1.2.1 of EN 300 392-12-17 [8]).

There are no elements in the NOT SUBSCRIBED information flow.

5.1.6 NOT SUPPORTED

NOT SUPPORTED is an unconfirmed information flow across relationship re from FE25 to FE21 or across relationship ra from FE21 to FE1 to inform the served user who has invoked SS-IC that that invocation has failed because the addressed SwMI does not support SS-IC.

NOTE: This information flow is optional.

5.2 Relationship of information flows to basic individual call information flows

Table 4 shows the relationship of the SS-IC information flows to those of basic call over both the air interface and the ISI.

NOTE 1: The basic call information flows are defined:

- for the air interface, if not explicitly in EN 300 392-2 [2], at least implicitly in clauses 11 and 14 of that ETS; and
- for the ISI, in EN 300 392-3-2 [3] in the case of an individual call, and in ETS 300 392-3-3 [4] in the case of a group call.

Table 4: Relationship of SS-IC information flows to basic call

Information flow	Independent of basic call?	With basic call?	Basic call flows
CANCEL	no	yes	U-INFO
INFORM	no	yes	D-SETUP, ISI-SETUP, D-INFO
INVOKE	no	yes	U-INFO
NOT SUBSCRIBED	no	yes	D-INFO
NOT SUPPORTED	yes	yes	D-INFO
BASIC CALL FAIL	no	yes	D-INFO

NOTE 2: Information flow relationship over ISI for the NOT SUPPORTED PDU is defined in EN 300 392-9 [6].

5.3 Service primitives

This clause lists SS-IC service primitives used to invoke or being a result of information flow sequences. The SS-IC service primitives are defined in EN 300 392-12-17 [8], clause 4.2.

The SS-IC service primitives for the served user at the MS/LS TNSS-SAP are:

- INVOKE request; and
- INVOCATION FAILURE indication.

There is only one SS-IC service primitive for another and affected users at the MS/LS TNSS-SAP INFORM indication.

5.4 Examples of information flow sequences

EN 300 392-12-17 [8], on SS-IC stage 3 description, specifies the signalling procedures in support of the information flow sequences specified in the following clauses. In addition, it specifies signalling procedures to cover other sequences arising from error situations, interactions with basic call, interactions with other supplementary services, different topologies etc.

In the figures, SS-IC information flows are represented by solid arrows and basic call information flows are represented by broken arrows. An ellipse embracing two information flows indicates that the two information flows occur together. Within a column representing an SS-IC functional entity, the numbers refer to functional entity actions listed in clause 5.5.

5.4.1 Successful invocation and operation

Figure 4 shows the information flow sequence for the successful SS-IC invocation. All the details of the basic call signalling are not shown.

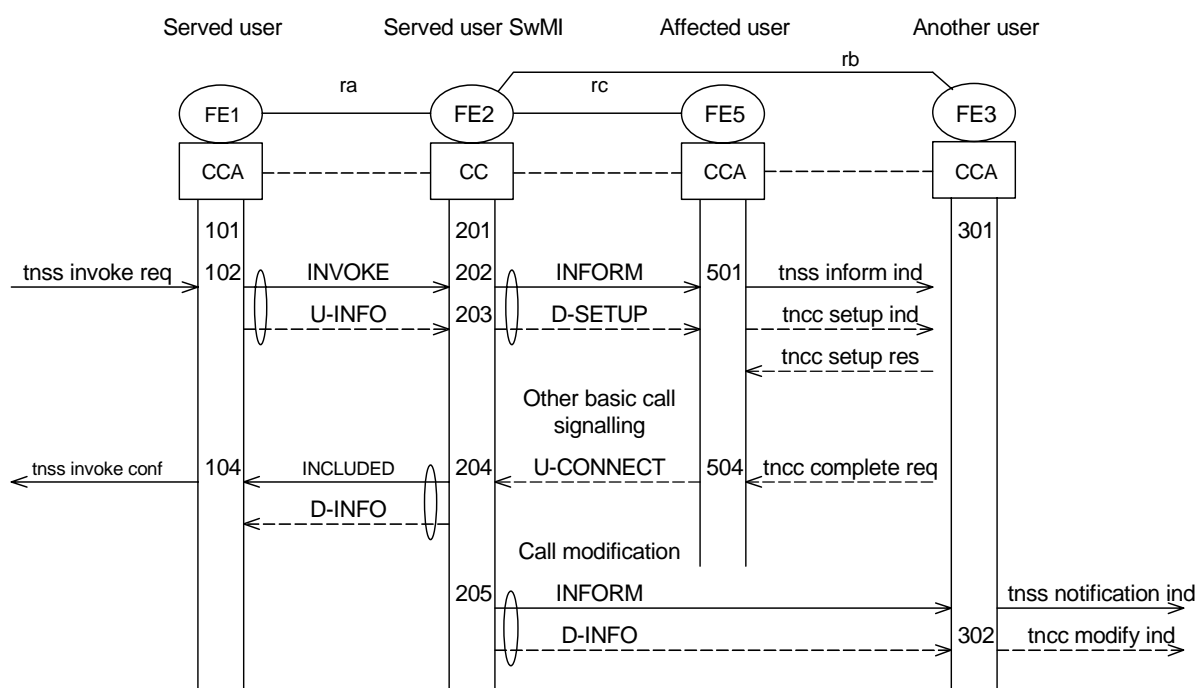

Figure 4: Successful invocation

5.4.2 Unsuccessful invocation

5.4.2.1 SS-IC not subscribed to

Figure 5 shows the information flow sequence when SS-IC invocation fails because SS-IC has not been subscribed for the calling user.

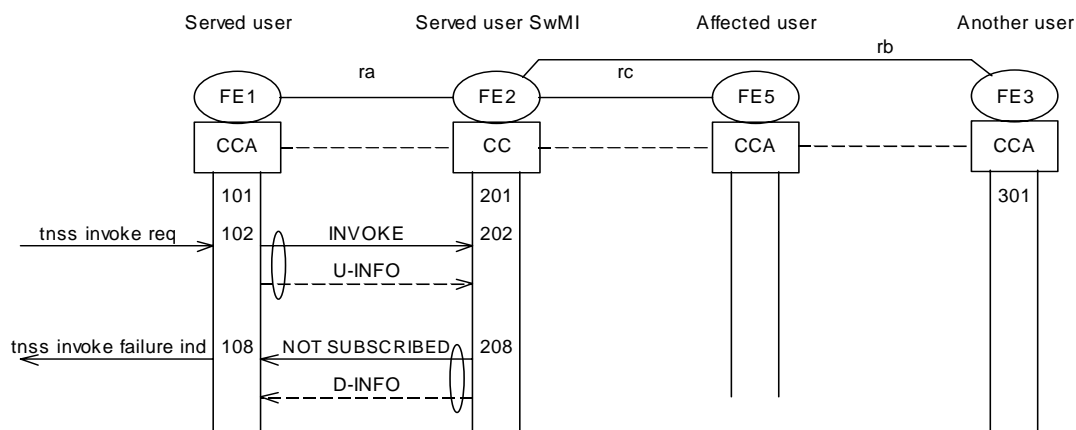

Figure 5: Failure of SS-IC invocation because of non-subscription

5.4.2.2 SS-IC failure due to basic call failure

Figure 6 shown the failure of SS-IC due to the failure of call set-up to the affected user. All the details of the basic call signalling are not shown.

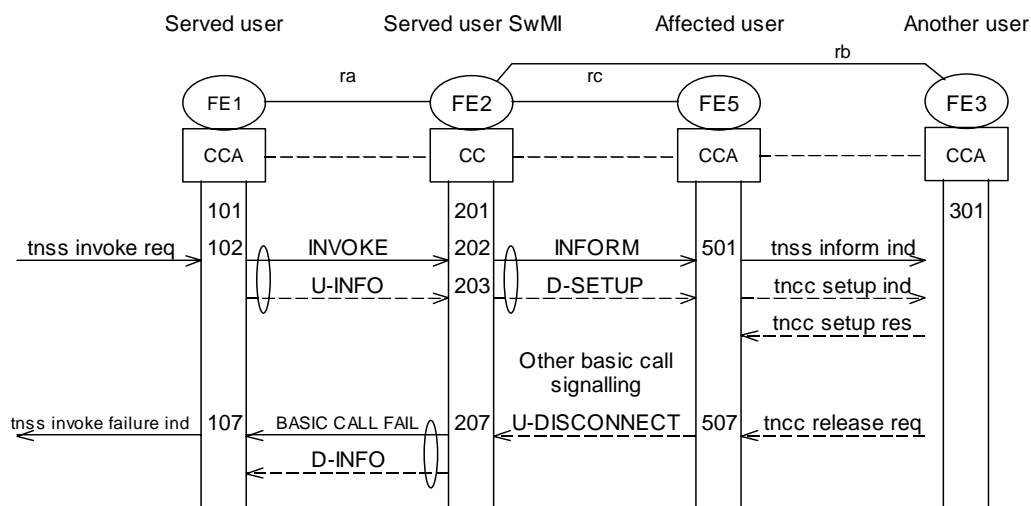

Figure 6: Failure of SS-IC invocation because of a basic call failure

5.4.2.3 SS-IC not supported

Figure 7 shows the information flow sequence when SS-IC invocation fails because the served user SwMI does not support SS-IC.

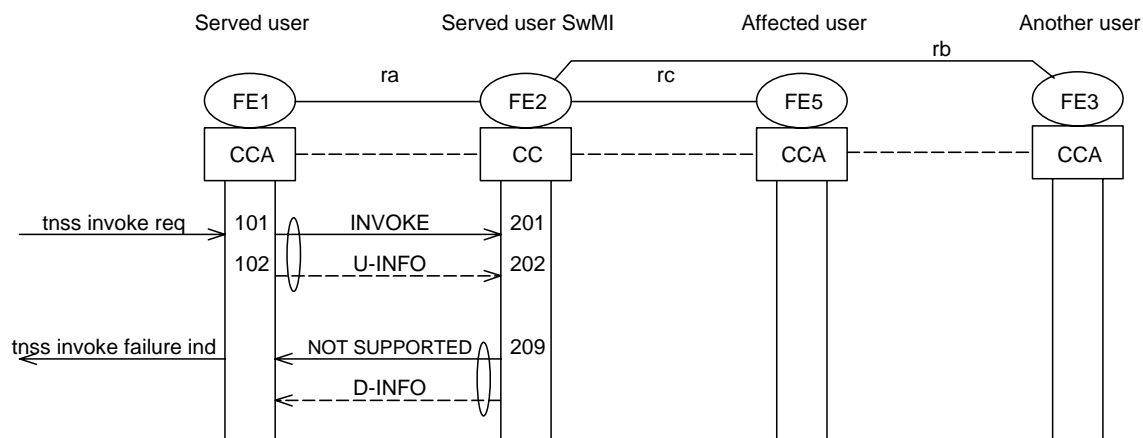

Figure 7: Failure of SS-IC invocation because SS-IC is not supported

5.4.3 SS-IC cancellation

Figure 8 shown the cancellation of SS-IC requested by the served user.

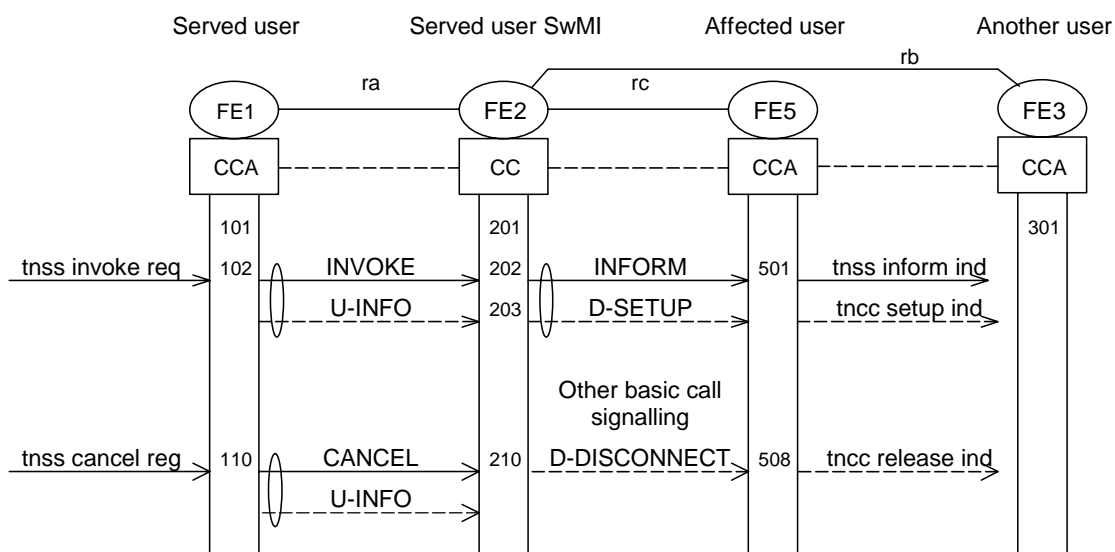

Figure 8: Cancellation of SS-IC by the served user

5.5 FE actions

These functional entity actions cover items presented in the previous scenarios. There may be other actions due to exceptional cases.

5.5.1 Functional Entity actions of FE1

- 101 Any basic call actions to ensure that the served used has an active call.
- 102 Receive the SS-IC invocation request from the user application and send to FE21/FE22 the corresponding INVOKE request/indication information flow.
- 104 Relay the received INCLUDED request/indication information flow to the user application in changing it into the INVOKE confirm primitive.
- 107 Relay the received BASIC CALL FAIL information flow to the user application in changing it into the INVOCATION FAILURE indication primitive.
- 108 Relay the received NOT SUBSCRIBED information flow to the user application in changing it into the INVOCATION FAILURE indication primitive.
- 109 Relay the received NOT SUPPORTED information flow to the user application in changing it into the INVOCATION FAILURE indication primitive.
- 110 Receive the SS-IC cancellation request from the user application and send to FE21/FE22 the corresponding CANCEL request information flow.

5.5.2 Functional Entity actions of FE21

- 201 Any basic call actions to ensure that the served used has an active call with another user or users.
 - 202 Receive the INVOKE request/indication information flow if sent by FE1. Check if SS-IC has been subscribed for the served user.
 - 203 As the SS-IC is supported try to set up a call to the affected user.
 - 204 Call setup to the affected use is completed successfully and served user is informed by an INCLUDED request/indication information flow.
 - 205 The other users in the original call are informed.
 - 207 The affected user does not accept the call.
- NOTE 1: Also other cases of call failure could be identified in this action such as called user busy or no answer or in group call case not enough important users available.
- 208 If SS-IC has not been subscribed for the served user, reject the INVOKE request/indication information flow from FE1 in sending to it the NOT SUBSCRIBED request/indication information flow.
 - 209 As the SS-IC is not supported, reject the INVOKE request/indication information flow from FE1 in sending to it a NOT SUPPORTED request/indication information flow.

NOTE 2: This information flow is actually generated by the generic supplementary services functional entity.

- 210 Receive CANCEL request/indication information flow and disconnect the to-be included (affected) user.

5.5.3 Functional Entity Actions of FE23

- 231 Any basic call action including passing of notification information and call modification into a group call.

5.5.4 Functional Entity actions of FE25

251 Any basic call action including passing of notification information and call modification into a group call.

5.5.5 Functional Entity actions of FE3

301 Any basic call actions to ensure that the served user has an active call.

302 Relay the received INFORM information flow to the user application in changing it into the NOTIFICATION primitive.

5.5.6 Functional Entity actions of FE5

501 Receive call set-up and the INFORM request/indication information flow from FE22 and pass its information to the user application.

504 The affected user has accepted to be included into the original call and all basic call modifications towards a group call are completed.

507 The called user rejects the call set-up.

508 The call set-up is cancelled.

NOTE: The included (affected) party cannot be disconnected by the CANCEL request/indication information flow, if the call is already accepted by the affected user. No warning of the situation is presented to the served user.

6 Allocation of functional entities to physical equipment

The allocations of functional entities to SwMIs and MS/LSs shall be as shown in table 5. If the included party is a group its group controlling SwMI shall be either the same as for the original call or group-linking mechanism of the basic call shall be used so that the group controlling SwMI of the original call will be the group controlling SwMI of the resulted call.

Table 5: Scenarios for the allocation of FEs to physical equipment/SwMI and MS/LSs in the case of invocation and operation

	FE1	FE21/FE22	FE25/FE23	FE5/FE3	FE23	FE3
Scenario 1	Served user MS/LS	Served user SwMI	Affected user SwMI	Affected user MS/LS	Another party SwMI	Another party MS/LS
Scenario 2	Served user MS/LS	Served user SwMI	Affected user PSTN/ISDN gateway	External affected user	Another party SwMI	Another party MS/LS
Scenario 3	Served user MS	Served user SwMI	Affected user SwMI	Affected user MS/LS	Another party PSTN/ISDN gateway	External another party
Scenario 4	Served user MS	Served user SwMI	Affected user PSTN/ISDN gateway	External affected user	Another party PSTN/ISDN gateway	External another party

7 Interworking considerations

The case where SS-IC extends to several TETRA networks has already been taken into account in the preceding clauses, except for the exchange of information related to the support, the subscription of SS-IC. Such exchange occurs when a subscriber migrates into an SwMI different from his home SwMI.

As defined in ETS 300 392-3-5 [5], such exchange is ensured by:

- the ANF-ISIMM PROFILE UPDATE request/indication information flow, which contains the information whether SS-IC has been subscribed to for the subscriber (which implies that SS-IC is supported by the concerned MS). If so, the corresponding ANF-ISIMM PROFILE UPDATE response/confirmation information flow contains the information whether SS-IC is supported by the visited SwMI.

More precisely, the information about the SS-IC subscription is carried by the sub-element SS-information in the element individual basic migration profile in the ANF-ISIMM PROFILE UPDATE request/indication information flow, while the response about the SS-IC support by the visited SwMI is carried by the sub-element SS-information response in the element individual basic migration profile in the ANF-ISIMM PROFILE UPDATE response/confirmation information flow.

Normally, when SS-IC has been subscribed to for a subscriber and is supported by his visited SwMI, his home SwMI shall download to the visited SwMI the SS-IC activation state when that subscriber (i.e. the served user) migrates in that SwMI.

The sub-element SS status of the above-mentioned sub-element SS-information shall then take the value corresponding to SS-IC subscribed to with SS-migration profile.

The downloading of a SS-IC activation state by the home SwMI to the visited SwMI shall be done using the (ANF-ISIMM) sub-element SS-migration profile (original) in the ANF-ISIMM SS-PROFILE UPDATE request/indication information flow. Table 6 defines the SS-IC information which shall then be included in the (ANF-ISIMM) sub-sub-element SS-ISI-PROFILE (original) of that sub-element SS-migration profile (original).

Table 6: SS-IC information in (ANF-ISIMM) SS-ISI-PROFILE (original)

Sub-element	Type
Activation state	M

The element activation state shall indicate whether the SS-IC has been subscribed or not subscribed.

In the case of an inclusion of an external user, SS-IC shall apply as specified for calls between TETRA users, except for the information flows INFORM if they cannot be extended to the external user by the external network.

If the include call supplementary service is available to the external user in the other network, and if that user invokes it in its network, the TETRA gateway may extend the INFORM information flows for that external supplementary services to the TETRA user in translating those information flows into the TETRA SS-IC INFORM.

History

Document history		
V1.1.1	November 2000	Public Enquiry PE 20010330: 2000-11-29 to 2001-03-30
V1.1.2	November 2001	Vote V 20020111: 2001-11-12 to 2002-01-11
V1.1.2	January 2002	Publication