

**Terrestrial Trunked Radio (TETRA);
Voice plus Data (V+D);
Part 11: Supplementary services stage 2;
Sub-part 1: Call Identification (CI)**



Reference

REN/TETRA-03096

Keywords

radio, TETRA, V+D

ETSI

650 Route des Lucioles
F-06921 Sophia Antipolis Cedex - FRANCE

Tel.: +33 4 92 94 42 00 Fax: +33 4 93 65 47 16

Siret N° 348 623 562 00017 - NAF 742 C
Association à but non lucratif enregistrée à la
Sous-Préfecture de Grasse (06) N° 7803/88

Important notice

Individual copies of the present document can be downloaded from:

<http://www.etsi.org>

The present document may be made available in more than one electronic version or in print. In any case of existing or perceived difference in contents between such versions, the reference version is the Portable Document Format (PDF). In case of dispute, the reference shall be the printing on ETSI printers of the PDF version kept on a specific network drive within ETSI Secretariat.

Users of the present document should be aware that the document may be subject to revision or change of status. Information on the current status of this and other ETSI documents is available at

<http://portal.etsi.org/tb/status/status.asp>

If you find errors in the present document, send your comment to:

editor@etsi.org

Copyright Notification

No part may be reproduced except as authorized by written permission.
The copyright and the foregoing restriction extend to reproduction in all media.

© European Telecommunications Standards Institute 2003.
All rights reserved.

DECT™, **PLUGTESTS™** and **UMTS™** are Trade Marks of ETSI registered for the benefit of its Members.
TIPHON™ and the **TIPHON logo** are Trade Marks currently being registered by ETSI for the benefit of its Members.
3GPP™ is a Trade Mark of ETSI registered for the benefit of its Members and of the 3GPP Organizational Partners.

Contents

Intellectual Property Rights	6
Foreword.....	6
1 Scope	8
2 References	8
3 Definitions and abbreviations.....	9
3.1 Definitions	9
3.2 Abbreviations	10
4 Supplementary Service Calling Line Identification Presentation (SS-CLIP) stage 2 specification	10
4.1 Functional model.....	10
4.1.1 Functional model description.....	10
4.1.2 Description of functional entities.....	11
4.1.2.1 Served User CGLI Reception, FE1	11
4.1.2.2 Served User current SwMI, CGLI Presentation, FE21	11
4.1.2.3 Group Controlling SwMI, FE22.....	12
4.1.3 Relationship of functional model to individual call functional model.....	12
4.1.4 Relationship of functional model to group call functional model.....	13
4.2 Information flows	13
4.2.1 Definition of information flows	13
4.2.1.1 CGLI (CallinG Line Identification)	14
4.2.2 Relationship of information flows to basic call information flows.....	14
4.2.3 Examples of information flow sequences	15
4.2.3.1 Normal operation of SS-CLIP.....	15
4.3 Functional entity actions	16
4.3.1 Functional entity actions of FE21	16
4.3.2 Functional entity actions of FE1	16
4.3.3 Functional entity actions of FE22	16
4.4 Allocation of functional entities to physical equipment	16
4.5 Interworking considerations	17
5 Supplementary Service Connected Line Identification Presentation (SS-COLP) stage 2 specification	17
5.1 Functional model.....	17
5.1.1 Functional model description.....	17
5.1.2 Description of functional entities.....	18
5.1.2.1 Served User, Calling User COLI Reception, FE1	18
5.1.2.2 Served User Current SwMI, COLI Presentation, FE21	18
5.1.2.3 Group Controlling SwMI, FE22.....	18
5.1.3 Relationship of functional model to basic individual call functional model.....	19
5.1.4 Relationship of functional model to basic group call functional model.....	20
5.2 Information flows	20
5.2.1 Definition of information flows	20
5.2.1.1 COLI (Connected Line Identification)	21
5.2.2 Relationship of information flows to basic call information flows.....	21
5.2.3 Examples of information flow sequences	22
5.2.3.1 Normal operation SS-COLP in case of individual call.....	22
5.2.4 Normal operation SS-COLP in case of group call	23
5.2.5 Functional entity actions	23
5.2.5.1 Functional entity actions of FE1	23
5.2.5.2 Functional entity actions of FE21	23
5.2.5.3 Functional entity actions of FE22	23
5.3 Allocation of functional entities to physical equipment	24
5.4 Interworking considerations	24
6 Supplementary Service Calling Line Identification Restriction stage 2 specification	24
6.1 Functional model.....	24

6.1.1	Functional model descriptions	24
6.1.1.1	Functional model description for SS-CLIR in case of Individual Call	25
6.1.1.2	Functional model description for SS-CLIR in case of Group Call.....	25
6.1.2	Description of functional entities	26
6.1.2.1	Restriction Request, FE1	26
6.1.2.2	Restriction Control, Group Controlling SwMI, FE22	26
6.1.3	Relationship of functional model to basic individual call SS-CLIR functional model.....	27
6.1.3.1	Relationship of functional model to basic group call SS-CLIR functional model	28
6.2	Information flows	28
6.2.1	Definition of information flows	28
6.2.1.1	RESTRICT	28
6.2.2	Relationship of information flows to basic call information flows.....	29
6.2.3	Examples of information flow sequences	29
6.2.3.1	Normal operation of SS-CLIR in case of individual call	30
6.2.3.2	Normal operation of SS-CLIR in case of Group Call	31
6.3	Functional entity actions	31
6.3.1	SS-CLIR Individual call	31
6.3.1.1	Functional entity actions of FE1	31
6.3.1.2	Functional entity actions of FE21	31
6.3.1.3	Functional entity actions of FE25	32
6.3.2	SS-CLIR Group call.....	32
6.3.2.1	Functional entity actions of FE1	32
6.3.2.2	Functional entity actions of FE21	32
6.3.2.3	Functional entity actions of FE22	32
6.4	Allocation of functional entities to physical equipment	32
6.5	Interworking considerations	32
7	Supplementary Service Connected Line Restriction stage 2 specification	33
7.1	Functional model.....	33
7.1.1	Functional model descriptions	33
7.1.1.1	Functional model description for SS-COLR in case of individual call	33
7.1.1.2	Functional model of SS-COLR in case of group call.....	34
7.1.2	Description of functional entities	35
7.1.2.1	Functional entities in case of SS-COLR individual call.....	35
7.1.2.1.1	Restriction Request, FE1	35
7.1.2.1.2	Restriction Control, FE21	35
7.1.2.2	Relationship of functional model to basic individual call COLR functional model.....	35
7.1.2.3	Functional entities in case of SS-COLR group call.....	36
7.1.2.3.1	Served User, FE1	36
7.1.2.3.2	Group controlling SwMI, FE22	36
7.1.2.3.3	Calling User, Affected user SwMI FE25.....	36
7.1.2.3.4	Calling User MS FE5	36
7.1.2.4	Relationship of functional model to basic group call COLR functional model	37
7.2	Information flows	37
7.2.1	Definition of information flows	37
7.2.1.1	RESTRICT	37
7.2.2	Relationship of information flows to basic call information flows.....	38
7.2.3	Examples of information flow sequences	38
7.2.3.1	Normal operation of SS-COLR in case of individual call.....	39
7.2.3.2	Normal operation of SS-COLR in case of Group Call	39
7.3	Functional entity actions	40
7.3.1	SS-COLR individual call	40
7.3.1.1	Functional entity actions of FE1	40
7.3.1.2	Functional entity actions of FE21	41
7.3.1.3	Functional entity actions of FE25	41
7.3.2	SS-COLR group call.....	41
7.3.2.1	Functional entity actions of FE1	41
7.3.2.2	Functional entity actions of FE22	41
7.3.2.3	Functional entity actions of FE25	41
7.3.2.4	Functional entity action of FE5.....	41
7.4	Allocation of functional entities to physical equipment	42

Annex A (informative): Bibliography.....43
History44

Intellectual Property Rights

IPRs essential or potentially essential to the present document may have been declared to ETSI. The information pertaining to these essential IPRs, if any, is publicly available for **ETSI members and non-members**, and can be found in ETSI SR 000 314: *"Intellectual Property Rights (IPRs); Essential, or potentially Essential, IPRs notified to ETSI in respect of ETSI standards"*, which is available from the ETSI Secretariat. Latest updates are available on the ETSI Web server (<http://webapp.etsi.org/IPR/home.asp>).

Pursuant to the ETSI IPR Policy, no investigation, including IPR searches, has been carried out by ETSI. No guarantee can be given as to the existence of other IPRs not referenced in ETSI SR 000 314 (or the updates on the ETSI Web server) which are, or may be, or may become, essential to the present document.

Foreword

This European Standard (Telecommunications series) has been produced by ETSI Project Terrestrial Trunked Radio (TETRA), and is now submitted for the ETSI standards One-step Approval Procedure.

The present document had been published as ETS 300 392-11-1. During the maintenance it was converted into an EN.

The present document is part 11, sub-part 1 of a multi-part deliverable covering the Terrestrial Trunked Radio (TETRA); Voice plus Data (V+D), as identified below:

- EN 300 392-1: "General network design";
- EN 300 392-2: "Air Interface (AI)";
- EN 300 392-3: "Interworking at the Inter-System Interface (ISI)";
- ETS 300 392-4: "Gateways basic operation";
- EN 300 392-5: "Peripheral Equipment Interface (PEI)";
- EN 300 392-7: "Security";
- EN 300 392-9: "General requirements for supplementary services";
- EN 300 392-10: "Supplementary services stage 1";

EN 300 392-11: "Supplementary services stage 2";

- EN 300 392-11-1: "Call Identification (CI)";**
- ETS 300 392-11-2: "Call Report (CR)";
- ETS 300 392-11-3: "Talking Party Identification (TPI)";
- EN 300 392-11-4: "Call Forwarding (CF)";
- ETS 300 392-11-5: "List Search Call (LSC)";
- EN 300 392-11-6: "Call Authorized by Dispatcher (CAD)";
- ETS 300 392-11-7: "Short Number Addressing (SNA)";
- EN 300 392-11-8: "Area selection";
- ETS 300 392-11-9: "Access priority";
- EN 300 392-11-10: "Priority Call (PC)";
- ETS 300 392-11-11: "Call Waiting (CW)";
- EN 300 392-11-12: "Call Hold (CH)";

ETS 300 392-11-13:	"Call Completion to Busy Subscriber (CCBS)";
EN 300 392-11-14:	"Late Entry (LE)";
ETS 300 392-11-16:	"Pre-emptive priority call";
EN 300 392-11-17:	"Include Call (IC)";
EN 300 392-11-18:	"Barring of Outgoing Calls (BOC)";
EN 300 392-11-19:	"Barring of Incoming Calls (BIC)";
ETS 300 392-11-20:	"Discreet Listening (DL)";
EN 300 392-11-21:	"Ambience Listening (AL)";
ETS 300 392-11-22:	"Dynamic Group Number Assignment (DGNA)";
ETS 300 392-11-23:	"Call Completion on No Reply (CCNR)";
ETS 300 392-11-24:	"Call Retention (CRT)";
EN 300 392-12:	"Supplementary services stage 3";
ETS 300 392-13:	"SDL model of the Air Interface (AI)";
ETS 300 392-14:	"Protocol Implementation Conformance Statement (PICS) proforma specification".
TS 100 392-15:	"TETRA frequency bands, duplex spacing and channel numbering";
TS 100 392-16:	"Network Performance Metrics";
TS 100 392-17:	"Part 17: TETRA V+D and DMO Release 1.1 specifications".

Proposed national transposition dates	
Date of latest announcement of this EN (doa):	3 months after ETSI publication
Date of latest publication of new National Standard or endorsement of this EN (dop/e):	6 months after doa
Date of withdrawal of any conflicting National Standard (dow):	6 months after doa

1 Scope

The present document specifies the stage 2 description of the Supplementary Services CLIP, CLIR and COLP all part of Call Identification for the Terrestrial Trunked Radio (TETRA). The term "Line" is used in the present document by extension to the air interface and to keep those supplementary service names at the Air Interface in TETRA Radio based network.

Calling Line Identification Presentation (SS-CLIP) is a supplementary service which is offered to the connected user and which provides either the calling user's identity (ITSI for TETRA) in case of individual call or the calling user identity (GTSI is presented as part of the normal group call set-up) in case of group call.

COnnected Line Identification Presentation (SS-COLP) is a supplementary service which is offered to the calling user and which provides the connected user's identity (connected ITSI for individual call, connected GTSI for a group call).

Calling/Connected Line Identification Restriction (SS-CLIR) is a supplementary service offered to a user to restrict presentation of that user's ITSI to another user. The generic term SS-CLIR covers in fact two different supplementary services: SS-CLIR (Calling Line Identity Restriction) and SS-COLR (COnnected Line identity Restriction). Contrary to ECMA-148 [9] and in line with public ISDN, the two services have been split in the present document to improve its readability.

Man-Machine Interface and charging principles are outside the present document.

Supplementary service specifications are produced in three stage according to the method defined in ITU-T Recommendation I.130 [1]. The stage 2 description identifies the functional capabilities and the information flows needed to support the supplementary service as specified in its stage 1 description (see EN 300 392-10-1 [7]). The stage 2 description is followed by the stage 3 description (see EN 300 392-12-1 [8], which specifies the protocols at the air interface and at the various Inter-System Interfaces (ISI) to support the service.

The present document is applicable to MS and SwMIs involved in the operation of those supplementary services. Specifications of interworking gateways to non-TETRA networks (mainly PSTN and ISDN) are outside the scope of the present document.

The stage 2 descriptions for the SS-CLIP, SS-CLIR and SS-COLP are derived from ECMA-148 [9] taken as normative reference for the corresponding supplementary services for Private Integrated Services Networks (PISNs).

NOTE: The stage 2 description is followed by the stage 3 description, which specifies the encoding rules for the information flows and process behaviour for the different entities in SwMI and MS.

2 References

The following documents contain provisions which, through reference in this text, constitute provisions of the present document.

- References are either specific (identified by date of publication and/or edition number or version number) or non-specific.
- For a specific reference, subsequent revisions do not apply.
- For a non-specific reference, the latest version applies.

Referenced documents which are not found to be publicly available in the expected location might be found at <http://docbox.etsi.org/Reference>.

- [1] ITU-T Recommendation I.130: "Method for the characterization of telecommunication services supported by an ISDN and network capabilities of an ISDN".
- [2] ETSI EN 300 171: "Private Integrated Services Network (PISN); Service description, functional capabilities and information flows; Circuit-mode 64 kbit/s bearer services [ISO/IEC 11574 (2000) modified]" .

- [3] ETSI EN 300 392-1: "Terrestrial Trunked Radio (TETRA); Voice plus Data (V+D); Part 1: General network design".
- [4] ETSI EN 300 392-3-2: "Terrestrial Trunked Radio (TETRA); Voice plus Data (V+D); Part 3: Interworking at the Inter-System Interface (ISI); Sub-part 2: Additional Network Feature Individual Call (ANF-ISIIC)".
- [5] ETSI EN 300 392-3-3: "Terrestrial Trunked Radio (TETRA); Voice plus Data (V+D); Part 3: Interworking at the Inter-System Interface (ISI); Sub-part 3: Additional Network Features Group Call (ANF-ISIGC)".
- [6] ETSI EN 300 392-9: "Terrestrial Trunked Radio (TETRA); Voice plus Data (V+D); Part 9: General requirements for supplementary services".
- [7] ETSI EN 300 392-10-1: "Terrestrial Trunked Radio (TETRA); Voice plus Data (V+D); Part 10: Supplementary services stage 1; Sub-part 1: Call Identification (CI)".
- [8] ETSI EN 300 392-12-1: "Terrestrial Trunked Radio (TETRA); Voice plus Data (V+D); Part 12: Supplementary services stage 3; Sub-part 1: Call Identification (CI)".
- [9] Standard ECMA-148: "Private Integrated Services Network (PISN) - Specification, Functional Model and Information Flows - Identification Supplementary Services, 3rd edition".

3 Definitions and abbreviations

3.1 Definitions

For the purposes of the present document, the following terms and definitions apply:

affected user: user the identity of which is either presented (SS-COLP), received (SS-CLIP), restricted of presentation (SS-CLIR) or restricted of reception (SS-COLR)

calling user identity: see EN 300 392-1 [3], clause 7.2 where ITSI and SSI are defined

NOTE: When the connected user and the calling user belongs to the same home SwMI, and according to clause 8.4.1 of EN 300 392-9 [6], this identity can be given using only the SSI part of the ITSI. In all other cases, the identity will be the full ITSI. In the case of a group call, the calling user identity is the individual calling user ITSI setting up the group call.

connected user: user that answers a call

NOTE: The connected user is not necessarily the called user, different from ECMA-148 [9].

connected user identity: identity of the connected user for identification purposes

NOTE 1: See EN 300 392-1 [3], clause 7.2 where ITSI and SSI are defined.

NOTE 2: When the connected user and the calling user belongs to the same home SwMI, and according to clause 8.4.1 of EN 300 392-9 [6], this identity can be given using only the SSI part of the ITSI. In all other cases, the identity will be the full ITSI. In the case of a group call, the connected user identity is not defined

presentation indicator: presentation indicator provides instructions on whether or not the provided calling line identity is allowed to be presented or not (restricted), or indicates that the number is not available

screening indicator: screening indicator provides information on the source and the quality of the provided information

served user(s): Served user in the case of SS-CLIP is the connected user for an individual call and the connected users for a group call; the served user in the case of SS-COLP is the calling user

NOTE: In the ECMA terminology, SS-CLIR includes the CLIR restriction of CLIP and the COLR restriction of COLP; in the present document SS-CLIR and SS-COLR are used preferably to a generic SS-CLIR term; thus in the case of SS-CLIR as applicable to the present document, the served user is the calling user and in the case of SS-COLR, the served user is the connected user

3.2 Abbreviations

For the purposes of the present document, the following abbreviations apply:

CC	Basic service call control functional entity
CCA	Basic service call control functional entity agent

NOTE: CC and CCA are applied as defined in EN 300 171 [2].

CGLI	CallinG Line Identification (ECMA)
CLI	Calling Line Identification
CLIP	Calling Line Identification Presentation
CLIR	Calling Line Identification Restriction
COLI	COnnected Line Identification
COLP	COnnected Line Presentation
COLR	COnnected Line Restriction
FE	Functional Entity
GTSI	Group TETRA Subscriber Identity
ISI	Inter System Interface
ITSI	Individual TETRA Subscriber Identity
PI	Presentation Indicator
req	request
SDL	Specification and Description Language
SS	Supplementary Service
SSI	Short Subscriber Identity
SwMI	Switching and Management Infrastructure
TETRA	Terrestrial Trunked Radio

4 Supplementary Service Calling Line Identification Presentation (SS-CLIP) stage 2 specification

4.1 Functional model

The functional model for TETRA SS-CLIP is different from the functional model for ECMA-148 [9] in particular with the addition of group call. Moreover, the TETRA terminology is used and the present document is in line with EN 300 392-9 [6].

4.1.1 Functional model description

The functional model shall comprise the following functional entities:

- FE1 Served User CGLI (CallinG Line Identification) Reception Functional Entity;
- FE21 Served User current SwMI CGLI Presentation Functional Entity;
- FE22 Group Controlling SwMI Functional Entity.

The following functional relationships shall exist between these FEs:

- ra between FE1 and FE21;
- rb between FE21 and FE22;
- rc between FE22 and FE21;
- rd between FE21 and FE1.

Figure 1 shows these FEs and relationships in the case of individual call while figure 2 shows these FEs and relationships in the case of group call.

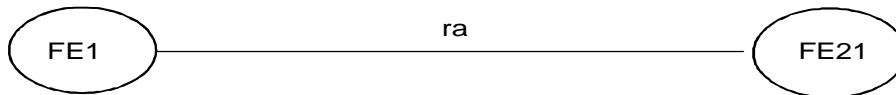

Figure 1: Functional model for SS-CLIP in the case of Individual Call

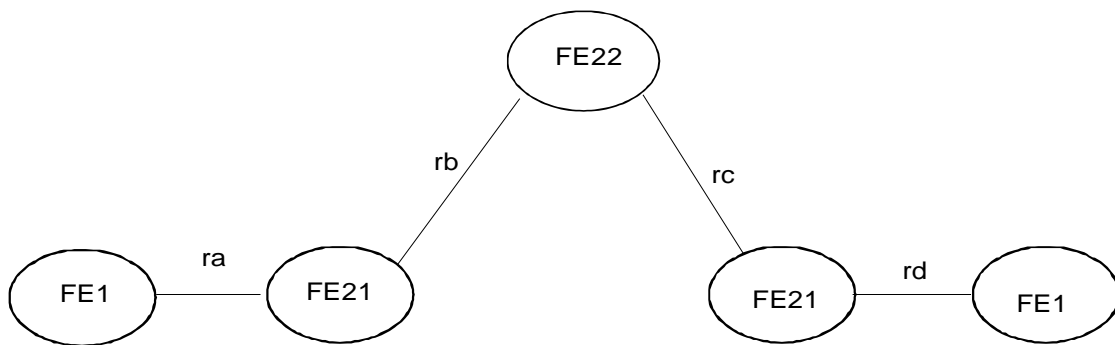

Figure 2: Functional model for SS-CLIP in the case of Group Call

According to stage 1 description in EN 300 392-10-1 [7], activation/deactivation of SS-CLIP is done by provision at subscription time; as a result, there is no activation/deactivation, no interrogation and/or no definition procedure; there shall be no authorized user for that SS-CLIP.

4.1.2 Description of functional entities

4.1.2.1 Served User CGLI Reception, FE1

This functional entity receives the information related to the calling user identity and delivers it either to the served/connected user in the case of an individual call or to the served/connected users in the case of a group call.

4.1.2.2 Served User current SwMI, CGLI Presentation, FE21

When an individual call is being set-up, FE21 shall determine if SS-CLIP is activated, and if so, the applicable presentation parameters (i.e. whether SS-CLIR has been invoked or not for that call). If yes, FE21 shall then invoke SS-CLIP and shall report to served user FE1 the calling user identity.

In the case of interworking, the presentation of an indicator "number not available due to interworking" shall be possible.

4.1.2.3 Group Controlling SwMI, FE22

SwMI FE22, the group controlling SwMI, shall determine if SS-CLIP is activated with or without restrictions and if so shall present to all connected users in the group call the identity of the calling user (ITSI). The calling user ITSI shall be provided to the connected user(s).

NOTE: The Group GTSI is always presented in a group call set-up whether or not SS-CLIP is activated or not; thus only the ITSI of the group calling user needs to be presented in the case where SS-CLIP is active.

4.1.3 Relationship of functional model to individual call functional model

FE21 shall be collocated with the terminating CC in the case of individual calls.

FE1 shall be collocated with each terminating CCA.

Figure 3 shows an example of the relationship between the model for SS-CLIP and the model for the basic call in the case of an individual call.

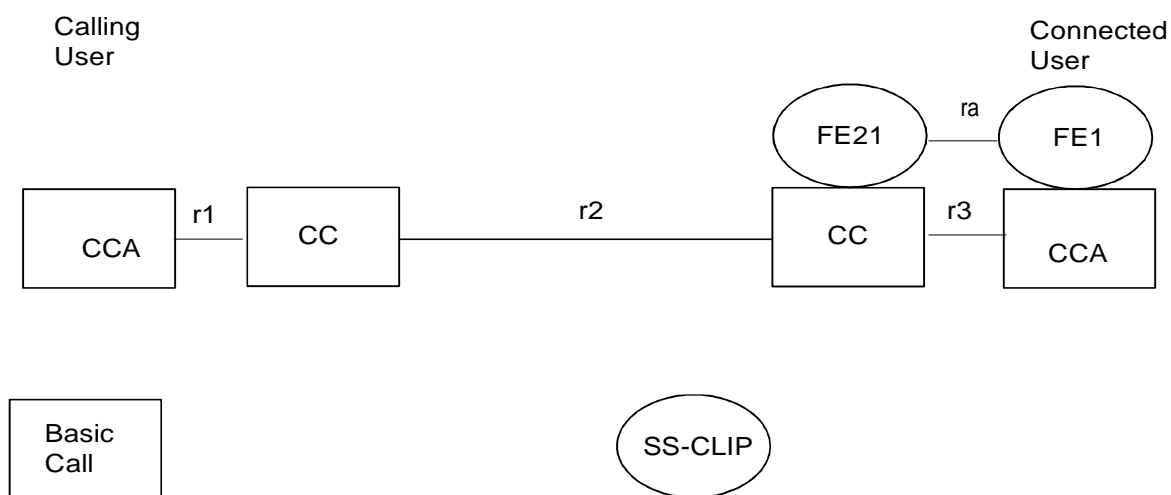

Figure 3: Example relationship between models for SS-CLIP and individual call

4.1.4 Relationship of functional model to group call functional model

FE21 shall be collocated either with each terminating CC for a group call.

FE1 shall be collocated with each terminating CCA.

Figure 4 shows an example of the relationship between the model for SS-CLIP and the model for the basic call in the case of a group call.

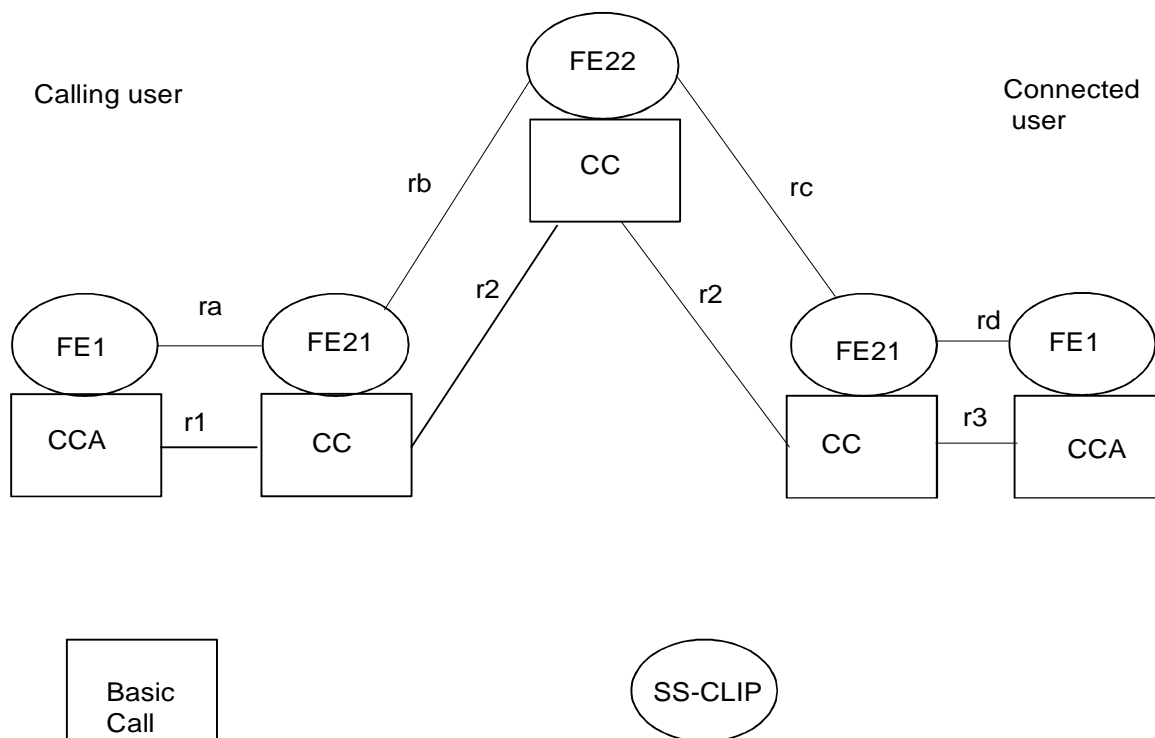

NOTE: FE22 and FE21 may be collocated.

Figure 4: Relationship between models for SS-CLIP and group call

4.2 Information flows

4.2.1 Definition of information flows

In the tables listing the information elements in information flows, the column headed "Request" indicates which of these information elements are mandatory (M) and which are optional (O) in a request/indication information flow, and the column headed "Confirm" indicates which of these information elements are mandatory (M) and which are optional (O) in a response/confirmation information flow.

4.2.1.1 CGLI (CallinG Line Identification)

CGLI is an unconfirmed information flow across ra which conveys calling line identification information either from FE21 to FE1 or from FE22 to FE1.

Table 1 lists the information elements within the CGLI indication information flow.

Table 1: Content of CGLI

Information element	Indication
Presentation Indicator	M
Calling user ITSI	C (see note 1)
External Subscriber Number	C (see notes 1, 2 and 3)
Screening Indicator	O (see note 4)
NOTE 1: Conditional upon restriction or not.	
NOTE 2: May be present only in the case of interworking.	
NOTE 3: May be accompanied by indicators (type of number, numbering) in the case of interworking, not to be presented to the MS.	
NOTE 4: In the case of interworking incoming calls, only one screening indicator (number not available due to interworking) needs be provided to the MS.	

CGLI indication shall always be included in the information flow at ra (regardless of the invocation or not of SS-CLIR). As a minimum, the CGLI shall contain one of the following presentation indicators:

- presentation of identity not restricted;
- presentation of identity restricted;
- calling user identity not available owing to interworking.

NOTE 1: The case of SS-CLIR override is an implementation option excepted when the override is required for the proper operation of supplementary services such as SS-CAD or SS-DL.

NOTE 2: In the cases where SS-CLIR is invoked and is overridden, it is recommended to inform the user who has invoked SS-CLIR that his invocation has been overridden.

In addition CGLI shall contain either the calling user identity (ITSI of individual user in case of TETRA call) or the calling interworking gateway ITSI and the external subscriber number (in case of interworking) if it is available and if presentation is not restricted (or if presentation is restricted and the connected user has an override capability).

In the case of interworking, the calling user identity, if present, shall be accompanied down to the terminating SwMI FE21 by the numbering plan identifier, the type of identity, and one of the following screening indicators:

- user provided, verified and passed;
- user provided, not screened (only occurs in certain interworking situations);
- network provided.

NOTE 3: The case of user provided CGLI is excluded in TETRA.

4.2.2 Relationship of information flows to basic call information flows

The CGLI request/indication information flow shall be sent across ra at the same time as the basic call information flow SETUP request/indication is sent across basic call relationship r1 (terminating CC to terminating CCA).

NOTE: The information content of CGLI is gained from information received in the basic call information flow SETUP request/indication received from basic call relationship r2, i.e. from the CC prior to the terminating CC. This information ultimately comes from the originating CC.

4.2.3 Examples of information flow sequences

EN 300 392-12-1 [8], on SS-CLIP stage 3 description, specifies the signalling procedures in support of the information flow sequences specified in the following clauses. In addition, it specifies signalling procedures to cover other sequences arising from service specific error situations, interactions with basic call, interactions with other supplementary services, different topologies etc.

In the figures, SS-CLIP information flows are represented by solid arrows and basic call information flows are represented by broken arrows. An ellipse embracing two information flows indicates that the two information flows occur together. Within a column representing an SS-CLIP functional entity, the numbers refer to functional entity actions listed in clause 4.3.

4.2.3.1 Normal operation of SS-CLIP

Figure 5 shows the information flow sequence for normal operation of SS-CLIP in the case of Individual Call. Figure 6 shows the information flow sequence for normal operation of SS-CLIP in the case of Group Call.

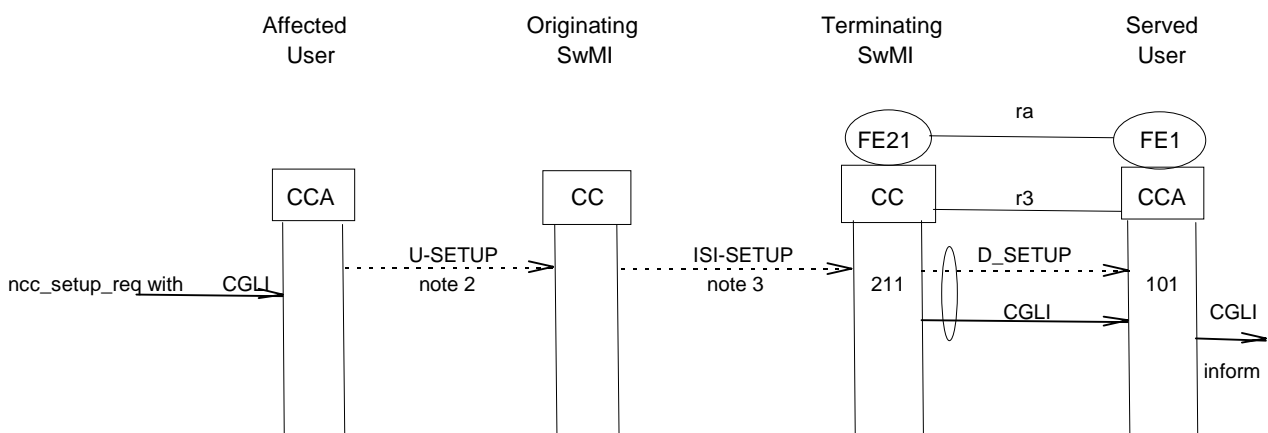

NOTE 1: Original ECMA-148 [9] figure where FE1 is replaced by FE21 and FE2 by FE1, where rx becomes ra 101 becomes 211 and 201 becomes 101.

NOTE 2: Basic call SETUP contains the CLIP information so that no additional flow is required at the MS.

NOTE 3: The only additional information flow in the ISI-SETUP is the transport of the type of number, numbering plan and screening indicator which are not received by the MS.

Figure 5: Information flow sequence normal operation of SS-CLIP in the case of individual call

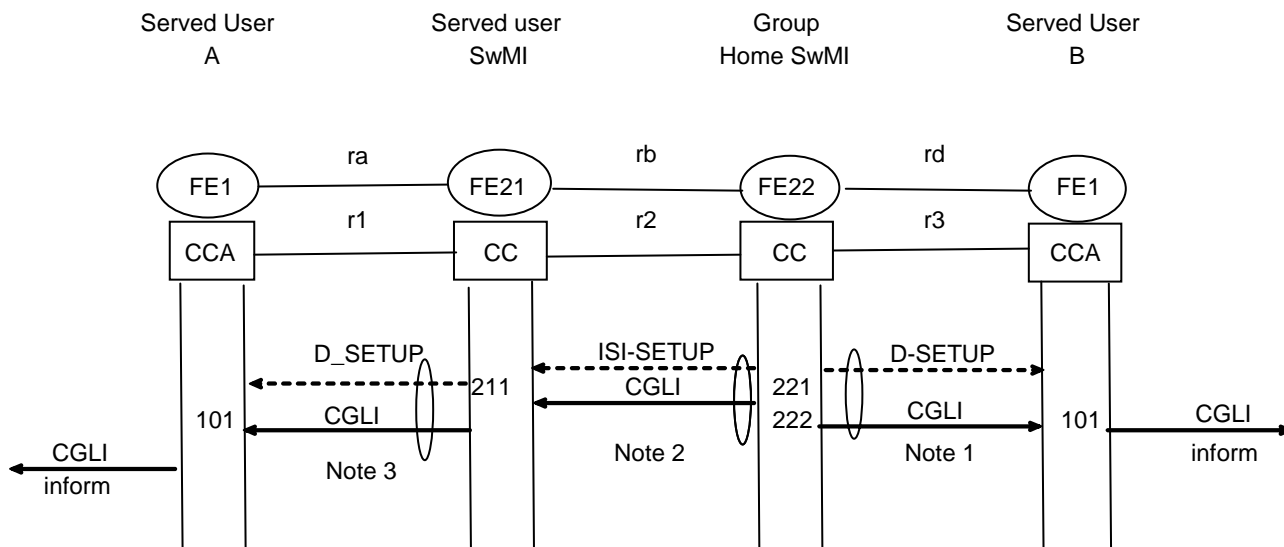

- NOTE 1: Several served users in the group obtain the CLIP from the calling user FE5, one of them served user B is assumed to be local (for this user FE21 and FE22 are collocated).
- NOTE 2: This figure is shown with the assumption that the group controlling SwMI is the CLIP controlling SwMI; FE21 is assumed to be collocated with FE22 on one side and separated on the other side.
- NOTE 3: The calling user is not represented on this figure; this figure applies to the case where only SS-CLIP is invoked, no SS-CLIR, no override.

Figure 6: Information flow sequence normal operation of SS-CLIP in the case of Group Call

4.3 Functional entity actions

The following FE actions shall occur at the points indicated in figures 5 and 6.

4.3.1 Functional entity actions of FE21

- 211 Receive calling user identity for transmission to FE1, taking into account any restriction on presentation of the identity and the connected user's authority to override such restriction. If the calling user identity is either not available or restricted, indicate this to FE1.

4.3.2 Functional entity actions of FE1

- 101 Pass any calling user identity received from FE21 to the served user.

4.3.3 Functional entity actions of FE22

- 221 Receive the group call set up from the calling user and indicate either locally or remotely to all users in the group the call set up with the identification of the calling user CGLI and the associated presentation indicators.

4.4 Allocation of functional entities to physical equipment

The allocations of FEs to physical equipment shown in table 2 shall apply.

Table 2: Scenarios for the allocation of FEs to physical equipment

FE22	FE21	FE1
Group Controlling SwMI	Terminating SwMI	Connected User MS

4.5 Interworking considerations

All FEs for SS-CLIP are always located within SwMIs and MS attached to SwMIs.

When SS-CLIP is invoked on behalf of a basic call terminated in another network, the basic call delivers to the served user's SwMI calling line identification information obtained from the other network. In the case of a public ISDN, the CC in the gateway SwMI uses the public ISDN's Calling Line Identification Presentation supplementary service to obtain this information. The External Subscriber Number (ESN) shall be accompanied down to the served user SwMI through ISI by the type of number, the numbering plan and the screening indicator. In the case where that screening indicator indicates "not available due to interworking", this information shall be presented to the end user.

In the case where the other network is unable to provide this information, the CC at the gateway SwMI provides instead an indication that the calling user identity is not available due to interworking.

Invocation of SS-CLIP by the external network is outside the scope of the present document.

NOTE: As a TETRA Gateway consideration, in the case of a call incoming to TETRA, the Calling Line Identification shall always be brought to the Gateway and it will be a gateway decision to provide CLIP in a certain format to the interworking network when this network is invoking SS-CLIP in its operation.

5 Supplementary Service Connected Line Identification Presentation (SS-COLP) stage 2 specification

5.1 Functional model

In order to use the TETRA terminology, to add group call and to handle cases of call forwarding not covered in ECMA-148 [9], the functional model of SS-COLP shall be different from the ECMA-148 [9] functional model.

In the case where SS-COLP is invoked and where the calling user calls a group, the GTSI of the group shall be presented to the calling user.

5.1.1 Functional model description

The functional model shall comprise the following functional entities:

- FE1 Served User COLI Reception (Calling User) Functional Entity;
- FE21 Served User current SwMI COLI Presentation Functional Entity;
- FE22 Group controlling SwMI Functional Entity.

The following functional relationships shall exist between these FEs:

- ra between FE1 and FE21;
- rb between FE1 and FE22.

Figure 7 shows these FEs and relationships in the case of an Individual Call and figure 8 shows these FEs and their relationship in case of a group call.

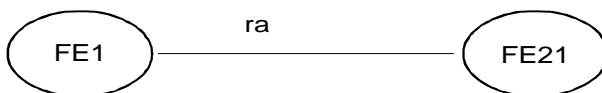

Figure 7: Functional model for SS-COLP in case of individual call

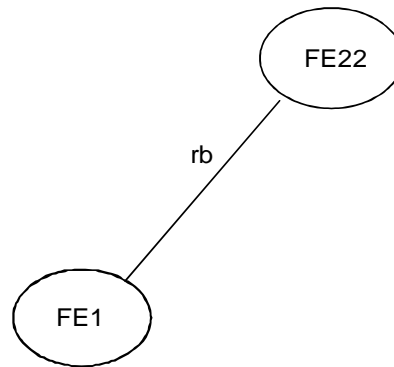

Figure 8: Functional model for SS-COLP in case of a group call

5.1.2 Description of functional entities

According to stage 1 description in EN 300 392-10-1 [7], activation/deactivation of SS-COLP is done by provision at subscription time; as a result, there is no activation/deactivation, no interrogation and/or no definition procedure; there shall be no authorized user for SS-COLP.

5.1.2.1 Served User, Calling User COLI Reception, FE1

This functional entity receives the connected user identity and associated indicators and delivers this information to the user.

5.1.2.2 Served User Current SwMI, COLI Presentation, FE21

SwMI FE21 shall present, unless restrictions apply and are not overridden, to the served user the Connected Line Identification as part of the call set-up. In the case of interworking, both the COLI of the gateway SwMI and the external subscriber shall be presented. In the case of interworking and where the number is not available, the presentation of the COLI shall be replaced by the presentation of a (screening) indicator "number not available due to interworking".

5.1.2.3 Group Controlling SwMI, FE22

SwMI FE22 shall present, unless restrictions apply and are not overridden, to the served user the Connected Line Identification as part of the call set-up with the eventual addition of call parameters, e.g. identification not provided due to interworking.

5.1.3 Relationship of functional model to basic individual call functional model

FE21 shall be collocated with the originating CC.

FE1 shall be collocated with the originating CCA.

Figure 9 shows an example of the relationship between the model for SS-COLP and the model for the basic individual call.

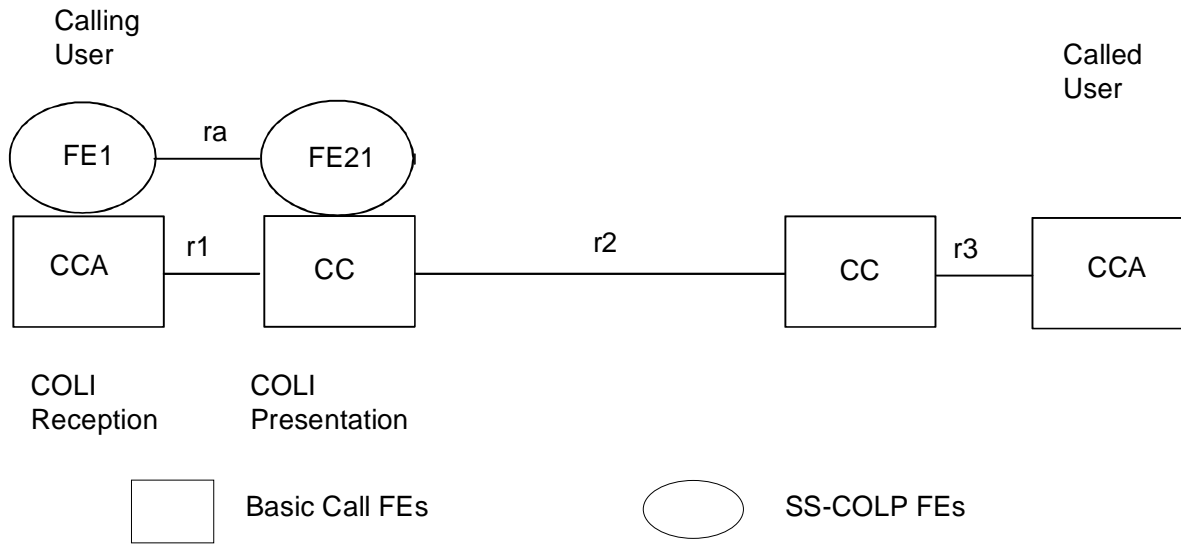

Figure 9: Example relationship between models for SS-COLP and basic individual call

5.1.4 Relationship of functional model to basic group call functional model

FE22 shall be collocated with the group controlling SwMI.

FE1 shall be collocated with the originating CCA.

Figure 10 shows an example of the relationship between the functional model for SS-COLP and the basic group call functional model.

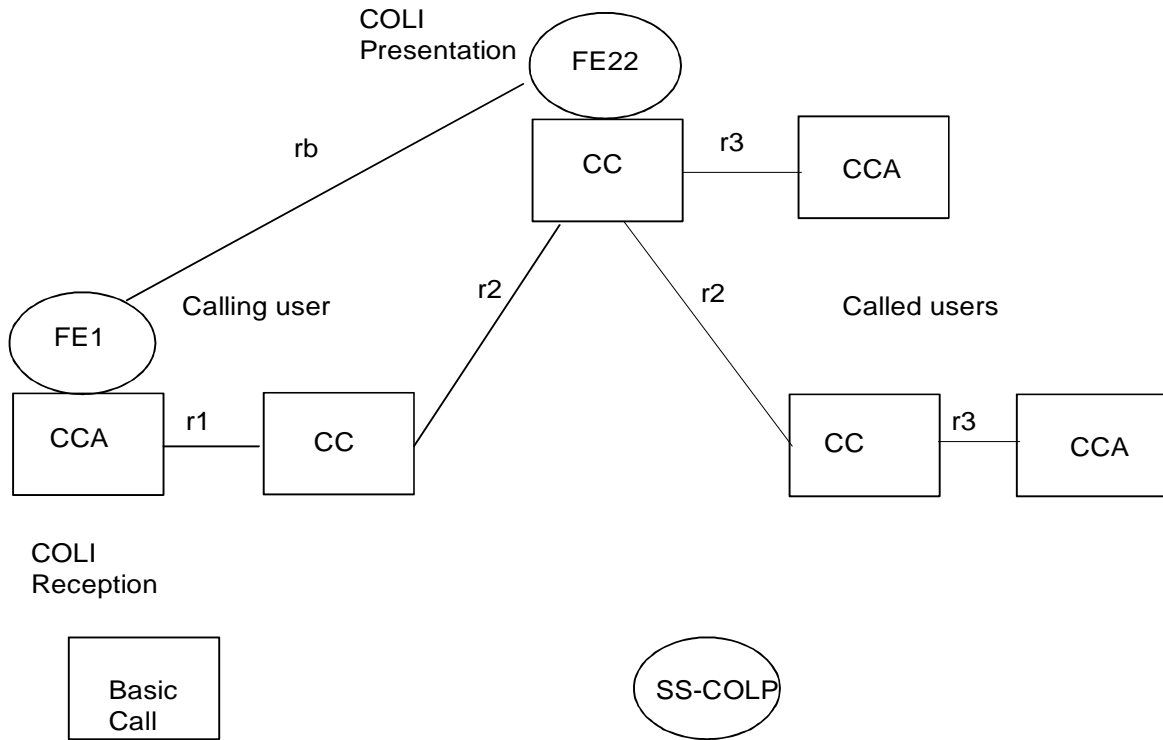

Figure 10: Example relationship between models for SS-COLP and basic group call

5.2 Information flows

5.2.1 Definition of information flows

In the tables listing the information elements in information flows, the column headed "Request" indicates which of these information elements are mandatory (M) and which are optional (O) in a request/indication information flow, and the column headed "Confirm" indicates which of these information elements are mandatory (M) and which are optional (O) in a response/confirmation information flow.

5.2.1.1 COLI (Connected Line Identification)

COLI is an unconfirmed information flow across either ra for individual call or rb for group call which conveys connected line identification information from either FE21 to FE1 or FE22 to FE1.

Table 3 lists the information elements within the COLI information flow.

Table 3: Content of COLI

Information element	Indication
Presentation Indicator	M
Connected ITSI and/or external subscriber number	C (see note 1)
Screening Indicators	O (see notes 2 and 3)
NOTE 1: Conditional upon restriction or not of COLP. NOTE 2: For TETRA calls, calling user identity is always network provided and screening indicator need not be provided. NOTE 3: In the case of interworking outgoing calls, the screening indicator will either be provided by the interworking network or be provided by the gateway SwMI as not available due to interworking.	

COLI indication shall always be included in the indication information flow at either ra or rb. As a minimum, COLI shall contain one of the following presentation indicators:

- presentation of identity not restricted;
- presentation of identity restricted;
- connected user identity not available owing to interworking.

In addition COLI shall contain the connected user identity (ITSI/GTSI in case of TETRA) if it is available and if presentation is not restricted (or if presentation is restricted and the calling user has an override service profile). In the case of a TETRA call, the connected user identity, shall be accompanied by the type of identity (ITSI, SSI) and shall be provided either by the connected user SwMI (not provided by the user) or by the group controlling SwMI.

In the case of interworking, the connected user identity, if present, shall be accompanied at least to the originating SwMI by the numbering plan identifier, the type of number, and on option one of the following screening indicators:

- network provided;
- user provided, verified and passed;
- user provided, not screened (only occurs in certain interworking situations).

5.2.2 Relationship of information flows to basic call information flows

The COLI indication information flow shall be sent across ra in the case of an individual call at the same time as the basic call information flow SETUP response/confirmation is sent across basic call relationship ra (originating CC to originating CCA); in the case of a group call, the COLI indication information flow shall be sent across rb at the same time as the basic call information SETUP response/confirmation.

NOTE: The information content of COLI is gained from information received in the basic call information flow SETUP response/confirmation received from basic call relationship r2, i.e., from the CC next to the originating CC. This information ultimately comes from the terminating CC and/or the terminating CCA.

5.2.3 Examples of information flow sequences

EN 300 392-12-1 [8], on SS-COLP stage 3 description, specifies the signalling procedures in support of the information flow sequences specified in the following clauses. In addition, it specifies signalling procedures to cover other sequences arising from service specific error situations, interactions with basic call, interactions with other supplementary services, different topologies etc.

In the figures, SS-COLP information flows are represented by solid arrows and basic call information flows are represented by broken arrows. An ellipse embracing two information flows indicates that the two information flows occur together. Within a column representing an SS-COLP functional entity, the numbers refer to functional entity actions listed in clause 5.2.5.

5.2.3.1 Normal operation SS-COLP in case of individual call

Figure 11 shows the information flow sequence for normal operation of SS-COLP in the case of individual call.

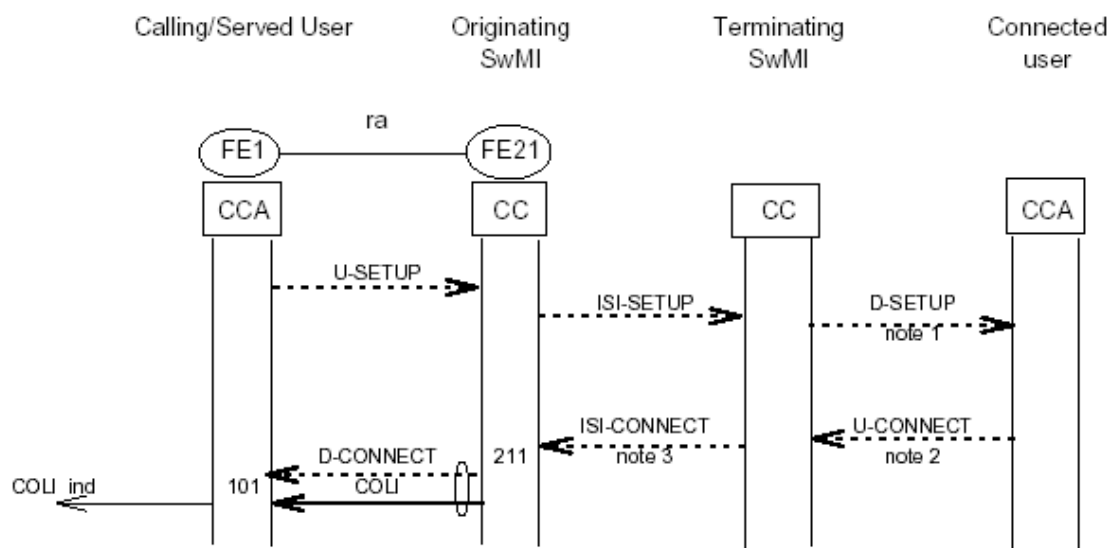

NOTE 1: The connected user is the last user reached in the case of call forwarding supplementary services activation.

NOTE 2: The U-CONNECT Basic Call contains all the information needed for SS-COLP so that no separate flow is needed.

NOTE 3: No additional information flow is shown; in the case of interworking the ISI CONNECT will carry the presentation indicator as part of basic call set up and will carry the screening indicator from the gateway to the served user SwMI in case of interworking.

Figure 11: Information flow sequence normal operation of SS-COLP in case of individual call

5.2.4 Normal operation SS-COLP in case of group call

Figure 12 shows the information flow sequence for normal operation of SS-COLP in the case of group call.

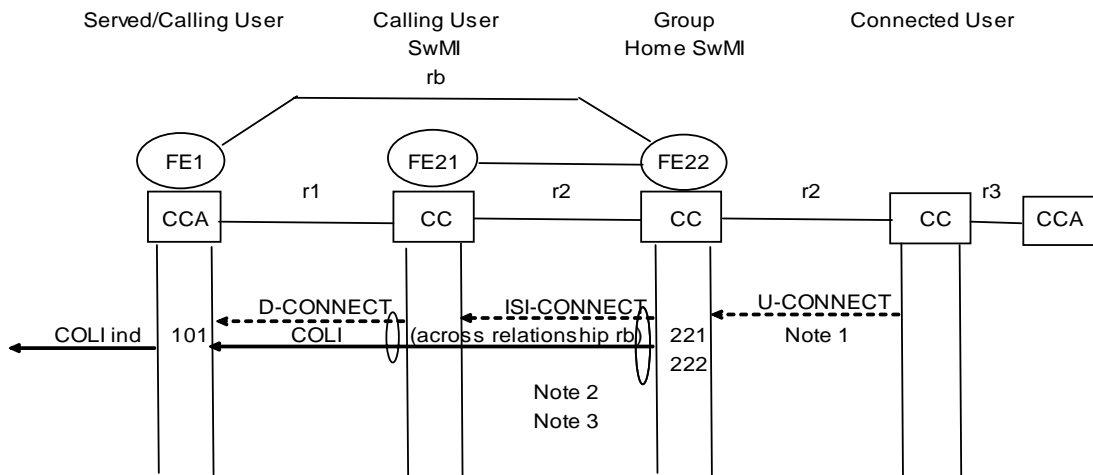

NOTE 1: The U-CONNECT Basic Call contains all the information needed for SS-COLP so that no separate flow is needed.

NOTE 2: It is assumed that at this point, call has been connected, D-SETUP has been broadcast and resources have been allocated in order for the group call GTSI to be presented to the calling user.

NOTE 3: In this figure, the only affected entity is actually the group controlling SwMI.

Figure 12: Information flow sequence normal operation of SS-COLP in case of group call

5.2.5 Functional entity actions

The following FE actions shall occur at the points indicated in figures 11 and 12.

5.2.5.1 Functional entity actions of FE1

101 To present any connected user identity received from either FE21 or FE22 to the calling user application.

5.2.5.2 Functional entity actions of FE21

210 To receive call connect from connected user SwMI.

211 To receive COLI, to check the presentation indicators and to send that indication in the connect message to FE1 served user.

5.2.5.3 Functional entity actions of FE22

220 To establish group call and to identify GTSI for that group call. Actual criteria that triggers COLI transmission is outside the scope of the present document.

221 To determine COLI, to check the presentation indicators and to send that indication in the connect message to FE1 served user via FE21.

5.3 Allocation of functional entities to physical equipment

The allocations of FEs to physical equipment shown in table 4 shall apply.

Table 4: Scenarios for the allocation of FEs to physical equipment

	FE1	FE22	FE21
Scenario1	Served User MS	Controlling SwMI CC	Served User CC

5.4 Interworking considerations

All FEs for SS-COLP are always located within SwMIs and MS attached to SwMIs.

When SS-COLP is invoked on behalf of a basic call which has its destination in another network, the basic call delivers to the served user's SwMI connected line identification information obtained from the other network. In the case of a public ISDN, the CC in the gateway SwMI uses the public ISDN's Connected Line Identification Presentation supplementary service to obtain this information.

Where the other network is unable to provide this information, the CC at the gateway SwMI provides instead an indication that the connected user identity is unavailable owing to either interworking or restriction.

The case where the external network requests SS-COLP from the TETRA network is outside the scope of the present document and is covered by external gateway specification.

NOTE 1: In the case of interworking, there is the additional need to carry the screening indicators both ways in the basic call as part of ISI.

NOTE 2: In the case of interworking incoming calls towards TETRA, the screening indicator will always be set to network provided by the gateway.

6 Supplementary Service Calling Line Identification Restriction stage 2 specification

6.1 Functional model

In order to use TETRA terminology and to handle cases particular to TETRA (in particular group calls), Functional Entities and Functional Models have been represented in different form from ECMA-148 [9]. Moreover, the ECMA text is rewritten in separating the cases of SS-CLIR and of SS-COLR.

6.1.1 Functional model descriptions

According to stage 1 description in EN 300 392-10-1 [7], activation/deactivation of SS-CLIR is done by provision at subscription time on a service profile basis for each user; as a result, there is no activation/deactivation, no interrogation and/or no definition procedure; there shall be no authorized user for SS-CLIR. However, SS-CLIR may be invoked either in a permanent mode (for all calls) or a temporary mode (specified by user per call); this temporary mode uses a default value in case no restriction information is provided by the calling/served user.

NOTE: It is recalled that, as an implementation option, SS-CLIR can be overridden.

6.1.1.1 Functional model description for SS-CLIR in case of Individual Call

The functional model for SS-CLIR shall comprise the following functional entities:

- FE1 Served User, Calling User, CLI Restriction Request Functional Entity;
- FE21 Restriction Control Functional Entity.

In the case of override, the additional functional entities need to be added:

- FE5 Affected user, Connected User, Override Functional Entity.

NOTE: In fact, FE5 may also be considered as an SS-Override Served User.

- FE25 Affected user, override control, Functional Entity.

The following functional relationships shall exist between these FEs:

- ra between FE1 and FE21.

In the case of override, the following additional relationships are needed:

- rb between FE21 and FE25;
- rc between FE25 and FE5.

Figure 13 shows these FEs and relationship.

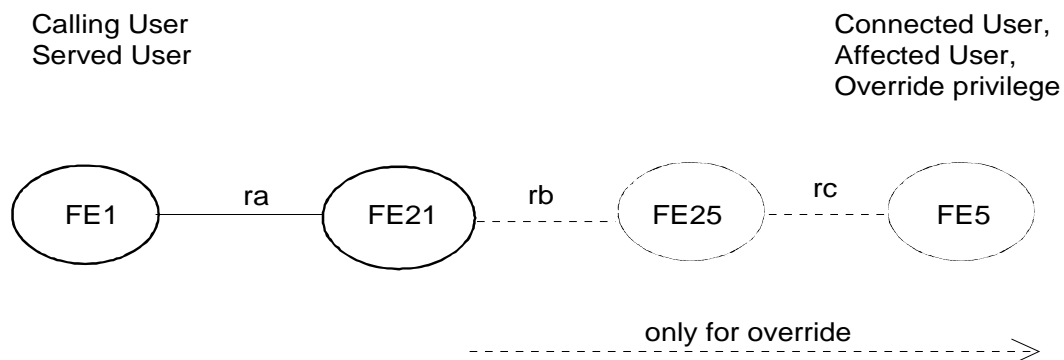

Figure 13: Functional model for SS-CLIR in case of Individual call

6.1.1.2 Functional model description for SS-CLIR in case of Group Call

The functional sub-model for SS-CLIR shall comprise the following functional entities:

- FE1 Served User, Calling User, CLI Restriction Request;
- FE22 Restriction Control, Group Control SwMI.

The following functional relationships shall exist between these FEs:

- rb between FE1 and FE22.

Figure 14 shows these FEs and relationships.

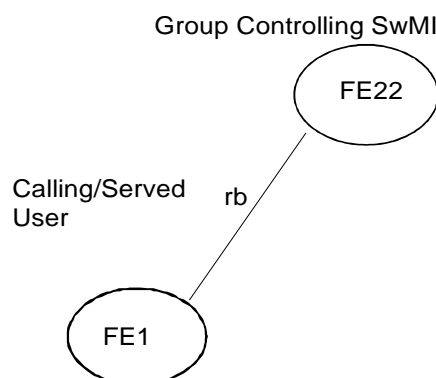

Figure 14: Functional model for SS-CLIR in case of group call

NOTE 1: It is assumed that override capability is either not provided or provided to all members of the group call so that no affected user needs to appear in the functional model.

NOTE 2: It is assumed that SS-CLIR is provided on a permanent basis for group calls.

6.1.2 Description of functional entities

6.1.2.1 Restriction Request, FE1

This functional entity is responsible for receiving user requests for bypass of the temporary mode default and passing them on to the Restriction Control FE22.

6.1.2.2 Restriction Control, Group Controlling SwMI, FE22

This functional entity is responsible for determining whether to invoke CLI restriction on behalf of a user in a group call, based on the user's service profile and any requests from FE1 for the bypass of the temporary mode default.

6.1.3 Relationship of functional model to basic individual call SS-CLIR functional model

FE21 shall be collocated with the CC local to the served user, i.e. the originating CC or the terminating CC.

FE1 shall be collocated with the served user's CCA.

FE21 shall be collocated with the served (calling) user's CC.

Figure 15 shows an example of the relationship between the model for SS-CLIR and the model for the basic individual call. SS-CLIR is available to the calling user (for calling line identification restriction).

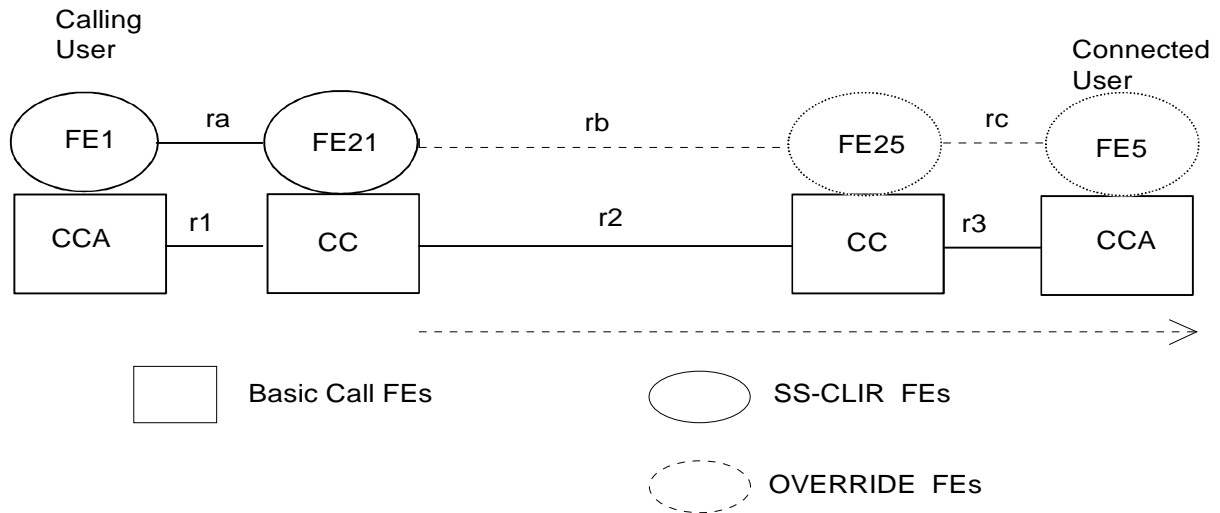

Figure 15: Example relationship between models for SS-CLIR and basic individual call

6.1.3.1 Relationship of functional model to basic group call SS-CLIR functional model

FE22 shall be collocated with the CC controlling the group call.

FE1 shall be collocated with the served user's CCA.

Figure 16 shows an example of the relationship between the model for SS-CLIR and the model for the basic group call. SS-CLIR is available to the calling user (for calling line identification restriction).

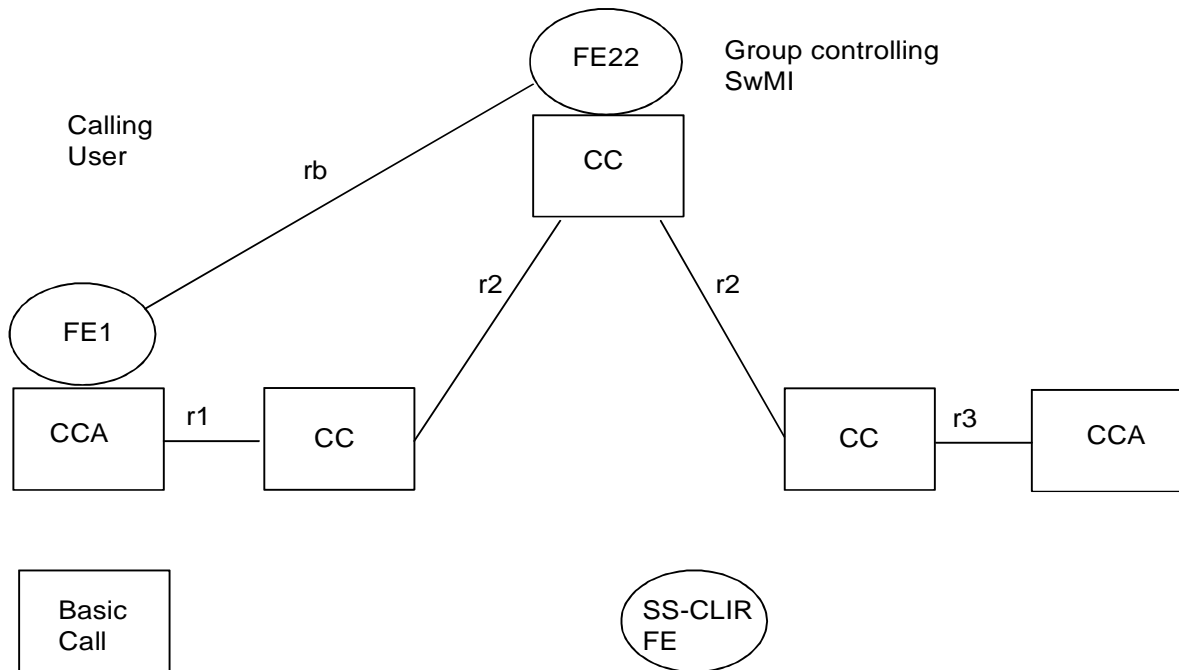

Figure 16: Example relationship between models for SS-CLIR and basic group call

6.2 Information flows

6.2.1 Definition of information flows

In the tables listing the information elements in information flows, the column headed "Request" indicates which of these information elements are mandatory (M) and which are optional (O) in a request/indication information flow, and the column headed "Confirm" indicates which of these information elements are mandatory (M) and which are optional (O) in a response/confirmation information flow.

6.2.1.1 RESTRICT

RESTRICT is an unconfirmed information flow across either ra or rb which conveys a user request to bypass the SS-CLIR temporary mode default from FE1 to FE21.

Table 5 lists the information elements within the RESTRICT information flow.

Table 5: Content of RESTRICT

Service element	Request
Presentation Indicator (PI)	M
CGLI Indicator	M

Service element RI shall be included in the RESTRICT request/indication information flow at either ra or rb. It shall contain at least two of the following indicators:

- presentation not restricted;
- presentation restricted;
- CGLI.

6.2.2 Relationship of information flows to basic call information flows

When the calling user wishes to bypass the SS-CLIR temporary mode default, the RESTRICT request/indication information flow shall be sent across either ra or rb at the same time as the basic call information flow SETUP request/indication is sent across basic call relationship r1 (originating CCA to originating CC) and shall be propagated through ISI to any SwMI affected in the call and to the terminating SwMI actually placing the call in final.

NOTE 1: If FE1 invokes SS-CLIR on behalf of the calling user (automatically or on request from the user), an indication that restriction applies is included in the basic call SETUP request/indication information flow across r2. It is then the responsibility of FEs of SS-CLIP to ensure that identification information is not presented to the other user.

NOTE 2: CGLI indication is carried to the terminating SwMI with the basic SETUP regardless of whether presentation of CLI is restricted or not. This allows to handle eventual cases of override and is the normal operation of the SwMI.

6.2.3 Examples of information flow sequences

EN 300 392-12-1 [8], on SS-CLIR stage 3 description, specifies the signalling procedures in support of the information flow sequences specified in the following clauses. In addition, it specifies signalling procedures to cover other sequences arising from service specific error situations, interactions with basic call, interactions with other supplementary services, different topologies etc.

In the figures, SS-CLIR information flows are represented by solid arrows and basic call information flows are represented by broken arrows. An ellipse embracing two information flows indicates that the two information flows occur simultaneously. Within a column representing an SS-CLIR functional entity, the numbers refer to functional entity actions listed in clause 6.3.1.

6.2.3.1 Normal operation of SS-CLIR in case of individual call

Figure 17 shows the information flow sequence for normal operation of SS-CLIR when invoked by the calling user in the case of an individual call. Figure 18 shows the information flow sequence for normal operation of SS-CLIR when invoked by the calling user in the case of a group call. The calling user SS-CLIR req indicates the user will to bypass the default mode and to impose its own restriction or non restriction in the case of temporary mode. If the user does not provide any restriction request, the default mode shall be set; the absence of RESTRICT information shall result in a CLI restriction OFF if default mode is non restricted and vice-versa. The RESTRICT request information flow is sent only when the served user wishes to bypass the SS-CLIR temporary mode default and shall carry the SS-CLIR request results "Presentation restricted" or "Presentation not restricted".

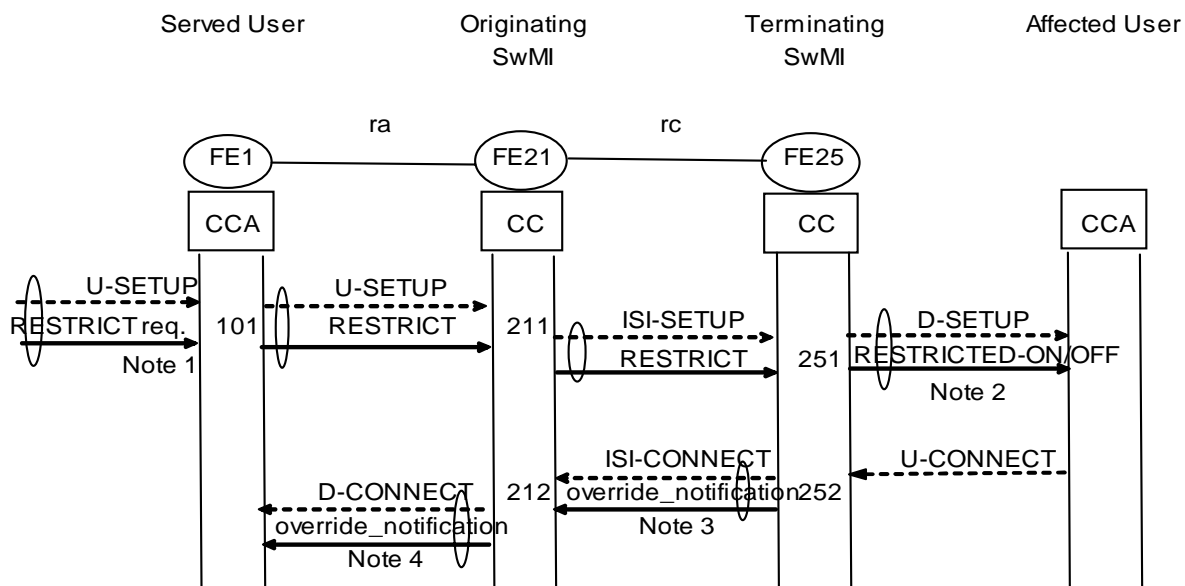

- NOTE 1: RESTRICT req. is always presented by the calling user and indicates restriction or no restriction. It is thus presented to the originating SwMI as a RESTRICT request and passed on in the ISI-SETUP message.
- NOTE 2: D-SETUP is presented without CLI in general; in the case where RESTRICT results in Presentation RESTRICTED ON, and SS-CLIP has been invoked, the affected user shall be informed in the D-SETUP of RESTRICTED ON; in the other case, no information is passed to the affected user. In the case where override is implemented and has taken place, the connected user gets an INFORM2 indicating that CGLI presentation is due to override.
- NOTE 3: Override notification is part of the ISI-CONNECT and uses the notification indicator.
- NOTE 4: Override is presented to the calling user in the notification information element.

Figure 17: Information flow sequence normal operation of SS-CLIR for Individual Call

6.2.3.2 Normal operation of SS-CLIR in case of Group Call

It is assumed that the ANF-ISIGC SETUP PDUs sent by the group controlling SwMI to each participating SwMI shall include the calling user identity as type 1 elements (exactly as the ANF-ISIIC SETUP PDU specified in [4]). This assumption shall be released once the ANF-ISIGC [5] is published.

It is assumed that the ANF-ISIGC SETUP PDUs sent by the group controlling SwMI to each participating SwMI shall include the information as to whether or not SS-CLIR has been invoked for the calling user as a type 1 element (exactly as the ANF-ISIIC SETUP PDU specified in [4]). This assumption shall be released once the ANF-ISIGC [5] is published.

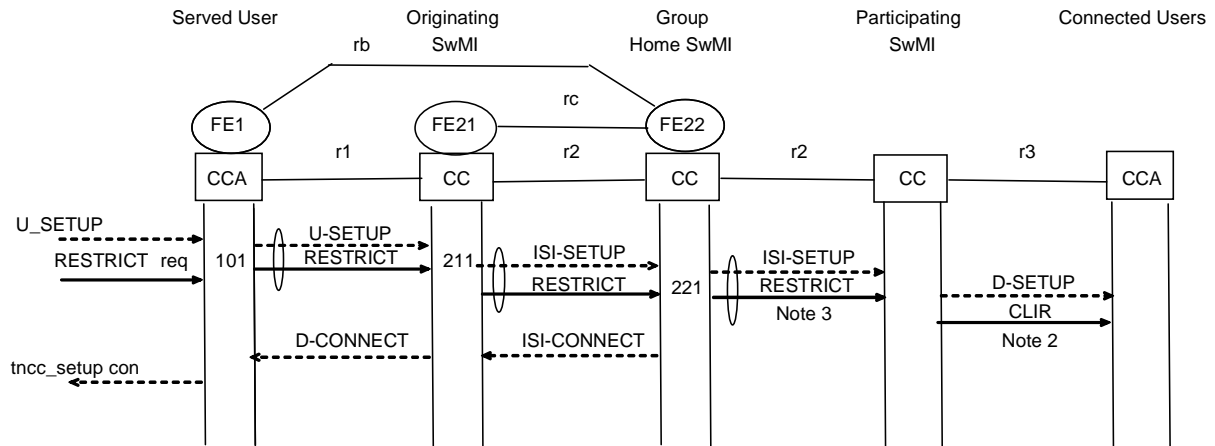

NOTE 1: RESTRICT req is always present and indicates either restriction or no restriction.

NOTE 2: D-SETUP is presented without CLI in general; in the case where RESTRICT results in Presentation RESTRICTED, and SS-CLIP has been invoked, the affected user shall be informed in the D-SETUP of SS-CLIR; in the other case (SS-CLIP not invoked), no information is passed to the affected user.

NOTE 3: The participating SwMI transforms the RESTRICT request into a non presentation of the calling user identity with the SS-CLIR invoked notification.

Figure 18: Information flow sequence normal operation of SS-CLIR for Group Call

6.3 Functional entity actions

The following FE actions shall occur at the points indicated in figure 17.

6.3.1 SS-CLIR Individual call

6.3.1.1 Functional entity actions of FE1

- 101 The served user indicates RESTRICTION or no RESTRICTION for that call and generates a SS-CLIR request sent to FE21.

6.3.1.2 Functional entity actions of FE21

- 211 Assign the appropriate presentation restriction indicator to the served user's ITSI identity, based on whether SS-CLIR permanent mode or temporary mode applies and, in the case of temporary mode, whether a request to restrict presentation or not has been received from FE1.
- 212 Receives the override inform information flow over ISI or locally and presents the information that SS-CLIR has been overridden as a notification to the served user FE1.

6.3.1.3 Functional entity actions of FE25

- 251 Receives the CLIP indication with the presentation indicator (Restricted ON/ restricted OFF) in the ISI-SET-UP and generates the proper D-SETUP with or without CLIP depending whether SS-CLIP is invoked, Restriction is ON/OFF and if override has been invoked. Presentation of restriction indicator is not required if SS-CLIP has not been invoked.
- 252 Receives U-SET-UP as part of basic call set-up, recognizes or not whether SS-CLIR override has been invoked for that call and generates either a normal ISI-CONNECT or a override-notification with the ISI-CONNECT.

6.3.2 SS-CLIR Group call

The following FE actions shall occur at the points indicated in figure 18.

6.3.2.1 Functional entity actions of FE1

- 101 The served user indicates RESTRICTION or no RESTRICTION for that call and generates a SS-CLIR request sent to FE22.

6.3.2.2 Functional entity actions of FE21

- 211 Acts as a relay in presenting to the group controlling SwMI the restrict/no restrict it received from the served user.

6.3.2.3 Functional entity actions of FE22

- 221 Assign the appropriate presentation restriction indicator to the served user's ITSI identity, based on whether SS-CLIR permanent mode or temporary mode applies and, in the case of temporary mode, whether a request to restrict presentation or not has been received from FE1.

NOTE: It is assumed that no override takes place in the case of group call and that the connect is just basic call set up.

6.4 Allocation of functional entities to physical equipment

The allocations of FEs to physical equipment shown in table 6 for SS-CLIR shall apply.

Table 6: Scenarios for the allocation of FEs to physical equipment for SS-CLIR

	FE22	FE21	FE1
Scenario 1	Group Controlling SwMI	Served user's SwMI (Originating SwMI)	Served user's MS

6.5 Interworking considerations

All FEs for SS-CLIR are always located within SwMIs and MS attached to SwMIs.

When SS-CLIR is invoked for a basic call (individual call or group call) which has its destination in another network, the basic call delivers to the other network an indication that presentation of the calling user identity is restricted. In the case of a public ISDN, the CC in the gateway SwMI uses the public ISDN's Calling Line Identification Restriction supplementary service to indicate this. The provision of the calling user identity to the other network in this situation depends on the arrangement with the other network.

7 Supplementary Service Connected Line Restriction stage 2 specification

7.1 Functional model

In order to use TETRA terminology and to handle cases particular to TETRA (in particular group calls), Functional Entities and Functional Models have been represented in different form from ECMA-148 [9]. Moreover, the ECMA text is rewritten in separating the cases of SS-CLIR and of SS-COLR.

7.1.1 Functional model descriptions

According to stage 1 description in EN 300 392-10-1 [7], activation/deactivation of SS-COLR is done by provision at subscription time on a service profile basis for each user; as a result, there is no activation/deactivation, no interrogation and/or no definition procedure; there shall be no authorized user for SS-COLR. However, SS-COLR may be invoked either in a permanent mode (for all calls) or a temporary mode (specified by user per call); this temporary mode uses a default value in case no restriction information is provided by the calling/served user.

In the case of group calls, only permanent mode shall be provided.

NOTE: It is recalled that, as an implementation option, SS-COLR can be overridden.

7.1.1.1 Functional model description for SS-COLR in case of individual call

The functional model for COLR shall comprise the following functional entities:

- FE1 Served User, Connected User, COL Restriction Request Functional Entity;
- FE21 Restriction Control Functional Entity.

In the case where override is provided for a user on a permanent mode basis, the two additional FEs need to be added to the model:

- FE25 Calling User SwMI Override Functional Entity;
- FE5 Calling User Override Functional entity.

The following functional relationships shall exist between these FEs:

- ra between FE1 and FE21.

In the case of override, the additional functional relationship shall exist:

- rb between FE21 and FE25;
- rc between FE25 and FE5.

Figure 19 shows these FEs and relationships.

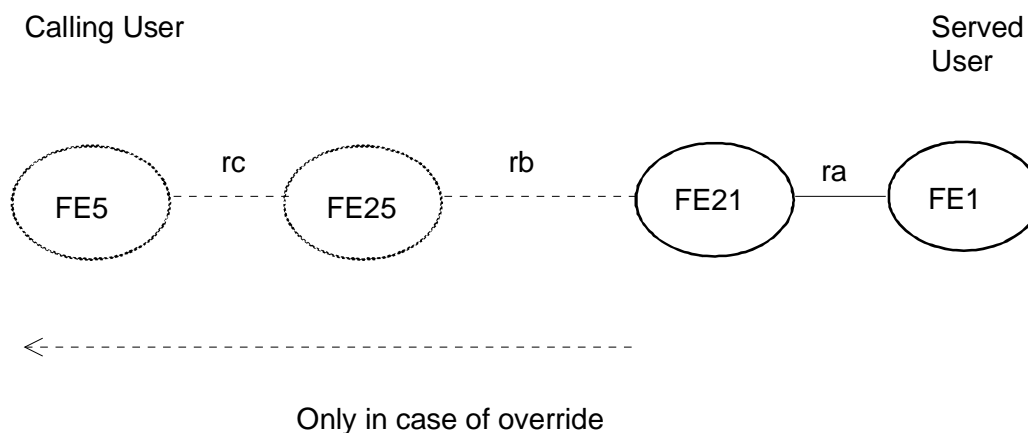

Figure 19: Functional model for SS-COLR in case of Individual call

7.1.1.2 Functional model of SS-COLR in case of group call

The functional sub-model for COLR shall comprise the following functional entities:

- FE1 Served User, Connected User, COL Restriction Request Functional Entity;
- FE22 Group controlling SwMI, Restriction Control Functional Entity;
- FE25 Calling user SwMI Functional Entity;
- FE5 Calling user Functional Entity.

The following functional relationships shall exist between these FEs:

- rb between FE22 and FE5.

In the case of override, the additional following relationship will exist:

- rc between FE22 and FE25;
- rd between FE25 and FE5.

Figure 20 shows these FEs and relationships.

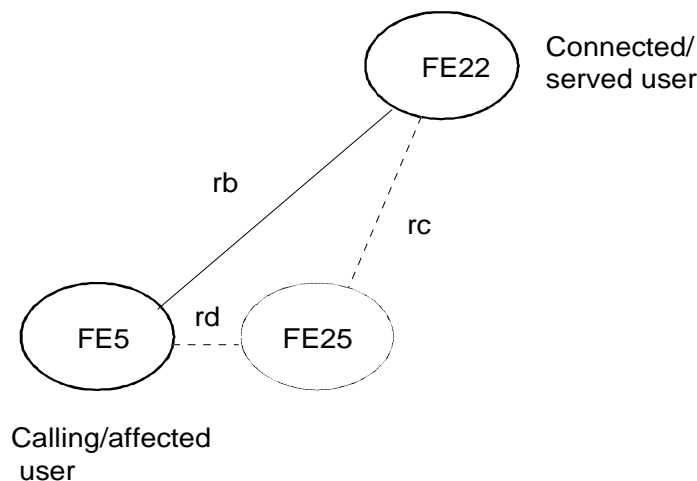

NOTE: The dotted FE and the dotted lines are needed in the case of override invocation.

Figure 20: Functional model for SS-COLR in case of group call

7.1.2 Description of functional entities

7.1.2.1 Functional entities in case of SS-COLR individual call

7.1.2.1.1 Restriction Request, FE1

This functional entity receives user requests for restriction of COLP in the case of temporary mode operation and passes them on to the Restriction Control FE21. It is associated to the connected user in a basic (individual only) call. In the case where override privilege has been invoked by the calling user, FE1 shall inform that SS-COLR has been overridden.

7.1.2.1.2 Restriction Control, FE21

This functional entity is responsible for determining whether to invoke COLI restriction on behalf of a user in a call, based on the user's service profile and any requests from FE1 for COLP restriction in the case of temporary mode operation. In the case of override, FE21 will inform FE1 that SS-COLR has been overridden by the calling user.

7.1.2.2 Relationship of functional model to basic individual call COLR functional model

FE21 shall be collocated with the CC local to the served user, i.e. the originating CC or the terminating CC.

FE1 shall be collocated with the served connected user's CCA.

In the case of override, FE25 will be collocated with the calling user CC and FE5 will be collocated with the calling user CCA.

Figure 21 shows an example of the relationship between the model for SS-COLR and the model for the basic individual call. SS-COLR is available to the connected user (for connected line identification restriction).

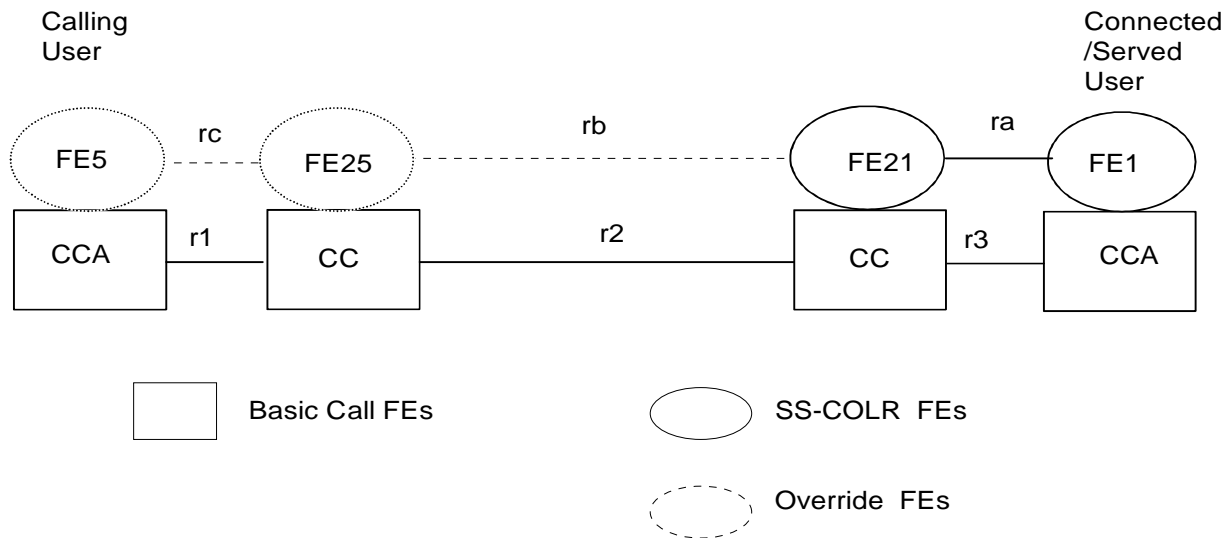

NOTE: The dotted FEs and relationships apply only in the case where override is implemented.

Figure 21: Example relationship between models for SS-COLR and basic individual call

7.1.2.3 Functional entities in case of SS-COLR group call.

7.1.2.3.1 Served User, FE1

According to EN 300 392-10-1 [7], in the case of group call, SS-COLR is either permanently provided or permanently non-provided. The setting of a new basic group call invokes SS-COLR in the case where SS-COLR is permanently provided.

NOTE: The served user in case of group call is in fact the group GTSI entity and is not necessarily associated to any MS.

7.1.2.3.2 Group controlling SwMI, FE22

This functional entity is responsible for determining whether to invoke COLI restriction on behalf of the group in a call, based on the group's service profile and any permanent provision of SS-COLR. FE22 will also indicate that calling user has invoked override privilege.

7.1.2.3.3 Calling User, Affected user SwMI FE25

This functional entity is required in the case of override implementation; in that case, it receives all relevant information concerning SS-COLR for the call being established, checks any override capability of the calling/affected user and provides either the COLR indication or the COLI indication (in case of override) to FE5.

7.1.2.3.4 Calling User MS FE5

This functional entity receives the indication that SS-COLR has been invoked at the same time as the basic call set-up and informs the calling user of that state. FE5 has initially requested SS-COLP at the same time as it requested basic group call set-up. In the case of override, FE5 may be informed of the fact that COLI presentation is due to override (implementation option).

Table 7 lists the information elements within the RESTRICT information flow.

Table 7: Content of RESTRICT

Service element	Request
Presentation Indicator (PI)	M
COLI Indicator	M

Service element PI Presentation Indicator shall be included in the RESTRICT request/indication information flow at ra in case of individual call and at rb in case of group call. It shall contain two of the following indicators:

- presentation not restricted;
- presentation restricted;
- COLI.

See the SS-COLP specification above for the content of the COLI indicator.

7.2.2 Relationship of information flows to basic call information flows

When the connected user wishes to set the SS-COLR temporary mode to a particular value (RESTRICTED or NOT RESTRICTED), the RESTRICT request/indication information flow shall be sent across ra at the same time as the basic call information flow CONNECT response/confirmation is sent across basic call relationship r1 (terminating CCA to terminating CC) in the case of an individual call.

In the case of a group call, permanent mode shall always apply so that information flow is not required.

NOTE: If FE1 invokes SS-COLR on behalf of the connected user (automatically or on request from the user), an indication that restriction applies is included in the basic call CONNECT response/confirmation information flow across r2. It is then the responsibility of FEs of SS-COLP respectively to ensure that identification information is not presented to the other user.

7.2.3 Examples of information flow sequences

EN 300 392-12-1 [8], on SS-COLR stage 3 description, specifies the signalling procedures in support of the information flow sequences specified in the following clauses. In addition, it specifies signalling procedures to cover other sequences arising from service specific error situations, interactions with basic call, interactions with other supplementary services, different topologies etc.

In the figures, SS-COLR information flows are represented by solid arrows and basic call information flows are represented by broken arrows. An ellipse embracing two information flows indicates that the two information flows occur simultaneously. Within a column representing an SS-COLR functional entity, the identities refer to functional entity actions listed in clause 7.3.1.

7.2.3.1 Normal operation of SS-COLR in case of individual call

Figure 23 shows the information flow sequence for normal operation of SS-COLR when invoked by the connected user in the case of an individual call. The connected user COLR req indicates the user will to bypass the default mode and to impose or not its own restriction in the case of temporary mode. If the connected user does not provide any restriction request, the default mode value shall be set; the absence of RESTRICT information shall result in COL restriction OFF if the default mode is non restricted and vice-versa. The RESTRICT information flow is sent only when the served user wishes to override the SS-COLR temporary mode default and shall carry the COLR request results "Presentation restricted" or "Presentation not restricted".

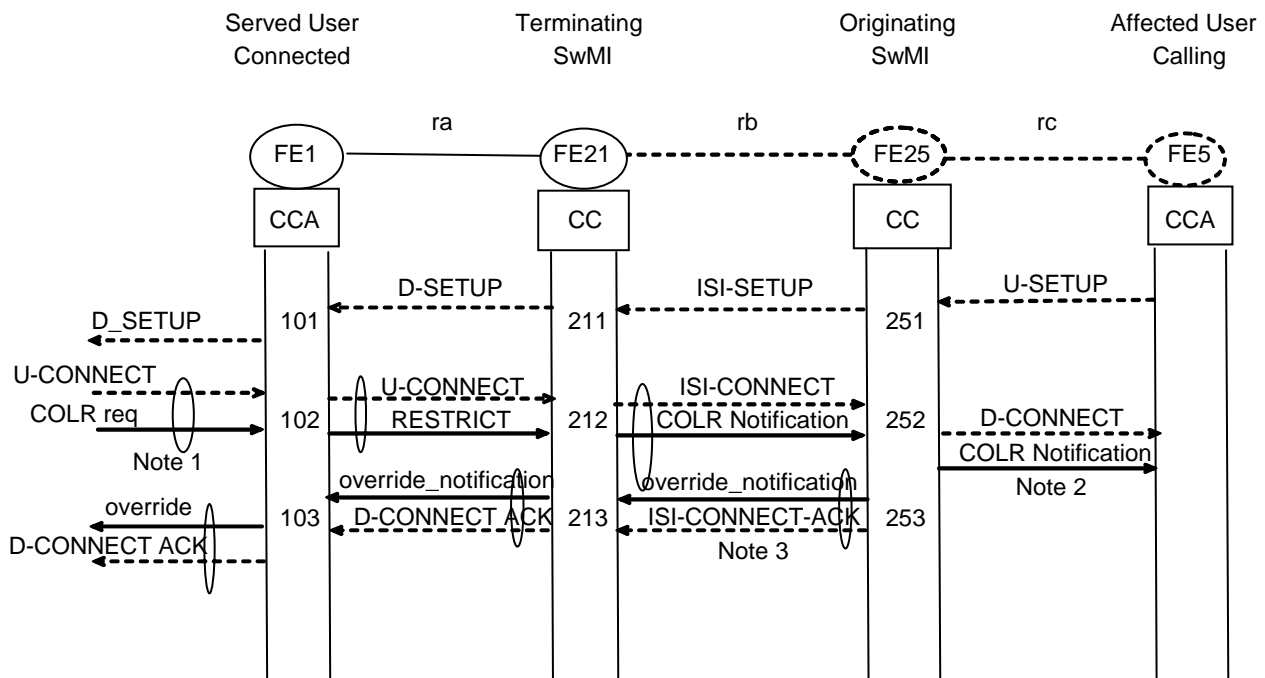

- NOTE 1: COLR-req is always presented in the case of temporary mode and contains RESTRICTION ON or NO RESTRICTION. It is thus presented to the originating SwMI with basic call and passed on in an ISI-CONNECT.
- NOTE 2: D-CONNECT is presented without COLI in general; in the case where CHANGE-COLR-MODE results in COLI Presentation RESTRICTED ON, and SS-COLP has been invoked, the calling user shall be informed in the D-SETUP of RESTRICTED ON; in the other case (where SS-COLP is not invoked), no information is passed to the calling user. In the case the calling user has override privilege, the connected user is informed that its SS-COLR invocation has been overridden in a notification indicator as part of the D-CONNECT ACKNOWLEDGE and the calling user will get the COLI.
- NOTE 3: Override notification is part of the ISI-CONNECT and uses the notification indicator.

Figure 23: Information flow sequence normal operation of SS-COLR in case of individual call

7.2.3.2 Normal operation of SS-COLR in case of Group Call

Main application of COLP is to indicate group call transfer (called GTSI is different from the connected GTSI). In the same manner, main application of SS-COLR in case of group call will be the non indication to the calling user that the group call has been forwarded.

It is assumed that the ANF-ISIGC SETUP PDUs sent by the group controlling SwMI to each participating SwMI shall include the connected user identity (GTSI) as type 1 elements (exactly as the ANF-ISIIC SETUP PDU specified in [4]); the GTSI may be the original GTSI or the GTSI of the group to which the group call has been transferred. This assumption will be confirmed at the publication of the ANF-ISIGC [5].

It is also assumed that the ANF-ISIGC SETUP PDUs sent by the group controlling SwMI to each participating SwMI shall include the information as to whether or not SS-COLP and SS-CLIR (interpreted here as SS-COLR) has been invoked for the connected group as a type 1 element (exactly as the ANF-ISIIC SETUP PDU specified in [4]); this assumption will be confirmed at the publication of the ANF-ISIGC [5].

Based on those assumptions, figure 24 shows the information flow sequence normal operation of SS-COLR in the case of a group call.

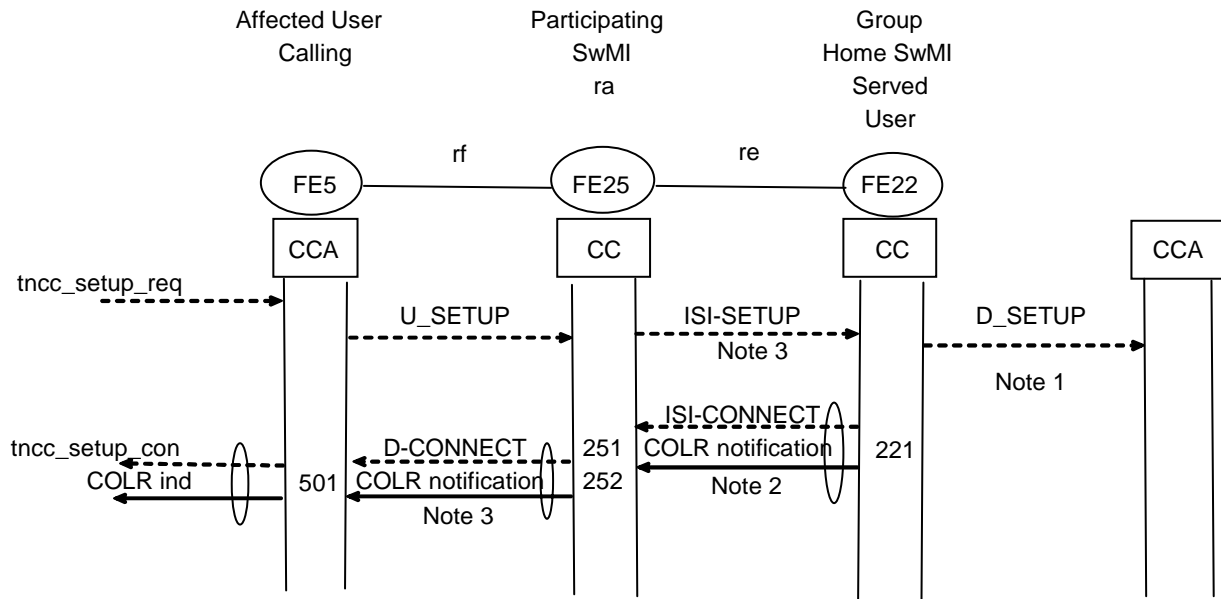

NOTE 1: There is no actual connected user need to generate the COLI indication (GTSI) for a group call if not restricted.

NOTE 2: The COLR invocation is carried in the notification element with the basic connect flow. No individual SS-COLR invocation is possible in group call. In the case where override is invoked it is assumed to be permanent and for all users in the group so that no additional information flow is needed, the group controlling SwMI has all the information needed.

NOTE 3: The basic ISI-SETUP does not need to carry the information that SS-COLP is invoked since the treatment of what is finally presented to the user is done in the calling user SwMI.

NOTE 4: It is assumed that if the calling user SwMI does not support SS-COLR, it most probably does not support SS-COLP either so that the calling user will not be presented with the connected GTSI even though it has reached the originating SwMI.

Figure 24: Information flow sequence normal operation of SS-COLR in case of group call

7.3 Functional entity actions

7.3.1 SS-COLR individual call

The following FE actions shall occur at the points indicated in the figure 23.

7.3.1.1 Functional entity actions of FE1

- 101 Receives a normal call set-up, presents it to the connected MS (no need to indicate that SS-COLP is invoked for that call).
- 102 If the served connected user wishes to set the restriction value in the case of temporary mode, FE1 generates a COLR request and sends it to FE21.
- 103 obtains the override-notification from the terminating SwMI and informs the MS that its request for restriction has been overridden by the calling user in the D-CONNECT-ACK.

7.3.1.2 Functional entity actions of FE21

- 211 Assign the appropriate presentation restriction indicator to the served connected user's ITSI identity, based on whether COLR permanent mode or temporary mode applies and, in the case of temporary mode, whether a request for COLR restriction or no restriction has been received from FE1.
- 212 Receives the COLR invocation in the case of temporary mode as part of the U-CONNECT and generates an ISI-CONNECT with the restriction of COLP.
- 213 Receives the information that the request for COLR has been overridden by the calling user and informs the connected user MS that its request for COLR has been overridden.

7.3.1.3 Functional entity actions of FE25

- 251 Normal call set-up with SS-COLP invoked (due to permanent invocation of SS-COLP for that calling user).
- 252 Receives the COLR notification with the CONNECT, determines that the calling user has override privilege or not and presents to the calling user MS the D-CONNECT as part of the basic call set-up with the notification according to SS-COLP invoked, SS-COLR invoked by connected user and override privilege.
- 253 In the case where override privilege applies, generate an override-notification with the CONNECT-ACK to inform the connected user that its request for COLR has been overridden.

7.3.2 SS-COLR group call

The following FE actions shall occur at the points indicated in the figure 24.

7.3.2.1 Functional entity actions of FE1

- NOTE: In the case of group call, there is no possible individual group member SS-COLR change of mode capability; SS-COLR is either invoked for the whole group or is not invoked at all. The criteria which triggers the sending of the COLI is outside the scope of the present document and is to be found in the ANF-ISIGC EN 300 392-3-3 [5].

7.3.2.2 Functional entity actions of FE22

- 221 To recognize the SS-COLR invocation for that GTSI and to present it in the basic ISI-GC CONNECT that contains the COLI and the presentation restriction indicator.

NOTE: The actual action which triggers the sending of the ISI-CONNECT is outside the scope of the present document and is to be found in the ANF-ISIGC EN 300 392-3-3 [5].

7.3.2.3 Functional entity actions of FE25

- 251 To receive the ISI basic call set-up, to extract the COLI as well as the presentation indicator and to recognize the SS-COLP invocation or non invocation state.
- 252 To present the basic call CONNECT with the indication that COLI presentation is restricted to FE5.

7.3.2.4 Functional entity action of FE5

- 501 To receive the basic call set-up with the indication that the COLI presentation is restricted and to inform the calling user of that fact in a COLR indication.

7.4 Allocation of functional entities to physical equipment

The allocations of FEs to physical equipment shown in table 8 for SS-COLR shall apply.

Table 8: Scenarios for the allocation of FEs to physical equipment for SS-COLR

	FE22	FE21	FE1
Scenario 1	Group Controlling SwMI	Served user's SwMI (Terminating SwMI)	Served user's MS

- 11.6 Interworking considerations

All FEs for SS-COLR are always located within SwMIs and MS attached to SwMIs.

When SS-COLR is invoked for a basic individual call which has originated in another network, the basic call delivers to the other network an indication that presentation of the connected user identity is restricted. In the case of a public ISDN, the CC in the gateway SwMI uses the public ISDN's Connected Line Identification Restriction supplementary service to indicate this. In the case where SS-COLR is invoked for a basic group call which has originated in another network, the gateway SwMI shall deliver to the other network an indication that presentation of the COLI is not possible due to the nature of the call. The provision of the connected user identity to the other network in this situation depends on the arrangement with the other network.

Annex A (informative): Bibliography

ETSI EN 300 392-2: "Terrestrial Trunked Radio (TETRA); Voice plus Data (V+D); Part 2: Air Interface (AI)".

ETSI EN 300 392-3-1: "Terrestrial Trunked Radio (TETRA); Voice plus Data (V+D); Part 3: Inter-working at the Inter-System Interface (ISI); Sub-part 1: General design".

ITU-T Recommendation Z.100: "Specification and Description Language (SDL)".

ETSI ETS 300 392-10-3: "Terrestrial Trunked Radio (TETRA); Voice plus Data (V+D); Part 10: Supplementary services stage 1; Sub-part 3: Talking Party Identification (TPI)".

ETSI EN 300 392-3-4: "Terrestrial Trunked Radio (TETRA); Voice plus Data (V+D); Part 3: Interworking at the Inter-System Interface (ISI); Sub-part 4: Additional Network Functions Short Data Service (ANF-ISISDS)".

ETSI EN 300 392-3-5: "Terrestrial Trunked Radio (TETRA); Voice plus Data (V+D); Part 3: Interworking at the Inter-System Interface (ISI); Sub-part 5: Additional Network Functions Mobility Management (ANF ISIMM)".

History

Document history		
Edition 1	August 1999	Publication as ETS 300 392-11-1
V1.2.0	August 2003	One-step Approval Procedure OAP 20031219; 2003-08-20 to 2003-12-19