

EN 300 386-2 V1.1.3 (1997-12)

European Standard (Telecommunications series)

**Electromagnetic compatibility
and Radio spectrum Matters (ERM);
Telecommunication network equipment;
ElectroMagnetic Compatibility (EMC) requirements;
Part 2: Product family standard**



European Telecommunications Standards Institute

Reference

DEN/ERM-EMC-103-2-2 (3koi0ie0.PDF)

Keywords

EMC, management, network, power supply,
switching, testing, transmission

ETSI Secretariat

Postal address

F-06921 Sophia Antipolis Cedex - FRANCE

Office address

650 Route des Lucioles - Sophia Antipolis
Valbonne - FRANCE
Tel.: +33 4 92 94 42 00 Fax: +33 4 93 65 47 16
Siret N° 348 623 562 00017 - NAF 742 C
Association à but non lucratif enregistrée à la
Sous-Préfecture de Grasse (06) N° 7803/88

X.400

c= fr; a=atlas; p=etsi; s=secretariat

Internet

secretariat@etsi.fr
<http://www.etsi.fr>

Copyright Notification

No part may be reproduced except as authorized by written permission.
The copyright and the foregoing restriction extend to reproduction in all media.

Contents

Intellectual Property Rights.....	5
Foreword	5
1 Scope.....	6
2 References.....	7
2.1 Normative references.....	7
2.2 Informative references	8
3 Definitions and abbreviations	9
3.1 Definitions	9
3.2 Abbreviations.....	10
4 Installation environment	11
5 Test methods and limits	11
5.1 Telecommunication centres	12
5.1.1 Telecommunication centres, enclosure port	12
5.1.2 Telecommunication centres, ports for outdoor signal lines	13
5.1.3 Telecommunication centres, ports for indoor signal lines	14
5.1.4 Telecommunication centres, ac power ports	15
5.1.5 Telecommunication centres, dc power ports	16
5.2 Other than telecommunication centres.....	17
5.2.1 Other than telecommunication centres, enclosure port.....	17
5.2.2 Other than telecommunication centres, ports for outdoor signal lines.....	18
5.2.3 Other than telecommunication centres, ports for indoor signal lines.....	19
5.2.4 Other than telecommunication centres, ac power ports	20
5.2.5 Other than telecommunication centres, dc power ports.....	21
6 General test configuration.....	22
7 General operational conditions during testing	22
8 General immunity and resistibility conditions	22
8.1 General performance criteria	22
9 Switching equipment specific requirements	23
9.1 Test configuration	23
9.2 Operational conditions	24
9.2.1 Emission.....	24
9.2.2 Immunity	25
9.3 Specific immunity and resistibility performance criteria	25
9.3.1 Digital port performance criteria	25
9.3.1.1 Performance criteria A (continuous phenomena).....	25
9.3.1.2 Performance criterion B (transient phenomena).....	25
9.3.1.3 Criteria C (interruptions).....	25
9.3.1.4 Criteria R (resistibility)	25
9.3.2 Analogue port performance criteria	26
9.3.2.1 Performance criteria A (continuous phenomena).....	26
9.3.2.2 Performance criteria B (transient phenomena).....	26
9.3.2.3 Criteria C (interruptions).....	26
9.3.2.4 Criteria R (resistibility)	26
10 Transmission equipment specific requirements.....	26
10.1 Test configuration	26
10.2 Operational conditions	27
10.2.1 Emission.....	27
10.2.2 Immunity	27
10.3 Specific immunity and resistibility performance criteria	28
10.3.1 Digital signal ports	28

10.3.1.1	Performance criterion A (continuous phenomena)	28
10.3.1.2	Performance criterion B (transient phenomena)	28
10.3.1.3	Performance criterion C (interruptions).....	28
10.3.1.4	Performance criterion R (resistibility)	28
10.3.2	Analogue voice frequency signal ports.....	29
10.3.2.1	Performance criterion A (continuous phenomena)	29
10.3.2.2	Performance criterion B (transient phenomena)	29
10.3.2.3	Performance criterion R (resistibility)	29
10.3.3	SDH and PDH interfaces.....	29
10.3.3.1	Tributary and aggregate interfaces.....	29
10.3.4	ISDN interfaces	29
10.3.4.1	Primary rate access ISDN interfaces.....	29
10.3.4.2	Network termination NT1 for ISDN "U" interfaces	29
10.3.4.3	Basic access ISDN interfaces	29
10.3.5	Analogue interfaces.....	29
10.3.5.1	Trunk interfaces and leased line interfaces	29
10.3.5.2	Subscriber interfaces.....	30
10.3.6	V.10, V.11, V.24, V.28, V.35, V.36, X.24 and similar V.- and X.- series interfaces.....	30
10.3.7	Ethernet and packet-data interfaces.....	30
10.3.7.1	Performance criterion A (continuous phenomena)	30
10.3.7.2	Performance criterion B (transient phenomena)	30
10.3.8	Service and maintenance interfaces.....	30
10.3.9	Synchronization interfaces	30
10.3.9.1	Performance criterion A (continuous phenomena)	30
10.3.9.2	Performance criteria B (transient phenomena)	30
10.3.10	Remote alarm interfaces.....	30
10.3.10.1	Performance criterion A (continuous phenomena)	30
10.3.10.2	Performance criterion B (transient phenomena)	31
10.3.10.3	Performance criteria R (resistibility)	31
11	Power supply equipment specific conditions.....	31
11.1	Test configuration	31
11.2	Operational conditions	32
11.2.1	Emission.....	32
11.2.2	Immunity	32
11.3	Specific immunity and resistibility performance criteria	32
11.3.1	Alternating current secondary interface.....	32
11.3.1.1	Performance criteria A (continuous phenomena).....	32
11.3.1.2	Performance criteria B (transient phenomena)	33
11.3.1.3	Performance criterion R (resistibility)	33
11.3.2	Direct current secondary interface.....	33
11.3.2.1	Performance criteria A (continuous phenomena).....	33
11.3.2.2	Performance criteria B (transient phenomena)	33
11.3.2.3	Performance criteria R (resistibility)	34
11.3.3	Control/signal interface	34
11.3.4	Tertiary supply interface	34
12	Supervisory equipment specific conditions	34
12.1	Test configuration	34
12.2	Operational conditions	36
12.3	Specific immunity and resistibility performance criteria	36
12.3.1	Performance criteria A (continuous phenomena)	36
12.3.2	Performance criteria B (transient phenomena).....	36
12.3.3	Performance criteria R (resistibility).....	36
Annex A (normative): Correlation between essential requirements and the provisions of the present document.....		37
History		38

Intellectual Property Rights

IPRs essential or potentially essential to the present document may have been declared to ETSI. The information pertaining to these essential IPRs, if any, is publicly available for **ETSI members and non-members**, and can be found in ETR 314: "*Intellectual Property Rights (IPRs); Essential, or potentially Essential, IPRs notified to ETSI in respect of ETSI standards*", which is available **free of charge** from the ETSI Secretariat. Latest updates are available on the ETSI Web server (<http://www.etsi.fr/ipr>).

Pursuant to the ETSI Interim IPR Policy, no investigation, including IPR searches, has been carried out by ETSI. No guarantee can be given as to the existence of other IPRs not referenced in ETR 314 (or the updates on <http://www.etsi.fr/ipr>) which are, or may be, or may become, essential to the present document.

Foreword

This European Standard (Telecommunications series) has been produced by ETSI Technical Committee Electromagnetic compatibility and Radio spectrum Matters (ERM).

The present document is part 2 of a multi-part document covering Telecommunication network equipment ElectroMagnetic Compatibility (EMC) requirements, as identified below:

Part 1: "Product family overview, compliance criteria and test levels";

Part 2: "Product family standard".

The present EN has been produced by ETSI in response to a mandate from the European Commission issued under Council Directive 83/189/EEC (as amended) laying down a procedure for the provision of information in the field of technical standards and regulations.

The present EN is intended to become a Harmonized Standard, the reference of which will be published in the Official Journal of the European Communities referencing the Council Directive on the approximation of the laws of the Member States relating to electromagnetic compatibility ("the EMC Directive") (89/336/EEC as amended).

Technical specifications relevant to the EMC Directive are given in annex A.

National transposition dates	
Date of adoption of this EN:	5 December 1997
Date of latest announcement of this EN (doa):	31 March 1998
Date of latest publication of new National Standard or endorsement of this EN (dop/e):	30 September 1998
Date of withdrawal of any conflicting National Standard (dow):	30 September 2002

1 Scope

The present document defines the product-specific performance criteria and operating conditions for equipment intended to be used within a telecommunications network (as defined in clause 3):

- **Switching equipment.** Such equipment includes:

- local telephone exchanges;
- remote switching concentrators;
- international switches;
- telex switches;
- network packet switches.

General purpose equipment which is used as a part of a switching system may be covered by the scope of other standards. For such equipment, if those other standards fully cover all the requirements of the present document, no further requirements are necessary. Switching equipment can also contain transmission functions, and this has to be recognized during testing.

- **Non-radio transmission equipment and ancillary equipment.** Such equipment includes:

- multiplexers;
- line equipment and repeaters, e.g. equipment for:
 - Synchronous Digital Hierarchy (SDH);
 - Plesiochronous Digital Hierarchy (PDH);
 - Asynchronous Transfer Mode;

such as:

- Digital Cross Connect systems;
- network terminations.

- **Power supply equipment.** Such equipment includes:

- central power plant;
- end of suite power supplies;
- uninterruptible power supplies;
- stabilized ac power supplies;
- and other dedicated telecommunication network power supplies;

but excludes equipment which is uniquely associated with or integrated in other equipment.

- **Supervisory equipment.** Such equipment includes:

- network management equipment;
- operator access maintenance equipment;
- traffic measurement systems;
- line test units;
- functional test units.

The function of *supervision* may either be performed by independent equipment or form part of other telecommunication equipment. If the function of supervision forms part of a telecommunication equipment, the performance may be evaluated simultaneously with other functions (such as switching and transmission) during EMC testing.

Supervisory equipment may also be used in conjunction with radio equipment.

The environmental classification used in the present document refers to ETS 300 386-1 [1], in particular to annex B (Classification of environmental conditions).

The requirements of the present document have been selected to ensure an adequate level of immunity for the apparatus covered by the scope of this document. The levels do not, however, cover extreme cases which may occur at any location but with a low probability of occurrence. In special cases, situations may arise where the levels of disturbance may exceed the immunity test levels specified in the present document. In these instances, special mitigation measures may have to be employed.

Equipment for cabled distribution systems for television and sound signals as defined in EN 50083-2 [24], equipment for submarine cable systems as defined in ITU-T Recommendation G.971 [34] and optical amplifiers as defined in ITU-T Recommendations G.661 [27] and G.662 [28] are outside the scope of the present document.

2 References

References may be made to:

- a) specific versions of publications (identified by date of publication, edition number, version number, etc.), in which case, subsequent revisions to the referenced document do not apply; or
- b) all versions up to and including the identified version (identified by "up to and including" before the version identity); or
- c) all versions subsequent to and including the identified version (identified by "onwards" following the version identity); or
- d) publications without mention of a specific version, in which case the latest version applies.

A non-specific reference to an ETS shall also be taken to refer to later versions published as an EN with the same number.

2.1 Normative references

- [1] ETS 300 386-1 (1994): "Equipment Engineering (EE); Telecommunication network equipment Electro-Magnetic Compatibility (EMC) requirements; Part 1: Product family overview, compliance criteria and test levels".
- [2] ETS 300 127 (1994): "Radiated emission testing of physically large telecommunication systems".
- [3] ETS 300 132-1 (1996): "Equipment Engineering (EE); Power supply interface at the input to telecommunications equipment Part 1: Operated by alternating current (ac)".
- [4] ETS 300 132-2 (1996): "Equipment Engineering (EE); Power supply interface at the input to telecommunications equipment Part 2: Operated by direct current (dc)".
- [5] ETR 238 (1995): "ETSI/CENELEC standardization programme for the development of Harmonized Standards related to Electro-Magnetic Compatibility (EMC) in the field of telecommunications".
- [6] EN 50082-1 (1992): "Electromagnetic compatibility - Generic immunity standard. Part 1: Domestic, commercial and light industry".
- [7] EN 55022 (1994): "Limits and methods of measurement of radio disturbance characteristics of information technology equipment".

- [8] EN 61000-3-2 (1995): "Electromagnetic Compatibility (EMC) Part 3: Limits Section 2: Limits for harmonic current emissions (equipment input current less than or equal to 16 A per phase)".
- [9] EN 61000-3-3 (1995): "Electromagnetic Compatibility (EMC) Part 3: Limits Section 3: Limitation of voltage fluctuations and flicker in low-voltage supply systems for equipment with rated current less than or equal to 16 A".
- [10] EN 61000-4-2 (1995): "Electromagnetic Compatibility (EMC); Part 4: Testing and Measurement Techniques; Section 2: Electrostatic discharge immunity test Basic EMC publication"
- [11] EN 61000-4-3 (1996): "Electromagnetic Compatibility (EMC); Part 4: Testing and Measurement Techniques; Section 3: Radiated, radio-frequency, electromagnetic field immunity test".
- [12] EN 61000-4-4 (1995): "Electromagnetic Compatibility (EMC); Part 4: Testing and Measurement Techniques; Section 4: Electrical fast transient/burst immunity test; Basic EMC publication".
- [13] EN 61000-4-5 (1995): "Electromagnetic Compatibility (EMC); Part 4: Testing and Measurement Techniques; Section 5: Surge immunity test".
- [14] EN 61000-4-6 (1996): "Electromagnetic Compatibility (EMC); Part 4: Testing and Measurement Techniques; Section 6: Conducted disturbances induced by radio-frequency fields".
- [15] EN 61000-4-11 (1994): "Electromagnetic Compatibility (EMC); Part 4: Testing and Measuring Techniques; Section 11: Voltage dips, short interruptions and voltage variations; Immunity tests".
- [16] ITU-T Recommendation K.20 (1993): "Resistibility of telecommunication switching equipment to overvoltages and overcurrents".
- [17] ITU-T Recommendation K.21 (1988): "Resistibility of subscribers' terminals to overvoltages and overcurrents".
- [18] ITU-T Recommendation O.41 (1995): "Psophometer for Use on Telephone-Type Circuits".
- [19] ITU-T Recommendation O.150 (1992): "Digital test patterns for performance measurements on digital transmission equipment".

2.2 Informative references

- [20] ETS 300 011 (1992): "Integrated Services Digital Network (ISDN); Primary rate user-network interface; Layer 1 specification and test principles".
- [21] ETS 300 012 (1992): "Integrated Services Digital Network (ISDN); Basic user-network interface; Layer 1 specification and test principles".
- [22] ETS 300 166 (1993): "Transmission and Multiplexing (TM); Physical and electrical characteristics of hierarchical digital interfaces for equipment using the 2 048 kbit/s-based plesiochronous or synchronous digital hierarchies".
- [23] ETS 300 232 (1993) as amended by Amendment 1 (1996): "Transmission and Multiplexing (TM); Optical interfaces for equipments and systems relating to the Synchronous Digital Hierarchy".
- [24] EN 50083-2 (1995): "Cabled distribution systems for television and sound signals; Part 2: Electromagnetic compatibility for equipment".
- [25] IEC 50 chapter 714 (1990): "International Electrotechnical Vocabulary. Chapter 714: Switching and signalling in telecommunications".
- [26] ISO/IEC 8802-3 (1993): "Information Technology; Local and metropolitan area networks; Part 3: Carrier sense multiple access with collision detection (CSMA/CD) access method and physical layer specifications".
- [27] ITU-T Recommendation G.661 (1993): "Definition and test methods for the relevant generic parameters of optical fibre amplifiers".

- [28] ITU-T Recommendation G.662 (1988): "Generic characteristics of optical fibre amplifier devices and sub-systems".
- [29] ITU-T Recommendation G.712 (1992): "Transmission performance characteristics of pulse code modulation".
- [30] ITU-T Recommendation G.812 (1988): "Timing requirements at the outputs of slave clocks suitable for plesiochronous operation of international digital links".
- [31] ITU-T Recommendation G.813 (1996): "Timing characteristics of SDH equipment slave clocks".
- [32] ITU-T Recommendation G.958 (1994): "Digital line systems based on the synchronous digital hierarchy for use on optical fibre cables".
- [33] ITU-T Recommendation G.961 (1993): "Digital transmission system on metallic local lines for ISDN Basic Rate Access".
- [34] ITU-T Recommendation G.971 (1993): "General features of optical fibre submarine cable systems".
- [35] ITU-T Recommendation Q.552 (1994): "Transmission characteristics at 2-wire analogue interfaces of digital exchanges".
- [36] ITU-T Recommendation V.10 (1994): "Electrical characteristics for unbalanced double-current interchange circuits operating at data signalling rates up to 100 kbit/s".
- [37] ITU-T Recommendation V.11 (1994): "Electrical characteristics for balanced double-current interchange circuits operating at data signalling rates up to 10 Mbit/s".
- [38] ITU-T Recommendation V.24 (1994): "List of definitions for interchange circuits between data terminal equipment (DTE) and data circuit-terminating equipment (DCE)".
- [39] ITU-T Recommendation V.28 (1994): "Electrical characteristics for unbalanced double-current interchange circuits".
- [40] ITU-T Recommendation V.35 (1984): "Data transmission at 48 kilobits per second using 60-108 kHz group band circuits".
- [41] ITU-T Recommendation V.36 (1988): "Modems for synchronous data transmission using 60 - 108 kHz group band circuits".
- [42] ITU-T Recommendation X.24 (1988): "List of definitions for interchange circuits between Data Terminal Equipment (DTE) and Data Circuit-terminating Equipment (DCE) on public data networks".
- [43] ITU-T Recommendation X.25 (1993): "Interface between data terminal equipment (DTE) and data circuit-terminating equipment (DCE) for terminals operating in the packet mode and connected to public data networks by dedicated circuit".
- [44] 89/336/EEC: "Council Directive of 3 May 1989 on the approximation of laws of the Member States relating to Electromagnetic Compatibility" (Official Journal L139 of 23/5/89) as modified by 92/31/EEC.

3 Definitions and abbreviations

3.1 Definitions

For the purposes of the present document, the definitions of ETS 300 386-1 [1] subclause 3.1 and the following definitions apply:

ac secondary interface: The output port of a ac power supply.

ac secondary voltage: The output of the ac power supply at the ac secondary interface.

NOTE 1: The ac secondary voltage may be either:

- a stabilized ac supply derived from a dc primary supply (e.g. where the power supply is an inverter); or
- derived from the ac primary supply (e.g. a stabilized power supply used where the quality of the primary supply is not sufficient to feed telecommunication equipment).

connection: A temporary association of transmission channels or telecommunication circuits, switching or other functional units set up to provide for the transfer of information between two or more points in a telecommunication network (IEC 50 [25], chapter 714-01-09).

dc secondary interface: The output port of a dc power supply.

dc secondary voltage: The output of the dc power supply at the dc secondary interface. The dc secondary voltage may be derived from the ac primary supply with or without a buffer battery.

enclosure port: The physical boundary of the Equipment Under Test (EUT) through which electromagnetic fields may emanate or on which they may impinge.

interface "A": The terminals at which a power supply is connected to the telecommunications equipment.

nominal voltage: The nominal value of voltage that designates the type of supply.

normal service: The service mode where telecommunications equipment operates within its specification.

performance criterion: The limits of acceptable behaviour of the equipment during and after the application of the electromagnetic phenomenon.

NOTE 2: Performance criteria A apply for continuous phenomena; performance criteria B and C apply for transient phenomena; and performance criteria R apply for resistibility phenomena.

port: A particular interface of the EUT with the external electromagnetic environment.

power supply: A power source (within the scope of the present document) to which telecommunications equipment is intended to be connected.

primary supply: The public mains or a locally generated ac or dc supply.

resistibility: The ability of telecommunication equipment or a network to withstand the effects of certain electrical, magnetic and electromagnetic phenomena up to a certain, specified extent, and in accordance with a specified criterion, e.g., the ability of a telecommunication device to withstand a surge voltage of 2 kV on its 230 V power port without being damaged.

secondary supply: The supply to the telecommunications equipment (e.g. racks or system blocks), derived from the primary supply.

system block: A functional group of equipment depending for its operation and performance upon the secondary power supply.

telecommunication network: A network operated under a licence granted by a national telecommunications authority which provides telecommunications between network termination points (NTPs) (i.e. excluding terminal equipment beyond the NTPs).

tertiary supply: A supply to the telecommunications equipment derived from the secondary supply.

3.2 Abbreviations

For the purposes of the present document, the abbreviations of ETS 300 386-1 [1] subclause 3.2 and the following abbreviations apply:

AM	Amplitude Modulation.
AV	Average

EUT	Equipment Under Test
N/A	Not Applicable
NTP	Network Termination Point
PDH	Plesiochronous Digital Hierarchy
PRBS	Pseudo Random Bit Sequence
QP	Quasi-Peak
rms	root-mean-square
T_r/T_h	Rise time (10 % to 90 %) and hold time (50 % to 50 %) of transient signal (see EN 61000-4-4 [12])
U_{pso}	Voltage measured with a psophometer conforming to Recommendation O.41 [18]

4 Installation environment

The installation environment for the Equipment Under Test (EUT) will normally be "telecommunication centre". Locations "other than telecommunication centre" apply where the EUT is to be operated specifically not within a telecommunication centre, e.g. within offices, customers' premises, streets, etc.

If no restrictions are specified in the product documentation for the installation environment, the product shall comply with the requirements of both environments, implying that the more severe test level shall be used when the test is performed. Equipment which meets the (more severe) requirements for "other than telecommunications centres" may be operated in either location.

5 Test methods and limits

The emission, immunity and resistibility requirements in the following tables are derived from the requirements for normal priority of service as defined in ETS 300 386-1 [1] using, for immunity, the lowest test levels. Emission, immunity and resistibility shall all be tested.

For additional information on general requirements for test methods and limits, see clauses 6 and 7 of ETS 300 386-1 [1]. The test levels are compiled in the following tables.

For power supply equipment, the following conducted immunity tests do not apply to the output power port (secondary interface) of the EUT:

- voltage dips;
- short interruptions and voltage variations.

5.1 Telecommunication centres

5.1.1 Telecommunication centres, enclosure port

	Environmental phenomenon	Unit	Test level and characteristic	Reference	Performance criterion	Remarks
Immunity						
5.1.1.1	Electrostatic discharge	kV kV	4 Contact Discharge 4 Air Discharge	EN 61000-4-2 [10]	B	
5.1.1.2	Radio frequency electromagnetic field amplitude modulated	MHz V/m % AM (1 kHz)	80 to 1 000 3 80	EN 61000-4-3 [11]	A	
Emission						
5.1.1.3	Radiated electromagnetic field at 10 m	MHz dB(μ V/m) MHz dB(μ V/m)	30 to 230 40 230 to 1 000 47	EN 55022 [7]	N/A	Physically large systems should be tested according to the procedures in ETS 300 127 [2].
Resistibility						
5.1.1.4	Electrostatic discharge	kV kV	8 Contact Discharge 15 Air Discharge	EN 61000-4-2 [10]	R	It is not necessary to perform this test for contact discharge with levels below the given resistibility limit. Lower levels than the given limits apply only for air discharge tests.

5.1.2 Telecommunication centres, ports for outdoor signal lines

	Environmental phenomenon	Unit	Test level and characteristic	Reference	Performance criterion	Remarks
Immunity						
5.1.2.1	Fast transients	kV T_r/T_h ns Rep. frequency kHz	0,5 5/50 5	EN 61000-4-4 [12]	B	
5.1.2.2	Surges	T_r/T_h μ s kV	10/700 1	EN 61000-4-5 [13]	B	
5.1.2.3	Radio frequency, conducted continuous	MHz V % AM (1 kHz) Source impedance Ω	0,15 to 80 3 80 150	EN 61000-4-6 [14]	A	
Emission						
N/A						
Resistibility						
5.1.2.4	Surges	T_r/T_h μ s kV	10/700 4	ITU-T Recommendation K.20 [16]	R	Only applies to ports for unscreened pair cables longer than 500 m. During this test, primary protection (as described in ITU-T K-series Recommendations) may be fitted to the port.
5.1.2.5	Surges	T_r/T_h μ s kV	10/700 1	ITU-T Recommendation K.20 [16]	R	Only applies to ports for unscreened pair cables longer than 500 m.
5.1.2.6	Power induction	V Hz ms	300 50 200	ITU-T Recommendation K.20 [16] table 1 figure 2/K.20, Switch S_2 operated	R	Only applies to ports intended to be connected to unscreened pair cables longer than 500 m.

Outdoor lines carrying dc power with superimposed signals shall be treated as outdoor signal lines.

For switching equipment which is intended to be installed in locations other than telecommunication centres, the requirements for immunity to surges on outdoor signal lines and to continuous conducted disturbances on signal lines are according to the requirements for telecommunication centres. This reduction is based - amongst other things - upon the screening effect of multi-pair cables and specific earthing/bonding techniques in use for switching equipment.

5.1.3 Telecommunication centres, ports for indoor signal lines

Only ports connected to inter-system cables are to be tested. Testing of ports for intra-system cabling (provided in all cases both ends are controlled by the same manufacturer) is left to the discretion of the manufacturer which is responsible for the correct installation of the cables.

	Environmental phenomenon	Unit	Test level and characteristic	Reference	Performance criterion	Remarks
Immunity						
5.1.3.1	Fast transients	kV T_r/T_h ns Rep. frequency kHz	0,5 5/50 5	EN 61000-4-4 [12]	B	Only applies when cables longer than 3 m are intended to be connected.
5.1.3.2	Surges	T_r/T_h μ s kV	1,2/50 (8/20) 0,5	EN 61000-4-5 [13] ETS 300 386-1 [1] subclause 6.4.2	B	Only applies when cables longer than 10 m are connected. The total output impedance of the surge generator shall be 42 Ω .
5.1.3.3	Radio frequency, conducted continuous	MHz V % AM (1 kHz) Source impedance Ω	0,15 to 80 3 80 150	EN 61000-4-6 [14]	A	Only applies when cables longer than 3 m are connected.
Emission						
N/A						
Resistibility						
N/A						
Indoor lines carrying dc power with superimposed signals shall be treated as indoor signal lines.						

5.1.4 Telecommunication centres, ac power ports

	Environmental phenomenon	Unit	Test level and characteristic	Reference	Performance criterion	Remarks
Immunity						
5.1.4.1	Fast transients	kV T_r/T_h ns Rep. frequency kHz	1 5/50 5	EN 61000-4-4 [12]	B	
5.1.4.2	Surges (line to line) (line to ground)	T_r/T_h μ s kV kV	1,2/50 (8/20) 0,5 1	EN 61000-4-5 [13]	B B	
5.1.4.3	Radio frequency, conducted continuous	MHz V % AM (1 kHz) Source impedance Ω	0,15 to 80 3 80 150	EN 61000-4-6 [14]	A	
Emission						
5.1.4.4	Radio frequency disturbance voltage	MHz dB(μ V) MHz dB(μ V)	0,15 to 0,5 66 AV; 79 QP 0,5 to 30 60 AV; 73 QP	EN 55022 [7]	N/A	
5.1.4.5	Harmonics	Hz mA	50 to 2 000 See basic std.	EN 61000-3-2 [8]	N/A	Applicability of test according to the scope of EN 61000-3-2 [8].
5.1.4.6	Voltage fluctuations (Flicker)	Limit	See basic std.	EN 61000-3-3 [9]	N/A	Applicability of test according to the scope of EN 61000-3-3 [9].
Resistibility						
5.1.4.7	Surges (line to line) (line to ground)	T_r/T_h μ s kV kV	1,2/50 (8/20) 1 2	EN 61000-4-5 [13]	R R	

5.1.5 Telecommunication centres, dc power ports

	Environmental phenomenon	Unit	Test level and characteristic	Reference	Performance criterion	Remarks
Immunity						
5.1.5.1	Fast transients	kV T_r/T_h ns Rep. frequency kHz	0,5 5/50 5	EN 61000-4-4 [12]	B	Only applicable when cables longer than 3 m are connected.
5.1.5.2	Radio frequency, conducted continuous	MHz V % AM (1 kHz) Source impedance Ω	0,15 to 80 3 80 150	EN 61000-4-6 [14]	A	Only applicable when cables longer than 3 m are connected.
Emission						
5.1.5.3	Radio frequency disturbance voltage	MHz dB(μ V) MHz dB(μ V) MHz dB(μ V)	0,02 to 0,15 -- AV; 79 QP 0,15 to 0,5 66 AV; 79 QP 0,5 to 30 60 AV; 73 QP	ETS 300 386-1 [1] subclause 7.2.3	N/A	
Resistibility						
N/A						

5.2 Other than telecommunication centres

5.2.1 Other than telecommunication centres, enclosure port

	Environmental phenomenon	Unit	Test level and characteristic	Reference	Performance criterion	Remarks
Immunity						
5.2.1.1	Electrostatic discharge	kV kV	6 contact discharge 8 air discharge	EN 61000-4-2 [10]	B	
5.2.1.2	Radio frequency electromagnetic field amplitude modulated	MHz V/m % AM (1 kHz)	80 to 1 000 3 80	EN 61000-4-3 [11]	A	
Emission						
5.2.1.3	Radiated electromagnetic field at 10 m	MHz dB(μ V/m) MHz dB(μ V/m)	30 to 230 30 230 to 1 000 37	EN 55022 [7]	N/A	Physically large systems are tested according to the procedures in ETS 300 127 [2]. Equipment not intended for use in residential, commercial and light industrial environments may meet the limits defined in subclause 5.1.1.3.
Resistibility						
5.2.1.4	Electrostatic discharge	kV kV	8 contact discharge 15 air discharge	EN 61000-4-2 [10]	R	It is not necessary to perform this test for conducted discharge with levels below the given resistibility limit. Lower levels than the given limits apply only for air discharge tests.

5.2.2 Other than telecommunication centres, ports for outdoor signal lines

	Environmental phenomenon	Unit	Test level and characteristic	Reference	Performance criterion	Remarks
Immunity						
5.2.2.1	Fast transients	kV T_r/T_h ns Rep. frequency kHz	0,5 5/50 5	EN 61000-4-4 [12]	B	
5.2.2.2	Surges	T_r/T_h μ s kV	10/700 1	EN 61000-4-5 [13]	B	
5.2.2.3	Radio frequency, conducted continuous	MHz V % AM (1 kHz) Source impedance Ω	0,15 to 80 3 80 150	EN 61000-4-6 [14]	A	
Emission						
N/A						
Resistibility						
5.2.2.4	Surges	T_r/T_h ms kV	10/700 4	ITU-T Recommendation K.20 [16], K.21 [17]	R	Only applies to ports for unshielded pair cables longer than 500 m. During this test, primary protection (as described in ITU-T K-series Recommendations) may be fitted to the port. Only to be applied when primary protection (as described in ITU-T K-series Recommendations) is fitted.
5.2.2.5	Surges	T_r/T_h μ s kV	10/700 1	ITU-T Recommendation K.20 [16]	R	Only applies to ports for unshielded pair cables longer than 500 m.
5.2.2.6	Power induction	V Hz ms	300 50 200	ITU-T Recommendation K.20 [16] table 1 figure 2/K.20, Switch S_2 operated	R	Only applies to ports for unshielded pair cables longer than 500 m.

Outdoor lines carrying dc power with superimposed signals shall be treated as outdoor signal lines.

For switching equipment which is intended to be installed in locations other than telecommunication centres, the requirements for immunity to surges on outdoor signal lines and to continuous conducted disturbances on signal lines are according to the requirements for telecommunication centres. This reduction is based - amongst other things - upon the screening effect of multi-pair cables and specific earthing/bonding techniques in use for switching equipment.

5.2.3 Other than telecommunication centres, ports for indoor signal lines

Only ports connected to inter-system cables are to be tested. Testing of ports for intra-system cabling (provided in all cases both ends are controlled by the same manufacturer) is left to the discretion of the manufacturer which is responsible for the correct installation of the cables.

	Environmental phenomenon	Unit	Test level and characteristic	Reference	Performance criterion	Remarks
Immunity						
5.2.3.1	Fast transients	kV T_r/T_h ns Rep. frequency kHz	0,5 5/50 5	EN 61000-4-4 [12]	B	Only applies when cables longer than 3 m are connected.
5.2.3.2	Surges	T_r/T_h μ s kV	1,2/50 (8/20) 0,5	EN 61000-4-5 [13], ETS 300 386-1 [1] subclause 6.4.2	B	Only applies when cables longer than 10 m are connected.
5.2.3.3	Radio frequency, conducted continuous	MHz V % AM (1 kHz) Source impedance Ω	0,15 to 80 3 80 150	EN 61000-4-6 [14]	A	Only applies when cables longer than 3 m are connected.
Emission						
N/A						
Resistibility						
N/A						

5.2.4 Other than telecommunication centres, ac power ports

	Environmental phenomenon	Unit	Test level and characteristic	Reference	Performance criterion	Remarks
Immunity						
5.2.4.1	Fast transients	kV T_r/T_h ns Rep. frequency kHz	1 5/50 5	EN 61000-4-4 [12]	B	
5.2.4.2	Surges (line to line) (line to ground)	T_r/T_h μ s kV kV	1,2/50 (8/20) 1 2	EN 61000-4-5 [13]	B B	
5.2.4.3	Radio frequency, conducted continuous	MHz V % AM (1 kHz) Source impedance Ω	0,15 to 80 3 80 150	EN 61000-4-6 [14]	A	
5.2.4.4	Voltage dips and short interruptions	Voltage reduction % Duration ms Voltage reduction % Duration ms Voltage reduction % Duration ms	>95 10 30 500 >95 5 000	EN 61000-4-11 [15]	B C C	
Emission						
5.2.4.5	Radio frequency disturbance voltage	MHz dB(μ V) MHz dB(μ V/m) MHz dB(μ V/m)	0,15 to 0,5 56 to 46 AV; 66 to 56 QP 0,5 to 5 46 AV; 56 QP 5 to 30 50 AV; 60 QP	EN 55022 [7]	N/A	
5.2.4.6	Harmonics	Hz mA	50 to 2 000 See basic std.	EN 61000-3-2 [8]	N/A	Applicability of test according to the scope of EN 61000-3-2 [8].
5.2.4.7	Voltage fluctuations (Flicker)	Limit	See basic std.	EN 61000-3-3 [9]	N/A	Applicability of test according to the scope of EN 61000-3-3 [9].
Resistibility						
5.2.4.8	Surges (line to line) (line to ground)	T_r/T_h μ s kV kV	1,2/50 (8/20) 2 4	EN 61000-4-5 [13]	R R	

5.2.5 Other than telecommunication centres, dc power ports

	Environmental phenomenon	Unit	Test level and characteristic	Reference	Performance criterion	Remarks
Immunity						
5.2.5.1	Fast transients	kV T_r/T_h ns Rep. frequency kHz	1 5/50 5	EN 61000-4-4 [12]	B	Applicable to cables which according to the manufacturer's specification may be longer than 3 m.
5.2.5.2	Radio frequency, conducted continuous	MHz V % AM (1 kHz) Source impedance Ω	0,15 to 80 3 80 150	EN 61000-4-6 [14]	A	Applicable to cables which according to the manufacturer's specification may be longer than 3 m.
Emission						
5.2.5.3	Radio frequency disturbance voltage	MHz dB(μ V) MHz dB(μ V) MHz dB(μ V)	0,02 to 0,15 -- AV; 79 QP 0,15 to 0,5 66 AV; 79 QP 0,5 to 30 60 AV; 73 QP	ETS 300 386-1 [1]	N/A	
Resistibility						
N/A						

6 General test configuration

The EUT shall be configured and operated in accordance with the basic EMC standards.

The signal or control ports shall be correctly terminated either by auxiliary equipment necessary to exercise the ports or by their nominal impedance.

Adequate measures shall be taken to avoid any effects of unwanted signals on the measuring equipment used to monitor the performance of the EUT.

The equipment test conditions shall be as close as possible to the installed conditions, as defined by the manufacturer. Wiring shall be consistent with the manufacturer's recommended procedures, and the equipment shall be in its housing with all covers and access panels in place as in normal operation, unless otherwise stated. If the equipment is designed to be mounted in a rack or cabinet, it should be tested in this configuration.

Signal ports are divided into two categories:

- main signal ports which provide the telecommunications service (third party traffic);
- auxiliary signal ports, i.e. ports for alarms, maintenance, etc., which are only used by the operator or the service provider.

A sufficient number of ports shall be correctly terminated to ensure that the test is representative of normal operating conditions and the selection of ports shall be specified in the test report.

The earth connections of the EUT shall be connected to a reference earth according to the manufacturer's specifications.

ESD shall be applied only to such points that are accessible to personnel during normal usage. The application of discharges to any point of the equipment other than the electrostatic protection point which is accessible only for maintenance purposes is not allowed unless specified by the manufacturer.

Only cables that are permanently connected shall be included.

The types of the cables connected to the EUT shall be indicated in the test report.

The test configurations shall be recorded in the test report.

7 General operational conditions during testing

The general operational conditions of clause 4 of ETS 300 386-1 [1] apply.

Special exercising equipment and/or software may be used with the object of reducing the test time and to simulate traffic conditions.

8 General immunity and resistibility conditions

If the minimum performance level or permissible performance loss is not specified in the following clauses or by the manufacturer, then either of these may be deduced from the product description and documentation, and what the user may reasonably expect from the apparatus if used as intended.

8.1 General performance criteria

The general performance criteria apply for those ports for which no specific performance criteria are defined (e.g. auxiliary ports) in the present document.

Performance criterion A: The apparatus shall continue to operate as intended after the test. No degradation of performance or loss of function is allowed below a performance level specified by the manufacturer when the apparatus is used as intended. In some cases the performance level may be replaced by a permissible loss of performance. If the minimum performance level or the permissible performance loss is not specified by the manufacturer, then either of these may be deduced from the product description and documentation and what the user may reasonably expect from the apparatus if used as intended.

Performance criteria B: The apparatus shall continue to operate as intended after the test. No degradation of performance or loss of function is allowed below a performance level specified by the manufacturer, when the apparatus is used as intended. In some cases the performance level may be replaced by a permissible loss of performance. During the exposure to an electromagnetic phenomenon, degradation of performance is, however, allowed. No change of actual operating state or stored data is allowed. If the minimum performance level or the permissible performance loss is not specified by the manufacturer, then either of these may be deduced from the product description and documentation and what the user may reasonably expect from the apparatus if used as intended.

Performance criteria C: As defined in clause 6 of EN 50082-1 [6]: Temporary loss of function is allowed, provided the function is self-recoverable or can be restored by the operation of the controls, or, in the case of switching equipment, by normal subsequent use.

Performance criteria R: The equipment shall withstand the test without damage or other disturbance (such as the corruption of software or misoperation of fault protection facilities) and shall operate properly within the specified limits after the transient electromagnetic phenomenon has ceased. (It is not necessary to operate properly while the test condition is present). The exposure may cause the operation of fuses or other specified devices which have to be replaced or reset before normal operation is restored.

9 Switching equipment specific requirements

9.1 Test configuration

In figure 1, two separate processes are monitored simultaneously. The first is the continuous process of establishing and clearing connections and the second is the stable situation of monitoring signal quality during testing. It is to be considered that at least a part of the setup for both processes covers the full signal path from subscriber to the network. The signal loop at the network end can either be established by test equipment or by a simple cable loop. In the later case the simulation of normal grounding and connection practice is required.

The test equipment may be digital or analogue signal analyser as required. The test equipment may also loop back the test signal.

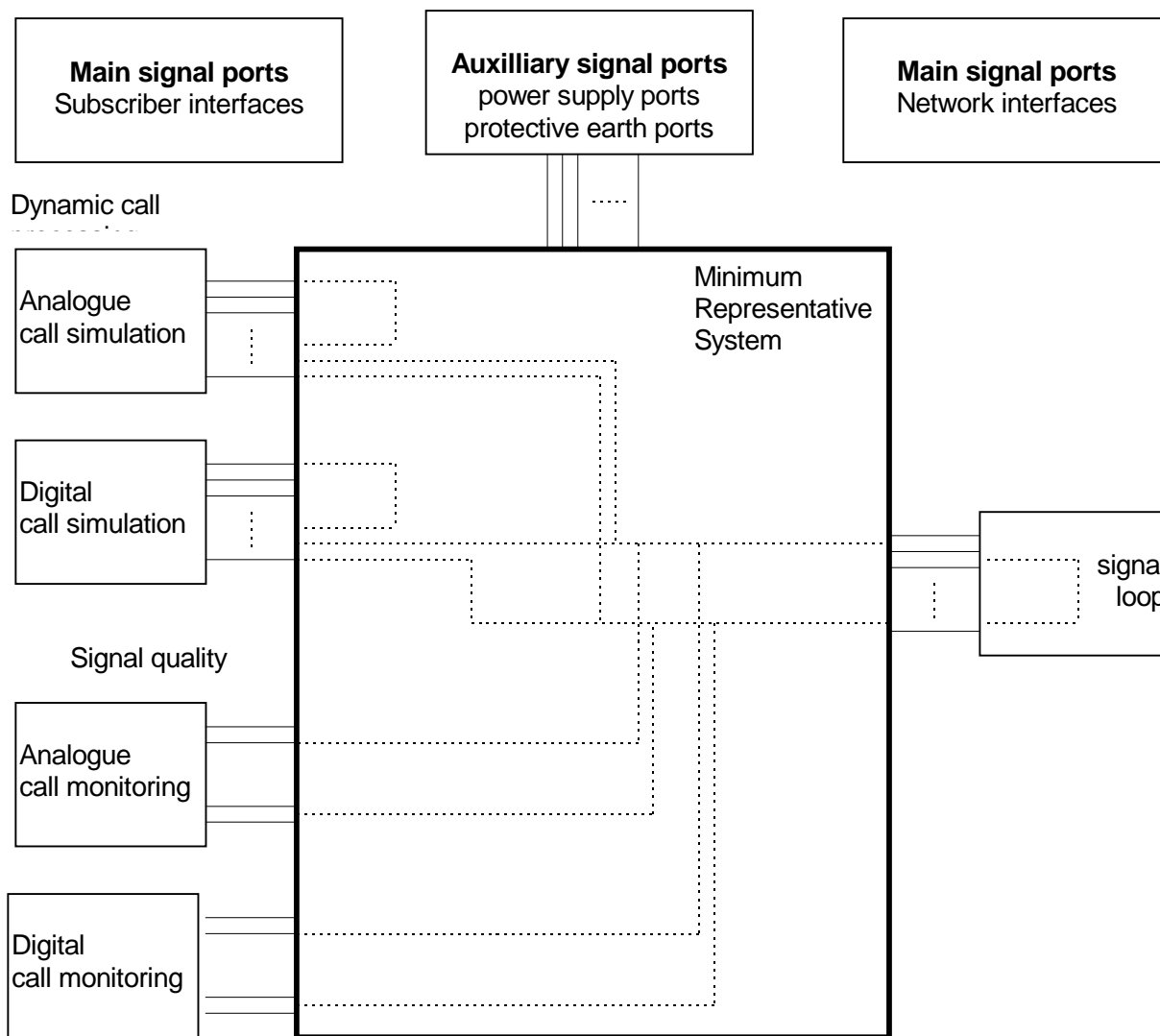

Figure 1: Schematic test configuration, switching equipment

If possible, cable harnesses shall be separated and the cables tested individually.

9.2 Operational conditions

The general conditions of clause 7 apply.

For switching equipment with less than 32 subscriber lines (analogue or digital), all the lines shall be driven. For switching equipment with more than 32 subscriber lines (analogue or digital) a choice of at least 32 lines shall be made among the available lines. In this case, as it is impossible to do tests at all ports, single ports of each type shall be selected for the testing. At least one port of each type shall be tested.

The ports shall be configured with their nominal impedance for a connection to another port. Auxiliary equipment may be used to simulate the functional termination of the ports.

Connections have to be provided which shall be established before the start of the tests and then maintained.

9.2.1 Emission

The general requirements for test methods are described in clause 7 of ETS 300 386-1 [1].

9.2.2 Immunity

During immunity testing using continuous phenomena, the following selected frequencies shall be investigated in addition to the sweep:

- the clock frequencies inside the specified frequency band of the test;
- 80; 120; 160; 230; 434; 460; 600; 863 and 900 MHz (± 1 %) (RF field);
- 0,2; 1,0; 7,1; 13,56; 21,0; 27,12; 40,68 MHz (± 1 %) (RF voltage).

9.3 Specific immunity and resistibility performance criteria

The performance criteria are based on the performance criteria given in ETR 238 [5]. For the switching equipment the following main signal ports are recognized:

- analogue ports (e.g. analogue subscribers' lines, analogue interfaces to transmission equipment);
- digital ports (e.g. digital subscribers' lines (ISDN), digital connections to transmission equipment).

The interfaces shall operate as described in the following subclauses.

9.3.1 Digital port performance criteria

9.3.1.1 Performance criteria A (continuous phenomena)

During the sweep:

- The established connections shall be maintained throughout testing and the transfer of information shall be within the limits of the manufacturer's specification.
- Loss of frame alignment or loss of synchronization are not allowed during each individual exposure (if applicable).

For selected frequencies (see subclause 9.2.2):

- It shall be possible to establish a connection between two ports.
- It shall be possible to clear a connection in a controlled manner.

9.3.1.2 Performance criterion B (transient phenomena)

- The established connections shall be maintained throughout testing.
- It shall be possible to establish a connection between two ports after the end of the transient disturbances.
- It shall be possible to clear a connection in a controlled manner after the end of the transient disturbances.

9.3.1.3 Criteria C (interruptions)

The general performance criteria C apply.

9.3.1.4 Criteria R (resistibility)

The general performance criteria R apply.

9.3.2 Analogue port performance criteria

9.3.2.1 Performance criteria A (continuous phenomena)

During the sweep:

- The established connections shall be maintained throughout testing.
- The noise level at a two wire analogue interface shall be less than -40 dBm at 600 Ω - (ignoring the nominal impedance of the port for practical reasons) if not otherwise stated by the manufacturer. The measurement shall be done selectively with a bandwidth ≤ 100 Hz at 1 kHz.
- Dialling tones shall be available (if applicable).

For selected frequencies (see subclause 9.2.2):

- It shall be possible to establish a connection between two ports.
- It shall be possible to clear a connection in a controlled manner.

9.3.2.2 Performance criteria B (transient phenomena)

- Established connections shall be maintained throughout testing.
- It shall be possible to establish a connection between two ports after the end of the transient disturbances.
- It shall be possible to clear a connection in a controlled manner after the end of the transient disturbances.

9.3.2.3 Criteria C (interruptions)

The general performance criteria C apply.

9.3.2.4 Criteria R (resistibility)

The general performance criteria R apply.

10 Transmission equipment specific requirements

10.1 Test configuration

Typically the EUT will be configured as shown in figure 2. The EMC test equipment is not shown.

The test configuration shall cover a representative set up of tributary signals within the aggregate interface signals.

In figure 2 a test signal is derived from a signal generator and looped through EUT. If the EUT supports several identical channels, these may be connected in series and the test signal may be looped through all the channels.

The test equipment may be digital or analogue signal analyser as required. The test equipment may also loop-back the test signal.

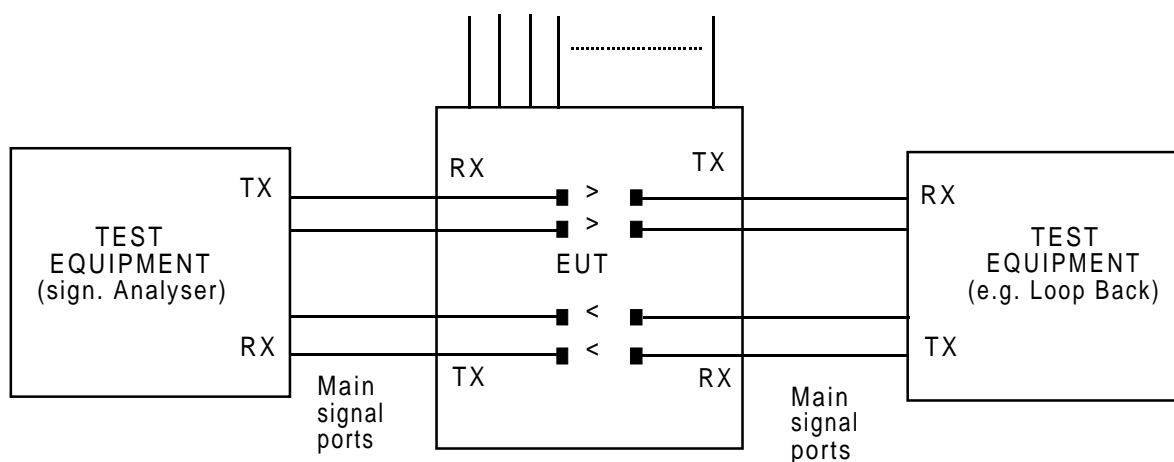

Figure 2: Schematic test configuration

10.2 Operational conditions

The general conditions of clause 7 apply.

An appropriate test signal shall be used. The test signal shall be stated in the test report. The preferred test signal is the Pseudo Random Bit Sequence (PRBS) appropriate for the bit rate of the channel (ITU-T Recommendation O.150 [19]).

The modes of operation during testing shall be recorded in the test report.

10.2.1 Emission

The measurements shall be made in the operating mode, with the EUT producing the maximum emission, consistent with normal applications. The EUT load shall be adjusted within the range specified by manufacturer in order to maximize the emission.

Conducted emission shall be measured on the power input and output ports.

10.2.2 Immunity

Immunity tests shall be performed at nominal values of all signal conditions and with a typical value of line attenuation as declared by the manufacturer.

Conducted immunity tests shall be applied to one port at a time.

Conducted immunity testing shall be performed on power input and output ports and on signal ports.

For surge testing the conducted immunity tests shall be performed on auxiliary (signal) ports that are permanently connected in the normal installation. If the specified maximum length of the connected line is less than 3 m, no conducted immunity test is necessary. For surge tests on indoor signal lines, no test is necessary if the specified maximum length is less than 10 m.

One signal port of each type found on the equipment shall be tested. If in normal installation practice multi-pair cables (e.g. 64 × balanced pairs) and composite cables (e.g. a combination of fibre and copper) are used, they are to be tested as one single cable. Cables bundled for aesthetic or routing purposes are to be tested individually.

The test generator shall be connected via the coupling network to one signal port. This port shall only be connected to the surge generator. During the test, the EUT and all ports (other than the one connected to the generator) shall comply with the given compliance criteria. After the surge has been applied the generator shall be disconnected from the port and the port checked against the compliance criteria. The compliance criteria shall contain functional aspects. Therefore, the test serves two purposes:

- a) the EMC test of the EUT;
- b) a test of resistibility of the port to which the generator is connected.

During immunity testing using continuous phenomena, the following selected frequencies shall be investigated in addition to the sweep:

- the clock frequencies inside the specified frequency band of the test;
- 80; 120; 160; 230; 434; 460; 600; 863 and 900 MHz (± 1 %) (RF field);
- 0,2; 1,0; 7,1; 13,56; 21,0; 27,12; 40,68 MHz (± 1 %) (RF voltage).

10.3 Specific immunity and resistibility performance criteria

10.3.1 Digital signal ports

The performance of the equipment shall be verified for digital signal ports:

- by measuring the number of induced bit errors on the main signal port during all exposures;
- by testing the functionality of the main signal port and the other signal ports after the exposure;
- by verifying that corruption of software and data held in memory has not occurred.

10.3.1.1 Performance criterion A (continuous phenomena)

The number of bit errors at the end of each individual exposure shall not exceed the maximum number of errors stated by the manufacturer for intended operation.

The number of errors is calculated as:

- (the maximum bit error ratio specified by the manufacturer) \times (bit rate) \times (test time).

The test time is taken to be the dwell time at each frequency of the exposure.

10.3.1.2 Performance criterion B (transient phenomena)

Loss of frame alignment or loss of synchronization is not allowed during each individual exposure. No alarms shall be generated as a result of the electromagnetic stress.

The above does not apply to surge testing where some loss of frame alignment may be expected. For this test, the EUT shall operate as intended following the cessation of the exposure.

10.3.1.3 Performance criterion C (interruptions)

The general performance criteria C apply.

10.3.1.4 Performance criterion R (resistibility)

The general performance criteria R apply.

10.3.2 Analogue voice frequency signal ports

The performance of the equipment shall be verified for analogue voice frequency signal ports:

- by measuring the audio signal break-through (demodulated 1 kHz) on the signal port during continuous exposures in both signal path directions covering both analogue to digital conversion and digital to analogue conversion;
- by testing the functionality of the main signal port and the other signal ports after the transient exposures;
- by verifying that corruption of software and data held in memory has not occurred.

10.3.2.1 Performance criterion A (continuous phenomena)

- The noise signal level received from the EUT measured in an impedance of 600 Ω shall not be greater than -40 dBm.
- Connections shall be maintained throughout the test.

10.3.2.2 Performance criterion B (transient phenomena)

- Connections shall be maintained throughout the test. The EUT shall return automatically to normal performance after the cessation of the exposure.

10.3.2.3 Performance criterion R (resistibility)

The general performance criteria R apply.

10.3.3 SDH and PDH interfaces

10.3.3.1 Tributary and aggregate interfaces

The criteria specified in subclause 10.3.1 apply to the interfaces specified in ETS 300 166 [22] (electrical interface) and ETS 300 232 [23], ITU-T Recommendation G.958 [32] (optical interfaces).

10.3.4 ISDN interfaces

10.3.4.1 Primary rate access ISDN interfaces

The criteria specified in subclause 10.3.1 apply to the interfaces specified in ETS 300 011 [20].

10.3.4.2 Network termination NT1 for ISDN "U" interfaces

The criteria specified in subclause 10.3.1 apply to the interfaces specified in ITU-T Recommendation G.961 [33].

10.3.4.3 Basic access ISDN interfaces

The criteria specified in subclause 10.3.1 apply to the interfaces specified in ETS 300 012 [21].

10.3.5 Analogue interfaces

10.3.5.1 Trunk interfaces and leased line interfaces

The criteria specified in subclause 10.3.2 apply to the interfaces specified in ITU-T Recommendation G.712 [29].

10.3.5.2 Subscriber interfaces

The criteria specified in subclause 10.3.2 apply to the interfaces specified in ITU-T Recommendation Q.552 [35].

10.3.6 V.10, V.11, V.24, V.28, V.35, V.36, X.24 and similar V.- and X.-series interfaces

The criteria specified in subclause 10.3.1 apply to the interfaces specified in ITU-T Recommendations V.10 [36], V.11 [37], V.24 [38], V.28 [39], V.35 [40], V.36 [41] and X.24 [42].

10.3.7 Ethernet and packet-data interfaces

To the interfaces specified in ISO/IEC 8802-3 [26] and ITU-T Recommendation X.25 [43], the criteria below apply.

10.3.7.1 Performance criterion A (continuous phenomena)

For interfaces which are intended for the transmission of third party data traffic, a selected port shall be connected to test equipment (e.g. a data communications analyser) as a single point-to-point data link. This will avoid excessive failed transmission attempts caused by data collisions and bus contention problems.

The interface shall be suitably exercised and monitored throughout the test period for errored frames.

No more than 5 % additional errored frames above the quiescent level shall be permitted during the exposure.

10.3.7.2 Performance criterion B (transient phenomena)

The data link connection shall be maintained.

10.3.8 Service and maintenance interfaces

The functional performance of ports of this type not intended to be permanently connected and therefore not subjected to immunity testing shall be verified according to the manufacturer's specification following cessation of the electromagnetic exposure on other ports.

10.3.9 Synchronization interfaces

The performance of slave clocks specified in ITU-T Recommendations G.812 [30] and G.813 [31] shall be checked with the equipment synchronized with an external source.

10.3.9.1 Performance criterion A (continuous phenomena)

During the exposure, synchronization shall not be lost.

10.3.9.2 Performance criteria B (transient phenomena)

No alarm indications shall persist after the exposure.

The functional performance according to the manufacturer's specification shall be verified following cessation of the exposure.

10.3.10 Remote alarm interfaces

These interfaces are defined by the manufacturer.

10.3.10.1 Performance criterion A (continuous phenomena)

No false alarms shall occur during continuous exposures.

10.3.10.2 Performance criterion B (transient phenomena)

No false alarm indications shall persist after the exposure.

10.3.10.3 Performance criteria R (resistibility)

The general performance criteria R apply.

11 Power supply equipment specific conditions

11.1 Test configuration

Typically the EUT will be configured as shown in figures 3 and 4. The EMC test equipment is not shown.

The earth connections of the EUT shall be connected to a reference earth according to the manufacturer specifications.

The EUT load shall be resistive unless otherwise specified by the manufacturer.

For EUT with dc output and battery back-up, EMC tests shall be performed without the battery unless otherwise specified.

Uninterruptible power supplies shall also be tested whilst feeding from the battery only (ac mains off).

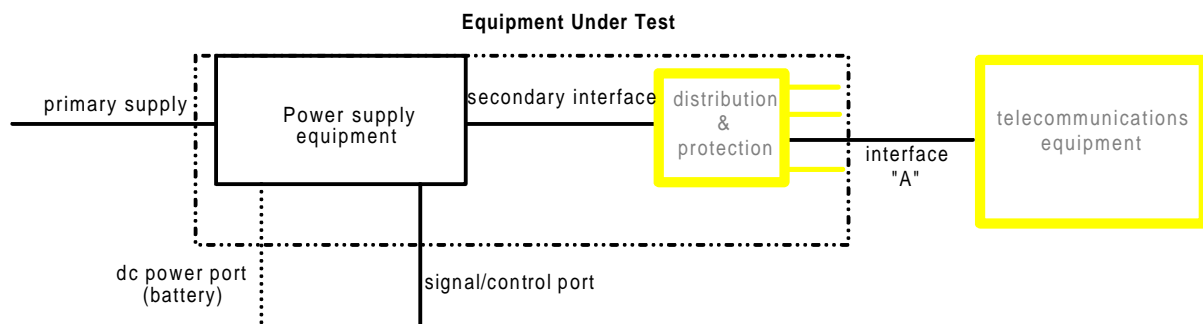

Figure 3: General identification of a power supply and its ports

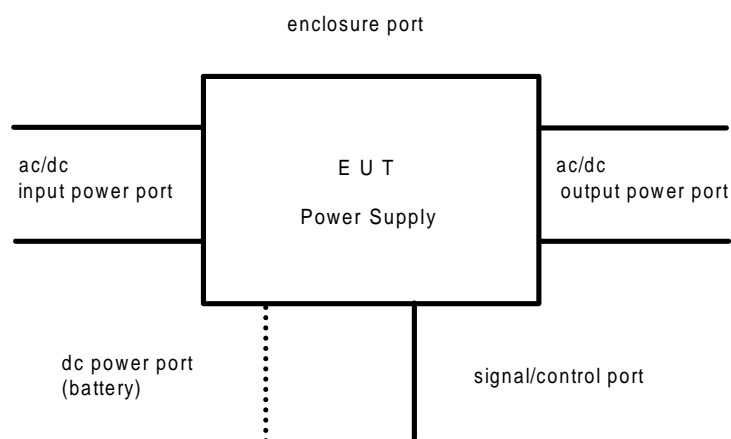

Figure 4: Port identifications of the EUT

11.2 Operational conditions

11.2.1 Emission

The measurements shall be made in the operating mode, with the EUT producing the maximum emission, consistent with normal applications. The EUT load shall be adjusted within the range specified by manufacturer in order to maximize the emission.

Conducted emission shall be measured on the power input and output ports.

The conducted emission tests shall only be performed on ports that are permanently connected in the normal installation.

11.2.2 Immunity

Immunity tests may be performed with the EUT operating at reduced output power: 50 % is recommended. The actual output power level for each test shall be stated in the test report.

Conducted immunity tests shall be performed on the power input and output ports, and on one signal/control interface of each type found on the equipment.

The conducted immunity tests need only be performed on ports that are permanently connected in the normal installation.

Power and control cables which according to the manufacturer's specification are not intended to be longer than 3 m in installed systems shall not be subjected to conducted immunity testing. However, cables that may be connected to an extensive network shall be subjected to the conducted immunity test.

11.3 Specific immunity and resistibility performance criteria

The ports of the power supply equipment (figure 4) that shall be monitored during the tests can be categorized as one of:

- dc secondary interface;
- ac secondary interface; or
- control/signal interface.

The manufacturer shall, at the time of submission of the equipment for test, supply the following information to be recorded in the test report:

- the primary functions of the power supply equipment to be tested;
- the intended functions of the power supply equipment, which shall be in accordance with the documentation accompanying the equipment and sales literature as appropriate;
- the auxiliary equipment to be combined with the power supply equipment;
- a list of ports, classified as ac/dc power port or control/signal port;
- the operating conditions.

11.3.1 Alternating current secondary interface

11.3.1.1 Performance criteria A (continuous phenomena)

- During the exposure, the ac secondary range shall be in accordance with the normal service condition defined in ETS 300 132-1 [3].
- The long-term voltage fluctuations at the ac secondary interface shall be within ± 10 % of the nominal voltage.

- During and after the exposure, the EUT shall operate without alarms, false alarm indications (power supply failure, protection failure, etc.) and false display indications.

11.3.1.2 Performance criteria B (transient phenomena)

- Voltage interruptions at the ac secondary interface shall last no longer than 20 ms. The time between two voltage interruptions shall be no less than 10 s;
- the voltage fluctuations at the ac secondary interface shall be in accordance with the requirements of ETS 300 132-1 [3]:
 - for < 500 ms with respect to rms value: no worse than $\pm 15\%$ of nominal value;
 - for < 2 ms with respect to actual value: no worse than $\pm 40\%$ of nominal value;
- the frequency at the ac secondary interface shall not vary by more than ± 3 Hz and shall return to the nominal value within 5 s;
- peaks with a duration shorter than 0,25 of one period (5 ms for a 50 Hz system) which appear during the exposure are permissible;
- after the exposure, the EUT shall operate without alarms or false alarm indications (power supply failure, protection failure, etc.) or false display indications;
- self recovery to normal performance shall occur at the cessation of the exposure.

11.3.1.3 Performance criterion R (resistibility)

The general performance criteria R apply.

11.3.2 Direct current secondary interface

11.3.2.1 Performance criteria A (continuous phenomena)

- During the exposure, the dc secondary voltage range shall be in accordance with the normal service conditions defined in ETS 300 132-2 [4].
- The maximum level of wide band noise at the dc secondary interface shall not exceed the limits specified in table 1 of ETS 300 132-2 [4].

Table 1: Level of wide band noise

Frequency	Voltages
25 Hz - 5 kHz	10 mV $U_{\text{pso, eff}}$ psophometrically, via CCITT weighting filter for commercial circuits

The reference method of measurement is with a psophometer conforming to ITU-T Recommendation O.41 [18].

- During and after the exposure, the EUT shall operate without alarms or false alarm indications (power supply failure, protection failure, etc.) and false display indications.

11.3.2.2 Performance criteria B (transient phenomena)

- After the exposure, the EUT shall operate without alarms or false alarm indications (power supply failure, protection failure, etc.) and false display indications;
- the dc secondary voltage during the exposure shall not exceed the following value:
 - for -48 V dc nominal value: -60 V;

for -60 V dc nominal value: -75 V;

- short peaks which appear during the application of the tests shall be ignored.

11.3.2.3 Performance criteria R (resistibility)

The general performance criteria R apply.

11.3.3 Control/signal interface

The control and signal ports need not be monitoring during the tests, because they are not considered to be primary functions.

11.3.4 Tertiary supply interface

To be considered only for special cases. Performance criteria should be derived from the product specifications.

12 Supervisory equipment specific conditions

12.1 Test configuration

Exercising equipment e.g. a traffic simulator used for testing of other functions and equipment e.g. switching equipment can also be used as exercising equipment for supervisory equipment. Figure 5 shows two examples for a possible test configuration. The EMC test equipment is not shown.

Parts of the supervisory equipment (e.g. terminals) may be connected together but installed at locations other than the supervised equipment. For the purpose of EMC testing, these parts may be tested simultaneously and at the same location as the supervised equipment.

Example A shows a configuration with an external traffic simulator. In example B a test load simulator software is used. The use of either or both configurations is possible. The EMC tests shall be carried out during normal operation of supervisory equipment.

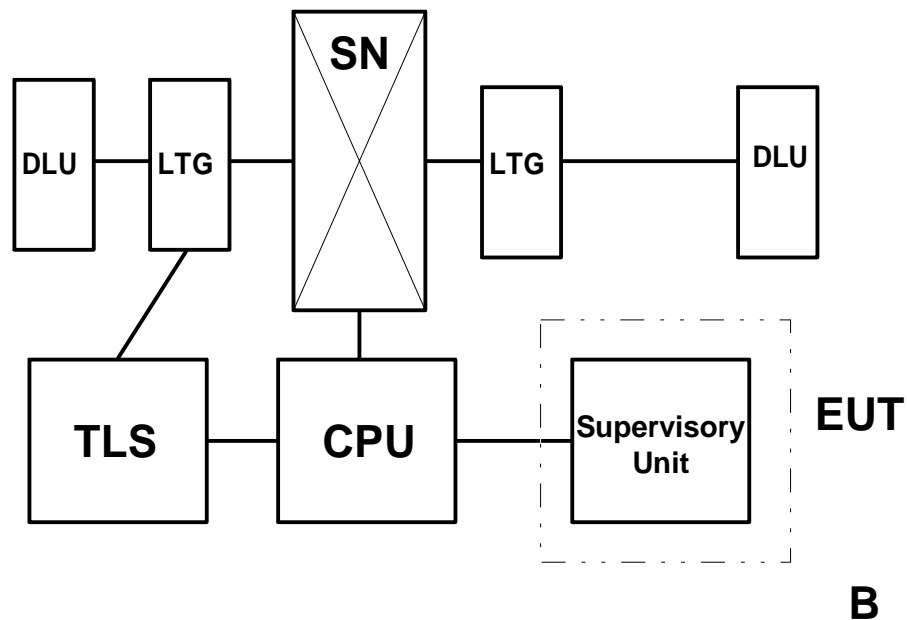
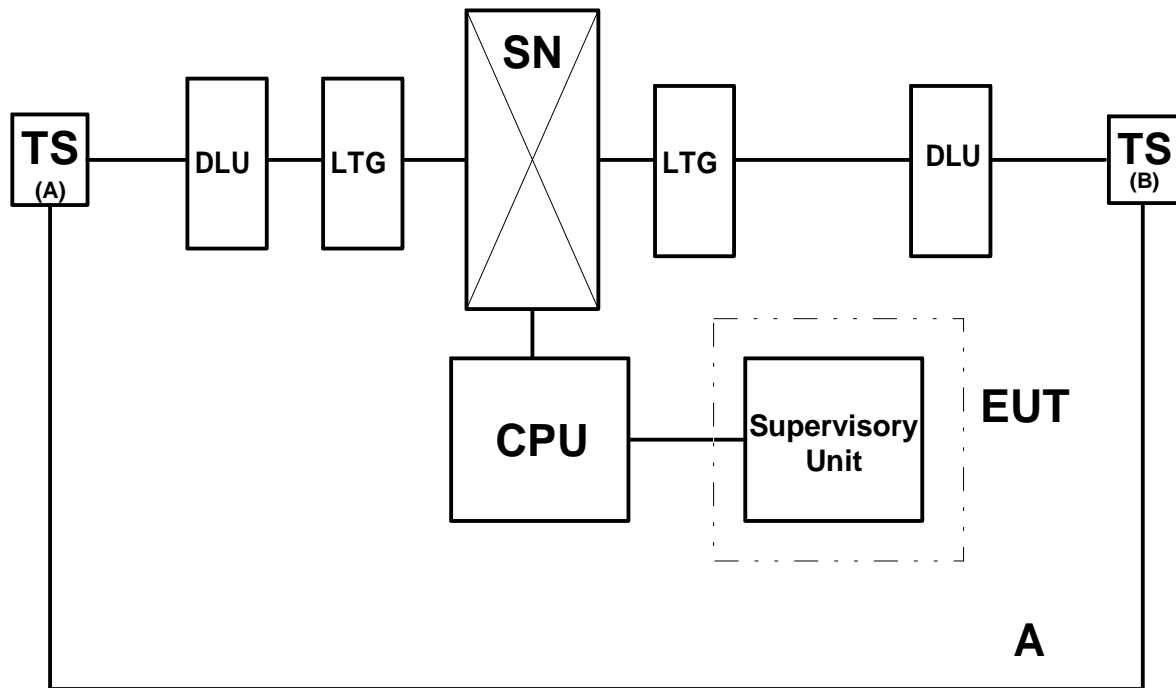

Legend:

CPU	= Central processing unit
DLU	= Digital line unit
LTG	= Line trunk group
SN	= Switching network
TLS	= Test load simulator
TS	= Traffic simulator

Figure 6: Two examples for the configuration of the EUT and exercising equipment

12.2 Operational conditions

The general conditions of clause 7 apply.

12.3 Specific immunity and resistibility performance criteria

12.3.1 Performance criteria A (continuous phenomena)

- The connection between the supervising and supervised equipment shall be maintained.
- No supervisory functions shall be affected by EMC testing.
- No false alarms, such as signal lamps or printer misprints shall occur.

12.3.2 Performance criteria B (transient phenomena)

- The supervisory equipment shall not affect the normal operation of the equipment being supervised.
- The operating speed of the supervising equipment may be reduced.
- Any minor priority supervisory function may be affected during EMC testing. These functions shall resume normal performance at cessation of the exposure. For example, false alarms shall reset.

12.3.3 Performance criteria R (resistibility)

The general performance criteria R apply.

Annex A (normative): Correlation between essential requirements and the provisions of the present document

This annex shows the essential requirements of the Directive [44] which are satisfied by conformance to each requirement of the present EN.

Table A.1: Essential requirements of the EC Council Directive, normal priority of service

Subclause	Title	Corresponding article of Council directive 89/336/EEC [44]
Emission		
5.1.4.4 & 5.2.4.5	Conducted emission. ac power port	4(a)
5.1.5.3 & 5.2.5.3	Conducted emission. dc power port	4(a)
5.1.1.3 & 5.2.1.3	Radiated emission	4(a)
5.1.4.5 & 5.2.4.6	Emission on ac power port. Harmonics	4(a)
5.1.4.6 & 5.2.4.7	Emission on ac power port. Flicker	4(a)
Immunity		
5.1.1.1 & 5.2.1.1	Electrostatic discharge	4(b)
5.1.1.2 & 5.2.1.2	Radiated electromagnetic fields	4(b)
5.1.2.1, 5.1.3.1, 5.2.2.1 & 5.2.3.1	Electrical fast transient/burst. Signal line ports	4(b)
5.1.4.1 & 5.2.4.1	Electrical fast transient/burst. ac power port	4(b)
5.1.5.1 & 5.2.5.1	Electrical fast transient/burst. dc power port	4(b)
5.1.2.2, 5.1.3.2, 5.2.2.2 & 5.2.3.2	Surges. Signal line ports	4(b)
5.1.4.2 & 5.2.4.2	Surges. ac power ports	4(b)
5.2.4.4	Voltage dips and short interruptions. ac power port	4(b)
5.1.2.3, 5.1.3.3, 5.2.2.3 & 5.2.3.3	Continuous conducted, radio frequency. Signal line port	4(b)
5.1.4.3 & 5.2.4.3	Continuous conducted, radio frequency. ac power port	4(b)
5.1.5.2 & 5.2.5.2	Continuous conducted, radio frequency. dc power port	4(b)
Resistibility		
(none)		

History

Document history			
Edition 1	September 1996	Public Enquiry on subparts 2, 3, 4	PE 114: 1996-09-23 to 1997-01-17
V1.1.3	August 1997	One-step Approval Procedure	OAP 9748: 1997-08-01 to 1997-11-28
V1.1.3	December 1997	Publication	