

ETSI EN 300 386 V1.2.1 (2000-03)

Candidate Harmonized European Standard (Telecommunications series)

**Electromagnetic compatibility
and Radio spectrum Matters (ERM);
Telecommunication network equipment;
ElectroMagnetic Compatibility (EMC) requirements**



Reference

REN/ERM-EMC-111

Keywords

EMC, network, testing

ETSI

Postal address

F-06921 Sophia Antipolis Cedex - FRANCE

Office address

650 Route des Lucioles - Sophia Antipolis
Valbonne - FRANCE
Tel.: +33 4 92 94 42 00 Fax: +33 4 93 65 47 16
Siret N° 348 623 562 00017 - NAF 742 C
Association à but non lucratif enregistrée à la
Sous-Préfecture de Grasse (06) N° 7803/88

Internet

secretariat@etsi.fr

Individual copies of this ETSI deliverable
can be downloaded from
<http://www.etsi.org>

If you find errors in the present document, send your
comment to: editor@etsi.fr

Important notice

This ETSI deliverable may be made available in more than one electronic version or in print. In any case of existing or perceived difference in contents between such versions, the reference version is the Portable Document Format (PDF). In case of dispute, the reference shall be the printing on ETSI printers of the PDF version kept on a specific network drive within ETSI Secretariat.

Copyright Notification

No part may be reproduced except as authorized by written permission.
The copyright and the foregoing restriction extend to reproduction in all media.

© European Telecommunications Standards Institute 2000.
All rights reserved.

Contents

Intellectual Property Rights	6
Foreword	6
1 Scope	7
2 References	8
3 Definitions and abbreviations	11
3.1 Definitions	11
3.2 Abbreviations	12
4 Installation environment.....	13
5 Immunity: test methods	13
5.1 Electrostatic discharge.....	13
5.2 Electrical fast transients/burst.....	13
5.3 Surges	13
5.3.1 Outdoor signal line ports.....	13
5.3.2 Indoor signal line ports	14
5.3.3 AC power ports.....	14
5.4 Immunity to continuous conducted signals.....	14
5.4.1 Low frequency (≤ 150 kHz).....	14
5.4.1.1 AC power port.....	14
5.4.1.2 DC power port.....	14
5.4.1.3 Signal line port	14
5.4.2 Radio frequency (> 150 kHz)	14
5.4.2.1 AC power port.....	14
5.4.2.2 DC power port.....	14
5.4.2.3 Signal line port	15
5.5 Immunity to radiated electromagnetic fields	15
5.6 Immunity to power supply disturbances: AC and DC power ports.....	15
5.6.1 Test of immunity to low frequency disturbances: AC power ports	15
6 Emission: test methods.....	15
6.1 AC power port	15
6.2 DC power port	15
6.3 Telecommunication Port	16
6.4 Radiated emission.....	16
7 Test levels and limits.....	17
7.1 Equipment operating in telecommunication centres	17
7.1.1 Telecommunication centres, enclosure port.....	17
7.1.2 Telecommunication centres, ports for outdoor signal lines.....	18
7.1.3 Telecommunication centres, ports for indoor signal lines.....	20
7.1.4 Telecommunication centres, AC power ports	21
7.1.5 Telecommunication centres, DC power ports	22
7.2 Equipment operating in locations other than telecommunication centres.....	23
7.2.1 Other than telecommunication centres, enclosure port	23
7.2.2 Other than telecommunication centres, ports for outdoor signal lines	24
7.2.3 Other than telecommunication centres, ports for indoor signal lines	26
7.2.4 Other than telecommunication centres, AC power ports.....	27
7.2.5 Other than telecommunication centres, DC power ports.....	28
8 General test configuration	29
9 General operational conditions during testing	29
9.1 Equipment configuration	29
9.2 Exercising equipment	30
9.3 Laboratory environment	30

10	General immunity and resistibility conditions	30
10.1	General performance criteria	30
11	Switching equipment specific requirements	31
11.1	Test configuration.....	31
11.2	Operational conditions	32
11.2.1	Emission	32
11.2.2	Immunity.....	32
11.3	Specific immunity and resistibility performance criteria.....	32
11.3.1	Digital port performance criteria	32
11.3.1.1	Performance criteria A (continuous phenomena).....	32
11.3.1.2	Performance criterion B (transient phenomena).....	33
11.3.1.3	Criteria C (interruptions).....	33
11.3.1.4	Criteria R (resistibility)	33
11.3.2	Analogue port performance criteria	33
11.3.2.1	Performance criteria A (continuous phenomena).....	33
11.3.2.2	Performance criteria B (transient phenomena).....	33
11.3.2.3	Criteria C (interruptions).....	33
11.3.2.4	Criteria R (resistibility)	33
12	Transmission equipment specific requirements	34
12.1	Test configuration.....	34
12.2	Operational conditions	34
12.2.1	Emission	34
12.2.2	Immunity.....	34
12.3	Specific immunity and resistibility performance criteria.....	35
12.3.1	Digital signal ports.....	35
12.3.1.1	Performance criterion A (continuous phenomena).....	35
12.3.1.2	Performance criterion B (transient phenomena).....	35
12.3.1.3	Performance criterion C (interruptions)	35
12.3.1.4	Performance criterion R (resistibility).....	35
12.3.2	Analogue voice frequency signal ports	35
12.3.2.1	Performance criterion A (continuous phenomena).....	36
12.3.2.2	Performance criterion B (transient phenomena).....	36
12.3.2.3	Performance criterion R (resistibility).....	36
12.3.3	SDH and PDH interfaces	36
12.3.3.1	Tributary and aggregate interfaces	36
12.3.4	ISDN interfaces	36
12.3.4.1	Primary rate access ISDN interfaces	36
12.3.4.2	Network termination NT1 for ISDN "U" interfaces.....	36
12.3.4.3	Basic access ISDN interfaces	36
12.3.5	Analogue interfaces	36
12.3.5.1	Trunk interfaces and leased line interfaces.....	36
12.3.5.2	Subscriber interfaces	36
12.3.6	V.10, V.11, V.24, V.28, V.36, X.24 and similar V.- and X.- series interfaces.....	36
12.3.7	Ethernet and packet-data interfaces	37
12.3.7.1	Performance criterion A (continuous phenomena).....	37
12.3.7.2	Performance criterion B (transient phenomena).....	37
12.3.8	Service and maintenance interfaces	37
12.3.9	Synchronization interfaces	37
12.3.9.1	Performance criterion A (continuous phenomena).....	37
12.3.9.2	Performance criteria B (transient phenomena).....	37
12.3.10	Remote alarm interfaces.....	37
12.3.10.1	Performance criterion A (continuous phenomena).....	37
12.3.10.2	Performance criterion B (transient phenomena).....	37
12.3.10.3	Performance criteria R (resistibility).....	37
13	Power supply equipment specific conditions.....	38
13.1	Test configuration.....	38
13.2	Operational conditions	38
13.2.1	Emission	38

13.2.2	Immunity.....	39
13.3	Specific immunity and resistibility performance criteria.....	39
13.3.1	Alternating current secondary interface	39
13.3.1.1	Performance criteria A (continuous phenomena).....	39
13.3.1.2	Performance criteria B (transient phenomena).....	39
13.3.1.3	Performance criterion R (resistibility).....	40
13.3.2	Direct current secondary interface	40
13.3.2.1	Performance criteria A (continuous phenomena).....	40
13.3.2.2	Performance criteria B (transient phenomena).....	40
13.3.2.3	Performance criteria R (resistibility).....	40
13.3.3	Control/signal interface.....	41
13.3.4	Tertiary supply interface	41
14	Supervisory equipment specific conditions	41
14.1	Test configuration.....	41
14.2	Operational conditions	42
14.3	Specific immunity and resistibility performance criteria.....	42
14.3.1	Performance criteria A (continuous phenomena).....	42
14.3.2	Performance criteria B (transient phenomena).....	43
14.3.3	Performance criteria R (resistibility).....	43
Annex A (normative):	Correlation between essential requirements and the provisions of the present document.....	44
Annex B (normative):	Surges: test method for ports of signal lines remaining within the building.....	45
B.1	Test set-up for ports with ISDN interface.....	45
Annex C (informative):	Evaluation of test results.....	48
History	50

Intellectual Property Rights

IPRs essential or potentially essential to the present document may have been declared to ETSI. The information pertaining to these essential IPRs, if any, is publicly available for **ETSI members and non-members**, and can be found in SR 000 314: *"Intellectual Property Rights (IPRs); Essential, or potentially Essential, IPRs notified to ETSI in respect of ETSI standards"*, which is available from the ETSI Secretariat. Latest updates are available on the ETSI Web server (<http://www.etsi.org/ipr>).

Pursuant to the ETSI IPR Policy, no investigation, including IPR searches, has been carried out by ETSI. No guarantee can be given as to the existence of other IPRs not referenced in SR 000 314 (or the updates on the ETSI Web server) which are, or may be, or may become, essential to the present document.

Foreword

This Candidate Harmonized European Standard (Telecommunications series) has been produced by ETSI Technical Committee Electromagnetic compatibility and Radio spectrum Matters (ERM).

The present document has been produced by ETSI in response to a mandate from the European Commission issued under Council Directive 98/34/EC [46] (as amended) laying down a procedure for the provision of information in the field of technical standards and regulations.

The present document is intended to become a Harmonized Standard, the reference of which will be published in the Official Journal of the European Communities referencing the Council Directive on the approximation of the laws of the Member States relating to electromagnetic compatibility ("the EMC Directive") (89/336/EEC [44] as amended).

Technical specifications relevant to the EMC Directive are given in annex A.

National transposition dates	
Date of adoption of this EN:	25 February 2000
Date of latest announcement of this EN (doa):	31 May 2000
Date of latest publication of new National Standard or endorsement of this EN (dop/e):	30 November 2000
Date of withdrawal of any conflicting National Standard (dow):	31 May 2003

1 Scope

The present document covers the EMC requirements for equipment intended to be used within a telecommunications network (as defined in clause 3). Examples of such equipment are:

- **Switching equipment.** Such equipment includes:
 - local telephone exchanges;
 - remote switching concentrators;
 - international switches;
 - telex switches;
 - network packet switches.
- General purpose equipment which is used as a part of a switching system may be covered by the scope of other standards. For such equipment, if those other standards fully cover all the requirements of the present document, no further requirements are necessary. Switching equipment can also contain transmission functions, and this has to be recognized during testing.
- **Non-radio transmission equipment and ancillary equipment.** Such equipment includes:
 - multiplexers;
 - line equipment and repeaters, e.g. equipment for:
 - Synchronous Digital Hierarchy (SDH);
 - Plesiochronous Digital Hierarchy (PDH);
 - Asynchronous Transfer Mode (ATM);

such as:

- Digital Cross Connect systems;
- network terminations;
- transmission equipment used in the access network like XDSL.
- **Power supply equipment.** Such equipment includes:
 - central power plant;
 - end of suite power supplies;
 - uninterruptible power supplies;
 - stabilized AC power supplies;
 - and other dedicated telecommunication network power supplies;but excludes equipment which is uniquely associated with or integrated in other equipment.
- **Supervisory equipment.** Such equipment includes:
 - network management equipment;
 - operator access maintenance equipment;
 - traffic measurement systems;
 - line test units;

- functional test units.

The function of *supervision* may either be performed by independent equipment or form part of other telecommunication equipment. If the function of supervision forms part of a telecommunication equipment, the performance may be evaluated simultaneously with other functions (such as switching and transmission) during EMC testing.

Supervisory equipment may also be used in conjunction with radio equipment.

The environmental classification used in the present document refers to TR 101 651 [45].

The requirements of the present document have been selected to ensure an adequate level of immunity for the apparatus covered by the scope of the present document. The levels do not, however, cover extreme cases which may occur at any location but with a low probability of occurrence. In special cases, situations may arise where the levels of disturbance may exceed the immunity test levels specified in the present document. In these instances, special mitigation measures may have to be employed.

Equipment for cabled distribution systems intended only for television and sound signals as defined in EN 50083-2 [4] and optical amplifiers as defined in ITU-T Recommendations G.661 [24] and G.662 [25] are outside the scope of the present document.

2 References

The following documents contain provisions which, through reference in this text, constitute provisions of the present document.

- References are either specific (identified by date of publication, edition number, version number, etc.) or non-specific.
- For a specific reference, subsequent revisions do not apply.
- For a non-specific reference, the latest version applies.
- A non-specific reference to an ETS shall also be taken to refer to later versions published as an EN with the same number.

- [1] CISPR 16-1: "Specifications for radio interference measuring apparatus and measurement methods".
- [2] EN 45001: "General criteria for the operation of testing laboratories".
- [3] EN 50082-1: "Electromagnetic compatibility - Generic immunity standard; Part 1: Residential, commercial and light industry".
- [4] EN 50083-2: "Cabled distribution systems for television and sound signals; Part 2: Electromagnetic compatibility for equipment".
- [5] EN 55022: "Limits and methods of measurement of radio disturbance characteristics of information technology equipment".
- [6] EN 61000-3-2: "Electromagnetic compatibility (EMC); Part 3: Limits; Section 2: Limits for harmonic current emissions (equipment input current up to and including 16 A per phase)".
- [7] EN 61000-3-3: "Electromagnetic compatibility (EMC); Part 3: Limits; Section 3: Limitation of voltage fluctuations and flicker in low-voltage supply systems for equipment with rated current up to and including 16 A".
- [8] EN 61000-4-2: "Electromagnetic compatibility (EMC); Part 4: Testing and measurement techniques; Section 2: Electrostatic discharge immunity test".
- [9] EN 61000-4-3: "Electromagnetic compatibility (EMC); Part 4: Testing and measurement techniques; Section 3: Radiated, radio-frequency, electromagnetic field immunity test".

- [10] EN 61000-4-4: "Electromagnetic compatibility (EMC); Part 4: Testing and measurement techniques; Section 4: Electrical fast transient/burst immunity test".
- [11] EN 61000-4-5: "Electromagnetic compatibility (EMC); Part 4: Testing and measurement techniques; Section 5: Surge immunity test".
- [12] EN 61000-4-6: "Electromagnetic compatibility (EMC); Part 4: Testing and measurement techniques; Section 6: Immunity to conducted disturbances, induced by radio-frequency fields".
- [13] EN 61000-4-11: "Electromagnetic compatibility (EMC); Part 4: Testing and measuring techniques; Section 11: Voltage dips, short interruptions and voltage variations immunity tests".
- [14] ETSI ETR 238: "ETSI/CENELEC standardization programme for the development of Harmonized Standards related to Electro-Magnetic Compatibility (EMC) in the field of telecommunications".
- [15] ETSI ETS 300 011: "Integrated Services Digital Network (ISDN); Primary rate user-network interface; Layer 1 specification and test principles".
- [16] ETSI ETS 300 012: "Integrated Services Digital Network (ISDN); Basic user-network interface; Layer 1 specification and test principles".
- [17] ETSI ETS 300 132-1: "Equipment Engineering (EE); Power supply interface at the input to telecommunications equipment; Part 1: Operated by alternating current (ac) derived from direct current (dc) sources".
- [18] ETSI ETS 300 132-2: "Equipment Engineering (EE); Power supply interface at the input to telecommunications equipment; Part 2: Operated by direct current (dc)".
- [19] ETSI ETS 300 166: "Transmission and Multiplexing (TM); Physical and electrical characteristics of hierarchical digital interfaces for equipment using the 2 048 kbit/s - based plesiochronous or synchronous digital hierarchies".
- [20] ETSI ETS 300 232: "Transmission and Multiplexing (TM); Optical interfaces for equipments and systems relating to the Synchronous Digital Hierarchy [ITU-T Recommendation G.957 (1993), modified]".
- [21] IEC 60050-161: "International Electrotechnical Vocabulary; Chapter 161: Electromagnetic compatibility".
- [22] IEC 60050-714: "International Electrotechnical Vocabulary - Chapter 714: Switching and signalling in telecommunications".
- [23] ISO/IEC 8802-3: "Information technology - Telecommunications and information exchange between systems - Local and metropolitan area networks; Specific requirements; Part 3: Carrier sense multiple access with collision detection (CSMA/CD) access method and physical layer specifications".
- [24] ITU-T Recommendation G.661: "Definition and test methods for the relevant generic parameters of optical amplifiers devices and subsystems".
- [25] ITU-T Recommendation G.662: "Generic characteristics of optical fibre amplifier devices and sub-systems".
- [26] ITU-T Recommendation G.712: "Transmission performance characteristics of pulse code modulation channels".
- [27] ITU-T Recommendation G.812: "Timing requirements of slave clocks suitable for use as node clocks in synchronization networks".
- [28] ITU-T Recommendation G.813: "Timing characteristics of SDH equipment slave clocks (SEC)".
- [29] ITU-T Recommendation G.958: "Digital line systems based on the synchronous digital hierarchy for use on optical fibre cables".

- [30] ITU-T Recommendation G.961: "Digital transmission system on metallic local lines for ISDN basic rate access".
- [31] ITU-T Recommendation K.20: "Resistibility of telecommunication switching equipment to overvoltages and overcurrents".
- [32] ITU-T Recommendation K.21: "Resistibility of subscribers' terminals to overvoltages and overcurrents".
- [33] EN 300 127: "Electromagnetic compatibility and Radio spectrum Matters (ERM); Radiated emission testing of physically large telecommunication systems".
- [34] ITU-T Recommendation O.41: "Psophometer for use on telephone-type circuits".
- [35] ITU-T Recommendation O.150: "General requirements for instrumentation for performance measurements on digital transmission equipment".
- [36] ITU-T Recommendation Q.552: "Transmission characteristics at 2-wire analogue interfaces of digital exchanges".
- [37] ITU-T Recommendation V.10: "Electrical characteristics for unbalanced double-current interchange circuits operating at data signalling rates nominally up to 100 kbit/s".
- [38] ITU-T Recommendation V.11: "Electrical characteristics for balanced double-current interchange circuits operating at data signalling rates up to 10 Mbit/s".
- [39] ITU-T Recommendation V.24: "List of definitions for interchange circuits between data terminal equipment (DTE) and data circuit-terminating equipment (DCE)".
- [40] ITU-T Recommendation V.28: "Electrical characteristics for unbalanced double-current interchange circuits".
- [41] ITU-T Recommendation V.36: "Modems for synchronous data transmission using 60 - 108 kHz group band circuits".
- [42] ITU-T Recommendation X.24: "List of definitions for interchange circuits between Data Terminal Equipment (DTE) and Data Circuit-terminating Equipment (DCE) on public data networks".
- [43] ITU-T Recommendation X.25: "Interface between Data Terminal Equipment (DTE) and Data Circuit-terminating Equipment (DCE) for terminals operating in the packet mode and connected to public data networks by dedicated circuit".
- [44] 89/336/EEC: "Council Directive of 3 May 1989 on the approximation of the laws of the member states relating to electromagnetic compatibility".
- [45] ETSI TR 101 651: "Electromagnetic compatibility and radio spectrum matters (ERM); Classification of the electromagnetic environment conditions for equipment in telecommunication networks".
- [46] 98/34/EC: "Directive 98/34/EC of the European Parliament and of the Council of 22 June 1998 laying down a procedure for the provision of information in the field of technical standards and regulations".

3 Definitions and abbreviations

3.1 Definitions

For the purposes of the present document, the following terms and definitions apply. The definitions taken from the IEC 60050-161 [21] have reference in parentheses:

AC secondary interface: output port of a AC power supply

AC secondary voltage: output of the AC power supply at the AC secondary interface

NOTE 1: The AC secondary voltage may be either:

- a stabilized AC supply derived from a DC primary supply (e.g. where the power supply is an inverter);
- or
- derived from the AC primary supply (e.g. a stabilized power supply used where the quality of the primary supply is not sufficient to feed telecommunication equipment).

burst (161-02-07): sequence of a limited number of distinct pulses or an oscillation of limited duration

connection: temporary association of transmission channels or telecommunication circuits, switching or other functional units set up to provide for the transfer of information between two or more points in a telecommunication network (IEC 60050-714 [22])

continuous disturbance (161-02-11): electromagnetic disturbance the effects of which on a particular device or equipment cannot be resolved into a succession of distinct effects

DC secondary interface: output port of a DC power supply

DC secondary voltage: output of the DC power supply at the DC secondary interface. The DC secondary voltage may be derived from the AC primary supply with or without a buffer battery

duration (of a voltage change) (161-08-03): interval of time for the voltage to increase or decrease from the initial value to the final value

duration (of a pulse): interval of time between the instants at which the instantaneous value of a pulse reaches 50 % of the pulse magnitude for the first and last time

enclosure port: physical boundary of the Equipment Under Test (EUT) through which electromagnetic fields may emanate or on which they may impinge

environment, environmental conditions: electromagnetic conditions external to the equipment, to which it is subjected at a certain time. The environmental conditions comprise a combination of single environmental parameters and their severity's

environmental parameters: present one or more properties of the electromagnetic environment

immunity (to a disturbance) (161-01-20): ability of a device, equipment or system to perform without degradation in the presence of an electromagnetic disturbance

impulsive disturbance (161-02-09): electromagnetic disturbance which, when incident on a particular device or equipment, manifests itself as a succession of distinct pulses or transients

interface "A": terminals at which a power supply is connected to the telecommunications equipment

nominal voltage: nominal value of voltage that designates the type of supply

normal service: service mode where telecommunications equipment operates within its specification

performance criterion: limits of acceptable behaviour of the equipment during and after the application of the electromagnetic phenomenon

NOTE 2: Performance criteria A apply for continuous phenomena; performance criteria B and C apply for transient phenomena; and performance criteria R apply for resistibility phenomena.

port: particular interface of the EUT with the external electromagnetic environment

power supply: power source (within the scope of the present document) to which telecommunications equipment is intended to be connected

primary supply: public mains or a locally generated AC or DC supply

pulse (161-02-02): abrupt variation of short duration of a physical quantity followed by a rapid return to the initial value

Radio Frequencies (RF): frequency range above 150 kHz

resistibility: ability of equipment having one or more telecommunication ports to withstand the effects of electrical, magnetic and electromagnetic phenomena in accordance with a specified criterion

rise time (of a pulse) (161-02-05): interval of time between the instants at which the instantaneous value of a pulse first reaches a specified lower value and then a specified upper value

NOTE 3: Unless otherwise specified, the lower and upper values are fixed at 10 % and 90 % of the pulse magnitude.

secondary supply: supply to the telecommunications equipment (e.g. racks or system blocks), derived from the primary supply

surge (voltage) (161-08-11): transient voltage wave propagating along a line or a circuit and characterized by a rapid increase followed by a slower decrease of the voltage

system block: functional group of equipment depending for its operation and performance upon the secondary power supply

telecommunication network: network operated under a licence granted by a national telecommunications authority which provides telecommunications between network termination points (NTPs) (i.e. excluding terminal equipment beyond the NTPs)

tertiary supply: supply to the telecommunications equipment derived from the secondary supply

transient (adjective or noun) (161-02-01): pertaining to or designating a phenomenon or a quantity which varies between two consecutive steady states during a time interval which is short compared with the timescale of interest

3.2 Abbreviations

For the purposes of the present document, the following abbreviations apply:

AC	Alternating Current
AM	Amplitude Modulation
AV	Average
DC	Direct Current
EMC	ElectroMagnetic Compatibility
ESD	Electrostatic Discharge
EUT	Equipment Under Test
N/A	Not Applicable
NTP	Network Termination Point
PDH	Plesiochronous Digital Hierarchy
PRBS	Pseudo Random Bit Sequence
QP	Quasi-Peak
RF	Radio Frequency
rms	root-mean-square
SDH	Synchronous Digital Hierarchy
T_r/T_h	Rise time (10 % to 90 %) and hold time (50 % to 50 %) of transient signal (see EN 61000-4-4 [10])
U_{pso}	Voltage measured with a psophometer conforming to ITU-T Recommendation O.41 [34]

4 Installation environment

The installation environments for the equipment covered by the present document are defined in TR 101 651 [45]. The environments defined are either:

- the telecommunication centre (Major and Minor);
- locations other than telecommunication centre e.g. within offices, customers' premises, outdoor locations, etc.

If no restrictions are specified in the product documentation for the installation environment, the equipment shall comply with the requirements of all environments, implying that the more severe test level shall be used when the test is performed. Equipment which meets the (more severe) requirements for "other than telecommunications centres" may be operated in either location.

5 Immunity: test methods

Where reference is made in the present document to specific "test levels" to be used for the tests, it is implicitly required that the EUT shall also fulfil the compliance criteria when tested at "test levels" lower than those specified. This requirement does not apply, however, to tests for immunity to continuous phenomena.

Conducted immunity tests shall be applied to one port at a time.

One signal port of each type found on the equipment shall be tested. If in normal installation practice multi-pair cables (e.g. 64 × balanced pairs) and composite cables (e.g. a combination of fibre and copper) are used, they are to be tested as one single cable. Cables bundled for aesthetic or routing purposes are to be tested individually.

5.1 Electrostatic discharge

The immunity test method and laboratory conditions are described in EN 61000-4-2 [8].

ESD shall be applied only to such points that are accessible to personnel during normal usage. The application of discharges to any point of the equipment other than the electrostatic protection point which is accessible only for maintenance purposes is not allowed unless specified by the manufacturer.

5.2 Electrical fast transients/burst

The immunity test method and laboratory conditions are described in EN 61000-4-4 [10].

5.3 Surges

5.3.1 Outdoor signal line ports

The immunity test method to be used for signal line ports is described in the EN 61000-4-5 [11].

Where normal functioning cannot be achieved because of the impact of the CDN on the EUT, no immunity test shall be required.

For resistibility tests according to the ITU-T Recommendations K.20 [31] and K.21 [32], the test generator shall be connected via the coupling network to one signal port. Other ports shall be configured for normal use. After the surge has been applied the generator shall be disconnected from the port and the port checked against the compliance criteria.

5.3.2 Indoor signal line ports

Annex B specifies an appropriate test method, dedicated to unshielded 4-wire balanced interface types with phantom DC power feeding and operating at bit rates up to and including 2 Mbit/s. This test method shall apply when the coupling/decoupling network specified in the EN 61000-4-5 [11] is not suitable for the bit rate of the signal port under test.

The test set up for shielded interface cables is specified in EN 61000-4-5 [11].

For ports connected to multi-conductor lines, for which the network according to annex B is not applicable, the networks according to EN 61000-4-5 [11] shall be used.

Where normal functioning cannot be achieved because of the impact of the CDN on the EUT, no immunity test shall be required.

5.3.3 AC power ports

The immunity test method to be used for AC power line ports is described in EN 61000-4-5 [11].

5.4 Immunity to continuous conducted signals

5.4.1 Low frequency (≤ 150 kHz)

5.4.1.1 AC power port

No requirements.

5.4.1.2 DC power port

No requirements.

5.4.1.3 Signal line port

No requirements.

5.4.2 Radio frequency (> 150 kHz)

5.4.2.1 AC power port

The test method to be used is described in EN 61000-4-6 [12].

Power cables, which according to the manufacturer's specification shall not be longer than 3 m, shall not be subjected to these tests.

5.4.2.2 DC power port

The test method to be used is described in EN 61000-4-6 [12].

Power cables, which according to the manufacturer's specification shall not be longer than 3 m, shall not be subjected to these tests.

The coupling/decoupling network type M1 (see EN 61000-4-6 [12]) shall be used when the DC return lead at the EUT side is to be connected to the equipment protective earth. If the DC return lead is not connected to the equipment protective earth then the coupling/decoupling network M2 shall be used.

5.4.2.3 Signal line port

The test method to be used is described in EN 61000-4-6 [12].

Signal cables, which according to the manufacturer's specification shall not be longer than 3 m, shall not be subjected to these tests.

5.5 Immunity to radiated electromagnetic fields

The test method to be used is described in EN 61000-4-3 [9].

5.6 Immunity to power supply disturbances: AC and DC power ports

5.6.1 Test of immunity to low frequency disturbances: AC power ports

Immunity to low frequency disturbances on the AC power ports, test methods are defined below.

Telecommunication equipment in telecommunication centres

- No requirements.

Telecommunication equipment, locations other than telecommunication centres

- The test method to be used is described in EN 61000-4-11 [13].

6 Emission: test methods

Clause 6 specifies requirements for the measurement of emissions from telecommunications network equipment.

Where not specified here, the EUT shall be configured, installed, arranged and operated in a manner consistent with normal operation.

6.1 AC power port

For conducted emission on AC power port in the frequency range 0,15 to 30 MHz, the test method specified in EN 55022 [5] shall apply.

6.2 DC power port

The measuring methods shall be those specified for the mains interface in EN 55022 [5] but shall be used in the frequency range 0,02 MHz to 30 MHz.

The EUT shall be connected to the DC power supply through an artificial network to provide a defined impedance across EUT at the point of measurement and to provide isolation from the noise on the DC power supply lines.

The artificial networks to be used are the ones described in CISPR 16-1 [1], section 2:

- 0,02 MHz to 0,15 MHz: subclause 8.2.1 ($50 \Omega // 50 \mu\text{H} + 5 \Omega$);
- 0,15 MHz to 30 MHz: subclause 8.2.2 ($50 \Omega // 50 \mu\text{H}$).

Figure 1 shows the general form for the measurement of interference voltages between each conductor and the reference ground plane. The DC return lead at the EUT side shall be connected to the protective earth if this is required by the equipment installation specification.

When the use of the artificial network is not suitable (e.g. when the artificial mains network with the current capacity of the EUT is not commercially available) the method described in CISPR 16-1 [1] for the voltage probe ($1\ 500\ \Omega$) shall be used.

Radio Frequency (RF) noise not produced by the device under test shall be at least 6 dB below the appropriate test limit level.

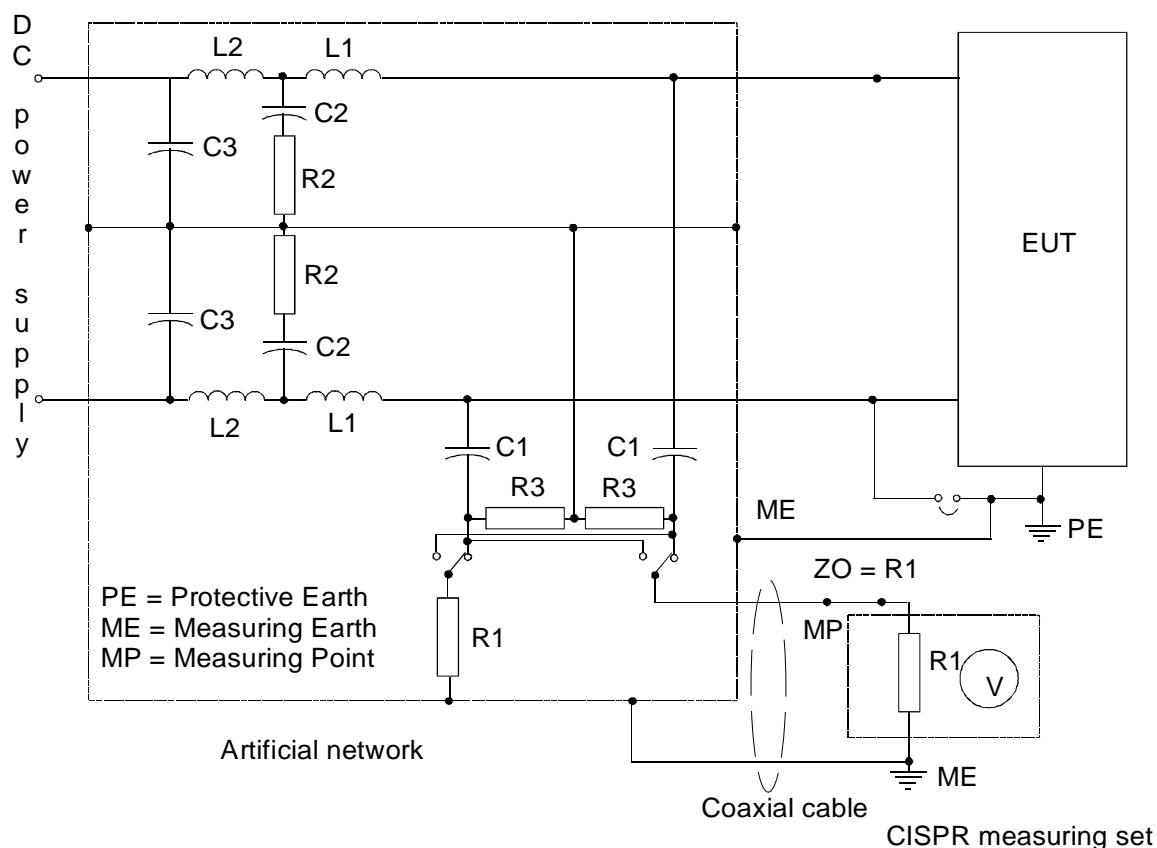

Figure 1: Measurement set-up for conducted emission on DC power interface

6.3 Telecommunication Port

For conducted emissions on telecommunications ports in the frequency range 0,15 MHz to 30 MHz, the test method specified in EN 55022 [5] shall apply.

Where measurement devices specified in EN 55022 [5] are not commercially available another suitable technique shall be used and detailed within the test report.

6.4 Radiated emission

For radiated emission in the frequency range 30 MHz to 1 000 MHz the test method specified in the EN 55022 [5] shall apply.

Where the EUT is considered to be physically large, the test methods and requirements prescribed by EN 300 127 [33] shall apply.

7 Test levels and limits

The test levels are compiled in the following tables.

7.1 Equipment operating in telecommunication centres

7.1.1 Telecommunication centres, enclosure port

Table 1

	Environmental phenomenon	Unit	Test level and characteristic	Reference	Performance criterion	Remarks
Immunity						
7.1.1.1	Electrostatic discharge	kV kV	4 Contact Discharge 4 Air Discharge	EN 61000-4-2 [8]	B	
7.1.1.2	Radio frequency electromagnetic field amplitude modulated	MHz V/m % AM (1 kHz)	80 to 1 000 3 80	EN 61000-4-3 [9]	A	
Emission						
7.1.1.3	Radiated electromagnetic field at 10 m	MHz dB(μV/m) MHz dB(μV/m)	30 to 230 40 230 to 1 000 47	EN 55022 [5]	N/A	Physically large systems should be tested according to the procedures in EN 300 127 [33].
Resistibility						
7.1.1.4	Electrostatic discharge	kV kV	8 Contact Discharge 15 Air Discharge	EN 61000-4-2 [8]	R	It is not necessary to perform this test for contact discharge with levels below the given resistibility limit. Lower levels than the given limits apply only for air discharge tests.

7.1.2 Telecommunication centres, ports for outdoor signal lines

Table 2

	Environmental phenomenon	Unit	Test level and characteristic	Reference	Performance criterion	Remarks
Immunity						
7.1.2.1	Fast transients	kV Tr/Th ns Rep. frequency kHz	0,5 5/50 5	EN 61000-4-4 [10]	B	
7.1.2.2	Surges	Tr/Th μ s kV	1,2/50 (8/20) 1	EN 61000-4-5 [11]	B	
7.1.2.3	Radio frequency, conducted continuous	MHz V % AM (1 kHz) Source impedance Ω	0,15 to 80 3 80 150	EN 61000-4-6 [12]	A	
Emission						
7.1.2.4	Conducted Emissions	MHz dB μ V dB μ V dB μ A dB μ A MHz dB μ V dB μ V dB μ A dB μ A	Class B 0,15 - 0,5 84 - 74 QP 74 - 64 AV 40 - 30 QP 30 - 20 AV 0,5 - 30 74 QP 64 AV 30 QP 20 AV	EN 55022 [5]	N/A	Provisionally, a relaxation of 10 dB over the frequency range of 6 MHz to 30 MHz is allowed for highspeed services having significant spectral density in this band. However, this relaxation is restricted to the common mode disturbance converted by the cable from the wanted signal
Resistibility						
7.1.2.5	Surges	Tr/Th μ s kV	10/700 4	ITU-T Recommendation K.20 [31]	R	Only applies to ports for unscreened pair cables longer than 500 m. During this test, primary protection (as described in ITU-T K-series Recommendations) may be fitted to the port.

	Environmental phenomenon	Unit	Test level and characteristic	Reference	Performance criterion	Remarks
7.1.2.6	Surges	Tr/Th μ s kV	10/700 1	ITU-T Recommendation K.20 [31]	R	Only applies to ports for unscreened pair cables longer than 500 m.
7.1.2.7	Power induction	V Hz ms	300 50 200	ITU-T Recommendation K.20 [31] table 1 figure 2, Switch S ₂ operated	R	Only applies to ports intended to be connected to unscreened pair cables longer than 500 m.
<p>NOTE 1: Outdoor lines carrying DC power with superimposed signals shall be treated as outdoor signal lines.</p> <p>NOTE 2: For switching equipment which is intended to be installed in locations other than telecommunication centres, the requirements for immunity to surges on outdoor signal lines and to continuous conducted disturbances on signal lines are according to the requirements for telecommunication centres. This reduction is based - amongst other things - upon the screening effect of multi-pair cables and specific earthing/bonding techniques in use for switching equipment.</p> <p>NOTE 3: The emission requirement only applies to telecommunications port as specified in EN 55022 [5]. The provisional relaxation of 10 dB will be reviewed no later than 3 years after the date of withdrawal based on the results and interference cases seen in this period. Wherever possible it is recommended to comply with the limits without the provisional relaxation.</p>						

7.1.3 Telecommunication centres, ports for indoor signal lines

Only ports connected to inter-system cables are to be tested. Testing of ports for intra-system cabling, e.g. local alarm and control, (provided in all cases both ends are controlled by the same manufacturer) is left to the discretion of the manufacturer which is responsible for the correct installation of the cables.

Table 3

	Environmental phenomenon	Unit	Test level and characteristic	Reference	Performance criterion	Remarks
Immunity						
7.1.3.1	Fast transients	kV Tr/Th ns Rep. frequency kHz	0,5 5/50 5	EN 61000-4-4 [10]	B	Only applies when cables longer than 3 m are intended to be connected.
7.1.3.2	Surges	Tr/Th μ s kV	1,2/50 (8/20) 0,5	EN 61000-4-5 [11] and subclause 5.3.2 of the present document	B	Only applies when cables longer than 10 m are connected.
7.1.3.3	Radio frequency, conducted continuous	MHz V % AM (1 kHz) Source impedance Ω	0,15 to 80 3 80 150	EN 61000-4-6 [12]	A	Only applies when cables longer than 3 m are connected.
Emission						
7.1.3.4	Conducted emission	MHz dB μ V dB μ V dB μ A dB μ A MHz dB μ V dB μ V dB μ A dB μ A	Class A 0,15 - 0,5 97 - 87 QP 84 - 74 AV 53 - 43 QP 40 - 30 AV 0,5 - 30 87 QP 74 AV 43 QP 30 AV	EN 55022 [5]	N/A	
Resistibility						
N/A						
NOTE 1: Indoor lines carrying DC power with superimposed signals shall be treated as indoor signal lines.						
NOTE 2: The emission requirement only applies to telecommunications port as specified in EN 55022 [5].						

7.1.4 Telecommunication centres, AC power ports

Table 4

	Environmental phenomenon	Unit	Test level and characteristic	Reference	Performance criterion	Remarks
Immunity						
7.1.4.1	Fast transients	kV Tr/Th ns Rep. frequency kHz	1 5/50 5	EN 61000-4-4 [10]	B	
7.1.4.2	Surges (line to line) (line to ground)	Tr/Th μ s kV kV	1,2/50 (8/20) 0,5 1	EN 61000-4-5 [11]	B B	
7.1.4.3	Radio frequency, conducted continuous	MHz V % AM (1 kHz) Source impedance Ω	0,15 to 80 3 80 150	EN 61000-4-6 [12]	A	
Emission						
7.1.4.4	Radio frequency disturbance voltage	MHz dB(μ V) MHz dB(μ V)	0,15 to 0,5 66 AV; 79 QP 0,5 to 30 60 AV; 73 QP	EN 55022 [5]	N/A	
7.1.4.5	Harmonics	Hz mA	50 to 2 000 See basic std.	EN 61000-3-2 [6]	N/A	Applicability of test according to the scope of EN 61000-3-2 [6].
7.1.4.6	Voltage fluctuations (Flicker)	Limit	See basic std.	EN 61000-3-3 [7]	N/A	Applicability of test according to the scope of EN 61000-3-3 [7].
Resistibility						
7.1.4.7	Surges (line to line) (line to ground)	Tr/Th μ s kV kV	1,2/50 (8/20) 1 2	EN 61000-4-5 [11]	R R	

7.1.5 Telecommunication centres, DC power ports

Table 5

	Environmental phenomenon	Unit	Test level and characteristic	Reference	Performance criterion	Remarks
Immunity						
7.1.5.1	Fast transients	kV Tr/Th ns Rep. frequency kHz	0,5 5/50 5	EN 61000-4-4 [10]	B	Only applicable when cables longer than 3 m are connected.
7.1.5.2	Radio frequency, conducted continuous	MHz V % AM (1 kHz) Source impedance Ω	0,15 to 80 3 80 150	EN 61000-4-6 [12]	A	Only applicable when cables longer than 3 m are connected.
Emission						
7.1.5.3	Radio frequency disturbance voltage	MHz dB (μ V) MHz dB (μ V) MHz dB (μ V)	0,02 to 0,15 -- AV; 79 QP 0,15 to 0,5 66 AV; 79 QP 0,5 to 30 60 AV; 73 QP	subclause 6.2 of the present document	N/A	
Resistibility						
N/A						

7.2 Equipment operating in locations other than telecommunication centres

7.2.1 Other than telecommunication centres, enclosure port

Table 6

	Environmental phenomenon	Unit	Test level and characteristic	Reference	Performance criterion	Remarks
Immunity						
7.2.1.1	Electrostatic discharge	kV kV	6 contact discharge 8 air discharge	EN 61000-4-2 [8]	B	
7.2.1.2	Radio frequency electromagnetic field amplitude modulated	MHz V/m % AM (1 kHz)	80 to 1 000 3 80	EN 61000-4-3 [9]	A	
Emission						
7.2.1.3	Radiated electromagnetic field at 10 m	MHz dB (µV/m) MHz dB (µV/m)	30 to 230 30 230 to 1 000 37	EN 55022 [5]	N/A	Physically large systems are tested according to the procedures in EN 300 127 [33]. Equipment not intended for use in residential, commercial and light industrial environments may meet the limits defined in subclause 7.1.1.3.
Resistibility						
7.2.1.4	Electrostatic discharge	kV kV	8 contact discharge 15 air discharge	EN 61000-4-2 [8]	R	It is not necessary to perform this test for contact discharge with levels below the given resistibility limit. Lower levels than the given limits apply only for air discharge tests.

7.2.2 Other than telecommunication centres, ports for outdoor signal lines

Table 7

	Environmental phenomenon	Unit	Test level and characteristic	Reference	Performance criterion	Remarks
Immunity						
7.2.2.1	Fast transients	kV Tr/Th ns Rep. frequency kHz	0,5 5/50 5	EN 61000-4-4 [10]	B	
7.2.2.2	Surges	Tr/Th μ s kV	1,2/50 (8/20) 1	EN 61000-4-5 [11]	B	
7.2.2.3	Radio frequency, conducted continuous	MHz V % AM (1 kHz) Source impedance Ω	0,15 to 80 3 80 150	EN 61000-4-6 [12]	A	
Emission						
7.2.2.4	Conducted emission	MHz dB μ V dB μ V dB μ A dB μ A MHz dB μ V dB μ V dB μ A dB μ A	Class B 0,15 - 0,5 84 - 74 QP 74 - 64 AV 40 - 30 QP 30 - 20 AV 0,5 - 30 74 QP 64 AV 30 QP 20 AV	EN 55022 [5]	N/A	Provisionally, a relaxation of 10 dB over the frequency range of 6 MHz to 30 MHz is allowed for highspeed services having significant spectral density in this band. However, this relaxation is restricted to the common mode disturbance converted by the cable from the wanted signal.
Resistibility						
7.2.2.5	Surges	Tr/Th ms kV	10/700 4	ITU-T Recommendations K.20 [31] and K.21 [32]	R	Only applies to ports for unscreened pair cables longer than 500 m. During this test, primary protection (as described in ITU-T K-series Recommendations) may be fitted to the port.
7.2.2.6	Surges	Tr/Th μ s kV	10/700 1	ITU-T Recommendation K.20 [31]	R	Only applies to ports for unscreened pair cables longer than 500 m.

	Environmental phenomenon	Unit	Test level and characteristic	Reference	Performance criterion	Remarks
7.2.2.7	Power induction	V Hz ms	300 50 200	ITU-T Recommendation K.20 [31] table 1 figure 2, Switch S ₂ operated	R	Only applies to ports for unshielded pair cables longer than 500 m.
<p>NOTE 1: Outdoor lines carrying DC power with superimposed signals shall be treated as outdoor signal lines.</p> <p>NOTE 2: For switching equipment which is intended to be installed in locations other than telecommunication centres, the requirements for immunity to surges on outdoor signal lines and to continuous conducted disturbances on signal lines are according to the requirements for telecommunication centres. This reduction is based - amongst other things - upon the screening effect of multi-pair cables and specific earthing/bonding techniques in use for switching equipment.</p> <p>NOTE 3: The emission requirement only applies to telecommunications port as specified in EN 55022 [5]. The provisional relaxation of 10 dB will be reviewed no later than 3 years after the date of withdrawal based on the results and interference cases seen in this period. Wherever possible it is recommended to comply with the limits without the provisional relaxation.</p>						

7.2.3 Other than telecommunication centres, ports for indoor signal lines

Only ports connected to inter-system cables are to be tested. Testing of ports for intra-system cabling, e.g. local alarm and control, (provided in all cases both ends are controlled by the same manufacturer) is left to the discretion of the manufacturer which is responsible for the correct installation of the cables.

Table 8

	Environmental phenomenon	Unit	Test level and characteristic	Reference	Performance criterion	Remarks
Immunity						
7.2.3.1	Fast transients	kV Tr/Th ns Rep. frequency kHz	0,5 5/50 5	EN 61000-4-4 [10]	B	Only applies when cables longer than 3 m are connected.
7.2.3.2	Surges	Tr/Th μ s kV	1,2/50 (8/20) 0,5	EN 61000-4-5 [11], and subclause 5.3.2 of the present document	B	Only applies when cables longer than 10 m are connected.
7.2.3.3	Radio frequency, conducted continuous	MHz V % AM (1 kHz) Source impedance Ω	0,15 to 80 3 80 150	EN 61000-4-6 [12]	A	Only applies when cables longer than 3 m are connected.
Emission						
7.2.3.4	Conducted emission	MHz dB μ V dB μ V dB μ A dB μ A MHz dB μ V dB μ V dB μ A dB μ A	Class B 0,15 - 0,5 84 - 74 QP 74 - 64 AV 40 - 30 QP 30 - 20 AV 0,5 - 30 74 QP 64 AV 30 QP 20 AV	EN 55022 [5]	N/A	Provisionally, a relaxation of 10 dB over the frequency range of 6 MHz to 30 MHz is allowed for highspeed services having significant spectral density in this band. However, this relaxation is restricted to the common mode disturbance converted by the cable from the wanted signal.
Resistibility						
N/A						
NOTE: The emission requirement only applies to telecommunications port as specified in EN 55022 [5]. The provisional relaxation of 10 dB will be reviewed no later than 3 years after the date of withdrawal based on the results and interference cases seen in this period. Wherever possible it is recommended to comply with the limits without the provisional relaxation.						

7.2.4 Other than telecommunication centres, AC power ports

Table 9

	Environmental phenomenon	Unit	Test level and characteristic	Reference	Performance criterion	Remarks
Immunity						
7.2.4.1	Fast transients	kV Tr/Th ns Rep. frequency kHz	1 5/50 5	EN 61000-4-4 [10]	B	
7.2.4.2	Surges (line to line) (line to ground)	Tr/Th μ s kV kV	1,2/50 (8/20) 1 2	EN 61000-4-5 [11]	B B	
7.2.4.3	Radio frequency, conducted continuous	MHz V % AM (1 kHz) Source impedance Ω	0,15 to 80 3 80 150	EN 61000-4-6 [12]	A	
7.2.4.4	Voltage dips and short interruptions	Voltage reduction % Duration ms Voltage reduction % Duration ms Voltage reduction % Duration ms	> 95 10 30 500 > 95 5 000	EN 61000-4-11 [13]	B C C	
Emission						
7.2.4.5	Radio frequency disturbance voltage	MHz dB (μ V) MHz dB (μ V/m) MHz dB (μ V/m)	0,15 to 0,5 56 to 46 AV; 66 to 56 QP 0,5 to 5 46 AV; 56 QP 5 to 30 50 AV; 60 QP	EN 55022 [5]	N/A	
7.2.4.6	Harmonics	Hz mA	50 to 2 000 See basic std.	EN 61000-3-2 [6]	N/A	Applicability of test according to the scope of EN 61000-3-2 [6].
7.2.4.7	Voltage fluctuations (Flicker)	Limit	See basic std.	EN 61000-3-3 [7]	N/A	Applicability of test according to the scope of EN 61000-3-3 [7].
Resistibility						
7.2.4.8	Surges (line to line) (line to ground)	Tr/Th μ s kV kV	1,2/50 (8/20) 2 4	EN 61000-4-5 [11]	R R	

7.2.5 Other than telecommunication centres, DC power ports

Table 10

	Environmental phenomenon	Unit	Test level and characteristic	Reference	Performance criterion	Remarks
Immunity						
7.2.5.1	Fast transients	kV Tr/Th ns Rep. frequency kHz	1 5/50 5	EN 61000-4-4 [10]	B	Applicable to cables which according to the manufacturer's specification may be longer than 3 m.
7.2.5.2	Radio frequency, conducted continuous	MHz V % AM (1 kHz) Source impedance Ω	0,15 to 80 3 80 150	EN 61000-4-6 [12]	A	Applicable to cables which according to the manufacturer's specification may be longer than 3 m.
Emission						
7.2.5.3	Radio frequency disturbance voltage	MHz dB (μ V) MHz dB (μ V) MHz dB (μ V)	0,02 to 0,15 -- AV; 79 QP 0,15 to 0,5 66 AV; 79 QP 0,5 to 30 60 AV; 73 QP	subclause 6.2 of the present document	N/A	
Resistibility						
N/A						

8 General test configuration

The EUT shall be configured and operated in accordance with the basic EMC standards.

The signal or control ports shall be correctly terminated either by auxiliary equipment necessary to exercise the ports or by their nominal impedance.

Adequate measures shall be taken to avoid any effects of unwanted signals on the measuring equipment used to monitor the performance of the EUT.

The equipment test conditions shall be as close as possible to the installed conditions, as defined by the manufacturer. Wiring shall be consistent with the manufacturer's recommended procedures, and the equipment shall be in its housing with all covers and access panels in place as in normal operation, unless otherwise stated. If the equipment is designed to be mounted in a rack or cabinet, it should be tested in this configuration.

Signal ports are divided into two categories:

- main signal ports which provide the telecommunications service (third party traffic);
- auxiliary signal ports, i.e. ports for alarms, maintenance, etc., which are only used by the operator or the service provider.

A sufficient number of ports shall be correctly terminated to ensure that the test is representative of normal operating conditions and the selection of ports shall be specified in the test report.

The earth connections of the EUT shall be connected to a reference earth according to the manufacturer's specifications.

Only cables that are permanently connected shall be included.

The types of the cables connected to the EUT shall be indicated in the test report.

The test configurations shall be recorded in the test report.

9 General operational conditions during testing

Clause 9 gives the general operational conditions. The general operational conditions shall allow for appropriate measuring of the emission and for testing of immunity. Special exercising equipment and/or software may be used with the object of reducing the test time and to simulate traffic conditions.

The tests described shall be performed with the Equipment Under Test (EUT) powered up, (i.e. connected to an appropriate power supply), and operating in a manner which is as representative of normal operation as possible.

Details on the evaluation of test results are given in annex C.

9.1 Equipment configuration

Power and signal distribution, grounding, interconnecting cabling and physical placement of equipment of a test system shall simulate the typical application and usage in so far as is practicable, and shall be in accordance with the relevant product specifications of the manufacturer.

The configuration that tends to maximize the EUT's emission or minimize its immunity is not usually intuitively obvious and in most instances selection will involve some trial and error testing. For example, interface cables may be moved or equipment re-orientated during initial stages of testing and the effects on the results observed.

Only configurations within the range of positions likely to occur in normal use need to be considered.

The configuration selected shall be fully detailed and documented in the test report, together with the justification for selecting that particular configuration.

9.2 Exercising equipment

The exercising equipment and other auxiliary equipment shall be sufficiently decoupled from the EUT so that the performance of such equipment does not significantly influence the test results.

9.3 Laboratory environment

For all the tests, the test laboratory environment shall be the one defined in the corresponding basic standards.

The electromagnetic environment of the test laboratory shall not influence the results.

The laboratory environment shall not exceed the limits specified by the manufacturer for normal operation of the EUT.

10 General immunity and resistibility conditions

If the minimum performance level or permissible performance loss is not specified in the following clauses or by the manufacturer, then either of these may be deduced from the product description and documentation, and what the user may reasonably expect from the apparatus if used as intended.

10.1 General performance criteria

The general performance criteria apply for those ports for which no specific performance criteria are defined (e.g. auxiliary ports) in the present document.

Performance criterion A:

The apparatus shall continue to operate as intended. No degradation of performance or loss of function is allowed below a performance level specified by the manufacturer when the apparatus is used as intended. In some cases the performance level may be replaced by a permissible loss of performance. If the minimum performance level or the permissible performance loss is not specified by the manufacturer, then either of these may be deduced from the product description and documentation and what the user may reasonably expect from the apparatus if used as intended.

Performance criterion B:

The apparatus shall continue to operate as intended after the test. No degradation of performance or loss of function is allowed below a performance level specified by the manufacturer, when the apparatus is used as intended. In some cases the performance level may be replaced by a permissible loss of performance. During the exposure to an electromagnetic phenomenon, degradation of performance is, however, allowed. No change of actual operating state or stored data is allowed. If the minimum performance level or the permissible performance loss is not specified by the manufacturer, then either of these may be deduced from the product description and documentation and what the user may reasonably expect from the apparatus if used as intended.

Performance criterion C:

As defined in clause 6 of EN 50082-1 [3]: Temporary loss of function is allowed, provided the function is self-recoverable or can be restored by the operation of the controls, or, in the case of switching equipment, by normal subsequent use.

Performance criterion R:

The equipment shall withstand the test without damage or other disturbance (such as the corruption of software or misoperation of fault protection facilities) and shall operate properly within the specified limits after the transient electromagnetic phenomenon has ceased. (It is not necessary to operate properly while the test condition is present). The exposure may cause the operation of fuses or other specified devices which have to be replaced or reset before normal operation is restored.

11 Switching equipment specific requirements

11.1 Test configuration

In figure 2, two separate processes are monitored simultaneously. The first is the continuous process of establishing and clearing connections and the second is the stable situation of monitoring signal quality during testing. It is to be considered that at least a part of the set-up for both processes covers the full signal path from subscriber to the network. The signal loop at the network end can either be established by test equipment or by a simple cable loop. In the later case the simulation of normal grounding and connection practice is required.

The test equipment may be digital or analogue signal analyser as required. The test equipment may also loop back the test signal.

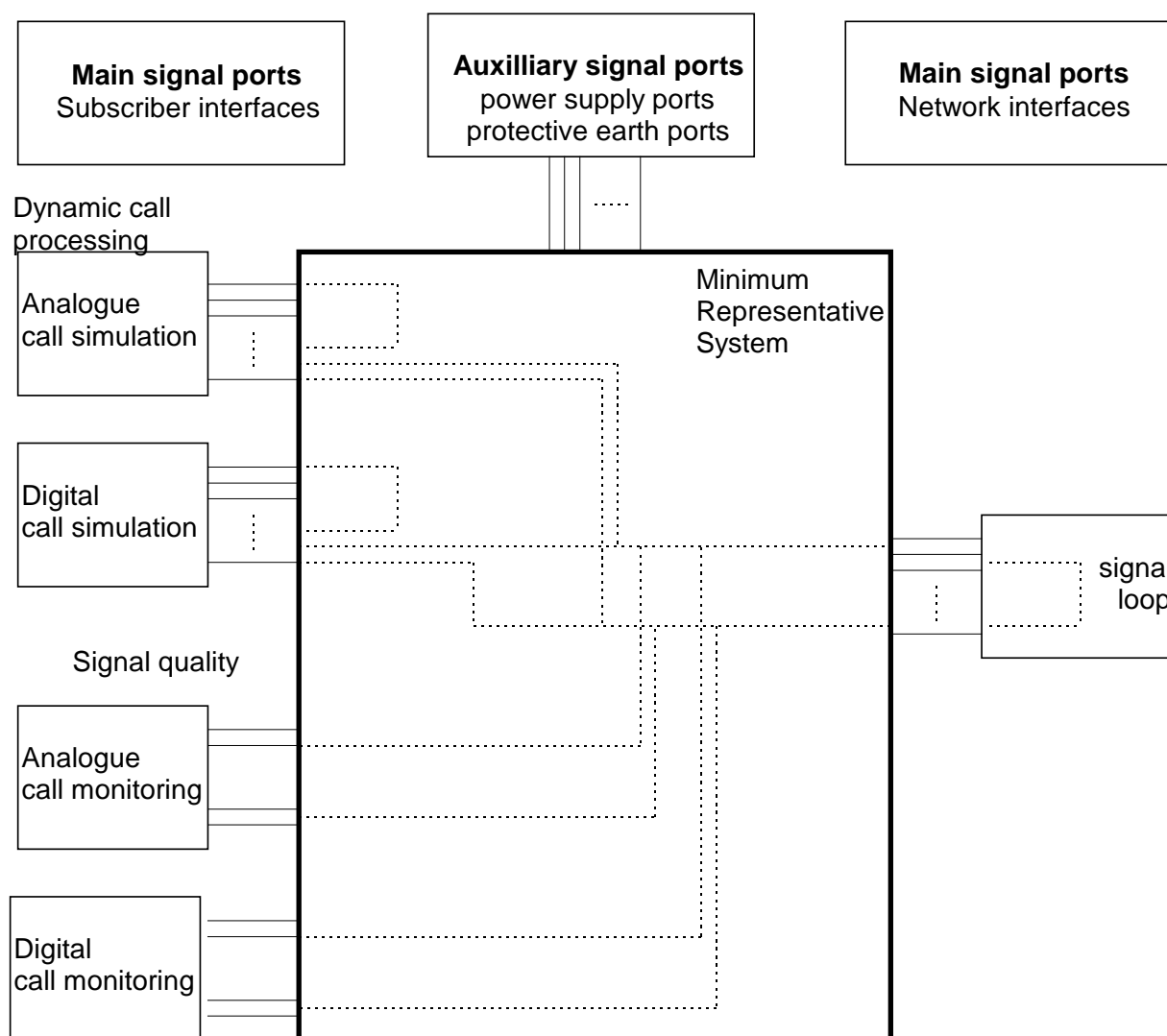

Figure 2: Schematic test configuration, switching equipment

If possible, cable harnesses shall be separated and the cables tested individually.

11.2 Operational conditions

The general conditions of clause 9 apply.

For switching equipment with less than 32 subscriber lines (analogue or digital), all the lines shall be driven. For switching equipment with more than 32 subscriber lines (analogue or digital) a choice of at least 32 lines shall be made among the available lines. In this case, as it is impossible to do tests at all ports, single ports of each type shall be selected for the testing. At least one port of each type shall be tested.

The ports shall be configured with their nominal impedance for a connection to another port. Auxiliary equipment may be used to simulate the functional termination of the ports.

Connections have to be provided which shall be established before the start of the tests and then maintained.

11.2.1 Emission

The general requirements for test methods are described in clause 6 of the present document.

11.2.2 Immunity

During immunity testing using continuous phenomena, the following selected frequencies shall be investigated in addition to the sweep:

- the clock frequencies inside the specified frequency band of the test;
- 80 MHz; 120 MHz; 160 MHz; 230 MHz; 434 MHz; 460 MHz; 600 MHz; 863 MHz and 900 MHz ($\pm 1\%$) (RF field);
- 0,2 MHz; 1,0 MHz; 7,1 MHz; 13,56 MHz; 21,0 MHz; 27,12 MHz and 40,68 MHz ($\pm 1\%$) (RF voltage).

11.3 Specific immunity and resistibility performance criteria

The performance criteria are based on the performance criteria given in ETR 238 [14]. For the switching equipment the following main signal ports are recognized:

- analogue ports (e.g. analogue subscribers' lines, analogue interfaces to transmission equipment);
- digital ports (e.g. digital subscribers' lines (ISDN), digital connections to transmission equipment).

The interfaces shall operate as described in the following subclauses.

11.3.1 Digital port performance criteria

11.3.1.1 Performance criteria A (continuous phenomena)

During the sweep:

- the established connections shall be maintained throughout testing and the transfer of information shall be within the limits of the manufacturer's specification;
- loss of frame alignment or loss of synchronization are not allowed during each individual exposure (if applicable).

For selected frequencies (see subclause 11.2.2):

- it shall be possible to establish a connection between two ports;
- it shall be possible to clear a connection in a controlled manner.

11.3.1.2 Performance criterion B (transient phenomena)

The established connections shall be maintained throughout testing except in the case of surge immunity testing at 1 kV where disconnection is allowed on the port being tested;

- it shall be possible to establish a connection between two ports after the end of the transient disturbances;
- it shall be possible to clear a connection in a controlled manner after the end of the transient disturbances.

11.3.1.3 Criteria C (interruptions)

The general performance criteria C apply.

11.3.1.4 Criteria R (resistibility)

The general performance criteria R apply.

11.3.2 Analogue port performance criteria

11.3.2.1 Performance criteria A (continuous phenomena)

During the sweep:

- the established connections shall be maintained throughout testing;
- the noise level at a two wire analogue interface shall be less than -40 dBm at 600 Ω (ignoring the nominal impedance of the port for practical reasons) if not otherwise stated by the manufacturer. The measurement shall be done selectively with a bandwidth \leq 100 Hz at 1 kHz;
- dialling tones shall be available (if applicable).

For selected frequencies (see subclause 11.2.2):

- it shall be possible to establish a connection between two ports;
- it shall be possible to clear a connection in a controlled manner.

11.3.2.2 Performance criteria B (transient phenomena)

Established connections shall be maintained throughout testing except in the case of surge immunity testing at 1 kV where disconnection is allowed on the port being tested.

- it shall be possible to establish a connection between two ports after the end of the transient disturbances;
- it shall be possible to clear a connection in a controlled manner after the end of the transient disturbances.

11.3.2.3 Criteria C (interruptions)

The general performance criteria C apply.

11.3.2.4 Criteria R (resistibility)

The general performance criteria R apply.

12 Transmission equipment specific requirements

12.1 Test configuration

Typically the EUT will be configured as shown in figure 3. The EMC test equipment is not shown.

The test configuration shall cover a representative set up of tributary signals within the aggregate interface signals.

In figure 3 a test signal is derived from a signal generator and looped through EUT. If the EUT supports several identical channels, these may be connected in series and the test signal may be looped through all the channels.

The test equipment may be digital or analogue signal analyser as required. The test equipment may also loop-back the test signal.

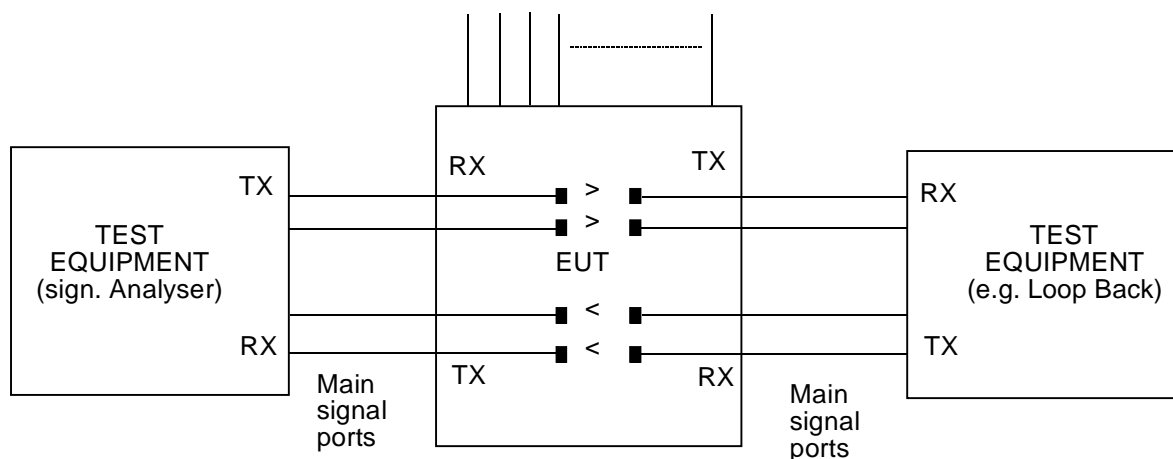

Figure 3: Schematic test configuration

12.2 Operational conditions

The general conditions of clause 9 apply.

An appropriate test signal shall be used. The test signal shall be stated in the test report. The preferred test signal is the Pseudo Random Bit Sequence (PRBS) appropriate for the bit rate of the channel (ITU-T Recommendation O.150 [35]).

The modes of operation during testing shall be recorded in the test report.

12.2.1 Emission

The measurements shall be made in the operating mode, with the EUT producing the maximum emission, consistent with normal applications. The EUT load shall be adjusted within the range specified by manufacturer in order to maximize the emission.

Conducted emission shall be measured on the power input and output ports.

12.2.2 Immunity

Immunity tests shall be performed at nominal values of all signal conditions and with a typical value of line attenuation as declared by the manufacturer.

Conducted immunity testing shall be performed on power input and output ports and on signal ports.

For surge testing the conducted immunity tests shall be performed on auxiliary (signal) ports that are permanently connected in the normal installation.

During immunity testing using continuous phenomena, the following selected frequencies shall be investigated in addition to the sweep:

- the clock frequencies inside the specified frequency band of the test;
- 80 MHz; 120 MHz; 160 MHz; 230 MHz; 434 MHz; 460 MHz; 600 MHz; 863 MHz and 900 MHz (± 1 %) (RF field);
- 0,2 MHz; 1,0 MHz; 7,1 MHz; 13,56 MHz; 21,0 MHz; 27,12 MHz and 40,68 MHz (± 1 %) (RF voltage).

12.3 Specific immunity and resistibility performance criteria

12.3.1 Digital signal ports

The performance of the equipment shall be verified for digital signal ports:

- by measuring the number of induced bit errors on the main signal port during all exposures;
- by testing the functionality of the main signal port and the other signal ports after the exposure;
- by verifying that corruption of software and data held in memory has not occurred.

12.3.1.1 Performance criterion A (continuous phenomena)

The number of bit errors at the end of each individual exposure shall not exceed the maximum number of errors stated by the manufacturer for intended operation.

The number of errors is calculated as:

- (the maximum bit error ratio specified by the manufacturer) \times (bit rate) \times (test time).

The test time is taken to be the dwell time at each frequency of the exposure.

12.3.1.2 Performance criterion B (transient phenomena)

Loss of frame alignment or loss of synchronization is not allowed during each individual exposure. No alarms shall be generated as a result of the electromagnetic stress.

The above does not apply to surge testing where some loss of frame alignment may be expected. For this test, the EUT shall operate as intended following the cessation of the exposure.

12.3.1.3 Performance criterion C (interruptions)

The general performance criteria C apply.

12.3.1.4 Performance criterion R (resistibility)

The general performance criteria R apply.

12.3.2 Analogue voice frequency signal ports

The performance of the equipment shall be verified for analogue voice frequency signal ports:

- by measuring the audio signal break-through (demodulated 1 kHz) on the signal port during continuous exposures in both signal path directions covering both analogue to digital conversion and digital to analogue conversion;
- by testing the functionality of the main signal port and the other signal ports after the transient exposures;
- by verifying that corruption of software and data held in memory has not occurred.

12.3.2.1 Performance criterion A (continuous phenomena)

The noise signal level received from the EUT measured in an impedance of 600 Ω shall not be greater than -40 dBm.

Connections shall be maintained throughout the test.

12.3.2.2 Performance criterion B (transient phenomena)

The established connections shall be maintained throughout testing except in the case of surge immunity testing at 1 kV where disconnection is allowed on the port being tested;

The EUT shall return automatically to normal performance after the cessation of the exposure.

12.3.2.3 Performance criterion R (resistibility)

The general performance criteria R apply.

12.3.3 SDH and PDH interfaces

12.3.3.1 Tributary and aggregate interfaces

The criteria specified in subclause 12.3.1 apply to the interfaces specified in ETS 300 166 [19] (electrical interface) and ETS 300 232 [20], ITU-T Recommendation G.958 [29] (optical interfaces).

12.3.4 ISDN interfaces

12.3.4.1 Primary rate access ISDN interfaces

The criteria specified in subclause 12.3.1 apply to the interfaces specified in ETS 300 011 [15].

12.3.4.2 Network termination NT1 for ISDN "U" interfaces

The criteria specified in subclause 12.3.1 apply to the interfaces specified in ITU-T Recommendation G.961 [30].

12.3.4.3 Basic access ISDN interfaces

The criteria specified in subclause 12.3.1 apply to the interfaces specified in ETS 300 012 [16].

12.3.5 Analogue interfaces

12.3.5.1 Trunk interfaces and leased line interfaces

The criteria specified in subclause 12.3.2 apply to the interfaces specified in ITU-T Recommendation G.712 [26].

12.3.5.2 Subscriber interfaces

The criteria specified in subclause 12.3.2 apply to the interfaces specified in ITU-T Recommendation Q.552 [36].

12.3.6 V.10, V.11, V.24, V.28, V.36, X.24 and similar V.- and X.- series interfaces

The criteria specified in subclause 12.3.1 apply to the interfaces specified in ITU-T Recommendations V.10 [37], V.11 [38], V.24 [39], V.28 [40], V.36 [41] and X.24 [42].

12.3.7 Ethernet and packet-data interfaces

To the interfaces specified in ISO/IEC 8802-3 [23] and ITU-T Recommendation X.25 [43], the criteria below apply.

12.3.7.1 Performance criterion A (continuous phenomena)

For interfaces which are intended for the transmission of third party data traffic, a selected port shall be connected to test equipment (e.g. a data communications analyser) as a single point-to-point data link. This will avoid excessive failed transmission attempts caused by data collisions and bus contention problems.

The interface shall be suitably exercised and monitored throughout the test period for errored frames.

No more than 5 % additional errored frames above the quiescent level shall be permitted during the exposure.

12.3.7.2 Performance criterion B (transient phenomena)

The established connections shall be maintained throughout testing except in the case of surge immunity testing at 1 kV where disconnection is allowed on the port being tested.

12.3.8 Service and maintenance interfaces

The functional performance of ports of this type not intended to be permanently connected and therefore not subjected to immunity testing shall be verified according to the manufacturer's specification following cessation of the electromagnetic exposure on other ports.

12.3.9 Synchronization interfaces

The performance of slave clocks specified in ITU-T Recommendations G.812 [27] and G.813 [28] shall be checked with the equipment synchronized with an external source.

12.3.9.1 Performance criterion A (continuous phenomena)

During the exposure, synchronization shall not be lost.

12.3.9.2 Performance criteria B (transient phenomena)

No alarm indications shall persist after the exposure.

The functional performance according to the manufacturer's specification shall be verified following cessation of the exposure.

12.3.10 Remote alarm interfaces

These interfaces are defined by the manufacturer.

12.3.10.1 Performance criterion A (continuous phenomena)

No false alarms shall occur during continuous exposures.

12.3.10.2 Performance criterion B (transient phenomena)

No false alarm indications shall persist after the exposure.

12.3.10.3 Performance criteria R (resistibility)

The general performance criteria R apply.

13 Power supply equipment specific conditions

13.1 Test configuration

Typically the EUT will be configured as shown in figures 4 and 5. The EMC test equipment is not shown.

The earth connections of the EUT shall be connected to a reference earth according to the manufacturer specifications.

The EUT load shall be resistive unless otherwise specified by the manufacturer.

For EUT with DC output and battery back-up, EMC tests shall be performed without the battery unless otherwise specified.

Uninterruptible power supplies shall also be tested whilst feeding from the battery only (AC mains off).

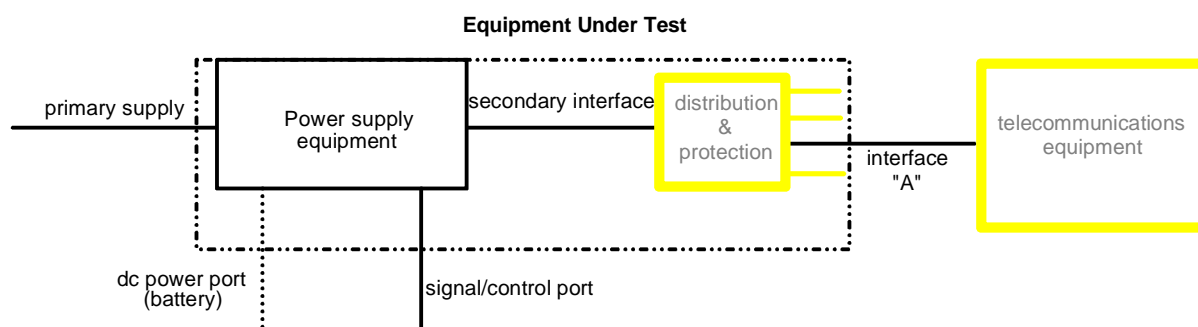

Figure 4: General identification of a power supply and its ports

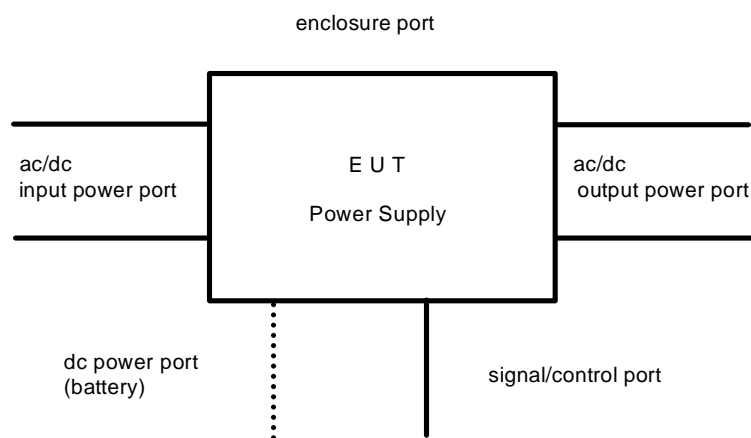

Figure 5: Port identifications of the EUT

13.2 Operational conditions

13.2.1 Emission

The measurements shall be made in the operating mode, with the EUT producing the maximum emission, consistent with normal applications. The EUT load shall be adjusted within the range specified by manufacturer in order to maximize the emission.

Conducted emission shall be measured on the power input and output ports.

The conducted emission tests shall only be performed on ports that are permanently connected in the normal installation.

13.2.2 Immunity

Immunity tests may be performed with the EUT operating at reduced output power: 50 % is recommended. The actual output power level for each test shall be stated in the test report.

Conducted immunity tests shall be performed on the power input and output ports, and on one signal/control interface of each type found on the equipment.

The conducted immunity tests need only be performed on ports that are permanently connected in the normal installation.

Power and control cables which according to the manufacturer's specification are not intended to be longer than 3 m in installed systems shall not be subjected to conducted immunity testing. However, cables that may be connected to an extensive network shall be subjected to the conducted immunity test.

13.3 Specific immunity and resistibility performance criteria

The ports of the power supply equipment (figure 5) that shall be monitored during the tests can be categorized as one of:

- DC secondary interface;
- AC secondary interface; or
- control/signal interface.

The manufacturer shall, at the time of submission of the equipment for test, supply the following information to be recorded in the test report:

- the primary functions of the power supply equipment to be tested;
- the intended functions of the power supply equipment, which shall be in accordance with the documentation accompanying the equipment and sales literature as appropriate;
- the auxiliary equipment to be combined with the power supply equipment;
- a list of ports, classified as AC/DC power port or control/signal port;
- the operating conditions.

13.3.1 Alternating current secondary interface

13.3.1.1 Performance criteria A (continuous phenomena)

During the exposure, the AC secondary range shall be in accordance with the normal service condition defined in ETS 300 132-1 [17].

The long-term voltage fluctuations at the AC secondary interface shall be within ± 10 % of the nominal voltage.

During and after the exposure, the EUT shall operate without alarms, false alarm indications (power supply failure, protection failure, etc.) and false display indications.

13.3.1.2 Performance criteria B (transient phenomena)

Voltage interruptions at the AC secondary interface shall last no longer than 20 ms. The time between two voltage interruptions shall be no less than 10 s.

The voltage fluctuations at the AC secondary interface shall be in accordance with the requirements of ETS 300 132-1 [17]:

- for < 500 ms with respect to rms value: no worse than ± 15 % of nominal value;
- for < 2 ms with respect to actual value: no worse than ± 40 % of nominal value.

The frequency at the AC secondary interface shall not vary by more than ± 3 Hz and shall return to the nominal value within 5 s.

Peaks with a duration shorter than 0,25 of one period (5 ms for a 50 Hz system) which appear during the exposure are permissible.

After the exposure, the EUT shall operate without alarms or false alarm indications (power supply failure, protection failure, etc.) or false display indications.

Self recovery to normal performance shall occur at the cessation of the exposure.

13.3.1.3 Performance criterion R (resistibility)

The general performance criteria R apply.

13.3.2 Direct current secondary interface

13.3.2.1 Performance criteria A (continuous phenomena)

During the exposure, the DC secondary voltage range shall be in accordance with the normal service conditions defined in ETS 300 132-2 [18].

The maximum level of wide band noise at the DC secondary interface shall not exceed the limits specified in table 2 of ETS 300 132-2 [18].

Table 11: Level of wide band noise

Frequency	Voltages
25 Hz to 5 kHz	10 mV Upso, eff psophometrically, via CCITT weighting filter for commercial circuits

The reference method of measurement is with a psophometer conforming to ITU-T Recommendation O.41 [34].

During and after the exposure, the EUT shall operate without alarms or false alarm indications (power supply failure, protection failure, etc.) and false display indications.

13.3.2.2 Performance criteria B (transient phenomena)

After the exposure, the EUT shall operate without alarms or false alarm indications (power supply failure, protection failure, etc.) and false display indications:

- the DC secondary voltage during the exposure shall not exceed the following value:
 - for -48 V DC nominal value: -60 V;
 - for -60 V DC nominal value: -75 V;
- short peaks which appear during the application of the tests shall be ignored.

13.3.2.3 Performance criteria R (resistibility)

The general performance criteria R apply.

13.3.3 Control/signal interface

The control and signal ports need not be monitoring during the tests, because they are not considered to be primary functions.

13.3.4 Tertiary supply interface

To be considered only for special cases. Performance criteria should be derived from the product specifications.

14 Supervisory equipment specific conditions

14.1 Test configuration

Exercising equipment e.g. a traffic simulator used for testing of other functions and equipment e.g. switching equipment can also be used as exercising equipment for supervisory equipment. Figure 6 shows two examples for a possible test configuration. The EMC test equipment is not shown.

Parts of the supervisory equipment (e.g. terminals) may be connected together but installed at locations other than the supervised equipment. For the purpose of EMC testing, these parts may be tested simultaneously and at the same location as the supervised equipment.

Example A shows a configuration with an external traffic simulator. In example B a test load simulator software is used. The use of either or both configurations is possible. The EMC tests shall be carried out during normal operation of supervisory equipment.

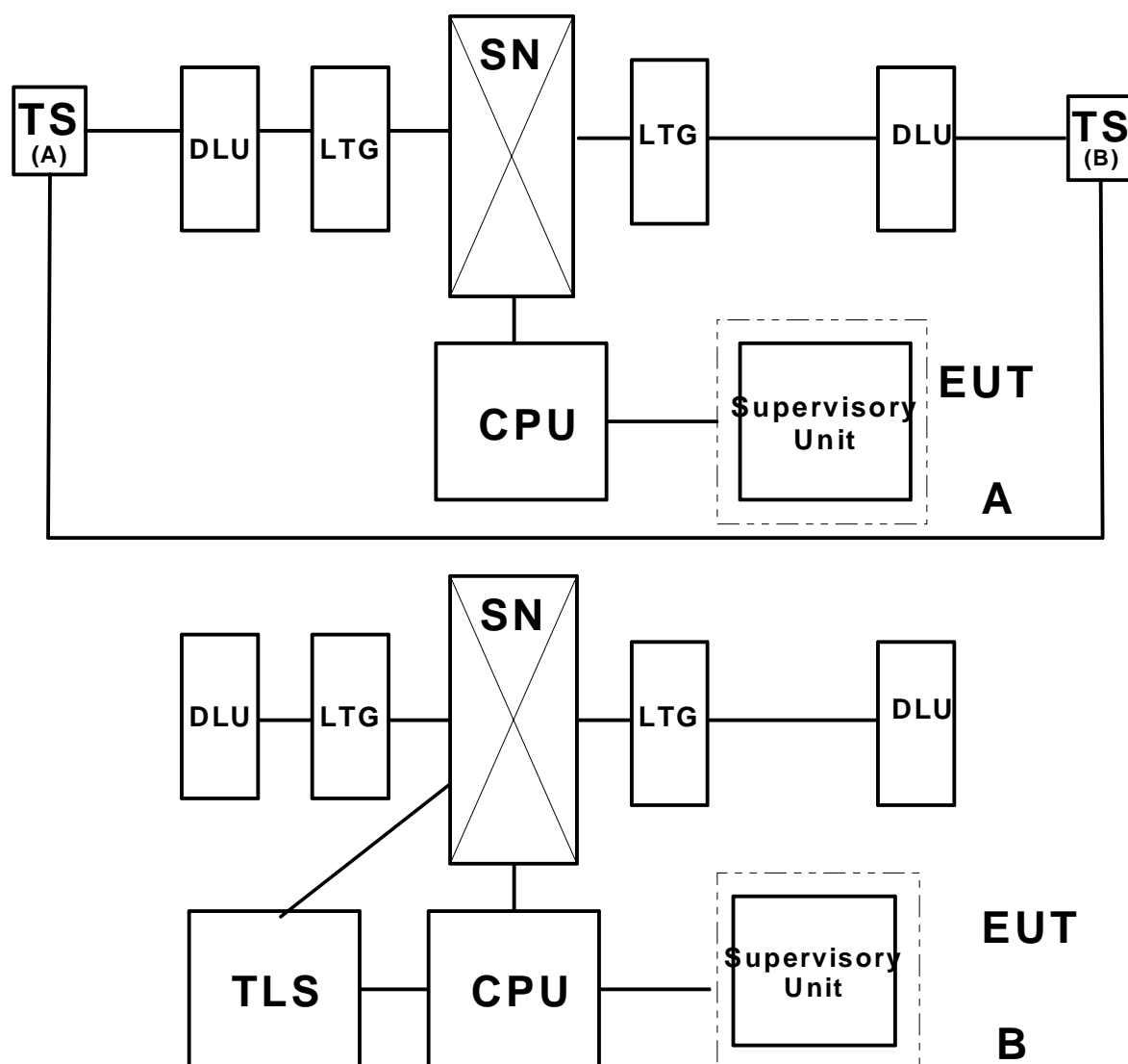

Legend: CPU = Central processing unit
 DLU = Digital line unit
 LTG = Line trunk group
 SN = Switching network
 TLS = Test load simulator
 TS = Traffic simulator

Figure 6: Two examples for the configuration of the EUT and exercising equipment

14.2 Operational conditions

The general conditions of clause 9 apply.

14.3 Specific immunity and resistibility performance criteria

14.3.1 Performance criteria A (continuous phenomena)

The connection between the supervising and supervised equipment shall be maintained.

No supervisory functions shall be affected by EMC testing.

No false alarms, such as signal lamps or printer misprints shall occur.

14.3.2 Performance criteria B (transient phenomena)

The supervisory equipment shall not affect the normal operation of the equipment being supervised.

The operating speed of the supervising equipment may be reduced.

Any minor priority supervisory function may be affected during EMC testing. These functions shall resume normal performance at cessation of the exposure. For example, false alarms shall reset.

14.3.3 Performance criteria R (resistibility)

The general performance criteria R apply.

Annex A (normative): Correlation between essential requirements and the provisions of the present document

Annex A shows the essential requirements of the Directive 89/336/EEC [44] which are satisfied by conformance to each requirement of the present document.

Table A.1: Essential requirements of the EC Council Directive

Subclause	Title	Corresponding article of Council directive 89/336/EEC [44]
Emission		
7.1.4.4 & 7.2.4.5	Conducted emission. AC power port	4(a)
7.1.5.3 & 7.2.5.3	Conducted emission. DC power port	4(a)
7.1.2.4, 7.1.3.4, 7.2.2.4 & 7.2.3.4	Conducted emission. Telecommunication port	4 (a)
7.1.1.3 & 7.2.1.3	Radiated emission	4(a)
7.1.4.5 & 7.2.4.6	Emission on AC power port. Harmonics	4(a)
7.1.4.6 & 7.2.4.7	Emission on AC power port. Flicker	4(a)
Immunity		
7.1.1.1 & 7.2.1.1	Electrostatic discharge	4(b)
7.1.1.2 & 7.2.1.2	Radiated electromagnetic fields	4(b)
7.1.2.1, 7.1.3.1, 7.2.2.1 & 7.2.3.1	Electrical fast transient/burst. Signal line ports	4(b)
7.1.4.1 & 7.2.4.1	Electrical fast transient/burst. AC power port	4(b)
7.1.5.1 & 7.2.5.1	Electrical fast transient/burst. DC power port	4(b)
7.1.2.2, 7.1.3.2, 7.2.2.2 & 7.2.3.2	Surges. Signal line ports	4(b)
7.1.4.2 & 7.2.4.2	Surges. AC power ports	4(b)
7.2.4.4	Voltage dips and short interruptions. AC power port	4(b)
7.1.2.3, 7.1.3.3, 7.2.2.3 & 7.2.3.3	Continuous conducted, radio frequency. Signal line port	4(b)
7.1.4.3 & 7.2.4.3	Continuous conducted, radio frequency. AC power port	4(b)
7.1.5.2 & 7.2.5.2	Continuous conducted, radio frequency. DC power port	4(b)
Resistibility		
(none)		

Annex B (normative): Surges: test method for ports of signal lines remaining within the building

Ports of signal lines remaining within the building, e.g. of ISDN-equipment with interfaces at basic and primary rate shall be tested with the surge test set-up as described in figure B.1.

An example of a coupling/decoupling network for an unshielded interface cable is described in figure B.2

The test generator to produce the test pulses $1,2/50 \mu\text{s}$ shall conform to EN 61000-4-5 [11]. The total source impedance (generator plus external resistor) shall be 40Ω .

At least 5 positive and 5 negative pulses with alternating polarity shall be applied to the EUT. The time interval between two pulses shall be according to EN 61000-4-5 [11].

B.1 Test set-up for ports with ISDN interface

Figures B.1 and B.2 show the test set-up for ports with ISDN interface.

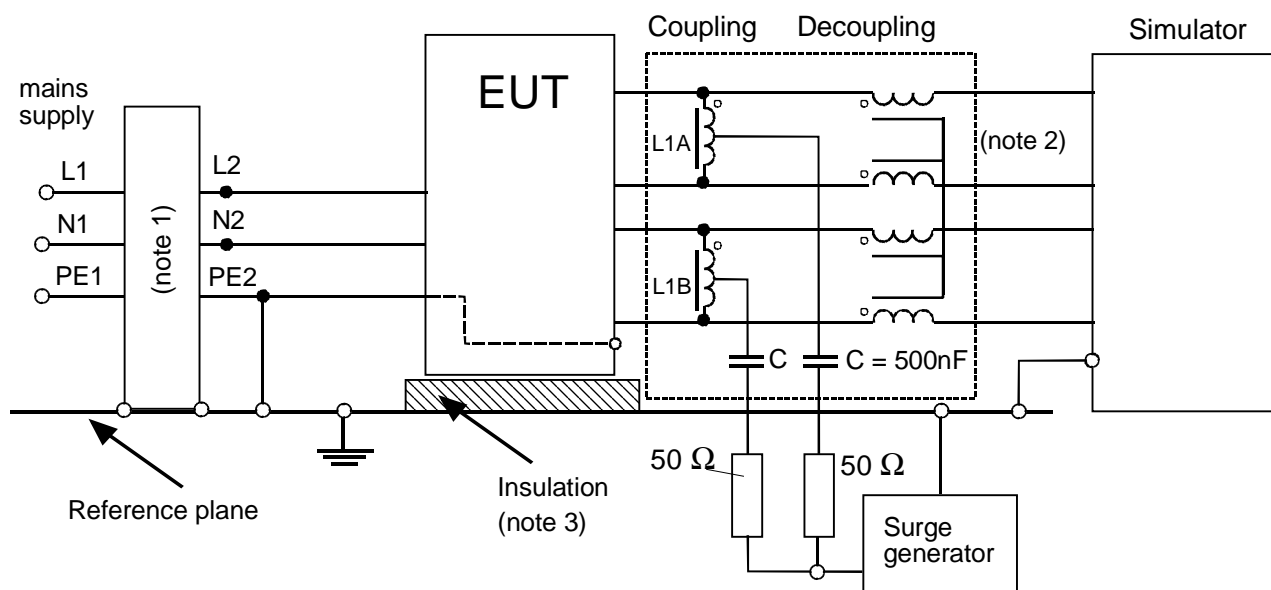

NOTE 1: The impedance matching network is used to decouple the mains and to provide low impedance to reference plane at EUT side. The impedance matching network is described in figure B.2.

NOTE 2: The coupling/decoupling network is described in figure B.3.

NOTE 3: Insulation thickness: 0,1 m for floor standing EUT; 0,5 mm for table top EUT.

NOTE 4: Interface wiring shall be placed 0,1 m above reference plane.

Figure B.1: Surge test set-up for basic rate and primary rate interface ports (using unshielded four wires interface cable)

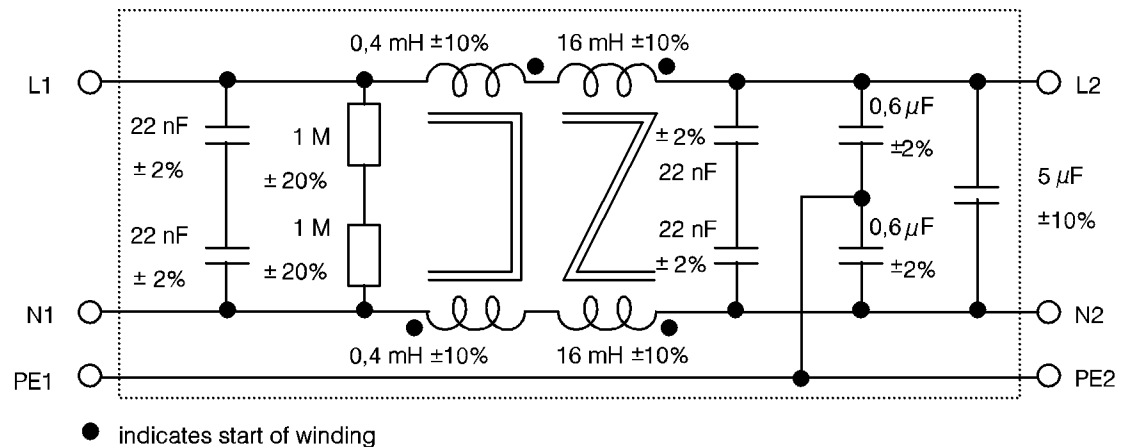

NOTE: The impedance matching network is required to protect the mains supply and the power source for remote power feeding from test overvoltages and to establish standard termination conditions for the test. It is used:

- to couple the EUT either to the ac mains or to the dc feeding source PS;
- to terminate the mains input with the low impedance port L2/N2, to standardize the presentation of the mains source;
- to feed the EUT from a high impedance port L1/N1 to allow for effective surge application at the feeding interface of the TE.

In conjunction with a coupling capacitance of 1 μF as incorporated in the coupling network figure B.1, a nominal pulse form of 1,2/50 μs shall be influenced by the high impedance port L1/N1 of the impedance matching networks; figure B.2, to a reduced time to half value of about 40 μs . For the nominal pulse form 10/700 μs the time to half value may be reduced to approximately 100 μs . This reduction is envisaged and in line with the statistics of overvoltages at mains socket-outlets.

Figure B.2: Impedance matching network

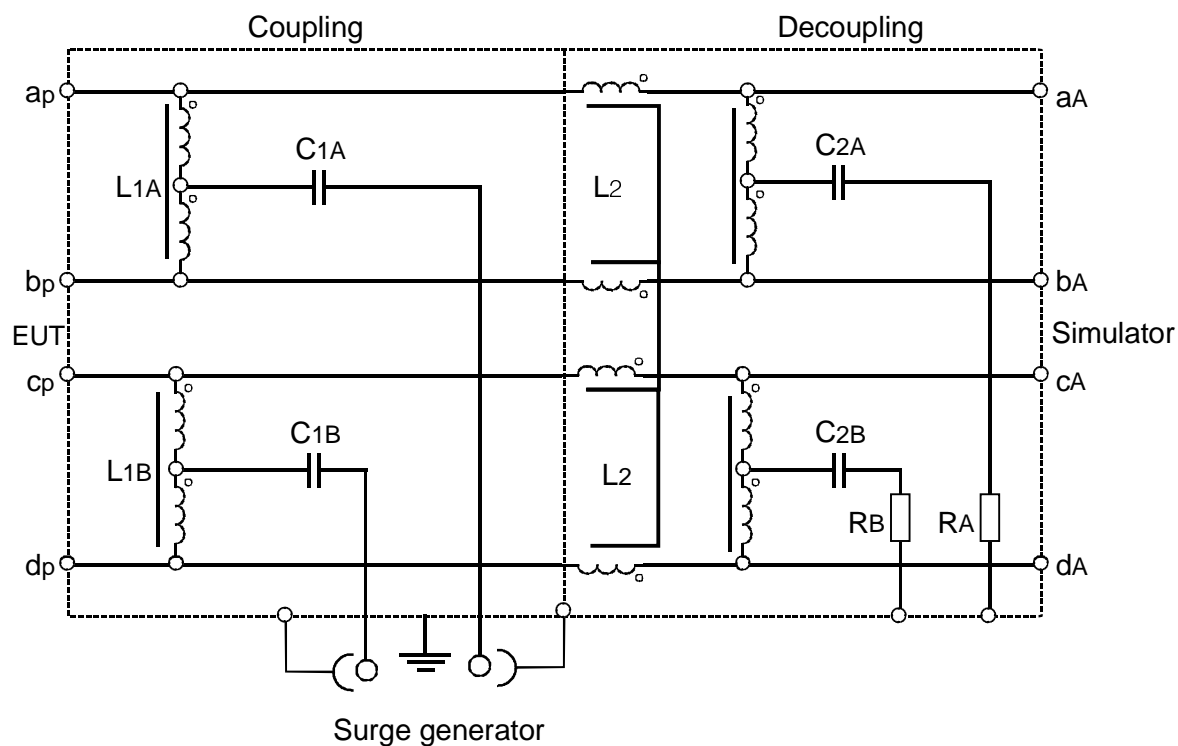

$C1A = C1B = 500 \text{ nF}$
 $L1A = L1B = 2 * 38 \text{ mH}$
 $L3A = L3B = 2 * 38 \text{ mH}$

$C2A = C2B = 1 \text{ } \mu\text{F}$
 $L2 = 4 * 100 \text{ mH}$

$RA = RB = 50 \text{ } \Omega$

NOTE: L2 shall be a 4-coil current compensated choke to avoid saturation of coils due to phantom power feeding.

Figure B.3: Example of a coupling/decoupling network for two symmetrical pairs for surge testing

Annex C (informative): Evaluation of test results

The test report will comprise:

- a) a detailed description of the EUT, the physical aspects of the set-up and of the earthing conditions;
- b) a list (and description) of the auxiliary equipment;
- c) a detailed description of the operation modes and operational status of the EUT during emission testing;
- d) the response of the EUT to the immunity test levels should be expressed in terms of the compliance criteria detailed in the present document;
- e) a description of the test conditions (including temperature and relative humidity) and test results together with the method of test. If the method used differs from the preferred method, then the deviations should be recorded and justification made in the test report;
- f) a statement of measurement uncertainty;
- g) the calibration status of all test equipment used;
- h) if an unrepeatable response occurs, this should be noted in the test report, but the response should not be taken into account in the assessment of the EUT.

The following additional items have been extracted from EN 45001 [2].

Test reports

The work carried out by the testing laboratory will be covered by a report which accurately, clearly and unambiguously presents the test results and all other relevant information.

Each test report should include at least the following information:

- a) name and address of testing laboratory and location where the test was carried out when different from the address of the testing laboratory;
- b) unique identification of report (such as serial number) and of each page, and total number of pages of the report;
- c) name and address of client;
- d) description and identification of the test item;
- e) date of receipt of test item and date(s) of performance of test;
- f) identification of the test specification or description of the method or procedure;
- g) description of sampling procedure, where relevant;
- h) any deviations, additions to or exclusions from the test specification, and any other information relevant to a specific test;
- i) identification of any non-standard test method or procedure utilized;
- j) measurements, examinations and derived results, supported by tables, graphs, sketches and photographs as appropriate, and any failures identified;
- k) a statement on measurement uncertainty (where relevant);
- l) a signature and title or an equivalent marking of person(s) accepting technical responsibility for the test report and date of issue;
- m) a statement to the effect that the test results relate only to the items tested;

- n) a statement that the report cannot be reproduced except in full without the written approval of the testing laboratory.

Particular care and attention needs to be paid to the arrangement of the test report, especially with regard to presentation of the test data and ease of assimilation by the reader. The format should be carefully and specifically designed for each type of test carried out, but the headings should be standardized as far as possible.

Corrections or additions to a test report after issue can be made only by a further document suitably marked, e.g. "Amendment/Addendum to test report serial number... (or as otherwise identified)", and should meet the relevant requirements of the preceding paragraphs.

A test report should not include any advice or Recommendation arising from the test results.

Test results should be presented accurately, clearly, completely and unambiguously in accordance with instructions that may be part of the test methods.

Quantitative results should be given together with calculated or estimated uncertainty.

Test results obtained on items which have been statistically selected from a larger lot, batch or production quantity are frequently used to infer the properties of the lot, batch or production quantity. Any extrapolation of the test results to the properties of the lot, batch or production quantity should be contained in a separate document.

NOTE: Test results could be measured values, findings from the visual examination or practical use of the test item, derived results or any other type of observation from the testing activities. Test results may be supported by tables, photographs or graphical information of any kind appropriately identified.

History

Document history		
V1.1.3	December 1997	Publication
V1.2.1	November 1998	Public Enquiry PE 9911: 1998-11-13 to 1999-03-12
V1.2.1	October 1999	One-step Approval Procedure OAP 200008: 1999-10-27 to 2000-02-25
V1.2.1	March 2000	Publication