

ETSI EN 300 376-1 V1.2.1 (1999-10)

European Standard (Telecommunications series)

**Telecommunications Management Network (TMN);
Q3 interface at the Access Network (AN)
for configuration management of V5 interfaces
and associated user ports;
Part 1: Q3 interface specification**



Reference

REN/TMN-02001-1 (3hc90ioo.PDF)

Keywords

TMN, information model, Q3 interface, AN, V5 interface, configuration, management

ETSI

Postal address

F-06921 Sophia Antipolis Cedex - FRANCE

Office address

650 Route des Lucioles - Sophia Antipolis
Valbonne - FRANCE
Tel.: +33 4 92 94 42 00 Fax: +33 4 93 65 47 16
Siret N° 348 623 562 00017 - NAF 742 C
Association à but non lucratif enregistrée à la
Sous-Préfecture de Grasse (06) N° 7803/88

Internet

secretariat@etsi.fr
Individual copies of this ETSI deliverable
can be downloaded from
<http://www.etsi.org>
If you find errors in the present document, send your
comment to: editor@etsi.fr

Copyright Notification

No part may be reproduced except as authorized by written permission.
The copyright and the foregoing restriction extend to reproduction in all media.

© European Telecommunications Standards Institute 1999.
All rights reserved.

Contents

Intellectual Property Rights	6
Foreword	6
Introduction	6
1 Scope	8
2 References	8
3 Definitions and abbreviations	9
3.1 Definitions	9
3.2 Abbreviations	10
4 Information model diagrams	11
4.1 Entity relationship diagram	11
4.1.1 Overview	11
4.1.2 V5 interface fragment	13
4.1.3 Communication path fragment	13
4.1.4 Protection fragment	15
4.2 Inheritance hierarchy	16
4.3 Naming hierarchy	16
5 Information model description	17
5.1 Managed object classes description	17
5.1.1 V5 fragment	17
5.1.2 Access fragment	18
5.1.2.1 Managed element (managedElement)	18
5.1.2.2 User port TTP (userPortTtp)	18
5.1.2.3 ISDN Basic Access (BA) user port (isdnBAUserPort)	18
5.1.2.4 ISDN Primary Rate Access (PRA) user port (isdnPRAUserPort)	19
5.1.2.5 PSTN user port (pstnUserPort)	19
5.1.2.6 Leased port (leasedPort)	19
5.1.2.7 User port bearer channel CTP (userPortBearerChannelCtp)	20
5.1.3 Supporting managed object classes	20
5.2 Attributes description	20
5.3 Actions description	20
5.4 Notifications description	20
6 Formal managed object classes definition	20
6.1 V5 fragment	21
6.2 Access fragment	21

7	Protocol requirements	22
Annex A (normative):	Mapping of V5 user port states on ITU-T Recommendation X.731 states	23
A.1	Mapping of V5 PSTN user port states on ITU-T Recommendation X.731 states	23
A.2	Mapping of V5 ISDN basic access user port states on ITU-T Recommendation X.731 states	24
A.3	Mapping of V5 ISDN primary rate access user port states on ITU-T Recommendation X.731 states	27
Annex B (normative):	Mapping of link control states on ITU-T Recommendation X.731 states	30
Annex C (normative):	TMN management service "V5 related configuration at the AN"	31
C.1	Task Information Base (TIB) A	31
C.1.1	Description	31
C.1.2	Components of service	31
C.1.2.1	General requirements	31
C.1.2.1.1	Association of user ports with V5 interfaces	31
C.1.2.1.2	Information flow across the Q3 interface	31
C.1.2.1.3	Compatibility between AN and LE	31
C.1.2.1.4	Configuration of bearer channels	31
C.1.2.2	V5 interface requirements	31
C.1.2.2.1	V5 interface and link IDs	31
C.1.2.2.2	Provisioning variant	32
C.1.2.2.3	Channel configuration	32
C.1.2.2.4	Association of interfaces with exchanges	32
C.1.2.2.5	Standby operation	32
C.1.2.2.6	Persistency checking	32
C.1.2.2.7	Global PSTN parameters	32
C.1.2.3	User port requirements	32
C.1.2.3.1	Operational threshold	32
C.1.2.3.2	Port blocking	32
C.1.2.3.3	User port addresses	32
C.1.2.3.4	Split ISDN ports	33
C.1.2.3.5	User requirements	33
C.1.2.3.6	ISDN with access digital sections	33
C.1.2.3.7	Port specific PSTN parameters	33
C.2	Management function list	33
C.2.1	User port functions	33
C.2.1.1	Insert a user port	33
C.2.1.2	Delete a user port	33
C.2.1.3	Modify a user port	33
C.2.1.4	Read a user port	34
C.2.2	V5 interface functions	34
C.2.2.1	Insert a V5 interface	34
C.2.2.2	Delete a V5 interface	34
C.2.2.3	Modify a V5 interface	34
C.2.2.4	Read a V5 interface	34
C.2.3	Cross-connection functions	34
C.2.3.1	Establish a connection	34
C.2.3.2	De-establish a connection	35
C.2.3.3	Modify a connection	35
C.2.3.4	Read a connection	35

Annex D (informative):	Functional architecture	36
Annex E (informative):	Link control message flows	40
Annex F (informative):	User port control message flows	41
F.1	Message flows for the mapping of PSTN user port states on ITU-T Recommendation X.731 states	41
F.1.1	Blocking initiated by AN	41
F.1.2	Blocking request initiated by AN.....	41
F.1.3	Blocking initiated by LE.....	42
F.1.4	Co-ordinated unblocking initiated by the LE.....	42
F.1.5	Co-ordinated unblocking initiated by the AN.....	43
F.2	Message flows for the mapping of ISDN basic access user port states on ITU-T Recommendation X.731 states	43
F.2.1	Blocking initiated by AN	44
F.2.2	Blocking initiated by the LE	45
F.2.3	Co-ordinated unblocking initiated by the LE.....	46
F.2.4	Co-ordinated unblocking initiated by the AN	47
F.3	Message flows for the mapping of ISDN primary rate access user port states on ITU-T Recommendation X.731 states	49
F.3.1	Blocking initiated by AN	50
F.3.2	Blocking initiated by the LE	50
F.3.3	Co-ordinated unblocking initiated by the LE.....	51
F.3.4	Co-ordinated unblocking initiated by the AN	51
Annex G (normative):	Location of the Q3 interface.....	53
Annex H (normative):	Summary of V5 requirement details	54
Annex J (normative):	Defaults and predefined items	55
	Bibliography	56
	History.....	58

Intellectual Property Rights

IPRs essential or potentially essential to the present document may have been declared to ETSI. The information pertaining to these essential IPRs, if any, is publicly available for **ETSI members and non-members**, and can be found in SR 000 314: "*Intellectual Property Rights (IPRs); Essential, or potentially Essential, IPRs notified to ETSI in respect of ETSI standards*", which is available from the ETSI Secretariat. Latest updates are available on the ETSI Web server (<http://www.etsi.org/ipr>).

Pursuant to the ETSI IPR Policy, no investigation, including IPR searches, has been carried out by ETSI. No guarantee can be given as to the existence of other IPRs not referenced in SR 000 314 (or the updates on the ETSI Web server) which are, or may be, or may become, essential to the present document.

Foreword

This European Standard (Telecommunications series) has been produced by ETSI Technical Committee Telecommunications Management Network (TMN).

The present document is part 1 of a multi-part European Standard (Telecommunications series) covering the Q3 interface specification at the Access Network (AN) for configuration management of V5 interfaces and associated user ports, as identified below:

Part 1: "Q3 interface specification";

Part 2: "Managed Object Conformance Statement (MOCS) proforma specification".

National transposition dates	
Date of adoption of this EN:	3 September 1999
Date of latest announcement of this EN (doa):	31 December 1999
Date of latest publication of new National Standard or endorsement of this EN (dop/e):	30 June 2000
Date of withdrawal of any conflicting National Standard (dow):	30 June 2000

Introduction

V5 interfaces, as described in EN 300 324-1 [3] and EN 300 347-1[4], operate between an exchange and an Access Network (AN) to support various narrowband services. These interfaces and their associated user ports have to be managed by the Operations Systems (OSs) within the Telecommunications Management Network (TMN).

ITU-T Recommendation G.803 [1] provides an abstracted view of telecommunications equipment, based on the essential functions that such equipment needs to perform. These functional components are modelled by objects, which represent the implementation-independent aspects of the equipment.

The following assumptions relating to the scope of the present document were to be considered:

- existing protocols should be used where possible, and the focus of the present document should be on defining the object models;
- the interface should not involve objects specific to the control of a leased line network which is not connected to the LE or of an external line test system;

- a model of the AN appears necessary. The model relevant to the present standards on the V5 interface and ports will be developed if it does not already exist elsewhere. Other object models outside the scope of the present document may share the same physical Q3 interface;
- the definition of OS functionality is outside the scope of the present document;
- security management is excluded from the present document, but aspects of security relating to configuration management are included;
- configuration management includes provisioning and the provisioning activity may include testing, but this testing is not included in the present document. It will be included in the specification relating to fault and performance management;
- the specification should cover the provisioning of national variants and type variants of lines. Existing modelling, such as the customer administration model, should be used for this, if possible;
- the specification should not cover general functions within the AN, such as multiplexing, cross-connection and transmission functions, unless some aspect impacts the configuration management of V5 interfaces and related ports;
- configuration management related to redundancy of V5 interfaces is within the scope of the present document, both for multiple V5 interfaces and for the individual links within a V5.2 interface;
- the definition of an object model for a transparent channel on the V5 interface which supports the synchronization of OSs is outside the scope of the present document;
- it is assumed that the relationship between directory numbers and equipment is kept in the OSs of the AN, so that the Q3 interface of the AN does not need to handle directory numbers.

1 Scope

The present document specifies the Q3 interface between an Access Network (AN) and the Telecommunications Management Network (TMN) for the support of configuration management functions for V5 interfaces, as described in EN 300 324-1 [3] and EN 300 347-1 [4], and their associated user ports. The management of transmission, media and services which are not related to V5 interfaces is outside the scope of the present document.

The Q3 interface is the TMN interface between network elements or Q-adapters which interface to Operations Systems (OSs) without mediation and between OSs and mediation devices. The location of the Q3 interface is illustrated in annex G.

Generic modelling of leased line ports which are associated with a V5 interface is within the scope of the present document, but the traffic from these ports can only be associated with 64 kbit/s bearer channels on the V5 interface.

The definition of OS functionality, and the specification of Qx interfaces and proprietary interfaces are outside the scope of the present document.

The present document does not constrain the logical or physical size of the AN or its geographical dispersion. The definition of the managed object class which represents an AN is outside the scope of the present document.

Existing protocols are used where possible, and the focus of the present document is on defining the object models.

NOTE: Configuration management includes provisioning and the provisioning activity may include testing, but this testing is not included in the present document. It is included in the specification relating to fault and performance management, EN 300 378-1 [6].

2 References

The following documents contain provisions which, through reference in this text, constitute provisions of the present document.

- References are either specific (identified by date of publication, edition number, version number, etc.) or non-specific.
- For a specific reference, subsequent revisions do not apply.
- For a non-specific reference, the latest version applies.
- A non-specific reference to an ETS shall also be taken to refer to later versions published as an EN with the same number.

- [1] ITU-T Recommendation G.803 (1997): "Architecture of transport networks based on the synchronous digital hierarchy (SDH)".
- [2] ETS 300 297: "Integrated Services Digital Network (ISDN); Access digital section for ISDN basic access".
- [3] EN 300 324-1: "V interfaces at the digital Local Exchange (LE); V5.1 interface for the support of Access Network (AN); Part 1: V5.1 interface specification".
- [4] EN 300 347-1: "V interfaces at the digital Local Exchange (LE); V5.2 interface for the support of Access Network (AN); Part 1: V5.2 interface specification".
- [5] EN 300 377-1: "Q3 interface at the Local Exchange (LE) for configuration management of V5 interfaces and associated customer profiles; Part 1: Q3 interface specification".
- [6] EN 300 378-1: "Q3 interface at the Access Network (AN) for fault and performance management of V5 interfaces and associated user ports; Part 1: Q3 interface specification".

- [7] EN 300 379-1: "Q3 interface at the Local Exchange (LE) for fault and performance management of V5 interfaces and associated customer profiles; Part 1: Q3 interface specification".
- [8] ITU-T Recommendation G.773 (1993): "Protocol suites for Q-interfaces for management of transmission systems".
- [9] ITU-T Recommendation G.784 (1994): "Synchronous Digital Hierarchy (SDH) management".
- [10] ITU-T Recommendation M.3010 (1996): "Principles for a telecommunications management network".
- [11] ITU-T Recommendation M.3100 (1995): "Generic network information model".
- [12] ITU-T Recommendation Q.811 (1997): "Lower layer protocol profiles for the Q3 and X interfaces".
- [13] ITU-T Recommendation Q.812 (1997): "Upper layer protocol profiles for the Q3 and X interfaces".
- [14] CCITT Recommendation X.208 (1988): "Specification of Abstract Syntax Notation One (ASN.1)".
- [15] Void.
- [16] ITU-T Recommendation X.721 | ISO/IEC 10165-2 (1992): "Information technology - Open systems interconnection - Structure of management information: Definition of management information".
- [17] ITU-T Recommendation X.731 | ISO/IEC 10164-2 (1992): "Information technology - Open systems interconnection - Systems management: State management function".
- [18] Void.
- [19] ITU-T Recommendation Q.824.5 (1997): "Stage 2 and stage 3 description for the Q3 interface - Customer administration: Configuration management of V5 interface environments and associated customer profiles".
- [20] ITU-T Recommendation G.960 (1993): "Access digital section for ISDN basic rate access".

3 Definitions and abbreviations

3.1 Definitions

For the purposes of the present document, the following terms and definitions apply:

Access Network (AN): see EN 300 324-1 [3].

bearer channel: see EN 300 324-1 [3].

Bearer Channel Connection (BCC): see EN 300 347-1 [4].

Communication channel (C-channel): see EN 300 324-1 [3].

Communication path (C-path): see EN 300 324-1 [3].

control protocol: see EN 300 324-1 [3].

D-channel signalling type (Ds-type) data: ISDN D-channel signalling type data with Service Access Point Identifier (SAPI) not equal to 16, and not equal to 32 to 62 (see EN 300 324-1 [3]).

envelope function address: see EN 300 324-1 [3].

frame type (f-type) data: ISDN D-channel data with SAPI in the range from 32 to 62 (see EN 300 324-1 [3]).

Local Exchange (LE): see EN 300 324-1 [3].

Operations System (OS): see ITU-T Recommendation M.3010 [10].

packet type (p-type) data: ISDN D-channel data with SAPI equal to 16 (see EN 300 324-1 [3]).

Permanent Line (PL): see EN 300 324-1 [3].

protection protocol: see EN 300 347-1 [4].

provisioning variant: see EN 300 324-1 [3].

semi-permanent leased line: see EN 300 324-1 [3].

time slot number: see EN 300 324-1 [3].

V5 interface: see EN 300 324-1 [3].

V5 time slot: object class representing a 64 kbit/s channel of a V5 interface that is used as bearer or communication channel. It is a subclass of "ITU-T Recommendation M.3100 [11]":connectionTerminationPointBidirectional.

V5 Trail Termination Point (TTP): object class representing a 2 Mbit/s interface that is used as V5.1 interface or as part of a V5.2 interface. It is a subclass of "ITU-T Recommendation M.3100 [11]": trailTerminationPointBidirectional.

X interface: see ITU-T Recommendation M.3010 [10].

3.2 Abbreviations

For the purposes of the present document, the following abbreviations apply:

AN	Access Network
ASN.1	Abstract Syntax Notation One (see CCITT Recommendation X.208 [14])
BA	Basic Access
BCC	Bearer Channel Connection
C-channel	Communication channel
C-path	Communication path
CTP	Connection Termination Point
DCC	Data Communications Channel
Ds-type	D-channel signalling type
f-type	frame type
FSM	Finite State Machine
ID	Identity, Identifier
ISDN	Integrated Services Digital Network
LE	Local Exchange
M/O	Mandatory/Optional
MPH	primitive between Physical layer and layer 2 Management
NE	Network Element
OS	Operations System
p-type	packet type
PL	Permanent Line
PRA	Primary Rate Access
PSTN	Public Switched Telephone Network
RDN	Relative Distinguished Name
SAPI	Service Access Point Identifier
TIB	Task Information Base
TMN	Telecommunications Management Network
TTP	Trail Termination Point

4 Information model diagrams

The entity relationship diagram is given in subclause 4.1 and the inheritance hierarchy (is a relationships) and naming hierarchy (containment relationships) are given in subclauses 4.2 and 4.3, respectively.

4.1 Entity relationship diagram

Figures 1 to 4 show the overall relationships between the various entities. These correspond to the managed objects which are manipulated at the Q3 interface.

For V5.1 interfaces, bearer channels on user ports are associated with bearer time slots on a V5.1 interface by configuration over the Q3 interface of the AN. For V5.2, bearer channels on user ports are associated with bearer time slots on a V5.2 interface by the V5.2 Bearer Channel Connection (BCC) protocol. For both V5.1 and V5.2, the association of user signalling with communication paths and the association between communication paths and logical communication channels on the V5 interface is by configuration over the Q3 interface of the AN. The association of logical communication channels with physical communication time slots on the V5 interface is initially established over the Q3 interface, but can be changed for V5.2 interfaces by the V5.2 protection protocol.

The AN treats time slots on the V5.2 interface which are used for semi-permanent connections like any other bearer time slot on a V5.2 interface.

Signalling protocols and their associated communication are modelled using various objects which represent the communication paths and the communication time slots. There are six classes of communication path objects. There is a single class for all Integrated Services Digital Network (ISDN) signalling with an attribute to distinguish between Ds-type, p-type, and f-type data. There are classes for Public Switched Telephone Network (PSTN) signalling, the control protocol, the BCC protocol, link control protocol, and the protection protocol. In addition to these six communication path object classes, there is also an object class which represents communication channels.

There is one instance of the appropriate object class per communication path and per communication channel. These are contained in instances of v5Interface.

V5 control messages relating to provisioning are managed by an optional object on the Q3 interface. These messages may not be required once a TMN X interface or an integrated OS is available.

If control messages relating to provisioning are not supported on the Q3 interface then a default value for provisioning variant will be automatically used on the V5 interface. All V5 interfaces will use this default value unless actively changed via the Q3 interface. The value of this default is all zeroes.

Protection group 1 and its contained protection unit(s) are to be instantiated for the V5.2 case only if there is more than one 2,048 Mbit/s link.

A Trail Termination Point (TTP) contains the Connection Termination Points (CTPs) at the higher network layer which it serves. This relationship allows the entity relationship diagram to be mapped onto the functional architecture (see annex D).

4.1.1 Overview

A single managedElement can contain a number of userPortTtps, a number of v5Interfaces, and a number of v5Ttps (which each represent a 2,048 Mbit/s link). There is a bi-directional association between each v5Interface and all of its related userPorts. Likewise there is a bi-directional relationship between each v5Interface and all of its related v5Ttps (2,048 Mbit/s links).

Each userPortTtp can contain a number of userPortBearerChannelCtps, one for each of its 64 kbit/s bearer channels. Each v5Ttp contains 31 v5TimeSlots which represent the CTPs corresponding to each of the 31 physical time slots which may be configured. Each userPortBearerChannelCtp can be associated with a unique v5TimeSlot for a V5.1 interface, but for the V5.2 case there is no corresponding association because the relationship is controlled by the V5.2 BCC protocol.

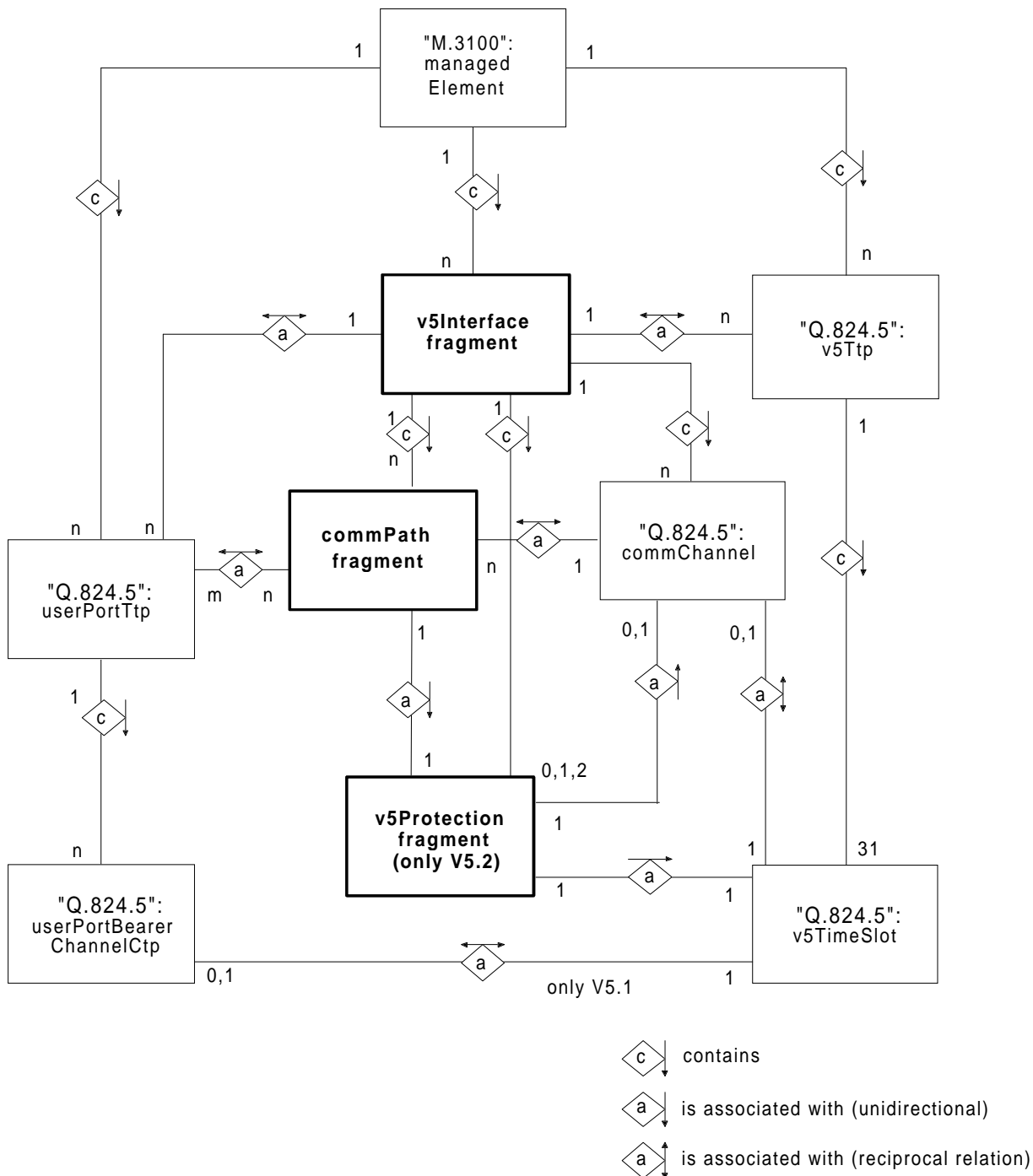

Figure 1: Entity relationship diagram - overview

Link blocking requests on the Link control protocol are generated by setting the administrative state attribute of the relevant instance of v5Ttp to shutting down. Only deferred blocking requests can be generated in this way. Deferred blocking requests on the Link control protocol cannot be generated by manipulating the object model. Port blocking requests for the Control protocol are generated by setting the administrative state attribute of the relevant instance of the subclass of userPortTtp to shutting down.

4.1.2 V5 interface fragment

Each v5Interface contains a number of communication path objects in its commPath fragment, a number of commChannels, and one or two v5ProtectionGroup objects if it represents a V5.2 interface. Each instance of v5Interface may contain an instance of v5Provision to support the V5 pre-provisioning messages.

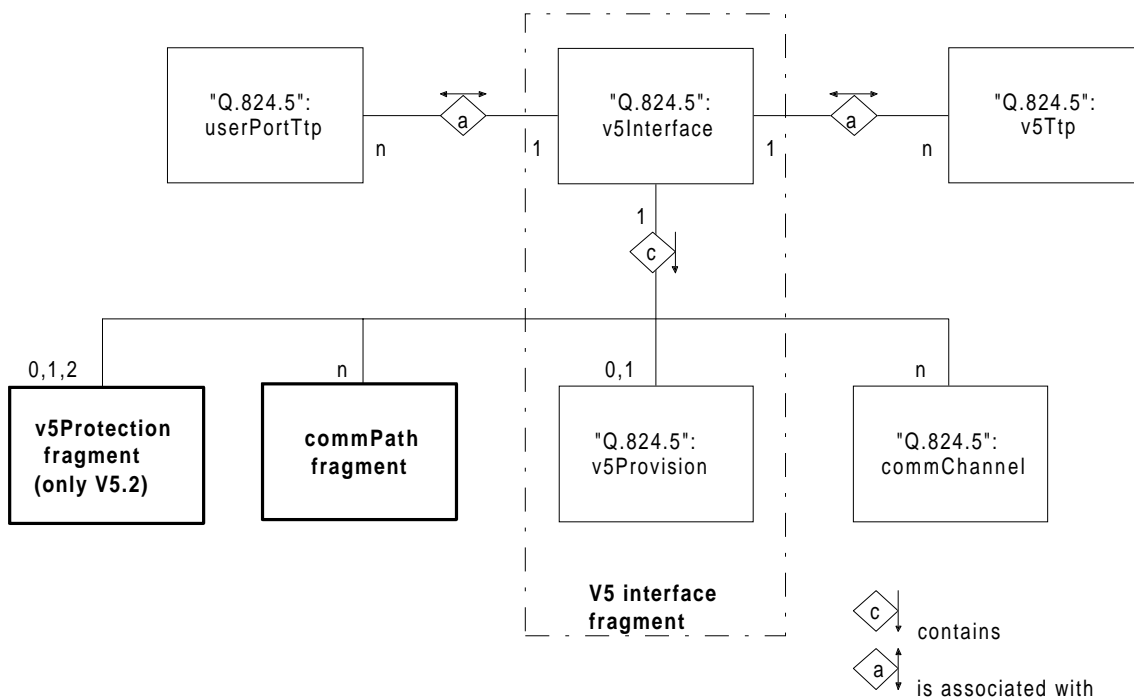

Figure 2: Entity relationship diagram - V5 interface fragment

4.1.3 Communication path fragment

Each ISDN userPortTtp can be associated with up to three isdnCommPaths, one for each type of ISDN signalling. Each isdnCommPath handles a certain type of ISDN signalling for a number of userPortTtps, and is associated with these. There may be more than one isdnCommPath contained in the v5Interface for each type of ISDN signalling.

The v5Interface contains a single controlCommPath. It contains a single pstnCommPath, but only if there are any PSTN userPortTtps associated with it. It also contains a single bccCommPath, a single protCommPath, and a single linkControlCommPath if it represents a V5.2 interface.

Each commChannel can be associated with up to three isdnCommPaths representing three different types of ISDN signalling. It can also be associated with the pstnCommPath. The commChannel which is associated with controlCommPath shall also be associated with the bccCommPath and with the linkControlCommPath if the v5Interface which contains it represents a V5.2 interface.

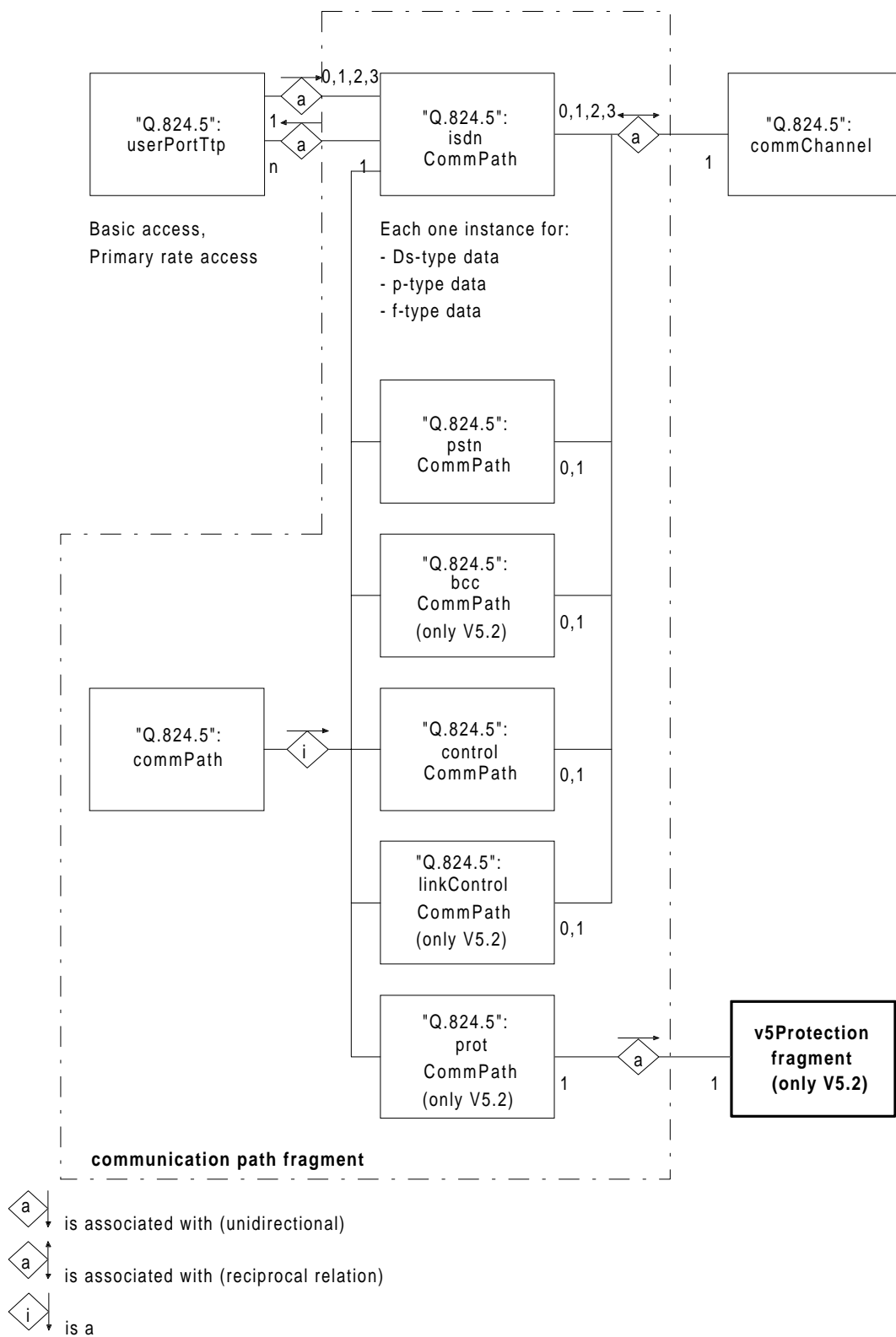

Figure 3: Entity relationship diagram - communication path fragment

4.1.4 Protection fragment

There is a bi-directional one-to-one association between commChannels and certain v5TimeSlots. Not every v5TimeSlot is associated with a commChannel. Some are used for bearer traffic and others are available for protection of commChannels on V5.2 interfaces. This protection adds onto the modelling for the V5.1 interfaces, and does not affect that modelling.

The time slots which may be associated with the commChannel which is associated with the controlCommPath are constrained by the V5 interface specifications EN 300 324-1 [3] and EN 300 347-1 [4]. A v5Interface which represents a V5.2 interface shall contain a v5ProtectionGroup of type 1 which contains two v5ProtectionUnits (see figure 4). One of these v5ProtectionUnits points to the protected commChannel which is associated with both the controlCommPath, the bccCommPath, and the linkControlCommPath. The corresponding pointer in the other v5ProtectionUnit is null. Both v5ProtectionUnits point to their associated v5TimeSlots. The containing v5ProtectionGroup of type 1 is pointed to by the protCommPath for the v5Interface, so there is an indirect mapping from the protCommPath through the v5ProtectionGroup of type 1, through its two contained v5ProtectionUnits onto its related v5TimeSlots.

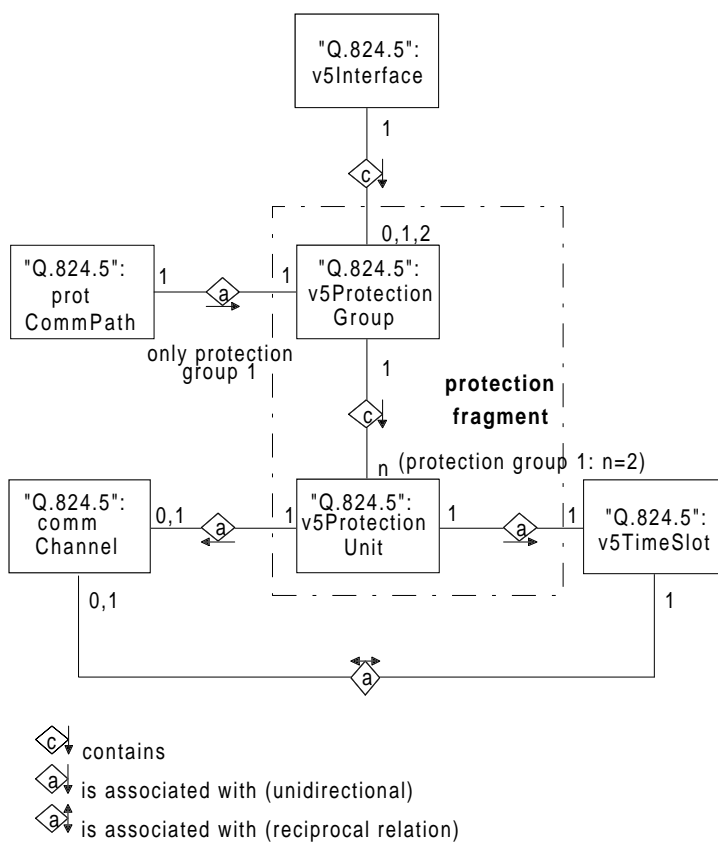
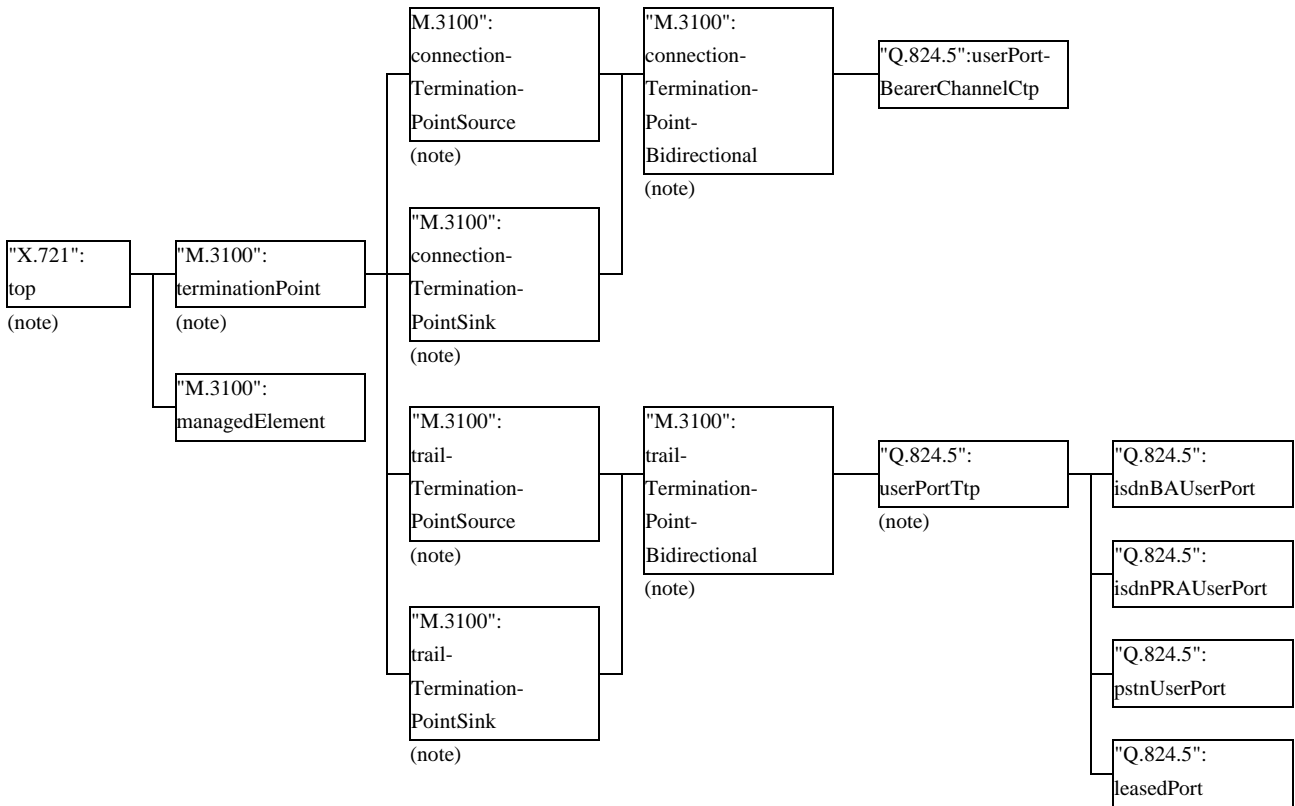

Figure 4: Entity relationship diagram - protection fragment

A v5Interface which represents a V5.2 interface also contains a v5ProtectionGroup of type 2 if other commChannels are protected (see figure 4). The v5ProtectionGroup of type 2 contains a number of v5ProtectionUnits, each of which points to its associated v5TimeSlot. The v5ProtectionUnits which point to active v5TimeSlots also point to the commChannels which are associated with the active v5TimeSlots. The corresponding pointers in the other v5ProtectionUnits are set to null.

4.2 Inheritance hierarchy

Figure 5 traces the inheritance from the highest level object "ITU-T Recommendation X.721 [16]":top to the managed objects defined in the present document.



NOTE: Non-instantiable object class.

Figure 5: Inheritance hierarchy

4.3 Naming hierarchy

Figure 6 shows the naming (i.e. containment) relationships for the AN's managed objects associated with configuration management.

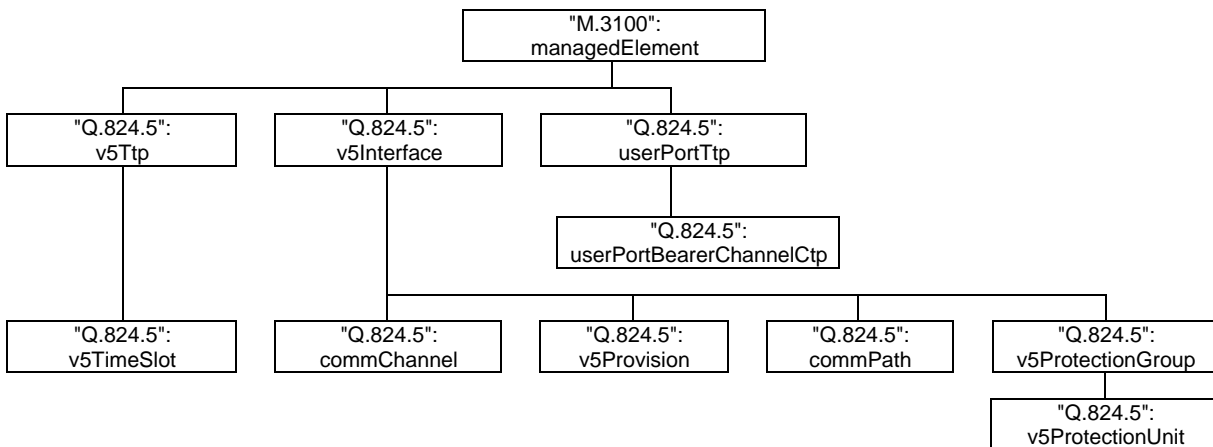

Figure 6: Naming hierarchy

5 Information model description

This clause provides a high-level informal description of the management information model for configuration management of the AN.

The principle managed objects for configuration management are logical constructs and do not represent physical equipment. The relationship between these managed objects and equipment is achieved by using the `supportedByObjectList` pointer in the logical managed objects to point to the equipment which supports them, and by using the `affectedObjectList` pointer on equipment to point to the logical managed objects that the equipment implements.

Subclause 5.1 contains a brief description for each object class used in the model covering:

- the purpose of the object class;
- the attributes defined for the object class;
- the relationship of the object class to other object classes.

In the tables listing the attributes of the object classes, the inherited attributes are only mentioned explicitly if their conditionality has been altered. The other inherited attributes are still present in these classes.

Subclause 5.2 describes attributes which are common to several object classes in the information model.

Subclause 5.3 describes actions which are common to several object classes in the information model.

Subclause 5.4 describes the common aspects of the notifications used in the information model.

5.1 Managed object classes description

Subclause 5.1 is divided into further subclauses which describe the fragments of the information model.

5.1.1 V5 fragment

The object classes of the V5 fragment are described in ITU-T Recommendation Q.824.5 [19]. The following classes are used in the AN:

- V5 interface (`v5Interface`);
- V5 TTP (`v5Ttp`);
- V5 time slot (`v5TimeSlot`);
- V5 provision (`v5Provision`);
- V5 communication channel (`commChannel`);
- ISDN communication path (`isdnCommPath`);
- PSTN communication path (`pstnCommPath`);
- BCC communication path (`bccCommPath`);
- control communication path (`controlCommPath`);
- protection communication path (`protCommPath`);
- link Control communication path (`linkControlCommPath`);
- V5 protection group (`v5ProtectionGroup`);
- V5 protection unit (`v5ProtectionUnit`).

5.1.2 Access fragment

The following classes are specific to the AN.

5.1.2.1 Managed element (managedElement)

The managed element object class is defined in ITU-T Recommendation M.3100 [11].

5.1.2.2 User port TTP (userPortTtp)

A user port TTP is an object class representing a generic user port on an AN. It is a specialization of the TTP bidirectional object class defined in ITU-T Recommendation M.3100 [11].

This managed object class is defined in ITU-T Recommendation Q.824.5 [19].

In addition to the inherited attributes, it has the attributes given in table 1.

Table 1

Name	M/C/O	Value set
"ITU-T Recommendation M.3100 [11]":tPId	M	RDN
"ITU-T Recommendation X.721 [16]":administrativeState	M	single
"ITU-T Recommendation Q.824.5 [19]":assocV5Interface	C	single
"ITU-T Recommendation Q.824.5 [19]":blockingStatus	C	single

5.1.2.3 ISDN Basic Access (BA) user port (isdnBAUserPort)

An ISDN BA user port is an object class representing an ISDN basic user port which is associated with a V5 interface on an AN. It is a specialization of the user port TTP object class.

This managed object class is defined in ITU-T Recommendation Q.824.5 [19].

In addition to the inherited attributes, it has the attributes given in table 2.

Table 2

Name	M/C/O	Value set
"ITU-T Recommendation Q.824.5 [19]":assocIsdnSignallingCommPath	M	single
"ITU-T Recommendation Q.824.5 [19]":assocPacketCommPath	M	single
"ITU-T Recommendation Q.824.5 [19]":assocFrameCommPath	M	single
"ITU-T Recommendation Q.824.5 [19]":envelopeFunctionAddress	M	single
"ITU-T Recommendation Q.824.5 [19]":accessDigitalSection	M	single
"ITU-T Recommendation Q.824.5 [19]":gradingEnabled	C	single
NOTE 1: accessDigitalSection: indicates whether the NT1 is implemented separately from the AN.		
NOTE 2: gradingEnabled: indicates for a port with an access digital section whether the grading messages should be sent to the LE.		

5.1.2.4 ISDN Primary Rate Access (PRA) user port (isdnPRAUserPort)

An ISDN PRA user port is an object class representing an ISDN primary rate user port which is associated with a V5 interface on an AN. It is a specialization of the user port TTP object class.

This managed object class is defined in ITU-T Recommendation Q.824.5 [19].

In addition to the inherited attributes, it has the attributes given in table 3.

Table 3

Name	M/C/O	Value set
"ITU-T Recommendation Q.824.5 [19]":assocIsdnSignallingCommPath	M	single
"ITU-T Recommendation Q.824.5 [19]":assocPacketCommPath	M	single
"ITU-T Recommendation Q.824.5 [19]":assocFrameCommPath	M	single
"ITU-T Recommendation Q.824.5 [19]":envelopeFunctionAddress	M	single
"ITU-T Recommendation Q.824.5 [19]":accessDigitalSection	M	single
"ITU-T Recommendation Q.824.5 [19]":gradingEnabled	C	single
NOTE 1: accessDigitalSection: indicates whether the NT1 is implemented separately from the AN.		
NOTE 2: gradingEnabled: indicates for a port with an access digital section whether the grading messages should be sent to the LE.		

5.1.2.5 PSTN user port (pstnUserPort)

A PSTN user port is an object class representing a PSTN user port which is associated with a V5 interface on an AN. It is a specialization of the user port TTP object class.

This managed object class is defined in ITU-T Recommendation Q.824.5 [19].

In addition to the inherited attributes, it has the attributes given in table 4.

Table 4

Name	M/C/O	Value set
"ITU-T Recommendation Q.824.5 [19]":layer3PortAddress	M	single
"ITU-T Recommendation Q.824.5 [19]":specialFeatures	M	set
NOTE: special Features: this attribute indicates whether or not there are any special features at the PSTN user port and what the features are if they are present.		

5.1.2.6 Leased port (leasedPort)

A leased port is an object class representing a generic leased line port on an AN. It is a specialization of the user port TTP object class. This object class may contain instances of other objects which give further details of leased line ports.

This managed object class is defined in ITU-T Recommendation Q.824.5 [19].

In addition to the inherited attributes, it has the attributes given in table 5.

Table 5

Name	M/C/O	Value set
"ITU-T Recommendation Q.824.5 [19]":v5UserPortAddress	M	single

5.1.2.7 User port bearer channel CTP (userPortBearerChannelCtp)

A user port bearer channel CTP is an object class representing a 64 kbit/s bearer channel of a user port. It is a specialization of the CTP bidirectional object class defined in ITU-T Recommendation M.3100 [11].

This managed object class is defined in ITU-T Recommendation Q.824.5 [19].

In addition to the inherited attributes, it has the attributes given in table 6.

Table 6

Name	M/C/O	Value set
"ITU-T Recommendation M.3100 [11]":cTPIId	M	RDN
"ITU-T Recommendation Q.824.5 [19]":assocTimeSlot	C	single
"ITU-T Recommendation Q.824.5 [19]":bearerChannelType	C	single
"ITU-T Recommendation X.721 [16]":administrativeState	O	single
NOTE 1: assocTimeSlot: points to the associated object which represents a time slot at the service interface to the local exchange or to another service node such as a leased line network node.		
NOTE 2: bearerChannelType: indicates whether or not the bearer channel is used for Permanent Line (PL) access.		

5.1.3 Supporting managed object classes

Refer to EN 300 377-1 [5] for the contents of this subclause.

5.2 Attributes description

Refer to EN 300 377-1 [5] for the contents of this subclause.

5.3 Actions description

Refer to EN 300 377-1 [5] for the contents of this subclause.

5.4 Notifications description

Refer to EN 300 377-1 [5] for the contents of this subclause.

6 Formal managed object classes definition

This clause specifies the object classes for all of the managed objects used in the management information model. These objects are defined by reference to other specifications.

6.1 V5 fragment

In this subclause the definitions of the classes of the AN V5 fragment are specified by importing from other specifications. In this context, the IMPORTS clause specifies the object classes which can be instantiated in the scope of the present document. The IMPORTS clause does not include uninstantiated super-classes.

Clarification of the use of the package "ITU-T Recommendation M.3100 [11]":
tmnCommunicationsAlarmInformationPackage in these imported classes is contained in EN 300 378-1 [6] and EN 300 379-1 [7].

BEGIN

IMPORTS

v5Interface,

v5Ttp,

v5TimeSlot,

v5Provision,

commChannel,

isdnCommPath,

pstnCommPath,

bccCommPath,

controlCommPath,

protCommPath,

linkControlCommPath,

v5ProtectionGroup,

v5ProtectionUnit

FROM "ITU-T Recommendation Q.824.5 [19]";

END

6.2 Access fragment

In this subclause, the definitions of the new classes specific to the AN are specified by importing from other specifications. In this context, the IMPORTS clause specifies the object classes which can be instantiated in the scope of the present document.

BEGIN

IMPORTS

managedElement

FROM "ITU-T Recommendation M.3100 [11]"

userPortTtp,

isdnBAUserPort,

isdnPRAUserPort,

pstnUserPort,

leasedPort,

userPortBearerChannelCtp

FROM "ITU-T Recommendation Q.824.5 [19]";

END

7 Protocol requirements

Protocol stacks are specified in ITU-T Recommendation Q.811 [12], ITU-T Recommendation Q.812 [13], ITU-T Recommendations G.773 [8] and the SDH Data Communications Channel (DCC) part of ITU-T Recommendation G.784 [9]. No special requirements are identified.

NOTE: In addition, it will be possible to use 64 kbit/s bearer channels and p-type and f-type data channels on a V5 interface. These will act as virtual user ports (see EN 300 324-1 [3]) and the initial port addresses cannot be configurable over the Q3 interface of the AN. Layer 1 and the envelope part of layer 2 of the V5 interface will be used for the lower layers of the protocol stack, but the higher layers will be the same as the stacks already specified in this clause. The initial configuration of a V5 interface to enable the use of 64 kbit/s bearer channels and p-type and f-type data channels may be through pre-definition of a default configuration or using a local craft interface.

Annex A (normative): Mapping of V5 user port states on ITU-T Recommendation X.731 states

This annex defines the mapping of PSTN user ports, ISDN basic access user ports and ISDN primary rate user ports on ITU-T Recommendation X.731 [17] states, including the case of permanent line capability.

A.1 Mapping of V5 PSTN user port states on ITU-T Recommendation X.731 states

State transition table A.1 shows the mapping of the V5 PSTN user port states on ITU-T Recommendation X.731 [17] operational and administrative states.

The locked/enabled state means that the port has been locked by the Q3 interface of the AN and that there are no local fault conditions.

In the "locked" state the operational state attribute only reflects AN internal failures, i.e. "enabled" means no AN fault and "disabled" means AN fault regardless of any knowledge about the LE side.

However, in the "unlocked" state the operational state attribute is changed from "enabled" to "disabled" due to AN fault or blocking by the LE. There the information about the presence of a local or access disabling reason needs to be available. A "local reason" entry is made when a "port-not-ok" message is received and removed when a "port-ok" messages arrives. A "remote reason" entry is made when MPH-BI is received and removed when MPH-UBR arrives. State 4 is also entered as part of the unblocking procedure if the OS sent UNLOCK to the port object and an acknowledgement from the LE needs to be awaited.

Table A.1

	state 1 locked disabled	state 2 locked enabled	state 3 shutting down	state 4 unlocked disabled	state 5 unlocked enabled
LOCK	-	-	MPH-BI; 2	no local reason: MPH-BI; 2 else: MPH-BI; 1	MPH-BI; 2
UNLOCK	; 4	MPH-UBR; 4	MPH-UBR; 5	-	-
SHUTDOWN	/	/	-	no local reason: MPH-BI; 2 else: MPH-BI; 1	MPH-BR; 3
MPH-BI	-;	-;	-; 2	-;	-; 4
MPH-UBR	-;	-;	MPH-BR;	no local reason: MPH-UBR; else: -;	/
MPH-UBI	/	/	SHUTDOWNRej;	-; 5	-
Port-ok	-; 2	/	/	MPH-UBR;	/
Port-not-ok	/	-; 1	MPH-BI; 1	MPH-BI;	MPH-BI; 4
NOTE:	Key: <output signal>;<new state> / = unexpected event - = no action				

Disabling reasons

Local:

Port-ok: disappearance/not existence of internal disabling reasons;

Port-not-ok: occurrence/presence of internal disabling reasons.

Remote:

MPH-BI: LE reason for blocking the port due to failure or management decision;

MPH-UBR: disappearance of an LE reason for blocking the port.

Sources of messages

LOCK, UNLOCK, SHUTDOWN are generated by the OS. MPH-BI, MPH-UBR, MPH-UBI are generated by the user port FSM. Port-ok, Port-not-ok are generated by an internal management entity, e.g. a resource manager, see figure A.1.

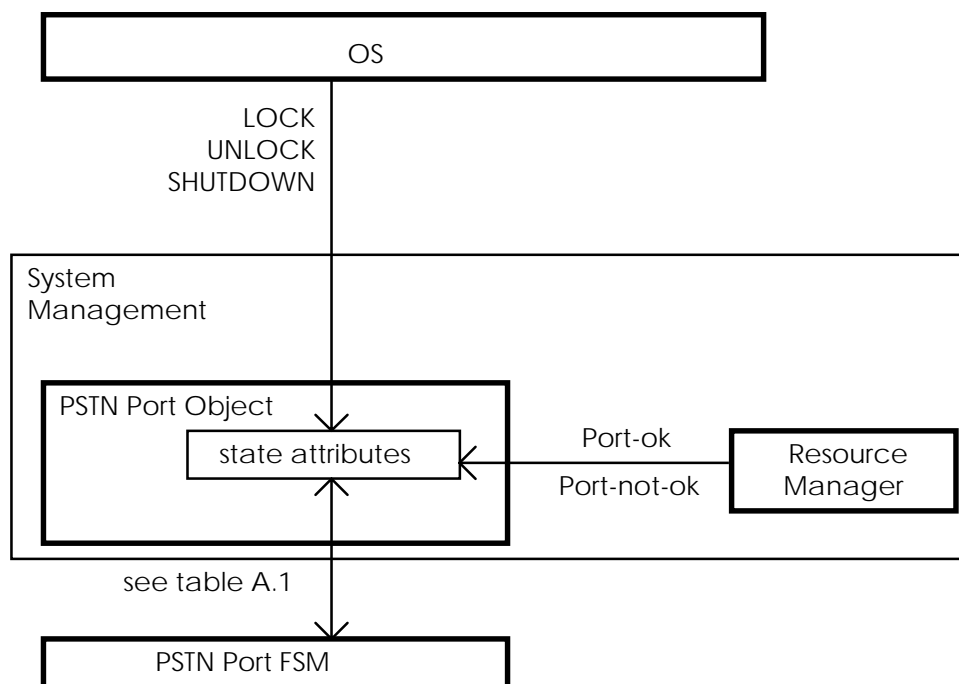

NOTE: This figure is for information only.

Figure A.1: General relationship between the PSTN port object and system management

A.2 Mapping of V5 ISDN basic access user port states on ITU-T Recommendation X.731 states

State transition table A.2 shows the mapping of the V5 ISDN basic access user port states on ITU-T Recommendation X.731 [17] operational and administrative states.

It covers both the use of the port for on-demand service and (partial or full) permanent line service. In table A.2 two variables are used for determining the transitions in case of permanent line service. PL_p is TRUE if the port is used for PL service. PL_a is TRUE if the port FSM is in one of the AN3.x PL activation states.

In the "locked" state the operational state attribute reflects only AN internal failures, i.e. "enabled" means no AN fault and "disabled" means AN fault regardless of any knowledge about the LE side.

However, in the "unlocked" state the operational state attribute is changed from "enabled" to "disabled" due to AN fault or blocking by the LE. There the information about the presence of a local or remote disabling reason needs to be available. A "local reason" entry is made when an internal disabling reason occurs and is removed when there is no internal reason for being disabled. A "remote reason" entry is made when MPH-BI is received and removed when MPH-UBR arrives. This information can be stored in the blockingStatus attribute of the port object. State 4 is also entered as part of the unblocking and activation procedure if the OS sends UNLOCK to the port object and an acknowledgement from the LE needs to be awaited.

Table A.2: State table for ISDN port object state attributes

	state 1 locked disabled	state 2 locked enabled	state 3 shutting down	state 4 unlocked disabled	state 5 unlocked enabled
LOCK	-	-	MPH-BI; 2	(if PLa: MPH-DR; else: MPH-BI, (if TPL1 running: stop TPL1)), if no local reason: -; 2 else: -; 1	if PLa: MPH-DR; 2 else: MPH-BI; 2
UNLOCK	-;4	MPH-UBR, (if PLp: start TPL1); 4	MPH-UBR; 5	-	-
SHUTDOWN	/	/	-	if PLa: / else: (if TPL1 running: stop TPL1), (if no local reason: MPH-BI; 2 else: MPH-BI; 1)	if PLp: / else: MPH-BR; 3
expiry of TPL1	/	/	/	if PLp: MPH-AR,; else: /	/
MPH-BI	-;	-;	-; 2	-;	if PLa: / else: (if PLp: MPH-AR); 4
MPH-UBR	-;	-;	/	no local reason: MPH-UBR; else: -	/
MPH-UBI	/	/	SHUTDOWNRej;	(if TPL1 running: stop TPL1);5	if PLa: / else: -;
MPH-T1	/	/	-	if PLa:-; else: /	if PLa: / else: -;
MPH-I1	/	/	-	/	if PLa: / else: -;
MPH-I2	MPH-DR;	MPH-DR;	-	if PLa: / else: MPH-DR;	if PLa: / else: -;
MPH-DSAI	MPH-DR;	MPH-DR;	-	if PLa:- else: MPH-DR;	if PLa: / else: -;
MPH-AI	MPH-DR;	MPH-DR;	-	if PLa: / else: MPH-DR;	-
MPH-I5	/	/	-	/	if PLa: / else: -;
MPH-DI	-	-	-	-	-
MPH-EI7	MPH-DR;	MPH-DR;	-	if PLa: - else: MPH-DR;	-
MPH-PAI	/	/	/	if PLa: -; 5 else: /	if PLa: - else: /
MPH-EI12	MPH-DR;	MPH-DR;	-	if PLa: / else: MPH-DR;	-
disappearance of internal disabling reasons	-; 2	/	/	MPH-UBR, (if PLp: start TPL1);	/

	state 1 locked disabled	state 2 locked enabled	state 3 shutting down	state 4 unlocked disabled	state 5 unlocked enabled
occurrence of internal disabling reasons	-	-; 1	MPH-BI; 1	if PLa: MPH-DR; else: (if TPL1 running: stop TPL1), MPH-BI;	if PLa: MPH-DR; 4 else: MPH-BI; 4
Key: <action>[,<action>][,(<action>)];<new state> / = unexpected event - = no action no local reason: blockStatus = none or blockStatus = remote PLp = Permanent Line provisioned. PLa = TRUE if the ISDN port FSM is in PL state AN3.0. The variable is updated by the system management					

Assumptions

- 1) PLa = TRUE means ISDN port FSM is in state AN3.x.
- 2) PLp = TRUE means at least one B-channel is provisioned as permanent line.
- 3) An unlocked enabled port provisioned for permanent line service rejects a SHUTDOWN from the OS. LOCK should be used to take this port out of service.
- 4) In case of a port without PL, the activation and deactivation status of layer 1 does not affect the enabled state. This status can be stored e.g. in an activation variable, not visible to the OS.
- 5) If the port object is in state 1 or 2, the ISDN port FSM is in one of AN1.x, or AN4.x, respectively. If the port object is in state 3, the ISDN port FSM is in an AN2.x state. If the port object is in state 4, the ISDN port FSM is in an AN1.x state or in AN3.1. If the port object is in state 5, the ISDN port FSM is in an AN2.x state, or in AN3.2.
- 6) If a port is provisioned for PL services, it is assumed to be enabled if layer 1 is activated, independent of the blocking status, which is relevant for on demand services.
- 7) The usual way to activate a port provisioned for PL is to send an unblock request (FE202) to the LE, which takes over responsibility for activating layer 1 after unblocking the port (see EN 300 324-1 [3]). This is reflected in MPH-AR being an unexpected event in state AN1.2 and AN2.0. A timer TPL1 is used to supervise this unblock procedure. If the LE does not respond within an appropriate time the AN becomes responsible for the activation of layer 1 and issues MPH-AR.
- 8) If a port provisioned for PL services is in the unlocked/enabled state and is blocked by the LE, the AN immediately starts re-activation of layer 1 by issuing MPH-AR and the port becomes enabled again after the successful activation. A short interruption of the PL service can be expected.
- 9) In case of semi-permanent connections the LE will reject a shutdown request (MPH-BR, FE205) from the AN by sending an unblock request (FE201, MPH-UBI). The OS of the AN shall then be notified to change the administrative state from SHUTTINGDOWN back to UNLOCKED.
- 10) Partial activation (states AN5.x) is not covered.

Disabling reasons

Local: occurrence/presence of internal disabling reasons, e.g. bit error rate $\geq 10^{-3}$.

Remote: MPH-BI: LE reason for blocking the port due to failure or management decision.

Enabling reasons

Local: disappearance/non-existence of internal disabling reasons, e.g. bit error rate $< 10^{-3}$.

Remote: MPH-UBR: disappearance of an LE reason for blocking the port.

Sources of messages

LOCK, UNLOCK, SHUTDOWN are generated by the OS. SHUTDOWNRej is sent from the ISDN port object to the OS. MPH-BI, MPH-UBR, MPH-UBI, MPH-T1, MPH-I1, MPH-I2, MPH-DSAI, MPH-AI, MPH-I5, MPH-DI, MPH-EI7, MPH-DB, MPH-DU, MPH-PAI, MPH-EI12 are generated by the user port FSM. Internal disabling reasons are detected, e.g. by a resource manager, see figure A.2.

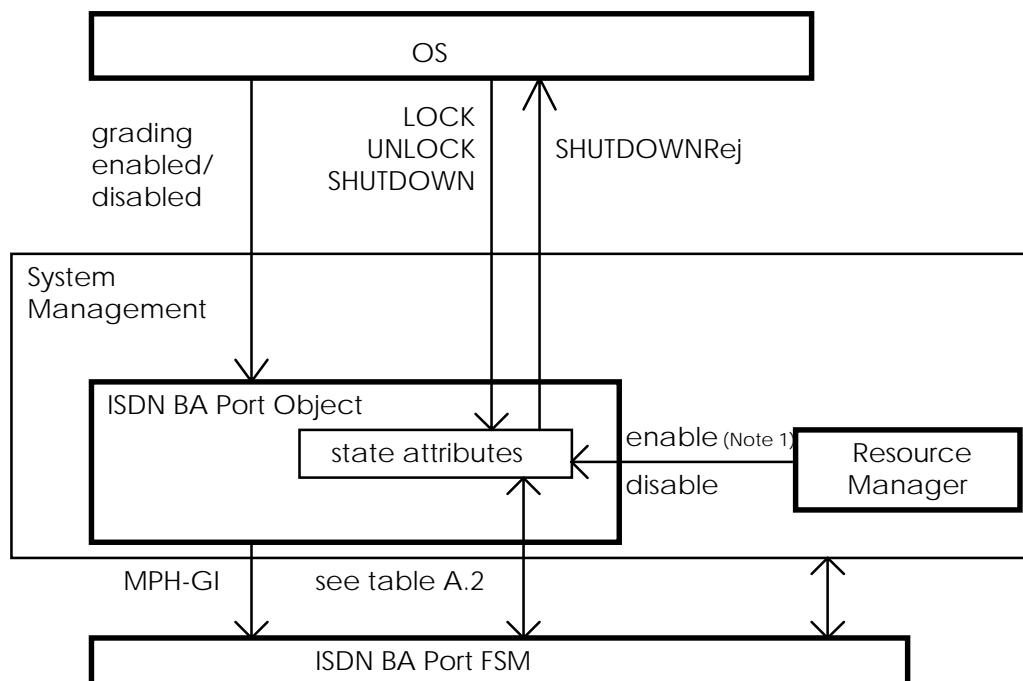

NOTE 1: enable: disappearance of internal disabling reasons;
 disable: occurrence of internal disabling reasons.

NOTE 2: This figure is for information only.

Figure A.2: Management entities controlling the ISDN port FSM

Port maintenance

Loopback tests (states AN4.x) can only be applied while the port is locked by the OS. These tests are not covered by the state mapping table A.2.

A.3 Mapping of V5 ISDN primary rate access user port states on ITU-T Recommendation X.731 states

State transition table A.3 shows the mapping of the V5 ISDN primary rate user port states on ITU-T Recommendation X.731 [17] operational and administrative states.

It covers both the use of the port for on-demand service and (partial or full) permanent line service. In table A.3 two variables are used for determining the transitions in case of permanent line service. PLp is TRUE if the port is used for PL service. PLa is TRUE if the port FSM is in the AN3.0 PL activation state.

In the "locked" state the operational state attribute reflects only AN internal failures, i.e. "enabled" means no AN fault and "disabled" means AN fault regardless of any knowledge about the LE side.

However, in the "unlocked" state the operational state attribute is changed from "enabled" to "disabled" due to AN fault or blocking by the LE. There the information about the presence of a local or remote disabling reason needs to be available. A "local reason" entry is made when an internal disabling reason occurs and is removed when there is no internal reason for being disabled. A "remote reason" entry is made when MPH-BI is received and removed when MPH-UBR arrives. This information can be stored in the blockingStatus attribute of the port object. State 4 is also entered as part of the unblocking and activation procedure if the OS sends UNLOCK to the port object and an acknowledgement from the LE needs to be awaited.

Table A.3: State table for ISDN primary rate access port object state attributes

	state 1 locked disabled	state 2 locked enabled	state 3 shutting down	state 4 unlocked disabled	state 5 unlocked enabled
LOCK	-	-	MPH-BI; 2	MPH-BI, (if TPL1 running: stop TPL1), if no local reason: -; 2 else: -; 1	MPH-BI; 2
UNLOCK	-; 4	MPH-UBR, (if PLp: start TPL1); 4	MPH-UBR; 5	-	-
SHUTDOWN	/	/	-	if PLp: / else: (if TPL1 running: stop TPL1), MPH-BI, (if no local reason: -; 2 else: -; 1)	if PLp: / else: MPH-BR; 3
expiry of TPL1	/	/	/	if PLp: MPH-PAR; else: /	/
MPH-BI	-;	-;	-; 2	if (no local reason AND PLp): MPH-UBR, start TPL1; else: - (note)	if PLa: - else: (if PLp: MPH-UBR, start TPL1); 4 (note)
MPH-UBR	-;	-;	/	if no local reason: MPH-UBR; else: -	/
MPH-UBI	/	/	SHUTDOWNRej	(if TPL1 running: stop TPL1); 5	-
MPH-PAI	/	/	/	if PLp: -; 5 else: /	if PLa: - else: /
disappearance of internal disabling reasons	-; 2	/	/	MPH-UBR, (if PLp: start TPL1);	/
occurrence of internal disabling reasons	/	-; 1	MPH-BI; 1	(if TPL1 running: stop TPL1), MPH-BI;	MPH-BI; 4
<p>Key: <action>[,<action>][,(<action>)];<new state> / = unexpected event - = no action no local reason: blockStatus = none or blockStatus = remote PLp = Permanent Line provisioned. PLa = TRUE if the ISDN port FSM is in PL state AN3.0. The variable is updated by the system management</p> <p>NOTE: MPH-UBR moves the port into local unblock which is necessary to reach AN3.0 in case of permanent lines provisioned. Subsequently MPH-PAR is issued on expiry of timer TPL1.</p>					

Assumptions

- 1) PLa = TRUE means ISDN port FSM is in state AN3.0.
- 2) PLp = TRUE means at least one B-channel is provisioned as permanent line.
- 3) An unlocked enabled port provisioned for permanent line service rejects a SHUTDOWN from the OS. LOCK should be used to take this port out of service.
- 4) If the port object is in state 1 or 2 the ISDN port FSM is in one of AN1.0x, or AN4.x, respectively. If the port object is in state 3 the ISDN port FSM is in AN2.0. If the port object is in state 4 the ISDN port FSM is in one of the AN1.x states. If the port object is in state 5 the ISDN port FSM is in AN2.0, or in AN3.0.

- 5) If a port provisioned for PL services is in the unlocked/enabled state and is blocked by the LE, the AN immediately starts re-activation of layer 1 by issuing MPH-UBR and MPH-PAR, and the port becomes enabled again after the successful activation. A short interruption of the PL service can be expected.
- 6) In case of semi-permanent connections the LE will reject a shutdown request (MPH-BR, FE205) from the AN by sending an unblock request (FE201, MPH-UBI). The OS of the AN shall then be notified to change the administrative state from SHUTTING DOWN back to UNLOCKED.

Disabling reasons

Local: occurrence/presence of internal disabling reasons, e.g. MPH-EIlo, MPH-EIc, etc.;
bit error rate $\geq 10^{-3}$.

Remote: MPH-BI: LE reason for blocking the port due to failure or management decision.

Enabling reasons

Local: disappearance/not existence of internal disabling reasons, e.g. MPH-NOF; bit error rate $< 10^{-3}$.

Remote: MPH-UBR: disappearance of an LE reason for blocking the port.

Sources of messages

LOCK, UNLOCK, SHUTDOWN are generated by the OS. SHUTDOWNRej is sent from the ISDN port object to the OS. MPH-BI, MPH-UBR, MPH-UBI, MPH-PAI are generated by the user port FSM. Internal disabling reasons are detected, e.g. by a resource manager, see figure A.3.

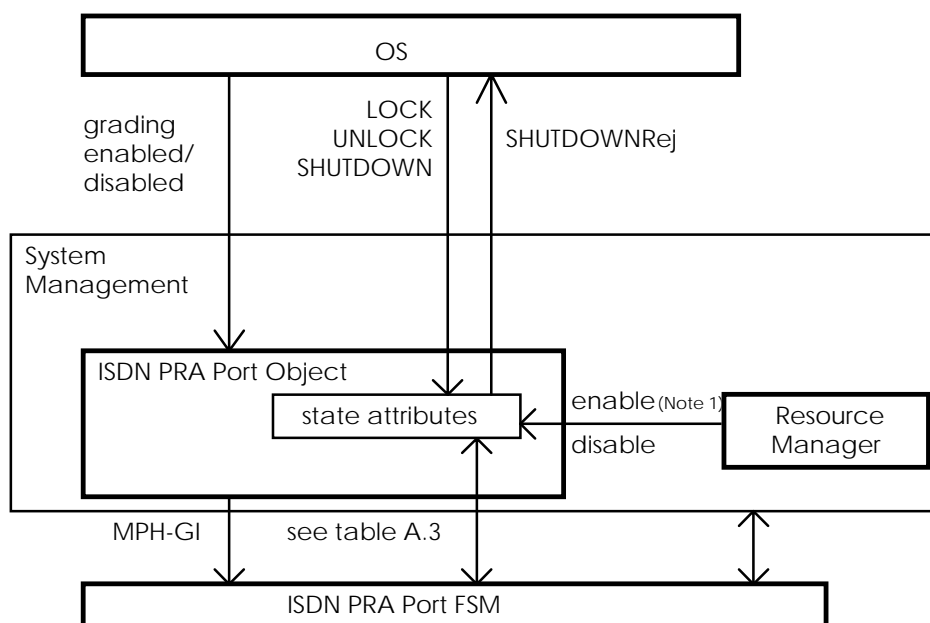

NOTE 1: enable: disappearance of internal disabling reasons;
disable: occurrence of internal disabling reasons.

NOTE 2: This figure is for information only.

Figure A.3: Management entities controlling the ISDN PRA port FSM

Port maintenance

Loopback tests (states AN4.x) can only be applied while the port is locked by the OS. These tests are not covered by the state mapping table A.3.

Annex B (normative): Mapping of link control states on ITU-T Recommendation X.731 states

The mapping of link control states on ITU-T Recommendation X.731 [17] states for the AN is described in EN 300 377-1 [5].

Annex C (normative): TMN management service "V5 related configuration at the AN"

C.1 Task Information Base (TIB) A

C.1.1 Description

The task requirements relate either to the V5 interfaces, or to the user ports, or arise from more general considerations.

C.1.2 Components of service

C.1.2.1 General requirements

These are the general requirements for the configuration management of V5 interfaces and related user ports via the Q3 interface of an AN.

C.1.2.1.1 Association of user ports with V5 interfaces

All relevant bearer channels and non-bearer communication of a user port shall go through one V5 interface. The association of user ports and their relevant bearer channels with V5 interfaces are controlled via the Q3 interface of the AN.

C.1.2.1.2 Information flow across the Q3 interface

All data for provisioning, including modification and cessation, of V5 interfaces and related user ports shall be handled by the Q3 interface of the AN. This includes the relevant data for the user interface (for example line circuit parameters).

The information flow for inventory and auditing functions in the AN shall be via the Q3 interface of the AN using a generic approach.

C.1.2.1.3 Compatibility between AN and LE

The TMN function has the responsibility for ensuring that the configuration of the LE and of the AN are compatible.

C.1.2.1.4 Configuration of bearer channels

Dynamic configuration of bearer channels (B-channels) via BCC for V5.2 is handled by the V5 interface and is not the concern of the Q3 interface of the AN. The configuration of bearer channels on the V5.1 interface is seldom changed and is handled over the Q3 interface of the AN.

C.1.2.2 V5 interface requirements

These are the requirements for the configuration management of V5 interfaces via the Q3 interface of an AN.

C.1.2.2.1 V5 interface and link IDs

The Q3 interface on the AN shall define both the interface ID and the link IDs for each V5 interface. These should be consistent with the fields allocated in the V5 interface specification (EN 300 324-1 [3] and EN 300 347-1 [4], respectively).

C.1.2.2.2 Provisioning variant

The Q3 interface on the AN may optionally define the provisioning variant label for each V5 interface. This should be consistent with the fields allocated in the V5 interface specification.

C.1.2.2.3 Channel configuration

The channel configuration related to the allocation of appropriate channels to p-type data, f-type data, operations and maintenance, BCC, and PSTN and ISDN signalling on the V5 interface shall be performed via the Q3 interface of the AN as part of provisioning.

C.1.2.2.4 Association of interfaces with exchanges

The Q3 interface of the AN is responsible for bringing up and taking down V5 interfaces as part of associating them with LEs.

C.1.2.2.5 Standby operation

The Q3 interface of the AN should be able to support stand-by of a V5 interface.

The support of 2 Mbit/s standby for V5.1 does not create any additional requirements for the information model.

For V5.2, there are additional requirements due to the protection protocol, and these may impact the configuration model.

C.1.2.2.6 Persistency checking

The parameters for the persistence checking procedure for error detection should be set through the Q3 interface of the AN.

C.1.2.2.7 Global PSTN parameters

The Q3 interface of the AN shall support the provisioning of global parameters such as timers, cadencing etc., which are related to PSTN services supported by the V5 interface and associated user ports.

C.1.2.3 User port requirements

These are the requirements for the configuration management of user ports via the Q3 interface of an AN.

C.1.2.3.1 Operational threshold

The Q3 interface of the AN is responsible for defining the threshold at which a user port is no longer operational for any service. If this does not involve a change during the lifetime of the equipment then it should not be supported by the Q3 interface.

C.1.2.3.2 Port blocking

The Q3 interface of the AN can request that a port be blocked for non-urgent configuration or reconfiguration. If the port is routed through a V5 interface to a LE then this request can only be granted by the LE via the V5 interface. This is intended to avoid interference with calls in progress, or calls being set up or cleared down.

The Q3 interface on the AN can request that a port be blocked for urgent configuration or reconfiguration. If the port is routed through a V5 interface to a LE the other side of the interface shall be informed of this blocking via the V5 interface.

C.1.2.3.3 User port addresses

Addressing information which identify user ports is assigned to the ports during provisioning via the Q3 interface of the AN.

C.1.2.3.4 Split ISDN ports

The Q3 interface of the AN can be used to configure an ISDN user port so that channels on that port can be split between the LE and leased lines which bypass the LE.

The TMN function has the responsibility of ensuring that the LE is informed about the availability of the B-channels on the user ports for services under the control of the LE.

C.1.2.3.5 User requirements

The Q3 interface has the responsibility of provisioning user port related to the V5 interface according to the requirements of the user.

C.1.2.3.6 ISDN with access digital sections

The Q3 interface shall be capable of supporting the communication associated with functional elements as specified in ETS 300 297 [2] (based on ITU-T Recommendation G.960 [20]) that are not communicated over the V5 interface.

C.1.2.3.7 Port specific PSTN parameters

The Q3 interface of the AN shall support the provisioning of port specific parameters such as timers, cadencing etc., which are related to PSTN services supported by the V5 interface and associated user ports.

C.2 Management function list

The management functions relate mostly to the TMN management service for customer access. The functions are associated with the user ports, the V5 interface, or the cross-connection between the two.

There are create and read functions in each of the three groups. There are insert and delete functions for the user ports and for V5 interfaces, and these are matched by the establish and de-establish functions for cross-connection.

C.2.1 User port functions

The user port functions are "insert", "delete", "modify" and "read".

C.2.1.1 Insert a user port

The Insert User Port function performs the following actions:

- assign port address;
- assign port type;
- assign port specific parameters.

C.2.1.2 Delete a user port

The Delete User Port function deletes the user port, including the items listed for the Insert User Port function defined in subclause C.2.1.1.

C.2.1.3 Modify a user port

It may not be appropriate to modify certain items relating to user ports unless the port is blocked. The Modify User Port function can be used to block and unblock ports and to modify the items, other than port address, listed for the Insert User Port function defined in subclause C.2.1.1.

C.2.1.4 Read a user port

The Read User Port function reads any of the items listed for the Insert User Port function defined in subclause C.2.1.1.

C.2.2 V5 interface functions

The V5 interface functions are "insert", "delete", "modify" and "read".

C.2.2.1 Insert a V5 interface

The Insert V5 interface function performs the following actions:

- assign interface ID;
- assign provisioning variant;
- assign grading thresholds;
- assign number of 2 Mbit/s links;
- define persistency checking;
- reserve time slots for communication channels;
- allocate communication channels.

C.2.2.2 Delete a V5 interface

The Delete V5 interface function deletes the V5 interface, including the items listed for the Insert V5 interface function defined in subclause C.2.2.1.

C.2.2.3 Modify a V5 interface

The Modify V5 interface function modifies one of the items, other than interface ID, listed for the Insert V5 interface function defined in subclause C.2.2.1. This function can be used to activate a change in provisioning on either side of a V5 interface.

C.2.2.4 Read a V5 interface

The Read V5 interface function reads any of the items listed for the Insert V5 interface function defined in subclause C.2.2.1. This function can be used to read interface ID and provisioning variant information from the other side of the V5 interface.

C.2.3 Cross-connection functions

The cross-connection functions are "establish", "de-establish", "modify" and "read".

C.2.3.1 Establish a connection

The Establish Connection function performs the following actions:

- assign access port to V5 interface, including V5 port address;
- assign port bearer channel to V5 bearer channel;
- assign PSTN signalling to V5 communication channel;
- assign ISDN Ds-type data to V5 communication channel;

- assign ISDN p-type data to V5 communication channel;
- assign ISDN f-type data to V5 communication channel.

C.2.3.2 De-establish a connection

The De-establish Connection function removes a connection which has been established by the Establish Connection function defined in subclause C.2.3.1.

C.2.3.3 Modify a connection

The Modify Connection function modifies one of the items listed for the Establish Connection function defined in subclause C.2.3.1.

C.2.3.4 Read a connection

The Read Connection function reads any of the items listed for the Establish Connection function defined in subclause C.2.3.1.

Annex D (informative): Functional architecture

Figures D.1 to D.4 represent the functional architecture for PSTN and ISDN, respectively.

TTPs and CTPs are used as a basis for defining object classes for modelling. The V5 ports and the user ports are identified as TTPs, with the user ports at a higher level than the V5 ports, i.e. the V5 layer either directly or indirectly serves the user ports. The user port layer is related to the V5 layer by cross connections.

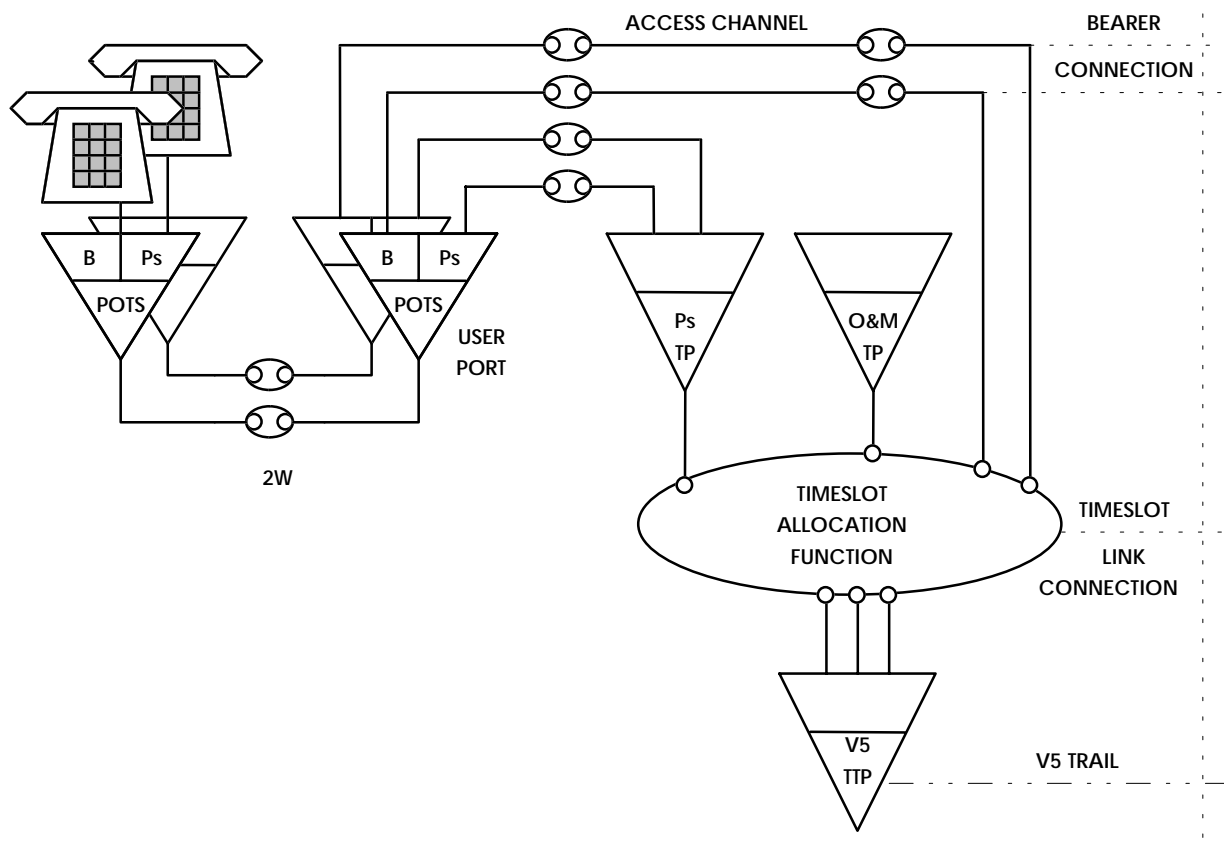

Figure D.1: Access network side V5 functional architecture for PSTN

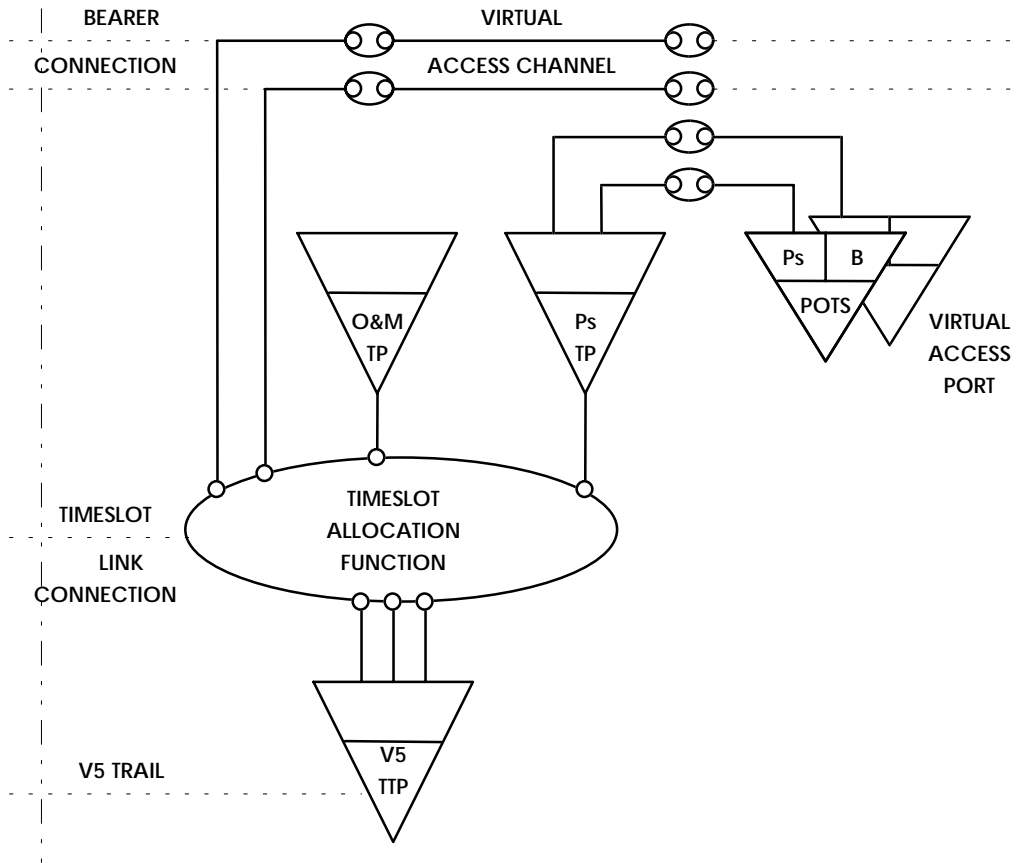

Figure D.2: Local exchange side V5 functional architecture for PSTN

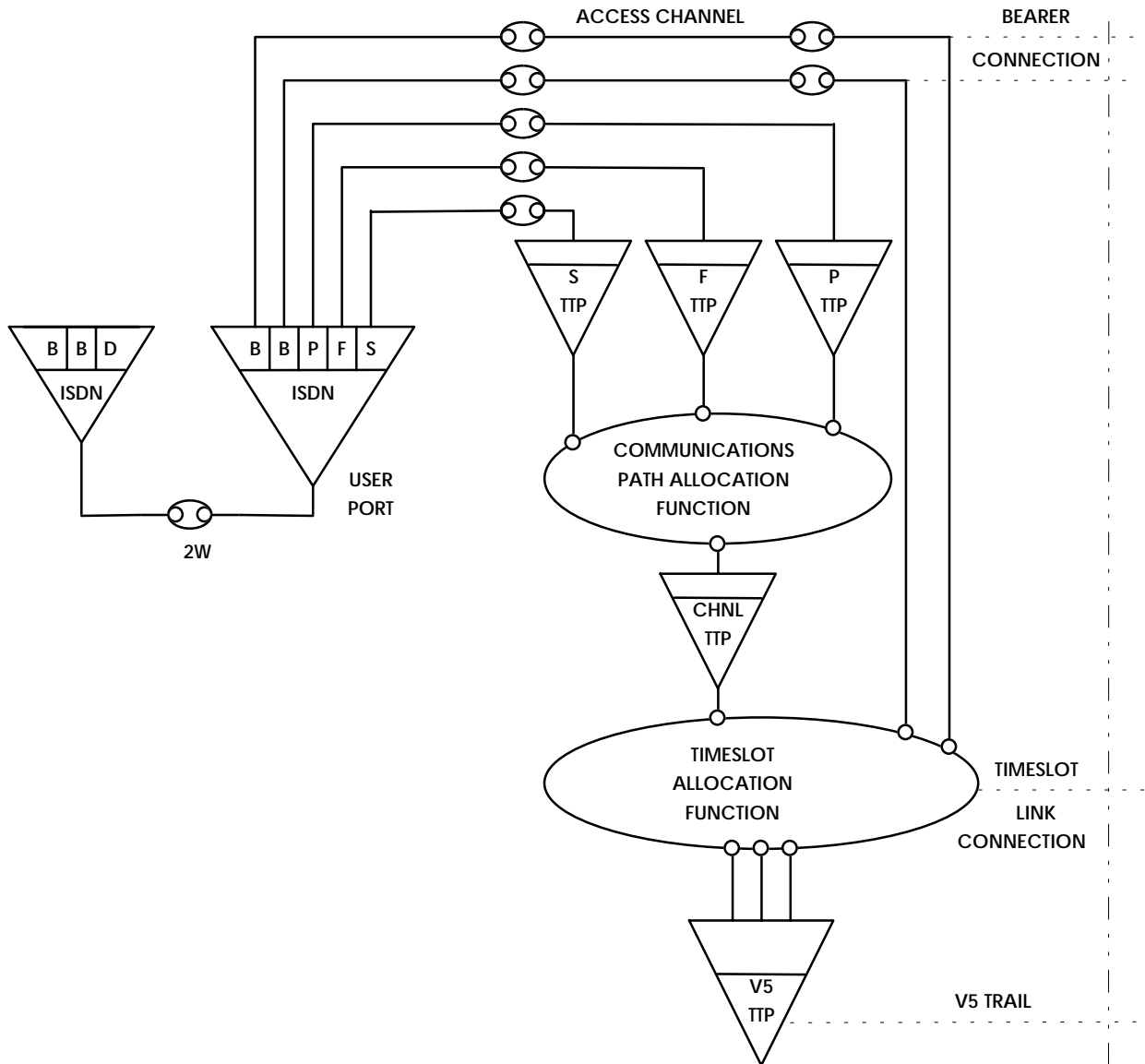

Figure D.3: Access network side V5 functional architecture for ISDN

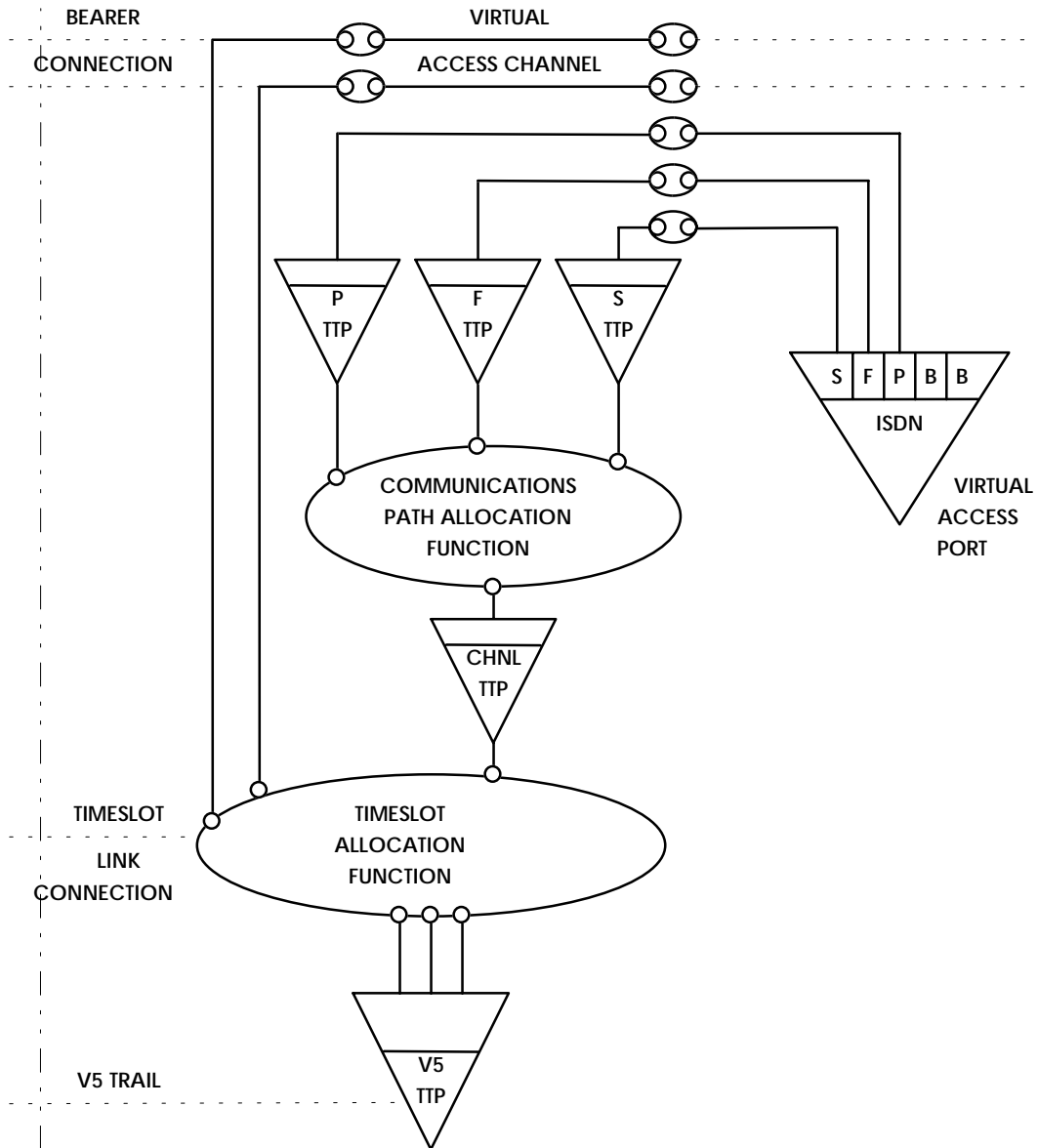

Figure D.4: Local exchange side V5 functional architecture for ISDN

Annex E (informative): Link control message flows

The link control message flows for the AN are described in EN 300 377-1 [5].

Annex F (informative): User port control message flows

This annex describes typical flows of control messages for PSTN user ports, ISDN basic access user ports and ISDN primary rate user ports on ITU-T Recommendation X.731 [17] states, including the case of permanent line capability.

F.1 Message flows for the mapping of PSTN user port states on ITU-T Recommendation X.731 states

A state and a message written in the same line means that this state is entered and the message is sent as part of the transition into this state. There are transitions where two messages are sent. Since the resource manager is not shown in a separate column "port-ok" and "port-not-ok" messages appear in brackets in the MPH message column. Notifications to the OS due to state transitions are not shown.

F.1.1 Blocking initiated by AN

Table F.1: Blocking initiated by AN

OS command	ITU-T Recommendation on X.731 state	MPH message	Port state	V5 message	Port state	MPH message	ITU-T Recommendation on X.731 state	OS command
	5		2.0		2.0		enabled	
LOCK→								
	2	MPH-BI→						
			1.0	FE204→				
					1.0	MPH-BI→		
							disabled	

F.1.2 Blocking request initiated by AN

Table F.2: Blocking request initiated by AN

OS command	ITU-T Recommendation on X.731 state	MPH message	Port state	V5 message	Port state	MPH message	ITU-T Recommendation on X.731 state	OS command
	5		2.0		2.0		enabled	
SHUTDOWN→								
	3	MPH-BR→						
			2.0	FE205→				
					2.0	MPH-BR→		
							enabled	
						←MPH-BI	(access free) disabled	
				←FE203	1.0			
		←MPH-BI	1.0					
	2							

F.1.3 Blocking initiated by LE

Table F.3: Blocking initiated by LE

OS command	ITU-T Recommendation on X.731 state	MPH message	Port state	V5 message	Port state	MPH message	ITU-T Recommendation on X.731 state	OS command
	5		2.0		2.0		enabled	
								←LOCK
						←MPH-BI	disabled	
				←FE203	1.0			
		←MPH-BI	1.0					
	4							

F.1.4 Co-ordinated unblocking initiated by the LE

Table F.4: AN administrative state is UNLOCKED (i.e. AN agrees to unblocking request from LE)

OS command	ITU-T Recommendation on X.731 state	MPH message	Port state	V5 message	Port state	MPH message	ITU-T Recommendation on X.731 state	OS command
	4		1.0		1.0		disabled	
								←UNLOCK
						←MPH-UBR	disabled	
				←FE201	1.1			
			1.2					
		←MPH-UBR						
	4	MPH-UBR→						
		←MPH-UBI	2.0	FE202→				
	5				2.0	MPH-UBI→		
							enabled	

Table F.5: AN administrative state is LOCKED in the meantime (i.e. AN rejects the unblocking request from LE)

OS command	ITU-T Recommendation on X.731 state	MPH message	Port state	V5 message	Port state	MPH message	ITU-T Recommendation on X.731 state	OS command
	1		1.0		1.0		disabled	
								←UNLOCK
						←MPH-UBR	disabled	
				←FE201	1.1			
		←MPH-UBR	1.2					
	1							

F.1.5 Co-ordinated unblocking initiated by the AN

Table F.6: Administrative state = LOCKED, Operational state = ENABLED

OS command	ITU-T Recommendation on X.731 state	MPH message	Port state	V5 message	Port state	MPH message	ITU-T Recommendation on X.731 state	OS command
	2		1.0		1.0		disabled	
UNLOCK→								
	4	MPH-UBR→						
			1.1	FE202→				
					1.2	MPH-UBR→		
						←MPH-UBR	disabled	
				←FE201	2.0	MPH-UBI→		
		←MPH-UBI	2.0				enabled	
	5							

Table F.7: Administrative state = UNLOCKED, Operational state = DISABLED

OS command	ITU-T Recommendation on X.731 state	MPH message	Port state	V5 message	Port state	MPH message	ITU-T Recommendation on X.731 state	OS command
	4		1.0		1.0		disabled	
		(←port-ok)						
	4	MPH-UBR→						
			1.1	FE202→				
					1.2	MPH-UBR→		
						←MPH-UBR	disabled	
				←FE201	2.0	MPH-UBI→		
		←MPH-UBI	2.0				enabled	
	5							

Table F.8: Administrative state = LOCKED, Operational state = ENABLED, LE local unblocked (LE1.1)

OS command	ITU-T Recommendation on X.731 state	MPH message	Port state	V5 message	Port state	MPH message	ITU-T Recommendation on X.731 state	OS command
	2		1.2		1.1		disabled	
UNLOCK→								
	4	MPH-UBR→						
		←MPH-UBI	2.0	FE202→				
	5				2.0	MPH-UBI→		
							enabled	

F.2 Message flows for the mapping of ISDN basic access user port states on ITU-T Recommendation X.731 states

The following message flows show the behaviour of the `isdnBAUserPort` object class in the case that at least one bearer channel is provisioned for permanent line capability. For a port not being provisioned for permanent line service, the message flows shown in EN 300 377-1 [5] are valid. A state and a message written in the same line imply that this state is entered and the message is sent as part of the transition into this state. There are transitions where more than one message is sent. Notifications to the OS due to state transitions are not shown.

F.2.1 Blocking initiated by AN

Table F.9: Port operational deactivated (AN2.0)

OS command	ITU-T Recommendation on X.731 state	MPH message	V1 FE DS↔ET	Port state	V5 FE	Port state	MPH message	ITU-T Recommendation on X.731 state	OS command
	5			2.0		2.0		enabled	
LOCK→									
	2	MPH-BI→		1.0	FE204→				
						1.0	MPH-BI→		
								disabled	

Table F.10: Port operational activation initiated (AN2.1)

OS command	ITU-T Recommendation on X.731 state	MPH message	V1 FE DS↔ET	Port state	V5 FE	Port state	MPH/PH message	ITU-T Recommendation on X.731 state	OS command
	5			2.1		2.1		enabled	
LOCK→									
	2	MPH-BI→							
			←FE5	1.0	FE204→				
						1.0	MPH-BI→ MPH-DI→ PH-DI→		
								disabled	
			FE6→						
		←MPH-DI		1.0					
	2								

Table F.11: Port operational and activated (AN2.2)

OS command	ITU-T Recommendation on X.731 state	MPH message	V1 FE DS↔ET	Port state	V5 FE	Port state	MPH/PH message	ITU-T Recommendation on X.731 state	OS command
	5			2.2		2.2		enabled	
LOCK→									
	2	MPH-BI→							
			←FE5	1.0	FE204→				
						1.0	MPH-BI→ MPH-DI→ PH-DI→		
								disabled	
			FE6→						
		←MPH-DI		1.0					
	2								

F.2.2 Blocking initiated by the LE

Table F.12: Port operational deactivated (AN2.0)

OS command	ITU-T Recommendation on X.731 state	MPH message	V1 FE DS↔ET	Port state	V5 FE	Port state	MPH/PH message	ITU-T Recommendation on X.731 state	OS command
	5			2.0		2.0		enabled	
							←MPH-BI	disabled	
					←FE203	1.0			
		←MPH-BI		1.0					
	4	MPH-AR→							
			←FE1	3.1					
			FE2→						
				3.1					
			FE3→						
		←MPH-DSAI		3.1					
	4		FE4→						
		←MPH-PAI		3.2					
	5								

Table F.13: Port operational activation initiated (AN2.1)

OS command	ITU-T Recommendation on X.731 state	MPH message	V1 FE DS↔ET	Port state	V5 FE	Port state	MPH/PH message	ITU-T Recommendation on X.731 state	OS command
	5			2.1		2.1		enabled	
							←MPH-BI	disabled	
					←FE203	1.0			
		←MPH-BI	←FE5	1.0					
	4	MPH-AR→							
			←FE1	3.1					
			FE2→						
				3.1					
			FE3→						
		←MPH-DSAI		3.1					
	4		FE4→						
		←MPH-PAI		3.2					
	5								

Table F.14: Port operational and activated (AN2.2)

OS command	ITU-T Recommendation on X.731 state	MPH message	V1 FE DS↔ET	Port state	V5 FE	Port state	MPH/PH message	ITU-T Recommendation on X.731 state	OS command
	5			2.2		2.2		enabled	
							←MPH-BI	disabled	
					←FE203	1.0			
		←MPH-BI	←FE5	1.0					
	4	MPH-AR→							
			←FE1	3.1					
			FE2→						
				3.1					
			FE3→						
		←MPH-DSAI		3.1					
	4		FE4→						
		←MPH-PAI		3.2					
	5								

F.2.3 Co-ordinated unblocking initiated by the LE

Table F.15: AN administrative state is UNLOCKED (i.e. AN agrees to unblocking request from LE)

OS command	ITU-T Recommendation on X.731 state	MPH message	V1 FE DS↔ET	Port state	V5 FE	Port state	MPH/PH message	ITU-T Recommendation on X.731 state	OS command
	4			1.0		1.0		disabled	
							←MPH-UBR	enabled req	
					←FE201	1.1			
		←MPH-UBR		1.2					
	4	MPH-UBR→							
		←MPH-UBI		2.0	FE202→				
	5					2.0	MPH-UBI→		
							←MPH-AR	enabled	
					←FE101	2.1			
	5	←MPH-I1	←FE1	2.1					
			FE2→						
				2.1					
			FE3→						
		←MPH-DSAI		2.1	FE103→				
	5					2.1	MPH-DSAI→		
			FE4→					enabled	
		←MPH-AI		2.2	FE104→				
	5					2.2	MPH-AI→ PH-AI→		
								enabled	

**Table F.16: AN administrative state is LOCKED in the meantime
(i.e. AN rejects the unblocking request from LE)**

OS command	ITU-T Recommendation on X.731 state	MPH message	V1 FE DS↔ET	Port state	V5 FE	Port state	MPH/PH message	ITU-T Recommendation on X.731 state	OS command
	1			1.0		1.0		disabled	
							←MPH-UBR	enabled req	
					←FE201	1.1			
		←MPH-UBR		1.2					
	1								

F.2.4 Co-ordinated unblocking initiated by the AN

Table F.17: Administrative state = LOCKED, Operational state = ENABLED

OS command	ITU-T Recommendation on X.731 state	MPH message	V1 FE DS↔ET	Port state	V5 FE	Port state	MPH/PH message	ITU-T Recommendation X.731 state
	2			1.0		1.0		disabled
UNLOCK→								
	(start TPL1) 4	MPH-UBR→						
				1.1	FE202→			
						1.2	MPH-UBR→	
							←MPH-UBR	disabled
					←FE201	2.0	MPH-UBI→	
		←MPH-UBI		2.0				enabled
	(stop TPL1) 5							
							←MPH-AR	
					←FE101	2.1		
	5	←MPH-I1	←FE1	2.1				
					FE2→			
				2.1				
					FE3→			
		←MPH-DSAI		2.1	FE103→			
	5					2.1	MPH-DSAI→	
					FE4→			enabled
		←MPH-AI		2.2	FE104→			
	5					2.2	MPH-AI→ PH-AI→	
								enabled

Table F.18: Administrative state = UNLOCKED, Operational state = DISABLED

OS command	ITU-T Recommendation on X.731 state	MPH message	V1 FE DS↔ET	Port state	V5 FE	Port state	MPH/PH message	ITU-T Recommendation on X.731 state	OS command
	4			1.0		1.0		disabled	
	(internal error) 4	MPH-BI→							
				1.0	FE204→				
						1.0			
	(no internal error, start TPL1) 4	MPH-UBR→							
				1.1	FE202→				
						1.2	MPH-UBR→		
							←MPH-UBR	disabled	
					←FE201	2.0	MPH-UBI→		
		←MPH-UBI		2.0				enabled	
	(stop TPL1) 5								
							←MPH-AR		
					←FE101	2.1			
		←MPH-I1	←FE1	2.1					
	5								
			FE2→						
				2.1					
			FE3→						
		←MPH-DSAI		2.1	FE103→				
	5					2.1	MPH-DSAI→		
			FE4→					enabled	
		←MPH-AI		2.2	FE104→				
	5					2.2	MPH-AI→ PH-AI→		
								enabled	

Table F.19: Administrative state = LOCKED, Operational state = ENABLED, LE local unblocked (LE1.1)

OS command	ITU-T Recommendation X.731 state	MPH message	V1 FE DS↔ET	Port state	V5 FE	Port state	MPH/PH message	ITU-T Recommendation X.731 state	OS command
	2			1.2		1.1		disabled	
UNLOCK→									
	(start TPL1) 4	MPH-UBR→							
		←MPH-UBI		2.0	FE202→				
	(stop TPL1) 5					2.0	MPH-UBI→		
								enabled	
							←MPH-AR		
					←FE101	2.1			
		←MPH-I1	←FE1	2.1					
	5								
			FE2→						
				2.1					
			FE3→						
		←MPH-DSAI		2.1	FE103→				
	5					2.1	MPH-DSAI →		
			FE4→					enabled	
		←MPH-AI		2.2	FE104→				
	5					2.2	MPH-AI→ PH-AI→		
								enabled	

F.3 Message flows for the mapping of ISDN primary rate access user port states on ITU-T Recommendation X.731 states

The following message flows show the behaviour of the `isdnPRAUserPort` object class in the case that at least one bearer channel is provisioned for permanent line capability. For a port not provisioned for permanent line service the messages flows shown in EN 300 377-1 [5] are valid. A state and a message written in the same line imply that this state is entered and the message is sent as part of the transition into this state. There are transitions where more than one message is sent. Notifications to the OS due to state transitions are not shown.

F.3.1 Blocking initiated by AN

Table F.20: Access operational (AN2.0)

OS command	ITU-T Recommendation on X.731 state	MPH message	V1 FE DS↔ET	Port state	V5 FE	Port state	MPH message	ITU-T Recommendation on X.731 state	OS command
	5			2.0		2.0		enabled	
LOCK→									
	2	MPH-BI→							
			←RAI	1.02	FE204→				
						1.0	MPH-BI→ PH-DI→ MPH-DI→		
								disabled	

F.3.2 Blocking initiated by the LE

Table F.21: Access operational (AN2.0)

OS command	ITU-T Recommendation on X.731 state	MPH message	V1 FE DS↔ET	Port state	V5 FE	Port state	MPH/PH message	ITU-T Recommendation on X.731 state	OS command
	5			2.0		2.0		enabled	
							←MPH-BI	disabled	
					←FE203	1.0			
		←MPH-BI	←RAI	1.02					
	(start TPL1) 4	MPH-UBR→							
				1.1	FE202→				
						1.2	MPH-UBR→		
								disabled	
	(expiry of TPL1) 4	MPH-PAR→							
		←MPH-PAI	←NOF	AN3.0					
	5								

F.3.3 Co-ordinated unblocking initiated by the LE

Table F.22: AN administrative state is UNLOCKED (i.e. AN agrees to unblocking request from LE)

OS command	ITU-T Recommendation on X.731 state	MPH message	V1 FE DS↔ET	Port state	V5 FE	Port state	MPH/PH message	ITU-T Recommendation on X.731 state	OS command
	4			1.02		1.0		disabled	
							←MPH-UBR	(enabled req)	
					←FE201	1.1			
		←MPH-UBR		1.22					
	4	MPH-UBR→							
		←MPH-UBI	←NOF	2.0	FE202→				
	5					2.0	MPH-AI→ PH-AI→		
								enabled	

Table F.23: AN administrative state is LOCKED in the meantime (i.e. AN rejects the unblocking request from LE)

OS command	ITU-T Recommendation on X.731 state	MPH message	V1 FE DS↔ET	Port state	V5 FE	Port state	MPH/PH message	ITU-T Recommendation on X.731 state	OS command
	1			1.01		1.0		disabled	
							←MPH-UBR	(enabled req)	
					←FE201	1.1			
		←MPH-UBR		1.21					
	1								

F.3.4 Co-ordinated unblocking initiated by the AN

Table F.24: Administrative state = LOCKED, Operational state = ENABLED

OS command	ITU-T Recommendation on X.731 state	MPH message	V1 FE DS↔ET	Port state	V5 FE	Port state	MPH/PH message	ITU-T Recommendation on X.731 state	OS command
	2			1.02		1.0		disabled	
UNLOCK→									
	(start TPL1) 4	MPH-UBR→							
				1.1	FE202→				
						1.2	MPH-UBR→		
							←MPH-UBR	disabled	
					←FE201	2.0	MPH-AI→ PH-AI→		
		←MPH-UBI	←NOF	2.0				enabled	
	(stop TPL1) 5								

Table F.25: Administrative state = UNLOCKED, Operational state = DISABLED

OS command	ITU-T Recommendation on X.731 state	MPH message	V! FE DS↔ET	Port state	V5 FE	Port state	MPH/PH message	ITU-T Recommendation on X.731 state	OS command
	4			1.02		1.0		disabled	
	(internal error) 4	MPH-BI→							
				1.02	FE204→				
						1.0			
	(no internal error, start TPL1) 4	MPH-UBR→							
				1.1	FE202→				
						1.2	MPH-UBR→		
							←MPH-UBR	disabled	
					←FE201	2.0	MPH-AI→ PH-AI→		
		←MPH-UBI	←NOF	2.0				enabled	
	(stop TPL1) 5								

Table F.26: Administrative state = LOCKED, Operational state = ENABLED, LE local unblocked (LE1.1)

OS command	ITU-T Recommendation on X.731 state	MPH message	V1 FE DS↔ET	Port state	V5 FE	Port state	MPH/PH message	ITU-T Recommendation on X.731 state	OS command
	2			1.22		1.1		disabled	
UNLOCK→									
	(start TPL1) 4	MPH-UBR→							
		←MPH-UBI	←NOF	2.0	FE202→				
	(stop TPL1) 5					2.0	MPH-AI→ PH-AI→		
								enabled	

Annex G (normative): Location of the Q3 interface

The Q3 interface is the TMN interface between an OS and Q-adapters, mediation devices or network elements (see figure G.1). The use of the present document at these points is mandatory. The specification of Qx interfaces and proprietary interfaces is outside the scope of the present document.

The Q3 interface places no constraint on the integration of the V5 configuration model for the AN with other object models relating to other aspects of the AN and the operation of these models over the same Q3 interface specified here.

There are also no constraints implied concerning the structure of the AN which supports the V5 interface. For example, at one extreme the AN might involve a simple direct connection between customers and exchanges, and at the other extreme it might involve a very large, highly complex transmission and switching network between them.

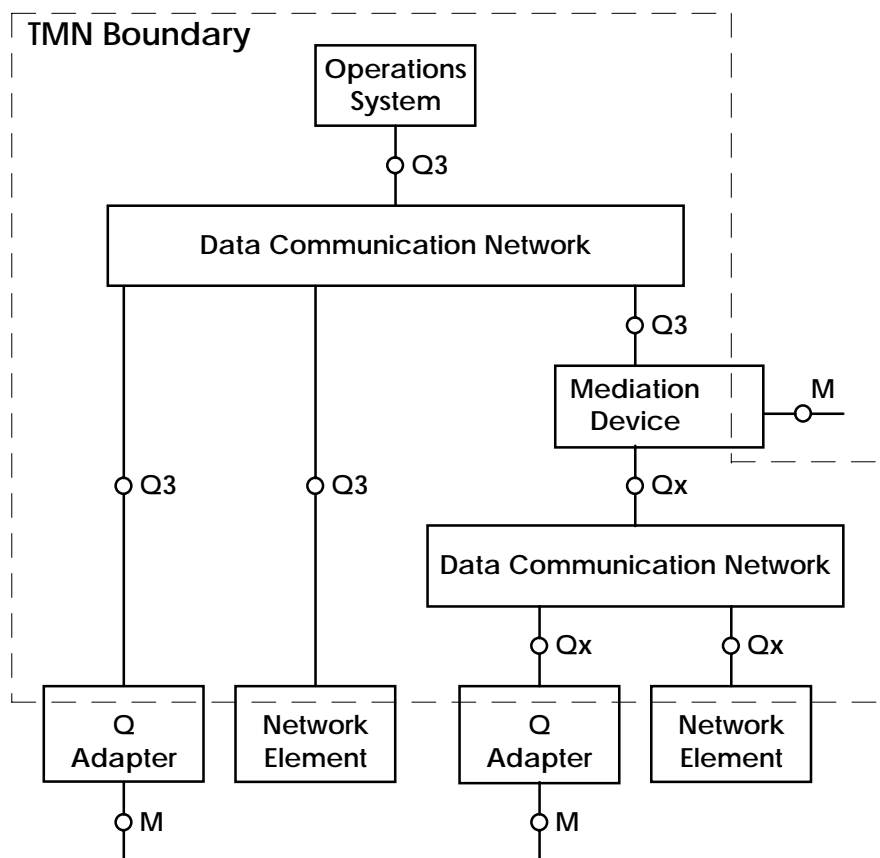

NOTE 1: Qx and M (proprietary) interfaces are outside the scope of the present document.

NOTE 2: A mediation device can only have a M interface if it contains Q-adapter functionality.

Figure G.1: Location of the Q3 interface

Annex H (normative): Summary of V5 requirement details

This annex summarizes the V5 related items which need to be provisioned over the Q3 interface.

1) Identification of V5 interfaces

The interface ID field is three octets.

The link ID field is one octet.

2) Allocation of bearer channels to user ports

3) Service allocation to bearer channels

4) The allocation of addresses to ISDN and PSTN ports

The PSTN address field is 15 bits.

The ISDN address field is 13 bits with certain addresses reserved for non-ISDN use.

5) The identification of new provisioning variants

The provisioning variant field is one octet.

6) Communication path allocation

The V5.1 interface can have up to 3 communication time slots. Time slot 16 is always used. There are constraints on the other two time slots.

7) Activation of ISDN BA for PL service

8) Activation of error performance monitoring for access digital sections

There are 2 grading levels.

9) PSTN line gain

Annex J (normative): Defaults and predefined items

A number of items are predefined, i.e. they need to be specified when equipment is procured, but they cannot be changed via the Q3 interface, and may not be visible over the Q3 interface. Items may also have default values which do not need to be specified via the Q3 interface. Predefined items and their defaults are specified here.

- 1) Specific PSTN parameters
- 2) Autonomous-signalling-sequence
- 3) The sequence-response information element
- 4) The cadenced-ringing information element
- 5) The recognition time of PSTN signals
- 6) Signal information elements
- 7) PSTN protocol state AN1
- 8) Grading thresholds

The thresholds for the generation of grading messages related to error performance, including the nature of these thresholds, the algorithm used and any hysteresis included are predefined.

- 9) Persistency check for V5 layer 1
- 10) CRC thresholds for V5 layer 1
- 11) PSTN line current
- 12) Provisioning variant

If the provisioning variant is not supported on the Q3 interface, for instance because of the existence of an integrated OS or of a TMN X interface, then a default value of all zeroes shall be automatically used on the V5 interface. All V5 interfaces shall use this default value unless actively changed via the Q3 interface.

- 13) Initial configuration

If the Q3 information is transported over a V5 interface then an initial configuration needs to be specified to support this. It is possible to use 64 kbit/s bearer channels and p- and f-type data channels on virtual user ports (see EN 300 324-1 [3]) of a V5 interface to transport the Q3 information.

Predefinition of the virtual user port on the AN side at least is required.

Bibliography

The following material, though not specifically referenced in the body of the present document (or not publicly available), gives supporting information.

- ETR 008 (1990): "Network Aspects (NA); The method for the characterization of the machine-machine interfaces utilized by a Telecommunications Management Network (TMN)".
- ETR 037 (1992): "Network Aspects (NA); Telecommunications Management Network (TMN); Objectives, principles, concepts and reference configurations".
- ETR 046 (1992): "Network Aspects (NA); Telecommunications Management Networks modelling guidelines".
- ETR 047 (1992): "Network Aspects (NA); Telecommunications Management Network (TMN); Management services".
- ETR 048 (1992): "Network Aspects (NA); Telecommunications Management Network (TMN); Management services prose descriptions".
- ETR 078 (1993): "Maintenance: Telecommunications Management Network; TMN interface specification methodology [CCITT Recommendation M.3020 (1992)]".
- ETS 300 150 (1992): "Transmission and Multiplexing (TM); Protocol suites for Q interfaces for management of transmission systems".
- EN 300 292 (1998): "Telecommunications Management Network (TMN); Functional specification of call routing information management on the Operations System/Network Element (OS/NE) interface".
- I-ETS 300 293 (1996): "Telecommunications Management Network (TMN); Generic managed objects".
- EN 300 304 (1998): "Synchronous Digital Hierarchy (SDH) information model for the Network Element (NE) view".
- ITU-T Recommendation G.774 (1992): "Synchronous Digital Hierarchy (SDH) management information model for the network element view".
- ITU-T Recommendation G.831 (1996): "Management capabilities of transport networks based on the Synchronous Digital Hierarchy (SDH)".
- ITU-T Recommendation X.710 (1997): "Information technology - Open Systems Interconnection - Common Management Information service".
- ITU-T Recommendation X.720 | ISO/IEC 10165-1 (1992): "Information technology - Open Systems Interconnection - Structure of management information: Management information model".
- ITU-T Recommendation X.722 | ISO/IEC 10165-4 (1992): "Information technology - Open Systems Interconnection - Structure of management information: Guidelines for the definition of managed objects".
- ITU-T Recommendation X.730 | ISO/IEC 10164-1 (1992): "Information technology - Open Systems Interconnection - Systems Management: Object management function".
- EN 300 291-1: "Telecommunications Management Network (TMN); Functional specification of Customer Administration (CA) on the Operations System/Network Element (OS/NE) interface; Part 1: Single line configurations".
- ITU-T Recommendation X.711 (1991): "Information technology - Open Systems Interconnection - Common management information protocol specification".

- ITU-T Recommendation X.732 | ISO/IEC 10164-3 (1992): "Information technology - Open Systems Interconnection - Systems Management: Attributes for representing relationships".

History

Document history		
Edition 1	December 1994	Publication as ETS 300 376-1
V1.2.1	April 1999	One-step Approval Procedure OAP 9935: 1999-04-30 to 1999-08-27
V1.2.1	October 1999	Publication