

Draft **EN 300 356-20** V3.1.5 (1997-12)

---

*European Standard (Telecommunications series)*

**Integrated Services Digital Network (ISDN);  
Signalling System No.7;  
ISDN User Part (ISUP) version 3 for the international interface;  
Part 20: Completion of Calls on No Reply (CCNR)  
supplementary service**

---



*European Telecommunications Standards Institute*

---

---

Reference

DEN/SPS-01036 (3at01ifc.PDF)

---

Keywords

ISDN, ISUP, SS7, supplementary service, CCNR

***ETSI Secretariat***

---

Postal address

F-06921 Sophia Antipolis Cedex - FRANCE

---

Office address

650 Route des Lucioles - Sophia Antipolis  
Valbonne - FRANCE  
Tel.: +33 4 92 94 42 00 Fax: +33 4 93 65 47 16  
Siret N° 348 623 562 00017 - NAF 742 C  
Association à but non lucratif enregistrée à la  
Sous-Préfecture de Grasse (06) N° 7803/88

---

X.400

c= fr; a=atlas; p=etsi; s=secretariat

---

Internet

secretariat@etsi.fr  
<http://www.etsi.fr>

---

***Copyright Notification***

No part may be reproduced except as authorized by written permission.  
The copyright and the foregoing restriction extend to reproduction in all media.

# Contents

Intellectual Property Rights.....	6
Foreword .....	6
1 Scope.....	8
2 Normative references .....	8
3 Definitions and abbreviations .....	9
3.1 Definitions .....	9
3.2 Abbreviations.....	10
4 Description.....	11
5 Operational requirements.....	11
5.1 Provision/withdrawal .....	11
5.2 Requirements on the originating network .....	11
5.3 Requirements on the terminating network.....	12
5.4 Requirements on the transit network.....	12
6 Coding requirements .....	12
6.1 Introduction.....	12
6.2 Coding requirements.....	12
6.2.1 ISUP protocol .....	12
6.2.1.1 Signalling aspects impacting the routing .....	12
6.2.1.2 CCNR Possible indicator in ACM/CPG .....	12
6.2.1.3 CCNR Call indicator .....	13
6.2.2 ASE for CCNR.....	13
6.2.2.1 General .....	13
6.2.2.1.1 Subsystem number .....	13
6.2.2.1.2 List of operations .....	13
6.2.2.1.3 List of parameter types.....	14
6.2.2.1.4 List of application errors.....	14
6.2.3 Abstract syntax, general .....	14
6.3 ASN.1 module .....	15
7 Signalling requirements .....	16
7.1 Activation/deactivation/registration.....	16
7.1.1 Activation.....	16
7.1.1.1 Actions at the originating local exchange .....	16
7.1.1.1.1 Normal procedure .....	16
7.1.1.1.2 Exceptional procedure .....	17
7.1.1.2 Actions at the destination local exchange .....	17
7.1.1.2.1 Normal procedures.....	17
7.1.1.2.2 Exceptional procedures.....	17
7.1.2 Deactivation .....	18
7.1.2.1 Actions at the originating local exchange .....	18
7.1.2.1.1 Normal procedures.....	18
7.1.2.1.2 Exceptional procedures.....	18
7.1.2.2 Actions at the destination local exchange .....	18
7.1.2.2.1 Normal procedures.....	18
7.1.2.2.2 Exceptional procedures.....	18
7.1.3 Registration .....	19
7.2 Erasure.....	19
7.3 Invocation and operation .....	19
7.3.1 Actions at the originating local exchange.....	19
7.3.1.1 Normal operation.....	19
7.3.1.2 Exceptional procedures.....	19
7.3.2 Actions at a transit exchange.....	20
7.3.2.1 Normal operation.....	20

7.3.2.2	Exceptional procedures.....	21
7.3.3	Actions at the outgoing international gateway exchange.....	21
7.3.3.1	Normal operation.....	21
7.3.3.2	Exceptional procedures.....	21
7.3.4	Actions at the incoming international gateway exchange.....	21
7.3.4.1	Normal operation.....	21
7.3.4.2	Exceptional procedures.....	21
7.3.5	Actions at the destination local exchange.....	21
7.3.5.1	Normal operation.....	21
7.3.5.2	Exceptional procedure.....	23
7.4	Use of TC and SCCP.....	24
7.4.1	Routing in the SCCP network.....	24
7.4.2	Number information used for routing.....	24
7.4.3	SCCP message return procedure.....	24
7.4.4	Primitives used between the CCNR-ASE and TC.....	25
7.5	Dialogue.....	25
7.5.1	General.....	25
7.5.2	Dialogue beginning.....	25
7.5.3	Dialogue continuation.....	26
7.5.4	Dialogue end.....	26
7.5.4.1	Basic end.....	26
7.5.4.2	Abnormal end.....	27
8	Interaction with other supplementary services.....	27
8.1	Call waiting (CW).....	27
8.2	Call transfer services.....	27
8.2.1	Explicit call transfer (ECT).....	27
8.3	Connected line identification presentation (COLP).....	27
8.4	Connected line identification restriction (COLR).....	27
8.5	Calling line identification presentation (CLIP).....	27
8.6	Calling line identification restriction (CLIR).....	28
8.7	Closed user group (CUG).....	28
8.8	Conference calling (CONF).....	28
8.9	Direct dialling in (DDI).....	28
8.10	Call diversion services.....	28
8.10.1	Call forwarding activated by user A.....	28
8.10.2	Call forwarding activated by user B.....	28
8.10.2.1	Originating local exchange.....	28
8.10.2.2	Destination local exchange (B).....	28
8.11	Line Hunting.....	29
8.12	Three party service (3PTY).....	29
8.13	User-to-user signalling (UUS).....	29
8.14	Multiple subscriber number (MSN).....	29
8.15	Call hold (HOLD).....	29
8.16	Advice of charge.....	29
8.16.1	AOC, charging information at call set-up time (AOC-S).....	29
8.16.2	AOC, charging information during the call (AOC-D).....	29
8.16.3	AOC, charging information at the end of a call (AOC-E).....	29
8.17	Subaddressing (SUB).....	29
8.18	Terminal portability (TP).....	29
8.19	Completion of calls to busy subscriber (CCBS).....	30
8.20	Malicious call identification (MCID).....	30
8.21	Completion of Calls on No Reply (CCNR).....	30
8.22	Message Waiting Indication (MWI).....	30
8.23	Outgoing Call Barring (OCB).....	30
8.24	Selective Call Forwarding (SCF).....	30
9	Interaction with other networks.....	30
9.1	Interworking with an ISUP network without an ISUP that fully supports the CCNR capability.....	30
9.2	Interworking with a network without CCNR-ASE capability.....	31
9.3	Interworking with a network without SCCP/TC capability.....	31

9.4	Interworking with an intermediate network without 1993 version of SCCP capability .....	31
9.5	Interworking with PSTN with analogue subscribers using the CCNR service .....	32
9.6	Interworking with PSTN user .....	32
9.7	Procedures for interworking with private ISDNs .....	32
9.7.1	Provision/withdrawal .....	32
9.7.2	Normal procedure .....	32
9.7.2.1	Activation/deactivation/registration .....	32
9.7.2.1.1	Activation .....	32
9.7.2.1.2	Deactivation .....	33
9.7.2.1.3	Registration .....	33
9.7.2.2	Erasure .....	33
9.7.2.3	Invocation and operation .....	33
9.7.3	Exceptional procedures .....	33
9.7.3.1	Activation/deactivation/registration .....	33
9.7.3.1.1	Activation .....	33
9.7.3.1.2	Deactivation .....	33
9.7.3.1.3	Registration .....	33
9.7.3.2	Erasure .....	33
9.7.3.3	Invocation and operation .....	33
9.7.3.3.1	Exceptional situation at destination B's side .....	33
9.7.3.3.2	Exceptional situation at user A's side .....	34
9.7.3.3.3	Network congestion .....	34
10	Signalling flows .....	34
10.1	Normal call - destination B provides the CCNR Possible indicator .....	34
10.2	Normal call - Successful CCNR request followed by a successful CCNR call set up .....	35
10.3	Unsuccessful CCNR request, terminal activated .....	36
10.4	Unsuccessful CCNR request, network decision .....	36
10.5	Successful CCNR request followed by an unsuccessful CCNR call set up .....	37
10.6	B idle at CCNR request from A .....	38
10.7	A busy when B becomes free .....	38
11	Parameter values .....	39
11.1	Timers in the originating local exchange .....	39
11.2	Timers in the destination local exchange .....	39
11.3	Interworking timers .....	39
12	Dynamic description .....	40
<b>Annex A (informative): Coding of the compatibility information .....</b>		<b>41</b>
A.1	CCNR Possible indicator parameter .....	41
A.2	CCSS Parameter .....	42
<b>Annex B (informative): Signalling Interworking .....</b>		<b>43</b>
B.1	Interworking at the Originating Local Exchange .....	43
B.1.1	CCNR call set-up .....	43
B.1.2	CCNR available indication .....	43
B.1.3	CCNR request .....	44
B.1.4	Remote user free .....	45
B.1.5	Suspend/Resume request .....	45
B.1.6	Deactivation request .....	45
B.2	Interworking at the Destination Local Exchange .....	46
B.2.1	CCNR call set-up .....	46
B.2.2	CCNR request .....	46
B.2.3	Remote user free .....	47
B.2.4	CCNR available indication .....	47
B.2.5	Suspend/Resume request .....	47
History .....		48

---

## Intellectual Property Rights

IPRs essential or potentially essential to the present document may have been declared to ETSI. The information pertaining to these essential IPRs, if any, is publicly available for **ETSI members and non-members**, and can be found in ETR 314: "*Intellectual Property Rights (IPRs); Essential, or potentially Essential, IPRs notified to ETSI in respect of ETSI standards*", which is available **free of charge** from the ETSI Secretariat. Latest updates are available on the ETSI Web server (<http://www.etsi.fr/ipr>).

Pursuant to the ETSI Interim IPR Policy, no investigation, including IPR searches, has been carried out by ETSI. No guarantee can be given as to the existence of other IPRs not referenced in ETR 314 (or the updates on <http://www.etsi.fr/ipr>) which are, or may be, or may become, essential to the present document.

---

## Foreword

This European Standard (Telecommunications series) has been produced by ETSI Technical Committee Signalling Protocols and Switching (SPS), and is now submitted for the Public Enquiry approval phase of the ETSI standards Two-step Approval Procedure.

The present document is part 20 of a multi-part standard covering the ISDN User Part (ISUP) version 3 for the international interface, as identified below:

- Part 1: "Basic services";
- Part 2: "ISDN supplementary services";
- Part 3: "Calling Line Identification Presentation (CLIP) supplementary service";
- Part 4: "Calling Line Identification Restriction (CLIR) supplementary service";
- Part 5: "Connected Line Identification Presentation (COLP) supplementary service";
- Part 6: "Connected Line Identification Restriction (COLR) supplementary service";
- Part 7: "Terminal Portability (TP) supplementary service";
- Part 8: "User-to-User Signalling (UUS) supplementary service";
- Part 9: "Closed User Group (CUG) supplementary service";
- Part 10: "Subaddressing (SUB) supplementary service";
- Part 11: "Malicious Call Identification (MCID) supplementary service";
- Part 12: "Conference call, add-on (CONF) supplementary service";
- Part 14: "Explicit Call Transfer (ECT) supplementary service";
- Part 15: "Diversion supplementary services";
- Part 16: "Call Hold (HOLD) supplementary service";
- Part 17: "Call Waiting (CW) supplementary service";
- Part 18: "Completion of Calls to Busy Subscriber (CCBS) supplementary service";
- Part 19: "Three party (3PTY) supplementary service".
- Part 20: "Completion of Calls on No Reply (CCNR) supplementary service";**
- Part 31: "Basic Services; PICS proforma specification";
- Part 32: "Basic Services; Test suite structure and test purposes";
- Part 33: "Basic Services; ATS and partial PIXIT proforma specification";
- Part 34: "Supplementary Services; PICS proforma specification";
- Part 35: "Supplementary Services; Test suite structure and test purposes";
- Part 36: "Supplementary Services; ATS and partial PIXIT proforma specification".

NOTE: Part 13 has not been issued.

In accordance with CCITT Recommendation I.130, the following three level structure is used to describe the supplementary telecommunication services as provided by European public telecommunications operators under the pan-European Integrated Services Digital Network (ISDN):

- Stage 1: is an overall service description, from the user's stand-point;
- Stage 2: identifies the functional capabilities and information flows needed to support the service described in stage 1; and
- Stage 3: defines the signalling system protocols and switching functions needed to implement the service described in stage 1.

The present document details the stage 3 aspects (signalling system protocols and switching functions) needed to support the CCNR supplementary service. The stage 1 aspects are detailed in EN 301 134.

NOTE: Currently no stage 2 document exists.

<b>Proposed national transposition dates</b>	
Date of latest announcement of this EN (doa):	3 months after ETSI publication
Date of latest publication of new National Standard or endorsement of this EN (dop/e):	6 months after doa
Date of withdrawal of any conflicting National Standard (dow):	6 months after doa

---

# 1 Scope

The present document specifies the stage three of the Completion of Calls on No Reply (CCNR) supplementary service for the ISDN as provided by the European public telecommunications operators by means of the Signalling System No.7 protocol. Stage three identifies the protocol procedures and switching functions needed to support a telecommunication service (see CCITT Recommendation I.130 [3]).

The present document specifies the additional requirements where the service is provided to the user via an intermediate ISDN.

The present document does not specify the additional requirements where the service is provided to the user via a telecommunications network that is not an ISDN.

Although the present document applies only to the international interconnection, the specification of functions, formats and codes of messages and signals, and actions performed at originating and destination local exchanges are retained. Formats, codes and procedures marked for national use are included for informative purposes for the international interface specification. If these items so marked are supported within a national network and operator's network, then it is proposed that they shall be supported in this manner.

NOTE: In the case where a national signalling system behaves differently, the international gateway exchange is to support both the national network concerned and the international network.

Charging aspects are outside the scope of the present document.

---

# 2 Normative references

References may be made to:

- a) specific versions of publications (identified by date of publication, edition number, version number, etc.), in which case, subsequent revisions to the referenced document do not apply; or
- b) all versions up to and including the identified version (identified by "up to and including" before the version identity); or
- c) all versions subsequent to and including the identified version (identified by "onwards" following the version identity); or
- d) publications without mention of a specific version, in which case the latest version applies.

A non-specific reference to an ETS shall also be taken to refer to later versions published as an EN with the same number.

- [1] CCITT Recommendation E.164 (1991): "Numbering plan for the ISDN era".
- [2] ITU-T Recommendation I.112 (1993) "Vocabulary of terms for ISDNs".
- [3] CCITT Recommendation I.130 (1988): "Method for the characterisation of telecommunication services supported by an ISDN and network capabilities of an ISDN".
- [4] ITU-T Recommendation I.210 (1993): "Principles of telecommunication services supported by an ISDN and the means to describe them".
- [5] CCITT Recommendation I.221 (1988): "Common specific characteristics of services".
- [6] CCITT Recommendation X.208 (1988): "Specification of Abstract Syntax Notation One (ASN.1)" and X.680 containing amendment 1.
- [7] ETS 300 009-1: "Integrated Services Digital Network (ISDN); Signalling System No.7; Signalling Connection Control Part (SCCP) (connectionless and connection-oriented class 2) to support international interconnection; Part 1: Protocol specification [ITU-T Recommendations Q.711 to Q.714 and Q.716 (1993), modified]".



- [8] ETS 300 287-1: "Integrated Services Digital Network (ISDN); Signalling System No.7; Transaction Capabilities (TC) version 2; Part 1: Protocol specification [ITU-T Recommendations Q.771 to Q.775 (1993), modified]".
- [9] ETS 300 121 (1993): "Integrated Services Digital Network (ISDN); Application of the ISDN User Part (ISUP) of CCITT Signalling System No.7 for international ISDN interconnections (ISUP version 1)".
- [10] EN 300 356-1 (V3): "Integrated Services Digital Network (ISDN); Signalling System No.7; ISDN User Part (ISUP) version 3 for the international interface; Part 1: Basic services [ITU-T Recommendations Q.761 to Q.764 (1997), modified]".
- [11] EN 300 356-2 (V3): "Integrated Services Digital Network (ISDN); Signalling System No.7; ISDN User Part (ISUP) version 3 for the international interface; Part 2: ISDN supplementary services [ITU-T Recommendation Q.730 (1997), modified]".
- [12] EN 301 134 (V1): "Integrated Services Digital Network (ISDN); Completion of Calls on No Reply (CCNR) supplementary service; Service description".
- [13] EN 300 356-18 (V3): "Integrated Services Digital Network (ISDN); Signalling System No.7; ISDN User Part (ISUP) version 3 for the international interface; Part 18: Completion of Calls to Busy Subscriber (CCBS) supplementary service [ITU-T Recommendation Q.733, clause 3 (1997), modified]".
- [14] EN 301 065-1 (V1): "Integrated Services Digital Network (ISDN); Completion of Calls on No Reply (CCNR) supplementary service; Digital Subscriber Signalling System No. one (DSS1) protocol; Part 1: Protocol specification".
- [15] CCITT Recommendation I.230 (1988): "Definition of bearer service categories".
- [16] CCITT Recommendation I.240 (1988): "Definition of teleservice categories".
- [17] ITU-T Recommendation F.721: "Videotelephony teleservice for ISDN".
- [18] ITU-T Recommendation Q.715 (1995): "SCCP user's guide".

---

## 3 Definitions and abbreviations

### 3.1 Definitions

For the purposes of the present document, the following definitions apply:

The following terms (i.e. a) through n)) are defined in EN 301 134 [12]. Abbreviated timer names are defined in the brackets.

- a) User A;
- b) Destination B;
- c) CCNR recall;
- d) CCNR call;
- e) Busy;
- f) CCNR busy;

In addition, a CCBS recall pending on user A is also considered as CCNR busy.

- g) Retention timer (CCNR-T1);
- h) CCNR service duration timer (CCNR-T3);

- i) CCNR recall timer (CCNR-T4);
- j) Destination B idle guard timer (CCNR-T8);
- k) Suspended CCNR request;
- l) CCNR request;
- m) Compatible terminal;
- n) Activity.

Other terms:

**retain option:** The retain option, if supported in both the originating and destination network, will maintain the CCNR request in the destination B queue, if a CCNR call has failed due to destination busy condition or because the destination B does not answer the CCNR call.

**long term denial:** The network cannot accept user A's request to activate the CCNR supplementary service and a later attempt to activate the CCNR supplementary service for the same destination B will also be rejected.

**short term denial:** The network temporarily cannot accept user A's request to activate the CCNR supplementary service. A later attempt to activate the CCNR supplementary service for the same destination B may succeed.

**CCNR call indicator:** Information sent in the forward direction, used in a CCNR supplementary service CCNR call set-up to distinguish this call from an ordinary call at the destination local exchange. This indicator is carried in the Call Completion Supplementary Service parameter in the IAM.

**CCNR possible indicator:** Indicator used in the CCNR Possible Indicator parameter in the ACM/CPG to indicate the possibility to invoke a possible succeeding CCNR service request.

**destination B does not answer the CCNR call:** After ACM (subscriber free) / CPG (alerting), either the calling user releases or a network release in forward or backward direction takes place.

## 3.2 Abbreviations

For the purposes of the present document, the following abbreviations apply:

ACM	Address Complete Message
ANM	Answer Message
ASE	Application Service Element
ASN.1	Abstract Syntax Notation one
ATP	Access Transport Parameter
CCBS	Completion of Calls to Busy Subscriber
CCNR	Completion of Calls on No Reply
CFB	Call Forwarding Busy
CFNR	Call Forwarding No Reply
CFU	Call Forwarding Unconditional
CLI	Calling Line Identification
CON	Connect message
CPG	Call Progress message
DLE	Destination Local Exchange
DSS1	Digital Subscriber Signalling System No. one
GT	Global Title
HLC	High Layer Compatibility
IAM	Initial Address Message
IPI	ISDN user part Preference Indicator
ISDN	Integrated Services Digital Network
ISPBX	Integrated Services Private Branch Exchange
ISUP	Integrated Services digital network User Part
LLC	Low Layer Compatibility
OLE	Originating Local Exchange

OU	Originating User
PSTN	Public Switched Telephony Network
REL	Release Message
RLC	Release Complete Message
SCCP	Signalling Connection Control Part
SDL	Specification and Description Language
SPC	Signalling Point Code
SSN	Sub System Number
SUB	Subaddress
TC	Transaction Capabilities
TE	Transit Exchange
TU	Terminating User
USI	User Service Information

---

## 4 Description

The CCNR supplementary service enables user A, encountering a destination B which does not answer the call (No Reply), to have the call completed without having to make a new call attempt when the destination becomes not busy after having initiated an activity.

When user A encounters a destination B which does not answer the call (No Reply), user A can request the CCNR supplementary service.

When user A requests the CCNR supplementary service, the network will monitor for destination B becoming not busy after having initiated an activity.

When destination B becomes not busy (i.e. access resources, e.g. at least one B-channel, are not busy) after having initiated an activity, then the network will wait a short time (as defined by the destination B idle guard timer) in order to allow the resources to be re-used for originating a call. If the resources are not re-used by destination B within this time, then the network will automatically recall user A.

When user A accepts the CCNR recall, then the network will automatically generate a CCNR call to destination B.

The CCNR supplementary service is applicable to all circuit-switched telecommunications services with the following exceptions:

- a) call 2 of the videotelephony teleservice (see ETS 300 264);
- b) all other circuit-switched telecommunications services requiring the use of more than one B-channel.

---

## 5 Operational requirements

### 5.1 Provision/withdrawal

The CCNR supplementary service may be provided to user A after prior arrangement with the service provider or may be generally available. The CCNR supplementary service shall be withdrawn by the service provider upon request of the subscriber or for service provider reasons.

See also stage one description EN 301 134 [12].

### 5.2 Requirements on the originating network

In order to operate the CCNR supplementary service, the originating local exchange shall have TC capabilities (ITU-T Recommendations Q.771-Q.775 [8]). The originating network shall have SCCP capability (ITU-T Recommendations Q.711-Q.714 [7]) for routing the TC operations.

## 5.3 Requirements on the terminating network

In order to operate the CCNR supplementary service, the destination local exchange shall have TC capabilities. The terminating network shall have SCCP capability for routing the TC operations.

## 5.4 Requirements on the transit network

The transit network shall have SCCP capability for routing the TC operations.

# 6 Coding requirements

## 6.1 Introduction

This chapter describes the coding of information needed to support the CCNR supplementary service. The coding is specified for the following two protocols:

- a) ISUP (ITU-T Recommendations Q.761 to Q.764 as modified by EN 300 356-1 [10]);
- b) ASE for CCNR.

## 6.2 Coding requirements

### 6.2.1 ISUP protocol

#### 6.2.1.1 Signalling aspects impacting the routing

For the CCNR call the IPI in the forward call indicators parameter in the IAM message shall be set to "ISDN User Part required all the way".

For some interaction cases, the service is possible without ISUP 1997 signalling capability. See clause 9.

#### 6.2.1.2 CCNR Possible indicator in ACM/CPG

An indication about the possibility of invocation of CCNR in the destination local exchange is given in the CCNR Possible Indicator parameter in the ACM (subscriber free) / CPG (alerting). As the first call is a basic call and as other signalling systems than "ISUP supporting CCNR" may be used, the CCNR Possible Indicator parameter is not always conveyed.

The format of the CCNR Possible Indicator parameter is shown in figure 1:

<b>8</b>	<b>7</b>	<b>6</b>	<b>5</b>	<b>4</b>	<b>3</b>	<b>2</b>	<b>1</b>
<b>H</b>	<b>G</b>	<b>F</b>	<b>E</b>	<b>D</b>	<b>C</b>	<b>B</b>	<b>A</b>

**Figure1: CCNR Possible Indicator Parameter**

The following codes are used in the CCNR Possible Indicator parameter field:

Bit A: CCNR Possible indicator

0 CCNR not possible

1 CCNR possible

Bits H-B: Spare

The code of the CCNR Possible Indicator parameter is XXXX XXXX

Rapporteur's note: Will be assigned by ITU-T. It was agreed to consider it during public enquiry.

### 6.2.1.3 CCNR Call indicator

The CCNR Call indicator is carried in the CCSS parameter in the IAM.

The format of the CCSS parameter is shown in figure 2.

8	7	6	5	4	3	2	1
H	G	F	E	D	C	B	A

**Figure 2: CCSS Parameter**

The following codes are used in the CCSS parameter field:

Bit A: CCSS Call indicator

0 no indication

1 CCSS call

Bits H-B: Spare

**CCSS call indicator:** Information sent in the forward direction used in a Call Completion supplementary service call set-up to distinguish this call from an ordinary call at the destination local exchange.

**CCSS parameter:** Information sent in an Initial Address message indicating that this call is a Call Completion Supplementary Service call.

The code of the CCSS parameter is 0100 1011.

## 6.2.2 ASE for CCNR

### 6.2.2.1 General

All ASN.1 symbols defined in the ASN.1 module of the stage 3 description of CCBS (ITU-T Recommendation Q733.3 as modified by EN 300 356-18 [13]) except the CcbsRequest operation are re-used for CCNR purposes.

#### 6.2.2.1.1 Subsystem number

The subsystem number (SSN) value 0000 1011 has been allocated to the ISDN supplementary services ASEs.

#### 6.2.2.1.2 List of operations

From originating local exchange to destination local exchange:

- |                          |         |
|--------------------------|---------|
| a) CCNR REQUEST (invoke) | class 1 |
| b) CCBS SUSPEND          | class 4 |
| c) CCBS RESUME           | class 4 |
| d) CCBS CANCEL           | class 4 |

From destination local exchange to originating local exchange:

- a) CCNR REQUEST (return result, error) class 1
- b) REMOTE USER FREE class 4
- c) CCBS CANCEL class 4

### 6.2.2.1.3 List of parameter types

Addressing and identification parameters:

- a) Calling party number;
- b) Called party number.

NOTE: If presentation of the calling party number is allowed, the country code shall be included in the calling party number in the originating local exchange, in case of an international outgoing call.

Service management parameters:

- a) Retain supported;
- b) Cancel cause.

Subscriber management parameters:

- a) User service information;
- b) User service information prime (see note);
- c) Access transport;

NOTE: The user service information prime parameter is used in the case of signalling procedures for connection type with fallback capability.

### 6.2.2.1.4 List of application errors

- a) Short term denial;
- b) Long term denial.

## 6.2.3 Abstract syntax, general

Subclause 6.3 specifies the abstract syntax for the CCNR ASE protocol using the Abstract Syntax Notation One (ASN.1) (CCITT Recommendation X.208 [6]).

The set of values each of which is a value of the ASN.1 type `TCAPMessages.MessageType` as defined in CCITT Recommendations Q.771 to Q.775 [8] with the ANY DEFINED BY definitions resolved by the operations and errors definitions included in subclause 6.3 form the abstract syntax for the CCNR ASE protocol.

- The set of encoding rules which are applicable to this abstract syntax are defined in CCITT Recommendations Q.771 to Q.775 [8]. The mapping of the OPERATION and ERROR MACROs to TC components is also described in CCITT Recommendations Q.771 to Q.775[8].
- The ASN.1 data type which follows the keywords "PARAMETER" or "RESULT" (for OPERATION and ERROR) is always optional from a syntactic point of view. However, except specific mention, it has to be considered as mandatory from a semantic point of view.
- When a mandatory element is missing in any component or inner data structure, a reject component is returned (if the dialogue still exist). The problem cause to be used is "Mistyped parameter".

## 6.3 ASN.1 module

Table 1 shows the definition of the operations, errors and types required for the CCNR supplementary service using ASN.1 as defined in CCITT Recommendations X.208 and X.680 [6] and using the OPERATION and ERROR macros as defined in CCITT Recommendations Q.771 to Q.775 [8].

The formal definition of the component types to encode these operations, errors and types is provided in CCITT Recommendations Q.771 to Q.775 [8].

All ASN.1 symbols defined in the ASN.1 module of the stage 3 description of CCBS (ITU-T Recommendation final draft CCBS [3]) except the CcbsRequest operation are re-used for CCNR purposes.

Rapporteur's note: With regard to the object identifier, the value of "X" will be assigned by ITU-T. It was agreed to consider it during public enquiry.

**Table 1: Definition of operations for the CCNR supplementary service**

```

CCNR-Protocol {itu-t recommendation q 733 X modules(2) operations-and-errors(1) version1(1)}

DEFINITIONS EXPLICIT TAGS ::=
BEGIN

IMPORTS
    OPERATION, ERROR
    FROM TCAPMessages
        {ccitt recommendation q 773 moduleA(0)} +
    CcbsCancel, CcbsSuspend, CcbsResume, RemoteUserFree, ShortTermDenial, LongTermDenial,
    CalledPartyNumber, CallingPartyNumber, CauseCode, USICode, AccessTransport,
    maxAccessTransportLength
    FROM CCBS-Protocol
        {itu-t recommendation q 733 3 modules(2) operations-and-errors(1) version1(1)};

-- operations types
CcnrRequest ::= OPERATION
    PARAMETER SEQUENCE {
        calledPartyNumber          CalledPartyNumber,
        retainSupported             BOOLEAN DEFAULT FALSE,
        userServiceInf             [1] IMPLICIT USICode OPTIONAL,
        callingPartyNumber         [2] IMPLICIT CallingPartyNumber OPTIONAL,
        userServiceInfPrime       [3] IMPLICIT USICode OPTIONAL,
        accessTransportParameter  [4] IMPLICIT AccessTransport OPTIONAL,...}
    RESULT SEQUENCE {
        retainSupported             BOOLEAN DEFAULT FALSE,...}
    ERRORS {
        ShortTermDenial,
        LongTermDenial}

--object identifier path
ccnrOID OBJECT IDENTIFIER ::= {itu-t recommendation q 733 X operations-and-errors(1)}

--operation values
ccnrRequest CcnrRequest ::= globalValue : {ccnrOID ccnrrequest(1)}

END -- of CCNR-Protocol

```

## 7 Signalling requirements

If the destination local exchange supports the CCNR supplementary service, then the destination local exchange shall set the CCNR Possible Indicator parameter in the ACM (subscriber free) / CPG (alerting) to indicate whether or not CCNR is possible.

E.g. if the destination local exchange knows that the CCNR is forbidden on the destination B user then the CCNR Possible Indicator parameter shall be set to "CCNR not possible". Otherwise the CCNR Possible Indicator parameter shall be set to "CCNR possible".

### 7.1 Activation/deactivation/registration

#### 7.1.1 Activation

##### 7.1.1.1 Actions at the originating local exchange

###### 7.1.1.1.1 Normal procedure

NOTE 1: When user A encounters a no reply destination B, the network will retain the call information for a defined period (retention timer), during which user A can activate the CCNR supplementary service.

With regard to the activation procedure and the handling of the first call, see stage one [12] and DSS1 specification [14].

NOTE 2: User A can have a limited number of CCNR requests outstanding. This limit is a network provider option (with a maximum value of 5).

When the originating local exchange has received from the destination local exchange an ACM/CPG with the CCNR Possible Indicator parameter, the originating local exchange shall convey that information to the call control.

NOTE 3: If the originating local exchange is supporting the CCNR supplementary service and this supplementary service is available to user A and the originating local exchange has received from the destination local exchange an ACM/CPG with a "CCNR possible" indication, the originating local exchange will start the basic call retention procedure. In case of a CCNR Possible Indicator parameter, received from the destination local exchange, with a "CCNR not possible" indication, no particular actions are made in the network.

If the originating local exchange receives a CCNR request and accepts this request, the originating local exchange shall send a CcnrRequest invoke component to the destination local exchange including the following information:

- The calledPartyNumber parameter shall contain the number of B;
- The userServiceInf parameter shall contain the bearer capability of the original call, if available;
- The retainSupported parameter shall indicate whether the originating local exchange supports the retain option;
- The callingPartyNumber parameter shall contain the number of A;

NOTE 4: The inclusion is a network provider option.

- The parameters userServiceInfPrime and accessTransport contain compatibility information of the original call;
- The TC-INVOKE primitive shall instruct the TC to start the CCNR request timer CCNR-T2

NOTE 5: Call information retained by the originating local exchange in support of CCNR will correspond to the following basic call parameters from the original call, if available:

- User service information;
- User service information prime;



- Access transport;
- Calling party number;
- Called party number;

NOTE 6: Interactions between CCNR and other supplementary services may require other information to be stored; see clause 8.

Upon receipt of the CcnrRequest return result component, the originating local exchange shall:

- 1) store the information whether the retainSupported parameter has been received or not;
- 2) return a CCNR request acceptance to user A to indicate that the service request has been accepted;
- 3) start the service duration timer CCNR-T3.

NOTE 7: The CCNR request timer CCNR-T2 is stopped by TC, when the TC-RESULT-L is received.

Having activated the completion of calls on no reply (CCNR) supplementary service, user A can originate and receive calls as normal.

#### 7.1.1.1.2 Exceptional procedure

On receipt of either a TC-P-ABORT, a TC-U-ABORT, a TC-U-REJECT or a TC-L-CANCEL primitive as response to the CcnrRequest invoke component, the service request shall be rejected with short term denial as a reason.

On receipt of a TC-NOTICE primitive as response to the CcnrRequest invoke component, the service request shall be rejected with long term denial as a reason.

#### 7.1.1.2 Actions at the destination local exchange

##### 7.1.1.2.1 Normal procedures

On receipt of a CcnrRequest invoke component, the destination local exchange shall:

- 1) store the information received in the CcnrRequest invoke component in the destination B queue;
- 2) return a CcnrRequest return result component to the originating local exchange;
  - if the retainSupported parameter received in the CcnrRequest invoke component indicates that the retain option is supported at the originating local exchange (coded TRUE), then the retainSupported parameter conveyed in the CcnrRequest return result component shall indicate whether the destination local exchange supports the retain option;
  - if the retainSupported parameter received in the CcnrRequest invoke component is coded FALSE, then the retainSupported parameter conveyed in the CcnrRequest return result component is set to the default value (FALSE);
- 3) start the service duration timer CCNR-T7;
- 4) monitor destination B for becoming not busy after having initiated an activity.

##### 7.1.1.2.2 Exceptional procedures

a) The CcnrRequest invoke component does not contain the UserServiceInformation parameter, needed for the compatibility check.

On receipt of a CcnrRequest invoke component not including the UserserviceInformation parameter, then the destination local exchange shall assign the UserServiceInformation parameter with the Bearer capability information corresponding to "3,1 kHz audio" call.

b) The activation of the CCNR supplementary service can not be accepted

When the activation of the CCNR supplementary service can not be accepted by the destination local exchange, it shall send a CcnrRequest return error component to the originating local exchange, indicating short term denial in the following cases:

- if there are already the maximum number of requests queued against destination B;
- if there is an interaction with a supplementary service, which prohibits the activation of the CCNR supplementary service against that destination;

for other cases it shall send a CcnrRequest return error component to the originating local exchange, indicating long term denial.

## 7.1.2 Deactivation

### 7.1.2.1 Actions at the originating local exchange

#### 7.1.2.1.1 Normal procedures

If a deactivation request is received from user A, the originating local exchange shall send a CcnrCancel invoke component to the destination local exchange, without a cancelCause parameter, for each concerned transaction. User A shall be informed that the deactivation is successful. The resources are released.

Deactivation of a CCNR request by any cancelCause received in a CcbsCancel invoke component shall result in this request being removed from the originating CCNR request register

#### 7.1.2.1.2 Exceptional procedures

A particular request for this service shall be automatically deactivated and user A is informed if:

- 1) The CCNR service duration timer (CCNR-T3) expires.

If the timer CCNR-T3 expires first, the originating local exchange shall send a CcbsCancel invoke component with cancelCause "CCNR-T3 Timeout", to the destination local exchange.

The resources are released in the originating local exchange

- 2) Non-acceptance of CCNR recall.

If user A does not accept the CCNR recall before the CCNR recall timer (CCNR-T4) expires, then the CCNR request shall be deactivated. The originating local exchange shall send a CcbsCancel invoke component, with the cancelCause "CCNR-T4 Timeout", to the destination local exchange.

### 7.1.2.2 Actions at the destination local exchange

#### 7.1.2.2.1 Normal procedures

Deactivation of a CCNR request by any cancelCause received in a CcbsCancel invoke component shall result in this request being removed from the destination B CCNR request queue.

#### 7.1.2.2.2 Exceptional procedures

A particular request for this service shall be automatically deactivated if the CCNR service supervision timer (CCNR-T7) expires.

If the timer CCNR-T7 expires first, the destination local exchange shall send a CcbsCancel invoke component with cancelCause "CCNR-T7 Timeout", to the originating local exchange.

The resources are released in the destination local exchange.

### 7.1.3 Registration

Not applicable.

## 7.2 Erasure

Not applicable.

## 7.3 Invocation and operation

### 7.3.1 Actions at the originating local exchange

#### 7.3.1.1 Normal operation

After the activation process described in subclause 7.1.1.1, the originating local exchange may receive a RemoteUserFree invoke component from the destination local exchange. In that case the originating local exchange shall recall user A (see DSS1 description [14]), and the CCNR recall timer CCNR-T4 shall be started.

If user A accepts the recall before the CCNR recall timer expires, then the originating local exchange shall stop timer CCNR-T4 and initiate the CCNR call to destination B by sending an IAM message, including the CCNR Call indicator and the retained call information (see subclause 7.1.1.1). The IPI in the forward call indicators parameter shall be set to "ISDN User Part required all the way".

#### 7.3.1.2 Exceptional procedures

##### a) User A is found to be busy or CCNR busy

If user A is found to be busy or CCNR busy, when RemoteUserFree invoke component has been received, then the CCNR request shall be suspended until user A becomes neither busy nor CCNR busy. The originating local exchange shall send a CcbsSuspend invoke component to the destination local exchange.

When user A is no longer busy or CCNR busy, the originating local exchange shall send a CcbsResume invoke component to the destination local exchange.

In case of the originating local exchange had sent several CcbsSuspend invoke components to different destination local exchanges and user A becomes neither busy nor CCNR busy, the originating local exchange shall send a CcbsResume invoke component to each destination local exchange for which there is a suspended CCNR request for which a compatible terminal at user A is neither busy nor CCNR busy.

##### b) User A reactivates the CCNR supplementary service

If user A does not wait for the CCNR recall to a particular destination B, but makes another call to the same destination B and requests the CCNR supplementary service again, as a network option, one of the following shall occur:

- 1) the network shall check if an identical CCNR request already exists:
  - if so, the original request shall be retained with the current request being discarded and user A shall be informed that the request has not been accepted because a CCNR request had already been stored against the requested destination B;
  - if not, then the network shall treat this as a new CCNR request.

In order to determine that the two CCNR requests are identical, the network shall only compare the basic call information, i.e. the bearer service and teleservice requirements, the destination selection information and calling user identity (if any); or

- 2) the network shall not check if an identical CCNR request already exists and the procedures of subclause 7.1.1.1.1 shall apply for this new CCNR request.

c) Destination B is busy upon arrival of the CCNR call

If the CCNR call fails, user A shall be informed as for the basic call procedures:

1) If the received Release message contains either cause #17 or #34, two possibilities exist:

- if the retain option is supported across the networks, the originating local exchange shall keep the transaction resources and shall not restart timer CCNR-T3. If user A attempts to activate CCNR again this shall be treated as described in subclause 7.3.1.2.b);
- if the retain option is not supported across the networks, the originating local exchange shall release the transaction resources. The CCNR request shall be deactivated and user A shall be informed accordingly.

2) If the received Release message does contain a cause value other than cause #17 or #34, the originating local exchange shall send a CcbsCancel invoke component to the destination local exchange. The CCNR request shall be deactivated and user A shall be informed accordingly.

NOTE 1: Some networks may take action to reduce the probability of network congestion on the CCNR call.

d) Destination B does not answer the CCNR call.

NOTE 2: See subclause 3.1, "Definitions".

If the originating local exchange has sent an Initial Address message including the CCSS parameter and receives, after the receipt of ACM (subscriber free) or CPG (alerting), a Release message with an appropriate cause value or an indication that user A disconnects the CCNR call, then one of the following actions shall apply:

- if the retain option is supported across the networks, the originating local exchange shall keep the transaction resources and shall not restart timer CCNR-T3. If user A attempts to activate CCNR again this shall be treated as described in subclause 7.3.1.2.b);
- if the retain option is not supported across the networks, the originating local exchange shall release the transaction resources. The CCNR request shall be deactivated and user A shall be informed accordingly. If user A attempts to activate CCNR again, one of the following procedures shall apply:
  - If the received ACM/CPG contained a CCNR Possible indicator the procedures of subclause 7.1.1.1 shall be followed.
  - If the received ACM/CPG did not contain a CCNR Possible indicator, interworking is applied and the procedures of subclause 9.1 shall be followed.

NOTE 3: Some networks may take action to reduce the probability of network congestion on the CCNR call.

e) The originating local exchange receives a TC-NOTICE indication primitive upon sending the CcbsSuspend invoke component.

If the originating local exchange receives a TC-NOTICE indication primitive upon sending the CcbsSuspend invoke component to the destination local exchange, then the timer CCNR-T3 is stopped, the request is deleted and the TC resources are released.

f) The originating local exchange receives a TC-NOTICE indication primitive upon sending the CcbsResume invoke component.

If the originating local exchange receives a TC-NOTICE indication primitive upon sending the CcbsResume invoke component to the destination local exchange, then the timer CCNR-T3 is stopped, the request is deleted and the TC resources are released.

## 7.3.2 Actions at a transit exchange

### 7.3.2.1 Normal operation

The transit exchange shall pass the CCNR Possible Indicator parameter, in ACM/CPG, transparently to the preceding exchange. It shall also pass the CCSS parameter, in the IAM, transparently to the succeeding exchange.

### 7.3.2.2 Exceptional procedures

None identified.

## 7.3.3 Actions at the outgoing international gateway exchange

### 7.3.3.1 Normal operation

The outgoing international gateway exchange shall pass the CCNR Possible Indicator parameter, in ACM/CPG, transparently to the preceding exchange. It shall also pass the CCSS parameter, in the IAM message, transparently to the succeeding exchange.

### 7.3.3.2 Exceptional procedures

None identified.

## 7.3.4 Actions at the incoming international gateway exchange

### 7.3.4.1 Normal operation

The incoming international gateway exchange shall pass the CCNR Possible Indicator parameter, in ACM/CPG, transparently to the preceding exchange. It shall also pass the CCSS parameter, in the IAM message, transparently to the succeeding exchange.

### 7.3.4.2 Exceptional procedures

None identified.

## 7.3.5 Actions at the destination local exchange

### 7.3.5.1 Normal operation

When destination B becomes not busy after having initiated an activity, then the destination local exchange shall check the status of the queue for destination B.

If there is an entry in the CCNR queue currently being processed then no further action shall be taken.

Otherwise, the entries in the CCNR queue are examined in order:

- If an entry is suspended, it is skipped over.
- If an entry is not suspended, it shall be selected and, the destination local exchange shall reserve on destination B's interface the resources (e.g. a B-channel) which are necessary to complete the CCNR call. Destination B can use the reserved access resources or other free resources in order to make an outgoing call.
- Check whether a compatible terminal at destination B is not busy. If there are no compatible terminal free, the entry is skipped over.
- If a compatible terminal is free, then the procedures as described below are followed.
- If all the entries in the queue have been checked without finding an entry which is not suspended and for which a compatible terminal is free, then the destination local exchange shall release the reserved resources.

The network shall start the "Destination B Idle Guard Timer" CCNR-T8 in the destination local exchange. When the timer CCNR-T8 expires, the selected CCNR request shall be processed.

When processing a CCNR request, provided that a compatible terminal is free and the reserved resources are still available at destination B, the destination local exchange shall start the CCNR recall procedure.

The CCNR recall procedure is defined as follows:

- send a RemoteUserFree invoke component to the originating local exchange; and
- start the CCNR recall timer CCNR-T9.

If an IAM is received by the destination local exchange, while the network has reserved resources on destination B's interface, the destination local exchange shall:

- 1) check whether this new incoming call includes a CCNR call indicator. A new incoming call without the CCNR call indicator shall not be offered to destination B if there are one or more CCNR requests in the destination B queue, which are not suspended and have service requirements and destination selection information identical to the new incoming call;
- 2) determine the resources engaged in the CCNR call based on the basic call information;
- 3) offer the call to the B user.

If user B is found compatible-free, the call is completed according to the basic call control procedures (ACM, ANM or CON messages).

- If the retain option is supported and when the destination local exchange has sent an Answer message or a Connect message, or
- if the retain option is not supported and when the destination local exchange has sent an Address Complete message (with subscriber free), a CPG (alerting) message or a Connect message, the destination local exchange shall:
  - release its TC resources;
  - stop the timers CCNR-T7 and CCNR-T9;
  - check whether there are free resources on the destination B interface:
    - if there are no free resources on the destination B interface then no further action shall be taken.
    - if there are free resources on the destination B interface then the destination local exchange shall service the queue for destination B as described above.

Several CCNR requests can be queued against one destination B in the destination B CCNR queue. The exact size of the destination B CCNR queue (from 1 to 5 entries) is a destination network provider option.

As a network option the destination network operator can reduce the CCNR queue size associated with individual users. The reduced size can have zero length.

Multiple CCNR requests towards the same destination shall be queued and processed on a first in, first out (FIFO) basis. The user A, whose CCNR request arrived first, will be informed first each time the destination B idle guard timer has expired after destination B has become not busy.

CCNR requests which have been suspended shall be skipped over and the next CCNR request in the queue shall be selected, and so on.

If the processing of a CCNR request results in suspending that CCNR request, or in deactivating that CCNR request, then the next CCNR request against destination B will be selected, and so on.

When a CCNR request becomes not suspended due to user A becoming not busy or not CCNR busy, and at that time destination B is not busy nor any other CCNR request from the same queue is being processed, then the destination B queue shall be serviced again without starting the destination B idle guard timer CCNR-T8.

If the whole queue has been processed and no CCNR call results, due to all CCNR requests being cancelled or suspended, then processing is complete and will only be restarted when one of the CCNR requests becomes not suspended.

### 7.3.5.2 Exceptional procedure

a) Resources or compatible terminal at destination B are no longer available when destination B idle guard timer expires.

If, when the destination B idle guard timer (CCNR-T8) expires, no access resources are available at destination B (e.g. no compatible terminal is present or destination B makes an outgoing call), then servicing of the destination B CCNR queue shall be deferred until the destination B becomes not busy again.

If, when the destination B idle guard timer (CCNR-T8) expires, all compatible terminals at destination B are busy, then the next request in the destination B CCNR queue shall be selected for processing.

b) Destination B receives a "RemoteUserFree" indication (this user being a user A for another call completion, e.g. CCBS or CCNR, request) while processing the destination B CCNR queue.

See interaction with CCNR in stage one [12] and DSS1 description [14].

c) Destination B is busy upon arrival of the CCNR call.

If destination B is again busy when the network attempts to make the CCNR call, then the procedures depend on whether the retain option is supported across the networks:

- 1) if the retain option is not supported across the networks, the corresponding CCNR request shall be cancelled. The destination local exchange shall send a normal REL message (cause #17 or #34) to the originating local exchange and shall release its resources.
- 2) if the retain option is supported across the networks, the original CCNR request shall retain its position in the queue. In this case the destination local exchange shall keep the transaction resources, shall continue to monitor destination B, shall not restart the timer CCNR-T7, shall stop timer CCNR-T9 and shall send a REL message (cause #17 or #34) to the originating local exchange.

The following procedure applies: The option applied by the originating local exchange and the destination local exchange is determined by a negotiation included in the CCNR request procedure.

The procedure without the option applies in each exchange if the retain option is not available in this exchange, or if the received retainOption parameter is coded FALSE.

The procedure with the option applies only if each exchange has this option available and has received a positive indication from the other one.

d) Destination B does not answer the CCNR call.

If destination B does not answer the CCNR call (as part of the same service provider option as in c) above), when the network attempts to make the CCNR call, then the procedures depend on whether the retain option is supported across the networks:

- 1) if the retain option is not supported across the networks, the corresponding CCNR request shall be cancelled. The destination local exchange shall release its resources.  
  
If user A activates CCNR again, this activation shall be considered as a new CCNR request, which will be put at the end of the destination B queue upon receipt of a new CnrRequest invoke component from the originating local exchange. In this case the CCNR duration timers CCNR-T3 and CCNR-T7 shall be restarted and user A shall receive a confirmation.
- 2) if the retain option is supported across the networks, the original CCNR request shall retain its position in the queue. In this case the destination local exchange shall keep the transaction resources, shall continue to monitor destination B, shall not restart the timer CCNR-T7, shall stop timer CCNR-T9.

The following procedure applies: The option applied by the originating local exchange and the destination local exchange is determined by a negotiation included in the CCNR request procedure.

The procedure without the option applies in each exchange if the retain option is not available in this exchange, or if the received retainOption parameter is coded FALSE.

The procedure with the option applies only if each exchange has this option available and has received a positive indication from the other one.

e) No CCNR call as result.

If no CCNR call results from the CCNR recall mechanism, the recall timer CCNR-T9 expires. In this case the destination local exchange shall send a CcbsCancel invoke component to the originating local exchange. The cancelCause shall indicate "CCNR-T9 Timeout". The network shall make any reserved access resources on destination B's interface available for use, if no other CCNR call is placed in the queue.

f) Receipt of a TC-NOTICE upon sending the RemoteUserFree invoke component.

If the destination local exchange receives a TC-NOTICE indication upon sending the RemoteUserFree invoke component to the originating local exchange, then the timers CCNR-T7 and CCNR-T9 are stopped, then the next active request in the queue, if available, will be served. The currently served request is deleted and the TC resources are released in the destination local exchange.

## 7.4 Use of TC and SCCP

The service monitoring and management signals are defined as TC-based application messages (i.e. operations and corresponding results, respectively error messages) as defined in CCITT Recommendations Q.771 to Q.775 [8]. The coding of these messages is given in subclause 6.3.

### 7.4.1 Routing in the SCCP network

For routing on the international interface and for routing based on the GT translation mechanism within national networks, the coding of the called party address and the calling party address in SCCP shall comply with the following restrictions:

- |                     |           |  |
|---------------------|-----------|--|
| - SSN indicator     | 1         | (SSN for ISDN supplementary services is always included)                           |
| - GT indicator      | 0100      | (includes translation type, numbering plan, encoding scheme and nature of address) |
| - translation type  | 0001 0001 | (translation table)  |
| - numbering plan    | 0001      | (ISDN/telephony numbering plan E.164)  |
| - routing indicator | 0         | (routing on global title)  |

Alternatively, for routing within a national network, the SCCP addressing method based on SPCs may apply. However, within large national networks, it would be advisable to use a hybrid addressing method based on SPCs for regional traffic and GT translation mechanism for long distance traffic, to keep the SS7 routing data manageable.

### 7.4.2 Number information used for routing

The exchange which initiates a dialogue using the GT translation mechanism, shall give its E.164 service centre address as GT in the SCCP calling address field. This precludes that number information sensible to privacy regulations (e.g. CLI) is used for routing on the international interface.

For routing on the international interface, the number information used for GT translation shall comply to the E.164 numbering schemes for Country code and National destination code.

### 7.4.3 SCCP message return procedure

The SCCP message return procedure is always requested by means of the TC-primitives between the CCNR-ASE and the TC protocols.



## 7.4.4 Primitives used between the CCNR-ASE and TC

With respect to the point of whether or not responses (return result or error) are treated as confirmation or separate indications, Q.771 indicates that the situation is as illustrated by figure 3:

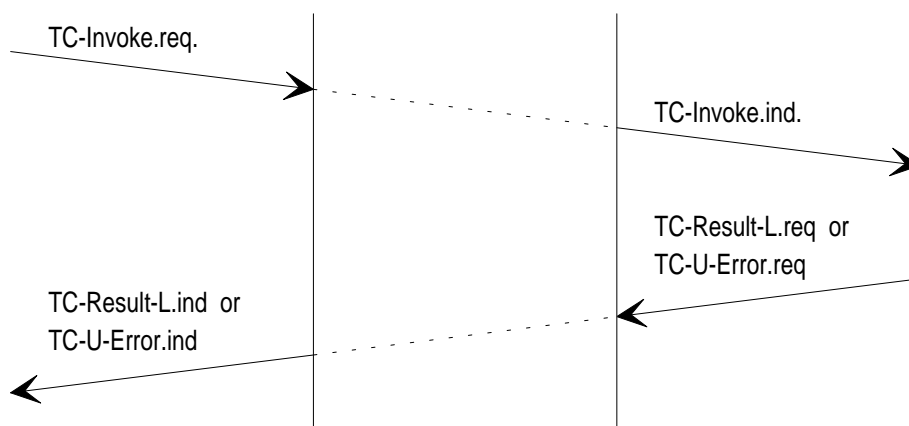

**Figure 3**

Since these are the primitives available from TC, it is a TC-RESULT-L.indication that the originating local exchange will receive in (positive) response to its TC-INVOKE.request.

## 7.5 Dialogue

### 7.5.1 General

The dialogue defined for the CCNR between the peer-to-peer entities (TC-Users) is a structured dialogue. The dialogue ID parameter is used in both operation handling and transmission (dialogue) handling primitives to determine which component(s) pertain(s) to which dialogue.

Each TC-User has its own reference for a given dialogue. These references are local references and mapping of these local references into protocol references transaction ID, included in the messages, is done by TC.

All the operations belong to the same dialogue.

Only class 1 and 4 operations are used.

Each TC message conveys only a single CCNR operation.

### 7.5.2 Dialogue beginning

The originating local exchange establishes the dialogue by using a TC-BEGIN request primitive with TC-INVOKE request primitive to transmit a CCNR request operation invoke component to the destination local exchange.

The destination local exchange responds by:

- Using the TC-CONTINUE request primitive with TC-INVOKE request primitive to transmit a CcnrRequest return result component, confirm the dialogue, and indicate that the CCNR request operation succeeds;
- Using the TC-END request primitive with TC-U-ERROR request primitive to transmit a CcnrRequest return error component, end the dialogue, and indicate that the CCNR request operation fails.

### 7.5.3 Dialogue continuation

The continuation of the dialogue is assumed by class 4 operations using TC-CONTINUE primitives. No result is provided for a class 4 operation. These operations are:

- RemoteUserFree;
- CcbsSuspend;
- CcbsResume.

### 7.5.4 Dialogue end

#### 7.5.4.1 Basic end

a) A dialogue end is requested by the CCNR application (originating or destination local exchange), by a TC-END request primitive with TC-INVOKE request primitive to transmit a CcbsCancel invoke component upon the following cases:

1) with cancelCause:

- at time-out of CCNR-T3 and CCNR-T4; (OLE);
- at time-out of CCNR-T7 and CCNR-T9; (DLE);

2) without cancelCause:

- receipt of a failure indication of the CCNR call from the call control (DLE);
- upon sending of the Release ISUP message with B busy (cause 17 or 34) if the "retain" option is not supported (DLE);
- when user A deactivates the service (OLE);
- in case of an unsuccessful CCNR call set up in the network (OLE);
- in case of any of the following call forwarding activation exists upon arrival of the CCNR call (DLE, see subclause 8.10.);
- CFU; or
- CFB, if the retain option is not supported.

b) A dialogue end is requested by the CCNR application (destination local exchange) by a TC-END request primitive without component primitive upon the following cases:

- if the retain option is supported, upon sending of the Answer message or Connect message from the destination local exchange;
- if the retain option is not supported, upon sending of the Address Complete message (with subscriber free), Call Progress message (with alerting) or Connect message from the destination local exchange.

c) A dialogue end is requested by the CCNR application (destination local exchange) by a TC-END request primitive with TC-U-ERROR request primitive to transmit a CcbsRequest return error component upon the following cases:

- if the maximum number of entries in the destination B queue is reached, see subclause 7.1.1.2.2;
- if the user has not subscribed to the given basic service;
- if there is no compatible terminal at destination B when using the status request procedure, see subclause 7.1.1.2.2;

- in case of one of the following call forwarding activation exists upon arrival of the CcnrRequest invoke component (see subclause 8.10);
  - CFU; or
  - CFB.
- d) A dialogue end is requested by the CCNR application by a TC-END request primitive with TC-U-REJECT request primitive in the following cases:
- if the component check fails.

#### 7.5.4.2 Abnormal end

- a) The TC-user may abandon the service. In this case a peer to peer information is delivered at the time the abort is issued, to the remote TC-User. TC-U-ABORT request primitives without abort reason is used in this case.
- b) If the CCNR request timer CCNR-T2 expires, at the originating local exchange, the CCNR-ASE receives a TC-L-CANCEL indication primitive as response to the CcnrRequest invoke component. In this case the service request shall also be rejected with short term denial as a reason.
- c) On receipt of a TC-NOTICE or a TC-P-ABORT indication primitive, the TC dialogue shall be terminated and the corresponding CCNR request shall be deleted.

---

## 8 Interaction with other supplementary services

### 8.1 Call waiting (CW)

No impact on either ISUP or CCNR-ASE.

### 8.2 Call transfer services

#### 8.2.1 Explicit call transfer (ECT)

No impact on either ISUP or CCNR-ASE.

### 8.3 Connected line identification presentation (COLP)

No impact on either ISUP or CCNR-ASE.

### 8.4 Connected line identification restriction (COLR)

No impact on either ISUP or CCNR-ASE.

### 8.5 Calling line identification presentation (CLIP)

No impact on either ISUP or CCNR-ASE.

## 8.6 Calling line identification restriction (CLIR)

The CLIR requirements from the original call shall be retained by the originating local exchange and used when the CCNR call is completed.

The CLIR requirements from the original call shall apply to the calling user's identity in the CcnrRequest operation, i.e. if the CLIR requirements indicate that the presentation of the calling user's identity is restricted, the calling user's identity shall not be included in the CcnrRequest operation.

## 8.7 Closed user group (CUG)

No impact on either ISUP or CCNR-ASE.

## 8.8 Conference calling (CONF)

No impact on either ISUP or CCNR-ASE.

## 8.9 Direct dialling in (DDI)

No impact on either ISUP or CCNR-ASE.

## 8.10 Call diversion services

### 8.10.1 Call forwarding activated by user A.

No impact on either ISUP or CCNR-ASE.

### 8.10.2 Call forwarding activated by user B.

#### 8.10.2.1 Originating local exchange

No impact on ISUP or CCNR ASE.

#### 8.10.2.2 Destination local exchange (B)

- a) If a CCNR call has to be forwarded, the forwarded IAM shall not contain the CCSS parameter.
- b) Upon the arrival of a CCNR call, if a CFU is activated, the CCNR call shall be forwarded as a normal call and the TC-dialogue is terminated by destination B according to subclause 7.5.4.1.a). The forwarded IAM message does not contain the CCSS parameter.
- c) Upon the arrival of a CCNR call, if a CFNR is activated, as a network option, the following can apply:
  - either the CCNR call is treated as "destination B does not answer the CCNR call" (see subclause 7.3.5.2 d);
  - or the TC-dialogue is terminated by destination B according to subclause 7.5.4.1.a). After expiry of the No Reply timer, the call is forwarded as a normal call. The CCSS parameter in the forwarded Initial Address message is deleted.
- d) Upon the arrival of a CCNR call, if a CFB is activated and if destination B is busy, as a network option, the CCNR call can be either:
  - treated as a "destination B busy upon arrival of a CCNR call" (see subclause 7.3.5.2.c);
  - forwarded as a normal call. The CCSS parameter in the forwarded IAM message is deleted. The TC-dialogue is terminated by destination B according to subclause 7.5.4.1.a).

- e) If destination B requests invocation of the call deflection supplementary service upon the arrival of a CCNR call, then the following actions shall result:
- if the request for call deflection was made before alerting, then the request shall be rejected. The CCNR call shall continue according to subclause 7.3.5; or
  - if the request for call deflection was made during alerting, then the request shall be accepted. The CCNR call shall be deflected as a normal call.

## 8.11 Line Hunting

No impact on ISUP or CCNR ASE.

## 8.12 Three party service (3PTY)

No impact on either ISUP or CCNR-ASE.

## 8.13 User-to-user signalling (UUS)

No impact on either ISUP or CCNR-ASE.

## 8.14 Multiple subscriber number (MSN)

No impact on either ISUP or CCNR-ASE.

## 8.15 Call hold (HOLD)

No impact on either ISUP or CCNR-ASE.

## 8.16 Advice of charge

### 8.16.1 AOC, charging information at call set-up time (AOC-S)

No impact on either ISUP or CCNR-ASE.

### 8.16.2 AOC, charging information during the call (AOC-D)

No impact on either ISUP or CCNR-ASE.

### 8.16.3 AOC, charging information at the end of a call (AOC-E)

No impact on either ISUP or CCNR-ASE.

## 8.17 Subaddressing (SUB)

No impact on either ISUP or CCNR-ASE.

## 8.18 Terminal portability (TP)

No impact on either ISUP or CCNR-ASE.

## 8.19 Completion of calls to busy subscriber (CCBS)

CCBS requests and CCNR requests against the same destination B shall be queued in the same queue. The maximum value of outstanding incoming Call Completion Supplementary Service (CCSS) requests at destination B shall apply to both CCBS and CCNR requests.

## 8.20 Malicious call identification (MCID)

No impact on either ISUP or CCNR-ASE.

## 8.21 Completion of Calls on No Reply (CCNR)

No impact on either ISUP or CCNR ASE.

## 8.22 Message Waiting Indication (MWI)

No impact on either ISUP or CCNR ASE.

## 8.23 Outgoing Call Barring (OCB)

When the CCNR call is barred, the corresponding CCNR request shall be deactivated.

## 8.24 Selective Call Forwarding (SCF)

No impact on either ISUP or CCNR ASE.

---

# 9 Interaction with other networks

When user A and destination B belong to different networks, the completion of calls on no reply (CCNR) supplementary service can be activated, if all the networks involved, support the completion of calls on no reply (CCNR) supplementary service, along the communication path between the two users.

## 9.1 Interworking with an ISUP network without an ISUP that fully supports the CCNR capability

**NOTE:** In the following text ISUP-X is an ISUP version with the capability of generating the CCNR Possible Indicator parameter for the CCNR supplementary service.

As the first call and the CCNR call are normal calls and as other ISUP versions than ISUP-X may be used, the support of the CCNR supplementary service is not always guaranteed, as the CCSS parameter and the CCNR Possible Indicator parameter are not always conveyed.

Although in ISUP-X the CCNR Possible Indicator parameter with "CCNR possible" is received in the ACM/CPG, the CCNR call may not succeed in some cases, e.g.:

- in case of interworking with ISUP blue book in a national network not supporting the transfer of a CCSS parameter in the Initial Address message;
- if the first call (transferring the CCNR Possible Indicator parameter) was routed via ISUP-X (or ISUP-92 in transit nodes) all along the way, whereas the CCNR call is routed through an intermediate exchange only supporting Q.767 (ETS 300 121 [9]). This may be the case both at interworking or at peer-to-peer interworking.

As a network option, the CCNR supplementary service may be supported within networks without ISUP-X capability (in local exchanges) or ISUP-92 (in transit exchanges). Even if no CCNR Possible Indicator parameter is received in the ACM/CPG, the originating local exchange will initiate the sending of a CcnrRequest invoke component if user A activates the CCNR service. The decision in the originating local exchange, whether a CCNR request from user A shall result in the sending of CcnrRequest invoke component, depends on the received information in the ACM/CPG. The outcome of that request depends on the result of the CcnrRequest return component or the TC-NOTICE indication primitive. In table 2, the complete result from the ACM / CPG message information, the CcnrRequest return result component and the TC-NOTICE indication primitive is shown.

As part of this network option, the signalling system shall support for the CCNR call the transfer of a CCNR call indicator in the Initial Address message. The coding of the CCNR call indicator and the interworking with ISUP-X and ISUP-92 is a national matter, which is outside the scope of the present document.

If the CCNR call fails due to received release message with cause #17 or #34 and if the retention option is supported across the networks, the originating local exchange shall keep the transaction resources and shall not restart the timer CCNR-T3.

**Table 2: Outcome of the service, related to the CCNR Possible indicator in combination with the CcnrRequest return result component and TC-NOTICE indication primitive**

	CCNR Possible indicator received (note 3)		no CCNR Possible indicator received
	CCNR possible	CCNR not possible	
CcnrRequest return result component received (SCCP/TC end-to-end)	service supported (note 1)	not applicable	service supported (note 1)
TC-NOTICE indication received (SCCP/TC not end-to-end)	service not supported (note 2)	not applicable	service not supported (note 2)
NOTE 1: CCNR accepted or short term denial.			
NOTE 2: Long term denial.			
NOTE 3: This indicator is contained in the CCNR Possible Indicator parameter.			

## 9.2 Interworking with a network without CCNR-ASE capability

If SCCP/TC capability is available from the originating local exchange towards a network not supporting the CCNR supplementary service, the following shall apply:

- At the destination node, if the indicated sub-system is not provisioned or is unavailable, SCCP will invoke the message return procedure. Alternatively, if the sub-system is available, but the CCNR ASE does not exist, the dialogue begin request will be rejected. (It is an implementation issue whether the rejection is by TC or the TC-user.)

## 9.3 Interworking with a network without SCCP/TC capability

If the originating local exchange is informed through the SCCP message return procedure with a TC-NOTICE indication primitive about the inability of SCCP/TC capability end-to-end, the dialogue ends. This implies that the CCNR supplementary service is not supported.

## 9.4 Interworking with an intermediate network without 1993 version of SCCP capability

If an intermediate network supports SCCP, but not the 1993 version, a received segmented CCNR request, carried in a XU DT message is not treated. No result is received by the originating TC, the CCNR request operation timer (CCNR-T2) expires and the service request is rejected according to subclause 3.5.1.1.2. For further information see the SCCP users guide (ITU-T Recommendation Q.715 [18]).

A received CCNR request, that is not segmented, is supported through interworking with the 1988 version of SCCP.

## 9.5 Interworking with PSTN with analogue subscribers using the CCNR service

If a specific completion of calls on no reply (CCNR) supplementary service, is supported by a PSTN for analogue subscribers (without TC/SCCP/ISUP), interworking with the ITU-T CCNR is a national matter. An international SCCP relay is probably needed.

This item is out of the scope of the present document.

## 9.6 Interworking with PSTN user

It should be possible to activate CCNR on a call meeting no reply between an ISDN and a PSTN user and vice versa, if CCNR is supported for the PSTN user. When one of the two networks is not able to determine busy/no busy/"having initiated an activity" status, the CCNR request will be rejected.

## 9.7 Procedures for interworking with private ISDNs

If the private network indicates to the destination local exchange that CCNR is possible and the destination local exchange can set the CCNR Possible indicator in the CCNR Possible Indicator parameter in the ACM (subscriber free) / CPG (alerting), then the CCNR Possible indicator should be set to "CCNR possible".

If the private network does not indicate to the destination local exchange that CCNR is possible, then the CCNR Possible indicator shall not be set.

As user A and/or B monitoring function is assumed by the private network, specific procedures apply in originating local exchange and/or destination local exchange in the case of interworking with one or two private networks.

The specific procedures are only described hereafter.

### 9.7.1 Provision/withdrawal

As indicated above, a specific category is dedicated to the private network's ISDN number.

### 9.7.2 Normal procedure

#### 9.7.2.1 Activation/deactivation/registration

##### 9.7.2.1.1 Activation

The "retainSupported" is coded TRUE, in the CCNR request, by the originating local exchange only if received from user A.

This information shall be sent to the ISPBX by the destination local exchange, and the "retainSupported" in the CCNR request return result is coded TRUE only if received from user B (if B ISPBX).

If received by the destination local exchange in the CCNR request, the CLI optional parameter is forwarded towards the private network B in order to allow interworking with existing private networks using CLI in a linkage mechanism.

The destination local exchange shall start the supervision timer  $T_{sup}$  on sending the CCNR request to the private network.

The originating local exchange shall start the supervision timer  $T_{sup}$  on receipt of a successful service activation indication.



### 9.7.2.1.2 Deactivation

If a deactivation request is received from user A, the originating local exchange shall send a CcbsCancel invoke component in a TC-END primitive to the destination local exchange for each concerned transaction. User A shall be informed that the deactivation is successful. The resources are released.

### 9.7.2.1.3 Registration

Not applicable.

### 9.7.2.2 Erasure

Not applicable.

### 9.7.2.3 Invocation and operation

The RemoteUserFree invoke component shall be sent by the destination local exchange to the originating local exchange only when a "Remote User Free" indication is received from the private network.

On successful completion of the CCNR call, the destination local exchange shall be informed by the private network of the successful outcome. The destination local exchange shall end the TC dialogue by means of a TC-END request primitive (basic end), without component primitive.

## 9.7.3 Exceptional procedures

### 9.7.3.1 Activation/deactivation/registration

#### 9.7.3.1.1 Activation

None identified.

#### 9.7.3.1.2 Deactivation

None identified.

#### 9.7.3.1.3 Registration

Not applicable.

### 9.7.3.2 Erasure

Not applicable.

### 9.7.3.3 Invocation and operation

#### 9.7.3.3.1 Exceptional situation at destination B's side

In case of Tsup expiry, the destination local exchange releases the TC relation. It has to send a CcbsCancel information to the private network and a TC-END request primitive with TC-INVOKE request primitive to transmit the CcbsCancel invoke component without cancelCause to the originating local exchange.

If a CCNR failure condition is encountered within the private network, the destination local exchange shall be informed. The destination local exchange shall end the TC dialogue by means of a TC-END request primitive (basic end), without component primitive.

### 9.7.3.3.2 Exceptional situation at user A's side

In case of Tsup expiry the originating local exchange releases the TC relation. It has to send a CcbsCancel information to the private network and a TC-END request primitive with TC-INVOKE component primitive to transmit the CcbsCancel invoke component without cancelCause to the destination local exchange.

If a CCNR failure condition is encountered within the private network, the originating local exchange shall be informed. The originating local exchange shall end the TC dialogue by means of a TC-END request primitive (basic end), with TC-INVOKE component primitive for CcbsCancel without cancelCause.

### 9.7.3.3.3 Network congestion

None identified.

## 10 Signalling flows

DSS1 items are shown if they are relevant to signalling interworking. Only the case with coincident S and T reference point is shown.

### 10.1 Normal call - destination B provides the CCNR Possible indicator

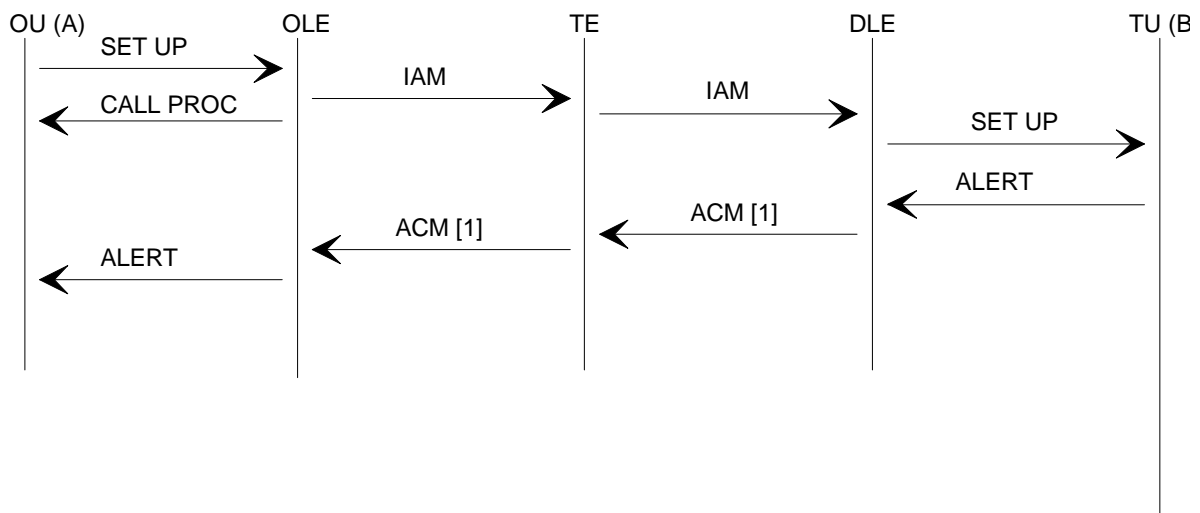

[1] ACM (subscriber free) with CCNR Possible Indicator parameter. Information about CCNR availability in the DLE is provided in this parameter.

NOTE: This figure shows the scenario where the ALERT message is mapped to an ACM (subscriber free). In other scenarios, the CPG may contain the alerting and CCNR possible indication.

Figure 4

## 10.2 Normal call - Successful CCNR request followed by a successful CCNR call set up

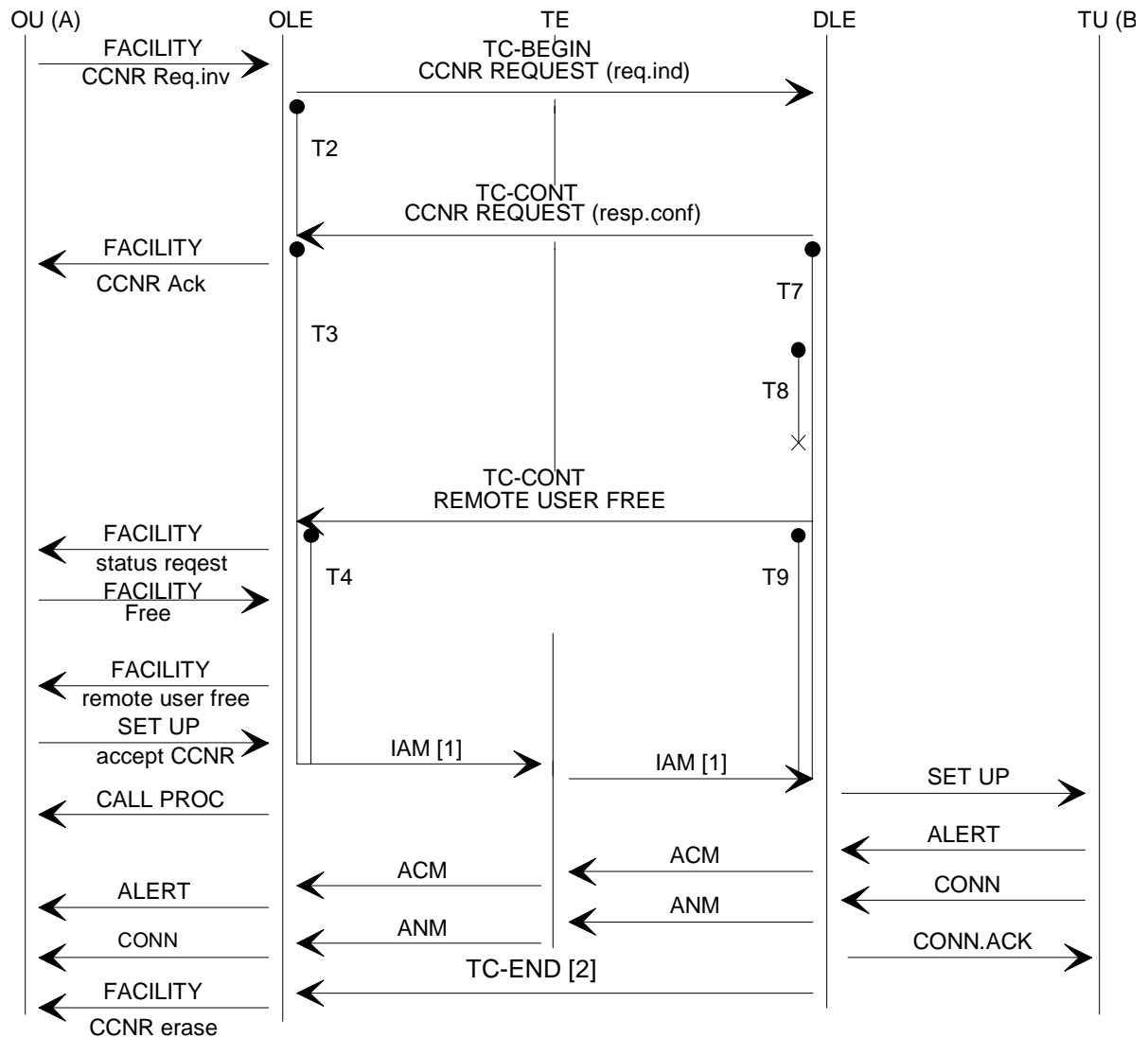

- [1] IAM with:  
 - ISUP required  
 - CCSS parameter
- [2] The case where the retain option is supported is shown.

Figure 5

### 10.3 Unsuccessful CCNR request, terminal activated

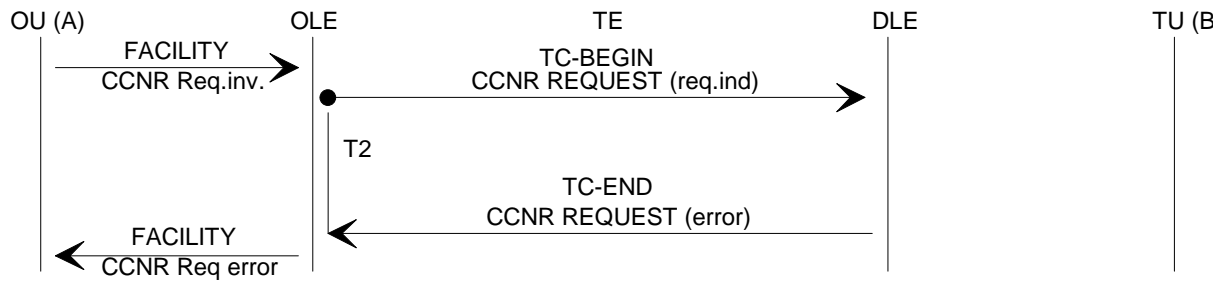

Figure 6

### 10.4 Unsuccessful CCNR request, network decision

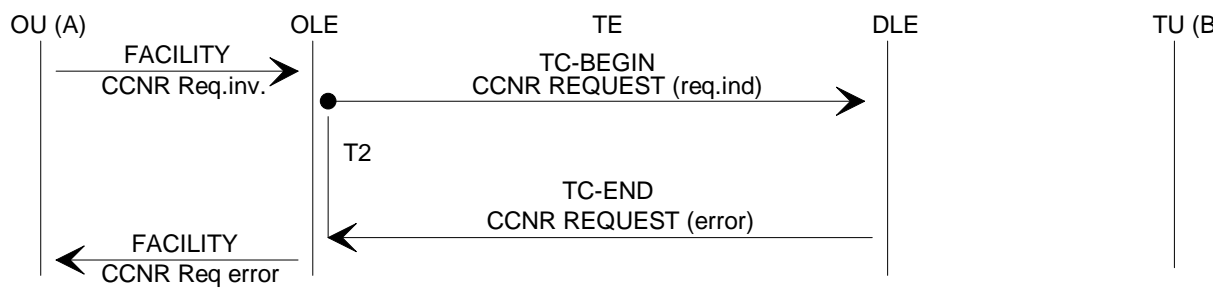
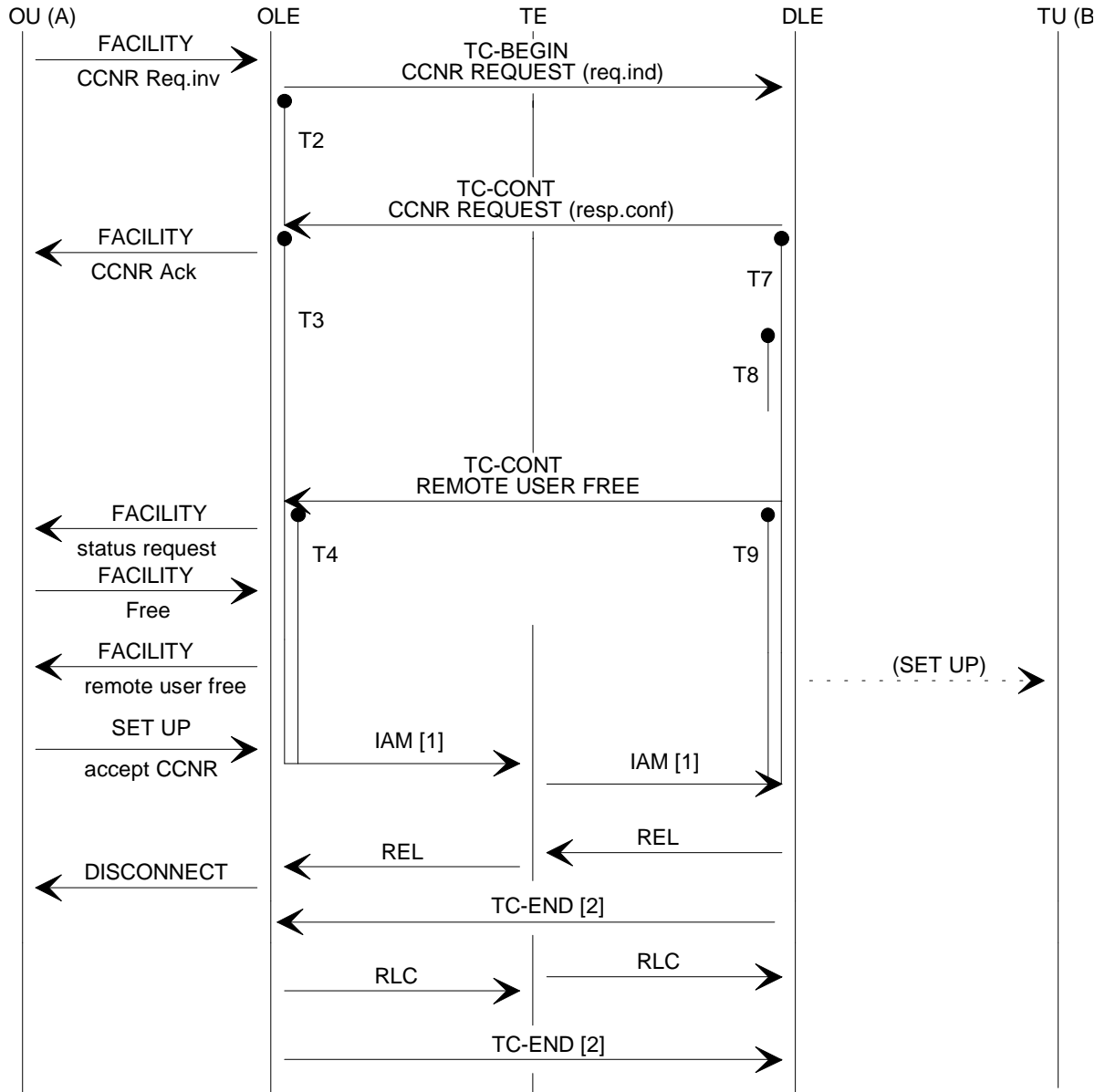

Figure 7

## 10.5 Successful CCNR request followed by an unsuccessful CCNR call set up



- [1] IAM with:  
 - ISUP required  
 - CCSS parameter
- [2] "Retain option not supported" is shown, the TC-END is sent from either DLE or OLE.

**Figure 8**

## 10.6 B idle at CCNR request from A

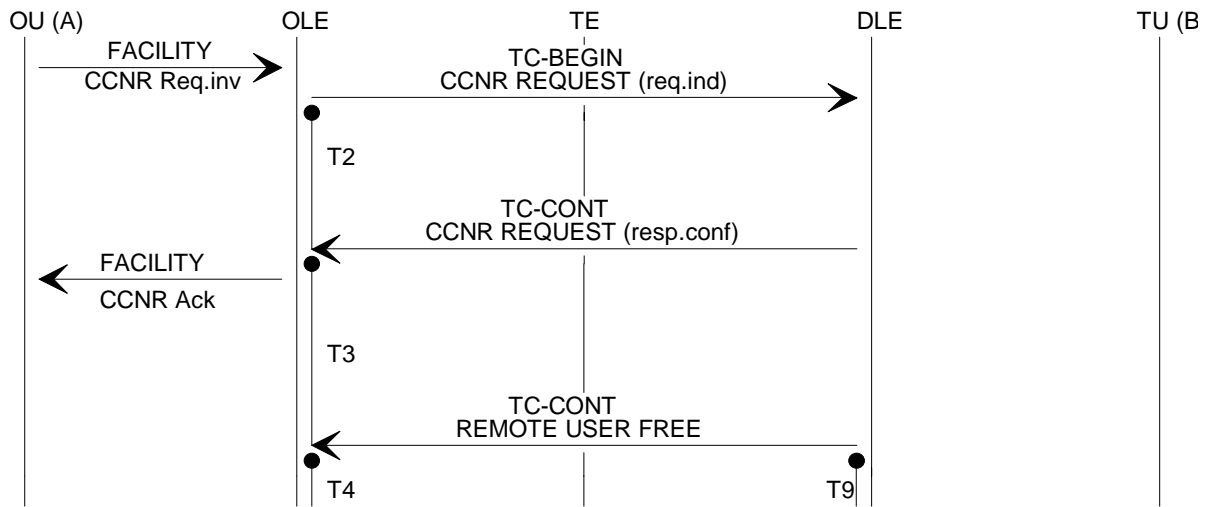

Figure 9

## 10.7 A busy when B becomes free

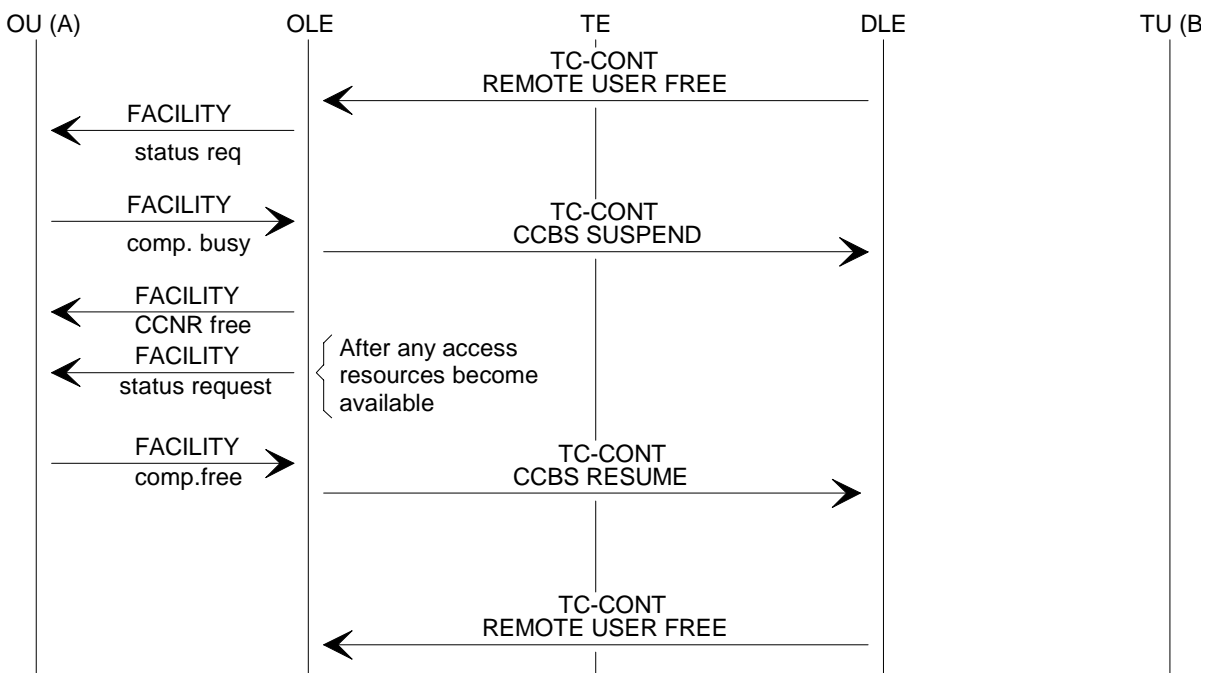

Figure 10

---

## 11 Parameter values

### 11.1 Timers in the originating local exchange

CCNR-T1 Retention timer:

This timer specifies the amount of time that the network retains all of the information supplied by the calling user if the call is terminated while destination B is being informed of the call. The minimum length of the timer is 15 seconds (see also stage one description [12]).

CCNR-T1 is started on receipt of a Release message, on expiry of the basic call answer timer T9, and on release of the calling user.

CCNR-T2 CCNR request operation timer:

Supervision of response to "request CCNR" sent from the originating local exchange to the destination local exchange. CCNR-T2 will expire if signalling is not possible, at signalling failures, or if the destination local exchange cannot respond. Duration = a few seconds.

CCNR-T3 CCNR service duration timer (OLE):

This timer specifies the maximum time the service will remain activated for user A within the network. The minimum value of this timer shall be 60 minutes, the maximum value shall be 180 minutes (see also stage one description [12]).

CCNR-T4 CCNR recall timer:

This timer specifies the maximum time the network will wait for a response from user A to a CCNR recall. The value of this timer is between 10 and 20 seconds (see also stage one description [12]).

### 11.2 Timers in the destination local exchange

CCNR-T7 CCNR service supervision timer:

CCNR-T7 expiry will only be meaningful if expiry of CCNR-T3 has not been notified to the destination exchange. CCNR-T7 shall have longer duration than CCNR-T3, i.e. CCNR-T7 shall expire at abnormal situations only. The value of this timer shall be 190 minutes. When CCNR-T7 expires, the CCNR request will be cancelled in the destination local exchange as well as in the originating local exchange.

CCNR-T8 Destination B idle guard timer:

The time the network will wait after destination B has become not busy after having initiated an activity before informing user A (i.e. before initiating a RemoteUserFree invoke component towards the originating local exchange). The maximum value of this timer shall 15 seconds (see also stage one description [12]).

CCNR-T9 Recall timer:

CCNR-T9 should expire at emergency only, i.e. the recall should be cancelled by CCNR-T4 in the originating local exchange if recall is not responded to. Duration of CCNR-T9 = 20 seconds + some seconds for CCNR call set-up.

### 11.3 Interworking timers

CCNR-Tsup Supervision timer:

This timer is used in the OLE or DLE whenever a private network is attached to these exchanges and the A user and destination B are in the private network. The duration of this timer shall be 190 minutes.

---

## 12 Dynamic description

The SDL diagrams for the CCNR supplementary service are for further study.



---

## Annex A (informative): Coding of the compatibility information

### A.1 CCNR Possible indicator parameter

It is proposed that the parameter compatibility information for the CCNR Possible indicator parameter should be coded as follows:

a) Nth upgraded parameter

XXXX XXXX      CCNR Possible Indicator parameter

Rapporteur's note:      See subclause 6.2.1.2.

b) Instruction indicators

bit    A:    Transit at intermediate exchange indicator  
         0    transit interpretation

bit    B:    Release call indicator  
         0    do not release call

bit    C:    Send notification indicator  
         0    do not send notification

bit    D:    Discard message indicator  
         0    do not discard message (pass on)

bit    E:    Discard parameter indicator  
         0    do not discard parameter (pass on)

bits   GF:   Pass on not possible indicator  
         10   discard parameter

bits   JI:   Broadband/Narrowband interworking indicator  
         11   discard parameter

---

## A.2 CCSS Parameter

It is proposed that the parameter compatibility information for the CCSS parameter should be coded as follows:

a) Nth upgraded parameter

0100 1011      CCSS parameter

b) Instruction indicators

bit    A:    Transit at intermediate exchange indicator

      0    transit interpretation

bit    B:    Release call indicator

      0    do not release call

bit    C:    Send notification indicator

      0    do not send notification

bit    D:    Discard message indicator

      0    do not discard message (pass on)

bit    E:    Discard parameter indicator

      0    do not discard parameter (pass on)

bits   GF:   Pass on not possible indicator

      10   discard parameter

bits   JI:   Broadband/Narrowband interworking indicator

      11   discard parameter

## Annex B (informative): Signalling Interworking

### B.1 Interworking at the Originating Local Exchange

#### B.1.1 CCNR call set-up

Table B.1

SETUP →	IAM →
Facility information element: CCBSCall invoke component or CCBS-T-Call invoke component	CCSS parameter: CCSS call

#### B.1.2 CCNR available indication

a) Coincident S and T reference point

Table B.2

← ALERTING	← ACM (subscriber free), ← CPG (alerting)
Facility information element: CallInfoRetain invoke component	CCNR Possible Indicator parameter: CCNR possible

b) T reference point

Table B.3

← ALERTING	← ACM (subscriber free), ← CPG (alerting)
Facility information element: CCBS-T-Available invoke component	CCNR Possible Indicator parameter: CCNR possible

### B.1.3 CCNR request

a) Coincident S and T reference point

**Table B.4**

<b>FACILITY →</b>	<b>TC-BEGIN →</b>
Facility information element:	
CCNRRequest invoke component	CcnrRequest invoke

**Table B.5**

<b>← FACILITY</b>	<b>← TC-CONTINUE</b>
Facility information element:	CcnrRequest return result
CCNRRequest return result	

b) T reference point

**Table B.6**

<b>REGISTER →</b>	<b>TC-BEGIN→</b>
Facility information element:	
CCNR-T-Request invoke component:	CcnrRequest invoke:
destinationAddress	calledPartyNumber
retentionSupported	retainSupported
q931InfoElement	userServiceInf (BC or BC 1)
	userServiceInfPrime (BC 2)
presentationAllowedIndicator	accessTransportParameter
originatingAddress	callingPartyNumber

**Table B.7**

<b>← FACILITY</b>	<b>← TC-CONTINUE</b>
Facility information element:	CcnrRequest return result
CCNR-T-Request return result	

## B.1.4 Remote user free

a) Coincident S and T reference point

**Table B.8**

← FACILITY	← TC-CONTINUE
Note: First, user A monitoring procedure takes place.  Facility information element:  CCBSRemoteUserFree invoke component	RemoteUserFree

b) T reference point

**Table B.9**

← FACILITY	← TC-CONTINUE
Facility information element:  CCBS-T-RemoteUserFree invoke component	RemoteUserFree

## B.1.5 Suspend/Resume request

a) Coincident S and T reference point

At the coincident S and T reference point, there are no specific signalling interworking aspects for CCNR.

b) T reference point

**Table B.10**

FACILITY →	TC-CONTINUE →
Facility information element:  CCBS-T-Suspend invoke component or CCBS-T-Resume invoke component	CcbsSuspend invoke component or CcbsResume invoke component

## B.1.6 Deactivation request

a) Coincident S and T reference point

**Table B.11**

FACILITY →	TC-END →
Facility information element:  CCBSDeactivate invoke component	CcbsCancel invoke component

b) T reference point

At the T reference point, there are no specific signalling interworking aspects for CCNR.

## B.2 Interworking at the Destination Local Exchange

### B.2.1 CCNR call set-up

- a) Coincident S and T reference point

At the coincident S and T reference point, there are no specific signalling interworking aspects for CCNR.

- b) T reference point

**Table B.12**

<b>IAM →</b>	<b>SETUP →</b>
CCSS parameter:	Facility information element:
CCSS call	CCBS-T-Call invoke component

### B.2.2 CCNR request

- a) Coincident S and T reference point

The receipt of TC-BEGIN with the CcnrRequest invoke component triggers the activation procedures at the destination local exchange.

- b) T reference point

**Table B.13**

<b>TC-BEGIN →</b>	<b>REGISTER →</b>
CcnrRequest invoke:	Facility information element:
CalledPartyNumber	CCNR-T-Request invoke component:
retainSupported	destinationAddress
userServiceInf (BC or BC1)	retentionSupported
userServiceInfPrime (BC 2)	q931InfoElement
accessTransportParameter	presentationAllowedIndicator
callingPartyNumber	originatingAddress

**Table B.14**

<b>← TC-CONTINUE</b>	<b>← FACILITY</b>
CcnrRequest return result	CCNR-T-Request return result

## B.2.3 Remote user free

- a) Coincident S and T reference point

The sending of TC-CONTINUE with RemoteUserFree invoke component is part of the CCNR recall procedure at the destination local exchange.

- b) T reference point

**Table B.15**

← TC-CONTINUE	← FACILITY
RemoteUserFree	Facility information element: CCBS-T-RemoteUserFree invoke component

## B.2.4 CCNR available indication

- a) Coincident S and T reference point

At the coincident S and T reference point, there are no specific signalling interworking aspects for CCNR.

- b) T reference point

**Table B.16**

← ACM (subscriber free), ← CPG (alerting)	← ALERTING
CCNR Possible Indicator parameter: CCNR possible	Facility information element: CCBS-T-Available invoke component

## B.2.5 Suspend/Resume request

- a) Coincident S and T reference point

At the coincident S and T reference point, there are no specific signalling interworking aspects for CCNR.

- b) T reference point

**Table B.17**

TC-CONTINUE →	FACILITY →
CcbsSuspend invoke component or CcbsResume invoke component	Facility information element: CCBS-T-Suspend invoke component or CCBS-T-Resume invoke component

---

## History

<b>Document history</b>		
V3.1.5	December 1997	Public Enquiry PE 9815: 1997-12-12 to 1998-04-10