

**V interfaces at the digital Local Exchange (LE);  
V5.2 interface for the support of Access Network (AN);  
Part 6: Abstract Test Suite (ATS) and partial Protocol  
Implementation eXtra Information for Testing (PIXIT) proforma  
specification for the network layer (LE side)**

---



---

**Reference**

REN/SPAN-09102-6

---

**Keywords**AN, ATS, LE, PIXIT, testing, V interface,  
V5 interface**ETSI**

---

**Postal address**

F-06921 Sophia Antipolis Cedex - FRANCE

---

**Office address**650 Route des Lucioles - Sophia Antipolis  
Valbonne - FRANCE  
Tel.: +33 4 92 94 42 00 Fax: +33 4 93 65 47 16  
Siret N° 348 623 562 00017 - NAF 742 C  
Association à but non lucratif enregistrée à la  
Sous-Préfecture de Grasse (06) N° 7803/88

---

**Internet**

secretariat@etsi.fr

Individual copies of this ETSI deliverable  
can be downloaded from  
<http://www.etsi.org>If you find errors in the present document, send your  
comment to: editor@etsi.fr

---

**Important notice**

This ETSI deliverable may be made available in more than one electronic version or in print. In any case of existing or perceived difference in contents between such versions, the reference version is the Portable Document Format (PDF). In case of dispute, the reference shall be the printing on ETSI printers of the PDF version kept on a specific network drive within ETSI Secretariat.

---

**Copyright Notification**

No part may be reproduced except as authorized by written permission.  
The copyright and the foregoing restriction extend to reproduction in all media.

© European Telecommunications Standards Institute 2000.  
All rights reserved.

# Contents

Intellectual Property Rights .....	5
Foreword .....	5
1 Scope .....	6
2 References .....	6
3 Definitions and abbreviations .....	7
3.1 Definitions .....	7
3.2 Abbreviations .....	7
4 Abstract test method.....	8
4.1 ATM.....	8
4.2 NWK layer protocol testing.....	8
4.3 Data link addresses .....	9
4.4 Execution of TCs.....	9
4.4.1 Handling of error indication.....	9
4.4.2 TC execution sequence .....	9
5 Untestable test purposes.....	9
5.1 Control protocol .....	9
5.2 PSTN protocol.....	10
5.3 Link control protocol.....	10
5.4 BCC Protocol .....	11
5.5 Protection protocol .....	11
6 Abstract test suite conventions.....	12
6.1 Naming conventions .....	12
6.1.1 Declaration part .....	12
6.1.2 Constraint part .....	13
6.1.3 Dynamic part.....	13
6.1.3.1 Test cases .....	13
6.1.3.2 Test steps.....	13
6.1.3.3 General aspects .....	13
6.1.4 ATS abbreviations .....	14
6.2 Implementation conventions.....	14
6.2.1 Declaration part .....	14
6.2.2 Constraint part .....	15
6.2.3 Dynamic part.....	15
6.2.4 Documentation.....	16
<b>Annex A (normative): Abstract test suite for NWK testing.....</b>	<b>17</b>
A.1 The TTCN Graphical form (TTCN.GR).....	17
A.2 The TTCN Machine Processable form (TTCN.MP) .....	17
<b>Annex B (normative): Partial PIXIT proforma.....</b>	<b>18</b>
B.1 Introduction .....	18
B.2 PIXIT proforma.....	18
B.2.1 Identification summary.....	18
B.2.2 Abstract test suite summary.....	18
B.2.3 Test laboratory.....	18
B.2.4 Client .....	19
B.2.5 SUT .....	19
B.2.6 Protocol layer information.....	19
B.2.6.1 Protocol identification .....	19

B.2.6.2 IUT information.....20

History .....27

---

## Intellectual Property Rights

IPRs essential or potentially essential to the present document may have been declared to ETSI. The information pertaining to these essential IPRs, if any, is publicly available for **ETSI members and non-members**, and can be found in SR 000 314: "*Intellectual Property Rights (IPRs); Essential, or potentially Essential, IPRs notified to ETSI in respect of ETSI standards*", which is available from the ETSI Secretariat. Latest updates are available on the ETSI Web server (<http://www.etsi.org/ipr>).

Pursuant to the ETSI IPR Policy, no investigation, including IPR searches, has been carried out by ETSI. No guarantee can be given as to the existence of other IPRs not referenced in SR 000 314 (or the updates on the ETSI Web server) which are, or may be, or may become, essential to the present document.

---

## Foreword

This European Standard (Telecommunications series) has been produced by ETSI Technical Committee Services and Protocols for Advanced Networks (SPAN), and is now submitted for the Public Enquiry phase of the ETSI standards Two-step Approval Procedure.

The present document is part 6 of a multi-part EN covering the V interfaces at the digital Local Exchange (LE); V5.2 interface for the support of Access Network (AN), as described below:

- Part 1: "V5.2 interface specification";
- Part 2: "Protocol Implementation Conformance Statement (PICS) proforma specification";
- Part 3: "Test Suite Structure and Test Purposes (TSS&TP) specification for the network layer (AN side)";
- Part 4: "Abstract Test Suite (ATS) and partial Protocol Implementation eXtra Information for Testing (PIXIT) proforma specification for the network layer (AN side)";
- Part 5: "Test Suite Structure and Test Purposes (TSS&TP) specification for the network layer (LE side)";
- Part 6: "Abstract Test Suite (ATS) and partial Protocol Implementation eXtra Information for Testing (PIXIT) proforma specification for the network layer";**
- Part 7: "Test Suite Structure and Test Purposes (TSS&TP) specification for the data link layer";
- Part 8: "Abstract Test Suite (ATS) and partial Protocol Implementation eXtra Information for Testing (PIXIT) proforma specification for the data link layer";
- Part 9: "Test specification for the physical layer".

<b>Proposed national transposition dates</b>	
Date of latest announcement of this EN (doa):	3 months after ETSI publication
Date of latest publication of new National Standard or endorsement of this EN (dop/e):	6 months after doa
Date of withdrawal of any conflicting National Standard (dow):	6 months after doa

---

# 1 Scope

This sixth part of EN 300 347 contains the Abstract Test Suite (ATS) as well as the Abstract Test Method (ATM) and the partial Protocol Implementation eXtra Information for Testing (PIXIT) proforma for the Network layer (NWK) of the V5.2 interface and parts of the system management of the Local Exchange (LE) side of a V5.2 interface.

The objective of the present document is to provide an ATS containing conformance tests which give a high probability of inter-operability of an Access Network (AN) and a LE from different manufacturers over the V5.2 interface.

ISO/IEC 9646-1 [7] and ISO/IEC 9646-2 [8] are used as the basis for the test methodology. The ATS is defined using the Tree and Tabular Combined Notation (TTCN) according to ISO/IEC 9646-3 [9].

The ATS in annex A describes a set of Test Cases (TCs) which are based on the Test Purposes (TPs) specified in EN 300 347-5 [6] (which is an extension of EN 300 324-5 [2]). The TCs provide the implementation of the TPs and can be converted into an executable test suite by using available TTCN translators and the corresponding tools.

Annex B provides the partial PIXIT proforma.

---

# 2 References

The following documents contain provisions which, through reference in this text, constitute provisions of the present document.

- References are either specific (identified by date of publication, edition number, version number, etc.) or non-specific.
- For a specific reference, subsequent revisions do not apply.
- For a non-specific reference, the latest version applies.
- A non-specific reference to an ETS shall also be taken to refer to later versions published as an EN with the same number.

- [1] EN 300 324-1: "V interfaces at the digital Local Exchange (LE); V5.1 interface for the support of Access Network (AN); Part 1: V5.1 interface specification".
- [2] EN 300 324-5: "V interfaces at the digital Local Exchange (LE); V5.1 interface for the support of Access Network (AN); Part 5: Test Suite Structure and Test Purposes (TSS&TP) specification for the network layer (LE side)".
- [3] EN 300 324-6: "V interfaces at the digital Local Exchange (LE); V5.1 interface for the support of Access Network (AN); Part 6: Abstract Test Suite (ATS) and partial Protocol Implementation eXtra Information for Testing (PIXIT) proforma specification for the network layer".
- [4] EN 300 347-1: "V interfaces at the digital Local Exchange (LE); V5.2 interface for the support of Access Network (AN); Part 1: V5.2 interface specification".
- [5] EN 300 347-2: "V interfaces at the digital Local Exchange (LE); V5.2 interface for the support of Access Network (AN); Part 2: Protocol Implementation Conformance Statement (PICS) proforma specification".
- [6] EN 300 347-5: "V interfaces at the digital Local Exchange (LE); V5.2 interface for the support of Access Network (AN); Part 5: Test Suite Structure and Test Purposes (TSS&TP) specification for the network layer (LE side)".
- [7] ISO/IEC 9646-1: "Information Technology - Open Systems Interconnection - Conformance testing methodology and framework - Part 1: General concepts".
- [8] ISO/IEC 9646-2: "Information Technology - Open Systems Interconnection - Conformance testing methodology and framework - Part 2: Abstract test suite specification".

- [9] ISO/IEC 9646-3: "Information Technology - Open Systems Interconnection - Conformance testing methodology and framework - Part 3: The Tree and Tabular Combined Notation (TTCN)".
- [10] ISO/IEC 9646-5: "Information Technology - Open Systems Interconnection - Conformance testing methodology and framework - Part 5: Requirements on test laboratories and clients for the conformance assessment process".
- [11] ETS 300 406: "Methods for Testing and Specification (MTS); Protocol and profile conformance testing specifications; Standardization methodology".
- [12] ETR 141: "Methods for Testing and Specification (MTS); Protocol and profile conformance testing specifications; The Tree and Tabular Combined Notation (TTCN) style guide".
- [13] EN 300 324-2: "V interfaces at the digital Local Exchange (LE); V5.1 interface for the support of Access Network (AN); Part 2: Protocol Implementation Conformance Statement (PICS) proforma specification".

## 3 Definitions and abbreviations

### 3.1 Definitions

For the purposes of the present document, all terms and definitions given in EN 300 324-6 [3] apply.

### 3.2 Abbreviations

For the purposes of the present document, the following abbreviations apply:

AN	Access Network
ASP	Abstract Service Primitive
ATM	Abstract Test Method
ATS	Abstract Test Suite
BCC	Bearer Channel Connection
BI	Invalid Behaviour
BO	Inopportune Behaviour
BV	Valid Behaviour
CA	CAbility test
CTRL	Control
DSAP	Data link SAP
FE	Function Element
FSM	Finite State Machine
IE	Information Element
ISDN	Integrated Services Digital Network
ISDN-BA	ISDN-Basic Access
IT	basic Interconnection Test
IUT	Implementation Under Test
L3addr	Layer 3 address
LC	Line Circuit
LT1	Lower Tester 1
MPH	Management Physical layer
NWK	Network Layer
PCO	Point of Control and Observation
PDU	Protocol Data Unit
PICS	Protocol Implementation Conformance Statement
PIXIT	Protocol Implementation eXtra Information for Testing
REQ	Request
SAP	Service Access Point
SUT	System Under Test
TP	Test Purposes

TSS	Test Suite Structure
TTCN	Tree and Tabular Combined Notation
UL	Upper Layer
UT	Upper Tester
V5DLaddr	V5 Data Link address

## 4 Abstract test method

This clause describes the Abstract Test Method (ATM) and the Point of Control and Observation (PCO) used to test the NWK of the V5.2 protocol for the LE components.

### 4.1 ATM

Principally, the remote test method is used for V5.2 LE NWK conformance testing. Certain V5.2 LE NWK TPs need also part of the service and national functions. Therefore, the embedded variant of the remote test method is applied.

The national dependent information is defined in the PIXIT.

### 4.2 NWK layer protocol testing

The V5.2 implementations do not offer a direct access to the upper service boundary. The remote test method was chosen because any co-ordination procedures can only be expressed in an informal way.

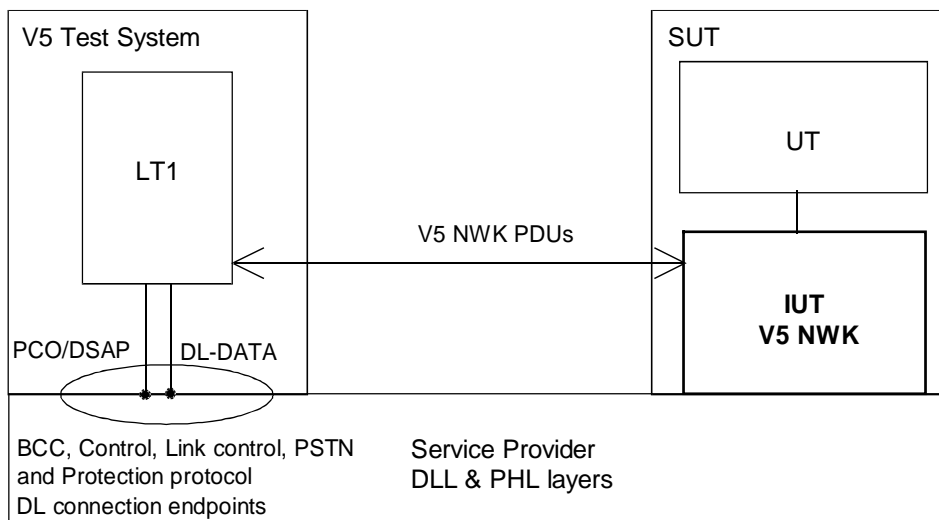

**Figure 1: Remote test method applied to the V5.2 NWK layer testing**

- LT1:** A Lower Tester (LT1) is located in a remote V5.2 test system. It controls and observes the behaviours of the IUT.
- DSAP:** A unique Data link Service Access Point (DSAP) is defined at the V5.2 interface and commonly used for exchanging service data of the different network layer protocol functional entities: PSTN, Control protocols.
- PCO:** The PCOs for NWK testing are located on the DSAP, PSAP, PSTN\_ACCESS and PCM\_ACCESS interfaces. All test events at the DSAP are specified in terms of data link layer Abstract Service Primitives (ASPs) and network layer PDUs. All test events at the PSAP are specified in terms of physical layer ASPs. All test events at PSTN\_ACCESS and PCM\_ACCESS are defined as ASPs.



**UT:** No explicit Upper Tester (UT) exists in the test system. However, the SUT needs to carry out some UL functions to achieve some effects of test co-ordination procedures. Designing ATS, the capability of the system management functions, such as controls of the IUT, its interactions with the Q interface may be taken into account. The controls of the IUT will be implied or informally expressed in the ATS, but no assumption shall be made regarding their feasibility or realization. Examples of such controls could be to provoke restarting IUT or blocking/unblocking procedures through Q interface.

## 4.3 Data link addresses

Within the DSAP, different V5DLaddr are used to identify each corresponding data link connection. Each network layer protocol functional entity can have only one data link connection, e.g. all PSTN signalling information share one data link connection.

Table 1 shows the allocated V5DLaddr used by the protocol function entities.

**Table 1: V5DLaddr**

Protocol	PSTN	Control	BCC	Protection	Link Control
V5DLaddr	8176	8177	8178	8179	8180

## 4.4 Execution of TCs

### 4.4.1 Handling of error indication

During the execution of the NWK ATS many error indications will be sent to the system management due to the invalid and the inopportune TCs. It is up to the IUT supplier to take the necessary precautions to avoid any impact on the test result.

### 4.4.2 TC execution sequence

The following test sequence shall be applied:

The TC containing the start-up procedure shall always be the first TC executed. Also in any case where the IUT has to be restarted this TC shall be first executed.

Protocol groups: CTRL ⇒ LINK ⇒ PROTECTION ⇒ BCC ⇒ PSTN.

Test groups: IT ⇒ CA ⇒ TI ⇒ BV ⇒ BO ⇒ BI.

Interactions between the different test groups are not considered. It is up to the IUT supplier to take the necessary precautions to avoid any impact on the test result.

---

## 5 Untestable test purposes

This clause contains a list of TPs which are not covered by in the ATS due to the chosen ATM or other restrictions.

### 5.1 Control protocol

Table 2 lists TPs which are not covered by the ATS due to unknown reaction of the IUT after testing the TPs or due to the fact they have the same purpose of TC already implemented.

**Table 2: Untestable TPs**

Test Purpose ID
TP1311S1_01
TP1313S0_01
TP1313SM_06
TP1313SM_07
TP1313SM_08
TP1313SM_09
TP1321S1_01
TP1324S1001
TP1324SM_05
TP1324SM_11
TP1325S1001
TP1325S2013
TP1325SM_11
TP1325SM_24
TP1326S1001
TP1326SM_06
TP1326SM_11

## 5.2 PSTN protocol

The test purposes listed in table 3 are not implemented in the ATS due to unknown reaction of the IUT after testing the TPs or due to the fact they have the same purpose of TC already implemented.

**Table 3: Untestable TPs**

Test Purpose ID
TP23__S1_04
TP23__S1_06
TP23__S2_08
TP23__S2_09
TP23__S4_07
TP23__S5_10
TP23__S6_01
TP26__S4_01

## 5.3 Link control protocol

Table 4 lists TPs which are not covered by the ATS due to existing optional procedures which may or may not be applied by the IUT.

**Table 4: Untestable TPs**

Test Purpose ID
TP31__SM_01
TP33_1S1_01
TP33_1SM_03
TP33_7S1002
TP33_7S1103
TP33_7S1112
TP33_7S1113
TP33_7S2001
TP33_7S2105
TP33_7S2134
TP33_7S2135
TP33_7S2204
TP33_7S2228
TP33_7S2229
TP33_7S2244
TP33_7SM_11
TP33_7SM_18
TP33_7SM_40

## 5.4 BCC Protocol

Table 5 lists TPs which are not covered by the ATS because it is not possible to fix the IUT re-provisioning Finite State Machine (FSM) in state LE1.

**Table 5: Untestable TPs**

Test Purpose ID
TP41__SM_01
TP42__SM_02
TP42__SM_03
TP42__SM_04
TP42__SM_05
TP43__SM_23
TP43__SM_24
TP43__SM_25

## 5.5 Protection protocol

Table 6 lists TPs which are not covered by the ATS because it is not possible to provoke the generation of the necessary MPHs from system management.

**Table 6: Untestable TPs**

Test Purpose ID
TP51__SM_01
TP53__S1_13
TP53__SM_04
TP53__SM_05
TP53__SM_15
TP56__S0_02
TP56__S1_04
TP56__S1_06
TP56__S1_07

---

## 6 Abstract test suite conventions

The ATS conventions are intended to give a better understanding of the ATS but they describe also the conventions made for the development of the ATS, thus for any later maintenance purposes or further development of the ATS the conventions described in this clause shall be considered.

The ATS conventions contain two clauses, the naming conventions and the implementation conventions. The naming conventions describe the structure of the naming of all ATS elements. The implementation conventions describe the functional structure of the ATS.

NOTE: To define the ATS, the guidelines given in ETS 300 406 [11] and ETR 141 [12] were considered.

### 6.1 Naming conventions

#### 6.1.1 Declaration part

The ID names of the following definitions are written in lowercase:

- structured type definitions;
- ASP type definitions;
- PDU type definitions.

The ID names of the following definitions are written in uppercase:

- Test Suite Parameter Declarations;
- Test Case Selection Expression Definitions;
- Test Suite Constant Declarations;
- Test Case Variable Declarations.

ID names of PDUs and structured types commence with a protocol identifier to define which protocol they are belonging to. The following identifiers are used:

- control protocol: `ctrl` e.g. `ctrl_common_control_ack`;
- PSTN signalling: `pstn` e.g. `pstn_signal_ack`.

ID names of PDUs and structured types which are used for invalid tests commence with "bi".

EXAMPLE 1: `bi_com_ctrl_two_mety`.

Complete names as defined in the specifications are used for ID names of declarations.

EXAMPLE 2: `ctrl_control_function_element`.

Test suite parameter ID names commence with TSP:

- PICS are identified by adding the letter "C": `TSPC_`. (e.g.: `TSPC_PSTN`);
- PIXIT are identified by adding the letter "X": `TSPX_`. (e.g.: `TSPX_PORT_ADDRESS`).

If a test suite parameter is representing a system parameter or value, only the parameter name is used.

EXAMPLE 3: `MR` (receive sequence number in signal message).

Test suite operations commence with TSO.

EXAMPLE 4: TSO\_INTEGER\_TO\_OCTETSTRING.

Test suite constant ID names commence with TSC.

EXAMPLE 5: TSC\_CFE\_FE201\_2\_UNBL.

If the constant is representing a system parameter or value, only the parameter name is used.

EXAMPLE 6: N01.

ID names of Timers commence with T. The same names as in the specification are used.

EXAMPLE 7: T01.

## 6.1.2 Constraint part

Constraint names commence with uppercase. The remaining part of the ID name is written in lowercase.

ID names of elements concerning the same subject have equivalent names in the declaration and the constraint part:

Declaration part: ctrl\_control\_function\_element;

Constraint part: Ctrl\_control\_function\_element.

The name of the modified constraint describes the particularity of the modified constraint.

EXAMPLE: Ctrl\_cc\_mand\_only (common control message which contains only the mandatory IEs).

If formal parameter lists are used, the variable names are written in lowercase. The variable name is the same as the name of the element it is representing.

## 6.1.3 Dynamic part

### 6.1.3.1 Test cases

The identifier of the TCs is constructed in the same way as for the TPs described in EN 300 347-5 [6], subclause 5.1.1, with the exception that "TP" is replaced by "TC".

TP identifier: TP1324S1106;

TC identifier: TC1324S1106.

### 6.1.3.2 Test steps

In TCs, test steps as well as local trees are used. To allow an easy distinction, the following naming is applied:

local tree: LTS\_[local\_tree\_name];

test step: STEP\_[test-step\_name].

### 6.1.3.3 General aspects

All verdict assignments are labelled. To allow an exact identification in which table the verdict was assigned, the following name convention is applied:

B	test Body
CS	status verification test steps (Check Status)
D	Default
E	Error handling test steps
PO	POstamble
PR	PReamble
S	test Step

Combinations of labels are also possible.

EXAMPLE: DPR --> label which is used in a default for preambles.

## 6.1.4 ATS abbreviations

These abbreviations are used to shorten identifier names:

addr	address
act	activate
acc	access
ack	acknowledgement
alloc	allocation
cau	cause
cc	common control
cfe	control function element
cfi	control function identifier
chan	channel
com	common
cpl	complete
ctrl	control
dl	data link
enq	enquiry
est	establish
func	function
ind	indication
interf	interface
mand	mandatory
mety	message type
mod	modified
par	parameter
pc	port control
pd	protocol discriminator
perform	performance
prog	progress
pr	protection protocol
prot	protocol
prov	provisioned
repro	re-provisioning
req	request
rest	restart
rsp	response
up	user port
var	variant
verify	verifying
vid	variant & interface ID

## 6.2 Implementation conventions

### 6.2.1 Declaration part

The comment line of single element TTCN tables (e.g. test suite constants) is used to give a reference where the format and content of the element is described in the relevant protocol specifications. Any particularity of the element format or content is described in the comment line.

The comment line in the header of multi-element TTCN tables (e.g. ASPs) is used to reference to the protocol specification.

The detailed comments are used to describe any particularity of the table.

In the ASP and PDU declarations, the comments column is used to identify if an element is mandatory or optional.

m: mandatory;

o: optional.

In the ASP and PDU declarations the comments column is further used to give information about the element value, in particular if the element contains a fixed spare value.

In tables where structure types are used the information element and the relevant structured type have always the same name, that allows to have the same structure as in the protocol standards is used to document the relation between information elements in a table and their specific description in an other clause of the protocol standard.

## 6.2.2 Constraint part

The ASPs and PDUs are defined in a way that all relevant element are parameterized. That improves the transparency of the constraints in the dynamic part, as all values which are relevant for the test are always present.

Generally the base constraint contains all possible parameters and the relevant formal parameter list which goes with the base constraint. In case where a specific message IE is not used at all in the ATS, the base constraint will not contain such an IE. The base constraints of the PSTN protocol contain all mandatory IEs. The optional IEs are defined in one element of type OCTETSTRING. The actual value and format of the optional IE has to be defined in the PIXITs according to the PSTN specifications which is implemented in the IUT.

Modified constraints have the same parameter list as the base constraint. Not used elements of the parameter list are set to a default value "ANY" in the dynamic part. The number of base constraints is reduced to a minimum.

The comment line of a constraint contains always the reference to the used specifications. The detailed comments sector is used to describe any particularity of the table.

## 6.2.3 Dynamic part

Some TCs need a particular initialization of the IUT environment conditions to run the actual test, e.g. for testing re-provisioning procedures. Such message sequence can be quite complicated and long. In cases where a Local Test Step (LTS) facilitates the TC structure, the preamble and the condition setting are described in a LTS called **LTS\_pre\_step**. All LTS\_pre\_steps are described in the detailed comment part of the TTCN table.

Some TCs need after the actual test a particular re-initialization of the IUT, e.g. after re-provisioning. Such message sequence can be quite complicated and long. In cases where a Local Test Step (LTS) facilitates the TC structure, the postamble and the re-initialization are described in a LTS called **LTS\_post\_step**. All LTS\_post\_steps are described in the detailed comment part of the TTCN table.

All events which are defined as a conformance requirements by the TP, cause a preliminary verdict PASS if the requirement is met.

All invalid events are handled in the default tree. FAIL verdicts are only assigned in the default tree. The default tree contains the error handling procedure for the particular TC.

The preamble, the test body and the postamble have different defaults, what allows a specific verdict handling, e.g. only INCONC verdicts are assigned in the preamble.

Test steps do not contain a default. That allows to apply them with no restrictions regarding the error handling.

All verdict assignments are labelled. According to ISO/IEC 9646-3 [9], clause E.2, labels should be written to the conformance log. This allows to identify where the test failed. To allow an exact identification in which table the verdict was assigned, the naming convention as described in subclause 6.1.3.3 is applied.

The labels of the same type are numbered sequentially if they are in the same TC, test step or default.

TPs which only reference to an other TP, e.g. BV TPs which were already defined as CA TPs, are only implemented ones, thus the numbering of the TCs is not always continues.

TPs which are listed in the untestable TP list in clause 5, or which reference to an other TP, e.g. BV TPs which were already defined as CA TPs, are not considered in the ATS, thus these TC identifiers are missing in the ATS and the numbering of the TCs is not always continues.

NWK implementation:

- 1) the PDUs used in implicit send have the same name as the system management message which has to be sent to the IUT to provoke the requested event;
- 2) the ATS rebuilds the PSTN functions. Therefore, the signal message sequence numbers M(S) and M(R) are implemented and used according to their function described in EN 300 347-1 [4];
- 3) TCs of the \*/PORT/TRANS test group which have to be applied either to the PSTN user port or the ISDN-BA user port depending on the provisioned application in the IUT, use a common TC definition where the L3addr is parameterized (TCV\_l3\_addr). The L3\_addr to be used during the execution is assigned in the test step STEP\_Ctrl\_pc\_trans\_init depending on the setting of the PICS which describe the provisioned data set. All of the TCs in the test groups \*/PORT/TRANS begin with the test step STEP\_Ctrl\_pc\_trans\_init.

## 6.2.4 Documentation

The comment line of the TC or test step header contains a reference to the relevant protocol specification.

The comment column of the dynamic behaviour part is used to number the test events which are relevant for the particular test or test operation.

Based on the numbering in the comment column all for the TC relevant events are described in the detailed comments part of each TTCN table.

Test procedures which cover a conformance requirement and lead to a preliminary or final verdict assignment are described as follows in the detailed comments part:

- **Expected event:** a specific receive event is expected;
- **Expected behaviour:** no event or a timer expiry is expected;
- **Expected status:** the IUT is expected to be in a particular status;



---

## Annex A (normative): Abstract test suite for NWK testing

This ATS has been produced using the Tree and Tabular Combined Notation (TTCN) according to ISO/IEC 9646-3 [9].

The ATS was developed on a separate TTCN software tool and therefore the TTCN tables are not completely referenced in the table of contents. The ATS itself contains a test suite overview part which provides additional information and references.

---

### A.1 The TTCN Graphical form (TTCN.GR)

The TTCN.GR representation of this ATS is contained in an Adobe Portable Document Format™ file (v52nle\_e2\_03.PDF contained in archive en\_30034706v020102c0.ZIP) which accompanies the present document.

---

### A.2 The TTCN Machine Processable form (TTCN.MP)

The TTCN.MP representation corresponding to this ATS is contained in an ASCII file (v52nle\_e2\_03.MP contained in archive en\_30034706v020102c0.ZIP) which accompanies the present document.

---

## Annex B (normative): Partial PIXIT proforma

Notwithstanding the provisions of the copyright clause related to the text of the present document, ETSI grants that users of the present document may freely reproduce the PIXIT proforma in this annex so that it can be used for its intended purposes and may further publish the completed PIXIT.

---

### B.1 Introduction

The PIXIT proforma are based on ISO/IEC 9646-5, any additional information needed can be found in the present document.

---

### B.2 PIXIT proforma

#### B.2.1 Identification summary

PIXIT Number:

.....

Test Laboratory Name:

.....

Date of Issue:

.....

Issued to:

.....

#### B.2.2 Abstract test suite summary

Protocol Specification: EN 300 347-1

Protocol to be tested: V5.2, LE network layer

ATS Specification: EN 300 347-6

Abstract Test Method: Remote test method, embedded variant

#### B.2.3 Test laboratory

Test Laboratory Identification:

.....

Test Laboratory Manager:

.....

Means of Testing:

.....

SAP Address:

.....

## B.2.4 Client

Client Identification:

.....

Client Test manager:

.....

Test Facilities required:

.....

## B.2.5 SUT

Name:

.....

Version:

.....

SCS Number:

.....

Machine configuration:

.....

Operating System Identification:

.....

IUT Identification:

.....

PICS Reference for IUT:

.....

Limitations of the SUT:

.....

Environmental Conditions:

.....

## B.2.6 Protocol layer information

### B.2.6.1 Protocol identification

Name: V5.2, network layer protocol for Control and PSTN

Version: .....

PICS References: EN 300 347-2

## B.2.6.2 IUT information

Table B.1: Addresses

Address name	Parameter type	Reference	Value
TSPX_CTRL_ISDNBA_PORT_ADDR	OCTETSTRING[11]	Port address of the ISDN-BA user port provisioned (EN 300 324-1, subclause 14.4.2.3)	
TSPX_CTRL_ISDNPRA_PORT_ADDR	OCTETSTRING[11]	Port address of the ISDN-BA user port provisioned (EN 300 324-1, subclause 14.4.2.3)	
TSPX_CTRL_PSTN_PORT_ADDR	OCTETSTRING[11]	Port address of the PSTN user port provisioned (EN 300 324-1, subclause 14.4.2.3)	
TSPX_CTRL_PSTN_PORT_ADDR_NOT_PROV	OCTETSTRING[11]	Port address of the PSTN user port which is not provisioned (EN 300 324-1, subclause 14.4.2.3)	
TSPX_V5DL_ADDR_BCC	OCTETSTRING[2]	V5DLaddr for the BCC protocol (see note) (EN 300 324-1, table 1)	default value: '1111 11?? 1110 010?'B
TSPX_V5DL_ADDR_CTRL	OCTETSTRING[2]	V5DLaddr for the Control protocol (see note) (EN 300 347-1, table 1)	default value: '1111 11?? 1110 001?'B
TSPX_V5DL_ADDR_LC	OCTETSTRING[2]	V5DLaddr for the Link control protocol (see note) (EN 300 347-1, table 1)	default value: '1111 11?? 1110 100?'B
TSPX_V5DL_ADDR_PR	OCTETSTRING[2]	V5DLaddr for the Protection protocol (see note) (EN 300 347-1, table 1)	default value: '1111 11?? 1110 011?'B
TSPX_V5DL_ADDR_PSTN	OCTETSTRING[2]	V5DLaddr for the PSTN protocol (see note) (EN 300 347-1, table 1)	default value: '1111 11?? 1110 000?'B
TSPX_SUBSCRIBER_NUMBER_ISDN	IA5String	Subscriber number for V5 ISDN subscriber, used for invoking ALLOCATION message for BCC testing.	
TSPX_SUBSCRIBER_NUMBER	IA5String	Subscriber number for V5 subscriber, used for invoking ESTABLISH message.	
NOTE:	The TSPX_V5DL_ADDR is used to address either the Control or PSTN NWK entity. The TSPX_V5DL_ADDR is part of the ASP send or received. Depending on the V5DLaddr format requested by the target implementation (LT1), the TSPX_V5DL_ADDR shall be coded according to EN 300 324-1, table 1.		

Table B.2: Parameter values

Parameter name	Parameter type	Reference	Parameter value
TSPX_BCC_REF_NUM	OCTETSTRING[2]	BCC Reference Number used to initialize a single BCC process (EN 300 347-1, subclause 17.4.1)	
TSPX_BCC_UP_ID_ISDN_BA	OCTETSTRING[2]	ISDN-BA User Port Identification Value (last two octets of UP IE) (EN 300 347-1, subclause 17.4.2.1)	
TSPX_BCC_UP_ID_ISDN_PRA	OCTETSTRING[2]	ISDN-PR User Port Identification Value (last two octets of UP IE) (EN 300 347-1, subclause 17.4.2.1)	
TSPX_BCC_UP_ID_PSTN	OCTETSTRING[2]	PSTN User Port Identification Value (last two octets of UP IE) (EN 300 347-1, subclause 17.4.2.1)	
TSPX_BCC_V5_LINK_ID_PRI	OCTETSTRING[1]	V5 2 048 kbit/s link identifier of the primary link (EN 300 347-1, subclause 17.4.2.3)	
TSPX_BCC_V5_LINK_ID_2ND	OCTETSTRING[1]	V5 2 048 kbit/s link identifier of the secondary link (ETS 300 347-1, subclause 17.4.2.3)	
TSPX_BCC_AUDIT_CAUSE_PSTN	OCTETSTRING	BCC reject cause to invoke AUDIT procedure for PSTN subscriber (ETS 300 347-1)	
TSPX_BCC_AUDIT_CAUSE_ISDN	OCTETSTRING	BCC reject cause to invoke AUDIT procedure for ISDN subscriber (ETS 300 347-1)	
TSPX_CTRL_INTERF_ID	OCTETSTRING[2]	Interface ID (EN 300 324-1, subclause 14.4.2.5.7, figure 4)	
TSPX_CTRL_VAR	OCTETSTRING[10]	Presently active variant of the IUT (EN 300 324-1, figure 39, table 55)	
TSPX_CTRL_VAR_NEW	OCTETSTRING[10]	Variant announced to become next active variant of the IUT (EN 300 324-1, figure 39, table 55)	
TSPX_CTRL_VAR_NOT_PROV	OCTETSTRING[10]	Not available Variant in the IUT (not provisioned) (EN 300 324-1, figure 39, table 55)	
TSPX_LC_L3_ADDR_MAIN	OCTETSTRING[2]	Layer 3 address IE of the 2 Mbit/s link used for the link control protocol tests (EN 300 324-1, subclause 14.4.2.3)	
TSPX_LC_L3_ADDR_2ND_LINK	OCTETSTRING[2]	Layer 3 address IE of the second 2 Mbit/s link used for the link control protocol tests (EN 300 324-1, subclause 14.4.2.3)	
TSPX_LC_L3_ADDR_NOT_PROV	OCTETSTRING[2]	Layer 3 address IE of a not provisioned V5.2 2 Mbit/s link (EN 300 324-1, subclause 14.4.2.3)	
TSPX_PR_LOGICAL_C_CHANN_ID_CHANN1	OCTETSTRING[2]	Logical C-channel 1 ID information element (EN 300 347-1, subclause 18.5.1)	
TSPX_PR_LOGICAL_C_CHANN_ID_CHANN2	OCTETSTRING[2]	Logical C-channel 2 ID information element (EN 300 347-1, subclause 18.5.1)	
TSPX_PR_LOGICAL_C_CHANN_ID_UNPROV	OCTETSTRING[2]	Logical C-channel ID information element with unprovisioned L3 address (EN 300 347-1, subclause 18.5.1)	
TSPX_PR_PHL_C_CHANN_ID_LINK_ID_1ST	OCTETSTRING[1]	Primary physical C-channel ID, V5 2 Mbit/s link ID in use (EN 300 347-1, subclause 18.5.3, figure 29)	
TSPX_PR_PHL_C_CHANN_ID_LINK_ID_2ND	OCTETSTRING[1]	Secondary physical C-channel ID, V5 2 Mbit/s link ID in use (EN 300 347-1, subclause 18.5.3, figure 29)	
TSPX_PR_PHL_C_CHANN_ID_TS_15	BITSTRING[5]	Physical C-channel ID, V5 time slot number 15 (EN 300 347-1, subclause 18.5.3, figure 29)	
TSPX_PR_PHL_C_CHANN_ID_TS_16	BITSTRING[5]	Physical C-channel ID, V5 time slot number 16 (EN 300 347-1, subclause 18.5.3, figure 29)	

Parameter name	Parameter type	Reference	Parameter value
TSPX_N3	INTEGER	Counter related to the DISCONNECT message and the timer T3. Default value is 2.	

Table B.3: Timer values

Timer name type	Reference	Timer range	Timer value
TSPX_TIMER_interface_startup	Time to wait the interface start-up procedure to finish.	value: 10 to 60 [s]	
TSPX_TIMER_link_failure	Time to wait for IUT to get to link failure state when link is disconnected.	value: 1 to 20 [s]	
TSPX_TIMER_T01_max	EN 300 324-1, table 58	value: 1 200 [ms] T01 + T01 tolerance + test environment tolerance	
TSPX_TIMER_T02_max	EN 300 324-1, table 58	value: 1 200 [ms] T02 + T02 tolerance + test environment tolerance	
TSPX_TIMER_T1_max	EN 300 324-1, table 28	value: 1 200 [ms] T1 + T1 tolerance + test environment tolerance	
TSPX_TIMER_T3_max	EN 300 324-1, table 28	value: 2 400 [ms] T3 + T3 tolerance + test environment tolerance	
TSPX_TIMER_T4_max	EN 300 324-1, table 28	value: 2 400 [ms] T4 + T4 tolerance + test environment tolerance	
TSPX_TIMER_AC_short	Watch dog timer if immediate ACtion is expected from the IUT.	value: 1 000 [ms]	
TSPX_TIMER_AC_long	Watch dog timer if an ACtion from the IUT is expected after an undefined time period.	value: 60 [s]	
TSPX_TIMER_WAIT_SONV_BACK	Time to wait before Switch-Over to New Variant is invoked to get initial provisioning variant.		
TSPX_TIMER_WAIT_PROT_BACK	Time to wait before Protection Switch-Over is invoked to get initial C-channel configuration.		
TSPX_TIMER_Tbcc1_max	EN 300 347-1, table 46	value: 500 to 1 800 [ms] Tbcc1 + Tbcc1 tolerance + test environment tolerance	
TSPX_TIMER_Tbcc2_max	EN 300 347-1, table 46	value: 2 000 to 2 400 [ms] Tbcc2 + Tbcc2 tolerance + test environment tolerance	
TSPX_TIMER_Tbcc3_max	EN 300 347-1, table 46	value: 2 000 to 2 400 [ms] Tbcc3 + Tbcc3 tolerance + test environment tolerance	
TSPX_TIMER_Tbcc4_max	EN 300 347-1, table 46	value: 500 to 1 800 [ms] Tbcc4 + Tbcc4 tolerance + test environment tolerance	
TSPX_TIMER_Tbcc5_max	EN 300 347-1, table 46	value: 500 to 1 800 [ms] Tbcc5 + Tbcc5 tolerance + test environment tolerance	
TSPX_TIMER_LCTO1_max	EN 300 347-1, table 23	value: 1 000 to 1 200 [ms] LCTO1 + LCTO1 tolerance + test environment tolerance	
TSPX_TIMER_TSO1_max	EN 300 347-1, table 64	value: 1 500 to 1 800 [ms] TSO1 + TSO1 tolerance + test environment tolerance	
TSPX_TIMER_TSO2_max	EN 300 347-1, table 64	value: 1 500 to 1 800 [ms] TSO2 + TSO2 tolerance + test environment tolerance	

Table B.4: Procedural information

Procedural name	Reference to EN 300 324-1	Valid?
TSPX_PSTN_TERMINATING_CALL_PRIORITY	Terminating calls have priority (val: TRUE) (subclause 13.5.3.3). If the parameter is not set (val: FALSE), originating calls have priority.	
TSPX_2ND_LINK_DISCONNECT	Test case selection parameter for 2nd link disconnection.	
TSPX_BCC_AUDIT_SUPPORTED	This parameter shall be set if this ATS is able to invoke the IUT to send AUDIT message.	
NOTE: All parameters are of type BOOLEAN.		

Table B.4 requests the national specific optional PSTN data, which shall be coded according to the PSTN standard to which the PSTN application of the IUT shall conform.

Table B.5: Optional information

PIXIT name	Related message	Reference to EN 300 324-1	Specific requirements	Value
TSPX_PSTN_COND_INFO_EST	ESTABLISH	13.3.1, table 5	Conditional part of ESTABLISH message received by LT1	
TSPX_PSTN_COND_INFO_EST_SEND	ESTABLISH	13.3.1, table 5	Conditional part of ESTABLISH message sent by LT1	
TSPX_PSTN_COND_INFO_EST_4_REP_OPT_IE	ESTABLISH	13.3.1, table 5 13.5.2.5 (error conditions) see also note	The conditional part shall contain 4 repeated conditional IE which are valid for the IUT to be tested.	
TSPX_PSTN_COND_INFO_EST_ONE_INCORR_COND_IE	ESTABLISH	13.4.5, table 17 13.5.2.9 (error conditions) see also note	The conditional part shall contain one incorrect conditional IE.	
TSPX_PSTN_COND_INFO_ESTONE_UNSPEC_IE	ESTABLISH	13.4.5, table 17 13.5.2.7 (error conditions) see also note	The conditional part shall contain one unspecified IE.	
TSPX_PSTN_COND_INFO_EST_TWO_DIFF_COND_IE	ESTABLISH	13.3.1, table 5 13.5.2.11 (error conditions) see also note	The conditional part shall contain two different conditional IEs.	
TSPX_PSTN_OPT_INFO_EST_ACK	ESTABLISH_ACK	13.3.2, table 6		
TSPX_COND_INFO_SIGNAL_DIGIT1	SIGNAL	13.3.3, table 7	Conditional information of a SIGNAL message which is sent from the AN to the LE and which represents the line signal of digit 1	
TSPX_COND_INFO_SIGNAL_DIGIT2	SIGNAL	13.3.3, table 7	Conditional information of a SIGNAL message which is sent from the AN to the LE and which represents the line signal of digit 2 (see note)	
TSPX_COND_INFO_SIGNAL_DIGIT3	SIGNAL	13.3.3, table 7	Conditional information of a SIGNAL message which is sent from the AN to the LE and which represents the line signal of digit 3 (see note)	
TSPX_COND_INFO_SIGNAL_LE	SIGNAL	13.3.3, table 7	Conditional information of a SIGNAL message which is sent from the LE to the AN	
NOTE: The PSTN messages which contain invalid optional information shall be coded according to the national PSTN specifications but the optional information shall be modified according to EN 300 324-1, subclause 13.5.2.				



Table B.6: Implicit send events

PIXIT name	Description	Selection
TSPX_IMPLICIT_EVENT_CTRL	This PIXIT is used to select/deselect CTRL test cases which use implicit send events and thus need manual operations (no automatic execution)	
TSPX_IMPLICIT_EVENT_PSTN	This PIXIT is used to select/deselect PSTN test cases which use implicit send events and thus need manual operations (no automatic execution)	
TSPX_IMPLICIT_EVENT_PSTN_SIGNAL	This PIXIT is used to select/deselect PSTN test cases which use implicit send events for SIGNAL messages and thus need manual operations (no automatic execution)	
TSPX_IMPLICIT_EVENT_LC	This PIXIT is used to select/deselect LCP test cases which use implicit send events and thus need manual operations (no automatic execution)	
TSPX_IMPLICIT_EVENT_BCC	This PIXIT is used to select/deselect BCC test cases which use implicit send events and thus need manual operations (no automatic execution)	
TSPX_IMPLICIT_EVENT_PROT	This PIXIT is used to select/deselect PROT test cases which use implicit send events and thus need manual operations (no automatic execution)	
TSPX_IMPLICIT_EVENT_ISDN	This PIXIT is used to select/deselect BCC test cases which use implicit send events involving ISDN user port and thus need manual operations (no automatic execution)	
TSPX_IMPLICIT_EVENT_PCM	This PIXIT is used to select/deselect use of implicit send events for PCM connect/disconnect and thus need manual operations (no automatic execution)	
NOTE: All parameters are of type BOOLEAN.		

Table B.7: Implicit send event procedures

Implicit event	Description	Procedural information
<IUT ! ctrl_com_ctrl> Ctrl_cc_no_interf_id(TSC_CFI_SWITCH_OVER_TO_NEW_VAR, TSPX_CTRL_VAR_NEW, -, -)	How can the sending of an COMMON CONTROL message (cfi: switch over to new variant) by the IUT be invoked?	
<IUT ! ctrl_com_ctrl> Ctrl_cc_mand_only(TSC_CFI_REST_REQ, -, -, -)	How can the sending of an COMMON CONTROL message (cfi: restart request) by the IUT be invoked?	
<IUT ! ctrl_com_ctrl> Ctrl_cc_mand_only(TSC_CFI_REQ_VID, -, -, -)	How can the sending of an COMMON CONTROL message (cfi: request variant & interface ID) by the IUT be invoked?	
<IUT ! ctrl_port_ctrl> Ctrl_pc (TCV_l3_addr, TSC_CFE_FE203_4_BL)	How can the sending of an PORT CONTROL message (cfe: block command) by the IUT (ISDN-BA entity) be invoked?	
<IUT ! ctrl_port_ctrl> Ctrl_pc_isdnba(TSC_CFE_FE201_2_UNBL)	How can the sending of an PORT CONTROL message (cfi: unblock request/ack) by the IUT (ISDN-BA entity) be invoked?	
<IUT ! ctrl_port_ctrl> Ctrl_pc_pstn(TCV_l3_addr, TSC_CFE_FE203_4_BL)	How can the sending of an PORT CONTROL message (cfe: block command) by the IUT (PSTN entity) be invoked?	
<IUT ! ctrl_port_ctrl> Ctrl_pc_pstn(TSC_CFE_FE201_2_UNBL)	How can the sending of an PORT CONTROL message (cfi: unblock request/ack) by the IUT (PSTN entity) be invoked?	
<IUT ! lc_link_ctrl> Lc_lc(TSPX_LC_L3_ADDR_MAIN, TSC_LCF_FE301_2_UNBL)	How can the sending of an LINK CONTROL message (lcf: FE301/2, link_unblock ack/req) by the IUT be invoked?	
<IUT ! lc_link_ctrl> Lc_lc(TSPX_LC_L3_ADDR_2ND_LINK, TSC_LCF_FE303_4_BL)	How can the sending of an LINK CONTROL message (lcf: FE303/4, link_block_cmd) by the IUT be invoked?	

Implicit event	Description	Procedural information
<IUT ! lc_link_ctrl> Lc_lc(TSPX_LC_L3_ADDR_2ND_LINK, TSC_LCF_FE305_DFBL)	How can the sending of an LINK CONTROL message (lcf: FE305, deferred_link_block_req) by the IUT be invoked?	
<IUT ! lc_link_ctrl> Lc_lc(TSPX_LC_L3_ADDR_2ND_LINK, TSC_LCF_FE306_NDFBL)	How can the sending of an LINK CONTROL message (lcf: FE306, non_deferred_link_block_req) by the IUT be invoked?	
<IUT ! lc_link_ctrl> Lc_lc(TSPX_LC_L3_ADDR_2ND_LINK, TSC_LCF_ID_REQ)	How can the sending of an LINK CONTROL message (lcf: FE-IDReq) by the IUT be invoked?	
<IUT ! pstn_est> Pstn_est	How can the sending of an PSTN ESTABLISH message by the IUT be invoked? (sending of a FE-subscriber_seizure message to the NWK entity)	
<IUT ! pstn_signal> Pstn_signal(S_R,TSPX_PSTN_COMD_INFO_SIGNAL_LE)	How can the sending of an PSTN SIGNAL message (digit 1) by the IUT be invoked? (sending of a FE-line_signal message (digit 1) message to the NWK entity)	
<IUT ! mdu_system_start_up>	How can a system start-up procedure in the IUT be invoked as described in EN 300 324-1, annex C, item 17?	
<IUT ! v52_2nd_link_disconnect>	How can the IUT internal event "persistent link failure condition" be invoked? (disconnecting the second V5.2 link)	
<IUT ! v52_2nd_link_connect>	How can the IUT internal event "disappearance of the persistent link failure condition" be invoked? (connecting the second V5.2 link)	
NOTE: <i>Procedural information</i> part shall provide the necessary information required to provoke the <i>Implicit event</i> described in <i>Description</i> part of this table.		

Table B.8: PICS information

PIXIT name	PICS item	Valid ?
TSPC_ISDNBA	EN 300 324-2, M1	
TSPC_PSTN	EN 300 324-2, M2	
TSPC_VERIFY_REPRO	EN 300 324-2, P5.2	
TSPC_REPRO_SYNC	EN 300 324-2, P5.3	
TSPC_ISDNPRA	EN 300 347-2, N12	
TSPC_V52_MULTIPLE_LINK	EN 300 347-2, N9	
TSPC_ACC_ALGT_SUPPORTED	EN 300 347-2, R5.2	
NOTE: All parameters are of type BOOLEAN.		

---

## History

<b>Document history</b>		
Edition 1	April 1999	Publication as ETS 300 347-6
V2.1.2	January 2000	Public Enquiry PE 200018: 2000-01-05 to 2000-05-05