

ETSI EN 300 347-3 V3.1.1 (2001-03)

European Standard (Telecommunications series)

**V interfaces at the digital Local Exchange (LE);
V5.2 interface for the support of Access Network (AN);
Part 3: Test Suite Structure and Test Purposes (TSS&TP)
specification for the network layer (AN side)**



ReferenceREN/SPAN-09102-3

KeywordsAN, LE, testing, TSS&TP, V interface,
V5 interface**ETSI**

650 Route des Lucioles
F-06921 Sophia Antipolis Cedex - FRANCE

Tel.: +33 4 92 94 42 00 Fax: +33 4 93 65 47 16

Siret N° 348 623 562 00017 - NAF 742 C
Association à but non lucratif enregistrée à la
Sous-Préfecture de Grasse (06) N° 7803/88

Important notice

Individual copies of the present document can be downloaded from:

<http://www.etsi.org>

The present document may be made available in more than one electronic version or in print. In any case of existing or perceived difference in contents between such versions, the reference version is the Portable Document Format (PDF). In case of dispute, the reference shall be the printing on ETSI printers of the PDF version kept on a specific network drive within ETSI Secretariat.

Users of the present document should be aware that the document may be subject to revision or change of status. Information on the current status of this and other ETSI documents is available at <http://www.etsi.org/tb/status/>

If you find errors in the present document, send your comment to:
editor@etsi.fr

Copyright Notification

No part may be reproduced except as authorized by written permission.
The copyright and the foregoing restriction extend to reproduction in all media.

© European Telecommunications Standards Institute 2001.
All rights reserved.

Contents

Intellectual Property Rights	6
Foreword.....	6
1 Scope.....	7
2 References.....	7
3 Definitions and abbreviations.....	8
3.1 Definitions.....	8
3.2 Abbreviations.....	8
4 Test Suite Structure (TSS).....	9
4.1 Overview.....	9
4.2 Test groups.....	10
4.2.1 Protocol groups.....	11
4.2.1.1 Control protocol.....	11
4.2.1.2 Public Switched Telephone Network (PSTN) protocol.....	11
4.2.1.3 Link control protocol.....	11
4.2.1.4 Bearer Channel Connection (BCC) protocol.....	11
4.2.1.5 Protection protocol.....	11
4.2.2 Main test groups.....	12
4.2.2.1 Basic Interconnection tests (IT).....	12
4.2.2.2 Capability tests (CA).....	12
4.2.2.3 Valid Behaviour tests (BV).....	12
4.2.2.4 Inopportune Behaviour tests (BO).....	12
4.2.2.5 Invalid Behaviour tests (BI).....	12
4.2.2.6 Timer expiry and counter mismatch tests (TI).....	12
4.2.2.6.1 Timers and counters of the Control protocol.....	12
4.2.2.6.2 Timers and counters of the PSTN protocol.....	13
4.2.2.6.3 Timers and counters of the Link control protocol.....	13
4.2.2.6.4 Timers and counters of the BCC protocol.....	13
4.2.2.6.5 Timers and counters of the Protection protocol.....	13
4.2.2.6.6 Timers and counters of the AN system management.....	13
4.3 Test step structure.....	14
4.3.1 State transitions.....	14
4.3.1.1 Start-up of V5.2 interface.....	14
4.3.1.2 Common control protocol (system management).....	16
4.3.1.3 Control protocol (PSTN port FSM).....	16
4.3.1.4 Control protocol (ISDN-BA port FSM).....	16
4.3.1.5 Control protocol (ISDN-PRA port FSM).....	16
4.3.1.6 PSTN protocol.....	16
4.3.1.7 Link control protocol.....	17
4.3.1.8 BCC protocol.....	17
4.3.1.9 Protection protocol.....	17
4.3.2 Preconditions.....	17
4.3.3 Preambles.....	18
4.3.4 Postambles.....	18
4.3.5 Status verification.....	18
4.3.5.1 PSTN protocol.....	18
4.3.5.2 Link control FSM.....	18
4.3.6 Common test steps.....	18
4.4 Defaults.....	18
4.5 Abstract Service Primitives (ASPs) and Protocol Data Units (PDUs).....	18
4.5.1 ASPs.....	18
4.5.2 PDUs.....	18
4.5.2.1 Common control protocol.....	18
4.5.2.2 Port control protocol.....	18
4.5.2.3 PSTN protocol.....	19

4.5.2.4	Link control protocol	19
4.5.2.5	BCC protocol	19
4.5.2.6	Protection protocol	19
4.5.3	Information elements	19
4.5.3.1	Variable length information elements.....	19
4.5.3.1.1	Control protocol	19
4.5.3.1.2	PSTN protocol	19
4.5.3.1.3	Link control protocol.....	20
4.5.3.1.4	BCC protocol	20
4.5.3.1.5	Protection protocol	20
4.5.3.2	Single octet information elements	20
4.5.3.2.1	Control protocol	20
4.5.3.2.2	PSTN protocol	20
4.5.3.2.3	Link control protocol.....	20
4.5.3.2.4	BCC protocol	20
4.5.3.2.5	Protection protocol	20
4.6	Timers and counters of the Abstract Test Suite (ATS).....	21
5	Test Purposes (TPs).....	22
5.1	Introduction.....	22
5.1.1	Test purpose naming convention	22
5.1.2	Source of test purpose definition	23
5.1.3	Test strategy	23
5.1.3.1	Common control protocol	23
5.1.3.2	Port control protocol	23
5.1.3.3	PSTN protocol.....	23
5.1.3.4	Link control protocol	24
5.1.3.5	BCC protocol	24
5.1.3.6	Protection protocol	24
5.1.4	Requirements not covered by test purposes.....	25
5.1.5	Initial states.....	25
5.1.6	Test and data configuration requirements.....	25
5.2	Control protocol	26
5.2.1	Basic interconnection tests (V5NWKAN/CTRL/IT)	26
5.2.2	Capability tests (V5NWKAN/CTRL/CA).....	26
5.2.3	Valid behaviour tests (V5NWKAN/CTRL/BV)	26
5.2.3.1	V5NWKAN/CTRL/BV/COM.....	26
5.2.3.1.1	V5NWKAN/CTRL/BV/COM/TRANS	26
5.2.3.1.2	V5NWKAN/CTRL/BV/COM/REST	26
5.2.3.1.3	V5NWKAN/CTRL/BV/COM/REVV	26
5.2.3.1.4	V5NWKAN/CTRL/BV/COM/ACCALGT	27
5.2.3.2	V5NWKAN/CTRL/BV/PORT.....	28
5.2.3.2.1	V5NWKAN/CTRL/BV/PORT/TRANS.....	28
5.2.3.2.2	V5NWKAN/CTRL/BV/PORT/PSTN	28
5.2.3.2.3	V5NWKAN/CTRL/BV/PORT/ISDNBA	28
5.2.3.2.4	V5NWKAN/CTRL/BV/PORT/ISDNPRA	29
5.2.4	Inopportune behaviour tests (V5NWKAN/CTRL/BO).....	30
5.2.4.1	V5NWKAN/CTRL/BO/COM.....	30
5.2.4.2	V5NWKAN/CTRL/BO/PORT.....	30
5.2.4.2.1	V5NWKAN/CTRL/BO/PORT/TRANS.....	30
5.2.4.2.2	V5NWKAN/CTRL/BO/PORT/PSTN	30
5.2.4.2.3	V5NWKAN/CTRL/BO/PORT/ISDNBA	30
5.2.4.2.4	V5NWKAN/CTRL/BO/PORT/ISDNPRA	31
5.2.5	Invalid behaviour tests (V5NWKAN/CTRL/BI)	31
5.2.6	Timer expiry and counter mismatch tests (V5NWKAN/CTRL/TI).....	31
5.3	PSTN protocol	31
5.4	Link control protocol	31
5.4.1	Basic interconnection tests (V5NWKAN/LINK/IT).....	31
5.4.2	Capability tests (V5NWKAN/LINK/CA)	31
5.4.3	Valid behaviour tests (V5NWKAN/LINK/BV).....	32
5.4.3.1	V5NWKAN/LINK/BV/TRANS.....	32
5.4.3.2	V5NWKAN/LINK/BV/LINK	32

5.4.4	Inopportune behaviour tests (V5NWKAN/LINK/BO).....	42
5.4.4.1	V5NWKAN/LINK/BO/TRANS.....	42
5.4.4.2	V5NWKAN/LINK/BO/LINK.....	43
5.4.5	Invalid behaviour tests (V5NWKAN/LINK/BI).....	45
5.4.5.1	V5NWKAN/LINK/BI/TRANS.....	45
5.4.6	Timer expiry and counter mismatch tests (V5NWKAN/LINK/TI).....	46
5.4.6.1	V5NWKAN/LINK/TI/TRANS.....	46
5.5	BCC protocol.....	47
5.5.1	Basic interconnection tests (V5NWKAN/BCC/IT).....	47
5.5.2	Capability tests (V5NWKAN/BCC/CA).....	47
5.5.3	Valid behaviour tests (V5NWKAN/BCC/BV).....	48
5.5.4	Inopportune behaviour tests (V5NWKAN/BCC/BO).....	51
5.5.5	Invalid behaviour tests (V5NWKAN/BCC/BI).....	52
5.5.6	Timer expiry and counter mismatch tests (V5NWKAN/BCC/TI).....	54
5.6	Protection protocol.....	54
5.6.1	Basic interconnection tests (V5NWKAN/PROTECT/IT).....	54
5.6.2	Capability tests (V5NWKAN/PROTECT/CA).....	55
5.6.3	Valid behaviour tests (V5NWKAN/PROTECT/BV).....	55
5.6.4	Inopportune behaviour tests (V5NWKAN/PROTECT/BO).....	59
5.6.5	Invalid behaviour tests (V5NWKAN/PROTECT/BI).....	60
5.6.6	Timer expiry and counter mismatch tests (V5NWKAN/PROTECT/TI).....	61
	Bibliography.....	63
	History.....	64

Intellectual Property Rights

IPRs essential or potentially essential to the present document may have been declared to ETSI. The information pertaining to these essential IPRs, if any, is publicly available for **ETSI members and non-members**, and can be found in ETSI SR 000 314: *"Intellectual Property Rights (IPRs); Essential, or potentially Essential, IPRs notified to ETSI in respect of ETSI standards"*, which is available from the ETSI Secretariat. Latest updates are available on the ETSI Web server (<http://www.etsi.org/ipr>).

Pursuant to the ETSI IPR Policy, no investigation, including IPR searches, has been carried out by ETSI. No guarantee can be given as to the existence of other IPRs not referenced in ETSI SR 000 314 (or the updates on the ETSI Web server) which are, or may be, or may become, essential to the present document.

Foreword

This European Standard (Telecommunications series) has been produced by ETSI Technical Committee Services and Protocols for Advanced Networks (SPAN).

The present document is part 3 of a multi-part deliverable covering the V interfaces at the digital Local Exchange (LE); V5.2 interface for the support of Access Network (AN), as described below:

- Part 1: "V5.2 interface specification";
- Part 2: "Protocol Implementation Conformance Statement (PICS) proforma specification";
- Part 3: "Test Suite Structure and Test Purposes (TSS&TP) specification for the network layer (AN side)";**
- Part 4: "Abstract Test Suite (ATS) and partial Protocol Implementation eXtra Information for Testing (PIXIT) proforma specification for the network layer (AN side)";
- Part 5: "Test Suite Structure and Test Purposes (TSS&TP) specification for the network layer (LE side)";
- Part 6: "Abstract Test Suite (ATS) and partial Protocol Implementation eXtra Information for Testing (PIXIT) proforma specification for the network layer (LE side)";
- Part 7: "Test Suite Structure and Test Purposes (TSS&TP) specification for the data link layer";
- Part 8: "Abstract Test Suite (ATS) and partial Protocol Implementation eXtra Information for Testing (PIXIT) proforma specification for the data link layer";
- Part 9: "Test specification for the physical layer".

National transposition dates	
Date of adoption of this EN:	23 March 2001
Date of latest announcement of this EN (doa):	30 June 2001
Date of latest publication of new National Standard or endorsement of this EN (dop/e):	31 December 2001
Date of withdrawal of any conflicting National Standard (dow):	31 December 2001

1 Scope

The present document contains the Test Suite Structure and Test Purposes (TSS&TP) for the network layer and parts of the system management of the Access Network (AN) side of a V5.2 interface.

The objective of the present document is to provide conformance tests giving a high probability of inter-operability of an AN and a Local Exchange (LE) from different manufacturers over the V5.2 interface. The present document covers only the procedures described in EN 300 347-1 [2].

ISO/IEC 9646-1 [4] and ISO/IEC 9646-2 [5] are used as the basis for the test methodology.

The present document needs to be read in conjunction with ETS 300 324-3 [1]. The two documents share a common format and clauses within ETS 300 324-3 [1] are directly referenced.

2 References

The following documents contain provisions which, through reference in this text, constitute provisions of the present document.

- References are either specific (identified by date of publication, edition number, version number, etc.) or non-specific.
- For a specific reference, subsequent revisions do not apply.
- For a non-specific reference, the latest version applies.
- A non-specific reference to an ETS shall also be taken to refer to later versions published as an EN with the same number.

- [1] ETSI ETS 300 324-3 (1999): "V interfaces at the digital Local Exchange (LE); V5.1 interface for the support of Access Network (AN); Part 3: Test Suite Structure and Test Purposes (TSS&TP) specification for the network layer (AN side)".
- [2] ETSI EN 300 347-1 (V2.2.2): "V interfaces at the digital Local Exchange (LE); V5.2 interface for the support of Access Network (AN); Part 1: V5.2 interface specification".
- [3] ETSI EN 300 347-2 (V2.1.3): "V interfaces at the digital Local Exchange (LE); V5.2 interface for the support of Access Network (AN); Part 2: Protocol Implementation Conformance Statement (PICS) proforma specification".
- [4] ISO/IEC 9646-1 (1995): "Information technology - Open systems interconnection - Conformance testing methodology and framework - Part 1: General concepts".
- [5] ISO/IEC 9646-2 (1995): "Information technology - Open systems interconnection - Conformance testing methodology and framework - Part 2: Abstract test suite specification".
- [6] ETSI ETS 300 347-7 (1999): "V interfaces at the digital Local Exchange (LE); V5.2 interface for the support of Access Network (AN); Part 7: Test Suite Structure and Test Purposes (TSS&TP) specification for the data link layer".

3 Definitions and abbreviations

3.1 Definitions

For the purposes of the present document, the terms and definitions given in ETS 300 324-3 [1], EN 300 347-1 [2] and the following apply.

incorrect information element: specified information element carrying information element types which are not defined in EN 300 347-1 [2]

specified information element: information element identifier as defined in EN 300 347-1 [2]

unspecified information element: information element identifier which is not defined in EN 300 347-1 [2]

3.2 Abbreviations

For the purposes of the present document, the following abbreviations apply:

AIS	Alarm Indication Signal
AN	Access Network
ASP	Abstract Service Primitive
ATS	Abstract Test Suite
BCC	Bearer Channel Connection
BI	Invalid Behaviour
BO	Inopportune Behaviour
BV	Valid Behaviour
CA	Capability
COM	Common control protocol
CTRL	Control
FE	Function Element
FSM	Finite State Machine
ID	Identifier
IE	Information Element
ISDN	Integrated Services Digital Network
ISDN-BA	ISDN Basic Access
ISDN-PRA	ISDN Primary Rate Access
IT	Basic Interconnection
IUT	Implementation Under Test
L3addr	Layer 3 address
LE	Local Exchange
LT1	Lower Tester 1
MDU	Management Data Unit
MPH	Management Physical layer
NWK	Network layer
PDU	Protocol Data Unit
PICS	Protocol Implementation Conformance Statement
PSTN	Public Switched Telephone Network
RAI	Remote Alarm Indication
REQ	Request
SN	Sequence Number
SUT	System Under Test
TE	Terminal Equipment (ISDN or PSTN)
TI	Timer
TP	Test Purpose
TS	Time Slot
TSS	Test Suite Structure
UP	User Port

4 Test Suite Structure (TSS)

4.1 Overview

Figure 1 shows the structure of the V5.2 NetWorK layer (NWK) test suite.

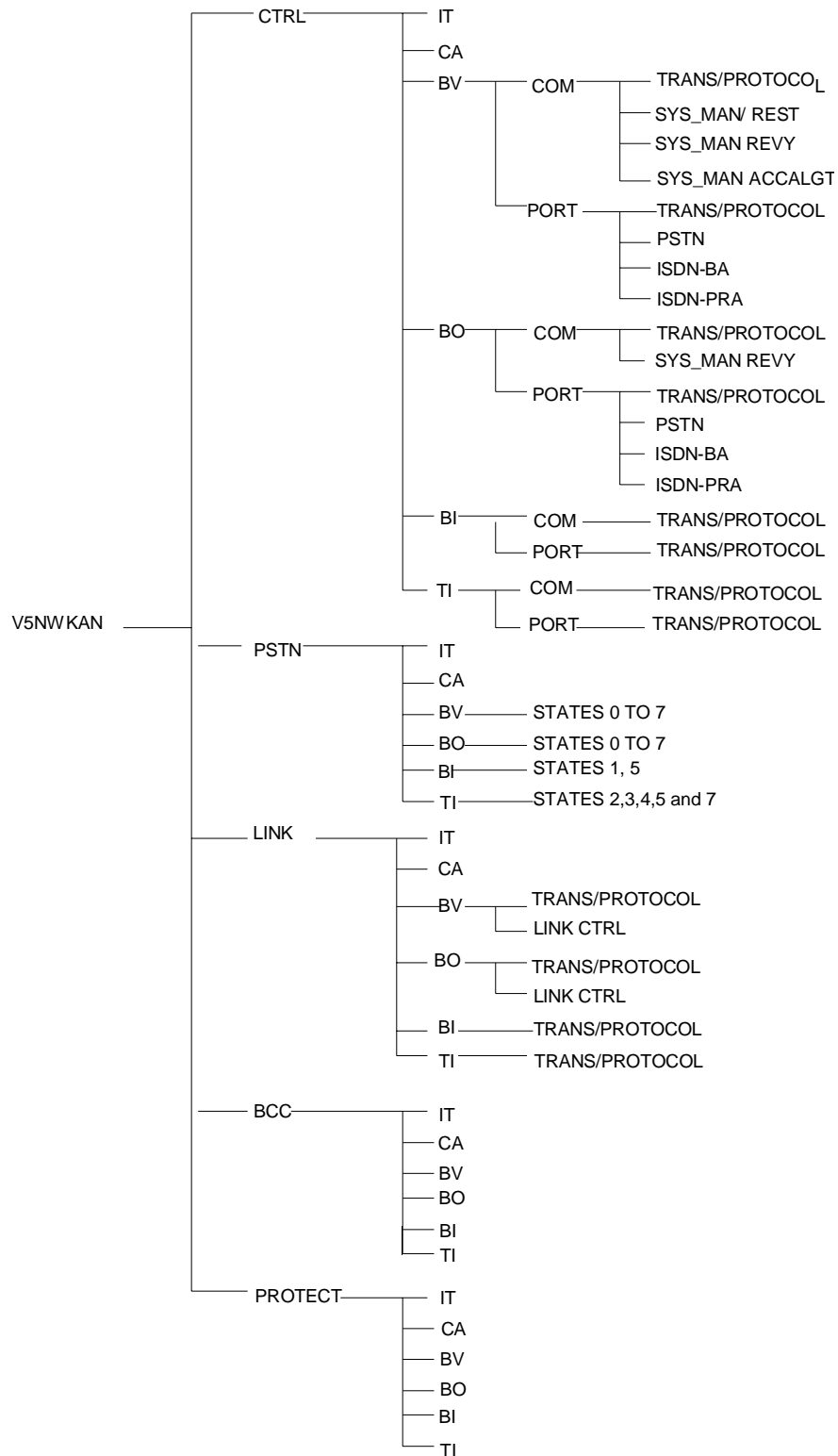

Figure 1: NWK AN test suite structure

4.2 Test groups

Figure 2 gives an overview of the various protocol entities of a V5.2 interface. Table 1 maps each protocol entity on tested protocol groups.

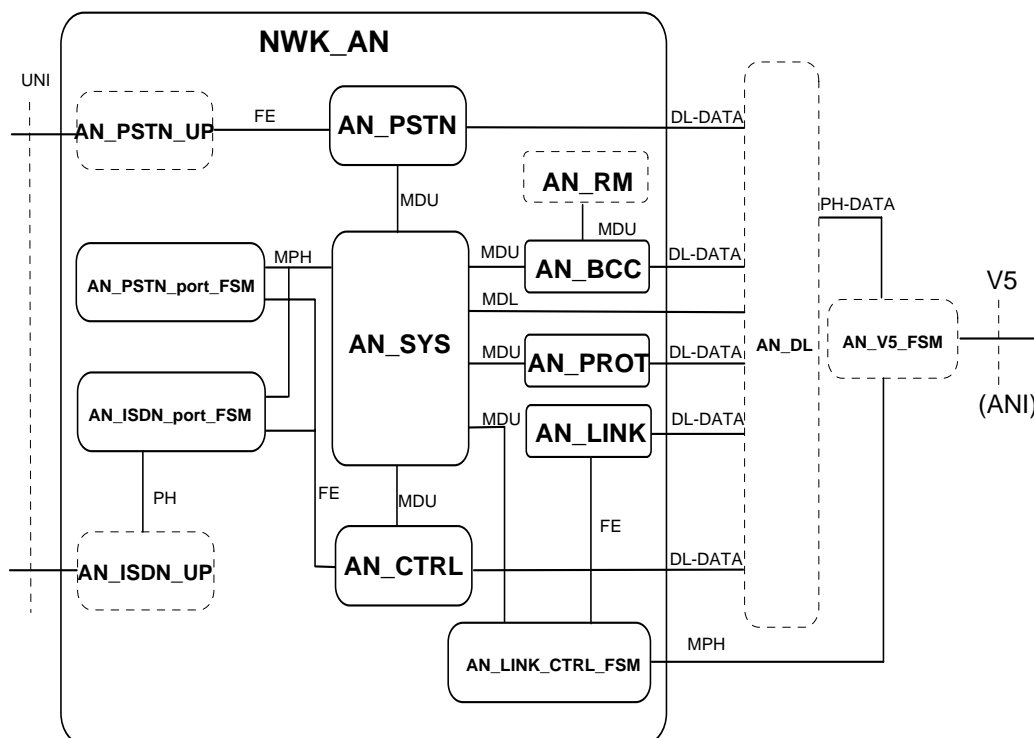

Figure 2: NWK AN - protocol entity overview

Table 1: Names used in figure 2 that correspond to EN 300 347-1 [2]

Network layer protocol entity	Protocol entity defined in EN 300 347-1 [2]	Protocol group reference
AN_PSTN_UP	AN_PSTN_user_port	4.2.1.1
AN_PSTN_port_FSM	AN_PSTN_user_port_FSM	4.2.1.1
AN_ISDN_port_FSM	AN_ISDN_BA_user_port_FSM AN_ISDN_PRA_user_port_FSM	4.2.1.1
AN_ISDN_UP	AN_ISDN_BA_user_port AN_ISDN_PRA_user_port	4.2.1.1
AN_CTRL	AN_control_protocol	4.2.1.1
AN_SYS	AN_system_management	4.2.1.1
AN_PSTN	AN_PSTN_protocol	4.2.1.2
AN_LINK	AN_link_control_protocol	4.2.1.3
AN_LINK_CTRL_FSM	AN_link_control_FSM	4.2.1.3
AN_RM	AN_resource_manager	4.2.1.4
AN_BCC	AN_BCC_protocol	4.2.1.4
AN_PROT	AN_protection_protocol	4.2.1.5

4.2.1 Protocol groups

4.2.1.1 Control protocol

The contents of this clause are identical to clause 4.2.1.1 of ETS 300 324-3 [1] with the following additions for the ISDN-PRA user port Finite State Machine (FSM).

Depending on provisioning the following configuration is tested:

AN_ISDN-PRA_user_port: The blocking, blocking request and co-ordinated unblocking procedures of the AN_ISDN-PRA_user_port_FSM are verified in the test group V5NWKAN/CTRL/BV/PORT/ISDNPRA and V5NWKAN/CTRL/BO/PORT/ISDNPRA.

4.2.1.2 Public Switched Telephone Network (PSTN) protocol

The contents of this clause are identical to clause 4.2.1.2 of ETS 300 324-3 [1].

4.2.1.3 Link control protocol

All tests in the Link control protocol (V5NWKAN/LINK) test group are intended to verify as thoroughly as possible the various procedures of the AN_link_control_protocol entity.

Depending on provisioning the following configurations are covered:

AN_link_control_protocol: The normal and exceptional procedures of the AN_link_control_protocol are verified in the test groups V5NWKAN/LINK/BV/TRANS, V5NWKAN/LINK/BO/TRANS and V5NWKAN/LINK/TI/TRANS. The error handling procedures are verified in the test group V5NWKAN/LINK/BI/TRANS.

AN_link_control_FSM: The link blocking, link blocking request, co-ordinated link unblocking and link identification procedures of the AN_link_control_FSM are verified in the test groups V5NWKAN/LINK/BV/LINK and V5NWKAN/LINK/BO/LINK.

4.2.1.4 Bearer Channel Connection (BCC) protocol

All tests in the BCC protocol (V5NWKAN/BCC) test group are intended to verify as thoroughly as possible the various procedures of the AN_BCC protocol entity.

The following BCC procedures are covered:

- normal and exceptional bearer channel allocation procedure;
- normal and exceptional bearer channel de-allocation procedure;
- audit procedure;
- AN internal failure notification procedure;
- error handling procedures.

4.2.1.5 Protection protocol

All tests in the Protection protocol (V5NWKAN/PROTECT) test group are intended to verify as thoroughly as possible the various procedures of the AN Protection protocol entity.

The following Protection protocol procedures are covered:

- transmission of Protection protocol messages;
- normal and exceptional sequence number reset procedure;
- normal and exceptional standard protection switch-over procedure initiated by AN side;

- normal and exceptional dedicated protection switch-over procedure initiated by OS AN;
- normal and exceptional switch-over procedure requested by AN side;
- error handling procedures.

4.2.2 Main test groups

4.2.2.1 Basic Interconnection tests (IT)

The contents of this clause are identical to clause 4.2.2.1 of ETS 300 324-3 [1].

4.2.2.2 Capability tests (CA)

The contents of this clause are identical to clause 4.2.2.2 of ETS 300 324-3 [1].

4.2.2.3 Valid Behaviour tests (BV)

The contents of this clause are identical to clause 4.2.2.3 of ETS 300 324-3 [1].

4.2.2.4 Inopportune Behaviour tests (BO)

The contents of this clause are identical to clause 4.2.2.4 of ETS 300 324-3 [1].

4.2.2.5 Invalid Behaviour tests (BI)

The contents of this clause are identical to clause 4.2.2.5 of ETS 300 324-3 [1].

4.2.2.6 Timer expiry and counter mismatch tests (TI)

The contents of this clause are identical to clause 4.2.2.6 of ETS 300 324-3 [1].

4.2.2.6.1 Timers and counters of the Control protocol

The contents of this clause are identical to clause 4.2.2.6.1 of ETS 300 324-3 [1] the addition for the accelerated alignment procedure. Additional timers are given in EN 300 347-1 [2], annex C, table C.1.

TU1A MDU-CTRL(UNBLOCK ALL RELEVANT PSTN AND ISDN PORTS REQUEST) to all PSTN and ISDN user port FSMs

TU2A MDU-CTRL(UNBLOCK ALL RELEVANT PSTN AND ISDN PORTS COMPLETED) to all PSTN and ISDN user port FSMs

TU1B MDU-CTRL(UNBLOCK ALL RELEVANT PSTN PORTS REQUEST) to all PSTN user port FSMs

TU2B MDU-CTRL(UNBLOCK ALL RELEVANT PSTN PORTS COMPLETED) to all PSTN user port FSMs

TU1C MDU-CTRL(UNBLOCK ALL RELEVANT ISDN PORTS REQUEST) to all ISDN user port FSMs

TU2C MDU-CTRL(UNBLOCK ALL RELEVANT ISDN PORTS COMPLETED) to all ISDN user port FSMs

TU1D MDU-CTRL(BLOCK ALL PSTN PORTS REQUEST) to all PSTN user port FSMs

TU2D MDU-CTRL(BLOCK ALL PSTN PORTS COMPLETED) to all PSTN user port FSMs

TU1E MDU-CTRL(BLOCK ALL ISDN PORTS REQUEST) to all ISDN user port FSMs

TU2E MDU-CTRL(BLOCK ALL ISDN PORTS COMPLETED) to all ISDN user port FSMs

4.2.2.6.2 Timers and counters of the PSTN protocol

The contents of this clause are identical to clause 4.2.2.6.2 of ETS 300 324-3 [1].

4.2.2.6.3 Timers and counters of the Link control protocol

Refer to EN 300 347-1 [2], table 23.

LCTO1 LINK CONTROL message sent

4.2.2.6.4 Timers and counters of the BCC protocol

Refer to EN 300 347-1 [2], table 46.

TBCC5 AN fault sent

4.2.2.6.5 Timers and counters of the Protection protocol

Refer to EN 300 347-1 [2], table 64.

TSO3 SWITCH-OVER REQ sent

TSO4 RESET SN COM sent

TSO5 RESET SN COM received

Refer to EN 300 347-1 [2], clause 18.6.2.

VP(S) Send State Variable

VP(R) Receive State Variable

4.2.2.6.6 Timers and counters of the AN system management

Refer to EN 300 347-1 [2], annex C, table C.1.

TR1 MDU-CTRL(restart request) to all PSTN protocol FSMs

TR2 MDU-CTRL(restart request) to or from CTRL protocol

TC1 MDL-RELEASE-INDICATION from CONTROL-DL

TC2 Expiry of TC1

TC3 MDL-RELEASE-INDICATION from PSTN-DL

TC4 MDL-RELEASE-INDICATION from LINK_CONTROL-DL

TC5 Expiry of TC4

TC6 MDL-RELEASE-INDICATION from BCC-DL

TC7 Expiry of TC6

TC8 Expiry of TC2, TC5 or TC7

TC9 Cold restart of V5 interface

TC10 First MDL-ESTABLISH-CONFIRM or MDL-ESTABLISH-INDICATION from the first of all V5.2 Data links startup

4.3 Test step structure

General dynamic behaviours are described in test steps which can be called from all test cases within the Abstract Test Suite (ATS):

- state transitions: (refer to clause 4.3.1);
- preconditions: (refer to clause 4.3.2);
- preambles: (refer to clause 4.3.3);
- postambles: (refer to clause 4.3.4);
- status verification: (refer to clause 4.3.5);
- common test steps: (refer to clause 4.3.6).

4.3.1 State transitions

The following clauses identify the test steps used in the ATS. In general, each test step represents a state transition. For example in the PSTN protocol, PSTN_AN1_2 is the test step which brings the AN PSTN protocol FSM from PSTN_path_state AN1 to PSTN_path_state AN2. The state transitions are declared in the parenthesis (originating state - destination state) which follow the test step names.

Six groups of state transitions are defined:

- STARTUP:** start up the V5 interface and put the Implementation Under Test (IUT) into the initial state as defined in clause 5.1.5;
- CTRL:** state transitions used to preamble and postamble the Control protocol before a test purpose can be performed;
- PSTN:** state transitions used to preamble and postamble the PSTN protocol before a test purpose can be performed;
- LINK:** state transitions used to preamble and postamble the Link control protocol before a test purpose can be performed;
- BCC:** state transitions used to preamble and postamble the BCC protocol before a test purpose can be performed;
- PROTECT:** state transitions used to preamble and postamble the Protection protocol before a test purpose can be performed.

To test the V5.2 interface certain sequences (i.e. preamble) shall be executed to reach the state which is the subject for the test purposes.

4.3.1.1 Start-up of V5.2 interface

The start-up procedure for a V5.2 interface depends on the provisioned data configuration. Therefore, the three PICS items N11, N12, M2 and N9 (see clause 6.6.1 of EN 300 347-2 [3]) are used to define the implemented configuration of the IUT.

NOTE 1: EN 300 347-2 [3] requires that at least one of the three PICS items N11, N12 and M2 shall be set.

NOTE 2: PICS item N9 defines the configuration of the IUT with multiple or one single 2 048 kbit/s digital links as a V5.2 interface. A single 2 048 kbit/s digital link have no protection function implemented.

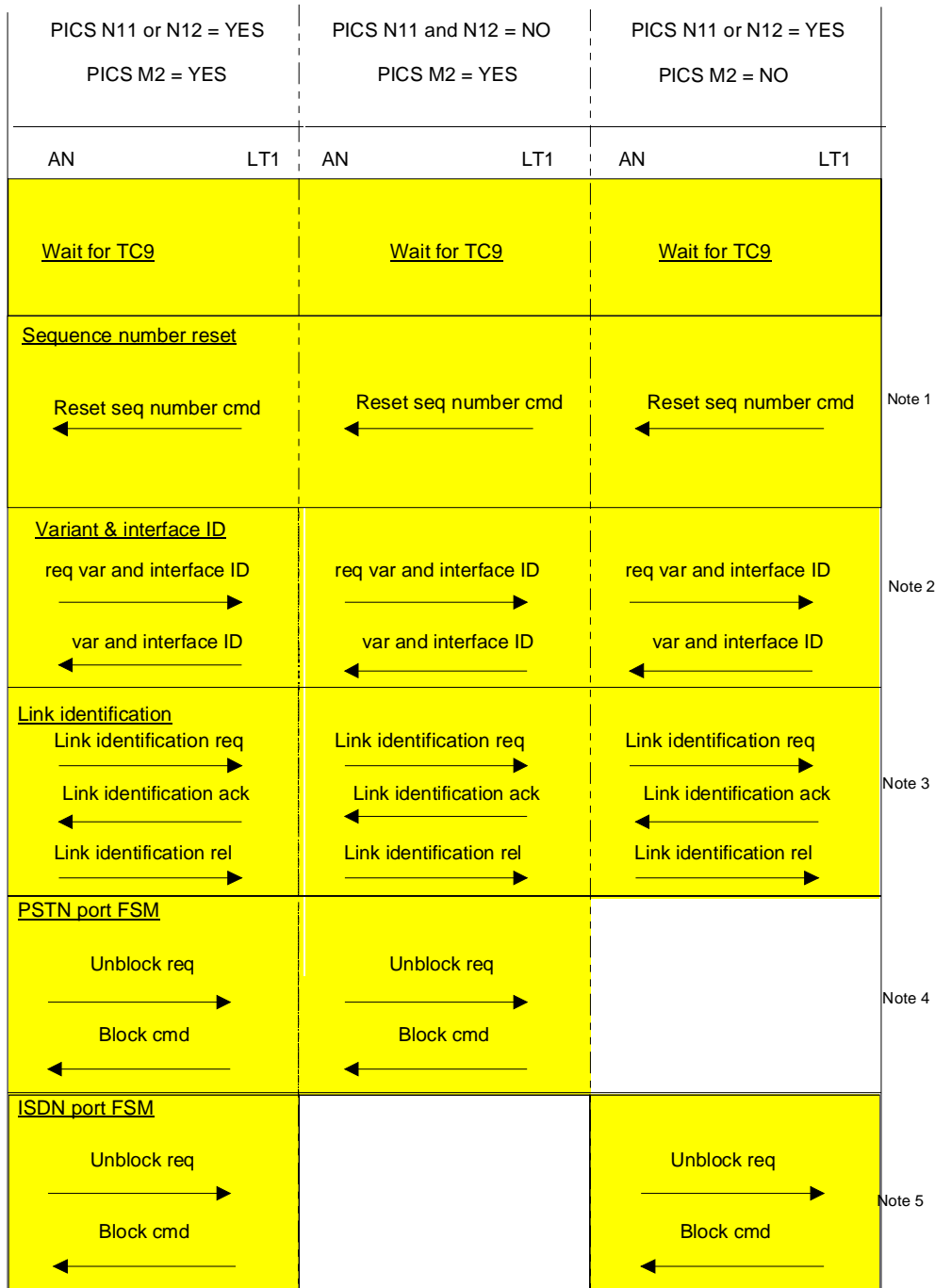

Note 1

Note 2

Note 3

Note 4

Note 5

- NOTE 1: A test of the IUT's capability of receiving a command to reset sequence number is covered in clause 5.6.2.
- NOTE 2: A test of the IUT's capability of receiving a request for the variant and interface ID is covered in clause 5.2.3.1.
- NOTE 3: The number of appearances of this part of the system start-up procedure depends on the configuration of the IUT. A test of the IUT's capability of receiving a link identification request is covered in clause 5.4.3.2. The link identification procedure is optional.
- NOTE 4: To reach the initial state of the IUT PSTN user port FSM as defined in clause 5.1.5, the IUT's unblocking request is rejected by LT1. Before rejecting the unblock request, it shall be verified that the IUT PSTN protocol has entered the PSTN_path_state AN6 (Port Blocked).
- NOTE 5: If the PICS items N11 and N12 are set to YES, this part of the system start-up procedure appears twice, once for the ISDN-BA port and once for the ISDN-PRA port. To reach the initial state of the IUT ISDN-BA user port FSM and/or the ISDN-PRA user port FSM as defined in clause 5.1.5, the IUT's unblocking request is rejected by LT1.

Figure 3: STARTUP_AN flow diagram

PICS item description:

N11: ISDN-BA ports supported;

N12: ISDN-PRA ports supported;

M2: PSTN ports supported;

N9: Multiple link V5.2 interface;

R5.4: Accelerated port state alignment.

NOTE 3: One port of each supported type shall be provisioned in a way that the IUT tries to enter the operational state for these ports after system start-up (see clause 5.1.6).

NOTE 4: At START_UP the LT1 will reject all request on accelerated port state alignment by respond with the control message UBA-rejected (see clause 5.1.6).

Depending on the setting of the PICS items, the start-up procedure is described in figure 3. This flow diagram describes the test step called STARTUP_AN.

4.3.1.2 Common control protocol (system management)

The contents of this clause are identical to clause 4.3.1.2 of ETS 300 324-3 [1].

4.3.1.3 Control protocol (PSTN port FSM)

The contents of this clause are identical to clause 4.3.1.3 of ETS 300 324-3 [1].

4.3.1.4 Control protocol (ISDN-BA port FSM)

The contents of this clause are identical to clause 4.3.1.4 of ETS 300 324-3 [1].

4.3.1.5 Control protocol (ISDN-PRA port FSM)

Refer to EN 300 347-1 [2], table 7.

CTRL_ISDNPRA_AN10_10

On receipt of a local unblock_req (MPH-UBR) the IUT shall send a message containing the control_function_element IE FE202 (unblock_req).

On receipt of a PORT CONTROL message containing the control_function_element IE FE203 (block_cmd) the IUT ISDN-PRA user port FSM shall re-enter state AN1.0.

CTRL_ISDNPRA_AN20_10

On receipt of a PORT CONTROL message containing the control_function_element IE FE203 (block_cmd) the IUT shall enter state AN1.0.

CTRL_ISDNPRA_AN10_20

On receipt of a PORT CONTROL message containing the control_function_element IE FE201 (unblock_req) the IUT shall respond with the PORT CONTROL message containing the control_function_element IE FE202 (unblock_ack) and then enter state AN2.0.

4.3.1.6 PSTN protocol

The contents of this clause are identical to clause 4.3.1.5 of ETS 300 324-3 [1].

4.3.1.7 Link control protocol

Refer to EN 300 347-1 [2], table 16.

LINK_AN20_10

On receipt of a LINK CONTROL message containing the link_control_function IE FE303 (link_block_cmd) the IUT link control FSM shall enter state AN1.0.

NOTE: The blocking of a V5.2 link results in a protection switching (if possible) of all C-paths carried by that link.

LINK_AN10_20

On receipt of a LINK CONTROL message containing the link_control_function IE FE301 (link_unblock_req) the IUT shall respond with the LINK CONTROL message containing the link_control_function IE FE302 (link_unblock_ack) and then enter state AN2.0.

4.3.1.8 BCC protocol

Refer to EN 300 347-1 [2], clause 17.5, table 48.

BCC_CONN

On receipt of an ALLOCATION message, the IUT shall send an ALLOCATION COMPLETE message.

BCC_REL

On receipt of a DE-ALLOCATION message, the IUT shall send a DE-ALLOCATION COMPLETE message.

BCC_FAULT

On receipt of an ALLOCATION message, the IUT shall send an ALLOCATION COMPLETE message. On detection of "AN internal failure" of the allocated connection, the IUT shall send an AN FAULT message containing the UP_ID IE, the ISDN_port_channel_ID (only for ISDN application) and the V5_TS_ID IE.

4.3.1.9 Protection protocol

Refer to EN 300 347-1 [2], clause 18.6, table 65.

PROTECT_SOANx_0

On receipt of a RESET SN COM message, the IUT shall send a RESET SN ACK message (IUT protection FSM enters state SOAN0).

Complete this test step by waiting for the expiration of timer TSO5.

PROTECT_BACK_TO_INIT1

On receipt of a SWITCH-OVER COM message containing the logical_C-channel_ID IE "logical C-channel 1" and the physical_C-channel_ID IE "TS 16 of primary link", the IUT shall send a SWITCH-OVER ACK message containing the same data.

PROTECT_BACK_TO_INIT2

On receipt of a SWITCH-OVER COM message containing the logical_C-channel_ID IE "logical C-channel 2" and the physical_C-channel_ID IE "TS 15 of primary link", the IUT shall send a SWITCH-OVER ACK containing the same data.

PROTECT_BACK_TO_INIT3

On receipt of a SWITCH-OVER COM message containing the logical_C-channel_ID IE "logical C-channel 3" and the physical_C-channel_ID IE "TS 31 of primary link", the IUT shall send a SWITCH-OVER ACK containing the same data.

4.3.2 Preconditions

The contents of this clause are identical to clause 4.3.2 of ETS 300 324-3 [1].

4.3.3 Preambles

The preamble test step group contains the test steps needed for initialization of the IUT before testing the particular test purpose. All combinations of the test steps defined in clause 4.3.1.2 to clause 4.3.1.9 can be used to create preambles. Each preamble shall start from the IUT initial state as defined in clause 5.1.5.

4.3.4 Postambles

After each test case the IUT shall be brought back to the initial state as defined in clause 5.1.5. All combinations of the test steps defined in clauses 4.3.1.2 to 4.3.1.9 can be used to create postambles.

4.3.5 Status verification

4.3.5.1 PSTN protocol

The contents of this clause are identical to clause 4.3.5 of ETS 300 324-3 [1].

4.3.5.2 Link control FSM

LINK_CHECK_ID (Path active)

On receipt of a message containing the link_control_function IE FE-IDReq (link_identification_req) the IUT shall send a message containing the link_control_function IE FE-IDAck (link_identification_ack) and frames with S_{a7} bit set to zero.

On receipt of a message containing the link_control_function IE FE-IDRel (link_identification_rel) the IUT shall send frames with S_{a7} bit set to one.

4.3.6 Common test steps

The contents of this clause are identical to clause 4.3.6 of ETS 300 324-3 [1].

4.4 Defaults

The contents of this clause are identical to clause 4.4 of ETS 300 324-3 [1].

4.5 Abstract Service Primitives (ASPs) and Protocol Data Units (PDUs)

4.5.1 ASPs

The contents of this clause are identical to clause 4.5.1 of ETS 300 324-3 [1].

4.5.2 PDUs

4.5.2.1 Common control protocol

The contents of this clause are identical to clause 4.3.4 of ETS 300 324-3 [1].

4.5.2.2 Port control protocol

The contents of this clause are identical to clause 4.3.4 of ETS 300 324-3 [1].

4.5.2.3 PSTN protocol

The contents of this clause are identical to clause 4.3.4 of ETS 300 324-3 [1].

4.5.2.4 Link control protocol

link_ctrl

link_ctrl_ack

4.5.2.5 BCC protocol

bcc_allocation

bcc_allocation_complete

bcc_allocation_reject

bcc_deallocation

bcc_deallocation_complete

bcc_deallocation_reject

bcc_audit

bcc_audit_complete

bcc_an_fault

bcc_an_fault_ack

bcc_protocol_error

4.5.2.6 Protection protocol

protect_switch_over_req

protect_switch_over_com

protect_os_switch_over_com

protect_switch_over_ack

protect_switch_over_reject

protect_protocol_error

protect_reset_sn_com

protect_reset_sn_ack

4.5.3 Information elements

4.5.3.1 Variable length information elements

4.5.3.1.1 Control protocol

The contents of this clause are identical to clause 4.5.3.1.1 of ETS 300 324-3 [1].

4.5.3.1.2 PSTN protocol

The contents of this clause are identical to clause 4.5.3.1.2 of ETS 300 324-3 [1].

4.5.3.1.3 Link control protocol

link_control_function

4.5.3.1.4 BCC protocol

bcc_user_port_ident

bcc_ISDN_port_channel_ident

bcc_V5-time_slot_ident

bcc_multi_slot_map

bcc_reject_cause

bcc_protocol_error_cause

bcc_connection_incomplete

4.5.3.1.5 Protection protocol

protect_sequence_number

protect_logical_c_channel_ident

protect_physical_c_channel_ident

protect_rejection_cause

protect_protocol_error_cause

4.5.3.2 Single octet information elements

4.5.3.2.1 Control protocol

The contents of this clause are identical to clause 4.5.3.2.1 of ETS 300 324-3 [1].

4.5.3.2.2 PSTN protocol

The contents of this clause are identical to clause 4.5.3.2.2 of ETS 300 324-3 [1].

4.5.3.2.3 Link control protocol

There are no single octet information elements defined within the Link control protocol.

4.5.3.2.4 BCC protocol

There are no single octet information elements defined within the BCC protocol.

4.5.3.2.5 Protection protocol

There are no single octet information elements defined within the Protection protocol.

4.6 Timers and counters of the Abstract Test Suite (ATS)

This clause describes the timers and counters used in the ATS. The **min** and **max** indications define if the timer value represents the minimum or maximum limit of a timer. The timer values contain some additional tolerances for delays caused by test simulators. Therefore, a bigger timer tolerance is given than defined in EN 300 347-1 [2]:

Minimum value of ATS timer = EN timer - EN tolerance;

Maximum value of ATS timer = EN timer + 2 x EN tolerance.

The repetition of messages by the IUT shall be tested in the following way: the message has to be repeated within the time period $T_{\min} < T < T_{\max}$. This testing procedure applies to the tests in the TI-test group only.

Timers used in the ATS are given in *Timer Declarations* part of the ATS.

Table 2 gives the ATS counters which are used in addition to those defined in clause 4.6 of ETS 300 324-3 [1].

Table 2: Protocol counter values and references to EN 300 347-1 [2]

ATS counter name	ATS counter value	Explanation	Reference to EN 300 347-1 [2]
NLCO1	1	Allowed number of repetitions of the LINK CONTROL message	clause 16, table 23
NBCC5	1	Allowed number of repetitions of the AN FAULT message	clause 17, table 46
NSO3	1	Allowed number of repetitions of the SWITCH-OVER REQ message	clause 18, table 64
NSO4	1	Allowed number of repetitions of the RESET SN COM message	clause 18, table 64

5 Test Purposes (TPs)

5.1 Introduction

The contents of this clause are identical to clause 5.1 of ETS 300 324-3 [1] and also valid for the V5.2 interface.

5.1.1 Test purpose naming convention

The identifier of a test purpose is built according to the scheme described in table 3.

Table 3: Test purpose identifier naming convention scheme

Identifier: TP<t><c><g1><g2><tpt><s><ss><nn>				
<t>	=	type of protocol:	1	Control protocol
			2	PSTN protocol
			3	Link control protocol
			4	BCC protocol
			5	Protection protocol
<c>	=	category:	1	IT, Basic Interconnection Tests
			2	CA, Capability Tests
			3	BV, Valid Behaviour Tests
			4	BO, Inopportune Behaviour Tests
			5	BI, Invalid Behaviour Tests
			6	TI, Timer Expiry and Counter Mismatch
<g1>	=	group level 1:	1	Common control
			2	Port control
			–	(underscore) Not relevant
<g2>	=	group level 2:	1	Transport
			2	System management procedure Restart
			3	System management procedure Re-provisioning & Verification
			4	PSTN
			5	ISDN-BA
			6	ISDN-PRA
			7	Link control
			8	System management procedure Accelerated alignment
			–	(underscore) Not relevant
<tpt>	=	test purpose type:	S	Single
			C	Combined
<s>	=	state	(0-9)	
			M	Multiple state transition
			–	(underscore) Not relevant
<ss>	=	substate	(0-9)	
			–	(underscore) Not relevant
<nn>	=	sequential number	(01-99)	

5.1.2 Source of test purpose definition

The TPs were developed based on EN 300 347-1 [2], clauses 14 to 18 and annexes A to E.

5.1.3 Test strategy

5.1.3.1 Common control protocol

To achieve a maximum of test coverage with an appropriate number of TPs the following selection criteria have been applied:

- a) the Common control protocol and the System management procedures are not tested on a per-state basis. The TPs step through the FSMs by testing the procedures and supervising the behaviour of the IUT at the interface;
- b) the error handling procedures of the Common control protocol are not exhaustively tested. Not all possible combinations of protocol errors in all protocol states are covered. The TPs cover only examples for each error handling procedure in state AN1 of the Common control protocol;
- c) for several TPs some activities by the testing person are required (invoking of certain procedures by the System Under Test (SUT)). These TPs are marked with (*).

5.1.3.2 Port control protocol

To achieve a maximum of test coverage with an appropriate number of TPs the following selection criteria have been applied:

- a) the Port control protocol, the ISDN-BA user port FSM, the ISDN-PRA user port FSM and the PSTN user port FSM are not tested on a per-state basis. The TPs step through the FSMs by testing the procedures and supervising the behaviour of the IUT at the interface;
- b) the error handling procedures of the Port control protocol are not exhaustively tested. Not all possible combinations of protocol errors in all protocol states are covered. The TPs cover only examples for each error handling procedure in state AN1 of the Port control protocol. During these tests the PSTN and ISDN-BA user port FSMs stay in state AN1.0;
- c) for several TPs some activities by the testing person are required (invoking of certain procedures by the SUT). These TPs are marked with (*);
- d) no differentiation between AN1.01 and AN1.02 for ISDN-PRA. Both substrates are handled as AN1.0;
- e) the accelerated alignment procedure is not generally tested in all port related TPs. In case of a request message from the IUT the LT1 will respond with reject that force the IUT to proceed with the existing procedure.

5.1.3.3 PSTN protocol

To achieve a maximum of test coverage with an appropriate number of TPs the following selection criteria have been applied:

- a) only the first up to the third values of the PSTN sequence number variables S(S), S(A), S(R), M(S), M(R) is covered;
- b) the error handling procedures of the PSTN protocol are not exhaustively tested. Not all possible combinations of protocol errors in all protocol states are covered. The TPs cover only examples for each error handling procedure in PSTN_path_state AN1. To easily perform some of the abstract test cases, some procedures are tested in PSTN_path_state AN5;
- c) the procedure for unexpected events of the PSTN protocol is exhaustively tested (all unexpected events in all PSTN_path_states are covered);
- d) for several TPs some activities by the testing person are required (invoking of certain procedures by the SUT). These TPs are marked with (*).

5.1.3.4 Link control protocol

To achieve a maximum of test coverage with an appropriate number of TPs the following selection criteria have been applied:

- a) the Link control protocol and the Link Control FSM are not tested on a per-state basis. The TPs step through the FSMs by testing the procedures and supervising the behaviour of the IUT at the V5.2 interface;
- b) the error handling procedures of the Link control protocol are not exhaustively tested. Not all possible combinations of protocol errors in all protocol states are covered. The test purposes cover only examples for each error handling procedure in state AN1 of the Link control protocol. During these tests the Link control FSM stays in state AN2.0;
- c) for several TPs some activities by the testing person are required (invoking of certain procedures by the SUT). These TPs are marked with (*);
- d) if PICS item N9 (see EN 300 347-2 [3]) is set to yes (multiple 2 048 kbit/s interface), there may be an impact of link control procedures on protection switching. This impact is tested in clause 5.6. Refer to clause 5.1.6 for the configuration which is required for the link control tests;
- e) if PICS item N9 (see EN 300 347-2 [3]) is set to no (single 2 048 kbit/s interface), persistent link failures are not tested in the link control test group;

NOTE: In this case, persistent link failures generate data link failures which are covered by ETS 300 347-7 [6].

- f) if PICS item N9 (see EN 300 347-2 [3]) is set to no, only the remote link blocking procedure is tested because blocking of a V5.2 link in a single link configuration may take the complete interface out of service;
- g) after each TP the remote link identification procedure is applied to check that the link is still operational.

5.1.3.5 BCC protocol

To achieve a maximum of test coverage with an appropriate number of TPs the following selection criteria have been applied:

- a) the BCC protocol is not tested on a per-state basis. The TPs step through the FSM by testing the procedures and supervising the behaviour of the IUT at the V5.2 interface;
- b) the BCC protocol entity in AN is tested without any call control related procedures;
- c) the error handling procedures of the BCC protocol are not exhaustively tested. Not all possible combinations of protocol errors in all protocol states are covered;
- d) for several TPs some activities by the testing person are required (invoking of certain procedures by the SUT). These TPs are marked with (*).

5.1.3.6 Protection protocol

To achieve a maximum of test coverage with an appropriate number of TPs the following selection criteria have been applied:

- a) the Protection protocol is not tested on a per-state basis. The TPs step through the FSM by testing the procedures and supervising the behaviour of the IUT at the V5.2 interface;
- b) the error handling procedures of the Protection protocol are not exhaustively tested. Not all possible combinations of protocol errors in all protocol states are covered. The test purposes cover only examples for each error handling procedure in state SOAN0 of the Protection protocol;
- c) for several TPs some activities by the testing person are required (invoking of certain procedures by the SUT). These TPs are marked with (*);

- d) there are three monitor functions defined which can create trigger events for an autonomous protection switch-over:
- layer 1 monitoring (trigger event: failure of a V5.2 link; refer to clause 18.1.5.1 of EN 300 347-1 [2]);
 - flag monitoring (trigger event: absence of flags, refer to clause 18.1.5.2 of EN 300 347-1 [2]);
 - data link monitoring (trigger event: data link failure, refer to clause 18.1.5.3 of EN 300 347-1 [2]).

The TPs use the generic term "prot_switch_over trigger event" to indicate any output of the monitor functions. Each TP using that term is valid for any trigger event.

5.1.4 Requirements not covered by test purposes

The contents of this clause are identical to clause 5.1.4 of ETS 300 324-3 [1] with the following additional items:

- it is not possible to verify the state of the ISDN-PRA port FSM, Link control protocol, the BCC protocol and the Protection protocol;
- the user failure/network failure indication procedure of the ISDN-PRA port FSM is not tested because there is no testable reaction on the V5-interface specified;
- it is not physically verified that bearer channels are connected correctly to the UP.

5.1.5 Initial states

The initial states of the various V5.2 protocols are defined as follows:

CTRL_COM_INIT	Refer to clause 5.1.5 of ETS 300 324-3 [1].
CTRL_PORT_INIT	This state is identical to the state in clause 5.1.5 of ETS 300 324-3 [1] with addition of ISDN-PRA.
PSTN_INIT	Refer to clause 5.1.5 of ETS 300 324-3 [1].
LINK_INIT	Initial state to start preambing the LINK test purposes AN1 (In Service State), Link control protocol AN2.0 (Link Operational State), Link Control FSM
BCC_INIT	Initial state to start preambing the BCC test purposes ANBcc0 (Null State), BCC Protocol
PROTECT_INIT	Initial state to start preambing the Protection test purposes. Active and stand-by C-channels are allocated according to clause 5.1.6. SOAN0 (Null State), Protection protocol

5.1.6 Test and data configuration requirements

The contents of this clause are identical to clause 5.1.6 of ETS 300 324-3 [1] with the following additions.

Each V5.2-link shall be provisioned in a way, that the IUT tries to enter the "link operational" state after system start-up.

If PICS item N9 (see EN 300 347-2 [3]) is set to yes, only the primary and secondary link shall be provisioned. Protection group 1 (logical C-channel 1) shall contain the control, link control, BCC and protection C-paths.

Protection group 2 shall consist of the following constituents:

- a) if only one of the PICS items N11, N12 or M2 is set to yes (see EN 300 347-2 [3]), the logical C-channel 2 shall contain the related C-path signalling;
- b) if at least two of the PICS items N11, N12 or M2 are set to yes (see EN 300 347-2 [3]), the related C-paths shall be mapped to two logical C-channels (2 and 3).

The logical C-channel 2 shall be located on TS 15 of the primary link. The logical C-channel 3 (if present) shall be located on TS 31 of the primary link. TS 15 of the secondary link shall be provisioned as standby channel for protection group 2.

The secondary link will be used for testing the link control procedures without provoking protection switching.

If PICS item N12 (see EN 300 347-2 [3]) is set to yes only one ISDN-PRA port shall be provisioned.

On receipt of a MDU-LAI the IUT system management shall apply the link identification procedure.

If PICS item R5.4 (see EN 300 347-2 [3]) is set to yes, the Accelerated port state alignment is implemented and the IUT have the possibility to send the primitive MDU-CTRL(UBA-request) to the LT1. In case of user port tests (see clause 5.2.3.2) the LT1 shall respond with the primitive MDU-CTRL(UBA-rejected).

5.2 Control protocol

5.2.1 Basic interconnection tests (V5NWKAN/CTRL/IT)

Initial state of the IUT: power on

Preamble: reset IUT

Postamble: -

TP11__SM_01 Run the test step STARTUP_AN (refer to clause 4.3.1.1).

(*)

5.2.2 Capability tests (V5NWKAN/CTRL/CA)

The contents of this clause are identical to clause 5.2.2 of ETS 300 324-3 [1].

5.2.3 Valid behaviour tests (V5NWKAN/CTRL/BV)

5.2.3.1 V5NWKAN/CTRL/BV/COM

5.2.3.1.1 V5NWKAN/CTRL/BV/COM/TRANS

The contents of this clause are identical to clause 5.2.3.1.1 of ETS 300 324-3 [1].

5.2.3.1.2 V5NWKAN/CTRL/BV/COM/REST

The contents of this clause are identical to clause 5.2.3.1.2 of ETS 300 324-3 [1].

5.2.3.1.3 V5NWKAN/CTRL/BV/COM/REVV

The contents of this clause are identical to clause 5.2.3.1.3 of ETS 300 324-3 [1].

5.2.3.1.4 V5NWKAN/CTRL/BV/COM/ACCALGT

Refer to EN 300 347-1 [2], clause 15.4.5 and annex C.

Initial state of the IUT: CTRL_COM_INIT, CTRL_PORT_INIT

Preamble: CTRL_ISDNPRA_AN20_10, CTRL_PSTN_AN20_10, CTRL_ISDNBA_AN20_10

Postamble: CTRL_ISDNPRA_AN20_10, CTRL_PSTN_AN20_10, CTRL_ISDNBA_AN20_10

TP1318S1_01 (note 1) On receipt of a COMMON CONTROL message containing the control_function_ID IE "UNBLOCK ALL RELEVANT PSTN AND ISDN PORTS REQUEST", the IUT shall send a COMMON CONTROL ACK message containing the same control_function_ID IE and a COMMON CONTROL message containing the control_function_ID IE "UNBLOCK ALL RELEVANT PSTN AND ISDN PORTS ACCEPTED".

On receipt of COMMON CONTROL ACK message, the IUT shall send a COMMON CONTROL message containing the control_function_ID IE "UNBLOCK ALL RELEVANT PSTN AND ISDN PORTS COMPLETED".

On receipt of COMMON CONTROL ACK message, the IUT shall not repeat the original message.

On receipt of a COMMON CONTROL message containing the control_function_ID IE "UNBLOCK ALL RELEVANT PSTN PORTS COMPLETED" the IUT shall send a COMMON CONTROL ACK message.

Refer to EN 300 347-1 [2], clause 15.4.5

TP1318S1_02 (note 1) On receipt of a COMMON CONTROL message containing the control_function_ID IE "UNBLOCK ALL RELEVANT PSTN PORTS REQUEST", the IUT shall send a COMMON CONTROL ACK message containing the same control_function_ID IE and a COMMON CONTROL message containing the control_function_ID IE "UNBLOCK ALL RELEVANT PSTN PORTS ACCEPTED".

On receipt of COMMON CONTROL ACK message, the IUT shall send a COMMON CONTROL message containing the control_function_ID IE "UNBLOCK ALL RELEVANT PSTN PORTS COMPLETED".

On receipt of COMMON CONTROL ACK message, the IUT shall not repeat the original message.

On receipt of a COMMON CONTROL message containing the control_function_ID IE "UNBLOCK ALL RELEVANT PSTN PORTS COMPLETED" the IUT shall send a COMMON CONTROL ACK message.

Refer to EN 300 347-1 [2], clause 15.4.5

TP1318S1_03 (note 1) On receipt of a COMMON CONTROL message containing the control_function_ID IE "UNBLOCK ALL RELEVANT ISDN PORTS REQUEST", the IUT shall send a COMMON CONTROL ACK message containing the same control_function_ID IE and a COMMON CONTROL message containing the control_function_ID IE "UNBLOCK ALL RELEVANT ISDN PORTS ACCEPTED".

On receipt of COMMON CONTROL ACK message, the IUT shall send a COMMON CONTROL message containing the control_function_ID IE "UNBLOCK ALL RELEVANT ISDN PORTS COMPLETED".

On receipt of COMMON CONTROL ACK message, the IUT shall not repeat the original message.

On receipt of a COMMON CONTROL message containing the control_function_ID IE "UNBLOCK ALL RELEVANT ISDN PORTS COMPLETED" the IUT shall send a COMMON CONTROL ACK message.

Refer to EN 300 347-1 [2], clause 15.4.5

- TP1318S1_04
(note 1)
- On receipt of a COMMON CONTROL message containing the control_function_ID IE "BLOCK ALL PSTN PORTS REQUEST", the IUT shall send a COMMON CONTROL ACK message containing the same control_function_ID IE and a COMMON CONTROL message containing the control_function_ID IE "BLOCK ALL PSTN PORTS ACCEPTED".
- On receipt of COMMON CONTROL ACK message, the IUT shall send a COMMON CONTROL message containing the control_function_ID IE "BLOCK ALL PSTN PORTS COMPLETED".
- On receipt of COMMON CONTROL ACK message, the IUT shall not repeat the original message.
- On receipt of a COMMON CONTROL message containing the control_function_ID IE "BLOCK ALL PSTN PORTS COMPLETED" the IUT shall send a COMMON CONTROL ACK message.
- Refer to EN 300 347-1 [2], clause 15.4.5
- TP1318S1_05
(note 1)
- On receipt of a COMMON CONTROL message containing the control_function_ID IE "BLOCK ALL ISDN PORTS REQUEST", the IUT shall send a COMMON CONTROL ACK message containing the same control_function_ID IE and a COMMON CONTROL message containing the control_function_ID IE "BLOCK ALL ISDN PORTS ACCEPTED".
- On receipt of COMMON CONTROL ACK message, the IUT shall send a COMMON CONTROL message containing the control_function_ID IE "BLOCK ALL ISDN PORTS COMPLETED".
- On receipt of COMMON CONTROL ACK message, the IUT shall not repeat the original message.
- On receipt of a COMMON CONTROL message containing the control_function_ID IE "BLOCK ALL ISDN PORTS COMPLETED" the IUT shall send a COMMON CONTROL ACK message.
- Refer to EN 300 347-1 [2], clause 15.4.5

This test case is only valid if PICS item R5.4 (see EN 300 347-2 [3]) is set to No.

- TP1318S1_06
(note 2)
- On receipt of a COMMON CONTROL message containing an alignment command, the IUT shall send a COMMON CONTROL ACK message containing the same control_function_ID IE and a REJECT message containing the same control_function_ID IE.
- Refer to EN 300 347-1 [2], clause 15.4.5

NOTE 1: These TPs are only applicable if PICS item R5.4 (see EN 300 347-2 [3]) is set to yes.

NOTE 2: These TPs are only applicable if PICS item R5.4(see EN 300 347-2 [3]) is set to no.

5.2.3.2 V5NWKAN/CTRL/BV/PORT

5.2.3.2.1 V5NWKAN/CTRL/BV/PORT/TRANS

The contents of this clause are identical to clause 5.2.3.2.1 of ETS 300 324-3 [1].

5.2.3.2.2 V5NWKAN/CTRL/BV/PORT/PSTN

The contents of this clause are identical to clause 5.2.3.2.2 of ETS 300 324-3 [1].

5.2.3.2.3 V5NWKAN/CTRL/BV/PORT/ISDNBA

The contents of this clause are identical to clause 5.2.3.2.3 of ETS 300 324-3 [1].

5.2.3.2.4 V5NWKAN/CTRL/BV/PORT/ISDNPRA

Refer to EN 300 347-1 [2], table 7 and figures L9.1 to L.9.11.

This test group is only valid if PICS item N12 (see EN 300 347-2 [3]) is set to yes.

As the Port control protocol transport is tested separately (see clause 5.2.3.2.1), the TRANSPORT protocol is not any more mentioned in the PORT CONTROL test purposes.

Initial state of the IUT: CTRL_COM_INIT, CTRL_PORT_INIT
 Preamble: CTRL_ISDNPRA_AN20_10,
 Postamble: CTRL_ISDNPRA_AN20_10

- TP1326SM_01 (*) On receipt of a local unblock_req (MPH-UBR) the IUT shall send a message containing the control_function_element IE FE202 (unblock_req).
- On receipt of a message containing the control_function_element IE FE201 (unblock_ack) the IUT ISDN-PRA user port FSM will enter state "Access operational", AN2.0.
- TP1326S1002 (*) On receipt of a local block_cmd (MPH-BI) the IUT shall send a message containing the control_function_element IE FE204 (block_cmd) and the IUT ISDN-PRA user port FSM will re-enter the state "Blocked", AN1.0.
- TP1326SM_03 On receipt of a message containing the control_function_element IE FE201 (unblock_req) the IUT shall send a message containing the control_function_element IE FE202 (unblock_ack) and the IUT ISDN-PRA user port FSM will enter state "Access operational", AN2.0.
- TP1326S1004 On receipt of a message containing the control_function_element IE FE203 (block_cmd) the IUT ISDN-PRA user port FSM will re-enter the state "Blocked", AN1.0.
- TP1326SM_05 (*) Verify the AN "Local blocking/unblocking".
- Preamble the TP with the TP1326SM_03 (clause 5.2.3.2.4) to reach the "Access operational" state.
- On receipt of a message containing the control_function_element IE FE201 (unblock_req) the IUT shall send a message containing the control_function_element IE FE202 (unblock_ack).
- On receipt of a local block_req (MPH-BR) the IUT shall send a message containing the control_function_element IE FE205 (block_req).
- On receipt of a message containing the control_function_element IE FE203 (block_cmd) and the IUT ISDN-PRA user port FSM shall return back to the state "Blocked", AN1.0.
- TP1326SM_06 (*) Verify the AN "Local blocking/unblocking".
- Preamble the TP with the TP1326SM_03 to reach the "Access operational" state.
- On receipt of a local unblock_req (MPH-UBR) the IUT shall send a message containing the control_function_element IE FE202 (unblock_req).
- On receipt of a local block_req (MPH-BR) the IUT shall send a message containing the control_function_element IE FE205 (block_req).
- On receipt of a local block_cmd (MPH-BI) the IUT shall send a message containing the control_function_element IE FE204 (block_cmd) and the IUT ISDN-PRA user port FSM shall return to the state "Blocked", AN1.0.

TP1326SM_07 (*)	<p>Verification of events in state AN1.0, "Local unblock".</p> <p>On receipt of a local unblock_req (MPH-UBR) the IUT shall send a message containing the control_function_element IE FE202 (unblock_req).</p> <p>On receipt of a local unblock_req (MPH-UBR) the second time, the IUT shall send a message containing the control_function_element IE FE202 (unblock_req) once more.</p> <p>On receipt of a local block_cmd (MPH-BI) the IUT shall send a message containing the control_function_element IE FE204 (block_cmd) and the IUT ISDN-PRA user port FSM shall re-enter the state port state AN1.0 (Blocked).</p>
TP1326S2008 (*)	<p>On receipt of grading in the AN_ISDNPRA_user_port the IUT shall send a FE206_grading. The IUT shall re-enter the port state AN 2.0 (Access operational).</p>
TP1326S2009 (*)	<p>On receipt of a FE207_D-channel_block, the IUT shall re-enter the port state AN 2.0 (Access operational).</p>
TP1326S2010 (*)	<p>On receipt of a FE208_D-channel_unblock the IUT shall re-enter the port state AN 2.0 (Access operational).</p>
TP1326S2011 (*)	<p>Verification of "User failure indication".</p> <p>On receipt of a user failure (MPH-UF) the IUT shall send a FE209 (TE_out_of_service). The IUT re-enter the port state AN1.0 (Blocked).</p>
TP1326S2012 (*)	<p>Verification of "Network failure indication".</p> <p>On receipt of a network failure (MPH-NF) the IUT shall send a FE210 (Failure_inside_network). The IUT re-enters the port state AN1.0 (Blocked).</p>

5.2.4 Inopportune behaviour tests (V5NWKAN/CTRL/BO)

The contents of this clause are identical to clause 5.2.4 of ETS 300 324-3 [1].

5.2.4.1 V5NWKAN/CTRL/BO/COM

The contents of this clause are identical to clause 5.2.4.1 of ETS 300 324-3 [1].

5.2.4.2 V5NWKAN/CTRL/BO/PORT

5.2.4.2.1 V5NWKAN/CTRL/BO/PORT/TRANS

The contents of this clause are identical to clause 5.2.4.2.1 of ETS 300 324-3 [1].

5.2.4.2.2 V5NWKAN/CTRL/BO/PORT/PSTN

The contents of this clause are identical to clause 5.2.4.2.2 of ETS 300 324-3 [1].

5.2.4.2.3 V5NWKAN/CTRL/BO/PORT/ISDNBA

The contents of this clause are identical to clause 5.2.4.2.3 of ETS 300 324-3 [1].

5.2.4.2.4 V5NWKAN/CTRL/BO/PORT/ISDNPRA

Refer to EN 300 347-1 [2], table 7 and figures L9.1 to L.9.11.

This test group is only valid if PICS item N12 (see EN 300 347-2 [3]) is set to yes.

As the Port control protocol is tested separately (see clause 5.2.3.2.1), the PORT CONTROL ACK messages are not mentioned in the following TPs any more.

Initial state of the IUT: CTRL_COM_INIT, CTRL_PORT_INIT
 Preamble: CTRL_ISDNPRA_AN20_10
 Postamble: CTRL_ISDNPRA_AN20_10

TP1426SM_01 On receipt of service grading (MPH-GI) the IUT shall send no message in the blocked state.
 (*)

TP1426SM_02 On receipt of a FE207 (D-channel_block), the IUT will remain in the port state AN 1.0
 (*) (Blocked).

TP1426SM_03 On receipt of a FE208 (D-channel_unblock), the IUT will remain in the port state AN 1.0
 (*) (Blocked).

5.2.5 Invalid behaviour tests (V5NWKAN/CTRL/BI)

The contents of this clause are identical to clause 5.2.5 of ETS 300 324-3 [1].

5.2.6 Timer expiry and counter mismatch tests (V5NWKAN/CTRL/TI)

The contents of this clause are identical to clause 5.2.6 of ETS 300 324-3 [1].

5.3 PSTN protocol

The contents of this clause are identical to clause 5.3 of ETS 300 324-3 [1].

5.4 Link control protocol

5.4.1 Basic interconnection tests (V5NWKAN/LINK/IT)

Initial state of the IUT: LINK_INIT
 Preamble: -
 Postamble: -

TP31__SM_01 Refer to TP11__SM_01 in clause 5.2.1.

5.4.2 Capability tests (V5NWKAN/LINK/CA)

Refer to EN 300 347-1 [2], table 24.

Initial state of the IUT: LINK_INIT
 Preamble: -
 Postamble: -

TP32__SM_01 On receipt of a LINK CONTROL message containing the link_control_function IE FE301 (link_unblock_req), the IUT shall send a LINK CONTROL ACK message containing the same link_control_function IE.

Refer to EN 300 347-1 [2], clause 16.2.4.4, table 16.

5.4.3 Valid behaviour tests (V5NWKAN/LINK/BV)

5.4.3.1 V5NWKAN/LINK/BV/TRANS

Refer to EN 300 347-1 [2], table 24.

Initial state of the IUT: LINK_INIT
 Preamble: -
 Postamble: -

TP33_1S1_01 Refer to TP32__SM_01 in clause 5.4.2.

TP33_1S2_02 On receipt of a LINK CONTROL ACK containing the link_control_function IE FE302 (link_unblock_req) after sending a LINK CONTROL message containing the link_control_function IE FE302 (link_unblock_req), the IUT shall not repeat the original message.

Refer to EN 300 347-1 [2], clause 16.2.4.4, table 16.

TP33_1SM_03 Check that the IUT is able to control messages in both directions at the same time:
 (*)
 On receipt of a FE302 (link_unblock_req) the IUT shall send a LINK CONTROL message containing the link_control_function IE FE302 (link_unblock_req).
 On receipt of a LINK CONTROL message containing the link_control_function IE FE301 (link_unblock_req), the IUT shall send a LINK CONTROL ACK message containing the same link_control_function IE.

On receipt of a LINK CONTROL ACK message containing the link_control_function IE FE302 (link_unblock_req), the IUT shall not repeat the original message.

Refer to EN 300 347-1 [2], clause 16.2.4.4, table 16.

5.4.3.2 V5NWKAN/LINK/BV/LINK

Refer to EN 300 347-1 [2], table 16.

As the Link control protocol is tested separately (see clause 5.2.3.2.1), the LINK CONTROL ACK messages are not mentioned in the following TPs any longer.

If PICS item N9 (see EN 300 347-2 [3]) is set to yes, all LINK CONTROL messages shall contain the Layer 3 address (L3addr) of the secondary link (if not stated otherwise).

Initial state of the IUT: LINK_INIT
 Preamble: -
 Postamble: LINK_CHECK_ID

TP33_7S2001 Non-persistent V5.2 link failure while link is operational.
 (*)

On detection of a non-persistent V5.2 link failure condition (Alarm Indication Signal (AIS) or Remote Alarm Indication (RAI) which disappears before expiration of TPERs, IUT Link Control FSM receives MPH_AI in state AN2.0) no message shall appear on the V5.2 interface.

Refer to EN 300 347-1 [2], clause 16.2.4.4, table 16.

- TP33_7S1002 Non-persistent V5.2 link failure while link is blocked.
 (*)
 (note 1) Preamble: LINK_AN20_10.
- On detection of a non-persistent V5.2 link failure condition (AIS or RAI which disappears before expiration of TPERS, IUT Link Control FSM receives MPH_AI in state AN1.0) no message shall appear on the V5.2 interface.
- After LT1 has unblocked the link (LINK_AN10_20) the IUT shall invoke the local link identification procedure.
- No postamble needed.
- Refer to EN 300 347-1 [2], clause 16.2.4.4, table 16.
- TP33_7S1103 Non-persistent V5.2 link failure while link is local unblocked.
 (*)
 (note 1) Preamble: LINK_AN20_10.
- On receipt of a MDU-LUBR (link_unblock_req) the IUT shall send a message containing the link_control_function IE FE302 (link_unblock_req).
- On detection of a non-persistent V5.2 link failure condition (AIS or RAI which disappears before expiration of TPERS, IUT Link Control FSM receives MPH_AI in state AN1.1) no message shall appear on the V5.2 interface.
- Postamble:
 LT1 sends a message containing the link_control_function IE FE301 (link_unblock_ack).
- Refer to EN 300 347-1 [2], clause 16.2.4.4, table 16.
- TP33_7S2204 Non-persistent V5.2 link failure while local link identification procedure.
 (*)
- Preamble:
 On receipt of a MDU-IDReq (link_identification_req) the IUT shall send a message containing the link_control_function IE FE-IDReq (link_identification_req).
- On detection of a non-persistent V5.2 link failure condition (AIS or RAI which disappears before expiration of TPERS, IUT Link Control FSM receives MPH_AI in state AN2.2) no message shall appear on the V5.2 interface.
- Postamble:
 LT1 sends a message containing the link_control_function IE FE-IDRej (link_identification_rej).
- Refer to EN 300 347-1 [2], clause 16.2.4.4, table 16.
- TP33_7S2105 Non-persistent V5.2 link failure while remote link identification procedure.
 (*)
- Preamble:
 On receipt of a message containing the link_control_function IE FE-IDReq (link_identification_req) the IUT shall send a message containing the link_control_function IE FE-IDAck (link_identification_ack) and frames with S_{a7} bit set to zero.
- On detection of a non-persistent V5.2 link failure condition (AIS or RAI which disappears before expiration of TPERS, IUT Link Control FSM receives MPH_AI in state AN2.1) no message shall appear on the V5.2 interface.
- Postamble:
 LT1 sends a message containing the link_control_function IE FE-IDRel (link_identification_rel).
- Refer to EN 300 347-1 [2], clause 16.2.4.4, table 16.

- TP33_7SM_06
(*
(note 1)
- Persistent V5.2 link failure while link is operational.
- On detection of a persistent V5.2 link failure condition (AIS or RAI persists until the expiration of TPERS, IUT Link Control FSM receives MPH_DI and enters state AN0.1) no message shall appear on the V5.2 interface.
- After the disappearance of the V5.2 link failure condition (IUT Link Control FSM receives MPH_AI and enters state AN2.0) the IUT shall invoke the local link identification procedure (see clause 5.1.6, IUT system management receives MDU_LAI).
- No postamble needed.
- Refer to EN 300 347-1 [2], clause 16.2.4.4, table 16.
- TP33_7SM_07
(*
(note 1)
- Persistent V5.2 link failure while link is blocked.
- Preamble: LINK_AN20_10
- On detection of a persistent V5.2 link failure condition (AIS or RAI persists until the expiration of TPERS, IUT Link Control FSM receives MPH_DI and enters state AN0.2) no message shall appear on the V5.2 interface.
- After the disappearance of the V5.2 link failure condition (IUT Link Control FSM receives MPH_AI and enters state AN1.0) no message shall appear on the V5.2 interface.
- After LT1 has unblocked the link (LINK_AN10_20) the IUT shall invoke the local link identification procedure.
- No postamble needed.
- Refer to EN 300 347-1 [2], clause 16.2.4.4, table 16.
- TP33_7SM_08
(*
(note 1)
- Persistent V5.2 link failure while link is local unblocked.
- Preamble:
LINK_AN20_10.
- On receipt of a MDU-LUBR (link_unblock_req) the IUT shall send a message containing the link_control_function IE FE302 (link_unblock_req).
- On detection of a persistent V5.2 link failure condition (AIS or RAI persists until the expiration of TPERS, IUT Link Control FSM receives MPH_DI and enters state AN0.2) no message shall appear on the V5.2 interface.
- After the disappearance of the V5.2 link failure condition (IUT Link Control FSM receives MPH_AI and enters state AN1.0) no message shall appear on the V5.2 interface.
- After LT1 has unblocked the link (LINK_AN10_20) the IUT shall invoke the local link identification procedure.
- No postamble needed.
- Refer to EN 300 347-1 [2], clause 16.2.4.4, table 16.

- TP33_7SM_09
(*
(note 1)
- Persistent V5.2 link failure while local link identification procedure.
- Preamble:
On receipt of a MDU-IDReq (link_identification_req) the IUT shall send a message containing the link_control_function IE FE-IDReq (link_identification_req).
- On detection of a persistent V5.2 link failure condition (AIS or RAI persists until the expiration of TPERS, IUT Link Control FSM receives MPH_DI and enters state AN0.1) the IUT shall send a message containing the link_control_function IE FE-IDRel (link_identification_rel).
- After the disappearance of the V5.2 link failure condition (IUT Link Control FSM receives MPH_AI and enters state AN2.0) the IUT shall invoke the local link identification procedure (see clause 5.1.6, IUT system management receives MDU_LAI).
- No postamble needed.
- Refer to EN 300 347-1 [2], clause 16.2.4.4, table 16.
- TP33_7SM_10
(*
(note 1)
- Persistent V5.2 link failure while remote link identification procedure.
- Preamble:
On receipt of a message containing the link_control_function IE FE-IDReq (link_identification_req) the IUT shall send a message containing the link_control_function IE FE-IDAck (link_identification_ack) and frames with S_{a7} bit set to zero.
- On detection of a persistent V5.2 link failure condition (AIS or RAI persists until the expiration of TPERS, IUT Link Control FSM receives MPH_DI and enters state AN0.1) the IUT no message shall appear on the V5.2 interface.
- LT1 sends a message containing the link_control_function IE FE-IDRel (link_identification_rel)
- After the disappearance of the V5.2 link failure condition (IUT Link Control FSM receives MPH_AI and enters state AN2.0) the IUT shall invoke the local link identification procedure (see clause 5.1.6, IUT system management receives MDU_LAI).
- No postamble needed.
- Refer to EN 300 347-1 [2], clause 16.2.4.4, table 16.
- TP33_7SM_11
(*
(note 1)
- Verify "Local Link Blocking/Unblocking" procedure while link is operational.
- On receipt of a MDU-LBI (link_block_cmd) the IUT shall send a message containing the link_control_function IE FE304 (link_block_cmd).
- On receipt of a MDU-LUBR (link_unblock_req) the IUT shall send a message containing the link_control_function IE FE302 (link_unblock_req).
- LT1 sends a message containing the link_control_function IE FE301 (link_unblock_ack) (IUT Link Control FSM enters state AN2.0).
- Refer to EN 300 347-1 [2], clause 16.2.4.4, table 16.

- TP33_7S1112
(*
(note 1)
- Verify "Repeated Local Link Unblocking" procedure.
- Preamble: LINK_AN20_10
On receipt of a MDU-LUBR (link_unblock_req) the IUT shall send a message containing the link_control_function IE FE302 (link_unblock_req).
- On receipt of a second MDU-LUBR (link_unblock_req) the IUT shall repeat the message containing the link_control_function IE FE302 (link_unblock_req).
- Additional postamble:
LT1 sends a message containing the link_control_function IE FE301 (link_unblock_ack) (IUT Link Control FSM enters state AN2.0).
- Refer to EN 300 347-1 [2], clause 16.2.4.4, table 16.
- TP33_7S1113
(*
(note 1)
- Verify "Cancelled Link Unblocking" procedure.
- Preamble: LINK_AN20_10
On receipt of a MDU-LUBR (link_unblock_req) the IUT shall send a message containing the link_control_function IE FE302 (link_unblock_req).
- On receipt of a MDU-LBI (link_block_cmd) the IUT shall send a message containing the link_control_function IE FE304 (link_block_cmd).
- Additional postamble: LINK_AN10_20.
- Refer to EN 300 347-1 [2], clause 16.2.4.4, table 16.
- TP33_7S1114
(*
(note 1)
- Verify "Rejected Link Unblocking" (FE303) procedure.
- Preamble: LINK_AN20_10
On receipt of a MDU-LUBR (link_unblock_req) the IUT shall send a message containing the link_control_function IE FE302 (link_unblock_req).
- On receipt of a message containing the link_control_function IE FE303 (link_block_cmd) (IUT Link control protocol enters state AN1.0) the IUT shall send a LINK CONTROL ACK message but no further event shall appear on the V5.2 interface.
- Additional postamble: LINK_AN10_20.
- Refer to EN 300 347-1 [2], clause 16.2.4.4, table 16.
- TP33_7SM_15
(note 1)
- Verify "Remote Link Blocking/Unblocking" procedure while link is operational.
- On receipt of a sequence of messages containing the link_control_function IEs FE303 (link_block_cmd), again FE303 (link_block_cmd) and FE301 (link_unblock_req) the IUT shall send a message containing the link_control_function IE FE302 (link_unblock_ack).
- Refer to EN 300 347-1 [2], clause 16.2.4.4, table 16.
- TP33_7SM_18
(*
(note 1)
- Verify "Deferred Link Blocking Request/Unblocking" procedure while link is operational.
- On receipt of a MDU-LBR (deferred_blocking_req), the IUT shall send a message containing the link_control_function IE FE305 (deferred_link_block_req).
- LT1 sends a message containing the link_control_function IE FE303 (link_block_cmd).
- On receipt of a MDU-LUBR (link_unblock_req), the IUT shall send a message containing the link_control_function FE302 (link_unblock_req).
- LT1 sends a message containing the link_control_function IE FE301 (link_unblock_ack).
- Refer to EN 300 347-1 [2], clause 16.2.4.4, table 16.

- TP33_7SM_19
(*
(note 1)
- Verify "Non-Deferred Link Blocking Request/Unblocking" procedure while link is operational.
- On receipt of a MDU-LBRN (non-deferred_blocking_req), the IUT shall send a message containing the link_control_function IE FE306 (non-deferred_link_block_req).
- LT1 sends a message containing the link_control_function IE FE303 (link_block_cmd).
- On receipt of a MDU-LUBR (link_unblock_req), the IUT shall send a message containing the link_control_function FE302 (link_unblock_req).
- LT1 sends a message containing the link_control_function IE FE301 (link_unblock_ack).
- Refer to EN 300 347-1 [2], clause 16.2.4.4, table 16.
- TP33_7SM_20
(*
(note 1)
- Verify "Local Blocking" procedure while persistent V5.2 link failure.
- Preamble:
Detection of a persistent V5.2 link failure condition (AIS or RAI persists until the expiration of TPERS, IUT Link Control FSM receives MPH_DI and enters state AN0.1).
- On receipt of a MDU-LBI (link_block_cmd) the IUT shall send a message containing the link_control_function IE FE304 (link_block_cmd).
- After LT1 has unblocked the link (LINK_AN10_20) and the disappearance of the V5.2 link failure condition the IUT shall invoke the local link identification procedure.
- No postamble needed.
- Refer to EN 300 347-1 [2], clause 16.2.4.4, table 16.
- TP33_7SM_21
(*
(note 1)
- Verify "Remote Blocking" procedure while persistent V5.2 link failure.
- Preamble:
Detection of a persistent V5.2 link failure condition (AIS or RAI persists until the expiration of TPERS, IUT Link Control FSM receives MPH_DI and enters state AN0.1).
- On receipt of a message containing the link_control_function IE FE303 (link_block_cmd) the IUT shall send a LINK CONTROL ACK message but no further event shall appear on the V5.2 interface.
- On receipt of a second message containing the link_control_function IE FE303 (link_block_cmd) the IUT shall send a LINK CONTROL ACK message but no further event shall appear on the V5.2 interface.
- On receipt of a message containing the link_control_function IE FE301 (link_unblock_req) the IUT shall send a message containing the link_control_function IE FE303 (link_block_cmd)
- After LT1 has unblocked the link (LINK_AN10_20) and the disappearance of the V5.2 link failure condition the IUT shall invoke the local link identification procedure.
- No postamble needed.
- Refer to EN 300 347-1 [2], clause 16.2.4.4, table 16.

- TP33_7S2222
(*
(note 1)
- Verify "Local Blocking procedure" procedure while local link identification.
- Preamble:
On receipt of a MDU-IDReq (link_identification_req) the IUT shall send a message containing the link_control_function IE FE-IDReq (link_identification_req).
- On receipt of a MDU-LBI (link_block_cmd) the IUT shall send a message containing the link_control_function IE FE304 (link_block_cmd).
- Postamble: LINK_AN10_20.
- Refer to EN 300 347-1 [2], clause 16.2.4.4, table 16.
- TP33_7S2223
(*
- Verify "Remote Unblocking" procedure while local link identification.
- Preamble:
On receipt of a MDU-IDReq (link_identification_req) the IUT shall send a message containing the link_control_function IE FE-IDReq (link_identification_req).
- On receipt of a message containing the link_control_function IE FE301 (link_unblock_req) and a subsequent MDU-IDReq (link_identification_req) the IUT shall send a message containing the link_control_function IE FE-IDReq (link_identification_req).
- Postamble:
LT1 sends a message containing the link_control_function IE FE-IDRej (link_identification_rej).
- Refer to EN 300 347-1 [2], clause 16.2.4.4, table 16.
- TP33_7S2224
(*
(note 1)
- Verify "Remote Blocking" procedure while local link identification.
- Preamble:
On receipt of a MDU-IDReq (link_identification_req) the IUT shall send a message containing the link_control_function IE FE-IDReq (link_identification_req).
- On receipt of a message containing the link_control_function IE FE303 (link_block_cmd) the IUT shall send a LINK CONTROL ACK message but no further event shall appear on the V5.2 interface.
- Postamble: LINK_AN10_20.
- Refer to EN 300 347-1 [2], clause 16.2.4.4, table 16.
- TP33_7S2125
- Verify "Remote Unblocking" procedure while remote link identification.
- Preamble:
On receipt of a message containing the link_control_function IE FE-IDReq (link_identification_req) the IUT shall send a message containing the link_control_function IE FE-IDAck (link_identification_ack) and frames with S_{a7} bit set to zero.
- On receipt of a message containing the link_control_function IE FE301 (link_unblock_req) the IUT shall send frames with S_{a7} bit set to one.

- TP33_7S2126
(note 1) Verify "Remote Blocking" procedure while remote link identification.
- Preamble:
On receipt of a message containing the link_control_function IE FE-IDReq (link_identification_req) the IUT shall send a message containing the link_control_function IE FE-IDAck (link_identification_ack) and frames with S_{a7} bit set to zero.
- On receipt of a message containing the link_control_function IE FE303 (link_block_cmd) the IUT shall send frames with S_{a7} bit set to one.
- Postamble: LINK_AN10_20.
- Refer to EN 300 347-1 [2], clause 16.2.4.4, table 16.
- TP33_7S0127
(*
(note 1) Preamble:
Detection of a persistent V5.2 link failure condition (AIS or RAI persists until the expiration of TPERS, IUT Link Control FSM receives MPH_DI and enters state AN0.1).
- On receipt of a message containing the link_control_function IE FE301 (link_unblock_req) the IUT shall send a message containing the link_control_function IE FE304 (link_block_cmd)
- After LT1 has unblocked the link (LINK_AN10_20) and the disappearance of the V5.2 link failure condition the IUT shall invoke the local link identification procedure.
- No postamble needed.
- TP33_7SM_28
(* Verify "Successful Local Link Identification" procedure while link is operational.
- On receipt of a MDU-IDReq (link_identification_req) the IUT shall send a message containing the link_control_function IE FE-IDReq (link_identification_req).
- LT1 sends frames with S_{a7} bit set to zero.
- On receipt of a message containing the link_control_function IE FE-IDAck (link_identification_ack) the IUT shall send a message containing the link_control_function IE FE-IDRel (link_identification_rel).
- Postamble:
LT1 sends frames with S_{a7} bit set to one.
- Refer to EN 300 347-1 [2], clause 16.2.4.4, table 16.
- TP33_7SM_29
(* Verify "Unsuccessful Local Link Identification" procedure while link is operational.
- On receipt of a MDU-IDReq (link_identification_req) the IUT shall send a message containing the link_control_function IE FE-IDReq (link_identification_req).
- On receipt of a message containing the link_control_function IE FE-IDAck (link_identification_ack) the IUT shall send a message containing the link_control_function IE FE-IDRel (link_identification_rel).
- Refer to EN 300 347-1 [2], clause 16.2.4.4, table 16.
- TP33_7SM_30
(* Verify "Rejected Local Link Identification" procedure while link is operational.
- On receipt of a MDU-IDReq (link_identification_req) the IUT shall send a message containing the link_control_function IE FE-IDReq (link_identification_req).
- On receipt of a message containing the link_control_function IE FE-IDRej (link_identification_rej) the IUT shall send a LINK CONTROL ACK message but no further message shall appear on the V5.2 interface.
- Refer to EN 300 347-1 [2], clause 16.2.4.4, table 16.

- TP33_7SM_31 Verify "Successful Remote Link Identification" procedure while link is operational.
- On receipt of a message containing the link_control_function IE FE-IDReq (link_identification_req) the IUT shall send a message containing the link_control_function IE FE-IDAck (link_identification_ack) and frames with S_{a7} bit set to zero.
- On receipt of a second message containing the link_control_function IE FE-IDReq (link_identification_req) the IUT shall send a LINK CONTROL ACK message but no further message shall appear on the V5.2 interface.
- On receipt of a message containing the link_control_function IE FE-IDRel (link_identification_rel) the IUT shall send frames with S_{a7} bit set to one.
- No postamble needed.
- Refer to EN 300 347-1 [2], clause 16.2.4.4, table 16.
- TP33_7S2232
(*) Verify "Link Identification Collision" procedure on one link.
- Preamble:
On receipt of a MDU-IDReq (link_identification_req) the IUT shall send a message containing the link_control_function IE FE-IDReq (link_identification_req).
- On receipt of a message containing the link_control_function IE FE-IDReq (link_identification_req) for the same link the IUT shall send a message containing the link_control_function IE FE-IDAck (link_identification_ack) and frames with S_{a7} bit set to zero.
- Postamble:
LT1 sends a message containing the link_control_function IE FE-IDRel (link_identification_rel).
- Refer to EN 300 347-1 [2], clause 16.2.4.3.5, 16.2.4 table 16.
- TP33_7S2233
(*)
(note 1) Verify "Link Identification Collision" procedure on different links.
- Preamble:
On receipt of a MDU-IDReq (link_identification_req) the IUT shall send a message containing the link_control_function IE FE-IDReq (link_identification_req).
- On receipt of a message containing the link_control_function IE FE-IDReq (link_identification_req) and L3addr of the primary link, the IUT shall send a message containing the link_control_function IE FE-IDAck (link_identification_ack) and L3addr of the primary link and frames with S_{a7} bit set to zero.
- Postamble:
LT1 sends a message containing the link_control_function IE FE-IDRel (link_identification_rel).
- Refer to EN 300 347-1 [2], clause 16.2.4.3.5, 16.2.4.4 table 16.
- TP33_7S1034
(note 1) Verify "Remote Link Identification" procedure while link is blocked.
- Preamble: LINK_AN20_10
- On receipt of a message containing the link_control_function IE FE-IDReq (link_identification_req) the IUT shall send a message containing the link_control_function IE FE304 (link_block_cmd).
- Additional postamble: LINK_AN10_20.
- Refer to EN 300 347-1 [2], clause 16.2.4.4, table 16.

- TP33_7S1035
(note 1)
- Preamble: LINK_AN20_10
- On receipt of a message containing the link_control_function IE FE-IDRel (link_identification_rel) the IUT shall send a LINK CONTROL ACK message but no further event shall appear on the V5.2 interface.
- Additional postamble: LINK_AN10_20.
- Refer to EN 300 347-1 [2], clause 16.2.4.4, table 16.
- TP33_7S1036
(note 1)
- Preamble: LINK_AN20_10
- On receipt of a message containing the link_control_function IE FE-IDRej (link_identification_rej) the IUT shall send a LINK CONTROL ACK message but no further event shall appear on the V5.2 interface.
- Additional postamble: LINK_AN10_20.
- Refer to EN 300 347-1 [2], clause 16.2.4.4, table 16.
- TP33_7S1137
(*
(note 1)
- Preamble: LINK_AN20_10
- On receipt of a MDU-LUBR (link_unblock_req) the IUT shall send a message containing the link_control_function IE FE302 (link_unblock_req).
- On receipt of a message containing the link_control_function IE FE-IDReq (link_identification_req) the IUT shall send a message containing the link_control_function IE FE-IDRej (link_identification_rej).
- Additional postamble: LINK_AN11_20.
- Refer to EN 300 347-1 [2], clause 16.2.4.4, table 16.
- TP33_7S1138
(*
(note 1)
- Preamble: LINK_AN20_10
- On receipt of a MDU-LUBR (link_unblock_req) the IUT shall send a message containing the link_control_function IE FE302 (link_unblock_req).
- On receipt of a message containing the link_control_function IE FE-IDRel (link_identification_rel) the IUT shall send a LINK CONTROL ACK message but no further event shall appear on the V5.2 interface.
- Additional postamble: LINK_AN11_20.
- Refer to EN 300 347-1 [2], clause 16.2.4.4, table 16.
- TP33_7S1139
(*
(note 1)
- Preamble: LINK_AN20_10
- On receipt of a MDU-LUBR (link_unblock_req) the IUT shall send a message containing the link_control_function IE FE302 (link_unblock_req).
- On receipt of a message containing the link_control_function IE FE-IDRej (link_identification_rej) the IUT shall send a LINK CONTROL ACK message but no further event shall appear on the V5.2 interface.
- Additional postamble: LINK_AN11_20.
- Refer to EN 300 347-1 [2], clause 16.2.4.4, table 16.

TP33_7SM_40 Remote link identification while persistent V5.2 link failure.
 (*) Preamble:
 (note 1) Detection of a persistent V5.2 link failure condition (AIS or RAI persists until the expiration of TPERS, IUT Link Control FSM receives MPH_DI and enters state AN0.1).

On receipt of a message containing the link_control_function IE FE-IDReq (link_identification_req) the IUT shall send a message containing the link_control_function IE FE304 (link_block_cmd).

On receipt of a second message containing the link_control_function IE FE-IDReq (link_identification_req) the IUT shall repeat the message containing the link_control_function IE FE304 (link_block_cmd).

After LT1 has unblocked the link (LINK_AN10_20) and the disappearance of the V5.2 link failure condition the IUT shall invoke the local link identification procedure.

No postamble needed.

Refer to EN 300 347-1 [2], clause 16.2.4.4, table 16.

TP33_7S0141 Preamble:
 (*) Detection of a persistent V5.2 link failure condition (AIS or RAI persists until the expiration of
 (note 1) TPERS, IUT Link Control FSM receives MPH_DI and enters state AN0.1).

On receipt of a message containing the link_control_function IE FE-IDReq (link_identification_req) the IUT shall send a LINK CONTROL ACK message but no further event shall appear on the V5.2 interface.

After the disappearance of the V5.2 link failure condition, the IUT shall invoke the local link identification procedure.

No postamble needed.

Refer to EN 300 347-1 [2], clause 16.2.4.4, table 16.

NOTE 1: These TPs are only applicable if PICS item N9 (see EN 300 347-2 [3]) is set to yes.

NOTE 2: These TPs are only applicable if PICS item N9 (see EN 300 347-2 [3]) is set to no.

5.4.4 Inopportune behaviour tests (V5NWKAN/LINK/BO)

5.4.4.1 V5NWKAN/LINK/BO/TRANS

Refer to EN 300 347-1 [2], table 24.

Initial state of the IUT: LINK_INIT

Preamble: -

Postamble: -

TP34_1S1_01 On receipt of a LINK CONTROL ACK message the IUT shall ignore the message.

5.4.4.2 V5NWKAN/LINK/BO/LINK

Refer to EN 300 347-1 [2], table 16.

Initial state of the IUT: LINK_INIT
 Preamble: -
 Postamble: LINK_CHECK_ID

TP34_7S0101 Preamble:
 (*) Detection of a persistent V5.2 link failure condition (AIS or RAI persists until the expiration of
 (note) TPERS, IUT Link Control FSM receives MPH_DI and enters state AN0.1).

On receipt of a message containing the link_control_function IE FE-IDAck (link_identification_ack) the IUT shall send a LINK CONTROL ACK message but no further event shall appear on the V5.2 interface.

On the disappearance of the V5.2 link failure condition the IUT shall invoke the local link identification procedure.

No postamble needed.

Refer to EN 300 347-1 [2], clause 16.2.4.4, table 16.

TP34_7S0202 Preamble:
 (*) LINK_AN20_10 and detection of a persistent V5.2 link failure condition (AIS or RAI persists
 (note) until the expiration of TPERS, IUT Link Control FSM receives MPH_DI and enters state AN0.2).

On receipt of a message containing the link_control_function IE FE-IDAck (link_identification_ack) the IUT shall send a LINK CONTROL ACK message but no further event shall appear on the V5.2 interface.

After LT1 has unblocked the link (LINK_AN10_20) and the disappearance of the V5.2 link failure condition the IUT shall invoke the local link identification procedure.

No postamble needed.

Refer to EN 300 347-1 [2], clause 16.2.4.4, table 16.

TP34_7S0203 Preamble:
 (*) LINK_AN20_10 and detection of a persistent V5.2 link failure condition (AIS or RAI persists
 (note) until the expiration of TPERS, IUT Link Control FSM receives MPH_DI and enters state AN0.2).

On receipt of a message containing the link_control_function IE FE-IDRel (link_identification_rel) the IUT shall send a LINK CONTROL ACK message but no further event shall appear on the V5.2 interface.

After LT1 has unblocked the link (LINK_AN10_20) and the disappearance of the V5.2 link failure condition the IUT shall invoke the local link identification procedure.

No postamble needed.

Refer to EN 300 347-1 [2], clause 16.2.4.4, table 16.

- TP34_7S0204
(*)
(note)
- Preamble:
LINK_AN20_10 and detection of a persistent V5.2 link failure condition (AIS or RAI persists until the expiration of TPERS, IUT Link Control FSM receives MPH_DI and enters state AN0.2).
- On receipt of a message containing the link_control_function IE FE-IDRej (link_identification_rej) the IUT shall send a LINK CONTROL ACK message but no further event shall appear on the V5.2 interface.
- After LT1 has unblocked the link (LINK_AN10_20) and the disappearance of the V5.2 link failure condition the IUT shall invoke the local link identification procedure.
- No postamble needed.
- Refer to EN 300 347-1 [2], clause 16.2.4.4, table 16.
- TP34_7S1005
(note)
- Preamble: LINK_AN20_10.
- On receipt of a message containing the link_control_function IE FE-IDAck (link_identification_ack) the IUT shall send a LINK CONTROL ACK message but no further event shall appear on the V5.2 interface.
- Additional postamble: LINK_AN10_20.
- Refer to EN 300 347-1 [2], clause 16.2.4.4, table 16.
- TP34_7S1106
(*)
(note)
- Preamble: LINK_AN20_10.
- On receipt of a MDU-LUBR (link_unblock_req) the IUT shall send a message containing the link_control_function IE FE302 (link_unblock_req).
- On receipt of a message containing the link_control_function IE FE-IDAck (link_identification_ack) the IUT shall send a LINK CONTROL ACK message but no further event shall appear on the V5.2 interface.
- Additional postamble: LINK_AN11_20.
- Refer to EN 300 347-1 [2], clause 16.2.4.4, table 16.
- TP34_7S2007
- On receipt of a message containing the link_control_function IE FE-IDAck (link_identification_ack) the IUT shall send a LINK CONTROL ACK message but no further event shall appear on the V5.2 interface.
- Refer to EN 300 347-1 [2], clause 16.2.4.4, table 16.
- TP34_7S2008
- On receipt of a message containing the link_control_function IE FE-IDRel (link_identification_rel) the IUT shall send a LINK CONTROL ACK message but no further event shall appear on the V5.2 interface.
- Refer to EN 300 347-1 [2], clause 16.2.4.4, table 16.
- TP34_7S2009
- On receipt of a message containing the link_control_function IE FE-IDRej (link_identification_rej) the IUT shall send a LINK CONTROL ACK message but no further event shall appear on the V5.2 interface.
- Refer to EN 300 347-1 [2], clause 16.2.4.4, table 16.

- TP34_7S2110 Preamble:
 On receipt of a message containing the link_control_function IE FE-IDReq (link_identification_req) the IUT shall send a message containing the link_control_function IE FE-IDAck (link_identification_ack) and frames with S_{a7} bit set to zero.
- On receipt of a message containing the link_control_function IE FE-IDRej (link_identification_rej) the IUT shall send a LINK CONTROL ACK message but no further event shall appear on the V5.2 interface.
- Postamble:
 On receipt of a message containing the link_control_function IE FE-IDRel (link_identification_rel) the IUT shall send frames with S_{a7} bit set to one.
- Refer to EN 300 347-1 [2], clause 16.2.4.4, table 16.
- TP34_7S2111 Preamble:
 On receipt of a message containing the link_control_function IE FE-IDReq (link_identification_req) the IUT shall send a message containing the link_control_function IE FE-IDAck (link_identification_ack) and frames with S_{a7} bit set to zero.
- On receipt of a message containing the link_control_function IE FE-IDAck (link_identification_ack) the IUT shall send a LINK CONTROL ACK message but no further event shall appear on the V5.2 interface.
- Postamble:
 On receipt of a message containing the link_control_function IE FE-IDRel (link_identification_rel) the IUT shall send frames with S_{a7} bit set to one.
- Refer to EN 300 347-1 [2], clause 16.2.4.4, table 16.
- TP34_7S2212 Preamble:
 (*) On receipt of a MDU-IDReq (link_identification_req) the IUT shall send a message containing the link_control_function IE FE-IDReq (link_identification_req).
- On receipt of a message containing the link_control_function IE FE-IDRel (link_identification_rel) the IUT shall send a LINK CONTROL ACK message but no further event shall appear on the V5.2 interface.
- Postamble:
 LT1 sends a message containing the link_control_function IE FE-IDRej (link_identification_rej).
- Refer to EN 300 347-1 [2], clause 16.2.4.4, table 16.

NOTE: These TPs are only applicable if PICS item N9 (see EN 300 347-2 [3]) is set to yes.

5.4.5 Invalid behaviour tests (V5NWKAN/LINK/BI)

Refer to EN 300 347-1 [2], clause 16.3.5.

5.4.5.1 V5NWKAN/LINK/BI/TRANS

Initial state of the IUT: LINK_INIT

Preamble: -

Postamble: -

TP35_1S1_01 Check that the IUT discards messages having less than 4 octets.

TP35_1S1_02 (protocol discriminator error)

Check that the IUT discards a message containing an unspecified protocol_discriminator IE.

TP35_1S1_03	(L3 address error)
	Check that the IUT discards a message containing an unprovisioned L3addr IE.
TP35_1S1_04	(message type error)
	Check that the IUT discards a message containing an unspecified message_type IE.
TP35_1S1_05	(repeated IE)
	Check that the IUT discards a message containing two repeated link_control_function IEs.
TP35_1S1_06	(mandatory IE missing)
	Check that the IUT discards a message containing no link_control_function IE.
TP35_1S1_07	(unrecognized IE)
	Check that the IUT discards a message containing an unspecified link_control_function.
TP35_1S1_08	(content error of mandatory IE)
	Check that the IUT discards a message containing an incorrect link_control_function IE.

5.4.6 Timer expiry and counter mismatch tests (V5NWKAN/LINK/TI)

5.4.6.1 V5NWKAN/LINK/TI/TRANS

Refer to EN 300 347-1 [2], table 24.

Initial state of the IUT: LINK_INIT

Preamble: -

Postamble: -

TP36_1S2_01	<p>Preamble:</p> <p>On receipt of a LINK CONTROL message containing the link_control_function IE FE301 (link_unblock_req) the IUT shall send a LINK CONTROL ACK message containing the same link_control_function IE.</p> <p>On receipt of a FE302 (link_unblock_ack) the IUT shall send a LINK CONTROL message containing the link_control_function IE FE302 (link_unblock_ack).</p> <p>On receipt of a LINK CONTROL ACK messages after NLCO1 repetitions of the LINK CONTROL message, the IUT shall stop repeating the original message.</p>
TP36_1S2_02	<p>Preamble:</p> <p>On receipt of a LINK CONTROL message containing the link_control_function IE FE301 (link_unblock_req) the IUT shall send a LINK CONTROL ACK message containing the same link_control_function IE.</p> <p>On receipt of a FE302 (link_unblock_ack) the IUT shall send a LINK CONTROL message containing the link_control_function IE FE302 (link_unblock_ack).</p> <p>On receipt of a LINK CONTROL ACK message containing not the same link_control_function IE, the IUT shall ignore the message.</p> <p>On receipt of a LINK CONTROL ACK messages after NLCO1 repetitions of the LINK CONTROL message, the IUT shall stop repeating the original message.</p>

5.5 BCC protocol

If not stated otherwise, the BCC messages sent by the IUT or LT1 shall have the following contents:

- a) each ALLOCATION/DE-ALLOCATION message shall contain the V5_TS_ID IE for TS 1 on the primary link;
- b) the override bit in the V5_TS_ID IE shall be set to zero;
- c) each response of the IUT respectively LT1 on BCC messages shall contain the same reference_number IE as the original message;
- d) for ISDN port applications, the ISDN_port_TS_ID IE shall contain the ISDN UP TS number 1 (channel B1).

The global pre- and postambles depend on the provisioned data configuration with relation to the PICS items N11, N12 and M2 (see EN 300 347-2 [3], clause 6.6.1).

Preambles given in a specific TP have to be applied after performing the global preamble, specific postambles have to be applied before performing the global postamble.

5.5.1 Basic interconnection tests (V5NWKAN/BCC/IT)

Initial state of the IUT: BCC_INIT
 Preamble: -
 Postamble: -

TP41__SM_01 Refer to TP11__SM_01 (clause 5.2.1).

5.5.2 Capability tests (V5NWKAN/BCC/CA)

Refer to EN 300 347-1 [2], table 48.

Initial state of the IUT: BCC_INIT
 Preamble: CTRL_PSTN_AN10_20, CTRL_ISDNBA_AN10_20, CTRL_ISDNPRA_AN10_20
 Postamble: CTRL_PSTN_AN20_10, CTRL_ISDNBA_AN20_10, CTRL_ISDNPRA_AN20_10

- TP42__S0_01 (note 1) "Allocation/De-allocation for PSTN UPs"
 On receipt of an ALLOCATION message containing a PSTN UP_ID IE, the IUT shall send an ALLOCATION COMPLETE message.
 On receipt of a DE-ALLOCATION message, the IUT shall send a DE-ALLOCATION COMPLETE message.
- TP42__S0_02 (note 2) "Allocation/De-allocation for ISDN BA UPs"
 On receipt of an ALLOCATION message containing an ISDN BA UP_ID IE, the IUT shall send an ALLOCATION COMPLETE message.
 On receipt of a DE-ALLOCATION message, the IUT shall send a DE-ALLOCATION COMPLETE message.
- TP42__S0_03 (note 3) "Allocation/De-allocation for ISDN PRA UPs"
 On receipt of an ALLOCATION message containing an ISDN PRA UP_ID IE, the IUT shall send an ALLOCATION COMPLETE message.
 On receipt of a DE-ALLOCATION message, the IUT shall send a DE-ALLOCATION COMPLETE message.

TP42__S0_04
(note 4) "Allocation/De-allocation of multi slot connections"

On receipt of an ALLOCATION message containing a multi-slot_map IE, the IUT shall send an ALLOCATION COMPLETE message.

On receipt of a DE-ALLOCATION message containing a multi-slot_map IE, the IUT shall send a DE-ALLOCATION COMPLETE message.

NOTE 1: This TP is only applicable if PICS item M2 (see EN 300 347-2 [3]) is set to yes.

NOTE 2: This TP is only applicable if PICS item N11 (see EN 300 347-2 [3]) is set to yes.

NOTE 3: This TP is only applicable if PICS item N12 (see EN 300 347-2 [3]) is set to yes.

NOTE 4: This TP is only applicable if PICS item N8 (see EN 300 347-2 [3]) is set to yes.

5.5.3 Valid behaviour tests (V5NWKAN/BCC/BV)

Refer to EN 300 347-1 [2], table 48.

Initial state of the IUT: BCC_INIT
 Preamble: CTRL_PSTN_AN10_20, CTRL_ISDNBA_AN10_20, CTRL_ISDNPRA_AN10_20
 Postamble: CTRL_PSTN_AN20_10, CTRL_ISDNBA_AN20_10, CTRL_ISDNPRA_AN20_10

TP43__S0_01
(note 1) "Repeated Allocation/De-allocation"

On receipt of an ALLOCATION message the IUT shall send an ALLOCATION COMPLETE message.

On receipt of a second ALLOCATION message containing the same data, the IUT shall send an ALLOCATION COMPLETE message.

On receipt of a DE-ALLOCATION message, the IUT shall send a DE-ALLOCATION COMPLETE message.

On receipt of a second DE-ALLOCATION message containing the same data, the IUT shall send a DE-ALLOCATION COMPLETE message.

TP43__S0_02
(note 2) "Override Allocation Request"

Preamble: BCC_CONN

On receipt of a second ALLOCATION message containing the same UP_ID IE, the same V5_TS_ID IE, but set override bit and the ISDN_port_TS_ID IE "B2", the IUT shall send an ALLOCATION COMPLETE message.

Postamble: BCC_REL

TP43__S0_03
(note 3) "Unsuccessful Allocation, Connection already present at PSTN UP"

Preamble: BCC_CONN

On receipt of a second ALLOCATION message containing the same PSTN UP_ID IE but a different V5_TS_ID IE (TS 2 on the primary link and set override bit), the IUT shall send an ALLOCATION REJECT message containing a reject_cause IE with cause type "connection already present at the PSTN UP to a different V5 TS" and diagnostic "UP_ID IE".

Postamble: BCC_REL

- TP43__S0_04
(note 1) "Unsuccessful Allocation, Connection already present at V5 TS"
Preamble: BCC_CONN
On receipt of a second ALLOCATION message containing a different UP_ID IE and the same V5_TS_ID IE, the IUT shall send an ALLOCATION REJECT message containing a reject_cause IE with cause type "connection already present at the V5 TS" and diagnostic "V5_TS_ID IE".
Postamble: BCC_REL
- TP43__S0_05
(note 2) "Unsuccessful Allocation, Connection already present at ISDN UP"
Preamble: BCC_CONN
On receipt of a second ALLOCATION message containing the same UP_ID IE, a different V5_TS_ID IE (TS 2 on the primary link) and the ISDN_port_TS_ID IE "B1", the IUT shall send an ALLOCATION REJECT message containing a reject_cause IE with cause type "connection already present at the ISDN UP TS to a different V5 TS" and diagnostic "V5_ISDN_port_channel_ID IE".
Postamble: BCC_REL
- TP43__S0_06
(note 1) "Unsuccessful Allocation, UP unavailable"
Preamble not applicable.
On receipt of an ALLOCATION message, the IUT shall send an ALLOCATION REJECT message containing a reject_cause IE with cause type "UP unavailable" and diagnostic "UP_ID IE".
- TP43__S0_07
(note 1) "Unsuccessful Allocation, UP not provisioned"
On receipt of an ALLOCATION message containing an UP_ID IE indicating an unprovisioned UP, the IUT shall send an ALLOCATION REJECT message containing a reject_cause IE with cause type "UP not provisioned" and diagnostic "UP_ID IE".
- TP43__S0_08
(note 1) "Unsuccessful Allocation, Invalid V5.2 link ID"
On receipt of an ALLOCATION message containing a non-present V5.2 link ID (link number 3), the IUT shall send an ALLOCATION REJECT message containing a reject_cause IE with cause type "invalid V5.2 link ID" and diagnostic "V5_TS_ID IE".
- TP43__S0_09
(note 4) "Unsuccessful allocation, Invalid UP TS ID"
On receipt of an ALLOCATION message containing an ISDN BA UP_ID IE and the ISDN_port_TS_ID IE "B3", the IUT shall send an ALLOCATION REJECT message containing a reject_cause IE with cause type "Invalid UP TS ID" and diagnostic "V5_ISDN_port_channel_ID IE".
- TP43__S0_10
(note 1) "Unsuccessful allocation, V5 TS being used as physical C channel"
On receipt of an ALLOCATION message containing a V5_TS_ID IE (TS 16 on the primary link), the IUT shall send an ALLOCATION REJECT message containing a reject_cause IE with cause type "V5 TS being used as physical C channel" and diagnostic "V5_TS_ID IE".
- TP43__S0_11
(note 6) "Unsuccessful allocation, V5 link unavailable"
Preamble: LINK_AN20_10 for secondary link.
On receipt of an ALLOCATION message containing a V5.2 link ID (secondary link), the IUT shall send an ALLOCATION REJECT message containing a reject_cause IE with cause type "V5 link unavailable" and diagnostic "V5_TS_ID IE".
Postamble: LINK_AN10_20 for secondary link.

- TP43__S0_12
(note 1) "Unsuccessful De-Allocation, Incompatible V5 TS data"
Preamble: BCC_CONN
On receipt of a DE-ALLOCATION message containing a different V5_TS_ID IE, the IUT shall send a DE-ALLOCATION REJECT message containing a reject_cause IE with cause type "De-allocation cannot be completed due to V5 TS incompatibility" and diagnostic "V5_TS_ID IE".
Postamble: BCC_REL
- TP43__S0_13
(note 1) "Unsuccessful De-Allocation, Incompatible port data"
Preamble: BCC_CONN
On receipt of a DE-ALLOCATION message containing a different UP_ID IE, the IUT shall send a DE-ALLOCATION REJECT message containing a reject_cause IE with cause type "De-allocation cannot be completed due to port data incompatibility" and diagnostic "UP_ID IE".
Postamble: BCC_REL
- TP43__S0_14
(note 2) "Unsuccessful De-Allocation, Incompatible UP TS data "
Preamble: BCC_CONN
On receipt of a DE-ALLOCATION message containing a different ISDN_port_TS_ID IE "B2", the IUT shall send a DE-ALLOCATION REJECT message containing a reject_cause IE with cause type "De-allocation cannot be completed due to UP TS data incompatibility" and diagnostic "ISDN_port_channel_ID IE".
Postamble: BCC_REL
- TP43__S0_15
(note 1) "UP ID based Audit"
Preamble: BCC_CONN
On receipt of an AUDIT message containing the same UP_ID IE, the IUT shall send an AUDIT COMPLETE message containing all relevant data.
Postamble: BCC_REL
- TP43__S0_16
(note 1) "V5 TS ID based Audit"
Preamble: BCC_CONN
On receipt of an AUDIT message containing the same V5_TS_ID IE, the IUT shall send an AUDIT COMPLETE message containing all relevant data.
Postamble: BCC_REL
- TP43__S0_17
(note 1) On receipt of an AUDIT message containing an UP_ID IE, the IUT shall send an AUDIT COMPLETE message containing the connection_incomplete IE "incomplete normal".
- TP43__S0_18
(note 1) On receipt of an AUDIT message containing an UP_ID IE indicating an unprovisioned UP, the IUT shall send an AUDIT COMPLETE message containing the connection_incomplete IE "UP not provisioned".
- TP43__S0_19
(note 1) On receipt of an AUDIT message containing the V5_TS_ID IE (TS 16 on primary link), the IUT shall send an AUDIT COMPLETE message containing the connection_incomplete IE "TS used as physical C-channel".
- TP43__S0_20
(note 1) On receipt of an AUDIT message containing a non-present V5.2 link ID, the IUT shall send an AUDIT COMPLETE message containing the connection_incomplete IE "invalid V5.2 link".

TP43__SM_21 (* (note 1)	"AN internal failure" Preamble BCC_CONN On detection of "AN internal failure" of the allocated connection, the IUT shall send an AN FAULT message containing the UP_ID IE, the ISDN_port_channel_ID (only for ISDN application) and the V5_TS_ID IE. LT1 sends an AN FAULT ACKNOWLEDGE message. Postamble: BCC_REL
-------------------------------	--

NOTE 1: It is sufficient to perform these TPs for one the main features N11, N12 or M2 (see EN 300 347-2 [3]).

NOTE 2: These TPs are only applicable if PICS items N11 or N12 (see EN 300 347-2 [3]) is set to yes.

NOTE 3: These TPs are only applicable if PICS item M2 (see EN 300 347-2 [3]) is set to yes.

NOTE 4: These TPs are only applicable if PICS item N11 (see EN 300 347-2 [3]) is set to yes.

NOTE 5: These TPs are only applicable if PICS item N12 (see EN 300 347-2 [3]) is set to yes.

NOTE 6: These TPs are only applicable if PICS item N9 (see EN 300 347-2 [3]) is set to yes.

5.5.4 Inopportune behaviour tests (V5NWKAN/BCC/BO)

Refer to EN 300 347-1 [2], table 48.

It is sufficient to perform these TPs for one the main features N11, N12 or M2 (see EN 300 347-2 [3]).

Initial state of the IUT:	BCC_INIT
Preamble:	CTRL_PSTN_AN10_20, CTRL_ISDNBA_AN10_20, CTRL_ISDNPRA_AN10_20
Postamble:	CTRL_PSTN_AN20_10, CTRL_ISDNBA_AN20_10, CTRL_ISDNPRA_AN20_10
TP44__S0_01	On receipt of an AN FAULT ACKNOWLEDGE message, the IUT shall send a PROTOCOL ERROR message containing the protocol_error_cause IE "Message not compatible with BCC protocol state" including corresponding diagnostic.
TP44__S1_02 (*	Preamble: BCC_FAULT On receipt of an ALLOCATION message, the IUT shall send a PROTOCOL ERROR message containing the protocol_error_cause IE "Message not compatible with BCC protocol state" including corresponding diagnostic. Postamble: LT1 sends an AN FAULT ACKNOWLEDGE message. BCC_REL
TP44__S1_03 (*	Preamble: BCC_FAULT On receipt of a DE-ALLOCATION message, the IUT shall send a PROTOCOL ERROR message containing the protocol_error_cause IE "Message not compatible with BCC protocol state" including corresponding diagnostic. Postamble: LT1 sends an AN FAULT ACKNOWLEDGE message. BCC_REL

TP44__S1_04 Preamble: BCC_FAULT
 (*)
 On receipt of an AUDIT message, the IUT shall send a PROTOCOL ERROR message containing the protocol_error_cause IE "Message not compatible with BCC protocol state" including corresponding diagnostic.

Postamble:
 LT1 sends an AN FAULT ACKNOWLEDGE message.
 BCC_REL

5.5.5 Invalid behaviour tests (V5NWKAN/BCC/BI)

Refer to EN 300 347-1 [2], clause 17.5.8.

It is sufficient to perform these TPs for one the main features N11, N12 or M2 (see EN 300 347-2 [3]).

Initial state of the IUT: BCC_INIT

Preamble: -

Postamble: -

- TP45__S0_01 Check that the IUT discards messages having less than 4 octets.
- TP45__S0_02 (Protocol discriminator error)
 On receipt of an ALLOCATION message containing an unspecified protocol_discriminator IE, the IUT shall send a PROTOCOL ERROR message containing the protocol_error_cause IE "Protocol discriminator error".
- TP45__S0_02a (BCC Reference Number coding error)
 On receipt of an ALLOCATION message containing an unspecified bcc_reference_number IE, the IUT shall send a PROTOCOL ERROR message containing the protocol_error_cause IE "BCC Reference Number coding error" including corresponding diagnostic.
- TP45__S0_03 (Message type error)
 On receipt of a message containing an unspecified message_type IE, the IUT shall send a PROTOCOL ERROR message containing the protocol_error_cause IE "Message type unrecognized" including corresponding diagnostic.
- TP45__S0_04 (Information element out of sequence)
 On receipt of an ALLOCATION message containing unsorted IEs (V5_TS_ID IE before UP_ID IE), the IUT shall send a PROTOCOL ERROR message containing the protocol_error_cause IE "Out of sequence information" including corresponding diagnostic and then shall send a PROTOCOL ERROR message containing the protocol_error_cause IE "Mandatory information element missing" including corresponding diagnostic.
- TP45__S0_05 (Repeated mandatory information elements)
 On receipt of an ALLOCATION message containing a repeated UP_ID IE followed by a V5_TS_ID IE, the IUT shall send a PROTOCOL ERROR message containing the protocol_error_cause IE "Repeated mandatory information element" including corresponding diagnostic.
- TP45__S0_06 On receipt of an ALLOCATION message containing an UP_ID IE and a repeated V5_TS_ID IE, the IUT shall send a PROTOCOL ERROR message containing the protocol_error_cause IE "Repeated mandatory information element" including corresponding diagnostic.
- TP45__S0_07 (Mandatory information element missing)
 On receipt of an ALLOCATION message containing no UP_ID IE, the IUT shall send a PROTOCOL ERROR message containing the protocol_error_cause IE "Mandatory information element missing" including corresponding diagnostic.

- TP45__S0_07b (Mandatory information element missing for conditional element)
- On receipt of an ALLOCATION message containing no V5_TS_ID in case of single time slot allocation, the IUT shall send a PROTOCOL ERROR message containing the protocol_error_cause IE "Mandatory information element missing" including corresponding diagnostic.
- TP45__S0_08 (Unrecognized information element)
- On receipt of an ALLOCATION message containing an additional unspecified IE, the IUT shall send a PROTOCOL ERROR message containing the protocol_error_cause IE "Unrecognized information element" including corresponding diagnostic and an ALLOCATION COMPLETE message.
- Postamble: BCC_REL
- TP45__S0_09 (Content error of mandatory information element)
- On receipt of an ALLOCATION message containing an incorrect UP_ID IE, the IUT shall send a PROTOCOL ERROR message containing the protocol_error_cause IE "Mandatory information element content error" including corresponding diagnostic.
- TP45__S0_10 (note 1)
- On receipt of an ALLOCATION message containing an incorrect ISDN_port_channel_ID IE, the IUT shall send a PROTOCOL ERROR message containing the protocol_error_cause IE "Mandatory information element content error" including corresponding diagnostic.
- TP45__S0_11 (note 2)
- On receipt of an ALLOCATION message containing an UP_ID IE, a V5_TS_ID IE and a multi-slot_map IE, the IUT shall send a PROTOCOL ERROR message containing the protocol_error_cause IE "Too many information elements" including corresponding diagnostic.
- TP45__S0_12
- Preamble: BCC_CONN
- On receipt of an AUDIT message containing the UP_ID IE and V5_TS IE, the IUT shall send a PROTOCOL ERROR message containing the protocol_error_cause IE "Too many information elements" including corresponding diagnostic.
- Postamble: BCC_REL
- TP45__S0_13
- Preamble: BCC_CONN
- (note 1)
- On receipt of an AUDIT message containing the UP_ID IE and no ISDN_port_channel_ID_IE, the IUT shall send a PROTOCOL ERROR message containing the protocol_error_cause IE "Mandatory information element missing " including corresponding diagnostic.
- Postamble: BCC_REL

NOTE 1: These TPs are only applicable if PICS items N11 or N12 (see EN 300 347-2 [3]) is set to yes.

NOTE 2: These TPs are only applicable if PICS item N8 (see EN 300 347-2 [3]) is set to yes.

5.5.6 Timer expiry and counter mismatch tests (V5NWKAN/BCC/TI)

Refer to EN 300 347-1 [2], table 48.

Initial state of the IUT: BCC_INIT

Preamble: -

Postamble: -

TP46__S1_01
(*)

Preamble: BCC_FAULT

On time out of timer TBCC5, the IUT shall repeat sending the AN FAULT message.

On receipt of an AN FAULT ACKNOWLEDGE message after NBCC5 repetitions of the AN FAULT message, the IUT shall stop repeating the original message.

Postamble: BCC_REL

TP46__S1_02
(*)

Preamble: BCC_FAULT

On time out of timer TBCC5, the IUT shall repeat sending the AN FAULT message.

On NBCC5+1 time outs of timer TBCC5, the IUT shall stop repeating the original message.

Postamble: BCC_REL

5.6 Protection protocol

This test group is only applicable if PICS item N9 (see EN 300 347-2 [3]) is set to yes.

If not stated otherwise, the PROTECT messages sent by the IUT or LT1 shall have the following contents:

- a) the SN IE shall be set according to the rules of EN 300 347-1 [2], clause 18.6.2. The initial value of the SN IE shall be 0 at the beginning of each TP;
- b) the logical_C-channel_ID IE shall point on logical C-channel 2 (protection group 2);
- c) the physical_C-channel_ID IE shall point on TS 15 on the secondary link. If not stated otherwise, the SWITCH-OVER REQ message shall not contain a physical_C-channel_ID IE;
- d) all LINK CONTROL messages shall contain L3addr of the primary link.

Each PROTECT message sent by LT1 and IUT has to be broadcasted over TS 16 of the primary and secondary link with identical SN IEs. This has to be verified by LT1, but is not mentioned explicitly in the TPs.

Preambles given in a specific TP have to be applied after performing the global preamble, specific postambles have to be applied before performing the global postamble.

5.6.1 Basic interconnection tests (V5NWKAN/PROTECT/IT)

Initial state of the IUT: PROTECT_INIT

Preamble: -

Postamble: -

TP51__SM_01 Refer to TP11__SM_01, clause 5.2.1

5.6.2 Capability tests (V5NWKAN/PROTECT/CA)

Refer to EN 300 347-1 [2], table 65.

Initial state of the IUT: PROTECT_INIT

Preamble: -

Postamble: -

TP52__S0_01 "Sequence number reset initiated by LT1- normal procedure"

On receipt of a RESET SN COM message, the IUT shall send a RESET SN ACK message.

On receipt of a second RESET SN COM message, the IUT shall not send a RESET SN ACK message.

TP52__S0_02 "Sequence number reset initiated by IUT- normal procedure"

On receipt of a SWITCH-OVER COM message containing a SN IE = 5, the IUT shall send a RESET SN COM message.

On receipt of a RESET SN ACK message, the IUT shall not repeat the original message.

5.6.3 Valid behaviour tests (V5NWKAN/PROTECT/BV)

Refer to EN 300 347-1 [2], table 65.

Initial state of the IUT: PROTECT_INIT

Preamble: PROTECT_SOANx_0

Postamble: PROTECT_SOANx_0

TP53__SM_01 "Standard Switch-Over requested by LT1 - normal procedure"

On receipt of a SWITCH-OVER COM message, the IUT shall send a SWITCH-OVER ACK message.

Postamble: PROTECT_BACK_TO_INIT2.

TP53__SM_02 "Dedicated OS-Switch-Over requested by LT1 - normal procedure without pre-emption"

On receipt of an OS-SWITCH-OVER COM message, the IUT shall send a SWITCH-OVER ACK message.

Postamble: PROTECT_BACK_TO_INIT2.

TP53__SM_03 "Dedicated OS-Switch-Over requested by LT1 - normal procedure with pre-emption"

On receipt of an OS-SWITCH-OVER COM message containing the physical_C-channel_ID IE "TS 31 of primary link", the IUT shall send a SWITCH-OVER ACK message followed by a SWITCH-OVER REQ message containing the logical_C-channel_ID IE "3".

On receipt of an SWITCH-OVER COM message containing the physical_C-channel_ID IE "TS 15 of secondary link", the IUT shall send a SWITCH-OVER ACK message.

Postamble:

STEP_PR_BACK_TO_INIT2

STEP_PR_BACK_TO_INIT3

- TP53__SM_04
(*) "Switch-Over requested by IUT - normal procedure, failure of V5.2 secondary link"
- Preamble:
Switch-over of logical C-channel "2" to the secondary link, timeslot 15.
- On receipt of the trigger event "failure of V5.2 link", indicating a failure of the secondary link, the IUT shall send a SWITCH-OVER REQ message containing the logical_C-channel_ID IE "2".
- On receipt of a SWITCH-OVER COM message containing the logical_C-channel_ID IE "2" and the physical_C-channel_ID IE "TS 15 of primary link", the IUT shall send a SWITCH-OVER ACK message containing the same data.
- On receipt of a SWITCH-OVER COM message, the IUT shall send a SWITCH-OVER ACK message.
- Postamble:
Disappearance of failure
- TP53__SM_05
(*) "Switch-Over requested by IUT - normal procedure, absence of flags"
- On receipt of the trigger event "absence of flags", indicating a failure of TS 16 of the primary link, the IUT shall send a SWITCH-OVER REQ message containing the logical_C-channel_ID IE "1".
- On receipt of a SWITCH-OVER COM message containing the logical_C-channel_ID IE "1" and the physical_C-channel_ID IE "TS 16 of secondary link", the IUT shall send a SWITCH-OVER ACK message containing the same data.
- Postamble:
Disappearance of failure
PROTECT_BACK_TO_INIT1.
- TP53__SM_06
(*) "Switch-Over requested by IUT - normal procedure, data link failure"
- On receipt of the trigger event "data link failure", indicating a failure of TS 16 of the primary link, the IUT shall send a SWITCH-OVER REQ message containing the logical_C-channel_ID IE "1".
- On receipt of a SWITCH-OVER COM message containing the logical_C-channel_ID IE "1" and the physical_C-channel_ID IE "TS 16 of secondary link", the IUT shall send a SWITCH-OVER ACK message containing the same data.
- Postamble:
Disappearance of failure
PROTECT_BACK_TO_INIT1
- TP53__SM_07
(*) "Switch-Over requested by IUT - normal procedure, blocking of secondary link"
- Preamble:
Switch-over of logical C-channel "2" to the secondary link, timeslot 15.
- On receipt of a LINK CONTROL message containing the link_control_function IE FE304 (link_block_cmd), the IUT shall send a SWITCH-OVER REQ message containing the logical_C-channel_ID IE "2".
- On receipt of a SWITCH-OVER COM message containing the logical_C-channel_ID IE "2" and the physical_C-channel_ID IE "TS 15 of primary link", the IUT shall send a SWITCH-OVER ACK message containing the same data.
- Postamble:
LINK_AN10_20

- TP53__SM_08 "Standard Switch-Over requested by LT1 - exceptional procedure: target physical C-channel not operational".
- Preamble: LINK_AN20_10 for secondary link.
- On receipt of SWITCH-OVER COM message, the IUT shall send a SWITCH-OVER REJECT message containing the rejection_cause_type IE "target physical C-channel not operational".
- Postamble: LINK_AN10_20 for secondary link.
- TP53__SM_09 "Standard Switch-Over requested by LT1 - exceptional procedure: target physical C-channel not provisioned".
- On receipt of SWITCH-OVER COM message containing the physical_C-channel_ID IE "TS 31 of secondary link", the IUT shall send a SWITCH-OVER REJECT message containing the rejection_cause_type IE "target physical C-channel not provisioned".
- TP53__SM_10 "Standard Switch-Over requested by LT1 - exceptional procedure: protection group mismatch".
- On receipt of SWITCH-OVER COM message containing the logical_C-channel_ID IE "1" and the physical_C-channel_ID IE "TS 15 of secondary link", the IUT shall send a SWITCH-OVER REJECT message containing the rejection_cause_type IE "protection group mismatch".
- TP53__SM_11 "Standard Switch-Over requested by LT1 - exceptional procedure: requested allocation exists already".
- On receipt of SWITCH-OVER COM message containing the physical_C-channel_ID IE "TS 15 of primary link", the IUT shall send a SWITCH-OVER REJECT message containing the rejection_cause_type IE "requested allocation exists already".
- TP53__SM_12 (note) "Standard Switch-Over requested by LT1 - exceptional procedure: target physical C-channel already has logical C-channel".
- On receipt of SWITCH-OVER COM message containing the physical_C-channel_ID IE "TS 31 of primary link", the IUT shall send a SWITCH-OVER REJECT message containing the rejection_cause_type IE "target physical C-channel already has logical C-channel".
- TP53__SM_13 "Standard Switch-Over requested by LT1 - exceptional procedure: TSO4 running".
- Preamble:
- On receipt of a SWITCH-OVER COM message containing a SN IE = 5, the IUT shall send a RESET SN COM message.
- On receipt of a SWITCH-OVER COM message, the IUT shall ignore the message (send no response).
- Postamble:
- On receipt of a RESET SN ACK message, the IUT shall not repeat the original message.
- TP53__SM_14 "Dedicated OS-Switch-Over requested by LT1 - exceptional procedure: target physical C-channel not provisioned".
- On receipt of OS-SWITCH-OVER COM message containing the physical_C-channel_ID IE "TS 31 of secondary link", the IUT shall send a SWITCH-OVER REJECT message containing the rejection_cause_type IE "target physical C-channel not provisioned".
- TP53__SM_15 "Dedicated OS-Switch-Over requested by LT1 - exceptional procedure: protection group mismatch".
- On receipt of an OS-SWITCH-OVER COM message containing the physical_C-channel_ID IE "TS 16 of secondary link", the IUT shall send a SWITCH-OVER REJECT message containing the rejection_cause_type IE "protection group mismatch".

- TP53__SM_16 "Dedicated OS-Switch-Over requested by LT1 - exceptional procedure: requested allocation exists already".
- On receipt of OS-SWITCH-OVER COM message containing the physical_C-channel_ID IE "TS 15 of primary link", the IUT shall send a SWITCH-OVER REJECT message containing the rejection_cause_type IE "requested allocation exists already".
- TP53__SM_17 "Dedicated OS-Switch-Over requested by LT1 - exceptional procedure: TSO4 running".
- Preamble:
On receipt of a SWITCH-OVER COM message containing a SN IE = 5, the IUT shall send a RESET SN COM message.
- On receipt of an OS-SWITCH-OVER COM message, the IUT shall ignore the message (send no response).
- Postamble:
On receipt of a RESET SN ACK message, the IUT shall not repeat the original message.
- TP53__SM_18 "Switch-Over requested by IUT - exceptional procedure, LT1 reject switch-over"
- On receipt of a LINK CONTROL message containing the link_control_function IE FE304 (link_block_cmd), the IUT shall send a SWITCH-OVER REQ message containing the logical_C-channel_ID IE "1".
- On receipt of a SWITCH-OVER REJ message containing the logical_C-channel_ID IE "1", the physical_C-channel_ID IE "TS 16 of secondary link" and the rejection_cause IE "target physical C-channel not operational", the IUT shall not repeat the original message.
- TP53__SM_19 "Switch-Over requested by IUT - exceptional procedure, LT1 resets SN, TSO5 not running"
- Preamble:
Switch-over of logical C-channel "2" to the secondary link, timeslot 15.
On receipt of a LINK CONTROL message containing the link_control_function IE FE304 (link_block_cmd), the IUT shall send a SWITCH-OVER REQ message containing the logical_C-channel_ID IE "2".
- On receipt of a RESET SN COM message the IUT shall send a RESET SN ACK and not repeat the SWITCH-OVER REQ message.
- Postamble:
LINK_AN10_20, PROTECT_BACK_TO_INIT2
- TP53__SM_21 "Switch-Over requested by IUT - exceptional procedure, LT1 sends RESET SN ACK"
- Preamble:
Switch-over of logical C-channel "2" to the secondary link, timeslot 15.
On receipt of a LINK CONTROL message containing the link_control_function IE FE304 (link_block_cmd), the IUT shall send a SWITCH-OVER REQ message containing the logical_C-channel_ID IE "2".
- On receipt of a RESET SN ACK message, the IUT shall repeat the SWITCH-OVER REQ message with SN IE =1 (after time out of timer TSO3).
- On receipt of a SWITCH-OVER COM message containing the logical_C-channel_ID IE "2" and the physical_C-channel_ID IE "TS 15 of primary link", the IUT shall send a SWITCH-OVER ACK message containing the same data.
- Postamble:
LINK_AN10_20

- TP53__SM_22 "Switch-Over requested by IUT - exceptional procedure, TO4 running"
- Preamble:
Switch-over of logical C-channel "2" to the secondary link, timeslot 15
- On receipt of a SWITCH-OVER COM message containing a SN IE = 5, the IUT shall send a RESET SN COM message.
- On receipt of a LINK CONTROL message containing the link_control_function IE FE304 (link_block_cmd), no PROTECT message shall appear on the V5.2 interface.
- On receipt of a RESET SN ACK message, the IUT shall send a SWITCH-OVER REQ message containing the logical_C-channel_ID IE "2".
- On receipt of a SWITCH-OVER COM message containing the logical_C-channel_ID IE "2" and the physical_C-channel_ID IE "TS 15 of primary link", the IUT shall send a SWITCH-OVER ACK message containing the same data.
- Postamble:
LINK_AN10_20
- TP53__SM_23 "Checking upper boundary of SN"
- On receipt of a SWITCH-OVER COM message containing the SN IE = 4, the IUT shall send a SWITCH-OVER ACK message.
- Postamble: PROTECT_BACK_TO_INIT2.

NOTE: These TPs are only applicable if at least two of the PICS items N11, N12 and M2 are set to yes (see EN 300 347-2 [3]).

5.6.4 Inopportune behaviour tests (V5NWKAN/PROTECT/BO)

Refer to EN 300 347-1 [2], table 65.

Initial state of the IUT: PROTECT_INIT
Preamble: PROTECT_SOANx_0
Postamble: PROTECT_SOANx_0

- TP54__S0_01 On receipt of a SWITCH-OVER REJECT message, the IUT shall send PROTOCOL ERROR containing the protocol_error_cause IE "Message not compatible with protection protocol state" with corresponding diagnostic.
- TP54__S0_02 On receipt of a RESET SN ACK message no message shall appear on the V5.2 interface.
- TP54__S0_03 On receipt of a SWITCH-OVER ACK message, the IUT shall send a PROTOCOL ERROR message containing the protocol_error_cause IE "message type unrecognized" with corresponding diagnostic.

5.6.5 Invalid behaviour tests (V5NWKAN/PROTECT/BI)

Refer to EN 300 347-1 [2], clause 18.6.6.

Initial state of the IUT: PROTECT_INIT
 Preamble: PROTECT_SOANx_0
 Postamble: PROTECT_SOANx_0

- TP55__S0_01 Check that the IUT discards messages having less than 4 octets.
- TP55__S0_02 (Protocol discriminator error)
 On receipt of a RESET SN COM message containing an unspecified protocol_discriminator IE, the IUT shall send a PROTOCOL ERROR message containing the protocol_error_cause IE "protocol discriminator error".
- TP55__S0_02a (Logical C-Channel identification error)
 On receipt of a SWITCH OVER COM message containing an unspecified logical_C-channel_ID IE, the IUT shall send a PROTOCOL ERROR message containing the protocol_error_cause IE "Logical C-Channel identification error".
- TP55__S0_02b (Logical C-Channel identification error)
 On receipt of a RESET SN COM message containing an invalid (non-zero) Logical C-Channel, the IUT shall ignore the message.
- TP55__S0_03 (Message type error)
 On receipt of a message containing an unspecified message_type IE, the IUT shall send a PROTOCOL ERROR message containing the protocol_error_cause IE "message type unrecognized" with corresponding diagnostic.
- TP55__S0_04 (Unrecognized information element)
 On receipt of a RESET SN ACK message containing a repeated message_type IE, the IUT shall send a PROTOCOL ERROR message containing the protocol_error_cause IE "Unrecognized information element" with corresponding diagnostic.
- TP55__S0_04a (Repeated mandatory information elements)
 On receipt of a SWITCH-OVER COM message containing two Physical_C-channel_ID IE, the IUT shall send a PROTOCOL ERROR message containing the protocol_error_cause IE "Repeated mandatory information element" with corresponding diagnostic.
- TP55__S0_05 (Mandatory information element missing)
 On receipt of a SWITCH-OVER COM message containing no Physical_C-channel_ID IE, the IUT shall send a PROTOCOL ERROR message containing the protocol_error_cause IE "Mandatory information element missing" with corresponding diagnostic.
- TP55__S0_06 (Unrecognized information element)
 On receipt of a RESET SN COM message containing an additional unspecified IE, the IUT shall send a PROTOCOL ERROR message containing the protocol_error_cause IE "Unrecognized information element" with corresponding diagnostic and a RESET SN ACK message.
- TP55__S0_07 (Content error of mandatory information element - IE too long)
 On receipt of a SWITCH-OVER COM message containing an incorrect Physical_C-channel_ID IE, the IUT shall send a PROTOCOL ERROR message containing the protocol_error_cause IE "Content error of mandatory information element" with corresponding diagnostic.

- TP55__S0_08 (Detection of protocol error while TSO4 running)
- Preamble:
On receipt of a SWITCH-OVER COM message containing a SN IE = 5, the IUT shall send a RESET SN COM message.
- On receipt of a SWITCH-OVER REQ message containing an unspecified protocol_discriminator IE, the IUT shall not send a PROTOCOL ERROR message or a SWITCH-OVER COM message.
- Postamble:
On receipt of a RESET SN ACK message, the IUT shall not repeat the original message.

5.6.6 Timer expiry and counter mismatch tests (V5NWKAN/PROTECT/TI)

Refer to EN 300 347-1 [2], table 65.

- Initial state of the IUT: PROTECT_INIT
Preamble: PROTECT_SOANx_0
Postamble: PROTECT_SOANx_0
- TP56__S0_01 Preamble:
On receipt of a SWITCH-OVER COM message containing a SN IE = 5, the IUT shall send a RESET SN COM message.
- On time out of timer TSO4, the IUT shall repeat sending the RESET SN COM message.
- On receipt of a RESET SN ACK message after NSO4 repetitions of the RESET SN COM message, the IUT shall stop repeating the original message.
- TP56__S0_02 Preamble:
On receipt of a SWITCH-OVER COM message containing a SN IE = 5, the IUT shall send a RESET SN COM message.
- On time out of timer TSO4, the IUT shall repeat sending the RESET SN COM message.
- On NSO4+1 time outs of timer TSO4, the IUT shall stop repeating the original message.
- TP56__S1_03 Preamble:
Switch-over of logical C-channel "2" to the secondary link, timeslot 15. On receipt of a LINK CONTROL message containing the link_control_function IE FE304 (link_block_cmd), the IUT shall send a SWITCH-OVER REQ message containing the logical_C-channel_ID IE "2".
- On time out of timer TSO3, the IUT shall repeat sending the SWITCH-OVER REQ message.
- On receipt of a SWITCH-OVER COM message containing the logical_C-channel_ID IE "2" and the physical_C-channel_ID IE "TS 15 of primary link" after NSO3 repetitions of the SWITCH-OVER REQ message, the IUT shall send a SWITCH-OVER ACK message containing the same data.
- Postamble:
LINK_AN10_20
- TP56__S1_04 Preamble:
On receipt of a LINK CONTROL message containing the link_control_function IE FE304 (link_block_cmd), the IUT shall send a SWITCH-OVER REQ message containing the logical_C-channel_ID IE "1".
- On time out of timer TSO3, the IUT shall repeat sending the SWITCH-OVER REQ message.
- On NSO3+1 time outs of timer TSO3, the IUT shall stop repeating the original message.
- Postamble:
LINK_AN10_20

TP56__SM_05

Preamble:

Switch-over of logical C-channel "2" to the secondary link, timeslot 15. On receipt of a LINK CONTROL message containing the link_control_function IE FE304 (link_block_cmd), the IUT shall send a SWITCH-OVER REQ message containing the logical_C-channel_ID IE "2".

On receipt of a SWITCH-OVER COM message containing a SN IE = 5, the IUT shall send a RESET SN COM message.

On receipt of a RESET SN ACK message, the IUT shall send a SWITCH-OVER REQ message containing the logical_C-channel_ID IE "2".

On receipt of a SWITCH-OVER COM message containing the logical_C-channel_ID IE "2" and the physical_C-channel_ID IE "TS 15 of primary link", the IUT shall send a SWITCH-OVER ACK message containing the same data.

Postamble:

LINK_AN10_20

Bibliography

The following material, though not specifically referenced in the body of the present document (or not publicly available), gives supporting information.

ETSI ETS 300 406: "Methods for Testing and Specification (MTS); Protocol and profile conformance testing specifications; Standardization methodology".

History

Document history		
Edition 1	February 1996	Publication as ETS 300 347-3
Edition 2	April 1999	Publication as ETS 300 347-3
V2.1.1	January 2000	Public Enquiry PE 200018: 2000-01-05 to 2000-05-05
V3.1.1	January 2001	Vote V 20010323: 2001-01-22 to 2001-03-23
V3.1.1	March 2001	Publication