

**V interfaces at the digital Local Exchange (LE);  
V5.1 interface for the support of Access Network (AN);  
Part 6: Abstract Test Suite (ATS) and partial Protocol  
Implementation eXtra Information for Testing (PIXIT) proforma  
specification for the network layer (LE side)**

---



---

**Reference**

REN/SPAN-09101-6

---

**Keywords**V interface, V5 interface, LE, ATS, PIXIT, testing,  
AN**ETSI**

---

**Postal address**

F-06921 Sophia Antipolis Cedex - FRANCE

---

**Office address**650 Route des Lucioles - Sophia Antipolis  
Valbonne - FRANCE  
Tel.: +33 4 92 94 42 00 Fax: +33 4 93 65 47 16  
Siret N° 348 623 562 00017 - NAF 742 C  
Association à but non lucratif enregistrée à la  
Sous-Préfecture de Grasse (06) N° 7803/88

---

**Internet**secretariat@etsi.fr  
Individual copies of this ETSI deliverable  
can be downloaded from  
<http://www.etsi.org>  
If you find errors in the present document, send your  
comment to: editor@etsi.fr

---

**Important notice**

This ETSI deliverable may be made available in more than one electronic version or in print. In any case of existing or perceived difference in contents between such versions, the reference version is the Portable Document Format (PDF). In case of dispute, the reference shall be the printing on ETSI printers of the PDF version kept on a specific network drive within ETSI Secretariat.

---

**Copyright Notification**

No part may be reproduced except as authorized by written permission.  
The copyright and the foregoing restriction extend to reproduction in all media.

© European Telecommunications Standards Institute 1999.  
All rights reserved.

# Contents

|  |           |
|--|-----------|
| Intellectual Property Rights .....                                   | 5         |
| Foreword .....   | 5         |
| 1 Scope .....  | 6         |
| 2 References .....   | 6         |
| 3 Definitions and abbreviations .....                                | 7         |
| 3.1 Definitions .....  | 7         |
| 3.2 Abbreviations .....  | 8         |
| 4 Abstract test method.....  | 9         |
| 4.1 ATM.....   | 9         |
| 4.2 NWK protocol testing .....                                       | 9         |
| 4.3 Data link addresses .....  | 10        |
| 4.4 Execution of TCs.....  | 10        |
| 4.4.1 Handling of error indication.....                              | 10        |
| 4.4.2 TC execution sequence .....                                    | 10        |
| 5 Untestable test purposes.....                                      | 11        |
| 5.1 Control protocol .....   | 11        |
| 5.2 PSTN protocol.....   | 11        |
| 6 Abstract test suite conventions.....                               | 12        |
| 6.1 Naming conventions .....   | 12        |
| 6.1.1 Declaration part .....   | 12        |
| 6.1.2 Constraint part .....  | 13        |
| 6.1.3 Dynamic part.....  | 13        |
| 6.1.3.1 Test cases .....   | 13        |
| 6.1.3.2 Test steps.....  | 13        |
| 6.1.3.3 General aspects .....  | 13        |
| 6.1.4 ATS abbreviations .....  | 14        |
| 6.2 Implementation conventions.....                                  | 14        |
| 6.2.1 Declaration part .....   | 14        |
| 6.2.2 Constraint part .....  | 15        |
| 6.2.3 Dynamic part.....  | 15        |
| 6.2.4 Documentation.....   | 16        |
| <b>Annex A (normative): Abstract test suite for NWK testing.....</b> | <b>17</b> |
| A1 The TTCN Graphical form (TTCN.GR).....                            | 17        |
| A2 The TTCN Machine Processable form (TTCN.MP) .....                 | 17        |
| <b>Annex B (normative): Partial PIXIT proforma.....</b>              | <b>18</b> |
| B.1 Introduction .....   | 18        |
| B.2 PIXIT proforma.....  | 18        |
| B.2.1 Identification summary .....                                   | 18        |
| B.2.2 Abstract test suite summary .....                              | 18        |
| B.2.3 Test laboratory.....   | 18        |
| B.2.4 Client .....   | 19        |
| B.2.5 SUT .....  | 19        |
| B.2.6 Protocol layer information.....                                | 20        |
| B.2.6.1 Protocol identification .....                                | 20        |
| B.2.6.2 IUT information.....   | 20        |

Bibliography .....24

History .....25

---

## Intellectual Property Rights

IPRs essential or potentially essential to the present document may have been declared to ETSI. The information pertaining to these essential IPRs, if any, is publicly available for **ETSI members and non-members**, and can be found in SR 000 314: "*Intellectual Property Rights (IPRs); Essential, or potentially Essential, IPRs notified to ETSI in respect of ETSI standards*", which is available from the ETSI Secretariat. Latest updates are available on the ETSI Web server (<http://www.etsi.org/ipr>).

Pursuant to the ETSI IPR Policy, no investigation, including IPR searches, has been carried out by ETSI. No guarantee can be given as to the existence of other IPRs not referenced in SR 000 314 (or the updates on the ETSI Web server) which are, or may be, or may become, essential to the present document.

---

## Foreword

This European Standard (Telecommunications series) has been produced by ETSI Technical Committee Services and Protocols for Advanced Networks (SPAN), and is now submitted for the Public Enquiry phase of the ETSI standards Two-step Approval Procedure.

The present document is part 6 of a multi-part EN covering the V5.1 interface for the support of Access Network (AN) as described below:

- Part 1: "V5.1 interface specification";
- Part 2: "Protocol Implementation Conformance Statement (PICS) proforma specification";
- Part 3: "Test Suite Structure and Test Purposes (TSS&TP) specification for the network layer (AN side)";
- Part 4: "Abstract Test Suite (ATS) and partial Protocol Implementation eXtra Information for Testing (PIXIT) proforma specification for the network layer (AN side)";
- Part 5: "Test Suite Structure and Test Purposes (TSS&TP) specification for the network layer (LE side)";
- Part 6: "Part 6: Abstract Test Suite (ATS) and partial Protocol Implementation eXtra Information for Testing (PIXIT) proforma specification for the network layer";**
- Part 7: "Test Suite Structure and Test Purposes (TSS&TP) specification for the data link layer";
- Part 8: "Abstract Test Suite (ATS) and partial Protocol Implementation eXtra Information for Testing (PIXIT) proforma specification for the data link layer";
- Part 9: "Test specification for the physical layer".

| <b>Proposed national transposition dates</b>   |                                 |
|--|---------------------------------|
| Date of latest announcement of this EN (doa):  | 3 months after ETSI publication |
| Date of latest publication of new National Standard or endorsement of this EN (dop/e): | 6 months after doa              |
| Date of withdrawal of any conflicting National Standard (dow):                         | 6 months after doa              |

---

# 1 Scope

This sixth part of EN 300 324 contains the Abstract Test Suite (ATS) as well as the Abstract Test Method (ATM) and the partial Protocol Implementation eXtra Information for Testing (PIXIT) proforma for the Network layer (NWK) of a V5.1 interface and parts of the system management of the Local Exchange (LE) side of a V5.1 interface.

The objective of the present document is to provide an ATS containing conformance tests which give a high probability of inter-operability of an Access Network (AN) and a LE from different manufacturers over the V5.1 interface.

ISO/IEC 9646-1 [5] and ISO/IEC 9646-2 [6] are used as the basis for the test methodology. The ATS is defined using the Tree and Tabular Combined Notation (TTCN) according to ISO/IEC 9646-3 [7].

The ATS in annex A describes a set of Test Cases (TCs) which are based on the Test Purposes (TPs) specified in EN 300 324-5 [3]. The TCs provide the implementation of the TPs and can be converted into an executable test suite by using available TTCN translators and the corresponding tools.

Annex B provides the partial PIXIT proforma.

---

# 2 References

The following documents contain provisions which, through reference in this text, constitute provisions of the present document.

- References are either specific (identified by date of publication, edition number, version number, etc.) or non-specific.
- For a specific reference, subsequent revisions do not apply.
- For a non-specific reference, the latest version applies.
- A non-specific reference to an ETS shall also be taken to refer to later versions published as an EN with the same number.

- [1] EN 300 324-1 including amendment A1: "V interfaces at the digital Local Exchange (LE); V5.1 interface for the support of Access Network (AN); Part 1: V5.1 interface specification".
- [2] EN 300 324-2: "V interfaces at the digital Local Exchange (LE); V5.1 interface for the support of Access Network (AN); Part 2: Protocol Implementation Conformance Statement (PICS) proforma".
- [3] EN 300 324-5: "V interfaces at the digital Local Exchange (LE); V5.1 interface for the support of Access Network (AN); Part 5: Test Suite Structure and Test Purposes (TSS&TP) specification for the network layer (LE side)".
- [4] ISO 7498: "Information Processing Systems - Open Systems Interconnection - Basic Reference Model".
- [5] ISO/IEC 9646-1: "Information Technology - Open Systems Interconnection - Conformance testing methodology and framework - Part 1: General concepts".
- [6] ISO/IEC 9646-2: "Information Technology - Open Systems Interconnection - Conformance testing methodology and framework - Part 2: Abstract test suite specification".
- [7] ISO/IEC 9646-3: "Information Technology - Open Systems Interconnection - Conformance testing methodology and framework - Part 3: The Tree and Tabular Combined Notation (TTCN)".
- [8] ISO/IEC 9646-5: "Information Technology - Open Systems Interconnection - Conformance testing methodology and framework - Part 5: Requirements on test laboratories and clients for the conformance assessment process".

---

## 3 Definitions and abbreviations

### 3.1 Definitions

For the purposes of the present document, the following terms and definitions apply, together with those given in EN 300 324-1 [1]:

**abstract test case:** refer to ISO/IEC 9646-1 [5]

NOTE: In the present document, the commonly used term TC is applied in the same way as ATC.

**abstract test suite:** refer to ISO/IEC 9646-1 [5]

**current provisioning variant:** ID for the presently active data set

**data link layer:** refer to ISO 7498 [4]

**embedded variant:** refer to ISO/IEC 9646-2 [6]

**implementation under test:** refer to ISO/IEC 9646-1 [5]

**incorrect information element:** specified information element carrying information element types not defined in EN 300 324-1 [1]

**invalid PSTN information element:** PSTN information element not according to national specific requirements

**invalid protocol data unit:** protocol Data Unit (PDU) which contains an incorrect message format

**invalid PSTN message:** PSTN message carrying information elements not according to national specific requirements

**lower tester:** refer to ISO/IEC 9646-1 [5]

**network layer:** refer to ISO 7498 [4]

**new provisioning variant:** ID for the data set which was announced to the IUT to become the next active data set through re-provisioning

**physical layer:** refer to ISO 7498 [4]

**PICS proforma:** refer to ISO/IEC 9646-1 [5]

**PIXIT proforma:** REFER to ISO/IEC 9646-1 [5]

**Point Of Control And Observation (PCO):** refer to ISO/IEC 9646-1 [5]

**Protocol Implementation Conformance Statement (PICS):** refer to ISO/IEC 9646-1 [5]

**Protocol Implementation eXtra Information For Testing (PIXIT):** refer to ISO/IEC 9646-1 [5]

**remote test method:** refer to ISO/IEC 9646-2 [6]

**specified information element:** information element ID defined in EN 300 324-1 [1]

**system under test:** refer to ISO/IEC 9646-1 [5]

**test purpose:** refer to ISO/IEC 9646-1 [5]

**unknown provisioning variant:** ID for a non-available data set

**unspecified information element:** information element ID not defined in EN 300 324-1 [1]

**valid information element:** PSTN information element according to national specific requirements

**valid PSTN message:** PSTN message carrying information elements according to national specific requirements

## 3.2 Abbreviations

For the purposes of the present document, the following abbreviations apply:

|          |   |
|----------|---|
| AN       | Access Network  |
| ASP      | Abstract Service Primitive                            |
| ATC      | Abstract Test Case                                    |
| ATM      | Abstract Test Method                                  |
| ATS      | Abstract Test Suite                                   |
| BI       | Invalid Behaviour                                     |
| BO       | Inopportune Behaviour                                 |
| BV       | Valid Behaviour                                       |
| CA       | CApability test                                       |
| CTRL     | Control   |
| DLL      | Data Link Layer                                       |
| DSAP     | Data link Service Access Point                        |
| FE       | Function Element                                      |
| ID       | Identifier  |
| IE       | Information Element                                   |
| ISDN     | Integrated Services Digital Network                   |
| ISDN-BA  | ISDN-Basic Access                                     |
| IT       | basic Interconnection Test                            |
| IUT      | Implementation Under Test                             |
| L3addr   | Layer 3 address                                       |
| LE       | Local Exchange  |
| LT1      | Lower Tester 1  |
| MPH      | Management Physical layer                             |
| NWK      | Network Layer   |
| PCO      | Point of Control and Observation                      |
| PDU      | Protocol Data Unit                                    |
| PHL      | Physical Layer  |
| PICS     | Protocol Implementation Conformance Statement         |
| PIXIT    | Protocol Implementation eXtra Information for Testing |
| PSTN     | Public Switched Telephone Network                     |
| SAP      | Service Access Point                                  |
| SUT      | System Under Test                                     |
| TC       | Test Case (abstract TC)                               |
| TI       | Timer Expiry and Counter Mismatch                     |
| TP       | Test Purpose  |
| TSS      | Test Suite Structure                                  |
| TTCN     | Tree and Tabular Combined Notation                    |
| UL       | Upper Layer   |
| UT       | Upper Tester  |
| V5DLaddr | V5 Data Link address                                  |



## 4 Abstract test method

This clause describes the Abstract Test Method (ATM) and the Point of Control and Observation (PCO) used to test the NWK of the V5.1 protocol for the LE components.

### 4.1 ATM

Principally, the remote test method is used for V5.1 LE NWK conformance testing. Certain V5.1 LE NWK TPs need also part of the service and national functions. Therefore, the embedded variant of the remote test method is applied.

The national dependent information is defined in the PIXIT.

### 4.2 NWK protocol testing

The V5.1 implementations do not offer a direct access to the upper service boundary. The remote test method was chosen because any co-ordination procedures can only be expressed in an informal way.

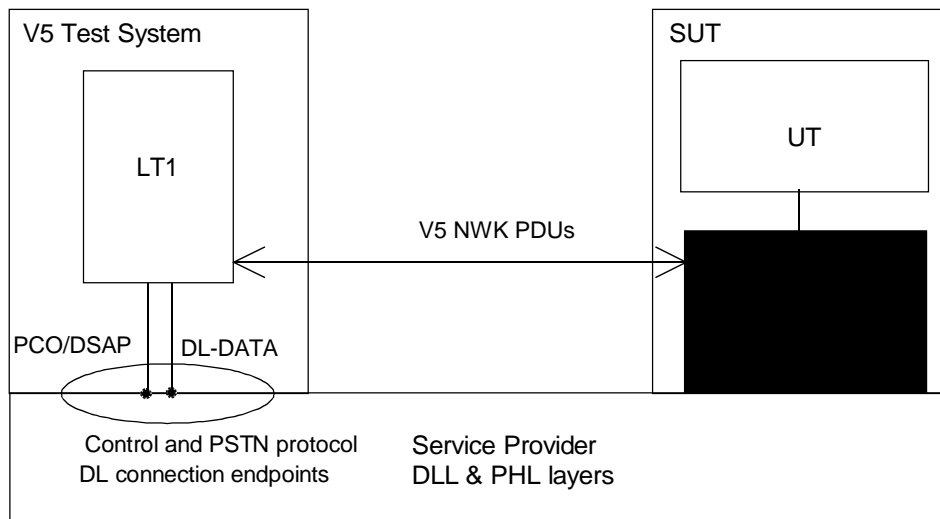

**Figure 1: Remote test method applied to the V5.1 NWK testing**

- LT1:** A Lower Tester (LT1) is located in a remote V5.1 test system. It controls and observes the behaviours of the IUT.
- DSAP:** A unique Data link Service Access Point (DSAP) is defined at the V5.1 interface and commonly used for exchanging service data of the different network layer protocol functional entities: PSTN, Control protocols.
- PCO:** The PCO for NWK testing is located on the DSAP. All test events at the PCO are specified in terms of data link Abstract Service Primitives (ASPs) and network layer PDUs.
- UT:** No explicit Upper Tester (UT) exists in the test system. However, the SUT needs to carry out some UL functions to achieve some effects of test co-ordination procedures. Designing ATS, the capability of the system management functions, such as controls of the IUT, its interactions with the Q interface may be taken into account. The controls of the IUT will be implied or informally expressed in the ATS, but no assumption shall be made regarding their feasibility or realization. Examples of such controls could be to provoke restarting IUT or blocking/unblocking procedures through Q interface.

## 4.3 Data link addresses

Within the DSAP, different V5DLaddr are used to identify each corresponding data link connection. Each network layer protocol functional entity can have only one data link connection, e.g. all PSTN signalling information share one data link connection.

Table 1 shows the allocated V5DLaddr used by the protocol function entities.

**Table 1: V5DLaddr**

| <b>Protocol</b> | <b>PSTN</b> | <b>Control</b> |
|-----------------|-------------|----------------|
| V5DLaddr        | 8176        | 8177           |

## 4.4 Execution of TCs

### 4.4.1 Handling of error indication

During the execution of the NWK ATS many error indications will be sent to the system management due to the invalid and the inopportune TCs. It is up to the IUT supplier to take the necessary precautions to avoid any impact on the test result.

### 4.4.2 TC execution sequence

The following test sequence shall be applied:

The TC containing the start-up procedure (TC11\_\_SM\_01) shall always be the first TC executed. Also in any case where the IUT has to be restarted this TC shall be first executed.

Protocol groups: CTRL ⇒ PSTN.

Test groups: IT ⇒ CA ⇒ TI ⇒ BV ⇒ BO ⇒ BI.

Interactions between the different test groups are not considered. It is up to the IUT supplier to take the necessary precautions to avoid any impact on the test result.

**NOTE:** This applies in particular to PORT CONTROL messages from ISDN ports while testing PSTN-related protocols and vice versa.

## 5 Untestable test purposes

This clause contains a list of TPs which are not covered by the ATS due to the chosen ATM or other restrictions.

### 5.1 Control protocol

Table 2 lists TPs which are not covered by the ATS due to the unknown reaction of the IUT after testing the TPs.

**Table 2: Untestable TPs (4)**

| Test Purpose ID |
|-----------------|
| TP1311S1_01     |
| TP1313S0_01     |
| TP1313SM_06     |
| TP1313SM_07     |
| TP1313SM_08     |
| TP1313SM_09     |
| TP1321S1_01     |
| TP1324S1001     |
| TP1324SM_05     |
| TP1324SM_11     |
| TP1325S1001     |
| TP1325S2013     |
| TP1325SM_11     |
| TP1325SM_24     |

### 5.2 PSTN protocol

The test purposes listed in table 3 are not implemented in the ATS due to unknown reaction of the IUT after testing the TPs.

**Table 3: Untestable TPs (6)**

| Test Purpose ID |
|-----------------|
| TP23_S1_04      |
| TP23_S1_06      |
| TP23_S2_08      |
| TP23_S2_09      |
| TP23_S4_07      |
| TP23_S5_10      |
| TP23_S6_01      |
| TP26_S4_01      |

---

## 6 Abstract test suite conventions

The ATS conventions are intended to give a better understanding of the ATS but they describe also the conventions made for the development of the ATS, thus for any later maintenance purposes or further development of the ATS the conventions described in this clause shall be considered.

The ATS conventions contain two clauses, the naming conventions and the implementation conventions. The naming conventions describe the structure of the naming of all ATS elements. The implementation conventions describe the functional structure of the ATS.

NOTE: To define the ATS, the guidelines given in ETS 300 406 and ETR 141 were considered.

### 6.1 Naming conventions

#### 6.1.1 Declaration part

The ID names of the following definitions are written in lowercase:

- structured type definitions;
- SP type definitions;
- PDU type definitions.

The ID names of the following definitions are written in uppercase:

- Test Suite Parameter Declarations;
- Test Case Selection Expression Definitions;
- Test Suite Constant Declarations;
- Test Case Variable Declarations.

ID names of PDUs and structured types commence with a protocol identifier to define which protocol they are belonging to. The following identifiers are used:

- control protocol: ctrl.e.g. ctrl\_common\_control\_ack;
- PSTN signalling: pstn e.g. pstn\_signal\_ack.

ID names of PDUs and structured types which are used for invalid tests commence with "bi".

EXAMPLE 1: bi\_com\_ctrl\_two\_mety.

Complete names as defined in the specifications are used for ID names of declarations.

EXAMPLE 2: ctrl\_control\_function\_element.

Test suite parameter ID names commence with TSP:

- PICS are identified by adding the letter "C": TSPC\_. (e.g.: TSPC\_PSTN);
- PIXIT are identified by adding the letter "X": TSPX\_. (e.g.: TSPX\_PORT\_ADDRESS).

If a test suite parameter is representing a system parameter or value, only the parameter name is used.

EXAMPLE 3: MR (receive sequence number in signal message).

Test suite operations commence with TSO.

EXAMPLE 4: TSO\_INTEGER\_TO\_O\_1.

Test suite constant ID names commence with TSC.

EXAMPLE 5: TSC\_CFE\_FE201\_2\_UNBL.

If the constant is representing a system parameter or value, only the parameter name is used.

EXAMPLE 6: N01.

ID names of timers commence with T. The same names as in the specification are used.

EXAMPLE 7: T01.

## 6.1.2 Constraint part

Constraint names commence with uppercase. The remaining part of the ID name is written in lowercase.

ID names of elements concerning the same subject have equivalent names in the declaration and the constraint part:

Declaration Part: ctrl\_control\_function\_element;

Constraint Part: Ctrl\_control\_function\_element.

The name of the modified constraint describes the particularity of the modified constraint.

EXAMPLE: Ctrl\_cc\_mand\_only (common control message which contains only the mandatory IEs).

If formal parameter lists are used, the variable names are written in lowercase. The variable name is the same as the name of the element it is representing.

## 6.1.3 Dynamic part

### 6.1.3.1 Test cases

The identifier of the TCs is constructed in the same way as for the TPs described in EN 300 324-5 [3], subclause 5.1.1, with the exception that "TP" is replaced by "TC":

TP identifier: TP1324S1106;

TC identifier: TC1324S1106.

### 6.1.3.2 Test steps

In TCs, test steps as well as local trees are used. To allow an easy distinction, the following naming is applied:

local tree: LTS\_[local\_tree\_name];

test step: STEP\_[test-step\_name].

### 6.1.3.3 General aspects

All verdict assignments are labelled. To allow an exact identification in which table the verdict was assigned, the following name convention is applied:

|    |   |
|----|---|
| B  | test Body                                     |
| CS | status verification test steps (Check Status) |
| D  | Default                                       |
| E  | Error handling test steps                     |
| PO | POstamble                                     |
| PR | PReamble                                      |
| S  | test Step                                     |

Combinations of labels are also possible.

EXAMPLE: DPR --> label which is used in a default for preambles.

## 6.1.4 ATS abbreviations

These abbreviations are used to shorten identifier names:

|         |                             |
|---------|-----------------------------|
| addr    | address                     |
| act     | activate                    |
| acc     | access                      |
| ack     | acknowledgement             |
| cau     | cause                       |
| cc      | common control              |
| cfe     | control function element    |
| cfi     | control function identifier |
| com     | common                      |
| ctrl    | control                     |
| dl      | data link                   |
| enq     | enquiry                     |
| est     | establish                   |
| func    | function                    |
| ind     | indication                  |
| interf  | interface                   |
| mand    | mandatory                   |
| mety    | message type                |
| mod     | modified                    |
| par     | parameter                   |
| pc      | port control                |
| pd      | protocol discriminator      |
| perform | performance                 |
| prog    | progress                    |
| prot    | protocol                    |
| prov    | provisioned                 |
| repro   | re-provisioning             |
| req     | request                     |
| rest    | restart                     |
| rsp     | response                    |
| var     | variant                     |
| verify  | verifying                   |
| vid     | variant & interface ID      |

## 6.2 Implementation conventions

### 6.2.1 Declaration part

The comment line of single element TTCN tables (e.g. test suite constants) is used to give a reference where the format and content of the element is described in the relevant protocol specifications. Any particularity of the element format or content is described in the comment line.

The comment line in the header of multi-element TTCN tables (e.g. ASPs) is used to reference to the protocol specification. The detailed comments are used to describe any particularity of the table.

In the ASP and PDU declarations, the comments column is used to identify if an element is mandatory, conditional, or optional:

- m: mandatory;
- c: conditional;
- o: optional.

In the ASP and PDU declarations the comments column is further used to give information about the element value, in particular if the element contains a fixed spare value.

In tables where structured types are used the information element and the relevant structured type have always the same name, that allows to have the same structure as in the protocol standards is used to document the relation between information elements in a table and their specific description in an other clause of the protocol standard.

## 6.2.2 Constraint part

The ASPs and PDUs are defined in a way that all relevant element are parameterized. That improves the transparency of the constraints in the dynamic part, as all values which are relevant for the test are always present.

Generally the base constraint contains all possible parameters and the relevant formal parameter list which goes with the base constraint. In case where a specific message IE is not used at all in the ATS, the base constraint will not contain such an IE. The base constraints of the PSTN protocol contain all mandatory IEs. The optional IEs are defined in one element of type OCTETSTRING. The actual value and format of the optional IE has to be defined in the PIXITs according to the PSTN specifications which is implemented in the IUT.

Modified constraints have the same parameter list as the base constraint. Unused elements of the parameter list are set to a default value OMIT ("-") in the dynamic part. The number of base constraints is reduced to a minimum.

The comment line of a constraint contains always the reference to the used specifications. The detailed comments sector is used to describe any particularity of the table.

## 6.2.3 Dynamic part

Some TCs need a particular initialization of the IUT environment conditions to run the actual test, e.g. for testing re-provisioning procedures. Such message sequence can be quite complicated and long. In cases where a Local Test Step (LTS) facilitates the TC structure, the preamble and the condition setting are described in a LTS called **LTS\_pre\_step**. All LTS\_pre\_steps are described in the detailed comment part of the TTCN table.

Some TCs need after the actual test a particular re-initialization of the IUT, e.g. after re-provisioning. Such message sequence can be quite complicated and long. In cases where a Local Test Step (LTS) facilitates the TC structure, the postamble and the re-initialization are described in a LTS called **LTS\_post\_step**. All LTS\_post\_steps are described in the detailed comment part of the TTCN table.

All events which are defined as a conformance requirements by the TP, cause a preliminary verdict PASS if the requirement is met.

All invalid events are handled in the default tree. FAIL verdicts are only assigned in the default tree. The default tree contains the error handling procedure for the particular TC.

The preamble, the test body and the postamble have different defaults, what allows a specific verdict handling, e.g. only INCONC verdicts are assigned in the preamble.

All verdict assignments are labelled. According to ISO/IEC 9646-3 [7], clause E 2, labels should be written to the conformance log. This allows to identify where the test failed. To allow an exact identification in which table the verdict was assigned, the naming convention as described in subclause 6.1.3.3 is applied

The labels of the same type are numbered sequentially if they are in the same TC, test step or default.

TPs which only reference to an other TP, e.g. BV TPs which were already defined as CA TPs, are only implemented ones, thus the numbering of the TCs is not always continuous.

TPs which are listed in the untestable TP list in clause 5, or which reference to an other TP, e.g. BV TPs which were already defined as CA TPs, are not considered in the ATS, thus these TC identifiers are missing in the ATS and the numbering of the TCs is not always continuous.

NWK implementation:

- 1) the ATS rebuilds the PSTN functions. Therefore the signal message sequence numbers M(S) and M(R) are implemented and used according to their function described in EN 300 324-1 [1];
- 2) TCs of the \*/PORT/TRANS test group which have to be applied either to the PSTN user port or the ISDN-BA user port depending on the provisioned application in the IUT, use a common TC definition where the L3addr is parameterized (TCV\_L3\_addr). The L3\_addr to be used during the execution is assigned in the test step STEP\_Ctrl\_pc\_trans\_init depending on the setting of the PICS which describe the provisioned data set. All of the TCs in the test groups \*/PORT/TRANS begin with the test step STEP\_Ctrl\_pc\_trans\_init.

Implicit send events:

The implicit send events defined within the ATS use PDUs. Some of them can be invoked from an other interface of the LE (V5 or network interface). As requested by ISO/IEC 9646-3 [7], subclause 14.9.6 for each type of implicit event a PIXIT was created to define how the implicit event can be invoked. For events which can be invoked from an other LE interface also the type of interface has to be defined.

**NOTE:** The implicit message mdu\_ctrl\_data\_set\_available is an IUT internal message and causes no event on the V5 interface. The roles of ISO/IEC 9646-3 [7], subclause 14.9.6 request that an implicit event shall describe the event which will be invoked at the PCO. For the special case where an IUT internal event should be invoked the implicit send message was created. This is a suitable solution as it is not possible to specify such events according to ISO/IEC 9646-3 [7], subclause 14.9.6.

## 6.2.4 Documentation

The comment line of the TC or test step header contains a reference to the relevant protocol specification.

The comment column of the dynamic behaviour part is used to number the test events which are relevant for the particular test or test operation.

Based on the numbering in the comment column all for the TC relevant events are described in the detailed comments part of each TTCN table.

Test procedures which cover a conformance requirement and lead to a preliminary or final verdict assignment are described as follows in the detailed comments part:

**Expected event:** a specific receive event is expected.

**Expected behaviour:** no event or a timer expiry is expected.

**Expected status:** the IUT is expected to be in a particular status.



---

## Annex A (normative): Abstract test suite for NWK testing

This ATS has been produced using the Tree and Tabular Combined Notation (TTCN) according to ISO/IEC 9646-3.

The ATS was developed on a separate TTCN software tool and therefore the TTCN tables are not completely referenced in the table of contents. The ATS itself contains a test suite overview part which provides additional information and references.

---

### A1 The TTCN Graphical form (TTCN.GR)

The TTCN.GR representation of this ATS is contained in an Adobe Portable Document Format™ file (v51nle\_e2\_04.PDF contained in archive en\_30032406v030101c0.ZIP) which accompanies the present document.

---

### A2 The TTCN Machine Processable form (TTCN.MP)

The TTCN.MP representation corresponding to this ATS is contained in an ASCII file (v51nle\_e2\_04 contained in archive en\_30032406v030101c0.ZIP) which accompanies the present document.

---

## Annex B (normative): Partial PIXIT proforma

Notwithstanding the provisions of the copyright clause related to the text of the present document, ETSI grants that users of the present document may freely reproduce the PIXIT proforma in this annex so that it can be used for its intended purposes and may further publish the completed PIXIT.

---

### B.1 Introduction

The PIXIT proforma are based on ISO/IEC 9646-5, any additional information needed can be found in the present document.

---

### B.2 PIXIT proforma

#### B.2.1 Identification summary

PIXIT Number:

.....

Test Laboratory Name:

.....

Date of Issue:

.....

Issued to:

.....

#### B.2.2 Abstract test suite summary

Protocol Specification: EN 300 324-1

Protocol to be tested: V5.1, LE network layer

ATS Specification: EN 300 324-6

Abstract Test Method: Remote test method, embedded variant

#### B.2.3 Test laboratory

Test Laboratory Identification:

.....

Test Laboratory Manager:

.....

Means of Testing:

.....

SAP Address:

.....

## B.2.4 Client

Client Identification:

.....

Client Test manager:

.....

Test Facilities required:

.....

## B.2.5 SUT

Name:

.....

Version:

.....

SCS Number:

.....

Machine configuration:

.....

Operating System Identification:

.....

IUT Identification:

.....

PICS Reference for IUT:

.....

Limitations of the SUT:

.....

Environmental Conditions:

.....

## B.2.6 Protocol layer information

### B.2.6.1 Protocol identification

Name: V5.1, network layer protocol for Control and PSTN

Version: .....

PICS References: EN 300 324-2

### B.2.6.2 IUT information

**Table B.1: Addresses**

| Address name  | Parameter type | Reference to EN 300 324-1  | Value |
|---|----------------|--|-------|
| TSPX_CTRL_ISDNBA_PORT_ADDR  | OCTETSTRING[2] | Port address of the ISDN-BA user port provisioned (subclause 14.4.2.3)           |       |
| TSPX_CTRL_PSTN_PORT_ADDR  | OCTETSTRING[2] | Port address of the PSTN user port provisioned (subclause 14.4.2.3)              |       |
| TSPX_CTRL_PSTN_PORT_ADDR_NOT_PROV   | OCTETSTRING[2] | Port address of the PSTN user port which is not provisioned (subclause 14.4.2.3) |       |
| TSPX_V5DL_ADDR_CTRL   | OCTETSTRING[2] | V5DLaddr for the Control protocol (see note)                                     |       |
| TSPX_V5DL_ADDR_PSTN   | OCTETSTRING[2] | V5DLaddr for the PSTN protocol (see note)  |       |
| TSPX_SUBSCRIBER_NUMBER  | IA5String      | Subscriber number for V5 subscriber, used for invoking ESTABLISH message.        |       |
| NOTE: The TSPX_V5DL_ADDR is used to address either the Control or PSTN NWK entity. The TSPX_V5DL_ADDR is part of the ASP send or received. Depending on the V5DLaddr format requested by the target implementation (LT1), the TSPX_V5DL_ADDR shall be coded according to EN 300 324-1, table 1. |                |  |       |

**Table B.2: Parameter values**

| Parameter name         | Parameter type | Reference to EN 300 324-1  | Parameter value |
|------------------------|----------------|--|-----------------|
| TSPX_CTRL_INTERF_ID    | OCTETSTRING[3] | Interface ID (figure 40, table 57)   |                 |
| TSPX_CTRL_VAR          | OCTETSTRING[1] | Presently active variant of the IUT (figure 39, table 55)                        |                 |
| TSPX_CTRL_VAR_NEW      | OCTETSTRING[1] | Variant announced to become next active variant of the IUT (figure 39, table 55) |                 |
| TSPX_CTRL_VAR_NOT_PROV | OCTETSTRING[1] | Not available variant in the IUT (not provisioned) (figure 39, table 55)         |                 |
| TSPX_N3                | INTEGER        | Counter related to the DISCONNECT message and the timer T3. Default value is 2.  |                 |

**Table B.3: Timer values**

| Timer name type            | Reference to EN 300 324-1  | Timer range   | Timer value |
|----------------------------|--|---|-------------|
| TSPX_TIMER_T01_max         | table 58   | value: 1 200 [ms]<br>T01 + T01 tolerance + test environment tolerance |             |
| TSPX_TIMER_T02_max         | table 58   | value: 1 200 [ms]<br>T02 + T02 tolerance + test environment tolerance |             |
| TSPX_TIMER_T1_max          | table 28   | value: 1 200 [ms]<br>T1 + T1 tolerance + test environment tolerance   |             |
| TSPX_TIMER_T3_max          | table 28   | value: 2 400 [ms]<br>T3 + T3 tolerance + test environment tolerance   |             |
| TSPX_TIMER_T4_max          | table 28   | value: 2 400 [ms]<br>T4 + T4 tolerance + test environment tolerance   |             |
| TSPX_TIMER_AC_short        | Watch dog timer if immediate ACTION is expected from the IUT.                                  | value: 1 000 [ms]   |             |
| TSPX_TIMER_AC_long         | Watch dog timer if an ACTION from the IUT is expected after an undefined time period.          | value: 60 [s]   |             |
| TSPX_TIMER_WAIT_SON V_BACK | Time to wait before Switch-Over to New Variant is invoked to get initial provisioning variant. |   |             |

**Table B.4: Procedural information**

| Procedural name                           | Reference to EN 300 324-1   | Valid? |
|---|---|--------|
| TSPX_PSTN_TERMINATING_CALL_PRIORITY       | Terminating calls have priority (val: TRUE) (subclause 13.5.3.3).<br>If the parameter is not set (val: FALSE), originating calls have priority. |        |
| NOTE: All parameters are of type BOOLEAN. |   |        |

Table B.4 requests the national specific optional PSTN data, which shall be coded according to the PSTN standard to which the PSTN application of the IUT shall conform.

Table B.5: Optional information

| PIXIT name  | Related message | Reference to EN 300 324-1  | Specific requirements   | Value |
|---|-----------------|--|---|-------|
| TSPX_PSTN_COND_INFO_EST   | ESTABLISH       | 13.3.1, table 5  | Conditional part of ESTABLISH message received by LT1   |       |
| TSPX_PSTN_COND_INFO_EST_SEND  | ESTABLISH       | 13.3.1, table 5  | Conditional part of ESTABLISH message sent by LT1   |       |
| TSPX_PSTN_COND_INFO_EST_4_REP_OPT_IE  | ESTABLISH       | 13.3.1, table 5<br>13.5.2.5 (error conditions)<br>see also note  | The conditional part shall contain 4 repeated conditional IEs which are valid for the IUT to be tested                                  |       |
| TSPX_PSTN_COND_INFO_EST_ONE_INCORR_COND_IE  | ESTABLISH       | 13.4.5, table 17<br>13.5.2.9 (error conditions)<br>see also note | The conditional part shall contain one incorrect conditional IE   |       |
| TSPX_PSTN_COND_INFO_EST_ONE_UNSPEC_IE   | ESTABLISH       | 13.4.5, table 17<br>13.5.2.7 (error conditions)<br>see also note | The optional part shall contain one unspecified IE  |       |
| TSPX_PSTN_COND_INFO_EST_TWO_DIFF_COND_IE  | ESTABLISH       | 13.3.1, table 5<br>13.5.2.11 (error conditions)<br>see also note | The optional part shall contain two different conditional IEs   |       |
| TSPX_PSTN_OPT_INFO_EST_ACK  | ESTABLISH_ACK   | 13.3.2, table 6  |   |       |
| TSPX_COND_INFO_SIGNAL_DIGIT1  | SIGNAL          | 13.3.3, table 7  | Conditional information of a SIGNAL message which is sent from the AN to the LE and which represents the line signal of digit 1 (note2) |       |
| TSPX_COND_INFO_SIGNAL_DIGIT2  | SIGNAL          | 13.3.3, table 7  | Conditional information of a SIGNAL message which is sent from the AN to the LE and which represents the line signal of digit 2 (note2) |       |
| TSPX_COND_INFO_SIGNAL_DIGIT3  | SIGNAL          | 13.3.3, table 7  | Conditional information of a SIGNAL message which is sent from the AN to the LE and which represents the line signal of digit 3 (note2) |       |
| TSPX_COND_INFO_SIGNAL_LE  | SIGNAL          | 13.3.3, table 7  | Conditional information of a SIGNAL message which is sent from the LE to the AN   |       |
| NOTE 1: The PSTN messages which contain invalid optional information shall be coded according to the national PSTN specifications but the optional information shall be modified according to EN 300 324-1, subclause 13.5.2. |                 |  |   |       |
| NOTE 2: These parameters are used in sequential SIGNAL messages sent by LT1. IUT shall accept the digit information provided by these parameters.   |                 |  |   |       |

Table B.6: Implicit send events

| PIXIT name                                | Description   | Selection |
|---|---|-----------|
| TSPX_IMPLICIT_EVENT_CTRL                  | This PIXIT is used to select/deselect CTRL test cases which use implicit send events and thus need manual operations (no automatic execution)                     |           |
| TSPX_IMPLICIT_EVENT_PSTN                  | This PIXIT is used to select/deselect PSTN test cases which use implicit send events and thus need manual operations (no automatic execution)                     |           |
| TSPX_IMPLICIT_EVENT_PSTN_SIGNAL           | This PIXIT is used to select/deselect PSTN test cases which use implicit send events for SIGNAL messages and thus need manual operations (no automatic execution) |           |
| NOTE: All parameters are of type BOOLEAN. |   |           |

Table B.7: Implicit send event procedures

| Implicit event  | Description  | Procedural information |
|---|--|------------------------|
| <IUT ! ctrl_com_ctrl><br>Ctrl_cc_no_interf_id(TSC_CFI_SWITCH_OVER_TO_NEW_VAR, TSPX_CTRL_VAR_NEW, -)   | How can the sending of an COMMON CONTROL message (cfi: switch over to new variant) by the IUT be invoked?                              |                        |
| <IUT ! ctrl_com_ctrl><br>Ctrl_cc_mand_only(TSC_CFI_REST_REQ, -, -, -)   | How can the sending of an COMMON CONTROL message (cfi: restart request) by the IUT be invoked?   |                        |
| <IUT ! ctrl_com_ctrl><br>Ctrl_cc_mand_only(TSC_CFI_REQ_VID, -, -, -)  | How can the sending of an COMMON CONTROL message (cfi: request variant & interface ID) by the IUT be invoked?                          |                        |
| <IUT ! ctrl_port_ctrl><br>Ctrl_pc_isdnba(TSC_CFE_FE101_ACT_ACC)   | How can the sending of an PORT CONTROL message (cfi: FE101, activate access ) by the IUT (ISDN-BA entity) be invoked?                  |                        |
| <IUT ! ctrl_port_ctrl><br>Ctrl_pc_isdnba(TSC_CFE_FE105_DEACT_ACC)   | How can the sending of an PORT CONTROL message (cfi: FE105, deactivate access ) by the IUT (ISDN-BA entity) be invoked?                |                        |
| <IUT ! ctrl_port_ctrl><br>Ctrl_pc_isdnba(TCV_I3_addr, TSC_CFE_FE203_4_BL)   | How can the sending of an PORT CONTROL message (cfe: block command) by the IUT (ISDN-BA entity) be invoked?                            |                        |
| <IUT ! ctrl_port_ctrl><br>Ctrl_pc_isdnba(TSC_CFE_FE201_2_UNBL)  | How can the sending of an PORT CONTROL message (cfi: unblock request/ack) by the IUT (ISDN-BA entity) be invoked?                      |                        |
| <IUT ! ctrl_port_ctrl><br>Ctrl_pc_pstn(TCV_I3_addr, TSC_CFE_FE203_4_BL)   | How can the sending of an PORT CONTROL message (cfe: block command) by the IUT (PSTN entity) be invoked?                               |                        |
| <IUT ! ctrl_port_ctrl><br>Ctrl_pc_pstn(TSC_CFE_FE201_2_UNBL)  | How can the sending of an PORT CONTROL message (cfi: unblock request/ack) by the IUT (PSTN entity) be invoked?                         |                        |
| <IUT ! pstn_est><br>Pstn_est  | How can the sending of an PSTN ESTABLISH message by the IUT be invoked? (sending of a FE-subscriber_seizure message to the NWK entity) |                        |
| <IUT ! pstn_signal><br>Pstn_signal(S_R, TSPX_PSTN_COND_INFO_SIGNAL_LE)  | How can the sending of an PSTN SIGNAL message by the IUT be invoked? (sending of a FE-line_signal message message to the NWK entity)   |                        |
| <IUT ! mdu_system_start_up>   | How can a system start-up procedure in the IUT be invoked as described in EN 300 324-1, annex C, item 17?                              |                        |
| NOTE: Procedural information part shall provide the necessary information required to provoke the <i>Implicit event</i> described in <i>Description</i> part of this table. |  |                        |

Table B.8: PICS information

| PIXIT name                                | PICS item          | Valid ? |
|---|--------------------|---------|
| TSPC_ISDNBA                               | EN 300 324-2, M1   |         |
| TSPC_PSTN                                 | EN 300 324-2, M2   |         |
| TSPC_VERIFY_REPRO                         | EN 300 324-2, P5.2 |         |
| TSPC_REPRO_SYNC                           | EN 300 324-2, P5.3 |         |
| NOTE: All parameters are of type BOOLEAN. |                    |         |

---

## Bibliography

The following material, though not specifically referenced in the body of the present document (or not publicly available), gives supporting information.

- ETS 300 406 (1995): "Methods for Testing and Specification (MTS); Protocol and profile conformance testing specifications; Standardization methodology".
- ETR 141 (1994): "Methods for Testing and Specification (MTS); Protocol and profile conformance testing specifications; The Tree and Tabular Combined Notation (TTCN) style guide".



---

## History

| <b>Document history</b> |               |  |
|-------------------------|---------------|--|
| Edition 1               | April 1999    | Publication as ETS 300 324-6                       |
| V3.1.1                  | December 1999 | Public Enquiry PE 200017: 1999-12-29 to 2000-04-28 |
|                         |               |  |
|                         |               |  |
|                         |               |  |