

# ETSI EN 300 299 V1.3.2 (2000-05)

---

*European Standard (Telecommunications series)*

**Broadband Integrated Services Digital Network (B-ISDN);  
Cell based user network access  
for 155 520 kbit/s and 622 080 kbit/s;  
Physical layer interfaces for B-ISDN applications**

---



---

**Reference**

REN/TM-06017-4

---

**Keywords**access, ATM, B-ISDN, interface, ISDN,  
transmission, UNI**ETSI**

---

650 Route des Lucioles  
F-06921 Sophia Antipolis Cedex - FRANCE

Tel.: +33 4 92 94 42 00 Fax: +33 4 93 65 47 16

Siret N° 348 623 562 00017 - NAF 742 C  
Association à but non lucratif enregistrée à la  
Sous-Préfecture de Grasse (06) N° 7803/88

---

**Important notice**

Individual copies of the present document can be downloaded from:

<http://www.etsi.org>

The present document may be made available in more than one electronic version or in print. In any case of existing or perceived difference in contents between such versions, the reference version is the Portable Document Format (PDF).

In case of dispute, the reference shall be the printing on ETSI printers of the PDF version kept on a specific network drive within ETSI Secretariat.

Users of the present document should be aware that the document may be subject to revision or change of status.

Information on the current status of this and other ETSI documents is available at <http://www.etsi.org/tb/status/>

If you find errors in the present document, send your comment to:

editor@etsi.fr

---

**Copyright Notification**

No part may be reproduced except as authorized by written permission.  
The copyright and the foregoing restriction extend to reproduction in all media.

© European Telecommunications Standards Institute 2000.  
All rights reserved.

# Contents

Intellectual Property Rights .....	6
Foreword .....	6
1 Scope .....	7
2 References .....	7
3 Definitions and abbreviations .....	8
3.1 Definitions .....	8
3.2 Abbreviations .....	8
4 Reference configuration at the user-network interface .....	9
4.1 Functional groups and reference points .....	9
4.2 Examples of physical realizations .....	10
4.3 Basic characteristics of the interfaces at $T_B$ and $S_B$ reference points .....	14
4.3.1 Characteristics of the interfaces at 155 520 kbit/s .....	14
4.3.1.1 Interface at the $T_B$ reference point .....	14
4.3.1.2 Interface at the $S_B$ reference point .....	14
4.3.1.3 Relationship between interfaces at $S_B$ and $T_B$ .....	14
4.3.2 Characteristics of the interfaces at 622 080 kbit/s .....	14
4.3.2.1 Interface at $T_B$ reference point .....	14
4.4 Relationship between ISDN interfaces .....	14
4.5 Functional groups characteristics .....	14
4.5.1 Network termination 1 for B-ISDN .....	15
4.5.2 Network termination 2 for B-ISDN (B-NT2) .....	15
4.5.3 Terminal equipment for B-ISDN (B-TE) .....	15
4.5.3.1 Terminal equipment type 1 for B-ISDN (B-TE1) .....	16
4.5.3.2 Terminal equipment type 2 for B-ISDN (B-TE2) .....	16
4.5.4 Terminal adapter for B-ISDN (B-TA) .....	16
5 User network interface specifications .....	16
5.1 Interface location with respect to reference configuration .....	16
5.2 Interface location with respect to the wiring configuration .....	16
6 Service and layering aspects of the physical layer .....	17
6.1 Services provided to the ATM-layer .....	17
6.2 Service primitives exchanged with the ATM layer .....	17
6.3 Sublayering of the physical layer .....	17
7 Physical medium characteristics of the UNI at 155 520 kbit/s .....	18
7.1 Characteristics of the interface at the $T_B$ and $S_B$ reference points .....	18
7.1.1 Bit rate and interface symmetry .....	18
7.1.2 Physical characteristics .....	18
7.1.2.1 Electrical interface .....	18
7.1.2.1.1 Interface range .....	18
7.1.2.1.2 Transmission medium .....	18
7.1.2.1.3 Electrical parameters at interface points $I_a$ and $I_b$ .....	18
7.1.2.1.4 Electrical connectors .....	18
7.1.2.1.5 Line coding .....	19
7.1.2.1.6 Electromagnetic Compatibility/Interference (EMC/EMI) requirements .....	19
7.1.2.2 Optical interface .....	20
7.1.2.2.1 Attenuation range .....	20
7.1.2.2.2 Transmission medium .....	20
7.1.2.2.3 Optical parameters .....	20
7.1.2.2.4 Optical connectors .....	21
7.1.2.2.5 Safety requirements .....	21
7.1.2.3 Jitter and wander .....	21

8	Physical medium characteristics of the UNI at 622 080 kbit/s .....	21
8.1	Characteristics of the interface at the T <sub>B</sub> and S <sub>B</sub> reference points .....	21
8.1.1	Bit rate and interface symmetry .....	21
8.1.2	Physical characteristics .....	22
8.1.2.1	Attenuation range .....	22
8.1.2.2	Transmission medium .....	22
8.1.2.3	Optical parameters .....	22
8.1.2.3.1	Line coding .....	22
8.1.2.3.2	Operating wavelength .....	22
8.1.2.3.3	Input and output port characteristics .....	22
8.1.2.4	Optical connectors .....	22
8.1.2.5	Safety requirements .....	22
8.1.2.6	Jitter and wander .....	23
9	Power feeding .....	23
9.1	Provision of power .....	23
9.2	Power available at B-NT1 .....	23
9.3	Feeding voltage .....	23
9.4	Safety and Protection requirements .....	23
9.4.1	Safety .....	23
9.4.2	Protection .....	24
10	Functions provided by the transmission convergence sublayer .....	24
10.1	Transfer capability .....	24
10.1.1	Interface at 155 520 kbit/s .....	24
10.1.2	Interface at 622 080 kbit/s .....	24
10.2	Physical layer aspects .....	24
10.2.1	Timing .....	24
10.2.2	Interface structure for 155 520 kbit/s and 622 080 kbit/s .....	24
10.3	Header Error Control (HEC) .....	25
10.3.1	HEC functions .....	25
10.3.2	HEC sequence generation .....	27
10.4	Idle cells .....	27
10.5	Cell delineation and scrambling .....	27
10.5.1	Cell delineation and scrambling objectives .....	27
10.5.1.1	Cell delineation algorithm .....	28
10.5.2	Cell delineation performance .....	29
10.5.3	Scrambler operation .....	29
10.5.3.1	Distributed Sample Scrambler (31 <sup>st</sup> order) operation .....	29
10.5.3.2	Transmitter operation .....	29
10.5.3.3	Receiver operation .....	30
10.5.3.4	State transition diagram and mechanism .....	31
11	UNI related OAM functions .....	32
11.1	Transmission overhead allocation .....	32
11.2	OAM cell identification .....	32
11.3	Allocation of OAM functions in information field .....	33
11.4	Maintenance signals .....	35
11.5	Transmission performance monitoring .....	35
11.6	Control communication .....	35
12	Operational functions .....	35
12.1	Description of signals at the interface .....	35
12.1.1	Signals defined in ITU-T Recommendation I.610 .....	35
12.1.2	Cell delineation signals .....	36
12.2	Definitions of state tables at network and user sides .....	36
12.2.1	Layer 1 states on the user side of the interface .....	36
12.2.2	Layer 1 states at the network side of the interface .....	37
12.2.3	Definition of primitives .....	39
12.2.4	State tables .....	40

<b>Annex A (informative):</b>	<b>Impact of random bit errors on cell delineation performance.....</b>	<b>43</b>
<b>Annex B (informative):</b>	<b>Distributed Sample Scrambler implementation example.....</b>	<b>45</b>
History .....		47

---

## Intellectual Property Rights

IPRs essential or potentially essential to the present document may have been declared to ETSI. The information pertaining to these essential IPRs, if any, is publicly available for **ETSI members and non-members**, and can be found in SR 000 314: "*Intellectual Property Rights (IPRs); Essential, or potentially Essential, IPRs notified to ETSI in respect of ETSI standards*", which is available from the ETSI Secretariat. Latest updates are available on the ETSI Web server (<http://www.etsi.org/ipr>).

Pursuant to the ETSI IPR Policy, no investigation, including IPR searches, has been carried out by ETSI. No guarantee can be given as to the existence of other IPRs not referenced in SR 000 314 (or the updates on the ETSI Web server) which are, or may be, or may become, essential to the present document.

---

## Foreword

This European Standard (Telecommunications series) has been produced by ETSI Technical Committee Transmission and Multiplexing (TM).

The present document defines the cell based user network access physical layer interfaces to be applied to the  $T_B$ ,  $S_B$  reference points of the reference configurations of the Broadband Integrated Services Digital Network (B-ISDN) User-Network Interface (UNI) at 155 520 kbit/s and 622 080 kbit/s, for B-ISDN applications. It addresses separately the Physical Media Dependant (PMD) and Transmission Convergence (TC) sublayers used at these interfaces and addresses also the implementation of UNI related physical layer Operations And Maintenance (OAM) functions.

The present document takes into account the recommendations given in ITU-T Recommendations I.413 [7], I.432.1 [8] and I.432.2 [9].

The present document includes an editorial improvement of the safety related provisions.

<b>National transposition dates</b>	
Date of latest announcement of this EN (doa):	31 August 2000
Date of latest publication of new National Standard or endorsement of this EN (dop/e):	28 February 2001
Date of withdrawal of any conflicting National Standard (dow):	28 February 2001

---

# 1 Scope

The present document defines the physical layer interface to be applied to the  $S_B$  and  $T_B$  reference points of the reference configurations of the Broadband Integrated Services Digital Network (B-ISDN) cell based User-Network Interface (UNI) at 155 520 kbit/s and 622 080 kbit/s. It addresses separately the Physical Media Dependant (PMD) and Transmission Convergence (TC) sublayers used at these interfaces, and addresses also the implementation of UNI related physical layer OAM functions.

The selection of the physical medium for the interfaces at the  $S_B$  and  $T_B$  reference points should take into account that optical fibre is agreed as the preferred medium to be used to cable customer equipment. However, in order to allow the use of existing cabling of customer equipment, other transmission media (e.g. twisted pairs and coaxial cables) should not be precluded. Also, implementations should allow terminal interchangeability.

The present document reflects in its structure and content the desire to take care of such early configurations and introduces a degree of freedom when choosing a physical medium at the physical layer.

---

# 2 References

The following documents contain provisions which, through reference in this text, constitute provisions of the present document.

- References are either specific (identified by date of publication, edition number, version number, etc.) or non-specific.
- For a specific reference, subsequent revisions do not apply.
- For a non-specific reference, the latest version applies.
- A non-specific reference to an ETS shall also be taken to refer to later versions published as an EN with the same number.

- [1] ITU-T Recommendation G.652 (1997): "Characteristics of a single-mode optical fibre cable".
- [2] ETSI ETS 300 166 (1993): "Transmission and Multiplexing (TM); Physical and electrical characteristics of hierarchical digital interfaces for equipment using the 2 048 kbit/s - based plesiochronous or synchronous digital hierarchies".
- [3] ETSI ETS 300 232 (1993): "Transmission and Multiplexing (TM); Optical interfaces for equipments and systems relating to the Synchronous Digital Hierarchy [ITU-T Recommendation G.957 (1993), modified]".
- [4] ITU-T Recommendation I.113 (1997): "Vocabulary of terms for broadband aspects of ISDN".
- [5] ITU-T Recommendation I.321 (1991): "B-ISDN protocol reference model and its application".
- [6] ITU-T Recommendation I.361 (1995): "B-ISDN ATM layer specification".
- [7] ITU-T Recommendation I.413 (1993): "B-ISDN user-network interface".
- [8] ITU-T Recommendation I.432.1 (1999): "B-ISDN user-network interface - Physical layer specification: General characteristics".
- [9] ITU-T Recommendation I.432.2 (1999): "B-ISDN user-network interface - Physical layer specification: 155 520 kbit/s and 622 080 kbit/s operation".
- [10] ITU-T Recommendation I.610 (1999): "B-ISDN operation and maintenance principles and functions".
- [11] ITU-T Recommendation X.200 (1994): "Information technology - Open Systems Interconnection - Basic reference model: The basic model".

- [12] ETSI ETS 300 404 (1997): "Broadband Integrated Services Digital Network (B-ISDN); B-ISDN Operation And Maintenance (OAM) principles and functions".
- [13] IEC 60825-1 (1993): "Safety of laser products: Part 1: Equipment classification, requirements and user's guide".
- [14] CENELEC EN 60950 (1992): "Safety of information technology equipment".
- [15] ITU-T Recommendation G.825: "The control of jitter and wander within digital networks which are based on the synchronous digital hierarchy (SDH)".
- [16] ITU-T Recommendation G.958 (1994): "Digital line systems based on the synchronous digital hierarchy for use on optical fibre cables".
- [17] ITU-T Recommendation G.826 (1999): "Error performance parameters and objectives for international, constant bit rate digital paths at or above the primary rate".
- [18] ETSI EG 201 212 (V1.2): "Electrical Safety; Classification of interfaces for equipment to be connected to telecommunication networks".

## 3 Definitions and abbreviations

### 3.1 Definitions

For the purposes of the present document, the definitions given in ITU-T Recommendation I.113 [4] apply, in particular for the definitions of **idle cell**, **valid cell** and **invalid cell**. In addition, the following definition applies:

**to be defined:** these items or values are not yet specified.

### 3.2 Abbreviations

For the purposes of the present document, the following abbreviations apply:

AI	Activation Indication
AIS	Alarm Indication Signal
ATM	Asynchronous Transfer Mode
BER	Bit Error Rate
B-ISDN	Broadband Integrated Services Digital Network
B-NT	B-ISDN Network Termination
B-TA	B-ISDN Terminal Adaptor
B-TE	B-ISDN Terminal Equipment
BIP	Bit Interleaved Parity
B-UNI	Broadband UNI
CATV	CABLE TeleVision
CEC	Cell Error Control
CI	Correction Indication
CLP	Cell Loss Priority
CMI	Coded Mark Inversion
CRC	Cyclic Redundancy Check
DI	Deactivate Indication
DSS	Distributed Sample Scrambler
EDC	Error Detection Code
EI	Error Indication
EMC	Electromagnetic Compatibility
EMI	ElectroMagnetic Interference
HEC	Header Error Control
ISDN	Integrated Services Digital Network
LAN	Local Area Network



LCD	Loss of Cell Delineation
LOM	Loss Of Maintenance cell
LOS	Loss Of Signal
LSB	Least Significant Bit
MA	Medium Adaptor
MBS	Monitoring Block Size
MPH	Management Physical Header
MSB	Most Significant Bit
NRZ	Non Return to Zero
OAM	Operation And Maintenance
OCD	Out of Cell Delineation
OSI	Open Systems Interconnection
P-AIS	Path Alarm Indication Signal
Ph-SAP	Physical layer Service Access Point
PH	Physical Header
PM	Physical Medium
ppm	parts per million
PRBS	Pseudo-Random Binary Sequence
PSN	Physical layer Sequence Number
RDI	Remote Defect Indication
REB	Remote Errored Blocks
SDH	Synchronous Digital Hierarchy
STI	Surface Transfer Impedance
TC	Transmission Convergence
TFV	Terminal Failure Voltage
UNI	User-Network Interface
VCI	Virtual Channel Identifier
VPI	Virtual Path Identifier

---

## 4 Reference configuration at the user-network interface

### 4.1 Functional groups and reference points

The reference configurations defined for Integrated Services Digital Network (ISDN) basic access and primary access are considered general enough to be applicable to all aspects of the B-ISDN accesses.

Figure 1 shows the B-ISDN reference configurations, which contain the following:

- functional groups: B-NT1, B-NT2, B-TE1, TE2, B-TE2, and B-TA;
- reference points: T<sub>B</sub>, S<sub>B</sub> and R.

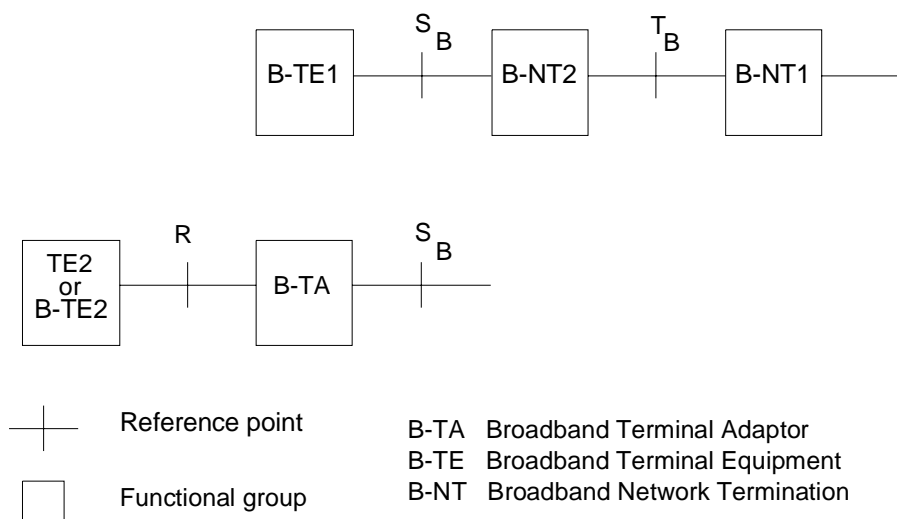

**Figure 1: B-ISDN reference configurations**

In order to clearly illustrate the broadband aspects, the notations for reference points and for functional groups with broadband capabilities are appended with the letter B (e.g. B-NT1,  $T_B$ ). The broadband functional groups are equivalent to the functional groups defined in ISDN. Interfaces at the R reference point may or may not have broadband capabilities.

Interfaces at reference points  $S_B$  and  $T_B$  will be standardized. These interfaces will support all ISDN services.

## 4.2 Examples of physical realizations

Figure 2 gives examples of physical configurations illustrating combinations of physical interfaces at various reference points. The examples cover configurations that could be supported by standardized interfaces at reference points  $S_B$  and  $T_B$ . Other configurations may also exist. For example, physical configurations of B-NT2 may be distributed, or use shared medium, to support Local Area Network (LAN) emulation and other applications.

Figure 3 illustrates possible physical configurations, but does not preclude alternative configurations. Whether a single interface at the  $S_B$  reference point can cover different configurations, as illustrated in figure 3, is for further study.

Figure 2 is subdivided into separate items as follows:

- figures 2a) and 2b) show separate interfaces at the  $S_B$  and  $T_B$  reference points;
- figures 2c) and 2d) show an interface at  $S_B$  but not at  $T_B$ ;
- figures 2e) and 2f) show an interface at  $T_B$  but not at  $S_B$ ;
- figures 2g) and 2h) show separate interfaces at S,  $S_B$  and  $T_B$ ;
- figures 2i) and 2j) show interfaces at  $S_B$  and  $T_B$  which are coincident.

Additionally, figures 2b), 2d), 2f), 2h) and 2j) show an interface at reference point R.

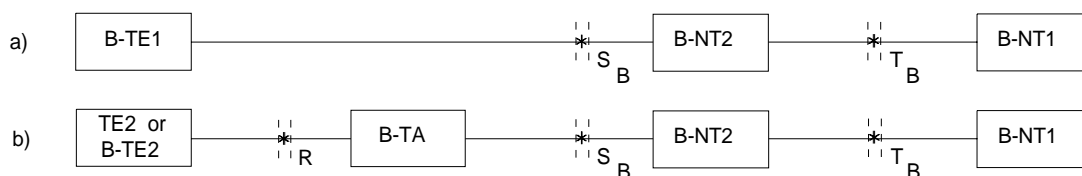

**Configurations where B-ISDN physical interfaces occur at reference points  $S_B$  and  $T_B$**

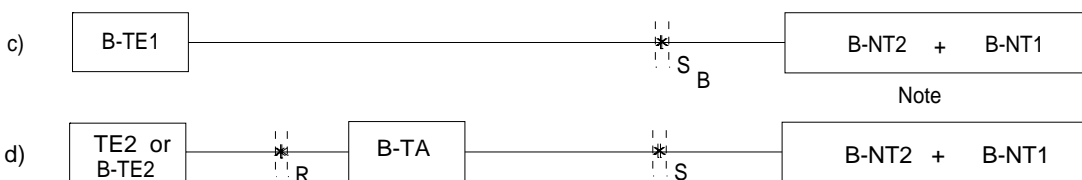

**Configurations where B-ISDN physical interfaces occur at reference point  $S_B$  only**



**Configurations where B-ISDN physical interfaces occur at reference point  $T_B$  only**

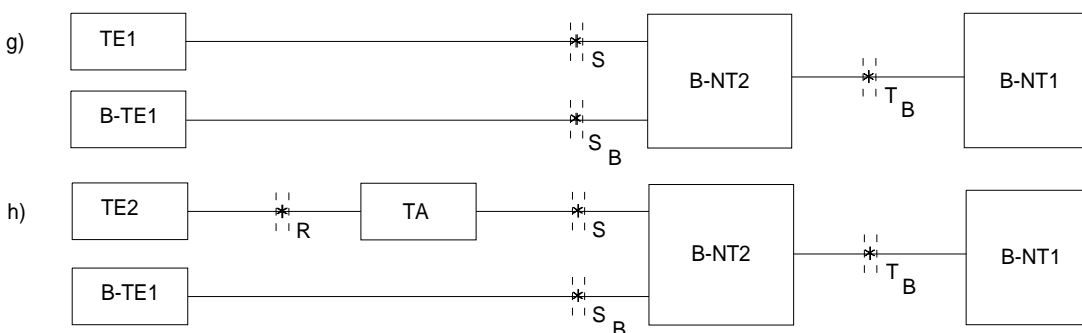

**Configurations where B-ISDN and ISDN physical interfaces occur at reference points  $S$ ,  $S_B$  and  $T_B$**

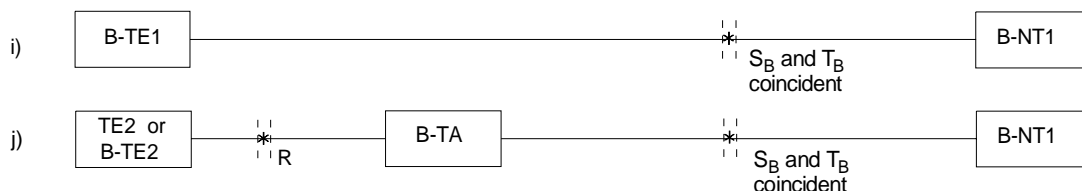

**Configurations where a single B-ISDN physical interface occurs at a location where both reference points  $S_B$  and  $T_B$  coincide**

 Physical interface at the designated reference point

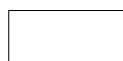
 Equipment implementing functional groups

NOTE: The needed for an access to a  $T_B$  reference point between B-NT1 and B-NT2 is for further study.

**Figure 2: Examples of physical configurations for broadband user applications**

a) centralized B-NT2 configuration:

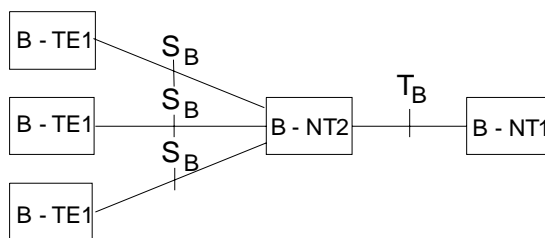

b) distributed B-NT2 configurations:

b1) generic configuration

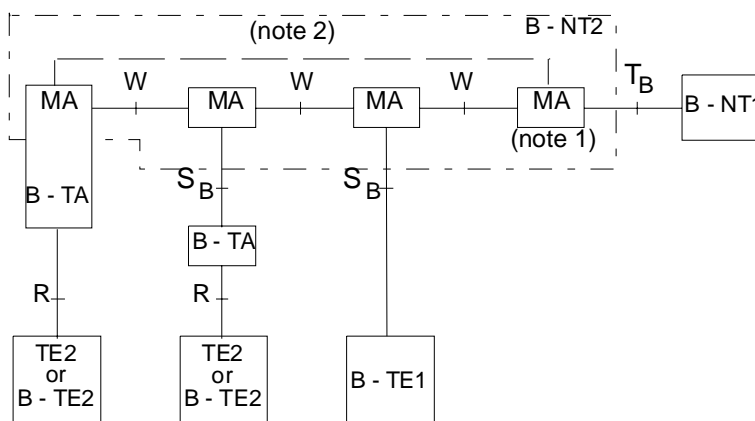

b2) physical configurations

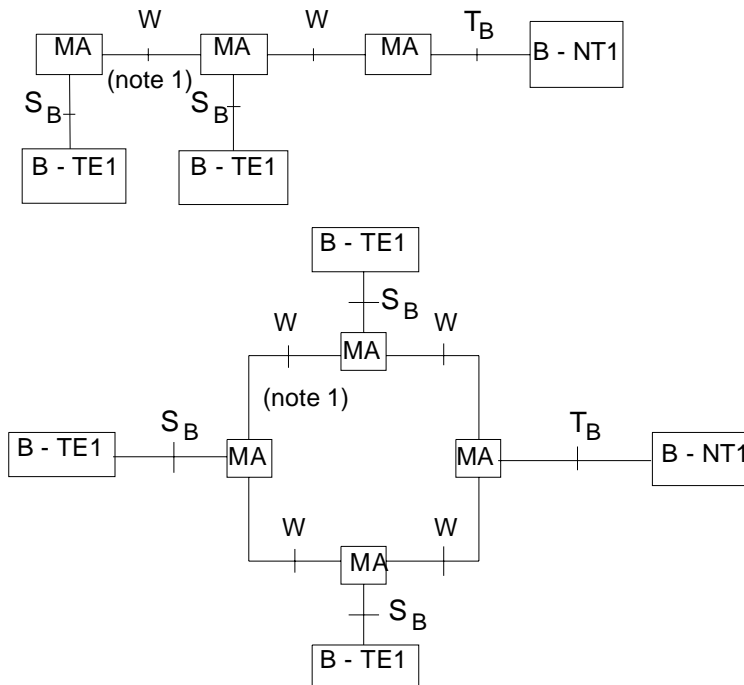
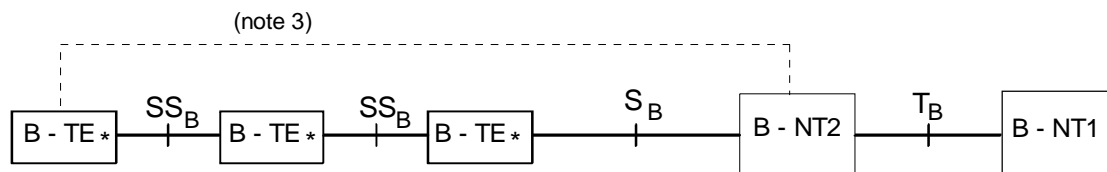

Figure 3 (sheet 1/2): Examples of physical configurations for multipoint applications

## c) multi-access B-TE configurations:

c1) generic configurations (note 7)



c2) physical configurations

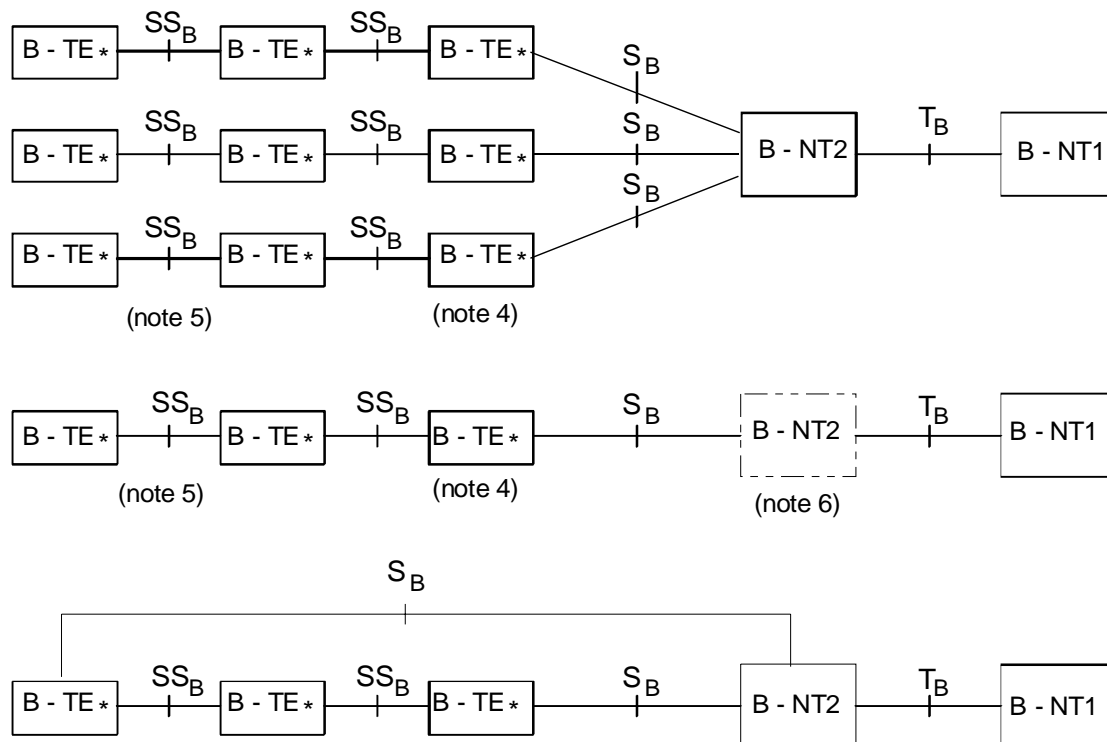

NOTE 1: Medium Adaptor (MA): accommodates the specific topology of the distributed B-NT2. The interface at W may include topology dependant elements and may be a non-standardized interface.

NOTE 2: There will be a physical link between these two MAs in the case of ring configurations.

NOTE 3: There will be a physical link between B-TE\* and B-NT2 in the case of ring configurations.

NOTE 4: The B-TE\* includes shared medium access functions.

NOTE 5: The measurable physical characteristics of the  $SS_B$  interface are identical to those of the  $S_B$  interface. The functional characteristics of the interface, however, may be a superset of those at the  $S_B$  interface.

NOTE 6: The B-NT2 may be null in the case of commonality between  $S_B$  and  $T_B$ .

NOTE 7: Additional termination functions (e.g. for loopback in bus configuration) and OAM functions may be necessary for multi-access B-TE configurations. Requirements and implementations of these functions are for further study.

Figure 3 (sheet 2/2): Examples of physical configurations for multipoint applications

## 4.3 Basic characteristics of the interfaces at $T_B$ and $S_B$ reference points

### 4.3.1 Characteristics of the interfaces at 155 520 kbit/s

#### 4.3.1.1 Interface at the $T_B$ reference point

There is only one interface per B-NT1 at the  $T_B$  reference point. The operation of the physical medium is point-to-point in the sense that there is only one sink (receiver) in front of one source (transmitter).

Point-to-multipoint configurations at  $T_B$  at Asynchronous Transfer Mode (ATM) and higher layers are for further study.

#### 4.3.1.2 Interface at the $S_B$ reference point

One or more  $S_B$  interfaces per B-NT2 are present. The interface at the  $S_B$  reference point is point-to-point at the physical layer in the sense that there is only one sink (receiver) in front of one source (transmitter) and may be point to multipoint at the other layers.

#### 4.3.1.3 Relationship between interfaces at $S_B$ and $T_B$

Configurations described in figures 2i) and 2j) require that the interface specifications at  $T_B$  and  $S_B$  should have a high degree of commonality, in order to ensure that a simple broadband terminal may be connected directly to the  $T_B$  interface.

The feasibility of achieving the needed commonality is for further study.

### 4.3.2 Characteristics of the interfaces at 622 080 kbit/s

#### 4.3.2.1 Interface at $T_B$ reference point

There is only one interface per B-NT1 at the  $T_B$  reference point. The operation of the physical medium is point-to-point in the sense that there is only one sink (receiver) in front of one source (transmitter).

Point-to-multipoint configurations at  $T_B$  at ATM and higher layers are for further study.

## 4.4 Relationship between ISDN interfaces

Figures 2g) and 2h) show configurations where B-ISDN and ISDN interfaces may occur at  $S_B$  and S respectively. In this case, B-NT2 functionalities have to ensure the interface capabilities for both S and  $S_B$ . Other configurations for supporting terminals at the interface at the S reference point may exist.

## 4.5 Functional groups characteristics

Lists of functions for each functional group are given below. Each particular function is not necessarily restricted to a single functional group. For example, "interface termination" functions are included in the function lists of B-NT1, B-NT2 and B-TE. The function lists for B-NT1, B-NT2, B-TE and B-TA are not exhaustive. Not all specific functions in a functional group need to be present in all implementations.

### 4.5.1 Network termination 1 for B-ISDN

This functional group includes functions broadly equivalent to layer 1 of the Open System Interconnection (OSI) reference model. Examples of B-NT1 functions are:

- line transmission termination;
- transmission interface handling;
- cell delineation;
- OAM functions.

### 4.5.2 Network termination 2 for B-ISDN (B-NT2)

This functional group includes functions broadly equivalent to layer 1 and higher layers of the ITU-T Recommendation X.200 [11] reference model. B-NT2 can be null in the case of commonality between  $T_B$  and  $S_B$ .

Examples of B-NT2 functions are:

- adaptation functions for different media and topologies (MA functions);
- functions of a distributed B-NT2;
- cell delineation;
- concentration;
- buffering;
- multiplexing/demultiplexing;
- resource allocation;
- usage parameter control;
- adaptation layer functions for signalling (for internal traffic);
- interface handling (for the  $T_B$  and  $S_B$  interfaces);
- OAM functions;
- signalling protocol handling;
- switching of internal connections.

B-NT2 implementations may be concentrated or distributed. In a specific access arrangement, the B-NT2 may consist only of physical connections. When present, implementations of the B-NT2 are locally powered.

### 4.5.3 Terminal equipment for B-ISDN (B-TE)

This functional group includes functions broadly belonging to layer 1 and higher layers of the ITU-T Recommendation X.200 [11] reference model.

Examples of B-TE functions are:

- user/user and user/machine dialogue and protocol;
- interface termination and other layer 1 functions;
- protocol handling for signalling;
- connection handling to other equipments;
- OAM functions.

The possibility of powering the B-TE via the  $S_B$  interface is for further study.

#### 4.5.3.1 Terminal equipment type 1 for B-ISDN (B-TE1)

This functional group includes functions belonging to the B-TE functional group with an interface that complies with the B-ISDN  $S_B$  and/or  $T_B$  interface ENs.

#### 4.5.3.2 Terminal equipment type 2 for B-ISDN (B-TE2)

This functional group includes functions belonging to the functional group B-TE but with a broadband interface that complies with interface recommendations other than the B-ISDN interface recommendations or interfaces not included in ITU-T Recommendations.

#### 4.5.4 Terminal adapter for B-ISDN (B-TA)

This functional group includes functions broadly belonging to layer 1 and higher layers of the ITU-T Recommendation X.200 [11] reference model that allow a TE2 or a B-TE2 terminal to be served by a B-ISDN user-network interface.

## 5 User network interface specifications

### 5.1 Interface location with respect to reference configuration

An interface point  $I_a$  is adjacent to the B-TE or the B-NT2 on their network side; interface point  $I_b$  is adjacent to the B-NT2 and to the B-NT1 on their user side (see figure 4).



Figure 4: Reference configuration at reference points  $S_B$  and  $T_B$

### 5.2 Interface location with respect to the wiring configuration

The interface points are located between the socket and the plug of the connector attached to the B-TE, B-NT2 or B-NT1. The location of the interface point is shown in figure 5.

In the present document, the term "B-NT" is used to indicate network terminating layer 1 aspects of B-NT1 and B-NT2 functional groups, and the term "TE" is used to indicate terminal terminating layer 1 aspects of B-TE1, B-TA and B-NT2 functional groups, unless otherwise indicated.



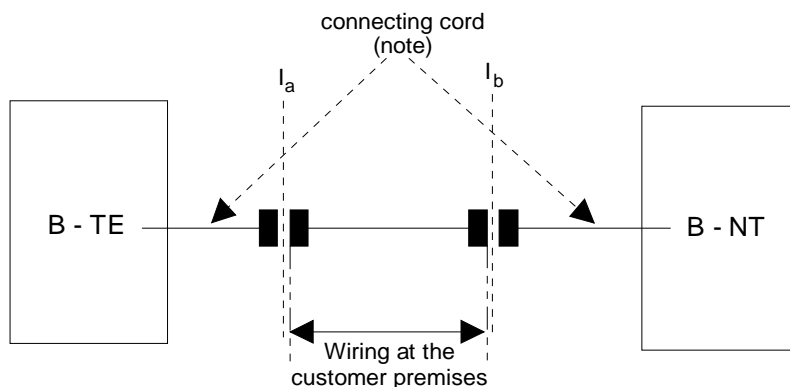

NOTE: The length of the connecting cord can be zero.

**Figure 5: Wiring configuration**

## 6 Service and layering aspects of the physical layer

### 6.1 Services provided to the ATM-layer

The physical layer provides for the transparent transmission of ATM-PDUs between Physical layer Service Access Points (Ph-SAP). The ATM-PDU is called ATM cell. The ATM cell is defined in ITU-T Recommendation I.361 [6]. As no addressing is implemented in the physical layer only a single Ph-SAP can exist at the boundary between physical layer and ATM layer. The interarrival time between cells passed to the ATM layer is not defined (asynchronous transmission). The physical layer provides the ATM layer with timing information.

### 6.2 Service primitives exchanged with the ATM layer

The service primitives between physical layer and ATM layer are defined in ITU-T Recommendation I.361 [6], subclause 3.2.

### 6.3 Sublayering of the physical layer

The physical layer is subdivided into two sublayers:

- the Physical Medium (PM) sublayer;
- the Transmission Convergence (TC) sublayer.

No service access point and service primitives are defined between the PM and the TC sublayers. The functions of the individual sublayer are defined in ITU-T Recommendation I.321 [5].

---

## 7 Physical medium characteristics of the UNI at 155 520 kbit/s

### 7.1 Characteristics of the interface at the $T_B$ and $S_B$ reference points

#### 7.1.1 Bit rate and interface symmetry

The bit rate of the interface is 155 520 kbit/s. The interface is symmetric, i.e. it has the same bit rate in both transmission directions.

The nominal bit rate in free running clock mode shall be 155 520 kbit/s with a tolerance of  $\pm 20$  ppm.

#### 7.1.2 Physical characteristics

Both optical and electrical interfaces are recommended. The implementation selected depends on the distance to be covered and user requirements arising from the details of the installation.

##### 7.1.2.1 Electrical interface

###### 7.1.2.1.1 Interface range

The maximum range of the interface depends on the specific attenuation of the transmission medium used. For example a maximum range of about 100 m for microcoax (4 mm diameter) and 200 m for Cable Television (CATV) type (7 mm diameter) cables can be achieved.

###### 7.1.2.1.2 Transmission medium

Two coaxial cables, one for each direction, shall be used. The wiring configuration shall be point-to-point.

The impedance shall be  $75 \Omega$  with a tolerance of  $\pm 5 \%$  in the frequency range 50 MHz to 200 MHz.

The attenuation of the electrical path between the interface points  $I_a$  and  $I_b$  shall be assumed to follow an approximate  $\sqrt{f}$  law and to have a maximum insertion loss of 20 dB at a frequency of 155 520 kHz.

###### 7.1.2.1.3 Electrical parameters at interface points $I_a$ and $I_b$

The digital signal presented at the output port and the port impedance shall conform to ETSI ETS 300 166 [2] for the interface at 155 520 kbit/s.

The digital signal presented at the input port and the port impedance shall conform to ETSI ETS 300 166 [2] for the interface at 155 520 kbit/s, modified by the characteristics of the interconnecting coaxial pair.

###### 7.1.2.1.4 Electrical connectors

The presentation of interface point  $I_b$  at B-NT1 or B-NT2 shall be via a socket.

The presentation of interface point  $I_a$  at B-TE or B-NT2 shall be using either:

- a) a socket, i.e. the connection shall be made to the equipment toward the network with a cable with plugs on both ends; or
- b) an integral connecting cord with plug on the free end.

### 7.1.2.1.5 Line coding

The line coding shall be Coded Mark Inversion (CMI), see ETSI ETS 300 166 [2].

### 7.1.2.1.6 Electromagnetic Compatibility/Interference (EMC/EMI) requirements

Shielding properties of connectors and cables are defined by the specification of the respective values for the Surface Transfer Impedance (STI). The template indicating the maximum STI values for CATV cables is given in figure 6. For connectors, these template values shall be multiplied by 10 (20 dB).

The immunity of the interface against induced noise on the transmission medium should be specified by means of a Terminal Failure Voltage (TFV), which is overlaid to the digital signal at the output port. Figure 7 shows a possible measurement configuration.

The receiver should tolerate a sinusoidal TFV with the values defined in figure 8 and table 1 without degradation of the Bit Error Ratio (BER) performance.

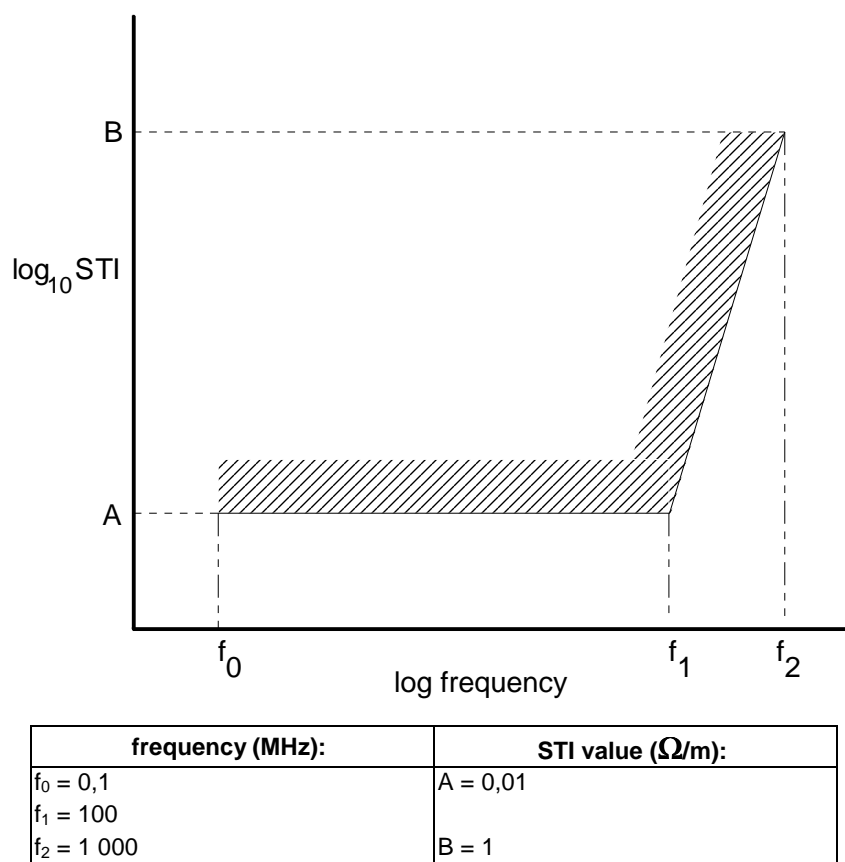

NOTE: The applicability of these values for microcoax cables is for further study.

**Figure 6: Maximum STI values as a function of frequency**

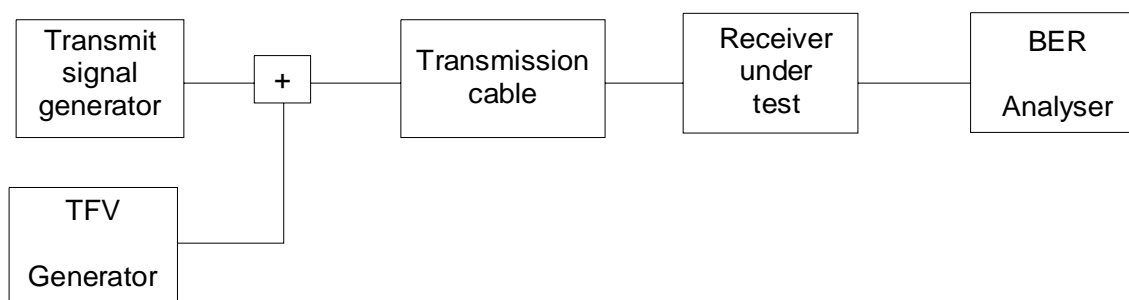

**Figure 7: Measurement configuration**

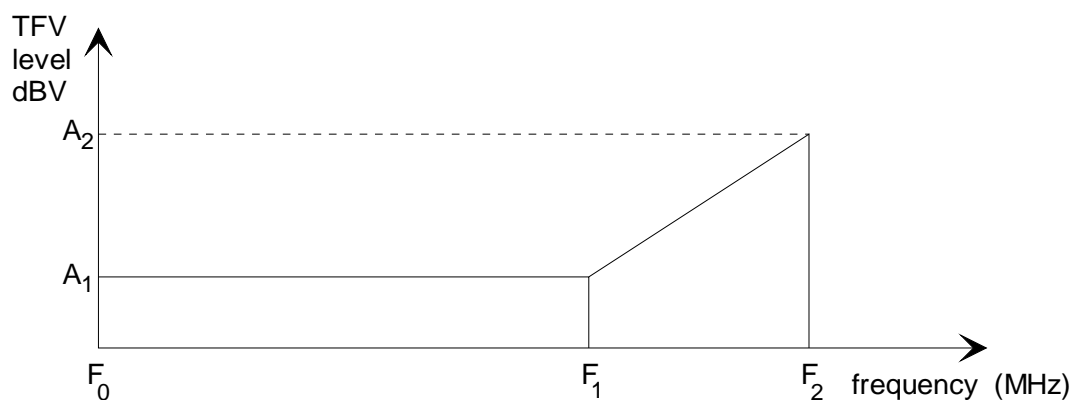

**Figure 8: Terminal Failure Voltage (TFV) frequency response**

**Table 1: TFV values**

frequency (MHz)	TFV amplitude (dBV) (0 dBV = 1 V <sub>op</sub> )
F <sub>0</sub> = 1	
F <sub>1</sub> = 200	A1 ≥ -17
F <sub>2</sub> = 400	A2 ≥ -11

## 7.1.2.2 Optical interface

### 7.1.2.2.1 Attenuation range

The attenuation of the optical path between the specification points S and R, as defined in ETSI ETS 300 232 [3], shall be in the range of 0 dB to 7 dB (see subclause 7.1.2.2.3.3).

### 7.1.2.2.2 Transmission medium

The transmission medium shall consist of two single mode fibres according to ITU-T Recommendation G.652 [1], one for each direction.

### 7.1.2.2.3 Optical parameters

#### 7.1.2.2.3.1 Line coding

The line coding shall be binary Non Return to Zero (NRZ).

The convention used for optical logic level is:

- emission of light for a binary ONE;
- no emission of light for a binary ZERO.

The extinction ratio shall be in accordance with ETSI ETS 300 232 [3], application code I-1.

#### 7.1.2.2.3.2 Operating wavelength

The operating wavelength shall be around 1 310 nm (second window) and in accordance with ETSI ETS 300 232 [3], application code I-1.

#### 7.1.2.2.3.3 Input and output port characteristics

The optical parameters shall be in accordance with ETSI ETS 300 232 [3], application code I-1. Some national application may use optical parameters for multi-mode fibres.

The specification points associated with interface points  $I_a$  and  $I_b$  correspond to measurement "reference points" S and R as defined in ETSI ETS 300 232 [3]. The optical parameters are specified for the transmitter and receiver at these specification points and for the optical path between these specification points, i.e. the connector at the interface is considered to be part of the equipment and not part of the fibre installation.

#### 7.1.2.2.4 Optical connectors

The presentation of interface point  $I_b$  at B-NT1 or B-NT2 shall be via a socket.

The presentation of interface point  $I_a$  at B-TE or B-NT2 shall be using either:

- a) a socket, i.e. the connection shall be made to the equipment toward the network with a cable with plugs on both ends; or
- b) an integral connecting cord with plug on the free end.

#### 7.1.2.2.5 Safety requirements

For safety reasons, the parameters for IEC 60825-1 [13], Class 1 devices shall not be exceeded, even under failure conditions.

#### 7.1.2.3 Jitter and wander

For both electrical and optical Broadband UNI (B-UNI), the interface output jitter shall be in accordance with the appropriate limit given in ITU-T Recommendation G.825 [15] for the electrical and optical interface.

Equipments having an electrical or optical B-UNI (e.g. B-NT1, B-NT2, B-TE) and which meet the output jitter tolerance and the jitter transfer specifications given in ITU-T Recommendations G.825 [15] and G.958 [16] respectively, are assured of proper operation when the interface output jitter conforms to the limits in ITU-T Recommendation G.825 [15].

---

## 8 Physical medium characteristics of the UNI at 622 080 kbit/s

### 8.1 Characteristics of the interface at the $T_B$ and $S_B$ reference points

#### 8.1.1 Bit rate and interface symmetry

The bit rate of the interface in at least one direction shall be 622 080 kbit/s. The following possible interfaces have been identified:

- a) an asymmetrical interface with 622 080 kbit/s in one direction and 155 520 kbit/s in the other direction;
- b) a symmetrical interface with 622 080 kbit/s in both directions.

If option a) is chosen, then the 155 520 kbit/s component should comply with the characteristics as given in clause 7.

The nominal bit rate in free running clock mode shall be 622 080 kbit/s with a tolerance of  $\pm 20$  ppm.

## 8.1.2 Physical characteristics

For the purposes of the present document, only the optical interface is considered.

### 8.1.2.1 Attenuation range

The attenuation of the optical path between the specification points S and R shall be in the range of 0 dB to 7 dB (see subclause 7.1.2.2.3.3).

### 8.1.2.2 Transmission medium

The transmission medium shall consist of two single mode fibres according to ITU-T Recommendation G.652 [1], one for each direction.

### 8.1.2.3 Optical parameters

#### 8.1.2.3.1 Line coding

The line coding shall be binary Non Return to Zero (NRZ).

The convention used for optical logic level is:

- emission of light for a binary ONE;
- no emission of light for a binary ZERO.

The extinction ratio shall be in accordance with ETSI ETS 300 232 [3], application code I-4.

#### 8.1.2.3.2 Operating wavelength

The operating wavelength shall be around 1 310 nm (second window) and in accordance with ETSI ETS 300 232 [3], application code I-4.

#### 8.1.2.3.3 Input and output port characteristics

The optical parameters shall be in accordance with ETSI ETS 300 232 [3], application code I-4.

The specification points associated with interface points  $I_a$  and  $I_b$  correspond to measurement reference points S and R as defined in ETSI ETS 300 232 [3]. The optical parameters are specified for the transmitter and receiver at these specification points and for the optical path between these specification points, i.e. the connector at the interface is considered to be part of the equipment and not part of the fibre installation.

### 8.1.2.4 Optical connectors

The presentation of interface point  $I_b$  at B-NT1 or B-NT2 shall be via a socket.

The presentation of interface point  $I_a$  at B-TE or B-NT2 shall be using either:

- a) a socket, i.e. the connection shall be made to the equipment toward the network with a cable with plugs on both ends; or
- b) an integral connecting cord with plug on the free end.

### 8.1.2.5 Safety requirements

For safety reasons, the parameters for IEC 60825-1 [13], Class 1 devices shall not be exceeded even under failure condition.

### 8.1.2.6 Jitter and wander

For both electrical and optical B-UNI, the interface output jitter shall be in accordance with the appropriate limit given in ITU-T Recommendation G.825 [15] for the electrical and optical interface.

Equipments having an electrical or optical B-UNI (e.g. B-NT1, B-NT2, B-TE) and which meet the output jitter tolerance and the jitter transfer specifications given in ITU-T Recommendations G.825 [15] and G.958 [16] respectively, are assured of proper operation when the interface output jitter conforms to the limits in ITU-T Recommendation G.825 [15].

---

## 9 Power feeding

### 9.1 Provision of power

The provision of power to the B-NT1 via the UNI network interface is optional. If the power is provided via the UNI, the following conditions shall apply:

- a separate pair of wires shall be used for the provision of power to the B-NT1 via the  $T_B$  reference point;
- the power sink shall be fed by either:
  - a source under the responsibility of the user when requested by the network provider;
  - a power supply unit under the responsibility of the network provider connected to the mains electric supply in the customer premises.
- the capability of the provision of power by the user side shall be available either:
  - as an integral part of the B-NT2/B-TE; and/or
  - physically separated from the B-NT2/B-TE as an individual power supply unit.
- a power source capable to feed more than one B-NT1 shall meet the requirements at each individual B-NT1 power-feeding interface at the same point in time;
- a short-circuit or overload condition in any B-NT1 shall not affect the power feeding interface of the other B-NT1s.

### 9.2 Power available at B-NT1

The power available at the B-NT1 via the UNI shall be at least 15 W.

### 9.3 Feeding voltage

The feeding voltage at the B-NT1 shall be in the range of -20 V to -57 V relative to ground.

### 9.4 Safety and Protection requirements

#### 9.4.1 Safety

Requirements for safety are outside the scope of the present document. Safety standards are published by CENELEC.

NOTE 1: An example of such a CENELEC product is EN 60950 [14].

NOTE 2: For safety categories of interfaces, see ETSI EG 201 212 [18].

## 9.4.2 Protection

In order to harmonize power source and sink requirements the following is required:

- a) the power source shall be protected against short-circuits and overload;
- b) the power sink of B-NT1 shall not be damaged by an interchange of wires.

---

# 10 Functions provided by the transmission convergence sublayer

## 10.1 Transfer capability

### 10.1.1 Interface at 155 520 kbit/s

The interface bit rate at the  $T_B$  and  $S_B$  reference points shall be 155 520 kbit/s. The bit rate available for the ATM cells (user information cells, signalling cells, OAM cells, unassigned cells and cells used for cell rate decoupling) excluding physical layer overhead cells (physical OAM cells and idle cells) shall be 149 760 kbit/s.

### 10.1.2 Interface at 622 080 kbit/s

The interface bit rate at the  $T_B$  and  $S_B$  reference points shall be 622 080 kbit/s. The bit rate available for the ATM cells (user information cells, signalling cells, OAM cells, unassigned cells and cells used for cell rate decoupling) excluding physical layer overhead cells (physical OAM cells and idle cells) shall be 599 040 kbit/s.

## 10.2 Physical layer aspects

The ATM cell shall be defined as in ITU-T Recommendation I.361 [6].

### 10.2.1 Timing

At the customer side of the interface at the  $T_B$  and  $S_B$  reference points the physical layer may derive its timing from the signal received across the interface or provide it locally by the clock of the customer equipment.

### 10.2.2 Interface structure for 155 520 kbit/s and 622 080 kbit/s

The interface structure consists of a continuous stream of cells. Each cell contains 53 octets. The maximum spacing between successive physical layer cells is 26 ATM layer cells, i.e. after 26 contiguous ATM layer cells have been transmitted, a physical layer cell is inserted in order to adapt the transfer capability to the interface rate. Physical layer cells are also inserted when no ATM layer cells are available.

The physical layer cells, which are inserted, can be either idle cells (see subclause 10.4) or physical layer OAM cells (see subclause 11.2), depending on the OAM requirements. The interface structure for both bit rates is shown in figure 9.





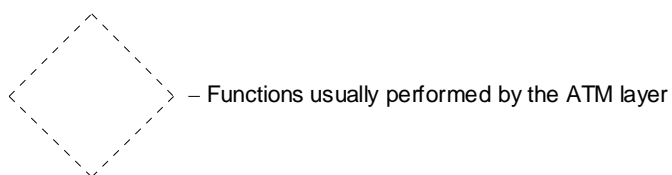
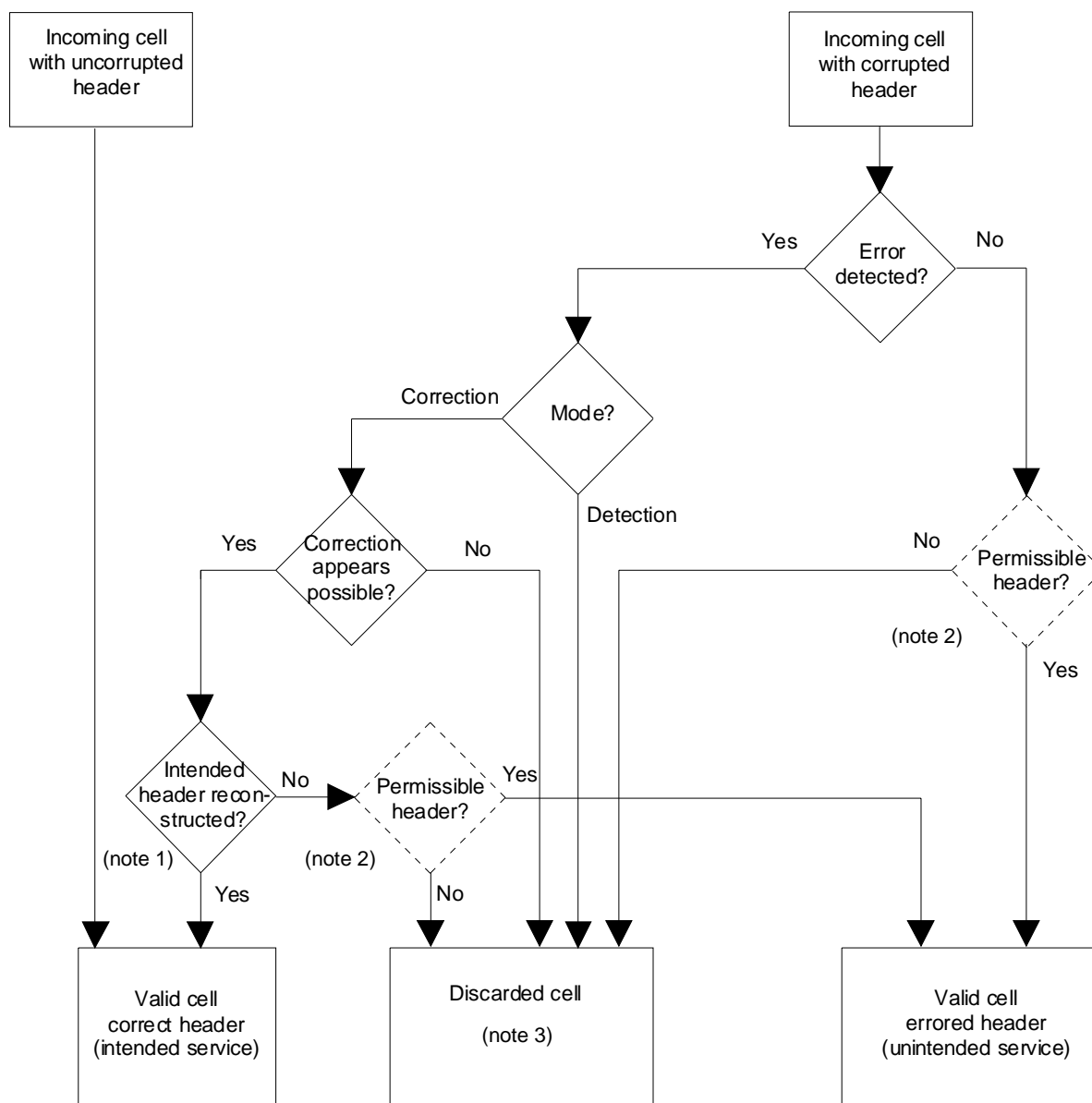

NOTE 1: Intended service means the service requested by the originator, while unintended service means a possible service, but not that required by the originator. Definition of "valid cell": a cell where the header is declared by the header error control process to be free errors (ITU-T Recommendation I.113 [4]).

NOTE 2: An example of an impermissible header is a header whose VPI/VCI is neither allocated to a connection nor pre-assigned to a particular function (idle cell, OAM cell, etc.). In many instances, the ATM layer will decide if the cell header is permissible.

NOTE 3: A cell is discarded if its header is declared to be invalid, or if the header is declared to be valid and the resulting header is impermissible.

**Figure 11: Consequences of errors in ATM cell header**

## 10.3.2 HEC sequence generation

The transmitter calculates the HEC value across the entire ATM cell header and inserts the result in the appropriate header field. The notation used to describe the HEC is based on the property of cyclic codes. (For example code vectors such as "1000000100001" can be represented by a polynomial  $P(x) = x^{12} + x^5 + 1$ ). The elements of a n-element code word are, therefore, the coefficients of a polynomial of order n-1. In this application, these coefficients can have the value 0 or 1 and the polynomial operations are performed using modulo 2 operations. The polynomial representing the content of a header excluding the HEC field is generated using the first bit of a header as the coefficient of the highest order term.

The HEC field shall be an 8-bit sequence. It shall be the remainder of the division (modulo 2) by the generator polynomial  $G(x) = x^8 + x^2 + x + 1$  of the product  $x^8$ , multiplied by the content of the header excluding the HEC field.

At the transmitter, the initial content of the register of the device computing the remainder of the division is pre-set to all 0s and is then modified by division of the header excluding the HEC field by the generator polynomial (as described above); the resulting remainder is transmitted as the 8-bit HEC.

To significantly improve the cell delineation performance in the case of bit-slips, the following is recommended:

- the check bits calculated by the use of the check polynomial are added (modulo 2) to an 8-bit pattern before being inserted in the last octet of the header;
- the recommended pattern is "01010101" (the left bit is the most significant bit);
- the receiver shall subtract (which is equal to add modulo 2) the same pattern from the 8 HEC bits before calculating the syndrome of the header.

This operation in no way affects the error detection/correction capabilities of the HEC. As an example if the first 4 octets of the header were all zeros the generated header before scrambling would be "00000000 00000000 00000000 00000000 01010101". The starting value for the polynomial check is all zeroes.

## 10.4 Idle cells

Idle cells cause no action at a receiving node except for cell delineation including HEC verification. They are inserted and discarded for cell rate decoupling.

Idle cells are identified by the standardized pattern for the cell header shown in table 2.

**Table 2: Header pattern for idle cell identification**

	Octet 1	Octet 2	Octet 3	Octet 4	Octet 5
Header pattern	00000000	00000000	00000000	00000001	HEC = Valid code 01010010

There is no significance to any of these individual fields from the point of view of the ATM layer, as physical layer OAM cells are not passed to the ATM layer.

The content of the information field is "01101010" repeated 48 times.

## 10.5 Cell delineation and scrambling

### 10.5.1 Cell delineation and scrambling objectives

Cell delineation is the process, which allows identification of the cell boundaries. The ATM cell header contains a HEC field, which is used to achieve cell delineation. The ATM signal is required to be self-supporting in the sense that it has to be transparently transported on every network interface without any constraints from the transmission systems used. Scrambling shall be used to improve the security and robustness of the HEC cell delineation mechanism as described in subclause 10.5.3. In addition it helps randomizing the data in the information field for possible improvement of the transmission performance.

### 10.5.1.1 Cell delineation algorithm

Cell delineation shall be performed by using the correlation between the header bits to be protected (32 bits) and the relevant control bits (8 bits) introduced in the header by the HEC using a shortened cyclic code with generating polynomial  $G(x) = x^8 + x^2 + x + 1$ .

Figure 12 shows the state diagram of the HEC cell delineation method.

NOTE: During the Acquisition and Verification states, only the last six bits of the HEC field are to be used for cell delineation checking, and all eight thereafter.

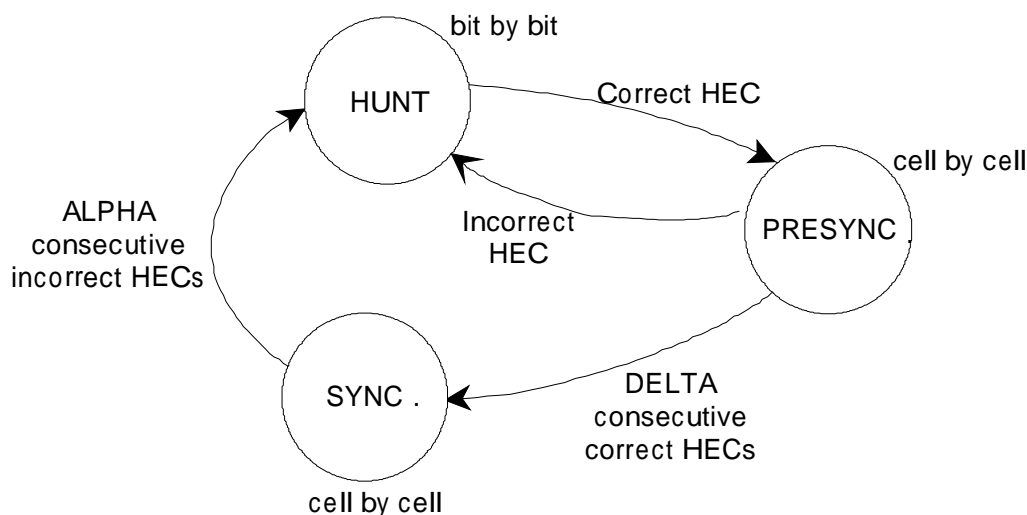

NOTE: The "correct HEC" means the header has no bit errors (syndrome is zero) and has not been corrected.

**Figure 12: Cell delineation state diagram**

The details of the state diagram are described below:

- 1) In the HUNT state, the delineation process is performed by checking bit by bit for the correct HEC (i.e. syndrome equals zero) for the assumed header field. Prior to descrambler synchronization, only the last six bits of the HEC are to be used for cell delineation checking. Once such an agreement is found, it is assumed that one header has been found, and the process enters the PRESYNC state. When octet boundaries are available within the receiving physical layer prior to cell delineation, the cell delineation process may be performed octet by octet.
- 2) In the PRESYNC state, the delineation process is performed by checking cell by cell for the correct HEC. Prior to descrambler synchronization, only the last six bits of the HEC field are to be used for cell delineation checking. The process repeats until the correct HEC has been confirmed DELTA times consecutively at which point the process moves to the SYNC state. If an incorrect HEC is found, the process returns to the HUNT state. The total number of consecutive correct HEC required to move from the HUNT state to the SYNC state is therefore DELTA + 1.
- 3) In the SYNC state, the cell delineation will be assumed to be lost if an incorrect HEC is obtained ALPHA times consecutively.
- 4) Cells with correct HECs (or cell headers with single bit errors, which are corrected) that are processed while the SYNC state shall be passed to the ATM layer provided the descrambler is in Steady state. Idle cells and physical layer OAM cells are not passed to the ATM layer.

The parameters ALPHA and DELTA shall be chosen to make the cell delineation process as robust and secure as possible, while satisfying the performance specified in subclause 10.5.2. Robustness against false indication of misalignments due to bit errors in the channel depends on ALPHA. Robustness against false delineation in the resynchronization process depends on the value of DELTA.

The values of ALPHA and DELTA shall be ALPHA = 7 and DELTA = 8.

## 10.5.2 Cell delineation performance

Figures A.1 and A.2 give provisional information on the performance of the cell delineation algorithm described in subclause 10.5.1.1 in the presence of random bit errors, for various values of ALPHA and DELTA.

## 10.5.3 Scrambler operation

The Distributed Sample Scrambler (DSS) is used for the cell based UNI.

The Distributed Sample Scrambler (DSS) is an additive scrambler that does not introduce error multiplication, and is of sufficiently high performance that an underlying PMD sub-layer can rely on it to provide a high degree of randomization.

### 10.5.3.1 Distributed Sample Scrambler (31<sup>st</sup> order) operation

The Distributed Sample Scrambler (DSS) is an example of a class of scrambler in which randomization of the transmitted data stream is achieved by modulo addition of a Pseudo Random Binary Sequence (PRBS). Descrambling at the receiver is achieved by modulo addition of an identical locally generated pseudo-random sequence having phase synchronization with the first in respect of the transmitted cells. The descrambler does not affect the performance of the 8 bit HEC mechanism during steady state operation.

Phase synchronization of a receiver PRBS with polynomial generator order  $r$  is achieved by sending  $r$  linearly independent source PRBS samples through the transmission channel as conveyed data samples. When received without error these  $r$  samples are sufficient to synchronize the phase of the PRBS generator at the receiver to that of the transmitter PRBS generator.

A simple timing skew between the source PRBS samples and the conveyed PRBS samples serves as a means of decoupling the sample times of the source PRBS samples from the conveyed PRBS samples. This enables linearly independent PRBS samples and faster synchronization to be achieved, simply by taking samples at equal intervals of half an ATM cell (212 bits) from the source PRBS generator.

### 10.5.3.2 Transmitter operation

The transmitter pseudo random binary sequence is added (modulo 2) to the complete cell bit by bit excepting the HEC field. The pseudo random sequence polynomial is:

$$x^{31} + x^{28} + 1$$

The HEC field for each cell is then modified by modulo 2 addition of the HEC calculated on the 32 bit of the scrambler sequence coincident with the first 32 header bits. This is equivalent to calculation of the HEC on the first 32 bits of the scrambled header. The first two bits of the HEC field are then modified, as follows, by two bits from the PRBS generator. The two bits from the PRBS generator will be referred to as the PRBS source bits and the two bits of the HEC field onto which they are mapped will be referred to as the PRBS transport bits.

To the first HEC bit (HEC<sub>8</sub>) is added (modulo 2) the value of PRBS generator that was added (modulo 2) 211 bits earlier to the previous cell payload. To the second bit of the HEC field is added (modulo 2) the current value of the PRBS generator. These samples are exactly half a cell apart (212 bits) and the first (U<sub>t-211</sub>) is delayed by 211 bits before conveyance (requiring a one bit store) (where 211 bits is 1 bit less than half a cell).

PRBS phase (as added to payload and all header except HEC).

U <sub>t-1</sub>	U <sub>t</sub>	U <sub>t+1</sub>	U <sub>t+2</sub>	U <sub>t+3</sub>	U <sub>t+4</sub>	U <sub>t+5</sub>	U <sub>t+6</sub>	U <sub>t+7</sub>	U <sub>t+8</sub>	U <sub>t+9</sub>
------------------	----------------	------------------	------------------	------------------	------------------	------------------	------------------	------------------	------------------	------------------

Resultant transmitted data element:

CLP	HEC <sub>8</sub>	HEC <sub>7</sub>							1 <sup>st</sup> payload bit	2 <sup>nd</sup> payload bit
+	+	+	HEC <sub>6</sub>	HEC <sub>5</sub>	HEC <sub>4</sub>	HEC <sub>3</sub>	HEC <sub>2</sub>	HEC <sub>1</sub>	+	+
U <sub>t-1</sub>	U <sub>t-211</sub>	U <sub>t+1</sub>							U <sub>t+8</sub>	U <sub>t+9</sub>

### 10.5.3.3 Receiver operation

Three basic states of receiver operation are defined (see figure 13):

- 1) acquisition of scrambler synchronization (following cell delineation);
- 2) verification of scrambler synchronization;
- 3) steady state operation.

#### **Receiver state 1): Acquisition of scrambler synchronization (following cell delineation)**

The principle of operation is as follows:

##### **Cell delineation**

The cell delineation mechanism is independent of the descrambler synchronization mechanism. However while the descrambler is in Acquisition or Verification states, the cell delineation is determined by using only the last six bits of the HEC field. This is because the first two bits of the HEC field have been modified by modulo 2 addition of the conveyed data samples and cannot therefore be used in delineation or HEC evaluation until the descrambler is synchronized (Steady state).

When the cell delineation process returns to HUNT state, the descrambler process shall return to Acquisition state.

##### **Acquisition of scrambler synchronization**

In Acquisition state, the conveyed bits ( $U_{t-211}$ ,  $U_{t+1}$ ) are extracted by modulo 2 addition of the predicted values for  $HEC_8$  and  $HEC_7$  to the received values. The predicted values correspond to bits  $HEC_8$  and  $HEC_7$  of the HEC value calculated over the first four octets of the received header.

Scrambler synchronization may for example be achieved by comparing the conveyed sample, every half-cell interval (212 bits), with the local bit generated by a recursive descrambler (see figure B.1). If these two bits are not identical, a constant correction vector is applied to the recursive descrambler through feed-forward taps. At time  $t$ , the sample conveyed in  $HEC_8$  ( $U_{t-211}$ ) is compared to the descrambler bit  $V_{t-211}$  that has been stored for 211 bits. At time  $t+212$ , the sample conveyed in  $HEC_7$  ( $U_{t+1}$ ) is compared to the descrambler bit  $V_{t+1}$  generated at time  $t+1$  (both  $U_{t+1}$  and  $V_{t+1}$  have been stored for 211 bits).

Because both samples are applied to the recursive descrambler 211 bits behind their point of modulo 2 addition to the transmitted data sequence, the recursive descrambler feed-forward taps are chosen to generate a sequence that is advanced by 211 samples. Similarly, the verification comparisons made in the recursive descrambler between the conveyed bits and their prediction is delay equalized using one bit stores as illustrated in figure B.1.

##### **Time to achieve descrambler synchronization**

Two bit samples are conveyed per cell, which are linearly independent. The minimum number of consecutive error free conveyed samples needed to synchronize the descrambler is equal to the degree of the scrambler polynomial, therefore, 16 cells provide the 31 samples necessary to synchronize the descrambler.

The descrambler synchronization process is not disabled during cell delineation, however, the descrambler will not begin to converge until the cell delineation mechanism has located the true position of the HEC field in the header and is no longer in its HUNT state. Therefore, the start of descrambler synchronization acquisition convergence will be coincident with the final transition from the HUNT state to the PRESYNC state of the cell delineation mechanism.

#### **Receiver state 2): Verification of descrambler synchronization**

The Verification state differs from the Acquisition state in that the recursive descrambler is no longer modified with synchronizing samples. Verification is needed because errors undetectable by the 6 bits HEC check may have occurred in the conveyed bits during the Acquisition phase. Verification tests the predicted PRBS in the receiver against the remote reference sequence given by the conveyed samples. To verify descrambler Acquisition phase overall such that the probability of false synchronization is less than  $10^{-6}$ , requires 16 verifications where the transmission error ratio is better than  $10^{-3}$ .

### Receiver state 3): Steady state operation (synchronized descrambler)

In this state the HEC<sub>8</sub> and HEC<sub>7</sub> bits can both be returned to normal use following their descrambling by the locally generated bits ( $V_{t-211}$ ,  $V_{t+1}$ ). Properties of error detection and correction are not affected by this process.

Both cell delineation and descrambler synchronization robustness to channel bit-slip are reliably monitored in this state by the existing cell delineation state machine. When the cell delineation process returns to HUNT state, the descrambler process shall return to Acquisition state.

### HEC regeneration and header scrambling

The HEC bits in the transmitted cell were modified prior to transmission to correspond to the HEC for the scrambled header. Optionally, to reverse this process where required and regenerate an HEC that corresponds to the unscrambled header, the HEC bits may be modified by modulo 2 addition of the CRC calculated on the 32 bits of the descrambler sequence coincident with the first 32 header bits.

### 10.5.3.4 State transition diagram and mechanism

The three states of the descrambler are:

- 1) acquisition;
- 2) verification; and
- 3) steady state.

The transition between these states may be determined by reference to the value of a single confidence counter (C) as follows:

initial state = acquisition, confidence counter initial value = 0.

#### **State 1: acquisition: confidence counter range 0 to X-1**

For every cell received correctly with no errors detected in HEC bits 1 to 6 the confidence counter is incremented by one and the two conveyed bits used to drive the recursive descrambler into synchronization.

Any error detected in the cell header results in a return to the initial state (the confidence counter being reset to zero).

Transition to the Verification state occurs when the confidence counter reaches X (X = 16).

#### **State 2: verification: confidence counter range X to Y-1**

For every cell received without detected errors in HEC bits 1 to 6, the two conveyed bits are compared to their predicted values. For each cell with two correct predictions received, the confidence counter is incremented. If one or two incorrect predictions are made then the counter is decremented. If the counter falls below V (V = 8) the system returns to the Acquisition initial state 1 and the confidence counter is reset.

Transition to the Steady state occurs when the counter reaches Y (Y = 24).

#### **State 3: steady state: confidence counter range Y to Z**

When the cell delineation process detects a non-zero syndrome with error bits confined to HEC<sub>8</sub> and HEC<sub>7</sub> the confidence counter is decremented, else it is incremented. The Acquisition state is returned to automatically should the counter drop below W (W = 16). The confidence counter has an upper limit of Z (Z = 24). The descrambler shall also return to the Acquisition state if the cell delineation process returns to HUNT state.

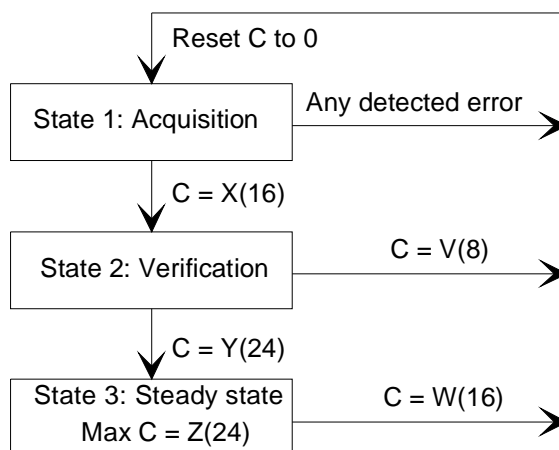

Figure 13: State transition diagram

## 11 UNI related OAM functions

The following OAM functions associated with the UNI have been identified and are described in ITU-T Recommendation I.610 [10] (with the amendments detailed in ETSI ETS 300 404 [12]):

- 1) transmission and reception of maintenance signals (e.g. Alarm Indication Signal (AIS) and Remote Defect Indication (RDI) signal);
- 2) performance monitoring;
- 3) control communications provisions.

Some overhead capacity needs to be allocated to these functions.

### 11.1 Transmission overhead allocation

Physical layer OAM cells are used for the conveyance of the physical layer OAM information. How often OAM cells are inserted should be determined by OAM requirements. However there can be no more than one physical layer OAM cell every 27 cells and not be less than one physical layer OAM cell every 513 cells per flow in operational status. It is recognized that during some phases, for example start up, it would be desirable to increase the insertion rate of the physical layer OAM cell for improving the system response. These spacings would apply only when the flow is actually implemented; it is recognized that not all applications will require implementations of all flows.

### 11.2 OAM cell identification

ITU-T Recommendation I.610 [10] identifies three types of physical layer OAM flows carried by maintenance cells using a specific pattern in the header:

- F1: regenerator level;
- F2: digital section level;
- F3: transmission path level.

The F1 cell carries the OAM functions for the regenerator level.

These physical layer OAM cells are inserted in the cell flow on a recurrent basis. If these physical layer OAM cells have to take priority over an ATM cell, this has to be done without restricting ATM layer transfer capability. The minimum periodicity of the cell is defined by the requirements on availability of the section as one F3 cell in 513 cells for the 622 080 kbit/s bit rate and as one F3 cell in 377 cells for the 155 520 kbit/s bit rate.



The OAM flow F2 is not used and the corresponding functions are supported by the F3 OAM flow because there is no frame multiplexing in the cell based physical layer and consequently, only two flows are needed, but the numbering is made with reference to the corresponding OAM flows for the SDH physical layer.

The F3 cell carries the OAM functions for the transmission path level. These physical layer OAM cells are inserted in the cell flow on a recurrent basis. If these physical layer OAM cells have to take priority over an ATM cell, this has to be done without restricting ATM layer transfer capability. The minimum periodicity of the cell is defined by the requirements on availability of the path as one F3 cell in 513 cells for the 622 080 kbit/s bit rate and as one F3 cell in 377 cells for the 155 520 kbit/s bit rate.

The physical layer OAM cells shall have a unique header so that they can be properly identified by the physical layer at the receiver. The patterns to be used are shown in table 3 (see note in table). The header patterns shown are given prior to scrambling.

**Table 3: Header pattern for OAM cell identification**

Flow	Octet 1	Octet 2	Octet 3	Octet 4	Octet 5
F1	00000000	00000000	00000000	00000011	HEC = valid code 01011100
F3	00000000	00000000	00000000	00001001	HEC = valid code 01101010
NOTE: There is no significance to any of these individual fields from the point of view of the ATM layer, as physical layer OAM cells are not passed to the ATM layer.					

### 11.3 Allocation of OAM functions in information field

When the OAM flows are implemented, the OAM cells can only be inserted as part of the Physical Layer cells, which are used to adapt the transfer capability to the interface rate. The OAM cells shall not be inserted at any other time in the cell flow.

The octet allocation for the F1 physical layer OAM and F3 physical layer OAM cells is shown in table 4.

**Table 4: Allocation of OAM functions in information field**

1	R	25	R
2	AIS (note 1)	26	R
3	PSN	27	R
4	R	28	R
5	R	29	R
6	R	30	RDI
7	R	31	R
8	EDC-B1	32	R
9	EDC-B2	33	R
10	EDC-B3	34	R
11	EDC-B4	35	R
12	EDC-B5	36	R
13	EDC-B6	37	R
14	EDC-B7	38	R
15	EDC-B8	39	R
16	R	40	R
17	R	41	R
18	R	42	R
19	R	43	R
20	R	44	R
21	R	45	R
22	R	46	REB
23	R	47	CEC (2) (note 2)
24	R	48	CEC (8) (note 2)
NOTE 1: for F1 OAM cells, this byte is coded 6A hexa.			
NOTE 2: MSB is bit 2 of byte 47 and LSB is bit 1 of byte 48. Bits 3 to 8 of byte 47 are set to 0.			
NOTE 3: Value in parentheses indicates the number of bits used.			

The following fields are identified for both F1 and F3 flows:

**Physical layer OAM Sequence Number (PSN):** Is designed to have a sufficiently large cycle compared with the duration of cell loss and insertion. 8 bits are allocated to the PSN. The counting is then done modulo 256.

**Error Detection Code (EDC):** This code is a Bit Interleaved Parity 8 (BIP8) calculated on a block of MBS (Monitoring Block Size) cells repeated for each monitored block. The number of monitored blocks is equal to 8. The field EDC-Bn corresponds to the BIP-8 calculated on the monitored block number n.

For the 155 520 kbit/s interface MBS=27. For the 622 080 kbit/s interface MBS = 54. For F3 cell number n (F1 cell number n), the first monitored block begins with the first cell following the F3 cell number n-1 (F1 cell number n-1). The last monitored block ends at the end of the F3 cell number n (F1 cell number n).

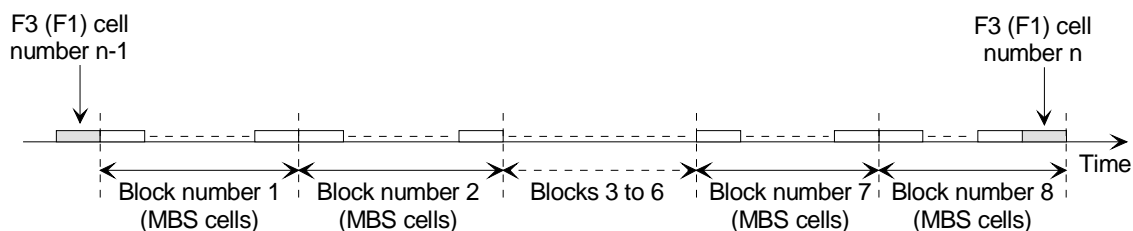

**Figure 14: Definition of the monitored block boundaries**

F1 and F3 OAM cells are not taken into account by the BIP-8 calculation. This means the BIP-8 calculation is stopped during F1 and F3 OAM cells. For the other cells (ATM layer cells and idle cells) the BIP-8 is calculated only on the cell payload before the scrambling is performed.

An octet is allocated for each EDC-Bn field. Each bit of the EDC-Bn field is equal to the BIP calculated on the same range bits of each monitored octet (i.e. the Most Significant Bit of each EDC-Bn octet is equal to the BIP calculated on the Most Significant Bit of each monitored octet).

**Remote Errored Blocks (REB):** Indicates to the far end the total number of errored blocks between two consecutive F1 or F3 OAM cells in accordance with anomalies a1 to a4 defined in annex D of ITU-T Recommendation G.826 [17]. For F3 OAM cells, the REB field shall be the value of a running counter (modulo 256) increased periodically by the number of errored blocks detected in one direction of transmission (in accordance with G.826 [17] Annex D). The value of this running counter shall be put in the REB field of each F3 OAM cell being sent in the opposite direction. By subtracting the values contained in the REB fields of two consecutively received valid F3 OAM cells (i.e. CEC field indicates a valid cell payload), the receiving system knows the total number of errored blocks measured by the far end system. This mechanism is identical for F1 OAM cells.

**Path Alarm Indication Signal (P-AIS):** This field is used only in the F3 OAM cells to alert the equipment in the direction of transmission that a failure has been detected. The coding of this field is as follows:

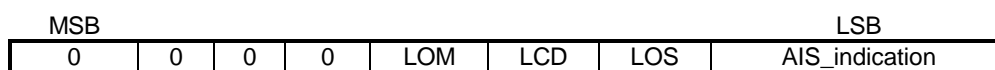

When a defect is detected (LOM, LCD or LOS), the corresponding bit is set to 1, else it is set to 0. When at least one defect is detected, the AIS\_indication bit is set to 1, else it is set to 0. For the F1 OAM cells, this field is reserved and coded 6A hexa.

**Path Remote Defect Indication (P-RDI) and Section Remote Defect Indication (S-RDI):** This field is used to alert the upstream equipment in the opposite direction of transmission that a defect has been detected along the downstream path. For the F1 flow the possible defects are LOM, LCD and LOS. For the F3 flow the possible defects are P\_AIS, LOM, LCD and LOS. The coding of this field is as follows:

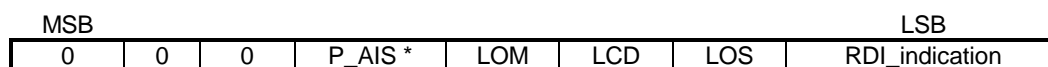

(\*) P\_AIS defect is only used in F3 OAM flow.

**Cell Error Control (CEC):** CEC is used to detect errors in the cell payload. A CRC 10 is used:

$$G(x) = x^{10} + x^9 + x^5 + x^4 + x + 1.$$

**Reserved field (R):** Contains the octet pattern of "0110 1010", which is the same as that of the idle cells.

## 11.4 Maintenance signals

The following maintenance signals are defined:

**Path Alarm Indication Signal (P-AIS):** This is used to alert the associated termination point in the direction of transmission that a defect has been detected and alarmed. The P-AIS indication signal is set when a LOS, LCD or LOM defect is detected at the section level.

**Path Remote Defect Indication (P-RDI):** This is provided to alert the equipment in the opposite direction of transmission that a defect has been detected along the path. It is set when a LCD, LOM, LOS or AIS signal has been detected at the path level. The time to set this signal needs to be as short as possible, but long enough to filter intermittent defect information. This time is to be defined. LCD is provided by the cell delineation algorithm. The time to indicate this state is to be defined. Loss of one OAM cell is detected when no F3 OAM cell is received when the maximum space between two F3 OAM cells is exceeded. A LOM is detected when two successive anomalies loss of one F3 OAM cell are detected. The method of detection of the AIS condition is for further study.

**Section Remote Defect Indication (S-RDI):** This is provided to alert the equipment in the opposite direction of transmission that a defect has been detected along the path. It is set when a LCD, LOM, LOS or unacceptable error performance has been detected at the regenerator section level. The time to set this signal needs to be as short as possible but long enough to filter intermittent defect information. This time is to be defined. LCD is provided by the cell delineation algorithm. The time to indicate this state is to be defined. Loss of one OAM cell is detected when no F1 OAM cell is received when the maximum space between two F1 OAM cells is exceeded. A LOM is detected when two successive anomalies Loss of one F1 OAM cell are detected. The method of detection of unacceptable error performance requires further study.

## 11.5 Transmission performance monitoring

Transmission performance monitoring across the UNI is performed to detect and report transmission errors. At the transmission path (F3) level, this function is performed on the ATM layer cells and idle cells. At the regenerator section (F1) level this function is performed on ATM layer cells, idle cells and higher-level PL-OAM cells. The PL-OAM cell carries the result for the monitoring of a certain number of blocks:

**error performance reporting:** This function reports to the equipment in the opposite direction of transmission, the results of the path error monitoring carried out (RDI). For a BIP, it gives the number of parity violations in each block, calculated at the receiving end by comparison with the result carried by the cell.

## 11.6 Control communication

The provision of a data communication channel is for further study.

# 12 Operational functions

## 12.1 Description of signals at the interface

### 12.1.1 Signals defined in ITU-T Recommendation I.610

The following signals related to maintenance are defined below:

- indication of LOS and LCD are generated within the functional equipment;

- Path-AIS, Section-RDI, Path-RDI are signals transmitted/received across the B-UNI.

**Loss of Signal (LOS):** LOS is considered to have occurred when the amplitude of the relevant signal has dropped below prescribed limits for a prescribed period.

**Loss of Maintenance flow (LOM):** Loss of one OAM cell is detected when no F3 or F1 OAM cell is received when the maximum space between two F3 or F1 OAM cells is exceeded. The defect LOM is declared when two successive anomalies Loss of one F3 or F1 OAM cell are detected.

**Path Alarm Indication Signal (P-AIS):** P-AIS is sent to alert equipment in the direction of transmission that a failure has been detected. P-AIS is octet 2 of the F3 physical layer OAM cell payload. The coding of P-AIS field for LOS, LCD and LOM defects is indicated in subclause 11.3.

**Section Remote Defect Indication (S-RDI):** S-RDI alerts equipment in the opposite direction of transmission that a defect has been detected. S-RDI is octet 30 of the F1 physical layer OAM cell payload. The coding of S-RDI field for LOS, LCD and LOM defects is indicated in subclause 11.3.

**Path Remote Defect Indication (P-RDI):** P-RDI alerts the associated path terminating equipment that a defect in the direction of transmission has been declared along the path. P-RDI is octet 30 of the F3 physical layer OAM cell payload. The coding of the P-RDI field for LOS, LCD, LOM and P-AIS is indicated in subclause 11.3.

### 12.1.2 Cell delineation signals

**Out of Cell Delineation (OCD):** an OCD anomaly occurs when the cell delineation process changes from SYNC to HUNT state while in working state (see figure 12). An OCD anomaly terminates when the PRESYNC to SYNC state transition occurs (see figure 12) or when the OCD anomaly persists and the LCD maintenance state is entered (see below).

**Loss of Cell Delineation (LCD):** an LCD defect occurs when an OCD anomaly (see above) has persisted for x milliseconds. An LCD defect terminates when the cell delineation process (refer to figure 12) enters and remains in the SYNC state for x continuous milliseconds. The value of x shall be in the range 1 to 4 for Cell-based UNIs.

## 12.2 Definitions of state tables at network and user sides

The user side and network side of the interface have to inform each other of the layer 1 states in relation to the different defects that could be detected.

For the purpose, two state tables are defined, one at the user side and one at the network side. States at the user side (F states) are defined in subclause 12.2.1 and states at the network side (G states) are defined in subclause 12.2.2. The state tables are defined in subclause 12.2.4.

Fault conditions FC1 to FC4 that could occur at the network side or between the network side and user side are defined in figure 15. These fault conditions directly affect the F and G states. Information on these fault conditions is exchanged between the user and network sides in the form of signals defined in subclause 12.1.

NOTE 1: Only stable states needed for OAM of the user and the network side of the interface (system reactions, user and network relevant information) are defined. The transient states relative to the detections of the error information are not taken into account, except for power on/off states F6 and G13.

NOTE 2: The user does not need to know where a failure is located in the network. The user should be informed on the availability and the continuity of the layer 1 service.

NOTE 3: The user has all information relative to the performance associated with each direction of its adjacent section. The supervision of the quality of this section is the user's responsibility.

### 12.2.1 Layer 1 states on the user side of the interface

**F0 state: loss of power on the user side:**

- in general, the TE can neither transmit nor receive signals.

**F1 state: operational state:**

- network timing and layer 1 service is available;
- the user side transmits and receives operational cells.

**F2 state: fault condition No. 1:**

- this fault state corresponds to the fault condition FC1;
- network timing is available at the user side;
- the user side transmits operational cells;
- the user side receives physical layer OAM cells containing P-RDI indication and not S-RDI.

**F3 state: fault condition No. 2:**

- this fault state corresponds to any combination of FC2 with FC1, FC3 and FC4;
- network timing may no longer be available through the link;
- the user side detects LOS, LCD;
- the user side transmits physical layer OAM cells with associated S-RDI and P-RDI.

**F4 state:**

- this fault state corresponds to fault condition FC3, or FC1 and FC3, or FC3 and FC4;
- network timing may no longer be available through the link;
- the user side detects P-AIS or LCD;
- the user side transmits physical layer OAM cells containing P-RDI indication.

**F5 state: fault condition No. 4:**

- this fault state corresponds to the fault condition FC4 or FC1 and FC4;
- network timing is available at the user side;
- the user side transmits operational cells;
- the user side receives physical layer OAM cells containing S-RDI and P-RDI indications.

**F6 state:**

- this fault corresponds to fault conditions FC3 + FC4 or FC3 + FC4 + FC1;
- network timing may no longer be available through the link;
- the user side receives physical layer OAM cells containing S-RDI and P-AIS;
- the user side transmits physical layer OAM cells containing P-RDI.

**F7 state: power on state:**

- this is a transient state and the user side may change the state after detection of the signal received.

## 12.2.2 Layer 1 states at the network side of the interface

**G0 state: loss of power on the network side:**

- in general, the B-NT1 can neither transmit nor receive any signal.

**G1 state: operational state:**

- the network timing and layer 1 service is available;
- the network side transmits and receives operational cells.

**G2 state: fault condition No. 1:**

- this fault state corresponds to the fault condition FC1;
- network timing is provided to the user side;
- the path terminating equipment within the access network detects LOS or LCD;
- the network side transmits physical layer OAM cells containing P-RDI indication and not S-RDI.

**G3 state: fault condition No. 2:**

- this fault state corresponds to the fault condition FC2;
- network timing may no longer be available through the link;
- the network side transmits operational cells;
- the network side receives physical layer OAM cells containing S-RDI and P-RDI indications.

**G4 state: fault condition No. 3:**

- this fault state corresponds to the fault condition FC3;
- network timing is not provided to the user side;
- the B-NT1 detects LOS from the access network;
- the network side transmits P-AIS;
- the network side receives physical layer OAM cells containing P-RDI indication.

**G5 state:**

- this fault state corresponds to the fault condition FC4 or FC2 and FC4;
- The network side detects LOS, LCD or LOM;
- the network side transmits physical layer OAM cells containing S-RDI and P-RDI indication to the user side.

**G6 state:**

- this fault state corresponds to fault conditions FC1 and FC2;
- network timing may no longer be available through the link;
- the network side transmits physical layer OAM cells containing P-RDI indication;
- the B-NT1 receives S-RDI and P-RDI indications from the user side and the path terminating equipment detects LOS or LCD.

**G7 state:**

- this fault state corresponds to fault conditions FC1 and FC3;
- network timing may no longer be available through the link;
- the network side transmits physical layer OAM cells containing P-AIS indication;
- the network side receives physical layer OAM cells containing P-RDI.

**G8 state:**

- this fault state corresponds to fault conditions FC1 and FC4 or FC1 and FC2 and FC4;
- the network side transmits physical layer OAM cells containing S-RDI and P-RDI indications to the user side.

**G9 state:**

- this fault state corresponds to fault conditions FC2 and FC3;
- network timing may no longer be available through the link;
- the network side transmits physical layer OAM cells containing P-AIS;
- the network side receives physical layer OAM cells containing S-RDI and P-RDI indications.

**G10 state:**

- this fault state corresponds to fault conditions FC3 and FC4 or FC2 and FC3 and FC4;
- network timing is not provided to the user side;
- the network side transmits physical layer OAM cells containing P-AIS and S-RDI indication to the user side.

**G11 state:**

- this fault state corresponds to fault conditions FC1 and FC2 and FC3;
- network timing may no longer be available through the link;
- the network side transmits P-AIS to the user side;
- the network side receives physical layer OAM cells containing S-RDI and P-RDI indications.

**G12 state:**

- this fault state corresponds to fault conditions FC1 and FC3 and FC4 or FC1 and FC2 and FC3 and FC4;
- network timing may no longer be available through the link;
- the network side transmits physical layer OAM cells containing P-AIS and S-RDI to the user side.

**G13 state: power on state:**

- this is a transient state and the network side may change the state after detection of the signal received.

### 12.2.3 Definition of primitives

The following primitives should be used between the physical media dependent layer and the management entity (Management Physical Header (MPH) and the upper layer (Physical Header (PH)) primitives):

MPH-AI	MPH Activate Indication (is used as error recovery and initialization information;
MPH-DI	MPH Deactivate Indication;
MPH-EIn	MPH Error Indication with parameter n (n defines the failure condition relevant to the reported error);
MPH-CIn	MPH Correction Indication with parameter n (n defines the failure condition relevant to the reported recovery);
PH-AI	PH Active Indication;
PH-DI	PH Deactivate Indication.

## 12.2.4 State tables

Operational functions are defined in table 5 for the layer 1 states at the user side of the interface and in table 6 for the network side.

### General information for the state table matrix consideration

Explanations of the symbols used in the table:

/	Impossible situation	-	No state change
x / y F/Gz	Issue x to upper level Issue management primitive y Go to state F/Gz	n.d.p.	no detection possible (remains in the same state)

Location of fault conditions:

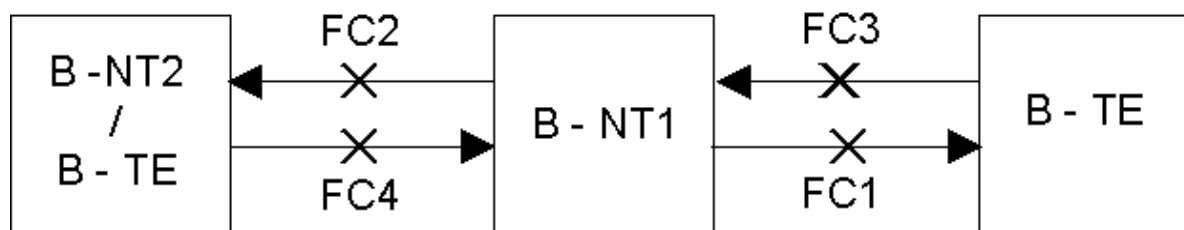

Fault condition	Definition
FC4	Fault in the upstream direction of the interface.
FC2	Fault in the downstream direction of the interface.
FC3	Fault in the downstream direction in access digital section.
FC1	Fault in the upstream direction in access digital section.

**Figure 15: Fault conditions and operational span of section path maintenance signals**



Table 5: F-State table: physical layer 1 state matrix at the user side (note 1)

	Initial state	F0	F1	F2	F3	F4	F5	F6	F7
Definition of the states	Operational condition or fault condition	Power off at user side	Operational	FC1	FC2 fault conditions (note 2)	FC3 or FC1 & FC3	FC4 or FC4 & FC1	FC3 & FC4 or FC3 & FC4 & FC1	Power on at user side
	Signal transmitted by user towards interface	No signal	Normal operational cells	Normal operational cells	Physical layer OAM cells with S-RDI & P-RDI	Physical layer OAM cells with P-RDI	Normal operational cells	Physical layer OAM cells with P-RDI	No signal
New event detected at receiving side	Loss of power at user side	/	PH-DI MPH-EI0 F0	MPH-EI0 F0	MPH-EI0 F0	MPH-EI0 F0	MPH-EI0 F0	MPH-EI0 F0	MPH-EI0 F0
	Return of power to user side	F7	/	/	/	/	/	/	/
	Normal operational cells from network side	/	-	PH-AI MPH-AI F1	PH-AI MPH-AI F1	PH-AI MPH-AI F1	PH-AI MPH-AI F1	PH-AI MPH-AI F1	PH-AI MPH-AI F1
	P-RDI (FC1)	/	PH-DI MPH-EI1 F2	-	ndp	-	-	-	MPH-EI1 F2
	LOS or LCD (FC2) (note 3)	/	PH-DI MPH-EI2 F3	MPH-EI2 F3	-	MPH-EI2 F3	MPH-EI2 F3	MPH-EI2 F3	MPH-EI2 F3
	P-AIS (FC3) or (FC1&FC3) (note 4)	/	PH-DI MPH-EI3 F4	MPH-EI3 F4	ndp	-	MPH-EI3 F4	-	MPH-EI3 F4
	P-RDI and S-RDI (FC4)	/	PH-DI MPH-EI4 F5	MPH-EI4 F5	ndp	MPH-EI4 F5	-	-	MPH-EI4 F5
	P-AIS & S-RDI & P-RDI	/	PH-DI MPH-EI3 MPH-EI4 F6	MPH-EI3 MPH-EI4 F6	ndp	MPH-EI4 F6	MPH-EI3 F6	-	MPH-EI3 & 4 F6

NOTE 1: The user side cannot distinguish between:

- FC2;
- FC2 + FC1;
- FC2 + FC3;
- FC2 + FC4;
- FC2 + FC1 + FC3;
- FC2 + FC1 + FC4;
- FC2 + FC3 + FC4; or
- FC2 + FC1 + FC3 + FC4.

NOTE 2: When FC2 occurs, other fault conditions (FC1 or FC3 or FC4) cannot be detected but they may occur simultaneously.

NOTE 3: When FC3 occurs, FC1 (P-RDI) cannot be detected but it may occur simultaneously.

Table 6: G-state table: physical layer 1 state matrix at the network side

	Initial state	G0	G1	G2	G3	G4	G5	G6	G7	G8	G9	G10	G11	G12	G13
Definition of the states	Operation condition or failure condition	Power off at NT1	Operational	FC1	FC2	FC3	FC4 or FC2 & FC4	FC1 & FC2	FC1 & FC3	FC1 & FC4 or FC1 & FC2 & FC4	FC2 & FC3	FC3 & FC4 or FC2 & FC3 & FC4	FC1 & FC2 & FC3	FC1 & FC3 & FC4 or FC1 & FC2 & FC3 & FC4	Power on at NT1
	Signal transmitted towards interface	No signal	Normal operational signal	Signal with P-RDI	Normal operational signal	Signal with P-AIS	Signal with S-RDI & P-RDI	Signal with P-RDI	Signal with P-AIS	Signal with S-RDI & P-RDI	Signal with P-AIS	Signal with P-AIS & S-RDI	Signal with P-AIS	Signal with P-AIS & S-RDI	No signal
New detected event	Loss of power or power down mode at NT1	–	PH-DI MPH-EI0 G0	MPH-EI0 G0	MPH-EI0 G0	MPH-EI0 G0	MPH-EI0 G0	MPH-EI0 G0	MPH-EI0 G0	MPH-EI0 G0	MPH-EI0 G0	MPH-EI0 G0	MPH-EI0 G0	MPH-EI0 G0	MPH-EI0 G0
	Return of power at NT1	MPH-CI0 G13	/	/	/	/	/	/	/	/	/	/	/	/	/
	Normal operational cells	/	–	PH-AI MPH-AI G1	PH-AI MPH-AI G1	PH-AI MPH-AI G1	PH-AI MPH-AI G1	PH-AI MPH-AI G1	PH-AI MPH-AI G1	PH-AI MPH-AI G1	PH-AI MPH-AI G1	PH-AI MPH-AI G1	PH-AI MPH-AI G1	PH-AI MPH-AI G1	PH-AI MPH-AI G1
New appearing event	Internal network failure FC1	/	PH-DI MPH-EI1 G2	–	MPH-EI1 G6	MPH-EI1 G7	MPH-EI1 G8	–	–	–	MPH-EI1 G11	MPH-EI1 G12	–	–	MPH-EI1 G2
	Reception of S-DRI & P-RDI (FC2)	/	PH-DI MPH-EI2 G3	MPH-EI2 G6	–	MPH-EI2 G9	n.d.p.	–	MPH-EI2 G11	n.d.p.	–	n.d.p.	–	n.d.p.	MPH-EI2 G3
	Internal network failure FC3 (note)	/	PH-DI MPH-EI3 G4	MPH-EI3 G7	MPH-EI3 G9	–	MPH-EI3 G10	MPH-EI3 G11	–	MPH-EI3 G12	–	–	–	–	MPH-EI3 G4
	LOS, LCD or LOM (FC4)	/	PH-DI MPH-EI4 G5	MPH-EI4 G8	MPH-EI4 G5	MPH-EI4 G10	–	MPH-EI4 G8	MPH-EI4 G12	–	MPH-EI4 G10	–	MPH-EI4 G12	–	MPH-EI4 G5
Dis-appearing FC	FC1	/	/	MPH-CI1 G1	/	/	/	MPH-CI1 G3	MPH-CI1 G4	MPH-CI1 G5	/	/	MPH-CI1 G9	MPH-CI1 G10	/
	FC2	/	/	/	MPH-CI2 G1	/	–	MPH-CI2 G2	/	–	MPH-CI2 G4	–	MPH-CI2 G7	–	/
	FC3	/	/	/	/	MPH-CI3 G1	/	/	MPH-CI3 G2	/	MPH-CI3 G3	MPH-CI3 G5	MPH-CI3 G6	MPH-CI3 G8	/
	FC4	/	/	/	/	/	MPH-CI4 G3	/	/	MPH-CI4 G6	/	MPH-CI4 G9	/	MPH-CI4 G11	/
NOTE: If FC3 represents a path related fault condition (e.g. LCD), the consequent reaction is not applicable for the state table, because this failure cannot be recognized at the network side. Therefore, no state change will occur.															

## Annex A (informative): Impact of random bit errors on cell delineation performance

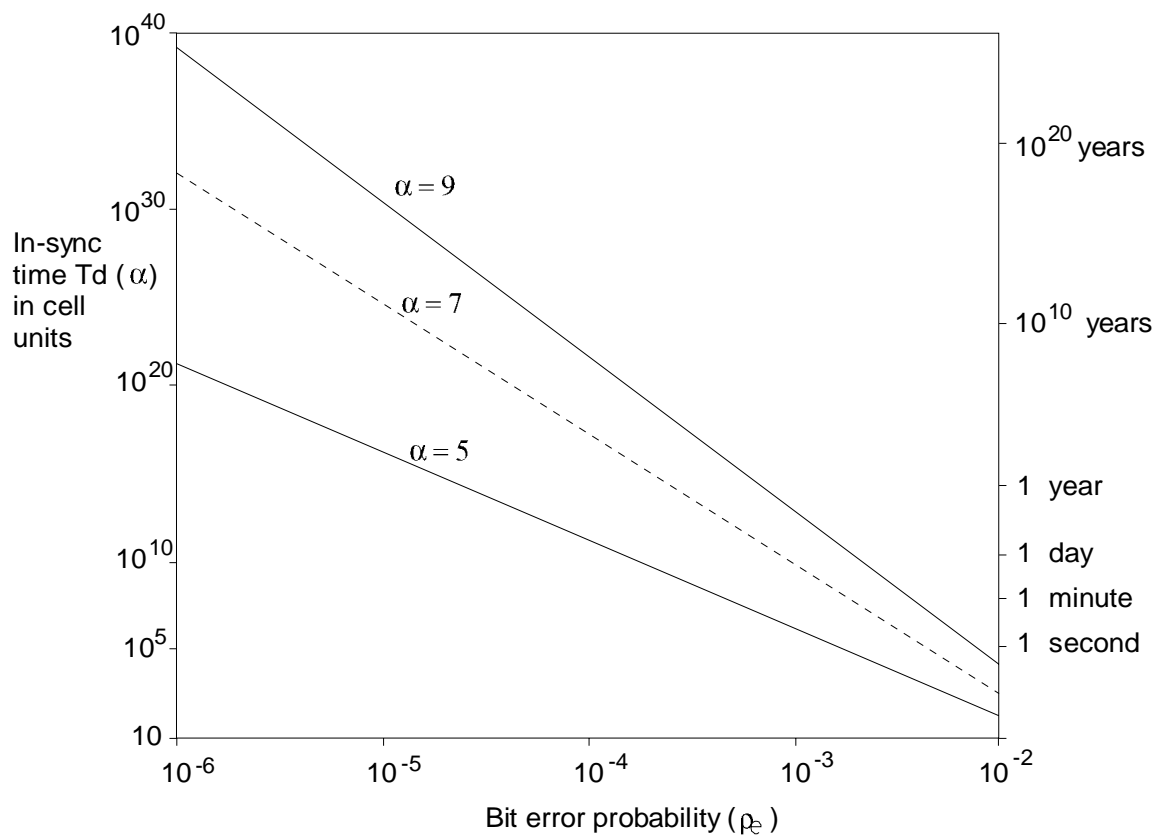

Figure A.1: Mean in-sync time versus bit error probability ( $T_d(\alpha)$  versus  $\rho_e$ )

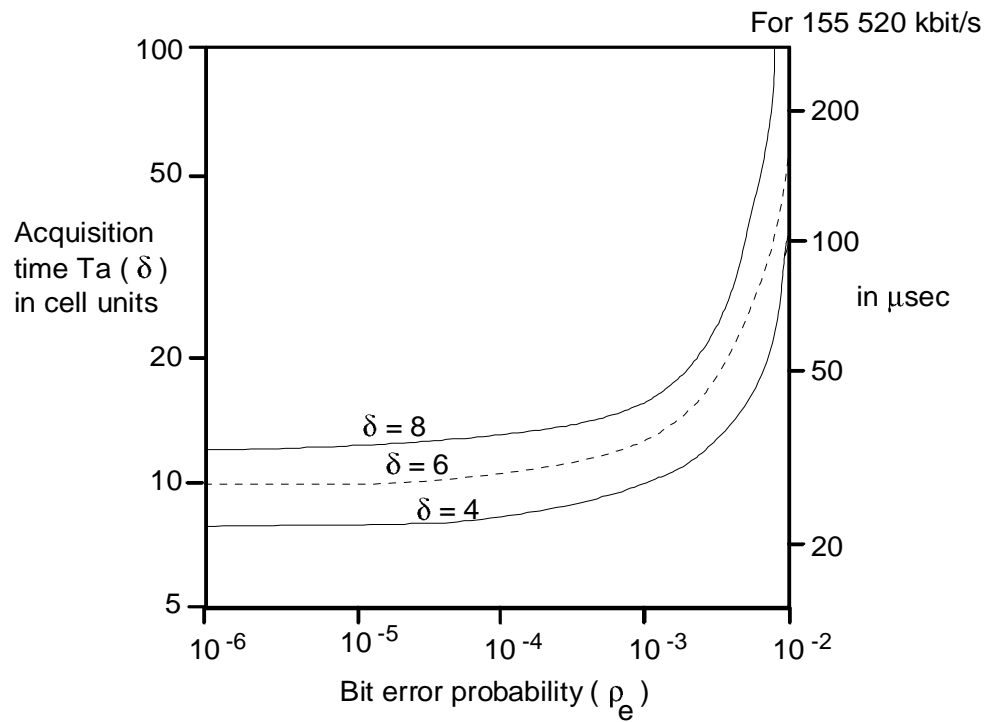

Figure A.2: Mean acquisition time versus bit error probability ( $T_a(\delta)$  versus  $\rho_e$ )

## Annex B (informative): Distributed Sample Scrambler implementation example

### Acquisition of scrambler synchronization

The conveyed bits are extracted by modulo 2 addition of the predicted values for HEC<sub>8</sub> and HEC<sub>7</sub> from the received values. Scrambler synchronization may, for example, be achieved by comparing the conveyed samples ( $U_{t-211}$ ,  $U_{t+1}$ ) at half-cell intervals to the recursive descrambler sequence  $V_t$  (figure B.1). In order to ensure the samples are compared with the recursive descrambler sequence at the same interval they were extracted from the source Pseudo-Random Binary Sequence (PRBS), the second sample  $U_{(t+1)}$  (derived from HEC<sub>7</sub>) is stored for 211 bits before it is used.

Additionally, because both samples are applied to the recursive descrambler 211 bits behind their point of modulo addition to the transmitted data sequence, the recursive descrambler feed-forward taps are chosen to generate a sequence that is advanced by 211 samples. Similarly, the verification comparison made in the recursive descrambler between the conveyed bits and their prediction is delay equalized using one bit stores as illustrated in figure B.1.

EXAMPLE: Implementation: the recursive descrambler.

Figure B.1 illustrates the recursive descrambler implementation. Notation of sample values indicates the important sample values in each cell, time being referenced to the conveyed PRBS sample being received with HEC<sub>8</sub>.

At time  $t$ :

- the receiver PRBS generator sample  $V_t$  is at the input to the lower D-type  $D_2$ ;
- the source PRBS sample  $S_t = U_{t-211}$  conveyed via HEC<sub>8</sub> is at input  $D_1$ ;
- the sample previously stored at the output of the lower D-type is  $Q_2 = V_{t-211}$ .

$$\text{EXOR}_2 = D_1 + Q_2 = U_{t-211} + V_{t-211}.$$

The multiplexer selects this output at time  $t$ . In the Acquisition state the feed-forward taps (constant correction vector) are applied to the descrambler if the AND gate output is high, that is if  $U_{t-211} \neq V_{t-211}$ .

At time  $t+1$ :

- the receiver sample  $V_{t+1}$  is at the input to  $D_2$ ;
- the sample  $S_{t+1} = U_{t+1}$  is at the input to  $D_1$ .

These values are latched on the following clock edge such that:

at time  $t + 2$  through until  $t - 212$ :

- $\text{EXOR}_1 = Q_2 + Q_1 = V_{t+1} + U_{t+1}$ .

The multiplexer selects this output at time  $t+212$ . In the Acquisition state the feed-forward taps (constant correction vector) are applied to the descrambler if the AND gate output is high, that is if  $U_{t+1} \neq V_{t+1}$ .

at time  $t + 213 = L + t - 211$  ( $L$  being the duration of a cell):

- $D_2 = V_{t+213} = V_{t-211+L}$  (which is latched on the following clock edge and held until the next cell cycle).

Figure B.1: Recursive descrambler implementation

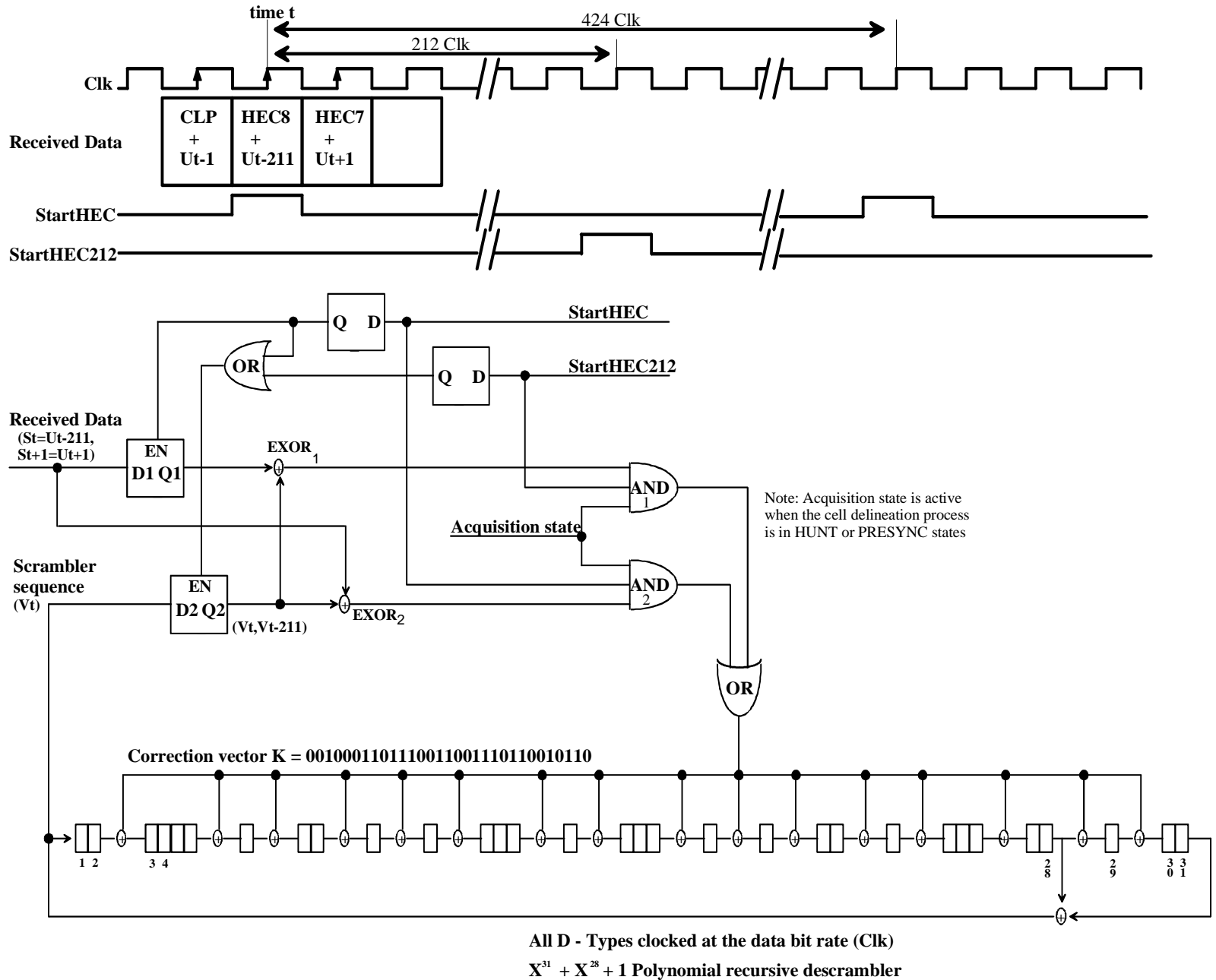

---

## History

<b>Document history</b>		
Edition 1	February 1995	Publication as ETS 300 299
Edition 2	June 1997	Publication as ETS 300 299
V1.3.1	August 1999	Publication
V1.3.2	May 2000	Publication