

Final draft **ETSI EN 300 296-1** V1.1.1 (2000-12)

---

*European Standard (Telecommunications series)*

**Electromagnetic compatibility  
and Radio spectrum Matters (ERM);  
Land Mobile Service;  
Radio equipment using integral antennas  
intended primarily for analogue speech;  
Part 1: Technical characteristics and methods of measurement**

---



---

**Reference**REN/ERM-RP02-042-1

---

---

**Keywords**analogue, mobile, PMR, radio, speech

---

**ETSI**

---

650 Route des Lucioles  
F-06921 Sophia Antipolis Cedex - FRANCE

---

Tel.: +33 4 92 94 42 00 Fax: +33 4 93 65 47 16

Siret N° 348 623 562 00017 - NAF 742 C  
Association à but non lucratif enregistrée à la  
Sous-Préfecture de Grasse (06) N° 7803/88

---

**Important notice**

---

Individual copies of the present document can be downloaded from:

<http://www.etsi.org>

The present document may be made available in more than one electronic version or in print. In any case of existing or perceived difference in contents between such versions, the reference version is the Portable Document Format (PDF). In case of dispute, the reference shall be the printing on ETSI printers of the PDF version kept on a specific network drive within ETSI Secretariat.

Users of the present document should be aware that the document may be subject to revision or change of status. Information on the current status of this and other ETSI documents is available at <http://www.etsi.org/tb/status/>

If you find errors in the present document, send your comment to:  
editor@etsi.fr

---

**Copyright Notification**

---

No part may be reproduced except as authorized by written permission.  
The copyright and the foregoing restriction extend to reproduction in all media.

© European Telecommunications Standards Institute 2000.  
All rights reserved.

# Contents

Intellectual Property Rights .....	7
Foreword .....	7
Introduction.....	8
1 Scope.....	9
2 References.....	9
3 Definitions, abbreviations and symbols .....	10
3.1 Definitions.....	10
3.2 Abbreviations .....	11
3.3 Symbols .....	11
4 General .....	11
4.1 Selection of equipment for testing purposes .....	11
4.2 Mechanical and electrical design.....	11
4.2.1 General .....	11
4.2.2 Controls .....	11
4.2.3 Transmitter shut-off facility.....	11
4.2.4 Marking .....	11
4.3 Interpretation of the measurement results.....	12
5 Technical characteristics .....	12
5.1 Transmitter parameter limits.....	12
5.1.1 Frequency error .....	12
5.1.2 Effective radiated power .....	13
5.1.3 Frequency deviation.....	14
5.1.3.1 Maximum permissible frequency deviation .....	14
5.1.4 Adjacent channel power.....	14
5.1.5 Spurious emissions .....	15
5.1.6 Transient frequency behaviour of the transmitter .....	15
5.2 Receiver parameter limits .....	16
5.2.1 Average usable sensitivity (field strength, speech).....	16
5.2.2 Amplitude characteristic .....	17
5.2.3 Co-channel rejection .....	17
5.2.4 Adjacent channel selectivity.....	17
5.2.5 Spurious response rejection .....	17
5.2.6 Intermodulation response rejection .....	18
5.2.7 Blocking or desensitization .....	18
5.2.8 Spurious radiations.....	18
6 Test conditions, power sources and ambient temperatures .....	19
6.1 Normal and extreme test conditions .....	19
6.2 Test power source.....	19
6.3 Normal test conditions.....	19
6.3.1 Normal temperature and humidity .....	19
6.3.2 Normal test power source.....	19
6.3.2.1 Mains voltage.....	19
6.3.2.2 Regulated lead-acid battery power sources used on vehicles .....	19
6.3.2.3 Other power sources .....	20
6.4 Extreme test conditions.....	20
6.4.1 Extreme temperatures.....	20
6.4.2 Extreme test source voltages .....	20
6.4.2.1 Mains voltage.....	20
6.4.2.2 Regulated lead-acid battery power sources used on vehicles .....	20
6.4.2.3 Power sources using other types of batteries.....	20
6.4.2.4 Other power sources .....	20
6.5 Procedure for tests at extreme temperatures.....	21

6.5.1	Procedure for equipment designed for continuous operation.....	21
6.5.2	Procedure for equipment designed for intermittent operation.....	21
7	General conditions .....	21
7.1	Test modulation.....	21
7.2	Artificial antenna.....	22
7.3	Test sites and general arrangements for radiated measurements .....	22
7.4	Transmitter automatic shut-off facility .....	22
7.5	Arrangement for test signals at the input of the transmitter .....	22
7.6	Arrangements for test signals at the input of the receiver via a test fixture or a test antenna .....	22
7.7	Receiver mute or squelch facility .....	22
7.8	Receiver rated audio output power .....	22
8	Methods of measurement for transmitter parameters .....	23
8.1	Frequency error.....	23
8.1.1	Definition .....	23
8.1.2	Method of measurement.....	23
8.2	Effective radiated power.....	23
8.2.1	Definition.....	23
8.2.2	Method of measurement.....	24
8.2.2.1	Maximum effective radiated power under normal test conditions.....	24
8.2.2.2	Average effective radiated power under normal test conditions.....	25
8.2.3	Method of measurements of maximum and average effective radiated power under extreme test conditions .....	26
8.3	Frequency deviation .....	26
8.3.1	Maximum permissible frequency deviation.....	26
8.3.1.1	Definition .....	26
8.3.1.2	Method of measurement.....	26
8.3.1.3	Analogue signals within the audio bandwidth.....	27
8.3.1.4	Analogue signals above the audio bandwidth .....	27
8.4	Adjacent channel power .....	27
8.4.1	Definition.....	27
8.4.2	Method of measurement.....	27
8.5	Radiated spurious emissions .....	28
8.5.1	Definition.....	28
8.5.2	Method of measurement.....	29
8.6	Transient frequency behaviour of the transmitter.....	31
8.6.1	Definitions .....	31
8.6.2	Method of measurement.....	31
9	Methods of measurement for receiver parameters.....	34
9.1	Average usable sensitivity (field strength, speech).....	34
9.1.1	Definition.....	34
9.1.2	Method of measurement under normal test conditions.....	34
9.1.3	Method of measurement under extreme test conditions .....	36
9.1.4	Reference for degradation measurements.....	36
9.1.4.1	Definition .....	36
9.1.4.2	Procedures for measurements using the test fixture.....	36
9.1.4.3	Procedures for measurements using the test site.....	37
9.2	Amplitude characteristic of receiver limiter.....	37
9.2.1	Definition.....	37
9.2.2	Method of measurement.....	37
9.3	Co-channel rejection .....	38
9.3.1	Definition.....	38
9.3.2	Method of measurement.....	38
9.4	Adjacent channel selectivity .....	39
9.4.1	Definition.....	39
9.4.2	Method of measurement.....	39
9.5	Spurious response rejection .....	40
9.5.1	Definition.....	40
9.5.2	Introduction to the method of measurement .....	40
9.5.3	Measurement arrangement .....	41
9.5.4	Method of the search.....	42

9.5.5	Method of measurement.....	43
9.6	Intermodulation response rejection .....	43
9.6.1	Definition.....	43
9.6.2	Method of measurement.....	44
9.7	Blocking or desensitization.....	45
9.7.1	Definition.....	45
9.7.2	Method of measurement.....	45
9.8	Spurious radiations.....	46
9.8.1	Definition.....	46
9.8.2	Method of measurement.....	47
10	Measurement uncertainty .....	49
<b>Annex A (normative): Radiated measurements.....</b>		<b>50</b>
A.1	Test sites and general arrangements for measurements involving the use of radiated fields .....	50
A.1.1	Open air test site .....	50
A.1.1.1	Description.....	50
A.1.1.2	Establishment of a relationship between signal levels and field strength .....	51
A.1.2	Anechoic chamber .....	51
A.1.2.1	General .....	51
A.1.2.2	Description.....	52
A.1.2.3	Influence of parasitic reflections.....	52
A.1.2.4	Mode of use .....	52
A.1.3	Stripline arrangement .....	54
A.1.3.1	General .....	54
A.1.3.2	Description.....	54
A.1.3.3	Calibration .....	54
A.1.3.4	Mode of use .....	54
A.1.4	Indoor test site .....	54
A.1.4.1	Description.....	54
A.1.4.2	Test for parasitic reflections .....	55
A.1.4.3	Mode of use .....	55
A.2	Standard position.....	56
A.3	Acoustic coupler .....	56
A.3.1	General .....	56
A.3.2	Description.....	57
A.3.3	Calibration.....	58
A.4	Test antenna .....	58
A.5	Substitution antenna.....	59
A.6	Test fixture.....	59
A.6.1	Description .....	59
A.6.2	Calibration.....	60
A.6.3	Mode of use.....	60
<b>Annex B (normative): Specifications for adjacent channel power measurement arrangements .....</b>		<b>61</b>
B.1	Power measuring receiver specification.....	61
B.1.1	General.....	61
B.1.2	IF filter .....	61
B.1.3	Oscillator and amplifier .....	63
B.1.4	Attenuation indicator.....	63
B.1.5	Level indicators .....	63
B.1.5.1	Rms level indicator .....	63
B.1.5.2	Peak level indicator.....	63

<b>Annex C (normative):</b>	<b>Graphical representation of the selection of equipment and frequencies for testing .....</b>	<b>64</b>
C.1	Tests on a single sample.....	64
C.2	Tests and samples needed when the switching range is a subset of the alignment range .....	65
C.3	Tests and samples for a family of equipment where the alignment range is a subset of the total operating frequency range.....	66
C.3.1	Test scenario 1 .....	66
C.3.2	Test scenario 2 .....	67
<b>Annex D (normative):</b>	<b>Test discriminator.....</b>	<b>68</b>
D.1	Characteristics of the test discriminator .....	68
<b>Annex E (informative):</b>	<b>Bibliography .....</b>	<b>69</b>
History .....		70

---

## Intellectual Property Rights

IPRs essential or potentially essential to the present document may have been declared to ETSI. The information pertaining to these essential IPRs, if any, is publicly available for **ETSI members and non-members**, and can be found in ETSI SR 000 314: *"Intellectual Property Rights (IPRs); Essential, or potentially Essential, IPRs notified to ETSI in respect of ETSI standards"*, which is available from the ETSI Secretariat. Latest updates are available on the ETSI Web server (<http://www.etsi.org/ipr>).

Pursuant to the ETSI IPR Policy, no investigation, including IPR searches, has been carried out by ETSI. No guarantee can be given as to the existence of other IPRs not referenced in ETSI SR 000 314 (or the updates on the ETSI Web server) which are, or may be, or may become, essential to the present document.

---

## Foreword

This European Standard (Telecommunications series) has been produced by ETSI Technical Committee Electromagnetic compatibility and Radio spectrum Matters (ERM), and is now submitted for the Vote phase of the ETSI standards Two-step Approval Procedure.

The present document is part 1 of a multi-part deliverable covering Land Mobile Service (RP02); Radio equipment using internal antennas intended primarily for analogue speech, as identified below:

**Part 1: "Technical characteristics and methods of measurement";**

Part 2: "Harmonized EN covering essential requirements under article 3.2 of the R&TTE Directive".

<b>Proposed national transposition dates</b>	
Date of latest announcement of this EN (doa):	3 months after ETSI publication
Date of latest publication of new National Standard or endorsement of this EN (dop/e):	6 months after doa
Date of withdrawal of any conflicting National Standard (dow):	6 months after doa

---

## Introduction

The present document is intended to specify the minimum performance and the methods of measurement of radio equipment for use in the land mobile service as specified in the scope.

The present document is based on ETS 300 296, which covers analogue radio equipment intended primarily for the transmission of speech for use in the Land Mobile Radio service and having an integral antenna.

Equipment similar to that covered by the present document, but having an RF connector is covered by ETS 300 086 (for details, see the scope of the present document as well as the scope of ETS 300 086).

Equipment intended to transmit signals to initiate a specific response is covered by EN 300 219 (for details, see the scope of the present document as well as the scope of EN 300 219), or by ETS 300 341 in the case of integral antenna equipment (for details, see the scope of the present document as well as the scope of ETS 300 341).

Equipment intended for the transmission of data is covered by ETS 300 113 (for details, see the corresponding scope), or by ETS 300 390 in the case of integral antenna equipment (for details, see the corresponding scope).

Requirements to be fulfilled by equipment designed to meet several standards can be found in Part 1, clause 4 of standards such as ETS 300 341 and/or ETS 300 390 as appropriate.

Angle modulation is used for radio equipment covered by the present document, but individual national administrations are free to choose the type of modulation. Channel separations, maximum transmitter output power/effective radiated power and the inclusion of automatic transmitter shut-off facility may all be conditions relating to the issue of a licence by the appropriate administration.

Annex A provides additional information concerning radiated measurements.

Annex B contains normative specifications for adjacent channel power measurement arrangements.

Annex C is a graphic representation corresponding to the selection of equipment for testing purposes.

Annex D contains specifications for the test discriminator used in transient measurements.

Clause 5 provides the appropriate limits. These limits have been chosen to ensure an acceptable grade of service and to minimize harmful interference to other equipment and services. They are based on the interpretation of the measurement results described in clause 4.3.

Provision for the placing on the market of radio equipment in EU Member States can be found in the R&TTE Directive (Directive 99/5/EC [1]). It can also be noted that some of the parameters considered as essential under the R&TTE Directive [1] had already been listed as essential under the EMC Directive.

The present document may also be used in CEPT Countries that are not EU Member States. For the benefit of these Countries, mechanisms for mutual recognition of type approval have been identified in Decision ERC/DEC/(97)10.

Alternatively, another approach may be used in Countries that have not implemented this Decision: type test measurements performed in an accredited test laboratory in one country would be accepted by the Administration in another country provided that the national regulatory requirements are met (CEPT recommendation ERC/REC 01-06).

Decision ERC/DEC/(97)10 also addresses issues related to total quality management.

The present document may, in particular, be used by accredited test laboratories for the assessment of the performance of the equipment. The performance of the equipment, in the case of conformity assessment measurements, shall be representative for the performance of the corresponding production model. In order to avoid any ambiguity in that assessment, the present document contains general instructions (clause 4), conditions (clauses 6 and 7) and methods of measurement (clauses 8 and 9).

The present document was drafted on the assumption that if equipment available on the market is required to be checked, it should be tested in accordance with the methods of measurement specified in the present document.



---

# 1 Scope

The present document covers the minimum characteristics considered necessary in order to avoid harmful interference and to make acceptable use of the available frequencies. It does not necessarily include all the characteristics which may be required by a user, nor does it necessarily represent the optimum performance achievable.

The present document applies to equipment with integral antennas, used in angle modulation systems in the land mobile service, operating on radio frequencies between 30 MHz and 1 000 MHz, with channel separations of 12,5 kHz, 20 kHz and 25 kHz, and is intended primarily for analogue speech.

The present document is based upon ETS 300 296, and is a general standard, the provisions of which may be superseded in whole or in part by specific standards for specific applications.

In the present document different requirements are given for the different radio frequency bands, channel separations, environmental conditions and types of equipment, where appropriate.

The type of equipment covered by the present document is handportable stations with integral antennas.

The present document covers angle modulation to be used for radio equipment, but individual national administrations are free to choose the type of modulation. Channel separations, maximum transmitter output power/effective radiated power and the inclusion of automatic transmitter shut-off facility may all be conditions attaching to the issue of a licence by the appropriate administration.

The present document is complementary to ETS 300 086, which covers radio equipment with an internal or external RF connector, for use in the land mobile service. It is primarily intended for omnidirectional applications.

Additional standards or specifications may be required for equipment such as that intended for connection to the Public Switched Telephone Network (PSTN).

---

# 2 References

The following documents contain provisions which, through reference in this text, constitute provisions of the present document.

- References are either specific (identified by date of publication and/or edition number or version number) or non-specific.
- For a specific reference, subsequent revisions do not apply.
- For a non-specific reference, the latest version applies.

- [1] Directive 1999/5/EC of the European Parliament and of the Council of 9 March 1999 on radio equipment and telecommunications equipment and the mutual recognition of their conformity (R&TTE Directive).
- [2] ETSI EN 300 793 (V1.1) (1998): "Electromagnetic compatibility and Radio spectrum Matters (ERM); Land mobile service; Presentation of equipment for type testing".
- [3] ETSI ETR 028 (1998): "Radio Equipment and Systems (RES); Uncertainties in the measurement of mobile radio equipment characteristics".
- [4] ETSI ETR 273 (1998): "Electromagnetic compatibility and Radio Spectrum Matters (ERM); Improvement of radiated methods of measurement (using test sites) and evaluation of the corresponding measurement uncertainties".
- [5] IEC 60489-3 (1988): "Methods of measurement for radio equipment used in the mobile services; Part 3: Receivers for A3E or F3E emissions".
- [6] ITU-T Recommendation O.41 (1994): "Psophometer for use on telephone-type circuits".

## 3 Definitions, abbreviations and symbols

### 3.1 Definitions

For the purposes of the present document, the following terms and definitions apply:

**angle modulation:** either phase modulation (G3) or frequency modulation (F3)

**audio frequency load:** audio frequency load is normally a resistor of sufficient power rating to accept the maximum audio output power from the equipment under test. The value of this resistor should be that stated by the manufacturer and equal to the impedance of the audio transducer at 1 000 Hz. In some cases it may be necessary to place an isolating transformer between the output terminals of the receiver under test and the load

**audio frequency termination:** audio frequency termination is any connection other than the audio frequency load which may be required for the purpose of testing the receiver. The termination device should be, as appropriate, either chosen by the manufacturer or agreed between the manufacturer and the testing laboratory and details included in test reports. If special equipment is required then it should be provided by the manufacturer

**band-stop filter (for the SINAD meter):** characteristics of the band-stop filter used in the audio distortion factor meter and SINAD meter should be such that at the output the 1 000 Hz tone will be attenuated by at least 40 dB and at 2 000 Hz the attenuation will not exceed 0,6 dB. The filter characteristic shall be flat within 0,6 dB over the ranges 20 Hz to 500 Hz and 2 000 Hz to 4 000 Hz. In the absence of modulation the filter must not cause more than 1 dB attenuation of the total noise power of the audio frequency output of the receiver under test

**integral antenna:** antenna designed to be connected to the equipment without the use of a 50  $\Omega$  external connector and considered to be part of the equipment. An integral antenna may be fitted internally or externally to the equipment

**psophometric weighting network:** psophometric weighting network is described in ITU-T Recommendation O.41 [6]

Types of measurements:

- **conducted measurements:** measurements which are made using a direct connection to the equipment under test;
- **radiated measurements:** measurements which involve the absolute measurement of a radiated field.

Types of station:

- **base station:** equipment fitted with an antenna socket, for use with an external antenna and intended for use in a fixed location;
- **handportable station:** equipment either fitted with an antenna socket or an integral antenna, or both, normally used on a stand-alone basis, to be carried on a person or held in the hand;
- **mobile station:** mobile equipment fitted with an antenna socket, for use with an external antenna, normally used in a vehicle or as a transportable station.

Types of tests:

- **full tests:** in all cases except where qualified as "limited", tests are performed according to the present document;
- **limited tests:** limited tests, as defined in EN 300 793 [2], are as follows:
  - transmitter frequency error, clause 8.1;
  - transmitter effective radiated power, clause 8.2;
  - transmitter adjacent channel power, clause 8.4;
  - receiver average usable sensitivity (field strength), clause 9.1;
  - receiver adjacent channel selectivity, clause 9.4.

## 3.2 Abbreviations

For the purposes of the present document, the following abbreviations apply:

AR1	(see clause 4.1)
AR2	(see clause 4.1)
dBc	dB relative to the carrier power
emf	electro-motive force
IF	Intermediate Frequency
OFR	Operating Frequency Range
RF	Radio Frequency
Rx	Receiver
SINAD	(signal + noise + distortion)/(noise + distortion)
SR	Switching Range
Tx	Transmitter
VSWR	Voltage Standing Wave Ratio

## 3.3 Symbols

For the purposes of the present document, the following symbols apply:

E <sub>o</sub>	Reference field strength (see annex A)
R <sub>o</sub>	Reference distance (see annex A)

---

# 4 General

## 4.1 Selection of equipment for testing purposes

For information regarding the selection of equipment for testing purposes, refer to EN 300 793 [2].

It is expected that the usage of similar measurement methodologies will make it more likely that different laboratories measuring the same equipment get comparable measurement results.

## 4.2 Mechanical and electrical design

### 4.2.1 General

The equipment shall be designed, constructed and manufactured in accordance with sound engineering practice, and with the aim of minimizing harmful interference to other equipment and services.

### 4.2.2 Controls

Those controls which if maladjusted might increase the interfering potentialities of the equipment shall not be easily accessible to the user.

### 4.2.3 Transmitter shut-off facility

When a timer for an automatic shut-off facility is operative, at the moment of the time-out the transmitter shall automatically be switched off. The activation of the transmitter key shall reset the timer.

### 4.2.4 Marking

The equipment shall be marked in a visible place. This marking shall be legible, tamperproof and durable.

The marking shall be in accordance with EC Directives and/or CEPT decisions or recommendations as appropriate.

## 4.3 Interpretation of the measurement results

The interpretation of results (e.g. results recorded in a test report) for the measurements described in the present document shall be as follows:

- a) the measured value related to the corresponding limit shall be used to decide whether an equipment meets the requirements for that parameter of the present document;
- b1) the values of the actual measurement uncertainty shall be, for each measurement, equal to or lower than the figures given in clause 10 (maximum acceptable value of the measurement uncertainties);
- b2) the actual measurement uncertainty of the laboratory carrying out the measurements, for each particular measurement, shall be included in the corresponding test report (if any).

For the test methods, according to the present document, the measurement uncertainty figures shall be calculated in accordance with ETR 028 [3] and shall correspond to an expansion factor (coverage factor)  $k = 1,96$  or  $k = 2$  (which provide confidence levels of respectively 95 % and 95,45 % in the case where the distributions characterizing the actual measurement uncertainties are normal (Gaussian)).

The particular expansion factor used for the evaluation of the measurement uncertainty shall be stated.

---

## 5 Technical characteristics

This clause contains the limit values of the parameters defined in clauses 8 and 9.

### 5.1 Transmitter parameter limits

#### 5.1.1 Frequency error

For the definition and the measuring method see clause 8.1.

The frequency error shall not exceed the values given in table 1 under normal, extreme or any intermediate set of conditions.

For practical reasons the measurements will be performed only under normal and extreme test conditions as stated in clause 8.1.

**Table 1: Frequency error**

Channel separation (kHz)	Frequency error limit (kHz)				
	below 47 MHz	47 MHz to 137 MHz	above 137 MHz to 300 MHz	above 300 MHz to 500 MHz	above 500 MHz to 1 000 MHz
20 & 25	± 0,60	± 1,35	± 2,00	± 2,00	± 2,50 (note)
12,5	± 0,60	± 1,00	± 1,50	± 1,50 (note)	No value specified

NOTE: For handportable stations having integral power supplies, the figures given in the table only apply to the limited temperature range 0°C to +30°C. However for the full extreme temperature conditions (clause 6.4.1) exceeding the limited temperature range above, the following frequency error limits apply:  
 ± 2,50 kHz between 300 MHz and 500 MHz;  
 ± 3,00 kHz between 500 MHz and 1 000 MHz.

## 5.1.2 Effective radiated power

For the definition and the measuring method see clause 8.2.

The maximum effective radiated power under normal test conditions shall be within  $d_f$  from the rated maximum effective radiated power.

The average effective radiated power under normal test conditions shall also be within  $d_f$  from the rated average effective radiated power.

The allowance for the characteristics of the equipment ( $\pm 1,5$  dB) shall be combined with the actual measurement uncertainty in order to provide  $d_f$ , as follows:

$$- d_f^2 = d_m^2 + d_e^2;$$

where uncertainty:

- $d_m$  is the actual measurement uncertainty;
- $d_e$  is the allowance for the equipment ( $\pm 1,5$  dB);
- $d_f$  is the final difference;
- all values shall be expressed in linear terms.

The variation of power due to the change of temperature and voltage for the measurements under extreme test conditions shall not exceed +2 dB or -3 dB (the measurements shall be performed using the test fixture).

In all cases the actual measurement uncertainty shall comply with clause 10.

Furthermore the maximum effective radiated power shall not exceed the maximum value allowed by the administrations.

Example of the calculation of  $d_f$ :

- $d_m$  = 6 dB (value acceptable, as indicated in the table of maximum uncertainties);
- = 3,98 in linear terms;
- $d_e$  = 1,5 dB (fixed value for all equipment fulfilling the requirements of the present document);
- = 1,41 in linear terms;
- $d_f^2$  =  $[3,98]^2 + [1,41]^2$ ;
- Therefore  $d_f$  = 4,22 in linear terms, or 6,25 dB.

This calculation shows that in this case  $d_f$  is in excess of 0,25 dB compared to  $d_m$ , the actual measurement uncertainty (6 dB).

### 5.1.3 Frequency deviation

For the definition and the measuring method see clause 8.3.

#### 5.1.3.1 Maximum permissible frequency deviation

The maximum permissible frequency deviation for modulation frequencies from the lowest frequency transmitted ( $f_1$ ) by the equipment (as declared by the manufacturer) up to ( $f_2$ ) shall be as given in table 2.

**Table 2: Frequency deviation**

Channel separation in kHz	Maximum Permissible Frequency Deviation (MPFD) in kHz
12,5	$\pm 2,5$
20	$\pm 4,0$
25	$\pm 5,0$

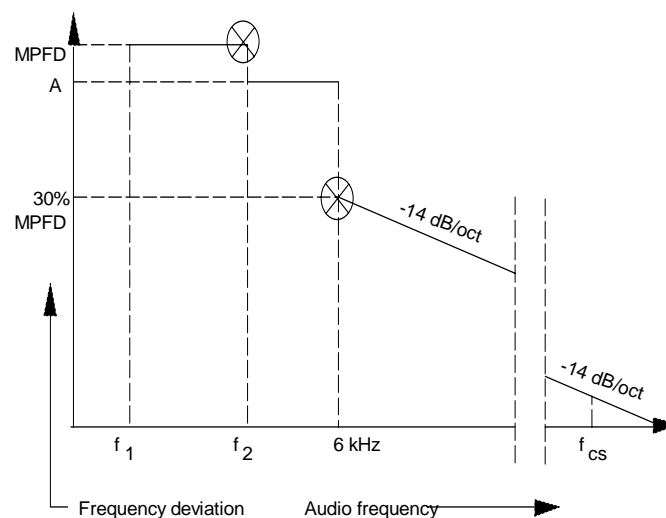

**Figure 1: Template showing the MPFD versus modulation frequencies**

Abbreviations:

- $f_1$  lowest appropriate frequency;
- $f_2$  3,0 kHz (for 20 kHz or 25 kHz channel separation); or  
2,55 kHz (for 12,5 kHz channel separation);
- MPFD maximum permissible frequency deviation between  $f_1$  and  $f_2$ , clause 5.1.3.1;
- A measured frequency deviation at  $f_2$ ;
- $f_{cs}$  frequency equal to channel separation.

#### 5.1.4 Adjacent channel power

For the definition and the measuring method see clause 8.4.

For channel separations of 20 kHz and 25 kHz, the adjacent channel power shall not exceed a value of 70,0 dB below the carrier power of the transmitter without the need to be below  $0,20 \mu\text{W}$ . For channel separations of 12,5 kHz, the adjacent channel power shall not exceed a value of 60,0 dB below the transmitter carrier power without the need to be below  $0,20 \mu\text{W}$ .

### 5.1.5 Spurious emissions

For the definition and the measuring method see clause 8.5.

The power of any spurious emission shall not exceed the values given in table 3.

**Table 3: Radiated emissions**

Frequency range	30 MHz to 1 GHz	above 1 GHz to 12,75 GHz
Tx operating	0,25 $\mu$ W (-36,0 dBm)	1,00 $\mu$ W (-30,0 dBm)
Tx standby	2,0 nW (-57,0 dBm)	20,0 nW (-47,0 dBm)

### 5.1.6 Transient frequency behaviour of the transmitter

For the definition and the measurement method see clause 8.6.

The transient periods are given in table 4. A graph of these transient periods for the case of equipment operating in the frequency range above 300 MHz to 500 MHz are shown in figure 11, clause 8.6.

**Table 4: Transient periods**

Frequency range	30 MHz to 300 MHz	above 300 MHz to 500 MHz	above 500 MHz to 1 000 MHz
$t_1$ (ms)	5,0	10,0	20,0
$t_2$ (ms)	20,0	25,0	50,0
$t_3$ (ms)	5,0	10,0	10,0

During the periods  $t_1$  and  $t_3$  the frequency difference shall not exceed the value of one channel separation.

During the period  $t_2$  the frequency difference shall not exceed the value of half a channel separation.

In the case of handportable stations with a transmitter maximum rated effective radiated power of less than 5 W, the frequency deviation during  $t_1$  and  $t_3$  may be greater than the value of one channel separation. The corresponding plot of frequency versus time during  $t_1$  and  $t_3$  shall be recorded in test reports.

## 5.2 Receiver parameter limits

### 5.2.1 Average usable sensitivity (field strength, speech)

For the definitions and the measurement method see clause 9.1.

For the average usable sensitivity limits, four categories of equipment are defined as follows:

**Category A:** equipment having an integral antenna fully within the case.

**Category B:** equipment having an extractable or fixed integral antenna, with an antenna length not exceeding 20 cm external to the case.

**Category C:** equipment having an extractable or fixed integral antenna, with an antenna length exceeding 20 cm external to the case.

**Category D:** equipment not covered by category A, B or C.

Under normal test conditions, the average usable sensitivity shall not exceed the following field strength values.

**Table 5a: Sensitivity limits for Categories A and D**

Frequency band (MHz)	Average usable sensitivity in dB relative to 1µV/m
30 to 400	30,0
> 400 to 750	31,5
> 750 to 1 000	33,0

**Table 5b: Sensitivity limits for Category B**

Frequency band (MHz)	Average usable sensitivity in dB relative to 1µV/m
30 to 130	21,0
> 130 to 300	22,5
> 300 to 440	24,5
> 440 to 600	26,5
> 600 to 800	28,5
> 800 to 1 000	31,0

#### Category C

At frequencies greater than 375 MHz the limits shall be as specified in table 5b.

In the case of frequencies less than or equal to 375 MHz a correction factor K shall be subtracted from the specified field strengths in table 5b.

- $K = 20 \log_{10} [(l + 20)/40]$ ;
- where l is the external part of the antenna in cm.

This correction only applies if the antenna length external to the case is less than  $(15\ 000/f_0 - 20)$  in cm, where  $f_0$  is the frequency in MHz.

For all categories of equipment, add 6 dB to the limit under normal test conditions to obtain the limit under extreme test conditions.



## 5.2.2 Amplitude characteristic

For the definition and the measurement method see clause 9.2.

Within the specified change in radio frequency input signal level, the change of audio output level shall not exceed 3,0 dB.

## 5.2.3 Co-channel rejection

For the definition and the measurement method see clause 9.3.

The value of the co-channel rejection ratio, expressed in dB, at any frequency of the unwanted signal within the specified range, shall be between:

- 8,0 dB and 0 dB for channel separations of 20 kHz and 25 kHz;
- 12,0 dB and 0 dB for a channel separation of 12,5 kHz.

## 5.2.4 Adjacent channel selectivity

For the definition and the measurement method see clause 9.4.

The adjacent channel selectivity of the equipment shall be such that under the specified test conditions, the given degradation shall not be exceeded for levels of the unwanted signal up to those given in table 6.

**Table 6: Adjacent channel selectivity**

Channel Separation (kHz)	Adjacent channel selectivity limit (dBmV/m)			
	Unwanted frequencies $\leq$ 68 MHz		Unwanted frequencies $>$ 68 MHz	
	Normal test conditions	Extreme test conditions	Normal test conditions	Extreme test conditions
20 & 25	75	65	$20 \log_{10}(f) + 38,3$	$20 \log_{10}(f) + 28,3$
12,5	65	55	$20 \log_{10}(f) + 28,3$	$20 \log_{10}(f) + 18,3$

NOTE: f is the carrier frequency in MHz

## 5.2.5 Spurious response rejection

For the definition and the measurement method see clause 9.5.

The spurious response rejection of the equipment shall be such that under the specified test conditions, the given degradation shall not be exceeded for levels of the unwanted signal up to:

- 75 dB $\mu$ V/m for unwanted signal frequencies  $\leq$  68 MHz;
- $(20 \log_{10}(f) + 38,3)$  dB $\mu$ V/m for unwanted signal frequencies  $>$  68 MHz;
- where f is the frequency in MHz.

## 5.2.6 Intermodulation response rejection

For the definition and the measurement method see clause 9.6.

The intermodulation response rejection of the equipment shall be such that under the specified test conditions, the given degradation shall not be exceeded for levels of the unwanted signal up to:

- 70 dB $\mu$ V/m for unwanted signal frequencies  $\leq$  68 MHz;
- $(20 \log_{10} (f) + 33,3)$  dB $\mu$ V/m for unwanted signal frequencies  $>$  68 MHz;
- where f is the frequency in MHz.

## 5.2.7 Blocking or desensitization

For the definition and the measurement method see clause 9.7.

The blocking level, for any frequency within the specified ranges, shall be:

- $\geq$  89 dB $\mu$ V/m for unwanted signal frequencies  $\leq$  68 MHz;
- $\geq (20 \log_{10} (f) + 52,3)$  dB $\mu$ V/m for unwanted signal frequencies  $>$  68 MHz;
- where f is the frequency in MHz.

## 5.2.8 Spurious radiations

For the definition and the measurement method see clause 9.8.

The power of any spurious radiation shall not exceed the values given in table 7.

**Table 7: Radiated components**

Frequency range	30 MHz to 1 GHz	above 1 GHz to 12,75 GHz
Limit	2,0 nW (-57,0 dBm)	20,0 nW (-47,0 dBm)

---

## 6 Test conditions, power sources and ambient temperatures

### 6.1 Normal and extreme test conditions

Measurements shall be made under normal test conditions, and also, where stated, under extreme test conditions.

### 6.2 Test power source

During measurements, the power source of the equipment shall be replaced by a test power source capable of producing normal and extreme test voltages as specified in clauses 6.3.2 and 6.4.2. The internal impedance of the test power source shall be low enough for its effect on the test results to be negligible. For the purpose of tests, the voltage of the power source shall be measured at the input terminals of the equipment.

If the equipment is provided with a permanently connected power cable, the test voltage shall be that measured at the point of connection of the power cable to the equipment.

For battery operated equipment the battery shall be removed and the test power source shall be applied as close to the battery terminals as practicable.

During tests the power source voltages shall be maintained within a tolerance of  $< \pm 1$  % relative to the voltage at the beginning of each test. The value of this tolerance is critical to power measurements, using a smaller tolerance will provide better measurement uncertainty values.

### 6.3 Normal test conditions

#### 6.3.1 Normal temperature and humidity

The normal temperature and humidity conditions for tests shall be any convenient combination of temperature and humidity within the following ranges:

- temperature: + 15°C to + 35°C;
- relative humidity: 20 % to 75 %.

When it is impracticable to carry out the tests under these conditions, a note to this effect, stating the ambient temperature and relative humidity during the tests, shall be added to test reports.

#### 6.3.2 Normal test power source

##### 6.3.2.1 Mains voltage

The normal test voltage for equipment to be connected to the mains shall be the nominal mains voltage. For the purpose of the present document, the nominal voltage shall be the declared voltage or any of the declared voltages for which the equipment was designed.

The frequency of the test power source corresponding to the ac mains shall be between 49 Hz and 51 Hz.

##### 6.3.2.2 Regulated lead-acid battery power sources used on vehicles

When the radio equipment is intended for operation from the usual types of regulated lead-acid battery power source used on vehicles, the normal test voltage shall be 1,1 times the nominal voltage of the battery. For nominal voltages of 6 V and 12 V, these are 6,6 V and 13,2 V respectively.

### 6.3.2.3 Other power sources

For operation from other power sources or types of battery (primary or secondary), the normal test voltage shall be that declared by the equipment manufacturer.

## 6.4 Extreme test conditions

### 6.4.1 Extreme temperatures

For tests at extreme temperatures, measurements shall be made in accordance with the procedures specified in clause 6.5, at the upper and lower temperatures of the following range:

- -20°C to +55°C.

For the purpose of clause 5.1.1 a) an additional extreme temperature range of 0°C to +30°C shall be used.

Test reports shall state the temperature range used.

### 6.4.2 Extreme test source voltages

#### 6.4.2.1 Mains voltage

The extreme test voltage for equipment to be connected to an ac mains source shall be the nominal mains voltage  $\pm 10\%$ .

#### 6.4.2.2 Regulated lead-acid battery power sources used on vehicles

When the equipment is intended for operation from the usual types of regulated lead-acid battery power sources used on vehicles the extreme test voltages shall be 1,3 and 0,9 times the nominal voltage of the battery. For a nominal voltage of 6 V, these are 7,8 V and 5,4 V respectively and for a nominal voltage of 12 V, these are 15,6 V and 10,8 V respectively.

#### 6.4.2.3 Power sources using other types of batteries

The lower extreme test voltages for equipment with power sources using the following batteries shall be:

- for the Leclanché or the lithium type of battery: 0,85 times the nominal voltage of the battery;
- for the mercury or nickel-cadmium type of battery: 0,9 times the nominal voltage of the battery.

No upper extreme test voltages apply.

In the case where no upper extreme test voltage above the nominal voltage is applicable, the corresponding four extreme test conditions are:

- $V_{\min} / T_{\min}$ ,  $V_{\min} / T_{\max}$ ;
- $(V_{\max} = \text{nominal}) / T_{\min}$ ,  $(V_{\max} = \text{nominal}) / T_{\max}$ .

#### 6.4.2.4 Other power sources

For equipment using other power sources, or capable of being operated from a variety of power sources, the extreme test voltages shall be, as appropriate, either those selected by the manufacturer or those agreed between the equipment manufacturer and the testing laboratory. They shall be recorded in test reports.

## 6.5 Procedure for tests at extreme temperatures

Before measurements are made the equipment shall have reached thermal balance in the test chamber. The equipment shall be switched off during the temperature stabilizing period.

In the case of equipment containing temperature stabilization circuits designed to operate continuously, the temperature stabilization circuits may be switched on for 15 minutes after thermal balance has been obtained, and the equipment shall then meet the specified requirements. For such equipment the manufacturer shall provide for the power source circuit feeding the crystal oven to be independent of the power source to the rest of the equipment.

If the thermal balance is not checked by measurements, a temperature stabilizing period of at least one hour, or such period as may be decided by the testing laboratory, shall be allowed. The sequence of measurements shall be chosen, and the humidity content in the test chamber shall be controlled so that excessive condensation does not occur.

### 6.5.1 Procedure for equipment designed for continuous operation

If the manufacturer states that the equipment is designed for continuous operation, the test procedure shall be as follows.

Before tests at the upper extreme temperature the equipment shall be placed in the test chamber and left until thermal balance is attained. The equipment shall then be switched on in the transmit conditions for a period of half an hour after which the equipment shall meet the specified requirements.

For tests at the lower extreme temperature the equipment shall be left in the test chamber until thermal balance is attained, then switched to the standby or receive condition for a period of one minute after which the equipment shall meet the specified requirements.

### 6.5.2 Procedure for equipment designed for intermittent operation

If the manufacturer states that the equipment is designed for intermittent operation, the test procedure shall be as follows.

Before tests at the upper extreme temperature the equipment shall be placed in the test chamber and left until thermal balance is attained. The equipment shall then be switched on for one minute in the transmit condition, followed by four minutes in the receive condition, after which the equipment shall meet the specified requirements.

For tests at the lower extreme temperature the equipment shall be left in the test chamber until thermal balance is attained, then switched to the standby or receive condition for one minute after which the equipment shall meet the specified requirements.

---

## 7 General conditions

### 7.1 Test modulation

The test modulation signals are baseband signals that modulate a carrier or signal generator. They are dependent upon the type of equipment under test and also the measurement to be performed.

Test modulating signals are:

- A-M1: a 1 000 Hz tone at a level which produces a deviation of 12 % of the channel separation;
- A-M2: a 1 250 Hz tone at a level which produces a deviation of 12 % of the channel separation;
- A-M3: a 400 Hz tone at a level which produces a deviation of 12 % of the channel separation. This signal is used as an unwanted signal.

## 7.2 Artificial antenna

Tests on the transmitter requiring the use of the test fixture shall be carried out with a substantially non-reactive non-radiating load of 50  $\Omega$  connected to the test fixture terminal.

## 7.3 Test sites and general arrangements for radiated measurements

For guidance on radiation test sites see annex A. Detailed descriptions of the radiated measurement arrangements are included in this annex.

## 7.4 Transmitter automatic shut-off facility

If the equipment is fitted with an automatic transmitter shut-off facility it shall be made inoperative for the duration of the measurements, unless it has to be left operative to protect the equipment. If the shut off facility is left operative the status of the equipment shall be indicated.

## 7.5 Arrangement for test signals at the input of the transmitter

For the purpose of the present document, the transmitter audio frequency modulation signal shall be applied to the microphone input terminals with the internal microphone disconnected, unless otherwise stated.

## 7.6 Arrangements for test signals at the input of the receiver via a test fixture or a test antenna

Sources of test signals for application to the receiver via a test fixture (clause A.6), a stripline (clause A.1.3) or a test antenna (clause A.4) shall be connected in such a way that the impedance presented to the test fixture, the stripline or the test antenna is 50  $\Omega$ . This requirement shall be met irrespective whether one or more signals using a combining network are applied to the receiver simultaneously.

The levels of the test signals shall be expressed in terms of the emf at the output of the source prior to connection to the receiver input connector.

The effects of any intermodulation products and noise produced in the test signal sources shall be negligible.

## 7.7 Receiver mute or squelch facility

If the receiver is equipped with a mute or squelch circuit, this shall be made inoperative for the duration of the measurements.

## 7.8 Receiver rated audio output power

The rated audio output power shall be the maximum power, declared by the manufacturer, for which all the requirements of the present document are met. With normal test modulation, clause 7.1, the audio output power shall be measured in a resistive load simulating the load with which the receiver normally operates. The value of this load shall be declared by the manufacturer.

## 8 Methods of measurement for transmitter parameters

When performing transmitter tests on equipment designed for intermittent operation, the specified maximum transmit time shall not be exceeded.

### 8.1 Frequency error

#### 8.1.1 Definition

The frequency error of the transmitter is the difference between the measured carrier frequency in the absence of modulation and the nominal frequency of the transmitter.

#### 8.1.2 Method of measurement

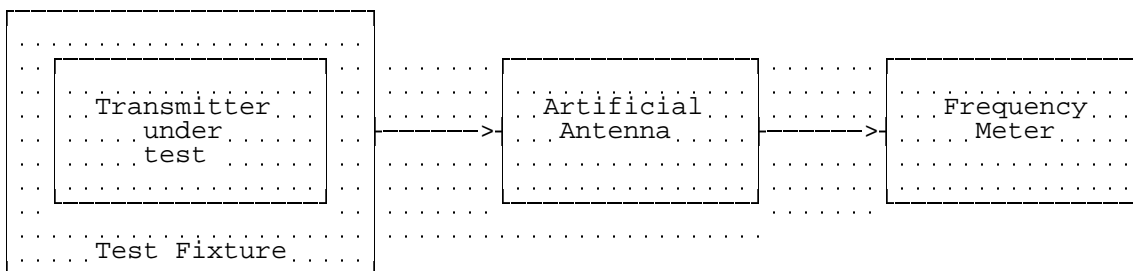

**Figure 2: Measurement arrangement**

The equipment shall be placed in a test fixture (clause A.6) connected to the artificial antenna (clause 7.2). The carrier frequency shall be measured in the absence of modulation. The measurement shall be made under normal test conditions (clause 6.3) and repeated under extreme test conditions (clauses 6.4.1 and 6.4.2 applied simultaneously).

### 8.2 Effective radiated power

Administrations may state the maximum value for the maximum effective radiated power of transmitters; this could be a condition for issuing the licence.

If the equipment is designed to operate with different carrier powers, the rated maximum effective radiated power for each level or range of levels shall be declared by the manufacturer. The power adjustment control shall not be accessible to the user.

The requirements of the present document shall be met for all power levels at which the transmitter is intended to operate. For practical reasons measurements shall be performed only at the lowest and the highest power level at which the transmitter is intended to operate.

#### 8.2.1 Definition

For the purpose of this measurement, the maximum effective radiated power is defined as the effective radiated power in the direction of maximum field strength under specific conditions of measurement, in the absence of modulation.

The rated maximum effective radiated power is the maximum effective radiated power declared by the manufacturer.

The average effective radiated power is defined as the average of the effective radiated power measured in 8 directions.

The rated average effective radiated power shall also be declared by the manufacturer.

## 8.2.2 Method of measurement

The measurements shall be made under normal test conditions, clause 6.3, and extreme test conditions, clauses 6.4.1 and 6.4.2 applied simultaneously.

### 8.2.2.1 Maximum effective radiated power under normal test conditions

test site

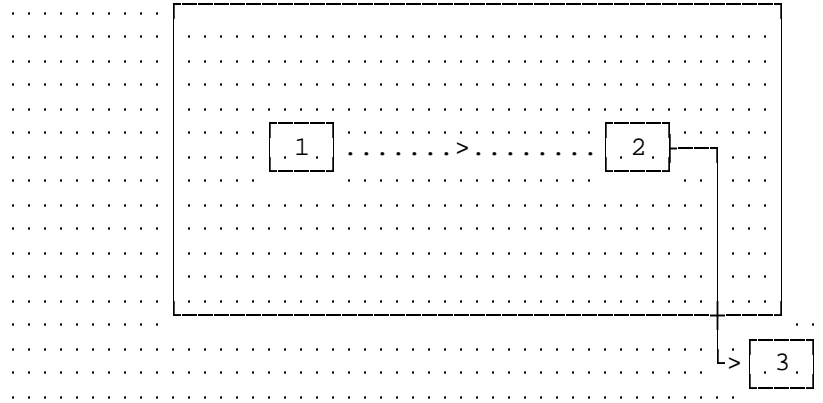

NOTE 1: Transmitter under test.

NOTE 2: Test antenna.

NOTE 3: Spectrum analyser or selective voltmeter (test receiver).

**Figure 3: Measurement arrangement**

- a) A test site, which fulfils the requirements for the specified frequency range of this measurement, shall be used. The test antenna shall be oriented initially for vertical polarization unless otherwise stated.

The transmitter under test shall be placed on the support in its standard position (clause A.2) and switched on without modulation.

- b) The spectrum analyser or selective voltmeter shall be tuned to the transmitter carrier frequency. The test antenna shall be raised or lowered through the specified height range until the maximum signal level is detected on the spectrum analyser or selective voltmeter.
- c) The transmitter shall be rotated through 360° around a vertical axis in order to find the direction of the maximum signal.
- d) The test antenna shall be raised or lowered again through the specified height range until a new maximum is obtained. This level shall be recorded. (This maximum may be a lower value than the value obtainable at heights outside the specified limits).

The test antenna may not need to be raised or lowered if the measurement is carried out on a test site according to clause A.1.2.



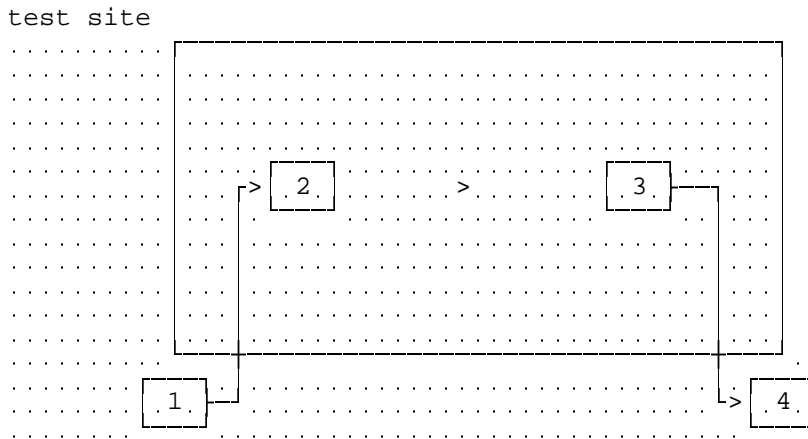

NOTE 1: Signal generator.

NOTE 2: Substitution antenna.

NOTE 3: Test antenna.

NOTE 4: Spectrum analyser or selective voltmeter (test receiver).

**Figure 4: Measurement arrangement**

- e) Using the measurement arrangement of figure 4 the substitution antenna, shall replace the transmitter antenna in the same position and in vertical polarization. The frequency of the signal generator shall be adjusted to the transmitter carrier frequency. The test antenna shall be raised or lowered as necessary to ensure that the maximum signal is still received.

The test antenna need not be raised or lowered if the measurement is carried out on a test site according to clause A.1.2.

The input signal to the substitution antenna shall be adjusted in level until an equal or a known related level to that detected from the transmitter is obtained in the test receiver.

The maximum carrier radiated power is equal to the power supplied by the signal generator, increased by the known relationship if necessary and after corrections due to the gain of the substitution antenna and the cable loss between the signal generator and the substitution antenna.

- f) Steps b) to e) above shall be repeated with the test antenna and the substitution antenna oriented in horizontal polarization.

### 8.2.2.2 Average effective radiated power under normal test conditions

- a) The procedures in steps b) to f) shall be repeated, except that in step c) the transmitter shall be rotated through 8 positions, 45° apart, starting at the position corresponding to the measured maximum effective radiated power.
- b) The average effective radiated power corresponding to the eight measured values is given by:

$$\text{average radiated power} = \frac{\sum_{l=1}^8 P_n}{8}$$

where  $P_n$  is the power corresponding to each of the eight positions.

### 8.2.3 Method of measurements of maximum and average effective radiated power under extreme test conditions

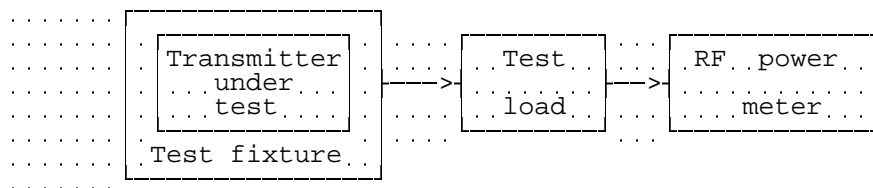

**Figure 5: Measurement arrangement**

- a) The measurement specified in clause 8.2.2 shall also be performed under extreme test conditions. Due to the impossibility of repeating the measurement on a test site under extreme temperature conditions, a relative measurement is performed, using the test fixture (clause A.6) and the measurement arrangement of figure 5.
- b) The power delivered to the test load is measured under normal test conditions (clause 6.3) and extreme test conditions (clauses 6.4.1 and 6.4.2 applied simultaneously), and the difference in dB is noted. This difference is algebraically added to the average effective radiated power under normal test conditions, in order to obtain the average effective radiated power under extreme test conditions.
- c) A similar calculation will provide the maximum effective radiated power.
- d) Additional uncertainties can occur under extreme test conditions due to the calibration of the test fixture.

## 8.3 Frequency deviation

The frequency deviation is the maximum difference between the instantaneous frequency of the modulated radio frequency signal and the carrier frequency in the absence of modulation.

### 8.3.1 Maximum permissible frequency deviation

#### 8.3.1.1 Definition

The maximum permissible frequency deviation is the maximum value of frequency deviation stated for the relevant channel separation.

#### 8.3.1.2 Method of measurement

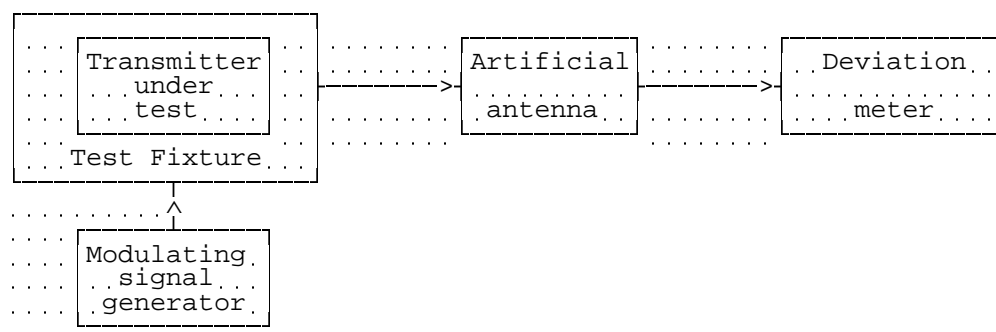

**Figure 6: Measurement arrangement**

The transmitter shall be placed in the test fixture (clause A.6) connected to the test load. The frequency deviation shall be measured by means of a deviation meter capable of measuring the maximum permissible frequency deviation, including that due to any harmonics and intermodulation products, which may be produced in the transmitter. The deviation meter bandwidth must be suitable to accommodate the highest modulating frequency and to achieve the required dynamic range.

### 8.3.1.3 Analogue signals within the audio bandwidth

- a) The modulation frequency shall be varied between the lowest frequency considered to be appropriate and  $f_2$  (see note). The level of this test signal shall be 20 dB above the level corresponding to a deviation at 1 000 Hz of 12 % of the channel separation.
- b) The maximum (positive or negative) frequency deviation shall be recorded.

NOTE:  $f_2$  is equal to 3 kHz or to 2,55 kHz for transmitters intended for 12,5 kHz channel separations.

### 8.3.1.4 Analogue signals above the audio bandwidth

- a) The modulation frequency shall be varied between  $f_2$  (see note) and a frequency equal to the channel separation for which the equipment is intended. The level of this signal shall correspond to a deviation at 1 000 Hz of 12 % of the channel separation.
- b) The maximum (positive or negative) frequency deviation shall be recorded.

NOTE:  $f_2$  is equal to 3 kHz or to 2,55 kHz for transmitters intended for 12,5 kHz channel separations.

## 8.4 Adjacent channel power

### 8.4.1 Definition

The adjacent channel power is that part of the total power output of a transmitter under defined conditions of modulation, which falls within a specified passband centred on the nominal frequency of either of the adjacent channels. This power is the sum of the mean power produced by the modulation, hum and noise of the transmitter.

It is specified either as the ratio expressed in decibels of the carrier power to the adjacent channel power or as an absolute value.

### 8.4.2 Method of measurement

The adjacent channel power may be measured with a power measuring receiver, which conforms to the requirements given in annex B.

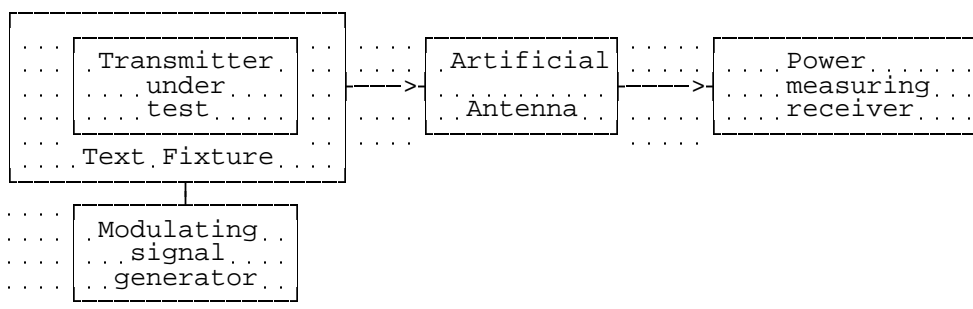

**Figure 7: Measurement arrangement**

- a) The transmitter under test shall be placed in the test fixture (clause A.6) connected via the artificial antenna (clause 7.2) to a power measuring receiver calibrated to measure rms power level. The level at the receiver input shall be within its allowed limit. The transmitter shall be operated at the maximum operational carrier power level.
- b) With the transmitter unmodulated, the tuning of the power measuring receiver shall be adjusted so that a maximum response is obtained. This is the 0 dB response point. The power measuring receiver attenuator setting and the reading of the meter shall be noted.
- c) The tuning of the power measuring receiver shall be adjusted away from the carrier so that its -6 dB response nearest to the transmitter carrier frequency is located at a displacement from the nominal frequency of the carrier as given in the following table.

**Table 8: Frequency displacement**

Channel separation (kHz)	Displacement (kHz)
12,5	8,25
20	13
25	17

The same result may be obtained by tuning the power measuring receiver (point D2 in the drawing of the power measuring filter shape) to the nominal frequency of the adjacent channel, if it has been suitably calibrated.

- d) The transmitter shall be modulated with a 1 250 Hz tone at a level which is 20 dB higher than that required to produce normal deviation.
- e) The power measuring receiver variable attenuator shall be adjusted to obtain the same meter reading as in step b) or a known relation to it. This value shall be noted.
- f) The ratio of adjacent channel power to carrier power is the difference between the attenuator settings in step b) and e), corrected for any differences in the reading of the meter.

Alternatively the absolute value of the adjacent channel power may be calculated from the above ratio and the transmitter carrier power.

For each adjacent channel, the adjacent channel power shall be recorded.

- g) Steps c) to f) shall be repeated with the power measuring receiver tuned to the other side of the carrier.
- h) The adjacent channel power of the equipment under test shall be expressed as the higher of the two values recorded in step f) for the upper and lower channels nearest to the channel considered.

## 8.5 Radiated spurious emissions

### 8.5.1 Definition

Spurious emissions are emissions at frequencies, other than those of the carrier and sidebands associated with normal modulation, radiated by the antenna and by the cabinet of the transmitter.

They are specified as the radiated power of any discrete signal.

## 8.5.2 Method of measurement

test site

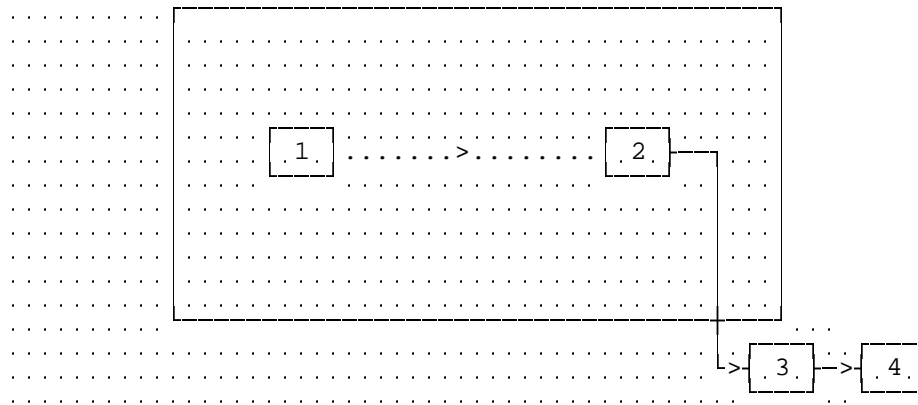

NOTE 1: Transmitter under test.

NOTE 2: Test antenna.

NOTE 3: High 'Q' (notch) or high pass filter.

NOTE 4: Spectrum analyser or selective voltmeter (test receiver).

**Figure 8: Measurement arrangement**

a) A test site, which fulfils the requirements of the specified frequency range of this measurement, shall be used.

The test antenna shall be oriented initially for vertical polarization and connected to a spectrum analyser or a selective voltmeter, through a suitable filter to avoid overloading of the spectrum analyser or selective voltmeter. The bandwidth of the spectrum analyser or selective voltmeter shall be between 10 kHz and 100 kHz, set to a suitable value to correctly perform the measurement.

- For the measurement of spurious emissions below the second harmonic of the carrier frequency the filter used shall be a high 'Q' (notch) filter centred on the transmitter carrier frequency and attenuating this signal by at least 30 dB.
  - For the measurement of spurious emissions at and above the second harmonic of the carrier frequency the filter used shall be a high pass filter with a stop band rejection exceeding 40 dB. The cut-off frequency of the high pass filter shall be approximately 1,5 times the transmitter carrier frequency.
  - The transmitter under test shall be placed on the support in its standard position (clause A.2) and shall be switched on without modulation.
- b) The radiation of any spurious emission shall be detected by the test antenna and spectrum analyser or selective voltmeter over the frequency range 30 MHz to 4 GHz, except for the channel on which the transmitter is intended to operate and its adjacent channels. In addition, for equipment operating on frequencies above 470 MHz, measurements shall be repeated over the frequency range 4 GHz to 12,75 GHz. The frequency of each spurious emission detected shall be recorded. If the test site is disturbed by interference coming from outside, this qualitative search may be performed in a screened room, with a reduced distance between the transmitter and the test antenna.
- c) At each frequency at which an emission has been detected, the spectrum analyser or selective voltmeter shall be tuned and the test antenna shall be raised or lowered through the specified height range until the maximum signal level is detected on the spectrum analyser or selective voltmeter.
- d) The transmitter shall be rotated through 360° about a vertical axis, until a higher maximum signal is received.
- e) The test antenna shall be raised or lowered again through the specified height range until a new maximum is obtained. This level shall be recorded.
- The test antenna may not need to be raised or lowered if the measurement is carried out on a test site according to clause A.1.2.

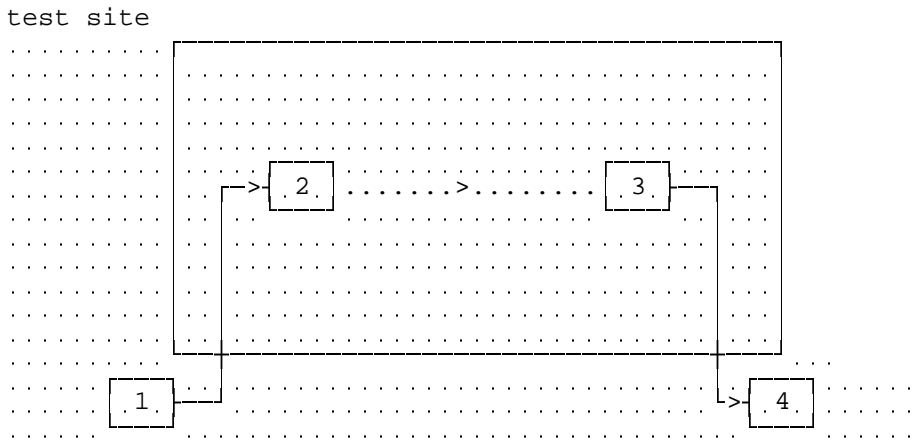

NOTE 1: Signal generator.

NOTE 2: Substitution antenna.

NOTE 3: Test antenna.

NOTE 4: Spectrum analyser or selective voltmeter (test receiver).

**Figure 9: Measurement arrangement**

- f) Using the measurement arrangement of figure 9, the substitution antenna shall replace the transmitter antenna in the same position and in vertical polarization. It shall be connected to the signal generator.
- g) At each frequency at which an emission has been detected, the signal generator, substitution antenna and spectrum analyser or selective voltmeter shall be correspondingly tuned. The test antenna shall be raised or lowered through the specified height range until the maximum signal level is detected on the spectrum analyser or selective voltmeter.
- The test antenna may not need to be raised or lowered if the measurement is carried out on a test site according to clause A.1.2.
  - The level of the signal generator giving the same signal level on the spectrum analyser or selective voltmeter as in item e) above shall be recorded. This value, after corrections due to the gain of the substitution antenna and the cable loss between the signal generator and the substitution antenna, is the radiated spurious emission at this frequency.
  - The resolution bandwidth of the measuring instrument shall be the smallest bandwidth available which is greater than the spectral width of the spurious component being measured. This shall be considered to be achieved when the next highest bandwidth causes less than 1 dB increase in amplitude. The conditions used in the measurement shall be recorded in test reports.
- h) Steps c) to g) above shall be repeated with the test antenna oriented in horizontal polarization.
- i) Steps c) to h) above shall be repeated with the transmitter in stand-by condition if this option is available.

## 8.6 Transient frequency behaviour of the transmitter

This measurement does not apply to transmitters intended for continuous transmission only.

### 8.6.1 Definitions

**Transient frequency behaviour of the transmitter:** the variation in time of the transmitter frequency difference from the nominal frequency of the transmitter when the RF output power is switched on and off.

- $t_{on}$ : according to the method of measurement described in clause 8.6.2 the switch-on instant  $t_{on}$  of a transmitter is defined by the condition when the output power, measured at the antenna terminal, exceeds 0,1 % of the full output power (-30 dBc).
- $t_1$ : period of time starting at  $t_{on}$  and finishing according to table 4, clause 5.1.6.
- $t_2$ : period of time starting at the end of  $t_1$  and finishing according to table 4, clause 5.1.6.
- $t_{off}$ : switch-off instant defined by the condition when the output power falls below 0,1 % of the full output power (-30 dBc).
- $t_3$ : period of time that finishing at  $t_{off}$  and starting according to table 4, clause 5.1.6.

### 8.6.2 Method of measurement

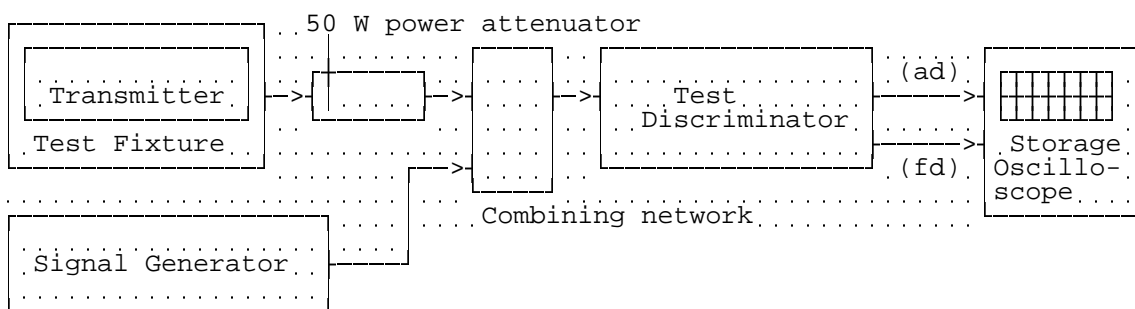

**Figure 10: Measurement arrangement**

The transmitter shall be placed in the test fixture (clause A.6) and the measurement arrangement shown in figure 10 shall be used.

Two signals shall be connected to the test discriminator (annex D) via a combining network, clause 7.6.

The transmitter output from the test fixture shall be connected to a 50  $\Omega$  power attenuator.

The output of the power attenuator shall be connected to the test discriminator via one input of the combining network.

A test signal generator shall be connected to the second input of the combining network.

The test signal shall be adjusted to the nominal frequency of the transmitter.

The test signal shall be modulated by a frequency of 1 kHz with a deviation equal to  $\pm$  the value of the relevant channel separation.

The test signal level shall be adjusted to correspond to 0,1 % of the power of the transmitter under test measured at the input of the test discriminator. This level shall be maintained throughout the measurement.

The amplitude difference (ad) and the frequency difference (fd) output of the test discriminator shall be connected to a storage oscilloscope.

The storage oscilloscope shall be set to display the channel corresponding to the (fd) input up to  $\pm 1$  channel frequency difference, corresponding to the relevant channel separation, from the nominal frequency.

The storage oscilloscope shall be set to a sweep rate of 10 ms/div and set so that the triggering occurs at 1 div from the left edge of the display.

The display will show the 1 kHz test signal continuously.

The storage oscilloscope shall then be set to trigger on the channel corresponding to the amplitude difference (ad) input at a low input level, rising.

The transmitter shall then be switched on, without modulation, to produce the trigger pulse and a picture on the display.

The result of the change in the ratio of power between the test signal and the transmitter output will, due to the capture ratio of the test discriminator, produce two separate sides on the picture, one showing the 1 kHz test signal, the other the frequency difference of the transmitter versus time.

The moment when the 1 kHz test signal is completely suppressed is considered to provide  $t_{on}$ .

The periods of time  $t_1$  and  $t_2$  as defined in table 4, clause 5.1.6, shall be used to define the appropriate template.

During the period of time  $t_1$  and  $t_2$  the frequency difference shall not exceed the values given in clause 5.1.6.

The frequency difference, after the end of  $t_2$ , shall be within the limit of the frequency error, clause 5.1.1.

The result shall be recorded as frequency difference versus time.

The transmitter shall remain switched on.

The storage oscilloscope shall be set to trigger on the channel corresponding to the amplitude difference (ad) input at a high input level, decaying and set so that the triggering occurs at 1 div. from the right edge of the display.

The transmitter shall then be switched off.

The moment when the 1 kHz test signal starts to rise is considered to provide  $t_{off}$ .

The period of time  $t_3$  as defined in table 4, clause 5.1.6, shall be used to define the appropriate template.

During the period of time  $t_3$  the frequency difference shall not exceed the values given in clause 5.1.6.

Before the start of  $t_3$  the frequency difference shall be within the limit of the frequency error, clause 5.1.1.

The result shall be recorded as frequency difference versus time.

Figure 11 represents the storage oscilloscope view  $t_1$ ,  $t_2$  and  $t_3$  for the case of equipment operating in the frequency range 300 MHz to 500 MHz.

If the display of the oscilloscope shows a large impulse immediately after the end of the calibration signal, there is a risk that this signal may be caused by the phase shift between the calibration signal and the transmitter.

To identify the source of the impulse, the following method can be used.

The impulse can be evaluated by repeating the test, e.g. for three times.

If the impulse remains constant in amplitude and exceeds the limit then the transmitter fails to meet the test.

If the impulse changes amplitude it is a phase shift occurring from the method of testing and this impulse shall be disregarded in the assessment of the test results.



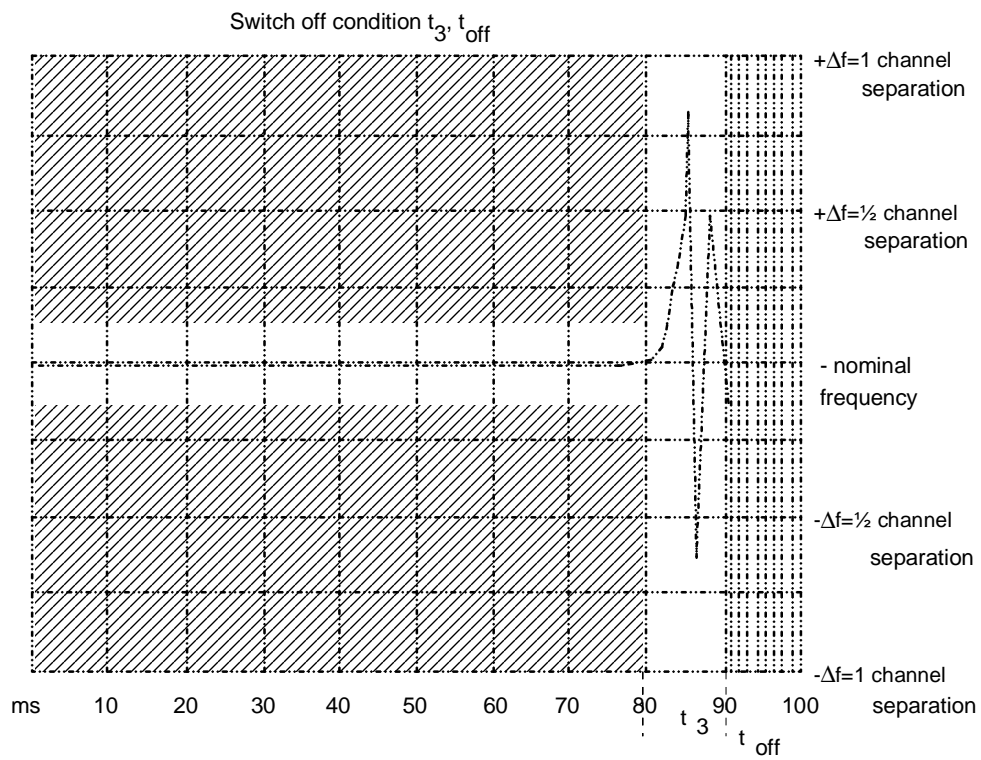
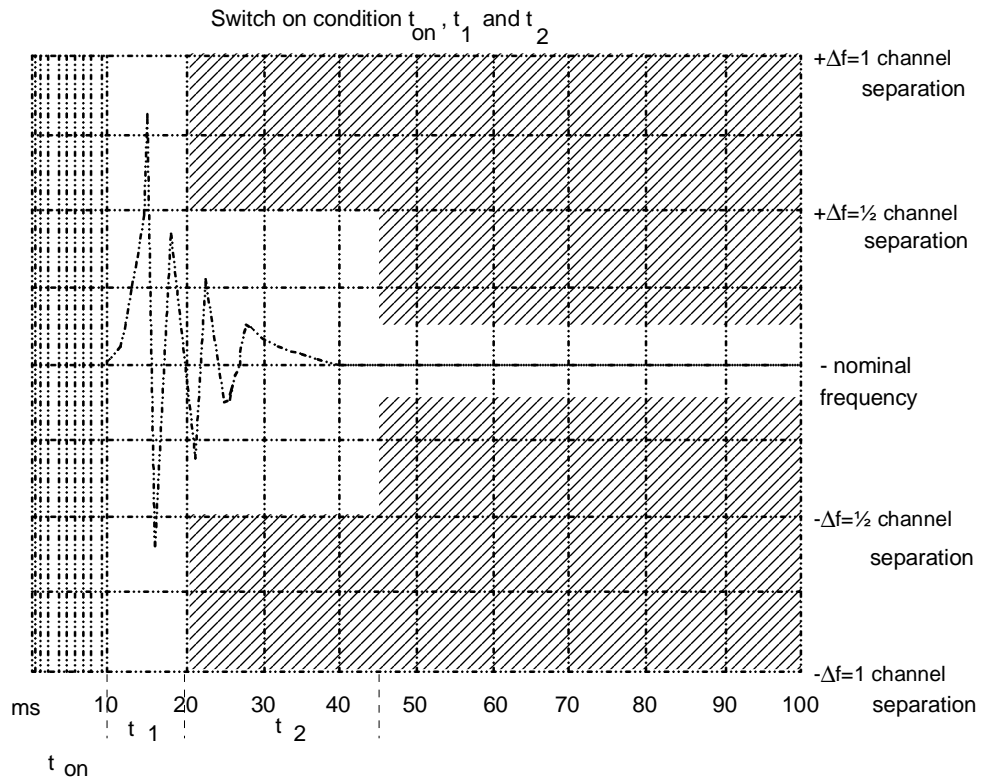

Figure 11: Storage oscilloscope view  $t_1$ ,  $t_2$  and  $t_3$

## 9 Methods of measurement for receiver parameters

### 9.1 Average usable sensitivity (field strength, speech)

#### 9.1.1 Definition

The average usable sensitivity (speech) expressed as field strength is the average field strength, expressed in  $\text{dB}\mu\text{V}/\text{m}$ , produced by a carrier at the nominal frequency of the receiver, modulated with the normal test signal (see clause 7.1) which will, without interference, produce after demodulation a SINAD ratio of 20 dB measured through a psophometric weighting network. The average is calculated from 8 measurements of field strength when the receiver is rotated in  $45^\circ$  increments starting at a particular orientation.

NOTE: The average usable sensitivity mostly differs only by a small amount from the maximum usable sensitivity to be found in a particular direction. This is due to the properties of the averaging process as used in the formula in clause 9.1.2 g). For instance, an error not exceeding 1,2 dB can be found if the sensitivity is equal in seven directions and is extremely bad in the eighth direction. For the same reason the starting direction (or angle) can be selected randomly.

#### 9.1.2 Method of measurement under normal test conditions

Arrangements shall be made to couple the equipment under test to the SINAD meter by a method which does not affect the radiated field (clause A.3).

A test site which fulfils the requirements for the specified frequency range of this measurement shall be used. The test antenna shall be orientated for vertical polarization or for the polarization in which the equipment under test is intended to operate.

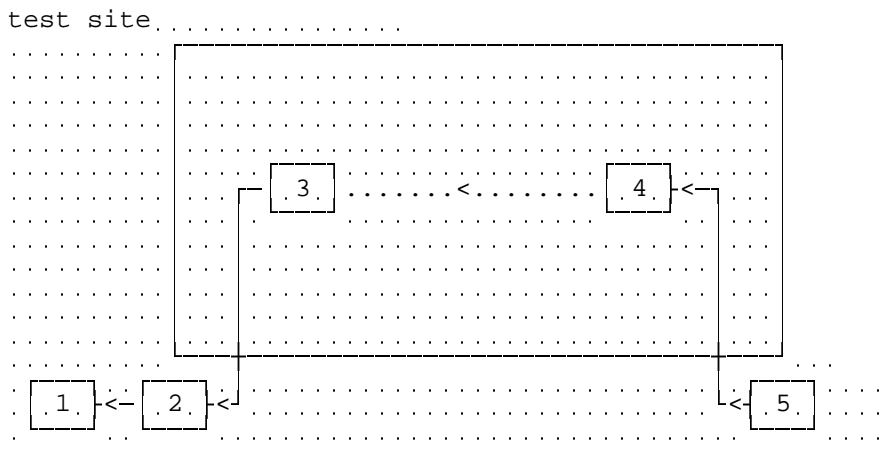

NOTE 1: SINAD meter and psophometric weighting network.

NOTE 2: AF load/acoustic coupler.

NOTE 3: Receiver under test.

NOTE 4: Test antenna.

NOTE 5: Signal generator.

**Figure 12: Measurement arrangement**

The receiver under test shall be placed on the support in its standard position (clause A.2) in a random orientation. A distortion factor meter incorporating a 1 000 Hz band-stop filter (or a SINAD meter) shall be connected to the receiver output terminals via a psophometric filter and an audio frequency load or by an acoustic coupler (see clause A.3.1) in order to avoid disturbing the electromagnetic field in the vicinity of the equipment.

The measurement procedure shall be as follows:

- a) A signal generator shall be connected to the test antenna:
  - the signal generator shall be at the nominal frequency of the receiver and shall be modulated by the normal test modulation A-M1 (see clause 7.1).
- b) Where possible, the receiver volume control shall be adjusted to give at least 50 % of the rated output power, clause 7.8, or, in the case of stepped volume controls, to the first step that provides an output power of at least 50 % of the rated output power:
  - the SINAD ratio shall be monitored.
- c) The level of the signal generator shall be adjusted until a psophometrically weighted SINAD ratio (or its acoustic equivalent) of 20 dB is obtained.
- d) The test antenna shall be raised or lowered through the specified height range to find the best psophometrically weighted SINAD ratio (or its acoustic equivalent).
- e) The level of the signal generator shall be re-adjusted until a SINAD ratio of 20 dB is obtained.
- f) The minimum signal generator level from step d) shall be noted.
- g) Steps c) to f) shall be repeated for the remaining seven positions 45° apart of the receiver and the corresponding values of the signal generator output which produces the psophometrically weighted SINAD ratio of 20 dB again (or its acoustic equivalent) shall be determined and noted.
- h) Using the relationship in clause A.1.1.2 (substitution method), calculate and record the eight field strengths  $X_i$  ( $i = 1, \dots, 8$ ) in  $\mu\text{V}/\text{m}$  corresponding to the levels of the signal generator noted above.
- i) The average usable sensitivity expressed as field strength  $E_{\text{mean}}$  ( $\text{dB}\mu\text{V}/\text{m}$ ) is given by:

$$E_{\text{mean}} = 20 \log \left( \sqrt{\frac{8}{\sum_{i=1}^8 \frac{1}{X_i^2}}} \right)$$

- where  $X_i$  represents each of the eight field strengths calculated in step h).
- j) The reference direction is defined as the direction at which the maximum sensitivity (i.e. corresponding to the minimum field strength recorded during the measurement) occurred in the eight position measurement:
  - the corresponding direction, height (where applicable) and this reference field strength value shall be recorded.

### 9.1.3 Method of measurement under extreme test conditions

Using the test fixture in the measurement arrangement of figure 13, the measurement of the average usable sensitivity shall also be performed under extreme test conditions.

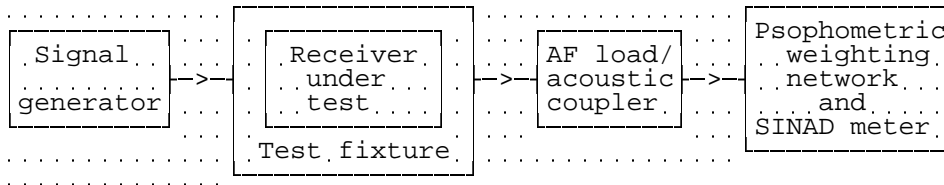

**Figure 13: Measurement arrangement**

The test signal input level providing a psophometrically weighted SINAD ratio of 20 dB (or its acoustic equivalent) shall be determined under extreme and under normal test conditions and the difference in dB shall be calculated. This difference shall be added to the average usable sensitivity to radiated fields expressed in dB $\mu$ V/m, as calculated in clause 9.1.2 step i), under normal test conditions, to obtain the sensitivity under extreme test conditions.

### 9.1.4 Reference for degradation measurements

#### 9.1.4.1 Definition

Degradation measurements are those measurements which are made on the receiver to establish the degradation of the performance of the receiver due to the presence of (an) unwanted (interfering) signal(s). For such measurements, the level of the wanted signal shall be adjusted to the level of the limit of the average usable sensitivity.

Degradation measurements are in two categories:

- a) those carried out on a test site (see clauses 9.5 (spurious response rejection), 9.7 (blocking or desensitization), and A.1);
- b) those carried out using a test fixture (see clauses 9.3 (co-channel rejection), 9.4 (adjacent channel selectivity), 9.6 (intermodulation response rejection) and A.6).

The test fixture is only used for those tests where the difference in frequency between the wanted and the unwanted test signals is very small in relation to the actual frequency, so that the coupling loss is the same for the wanted and unwanted test signals fed into the test fixture.

#### 9.1.4.2 Procedures for measurements using the test fixture

The test fixture is coupled to the signal generators via a combining network to provide the wanted and unwanted test input signals to the receiver in the test fixture. It is necessary therefore to establish the output level of the wanted test signal from the signal generator that results in a signal at the receiver (in the test fixture), which corresponds with the average usable sensitivity (radiated) as specified in clause 5.2.1.

This test output level from the signal generator for the wanted test signal is then used for all the receiver measurements using the test fixture.

The method for determining the test output level from the signal generator is as follows:

- a) the actual average usable sensitivity of the receiver is measured in accordance with clause 9.1.2 i) and expressed as a field strength;
- b) the difference between the limit of the average usable sensitivity specified in clause 5.2.1 and this actual average usable sensitivity, expressed in dB, is noted;

- c) the receiver is then mounted in the test fixture;
- the signal generator providing the wanted input signal is coupled to the test fixture via a combining network. All other input ports of the combining network are terminated in  $50 \Omega$  loads;
  - the output from the signal generator with normal test modulation A-M1 (see clause 7.1) is adjusted so that a SINAD ratio of 20 dB is obtained (with a psophometric filter). This output level is then increased by an amount corresponding to the difference expressed in dB calculated in clause 9.1.4.2 b);
  - the output level of the signal generator is defined as being the level equivalent to the limit of the average usable sensitivity, for the category of equipment used, expressed as a field strength (see clause 5.2.1).

### 9.1.4.3 Procedures for measurements using the test site

When measurements are carried out on a test site, the wanted and unwanted signals shall be calibrated in terms of  $\text{dB}\mu\text{V}/\text{m}$  at the location of the equipment under test.

For measurements according to clauses 9.5 (spurious response rejection), 9.7 (blocking or desensitization) and A.2, the height of the test antenna and the direction (angle) of the equipment under test shall be that recorded in clause 9.1.2 j) (reference direction).

## 9.2 Amplitude characteristic of receiver limiter

### 9.2.1 Definition

The amplitude characteristic of the receiver limiter is the relationship between the radio frequency input level of a specified modulated signal and the audio frequency level at the receiver output.

### 9.2.2 Method of measurement

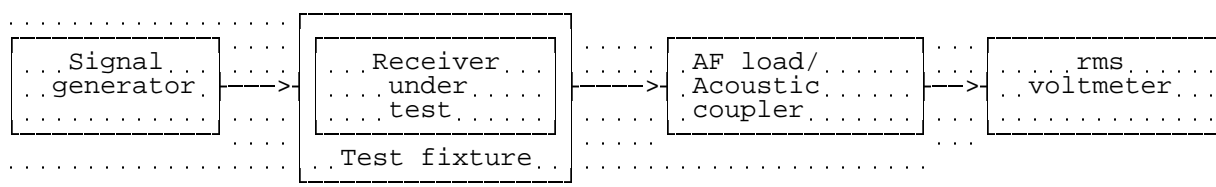

**Figure 14: Measurement arrangement**

The measurement procedure shall be as follows:

- a) The receiver shall be placed in the test fixture.

A test signal at the nominal frequency of the receiver, with test modulation A-M1 (clause 7.1) at a level which is equivalent to the limit of the average usable sensitivity, for the category of equipment used, expressed as a field strength (clause 5.2.1) shall be applied to the input of the test fixture.

- b) The audio output shall be adjusted to give a level of approximately 25 % of the rated output power (clause 7.8). In the case of a stepped volume control, the control shall be set to the first step that provides an output power of at least 25 % of the rated output power.

The level shall be recorded.

- c) The input signal shall be increased by 70 dB and the level of the audio output shall be recorded;
- d) The amplitude characteristic of the receiver is recorded as the change in level of the audio output measured in steps b) and c) expressed in dB.

## 9.3 Co-channel rejection

### 9.3.1 Definition

The co-channel rejection is a measure of the capability of the receiver to receive a wanted modulated signal without exceeding a given degradation due to the presence of an unwanted modulated signal, both signals being at the nominal frequency of the receiver.

### 9.3.2 Method of measurement

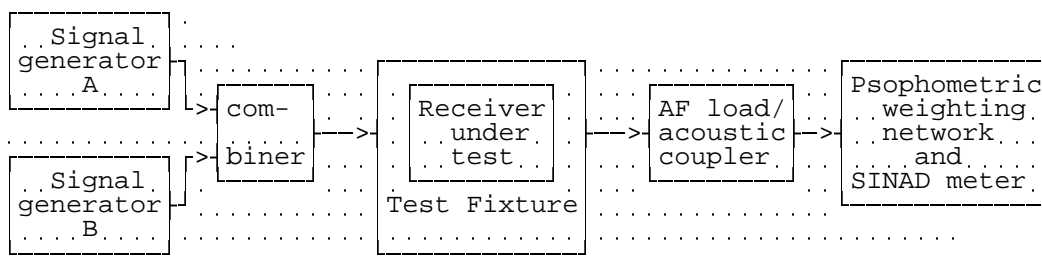

**Figure 15: Measurement arrangement**

The measurement procedure shall be as follows:

- a) the receiver shall be placed in the test fixture (clause A.6).

Two signal generators A and B shall be connected to the test fixture via a combining network.

The wanted signal, provided by signal generator A, shall be at the nominal frequency of the receiver and shall have normal test modulation A-M1 (see clause 7.1).

The unwanted signal, provided by signal generator B, shall be modulated with signal A-M3 (see clause 7.1). Both input signals shall be at the nominal frequency of the receiver under test.

- b) Initially, signal generator B (unwanted signal) shall be switched off (maintaining its output impedance).

The level of the wanted signal from generator A shall be adjusted to a level which is equivalent to the level of the limit of the average usable sensitivity, for the category of equipment used, expressed as a field strength (clauses 5.2.1 and 9.1.4).

Where possible, the receiver volume control shall be adjusted to give at least 50 % of the rated output power, clause 7.8, or, in the case of stepped volume controls, to the first step that provides an output power of at least 50 % of the rated output power.

- c) The unwanted signal from generator B shall then be switched on;
- d) The level of signal generator B shall be adjusted so that the unwanted signal causes:
  - a reduction of 3 dB in the output level of the wanted signal; or
  - a reduction to 14 dB of the SINAD ratio at the receiver output (with a psophometric filter), whether or not measured acoustically;

whichever occurs first.

- e) The level of the unwanted signal shall be noted;
- f) For each frequency of the unwanted signal, the co-channel rejection ratio shall be expressed as the ratio, in dB, of the level of the unwanted signal to the level of the wanted signal.

This ratio shall be recorded.

- g) The measurement shall be repeated for displacements of the unwanted signal of  $\pm 6\%$  and  $\pm 12\%$  of the channel separation;

- h) The co-channel rejection of the equipment under test shall be expressed as the lowest of the five values expressed in dB, recorded in step f).

The value of the co-channel rejection ratio, expressed in dB, is generally negative (therefore, for example, -12 dB is lower than -8 dB).

## 9.4 Adjacent channel selectivity

### 9.4.1 Definition

The adjacent channel selectivity is a measure of the capability of the receiver to receive a wanted modulated signal without exceeding a given degradation due to the presence of an unwanted signal which differs in frequency from the wanted signal by an amount equal to the adjacent channel separation for which the equipment is intended.

### 9.4.2 Method of measurement

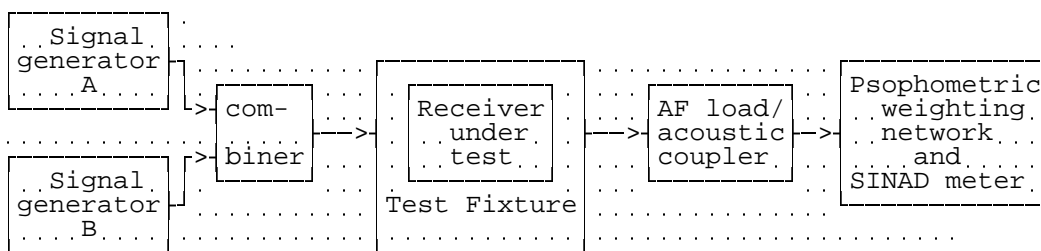

**Figure 16: Measurement arrangement**

The measurement procedure shall be as follows:

- a) The receiver shall be placed in the test fixture (clause A.6).

Two signal generators A and B shall be connected to the test fixture via a combining network.

The wanted signal, provided by signal generator A, shall be at the nominal frequency of the receiver and shall have normal test modulation A-M1 (see clause 7.1).

The unwanted signal, provided by signal generator B, shall be modulated with signal A-M3 (see clause 7.1) and shall be at the frequency of the channel immediately above that of the wanted signal.

- b) Initially, signal generator B (unwanted signal) shall be switched off (maintaining the output impedance).

The level of the wanted signal from generator A shall be adjusted to the level which is equivalent to the level of the limit of the average usable sensitivity, for the category of equipment used, expressed as a field strength (clauses 5.2.1 and 9.1.4).

Where possible, the receiver volume control shall be adjusted to give at least 50 % of the rated output power, clause 7.8, or, in the case of stepped volume controls, to the first step that provides an output power of at least 50 % of the rated output power.

- c) The unwanted signal from signal generator B shall then be switched on;
- d) The level of signal generator B shall be adjusted so that the unwanted signal causes:
- a reduction of 3 dB in the output level of the wanted signal; or
  - a reduction to 14 dB of the SINAD ratio at the receiver output (with a psophometric filter), whether or not measured acoustically;

whichever occurs first.

- e) The level of the unwanted signal shall be noted;

- f) For each adjacent channel, the selectivity shall be expressed as the ratio in dB of level of the unwanted signal to the level of the wanted signal.

It shall then be converted back into field strengths of the unwanted signals at the receiver location and expressed in dB $\mu$ V/m.

This value shall be recorded.

- g) The measurement shall be repeated with the unwanted signal at the frequency of the channel below that of the wanted signal;
- h) The adjacent channel selectivity of the equipment under test shall be expressed as the lower of the two values calculated in step f) for the upper and lower channels nearest to the receiving channel;
- i) The measurement shall be repeated under extreme test conditions (clauses 6.4.1 and 6.4.2 applied simultaneously), with the level of the wanted signal adjusted to a level which is equivalent to the level of the limit of the average usable sensitivity (under extreme test conditions), for the category of equipment used, expressed as a field strength (see clauses 5.2.1 and 9.1.4).

## 9.5 Spurious response rejection

Spurious responses may occur at all frequencies throughout the frequency spectrum and the requirements of the present document shall be met for all frequencies. However, for practical reasons the measurements shall be performed as specified in the present document. More specifically, this method of measurement is not intended to capture all spurious responses but selects those that have a high probability of being present. However, in a limited frequency range close to the nominal frequency of the receiver, it has been considered impossible to determine the probability of a spurious response and therefore a search shall be performed over this limited frequency range. This method provides a high degree of confidence that the equipment also meets the requirements at frequencies not being measured.

### 9.5.1 Definition

The spurious response rejection is a measure of the capability of the receiver to receive a wanted modulated signal without exceeding a given degradation due to the presence of an unwanted modulated signal at any other frequency, at which a response is obtained.

### 9.5.2 Introduction to the method of measurement

To determine the frequencies at which spurious responses can occur the following calculations shall be made:

- a) Calculation of the "limited frequency range":
- the limited frequency range is defined as the frequency of the local oscillator signal ( $f_{LO}$ ) applied to the 1<sup>st</sup> mixer of the receiver plus or minus the sum of the intermediate frequencies ( $f_{i1}, \dots, f_{in}$ ) and a half the switching range (sr) of the receiver, see clause 4.

Hence, the frequency  $f_l$  of the limited frequency range is:

$$f_{LO} - \sum_{j=1}^{j=n} f_{Ij} - \frac{SR}{2} \leq f_l \leq f_{LO} + \sum_{j=1}^{j=n} f_{Ij} + \frac{SR}{2}$$



b) Calculation of frequencies outside the limited frequency range:

- a calculation of the frequencies at which spurious responses can occur outside the range determined in a) is made for the remainder of the frequency range of interest, as appropriate, see clause 9.5.5 d);
- the frequencies outside the limited frequency range are equal to the harmonics of the frequency of the local oscillator signal ( $f_{LO}$ ) applied to the 1st mixer of the receiver plus or minus the 1st intermediate frequency ( $f_{IF}$ ) of the receiver;
- hence, the frequencies of these spurious responses are:
  - $n f_{LO} \pm f_{IF}$ ;

where  $n$  is an integer greater than or equal to 2.

The measurement of the first image response of the receiver shall initially be made to verify the calculation of spurious response frequencies.

For the calculations a) and b) above, the manufacturer shall state the frequency of the receiver, the frequency of the local oscillator signal ( $f_{LO}$ ) applied to the 1st mixer of the receiver, the intermediate frequencies ( $f_{IF}$ ,  $f_{IF2}$ , etc.), and the switching range ( $sr$ ) of the receiver.

### 9.5.3 Measurement arrangement

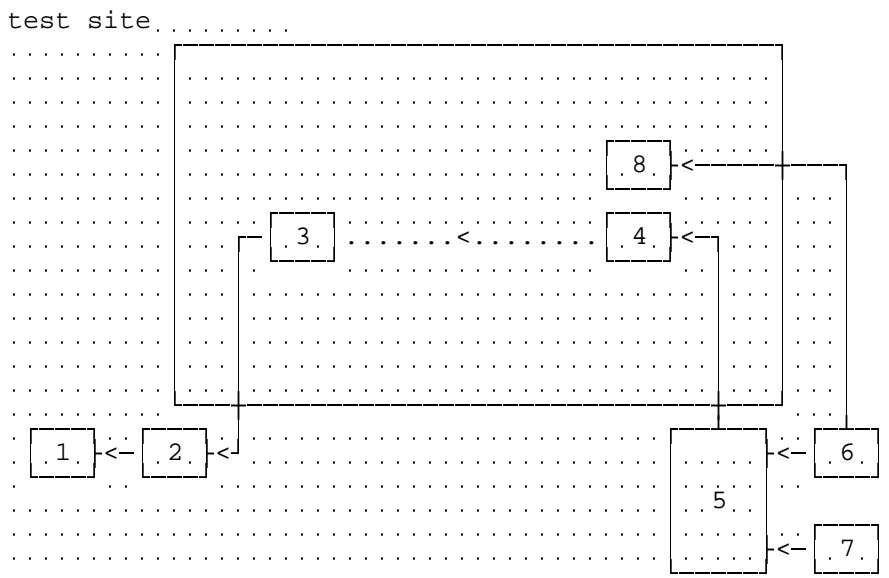

- NOTE 1: Psophometric weighting network and SINAD meter.  
 NOTE 2: AF load/acoustic coupler.  
 NOTE 3: Receiver under test.  
 NOTE 4: Wide band test antenna.  
 NOTE 5: Combining network (used only when one antenna is used).  
 NOTE 6: Signal generator A.  
 NOTE 7: Signal generator B.  
 NOTE 8: Test antenna for the wanted signal (see clause 9.5.3 e)).

**Figure 17: Measurement arrangement**

The measurement arrangements shall be as follows:

- a) A test site corresponding to that for the measurement of the average usable sensitivity shall be used (see clause 9.1);
- b) The height of the wide band test antenna and the direction (angle) of the equipment under test shall be positioned as indicated in clauses 9.1.2 and 9.1.4;
- c) During the course of the measurement it may be necessary to radiate high powers in a broad frequency range, and care must be taken to avoid the signals causing interference to existing services that may be operating in the neighbourhood;

- d) In the presence of a reflective ground plane the height of the wide band test antenna has to be altered to optimize the reflections from the ground plane. This cannot be done simultaneously for two different frequencies.

If vertical polarization is used, the ground floor reflection can be effectively eliminated by the use of an appropriate monopole located directly on the ground plane (rod antenna).

- e) In case the wide band test antenna does not cover the necessary frequency range, alternatively two different and sufficiently decoupled antennas may be used;
- f) The equipment under test shall be placed on the support in its standard position (see clause A.2) and in the reference direction as indicated in clauses 9.1.2 and 9.1.4.

#### 9.5.4 Method of the search

The search shall be performed as follows, using the arrangement of clause 9.5.3.

- a) Two signal generators A and B shall be connected to the wide band test antenna via a combining network, where appropriate, or alternatively to two different antennas in accordance with clause 9.5.3 e).

The wanted signal, provided by signal generator A, shall be at the nominal frequency of the receiver and shall have normal test modulation A-M1 (see clause 7.1).

The unwanted signal, provided by signal generator B, shall be modulated with a frequency of 400 Hz at a level producing a deviation of  $\pm 5$  kHz.

- b) Initially, signal generator B (unwanted signal) shall be switched off (maintaining the output impedance).

The level of the wanted signal from generator A shall be adjusted to the level of the limit of the average usable sensitivity, for the category of equipment used, expressed as a field strength, and by using the calibration in the procedure of clause 9.1.4.3 (see clauses 5.2.1 and 9.1.4).

- c) The unwanted signal from generator B shall then be switched on.

The level of signal generator B shall be adjusted to provide a field strength which is at least 10 dB above the limit of the spurious response rejection (see clause 5.2.5) measured at the receiver location, even when on some types of test sites the level of the unwanted signal varies considerably with the frequency due to ground reflections.

The frequency of the unwanted signal shall be varied in increments of 10 kHz over the limited frequency range (see clause 9.5.2 a) and over the frequencies in accordance with the calculations outside of this frequency range (see clause 9.5.2 b).

- d) The SINAD ratio shall be monitored;
- e) If the SINAD ratio is better than 20 dB then no spurious response effects have been detected and the measurement shall be continued on the next increment of frequency;
- f) If the SINAD ratio is worse than 20 dB then the level of the unwanted signal shall be reduced in steps of 1 dB until a SINAD ratio of 20 dB or better is obtained;
- g) In the case where a reflective ground floor is used the antenna height shall be varied as appropriate, at each change of unwanted signal level in an attempt to obtain a SINAD ratio of 20 dB or better.

The test antenna may not need to be raised or lowered if a test site according to clause A.1.2 is used, or if the ground floor reflection can effectively be eliminated (see clause 9.5.3 d).

- h) The frequency of any spurious response detected during the search, and the antenna position and its height shall be recorded for the use in the measurements in accordance with clause 9.5.5.

## 9.5.5 Method of measurement

At each frequency where a spurious response has been found, within and outside the limited frequency range, the measurement shall be performed as follows.

- a) The measurement arrangement is identical to that in clause 9.5.4.

Two signal generators A and B shall be connected to the wide band test antenna via a combining network, where appropriate, or alternatively to two different antennas in accordance with clause 9.5.3 e).

The wanted signal, provided by signal generator A, shall be at the nominal frequency of the receiver and shall have normal test modulation A-M1 (see clause 7.1).

The unwanted signal, provided by signal generator B, shall be modulated with a frequency of 400 Hz with a deviation of 12 % of the channel separation (A-M3).

- b) Initially, signal generator B (unwanted signal) shall be switched off (maintaining the output impedance).

The level of the wanted signal from signal generator A shall be adjusted to the level of the limit of the average usable sensitivity (see clause 9.1.4), for the category of equipment used (see clause 5.2.1), expressed in field strength when measured at the receiver location.

Where possible, the receiver volume control shall be adjusted to give at least 50 % of the rated output power, clause 7.8, or, in the case of stepped volume controls, to the first step that provides an output power of at least 50 % of the rated output power.

- c) The unwanted signal from generator B shall then be switched on;
- d) The SINAD ratio shall be monitored;
- e) The level of the unwanted signal shall be adjusted until a SINAD ratio of 14 dB with a psophometric filter is obtained.

The level of the unwanted signal shall then be noted.

- f) The frequency of the unwanted signal shall be stepped up and down in increments of 20 % of the channel separation and step e) shall be repeated until the lowest level is found.

For each frequency, the spurious response rejection shall be expressed as the level in dB $\mu$ V of the field strength of the unwanted signal at the receiver location, corresponding to the lowest value noted during steps e).

This value shall be recorded.

- g) The measurement shall be repeated at all spurious response frequencies found during the search over the limited frequency range, clause 9.5.2, and at frequencies calculated for the remainder of the spurious response frequencies in the frequency range  $f_{RX}/3,2$  MHz or 30 MHz, whichever is higher to  $3,2 \times f_{RX}$ , where  $f_{RX}$  is the nominal frequency of the receiver, with the antenna position and height noted in clause 9.5.4 h);
- h) The spurious response rejection of the equipment under test shall be expressed as the level in dB $\mu$ V/m of the field strength of the unwanted signal, at the receiver location, corresponding to the lowest value recorded in step f).

## 9.6 Intermodulation response rejection

### 9.6.1 Definition

The intermodulation response rejection is a measure of the capability of the receiver to receive a wanted modulated signal, without exceeding a given degradation due to the presence of two or more unwanted signals with a specific frequency relationship to the wanted signal frequency.

## 9.6.2 Method of measurement

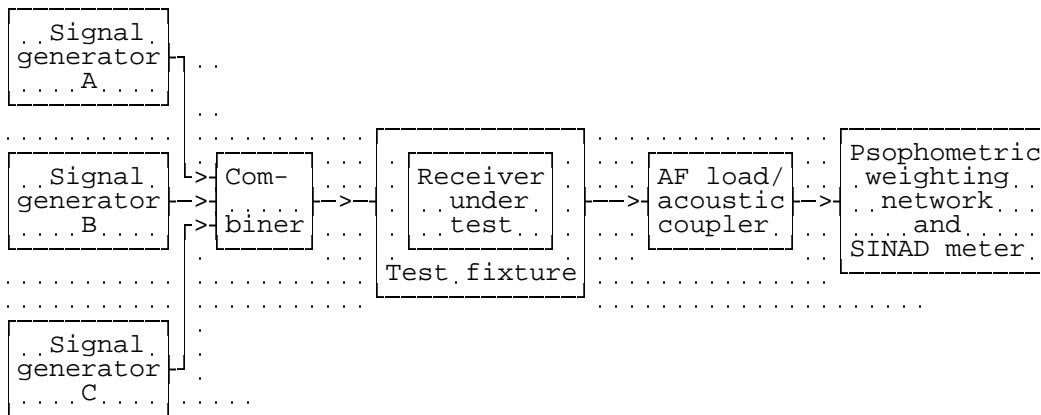

**Figure 18: Measurement arrangement**

The measurement procedure shall be as follows:

- a) The receiver shall be placed in a test fixture (clause A.6).

Three signal generators, A, B and C shall be connected to the test fixture via a combining network.

The wanted signal, provided by signal generator A, shall be at the nominal frequency of the receiver and shall have normal test modulation A-M1 (see clause 7.1).

The first unwanted signal, provided by signal generator B, shall be unmodulated and adjusted to the frequency 50 kHz above the nominal frequency of the receiver.

The second unwanted signal, provided by signal generator C, shall be modulated with signal A-M3 (see clause 7.1) and adjusted to a frequency 100 kHz above the nominal frequency of the receiver.

- b) Initially, signal generators B and C (unwanted signals) shall be switched off (maintaining the output impedances).

The level of the wanted signal from generator A shall be adjusted to a level which is equivalent to the level of the limit of the average usable sensitivity, for the category of equipment used, expressed as a field strength (clauses 5.2.1 and 9.1.4).

Where possible, the receiver volume control shall be adjusted to give at least 50 % of the rated output power, clause 7.8, or, in the case of stepped volume controls, to the first step that provides an output power of at least 50 % of the rated output power.

- c) The two unwanted signals from signal generators B and C shall then be switched on;
- d) Their levels shall be maintained equal and shall be adjusted so that the unwanted signal causes:
  - a reduction of 3 dB in the output level of the wanted signal; or
  - a reduction to 14 dB of the SINAD ratio at the receiver output (with a psophometric filter) whether or not measured acoustically;

whichever occurs first.

- e) The level of the unwanted signals shall be noted;
- f) For each configuration of the unwanted signals, the intermodulation response rejection shall be expressed as the ratio in dB of the level of the unwanted signals to the level of the wanted signal.

It shall then be converted back into field strength of the unwanted signals at the receiver location and expressed in  $\text{dB}\mu\text{V}/\text{m}$ .

This value shall be recorded.

- g) The measurement shall be repeated with the unwanted signal generator B at the frequency 50 kHz below that of the wanted signal and the frequency of the unwanted signal generator C at the frequency 100 kHz below that of the wanted signal;
- h) the intermodulation response rejection of the equipment under test shall be expressed as the lower of the two values recorded in step f).

## 9.7 Blocking or desensitization

### 9.7.1 Definition

Blocking or desensitization is a measure of the capability of the receiver to receive a wanted modulated signal without exceeding a given degradation due to the presence of an unwanted signal at any frequency other than those of the spurious responses or of the adjacent channels.

### 9.7.2 Method of measurement

- 1) Psophometric weighting network and SINAD meter;
- 2) AF load/acoustic coupler;
- 3) Receiver under test;
- 4) Wide band test antenna;
- 5) Combining network;
- 6) Signal generator A;
- 7) Signal generator B.

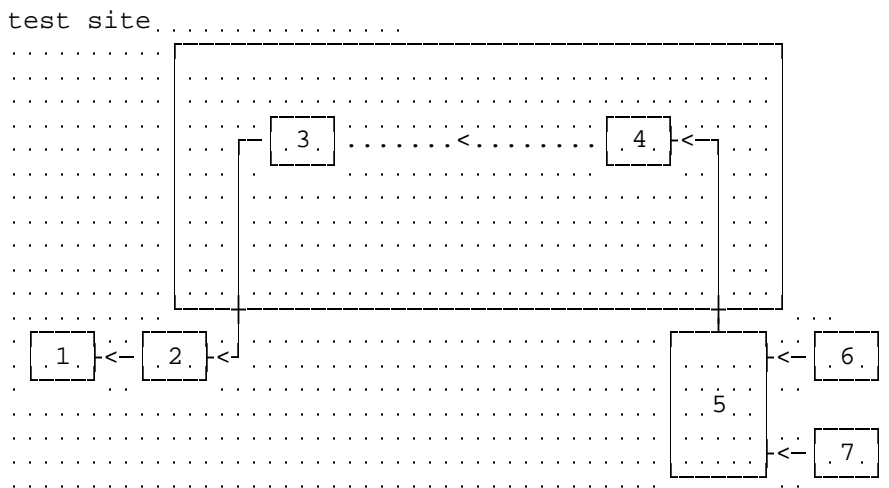

**Figure 19: Measurement arrangement**

A test site corresponding to that for the measurement of the average usable sensitivity shall be used (see clause 9.1).

The equipment under test shall be placed on the support in its standard position (see clause A.2) and in the reference direction (see clause 9.1.2 k)).

The measurement procedure shall be as follows:

- a) Two signals generators A and B shall be connected to the wideband test antenna via a combining network.

The wanted signal, provided by signal generator A, shall be at the nominal frequency of the receiver and shall have normal test modulation A-M1, (see clause 7.1).

The unwanted signal, provided by signal generator B, shall be unmodulated and shall be at a frequency from 1 MHz to 10 MHz away from the nominal frequency of the receiver.

For practical reasons the measurements shall be carried out at frequencies of the unwanted signal at approximately  $\pm 1$  MHz,  $\pm 2$  MHz,  $\pm 5$  MHz and  $\pm 10$  MHz, avoiding those frequencies at which spurious responses occur (see clause 9.5).

- b) Initially, signal generator B (unwanted signal) shall be switched off (maintaining the output impedance):
- the level of the wanted signal from generator A shall be adjusted to the level of the limit of the average usable sensitivity expressed as a field strength (see clauses 5.2.1 and 9.1.4);
  - where possible, the receiver volume control shall be adjusted to give at least 50 % of the rated output power, clause 7.8, or, in the case of stepped volume controls, to the first step that provides an output power of at least 50 % of the rated output power. The obtained audio output level shall be noted;
- c) The unwanted signal from generator B shall then be switched on;
- d) The level of generator B shall be adjusted so that the unwanted signal causes:
- a reduction of 3 dB in the output level of the wanted signal; or
  - a reduction to 14 dB of the SINAD ratio at the receiver output (with a psophometric filter), whether or not measured acoustically;

whichever occurs first.

- e) The level of the unwanted signal shall be noted;
- f) For each frequency, the blocking or desensitization shall be expressed as the level in  $\text{dB}\mu\text{V}/\text{m}$  of the field strength of the unwanted signal at the receiver location.

This value shall be recorded.

- g) The measurement shall be repeated for all the remaining frequencies of the list given in step a);
- h) The blocking or desensitization of the equipment under test shall be expressed as the level in  $\text{dB}\mu\text{V}/\text{m}$  of the field strength of the unwanted signal, at the receiver location, corresponding to the lowest value recorded in step f).

## 9.8 Spurious radiations

### 9.8.1 Definition

Spurious radiations from the receiver are components at any frequency radiated by the equipment and its antenna.

They are specified as the radiated power of any discrete signal.

## 9.8.2 Method of measurement

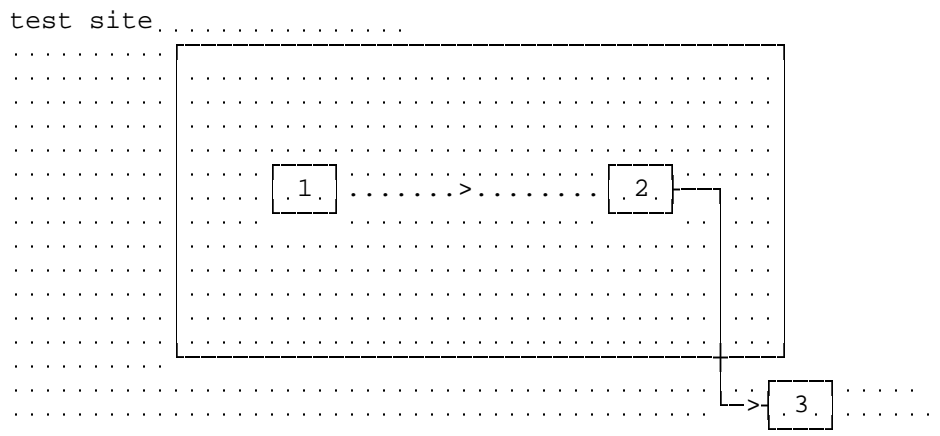

NOTE 1: Receiver under test.

NOTE 2: test antenna.

NOTE 3: spectrum analyser or selective voltmeter (test receiver).

**Figure 20: Measurement arrangement**

The measurement procedure shall be as follows:

- a) A test site, which fulfils the requirements of the specified frequency range of this measurement, shall be used.

The test antenna shall be oriented for vertical polarization and connected to a spectrum analyser or a selective voltmeter. The resolution bandwidth of the spectrum analyser or selective voltmeter shall be the smallest bandwidth available which is greater than the spectral width of the spurious component being measured. This shall be considered to be achieved when the next highest bandwidth causes less than 1 dB increase in amplitude. The conditions used in the measurement shall be recorded in test reports.

- b) The receiver under test shall be placed on the support in its standard position (see clause A.2). The radiation of any spurious component shall be detected by the test antenna and spectrum analyser or selective voltmeter over the frequency range 30 MHz to 4 GHz. In addition, for equipment operating on frequencies above 470 MHz, measurements shall be repeated over the frequency range 4 GHz to 12,75 GHz.

The frequency of each spurious component shall be recorded. If the test site is disturbed by radiation coming from outside, this qualitative search may be performed in a screened room with reduced distance between the receiver and the test antenna.

- c) At each frequency at which a component has been detected, the spectrum analyser or selective voltmeter shall be tuned and the test antenna shall be raised or lowered through the specified height range until the maximum signal level is detected on the spectrum analyser or selective voltmeter;
- d) The receiver shall be rotated through 360° around a vertical axis, until higher maximum signal is received;
- e) The test antenna shall be raised or lowered again through the specified height range until a maximum is obtained. This level shall be recorded.

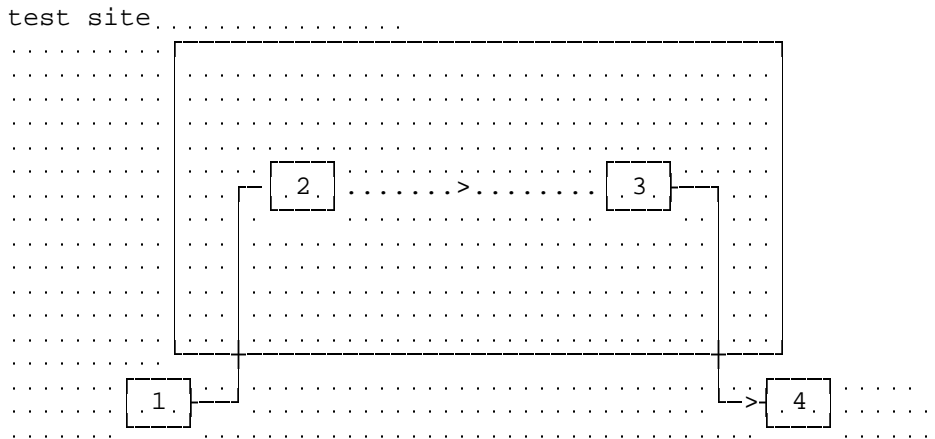

NOTE 1: Signal generator.

NOTE 2: Substitution antenna.

NOTE 3: Test antenna.

NOTE 4: Spectrum analyser or selective voltmeter (test receiver).

**Figure 21: Measurement arrangement**

- f) Using the measurement arrangement in figure 21, the substitution antenna shall replace the receiver antenna in the same position and in vertical polarization. It shall be connected to the signal generator;
- g) For each frequency at which a component has been detected, the signal generator and spectrum analyser or selective voltmeter shall be tuned and the test antenna shall be raised or lowered through the specified height range until the maximum signal level is detected on the spectrum analyser or selective voltmeter.

The test antenna may not need to be raised or lowered if the measurement is carried out on a test site according to clause A.1.2.

The level of the signal generator giving the same signal level on the spectrum analyser or selective voltmeter as in step e) shall be recorded. This value, after correction due to the gain of the substitution antenna and the cable loss between the signal generator and the substitution antenna, is the radiated spurious component at this frequency.

- h) Measurements of steps b) to g) shall be repeated with the test antenna oriented in horizontal polarization.



## 10 Measurement uncertainty

Absolute measurement uncertainties: maximum values

- Valid up to 1 GHz for the RF parameters unless otherwise stated;
- RF frequency  $< \pm 1 \times 10^{-7}$ ;
- Radiated RF power  $< \pm 6$  dB;
- Conducted RF power variations using a test fixture  $< \pm 0,75$  dB.
- Maximum frequency deviation:
  - within 300 Hz to 6 kHz of audio frequency  $< \pm 5$  %;
  - within 6 kHz to 25 kHz of audio frequency  $< \pm 3$  dB.
- Deviation limitation  $< \pm 5$  %;
- Adjacent channel power  $< \pm 5$  dB;
- Audio output power  $< \pm 0,5$  dB;
- Amplitude characteristic of receiver limiter  $< \pm 1,5$  dB;
- Sensitivity at 20 dB SINAD  $< \pm 3$  dB;
- Two-signal measurement, valid to 4 GHz (using a test fixture)  $< \pm 4$  dB;
- Two-signal measurements using radiated fields<sup>1)</sup>  $< \pm 6$  dB;
- Three-signal measurement (using a test fixture)  $< \pm 3$  dB;
- Radiated emission of transmitter, valid to 12,75 GHz  $< \pm 6$  dB;
- Radiated emission of receiver, valid to 12,75 GHz  $< \pm 6$  dB;
- Transmitter transient time  $< \pm 20$  %;
- Transmitter transient frequency  $< \pm 250$  Hz.

For the test methods, according to the present document, the measurement uncertainty figures shall be calculated in accordance with ETR 028 [3] and shall correspond to an expansion factor (coverage factor)  $k = 1,96$  or  $k = 2$  (which provide confidence levels of respectively 95 % and 95,45 % in the case where the distributions characterizing the actual measurement uncertainties are normal (Gaussian)).

The values given in the table above are based on such expansion factors.

The particular expansion factor used for the evaluation of the measurement uncertainty shall be stated.

ETR 273 [4] provides further information concerning the usage of test sites.

## Annex A (normative): Radiated measurements

### A.1 Test sites and general arrangements for measurements involving the use of radiated fields

Any of the following four test sites may be used.

#### A.1.1 Open air test site

##### A.1.1.1 Description

The term "open air" shall be understood from an electromagnetic point of view. Such a test site may be really in open air or alternatively with walls and ceiling transparent to the radio waves at the frequencies considered.

An open air test site can be used to perform the measurements using the radiated measurement methods described in clauses 8 and 9. Absolute or relative measurements can be performed on transmitters or on receivers; absolute measurements of field strength require a calibration of the test site.

Sufficient precautions shall be taken to ensure that reflections from extraneous objects adjacent to the site do not degrade the measurement results, in particular:

- no extraneous conducting objects having any dimension in excess of a quarter wavelength of the highest frequency tested shall be in the immediate vicinity of the site;
- all cables shall be as short as possible; as much of the cables as possible shall be on the ground plane or preferably below; and the low impedance cables shall be screened.

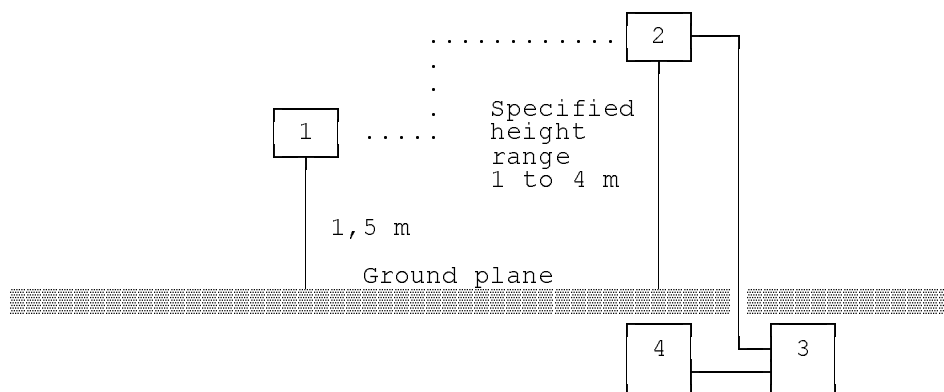

NOTE 1: equipment under test.

NOTE 2: test antenna.

NOTE 3: high pass filter (necessary for strong fundamental Tx radiation).

NOTE 4: spectrum analyser or measuring receiver.

**Figure A.1: Measuring arrangement**

### A.1.1.2 Establishment of a relationship between signal levels and field strength

This procedure allows the creation, in a given place, of a known field strength by the means of a signal generator connected to a test antenna. It is valid **only** at a given frequency for a given polarization and for the exact position of the test antenna.

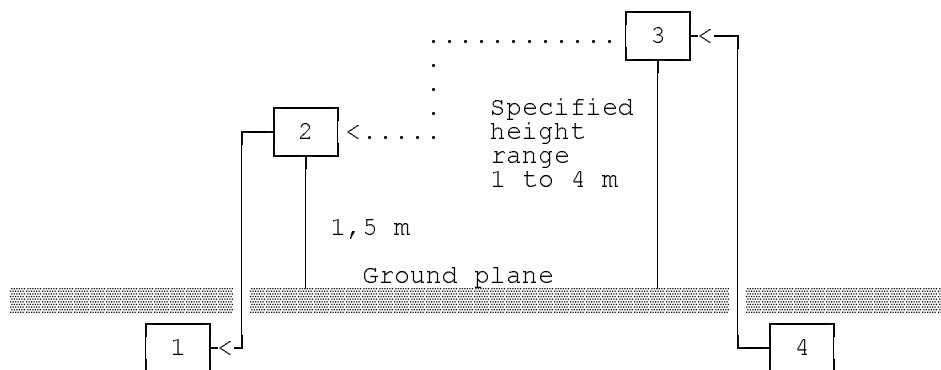

- NOTE 1: selective voltmeter.  
 NOTE 2: substitution antenna.  
 NOTE 3: test antenna.  
 NOTE 4: signal generator.

**Figure A.2: Measuring arrangement**

All the equipment shall be adjusted to the frequency used.

The test antenna and the substitution antenna shall have the same polarization.

The substitution antenna connected to the selective voltmeter constitutes a calibrated field strength meter.

- The signal generator level shall be adjusted to produce the required field strength as measured on the selective voltmeter;
- The test antenna shall be raised or lowered through the specified range until the maximum signal level is detected on the selective voltmeter;
- The signal generator level shall be readjusted to produce the required field strength as measured on the selective voltmeter. Thus a relationship has been established between the signal generator level and the field strength.

## A.1.2 Anechoic chamber

### A.1.2.1 General

An anechoic chamber is a well shielded chamber covered inside with radio frequency absorbing material and simulating a free space environment. It is an alternative site on which to perform the measurements using the radiated measurement methods described in clauses 8 and 9. Absolute or relative measurements can be performed on transmitters or on receivers. Absolute measurements of field strength require a calibration of the anechoic chamber. The test antenna, equipment under test and substitution antenna are used in a way similar to that at the open air test site, but are all located at the same fixed height above the floor.

### A.1.2.2 Description

An anechoic chamber should meet the requirements for shielding loss and wall return loss as shown in figure A.3. Figure A.4 shows an example of the construction of an anechoic chamber having a base area of 5 m by 10 m and a height of 5 m. The ceiling and walls are coated with pyramidally formed absorbers approximately 1 m high. The base is covered with special absorbers which form the floor. The available internal dimensions of the chamber are 3 m x 8 m x 3 m, so that a maximum measuring distance of 5 m in the middle axis of this chamber is available (see Bibliography). The floor absorbers reject floor reflections so that the antenna height need not be changed. Anechoic chambers of other dimensions may be used.

At 100 MHz the measuring distance can be extended up to a maximum of 2 wavelengths.

### A.1.2.3 Influence of parasitic reflections

For free-space propagation in the far field the relationship of the field strength  $E$  and the distance  $R$  is given by  $E = E_0 (R_0/R)$ , where  $E_0$  is the reference field strength and  $R_0$  is the reference distance. This relationship allows relative measurements to be made as all constants are eliminated within the ratio and neither cable attenuation nor antenna mismatch or antenna dimensions are of importance.

If the logarithm of the foregoing equation is used, the deviation from the ideal curve can be easily seen because the ideal correlation of field strength and distance appears as a straight line. The deviations occurring in practice are then clearly visible. This indirect method shows quickly and easily any disturbances due to reflections and is far less difficult than the direct measurement of reflection attenuation.

With an anechoic chamber of the dimensions given above at low frequencies below 100 MHz there are no far field conditions, but the wall reflections are stronger, so that careful calibration is necessary. In the medium frequency range from 100 MHz to 1 GHz the dependence of the field strength to the distance meets the expectations very well. Above 1 GHz, because more reflections will occur, the dependence of the field strength to the distance will not correlate so closely.

### A.1.2.4 Mode of use

The mode of use is the same as for an open air test site, the only difference being that the test antenna does not need to be raised and lowered whilst searching for a maximum, which simplifies the method of measurement.

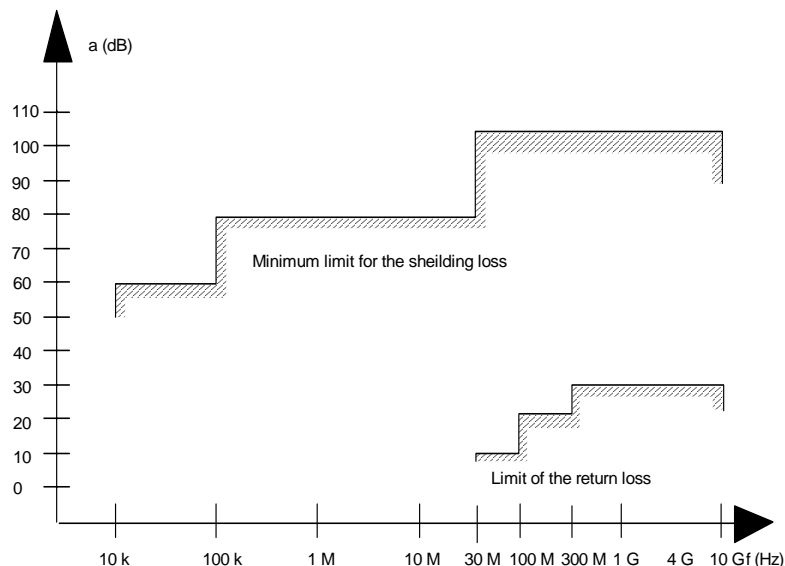
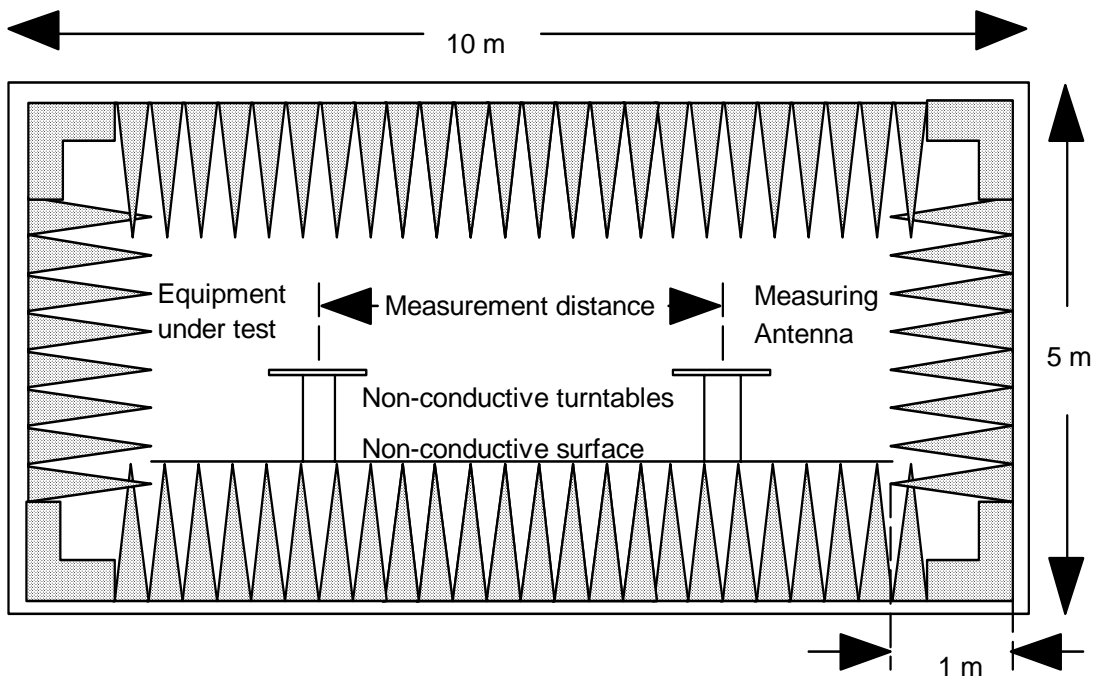

Figure A.3: Specification for shielding and reflections



Ground plan

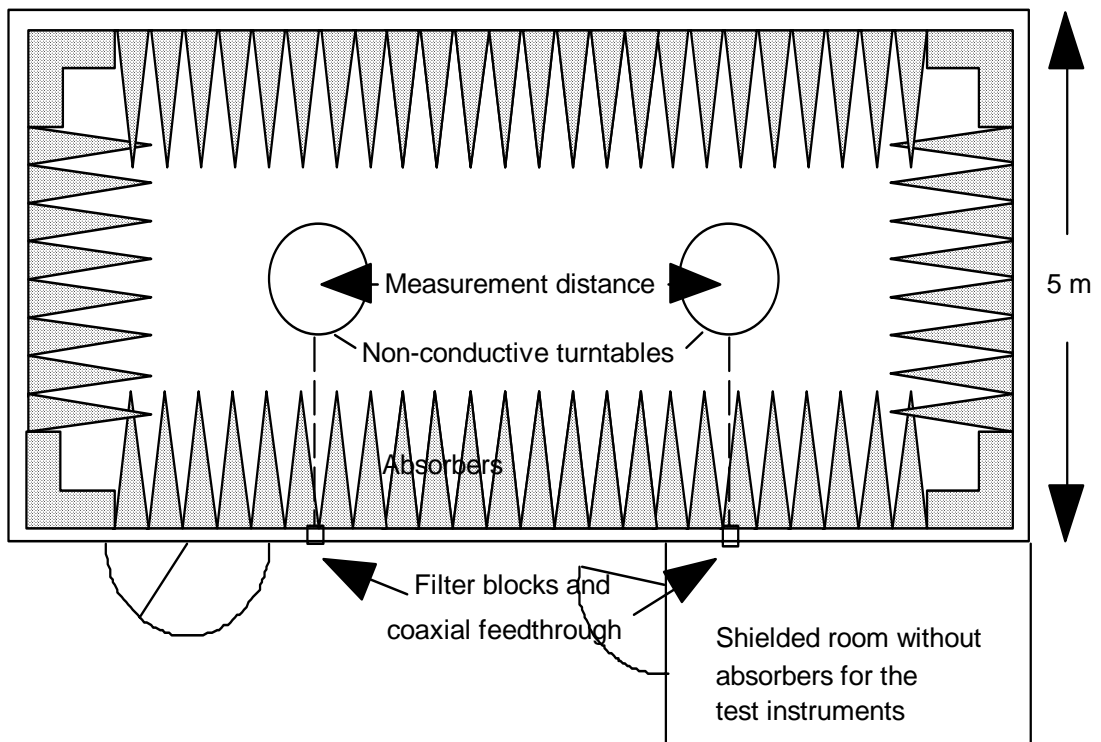

Figure A.4: Anechoic shielded chamber for simulated free space measurements

## A.1.3 Stripline arrangement

### A.1.3.1 General

The stripline arrangement is a RF coupling device for coupling the integral antenna of an equipment to a 50  $\Omega$  radio frequency terminal. This allows the radiated measurements to be performed without an open air test site but in a restricted frequency range. Absolute or relative measurements can be performed; absolute measurements require a calibration of the stripline arrangement.

### A.1.3.2 Description

The stripline is made of three highly conductive sheets forming part of a transmission line which allows the equipment under test to be placed within a known electric field. They must be sufficiently rigid to support the equipment under test.

Two examples of stripline characteristics are given below:

- IEC 60489-3 App. JFTZ No 512 TB 9;
- useful frequency range: MHz      1 to 200      0,1 to 4 000;
- equipment size limits: length      200 mm      1 200 mm;
- (antenna included): width      200 mm      1 200 mm;
- height      250 mm      400 mm.

### A.1.3.3 Calibration

The aim of calibration is to establish at any frequency a relationship between the voltage applied by the signal generator and the field strength at the designated test area inside the stripline.

### A.1.3.4 Mode of use

The stripline arrangement may be used for all radiated measurements within its calibrated frequency range.

The method of measurement is the same as the method using an open air test site with the following change. The stripline arrangement input socket is used instead of the test antenna.

## A.1.4 Indoor test site

### A.1.4.1 Description

An indoor test site is a partially screened site, where the wall located behind the test sample is covered with a radio frequency absorbing material and a corner reflector is used with the test antenna. It may be used when the frequency of the signals being measured is greater than 80 MHz.

The measurement site may be a laboratory room with a minimum area of 6 m by 7 m and at least 2,7 m in height.

Apart from the measuring apparatus and the operator, the room shall be as free as possible from reflecting objects other than the walls, floor and ceiling.

The potential reflections from the wall behind the equipment under test are reduced by placing a barrier of absorbent material in front of it. The corner reflector around the test antenna is used to reduce the effect of reflections from the opposite wall and from the floor and ceiling in the case of horizontally polarized measurements. Similarly, the corner reflector reduces the effects of reflections from the side walls for vertically polarized measurements. For the lower part of the frequency range (below approximately 175 MHz) no corner reflector or absorbent barrier is needed. For practical reasons, the half wavelength antenna in figure A.5 may be replaced by an antenna of constant length, provided that this length is between a quarter wavelength and one wavelength at the frequency of measurement and the sensitivity of the measuring system is sufficient. In the same way the distance of half wavelength to the apex may be varied.

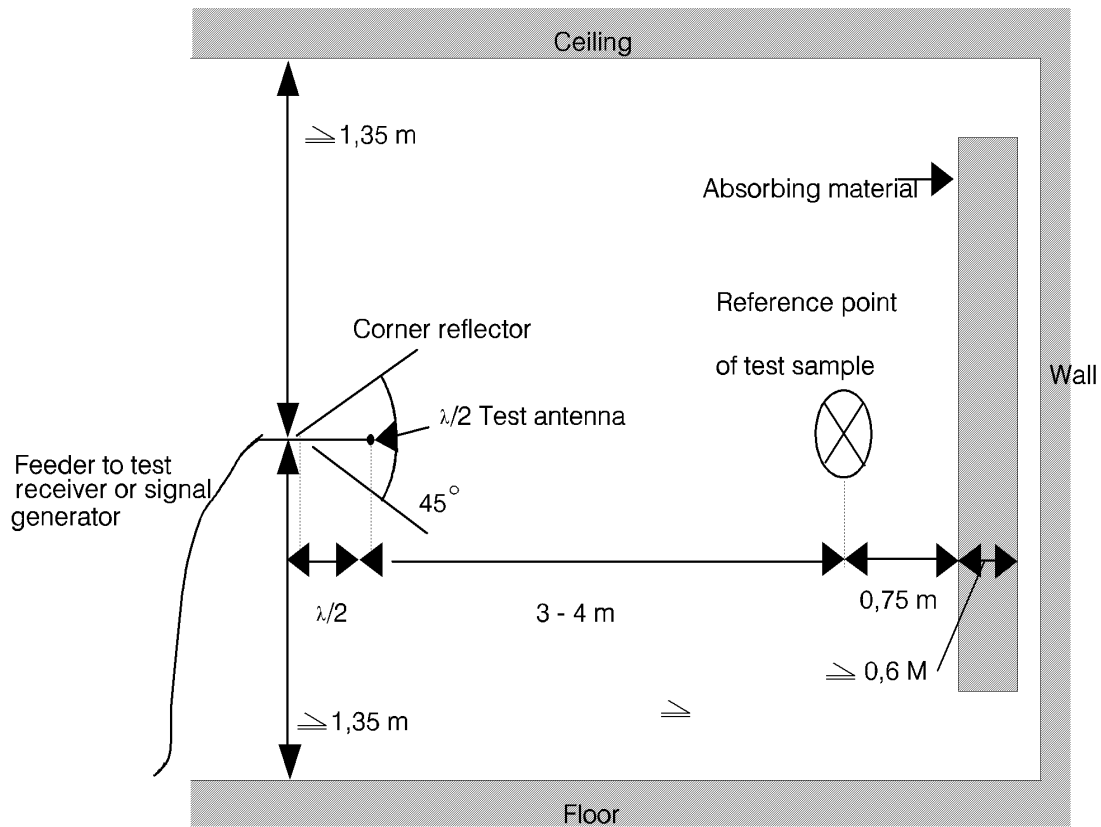

Figure A.5: Indoor test site arrangement (shown for horizontal polarization)

#### A.1.4.2 Test for parasitic reflections

To ensure that errors are not caused by the propagation path approaching the point at which phase cancellation between direct and the remaining reflected signals occurs, the substitution antenna shall be moved through a distance of  $\pm 10$  cm in the direction of the test antenna as well as in the two directions perpendicular to this first direction.

If these changes of distance cause a signal change of greater than 2 dB, the test sample should be repositioned until a change of less than 2 dB is obtained.

#### A.1.4.3 Mode of use

The mode of use is the same as for an open air test site, the only difference being that the test antenna does not need to be raised and lowered whilst searching for a maximum, which simplifies the method of measurement.

---

## A.2 Standard position

The standard position in all test sites, except the stripline arrangement, for equipment which is not intended to be worn on a person, including hand-held equipment, shall be on a non conducting support, height 1,5 m, capable of rotating about a vertical axis through the equipment. The standard position of the equipment shall be the following:

- a) For equipment with an internal antenna, it shall be placed in the position closest to normal use as declared by the manufacturer;
- b) For equipment with a rigid external antenna, the antenna shall be vertical;
- c) For equipment with a non-rigid external antenna, the antenna shall be extended vertically upwards by a non-conducting support.

Equipment, which is intended to be worn on a person, may be tested using a simulated man as support.

The simulated man comprises a rotatable acrylic tube filled with salt water, placed on the ground.

The container shall have the following dimensions:

- height 1,7 m  $\pm$  0,1 m;
- inside diameter 300 mm  $\pm$  5 mm;
- sidewall thickness 5 mm  $\pm$  0,5 mm.

The container shall be filled with a salt (NaCl) solution of 1,5 g per litre of distilled water.

The equipment shall be fixed to the surface of the simulated man, at the appropriate height for the equipment.

NOTE: To reduce the weight of the simulated man it may be possible to use an alternative tube, which has a hollow centre of 220 mm maximum diameter.

In the stripline arrangement the equipment under test or the substitution antenna is placed in the designated test area in the normal operational position, relative to the applied field, on a pedestal made of a low dielectric material (dielectric constant less than 2).

---

## A.3 Acoustic coupler

### A.3.1 General

When radiation measurements are performed, on the receiver, the audio output voltage should be conducted from the receiver to the measuring equipment, without perturbing the field near the receiver.

This perturbation can be minimized by using wires with high resistivity associated to a test equipment with a high input impedance (IEC 60489-3 [5], appendix F).

When this situation is not applicable, an acoustic coupler shall be used.

NOTE: When using this acoustic coupler care should be exercised that possible ambient noise does not influence the test result.



## A.3.2 Description

The acoustic coupler comprises of, a plastic funnel, an acoustic pipe and a microphone with a suitable amplifier.

- The acoustic pipe shall be long enough (e.g. 2 m) to reach from the equipment under test to the microphone, which is located in a position that will not disturb the RF field. The acoustic pipe shall have an inner diameter of about 6 mm and a wall thickness of about 1,5 mm and should be sufficiently flexible to allow the platform to rotate.
- The plastic funnel shall have a diameter appropriate to the size of the loudspeaker in the equipment under test, with soft foam rubber glued to its edge, it shall be fitted to one end of the acoustic pipe and the microphone shall be fitted to the other end. It is very important to fix the centre of the funnel in a reproducible position relative to the equipment under test, since the position of the centre has a strong influence on the frequency response that will be measured. This can be achieved by placing the equipment in a close fitting acoustic mounting jig, supplied by the manufacturer, of which the funnel is an integral part.
- The microphone shall have a response characteristic flat within 1 dB over a frequency range of 50 Hz to 20 kHz, a linear dynamic range of at least 50 dB. The sensitivity of the microphone and the receiver audio output level shall be suitable to measure a signal to noise ratio of at least 40 dB at the nominal audio output level of the equipment under test. Its size should be sufficiently small to couple to the acoustic pipe.
- The frequency correcting network shall correct the frequency response of the acoustic coupler so that the acoustic SINAD measurement is valid, IEC 60489-3 [5] appendix F.

### A.3.3 Calibration

The aim of the calibration of the acoustic coupler is to determine the acoustic SINAD ratio, which is equivalent to the SINAD ratio at the receiver output.

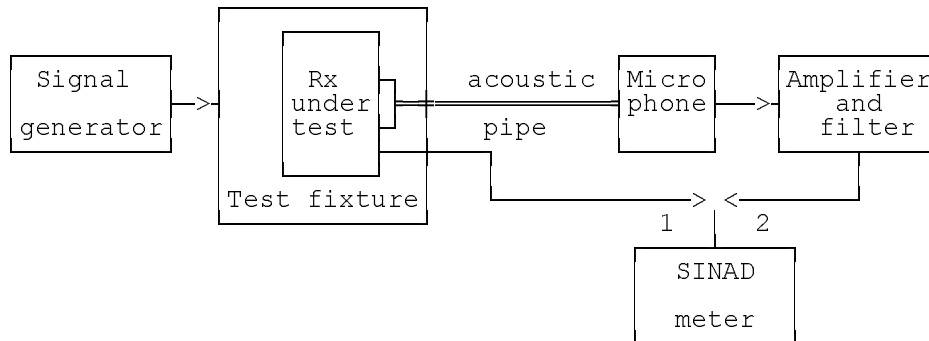

- a) The acoustic coupler shall be mounted to the equipment, if necessary using a test fixture. A direct electrical connection to the terminals of the output transducer will be made. A signal generator shall be connected to the receiver input (or to the test fixture input). The signal generator shall be at the nominal frequency of the receiver and shall be modulated by the normal test modulation;
- b) Where possible, the receiver volume control shall be adjusted to give at least 50 % of the rated audio output power and, in the case of stepped volume controls, to the first step that provides an output power of at least 50 % of the rated audio output power;
- c) The test signal input level shall be reduced until an electrical SINAD ratio of 20 dB is obtained, the connection being in position 1. The signal input level shall be recorded;
- d) With the same signal input level, the acoustic equivalent SINAD ratio shall be measured and recorded, the connection being in position 2;
- e) Steps c) and d) above shall be repeated for an electrical SINAD ratio of 14 dB, and the acoustic equivalent SINAD ratio measured and recorded.

**Figure A.6: Measuring arrangement for calibration**

## A.4 Test antenna

When the test site is used for radiation measurements the test antenna is used to detect the field from both the test sample and the substitution antenna. When the test site is used for the measurement of receiver characteristics the antenna is used as a transmitting antenna. This antenna is mounted on a support capable of allowing the antenna to be used in either horizontal or vertical polarization and for the height of its centre above the ground to be varied over the specified range. Preferably test antennas with pronounced directivity should be used. The size of the test antenna along the measurement axis shall not exceed 20 % of the measuring distance.

---

## A.5 Substitution antenna

The substitution antenna is used to replace the equipment under test. For measurements below 1 GHz the substitution antenna shall be a half wavelength dipole resonant at the frequency under consideration, or a shortened dipole, calibrated to the half wavelength dipole. For measurements between 1 GHz and 4 GHz either a half wavelength dipole or a horn radiator may be used. For measurements above 4 GHz a horn radiator shall be used. The centre of this antenna shall coincide with the reference point of the test sample it has replaced. This reference point shall be the volume centre of the sample when its antenna is mounted inside the cabinet, or the point where an external antenna is connected to the cabinet.

The distance between the lower extremity of the dipole and the ground shall be at least 30 cm.

NOTE: The gain of a horn antenna is generally expressed relative to an isotropic radiator.

---

## A.6 Test fixture

### A.6.1 Description

The test fixture is a radio frequency coupling device associated with an integral antenna equipment for coupling the integral antenna to a 50  $\Omega$  radio frequency terminal at the working frequencies of the equipment under test. This allows certain measurements to be performed using the conducted measurement methods. Only relative measurements may be performed and only those at or near frequencies for which the test fixture has been calibrated.

In addition, the test fixture shall provide:

- a) a connection to an external power supply;
- b) an audio interface either by direct connection or by an acoustic coupler.

The test fixture normally shall be provided by the manufacturer.

The performance characteristics of the test fixture shall conform to the following basic parameters:

- a) the coupling loss shall not be greater than 30 dB;
- b) a coupling loss variation over the frequency range used in the measurement which does not exceed 2 dB;
- c) circuitry associated with the RF coupling shall contain no active or non linear devices;
- d) the VSWR at the 50  $\Omega$  socket shall not be greater than 1,5 over the frequency range of the measurements;
- e) the coupling loss shall be independent of the position of the test fixture and be unaffected by the proximity of surrounding objects or people. The coupling loss shall be reproducible when the equipment under test is removed and replaced;
- f) the coupling loss shall remain substantially constant when the environmental conditions are varied.

In the case of measurements to be performed by a third party, the performance characteristics of the test fixture shall be approved by the testing laboratory.

The characteristics and calibration shall be included in test reports.

## A.6.2 Calibration

The calibration of the test fixture establishes a relationship between the output of the signal generator and the field strength applied to the equipment inside the test fixture.

The calibration is valid **only** at a given frequency and for a given polarization of the reference field.

- 1) AF load/acoustic coupler;
- 2) distortion factor/audio level meter and psophometric filter.

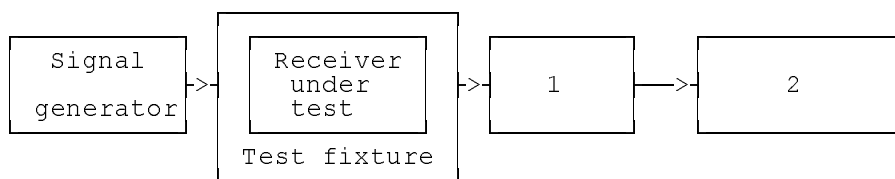

- a) Using the method described in clause 9.1, measure the sensitivity expressed as field strength, and note the value of this field strength in dBmV/m and the polarization used;
- b) The receiver is now placed in the test fixture which is connected to the signal generator. The level of the signal generator producing a SINAD of 20 dB shall be noted;
- c) The calibration of the test fixture is thus the linear relationship between the field strength in dBmV/m and the signal generator level in dBmV emf.

**Figure A.7: Measuring arrangement for calibration**

## A.6.3 Mode of use

The test fixture may be used to facilitate some of the measurements in clauses 8 and 9 on equipment with an integral antenna.

It is used in the radiated carrier power and usable sensitivity expressed as a field strength measurements in clauses 8 and 9 to enable a measurement to be made under extreme test conditions.

For the transmitter measurements calibration is not required.

For the receiver measurements calibration is necessary.

To apply the specified wanted signal level expressed in field strength, convert it into the signal generator level (emf) using the calibration of the test fixture. Apply this value with the signal generator.

## Annex B (normative): Specifications for adjacent channel power measurement arrangements

### B.1 Power measuring receiver specification

#### B.1.1 General

The power measuring receiver is used for the measurement of the transmitter adjacent channel power. It consists of a mixer and oscillator, an IF filter, an amplifier, a variable attenuator and a level indicator as shown below.

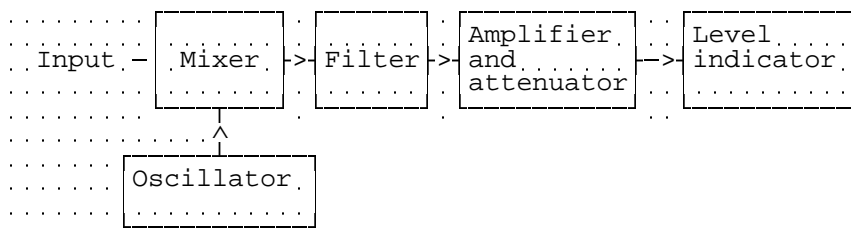

**Figure B.1: Power measuring receiver**

The technical characteristics of the power measuring receiver are given in the following clauses.

#### B.1.2 IF filter

The IF filter shall be within the limits of the selectivity characteristics given in the following diagram. Depending on the channel separation, the selectivity characteristics shall keep the frequency separations and tolerances given in the following table. The minimum attenuation of the filter outside the 90 dB attenuation points must be equal to or greater than 90 dB.

**NOTE:** A symmetrical filter can be used provided that each side meets the tighter tolerances and the D2 points have been calibrated relative to the -6 dB response. When a non-symmetrical filter is used the receiver should be designed such that the tighter tolerance is used close to the carrier.

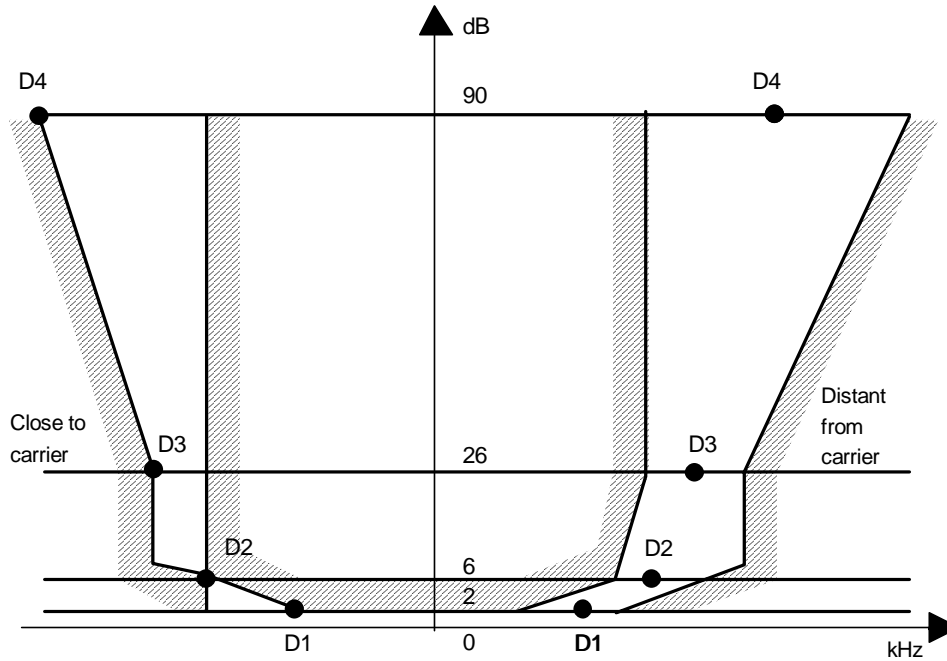

Figure B.2: Limits of the selectivity characteristic

Table B.1: Selectivity characteristic

Channel separation (kHz)	Frequency separation of filter curve from nominal centre frequency of adjacent channel (kHz)			
	D1	D2	D3	D4
12,5	3	4,25	5,5	9,4
20	4	7,0	8,25	12,25
25	5	8,0	9,25	13,25

Depending on the channel separation, the attenuation points shall not exceed the tolerances given in table B.2 and table B.3.

Table B.2: Attenuation points close to carrier

Channel separation (kHz)	Tolerance range (kHz)			
	D1	D2	D3	D4
12,5	+1,35	±0,1	-1,35	-5,35
20	+3,1	±0,1	-1,35	-5,35
25	+3,1	±0,1	-1,35	-5,35

Table B.3: Attenuation points distant from the carrier

Channel separation (kHz)	Tolerance range (kHz)			
	D1	D2	D3	D4
12,5	±2,0	±2,0	±2,0	+2,0
				-6,0
20	±3,0	±3,0	±3,0	+3,0
				-7,0
25	±3,5	±3,5	±3,5	+3,5
				-7,5

The minimum attenuation of the filter outside the 90 dB attenuation points shall be equal to or greater than 90 dB.

**Table B.4: Frequency displacement**

Channel separation (kHz)	Specified necessary bandwidth (kHz)	Displacement from the -6 dB point (kHz)
12,5	8,5	8,25
20	14	13
25	16	17

The tuning of the power measuring receiver shall be adjusted away from the carrier so that the -6 dB response nearest to the transmitter carrier frequency is located at a displacement from the nominal carrier frequency as given in table B.4.

### B.1.3 Oscillator and amplifier

The measurement of the reference frequencies and the setting of the local oscillator frequency shall be within  $\pm 50$  Hz.

The mixer, oscillator and the amplifier shall be designed in such a way that the measurement of the adjacent channel power of an unmodulated test signal source, whose noise has a negligible influence on the measurement result, yields a measured value of  $\leq -90$  dB for channel separation of 20 kHz and 25 kHz and of  $\leq -80$  dB for a channel separation of 12,5 kHz referred to the level of the test signal source.

The linearity of the amplifier shall be such that an error in the reading of no more than 1,5 dB will be obtained over an input level variation of 100 dB.

### B.1.4 Attenuation indicator

The attenuation indicator shall have a minimum range of 80 dB and a resolution of 1 dB.

### B.1.5 Level indicators

Two level indicators are required to cover the rms and the peak transient measurement.

#### B.1.5.1 Rms level indicator

The rms level indicator shall accurately indicate non-sinusoidal signals within a ratio of 10:1 between peak value and rms value.

#### B.1.5.2 Peak level indicator

The peak level indicator shall accurately indicate and store the peak power level. For the transient power measurement the indicator bandwidth shall be greater than twice the channel separation.

A storage oscilloscope or a spectrum analyser may be used as a peak level indicator.

## Annex C (normative): Graphical representation of the selection of equipment and frequencies for testing

Information regarding the selection of equipment for testing purposes can be found in EN 300 793 [2].

The following graphs, imported from EN 300 793 [2], illustrate the principles used in that standard, in particular, concepts such as full and limited tests. For further details concerning the present annex (e.g. definitions, references), please, refer to EN 300 793 [2].

### C.1 Tests on a single sample

If the Operating Frequency Range (OFR) of each equipment corresponds to its alignment range (AR0, AR1, AR2, or AR3) then only one sample shall be tested.

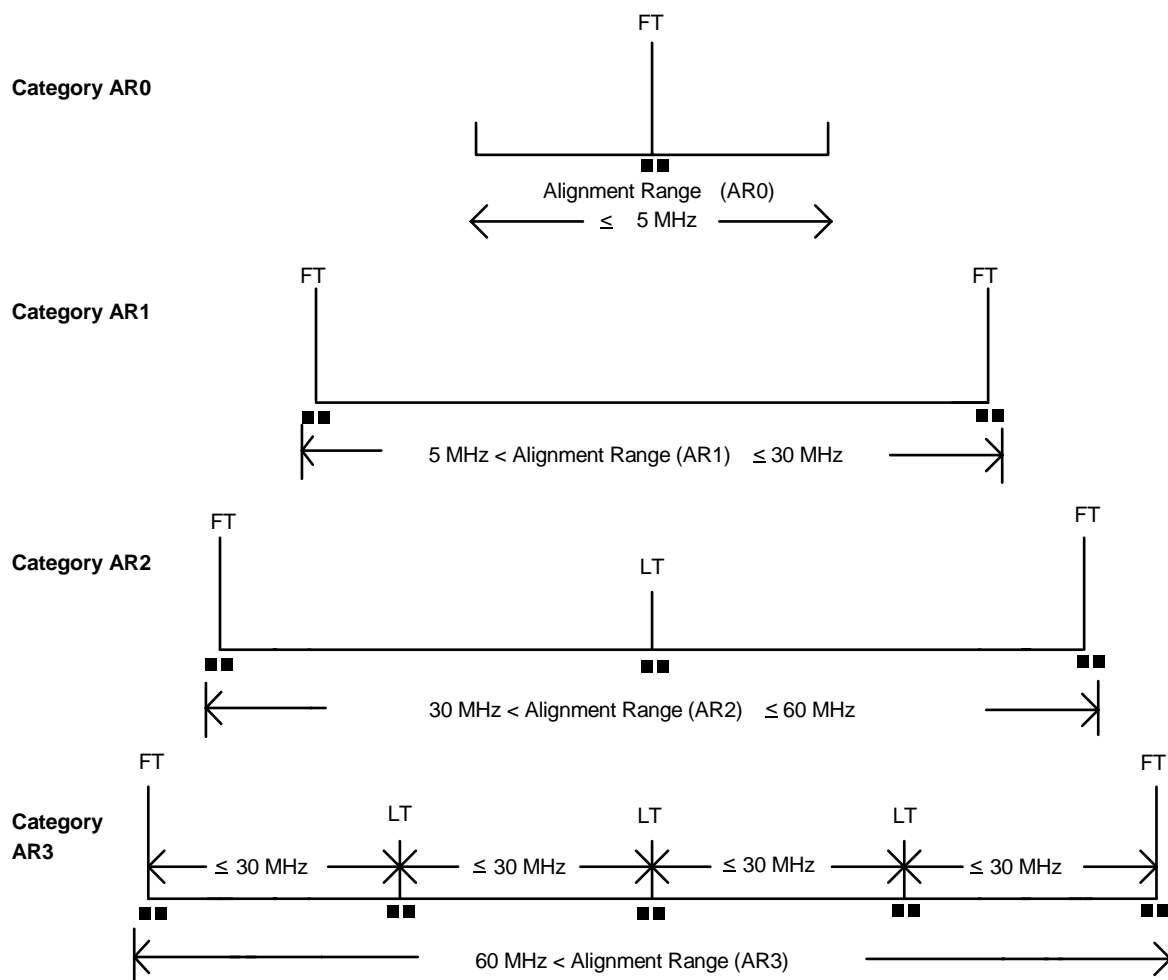

- NOTE 1: AR0, AR1, AR2, AR3 Categories of alignment range, see clause 4.3.  
 NOTE 2: FT Full tests.  
 NOTE 3: LT Limited tests.  
 NOTE 4: ■■ 50 kHz range in which tests are carried out.

**Figure C.1: Tests on a single sample for equipment that has a switching range equal to its alignment range**



## C.2 Tests and samples needed when the switching range is a subset of the alignment range

In order to cover an alignment range several separate samples, having different switching ranges (SR) within the alignment range, may be needed. Samples shall be then provided for testing in accordance with clauses 4.4, 4.5, 4.6, and 4.7, as appropriate. The following examples assume a switching range (SR) of 5 MHz.

### Category AR1



2 Samples, 2 FT

### Category AR2

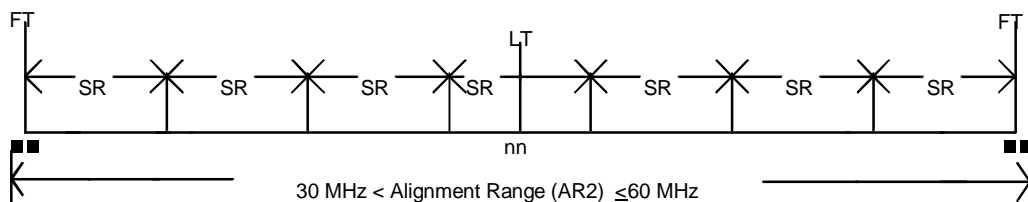

3 Samples, 2 FT, 1 LT.

### Category AR3

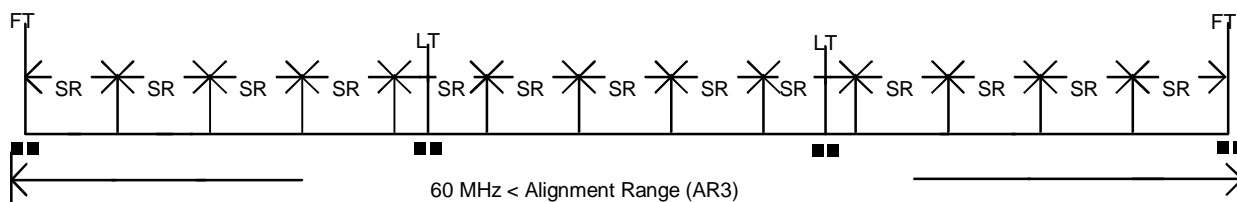

4 Samples, 2 FT, 2 LT.

- NOTE 1: SR                      Switching Range, see clause 4.2.  
 NOTE 2: AR1, AR2, AR3      Categories of alignment range, see clause 4.3.  
 NOTE 3: FT                      Full tests.  
 NOTE 4: LT                      Limited tests.  
 NOTE 5: ■■                      50 kHz range in which tests are carried out.

**Figure C.2: Tests on equipment having switching ranges that are subsets of their alignment range**

## C.3 Tests and samples for a family of equipment where the alignment range is a subset of the total operating frequency range

If the alignment range of a piece of equipment is a subset of the total operating frequency range then the operating frequency range shall be divided into appropriate categories of alignment range. Samples shall be then provided for testing in accordance with clauses 4.4, 4.5, 4.6, and 4.7 of EN 300 793 [2], as appropriate.

For example the applicant seeks type approval for a family of equipment having an operating frequency range of 403 MHz to 470 MHz. The equipment to be tested does not cover this range with one category of alignment range.

### C.3.1 Test scenario 1

The Operating Frequency Range (OFR) could be covered by two alignment ranges a) and b), implemented in samples a) and b):

- a) 403 MHz to 430 MHz: This is category AR1;
- b) 425 MHz to 470 MHz: This is category AR2.

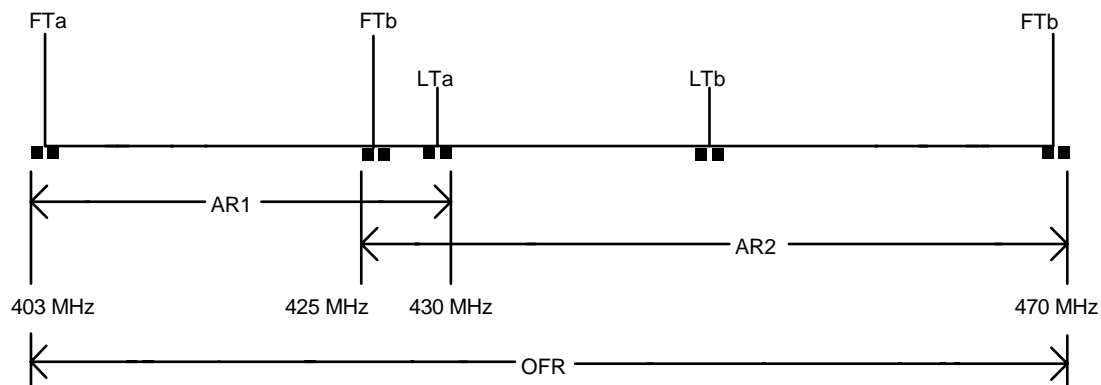

- NOTE 1: OFR                    Operating Frequency Range, see clause 4.2.
- NOTE 2: AR1, AR2        Categories of alignment range, see clause 4.3.
- NOTE 3: FTa                Full tests on sample(s) a).
- NOTE 4: LTa                Limited tests on sample(s) a).
- NOTE 5: FTb                Full tests on sample(s) b).
- NOTE 6: LTb                Limited test on sample(s) b).
- NOTE 7: ■■                 50 kHz range in which tests are carried out.

This example requires a minimum of two test samples and a maximum of five test samples to cover the operating frequency range.

**Figure C.3: Tests on family member equipment having alignment ranges that are subsets of the total operating frequency range (Example 1)**

## C.3.2 Test scenario 2

The Operating Frequency Range (OFR) could alternatively be covered by three alignment ranges of category AR1, implemented in samples a), b) and c):

- a) 403 MHz to 430 MHz: this is category AR1;
- b) 425 MHz to 450 MHz: this is category AR1;
- c) 450 MHz to 470 MHz: this is category AR1.

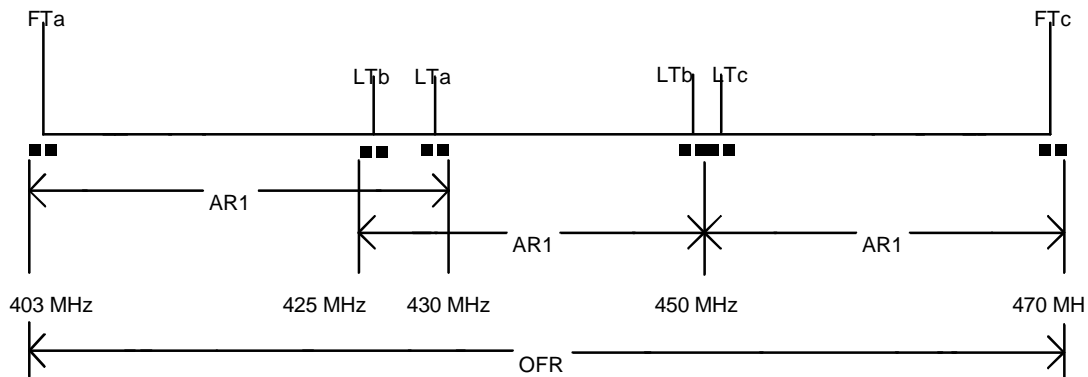

- NOTE 1: OFR Operating Frequency Range, see clause 4.2.
- NOTE 2: AR1 Second category of alignment range, see clause 4.3.
- NOTE 3: FTa Full tests on sample(s) a).
- NOTE 4: LTa Limited tests on sample(s) a).
- NOTE 5: LTb Limited test on sample(s) b).
- NOTE 6: FTc Full tests on sample(s) c).
- NOTE 7: LTc Limited tests on sample(s) c).
- NOTE 8: ■■ 50 kHz range in which tests are carried out.

This example requires a minimum of three test samples and a maximum of six test samples to cover the operating frequency range.

**Figure C.4: Tests on family member equipment having alignment ranges that are subsets of the total operating frequency range (Example 2)**

---

## Annex D (normative): Test discriminator

### D.1 Characteristics of the test discriminator

The test discriminator consists of a mixer and local oscillator (auxiliary frequency) to convert the transmitter frequency to be measured into the frequency of a broadband limiter amplifier and of a broadband discriminator with the following characteristics:

- the discriminator shall be sensitive and accurate enough to cope with transmitter carrier powers as low as 1 mW;
- the discriminator must be fast enough to display the frequency deviation (approx. 100 kHz/100  $\mu$ s);
- the discriminator output shall be dc coupled.

---

## Annex E (informative): Bibliography

- Construction of a Stripline. Technical Report FTZ No 512 TB 9.
- Ketterling, H-P: Verification of the performance of fully and semi-anechoic chambers for radiation measurements and susceptibility/immunity testing, 1991, Leatherhead/Surrey.
- ETSI ETS 300 086 (1991): "Radio Equipment and Systems (RES); Land mobile group; Technical characteristics and test conditions for radio equipment with an internal or external RF connector intended primarily for analogue speech".
- ETSI ETS 300 113 (1996): "Radio Equipment and Systems (RES); Land mobile service; Technical characteristics and test conditions for radio equipment intended for the transmission of data (and speech) and having an antenna connector".
- ETSI EN 300 219 (V1.2): "Electromagnetic compatibility and Radio spectrum Matters (ERM); Land Mobile Service (RP 02); Technical characteristics and test conditions for radio equipment transmitting signals to initiate a specific response in the receiver".
- ETSI ETS 300 296 (1994): "Radio Equipment and Systems (RES); Land mobile service; Technical characteristics and test conditions for radio equipment using integral antennas intended primarily for analogue speech".
- ETSI ETS 300 341 (1995): "Radio Equipment and Systems (RES); Land mobile service; Technical characteristics and test conditions for radio equipment using an integral antenna transmitting signals to initiate a specific response in the receiver".
- ETSI ETS 300 390 (1996): "Radio Equipment and Systems (RES); Land mobile service; Technical characteristics and test conditions for radio equipment intended for the transmission of data (and speech) and using an integral antenna".
- ETSI ETS 300 471 (1995): "Radio Equipment and Systems (RES); Land mobile service; Access protocol, occupation rules and corresponding technical characteristics of radio equipment for the transmission of data on shared channels".
- CEPT Decision ERC/DEC/(97)10 (1997): "ERC Decision of 30 June 1997 on the Mutual Recognition of Conformity Assessment Procedures Including Marking of Radio Equipment and Radio Terminal Equipment".
- CEPT Recommendation ERC/REC 01-06 (1994): "Procedure for mutual recognition of type testing and type approval for radio equipment".

---

## History

<b>Document history</b>			
V1.1.1	March 2000	Public Enquiry	PE 20000630: 2000-03-01 to 2000-06-30
V1.1.1	December 2000	Vote	V 20010223: 2000-12-25 to 2001-02-23