

**Telecommunications Management Network (TMN);
Functional specification of Customer Administration (CA)
on the Operations System/Network Element
(OS/NE) interface;
Part 2: Multi line configurations**



Reference

DEN/TMN-00042

Keywords

configuration, management, NE, Q3 interface,
service, TMN

ETSI

650 Route des Lucioles
F-06921 Sophia Antipolis Cedex - FRANCE

Tel.: +33 4 92 94 42 00 Fax: +33 4 93 65 47 16

Siret N° 348 623 562 00017 - NAF 742 C
Association à but non lucratif enregistrée à la
Sous-Préfecture de Grasse (06) N° 7803/88

Important notice

Individual copies of the present document can be downloaded from:

<http://www.etsi.org>

The present document may be made available in more than one electronic version or in print. In any case of existing or perceived difference in contents between such versions, the reference version is the Portable Document Format (PDF). In case of dispute, the reference shall be the printing on ETSI printers of the PDF version kept on a specific network drive within ETSI Secretariat.

Users of the present document should be aware that the document may be subject to revision or change of status. Information on the current status of this and other ETSI documents is available at

<http://portal.etsi.org/tb/status/status.asp>

If you find errors in the present document, send your comment to:

editor@etsi.fr

Copyright Notification

No part may be reproduced except as authorized by written permission.
The copyright and the foregoing restriction extend to reproduction in all media.

© European Telecommunications Standards Institute 2001.
All rights reserved.

Contents

Intellectual Property Rights	8
Foreword.....	8
Introduction	8
1 Scope	9
2 References	9
3 Definitions and abbreviations.....	10
3.1 Definitions	10
3.2 Abbreviations	11
4 Functional requirements	11
4.1 Manage service provision.....	11
4.2 Administer service facilities and supplementary services	12
4.3 Administer customer line	12
5 Information model diagrams	12
5.1 Entity relationship diagrams.....	12
5.2 Inheritance hierarchy	14
5.3 Naming hierarchy	16
6 Information model description	17
6.1 Object class descriptions	17
6.1.1 Managed element.....	18
6.1.2 Access port fragment	18
6.1.2.1 Access port.....	18
6.1.2.2 ETSI access port.....	18
6.1.2.3 ETSI access port analogue	18
6.1.2.4 ETSI access port digital	18
6.1.2.5 ETSI access port ISDN basic rate	18
6.1.2.6 ETSI access port ISDN primary rate.....	18
6.1.2.7 Access channel.....	19
6.1.2.8 ETSI access channel.....	19
6.1.2.9 Access port profile	19
6.1.3 Multi line grouping fragment.....	19
6.1.3.1 Multi line group	19
6.1.3.2 ETSI routing block.....	20
6.1.4 Directory number fragment.....	21
6.1.4.1 Directory number	21
6.1.4.2 ETSI directory number E.164	21
6.1.4.3 Local destination	21
6.1.5 Customer profile fragment.....	21
6.1.5.1 Customer profile	21
6.1.5.2 ETSI customer profile	21
6.1.5.3 Multi line customer profile.....	21
6.1.5.4 Customized Resource	22
6.1.5.5 ETSI customized Resource	22
6.1.5.6 Multi line group member	22
6.1.5.7 Additional PBX number.....	23
6.1.5.8 D-channel primary rate access resource.....	23
6.1.6 Bearer service fragment	23
6.1.6.1 Bearer service.....	23
6.1.6.2 ETSI bearer service	23
6.1.7 Teleservice fragment.....	24
6.1.7.1 Teleservice	24
6.1.7.2 ETSI teleservice	24
6.1.8 Service dependent supplementary service fragment	24

6.1.8.1	Supplementary service service dependent.....	24
6.1.8.2	Customized supplementary service	24
6.1.9	Service independent supplementary service fragment.....	25
6.1.9.1	Supplementary service service independent.....	25
6.1.9.2	ETSI supplementary service service independent	25
6.1.9.3	A-subscriber number identification.....	25
6.1.9.4	Charging information	26
6.1.9.5	Connect pilot line first.....	26
6.1.9.6	Direct circuit access	26
6.1.9.7	Dual homing.....	26
6.1.9.8	ISDN line reserved.....	27
6.1.9.9	Line huntgroup withdrawal	27
6.1.9.10	Metering information	27
6.1.9.11	SCI allowance	28
6.1.9.12	Trunk huntgroup withdrawal.....	28
6.1.10	General services.....	28
6.1.10.1	Catalogued supplementary service.....	28
6.1.10.2	Catalogued teleservice	29
6.1.10.3	General ISDN service container.....	29
6.1.10.4	General PSTN service container	29
6.1.10.5	Non ISDN service	29
6.1.11	Service provision fragment	29
6.1.11.1	Service manager	29
6.1.11.2	Configuration service manager	29
6.1.11.3	Multi line configuration service manager	30
6.1.11.4	Service package.....	30
6.1.11.5	Reference service configuration.....	30
6.2	Attributes description	30
6.2.1	Relative distinguished name	30
6.2.2	Relationship attributes	30
6.2.3	State attributes	30
6.3	ACTIONS description.....	31
6.4	Notifications description	31
7	Formal object class definitions.....	31
7.1	Definition of object classes	31
7.1.1	Managed element.....	31
7.1.2	Access port fragment	31
7.1.2.1	Access port.....	31
7.1.2.2	ETSI access port.....	32
7.1.2.3	ETSI access port analogue	32
7.1.2.4	ETSI access port digital	32
7.1.2.5	ETSI access port ISDN basic rate	32
7.1.2.6	ETSI access port ISDN primary rate.....	32
7.1.2.7	Access channel.....	32
7.1.2.8	ETSI access channel.....	32
7.1.2.9	Access port profile	32
7.1.3	Multi line grouping fragment.....	32
7.1.3.1	Multi line group	32
7.1.3.2	ETSI routing block.....	33
7.1.4	Directory number fragment.....	33
7.1.4.1	Directory number	33
7.1.4.2	ETSI directory number E.164	33
7.1.4.3	Local destination	33
7.1.5	Customer profile fragment.....	33
7.1.5.1	Customer profile	33
7.1.5.2	ETSI customer profile	33
7.1.5.3	Multi line customer profile.....	33
7.1.5.4	Customized resource	34
7.1.5.5	ETSI customized resource.....	34
7.1.5.6	Multi line group member	34
7.1.5.7	Additional PBX number.....	34

7.1.5.8	D-channel primary rate access resource	35
7.1.6	Bearer service fragment	35
7.1.6.1	Bearer service	35
7.1.6.2	ETSI bearer service	35
7.1.7	Teleservice fragment	35
7.1.7.1	Teleservice	35
7.1.7.2	ETSI teleservice	35
7.1.8	Service dependent supplementary service fragment	35
7.1.8.1	Supplementary service service dependent	35
7.1.8.2	Customized supplementary service	35
7.1.9	Service independent supplementary service fragment	35
7.1.9.1	Supplementary service service independent	35
7.1.9.2	ETSI supplementary service service independent	36
7.1.9.3	A-subscriber number identification	36
7.1.9.4	Charging information	36
7.1.9.5	Connect pilot line first	36
7.1.9.6	Direct circuit access	36
7.1.9.7	Dual homing	37
7.1.9.8	ISDN line reserved	37
7.1.9.9	Line huntgroup withdrawal	37
7.1.9.10	Metering information	38
7.1.9.11	SCI allowance	38
7.1.9.12	Trunk huntgroup withdrawal	38
7.1.10	General services	38
7.1.10.1	Catalogued supplementary service	38
7.1.10.2	Catalogued teleservice	38
7.1.10.3	General ISDN service container	38
7.1.10.4	General PSTN service container	39
7.1.10.5	Non ISDN service	39
7.1.11	Service provision fragment	39
7.1.11.1	Service manager	39
7.1.11.2	Configuration service manager	39
7.1.11.3	Multi line configuration service manager	39
7.1.11.4	Service package	39
7.1.11.5	Reference service configuration	39
7.2	Name bindings	39
7.2.1	Multi line group-multi line customer profile	39
7.2.2	ETSI routing block-multi line customer profile	40
7.3	Definition of packages	40
7.3.1	Line signalling	40
7.3.2	Maintenance blocking package	40
7.3.3	Multi line group pointer list package	40
7.3.4	Register signalling package	40
7.3.5	Terminating characteristics package	40
7.3.6	Withdrawal notification package	41
7.4	Definition of attributes	41
7.5	Definition of behaviours	44
7.6	Definition of actions	44
7.7	Definition of notifications	44
7.8	ASN.1 defined types module	44
Annex A (normative):	Assignment of services	47
Annex B (informative):	Requirements for multi line configurations	48
B.1	Access configurations	48
B.1.1	Multi line hunt group	48
B.1.2	PBX without DDI	48
B.1.2.1	Access with analogue subscriber lines (line circuit level)	48
B.1.2.2	Access at PCM span level (not ISDN PRA)	48
B.1.3	Non ISDN PABX with DDI	48
B.1.4	ISDN PABX with DDI	49

B.1.5	Mixed PABX.....	49
B.2	Entities.....	49
B.3	Directory number issues.....	49
B.4	Hunting/selection aspects.....	50
B.5	Supplementary services.....	50
B.6	PABX signalling issues.....	51
B.7	Issues related to calls from multi/P(A)BX lines.....	52
B.8	Additional characteristics on PBX DN level.....	52
B.9	Additional characteristics of the individual line.....	52
B.10	Special features.....	52
B.11	Sources.....	53
Annex C (informative): Object classes defined in the ITU-T Recommendation Q.824 series which are not used in the context of the present document		54
C.1	ITU-T Recommendation Q.824.0.....	54
C.2	ITU-T Recommendation Q.824.1.....	54
C.3	ITU-T Recommendation Q.824.2.....	55
C.4	ITU-T Recommendation Q.824.3.....	55
C.5	ITU-T Recommendation Q.824.4.....	55
Annex D (informative): Examples for customer configurations		56
D.1	ISDN PABX with DDI with 3 lines (2 terminating, 1 originating), all linked to an instance of etsiDirectoryNumberE164.....	56
D.2	ISDN PABX with DDI with 3 lines, only customerProfile is linked to an instance of etsiDirectoryNumberE164.....	57
D.3	Mixed PABX (analogue and ISDN) DDI with 3 lines (2 lines ISDN, 1 line analogue), all linked to an instance of etsiDirectoryNumberE164.....	58
D.4	ISDN PABX (with DDI) on PA with 3 PABX lines, all linked to an instance of etsiDirectoryNumberE164. PABX has additional directory numbers.....	59
Annex E (informative): Trunk Hunting (TH) supplementary service; service description		60
E.1	Description.....	60
E.2	Procedures.....	60
E.2.1	Provision and withdrawal.....	60
E.2.2	Normal procedures.....	61
E.2.2.1	Activation, deactivation and registration.....	61
E.2.2.2	Erasure.....	61
E.2.2.3	Invocation and operation.....	61
E.2.2.4	Interrogation.....	62
E.2.3	Exceptional procedures.....	62
E.2.3.1	Activation, deactivation and registration.....	62
E.2.3.2	Erasure.....	62
E.2.3.3	Invocation and operation.....	62
E.2.3.4	Interrogation.....	62
E.3	Intercommunication considerations.....	62
E.3.1	Interworking with non-ISDNs.....	62
E.3.2	Interworking with private ISDNs.....	63

E.4	Interaction with other supplementary services	63
E.4.1	Advice of charge services.....	63
E.4.1.1	Advice of charge at call set-up time.....	63
E.4.1.2	Advice of charge during the call.....	63
E.4.1.3	Advice of charge at the end of a call.....	63
E.4.2	Call waiting	63
E.4.3	Call hold	63
E.4.4	Explicit call transfer	63
E.4.5	Number identification services.....	63
E.4.5.1	Calling line identification presentation	63
E.4.5.2	Calling line identification restriction	63
E.4.5.3	Connected line identification presentation.....	64
E.4.5.4	Connected line identification restriction	64
E.4.6	Closed user group.....	64
E.4.7	Call completion services	64
E.4.7.1	Completion of calls to busy subscriber	64
E.4.7.2	Completion of calls on no reply.....	64
E.4.8	Conference services.....	64
E.4.8.1	Conference call, add-on	64
E.4.8.2	Conference call, meet-me	64
E.4.9	Direct dialling in.....	65
E.4.10	Diversion services	65
E.4.10.1	Call forwarding unconditional	65
E.4.10.2	Call forwarding busy	65
E.4.10.3	Call forwarding no reply.....	65
E.4.10.4	Call deflection.....	65
E.4.10.5	Selective call forwarding	65
E.4.11	Freephone	65
E.4.12	Malicious call identification	66
E.4.13	Multiple subscriber number.....	66
E.4.14	Subaddressing.....	66
E.4.15	Terminal portability.....	66
E.4.16	Three party	66
E.4.17	User-to-user signalling	66
E.4.18	Hunting services	66
E.4.18.1	Line hunting.....	66
E.4.18.2	Trunk hunting	66
E.4.19	Call barring services.....	66
E.4.19.1	Outgoing call barring-fixed.....	66
E.4.19.2	Outgoing call barring-user controlled.....	66
E.5	Interaction with other services	66
E.5.1	Universal access number	66
E.5.2	Virtual card calling	67
E.5.3	Premium rate	67
E.5.4	Televoting.....	67
E.5.5	Universal personal telecommunication	67
E.5.6	Remote control	67
Annex F (informative):	Bibliography.....	68
History		69

Intellectual Property Rights

IPRs essential or potentially essential to the present document may have been declared to ETSI. The information pertaining to these essential IPRs, if any, is publicly available for **ETSI members and non-members**, and can be found in ETSI SR 000 314: "*Intellectual Property Rights (IPRs); Essential, or potentially Essential, IPRs notified to ETSI in respect of ETSI standards*", which is available from the ETSI Secretariat. Latest updates are available on the ETSI Web server (<http://www.etsi.org/legal/home.htm>).

Pursuant to the ETSI IPR Policy, no investigation, including IPR searches, has been carried out by ETSI. No guarantee can be given as to the existence of other IPRs not referenced in ETSI SR 000 314 (or the updates on the ETSI Web server) which are, or may be, or may become, essential to the present document.

Foreword

This European Standard (Telecommunications series) has been produced by ETSI Technical Committee Telecommunications Management Network (TMN), and is now submitted for the ETSI standards One-step Approval Procedure.

The present document is part 2 of a multi-part deliverable covering the Telecommunications Management Network (TMN); Functional specification of Customer Administration (CA) on the Operations System/Network Element (OS/NE) interface, as identified below:

Part 1: "Single line configurations";

Part 2: "Multi line configurations".

Proposed national transposition dates	
Date of latest announcement of this EN (doa):	3 months after ETSI publication
Date of latest publication of new National Standard or endorsement of this EN (dop/e):	6 months after doa
Date of withdrawal of any conflicting National Standard (dow):	6 months after doa

Introduction

For the present document, the following priority was assigned for the scope of the customer administration model:

- modelling of analogue, digital and Integrated Services Digital Network (ISDN) multi line customer installation configurations.

Extendibility to cover all ETSI ISDN teleservices, bearer services and supplementary services, Private Branch Exchanges (PBXs), mobile customers, ATM, cordless and Universal Personal Telecommunication (UPT) customers, centrex, packet switching, the full range of CEPT services, non-standardized services (e.g. dual homing, etc.) is foreseen via subclassing (see entity-relationship diagram clause 5.1, and descriptions in clause 6.1).

In the present document, the customer administration model is restricted to modelling of semi-permanent customer data. Call processing and dynamic (state) information are no subject of the present document.

The present document is based on the ITU-T Recommendations Q.824.0 [9] to Q.824.4 [13] and on EN 300 291-1 [2], from which all relevant object classes were subclassed as far as necessary.

1 Scope

The present document specifies the management aspects of Customer Administration (CA) for Public Switched Telephone Network (PSTN), and public Integrated Services Digital Network (ISDN), in line with descriptions in ETR 047 [22], and restricted to service provisioning and service configuration only. The identified requirements are documented in annex B of the present document. Within the present document, not only terminating, but as well originating aspects of ISDN and PSTN multi line configurations are considered.

The model is restricted to the Operations System to Network Element (OS/NE) interface.

The present document focuses on the configuration management aspects of multi line configurations, regarding the framework as given in EN 300 291-1 [2], in ITU-T Recommendations Q.824 series [9] to [13], in the CEPT Handbook [19] on services and facilities, in EN 300 650 [23] and in ITU-T Recommendation I.252.6 [7].

As far as necessary, object classes representing supplementary services required for multi line configurations are defined within the present document.

2 References

The following documents contain provisions which, through reference in this text, constitute provisions of the present document.

- References are either specific (identified by date of publication, edition number, version number, etc.) or non-specific.
- For a specific reference, subsequent revisions do not apply.
- For a non-specific reference, the latest version applies.

- [1] ETSI ETS 300 062: "Integrated Services Digital Network (ISDN); Direct Dialling In (DDI) supplementary service; Service Description".
- [2] ETSI EN 300 291-1 (V1.2.1): "Telecommunications Management Network (TMN); Functional specification of Customer Administration (CA) on the Operations System/Network Element (OS/NE) interface; Part 1: Single line configurations".
- [3] ETSI EN 300 292 (V1.2.1): "Telecommunications Management Network (TMN); Functional specification of call routing information management on the Operations System/Network Element (OS/NE) interface".
- [4] ITU-T Recommendation E.164: "The international public telecommunication numbering plan".
- [5] ITU-T Recommendation E.502: "Traffic measurement requirements for digital telecommunication exchanges".
- [6] ITU-T Recommendation I.210: "Principles of telecommunication services supported by an ISDN and the means to describe them".
- [7] ITU-T Recommendation I.252.6 (1988): "Line Hunting (LH)".
- [8] ITU-T Recommendation M.3100: "Generic network information model".
- [9] ITU-T Recommendation Q.824.0 (1995): "Common information".
- [10] ITU-T Recommendation Q.824.1 (1995): "Integrated Services Digital Network (ISDN) basic and primary rate access".
- [11] ITU-T Recommendation Q.824.2 (1995): "Integrated Services Digital Network (ISDN) supplementary services".
- [12] ITU-T Recommendation Q.824.3 (1995): "Integrated Services Digital Network (ISDN) optional user facilities".

- [13] ITU-T Recommendation Q.824.4 (1995): "Integrated Services Digital Network (ISDN) teleservices".
- [14] ITU-T Recommendation X.720 (ISO/IEC 10165-1): "Information technology - Open Systems Interconnection - Structure of management information: Management information model".
- [15] ITU-T Recommendation X.721 (ISO/IEC 10165-2): "Information technology - Open Systems Interconnection - Structure of management information: Definition of management information".
- [16] ITU-T Recommendation X.730 (ISO/IEC 10164-1): "Information technology - Open Systems Interconnection - Systems Management: Object management function".
- [17] ITU-T Recommendation X.731 (ISO/IEC 10164-2): "Information technology - Open Systems Interconnection - Systems Management: State management function".
- [18] ITU-T Recommendation X.732 (ISO/IEC 10164-3): "Information technology - Open Systems Interconnection - Systems Management: Attributes for representing relationships".
- [19] CEPT Handbook on services and facilities offered to the subscribers in modern telephone systems (3rd Edition 1981) .
- [20] ETSI EN 301 479: "Integrated Services Digital Network (ISDN); Line Hunting (LH) supplementary service; Service description".
- [21] ETSI ETR 010: "ISDN Standards Management (ISM); The ETSI Basic Guide on the European Integrated Services Digital Network (ISDN)".
- [22] ETSI ETR 047: "Network Aspects (NA); Telecommunications Management Network (TMN) Management services".
- [23] ETSI EN 300 650: "Integrated Services Digital Network (ISDN); Message Waiting Indication (MWI) supplementary service; Service description".
- [24] ITU-T Recommendation Q.821: "Stage 2 and stage 3 description for the Q3 interface - Alarm surveillance".
- [25] ITU-T Recommendation X.711: "Information technology - Open Systems Interconnection - Common Management Information Protocol: Specification".
- [26] ETSI ETS 300 345: "Integrated Services Digital Network (ISDN); Interworking between public ISDNs and private ISDNs for the provision of telecommunication services; General aspects".

3 Definitions and abbreviations

3.1 Definitions

For the purposes of the present document, the following terms and definitions apply:

customer administration: function of managing customer service provisioning information on an exchange.

multi line configuration: customer configuration where the customer installation (e.g. a PBX) may be accessed to the exchange by more than one line with a common directory number (see clause B.1 of EN 300 291-2)

pilot directory number: directory number with which the multi line configuration can be addressed

NOTE: In the case of a PBX, it may be the directory number which leads to the operator position of the PBX.

pilot line: physical line associated with a pilot directory number and is e.g. used to start sequential hunting

The definitions of the managed object classes are described in clause 6 and formally defined in clause 7.

The definitions of all ISDN teleservices, bearer services and supplementary services may be found in the ETS/EN listed in clause 6 of ETR 010 [21].

3.2 Abbreviations

For the purposes of the present document, the following abbreviations apply:

ASN.1	Abstract Syntax Notation One
ATM	Asynchronous Transfer Mode
BRA	Basic Rate Access
BRA	ISDN Basic Rate Access
DDI	Direct Dialling In
DSS1	Digital Signalling System No.1
GDMO	Guidelines for the Definition of Managed Objects
ISDN	Integrated Services Digital Network
LSN	Line Service Number
M/C/O	Mandatory/Conditional/Optional
MFC	Multi Frequency Code
NE	Network Element
OS	Operations System
PABX	Private Automatic Branch Exchange (with DDI)
PBX	Private Branch Exchange (without DDI)
PCM	Pulse Code Modulation
PDN	pilot directory number
PRA	ISDN primary rate access
PRA	Primary Rate Access
PSTN	Public Switched Telephone Network
QSIG	Q Signalling
RDN	Relative Distinguished Name
RSN	Remote Service Number
SCI	Subscriber Controlled Input
TIB	Task Information Base
TMN	Telecommunications Management Network
UPT	Universal Personal Telecommunications

4 Functional requirements

The functional requirements are derived from the TIB A specified in ETR 047 [22] for the customer administration service.

The requirements as identified for multi line configurations are documented in annex B.

Customer administration is a management activity that the network operator performs in order to exchange with the customer all the customer related management data and functions required to offer a telecommunication service and to exchange with the network all the customer related management data and functions necessary for the network to produce that telecommunication service.

In a wide sense, this could include interactions for the purpose of service provision management, configuration administration, fault administration, charging (including detailed billing) administration, complaints administration, quality of service administration, traffic measurement administration, etc. Here, however, only customer administration in the more traditional sense of service provision and service configuration has been included.

The components of service mentioned hereafter are within the scope of the present document.

4.1 Manage service provision

After receiving a customer order, find an available directory number and a suitable access port in an appropriate exchange and connect these.

4.2 Administer service facilities and supplementary services

Record user service requirements as data related to directory number. Some services can be both customer controlled and operator controlled.

Examples for service facilities and supplementary services are malicious call tracing, charging observation, traffic restriction, line hunt group withdrawal, etc.

4.3 Administer customer line

Administer line characteristics which are relevant for the local exchange (e.g. line status, traffic direction).

5 Information model diagrams

The following information model diagrams have been drawn for the purpose of clarifying the relations between the different object classes of customer administration. There are three different types of diagrams:

- entity relationship models, showing the relations of the different managed objects;
- inheritance hierarchy, showing how managed objects are derived from each other (i.e. the different paths of inherited characteristics of the different managed objects);
- naming hierarchy showing the derivation of names for managed objects (i.e. the different naming paths for instances of managed objects).

These three different diagrams are only for clarification. The formal specification in terms of Guidelines for the Definition of Managed Objects (GDMO) templates and Abstract Syntax Notation One (ASN.1) type definitions are the relevant information for the implementation of the present document.

5.1 Entity relationship diagrams

Figure 1 shows the relationships of the object classes defining an ISDN/PSTN customer configuration. The service fragment indicated in figure 1 is detailed in figure 2 of EN 300 291-1 [2].

Object classes defined in the present document are indicated in the entity relationship diagrams by **bold** letters.

The relationships of object classes defined in other documents are only shown as far as needed.

5.2 Inheritance hierarchy

Figures 2 to 7 show the inheritances of the object classes defined in the present document. The inheritances of object classes referenced from other documents but not subclassed in the present document are defined in the referenced documents. As well, the inheritance of the service related object classes (subclasses) defined in the present document is not shown in these figures. Within the present document they are to be found in the fragment where their superclass is defined. Object classes defined in the present document are highlighted in **bold** letters.

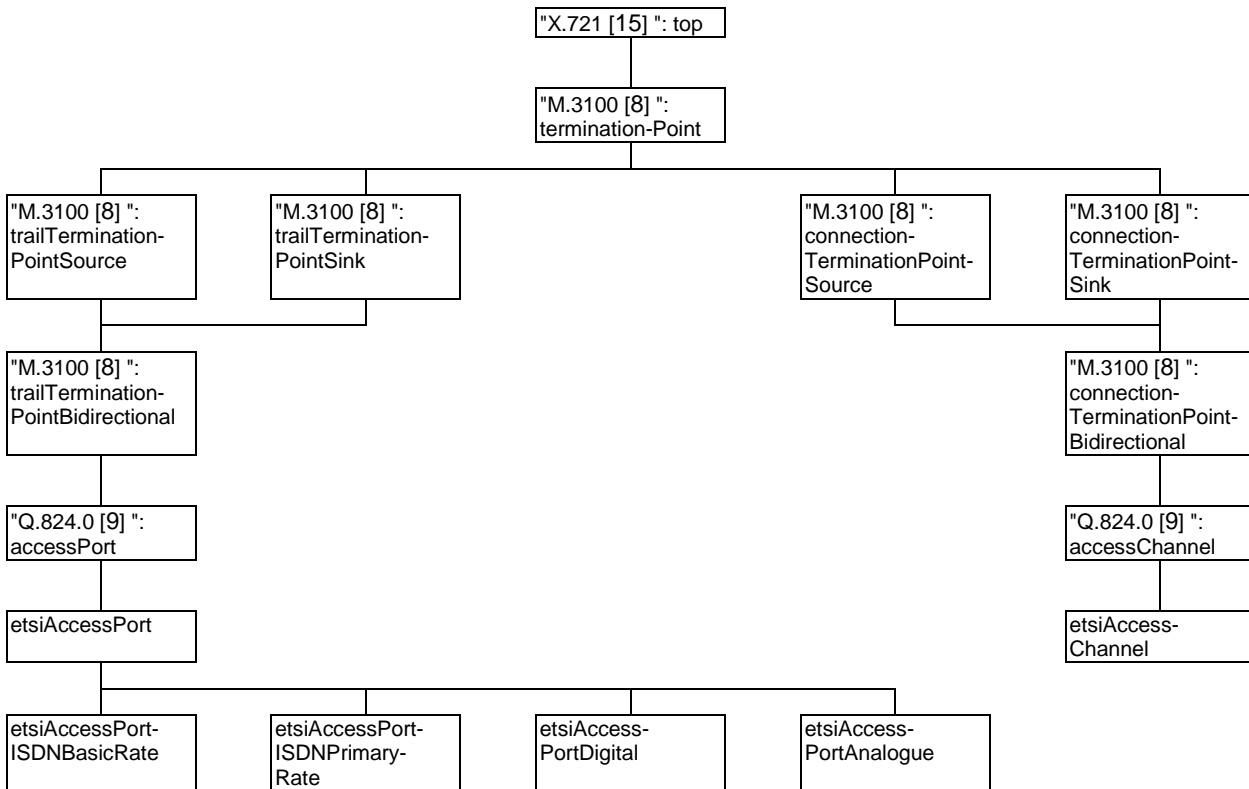

Figure 2: Inheritance hierarchy (part 1)

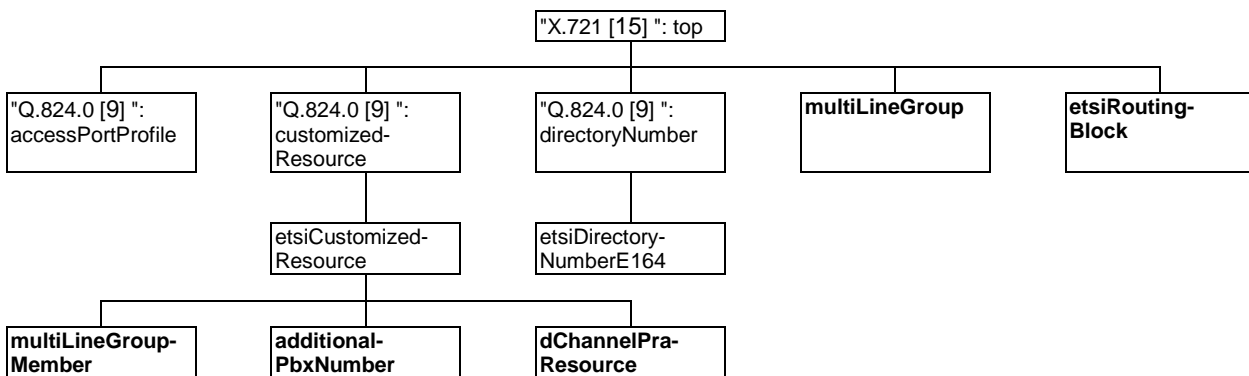

Figure 3: Inheritance hierarchy (part 2)

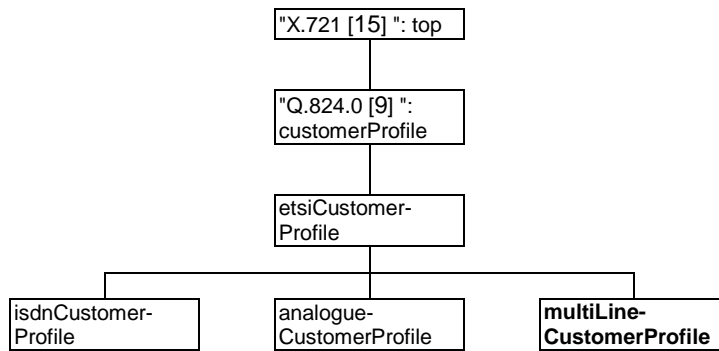

Figure 4: Inheritance hierarchy (part 3)

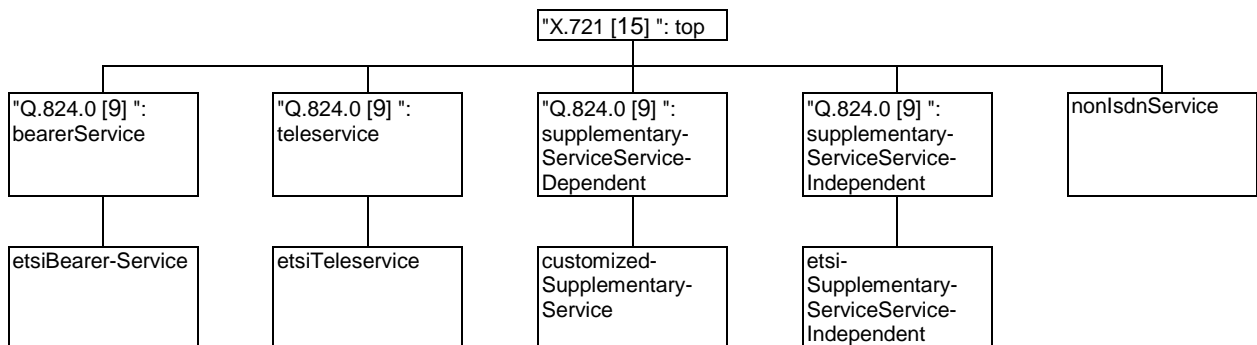

Figure 5: Inheritance hierarchy (part 4)

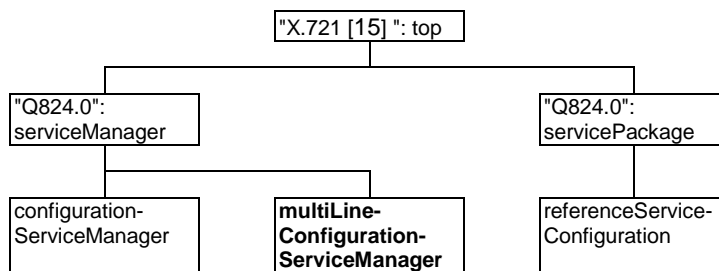

Figure 6: Inheritance hierarchy (part 5)

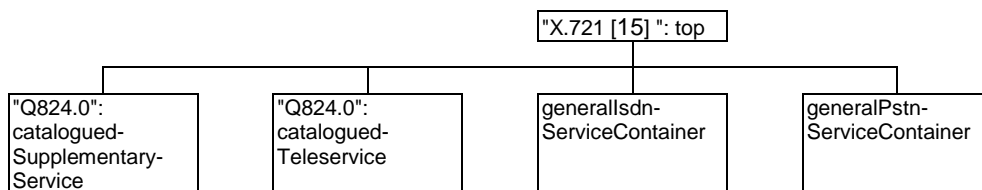

Figure 7: Inheritance hierarchy (part 6)

5.3 Naming hierarchy

Figures 8 to 11 show the name bindings (containment relationships) of the object classes defined in the present document. The name bindings of object classes referenced from other documents are defined in the referenced documents. They are only indicated in this table where necessary. Object classes defined in the present document are highlighted in **bold** letters.

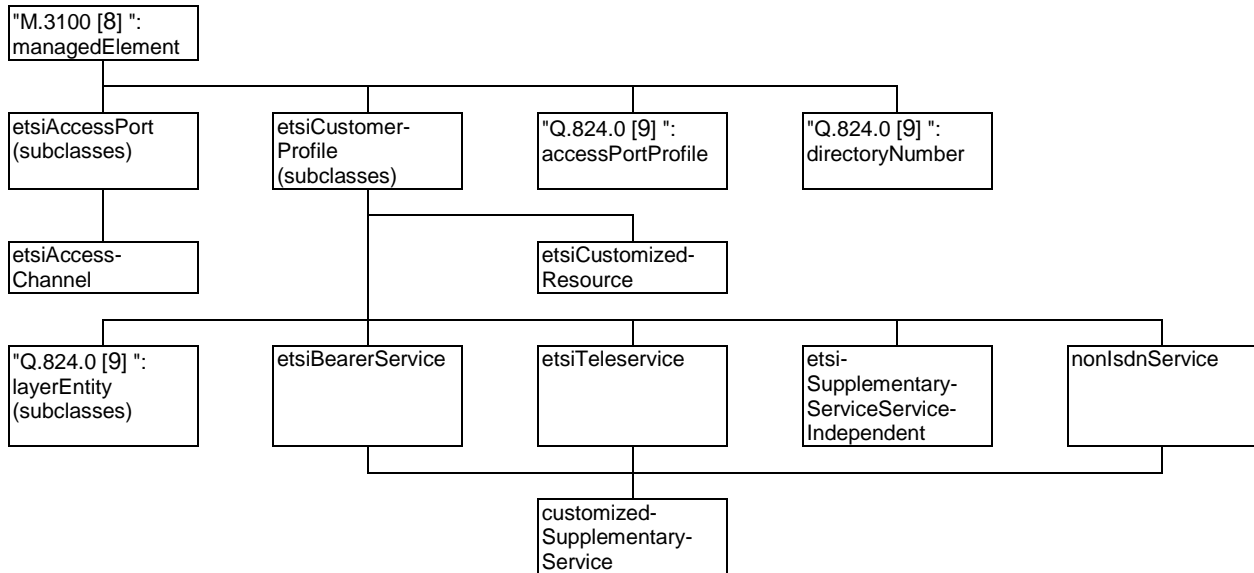

Figure 8: Naming hierarchy (part 1)

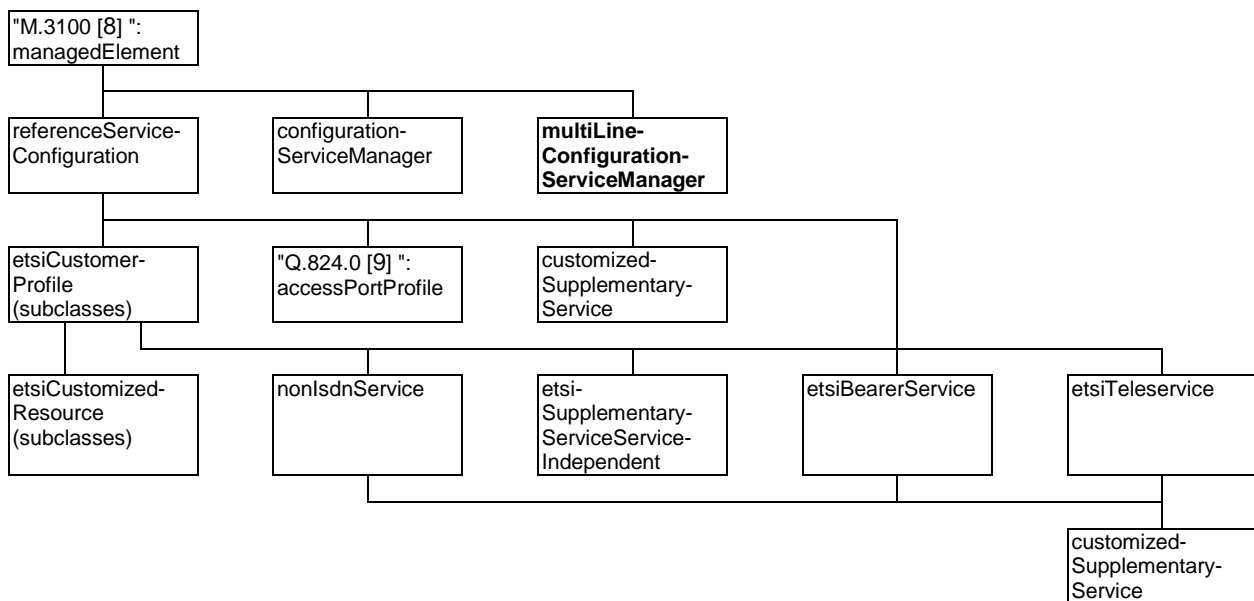

Figure 9: Naming hierarchy (part 2)

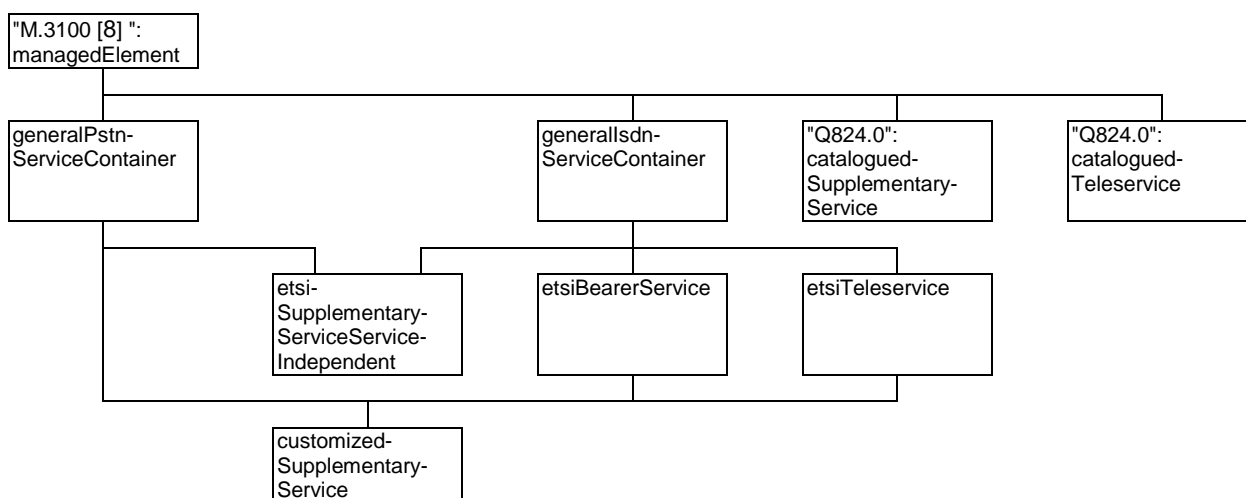

Figure 10: Naming hierarchy (part 3)

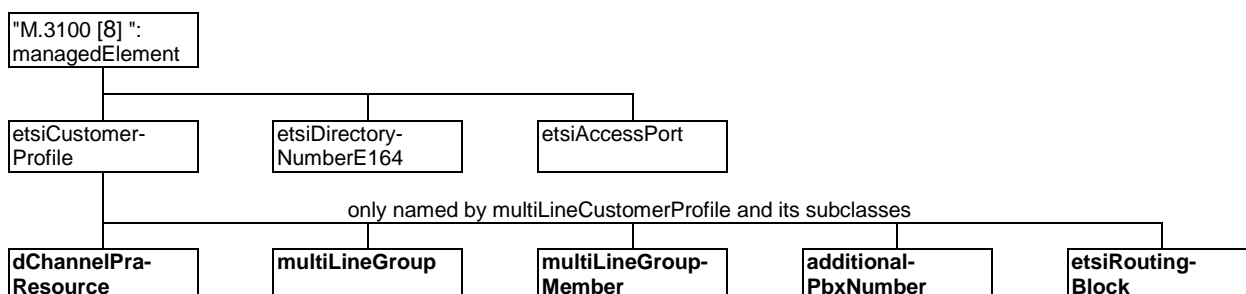

Figure 11: Naming hierarchy (part 4)

6 Information model description

This clause provides a high-level informal description of the customer administration information model.

Clause 6.1 contains a brief description for each object class used in the model covering:

- the purpose of the object class;
- the attributes defined for the object class; and
- the relationship of the object class to other object classes.

Attributes which are common to several object classes are described in clause 6.2.

Clause 6.3 describes actions which are influencing several object classes in the information model.

Clause 6.4 describes the common aspects of the notifications used in the information model.

6.1 Object class descriptions

This clause is divided into clauses in which the object classes of the information model are described, where they are not described in other documents. In these cases, references are given.

In the tables listing the attributes of the object classes, the attributes inherited from ITU-T Recommendation X.721 [15] top are not mentioned explicitly, although they are present in these object classes as defined in ITU-T Recommendation X.721 [15].

6.1.1 Managed element

The managedElement object class represents the location where the Q3 interface and its associated resources are provided. This managed object class is defined in ITU-T Recommendation M.3100 [8].

6.1.2 Access port fragment

6.1.2.1 Access port

The accessPort object class is defined in ITU-T Recommendation Q.824.0 [9]. It represents the resource concept and is used to identify the resource capabilities supporting a customer services. The resource abstraction is defined as the trail termination points that terminates trails between the switching network element and the customer premise equipment. These trail termination points send the signalling and service information to the customer.

6.1.2.2 ETSI access port

The etsiAccessPort is derived from ITU-T Recommendation Q.824.0 [9]: accessPort. It represents the resource concept and is used to identify the resource capabilities supporting a customer services.

This object class is defined in EN 300 291-1 [2].

6.1.2.3 ETSI access port analogue

The etsiAccessPortAnalogue object class is the conventional two-wire loop access to an analogue customer equipment. It is derived from etsiAccessPort.

This object class is defined in EN 300 291-1 [2].

6.1.2.4 ETSI access port digital

The etsiAccessPortDigital object class represents the termination of any non-ISDN digital access. It is derived from etsiAccessPort.

This object class is defined in EN 300 291-1 [2].

6.1.2.5 ETSI access port ISDN basic rate

The etsiAccessPortISDNBasicRate is derived from etsiAccessPort. It represents the resource concept and is used to identify the resource capabilities supporting a customer's services.

The etsiAccessPortISDNBasicRate object class supports up to 2 B-channels of 64 kbit/s for transfer of information and data and 1 D-channel of 16 kbit/s for signalling and data transfer (2 B + D).

This object class is defined in EN 300 291-1 [2].

6.1.2.6 ETSI access port ISDN primary rate

The etsiAccessPortISDNPrimaryRate is derived from etsiAccessPort. It represents the resource concept and is used to identify the resource capabilities supporting a customer's services.

The etsiAccessPortISDNPrimaryRate object class supports up to 30 B-channels of 64 kbit/s for transfer of information and data and 1 D-channel of 64 kbit/s for signalling and data transfer (30 B + D).

This object class is defined in EN 300 291-1 [2].

6.1.2.7 Access channel

The accessChannel object class is defined in ITU-T Recommendation Q.824.0 [9]. It represents an individual ISDN B-channel or D-channel of an ISDN access port or an individual channel of a digital access port. This object class is a specialization of the bi-directional connection termination point object class defined in ITU-T Recommendation M.3100 [8].

The number of access channels belonging to an access port depends on the access port architecture. This object class may be related to a set of customizedResource or its subclasses when services shall be provisioned on a per access channel basis.

6.1.2.8 ETSI access channel

The etsiAccessChannel is derived from ITU-T Recommendation Q.824.0 [9]: accessChannel. It represents an individual ISDN B-channel or D-channel of an ISDN access port or an individual channel of a digital access port.

It identifies the set of attributes which apply in common to all types of ISDN and digital access channels. Instances of this object class are contained within ISDN or digital access ports.

This object class is defined in EN 300 291-1 [2].

6.1.2.9 Access port profile

The accessPortProfile object class is defined in ITU-T Recommendation Q.824.0 [9].

The accessPortProfile object class (and its subclasses) represents those aspects of an exchange access that cannot be configured until subscription at which time the mode in which the access port is to be used by the customer is known.

6.1.3 Multi line grouping fragment

6.1.3.1 Multi line group

This object class represents a group of lines of a multi line configuration characterized by:

- same directionality;
- same access type.

The routingBlockPtrList attribute as backward pointer to etsiRoutingBlock instances shall be maintained by the resource according to associations of etsiRoutingBlock instances to multiLineGroup instances.

It is to be considered that the "ITU-T Recommendation Q.824.0 [9]: administeredCircuitEndPointSubgroup object class and its superclass "ITU-T Recommendation M.3100 [8]: circuitEndPointSubgroup" are containing attributes and actions which are not needed for customer administration or would require a re-definition respectively. Therefore, the multiLineGroup object class is defined in parallel to the mentioned administeredCircuitEndPointSubgroup object class.

It is derived from "ITU-T Recommendation X.721 [15]: 1992": top.

Table 1

Name	M/C/O	Value Set
multiLineGroupId	M	single
trafficDirectionality	M	single
accessType	M	single
ITU-T Recommendation Q.824.0 [9] ": routingBlockPtrList	M	single
selectionMethod	C	single
startSend	C	single
endOfSelection	C	single
digitsForHolding	C	single
minMax	C	single
"ITU-T Recommendation X.721 [15]: 1992": administrativeState	O	single
"EN 300 291-1 [2] (1999)": maintBlocking	O	single
registerSignalling	O	single
multiLineGroupId		gives the RDN.
trafficDirectionality		gives the directionality of the multi line group according to ITU-T Recommendation E.502 [5].
accessType		gives the type of access (e.g. analogue or ISDN).
routingBlockPtrList		points to instances of ETSI routing block object class.
selectionMethod		defines the method for selecting an access such as sequential, cyclic, etc.
startSend		specifies from which digit on the dial information shall be sent to the PABX.
endOfSend		specifies the method to be used to detect end of selection.
digitsForHolding		gives the number of digits that shall be received additionally to the digits of the fixed part of the pilot directory number before a PABX link is seized.
minMax		gives the minimal and maximal length of the directory number used to determine the end of dialling for a PABX with DDI.
administrativeState		gives the administrative state of the multi line group.
maintBlocking		indicates whether the multi line group is blocked for maintenance reasons.
registerSignalling		indicates the type of register signalling used between exchange and customer equipment.

6.1.3.2 ETSI routing block

The ETSI routing block managed object class associates an ordered list of multi line groups with a list of directory numbers. This list of multi line groups is ordered so that the preference of multi line groups to use for a particular directory number can be expressed.

This object class shall only be used if in a customer configuration hunting algorithms between multiLineGroups (multiLineGroup overflow) are required which are different from the default exchange algorithm (e.g. search first ISDN terminating, then ISDN both ways, then analogue terminating, then analogue both ways for an ISDN speech terminating call).

It is to be considered that the "ITU-T Recommendation Q.824.0 [9] ": routingBlock object class is containing attributes and actions which are not needed for customer administration or would require a re-definition respectively. Therefore, the etsiRoutingBlock object class is defined in parallel to the mentioned "ITU-T Recommendation Q.824.0 [9] ": routingBlock object class.

It is derived from "ITU-T Recommendation X.721 [15]: 1992": top.

Table 2

Name	M/C/O	Value Set
etsiRoutingBlockId	M	single
ITU-T Recommendation Q.824.0 [9] ": directoryNumberPtrList	M	set
orderedMultiLineGroupList	M	single
etsiRoutingBlockId		gives the RDN.
directoryNumberPtrList		is a set-valued attribute whose value(s) points to instances of the directory number object class or its subclasses.
orderedMultiLineGroupList		gives the sequence of multi line groups for hunting.

6.1.4 Directory number fragment

6.1.4.1 Directory number

The `directoryNumber` object class is a resource in its own right. It is a constituent part of the user interface and is directly related to one or more dialling plans being part of the managed element.

The `directoryNumber` object class is defined in ITU-T Recommendation Q.824.0 [9]. It has no instantiations of itself.

6.1.4.2 ETSI directory number E.164

The `etsiDirectoryNumberE164` represents directory numbers belonging to the ISDN numbering plan defined in ITU-T Recommendation E.164 [4].

This object class is defined in EN 300 291-1 [2].

6.1.4.3 Local destination

The `localDestination` object class as defined in EN 300 292 [3] represents the grouping of directory numbers of an exchange, as used e.g. for the definition of DDI ranges.

6.1.5 Customer profile fragment

6.1.5.1 Customer profile

The `customerProfile` object class represents a single point of reference used to bind together a range of services and resources for customer administration purposes. It is a class of managed objects representing the characteristics of the directory number(s) assigned to an individual customer, independent of the access type and bearer service.

The `customerProfile` object class is defined in ITU-T Recommendation Q.824.0 [9].

6.1.5.2 ETSI customer profile

The ETSI customer profile object class provides a single point of reference for a customer's installation to one or more ISDN, analogue, and/or digital lines. An instance of an `etsiCustomerProfile` subclass may be related to zero, one, or more instances of `accessPortProfile` and/or one instance of `etsiDirectoryNumberE164`.

The `etsiCustomerProfile` object class is not instantiated.

This object class is defined in EN 300 291-1 [2].

6.1.5.3 Multi line customer profile

This object class is the reference point for the services, directory numbers, and access ports being part of the related multi line customer configuration.

Each line of a multi line configuration, i.e. as well the pilot line if associated with a physical line, is represented by an instance of `multiLineGroupMember` contained in an instance of this object class.

The `directoryNumberPtrList` attribute shall point to only one `etsiDirectoryNumberE164` instance which is giving the pilot directory number of the customer configuration.

The ITU-T Recommendation Q.824.0 [9]: `accessPortProfilePointerList` attribute shall always be empty set.

The `originForRouteing`, `originForCharging`, and `originForAnalysis` packages shall not be instantiated with the `multiLineCustomerProfile` object class.

The default value defined for the `customerType` attribute within its superclass is not applicable for this object class.

This object class is derived from "EN 300 291-1 [2]: `etsiCustomerProfile`".

Table 3

Name	M/C/O	Value Set
operatorNumber	M	single
multiLineConfigurationType	M	single
operatorNumber	gives the operator position number.	
multiLineConfigurationType	gives the type of multi line configuration (standard, QSIG,...).	

6.1.5.4 Customized Resource

The customizedResource object class is defined in ITU-T Recommendation Q.824.0 [9].

6.1.5.5 ETSI customized Resource

The etsiCustomizedResource object class allows refinement of the service provisioning for a customer. It allows association of a set of services to:

- one or more access ports;
- one or more DNs;
- one or more access channels.

The channels may span more than one access port. The etsiCustomizedResource object class also allows association between DNs and access ports without any services associated with them.

This object class is defined in EN 300 291-1 [2].

6.1.5.6 Multi line group member

The multiLineGroupMember object class represents the logical view on an individual line of a multi line configuration.

If a line is assigned to more than one multi line group, a line shall be represented within each multi line group by each one multi line group member instance.

An instance of this object class shall not be associated to more than one instance of access channel or access port profile respectively.

The multi line group member shall only be assigned to a multi line group and an access port profile/access channel with consistent characteristics.

The directionality package shall not be instantiated with this object class.

This object class is derived from "EN 300 291-1 [2]: etsiCustomizedResource".

Table 4

Name	M/C/O	Value Set
lineNumber	M	single
multiLineGroupPtr	M	single
lineCategory	M	single
pbxLineSignalling	C	single
"EN 300 292 [3] (1998)": originForRouteing	C	single
"EN 300 291-1 [2] (1999)": originForCharging	C	single
"EN 300 292 [3] (1998)": originForAnalysis	C	single
lineNumber	gives the line number within the customer configuration.	
multiLineGroupPtr	gives the multiLineGroup object instance to which this multiLineGroupMember belongs.	
lineCategory	gives the line category.	
pbxLineSignalling	gives the type of signalling on the analogue line between exchange and P(A)BX.	
originForRouteing	groups customer profiles for call routeing purposes as defined in EN 300 292 [3].	
originForCharging	groups customer profiles for charging and/or tariffing purposes.	
originForAnalysis	groups customer profiles for digit analysis purposes within the call routeing context as defined in EN 300 292 [3].	

6.1.5.7 Additional PBX number

If for a multi line configuration the assigned directory numbers are e.g. not consecutive, an additional PBX directory number has to be assigned. This is configured by means of the additional PBX number object class.

This object class represents the assignment of an additional directory number to a multi line configuration, if this directory number shall not be directly related to individual lines of the multi line configuration represented by multiLineGroupMember instances. The directoryNumberPtrList shall point to only one directory number instance, whereas all other relationship attributes shall be empty set.

This object class is derived from "ITU-T Recommendation Q.824.0 [9] (1996): customizedResource".

Table 5

Name	M/C/O	Value Set
multiLineGroupPtrList	O	set
multiLineGroupPtrList		gives in a list the multiLineGroup instances for which this additional PBX number is valid.

6.1.5.8 D-channel primary rate access resource

This object class is used to indicate the assignment of a dedicated D channel to a customer configuration, which may be shared with other customer configurations. The accessChannelPtrList attribute shall point to one instance of access channel contained in an etsiAccessPortISDNPrimaryRate instance, representing the dedicated D channel. The bearerServicePtrList, the teleServicePtrList, and the directoryNumberPtrList attributes shall be empty set.

This object class is derived from "ITU-T Recommendation Q.824.0 [9] (1996): customizedResource".

Table 6

Name	M/C/O	Value Set
sharedDChannel	M	single
sharedDChannel		indicates whether the D channel is shared with other customer configurations (TRUE) or not (FALSE).

6.1.6 Bearer service fragment

6.1.6.1 Bearer service

This object class is defined in ITU-T Recommendation Q.824.0 [9].

This object class contains the characteristics common to all bearer services as defined in ITU-T Recommendation I.210 [6]. A bearer service may be associated with a set of supplementary services.

This object class is not instantiated.

6.1.6.2 ETSI bearer service

This object class is derived from ITU-T Recommendation Q.824.0 [9]: bearerService.

The references of its subclasses to the service describing standards are given in annex A of EN 300 291-1 [2].

This object class is not instantiated.

This object class and its subclasses are defined in EN 300 291-1 [2].

6.1.7 Teleservice fragment

6.1.7.1 Teleservice

This object class is defined in ITU-T Recommendation Q.824.0 [9].

It contains the characteristics common to all teleservices as defined in ITU-T Recommendation I.210 [6]. A teleservice may or may not be associated with a set of supplementary services.

This object class is not instantiated.

6.1.7.2 ETSI teleservice

This object class is derived from "ITU-T Recommendation Q.824.0 [9] (1996): teleservice".

The references of its subclasses to the service describing standards are given in annex A of EN 300 291-1 [2].

This object class is not instantiated.

This object class and its subclasses are defined in EN 300 291-1 [2].

6.1.8 Service dependent supplementary service fragment

A supplementary service is considered being service dependent, if it is configurable on a per teleservice and/or bearer service basis according to the underlying service definitions. Configurability does not only mean the presence of attributes, but may as well be given by presence or absence of respective supplementary service instances in a service configuration.

It is to be regarded that services defined hereafter may apply both to ISDN and PSTN.

6.1.8.1 Supplementary service service dependent

This object class is defined in ITU-T Recommendation Q.824.0 [9].

It represents the supplementary services providing additional capabilities to be used with a basic telecommunication service.

This object class is not instantiated.

6.1.8.2 Customized supplementary service

This object class is derived from "ITU-T Recommendation Q.824.0 [9]: supplementaryServiceServiceDependent".

It represents the supplementary services providing additional capabilities to be used with a basic telecommunication service. It may represent:

- an ISDN supplementary service as defined in ETSI;
- a CEPT supplementary service as defined in the CEPT Handbook [19] on services and facilities;
- a non-standard supplementary service, i.e. operator-specific service.

A customized supplementary service may be related with a bearer service or teleservice thereby supplementing this service.

The references of its subclasses to the service describing standards are given in annex A of EN 300 291-1 [2].

This object class is not instantiated.

This object class and its subclasses are defined in EN 300 291-1 [2].

As far as in accordance with the service description, service defining object classes derived from this object class and defined in EN 300 291-1 [2] may be assigned to multi line configurations.

6.1.9 Service independent supplementary service fragment

A supplementary service is considered being service independent, if it is applicable to multiple services in a uniform manner according to the underlying service definitions.

If in future additional requirements arise, the need might occur to redefine a supplementary service given hereafter as service dependent.

It is to be regarded that services defined hereafter may apply both to ISDN and PSTN.

6.1.9.1 Supplementary service service independent

This object class is defined in ITU-T Recommendation Q.824.0 [9].

It represents the supplementary services providing additional capabilities to be used independent from a basic telecommunication service.

This object class is not instantiated.

6.1.9.2 ETSI supplementary service service independent

This object class is derived from "ITU-T Recommendation Q.824.0 [9] (1996): supplementaryServiceServiceIndependent".

It represents the supplementary services providing additional capabilities to be used with a basic telecommunication service. It may represent:

- an ISDN supplementary service as defined in ETSI;
- a CEPT supplementary service as defined in the CEPT Handbook [19] on services and facilities;
- a non-standard supplementary service, i.e. operator-specific service.

The references of its subclasses to the service describing standards are given in annex A of EN 300 291-1 [2].

This object class is not instantiated.

This object class and further subclasses of it are defined in EN 300 291-1 [2].

As far as in accordance with the service description, service defining object classes derived from this object class and defined in EN 300 291-1 [2] may be assigned to multi line configurations.

6.1.9.3 A-subscriber number identification

The aNumberIdentification object class is used to identify the directory number for calling line identification of a customer configuration. This object class applies only to multi line configurations.

This service can be assigned both to multi line customer profile object instances and multi line group member object instances or subclasses of each.

It is a subclass of etsiSupplementaryServiceServiceIndependent.

If this object class is not instantiated within a customer configuration, the default value as defined on exchange level shall be used for this service.

Table 7

Name	M/C/O	Value Set
dnTypeForANumberIdentification	M	single
dnTypeForANumberIdentification	gives the directory number for calling line identification of a customer configuration.	

6.1.9.4 Charging information

The chargingInformation object class is used to identify which directory number is to be used in the usage metering records for identification of the charged party. This object class applies only to multi line configurations.

If no meteringInformation object instance is present within the customer configuration, but metering information is required, an instance of this object class serves as well for the metering information of the associated resource(s) as given in the values of its attributes.

This service can be assigned both to multi line customer profile object instances and multi line group member object instances or subclasses of each.

It is a subclass of etsiSupplementaryServiceServiceIndependent.

If this object class is not instantiated within a customer configuration, the default value as defined on exchange level shall be used for this service.

Table 8

Name	M/C/O	Value Set
dnTypeForAma	M	single
dnTypeForAma	identifies how charging is performed on a customer configuration.	

6.1.9.5 Connect pilot line first

The assignment of this object to a customer configuration indicates that the pilot line shall be used first for hunting purposes. The customizedResourcePtrList attribute shall point to the multi line group member instance which is representing the pilot line.

No individual attributes were identified.

This service can only be assigned to multi line customer profile object instances or its subclasses.

The preconditions for assigning services to multi line configurations as given in table A.1 shall be regarded.

This object class is derived from etsiSupplementaryServiceServiceIndependent.

6.1.9.6 Direct circuit access

The dca object class gives information how direct circuit access shall be treated in a multi line configuration.

This service can only be assigned to multi line group member object instances or its subclasses.

The preconditions for assigning services to multi line configurations as given in table A.1 shall be regarded.

This object class is derived from etsiSupplementaryServiceServiceIndependent.

Table 9

Name	M/C/O	Value Set
hunt	M	single
hunt	indicates whether hunting is performed on direct circuit access or not (TRUE: call processing is continuing with the next line(s) in the hunt group in busy cases; FALSE: in busy cases, the traffic goes to loss).	

6.1.9.7 Dual homing

The dualHoming object class provides in the case that a P(A)BX is accessed to two exchanges, probably under the same directory number, the routing/IN information to reach the configuration in the other exchange.

This service can only be assigned to multi line customer profile object instances or its subclasses.

The preconditions for assigning services to multi line configurations as given in table A.1 shall be regarded.

It is a subclass of etsiSupplementaryServiceServiceIndependent.

Table 10

Name	M/C/O	Value Set
dualHomingNumber	M	single
dualHomingNumber		gives the routing/IN information to reach the configuration in the other exchange.

6.1.9.8 ISDN line reserved

The isdnLineReserved object class is used for the reservation of ISDN lines exclusively for ISDN services in mixed configurations.

No individual attributes were identified.

This service can only be assigned to multi line customer profile object instances or its subclasses.

This object class is derived from etsiSupplementaryServiceServiceIndependent.

6.1.9.9 Line huntgroup withdrawal

The lineHuntgroupWithdrawal object class indicates the withdrawal of parts of the customer configuration from line hunting.

The value of the customizedResourcePointerList attribute indicates which multi line group member(s) is (are) authorized to activate the service.

This service can only be assigned to multi line group member object instances or its subclasses, and if the line hunting service as defined in EN 301 479 [20] is assigned to the customer configuration.

The preconditions for assigning services to multi line configurations as given in table A.1 shall be regarded.

This object class is derived from etsiSupplementaryServiceServiceIndependent.

Table 11

Name	M/C/O	Value Set
withdrawnMultiLineMembers	M	set
withdrawalNotification	O	single
withdrawnMultiLineMembers		indicates which multi line group member(s) is (are) withdrawn from hunting.
withdrawalNotification		indicates whether the user receives a notification that the associated multi line group member is withdrawn (TRUE), or does not receive a notification of withdrawal (FALSE).

6.1.9.10 Metering information

The meteringInformation object class is used to identify the directory number for collection of the metering counter information to a customer configuration. This object class applies only to multi line configurations.

This service can be assigned both to multi line customer profile object instances and multi line group member object instances or subclasses of each.

It is a subclass of etsiSupplementaryServiceServiceIndependent.

If this object class is not instantiated within a customer configuration, the default value as defined on exchange level shall be used for this service.

Table 12

Name	M/C/O	Value Set
dnTypeForMetering	M	single
dnTypeForMetering		provides the directory number for collection of the metering counter information to a customer configuration.

6.1.9.11 SCI allowance

The lines (represented by multiLineGroupMember instances) pointed at by the sciAllowance object are authorized to perform SCI related to the multi line configuration.

No individual attributes were identified.

This service can only be assigned to multi line group member object instances or its subclasses, and if the line hunting service as defined in EN 301 479 [20] is assigned to the customer configuration.

The preconditions for assigning services to multi line configurations as given in table A.1 shall be regarded.

This object class is derived from etsiSupplementaryServiceServiceIndependent.

6.1.9.12 Trunk huntgroup withdrawal

The trunkHuntgroupWithdrawal object class indicates the withdrawal of parts of the customer configuration from trunk hunting.

The value of the customizedResourcePointerList attribute indicates which multi line group member(s) is (are) authorized to activate the service.

This service can only be assigned to multi line group member object instances or its subclasses, and if the trunk hunting service as defined in annex E is assigned to the customer configuration.

The preconditions for assigning services to multi line configurations as given in table A.1 shall be regarded.

This object class is derived from etsiSupplementaryServiceServiceIndependent.

Table 13

Name	M/C/O	Value Set
withdrawnMultiLineMembers	M	set
withdrawnMultiLineMembers		indicates which multi line group member(s) is (are) withdrawn from hunting.

6.1.10 General services

The object classes given hereafter are placeholders for methods of general service provision to all customer configurations accessed to an exchange. With the catalogued service object classes, superclasses are provided for teleservice and supplementary service facilities to be configured on exchange base. Appropriate subclasses may be derived from them. The service container object classes are superior object classes for e.g. supplementary services defined in the present document, which may be subject to be provided on a general base to all customer configurations.

6.1.10.1 Catalogued supplementary service

This object class is defined in ITU-T Recommendation Q.824.0 [9].

The catalogued supplementary service managed object class is a superclass for other service subclasses that have attributes that are not customizable by the customer. The subclasses will be defined once candidates for the non-customizable attributes have been identified.

This object class is not instantiated.

6.1.10.2 Catalogued teleservice

This object class is defined in ITU-T Recommendation Q.824.0 [9].

The catalogued teleservice managed object class defines a communication service that makes available layer 4 - layer 7 capabilities, and has attributes that are not customizable by the customer. This object class is a superclass from which specific catalogued teleservice objects may be derived as subclasses.

This object class is not instantiated.

6.1.10.3 General ISDN service container

The General ISDN service container is the superior object class for supplementary services available to all ISDN customer configurations.

It is to be considered that a service configuration within a customer configuration overrides this general service configuration.

This object class shall only be used for the general provision of services for which the resource (i.e. the exchange) is capable to provide them generally on exchange level.

This object class is defined in EN 300 291-1 [2].

6.1.10.4 General PSTN service container

The General PSTN service container is the superior object class for supplementary services available to all PSTN customer configurations.

It is to be considered that a service configuration within a customer configuration overrides this general service configuration.

This object class shall only be used for the general provision of services for which the resource (i.e. the exchange) is capable to provide them generally on exchange level.

This object class is defined in EN 300 291-1 [2].

6.1.10.5 Non ISDN service

The non-ISDN service object class is defined to allow the creation of specific supplementary services for analogue customer profiles.

This object class is defined in EN 300 291-1 [2].

6.1.11 Service provision fragment

6.1.11.1 Service manager

The serviceManager is a support object that is needed complete the exchange provisioning without a detailed knowledge of the provisioning model. The serviceManager is a superclass object that can be subclassed to support specific actions for specific functions or technologies. The serviceManager is used in conjunction with servicePackage object instances to perform these actions. The servicePackage contains instances of managed objects with initial values that are used in creating all or part of a customer's service.

The serviceManager object class is defined in ITU-T Recommendation Q.824.0 [9].

6.1.11.2 Configuration service manager

The configurationServiceManager object class is derived from "ITU-T Recommendation Q.824.0 [9] (1996): serviceManager".

The configurationServiceManager performs actions which establish customer configurations and services. In addition, the configurationServiceManager performs actions which change directory number and access port assignments.

This object class is defined in EN 300 291-1 [2].

6.1.11.3 Multi line configuration service manager

This object class is used to create the core object instances of a multi line configuration (e.g. customer profile, services) and the relationship to directory number according to the referenced referenceServiceConfiguration instance by means of the ACTION establishMultiLineConfiguration.

No individual attributes were identified.

This object class is derived from "ITU-T Recommendation Q.824.0 [9] (1996): serviceManager".

6.1.11.4 Service package

This object class is used to group instances of different object classes that are used to provide initial values for attributes of service objects created by the serviceManager object class.

The servicePackage object class is defined in ITU-T Recommendation Q.824.0 [9].

6.1.11.5 Reference service configuration

The referenceServiceConfiguration object class is derived from "ITU-T Recommendation Q.824.0 [9] (1996): servicePackage".

An instance of this object class contains reference profiles for service assignments which are referenced in ACTIONS on an instance of configurationServiceManager, multiLineConfigurationserviceManager, or their subclasses.

This object class is defined in EN 300 291-1 [2].

6.2 Attributes description

This clause provides the description of all generic attributes used within the customer administration model. It is to be regarded that they are either inherited from superclasses, or attributes defined in the present document are derived from them.

6.2.1 Relative distinguished name

The semantics of the RDN attribute type are specified in ITU-T Recommendation X.720 [14]. This attribute type is used to identify an instance of a managed object uniquely within the scope of its immediate superior in the management information tree.

6.2.2 Relationship attributes

Relationship attributes of managed objects for customer administration conform to the generic relationship model as defined by ITU-T Recommendation X.732 [18]. In general the group relationship is utilized.

6.2.3 State attributes

State related attributes of managed objects in this information model comprise the generic state model as defined by ITU-T Recommendation X.731 [17].

6.3 ACTIONS description

The following ACTIONS are defined/referred within the present document.

Table 14

ACTION	Purpose
establishMultiLineCustomerConfiguration	The ACTION copies the subtree (e.g. of a customerProfile) contained under an instance of referenceServiceConfiguration to a customer configuration contained in managedElement. It establishes the links from the customerProfile to the etsiDirectoryNumberE164 and vice versa. Further data of existing object instances of the customer configuration (e.g. data which are configurable on a per subscriber basis, like additionalPbxNumber, multiLineGroup, and etsiRoutingBlock) as well as relationships between object instances can be given with parameter customerData.
"EN 300 291-1 [2] (1999)": changeDirectoryNumber	This ACTION is used to change the etsiE164DirectoryNumber for a given customer profile. The ACTION request identifies the customer profile with the old etsiE164DirectoryNumber. The request also indicates the new etsiE164DirectoryNumber to be used and the interceptTreatmentTerm to be applied to the old etsiE164DirectoryNumber.

6.4 Notifications description

The following generic notifications will be utilized by the customer administration:

- object creation according to ITU-T Recommendations X.721 [15] and X.730 [16];
- object deletion according to ITU-T Recommendations X.721 [15] and X.730 [16];
- attribute value change according to ITU-T Recommendations X.721 [15] and X.730 [16];
- state change according to ITU-T Recommendations X.721 [15] and X.731 [17];
- relationship change according to ITU-T Recommendations X.721 [15] and X.732 [18].

It is to be considered that in most cases these notifications applying to the object classes defined in the present document are inherited from their superclasses defined in the ITU-T Recommendation Q.824 series.

7 Formal object class definitions

7.1 Definition of object classes

7.1.1 Managed element

The managedElement object class is defined in ITU-T Recommendation M.3100 [8].

7.1.2 Access port fragment

7.1.2.1 Access port

The accessPort object class is defined in ITU-T Recommendation Q.824.0 [9].

7.1.2.2 ETSI access port

This object class is defined in EN 300 291-1 [2].

7.1.2.3 ETSI access port analogue

This object class is defined in EN 300 291-1 [2].

7.1.2.4 ETSI access port digital

This object class is defined in EN 300 291-1 [2].

7.1.2.5 ETSI access port ISDN basic rate

This object class is defined in EN 300 291-1 [2].

7.1.2.6 ETSI access port ISDN primary rate

This object class is defined in EN 300 291-1 [2].

7.1.2.7 Access channel

The accessChannel object class is defined in ITU-T Recommendation Q.824.0 [9].

7.1.2.8 ETSI access channel

This object class is defined in EN 300 291-1 [2].

7.1.2.9 Access port profile

The accessPortProfile object class is defined in ITU-T Recommendation Q.824.0 [9].

7.1.3 Multi line grouping fragment

7.1.3.1 Multi line group

```
multiLineGroup MANAGED OBJECT CLASS
DERIVED FROM "ITU-T Recommendation X.721 [15]:1992": top;
CHARACTERIZED BY
multiLineGroupPkg PACKAGE
  BEHAVIUR
  multiLineGroupBhv BEHAVIOUR
  DEFINED AS "This object class represents a group of lines of a multi line configuration
  characterized by
  - same directionality
  - same access type
  The routingBlockPtrList attribute as backward pointer to etsiRoutingBlock instances shall be
  maintained by the resource according to associations of etsiRoutingBlock instances to
  multiLineGroup instances.";;
  ATTRIBUTES
    multiLineGroupId                GET SET-BY-CREATE,
    trafficDirectionality           GET SET-BY-CREATE,
    accessType                      GET SET-BY-CREATE,
    "ITU-T Recommendation Q.824.0 [9] (1996)": routingBlockPtrList INITIAL VALUE {} GET;;;
  CONDITIONAL PACKAGES
    terminatingCharacteristicsPkg PACKAGE
    PRESENT IF "the traffic directionality has the value terminating or both ways",
    "ITU-T Recommendation X.721 [15]:1992": administrativeStatePackage
    PRESENT IF "an instance supports it",
    maintenanceBlockingPkg
    PRESENT IF "an instance supports it",
    registerSignallingPkg PACKAGE
    PRESENT IF "an instance supports it";
REGISTERED AS {oca2ManagedObjectClass 1};
```

7.1.3.2 ETSI routing block

```
etsiRoutingBlock MANAGED OBJECT CLASS
  DERIVED FROM "ITU-T Recommendation X.721 [15]:1992": top;
  CHARACTERIZED BY
    etsiRoutingBlockPkg PACKAGE
      BEHAVIOUR
        etsiRoutingBlockBhv BEHAVIOUR
          DEFINED AS "The ETSI routing block managed object class associates an ordered list of multi
line groups with a list of directory numbers. This list of multi line groups is ordered so
that the preference of multi line groups to use for a particular directory number can be
expressed.
This object class shall only be used if in a customer configuration hunting algorithms
between multiLineGroups (multiLineGroup overflow) are required which are different from the
default exchange algorithm (e.g. search first ISDN terminating, then ISDN both ways, then
analogue terminating, then analogue both ways for an ISDN speech terminating call).";
          ATTRIBUTES
            etsiRoutingBlockId                                     GET SET-BY-CREATE,
            "ITU-T Recommendation Q.824.0 [9] (1996)": directoryNumberPtrList  GET-REPLACE ADD-REMOVE,
            orderedMultiLineGroupList                                     GET-REPLACE;
REGISTERED AS {oca2ManagedObjectClass 2};
```

7.1.4 Directory number fragment

7.1.4.1 Directory number

The directoryNumber object class is defined in ITU-T Recommendation Q.824.0 [9]. It has no instantiations of itself.

7.1.4.2 ETSI directory number E.164

This object class is defined in EN 300 291-1 [2].

7.1.4.3 Local destination

The localDestination object class as defined in EN 300 292 [3] represents the grouping of directory numbers of an exchange, as used e.g. for the definition of DDI ranges.

7.1.5 Customer profile fragment

7.1.5.1 Customer profile

The customerProfile object class is defined in ITU-T Recommendation Q.824.0 [9].

7.1.5.2 ETSI customer profile

This object class is defined in EN 300 291-1 [2].

7.1.5.3 Multi line customer profile

```
multiLineCustomerProfile MANAGED OBJECT CLASS
  DERIVED FROM "EN 300 291-1 [2] (1999)": etsiCustomerProfile;
  CHARACTERIZED BY
    multiLineCustomerProfilePkg PACKAGE
      BEHAVIOUR
        multiLineCustomerProfileBhv BEHAVIOUR
          DEFINED AS "This object class is the reference point for the services, directory numbers,
and access ports being part of the related multi line customer configuration.
Each line of a multi line configuration, i.e. as well the pilot line if associated with a
physical line, is represented by an instance of multiLineGroupMember contained in an
instance of this object class.
The directoryNumberPtrList attribute shall point to only one etsiDirectoryNumberE164
instance which is giving the pilot directory number of the customer configuration.
The 'ITU-T Recommendation Q.824.0 [9] (1996)':accessPortProfilePointerList attribute shall
always be empty set.
The originForRouteing, originForCharging, and originForAnalysis packages shall not be
instantiated with the multiLineCustomerProfile object class.
```

The default value defined for the customerType attribute within its superclass is not applicable for this object class.;;

```

ATTRIBUTES
"EN 300 291-1 [2] (1999)": customerType      PERMITTED VALUE
                                         CustomerAdminModuleV2Part2.PermittedCustomerType
                                         GET-REPLACE,
"EN 300 291-1 [2] (1999)": customerCategory PERMITTED VALUE
                                         CustomerAdminModuleV2Part2.PermittedCustomerCategory
                                         GET-REPLACE,
operatorNumber                            DEFAULT VALUE
                                         CustomerAdminModuleV2Part2.operatorNumberDefault
                                         GET-REPLACE,
multiLineConfigurationType                DEFAULT VALUE
                                         CustomerAdminModuleV2Part2.multiLineConfigurationTypeDefault
                                         GET-REPLACE;;;
REGISTERED AS {oca2ManagedObjectClass 3};

```

7.1.5.4 Customized resource

The customizedResource object class is defined in ITU-T Recommendation Q.824.0 [9].

7.1.5.5 ETSI customized resource

This object class is defined in EN 300 291-1 [2].

7.1.5.6 Multi line group member

```

multiLineGroupMember MANAGED OBJECT CLASS
DERIVED FROM "EN 300 291-1 [2] (1999)": etsiCustomizedResource;
CHARACTERIZED BY
multiLineGroupMemberPkg PACKAGE
  BEHAVIOUR
  multiLineGroupMemberBhv BEHAVIOUR
  DEFINED AS "The multiLineGroupMember object class represents the logical view on an
  individual line of a multi line configuration.
  If a line is assigned to more than one multi line group, a line shall be represented within
  each multi line group by each one multi line group member instance.
  An instance of this object class shall not be associated to more than one instance of access
  channel or access port profile respectively.
  The multi line group member shall only be assigned to a multi line group and an access port
  profile/access channel with consistent characteristics.
  The directionality package shall not be instantiated with this object class.;;
  ATTRIBUTES
  lineNumber          GET-REPLACE,
  multiLineGroupPtr   GET-REPLACE,
  lineCategory        GET-REPLACE;;;
CONDITIONAL PACKAGES
  pbxLineSignallingPkg
  PRESENT IF " the multiLineMember instance is related to a non ISDN digital access group",
  "EN 300 291-1 [2] (1999)": originForRouteingPkg
  PRESENT IF "aspects for call routeing purposes are to be considered",
  "EN 300 291-1 [2] (1999)": originForChargingPkg
  PRESENT IF "aspects for charging and/or tariffing purposes are to be considered",
  "EN 300 291-1 [2] (1999)": originForAnalysisPkg
  PRESENT IF "aspects for digit analysis purposes within the call routeing context are to be
  considered";
REGISTERED AS {oca2ManagedObjectClass 4};

```

7.1.5.7 Additional PBX number

```

additionalPbxNumber MANAGED OBJECT CLASS
DERIVED FROM "ITU-T Recommendation Q.824.0 [9] (1996)": customizedResource;
CHARACTERIZED BY
additionalPbxNumberPkg PACKAGE
  BEHAVIOUR
  additionalPbxNumberBhv BEHAVIOUR
  DEFINED AS "This object class represents the assignment of an additional directory number to
  a multi line configuration, if this directory number shall not be directly related to
  individual lines of the multi line configuration represented by multiLineGroupMember
  instances. The directoryNumberPtrList shall point to only one directory number instance,
  whereas all other relationship attributes shall be empty set.;;;;
CONDITIONAL PACKAGES
  multiLineGroupPtrListPkg

```

```
PRESENT IF "required by the customer configuration";
REGISTERED AS {oca2ManagedObjectClass 5};
```

7.1.5.8 D-channel primary rate access resource

```
dChannelPraResource MANAGED OBJECT CLASS
DERIVED FROM "ITU-T Recommendation Q.824.0 [9] (1996)": customizedResource;
CHARACTERIZED BY
dChannelPraResourcePkg PACKAGE
BEHAVIOUR
dChannelPraResourceBhv BEHAVIOUR
DEFINED AS "This object class is used to indicate the assignment of a dedicated D channel to
a customer configuration, which may be shared with other customer configurations. The
accessChannelPtrList attribute shall point to one instance of access channel contained in an
etsiAccessPortISDNPrimaryRate instance, representing the dedicated D channel. The
bearerServicePtrList, the teleServicePtrList, and the directoryNumberPtrList attributes
shall be empty set.";;
ATTRIBUTES
sharedDChannel DEFAULT VALUE FALSE
GET-REPLACE;;;
REGISTERED AS {oca2ManagedObjectClass 6};
```

7.1.6 Bearer service fragment

7.1.6.1 Bearer service

This object class is defined in ITU-T Recommendation Q.824.0 [9].

7.1.6.2 ETSI bearer service

This object class is defined in EN 300 291-1 [2].

7.1.7 Teleservice fragment

7.1.7.1 Teleservice

This object class is defined in ITU-T Recommendation Q.824.0 [9].

7.1.7.2 ETSI teleservice

This object class is defined in EN 300 291-1 [2].

7.1.8 Service dependent supplementary service fragment

7.1.8.1 Supplementary service service dependent

This object class is defined in ITU-T Recommendation Q.824.0 [9].

7.1.8.2 Customized supplementary service

This object class is defined in EN 300 291-1 [2].

7.1.9 Service independent supplementary service fragment

It is to be regarded that services defined hereafter may apply both to ISDN and PSTN.

7.1.9.1 Supplementary service service independent

This object class is defined in ITU-T Recommendation Q.824.0 [9].

7.1.9.2 ETSI supplementary service service independent

This object class is defined in EN 300 291-1 [2].

7.1.9.3 A-subscriber number identification

```
aNumberIdentification MANAGED OBJECT CLASS
  DERIVED FROM "EN 300 291-1 [2] (1999)": etsiSupplementaryServiceServiceIndependent;
  CHARACTERIZED BY
  aNumberIdentificationPkg PACKAGE
    BEHAVIOUR
    aNumberIdentificationBhv BEHAVIOUR
  DEFINED AS "The aNumberIdentification object class is used to identify the directory number
  for calling line identification of a customer configuration. This object class applies only
  to multi line configurations.
  This service can be assigned both to multi line customer profile object instances and multi
  line group member object instances or subclasses of each.";;
  ATTRIBUTES
  dnTypeForANumberIdentification GET-REPLACE;;;
REGISTERED AS {oca2ManagedObjectClass 7};
```

7.1.9.4 Charging information

```
chargingInformation MANAGED OBJECT CLASS
  DERIVED FROM "EN 300 291-1 [2] (1999)": etsiSupplementaryServiceServiceIndependent;
  CHARACTERIZED BY
  chargingInformationPkg PACKAGE
    BEHAVIOUR
    chargingInformationBhv BEHAVIOUR
  DEFINED AS "The chargingInformation object class is used to identify which directory number
  is to be used in the usage metering records for identification of the charged party. This
  object class applies only to multi line configurations.
  If no meteringInformation object instance is present within the customer configuration, but
  metering information is required, an instance of this object class serves as well for the
  metering information of the associated resource(s) as given in the values of its attributes.
  This service can be assigned both to multi line customer profile object instances and multi
  line group member object instances or subclasses of each.";;
  ATTRIBUTES
  dnTypeForAma GET-REPLACE;;;
REGISTERED AS {oca2ManagedObjectClass 8};
```

7.1.9.5 Connect pilot line first

```
connectPilotLineFirst MANAGED OBJECT CLASS
  DERIVED FROM "EN 300 291-1 [2] (1999)": etsiSupplementaryServiceServiceIndependent;
  CHARACTERIZED BY
  connectPilotLineFirstPkg PACKAGE
    BEHAVIOUR
    connectPilotLineFirstBhv BEHAVIOUR
  DEFINED AS "The assignment of this object to a customer configuration indicates that the
  pilot line shall be used first for hunting purposes. The customizedResourcePtrList attribute
  shall point to the multi line group member instance which is representing the pilot line.
  This service can only be assigned to multi line customer profile object instances or its
  subclasses.
  The preconditions for assigning services to multi line configurations as given in table A1
  in annex A shall be regarded.";;;
REGISTERED AS {oca2ManagedObjectClass 9};
```

7.1.9.6 Direct circuit access

```
dca MANAGED OBJECT CLASS
  DERIVED FROM "EN 300 291-1 [2] (1999)": etsiSupplementaryServiceServiceIndependent;
  CHARACTERIZED BY
  dcaPkg PACKAGE
    BEHAVIOUR
    dcaBhv BEHAVIOUR
  DEFINED AS "The dca object class gives information how direct circuit access shall be
  treated in a multi line configuration.
  This service can only be assigned to multi line group member object instances or its
  subclasses.
  The preconditions for assigning services to multi line configurations as given in table A1
  in annex A shall be regarded.";;
```

```

ATTRIBUTES
  hunt      DEFAULT VALUE FALSE
            GET-REPLACE;;;
REGISTERED AS {oca2ManagedObjectClass 10};

```

7.1.9.7 Dual homing

```

dualHoming MANAGED OBJECT CLASS
  DERIVED FROM "EN 300 291-1 [2] (1999)": etsiSupplementaryServiceServiceIndependent;
  CHARACTERIZED BY
  dualHomingPkg PACKAGE
    BEHAVIOUR
      dualHomingBhv BEHAVIOUR
        DEFINED AS "The dualHoming object class provides in the case that a P(A)BX is accessed to
        two exchanges, probably under the same directory number, the routeing/IN information to
        reach the configuration in the other exchange.
        This service can only be assigned to multi line customer profile object instances or its
        subclasses.
        The preconditions for assigning services to multi line configurations as given in table A1
        in annex A shall be regarded.";;
    ATTRIBUTES
      dualHomingNumber  GET-REPLACE;;;
REGISTERED AS {oca2ManagedObjectClass 11};

```

7.1.9.8 ISDN line reserved

```

isdnLineReserved MANAGED OBJECT CLASS
  DERIVED FROM "EN 300 291-1 [2] (1999)": etsiSupplementaryServiceServiceIndependent;
  CHARACTERIZED BY
  isdnLineReservedPkg PACKAGE
    BEHAVIOUR
      isdnLineReservedBhv BEHAVIOUR
        DEFINED AS "The isdnLineReserved object class is used for the reservation of ISDN lines
        exclusively for ISDN services in mixed configurations.
        This service can only be assigned to multi line customer profile object instances or its
        subclasses.";;;
REGISTERED AS {oca2ManagedObjectClass 12};

```

7.1.9.9 Line huntgroup withdrawal

```

lineHuntgroupWithdrawal MANAGED OBJECT CLASS
  DERIVED FROM "EN 300 291-1 [2] (1999)": etsiSupplementaryServiceServiceIndependent;
  CHARACTERIZED BY
  lineHuntgroupWithdrawalPkg PACKAGE
    BEHAVIOUR
      lineHuntgroupWithdrawalBhv BEHAVIOUR
        DEFINED AS "The lineHuntgroupWithdrawal object class indicates the withdrawal of parts of
        the customer configuration from line hunting.
        The value of the customizedResourcePointerList attribute indicates which multi line group
        member(s) is (are) authorized to activate the service.
        This service can only be assigned to multi line group member object instances or its
        subclasses, and if the line hunting service as defined in EN 301 479 [20] is assigned to the
        customer configuration.
        The preconditions for assigning services to multi line configurations as given in table A1
        in annex A shall be regarded.";;
    ATTRIBUTES
      withdrawnMultiLineMembers  GET-REPLACE ADD-REMOVE;;;
  CONDITIONAL PACKAGES
    withdrawalNotificationPkg
      PRESENT IF "required by service administration";
REGISTERED AS {oca2ManagedObjectClass 13};

```

7.1.9.10 Metering information

```
meteringInformation MANAGED OBJECT CLASS
  DERIVED FROM "EN 300 291-1 [2] (1999)": etsiSupplementaryServiceServiceIndependent;
  CHARACTERIZED BY
    meteringInformationPkg PACKAGE
      BEHAVIOUR
        meteringInformationBhv BEHAVIOUR
          DEFINED AS "The meteringInformation object class is used to identify the directory number
            for collection of the metering counter information to a customer configuration. This object
            class applies only to multi line configurations.
            This service can be assigned both to multi line customer profile object instances and multi
            line group member object instances or subclasses of each.";;
          ATTRIBUTES
            dnTypeForMetering GET-REPLACE;;;
REGISTERED AS {oca2ManagedObjectClass 14};
```

7.1.9.11 SCI allowance

```
sciAllowance MANAGED OBJECT CLASS
  DERIVED FROM "EN 300 291-1 [2] (1999)": etsiSupplementaryServiceServiceIndependent;
  CHARACTERIZED BY
    sciAllowancePkg PACKAGE
      BEHAVIOUR
        sciAllowanceBhv BEHAVIOUR
          DEFINED AS "The lines (represented by multiLineGroupMember instances) pointed at by the
            sciAllowance object are authorized to perform SCI related to the multi line configuration.
            This service can only be assigned to multi line group member object instances or its
            subclasses, and if the line hunting service as defined in EN 301 479 [20] is assigned to the
            customer configuration.
            The preconditions for assigning services to multi line configurations as given in table A1
            in annex A shall be regarded.";;;
REGISTERED AS {oca2ManagedObjectClass 15};
```

7.1.9.12 Trunk huntgroup withdrawal

```
trunkHuntgroupWithdrawal MANAGED OBJECT CLASS
  DERIVED FROM "EN 300 291-1 [2] (1999)": etsiSupplementaryServiceServiceIndependent;
  CHARACTERIZED BY
    trunkHuntgroupWithdrawalPkg PACKAGE
      BEHAVIOUR
        trunkHuntgroupWithdrawalBhv BEHAVIOUR
          DEFINED AS "The huntgroupWithdrawal object class indicates the withdrawal of parts of the
            customer configuration from line hunting.
            The value of the customizedResourcePointerList attribute indicates which multi line group
            member(s) is (are) authorized to activate the service.
            This service can only be assigned to multi line group member object instances or its
            subclasses, and if the trunk hunting service as defined in annex E is assigned to the
            customer configuration.
            The preconditions for assigning services to multi line configurations as given in table A1
            in annex A shall be regarded.";;
          ATTRIBUTES
            withdrawnMultiLineMembers GET-REPLACE ADD-REMOVE;;;
REGISTERED AS {oca2ManagedObjectClass 16};
```

7.1.10 General services

In this clause, services are defined which are subject to be provided on a per exchange basis.

7.1.10.1 Catalogued supplementary service

This object class is defined in ITU-T Recommendation Q.824.0 [9].

7.1.10.2 Catalogued teleservice

This object class is defined in ITU-T Recommendation Q.824.0 [9].

7.1.10.3 General ISDN service container

This object class is defined in EN 300 291-1 [2].

7.1.10.4 General PSTN service container

This object class is defined in EN 300 291-1 [2].

7.1.10.5 Non ISDN service

This object class is defined in EN 300 291-1 [2].

7.1.11 Service provision fragment

7.1.11.1 Service manager

The serviceManager object class is defined in ITU-T Recommendation Q.824.0 [9].

7.1.11.2 Configuration service manager

This object class is defined in EN 300 291-1 [2].

7.1.11.3 Multi line configuration service manager

```
multiLineConfigurationServiceManager MANAGED OBJECT CLASS
  DERIVED FROM "ITU-T Recommendation Q.824.0 [9] (1996)": serviceManager;
  CHARACTERIZED BY
  multiLineConfigurationServiceManagerPkg PACKAGE
    BEHAVIOUR
      multiLineConfigurationServiceManagerBhv BEHAVIOUR
      DEFINED AS "This object class is used to create the core object instances of a multi line
configuration (e.g. customer profile, services) and the relationship to directory number
according to the referenced referenceServiceConfiguration instance by means of the ACTION
establishMultiLineConfiguration.";;
    ACTIONS
      establishMultiLineCustomerConfiguration "ITU-T Recommendation Q.824.1 [10] (1996)":
      invalidReferenceError,
      "EN 300 291-1 [2] (1999)": changeDirectoryNumber "ITU-T Recommendation Q.824.1 [10] (1996)":
      invalidReferenceError;;
  REGISTERED AS {oca2ManagedObjectClass 17};
```

7.1.11.4 Service package

The servicePackage object class is defined in ITU-T Recommendation Q.824.0 [9].

7.1.11.5 Reference service configuration

This object class is defined in EN 300 291-1 [2].

7.2 Name bindings

7.2.1 Multi line group-multi line customer profile

```
multiLineGroup-multiLineCustomerProfile NAME BINDING
  SUBORDINATE OBJECT CLASS      multiLineGroup AND SUBCLASSES;
  NAMED BY SUPERIOR OBJECT CLASS multiLineCustomerProfile AND SUBCLASSES;
  WITH ATTRIBUTE                multiLineGroupId
  CREATE WITH-REFERENCE-OBJECT, WITH-AUTOMATIC-INSTANCE-NAMING;
  DELETE;
  REGISTERED AS {oca2NameBinding 1};
```

7.2.2 ETSI routing block-multi line customer profile

```
etsiRoutingBlock-multiLineCustomerProfile NAME BINDING
SUBORDINATE OBJECT CLASS      etsiRoutingBlock AND SUBCLASSES;
NAMED BY SUPERIOR OBJECT CLASS multiLineCustomerProfile AND SUBCLASSES;
WITH ATTRIBUTE                 etsiRoutingBlockId
CREATE WITH-REFERENCE-OBJECT, WITH-AUTOMATIC-INSTANCE-NAMING;
DELETE;
REGISTERED AS {oca2NameBinding 2};
```

7.3 Definition of packages

7.3.1 Line signalling

```
pbxLineSignallingPkg PACKAGE
ATTRIBUTES
  pbxLineSignalling      GET-REPLACE;;
REGISTERED AS {oca2Package 1};
```

7.3.2 Maintenance blocking package

```
maintenanceBlockingPkg PACKAGE
ATTRIBUTES
  "EN 300 291-1 [2] (1999)": maintBlocking      DEFAULT VALUE
                                                                    CustomerAdminModuleV2.maintBlockingDefault
                                                                    GET-REPLACE;;
REGISTERED AS {oca2Package 2};
```

7.3.3 Multi line group pointer list package

```
multiLineGroupPtrListPkg PACKAGE
ATTRIBUTES
  multiLineGroupPtrList      GET-REPLACE ADD-REMOVE;;
REGISTERED AS {oca2Package 3};
```

7.3.4 Register signalling package

```
registerSignallingPkg PACKAGE
ATTRIBUTES
  registerSignalling      GET-REPLACE;;
REGISTERED AS {oca2Package 4};
```

7.3.5 Terminating characteristics package

```
terminatingCharacteristicsPkg PACKAGE
ATTRIBUTES
  selectionMethod      GET-REPLACE,
  startSend            DEFAULT VALUE
                                                                    DEFAULT VALUE DERIVATION RULE
                                                                    startSendDefaultBhv BEHAVIOUR
                                                                    DEFINED AS "It is to be set to the value of the length +1 of the directory
                                                                    number's part which is common for all extensions";
                                                                    GET-REPLACE,
  endOfSelection      DEFAULT VALUE
                                                                    DEFAULT VALUE DERIVATION RULE
                                                                    endOfSendDefaultBhv BEHAVIOUR
                                                                    DEFINED AS "The value signalled is used for analogue multi line groups with
                                                                    specified register signalling and ISDN multi line groups both with DDI. In
                                                                    all other cases with DDI, it is programmed. If the multi line group is non-
                                                                    DDI, notDefined shall be assigned.";
                                                                    GET-REPLACE,
  digitsForHolding    DEFAULT VALUE
                                                                    CustomerAdminModuleV2Part2.digitsForHoldingDefault
                                                                    GET-REPLACE,
  minMax              GET-REPLACE;;
REGISTERED AS {oca2Package 5};
```

7.3.6 Withdrawal notification package

```
withdrawalNotificationPkg PACKAGE
  ATTRIBUTES
    withdrawalNotification      GET-REPLACE;;
REGISTERED AS {oca2Package 6};
```

7.4 Definition of attributes

It is to be regarded that the attribute syntax of some attributes is defined in the ASN.1 defined types module of EN 300 291-1 [2] (CustomerAdminModuleV2).

```
accessType ATTRIBUTE
  WITH ATTRIBUTE SYNTAX CustomerAdminModuleV2Part2.AccessType;
  MATCHES FOR EQUALITY;
  BEHAVIOUR
    accessTypeBhv BEHAVIOUR
  DEFINED AS "It gives the type of access (e.g. analogue or ISDN).";
REGISTERED AS {oca2Attribute 1};

digitsForHolding ATTRIBUTE
  WITH ATTRIBUTE SYNTAX CustomerAdminModuleV2Part2.DigitsForHolding;
  MATCHES FOR EQUALITY;
  BEHAVIOUR
    digitsForHoldingBhv BEHAVIOUR
  DEFINED AS "It gives the number of digits that shall be received additionally to the digits of
the fixed part of the pilot directory number before a PABX link is seized.";
REGISTERED AS {oca2Attribute 2};

dnTypeForAma ATTRIBUTE
  WITH ATTRIBUTE SYNTAX CustomerAdminModuleV2Part2.DnType;
  MATCHES FOR EQUALITY;
  BEHAVIOUR
    dnTypeForAmaBhv BEHAVIOUR
  DEFINED AS "It identifies how charging is performed on a customer configuration.";
REGISTERED AS {oca2Attribute 3};

dnTypeForANumberIdentification ATTRIBUTE
  WITH ATTRIBUTE SYNTAX CustomerAdminModuleV2Part2.DnType;
  MATCHES FOR EQUALITY;
  BEHAVIOUR
    dnTypeForANumberIdentificationBhv BEHAVIOUR
  DEFINED AS "It gives the directory number for calling line identification of a customer
configuration.";
REGISTERED AS {oca2Attribute 4};

dnTypeForMetering ATTRIBUTE
  WITH ATTRIBUTE SYNTAX CustomerAdminModuleV2Part2.DnType;
  MATCHES FOR EQUALITY;
  BEHAVIOUR
    dnTypeForMeteringBhv BEHAVIOUR
  DEFINED AS "It provides the directory number for collection of the metering counter information
to a customer configuration.";
REGISTERED AS {oca2Attribute 5};

dualHomingNumber ATTRIBUTE
  WITH ATTRIBUTE SYNTAX CustomerAdminModuleV2.DialledDigits;
  MATCHES FOR EQUALITY;
  BEHAVIOUR
    dualHomingNumberBhv BEHAVIOUR
  DEFINED AS "It gives the routing/IN information to reach the configuration in the other
exchange.";
REGISTERED AS {oca2Attribute 6};

endOfSelection ATTRIBUTE
  WITH ATTRIBUTE SYNTAX CustomerAdminModuleV2Part2.EndOfSelection;
  MATCHES FOR EQUALITY;
  BEHAVIOUR
    endOfSelectionBhv BEHAVIOUR
  DEFINED AS "It specifies the method to be used to detect end of selection.";
REGISTERED AS {oca2Attribute 7};
```

```

etsiRoutingBlockId ATTRIBUTE
  WITH ATTRIBUTE SYNTAX CustomerAdminModuleV2.NameType;
  MATCHES FOR EQUALITY;
  BEHAVIOUR
  etsiRoutingBlockIdBhv BEHAVIOUR
  DEFINED AS "It gives the RDN.";;
REGISTERED AS {oca2Attribute 8};

hunt ATTRIBUTE
  WITH ATTRIBUTE SYNTAX CustomerAdminModuleV2.TrueFalse;
  MATCHES FOR EQUALITY;
  BEHAVIOUR
  huntBhv BEHAVIOUR
  DEFINED AS "It indicates whether hunting is performed on direct circuit access or not (TRUE:
  call processing is continuing with the next line(s) in the hunt group in busy cases; FALSE: in
  busy cases, the traffic goes to loss).";;
REGISTERED AS {oca2Attribute 9};

lineCategory ATTRIBUTE
  WITH ATTRIBUTE SYNTAX CustomerAdminModuleV2Part2.LineCategory;
  MATCHES FOR EQUALITY;
  BEHAVIOUR
  lineCategoryBhv BEHAVIOUR
  DEFINED AS "It gives the line category.";;
REGISTERED AS {oca2Attribute 10};

lineNumber ATTRIBUTE
  WITH ATTRIBUTE SYNTAX CustomerAdminModuleV2.Number;
  MATCHES FOR EQUALITY, ORDERING;
  BEHAVIOUR
  lineNumberBhv BEHAVIOUR
  DEFINED AS "It gives the line number within the customer configuration.";;
REGISTERED AS {oca2Attribute 11};

minMax ATTRIBUTE
  WITH ATTRIBUTE SYNTAX CustomerAdminModuleV2Part2.MinMax;
  MATCHES FOR EQUALITY;
  BEHAVIOUR
  minMaxBhv BEHAVIOUR
  DEFINED AS "It gives the minimal and maximal length of the directory number used to determine
  the end of dialling for a PABX with DDI.";;
REGISTERED AS {oca2Attribute 12};

multiLineConfigurationType ATTRIBUTE
  WITH ATTRIBUTE SYNTAX CustomerAdminModuleV2Part2.MultiLineConfigurationType;
  MATCHES FOR EQUALITY;
  BEHAVIOUR
  multiLineConfigurationTypeBhv BEHAVIOUR
  DEFINED AS "It gives the type of multi line configuration (standard, QSIG,...).";;
REGISTERED AS {oca2Attribute 13};

multiLineGroupId ATTRIBUTE
  WITH ATTRIBUTE SYNTAX CustomerAdminModuleV2.NameType;
  MATCHES FOR EQUALITY;
  BEHAVIOUR
  multiLineGroupIdBhv BEHAVIOUR
  DEFINED AS "It gives the RDN.";;
REGISTERED AS {oca2Attribute 14};

multiLineGroupPtr ATTRIBUTE
  WITH ATTRIBUTE SYNTAX CustomerAdminModuleV2Part2.MultiLineGroupPtr;
  MATCHES FOR EQUALITY;
  BEHAVIOUR
  multiLineGroupPtrBhv BEHAVIOUR
  DEFINED AS "It gives the multiLineGroup object instance to which this multi line group member
  belongs.";;
REGISTERED AS {oca2Attribute 15};

multiLineGroupPtrList ATTRIBUTE
  WITH ATTRIBUTE SYNTAX CustomerAdminModuleV2Part2.MultiLineGroupPtrList;
  MATCHES FOR EQUALITY;
  BEHAVIOUR
  multiLineGroupPtrListBhv BEHAVIOUR
  DEFINED AS "It gives in a list the multiLineGroup object instances to which this object instance
  is related.";;
REGISTERED AS {oca2Attribute 16};

```

```

operatorNumber ATTRIBUTE
  WITH ATTRIBUTE SYNTAX CustomerAdminModuleV2Part2.OperatorNumber;
  MATCHES FOR EQUALITY;
  BEHAVIOUR
  operatorNumberBhv BEHAVIOUR
  DEFINED AS "It gives the operator position number.";;
REGISTERED AS {oca2Attribute 17};

orderedMultiLineGroupList ATTRIBUTE
  WITH ATTRIBUTE SYNTAX CustomerAdminModuleV2Part2.OrderedMultiLineGroupList;
  MATCHES FOR EQUALITY;
  BEHAVIOUR
  orderedMultiLineGroupListBhv BEHAVIOUR
  DEFINED AS "It gives the sequence of multi line groups for hunting.";;
REGISTERED AS {oca2Attribute 18};

pbxLineSignalling ATTRIBUTE
  WITH ATTRIBUTE SYNTAX CustomerAdminModuleV2Part2.PbxLineSignalling;
  MATCHES FOR EQUALITY;
  BEHAVIOUR
  pbxLineSignallingBhv BEHAVIOUR
  DEFINED AS "It gives the type of signalling on the analogue line between exchange and P(A)BX.";;
REGISTERED AS {oca2Attribute 19};
registerSignalling ATTRIBUTE
  WITH ATTRIBUTE SYNTAX CustomerAdminModuleV2Part2.RegisterSignalling;
  MATCHES FOR EQUALITY;
  BEHAVIOUR
  registerSignallingBhv BEHAVIOUR
  DEFINED AS "It indicates the type of register signalling used between exchange and customer
  equipment (TRUE) or not (FALSE).";
REGISTERED AS {oca2Attribute 20};

selectionMethod ATTRIBUTE
  WITH ATTRIBUTE SYNTAX CustomerAdminModuleV2Part2.SelectionMethod;
  MATCHES FOR EQUALITY;
  BEHAVIOUR
  selectionMethodBhv BEHAVIOUR
  DEFINED AS "It defines the method for selecting an access such as sequential, cyclic, etc.";;
REGISTERED AS {oca2Attribute 21};

sharedDChannel ATTRIBUTE
  WITH ATTRIBUTE SYNTAX CustomerAdminModuleV2.TrueFalse;
  MATCHES FOR EQUALITY;
  BEHAVIOUR
  sharedDChannelBhv BEHAVIOUR
  DEFINED AS "It indicates whether the D channel is shared with other customer configurations
  (TRUE) or not (FALSE).";
REGISTERED AS {oca2Attribute 22};

startSend ATTRIBUTE
  WITH ATTRIBUTE SYNTAX CustomerAdminModuleV2Part2.StartSend;
  MATCHES FOR EQUALITY;
  BEHAVIOUR
  startSendBhv BEHAVIOUR
  DEFINED AS "It specifies from which digit on the dial information shall be sent to the PABX.";;
REGISTERED AS {oca2Attribute 23};

trafficDirectionality ATTRIBUTE
  WITH ATTRIBUTE SYNTAX CustomerAdminModuleV2Part2.TrafficDirectionality;
  MATCHES FOR EQUALITY;
  BEHAVIOUR
  trafficDirectionalityBhv BEHAVIOUR
  DEFINED AS "It gives the directionality of the multi line group according to ITU-T
  Recommendation E.502 [5].";
REGISTERED AS {oca2Attribute 24};

withdrawnMultiLineMembers ATTRIBUTE
  DERIVED FROM "ITU-T Recommendation Q.824.0 [9] (1996)": customizedResourcePointerList;
  MATCHES FOR EQUALITY;
  BEHAVIOUR
  withdrawnMultiLineMembersBhv BEHAVIOUR
  DEFINED AS "It indicates which multi line group member(s) is (are) withdrawn from hunting.";;
REGISTERED AS {oca2Attribute 25};

```

```

withdrawalNotification ATTRIBUTE
  WITH ATTRIBUTE SYNTAX CustomerAdminModuleV2.TrueFalse;
  MATCHES FOR EQUALITY;
  BEHAVIOUR
  withdrawalNotificationBhv BEHAVIOUR
  DEFINED AS "It indicates whether the user receives a notification that the associated multi line
  group member is withdrawn (TRUE), or does not receive a notification of withdrawal (FALSE).";
REGISTERED AS {oca2Attribute 26};

```

7.5 Definition of behaviours

No general behaviours were identified.

7.6 Definition of actions

```

establishMultiLineCustomerConfiguration ACTION
  BEHAVIOUR
  establishMultiLineCustomerConfigurationBhv BEHAVIOUR
  DEFINED AS "The action copies the subtree (e.g. of a customerProfile) contained under an
  instance of referenceServiceConfiguration to a customer configuration contained in
  managedElement. It establishes the links from the customerProfile to the
  etsiDirectoryNumberE164 and vice versa.
  If the referenceServiceConfiguration instance does not exist, the agent returns an invalid
  reference error.
  The link to etsiDirectoryNumberE164 is indicated with parameter directoryNumber.
  Further data of existing object instances of the customer configuration (e.g. data which are
  configurable on a per subscriber basis, like additionalPbxNumber, multiLineGroup, and
  etsiRoutingBlock) can be given with parameter customerData. The subcomponent attributeList
  of parameter customerData indicates how the data of the reference object classes/object
  instances (components of customerData) are replaced for the customer configuration to be
  instantiated. This includes as well the pointers between the object instances, if they are
  not set by the resource automatically.
  This action shall not be used for the creation of multiLineGroupMember instances.
  It has to be verified that the resulting customer configuration is consistent in itself.
  Inconsistent pointers given with the EstablishMultiLineCustomerConfigurationRequest are to
  be indicated by the resource using the parameter invalidReferenceError, where the object
  instance of the referenced configuration and/or given in the customerData values leading to
  inconsistencies shall be given.
  If the naming attribute(s) is (are) not given, automatic instance naming is applied.
  If the action is successful, the reply shall contain at least a list of object instances
  created subordinate to managed element. It may as well contain all instances of the created
  subtree.
  If the action is not successful, the MIB is left unaffected (unchanged).";
  MODE CONFIRMED;
  WITH INFORMATION SYNTAX
  CustomerAdminModuleV2Part2.EstablishMultiLineCustomerConfigurationRequest;
  WITH REPLY SYNTAX CustomerAdminModuleV2.ManagedInstancesNames;
REGISTERED AS {oca2Action 1};

```

7.7 Definition of notifications

No specific notifications were identified.

7.8 ASN.1 defined types module

```

CustomerAdminModuleV2Part2 {ccitt(0) identified-organization(4) etsi(0) customerAdministration(291)
  part2(2) informationModel(1) asn1Module(2) asn1DefinedTypesModule(0)}

DEFINITIONS IMPLICIT TAGS ::=

BEGIN

IMPORTS
  -- ITU-T Recommendation X.711 [25]
  ObjectClass, ObjectInstance, Attribute, Scope, CMISFilter
  FROM CMIP-1 {joint-iso-ccitt ms(9) cmip(1) version1(1) protocol(3)}
  -- ITU-T Recommendation X.721 [24]
  AttributeList
  FROM Attribute-ASN1Module {joint-iso-ccitt ms(9) smi(3) part2(2) asn1Module(2) 1}

```

```

-- ITU-T Recommendation Q.821 [24]
  InterceptTreatmentTerm
  FROM CACommonModule {itu-t(0) recommendation (0) q(17) ca(824) dot(127) common(0)
  informationModel(0) asnlModules(2) cACCommonModule(0)}
-- EN 300 291-1 [2]
  CustomerCategory, CustomerData, CustomerType, DialedDigits
  FROM CustomerAdminModuleV2 {ccitt(0) identified-organization(4) etsi(0)
  customerAdministration(291) part1(1) informationModel(1) asnlModule(2)
  asnlDefinedTypesModule(0)};

oca2InformationModel    OBJECT IDENTIFIER ::= {ccitt(0) identified-organization(4) etsi(0)
                        customerAdministration(291) part2(2) informationModel(1)}
oca2ManagedObjectClass OBJECT IDENTIFIER ::= {oca2InformationModel managedObjectClass (3)}
oca2Package             OBJECT IDENTIFIER ::= {oca2InformationModel package (4)}
oca2Parameter           OBJECT IDENTIFIER ::= {oca2InformationModel parameter (5)}
oca2NameBinding         OBJECT IDENTIFIER ::= {oca2InformationModel nameBinding (6)}
oca2Attribute           OBJECT IDENTIFIER ::= {oca2InformationModel attribute (7)}
oca2Action              OBJECT IDENTIFIER ::= {oca2InformationModel action (9)}
oca2Notification        OBJECT IDENTIFIER ::= {oca2InformationModel notification (10)}

AccessType ::= ENUMERATED {
  isdn (0),
  analogue (1),
  digital (2)}

DigitsForHolding ::= CHOICE {
  notDefined [0] NULL,
  defined [] INTEGER}

DnType ::= CHOICE {
  chargingNumber [0] DialedDigits,
  specificDnType [] SpecificDnType}

EndOfSelection ::= ENUMERATED {
  not defined (0),
  signalled (1),
  programmed (2)}

EstablishMultiLineCustomerConfigurationRequest ::= SEQUENCE {
  referenceServiceConfigurationInstance ObjectInstance,
  directoryNumber ObjectInstance,
  customerData CustomerData OPTIONAL}

LineCategory ::= ENUMERATED {
  basicRateAccess (0),
  primaryRateAccessBChannelPrioritized (1),
  primaryRateAccessBChannelNonPrioritized (2),
  frameHandlerBdChannel (3),
  frameHandlerBdDemux (4),
  nonIsdn (5) --covers analogue and digital lines}

MinMax ::= CHOICE {
  notDefined [0] NULL,
  defined [] SEQUENCE {
    minimal INTEGER,
    maximal INTEGER}}

MultiLineConfigurationType ::= CHOICE {
  general ENUMERATED {
    standard (0),
    qsig (1)},
  specific INTEGER}
-- specific is to be used for the definition of implementation specific multi line configuration
-- types which are not covered by standard and qsig value. The use of this value is optional.

MultiLineGroupPtr ::= ObjectInstance
-- refers to one multiLineGroup instance

MultiLineGroupPtrList ::= SET OF ObjectInstance
-- refers to a set of multiLineGroup instances

OperatorNumber ::= CHOICE {
  absent [0] NULL,
  dialedDigits [] DialedDigits}

OrderedMultiLineGroupList ::= SEQUENCE OF ObjectInstance
-- refers to multiLineGroup instances

```

```

PbxLineSignalling ::= INTEGER

RegisterSignalling ::= ENUMERATED {
    notDefined      (0),
    withoutDDI     (1),
    mfcR2           (2),
    dtmf            (3),
    pulseDialling  (4),
    singleFrequency (3)}

SelectionMethod ::= CHOICE {
    notDefined [0] NULL,
    defined   [] ENUMERATED {
        sequential (0),
        cyclic     (1),
        uniform    (2),
        random     (3)}}

SpecificDnType ::= ENUMERATED {
    pilotDN      (0),
    individualLine (1),
    operatorNumber (2)}

StartSend ::= CHOICE {
    notDefined [0] NULL,
    defined    [] INTEGER}

TrafficDirectionality ::= ENUMERATED {
    originating (0),
    terminating (1),
    both ways   (2)}
-- directionality definitions according to ITU-T Recommendation E.502 [5]

-- default value definitions

digitsForHoldingDefault      digitsForHolding      ::= defined{0}
maintBlockingDefault        maintBlocking          ::= unlocked
multiLineConfigurationTypeDefault general                ::= standard{0}
operatorNumberDefault       operatorNumber                ::= absent

-- permitted value definitions

PermittedCustomerCategory ::= customerCategory{standard}
PermittedCustomerType     ::= customerType{multiLinePBX|multiLineNonPBX}

END -- of CustomerAdminModuleV2Part2

```

Annex A (normative): Assignment of services

The preconditions for assigning services to multi line configurations as given in table A.1 shall be regarded.

Table A.1

Service	Service assignment to		Other preconditions
	non-P(A)BX configuration	P(A)BX configuration	
connectPilotLineFirst	yes	no	No
dca	yes	no	terminating/both ways
dualHoming	no	yes	No
lineHuntgroupWithdrawal	yes	no	line for SCI
sciAllowance	yes	no	originating/both ways
trunkHuntgroupWithdrawal	no	yes	No
NOTE: No: no specific precondition.			

Annex B (informative): Requirements for multi line configurations

Based on international, national requirements (for which a common interest seems to exist) and on present implementations the following requirements relevant for the present document have been identified.

Requirements not covered by ETSI service descriptions are flagged with (*).

B.1 Access configurations

B.1.1 Multi line hunt group

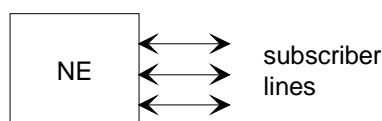

The subscriber lines could be analogue or ISDN basic rate access (BRA) or a mixture of analogue and ISDN lines.

ETSI service description on line hunting (see source/1/) also states that ISDN primary rate accesses (PRA), as a network provider option, can be part of the accesses.

B.1.2 PBX without DDI

B.1.2.1 Access with analogue subscriber lines (line circuit level)

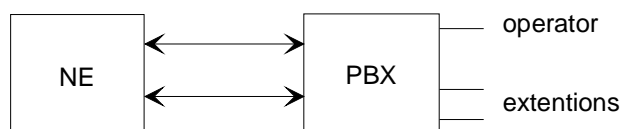

B.1.2.2 Access at PCM span level (not ISDN PRA)

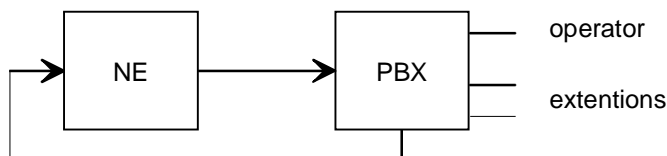

Originating accesses to NE are at PCM span level, with e.g. touch-tone register signalling and R2 digital line signalling (*).

Terminating traffic to PABX handled via analogue lines.

B.1.3 Non ISDN PABX with DDI

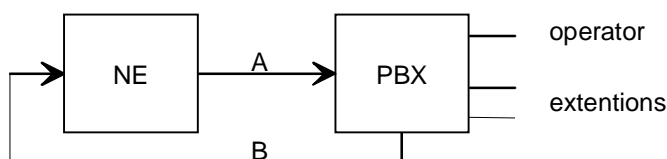

Accesses A are PCM spans using e.g. MFC register signalling and R2 digital line signalling (*).

Accesses B could be:

- PCM spans using e.g. touch tone register signalling and R2 digital line signalling (*); or
- analogue subscriber lines.

B.1.4 ISDN PABX with DDI

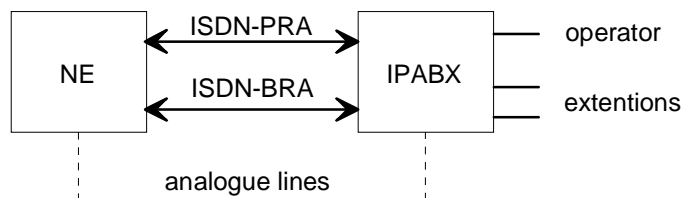

B.1.5 Mixed PABX

Can have digital and analogue accesses (see figure above with dotted lines).

In addition to the above basic access configurations present implementations (*) support also:

- QSIG:** QSIG is a protocol for the interconnection of private telecom exchanges. It is based on ETSI DSS1. To realize corporate networks based on VPN to support the transport of the QSIG feature information transparently between private telecom networks with the D channel protocol QSIG.
- RSN:** special PBX type for remote subscriber controlled input.

B.2 Entities

Attributes can be assigned to one of the 3 entities:

- 1) on PBX level (on directory number [DN] of the PBX that is the "prefix" of a PABX-DDI or the hunt group number of a multi line hunt group);
- 2) on multi line hunting group level (MLHG) (*);
- 3) defines the characteristics common for a number of accessPorts/channels such as the directionality (terminating, originating, or both way), type of accesses (ISDN or non ISDN) and some signalling related attributes for PABX-DDI;
- 4) on individual PBX line level.

B.3 Directory number issues

A PBX is addressed by a directory number (DN).

For a multi line configuration this is the hunt group number (also called pilot DN).

For a PABX with DDI this is the part of the extension numbers (pilot DN) which is common for all extensions of the PABX.

Possibility should exist to have several pilot DN (*) assigned to a same PABX-DDI customer to allow flexible assignment of DDI extension numbers (non continuous groups of numbers).

Only one pilot DN will however be used for the administration of the PABX.

Also to an individual line of the PBX a DN (line SN) can be assigned to allow e.g. direct calling of this individual line without hunting.

It should be possible to identify the operator number of a P(A)BX (*).

Several users with one or more PABXs with DDI may share the same PRA and with that the same D-channel (*).

Application: e.g. several companies in the same building share the same PBX equipment.

B.4 Hunting/selection aspects

Selection method

- a) Values: sequential, circular (*), uniform (cyclic), random (*).

If the line hunting (LH) is not provided without subscription option selection method, the service provider shall determine the selection method.

- b) Line number (*).

To each individual PBX line a line number is assigned. The member's line hunt number in the hunt group. Line numbers are unique only per hunt group but not per PBX consisting of more than one hunt group.

This is required for especially for sequential hunting to know in which order the lines are to be searched for an idle line.

Allow starting hunting from a dialled DN which is a member of the hunt group (*)

Two cases are to be distinguished:

- DCANORM identifies that **no** hunting is to occur if an individual member of the group is directly dialled by its individual DN;
- DCAHUNT identifies that hunting is to occur if an individual member of the group is directly dialled by its individual DN.

Night service (DCANORM).

The member has a separate line service number (LSN) sometimes also called night service number.

When this bit is set the PBXLN can be addressed directly by dialling the LSN of the PBXLN.

A hunt group member may have an LSN and neither DCANORM nor DCAHUNT is set. In this case, the LSN functions as account number only (PBX is not reachable by dialling this number).

Select pilot line first (*)

If this hunting method is specified, the hunting for a free line starts with the pilot line.

Hunt group withdrawal

- a) A request (SCI) by an access of the hunt group in order to temporarily prevent the access from receiving calls to the hunt group.

If the service provider supports the option hunt group withdrawal, then the subscription option for hunt group withdrawal shall be available to all accesses of the hunt group.

- b) Subscription option: User receives notification, that his access is currently withdrawn from one or more hunt groups.

B.5 Supplementary services

It should be possible to assign supplementary services at PBX level but also at individual line level.

B.6 PABX signalling issues

Dial procedure (*)

Specifies the register signalling on the "trunks" connecting a NE with a non ISDN PABX-DDI.

Values:

- MFC-R2 signalling;
- multi frequency;
- without DDI;
- pulse dialling;
- single frequency dialling.

Parameters not allowed for ISDN operation modes.

Parameters only relevant for PABX-DDI

Start position digits to send: The number of digits to be sent to the PABX-DDI.

Specifies from which digit on the dial information must be sent to the PABX.

Format of DDI number to be sent to the called PABX (*)

Values:

- DDI digits only;
- Subscriber number;
- National number;
- International number.

Identification of Line signalling used on the non-ISDN 'trunks' connecting the non-ISDN PABX-DDI (*)

Min/max. number of digits (*)

Identification of end of digit reception due to open numbering plans.

Defines minimum and maximum length of the DN and is used to determine dial end for PBXs with DDI. Dial end is reached after entering the max. number of digits or, after the min number of digits have been received and time out is elapsed.

Digit number for holding (*)

In order to avoid unnecessary B side seizures, lines are only seized after the specified numbers of digits have been received.

End of selection (EOS) (*)

Specifies the method to be used to detect end of selection.

Values:

- Programmed: the end of selection is programmed, i.e. determined by a time limit exceeded after translation of a minimal number of digits, or after translation of a maximum number of digits.
(see minmax).
- Signalled end of selection: dial end will be signalled from the B side.

B.7 Issues related to calls from multi/P(A)BX lines

Identification of the call on individual, pilot line or operator number (*).

Charging on individual, pilot line or operator number (*).

Calls to special service numbers dealing with the maintenance of lines are identified on the particular national DN of the access. Other calls are identified on the LH number or operator number (*).

Charging record (AMA) on LSN or PDN (*).

Metering of line under LSN or PDN.

B.8 Additional characteristics on PBX DN level

Maintenance blocked, administrative blocked, account suspension (*).

Additional characteristics on multi line hunt group level:

- Blockings (administrative, maintenance).

B.9 Additional characteristics of the individual line

Terminal type/ PBX line category:

Values:

- non-ISDN;
- ISDN;
- member is used as a B channel of a PRA with fixed assignment.

Activation allowance:

Services can be subscribed to the hunt group identified by the hunt group number. Some supplementary services on the hunt group number which need special authorization can only be activated and deactivated from an access which is a member of the hunt group and on which the option " activation allowance" is subscribed to.

Blockings(*):

Administrative blocked, maintenance blocked.

Slave(*):

To B-channels, priority for seizing has to be assignable in order to avoid collisions between exchange's and customer installation's seizures.

B.10 Special features

Dual homing (*)

Enables a PBX to be connected to 2 NEs.

B.11 Sources

The following international standardization documents have been identified as sources for definition of the requirements:

- CEPT service 12.2 (1981): "Line hunting";
- EN 301 479 [20]: "Integrated Services Digital Network (ISDN); Line Hunting (LH) supplementary service; Service description";
- ITU-T Recommendation I.252.6 [7]: "Line Hunting (LH)";
- ETS 300 062 [1]: "Integrated Services Digital Network (ISDN); Direct Dialling In (DDI) supplementary service; Service Description";
- CEPT service 12.1.1 (1981): "Direct dialling in".

Annex C (informative): Object classes defined in the ITU-T Recommendation Q.824 series which are not used in the context of the present document

The paragraph numbers given hereafter with the object classes refer to the respective ITU-T Recommendation.

C.1 ITU-T Recommendation Q.824.0

- 3.4 Administered Circuit Endpoint Subgroup
- 3.8 Directory Number E164
- 3.11 Routing Block
- 4.1 Catalogued Optional User Facilities
- 4.5 Optional User Facilities

C.2 ITU-T Recommendation Q.824.1

- 3.1.1 Access Channel B-Channel
- 3.1.2 Access Channel D-Channel
- 3.2.1 Access Port ISDN Basic Rate
- 3.2.2 Access Port ISDN Primary Rate
- 3.3.1 Access Port Profile ISDN
- 3.3.2 Access Port Profile ISDN Basic Rate
- 3.3.3 Access Port Profile ISDN Primary Rate
- 3.3.4 Calling Number Screening
- 3.3.5 Network User Identification
- 4.1 Catalogued Access Port ISDN Primary Rate
- 4.2 Catalogued Access Port Profile ISDN
- 4.3 Catalogued Access Port Profile ISDN Basic Rate
- 4.4 Catalogued Layer Entity DSS1
- 4.5 Catalogued Layer Entity LAPD
- 5.1 Terminal Configuration
- 5.2 Terminal Service Profile
- 6.1.1 Bearer Service For 384 kbit/s Data
- 6.1.2 Bearer Service For 1536 kbit/s Data
- 6.1.3 Bearer Service For 1920 kbit/s Data
- 6.1.4 Bearer Service For Multiple Rate Data
- 6.1.5 Circuit 3,1 kHz
- 6.1.6 Circuit Combined Switched Digital Data
- 6.1.7 Circuit Combined Voice Band
- 6.1.8 Circuit MultiUse
- 6.1.9 Bearer Service For 64 kbit/s Data (Unrestricted) Rate Adapted From 56 kbit/s
- 6.1.10 Circuit Speech
- 6.1.11 Circuit Unrestricted Digital Data
- 6.1.12 Packet
- 6.1.13 Packet B Channel
- 6.1.14 Packet D Channel
- 7.1 Service Manager ISDN
- 7.2 Service Manager Retrieve Service

C.3 ITU-T Recommendation Q.824.2

- 3.1.1 ISDN Circuit Service Set
- 3.1.2 Service Restrictions
- 3.2.1 Advice of Charge at Call Set-Up Time
- 3.2.2 Advice of Charge During the Call
- 3.2.3 Advice of Charge End of The Call
- 3.2.4 Call Deflection
- 3.2.5 Call Forwarding Busy
- 3.2.6 Call Forwarding No Reply
- 3.2.7 Call Forwarding Unconditional
- 3.2.8 Call Hold
- 3.2.9 Call Transfer
- 3.2.10 Call Waiting
- 3.2.11 CLIP
- 3.2.12 CLIR
- 3.2.13 Conference Calling
- 3.2.14 Direct Dialling In
- 3.2.15 Malicious Call Identification
- 3.2.16 Multiple Subscriber Number
- 3.2.17 Outgoing Call Barring
- 3.2.18 Three Party
- 3.2.19 User-to-User Signalling
- 4.1 Catalogued Call Hold

C.4 ITU-T Recommendation Q.824.3

- 2.1.1 Service X25 Permanent Virtual Circuit (PVC)
- 2.1.2 Semi-Permanent Access To Packet Handler
- 2.2.1 ChargingControl
- 2.2.2 Call Restrictions
- 2.2.3 Path Control

C.5 ITU-T Recommendation Q.824.4

- 3.1 Telefax 4
- 3.2 Telephony
- 3.3 Teletex

Annex D (informative): Examples for customer configurations

This annex gives examples for customer configurations on object instance basis.

In these examples, the service assignment to the customer configurations is partly not drawn.

D.1 ISDN PABX with DDI with 3 lines (2 terminating, 1 originating), all linked to an instance of etsiDirectoryNumberE164

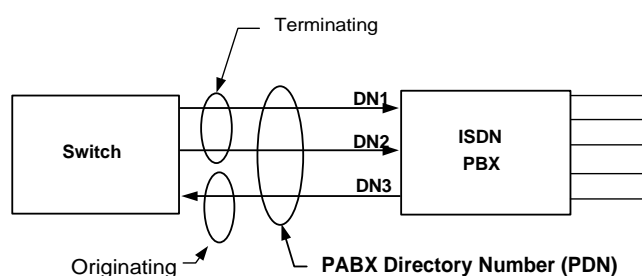

Figure D.1: Physical configuration

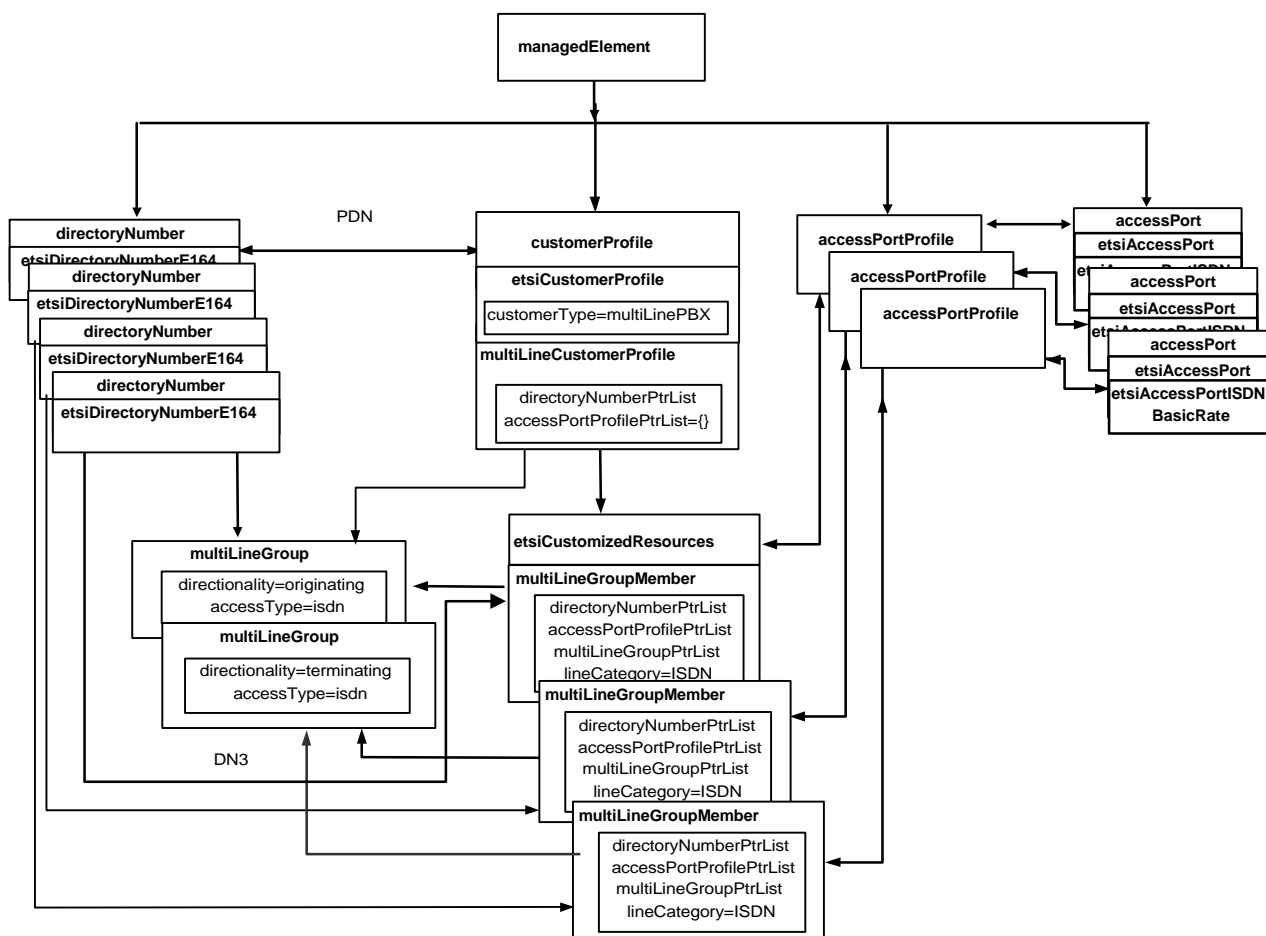

Figure D.2: Logical configuration

D.2 ISDN PABX with DDI with 3 lines, only customerProfile is linked to an instance of etsiDirectoryNumberE164

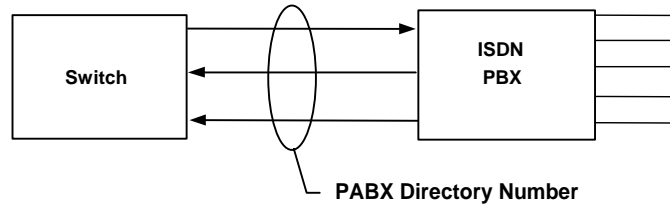

Figure D.3: Physical configuration

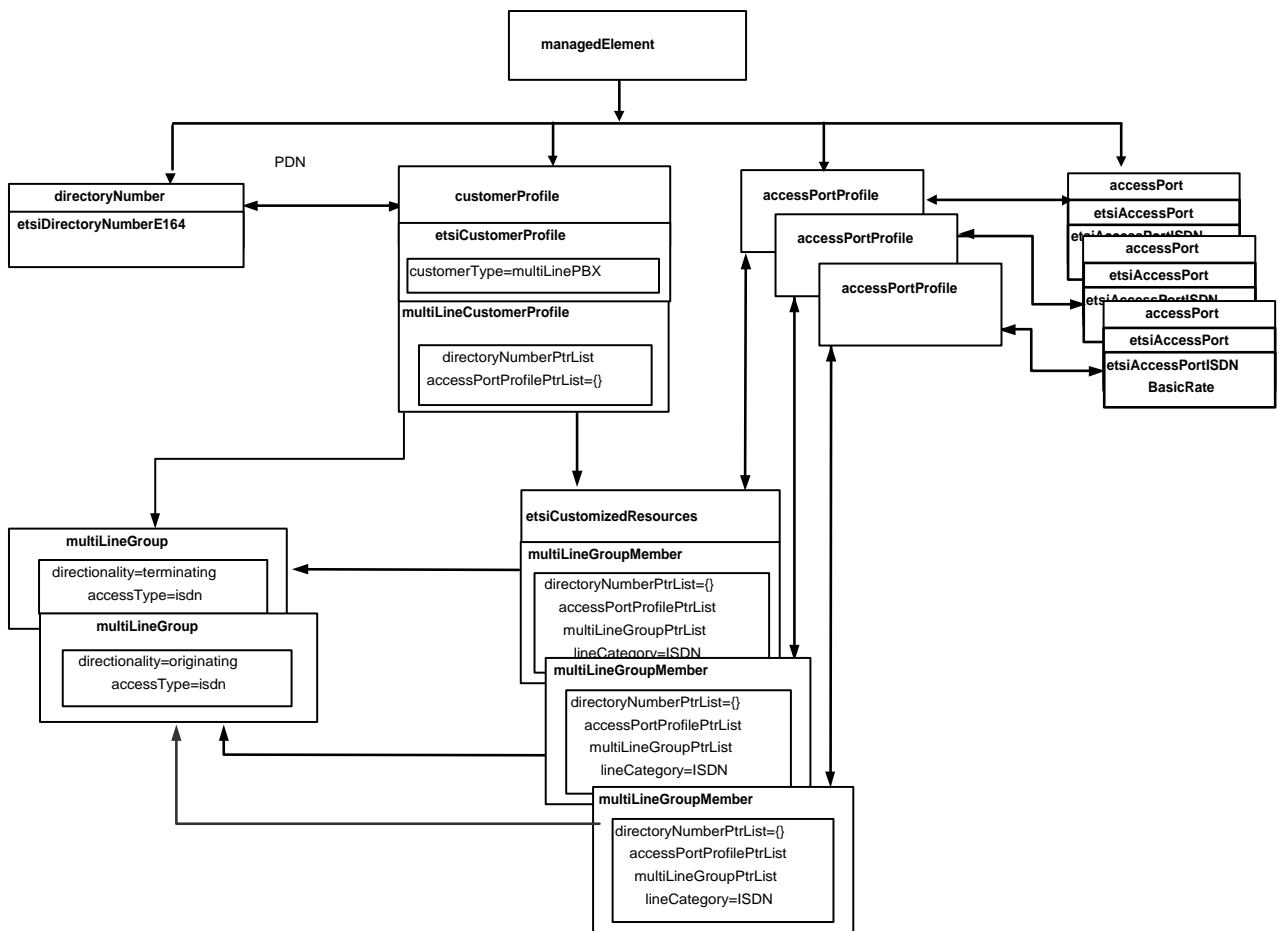

Figure D.4: Logical configuration

D.3 Mixed PABX (analogue and ISDN) DDI with 3 lines (2 lines ISDN, 1 line analogue), all linked to an instance of etsiDirectoryNumberE164

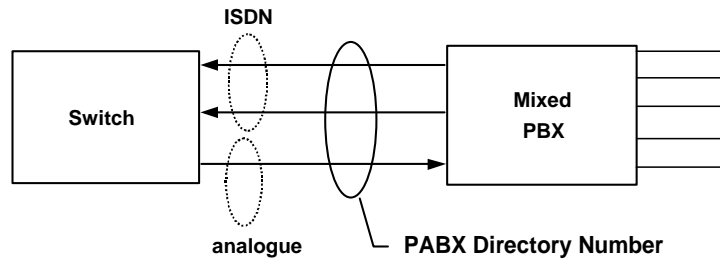

Figure D.5: Physical configuration

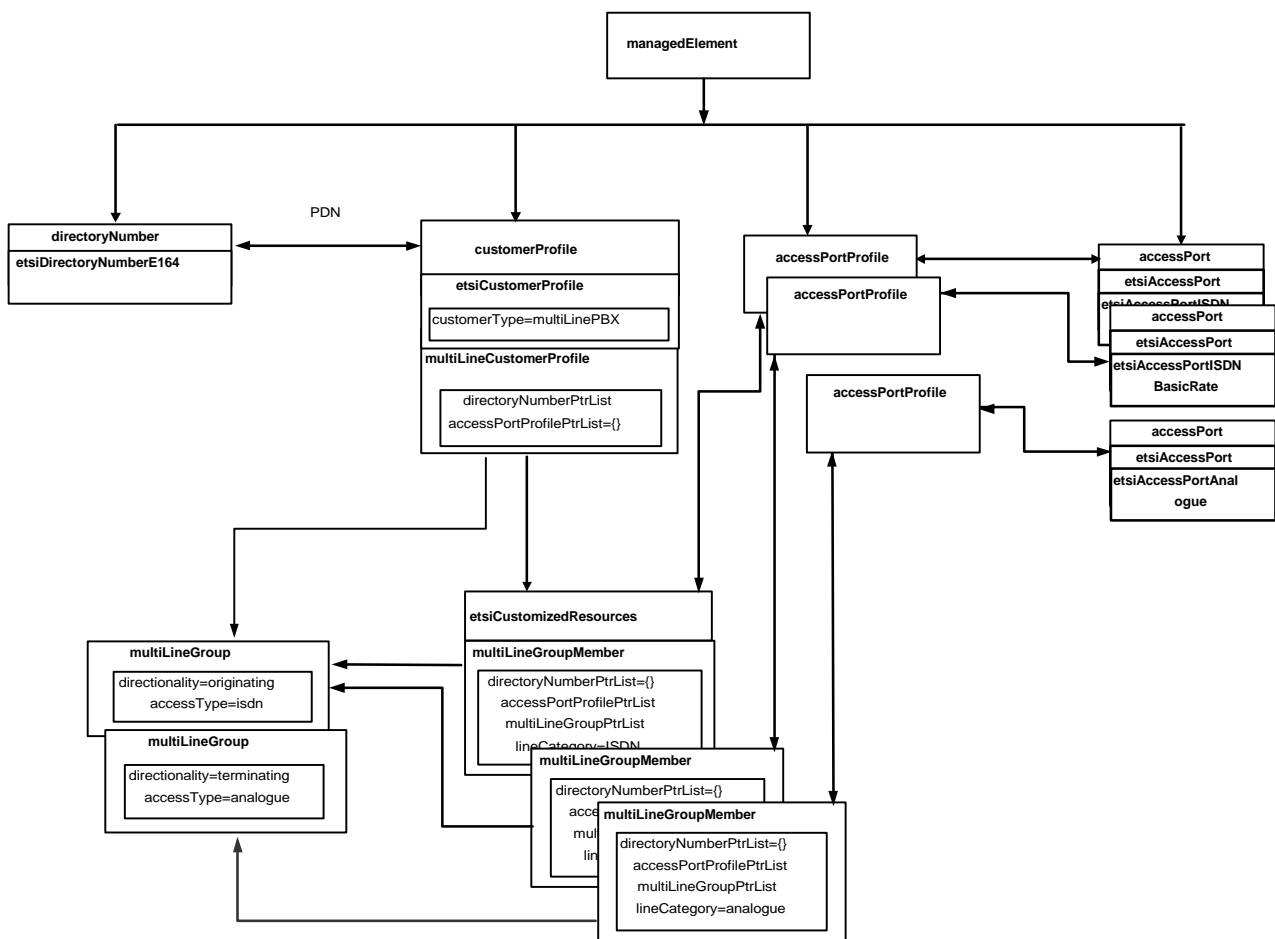

Figure D.6: Logical configuration

D.4 ISDN PABX (with DDI) on PA with 3 PABX lines, all linked to an instance of etsiDirectoryNumberE164. PABX has additional directory numbers

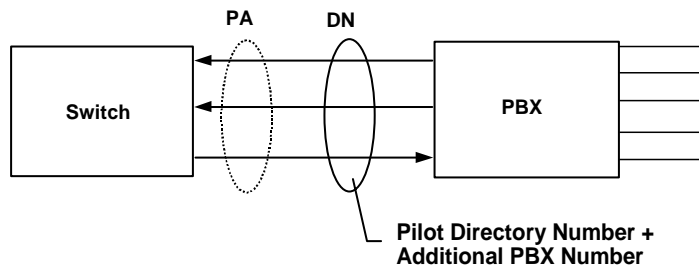

Figure D.7: Physical configuration

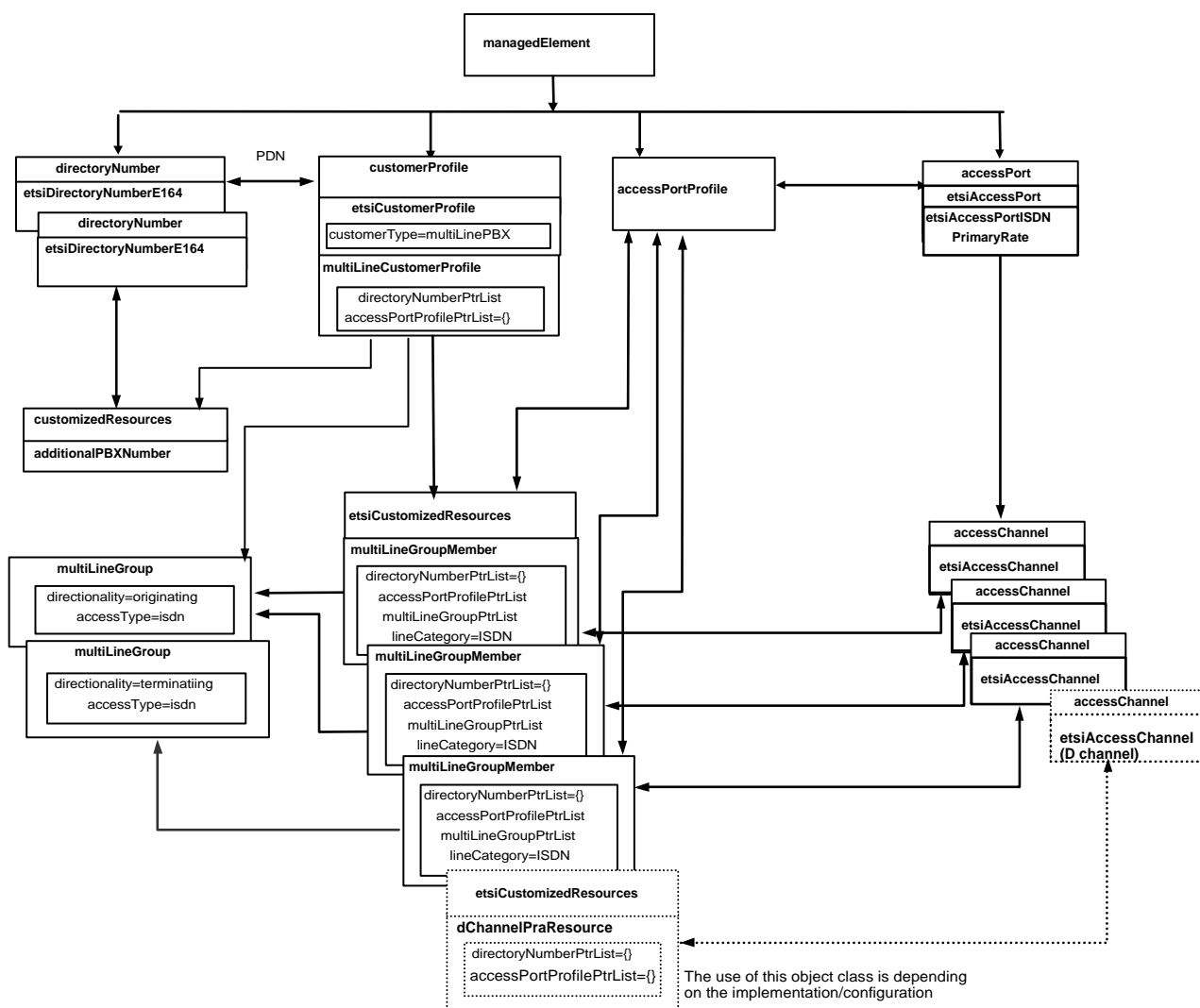

Figure D.8: Logical configuration

Annex E (informative): Trunk Hunting (TH) supplementary service; service description

Since trunk hunting is a supplementary service which is used in several networks, a trunk hunting related object class (trunk huntgroup withdrawal) is provided within the present document.

For describing the trunk hunting supplementary service, ETSI SPAN2 agreed the work item DE/NA-020028 (DEN/SPAN-020028): "Integrated Services Digital Network (ISDN); Trunk Hunting (TH) supplementary service; Service description". This work item was stopped.

As background information to the trunk hunting supplementary service, from Draft Version 4 (September 1998) of DE/NA-020028, which is the latest version, an excerpt is given hereafter.

E.1 Description

The TH supplementary service is intended for use on accesses to which a private ISDN is connected to the public ISDN at the T reference point.

The TH supplementary service enables calls to an ISDN number assigned to the private ISDN (i.e. the hunt group number) to be offered to a free access in a hunt group. The hunt group can comprise basic accesses, primary rate accesses, or a mixture of these types of accesses. If a mixture of types of accesses are applied then care in the cyclic and uniform hunting.

The TH supplementary service applies to accesses within a hunt group that are connected to the same exchange. As a service provider option the TH supplementary service can be used to create a multi-nodal service that allows trunk hunting across accesses on multiple exchanges. The specification of the multi-nodal service is outside the scope of the present document, however annex A considers some of the implications of this service.

As a service provider option an access can be member of more than one hunt group. The maximum number of hunts groups of which one access can be a member, shall be a service provider option with an upper limit of 15.

The method of selecting the access shall be either sequential, uniform or cyclic hunting.

As a service provider option, the TH supplementary service can be offered with the possibility for hunt group withdrawal. If the option of "hunt group withdrawal" is supported by the service provider, the served user can request that an access can be temporarily prevented from receiving calls to the hunt group.

E.2 Procedures

E.2.1 Provision and withdrawal

The TH supplementary service shall be provided after prior arrangement with the service provider. To establish the hunt group, a list of the accesses shall be provided to identify the accesses which form the hunt group. Only accesses under the control of a single public network exchange can be included in a hunt group.

As a service provider option, the TH supplementary service can be offered with the subscription option given in table E.1.

If the service provider supports the option "hunt group withdrawal" then the subscription option for "hunt group withdrawal" shall be available to all accesses of the hunt group.

Table E.1: Subscription option applying for the whole hunt group

Subscription Option	Values
Selection Method	<ul style="list-style-type: none"> • sequential hunting • cyclic hunting • uniform hunting
Hunt group withdrawal	<ul style="list-style-type: none"> • available • not available

If the TH supplementary service is provided without the subscription option "selection method", the service provider shall determine the selection method.

If the service provider does not offer the subscription option "hunt group withdrawal", then the accesses cannot be withdrawn from the hunt group.

The TH supplementary service shall be withdrawn by the service provider upon request of the subscriber or for service provider reasons.

E.2.2 Normal procedures

E.2.2.1 Activation, deactivation and registration

The TH supplementary service shall be activated on provision and deactivated on withdrawal. No procedures for registration shall be provided.

If the service provider option "hunt group withdrawal" is supported, the private ISDN can, by means of control procedures associated with an access, request that calls to the hunt group shall not be presented to that access. After the served user has requested that an access shall temporarily be withdrawn from the hunt group, invocation of the TH supplementary service shall not select that access for the presentation of calls.

When temporarily withdrawing an access from a hunt group, the served user shall include in the request the hunt group number, if this access is a member of more than one hunt group. It shall also be possible to withdraw from all hunt groups with one operation if the served user's access is a member of more than one hunt group.

A request for withdrawal of an access that already has been withdrawn from the indicated hunt group shall be accepted and a positive response shall be given.

After the private ISDN has temporarily prevented an access of a hunt group from receiving calls, it can cancel this arrangement by means of control procedures associated with this access. As a result of this cancellation, calls to the hunt group can be presented to this access once again.

When cancelling this arrangement, the served user shall include in the request the hunt group number, if this access is a member of more than one hunt group. It shall also be possible to cancel all withdrawals with one operation if the served user's access has been withdrawn from more than one hunt group.

A request for cancellation of the withdrawal of an access that has not been withdrawn from the indicated hunt group shall be accepted and a positive response shall be given.

E.2.2.2 Erasure

Not applicable.

E.2.2.3 Invocation and operation

The TH supplementary service shall be invoked automatically by the network on calls to the hunt group number. A free access in the hunt group shall be selected according to the selection method provided to the served user.

Once an access is selected, the network shall indicate the arrival of an incoming call to the served user and the procedures of the TH supplementary service are considered complete.

The served user's ability to originate calls shall be unaffected by the TH supplementary service.

E.2.2.4 Interrogation

Not applicable.

E.2.3 Exceptional procedures

E.2.3.1 Activation, deactivation and registration

If the service provider cannot comply with the request for hunt group withdrawal, the service provider shall reject the request and give the reason for rejection. Possible reasons for rejection are:

- when the served user provides a wrong hunt group number to identify the hunt group from which he wants to withdraw; or
- when the served user provides no hunt group number, although the access used is a member of more than one hunt group; or
- when hunt group withdrawal is not supported by the service provider.

If the service provider cannot comply with the request to cancel hunt group withdrawal, the service provider shall reject the request and give the reason for rejection. Possible reasons for rejection are:

- when the served user provides a wrong hunt group number to identify the hunt group for which he wants to cancel the withdrawal; or
- when the served user provides no hunt group number, although he is a member of more than one hunt group; or
- when hunt group withdrawal is not supported by the service provider.

E.2.3.2 Erasure

Not applicable.

E.2.3.3 Invocation and operation

If no free access is available, the TH supplementary service shall be considered unsuccessful and the call establishment shall be ceased. This shall be indicated to the calling user according to the basic call procedures.

Once the network has indicated the arrival of the incoming call to the served user on an access, then failures due to called user state shall be reported by means of basic call procedures.

If all accesses have been withdrawn from a hunt group, the hunt group shall be considered as though no channels are available and call establishment shall be ceased. This shall be indicated to the calling user according to the basic call procedures.

E.2.3.4 Interrogation

Not applicable.

E.3 Intercommunication considerations

E.3.1 Interworking with non-ISDNs

The TH supplementary service can be invoked on calls which originate in non-ISDNs.

E.3.2 Interworking with private ISDNs

The present document describes the mechanism which enables a public ISDN to select an access from a group of accesses which are connected to a private ISDN.

Interworking with private ISDNs shall include the requirements given in ETS 300 345 [26]. The service shall be based on a local provision as defined in clause 6 of ETS 300 345 [26].

E.4 Interaction with other supplementary services

Supplementary services can be subscribed to in association with the hunt group number.

NOTE: It is the responsibility of the private ISDN to prevent unauthorized activation/deactivation of supplementary services (e.g. call forwarding unconditional supplementary service) for the hunt group.

E.4.1 Advice of charge services

E.4.1.1 Advice of charge at call set-up time

No impact, i.e. neither supplementary service shall affect the operation of the other supplementary service.

E.4.1.2 Advice of charge during the call

No impact, i.e. neither supplementary service shall affect the operation of the other supplementary service.

E.4.1.3 Advice of charge at the end of a call

No impact, i.e. neither supplementary service shall affect the operation of the other supplementary service.

E.4.2 Call waiting

The call waiting supplementary service shall not be provided for a hunt group number.

E.4.3 Call hold

Not applicable.

E.4.4 Explicit call transfer

No impact, i.e. neither supplementary service shall affect the operation of the other supplementary service.

E.4.5 Number identification services

E.4.5.1 Calling line identification presentation

No impact, i.e. neither supplementary service shall affect the operation of the other supplementary service.

E.4.5.2 Calling line identification restriction

No impact, i.e. neither supplementary service shall affect the operation of the other supplementary service.

E.4.5.3 Connected line identification presentation

No impact, i.e. neither supplementary service shall affect the operation of the other supplementary service.

E.4.5.4 Connected line identification restriction

No impact, i.e. neither supplementary service shall affect the operation of the other supplementary service.

E.4.6 Closed user group

No impact, i.e. neither supplementary service shall affect the operation of the other supplementary service.

E.4.7 Call completion services

E.4.7.1 Completion of calls to busy subscriber

The completion of calls to busy subscriber supplementary service cannot be activated towards a hunt group, i.e. in the case of no channels available.

NOTE: When the TH supplementary service is completed (i.e. a free access or B-channel is found and the call is presented to the private ISDN) and, if the private ISDN supports the functionality for the completion of calls to busy subscriber supplementary service, then the completion of calls to busy subscriber supplementary service can be activated against a busy user on the private ISDN.

E.4.7.2 Completion of calls on no reply

Not applicable.

NOTE 1: When the TH supplementary service is completed (i.e. a free access or B-channel is found and the call is presented to the private ISDN) and if the private ISDN supports the functionality for the completion of calls on no reply supplementary service then the completion of calls on no reply supplementary service can be activated against a user on the private ISDN.

NOTE 2: If completion of calls on no reply supplementary service is invoked from a hunt group member and the hunt group number is given as the calling party number then the CCNR recall may not be returned to the originator of the CCNR request.

The completion of calls on no reply supplementary service can be allocated towards a hunt group number and users on an access who originate a call with the hunt group number as the calling party number will be able to invoke the completion of calls on no reply supplementary service if it is subscribed to.

E.4.8 Conference services

E.4.8.1 Conference call, add-on

Not applicable.

E.4.8.2 Conference call, meet-me

No impact, i.e. neither supplementary service shall affect the operation of the other supplementary service.

E.4.9 Direct dialling in

The DDI supplementary service states that in the case of interaction with other supplementary services these supplementary services shall be applicable to the whole access unless stated otherwise. The TH supplementary service allows supplementary services to be subscribed to in association with the hunt group number(s) and covers the interactions for this situation. Where both the TH supplementary service and DDI supplementary service are provided against an access the interactions described in the present document shall take precedence over those described in the ETS for the DDI supplementary service.

E.4.10 Diversion services

E.4.10.1 Call forwarding unconditional

When the call forwarding unconditional supplementary service has been activated, then the call forwarding unconditional supplementary service shall take precedence over the TH supplementary service.

If the call forwarding unconditional supplementary service has been activated, the notification that the call has been forwarded shall be sent to only one of the accesses belonging to the hunt group.

E.4.10.2 Call forwarding busy

When the call forwarding busy supplementary service has been activated, then when all accesses are busy or withdrawn from the hunt group the call forwarding busy supplementary service shall be invoked.

If the call forwarding busy supplementary service has been activated, the notification that the call has been forwarded shall be sent to only one of the accesses belonging to the hunt group.

E.4.10.3 Call forwarding no reply

No impact, i.e. neither supplementary service shall affect the operation of the other supplementary service.

If the call forwarding no reply supplementary service has been activated, the notification that the call has been forwarded shall be sent to only one of the accesses belonging to the hunt group.

E.4.10.4 Call deflection

No impact, i.e. neither supplementary service shall affect the operation of the other supplementary service.

E.4.10.5 Selective call forwarding

When the selective call forwarding supplementary service has been activated unconditionally and if an incoming call matches the selection conditions, then the selective call forwarding supplementary service shall take precedence over the TH supplementary service.

When the selective call forwarding supplementary service has been activated on busy and if an incoming call matches the selection conditions, then when all accesses are busy or withdrawn from the hunt group the selective call forwarding supplementary service shall be invoked.

When the selective call forwarding supplementary service has been activated on no reply, then there is no impact, i.e. neither supplementary service shall affect the operation of the other supplementary service.

E.4.11 Freephone

No impact, i.e. neither supplementary service shall affect the operation of the other supplementary service.

E.4.12 Malicious call identification

No impact, i.e. neither supplementary service shall affect the operation of the other supplementary service.

E.4.13 Multiple subscriber number

Not applicable.

E.4.14 Subaddressing

No impact, i.e. neither supplementary service shall affect the operation of the other supplementary service.

E.4.15 Terminal portability

Not applicable.

E.4.16 Three party

Not applicable.

E.4.17 User-to-user signalling

No impact, i.e. neither supplementary service shall affect the operation of the other supplementary service.

E.4.18 Hunting services

E.4.18.1 Line hunting

Not applicable.

E.4.18.2 Trunk hunting

Not applicable.

E.4.19 Call barring services

E.4.19.1 Outgoing call barring-fixed

No impact, i.e. neither supplementary service shall affect the operation of the other supplementary service.

E.4.19.2 Outgoing call barring-user controlled

No impact, i.e. neither supplementary service shall affect the operation of the other supplementary service.

E.5 Interaction with other services

E.5.1 Universal access number

No impact, i.e. neither supplementary service shall affect the operation of the other supplementary service.

E.5.2 Virtual card calling

No impact, i.e. neither supplementary service shall affect the operation of the other supplementary service.

E.5.3 Premium rate

No impact, i.e. neither supplementary service shall affect the operation of the other supplementary service.

E.5.4 Televoting

No impact, i.e. neither supplementary service shall affect the operation of the other supplementary service.

E.5.5 Universal personal telecommunication

No impact, i.e. neither supplementary service shall affect the operation of the other supplementary service.

E.5.6 Remote control

The TH supplementary service can be remotely controlled.

Annex F (informative): Bibliography

- ETSI ETS 300 050: "Integrated Services Digital Network (ISDN); Multiple Subscriber Number (MSN) supplementary service; Service Description".
- ITU-T Recommendation Q.824.5 (1995): "Configuration management of V5 interface environments and associated customer profiles".
- ITU-T Recommendation X.121 (1992): "International numbering plan for public data networks".
- ITU-T Recommendation X.722 (ISO/IEC 10165-4): "Information technology - Open Systems Interconnection - Structure of Management Information: Guidelines for the definition of managed objects".
- ETSI ETR 037: "Network Aspects (NA); Telecommunications Management Network (TMN); Objectives, principles, concepts and reference configurations".
- ETSI ETR 046: "Network Aspects (NA); Telecommunications management networks modelling guidelines".
- ETSI ETR 078: "Maintenance: Telecommunications management network; TMN interface specification methodology [CCITT Recommendation M.3020 (1992)]".
- ETSI ETR 088: "Network Aspects (NA); Time/type of day dependant scheduling function support object classes".
- ITU-T Recommendation M.3010 (1992): "Principles for a Telecommunications management network".
- CEPT service 12.2 (1981): "Line hunting".
- CEPT service 12.1.1 (1981): "Direct dialling in".

History

Document history			
V0.0.5	December 1999	Public Enquiry	PE 200017: 1999-12-29 to 2000-04-28
V1.1.0	October 2001	One-step Approval Procedure	OAP 20020301: 2001-10-31 to 2002-03-01