

ETSI EN 300 286-6 V1.4.1 (2003-01)

European Standard (Telecommunications series)

**Integrated Services Digital Network (ISDN);
User-to-User Signalling (UUS) supplementary service;
Digital Subscriber Signalling System No. one (DSS1) protocol;
Part 6: Abstract Test Suite (ATS) and partial Protocol
Implementation eXtra Information for Testing (PIXIT)
proforma specification for the network**



Reference

REN/SPAN-130308-2

Keywords

ATS, DSS1, ISDN, network, PIXIT,
supplementary service, UUS

ETSI

650 Route des Lucioles
F-06921 Sophia Antipolis Cedex - FRANCE

Tel.: +33 4 92 94 42 00 Fax: +33 4 93 65 47 16

Siret N° 348 623 562 00017 - NAF 742 C
Association à but non lucratif enregistrée à la
Sous-Préfecture de Grasse (06) N° 7803/88

Important notice

Individual copies of the present document can be downloaded from:

<http://www.etsi.org>

The present document may be made available in more than one electronic version or in print. In any case of existing or perceived difference in contents between such versions, the reference version is the Portable Document Format (PDF). In case of dispute, the reference shall be the printing on ETSI printers of the PDF version kept on a specific network drive within ETSI Secretariat.

Users of the present document should be aware that the document may be subject to revision or change of status. Information on the current status of this and other ETSI documents is available at

<http://portal.etsi.org/tb/status/status.asp>

If you find errors in the present document, send your comment to:

editor@etsi.org

Copyright Notification

No part may be reproduced except as authorized by written permission.
The copyright and the foregoing restriction extend to reproduction in all media.

© European Telecommunications Standards Institute 2003.
All rights reserved.

DECT™, PLUGTESTS™ and UMTS™ are Trade Marks of ETSI registered for the benefit of its Members.
TIPHON™ and the TIPHON logo are Trade Marks currently being registered by ETSI for the benefit of its Members.
3GPP™ is a Trade Mark of ETSI registered for the benefit of its Members and of the 3GPP Organizational Partners.

Contents

Intellectual Property Rights	6
Foreword.....	6
1 Scope	7
2 References	7
3 Definitions and abbreviations.....	8
3.1 Definitions	8
3.2 Abbreviations	8
4 Abstract Test Method (ATM).....	9
4.1 Description of ATM used.....	9
4.1.1 Conventions for test components and PCOs.....	9
4.1.2 Conventions for variables and parameters	11
4.1.3 Special conventions for the UUS supplementary service	12
4.1.4 Conventions for point-to-multipoint configurations	12
4.2 Alternative ATM.....	13
5 Untestable Test Purposes (TPs).....	14
6 ATS conventions	14
6.1 Declarations part	14
6.1.1 Type definitions	14
6.1.1.1 Simple type definitions	14
6.1.1.2 Structured type definitions	15
6.1.1.2.1 TTCN structured type definitions.....	15
6.1.1.2.2 ASN.1 structured type definitions	15
6.1.1.3 Abstract Service Primitive (ASP) type definitions.....	16
6.1.1.3.1 TTCN ASP type definitions	16
6.1.1.3.2 ASN.1 ASP type definitions.....	16
6.1.1.4 PDU type definitions.....	16
6.1.1.4.1 TTCN PDU type definitions.....	16
6.1.1.4.2 ASN.1 PDU type definitions	16
6.1.2 Test suite constants	17
6.1.3 Test suite parameters	17
6.1.4 Variables.....	17
6.1.4.1 Test suite variables.....	17
6.1.4.2 Test case variables.....	17
6.1.5 Test suite operation definitions.....	17
6.2 Constraints part	17
6.2.1 Structured type constraint declaration.....	17
6.2.2 ASN.1 type constraint declaration	18
6.2.2.1 Specification of encoding rules.....	19
6.2.3 ASP type constraint declaration.....	19
6.2.3.1 ASN.1 ASP type constraint declaration	19
6.2.3.2 TTCN ASP type constraint declaration.....	19
6.2.4 PDU type constraint declaration	20
6.2.4.1 ASN.1 PDU type constraint declaration.....	20
6.2.4.2 TTCN PDU type constraint declaration	20
6.2.5 Chaining of constraints	20
6.2.5.1 Static chaining.....	20
6.2.5.2 Dynamic chaining	20
6.2.6 Derived constraints	20
6.2.7 Parameterized constraints	20
6.2.8 Value assignment.....	20
6.2.8.1 Specific values	20
6.2.8.2 Matching values	21
6.3 Dynamic part.....	21

6.3.1	Test cases	21
6.3.2	Test steps	21
6.3.2.1	PTC1_IN	21
6.3.2.2	PTC1_OUT	21
6.3.3	Defaults	21
7	ATS to TP map	21
8	PCTR conformance	22
9	PIXIT conformance	22
10	ATS conformance	22
Annex A (normative): Protocol Conformance Test Report (PCTR) proforma.....		23
A.1	Identification summary.....	23
A.1.1	Protocol conformance test report.....	23
A.1.2	IUT identification	23
A.1.3	Testing environment.....	23
A.1.4	Limits and reservations	24
A.1.5	Comments.....	24
A.2	IUT conformance status	24
A.3	Static conformance summary	24
A.4	Dynamic conformance summary.....	24
A.5	Static conformance review report.....	25
A.6	Test campaign report.....	25
A.7	Observations.....	29
Annex B (normative): Partial PIXIT proforma		30
B.1	Identification summary.....	30
B.2	ATS summary	30
B.3	Test laboratory.....	30
B.4	Client (of the test laboratory)	31
B.5	System Under Test (SUT)	31
B.6	Protocol information.....	32
B.6.1	Protocol identification	32
B.6.2	Parameter values	32
B.6.3	Codings of information elements	32
B.6.4	Configuration of IUT.....	33
B.6.5	Timer values.....	33
B.7	Basic call PIXIT items	34
B.7.1	Parameter values - information element codings.....	34
Annex C (normative): Abstract Test Suite (ATS)		35
C.1	The TTCN Graphical form (TTCN.GR)	35
C.2	The TTCN Machine Processable form (TTCN.MP).....	35
Annex D (informative): General structure of ATS.....		36
Annex E (informative): Change record.....		37
E.1	Changes between EN 300 286-6 V1.2.4 and V1.3.3.....	37
E.2	Changes between ETS 300 286-6 Edition 1 and EN 300 286-6 V1.2.4.....	37

E.3	Changes between EN 300 286-6 V1.4.1 and V1.3.3.....	37
E.4	Changes between EN 300 286-6 V1.2.4 and V1.3.3.....	38
History	39

Intellectual Property Rights

IPRs essential or potentially essential to the present document may have been declared to ETSI. The information pertaining to these essential IPRs, if any, is publicly available for **ETSI members and non-members**, and can be found in ETSI SR 000 314: "*Intellectual Property Rights (IPRs); Essential, or potentially Essential, IPRs notified to ETSI in respect of ETSI standards*", which is available from the ETSI Secretariat. Latest updates are available on the ETSI Web server (<http://webapp.etsi.org/IPR/home.asp>).

All published ETSI deliverables shall include information which directs the reader to the above source of information.

Foreword

This European Standard (Telecommunications series) has been produced by ETSI Technical Committee Services and Protocols for Advanced Networks (SPAN).

The present document is part 6 of a multi-part standard covering the Integrated Services Digital Network (ISDN); User-to-User Signalling (UUS) supplementary service; Digital Subscriber Signalling System No. one (DSS1) protocol, as described below:

- Part 1: "Protocol specification";
- Part 2: "Protocol Implementation Conformance Statement (PICS) proforma specification";
- Part 3: "Test Suite Structure and Test Purposes (TSS&TP) specification for the user";
- Part 4: "Abstract Test Suite (ATS) and partial Protocol Implementation eXtra Information for Testing (PIXIT) proforma specification for the user";
- Part 5: "Test Suite Structure and Test Purposes (TSS&TP) specification for the network";
- Part 6: "Abstract Test Suite (ATS) and partial Protocol Implementation eXtra Information for Testing (PIXIT) proforma specification for the network".**

National transposition dates	
Date of adoption of this EN:	27 December 2002
Date of latest announcement of this EN (doa):	31 March 2003
Date of latest publication of new National Standard or endorsement of this EN (dop/e):	30 September 2003
Date of withdrawal of any conflicting National Standard (dow):	30 September 2003

1 Scope

The present document specifies the Abstract Test Suite (ATS) and partial Protocol Implementation eXtra Information for Testing (PIXIT) proforma for the Network side of the T reference point or coincident S and T reference point (as defined in ITU-T Recommendation I.411 [11]) of implementations conforming to the stage three standard for the User-to-User Signalling (UUS) supplementary service for the pan-European Integrated Services Digital Network (ISDN) by means of the Digital Subscriber Signalling System No. one (DSS1) protocol, EN 300 286-1 [3].

EN 300 286-5 [5] specifies the Test Suite Structure and Test Purposes (TSS&TP) related to this ATS and partial PIXIT proforma specification. Other parts specify the TSS&TP and the ATS and partial PIXIT proforma for the User side of the T reference point or coincident S and T reference point of implementations conforming to EN 300 286-1 [3].

2 References

The following documents contain provisions which, through reference in this text, constitute provisions of the present document.

- References are either specific (identified by date of publication and/or edition number or version number) or non-specific.
- For a specific reference, subsequent revisions do not apply.
- For a non-specific reference, the latest version applies.

Referenced documents which are not found to be publicly available in the expected location might be found at <http://docbox.etsi.org/Reference>.

- [1] ETSI EN 300 403-1: "Integrated Services Digital Network (ISDN); Digital Subscriber Signalling System No. one (DSS1) protocol; Signalling network layer for circuit-mode basic call control; Part 1: Protocol specification [ITU-T Recommendation Q.931 (1993), modified]".
- [2] ETSI EN 300 196-1: "Integrated Services Digital Network (ISDN); Generic functional protocol for the support of supplementary services; Digital Subscriber Signalling System No. one (DSS1) protocol; Part 1: Protocol specification".
- [3] ETSI EN 300 286-1: "Integrated Services Digital Network (ISDN); User-to-User Signalling (UUS) supplementary service; Digital Subscriber Signalling System No. one (DSS1) protocol; Part 1: Protocol specification".
- [4] ETSI EN 300 286-2: "Integrated Services Digital Network (ISDN); User-to-User Signalling (UUS) supplementary service; Digital Subscriber Signalling System No. one (DSS1) protocol; Part 2: Protocol Implementation Conformance Statement (PICS) proforma specification".
- [5] ETSI EN 300 286-5 (V1.2.4): "Integrated Services Digital Network (ISDN); User-to-User Signalling (UUS) supplementary service; Digital Subscriber Signalling System No. one (DSS1) protocol; Part 5: Test Suite Structure and Test Purposes (TSS&TP) specification for the network".
- [6] ISO/IEC 9646-1: "Information technology - Open System Interconnection - Conformance testing methodology and framework - Part 1: General concepts".
- [7] ISO/IEC 9646-2: "Information technology - Open Systems Interconnection - Conformance testing methodology and framework - Part 2: Abstract Test Suite specification".
- [8] ISO/IEC 9646-3: "Information technology - Open Systems Interconnection - Conformance testing methodology and framework - Part 3: The Tree and Tabular Combined Notation (TTCN)".
- [9] ISO/IEC 9646-4: "Information technology - Open Systems Interconnection - Conformance testing methodology and framework - Part 4: Test realization".

- [10] ISO/IEC 9646-5: "Information technology - Open Systems Interconnection - Conformance testing methodology and framework - Part 5: Requirements on test laboratories and clients for the conformance assessment process".
- [11] ITU-T Recommendation I.411: "ISDN user-network interfaces - Reference configurations".
- [12] ITU-T Recommendation X.209: "Specification of basic encoding rules for Abstract Syntax Notation One (ASN.1)".

3 Definitions and abbreviations

3.1 Definitions

For the purposes of the present document, the following terms and definitions apply:

Abstract Test Suite (ATS): See ISO/IEC 9646-1 [6].

Implementation Under Test (IUT): See ISO/IEC 9646-1 [6].

Lower Tester (LT): See ISO/IEC 9646-1 [6].

PICS proforma: See ISO/IEC 9646-1 [6].

PIXIT proforma: See ISO/IEC 9646-1 [6].

Point of Control and Observation (PCO): See ISO/IEC 9646-1 [6].

Protocol Implementation Conformance Statement (PICS): See ISO/IEC 9646-1 [6].

Protocol Implementation Extra Information for Testing (PIXIT): See ISO/IEC 9646-1 [6].

System Under Test (SUT): See ISO/IEC 9646-1 [6].

Upper Tester (UT): See ISO/IEC 9646-1 [6].

3.2 Abbreviations

For the purposes of the present document, the following abbreviations apply:

ASP	Abstract Service Primitive
ATM	Abstract Test Method
ATS	Abstract Test Suite
BER	Basic Encoding Rules
CM	Co-ordination Message
CP	Co-ordination Point
DSS1	Digital Subscriber Signalling System No. one
ExTS	Executable Test Suite
ISDN	Integrated Services Digital Network
IUT	Implementation Under Test
LT	Lower Tester
MOT	Means Of Testing
MTC	Main Test Component
PCO	Point of Control and Observation
PDU	Protocol Data Unit
PICS	Protocol Implementation Conformance Statement
PIXIT	Protocol Implementation eXtra Information for Testing
PTC	Parallel Test Component
SUT	System Under Test
TP	Test Purpose
TTCN	Tree and Tabular Combined Notation
UT	Upper Tester

4 Abstract Test Method (ATM)

4.1 Description of ATM used

The requirement for testing the network Implementation Under Test (IUT) is to focus on the behaviour of the network IUT at the user-network interface where a T reference point or coincident S and T reference point applies. Thus the IUT is the network DSS1 protocol entity at a particular user-network interface and is not the whole network.

It is possible to specify an Abstract Test Suite (ATS) based on a single party (remote) test method for such an IUT. However, it is considered that an ATS based on such an approach is of limited use as the only way to specify IUT generated Protocol Data Units (PDUs) is to use the "implicit send" statement. Many users of such an ATS would replace the "implicit send" statements with descriptions of the behaviour at other interfaces.

An ATS based on a multi-party test method is considered to be more useful in that it is closer to how a real test suite would be constructed. Such a test method specifies behaviour at multiple network interfaces. One very important limitation here is that tests are focused on one particular interface. Thus the test system is made up one Main Test Component (MTC) and one or more Parallel Test Components (PTCs), see figure 1.

4.1.1 Conventions for test components and PCOs

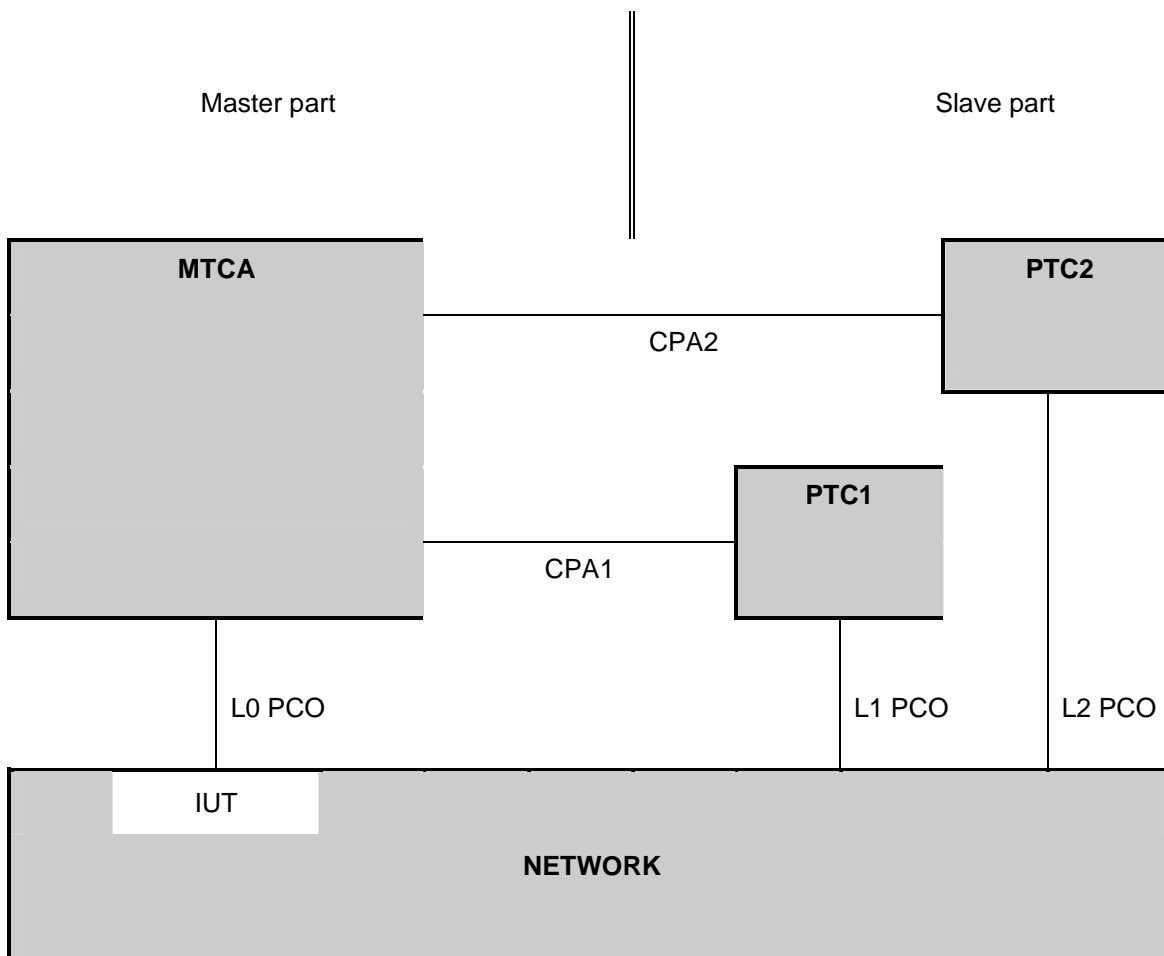

Figure 1: Multi-party test method

In a master/slave arrangement, the MTC is considered to be the master while the PTCs are the slaves. The "slave" testers are only an explicit description of how to deal with the "other" interfaces during the testing process, i.e. "how to make the IUT send the required message".

This means, in particular, that the verdict will only be assigned from the protocol aspects observed on the interface under test (i.e. by the "master" tester), as it would be observed by a terminal connected to this interface. A failure in the correlation between the protocol at the different interfaces to which the different testers are connected, i.e. in the mechanism of the functional service itself, will not cause a FAIL verdict. For instance, if the IUT fails to send a message on the tested interface after another interface has received the proper stimulus, the verdict will be INCONCLUSIVE.

The MTC MTCA has two functions in this configuration. Firstly, it has the MTC function of controlling the one or more PTCs. Thus it is responsible for starting the PTCs and afterwards co-ordinates activities by exchanging Co-ordination Messages (CMs) with the PTCs. Secondly it is responsible for the behaviour of the Lower Tester (LT) at Point of Control and Observation (PCO) L0.

A combination of the remote and multi-party test methods is applied. As can be seen from figure 1, several PCOs are used. All PCOs reside at the service access points between layers 2 and 3.

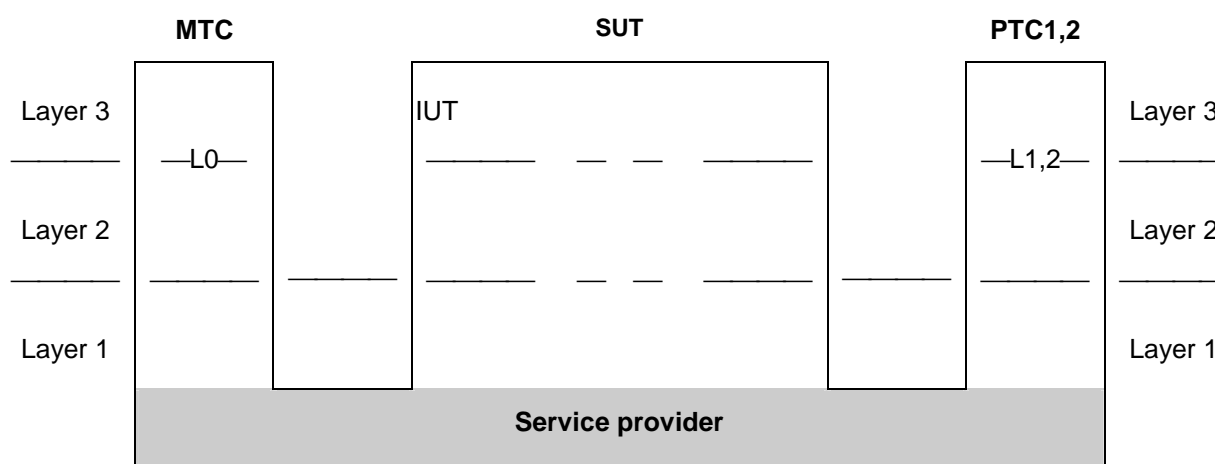

Figure 2: Combination of the remote and multi-party test methods

The MTC PCO is named "L0" ("L" for Lower). The L0 PCO is used to control and observe the behaviour of the IUT and test case verdicts are assigned depending on the behaviour observed at this PCO. The PTCs PTC1, PTC2 etc. use PCOs L1, L2, etc. These PCOs are used to control and, in a limited way, observe the behaviour of the network equipment at interfaces other than the one under test. No verdicts are assigned at these PCOs.

As stated in a previous clause, the non-receipt of network generated messages at L0, which are stimulated by events at the L1, L2, etc., will result in INCONCLUSIVE rather than FAIL verdicts being assigned.

4.1.2 Conventions for variables and parameters

MTCA

call reference	CREF1	(to PTC1)
B channel (basic)	bch_num1	
channel nr (primary)	CH_NUM1	

call reference	CREF2	(to PTC2)
B channel (basic)	bch_num2	
channel nr (primary)	CH_NUM2	

PCO L0 IPN0, LIPN0

PTC1

call reference	P1CREF
B channel (basic)	P1_bch_num
channel nr (primary)	P1_CH_NUM

PCO L1 IPN1, LIPN1

PTC2

call reference	P2CREF
B channel (basic)	P2_bch_num
channel nr (primary)	P2_CH_NUM

PCO L2 IPN2, LIPN2

4.1.3 Special conventions for the UUS supplementary service

To begin a conference from the Null Call State, a remote user is not required. The CREF1 will be used without the PTC1. To add a party to the conference, a remote user with CREF2 using PTC2 is called.

Some remote user test cases use 2 parties. To do that the first party is added by using the CREF2 with PTC1. After the party has been added to the conference, CREF2 will be released. Then it is possible to add the second party by using CREF2 with PTC2.

4.1.4 Conventions for point-to-multipoint configurations

For this group, PTC2 is connected to the same basic access as the MTC. Thus messages sent to the MTC via the broadcast data link will be received at PTC2 via PCO L2 as well. Both the MTC and PTC2 will send messages on the same access using the same call reference value. A distinction between the two message flows related to the PCOs L0 and L2 can still be made, as they use different data link entities. This approach, representing a slight modification in the test method, is illustrated in figure 3. This shows that the part of the network considered to be the IUT is connected to both the MTC and PTC2.

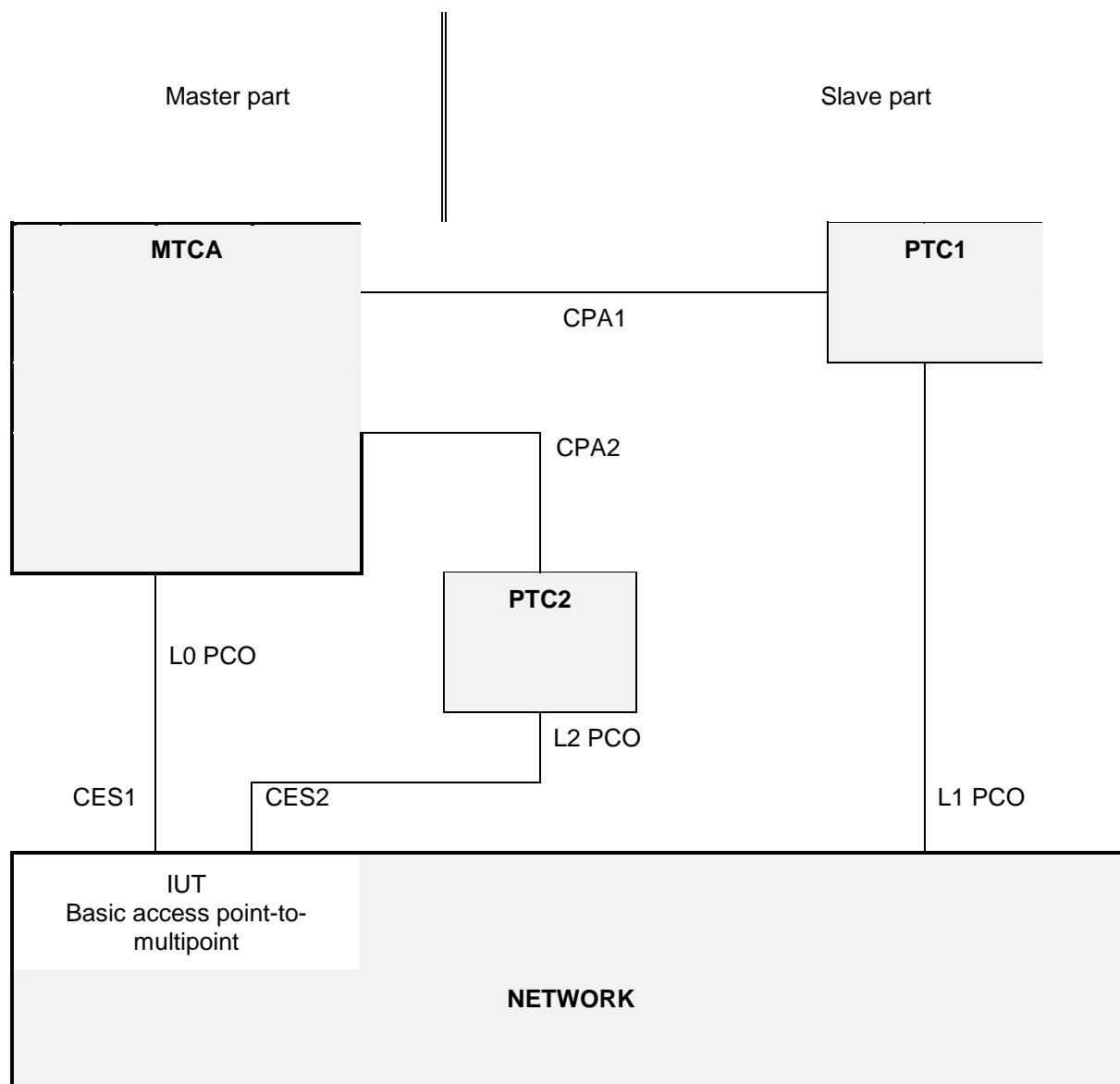

Figure 3: Multi-party test method - modified for point-to-multipoint configurations

4.2 Alternative ATM

As stated in clause 4.1, an ATS based on a single-party (remote) ATM is possible. Such an ATS may be generated from the one specified in the present document. The following general steps should be taken:

- 1) remove all PTC behaviour;
- 2) remove all CREATE statements;
- 3) replace CMs which are used to provoke PDUs at the MTC, with implicit send statements.

An example, showing the difference between the multi-party ATM and single-party ATM for a single test case, is given in tables 1 and 2.

Table 1: Test case dynamic behaviour table using multi-party ATM

TEST CASE DYNAMIC BEHAVIOUR					
Test Case Name		HOLD_N04_001			
Group		RemoteUser_ST_OR_T/Holding/			
Purpose		Ensure that the IUT, while in the Active call state N10, to notify the non-served user that the call is held sends a NOTIFY message with a notification indicator coded as "remote hold" to user B and remains in the Active call state.			
Default Configuration		DF69901(1) UUSIG1			
Comments		9.2.1 valid optional			
Nr	Label	BEHAVIOUR DESCRIPTION	CREF	V	COMMENTS
1		CREATE (PTC1: PTC1_IN_servedUser)			
2		+PR31002			preamble N10
3		CPAL!CP_M START TWAIT	S_HL		
4		L0?NOTIFYr	A_NO20(CREF1,hold_NID)	(P)	
5		+CS59901(10,1)			check N10
6		?TIMEOUT TWAIT		(I)	
7		+PO49901(1)			postamble N0
DETAILED COMMENTS:					

Table 2: Test case dynamic behaviour table using single-party ATM

TEST CASE DYNAMIC BEHAVIOUR					
Test Case Name		HOLD_N04_001			
Group		RemoteUser_ST_OR_T/Holding/			
Purpose		Ensure that the IUT, while in the Active call state N10, to notify the non-served user that the call is held sends a NOTIFY message with a notification indicator coded as "remote hold" to user B and remains in the Active call state.			
Default Configuration		DF69901(1)			
Comments		9.2.1 valid optional			
Nr	Label	BEHAVIOUR DESCRIPTION	CREF	V	COMMENTS
1		+PR31002			preamble N10
2		<IUT!NOTIFY>	NO20(CREF1,hold_NID)		
3		L0?NOTIFYr	A_NO20(CREF1,hold_NID)	(P)	
4		+CS59901(10,1)			check N10
5		?TIMEOUT TWAIT		(I)	
6		+PO49901(1)			postamble N0
DETAILED COMMENTS:					

5 Untestable Test Purposes (TPs)

None.

6 ATS conventions

This clause is structured similarly to the structure of a Tree and Tabular Combined Notation (TTCN) ATS. However, the names of the clauses are arranged in a way more suitable to the present document.

6.1 Declarations part

6.1.1 Type definitions

6.1.1.1 Simple type definitions

Where appropriate, simple types have a length, a value list or a range restriction attached.

Simple types defined as being of some string type (e.g. BIT STRING, OCTET STRING), have a length restriction or a value list attached.

Simple types, defined as being of INTEGER type, have a value list or a range restriction attached.

6.1.1.2 Structured type definitions

6.1.1.2.1 TTCN structured type definitions

All structured type definitions are provided with a full name.

All elements in every structured type definition, defined as being of some string type (e.g. BIT STRING, OCTET STRING), have a length restriction attached.

If an element in a structured type definition is defined as being of a referenced type, the (possible) restriction is defined in that referenced type.

For information elements the identifier, which is unique for each element, has its type defined as a simple type where the value list is restricted to the single value which is the identifier itself. This has the advantage that it allows a test system derived from this ATS to easily identify information elements embedded in messages. An ATS where information element identifiers are represented as unrestricted types can present difficulties for a derived test system in the case where it needs to find one information element embedded in a number of others and the constraints for the other elements have the any-or-omit value. In such a case the test system cannot easily find the beginning of each information element.

6.1.1.2.2 ASN.1 structured type definitions

ASN.1 has been used for three major reasons. First, types defined in ASN.1 can model problems that "pure" TTCN cannot. For instance, data structures modelling ordered or unordered sequences of data are preferably defined in ASN.1. Second, ASN.1 provides a better restriction mechanism for type definitions by using sub-type definitions. Third, it is necessary to use ASN.1 to reproduce the type definitions for remote operation components as specified in the base standards.

The fact that ASN.1 provides a better restriction mechanism for type definitions is used for the purpose of achieving type-compatibility.

Tables 3 and 4 show the typical use of ASN.1. The FIE type in table 3 is written in ASN.1 to permit the use of the SET OF construction in the components field. Constraints of the FIE type can therefore be written using the SUPERSET function which allows to match a single component which may be delivered together with a set of other components. Table 4 shows the reject component type which is defined following the ASN.1 declaration in EN 300 196-1 [2].

Table 3: ASN.1 type definition FIE

ASN.1 Type Definition	
Type Name	: FIE
Comments	: Facility information element taken from EN 300 196-1; 11.2.2.1. Specified here for both send & receive event.
Type Definition	
SEQUENCE {	
informationElementIdentifier	FIE_I,
length	FIE_LengthType,
extBit	BIT STRING (SIZE (1)),
spareBits	BIT STRING (SIZE (2)),
protocolProfile	BIT STRING (SIZE (5)),
components	SET OF Component }

Table 4: ASN.1 type definition RejectComponent

ASN.1 Type Definition	
Type Name	: RejectComponent
Comments	: Reject Component is not specific to any particular operation. The invokeID may be used to identify a specific operation.
Type Definition	
SEQUENCE {	
invokedID	CHOICE {
invokeID	InvokeIDType,
null	NULL },
problem	CHOICE {
generalProblem	[2] IMPLICIT GeneralProblem,
invokeProblem	[1] IMPLICIT InvokeProblem,
returnResultProblem	[2] IMPLICIT ReturnResultProblem,
returnErrorProblem	[3] IMPLICIT ReturnErrorProblem }

Table 5 shows an example of how ASN.1 can be used to model unordered sequences.

Table 5: ASN.1 type definition FIES

ASN.1 Type Definition	
Type Name	: FIES
Comments	:
Type Definition	
SET OF FIE	

The possibility to use TTCN and ASN.1 in combination is used, i.e. referring to an ASN.1 type from a TTCN type.

6.1.1.3 Abstract Service Primitive (ASP) type definitions

6.1.1.3.1 TTCN ASP type definitions

TTCN ASP type definitions only contain one PDU or no PDU at all. The relationship between an ASP type and a PDU type is one-to-one. That is, there exists one ASP type definition for each PDU type definition (if that ASP type contains a PDU).

All TTCN ASP type definitions are provided with a full identifier.

Some ASPs are not parameterized as shown in the example in table 6. Such ASPs are only used for requesting or receiving service from the lower layer.

Table 6: TTCN ASP type definition DL_REL_IN

TTCN ASP Type Definition		
ASP NAME : DL_REL_IN(DL_RELEASE_INDICATION)		
PCO Type : SAP		
Comments :		
Parameter Name	Parameter Type	Comments
Detailed Comments :		

Table 7 shows an example of a parameterized ASP. All ASPs containing PDUs contain only that PDU and no other parameters.

Table 7: TTCN ASP type definition DL_DATA_RQ_ALERT

TTCN ASP Type Definition		
ASP NAME : DL_DATA_RQ_ALERT(DL_DATA_REQUEST)		
PCO Type : SAP		
Comments :		
Parameter Name	Parameter Type	Comments
mun (MessageUnit)	ALERT_PDU	
Detailed Comments :		

6.1.1.3.2 ASN.1 ASP type definitions

There are no ASN.1 ASP type definitions in the ATS.

6.1.1.4 PDU type definitions

6.1.1.4.1 TTCN PDU type definitions

The TTCN PDU type reflects the actual data being transferred or received. All PDUs are embedded in ASPs.

If a specific PDU type definition contains elements defined in terms of a pre-defined type, that element has a restriction attached to it.

6.1.1.4.2 ASN.1 PDU type definitions

There are no ASN.1 PDU type definitions in the ATS.

6.1.2 Test suite constants

No test suite constants are used or defined in this ATS.

6.1.3 Test suite parameters

Each test suite parameter is defined in terms of a predefined type or a referenced type. A referenced type is used when it is necessary to attach restrictions to these type definitions (it is not allowed to include restrictions directly in the test suite parameter table). The referenced type can have a length or value restriction attached to it in its declaration table.

6.1.4 Variables

6.1.4.1 Test suite variables

No test suite variables are used or defined in this ATS.

6.1.4.2 Test case variables

Each test case variable is defined in terms of a predefined type or a referenced type. A referenced type is used when it is necessary to attach restrictions to these type definitions (it is not allowed to include restrictions directly in the test case variable table). The referenced type can have a length or value restriction attached to it in its declaration table.

Where test case variables are used in constraints, they are passed as formal parameters.

6.1.5 Test suite operation definitions

The description part of a test suite operation definition uses either natural language or meta C.

Table 8: Test suite operation definition ASSIGN_CHI

Test Suite Operation Definition	
Operation Name	: ASSIGN_CHI(basic, primary : CHI; basic_flag : BOOLEAN)
Result Type	: CHI
Comments	: This operation is used to assign a correct Channel identification information element to PDUs dependent on the type of access that is tested.
Description	
<pre> { if(basic_flag) return basic; else return primary } </pre>	
Detailed comments	:

The test suite operation definition shown in table 8 is used in the constraints part when assigning an element of type CHI a value. As previously described, the CHI type can be defined in two ways depending on whether the ATS is testing basic or primary rate access. This operation is used to assign a value to an element of CHI type. It takes three parameters:

```

primary:      a constraint of type CHI valid for primary rate access;
basic:        a constraint of type CHI valid for basic access;
basic_flag: a Boolean value: TRUE if basic access is applicable, FALSE otherwise.

```

This operation returns the correct constraint according to the Boolean flag `basic_flag`. That constraint will then be assigned to the specific element of type CHI.

6.2 Constraints part

6.2.1 Structured type constraint declaration

For every structured type definition there exists one or more structured type constraint.

6.2.2 ASN.1 type constraint declaration

Constraints of this type are used to assign the corresponding type a specific value. These constraints are used for the purpose of modelling unordered data or specific types that cannot be expressed in TTCN.

A value assigned to an element of type SET OF differs depending on whether it is a send or receive constraint.

Table 9: ASN.1 type constraint declaration fIEs (send constraint)

ASN.1 Type Constraint Declaration	
Constraint Name	: fIEs(comp : Component)
ASN.1 Type	: FIE
Derivation Path	:
Comments	: Send FIE which will contain one component "comp".
Description	
{	
informationElementIdentifier	'00011100'B,
length	CALC_FIE_LENGTH(comp),
extBit	'1'B,
spareBits	'00'B,
protocolProfile	'10001'B,
components	{comp}
}	
Detailed comments	:

NOTE 1: The last element in the constraint, *components*, is of type *SET OF Component* where *Component* is structured data of some type.

If the constraint is a send constraint (as in table 9) the value for the component element is stated as "{comp}" where comp is an argument received as a parameter. The "{" and "}" turns the value into a SET OF value which is correct according to that element's type definition.

Table 10: ASN.1 type constraint declaration fIEr (receive constraint)

ASN.1 Type Constraint Declaration	
Constraint Name	: fIEr(comp : Component)
ASN.1 Type	: FIE
Derivation Path	:
Comments	: A received FIE which can contain several components, but which contains at least "comp".
Description	
{	
informationElementIdentifier	'00011100'B,
length	'????????'B,
extBit	'1'B,
spareBits	'00'B,
protocolProfile	'10001'B,
components	SUPERSET({comp})
}	
Detailed comments	:

NOTE 2: The last element in the constraint, named *components*, is of type *SET OF Component* where *Component* is structured data of some type.

If the constraint is a receive constraint (as in table 10) the corresponding matching value is assigned by using SUPERSET. The key-word SUPERSET has an argument that is type compatible with the type definition of that field. In table 10, the element named *components* is defined as "SET OF Component" and this implies that the argument to SUPERSET should be of type SET OF Component. This is achieved the same way as for send constraints, enclosing the value in curly brackets.

The semantic of SUPERSET is stated in ISO/IEC 9646-3 [8], clause 11.6.4.7. In short it defines the semantic as follows: "A value that uses SUPERSET matches the incoming value if, and only if, the incoming value contains **at least all of the elements** defined within the SUPERSET, and **may contain more elements**." This is exactly the semantic definition used in this ATS.

6.2.2.1 Specification of encoding rules

At the time of specifying this ATS the mechanisms related to encoding of ASN.1 types, specified in DAM-2 of ISO/IEC 9646-3 [8], were not yet stable. Nevertheless as there is a variation in the encoding rules as applied to ASN.1 types and constraints specified in this ATS, a mechanism is used to differentiate the different encoding rules. Given the non-finalized status of DAM-2, a solution which is broadly in the spirit of DAM-2 has been created. Comment fields have been used as a means of including the encoding rules.

For ASN.1 used in this ATS, two variations of encoding rules are used. One is the commonly known Basic Encoding Rules (BER) as specified in ITU-T Recommendation X.209 [12]. In the second case, the encoding is according to ISDN, i.e. the ASN.1 data types are a representation of structures contained within the ISDN specification (basic call, Generic functional protocol or individual supplementary service). For example, if octets of an information element are specified in ASN.1 as a SEQUENCE then this should be encoded in an Executable Test Suite (ExTS) as any other ISDN information element specified using tabular TTCN. This ISDN encoding variation is the default encoding rule for this ATS. This means that all ASN.1 constraint tables are encoded using ISDN (non-BER) encoding unless stated otherwise. BER encoding should never be applied to an ASN.1 constraint where BER encoding has not been specified.

For BER encoding, an indication is given in the comments field of the table header. For this ATS such indications appear in the ASN.1 type constraint declaration tables only. In the first line of the table header comment field, the notation "ASN1_Encoding: BER" is used.

NOTE: Within BER, there are a number of variations for the encoding of lengths of fields. According to EN 300 196-1 [2], an IUT should be able to interpret all length forms within BER for received PDUs. When sending PDUs containing BER encoding, EN 300 196-1 [2] gives guidelines but makes no restrictions on the length forms within BER which an IUT may apply.

In relation to components sent by the tester to the IUT, implementors of this ATS shall use a variety of length forms such that at least one of each of the length forms is sent to the IUT during a test campaign. The variations of length forms to be used are indefinite, short definite and long definite.

In this particular ATS all ASN.1 type constraints which are of type "Component" are to be encoded using BER.

Table 11: ASN.1 type constraint declaration showing use of encoding variation

ASN.1 Type Constraint Declaration	
Constraint Name :	Beg3PTYinv
ASN.1 Type :	Component
Derivation Path :	
Comments :	ASN1_Encoding: BER Receive component: Begin3PTY invoke component
Description	
begin3PTY_Components	
begin3PTY_InvokeComp	
{ invokeID ? ,	
operation_value localValue 4 }	
Detailed comments :	

6.2.3 ASP type constraint declaration

6.2.3.1 ASN.1 ASP type constraint declaration

No ASN.1 ASP type constraint declaration exists in this ATS.

6.2.3.2 TTCN ASP type constraint declaration

For TTCN ASP constraint declarations there is a one-to-one relationship between its type and the constraint. That is, there is only one constraint for each TTCN ASP Type Declaration. The reason for this is that the ASPs are used only for carrying a specific PDU value. The many ASP constraints (and types) could have been avoided by using the meta type **PDU**, but that was not suitable as values inside a specific PDU have to be referenced. To reference elements inside a value of meta type **PDU** is not allowed according to ISO/IEC 9646-3 [8], so each ASP has to be defined as having a parameter of a specific PDU type.

In all ASP constraints the embedded PDU constraint is either chained static or "semi-dynamic". That is, the PDU constraint is always fixed to a specific ASP constraint but it (the PDU) may be parameterized.

All ASP constraints have a specific value for its parameter. No matching symbols are used in ASPs.

6.2.4 PDU type constraint declaration

6.2.4.1 ASN.1 PDU type constraint declaration

No ASN.1 PDU type constraint declaration exists in this ATS.

6.2.4.2 TTCN PDU type constraint declaration

PDU constraints are used for assigning values or patterns to the data being sent or received.

6.2.5 Chaining of constraints

6.2.5.1 Static chaining

Static chaining, that is a fixed reference to a specific constraint, is used in this ATS. The static chaining is used for static binding of both variables and sub-structures.

6.2.5.2 Dynamic chaining

Dynamic chaining is achieved when having a reference to a value which is unknown. The only thing known (before run-time) is the type of that reference. The reference is passed as a parameter. Strict dynamic chaining is not used in this ATS. What is used is something that is called "semi-dynamic chaining". The definition of semi-dynamic chaining is that the fixed reference is parameterized with an unknown value. That value is received as a parameter.

Table 12: TTCN ASP constraint declaration A_RST1

TTCN ASP Constraint Declaration		
Constraint Name : A_RST1 (FLAG : INTEGER)		
ASN.1 Type : DL_DAT_IN_RESTARTr		
Derivation Path :		
Comments :		
Parameter Name	Parameter Value	Comments
mun	RST1 (FLAG)	RST1 (FLAG)
Detailed comments :		

Table 12 is an example of semi-dynamic chaining. The TTCN ASP constraint is parameterized with an INTEGER value named FLAG. That value is passed further down in the structure as a parameter to a static named PDU constraint reference.

6.2.6 Derived constraints

No derivation of any constraint is used. All constraints are considered to be base constraints.

6.2.7 Parameterized constraints

Parameterized constraints are used in this ATS.

6.2.8 Value assignment

6.2.8.1 Specific values

For specific value assignment both explicit values and references to explicit values are used.

6.2.8.2 Matching values

As matching values the following mechanisms are used:

Instead of Value:

AnyOrOmit	"*"
AnyValue	"?"
SuperSet	SUPERSET
Omit	"_"

Inside value:

AnyOne	"?"
AnyOrNone	"*"

6.3 Dynamic part

6.3.1 Test cases

Each test case contains the TP text from EN 300 286-5 [5]. To be able to read and understand the test case dynamic behaviour it is recommended that the test steps are understood first.

6.3.2 Test steps

6.3.2.1 PTC1_IN

This test step describes the behaviour of the PTC1 for support of an incoming call at the MTC (served user side). Thus PTC1 is the originator of the call. The PTC1 receives a CM from the MTC in order to send the SETUP message which begins the call establishment. The test step is terminated by receipt of a RELEASE message or by appropriate CM from the MTC.

6.3.2.2 PTC1_OUT

This test step describes the behaviour of the PTC1 for support of an outgoing call at the MTC (served user side). Thus PTC1 is at the destination side of the call. The test step is terminated by receipt of a RELEASE message or by appropriate CM from the MTC.

The behaviour is regulated from the MTC by means of CMs sent via CPA1 Co-ordination Point (CP). Thus if the PTC is expected to receive a message it receives a CM beforehand telling it what message to expect. On the other hand if the MTC wishes to receive a message from the IUT it may do this by first sending a CM to PTC1. Depending on the contents of the CM PTC1 may then send a message to the IUT eventually provoking the IUT to send a message at the side of the MTC.

6.3.3 Defaults

Note the use of the RETURN statement which is defined in DAM1 of ISO/IEC 9646-3 [8]. This allows valid background behaviour to be handled in the default tree with a possibility to return to the original set of alternatives in the test case.

7 ATS to TP map

The identifiers used for the TPs are reused as test case names. Thus there is a straightforward one-to-one mapping.

8 PCTR conformance

A test laboratory, when requested by a client to produce a Protocol Conformance Test Report (PCTR), is required, as specified in ISO/IEC 9646-5 [10], to produce a PCTR conformant with the PCTR template given in annex B of ISO/IEC 9646-5 [10].

Furthermore, a test laboratory, offering testing for the ATS specification contained in annex C, when requested by a client to produce a PCTR, is required to produce a PCTR conformant with the PCTR proforma contained in annex A of the present document.

A PCTR which conforms to this PCTR proforma specification shall preserve the content and ordering of the clauses contained in annex A. clause A.6 of the PCTR may contain additional columns. If included, these shall be placed to the right of the existing columns. Text in italics may be retained by the test laboratory.

9 PIXIT conformance

A test realizer, producing an ExTS for the ATS specification contained in annex C, is required, as specified in ISO/IEC 9646-4 [9], to produce an augmented partial PIXIT proforma conformant with this partial PIXIT proforma specification.

An augmented partial PIXIT proforma which conforms to this partial PIXIT proforma specification shall, as a minimum, have contents which are technically equivalent to annex B. The augmented partial PIXIT proforma may contain additional questions that need to be answered in order to prepare the Means Of Testing (MOT) for a particular IUT.

A test laboratory, offering testing for the ATS specification contained in annex C, is required, as specified in ISO/IEC 9646-5 [10], to further augment the augmented partial PIXIT proforma to produce a PIXIT proforma conformant with this partial PIXIT proforma specification.

A PIXIT proforma which conforms to this partial PIXIT proforma specification shall, as a minimum, have contents which are technically equivalent to annex B. The PIXIT proforma may contain additional questions that need to be answered in order to prepare the test laboratory for a particular IUT.

10 ATS conformance

The test realizer, producing MOT and ExTS for this ATS specification, shall comply with the requirements of ISO/IEC 9646-4 [9]. In particular, these concern the realization of an ExTS based on each ATS. The test realizer shall provide a statement of conformance of the MOT to this ATS specification.

An ExTS which conforms to this ATS specification shall contain test groups and test cases which are technically equivalent to those contained in the ATS in annex C. All sequences of test events comprising an abstract test case shall be capable of being realized in the executable test case. Any further checking which the test system might be capable of performing is outside the scope of this ATS specification and shall not contribute to the verdict assignment for each test case.

Test laboratories running conformance test services using this ATS shall comply with ISO/IEC 9646-5 [10].

A test laboratory which claims to conform to this ATS specification shall use an MOT which conforms to this ATS.

Annex A (normative): Protocol Conformance Test Report (PCTR) proforma

Notwithstanding the provisions of the copyright clause related to the text of the present document, ETSI grants that users of the present document may freely reproduce the PCTR proforma in this annex so that it can be used for its intended purposes and may further publish the completed PCTR.

A.1 Identification summary

A.1.1 Protocol conformance test report

PCTR number:	
PCTR date:	
Corresponding SCTR number:	
Corresponding SCTR date:	
Test laboratory identification:	
Test laboratory manager:	
Signature:	

A.1.2 IUT identification

Name:	
Version:	
Protocol specification:	EN 300 286-1
PICS:	
Previous PCTRs (if any):	

A.1.3 Testing environment

PIXIT Reference number:	
ATS Specification:	EN 300 286-6
Abstract Test Method:	Multi-party test method (see ISO/IEC 9646-2)
Means of Testing identification:	
Dates of testing:	
Conformance log reference(s):	
Retention date for log reference(s):	

A.1.4 Limits and reservations

Additional information relevant to the technical contents or further use of the test report, or to the rights and obligations of the test laboratory and the client, may be given here. Such information may include restriction on the publication of the report.

.....

.....

.....

.....

A.1.5 Comments

Additional comments may be given by either the client or the test laboratory on any of the contents of the PCTR, for example, to note disagreement between the two parties.

.....

.....

.....

.....

A.2 IUT conformance status

This IUT has/has not been shown by conformance assessment to be non-conforming to the specified protocol specification.

Strike the appropriate words in this sentence. If the PICS for this IUT is consistent with the static conformance requirements (as specified in clause A.3 of this report) and there are no "FAIL" verdicts to be recorded (in clause A.6) strike the word "has", otherwise strike the words "has not".

A.3 Static conformance summary

The PICS for this IUT is/is not consistent with the static conformance requirements in the specified protocol.

Strike the appropriate words in this sentence.

A.4 Dynamic conformance summary

The test campaign did/did not reveal errors in the IUT.

Strike the appropriate words in this sentence. If there are no "FAIL" verdicts to be recorded (in clause A.6 of this report) strike the word "did", otherwise strike the words "did not".

Summary of the results of groups of tests:

.....

.....

.....

.....

A.5 Static conformance review report

If clause A.3 indicates non-conformance, this clause itemizes the mismatches between the PICS and the static conformance requirements of the specified protocol specification.

.....

.....

.....

.....

.....

.....

.....

.....

.....

.....

A.6 Test campaign report

ATS reference	Selected? (Y/N)	Run? (Y/N)	Verdict	Observations
UUS_N01_001				
UUS_N01_002				
UUS_N01_003				
UUS_N02_001				
UUS_N02_002				
UUS_N02_003				
UUS_N02_004				
UUS_N02_005				
UUS_N02_006				
UUS_N03_001				
UUS_N03_002				
UUS_N03_003				
UUS_N04_002				
UUS_N04_003				
UUS_N04_004				
UUS_N04_006				
UUS_N04_007				
UUS_N04_008				
UUS_N04_010				
UUS_N04_011				
UUS_N04_012				
UUS_N06_001				
UUS_N06_002				
UUS_N06_003				
UUS_N06_004				
UUS_N06_005				
UUS_N06_006				
UUS_N06_007				
UUS_N06_008				
UUS_N06_009				
UUS_N07_001				
UUS_N07_002				
UUS_N07_003				
UUS_N07_004				
UUS_N07_005				
UUS_N07_006				
UUS_N07_007				
UUS_N07_008				
UUS_N07_009				

ATS reference	Selected? (Y/N)	Run? (Y/N)	Verdict	Observations
UUS_N07_010				
UUS_N07_011				
UUS_N08_001				
UUS_N08_002				
UUS_N08_003				
UUS_N08_004				
UUS_N08_005				
UUS_N08_006				
UUS_N08_007				
UUS_N09_001				
UUS_N09_002				
UUS_N09_003				
UUS_N09_004				
UUS_N09_005				
UUS_N09_006				
UUS_N09_007				
UUS_N09_008				
UUS_N09_009				
UUS_N10_001				
UUS_N10_002				
UUS_N10_003				
UUS_N10_004				
UUS_N10_005				
UUS_N10_006				
UUS_N10_007				
UUS_N10_008				
UUS_N11_001				
UUS_N11_002				
UUS_N11_003				
UUS_N11_004				
UUS_N11_005				
UUS_N11_006				
UUS_N12_001				
UUS_N13_001				
UUS_N13_002				
UUS_N13_003				
UUS_N13_004				
UUS_N13_005				
UUS_N13_006				
UUS_N13_007				
UUS_N13_008				
UUS_N13_009				
UUS_N13_010				
UUS_N13_011				
UUS_N13_012				
UUS_N13_013				
UUS_N13_014				
UUS_N13_015				
UUS_N13_016				
UUS_N13_017				
UUS_N13_018				
UUS_N13_019				
UUS_N13_020				
UUS_N13_021				
UUS_N13_022				
UUS_N13_023				
UUS_N13_024				
UUS_N13_025				
UUS_N13_026				
UUS_N13_027				
UUS_N13_028				

ATS reference	Selected? (Y/N)	Run? (Y/N)	Verdict	Observations
UUS_N13_029				
UUS_N13_030				
UUS_N13_031				
UUS_N13_032				
UUS_N13_033				
UUS_N13_034				
UUS_N13_035				
UUS_N13_036				
UUS_N13_037				
UUS_N13_038				
UUS_N13_039				
UUS_N13_040				
UUS_N13_041				
UUS_N13_042				
UUS_N13_043				
UUS_N13_044				
UUS_N13_045				
UUS_N13_046				
UUS_N13_047				
UUS_N13_048				
UUS_N13_049				
UUS_N13_050				
UUS_N13_051				
UUS_N13_052				
UUS_N13_053				
UUS_N14_001				
UUS_N14_002				
UUS_N14_003				
UUS_N14_004				
UUS_N14_005				
UUS_N14_006				
UUS_N14_007				
UUS_N14_008				
UUS_N14_009				
UUS_N14_010				
UUS_N14_011				
UUS_N14_012				
UUS_N14_013				
UUS_N14_014				
UUS_N15_001				
UUS_N16_001				
UUS_N16_002				
UUS_N16_003				
UUS_N16_004				
UUS_N16_005				
UUS_N16_006				
UUS_N16_007				
UUS_N16_008				
UUS_N16_009				
UUS_N16_010				
UUS_N16_011				
UUS_N16_012				
UUS_N16_013				
UUS_N16_014				
UUS_N16_015				
UUS_N16_016				
UUS_N16_017				
UUS_N16_018				
UUS_N16_019				
UUS_N16_020				
UUS_N17_001				
UUS_N17_002				

ATS reference	Selected? (Y/N)	Run? (Y/N)	Verdict	Observations
UUS_N17_003				
UUS_N17_004				
UUS_N17_005				
UUS_N17_006				
UUS_N17_007				
UUS_N17_008				
UUS_N17_009				
UUS_N17_010				
UUS_N17_011				
UUS_N17_012				
UUS_N17_013				
UUS_N17_014				
UUS_N17_015				
UUS_N17_016				
UUS_N17_017				
UUS_N17_018				
UUS_N18_001				
UUS_N18_002				
UUS_N18_003				
UUS_N18_004				
UUS_N18_005				
UUS_N18_006				
UUS_N18_007				
UUS_N18_008				
UUS_N18_009				
UUS_N18_011				
UUS_N18_012				
UUS_N18_013				
UUS_N19_001				
UUS_N19_002				
UUS_N19_003				
UUS_N19_004				
UUS_N19_005				
UUS_N19_006				
UUS_N19_007				
UUS_N19_008				
UUS_N19_009				
UUS_N19_010				
UUS_N19_011				
UUS_N19_012				
UUS_N19_013				
UUS_N19_014				
UUS_N19_015				
UUS_N19_016				
UUS_N19_017				
UUS_N19_018				
UUS_N19_019				
UUS_N19_020				
UUS_N19_021				
UUS_N19_022				
UUS_N20_001				
UUS_N20_002				
UUS_N20_003				
UUS_N20_004				
UUS_N20_005				
UUS_N20_006				
UUS_N20_007				
UUS_N20_008				
UUS_N20_009				
UUS_N20_010				
UUS_N20_012				
UUS_N20_013				

ATS reference	Selected? (Y/N)	Run? (Y/N)	Verdict	Observations
UUS_N21_001				
UUS_N21_002				
UUS_N21_003				
UUS_N21_004				
UUS_N21_005				
UUS_N21_006				
UUS_N21_007				
UUS_N21_008				
UUS_N21_010				
UUS_N21_011				
UUS_N22_001				
UUS_N22_002				
UUS_N22_003				
UUS_N22_004				
UUS_N22_005				
UUS_N22_006				
UUS_N22_007				
UUS_N22_008				
UUS_N22_009				
UUS_N22_011				
UUS_N22_012				

A.7 Observations

Additional information relevant to the technical content of the PCTR are given here.

.....

.....

.....

.....

.....

.....

.....

.....

Annex B (normative): Partial PIXIT proforma

Notwithstanding the provisions of the copyright clause related to the text of the present document, ETSI grants that users of the present document may freely reproduce the partial PIXIT proforma in this annex so that it can be used for its intended purposes and may further publish the completed PIXIT.
--

B.1 Identification summary

PIXIT number:

.....

Test laboratory name:

.....

Date of issue:

.....

Issued to:

.....

B.2 ATS summary

Protocol specification: EN 300 286-1

ATS specification: EN 300 286-6

Abstract test method: Multi-party test method (see ISO/IEC 9646-2)

B.3 Test laboratory

Test laboratory identification:

.....

Accreditation status of the test service:

.....

Accreditation reference:

.....

Test laboratory manager:

.....

Test laboratory contact:

.....

Means of testing:

.....

Test laboratory instructions for completion:

.....

B.4 Client (of the test laboratory)

Client identification:

.....

Client test manager:

.....

Client contact:

.....

Test facilities required:

.....

B.5 System Under Test (SUT)

Name:

.....

Version:

.....

SCS reference:

.....

Machine configuration:

.....

Operating system identification:

.....

IUT identification:

.....

PICS (all layers):

.....

.....

Limitations of the SUT:

.....

Environmental conditions:

.....

B.6 Protocol information

B.6.1 Protocol identification

Specification reference: EN 300 286-1

Protocol version:

PICS reference:

NOTE: The PICS reference should reference a completed PICS which is conformant with the PICS proforma contained in EN 300 286-2.

B.6.2 Parameter values

Table B.1: Parameter values

Item	Question	Supported? (Y/N)	Allowed values	Value
1.1	Does the IUT support Basic Access?		N/A	N/A
1.2	What length of Call Reference value is used?		1, 2	
1.3	Does the IUT allow the release and re-establishment of the layer 2 multiple frame established operation at the start of each test case? (note)		N/A	N/A
NOTE:	This procedure is used to re-initialize all layer 2 counters before starting a test case. The value of this PIXIT item can be set to "No" for accesses where the layer 2 multiple frame established operation release and re-establishment may cause problems.			

B.6.3 Codings of information elements

Table B.2: Codings of information elements

Item	Information element: provide, if possible, ...	Supported? (Y/N)	Value
2.1	a coding of a Bearer Capability information element, which the IUT is NOT compatible with.		

B.6.4 Configuration of IUT

Table B.3: Actions required to configure the IUT

Item	Action:	Supported? (Y/N)	Stimulus (action taken)
	What actions, if possible, have to be taken to configure the IUT.	(Y/N)	
3.1	So that no private ISDN is connected to (S/T reference point).		
3.2	To not accept (temporarily) the implicit request of Service 1.		
3.3	To have no resources available for Service 1 (explicit request).		
3.4	For access NOT subscribed to UUS Service 1 supplementary service (explicit request).		
3.5	For access NOT subscribed to UUS Service 2 supplementary service.		
3.6	For access NOT subscribed to UUS Service 3 supplementary service.		
3.7	So that it does not know that a point to point arrangement exists at the remote user interface.		
3.8	To accept the request of Service 3 at the called user side.		
3.9	So that it can transmit the error value "rejectedByNetwork".		
3.10	So that User User Information is delivered to the remote user even when the access related to the served user's interface is only in the Outgoing Call Proceeding call state N03.		
3.11	So that two interfaces of the test tool (PTC1 and PTC2) can be connected to the tested basic access (point-to-multipoint configuration).		

B.6.5 Timer values

Table B.4: Timer values

Item	Timer duration	Supported? (Y/N)	Allowed values	Value
4.1	Maximum value for T1-UUS3 duration in s?		(> 12)	
4.2	Maximum value for T2-UUS3 duration in s?		(> 12)	
4.3	Wait for the test operator to perform an implicit send action or to wait for a PTC to react (TWAIT).			
4.4	Wait for the IUT to respond to a stimulus sent by the tester (TAC).			
4.5	Control that the IUT does not respond to a stimulus sent by the tester (TNOAC).			
4.6	Maximum value for T303 duration in s?.			
NOTE:	The IUT provider may fill in a value range rather than a fixed value for the test management timers. During test execution the test laboratory will choose specific values for the timers dependant on the means of testing used. These specific values may even be beyond the range given by the IUT provider, if this is necessary for achieving satisfactory test results.			

B.7 Basic call PIXIT items

B.7.1 Parameter values - information element codings

Table B.5: Codings of information elements

Item	Information element: provide, if possible, ...	Supported? (Y/N)	Value
N1.1	a coding of a Bearer Capability information element, which the IUT is compatible with, for the purpose of accepting received SETUP messages and which may be used in SETUP messages to be transmitted;		
N1.2	a coding of a High layer compatibility information element, which the IUT is compatible with, for the purpose of accepting received SETUP messages and which may be used in SETUP messages to be transmitted;		
N1.3	a coding of a Low layer compatibility information element, which the IUT is compatible with, for the purpose of accepting received SETUP messages and which may be used in SETUP messages to be transmitted;		
N1.4	a Called party number information element, which the IUT is compatible with, for ...		
N1.4.1	served user access		
N1.4.2	first remote user access		
N1.4.3	second remote user access		
N1.4.4	third remote user access		
N1.5	preferred channel number to be used for the purpose of accepting received SETUP messages, for ... (note 1)		
N1.5.1	single call at served user side		
N1.5.2	second call at served user side		
N1.5.3	first call at remote user side		
N1.5.4	second call at remote user side		
N1.5.5	third call at remote user side		
NOTE 1: Items N1.5.1 to N1.5.5 are applicable for primary rate access only.			
NOTE 2: As this is a general table used for all supplementary services, all items N1.4.1 to N1.4.4, and N1.5.1 to N1.5.5 (if primary rate access is supported), are not always required, but should be supplied if possible.			

Annex C (normative): Abstract Test Suite (ATS)

This ATS has been produced using the Tree and Tabular Combined Notation (TTCN) according to ISO/IEC 9646-3 [8].

The ATS was developed on a separate TTCN software tool and therefore the TTCN tables are not completely referenced in the table of contents. The ATS itself contains a test suite overview part which provides additional information and references.

C.1 The TTCN Graphical form (TTCN.GR)

The TTCN.GR representation of this ATS is contained in an Adobe Portable Document Format™ file (uus_n_v211.pdf contained in archive en_30028606v010401p0.ZIP) which accompanies the present document.

C.2 The TTCN Machine Processable form (TTCN.MP)

The TTCN.MP representation corresponding to this ATS is contained in an ASCII file (uus_n_v211.mp contained in archive en_30028606v010401p0.ZIP) which accompanies the present document.

NOTE: Where an ETSI Abstract Test Suite (in TTCN) is published in both .GR and .MP format these two forms shall be considered equivalent. In the event that there appears to be syntactical or semantic differences between the two then the problem shall be resolved and the erroneous format (whichever it is) shall be corrected.

Annex D (informative): General structure of ATS

This annex gives a simple listing of the order of types of tables which appear in a typical supplementary service ATS. This is intended as an aid in helping readers find particular clauses quickly.

Test Suite Overview

Test Suite Structure

Test Case Index

Test Step Index

Default Index

Declarations Part

Simple Type Definitions

Structured Type Definitions

ASN.1 Type Definitions

Test Suite Operation Definitions

Test Suite Parameter Declarations

Test Case Selection Expression Definitions

Test Suite Constant Declarations

Test Case Variable Declarations

PCO Declarations

Co-ordination Point Declarations

Timer Declarations

Test Component Declarations

Test Components Configuration Declarations

TTCN ASP Type Definition

TTCN PDU Type Definition

TTCN CM Type Definition

Alias Definitions

Constraints Part

Structured Type Constraint Declarations

ASN.1 Type Constraint Declarations

TTCN ASP Constraint Declarations

TTCN PDU Constraint Declarations

TTCN CM Constraint Declarations

Dynamic Part

Test Case Dynamic Behaviour

Test Step Dynamic Behaviour

Default Dynamic Behaviour

Annex E (informative): Change record

E.1 Changes between EN 300 286-6 V1.2.4 and V1.3.3

Revised ATS.

E.2 Changes between ETS 300 286-6 Edition 1 and EN 300 286-6 V1.2.4

The following changes have been done:

- conversion to EN layout;
- replacement of references to ETS 300 102 with EN 300 403;
- substitution of non-specific references to basic standards where the intention is to refer to the latest version.

E.3 Changes between EN 300 286-6 V1.4.1 and V1.3.3

Changes in the present document:

Item	description of changes
Annex B, table B.4, item 4.6	New PIXIT item to describe the T303 duration parameter.

Changes in the ATS:

Item or Test case ID	description of changes
PX_T303max	Parameter to enter the maximum value for T303 duration.
T303max	Timer to check expiry of T303
UUS_N13_002 and 004	Change test purpose according to EN 300 286-5 [5] V2.0.0. Remove the rows #8, #10, #20 and #21 (receipt of RELEASE COMPLETE message for CES 2). Replace Check_State_s(1,19) with Check_State_s(1,7) Replace CS59901(1,10) with CS59901(1,7)
UUS_N13_011 to 016 UUS_N16_003 to 005	Change test purpose according to EN 300 286-5 [5] V2.0.0. On row #5: add START T303max On row#8: add CANCEL T303max On row#9 replace 0 with 22 in Check_State_s On row#11: replace CS50001(1) with CS59901(1,22) On row#16 replace TWAIT with T303max In detailed comment, change in comment (5) RELEASE COMPLETE with DISCONNECT.
UUS_N13_050	Change test purpose according to EN 300 286-5 [5] V2.0.0. On row #9 replace A_DI20 with A_DI27, and remove the UUSre() parameter.
UUS_N19_019	Change test purpose according to EN 300 286-5 [5] V2.0.0. Remove the rows #8, #9, #11, #19, #20, #23 and #24 Remove detailed comment (6) On new row #9 replace 19 with 22 in Check_State_s On new row #11 replace 12 with 22 in CS59901 On new row #16 replace TWAIT by T303max.
UUS_N19_022	Change test purpose according to EN 300 286-5 [5] V2.0.0.
UUS_N12_0001, PR30601, PR32501, PRE_N06_S1_impRQ, PRE_N25_S1_impact, SBr ASP constraint	Add receive events to handle broadcast SETUP and add the ASP constraint SBr for this purpose.
Error (ASN.1 Type Definition)	Switch the values of the error code points: rejectedByUser and rejectedByNetwork.
UUS_N22_006 to 012	Replace TAC with TWAIT in the row #4.
UUS_N14_002	Replace the selection reference PTMP with PTMPandSupServ1ExplReq.
RC24 PDU constraint	Replace CAU4 with CAU2.
UUS_N19_002	Replace S2 with S3 in the row #4.
UUS_N19_005 and 006	Add START TAWIT and CANCEL TWAIT as in UUS_N19_007.

E.4 Changes between EN 300 286-6 V1.2.4 and V1.3.3

ATS corrections according to the comment from Italtel in SPAN#8TD043

History

Document history		
Edition 1	August 1998	Publication as ETS 300 286-6
V1.2.4	December 1998	Publication
V1.3.3	May 2000	Publication
V1.4.1	August 2002	One-step Approval Procedure OAP 20021227: 2002-08-28 to 2002-12-27
V1.4.1	January 2003	Publication