

Draft **EN 300 286-1** V1.2.3 (1998-02)

---

*European Standard (Telecommunications series)*

**Integrated Services Digital Network (ISDN);  
User-to-User Signalling (UUS) supplementary service;  
Digital Subscriber Signalling System No. one (DSS1) protocol;  
Part 1: Protocol specification**

---



*European Telecommunications Standards Institute*

---

---

Reference

REN/SPS-05145-T-1 (2nc90iq0.PDF)

---

Keywords

ISDN, UUS, DSS1, supplementary service

***ETSI Secretariat***

---

Postal address

F-06921 Sophia Antipolis Cedex - FRANCE

---

Office address

650 Route des Lucioles - Sophia Antipolis  
Valbonne - FRANCE  
Tel.: +33 4 92 94 42 00 Fax: +33 4 93 65 47 16  
Siret N° 348 623 562 00017 - NAF 742 C  
Association à but non lucratif enregistrée à la  
Sous-Préfecture de Grasse (06) N° 7803/88

---

X.400

c= fr; a=atlas; p=etsi; s=secretariat

---

Internet

secretariat@etsi.fr  
<http://www.etsi.fr>

---

***Copyright Notification***

No part may be reproduced except as authorized by written permission.  
The copyright and the foregoing restriction extend to reproduction in all media.

# Contents

Intellectual Property Rights.....	5
Foreword .....	5
1 Scope.....	7
2 Normative references .....	7
3 Definitions.....	8
4 Abbreviations.....	10
5 Description.....	10
5.1 Service 1 .....	11
5.2 Service 2 .....	11
5.3 Service 3 .....	11
6 Operational requirements.....	11
6.1 Provision and withdrawal.....	11
6.2 Requirements on the originating network side.....	12
6.3 Requirements on the destination network side.....	12
7 Coding requirements .....	12
7.1 Coding of the Facility information element component.....	12
7.2 Definition of messages.....	13
7.2.1 CONGESTION CONTROL .....	13
7.2.2 USER INFORMATION.....	13
7.3 Definition of information elements .....	14
7.3.1 Congestion level.....	14
7.3.2 More data .....	14
7.3.3 User-user .....	14
8 State definitions .....	15
9 Signalling procedures at the coincident S and T reference point .....	16
9.1 Service 1 .....	16
9.1.1 Activation, deactivation and registration.....	16
9.1.1.1 Service 1 - implicitly requested .....	17
9.1.1.1.1 Normal operation .....	17
9.1.1.1.2 Exceptional procedures.....	17
9.1.1.2 Service 1 - explicitly requested.....	17
9.1.1.2.1 Normal operation .....	17
9.1.1.2.2 Exceptional procedures.....	18
9.1.2 Invocation.....	19
9.1.2.1 Service 1 invocation during call establishment.....	20
9.1.2.1.1 Normal operation .....	20
9.1.2.1.2 Exceptional procedures.....	20
9.1.2.2 Service 1 invocation during call clearing.....	20
9.1.2.2.1 Normal operation .....	20
9.1.2.2.2 Exceptional procedures.....	21
9.2 Service 2 .....	21
9.2.1 Activation, deactivation and registration.....	21
9.2.1.1 Normal operation.....	21
9.2.1.2 Exceptional procedures.....	22
9.2.2 Invocation.....	24
9.2.2.1 Normal operation.....	24
9.2.2.2 Exceptional procedures.....	24
9.3 Service 3 .....	25
9.3.1 Activation, deactivation and registration.....	26
9.3.1.1 Service 3 request during call establishment.....	26
9.3.1.1.1 Normal operation .....	26

9.3.1.1.2	Exceptional procedures .....	26
9.3.1.2	Service 3 request during the Active (N10, U10) call state.....	28
9.3.1.2.1	Normal operation .....	28
9.3.1.2.2	Exceptional procedures .....	28
9.3.2	Invocation.....	29
9.3.2.1	Normal operation.....	29
9.3.2.2	Exceptional procedures.....	29
9.3.3	Flow control .....	30
9.3.3.1	Normal operation.....	30
9.3.3.2	Exceptional procedures.....	30
10	Procedures for interworking with private ISDNs .....	30
11	Interaction with other networks .....	31
11.1	Interworking with an ISDN network supporting only a maximum User-user information element length of 35 octets.....	31
11.2	Interaction with non-ISDN.....	31
12	Interaction with other supplementary services.....	31
13	Parameter values (timers).....	31
14	Dynamic description (SDL diagrams) .....	31
14.1	Service 1 .....	33
14.1.1	User .....	33
14.1.2	Network.....	37
14.2	Service 2 .....	43
14.2.1	User .....	43
14.2.2	Network.....	46
14.3	Service 3 .....	52
14.3.1	User .....	52
14.3.2	Network.....	57
<b>Annex A (informative): Signalling flows .....</b>		<b>64</b>
A.1	Service 1, implicit request, point-to-multipoint .....	65
A.2	Service 1, implicit request, point-to-point .....	68
A.3	Service 1, explicit request, point-to-multipoint .....	70
A.4	Service 1, explicit request, point-to-point.....	74
A.5	Service 2.....	76
A.6	Service 3, request during call establishment, point-to-multipoint .....	78
A.7	Service 3, request during the Active (N10, U10) call state .....	79
A.8	Service 3, flow control.....	80
<b>Annex B (informative): Diagrammatic description of coding requirements.....</b>		<b>81</b>
B.1	UUS request invoke component (typical example) .....	81
B.2	UUS return result component (typical example) .....	82
B.3	UUS return error component (typical example) .....	82
<b>Annex C (informative): Changes with respect to the previous ETS 300 286-1 .....</b>		<b>83</b>
<b>Annex D (informative): Bibliography.....</b>		<b>84</b>
History .....		85

---

## Intellectual Property Rights

IPRs essential or potentially essential to the present document may have been declared to ETSI. The information pertaining to these essential IPRs, if any, is publicly available for **ETSI members and non-members**, and can be found in ETR 314: "*Intellectual Property Rights (IPRs); Essential, or potentially Essential, IPRs notified to ETSI in respect of ETSI standards*", which is available **free of charge** from the ETSI Secretariat. Latest updates are available on the ETSI Web server (<http://www.etsi.fr/ipr>).

Pursuant to the ETSI Interim IPR Policy, no investigation, including IPR searches, has been carried out by ETSI. No guarantee can be given as to the existence of other IPRs not referenced in ETR 314 (or the updates on <http://www.etsi.fr/ipr>) which are, or may be, or may become, essential to the present document.

---

## Foreword

This European Standard (Telecommunications series) has been produced by ETSI Technical Committee Signalling Protocols and Switching (SPS), and is now submitted for the ETSI standards One-step Approval Procedure.

The present document is part 1 of a multi-part standard covering the Digital Subscriber Signalling System No. one (DSS1) protocol specification for the Integrated Services Digital Network (ISDN) User-to-User Signalling (UUS) supplementary service, as described below:

**Part 1: "Protocol specification";**

Part 2: "Protocol Implementation Conformance Statement (PICS) proforma specification";

Part 3: "Test Suite Structure and Test Purposes (TSS&TP) specification for the user";

Part 4: "Abstract Test Suite (ATS) and partial Protocol Implementation eXtra Information for Testing (PIXIT) proforma specification for the user";

Part 5: "Test Suite Structure and Test Purposes (TSS&TP) specification for the network";

Part 6: "Abstract Test Suite (ATS) and partial Protocol Implementation eXtra Information for Testing (PIXIT) proforma specification for the network".

In accordance with CCITT Recommendation I.130, the following three level structure is used to describe the supplementary telecommunication services as provided by European public telecommunications operators under the pan-European ISDN:

- Stage 1: is an overall service description, from the user's standpoint;
- Stage 2: identifies the functional capabilities and information flows needed to support the service described in stage 1; and
- Stage 3: defines the signalling system protocols and switching functions needed to implement the service described in stage 1.

The present document details the stage 3 aspects (signalling system protocols and switching functions) needed to support the UUS supplementary service. The stage 1 and stage 2 aspects are detailed in ETS 300 284 and ETR 285, respectively.

The present version updates the references to the basic call specifications.

**Proposed national transposition dates**

Date of latest announcement of this EN (doa):	3 months after ETSI publication
Date of latest publication of new National Standard or endorsement of this EN (dop/e):	6 months after doa
Date of withdrawal of any conflicting National Standard (dow):	6 months after doa

---

# 1 Scope

This first part of EN 300 286 specifies the stage three of the User-to-User Signalling (UUS) supplementary service for the pan-European Integrated Services Digital Network (ISDN) as provided by European public telecommunications operators at the T reference point or coincident S and T reference point (as defined in ITU-T Recommendation I.411 [4]) by means of the Digital Subscriber Signalling System No. one (DSS1) protocol. Stage three identifies the protocol procedures and switching functions needed to support a telecommunication service (see CCITT Recommendation I.130 [2]).

In addition the present document specifies the protocol requirements at the T reference point where the service is provided to the user via a private ISDN.

The present document does not specify the additional protocol requirements where the service is provided to the user via a telecommunication network that is not an ISDN.

The UUS supplementary service enables a user to send/receive a limited amount of information to/from another user over the signalling channel in association with a call to the other user.

The UUS supplementary service is applicable to all circuit-switched telecommunication services.

Further parts of EN 300 286 specify the method of testing required to identify conformance to the present document.

The present document is applicable to equipment supporting the UUS supplementary service to be attached at either side of a T reference point or coincident S and T reference points when used as an access to the public ISDN.

---

# 2 Normative references

References may be made to:

- a) specific versions of publications (identified by date of publication, edition number, version number, etc.), in which case, subsequent revisions to the referenced document do not apply; or
- b) all versions up to and including the identified version (identified by "up to and including" before the version identity); or
- c) all versions subsequent to and including the identified version (identified by "onwards" following the version identity); or
- d) publications without mention of a specific version, in which case the latest version applies.

A non-specific reference to an ETS shall also be taken to refer to later versions published as an EN with the same number.

- |     |   |
|-----|---|
| [1] | ITU-T Recommendation I.112: "Vocabulary of terms for ISDNs".  |
| [2] | CCITT Recommendation I.130 (1988): "Method for the characterisation of telecommunication services supported by an ISDN and network capabilities of an ISDN".  |
| [3] | ITU-T Recommendation I.210: "Principles of telecommunication services supported by an ISDN and the means to describe them".   |
| [4] | ITU-T Recommendation I.411 (1993): "ISDN user-network interfaces - Reference configurations".   |
| [5] | CCITT Recommendation X.25 (1988): "Interface between Data Terminal Equipment (DTE) and Data Circuit-terminating Equipment (DCE) for terminals operating in the packet mode and connected to public data networks by dedicated circuit". |
| [6] | CCITT Recommendation X.208 (1988): "Specification of Abstract Syntax Notation One (ASN.1)".   |
| [7] | CCITT Recommendation X.219 (1988): "Remote Operations: Model, Notation and Service definitions".  |

- [8] CCITT Recommendation X.244 (1988): "Procedure for exchange of protocol identification during virtual call establishment on packet switched public data networks".
- [9] CCITT Recommendation Z.100 (1988): "Specification and description language (SDL)".
- [10] EN 300 403-1: "Integrated Services Digital Network (ISDN); Digital Subscriber Signalling System No. one (DSS1) protocol; Signalling network layer for circuit-mode basic call control; Part 1: Protocol specification [ITU-T Recommendation Q.931 (1993), modified]".
- [11] EN 300 403-2: "Integrated Services Digital Network (ISDN); Digital Subscriber Signalling System No. one (DSS1) protocol; Signalling network layer for circuit-mode basic call control; Part 2: Specification and Description Language (SDL) diagrams".
- [12] EN 300 195-1: "Integrated Services Digital Network (ISDN); Supplementary service interactions; Digital Subscriber Signalling System No. one (DSS1) protocol; Part 1: Protocol specification".
- [13] EN 300 196-1: "Integrated Services Digital Network (ISDN); Generic functional protocol for the support of supplementary services; Digital Subscriber Signalling System No. one (DSS1) protocol; Part 1: Protocol specification".

---

## 3 Definitions

For the purposes of the present document, the following definitions apply:

**call control message:** A message as defined in EN 300 403-1 [10], subclause 3.1, which on sending or receipt causes a change of the call state at either the network or the user. Call control messages also include the PROGRESS message but not the INFORMATION message.

NOTE: For the purposes of other standards, the information message may be considered as a call control message.

**called network:** The network to which the called user is attached.

**called user:** A user that receives a call request which may include a request of the UUS supplementary service.

**calling network:** The network to which the calling user is attached.

**calling user:** A user that initiates a call and may include a request of the UUS supplementary service in the call request.

**contention:** Contention exists when the called user has a point-to-multipoint arrangement and multiple responses to an incoming call are sent to the network. These responses may carry different information related to the UUS supplementary service.

**explicit request:** An explicit request of a UUS supplementary service is one where the request is explicitly identified by including a Facility information element with an appropriate component in either the SETUP or FACILITY message sent by the served user. The explicit request requires an explicit response (acceptance or rejection).

**explicit service 1:** Service 1 explicitly requested.

**implicit request:** An implicit request of a UUS supplementary service is one where the request is implicitly identified by including a User-user information element in the SETUP message sent by the served user.

**implicit service 1:** Service 1 implicitly requested.

**Integrated Services Digital Network (ISDN):** See ITU-T Recommendation I.112 [1], definition 308.

**invoke component:** See EN 300 196-1 [13], subclause 8.2.2.1. Where reference is made to an "xxxx" invoke component, an invoke component is meant with its operation value set to the value of the operation "xxxx".

**network:** The DSS1 protocol entity at the network side of the user-network interface.



**point-to-multipoint arrangement:** In the context of the present document, a point-to-multipoint arrangement exists at the called user's interface, if the network has the knowledge that the point-to-multipoint layer 3 procedures shall be applied at the called user's interface. Consequently, responses from more than one terminal are accepted in case of an incoming call.

**point-to-point arrangement:** In the context of this standard, a point-to-point arrangement exists at the called user's interface, if the network has the knowledge that the point-to-point layer 3 procedures shall be applied at the called user's interface. Consequently, a response from only one user is accepted in case of an incoming call.

**preferred request:** A preferred request of a UUS supplementary service is one where the call setup shall continue even if the request for the UUS supplementary service cannot be accepted.

**premature clearing:** The calling or called user initiates call clearing before the call has reached the Active (N10, U10) call state.

**receiving network:** The network to which the receiving user is attached.

**receiving user:** The user receiving USER INFORMATION messages as part of service 2 or 3.

**reject component:** See EN 300 196-1 [13], subclause 8.2.2.4.

**remote network:** The network to which the remote user is attached.

**remote user:** The user who receives a request for service 3 in the Active (U10) call state.

**required request:** A required request of a UUS supplementary service is one where the call setup shall be rejected if the request for the UUS supplementary service cannot be accepted.

**requesting network:** The network to which the requesting user is attached.

**requesting user:** The user who sends a request for the UUS supplementary service 3 in the Active (U10) call state.

**return error component:** See EN 300 196-1 [13], subclause 8.2.2.3. Where reference is made to an "xxxx" return error component, a return error component is meant which is related to an "xxxx" invoke component".

**return result component:** See EN 300 196-1 [13], subclause 8.2.2.2. Where reference is made to an "xxxx" return result component, a return result component is meant which is related to an "xxxx" invoke component".

**sending network:** The network to which the sending user is attached.

**sending user:** The user sending USER INFORMATION messages as part of service 2 or 3.

**served user:** The user who is the requester of the UUS supplementary service. For service 1 and service 2, the served user is always at the originating side. For service 3, the served user may be at the originating or the destination side.

**service; telecommunication service:** See ITU-T Recommendation I.112 [1], definition 201.

**service 1:** A form of the UUS supplementary service where UUI can be sent and received as part of call control messages for originating and terminating calls.

**service 2:** A form of the UUS supplementary service where UUI can be sent and received independently of call control messages in the alerting phase of a call.

**service 3:** A form of the UUS supplementary service where UUI can be sent and received independently of call control messages once the connection has been established.

**supplementary service:** See ITU-T Recommendation I.210 [3], subclause 2.4.

**user:** The DSS1 protocol entity at the user side of the user-network interface.

**user information:** The information contained in octet 4 and onwards of the User-user information element.

**User-To-User Information (UUI):** The information transferred between users in the User-user information element by the UUS supplementary service.

---

## 4 Abbreviations

For the purposes of the present document, the following abbreviations apply:

ASN.1	Abstract Syntax Notation one
DSS1	Digital Subscriber Signalling System No. one
ISDN	Integrated Services Digital Network
SDL	Specification and Description Language
UUI	User-to-User Information
UUS	User-to-User Signalling

---

## 5 Description

The UUS supplementary service enables a user to send/receive a limited amount of user-generated information (i.e. the User-user information element and, in addition for services 2 and 3, the More data information element) to/from another user. This information shall be passed transparently (i.e. without modification of content) through the network over the signalling channel in association with the call. The network shall not interpret or act upon this information.

The information is contained in either call control messages or in separate USER INFORMATION messages. The amount of information (i.e. the User-user information element content) is limited to 128 octets per message.

NOTE: During an interim period of time, some networks may support only the transfer of 32 octets of UUI per message on service 1.

Within the UUS supplementary service three different services may be provided by the network:

- service 1: exchange of user-to-user information between users during the setup and clearing phases of a call, within call control messages;
- service 2: exchange of user-to-user information between users in the alerting phase of a call, within USER INFORMATION messages;
- service 3: exchange of user-to-user information between users in the active phase of a call, within USER INFORMATION messages.

Services 1, 2 and 3 may be used individually or in any combination in association with a single call.

Services 1, 2 and 3 are requested by the calling user. As a network option, service 3 can be requested by the called user during the active phase of a call.

Service 1 may be requested either implicitly or explicitly. Services 2 and 3 are always requested explicitly. Networks supporting the UUS supplementary service 1 shall support at least the service 1 implicitly requested.

In case of explicit request, the calling user shall, at call setup, specify whether the requested UUS supplementary service(s) is(are) required or preferred for the call (required request/preferred request).

The UUS supplementary service can be used in conjunction with the videotelephony teleservice. For videotelephony calls involving two connections, the procedures in the present document for activation and invocation (including flow control) apply independently for each connection.

## 5.1 Service 1

For this service, both users may exchange UUI during the setup and the clearing phases of a call by including UUI in basic call control messages.

In addition, if a point-to-multipoint arrangement exists at the called user's interface, the following applies:

- in the network-to-called-user direction: in case of premature clearing by the calling user, UUI shall, if provided in the clearing request, be delivered to all terminals having confirmed the call at this time;
- in the called user-to-network direction: if UUI is sent in the alerting indication, it is up to the called user to avoid contention. In case the call is cleared by the called user before the active phase by means of multiple clearing messages, the UUI (if any) received together with the selected rejection cause shall be sent to the calling user.

## 5.2 Service 2

For this service, both users may send UUI after the alerting indication has been sent/received and until the connect indication has been sent/received. As a network option, the network can deliver the UUI to the called user after the connection has been established.

The UUI is sent in USER INFORMATION messages and is limited to two messages in each direction.

Service 2 is only applicable if a point-to-point arrangement exists at the called user's interface.

## 5.3 Service 3

For this service, both users may send UUI in the active phase of a call using USER INFORMATION messages.

The network shall provide flow control limiting the number of messages exchanged in a certain period of time. The flow control of each direction shall be operated independently.

---

# 6 Operational requirements

## 6.1 Provision and withdrawal

The UUS supplementary service shall be provided to the user after prior arrangement with the network. No subscription is required for the remote user.

As a network option, one or any combination of the following possibilities can be provided separately or globally:

- service 1 implicit, or service 1 implicit together with service 1 explicit;
- service 2;
- service 3.

The UUS supplementary service shall be withdrawn by the network upon request of the subscriber or for network reasons.

As a network option, withdrawal can be done separately per service provided, or globally for all services provided to the served user.

## 6.2 Requirements on the originating network side

The originating network shall be able to receive UUI from the user and convey it towards the destination network; and to receive UUI from the destination network and convey it to the user.

For services 2 and 3, the network shall control the flow of UUI received from the local user.

The originating network shall check that the service has been activated; otherwise appropriate error handling shall take place.

## 6.3 Requirements on the destination network side

For the destination network the same requirements apply as for the originating network side.

# 7 Coding requirements

## 7.1 Coding of the Facility information element component

Table 1 shows the definition of the operation and errors required for the UUS supplementary service using ASN.1 as defined in CCITT Recommendation X.208 [6] and using the OPERATION and ERROR macro as defined in figure 4/X.219 of CCITT Recommendation X.219 [7].

The formal definition of the component types to encode these operations and errors is provided in EN 300 196-1 [13], annex D, subclause D.1.

The inclusion of components in Facility information elements is defined in EN 300 196-1 [13], subclause 11.2.2.1.

All components (invoke, return result, return error and reject) shall be included within a Facility information element. This Facility information element may be included in any appropriate message as specified in EN 300 196-1 [13], subclause 8.3.1.1, unless a more restrictive specification is given in clause 9.

**Table 1: Operation and error definitions for the UUS supplementary service**

```

User-To-User-Signalling-Operations {ccitt identified-organization etsi(0) 286
    operations-and-errors(1)}

DEFINITIONS ::=
BEGIN

EXPORTS
    UserUserService, RejectedByUser, RejectedByNetwork, Service, Preferred;

IMPORTS
    OPERATION, ERROR
    FROM Remote-Operation-Notation
        {joint-iso-ccitt remote-operations(4) notation (0)};

UserUserService ::= OPERATION
    ARGUMENT SEQUENCE {
        [1] IMPLICIT Service,
        [2] IMPLICIT Preferred}
    RESULT
    ERRORS {rejectedByUser, rejectedByNetwork}

Service ::= INTEGER {
    service1 (1),
    service2 (2),
    service3 (3)}
    (1..3)

Preferred ::= BOOLEAN -- True = preferred request
    -- False = required request

RejectedByNetwork ::= ERROR
RejectedByUser ::= ERROR

userUserService UserUserService ::= 1
rejectedByNetwork RejectedByNetwork ::= 1
rejectedByUser RejectedByUser ::= 2

END -- of User-To-User-Signalling-Operations

```

## 7.2 Definition of messages

This subclause gives the message structure for the messages used in the UUS supplementary service. The general definition of the message structure and the key to the interpretation can be found in EN 300 403-1 [10], clause 3.

### 7.2.1 CONGESTION CONTROL

This message is sent by the network to indicate the establishment or termination of flow control on the transmission of USER INFORMATION messages. See table 2.

**Table 2: Congestion control message content**

Message type: CONGESTION CONTROL

Message type value: 01111001

Significance: local

Direction: network-to-user

Information Element	Reference	Direction	Type	Length
Protocol discriminator	4.2/EN 300 403-1	n → u	M	1
Call reference	4.3/EN 300 403-1	n → u	M	2 - 3
Message type	4.4/EN 300 403-1	n → u	M	1
Congestion level	7.3.1	n → u	M	1
Cause	4.5/EN 300 403-1	n → u	O (note 1)	2 - 32
Display	4.5/EN 300 403-1	n → u	O (note 2)	2 - 82
NOTE 1: Included if user-to-user information has been discarded as a result of flow control.				
NOTE 2: Included if the network provides information that can be presented to the user.				

### 7.2.2 USER INFORMATION

This message is sent by the user to the network to transfer information to the remote user. This message is also sent by the network to the user to deliver information from the other user. See table 3.

**Table 3: User information**

Message type: USER INFORMATION

Message type value: 0010 0000

Significance: access

Direction: both

Information Element	Reference	Direction	Type	Length
Protocol discriminator	4.2/EN 300 403-1	both	M	1
Call reference	4.3/EN 300 403-1	both	M	2 - 3
Message type	4.4/EN 300 403-1	both	M	1
More data	7.3.2	both	O (note)	1
User-user	7.3.3	both	M	3 - 131
NOTE: Included by the sending user to indicate that another USER INFORMATION message pertaining to the same message block will follow.				

## 7.3 Definition of information elements

This subclause gives the coding for the information elements used in the UUS supplementary service. The general definition of the information element structure can be found in EN 300 403-1 [10], clause 4.

### 7.3.1 Congestion level

The purpose of the Congestion level information element is to describe the congestion status of the call. It is a single octet information element coded as shown in figure 1 and table 4.

8	7	6	5	4	3	2	1	Octet
1	Congestion level 0 1 1			Congestion level				1
								Information element identifier

**Figure 1: Congestion level information element**

**Table 4: Congestion level information element**

<b>Congestion level (octet 1)</b>	
<b>Bits</b>	
<b>4 3 2 1</b>	
0 0 0 0	receiver ready
1 1 1 1	receiver not ready
All other values are reserved.	

### 7.3.2 More data

The More data information element is sent by the user to the network in a USER INFORMATION message, and delivered by the network to the destination user in the corresponding USER INFORMATION message. The presence of the More data information element indicates to the destination user that another USER INFORMATION message will follow, containing information belonging to the same block.

The use of the More data information element is not supervised by the network.

The More data information element is coded as shown in figure 2.

8	7	6	5	4	3	2	1	Octet
1	0	1	0	0	0	0	0	1
More data								
								Information element identifier

**Figure 2: More data information element**

### 7.3.3 User-user

The purpose of the User-user information element is to convey information between ISDN users. This information is not interpreted by the network, but is carried transparently and delivered to the receiving user(s).

The User-user information element is coded as shown in figure 3 and table 5. There are no restrictions on the contents of the user information field.

In addition to the USER INFORMATION message, the User-user information element can be included in the SETUP, ALERTING, CONNECT, DISCONNECT, PROGRESS, RELEASE and RELEASE COMPLETE messages.

NOTE 1: On service 1, during an interim period of time, some networks may only support the transfer of 35 octets of the User-user information element per message.

NOTE 2: The User-user information element is transported transparently by an ISDN between a call originating entity, e.g. a calling user, and the addressed entity, e.g. a user or a high layer function network node addressed by the call originating entity.

8	7	6	5	4	3	2	1	Octet
0	1	1	1	1	1	1	0	1
User-user Information element identifier								1
Length of user-user contents								2
Protocol discriminator								3
User information								4 etc.

**Figure 3: User-user information element**

**Table 5: User-user information element**

<b>Protocol discriminator (octet 3)</b>	
<b>Bits</b>	
<b>8 7 6 5 4 3 2 1</b>	
0 0 0 0 0 0 0 0	User-specific protocol (note 1)
0 0 0 0 0 0 0 1	OSI high layer protocol
0 0 0 0 0 0 1 0	CCITT Recommendation X.244 (note 2)
0 0 0 0 0 0 1 1	Reserved for system management convergence function
0 0 0 0 0 1 0 0	IA5 characters (note 4)
0 0 0 0 0 1 1 1	CCITT Recommendation V.120 rate adaption
0 0 0 0 1 0 0 0	CCITT Recommendation Q.931 (I.451) user-network call control messages
0 0 0 1 0 0 0 0	} reserved for other network layer or layer 3 protocols, through } including CCITT Recommendation X.25
0 0 1 1 1 1 1 1	
0 1 0 0 0 0 0 0	} national use
0 1 0 0 0 1 1 1	
0 1 0 0 1 0 0 0	} reserved for ETSI
0 1 0 0 1 1 1 1	
0 1 0 1 0 0 0 0	} reserved for other network layer or layer 3 protocols, through } including CCITT Recommendation X.25
1 1 1 1 1 1 1 0	
All other values are reserved.	
NOTE 1: The user information is structured according to user needs.	
NOTE 2: The user information is structured according to CCITT Recommendation X.244 [8] which specifies the structure of CCITT Recommendation X.25 [5] call user data.	
NOTE 3: These values are reserved to discriminate these protocol discriminators from the first octet of a CCITT Recommendation X.25 [5] packet including a general format identifier.	
NOTE 4: The user information consists of IA5 characters.	

## 8 State definitions

The call states associated with basic call control according to EN 300 403-1 [10] shall apply.

The following UUS supplementary service specific states are defined for the user:

- Idle: the service is deactivated;
- Calling User Request: waiting for a response to a service requested during outgoing call setup;
- Active: the service is activated;
- Requesting User Request: waiting for a response to a service 3 request sent by the requesting user during the Active (U10) call state.

The following UUS supplementary service specific states are defined for the network:

- Idle: the service is deactivated;
- Calling Network Request: waiting for a response to a service requested during outgoing call setup;
- Called Network Request: waiting for a response to a service requested during incoming call setup;
- Active: the service is activated;
- Requesting Network Request: waiting for a response to a service 3 request sent by the requesting user during the Active (N10) call state;
- Remote Network Request: waiting for a response to a service 3 request sent to the remote user during the Active (N10) call state.

---

## 9 Signalling procedures at the coincident S and T reference point

If the calling user requests any UUS supplementary service at the time of sending the SETUP message, the calling user shall specify whether or not the requested UUS service(s) is(are) required for the call. If service 1 is implicitly requested it is a preferred request. If specified as required the call request shall be rejected if the UUI cannot be passed to the remote user. If not specified as required (i.e. specified as preferred) the call request shall be completed even if the UUI cannot be passed to the remote user.

If the calling user, during call establishment, wants to request more than one UUS supplementary service, each service shall be requested independently in the same SETUP message. If any service has been requested as required and this service is rejected by the network or the called user, then the call shall be released according to the procedures specified in subclause 9.1.1.2.2, 9.2.1.2 or 9.3.1.1.2 as appropriate.

If service 3 is requested during the Active (N10, U10) call state of a call, only the preferred request is applicable.

For services requested during call request, normal call establishment procedures, as described in EN 300 403-1 [10], subclauses 5.1 and 5.2, shall apply.

### 9.1 Service 1

#### 9.1.1 Activation, deactivation and registration

Activation is performed using either the implicit or explicit request procedure. If the calling user requests service 1 implicitly, i.e. includes the User-user information element in the SETUP message, then the procedures in subclause 9.1.1.1 shall be followed. If the calling user requests service 1 explicitly, then the procedures in subclause 9.1.1.2 shall be followed. If a received SETUP message includes both an explicit request and a User-user information element, the calling network and the called user shall treat this as a service 1 explicit request with related UUI.

**NOTE:** If the calling network receives a SETUP message containing an explicit service 1 request and in addition a User-user information element and the calling network only supports the implicit service 1, the calling network interprets the presence of the User-user information element as a request for the implicit service 1 and treats the explicit service 1 request as unrecognised information. However, the absence of a response will be treated according to the exceptional procedures in subclause 9.1.1.2.2, and the service will not be activated at the calling user.

The service is automatically deactivated when the associated call is cleared.

Registration is not applicable.



### 9.1.1.1 Service 1 - implicitly requested

#### 9.1.1.1.1 Normal operation

To activate service 1 implicitly, the calling user shall include a User-user information element in the SETUP message sent to the calling network as part of normal call request. If the calling network accepts the request, this same User-user information element shall be delivered unchanged in the SETUP message sent by the called network to the called user.

This service is implicitly requested as preferred.

When the request is sent to the called user, the service is activated in the network and at the called user.

No acceptance by the called user is given for activating this service.

For activation purposes, the User-user information element shall be at least three octets long as defined in subclause 7.3.3. When activating the service, the calling user may include user information in the User-user information element as part of the service invocation.

#### 9.1.1.1.2 Exceptional procedures

If the calling network for any reason cannot accept the implicit service 1 request received in the SETUP message, the calling network shall discard the received User-user information element without disrupting normal call handling. No UUS supplementary service specific rejection indication shall be sent to the calling user.

If the called user for any reason cannot accept the implicit service 1 request received in the SETUP message, the called user shall discard the received User-user information element without disrupting normal call handling. No UUS supplementary service specific rejection indication shall be given to the called network.

If a SETUP message is received containing a User-user information element of less than 3 octets in length, the calling network or called user shall treat the SETUP message as if the User-user information element was not present, according to the procedures in EN 300 403-1 [10].

### 9.1.1.2 Service 1 - explicitly requested

If a point-to-multipoint arrangement exists at the called user's interface, more than one ALERTING and/or CONNECT message may be received by the called network. In this case, the called network shall take action on service 1 acceptance and rejection information in the following messages:

- the first received ALERTING message; or
- the first received CONNECT message if not preceded by an ALERTING message; or
- the first received CONNECT message if the first received ALERTING message does not contain service 1 information.

Service 1 acceptance or rejection in any other ALERTING or CONNECT messages shall be discarded.

NOTE: In case of a point-to-multipoint arrangement, it is the called user's responsibility to avoid contention if more than one ALERTING message is sent to the called network.

#### 9.1.1.2.1 Normal operation

Service 1 is explicitly requested by the calling user when including a Facility information element with a UserUserService invoke component according to the procedures in subclause 8.3.1.1 of EN 300 196-1 [13] indicating service 1 in the SETUP message sent to the calling network. If the calling network accepts the request, this request shall also be included according to the procedures in subclause 8.3.1.1 (for a point-to-point arrangement at the called user's interface) or subclause 8.3.1.2 (for a point-to-multipoint arrangement at the called user's interface) of EN 300 196-1 [13] in the SETUP message sent by the called network to the called user. The UserUserService invoke component shall also indicate whether the service is "required" or "preferred".

If the called user accepts the request, the called user shall include a Facility information element with a UserUserService return result component according to the procedures in subclause 8.3.1.1 (for a point-to-point arrangement at the called user's interface) or subclause 8.3.1.2 (for a point-to-multipoint arrangement at the called user's interface) of EN 300 196-1 [13] either in the ALERTING or in the CONNECT message sent to the called network. This explicit acceptance shall be included according to the procedures in subclause 8.3.1.1. of EN 300 196-1 [13] in the corresponding ALERTING or CONNECT message sent by the calling network to the calling user.

When the request is accepted by the network and the called user, the service is activated and the User-user information element may be included in subsequent call control messages. The User-user information element may also be included in the messages used for activation.

In case of premature clearing where the called user clears the call before an ALERTING or a CONNECT message with a service 1 acceptance is sent to the called network, the called user may include the service 1 acceptance in a DISCONNECT, RELEASE (in case of call clearing failure, see EN 300 403-1 [10], subclause 5.3.3) or RELEASE COMPLETE message. This explicit acceptance shall be included in the DISCONNECT message sent by the calling network to the calling user. If multiple clearing messages are received from a point-to-multipoint arrangement, the called network shall select the Facility information element according to the rules for the selection of the User-user information element given in subclause 9.1.2.2.1 b). The calling network shall include the UII, if present, in a User-user information element contained in the DISCONNECT message sent to the calling user.

#### 9.1.1.2.2 Exceptional procedures

A service 1 request is rejected by the calling network or the called user by including a UserUserService return error component with an error value in a Facility information element, sent in an appropriate message according to the procedures in subclauses 8.3.1.1 (rejected by the calling network) and 8.3.1.1 or 8.3.1.2 (rejected by the called user) of EN 300 196-1 [13].

If the call is rejected by the calling network due to normal call handling reasons (e.g. "bearer service not available") or if the calling network receives a clearing indication without an explicit service 1 acceptance or rejection from the called network, then no explicit service 1 rejection shall be given to the calling user.

If the calling network wants to reject the service 1 request (e.g. resources not available or service 1 is not subscribed to) and it was requested as "preferred", normal call handling shall continue and the calling network shall include a service 1 rejection with the error value "rejectedByNetwork" in a SETUP ACKNOWLEDGE, CALL PROCEEDING, PROGRESS, ALERTING or CONNECT message sent to the calling user.

If the calling network wants to reject the service 1 request (e.g. resources not available or service 1 is not subscribed to) and it was requested as "required", the calling network shall send a DISCONNECT or RELEASE COMPLETE message (depending on the state of the call) with e.g. cause #47 "resources unavailable" or #50 "requested facility not subscribed" to the calling user. A service 1 rejection with the error value "rejectedByNetwork" shall also be included in the message.

If the calling network does not receive an explicit service 1 acceptance or rejection either in the alerting or the connect indication from the called network, the following procedures shall apply:

- if the service 1 had been requested as "preferred", the calling network shall include a service 1 rejection with the error value "rejectedByNetwork" in the CONNECT message sent to the calling user;
- if service 1 had been requested as "required", the calling network shall clear the call towards the calling user indicating a service 1 rejection with the error value "rejectedByNetwork" and cause #69 "requested facility not implemented" in a DISCONNECT message. Furthermore, the calling network shall send a disconnect indication with cause #31 "normal, unspecified" to the called network.

If the calling user does not receive an explicit service 1 acceptance or rejection either in the ALERTING or in the CONNECT message or receives a reject component, the following procedures shall apply:

- the calling user shall ignore any received reject component;
- if the service 1 request indicates "preferred", the calling user shall continue normal call handling and assume that service 1 is not activated in the network;
- if the service 1 request indicates "required", the calling user shall clear the call with cause #16 "normal call clearing" according to the procedures specified in subclause 5.3.3 of EN 300 403-1 [10].

If the called user wants to clear the call for reasons not related to the UUS supplementary service, the called user shall not include any service 1 related information in the RELEASE COMPLETE or DISCONNECT message sent to the called network.

If the called user wants to reject the service 1 request, and it was requested as "preferred", the called user shall include a service 1 rejection with the error value "rejectedByUser" in the first response to the SETUP message, i.e. an ALERTING or a CONNECT message sent to the called network. The called network shall include the error value in the corresponding alerting or connect indication sent to the calling network. The calling network shall also include this rejection in the corresponding ALERTING or CONNECT message sent to the calling user.

If the called user wants to reject the service 1 request, and it was requested as "required", the called user shall send a RELEASE COMPLETE or DISCONNECT message with cause #29 "facility rejected" to the called network. A service 1 rejection with the error value "rejectedByUser" shall also be included in the message. The called network shall follow the procedures in subclause 5.2.5.3 of EN 300 403-1 [10] and when the called network initiates call clearing towards the calling network, it shall include the cause value and the error value received from the called user. If multiple clearing messages are received in a point-to-multipoint arrangement, the called network shall select the Facility information element according to the rules for the selection of the User-user information element given in subclause 9.1.2.2.1 b). The calling network shall include the cause value and the error value received from the called network in the DISCONNECT message sent to the calling user.

If the called network receives an ALERTING or CONNECT message from the called user including an explicit service 1 rejection and the service was requested as "required", the called network shall clear the call towards the calling network indicating cause #69 "requested facility not implemented" and the error value "rejectedByUser". In addition, the called network shall send a DISCONNECT message with cause #31 "normal, unspecified" to the called user. In the case of a point-to-multipoint arrangement, the other responding users shall be cleared using the procedure as described in subclause 5.2.9 of EN 300 403-1 [10]. The calling network shall include the cause value and the error value received from the called network in the DISCONNECT message sent to the calling user.

If the called network does not receive an explicit service 1 acceptance or rejection either in the ALERTING or in the CONNECT message (e.g. the called user cannot recognize or interpret the Facility information element or sends a reject component), the following procedures shall apply:

- the called network shall ignore any received reject component;
- if the service 1 request indicates "preferred", the called network shall include a service 1 rejection with the error value "rejectedByUser" in the connect indication sent to the calling network. The calling network shall include the received error value in the CONNECT message sent to the calling user;
- if the service 1 request indicates "required", the called network shall clear the call towards the calling network indicating cause #69 "requested facility not implemented" and a service 1 rejection with the error value "rejectedByUser". The calling network shall include the received cause value and error value in the DISCONNECT message sent to the calling user. Furthermore, the called network shall send a DISCONNECT message with cause #31 "normal, unspecified" to the called user. In the case of a point-to-multipoint arrangement, the other responding users shall be cleared using the procedure as described in subclause 5.2.9 of EN 300 403-1 [10].

If the call is cleared by the called user before an explicit service 1 acceptance or rejection has been sent to the calling user and if an explicit service 1 acceptance or rejection is not included in the clearing message from the called user, the called network shall not include any service 1 related information in the clearing indication sent to the calling network. The calling network shall not include any service 1 related information in the DISCONNECT message sent to the calling user.

## 9.1.2 Invocation

Service 1 may be invoked (i.e. transfer of UUI) during call establishment or during call clearing. To invoke the service it shall be activated as described in subclauses 9.1.1.1 or 9.1.1.2.

### 9.1.2.1 Service 1 invocation during call establishment

#### 9.1.2.1.1 Normal operation

To invoke service 1 during call establishment the calling user shall include a User-user information element in the SETUP message sent to the calling network (i.e. at the same time as activating service 1) and this same User-user information element shall be included in the SETUP message sent by the called network to the called user.

The called user may include a User-user information element in the first ALERTING and the first CONNECT message(s) sent to the calling user through the network. User-user information elements received in subsequent ALERTING messages shall be discarded by the called network. User-user information elements received in subsequent CONNECT messages shall be discarded by the called network.

NOTE: In case of a point-to-multipoint arrangement, it is the called user's responsibility to avoid contention if more than one ALERTING message is sent to the network.

#### 9.1.2.1.2 Exceptional procedures

If the calling network receives a SETUP message from the calling user including a User-user information element with an overall length exceeding 131 octets, the calling network shall discard the User-user information element; take action on the remaining contents of the message and, as a network option, send a STATUS message to the calling user containing cause #43 "access information discarded".

If the calling user receives an ALERTING or CONNECT message from the calling network including a User-user information element and the service 1 is not activated or the overall length of the User-user information element exceeds 131 octets, the calling user shall discard the User-user information element, take action on the remaining contents of the message received from the calling network and, as a user option, send a STATUS message to the calling network containing cause #43 "access information discarded".

If the called network receives an ALERTING or CONNECT message from the called user including a User-user information element and the service 1 is not activated or the overall length of the User-user information element exceeds 131 octets, the called network shall discard the User-user information element. If discard occurs, the called network shall take action on the remaining contents of the message received from the called user and, as a network option, send a STATUS message to the called user containing cause #43 "access information discarded".

If the called user receives a SETUP message from the called network including a User-user information element with an overall length exceeding 131 octets, the called user shall discard the User-user information element, take action on the remaining contents of the message and, as a user option, send a STATUS message to the called network containing cause #43 "access information discarded".

### 9.1.2.2 Service 1 invocation during call clearing

#### 9.1.2.2.1 Normal operation

To invoke service 1 during call clearing, either user shall include a User-user information element in the first message used to initiate the normal call clearing phase (see EN 300 403-1 [10], subclauses 5.3.3 and 5.3.4).

Either network shall transfer the information contained in the User-user information element to the calling user or the called user in the first clearing message sent to that user. Such transfer is only performed if the information is received at the calling network or the called network before sending a clearing message to its user; otherwise, the information is discarded without sending any notification.

##### a) Clearing initiated by the calling user:

To invoke service 1, the calling user shall include a User-user information element in the DISCONNECT message sent to the calling network. This User-user information element shall be included in the DISCONNECT message sent by the called network to the called user.

In the case of premature clearing by the calling user, where the called user has a point-to-multipoint arrangement, the called network shall include the User-user information element in a RELEASE message to each called user that has already responded to the incoming call, i.e. in call states N25, N9, N7 and N8;

b) Clearing initiated by the called user:

If the call has reached the Active (U10) call state, the called user shall include a User-user information element in the DISCONNECT message sent to the called network to invoke service 1.

In case of premature clearing in a point-to-point arrangement, the called user may include a User-user information element in a DISCONNECT or RELEASE COMPLETE message.

In case of premature clearing in a point-to-multipoint arrangement, the procedures in EN 300 403-1 [10], subclause 5.2.5.3 apply. If multiple clearing messages are received, the called network shall retain the User-user information elements along with the retained causes. When a cause is selected to be sent to the calling user, the associated User-user information element shall also be included. If the clearing message with the highest priority cause does not contain a User-user information element and subsequent clearing messages with causes of lower or equal priority do contain User-user information elements, then no User-user information element shall be sent to the calling user. If clearing messages with causes of equal priority contain User-user information elements, then the User-user information element, if any, contained in the first received clearing message with that highest priority cause shall be sent to the calling user.

The calling network shall include the User-user information element, if any, in the DISCONNECT message sent to the calling user. However, if the calling network is providing in-band information to the calling user, and chooses not to initiate clearing procedures at that time, the calling network may deliver the User-user information element, if any, in a PROGRESS message sent to the calling user.

In case of call clearing failure (see EN 300 403-1 [10], subclauses 5.3.3 and 5.3.4) where a DISCONNECT message is not acknowledged and a RELEASE message is sent by the calling or called user or the calling or called network, the User-user information element may be repeated in the RELEASE message.

#### 9.1.2.2.2 Exceptional procedures

The calling or called network shall discard the User-user information element if it is received from either user in a DISCONNECT, RELEASE or RELEASE COMPLETE message without service 1 being activated, or if the overall length of the User-user information element exceeds 131 octets, take action on the remaining contents of the message received from the user and shall, as a network option, include cause #43 "access information discarded" in the next sequential clearing message sent to the calling or called user. If the user initiating the clearing has sent a RELEASE COMPLETE message, the calling or called network shall consider the call as cleared to that user; no additional action shall be taken.

The calling or called user shall discard the User-user information element if it is received from either network in a DISCONNECT, RELEASE or RELEASE COMPLETE message without service 1 being activated, or if the overall length of the User-user information element exceeds 131 octets, take action on the remaining contents of the message received from the network and shall, as a user option, include cause #43 "access information discarded" in the next sequential clearing message sent to the calling or called network.

## 9.2 Service 2

Service 2 is only applicable if a point-to-point arrangement exists at the called user's interface.

### 9.2.1 Activation, deactivation and registration

#### 9.2.1.1 Normal operation

Activation is performed during the setup of a call.

In order to activate service 2, the calling user shall include a Facility information element with a UserUserService invoke component according to the procedures in subclause 8.3.1.1 of EN 300 196-1 [13] indicating service 2 in the SETUP message sent to the calling network. If the calling network accepts the request, this request shall also be included according to the procedures in subclause 8.3.1.1 of EN 300 196-1 [13] in the SETUP message sent by the called network to the called user. The UserUserService invoke component shall also indicate whether the service is "required" or "preferred".

If the called user accepts the request, the called user shall include a Facility information element with a UserUserService return result component according to the procedures in subclause 8.3.1.1 of EN 300 196-1 [13] in the ALERTING message sent to the called network. This explicit acceptance shall also be included in the ALERTING message sent by the calling network to the calling user.

If the ALERTING message is not part of normal call handling for a call, service 2 is not applicable for this call.

The service is activated when the request is accepted by the calling and called network and by the called user.

If the network option allowing the called network to transfer USER INFORMATION messages after the Active (N10) call state has been entered is not supported by the network, service 2 is automatically deactivated when the associated call is leaving the alerting phase. If this network option is supported, service 2 is automatically deactivated when the associated call leaves the Active (N10, U10) call state.

Registration is not applicable.

### 9.2.1.2 Exceptional procedures

A service 2 request is rejected by the calling network or the called user by including a UserUserService return error component with an error value in a Facility information element, sent in an appropriate message according to the procedures in subclauses 8.3.1.1 of EN 300 196-1 [13].

If the call is rejected by the calling network due to normal call handling reasons (e.g. "bearer service not available") or if the calling network receives a clearing indication without an explicit service 2 acceptance or rejection from the called network, then no explicit service 2 rejection shall be given to the calling user.

If the calling network wants to reject the service 2 request (e.g. resources not available or service 2 is not subscribed to) and it was requested as "preferred", normal call handling shall continue and the calling network shall include a service 2 rejection with the error value "rejectedByNetwork" in the SETUP ACKNOWLEDGE, CALL PROCEEDING, PROGRESS or ALERTING message sent to the calling user.

If the calling network wants to reject the service 2 request (e.g. resources not available or service 2 is not subscribed to) and it was requested as "required", the calling network shall send a DISCONNECT or RELEASE COMPLETE message (depending on the state of the call) with e.g. cause #47 "resources unavailable" or #50 "requested facility not subscribed" to the calling user. A service 2 rejection with the error value "rejectedByNetwork" shall also be included in the message.

If the calling network does not receive an explicit service 2 acceptance or rejection in the alerting indication from the called network, the following procedures shall apply:

- if the service 2 had been requested as "preferred", the calling network shall include a service 2 rejection with the error value "rejectedByNetwork" in the ALERTING message sent to the calling user;
- if service 2 had been requested as "required", the calling network shall clear the call towards the calling user indicating a service 2 rejection with the error value "rejectedByNetwork" and cause #69 "requested facility not implemented" in a DISCONNECT message. Furthermore, the calling network shall send a disconnect indication with cause #31 "normal, unspecified" to the called network.

If the calling user does not receive an explicit service 2 acceptance or rejection in the ALERTING message or receives a reject component, the following procedures shall apply:

- the calling user shall ignore any received reject component;
- if the service 2 request indicates "preferred", the calling user shall continue normal call handling and consider that service 2 is not activated in the network;
- if the service 2 request indicates "required", the calling user shall clear the call with cause #16 "normal call clearing" according to the procedures specified in subclause 5.3.3 of EN 300 403-1 [10].

If the calling user has requested service 2 but does not receive an ALERTING message before receiving the CONNECT message, the following procedures shall apply:

- if the service 2 request indicates "preferred", the calling user shall continue normal call handling and assume that service 2 is not activated in the network;
- if the service 2 request indicates "required", the calling user shall clear the call with cause #16 "normal call clearing" according to the procedures specified in subclause 5.3.3 of EN 300 403-1 [10].

If the called user wants to clear the call for reasons not related to the UUS supplementary service, the called user shall not include any service 2 related information in the RELEASE COMPLETE or DISCONNECT message sent to the called network.

If the called user wants to reject the service 2 request, and it was requested as "preferred", the called user shall include a service 2 rejection with the error value "rejectedByUser" in the ALERTING message sent to the called network. The called network shall include the error value in the alerting indication sent to the calling network. The calling network shall also include this error value in the ALERTING message sent to the calling user.

If the called user wants to reject the service 2 request, and it was requested as "required", the called user shall send a RELEASE COMPLETE or DISCONNECT message with cause #29 "facility rejected" to the called network. A service 2 rejection with the error value "rejectedByUser" shall also be included in the message. The called network shall include the cause value and the error value received from the called user in the clearing request sent to the calling network. The calling network shall include the received cause value and the error value in the DISCONNECT message sent to the calling user.

If the called network receives an ALERTING message from the called user including an explicit service 2 rejection and the service was requested as "required", the called network shall clear the call towards the calling network indicating cause #69 "requested facility not implemented" and the error value "rejectedByUser". In addition, the called network shall send a DISCONNECT message with cause #31 "normal, unspecified" to the called user. The calling network shall include the cause value and the error value received from the called network in the DISCONNECT message sent to the calling user.

If the called network does not know that a point-to-point arrangement exists at the called user's interface, any service 2 request (preferred or required) shall be rejected as follows:

- if the service 2 request indicates "preferred", the called network shall include the error value "rejectedByUser" in the alerting indication sent to the calling network. The calling network shall include the error value in the ALERTING message sent to the calling user;
- if the service 2 request indicates "required", the called network shall clear the call towards the calling network indicating cause #69 "requested facility not implemented" and the error value "rejectedByUser". The call shall not be offered to the called user. The calling network shall include the received cause value and error value in the DISCONNECT message sent to the calling user.

If the called network does not receive an ALERTING message prior to the CONNECT message, any service 2 request (preferred or required) shall be rejected as follows:

- if the service 2 request indicates "preferred", the called network shall include a service 2 rejection with the error value "rejectedByUser" in the connect indication sent to the calling network. The calling network shall include the received error value in the CONNECT message sent to the calling user;
- if the service 2 request indicates "required", the called network shall clear the call towards the calling network indicating cause #69 "requested facility not implemented" and a service 2 rejection with the error value "rejectedByUser". The calling network shall include the received cause value and error value in the DISCONNECT message sent to the calling user.

If the called network does not receive an explicit service 2 acceptance or rejection in the ALERTING message (e.g. the called user cannot recognize or interpret the Facility information element or sends a reject component), the following procedures shall apply:

- the called network shall ignore any received reject component;
- if the service 2 request indicates "preferred", the called network shall include a service 2 rejection with the error value "rejectedByUser" in the alerting indication sent to the calling network. The calling network shall include the received error value in the ALERTING message sent to the calling user;
- if the service 2 request indicates "required", the called network shall clear the call towards the calling network indicating cause #69 "requested facility not implemented" and a service 2 rejection with the error value "rejectedByUser". The calling network shall include the received error value and cause value in the DISCONNECT message sent to the calling user. Furthermore, the called network shall send a DISCONNECT message with cause #31 "normal, unspecified" shall be sent to the called user.

If the call is cleared by the called user before an explicit service 2 acceptance or rejection has been sent to the calling user and if an explicit service 2 acceptance or rejection is not included in the clearing message from the called user, the called network shall not include any service 2 related information in the clearing indication sent to the calling network. The calling network shall not include any service 2 related information in the DISCONNECT message sent to the calling user.

## 9.2.2 Invocation

### 9.2.2.1 Normal operation

When service 2 is activated, either user can invoke service 2 by sending User-user information elements contained in USER INFORMATION messages to the network.

The sending users can send USER INFORMATION messages after the ALERTING message has been sent or received and before the CONNECT message has been sent or received. The network shall transfer up to two USER INFORMATION messages in each direction after the ALERTING message has been sent or received and before the CONNECT message has been sent or received. As a network option, the calling network shall accept the USER INFORMATION messages from the calling user and the called network shall deliver them to the called user after the calling and called network have entered the Active (N10) call state.

**NOTE:** An example of this situation occurs when the CONNECT message sent by the calling network to the calling user crosses the USER INFORMATION messages sent by the calling user.

The sending user may also include the More data information element in the USER INFORMATION message to indicate to the receiving user that another USER INFORMATION message containing information belonging to the same block will follow. The use of the More data information element is not supervised by neither the calling network nor the called network.

Sending or receiving of USER INFORMATION messages does not change the state of the call.

### 9.2.2.2 Exceptional procedures

In the following cases the calling network shall discard the USER INFORMATION message and, as a network option, send a STATUS message with cause #43 "access information discarded" to the calling user:

- if the calling network receives a USER INFORMATION message from the calling user in the Call Delivered (N4) call state while service 2 is not activated;
- if the calling network supports the network option specified in subclause 9.2.2.1 and receives a USER INFORMATION message from the calling user in the Active (N10) call state while service 2 is not activated;
- if the calling network receives more than two USER INFORMATION messages from the calling user;
- if the calling network receives a USER INFORMATION message from the calling user with a User-user information element exceeding 131 octets.



In the following cases the calling network shall discard the USER INFORMATION message and follow the basic call error handling procedures in subclause 5.8 of EN 300 403-1 [10]:

- if the calling network does not support the network option specified in subclause 9.2.2.1 and receives a USER INFORMATION message from the calling user in any other call state than the Call Delivered (N4) call state;
- if the calling network supports the network option specified in subclause 9.2.2.1 and receives a USER INFORMATION message from the calling user in any other call state than the Call Delivered (N4) call state and the Active (N10) call state.

In the following cases the calling user shall discard the USER INFORMATION message and, as a user option, send a STATUS message with cause #43 "access information discarded" to the calling network:

- if the calling user receives a USER INFORMATION message from the calling network in the Call Delivered (U4) call states while service 2 is not activated;
- if the calling user receives a USER INFORMATION message from the calling network with a User-user information element exceeding 131 octets.

If the calling user receives a USER INFORMATION message from the calling network in any other call state than the Call Delivered (U4) call state, the calling user shall discard the received USER INFORMATION message and follow the basic call error handling procedures specified in subclause 5.8 of EN 300 403-1 [10].

In the following cases the called network shall discard the USER INFORMATION message and, as a network option, send a STATUS message with cause #43 "access information discarded" to the called user:

- if the called network receives a USER INFORMATION message from the called user in the Call Received (N7) call state while service 2 is not activated;
- if the called network receives more than two USER INFORMATION messages from the called user;
- if the called network receives a USER INFORMATION message from the called user with a User-user information element exceeding 131 octets.

If the called network receives a USER INFORMATION message from the called user in any other call state than the Call Received (N7) call state, the called network shall discard the received USER INFORMATION message and follow the basic call error handling procedures specified in subclause 5.8 of EN 300 403-1 [10].

In the following cases the called user shall discard the USER INFORMATION message and, as a user option, send a STATUS message with cause #43 "access information discarded" to the called network:

- if the called user receives a USER INFORMATION message from the called network in the Call Received (U7) call state and the Active (U10) call state while service 2 is not activated;
- if the called user receives a USER INFORMATION message from the called network with a User-user information element exceeding 131 octets.

If the called user receives a USER INFORMATION message from the called network in any other call state than the Call Received (U7) call state and the Active (U10) call state, the called user shall discard the received USER INFORMATION message and follow the basic call error handling procedures specified in subclause 5.8 of EN 300 403-1 [10].

## 9.3 Service 3

If a point-to-multipoint arrangement exists at the called user's interface, more than one ALERTING and/or CONNECT message may be received by the called network. In this case, the called network shall take action on the service 3 acceptance and rejection information in the first received CONNECT message. Service 3 information in any other ALERTING or CONNECT messages shall be discarded.

### 9.3.1 Activation, deactivation and registration

Activation is performed either during the setup of a call or during the Active (N10, U10) state of a call. If the calling user requests service 3 during the setup of a call, then the procedures in subclause 9.3.1.1 shall be followed. If the requesting user requests service 3 during the Active (U10) call state, the procedures in subclause 9.3.1.2 shall be followed.

The service is automatically deactivated when the associated call leaves the Active (N10, U10) call state.

Registration is not applicable.

#### 9.3.1.1 Service 3 request during call establishment

##### 9.3.1.1.1 Normal operation

In order to activate service 3 during call establishment, the calling user shall include a Facility information element with a UserUserService invoke component according to the procedures in subclause 8.3.1.1 of EN 300 196-1 [13] indicating service 3 in the SETUP message sent to the calling network. If the calling network accepts the request, this request shall also be included according to the procedures in subclause 8.3.1.1 (for a point-to-point arrangement at the called user's interface) or subclause 8.3.1.2 (for a point-to-multipoint arrangement at the called user's interface) of EN 300 196-1 [13] in the SETUP message sent by the called network to the called user. The UserUserService invoke component shall also indicate whether the service is "required" or "preferred".

If the called user accepts the request, the called user shall include a Facility information element with a UserUserService return result component according to the procedures in subclause 8.3.1.2 of EN 300 196-1 [13] in the CONNECT message sent to the called network. This explicit acceptance shall be included according to the procedures in subclause 8.3.1.1 of EN 300 196-1 [13] in the corresponding CONNECT message sent by the calling network to the calling user.

The service is activated when the request is accepted by the calling and called network and by the called user.

##### 9.3.1.1.2 Exceptional procedures

A service 3 request is rejected by the calling network or the called user by including a UserUserService return error component with an error value in a Facility information element, sent in an appropriate message according to the procedures in subclauses 8.3.1.1 (rejected by the calling network) and 8.3.1.1 or 8.3.1.2 (rejected by the called user) of EN 300 196-1 [13].

If the call is rejected by the network due to normal call handling reasons (e.g. "bearer service not available"), or if the calling network receives a clearing indication without an explicit service 3 acceptance or rejection from the called network, then no explicit service 3 rejection shall be given to the calling user.

If the calling network wants to reject the service 3 request (e.g. resources not available or service 3 is not subscribed to) and it was requested as "preferred", normal call handling shall continue and the calling network shall include a service 3 rejection with the error value "rejectedByNetwork" in the SETUP ACKNOWLEDGE, CALL PROCEEDING, PROGRESS, ALERTING or CONNECT message sent to the calling user.

If the calling network wants to reject the service 3 request (e.g. resources not available or service 3 is not subscribed to) and it was requested as "required", the calling network shall send a DISCONNECT or RELEASE COMPLETE message (depending on the state of the call) with e.g. cause #47 "resources unavailable" or #50 "requested facility not subscribed" to the calling user. A service 3 rejection with the error value "rejectedByNetwork" shall also be included in the message.

If the calling network does not receive an explicit service 3 acceptance or rejection in the connect indication from the called network, the following procedures shall apply:

- if the service 3 had been requested as "preferred", the calling network shall include a service 3 rejection with the error value "rejectedByNetwork" in the CONNECT message sent to the calling user;
- if service 3 had been requested as "required", the calling network shall clear the call towards the calling user indicating a service 3 rejection with the error value "rejectedByNetwork" and cause #69 "requested facility not implemented" in a DISCONNECT message. Furthermore, the calling network shall send a disconnect indication with cause #31 "normal, unspecified" to the called network.

If the calling user does not receive an explicit service 3 acceptance or rejection in the CONNECT message or receives a reject component, the following procedures shall apply:

- the calling user shall ignore any received reject component;
- if the service 3 request indicates "preferred", the calling user shall continue normal call handling and assume that service 3 is not activated in the network;
- if the service 3 request indicates "required", the calling user shall clear the call with cause #16 "normal clearing" according to the procedures specified in subclause 5.3.3 of EN 300 403-1 [10].

If the called user wants to clear the call for reasons not related to the UUS supplementary service, the called user shall not include any service 3 related information in the RELEASE COMPLETE or DISCONNECT message sent to the called network.

If the called user wants to reject the service 3 request, and it was requested as "preferred", the called user shall include a service 3 rejection with the error value "rejectedByUser" in the CONNECT message sent to the called network. The called network shall include the error value in the connect indication sent to the calling network. The calling network shall include the rejection in the CONNECT message sent to the calling user.

If the called user wants to reject the service 3 request, and it was requested as "required", the called user shall send a RELEASE COMPLETE or DISCONNECT message with cause #29 "facility rejected" to the called network. A service 3 rejection with the error value "rejectedByUser" shall also be included in the message. The called network shall follow the procedures in subclause 5.2.5.3 of EN 300 403-1 [10] and when the called network initiates call clearing towards the calling network, it shall include the cause value and the error value received from the called user. If multiple clearing messages are received in a point-to-multipoint arrangement, the called network shall select the Facility information element according to the rules for the selection of the User-user information element given in subclause 9.1.2.2.1 b). The calling network shall include the cause value and the error value received from the called network in the DISCONNECT message sent to the calling user.

If the called network receives a CONNECT message from the called user including an explicit service 3 rejection and the service was requested as "required", the called network shall clear the call towards the calling network indicating cause #69 "requested facility not implemented" and the error value "rejectedByUser". In addition, the called network shall send a DISCONNECT message with cause #31 "normal, unspecified" to the called user. In the case of a point-to-multipoint arrangement, the other responding users shall be cleared using the procedure as described in subclause 5.2.9 of EN 300 403-1 [10]. The calling network shall include the cause value and the error value received from the called network in the DISCONNECT message sent to the calling user.

If the called network does not receive an explicit service 3 acceptance or rejection in the CONNECT message (e.g. the called user cannot recognize or interpret the Facility information element or sends a reject component), the following procedures shall apply:

- the called network shall ignore any received reject component;
- if the service 3 request indicates "preferred", the called network shall include a service 3 rejection with the error value "rejectedByUser" in the connect indication sent to the calling network. The calling network shall include the received error value in the CONNECT message sent to the calling user;
- if the service 3 request indicates "required", the called network shall clear the call towards the calling network indicating cause #69 "requested facility not implemented" and a service 3 rejection with the error value "rejectedByUser". The calling network shall include the received cause value and error value in the DISCONNECT sent to the calling user. Furthermore, the called network shall send a DISCONNECT message with cause #31 "normal, unspecified" to the called user. In the case of a point-to-multipoint arrangement, the other responding users shall be cleared using the procedure as described in subclause 5.2.9 of EN 300 403-1 [10].

If the call is cleared by the called user before an explicit service 3 acceptance or rejection has been sent to the calling user and if an explicit service 3 acceptance or rejection is not included in the clearing message from the called user, the called network shall not include any service 3 related information in the clearing indication sent to the calling network. The calling network shall not include any service 3 related information in the DISCONNECT message sent to the calling user.

### 9.3.1.2 Service 3 request during the Active (N10, U10) call state

#### 9.3.1.2.1 Normal operation

During the Active (U10) call state, the calling user or, as a network option, the called user can activate service 3.

To activate service 3 during the Active (N10, U10) call state, the requesting user shall include a Facility information element with a UserUserService invoke component according to the procedures in subclause 8.3.1.1 of EN 300 196-1 [13] indicating service 3 in a FACILITY message sent to the requesting network and start timer T3-UUS3. The requesting network shall send this request to the remote network. When the remote network receives the service 3 request from the requesting network, it shall include this request according to the procedures in subclause 8.3.1.1 of EN 300 196-1 [13] in a FACILITY message sent to the remote user and start timer T1-UUS3.

Only the preferred request is applicable.

If the remote user accepts the request, the remote user shall send a Facility information element with a UserUserService return result component according to the procedures in subclause 8.3.1.1 of EN 300 196-1 [13] in a FACILITY message to the remote network. Upon receiving the FACILITY message, the remote network shall stop timer T1-UUS3 and indicate this acceptance to the requesting network. The requesting network shall include this acceptance according to the procedures in subclause 8.3.1.1 of EN 300 196-1 [13] in a FACILITY message sent to the requesting user.

When the requesting user receives the service 3 acceptance, the requesting user shall stop timer T3-UUS3 and consider the service as activated.

When the request is accepted by the network and by the remote user, the service is activated and each user may send USER INFORMATION messages to each other during the Active (N10, U10) call state of the call.

#### 9.3.1.2.2 Exceptional procedures

A service 3 request is rejected by the requesting network or the remote user by including a UserUserService return error component with an error value in a Facility information element, sent in a FACILITY message according to the procedures in subclause 8.3.1.1 of EN 300 196-1 [13].

If the requesting network wants to reject the service 3 request (e.g. resources are not available, service 3 was requested in a call state other than the Active (N10, U10) call state, service 3 is not subscribed to or service 3 was requested as "required"), a FACILITY message including a service 3 rejection with the error value "rejectedByNetwork" shall be returned to the requesting user.

If a reject component is received by the requesting user and the invoke identifier is included, the requesting user shall consider the requested service as not activated.

If the requesting user receives a service 3 rejection, the requesting user shall stop timer T3-UUS3 and consider the service as not activated.

If timer T3-UUS3 expires (i.e. no response has been received from the requesting network), the requesting user shall consider that service 3 is not activated.

If the remote user wants to reject the service 3 request, a FACILITY message including a service 3 rejection with the error value "rejectedByUser" is returned to the remote network. The remote network shall then stop timer T1-UUS3 and indicate the rejection to the requesting network. When the requesting network has received this rejection indication, it shall send a FACILITY message including the received error value to the requesting user.

If the remote network receives a reject component from the remote user, which can be related to the UUS supplementary service, it shall stop timer T1-UUS3 and indicate the rejection to the requesting network. When the requesting network has received this rejection indication, it shall send a FACILITY message including the received error value to the requesting user.

If timer T1-UUS3 expires (i.e. no response has been received from the remote user), the remote network shall reject the service 3 request toward the requesting network. Upon receiving this rejection, the requesting network shall send a FACILITY message including a service 3 rejection with the error value "rejectedByUser" to the requesting user.

Collision of requests for service 3 occurs when there is an outstanding request for service 3 and a subsequent request is received from the remote user. In this situation the entities (user or network) observing the collision shall reject the second request with a FACILITY message including a service 3 rejection with the error value "rejectedByUser" or "rejectedByNetwork". Consequently, both requests will be rejected (see clause 14 for details).

If the requesting network receives a FACILITY message including a Facility information element with a UserUserService invoke component according to the procedures in subclause 8.3.1.1 of EN 300 196-1 [13] indicating service 3, but the service 3 is already activated, the network shall send a Facility information element with a UserUserService return result component according to the procedures in subclause 8.3.1.1 of EN 300 196-1 [13] in a FACILITY message to the requesting user.

## 9.3.2 Invocation

NOTE: USER INFORMATION messages received in the Active (N10, U10) call state can be related to service 2 or service 3 and therefore be processed according to subclauses 9.2.2 or 9.3.2.

### 9.3.2.1 Normal operation

When service 3 is activated, either user can invoke service 3 by sending User-user information elements contained in USER INFORMATION messages to the network.

The More data information element may also be included in the USER INFORMATION message by the sending user to indicate to the receiving user that another USER INFORMATION message containing information belonging to the same block will follow. The use of the More data information element is not supervised by the network; in particular, integrity of fragmented blocks using this procedure is not guaranteed.

### 9.3.2.2 Exceptional procedures

In the following cases the sending network shall discard the USER INFORMATION message and, as a network option, send a STATUS message with cause #43 "access information discarded" to the sending user:

- if the sending network receives a USER INFORMATION message in the Active (N10) call state, but service 3 is not activated;
- if the sending network receives a USER INFORMATION message with a User-user information element longer than 131 octets.

If the sending network receives a USER INFORMATION message in any other call state than the Active (N10), the sending network shall discard the USER INFORMATION and follow basic call error handling procedures defined in subclause 5.8 of EN 300 403-1 [10].

In the following cases the receiving user shall discard the USER INFORMATION message and, as a user option, send a STATUS message with cause #43 "access information discarded" to the receiving network:

- if the receiving user receives a USER INFORMATION message in the Active (U10) call state, but service 3 is not activated;
- if the receiving user receives a USER INFORMATION message with a User-user information element longer than 131 octets.

If the receiving user receives a USER INFORMATION message in any other call state than the Active (U10), the receiving user shall discard the USER INFORMATION message and follow basic call error handling procedures defined in subclause 5.8 of EN 300 403-1 [10].

### 9.3.3 Flow control

#### 9.3.3.1 Normal operation

Network flow control mechanisms shall exist after the call has entered the Active (N10, U10) call state to restrict USER INFORMATION message flow in each direction.

A burst capability of sending N USER INFORMATION messages shall immediately be available to each user, where N initially equals the value of the burst parameter X. The value of N shall be decremented by one for every USER INFORMATION message sent by the user and incremented by Y at regular intervals of T2-UUS3. If the value of N exceeds X when N is incremented by Y, then the value of N shall be set to X.

The burst parameter X shall be set to a value of  $X = 16$  and the replenishment parameter Y shall be set to  $Y = 8$ .

If the network receives more than N USER INFORMATION messages within the period T2-UUS3, the excess message(s) shall be discarded. The network shall respond to the first discarded message with a CONGESTION CONTROL message including a Congestion level information element indicating "receiver not ready". The CONGESTION CONTROL message shall also include a cause #43 "access information discarded". Subsequently received USER INFORMATION messages shall be discarded by the network without any indication to the user.

When the flow control restrictions are removed (i.e. timer T2-UUS3 expires) then, if a USER INFORMATION message has been discarded due to that restriction, a CONGESTION CONTROL message indicating "receiver ready" shall be sent to the user. If no USER INFORMATION message has been discarded, no indication shall be sent.

The user cannot flow control USER INFORMATION messages received from the network.

#### 9.3.3.2 Exceptional procedures

If the receiving network receives a CONGESTION CONTROL message from the receiving user in the Active (N10) call state, a STATUS message with cause #111 "protocol error, unspecified" shall be sent to the receiving user and no further action shall be taken.

If the receiving network receives a CONGESTION CONTROL message from the receiving user in any other call state than the Active (N10) call state, the receiving network shall follow the procedures specified in subclause 5.8 of EN 300 403-1 [10].

---

## 10 Procedures for interworking with private ISDNs

The procedures described in clause 9 shall apply with the following exceptions:

- the exceptional procedures described in subclauses 9.1.2.1.2, 9.2.2.2 and 9.3.2.2 apply except that the network shall not send STATUS messages to the private network. However, STATUS messages generated as part of basic call may be sent;
- when a UUS supplementary service request is rejected by the private network both error values "rejectedByUser" and "rejectedByNetwork" can be indicated by the private network;
- where procedures specify that the called network generates an error value of "rejectedByUser" due to the absence of an acceptance or rejection from the called user (private network), then an error value of "rejectedByNetwork" shall be used instead;

NOTE 1: The current ISUP implementation (ETS 300 356-8 (1995)) does not support the conveyance of both the error value "rejectedByUser" and the error value "rejectedByNetwork" from the destination network to the originating network. ISUP can only support one error indication. This error indication will at the originating network side be translated to "rejectedByUser" and sent to the calling user. Consequently, if the error value "rejectedByNetwork" is generated by the destination network or is received by the destination network from the private network, it will be indicated as "rejectedByUser" to the calling user.

- the network shall not flow control USER INFORMATION messages received from the private network, i.e. the procedures described in subclause 9.3.3 are not applicable.

NOTE 2: The actions to be taken if the private network violates the flow control limit as specified in subclause 9.3.3 at the interface to which the user generating UUI is attached, e.g. an interface at the S reference point, are implementation dependent and are outside the scope of the present document.

---

## 11 Interaction with other networks

### 11.1 Interworking with an ISDN network supporting only a maximum User-user information element length of 35 octets

NOTE: If a User-user information element with a length exceeding 35 octets is received by a network supporting only a maximum length of 35 octets, the receiving network will discard the User-user information element.

If interworking occurs with a network supporting only a maximum User-user information element length of 35 octets, no notification shall be given to the calling user or called user sending the user information.

### 11.2 Interaction with non-ISDN

In the case of interworking with a non-ISDN network or with a non-ISDN called user, a Progress indicator information element indicating #1 "call is not end-to-end ISDN; further progress information may be available in-band" or #2 "destination address is non-ISDN", respectively, is sent to the calling user as part of basic call.

This progress information shall serve as an indication that the requested service cannot be guaranteed.

---

## 12 Interaction with other supplementary services

The interaction of the UUS supplementary service with other supplementary services shall be as specified in EN 300 195-1 [12].

---

## 13 Parameter values (timers)

T1-UUS3 (see subclause 9.3.1.2): 10 s

T2-UUS3 (see subclause 9.3.3): 10 s

T3-UUS3 (see subclause 9.3.1.2): 10 s

---

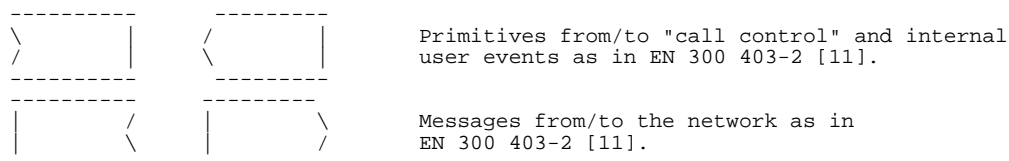
## 14 Dynamic description (SDL diagrams)

The dynamic descriptions in figures 6 to 11 are specified according to CCITT Recommendation Z.100 [9].

The following figures contain the user side SDL diagrams:

- Figure 6: Service 1, user side process;
- Figure 8: Service 2, user side process;
- Figure 10: Service 3, user side process.

In the context of the present document, the direction of the input symbol and the output symbol at the user side is defined in figure 4:

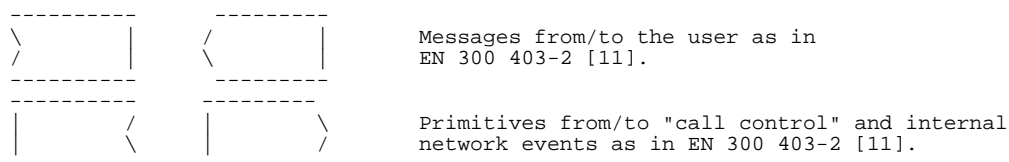


**Figure 4: Definition of symbols direction at the user side**

The following figures contain the network side SDL diagrams:

- Figure 7: Service 1, network side process SDL;
- Figure 9: Service 2, network side process SDL;
- Figure 11: Service 3, network side process SDL.

In the context of the present document, the direction of the input symbol and the output symbol at the network is defined in figure 5:



**Figure 5: Definition of symbols direction at the network side**

#### Abbreviations used in the SDL diagrams

Uuie	User-user information element
(Uuie)	User-user information element included if UUI is included in the received event
UUI	User-to-user information
(UUI)	User-to-user information included if a Uuie is included in the received message
RR	Return Result
RE1	Return Error (rejected by the network)
RE2	Return Error (rejected by the user)
REr	The received Return Error is included
ALERT	ALERTING message
CALL PROC	CALL PROCEEDING message
CON CON	CONGESTION CONTROL message
CONN	CONNECT message
DISC	DISCONNECT message
FAC	FACILITY message
PROG	PROGRESS message
REL	RELEASE message
REL COMP	RELEASE COMPLETE message
SETUP	SETUP message
SETUP ACK	SETUP ACKNOWLEDGE message
USER INFO	USER INFORMATION message



## 14.1 Service 1

## 14.1.1 User

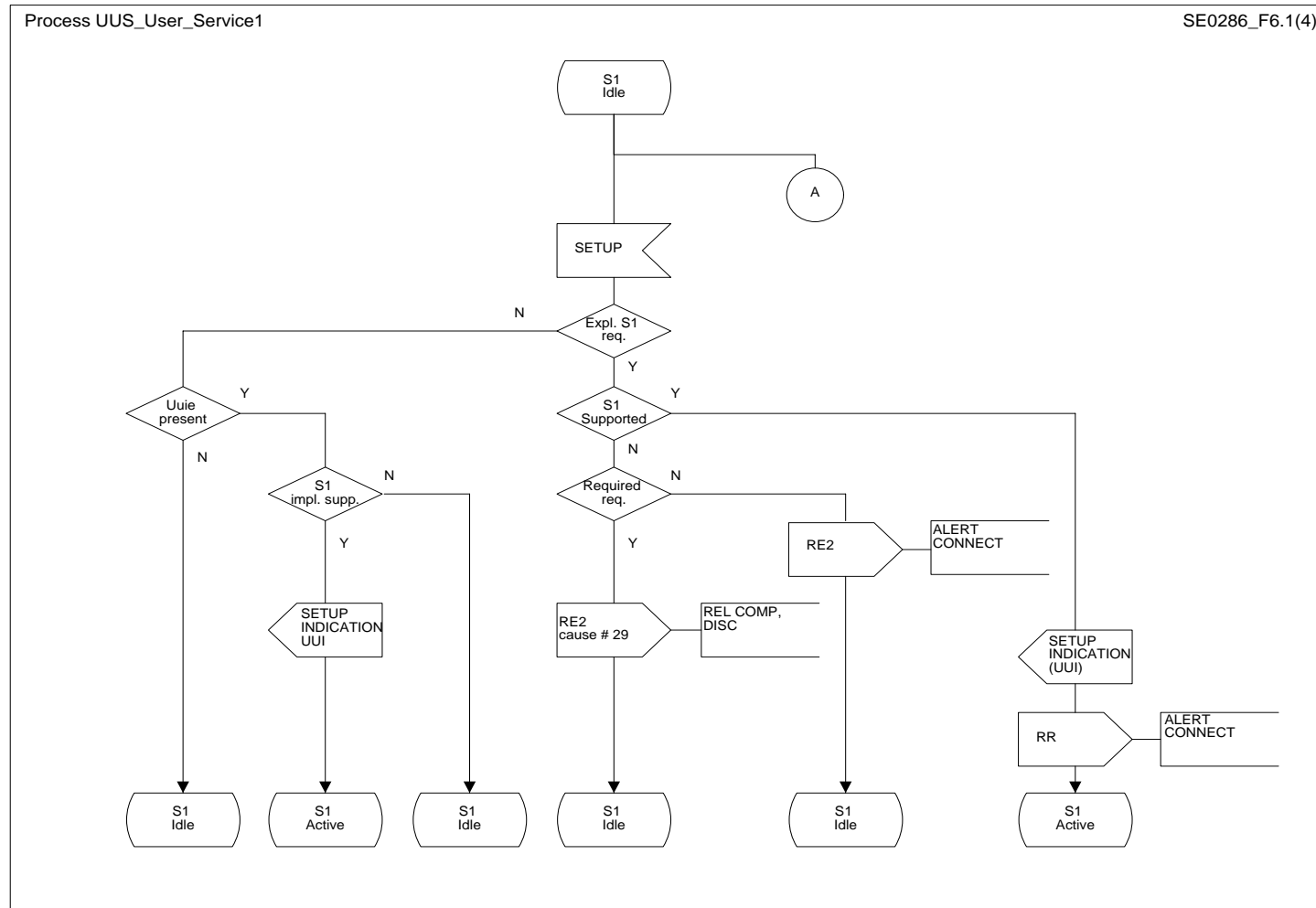


Figure 6 (sheet 1 of 4): UUS supplementary service, service 1, called user side process

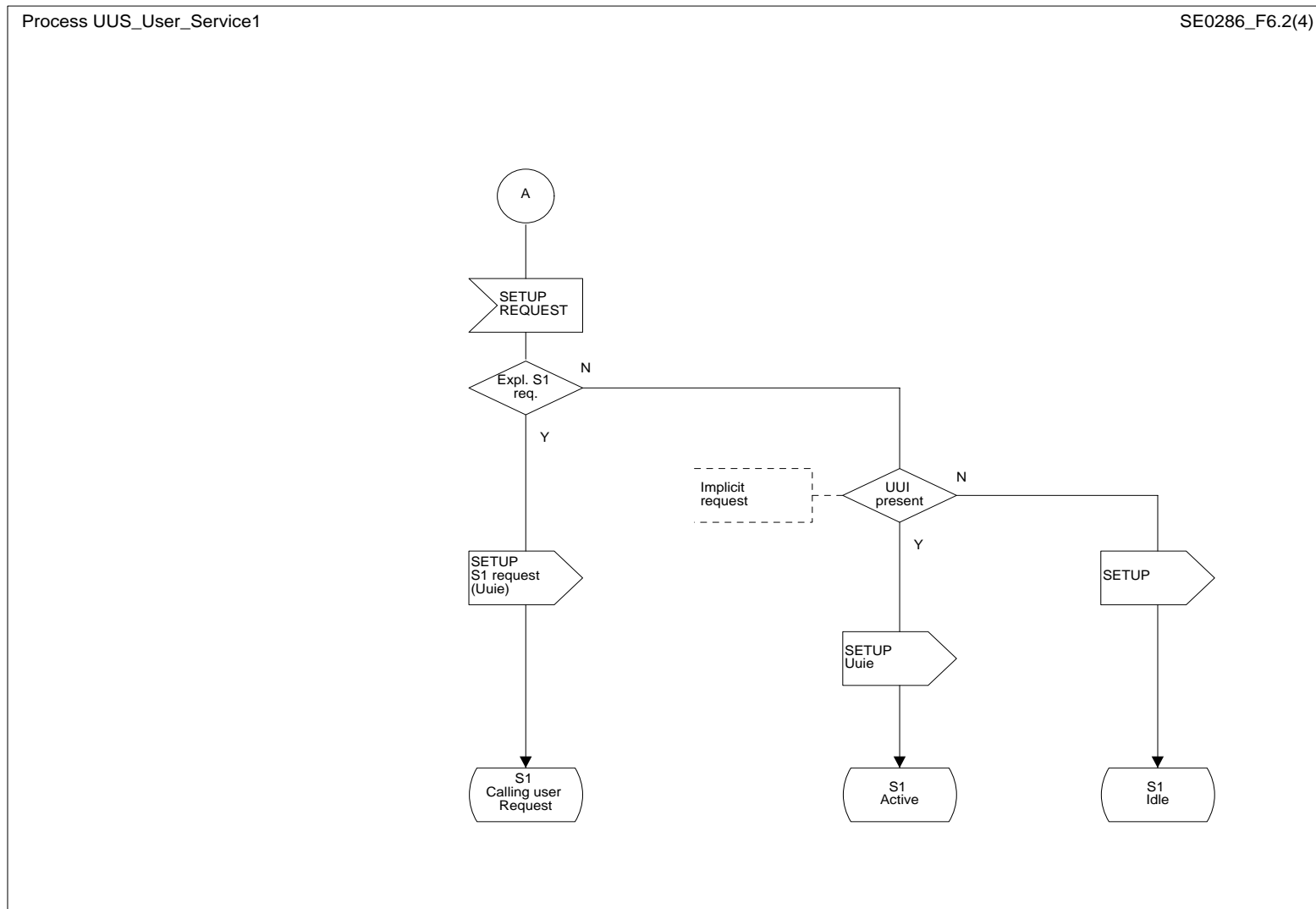


Figure 6 (sheet 2 of 4): UUS supplementary service, service 1, calling user side process

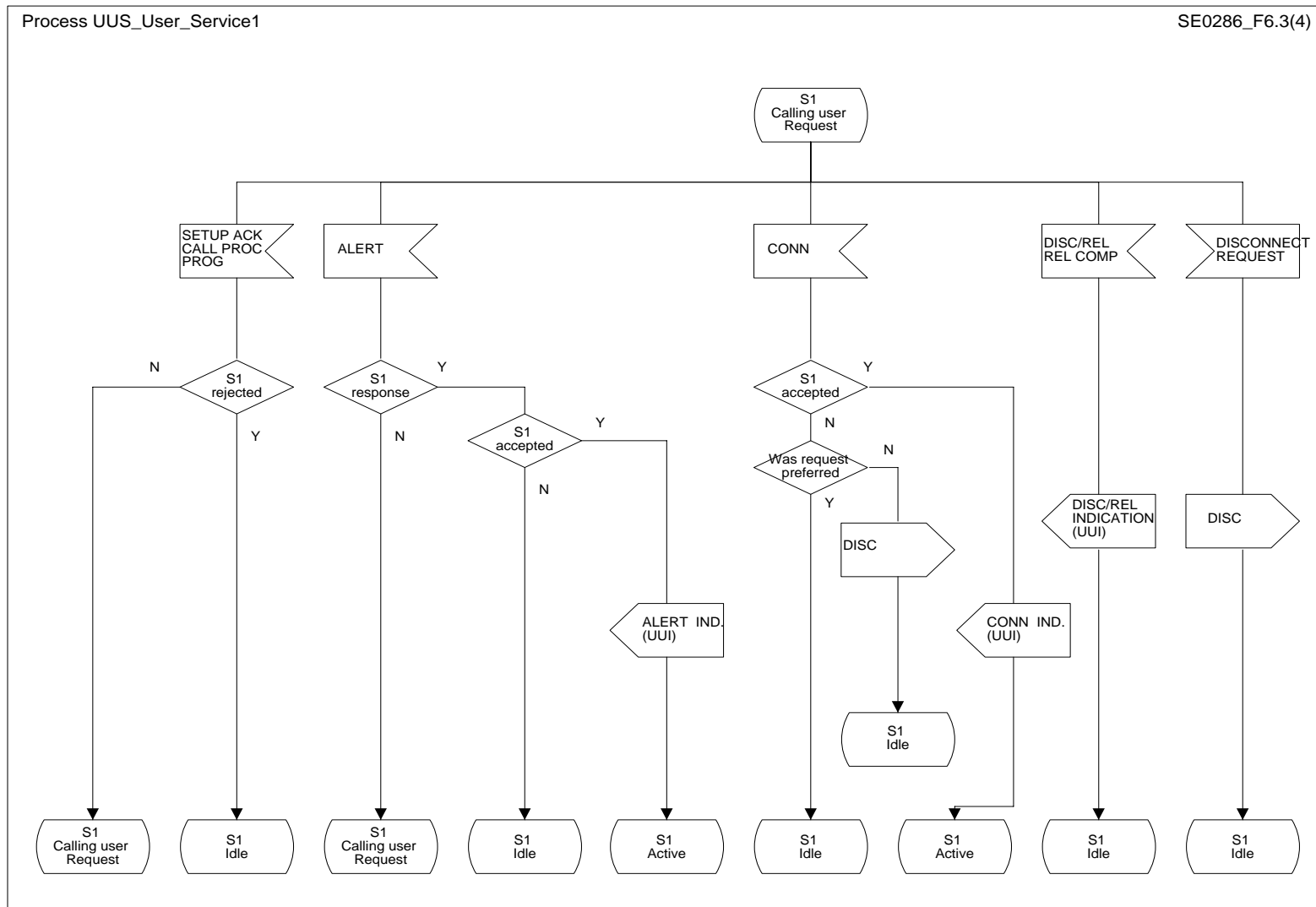


Figure 6 (sheet 3 of 4): UUS supplementary service, service 1, calling user side process

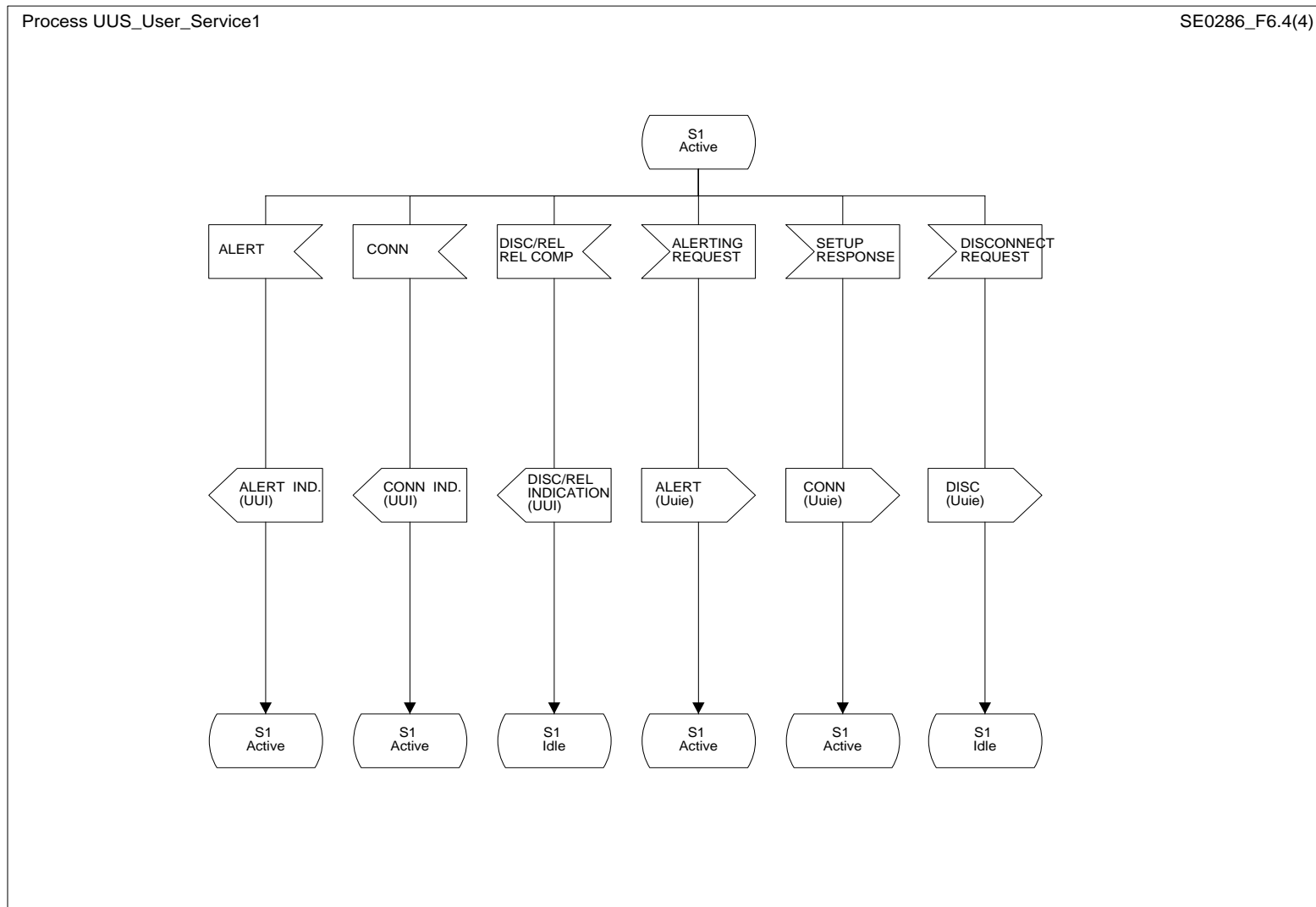


Figure 6 (sheet 4 of 4): UUS supplementary service, service 1, calling and called user side process

## 14.1.2 Network

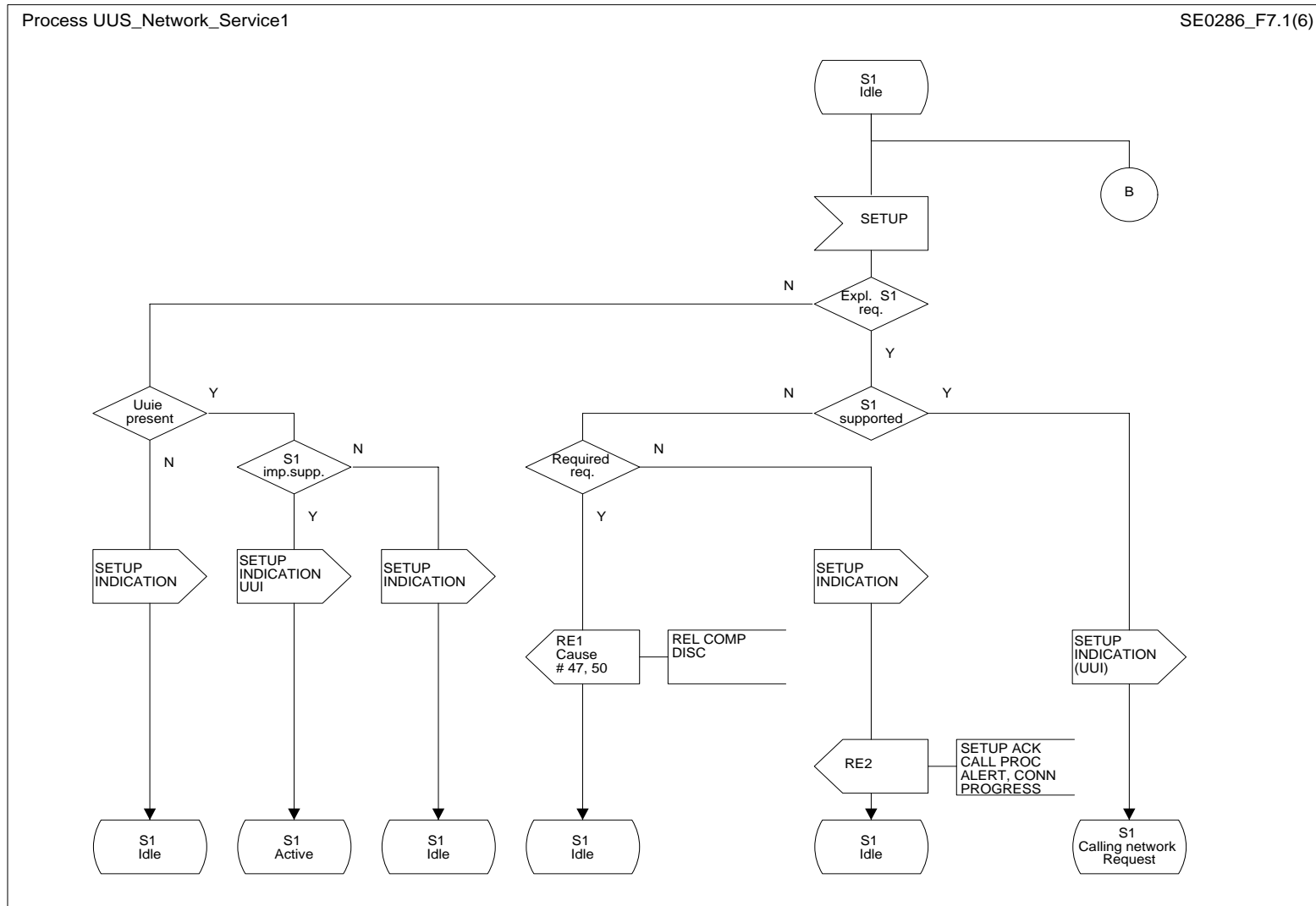


Figure 7 (sheet 1 of 6): UUS supplementary service, service 1, calling network side process

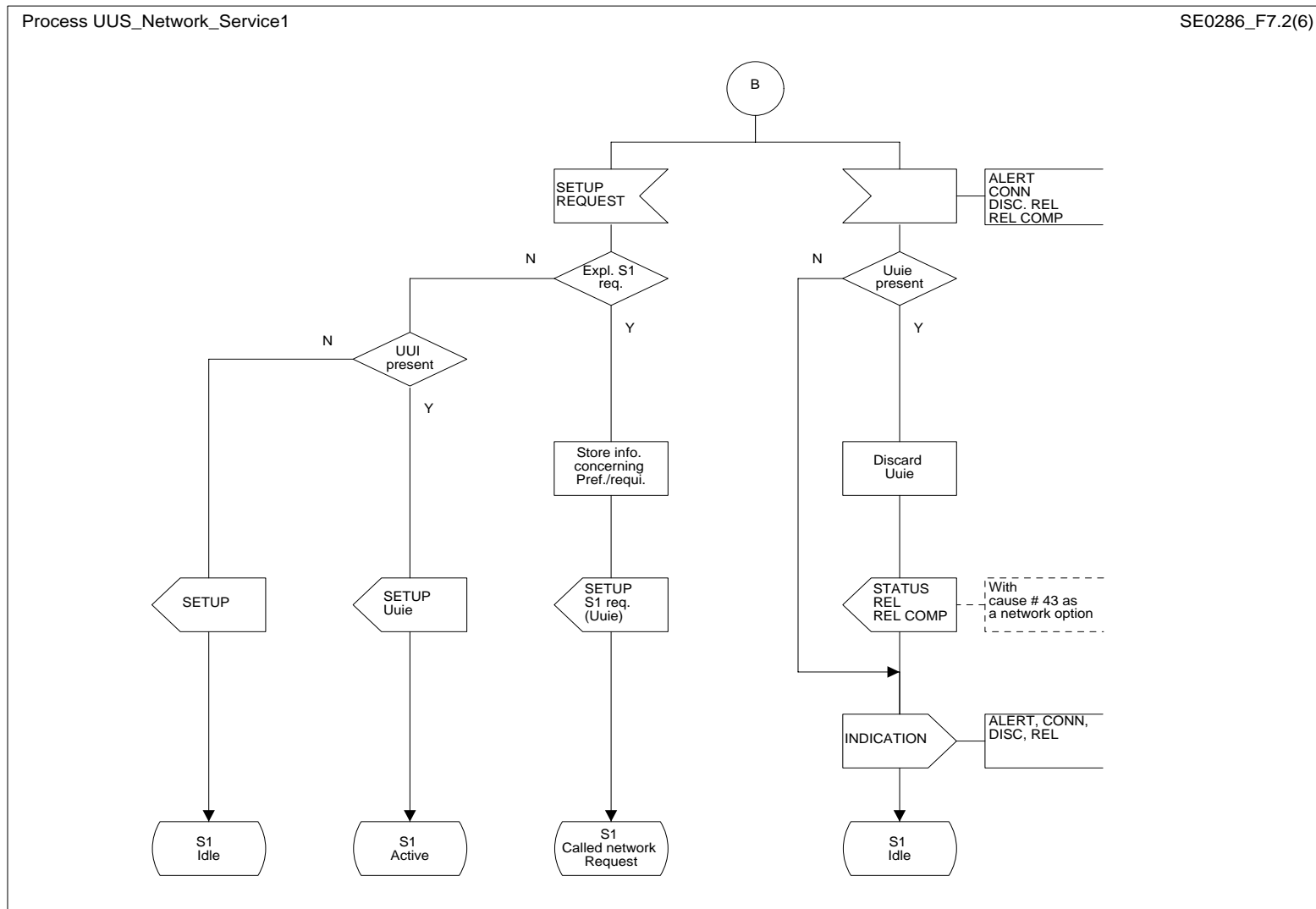


Figure 7 (sheet 2 of 6): UUS supplementary service, service 1, called network side process

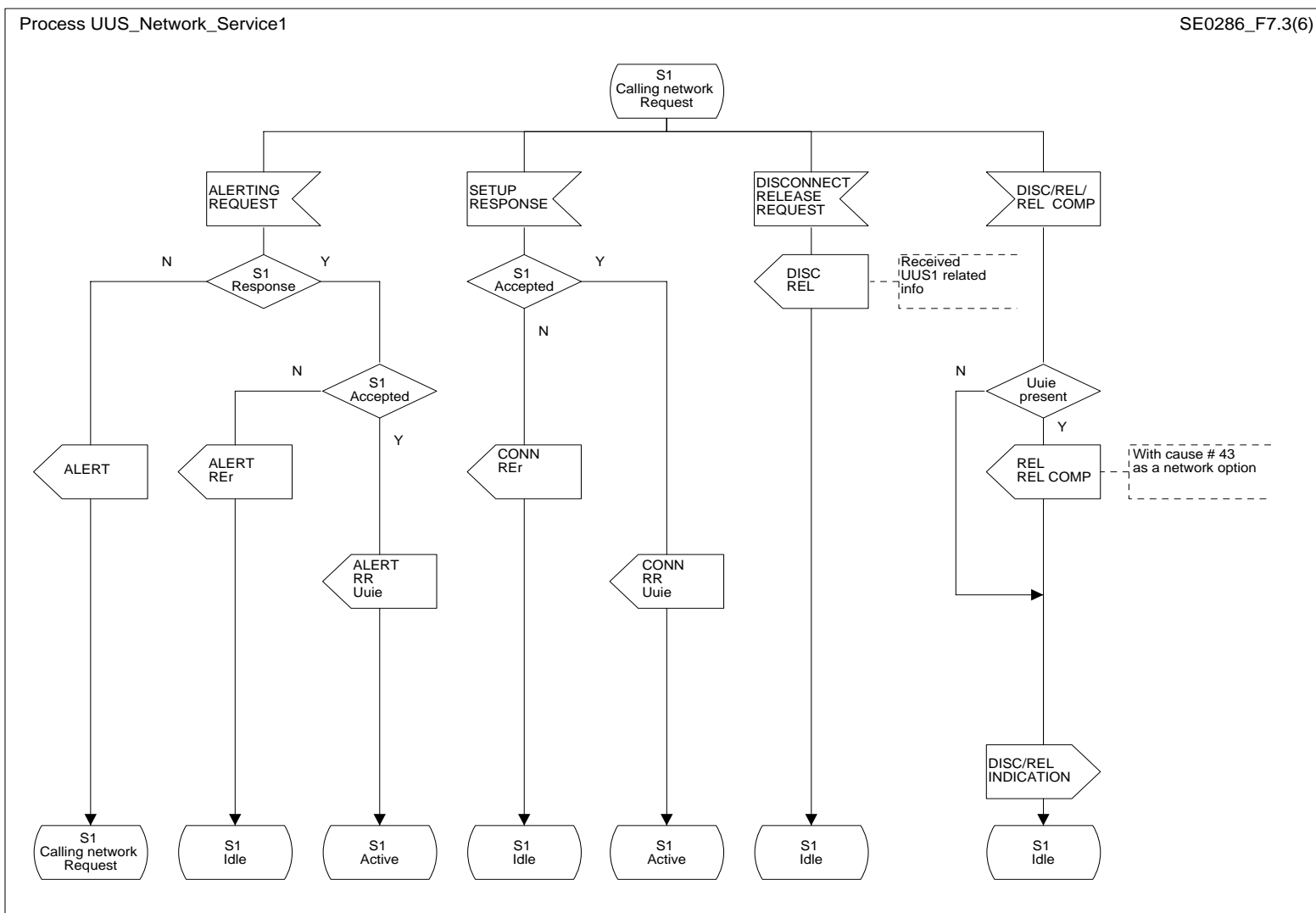


Figure 7 (sheet 3 of 6): UUS supplementary service, service 1, calling network side process

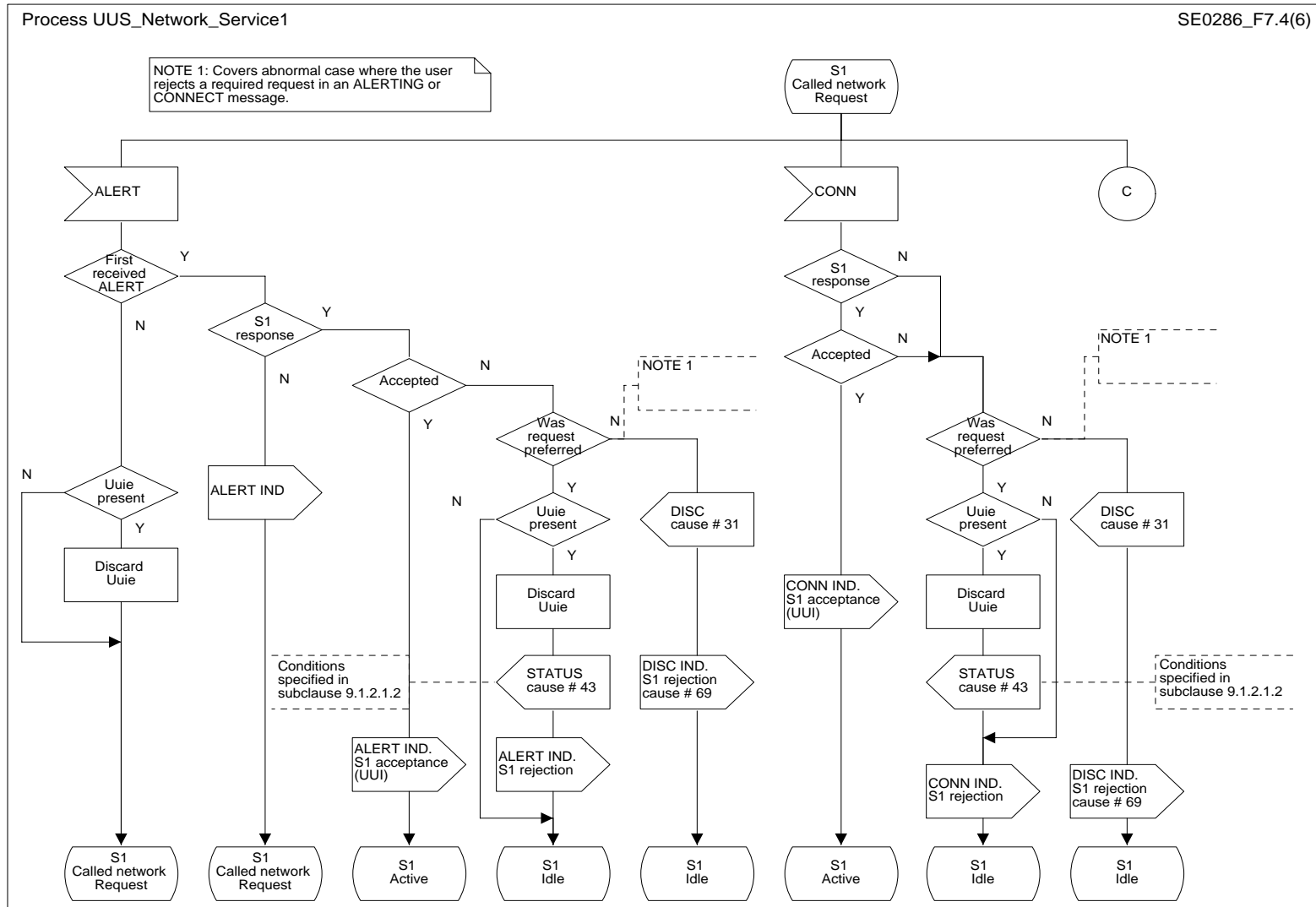


Figure 7 (sheet 4 of 6): UUS supplementary service, service 1, called network side process



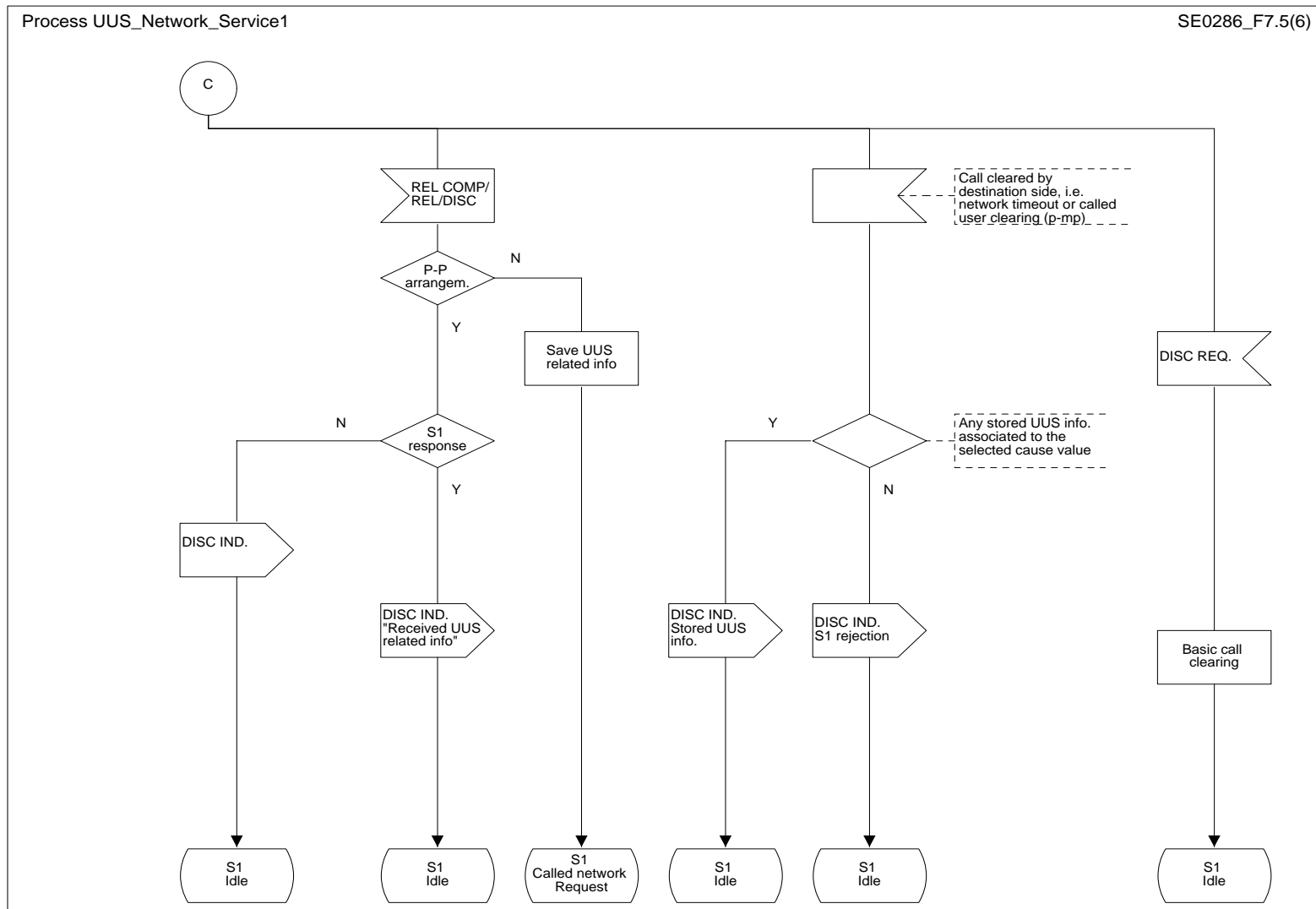


Figure 7 (sheet 5 of 6): UUS supplementary service, service 1, called network side process

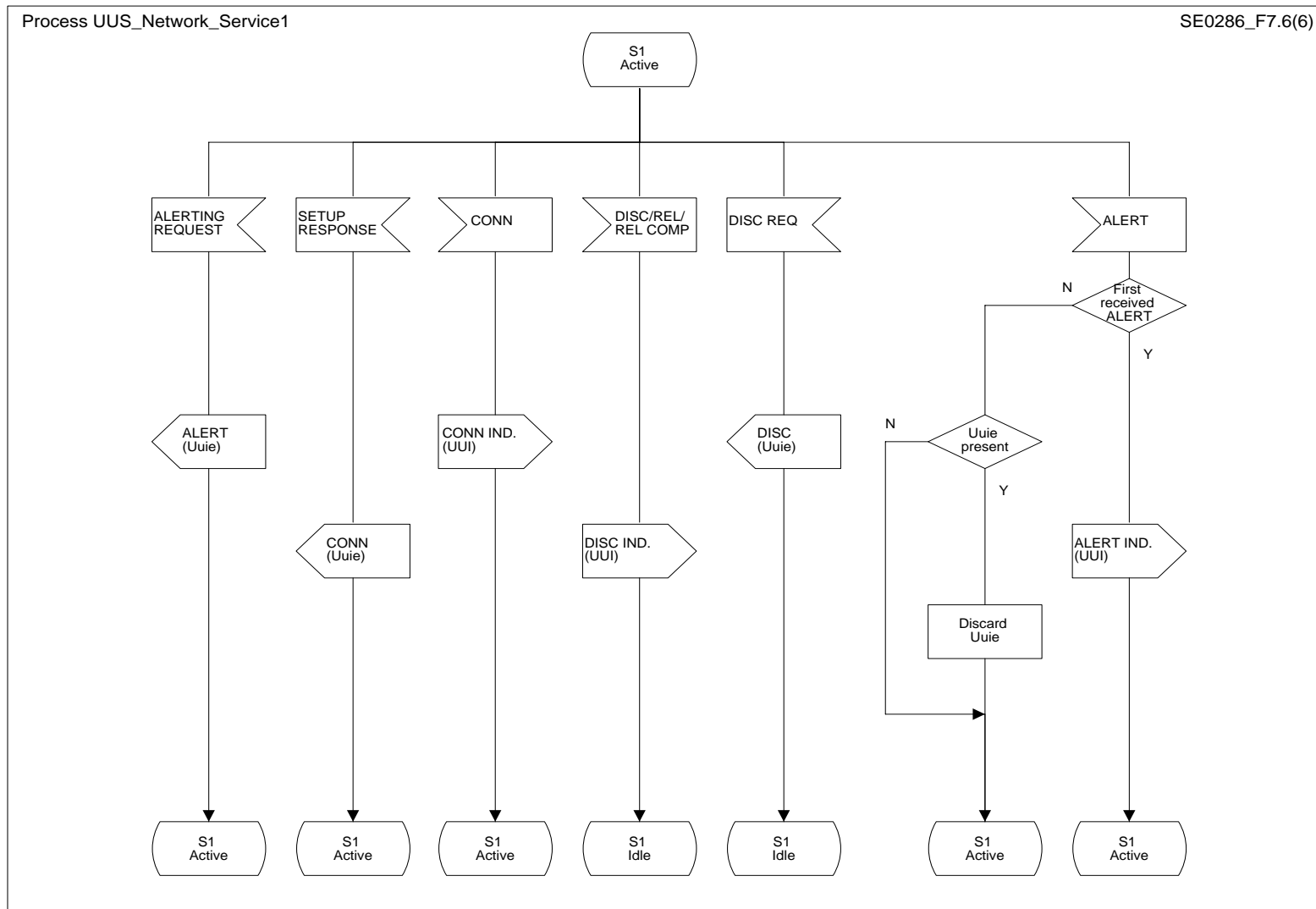


Figure 7 (sheet 6 of 6): UUS supplementary service, service 1, calling and called network side process

## 14.2 Service 2

### 14.2.1 User

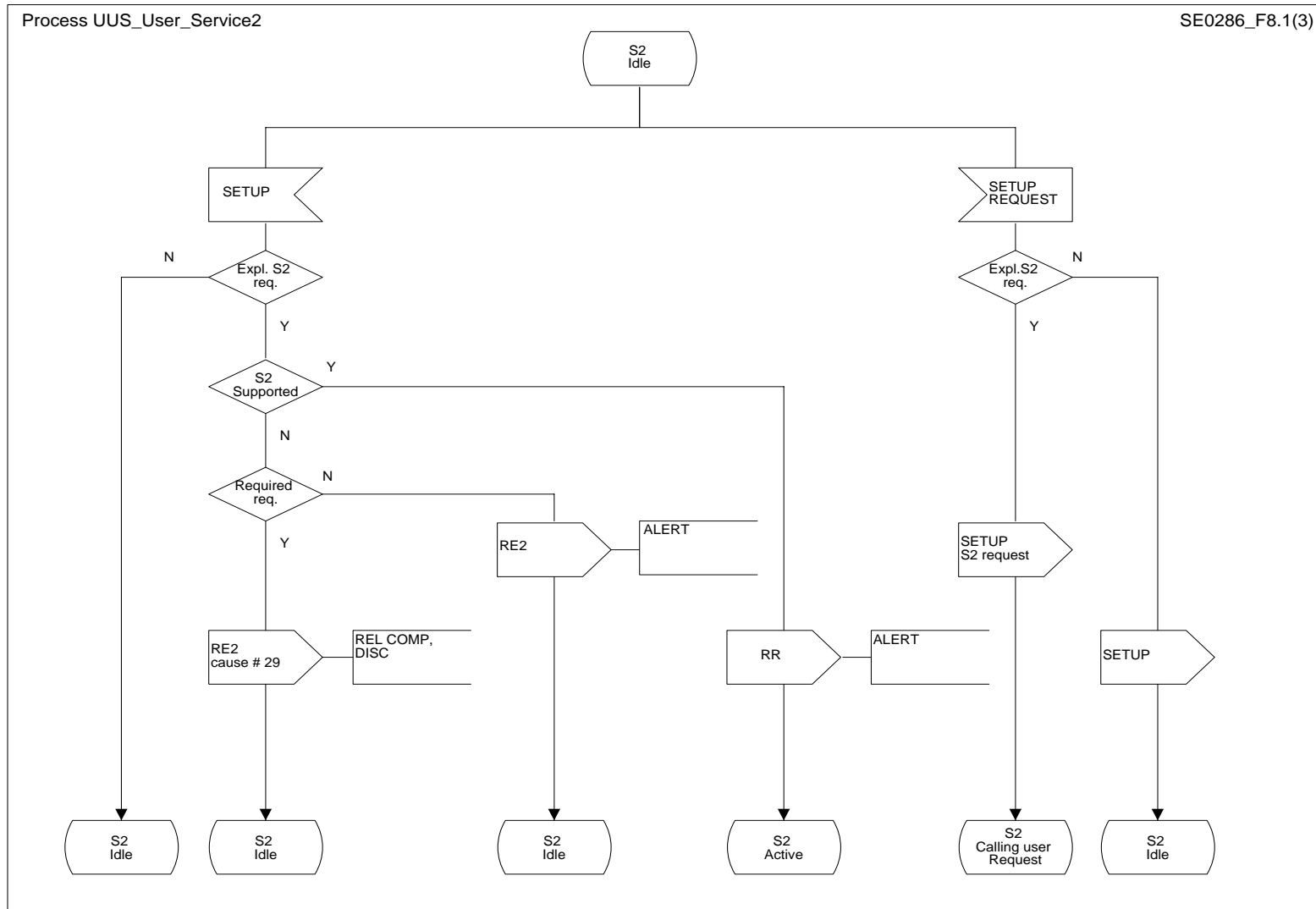


Figure 8 (sheet 1 of 3): UUS supplementary service, service 2, calling and called user side process

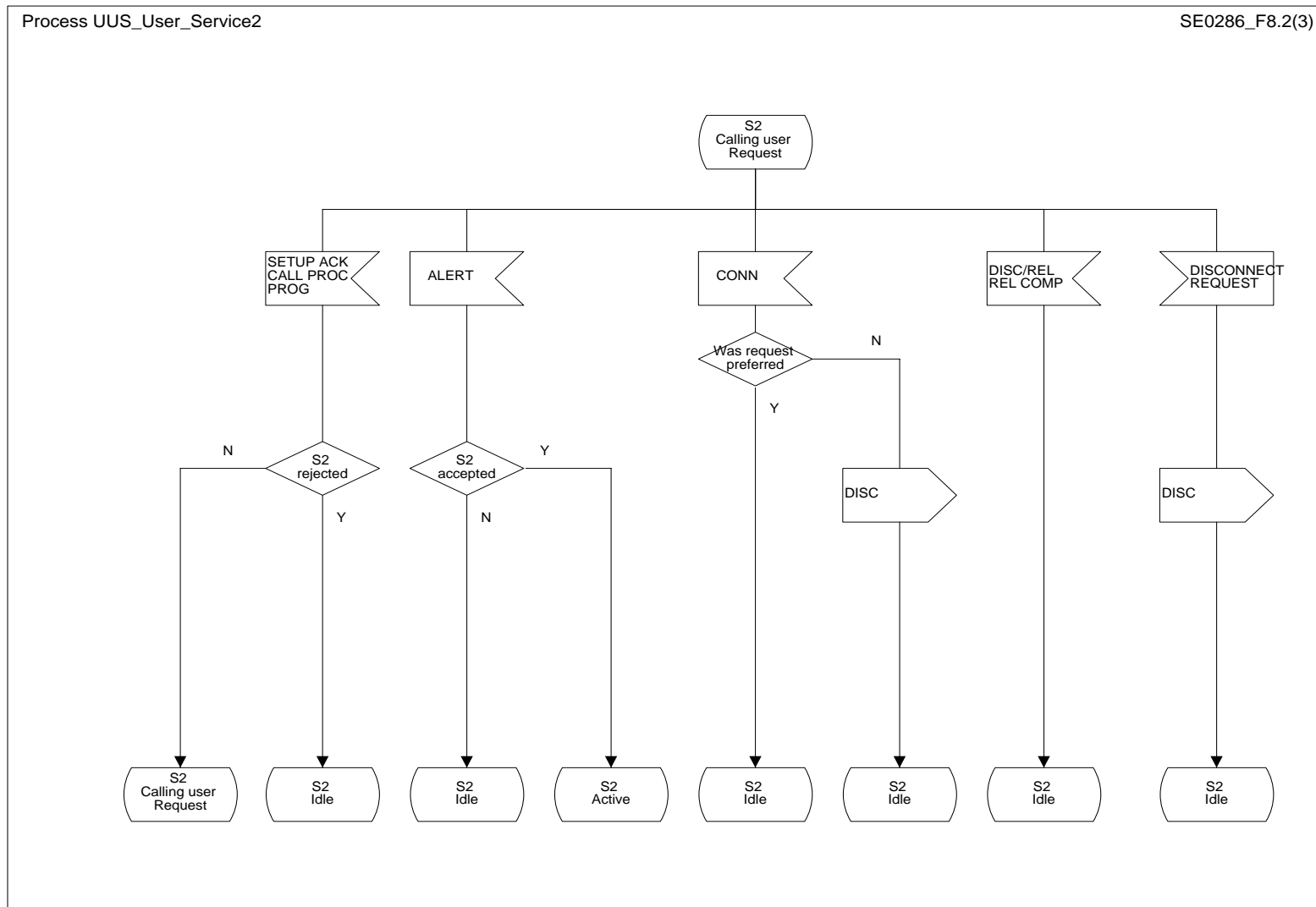


Figure 8 (sheet 2 of 3): UUS supplementary service, service 2, calling user side process

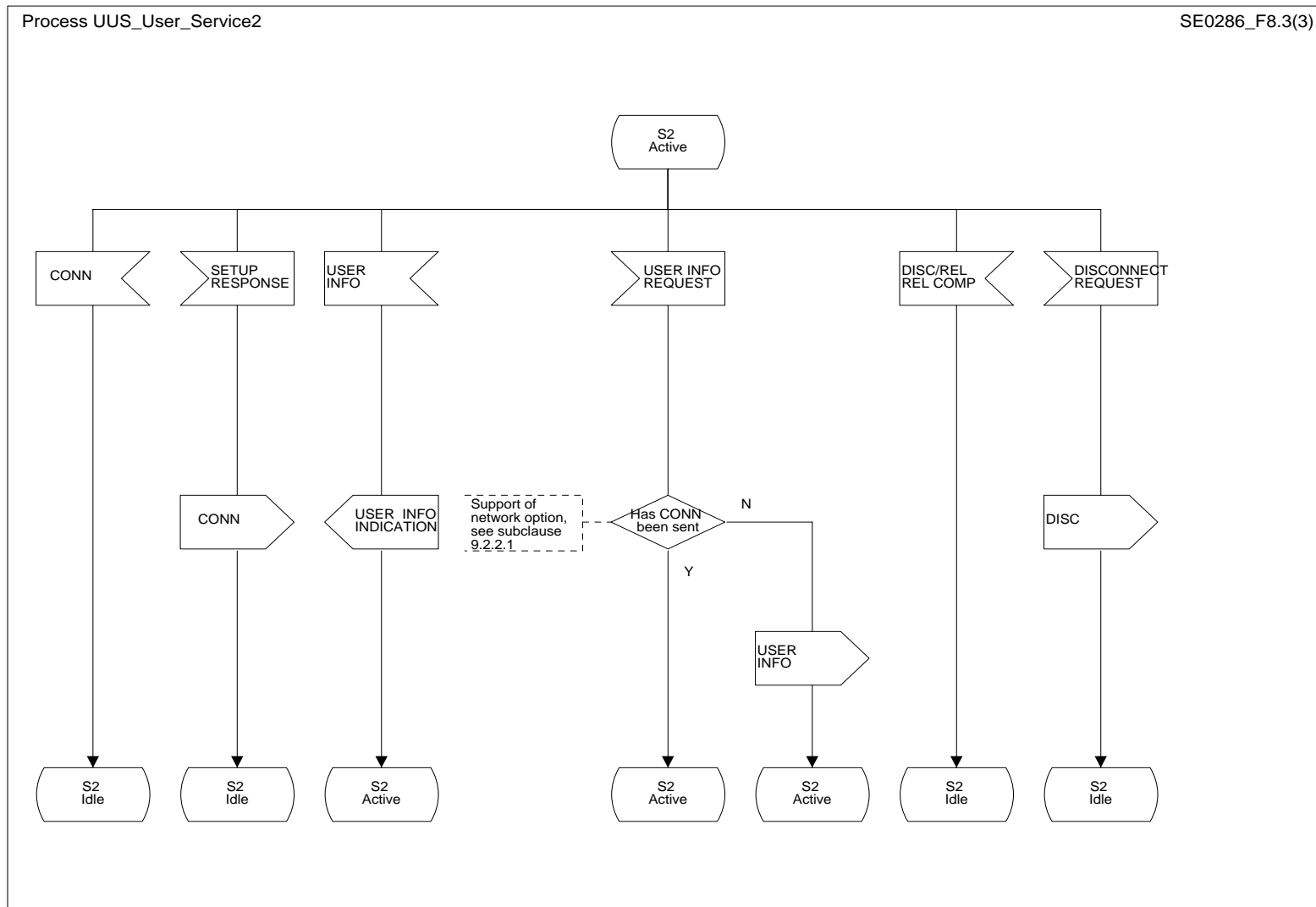


Figure 8 (sheet 3 of 3): UUS supplementary service, service 2, calling and called user side process

14.2.2 Network

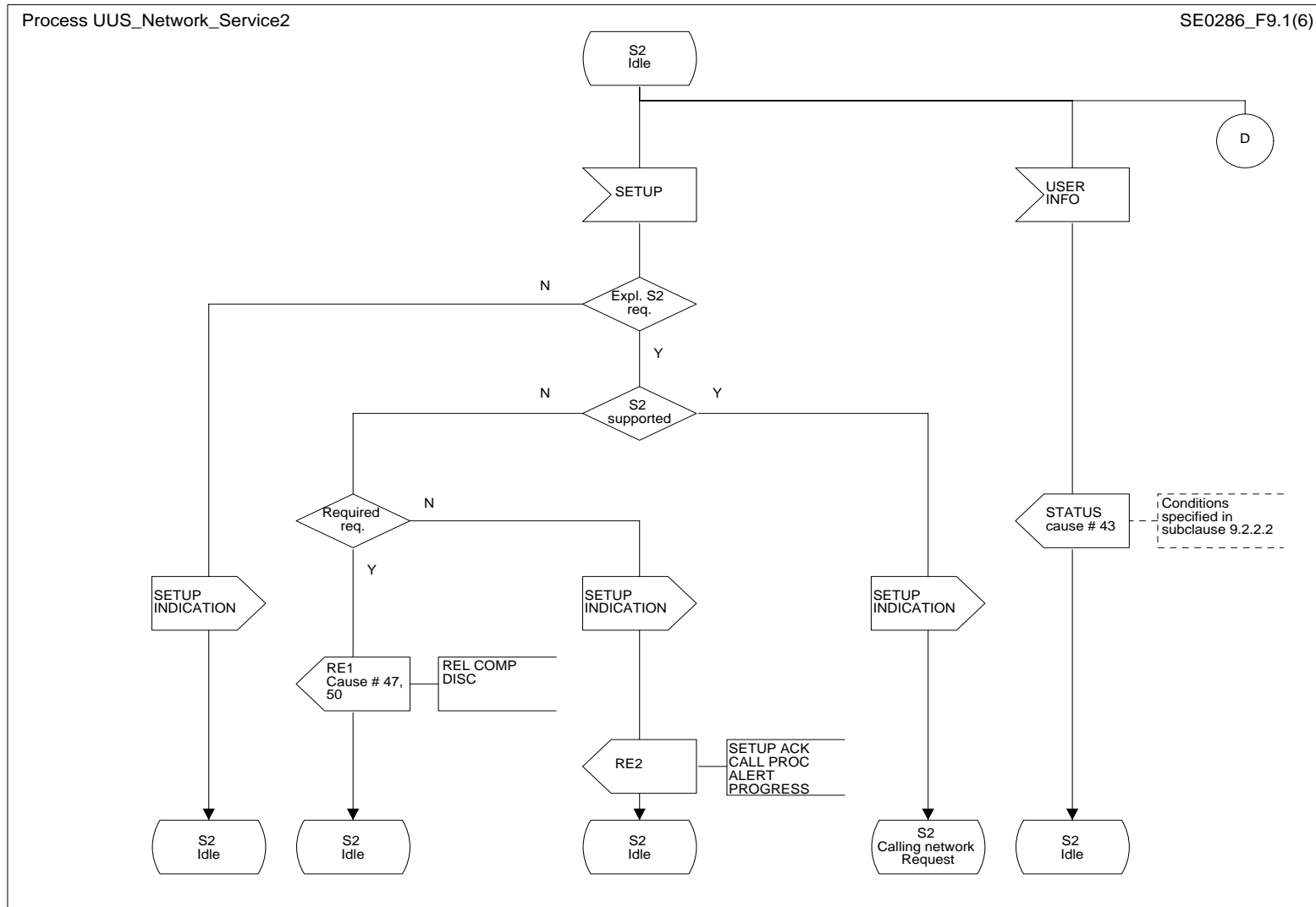


Figure 9 (sheet 1 of 6): UUS supplementary service, service 2, calling network side process

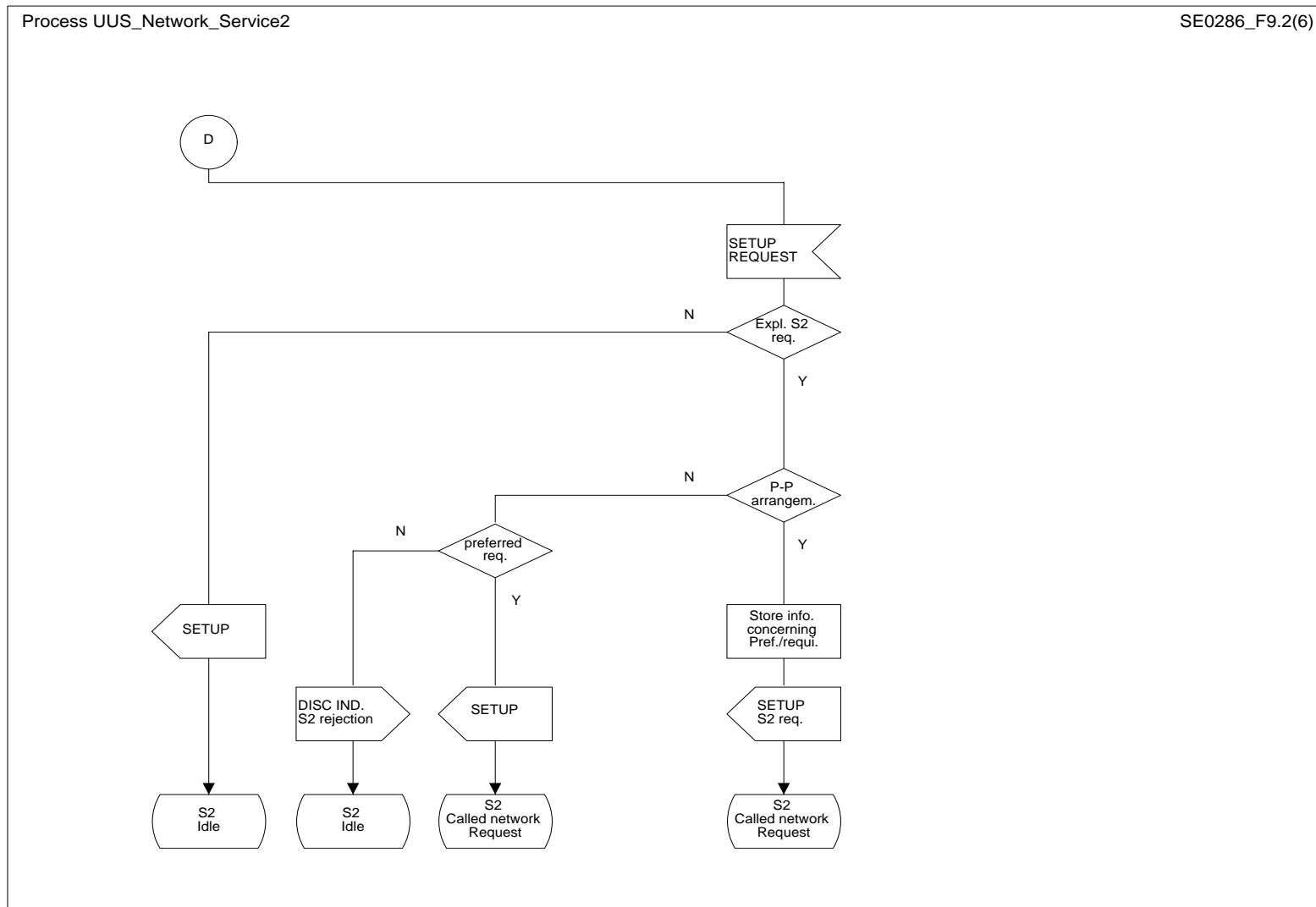


Figure 9 (sheet 2 of 6): UUS supplementary service, service 2, called network side process

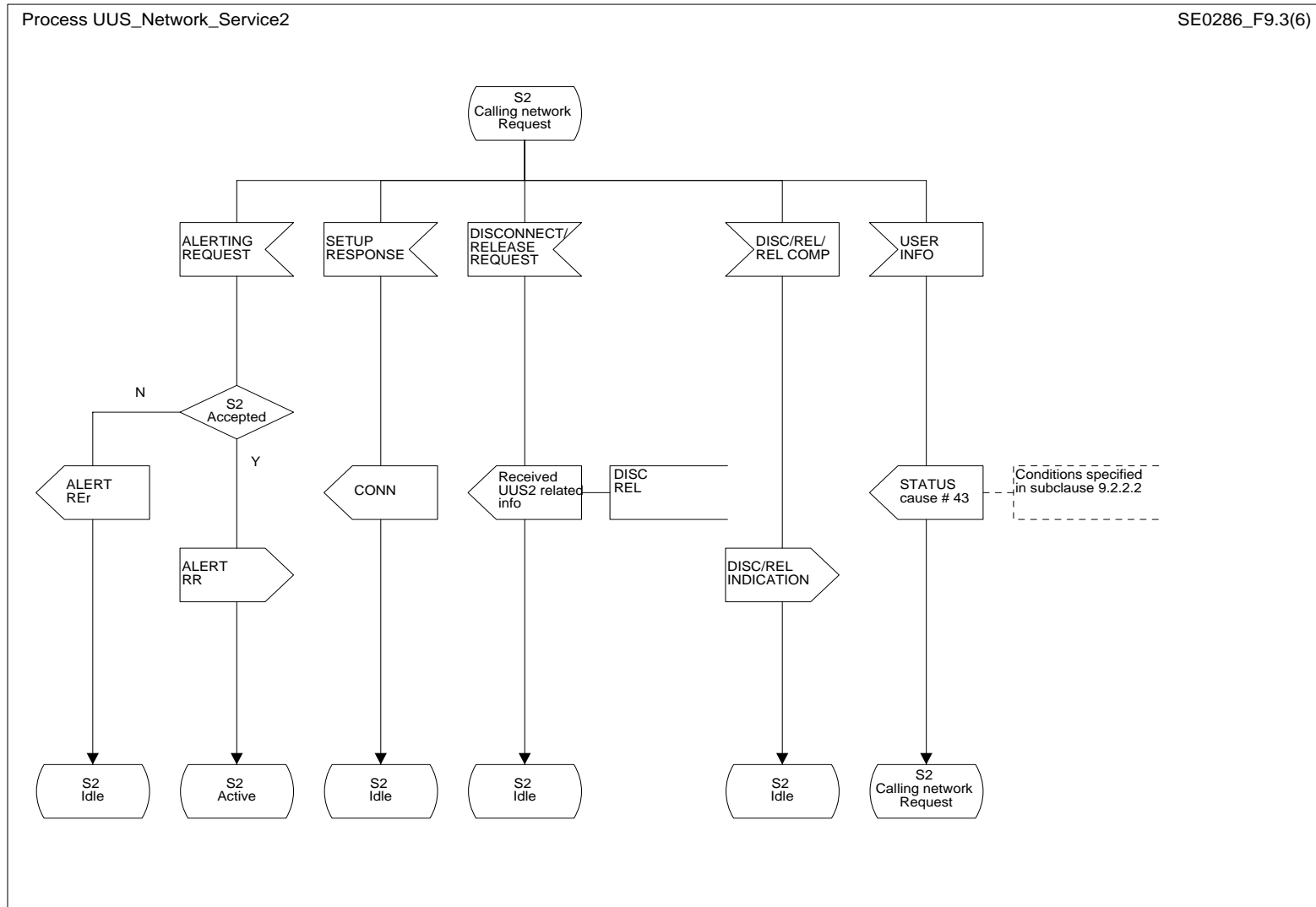


Figure 9 (sheet 3 of 6): UUS supplementary service, service 2, calling network side process



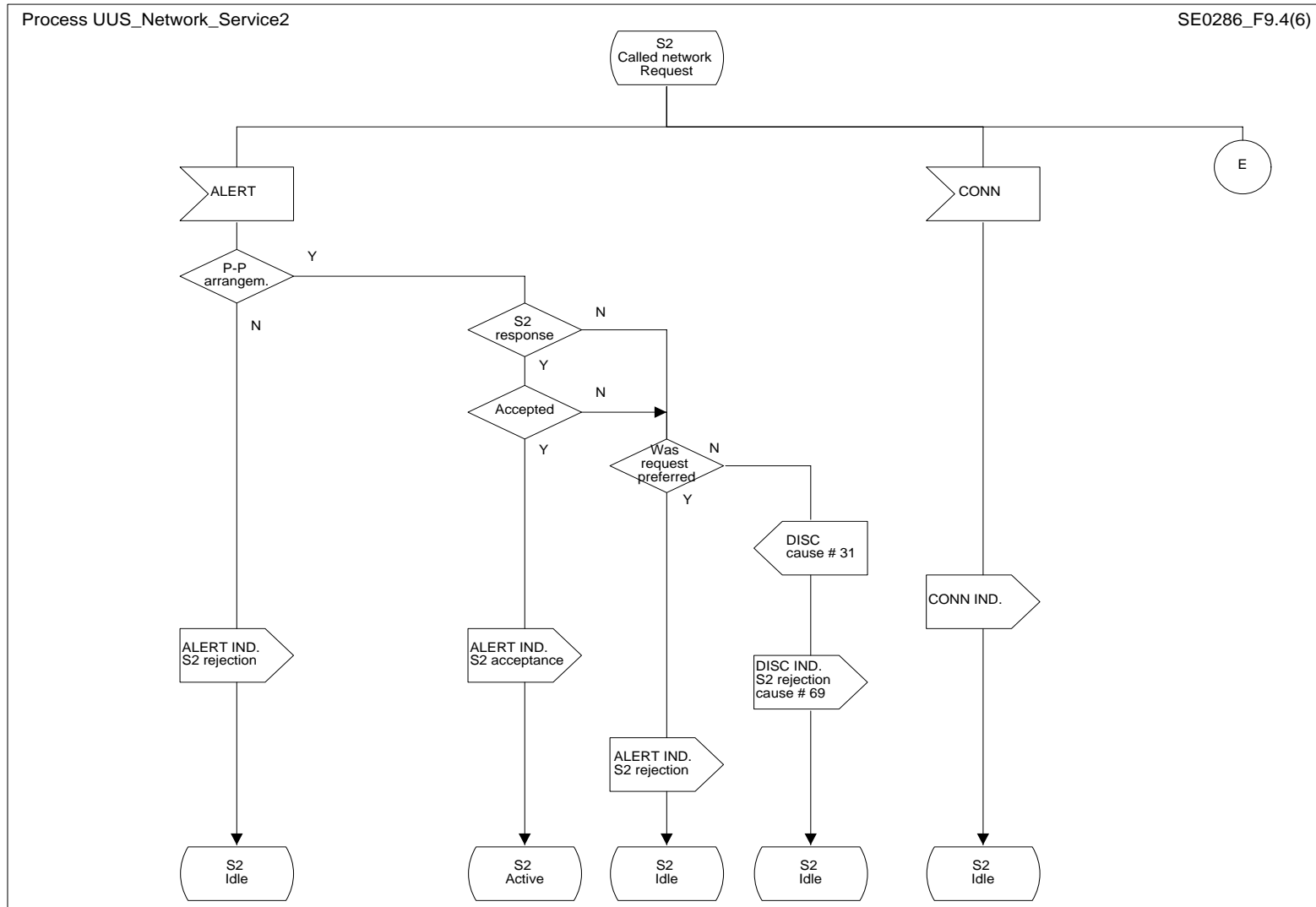


Figure 9 (sheet 4 of 6): UUS supplementary service, service 2, called network side process

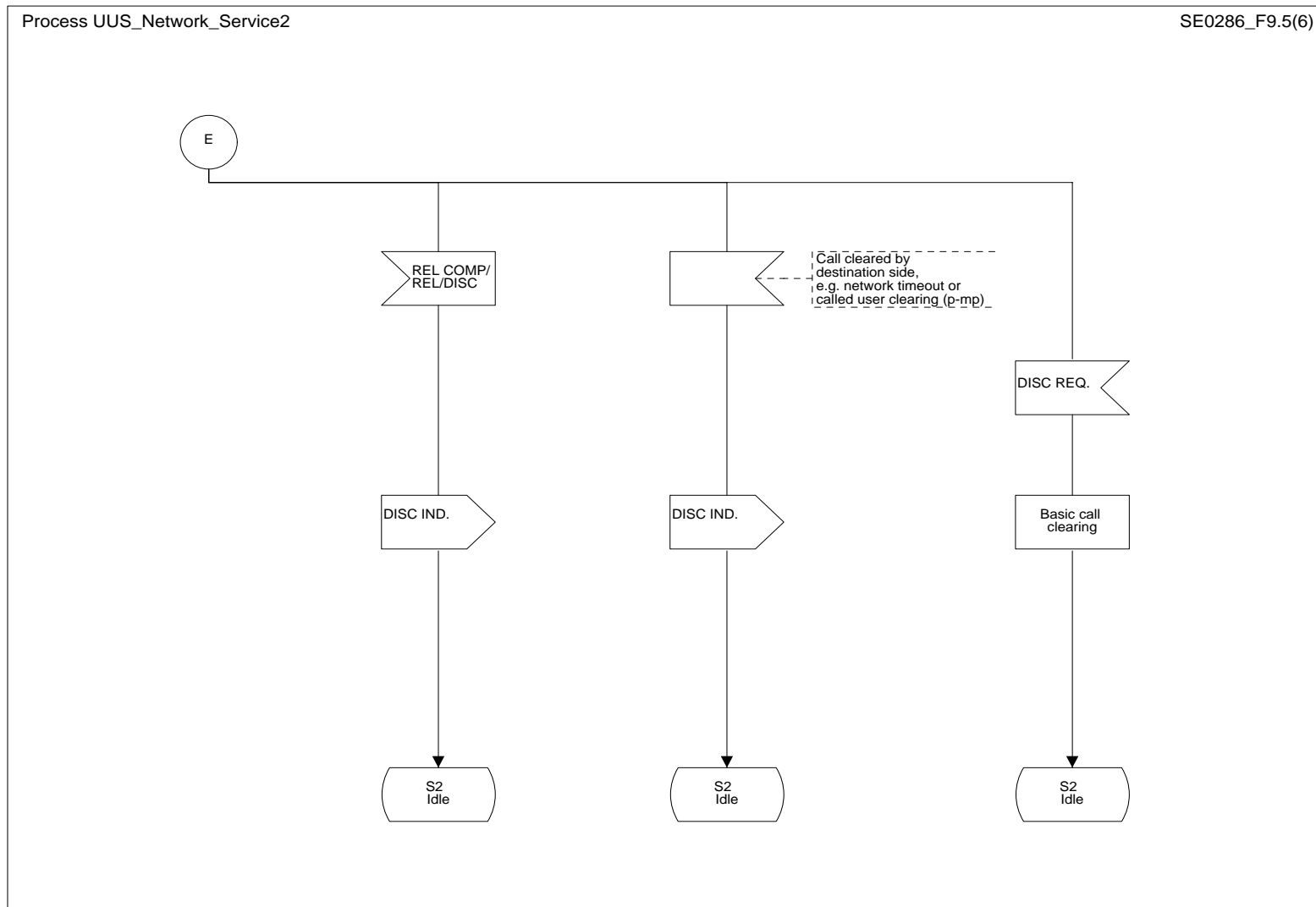


Figure 9 (sheet 5 of 6): UUS supplementary service, service 2, called network side process

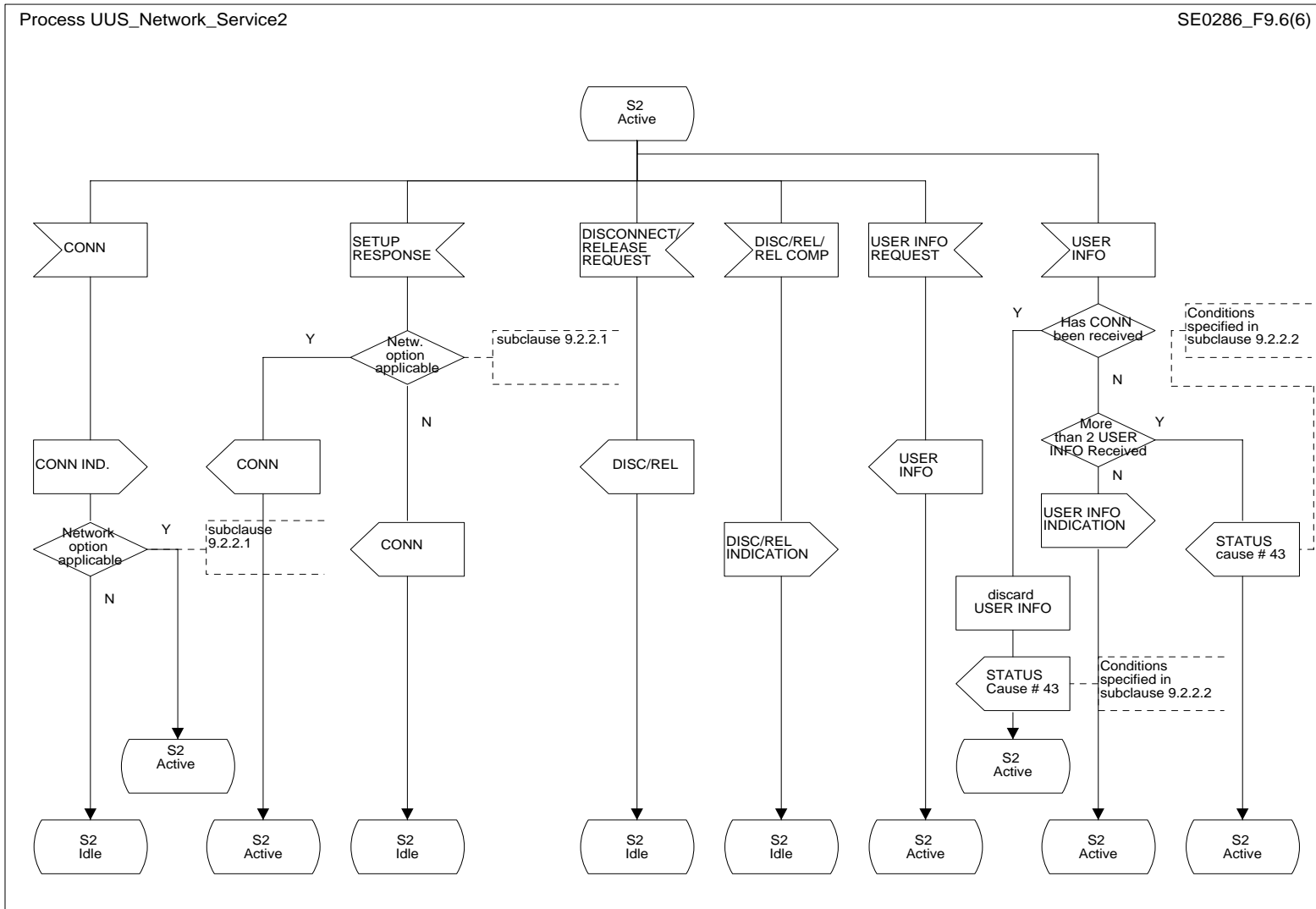


Figure 9 (sheet 6 of 6): UUS supplementary service, service 2, calling and called network side process

### 14.3 Service 3

#### 14.3.1 User

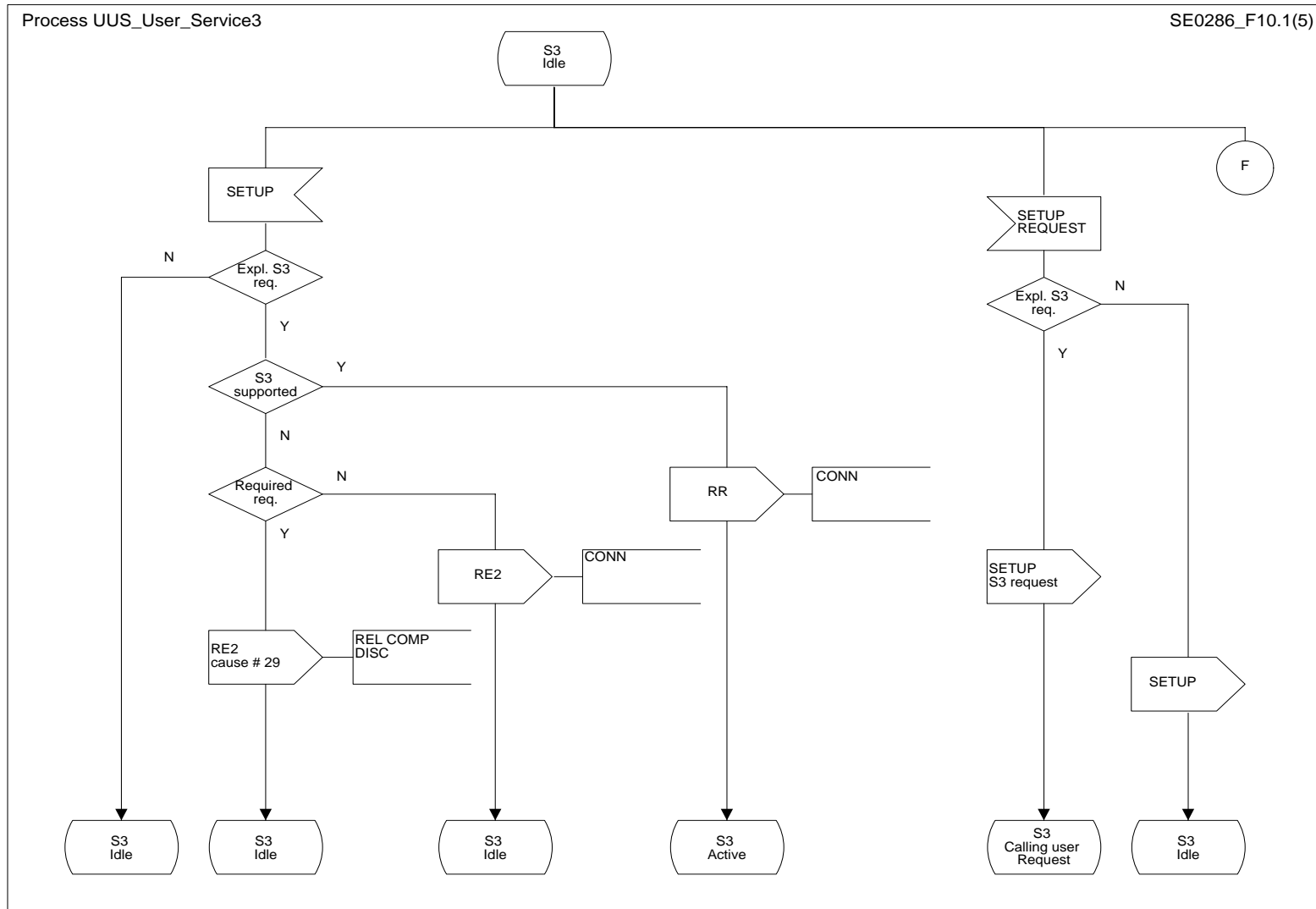


Figure 10 (sheet 1 of 5): UUS supplementary service, service 3, calling and called user side process

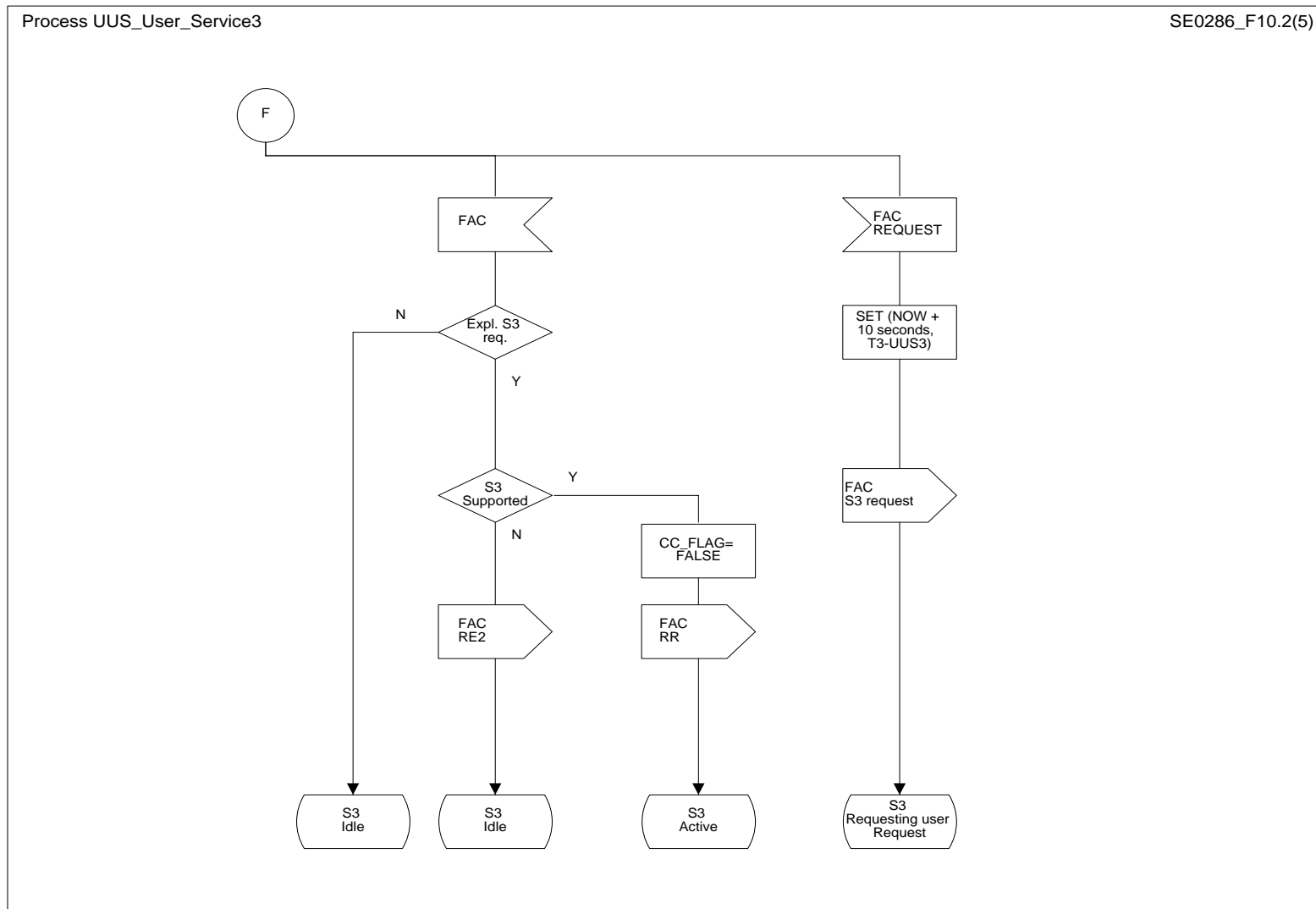


Figure 10 (sheet 2 of 5): UUS supplementary service, service 3, requesting and remote user side process

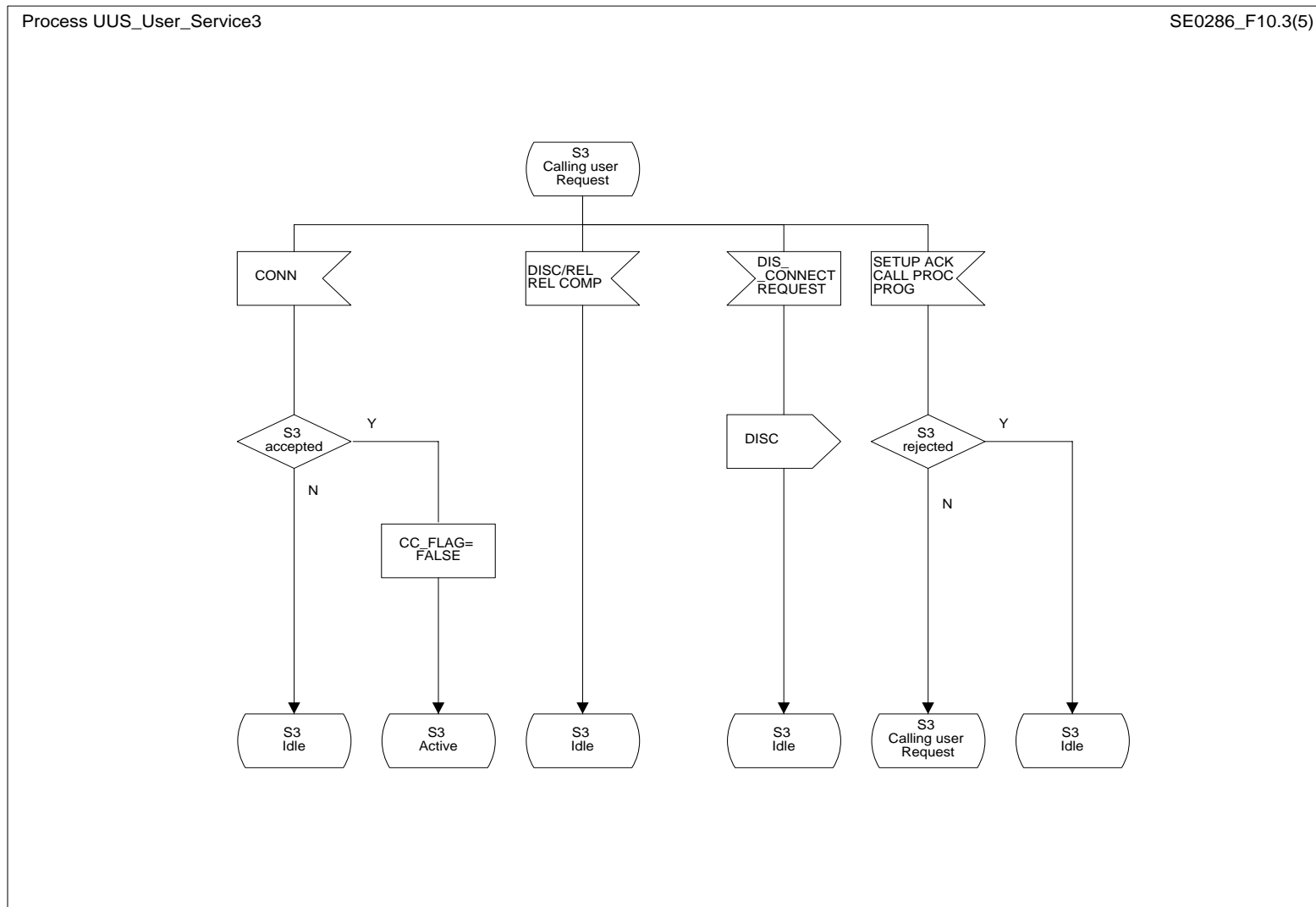


Figure 10 (sheet 3 of 5): UUS supplementary service, service 3, calling user side process

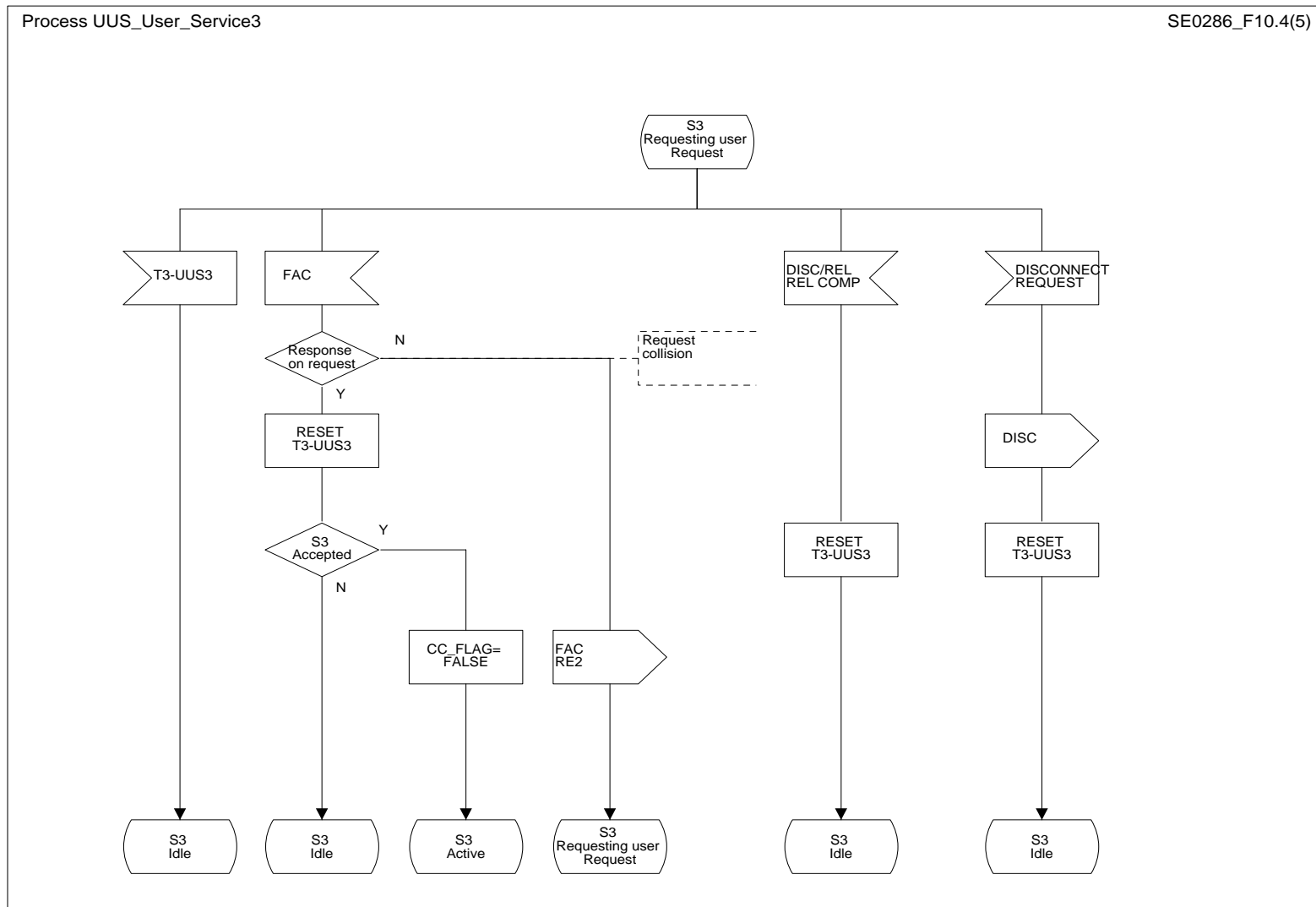


Figure 10 (sheet 4 of 5): UUS supplementary service, service 3, requesting user side process

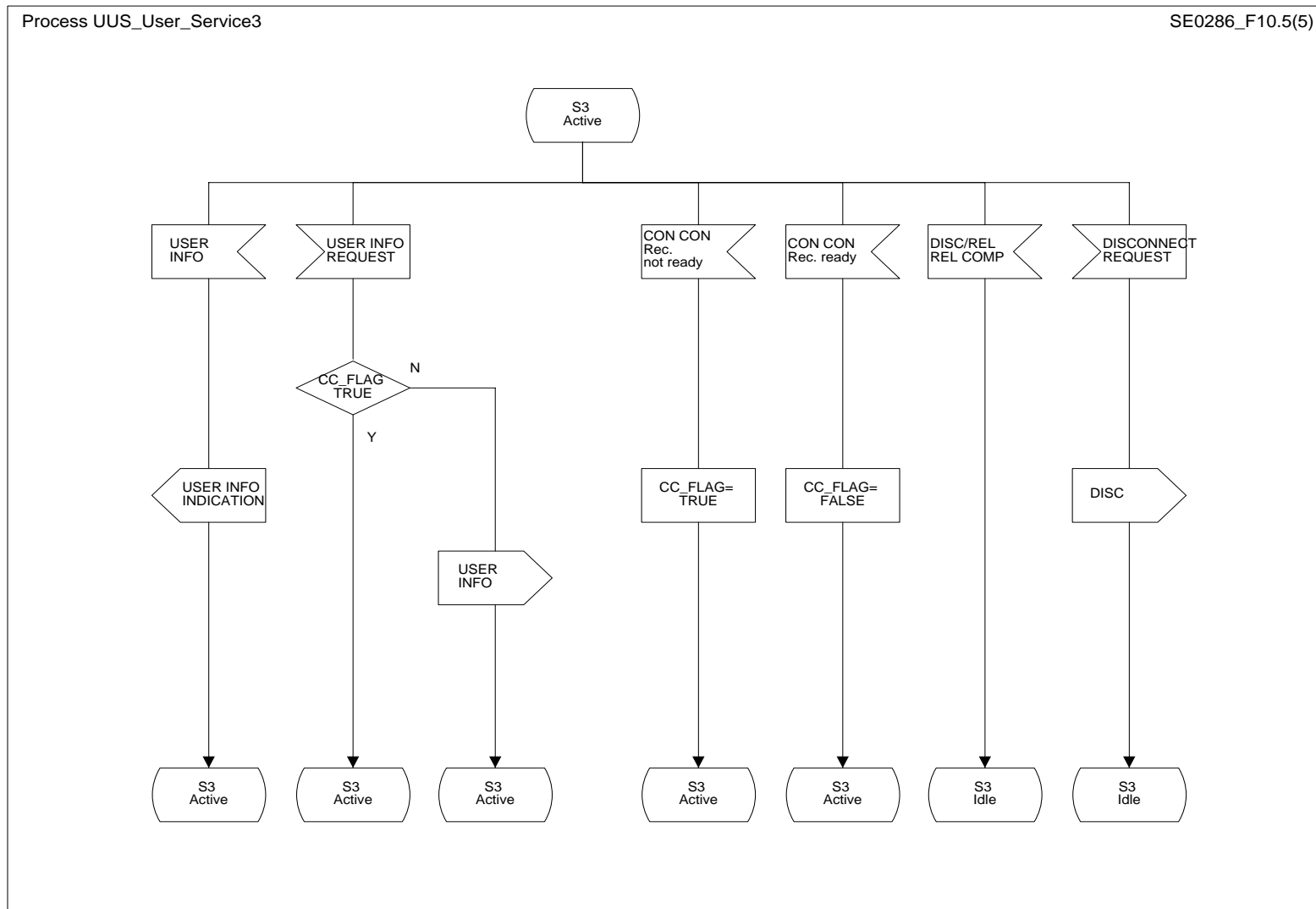


Figure 10 (sheet 5 of 5): UUS supplementary service, service 3, sending and receiving user side process



14.3.2 Network

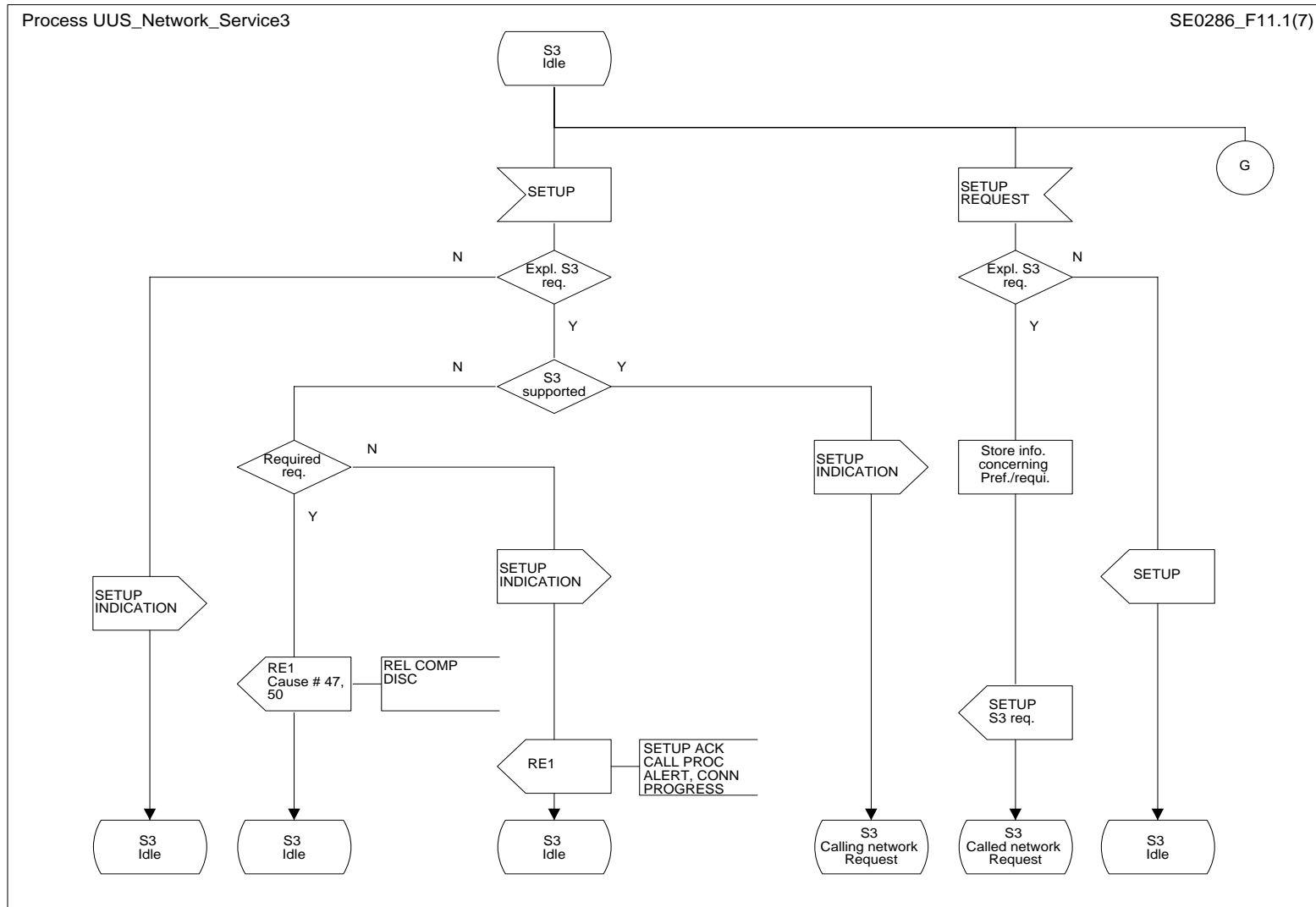


Figure 11 (sheet 1 of 7): UUS supplementary service, service 3, calling and called network side process

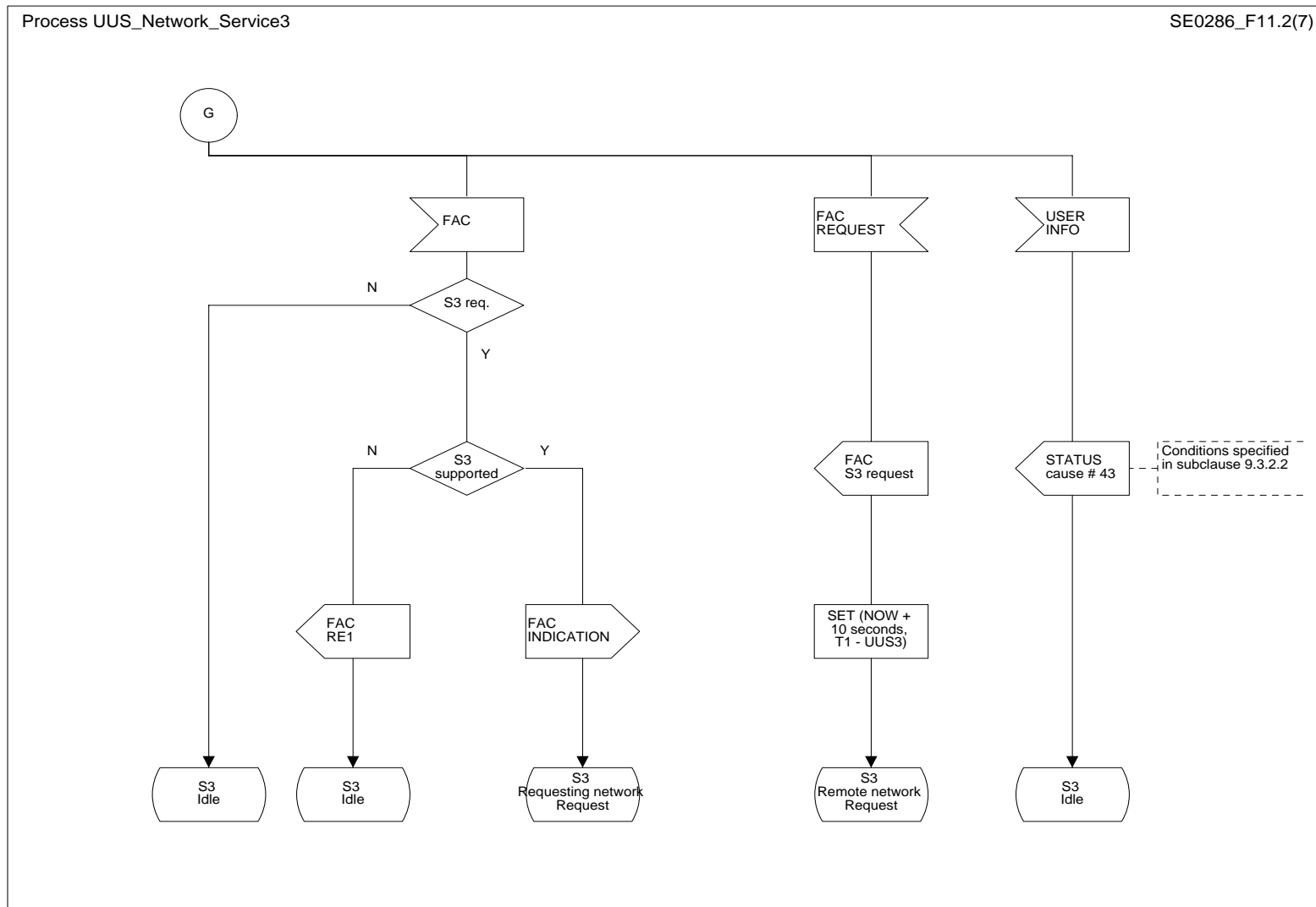


Figure 11 (sheet 2 of 7): UUS supplementary service, service 3, requesting and remote network side process

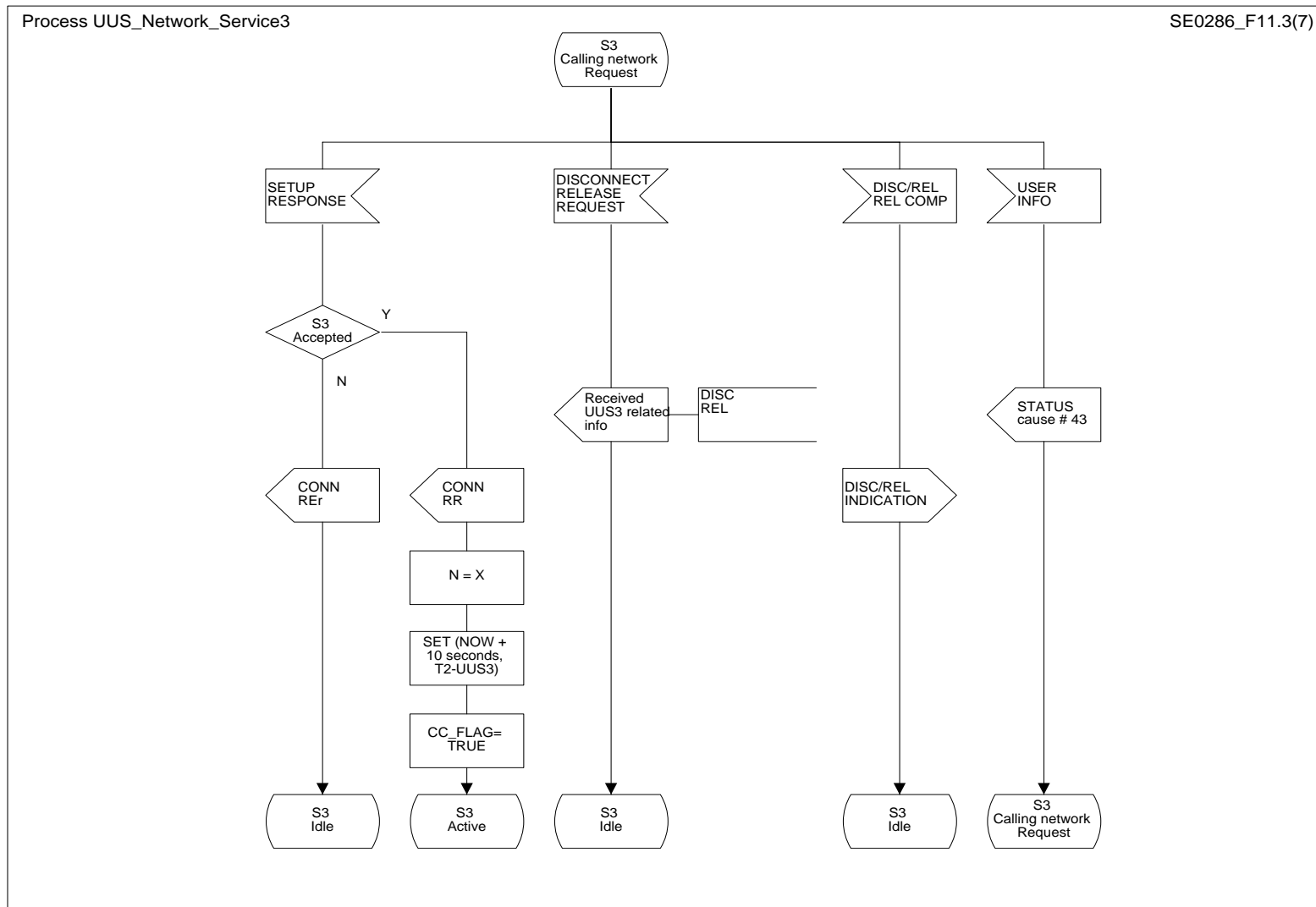


Figure 11 (sheet 3 of 7): UUS supplementary service, service 3, calling network side process

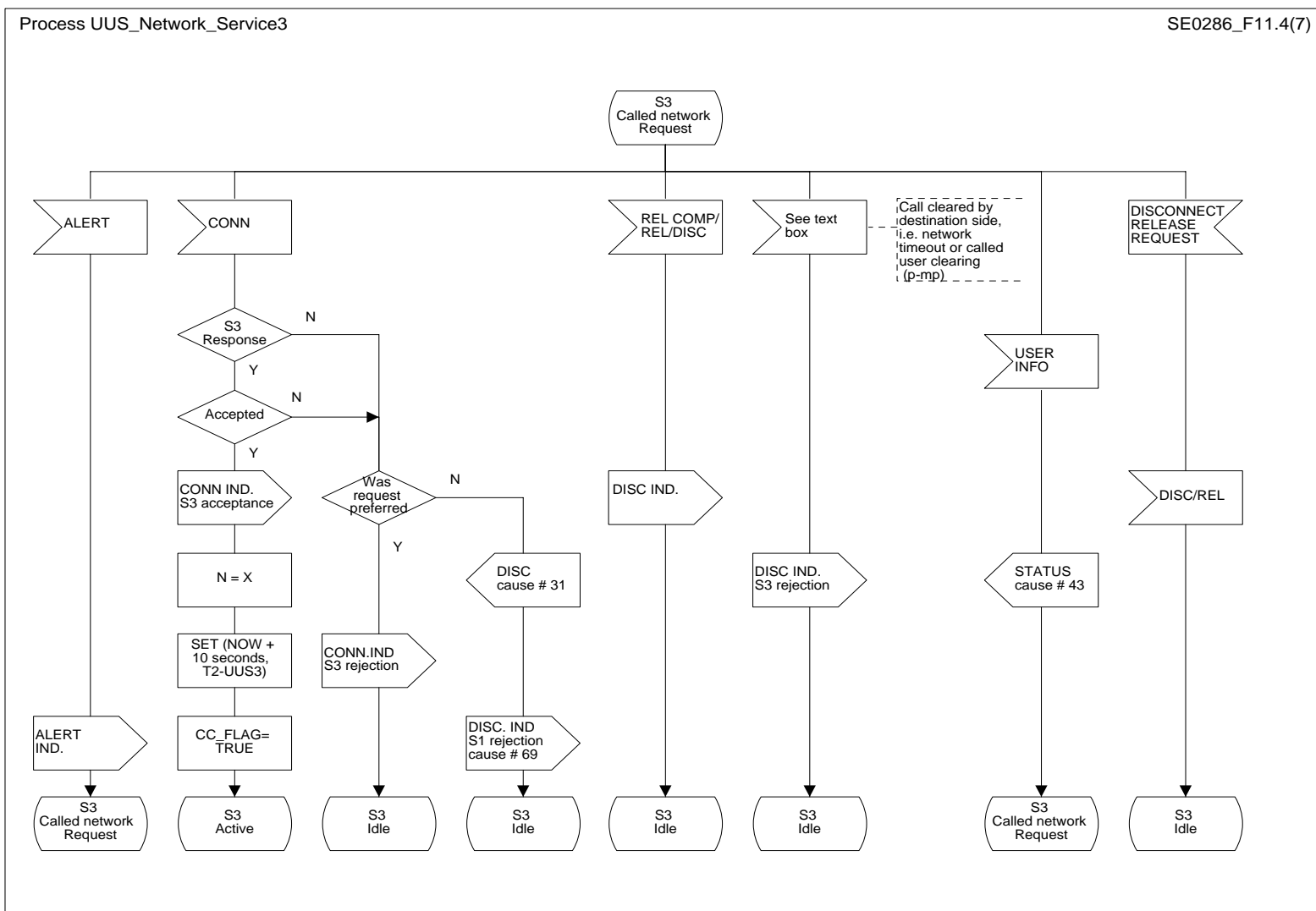


Figure 11 (sheet 4 of 7): UUS supplementary service, service 3, called network side process

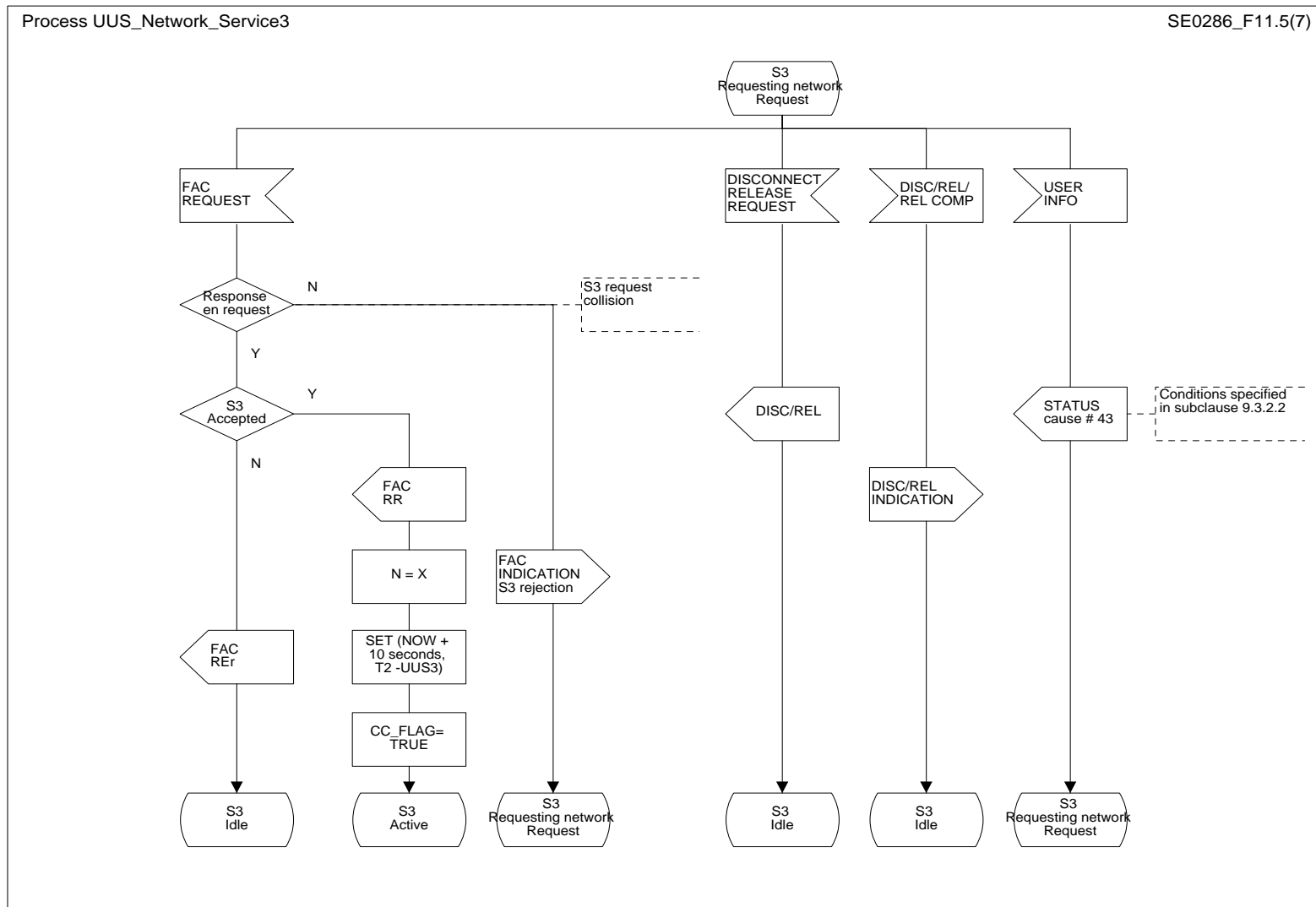


Figure 11 (sheet 5 of 7): UUS supplementary service, service 3, requesting network side process

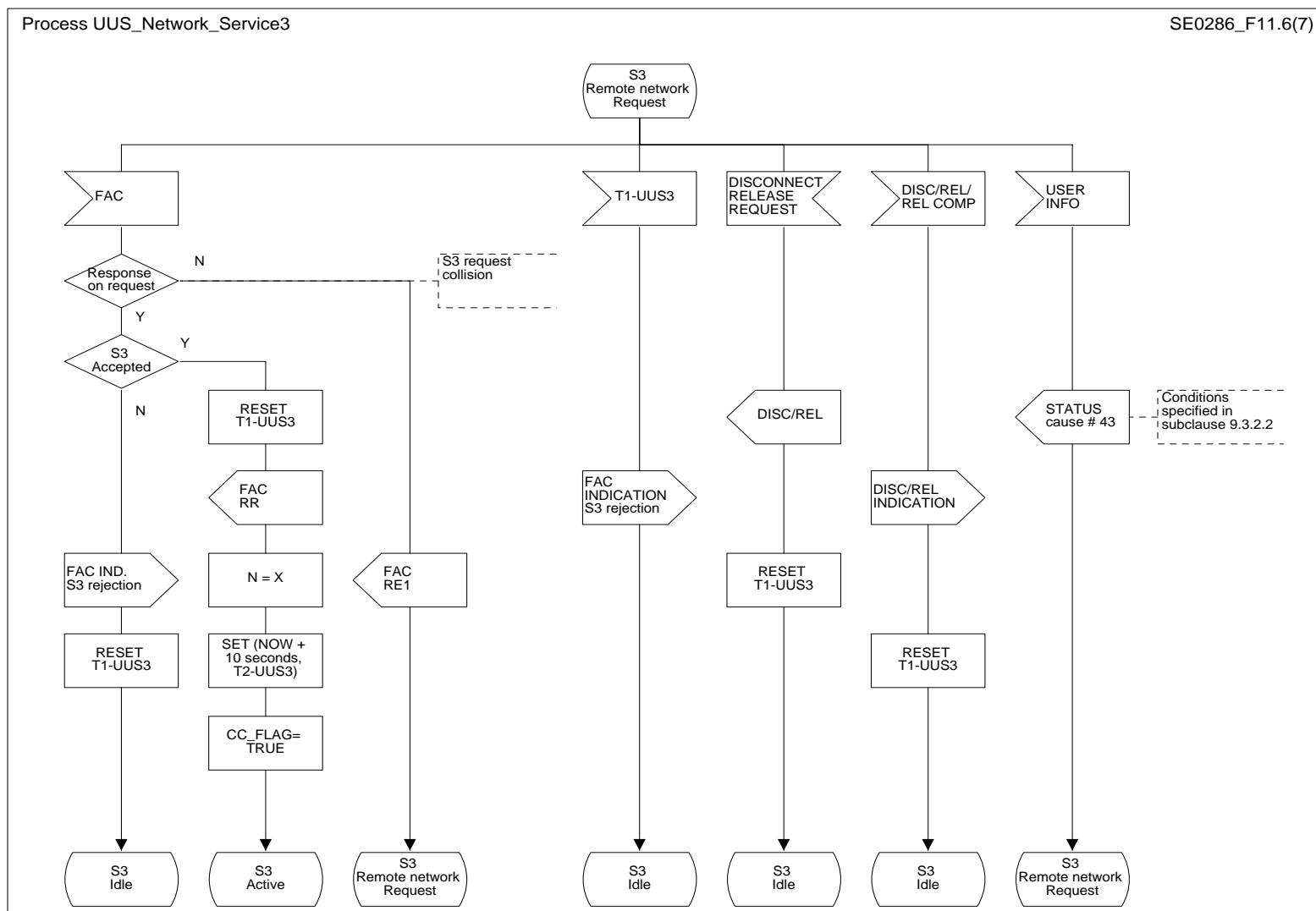


Figure 11 (sheet 6 of 7): UUS supplementary service, service 3, remote network side process

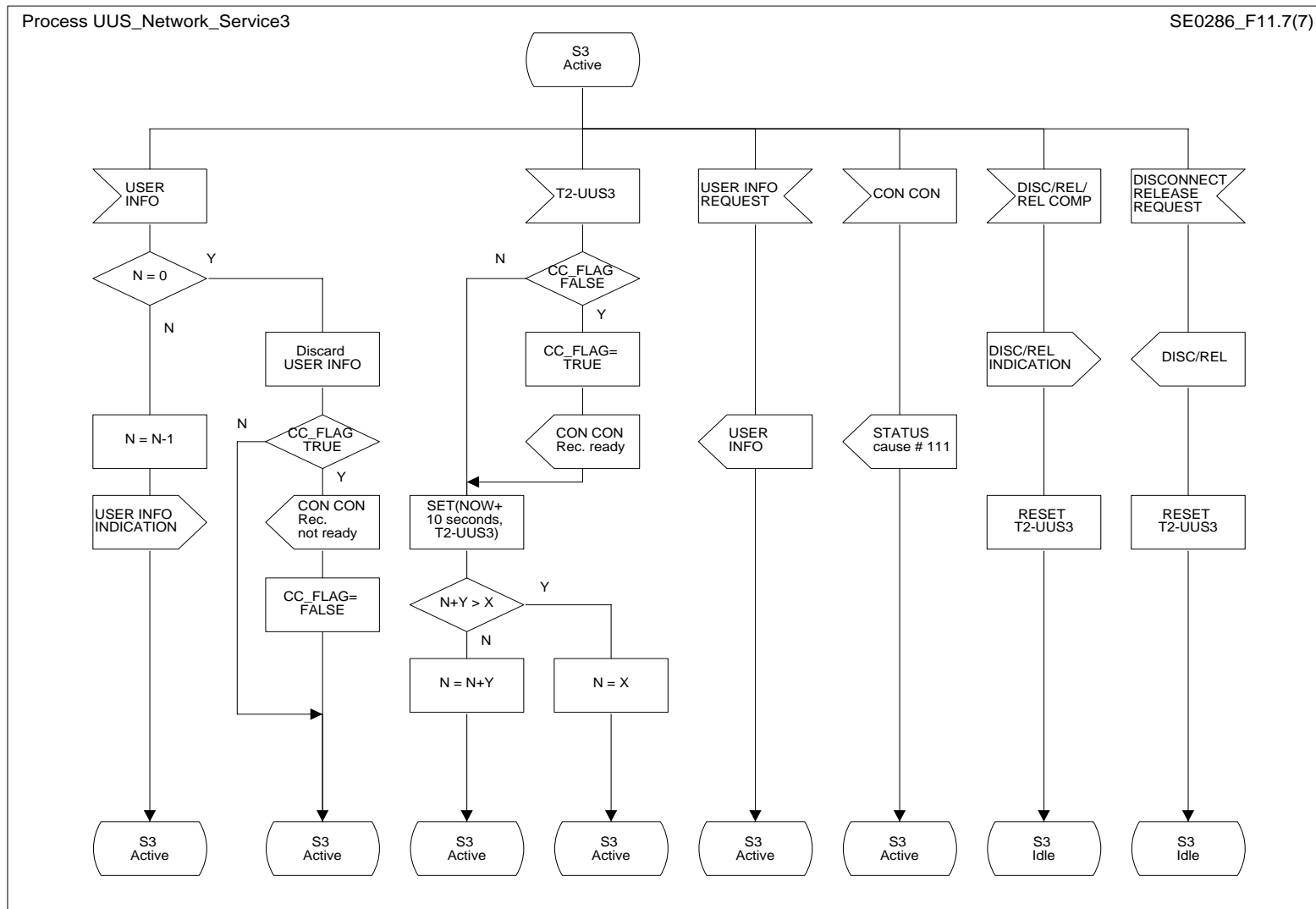


Figure 11 (sheet 7 of 7): UUS supplementary service, service 3, sending and receiving network side process

## Annex A (informative): Signalling flows

This annex contains arrow diagrams showing the DSS1 signalling for different cases of UUS.

### Abbreviations used in the signalling diagrams

p-mp	Point-to-multipoint arrangement at the called user's interface
p-p	Point-to-point arrangement at the called user's interface
Rr	Facility information element indicating "Return result"
Re	Facility information element indicating "Return error"
RR	Congestion level information element indicating "Receiver ready"
RNR	Congestion level information element indicating "Receiver not ready"
S1 pr	Facility information element indicating "Service 1 preferred request"
S1 rer	Facility information element indicating "Service 1 required request"
S2 pr	Facility information element indicating "Service 2 preferred request"
S2 rer	Facility information element indicating "Service 2 required request"
S3 pr	Facility information element indicating "Service 3 preferred request"
S3 rer	Facility information element indicating "Service 3 required request"
Uuie	User-user information element
ALERT	ALERTING message
CALL PROC	CALL PROCEEDING message
CON CON	CONGESTION CONTROL message
CONN	CONNECT message
CONN ACK	CONNECT ACKNOWLEDGE message
DISC	DISCONNECT message
FAC	FACILITY message
REL	RELEASE message
REL COMP	RELEASE COMPLETE message
SETUP	SETUP message
SETUP ACK	SETUP ACKNOWLEDGE message
USER INFO	USER INFORMATION message

The following signalling cases are shown:

#### A.1 Service 1, implicit request, point-to-multipoint

- Figure A.1: Call establishment phase
- Figure A.2: Normal call clearing initiated by the calling user
- Figure A.3: Normal call clearing initiated by the called user
- Figure A.4: Premature clearing initiated by the calling user
- Figure A.5: Premature clearing initiated by the called user

#### A.2 Service 1, implicit request, point-to-point

- Figure A.6: Call establishment phase
- Figure A.7: Normal call clearing initiated by the calling user
- Figure A.8: Normal call clearing initiated by the called user
- Figure A.9: Premature clearing initiated by the calling user
- Figure A.10: Premature clearing initiated by the called user

#### A.3 Service 1, explicit request, point-to-multipoint

- Figure A.11: Call establishment phase, successful request, preferred or required
- Figure A.12: Call establishment phase, unsuccessful request, preferred
- Figure A.13: Call establishment phase, unsuccessful request, required
- Figure A.14: Premature clearing initiated by the calling user
- Figure A.15: Premature clearing initiated by the called user



#### A.4 Service 1, explicit request, point-to-point

Figure A.16: Call establishment phase, successful request, preferred or required

Figure A.17: Call establishment phase, unsuccessful request, preferred

Figure A.18: Call establishment phase, unsuccessful request, required

Figure A.19: Premature clearing initiated by the calling user

Figure A.20: Premature clearing initiated by the called user

#### A.5 Service 2

Figure A.21: Successful request, preferred or required

Figure A.22: Unsuccessful request, preferred

Figure A.23: Unsuccessful request, required

Figure A.24: Transfer of USER INFO after answer (network option)

#### A.6 Service 3, request during call establishment, point-to-multipoint

Figure A.25: Successful request, preferred or required

Figure A.26: Unsuccessful request, preferred

Figure A.27: Unsuccessful request, required

#### A.7 Service 3, request during the Active (N10, U10) call state

Figure A.28: Successful request

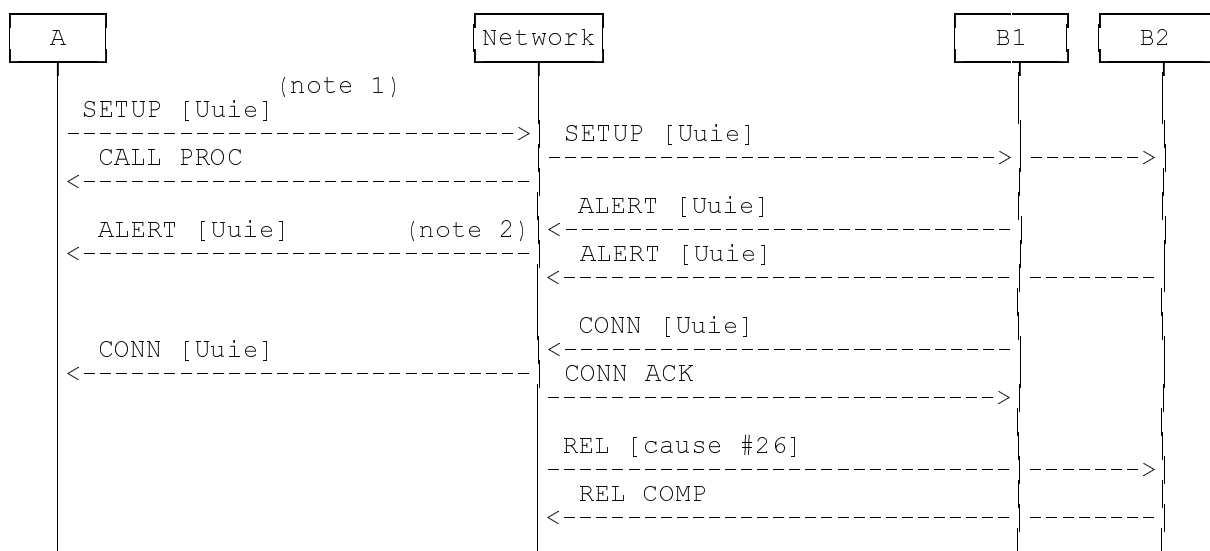
Figure A.29: Unsuccessful request

#### A.8 Service 3, flow control

Figure A.30: Limit for number of USER INFOs not exceeded

Figure A.31: Limit for number of USER INFOs exceeded

## A.1 Service 1, implicit request, point-to-multipoint



NOTE 1: For activation purposes, the Uuie shall be at least 3 octets long, but may also include UUI if invocation and activation are coexistent.

NOTE 2: Uuie in subsequent ALERTING messages shall be discarded. The called user shall be aware that contention may take place if different Uuies are included in the ALERTING messages.

**Figure A.1: Call establishment phase**

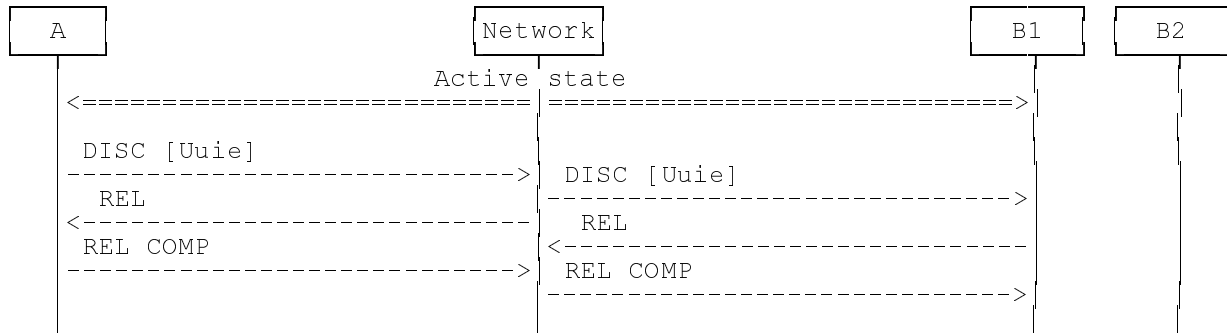


Figure A.2: Normal call clearing initiated by the calling user

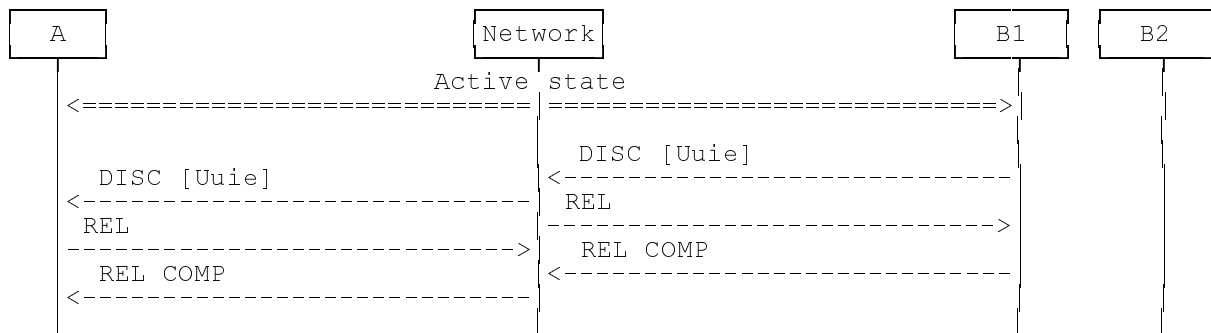


Figure A.3: Normal call clearing initiated by the called user

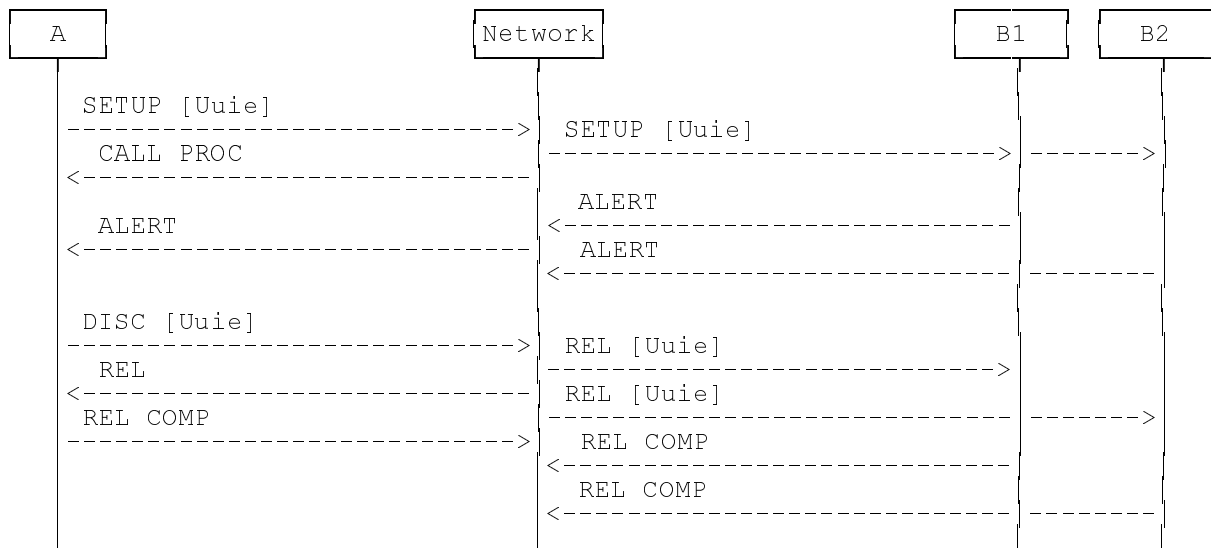
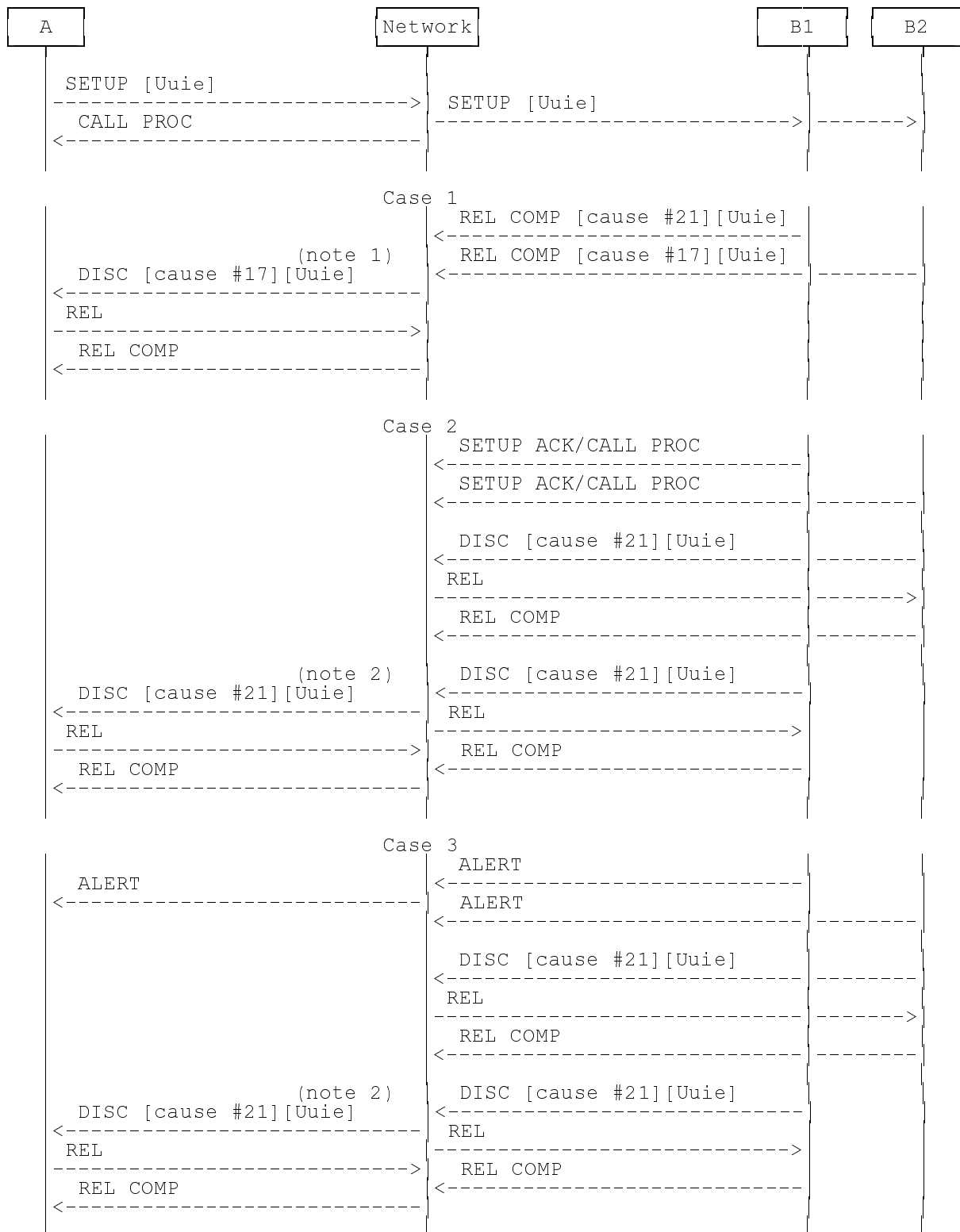


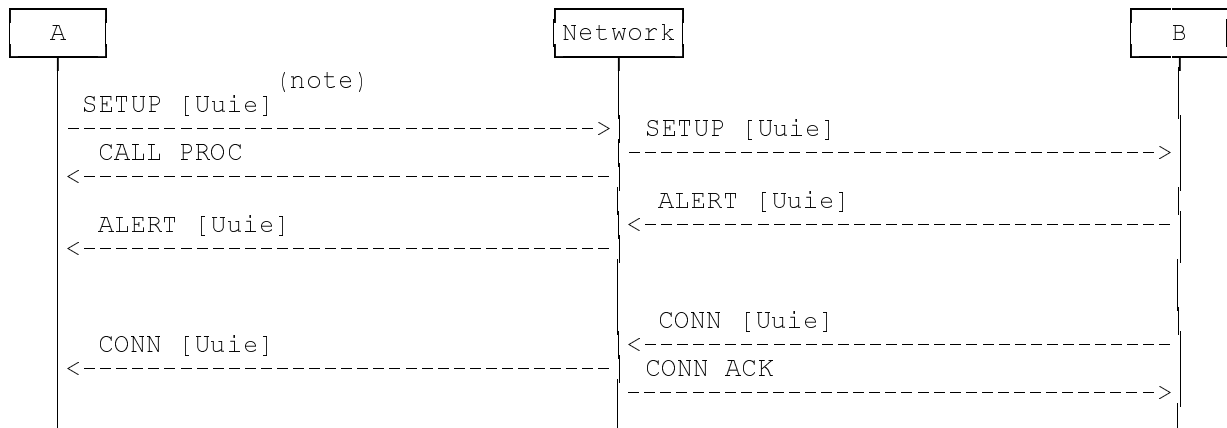
Figure A.4: Premature clearing initiated by the calling user



NOTE 1: The Uuie from user B2 (cause with highest priority) is used.  
 NOTE 2: The Uuie from user B2 (first received DISCONNECT) is used.

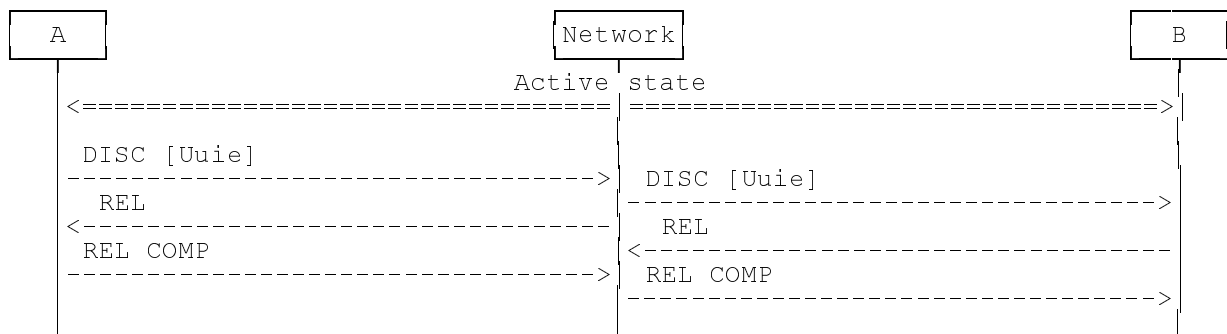
**Figure A.5: Premature clearing initiated by the called user**

## A.2 Service 1, implicit request, point-to-point

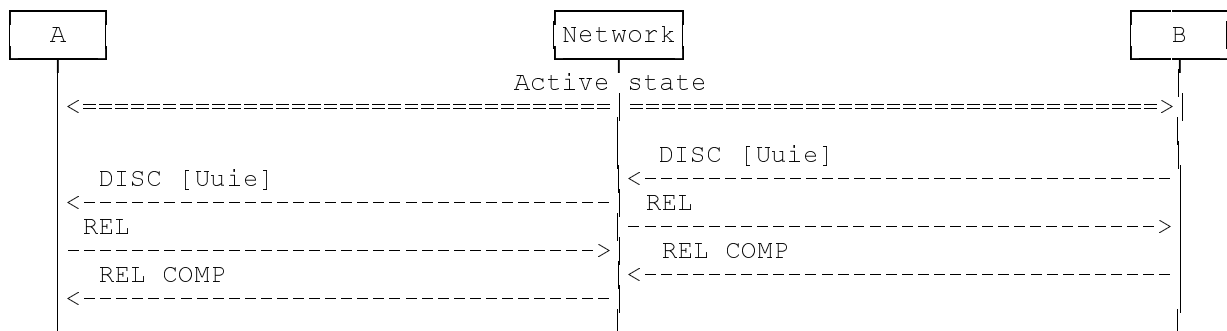


NOTE: For activation purposes, the Uuie shall be at least 3 octets long, but may also include UUI if invocation and activation are coexistent.

**Figure A.6: Call establishment phase**



**Figure A.7: Normal call clearing initiated by the calling user**



**Figure A.8: Normal call clearing initiated by the called user**

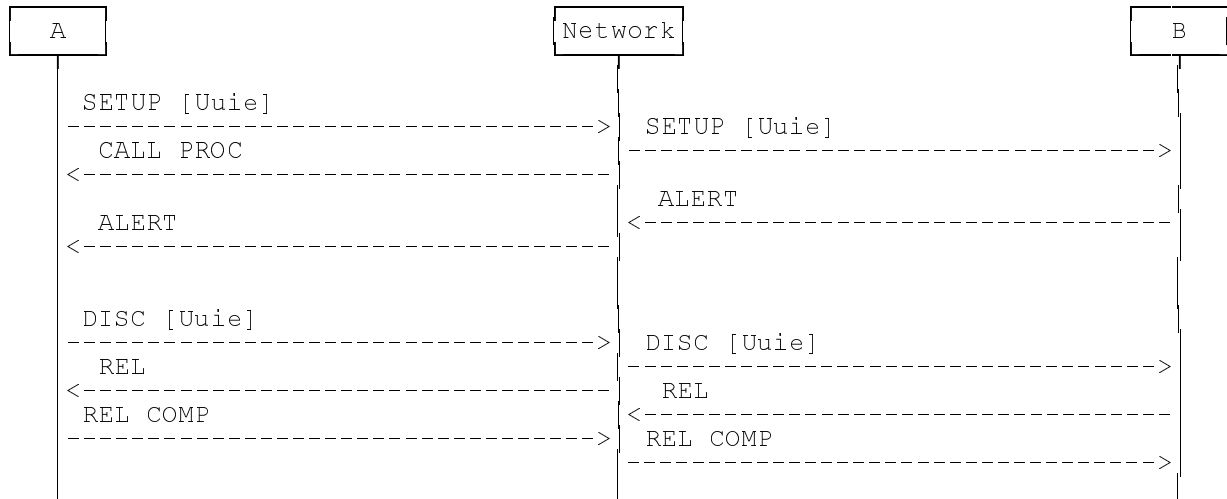


Figure A.9: Premature clearing initiated by the calling user

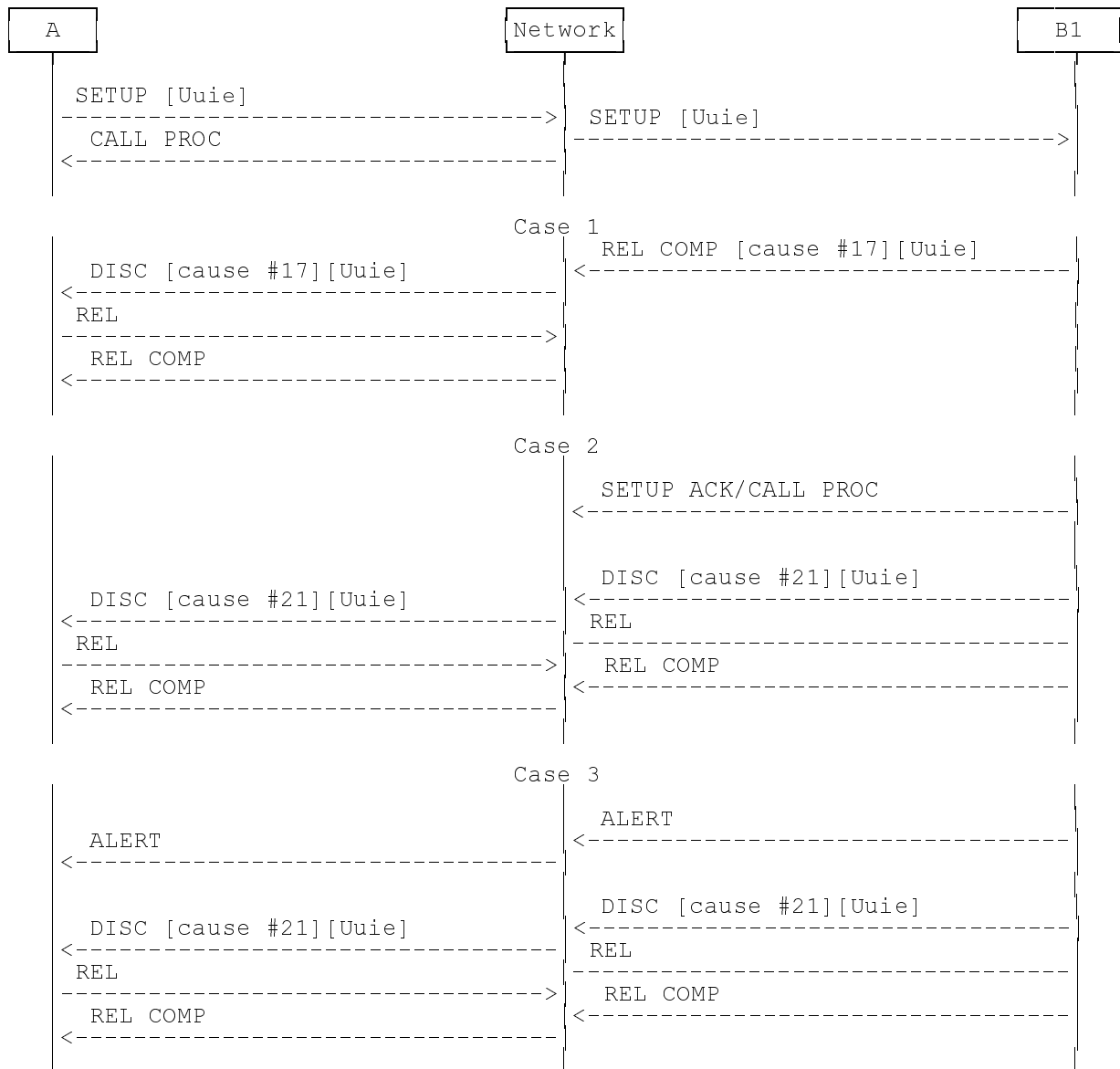
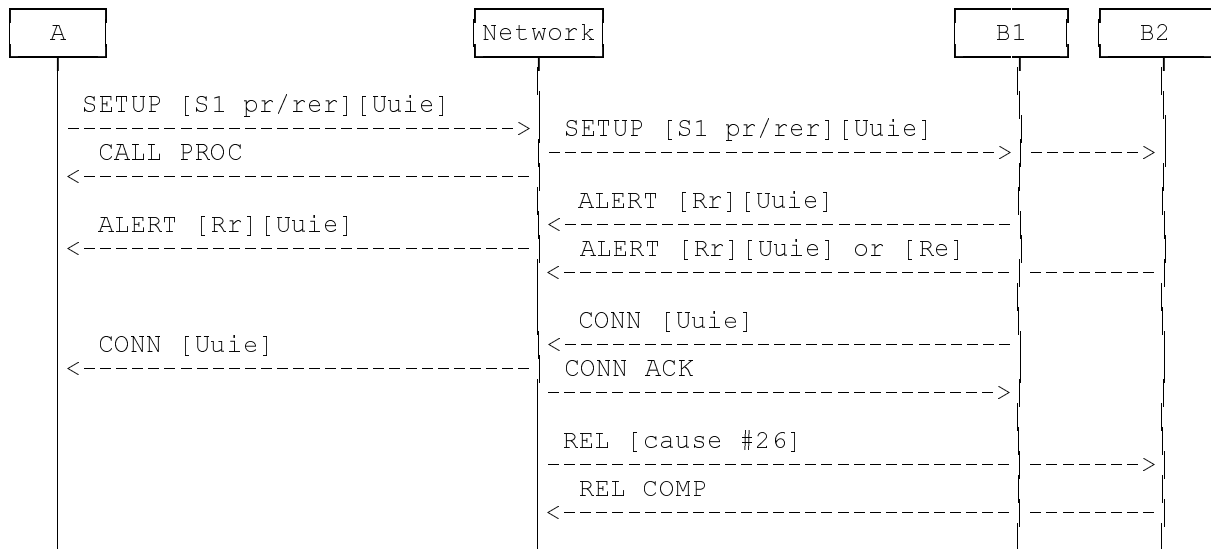
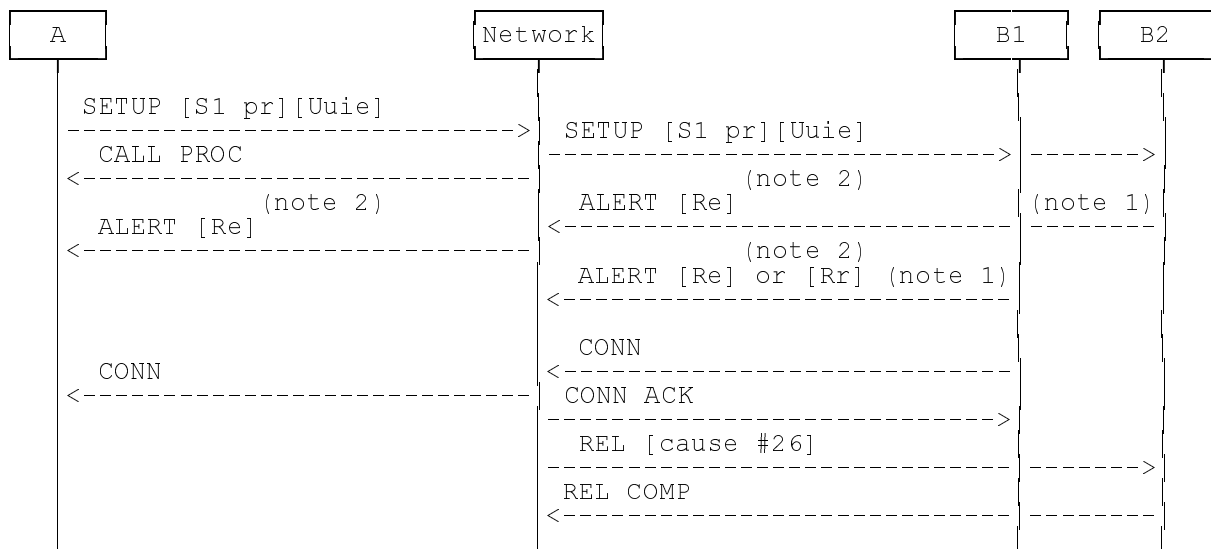


Figure A.10: Premature clearing initiated by the called user

## A.3 Service 1, explicit request, point-to-multipoint



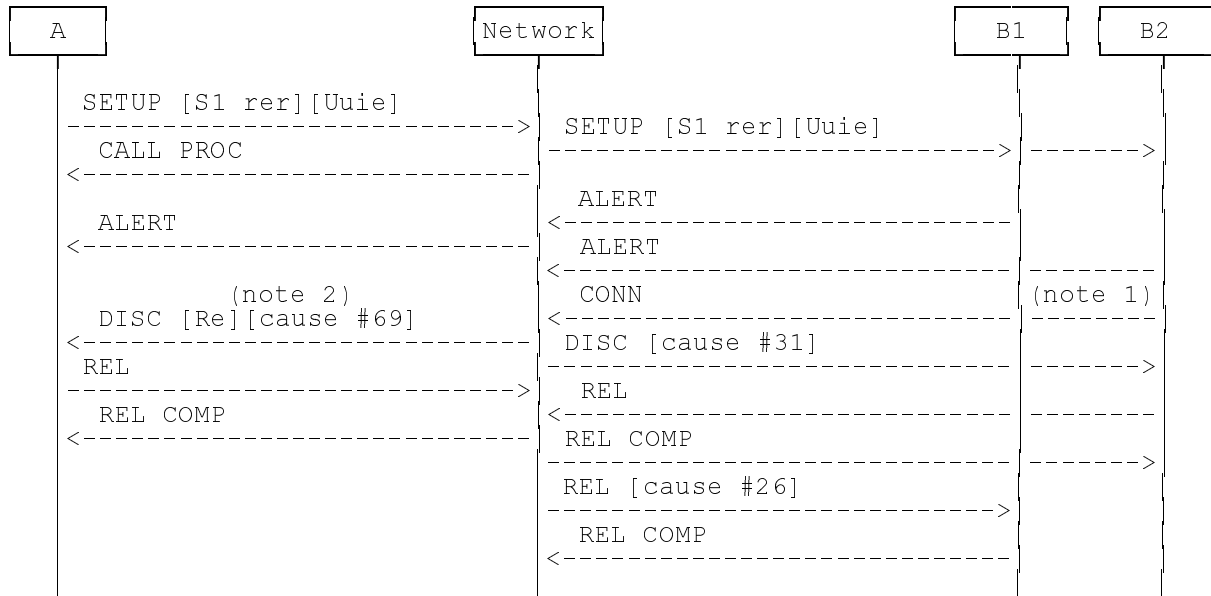
**Figure A.11: Call establishment phase, successful request, preferred or required**



NOTE 1: Called user cannot accept the service request.

NOTE 2: The error value shall be "rejectedByUser".

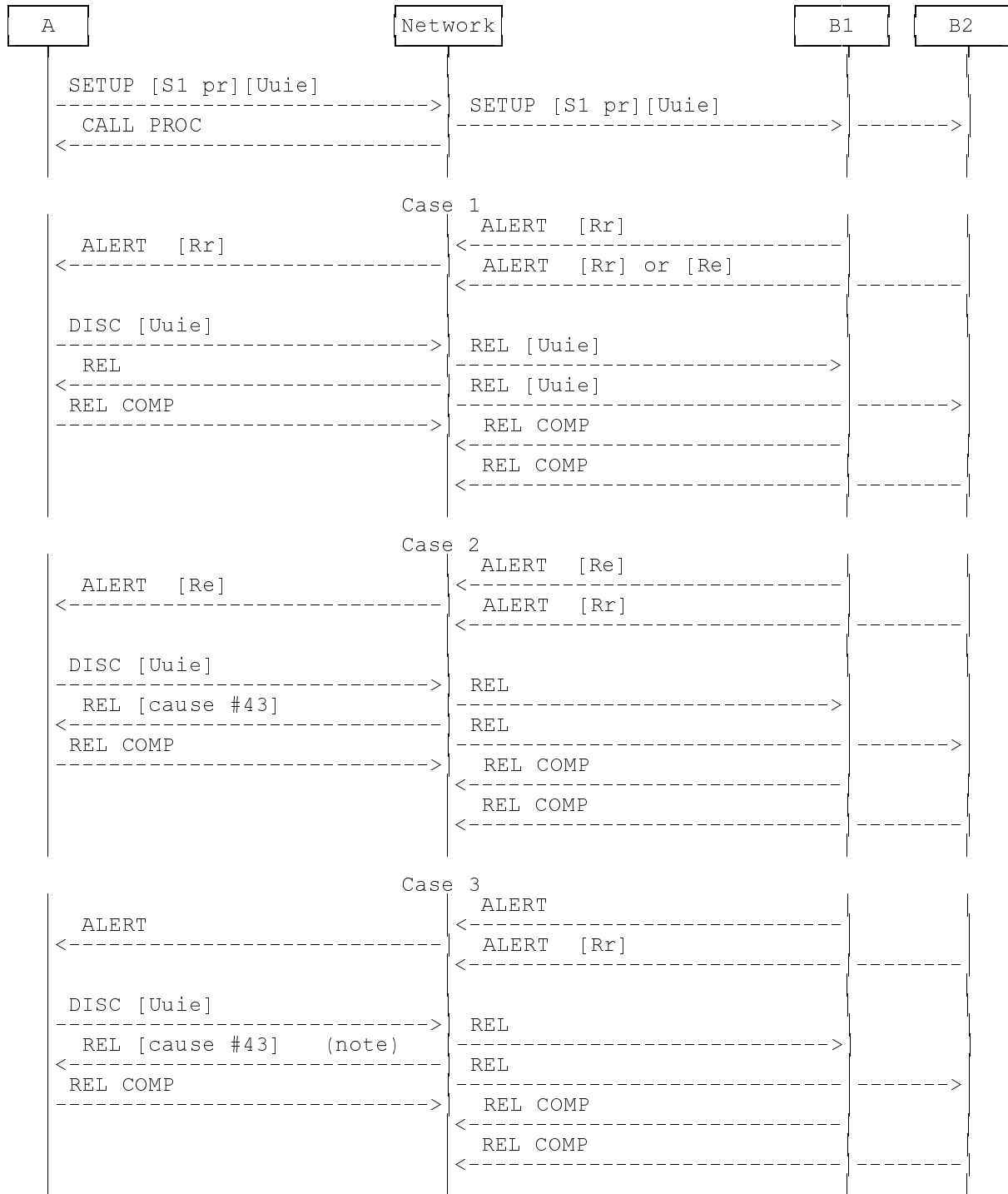
**Figure A.12: Call establishment phase, unsuccessful request, preferred**



NOTE 1: Called user does not respond to the request.

NOTE 2: The error value shall be "rejectedByUser".

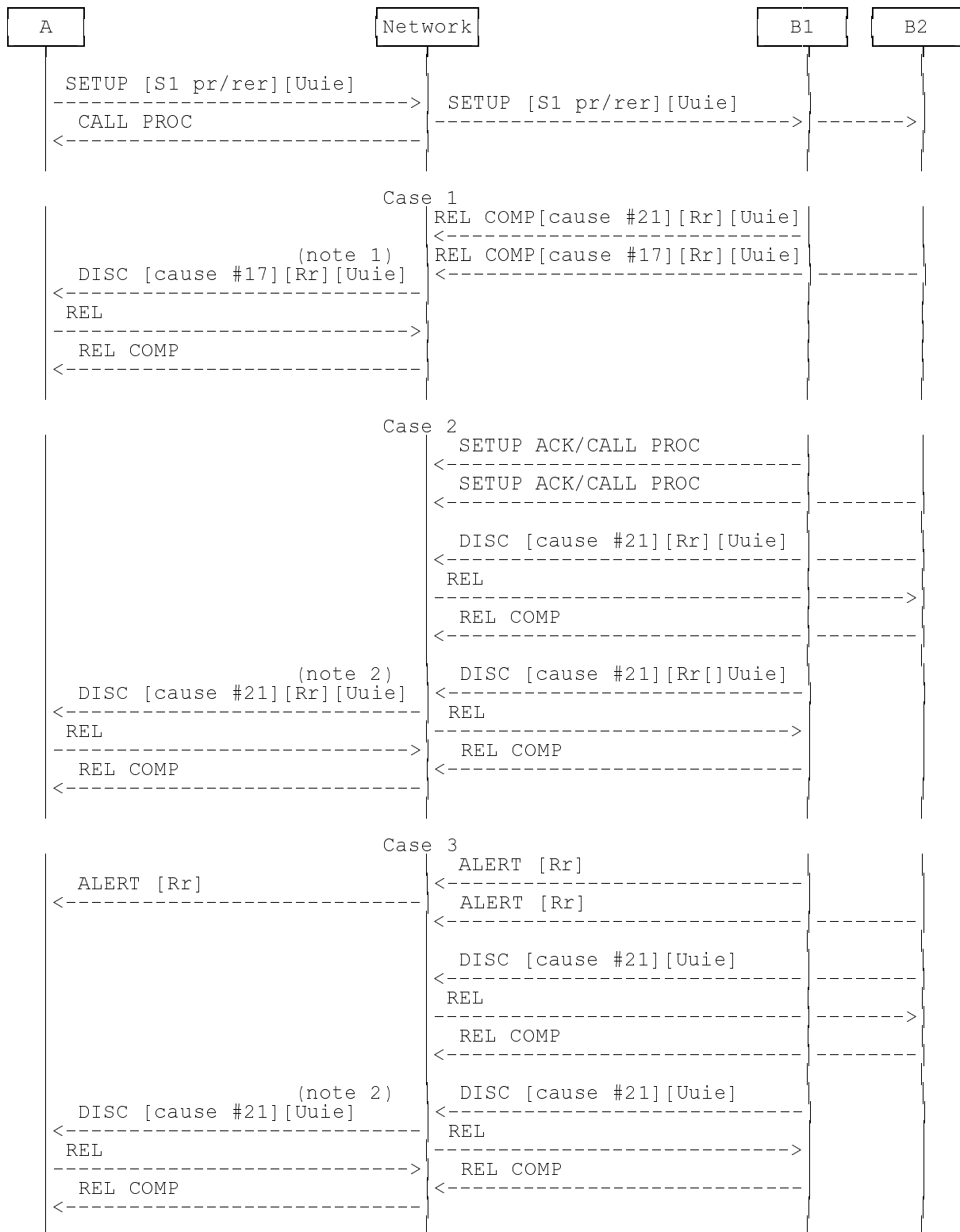
**Figure A.13: Call establishment phase, unsuccessful request, required**



NOTE: The inclusion of the Cause information element is a network option.

**Figure A.14: Premature clearing initiated by the calling user**



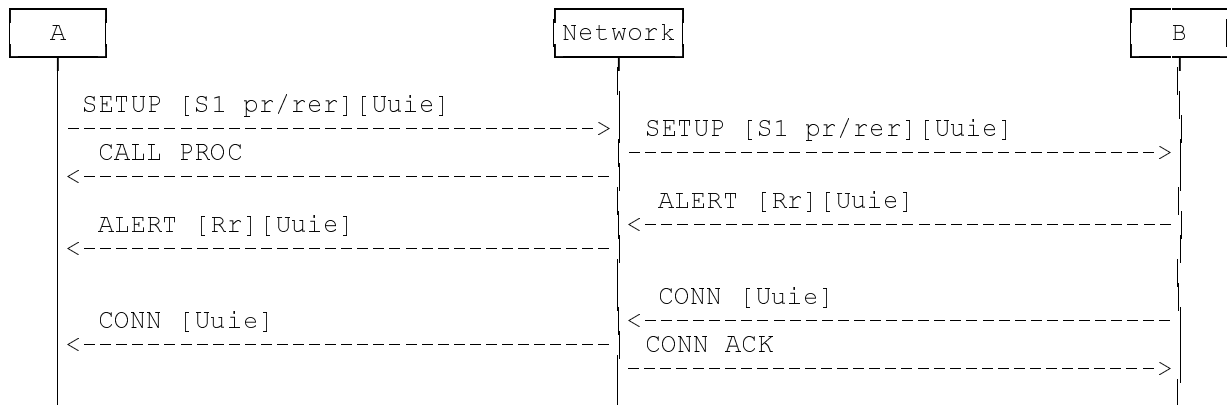


NOTE 1: The Uuie from user B2 (cause with highest priority) is used.

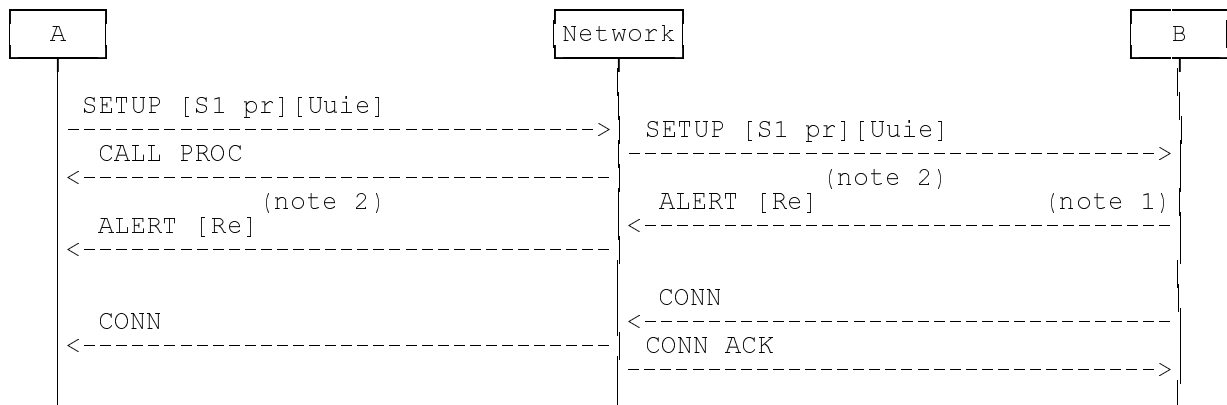
NOTE 2: The Uuie from user B2 (first received DISCONNECT) is used.

**Figure A.15: Premature clearing initiated by the called user**

## A.4 Service 1, explicit request, point-to-point



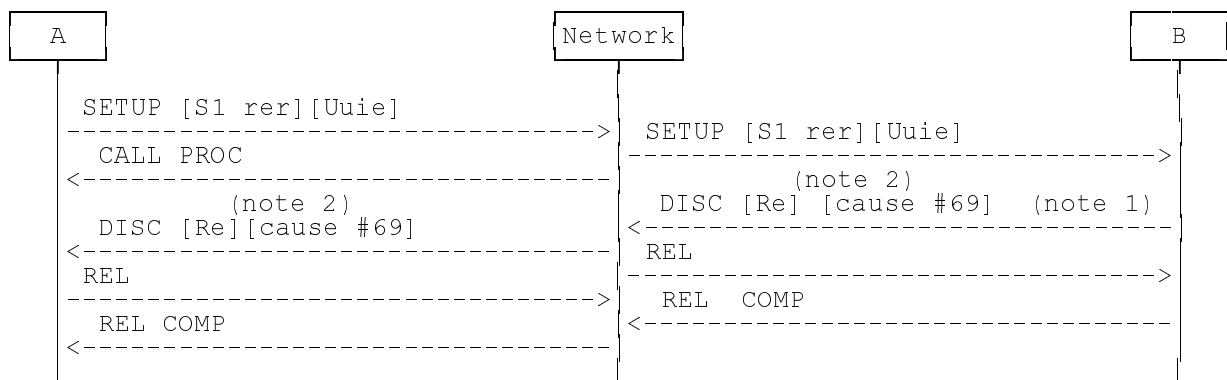
**Figure A.16: Call establishment phase, successful request, preferred or required**



NOTE 1: Called user cannot accept the service request.

NOTE 2: The error value shall be "rejectedByUser".

**Figure A.17: Call establishment phase, unsuccessful request, preferred**



NOTE 1: Called user cannot accept the service request.

NOTE 2: The error value shall be "rejectedByUser".

**Figure A.18: Call establishment phase, unsuccessful request, required**

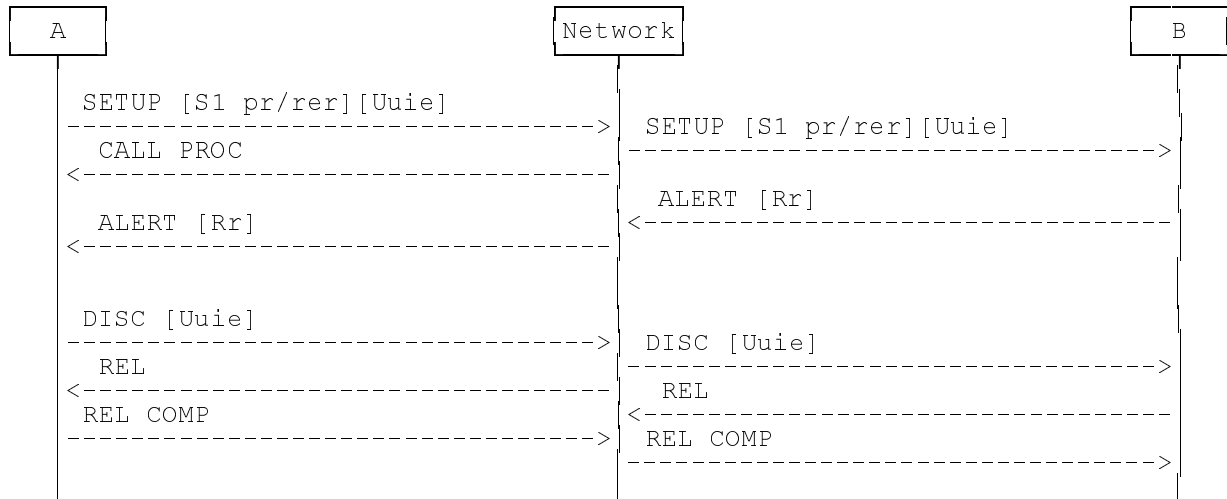


Figure A.19: Premature clearing initiated by the calling user

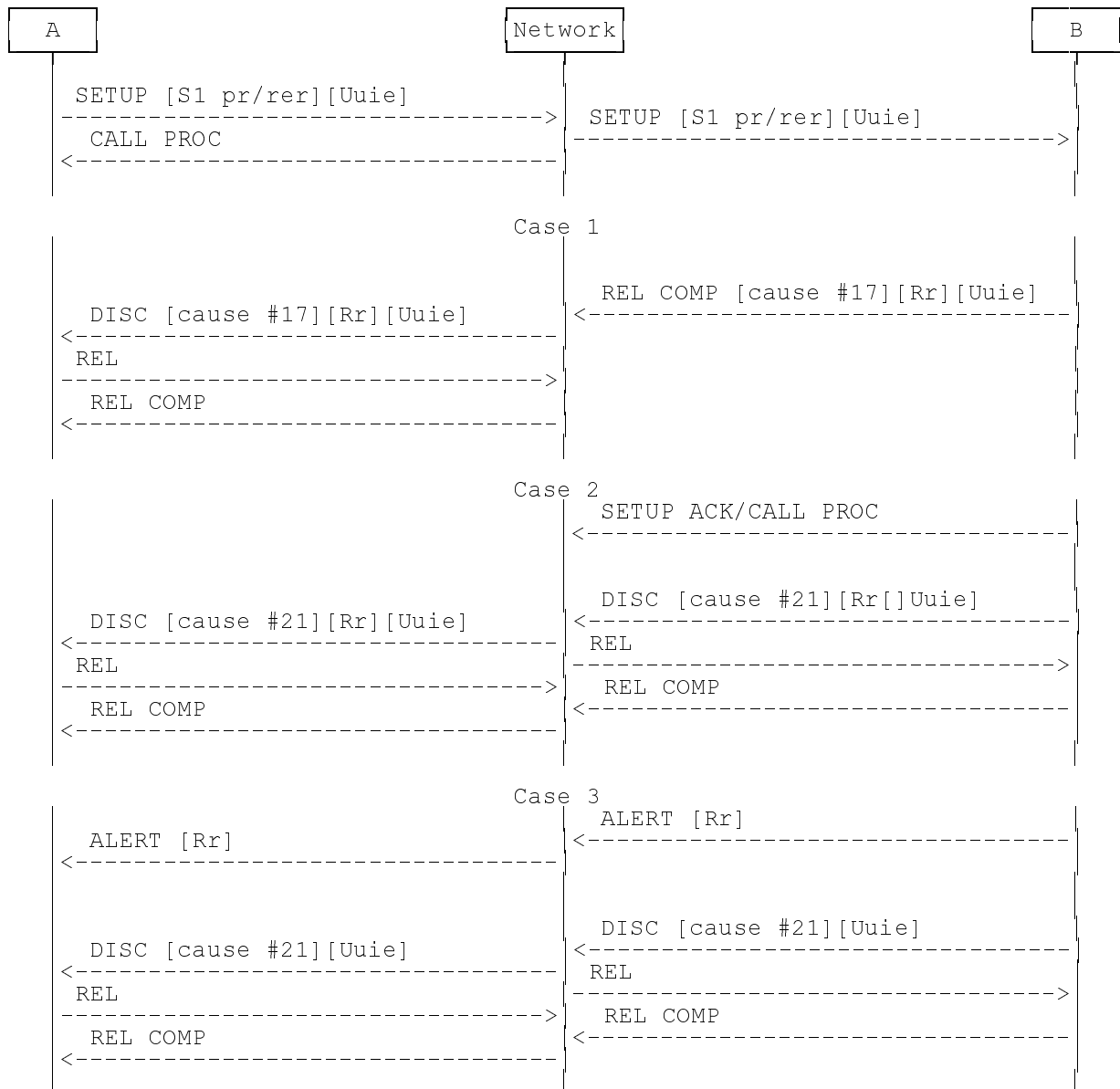
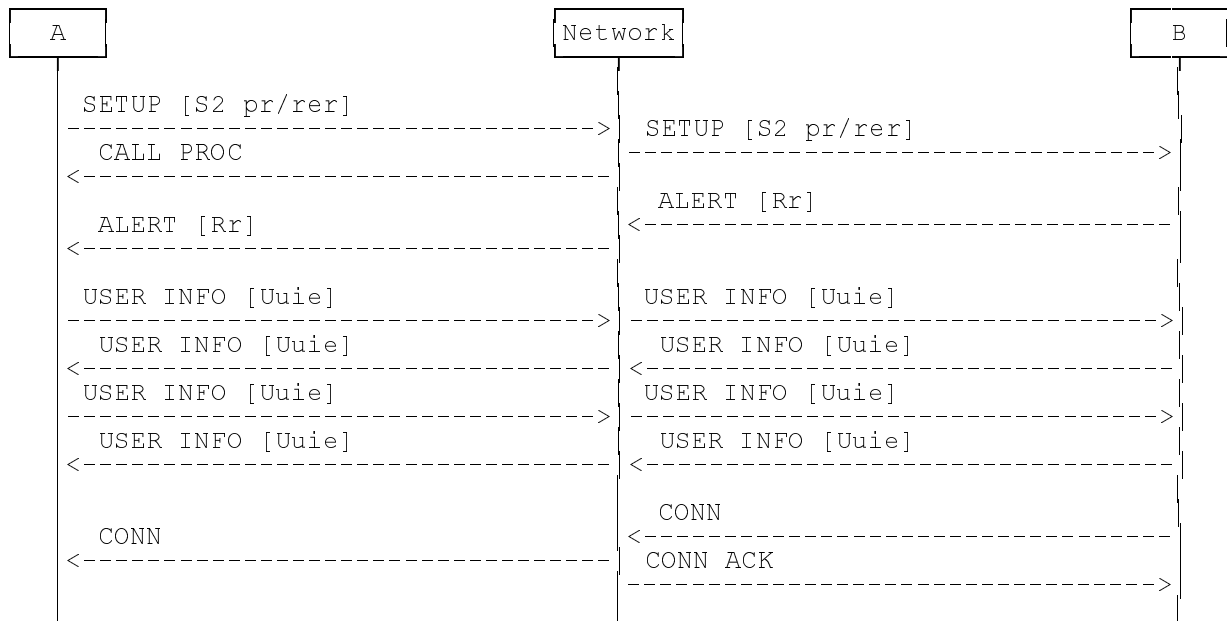
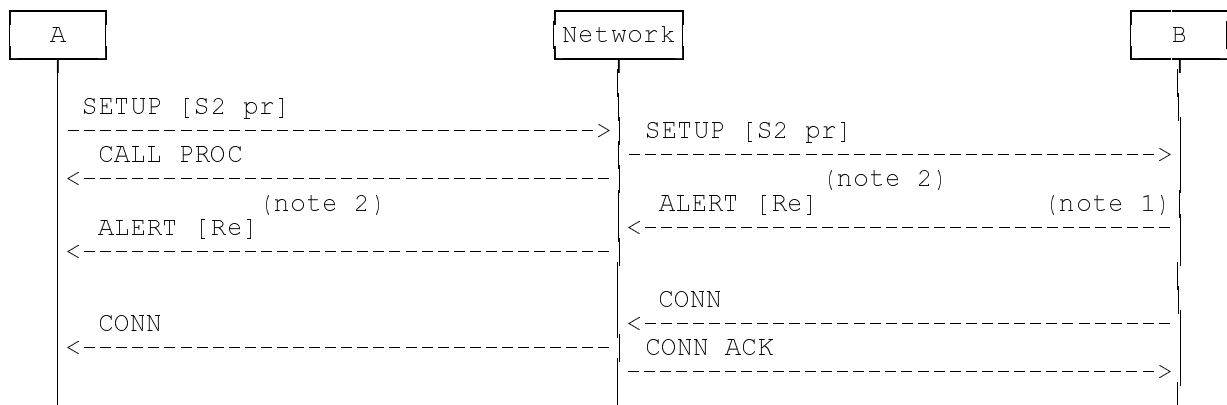


Figure A.20: Premature clearing initiated by the called user

## A.5 Service 2



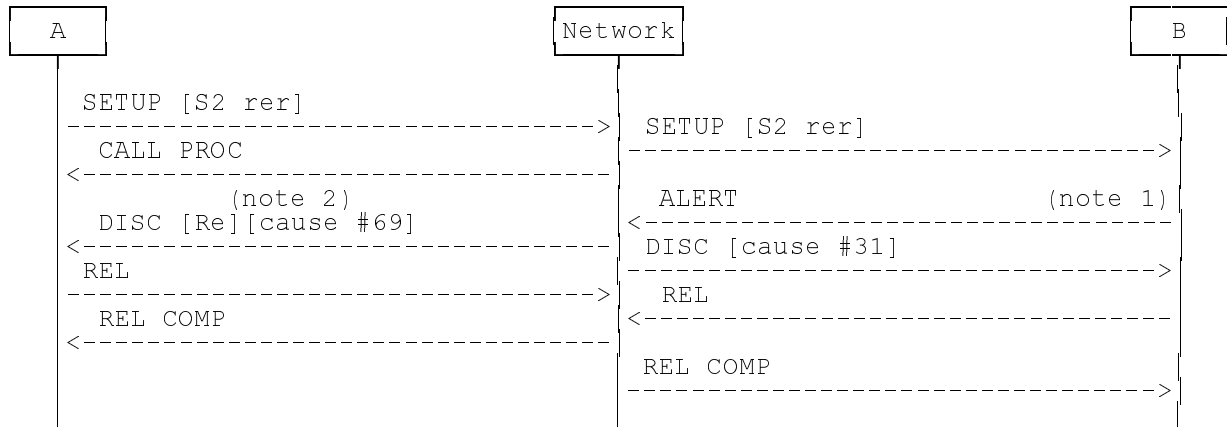
**Figure A.21: Successful request, preferred or required**



NOTE 1: Called user cannot accept the service request.

NOTE 2: The error value shall be "rejectedByUser".

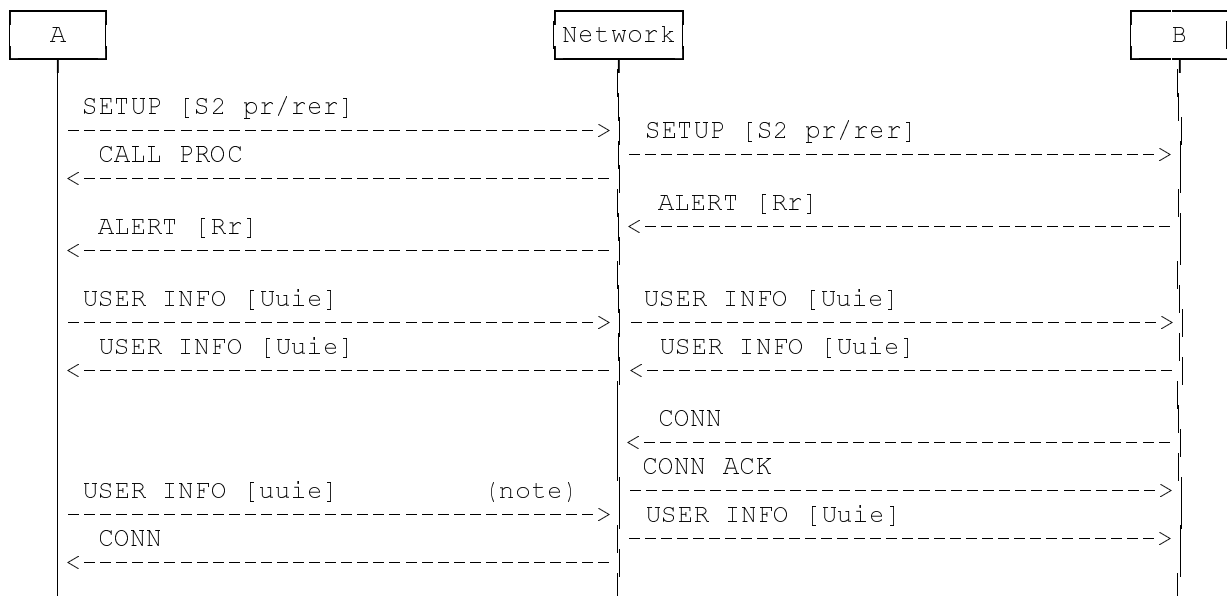
**Figure A.22: Unsuccessful request, preferred**



NOTE 1: Called user does not respond to the request.

NOTE 2: The error value shall be "rejectedByUser".

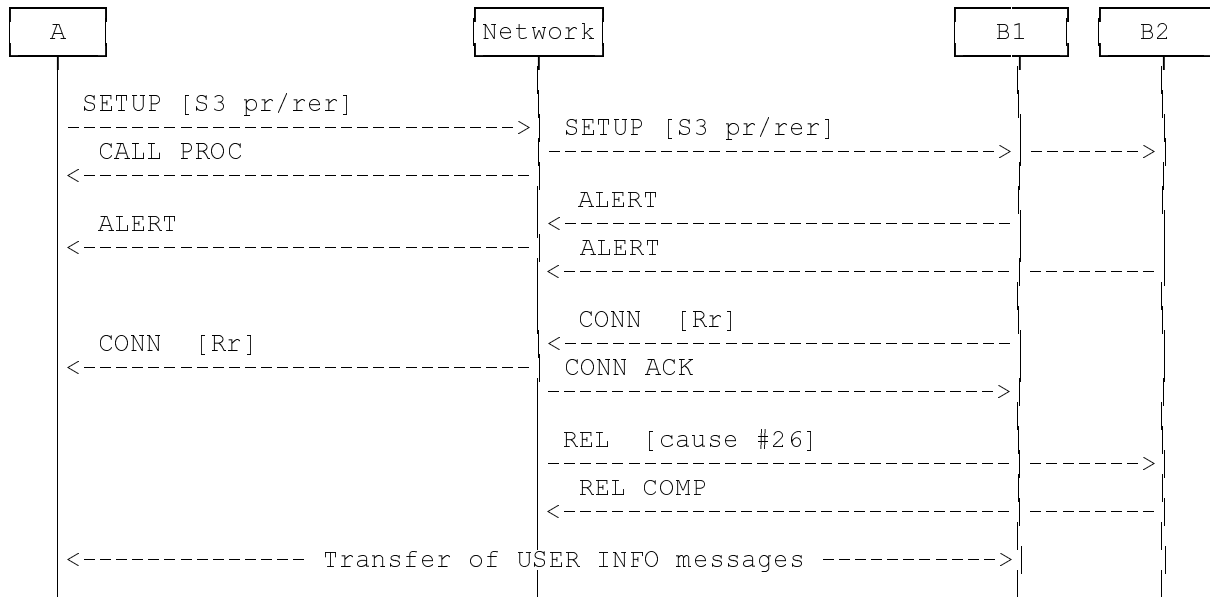
**Figure A.23: Unsuccessful request, required**



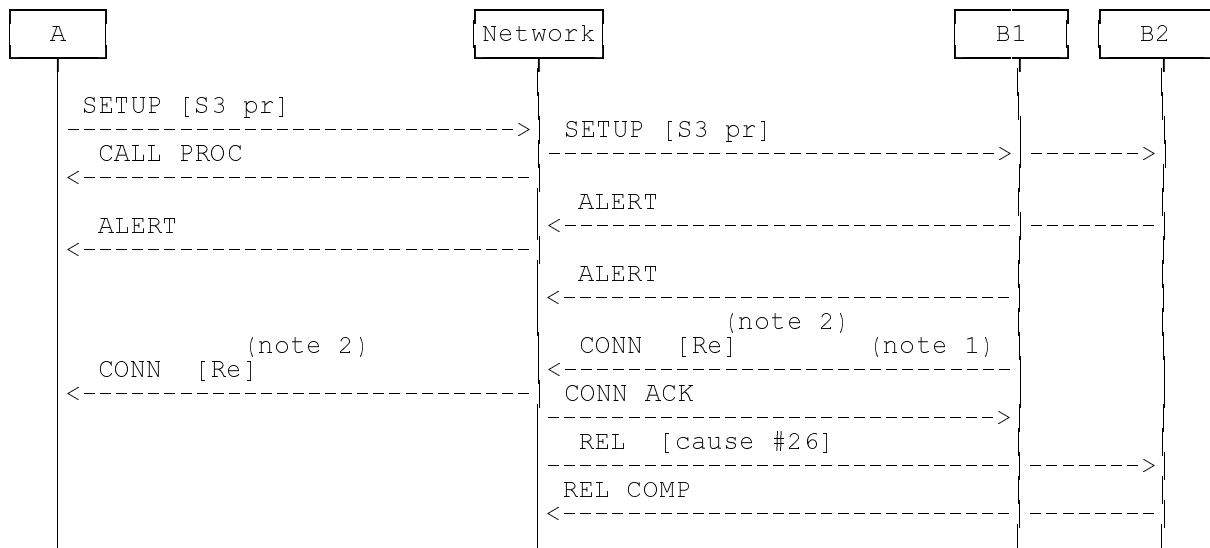
NOTE: The second USER INFORMATION message sent by the calling user crosses the CONNECT message sent from the network.

**Figure A.24: Transfer of USER INFO after answer (network option)**

## A.6 Service 3, request during call establishment, point-to-multipoint



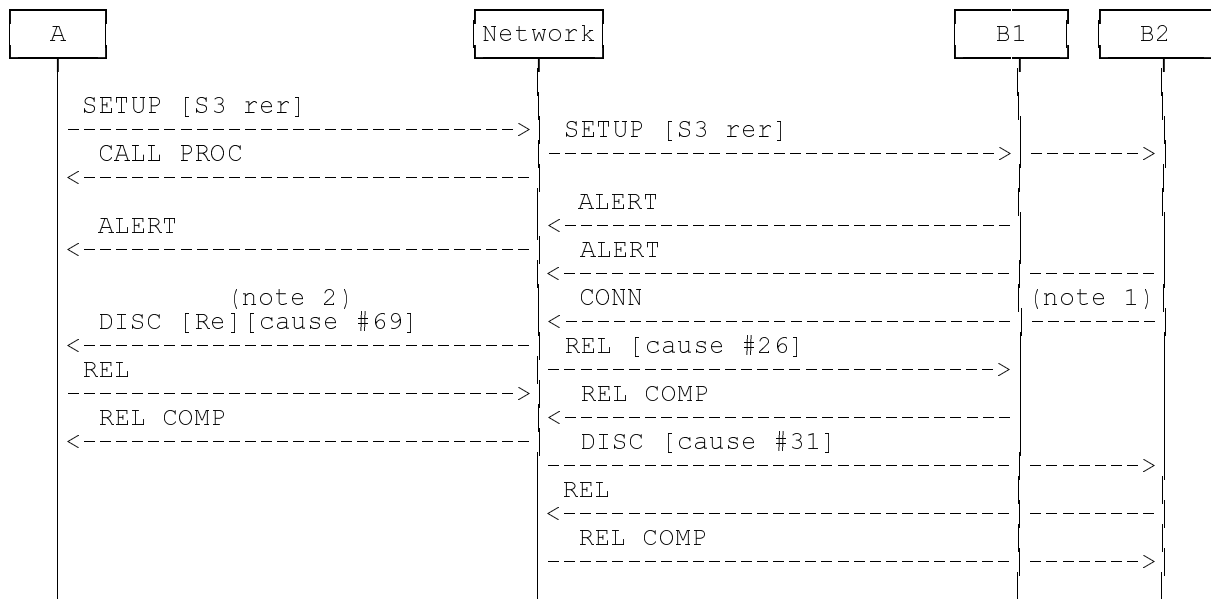
**Figure A.25: Successful request, preferred or required**



NOTE 1: Called user cannot accept the service request.

NOTE 2: The error value shall be "rejectedByUser".

**Figure A.26: Unsuccessful request, preferred**

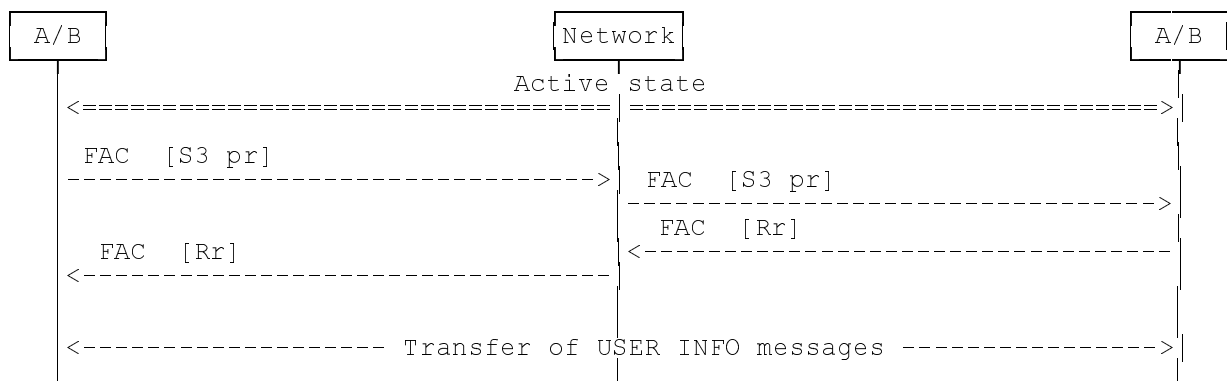


NOTE 1: Called user does not respond to the service request.

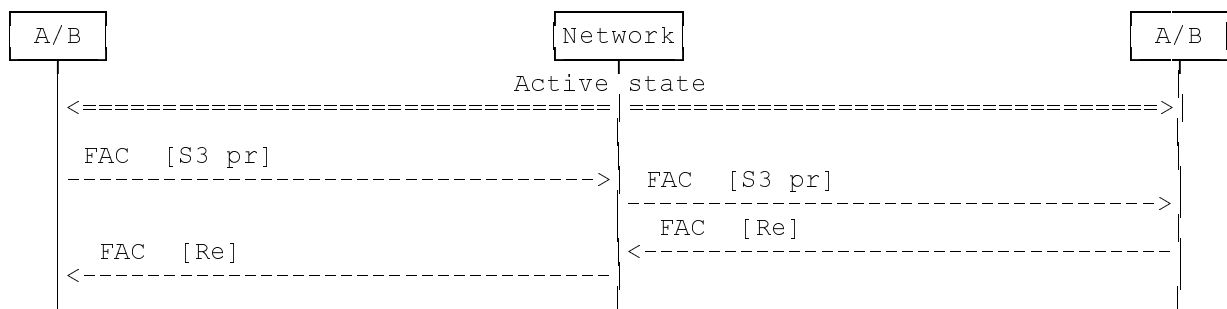
NOTE 2: The error value shall be "rejectedByUser".

**Figure A.27: Unsuccessful request, required**

## A.7 Service 3, request during the Active (N10, U10) call state

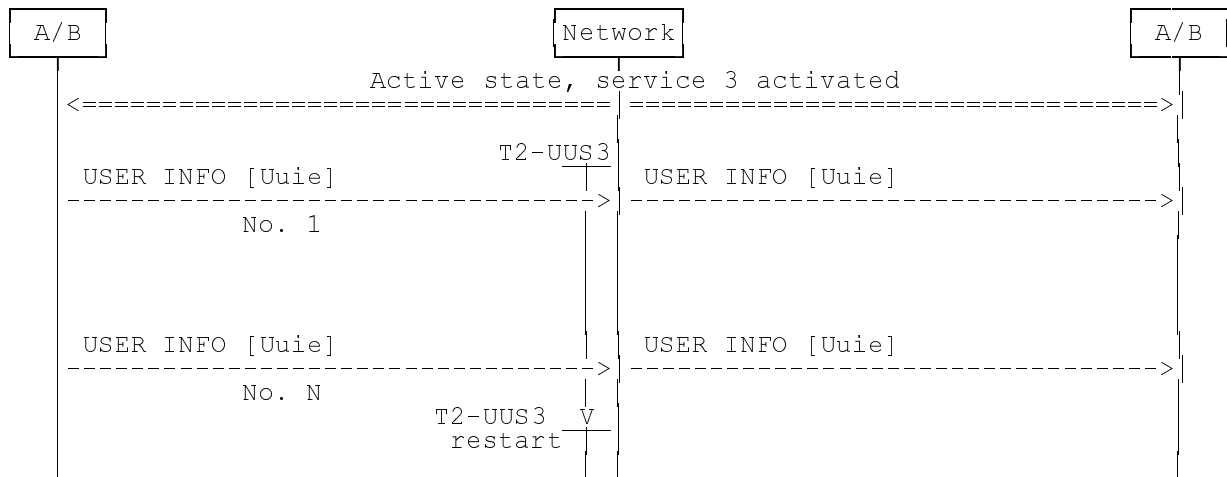


**Figure A.28: Successful request**

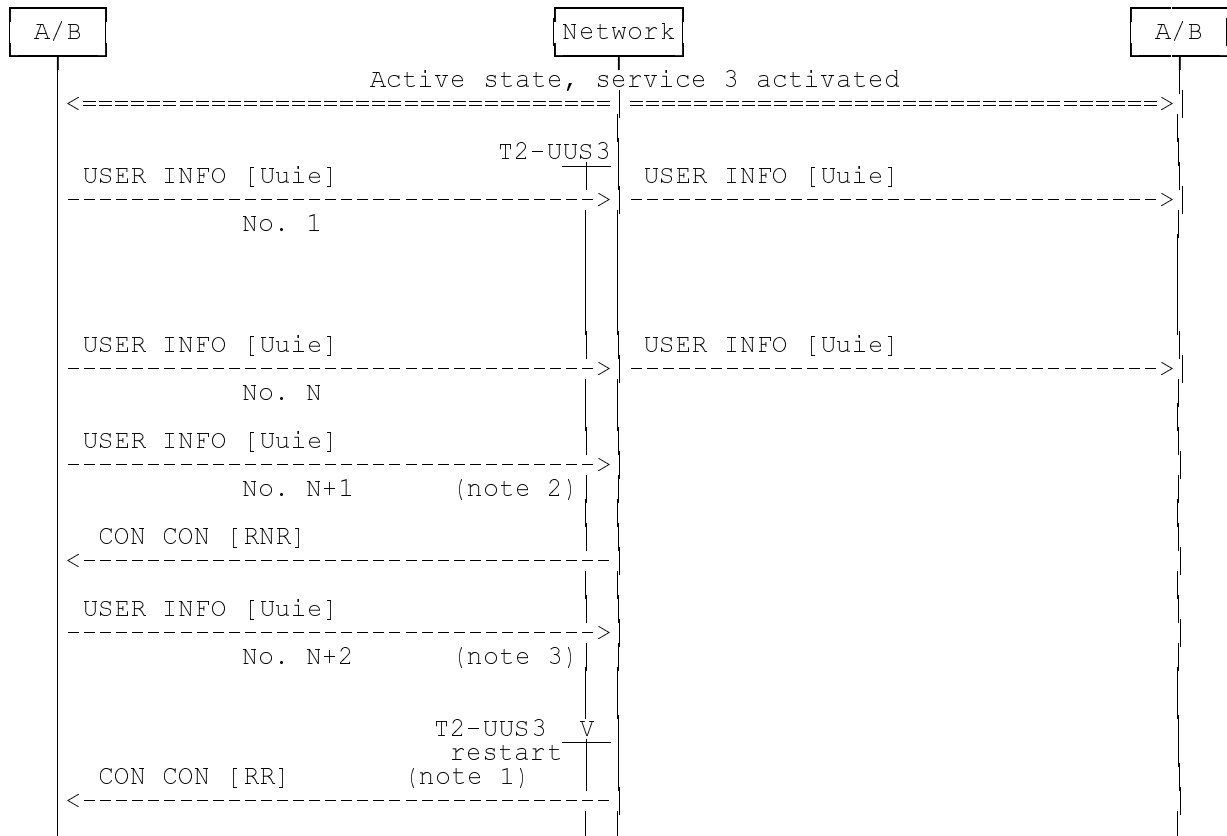


**Figure A.29: Unsuccessful request**

## A.8 Service 3, flow control



**Figure A.30: Limit for number of USER INFOs not exceeded**



NOTE 1: N is updated ( $N=N+Y$ ).

NOTE 2: The USER INFORMATION message is discarded and an indication is sent to the sending user.

NOTE 3: The USER INFORMATION message is discarded without indication to the sending user.

**Figure A.31: Limit for number of USER INFOs exceeded**



## Annex B (informative): Diagrammatic description of coding requirements

Examples component structures for the UUS supplementary service are shown in figures B.1 to B.3. In case of discrepancies between this annex and subclause 7.1, subclause 7.1 takes precedence.

### B.1 UUS request invoke component (typical example)

Invoke Component type	10100001	context-spec, const, 1
Invoke Component length	0XXXXXXX	
Invoke Component contents:		
Invoke Identifier type	00000010	univ, prim, 2 (INTEGER)
Invoke Identifier length	0XXXXXXX	
Invoke Identifier contents	XXXXXXXX	invoke id value
OPERATION type	00000010	univ, prim, 2 (INTEGER)
OPERATION length	00000001	
OPERATION contents	00000001	userUserService operation
SEQUENCE type	00110000	univ, const, 16 (SEQ)
SEQUENCE length	00000110	
SEQUENCE contents:		
Service type	10000001	context-spec, prim, 1 (INTEGER)
Service length	00000001	
Service contents	00000001	service 1
	00000010	service 2
	00000011	service 3
Preferred type	10000010	context-spec, prim, 2 (BOOLEAN)
Preferred length	00000001	
Preferred contents	00000000	FALSE (required request)
	TTTTTTTT	TRUE (preferred request)
		(note)

NOTE: Any value of "TTTTTTTT" other than "00000000" represents the value TRUE.

**Figure B.1: UUS request invoke component**

## B.2 UUS return result component (typical example)

Return Result comp. type	10100010 context-spec, const, 2
Return Result comp. length	0XXXXXXXX
Return Result comp. contents	
Invoke Identifier type	00000010 univ, prim, 2 (INTEGER)
Invoke Identifier length	0XXXXXXXX
Invoke Identifier contents	XXXXXXXXX invoke id value

Figure B.2: UUS return result component

## B.3 UUS return error component (typical example)

Return Error comp. type	10100011 context-spec, const, 3
Return Error comp. length	0XXXXXXXX
Return Error comp. contents	
Invoke Identifier type	00000010 univ, prim, 2 (INTEGER)
Invoke Identifier length	0XXXXXXXX
Invoke Identifier contents	XXXXXXXXX invoke id value
ERROR type	00000010 univ, prim, 2 (INTEGER)
ERROR length	00000001
ERROR contents	00000001 rejected by network 00000010 rejected by user

Figure B.3: UUS return error component

---

## Annex C (informative): Changes with respect to the previous ETS 300 286-1

The following changes have been done:

- conversion to EN layout;
- replacement of references to ETS 300 102 with EN 300 403;
- substitution of non-specific references to basic standards where the intention is to refer to the latest version.

---

## Annex D (informative): Bibliography

- CCITT Recommendation Q.931 (1988): "ISDN user-network interface layer 3 specification for basic call control".
- CCITT Recommendation V.120 (1988): "Support by an ISDN of data terminal equipment with V-series type interfaces with provision for statistical multiplexing".
- ETS 300 356-8 (1995): "Integrated Services Digital Network (ISDN); Signalling System No.7; ISDN User Part (ISUP) version 2 for the international interface; Part 8: User-to-User Signalling (UUS) supplementary service [ITU-T Recommendation Q.737, clause 1 (1993), modified]".

---

## History

<b>Document history</b>		
Edition 1	March 1996	Publication as ETS 300 286-1
V1.2.3	February 1998	One-step Approval Procedure OAP 9824: 1998-02-13 to 1998-06-12