

ETSI EN 300 234 V1.3.2 (2001-11)

European Standard (Telecommunications series)

**Fixed Radio Systems;
Point-to-point equipment;
High capacity digital radio systems carrying
1 x STM-1 signals and operating in frequency bands with
about 30 MHz channel spacing and alternated arrangements**



Reference

REN/TM-04075a

Keywordsarchitecture, DRRS, point-to-point, SDH,
transmission**ETSI**

650 Route des Lucioles
F-06921 Sophia Antipolis Cedex - FRANCE

Tel.: +33 4 92 94 42 00 Fax: +33 4 93 65 47 16

Siret N° 348 623 562 00017 - NAF 742 C
Association à but non lucratif enregistrée à la
Sous-Préfecture de Grasse (06) N° 7803/88

Important notice

Individual copies of the present document can be downloaded from:

<http://www.etsi.org>

The present document may be made available in more than one electronic version or in print. In any case of existing or perceived difference in contents between such versions, the reference version is the Portable Document Format (PDF). In case of dispute, the reference shall be the printing on ETSI printers of the PDF version kept on a specific network drive within ETSI Secretariat.

Users of the present document should be aware that the document may be subject to revision or change of status. Information on the current status of this and other ETSI documents is available at

<http://portal.etsi.org/tb/status/status.asp>

If you find errors in the present document, send your comment to:

editor@etsi.fr

Copyright Notification

No part may be reproduced except as authorized by written permission.
The copyright and the foregoing restriction extend to reproduction in all media.

© European Telecommunications Standards Institute 2001.
All rights reserved.

Contents

| | |
|--|----|
| Intellectual Property Rights | 5 |
| Foreword..... | 5 |
| 1 Scope | 6 |
| 2 References | 7 |
| 3 Symbols and abbreviations..... | 9 |
| 3.1 Symbols..... | 9 |
| 3.2 Abbreviations | 9 |
| 4 General characteristics | 10 |
| 4.1 Frequency bands and channel arrangements | 10 |
| 4.1.1 Channel arrangements..... | 10 |
| 4.2 Compatibility requirements between systems | 10 |
| 4.3 Performance and availability requirements | 10 |
| 4.4 Environmental conditions..... | 11 |
| 4.4.1 Equipment within weather protected locations (indoor locations)..... | 11 |
| 4.4.2 Equipment for non-weather protected locations (outdoor locations)..... | 11 |
| 4.5 Power supply | 11 |
| 4.6 Electromagnetic compatibility..... | 11 |
| 4.7 System block diagram | 12 |
| 4.8 Telecommunications Management Network (TMN) interface..... | 12 |
| 4.9 Branching/feeder/antenna characteristics | 12 |
| 4.9.1 Antenna radiation patterns | 12 |
| 4.9.2 Antenna cross-Polar Discrimination (XPD) | 12 |
| 4.9.3 Antenna Inter-Port Isolation (IPI)..... | 12 |
| 4.9.4 Waveguide flanges (or other connectors) | 12 |
| 4.9.5 Return loss | 13 |
| 5 System parameters..... | 13 |
| 5.1 Transmission capacity | 13 |
| 5.2 Baseband parameters | 13 |
| 5.2.1 Plesiochronous interfaces | 13 |
| 5.2.2 SDH baseband interface..... | 13 |
| 5.3 Transmitter characteristics..... | 13 |
| 5.3.1 Transmitter power range | 14 |
| 5.3.2 Transmit power and frequency control | 14 |
| 5.3.2.1 Automatic Transmit Power Control (ATPC) | 14 |
| 5.3.2.2 Remote Transmit Power Control (RTPC)..... | 14 |
| 5.3.2.3 Remote Frequency Control (RFC) | 15 |
| 5.3.3 Transmitter output power tolerance | 15 |
| 5.3.4 Transmit Local Oscillator (LO) frequency arrangements | 15 |
| 5.3.5 RF spectrum mask | 15 |
| 5.3.6 Discrete CW components exceeding the spectrum mask limit | 20 |
| 5.3.6.1 Spectral lines at the symbol rate..... | 20 |
| 5.3.6.2 Additional CW components | 20 |
| 5.3.7 Spurious emissions | 21 |
| 5.3.7.1 Spurious emissions - external..... | 22 |
| 5.3.7.2 Spurious emissions - internal | 22 |
| 5.3.8 Radio frequency tolerance | 22 |
| 5.4 Receiver characteristics | 22 |
| 5.4.1 Input level range | 22 |
| 5.4.2 Receiver image rejection | 23 |
| 5.4.3 Spurious emissions | 23 |
| 5.4.3.1 Spurious emissions - external..... | 23 |
| 5.4.3.2 Spurious emissions - internal | 23 |
| 5.4.4 Innermost channel receiver selectivity for L6 GHz | 24 |

| | | |
|--|---|-----------|
| 5.5 | System performance without diversity | 25 |
| 5.5.1 | BER as a function of Receiver input Signal Level (RSL)..... | 25 |
| 5.5.2 | Equipment Residual BER | 25 |
| 5.5.3 | Interference sensitivity..... | 25 |
| 5.5.3.1 | Co-channel interference sensitivity | 26 |
| 5.5.3.2 | Adjacent channel interference | 26 |
| 5.5.3.3 | CW spurious interference..... | 26 |
| 5.5.4 | Distortion sensitivity..... | 27 |
| 5.6 | System characteristics with diversity | 27 |
| 5.6.1 | Differential delay compensation | 27 |
| 5.6.2 | BER performance | 27 |
| Annex A (informative): Additional information..... | | 28 |
| A.1 | Cross-Polar Discrimination (XPD) | 28 |
| A.2 | Branching/feeder/antenna requirements..... | 28 |
| A.2.1 | Return loss | 28 |
| A.2.2 | Intermodulation products | 28 |
| A.2.3 | Interport isolation | 28 |
| A.3 | Automatic Transmit Power Control (ATPC) | 28 |
| A.4 | RBER | 29 |
| A.5 | Co-channel and adjacent channel interference | 30 |
| Annex B: Void33 | | |
| Annex C (normative): System type codes for regulatory procedures..... | | 34 |
| Annex D (informative): Bibliography..... | | 35 |
| History | | 36 |

Intellectual Property Rights

IPRs essential or potentially essential to the present document may have been declared to ETSI. The information pertaining to these essential IPRs, if any, is publicly available for **ETSI members and non-members**, and can be found in ETSI SR 000 314: *"Intellectual Property Rights (IPRs); Essential, or potentially Essential, IPRs notified to ETSI in respect of ETSI standards"*, which is available from the ETSI Secretariat. Latest updates are available on the ETSI Web server (<http://www.etsi.org/legal/home.htm>).

Pursuant to the ETSI IPR Policy, no investigation, including IPR searches, has been carried out by ETSI. No guarantee can be given as to the existence of other IPRs not referenced in ETSI SR 000 314 (or the updates on the ETSI Web server) which are, or may be, or may become, essential to the present document.

Foreword

This European Standard (Telecommunications series) has been produced by ETSI Technical Committee Transmission and Multiplexing (TM).

The present document contains the minimum technical requirements to ensure compatibility of products and conformance with radio regulations across ETSI member states. Radio terminals from different manufacturers are not required to interwork at radio frequency (i.e. no common air interface). However, terminals may be combined with other manufacturers' equipment on a Radio Frequency (RF) branching network for operation on different polarizations.

The present document defines the requirements of radio terminal and radio relay equipment and associated interfaces. The requirements for multiplex, network management and antenna/feeder equipment may be addressed elsewhere.

| National transposition dates | |
|--|------------------|
| Date of latest announcement of this EN (doa): | 28 February 2002 |
| Date of latest publication of new National Standard or endorsement of this EN (dop/e): | 31 August 2002 |
| Date of withdrawal of any conflicting National Standard (dow): | 31 August 2002 |

1 Scope

The present document specifies parameters for high capacity STM-1 digital radio-relay systems designed to operate in defined bands up to 15 GHz. The channel spacing between adjacent cross-polar channels is generally approximately 30 MHz. Operation in the Adjacent Channel alternated cross-polar mode is foreseen. The present document specifies the minimum performance parameters for terrestrial fixed service radio communications equipment operating in the frequency bands up to 15 GHz and contains a revision from the previous version, in the area of:

- modification of the RF spectrum masks taking into account the compatibility requirements.

Recognizing that in some geographical areas there is a high demand for spectrum two different grades of system has been defined:

- Class 5 Grade A: equipment spectral efficiency based on typically 64 or 128-states modulation scheme (e.g. 64-QAM, 128-QAM, or equivalent) to be deployed, on parallel routes, with cross-polar adjacent channel with less stringent adjacent channel performance (see table 8) or for trunked multi-channel applications;
- Class 5 Grade B: equipment spectral efficiency based on typically 64 or 128-states modulation scheme (e.g. 64-QAM, 128-QAM, or equivalent) to be deployed, on parallel routes, with cross-polar adjacent channel with more stringent adjacent channel performance (see table 9).

The above classes are indicative only and do not imply any constraint to the actual modulation format, provided that all the requirements in the present document are met.

- Introduction of unique system type codes for regulatory reference to the various system types detailed in the present document, refer to new annex C (normative) and related categories of equipment classes of spectral efficiency.
- Additional specification for CW spectral lines exceeding the spectrum mask.

The applications of these digital radio-relay systems are anticipated to be in the trunk, regional and access networks, at data rates of Synchronous Transport Module, level 1 (STM-1). The parameters to be specified fall into two categories:

- a) those that are required to provide compatibility between channels from different sources of equipment on the same route connected either to separate antennas or separate polarizations of the same antenna. This category also includes parameters providing compatibility with the existing radio-relay network;
- b) parameters defining the transmission quality of the proposed system.

The standardization deals with RF and baseband characteristics. Antenna/feeder system requirements are covered in EN 300 833 [29].

Two possible baseband interfaces for SDH systems have to be considered: one for STM-1 and another for 140 Mbit/s signals.

The present document does not contain aspects related to test procedures and test conditions, however they are to be found in EN 301 126-1 [27].

Safety aspects are outside the mandate of ETSI and they will not be considered in the present document. However compliance to EN 60950 [43] will be required to comply with Directive 1999/5/EC [44] (R&TTE Directive).

Technical background for most of the parameters and requirements referred in the present document may be found in TR 101 036-1 [28].

2 References

The following documents contain provisions which, through reference in this text, constitute provisions of the present document.

- References are either specific (identified by date of publication and/or edition number or version number) or non-specific.
- For a specific reference, subsequent revisions do not apply.
- For a non-specific reference, the latest version applies.

- [1] ITU-R Recommendation F.382-7: "Radio-frequency channel arrangements for radio-relay systems operating in the 2 and 4 GHz bands".
- [2] ITU-R Recommendation F.635-5: "Radio-frequency channel arrangements based on a homogeneous pattern for radio-relay systems operating in the 4 GHz band".
- [3] ITU-R Recommendation F.385-6: "Radio-frequency channel arrangements for radio-relay systems operating in the 7 GHz band".
- [4] ITU-R Recommendation F.383-6: "Radio-frequency channel arrangements for high capacity radio-relay systems operating in the lower 6 GHz band".
- [5] ITU-R Recommendation F.386-6 (Annex I): "Radio-frequency channel arrangements for medium and high capacity analogue or digital radio-relay systems operating in the 8 GHz band".
- [6] ITU-R Recommendation F.497-6: "Radio-frequency channel arrangements for radio-relay systems operating in the 13 GHz frequency band".
- [7] ITU-R Recommendation F.636-3: "Radio-frequency channel arrangements for radio-relay systems operating in the 15 GHz band".
- [8] CEPT/ERC Recommendation 12-08: "Harmonized radio frequency channel arrangements and block allocations for low, medium and high capacity systems in the band 3 600 MHz to 4 200 MHz".
- [9] CEPT/ERC Recommendation 14-01: "Radio-frequency channel arrangements for high capacity analogue and digital radio-relay systems operating in the band 5 925 MHz to 6 425 MHz".
- [10] CEPT/ERC Recommendation 12-02: "Harmonized radio frequency channel arrangements for analogue and digital terrestrial fixed systems operating in the band 12,75 GHz to 13,25 GHz".
- [11] CEPT/ERC Recommendation 12-07: "Harmonized radio frequency channel arrangements for digital terrestrial fixed systems operating in the band 15,23 GHz to 15,35 GHz".
- [12] ITU-R Recommendation F.750-3: "Architectures and functional aspects of radio-relay systems for synchronous digital hierarchy (SDH)based networks".
- [13] ITU-R Recommendation F.751-2: "Transmission characteristics and performance requirements of radio-relay systems for SDH-based networks".
- [14] ITU-R Recommendation F.1189-1: "Error performance objectives for constant bit rate digital paths at or above the primary rate carried by digital radio-relay systems which may form part or all of the national portion of a 27 500 km hypothetical reference path".
- [15] ITU-R Recommendation F.1092-1: "Error performance objectives for constant bit rate digital path at or above the primary rate carried by digital radio-relay systems which may form part of the international portion of a 27 500 km hypothetical reference path".
- [16] ETSI ETS 300 019 (all parts): "Equipment Engineering (EE); Environmental conditions and environmental tests for telecommunications equipment".

- [17] ETSI ETS 300 132-1: "Equipment Engineering (EE); Power supply interface at the input to telecommunications equipment; Part 1: Operated by alternating current (ac) derived from direct current (dc) sources".
- [18] ETSI ETS 300 132-2: "Equipment Engineering (EE); Power supply interface at the input to telecommunications equipment; Part 2: Operated by direct current (dc)".
- [19] ITU-T Recommendation G.703 (1998): "Physical/electrical characteristics of hierarchical digital interfaces".
- [20] ITU-T Recommendation G.707 (1996): "Network node interface for the synchronous digital hierarchy (SDH)".
- [21] ITU-T Recommendation G.773 (1993): "Protocol suites for Q-interfaces for management of transmission systems".
- [22] ITU-T Recommendation G.784 (1999): "Synchronous digital hierarchy (SDH) management".
- [23] ITU-T Recommendation G.826 (1999): "Error performance parameters and objectives for international, constant bit rate digital paths at or above the primary rate".
- [24] ITU-T Recommendation G.827 (2000): "Availability parameters and objectives for path elements of international constant bit-rate digital paths at or above the primary rate".
- [25] ITU-T Recommendation G.957 (1999): "Optical interfaces for equipments and systems relating to the synchronous digital hierarchy".
- [26] ETSI EN 300 385: "Electromagnetic compatibility and Radio spectrum Matters (ERM); ElectroMagnetic Compatibility (EMC) standard for fixed radio links and ancillary equipment".
- [27] ETSI EN 301 126-1: "Fixed Radio Systems; Conformance testing; Part 1: Point-to-Point equipment - Definitions, general requirements and test procedures".
- [28] ETSI TR 101 036-1: "Fixed Radio Systems; Point-to-point equipment; Generic wordings for standards on digital radio systems characteristics; Part 1: General aspects and point-to-point equipment parameters".
- [29] ETSI EN 300 833: "Fixed Radio Systems; Point-to-point Antennas; Antennas for point-to-point fixed radio systems operating in the frequency band 3 GHz to 60 GHz".
- [30] ETSI ETS 300 635: "Transmission and Multiplexing (TM); Synchronous Digital Hierarchy (SDH); Radio specific functional blocks for transmission of M x STM-N".
- [31] ETSI EN 300 645: "Telecommunications Management Network (TMN); Synchronous Digital Hierarchy (SDH) radio relay equipment; Information model for use on Q interfaces".
- [32] ETSI EN 300 417 (all parts): "Transmission and Multiplexing (TM); Generic requirements of transport functionality of equipment".
- [33] ETSI EN 301 167: "Transmission and Multiplexing (TM); Management of Synchronous Digital Hierarchy (SDH) transmission equipment; Fault management and performance monitoring; Functional description".
- [34] CEPT/ERC Recommendation 74-01: "Spurious emissions".
- [35] ITU-T Recommendation O.151 (1992): "Error performance measuring equipment operating at the primary rate and above".
- [36] ITU-T Recommendation O.181 (1996): "Equipment to assess error performance on STM-N interfaces".
- [37] IEC Publication 154-2: "Flanges for waveguides. Part 2: Relevant specifications for flanges for ordinary rectangular waveguides".
- [38] CEPT/ERC Recommendation T/L 04-04: "Harmonization of 140 Mbit/s digital radio relay systems for operation below 10 GHz utilizing 64 QAM at about 30 MHz spacing".

- [39] ETSI EN 301 489-1: "Electromagnetic compatibility and Radio spectrum Matters (ERM); ElectroMagnetic Compatibility (EMC) standard for radio equipment and services; Part 1: Common technical requirements".
- [40] ETSI EN 301 489-4: "Electromagnetic compatibility and Radio spectrum Matters (ERM) ElectroMagnetic Compatibility (EMC) standard for radio equipment and services; Part 4: Specific conditions for fixed radio links and ancillary equipment and services".
- [41] ETSI TR 101 035 (V1.1.2): "Transmission and Multiplexing (TM); Synchronous Digital Hierarchy (SDH) aspects regarding Digital Radio Relay Systems (DRRS)".
- [42] Council Directive 89/336/EEC of 3 May 1989 on the approximation of the laws of the Member States relating to electromagnetic compatibility.
- [43] EN 60950: "Safety of information technology equipment".
- [44] Directive 1999/5/EC of the European Parliament and of the Council of 9 March 1999 on radio equipment and telecommunications terminal equipment and the mutual recognition of their conformity.

3 Symbols and abbreviations

3.1 Symbols

For the purposes of the present document, the following symbols apply:

| | |
|--------|--|
| dB | decibel |
| dBc | decibel relative to mean carrier power |
| dBm | decibel relative to 1 milliWatt |
| GHz | GigaHertz |
| kHz | kiloHertz |
| Mbit/s | Mega-bits per second |
| MHz | MegaHertz |
| ppm | parts per million |

3.2 Abbreviations

For the purposes of the present document, the following abbreviations apply:

| | |
|-------|--|
| ATPC | Automatic Transmit Power Control |
| BBER | Background Block Error Ratio |
| BER | Bit Error Ratio |
| BWe | evaluation BandWidth (resolution bandwidth in which spectrum components are measured) |
| C/I | Carrier to Interference ratio |
| CEPT | Conférence des Administrations Européennes des Postes et Télécommunications |
| CMI | Coded Mark Inversion |
| CSmin | minimum practical Channel Separation (for a given radio-frequency channel arrangement) |
| CW | Continuous Wave |
| DC | Direct Current |
| DRRS | Digital Radio Relay Systems |
| EMC | ElectroMagnetic Compatibility |
| ERC | European Radiocommunications Committee |
| ESR | Errored Seconds Ratio |
| IEC | International Electrotechnical Commission |
| IF | Intermediate Frequency |
| IPI | Inter-Port Isolation |
| ITU-R | International Telecommunication Union-Radiocommunications standardization sector |
| ITU-T | International Telecommunication Union-Telecommunications standardization sector |
| LO | Local Oscillator |

| | |
|-------|---------------------------------------|
| PDH | Plesiochronous Digital Hierarchy |
| PRBS | Pseudo Random Binary Sequence |
| QAM | Quadrature Amplitude Modulation |
| RBER | Residual BER |
| RF | Radio Frequency |
| RFC | Remote Frequency Control |
| RSL | Receive Signal Level |
| RTPC | Remote Transmit Power Control |
| SDH | Synchronous Digital Hierarchy |
| SOH | Section OverHead |
| STM-N | Synchronous Transport Module, level N |
| TM | ETSI TC-Transmission and Multiplexing |
| TMN | Telecommunications Management Network |
| XPD | cross-Polar Discrimination |

4 General characteristics

4.1 Frequency bands and channel arrangements

4.1.1 Channel arrangements

The equipment shall operate on one or more of the channels as defined below.

| | |
|---------------|---|
| 4 GHz | The channel plan shall be in accordance with CEPT/ERC Recommendation 12-08 [8] annex A, part 2 or ITU-R Recommendations F.382-7 [1] or F.635-5 [2]. |
| 6L GHz | The channel plan shall be in accordance with CEPT/ERC Recommendation 14-01 [9] or ITU-R Recommendation F.383-6 [4]. |
| 7 GHz | The channel plan shall be in accordance with ITU-R Recommendation F.385-6 [3]. |
| 8L GHz | The channel plan shall be in accordance with ITU-R Recommendation F.386-6 [5]. |
| 13 GHz | The channel plan shall be in accordance with CEPT/ERC Recommendation 12-02 [10] or ITU-R Recommendation F.497-6 [6]. |
| 15 GHz | The channel plan shall be in accordance with CEPT/ERC Recommendation 12-07 [11] or ITU-R Recommendation F.636-3 [7]. |

4.2 Compatibility requirements between systems

The compatibility requirements between systems are as follows:

- a) there shall be no requirement to operate transmitting equipment from one manufacturer with receiving equipment from another;
- b) there may be a requirement to multiplex different manufacturers equipment on the same polarization of the same antenna;
- c) there may be a requirement to multiplex different manufacturers equipment on different polarization of the same antenna. This will not apply to systems with integral antenna.

4.3 Performance and availability requirements

Equipment shall be designed in order to meet network performance and availability requirements foreseen by ITU-T Recommendations G.826 [23] and G.827 [24] following the criteria defined in ITU-R Recommendations F.1092-1 [15] and F.1189-1 [14] for international or national portion of the digital path.

4.4 Environmental conditions

The equipment shall be required to meet the environmental conditions set out in ETS 300 019 [16] which defines weather protected and non-weather protected locations, classes and test severity.

The manufacturer shall state which class the equipment is designed to withstand.

4.4.1 Equipment within weather protected locations (indoor locations)

Equipment intended for operation within temperature controlled locations or partially temperature controlled locations shall meet the requirements of ETS 300 019 [16] classes 3.1 and 3.2 respectively.

Optionally, the more stringent requirements of ETS 300 019 [16] classes 3.3 (non-temperature controlled locations), 3.4 (sites with heat trap) and 3.5 (sheltered locations) may be applied.

4.4.2 Equipment for non-weather protected locations (outdoor locations)

Equipment intended for operation within non-weather protected locations shall meet the requirements of ETS 300 019 [16], class 4.1 or 4.1E.

Class 4.1 applies to many European countries and class 4.1E applies to all European countries.

4.5 Power supply

The power supply interface shall be in accordance with the characteristics of one or more of the secondary voltages foreseen in ETS 300 132-1 [17] and ETS 300 132-2 [18].

NOTE: Some applications may require secondary voltages that are not covered by ETS 300 132-1 [17] and ETS 300 132-2 [18].

For DC systems, the positive pole of the voltage supply will be earthed at the source.

4.6 Electromagnetic compatibility

Equipment shall operate under the conditions specified in EN 300 385 [26] or in relevant parts of the multi-part standard EN 301 489-1 [39] and EN 301 489-4 [40].

4.7 System block diagram

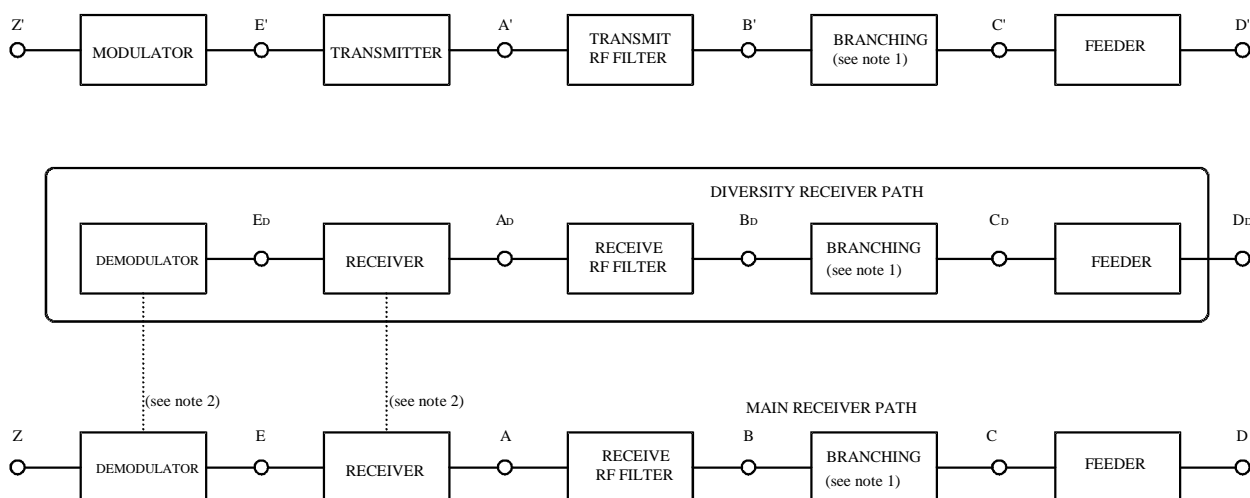

NOTE 1: For the purpose of defining the measurement points, the branching network does not include a hybrid.

NOTE 2: Connection at RF, IF or baseband.

NOTE 3: The points shown above are reference points only; points C and C', D and D' in general coincide.

NOTE 4: Points B and C, B' and C' may coincide when simple duplexer is used.

Figure 1: System block diagram

4.8 Telecommunications Management Network (TMN) interface

For SDH equipment the general requirements for TMN interface and functionality are given by:

- EN 300 417-1-1 [32], EN 300 417-2-1 [32], EN 300 417-3-1 [32], EN 300 417-4-1 [32], EN 300 417-5-1 [32], EN 300 417-6-1 [32], EN 301 167 [33], ETS 300 635 [30] and EN 300 645 [31], ITU-T Recommendations G.784 [22] and G.773 [21], ITU-R Recommendations F.750-3 [12] and F.751-2 [13].

NOTE: The standardization of TMN interface functionality is under study in ETSI TMN and will be applicable to the radio relay systems considered in the present document.

4.9 Branching/feeder/antenna characteristics

4.9.1 Antenna radiation patterns

See EN 300 833 [29].

4.9.2 Antenna cross-Polar Discrimination (XPD)

See EN 300 833 [29].

4.9.3 Antenna Inter-Port Isolation (IPI)

See EN 300 833 [29].

4.9.4 Waveguide flanges (or other connectors)

When flanges are required at reference point C, C', they shall be in accordance with the types detailed in IEC 154-2 [37], depending on the frequency band.

4.9.5 Return loss

For systems which intend to apply to the compatibility requirements under clause 4.2. The minimum return loss shall be 26 dB at point C and C' over the full RF band and measured back in the direction to the transmitter.

Equipment according to the present document may also have system configurations with integral antennas or very similar technical solutions, without long feeder connections; return loss is not considered an essential requirement. When the antenna is an integral part of the equipment there shall be no requirement.

For feeder/antenna return loss requirement see annex A.

5 System parameters

5.1 Transmission capacity

Payload bit rates considered in the present document are:

- 139,264 Mbit/s; and
- 155,520 Mbit/s (STM-1).

In the following clauses, these capacities will be simply referred as 140 Mbit/s, and 155 Mbit/s (STM-1) respectively.

5.2 Baseband parameters

All the following specified baseband parameters refer to point Z and Z' of figure 1. Parameters for service channels and wayside traffic channels are outside the scope of the present document.

5.2.1 Plesiochronous interfaces

Plesiochronous interfaces at 140 Mbit/s shall comply with ITU-T Recommendation G.703 [19].

5.2.2 SDH baseband interface

The SDH baseband interface shall be in accordance with:

- ITU-T Recommendations G.703 [19], G.707 [20], G.784 [22] and G.957 [25], ETS 300 635 [30], EN 300 417-1-1 [32], EN 300 417-2-1 [32], EN 300 417-3-1 [32], EN 300 417-4-1 [32], EN 300 417-5-1 [32] and EN 300 417-6-1 [32].

Two STM-1 interfaces shall be possible:

- CMI electrical (ITU-T Recommendation G.703 [19]);
- optical (ITU-T Recommendation G.957 [25]).

The use of reserved bytes contained in the Section OverHead (SOH), and their termination shall be in accordance with ITU-R Recommendation F.750-3 [12]. Further details on the possible use of the SOH bytes including additional RFCOH or RSCOH are given in TR 101 035 [41].

5.3 Transmitter characteristics

The specified transmitter characteristics shall be met with the appropriate baseband signals applied at reference point Z' of figure 1. For PDH interface this shall be a Pseudo Random Binary Sequence (PRBS) according to ITU-T Recommendation O.151 [35] while for SDH interface ITU-T Recommendation O.181 [36] test signal applies.

5.3.1 Transmitter power range

Transmitter maximum mean output power at reference point C' of the system block diagram (see figure 1) shall not exceed +38 dBm (including tolerance and, if applicable, ATPC/RTPC influence).

For the purpose of system engineering four classes of nominal output power are defined (see intervals in table 1).

Table 1

| | | |
|----------------|-----------|-----------|
| Class A | | < +26 dBm |
| Class B | ≥ +26 dBm | < +31 dBm |
| Class C | ≥ +29 dBm | < +34 dBm |
| Class D | ≥ +34 dBm | |

NOTE 1: The manufacturer will state, in the conformance test, if ATPC is optional or fixed feature.

NOTE 2: The technological evolution may result in equipment falling outside of the range(s) foreseen in this clause. In this case the equipments of different output power sub-ranges are not considered to require individual type approval, however their use is subject to individual national agreements.

A capability for output power level adjustment may be required for regulatory purposes, in which case the range of adjustment, either by fixed or automatic attenuators, should be in steps of 5 dB or less.

5.3.2 Transmit power and frequency control

5.3.2.1 Automatic Transmit Power Control (ATPC)

ATPC is an optional feature. Equipment with ATPC will be subject to manufacturer declaration of ATPC ranges and related tolerances. The manufacturer shall declare if the equipment is designed with ATPC as a fixed permanent feature. Testing shall be carried out with output power level corresponding to:

- ATPC set manually to a fixed value for system performance (see clauses 5.5 and 5.6);
- ATPC set at maximum available power for transmit performance (see clause 5.3).

It shall be verified that the emitted RF spectrum is within the absolute RF spectrum mask evaluated for the maximum available output power of the equipment, including the attenuation introduced by RTPC, if any.

NOTE: Where the use of ATPC is considered compulsory for regulatory purposes the transmitter output power must meet the spectrum mask limits throughout the ATPC range.

The ATPC range is the power interval from the nominal output power level to the lowest power amplifier output level (at point B') with ATPC.

5.3.2.2 Remote Transmit Power Control (RTPC)

RTPC is an optional feature. Equipment with RTPC will be subject to manufacturer declaration of RTPC ranges and related tolerances. Testing shall be carried out with output power level corresponding to RTPC set to the maximum nominal power for transmit performance (see clause 5.3) and for system performance (see clauses 5.5 and 5.6).

The RF spectrum mask shall be verified in three points (low, medium, and high) of the RTPC power excursion and with ATPC set to maximum available power (if any). When these spectrum measurements are made difficulties may be experienced. Actual measurement methods shall be addressed in further investigations and will be defined in the conformance testing standard, EN 301 126-1 [27].

RTPC range should be restricted, taking into account the wideband noise generated by the transmitter chain, to ensure the spectrum mask requirements are met throughout the transmitter output power range.

NOTE: Where the use of ATPC is considered compulsory for regulatory purposes the transmitter output power must meet the spectrum mask limits throughout the ATPC range.

5.3.2.3 Remote Frequency Control (RFC)

RFC is an optional feature. Equipment with RFC will be subject to manufacturer declaration of RFC ranges and related change frequency procedure. Testing shall be carried out including:

- RFC setting procedure at least for three frequencies (lower, centre and higher of the covered range);
- RFC setting procedure shall not produce emissions outside the previous and final frequency spectrum mask.

5.3.3 Transmitter output power tolerance

The nominal output power shall be declared by the supplier.

The tolerance of the nominal output power shall be within:

- for systems operating within non-weather protected locations classes 4.1 and 4.1E and within classes 3.3, 3.4 and 3.5 weather protected locations defined in ETS 300 019 [16]:
 - nominal output power ± 2 dB;
- for systems operating within other classes of weather protected locations defined in ETS 300 019 [16]:
 - nominal output power ± 1 dB.

5.3.4 Transmit Local Oscillator (LO) frequency arrangements

There shall be no requirement on LO frequency arrangement.

5.3.5 RF spectrum mask

Clause 4.2 provides compatibility requirements. The compatibility requirements provide options for single-channel and multi-channel RF branching systems. When considering the compatibility requirements in clause 4.2b) and 4.2c), the RF spectrum mask shall take into consideration the effects of system interoperability when selecting normal channels or the innermost channel (see below). The spectrum masks are defined in figures 2, 3 and 4 for the following applications per clause 4.2:

- Limits of masks in figures 5 and 6 are for systems which are not intended to comply with any compatibility requirements under clause 4.2.
- Limits of masks in figures 2, 3 and 4 are for normal and innermost channels of systems which are intended to comply with compatibility requirement under clause 4.2b. The limits marked (a) in figures 2, 3 and 4 shall be verified directly by measurement. Since it is not possible to measure attenuation values up to 105 dB directly, values of the relative power spectral density below -65 dB in figures 2, 3 and 4 (curve b) should be subject to a supplier declaration.

NOTE: These values may be evaluated by adding a measured filter characteristic to the spectrum at A' of figures 2, 3 and 4. Due to limitations of some spectrum analysers, difficulties may be experienced when testing high capacity/wideband systems. In this event, the following options are to be considered: measurement using high performance spectrum analyser, use of notch filters and two step measurement technique. Where difficulties are experienced, the plots of one test conducted at ambient and environmental extremes may be produced as evidence to conformance to the spectrum mask.

If, depending on application, administrations or operating companies do not require compatibility with systems specified in CEPT/ERC Recommendation T/L 04-04 [38], a slightly relaxed spectrum mask as given in figures 2, 3 and 4, curve (c), may be applied. However, all other specifications in the present document shall be met.

For the lower 6 (L6) band, where the centre gap (44,49 MHz) is particularly small, a mask is specified for the innermost edges of the centre gap channels 8 and 1', the mask is given in figure 3.

A mask for the innermost channels in the 7 GHz band (centre gap 56 MHz) is given in figure 4.

Masks shall be measured with a modulating baseband test signal given by ITU-T Recommendation O.151 [35] in the case of PDH signals or by ITU-T Recommendation O.181 [36] for SDH.

The 0 dB level shown on the spectrum masks relates to the spectral power density of the nominal centre frequency disregarding residual carrier.

The masks do not include frequency tolerance.

When up conversion is performed from a 70 MHz intermediate frequency, the limit of the residual LO emission at point C' will not be limited by the spectrum mask but shall meet the limits of spurious emissions, either the external (see clause 5.3.6.2) or if applicable the internal requirement (see clause 5.3.7.2) whichever is the more stringent.

The spectrum analyser settings for measuring the RF spectrum mask detailed are shown in table 2.

Table 2: Spectrum analyser settings

| Parameter | Setting |
|------------------------|---------|
| IF bandwidth | 100 kHz |
| Total sweep width | 200 MHz |
| Total scan time | Auto |
| Video filter bandwidth | 0,3 kHz |

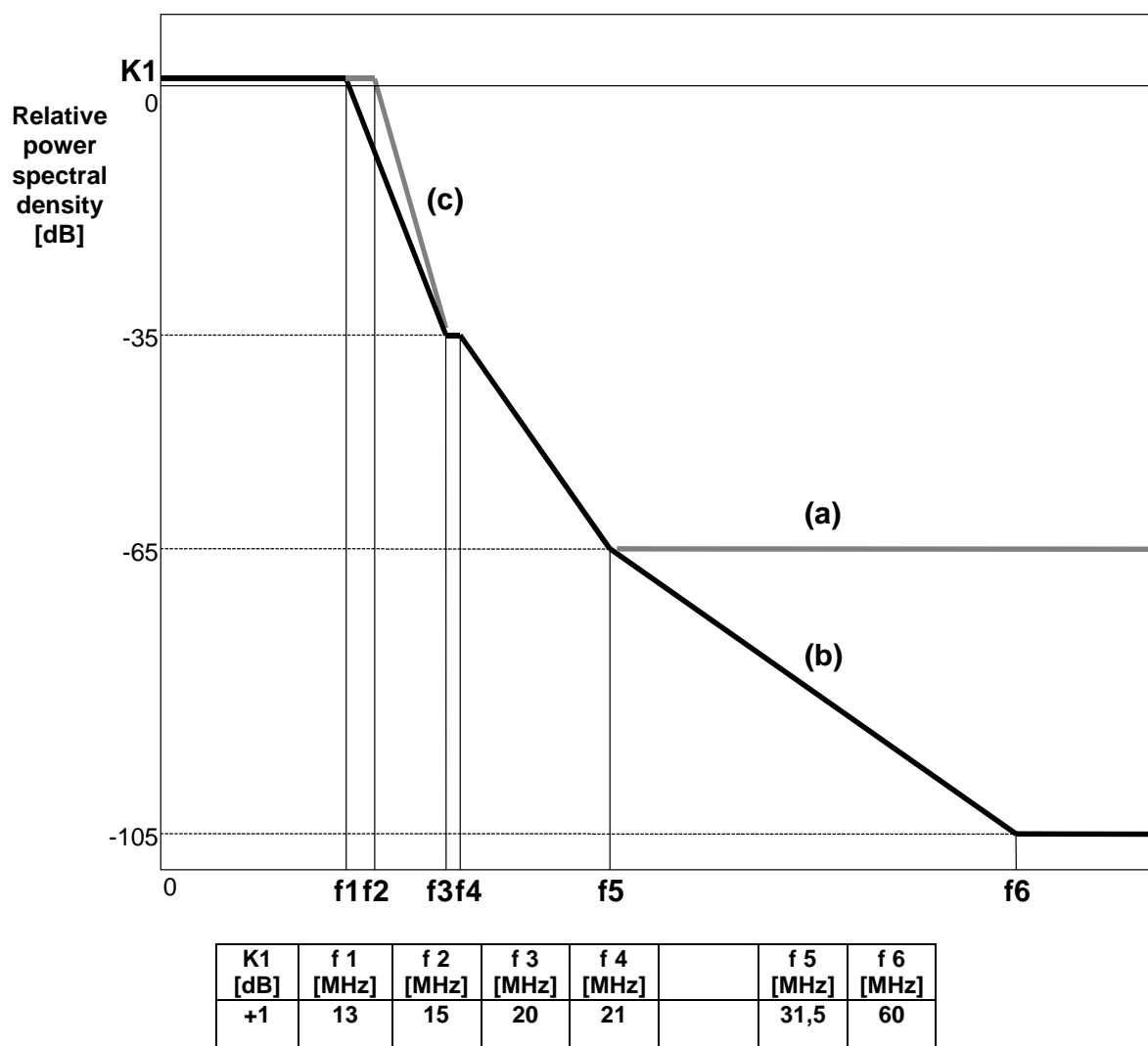

Figure 2: Limits of spectral power density for normal channels (class 5 Grade A) with compatibility requirements, see clause 4.2 (reference point B')

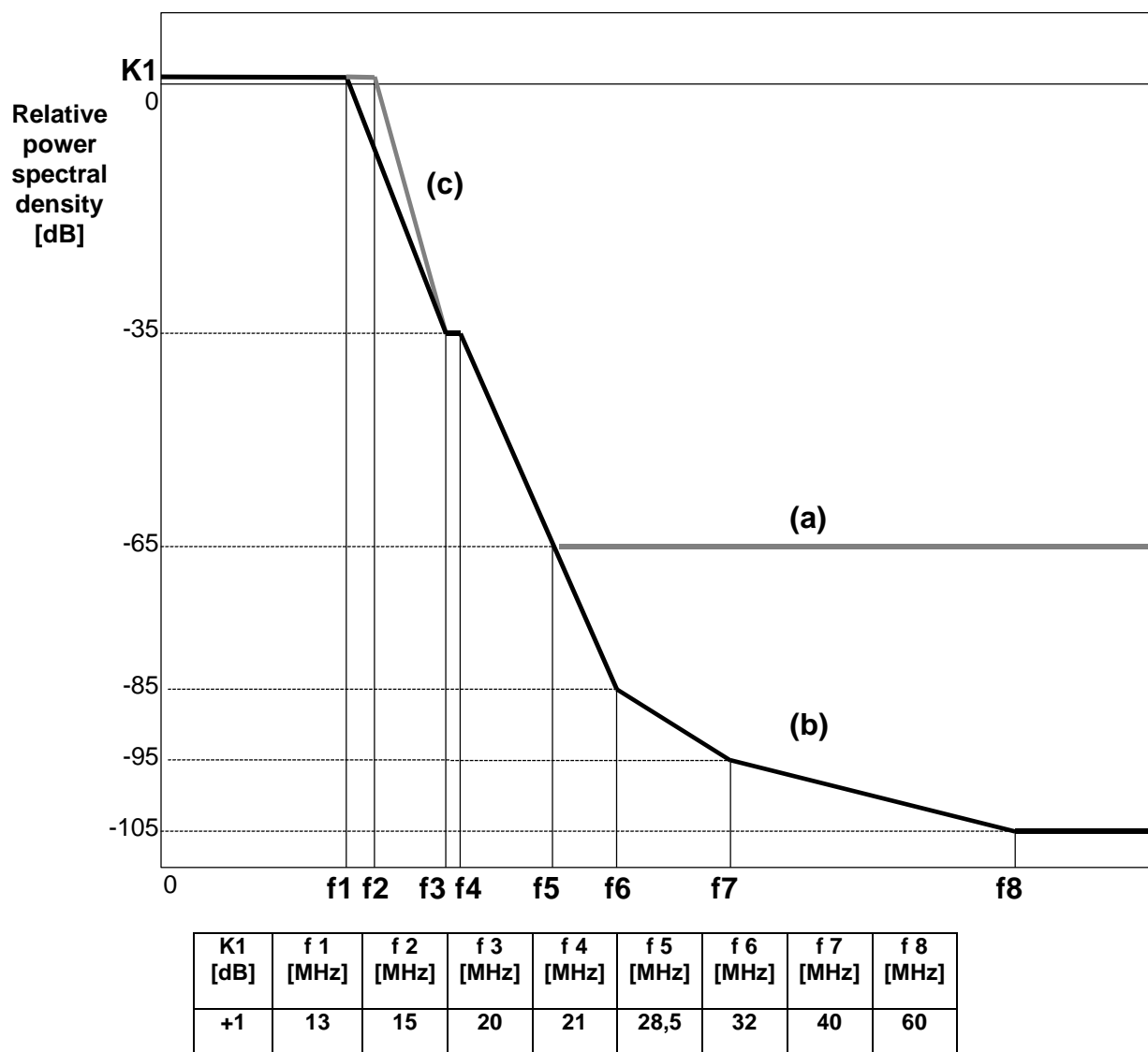

Figure 3: Limits of spectral power density for the innermost channels (class 5 Grade A), L6 GHz band with compatibility requirements, see clause 4.2 (reference point B')

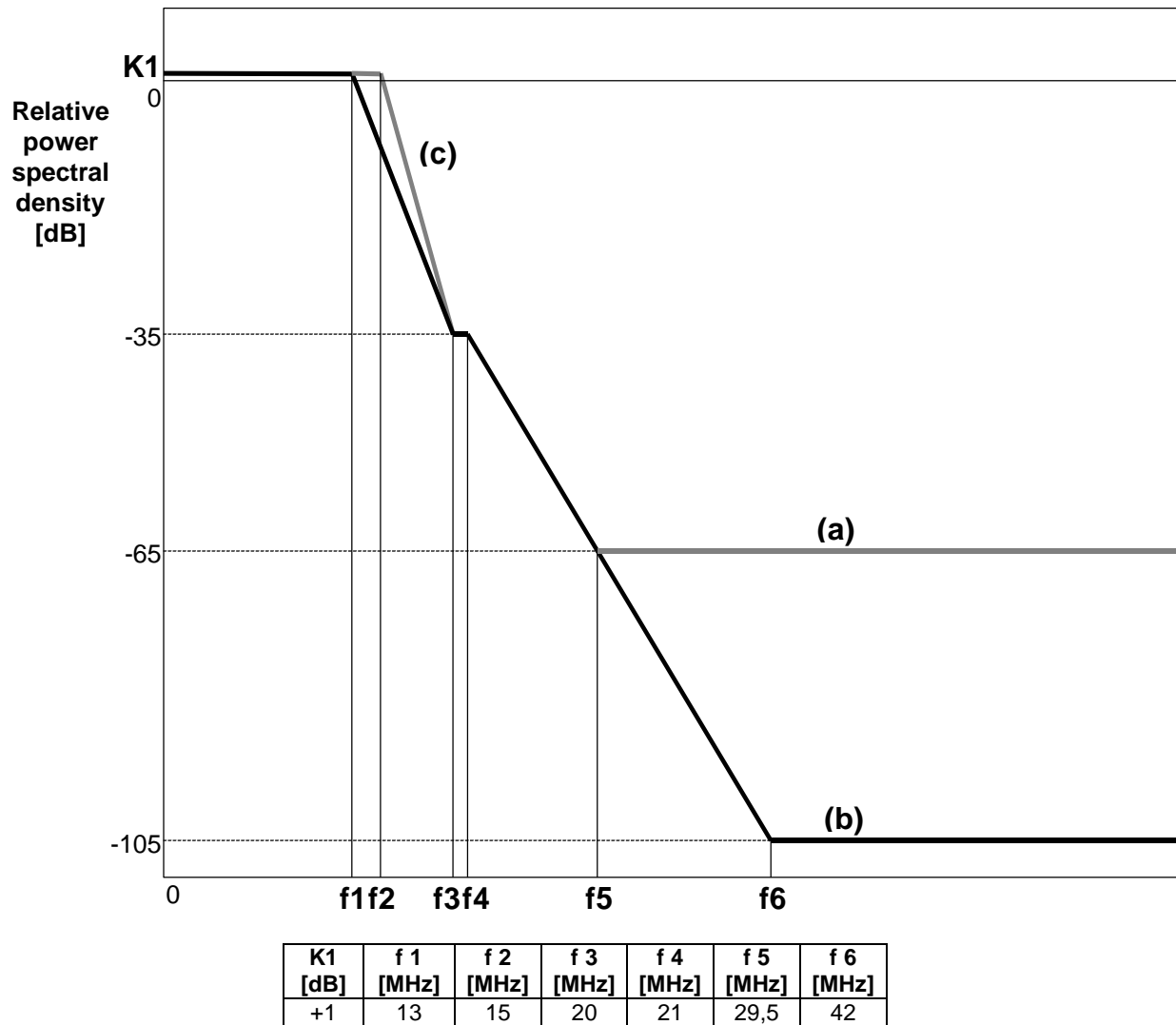
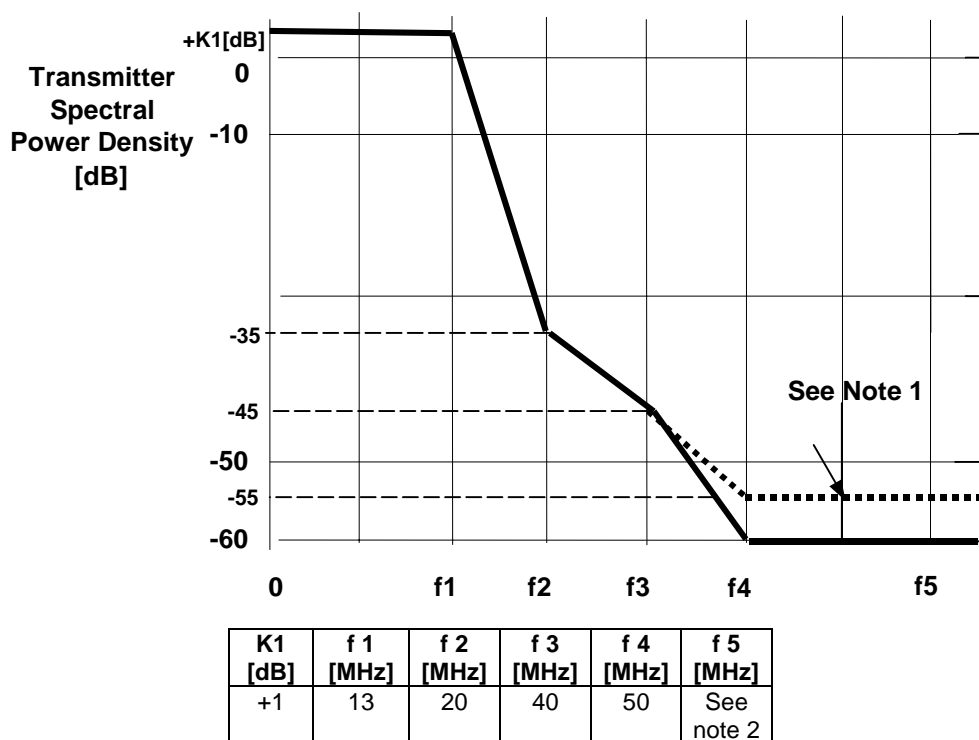

Figure 4: Limits of spectral power density for the inner edges of innermost channels (class 5 Grade A) in the 7 GHz band with 56 MHz centre gap with compatibility requirements, see clause 4.2 (reference point B')



NOTE 1: The spectral noise floor at -60 dB is applied to systems operating in frequency bands below 10 GHz. For systems operating at 13 GHz and 15 GHz the spectral noise floor is -55 dB.

NOTE 2: Mask boundary = 2,5 x (CS)
 70 MHz for CS = 28 MHz
 72,5 MHz for CS = 29 MHz
 74,125 MHz for CS = 29,65 MHz
 75 MHz for CS = 30 MHz.

Figure 5: Limits of spectral power density for normal channels in all frequency bands for class 5 Grade A without compatibility requirements of clause 4.2 (reference point C')

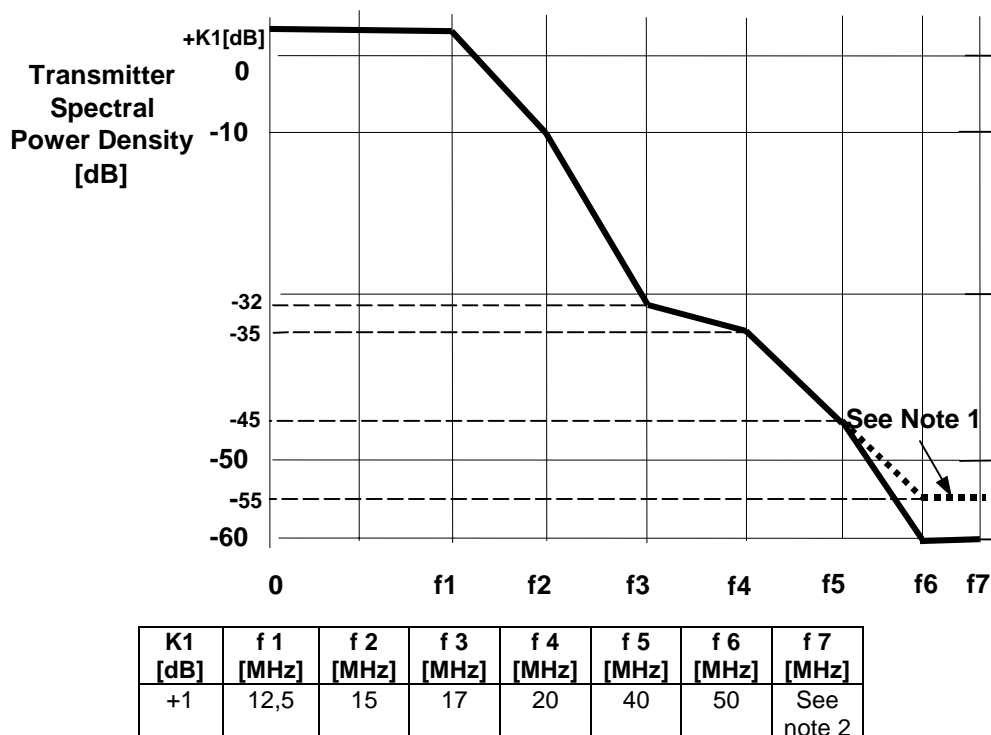

NOTE 1: The spectral noise floor at -60 dB is applied to systems operating in frequency bands below 10 GHz. For systems operating at 13 GHz and 15 GHz the spectral noise floor is -55 dB.

NOTE 2: Mask boundary = 2,5 x (CS)
 70 MHz for CS = 28 MHz
 72,5 MHz for CS = 29 MHz
 74,125 MHz for CS = 29,65 MHz
 75 MHz for CS = 30 MHz.

Figure 6: Limits of spectral power density for normal channels in all frequency bands for class 5 Grade B without compatibility requirements of clause 4.2 (reference point C')

5.3.6 Discrete CW components exceeding the spectrum mask limit

5.3.6.1 Spectral lines at the symbol rate

The power level (reference point B') of spectral lines at a distance from the channel centre frequency equal to the symbol rate shall be less than or equal to -37 dBm.

5.3.6.2 Additional CW components

Should CW components exceed the spectrum mask, an additional allowance is given.

Those lines shall not:

- exceed the mask by a factor more than $\{10 \log (CS_{\min}/IF_{\text{bandwidth}}) - 10\}$ dB (see note);
- be spaced each other in frequency by less than CS_{\min} .

Where:

- CSmin = 10 MHz for 4 GHz band;
- CSmin = 14,825 MHz for 6L GHz band;
- CSmin = 7 MHz for 7 and 8 GHz band;
- CSmin = 1,75 MHz for 13 and 15 GHz band.

IF bandwidth is the recommended resolution bandwidth reported in table 2.

NOTE: In case the calculation of the allowance factor will result in a negative value, no additional allowance is then permitted.

Figure 7 shows a typical example of this requirement.

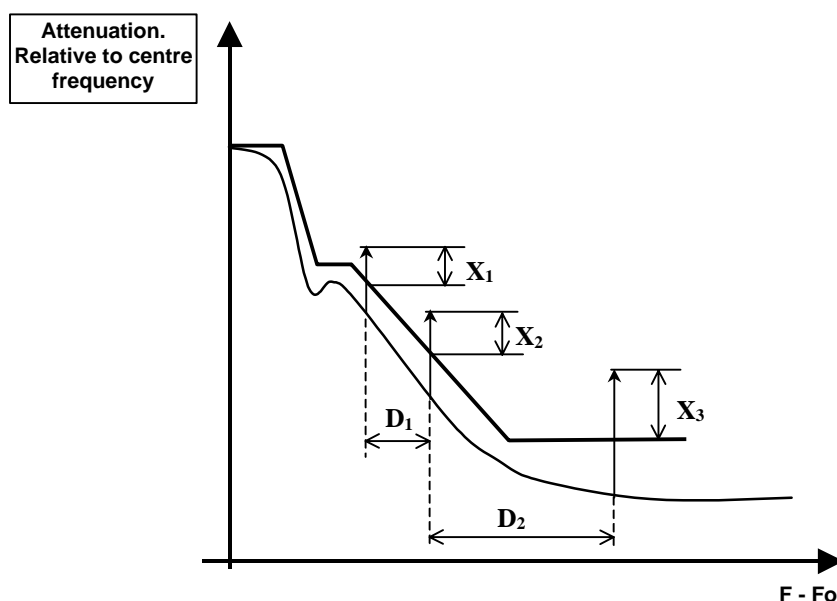

$$X_1, X_2, X_3 \text{ [dB]} \leq 10\log(\text{CSmin}/\text{BWe}) - 10$$

$$D_1, D_2 \geq \text{CSmin}$$

Figure 7: CW lines exceeding the spectrum mask (typical example)

5.3.7 Spurious emissions

It is necessary to define spurious emissions from transmitters for two reasons:

- to limit interference into other systems operating wholly externally to the system under consideration (external emissions), which limits are referred by CEPT/ERC Recommendation 74-01 [34];
- to limit local interference within the system where transmitters and receivers are directly connected via the filter and branching systems.

This leads to two sets of spurious emissions limits where the specific limits given for "internal" interference are required to be no greater than the 'external' level limits.

5.3.7.1 Spurious emissions - external

According to CEPT/ERC Recommendation 74-01 [34] the external spurious emissions are defined as emissions at frequencies which are removed from the nominal carrier frequency more than $\pm 250\%$ of the relevant channel separation.

Outside the band of $\pm 250\%$ of the relevant channel separation (CS), the Fixed Service radio systems spurious emissions limits, defined by CEPT/ERC Recommendation 74-01 [34] together with the frequency range to consider for conformance measurement, shall apply at reference point C'.

5.3.7.2 Spurious emissions - internal

The levels of the spurious emissions from the transmitter, referenced to point B' of figure 1 are specified below.

The required level will be the total average level of the emission under consideration.

Table 3: Internal levels for the transmitter spurious emissions

| Spurious emission frequency relative to channel assigned frequency | Specification limit | Controlling factor for requirement application |
|---|---------------------|---|
| The level of all spurious signals both discrete CW and noise-like evaluated as total signal level | ≤ -90 dBm | If spurious signal's frequency falls within receiver half band, for digital systems with compatibility requirements as in clause 4.2b |
| | ≤ -70 dBm | If spurious signal's frequency falls within receiver half band, for digital systems with compatibility requirements as in clause 4.2c |

Requirements for internal spurious emissions are not necessary for systems that are not intended to comply with any compatibility requirements under clause 4.2.

5.3.8 Radio frequency tolerance

For all frequency bands considered, maximum radio frequency tolerance shall not exceed:

- ± 30 ppm for operation in environmental classes 3.1 and 3.2;
- ± 50 ppm or ± 400 kHz, whichever is the more stringent, for operation in other environmental classes.

This limit includes both short-term factors (environmental effects) and long-term ageing effects.

5.4 Receiver characteristics

5.4.1 Input level range

The lower limit for the receiver input level shall be given by the threshold level for Bit Error Ratio (BER) = 10^{-3} . The upper limit for the receiver input level, where a BER of 10^{-3} is not exceeded shall be -17 dBm; a BER of 10^{-10} may only be exceeded for levels greater than -21 dBm. These limits apply without interference and are referenced to point B.

For systems that are not intended to comply with any compatibility requirements under clause 4.2, the upper limit for the receiver input level, where a BER of 10^{-3} is not exceeded shall be -20 dBm. A BER of 10^{-10} may only be exceeded for levels greater than -24 dBm.

For equipment designed to operate only with ATPC as a fixed permanent feature, the above maximum input levels are reduced by an amount up to the ATPC range.

5.4.2 Receiver image rejection

The receiver image(s) rejection shall be as listed in table 4.

Table 4: Receiver image rejection

| Controlling factor | Image rejection |
|---|-----------------|
| a) if image(s) frequency falls within receiver half band and branching on different polarizations is used as defined by the compatibility requirements in clause 4.2c | ≥ 90 dB |
| b) in systems not intended to fulfil any compatibility requirements in clause 4.2 | Not Applicable |
| c) if image(s) frequency falls within receiver half band and branching on same polarization is used as defined in clause 4.2b or in the transmitter half band on different polarization as defined by the compatibility requirements in clause 4.2c | ≥ 100 dB |
| d) if image(s) frequency falls within transmitter half band and branching on same polarization is used as defined by the compatibility requirements in clause 4.2b | ≥ 120 dB |

5.4.3 Spurious emissions

Spurious emissions from the receiver are emissions at any frequency, measured at point C.

It is necessary to define spurious emissions from receivers for two reasons:

- to limit interference into other systems operating wholly externally to the system under consideration (external emissions), which limits are referred by CEPT/ERC Recommendation 74-01 [34];
- to limit local interference within the Sub-STM-1 system where transmitters and receivers are directly connected via the filter and branching systems.

This leads to two sets of spurious emissions limits where the specific limits given for 'internal' interference are required to be no greater than the 'external' level limits.

5.4.3.1 Spurious emissions - external

At reference point C, the limit values of CEPT/ERC Recommendation 74-01 [34] shall apply.

5.4.3.2 Spurious emissions - internal

Spurious emissions limits, referenced to point B, are specified in table 5.

The required level will be the total average level integrated over the bandwidth of the emission under consideration.

Table 5: Limits of spurious emissions - internal

| Specification Limit | Controlling factor |
|---------------------|---|
| ≤ -110 dBm | Spurious falling in the same receiver half-band For systems with compatibility requirements of clause 4.2b |
| ≤ -90 dBm | Spurious falling in the same receiver half-band For systems with compatibility requirements of clause 4.2c |

For systems without compatibility requirements of clause 4.2 there is no requirement.

In addition, when compatibility with FDM systems on the same branching/antenna system is required and the digital equipment uses 70 MHz intermediate frequency, the LO residual emission, at reference point B, shall be:

- ≤ -125 dBm: for systems with compatibility requirements of clause 4.2b in the 7 GHz band;
- ≤ -110 dBm: for systems with compatibility requirements of clause 4.2b in all other band and with compatibility requirements of clause 4.2c in all bands.

5.4.4 Innermost channel receiver selectivity for L6 GHz

For systems which are intended to comply with compatibility requirement under clause 4.2b and 4.2c, to guarantee innermost TX/RX channel compatibility in L6 GHz band, the inner side of the innermost receiver shall be within the mask given in figure 8.

Since it is not considered feasible to make a practical measurement of this characteristic, the manufacturer shall supply the design data of the filters implemented on this receiver.

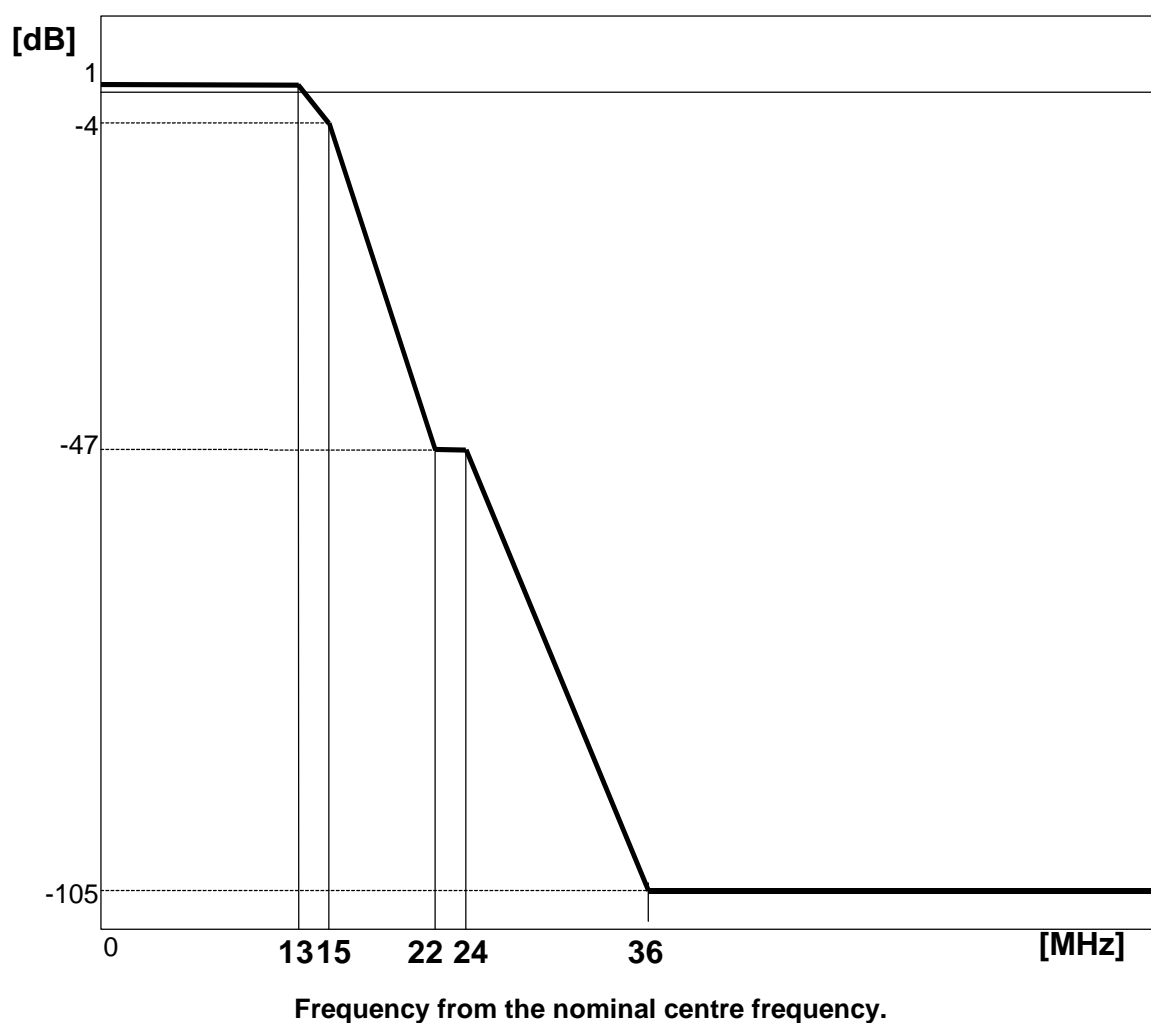

Figure 8: Overall minimum receiver selectivity of the inner side of innermost receiver for L6 GHz band (class 5 Grade A) with compatibility requirements, see clause 4.2

5.5 System performance without diversity

All parameters are referred to reference point C (for systems with simple duplexer) or B (for systems with multi-channel branching system) of the system block diagram (see figure 1). Losses in RF couplers used for protected systems are not taken into account in the limits specified below.

All measurements shall be carried out with the test signals defined in clause 5.3.

5.5.1 BER as a function of Receiver input Signal Level (RSL)

Receiver BER thresholds (dBm) referred to reference point C (for systems with simple duplexer) or B (for systems with multi-channel branching system) of the system block diagram (see figure 1) for a BER of 10^{-3} , 10^{-6} and 10^{-10} shall be equal to or lower than those stated in table 6.

Table 6: BER performance thresholds

| RSL @ BER → | RSL @ 10^{-3} [dBm] | RSL @ 10^{-6} [dBm] | RSL @ 10^{-10} [dBm] |
|-------------------------|--------------------------|--------------------------|---------------------------|
| Frequency bands ↓ | | | |
| < 10 GHz | -71 | -67 | -63 |
| 13 GHz | -70 | -66 | -62 |
| 15 GHz | -69,5 | -65,5 | -61,5 |

For outdoor and partially outdoor systems that are not subject to the compatibility requirements as stated in clause 4.2, there is a 2 dB relaxation on the above BER performance thresholds.

5.5.2 Equipment Residual BER

The RBER level under simulated operating conditions without interference shall be guaranteed with a signal level at reference point C which is between 10 dB and 35 dB above the level which gives BER = 10^{-6} (as specified in clause 5.5.1). For equipment designed to operate only with ATPC as a fixed permanent feature, this range could be reduced by an amount equal to the ATPC range. To guarantee a higher degree of service, see clause A.4, the network operator may require equipment to meet a RBER limit with the first adjacent channel interferer. In this case the RBER level under simulated operating conditions with interference shall be guaranteed with a signal level at reference point C which is between 15 dB and 35 dB above the level which gives BER = 10^{-6} (as specified in clause 5.5.1). The interferer level shall be set to represent a Carrier to Interference ratio (C/I) of +15,5 dB.

The RBER shall be less than 10^{-12} .

This requirement is intended for the payload bit rates defined in clause 5.1.

EN 301 126-1 [27] recognizes that this requirement is subject to a supplier declaration only. However, in clause A.4 some background information relating to the actual test methods and test confidence is given.

5.5.3 Interference sensitivity

All receive signal levels and Carrier to Interference ratio (C/I) measurements are referred to reference point C (for systems with simple duplexer) or B (for systems with multi-channel branching system) of the RF system block diagram (see figure 1).

Interference sensitivity characteristics specified in the present document are based on those defined in CEPT/ERC Recommendation T/L 04-04 [38] for 140 Mbit/s 64 QAM systems and take into account improvement of receiver threshold characteristics.

5.5.3.1 Co-channel interference sensitivity

The limits of Co-channel Interference shall be as in table 7, giving maximum C/I values for 1 dB and 3 dB degradation of the 10^{-6} BER limits specified in clause 5.5.1.

For frequency co-ordination purpose intermediate values may be found in figure A.1.

Table 7: Co-channel interference sensitivity

| Degradation → | C/I at BER = @ 10^{-6} RSL degradation | |
|-----------------|--|------|
| | 1 dB | 3 dB |
| Class 5 Grade A | 34 | 31 |
| Class 5 Grade B | 37 | 33 |

5.5.3.2 Adjacent channel interference

The limits of adjacent channel interference shall be as given in table 8 for like modulated signals spaced of 1 channel spacing, giving maximum C/I values for 1 dB and 3 dB degradation of the 10^{-6} BER limits specified in clause 5.5.1. These figures relate to equipment class 5 Grade A with a lower performance allowing the implementation of systems in a less dense environment.

For frequency co-ordination purpose intermediate values may be found in figure A.2.

Table 8: First adjacent channel interference sensitivity for class 5 Grade A systems

| Channel spacing | degradation → | C/I at BER = 10^{-6} RSL degradation | |
|------------------|---------------|--|------|
| | | 1 dB | 3 dB |
| 29 MHz to 30 MHz | | 8,5 | 5,5 |
| 28 MHz | | 12,5 | 9,5 |

The limits of adjacent channel interference shall be as given in table 9 for like modulated signals spaced of 1 channel spacing, giving maximum C/I values for 1 dB and 3 dB degradation of the 10^{-6} BER limits specified in clause 5.5.1. These figures relate to equipment class 5 Grade B with a better adjacent channel performance allowing the implementation of systems into a densely populated environment.

For frequency co-ordination purpose intermediate values may be found in figure A.2.

Table 9: First adjacent channel interference sensitivity for class 5 Grade B systems

| Frequency bands | degradation → | C/I at BER = 10^{-6} RSL degradation | |
|-----------------|---------------|--|------|
| | | 1 dB | 3 dB |
| All Bands | | +3 | -1 |

5.5.3.3 CW spurious interference

For a receiver operating at the 10^{-6} BER threshold given in table 5, the introduction of a CW interferer at a level of +30 dB with respect to the wanted signal and at any frequency in the range 30 MHz to the second harmonic of the upper frequency of the band, excluding frequencies either side of the wanted centre frequency of the RF channel by up to 250 % the channel spacing, shall not result in a BER greater than 10^{-5} .

NOTE: When waveguide is used between ref. point A and C, which length is higher than twice the free space wavelength of the cut-off frequency (F_c), the lower limit of measurement will be increased to $0,7 F_c$ and to $0,9 F_c$ when the length is higher than 4 times the same wavelength.

This test is designed to identify specific frequencies at which the receiver may have a spurious response, e.g. image frequency, harmonics of the receive filter, etc. The actual test range should be adjusted accordingly. The test is not intended to imply a relaxed specification at all out of band frequencies elsewhere specified in the present document.

5.5.4 Distortion sensitivity

For two path propagation with a delay of 6,3 ns and a BER of 10^{-3} the width of the signature shall not exceed ± 17 MHz relative to the assigned channel centre frequency, the depth shall not be less than 14 dB.

For two path propagation with a delay of 6,3 ns and a BER of 10^{-6} the width of the signature shall not exceed ± 20 MHz relative to the assigned channel centre frequency, the depth shall not be less than 11 dB.

These limits are both valid for minimum and non-minimum phase cases.

The limits specified for BER = 10^{-3} shall also be verified by the loss-of-synchronization and re-acquisition signatures.

5.6 System characteristics with diversity

Space-, angle- and frequency-diversity techniques are applicable. In this clause only combining techniques are considered.

5.6.1 Differential delay compensation

It shall be possible to compensate for differential absolute delays due to antennas, feeders and cable connections on the two diversity paths. The range of adjustment shall be at least 75 ns of differential absolute delay.

5.6.2 BER performance

When both receiver inputs (main and diversity, points B and BD) are fed with low level input signals of the same level at an arbitrary phase difference, input level limits for specified BER values shall be:

- for IF or baseband combining systems, 2,5 dB below those given in clause 5.5.1 for the case without diversity;
- for RF combining systems, 1,5 dB below those given in clause 5.5.1 for the case without diversity.

Annex A (informative): Additional information

A.1 Cross-Polar Discrimination (XPD)

The measured effective XPD over a typical hop (50 km at frequencies below 10 GHz, 25 km at 13 GHz and 18 km at 15 GHz) under no-fading conditions shall not be less than 28 dB.

A.2 Branching/feeder/antenna requirements

Equipment according to the present document may also have system configurations with integral antennas or very similar technical solutions, without long feeder connections; the following are not considered essential requirements. When the antenna is an integral part of the equipment there shall be no requirement.

A.2.1 Return loss

For systems which intend to comply with compatibility requirements under clause 4.2, the minimum return loss should be 26 dB at point C and C' over the full RF band and measured towards the antenna. In the same condition, for systems which are not intended to comply with any compatibility requirement under clause 4.2 and use "long" feeder connection, the minimum return loss should be 20 dB.

A.2.2 Intermodulation products

Each intermodulation product caused by different transmitters linked at point C' to a measurement test set with a return loss higher than 23 dB is assumed to be less than -110 dBm referenced to point B' with an output power of about 28 dBm per transmitter.

A.2.3 Interport isolation

This is not to be less than 40 dB.

A.3 Automatic Transmit Power Control (ATPC)

ATPC may be useful in some circumstances, e.g.:

- to reduce interference between neighbouring systems or adjacent channels of the same system;
- to improve compatibility with analogue and digital systems at nodal stations;
- to improve residual BER or RBER performance;
- to reduce upfading problems;
- to reduce transmitter power consumption;
- to reduce digital-to-digital and digital to analogue distant interference between hops which re-use the same frequency;
- to increase system gain as a countermeasure against rainfall attenuation.

ATPC as an optional feature is aimed at driving the transmit power amplifier output level from a proper minimum which facilitates the radio network planning requirements and which is used under normal propagation conditions up to a maximum value which fulfils all the specifications defined in the present document.

The ATPC range should not exceed 25 dB. When compatibility with analogue systems is required, the lowest power amplifier output level should not be less than +10 dBm; this may result in a reduced ATPC range.

For planning considerations in a nodal environment a system equipped with ATPC can be considered to operate with its minimum transmitter power.

When ATPC is a fixed feature, the ATPC range is defined as the power interval from the maximum (including tolerances) output power level to the lowest transmitter output power level (at reference point B') with ATPC; when it is optional two ranges may be defined, a "down-range" from the nominal level to the minimum (including tolerances) and an "up-range" from the nominal level to the maximum (including tolerances).

A.4 RBER

In particular applications, where there is a high density of radio links in a specific area, e.g. nodal site, closely located radios may use adjacent channels. Therefore to guarantee the grade of service the equipment will need to meet RBER criteria in the presence of an adjacent channel interferer.

The RBER is standardized in order to match the ESR (or the BBER) performance required by ITU-R transmission performance recommendations.

To have sufficient confidence in the measurement, where the BER is relatively low compared to the actual pay load, the test time is very long. The actual background to this measurement and the BER figures are detailed in TR 101 036-1 [28].

When error correction is a fitted feature it may be possible to reduce the measurement time by estimating the RBER using the relevant formula declared by the supplier.

Another option is to ensure that no errors occur during the minimum recording time shown in table A.1.

Table A.1: Zero errors recording times

| Bit-rate under test [Mbit/s] | Minimum recording time [minutes] | errors |
|---------------------------------|-------------------------------------|--------|
| 140/155 | 108 | 0 |

A.5 Co-channel and adjacent channel interference

The performances for co-channel and adjacent channel spaced by one channel spacing C/I are reported in clauses 5.5.3.1 and 5.5.3.2 respectively, for 1 dB and 3 dB degradation only; figures A.1 and A.2 give the reference behaviour for other values of degradation.

Receiver Input Level at Reference Point C
relative to BER 10^{-6} threshold (X) as provided by subclause 5.5.1.

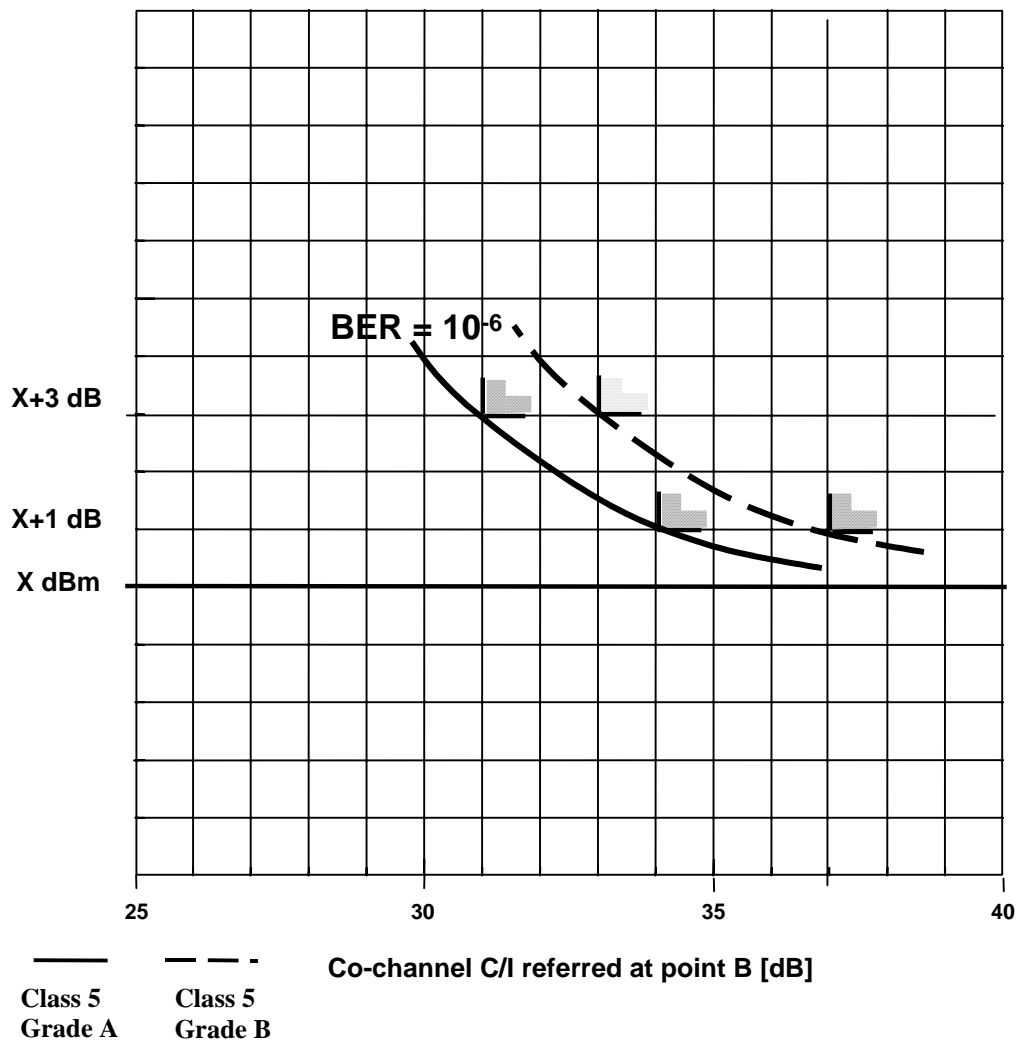

Figure A.1: Co-channel interference threshold degradation

Receiver Input Level at Reference Point C
relative to BER 10^{-6} threshold (X) as provided by clause 5.5.1

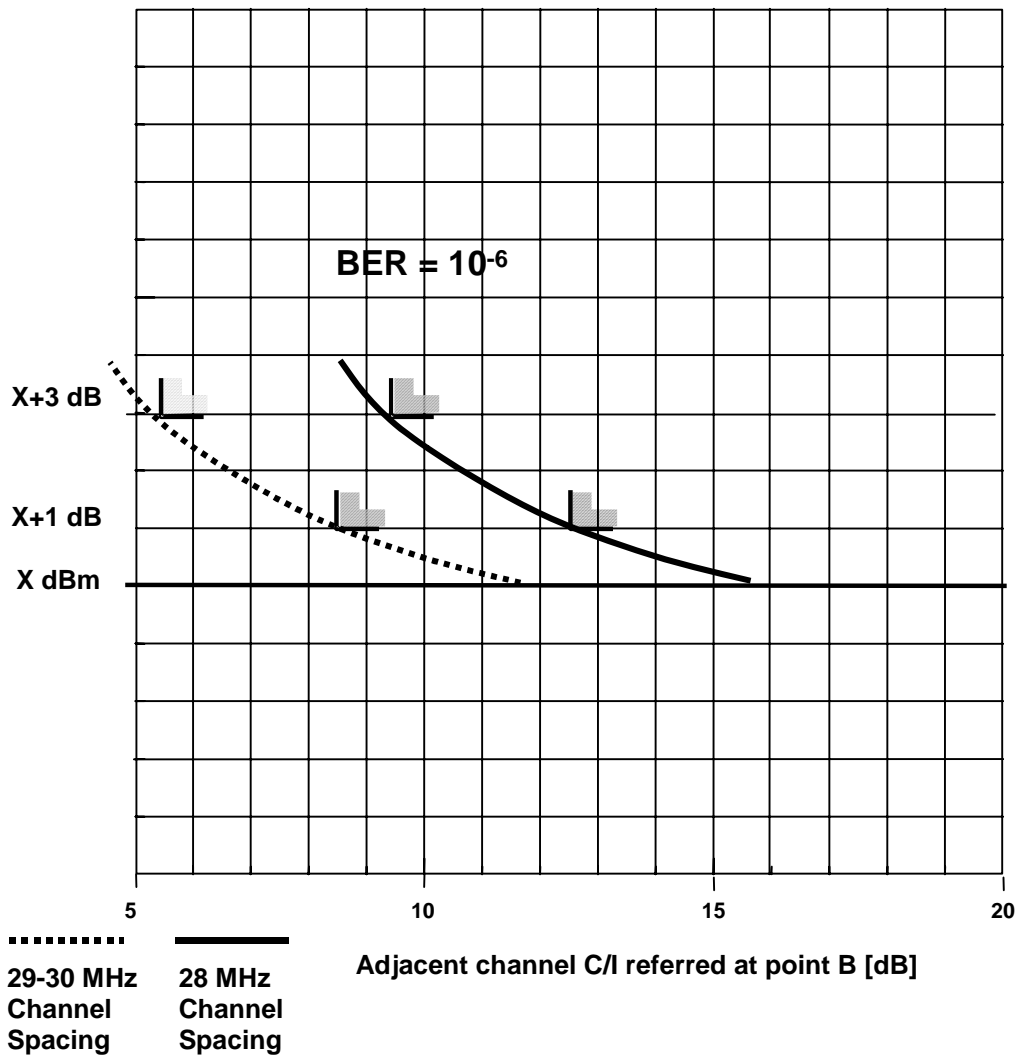

Figure A.2: First adjacent channel interference threshold degradation for Class 5 Grade A systems

Receiver Input Level at Reference Point C
relative to BER 10^{-6} threshold (X) as provided by clause 5.5.1

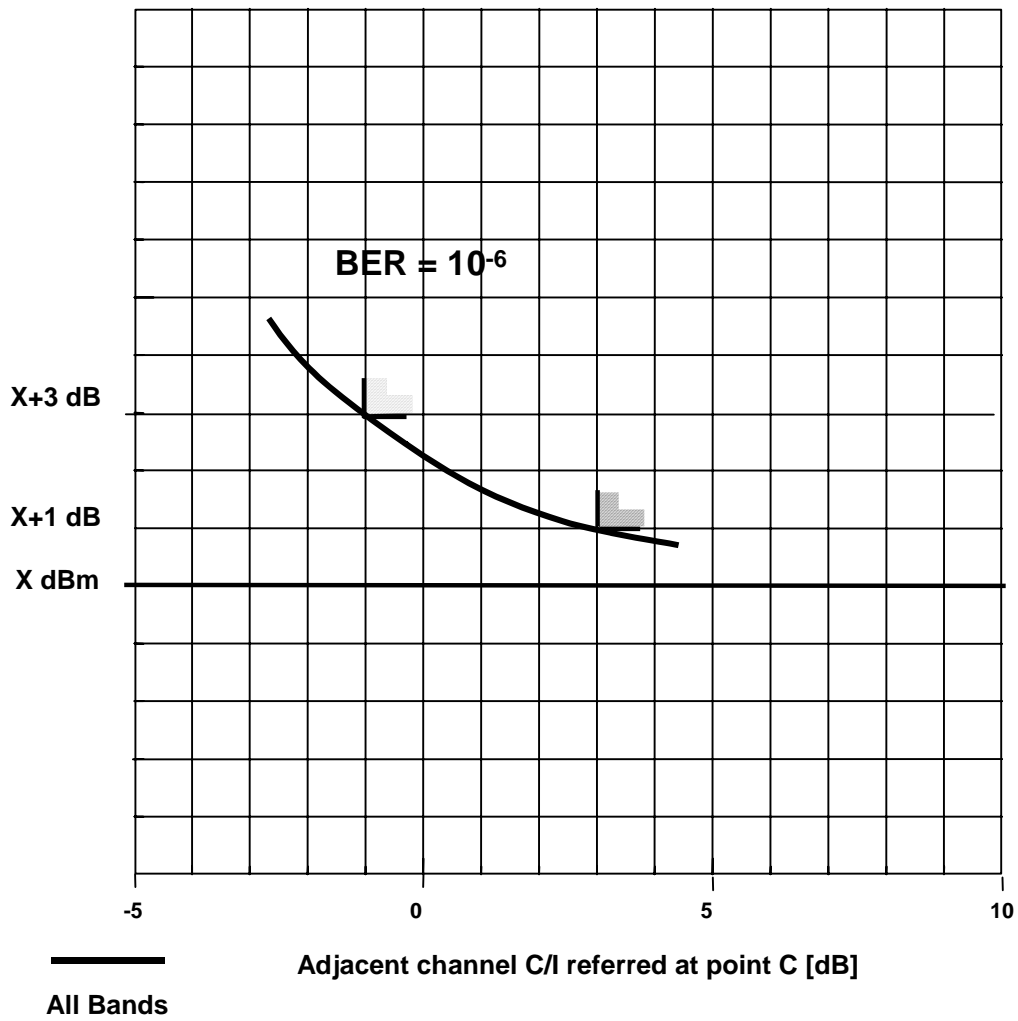

Figure A.3: First adjacent channel interference threshold degradation for class 5 Grade B systems

Annex B:
Void

Annex C (normative): System type codes for regulatory procedures

System types reported in the present document shall be identified with the codes reported in table C1.

Table C.1: System type codes for radio equipment reported in EN 300 234 relevant to regulatory procedures for national licensing

| Spectrum efficiency class ↓ | Grade of equipment | Bit-rate [Mbit/s] ↓ | System Type codes ↓ |
|---------------------------------------|---------------------------|-------------------------------|-------------------------------|
| 5 | A | 155 | 01 |
| 5 | B | 155 | 02 |

Annex D (informative): Bibliography

ETSI EN 301 390: "Fixed Radio Systems; Point-to-point and Point-to-Multipoint Systems; Spurious emissions and receiver immunity at equipment/antenna port of Digital Fixed Radio Systems".

History

| Document history | | |
|-------------------------|---------------|----------------------------|
| Edition 1 | July 1995 | Publication as ETS 300 234 |
| V1.2.1 | October 1998 | Publication |
| V1.3.1 | February 2001 | Publication |
| V1.3.2 | November 2001 | Publication |
| | | |