

ETSI EN 300 176-2 V1.5.1 (2004-01)

European Standard (Telecommunications series)

Digital Enhanced Cordless Telecommunications (DECT); Test specification; Part 2: Speech



Reference

REN/DECT-000220

Keywords

DECT, radio, regulation, speech, testing, voice

ETSI

650 Route des Lucioles
F-06921 Sophia Antipolis Cedex - FRANCE

Tel.: +33 4 92 94 42 00 Fax: +33 4 93 65 47 16

Siret N° 348 623 562 00017 - NAF 742 C
Association à but non lucratif enregistrée à la
Sous-Préfecture de Grasse (06) N° 7803/88

Important notice

Individual copies of the present document can be downloaded from:

<http://www.etsi.org>

The present document may be made available in more than one electronic version or in print. In any case of existing or perceived difference in contents between such versions, the reference version is the Portable Document Format (PDF). In case of dispute, the reference shall be the printing on ETSI printers of the PDF version kept on a specific network drive within ETSI Secretariat.

Users of the present document should be aware that the document may be subject to revision or change of status. Information on the current status of this and other ETSI documents is available at

<http://portal.etsi.org/tb/status/status.asp>

If you find errors in the present document, send your comment to:

editor@etsi.org

Copyright Notification

No part may be reproduced except as authorized by written permission.
The copyright and the foregoing restriction extend to reproduction in all media.

© European Telecommunications Standards Institute 2004.
All rights reserved.

DECT™, **PLUGTESTS™** and **UMTS™** are Trade Marks of ETSI registered for the benefit of its Members.
TIPHON™ and the **TIPHON logo** are Trade Marks currently being registered by ETSI for the benefit of its Members.
3GPP™ is a Trade Mark of ETSI registered for the benefit of its Members and of the 3GPP Organizational Partners.

Contents

Intellectual Property Rights	7
Foreword.....	7
1 Scope	8
2 References	9
3 Definitions, symbols and abbreviations	10
3.1 Definitions	10
3.2 Symbols.....	12
3.3 Abbreviations	12
4 Interpretation of the measurement results	13
5 General test requirements	13
5.1 Test philosophy	13
5.1.1 Equipment supporting an ETSI approved profile	13
5.1.2 Equipment not supporting an ETSI approved profile	14
5.1.3 Applicant's declaration.....	15
5.2 Low noise room.....	15
5.3 Lower Tester (LT).....	15
5.3.1 Description.....	15
5.3.2 Connections between the EUT and the LT	15
5.3.3 Functions and abilities	15
5.3.4 Measurement uncertainty.....	15
6 General testing conditions	16
6.1 Environment for tests	16
6.2 Power supply limitations	16
6.3 Power source	16
7 Speech and telephony tests.....	16
7.1 Test configurations	16
7.1.1 General.....	16
7.1.2 Testing a DECT system	17
7.1.3 Testing a separate PP or FP	17
7.1.4 Reference FP (ReFP) and Reference PP (RePP).....	18
7.1.5 Applicability of tests.....	19
7.2 Digital signal level.....	19
7.3 General conditions of test.....	20
7.4 Ideal codec.....	20
7.5 Electro-acoustical equipment	20
7.6 Speech coding scheme.....	21
7.6.1 Requirement for speech coding algorithm	21
7.6.2 Applicant's declaration on speech coding algorithm.....	21
7.6.3 Requirement for the TAP in the FP	21
7.6.4 Applicant's declaration on the TAP in the FP	21
7.7 PP sending frequency response	21
7.7.1 Requirement.....	21
7.7.2 Method of measurement	22
7.8 PP receiving frequency response.....	22
7.8.1 Requirement.....	23
7.8.2 Method of measurement	23
7.9 PP loudness rating	24
7.9.1 Requirement.....	24
7.9.2 Method of measurement	24
7.9.2.1 SLR _H	24
7.9.2.2 RLR _H	24

7.10	User controlled volume control in the PP	24
7.10.1	Requirement.....	24
7.10.2	Method of measurement	25
7.10.2.1	SLR _H	25
7.10.2.2	RLR _H	25
7.11	PP talker sidetone masking rating	25
7.11.1	Requirement.....	25
7.11.2	Method of measurement	25
7.12	Listener SideTone (LST).....	25
7.12.1	LSTR requirement	25
7.12.2	Protocol requirement for EUTs with declared noise rejection capability	26
7.12.3	Method of measurement for LSTR	26
7.12.4	Method of measurement for the protocol requirement for EUTs with declared noise rejection capability applying to be tested separately	26
7.12.5	Applicant's declaration for the protocol requirement for EUTs applying to be tested as a DECT system	27
7.13	Terminal Coupling Loss (TCLw) of a PP	27
7.13.1	TCLw requirement.....	27
7.13.2	Protocol requirement.....	27
7.13.3	Method of measurement for TCLw for a PP being tested separately	27
7.13.4	Method of measurement for TCLw for a PP being tested as part of a DECT system.....	28
7.13.5	Method of measurement for the protocol requirement for EUTs applying to be tested separately.....	28
7.13.6	Applicant's declaration for the protocol requirement for EUTs applying to be tested as a DECT system	28
7.14	FP echo control functions with a 4-wire interface.....	28
7.14.1	Static requirements	28
7.14.2	Dynamic requirements.....	29
7.14.2.1	Minimum TCLw	29
7.14.2.2	Full TCLw.....	29
7.14.3	Artificial echo loss of a FP with a 4-wire interface	29
7.14.3.1	Requirement for artificial echo loss	29
7.14.3.2	Requirement for the ability to disable the artificial echo loss	29
7.14.3.3	Method of measurement of artificial echo loss	29
7.14.3.4	Method of measurement for ability to disable artificial echo loss.....	30
7.14.3.4.1	EUTs being tested as separate items.....	30
7.14.3.4.2	EUTs being tested as a DECT system with a PP having full TCLw	30
7.14.4	Echo control device of a FP with a 4-wire interface	30
7.14.4.1	Requirement for the echo control device	30
7.14.4.2	Requirement for the ability to disable the echo control device	30
7.14.4.3	Method of measurement for the echo control device	30
7.14.4.4	Method of measurement for the ability to disable the echo control function	30
7.14.4.4.1	EUTs being tested as separate items.....	30
7.14.4.4.2	EUTs being tested as a DECT system with a PP having full TCLw	31
7.15	Stability loss - fixed geometry.....	31
7.15.1	Requirement.....	31
7.15.2	Method of measurement	31
7.16	Stability loss variable geometry	31
7.16.1	Requirement.....	31
7.16.2	Method of measurement	31
7.17	Sending distortion.....	32
7.17.1	Requirement.....	32
7.17.2	Method of measurement	32
7.18	Receiving distortion	32
7.18.1	Requirement.....	32
7.18.2	Method of measurement	32
7.19	Side tone distortion.....	32
7.19.1	Requirement.....	32
7.19.2	Method of measurement	32
7.20	Out of band (sending).....	33
7.20.1	Requirement.....	33
7.20.2	Method of measurement	33

7.21	Out of band (receiving)	33
7.21.1	Requirement.....	33
7.21.2	Method of measurement	33
7.22	Sending noise	34
7.22.1	Requirement.....	34
7.22.2	Method of measurement	34
7.23	Sending noise (narrow band).....	34
7.23.1	Requirement.....	34
7.23.2	Method of measurement	34
7.24	Receiving noise	34
7.24.1	Requirement.....	34
7.24.2	Method of measurement	34
7.25	Sampling frequency level (receiving).....	35
7.25.1	Requirement.....	35
7.25.2	Method of measurement	35
7.26	Acoustic shock	35
7.27	DECT network delay.....	35
7.27.1	Requirement.....	35
7.27.2	Method of measurement	35
7.28	PP delay.....	37
7.28.1	Requirement.....	37
7.28.2	Method of measurement	37
7.29	FP delay.....	38
7.29.1	Requirement.....	38
7.29.2	Method of measurement	38
7.30	Echo control at the network side	40
7.30.1	Requirement.....	40
7.30.2	Method of measurement	40
7.30.2.1	4-wire interface	40
7.30.2.2	Analogue 2-wire interface	41
7.30.2.2.1	Requirement 1	41
7.30.2.2.2	Requirement 2	42
7.31	Variation of gain with input level-sending	43
7.31.1	Requirement.....	43
7.31.2	Method of measurement	43
7.32	Variation of gain with input level-receiving.....	43
7.32.1	Requirement.....	43
7.32.2	Method of measurement	44
7.33	Additional requirements for DECT systems provided with a 2-wire PSTN interface.....	44
7.33.1	General.....	44
7.33.1.1	Polarity independence	44
7.33.1.2	Feed Conditions	44
7.33.1.3	Power supply.....	44
7.33.1.4	Volume control	44
7.33.2	Speech performance characteristics	45
7.33.2.1	Sensitivity/frequency response.....	45
7.33.2.2	Sending and Receiving Loudness Ratings (SLR and RLR)	45
7.33.2.3	Sidetone.....	45
7.33.2.4	Distortion	45
7.33.2.5	Linearity (variation of gain with input level)	45
7.33.2.6	Noise	45
7.33.2.7	Instability	45
7.33.2.8	Echo return loss.....	45
8	Loudspeaking and handsfree telephony	46
Annex A (informative): Justification for Requirements		47
Annex B (informative): Description of the CSS.....		49
B.1	General	49
B.2	Test signal	49

B.3	Measurement	50
B.4	Calculation	50
Annex C (normative):	Description of the cross-correlation method	53
C.1	Test signal	53
C.2	Calculation	53
Annex D (informative):	Acoustic shock requirements	54
D.1	Continuous signal	54
D.2	Peak signal.....	54
Annex E (informative):	Bibliography.....	55
History		56

Intellectual Property Rights

IPRs essential or potentially essential to the present document may have been declared to ETSI. The information pertaining to these essential IPRs, if any, is publicly available for **ETSI members and non-members**, and can be found in ETSI SR 000 314: "*Intellectual Property Rights (IPRs); Essential, or potentially Essential, IPRs notified to ETSI in respect of ETSI standards*", which is available from the ETSI Secretariat. Latest updates are available on the ETSI Web server (<http://webapp.etsi.org/IPR/home.asp>).

Pursuant to the ETSI IPR Policy, no investigation, including IPR searches, has been carried out by ETSI. No guarantee can be given as to the existence of other IPRs not referenced in ETSI SR 000 314 (or the updates on the ETSI Web server) which are, or may be, or may become, essential to the present document.

Foreword

This European Standard (Telecommunications series) has been produced by ETSI Project Digital Enhanced Cordless Telecommunications (DECT).

The present document contains text pertaining to approval testing of the Digital Enhanced Cordless Telecommunications (DECT) Common Interface. Such text should be considered as guidance to approval (or licensing) authorities.

Details of the DECT Common Interface may be found in EN 300 175 parts 1 [1] to 8 [8]. Further details of the DECT system may be found in the ETSI Technical Reports, TR 101 178 [31] and ETR 043 [32].

The present document is part 2 of a multi-part deliverable covering the approval test specification for Digital Enhanced Cordless Telecommunications (DECT), as identified below:

Part 1: "Radio";

Part 2: "Speech".

National transposition dates	
Date of adoption of this EN:	19 December 2003
Date of latest announcement of this EN (doa):	31 March 2004
Date of latest publication of new National Standard or endorsement of this EN (dop/e):	30 September 2004
Date of withdrawal of any conflicting National Standard (dow):	30 September 2004

1 Scope

The present document specifies the tests applicable to all Digital Enhanced Cordless Telecommunications (DECT) equipment accessing the DECT frequency band 1 880 MHz to 1 900 MHz (including provisions for testing other or extended frequency bands) and the tests applicable to DECT speech transmission using ITU-T Recommendation G.726 [17] ADPCM speech codec at 32 kbit/s.

The aims of the present document are to ensure:

- efficient use of frequency spectrum;
- no harm done to any connected network and its services;
- no harm done to other radio networks and services;
- no harm done to other DECT equipment or its services;
- interworking of terminal equipment via the public telecommunications network,

through testing those provisions of EN 300 175, parts 1 [1] to 8 [8] which are relevant to these aims.

The tests of EN 300 176 are split into two parts:

- part 1 covers testing of radio frequency parameters, security elements and those DECT protocols that facilitate the radio frequency tests and efficient use of frequency spectrum;
- part 2 (the present document) describes testing of DECT 32 kbit/s ADPCM speech requirements between network interface and DECT PT, or between a DECT CI air interface and alternatively a DECT PT or FT. This part is not applicable to terminal equipment specially designed for the disabled (e.g. with amplification of received speech as an aid for the hard of hearing).

DECT terminal equipment consists of the following elements:

- a) Fixed Part (FP);
- b) Portable Part (PP);
- c) Cordless Terminal Adapter (CTA);
- d) Wireless Relay Station (WRS) (FP and PP combined).

The present document is structured to allow tests of either:

- a) the FP and PP together; or
- b) the FP and PP as separate items.

Where the DECT FP is connected to a PSTN, and there are any peculiarities in the requirements for voice telephony, these shall be accommodated within the FP.

2 References

The following documents contain provisions which, through reference in this text, constitute provisions of the present document.

- References are either specific (identified by date of publication and/or edition number or version number) or non-specific.
- For a specific reference, subsequent revisions do not apply.
- For a non-specific reference, the latest version applies.

Referenced documents which are not found to be publicly available in the expected location might be found at <http://docbox.etsi.org/Reference>.

- [1] ETSI EN 300 175-1: "Digital Enhanced Cordless Telecommunications (DECT); Common Interface (CI); Part 1: Overview".
- [2] ETSI EN 300 175-2: "Digital Enhanced Cordless Telecommunications (DECT); Common Interface (CI); Part 2: Physical layer (PHL)".
- [3] ETSI EN 300 175-3: "Digital Enhanced Cordless Telecommunications (DECT); Common Interface (CI); Part 3: Medium Access Control (MAC) layer".
- [4] ETSI EN 300 175-4: "Digital Enhanced Cordless Telecommunications (DECT); Common Interface (CI); Part 4: Data Link Control (DLC) layer".
- [5] ETSI EN 300 175-5: "Digital Enhanced Cordless Telecommunications (DECT); Common Interface (CI); Part 5: Network (NWK) layer".
- [6] ETSI EN 300 175-6: "Digital Enhanced Cordless Telecommunications (DECT); Common Interface (CI); Part 6: Identities and addressing".
- [7] ETSI EN 300 175-7: "Digital Enhanced Cordless Telecommunications (DECT); Common Interface (CI); Part 7: Security features".
- [8] ETSI EN 300 175-8: "Digital Enhanced Cordless Telecommunications (DECT); Common Interface (CI); Part 8: Speech coding and transmission".
- [9] ETSI ETS 300 111: "Integrated Services Digital Network (ISDN); Telephony 3,1 kHz teleservice; Service description".
- [10] ETSI TBR 008 (1998): "Integrated Services Digital Network (ISDN); Telephony 3,1 kHz teleservice; Attachment requirements for handset terminals".
- [11] ITU-T Recommendation G.101 (2003): "The transmission plan".
- [12] ITU-T Recommendation G.111 (1993): "Loudness ratings (LRs) in an international connection".
- [13] ITU-T Recommendation G.122 (1993): "Influence of national systems on stability and talker echo in international connections".
- [14] ITU-T Recommendation G.223 (1988): "Assumptions for the calculation of noise on hypothetical reference circuits for telephony".
- [15] ITU-T Recommendation G.711 (1988): "Pulse code modulation (PCM) of voice frequencies".
- [16] ITU-T Recommendation G.712 (2001): "Transmission performance characteristics of pulse code modulation channels".
- [17] ITU-T Recommendation G.726 (1990): "40, 32, 24, 16 kbit/s Adaptive Differential Pulse Code Modulation (ADPCM)".
- [18] ITU-T Recommendation O.132 (1988): "Quantizing distortion measuring equipment using a sinusoidal test signal".

- [19] ITU-T Recommendation O.133 (1993): "Equipment for measuring the performance of PCM encoders and decoders".
- [20] ITU-T Recommendation P.50 (1999): "Artificial voices".
- [21] ITU-T Recommendation P.51 (1996): "Artificial mouth".
- [22] ITU-T Recommendation P.57 (2002): "Artificial ears".
- [23] ITU-T Recommendation P.64 (1999): "Determination of sensitivity/frequency characteristics of local telephone systems".
- [24] ITU-T Recommendation P.79 (1999): "Calculation of loudness ratings for telephone sets".
- [25] ISO 3 (1973): "Preferred numbers - Series of preferred numbers".
- [26] ISO 9614: "Acoustics - Determination of sound power levels of noise sources using sound intensity".
- [27] ETSI TBR 038: "Public Switched Telephone Network (PSTN); Attachment requirements for a terminal equipment incorporating an analogue handset function capable of supporting the justified case service when connected to the analogue interface of the PSTN in Europe".
- [28] ETSI EN 300 700: "Digital Enhanced Cordless Telecommunications (DECT); Wireless Relay Station (WRS)".
- [29] ETSI EN 300 176-1: "Digital Enhanced Cordless Telecommunications (DECT); Test specification; Part 1: Radio".
- [30] ETSI I-ETS 300 245-3: "Integrated Services Digital Network (ISDN); Technical characteristics of telephony terminals; Part 3: Pulse Code Modulation (PCM) A-law, loudspeaking and handsfree telephony".
- [31] ETSI TR 101 178: "Digital Enhanced Cordless Telecommunications (DECT); A High Level Guide to the DECT Standardization".
- [32] ETSI ETR 043: "Digital Enhanced Cordless Telecommunications (DECT); Common Interface (CI); Services and facilities requirements specification".
- [33] Council Directive 73/23/EEC of 19 February 1973 on the harmonization of the laws of Member States relating to electrical equipment designed for use within certain voltage limits (Low Voltage Directive).

3 Definitions, symbols and abbreviations

3.1 Definitions

For the purposes of the present document, the following terms and definitions apply:

Acoustic Reference Level (ARL): acoustic level that corresponds to a power level of -10 dBm₀ at the TAP

conducted measurements: measurements which are made using a direct connection to the Equipment Under Test (EUT)

dBPa: sound pressure level relative to 1 Pa (no weighting)

duplex bearer: use of two simplex bearers operating in opposite directions on two physical channels. These pairs of channels always use the same radio Frequency (RF) carrier and always use evenly spaced slots (i.e. separated by 0,5 Time Division Multiple Access (TDMA) frame)

Cordless Terminal Adapter (CTA): physical grouping that contains a DECT portable termination and a line interface

Equipment Under Test (EUT): equipment submitted to the test laboratory for type examination

fixed geometry PP: PP in which the electro-acoustic transducers and their associated acoustic components are held in fixed relative positions and/or orientations during all on-line conditions of the PP

Fixed Part (DECT Fixed Part) (FP): physical grouping that contains all of the elements in the DECT network between the local network and the DECT air interface

NOTE: A DECT fixed part contains the logical elements of at least one fixed radio termination, plus additional implementation specific elements.

Fixed radio Termination (FT): logical group of functions that contains all of the DECT processes and procedures on the fixed side of the DECT air interface

NOTE: A fixed radio termination only includes elements that are defined in EN 300 175 parts 1 [1] to 8 [8]. This includes radio transmission elements (layer 1) together with a selection of layer 2 and layer 3 elements.

Full Slot (SLOT): one 24th of a TDMA frame which is used to support one physical channel

handset echo: echo, perceptible by the far-end user, resulting from the coupling between the receive and send directions of the handset, mostly due to acoustic coupling between transducers

NOTE: It is particularly cumbersome in communications including a satellite and an echo canceller, as the DECT handset echo may be out of range of the echo canceller.

inter-operability: capability of fixed parts and portable parts, that enable a portable part to obtain access to teleservices in more than one location area and/or from more than one operator (more than one service provider)

Local echo Loss (LLe): sum of the reflections measured at the digital interface of the RePP

NOTE: It is calculated according to ITU-T Recommendation G.122 [13], annex B.4, Trapezoidal rule.

Lower Tester (LT): logical grouping that contains the test equipment, a functionally equivalent DECT PT, a functionally equivalent DECT FT and a test controller

network echo: echo, perceptible by the DECT user, resulting from reflections in the network. It is mostly due to hybrid impairments at both ends of the communication. The protection consists of an additional echo loss located in the receive path of the DECT system

Portable HandSet (PHS): single physical grouping that contains all of the portable elements that are needed to provide a teleservice to the user

NOTE: Portable handset is a subset of all possible portable parts. This subset includes all physical groupings that combine one portable radio termination plus at least one portable application in a single physical box.

Portable Part (PP): physical grouping that contains all elements between the user and the DECT air interface

NOTE 1: Portable Part (PP) is a generic term that may describe one or several physical pieces.

NOTE 2: A portable part is logically divided into one portable termination plus one or more portable applications.

Portable radio Termination (PT): logical group of functions that contains all of the DECT processes and procedures on the portable side of the DECT air interface

NOTE: A PT only includes elements that are defined in EN 300 175 parts 1 [1] to 8 [8]. This includes radio transmission elements together with a selection of layer 2 and layer 3 elements.

public: attribute indicating that the application of the so qualified term is used to provide access to a public network for the general public

NOTE: The term does not imply any legal or regulatory aspect, nor does it imply any aspects of ownership.

Test Access Point (TAP): digital interface with a relative level of 0 dB_r providing the access to the PCM speech channels in both transmission directions

telephony 3,1 kHz teleservice: definition for telephony 3,1 kHz teleservice is to be found in ETS 300 111

NOTE: Work is currently being undertaken by ETSI to analyse the mouth-to-ear characteristics of voice communication. The results of this work can have consequences for the essential requirements of the present document.

test laboratory: body which performs testing and is designated to perform third party testing

variable geometry PP: PP that allows the position and/or orientation of its electro-acoustic transducers and their associated acoustic components to be changed during all on-line conditions of the PP

3.2 Symbols

For the purposes of the present document, the following symbols apply:

dBm	dB relative to 1 mW
dBm0	absolute power level in decibels referred to a point of zero relative level
dBPa	sound pressure level relative to 1 Pa, expressed in dB
dBr	relative power level in decibels
L_{in}	input level
L_{out}	output level
LL_e	Local echo Loss
L_{meST}	Telephone Sidetone Path Loss
Ssi(diff)	The difference of the send sensitivities between diffuse and direct sound
Ssi(direct)	The sending sensitivities for the direct sound

3.3 Abbreviations

For the purposes of the present document, the following abbreviations apply:

ADPCM	Adaptive Differential Pulse Code Modulation
ARL	Acoustic Reference Level
CSS	Composite Source Signal
CTA	Cordless Terminal Adapter
e.m.f	electromotive force
ERP	Ear Reference Point
EUT	Equipment Under Test
FFT	Fast Fourier Transformation
FP	Fixed Part
FT	Fixed radio Termination
GAP	Generic Access Profile
LNR	Low Noise Room
LRGP	Loudness Rating Guard-ring Position
LST	Listener Sidetone
LSTR	Listener Sidetone Rating
LT	Lower Tester
MRP	Mouth Reference Point
PCM	Pulse Code Modulation
PHS	Portable HandSet
PP	Portable Part
PT	Portable radio Termination
ReFP	Reference Fixed Part (for speech testing)
RePP	Reference Portable Part (for speech testing)
RF	Radio Frequency
RH	Relative Humidity
RLR_H	Receiving Loudness Rating of the Handset
rms	root mean square
SL	Linear input Signal, see ITU-T Recommendation G.726
SLR_H	Sending Loudness Rating of the Handset

SR	Reconstructed Signal, see ITU-T Recommendation G.726
STMR	SideTone Masking Rating
TAP	Test Access Point
TCL	Terminal Coupling Loss
TCLw	weighted Terminal Coupling Loss
TDMA	Time Division Multiple Access
TELR	Talker Echo Loudness Rating
WRS	Wireless Relay Stations

4 Interpretation of the measurement results

The interpretation of the results recorded in a test report for the measurements described in the present document shall be as follows:

- a) the measured value related to the corresponding limit shall be used to decide whether an equipment meets the minimum requirements of the standard;
- b) the actual measurement uncertainty of the test laboratory carrying out the measurement, for each particular measurement, shall be included in the test report;
- c) the values of the actual measurement uncertainty shall be, for each measurement, equal to or lower than the values in clause 5.3.4.

5 General test requirements

Those functions and procedures which are optional, as indicated directly or indirectly by "if provided", shall be subject to a conformance test if they are implemented. Whether an optional function/procedure has been implemented shall be indicated by the Apparatus Suppliers declaration.

Wireless Relay Stations (WRS), EN 300 700 [28], tested according to the DECT test specification (see EN 300 176-1 [29]), also belong to telephony applications. Testing according to the present document is however not applicable to a WRS.

NOTE: A WRS conforms to a defined frame multiplexing scheme, see EN 300 700 [28], which provides a transparent digital bit pipe for the user data, and which automatically provides an acceptable upper bound of the incremental delay introduced by a WRS. See EN 300 175-8 [8], clause 8.4.1 for modified echo control requirements for multi-hop architectures.

5.1 Test philosophy

5.1.1 Equipment supporting an ETSI approved profile

Equipment falling into this category is defined in EN 300 175-1 [1].

In this case, a test equipment capable of emulating a PT or FT that conforms to EN 300 175 parts 1 [1] to 8 [8] operating an ETSI approved profile corresponding to that supported by the EUT is required. Consequently, each test set-up consists of the test equipment being connected to the EUT, either by a radio link or via an antenna connector, and a call being established. Figures 1 and 2 show the possible test configurations.

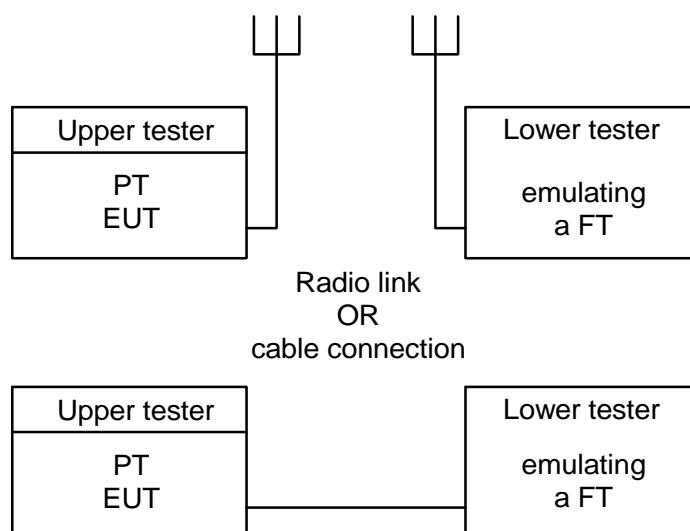

Figure 1: The EUT is a PT

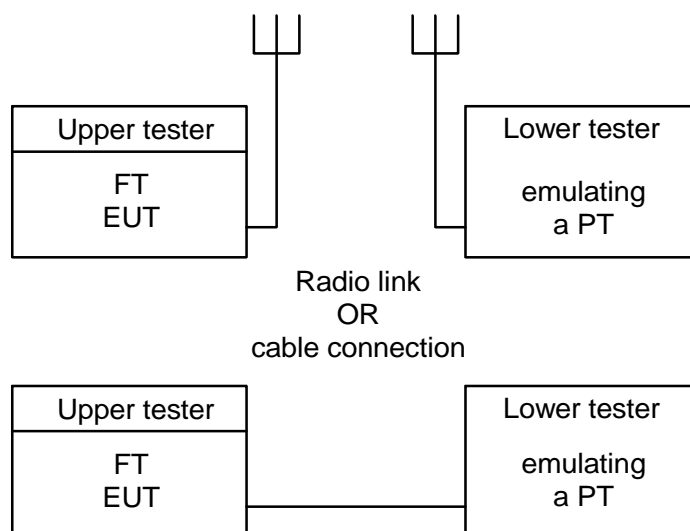

Figure 2: The EUT is an FT

Figures 1 and 2 also show that, if available, the EUT can sometimes be connected to the LT by an antenna connector. This is normally preferred in order to minimize the measurement uncertainties.

The Lower Tester (LT) will consist of the general test equipment with the functionality as described in clause 5.3. Also it will include an RF interface which can emulate the DECT Common Interface.

5.1.2 Equipment not supporting an ETSI approved profile

Equipment falling into this category is defined in EN 300 175-1 [1].

If an LT is available that can establish a speech connection with the EUT and the EUT supports, where required, the <<TERMINAL CAPABILITY>> information element as described in EN 300 175-5 [5], clause 7.7.41, then test of an FP and a PP as a separate item is supported, and the test philosophy described in clause 5.1.1 shall be applicable.

If an LT is not available that can establish a speech connection with the EUT or the EUT does not support, where required, the <<TERMINAL CAPABILITY>> information element as described in EN 300 175-5 [5], clause 7.7.41, then the FP and PP shall be tested as a pair. The applicant shall describe to the test laboratory how a call is established, maintained and released.

However, when a PT or FT is to be tested as a separate item, the applicant shall provide the test laboratory with a means for establishing, maintaining and releasing a speech connection in order to test the EUT.

5.1.3 Applicant's declaration

Where parameters, capabilities, etc. are subject to applicant's declaration and not a specific test, it will be the applicant's responsibility to:

- a) supply a Declaration of Implementation, in which the Applicant explicitly affirms the implementation in the equipment of certain parameters and capabilities;
- b) be prepared to submit upon request supporting design information, including circuit designs and software source code, demonstrating the implementation of said capabilities;
- c) be prepared to supply upon request such test results as are practicable, including the test methods, which support the declaration.

NOTE: This applies also where adaptive volume control methods are provided for noise rejection and/or echo control capabilities which e.g. have to be switched inactive for some of the tests described below and/or where new test methods have to be declared.

5.2 Low noise room

Low noise refers to audio sound and not RF radiation.

The test space shall be practically free-field (anechoic) down to a lowest frequency of 275 Hz, and be such that the handset lies totally within the free field volume. This shall be met if deviations from the ideal free field conditions are less than ± 1 dB. The ambient noise level shall be less than -64 dBPa (A). Measurements made in the low noise room shall satisfy the measurement uncertainty requirements described in clause 5.3.4.

5.3 Lower Tester (LT)

5.3.1 Description

The LT is a logical grouping that contains a ReFP, RePP, the measurement equipment and the controller of the DECT testing system. The LT has the job of establishing the speech path, performing calculations (e.g. signal processing) and interacting with the EUT for the various tests. The LT shall implement the mandatory parts of the DECT specification (see part A of the present document) and any ETSI approved profiles.

When testing EUTs that do not support an ETSI approved profile, the LT is not required to have implemented an ETSI approved profile. See clause 5.1.2.

5.3.2 Connections between the EUT and the LT

This is specified in each test case.

5.3.3 Functions and abilities

The LT shall include all the functions necessary to perform the tests and measurements as described in the present document according to the measurement uncertainties described in clause 5.3.4.

5.3.4 Measurement uncertainty

The following values of measurement uncertainty (or better) associated with each measurement parameter apply to all of the test cases described in the present document:

electrical signal power: $\pm 0,2$ dB for levels ≥ -50 dBm;

electrical signal power: $\pm 0,4$ dB for levels < -50 dBm;

sound pressure:	$\pm 0,7$ dB;
time:	± 5 %;
frequency:	± 2 %.

NOTE: When measuring sampled systems, it is advisable to avoid measuring at multiples of the sampling frequency. A tolerance of ± 2 % of the frequencies, may be used to avoid this problem, except at 4 kHz where only the -2 % tolerance may be used.

The measurement uncertainty is defined as the combined effects of all sources of errors at a confidence level of at least 95 %.

6 General testing conditions

6.1 Environment for tests

The following conditions shall apply during all tests:

- ambient temperature: $+15^{\circ}\text{C}$ to $+35^{\circ}\text{C}$;
- atmospheric pressure: 86 to 106 kPa;
- Relative Humidity (RH): 5 % to 75 % non-condensing.

Except that the tests shall not be performed outside the operating limits for the terminal equipment as stated by the supplier.

6.2 Power supply limitations

For apparatus that is directly powered from the mains supply all tests shall be carried out within 5 % of the normal operating voltage.

If apparatus is powered with other means and those means are not supplied as part of the apparatus, e.g. batteries, stabilized power supplies, d.c., etc., all tests shall be carried out within the power supply limit declared by the supplier. If the power supply is a.c., the tests shall be conducted within 4 % of the stated frequency as declared by the supplier.

6.3 Power source

The EUT's battery or mains power supply (whichever is appropriate) shall be used throughout the tests.

7 Speech and telephony tests

7.1 Test configurations

7.1.1 General

A DECT system comprises a PP and a FP. As these parts are not always purchased together, it shall be a requirement that either the complete system or each of the two separate parts shall be capable of being tested. However, a PP, together with a reference FP (ReFP), or a FP, together with a reference PP (RePP), can be considered to represent the relevant characteristics of the complete system. ReFP and RePP referred to in the following clauses, are part of the LT described in clause 5.3.1.

7.1.2 Testing a DECT system

Complete system tests involve the two-way transmission between the acoustic input and output of a PP and a digital TAP reference point of a FP. The general test methods described in clause 7.1.3 are applicable except that the ReFP and the RePP are replaced by a FP or a PP of the DECT system, unless otherwise stated. EUTs supplied as a DECT system shall only be tested as a complete DECT system.

For a DECT system provided with a 2-wire PSTN interface, the system tests **also** involve the two-way transmission between the acoustic input and output of the PP and the 2-wire interface of the FP.

7.1.3 Testing a separate PP or FP

If an LT is available that can establish a speech connection with the EUT and the EUT supports, where required, the <<TERMINAL CAPABILITY>> information element as described in clause 7.7.41 of EN 300 175-5 [5] then test of a FP or a PP as a separate item is supported.

NOTE: Inter-operability between EUTs that are tested separately is only feasible if they use the same profile.

The performance of the PP shall be measured by means of a Reference Fixed Part, (ReFP). The performance of the FP shall be measured by means of a Reference Portable Part (RePP).

The ReFP and RePP shall provide the equivalent of true air interface measurements and therefore shall not contain circuitry which will modify the true air interface speech frequency performance. To meet these requirements, measurements shall be referred to a uniform PCM reference point. The ITU-T Recommendation G.726 [17] at 32 kbit/s algorithm requires such a uniform interface, although in the case of DECT it may not be physically available.

The transcoding algorithms are specified such that encoding and decoding are symmetrical, i.e. with an encoder and decoder connected in tandem, the "levels" of the digital signals at the uniform PCM input to the encoder and output from the decoder are identical. Once the speech channel signals are in the digital domain they are essentially lossless and hence the level at the air interface can be related to any digital interface.

Ideally, to measure the send signals from the PP at the air interface, a PCM level meter should be connected to the reference decoder uniform PCM output, and to generate receive signals for the PP at the air interface, a PCM signal generator should be connected to the reference encoder uniform PCM input.

A more practical means of measuring the speech channel performance may be achieved by converting the uniform PCM to standard μ or A law PCM and then using a standard PCM test set and applying the appropriate correction factor as defined in ITU-T Recommendation G.711 [15] and ITU-T Recommendation G.726 [17] at 32 kbit/s, (although this can have a negative effect on some parameters such as distortion).

Two possible general test methods are described here. The first is commonly called the direct digital processing approach. In this approach, the digital bit-stream is operated upon directly (see figure 3).

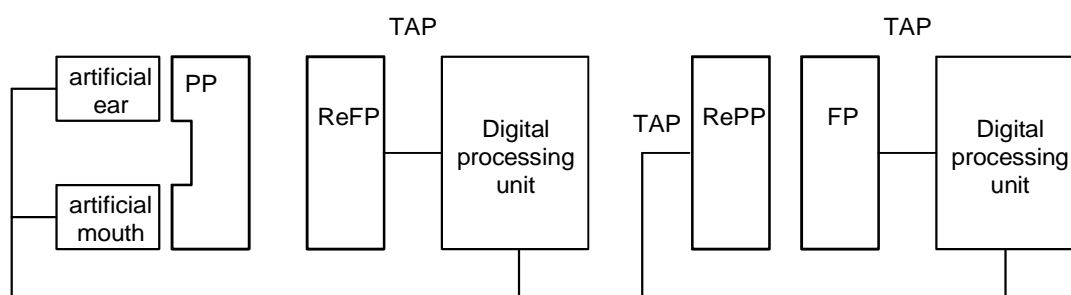

Figure 3: The direct digital processing approach test configurations for a separate PP and a separate FP

The second measurement method involves the use of an ideal codec. In this case, a codec is used to convert the digital bit-stream to the equivalent analogue value, so that existing test procedures and existing analogue measuring equipment can be used (see figure 4).

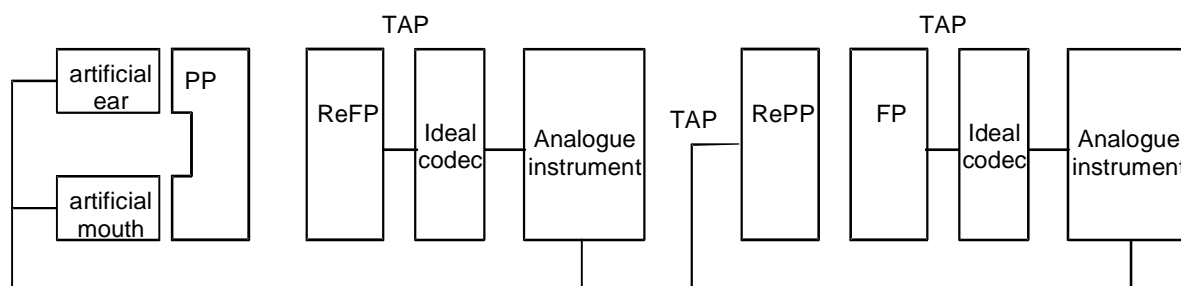

Figure 4: The ideal codec approach (Test configuration for a separate PP and a separate FP)

For FP EUTs provided with a 2-wire interface, additional tests including the 2-wire interface are defined in clause 7.33.

7.1.4 Reference FP (ReFP) and Reference PP (RePP)

A ReFP and RePP are shown in figures 3 and 4, and they incorporate the specified transcoder algorithm as described in ITU-T Recommendation G.726 [17] at 32 kbit/s.

Both the Reference FP and the Reference PP shall have the ability to loopback the ADPCM signal with a 5 ms delay.

NOTE: This 5 ms delay corresponds to the delay between the receive and transmit timeslots of a duplex bearer.

The reference PP shall have a value of TCLw of $36 \text{ dB} \pm 2 \text{ dB}$.

The uniform PCM reference points, points C and D in figure 5, are those designated SR and SL in ITU-T Recommendation G.726 [17] at 32 kbit/s.

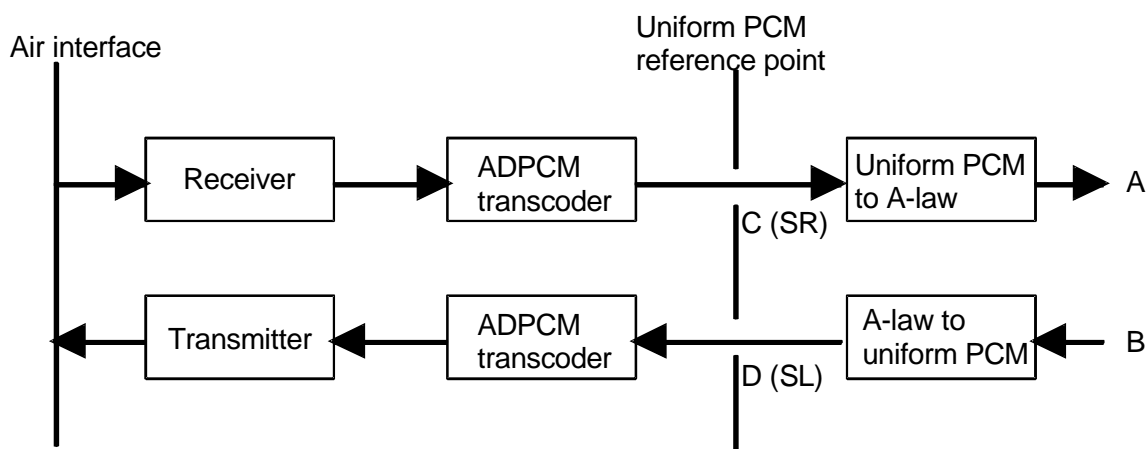

Figure 5: Reference FP and PP

7.1.5 Applicability of tests

Table 1 indicates whether each test is applicable to the PP, FP or to the system (PP and FP combined). It is intended for information only.

Table 1

Clause Number of test	Applicable to		
	PP	FP	System
7.6	■	■	■
7.7	■		■
7.8	■		■
7.9	■		■
7.10	■		■
7.11	■		■
7.12	■		■
7.13	■		■
7.14		■	■
7.15	■		■
7.16	■		■
7.17	■		■
7.18	■		■
7.19	■		■
7.20	■		■
7.21	■		■
7.22	■		■
7.23	■		■
7.24	■		■
7.25	■		■
7.26			
7.27			■
7.28	■		
7.29		■	
7.30		■	■
7.31	■		■
7.32	■		■
7.33		■	■

7.2 Digital signal level

The "level" of the digital signal at the uniform companded PCM and ADPCM interfaces are defined in dBm0. A 1 kHz sine wave whose peak signal corresponds with the maximum PCM code is assigned a level of +3,14 dBm0 (ITU-T Recommendation G.711 [15]).

The relationship between the PCM encoding law and the audio signal level is defined in ITU-T Recommendation G.711 [15]. The theoretical load capacity of ITU-T Recommendation G.726 [17] at 32 kbit/s ADPCM is the same as for A-law PCM.

For sensitivity and loudness rating calculations the nominal voltage assigned to a digital signal is calculated assuming an associated impedance of 600 Ω . Thus 0 dBm0 is equivalent to a voltage of -2,2 dBV.

The digital line interface is a 0 dBr point in accordance with ITU-T Recommendation G.101 [11]. As the various digital transcoding algorithms are essentially loss-less, the relative level is constant over the whole digital path in the PP and the FP except the signal processing described in the present document. Compliance shall be checked by supplier's declaration (see note in clause 5.1.3).

7.3 General conditions of test

Unless otherwise stated, the tests are made under the normal operating conditions specified in clause 6.2.

The PP or FP under test shall be tested in conjunction with the ReFP or the RePP respectively, separated by some distance, ensuring proper operation of the radio link. In addition, the room shall be a relatively noiseless RF environment such that the normal handshaking between FP and PP is maintained. A connection shall be established and maintained for a two-way speech transmission.

Unless otherwise stated in a particular test, where the PP under test has fixed geometry, the PP shall be placed in the LRGP as described in ITU-T Recommendation P.64 [23], annex C. Where the PP has variable geometry, the front plane of the mouthpiece shall be mounted 15 mm in front of the lip ring and coaxial with the artificial mouth. A PP with variable geometry, having a natural position during on-line conditions shall be regarded as being a fixed geometry PP.

The tests defined in clauses 7.14 and 7.30, regarding echoes, are defined for steady states. It shall be possible to disable every echo control function implemented in the FP. The applicant shall declare to the test laboratory how this is done.

Unless otherwise stated, if a user-controlled volume control is provided at the PP, the requirements apply for all positions of the volume control, and the compliance tests shall be carried out at the maximum setting of this volume control.

NOTE: ITU-T Recommendation P.64 [23] allows the use of alternative signal sources for measurements of loudness ratings. If such a signal source is used, it is the responsibility of the test laboratory to ensure that the method used can obtain equivalent results.

7.4 Ideal codec

The ideal codec approach uses a codec to convert the companded digital bit stream to the equivalent analogue values, so that existing test equipment and procedures may be used. This codec shall be a high quality codec whose characteristics are close to ideal. The codec shall have characteristics such as attenuation/frequency distortion, idle channel noise, quantizing distortion etc. which exceed the reference codec requirements specified in ITU-T Recommendation O.133 [19], clause 4 so as not to mask the corresponding parameters of the apparatus under test. The linear A/D and D/A converters used by the codec shall have at least 14 bit resolution, and the filter response shall lie within the upper and lower limits given in table 2.

Table 2: Frequency/sensitivity response of an ideal codec

	Frequency Hz	Loss dB
Lower limit	0	0,0
	80	0,0
	80	-0,25
	3 600	-0,25
	3 600	0,0
	4 000	0,0
Upper limit	100	+40,0
	100	+0,25
	3 000	+0,25
	3 000	+0,9
	3 400	+0,9
	3 400	+40,0

The limit curves shall be determined by straight lines joining successive co-ordinates given in table 2, when the loss is plotted on a linear axis against frequency on a logarithmic axis.

7.5 Electro-acoustical equipment

The artificial mouth shall conform to ITU-T Recommendation P.51 [21]. The artificial ear shall conform to ITU-T Recommendation P.57 [22].

7.6 Speech coding scheme

7.6.1 Requirement for speech coding algorithm

The speech coding algorithm shall conform to ITU-T Recommendation G.726 [17] at 32 kbit/s, for 32 kbit/s ADPCM.

The A-law companding and synchronous tandem adjustment may be omitted in FPs with an analogue line interface and in PPs.

NOTE: ITU-T Recommendation G.726 [17] at 32 kbit/s codecs support the use of the voice channel for telefax of group 2 and group 3. For group 3 the data speed, which is automatically negotiated, is in practice typically limited to 9,6 kbit/s.

The ADPCM words comprised in each burst shall be transmitted in chronological order, and with the most significant bit transmitted first within each word.

7.6.2 Applicant's declaration on speech coding algorithm

For these highly integrated products, it is not intended to require a PCM interface (uniform or logarithmic) for testing purposes only. Compliance shall be by applicant's declaration (see clause 5.1.3).

7.6.3 Requirement for the TAP in the FP

The TAP of the FP shall be equivalent to the PCM interface of the speech coding algorithm.

7.6.4 Applicant's declaration on the TAP in the FP

The applicant shall declare that the TAP of the FP is equivalent to the PCM interface of the speech coding algorithm.

7.7 PP sending frequency response

7.7.1 Requirement

The sending sensitivity/frequency response (from MRP to the digital interface) shall be within a mask as defined in table 3 and figure 6.

Table 3: Sending sensitivity-frequency mask

Frequency (Hz)	Upper limit (dB)	Lower limit (dB)
100	-9	
200	0	
300	0	-14
800	0	-10
2 000	4	-8
3 400	4	-11
4 000	4	
8 000	-13	

NOTE 1: The limits at intermediate frequencies lie on straight lines drawn between the given values on a logarithmic (Hz) - linear (dB) scale.
NOTE 2: All dB levels are on an arbitrary scale.

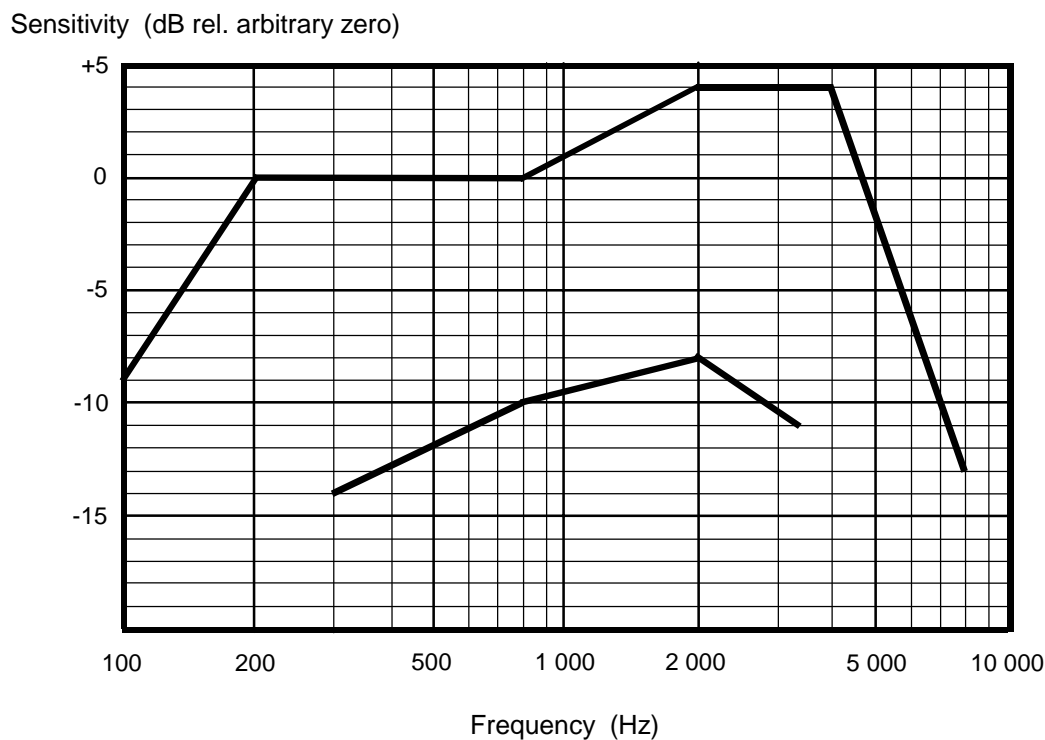

Figure 6: Sending frequency response tolerance mask

7.7.2 Method of measurement

The handset shall be mounted in the LRGP (see ITU-T Recommendation P.64 [23], annex C), and the earpiece sealed to the knife-edge of an artificial ear.

A pure tone signal of -4,7 dBPa shall be applied at the MRP as described in ITU-T Recommendation P.64 [23], using an artificial mouth conforming to ITU-T Recommendation P.51 [21].

A digital measuring instrument, or an ideal codec followed by an analogue level measuring set, shall be connected to point A of the ReFP as shown in figure 5, or to the TAP-reference point of a FP.

Measurements shall be made at one twelfth-octave intervals as given by the R40 series of preferred numbers in ISO 3 [25] for frequencies from 100 Hz to 8 kHz inclusive. At each frequency the level for an input sound pressure of -4,7 dBPa shall be measured.

7.8 PP receiving frequency response

See EN 300 175-8 [8], clause 7.1.2.

7.8.1 Requirement

The receiving sensitivity-frequency response (from the digital interface to the ERP) shall be within a mask as defined in table 4 and shown in figure 7. The proposed receiving frequency response tolerance mask is applicable for all types of couplers (type 1, 3.2, 3.3, 3.4).

Table 4: Receiving sensitivity-frequency mask

Frequency (Hz)	Upper limit (dB)	Lower limit (dB)
100	-10	
200	2	
300		-9
1 000		-7
3 400		-12
4 000	2	
8 000	-15	

NOTE 1: The limits at intermediate frequencies lie on a straight line drawn between the given values on a logarithmic (Hz) - linear (dB) scale.
NOTE 2: All dB levels are on an arbitrary scale.

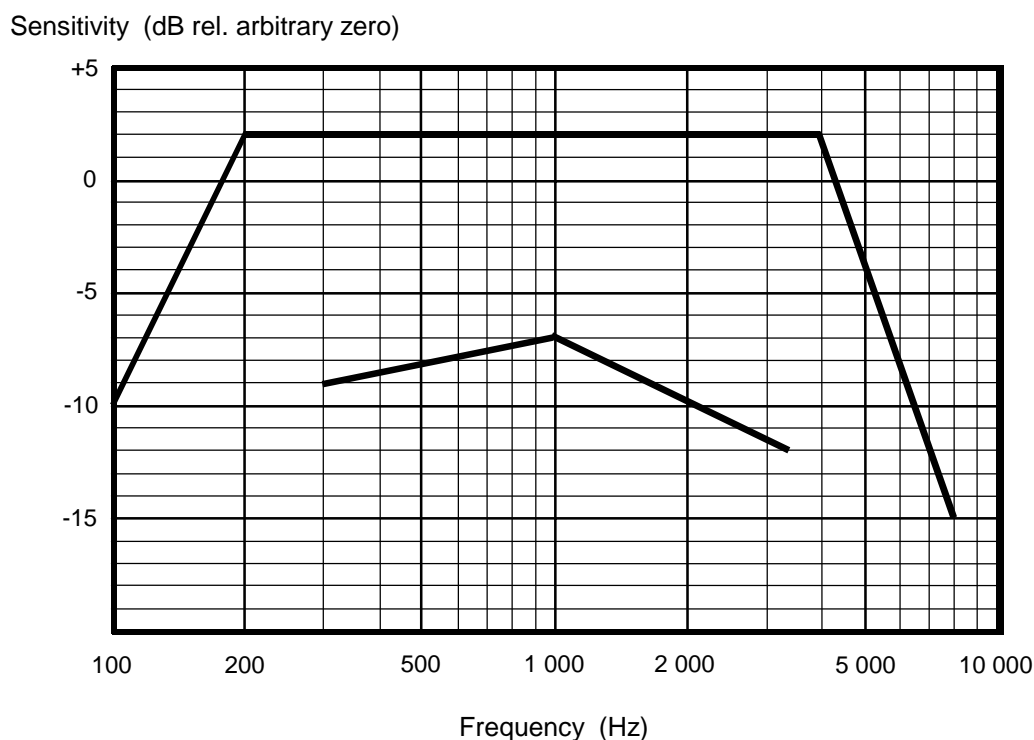

Figure 7: Receiving frequency response tolerance mask

7.8.2 Method of measurement

A digital signal generator, or an analogue signal generator followed by an ideal codec, shall be connected to point B of the ReFP as shown in figure 5, and the level shall be adjusted to produce a level of -16 dBm₀ at the uniform PCM reference point.

The receiving sensitivity/frequency response shall be determined as described in clause 9 of ITU-T Recommendation P.64 [23] and by using the procedure described in clause 11 of the Recommendation. The sound pressure is measured at the fundamental frequency of the stimulus. The results are expressed in dBPa/V.

Measurements shall be made at 1/12 octave intervals at the preferred frequencies given by the R40 series preferred numbers in ISO 3 [25] for frequencies from 100 Hz to 8 kHz.

7.9 PP loudness rating

7.9.1 Requirement

The nominal values are: Sending Loudness Rating (SLR_H) = 7 dB and Receiving Loudness Rating (RLR_H) = 3 dB. The SLR_H shall be $7 \text{ dB} \pm 3,5 \text{ dB}$. The RLR_H shall be $3 \text{ dB} \pm 3,5 \text{ dB}$.

7.9.2 Method of measurement

7.9.2.1 SLR_H

To determine the SLR_H , the sending sensitivity shall be measured as described in clause 7.7.2 at each of the 14 frequencies given in table 1 of ITU-T Recommendation P.79 [24], bands 4 to 17.

The sensitivity shall be expressed in terms of dBV/Pa and the SLR shall be calculated according to ITU-T Recommendation P.79 [24], formula 2.1, over bands 4 to 17, using $m = 0,175$ and the sending weighting factors from ITU-T Recommendation P.79 [24], table 1.

7.9.2.2 RLR_H

To determine the RLR_H , the receiving sensitivity shall be measured as described in clause 7.8.2 at each of the 14 frequencies listed in table 1 of ITU-T Recommendation P.79 [24], bands 4 to 17.

The sensitivity shall be expressed in terms of dBPa/V and the RLR shall be calculated according to ITU-T Recommendation P.79 [24], formula 2.1, over bands 4 to 17, using $m = 0,175$ and the receiving weighting factors from table 1 of this Recommendation.

The artificial ear sensitivity shall be corrected using the real ear correction of table 2 of ITU-T Recommendation P.79 [24].

7.10 User controlled volume control in the PP

7.10.1 Requirement

A user-controlled volume control shall be provided in all PP equipment, except where that incorporates an adaptive volume control in the PP.

When adjusting the volume control from nominal to maximum setting, the decrease in RLR_H shall be not less than 6 dB.

Where user controlled volume control is provided instead of an adaptive volume control, adjust the volume control to the setting (nominal) where the RLR is closest to its nominal value. At this setting the RLR_H and SLR_H shall simultaneously meet the values given in clause 7.9.1, including the tolerances. A "joint acting" volume control is where the PP can simultaneously change the values of SLR and RLR in opposite directions.

The RLR_H and SLR_H shall not exceed the limits given in tables 5 and 6.

Table 5: Absolute limits for "joint-acting" volume control

Volume setting	Maximum	Minimum
RLR_H	-13 dB	19 dB
SLR_H	17 dB	3 dB

Table 6: Absolute limits for a receiving volume control

Volume setting	Maximum	Minimum
RLR _H	-13 dB	19 dB

NOTE: Minimum setting: the setting where the RLR has its maximum value.

7.10.2 Method of measurement

7.10.2.1 SLR_H

The method of measurement and test conditions shall be as laid down in clause 7.9.2.1.

7.10.2.2 RLR_H

The method of measurement and test conditions shall be as laid down in clause 7.9.2.2.

7.11 PP talker sidetone masking rating

7.11.1 Requirement

The sidetone path shall be implemented in the PP.

The nominal value of the SideTone Masking Rating (STMR) shall be 13 dB. The value of the STMR shall be 10 dB to 18 dB referred to nominal values of SLR_H and RLR_H (SLR_H = 7 dB and RLR_H = 3 dB).

7.11.2 Method of measurement

For the test the digital input in the receiving direction shall be driven by a signal corresponding to PCM decoder value number 1.

Where a user controlled volume control is provided, the measurements shall be carried out at a setting which shall be as close as possible to the nominal value of the RLR (RLR = 3 dB).

The handset shall be mounted in the LRGP and the earpiece shall be sealed to the knife-edge of the artificial ear. A pure tone signal of -4,7 dBPa shall be applied at the mouth reference point. For each frequency given in ITU-T Recommendation P.79 [24], table 3, bands 1 to 20, the sound pressure in the artificial ear shall be measured.

The sidetone path loss Lme_{ST} as expressed in dB and the STMR (in dB) shall be calculated from the formula 2.1 of ITU-T Recommendation P.79 [24], using $m = 0,225$ and the weighting factors in table 3 of ITU-T Recommendation P.79 [24].

7.12 Listener SideTone (LST)

7.12.1 LSTR requirement

For PPs with the optional noise rejection capability as declared by the applicant, the value of the LSTR shall not be less than 15 dB referred to the nominal values of SLR_H and RLR_H.

Alternatively the value of the weighted average D of the difference of the send sensitivities between diffuse and direct sound shall be measured and shall not be less than +0 dB. One of both alternatives shall be declared by the applicant.

7.12.2 Protocol requirement for EUTs with declared noise rejection capability

The FP shall know whether or not the PP has implemented the noise rejection capability before or at call set-up.

7.12.3 Method of measurement for LSTR

A diffuse sound field of pink noise shall be calibrated in the absence of any local obstacles. The averaged field shall be uniform to within ± 3 dB within a radius of 0,15 m of the MRP, when measured in one-third octave bands from 100 Hz to 8 kHz (bands 1 to 20).

NOTE 1: The pressure intensity index as defined in ISO 9614 [26] may prove to be a suitable method for assessing the diffuse field.

NOTE 2: Where more than one loudspeaker is used to produce the desired sound field, the loudspeakers may require to be fed with non-coherent electrical signals to eliminate standing waves and other interference effects.

Where a user controlled volume control is provided, the measurements shall be carried out at a setting which shall be as close as possible to the nominal value of the RLR (RLR = 3 dB).

A calibrated half-inch microphone shall be mounted at MRP. The sound field shall be measured in 1/3 octave bands. The power density spectrum shall be band limited "pink noise" (100 Hz to 8 kHz) and the level shall be adjusted to -24 dBPa (A). The tolerance on this level shall be ± 1 dB.

The artificial mouth and ear shall be placed in the correct position relative to MRP, the handset shall be mounted at LRGP and the earpiece shall be sealed to the knife-edge of the artificial ear.

NOTE 3: It is important to mount the handset as tight as possible to the knife edge of the artificial ear to eliminate the influence of any ear-cap leakage in the range of 100 Hz to 300 Hz as much as possible as mentioned in ITU-T Recommendation G.111 [12].

Measurements shall be made in one-third octave bands for the 20 bands centred at 100 Hz to 8 kHz (bands 1 to 20). For each band the sound pressure in the artificial ear shall be measured by connecting a suitable measuring set to the artificial ear.

The listener sidetone path loss shall be expressed in dB and the LSTR shall be calculated from the ITU-T Recommendation P.79 [24], formula 2.1, using $m = 0,225$ and the weighting factors in table 3 of the Recommendation.

For the weighted average D of the difference of the send sensitivities between diffuse and direct sound the diffuse sound sensitivities measured as specified above shall be used for the calculation as $S_{si}(\text{diff})$ at 14 bands from 200 Hz to 4 kHz. The sending sensitivities for the direct sound $S_{si}(\text{direct})$ shall be measured according to clause 7.7.2, but at one-third octave bands for 14 bands centred at 200 Hz to 4 kHz with the test signal pink noise as specified above. D is computed with $S_{si}(\text{diff})$ and $S_{si}(\text{direct})$ from the ITU-T Recommendation P.79 [24], formulas E-3 and E-2 and the coefficients K_i in table E.1 in ITU-T Recommendation P.79 [24].

7.12.4 Method of measurement for the protocol requirement for EUTs with declared noise rejection capability applying to be tested separately

Clause 7.1.3 clarifies which EUTs are applicable to this clause:

- a) the test personnel shall make a call from the PP including the relevant message that includes the <<TERMINAL CAPABILITY>> information element. If the EUT conforms to an ETSI defined profile, the relevant message defined by this profile shall be used;
- b) the LT shall verify that the <<TERMINAL CAPABILITY>> information element is included in the relevant message and that it indicates correctly whether the PP ambient noise rejection capability has been implemented (see EN 300 175-5 [5], clause 7.7.41).

7.12.5 Applicant's declaration for the protocol requirement for EUTs applying to be tested as a DECT system

Clause 7.1.2 clarifies which EUTs are applicable to this clause.

The applicant shall declare one of the following:

- 1) all PPs in the DECT system have identical noise rejection capability and this is known at all FPs; or
- 2) PPs indicate to the FP at call set-up whether they have implemented the noise rejection capability by some protocol means that the FP understands.

7.13 Terminal Coupling Loss (TCLw) of a PP

7.13.1 TCLw requirement

The weighted Terminal Coupling Loss (TCLw) defined from the PP digital input to the PP digital output shall meet one of the following options:

- a) $TCLw > 46$ dB at nominal setting of the volume control corrected to the nominal values of RLR_H and SLR_H .
For all positions of volume control the TCLw shall not be less than 35 dB;

NOTE 1: This is the recommended option.

- b) $TCLw > 34$ dB.

NOTE 2: Since there is no statement for option b) on volume control settings, the conditions in the 5th paragraph of clause 7.3 apply.

If the PP is designed to meet option a), this option shall be declared by the applicant.

7.13.2 Protocol requirement

The FP shall know if TCLw option a) has been implemented in the PP.

7.13.3 Method of measurement for TCLw for a PP being tested separately

The PP shall be suspended in free air:

- a) a digital signal generator, or an analogue signal generator followed by an ideal codec, shall be connected to point B of the ReFP as shown in figure 5;
- b) the signal generator shall be set to provide a signal level of -10 dBm₀ at the uniform PCM point D of figure 5;
- c) the PP shall be suspended in free air in a low noise room (see clause 5.2) in such a way that the inherent mechanical coupling of the handset shall not be affected;
- d) the level at the uniform PCM reference point, point C of figure 5, shall be evaluated using the level meter for one twelfth-octave intervals as given by the R40 series of preferred numbers in ISO 3 [25] for frequencies 300 Hz to 3 350 Hz;
- e) the TCLw, shall be calculated according to ITU-T Recommendation G.122 [13], annex B.4, Trapezoidal rule;
- f) for the option a) in clause 7.13.1, TCLw requirement, the results of the measurements of Terminal Coupling Loss (TCL) shall be corrected by the sending noise if it is requested by the apparatus supplier. In this case two alternative methods are applicable:
 - 1) for every 1/12th octave band the sending noise shall be measured without psophometric weighting and then power subtracted from the measured TCL value;

- 2) the TCLw shall be calculated as a power integration in accordance to the equation in ITU-T Recommendation G.122 [13], clause 4.2. The sending noise shall be measured without psophometric weighting and power subtracted from every measured TCL value.

7.13.4 Method of measurement for TCLw for a PP being tested as part of a DECT system

- a) Disable any artificial echo loss or echo control device;
- b) a digital signal generator, or an analogue signal generator followed by an ideal codec, shall be connected to the TAP-reference point of the FP;
- c) b), c), d) and e) in clause 7.13.3 are repeated.

7.13.5 Method of measurement for the protocol requirement for EUTs applying to be tested separately

Clause 7.1.3 clarifies which EUTs are applicable to this clause. This requirement does not apply if the PP implements minimum TCLw (option b):

- a) the test personnel shall make a call from the PP including the relevant message that includes the <<TERMINAL CAPABILITY>> information element. If the EUT conforms to an ETSI defined profile, the relevant message defined by this profile shall be used;
- b) the LT shall verify that the <<TERMINAL CAPABILITY>> information element is included in the relevant message and that it indicates correctly whether full TCLw (option a)) has been implemented (see EN 300 175-5 [5], clause 7.7.41).

7.13.6 Applicant's declaration for the protocol requirement for EUTs applying to be tested as a DECT system

Clause 7.1.3 clarifies which EUTs are applicable to this clause. This requirement does not apply if the PP implements minimum TCLw (option b).

The applicant shall declare one of the following:

- 1) all PPs in the DECT system have full TCLw implemented and this is known at all FPs; or
- 2) PPs indicate to the FP at call set-up whether they have implemented full TCLw by some protocol means that the FP understands.

7.14 FP echo control functions with a 4-wire interface

7.14.1 Static requirements

If the EUT (FP) is part of a DECT System (see clause 7.1.2) where the PP implements minimum TCLw (see clause 7.13) or the EUT is being tested as a separate item (see clause 7.1.3) then the EUT shall implement one of the two following alternatives:

- a) artificial echo loss (see clause 7.14.3);
- b) echo control device (see clause 7.14.4).

However, if the EUT (FP) is being tested as part of a DECT System (see clause 7.1.2) where the PP always implements full TCLw then artificial echo loss and an echo control device shall not be implemented or shall be disabled and the requirements in clauses 7.14.3 and 7.14.4 do not apply.

7.14.2 Dynamic requirements

7.14.2.1 Minimum TCLw

If the FP receives no information concerning the TCLw value of the PP, the FP shall default to the assumption that the PP fulfils option b) of clause 7.13.1 and it shall enable either an artificial echo loss or an echo control device. Routing information as described in EN 300 175-8 [8], clause 7.4.1.2 shall not be available during the test.

NOTE: Installed DECT equipment may disable the functions a) or b) e.g. internal calls, local calls or non-speech services as described in EN 300 175-8 [8], clause 7.4.1.2.

7.14.2.2 Full TCLw

For FPs that are tested separately, then receipt of the <<TERMINAL CAPABILITY>> information element indicating full TCLw shall disable any artificial echo loss or echo control device.

For FPs that are being tested as part of a DECT System with PPs in the system implementing both Minimum TCLw and full TCLw then the FP shall, on receipt of a full TCLw indication message, disable any artificial echo loss or echo control device.

7.14.3 Artificial echo loss of a FP with a 4-wire interface

7.14.3.1 Requirement for artificial echo loss

An artificial echo path shall be implemented into the FP between the line input and the line output, as shown in figure 8. The loss of that echo path shall be $24 \text{ dB} \pm 2 \text{ dB}$.

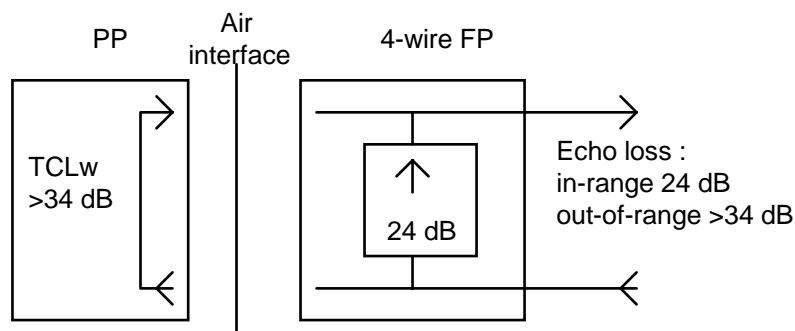

Figure 8

7.14.3.2 Requirement for the ability to disable the artificial echo loss

This requirement shall be applicable to all FPs tested as separate items and FPs tested as part of a DECT System where all PPs do not have $\text{TCLw} > 46 \text{ dB}$.

The FP shall disable the artificial echo loss on receipt of a protocol message from the PP indicating full TCLw.

7.14.3.3 Method of measurement of artificial echo loss

The FP shall have its artificial echo path activated and the speech path via the air interface de-activated. Any echo control device as specified in clause 7.14.4 shall be disabled.

A digital signal generator, or analogue signal generator followed by an ideal codec shall be connected to the TAP-interface of the FP.

The signal generator shall be set to provide a signal level of -10 dBm_0 at the input of the TAP-interface.

The level at the output of the TAP-interface shall be evaluated using the level meter for one twelfth-octave intervals as given by the R40 series of preferred numbers in ISO 3 [25] for frequencies 300 Hz to 3 350 Hz.

The artificial echo loss shall be calculated according to ITU-T Recommendation G.122 [13].

7.14.3.4 Method of measurement for ability to disable artificial echo loss

7.14.3.4.1 EUTs being tested as separate items

- 1) The LT shall set-up a call with the EUT and send the relevant message containing the <<TERMINAL CAPABILITY>> information element as described in EN 300 175-5 [5], clause 7.7.41, indicating full TCLw. If the EUT conforms to an ETSI defined profile, the relevant message defined by this profile shall be used;
- 2) repeat the test described in clause 7.14.3.3;
- 3) the artificial echo loss shall be greater than 34 dB.

7.14.3.4.2 EUTs being tested as a DECT system with a PP having full TCLw

- 1) The PP of the DECT System shall be used to set-up a call, with a full TCLw indication, with the EUT;
- 2) repeat the test described in clause 7.14.3.3;
- 3) the artificial echo loss shall be greater than 46 dB.

7.14.4 Echo control device of a FP with a 4-wire interface

7.14.4.1 Requirement for the echo control device

An echo control device shall be implemented into the FP. The TCLw of the DECT system, defined from the FP line input to the FP line output, shall be at least 46 dB.

7.14.4.2 Requirement for the ability to disable the echo control device

This requirement shall be applicable to all FPs tested as separate items and FPs tested as part of a DECT System where all PPs do not have TCLw > 46 dB.

The FP shall disable the artificial echo loss on receipt of a protocol message from the PP indicating full TCLw.

7.14.4.3 Method of measurement for the echo control device

The FP shall have its echo control device activated and no activated artificial echo path.

A digital signal generator, or analogue signal generator followed by an ideal codec shall be connected to the TAP-interface of the FP.

The signal generator shall be set to provide a signal level of -10 dBm0 at the input of the TAP-interface.

The input of the TAP-interface at the RePP shall be connected to the output of the TAP-interface at the RePP with a 34 dB loss.

The level at the output of the TAP-interface at the FP shall be evaluated using the level meter for one twelfth octave intervals as given by the R40 series of preferred numbers in ISO 3 [25] for frequencies 300 Hz to 3 350 Hz.

The TCLw shall be calculated according to ITU-T Recommendation G.122 [13], annex B.4, Trapezoidal rule.

7.14.4.4 Method of measurement for the ability to disable the echo control function

7.14.4.4.1 EUTs being tested as separate items

- 1) The LT shall set-up a call with the EUT and send the relevant message containing the <<TERMINAL CAPABILITY>> information element as described in EN 300 175-5 [5], clause 7.7.41, indicating full TCLw. If the EUT conforms to an ETSI defined profile, the relevant message defined by this profile shall be used;

- 2) repeat the test described in clause 7.14.4.3;
- 3) the TCLw shall be less than 46 dB.

7.14.4.4.2 EUTs being tested as a DECT system with a PP having full TCLw

- 1) The PP of the DECT System shall be used to set-up a call, with a full TCLw indication, with the EUT;
- 2) repeat the test described in clause 7.13.4;
- 3) the TCLw shall be as measured in clause 7.13.4.

7.15 Stability loss - fixed geometry

7.15.1 Requirement

The attenuation from the digital input to the digital output shall be at least 6 dB at all frequencies in the range of 200 Hz to 4 000 Hz.

7.15.2 Method of measurement

- a) With the digital signal generator, or the analogue signal generator, followed by an ideal codec, set to provide a signal level of -10 dBm0 at the uniform PCM point B of figure 5, the attenuation from the input B to the output A shall be measured at one-twelfth octave intervals for frequencies in the range 200 Hz to 4 000 Hz under the conditions in b);
- b) the PP shall be placed on one inside surface of three perpendicular plane smooth hard surfaces forming a corner. Each corner shall extend 0,5 m from the apex of the corner. One surface shall be marked with a diagonal line extending from the corner and a reference position marked on the line 250 mm from the corner;

the PP shall be positioned centrally along the diagonal line with the earcap nearer to the apex of the corner such that:
 - 1) the mouthpiece and earcap shall face towards the surface; and
 - 2) the extremity of the PP shall coincide with "the normal to the reference point".

7.16 Stability loss variable geometry

7.16.1 Requirement

The attenuation from the digital input to the digital output shall be at least 6 dB at all frequencies in the range of 200 Hz to 4 000 Hz.

7.16.2 Method of measurement

The equipment shall meet the requirement in at least one of the two following conditions:

- a) if the movement and orientation of the acoustic elements are fixed by means of a hinge or similar mechanism while the PP is active, the requirement shall be met for these fixed positions. The measurement shall be carried out in the corner described under point b) of clause 7.15.2. In the just off-hook position the measurement shall be carried out under free field conditions;
- b) if the movement and orientation of the acoustic elements are not fixed while the PP is active, the requirement shall be met for any position and orientation that can be achieved. The measurement shall be carried out in the corner described under point b) of clause 7.15.2.

With the digital signal generator, or the analogue signal generator followed by an ideal codec, set to provide a signal level of -10 dBm0 at the uniform PCM point D of figure 5, the attenuation from the input B to the output A shall be measured at one twelfth octave intervals for frequencies in the range 200 Hz to 4 000 Hz.

7.17 Sending distortion

7.17.1 Requirement

The ratio of signal to total distortion (harmonic and quantizing) measured at the line interface shall not be less than 33 dB.

7.17.2 Method of measurement

NOTE: The test methods defined in TBR 008 [10] are inappropriate when ADPCM coding is used. A provisional method of measurement is therefore provided. A more general method of measurement is under study.

A pure tone signal of -4,7 dBPa and nominal frequency between 1 004 Hz and 1 025 Hz shall be applied at the MRP as described in ITU-T Recommendation P.64 [23], using an artificial mouth conforming to ITU-T Recommendation P.51 [21].

A digital measuring instrument, or an ideal codec followed by an analogue level measuring set, shall be connected to point A of the ReFP as shown in figure 5 or to the TAP-reference point of a FP.

The ratio of the signal to total distortion power at the output A shall be measured with the psophometric noise weighting as described in ITU-T Recommendation G.712 [16] and ITU-T Recommendation O.132 [18].

7.18 Receiving distortion

7.18.1 Requirement

The ratio of signal to total distortion (harmonic and quantizing) measured at the ERP shall not be less than 33 dB.

7.18.2 Method of measurement

NOTE: A more general method of measurement is under study.

A digital signal generator, or an analogue signal generator, followed by an ideal codec, shall be connected to point B of the ReFP, as shown in figure 5, or to the TAP-reference point of a FP, and the level shall be adjusted to produce a digitally simulated sine-wave of nominal frequency between 1 004 Hz and 1 025 Hz at a level of -10 dBm0 at the uniform PCM reference point D.

The ratio of signal to total distortion power of the signal output in the artificial ear shall be measured with the psophometric noise weighting. See figures 3 and 4, ITU-T Recommendation G.712 [16] and ITU-T Recommendation O.132 [18].

7.19 Side tone distortion

7.19.1 Requirement

The third harmonic distortion generated by the PP shall not be greater than 10 %.

7.19.2 Method of measurement

The PP shall be mounted at the LRGP and the earpiece shall be sealed to the knife-edge of the artificial ear. An instrument capable of measuring the third harmonic distortion of signals with fundamental frequencies in the range of 315 Hz to 1 000 Hz shall be connected to the artificial ear.

A pure-tone signal of -4,7 dBPa shall be applied at the mouth reference point at frequencies of 315 Hz, 500 Hz and 1 000 Hz. For each frequency, the third harmonic distortion shall be measured in the artificial ear.

7.20 Out of band (sending)

7.20.1 Requirement

With any sine-wave signal above 4,6 kHz and up to 8 kHz applied at the MRP at a level of -4,7 dBPa, the level of any image frequency produced at the digital interface shall be below a reference level obtained at 1 kHz (-4,7 dBPa at MRP) by at least the amount in dB specified in table 7.

Table 7: Discrimination levels - sending

Boundaries of signal frequencies	Limit (minimum)
4,6 kHz	30 dB
8 kHz	40 dB

The limits at intermediate frequencies lie on a straight line drawn between the given values on a log (frequency) - linear (dB) scale.

7.20.2 Method of measurement

- A digital measuring instrument, or an ideal codec followed by an analogue level measuring set, shall be connected to point A of the ReFP as shown in figure 5 or to the TAP-reference point of a FP;
- a pure sine wave of level -4,7 dBPa shall be applied at the MRP;
- for applied frequencies of 4,65 kHz, 5,0 kHz, 6,0 kHz, 6,5 kHz, 7,0 kHz and 7,5 kHz, the level of the corresponding image frequency shall be measured.

7.21 Out of band (receiving)

7.21.1 Requirement

With a digitally-simulated sine-wave signal in the frequency range of 300 Hz to 3 400 Hz at a level of -10 dBm0 applied at the digital interface, the level of spurious out-of-band image signals in the frequency range of 4,6 kHz to 8 kHz measured selectively at the ERP shall be lower than the in-band acoustic level produced by a digital signal at 1 kHz set at the level specified in table 8.

Table 8: Discrimination levels - receiving

Boundaries of signal frequencies	Equivalent i/p level of 1 kHz
4,6 kHz	-35 dBm0
8 kHz	-45 dBm0

The limits at intermediate frequencies lie on a straight line drawn between the given values on a log(frequency)-linear(dB) scale.

7.21.2 Method of measurement

A digital signal generator, or an analogue signal generator followed by an ideal codec, shall be connected to point B of the ReFP as shown in figure 5 or to the TAP-reference point of a FP, and shall be set to provide a signal level of -10 dBm0 at the uniform PCM reference point D.

For input signals at the frequencies 500 Hz, 1 000 Hz, 2 000 Hz, and 3 150 Hz, the level of the corresponding image signals at frequencies up to 8 kHz shall be measured at the ear reference point.

7.22 Sending noise

7.22.1 Requirement

The noise produced by the apparatus in the sending direction shall not exceed -64 dBm_{0p}.

7.22.2 Method of measurement

The PP shall be mounted at the LRGP and the earpiece sealed to the knife-edge of the artificial ear in an acoustically quiet environment (ambient noise less than -64 dBPa (A)).

A digital measuring instrument, or an ideal codec followed by an analogue level measuring set, shall be connected to point A of the ReFP as shown in figure 5, or to the TAP-reference point of a FP.

The noise level at the PCM interface point A shall be measured using psophometric weighting as described in ITU-T Recommendation G.223 [14], table 4.

7.23 Sending noise (narrow band)

7.23.1 Requirement

The narrow-band noise (due to TDMA) produced by the apparatus in the sending direction, and contained within any 10 Hz bandwidth between the frequency limits 300 Hz to 3 400 Hz, shall not exceed -73 dBm₀.

7.23.2 Method of measurement

The PP shall be mounted at the LRGP and the earpiece sealed to the knife-edge of the artificial ear in the Low Noise Room (LNR).

An ideal codec followed by a selective measuring set or spectrum analyser with an effective bandwidth of 10 Hz shall be connected to point A of the ReFP as shown in figure 5, or to the TAP-reference point of a FP.

The rms voltage of the 10 Hz band limited signal shall be measured within the frequency range 305 Hz to 3 395 Hz.

7.24 Receiving noise

7.24.1 Requirement

If no user-controlled receiving volume control is provided, or if it is provided, at the setting where the RLR_H is equal to the nominal value, the noise produced by the apparatus and measured at the ERP shall not exceed -54 dBPa (A).

7.24.2 Method of measurement

A digital signal generator, or an analogue signal generator followed by an ideal codec, shall be connected to point B of the ReFP as shown in figure 5, or to the TAP-reference point of a FP, and shall be set to provide a signal corresponding to decoder value number 1 at the uniform PCM reference point D.

With an ambient noise level not exceeding -64 dBPa (A), the noise level in the artificial ear shall be measured.

7.25 Sampling frequency level (receiving)

7.25.1 Requirement

The level of the 8 kHz measured selectively at the ERP shall be less than -70 dBPa.

7.25.2 Method of measurement

A digital signal generator, or an analogue signal generator followed by an ideal codec, shall be connected to point B of the ReFP as shown in figure 5, or to the TAP-reference point of a FP, and shall be set to provide a signal corresponding to decoder value number 1 at the uniform PCM reference point D.

With an ambient noise level not exceeding -64 dBPa (A), the level of any 8 kHz signal in the artificial ear shall be measured.

7.26 Acoustic shock

The essential requirements and test for acoustic shock are not within the scope of the present document. They are covered by the Council Directive 73/23/EEC [33], (the Low Voltage Directive).

For information see annex D.

7.27 DECT network delay

This test shall only apply when testing a FP and a PP as a pair.

7.27.1 Requirement

The sum of the delays from the MRP to the electrical line interface and from the electrical line interface to the ERP (round-trip delay) shall not exceed 28,5 ms, for a digital line interface. If an analogue line interface is provided, the delay shall not exceed 29 ms including the A/D and D/A converters at the interface to the external network.

7.27.2 Method of measurement

The PP shall be mounted in the LRGP. The earpiece shall be sealed to the knife-edge of the artificial ear. The delay in send and receive directions shall be measured separately from MRP to the electrical interface (D_s) and from the electrical interface to ERP (D_r). The acoustic input level shall be -4,7 dBPa. The level of the input signal at the electrical interface shall be adjusted to give -10 dBm0 at the TAP-reference point.

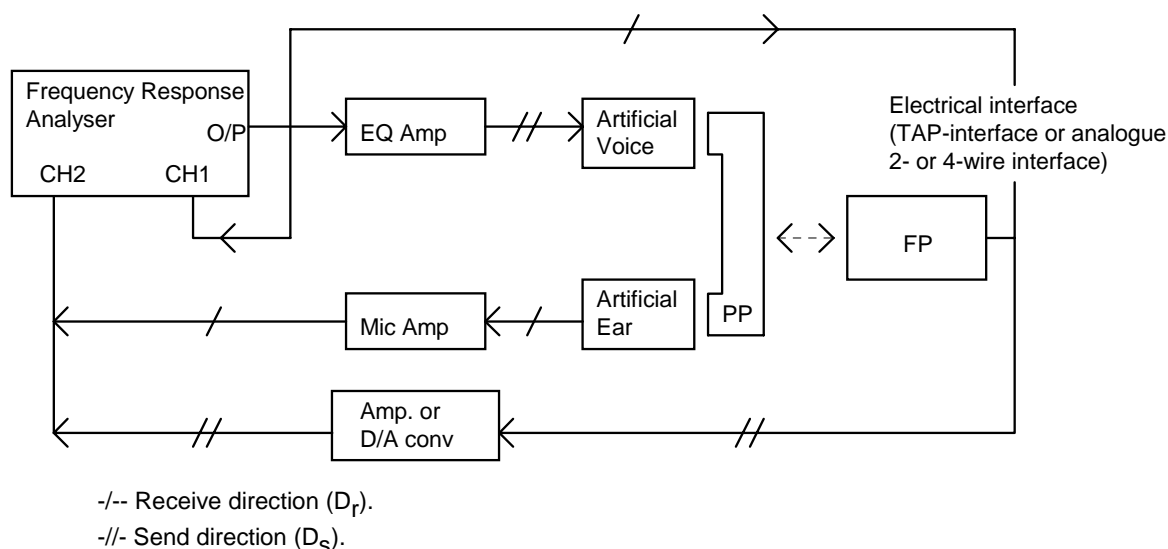

Figure 9: DECT network delay test configuration

The delay shall be measured alternatively:

- a) by the cross-correlation method as described in annex C;
- b) by the method based on group delay.

For each of the nominal frequencies (f_0) given in table 9 in turn, the delay at each value of f_0 shall be derived from the measurements at the corresponding values of f_1 and f_2 .

Table 9: Frequencies for delay measurement

f_0 (Hz)	f_1 (Hz)	f_2 (Hz)
500	495	505
630	625	635
800	795	805
1 000	995	1 005
1 250	1 245	1 255
1 600	1 595	1 605
2 000	1 995	2 005
2 500	2 495	2 505

For each value of f_0 , the delay shall be evaluated as follows:

- 1) output the frequency f_1 from the frequency response analyser;
- 2) measure the phase shift in degrees between CH1 and CH2 (P_1);
- 3) output the frequency f_2 from the frequency response analyser;
- 4) measure the phase shift in degrees between CH1 and CH2 (P_2);
- 5) compute the delay in milliseconds using the formula:

$$D = [-1\,000 \times (P_1 - P_2)] / [360 \times (f_1 - f_2)]$$

The measured phases P_2 and P_1 shall be used as original values. It is possible to have negative values at individual frequencies. Care shall be taken that this real effect is not confused with measurement effects caused by passing 360° .

The delay introduced by the artificial mouth shall be measured by mounting the artificial ear microphone at the MRP. The delay of all additional test equipment D_e shall be determined using the procedures described above.

The delay of the item under test shall be deduced from the formula:

$$D = D_s + D_r - D_e$$

- 6) the network delay (PP and FP combined) shall be the mean value of the 8 measured delay values of D .

7.28 PP delay

This test shall only apply when testing a separate PP.

7.28.1 Requirement

The sum of the delays from the MRP to the air interface and from the air interface to the ERP (round-trip delay) shall not exceed 14,5 ms.

7.28.2 Method of measurement

A ReFP with a known 2-way delay D_{ReFP} between the air interface and the digital line interface shall be used. The PP shall be mounted at LRGP. The earpiece shall be sealed to the knife-edge of the artificial ear. The delay in send and receive directions shall be measured separately from MRP to the digital interface (D_s) and from the digital interface to ERP (D_r). The acoustic input level shall be 4,7 dBPa. The level of the input signal at the electrical interface shall be adjusted to give -10 dBm0 at the TAP-reference point.

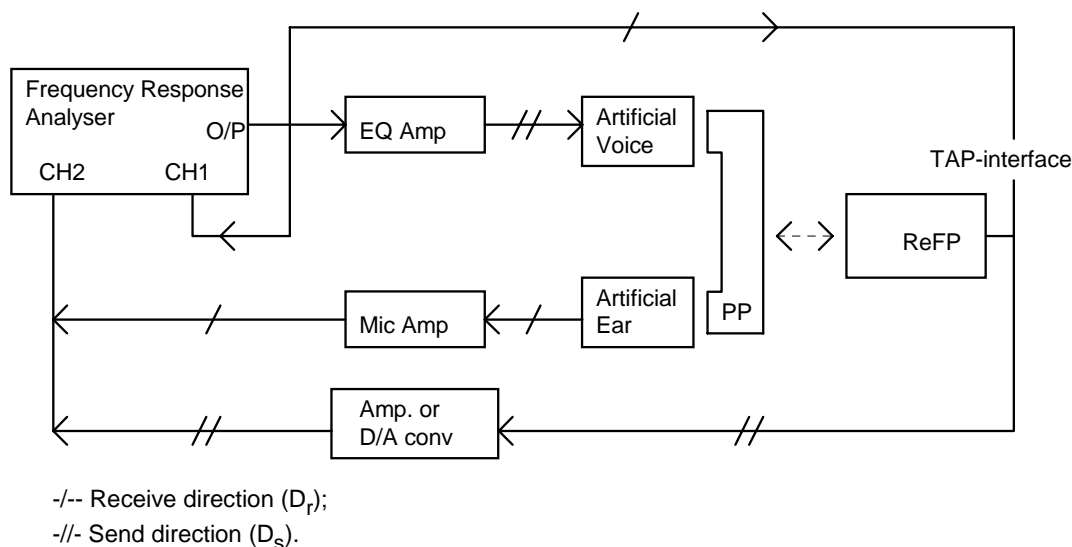

Figure 10: PP delay test configuration

The delay shall be measured alternatively:

- by the cross-correlation method as described in annex C;
- by the method based on group delay.

For each of the nominal frequencies (f_0) given in table 9 in turn, the delay at each value of f_0 shall be derived from the measurements at the corresponding values of f_1 and f_2 .

For each value of f_0 , the delay shall be evaluated as follows:

- 1) output the frequency f_1 from the frequency response analyser;
- 2) measure the phase shift in degrees between CH1 and CH2 (P_1);
- 3) output the frequency f_2 from the frequency response analyser;
- 4) measure the phase shift in degrees between CH1 and CH2 (P_2);
- 5) compute the delay in milliseconds using the formula:

$$D = [-1\ 000 \times (P_1 - P_2)] / [360 \times (f_1 - f_2)]$$

The measured phases P_2 and P_1 shall be used as original values. It is possible to have negative values at individual frequencies. Care shall be taken that this real effect is not confused with measurement effects caused by passing 360° .

The delay introduced by the artificial mouth shall be measured by mounting the artificial ear microphone at the MRP. The delay of all additional test equipment D_e shall be determined using the procedures described above.

The delay of the item under test shall be deduced from the formula:

$$D = D_s + D_r - D_e - D_{ReFP}$$

- 6) the PP delay shall be the mean value of the 8 measured delay values of D .

7.29 FP delay

This test shall apply when testing a separate FP.

7.29.1 Requirement

The sum of the delays from the electrical line interface to the air interface and from the air interface to the electrical line interface (round-trip delay) shall not exceed 15 ms for a digital line interface. If an analogue line interface is provided the delay shall not exceed 15,5 ms.

7.29.2 Method of measurement

A RePP with a known 2-way delay D_{RePP} between the air interface and the acoustical interface shall be used. The PP shall be mounted at LRGP. The earpiece shall be sealed to the knife-edge of the artificial ear. The delay in send and receive direction shall be measured separately from MRP to the electrical interface (D_s) and from electrical to ERP (D_r). The acoustic input level shall be -4,7 dBPa. The level of the input signal at the electrical interface shall be adjusted to give -10 dBm0 at the TAP-reference point.

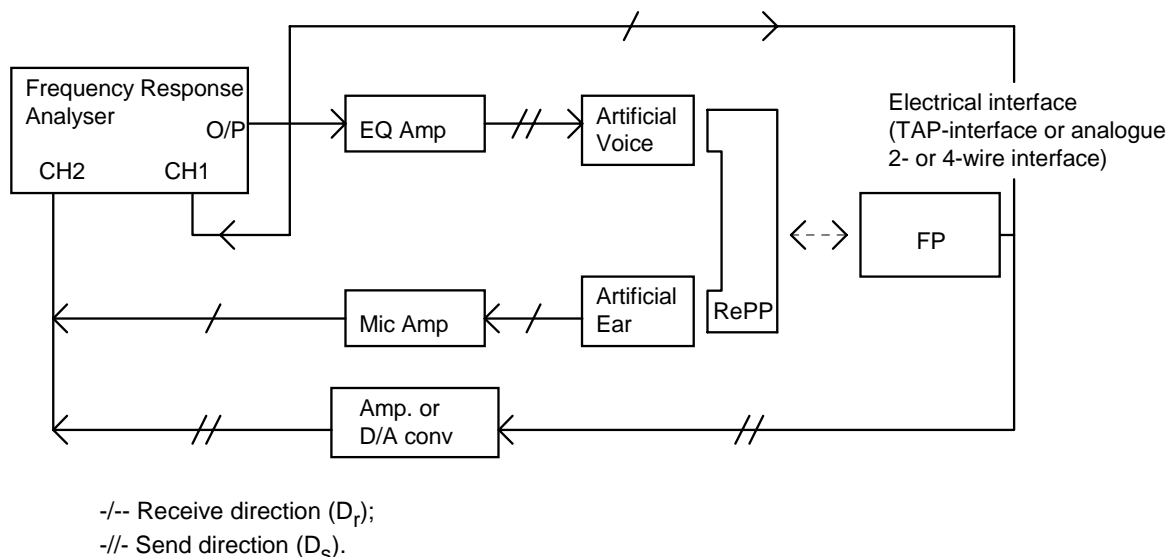

Figure 11: FP delay test configuration

The delay shall be measured alternatively:

- a) by the cross-correlation method as described in annex C;
- b) by the method based on group delay.

For each of the nominal frequencies (f_0) given in the table 9 in turn, the delay at each value of f_0 shall be derived from the measurements at the corresponding values of f_1 and f_2 .

For each value of f_0 , the delay shall be evaluated as follows:

- 1) output the frequency f_1 from the frequency response analyser;
- 2) measure the phase shift in degrees between CH1 and CH2 (P_1);
- 3) output the frequency f_2 from the frequency response analyser;
- 4) measure the phase shift in degrees between CH1 and CH2 (P_2);
- 5) compute the delay in milliseconds using the formula:

$$D = [-1\ 000 \times (P_1 - P_2)] / [360 \times (f_1 - f_2)]$$

The measured phases P_2 and P_1 shall be used as original values. It is possible to have negative values at individual frequencies. Care shall be taken that this real effect is not confused with measurement effects caused by passing 360° .

The delay introduced by the artificial mouth shall be measured by mounting the artificial ear microphone at the MRP. The delay of all additional test equipment D_e shall be determined using the procedures described above.

The delay of the item under test shall be deduced from the formula:

$$D = D_s + D_r - D_e - D_{ReFP}$$

- 6) the FP delay shall be the mean value of the 8 measured delay values of D .

7.30 Echo control at the network side

7.30.1 Requirement

The network echo shall be controlled by inserting into the receiving speech path of the FP an echo loss meeting the requirements as defined in table 10.

Table 10: Network echo control requirements

Echo path delay (2-way)	
Requirement 1: 0 ms to 4 ms	TELR \geq 24 dB
Requirement 2: 0 ms to 60 ms	Extra echo loss \geq 9 dB

Requirement 1 applies only to FP with an analogue 2-wire line interface. Requirement 2 applies for both 2 and 4-wire line interfaces. If the echo control device in the FP contains a soft suppresser, it is recommended not to suppress more than 12 dB.

The 24 dB TELR limit applies for a PP with nominal values for SLR_H and RLR_H ($SLR_H = 7$ dB, $RLR_H = 3$ dB) and it corresponds to $LL_e = 24 - 7 - 3 = 14$ dB at the TAP. This requirement shall be met when the FP is terminated with the three terminating impedances, a, b and c, defined in TBR 038 [27], clause A.2.3. Depending on routing information, on type of service and manually by the user, it may be possible to connect and disable each of the echo control functions which perform the respective requirements 1 and 2.

7.30.2 Method of measurement

It shall be possible to disable every echo control function implemented in the FP. During this test, the echo control device specified in EN 300 175-8 [8], clause 7.4.1.2b) shall be disabled. The applicant shall declare to the test laboratory, how this shall be done.

The test method Composite Source Signal (CSS) as described in detail in the ITU-T Recommendation P.51 [21] and reported in annex B may be used as an alternative to the test method specified below.

7.30.2.1 4-wire interface

A signal source shall be connected to the input and a level meter to the output of the TAP interface of the RePP (see figure 12). The source shall deliver a digital signal at a level of $L_{in} = -20$ dBm0 derived from the ITU-T Recommendation P.50 [20] assuming a flat sending frequency response of the RePP.

The TAP interface of the FP shall be connected to a delay circuit. The signal shall be looped back to provide an echo. The attenuator shall be adjusted to give a local echo loss, LL_e of 15 dB at the RePP, when the network echo control of the FP is disabled.

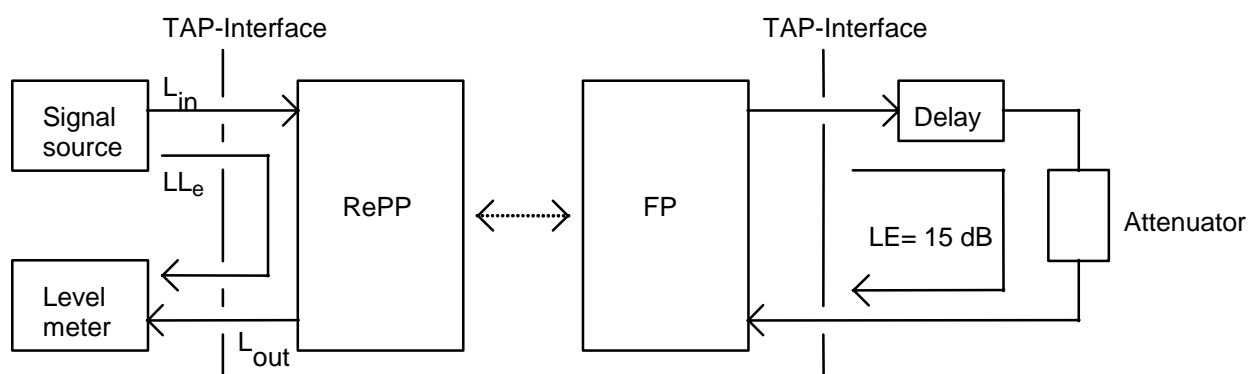

Figure 12: FP with 4-wire interface

With the network echo control enabled, the output level L_{out} shall be measured at the delays 0, 20 and 60 ms. Five measurements shall be made at each delay and the mean value shall be determined. The input signal shall be applied for more than 2 seconds before measuring. The LL_e at the TAP interface of the RePP shall be at least

$15 \text{ dB} + 9 \text{ dB} = 24 \text{ dB}$. All echo values shall be calculated according to ITU-T Recommendation G.122 [13]. If no RePP is available for testing, a suitable accessible PCM reference point in the FP may be used if such a point is not accessible in the PP. If such a point is not accessible in the PP or FP, the PP shall be placed in the LRGP with its sidetone path disconnected and the artificial voice shall be applied at the MRP. The input signal levels shall be adjusted to correspond to the levels specified for the TAP-interface of the RePP corresponding with $SLR_H = 7 \text{ dB}$. Talker Echo Loudness Rating (TELR), shall be measured instead of the LL_e at the RePP. TELR shall be at least $15 \text{ dB} + 9 \text{ dB} + 7 \text{ dB} + 3 \text{ dB} = 34 \text{ dB}$ when corrected to nominal values of SLR_H and RLR_H ($SLR_H = 7 \text{ dB}$, $RLR_H = 3 \text{ dB}$).

7.30.2.2 Analogue 2-wire interface

The DECT system consisting of the FP EUT and the RePP shall meet the SLR and RLR requirements for a 2-wire PSTN interface in clause 7.33 with a RePP having $SLR_H = 7 \text{ dB}$ and $RLR_H = 3 \text{ dB}$.

7.30.2.2.1 Requirement 1

The measurement shall be made with the time dispersion inherent in the 2-4 wire hybrid circuit with the terminating impedance Z_R . The applicant shall declare that the control range of the echo control device is not less than 4 ms.

A signal source shall be connected to the input and a level meter to the output of the TAP interface of the RePP (see figure 13a). The source shall deliver a digital signal at a level of $L_{in} = -20 \text{ dBm0}$ derived from the ITU-T Recommendation P.50 [20] assuming a flat sending frequency response of the RePP.

The 2-wire interface of the FP shall be terminated by the impedance Z_R (see figure 13b). The extra echo loss of requirement 2 (see table 10) shall be set to the lowest value that can be selected according to routing information.

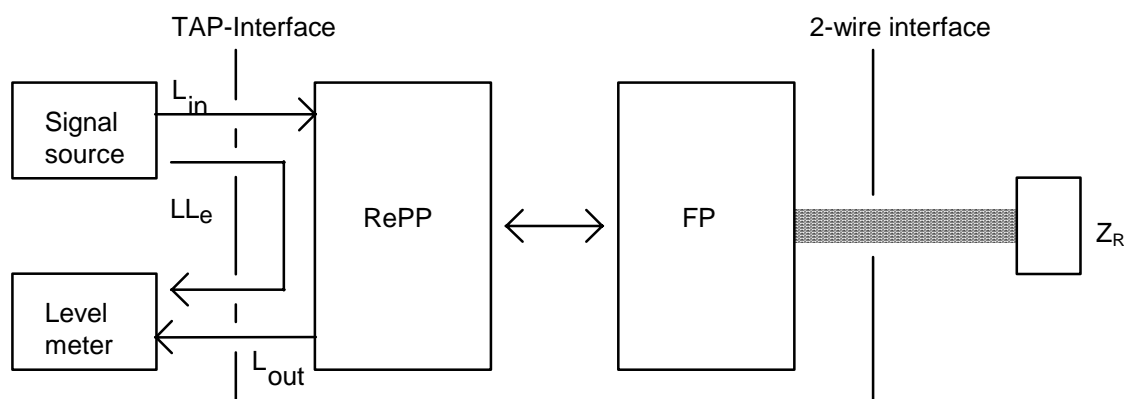

Figure 13a: FP with analogue 2-wire interface

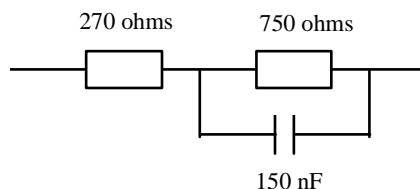

Figure 13b: Terminating impedance Z_R

Five measurements shall be made of L_{out} and the mean value shall be determined. The input signal shall be applied for at least 2 seconds before measuring. The local echo loss, LL_e shall be at least 14 dB (which corresponds to $TELR > 24 \text{ dB}$ assuming nominal values of SLR_H and RLR_H). All echo values shall be calculated according to ITU-T Recommendation G.122 [13].

The tests shall be repeated with Z_R replaced by each of the two terminating impedances, a and c, defined in TBR 038 [27], clause A.2.3.

If no RePP is available for testing, a suitable accessible PCM reference point in the FP may be used, if such a point is not accessible in the PP. If such a point is not accessible in the PP or FP, the PP shall be placed in the LRGP with its sidetone disconnected and white noise shall be applied at the MRP. The input signal levels shall be adjusted to correspond to the levels specified for the TAP-interface of the RePP assuming that $SLR_H = 7$ dB. TELR shall be measured instead of the LLe at the RePP. TELR shall be at least 14 dB + 7 dB + 3 dB = 24 dB when corrected to nominal values of SLR_H and RLR_H ($SLR_H = 7$ dB, $RLR_H = 3$ dB).

7.30.2.2.2 Requirement 2

If the option is available to reduce or disable the extra echo loss for requirement 2 (see table 10) depending upon routing information the applicant shall declare to the test laboratory how this is done.

A signal source shall be connected to the input and a level meter to the output of the TAP interface of the RePP (see figure 14). The source shall deliver a digital signal at a level of $L_{in} = -20$ dBm0 derived from the ITU-T Recommendation P.50 [20] assuming a flat sending frequency response of the RePP.

The 2-wire interface of the FP shall be connected to a 2-wire to 4-wire hybrid circuit with a nominal input impedance Z_R (see figure 13b). The 4-wire side of the hybrid shall be connected to a circuit providing 60 ms delay. The signal shall be looped back to provide an echo. The attenuator shall be adjusted to give a local echo loss, LLe of 15 dB at the RePP when the echo control functions of the FP are disabled.

The echo control functions for requirements 1 and 2 are reactivated. The output level L_{out} shall be measured five times and the mean value shall be determined. The input signal L_{in} , shall be applied for at least 2 seconds before is measuring. L_{out} shall be measured during a time window of 20 ms to 60 ms from the switch-off time of the input L_{in} . L_{in} shall be below -50 dBm0, 10 ms after the switch-off time.

The LL_e shall be at least 24 dB. The LLe shall be calculated according to ITU-T Recommendation G.122 [13].

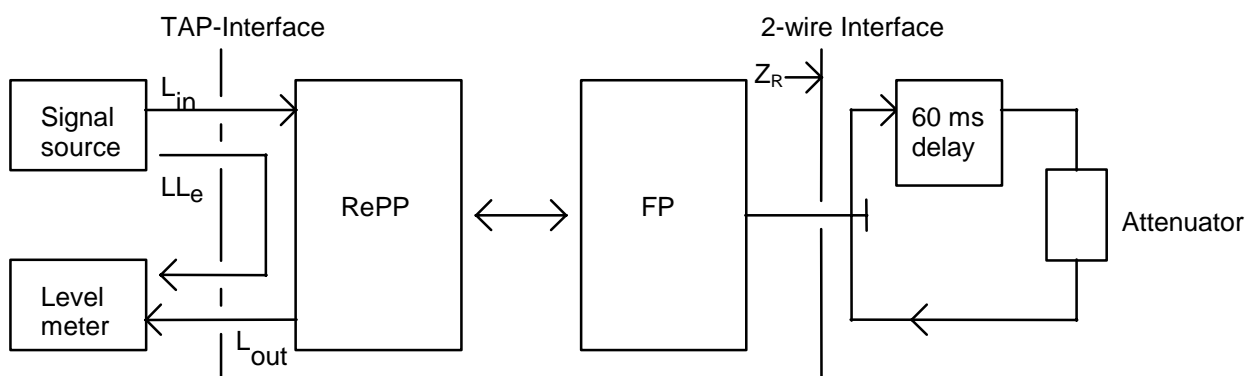

Figure 14: FP with analogue 2-wire interface

If a RePP is not available for testing, a suitable accessible PCM reference point in the FP may be used if such a point is not accessible in the PP. If such a point is not accessible in the PP or FP, the PP shall be placed in the LRGP with its sidetone disconnected and white noise shall be applied at the MRP. The input signal levels shall be adjusted to correspond to the levels specified for the TAP-interface of the RePP corresponding with $SLR_H = 7$ dB. TELR shall be measured instead of the LLe of the RePP. TELR shall be at least 24 dB + 7 dB + 3 dB = 34 dB when corrected to nominal values of SLR_H and RLR_H ($SLR_H = 7$ dB, $RLR_H = 3$ dB).

7.31 Variation of gain with input level-sending

7.31.1 Requirement

The gain variation relative to the gain for ARL shall remain within the limits given in table 11.

Table 11: Variation of gain with input level, sending

Sending dB relative to ARL	Upper limit (dB)	Lower limit (dB)
+13	1	-11
	1	note
+4	1	-2
-30	1	-2
-30	1	-infinity
-40	1	
-45	6	

NOTE: The limits for intermediate levels can be found by drawing straight lines between the breaking points in the table on a linear (dB signal level) - linear (dB gain) scale.

7.31.2 Method of measurement

The handset shall be mounted at LRGP and the earpiece shall be sealed to the knife-edge of the artificial ear.

A sine-wave signal with a frequency in the range 1 004 Hz to 1 025 Hz shall be applied at the MRP. The level of this signal shall be adjusted until the output of the terminal is -10 dBm0. The level of the signal at the MRP is then the ARL.

The test signal shall be applied at the following levels:

-45, -40, -35, -30, -25, -20, -15, -10, -5, 0, 5, 10, 13 dB relative to ARL.

The variation of gain relative to the gain for ARL shall be measured.

NOTE: Selective measurement may be used to avoid the effects of ambient noise.

For FPs having an echo control device (see clause 7.14.4) and are being tested as part of a DECT system where not all PPs have $TCL_w > 46$ dB (see clause 7.13), the measurement shall be performed with the echo control device disabled. The FP shall incorporate the means to disable the echo control device for this measurement.

7.32 Variation of gain with input level-receiving

7.32.1 Requirement

The gain variation relative to the gain at an input level of -10 dBm0, shall be within the limits given in table 12.

Table 12: Variation of gain with input level, receiving

Receiving level at the digital interface	Upper limit (dB)	Lower limit (dB)
+3 dBm0	1	-11
	1	note
-6 dBm0	1	-2
-50 dBm0	1	-2
-50 dBm0	1	-infinity

NOTE: The limits for intermediate levels can be found by drawing straight lines between the breaking points in the table on a linear (dB signal level) - linear (dB gain) scale.

7.32.2 Method of measurement

The handset shall be mounted at LRGP and the earpiece shall be sealed to the knife-edge of the artificial ear.

A digitally simulated sine-wave signal with a frequency in the range 1 004 Hz to 1 025 Hz shall be applied at the digital interface at the following levels:

-50, -45, -40, -35, -30, -25, -20, -15, -10, -5, 0, 3 dBm0.

The variation of gain relative to the gain at an input level of -10 dBm0 shall be measured in the artificial ear.

NOTE: Selective measurement may be used to avoid the effects of ambient noise.

7.33 Additional requirements for DECT systems provided with a 2-wire PSTN interface

The following additional requirements and test principles apply for complete systems or for a separate FP, when the DECT FP is provided with a 2-wire PSTN interface.

These additional requirements and test methods are based on TBR 038 [27] with necessary deviations justified from the following:

- Any additional provision to meet these additional requirements shall be accommodated within the FP;
- mandatory tests already performed at the 4-wire TAP interface;
- requirements justified by the basic principles of the DECT standard including the digital radio link, the additional delay introduced and the use of small light weight portable handsets.

When testing a separate FP, the tests shall be carried out on the EUT FP in conjunction with a RePP meeting the applicable speech performance characteristics. The RePP shall have nominal values of SLR_H and RLR_H ($SLR_H = 7$ dB, $RLR_H = 3$ dB), or else, the acceptance criteria of the requirements below shall be adjusted according to the deviations from nominal values.

When testing a complete DECT system, the user-controlled volume control provided at the PP, shall be set as close as possible to the nominal value of SLR_H and RLR_H , unless otherwise stated.

7.33.1 General

7.33.1.1 Polarity independence

The requirements and associated test methods of clause 4.1.1 of TBR 038 [27] shall apply.

7.33.1.2 Feed Conditions

The requirements and associated test methods of clause 4.1.2 of TBR 038 [27] shall apply.

7.33.1.3 Power supply

The requirements and associated test methods of clause 4.1.3 of TBR 038 [27] shall apply.

7.33.1.4 Volume control

No additional requirements apply.

The requirements on volume control setting during the compliance tests are covered by the introductory text of clause 7.33. No additional test corresponding to clause 4.1.4 of TBR 038 [27] shall apply. Accuracy requirement of volume control setting is covered by tests of clause 7.9, where the implicit requirement is that a setting shall be found so the loudness rating requirements for the handset are met.

7.33.2 Speech performance characteristics

The test laboratory shall perform the tests in such a way, that the results are not affected by the delay in the DECT radio interface, nor by improper activation of the DECT echo control functions. The DECT echo control functions may be disabled during the tests.

7.33.2.1 Sensitivity/frequency response

The test methods of clause 4.2.1 of TBR 038 [27] shall apply.

The sensitivity curves from clauses 7.7 and 7.8 shall be used.

7.33.2.2 Sending and Receiving Loudness Ratings (SLR and RLR)

The requirements and associated test methods of clause 4.2.2 of TBR 038 [27] shall apply, except that the RLR acceptance criteria shall be $-8 \text{ dB} + 7 \text{ dB} / -4 \text{ dB}$ for feeding resistance R_f set to $2\ 800 \ \Omega$, $1\ 000 \ \Omega$ and $500 \ \Omega$.

NOTE: The basic DECT requirements (echo control, signal levels for A/D converters etc.) are optimized for digital (ISDN) transmission characteristics. Analogue transmissions over a modern network (from equipment using TBR 038 [27] values of SLR and RLR) often provide higher receive levels than a digital (ISDN) connection would. Therefore, noting that DECT PPs have a volume control with at least 6 dB gain, it should be allowed to design DECT FP equipment with a receive gain providing typical nominal RLR around -4 dB . This implies for this example that the gain from the 2-wire interface to the EUT FP TAP interface should be $3 \text{ dB} - (-4 \text{ dB}) = 7 \text{ dB}$.

7.33.2.3 Sidetone

No additional requirements apply. Corresponding requirements of clause 4.2.3 of TBR 038 [27] are met by the mandatory tests of clauses 7.11 (sidetone path available in the PP) and 7.30.2.2.1 (delayed sidetone from the 4-wire/2-wire hybrid).

7.33.2.4 Distortion

The requirements and associated test methods of clause 4.2.4 of TBR 038 [27] shall apply, except that the test with input e.m.f. of 0 dBV in clause 4.2.4.2 of TBR 038 [27] shall be deleted.

NOTE: The 0 dBV level is too high and is not applicable to a digital system like DECT.

7.33.2.5 Linearity (variation of gain with input level)

No additional requirements apply. Corresponding requirements of clause 4.2.5 of TBR 038 [27] are met by the mandatory more strict tests of clauses 7.31 and 7.32.

7.33.2.6 Noise

The requirements and associated test methods of clause 4.2.6 of TBR 038 [27] shall apply, except in the test of clause 4.2.6.1 of TBR 038 [27], where the noise acceptance criteria shall be -60 dBVp for feeding resistance R_f set to $2\ 800 \ \Omega$, $1\ 000 \ \Omega$ and $500 \ \Omega$.

NOTE: The requirement has to be consistent with the requirement of clause 7.22 for a digital system like DECT.

7.33.2.7 Instability

No additional requirements apply. Corresponding requirements of clause 4.2.7 of TBR 038 [27] are met by the mandatory tests of clause 7.15.

7.33.2.8 Echo return loss

The requirements and associated test methods of clause 4.2.8 of TBR 038 [27] shall apply.

8 Loudspeaking and handsfree telephony

Loudspeaking and handsfree telephony may each optionally be provided. Speech performance requirements for these additional facilities are outside the scope of the present document.

If loudspeaking and/or handsfree telephony is implemented in telephony 3,1 kHz terminals, the terminals in handset mode shall fulfil the speech transmission requirements of clause 7.

Annex A (informative): Justification for Requirements

For information, the table A.1 shows the EN Requirements Table.

The EN Requirements Table (EN-RT) serves a number of purposes, as follows:

- it provides a tabular summary of all the requirements;
- it shows the status of each EN-R, whether it is essential to implement in all circumstances (Mandatory), or whether the requirement is dependent on the supplier having chosen to support a particular optional service or functionality (Optional). In particular it enables the EN-Rs associated with a particular optional service or functionality to be grouped and identified;
- when completed in respect of a particular equipment it provides a means to undertake the static assessment of conformity with the EN.

Table A.1: EN Requirements Table (EN-RT)

EN Reference		EN 300 176-2					
Test case No.	Clause number	EN-R (see key)	Status			Support (Y/N)	Comments
			PP	FP	System		
R.1	7.6	Speech coding scheme	M	M	M		
R.2	7.7	PP sending frequency response	M		M		
R.3	7.8	PP receiving frequency response	M		M		
R.4	7.9	PP loudness rating	M		M		
R.5	7.10	User controlled volume control in the PP	M		M		
R.6	7.11	PP talker sidetone masking rating	M		M		
R.7	7.12	Listener SideTone (LST)	O		O		
R.8	7.13	Terminal Coupling Loss (TCLw) of a PP	M		M		
R.9	7.14	FP echo control functions with a 4-wire interface		M	M		
R.10	7.15	Stability loss - fixed geometry	M		M		
R.11	7.16	Stability loss variable geometry	M		M		
R.12	7.17	Sending distortion	M		M		
R.13	7.18	Receiving distortion	M		M		
R.14	7.19	Side tone distortion	M		M		
R.15	7.20	Out of band (sending)	M		M		
R.16	7.21	Out of band (receiving)	M		M		
R.17	7.22	Sending noise	M		M		
R.18	7.23	Sending noise (narrow band)	M		M		
R.19	7.24	Receiving noise	M		M		
R.20	7.25	Sampling frequency level (receiving)	M		M		
R.21	7.26	Acoustic shock					
R.22	7.27	DECT network delay			M		
R.23	7.28	PP delay	M				
R.24	7.29	FP delay		M			
R.25	7.30	Echo control at the network side		M	M		
R.26	7.31	Variation of gain with input level-sending	M		M		

EN Reference		EN 300 176-2					
Test case No.	Clause number	EN-R (see key)	Status			Support (Y/N)	Comments
			PP	FP	System		
R.27	7.32	Variation of gain with input level-receiving	M		M		
R.28	7.33	2-wire interface test		M	M		

Table A.2 provides a detailed listing of the test cases contained in test case R.28 of table A.1.

Table A.2: EN Requirements Table (EN-RT) for test case R.28 of table A.1

EN Reference		EN 300 176-2					
Test case No.	Clause number	EN-R (see key)	Status			Support (Y/N)	Comments
			PP	FP	System		
R.28.1	7.33.1.1	Polarity independence		M	M		
R.28.2	7.33.1.2	Feeding Conditions		M	M		
R.28.3	7.33.1.3	Power Supply		M	M		
R.28.4	7.33.2.1	Sensitivity/frequency response		M	M		
R.28.5	7.33.2.2	Sending and Receiving Loudness Rating		M	M		
R.28.6	7.33.2.4	Distortion		M	M		
R.28.7	7.33.2.6	Noise		M	M		
R.28.8	7.33.2.8	Echo Return Loss		M	M		

Key to columns:

No Table entry number;

Reference Clause reference number of conformance requirement within the present document;

EN-R Title of conformance requirement within the present document;

Status Status of the entry as follows:

M: Mandatory, shall be implemented under all circumstances;

O: Optional, may be provided, but if provided shall be implemented in accordance with the requirements;

O.n: this status is used for mutually exclusive or selectable options among a set. The integer "n" shall refer to a unique group of options within the EN-RT. A footnote to the EN-RT shall explicitly state what the requirement is for each numbered group. For example, "It is mandatory to support at least one of these options", or, "It is mandatory to support exactly one of these options".

Comments To be completed as required.

Annex B (informative): Description of the CSS

B.1 General

The Composite Source Signal is composed as a time multiplex of at least three signal sources with a:

- voiced signal to simulate voice properties for a certain activation of the transfer function;
- deterministic signal for measuring the transfer function;
- pause "signal" providing amplitude modulation.

The CSS is described in detail in ITU-T Recommendation P.51 [21] and specified in annex B of I-ETS 300 245-3 [30].

For the measurement of a DECT system the PP shall be placed in the LRGP and the test signal of the CSS shall be applied at the MRP with a level of -4,7 dBPa. For the measurement of the FP the test signal of the CSS shall be applied at the TAP of the RePP or the PP with a level of -10 dBm0. Only one measurement shall be made.

B.2 Test signal

The test signal with the characteristic as described below is applied to the input Lin at the RePP (figure 12). The measurement starts on the output Lout of the RePP (figure 12) 28 ms after the starting of the periodical white noise. The duty cycle of the measurement shall be identical with the duty cycle of the periodical white noise.

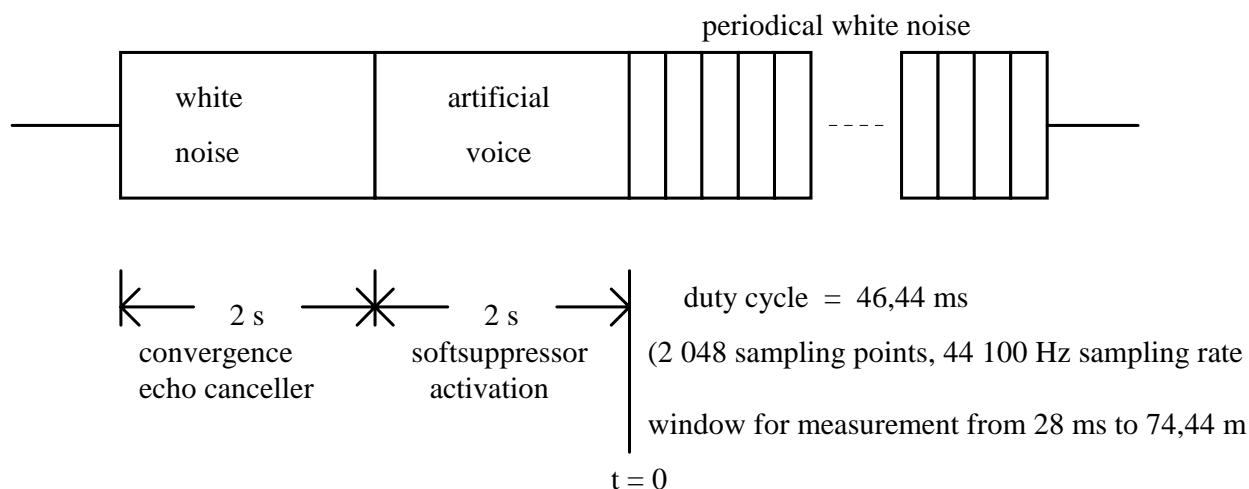

Figure B.1

Artificial voice: according to ITU-T Recommendation P.50 [20] white noise band limited 100 Hz to 10 kHz.

Table B.1

Upper limit		Lower limit	
45 Hz	-36 dB	< 100 Hz	-∞ dB
90 Hz	-21 dB	100 Hz	-26,5 dB
		200 Hz	-19,5 dB
		5 000 Hz	-5,5 dB
11 200 Hz	0 dB	10 000 Hz	-6,5 dB
22 400 Hz		> 10 000 Hz	-∞ dB

B.3 Measurement

Care should be taken for the sampling of L_{in} and L_{out} with an identical starting. The transfer function from L_{in} to L_{out} is determined by the levels P_{out} and P_{in} (at L_{out} and L_{in} respectively):

$$S_{io} = 20 \log_{10} \left(\frac{P_{out}}{P_{in}} \right) \quad (B.1)$$

For the determination of the transfer function an identical part of the recorded signals L_{in} and L_{out} shall be cut out (window). The time period of the window shall be identical with the time period of the white noise. For the certain receive measurement of the reflected signal the window shall start after a time period which is greater than the delay of the echo path (delay of the window).

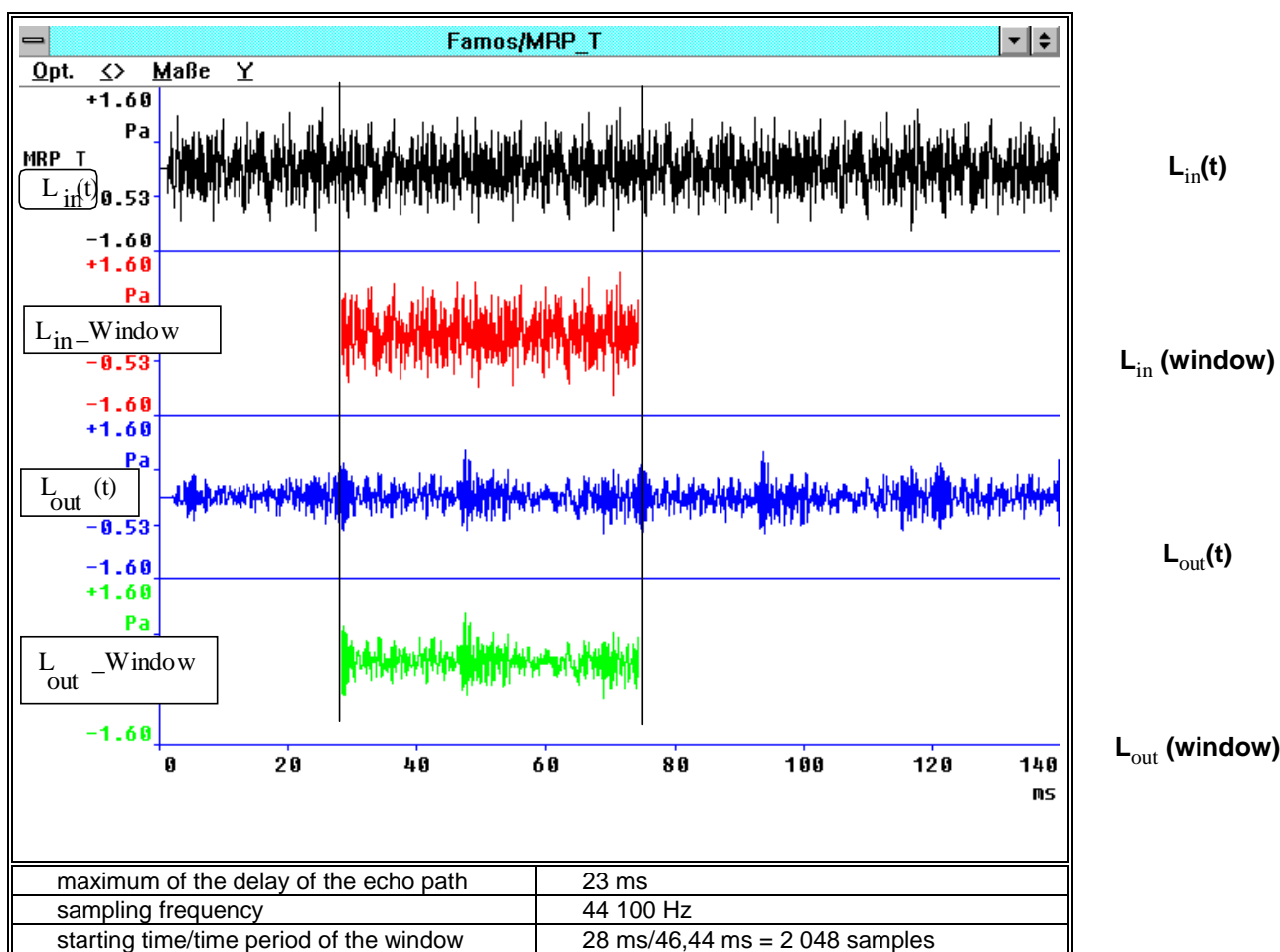

Figure B.2

B.4 Calculation

The cut signals shall be used for the calculation of the sensitivity S_{io} by application of the Fast Fourier Transformation (FFT):

$S_{io} = \text{FFT}[L_{outwindow}]/\text{FFT}[L_{inwindow}]$ for the window length of the FFT = time period of the test signal.

The time period of the window shall be applied to the FFT for the calculation to assure that all parts of the period of the test signal are used.

According to the applied bandwidth for the calculation of the Echo Loss the calculated sensitivity S_{io} shall be corrected at the upper and the lower frequency range. The values of the modulus and the phase (imaginary part) shall be reset ($-\infty$ dB) for frequencies < 200 Hz and $> 4\,000$ Hz.

$$S_{io_{corrected}} = S_{io} \Big|_{200 \text{ Hz to } 4\,000 \text{ Hz, other values equal to } 0} \quad (\text{B.2})$$

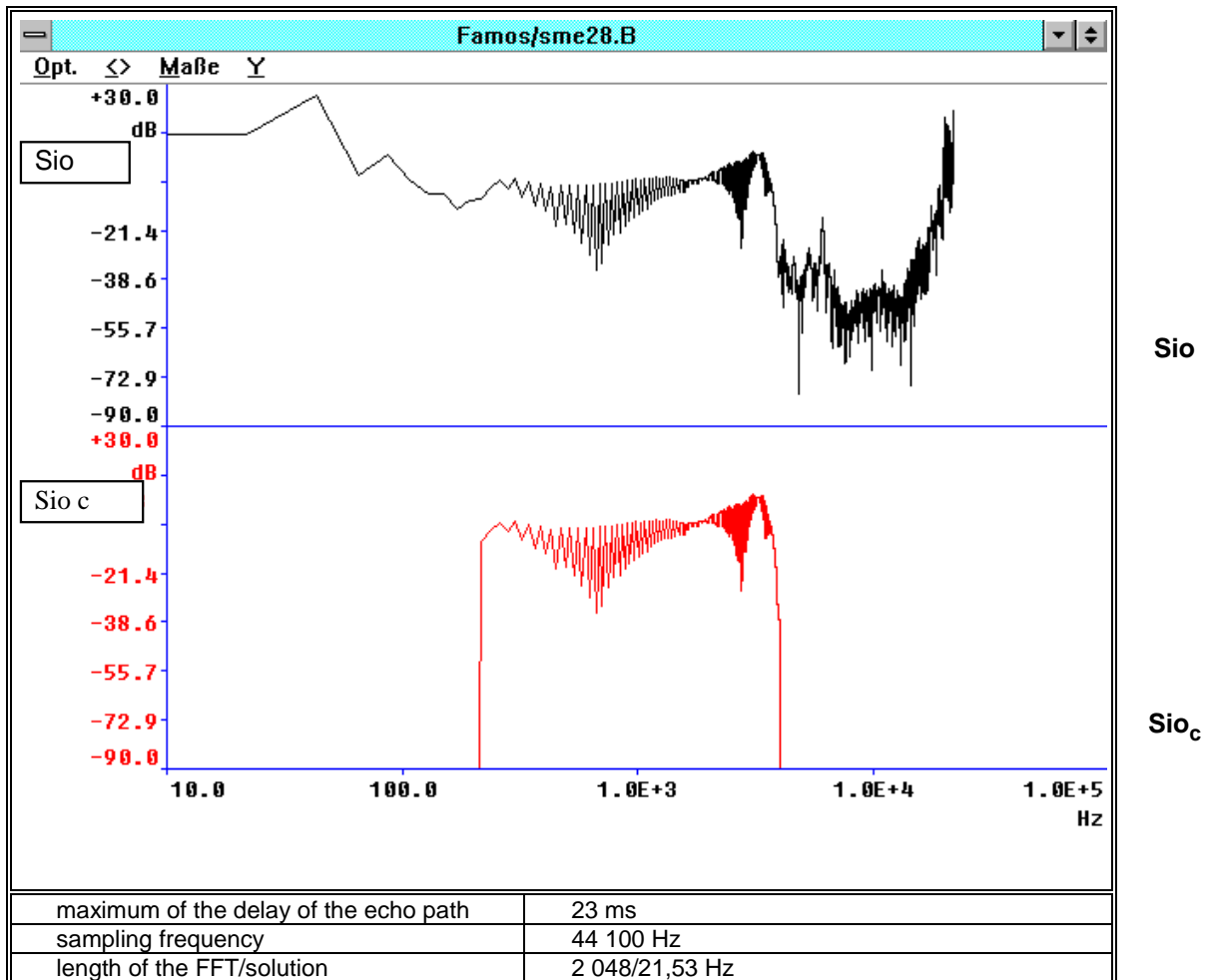

Figure B.3

The Inverse Fourier Transformation applied to the corrected transfer function S_{io_c} provides the impulse response at the time domain:

$$Im_{\text{impulse response}} = \text{iFFT}(S_{io_c}) \quad (\text{B.3})$$

The impulse response demonstrates clearly the different delays for the echo and the sidetone:

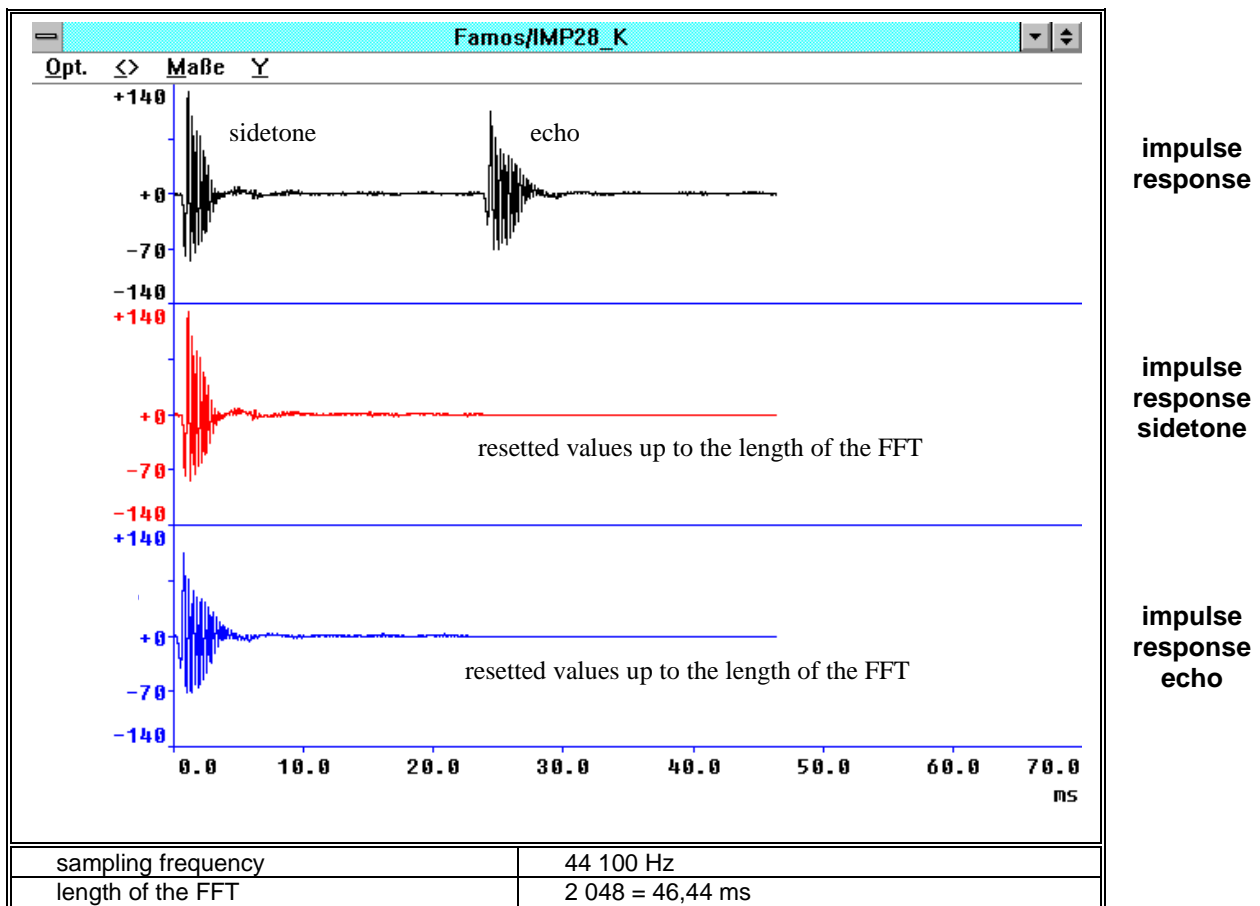

Figure B.4

The separation at the time of the echo and the sidetone at the L_{out} are possible by use of windows at the impulse response. The windows shall overlap completely the relevant time period for the specific part of the impulse response which will be considered.

The separation of this part which corresponds to the echo by use of a special window results to a new specific echo impulse response. For the further use of this new signal the echo impulse response shall be completed by adding zeroes for this time period where the sidetone was extracted. The calculation of the echo transfer function at the frequency domain is provided by the Fourier Transformation about a rectangular window at the echo impulse response.

$$S_{io_echo} = \text{FFT}(\text{Im}_{\text{impulse response sidetone}}) \Big|_{\text{rectangular window}} \quad (\text{B.4})$$

Annex C (normative): Description of the cross-correlation method

C.1 Test signal

The character of the test signal shall be:

- periodical white noise;
- crest factor 11 dB \pm 1 dB;
- time period $T/2 \leq 20$ ms;
- band limitation according to a third octave solution.

Table C.1

Upper limit		Lower limit	
100 Hz	-30 dB		
400 Hz	0 dB		
		500 Hz	-2 dB to $-\infty$
		2 500 Hz	+5 dB to $-\infty$
3 000 Hz	+8,75 dB		
20 000 Hz	-16 dB		
NOTE 1: The limits at intermediate frequencies lie on a straight line drawn between the given values on a logarithmic (Hz) - linear (dB) scale.			
NOTE 2: All dB levels are on an arbitrary scale.			

C.2 Calculation

The cross-correlation function $xy(\tau)$ between the input signal $S_x(t)$ and the output signal $S_y(t)$ is calculated in the time domain:

$$\Phi_{xy}(\tau) = \lim_{T \rightarrow \infty} \frac{1}{T} \int_{-T/2}^{+T/2} S_x(t) S_y(t + \tau) dt \quad (\text{C.1})$$

The measurement window T shall be exactly identical with the time period T of the test signal.

The delay is calculated from the envelope $E(\tau)$ of the cross-correlation function $xy(\tau)$. The maximum of the envelope function occurs in correspondence to the measured delay. The envelope $E(\tau)$ is calculated by the Hilbert transformation $H\{xy(\tau)\}$ of the cross-correlation:

$$H\{xy(\tau)\} = \int_{-\infty}^{+\infty} \frac{\Phi_{xy}(u)}{\pi(\tau-u)} du \quad (\text{C.2})$$

$$E(\tau) = \sqrt{[\Phi_{xy}(\tau)]^2 + \{H[\Phi_{xy}(\tau)]\}^2} \quad (\text{C.3})$$

It is assumed that the measured delay is less than $T/2$. The delay of the test equipment shall be subtracted from the calculated result.

Annex D (informative): Acoustic shock requirements

The prevention of acoustic shock is a safety requirement arising from the Low Voltage Directive [33]. In the absence of any relevant safety standard, a supplier's self-declaration may be based on the following recommendations. The limits advised are based on sound pressure levels measured at ITU-T Recommendation P.57 [22], Type 1 artificial ear. For other types of artificial ears different sound pressure levels may be required.

D.1 Continuous signal

With a digitally encoded signal representing the maximum possible signal at the digital interface, the sound pressure level in the artificial ear should not exceed 24 dBPa_(RMS). Compliance shall be checked by the following test:

- a) the PP is mounted in the LRGP and the earpiece is sealed to the knife-edge of the artificial ear;
- b) a digital signal generator is connected at the digital interface. It is set to deliver the digitally encoded equivalent of a square-wave, with a peak code equal to the maximum code which can be sent over the digital line interface at frequencies in third-octave intervals as given by the R.10 series of preferred numbers in ISO 3 [25] for frequencies from 200 Hz to 4 kHz. For each frequency, the sound pressure level in the artificial ear should be measured.

D.2 Peak signal

The receiving equipment should limit the peak sound pressure in the artificial ear to less than 36 dBPa. Conformance test methods are for further study. Until such methods exist, compliance should be checked by the supplier's declaration of conformance.

Annex E (informative): Bibliography

ETSI EN 300 444: "Digital Enhanced Cordless Telecommunications (DECT); Generic Access Profile (GAP)".

ITU-T Recommendation P.501 (1996): "Test signals for use in telephony".

History

Document history		
Edition 1	October 1992	Publication as I-ETS 300 176
Edition 2	November 1996	Publication as ETS 300 176-2
V1.3.2	June 1999	Publication
V1.4.1	February 2001	Publication
V1.5.0	August 2003	One-step Approval Procedure OAP 20031219: 2003-08-20 to 2003-12-19
V1.5.1	January 2004	Publication