

# ETSI EN 300 132-3 V2.3.1 (2023-01)



**Environmental Engineering (EE);  
Power supply interface at the input of  
Information and Communication Technology (ICT) equipment;  
Part 3: Up to 400 V Direct Current (DC)**

---

**Reference**

REN/EE-02103

---

**Keywords**

environment, interface, power supply

**ETSI**

---

650 Route des Lucioles  
F-06921 Sophia Antipolis Cedex - FRANCE

Tel.: +33 4 92 94 42 00 Fax: +33 4 93 65 47 16

Siret N° 348 623 562 00017 - APE 7112B  
Association à but non lucratif enregistrée à la  
Sous-Préfecture de Grasse (06) N° w061004871

---

**Important notice**

The present document can be downloaded from:

<http://www.etsi.org/standards-search>

The present document may be made available in electronic versions and/or in print. The content of any electronic and/or print versions of the present document shall not be modified without the prior written authorization of ETSI. In case of any existing or perceived difference in contents between such versions and/or in print, the prevailing version of an ETSI deliverable is the one made publicly available in PDF format at [www.etsi.org/deliver](http://www.etsi.org/deliver).

Users of the present document should be aware that the document may be subject to revision or change of status.

Information on the current status of this and other ETSI documents is available at

<https://portal.etsi.org/TB/ETSIDeliverableStatus.aspx>

If you find errors in the present document, please send your comment to one of the following services:

<https://portal.etsi.org/People/CommitteeSupportStaff.aspx>

If you find a security vulnerability in the present document, please report it through our  
Coordinated Vulnerability Disclosure Program:

<https://www.etsi.org/standards/coordinated-vulnerability-disclosure>

---

**Notice of disclaimer & limitation of liability**

The information provided in the present deliverable is directed solely to professionals who have the appropriate degree of experience to understand and interpret its content in accordance with generally accepted engineering or other professional standard and applicable regulations.

No recommendation as to products and services or vendors is made or should be implied.

In no event shall ETSI be held liable for loss of profits or any other incidental or consequential damages.

Any software contained in this deliverable is provided "AS IS" with no warranties, express or implied, including but not limited to, the warranties of merchantability, fitness for a particular purpose and non-infringement of intellectual property rights and ETSI shall not be held liable in any event for any damages whatsoever (including, without limitation, damages for loss of profits, business interruption, loss of information, or any other pecuniary loss) arising out of or related to the use of or inability to use the software.

---

**Copyright Notification**

No part may be reproduced or utilized in any form or by any means, electronic or mechanical, including photocopying and microfilm except as authorized by written permission of ETSI.

The content of the PDF version shall not be modified without the written authorization of ETSI.

The copyright and the foregoing restriction extend to reproduction in all media.

© ETSI 2023.  
All rights reserved.

# Contents

Intellectual Property Rights .....	5
Foreword.....	5
Modal verbs terminology.....	6
1 Scope .....	7
2 References .....	7
2.1 Normative references .....	7
2.2 Informative references.....	8
3 Definition of terms, symbols and abbreviations.....	8
3.1 Terms.....	8
3.2 Symbols.....	10
3.3 Abbreviations .....	10
4 Power interface "A3" .....	11
5 DC interface requirements.....	11
5.0 General .....	11
5.1 Nominal voltage .....	11
5.2 Normal service voltage range at interface "A3" .....	12
5.3 Normal operating voltage range at interface "A3" .....	12
5.4 Reference test voltage ( $U_T$ ) at interface "A3".....	12
5.5 Abnormal service voltage ranges at interface "A3".....	12
6 Abnormal conditions: Voltage variations, voltage dips, short interruptions and voltage surges at interface "A3" .....	13
6.0 General .....	13
6.1 Voltage variations.....	13
6.2 Voltage dips.....	14
6.3 Short interruptions.....	14
6.4 Voltage surges .....	15
7 DC Supply protection.....	16
8 Maximum steady state current $I_m$ , in the normal service voltage range .....	16
9 Inrush current on connection to interface "A3" .....	17
9.1 Limits .....	17
9.2 Measurements.....	18
10 Installation and Cabling, Earthing and Bonding .....	19
11 Electrical Safety requirements.....	19
12 EMC requirements at the input of ICT equipment.....	20
<b>Annex A (informative): Power supply considerations.....</b>	<b>21</b>
<b>Annex B (informative): Identification of interface "A3" .....</b>	<b>22</b>
<b>Annex C (informative): Calculation of the extreme DC voltage range at interface "A3" .....</b>	<b>23</b>
<b>Annex D (informative): Guide for defining inrush current energy, measuring inrush current and test generator peak inrush current drive capability.....</b>	<b>24</b>
D.0 General .....	24
D.1 Measurement .....	24
D.2 Test generator peak inrush current drive capability .....	25
D.3 Example of inrush current waveform.....	25

<b>Annex E (informative):</b>	<b>Dimensioning of over-current protective devices.....</b>	<b>27</b>
<b>Annex F (informative):</b>	<b>Details of the voltage transient measurement in the most common case of distribution and protective devices .....</b>	<b>28</b>
<b>Annex G (informative):</b>	<b>Diagram of voltage ranges and values at the interface "A3" .....</b>	<b>30</b>
<b>History .....</b>		<b>31</b>

# Intellectual Property Rights

## Essential patents

IPRs essential or potentially essential to normative deliverables may have been declared to ETSI. The declarations pertaining to these essential IPRs, if any, are publicly available for **ETSI members and non-members**, and can be found in ETSI SR 000 314: "*Intellectual Property Rights (IPRs); Essential, or potentially Essential, IPRs notified to ETSI in respect of ETSI standards*", which is available from the ETSI Secretariat. Latest updates are available on the ETSI Web server (<https://ipr.etsi.org/>).

Pursuant to the ETSI Directives including the ETSI IPR Policy, no investigation regarding the essentiality of IPRs, including IPR searches, has been carried out by ETSI. No guarantee can be given as to the existence of other IPRs not referenced in ETSI SR 000 314 (or the updates on the ETSI Web server) which are, or may be, or may become, essential to the present document.

## Trademarks

The present document may include trademarks and/or tradenames which are asserted and/or registered by their owners. ETSI claims no ownership of these except for any which are indicated as being the property of ETSI, and conveys no right to use or reproduce any trademark and/or tradename. Mention of those trademarks in the present document does not constitute an endorsement by ETSI of products, services or organizations associated with those trademarks.

**DECT™**, **PLUGTESTS™**, **UMTS™** and the ETSI logo are trademarks of ETSI registered for the benefit of its Members. **3GPP™** and **LTE™** are trademarks of ETSI registered for the benefit of its Members and of the 3GPP Organizational Partners. **oneM2M™** logo is a trademark of ETSI registered for the benefit of its Members and of the oneM2M Partners. **GSM®** and the GSM logo are trademarks registered and owned by the GSM Association.

# Foreword

This European Standard (EN) has been produced by ETSI Technical Committee Environmental Engineering (EE).

The present document concerns the requirements for the interface between Information and Communication Technology (ICT) equipment and its power supply. It includes requirements relating to its stability and measurement. Various other references, detailed measurement and test arrangements are contained in informative annexes.

The introduced interface up to 400 V Direct Current (DC) is considering power consumption increase and equipment power density increase in order to get higher energy efficiency with less material than with low voltage -48 VDC or permanent AC powering solution.

The up to 400 VDC interface could also simplify the use of renewable energy source with DC output such as photovoltaic generator.

The present document is part 3 of a multi-part deliverable covering Environmental Engineering (EE); Power supply interface at the input to Information and Communication Technology (ICT) equipment, as identified below:

Part 1: "Alternating Current (AC)";

Part 2: "-48 V Direct Current (DC)";

**Part 3: "Up to 400 V Direct Current (DC)".**

National transposition dates	
Date of adoption of this EN:	18 January 2023
Date of latest announcement of this EN (doa):	30 April 2023
Date of latest publication of new National Standard or endorsement of this EN (dop/e):	31 October 2023
Date of withdrawal of any conflicting National Standard (dow):	31 October 2023

---

## Modal verbs terminology

In the present document "**shall**", "**shall not**", "**should**", "**should not**", "**may**", "**need not**", "**will**", "**will not**", "**can**" and "**cannot**" are to be interpreted as described in clause 3.2 of the [ETSI Drafting Rules](#) (Verbal forms for the expression of provisions).

"**must**" and "**must not**" are **NOT** allowed in ETSI deliverables except when used in direct citation.

---

# 1 Scope

The present document contains requirements and measurements methods for the physical interface "A3" that is situated between the power supply system(s) and the power consuming ICT equipment:

- the nominal voltage at power interface "A3" of ICT equipment defined in the present document is DC voltage up to 400 V;
- the output performance of the power equipment including the cable network at the interface "A3";
- the input of the ICT equipment connected to interface "A3".

The DC power can be supplied by a DC output power system e.g. via on-grid AC rectifiers, from DC/DC converters in solar systems, fuel cells, standby generators including a battery backup.

The present document aims at providing compatibility at interface "A3" between the power supply equipment and different ICT equipment (including/monitoring, cooling system, etc.) connected to the same power supply.

The requirements are defined for the purpose of the present document to:

- identify a power supply system with the same characteristics for all ICT equipment defined in the area of application; the area of application may be any location where the interface "A3" is used i.e. telecommunication centres, Radio Base Stations, datacentres and customer premises;
- facilitate interworking of different loads;
- facilitate the standardization of power supply systems for ICT equipment;
- facilitate the installation, operation and maintenance in the same network of ICT equipment and systems from different origins;
- secure robustness against temporary voltage deviations and transients during abnormal conditions.

General requirements for safety and EMC are out of the scope of the present document series unless specific requirement not defined in existing safety or EMC standards.

---

## 2 References

### 2.1 Normative references

References are either specific (identified by date of publication and/or edition number or version number) or non-specific. For specific references, only the cited version applies. For non-specific references, the latest version of the referenced document (including any amendments) applies.

Referenced documents which are not found to be publicly available in the expected location might be found at <https://docbox.etsi.org/Reference>.

NOTE: While any hyperlinks included in the present clause were valid at the time of publication, ETSI cannot guarantee their long term validity.

The following referenced documents are necessary for the application of the present document.

- [1] IEC 60947-2: "Low-voltage switchgear and controlgear - Part 2: Circuit-breakers".
- [2] IEC 60269-1: "Low-voltage fuses - Part 1: General requirements".
- [3] IEC 61000-4-5: "Electromagnetic compatibility (EMC) - Part 4-5: Testing and measurement techniques - Surge immunity test".

- [4] IEC 61000-4-29: "Electromagnetic compatibility (EMC) - Part 4-29: Testing and measurement techniques - Voltage dips, short interruptions and voltage variations on d.c. input power port immunity tests".
- [5] IEC 60898-2: "Electrical accessories - Circuit-breakers for overcurrent protection for household and similar installations - Part 2: Circuit-breakers for AC and DC operation".
- [6] ETSI EN 301 605 (V1.1.1) (2013): "Environmental Engineering (EE); Earthing and bonding of 400 VDC data and telecom (ICT) equipment".
- [7] Recommendation ITU-T L.1207 (2018): "Progressive migration of a telecommunication/information and communication technology site to 400 VDC sources and distribution".
- [8] IEC 60364-4-41: "Low voltage electrical installations - Part 4-41: Protection for safety - Protection against electric shock".
- [9] EN 60445: "Basic and safety principle for man-machine interface, marking and identification- Identification of equipment terminals, conductor terminations and conductors", (produced by CENELEC).
- [10] Recommendation ITU-T L.1203 (2016): "Colour and marking identification of up to 400 VDC power distribution for information and communication technology systems".

## 2.2 Informative references

References are either specific (identified by date of publication and/or edition number or version number) or non-specific. For specific references, only the cited version applies. For non-specific references, the latest version of the referenced document (including any amendments) applies.

NOTE: While any hyperlinks included in this clause were valid at the time of publication, ETSI cannot guarantee their long term validity.

The following referenced documents are not necessary for the application of the present document but they assist the user with regard to a particular subject area.

- [i.1] ETSI EN 300 132-2: "Environmental Engineering (EE); Power supply interface at the input of Information and Communication Technology (ICT) equipment; Part 2: -48 V Direct Current (DC)".
- [i.2] IEC 60050-601: "International Electrotechnical Vocabulary. Chapter 601: Generation, transmission and distribution of electricity - General".
- [i.3] ETSI EN 300 386: "Telecommunication network equipment; ElectroMagnetic Compatibility (EMC) requirements; Harmonised Standard covering the essential requirements of the Directive 2014/30/EU".
- [i.4] EN 62368-1: "Audio/video, information and communication technology equipment - Part 1: Safety requirements", (produced by CENELEC).

---

## 3 Definition of terms, symbols and abbreviations

### 3.1 Terms

For the purposes of the present document, the following terms apply:

**abnormal service voltage ranges:** steady-state voltage ranges over which the ICT equipment will not be expected to maintain normal service but will survive undamaged



**area of application:** any location where the interface "A3" is used

NOTE: I.e. telecommunication centres, Radio Base Stations, datacentres and customer premises.

**customer premises:** any location which is the sole responsibility of the customer

**dual feeding system:** independent power systems i.e. two separate power sources (A+B)

**high-ohmic distribution system:** distribution system in which the equipment is connected separately to the battery with added impedance

NOTE 1: The high impedance can be achieved with long cables and in some cases additional resistors are installed.

NOTE 2: With this distribution the undervoltage effects of fuse blowing transients are reduced on other equipment connected to the battery.

**ICT equipment:** telecommunication or datacommunication equipment

**independent power distribution:** redundant power distribution i.e. dual feeders (A+B) from two separate power sources (A+B) or a single power source

NOTE: Equipment having two power feeds is fitted with OR-ing devices or separate power supply units.

**interface "A3":** power interface at the input terminals of ICT, physical point, at which power supply is connected in order to operate the ICT equipment

**IT system:** The codes used have the following meanings:

- First letter: Relationship of the power system to earth:  
**I:** all live parts isolated from earth, or one point connected to earth through a high impedance
- Second letter: Relationship of the exposed-conductive-parts of the installation to earth:  
**T:** direct electrical connection of exposed-conductive-parts to earth, independently of the earthing of any point of the power system

NOTE: See ETSI EN 301 605 [6].

**load unit:** power consuming equipment, that is part of a system block

**nominal voltage:** value of the voltage by which the electrical installation or part of the electrical installation is designated and identified

NOTE: This definition is based on nominal voltage defined in IEC 60050-601 [i.2].

**normal operating condition:** typical environmental and powering conditions for operation of ICT equipment, power supply, power distribution and battery

**normal operating voltage:** typical value of the voltage at "A3" interface within the normal operating voltage range

**normal operating voltage range:** voltage range at "A3" interface where the system operates most of the time, e.g. in general linked to battery floating voltage

**normal service:** service mode where ICT equipment operates within its specification

**normal service voltage range:** range of the steady-state voltage at the "A3" interface over which the equipment will maintain normal service

NOTE: In general this wider than the normal operating voltage range as it includes a part of the battery discharge voltage range.

**operating voltage:** value of the voltage under normal conditions, at a given instant and a given point ("A3" interface) of the system

**power supply network:** network interconnecting the power source and the ICT equipment

**reference test voltage:** voltage used as a reference to define the test voltage in the present document

NOTE: The test voltage may be also a percentage of this voltage.

**system block:** functional group of ICT equipment depending for its operation and performance on its connection to the same power supply

**telecommunication centre:** any location where ICT equipment is installed and is the sole responsibility of the operator

## 3.2 Symbols

For the purposes of the present document, the following symbols apply:

$\Omega$	ohm
k $\Omega$	Kilo ohm
$^{\circ}\text{C}$	Celsius
A	Ampere
di/dt	derivative of a considered current versus time
Hz	Hertz
I	current
$I_m$	maximum steady state current drain at 260 VDC at interface "A3"
$I_{mss}$	maximum steady state current drain in the abnormal service voltage range at interface "A3"
$I_n$	current rating of the over-current protective device
$I_p$	peak inrush current at interface "A3"
$I_{UT}$	maximum steady state current drain at $U_T$ at interface "A3"
m	meter
ms	milli seconds
s	seconds
$T_{50}$	time duration of the inrush current pulse at 50 % of $I_p$
$U_o$	output voltage range of a generator
$U_T$	Reference Test Voltage
V	Volt
W	Watt
$\mu\text{s}$	micro seconds

## 3.3 Abbreviations

For the purposes of the present document, the following abbreviations apply:

AC	Alternating Current
B	Battery
CB	Circuit Breaker
CLD	Current Limiting Device
DC	Direct Current
DC/DC	DC converter
EE	Environmental Engineering
EMC	ElectroMagnetic Compatibility
EN	European Standard
EUT	Equipment Under Test
ICT	Information and Communication Technology
PE	Protective Earth
S	manual Switch or contactor
T	current Transducer
VAC	Volts Alternating Current
VDC	Volts Direct Current
VRLA	Valve Regulated Lead Acid

## 4 Power interface "A3"

The power supply interface "A3" in figure 1, is a physical point to which all the requirements are related. This point is situated at the power input terminals of the ICT equipment.

Examples of configurations in which interface "A3" is identified are given in annex B.

Basic rules for marking of conductors and connectors shall be in accordance with IEC 60445 [9].

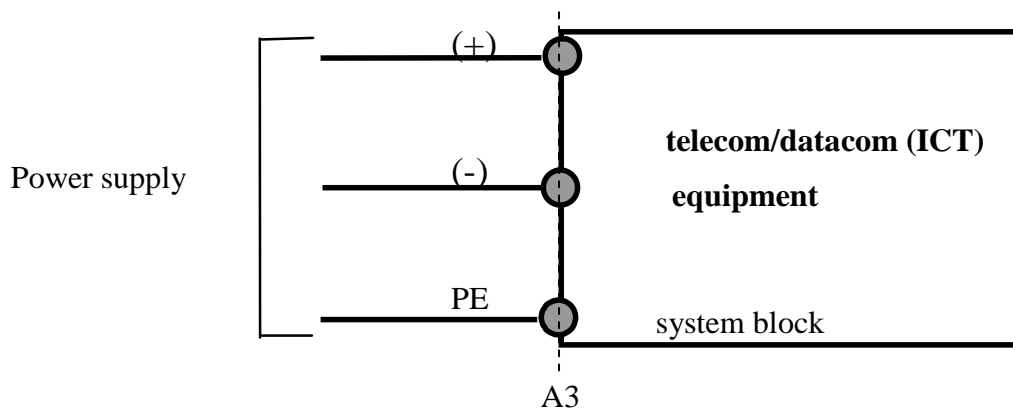

(+) Positive DC terminal.  
 (-) Negative DC terminal.  
 PE Protective Earth.

Figure 1: General identification of the interface "A3"

## 5 DC interface requirements

### 5.0 General

The definition of the DC interface voltages ranges and typical operating voltage values are illustrated in annex G.

### 5.1 Nominal voltage

The selected battery in general determines this nominal voltage, the operating voltage and the normal service voltage range in the system.

NOTE 1: For example, 336 V is a nominal voltage defined with 168 lead-acid battery cells multiplied by the nominal cell voltage 2 V. This nominal DC voltage is equivalent to 48 V multiplied by 7. It allows the use of existing 48 V battery rack (e.g. Lithium battery racks). There may be other nominal voltage defined with different number of cells e.g. 156 lead-acid battery cells that lead to 312 V nominal voltage. Other battery technologies are possible in the future and will influence nominal voltage as well. For detailed calculation, refer to the annex C.

NOTE 2: In an architecture with a boost converter down-stream the battery, the operating voltage is linked to the Nominal Voltage determined in clause 5.1 provided that converter output voltage is within the Normal Service Voltage range.

## 5.2 Normal service voltage range at interface "A3"

The normal service voltage range at powering interface "A3" of ICT equipment shall be as follows:

- minimum voltage: 260 VDC;
- maximum voltage: 400 VDC.

NOTE 1: The voltage at the output of the power supply takes into account the voltage drop in the cable at maximum steady current  $I_m$  and/or the maximum battery charge to stay in the normal service voltage range at the interface "A3" as explained in annexes A, B, C and G.

NOTE 2: For examples on how to calculate normal service voltage range, refer to annex C.

## 5.3 Normal operating voltage range at interface "A3"

The normal operating voltage range at interface "A3" is defined by the voltage levels where the system will operate most of the time under normal operating conditions; this range shall be within the normal service voltage range.

The normal operating voltage is a typical voltage inside the normal operating voltage range.

NOTE 1: Examples of normal operating voltages are 354 V and 380 V.  
354 V corresponds to 156 VRLA cells in floating mode (351 V to 359 V with 2,25 V to 2,30 V per cell) and with no voltage drop in the power distribution.  
380 V corresponds to 168 VRLA cells in floating mode (378 V to 386 V with 2,25 V to 2,30 V per cell) and with no voltage drop in the power distribution.

NOTE 2: For examples on how to calculate normal operating voltage range, refer to annex C.

## 5.4 Reference test voltage ( $U_T$ ) at interface "A3"

The reference test voltage ( $U_T$ ) for ICT equipment is defined at:

$$U_T = 365 \text{ V} \pm 15 \text{ V}$$

NOTE: The powering solution should work in any site even with very long power cables i.e.  $U_T$  at the input of ICT equipment is lower than power supply output. For constant power ICT equipment, the current is increasing as a function of decreasing voltage.

## 5.5 Abnormal service voltage ranges at interface "A3"

The ICT equipment may be subjected to steady state voltage out of the normal service voltage range. Limits of abnormal service voltage range are defined as follows:

- $0 \text{ V} < U < 260 \text{ V}$
- $400 \text{ V} < U < 410 \text{ V}$  for 1 s
- $410 \text{ V} < U < 420 \text{ V}$  for maximum 10 ms

For example, it may be generated from undervoltage or overvoltage at battery end of discharge cycle or battery end of charge or rectifier regulation/control failures.

ICT equipment with interface "A3" shall not suffer any damage when subjected to the abnormal voltage range.

After the restoration of the supply from the abnormal service voltage range to the normal service voltage range, the ICT equipment shall fulfil the following performance criteria:

- the ICT equipment shall not suffer any damage;
- the ICT equipment shall be able to automatically resume operation according to its specifications when the voltage comes back into the normal service voltage range.

NOTE: The second criterion implies that abnormal service voltage should not lead to the disconnection of power supply units e.g. by causing circuit breakers, fuses or other such devices to operate.

## 6 Abnormal conditions: Voltage variations, voltage dips, short interruptions and voltage surges at interface "A3"

### 6.0 General

Under abnormal conditions, voltage values outside the normal service voltage range may occur for short time.

The deviations from the steady-state voltage at the "A3" interface may be caused by:

- Voltage variations.
- Voltage dips.
- Voltage interruptions.
- Voltage surges.

The tests for voltage dips, short interruption and voltage variations shall be conducted in accordance with standard IEC 61000-4-29 [4], chapter 6.1.

The tests for voltage surges shall be conducted in accordance with standard IEC 61000-4-5 [3].

Specific criteria to ICT equipment are defined in each test of table 1. The detailed specification of the generator is in IEC 61000-4-29 [4], chapter 6.1. The tests shall be performed on individual modules/subsystems.

### 6.1 Voltage variations

Test voltages, power supply network and compliance criteria at interface "A3" are defined in table 1.

The test applies to equipment with single and multiple power supply inputs at interface "A3".

**Table 1**

Test level of Normal service voltage step variation (see note 1)	Voltage step duration	Compliance Criteria on ICT equipment	Comments
From $U_T$ to 260 V, back to $U_T$	1 min	Criteria a) Normal service performance during and after the test	Test of minimum operating voltage at "A3" within the Normal Service Voltage Range
From $U_T$ to 400 V, back to $U_T$	1 min	Criteria a) Normal service performance during and after the test	Test of maximum operating voltage at "A3" within the Normal Service Voltage Range
From $U_T$ to 410 V, back to $U_T$	1 s	Criteria b) Temporary loss of function or degradation of performance, automatic recovery to normal performance after the test	Test of non-destruction for a continuous voltage above 400 V and up to 410 V (see note 2)
From $U_T$ to 420 V, back to $U_T$	10 ms	Criteria b) Temporary loss of function or degradation of performance, automatic recovery to normal performance after the test	Test of voltage rise variation outside Normal Service Voltage Range

NOTE 1: The test generator voltage step rise and fall time shall be between 1  $\mu$ s and 50  $\mu$ s on 500  $\Omega$  resistive load.  
NOTE 2: 1 s is considered as sufficient test duration to mimic unlimited time duration.

In the case of ICT equipment with power supply input redundancy (e.g. A and B), this test shall be performed:

- With A and B powered, simultaneously on both power supply inputs.
- At each power supply input at a time with and without the second power supply input.

NOTE: The specified voltages are measured at interface "A3". It should be noted that if interface "A3" is at any point other than the telecommunications equipment interface as presented in annex B, there will be a voltage drop between interface "A3" and the equipment terminals.

## 6.2 Voltage dips

Test voltages, power supply network and compliance criteria at interface "A3" are defined in table 2.

The test applies to equipment with single and multiple power supply inputs at interface "A3".

**Table 2**

Test level of voltage dips (see note)	Voltage dip Duration	Compliance Criteria on ICT equipment	Comments
From $U_T$ to 260 V, back to $U_T$	10 ms	Criteria a) Normal performance	Test of minimum operating voltage at "A3" within the Normal Service Voltage Range

NOTE: The test generator voltage dips rise and fall time shall be between 1  $\mu$ s and 50  $\mu$ s on 500  $\Omega$  resistive load.

In the case of ICT equipment with power supply input redundancy (e.g. A and B), this test shall be performed:

- With A and B powered, simultaneously on both power supply inputs.
- At each power supply input at a time with and without the second power supply input.

## 6.3 Short interruptions

Test voltages, power supply network and compliance criteria at interface "A3" are defined in table 3.

The test applies to equipment with single and multiple power supply inputs at interface "A3".

**Table 3**

Test level of voltage interruption (see note)	Power Supply Network	Interruption Duration	Compliance Criteria on ICT equipment	Comments
$U_T$ to 0 V back to $U_T$	Low Impedance (short circuit)	10 ms	Criteria a) Normal performance	Test of holdup time during fault clearing due to a short-circuit in the system
$U_T$ to 0 V back to $U_T$	High Impedance (open circuit)	1 s	Criteria b) Temporary loss of function or degradation of performance, automatic recovery to normal performance after the test	Test of automatic recovery after an extended = 1 s interruption of the operating voltage at interface "A3"

NOTE: The test generator voltage interruption fall and rise time shall be between 1  $\mu$ s and 50  $\mu$ s on 500  $\Omega$  resistive load.

In the case of ICT equipment with power supply input redundancy (e.g. A and B), this test shall be performed:

- With A and B powered, simultaneously on both power supply inputs.
- At each power supply input at a time with and without the second power supply input.

NOTE 1: With reference to sections 6.1.1 and 6.1.2 of IEC 61000-4-29 [4] the definition of Low Impedance is a generator output impedance < 0,5  $\Omega$  and High Impedance > 100 k  $\Omega$ .

NOTE 2: The purpose of the second test above (High Impedance) is to test the performance of the system during a power start-up of the system from 0 V (i.e. all system capacitors are fully discharged). This reflects reset of a tripped circuit-breaker on "A3" interface or a DC interruptions in the network caused by voltage transients. This reset can also occur with recovery of "A3" interface voltage following the restoration of 230 VAC mains after an AC mains interruption longer than the battery backup time.

## 6.4 Voltage surges

Voltage surges may occur at interface "A3" when faults (e.g. short circuits) occur in the power supply network.

The voltage surges due to short-circuit and protective device clearance are characterized by a voltage drop in the steady state abnormal service voltage range: 0 VDC to 260 VDC, followed by an overvoltage often in excess of the maximum steady state abnormal service voltage range and dependent upon the power distribution up to interface "A3" and the ICT equipment connected to interface "A3".

Test voltages, supply network and compliance criteria at interface "A3" are defined in table 4.

The test applies to equipment with single and multiple power supply inputs at interface "A3".

NOTE 1: The purpose of the present clause is thus to address the energy and the subsequent so-called "Fuse blowing transient" associated with a short-circuit condition.

NOTE 2: Other voltage surges induced from other external sources belong to EMC generic requirements.

NOTE 3: Due to the lack of commercial test generator for testing the voltage surges according to the present clause references are however given to EMC standard in order to re-use the so-called combination wave generator specified in IEC 61000-4-5 [3].

**Table 4**

Test Voltage	Power Supply Network	Generator output impedance	Wave shape	Energy level reference	Compliance Criteria on ICT equipment	Comments
500 V	Line to line	2 $\Omega$	1,2/50 $\mu$ s (8/20 $\mu$ s)	1 Ws	Criteria a) Normal performance	Test of voltage rise variation outside abnormal service voltage range (e.g. after fuse blow, switching) Test voltage polarity shall be the same as "A3" interface
500 V 1 kV	Line to ground	2 $\Omega$ 12 $\Omega$	1,2/50 $\mu$ s (8/20 $\mu$ s)	1 Ws	Criteria a) Normal performance	Test of voltage rise variation outside abnormal service voltage range (e.g. after fuse blow, switching) Test voltage polarity shall be the same as "A3" interface
2 kV 1 kV	Line to line	2 $\Omega$	1,2/50 $\mu$ s (8/20 $\mu$ s)	10 Ws	Criteria b) Temporary loss of function degradation of performance, automatic recovery to Normal Performance after the test	Test of automatic system recovery after a line-to-line short-circuit condition. Test voltage polarity shall be the same as "A3" interface
2 kV	Line to ground	2 $\Omega$ 12 $\Omega$	1,2/50 $\mu$ s (8/20 $\mu$ s)	10 Ws	Criteria b) Temporary loss of function degradation of performance, automatic recovery to Normal Performance after the test	Test of automatic system recovery after a line-to-ground (line-to-PE) short-circuit condition. Test voltage polarity shall be the same as "A3" interface

In the case of ICT equipment with power supply input redundancy (e.g. A and B), this test shall be performed:

- With A and B powered, simultaneously on both power supply inputs.
- At each power supply input at a time with and without the second power supply input.

NOTE 4: The grounding arrangement (positive pole or negative pole connected to ground, or mid-point to ground, etc.) determines the polarity of the test voltage in table 4. For example, for a +400 VDC power supply having its negative pole connected to ground, the polarity of the test voltage should be *positive only*.

See annex F for details, which is inside the abnormal service voltage range.

NOTE 5: Lengthening of the interruption to service (equipment is not functioning as intended) due to the recovery of software should be declared in the test report (i.e. details about the service interruption).

NOTE 6: To prevent system malfunctioning additional arrangements concerning the power supply system may be necessary.

For example:

- Dual feeding system.
- High-ohmic distribution system.
- Independent power distribution.

NOTE 7: Special precautions are normally taken in power distribution network to fulfil compliance criteria a) for mission critical ICT equipment i.e. to prevent functional disturbances due to the voltage surges treated in the present clause.

## 7 DC Supply protection

The supply at interface "A3" shall be protected, (when operating on DC current), by DC rated fuses in compliance with IEC 60269-1 [2] or DC rated circuits breakers in compliance with IEC 60947-2 [1] or IEC 60898-2 [5].

Annex E gives a guideline on the selection and sizing of the over-current protective devices.

## 8 Maximum steady state current $I_m$ , in the normal service voltage range

$I_m$  is the maximum steady state current at the minimum voltage (260 VDC) at interface "A3" for fully equipped and fully loaded ICT equipment. Operating current at any voltage in the normal service voltage range shall not exceed  $I_m$  after 1 s.

Protection devices (e.g. circuit breakers, fuses or equivalent devices) shall be defined for a rated current of 1,2 times  $I_m$  to avoid tripping in the normal service voltage range.

NOTE 1: In case of constant power load characteristics, the factor 1,2 allows the lowest value of the input voltage range of the dc/dc-converter to be 217 V (260/1,2) at start up.

NOTE 2: For shorter times see Inrush Current Graph (see figure 3).



## 9 Inrush current on connection to interface "A3"

### 9.1 Limits

When equipment is switched on, the initial current is called inrush current, until the equipment reaches a steady state. A current pulse, exceeding the steady state current, can often be observed.

NOTE 1: For example, when no current limitation is applied, a pulse peak value of more than 250 A can be observed for an equipment having a steady state current of 1 A.

NOTE 2: One or several inrush current pulses may appear during the very first second of the start-up sequence.

To avoid clearance of protective devices due to excessive current and energy during the very first second of the start-up sequence the inrush current pulse(s) shall be limited in magnitude and in time duration according to figure 3.

The measured inrush currents and the subsequent calculation according figure 2 shall have an  $I_p/I_{UT}$ -ratio and corresponding  $T_{50}$ -value below the limiting curve of figure 3.

This requirement is not applicable on ICT equipment with power consumption max 250 W at  $U_T$  and protected by protective device rated minimum 2 A. The energy content in unlimited inrush current of max 250 W equipment is under normal conditions below the level required for clearance of the protective device rated minimum 2 A.

When power is applied at the test voltage of  $U_T$  at interface "A3" (as defined in annex B), the ratio  $I_p/I_{UT}$  shall not exceed the limits shown in figure 3. Pulse time duration  $T_{50}$  (at 50 % of  $I_p$ ) and inrush current pulse reflecting approximation of energy content are defined in figure 2.

NOTE 3: For pulse duration  $T_{50} < 0,5$  ms, the inrush current is not considered due to too low "energy content" to trip a protective device.

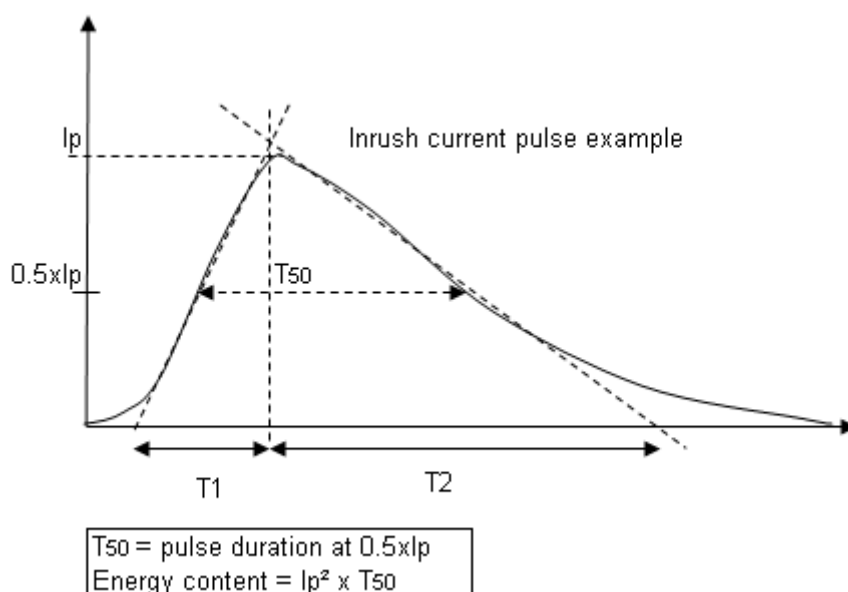

**Figure 2: Inrush current pulse shape used to approximately define the energy content of the pulse**

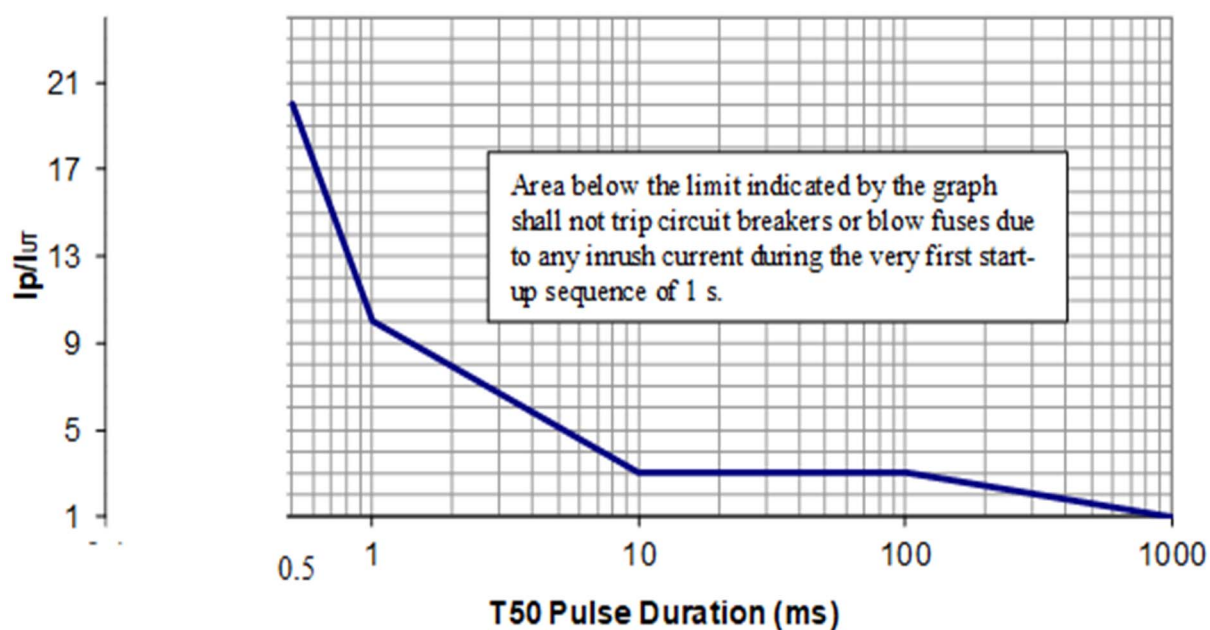

**Figure 3: Maximum inrush current characteristics for telecommunications and datacom**

NOTE 4: This graph is a combined graph for fuses, hydraulic magnetic and thermal magnetic circuit breakers. Fuses according IEC 60269-1 [2] (gG type), circuit breakers according IEC 60947-2 [1] and IEC 60898-2 [5].

NOTE 5: Test conditions for figure 3 are according to ICT equipment > 250 W at  $U_T$ .

## 9.2 Measurements

The test generator and test set-up for inrush current measurement are shown in figure 4.

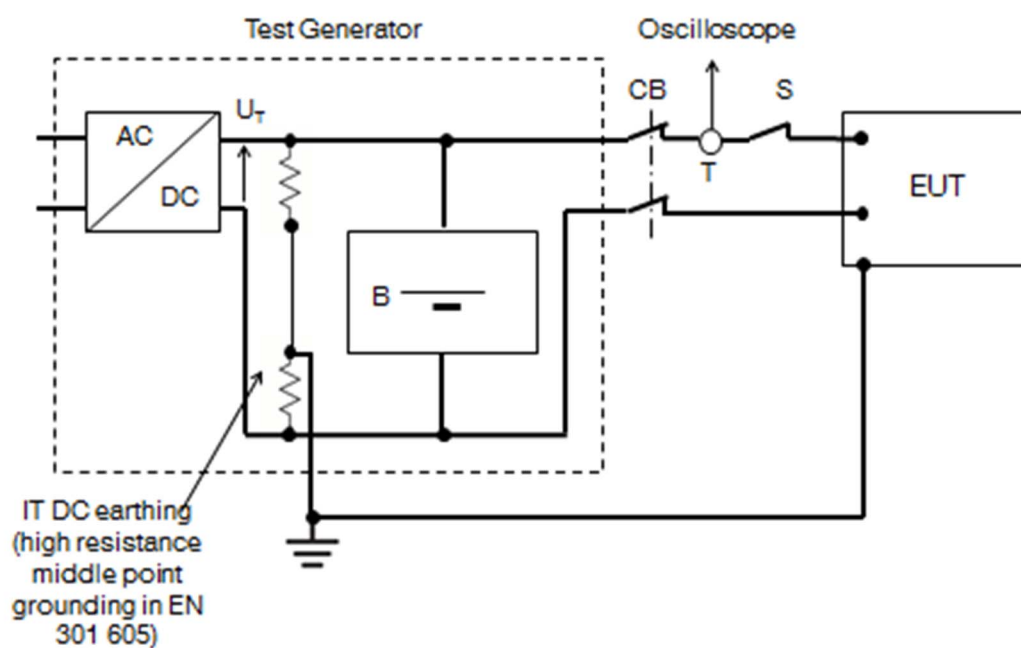

**Figure 4: Inrush current test set-up**

- The test generator shall be able to supply 50 A at  $U_T$  (about 15 kW).
- The battery B shall have the operating voltage defined in clause 5.3.
- For testing a 50 A EUT, the voltage at the load during inrush current should remain in the normal service voltage range  $> 260$  V (maximum voltage drop of 120 V).

NOTE 1: For  $U_T = 380$  V, it can be obtained with a fast discharge lead-acid battery having 168 cells in series and at least 40 Ah capacity. Other technology can be used, e.g. 7 Lithium 48 V racks in series provided that the internal overcurrent allows to remain above 260 V during the inrush current test.

NOTE 2: Considering the total connexion resistance and a voltage drop of 100 V at an average current of 500 A over the first 10 ms of inrush current, the battery internal resistance should be lower than 160 m $\Omega$  (about 1 m $\Omega$  per lead-acid cell).

- The oscilloscope shall be galvanic isolated from the AC mains, (i.e. through isolation transformer).
- CB - 2-pole circuit breaker, with minimum rating 63 A/440 VDC, breaking capacity minimum 6 kA.
- S - Manual switch or contactor for peak current 10 kA,  $T_{50} < 10$  ms and 400 VDC.
- T - Current transducer (low-ohmic shunt or clamp-on meter with bandwidth  $> 10$  kHz).
- Total connection resistance (cable + current transducer + CB + switch)  $< 40$  m $\Omega$ .
- A short cabling of low inductance and resistance (e.g.  $< 2$  m, twisted cable or two-core cable) shall be used.
- More information and guidelines for inrush current measurement can be found in annex D.

---

## 10 Installation and Cabling, Earthing and Bonding

Earthing and bonding of ICT equipment operated by Direct Current (DC) source up to 400 VDC shall comply to ETSI EN 301 605 [6].

To avoid the risk of down-time and possible destruction of equipment, due to confusion in cabling of different voltage distribution in the same building, the Recommendation ITU-T L.1203 [10] shall be used for complementary identification of up to 400 VDC power distribution equipment used for ICT systems power feeding at interface "A3".

The installation shall also comply with Recommendation ITU-T L.1207 [7] which ensures proper earthing and bonding and high availability in all migration towards 400 VDC use cases in existing buildings.

NOTE 1: A common migration use case is that -48 VDC ICT equipment will remain in existing telecom buildings and be powered by a "400 V to -48 V" DC/DC-conversion stage. If equipment has dual -48 V power input and distribution, there may be two independent "400 V to -48 V" DC/DC-converters, to avoid a common mode failure. On the 48 VDC distribution side, an electronic circuit breaker can also be considered for removing short circuit in less time than the ICT power supply hold-up time.

NOTE 2: ETSI standards equivalent to Recommendation ITU-T L.1203 [10] and Recommendation ITU-T L.1207 [7], could be used as soon as they will be published by ETSI.

---

## 11 Electrical Safety requirements

The basic safety requirements are not covered by the present document.

NOTE: Information technology equipment safety is defined in EN 62368-1 [i.4] for mains-powered or battery-powered information technology equipment, including business equipment and associated equipment, with rated voltage not exceeding 600 V. EN 62368-1 [i.4] brings some information. Electrical installation and power supply safety is covered by relevant IEC standards. The installation of power systems and distribution providing A3 interface is based on the basic requirements of IEC 60364-4-41 [8].

---

## 12 EMC requirements at the input of ICT equipment

EMC requirements are not covered by the present document.

NOTE 1: ICT equipment EMC is defined in ETSI EN 300 386 [i.3], other EMC requirements for the building power distribution are covered by relevant IEC standards and interference between distribution are covered by relevant Recommendations ITU-T.

Narrow band noise is not applicable for this "A3" interface.

NOTE 2: Specific needs to power legacy ICT equipment from a common 400 VDC source may appear. In general the solution is to use converters (400 VDC/-48 VDC) from interface "A3" to interface to "A" defined in ETSI EN 300 132-2 [i.1]. For such converters, the noise requirements of ETSI EN 300 132-2 [i.1] are applicable at the interface "A".

---

## Annex A (informative): Power supply considerations

The increase of service and the new packet switching network has led to more ICT equipment in the same existing telecommunication centres. The power consumption related to the standard phone services with ICT equipment in -48 V decreases, but the power needed by these new services and packet networks increases and the power interface is generally ac voltage, the standard interface in the computer field.

Moreover, the density of electronic integration in telecommunication and computer fields increases, requiring more power density. Generally higher current is needed on the powering wire.

Consequently, the nominal voltages proposed in the present document have been defined with consideration to the:

- need to unify the power supply of the ICT equipment and the Information Technology Equipment;
- desire to decrease the losses in the power distribution wire as well as copper cross-section;
- need to maintain a highly reliable power source for telecommunication centres or datacentres;
- enabling the use of the same DC interface in customer premises for powering ICT equipment.

The corresponding power supply can be based on a range of different configurations including:

- mains + rectifier;
- mains + rectifier + battery;
- rectifier + battery + other DC source input (e.g. from renewable energy controller of photovoltaic type);
- mains + back-up generator (e.g. diesel generator) at the input;
- any redundancy and modularity of the previous solution;
- if a DC energy storage device (e.g. battery) is used, it should be selected/designed to fit into the normal service voltage range;
- selection should take account of:
  - battery charging voltage ( $\leq 400$  V);
  - battery end of discharge voltage and voltage drop in the distribution system.

## Annex B (informative): Identification of interface "A3"

Interface "A3" is defined as the terminals at which the ICT equipment is connected to the power supply or the power distribution.

This is shown in figure B.1.

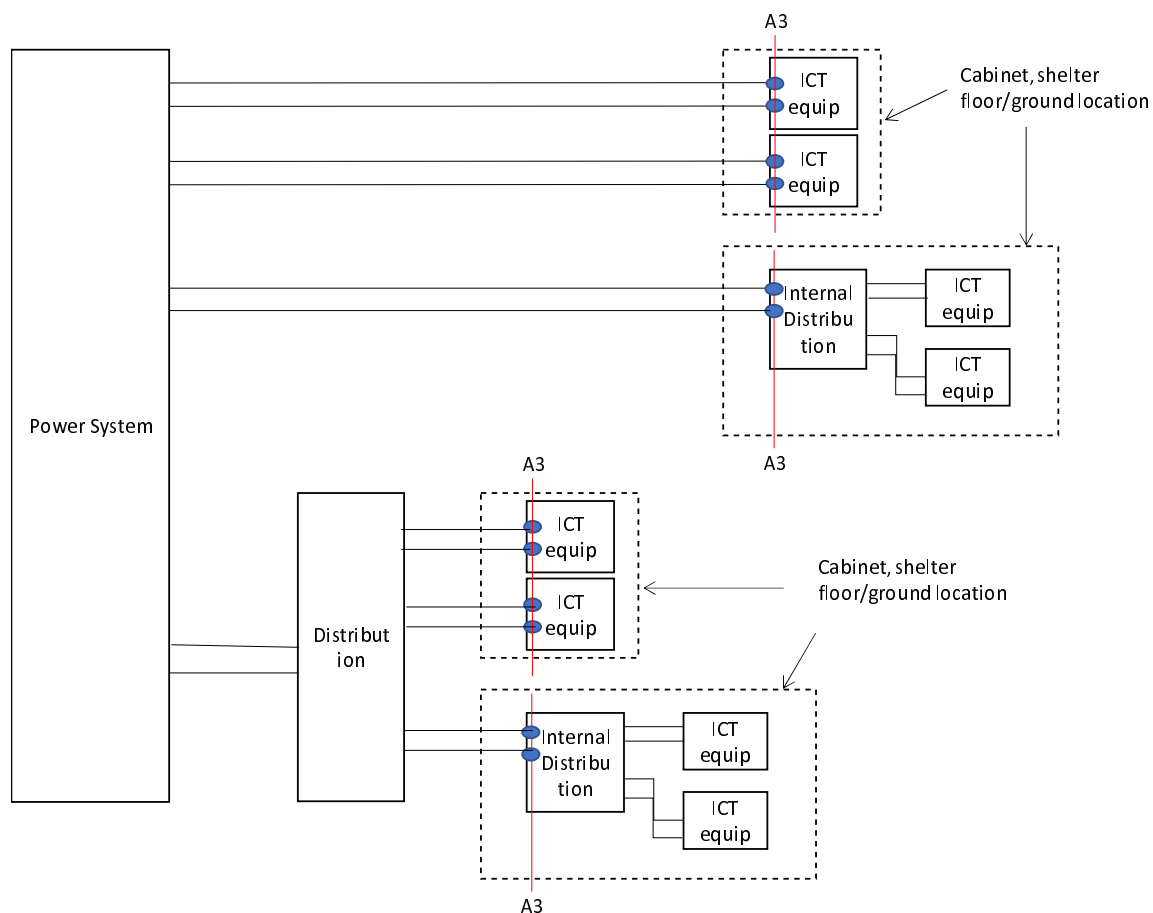

NOTE 1: The figure is a drawing of the power system and does not show the PE conductor.

NOTE 2: In normal operation the voltage at the output of the power supply is always higher than the voltage at the interface "A3", due to voltage drop in the distribution cables.

**Figure B.1: Identification of interface "A3" (three possible configurations)**

## Annex C (informative): Calculation of the extreme DC voltage range at interface "A3"

The battery voltage range between charge and discharge conditions defines the DC voltage range. For the example of calculation, only the lead-acid battery composed of 168 cells or 156 cells, is considered. Other battery technologies are also possible in the future with different voltage range that should be inside the normal service voltage range.

Battery voltage range:

- The high voltage at end of fast charge of lead acid battery is limited to 2,375 V per cell which is the same as for the 48 V interface maximum value in boost mode, e.g.  $168 \times 2,375 \text{ V} = 399 \text{ V}$ .
- This maximum voltage may correspond also to a value close to  $7 \times 57 = 399 \text{ V}$  as defined in ETSI EN 300 132-2 [i.1].
- The maximum normal voltage is set around 400 V at the input of ICT equipment.
- The low voltage at end of fast discharge of lead acid battery (i.e. 15 min discharge rate) is limited to 1,65 V per cell. The maximum voltage drop should also be considered.
- The minimum normal voltage is therefore equal to:  $1,65 \text{ V} \times 168 = 277 \text{ V}$ , which allows a voltage drop in the cable of 17 V in case of minimum 260 V at input of the ICT equipment.
- Another calculation can be  $1,7 \times 156 = 265 \text{ V}$ , and it allows 5 V voltage drop with the same minimum voltage at input of ICT equipment.
- The minimum normal voltage is then set at 260 V at the input of ICT equipment with some margin.

In the following, are also given examples of calculation of operating voltage and operating voltage range for 168 lead-acid battery cells with temperature effect and voltage drop in the cable. The battery operating voltage range is defined by the reference cell floating voltage range from 2,18 V to 2,27 V between 20 °C and 25 °C and the temperature voltage coefficient of -3 mV/°C from 0 °C to 40 °C. The minimum ICT equipment operating voltage range is then the battery voltage minus the voltage drop in the DC distribution cable. Assuming constant power, the drop is lower at operating voltage than at end of battery discharge.

- Without voltage drop in the cable:
  - the minimum operating voltage with reference minimum floating voltage cell is at 40 °C is:  
 $(2,18 - (0,003 \times (40 - 20))) \times 168 = 356 \text{ V};$
  - the maximum operating voltage is at 0 °C with reference maximum floating voltage cell is:  
 $(2,27 - (0,003 \times (0 - 20))) \times 168 = 391 \text{ V};$
  - at 20 °C, the operating voltage with reference minimum floating cell voltage cell is:  
 $2,18 \times 168 = 366 \text{ V}.$

NOTE: Considering 0 to 40 °C temperature range, the possible 168 cells lead-acid battery floating voltage range, and 5 to 8 V voltage drop, the operating voltage would be ranging from 348 V to 386 V. With a 156 cells battery, the floating voltage range would be 323 V to 358 V.

---

## Annex D (informative): Guide for defining inrush current energy, measuring inrush current and test generator peak inrush current drive capability

### D.0 General

The criteria for defining an accepted inrush current energy content is related to the risk of clearance of the applied protective device. Circuit breakers in general requires less current energy content for clearance than fuses at the same current rating. That is why the tripping characteristics of hydraulic magnetic and thermal magnetic circuit breakers have been used as the basis for selection of limits for inrush current. The inrush current limits have been selected to meet circuit breaker tripping characteristic requirement Curve C ( $7 \times I_n$  DC at 0,1 s) with enough safe margin. The inrush current limits for pulses below 10 ms have been selected based on tests of required pre-arc energy for clearance of circuit breakers and data from circuit breaker manufacturers.

The pre-arc energy is the energy content required for opening the contact in the circuit breaker (creation of arc) and reaching the cut-off current limit. The "point of no return" is reached and the fault current is falling down to zero.

---

### D.1 Measurement

The procedure to measure inrush current is as follows:

- a) Use a storage oscilloscope, which can record values of  $di/dt$  of at least 10 A/ $\mu$ s.
- b) Make sure that the battery is fully charged at rectifier output floating voltage 380 V  $\pm$  5 V (valid for 168 VRLA cells).
- c) The test is performed at the output voltage level  $U_T$  of the rectifier. The battery should be able to provide a minimum current,  $I_p$  of 1 500 A at short circuit (see clause D.2).



## D.2 Test generator peak inrush current drive capability

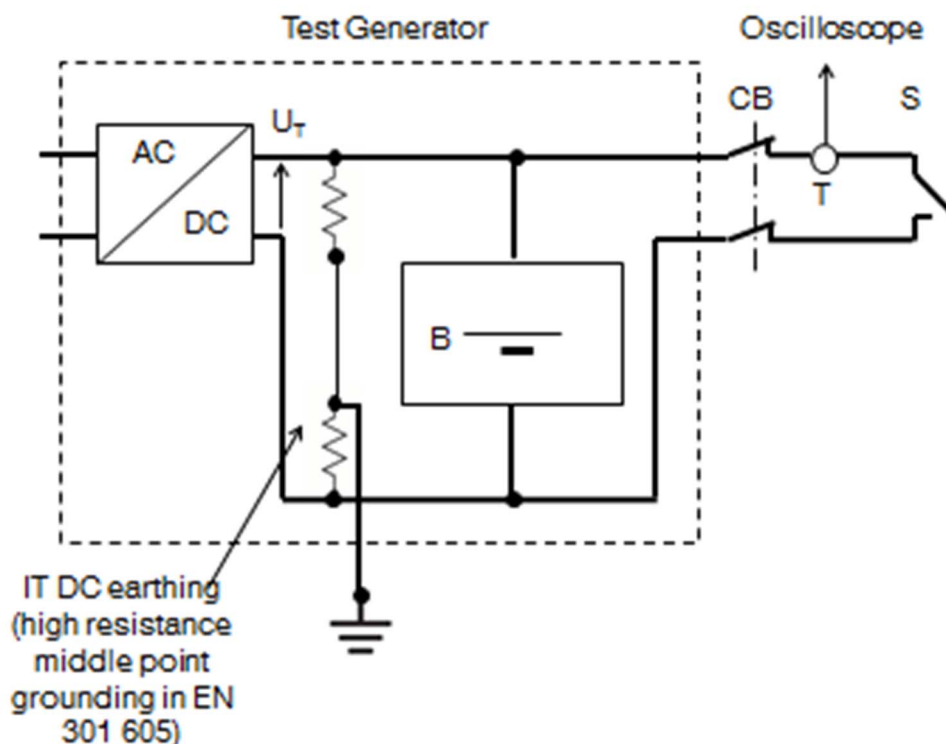

**Figure D.1: Test set-up for measuring test generator peak inrush current drive capability in short circuit test**

- T- Current transducer (low-ohmic shunt or high bandwidth clamp-on).
- CB - 2-pole circuit breaker,  $\geq 63$  A/440 VDC, breaking capacity minimum 6 kA.
- S - Manual switch or contactor for peak current 10 kA,  $T_{50} < 10$  ms and 400 VDC.
- Total connection resistance  $< 40$  m $\Omega$ , (total resistance of cable + current transducer + CB + switch/contactor).

EXAMPLE: 63 A/440 V CB plus 2 m  $\times$  6 mm<sup>2</sup> cable bring a resistance of 20-25 m $\Omega$  at short circuit.

The measured peak short circuit current should be greater than 1 500 A. If the level of 1 500 A is not reached, it may depend either on too high battery resistance (more strings in parallel or higher Ah is recommended).

## D.3 Example of inrush current waveform

Figure D.2 shows a typical inrush current pulse to a small ICT equipment with a power rating less than 250 W fed by 350 VDC.

NOTE: The equipment is originally designed for 230 VAC and has no built-in active or passive current limiting device its input.

$$I_p = 54 \text{ A}, T_{50} = 0,7 \text{ ms and } I_{UT} = 0,43 \text{ A (150 W)} \geq I_p/I_{UT} = 125.$$

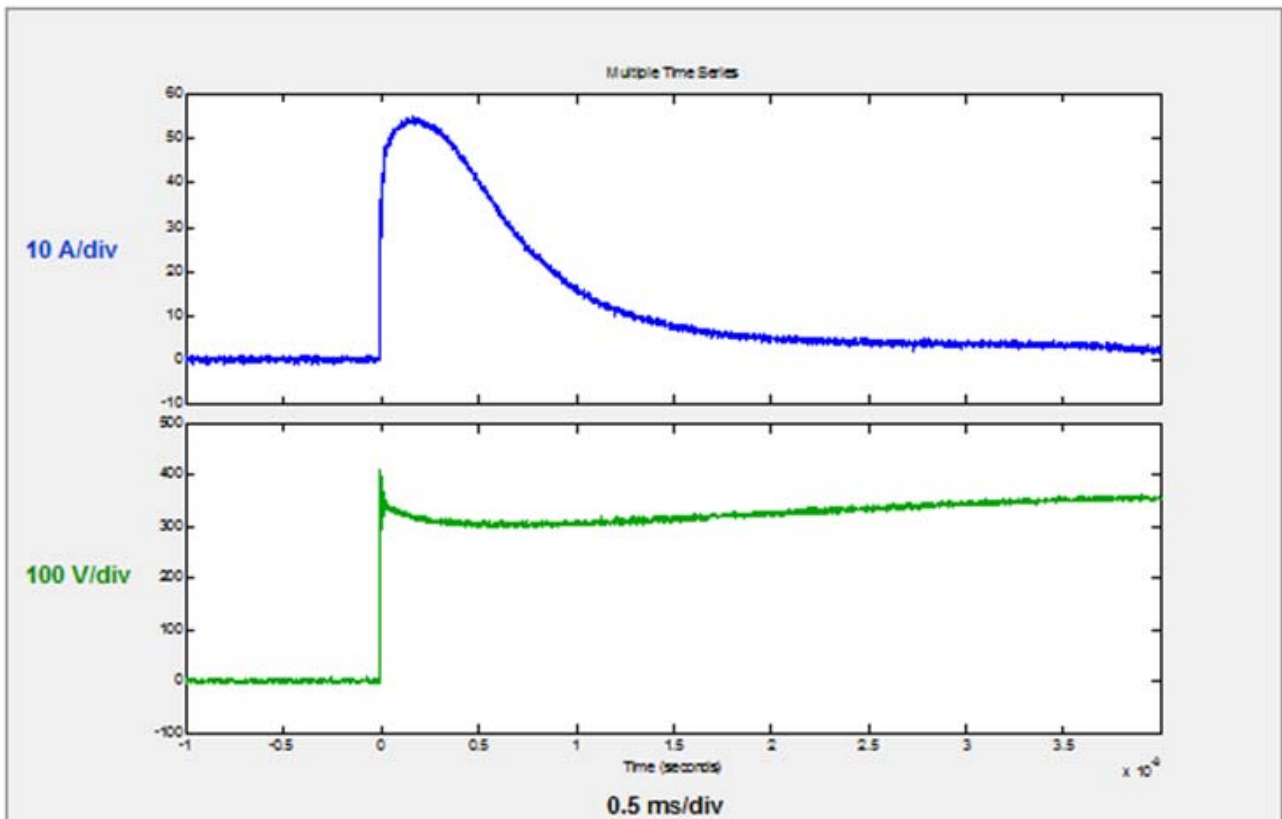

Figure D.2: Example of inrush current measured on small ICT equipment

---

## Annex E (informative): Dimensioning of over-current protective devices

It is common practice to use fuses or breakers in the DC network distribution with a nominal trip value, which is  $> 1,5$  times  $I_m$  ( $1,5 = 1,2 \times 1/0,8$ ). This considers:

- A factor of 1,2 for maximum steady state current in abnormal service voltage range.
- A safety factor of 0,8 that includes temporary over load, technology, ageing, de-latch current, etc.

NOTE: Temperature derating factor should be additionally considered depending on chosen technology for the protective device. A CB according to IEC 60898-2 [5] with a rated current of 16 A at 30 °C would have a rated current of 14,3 A at 60 °C.

## Annex F (informative): Details of the voltage transient measurement in the most common case of distribution and protective devices

A protective device operation transient results from a low impedance fault to ground on the equipment side of a protective device (fuse or circuit breaker) connected to a power distribution bus. The bus voltage is reduced due to high current flowing to ground through the protective device and the short-circuit to ground. When the protective device opens, the release energy stored in the inductance of the battery circuit causes an initial high voltage overshoot of short duration, followed by a longer interval voltage overshoot that decays toward the steady state bus voltage.

In the present document, in clause 6.4, tests are defined to verify the susceptibility of the equipment when a short circuit or overload condition occurs on the power distribution bus.

One technique to reduce the effect of a short circuit on the power distribution bus (i.e. transient voltage dip at Interface "A3") is to connect each load equipment separately all the way from the primary distribution unit at the battery with sufficiently high impedance (long cables or a Current Limiting Device (CLD) which limits the short-circuit current). In this way both the voltage dip across the common busbar at the power source is limited as well as the energy content in the fuse blowing transient associated with the opening of overcurrent protection device.

Normally hold-up capacitors are installed at the power entrance point of the equipment, to bridge larger voltage drops as a result of short and/or more moderate cable lengths.

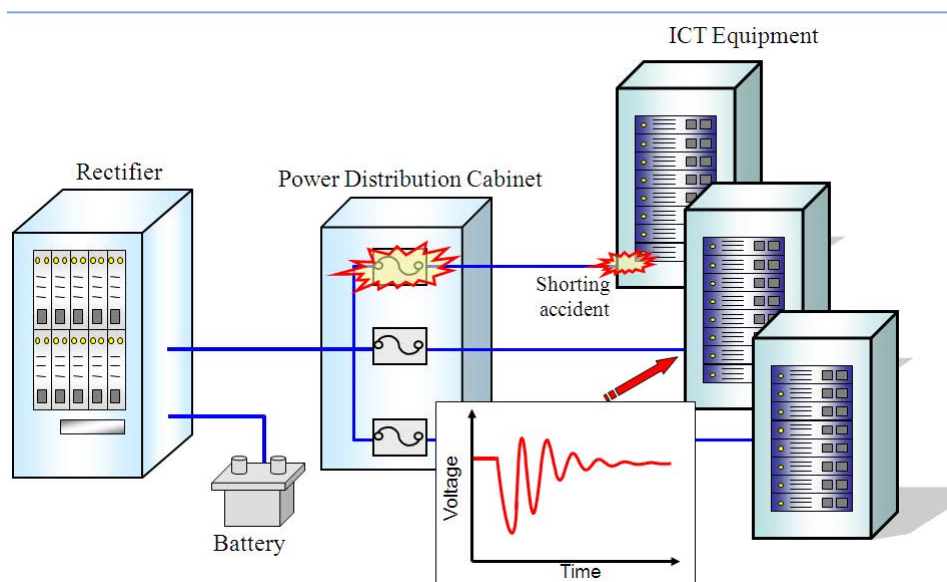

**Figure F.1: Definition of transient voltage impact**

Experiences of fuse/circuit breaker blowing transients on 400 VDC distribution systems have been carried out. The transient is measured at interface "A3" on one equipment, when the fault occurs on another equipment interface "A3" (see figure F.1 and the case of a shorting accident).

The parameters of the proposed tests are:

- Cable lengths (between the power system and the load) of 3 m, 10 m, 30 m and 50 m; cables being sized with a maximum voltage drop of 10 V between the power system and the load.
- Load of 1 kW via a DC/DC converter to simulate an ICT equipment.
- A suitable test generator defined in existing EMC standards for use in testing 400 VDC ICT equipment being identified from existing solutions.
- Existing circuit breakers and fuses for 400 V being representative of the majority of possible solutions chosen after a worldwide collection of information.

NOTE 1: The fault current can reach kA, the voltage transient level voltage more than 200 V and the overvoltage last some tens of  $\mu$ s to tens of ms.

NOTE 2: The simulation principle of figure F.1 has been implemented in the simulator circuit of figure F.2. The floating battery voltage is 380 V. With a very short line of 3 m the maximum observed voltage transient is obtained.

With a prototype fuse of 30 A, the voltage at interface "A3" (figure F.3) stays above 350 VDC, and below 405 VDC. The voltage drop is in the normal service voltage range while the voltage peak is in the abnormal service voltage range (400 VDC to 410 VDC). The time duration is 0,1 ms.

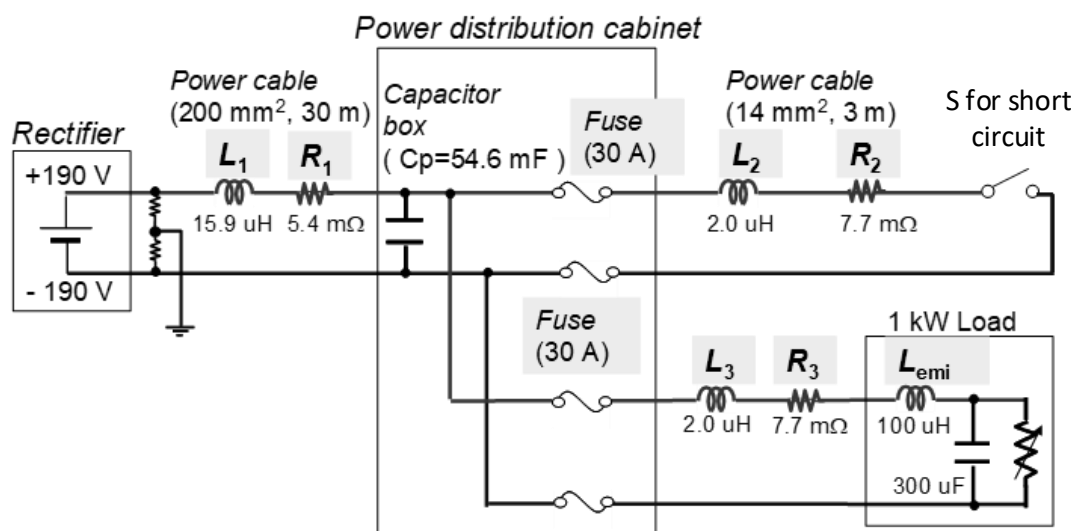

Figure F.2: Example of simulation circuit for short circuit and voltage transient measurement

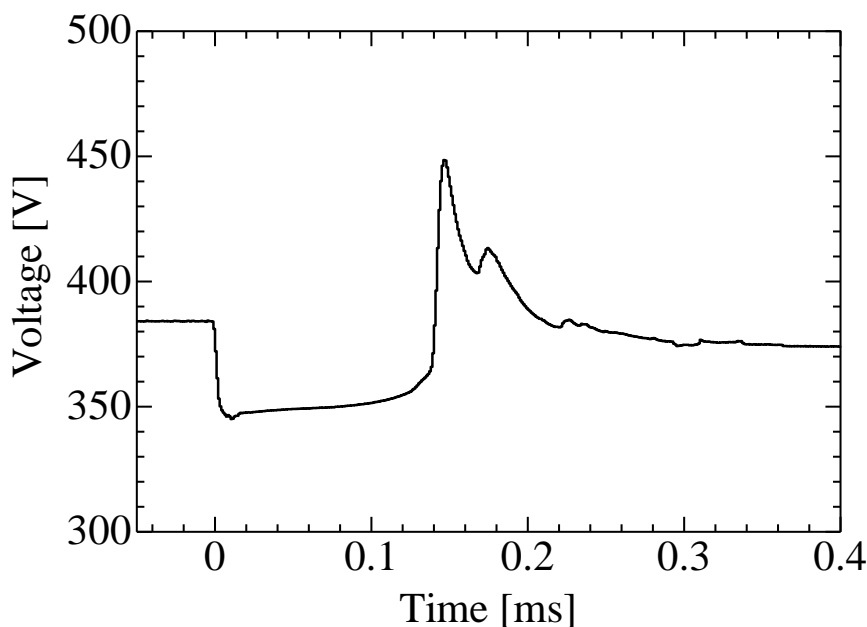

Figure F.3: Example of result of short circuit and voltage transient measurement on simulation circuit described in figure F.2

## Annex G (informative): Diagram of voltage ranges and values at the interface "A3"

The present annex provides a diagram of the voltage definition contained in the present document (figure G.1).

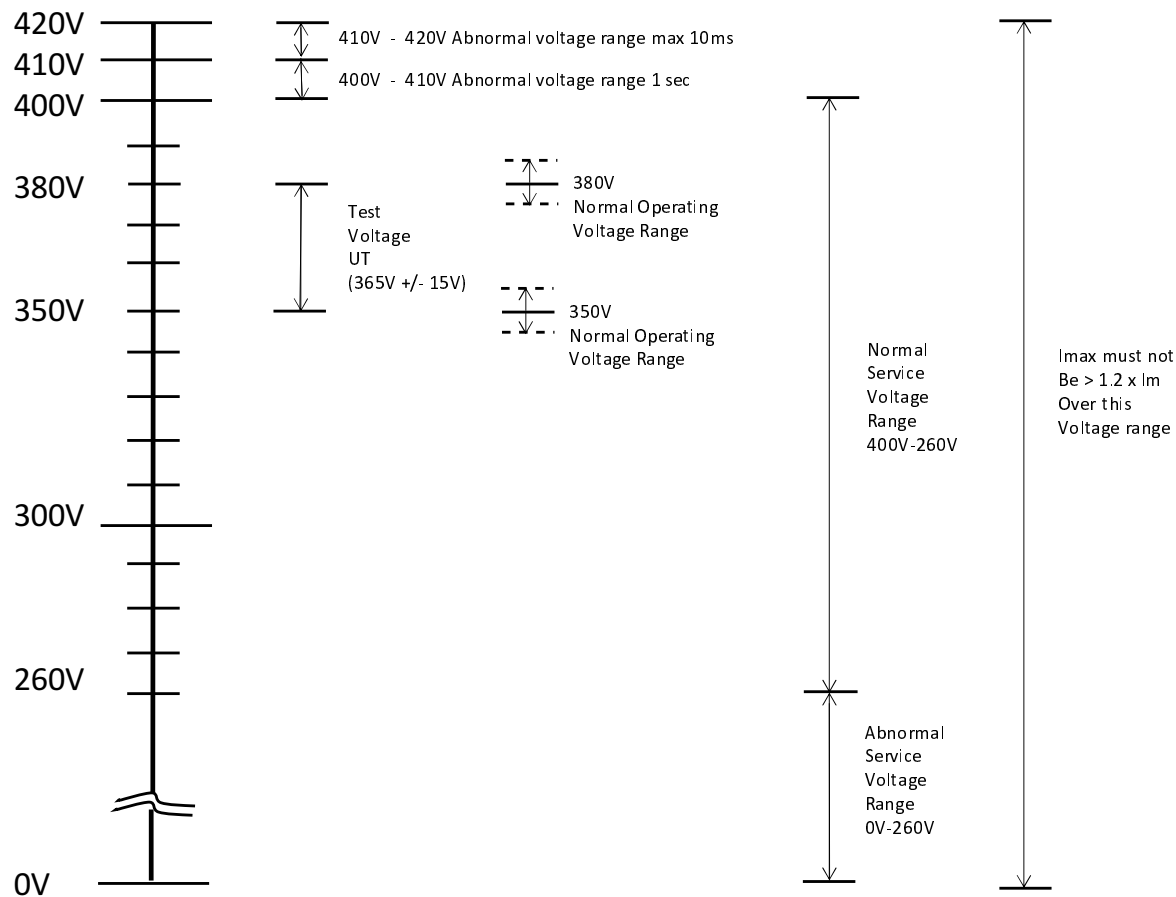

Figure G.1: Diagram of DC voltage ranges and values at the interface "A3"

---

# History

<b>Document history</b>		
V1.2.1	August 2003	Publication
V2.1.1	February 2012	Publication as ETSI EN 300 132-3-0 (Withdrawn) and ETSI EN 300 132-3-1
V2.2.1	July 2021	Publication
V2.2.3	October 2022	EN Approval Procedure AP 20230118: 2022-10-20 to 2023-01-18
V2.3.1	January 2023	Publication