



**Environmental Engineering (EE);
Power supply interface at the input to
Information and Communication Technology (ICT)
equipment;
Part 1: Alternating Current (AC)**

Reference

REN/EE-02102

Keywords

environment, interface, power supply

ETSI

650 Route des Lucioles
F-06921 Sophia Antipolis Cedex - FRANCE

Tel.: +33 4 92 94 42 00 Fax: +33 4 93 65 47 16

Siret N° 348 623 562 00017 - APE 7112B
Association à but non lucratif enregistrée à la
Sous-Préfecture de Grasse (06) N° w061004871

Important notice

The present document can be downloaded from:

<http://www.etsi.org/standards-search>

The present document may be made available in electronic versions and/or in print. The content of any electronic and/or print versions of the present document shall not be modified without the prior written authorization of ETSI. In case of any existing or perceived difference in contents between such versions and/or in print, the prevailing version of an ETSI deliverable is the one made publicly available in PDF format at www.etsi.org/deliver.

Users of the present document should be aware that the document may be subject to revision or change of status.

Information on the current status of this and other ETSI documents is available at

<https://portal.etsi.org/TB/ETSIDeliverableStatus.aspx>

If you find errors in the present document, please send your comment to one of the following services:

<https://portal.etsi.org/People/CommitteeSupportStaff.aspx>

If you find a security vulnerability in the present document, please report it through our
Coordinated Vulnerability Disclosure Program:

<https://www.etsi.org/standards/coordinated-vulnerability-disclosure>

Notice of disclaimer & limitation of liability

The information provided in the present deliverable is directed solely to professionals who have the appropriate degree of experience to understand and interpret its content in accordance with generally accepted engineering or other professional standard and applicable regulations.

No recommendation as to products and services or vendors is made or should be implied.

In no event shall ETSI be held liable for loss of profits or any other incidental or consequential damages.

Any software contained in this deliverable is provided "AS IS" with no warranties, express or implied, including but not limited to, the warranties of merchantability, fitness for a particular purpose and non-infringement of intellectual property rights and ETSI shall not be held liable in any event for any damages whatsoever (including, without limitation, damages for loss of profits, business interruption, loss of information, or any other pecuniary loss) arising out of or related to the use of or inability to use the software.

Copyright Notification

No part may be reproduced or utilized in any form or by any means, electronic or mechanical, including photocopying and microfilm except as authorized by written permission of ETSI.

The content of the PDF version shall not be modified without the written authorization of ETSI.

The copyright and the foregoing restriction extend to reproduction in all media.

© ETSI 2022.

All rights reserved.

Contents

Intellectual Property Rights	5
Foreword.....	5
Modal verbs terminology.....	6
1 Scope	7
2 References	7
2.1 Normative references	7
2.2 Informative references.....	8
3 Definition of terms, symbols and abbreviations.....	8
3.1 Terms.....	8
3.2 Symbols.....	9
3.3 Abbreviations	10
4 Power Interface "A1"	10
5 AC interface requirements "A1"	12
5.0 Introduction	12
5.1 Nominal voltage at interface "A1"	12
5.2 Normal service voltage range categories at interface "A1"	13
5.3 Reference test voltage at interface "A1".....	13
5.4 Abnormal service voltage ranges at interface "A1".....	14
6 Voltage variations, voltage dips, short interruptions and voltage surges at interface "A1"	14
6.0 Introduction	14
6.1 Voltage variations.....	15
6.2 Voltages dips	16
6.3 Short interruptions	16
6.4 Voltage surges	17
7 AC Supply protection on interface "A1"	18
8 Maximum steady state current I_m in the normal service voltage range at interface "A1"	18
9 Inrush current on interface "A1"	18
9.1 Limits	18
9.2 Measurement method	19
9.3 Protective device ratings	20
10 Earthing and Bonding.....	20
11 Electrical Safety requirements.....	20
12 EMC requirements at the input of ICT equipment.....	20
Annex A (informative):	ICT power supply configurations providing a unified power interface in the present document
	21
Annex B (normative):	Identification of interface "A1"
	23
Annex C (informative):	Calculation of the extreme AC voltage range at interface "A1"
	24
Annex D (informative):	Dimensioning of over-current protective devices.....
	25
Annex E (normative):	Test generator for voltage dips, short interruptions and voltage variations
	26
Annex F (informative):	Details of the voltage surges measurement in the most common case of distribution and protective devices
	27

Annex G (informative):	Guide for measuring inrush current and for transferring the recorded pulses onto the limit chart.....	28
G.1	Measurement	28
G.2	Pulse waveform transformation.....	28
History	30

Intellectual Property Rights

Essential patents

IPRs essential or potentially essential to normative deliverables may have been declared to ETSI. The declarations pertaining to these essential IPRs, if any, are publicly available for **ETSI members and non-members**, and can be found in ETSI SR 000 314: "*Intellectual Property Rights (IPRs); Essential, or potentially Essential, IPRs notified to ETSI in respect of ETSI standards*", which is available from the ETSI Secretariat. Latest updates are available on the ETSI Web server (<https://ipr.etsi.org/>).

Pursuant to the ETSI Directives including the ETSI IPR Policy, no investigation regarding the essentiality of IPRs, including IPR searches, has been carried out by ETSI. No guarantee can be given as to the existence of other IPRs not referenced in ETSI SR 000 314 (or the updates on the ETSI Web server) which are, or may be, or may become, essential to the present document.

Trademarks

The present document may include trademarks and/or tradenames which are asserted and/or registered by their owners. ETSI claims no ownership of these except for any which are indicated as being the property of ETSI, and conveys no right to use or reproduce any trademark and/or tradename. Mention of those trademarks in the present document does not constitute an endorsement by ETSI of products, services or organizations associated with those trademarks.

DECT™, **PLUGTESTS™**, **UMTS™** and the ETSI logo are trademarks of ETSI registered for the benefit of its Members. **3GPP™** and **LTE™** are trademarks of ETSI registered for the benefit of its Members and of the 3GPP Organizational Partners. **oneM2M™** logo is a trademark of ETSI registered for the benefit of its Members and of the oneM2M Partners. **GSM®** and the GSM logo are trademarks registered and owned by the GSM Association.

Foreword

This draft European Standard (EN) has been produced by ETSI Technical Committee Environmental Engineering (EE), and is now submitted for the combined Public Enquiry and Vote phase of the ETSI standards EN Approval Procedure.

The present document is part 1 of a multi-part deliverable covering Environmental Engineering (EE); Power supply interface at the input to Information and Communication Technology (ICT) equipment, as identified below:

Part 1: "Alternating Current (AC)";

Part 2: "-48 V Direct Current (DC)";

Part 3: "Up to 400 V Direct Current (DC)";

Proposed national transposition dates	
Date of latest announcement of this EN (doa):	3 months after ETSI publication
Date of latest publication of new National Standard or endorsement of this EN (dop/e):	6 months after doa
Date of withdrawal of any conflicting National Standard (dow):	6 months after doa

Modal verbs terminology

In the present document "**shall**", "**shall not**", "**should**", "**should not**", "**may**", "**need not**", "**will**", "**will not**", "**can**" and "**cannot**" are to be interpreted as described in clause 3.2 of the [ETSI Drafting Rules](#) (Verbal forms for the expression of provisions).

"**must**" and "**must not**" are **NOT** allowed in ETSI deliverables except when used in direct citation.

1 Scope

The present document contains requirements for the input of the ICT equipment connected to interface "A1".

The voltage at interface "A1" defined in the present document is single phase and three phase AC.

The following voltage range categories are covered:

- Narrow single phase "A1"_{n-1p} and narrow three phase "A1"_{n-3p} AC voltage range defined to comply with nominal European AC voltages defined in IEC 60038 [i.2].
- Wide single phase "A1"_{w-1p} and wide three phase "A1"_{w-3p} AC voltage range for worldwide nominal AC voltages. This wide voltage range is based on the nominal voltages defined in IEC 60038 [i.2].

The present document aims at providing compatibility between the power supply equipment and both the ICT equipment, and the different load units connected to the same interface "A1" (e.g. control/monitoring, cooling system, etc.).

The purpose of the present document is:

- to identify a power supply system with the same characteristics for all ICT equipment defined in the area of application; the area of application may be any location where the interface "A1" is used i.e. telecommunication centres, Radio Base Stations, datacentres and customer premises;
- to facilitate interworking of different (types of) loads;
- to facilitate the standardization of power supply systems for ICT equipment;
- to facilitate the installation, operation and maintenance in the same network of ICT equipment and systems from different origins. General requirements for safety and EMC are out of the scope of the present document series unless specific requirement not defined in existing safety or EMC standards.

The present document concerns the requirements for the interface between Information and Communication Technology (ICT) equipment and its power supply. It includes requirements relating to its stability and measurement. Various other references and detailed measurement and test arrangements are contained in informative annexes.

2 References

2.1 Normative references

References are either specific (identified by date of publication and/or edition number or version number) or non-specific. For specific references, only the cited version applies. For non-specific references, the latest version of the referenced document (including any amendments) applies.

Referenced documents which are not found to be publicly available in the expected location might be found at <https://docbox.etsi.org/Reference/>.

NOTE: While any hyperlinks included in this clause were valid at the time of publication, ETSI cannot guarantee their long term validity.

The following referenced documents are necessary for the application of the present document.

- [1] IEC 60947-2: "Low-voltage switchgear and controlgear - Part 2: Circuit-breakers".
- [2] IEC 60269-1: "Low-voltage fuses - Part 1: General requirements".
- [3] IEC 61000-4-5:2014+AMD1:2017: "Electromagnetic compatibility (EMC) - Part 4-5: Testing and measurement techniques - Surge immunity test".

- [4] IEC 61000-4-11:2020: "Electromagnetic compatibility (EMC) - Part 4-11: Testing and measurement techniques - Voltage dips, short interruptions and voltage variations immunity tests for equipment with input current up to 16 A per phase".

2.2 Informative references

References are either specific (identified by date of publication and/or edition number or version number) or non-specific. For specific references, only the cited version applies. For non-specific references, the latest version of the referenced document (including any amendments) applies.

NOTE: While any hyperlinks included in this clause were valid at the time of publication, ETSI cannot guarantee their long term validity.

The following referenced documents are not necessary for the application of the present document but they assist the user with regard to a particular subject area.

- [i.1] ETSI ETS 300 132-1 (Edition 1): "Equipment Engineering (EE); Power supply interface at the input to telecommunications equipment; Part 1: Operated by alternating current (ac) derived from direct current (dc) sources".
- [i.2] IEC 60038:2009+AMD1:2021: "IEC standard voltages".
- [i.3] IEC 60050-601: "International Electrotechnical Vocabulary (IEV) Part 601: Generation, transmission and distribution of electricity - General".
- [i.4] Void.
- [i.5] Void.
- [i.6] Void.
- [i.7] Void.
- [i.8] IEC 60445: "Basic and safety principle for man-machine interface, marking and identification - Identification of equipment terminals, conductor terminations and conductors".
- [i.9] IEC 60898-1:2015: "Electrical accessories - Circuit-breakers for overcurrent protection for household and similar installations - Part 1: Circuit-breakers for a.c. operation".
- [i.10] IEC 60898-2: "Electrical accessories - Circuit-breakers for overcurrent protection for household and similar installations - Part 2: Circuit-breakers for AC and DC operation".
- [i.11] IEC 60364 series: "Low-voltage electrical installations".
- [i.12] IEC 62040 series: "Uninterruptible power systems (UPS)".
- [i.13] IEC 60050-351:2006: "International Electrotechnical Vocabulary (IEV) - Part 351: Control technology".

3 Definition of terms, symbols and abbreviations

3.1 Terms

For the purposes of the present document, the following terms apply:

abnormal service voltage ranges: steady-state voltage ranges over which the ICT equipment will not be expected to maintain normal service but will survive undamaged

area of application: any location where the interface "A1" is used i.e. telecommunication centres, Radio Base Stations, datacentres and customer premises

customer premises: location which is the sole responsibility of the customer

ICT equipment: device, in the telecommunication network infrastructure, that provides an ICT service

interface A: interface, physical point, at which -48 VDC power supply is connected in order to operate the ICT equipment

interface "A1": interface, physical point, at which AC power supply is connected in order to operate the ICT equipment

NOTE: "A1"_n and "A1"_w are used for different voltage ranges: narrow and wide respectively.

interface A3: interface, physical point, at which 400 VDC power supply is connected in order to operate the ICT equipment

load unit: power consuming equipment, that is part of a system block

nominal voltage: value of the voltage by which the electrical installation or part of the electrical installation is designated and identified

NOTE: This definition is based on IEC 60050-601 [i.3].

normal service: service mode where ICT equipment operates within its specification

normal service voltage range: range of the steady-state voltage at the "A1" interface over which the equipment will maintain normal service

power supply: power supply to which ICT equipment is intended to be connected

reference test voltage: voltage used as a reference to define the test voltage in the present document

NOTE: The test voltage may be also a percentage of this voltage.

system block: functional group of ICT equipment depending for its operation and performance on its connection to the same power supply

steady-state: state of a system at which all state and output variables remain constant in time while all input variables are constant

NOTE: This definition is numbered 351-24-09 in IEC 60050-351:2006 [i.13].

telecommunication centre: any location where ICT equipment is installed and is the sole responsibility of the operator

3.2 Symbols

For the purposes of the present document, the following symbols apply:

"A1" _{n-1p}	Single phase narrow voltage range at interface "A1"
"A1" _{n-3p}	Three phase narrow voltage range at interface "A1"
"A1" _{w-1p}	Single phase wide voltage range at interface "A1"
"A1" _{w-3p}	Three phase wide voltage range at interface "A1"
I_m	Maximum steady state current drain at interface "A1"
I_t	Instantaneous surge current at interface "A1"
I_{UT}	Maximum input current (at AC RMS), stated by the manufacturer, for a fully-equipped and loaded system block behind interface "A1"
U_T	Reference test voltage for narrow voltage range
U_{TW1min}	Minimum reference test voltage for wide voltage range for single phase or 3 phase line to neutral
U_{TW1max}	Maximum reference test voltage for wide voltage range for single phase or 3 phase line to neutral
U_{TW2min}	Minimum reference test voltage for wide voltage range for 3 phase
U_{TW2max}	Maximum reference test voltage for wide voltage range for 3 phase

3.3 Abbreviations

For the purposes of the present document, the following abbreviations apply:

AC Alternating Current

NOTE: Also when used as a suffix to units of measurement.

DC Direct Current

NOTE: Also when used as a suffix to units of measurement.

EMC ElectroMagnetic Compatibility

EUT Equipment Under Test

ICT Information and Communication Technology

L Phase conductor

LISN Line Impedance Stabilization Networks

N Neutral conductor

PE Protective Earth

RMS Root Mean Square

UPS Uninterruptible Power Supply

VAC Volts Alternating Current

VDC Volts Direct Current

4 Power Interface "A1"

The power supply interface, interface "A1" of figure 1, is a physical point to which all the requirements are related. This point is situated between the power supply system(s) and the power consuming ICT equipment of the area of application defined in the scope of the present document.

An example of configurations in which interface "A1" is identified is given in annex B.

Interface "A1" is located at the power terminals of the ICT equipment or system as defined by the manufacturer in accordance to IEC 60445 [i.8].

NOTE 1: Subject to the installation preconditions, this point may be located at any other point between the power supply system and the ICT equipment by mutual agreement of the relevant parties.

NOTE 2: The power supply can be derived from AC grid e.g. through AC bypass of UPS or inverters.

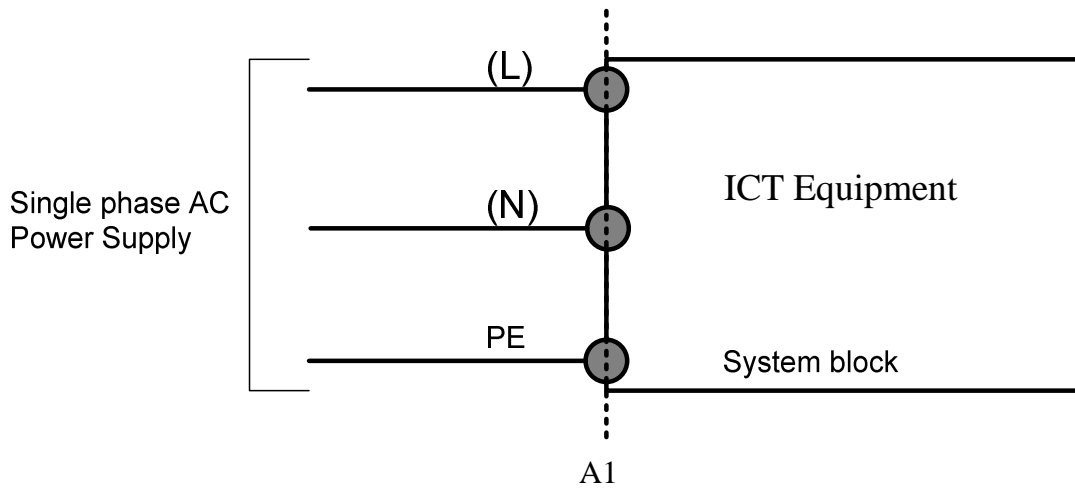

- (L) Live AC terminal in single phase supply.
- (N) Neutral AC terminal.
- PE Protective Earth.

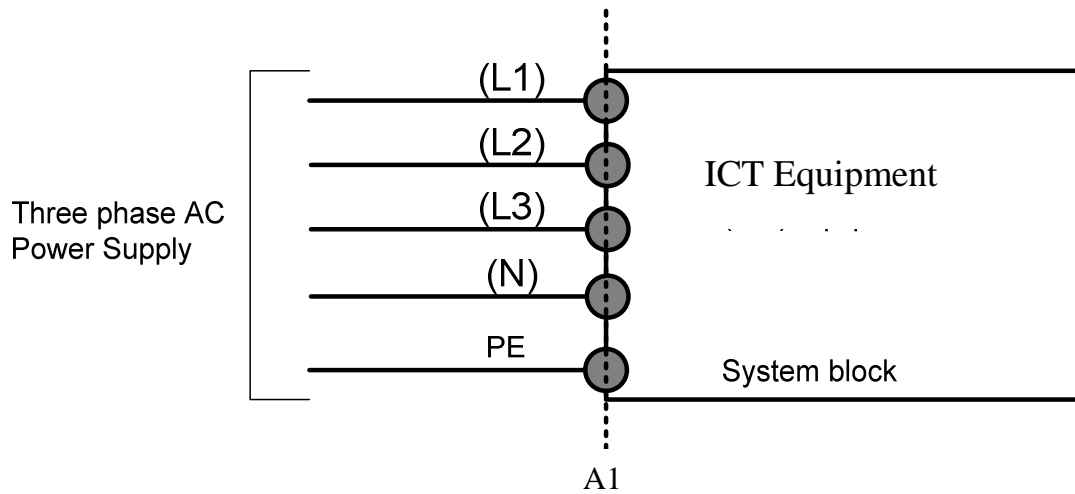

- (L1, L2, L3) Live AC terminals in 3 phases supply.
- (N) Optional Neutral AC terminal.
- PE Protective Earth.

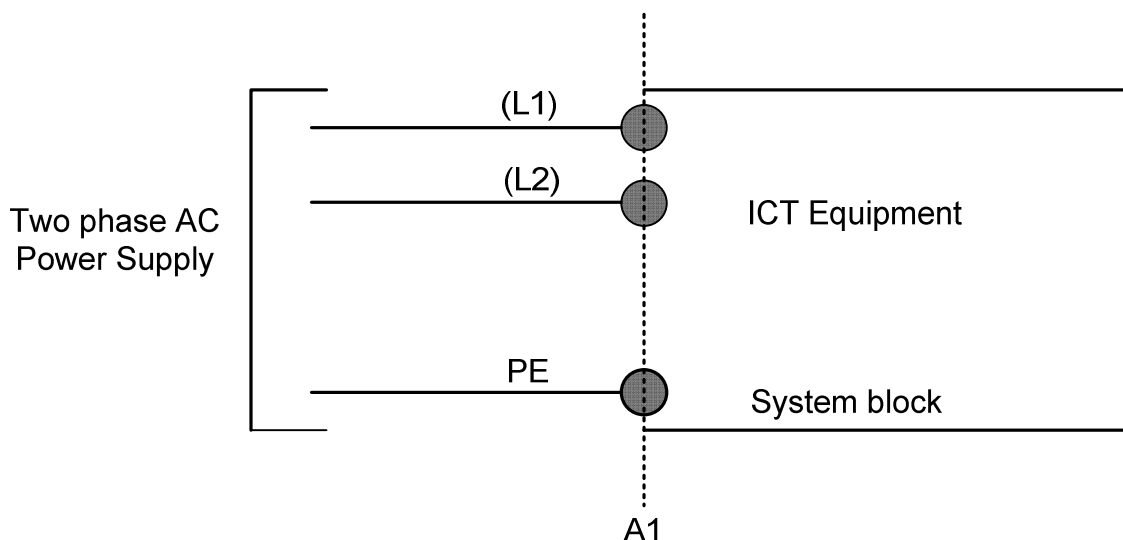

(L1, L2) Live AC terminals in 2 phases supply.
PE Protective Earth.

Figure 1: General identification of the interface "A1" in single, dual and 3 phase AC supply

5 AC interface requirements "A1"

5.0 Introduction

The definition of the AC interface voltages ranges and typical operating voltage values are defined in the following subclauses of clause 5.

5.1 Nominal voltage at interface "A1"

In Europe, the AC input voltage of the ICT equipment shall comply with the nominal single phase voltage of 230 V AC and for three phase it shall comply with 400 V AC at a power frequency of 50 Hz.

NOTE 1: Nominal voltage as defined in table 1 of IEC 60038 [i.2].

ICT equipment intended for worldwide use is recommended to comply with nominal voltages and frequencies defined in table 1 of the present document.

NOTE 2: Nominal voltages as defined in table 1 of the present document and table 6 of IEC 60038 [i.2], except for 115 V and 127 V AC single phase which is also used in some countries.

Table 1: Nominal voltages

AC Single phase voltages (50 Hz or 60 Hz)	AC Three phase voltages (50 Hz or 60 Hz)
100, 110, 115, 120, 127, 200, 220, 230, 240	200, 208, 220, 240, 380, 400, 415

5.2 Normal service voltage range categories at interface "A1"

The normal service voltage range categories at powering interface "A1" of ICT equipment shall be as follows:

- Normal service voltage range (Narrow) - Single phase ("A1"_{n-1p}): 197 - 253 VAC RMS (line to neutral)

NOTE 1: The minimum voltage at interface "A1"_{n-1p} is calculated as 230 V nominal -10 % at the incoming supply terminals of a building and a further -4 % maximum voltage drop allowance on the AC distribution within the building.

NOTE 2: The maximum voltage at interface "A1"_{n-1p} is calculated as 230 V nominal +10 %.

- Normal service voltage range (Narrow) - Three phase ("A1"_{n-3p}): 344 – 440 VAC RMS (line to line)

NOTE 3: The minimum voltage at interface "A1"_{3p-n} is calculated as 400 V nominal -10 % at the incoming supply terminals of a building and a further -4 % maximum voltage drop allowance on the AC distribution within the building.

NOTE 4: The maximum voltage at interface "A1"_{3p-n} is calculated as 400 V nominal +10 %.

- Normal service voltage range (wide) Single phase ("A1"_{w-1p}) 86-264 VAC (line to neutral)

NOTE 5: The minimum voltage at interface "A1"_{w-1p} is calculated as 100 V nominal -10 % at the incoming supply terminals of a building and a further -4 % maximum voltage drop allowance on the AC distribution within the building.

NOTE 6: The maximum voltage at interface "A1"_{w-1p} is calculated as 240 V nominal +10 %.

- Normal service voltage range (wide) - Three phase ("A1"_{w-3p}) 172-456 VAC (line to neutral)

NOTE 7: The minimum voltage at interface "A1"_{w-3p} is calculated as 200 V nominal -10 % at the incoming supply terminals of a building and a further -4 % maximum voltage drop allowance on the AC distribution within the building.

NOTE 8: The maximum voltage at interface "A1"_{w-3p} is calculated as 415 V nominal +10 %.

5.3 Reference test voltage at interface "A1"

The reference test voltage (U_T) for ICT equipment shall be:

- 1) $U_T = 230$ V for single phase or 3 phase line to neutral equipment (test voltage for narrow voltage range)
- 2) $U_T = 400$ V for three phase equipment (test voltage for narrow voltage range line to line)

Two test voltages shall be used for wide voltage range equipment:

- 1) $U_{TW1min} = 100$ and $U_{TW1max} = 240$ V for single phase or 3 phase line to neutral equipment (test voltage for wide voltage range)
- 2) $U_{TW2min} = 200$ and $U_{TW2max} = 415$ V for three phase equipment (test voltage for wide voltage range line to line)

NOTE: The powering solution should work in any site even with very long power cables i.e. U_T at the input of ICT equipment is lower than power supply output. For constant power ICT equipment, the current is increasing as a function of decreasing voltage.

5.4 Abnormal service voltage ranges at interface "A1"

The ICT equipment may be subject to steady state voltage out of the normal service voltage range. Limits of abnormal service voltage range are defined as follows:

- $0\text{ V} < U < 197\text{ V}$ for narrow range single phase (line to neutral interface)
- $0\text{ V} < U < 86\text{ V}$ for wide range single phase (line to neutral interface)
- $0\text{ V} < U < 344\text{ V}$ for narrow range three phase (line to line interface)
- $0\text{ V} < U < 172\text{ V}$ for wide range three phase (line to line interface)

After the restoration of the supply from the abnormal service voltage range to the normal service voltage range, the ICT equipment shall fulfil the following performance criteria:

- the ICT equipment shall not suffer any damage;
- the ICT equipment shall be able to automatically resume operation according to its specifications when the voltage comes back into the normal service voltage range.

NOTE: The second criterion implies that abnormal service voltage should not lead to the disconnection of power supply units e.g. by causing circuit breakers, fuses or other such devices to operate.

6 Voltage variations, voltage dips, short interruptions and voltage surges at interface "A1"

6.0 Introduction

Under abnormal conditions, voltage values outside the normal service voltage range may occur for short time.

The deviations from the steady-state voltage at the "A1" interface may be caused by:

- Voltage variations.
- Voltage dips.
- Voltage interruptions.
- Voltage surges.

The tests for voltage dips, short interruption and voltage variations shall be conducted in accordance with standard IEC 61000-4-11 [4], annex E.

NOTE 1: Clause 6.1.1 of IEC 61000-4-11 [4] defines generator output impedance.

The tests for voltage surges shall be conducted in accordance with standard IEC 61000-4-5 [3].

Specific criteria to ICT equipment are defined in each test table below. The tests shall be performed on individual modules/subsystems.

The test shall be done at the test voltages corresponding to the voltage range of the product defined in clause 5.3.

In 3 phases, the defined tests shall be done on 1, 2 and 3 phases, to cover all events (grid disturbance from or interruption, local line short circuit, etc.).

NOTE 2: Clause 6 states the minimum requirements at "A1" power interface to Telecom/ICT input interface when power supply includes a bypass with AC input. Higher immunity levels may be required when equipment is directly connected to public utility AC grid.

For all the following tests compliance criteria are defined as:

- Criteria a): The EUT shall continue to operate as intended during and after the test. No degradation of performance or loss of function is allowed below a performance level specified by the manufacturer, when the apparatus is used as intended.
- Criteria b): Temporary loss of function or degradation of performance, which ceases after the disturbance ceases, and from which the EUT recovers its normal performance, without operator intervention.

NOTE 3: In the present document, the EUTs is the ICT equipment.

6.1 Voltage variations

The purpose of the following tests are not to check equipment dynamic behaviour during rise and fall times from U_T to minimum or maximum voltage of the voltage range and then back to U_T . Therefore dV/dt are not specified. The voltages values, testing times and test criteria shall be as defined in the following tables.

Starting point of the voltage variations shall be positioned at zero crossings.

Table 2: Narrow voltage range Single phase (test at 50 Hz)

Voltage	Duration	Compliance Criteria on ICT equipment	Comments
From U_T to 197 V, back to U_T	1 min	Criteria a) Normal performance	Test of minimum operating voltage at "A1" within the normal service voltage range.
From U_T to 253 V, back to U_T	1 min	Criteria a) Normal performance	Test of maximum operating voltage at "A1" within the normal service voltage range.

Table 3: Narrow voltage range Three phase (Line to Line; test at 50 Hz)

Voltage	Duration	Compliance Criteria on ICT equipment	Comments
From U_T to 344 V, back to U_T	1 min	Criteria a) Normal performance	Test of minimum operating voltage at "A1" within the normal service voltage range.
From U_T to 440 V, back to U_T	1 min	Criteria a) Normal performance	Test of maximum operating voltage at "A1" within the normal service voltage range.

Table 4: Wide voltage range Single phase (test at 50 Hz and 60 Hz)

Voltage	Duration	Compliance Criteria on ICT equipment	Comments
From U_{TW1min} to 86 V, back to U_{TW1min}	1 min	Criteria a) Normal performance	Test of minimum operating voltage at "A1" within the normal service voltage range.
From U_{TW1max} to 264 V, back to U_{TW1max}	1 min	Criteria a) Normal performance	Test of maximum operating voltage at "A1" within the normal service voltage range.

Table 5: Wide voltage range Three phase (Line to Line; test at 50 Hz and 60 Hz)

Voltage	Duration	Compliance Criteria on ICT equipment	Comments
From U_{TW2min} to 172 V, back to U_{TW2min}	1 min	Criteria a) Normal performance	Test of minimum operating voltage at "A1" within the normal service voltage range.
From U_{TW2max} to 456 V, back to U_{TW2max}	1 min	Criteria a) Normal performance	Test of maximum operating voltage at "A1" within the normal service voltage range.

6.2 Voltages dips

Starting point of the voltage dips shall be positioned at zero crossings.

Table 6: Narrow voltage range Single phase (test at 50 Hz and 60 Hz)

Voltage	Duration	Compliance Criteria on ICT equipment	Comments
From U_T to 197 V, back to U_T	10 ms	Criteria a) Normal performance	Test of minimum operating voltage at "A1" within the normal service voltage range.

Table 7: Narrow voltage range Three phase (Line to Line; test at 50 Hz and 60 Hz)

Voltage	Duration	Compliance Criteria on ICT equipment	Comments
From U_T to 344 V, back to U_T	10 ms	Criteria a) Normal performance	Test of minimum operating voltage at "A1" within the normal service voltage range.

Table 8: Wide voltage range Single phase (test at 50 Hz and 60 Hz)

Voltage	Duration	Compliance Criteria on ICT equipment	Comments
From U_{TW1min} to 86 V, back to U_{TW1min}	10 ms	Criteria a) Normal performance	Test of minimum operating voltage at "A1" within the normal service voltage range.
From U_{TW1max} to 206 V, back to U_{TW1max}	10 ms	Criteria a) Normal performance	Test of minimum operating voltage at "A1" within the normal service voltage range.

Table 9: Wide voltage range Three phase (Line to Line; test at 50 Hz and 60 Hz)

Voltage	Duration	Compliance Criteria on ICT equipment	Comments
From U_{TW2min} to 172 V, back to U_{TW2min}	10 ms	Criteria a) Normal performance	Test of minimum operating voltage at "A1" within the normal service voltage range.
From U_{TW2max} to 357 V, back to U_{TW2max}	10 ms	Criteria a) Normal performance	Test of minimum operating voltage at "A1" within the normal service voltage range.

6.3 Short interruptions

Starting point of the short interruptions shall be positioned at zero crossings.

Table 10: Single phase and three phase (test at 50 Hz and 60 Hz)

Voltage	Supply Network	Duration	Compliance Criteria on ICT equipment	Comments
U_T to 0 V back to U_T	Low Impedance (short circuit)	10 ms	Criteria a) Normal performance	Test of holdup time during fault clearing due to a short-circuit in the system.
U_{TW1min} to 0 V back to U_{TW1min}	Low Impedance (short circuit)	10 ms	Criteria a) Normal performance	Test of holdup time during fault clearing due to a short-circuit in the system.
U_{TW2min} to 0 V back to U_{TW2min}	Low Impedance (short circuit)	10 ms	Criteria a) Normal performance	Test of holdup time during fault clearing due to a short-circuit in the system.
NOTE: Voltage interruption for U_{TW2Max} is not defined because this voltage is very close to U_T value and therefore covered by the voltage interruption at U_T .				

6.4 Voltage surges

Voltage surges may occur at interface "A1" when faults (e.g. short circuits) occur in the power distribution system.

The voltage surges due to short-circuit and protective device clearance are characterized by a voltage drop in the steady state abnormal service voltage range:

- 0 V to 197 V single phase narrow voltage range.
- 0 V to 344 V three phase narrow voltage range.
- 0 V to 86 V single phase wide voltage range.
- 0 V to 172 V three phase wide voltage range.

The voltage drop is followed by an overvoltage often in excess of the maximum steady state abnormal service voltage range and dependent upon the power distribution up to interface "A1" and the ICT equipment connected to interface "A1".

The immunity test method for AC power line ports shall be in accordance to IEC 61000-4-5 [3].

NOTE 1: The purpose of the present clause is thus to address the energy and the subsequent so-called "Fuse blowing transient" associated with a short-circuit condition.

NOTE 2: Other voltage surges induced from other external sources belong to EMC generic requirements.

Table 11: Single phase and three phase (test at 50 Hz only)

Test Voltage	Supply Network	Generator output impedance	Wave shape	Compliance Criteria on ICT equipment	Comments
1 kV	Line to Line	2 Ω	1,2/50 μs (8/20 μs)	Criteria a) Normal performance	Test of voltage rise variation outside abnormal service voltage range (e.g. after fuse blow, switching).
2 kV	Line to Ground	12 Ω	1,2/50 μs (8/20 μs)	Criteria a) Normal performance	Test of voltage rise variation outside abnormal service voltage range (e.g. after fuse blow, switching).
2 kV	Line to Line	2 Ω	1,2/50 μs (8/20 μs)	Criteria b) Temporary loss of function degradation of performance, automatic recovery to Normal Performance after the test	Test of automatic system recovery after a line-to-line short-circuit condition.
4 kV	Line to Ground	12 Ω	1,2/50 μs (8/20 μs)	Criteria b) Temporary loss of function degradation of performance, automatic recovery to Normal Performance after the test	Test of automatic system recovery after a line-to-ground (line-to-PE) short-circuit condition.

NOTE 3: Lengthening of the interruption to service (equipment is not functioning as intended) due to the recovery of software should be declared in the test report (i.e. details about the service interruption).

NOTE 4: To prevent system malfunctioning additional arrangements concerning the power supply system may be necessary.

- For example:
 - Dual feeding system.
 - Independent power distribution.

NOTE 5: Special precautions are normally taken in power distribution network to fulfil compliance criteria a) for mission critical ICT equipment i.e. to prevent functional disturbances due to the voltage surges treated in the present clause.

Five positive and five negative impulses shall be applied at each: 0° , 90° , 270° . When testing 3-phase systems, the synchronization of phase angles shall be taken from the same line under test, e.g. when applying surge impulses between L2 and L3, the phase angle synchronization shall be the voltage between L2 and L3.

7 AC Supply protection on interface "A1"

The supply at interface "A1" shall be protected, (when operating on AC current), by AC rated fuses in compliance with IEC 60269-1 [2] or AC rated circuits breakers in compliance with IEC 60947-2 [1].

NOTE: IEC 60269-1 [2] or IEC 60947-2 [1] are used for industrial installations, compared to IEC 60898-1 [i.9] and IEC 60898-2 [i.10] which are relevant to household installations (Noise free environment).

Annex D gives a guideline on the selection and sizing of the over-current protective devices.

The energy content of the inrush current shall also be taken into account when specifying the power supply system up to interface "A1".

8 Maximum steady state current I_m in the normal service voltage range at interface "A1"

I_m is defined for fully equipped and fully loaded ICT equipment considering the following requirements:

- the maximum steady state I_m shall be measured in the applicable normal service voltage ranges defined in clause 5.2.

NOTE 1: The maximum steady state current I_m should be measured after the inrush current has decayed, which is expected after a time of 1 s.

NOTE 2: Fully equipped and loaded equipment is defined by the manufacturer. For customer equipment, there can be restricted performance at lower voltage range.

9 Inrush current on interface "A1"

9.1 Limits

The ratio of the instantaneous surge current I_t to maximum current I_m at interface "A1", under any random sequence of switching operations, shall not exceed the limits shown in figure 2.

The parameters are defined as follows:

- I_t inrush current (magnitude of instantaneous values);
- I_m maximum input current (at AC RMS), stated by the manufacturer, for a fully-equipped and loaded system block behind interface "A1".

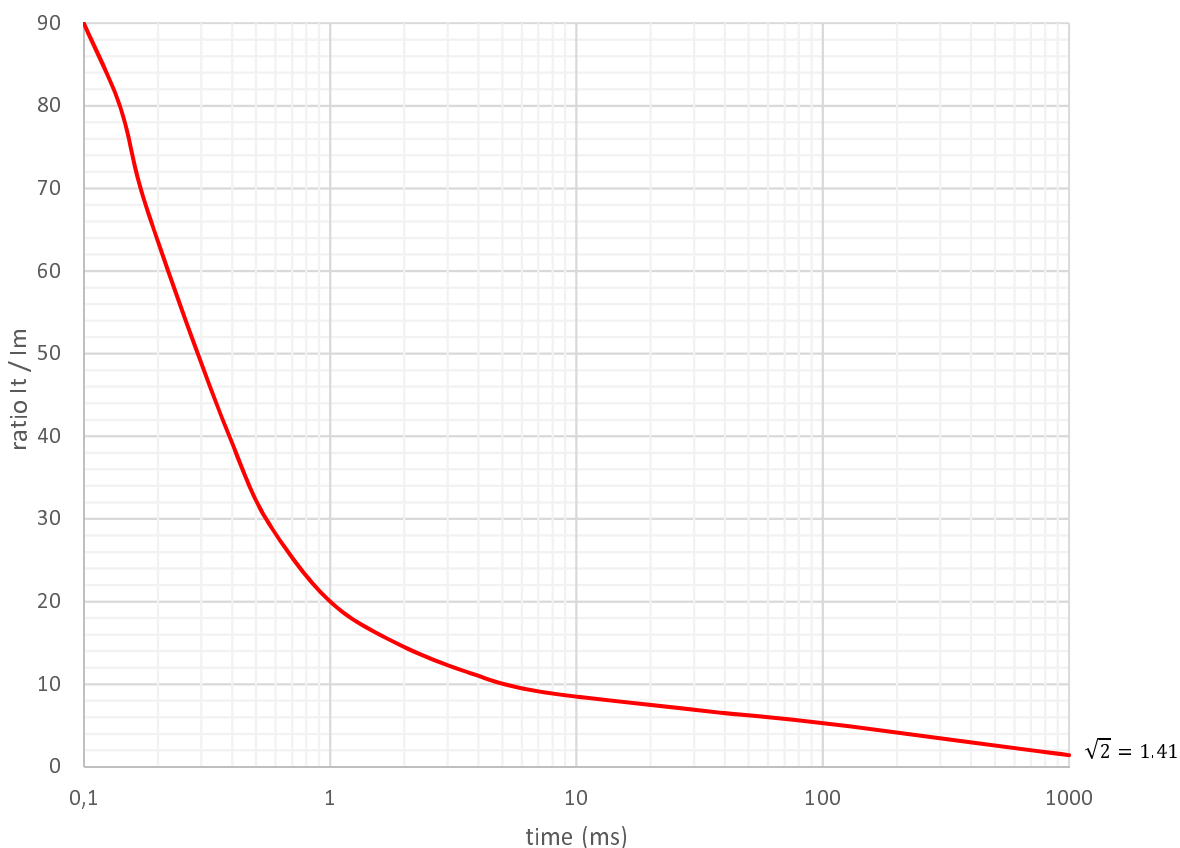

Figure 2: Maximum (absolute magnitude) inrush current characteristic for telecommunications equipment

9.2 Measurement method

The circuit for measuring the surge current drawn by the equipment shall be as shown in figure 3. The measurement shall be made with the telecommunications equipment powered at the nominal secondary voltage and rated load condition (annex G gives guidance on taking these measurements).

Test conditions:

- If the current sensor is a resistor, the value of the resistance R shall be reduced by the value of the resistance of the current sensor.
- Values for I_m , R and L are:
 - R = 200 m Ω +/- 10% (approximately 10 metres 2 x 1,5 mm² copper wiring).
 - L = 10 μ H +/- 10 % (approximately 10 metres 2 x 1,5 mm² copper wiring).
 - I_m (as specified by the manufacturer).
 - The impedance of the supply network depends on the impedance of the conductors and the fuses. While carrying out the surge current test, the RMS AC voltage at the input of the LISN, as shown in figure 3, should remain within limits by using a power supply with a low impedance in relation to that of the LISN.

NOTE 1: The LISN in figure 3 can have L and R on one line or L/2 and R/2 on each line.

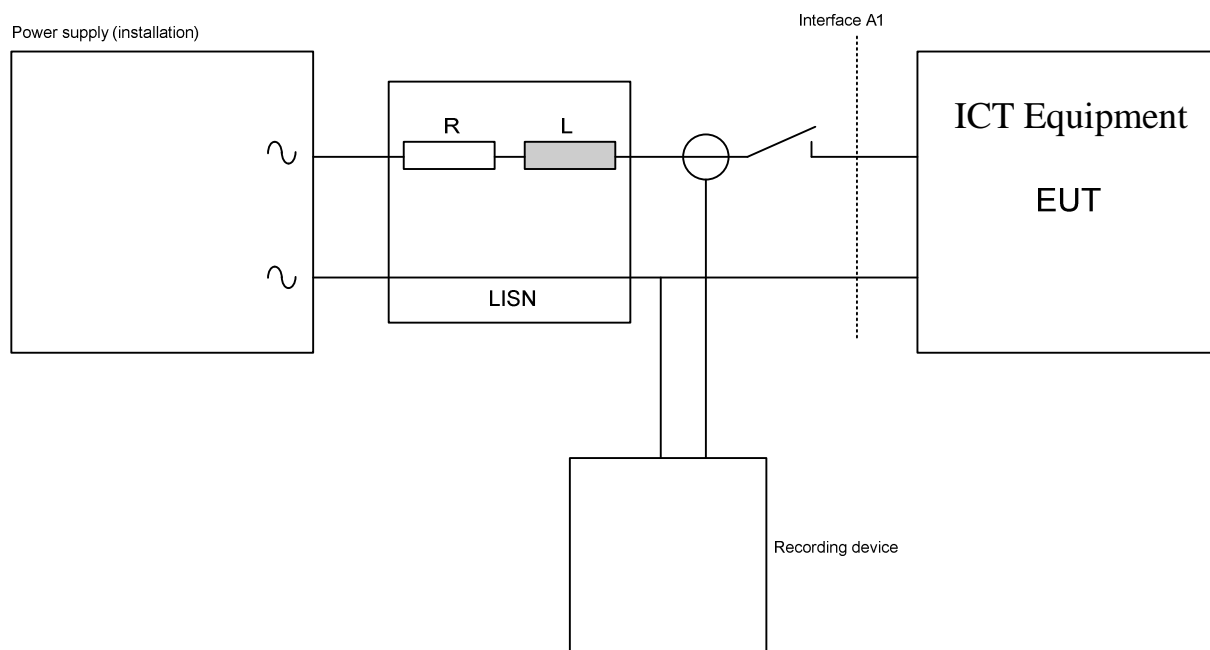

Figure 3: Surge current test circuit for AC interfaces on single phase AC equipment

NOTE 2: For equipment with 3 phase AC power interfaces, the testing circuit shown in figure 3 needs to be duplicated for each phase.

9.3 Protective device ratings

The energy content of the inrush characteristic shall be taken into account when specifying the equipment and the protective devices between the power plant output and interface "A1".

10 Earthing and Bonding

Earthing and bonding of telecommunications ICT equipment operated by AC current are not covered by the present document.

NOTE: Earthing and bonding for Alternating Current (AC) source system are defined in IEC 60364-5-54 [i.11].

11 Electrical Safety requirements

The safety requirements are not covered by the present document.

12 EMC requirements at the input of ICT equipment

EMC requirements are not covered by the present document.

Annex A (informative): ICT power supply configurations providing a unified power interface in the present document

The increase of service and the new packet switching network has led to more ICT equipment in the same existing telecommunication centres. The power consumption related to the standard phone services with telecommunications ICT equipment in -48 V decreases, but the power needed by these new services and packet networks increases and the power interface is generally AC voltage, the standard interface in the computer field.

Moreover, the density of electronic integration in telecommunication and computer fields increases, requiring more power density. Generally higher current is needed on the powering wire.

As a consequence, the nominal voltages proposed in the present document have been defined with consideration to the:

- need to unify the power supply of the ICT equipment and the Information Technology Equipment;
- desire to decrease the losses in the power distribution wire as well as copper cross-section;
- need to maintain a highly reliable power source for telecommunication centres or data-centres;
- enabling the use of the same AC interface in customer premises for powering ICT equipment.

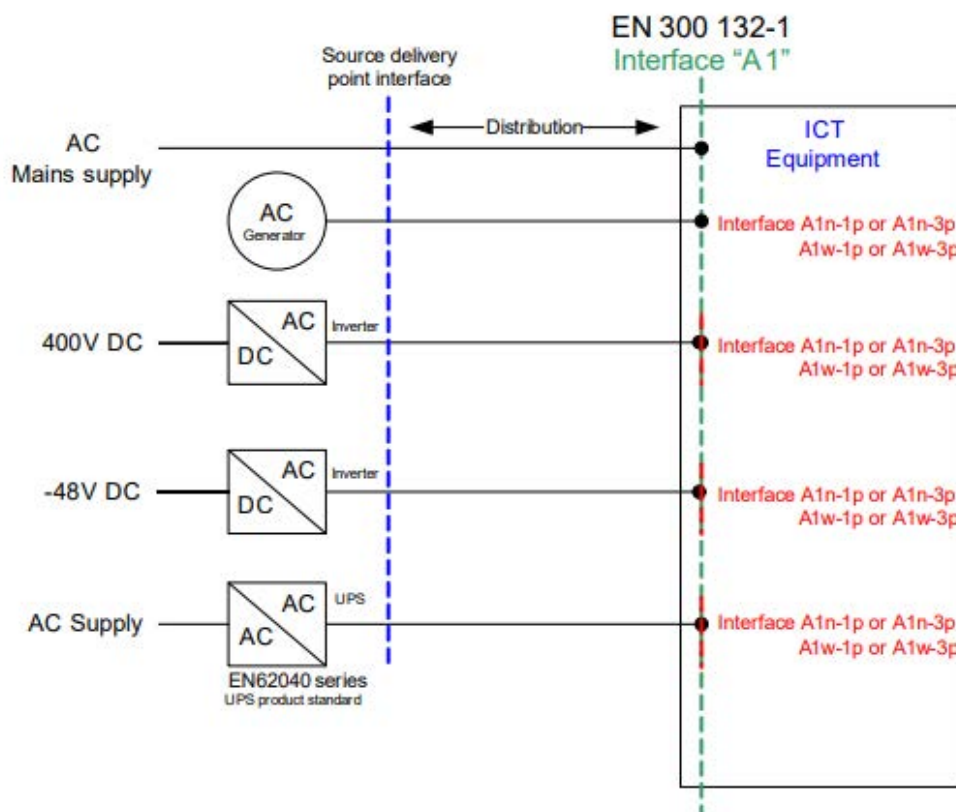

Figure A.1: Different power sources for power interface defined in the present document

NOTE 1: For standardized AC range, refer to clause 5.

The corresponding power supply can be based on a range of different configurations as seen on figure A.1 including:

- mains;
- back-up generator (e.g. diesel generator);
- 400 VDC input inverter;
- -48 VDC input inverter;

NOTE 2: Previously in the ETSI ETS 300 132-1 [i.1].

- AC UPS;
- inverter using renewable energy of photovoltaic type;
- any redundancy and modularity of the previous solution.

Selection should take account of voltage drop in the distribution system.

Annex B (normative): Identification of interface "A1"

The identification of Interface "A1" shall be the terminals at which the telecommunications ICT equipment is connected to the power supply as shown in figure B.1.

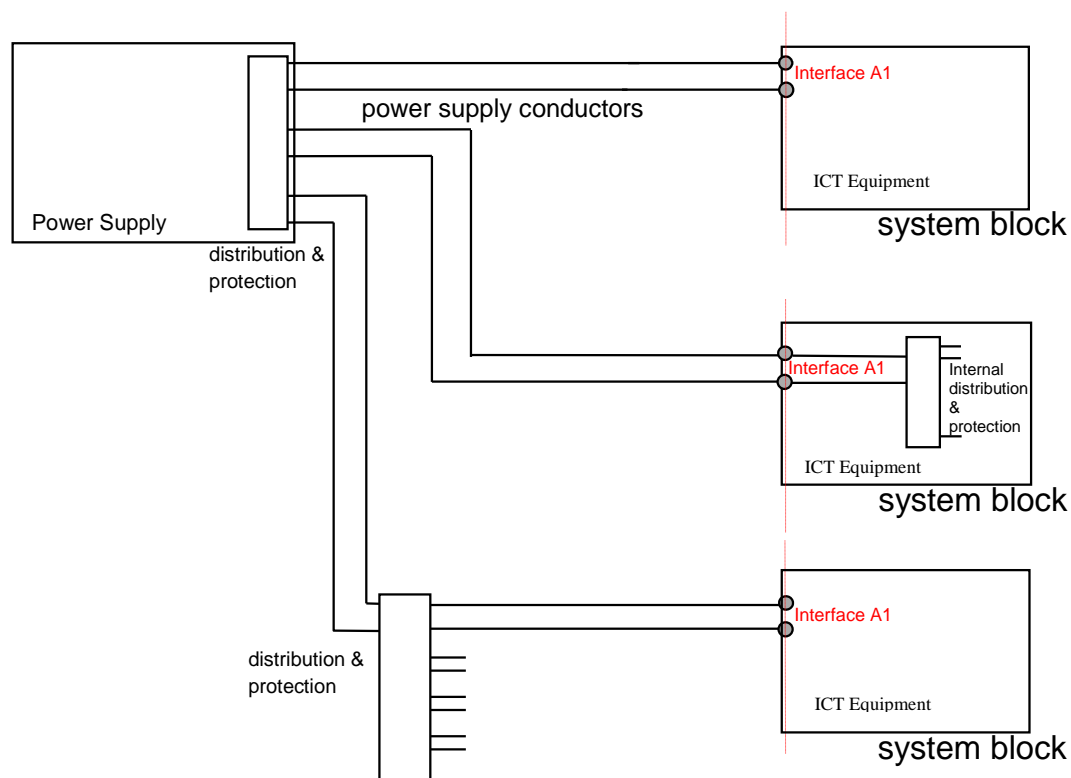

NOTE 1: The figure is a drawing of the power system and does not show the PE conductor.

NOTE 2: In normal operation the voltage at the output of the power supply is always higher than the voltage at the interface "A1", due to voltage drop in the distribution cables.

Figure B.1: Identification of interface "A1" (three possible configurations)

Annex C (informative): Calculation of the extreme AC voltage range at interface "A1"

- The minimum normal voltage is equal to minimum AC voltage single and 3 phase narrow and wide range on mains minus the maximum voltage drop (-4 %) in the cables.
- This recommended max voltage drop may be overridden by a smaller voltage drop determined by the safety rules in IEC 60364 series [i.11] stipulating max current carrying capacity cable withstand temperature, ambient temperature, laying of the cable (dense or free).
- The minimum normal voltage is then set at narrow or wide minimum value at the input of ICT equipment with some margin.

Annex D (informative): Dimensioning of over-current protective devices

It is common practice to use fuses or breakers in the AC network distribution with a nominal trip value, which is superior to 1,25 times I_m , where I_m is the maximum input current (at AC RMS), stated by the manufacturer, for a fully-equipped and loaded system block behind interface "A1".

This takes into account:

- Maximum load current at negative tolerances plus voltage drop in the installation e.g. 230 VAC (-10 % plus -4 %).
- A safety factor of 0,8 that includes temporary overload, technology, ageing, de-latch current, nuisance tripping, etc.

NOTE: Temperature derating factor should be additionally considered depending on chosen technology for the protective device.

Annex E (normative): Test generator for voltage dips, short interruptions and voltage variations

The specification of the test generator should be in accordance with IEC 61000-4-11 [4]:

- Short interruptions, dips, and variations of the output voltage: as given in tables in clauses 6.1, 6.2 and 6.3.
- Output voltage variation with the load (0 to rated current): less than 5 %.
- Ripple content: less than 1 % of the output voltage.
- Rise and fall time of the voltage change, generator loaded with 100 ohm resistive load: between 1,2 μ s and 50 μ s.
- Overshoot/undershoot of the output voltage, generator loaded with 100 ohm resistive load: less than 10 % of the change in voltage.
- Output current (steady state) (I_o): up to 25 A.

NOTE: The slew rate of the voltage change at the output of the generator can range from a few V/ μ s up to hundreds V/ μ s, depending on the output voltage change.

The test generator steady state power/current capability should be at least 20 % greater than the EUT power/current ratings.

The test generator, during the generation of short interruptions, shall be able to:

- operate in "low impedance" condition, using test generator defined in IEC 61000-4-11 [4], absorbing inrush current from the load (if any); or
- operate in "high impedance" condition, (i.e. open switch/circuit), blocking reverse current from the load.

Annex F (informative): Details of the voltage surges measurement in the most common case of distribution and protective devices

A protective device operation transient results from a low impedance fault to ground on the equipment side of a protective device (fuse or circuit breaker) connected to a power distribution bus. The bus voltage is reduced due to high current flowing to ground through the protective device and the short ground. When the protective device opens, the release energy stored in the inductance of the bus causes an initial high voltage overshoot of short duration, followed by a longer interval voltage overshoot that decays toward the steady state bus voltage.

In the present document, in clause 6.4, tests are defined to verify the susceptibility of the equipment when a short circuit or overload condition occurs on the power distribution bus.

Annex G (informative): Guide for measuring inrush current and for transferring the recorded pulses onto the limit chart

G.1 Measurement

- a) Use a storage oscilloscope which can record values of dI/dt of at least $10 \text{ A}/\mu\text{s}$.
- b) When measuring the AC supply, record the first or highest pulse. As with the dc measurements, a sufficiently long time-base should be used to allow pulse width measurements to be taken. The peak value of the pulse train for a duration of 1 second should be recorded (refer to figure G.1).
- c) Several readings should be taken to ensure that the worst case value is recorded.

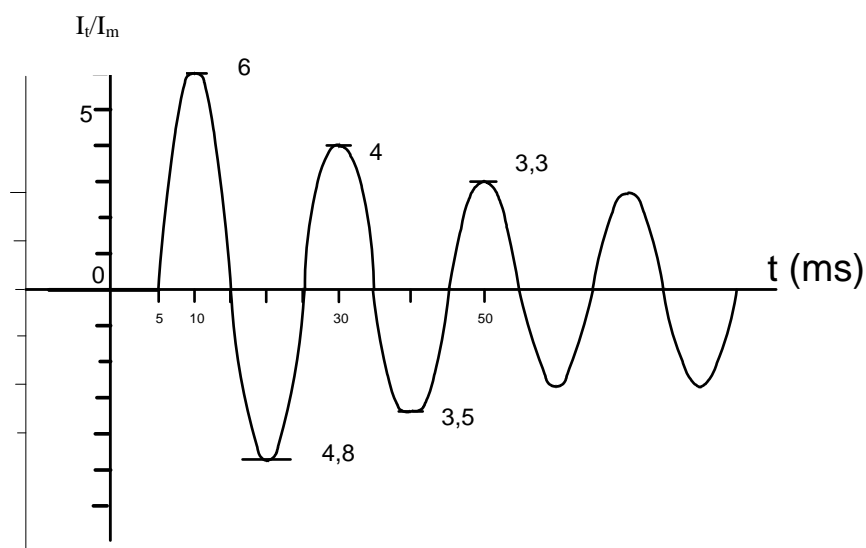

Figure G.1: Typical current pulse train and associated measurements

G.2 Pulse waveform transformation

- a) Pulse train:
 - For a pulse train from the AC supply measurements, (as in figure G.1) proceed as follows:
 - use the pulse train from the worst case measurement;
 - measure the peak value (I_t) of each pulse;
 - produce the ratios for (I_t/I_m);
 - plot the (I_t/I_m) values onto figure 2 using the start of the first pulse as reference for the time origin.
- b) Highest pulse from the AC system:
 - measure the width of the current pulse at different levels;
 - plot the current ratios against their corresponding time values onto figure 2.
- c) Figure G.2 shows the AC pulse train from figure G.1 transferred onto the limit chart of figure 2.

NOTE: Occasionally, more than one inrush pulse may appear, due to special arrangements for limiting the amplitude of single pulses or because the load (telecommunications equipment) starts in sequences. Under these conditions, the limit should be interpreted separately for each different start-up sequence where there is more than 1 second between each. The protective device in the distribution network should not operate.

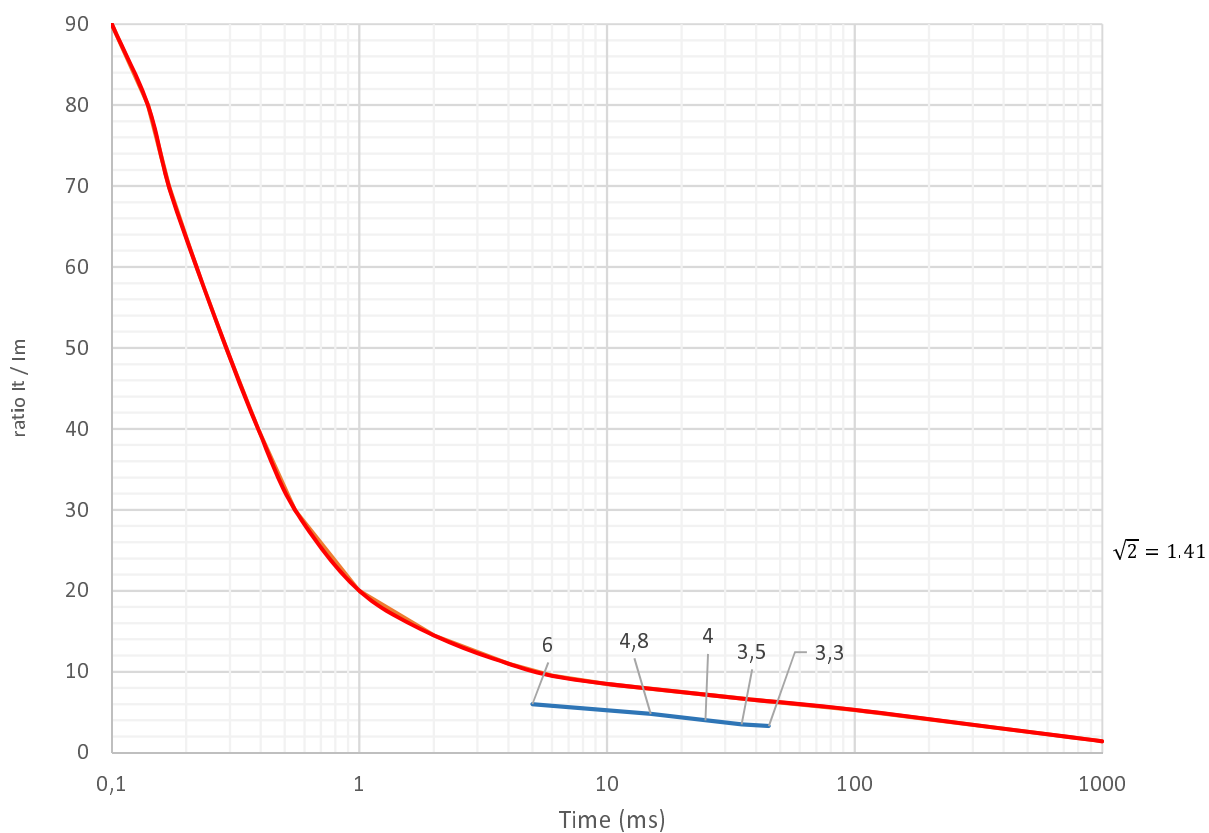

Figure G.2: Maximum values for typical inrush currents plotted against limit curve

History

Document history		
Edition 1	September 1996	Publication as ETSI ETS 300 132-1
V2.1.1	March 2019	Publication
V2.1.6	August 2022	EN Approval Procedure AP 20221030: 2022-08-01 to 2022-10-31