

EN 300 130-1 V1.2.4 (1998-06)

European Standard (Telecommunications series)

**Integrated Services Digital Network (ISDN);
Malicious Call Identification (MCID) supplementary service;
Digital Subscriber Signalling System No. one (DSS1) protocol;
Part 1: Protocol specification**



Reference

REN/SPS-05145-N-1 (17c90iqo.PDF)

Keywords

ISDN, MCID, DSS1, supplementary service

ETSI

Postal address

F-06921 Sophia Antipolis Cedex - FRANCE

Office address

650 Route des Lucioles - Sophia Antipolis
Valbonne - FRANCE
Tel.: +33 4 92 94 42 00 Fax: +33 4 93 65 47 16
Siret N° 348 623 562 00017 - NAF 742 C
Association à but non lucratif enregistrée à la
Sous-Préfecture de Grasse (06) N° 7803/88

Internet

secretariat@etsi.fr
<http://www.etsi.fr>
<http://www.etsi.org>

Copyright Notification

No part may be reproduced except as authorized by written permission.
The copyright and the foregoing restriction extend to reproduction in all media.

© European Telecommunications Standards Institute 1998.
All rights reserved.

Contents

Intellectual Property Rights.....	4
Foreword.....	4
1 Scope	6
2 Normative references.....	6
3 Definitions	7
4 Abbreviations.....	7
5 Description	7
6 Operational requirements	7
6.1 Provision and withdrawal.....	7
6.2 Requirements on the originating network side.....	7
6.3 Requirements on the destination network side	8
7 Coding requirements.....	8
8 State definitions.....	8
9 Signalling procedures at the coincident S and T reference point	8
9.1 Activation, deactivation and registration	8
9.2 Invocation procedures.....	9
9.2.1 Normal operation	9
9.2.2 Exceptional procedures	9
10 Procedures for interworking with private ISDNs	9
11 Interactions with other networks.....	9
12 Interactions with other supplementary services.....	10
13 Parameter values (timers).....	10
14 Dynamic description (SDL diagrams).....	11
Annex A (informative): Signalling flows	12
Annex B (informative): mCIDRequest components.....	13
Annex C (informative): Changes with respect to the previous ETS 300 130-1.....	15
History.....	16

Intellectual Property Rights

IPRs essential or potentially essential to the present document may have been declared to ETSI. The information pertaining to these essential IPRs, if any, is publicly available for **ETSI members and non-members**, and can be found in SR 000 314: "*Intellectual Property Rights (IPRs); Essential, or potentially Essential, IPRs notified to ETSI in respect of ETSI standards*", which is available **free of charge** from the ETSI Secretariat. Latest updates are available on the ETSI Web server (<http://www.etsi.fr/ipr> or <http://www.etsi.org/ipr>).

Pursuant to the ETSI IPR Policy, no investigation, including IPR searches, has been carried out by ETSI. No guarantee can be given as to the existence of other IPRs not referenced in SR 000 314 (or the updates on the ETSI Web server) which are, or may be, or may become, essential to the present document.

Foreword

This European Standard (Telecommunications series) has been produced by ETSI Technical Committee Signalling Protocols and Switching (SPS).

The present document is part 1 of a multi-part standard covering the Digital Subscriber Signalling System No. one (DSS1) protocol specification for the Integrated Services Digital Network (ISDN) Malicious Call Identification (MCID) supplementary service, as described below:

Part 1: "Protocol specification";

Part 2: "Protocol Implementation Conformance Statement (PICS) proforma specification";

Part 3: "Test Suite Structure and Test Purposes (TSS&TP) specification for the user";

Part 4: "Abstract Test Suite (ATS) and partial Protocol Implementation eXtra Information for Testing (PIXIT) proforma specification for the user";

Part 5: "Test Suite Structure and Test Purposes (TSS&TP) specification for the network";

Part 6: "Abstract Test Suite (ATS) and partial Protocol Implementation eXtra Information for Testing (PIXIT) proforma specification for the network".

In accordance with CCITT Recommendation I.130, the following three level structure is used to describe the supplementary telecommunication services as provided by European public telecommunications operators under the pan-European Integrated Services Digital Network (ISDN):

- Stage 1: is an overall service description, from the user's stand-point;
- Stage 2: identifies the functional capabilities and information flows needed to support the service described in stage 1; and
- Stage 3: defines the signalling system protocols and switching functions needed to implement the service described in stage 1.

The present document details the stage 3 aspects (signalling system protocols and switching functions) needed to support the Malicious Call Identification (MCID) supplementary service. The stage 1 and stage 2 aspects are detailed in ETS 300 128 and ETS 300 129, respectively.

The present version updates the references to the basic call specifications.

National transposition dates

Date of adoption of this EN:	19 June 1998
Date of latest announcement of this EN (doa):	30 September 1998
Date of latest publication of new National Standard or endorsement of this EN (dop/e):	31 March 1999
Date of withdrawal of any conflicting National Standard (dow):	31 March 1999

1 Scope

This first part of EN 300 130 specifies the stage three of the Malicious Call Identification (MCID) supplementary service for the pan-European Integrated Services Digital Network (ISDN) as provided by European public telecommunications operators at the T reference point or coincident S and T reference point (as defined in CCITT Recommendation I.411 [1]) by means of the Digital Subscriber Signalling System No. one (DSS1) protocol. Stage three identifies the protocol procedures and switching functions needed to support a telecommunication service (see CCITT Recommendation I.130 [2]).

In addition the present document specifies the protocol requirements at the T reference point where the service is provided to the user via a private ISDN.

The present document does not specify the additional protocol requirements where the service is provided to the user via a telecommunications network that is not an ISDN.

The MCID supplementary service enables a user to request that the source of an incoming call is identified and registered in the network.

The MCID supplementary service is applicable to all circuit-switched telecommunication services.

Further parts of the present document specify the method of testing required to identify conformance to the present document.

The present document is applicable to equipment supporting the MCID supplementary service, to be attached at either side of a T reference point or coincident S and T reference point when used as an access to the public ISDN.

2 Normative references

References may be made to:

- a) specific versions of publications (identified by date of publication, edition number, version number, etc.), in which case, subsequent revisions to the referenced document do not apply; or
- b) all versions up to and including the identified version (identified by "up to and including" before the version identity); or
- c) all versions subsequent to and including the identified version (identified by "onwards" following the version identity); or
- d) publications without mention of a specific version, in which case the latest version applies.

A non-specific reference to an ETS shall also be taken to refer to later versions published as an EN with the same number.

- [1] CCITT Recommendation I.411 (1988): "ISDN user-network interfaces - Reference configurations".
- [2] CCITT Recommendation I.130 (1988): "Method for the characterisation of telecommunication services supported by an ISDN and network capabilities of an ISDN".
- [3] EN 300 195-1: "Integrated Services Digital Network (ISDN); Supplementary service interactions; Digital Subscriber Signalling System No. one (DSS1) protocol; Part 1: Protocol specification".
- [4] CCITT Recommendation Z.100 (1988): "Functional Specification and Description Language (SDL)".
- [5] EN 300 403-1: "Integrated Services Digital Network (ISDN); Digital Subscriber Signalling System No. one (DSS1) protocol; Signalling network layer for circuit-mode basic call control; Part 1: Protocol specification [ITU-T Recommendation Q.931 (1993), modified]".
- [6] EN 300 196-1: "Integrated Services Digital Network (ISDN); Generic functional protocol for the support of supplementary services; Digital Subscriber Signalling System No. one (DSS1) protocol; Part 1: Protocol specification".

- [7] CCITT Recommendation I.210: "Principles of telecommunication services supported by an ISDN and the means to describe them".
- [8] CCITT Recommendation I.112: "Vocabulary of terms for ISDN".
- [9] CCITT Recommendation X.208 (1988): "Specification of Abstract Syntax Notation One (ASN.1)".
- [10] CCITT Recommendation I.330 (1988): "ISDN Numbering and Addressing Principles".
- [11] CCITT Recommendation X.219 (1988): "Remote Operations: Model, Notation and Service Definition".

3 Definitions

For the purposes of the present document, the following definitions apply:

call information: Call information consists of the called party number, the calling party number, the time and date of the request, and, as a network option, the calling party subaddress, if provided by the calling user.

Integrated Services Digital Network (ISDN): See CCITT Recommendation I.112 [8], § 2.3, definition 308.

network: The DSS1 protocol entity at the network side of the user-network interface.

service; telecommunication service: See CCITT Recommendation I.112 [8], § 2.2, definition 201.

subaddress: See CCITT Recommendation I.330 [10], § 5.4.

supplementary service: See CCITT Recommendation I.210 [7], § 2.4.

user: The DSS1 protocol entity at the user side of the user-network interface.

4 Abbreviations

For the purposes of the present document, the following abbreviations apply:

ASN.1	Abstract Syntax Notation One
DSS1	Digital Subscriber Signalling System No. one
ISDN	Integrated Services Digital Network
MCID	Malicious Call Identification

5 Description

The MCID supplementary service shall allow, by an appropriate user request, the storage and registration of the call information.

6 Operational requirements

6.1 Provision and withdrawal

The MCID supplementary service shall be provided and withdrawn after prior arrangement with the administration.

6.2 Requirements on the originating network side

Not applicable.

6.3 Requirements on the destination network side

Not applicable.

7 Coding requirements

Table 1 shows the definition of the operation required for the MCID supplementary service using ASN.1 as defined in CCITT Recommendation X.208 [9] and using the OPERATION macro as defined in CCITT Recommendation X.219 [11], figure 4/X.219.

Table 1

```

MCID-Operations {ccitt identified-organization etsi (0) 130 operations-and-errors (1)}
DEFINITIONS ::=
BEGIN
EXPORTS
    MCIDRequest;
IMPORTS
    OPERATION
    FROM Remote-Operation-Notation
        {joint-iso-ccitt remote-operations(4) notation (0)}
    notAvailable,
    notSubscribed,
    invalidCallState,
    notIncomingCall,
    supplementaryServiceInteractionNotAllowed
    FROM General-Errors
        {ccitt identified-organization etsi (0) 196 general errors};
MCIDRequest ::=
    OPERATION
    RESULT
    ERRORS {notSubscribed,
            notAvailable,
            invalidCallState,
            notIncomingCall,
            supplementaryServiceInteractionNotAllowed}
mCIDRequest MCIDRequest ::= 3
END -- of MCID-Operations

```

8 State definitions

The states associated with basic call control according to EN 300 403-1 [5] shall apply.

9 Signalling procedures at the coincident S and T reference point

9.1 Activation, deactivation and registration

Not applicable.

9.2 Invocation procedures

9.2.1 Normal operation

To invoke the MCID supplementary service the called user shall send a mCIDRequest invoke component carried by a Facility information element in a FACILITY message according to the procedures of subclause 8.3.1.1 of EN 300 196-1 [6].

To indicate that the service has been accepted the network shall send a mCIDRequest return result component carried by a Facility information element in a FACILITY message according to the procedures of subclause 8.3.1.1 of EN 300 196-1 [6].

The FACILITY message shall be sent using the call reference as used for the previous call control messages for the call for which the MCID supplementary service is to be invoked.

9.2.2 Exceptional procedures

If the mCIDRequest invoke component is received from the called party in any other state than the Active state (N10) or the Disconnect Indication state (N12), then the network shall not invoke the MCID supplementary service and shall send a mCIDRequest return error component carried by a Facility information element in a FACILITY message according to the procedures of subclause 8.3.1.1 of EN 300 196-1 [6]. The error shall indicate "invalidCallState".

If the MCID supplementary service is not subscribed, the network shall send a mCIDRequest return error component carried by a Facility information element in a FACILITY message according to the procedures of subclause 8.3.1.1 of EN 300 196-1 [6]. The error shall indicate "notSubscribed".

If the MCID supplementary service is invoked for an outgoing call, the network shall send a mCIDRequest return error component carried by a Facility information element in a FACILITY message according to the procedures of subclause 8.3.1.1 of EN 300 196-1 [6]. The error shall indicate "notIncomingCall".

If the network receives from the user a RELEASE message before sending a mCIDRequest return result or return error component in response to the previous invoke component, the network shall process the mCIDRequest invoke component as appropriate, however the network may send an indication of the result of the invocation by including the appropriate component carried by a Facility information element in the RELEASE COMPLETE message according to the procedures of subclause 8.3.1.1 of EN 300 196-1 [6].

If it is not possible to register any call information, the network shall send a mCIDRequest return error component carried by a Facility information element in a FACILITY message according to the procedures of subclause 8.3.1.1 of EN 300 196-1 [6]. The error shall indicate "notAvailable".

If the MCID supplementary service is invoked when another supplementary service is already activated or has already been invoked, and the network does not allow this MCID supplementary service invocation in combination with the other supplementary service, the network shall send a mCIDRequest return error component carried by a Facility information element in a FACILITY message according to the procedures of subclause 8.3.1.1 of EN 300 196-1 [6]. The error shall indicate "supplementaryserviceInteractionNotAllowed".

10 Procedures for interworking with private ISDNs

The procedures as specified in subclause 9.2 shall apply.

11 Interactions with other networks

No impact.

12 Interactions with other supplementary services

The interactions of the MCID supplementary service with other supplementary services shall be as specified in EN 300 195-1 [3].

13 Parameter values (timers)

The timers associated with basic call control according to EN 300 403-1 [5] shall apply.

14 Dynamic description (SDL diagrams)

The dynamic description of the MCID supplementary service shall be as shown in figure 1, according to the Specification and Description Language (SDL) specified in CCITT Recommendation Z.100 [4].

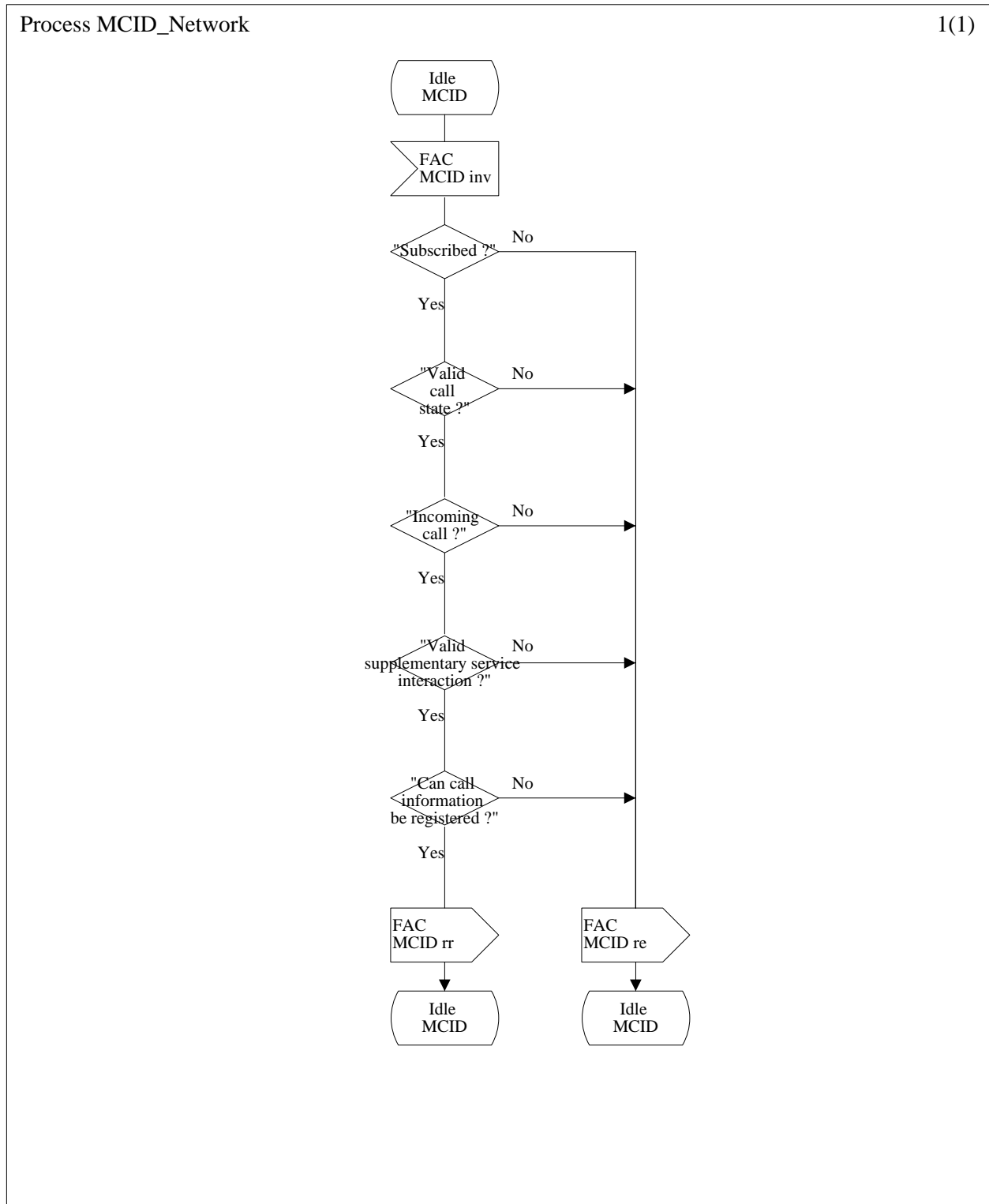

Figure 1: MCID supplementary service network side dynamic description

Annex A (informative): Signalling flows

Example signalling flows for the MCID supplementary service are shown in figures A.1 and A.2.

Key to figures A.1 and A.2

Layer three messages:

CONN	CONNECT
CONN ACK	CONNECT ACKNOWLEDGE
FAC	FACILITY
REL	RELEASE
REL COMP	RELEASE COMPLETE

Layer three message information elements/parameters:

CR	Call Reference
inv	invoke component type
rr	return result component type

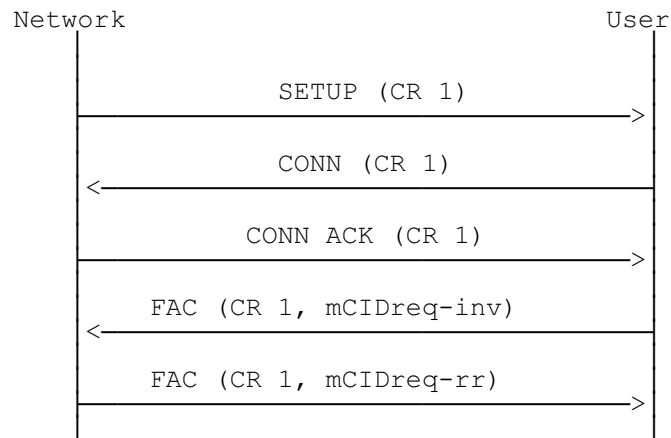

Figure A.1: Successful MCID supplementary service invocation during the Active state (N10, U10)

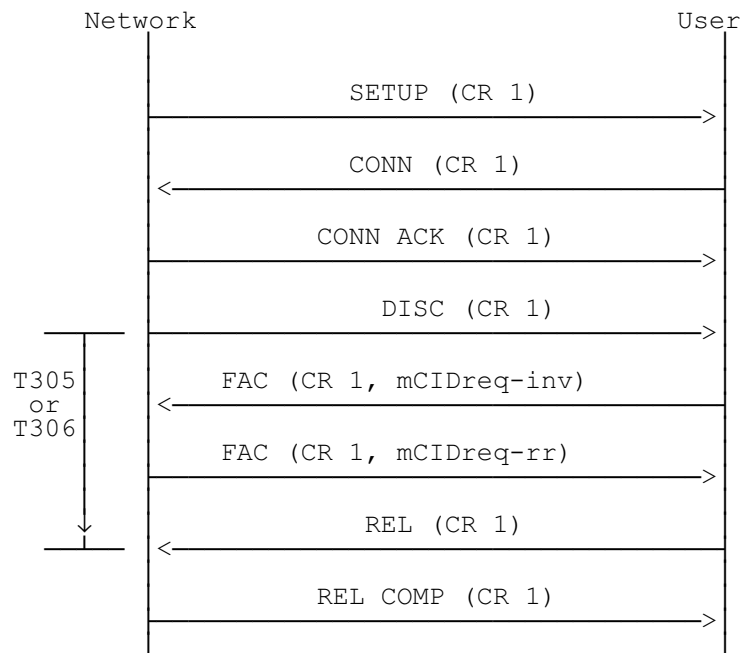
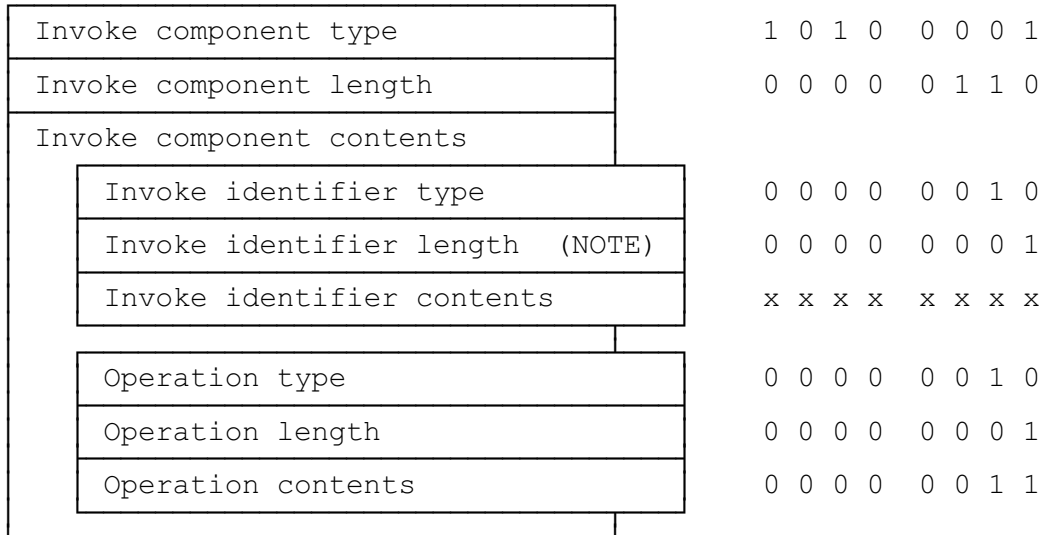

Figure A.2: Successful MCID supplementary service invocation during the Disconnect Indication state (N12)

Annex B (informative): mCIDRequest components

Example component structures for the MCID supplementary service are shown in figures B.1, B.2 and B.3.

In cases of discrepancies between this annex and clause 7. Clause 7 is considered as the prime source.



NOTE: The length of the invoke identifier is either 1 or 2 octets.

Figure B.1: Example mCIDRequest invoke component

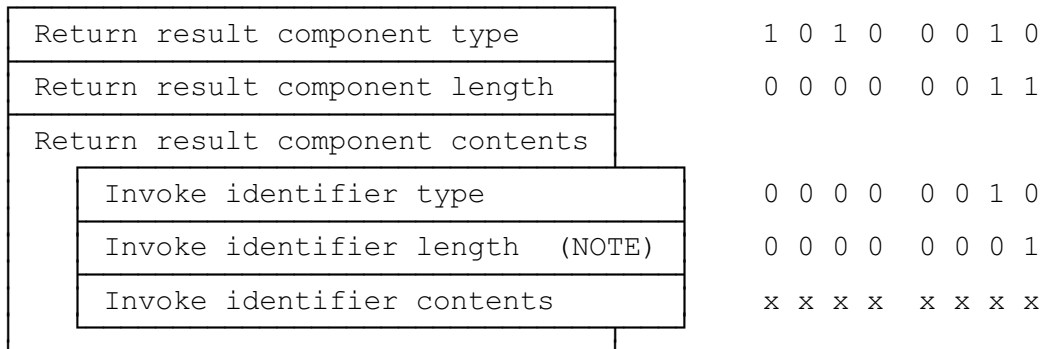

NOTE: The length of the invoke identifier is either 1 or 2 octets.

Figure B.2: Example mCIDRequest return result component

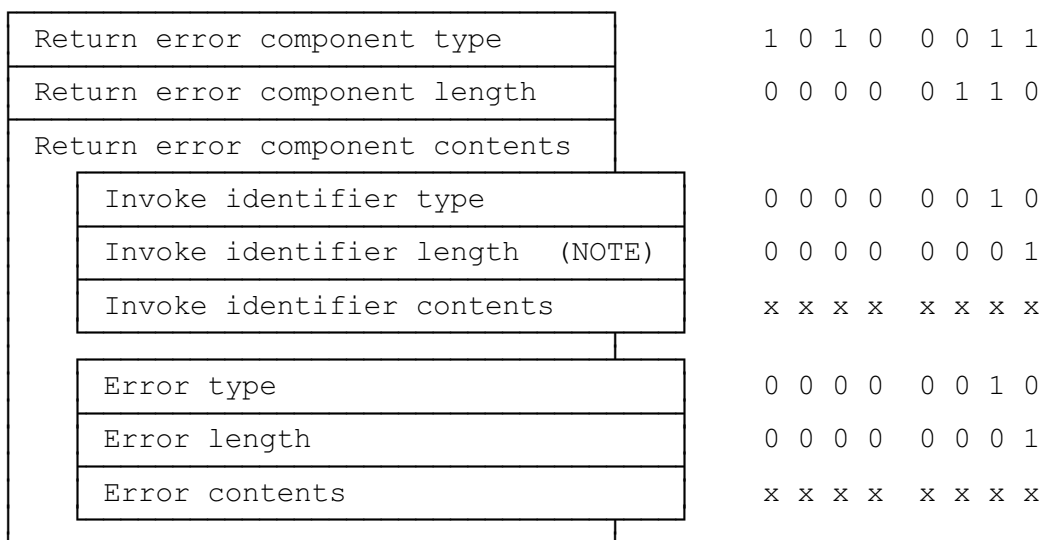

NOTE: The length of the invoke identifier is either 1 or 2 octets.

Figure B.3: Example mCIDRequest return error component

Annex C (informative): Changes with respect to the previous ETS 300 130-1

The following changes have been done:

- conversion to EN layout;
- replacement of references to ETS 300 102 with EN 300 403;
- substitution of non-specific references to basic standards where the intention is to refer to the latest version.

History

Document history		
Edition 1	May 1992	Publication as ETS 300 130-1
V1.2.3	February 1998	One-step Approval Procedure OAP 9824: 1998-02-13 to 1998-06-12
V1.2.4	June 1998	Publication