

Draft **EN 300 127** V1.2.1 (1998-11)

---

*European Standard (Telecommunications series)*

**Electromagnetic compatibility  
and Radio spectrum Matters (ERM);  
Radiated emission testing of physically large  
telecommunication systems**

---



---

**Reference**

REN/ERM-EMC-112 (16c00ioo.PDF)

---

**Keywords**

emc, emission

**ETSI**

---

**Postal address**

F-06921 Sophia Antipolis Cedex - FRANCE

---

**Office address**

650 Route des Lucioles - Sophia Antipolis  
Valbonne - FRANCE  
Tel.: +33 4 92 94 42 00 Fax: +33 4 93 65 47 16  
Siret N° 348 623 562 00017 - NAF 742 C  
Association à but non lucratif enregistrée à la  
Sous-Préfecture de Grasse (06) N° 7803/88

---

**Internet**

secretariat@etsi.fr  
Individual copies of this ETSI deliverable  
can be downloaded from  
<http://www.etsi.org>

---

**Copyright Notification**

No part may be reproduced except as authorized by written permission.  
The copyright and the foregoing restriction extend to reproduction in all media.

© European Telecommunications Standards Institute 1998.  
All rights reserved.

---

# Contents

Intellectual Property Rights.....	4
Foreword .....	4
1 Scope.....	5
2 References.....	5
3 Definitions and abbreviations .....	5
3.1 Definitions .....	5
3.2 Abbreviations.....	6
4 Requirements .....	6
4.1 Determination of minimum representative system.....	6
4.2 New functional modules .....	6
5 General operational conditions .....	6
5.1 Equipment configuration.....	6
5.1.1 Equipment boundary .....	7
5.2 Equipment cable layout.....	7
5.2.1 Intra-system cabling .....	7
5.2.2 Interface cabling.....	7
5.2.2.1 Unscreened cable systems .....	7
5.2.2.1.1 Overhead cable systems .....	8
5.2.2.1.2 Raised floors .....	8
5.2.2.2 Screened cable systems.....	8
5.3 Exercising equipment.....	8
5.4 Laboratory environment.....	8
6 Test results report.....	9
7 Test site requirements .....	9
8 Measurement method.....	10
History .....	16

---

## Intellectual Property Rights

IPRs essential or potentially essential to the present document may have been declared to ETSI. The information pertaining to these essential IPRs, if any, is publicly available for **ETSI members and non-members**, and can be found in SR 000 314: *"Intellectual Property Rights (IPRs); Essential, or potentially Essential, IPRs notified to ETSI in respect of ETSI standards"*, which is available **free of charge** from the ETSI Secretariat. Latest updates are available on the ETSI Web server (<http://www.etsi.org/ipr>).

Pursuant to the ETSI IPR Policy, no investigation, including IPR searches, has been carried out by ETSI. No guarantee can be given as to the existence of other IPRs not referenced in SR 000 314 (or the updates on the ETSI Web server) which are, or may be, or may become, essential to the present document.

---

## Foreword

This European Standard (Telecommunications series) has been produced by ETSI Technical Committee Electromagnetic compatibility and Radio spectrum Matters (ERM), and is now submitted for the ETSI standards One-step Approval Procedure.

The present document specifies the technical requirements for the radiated emission measurement procedure for physically large systems used within the public telecommunication network. A minimum representative system is defined, which is used for compliance testing of physically large telecommunication systems.

<b>Proposed national transposition dates</b>	
Date of latest announcement of this EN (doa):	3 months after ETSI publication
Date of latest publication of new National Standard or endorsement of this EN (dop/e):	6 months after doa
Date of withdrawal of any conflicting National Standard (dow):	6 months after doa

---

# 1 Scope

The present document specifies the technical requirements for the radiated emission measurement procedure for physically large systems used within the telecommunication network, with the exception of radio equipment.

It applies to physically large systems which are comprised of equipment's or systems requiring installation documentation specific for those sites at which they are to be installed. In order to demonstrate compliance of such systems, a minimum representative system is defined, which is used for compliance testing. Installations built from units of the complying minimum representative system are deemed to satisfy the radiated emission requirements.

The minimum representative system is representative of installed systems in terms of function (which includes at least one of each functional unit type) and electromagnetic radiation characteristics. The minimum representative system is subsequently referred to in the present document as the Equipment Under Test (EUT), to be used for compliance testing.

Minimum representative systems shall be tested on an Open Area Test Site (OATS) or in a suitable chamber, the limits to be used are those as specified in EN 55022 [1].

---

# 2 References

The following documents contain provisions which, through reference in this text, constitute provisions of the present document.

- References are either specific (identified by date of publication, edition number, version number, etc.) or non-specific.
- For a specific reference, subsequent revisions do not apply.
- For a non-specific reference, the latest version applies.
- A non-specific reference to an ETS shall also be taken to refer to later versions published as an EN with the same number.

- [1] EN 55022 (1987): "Limits and methods of measurement of radio disturbance characteristics of information technology equipment".
- [2] CISPR 16-1: "Specification for radio disturbance and immunity measuring apparatus and methods - Part 1: Radio disturbance and immunity measuring apparatus
- [3] IEC 60050-161 (1990): "International Electrotechnical Vocabulary. Chapter 161: Electromagnetic compatibility".

---

# 3 Definitions and abbreviations

## 3.1 Definitions

For the purposes of the present document, the following definitions, together with those from IEC 60050-161 [3], apply:

**system:** a set of sub-systems which, when connected together, produce a fully operational product and is intended to be marketed as such.

**sub-system:** a grouping of functional units which perform specific functions within the host system and which communicates with other equipment via well-defined interfaces and protocols.

**functional unit:** a grouping of electronic hardware which performs specific functions, but may be connected with other functional units to produce the required sub-system.

**new functional module:** a replacement and/or addition for any grouping or arrangement of electronic hardware (with its associated mechanical packaging and interconnections), which enhances or improves the system operation.

**test site:** this should be an OATS, with reflecting ground plane, or a suitable chamber with reflecting ground plane.

**minimum representative system:** the minimum representative system is representative of installed systems in terms of function (which includes at least one of each functional unit type) and electromagnetic radiation characteristics. This shall be equipped to at least the minimum configuration which could be offered for sale for use as an actual system. It excludes any operational equipment connected for the purpose of monitoring or system measurements and which are connected for a temporary period. An example of how the EUT is to be selected is given in figure 1.

**cable distribution point:** the cable distribution point is the interface at which cabling shall be terminated; this unit is the point at which cabling from the system is connected to the cabling from external units.

**physically large system:** a group of racks functionally connected to form a commercially specified system, which has a total dimension exceeding that which is practical for testing on a conventional 10 m test site.

## 3.2 Abbreviations

For the purposes of the present document, the following abbreviations apply:

EUT	Equipment Under Test
OATS	Open Area Test Site

---

## 4 Requirements

The recommended method for determining the minimum representative system is given here.

### 4.1 Determination of minimum representative system

The minimum representative system is a system which contains the minimum number of units needed to perform all functions specified for the system.

### 4.2 New functional modules

Functional modules used in the system tests may be individually characterized in a defined test facility (see subclause 5.1). This characterization may then be used as a reference to determine the effect of any significant design changes.

Using this technique, the performance of new functional modules may be assessed and the test plan written in such a way as to demonstrate that the representative system continues to conform when a functional module has been replaced by a new functional module. The results obtained for new functional modules shall be compared with those from the previous module.

The manufacturer shall clearly demonstrate and document the reasons why a new functional module does not require a complete representative system re-test. If the module constitutes a major change to the system configuration, a complete representative system test shall be performed.

---

## 5 General operational conditions

### 5.1 Equipment configuration

The EUT shall conform to the manufacturer's normal installation practice. There exists for each EUT a minimum set of interface lines which is required for the operation of the system and this number shall be defined for each EUT and identified in the test report.

The sources of maximum emission shall be identified by measuring each functional unit on an individual basis and, where applicable, its position in a rack.

The EUT shall then be assembled in such a way that emissions are maximized within any limitations imposed by normal installation practice.

### 5.1.1 Equipment boundary

For the purpose of defining the system boundary from which the test distance is taken, the equipment boundary shall be the straight line envelope around the EUT; this includes the cables specified for attachment to the EUT for the purpose of test. Measurement distances are to be taken from this line.

## 5.2 Equipment cable layout

### 5.2.1 Intra-system cabling

All cables internal to the system, and used for its operation, shall be connected and be of such a length and type required for the normal operation of the system. These shall be routed in accordance with the relevant system installation instructions, such that these are typical of an installed system.

The system shall normally be configured in accordance with EN 55022 requirements for floor standing equipment. An alternative set-up using a raised floor is acceptable for systems operated in this way.

If raised floor systems are to be characterized as the worst case and used for testing, and if the inter-unit cable routing is into the raised floor system, the effect of the raised floor system shall be examined. The raised floor shall be left in place if it forms part of the system screen, but where the raised floor is not intended to be used as a screen, then in order to prevent accidental screening of emissions, the floor panels shall be removed for the duration of the test.

### 5.2.2 Interface cabling

Cables between the system, the distribution point and external units, shall be of the type as specified by the system supplier or as detailed by customer requirements, and shall follow the relevant system installation practice. Care shall be taken to ensure that noise from the test and exercising equipment does not contribute to the emissions from the representative system. The method of orientating and terminating the cables shall be noted in the test report.

The emission contributions from the system, cables and distribution point (where all of these elements are involved) are difficult to separate; there are two cases to be considered:

- 1) unshielded cable systems;
- 2) shielded cable systems.

Shielding is achieved by one of two methods:

- a) by use of shielded cabling;
- b) by the use of a shielded floor or ducted systems in which unshielded cabling is run.

Measurement of these installation practices is performed as described in subclauses 5.2.2.1 and 5.2.2.2.

#### 5.2.2.1 Unshielded cable systems

Wherever the distribution point is located, measurement shall be made using a length of unshielded cabling configured as described in subclauses 5.2.2.1.1 and 5.2.2.1.2. Beyond this minimum length, the cabling shall be taken off the measurement site below the ground plane to the exercising equipment. Where this is not practicable, the cabling may run in shielded sleeving which is bonded to the measurement site ground plane.

Two types of cable installation practice shall be considered.

#### 5.2.2.1.1 Overhead cable systems

An overhead cable system is defined as one where cables are routed above the equipment. On exiting from the EUT, all cabling shall run perpendicularly from the EUT in the horizontal plane for 1,5 metres, before dropping to the ground plane.

Support of the cabling shall be of the type specified by the system supplier, or as detailed by customer requirements, and shall follow the relevant system installation practice. Where the system supplier or customer do not specify cable supports, then non-conducting unscreened cable supports shall be used. The height and position of the cables shall be noted in the test report (see figure 2). The cabling shall be taken off the measurement site below the ground plane to the exercising equipment. Where this is not practicable, the cabling may run in screened sleeving which is bonded to the measurement site ground plane.

#### 5.2.2.1.2 Raised floors

Where a raised floor system is used (but the raised floor does not form part of the screen) then all cabling shall drop through the raised floor towards the ground plane and run perpendicularly from the EUT in the horizontal plane for 1,5 metres, the raised floor being removed (see subclause 5.2.1). The cabling shall then be taken off the measurement site below the ground plane to the exercising equipment. Where this is not practicable, the cabling may run in screened sleeving which is bonded to the measurement site ground plane. All exposed, unscreened cabling, shall be on a support at a height of 10 cm (see figure 3).

The support shall be of the type specified by the system supplier, or as detailed by customer requirements, and shall follow the relevant system installation practice. Where the system supplier or customer do not specify cable supports, then non-conducting, unscreened cable supports shall be used.

#### 5.2.2.2 Screened cable systems

Where a screened cabling system is used throughout the installation, cabling typical of the installation practice shall be used during testing. Coaxial cables connected to the system is an example of screened cabling.

Where screened cabling is used between a system and an unscreened distribution point, and unscreened cabling is used beyond that point, then a test configuration shall be adopted which exposes the unscreened cabling to the measurement antenna. This shall be achieved by arranging the EUT with an unscreened distribution point located at the closest possible point to the system and forming part of the EUT. The unscreened cabling shall then be exposed, following the principles as defined in subclause 5.2.2.1.

The length of screened cabling between the system and the unscreened distribution point shall be the minimum length which could be used on any real installation. This minimum length shall be defined by the system supplier and the excess length shall be bundled for low inductance. This length should be 10 m, unless otherwise specified. Figure 4 shows an example of such a test set-up.

### 5.3 Exercising equipment

The exercising equipment shall be sufficiently isolated from the EUT such that the exercising equipment does not significantly influence the test results.

### 5.4 Laboratory environment

Unless otherwise specified, the test environment shall conform to the manufacturer's operating climatic conditions for the equipment.



---

## 6 Test results report

The test report shall include all test conditions and results together with the methods of test used. The selection shall show that the functional units so tested are those that would form the basis of a minimum installable system. Included in the test report shall be:

- a) selection procedure for the EUT;
- b) reasons for the selection of those functional units;
- c) description of cable layout, details of the distribution point, if used;
- d) description of actions taken to maximize the emissions from the EUT;
- e) a description of the exercising equipment used to exercise the EUT;
- f) a detailed description of the operational modes of the EUT used during the tests;
- g) a description of the test conditions including photographs and plan of the site and EUT where appropriate;
- h) the test results;
- i) a statement regarding the calibration status of the test equipment;
- j) a description of the test site;
- k) a detailed description of the equipment comprising the EUT;
- l) a description of the software used to exercise the EUT.

---

## 7 Test site requirements

When testing large systems, considerable problems may be encountered when using most commercially available sites, one of which is the determination of system emissions in the presence of large ambient signals.

Most available techniques are not suitable since:

- a) the EUT cannot easily be switched on or off;
- b) moving the receive antenna closer to the EUT is not feasible due to the restricted capture of the emissions from large EUTs by the antenna.

Furthermore, for reasons of economy, it may be desirable to measure radiated emission and test of radiated immunity at the same facility.

The test equipment to be used and the conditions of the test site are described in EN 55022 [1], and CISPR 16-1 [2]. Figure 5 is an example of a measurement arrangement which gives the minimum dimensions of an OATS. The test site shall meet the site attenuation requirements of CISPR 16-1 [2].

---

## 8 Measurement method

The EUT shall be working in accordance with its functional specification, and should be exercised as fully as necessary during testing, to ensure that the maximum emissions are achieved.

Where the EUT is not capable of being mounted on a turn-table, it shall be assembled on the ground plane (but isolated from it).

Where the representative system may be mounted on a large platform, the platform shall be sufficiently rigid to carry the EUT without undue flexing. The platform will need to be efficiently earthed to the ground plane and its maximum height will not exceed 400 mm. The EUT will be insulated from the platform and earthed, following normal equipment earthing installation procedures.

The antenna shall be scanned in height between one and four metres in order to maximize the level of the received emissions. Measurement shall be made in both horizontal and vertical polarizations. The antenna shall be placed at 10 m from the border of the EUT, with cable layout as described in subclause 5.2 and with reference to figures 2, 3, 4.

The measurements shall be performed according to the following procedures (the method used shall be indicated in the test report):

- measurement of the emission pattern shall be made at eight equally spaced radials;
- the measurement shall be performed in only one direction. In this case the EUT shall meet the specified limits minus 10 dB. The measurement direction shall be chosen as that considered to be likely to produce the worst case emissions (results from previous pre-compliance or shielding effectiveness tests, etc. can be used to help determine this). The direction chosen shall be indicated in the test report.

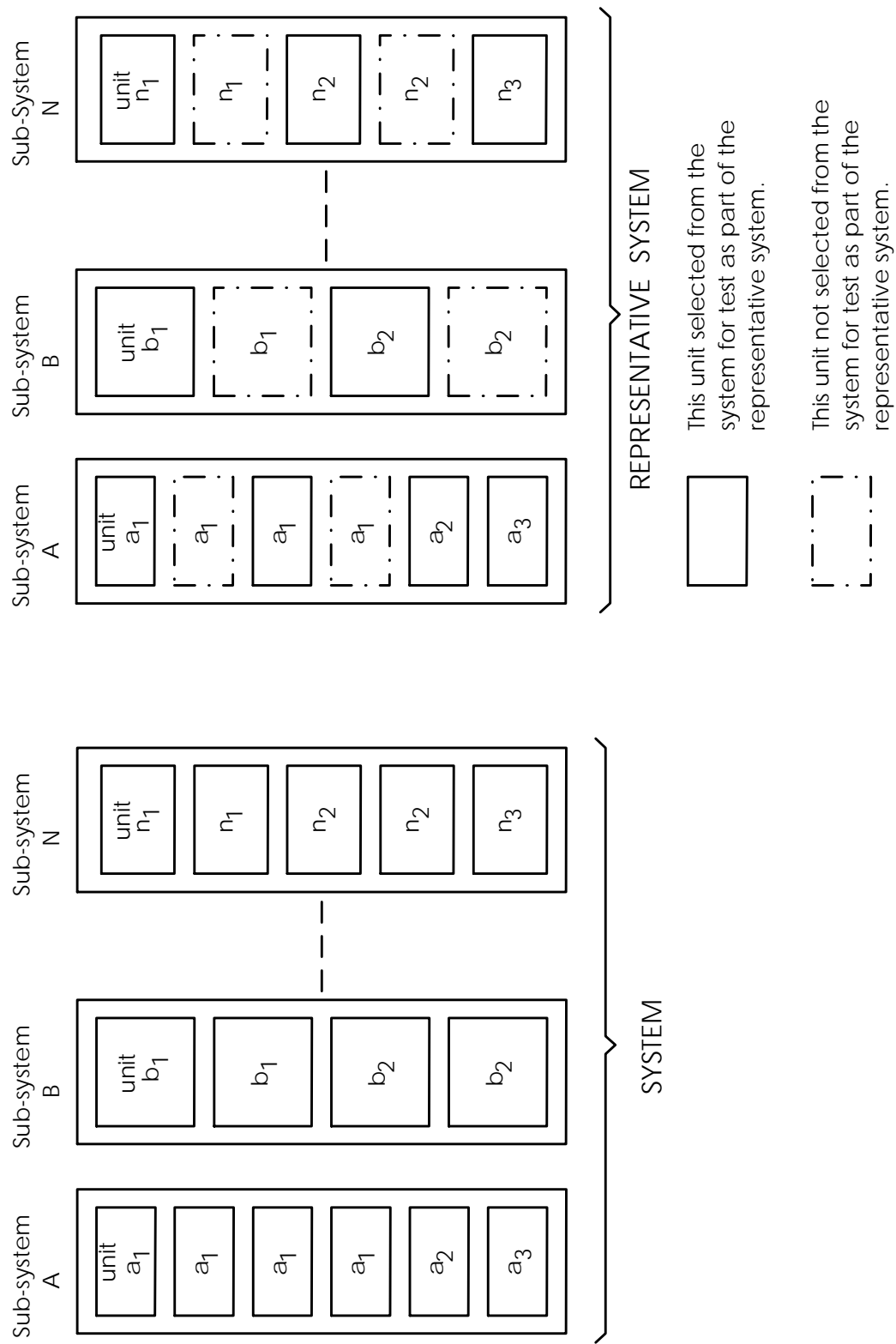
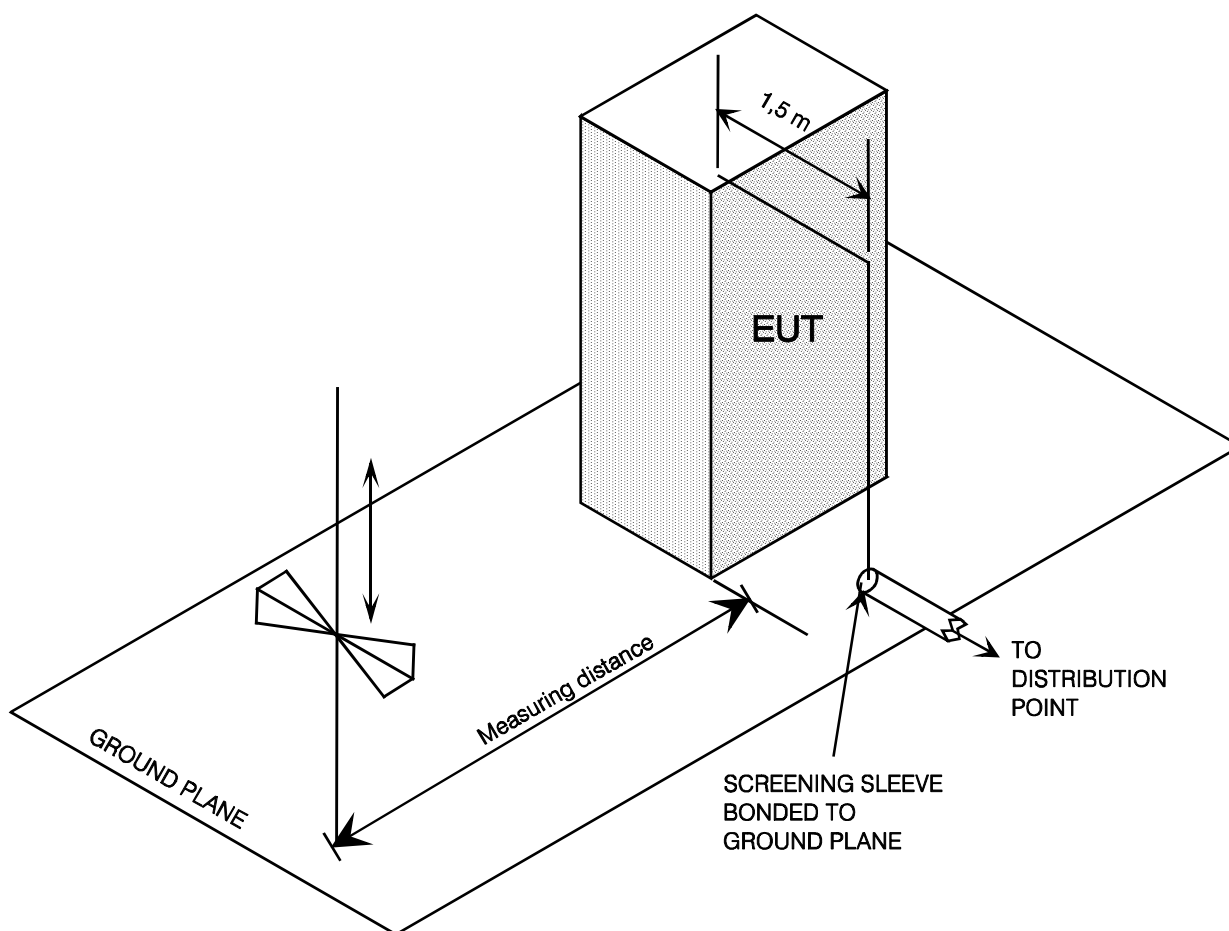

Figure 1: Example of selection of representative system



NOTE 1: The EUT is separated from the ground plane with an electrically isolating support, and electrically bonded to the site power supply ground using normal installation practice as possible.

NOTE 2: For clarity, only a single rack EUT is shown.

NOTE 3: Antenna scanned in height between 1 and 4 metres for horizontal and vertical polarization.

**Figure 2: Overhead cable systems - example for a test set-up**

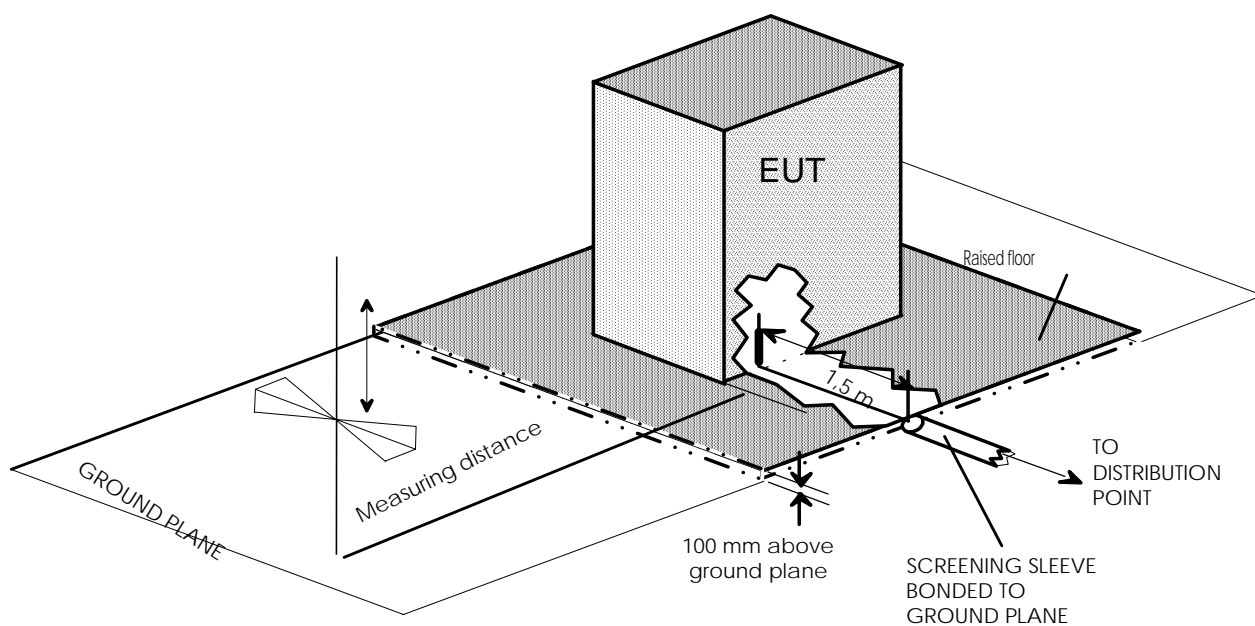

NOTE 1: If the raised floor does not form part of the screen the floor panels are removed. The raised floor is isolated from the EUT screen.

NOTE 2: For clarity, only a single rack EUT is shown.

NOTE 3: Antenna scanned in height between 1 and 4 metres for horizontal and vertical polarization.

**Figure 3: Raised floor - example for a test set-up**

Legend:

- ① Minimum Representative telecommunications System (MRS, EUT). For clarity, a three racks configuration is shown.
- ② Typical unscreened distribution point.
- ③ Screened cabling between MRS and unscreened distribution point, bundled to low inductance.
- ④ Unscreened signal cabling.
- ⑤ Power cables.

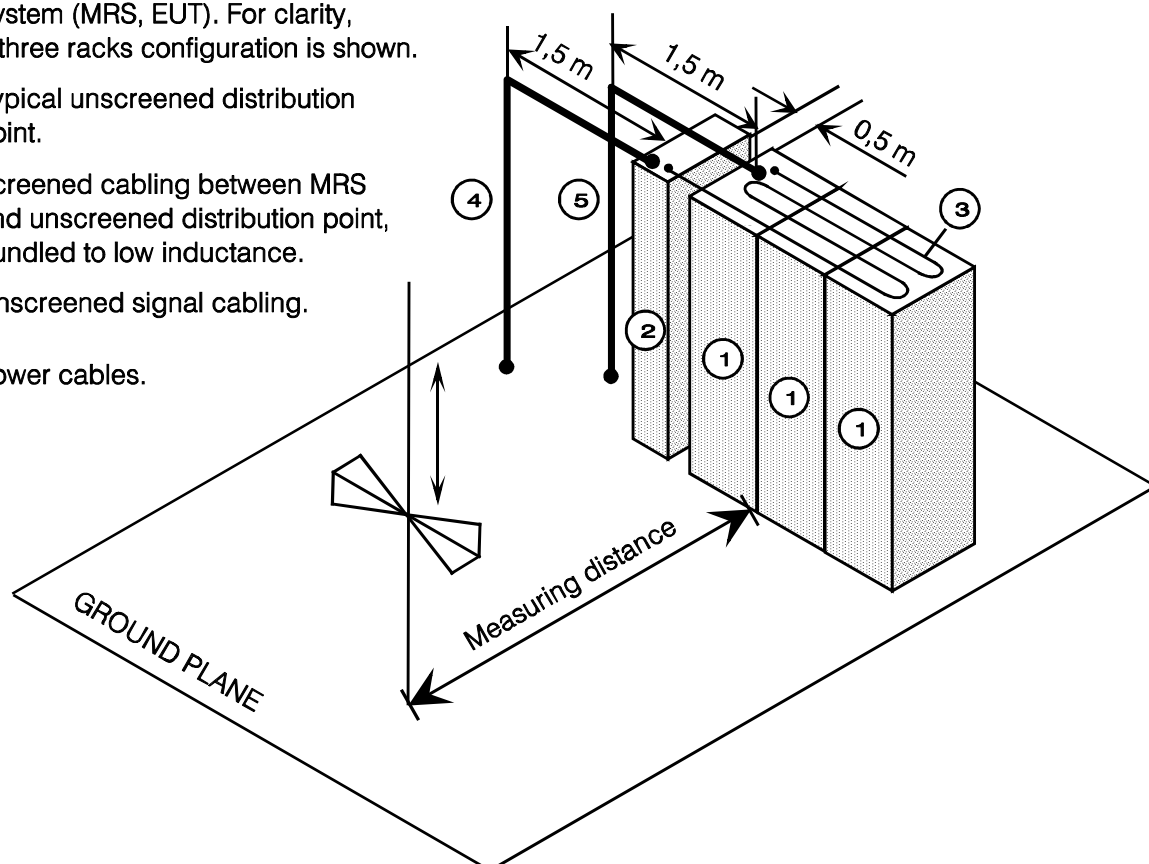

NOTE: Antenna scanned in height between 1 and 4 metres for horizontal and vertical polarization.

**Figure 4: Screened cable systems with unscreened distribution point**

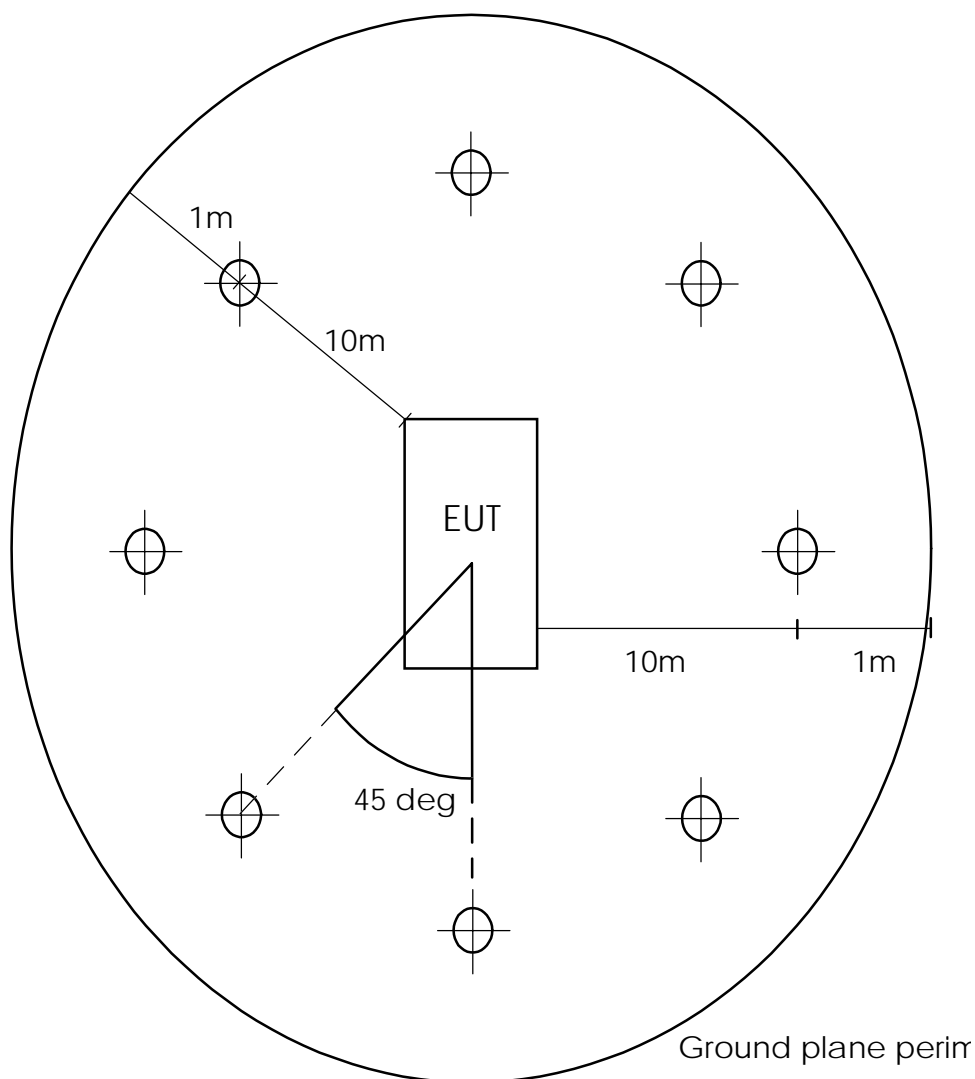

NOTE: The envelope of the EUT in this figure includes the cables as shown in figures 2, 3 and 4

**Figure 5: Example of an 8 radial position measurement site**

---

## History

<b>Document history</b>		
Edition 1	January 1994	Publication as ETS 300 127
V1.2.1	November 1998	One-step Approval Procedure      OAP 9912: 1998-11-20 to 1999-03-19