

ETSI EN 300 086-1 V1.3.1 (2008-09)

European Standard (Telecommunications series)

**Electromagnetic compatibility
and Radio spectrum Matters (ERM);
Land Mobile Service;
Radio equipment with an internal or external RF
connector intended primarily for analogue speech;
Part 1: Technical characteristics and
methods of measurement**



ReferenceREN/ERM-TGDMR-258-1

Keywordsanalogue, antenna, mobile, PMR, radio, speech

ETSI

650 Route des Lucioles
F-06921 Sophia Antipolis Cedex - FRANCE

Tel.: +33 4 92 94 42 00 Fax: +33 4 93 65 47 16

Siret N° 348 623 562 00017 - NAF 742 C
Association à but non lucratif enregistrée à la
Sous-Préfecture de Grasse (06) N° 7803/88

Important notice

Individual copies of the present document can be downloaded from:

<http://www.etsi.org>

The present document may be made available in more than one electronic version or in print. In any case of existing or perceived difference in contents between such versions, the reference version is the Portable Document Format (PDF). In case of dispute, the reference shall be the printing on ETSI printers of the PDF version kept on a specific network drive within ETSI Secretariat.

Users of the present document should be aware that the document may be subject to revision or change of status. Information on the current status of this and other ETSI documents is available at

<http://portal.etsi.org/tb/status/status.asp>

If you find errors in the present document, please send your comment to one of the following services:

http://portal.etsi.org/chaicor/ETSI_support.asp

Copyright Notification

No part may be reproduced except as authorized by written permission.
The copyright and the foregoing restriction extend to reproduction in all media.

© European Telecommunications Standards Institute 2008.
All rights reserved.

DECTTM, **PLUGTESTS**TM, **UMTS**TM, **TIPHON**TM, the TIPHON logo and the ETSI logo are Trade Marks of ETSI registered for the benefit of its Members.

3GPPTM is a Trade Mark of ETSI registered for the benefit of its Members and of the 3GPP Organizational Partners.

Contents

Intellectual Property Rights	6
Foreword.....	6
1 Scope	7
2 References	7
2.1 Normative references	8
2.2 Informative references.....	8
3 Definitions, symbols and abbreviations	8
3.1 Definitions	8
3.2 Symbols.....	9
3.3 Abbreviations	10
4 General	10
4.1 Selection of equipment for testing purposes	10
4.1.1 Choice of model for testing	10
4.1.1.1 Auxiliary test equipment	11
4.1.1.2 Declarations by the provider	11
4.2 Mechanical and electrical design.....	11
4.2.1 General.....	11
4.2.2 Controls	11
4.2.3 Transmitter shut-off facility.....	11
4.3 Marking.....	11
5 Test conditions, power sources and ambient temperatures	11
5.1 Normal and extreme test conditions	11
5.2 Test power source.....	12
5.3 Normal test conditions.....	12
5.3.1 Normal temperature and humidity	12
5.3.2 Normal test power source	12
5.3.2.1 Mains voltage.....	12
5.3.2.2 Regulated lead-acid battery power sources used on vehicles.....	12
5.3.2.3 Other power sources.....	12
5.4 Extreme test conditions	13
5.4.1 Extreme temperatures	13
5.4.2 Extreme test source voltages.....	13
5.4.2.1 Mains voltage.....	13
5.4.2.2 Regulated lead-acid battery power sources used on vehicles.....	13
5.4.2.3 Power sources using other types of batteries.....	13
5.4.2.4 Other power sources.....	13
5.5 Procedure for tests at extreme temperatures.....	14
5.5.1 Procedure for equipment designed for continuous transmission.....	14
5.5.2 Procedure for equipment designed for intermittent transmission	14
5.5.3 Testing of equipment that does not have an external 50 Ω RF connector (integral antenna equipment).....	14
6 General test conditions	15
6.1 Arrangements for test signals applied to the receiver input.....	15
6.2 Receiver mute or squelch facility	15
6.3 Artificial antenna.....	15
6.4 Test sites and general arrangements for radiated measurements.....	15
6.5 Arrangement for test signals at the input of the transmitter	15
6.6 Receiver rated audio output power.....	15
6.7 Tests of equipment with a duplex filter	15
7 Technical characteristics of the transmitter.....	16
7.1 Frequency error	16
7.1.1 Definition.....	16

7.1.2	Method of measurement	16
7.1.3	Limits.....	16
7.2	Transmitter power (conducted)	17
7.2.1	Definitions	17
7.2.2	Method of measurement	17
7.2.3	Limits.....	17
7.3	Maximum effective radiated power.....	17
7.3.1	Definition.....	17
7.3.2	Methods of measurement.....	18
7.3.3	Limits.....	20
7.4	Frequency deviation	21
7.4.1	Definition.....	21
7.4.2	Method of measurement	21
7.4.2.1	Maximum permissible frequency deviation	21
7.4.2.2	Response of the transmitter to modulation frequencies above 3 kHz	21
7.4.3	Limits.....	21
7.4.3.1	Maximum permissible frequency deviation	21
7.4.3.2	Response of the transmitter to modulation frequencies above 3 kHz	22
7.5	Adjacent and alternate channel power.....	22
7.5.1	Definition.....	22
7.5.2	Method of measurement	23
7.5.3	Limits.....	24
7.6	Unwanted emissions in the spurious domain.....	24
7.6.1	Definition.....	24
7.6.2	Method of measuring the power level	25
7.6.3	Method of measuring the effective radiated power.....	26
7.6.4	Limits.....	28
7.7	Intermodulation attenuation.....	29
7.7.1	Definition.....	29
7.7.2	Method of measurement	30
7.7.3	Limits.....	31
7.8	Void.....	31
8	Technical characteristics of the receiver	31
8.1	Maximum usable sensitivity (conducted).....	31
8.1.1	Definition.....	31
8.1.2	Method of measurement	31
8.1.3	Limits.....	31
8.2	Maximum usable sensitivity (field strength)	32
8.2.1	Definition.....	32
8.2.2	Method of measurement	32
8.2.3	Limits.....	33
8.3	Co-channel rejection.....	33
8.3.1	Definition.....	33
8.3.2	Method of measurement	33
8.3.3	Limits.....	33
8.4	Adjacent channel selectivity.....	34
8.4.1	Definition.....	34
8.4.2	Method of measurement	34
8.4.3	Limits.....	34
8.5	Spurious response rejection	34
8.5.1	Definition.....	34
8.5.2	Introduction to the method of measurement	35
8.5.3	Method of measurement	35
8.5.3.1	Method of search over the "limited frequency range".....	35
8.5.3.2	Method of measurement - Step 2	36
8.5.4	Limits.....	36
8.6	Intermodulation response rejection	36
8.6.1	Definition.....	36
8.6.2	Method of measurement	36
8.6.3	Limits.....	37

8.7	Blocking or desensitization	37
8.7.1	Definition	37
8.7.2	Method of measurement	37
8.7.3	Limits	37
8.8	Spurious radiations	38
8.8.1	Definition	38
8.8.2	Method of measuring the power level	38
8.8.3	Method of measuring the effective radiated power	39
8.8.4	Limits	40
9	Duplex operation	41
9.1	Receiver desensitization (with simultaneous transmission and reception)	41
9.1.1	Definition	41
9.1.2	Method of measurement when the equipment operates with a duplex filter	41
9.1.3	Measuring method when the equipment operates with two antennas	41
9.1.4	Limits	42
9.2	Receiver spurious response rejection (with simultaneous transmission and reception)	42
9.2.1	Definition	42
9.2.2	Method of measurement	42
9.2.3	Limits	43
10	Measurement uncertainty	43
Annex A (normative): Radiated measurement.....		45
A.1	Test sites and general arrangements for measurements involving the use of radiated fields	45
A.1.1	Anechoic chamber	45
A.1.2	Anechoic chamber with a conductive ground plane	46
A.1.3	Open Area Test Site (OATS)	47
A.1.4	Test antenna	48
A.1.5	Substitution antenna	48
A.1.6	Measuring antenna	49
A.2	Guidance on the use of radiation test sites	49
A.2.1	Verification of the test site	49
A.2.2	Preparation of the EUT	49
A.2.3	Power supplies to the EUT	49
A.2.4	Volume control setting for analogue speech tests	49
A.2.5	Range length	50
A.2.6	Site preparation	50
A.3	Coupling of signals	51
A.3.1	General	51
A.3.2	Data signals	51
A.3.3	Speech and analogue signals	51
A.3.3.1	Acoustic coupler description	51
A.3.3.2	Calibration	52
Annex B (normative): Specification for some particular measurement arrangements.....		53
B.1	Power measuring receiver specification	53
B.1.1	IF filter	53
B.1.2	Attenuation indicator	54
B.1.3	RMS value indicator	54
B.1.4	Oscillator and amplifier	54
B.2	Spectrum analyser specification	55
B.2.1	Adjacent and alternate channel power measurement	55
B.2.2	Unwanted emissions measurement	55
B.3	Integrating and power summing device	55
Annex C (informative): Bibliography.....		56
History		57

Intellectual Property Rights

IPRs essential or potentially essential to the present document may have been declared to ETSI. The information pertaining to these essential IPRs, if any, is publicly available for **ETSI members and non-members**, and can be found in ETSI SR 000 314: "*Intellectual Property Rights (IPRs); Essential, or potentially Essential, IPRs notified to ETSI in respect of ETSI standards*", which is available from the ETSI Secretariat. Latest updates are available on the ETSI Web server (<http://webapp.etsi.org/IPR/home.asp>).

Pursuant to the ETSI IPR Policy, no investigation, including IPR searches, has been carried out by ETSI. No guarantee can be given as to the existence of other IPRs not referenced in ETSI SR 000 314 (or the updates on the ETSI Web server) which are, or may be, or may become, essential to the present document.

Foreword

This European Standard (Telecommunications series) has been produced by ETSI Technical Committee Electromagnetic compatibility and Radio spectrum Matters (ERM).

The present document is part 1 of a multi-part deliverable covering the Land Mobile Service; Radio equipment with an internal or external RF connector intended primarily for analogue speech, as identified below:

Part 1: "Technical characteristics and methods of measurement";

Part 2: "Harmonized EN covering essential requirements under article 3.2 of the R&TTE Directive".

National transposition dates	
Date of adoption of this EN:	23 September 2008
Date of latest announcement of this EN (doa):	31 December 2008
Date of latest publication of new National Standard or endorsement of this EN (dop/e):	30 June 2009
Date of withdrawal of any conflicting National Standard (dow):	30 June 2009

1 Scope

The present document covers the technical requirements for radio transmitters and receivers used in stations in the Private Mobile Radio (PMR) service.

It applies to use in the land mobile service, operating on radio frequencies between 30 MHz and 1 GHz, with channel separations of 12,5 kHz, 20 kHz and 25 kHz, primarily intended for analogue speech.

Table 1: Radiocommunications service frequency bands

Radiocommunications service frequency bands	
Transmit	30 MHz to 1 000 MHz
Receive	30 MHz to 1 000 MHz

The equipment comprises a transmitter and associated modulator and/or a receiver and associated demodulator. The types of equipment covered by the present document are as follows:

- base station (equipment fitted with an antenna connector, intended for use in a fixed location);
- mobile station (equipment fitted with an antenna connector, normally used in a vehicle or as a transportable);
- and those hand portable stations:
 - a) fitted with an antenna connector; or
 - b) without an external antenna connector, but fitted with a permanent internal or a temporary internal 50 Ω Radio Frequency (RF) connector which allows access to the transmitter output and the receiver input.

Hand portable equipment without an external or internal RF connector and without the possibility of having a temporary internal 50 Ω RF connector is not covered by the present document.

NOTE: Hand portable equipment without an external or internal RF connector and without the possibility of having a temporary internal 50 Ω RF connector is not covered by the present document (integral antenna equipment is covered by EN 300 296 [i.1]).

2 References

References are either specific (identified by date of publication and/or edition number or version number) or non-specific.

- For a specific reference, subsequent revisions do not apply.
- Non-specific reference may be made only to a complete document or a part thereof and only in the following cases:
 - if it is accepted that it will be possible to use all future changes of the referenced document for the purposes of the referring document;
 - for informative references.

Referenced documents which are not found to be publicly available in the expected location might be found at <http://docbox.etsi.org/Reference>.

For online referenced documents, information sufficient to identify and locate the source shall be provided. Preferably, the primary source of the referenced document should be cited, in order to ensure traceability. Furthermore, the reference should, as far as possible, remain valid for the expected life of the document. The reference shall include the method of access to the referenced document and the full network address, with the same punctuation and use of upper case and lower case letters.

NOTE: While any hyperlinks included in this clause were valid at the time of publication ETSI cannot guarantee their long term validity.

2.1 Normative references

The following referenced documents are indispensable for the application of the present document. For dated references, only the edition cited applies. For non-specific references, the latest edition of the referenced document (including any amendments) applies.

- [1] ETSI TR 100 028 (V1.4.1) (all parts): "Electromagnetic compatibility and Radio spectrum Matters (ERM); Uncertainties in the measurement of mobile radio equipment characteristics".
- [2] ITU-T Recommendation O.41: " Psophometer for use on telephone-type circuits".

2.2 Informative references

The following referenced documents are not essential to the use of the present document but they assist the user with regard to a particular subject area. For non-specific references, the latest version of the referenced document (including any amendments) applies.

- [i.1] ETSI EN 300 296 (all parts): "ElectroMagnetic Compatibility and Radio Spectrum Matters (ERM); Land Mobile Service; Radio equipment using integral antennas intended primarily for analogue speech".
- [i.2] ETSI EN 300 793 (V1.1.1): "Electromagnetic compatibility and Radio spectrum Matters (ERM); Land mobile service; Presentation of equipment for type testing".
- [i.3] ETSI TR 102 273 (V1.2.1) (all parts): "Electromagnetic compatibility and Radio spectrum Matters (ERM); Improvement on Radiated Methods of Measurement (using test site) and evaluation of the corresponding measurement uncertainties".
- [i.4] ANSI C63.5 (2004): "American National Standard for Calibration of Antennas Used for Radiated Emission Measurements in Electromagnetic Interference (EMI) Control-Calibration of Antennas (9 kHz to 40 GHz)".
- [i.5] IEC 60489-3 (1988): "Methods of measurement for radio equipment used in the mobile services. Part 3: Receivers for A3E or F3E emissions".
- [i.6] CEPT/ERC/REC 74-01E: "Unwanted emissions in the spurious domain". (Hradec Kralove 2005).

3 Definitions, symbols and abbreviations

3.1 Definitions

For the purposes of the present document, the following terms and definitions apply:

50 Ω : 50 ohm non-reactive impedance

adjacent channel: channel offset from the wanted channel by the channel spacing, see figure 1

alternate channels: two channels offset from the wanted channel by double the channel spacing, see figure 1

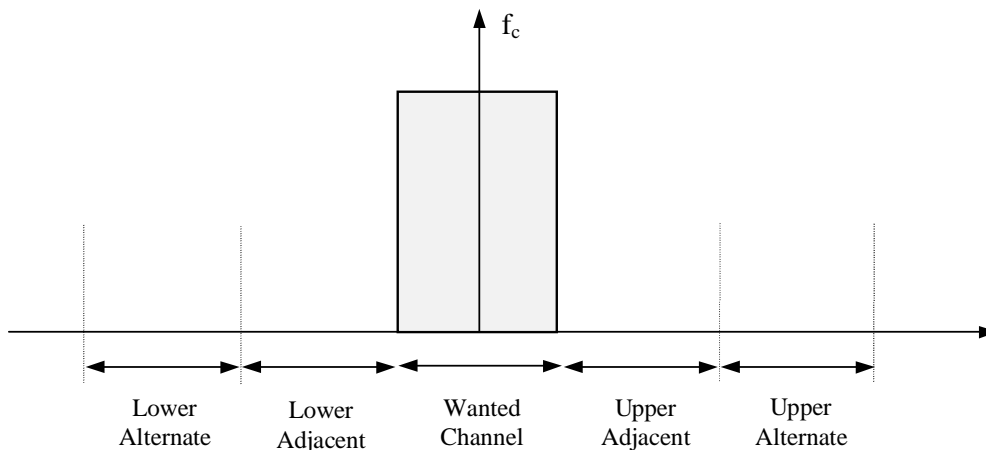

Figure 1: Adjacent and alternate channel definitions

angle modulation: either phase modulation or frequency modulation

base station: equipment fitted with an antenna connector, for use with an external antenna, and intended for use in a fixed location

conducted measurements: measurements which are made using a direct 50 Ω connection to the equipment under test

hand portable station: equipment either fitted with an antenna connector or an integral antenna, or both, normally used on a stand-alone basis, to be carried on a person or held in the hand

integral antenna: antenna designed to be connected to the equipment without the use of a 50 Ω external connector and considered to be part of the equipment

NOTE: An integral antenna may be fitted internally or externally to the equipment.

Listen Before Transmit mode (LBT): monitoring mode in which the RF channel is checked for activity before transmitting and equipment is designed to automatically prevent transmission for interference reduction purposes if a signal is detected on the channel

mobile station: mobile equipment fitted with an antenna connector, for use with an external antenna, normally used in a vehicle or as a transportable station

radiated measurements: measurements which involve the absolute measurement of a radiated field

SINAD metre: measurement instrument used to measure SND/ND

3.2 Symbols

For the purposes of the present document, the following symbols apply:

E_o reference field strength

NOTE: See annex A.

F_{cs} frequency equal to channel separation
 f_{I1} 1st intermediate frequency
 f_{I2} 2nd intermediate frequency
 f_{In} nth intermediate frequency
 f_l frequency of the limited frequency range
 f_{LO} Local oscillator frequency
 R_o reference distance

NOTE: See annex A.

T_{max} Maximum extreme test temperature
 T_{min} Minimum extreme test temperature
 V_{max} Maximum extreme test voltage
 V_{min} Minimum extreme test voltage
 Ω ohm

3.3 Abbreviations

For the purposes of the present document, the following abbreviations apply:

CSP Channel SeParation
 CW Continuous Wave
 dB decibel
 dBm dB relative to 1 mW
 DC Direct Current
 emf electromotive force
 EUT Equipment Under Test
 IF Intermediate Frequency
 LBT Listen Before Transmit mode
 MPFD Maximum Permissible Frequency Deviation
 OATS Open Area Test Site
 PMR Private Mobile Radio
 RF Radio Frequency
 rms root mean squared
 SINAD received signal quality based on (Signal + Noise + Distortion)/(Noise + Distortion)
 SND/ND (Signal + Noise + Distortion)/(Noise + Distortion)
 sr switching range
 Tx Transmitter
 VSWR Voltage Standing Wave Ratio

4 General

4.1 Selection of equipment for testing purposes

Each equipment to be tested shall fulfil the requirements of the present document on all frequencies over which it is intended to operate.

The provider or manufacturer shall declare the frequency ranges, the range of operating conditions and power requirements as applicable, to establish the appropriate test conditions.

Additionally, technical documentation and operating manuals, sufficient to make the test, shall be supplied.

Guidance on the presentation of equipment is also given in EN 300 793 [i.2].

4.1.1 Choice of model for testing

The provider or manufacturer shall provide one or more samples of the equipment, as appropriate for testing.

Stand-alone equipment shall be complete with any ancillary equipment needed for testing.

If an equipment has several optional features, considered not to affect the RF parameters then the tests need only to be performed on the equipment configured with the combination of features considered to be the most complex.

Where practicable, equipment to be tested shall provide a 50 Ω connector for conducted RF power level measurements.

In the case of integral antenna equipment, if the equipment does not have a internal permanent 50 Ω connector then it is permissible to supply a second sample of the equipment with a temporary antenna connector fitted to facilitate testing.

The performance of the equipment to be tested shall be representative of the performance of the corresponding production model.

4.1.1.1 Auxiliary test equipment

All necessary auxiliary test equipment, setting up instructions and other product information shall accompany the equipment to be tested.

4.1.1.2 Declarations by the provider

The provider or manufacturer shall declare the necessary information of the equipment with respect to all technical requirements set by the present document.

4.2 Mechanical and electrical design

4.2.1 General

The equipment shall be designed, constructed and manufactured in accordance with good engineering practice, and with the aim of minimizing harmful interference to other equipment and services.

4.2.2 Controls

Those controls, which if maladjusted, might increase the interfering potentialities of the equipment shall not be accessible for adjustment by the user.

4.2.3 Transmitter shut-off facility

When a timer for an automatic shut-off facility is operative, at the moment of the time-out the transmitter shall automatically be switched off (the re-activation of the transmitter shall reset the timer).

A shut-off facility shall be inoperative for the duration of the measurements unless it has to remain operative to protect the equipment. If the shut-off facility is left operative the status of the equipment shall be indicated.

4.3 Marking

The equipment shall be marked in a visible place. This marking shall be legible, tamperproof and durable.

The marking shall be in accordance with EC Directives and/or CEPT decisions or recommendations as appropriate.

5 Test conditions, power sources and ambient temperatures

5.1 Normal and extreme test conditions

Testing shall be performed under normal test conditions, and also, where stated, under extreme test conditions.

The test conditions and procedures shall be as specified in clauses 5.2 to 5.5.

5.2 Test power source

During testing the power source of the equipment shall be replaced by a test power source capable of producing normal and extreme test voltages as specified in clauses 5.3.2 and 5.4.2. The internal impedance of the test power source shall be low enough for its effect on the test results to be negligible. For the purpose of tests, the voltage of the power source shall be measured at the input terminals of the equipment.

For battery operated equipment the battery shall be removed and the test power source shall be applied as close to the battery terminals as practicable.

During tests of DC powered equipment the power source voltages shall be maintained within a tolerance of $< \pm 1$ % relative to the voltage at the beginning of each test. The value of this tolerance is critical for power measurements. Using a smaller tolerance will provide better measurement uncertainty values.

5.3 Normal test conditions

5.3.1 Normal temperature and humidity

The normal temperature and humidity conditions for tests shall be any convenient combination of temperature and humidity within the following ranges:

- temperature: +15 °C to +35 °C;
- relative humidity: 20 % to 75 %.

When it is impracticable to carry out the tests under these conditions, a note to this effect, stating the ambient temperature and relative humidity during the tests, shall be added to the test report.

5.3.2 Normal test power source

5.3.2.1 Mains voltage

The normal test voltage for equipment to be connected to the mains shall be the nominal mains voltage. For the purpose of the present document, the nominal voltage shall be the declared voltage or any of the declared voltages for which the equipment was designed.

The frequency of the test power source corresponding to the ac mains shall be between 49 Hz and 51 Hz.

5.3.2.2 Regulated lead-acid battery power sources used on vehicles

When the radio equipment is intended for operation from the usual types of regulated lead-acid battery power source used on vehicles the normal test voltage shall be 1,1 times the nominal voltage of the battery (for nominal voltages of 6 V and 12 V, these are 6,6 V and 13,2 V respectively).

5.3.2.3 Other power sources

For operation from other power sources or types of battery (primary or secondary), the normal test voltage shall be that declared by the equipment manufacturer.

5.4 Extreme test conditions

5.4.1 Extreme temperatures

For tests at extreme temperatures, measurements shall be made in accordance with the procedures specified in clause 5.5, at the upper and lower temperatures of one of the following two ranges:

- -20 °C to +55 °C;
All mobile and handportable equipment.
Base stations for outdoor/uncontrolled climate conditions.
- 0 °C to +40 °C;
Base stations for indoor/controlled climate conditions.

In the case of base station equipment, the manufacturer shall declare which conditions the equipment is intended to be installed in.

5.4.2 Extreme test source voltages

5.4.2.1 Mains voltage

The extreme test voltage for equipment to be connected to an ac mains source shall be the nominal mains voltage $\pm 10\%$.

5.4.2.2 Regulated lead-acid battery power sources used on vehicles

When the equipment is intended for operation from the usual types of regulated lead-acid battery power sources used on vehicles the extreme test voltages shall be 1,3 and 0,9 times the nominal voltage of the battery (for a nominal voltage of 6 V, these are 7,8 V and 5,4 V respectively and for a nominal voltage of 12 V, these are 15,6 V and 10,8 V respectively).

5.4.2.3 Power sources using other types of batteries

The lower extreme test voltages for equipment with power sources using batteries shall be as follows:

- for the nickel metal-hydrate, leclanché or lithium type: 0,85 times the nominal battery voltage;
- for the mercury or nickel-cadmium type: 0,9 times the nominal battery voltage.

No upper extreme test voltages apply.

In the case where no upper extreme test voltage the nominal voltage is applicable, the corresponding four extreme test conditions are:

- V_{\min}/T_{\min} , V_{\min}/T_{\max} ;
- $(V_{\max} = \text{nominal})/T_{\min}$, $(V_{\max} = \text{nominal})/T_{\max}$.

5.4.2.4 Other power sources

For equipment using other power sources, or capable of being operated from a variety of power sources, the extreme test voltages shall be those declared by the equipment manufacturer.

5.5 Procedure for tests at extreme temperatures

Before measurements are made the equipment shall have reached thermal balance in the test chamber. The equipment shall be switched off during the temperature stabilizing period.

In the case of equipment containing temperature stabilization circuits designed to operate continuously, the temperature stabilization circuits may be switched on for 15 minutes after thermal balance has been obtained, and the equipment shall then meet the specified requirements. For such equipment the manufacturer shall provide for the power source circuit feeding the crystal oven to be independent of the power source for the rest of the equipment.

If the thermal balance is not checked by measurements, a temperature stabilizing period of at least one hour, or a longer period as may be decided by the testing laboratory, shall be allowed. The sequence of measurements shall be chosen, and the humidity content in the test chamber shall be controlled so that excessive condensation does not occur.

5.5.1 Procedure for equipment designed for continuous transmission

If the manufacturer states that the equipment is designed for continuous transmission, the test procedure shall be as follows.

Before tests at the upper extreme temperature, the equipment shall be placed in the test chamber, and left until thermal balance is attained. The equipment shall then be switched on in the transmit condition for a period of half an hour, after which the equipment shall meet the specified requirements.

Before tests at the lower extreme temperature, the equipment shall be left in the test chamber until thermal balance is attained, then switched to the standby or receive condition for a period of one minute, after which the equipment shall meet the specified requirements.

5.5.2 Procedure for equipment designed for intermittent transmission

If the manufacturer states that the equipment is designed for intermittent transmission, the test procedure shall be as follows.

Before tests at the upper extreme temperature, the equipment shall be placed in the test chamber, and left until thermal balance is attained. The equipment shall then be switched on for one minute in the transmit condition, followed by four minutes in the receive condition, after which the equipment shall meet the specified requirements.

For tests at the lower extreme temperature, the equipment shall be left in the test chamber until thermal balance is attained, then switched to the standby or receive condition for one minute, after which the equipment shall meet the specified requirements.

5.5.3 Testing of equipment that does not have an external 50 Ω RF connector (integral antenna equipment)

Where equipment has an internal 50 Ω connector it shall be permitted to perform the tests at this connector.

Equipment may also have a temporary internal 50 Ω connector installed for the purposes of testing.

No connection shall be made to any internal permanent or temporary antenna connector during the performance of radiated emissions measurements, unless such action forms an essential part of the normal intended operation of the equipment, as declared by the manufacturer.

6 General test conditions

6.1 Arrangements for test signals applied to the receiver input

For normal test modulation, the modulation frequency shall be 1 kHz and the resultant frequency deviation shall be 60 % of the maximum permissible frequency deviation for the clause 7.4.3.1.

The test signal shall be substantially free from amplitude modulation.

Sources of test signals for application to the receiver input shall be connected in such a way that the source impedance presented to the receiver input is 50 Ω (non-reactive, clause 6.3).

This requirement shall be met irrespective of whether one or more signals using a combining network are applied to the receiver simultaneously.

The levels of the test signals at the receiver input terminals (RF connector) shall be expressed in terms of emf.

The effects of any intermodulation products and noise produced in the test signal sources shall be negligible.

6.2 Receiver mute or squelch facility

If the receiver is equipped with a mute or squelch circuit, this shall be made inoperative for the duration of the measurements.

6.3 Artificial antenna

Tests shall be carried out using an artificial antenna, which shall be a substantially non-reactive non-radiating load of 50 Ω connected to the antenna connector.

6.4 Test sites and general arrangements for radiated measurements

For guidance on radiation test sites see annex A. Detailed descriptions of the radiated measurement arrangements are included in this annex.

6.5 Arrangement for test signals at the input of the transmitter

For the purpose of the present document, the transmitter audio frequency modulation signal shall be applied to the microphone input terminals with the internal microphone disconnected, unless otherwise stated.

6.6 Receiver rated audio output power

The rated audio output power shall be the maximum power, declared by the manufacturer, for which all the requirements of the present document are met. With normal test modulation, the audio output power shall be measured in a resistive load simulating the load with which the receiver normally operates. The value of this load shall be declared by the manufacturer.

6.7 Tests of equipment with a duplex filter

If the equipment is provided with a built-in duplex filter or a separate associated filter, the requirements of the present document shall be met when the measurements are carried out using the antenna connector of this filter.

7 Technical characteristics of the transmitter

7.1 Frequency error

7.1.1 Definition

The frequency error of the transmitter is the difference between the measured carrier frequency in the absence of modulation and the nominal frequency of the transmitter.

7.1.2 Method of measurement

The equipment shall operate in continuous transmission mode during the time necessary to perform the measurement of the frequency.

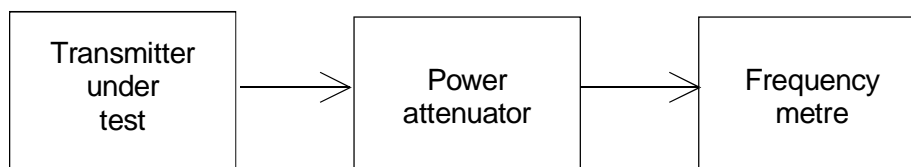

Figure 2: Measurement arrangement

The equipment shall be connected to the artificial antenna.

The measurement arrangement in figure 2 shall be used.

The carrier frequency shall be measured in the absence of modulation. The measurement shall be made under normal test conditions (see clause 5.3) and extreme test conditions (see clause 5.4).

7.1.3 Limits

The frequency error shall not exceed the values given in table 2, under normal and extreme test conditions.

Table 2

Channel separation (kHz)	Frequency error limit (kHz)				
	below 47 MHz	47 MHz to 137 MHz	above 137 MHz to 300 MHz	above 300 MHz to 500 MHz	above 500 MHz to 1 000 MHz
20 and 25	±0,60	±1,35	±2,00	±2,00	±2,50 (a)
12,5	±0,60	±1,00	±1,00 (B) ±1,50 (M)	±1,00 (B) ±1,50 (a) (M)	±1,5 (B) ±2,5 (a) (M)

NOTE: (B) = base station.
(M) = mobile or hand portable station.
(a) = for hand portable stations having integral power supplies, the frequency error shall not be exceeded over a temperature range of 0 °C to + 40 °C.
Under extreme temperature conditions (clause 5.4.1), the frequency error shall not exceed ±2,50 kHz for a channel separation of 12,5 kHz between 300 MHz and 500 MHz, and ±3,00 kHz for channel separations of 20 kHz and 25 kHz between 500 MHz and 1 000 MHz.

7.2 Transmitter power (conducted)

7.2.1 Definitions

The transmitter power (conducted) is the mean power delivered to the artificial antenna during a radio frequency cycle, in the absence of modulation.

The rated output power is the transmitter power (conducted) of the equipment declared by the manufacturer.

7.2.2 Method of measurement

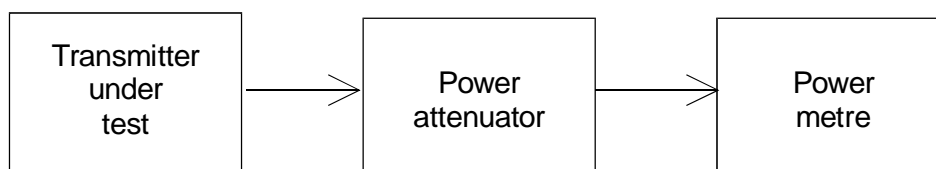

Figure 3: Measurement arrangement

For practical reasons, measurements shall be performed only at the lowest and highest power level at which the transmitter is intended to operate.

The measurement arrangement in figure 3 shall be used.

The measurement shall be performed in the absence of modulation.

The transmitter shall be set in continuous transmission mode.

The transmitter shall be connected to a power attenuator and the mean power delivered to this artificial antenna shall be measured.

The measurement shall be made under normal test conditions (see clause 5.3) and extreme test conditions (see clause 5.4).

7.2.3 Limits

The transmitter power (conducted) under the specified conditions of measurement (see clause 7.2.2) and at normal test conditions (see clause 5.3), shall be within $\pm 1,5$ dB of the rated carrier power (conducted).

The transmitter power (conducted) under extreme test conditions (see clause 5.4) shall be within $+2,0$ dB and $-3,0$ dB of the rated output power.

NOTE: It is assumed that the appropriate National Administration will state the maximum permitted transmitter output power.

7.3 Maximum effective radiated power

7.3.1 Definition

This measurement applies only to equipment without an external antenna connector.

The effective radiated power is the power radiated in the direction of the maximum field strength under specified conditions of measurements, in the absence of modulation.

The rated effective radiated power is the effective radiated power of the equipment as declared by the manufacturer.

If the equipment is designed to operate with different transmitter powers, the rated power for each level, or range of levels, shall be declared by the manufacturer.

The requirements of the present document shall be met for all power levels at which the transmitter is intended to operate.

7.3.2 Methods of measurement

This measurement applies only to equipment without an external antenna connector.

For practical reasons measurements shall be performed only at the lowest and highest power level at which the transmitter is intended to operate. The equipment and its antenna shall be mounted in a normal installation in its normal operating position.

The measurement shall be carried out under normal test conditions only.

The transmitter shall be set in continuous transmission mode.

The measurement arrangements in figures 4 and 5 shall be used.

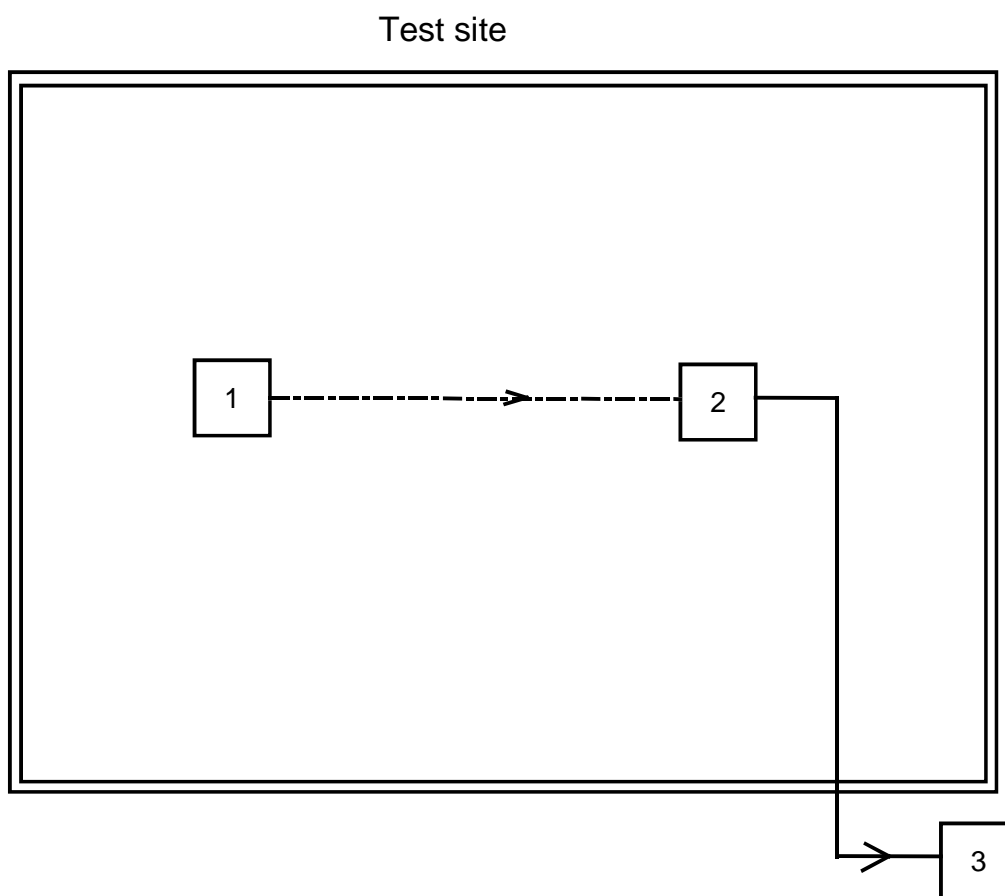

NOTE: 1 = Transmitter under test.
2 = Test antenna.
3 = Spectrum analyser or selective voltmeter (test receiver).

Figure 4: Measurement arrangement

Test site

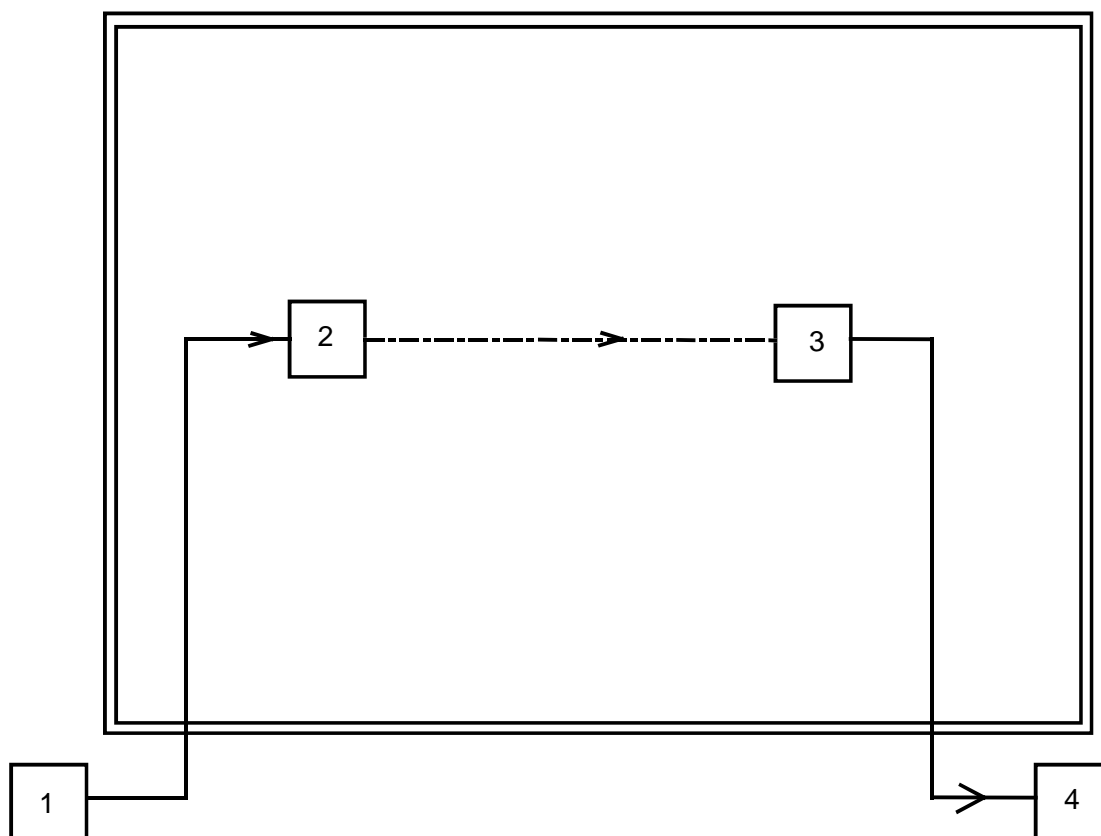

NOTE: 1 = Signal generator.
 2 = Substitution antenna.
 3 = Test antenna.
 4 = Spectrum analyser or selective voltmeter (test receiver).

Figure 5: Measurement arrangement

- a) A test site, selected from annex A, which fulfils the requirements of the specified frequency range of this measurement shall be used. The test antenna shall be orientated initially for vertical polarization unless otherwise stated.
- b) The transmitter under test shall be placed at the specified height on a non-conducting support in the position closest to normal use as declared by the manufacturer. This position shall be recorded in test reports.
- c) The spectrum analyser or selective voltmeter shall be tuned to the transmitter frequency. The test antenna shall be raised or lowered through the specified height range until the maximum signal level is detected on the spectrum analyser or selective voltmeter.
- d) The test antenna need not be raised or lowered if the measurement is carried out on a test site according to clause A.1.1 (i.e. an anechoic chamber).
- e) The transmitter shall be rotated through 360° about a vertical axis until a higher maximum signal is received.
- f) The test antenna shall be raised or lowered again through the specified height range until a maximum is obtained. This level shall be recorded. (This maximum may be a lower value than the value obtainable at heights outside the specified limits).
- g) The test antenna need not be raised or lowered if the measurement is carried out on a test site according to clause A.1.1 (i.e. an anechoic chamber).
- h) Using the measurement arrangement of figure 5, the substitution antenna (see clause A.1.5) shall replace the transmitter antenna in the same position and in vertical polarization. The frequency of the signal generator shall be adjusted to the transmitter carrier frequency. The test antenna shall be raised or lowered as necessary to ensure that the maximum signal is still received.

- i) The test antenna need not be raised or lowered if the measurement is carried out on a test site according to clause A.1.1 (i.e. an anechoic chamber).
- j) The input signal to the substitution antenna shall be adjusted in level until an equal or a known related level to that detected from the transmitter is obtained in the test receiver. The maximum transmitter radiated power is equal to the power supplied by the signal generator, increased by the known relationship if necessary and after corrections due to the gain of the substitution antenna and the cable loss between the signal generator and the substitution antenna.
- k) Steps b) to e) above shall be repeated with the test antenna and the substitution antenna orientated in horizontal polarization.

The measure of the effective radiated power is the larger of the two power levels recorded at the input to the substitution antenna, corrected for the gain of the antenna if necessary.

7.3.3 Limits

The effective radiated power under normal test conditions shall be within d_f from the rated effective radiated power.

The allowance for the characteristics of the equipment ($\pm 1,5$ dB) shall be combined with the actual measurement uncertainty in order to provide d_f , as follows:

$$d_f^2 = d_m^2 + d_e^2$$

Where:

- d_m is the actual measurement uncertainty;
- d_e is the allowance for the equipment (1,5 dB);
- d_f is the final difference.

All values shall be expressed in linear terms.

In all cases the actual measurement uncertainty shall comply with clause 10.

Example of the calculation of d_f :

- $d_m = 6$ dB (value acceptable, as indicated in the table of maximum uncertainties);
- $= 3,98$ in linear terms;
- $d_e = 1,5$ dB (fixed value for all equipment fulfilling the requirements of the present document);
- $= 1,41$ in linear terms;
- $d_f^2 = (3,98)^2 + (1,41)^2$.

Therefore, $d_f = 4,22$ in linear terms, or 6,25 dB.

This calculation shows that in this case d_f is in excess by 0,25 dB compared to d_m , the actual measurement uncertainty (6 dB).

NOTE: The effective radiated power should not exceed the maximum value allowed by the Administrations.

7.4 Frequency deviation

7.4.1 Definition

The frequency deviation is the maximum difference between the instantaneous frequency of the modulated radio frequency signal and the carrier frequency in the absence of modulation.

The maximum permissible frequency deviation is the maximum value of frequency deviation stated for the relevant channel separation.

7.4.2 Method of measurement

7.4.2.1 Maximum permissible frequency deviation

The maximum permissible frequency deviation (positive or negative) shall be measured at the output of the transmitter connected to a 50 Ω power attenuator, by means of a deviation metre capable of measuring the maximum permissible frequency deviation, including that due to any harmonics and intermodulation products which may be generated in the transmitter.

The modulation frequency shall be varied between the lowest frequency considered to be appropriate, and 3 kHz (see note).

NOTE: 2,55 kHz for transmitters intended for 12,5 kHz channel separation.

The level of this test signal shall be 20 dB above the level of the normal test modulation, clause 6.1.

The transmitter shall be operated under normal test conditions, see clause 5.3.

7.4.2.2 Response of the transmitter to modulation frequencies above 3 kHz

The transmitter shall be operated under normal test conditions, clause 5.3, and connected via a 50 Ω power attenuator to the deviation metre.

The transmitter shall be modulated by normal test modulation, clause 6.1.

With a constant input level of the modulation signal, the modulation frequency shall be varied between 3 kHz (see note) and a frequency equal to the channel separation for which the equipment is intended.

NOTE: 2,55 kHz for transmitters intended for 12,5 kHz channel separation.

The maximum (positive or negative) frequency deviation shall be measured by means of the deviation metre.

7.4.3 Limits

7.4.3.1 Maximum permissible frequency deviation

The maximum permissible frequency deviation for modulation frequencies from the lowest frequency transmitted (f_1) by the equipment (as declared by the manufacturer) up to (f_2) shall be as given in table 3.

Table 3

Channel separation (kHz)	Maximum permissible frequency deviation (kHz)
12,5	$\pm 2,5$
20	$\pm 4,0$
25	$\pm 5,0$

7.4.3.2 Response of the transmitter to modulation frequencies above 3 kHz

The frequency deviation at modulation frequencies between 3,0 kHz (for equipment operating with 20 kHz or 25 kHz channel separations) and 2,55 kHz (for equipment operating with 12,5 kHz channel separation) and 6,0 kHz shall not exceed the frequency deviation at a modulation frequency of 3,0 kHz/2,55 kHz. At 6,0 kHz the deviation shall be not more than 30,0 % of the maximum permissible frequency deviation.

The frequency deviation at modulation frequencies between 6,0 kHz and a frequency equal to the channel separation for which the equipment is intended shall not exceed that given by a linear representation of the frequency deviation (dB) relative to the modulation frequency, starting at the 6,0 kHz limit and having a slope of -14,0 dB per octave. These limits are illustrated in figure 6.

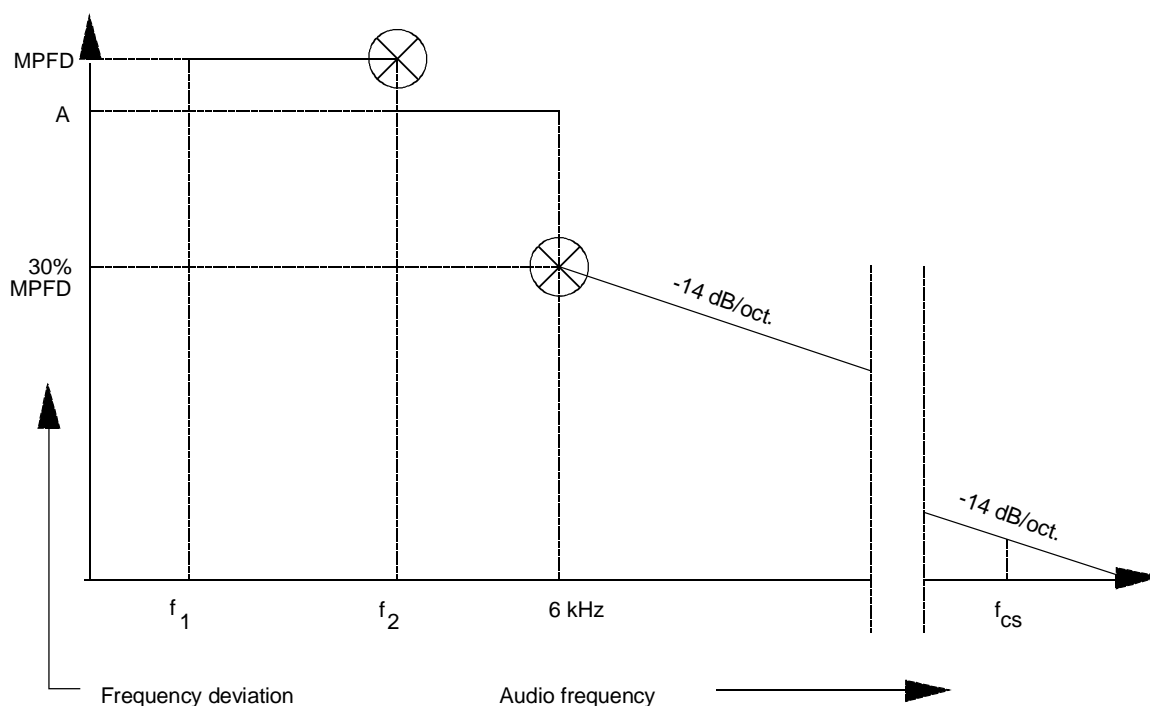

NOTE: Abbreviations:
 f_1 = lowest appropriate frequency
 f_2 = 3,0 kHz (for 20 kHz or 25 kHz channel separation), or
 2,55 kHz (for 12,5 kHz channel separation)
 MPFD = Maximum Permissible Frequency Deviation, see clause 7.4.3.1
 A = measured frequency deviation at f_2
 f_{cs} = frequency equal to channel separation

Figure 6

7.5 Adjacent and alternate channel power

7.5.1 Definition

The adjacent and alternate channel power is that part of the total power output of a transmitter under defined conditions of modulation, which falls within a specified pass-band centred on the nominal frequency of either of the adjacent and alternate channels. This power is the sum of the mean power produced by the modulation, hum and noise of the transmitter.

7.5.2 Method of measurement

This test measures the power transmitted in the adjacent and alternate channel(s) during continuous modulation.

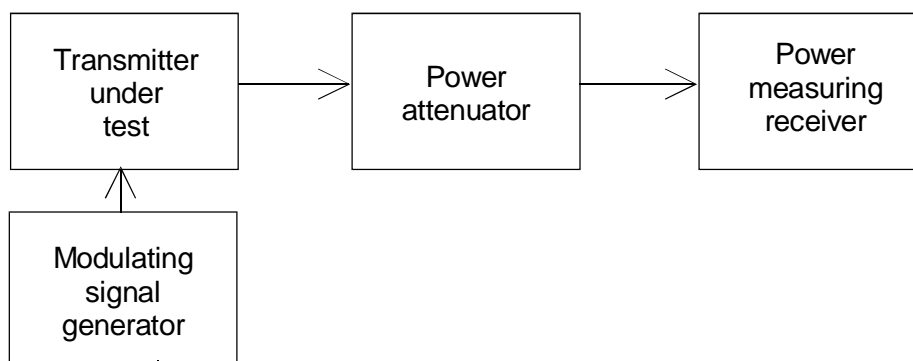

Figure 7: Measurement arrangement

During the test, the transmitter shall be set in continuous transmission mode. If this is not possible, the measurements shall be carried out in a period shorter than the duration of the transmission. Averaging measurements with 100 samples are possible.

The measurement arrangement in figure 7 shall be used.

The adjacent channel power may be measured, as follows, with a power measuring receiver which conforms to annex B (referred to in this clause as the "receiver"):

- the transmitter shall be operated at the transmitter power determined in clause 7.2 under normal test conditions (see clause 5.3). The output of the transmitter shall be linked to the input of the "receiver" by a connecting device such that the impedance presented to the transmitter is 50 Ω and the level at the "receiver input" is appropriate;
- with the transmitter unmodulated, the tuning of the "receiver" shall be adjusted so that a maximum response is obtained. This is the 0 dB response point. The "receiver" attenuator setting and the reading of the metre shall be recorded;
- the frequency of the "receiver" shall be adjusted above the carrier so that the "receiver" -6 dB response nearest to the transmitter carrier frequency is located at a displacement from the nominal carrier frequency as given in table 4a;

Table 4a: Frequency displacement

Channel separation (kHz)	Specified necessary bandwidth (kHz)	Displacement of the -6 dB point from the nominal carrier frequency (kHz)
12,5	8,5	8,25
20	14	13
25	16	17

- the transmitter shall be modulated by a test signal of 1 250 Hz at a level which is 20 dB higher than that required to produce 60 % of the maximum permissible deviation, clause 7.4.3.1;
- the "receiver" variable attenuator shall be adjusted to obtain the same metre reading as in step b), or a known relation to it;
- the ratio of the adjacent channel power to the carrier power is the difference between the attenuator settings in steps b) and e), corrected for any differences in the reading of the metre.

For each adjacent channel, the adjacent channel power shall be recorded.

- the measurement shall be repeated with the frequency of the "receiver" adjusted below the carrier so that the "receiver" -6 dB response nearest to the transmitter carrier frequency is located at a displacement from the nominal carrier frequency as given in table 4a;
- the adjacent channel power of the equipment under test shall be expressed as the higher of the two values recorded in step f) for the upper and lower channels nearest to the channel considered.

Steps c) to f) shall be repeated for the alternate channels with the values in table 4b.

Table 4b: Frequency displacement

Channel separation (kHz)	Specified necessary bandwidth (kHz)	Displacement of the -6 dB point from the nominal carrier frequency (kHz)
12,5	8,5	20,25
20	14	33
25	16	42

For each alternate channel, the alternate channel power shall be recorded.

- the measurement shall be repeated with the frequency of the "receiver" adjusted below the carrier so that the "receiver" -6 dB response nearest to the transmitter carrier frequency is located at a displacement from the nominal carrier frequency as given in table 4b;
- the alternate channel power of the equipment under test shall be expressed as the higher of the two values recorded in step f) for the upper and lower channels nearest to the channel considered.

7.5.3 Limits

For a channel separation of 12,5 kHz, 20 kHz and 25 kHz, the adjacent channel power shall not exceed a value of 60,0 dB below the transmitter power (conducted) without the need to be below 0,2 μ W (-37 dBm).

For a channel separation of 12,5 kHz, 20 kHz and 25 kHz, the alternate channel power shall not exceed a value of 70,0 dB below the transmitter power (conducted) without the need to be below 0,2 μ W (-37 dBm).

7.6 Unwanted emissions in the spurious domain

7.6.1 Definition

Spurious emissions are emissions at frequencies other than those of the carrier and sidebands associated with normal modulation.

The level of spurious emissions shall be measured by:

either:

- a) their power level in a specified load (conducted spurious emission); and
- b) their effective radiated power when radiated by the cabinet and structure of the equipment (cabinet radiation);

or

- c) their effective radiated power when radiated by the cabinet and by the integral antenna, in the case of hand portable equipment fitted with such an antenna and no external RF connector.

NOTE: i.e. ((a and b) or c).

7.6.2 Method of measuring the power level

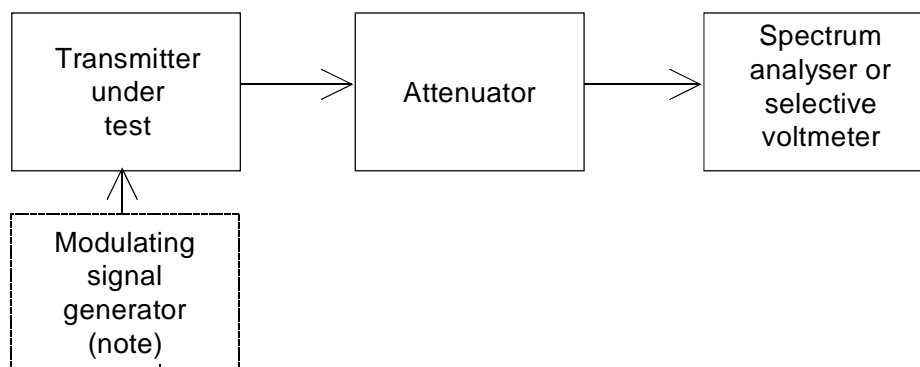

NOTE: Used only if it is not possible to perform the measurement with the transmitter unmodulated.

Figure 8: Measurement arrangement

This method applies only to equipment having an external connector.

The measurement arrangement in figure 8 shall be used.

Spurious emissions shall be measured as the power level of any discrete signal (excluding the wanted signal) delivered into a 50 Ω load. This may be done by connecting the transmitter output through an attenuator to a spectrum analyser (see clause B.2) or selective voltmeter, or by monitoring the relative levels of the spurious signals delivered to an artificial antenna.

If possible, the measurement shall be made with the transmitter unmodulated. If this is not possible, the transmitter shall be modulated by the normal test signal.

If possible, the transmitter shall be set in continuous transmission mode. If this is not possible, this fact shall be stated in the test report and precautions shall be taken to ensure that all spurious emissions are correctly detected and measured. It may be necessary to extend the duration of the bursts.

The measurements shall be made, for equipment operating on frequencies not exceeding 470 MHz, in the frequency range 9 kHz to 4 GHz, except for the channel on which the transmitter is intended to operate, and its adjacent and alternate channels.

For equipment operating on frequencies above 470 MHz the measurements shall also be performed over the frequency range 4 GHz to 12,75 GHz if emissions are detected within 10 dB of the of the specified limit between 1,5 GHz and 4 GHz, except for the channel on which the transmitter is intended to operate, and its adjacent and alternate channels.

The measurement shall be repeated with the transmitter in the "stand-by" position.

The resolution bandwidth of the measuring instrument shall be the smallest bandwidth available which is greater than the spectral width of the spurious component being measured. This shall be considered to be achieved when the next highest bandwidth causes less than 1 dB increase in amplitude.

As a general rule, the resolution bandwidth of the measuring receiver should be equal to the reference bandwidth.

"To improve measurement accuracy, sensitivity and efficiency, the resolution bandwidth can be different from the reference bandwidth. When the resolution bandwidth is smaller than the reference bandwidth, the result should be integrated over the reference bandwidth. When the resolution bandwidth is greater than the reference bandwidth, the result for broadband spurious emissions should be normalized to the bandwidth ratio. For discrete spur, normalization is not applicable, while integration over the reference bandwidth is still applicable." (Extract from CEPT/ERC/REC 74-01 [i.6], recommend 4, page 5).

The conditions used in the relevant measurements shall be reported in the test report.

7.6.3 Method of measuring the effective radiated power

Test site

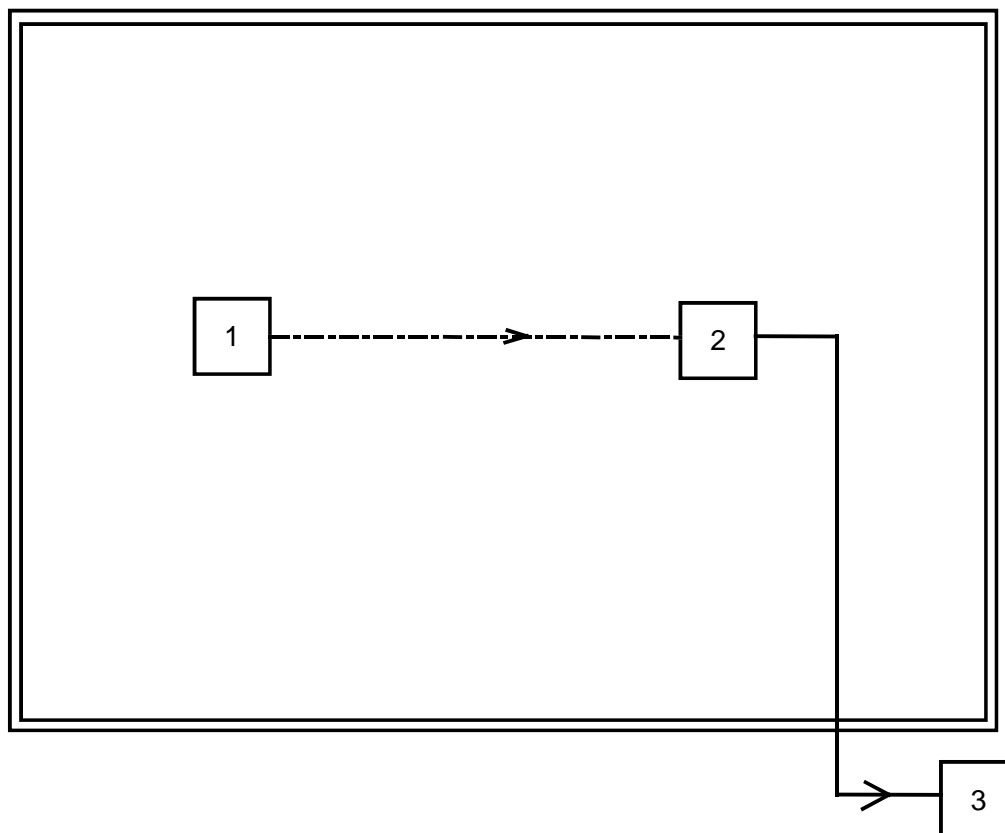

NOTE: 1 = Transmitter under test.
2 = Test antenna.
3 = Spectrum analyser or selective voltmeter (test receiver).

Figure 9: Measurement arrangement

The measurement arrangement in figure 9 shall be used.

The radiation of any spurious components shall be detected by the test antenna and receiver, over the frequency range 30 MHz to 4 GHz, except for the channel on which the transmitter is intended to operate and its adjacent and alternate channels.

For equipment operating on frequencies above 470 MHz the measurements shall also be performed over the frequency range 4 GHz to 12,75 GHz if emissions are detected within 10 dB of the specified limit between 1,5 GHz and 4 GHz, except for the channel on which the transmitter is intended to operate, and its adjacent and alternate channels.

For equipment operating on frequencies above 470 MHz the measurements shall also be performed over the frequency range 4 GHz to 12,75 GHz if emissions are detected within 10 dB of the of the specified limit between 1,5 GHz and 4 GHz.

The measurements are performed excluding the five contiguous channels centred on the channel on which the transmitter is intended to operate.

The measurement procedure shall be as follows:

- a) On a test site, fulfilling the requirements of annex A, the sample shall be placed at the specified height on the support.
- b) The transmitter shall be operated at the carrier power as specified under clause 7.2, delivered to:
 - an artificial antenna for equipment having an external antenna connector; or
 - to the integral antenna.
- c) If possible, the measurement shall be made with the transmitter unmodulated. If this is not possible, the transmitter shall be modulated by the normal test signal as appropriate (see clause 6.1).

The transmitter shall be set in continuous transmission mode. If this is not possible, this fact shall be stated in the test report and precautions shall be taken to ensure that all spurious emissions are correctly detected and measured.

The resolution bandwidth of the measuring instrument shall be the smallest bandwidth available which is greater than the spectral width of the spurious component being measured. This shall be considered to be achieved when the next highest bandwidth causes less than 1 dB increase in amplitude.

As a general rule, the resolution bandwidth of the measuring receiver should be equal to the reference bandwidth.

"To improve measurement accuracy, sensitivity and efficiency, the resolution bandwidth can be different from the reference bandwidth. When the resolution bandwidth is smaller than the reference bandwidth, the result should be integrated over the reference bandwidth. When the resolution bandwidth is greater than the reference bandwidth, the result for broadband spurious emissions should be normalized to the bandwidth ratio. For discrete spur, normalization is not applicable, while integration over the reference bandwidth is still applicable." (Extract from CEPT/ERC/REC 74-01 [i.6], recommend 4, page 5).

The conditions used in the relevant measurements shall be reported in the test report.

- a) At each frequency at which a component is detected, the sample shall be rotated to obtain maximum response and the effective radiated power of that component determined by a substitution measurement, using the measurement arrangement of figure 10.
- b) The value of the effective radiated power of that component shall be recorded.
- c) The measurements shall be repeated with the test antenna in the orthogonal polarization plane.
- d) The measurements shall be repeated with the transmitter in the "stand-by" position.

Test site

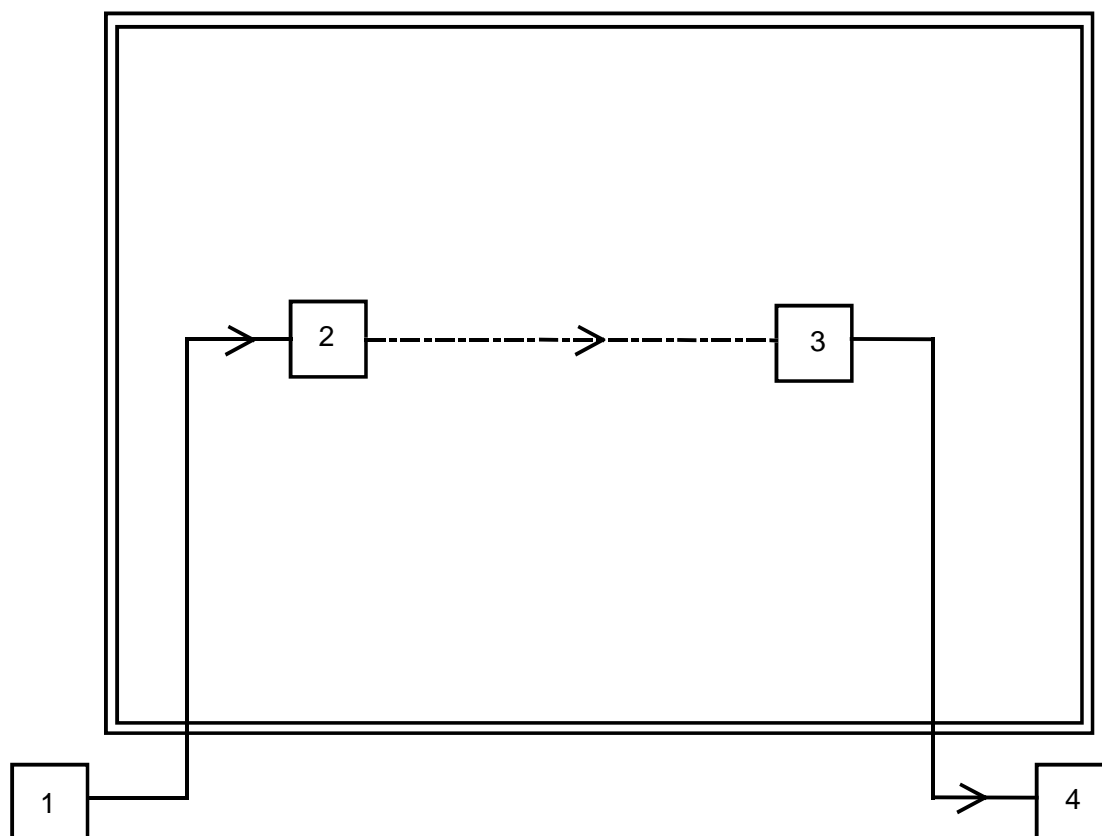

NOTE: 1 = Signal generator.
 2 = Substitution antenna.
 3 = Test antenna.
 4 = Spectrum analyser or selective voltmeter (test receiver).

Figure 10: Measurement arrangement

7.6.4 Limits

The power of any spurious emission shall not exceed the values given in tables 5a and 5b.

Table 5a: Conducted emissions

Frequency range	Tx operating	Tx standby
9 kHz to 1 GHz	0,25 μ W (-36 dBm)	2,0 nW (-57 dBm)
above 1 GHz to 4 GHz, or above 1 GHz to 12,75 GHz	1,00 μ W (-30 dBm)	20 nW (-47 dBm)

Table 5b: Radiated emissions

Frequency range	Tx operating	Tx standby
30 MHz to 1 GHz	0,25 μ W (-36 dBm)	2,0 nW (-57 dBm)
above 1 GHz to 4 GHz, or above 1 GHz to 12,75 GHz	1,00 μ W (-30 dBm)	20 nW (-47 dBm)

In the case of radiated measurements for hand portable stations the following conditions apply:

- for equipment with an internal integral antenna, the normal antenna shall remain connected;
- for equipment with an external antenna connector, an artificial antenna (see clause 6.3) shall be connected to the connector for the test.

The reference bandwidths used shall be as stated in tables 6a to 6c.

Table 6a: Reference bandwidths to be used for the measurement of spurious emission

Frequency range	RBW
9 kHz to 150 kHz	1 kHz
150 kHz to 30 MHz	10 kHz
30 MHz to 1 GHz	100 kHz
1 GHz to 12,75 GHz	1 MHz

Table 6b: Reference bandwidths to be used close to the wanted emission for equipment operating below 1 GHz

Frequency offset from carrier	RBW
250 % of the CSP to 100 kHz	1 kHz
100 kHz to 500 kHz	10 kHz

Table 6c: Reference bandwidths to be used close to the wanted emission for equipment operating above 1 GHz

Frequency offset from carrier	RBW
250 % of the CSP to 100 kHz	1 kHz
100 kHz to 500 kHz	30 kHz
500 kHz to 1 MHz	300 kHz

Best measurement practice:

The resolution bandwidth of the measuring receiver should be equal to the reference bandwidth as given in the tables 6a to 6c. To improve measurement accuracy, sensitivity and efficiency, the resolution bandwidth can be different from the reference bandwidth. When the resolution bandwidth is smaller than the reference bandwidth, the result should be integrated over the reference bandwidth. When the resolution bandwidth is greater than the reference bandwidth, the result for broadband spurious emissions should be normalized to the bandwidth ratio. For discrete spurious emissions, normalization is not applicable, while integration over the reference bandwidth is still applicable.

7.7 Intermodulation attenuation

7.7.1 Definition

For the purpose of the present document the intermodulation attenuation is a measure of the capability of a transmitter to inhibit the generation of signals in its non-linear elements caused by the presence of the transmitter power and an interfering signal entering the transmitter via its antenna.

This requirement applies only to transmitters to be used in base stations (fixed).

7.7.2 Method of measurement

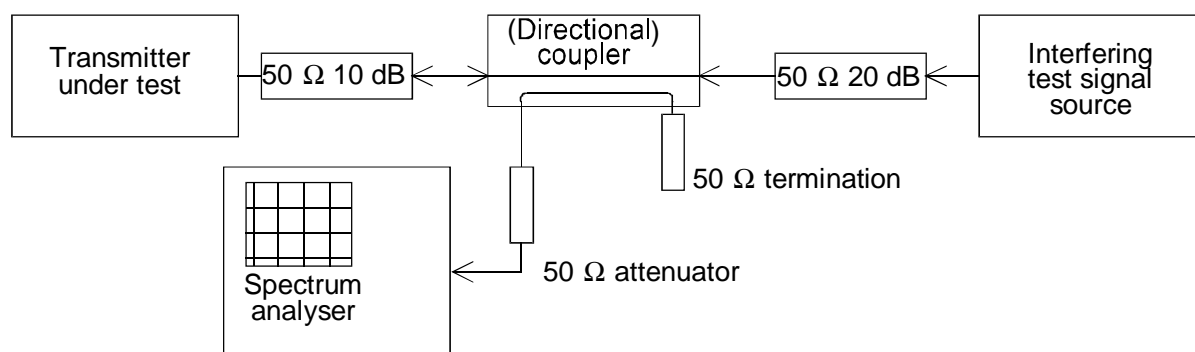

Figure 11: Measurement arrangement

The measurement arrangement shown in figure 11 shall be used.

The transmitter shall be connected to a 50 Ω 10 dB power attenuator and via a (directional) coupler to a spectrum analyser. An additional attenuator may be required between the directional coupler and the spectrum analyser to avoid overloading.

In order to reduce the influence of mismatch errors it is important that the 10 dB power attenuator is coupled to the transmitter under test with the shortest possible connection.

The interfering test signal source may be either a transmitter providing the same power output as the transmitter under test and be of a similar type, or a signal generator and a linear power amplifier capable of delivering the same output power as the transmitter under test.

The directional coupler shall have an insertion loss of less than 1 dB, a sufficient bandwidth and a directivity of more than 20 dB.

The transmitter under test and the test signal source shall be physically separated in such a way that the measurement is not influenced by direct radiation.

The transmitter under test shall be unmodulated and the spectrum analyser adjusted to give a maximum indication with a frequency scan width of 500 kHz. The transmitter under test shall be set in continuous transmission mode. If this is not possible, the measurement shall be carried out in a period shorter than the duration of the transmitted burst.

The interfering test signal source shall be unmodulated and the frequency shall be within 50 kHz to 100 kHz above the frequency of the transmitter under test.

The frequency shall be chosen in such a way that the intermodulation components to be measured do not coincide with other spurious components. The power output of the interfering test signal source shall be adjusted to the carrier power level of the transmitter under test by the use of a power metre.

The intermodulation component shall be measured by direct observation on the spectrum analyser of the ratio of the largest third order intermodulation component with respect to the carrier.

This value shall be recorded.

This measurement shall be repeated with the interfering test signal source at a frequency within 50 kHz to 100 kHz below the frequency of the transmitter under test.

The intermodulation attenuation of the equipment under test shall be expressed as the lowest of the two values recorded in figure 11.

7.7.3 Limits

Two classes of transmitter intermodulation attenuation are defined, the equipment shall fulfil one of the requirements:

- in general the intermodulation attenuation ratio shall be at least 40,0 dB for any intermodulation component;
- for base station equipment to be used in special service conditions (e.g. at sites where more than one transmitter will be in service) or when the regulatory authority makes it a condition of the licence, the intermodulation attenuation ratio shall be at least 70,0 dB for any intermodulation component. In the case where the performance is achieved by additional internal or external isolating devices (such as circulators) these are expected to be available at the time the measurements are made and shall be used for the measurements.

7.8 Void

Table 7: Void

8 Technical characteristics of the receiver

8.1 Maximum usable sensitivity (conducted)

8.1.1 Definition

The maximum usable sensitivity (conducted) of the receiver is the minimum level of signal (emf) at the receiver input, at the nominal frequency of the receiver and with normal test modulation which will produce:

- an audio frequency output power of at least 50 % of the rated power output; and
- a SND/ND ratio of 20 dB, measured at the receiver output through a telephone psophometric weighting network as described in ITU-T Recommendation O.41 [2] Red Book 1984.

8.1.2 Method of measurement

The test signal, at the nominal frequency of the receiver, with normal test modulation, at an emf. of 6 dB μ V, value of the limit for the maximum usable sensitivity, shall be applied to the receiver input connector.

An audio frequency output load, a SINAD metre and a psophometric telephone weighting network shall be connected to the receiver output terminals.

Where possible, the receiver volume control shall be adjusted to give at least 50 % of the rated output power, in the case of stepped volume controls, to the first step that provides an output power of at least 50 % of the rated output power.

The test signal input level shall be reduced until a SND/ND ratio of 20 dB is obtained.

The test signal input level under these conditions is the value of the maximum usable sensitivity.

The measurement shall be made under normal test conditions and repeated under extreme test conditions.

Under extreme test conditions, the receiver audio output power shall be within $\pm 3,0$ dB of the value obtained under normal test condition.

8.1.3 Limits

The maximum usable sensitivity shall not exceed an electromotive force (emf) of +6,0 dB μ V under normal test conditions, and an emf of +12,0 dB μ V under extreme test conditions.

8.2 Maximum usable sensitivity (field strength)

8.2.1 Definition

The maximum usable sensitivity of the receiver is the minimum field strength present at the location of the receiver at the nominal frequency of the receiver and with normal test modulation which will fulfil the requirements of clause 8.1.

This measurement applies only to equipment without an external antenna connector.

8.2.2 Method of measurement

On a test site, selected from annex A, the equipment shall be placed at the specified height on a non-conducting support and in the position closest to normal use as declared by the manufacturer.

The test antenna shall be orientated for vertical polarization and the length of the test antenna shall be chosen to correspond to the frequency of the receiver.

The input of the test antenna shall be connected to a signal generator.

The signal generator shall be tuned to the frequency of the receiver under test and its output level shall be adjusted to 100 dB μ V.

The signal generator shall be modulated with normal test modulation.

An audio frequency output load, a SINAD metre and a psophometric telephone weighting network shall be coupled to the receiver loudspeaker/transducer via an acoustic measuring arrangement described in clause A.3.3.1.

Where possible, the receiver volume control shall be adjusted to give at least 50 % of the rated output power or, in the case of stepped volume controls, to the first step that provides an output power of at least 50 % of the rated output power.

The test signal output level shall be reduced until the acoustic SND/ND ratio of 20 dB is obtained.

The test antenna shall be raised and lowered through the specified range of height to find the lowest level of the test signal that produces an acoustic SND/ND ratio of 20 dB.

The receiver shall then be rotated through 360° in the horizontal plane, to find the lowest level of the test signal that produces an acoustic SND/ND ratio of 20 dB.

The input signal level to the test antenna shall be maintained.

The receiver shall be replaced by a substitution antenna as defined in clause A.1.5.

The substitution antenna shall be orientated for vertical polarization and the length of the substitution antenna shall be adjusted to correspond to the frequency of the receiver.

The substitution antenna shall be connected to a calibrated measuring receiver.

The test antenna shall be raised and lowered through the specified range of height to ensure that the maximum signal is received.

The signal level measured with the calibrated measuring receiver shall be recorded as the field strength in dB μ V/m.

The measurement shall be repeated with the test antenna and the substitution antenna orientated for horizontal polarization.

The measure of the maximum usable sensitivity expressed as field strength is the minimum of the two signal levels recorded at the input to the calibrated measuring receiver, corrected for the gain of the antenna if necessary.

8.2.3 Limits

The maximum usable sensitivity shall not exceed the field strength value shown in table 8.

Table 8

Frequency band (MHz)	Field strength in dB relative to 1 μ V/m
	Normal test conditions
30 to 100	14,0
100 to 230	20,0
230 to 470	26,0
470 to 1 000	32,0

8.3 Co-channel rejection

8.3.1 Definition

The co-channel rejection is a measure of the capability of the receiver to receive a wanted modulated signal without exceeding a given degradation due the presence of an unwanted modulated signal, both signals being at the nominal frequency of the receiver.

8.3.2 Method of measurement

The two input signals shall be connected to the receiver via a combining network.

The wanted test signal, at the nominal frequency of the receiver, with normal test modulation at an e.m.f. of 6 dB μ V, value of the limit for the maximum usable sensitivity, shall be applied to the receiver input connector via one input of the combining network.

The unwanted test signal, at the nominal frequency of the receiver, modulated with a frequency of 400 Hz at a deviation of 60 % of the maximum permissible frequency deviation, clause 7.4.3.1 shall be applied to the receiver input connector via the second input of the combining network.

The amplitude of the unwanted test signal shall be adjusted until the SND/ND ratio, psophometrically weighted, at the output of the receiver is reduced to 14 dB.

The measure of the co-channel rejection is the ratio in dB of the level of the unwanted test signal to the level of the wanted test signal at the receiver input for which the specified reduction in SND/ND ratio occurs.

This ratio shall be recorded.

The measurement shall be repeated for displacements of the unwanted test signal of $\pm 1\ 500$ Hz and $\pm 3\ 000$ Hz.

The lowest value of the five measurement results recorded shall be recorded as the co-channel rejection.

8.3.3 Limits

The value of the co-channel rejection ratio, expressed in dB, at the signal displacements given in the method of measurement, shall be:

- between -8,0 dB and 0 dB, for channel separations of 20 kHz and 25 kHz;
- between -12,0 dB and 0 dB, for channel separations of 12,5 kHz.

8.4 Adjacent channel selectivity

8.4.1 Definition

The adjacent channel selectivity is a measure of the capability of the receiver to receive a wanted modulated signal without exceeding a given degradation due to the presence of an unwanted signal which differs in frequency from the wanted signal by an amount equal to the adjacent channel separation for which the equipment is intended.

8.4.2 Method of measurement

The two input signals shall be connected to the receiver via a combining network.

The wanted test signal, at the nominal frequency of the receiver, with normal test modulation at an e.m.f. of 6 dB μ V, value of the limit for the maximum usable sensitivity, shall be applied to the receiver input connector via one input of the combining network.

The unwanted test signal, at the frequency of one channel separation above the nominal frequency of the receiver, modulated with a frequency of 400 Hz at a deviation of 60 % of the maximum permissible frequency deviation, clause 7.4.3.1, shall be applied to the receiver input connector via the second input of the combining network.

The amplitude of the unwanted test signal shall be adjusted until the SND/ND ratio, psophometrically weighted, at the output of the receiver is reduced to 14 dB.

The measure of the adjacent channel selectivity is the ratio in dB of the level of the unwanted test signal to the level of the wanted test signal at the receiver input for which the specified reduction in SND/ND ratio occurs.

This ratio shall be recorded.

The measurement shall be repeated with an unwanted signal at the frequency of the channel below that of the wanted signal.

The two noted ratios shall be recorded as the upper and lower adjacent channel selectivity.

The measurements shall be repeated under extreme test conditions with the amplitude of the wanted test signal adjusted to an emf of 12 dB μ V.

8.4.3 Limits

The adjacent channel selectivity for different channel separations shall not be less than the values given in table 9.

Table 9: Adjacent channel selectivity

	Channel separation	
	12,5 kHz	20/25 kHz
Normal test conditions	60,0 dB	70,0 dB
Extreme test conditions	50,0 dB	60,0 dB

8.5 Spurious response rejection

8.5.1 Definition

The spurious response rejection is a measure of the capability of the receiver to receive a wanted modulated signal without exceeding a given degradation due to the presence of an unwanted modulated signal at any other frequency, at which a response is obtained.

8.5.2 Introduction to the method of measurement

Spurious responses may occur at all frequencies throughout the frequency spectrum and the requirements of the present document shall be met for all frequencies. However, for practical reasons the measurements shall be performed as specified in the present document. More specifically, this method of measurement is not intended to capture all spurious responses but selects those that have a high probability of being present. However, in a limited frequency range close to the nominal frequency of the receiver, it has been considered impossible to determine the probability of a spurious response and therefore a search shall be performed over this limited frequency range. This method provides a high degree of confidence that the equipment also meets the requirements at frequencies not being measured.

To determine the frequencies at which spurious responses can occur the following calculations shall be made:

a) calculation of the "limited frequency range":

- the limited frequency range is defined as the frequency of the local oscillator signal (f_{LO}) applied to the first mixer of the receiver plus or minus the sum of the intermediate frequencies (f_{I1}, \dots, f_{In}) and a half the switching range (sr) of the receiver;
- hence, the frequency f_l of the limited frequency range is:

$$f_{LO} - \sum_{j=1}^{j=n} f_{Ij} - \frac{sr}{2} \leq f_l \leq f_{LO} + \sum_{j=1}^{j=n} f_{Ij} + \frac{sr}{2}$$

b) calculation of frequencies outside the limited frequency range:

- a calculation of the frequencies at which spurious responses can occur outside the range determined in a) is made for the remainder of the frequency range of interest, as appropriate;
- the frequencies outside the limited frequency range are equal to the harmonics of the frequency of the local oscillator signal (f_{LO}) applied to the first mixer of the receiver plus or minus the first intermediate frequency (f_{I1}) of the receiver;
- hence, the frequencies of these spurious responses are:

$$nf_{LO} \pm f_{I1}$$

- where n is an integer greater than or equal to 2;

the measurement of the first image response of the receiver shall initially be made to verify the calculation of spurious response frequencies.

For the calculations a) and b) above, the manufacturer shall state the frequency of the receiver, the frequency of the local oscillator signal (f_{LO}) applied to the 1st mixer of the receiver, the intermediate frequencies (f_{I1} , f_{I2} etc.) and the switching range (sr) of the receiver.

8.5.3 Method of measurement

8.5.3.1 Method of search over the "limited frequency range"

The two input signals shall be connected to the receiver via a combining network.

The wanted test signal, at the nominal frequency of the receiver, with normal test modulation at an e.m.f. of 6 dB μ V, value of the limit for the maximum usable sensitivity, shall be applied to the receiver input connector via one input of the combining network.

The unwanted test signal, modulated with a frequency of 400 Hz at a deviation of 60 % of the maximum permissible frequency deviation, clause 7.4.3.1, at an emf of 86 dB μ V, shall be applied to the receiver input connector via the second input of the combining network.

The frequency of the unwanted signal shall be varied incrementally over the "limited frequency range".

The incremental steps of the frequency of the unwanted signal shall be 5 kHz.

The frequency of any spurious response detected during the search shall be recorded for the use in measurements in accordance with clause 8.5.3.2.

8.5.3.2 Method of measurement - Step 2

The two input signals shall be connected to the receiver via a combining network.

The wanted test signal, at the nominal frequency of the receiver, with normal test modulation at an e.m.f. of 6 dB μ V, value of the limit for the maximum usable sensitivity, shall be applied to the receiver input connector via one input of the combining network.

The unwanted test signal, modulated with a frequency of 400 Hz at a deviation of 60 % of the maximum permissible frequency deviation, clause 7.4.3.1, at an emf of 86 dB μ V, shall be applied to the receiver input connector via the second input of the combining network.

The measurement shall be performed at all spurious response frequencies found during the search over the "limited frequency range" and at frequencies calculated for the remainder of the spurious response frequencies in the frequency range 100 kHz to 2 GHz for equipment operating on frequencies below 470 MHz, or in the frequency range of 100 kHz to 4 GHz for equipment operating on frequencies above 470 MHz.

At each frequency at which a spurious response occurs, the input level shall be adjusted until the SND/ND ratio, psophometrically weighted, is reduced to 14 dB.

The measure of the spurious response rejection is the ratio in dB of the level of the unwanted test signal to the level of the wanted test signal at the receiver input for which the specified reduction in SND/ND ratio occurs.

The ratio shall be recorded as the spurious response rejection for each spurious response obtained.

8.5.4 Limits

At any frequency separated from the nominal frequency of the receiver by two channels or more, the spurious response rejection shall not be less than 70,0 dB.

8.6 Intermodulation response rejection

8.6.1 Definition

The intermodulation response rejection is a measure of the capability of the receiver to receive a wanted modulated signal, without exceeding a given degradation due to the presence of two or more unwanted signals with a specific frequency relationship to the wanted signal frequency.

8.6.2 Method of measurement

Three input signals shall be connected to the receiver via a combining network.

The wanted test signal (A), at the nominal frequency of the receiver, with normal test modulation at a deviation of 60 % of the maximum permissible frequency deviation (see clause 7.4.3.1) at an emf of 6 dB μ V, value of the limit for the maximum usable sensitivity, shall be applied to the receiver input connector via one input of the combining network.

The unwanted test signal (B), at the frequency 25 kHz above the nominal frequency of the receiver, without modulation, shall be applied to the receiver input connector via the second input of the combining network.

The unwanted test signal (C), at the frequency 50 kHz above the nominal frequency of the receiver, modulated with a frequency of 400 Hz at a deviation of 60 % of the maximum permissible frequency deviation (see clause 7.4.3.1) shall be applied to the receiver input connector via the third input of the combining network.

The amplitude of the unwanted test signals (B) and (C) shall be maintained equal and adjusted until the SND/ND ratio, psophometrically weighted, at the output of the receiver is reduced to 14 dB.

The measure of the intermodulation response rejection is the ratio in dB of the level of the unwanted test signals to the level of the wanted test signal at the receiver input for which the specified reduction in SND/ND ratio occurs.

This ratio shall be recorded.

The measurement shall be repeated with the unwanted signal from signal generator (B) at a frequency 50 kHz above the wanted signal and with the unwanted signal from signal generator (C) at a frequency 100 kHz above the wanted signal.

The two sets of measurements described above shall be repeated with the unwanted signals below the nominal frequency of the receiver by the specified amounts.

8.6.3 Limits

The intermodulation response rejection ratio shall not be less than 70,0 dB for base station equipment and 65,0 dB for mobile and hand portable equipment.

8.7 Blocking or desensitization

8.7.1 Definition

Blocking is a measure of the capability of the receiver to receive a wanted modulated signal without exceeding a given degradation due to the presence of an unwanted input signal at any frequencies other than those of the spurious responses or the adjacent channels.

8.7.2 Method of measurement

The two input signals shall be connected to the receiver via a combining network.

The wanted test signal, at the nominal frequency of the receiver, with normal test modulation, at an emf of 6 dB μ V, value of the limit for the maximum usable sensitivity, shall be applied to the receiver input connector via one input of the combining network.

Where possible, the receiver volume control shall be adjusted to give at least 50 % of the rated output power or, in the case of stepped volume controls, to the first step that provides an output power of at least 50 % of the rated output power.

The obtained audio output level shall be noted.

The unwanted test signal, at a frequency from 1 MHz to 10 MHz offset from the nominal frequency of the receiver, without modulation, shall be applied to the receiver input connector via the second input of the combining network.

For practical reasons the measurements will be carried out at frequencies of the unwanted signal at approximately ± 1 MHz, ± 2 MHz, ± 5 MHz and ± 10 MHz.

The amplitude of the unwanted test signal shall be adjusted until:

- a reduction of 3 dB in the audio output level of the wanted signal; or
- the SND/ND ratio, psophometrically weighted, at the output of the receiver is reduced to 14 dB;

whichever occurs first. This level shall be noted.

The measure of the blocking or desensitization is the ratio in dB of the level of the unwanted test signal to the level of the wanted test signal at the receiver input for which the specified reduction in audio output level or in the SND/ND ratio occurs.

This ratio shall be recorded for each of the eight noted levels as the blocking or desensitization.

8.7.3 Limits

The blocking ratio for any frequency within the specified ranges shall not be less than 84,0 dB, except at frequencies on which spurious responses are found.

8.8 Spurious radiations

8.8.1 Definition

Spurious radiations from the receiver are emissions at any frequency, radiated by the equipment and its antenna.

The level of spurious radiations shall be measured by:

either:

- a) their power level in a specified load (conducted spurious emission); and
- b) their effective radiated power when radiated by the cabinet and structure of the equipment (cabinet radiation);

or

- c) their effective radiated power when radiated by the cabinet and by the integral antenna, in the case of hand portable equipment fitted with such an antenna and no external RF connector.

NOTE: i.e. ((a and b) or c).

8.8.2 Method of measuring the power level

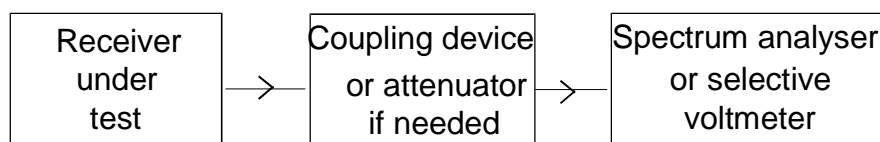

Figure 12: Measurement arrangement

The measurement arrangement in figure 12 shall be used.

This method applies only to equipment having an external antenna connector. Spurious radiations shall be measured as the power level of any discrete signal at the input terminals of the receiver. The receiver input terminals are connected to a spectrum analyser or selective voltmeter having an input impedance of 50 Ω and the receiver is switched on.

If the detecting device is not calibrated in terms of power input, the level of any detected components shall be determined by a substitution method using a signal generator.

Radiation of any spurious components shall be detected by the test antenna and receiver, over the frequency range 30 MHz to 4 GHz. For equipment operating on frequencies above 470 MHz the measurements shall also be performed over the frequency range 4 GHz to 12,75 GHz if emissions are detected within 10 dB of the of the specified limit between 1,5 GHz and 4 GHz.

8.8.3 Method of measuring the effective radiated power

Test site

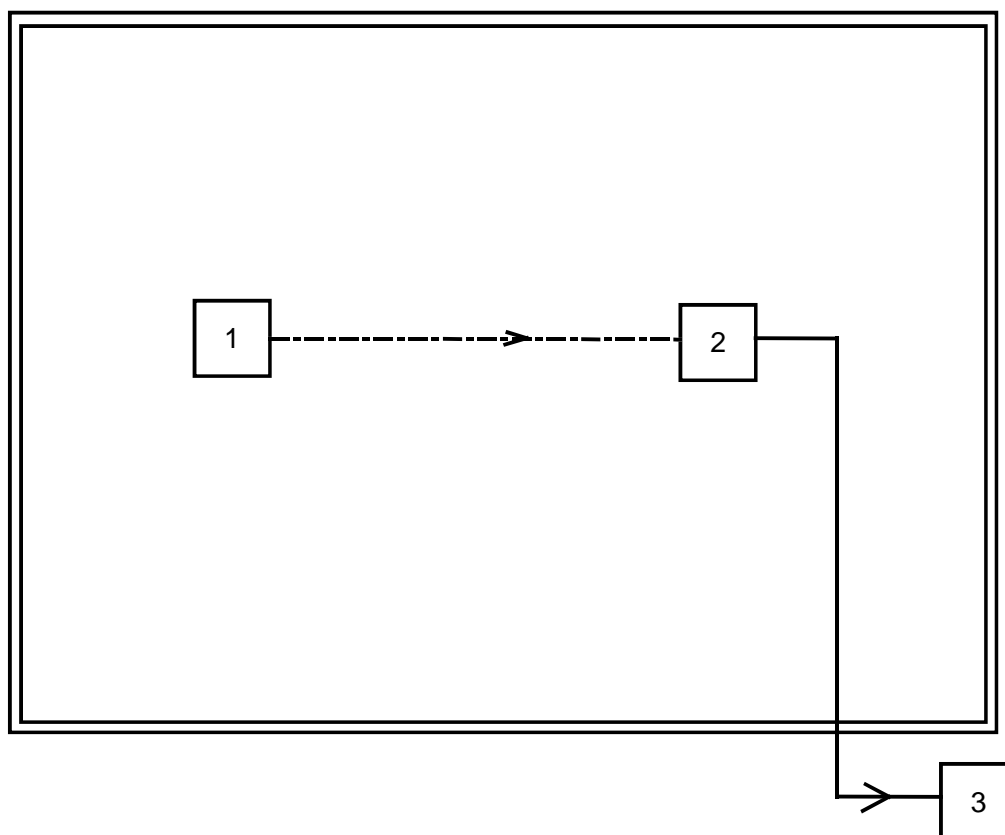

NOTE: 1 = Receiver under test.
2 = Test antenna.
3 = Spectrum analyser or selective voltmeter (test receiver).

Figure 13: Measurement arrangement

The measurement arrangement in figure 13 shall be used.

The measurement procedure shall be as follows:

- a) on a test site, fulfilling the requirements of annex A, the sample shall be placed at the specified height on the non-conducting support;
 - the receiver shall be operated from a power source via a radio frequency filter to avoid radiation from the power leads;
- b) the receiver shall be connected:
 - to an artificial antenna for equipment having an external antenna connector; or
 - to the integral antenna;

- c) radiation of any spurious components shall be detected over the frequency range 30 MHz to 4 GHz;

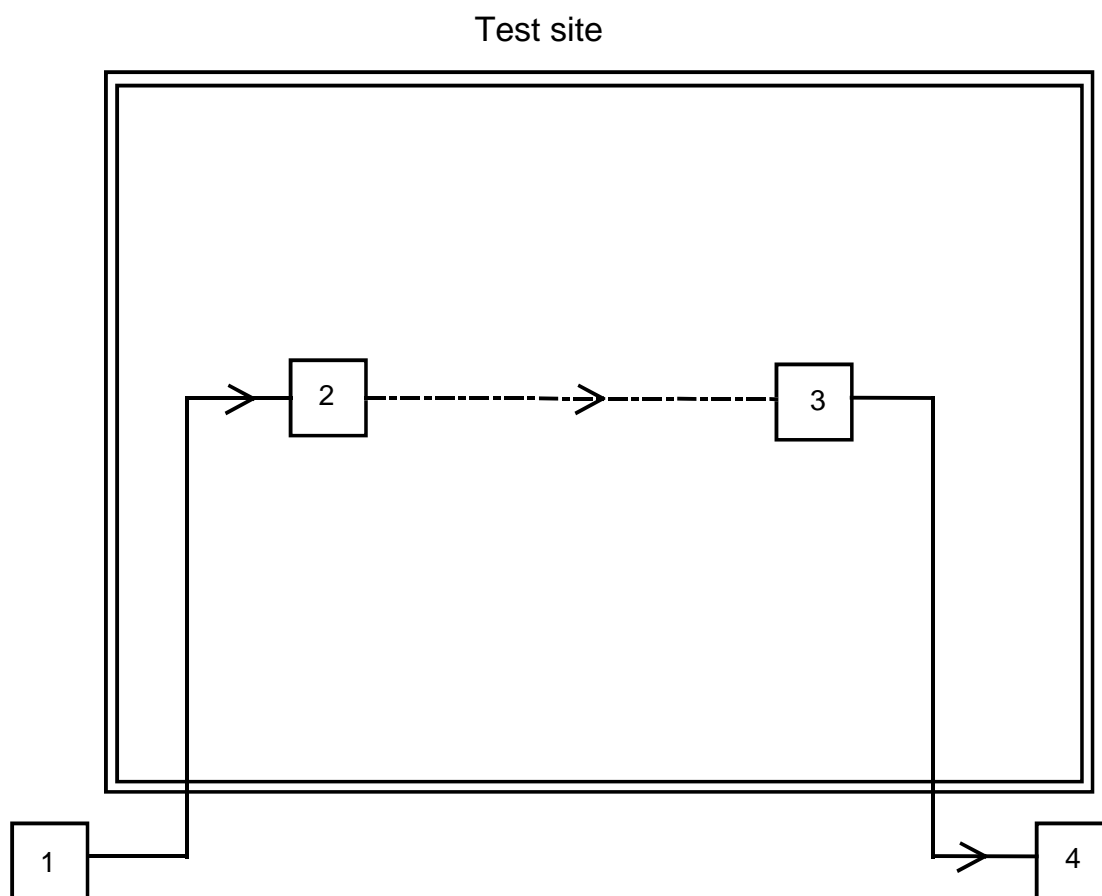

NOTE: 1 = Signal generator.
 2 = Substitution antenna.
 3 = Test antenna.
 4 = Spectrum analyser or selective voltmeter (test receiver).

Figure 14: Measurement arrangement

- d) at each frequency at which a component is detected, the sample shall be rotated to obtain maximum response and the effective radiated power of that component determined by a substitution measurement, using the measurement arrangement of figure 14;
- e) the value of the effective radiated power of that component shall be recorded;
- f) the measurement shall be repeated with the test antenna in the orthogonal polarization plane.

8.8.4 Limits

The power of any spurious radiation shall not exceed the values given in tables 10 and 11.

Table 10: Conducted components

Frequency range	Limit
9 kHz to 1 GHz	2,0 nW (-57 dBm)
above 1 GHz to 4 GHz, or above 1 GHz to 12,75 GHz	20,0 nW (-47 dBm)

Table 11: Radiated components

Frequency range	Limit
30 MHz to 1 GHz	2,0 nW (-57 dBm)
above 1 GHz to 4 GHz	20,0 nW (-47 dBm)

Table 12: Reference bandwidths to be used for the measurement of spurious radiations

Frequency range	RBW
9 kHz to 150 kHz	1 kHz
150 kHz to 30 MHz	10 kHz
30 MHz to 1 GHz	100 kHz
1 GHz to 12,75 GHz	1 MHz

9 Duplex operation

9.1 Receiver desensitization (with simultaneous transmission and reception)

9.1.1 Definition

The desensitization is the degradation of the sensitivity of the receiver resulting from the transfer of power from the transmitter to the receiver due to coupling effects. It is expressed as the difference in dB between the maximum usable sensitivity levels (conducted), with and without simultaneous transmissions.

9.1.2 Method of measurement when the equipment operates with a duplex filter

The antenna connector shall be connected to a 50 Ω power attenuator, through a coupling device.

The test signal, with normal test modulation shall be connected to the coupling device in such a way as not to affect the impedance matching.

The transmitter shall be operated at the rated output power.

The transmitter shall be modulated by a frequency of 400 Hz at a deviation of 60 % of the maximum permissible frequency deviation, clause 7.4.3.1.

The receiver sensitivity shall be measured in accordance with clause 8.1.

The output level of the signal generator shall be recorded as C in dB μ V.

The transmitter shall be switched off and the receiver sensitivity measured.

The output level of the signal generator shall be recorded as D in dB μ V.

The desensitization is the difference between the values of C and D.

9.1.3 Measuring method when the equipment operates with two antennas

The transmitter RF output shall be connected to a power attenuator.

The output of the power attenuator shall be connected to the receiver input through a coupling device.

The attenuation between transmitter and receiver shall be 30 dB.

The test signal, with normal test modulation shall be connected to the coupling device in such a way as not to affect the impedance matching.

The transmitter shall be operated at the rated output power.

The transmitter shall be modulated by a frequency of 400 Hz at a deviation of 60 % of the maximum permissible frequency deviation, clause 7.4.3.1.

The receiver sensitivity shall be measured in accordance with clause 8.1.

The output level of the signal generator shall be recorded as C in dB μ V.

The transmitter shall be switched off and the receiver sensitivity measured.

The output level of the signal generator shall be recorded as D in dB μ V.

The desensitization is the difference between the values of C and D.

9.1.4 Limits

The desensitization shall not exceed 3,0 dB and the limit of maximum usable sensitivity under normal test conditions shall be met.

9.2 Receiver spurious response rejection (with simultaneous transmission and reception)

9.2.1 Definition

The spurious response rejection, under duplex operation, is a measure of the capability of the receiver to achieve a specific spurious response rejection ratio when receiving a wanted modulated signal in the presence of:

- a) an unwanted signal at any other frequency, at which a response may be obtained; and
- b) the unmodulated signal of the transmitter operating at duplex frequency distance, at the rated output power and attenuated by the duplex filter or by the distance between the antennas.

9.2.2 Method of measurement

If the equipment is designed for duplex operation, the following additional measurement shall be carried out to ensure satisfactory duplex operation.

Equipment made available for such measurements shall be fitted with a duplex filter.

Duplex measurements shall be carried out on a single pair of frequencies only, as specified by the manufacturer (in consultation with the appropriate testing laboratory (if appropriate)).

Measurement for Duplex operation shall be carried out when, and only when, the equipment under test, either operating in continuous or discontinuous mode of operation, is transmitting and receiving signals simultaneously at the antenna(s).

For all measurements for Duplex operation the equipment (transmission and reception) shall be operated in its normal transmission mode.

The receiver spurious response rejection under duplex operation shall be measured as specified in clause 8.5 with the measurement arrangement described in clauses 9.1.2 or 9.1.3, except that the transmitter shall be unmodulated. The transmitter shall be operated at the carrier output power as defined in clause 7.2.

The measurement shall be performed around frequencies f_m derived from the expressions:

$$(p)f_t + (q)f_r = f_m \text{ and } f_m = (n)f_t \pm f_{I1};$$

where:

- f_t is the transmitter frequency;
- f_r is the receiver frequency;

and

- f_{I1} is the first IF of the receiver;
- $n \geq 2$.

Particular attention should be made to the following values:

$$(p) = -1, (q) = 2 \text{ and } (p) = 2, (q) = -1$$

It should be noted that the method of measurement described may cause errors at certain frequencies due to the effect of signal generator intermodulation. To overcome such errors, a band stop filter at the transmitting frequency may be used, in conjunction with the signal generator combining network.

9.2.3 Limits

At any frequency separated from the nominal frequency of the receiver by two channels or more, the spurious response rejection ratio shall be greater than 67,0 dB.

10 Measurement uncertainty

The interpretation of the results recorded in the test report for the measurements described in the present document shall be as follows:

- the measured value related to the corresponding limit shall be used to decide whether an equipment meets the requirements of the present document;
- the value of the measurement uncertainty for the measurement of each parameter shall be separately included in the test report;
- the value of the measurement uncertainty shall be, for each measurement, equal to or lower than the figures in table 13.

Table 13: Absolute measurement uncertainties: maximum values

Parameter	Uncertainty
Radio Frequency	$\pm 1 \times 10^{-7}$
RF Power (up to 160 W)	$\pm 0,75$ dB
Radiated RF power	± 6 dB
Adjacent channel power	± 5 dB
Conducted spurious emission of transmitter valid up to 12,75 GHz	± 4 dB
Conducted spurious emission of receiver, valid up to 12,75 GHz	± 7 dB
Two-signal measurement, valid up to 4 GHz	± 4 dB
Three-signal measurement	± 3 dB
Radiated emission of the transmitter, valid up to 4 GHz	± 6 dB
Radiated emission of receiver, valid up to 4 GHz	± 6 dB
Transmitter intermodulation	± 3 dB

Parameter	Uncertainty
Receiver desensitization (duplex operation)	$\pm 0,5$ dB
Temperature	± 1 °C
Humidity	± 10 %
NOTE: Valid up to 1 GHz for the RF parameters unless otherwise stated.	

For the test methods, according to the present document, the measurement uncertainty figures shall be calculated in accordance with TR 100 028 [1] and shall correspond to an expansion factor (coverage factor) $k = 1,96$ or $k = 2$ (which provide confidence levels of respectively 95 % and 95,45 % in the case where the distributions characterizing the actual measurement uncertainties are normal (Gaussian)).

Table 13 is based on such expansion factors.

The particular expansion factor used for the evaluation of the measurement uncertainty shall be stated.

TR 102 273 [i.3] provides further information concerning the usage of test sites.

Annex A (normative): Radiated measurement

A.1 Test sites and general arrangements for measurements involving the use of radiated fields

This annex introduces three most commonly available test sites, an Anechoic Chamber, an Anechoic Chamber with a ground plane and an Open Area Test Site (OATS), which may be used for radiated tests. These test sites are generally referred to as free field test sites. Both absolute and relative measurements can be performed in these sites. Where absolute measurements are to be carried out, the chamber should be verified. A detailed verification procedure is described in TR 102 273 [i.3] relevant parts 2, 3 and 4.

NOTE: To ensure reproducibility and traceability of radiated measurements only these test sites should be used in measurements in accordance with the present document.

A.1.1 Anechoic chamber

An anechoic chamber is an enclosure, usually shielded, whose internal walls, floor and ceiling are covered with radio absorbing material, normally of the pyramidal urethane foam type. The chamber usually contains an antenna support at one end and a turntable at the other. A typical anechoic chamber is shown in figure A.1.

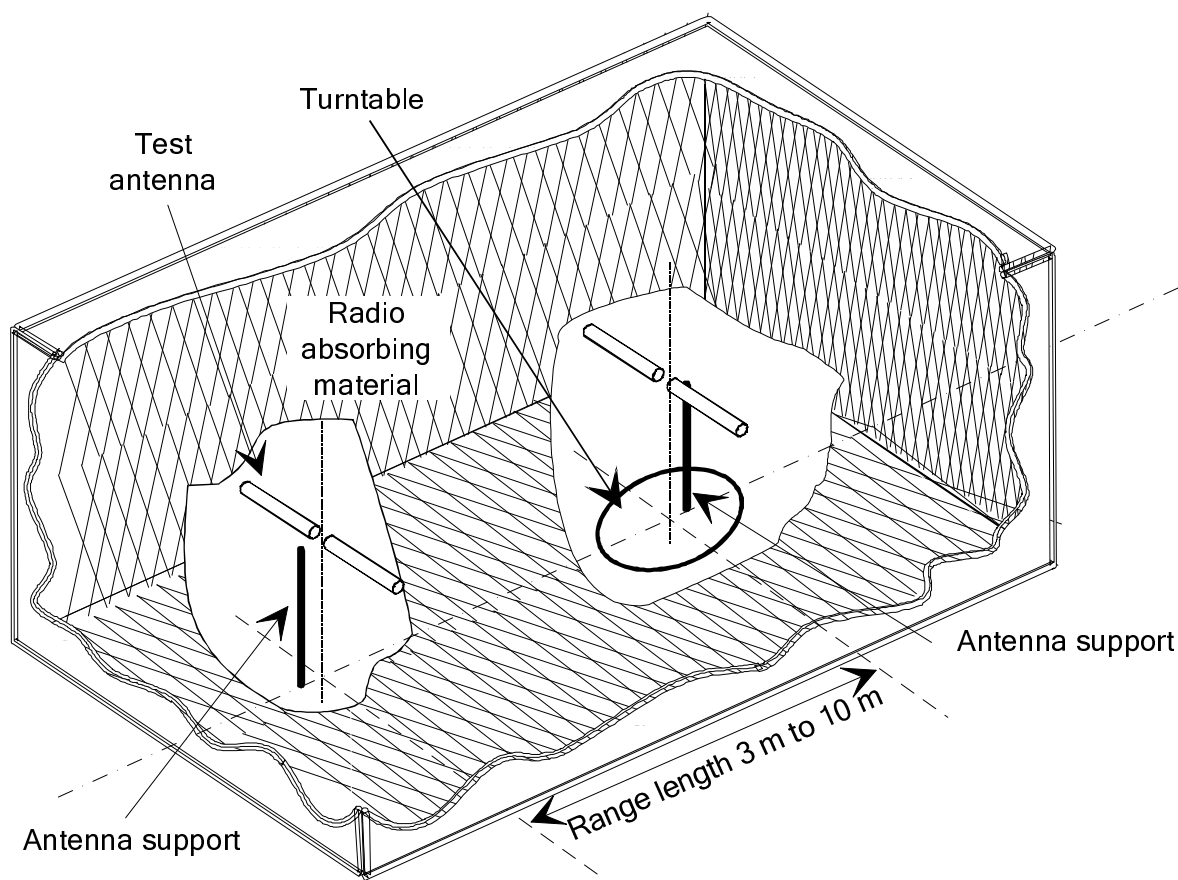

Figure A.1: A typical anechoic chamber

The chamber shielding and radio absorbing material work together to provide a controlled environment for testing purposes. This type of test chamber attempts to simulate free space conditions.

The shielding provides a test space, with reduced levels of interference from ambient signals and other outside effects, whilst the radio absorbing material minimizes unwanted reflections from the walls and ceiling which can influence the measurements. In practice it is relatively easy for shielding to provide high levels (80 dB to 140 dB) of ambient interference rejection, normally making ambient interference negligible.

A turntable is capable of rotation through 360° in the horizontal plane and it is used to support the test sample (EUT) at a suitable height (e.g. 1 m) above the ground plane. The chamber shall be large enough to allow the measuring distance of at least 3 m or $2(d_1 + d_2)^2/\lambda$ (m), whichever is greater (see to clause A.2.5). The distance used in actual measurements shall be recorded with the test results.

The anechoic chamber generally has several advantages over other test facilities. There is minimal ambient interference, minimal floor, ceiling and wall reflections and it is independent of the weather. It does however have some disadvantages which include limited measuring distance and limited lower frequency usage due to the size of the pyramidal absorbers. To improve low frequency performance, a combination structure of ferrite tiles and urethane foam absorbers is commonly used.

All types of emission, sensitivity and immunity testing can be carried out within an Anechoic Chamber without limitation.

A.1.2 Anechoic chamber with a conductive ground plane

An anechoic chamber with a conductive ground plane is an enclosure, usually shielded, whose internal walls and ceiling are covered with radio absorbing material, normally of the pyramidal urethane foam type. The floor, which is metallic, is not covered and forms the ground plane. The chamber usually contains an antenna mast at one end and a turntable at the other. A typical anechoic chamber with a conductive ground plane is shown in figure A.2.

This type of test chamber attempts to simulate an ideal Open Area Test Site whose primary characteristic is a perfectly conducting ground plane of infinite extent.

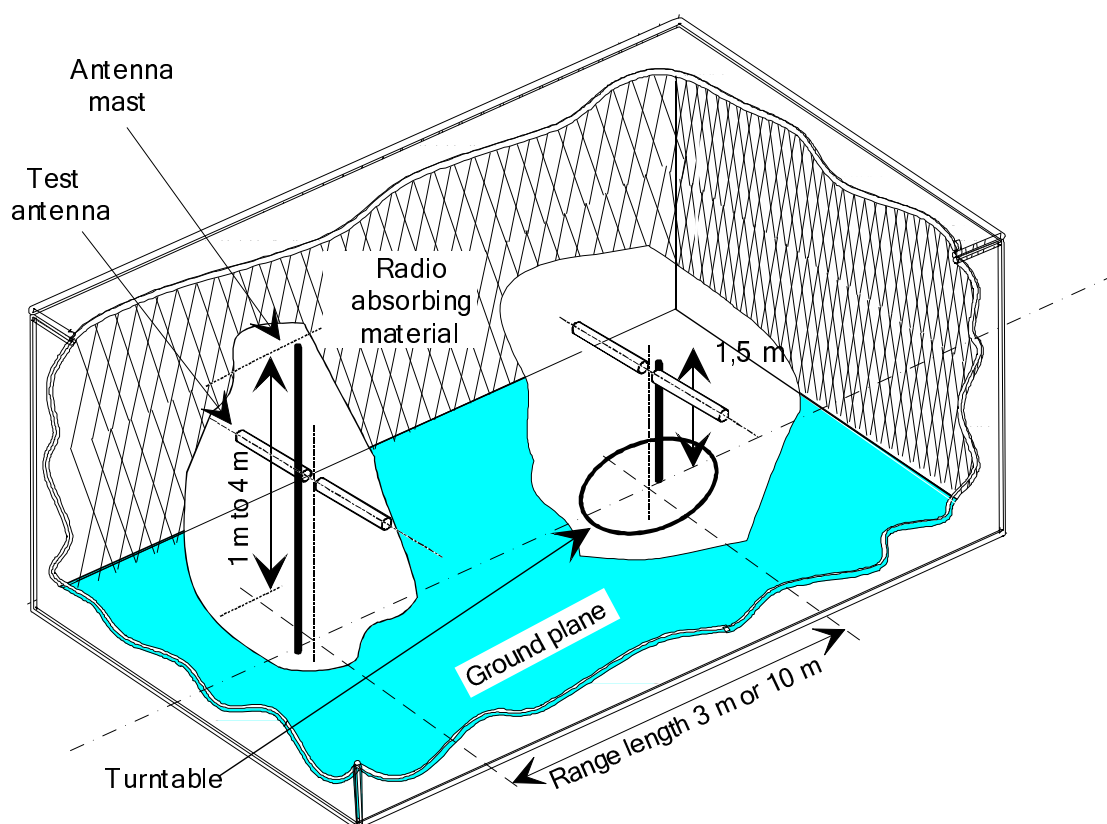

Figure A.2: A typical anechoic chamber with a conductive ground plane

In this facility the ground plane creates the wanted reflection path, such that the signal received by the receiving antenna is the sum of the signals from both the direct and reflected transmission paths. This creates a unique received signal level for each height of the transmitting antenna (or EUT) and the receiving antenna above the ground plane.

The antenna mast provides a variable height facility (from 1 to 4 metres) so that the position of the test antenna can be optimized for maximum coupled signal between antennas or between a EUT and the test antenna.

A turntable is capable of rotation through 360° in the horizontal plane and it is used to support the test sample (EUT) at a specified height, usually 1,5 metres above the ground plane. The chamber shall be large enough to allow the measuring distance of at least 3 m or $2(d_1 + d_2)/\lambda$ (m), whichever is greater (see clause A.2.5). The distance used in actual measurements shall be recorded with the test results.

Emission testing involves firstly "peaking" the field strength from the EUT by raising and lowering the receiving antenna on the mast (to obtain the maximum constructive interference of the direct and reflected signals from the EUT) and then rotating the turntable for a "peak" in the azimuth plane. At this height of the test antenna on the mast, the amplitude of the received signal is noted. Secondly the EUT is replaced by a substitution antenna (positioned at the EUT's phase or volume centre) which is connected to a signal generator. The signal is again "peaked" and the signal generator output adjusted until the level, noted in stage one, is again measured on the receiving device.

Receiver sensitivity tests over a ground plane also involve "peaking" the field strength by raising and lowering the test antenna on the mast to obtain the maximum constructive interference of the direct and reflected signals, this time using a measuring antenna which has been positioned where the phase or volume centre of the EUT will be during testing. A transform factor is derived. The test antenna remains at the same height for stage two, during which the measuring antenna is replaced by the EUT. The amplitude of the transmitted signal is reduced to determine the field strength level at which a specified response is obtained from the EUT.

A.1.3 Open Area Test Site (OATS)

An Open Area Test Site comprises a turntable at one end and an antenna mast of variable height at the other end above a ground plane which, in the ideal case, is perfectly conducting and of infinite extent. In practice, while good conductivity can be achieved, the ground plane size has to be limited. A typical Open Area Test Site is shown in figure A.3.

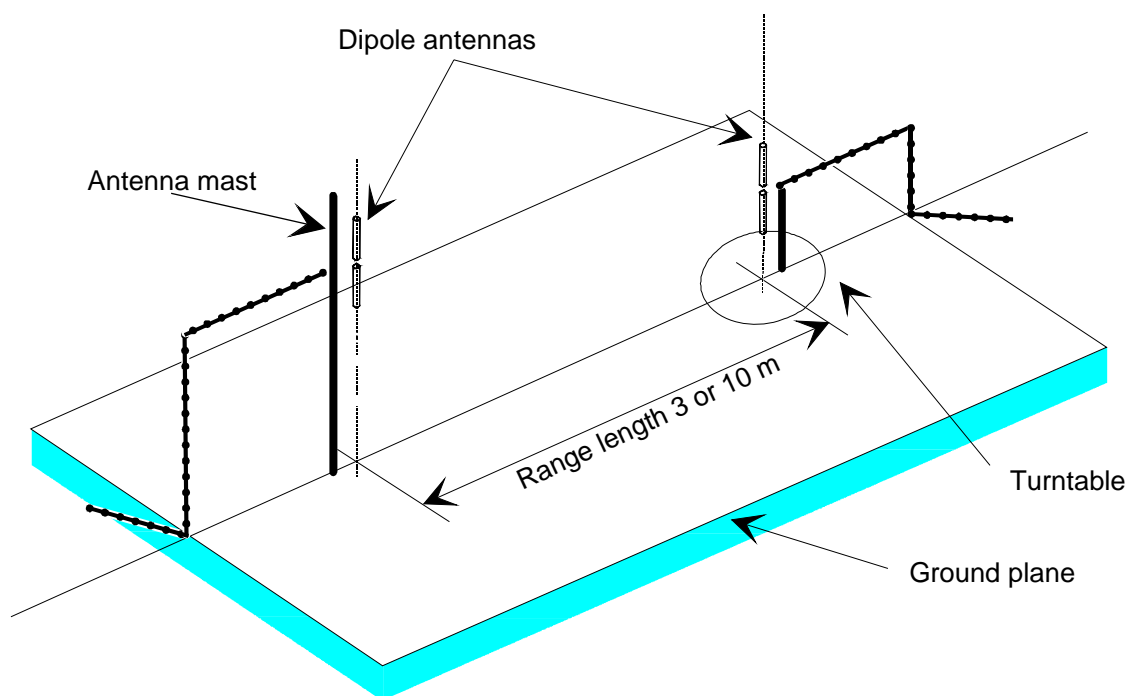

Figure A.3: A typical Open Area Test Site

The ground plane creates a wanted reflection path, such that the signal received by the receiving antenna is the sum of the signals received from the direct and reflected transmission paths. The phasing of these two signals creates a unique received level for each height of the transmitting antenna (or EUT) and the receiving antenna above the ground plane.

Site qualification concerning antenna positions, turntable, measurement distance and other arrangements are same as for anechoic chamber with a ground plane. In radiated measurements an OATS is also used by the same way as anechoic chamber with a ground plane.

Typical measuring arrangement common for ground plane test sites is presented in the figure A.4.

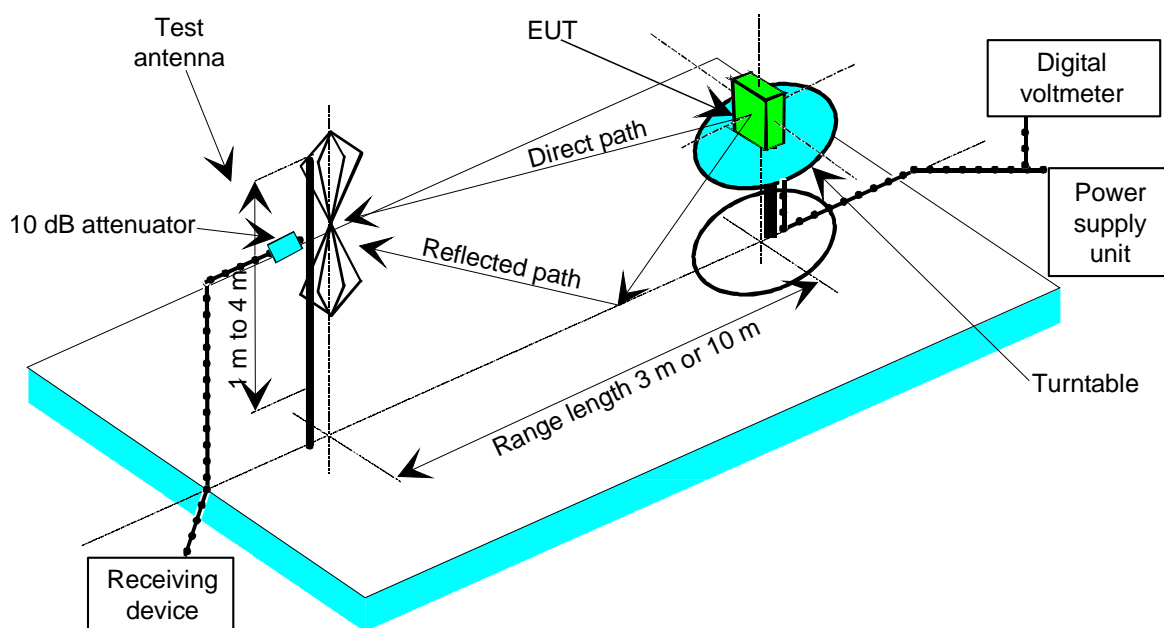

Figure A.4: Measuring arrangement on ground plane test site (OATS set-up for spurious emission testing)

A.1.4 Test antenna

A test antenna is always used in radiated test methods. In emission tests (i.e. frequency error, effective radiated power, spurious emissions and adjacent channel power) the test antenna is used to detect the field from the EUT in one stage of the measurement and from the substitution antenna in the other stage. When the test site is used for the measurement of receiver characteristics (i.e. sensitivity and various immunity parameters) the antenna is used as the transmitting device.

The test antenna should be mounted on a support capable of allowing the antenna to be used in either horizontal or vertical polarization which, on ground plane sites (i.e. Anechoic Chambers with ground planes and Open Area Test Sites), should additionally allow the height of its centre above the ground to be varied over the specified range (usually 1 to 4 metres).

In the frequency band 30 MHz to 1 000 MHz, dipole antennas (constructed in accordance with ANSI C63.5 [i.4]) are generally recommended. For frequencies of 80 MHz and above, the dipoles should have their arm lengths set for resonance at the frequency of test. Below 80 MHz, shortened arm lengths are recommended. For spurious emission testing, however, a combination of biconical antennas (commonly termed "bicones" and log periodic dipole array antennas (commonly termed "log periodics") could be used to cover the entire 30 MHz to 1 000 MHz band. Above 1 000 MHz, waveguide horns are recommended although, again, log periodics could be used.

NOTE: The gain of a horn antenna is generally expressed relative to an isotropic radiator.

A.1.5 Substitution antenna

The substitution antenna is used to replace the EUT for tests in which a transmitting parameter (i.e. frequency error, effective radiated power, spurious emissions and adjacent channel power) is being measured. For measurements in the frequency band 30 MHz to 1 000 MHz, the substitution antenna should be a dipole antenna (constructed in accordance with ANSI C63.5 [i.4]). For frequencies of 80 MHz and above, the dipoles should have their arm lengths set for resonance at the frequency of test. Below 80 MHz, shortened arm lengths are recommended. For measurements above 1 000 MHz, a waveguide horn is recommended. The centre of this antenna should coincide with either the phase centre or volume centre.

A.1.6 Measuring antenna

The measuring antenna is used in tests on a EUT in which a receiving parameter (i.e. sensitivity and various immunity tests) is being measured. Its purpose is to enable a measurement of the electric field strength in the vicinity of the EUT. For measurements in the frequency band 30 MHz to 1 000 MHz, the measuring antenna should be a dipole antenna (constructed in accordance with ANSI C63.5 [i.4]. For frequencies of 80 MHz and above, the dipoles should have their arm lengths set for resonance at the frequency of test. Below 80 MHz, shortened arm lengths are recommended. The centre of this antenna should coincide with either the phase centre or volume centre (as specified in the test method) of the EUT.

A.2 Guidance on the use of radiation test sites

This clause details procedures, test equipment arrangements and verification that should be carried out before any of the radiated test are undertaken. These schemes are common to all types of test sites described in annex A.

A.2.1 Verification of the test site

No test should be carried out on a test site which does not possess a valid certificate of verification. The verification procedures for the different types of test sites described in annex A (i.e. Anechoic Chamber, Anechoic Chamber with a ground plane and Open Area Test Site) are given in TR 102 273 [i.3] parts 2, 3 and 4, respectively.

A.2.2 Preparation of the EUT

The manufacturer should supply information about the EUT covering the operating frequency, polarization, supply voltage(s) and the reference face. Additional information, specific to the type of EUT should include, where relevant, carrier power, channel separation, whether different operating modes are available (e.g. high and low power modes) and if operation is continuous or is subject to a maximum test duty cycle (e.g. 1 minute on, 4 minutes off).

Where necessary, a mounting bracket of minimal size should be available for mounting the EUT on the turntable. This bracket should be made from low conductivity, low relative dielectric constant (i.e. less than 1,5) material(s) such as expanded polystyrene, balsawood, etc.

A.2.3 Power supplies to the EUT

All tests should be performed using power supplies wherever possible, including tests on EUT designed for battery-only use. In all cases, power leads should be connected to the EUT's supply terminals (and monitored with a digital voltmeter) but the battery should remain present, electrically isolated from the rest of the equipment, possibly by putting tape over its contacts.

The presence of these power cables can, however, affect the measured performance of the EUT. For this reason, they should be made to be "transparent" as far as the testing is concerned. This can be achieved by routing them away from the EUT and down to the either the screen, ground plane or facility wall (as appropriate) by the shortest possible paths. Precautions should be taken to minimize pick-up on these leads (e.g. the leads could be twisted together, loaded with ferrite beads at 0,15 metre spacing or otherwise loaded).

A.2.4 Volume control setting for analogue speech tests

Unless otherwise stated, in all receiver measurements for analogue speech the receiver volume control where possible, should be adjusted to give at least 50 % of the rated audio output power. In the case of stepped volume controls, the volume control should be set to the first step that provides an output power of at least 50 % of the rated audio output power. This control should not be readjusted between normal and extreme test conditions in tests.

A.2.5 Range length

The range length for all these types of test facility should be adequate to allow for testing in the far-field of the EUT i.e. it should be equal to or exceed:

$$\frac{2(d_1 + d_2)^2}{\lambda}$$

Where:

- d_1 is the largest dimension of the EUT/dipole after substitution (m);
- d_2 is the largest dimension of the test antenna (m);
- λ is the test frequency wavelength (m).

It should be noted that in the substitution part of this measurement, where both test and substitution antennas are half wavelength dipoles, this minimum range length for far-field testing would be:

$$2\lambda$$

It should be noted in test reports when either of these conditions is not met so that the additional measurement uncertainty can be incorporated into the results.

NOTE 1: For the fully anechoic chamber, no part of the volume of the EUT should, at any angle of rotation of the turntable, fall outside the "quiet zone" of the chamber at the nominal frequency of the test.

NOTE 2: The "quiet zone" is a volume within the Anechoic Chamber (without a ground plane) in which a specified performance has either been proven by test, or is guaranteed by the designer/manufacturer. The specified performance is usually the reflectivity of the absorbing panels or a directly related parameter (e.g. signal uniformity in amplitude and phase). It should be noted however that the defining levels of the quiet zone tend to vary.

NOTE 3: For the anechoic chamber with a ground plane, a full height scanning capability, i.e. 1 to 4 metres, should be available for which no part of the test antenna should come within 1 metre of the absorbing panels. For both types of Anechoic Chamber, the reflectivity of the absorbing panels should not be worse than -5 dB.

NOTE 4: For both the anechoic chamber with a ground plane and the Open Area Test Site, no part of any antenna should come within 0,25 metre of the ground plane at any time throughout the tests. Where any of these conditions cannot be met, measurements should not be carried out.

A.2.6 Site preparation

The cables for both ends of the test site should be routed horizontally away from the testing area for a minimum of 2 metres (unless, in the case both types of anechoic chamber, a back wall is reached) and then allowed to drop vertically and out through either the ground plane or screen (as appropriate) to the test equipment. Precautions should be taken to minimize pick up on these leads (e.g. dressing with ferrite beads, or other loading). The cables, their routing and dressing should be identical to the verification set-up.

NOTE: For ground reflection test sites (i.e. anechoic chambers with ground planes and Open Area Test Sites) which incorporate a cable drum with the antenna mast, the 2 metres requirement may be impossible to comply with.

Calibration data for all items of test equipment should be available and valid. For test, substitution and measuring antennas, the data should include gain relative to an isotropic radiator (or antenna factor) for the frequency of test. Also, the VSWR of the substitution and measuring antennas should be known.

The calibration data on all cables and attenuators should include insertion loss and VSWR throughout the entire frequency range of the tests. All VSWR and insertion loss figures should be recorded in the log book results sheet for the specific test.

Where correction factors/tables are required, these should be immediately available.

For all items of test equipment, the maximum errors they exhibit should be known along with the distribution of the error e.g.:

- cable loss: $\pm 0,5$ dB with a rectangular distribution;
- measuring receiver: 1,0 dB (standard deviation) signal level accuracy with a Gaussian error distribution.

At the start of measurements, system checks should be made on the items of test equipment used on the test site.

A.3 Coupling of signals

A.3.1 General

The presence of leads in the radiated field may cause a disturbance of that field and lead to additional measurement uncertainty. These disturbances can be minimized by using suitable coupling methods, offering signal isolation and minimum field disturbance (e.g. optical and acoustic coupling).

A.3.2 Data signals

Isolation can be provided by the use of optical, ultrasonic or infra-red means. Field disturbance can be minimized by using a suitable fibre optic connection. ultrasonic or infra-red radiated connections require suitable measures for the minimization of ambient noise.

A.3.3 Speech and analogue signals

Where an audio output socket is not available an acoustic coupler should be used.

When using the acoustic coupler, care should be exercised that possible ambient noise does not influence the test result.

A.3.3.1 Acoustic coupler description

The acoustic coupler comprises a plastic funnel, an acoustic pipe and a microphone with a suitable amplifier. The materials used to fabricate the funnel and pipe should be of low conductivity and of low relative dielectric constant (i.e. less than 1,5).

- The acoustic pipe should be long enough to reach from the EUT to the microphone which should be located in a position that will not disturb the RF field. The acoustic pipe should have an inner diameter of about 6 mm and a wall thickness of about 1,5 mm and should be sufficiently flexible so as not to hinder the rotation of the turntable.
- The plastic funnel should have a diameter appropriate to the size of the loudspeaker in the EUT, with soft foam rubber glued to its edge, it should be fitted to one end of the acoustic pipe and the microphone should be fitted to the other end. It is very important to fix the centre of the funnel in a reproducible position relative to the EUT, since the position of the centre has a strong influence on the frequency response that will be measured. This can be achieved by placing the EUT in a close fitting acoustic mounting jig, supplied by the manufacturer, of which the funnel is an integral part.
- The microphone should have a response characteristic flat within 1 dB over a frequency range of 50 Hz to 20 kHz, a linear dynamic range of at least 50 dB. The sensitivity of the microphone and the receiver audio output level should be suitable to measure a signal to noise ratio of at least 40 dB at the nominal audio output level of the EUT. Its size should be sufficiently small to couple to the acoustic pipe.
- The frequency correcting network should correct the frequency response of the acoustic coupler so that the acoustic SINAD measurement is valid (see IEC 60489-3 [i.5], appendix F).

A.3.3.2 Calibration

The aim of the calibration of the acoustic coupler is to determine the acoustic SINAD ratio which is equivalent to the SINAD ratio at the receiver output.

Annex B (normative): Specification for some particular measurement arrangements

B.1 Power measuring receiver specification

The power measuring receiver consists of a mixer, an IF filter, an oscillator, an amplifier, a variable attenuator and a root mean squared (rms) value indicator.

Instead of the Variable attenuator with the rms value indicator it is also possible to use a rms voltmeter calibrated in dB. The technical characteristics of the power measuring receiver are given in clauses B.1.1 to B.1.4.

An alternative measuring method shall consist in using, in place of the IF filter and the rms voltmeter calibrated in dB, a spectrum analyser with a resolution bandwidth of 100 Hz and integrating the power of all the 100 Hz sub-band measurements, over a total bandwidth of $\pm D2$ (see table B.1).

Spectrum analyser should use the rms measurement mode.

B.1.1 IF filter

The IF filter shall be within the limits of the selectivity characteristic of figure B.1.

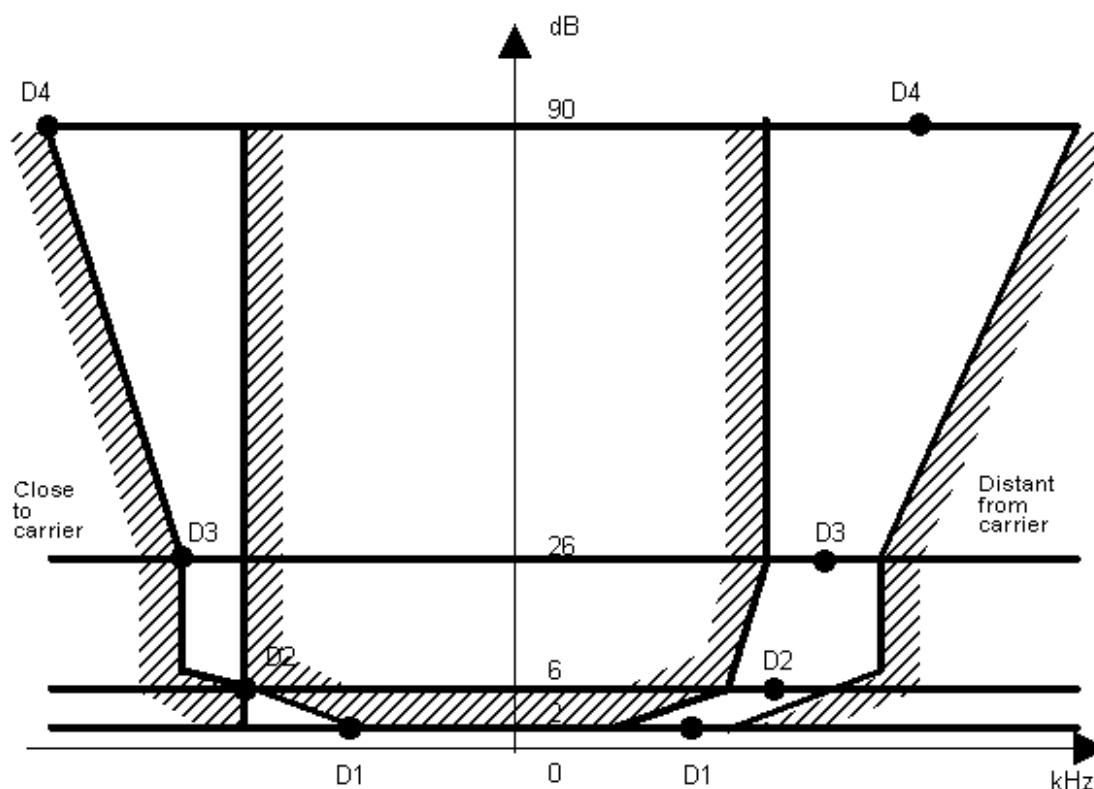

Figure B.1: IF filter

Depending on the channel separation, the selectivity characteristic shall keep the frequency separations from the nominal centre frequency of the adjacent channel as stated in table B.1.

Table B.1: Selectivity characteristic

Channel separation (kHz)	Frequency separation of filter curve from nominal centre frequency of adjacent channel (kHz)			
	D1	D2	D3	D4
12,5	3	4,25	5,5	9,5
20	4	7,0	8,25	12,25
25	5	8,0	9,25	13,25

Depending on the channel separation, the attenuation points shall not exceed the tolerances as stated in tables B.2 and B.3.

Table B.2: Attenuation points close to carrier

Channel separation (kHz)	Tolerances range (kHz)			
	D1	D2	D3	D4
12,5	+1,35	±0,1	-1,35	-5,35
20	+3,1	±0,1	-1,35	-5,35
25	+3,1	±0,1	-1,35	-5,35

Table B.3: Attenuation points distant from the carrier

Channel separation (kHz)	Tolerance range (kHz)			
	D1	D2	D3	D4
12,5	±2,0	±2,0	±2,0	+2,0 -6,0
20	±3,0	±3,0	±3,0	+3,0 -7,0
25	±3,5	±3,5	±3,5	+3,5 -7,5

The minimum attenuation of the filter, outside the 90 dB attenuation points, shall greater than or equal to 90 dB.

B.1.2 Attenuation indicator

The attenuation indicator shall have a minimum range of 80 dB and a reading accuracy of 1 dB. With a view to future regulations, an attenuation of 90 dB or more is recommended.

B.1.3 RMS value indicator

The instrument shall accurately indicate non-sinusoidal signals in a ratio of up to 10:1 between peak value and rms value.

B.1.4 Oscillator and amplifier

The oscillator and the amplifier shall be designed in such a way that the measurement of the adjacent channel power of a low-noise unmodulated transmitter, whose self-noise has a negligible influence on the measurement result, yields a measured value of ≤ -90 dB for channel separations of 20 kHz and 25 kHz and of ≤ -80 dB for a channel separation of 12,5 kHz, referred to the carrier of the oscillator.

B.2 Spectrum analyser specification

B.2.1 Adjacent and alternate channel power measurement

The characteristics of the spectrum analyser shall meet at least the following requirements:

- the reading accuracy of the frequency marker shall be within ± 100 Hz;
- the accuracy of relative amplitude measurements shall be within $\pm 3,5$ dB.

It shall be possible to adjust the spectrum analyser to allow the separation on its screen of two equal amplitude components with a frequency difference of 200 Hz.

For statistically distributed modulations, the spectrum analyser and the integrating device (when appropriate) needs to allow determination of the power spectral density (energy per time and bandwidth), which has to be integrated over the bandwidth in question. It shall be possible to sum the effective power of all discrete components, the spectral power density and the noise power in the selected bandwidth and to measure this as a ratio relative to the carrier power.

The spectrum analyser should have a dynamic range greater than 90 dB and the average phase noise in the adjacent channels shall be such that measurement of adjacent channel power is not limited by phase noise. In order to confirm this, the selected measurement technique for clause 7.4.2 shall be used to measure the adjacent channel power with a CW signal source with phase noise of less than -120 dBc/Hz in the centre of the adjacent channel. The following performance shall be achieved:

- the maximum adjacent channel power observed with these conditions shall not exceed -70 dBc;
- the maximum alternate channel power measured with these conditions shall not exceed -80 dBc.

NOTE: A resolution bandwidth of 500 Hz may be used for this measurement as an alternative to the usual 100 Hz to reduce measurement time.

B.2.2 Unwanted emissions measurement

The specification shall include the following requirements.

It shall be possible, using a resolution bandwidth of 1 kHz, to measure the amplitude of a signal, or noise at a level 3 dB or more above the noise level of the spectrum analyser, as displayed on the screen, to an accuracy of ± 2 dB in the presence of the wanted signal.

The accuracy of relative amplitude measurements shall be within ± 1 dB.

For statistically distributed modulations, the spectrum analyser and the integrating device (when appropriate) shall allow determination of the real spectral power density (energy per time and bandwidth), which has to be integrated over the bandwidth in question.

B.3 Integrating and power summing device

The integrating and power summing device is connected to the video output of the spectrum analyser, referred to in clause B.2.

It shall be possible to sum the effective power of all discrete components, the spectral power density and the noise power in the selected bandwidth and to measure this as a ratio relative to the carrier power.

Annex C (informative): Bibliography

Directive 1999/5/EC of the European Parliament and of the Council of 9 March 1999 on radio equipment and telecommunications terminal equipment and the mutual recognition of their conformity (R&TTE Directive).

History

Document history		
Edition 1	January 1991	Publication as ETS 300 086
Amendment 1	November 1996	Amendment 1 to 1 st Edition of ETS 300 086
Amendment 2	March 1997	Amendment 2 to 1 st Edition of ETS 300 086
V1.2.1	March 2001	Publication
V1.3.1	December 2007	Public Enquiry PE 20080418: 2007-12-19 to 2008-04-18
V1.3.1	July 2008	Vote V 20080923: 2008-07-25 to 2008-09-23
V1.3.1	September 2008	Publication