

Final draft **ETSI EN 300 086-1** V1.2.1 (2000-12)

European Standard (Telecommunications series)

**Electromagnetic compatibility
and Radio spectrum Matters (ERM);
Land Mobile Service;
Radio equipment with an internal or external RF
connector intended primarily for analogue speech;
Part 1: Technical characteristics and methods of measurement**



Reference

REN/ERM-RP02-041-1

Keywords

analogue, antenna, mobile, PMR, radio, speech

ETSI

650 Route des Lucioles
F-06921 Sophia Antipolis Cedex - FRANCE

Tel.: +33 4 92 94 42 00 Fax: +33 4 93 65 47 16

Siret N° 348 623 562 00017 - NAF 742 C
Association à but non lucratif enregistrée à la
Sous-Préfecture de Grasse (06) N° 7803/88

Important notice

Individual copies of the present document can be downloaded from:

<http://www.etsi.org>

The present document may be made available in more than one electronic version or in print. In any case of existing or perceived difference in contents between such versions, the reference version is the Portable Document Format (PDF). In case of dispute, the reference shall be the printing on ETSI printers of the PDF version kept on a specific network drive within ETSI Secretariat.

Users of the present document should be aware that the document may be subject to revision or change of status. Information on the current status of this and other ETSI documents is available at <http://www.etsi.org/tb/status/>

If you find errors in the present document, send your comment to:
editor@etsi.fr

Copyright Notification

No part may be reproduced except as authorized by written permission.
The copyright and the foregoing restriction extend to reproduction in all media.

© European Telecommunications Standards Institute 2000.
All rights reserved.

Contents

Intellectual Property Rights	7
Foreword.....	7
Introduction.....	8
1 Scope.....	9
2 References.....	9
3 Definitions, abbreviations and symbols	10
3.1 Definitions	10
3.2 Abbreviations.....	11
3.3 Symbols.....	11
4 General.....	11
4.1 Selection of equipment for testing purposes.....	11
4.2 Mechanical and electrical design.....	11
4.2.1 General.....	11
4.2.2 Controls.....	11
4.2.3 Transmitter shut-off facility.....	11
4.2.4 Marking.....	11
4.3 Interpretation of the measurement results.....	12
5 Technical characteristics	12
5.1 Transmitter parameter limits.....	12
5.1.1 Frequency error.....	12
5.1.2 Carrier power (conducted).....	13
5.1.3 Effective radiated power	13
5.1.4 Frequency deviation.....	13
5.1.4.1 Maximum permissible frequency deviation	13
5.1.4.2 Response of the transmitter to modulation frequencies above 3 kHz	13
5.1.5 Adjacent channel power	14
5.1.6 Spurious emissions.....	14
5.1.7 Intermodulation attenuation.....	15
5.1.8 Transient frequency behaviour of the transmitter	15
5.2 Receiver parameter limits	15
5.2.1 Maximum usable sensitivity	15
5.2.2 Maximum usable sensitivity (field strength)	16
5.2.3 Amplitude characteristic.....	16
5.2.4 Co-channel rejection	16
5.2.5 Adjacent channel selectivity	16
5.2.6 Spurious response rejection	16
5.2.7 Intermodulation response rejection	16
5.2.8 Blocking or desensitization	17
5.2.9 Spurious radiations.....	17
5.3 Duplex operation - receiver limits.....	17
5.3.1 Receiver desensitization and maximum usable sensitivity	17
5.3.2 Receiver spurious response rejection	17
6 Test conditions, power sources and ambient temperatures	18
6.1 Normal and extreme test conditions	18
6.2 Test Power source	18
6.3 Normal test conditions.....	18
6.3.1 Normal temperature and humidity	18
6.3.2 Normal test power source.....	18
6.3.2.1 Mains voltage.....	18
6.3.2.2 Regulated lead-acid battery power sources used on vehicles	18
6.3.2.3 Other power sources	19
6.4 Extreme test conditions.....	19

6.4.1	Extreme temperatures.....	19
6.4.2	Extreme test source voltages	19
6.4.2.1	Mains voltage.....	19
6.4.2.2	Regulated lead-acid battery power sources used on vehicles	19
6.4.2.3	Power sources using other types of batteries.....	19
6.4.2.4	Other power sources	19
6.5	Procedure for tests at extreme temperatures.....	20
6.5.1	Procedure for equipment designed for continuous operation.....	20
6.5.2	Procedure for equipment designed for intermittent operation.....	20
7	General conditions	20
7.1	Normal test modulation	20
7.2	Artificial antenna.....	20
7.3	Test sites and general arrangements for radiated measurements	21
7.4	Transmitter automatic shut-off facility	21
7.5	Arrangement for test signals at the input of the transmitter	21
7.6	Arrangements for test signals at the input of the receiver	21
7.7	Receiver mute or squelch facility	21
7.8	Receiver rated audio output power	21
7.9	Tests of equipment with a duplex filter	21
8	Methods of measurement for transmitter parameters	22
8.1	Frequency error	22
8.1.1	Definition	22
8.1.2	Method of measurement.....	22
8.2	Carrier power (conducted).....	22
8.2.1	Definitions.....	22
8.2.2	Method of measurement.....	22
8.3	Effective radiated power (field strength)	22
8.3.1	Definitions.....	22
8.3.2	Method of measurement.....	23
8.4	Frequency deviation	24
8.4.1	Maximum permissible frequency deviation.....	24
8.4.1.1	Definition	24
8.4.1.2	Method of measurement.....	24
8.4.2	Response of the transmitter to modulation frequencies above 3 kHz.....	24
8.4.2.1	Definition	24
8.4.2.2	Method of measurement.....	24
8.5	Adjacent channel power	24
8.5.1	Definition	24
8.5.2	Methods of measurement	25
8.6	Spurious emissions.....	25
8.6.1	Definition	25
8.6.2	Method of measuring the power level in a specified load, clause 8.6.1 a).....	26
8.6.3	Method of measuring the effective radiated power, clause 8.6.1 b).....	26
8.6.4	Method of measuring the effective radiated power, clause 8.6.1 c).....	27
8.7	Intermodulation attenuation	27
8.7.1	Definition	27
8.7.2	Method of measurement.....	27
8.8	Transient frequency behaviour of the transmitter.....	28
8.8.1	Definitions.....	28
8.8.2	Method of measurement.....	29
9	Methods of measurement for receiver parameters.....	32
9.1	Maximum usable sensitivity (conducted)	32
9.1.1	Definition	32
9.1.2	Method of measuring the SND/ND ratio.....	32
9.2	Maximum usable sensitivity (field strength).....	32
9.2.1	Definition	32
9.2.2	Method of measurement.....	32
9.3	Amplitude characteristic of the receiver	33
9.3.1	Definition	33
9.3.2	Method of measurement.....	33

9.4	Co-channel rejection.....	34
9.4.1	Definition	34
9.4.2	Method of measurement.....	34
9.5	Adjacent channel selectivity	34
9.5.1	Definition	34
9.5.2	Method of measurement.....	34
9.6	Spurious response rejection	35
9.6.1	Definition	35
9.6.2	Introduction to the method of measurement	35
9.6.2.1	Method of search over the "limited frequency range".....	35
9.6.2.2	Method of measurement.....	36
9.7	Intermodulation response rejection	36
9.7.1	Definition	36
9.7.2	Method of measurement.....	36
9.8	Blocking or desensitization.....	37
9.8.1	Definition	37
9.8.2	Method of measurement.....	37
9.9	Spurious radiations.....	38
9.9.1	Definition	38
9.9.2	Method of measuring the power level in a specified load, clause 9.9.1 a).....	38
9.9.3	Method of measuring the effective radiated power, clause 9.9.1 b).....	38
9.9.4	Method of measuring the effective radiated power, clause 9.9.1 c).....	39
10	Duplex operation	39
10.1	Receiver desensitization with simultaneous transmission and reception	39
10.1.1	Definition	39
10.1.2	Method of measurement when the equipment operates with a duplex filter.....	39
10.1.3	Measuring method when the equipment operates with two antennas.....	40
10.2	Receiver spurious response rejection.....	40
11	Measurement uncertainty	41
Annex A (normative): Radiated measurement		42
A.1	Test sites and general arrangements for measurements involving the use of radiated fields	42
A.1.1	Anechoic Chamber	42
A.1.2	Anechoic Chamber with a conductive ground plane	43
A.1.3	Open Area Test Site (OATS).....	44
A.1.4	Test antenna	45
A.1.5	Substitution antenna	46
A.1.6	Measuring antenna	46
A.2	Guidance on the use of radiation test sites	47
A.2.1	Verification of the test site.....	47
A.2.2	Preparation of the EUT.....	47
A.2.3	Power supplies to the EUT	47
A.2.4	Volume control setting for analogue speech tests	47
A.2.5	Range length	48
A.2.6	Site preparation	48
A.3	Coupling of signals	49
A.3.1	General	49
A.3.2	Data Signals.....	49
A.3.3	Speech and analogue signals.....	49
A.3.3.1	Acoustic coupler description	49
A.3.3.2	Calibration.....	50
Annex B (normative): Specifications for adjacent channel power measurement arrangements		51
B.1	Power measuring receiver specification.....	51
B.1.1	IF filter.....	51
B.1.2	Variable attenuator	52
B.1.3	Rms value indicator.....	52

B.1.4	Oscillator and amplifier	53
Annex C (normative):	Graphical representation of the selection of equipment and frequencies for testing.....	54
C.1	Tests on a single sample.....	54
C.2	Tests and samples needed when the switching range is a subset of the alignment range	55
C.3	Tests and samples for a family of equipment where the alignment range is a subset of the total operating frequency range.....	56
C.3.1	Test scenario 1	56
C.3.2	Test scenario 2	57
Annex D (normative):	Bibliography.....	58
History		59

Intellectual Property Rights

IPRs essential or potentially essential to the present document may have been declared to ETSI. The information pertaining to these essential IPRs, if any, is publicly available for **ETSI members and non-members**, and can be found in ETSI SR 000 314: "*Intellectual Property Rights (IPRs); Essential, or potentially Essential, IPRs notified to ETSI in respect of ETSI standards*", which is available from the ETSI Secretariat. Latest updates are available on the ETSI Web server (<http://www.etsi.org/ipr>).

Pursuant to the ETSI IPR Policy, no investigation, including IPR searches, has been carried out by ETSI. No guarantee can be given as to the existence of other IPRs not referenced in ETSI SR 000 314 (or the updates on the ETSI Web server) which are, or may be, or may become, essential to the present document.

Foreword

This European Standard (Telecommunications series) has been produced by ETSI Technical Committee Electromagnetic compatibility and Radio spectrum Matters (ERM), and is now submitted for the Vote phase of the ETSI standards Two-step Approval Procedure.

The present document is part 1 of a multi-part deliverable covering the Electromagnetic compatibility and Radio Spectrum Matters (ERM); Land Mobile Service; Radio equipment with an internal or external RF connector intended primarily for analogue speech, as identified below:

Part 1: "Technical characteristics and methods of measurement";

Part 2: "Harmonized EN covering essential requirements under article 3.2 of the R&TTE Directive".

Proposed national transposition dates	
Date of latest announcement of this EN (doa):	3 months after ETSI publication
Date of latest publication of new National Standard or endorsement of this EN (dop/e):	6 months after doa
Date of withdrawal of any conflicting National Standard (dow):	6 months after doa

Introduction

The present document is intended to specify the minimum performance and the methods of measurement of radio equipment for use in the land mobile service as specified in the scope.

The present document is based upon ETS 300 086 [2].

Equipment similar to that covered by the present document, but having an integral antenna is covered by EN 300 296 (for details, see the scope of the present document as well as the scope of EN 300 296).

Equipment intended to transmit signals to initiate a specific response is covered by EN 300 219 (for details, see the scope of the present document as well as the scope of EN 300 219), or by EN 300 341 in the case of integral antenna equipment (for details, see the scope of the present document as well as the scope of EN 300 341).

Equipment intended for the transmission of data is covered by EN 300 113 (for details, see the corresponding scope), or by EN 300 390 in the case of integral antenna equipment (for details, see the corresponding scope).

Angle modulation is used for radio equipment covered by the present document, but individual national administrations are free to choose the type of modulation. Channel separations, maximum transmitter output power / effective radiated power, class of transmitter intermodulation attenuation and the inclusion of automatic transmitter shut-off facility may all be conditions relating to the issue of a licence by the appropriate administration.

Annex A provides additional information concerning radiated measurements.

Annex B contains normative specifications for adjacent channel power measurement arrangements.

Annex C is a graphic representation corresponding to the selection of equipment for testing purposes.

Clause 5 provides the appropriate limits. These limits have been chosen to ensure an acceptable grade of service and to minimize harmful interference to other equipment and services. They are based on the interpretation of the measurement results described in clause 4.3.

Provision for the placing on the market of radio equipment in EU Member States can be found in the R&TTE Directive (Directive 99/5/EC [1]). It can also be noted that some of the parameters considered as essential under the R&TTE Directive had already been listed as essential under the EMC Directive.

The present document may also be used in CEPT Countries that are not EU Member States. For the benefit of these Countries, mechanisms for mutual recognition of type approval have been identified in Decision ERC/DEC/(97)10.

Alternatively, another approach may be used in Countries that have not implemented this Decision: type test measurements performed in an accredited test laboratory in one country would be accepted by the Administration in another country provided that the national regulatory requirements are met (CEPT recommendation ERC/REC 01-06).

Decision ERC/DEC/(97)10 also addresses issues related to total quality management.

The present document may, in particular, be used by accredited test laboratories for the assessment of the performance of the equipment. The performance of the equipment, in the case of conformity assessment measurements, shall be representative for the performance of the corresponding production model. In order to avoid any ambiguity in that assessment, the present document contains general instructions (clause 4), conditions (clauses 6 and 7) and methods of measurement (clauses 8, 9 and 10).

The present document was drafted on the assumption that if equipment available on the market is required to be checked, it should be tested in accordance with the methods of measurement specified in the present document.

1 Scope

The present document covers the minimum characteristics considered necessary in order to avoid harmful interference and to make acceptable use of the available frequencies. It does not necessarily include all the characteristics which may be required by a user, nor does it necessarily represent the optimum performance achievable.

The present document applies to angle modulation systems for use in the land mobile service, operating on radio frequencies between 30 MHz and 1 000 MHz, with channel separations of 12,5 kHz, 20 kHz and 25 kHz, and is intended primarily for analogue speech.

In the present document different requirements are given for the different radio frequency bands, channel separations, environmental conditions and types of equipment, where appropriate.

The types of equipment covered by the present document are as follows:

- base station: equipment fitted with an antenna socket;
- mobile station: equipment fitted with an antenna socket;
- hand portable stations:
 - a) fitted with an antenna socket; or
 - b) without an external antenna socket (integral antenna equipment) but fitted with a permanent internal or a temporary internal 50 Ω R.F. connector which allows access to the transmitter output and the receiver input.

For the type of equipment defined in (b) the additional measurements which shall be made using the equipment antenna connected to the station (and not using any connector) are as follows:

- transmitter effective radiated power;
- transmitter radiated spurious emissions;
- receiver maximum usable sensitivity (field strength);
- receiver radiated spurious emissions.

Hand portable equipment without an external or internal RF connector and without the possibility of having a temporary internal 50 Ω RF connector is not covered by the present document (integral antenna equipment is covered by EN 300 296 for details, see the corresponding scope).

2 References

The following documents contain provisions which, through reference in this text, constitute provisions of the present document.

- References are either specific (identified by date of publication and/or edition number or version number) or non-specific.
- For a specific reference, subsequent revisions do not apply.
- For a non-specific reference, the latest version applies.

[1] Directive 1999/5/EC of the European Parliament and of the Council of 9 March 1999 on radio equipment and telecommunications terminal equipment and the mutual recognition of their conformity (R&TTE Directive).

[2] ETSI ETS 300 086: "Radio Equipment and Systems (RES); Land mobile group; Technical characteristics and test conditions for radio equipment with an internal or external RF connector intended primarily for analogue speech".

- [3] ETSI EN 300 793: "Electromagnetic compatibility and Radio spectrum Matters (ERM); Land mobile service; Presentation of equipment for type testing".
- [4] ETSI ETR 028 (1998): "Radio Equipment and Systems (RES); Uncertainties in the measurement of mobile radio equipment characteristics".
- [5] ETSI ETR 273: "Electromagnetic compatibility and Radio Spectrum Matters (ERM): Improvement of radiated methods of measurement (using test sites) and evaluation of the corresponding measurement uncertainties".
- [6] IEC 489-3: "Methods of measurement for radio equipment used in the mobile services. Part 3: Receivers for A3E or F3E emissions".
- [7] ANSI C63.5 (1988): "Electromagnetic Compatibility-Radiated Emission Measurements in Electromagnetic Interference (EMI) Control - Calibration of Antennas".
- [8] ITU-T Recommendation O.41 (1994): "Psophometer for use on telephone-type circuits".

3 Definitions, abbreviations and symbols

3.1 Definitions

For the purposes of the present document, the following terms and definitions apply:

base station: equipment fitted with an antenna socket, for use with an external antenna, and intended for use in a fixed location.

mobile station: mobile equipment fitted with an antenna socket, for use with an external antenna, normally used in a vehicle or as a transportable station.

hand portable station: equipment either fitted with an antenna socket or an integral antenna, or both, normally used on a stand-alone basis, to be carried on a person or held in the hand.

integral antenna: antenna designed to be connected to the equipment without the use of a 50 Ω external connector and considered to be part of the equipment. An integral antenna may be fitted internally or externally to the equipment.

angle modulation: either phase modulation (G3) or frequency modulation (F3).

full tests: in all cases except where qualified as "limited", tests shall be performed according to the present document.

limited tests: limited tests, as defined in EN 300 793 [3], are as follows:

- transmitter frequency error, clause 8.1;
- transmitter carrier power conducted, clause 8.2;
- transmitter effective radiated power, clause 8.3, integral antenna equipment only;
- transmitter adjacent channel power, clause 8.5;
- receiver maximum usable sensitivity (conducted), clause 9.1;
- receiver maximum usable sensitivity (field strength), clause 9.2, integral antenna equipment only;
- receiver adjacent channel selectivity, clause 9.5.

conducted measurements: measurements which are made using a direct 50 Ω connection to the equipment under test.

radiated measurements: measurements which involve the absolute measurement of a radiated field.

3.2 Abbreviations

For the purposes of the present document, the following abbreviations apply:

SND/ND	(signal + noise + distortion)/(noise + distortion)
RF	radio frequency
IF	intermediate frequency
Tx	transmitter

3.3 Symbols

For the purposes of the present document, the following symbols apply:

E _o	reference field strength, annex A
R _o	reference distance, annex A

4 General

4.1 Selection of equipment for testing purposes

For information regarding the selection of equipment for testing purposes, refer to EN 300 793 [3].

It is expected that the usage of similar measurement methodologies will make it more likely that different laboratories measuring the same equipment get comparable measurement results.

4.2 Mechanical and electrical design

4.2.1 General

The equipment shall be designed, constructed and manufactured in accordance with sound engineering practice, and with the aim of minimizing harmful interference to other equipment and services.

4.2.2 Controls

Those controls which if maladjusted might increase the interfering potentialities of the equipment shall not be accessible to the user.

4.2.3 Transmitter shut-off facility

When a timer for an automatic shut-off facility is operative, at the moment of the time-out the transmitter shall automatically be switched off. The activation of the transmitter key shall reset the timer.

4.2.4 Marking

The equipment shall be marked in a visible place. This marking shall be legible, tamperproof and durable.

The marking shall be in accordance with EC Directives and/or CEPT decisions or recommendations as appropriate.

4.3 Interpretation of the measurement results

The interpretation of the results (e.g. results recorded in a test report) for the measurements described in the present document shall be as follows:

- a) the measured value related to the corresponding limit shall be used to decide whether an equipment meets the requirements for that parameter of the present document;
- b1) the values of the actual measurement uncertainty shall be, for each measurement, equal to or lower than the figures given in clause 11 (maximum acceptable values of the measurement uncertainties);
- b2) the actual measurement uncertainty of the laboratory carrying out the measurements, for each particular measurement, shall be included in the corresponding test report (if any).

For the test methods, according to the present document, the measurement uncertainty figures shall be calculated in accordance with ETR 028 [4] and shall correspond to an expansion factor (coverage factor) $k = 1,96$ or $k = 2$ (which provide confidence levels of respectively 95 % and 95,45 % in the case where the distributions characterizing the actual measurement uncertainties are normal (Gaussian)).

The particular expansion factor used for the evaluation of the measurement uncertainty shall be stated.

5 Technical characteristics

This clause contains the limit values of the parameters defined in clauses 8 to 10.

5.1 Transmitter parameter limits

5.1.1 Frequency error

For the definition and the measuring method see clause 8.1.

The frequency error shall not exceed the values given in table 1 under normal, extreme or any intermediate set of conditions.

For practical reasons the measurements will be performed only under normal and extreme test conditions as stated in clause 8.1.

Table 1

Channel separation (kHz)	Frequency error limit (kHz)				
	below 47 MHz	47 MHz to 137 MHz	above 137 MHz to 300 MHz	above 300 MHz to 500 MHz	above 500 MHz to 1 000 MHz
20 & 25	$\pm 0,60$	$\pm 1,35$	$\pm 2,00$	$\pm 2,00$	$\pm 2,50$ (a)
12,5	$\pm 0,60$	$\pm 1,00$	$\pm 1,00$ (B) $\pm 1,50$ (M)	$\pm 1,00$ (B) $\pm 1,50$ (a) (M)	No value specified

NOTE: - B = base station.
 - M = mobile or hand portable station.
 - (a) = for hand portable stations having integral power supplies, the frequency error shall not be exceeded over a temperature range of 0°C to +30°C.
 Under extreme temperature conditions (clause 6.4.1), the frequency error shall not exceed $\pm 2,50$ kHz for a channel separation of 12,5 kHz between 300 MHz and 500 MHz, and $\pm 3,00$ kHz for channel separations of 20 kHz and 25 kHz between 500 MHz and 1 000 MHz.

5.1.2 Carrier power (conducted)

For the definition and the measuring method see clause 8.2.

The carrier output power (conducted) under normal test conditions shall be within $\pm 1,50$ dB of the rated output power.

Furthermore, the carrier output power (conducted) shall not exceed the maximum value allowed by the Administrations.

The carrier output power (conducted) under extreme test conditions shall be within $+2,0$ dB and $-3,0$ dB of the rated output power.

5.1.3 Effective radiated power

This measurement applies only to equipment without an external 50Ω antenna connection.

For the definition and the measuring method see clause 8.3.

The effective radiated power under normal test conditions shall be within $\pm 7,5$ dB of the rated effective radiated power.

Furthermore, the effective radiated power shall not exceed the maximum value allowed by the Administrations.

The measurement shall be carried out under normal conditions only.

5.1.4 Frequency deviation

For the definition and the measuring method see clause 8.4.

5.1.4.1 Maximum permissible frequency deviation

The maximum permissible frequency deviation for modulation frequencies from the lowest frequency transmitted (f_1) by the equipment (as declared by the manufacturer) up to (f_2) shall be as given in table 2.

Table 2

Channel separation (kHz)	Maximum permissible frequency deviation (kHz)
12,5	$\pm 2,5$
20	$\pm 4,0$
25	$\pm 5,0$

5.1.4.2 Response of the transmitter to modulation frequencies above 3 kHz

The frequency deviation at modulation frequencies between 3,0 kHz (for equipment operating with 20 kHz or 25 kHz channel separations) and 2,55 kHz (for equipment operating with 12,5 kHz channel separation) and 6,0 kHz shall not exceed the frequency deviation at a modulation frequency of 3,0 kHz/2,55 kHz. At 6,0 kHz the deviation shall be not more than 30,0 % of the maximum permissible frequency deviation.

The frequency deviation at modulation frequencies between 6,0 kHz and a frequency equal to the channel separation for which the equipment is intended shall not exceed that given by a linear representation of the frequency deviation (dB) relative to the modulation frequency, starting at the 6,0 kHz limit and having a slope of $-14,0$ dB per octave. These limits are illustrated in figure 1.

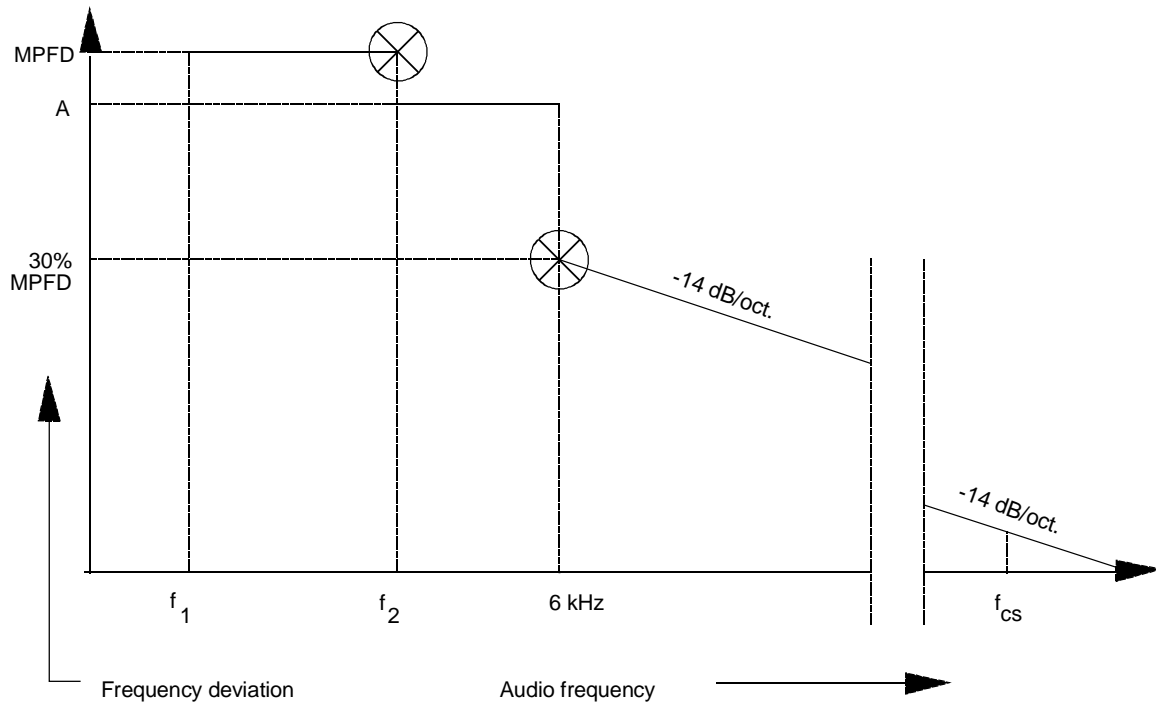

NOTE:

Abbreviations:

- f1 lowest appropriate frequency
 f2 3,0 kHz (for 20 kHz or 25 kHz channel separation), or
 2,55 kHz (for 12,5 kHz channel separation)
 MPFD maximum permissible frequency deviation, clause 5.1.4.1
 A measured frequency deviation at f2
 fcs frequency equal to channel separation

Figure 1

5.1.5 Adjacent channel power

For the definition and the measuring method see clause 8.5.

For channel separations of 20 kHz and 25 kHz, the adjacent channel power shall not exceed a value of 70,0 dB below the carrier power of the transmitter without the need to be below 0,20 μ W. For channel separations of 12,5 kHz, the adjacent channel power shall not exceed a value of 60,0 dB below the transmitter carrier power without the need to be below 0,20 μ W.

5.1.6 Spurious emissions

For the definition and the measuring method see clause 8.6.

The power of any spurious emission shall not exceed the values given in tables 3 and 4.

Table 3: Conducted emissions

Frequency range	9 kHz to 1 GHz	above 1 GHz to 4 GHz, or above 1 GHz to 12,75 GHz, see clause 8.6.2.
Tx operating	0,25 μ W (-36,0 dBm)	1,00 μ W (-30,0 dBm)
Tx standby	2,0 nW (-57,0 dBm)	20,0 nW (-47,0 dBm)

Table 4: Radiated emissions

Frequency range	30 MHz to 1 GHz	above 1 GHz to 4 GHz
Tx operating	0,25 μ W (-36,0 dBm)	1,00 μ W (-30,0 dBm)
Tx standby	2,0 nW (-57,0 dBm)	20,0 nW (-47,0 dBm)

In the case of radiated measurements for hand portable stations the following conditions apply:

- internal integral antenna: the normal antenna shall be connected;
- external antenna socket: an artificial load shall be connected to the socket for the test.

5.1.7 Intermodulation attenuation

This requirement applies only to transmitters to be used in base stations (fixed).

For the definition and the measurement method see clause 8.7.

Two classes of transmitter intermodulation attenuation are defined, the equipment shall fulfil one of the requirements as follows:

- the intermodulation attenuation ratio shall be at least 40,0 dB for any intermodulation component;
- for base stations to be used in special service conditions (e.g. at sites where more than one transmitter will be in service) or when the regulatory authority makes it a condition of the licence, the intermodulation attenuation ratio shall be at least 70,0 dB for any intermodulation component. In the case where the performance is achieved by additional internal or external isolating devices (such as circulators) these are expected to be available at the time the measurements are made and shall be used for the measurements.

5.1.8 Transient frequency behaviour of the transmitter

For the definition and the measurement method see clause 8.8.

The transient periods are given in table 5 and shown in figure 4, clause 8.8.

Table 5

	30 MHz to 300 MHz	above 300 MHz to 500 MHz	above 500 MHz to 1 000 MHz
t1 (ms)	5,0	10,0	20,0
t2 (ms)	20,0	25,0	50,0
t3 (ms)	5,0	10,0	10,0

During the periods t_1 and t_3 the frequency difference shall not exceed the value of 1 channel separation.

During the period t_2 the frequency difference shall not exceed the value of half a channel separation.

In the case of hand portable stations with a transmitter output power of less than 5 W, the frequency deviation during t_1 and t_3 may be greater than one channel. The corresponding plot of frequency versus time during t_1 and t_3 shall be recorded in test reports.

5.2 Receiver parameter limits

5.2.1 Maximum usable sensitivity

For the definition and the measurement method see clause 9.1.

The maximum usable sensitivity shall not exceed an e.m.f. of 6,0 dB μ V under normal test conditions, and an e.m.f. of 12,0 dB μ V under extreme test conditions.

5.2.2 Maximum usable sensitivity (field strength)

This measurement applies only to equipment without a 50 Ω external antenna connector.

For the definition and the measurement method see clause 9.2.

The maximum usable sensitivity shall not exceed the field strength value shown in table 6.

Table 6

Frequency band MHz	Field strength in dB relative to 1 $\mu\text{V/m}$
	Normal test conditions
30 to 100	14,0
100 to 230	20,0
230 to 470	26,0
470 to 1 000	32,0

5.2.3 Amplitude characteristic

For the definition and the measurement method see clause 9.3.

Within the specified change in radio frequency input signal level, the change of audio output level shall not exceed 3,0 dB.

5.2.4 Co-channel rejection

For the definition and the measurement method see clause 9.4.

The value of the co-channel rejection ratio, expressed in dB, at any frequency of the unwanted signal within the specified range, shall be between:

- -8,0 dB and 0 dB for channel separations of 20 kHz and 25 kHz;
- -12,0 dB and 0 dB for channel separation of 12,5 kHz.

5.2.5 Adjacent channel selectivity

For the definition and the measurement method see clause 9.5.

For channel separations of 20 kHz and 25 kHz, the adjacent channel selectivity shall not be less than 70,0 dB under normal test conditions and not less than 60,0 dB under extreme test conditions.

For channel separations of 12,5 kHz, the adjacent channel selectivity shall not be less than 60,0 dB under normal test conditions and not less than 50,0 dB under extreme test conditions.

5.2.6 Spurious response rejection

For the definition and the measurement method see clause 9.6.

At any frequency separated from the nominal frequency of the receiver by more than one channel, the spurious response rejection ratio shall not be less than 70,0 dB.

5.2.7 Intermodulation response rejection

For the definition and the measurement method see clause 9.7.

The intermodulation response rejection ratio shall not be less than 70,0 dB for base stations and 65,0 dB for mobile and hand portable stations.

5.2.8 Blocking or desensitization

For the definition and the measurement method see clause 9.8.

The blocking ratio, for any frequency within the specified ranges, shall not be less than 84,0 dB, except at frequencies on which spurious responses are found, clause 9.6.

5.2.9 Spurious radiations

For the definition and the measurement method see clause 9.9.

The power of any spurious radiation shall not exceed the values given in tables 7 and 8.

Table 7: Conducted components

Frequency range	9 kHz to 1 GHz	above 1 GHz to 4 GHz, or above 1 GHz to 12,75 GHz, see clause 9.9.2.
Limit	2,0 nW (-57,0 dBm)	20,0 nW (-47,0 dBm)

Table 8: Radiated components

Frequency range	30 MHz to 1 GHz	above 1 GHz to 4 GHz
Limit	2,0 nW (-57,0 dBm)	20,0 nW (-47,0 dBm)

In the case of radiated measurements for hand portable stations the following conditions apply:

- internal integral antenna: the normal antenna shall be connected;
- external antenna socket: an artificial load shall be connected to the socket for the test.

5.3 Duplex operation - receiver limits

With simultaneous transmission and reception.

5.3.1 Receiver desensitization and maximum usable sensitivity

For the definition and the measurement method see clause 10.1.

The desensitization shall not exceed 3,0 dB, and the limit of maximum usable sensitivity under normal test conditions, clause 5.2.1, shall be met.

5.3.2 Receiver spurious response rejection

For the definition and the measurement method see clause 10.2.

At any frequency separated from the nominal frequency of the receiver by more than two channels, the spurious response rejection ratio shall not be less than 67,0 dB.

6 Test conditions, power sources and ambient temperatures

6.1 Normal and extreme test conditions

Measurements shall be made under normal test conditions, and also, where stated, under extreme test conditions.

6.2 Test Power source

During measurements, the power source of the equipment shall be replaced by a test power source capable of producing normal and extreme test voltages as specified in clauses 6.3.2 and 6.4.2. The internal impedance of the test power source shall be low enough for its effect on the test results to be negligible. For the purpose of tests, the voltage of the power source shall be measured at the input terminals of the equipment.

If the equipment is provided with a permanently connected power cable, the test voltage shall be that measured at the point of connection of the power cable to the equipment.

In equipment with incorporated batteries the test power source shall be applied as close to the battery terminals as practicable.

During tests the power source voltages shall be maintained within a tolerance of $< \pm 3$ % relative to the voltage at the beginning of each test. The value of this tolerance is critical to power measurements, using a smaller tolerance will provide better measurement uncertainty values.

6.3 Normal test conditions

6.3.1 Normal temperature and humidity

The normal temperature and humidity conditions for tests shall be any convenient combination of temperature and humidity within the following ranges:

- temperature: +15 °C to +35 °C;
- relative humidity: 20 % to 75 %.

When it is impracticable to carry out the tests under these conditions, a note to this effect, stating the ambient temperature and relative humidity during the tests, shall be added to test reports.

6.3.2 Normal test power source

6.3.2.1 Mains voltage

The normal test voltage for equipment to be connected to the mains shall be the nominal mains voltage. For the purpose of the present document, the nominal voltage shall be the declared voltage or any of the declared voltages for which the equipment was designed.

The frequency of the test power source corresponding to the AC mains shall be between 49 Hz and 51 Hz.

6.3.2.2 Regulated lead-acid battery power sources used on vehicles

When the radio equipment is intended for operation from the usual types of regulated lead-acid battery power source used on vehicles, the normal test voltage shall be 1,1 times the nominal voltage of the battery (6 V, 12 V etc).

6.3.2.3 Other power sources

For operation from other power sources or types of battery (primary or secondary), the normal test voltage shall be that declared by the equipment manufacturer.

6.4 Extreme test conditions

6.4.1 Extreme temperatures

For tests at extreme temperatures, measurements shall be made in accordance with the procedures specified in clause 6.5, at the upper and lower temperatures of the following range:

-20 °C to + 55°C.

For the purpose of note (a) to table 1 in clause 5.1.1, an additional reduced extreme temperature range of 0°C to +30°C shall be used when appropriate.

Test reports shall state the temperature range used.

6.4.2 Extreme test source voltages

6.4.2.1 Mains voltage

The extreme test voltage for equipment to be connected to an AC mains source shall be the nominal mains voltage $\pm 10\%$.

6.4.2.2 Regulated lead-acid battery power sources used on vehicles

When the equipment is intended for operation from the usual types of regulated lead-acid battery power sources used on vehicles the extreme test voltages shall be 1,3 and 0,9 times the nominal voltage of the battery (6 V, 12 V, etc).

6.4.2.3 Power sources using other types of batteries

The lower extreme test voltages for equipment with power sources using the following batteries shall be:

- for the Leclanché or the lithium type of battery: 0,85 times the nominal voltage of the battery;
- for the mercury or nickel-cadmium type of battery: 0,9 times the nominal voltage of the battery.

No upper extreme test voltages apply.

In the case where no upper extreme test voltage above the nominal voltage is applicable, the corresponding four extreme test conditions are:

- V_{\min} / T_{\min} , V_{\min} / T_{\max} ;
- $(V_{\max} = \text{nominal}) / T_{\min}$, $(V_{\max} = \text{nominal}) / T_{\max}$.

6.4.2.4 Other power sources

For equipment using other power sources, or capable of being operated from a variety of power sources, the extreme test voltages shall be, as appropriate, either those selected by the manufacturer or those agreed between the equipment manufacturer and the testing laboratory. They shall be recorded in test reports.

6.5 Procedure for tests at extreme temperatures

Before measurements are made the equipment shall have reached thermal balance in the test chamber. The equipment shall be switched off during the temperature-stabilizing period.

In the case of equipment containing temperature stabilization circuits designed to operate continuously, the temperature stabilization circuits may be switched on for 15 minutes after thermal balance has been obtained, and the equipment shall then meet the specified requirements. For such equipment the manufacturer shall provide for the power source circuit feeding e.g. the crystal oven to be independent of the power source to the rest of the equipment.

If the thermal balance is not checked by measurements, a temperature-stabilizing period of at least one hour, or such period as may be decided by the testing authority, shall be allowed. The sequence of measurements shall be chosen, and the humidity content in the test chamber shall be controlled so that excessive condensation does not occur.

6.5.1 Procedure for equipment designed for continuous operation

If the manufacturer states that the equipment is designed for continuous operation, the test procedure shall be as follows.

Before tests at the upper extreme temperature the equipment shall be placed in the test chamber and left switched off until thermal balance is attained. The equipment shall then be switched on in the transmit conditions for a period of half an hour after which the equipment shall meet the specified requirements.

For tests at the lower extreme temperature the equipment shall be left switched off in the test chamber until thermal balance is attained, then switched to the standby or receive condition for a period of one minute after which the equipment shall meet the specified requirements.

6.5.2 Procedure for equipment designed for intermittent operation

If the manufacturer states that the equipment is designed for intermittent operation, the test procedure shall be as follows.

Before tests at the upper extreme temperature the equipment shall be placed in the test chamber and left switched off until thermal balance is attained. The equipment shall then be switched on for one minute in the transmit condition, followed by four minutes in the receive condition, after which the equipment shall meet the specified requirements.

For tests at the lower extreme temperature the equipment shall be left switched off in the test chamber until thermal balance is attained, then switched to the standby or receive condition for one minute after which the equipment shall meet the specified requirements.

7 General conditions

7.1 Normal test modulation

For normal test modulation, the modulation frequency shall be 1 kHz and the resulting frequency deviation shall be 60 % of the maximum permissible frequency deviation, clause 5.1.4.1. The test signal shall be substantially free from amplitude modulation.

7.2 Artificial antenna

Tests shall be carried out using an artificial antenna, which shall be a substantially non-reactive non-radiating load of 50 Ω connected to the antenna connector.

7.3 Test sites and general arrangements for radiated measurements

For guidance on radiation test sites see annex A. Detailed descriptions of the radiated measurement arrangements are included in this annex.

7.4 Transmitter automatic shut-off facility

If the equipment is fitted with an automatic transmitter shut-off facility, it shall be made inoperative for the duration of the measurements, unless it has to remain operative to protect the equipment. If the shut off facility is left operative the status of the equipment shall be indicated.

7.5 Arrangement for test signals at the input of the transmitter

For the purpose of the present document, the transmitter audio frequency modulation signal shall be applied the microphone input terminals with the internal microphone disconnected, unless otherwise stated.

7.6 Arrangements for test signals at the input of the receiver

Test signal sources, which are applied to the receiver, shall present an impedance of 50 Ω to the receiver input. This requirement shall be met irrespective whether one or more signals using a combining network are applied to the receiver simultaneously.

The levels of the test signals shall be expressed in terms of the e.m.f. at the receiver input connector.

The effects of any intermodulation products and noise produced in the test signal sources shall be negligible.

7.7 Receiver mute or squelch facility

If the receiver is equipped with a mute or squelch circuit, this shall be made inoperative for the duration of the measurements.

7.8 Receiver rated audio output power

The rated audio output power shall be the maximum power, declared by the manufacturer, for which all the requirements of the present document are met. With normal test modulation, clause 7.1, the audio output power shall be measured in a resistive load simulating the load with which the receiver normally operates. The value of this load shall be declared by the manufacturer.

7.9 Tests of equipment with a duplex filter

If the equipment is provided with a built-in duplex filter or a separate associated filter, the requirements of the present document shall be met when the measurements are carried out using the antenna connector of this filter.

8 Methods of measurement for transmitter parameters

8.1 Frequency error

8.1.1 Definition

The frequency error of the transmitter is the difference between the measured carrier frequency in the absence of modulation and the nominal frequency of the transmitter.

8.1.2 Method of measurement

The carrier frequency shall be measured in the absence of modulation with the transmitter connected to a 50 Ω power attenuator.

The measurement shall be made under normal test conditions, clause 6.3, and repeated under extreme test conditions, clauses 6.4.1 and 6.4.2 applied simultaneously.

8.2 Carrier power (conducted)

It is assumed that Administrations will state the maximum transmitter output power/effective radiated power; this could be a condition for issuing the licence.

If the equipment is designed to operate with different carrier powers, the rated power for each level or range of levels shall be declared by the manufacturer. The power adjustment control shall not be accessible to the user.

The requirements of the present document shall be met for all power levels at which the transmitter is intended to operate. For practical reasons measurements shall be performed only at the lowest and the highest power level at which the transmitter is intended to operate.

8.2.1 Definitions

The transmitter carrier power (conducted) is the mean power delivered to the artificial antenna during a radio frequency cycle, in the absence of modulation.

The rated output power is the carrier power (conducted) of the equipment declared by the manufacturer.

8.2.2 Method of measurement

The transmitter shall be connected to a 50 Ω power attenuator, and the power delivered to this artificial antenna shall be measured.

The measurements shall be made under normal test conditions, clause 6.3, and extreme test conditions, clauses 6.4.1 and 6.4.2 applied simultaneously.

8.3 Effective radiated power (field strength)

This measurement applies only to equipment without an external antenna connector.

8.3.1 Definitions

The effective radiated power is the power radiated in the direction of the maximum field strength under specified conditions of measurements, in the absence of modulation.

The rated effective radiated power is the effective radiated power of the equipment as declared by the manufacturer.

8.3.2 Method of measurement

On a test site, selected from annex A, the equipment shall be placed at the specified height on a non-conducting support and in the position closest to normal use as declared by the manufacturer.

The test antenna shall be orientated for vertical polarization and the length of the test antenna shall be chosen to correspond to the frequency of the transmitter.

The output of the test antenna shall be connected to a measuring receiver.

The transmitter shall be switched on without modulation and the measuring receiver shall be tuned to the frequency of the transmitter under test.

The test antenna shall be raised and lowered through the specified range of height until a maximum signal level is detected by the measuring receiver.

The transmitter shall then be rotated through 360° in the horizontal plane until the maximum signal level is detected by the measuring receiver.

The maximum signal level detected by the measuring receiver shall be noted.

The transmitter shall be replaced by a substitution antenna as defined in clause A.1.5.

The substitution antenna shall be orientated for vertical polarization and the length of the substitution antenna shall be adjusted to correspond to the frequency of the transmitter.

The substitution antenna shall be connected to a calibrated signal generator.

The input attenuator setting of the measuring receiver shall be adjusted in order to increase the sensitivity of the measuring receiver.

The test antenna shall be raised and lowered through the specified range of height to ensure that the maximum signal is received.

The input signal to the substitution antenna shall be adjusted to the level that produces a level detected by the measuring receiver, that is equal to the level noted while the transmitter radiated power was measured, corrected for the change of input attenuator setting of the measuring receiver.

The input level to the substitution antenna shall be recorded as power level, corrected for the change of input attenuator setting of the measuring receiver.

The measurement shall be repeated with the test antenna and the substitution antenna orientated for horizontal polarization.

The measure of the effective radiated power is the larger of the two power levels recorded, at the input to the substitution antenna, corrected for gain of the antenna if necessary.

8.4 Frequency deviation

The frequency deviation is the maximum difference between the instantaneous frequency of the modulated radio frequency signal and the carrier frequency in the absence of modulation.

8.4.1 Maximum permissible frequency deviation

8.4.1.1 Definition

The maximum permissible frequency deviation is the maximum value of frequency deviation stated for the relevant channel separation.

8.4.1.2 Method of measurement

The frequency deviation shall be measured at the output of the transmitter connected to a 50 Ω power attenuator, by means of a deviation meter capable of measuring the maximum deviation, including that due to any harmonics and intermodulation products which may be generated in the transmitter.

The modulation frequency shall be varied between the lowest frequency considered to be appropriate, and 3 kHz.

The level of this test signal shall be 20 dB above the level of the normal test modulation, clause 7.1.

8.4.2 Response of the transmitter to modulation frequencies above 3 kHz

8.4.2.1 Definition

The response of the transmitter to modulation frequencies above 3 kHz (see note) is expressed as the frequency deviation in relation to the modulation frequencies above 3 kHz (see note).

NOTE: 2,55 kHz for transmitters intended for 12,5 kHz channel separation.

8.4.2.2 Method of measurement

The transmitter shall be operated under normal test conditions, clause 6.3, and connected via a 50 Ω power attenuator to the deviation meter.

The transmitter shall be modulated by normal test modulation, clause 7.1.

With a constant input level of the modulation signal, the modulation frequency shall be varied between 3 kHz (see note) and a frequency equal to the channel separation for which the equipment is intended.

NOTE: 2,55 kHz for transmitters intended for 12,5 kHz channel separation.

The frequency deviation shall be measured by means of the deviation meter.

8.5 Adjacent channel power

8.5.1 Definition

The adjacent channel power is that part of the total output power of a transmitter under defined conditions of modulation, which falls within a specified passband centred on the nominal frequency of either of the adjacent channels.

This power is the sum of the mean power produced by the modulation, hum and noise of the transmitter.

8.5.2 Methods of measurement

The adjacent channel power may be measured with a power-measuring receiver, which conforms to the requirements given in annex B referred to in this clause as the "receiver".

- a) The transmitter shall be operated at the carrier power determined in clause 8.2 under normal test conditions, clause 6.3.

The output of the transmitter shall be connected to the input of the "receiver" by a 50 Ω power attenuator, to ensure that the impedance presented to the transmitter is 50 Ω and the level at the "receiver" input is appropriate.

- b) With the transmitter unmodulated, the tuning of the "receiver" shall be adjusted so that a maximum response is obtained. This is the 0 dB reference point. The "receiver" variable attenuator setting and the reading of the rms value indicator shall be recorded. If an unmodulated carrier cannot be obtained then the measurement shall be made with the transmitter modulated with normal test modulation, clause 7.1, in which case this fact shall be recorded in test reports.
- c) The frequency of the "receiver" shall be adjusted above the carrier so that the "receiver" -6 dB response nearest to the transmitter carrier frequency is located at a displacement from the nominal carrier frequency as given in table 9.

Table 9: Frequency displacement

Channel separation (kHz)	Specified necessary bandwidth (kHz)	Displacement from the -6 dB point (kHz)
12,5	8,5	8,25
20	14	13
25	16	17

- d) The transmitter shall be modulated by a test signal of 1 250 Hz at a level which is 20 dB higher than that required to produce 60 % of the maximum permissible deviation, clause 5.1.4.1.
- e) The "receiver" variable attenuator shall be adjusted to obtain the same reading as in step b) or a known relation to it.
- f) The ratio of adjacent channel power to carrier power is the difference between the attenuator settings in steps b) and e), corrected for any differences in the reading of the rms value indicator.
- g) The measurement shall be repeated with the frequency of the "receiver" adjusted below the carrier so that the "receiver" -6 dB response nearest to the transmitter carrier frequency is located at a displacement from the nominal carrier frequency as given in table 9.

8.6 Spurious emissions

8.6.1 Definition

Spurious emissions are emissions at frequencies other than those of the carrier and sidebands associated with normal test modulation. The level of spurious emissions shall be measured as:

either:

- a) their power level in a specified load (conducted spurious emission); and
- b) their effective radiated power when radiated by the cabinet and structure of the equipment (cabinet radiation); or
- c) their effective radiated power when radiated by the cabinet and the integral antenna, in the case of hand portable equipment fitted with such an antenna and no external RF connector.

8.6.2 Method of measuring the power level in a specified load, clause 8.6.1 a)

This method applies only to equipment with an external antenna connector.

The transmitter shall be connected to a 50 Ω power attenuator.

The output of the power attenuator shall be connected to a measuring receiver.

The transmitter shall be switched on without modulation, and the measuring receiver, annex A, shall be tuned over the frequency range 9 kHz to 4 GHz for equipment operating on frequencies below 470 MHz, or in the frequency range of 9 kHz to 12,75 GHz for equipment operating on frequencies above 470 MHz.

At each frequency at which a spurious component is detected, the power level shall be recorded as the conducted spurious emission level delivered into the specified load, except for the channel on which the transmitter is intended to operate and the adjacent channels.

The measurements shall be repeated with the transmitter on stand-by.

8.6.3 Method of measuring the effective radiated power, clause 8.6.1 b)

This method applies only to equipment with an external antenna connector.

On a test site, selected from annex A, the equipment shall be placed at the specified height on a non-conducting support and in the position closest to normal use as declared by the manufacturer.

The transmitter antenna connector shall be connected to an artificial antenna, clause 7.2.

The test antenna shall be orientated for vertical polarization and the length of the test antenna shall be chosen to correspond to the instantaneous frequency of the measuring receiver.

The output of the test antenna shall be connected to a measuring receiver.

The transmitter shall be switched on without modulation, and the measuring receiver shall be tuned over the frequency range 30 MHz to 4 GHz, except for the channel on which the transmitter is intended to operate and its adjacent channels.

At each frequency at which a spurious component is detected, the test antenna shall be raised and lowered through the specified range of heights until a maximum signal level is detected on the measuring receiver.

The transmitter shall then be rotated through 360° in the horizontal plane, until the maximum signal level is detected by the measuring receiver.

The maximum signal level detected by the measuring receiver shall be noted.

The transmitter shall be replaced by a substitution antenna as defined in clause A.1.5.

The substitution antenna shall be orientated for vertical polarization and the length of the substitution antenna shall be adjusted to correspond to the frequency of the spurious component detected.

The substitution antenna shall be connected to a calibrated signal generator.

The frequency of the calibrated signal generator shall be set to the frequency of the spurious component detected.

The input attenuator setting of the measuring receiver shall be adjusted in order to increase the sensitivity of the measuring receiver, if necessary.

The test antenna shall be raised and lowered through the specified range of heights to ensure that the maximum signal is received.

The input signal to the substitution antenna shall be adjusted to the level that produces a level detected by the measuring receiver, that is equal to the level noted while the spurious component was measured, corrected for the change of input attenuator setting of the measuring receiver.

The input level to the substitution antenna shall be recorded as power level, corrected for the change of input attenuator setting of the measuring receiver.

The measurement shall be repeated with the test antenna and the substitution antenna orientated for horizontal polarization.

The measure of the effective radiated power of the spurious components is the larger of the two power levels recorded for each spurious component at the input to the substitution antenna, corrected for the gain of the antenna if necessary.

The measurements shall be repeated with the transmitter on stand-by.

8.6.4 Method of measuring the effective radiated power, clause 8.6.1 c)

This measurement applies only to equipment without an external antenna connector.

The method of measurement shall be performed according to clause 8.6.3, except that the transmitter output shall be connected to the integral antenna and not to an artificial antenna.

8.7 Intermodulation attenuation

This requirement applies only to transmitters to be used in base stations (fixed).

8.7.1 Definition

Intermodulation attenuation is the capability of a transmitter to avoid the generation of signals in the non-linear elements caused by the presence of the carrier and an interfering signal entering the transmitter via the antenna.

It is specified as the ratio, in dB, of the power level of the third order intermodulation product to the carrier power level.

8.7.2 Method of measurement

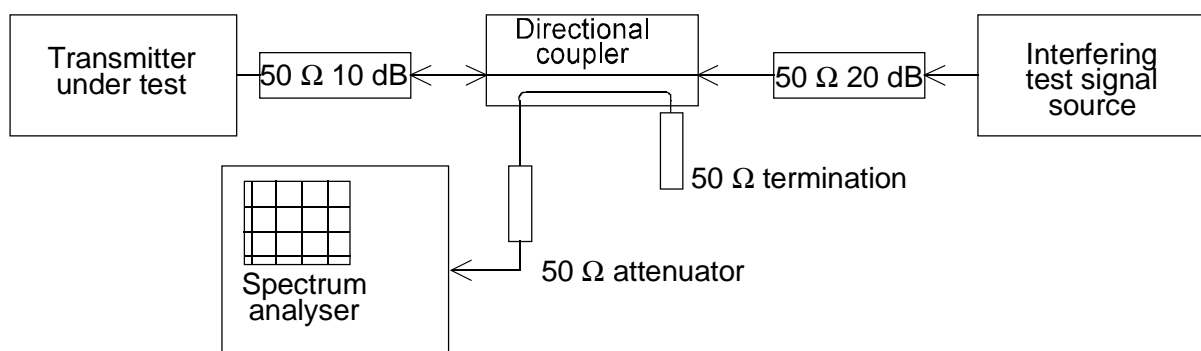

Figure 2: Measurement arrangement

The measurement arrangement shown in figure 2 shall be used.

The transmitter shall be connected to a 50 Ω 10 dB power attenuator and via a directional coupler to a spectrum analyser. An additional attenuator may be required between the directional coupler and the spectrum analyser to avoid overloading the spectrum analyser.

In order to reduce the influence of mismatch errors it is important that the 10 dB power attenuator is coupled to the transmitter under test with the shortest possible connection.

The interfering test signal source is connected to the other end of the directional coupler via a 50 Ω 20 dB power attenuator.

The interfering signal source may be either:

- a transmitter providing the same power output as the transmitter under test and be of a similar type, or
- a signal generator and a linear power amplifier capable of delivering the same output power as the transmitter under test.

The directional coupler shall have an insertion loss of less than 1 dB, a sufficient bandwidth and a directivity of more than 20 dB.

The transmitter under test and the test signal source shall be physically separated in such a way that the measurement is not influenced by direct radiation.

The transmitter under test shall be unmodulated and the spectrum analyser adjusted to give a maximum indication with a frequency scan width of 500 kHz.

The interfering test signal source shall be unmodulated and the frequency shall be within 50 kHz to 100 kHz above the frequency of the transmitter under test.

The frequency shall be chosen in such a way that the intermodulation components to be measured do not coincide with other spurious components.

The power output of the interfering test signal source shall be adjusted to the carrier power level of the transmitter under test by the use of a power meter.

The intermodulation component shall be measured by direct observation on the spectrum analyser and the ratio of the largest third order intermodulation component to the carrier recorded.

This measurement shall be repeated with the interfering test signal source at a frequency within 50 kHz to 100 kHz below the frequency of the transmitter under test.

8.8 Transient frequency behaviour of the transmitter

8.8.1 Definitions

The transient frequency behaviour of the transmitter is the variation in time of the transmitter frequency difference from the nominal frequency of the transmitter when the RF output power is switched on and off.

t_{on}: according to the method of measurement described in clause 8.8.2 the switch-on instant t_{on} of a transmitter is defined by the condition when the output power, measured at the antenna terminal, exceeds 0,1 % of the nominal power.

t₁: period of time starting at t_{on} and finishing according to table 5, clause 5.1.8.

t₂: period of time starting at the end of t₁ and finishing according to table 5, clause 5.1.8.

t_{off}: switch-off instant defined by the condition when the nominal power falls below 0,1 % of the nominal power.

t₃: period of time that finishing at t_{off} and starting according to table 5, clause 5.1.8.

8.8.2 Method of measurement

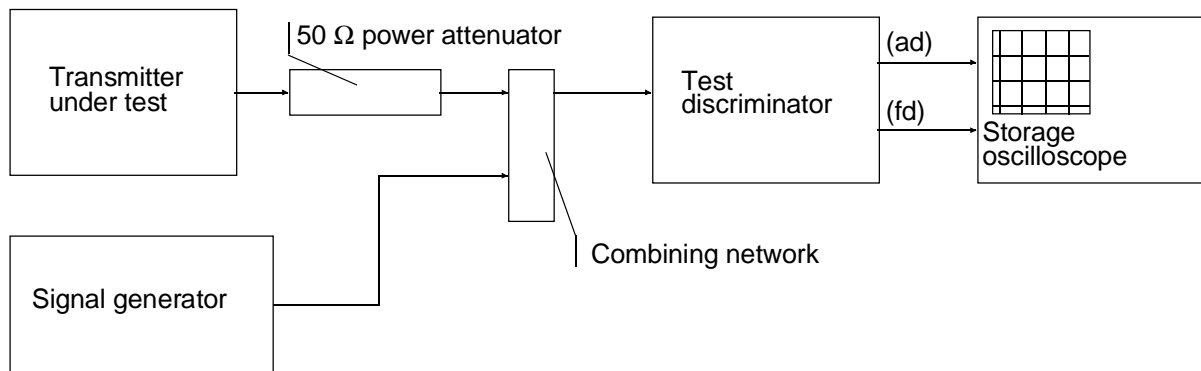

Figure 3: Measurement arrangement

The measurement arrangement shown in figure 3 shall be used.

Two signals shall be connected to the test discriminator via a combining network, clause 7.6.

The transmitter shall be connected to a 50 Ω power attenuator.

The output of the power attenuator shall be connected to the test discriminator via one input of the combining network.

A test signal generator shall be connected to the second input of the combining network.

The test signal shall be adjusted to the nominal frequency of the transmitter.

The test signal shall be modulated by a frequency of 1 kHz with a deviation equal to \pm the value of the relevant channel separation.

The test signal level shall be adjusted to correspond to 0,1 % of the power of the transmitter under test measured at the input of the test discriminator. This level shall be maintained throughout the measurement.

The amplitude difference (ad) and the frequency difference (fd) output of the test discriminator shall be connected to a storage oscilloscope.

The storage oscilloscope shall be set to display the channel corresponding to the (fd) input up to ± 1 channel frequency difference, corresponding to the relevant channel separation, from the nominal frequency.

The storage oscilloscope shall be set to a sweep rate of 10 ms/div and set so that the triggering occurs at 1 div from the left edge of the display.

The display will show the 1 kHz test signal continuously.

The storage oscilloscope shall then be set to trigger on the channel corresponding to the amplitude difference (ad) input at a low input level, rising.

The transmitter shall then be switched on, without modulation, to produce the trigger pulse and a picture on the display.

The result of the change in the ratio of power between the test signal and the transmitter output will, due to the capture ratio of the test discriminator, produce two separate sides on the picture, one showing the 1 kHz test signal, the other the frequency difference of the transmitter versus time.

The moment when the 1 kHz test signal is completely suppressed is considered to provide ton.

The periods of time t_1 and t_2 as defined in table 5, clause 5.1.8, shall be used to define the appropriate template.

During the period of time t_1 and t_2 the frequency difference shall not exceed the values given in clause 5.1.8.

The frequency difference, after the end of t_2 , shall be within the limit of the frequency error, clause 5.1.1.

The result shall be recorded as frequency difference versus time.

The transmitter shall remain switched on.

The storage oscilloscope shall be set to trigger on the channel corresponding to the amplitude difference (ad) input at a high input level, decaying and set so that the triggering occurs at 1 div. from the right edge of the display.

The transmitter shall then be switched off.

The moment when the 1 kHz test signal starts to rise is considered to provide t_{off} .

The period of time t_3 as defined in table 5, clause 5.1.8, shall be used to define the appropriate template.

During the period of time t_3 the frequency difference shall not exceed the values given in clause 5.1.8.

Before the start of t_3 the frequency difference shall be within the limit of the frequency error, clause 5.1.1.

The result shall be recorded as frequency difference versus time.

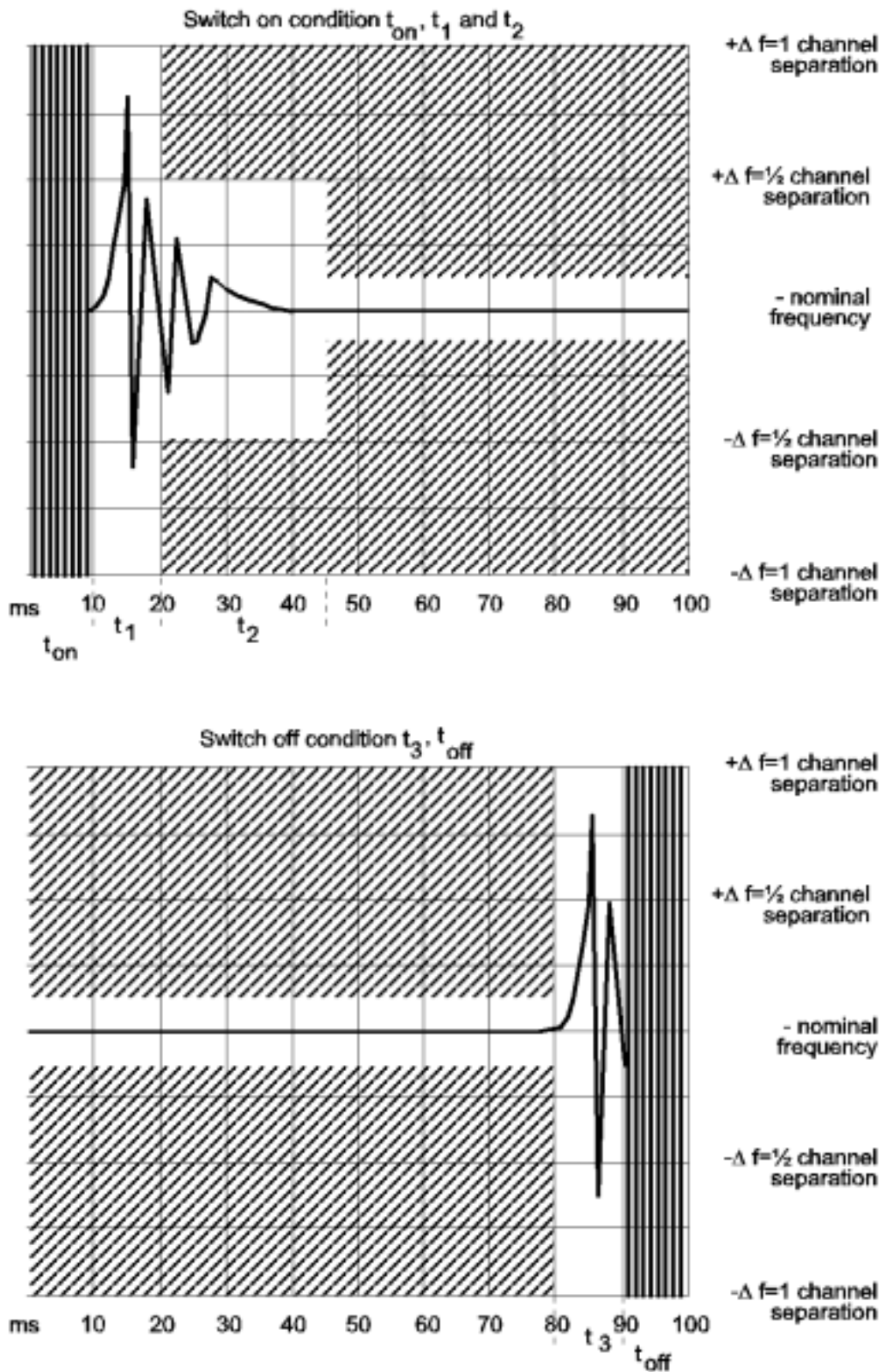
Figure 4: Storage oscilloscope view t_1 , t_2 and t_3

9 Methods of measurement for receiver parameters

9.1 Maximum usable sensitivity (conducted)

9.1.1 Definition

The maximum usable sensitivity (conducted) of the receiver is the minimum level of signal (e.m.f.) at the receiver input, at the nominal frequency of the receiver and with normal test modulation, clause 7.1, which will produce:

- an audio frequency output power of at least 50 % of the rated power output, clause 7.8, and
- a SND/ND ratio of 20 dB, measured at the receiver output through a telephone psophometric weighting network as described in ITU-T Recommendation O.41 [8] Red Book 1984.

9.1.2 Method of measuring the SND/ND ratio

The test signal, at the nominal frequency of the receiver, with normal test modulation, clause 7.1, at an e.m.f. of 6 dB μ V, value of the limit for the maximum usable sensitivity, shall be applied to the receiver input connector.

An audio frequency output load, a SINAD meter and a psophometric telephone weighting network as mentioned in clause 9.1.1, shall be connected to the receiver output terminals.

Where possible, the receiver volume control shall be adjusted to give at least 50 % of the rated output power, clause 7.8 or, in the case of stepped volume controls, to the first step that provides an output power of at least 50 % of the rated output power.

The test signal input level shall be reduced until a SND/ND ratio of 20 dB is obtained.

The test signal input level under these conditions is the value of the maximum usable sensitivity.

The measurement shall be made under normal test conditions, clause 6.3 and repeated under extreme test conditions, clauses 6.4.1 and 6.4.2 applied simultaneously.

Under extreme test conditions, the receiver audio output power shall be within $\pm 3,0$ dB of the value obtained under normal test condition.

9.2 Maximum usable sensitivity (field strength)

This method applies only to equipment without an external antenna connector.

9.2.1 Definition

The maximum usable sensitivity of the receiver is the minimum field strength present at the location of the receiver, at the nominal frequency of the receiver and with normal test modulation, clause 7.1, which will fulfil the requirements of clause 9.1.1.

9.2.2 Method of measurement

On a test site, selected from annex A, the equipment shall be placed at the specified height on a non-conducting support and in the position closest to normal use as declared by the manufacturer.

The test antenna shall be orientated for vertical polarization and the length of the test antenna shall be chosen to correspond to the frequency of the receiver.

The input of the test antenna shall be connected to a signal generator.

The signal generator shall be tuned to the frequency of the receiver under test and its output level shall be adjusted to 100 dB μ V.

The signal generator shall be modulated with normal test modulation according to clause 7.1.

An audio frequency output load, a SINAD meter and a psophometric telephone weighting network as mentioned in clause 9.1.1 shall be coupled to the receiver loudspeaker/transducer via an acoustic measuring arrangement described in clause A.3.3.1.

Where possible, the receiver volume control shall be adjusted to give at least 50 % of the rated output power, clause 7.8, or, in the case of stepped volume controls, to the first step that provides an output power of at least 50 % of the rated output power.

The test signal output level shall be reduced until the acoustic SND/ND ratio of 20 dB is obtained.

The test antenna shall be raised and lowered through the specified range of height to find the lowest level of the test signal that produces an acoustic SND/ND ratio of 20 dB.

The receiver shall then be rotated through 360° in the horizontal plane, to find the lowest level of the test signal that produces an acoustic SND/ND ratio of 20 dB.

The input signal level to the test antenna shall be maintained.

The receiver shall be replaced by a substitution antenna as defined in clause A.1.5.

The substitution antenna shall be orientated for vertical polarization and the length of the substitution antenna shall be adjusted to correspond to the frequency of the receiver.

The substitution antenna shall be connected to a calibrated measuring receiver.

The test antenna shall be raised and lowered through the specified range of height to ensure that the maximum signal is received.

The signal level measured with the calibrated measuring receiver shall be recorded as the field strength in dB μ V/m.

The measurement shall be repeated with the test antenna and the substitution antenna orientated for horizontal polarization.

The measure of the maximum usable sensitivity expressed as field strength is the minimum of the two signal levels recorded as the input to the calibrated measuring receiver, corrected for the gain of the antenna if necessary.

9.3 Amplitude characteristic of the receiver

9.3.1 Definition

The amplitude characteristic of the receiver is the relationship between the radio frequency input level of a specified modulated signal and the audio frequency level at the receiver output.

9.3.2 Method of measurement

The test signal, at the nominal frequency of the receiver, with normal test modulation, clause 7.1, at an e.m.f. of 6 dB μ V, value of the limit for the maximum usable sensitivity, shall be applied to the receiver input connector.

The audio output level shall be adjusted to approximately 25 % of the rated output power, clause 7.8.

The audio output level shall be recorded.

The input signal shall be increased to an e.m.f. of 100 dB μ V and the level of the audio output shall again be measured.

The audio output level shall be recorded.

The measure of the amplitude characteristics of the receiver is the ratio between the two obtained audio output levels recorded in dB.

9.4 Co-channel rejection

9.4.1 Definition

The co-channel rejection is the capability of the receiver to receive a wanted modulated signal at the nominal frequency without exceeding a given degradation due to the presence of an unwanted modulated signal at the nominal frequency of the receiver.

9.4.2 Method of measurement

The two input signals shall be connected to the receiver via a combining network, clause 7.6.

The wanted test signal, at the nominal frequency of the receiver, with normal test modulation, clause 7.1, at an e.m.f. of 6 dB μ V, value of the limit for the maximum usable sensitivity, shall be applied to the receiver input connector via one input of the combining network.

The unwanted test signal, at the nominal frequency of the receiver, modulated with a frequency of 400 Hz at a deviation of 60 % of the maximum permissible frequency deviation, clause 5.1.4.1, shall be applied to the receiver input connector via the second input of the combining network.

The amplitude of the unwanted test signal shall be adjusted until the SND/ND ratio, psophometrically weighted, at the output of the receiver is reduced to 14 dB.

The measure of the co-channel rejection is the ratio in dB of the level of the unwanted test signal to the level of the wanted test signal at the receiver input for which the specified reduction in SND/ND ratio occurs.

This ratio shall be recorded.

The measurement shall be repeated for displacements of the unwanted test signal of ± 1 500 Hz and ± 3 000 Hz.

The lowest value of the five measurement results recorded shall be recorded as the co-channel rejection.

9.5 Adjacent channel selectivity

9.5.1 Definition

The adjacent channel selectivity is the capability of the receiver to receive a wanted modulated signal at the nominal frequency without exceeding a given degradation due to the presence of an unwanted modulated signal in the adjacent channel.

9.5.2 Method of measurement

The two input signals shall be connected to the receiver via a combining network, clause 7.6.

The wanted test signal, at the nominal frequency of the receiver, with normal test modulation, clause 7.1, at an e.m.f. of 6 dB μ V, value of the limit for the maximum usable sensitivity, shall be applied to the receiver input connector via one input of the combining network.

The unwanted test signal, at the frequency of one channel separation above the nominal frequency of the receiver, modulated with a frequency of 400 Hz at a deviation of 60 % of the maximum permissible frequency deviation, clause 5.1.4.1, shall be applied to the receiver input connector via the second input of the combining network.

The amplitude of the unwanted test signal shall be adjusted until the SND/ND ratio, psophometrically weighted, at the output of the receiver is reduced to 14 dB.

The measure of the adjacent channel selectivity is the ratio in dB of the level of the unwanted test signal to the level of the wanted test signal at the receiver input for which the specified reduction in SND/ND ratio occurs.

This ratio shall be recorded.

The measurement shall be repeated with an unwanted signal at the frequency of the channel below that of the wanted signal.

The two noted ratios shall be recorded as the upper and lower adjacent channel selectivity.

The measurements shall be repeated under extreme test conditions, clauses 6.4.1 and 6.4.2 applied simultaneously, with the amplitude of the wanted test signal adjusted to an e.m.f. of 12 dB μ V.

9.6 Spurious response rejection

9.6.1 Definition

The spurious response rejection is the capability of the receiver to discriminate between the wanted modulated signal at the nominal frequency and an unwanted signal at any other frequency at which a response is obtained.

9.6.2 Introduction to the method of measurement

To determine the frequencies at which spurious responses can occur the following calculations shall be made:

- a) calculation of the "limited frequency range".

The "limited frequency range" is equal to:

- the frequency of the local oscillator signal (f_{lo}) applied to the 1st mixer of the receiver \pm the sum of the intermediate frequencies (if_1, \dots, if_n) and a half the switching range (sr) of the receiver, clause 4.1 and EN 300 793 [3];

hence:

- the "limited frequency range" = $f_{lo} \pm (if_1 + if_2 + \dots + if_n + sr/2)$.

- b) calculation of frequencies outside the "limited frequency range".

A calculation of the frequencies at which spurious responses can occur outside the range determined in (a) is made for the remainder of the frequency range of interest, as appropriate, clause 9.6.2.2.

The frequencies outside the "limited frequency range" are equal to:

- the harmonics of the frequency of the local oscillator signal (f_{lo}) applied to the 1st mixer of the receiver \pm the numeric value of the 1st intermediate frequency (if_1) of the receiver;

hence:

- the frequencies of these spurious responses = $nf_{lo} \pm if_1$.

where 'n' is an integer greater than or equal to 2.

For the calculations (a) and (b) above the manufacturer shall state the frequency of the receiver, the frequency of the local oscillator signal (f_{lo}) applied to the 1st mixer of the receiver, the intermediate frequencies (if_1 , if_2 etc.) and the switching range (sr) of the receiver.

9.6.2.1 Method of search over the "limited frequency range"

The two input signals shall be connected to the receiver via a combining network, clause 7.6.

The wanted test signal, at the nominal frequency of the receiver, with normal test modulation, clause 7.1, at an e.m.f. of 6 dB μ V, value of the limit for the maximum usable sensitivity, shall be applied to the receiver input connector via one input of the combining network.

The unwanted test signal, modulated with a frequency of 400 Hz at a deviation of ± 5 kHz, at an e.m.f. of 86 dB μ V, shall be applied to the receiver input connector via the second input of the combining network.

The frequency of the unwanted signal shall be varied incrementally over the "limited frequency range".

The incremental steps of the frequency of the unwanted signal shall be 5 kHz.

The frequency of any spurious response detected during the search shall be recorded for the use in measurements in accordance with clause 9.6.2.2.

9.6.2.2 Method of measurement

The two input signals shall be connected to the receiver via a combining network, clause 7.6.

The wanted test signal, at the nominal frequency of the receiver, with normal test modulation, clause 7.1, at an e.m.f. of 6 dB μ V, value of the limit for the maximum usable sensitivity, shall be applied to the receiver input connector via one input of the combining network.

The unwanted test signal, modulated with a frequency of 400 Hz at a deviation of 60 % of the maximum permissible frequency deviation, clause 5.1.4.1, at an e.m.f. of 86 dB μ V, shall be applied to the receiver input connector via the second input of the combining network.

The measurement shall be performed at all spurious response frequencies found during the search over the "limited frequency range", clause 9.6.2.1, and at frequencies calculated for the remainder of the spurious response frequencies in the frequency range 100 kHz to 2 GHz for equipment operating on frequencies below 470 MHz, or in the frequency range of 100 kHz to 4 GHz for equipment operating on frequencies above 470 MHz.

At each frequency at which a spurious response occurs, the input level shall be adjusted until the SND/ND ratio, psophometrically weighted, is reduced to 14 dB.

The measure of the spurious response rejection is the ratio in dB of the level of the unwanted test signal to the level of the wanted test signal at the receiver input for which the specified reduction in SND/ND ratio occurs.

The ratio shall be recorded as the spurious response rejection for each spurious response obtained.

9.7 Intermodulation response rejection

9.7.1 Definition

The intermodulation response rejection is the capability of a receiver to receive a wanted modulated signal at the nominal frequency without exceeding a given degradation due to the presence of two or more unwanted signals with a specific frequency relationship to the wanted signal frequency.

9.7.2 Method of measurement

Three input signals shall be connected to the receiver via a combining network, clause 7.6.

The wanted test signal (A), at the nominal frequency of the receiver, with normal test modulation, clause 7.1, at an e.m.f. of 6 dB μ V, value of the limit for the maximum usable sensitivity, shall be applied to the receiver input connector via one input of the combining network.

The unwanted test signal (B), at the frequency 25 kHz above the nominal frequency of the receiver, without modulation, shall be applied to the receiver input connector via the second input of the combining network.

The unwanted test signal (C), at the frequency 50 kHz above the nominal frequency of the receiver, modulated with a frequency of 400 Hz at a deviation of 60 % of the maximum permissible frequency deviation, clause 5.1.4.1, shall be applied to the receiver input connector via the third input of the combining network.

The amplitude of the unwanted test signals (B) and (C) shall be maintained equal and adjusted until the SND/ND ratio, psophometrically weighted, at the output of the receiver is reduced to 14 dB.

The measure of the intermodulation response rejection is the ratio in dB of the level of the unwanted test signals to the level of the wanted test signal at the receiver input for which the specified reduction in SND/ND ratio occurs.

This ratio shall be recorded.

The measurement shall be repeated with the unwanted signal from signal generator (B) at a frequency 50 kHz above the wanted signal and with the unwanted signal from signal generator (C) at a frequency 100 kHz above the wanted signal.

The two sets of measurements described above shall be repeated with the unwanted signals below the nominal frequency of the receiver by the specified amounts.

9.8 Blocking or desensitization

9.8.1 Definition

Blocking is a change (generally a reduction) in the wanted audio output power of a receiver or a reduction of the SND/ND ratio due to an unwanted signal on another frequency.

9.8.2 Method of measurement

The two input signals shall be connected to the receiver via a combining network, clause 7.6.

The wanted test signal, at the nominal frequency of the receiver, with normal test modulation, clause 7.1, at an e.m.f. of 6 dB μ V, value of the limit for the maximum usable sensitivity, shall be applied to the receiver input connector via one input of the combining network.

Where possible, the receiver volume control shall be adjusted to give at least 50 % of the rated output power, clause 7.8, or, in the case of stepped volume controls, to the first step that provides an output power of at least 50 % of the rated output power.

The obtained audio output level shall be noted.

The unwanted test signal, at a frequency from 1 MHz to 10 MHz offset from the nominal frequency of the receiver, without modulation, shall be applied to the receiver input connector via the second input of the combining network.

For practical reasons the measurements will be carried out at frequencies of the unwanted signal at approximately ± 1 MHz, ± 2 MHz, ± 5 MHz and ± 10 MHz.

The amplitude of the unwanted test signal shall be adjusted until:

- a reduction of 3 dB in the audio output level of the wanted signal; or
- the SND/ND ratio, psophometrically weighted, at the output of the receiver is reduced to 14 dB;

whichever occurs first. This level shall be noted.

The measure of the blocking or desensitization is the ratio in dB of the level of the unwanted test signal to the level of the wanted test signal at the receiver input for which the specified reduction in audio output level or in the SND/ND ratio occurs.

This ratio shall be recorded for each of the eight noted levels as the blocking or desensitization.

9.9 Spurious radiations

9.9.1 Definition

Spurious radiations from the receiver are components at any frequency, radiated by the equipment and antenna.

The level of spurious radiations shall be measured as:

either:

- a) their power level in a specified load (conducted spurious emission); and
- b) their effective radiated power when radiated by the cabinet and structure of the equipment (cabinet radiation); or
- c) their effective radiated power when radiated by the cabinet and the integral antenna, in the case of hand portable equipment fitted with such an antenna and no external RF connector.

9.9.2 Method of measuring the power level in a specified load, clause 9.9.1 a)

This method applies only to equipment with an external antenna connector.

The receiver shall be connected to a 50 Ω attenuator.

The output of the attenuator shall be connected to a measuring receiver.

The receiver shall be switched on, and the measuring receiver shall be tuned over the frequency range 9 kHz to 4 GHz for equipment operating on frequencies below 470 MHz, or in the frequency range of 9 kHz to 12,75 GHz for equipment operating on frequencies above 470 MHz.

At each frequency at which a spurious component is detected, the power level shall be recorded as the spurious level delivered into the specified load.

9.9.3 Method of measuring the effective radiated power, clause 9.9.1 b)

This method applies only to equipment with an external antenna connector.

On a test site, selected from annex A, the equipment shall be placed at the specified height on a non-conducting support and in the position closest to normal use as declared by the manufacturer.

The receiver antenna connector shall be connected to an artificial antenna, clause 7.2.

The test antenna shall be orientated for vertical polarization and the length of the test antenna shall be chosen to correspond to the instant frequency of the measuring receiver.

The output of the test antenna shall be connected to a measuring receiver.

The receiver shall be switched on and the measuring receiver shall be tuned over the frequency range 30 MHz to 4 GHz.

At each frequency at which a spurious component is detected, the test antenna shall be raised and lowered through the specified range of height until a maximum signal level is detected by the measuring receiver.

The receiver shall then be rotated through 360° in the horizontal plane until the maximum signal level is detected by the measuring receiver.

The maximum signal level detected by the measuring receiver shall be noted.

The receiver shall be replaced by a substitution antenna as defined in clause A.1.5.

The substitution antenna shall be orientated for vertical polarization and the length of the substitution antenna shall be adjusted to correspond to the frequency of the spurious component detected.

The substitution antenna shall be connected to a calibrated signal generator.

The frequency of the calibrated signal generator shall be set to the frequency of the spurious component detected.

The input attenuator setting of the measuring receiver shall be adjusted in order to increase the sensitivity of the measuring receiver, if necessary.

The test antenna shall be raised and lowered through the specified range of height to ensure that the maximum signal is received.

The input signal to the substitution antenna shall be adjusted to the level that produces a level detected by the measuring receiver, that is equal to the level noted while the spurious component was measured, corrected for the change of input attenuator setting of the measuring receiver.

The input level to the substitution antenna shall be recorded as power level, corrected for the change of input attenuator setting of the measuring receiver.

The measurement shall be repeated with the test antenna and the substitution antenna orientated for horizontal polarization.

The measure of the effective radiated power of the spurious components is the larger of the two power levels recorded for each spurious component at the input to the substitution antenna, corrected for the gain of the antenna if necessary.

9.9.4 Method of measuring the effective radiated power, clause 9.9.1 c)

This measurement applies only to equipment without an external antenna connector.

The method of measurement shall be performed according to clause 9.9.3, except that the receiver input shall be connected to the integral antenna and not to an artificial antenna.

10 Duplex operation

If the equipment is designed for duplex operation, the following additional measurements shall be carried out to ensure satisfactory duplex operation.

Equipment made available for such measurements shall be fitted with a duplex filter.

10.1 Receiver desensitization with simultaneous transmission and reception

10.1.1 Definition

The receiver desensitization is the capability of the receiver to receive a wanted modulated signal at the nominal frequency without exceeding a given degradation due to the presence of an unwanted modulated signal (the attenuated power from the transmitter).

10.1.2 Method of measurement when the equipment operates with a duplex filter

The antenna connector shall be connected to a 50 Ω power attenuator, through a coupling device.

The test signal, with normal test modulation, clause 7.1, shall be connected to the coupling device in such a way as not to affect the impedance matching.

The transmitter shall be operated at the rated output power as defined in clause 8.2.

The transmitter shall be modulated by a frequency of 400 Hz with a frequency deviation of 60 % of the maximum permissible frequency deviation, clause 5.1.4.1.

The receiver sensitivity shall be measured in accordance with clause 9.1.

The output level of the signal generator shall be recorded as C in dB μ V.

The transmitter shall be switched off and the receiver sensitivity measured.

The output level of the signal generator shall be recorded as D in dB μ V.

The desensitization is the difference between the values of C and D.

10.1.3 Measuring method when the equipment operates with two antennas

The transmitter RF output shall be connected to a power attenuator.

The output of the power attenuator shall be connected to the receiver input through a coupling device.

The attenuation between transmitter and receiver shall be 30 dB.

The test signal, with normal test modulation, clause 7.1, shall be connected to the coupling device in such a way as not to affect the impedance matching.

The transmitter shall be operated at the rated output power as defined in clause 8.2.

The transmitter shall be modulated by a frequency of 400 Hz with a frequency deviation of 60 % of the maximum permissible frequency deviation, clause 5.1.4.1.

The receiver sensitivity shall be measured in accordance with clause 9.1.

The output level of the signal generator shall be recorded as C in dB μ V.

The transmitter shall be switched off and the receiver sensitivity measured.

The output level of the signal generator shall be recorded as D in dB μ V.

The desensitization is the difference between the values of C and D.

10.2 Receiver spurious response rejection

The receiver spurious response rejection is measured as specified in clause 9.6 with the equipment arrangement described in clause 10.1.2 or 10.1.3, except that the transmitter shall be unmodulated.

The transmitter shall be operated at the rated output power as defined in clause 8.2.

11 Measurement uncertainty

Table 10: Absolute measurement uncertainties: maximum values

Valid up to 1 GHz for the RF parameters unless otherwise stated.	
RF frequency	< $\pm 1 \times 10^{-7}$
RF power	< $\pm 0,75$ dB
Maximum frequency deviation:	
- within 300 Hz to 6 kHz of audio frequency	< ± 5 %
- within 6 kHz to 25 kHz of audio frequency	< ± 3 dB
Deviation limitation	< ± 5 %
Adjacent channel power	< ± 5 dB
Conducted emission of transmitter	< ± 4 dB
Conducted emission of transmitter, valid to 12,75 GHz	< ± 7 dB
Audio output power	< $\pm 0,5$ dB
Amplitude characteristic of receiver limiter	< $\pm 1,5$ dB
Sensitivity at 20 dB SINAD	< ± 3 dB
Conducted emission of receiver	< ± 3 dB
Conducted emission of receiver, valid to 12,75 GHz	< ± 6 dB
Two-signal measurement, valid to 4 GHz	< ± 4 dB
Three-signal measurement	< ± 3 dB
Radiated emission of transmitter, valid to 4 GHz	< ± 6 dB
Radiated emission of receiver, valid to 4 GHz	< ± 6 dB
Transmitter transient time	< ± 20 %
Transmitter transient frequency	< ± 250 Hz
Transmitter intermodulation	< ± 3 dB
Receiver desensitization (duplex operation)	< $\pm 0,5$ dB

For the test methods, according to the present document, the measurement uncertainty figures shall be calculated in accordance with ETR 028 [4] and shall correspond to an expansion factor (coverage factor) $k = 1,96$ or $k = 2$ (which provide confidence levels of respectively 95 % and 95,45 % in the case where the distributions characterizing the actual measurement uncertainties are normal (Gaussian)).

Table 10 is based on such expansion factors.

The particular expansion factor used for the evaluation of the measurement uncertainty shall be stated.

ETR 273 [5] provides further information concerning the usage of test sites.

Annex A (normative): Radiated measurement

A.1 Test sites and general arrangements for measurements involving the use of radiated fields

This annex introduces three most commonly available test sites, an Anechoic Chamber, an Anechoic Chamber with a ground plane and an Open Area Test Site (OATS), which may be used for radiated tests. These test sites are generally referred to as free field test sites. Both absolute and relative measurements can be performed in these sites. Where absolute measurements are to be carried out, the chamber should be verified. A detailed verification procedure is described in ETR 273 [5] relevant parts 2, 3 and 4.

NOTE: To ensure reproducibility and traceability of radiated measurements only these test sites should be used in measurements in accordance with the present document.

A.1.1 Anechoic Chamber

An Anechoic Chamber is an enclosure, usually shielded, whose internal walls, floor and ceiling are covered with radio absorbing material, normally of the pyramidal urethane foam type. The chamber usually contains an antenna support at one end and a turntable at the other. A typical Anechoic Chamber is shown in figure A.1.

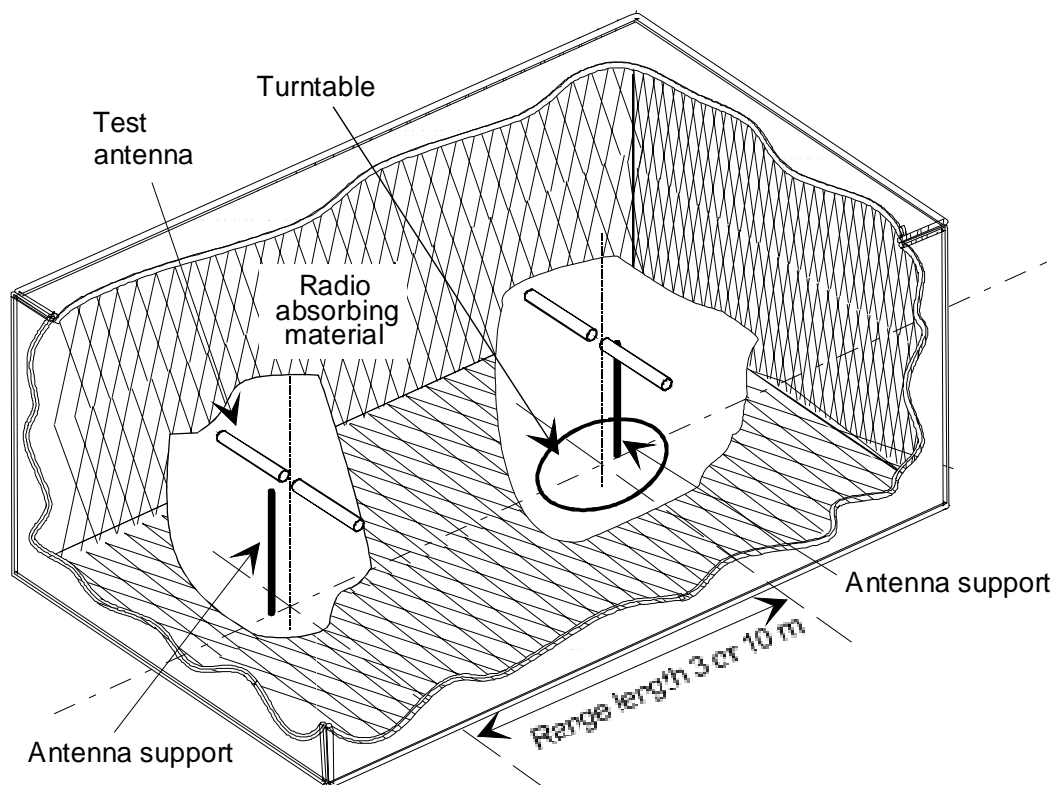

Figure A.1: A typical Anechoic Chamber

The chamber shielding and radio absorbing material work together to provide a controlled environment for testing purposes. This type of test chamber attempts to simulate free space conditions.

The shielding provides a test space, with reduced levels of interference from ambient signals and other outside effects, whilst the radio absorbing material minimizes unwanted reflections from the walls and ceiling which can influence the measurements. In practice it is relatively easy for shielding to provide high levels (80 dB to 140 dB) of ambient interference rejection, normally making ambient interference negligible.

A turntable is capable of rotation through 360° in the horizontal plane and it is used to support the test sample (EUT) at a suitable height (e.g. 1 m.) above the ground plane. The chamber shall be large enough to allow the measuring distance of at least 3 m or $2(d_1 + d_2)^2 / \lambda$ (m), whichever is greater (see clause A.2.5). The distance used in actual measurements shall be recorded with the test results.

The Anechoic Chamber generally has several advantages over other test facilities. There is minimal ambient interference, minimal floor, ceiling and wall reflections and it is independent of the weather. It does however have some disadvantages which include limited measuring distance and limited lower frequency usage due to the size of the pyramidal absorbers. To improve low frequency performance, a combination structure of ferrite tiles and urethane foam absorbers is commonly used.

All types of emission, sensitivity and immunity testing can be carried out within an Anechoic Chamber without limitation.

A.1.2 Anechoic Chamber with a conductive ground plane

An Anechoic Chamber with a conductive ground plane is an enclosure, usually shielded, whose internal walls and ceiling are covered with radio absorbing material, normally of the pyramidal urethane foam type. The floor, which is metallic, is not covered and forms the ground plane. The chamber usually contains an antenna mast at one end and a turntable at the other. A typical Anechoic Chamber with a conductive ground plane is shown in figure A.2.

This type of test chamber attempts to simulate an ideal Open Area Test Site whose primary characteristic is a perfectly conducting ground plane of infinite extent.

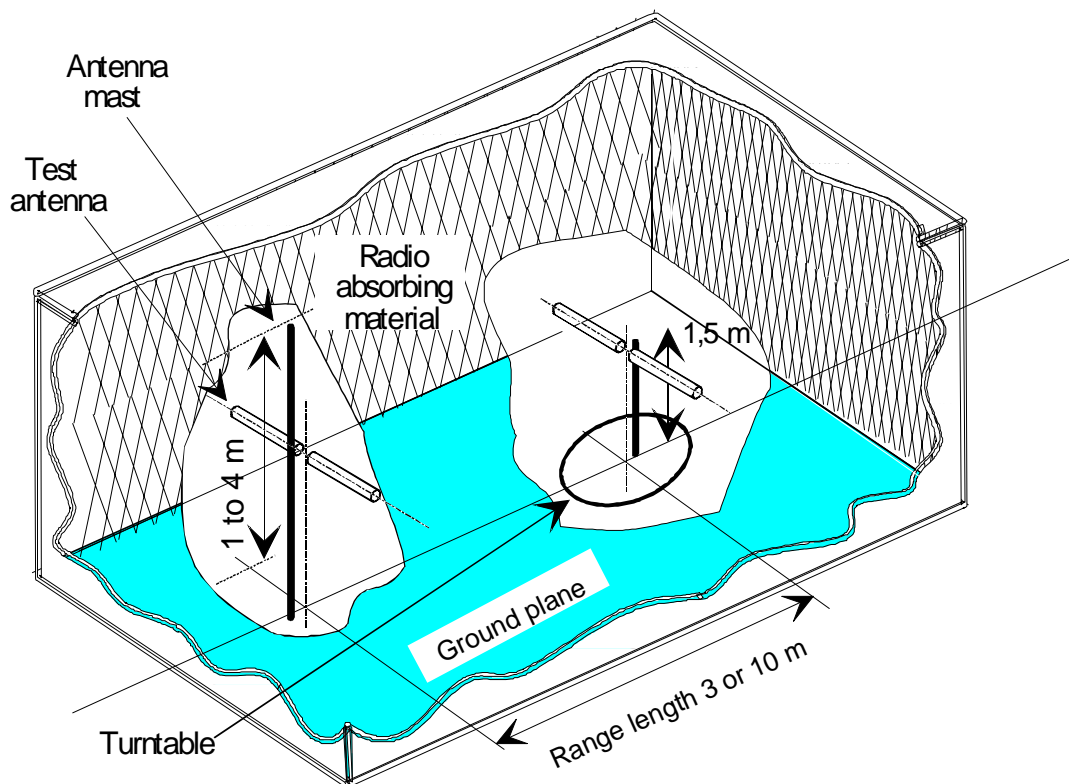

Figure A.2: A typical Anechoic Chamber with a conductive ground plane

In this facility the ground plane creates the wanted reflection path, such that the signal received by the receiving antenna is the sum of the signals from both the direct and reflected transmission paths. This creates a unique received signal level for each height of the transmitting antenna (or EUT) and the receiving antenna above the ground plane.

The antenna mast provides a variable height facility (from 1 m to 4 m) so that the position of the test antenna can be optimized for maximum coupled signal between antennas or between a EUT and the test antenna.

A turntable is capable of rotation through 360° in the horizontal plane and it is used to support the test sample (EUT) at a specified height, usually 1,5 m. above the ground plane. The chamber shall be large enough to allow the measuring distance of at least 3 m or $2(d_1 + d_2)^2 / \lambda$ (m), whichever is greater (see clause A.2.5). The distance used in actual measurements shall be recorded with the test results.

Emission testing involves firstly 'peaking' the field strength from the EUT by raising and lowering the receiving antenna on the mast (to obtain the maximum constructive interference of the direct and reflected signals from the EUT) and then rotating the turntable for a 'peak' in the azimuth plane. At this height of the test antenna on the mast, the amplitude of the received signal is noted. Secondly the EUT is replaced by a substitution antenna (positioned at the EUT's phase or volume centre), which is connected to a signal generator. The signal is again 'peaked' and the signal generator output adjusted until the level, noted in stage one, is again measured on the receiving device.

Receiver sensitivity tests over a ground plane also involve 'peaking' the field strength by raising and lowering the test antenna on the mast to obtain the maximum constructive interference of the direct and reflected signals, this time using a measuring antenna which has been positioned where the phase or volume centre of the EUT will be during testing. A transform factor is derived. The test antenna remains at the same height for stage two, during which the measuring antenna is replaced by the EUT. The amplitude of the transmitted signal is reduced to determine the field strength level at which a specified response is obtained from the EUT.

A.1.3 Open Area Test Site (OATS)

An Open Area Test Site comprises a turntable at one end and an antenna mast of variable height at the other end above a ground plane which, in the ideal case, is perfectly conducting and of infinite extent. In practice, whilst good conductivity can be achieved, the ground plane size has to be limited. A typical Open Area Test Site is shown in figure A.3.

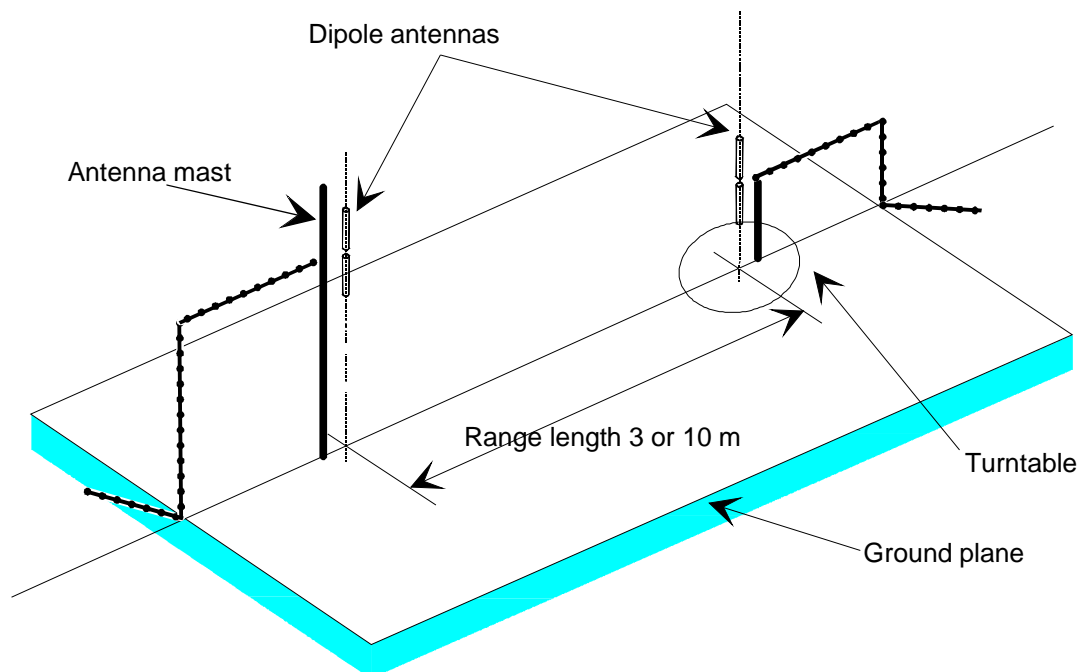

Figure A.3: A typical Open Area Test Site

The ground plane creates a wanted reflection path, such that the signal received by the receiving antenna is the sum of the signals received from the direct and reflected transmission paths. The phasing of these two signals creates a unique received level for each height of the transmitting antenna (or EUT) and the receiving antenna above the ground plane.

Site qualification concerning antenna positions, turntable, measurement distance and other arrangements are same as for Anechoic Chamber with a ground plane. In radiated measurements an OATS is also used by the same way as anechoic chamber with a ground plane.

Typical measuring arrangement common for ground plane test sites is presented in the figure A.4.

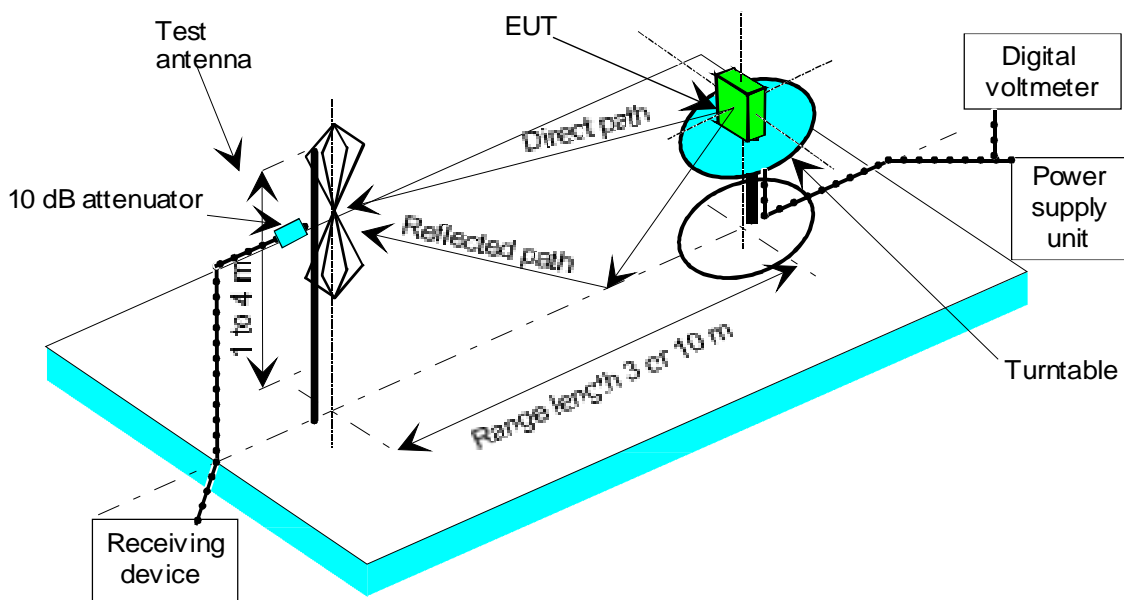

Figure A.4: Measuring arrangement on ground plane test site (OATS set-up for spurious emission testing)

A.1.4 Test antenna

A test antenna is always used in radiated test methods. In emission tests (i.e. frequency error, effective radiated power, spurious emissions and adjacent channel power) the test antenna is used to detect the field from the EUT in one stage of the measurement and from the substitution antenna in the other stage. When the test site is used for the measurement of receiver characteristics (i.e. sensitivity and various immunity parameters) the antenna is used as the transmitting device.

The test antenna should be mounted on a support capable of allowing the antenna to be used in either horizontal or vertical polarization which, on ground plane sites (i.e. Anechoic Chambers with ground planes and Open Area Test Sites), should additionally allow the height of its centre above the ground to be varied over the specified range (usually 1 metre to 4 metres).

In the frequency band 30 MHz to 1 000 MHz, dipole antennas (constructed in accordance with ANSI C63.5 [7]) are generally recommended. For frequencies of 80 MHz and above, the dipoles should have their arm lengths set for resonance at the frequency of test. Below 80 MHz, shortened arm lengths are recommended. For spurious emission testing, however, a combination of bicones and log periodic dipole array antennas (commonly termed 'log periodics') could be used to cover the entire 30 MHz to 1 000 MHz band. Above 1 000 MHz, waveguide horns are recommended although, again, log periodics could be used.

NOTE: The gain of a horn antenna is generally expressed relative to an isotropic radiator.

A.1.5 Substitution antenna

The substitution antenna is used to replace the EUT for tests in which a transmitting parameter (i.e. frequency error, effective radiated power, spurious emissions and adjacent channel power) is being measured. For measurements in the frequency band 30 MHz to 1 000 MHz, the substitution antenna should be a dipole antenna (constructed in accordance with ANSI C63.5 [7]). For frequencies of 80 MHz and above, the dipoles should have their arm lengths set for resonance at the frequency of test. Below 80 MHz, shortened arm lengths are recommended. For measurements above 1 000 MHz, a waveguide horn is recommended. The centre of this antenna should coincide with either the phase centre or volume centre.

A.1.6 Measuring antenna

The measuring antenna is used in tests on a EUT in which a receiving parameter (i.e. sensitivity and various immunity tests) is being measured. Its purpose is to enable a measurement of the electric field strength in the vicinity of the EUT. For measurements in the frequency band 30 MHz to 1 000 MHz, the measuring antenna should be a dipole antenna (constructed in accordance with ANSI C63.5 [7]). For frequencies of 80 MHz and above, the dipoles should have their arm lengths set for resonance at the frequency of test. Below 80 MHz, shortened arm lengths are recommended. The centre of this antenna should coincide with either the phase centre or volume centre (as specified in the test method) of the EUT.

A.2 Guidance on the use of radiation test sites

This clause details procedures, test equipment arrangements and verification that should be carried out before any of the radiated tests are undertaken. These schemes are common to all types of test sites described in annex A.

A.2.1 Verification of the test site

No test should be carried out on a test site, which does not possess a valid certificate of verification. The verification procedures for the different types of test sites described in annex A (i.e. Anechoic Chamber, Anechoic Chamber with a ground plane and Open Area Test Site) are given in ETR 273 [5] parts 2, 3 and 4, respectively.

A.2.2 Preparation of the EUT

The manufacturer should supply information about the EUT covering the operating frequency, polarization, supply voltage(s) and the reference face. Additional information, specific to the type of EUT should include, where relevant, carrier power, channel separation, whether different operating modes are available (e.g. high and low power modes) and if operation is continuous or is subject to a maximum test duty cycle (e.g. 1 minute on, 4 minutes off).

Where necessary, a mounting bracket of minimal size should be available for mounting the EUT on the turntable. This bracket should be made from low conductivity, low relative dielectric constant (i.e. less than 1,5) material(s) such as expanded polystyrene, balsawood, etc.

A.2.3 Power supplies to the EUT

All tests should be performed using power supplies wherever possible, including tests on EUT designed for battery-only use. In all cases, power leads should be connected to the EUT's supply terminals (and monitored with a digital voltmeter) but the battery should remain present, electrically isolated from the rest of the equipment, possibly by putting tape over its contacts.

The presence of these power cables can, however, affect the measured performance of the EUT. For this reason, they should be made to be "transparent" as far as the testing is concerned. This can be achieved by routing them away from the EUT and down to the either the screen, ground plane or facility wall (as appropriate) by the shortest possible paths. Precautions should be taken to minimize pick-up on these leads (e.g. the leads could be twisted together, loaded with ferrite beads at 0,15 m spacing or otherwise loaded).

A.2.4 Volume control setting for analogue speech tests

Unless otherwise stated, in all receiver measurements for analogue speech the receiver volume control where possible, should be adjusted to give at least 50 % of the rated audio output power. In the case of stepped volume controls, the volume control should be set to the first step that provides an output power of at least 50 % of the rated audio output power. This control should not be readjusted between normal and extreme test conditions in tests.

A.2.5 Range length

The range length for all these types of test facility should be adequate to allow for testing in the far field of the EUT i.e. it should be equal to or exceed:

$$\frac{2(d_1 + d_2)^2}{\lambda}$$

where:

d_1 is the largest dimension of the EUT/dipole after substitution (m);

d_2 is the largest dimension of the test antenna (m);

λ is the test frequency wavelength (m).

It should be noted that in the substitution part of this measurement, where both test and substitution antennas are half wavelength dipoles, this minimum range length for far-field testing would be:

$$2\lambda$$

It should be noted in test reports when either of these conditions is not met so that the additional measurement uncertainty can be incorporated into the results.

NOTE 1: **For the fully Anechoic Chamber**, no part of the volume of the EUT should, at any angle of rotation of the turntable, fall outside the "quiet zone" of the chamber at the nominal frequency of the test.

NOTE 2: The "quiet zone" is a volume within the Anechoic Chamber (without a ground plane) in which a specified performance has either been proven by test, or is guaranteed by the designer/manufacturer. The specified performance is usually the reflectivity of the absorbing panels or a directly related parameter (e.g. signal uniformity in amplitude and phase). It should be noted however that the defining levels of the quiet zone tend to vary.

NOTE 3: **For the Anechoic Chamber with a ground plane**, a full height scanning capability, i.e. 1 to 4 m, should be available for which no part of the test antenna should come within 1 m of the absorbing panels. For both types of Anechoic Chamber, the reflectivity of the absorbing panels should not be worse than -5 dB.

NOTE 4: **For both the Anechoic Chamber with a ground plane and the Open Area Test Site**, no part of any antenna should come within 0,25 m of the ground plane at any time throughout the tests. Where any of these conditions cannot be met, measurements should not be carried out.

A.2.6 Site preparation

The cables for both ends of the test site should be routed horizontally away from the testing area for a minimum of 2 m (unless, in the case both types of Anechoic Chamber, a back wall is reached) and then allowed to drop vertically and out through either the ground plane or screen (as appropriate) to the test equipment. Precautions should be taken to minimize pick up on these leads (e.g. dressing with ferrite beads, or other loading). The cables, their routing and dressing should be identical to the verification set-up.

NOTE: For ground reflection test sites (i.e. Anechoic Chambers with ground planes and Open Area Test Sites), which incorporate a cable drum with the antenna mast, the 2 m requirement may be impossible to comply with.

Calibration data for all items of test equipment should be available and valid. For test, substitution and measuring antennas, the data should include gain relative to an isotropic radiator (or antenna factor) for the frequency of test. Also, the VSWR of the substitution and measuring antennas should be known.

The calibration data on all cables and attenuators should include insertion loss and VSWR throughout the entire frequency range of the tests. All VSWR and insertion loss figures should be recorded in the logbook results sheet for the specific test.

Where correction factors/tables are required, these should be immediately available.

For all items of test equipment, the maximum errors they exhibit should be known along with the distribution of the error e.g.:

- cable loss: $\pm 0,5$ dB with a rectangular distribution;
- measuring receiver: 1,0 dB (standard deviation) signal level accuracy with a Gaussian error distribution.

At the start of measurements, system checks should be made on the items of test equipment used on the test site.

A.3 Coupling of signals

A.3.1 General

The presence of leads in the radiated field may cause a disturbance of that field and lead to additional measurement uncertainty. These disturbances can be minimized by using suitable coupling methods, offering signal isolation and minimum field disturbance (e.g. optical and acoustic coupling).

A.3.2 Data Signals

Isolation can be provided by the use of optical, ultra sonic or infrared means. Field disturbance can be minimized by using a suitable fibre optic connection. Ultra sonic or infrared radiated connections require suitable measures for the minimization of ambient noise.

A.3.3 Speech and analogue signals

Where an audio output socket is not available an acoustic coupler should be used.

When using the acoustic coupler, care should be exercised that possible ambient noise does not influence the test result.

A.3.3.1 Acoustic coupler description

The acoustic coupler comprises a plastic funnel, an acoustic pipe and a microphone with a suitable amplifier. The materials used to fabricate the funnel and pipe should be of low conductivity and of low relative dielectric constant (i.e. less than 1,5).

- The acoustic pipe should be long enough to reach from the EUT to the microphone, which should be located in a position that will not disturb the RF field. The acoustic pipe should have an inner diameter of about 6 mm and a wall thickness of about 1,5 mm and should be sufficiently flexible so as not to hinder the rotation of the turntable.
- The plastic funnel should have a diameter appropriate to the size of the loudspeaker in the EUT, with soft foam rubber glued to its edge, it should be fitted to one end of the acoustic pipe and the microphone should be fitted to the other end. It is very important to fix the centre of the funnel in a reproducible position relative to the EUT, since the position of the centre has a strong influence on the frequency response that will be measured. This can be achieved by placing the EUT in a close fitting acoustic mounting jig, supplied by the manufacturer, of which the funnel is an integral part.
- The microphone should have a response characteristic flat within 1 dB over a frequency range of 50 Hz to 20 kHz, a linear dynamic range of at least 50 dB. The sensitivity of the microphone and the receiver audio output level should be suitable to measure a signal to noise ratio of at least 40 dB at the nominal audio output level of the EUT. Its size should be sufficiently small to couple to the acoustic pipe.
- The frequency-correcting network should correct the frequency response of the acoustic coupler so that the acoustic SINAD measurement is valid (see IEC 489-3 [6] Appendix F).

A.3.3.2 Calibration

The aim of the calibration of the acoustic coupler is to determine the acoustic SINAD ratio, which is equivalent to the SINAD ratio at the receiver output.

Annex B (normative): Specifications for adjacent channel power measurement arrangements

B.1 Power measuring receiver specification

The power measuring receiver consists of a mixer, an IF filter, and oscillator, an amplifier, a variable attenuator and an rms value indicator. Instead of the variable attenuator with the rms value indicator it is also possible to use an rms voltmeter calibrated in dB as the rms value indicator. The technical characteristics of the power-measuring receiver are given in clauses B.1.1 to B.1.4.

B.1.1 IF filter

The IF filter shall be within the limits of the following selectivity characteristic.

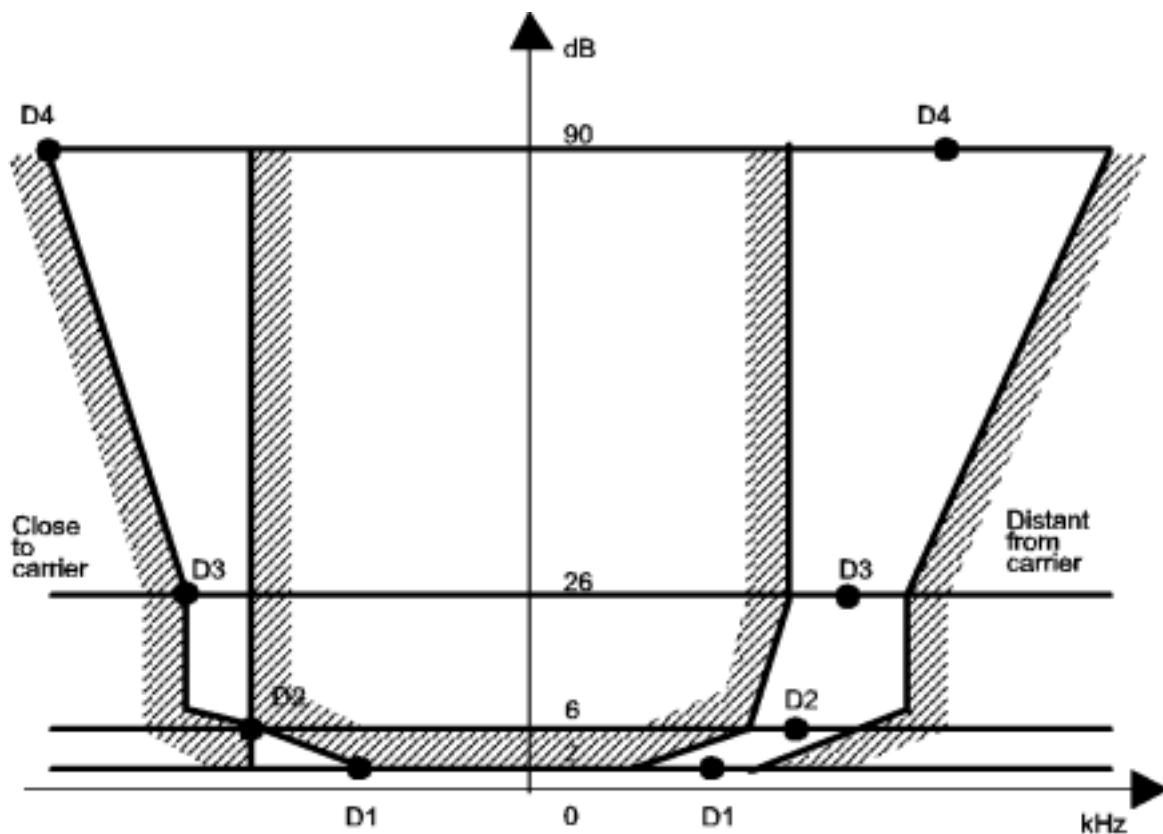

Figure B.1

Depending on the channel separation, the selectivity characteristic shall keep the following frequency separations from the nominal centre frequency of the adjacent channel:

Table B.1: Selectivity characteristic

Channel separation (kHz)	Frequency separation of filter curve from nominal centre frequency of adjacent channel (kHz)			
	D1	D2	D3	D4
12,5	3	4,25	5,5	9,5
20	4	7,0	8,25	12,25
25	5	8,0	9,25	13,25

Depending on the channel separation, the attenuation points shall not exceed the tolerances given in table B.2 and table B.3.

Table B.2: Attenuation points close to carrier

Channel separation (kHz)	Tolerance range (kHz)			
	D1	D2	D3	D4
12,5	+1,35	±0,1	-1,35	-5,35
20	+3,1	±0,1	-1,35	-5,35
25	+3,1	±0,1	-1,35	-5,35

Table B.3: Attenuation points distant from the carrier

Channel separation (kHz)	Tolerance range (kHz)			
	D1	D2	D3	D4
12,5	±2,0	±2,0	±2,0	+2,0 -6,0
20	±3,0	±3,0	±3,0	+3,0 -7,0
25	±3,5	±3,5	±3,5	+3,5 -7,5

The minimum attenuation of the filter outside the 90 dB attenuation points shall be equal to or greater than 90 dB.

Table B.4: Frequency displacement

Channel separation (kHz)	Specified necessary bandwidth (kHz)	Displacement from the -6 dB point (kHz)
12,5	8,5	8,25
20	14	13
25	16	17

The tuning of the power-measuring receiver shall be adjusted away from the carrier so that the -6 dB response nearest to the transmitter carrier frequency is located at a displacement from the nominal carrier frequency as given in table B.4.

B.1.2 Variable attenuator

The variable attenuator shall have a minimum range of 80 dB and a resolution of 1 dB.

B.1.3 Rms value indicator

The instrument shall accurately indicate non-sinusoidal signals in a ratio of up to 10:1 between peak value and rms value.

B.1.4 Oscillator and amplifier

The oscillator and the amplifier shall be designed in such a way that the measurement of the adjacent channel power of a low-noise unmodulated transmitter, whose self-noise has a negligible influence on the measurement result, yields a measured value of ≤ -90 dB for channel separations of 20 kHz and 25 kHz and of ≤ -80 dB for a channel separation of 12,5 kHz, referred to the carrier of the oscillator.

Annex C (normative): Graphical representation of the selection of equipment and frequencies for testing

Information regarding the selection of equipment for testing purposes can be found in EN 300 793 [3].

The following graphs, imported from EN 300 793 [3], illustrate the principles used in that standard, in particular, concepts such as full and limited tests. For further details concerning the present annex (e.g. definitions, references), please, refer to EN 300 793 [3].

C.1 Tests on a single sample

If the Operating Frequency Range (OFR) of each equipment corresponds to its alignment range (AR0, AR1, AR2, or AR3) then only one sample shall be tested.

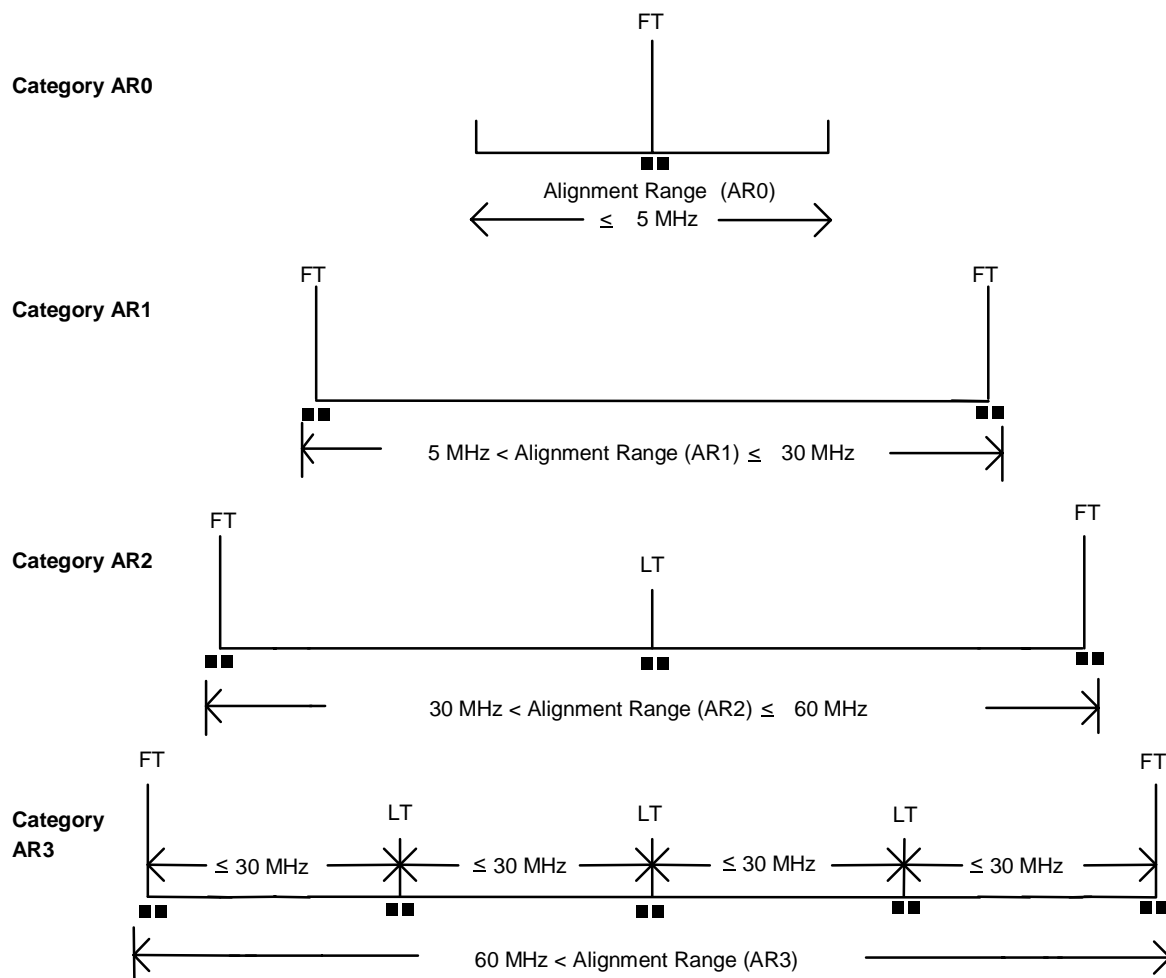
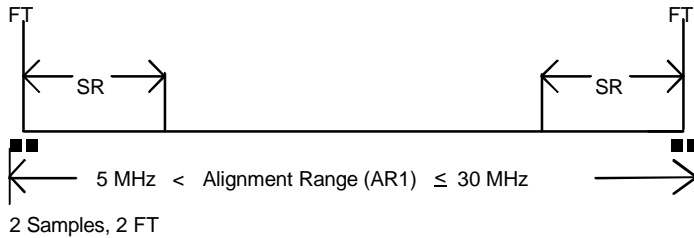

Figure C.1: Tests on a single sample for equipment that has a switching range equal to its alignment range

C.2 Tests and samples needed when the switching range is a subset of the alignment range

In order to cover an alignment range several separate samples, having different switching ranges (SR) within the alignment range, may be needed. Samples shall be then provided for testing in accordance with clauses 4.4, 4.5, 4.6, and 4.7 in EN 300 793 [3], as appropriate. The following examples assume a switching range (SR) of 5 MHz.

Category AR1



2 Samples, 2 FT

Category AR2

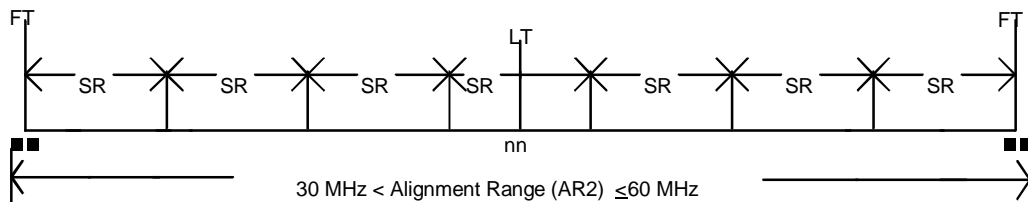

3 Samples, 2 FT, 1 LT.

Category AR3

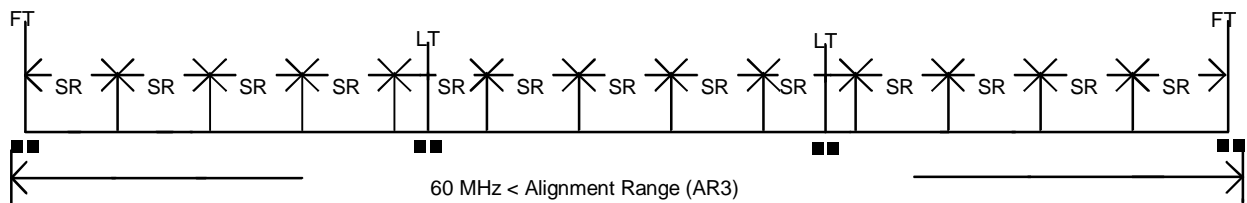

4 Samples, 2 FT, 2 LT.

NOTE:

- SR: Switching Range, see clause 4.2 in EN 300 793 [3]
- AR1, AR2, AR3: Categories of alignment range, see clause 4.3 in EN 300 793 [3]
- FT: Full tests
- LT: Limited tests
- ■: 50 kHz range in which tests are carried out

Figure C.2: Tests on equipment having switching ranges that are subsets of their alignment range

C.3 Tests and samples for a family of equipment where the alignment range is a subset of the total operating frequency range

If the alignment range of a piece of equipment is a subset of the total operating frequency range then the operating frequency range shall be divided into appropriate categories of alignment range. Samples shall be then provided for testing in accordance with clauses 4.4, 4.5, 4.6, and 4.7 in EN 300 793[3], as appropriate.

For example the applicant seeks type approval for a family of equipment having an operating frequency range of 403 MHz to 470 MHz. The equipment to be tested does not cover this range with one category of alignment range.

C.3.1 Test scenario 1

The Operating Frequency Range (OFR) could be covered by two alignment ranges a) and b), implemented in samples a) and b):

- a) 403 MHz to 430 MHz: This is category AR1;
- b) 425 MHz to 470 MHz: This is category AR2.

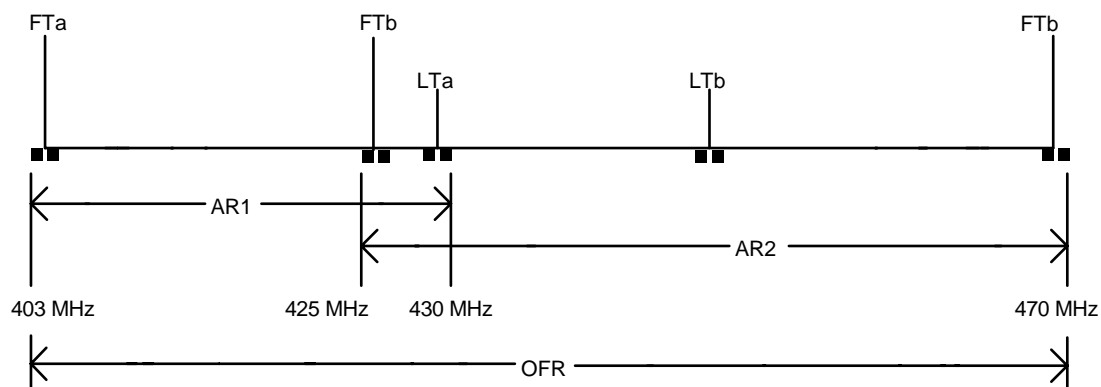

NOTE 1:

- OFR: Operating Frequency Range, see clause 4.2 in EN 300 793 [3]
- AR1, AR2: Categories of alignment range, see clause 4.3 in EN 300 793 [3]
- FTa: Full tests on sample(s) a)
- LTa: Limited tests on sample(s) a)
- FTb: Full tests on sample(s) b)
- LTb: Limited test on sample(s) b)
- : 50 kHz range in which tests are carried out

NOTE 2: This example requires a minimum of two test samples and a maximum of five test samples to cover the operating frequency range.

Figure C.3: Tests on family member equipment having alignment ranges that are subsets of the total operating frequency range (Example 1)

C.3.2 Test scenario 2

The Operating Frequency Range (OFR) could alternatively be covered by three alignment ranges of category AR1, implemented in samples a), b) and c):

- a) 403 MHz to 430 MHz: this is category AR1;
- b) 425 MHz to 450 MHz: this is category AR1;
- c) 450 MHz to 470 MHz: this is category AR1.

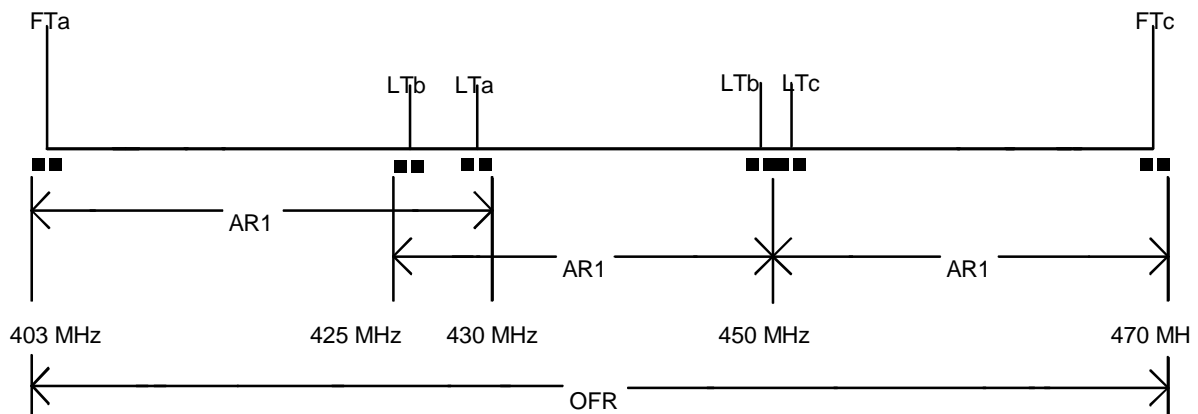

NOTE 1:

- OFR: Operating Frequency Range, see clause 4.2 in EN 300 793[3]
- AR1: Second category of alignment range, see clause 4.3 in EN 300 793[3]
- FTa: Full tests on sample(s) a)
- LTa: Limited tests on sample(s) a)
- LTb: Limited test on sample(s) b)
- FTc: Full tests on sample(s) c)
- LTc: Limited tests on sample(s) c)
- : 50 kHz range in which tests are carried out

NOTE 2: This example requires a minimum of three test samples and a maximum of six test samples to cover the operating frequency range.

Figure C.4: Tests on family member equipment having alignment ranges that are subsets of the total operating frequency range (Example 2)

Annex D (normative): Bibliography

- ETSI ETS 300 113: "Radio Equipment and Systems (RES); Land mobile service; Technical characteristics and test conditions for radio equipment intended for the transmission of data (and speech) and having an antenna connector".
- ETSI I-ETS 300 219: "Radio Equipment and Systems (RES); Land mobile service; Technical characteristics and test conditions for radio equipment transmitting signals to initiate a specific response in the receiver".
- ETSI ETS 300 296: "Radio Equipment and Systems (RES); Land mobile service; Technical characteristics and test conditions for radio equipment using integral antennas intended primarily for analogue speech".
- ETSI ETS 300 341: "Radio Equipment and Systems (RES); Land mobile service; Technical characteristics and test conditions for radio equipment using an integral antenna transmitting signals to initiate a specific response in the receiver".
- ETSI ETS 300 390: "Radio Equipment and Systems (RES); Land mobile service; Technical characteristics and test conditions for radio equipment intended for the transmission of data (and speech) and using an integral antenna".
- ETSI ETS 300 471: "Radio Equipment and Systems (RES); Land mobile service; Access protocol, occupation rules and corresponding technical characteristics of radio equipment for the transmission of data on shared channels".
- ETSI EN 301 166: "Electromagnetic compatibility and Radio spectrum Matters (ERM); Land mobile service; Technical characteristics and test conditions for radio equipment for analogue and/or digital communication (speech and/or data) and operating on narrowband channels and having an antenna connector".
- CEPT Recommendation T/R 24-01: "Specifications of equipments for use in the Land Mobile Service".
- CEPT Recommendation T/R 01-06: "Procedures for type testing and approval for radio equipment intended for non public systems".
- ERC/DEC/(95)02: "ERC Decision of 1st December 1995 on the Adoption of National Type Approval Regulations for Equipment to be Used in the Land Mobile Service Using Angle Modulation Based on the European Telecommunications Standard (ETS) 300 086".
- ERC/DEC/(97)10: "ERC Decision of 30 June 1997 on the Mutual Recognition of Conformity Assessment Procedures Including Marking of Radio Equipment and Radio Terminal Equipment".

History

Document history		
Edition 1	January 1991	Publication as ETS 300 086
V1.2.1	February 2000	Public Enquiry PE 200024: 2000-02-16 to 2000-06-16
V1.2.1	December 2000	Vote V 20010223: 2000-12-25 to 2001-02-23