

**Telecommunications and Internet converged Services and
Protocols for Advanced Networking (TISPAN);
Architectural scenarios and applicability for
different SIGTRAN adaptation layers;
SIGTRAN scenarios**



Reference

DEG/TISPAN-03013-Tech

Keywords

architecture, protocol, SIGTRAN, M2UA, M3UA,
SUA

ETSI

650 Route des Lucioles
F-06921 Sophia Antipolis Cedex - FRANCE

Tel.: +33 4 92 94 42 00 Fax: +33 4 93 65 47 16

Siret N° 348 623 562 00017 - NAF 742 C
Association à but non lucratif enregistrée à la
Sous-Préfecture de Grasse (06) N° 7803/88

Important notice

Individual copies of the present document can be downloaded from:

<http://www.etsi.org>

The present document may be made available in more than one electronic version or in print. In any case of existing or perceived difference in contents between such versions, the reference version is the Portable Document Format (PDF). In case of dispute, the reference shall be the printing on ETSI printers of the PDF version kept on a specific network drive within ETSI Secretariat.

Users of the present document should be aware that the document may be subject to revision or change of status. Information on the current status of this and other ETSI documents is available at

<http://portal.etsi.org/tb/status/status.asp>

If you find errors in the present document, please send your comment to one of the following services:

http://portal.etsi.org/chaicor/ETSI_support.asp

Copyright Notification

No part may be reproduced except as authorized by written permission.
The copyright and the foregoing restriction extend to reproduction in all media.

© European Telecommunications Standards Institute 2004.
All rights reserved.

DECTTM, **PLUGTESTS**TM and **UMTS**TM are Trade Marks of ETSI registered for the benefit of its Members.
TIPHONTM and the **TIPHON logo** are Trade Marks currently being registered by ETSI for the benefit of its Members.
3GPPTM is a Trade Mark of ETSI registered for the benefit of its Members and of the 3GPP Organizational Partners.

Contents

Intellectual Property Rights	4
Foreword.....	4
Introduction	4
1 Scope	5
2 References	5
3 Definitions and abbreviations.....	6
3.1 Definitions	6
3.2 Abbreviations	6
4 Network architectures using SS7 over IP	7
4.1 General architectural considerations	7
4.2 General protocol aspects	9
4.2.1 SS7 protocol stack in TDM/ATM networks	9
4.2.2 SS7 protocol stack in TDM/ATM and IP networks.....	10
4.2.2.1 MTP2-User Peer-to-Peer Adaptation Layer (M2PA).....	10
4.2.2.2 Message Transfer Part 2 User Adaptation Layer (M2UA).....	11
4.2.2.3 Message Transfer Part 3 User Adaptation Layer (M3UA).....	12
4.2.2.3.1 SS7 network impacts with IETF based M3UA during failure situations.....	13
4.2.2.3.2 SS7 network impacts with ETSI based M3UA during failure situations.....	17
4.2.2.4 Signalling Connection Control Part User Adaptation Layer (SUA)	18
4.3 Architectural considerations STP network segment.....	18
4.4 Architectural considerations SEP access segment.....	22
4.4.1 Quasi-associated signalling.....	24
4.4.2 Associated signalling	25
4.5 Architectural considerations database segment.....	28
4.6 Security considerations.....	30
Annex A (informative): Graphical representation of interworking scenarios.....	32
Annex B (informative): Bibliography.....	33
History	34

Intellectual Property Rights

IPRs essential or potentially essential to the present document may have been declared to ETSI. The information pertaining to these essential IPRs, if any, is publicly available for **ETSI members and non-members**, and can be found in ETSI SR 000 314: "*Intellectual Property Rights (IPRs); Essential, or potentially Essential, IPRs notified to ETSI in respect of ETSI standards*", which is available from the ETSI Secretariat. Latest updates are available on the ETSI Web server (<http://webapp.etsi.org/IPR/home.asp>).

Pursuant to the ETSI IPR Policy, no investigation, including IPR searches, has been carried out by ETSI. No guarantee can be given as to the existence of other IPRs not referenced in ETSI SR 000 314 (or the updates on the ETSI Web server) which are, or may be, or may become, essential to the present document.

Foreword

This ETSI Guide (EG) has been produced by ETSI Technical Committee Telecommunications and Internet converged Services and Protocols for Advanced Networking (TISPAN).

Introduction

The present document records the recommendations from ETSI Technical Committee TISPAN regarding the use of the different IETF SIGTRAN adaptation layer protocols in certain network scenarios. Especially it is intended to provide a guideline for network operators heading to introduce SS7 over IP.

1 Scope

The present document summarizes guidelines regarding the application of adaptation layers originally developed by IETF Work Group SIGTRAN and later on endorsed by ETSI.

2 References

The following documents contain provisions which, through reference in this text, constitute provisions of the present document.

- References are either specific (identified by date of publication and/or edition number or version number) or non-specific.
- For a specific reference, subsequent revisions do not apply.
- For a non-specific reference, the latest version applies.

Referenced documents which are not found to be publicly available in the expected location might be found at <http://docbox.etsi.org/Reference>.

- [1] ETSI TS 102 141: "Services and Protocols for Advanced Networks (SPAN); MTP/SCCP/SSCOP and SIGTRAN (Transport of SS7 over IP); Message transfer part 2 User Adaptation layer (M2UA) [Endorsement of RFC 3331 (2002), modified]".
- [2] ETSI TS 102 142: "Services and Protocols for Advanced Networks (SPAN); MTP/SCCP/SSCOP and SIGTRAN (Message of SS7 over IP); Message transfer part 3 User Adaptation layer (M3UA) [Endorsement of RFC 3332 (2002), modified]".
- [3] ETSI TS 102 143: "Services and Protocols for Advanced Networks (SPAN); MTP/SCCP/SSCOP and SIGTRAN (Transport of SS7 over IP); Signalling connection control part User Adaptation layer (SUA) [Endorsement of SIGTRAN-SUA-14 (December 2002), modified]".
- [4] ETSI TS 129 202: "Universal Mobile Telecommunications System (UMTS); Signalling System No. 7 (SS7) signalling transport in core network; Stage 3 (3GPP TS 29.202 version 5.2.0 Release 5)".
- [5] I-D ACTION draft-ietf-sigtran-m2pa-12.txt: "SS7 MTP2-User Peer-to-Peer Adaptation Layer".
- [6] Implementors' Guide (12/2000) for Recommendation Q.704 (07/96) published by ITU-T Study Group 11 COM 11-R 6-E January 2001.
- [7] ITU-T Recommendation Q.2210: "Message transfer part level 3 functions and messages using the services of ITU-T Recommendation Q.2140".
- [8] ITU-T Recommendation Q.701: "Functional description of the message transfer part (MTP) of Signalling System No. 7".
- [9] ITU-T Recommendation Q.702: "Signalling data link".
- [10] ITU-T Recommendation Q.703: "Signalling link".
- [11] ITU-T Recommendation Q.704: "Signalling network functions and messages".
- [12] ITU-T Recommendation Q.705: "Signalling network structure".
- [13] ITU-T Recommendation Q.706: "Message transfer part signalling performance".
- [14] ITU-T Recommendation Q.707: "Testing and maintenance".
- [15] ITU-T Recommendation Q.708: "Assignment procedures for international signalling point codes".
- [16] ITU-T Recommendation Q.709: "Hypothetical signalling reference connection".

- [17] ITU-T Recommendation Q.2140: "B-ISDN ATM adaptation layer - Service specific coordination function for signalling at the network node interface (SSCF AT NNI)".
- [18] ETSI EN 300 008-1: "Integrated Services Digital Network (ISDN); Signalling System No.7; Message Transfer Part (MTP) to support international interconnection; Part 1: Protocol specification [ITU-T Recommendations Q.701, Q.702, Q.703, Q.704, Q.705, Q.706, Q.707 and Q.708 modified]".
- [19] ETSI EN 300 436-1: "Broadband Integrated Services Digital Network (B-ISDN); Signalling ATM Adaptation Layer (SAAL); Service Specific Connection Oriented Protocol (SSCOP); Part 1: Protocol specification [ITU-T Recommendation Q.2110, modified]".
- [20] ETSI EN 301 004-1: "Broadband Integrated Services Digital Network (B-ISDN); Signalling System No.7; Message Transfer Part (MTP) level 3 functions and messages to support international interconnection; Part 1: Protocol specification [ITU-T Recommendation Q.2210 (1996), modified]".
- [21] ETSI ETS 300 438-1: "Broadband Integrated Services Digital Network (B-ISDN); Signalling ATM Adaptation Layer (SAAL); Service Specific Co-ordination Function (SSCF) for support of signalling at the Network Node Interface (NNI); Part 1: Specification of SSCF at NNI [ITU-T Recommendation Q.2140 (1995), modified]".
- [22] ITU-T Recommendation Q.1901: "Bearer Independent Call Control protocol".
- [23] ITU-T Recommendation H.248: "Gateway control protocol".
- [24] IETF RFC 3436: "Transport Layer Security over Stream Control Transmission Protocol".
- [25] IETF RFC 3332: "Signalling System 7 (SS7) Message Transfer Part 3 (MTP3) - User Adaptation Layer (M3UA)".
- [26] ITU-T Recommendation G.711: "Pulse code modulation (PCM) of voice frequencies".

3 Definitions and abbreviations

3.1 Definitions

For the purposes of the present document, the following terms and definitions apply:

MTP-L3: general term for the functionality provided by MTP Level 3 when no details regarding special functionality to support lower layer functionality needs to distinguished

MTP3: MTP-L3 functionality as defined by ITU-T Recommendation Q.704 along with support for narrowband TDM based SS7 links

MTP3b: MTP-L3 functionality as defined by ITU-T Recommendation Q.2210 to support highspeed and broadband SS7 links that require the exchange of longer sequence numbers in chase of change-over

3.2 Abbreviations

For the purposes of the present document, the following abbreviations apply:

AS	Application Server
ASP	Application Server Process
ATM	Asynchronous Transfer Mode
BLO	Blocking message
CCBS	Call Completion to Busy Subscriber
IPSEP	IP based Signalling End Point
IPSP	IP based Signalling Point
ISDN	Integrated Services Digital Network
ISUP	ISDN User Part

MGC	Media Gateway Controller also referred to as Softswitch
MSU	Message Signal Unit
SAAL	Signalling ATM Adaption Layer
SCCP	Signalling Connection Control Part
SCP	Service Control Point
SEP	Signalling End Point
SG	Signalling Gateway
SGP	Signalling Gateway Process
SS7oIP	SS7 over IP
STP	Signalling Transfer Point
STPG	Signalling Transfer Point Gateway
SU	Signal Units
TDM	Time Division Multiplex
TfA	Transfer Allowed (as defined in ITU-T Recommendation Q.704)
TfP	Transfer Prohibited (as defined in ITU-T Recommendation Q.704)
TLS	Transport Layer Security
UP	User Part (as defined in ITU-T Recommendation Q.704)
UPU	User Part Unavailable
XCA	Acknowledgement Changeover Order
XCO	Extended Changeover Order

4 Network architectures using SS7 over IP

4.1 General architectural considerations

To allow a structured approach for architectural considerations regarding the use of SIGTRAN adaptation layers, the following example SS7 network is used. It should be noted that the SS7 network is assumed to meet today's fixed and mobile network operators needs.

The usage of SS7oIP for 3GPP scenarios is covered in the appropriate 3GPP specifications, TS 129 202 [4].

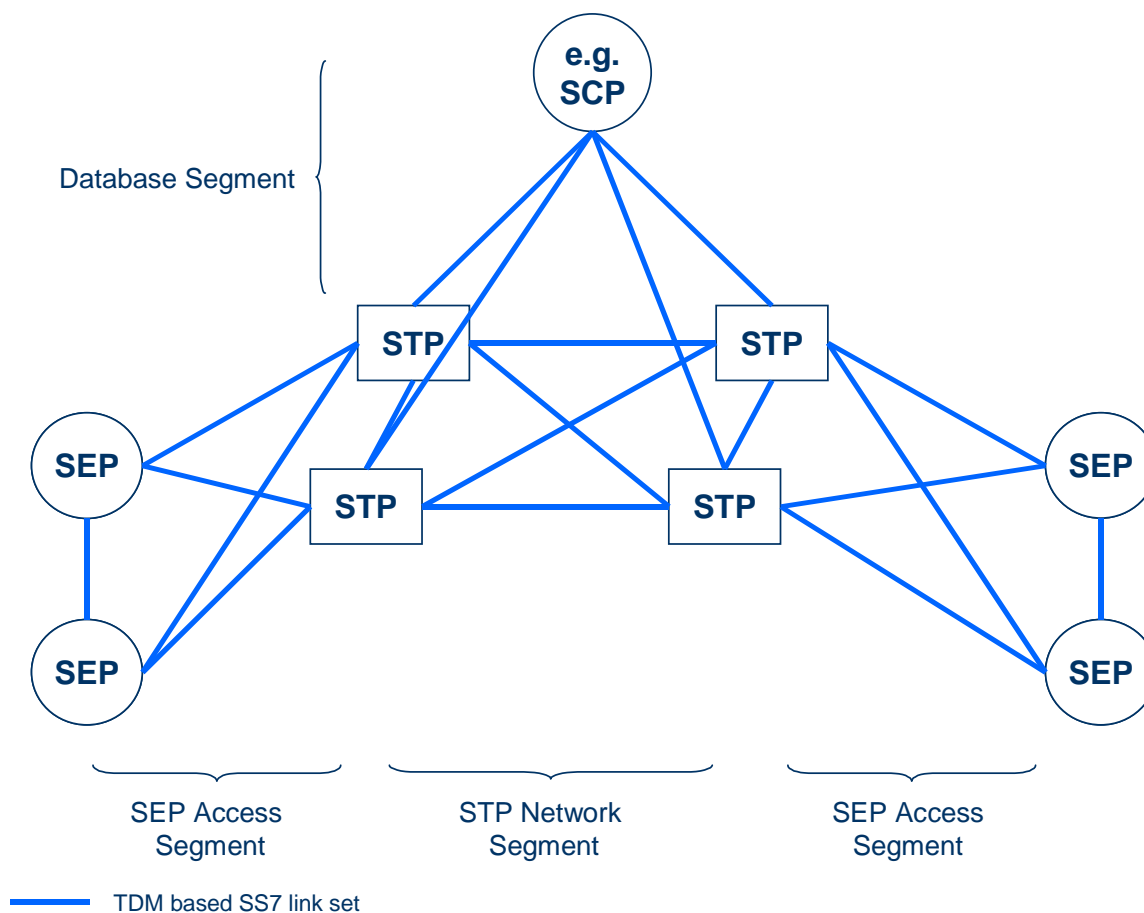

Figure 1: General SS7 network architecture

This network could be formally subdivided into different segments, namely:

- **SEP Access Segment**
 - connection of Signalling Endpoints (SEP) with each other.
 - associated signalling mode -
 - connection of Signalling Endpoints (SEP) with Signalling Transfer Points (STP).
 - quasi-associated signalling mode -
- **STP Network Segment**
 - connection between the Signalling Transfer Points (STP).
- **Database Segment**
 - connection between the Signalling Transfer Points (STP) and specialized SS7 nodes providing functions for the Intelligent Network or Mobile Network.

This partitioning is introduced to reflect the fact that some of the protocols out of the SIGTRAN suite have been designed to serve highly specialized scenarios.

Table 1 summarizes requirements for introduction of SS7 over IP in existing SS7 networks.

The requirement "stepwise introduction of SS7oIP" is to ensure that there is no impact on the SS7 network parts that do not migrate from continued use of a circuit based network to an IP based network. Only bilateral agreements between the effected nodes are acceptable.

The requirement "SI independency" is to ensure that the introduction of SS7oIP does not introduce different signalling paths for signalling messages belonging to different MTP User Parts between any two signalling nodes.

The requirement "seamless interworking between SS7 link sets" is to ensure that nodes having only conventional SS7 links can coexist with nodes using SS7oIP in the same MTP network without causing interoperability problems.

An "X" in table 1 indicates that the corresponding requirement is considered essential. An "-" indicates that the corresponding requirement is not considered essential.

Table 1: Requirements for introduction of SS7 over IP in existing SS7 networks

Requirement	SEP Access Segment		STP network segment	Database segment
	SEP to SEP	SEP to STP		
stepwise introduction of SS7oIP	X	X	X	X
provide SI independency	X	X	X	- (see note 1')
seamless interworking between SS7 link sets	- (see note 2)	X	X	X

NOTE 1: Only SCCP messages are used to communicate with nodes in the database segment.
NOTE 2: An SEP is not transferring incoming messages from one link/link set to another one.

4.2 General protocol aspects

4.2.1 SS7 protocol stack in TDM/ATM networks

The conventional SS7 protocol stack as defined by ITU-T in Recommendations Q.701 [8] up to Q.709 [16], Q.2210 [7], Q.2140 [17] and modified by ETSI in EN 300 008-1 [18], EN 300 436-1 [19], EN 301 004-1 [20] and ETS 300 438-1 [21] is shown below.

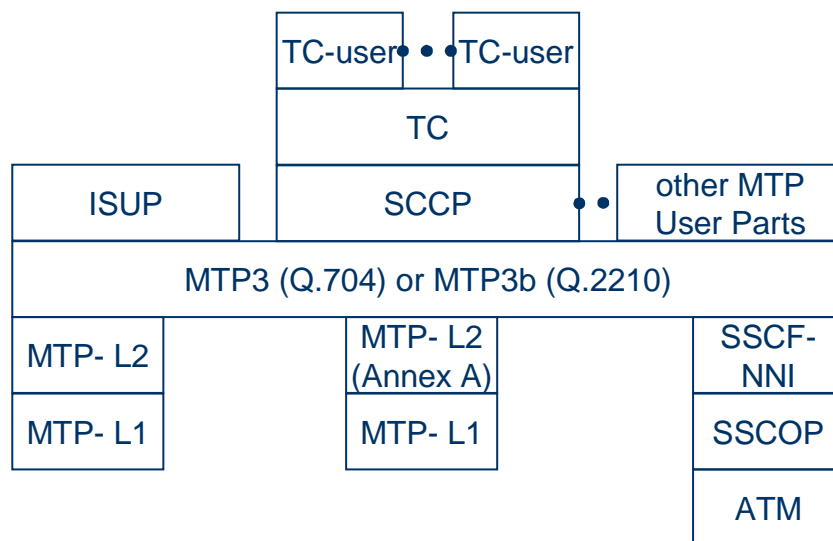

Figure 2: SS7 Protocol stack (TDM and ATM transport protocols only)

It is important to recognize that usage of the high speed option (annex A of ITU-T Recommendation Q.703 [10]) and the ATM based protocols using the SAAL protocol stack require the use of MTP3b according to ITU-T Recommendation Q.2210 [7] (EN 301 004-1 [20]) to accommodate the usage of longer sequence numbers carried in XCO and XCA messages. An SEP with MTP3 according to ITU-T Recommendation Q.704 [11] will not be able to handle these messages, because they are not defined in ITU-T Recommendation Q.704 [11]. An STP will pass these messages on if received in transit.

4.2.2 SS7 protocol stack in TDM/ATM and IP networks

4.2.2.1 MTP2-User Peer-to-Peer Adaptation Layer (M2PA)

The IETF defined protocol M2PA together with SCTP provide similar functionality as MTP-L2 or SSCOP/SSCF-NNI in TDM/ATM networks.

There is no endorsement document for the M2PA protocol available from ETSI right now.

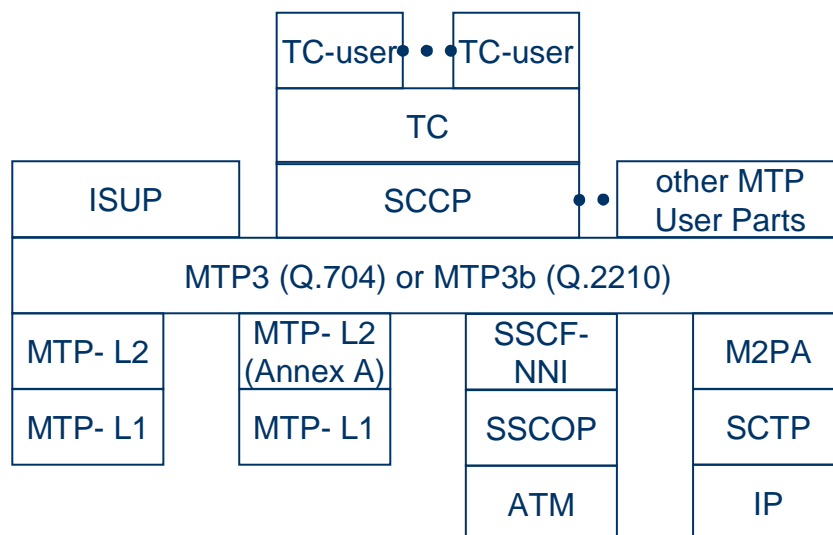

Figure 3: Positioning of M2PA in the SS7 Protocol stack

As already noted for the high speed option according to annex A of ITU-T Recommendation Q.703 [10] and ATM based SS7 protocol stack, introduction of M2PA requires to have MTP3b according to ITU-T Recommendation Q.2210 [7] (EN 301 004-1 [20]) to allow the longer sequence numbers of M2PA to be carried in XCO and XCA messages. An SEP supporting only MTP3 according to Q.704 will not be able to handle these messages, because they are not defined in ITU-T Recommendation Q.704 [11]. This fact is not correctly considered in the IETF document on M2PA [5].

M2PA could be used throughout the SS7 network, e.g. in order to provide higher bandwidth to an adjacent SS7 node. Between adjacent SS7 nodes using M2PA based signalling links, the use of at least two M2PA based links per link set should be considered.

Since one M2PA link uses one SCTP association, multiple SCTP associations would be necessary.

NOTE: Having multiple SCTP associations between two adjacent SS7 nodes requires to have multiple SCTP endpoints at least in one Signalling Point. This could be achieved e.g. by using different source port numbers for every SCTP endpoint when initiating the SCTP associations.

The use of a single M2PA based link in a link set between two adjacent nodes is not encouraged, because it would introduce additional head-of-line blocking in case of retransmissions on SCTP level, as M2PA does not use the streams concept of SCTP. More details on this are given in figure 17 and figure 18.

For a complete view regarding the other currently allocated MTP-L3 user parts table 2 should be consulted [7].

The service indicator codes *for the international signalling network* are allocated as follows.

Table 2: Currently allocated service indicator codes for the international signalling network

SI value (Hex)	
00	Signalling network management messages (formally not an UP)
01	Signalling network testing and maintenance messages (formally not an UP)
02	Reserved
03	SCCP
04	Telephone User Part
05	ISDN User Part
06	Reserved
07	Reserved
08	MTP Tester
09	Broadband ISDN User Part
0A	Satellite ISDN User Part
0B	Signal Processing Network Equipment User Part
0C	Reserved for AAL type 2 Signalling Transport Converter
0D	Bearer Independent Call Control (BICC, Q.1901)
0E	Reserved for Gateway Control Protocol (GCP, H.248)
0F	Reserved for extension

4.2.2.2 Message Transfer Part 2 User Adaptation Layer (M2UA)

The M2UA protocol, along with SCTP allows to "bridge" between TDM and IP networks, where one of the two adjacent SS7 nodes resides in the TDM domain and the other one is located in the IP domain.

The ETSI endorsed M2UA is contained in document TS 102 141 [1]. Some optional functionalities are not part of M2UA according to the ETSI specifications. However, the removal of these optional functionalities does in no way hinder the interoperability with the IETF compliant M2UA protocol.

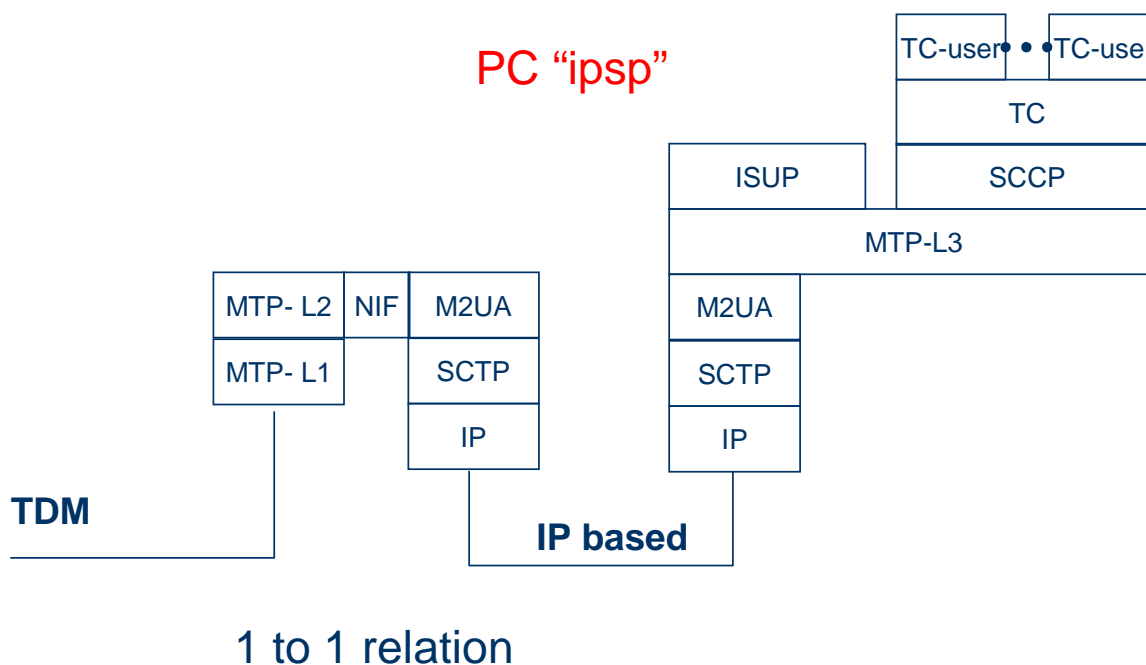

Figure 4: Positioning of M2UA in the SS7 protocol stack

Not having an MTP-L3 at the "bridge", there is a one-to-one relation between the TDM and IP side and the maximum achievable throughput towards the IPSP is still limited by the TDM side, therefore no gain in bandwidth for transporting SS7 messages between those two nodes. In case of having more than one signalling link to be backhauled from the signalling gateway, the following should be taken into account:

- M2UA provides an "interface identifier" which in turn would allow to backhaul all signalling links handled by a single gateway over an SCTP association without the necessity to use different streams per signalling link. However, this would introduce "head-of-line" blocking in case of retransmissions;
- mapping the different signalling links onto different streams on the same SCTP association circumvents this problem;
- use of different SCTP associations per signalling link is only necessary if backhauling to different destinations (different IPSPs in figure 4) is required.

4.2.2.3 Message Transfer Part 3 User Adaptation Layer (M3UA)

The M3UA protocol interfaces with the SS7 stack at MTP-L3, thus providing a means to convey all messages destined to a certain adjacent point code. MTP L3 Network Management messages for the adjacent SS7 node are converted into messages of the M3UA protocol.

The ETSI endorsed M3UA is contained in TS 102 142 [2]. Some optional functionalities are not part of M3UA according to the ETSI specifications. An essential restriction in the ETSI specification is the requirement to use different point codes for the SG and the ASP (located in the IPSP in figure 5). This is to allow the use of MTP-L3 network management messages in case of node failures in the IP network. Thus the node residing on the TDM/IP network edge could be considered as STP providing seamless access to an SS7 node located in the IP network. It is essential to recognize that the introduction of the additional point code for the SG eventually changes the signalling relation from "associated" to "quasi-associated" and thus might impact the adjacent nodes.

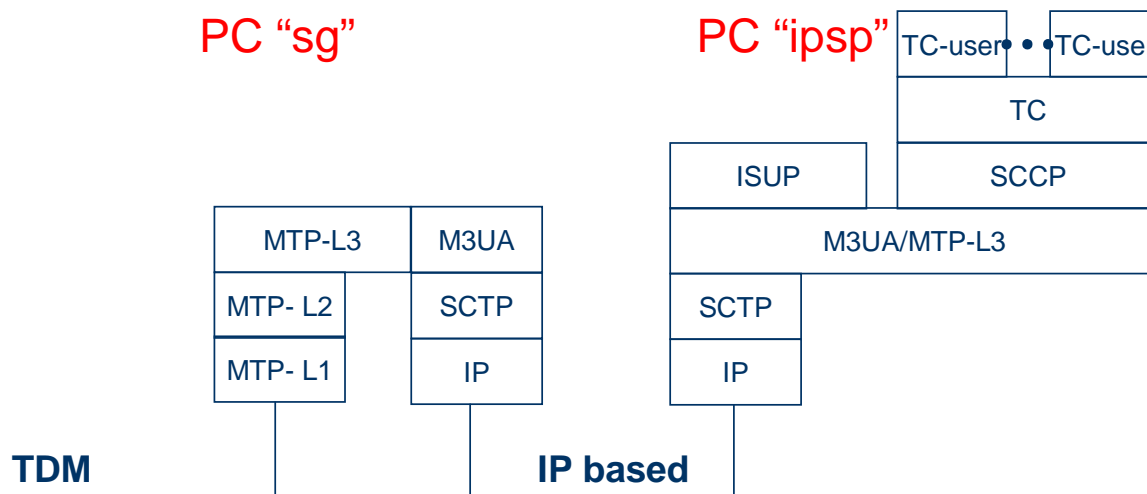

**ETSI TS 102 142:
SG has an SS7 Point Code different from the IPSP**

Figure 5: Positioning of M3UA in the SS7 protocol stack

To highlight the ETSI requirement of having different point codes at the signalling gateway and the IP based Signalling Point, figure 5 shows "M3UA/MTP-L3" for the IPSP. This should not raise the requirement of having a complete MTP-L3 implementation here.

As already mentioned, it is essential to avoid potential message blocking introduced by sending all M3UA messages via a single SCTP stream. It is strongly recommended to use different SCTP streams for MSUs having e.g. different SLS values. Note that other distribution mechanisms are possible but not described here.

Generally it has to be ensured that MSUs belonging to the same transaction (e.g. an ISUP call) are sent over the same SCTP stream. Furthermore, M3UA protocol does not enforce the usage of the same distribution mechanism on both sides.

4.2.2.3.1 SS7 network impacts with IETF based M3UA during failure situations

For discussing some failure situations, the following SS7 network scenario is assumed. Whether associated or quasi-associated signalling mode is used is of no importance at the moment. Two TDM based signalling endpoints have a signalling relationship with an IP based signalling endpoint, consisting of a signalling gateway and a media gateway controller.

RFC 3332 [25] allows the SG and the MGC to be identified in the SS7 network with the same point code. This is often referred to as "single point code model". It certainly has the advantage of not requiring the introduction of an additional point code, thus changing the nature of the signalling mode from associated to quasi-associated as seen from the two SEPs denoted with "a" and "m".

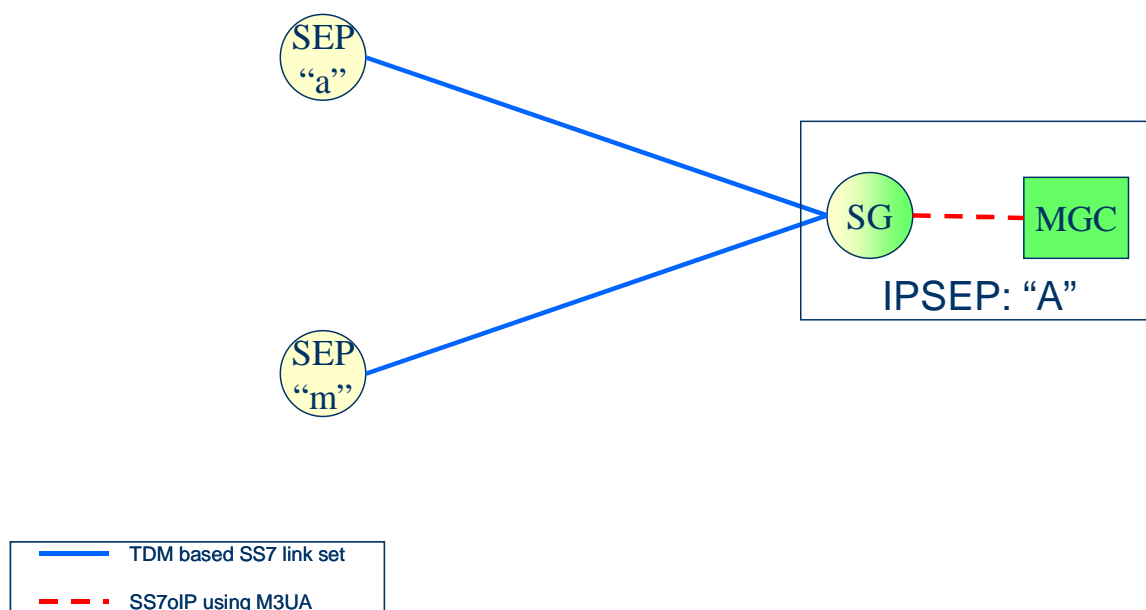

Figure 6: Networking example where the IPSEP (SG and MGC) uses a single point code "A"

Without further detail about the internal structure of point code "A", the use of a single point code for SG and MGC does not allow the SG to send TFP messages if it loses connectivity to the MGC. According to the MTP L3 specifications, the SG has to use the "User Part Unavailable" (UPU) procedure. Using this method, the concerned SEPs themselves are obliged to send test messages to detect when the User Part is available again. Consequently the UPU procedure has to be supported actively by all SS7 nodes communicating with node "A".

The internal organization of the "MGC" is done in a way to use different Application Servers (AS) for ISUP and SCCP traffic. For simplicity reasons only one "Signalling Gateway Process" (SGP) is shown). If connectivity with only one AS, e.g. AS-SCCP is lost, the SG has to signal the failure of the effected User Part using the UPU procedure as described before.

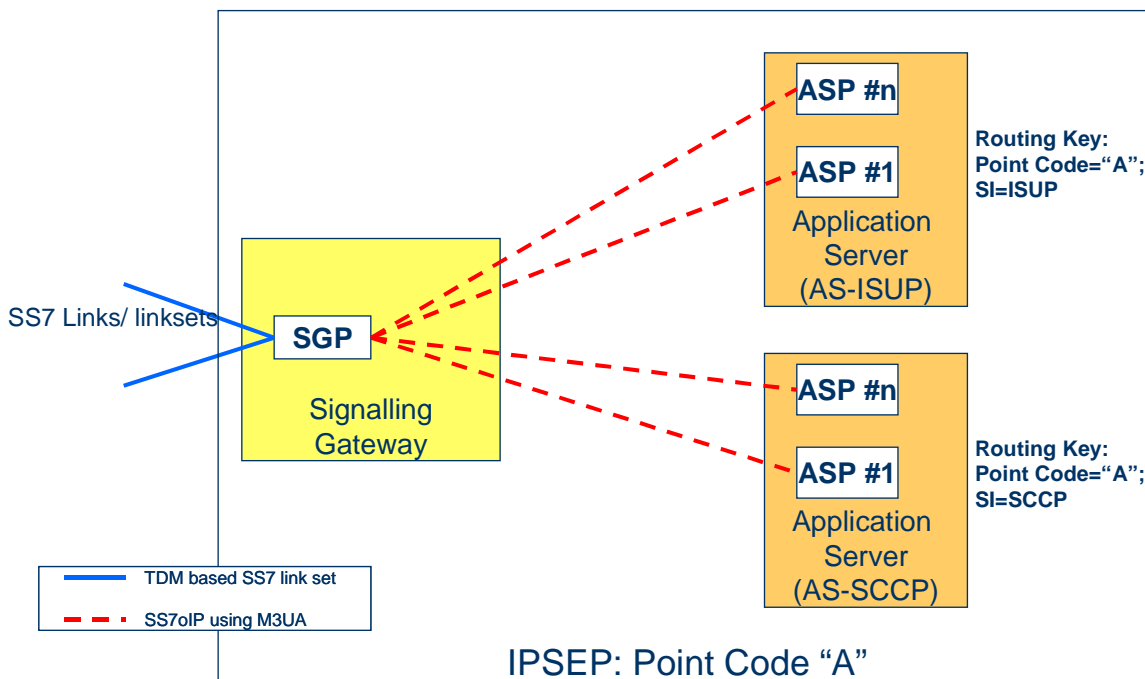

Figure 7: Internal structure of the SS7 signalling point "A" - one AS serving one UP

From an SS7 network management point of view, the situation becomes more complicated, when the traffic for one User Part, e.g. ISUP, is distributed for load-sharing reasons over several Application Servers, whereby every AS serves a certain, non-overlapping circuit range. If connectivity to one AS is lost, the signalling gateway has to use ISUP maintenance messages like "circuit blocking" (BLO) to stop usage of currently not reachable circuits that are dealt with by the AS. Using the UPU procedure is not possible, as its use would stop the traffic for the complete user part and not only for the affected circuits.

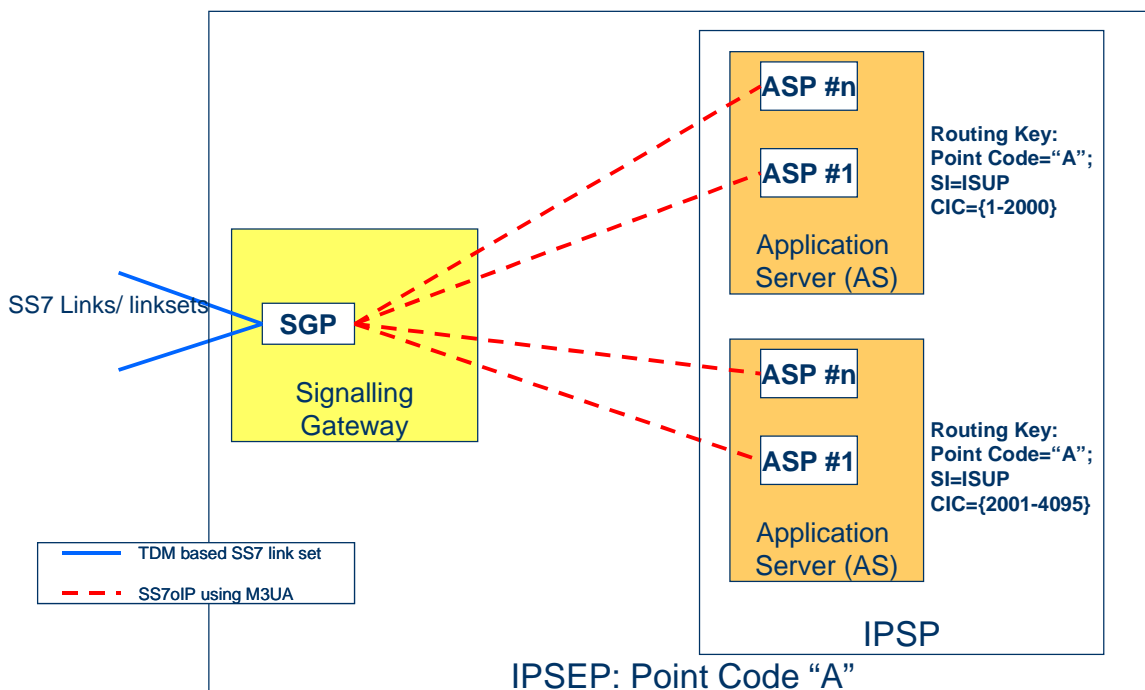

Figure 8: Internal structure of the SS7 signalling point "A" - multiple AS serving same UP

RFC 3332 [25] states in section 1.4.1 that an ASP or group of ASPs could be represented in the SS7 network with a point code different from the point code of the SG. Thus the SG acts like an STP.

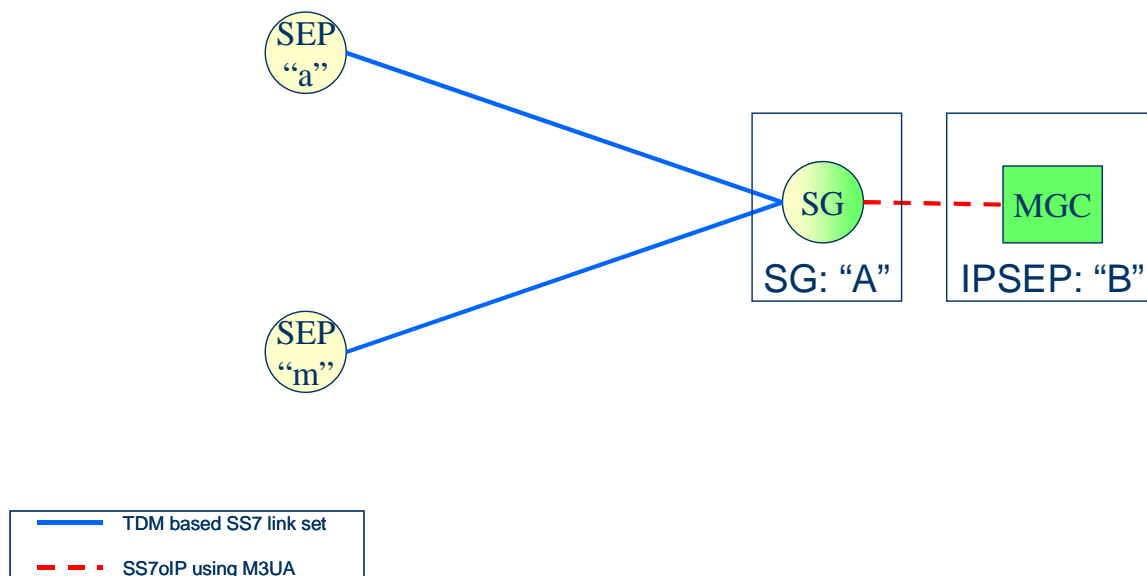

Figure 9: Networking example where SG and MGC have different point codes

Compared to the situation with the "single point code model" this allows the SG to send TFP messages if there is no longer a connection to point code "B". The signalling endpoints are automatically informed via TFA messages if point code "B" becomes available again. There is no necessity to use the UPU procedure.

If, however, the internal structure of point code "B" is as shown below, the SG has no other possibility than still using the UPU procedure when e.g. connectivity to the AS serving the ISDN user part is lost.

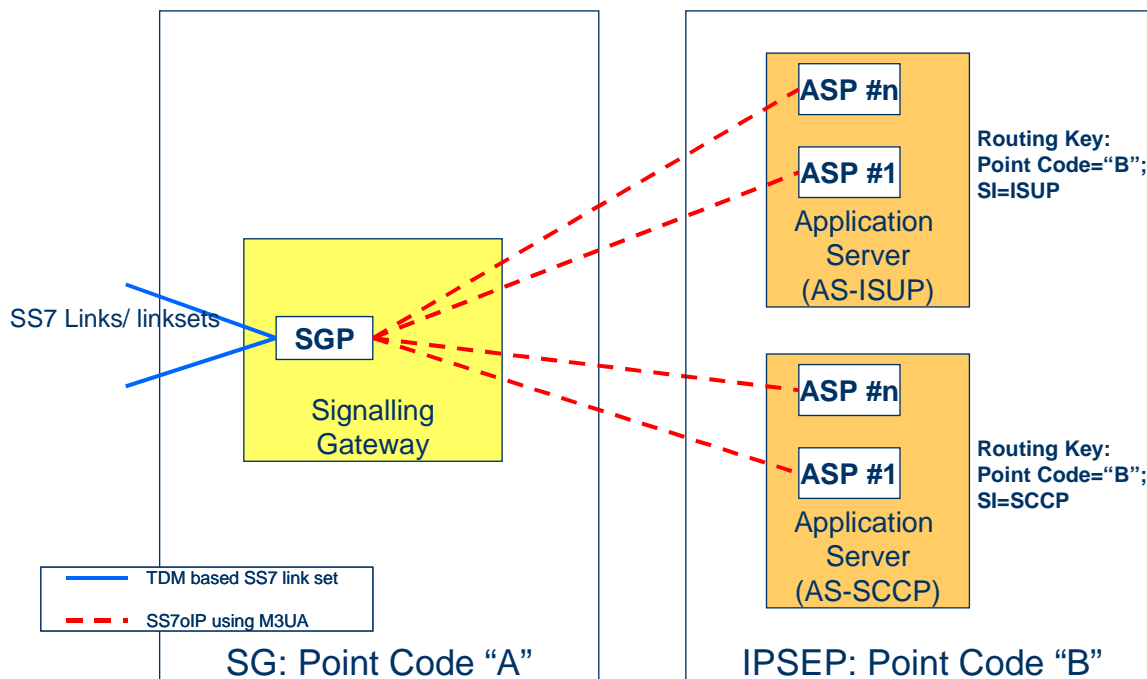

Figure 10: Internal structure of the SS7 signalling point "B" - one AS serving one UP

From the SS7 network management point of view, there is also no improvement in case there are several ASs serving different circuit ranges. The SG has to perform ISUP maintenance procedures to block only the affected circuits.

Network management is even more problematic, in case two Signalling Gateways, acting as STPs, are connected with each other, as shown in figure 11.

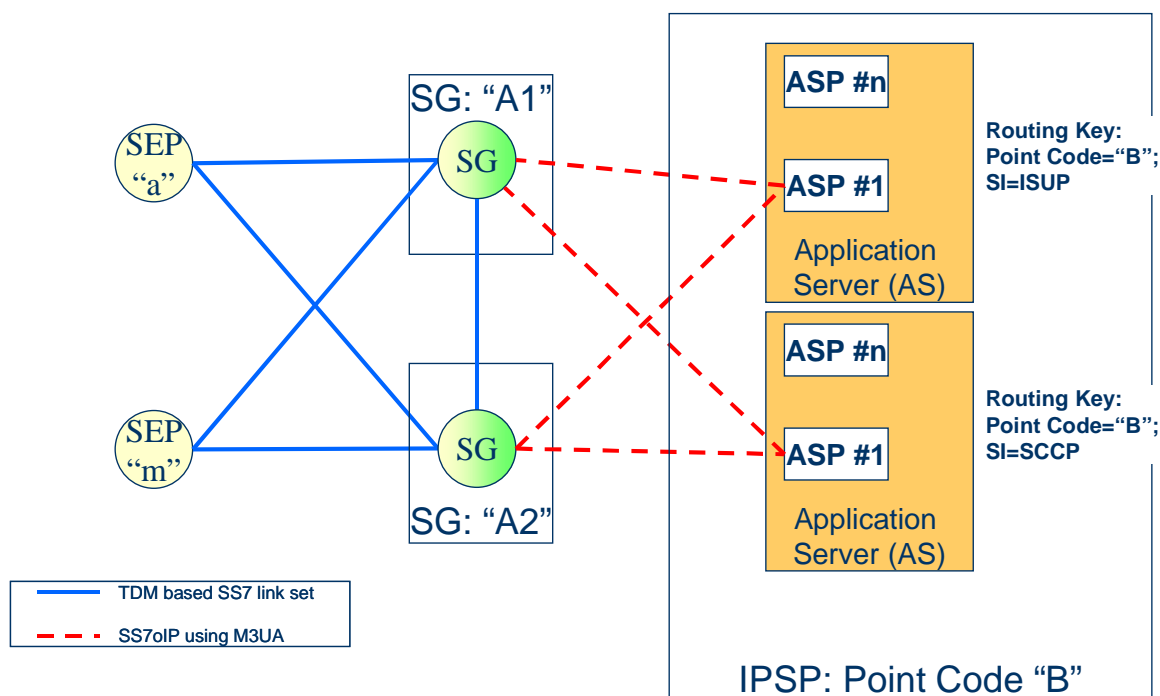

Figure 11: Internal structure of the SS7 signalling point "B" - one AS serving one UP

If signalling gateway "A1" loses connectivity with the application server serving the ISDN user part, there is no standard MTP Level 3 procedure to divert only the ISUP messages to the signalling Gateway "A2". Use of the UPU procedure would stop all traffic for the concerned user part, even where signalling gateway "A2" could still communicate with the application server serving the ISDN user part. Additionally, signalling gateway "A1" has not even the means to inform SEP "a" - SEP "m" that they should stop using the signalling route via "A1" for ISUP traffic only. The only MTP L3 conformant method would be to stop all signalling traffic for "B" that is sent over "A1" by using TFP. But this method then removes the redundancy intentionally built in by using two signalling gateways.

The standard MTP Level 3 specifications do not envisage the usage of different routes for different MTP User Parts. Main reason being that MTP Network Management messages, used to divert signalling traffic to other routes, like TFA/TFP deal only with the availability/unavailability of complete point codes.

This error scenario clearly shows that the flexibility built into M3UA to distribute the "work load" to different independent Application Servers leads to not acceptable unbalanced load situations.

4.2.2.3.2 SS7 network impacts with ETSI based M3UA during failure situations

After the previous discussion, it is obvious that any distribution of signalling messages to a finer granularity than the one that could be signalled with MTP Level 3 methods can cause unacceptable network situations. Therefore restrictions on granularity of the routing keys like those required in TS 102 142 [2] are the logical consequence to avoid these problems right from the start. The result is that ASs supporting different MTP Level 3 User Parts (e.g. ISUP or SCCP) should have different SS7 point codes assigned, however, this is not considered a useful solution when a close interaction between ISUP and SCCP is required as e.g. for ISDN Supplementary services like CCBS.

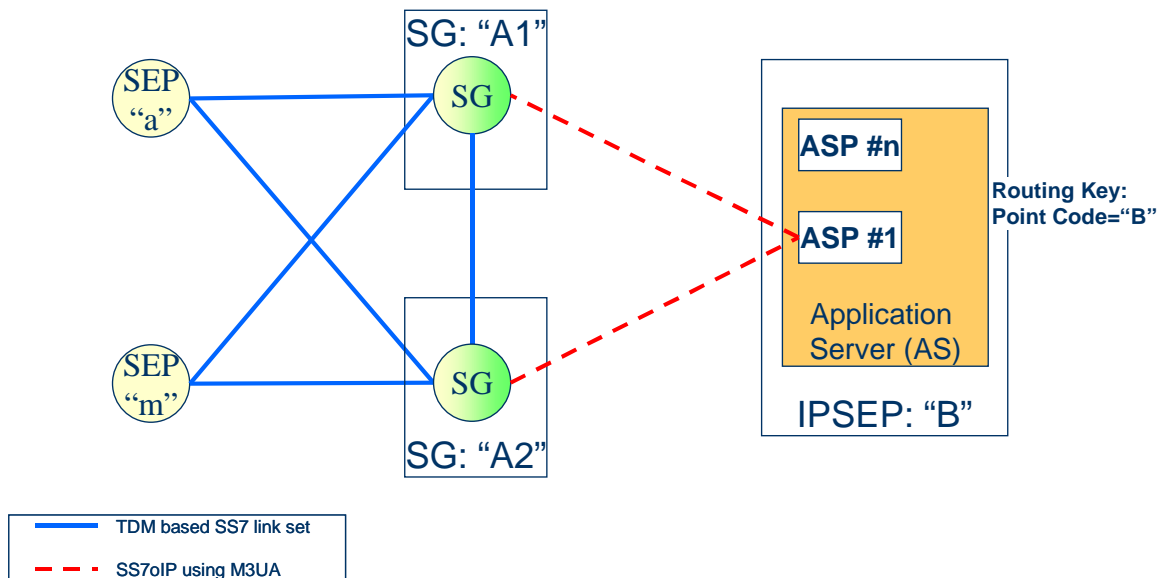

Figure 12: Internal structure of the SS7 signalling point "B" - one AS serving the complete point code

Any failure situation between the signalling gateways "A1"/"A2" and the application server "B" could be signalled using TFP/TFA messages in full accordance with the SS7 MTP specifications. No reaction in the MTP-L3 User Part level is required to inform all SS7 nodes when the path is re-established.

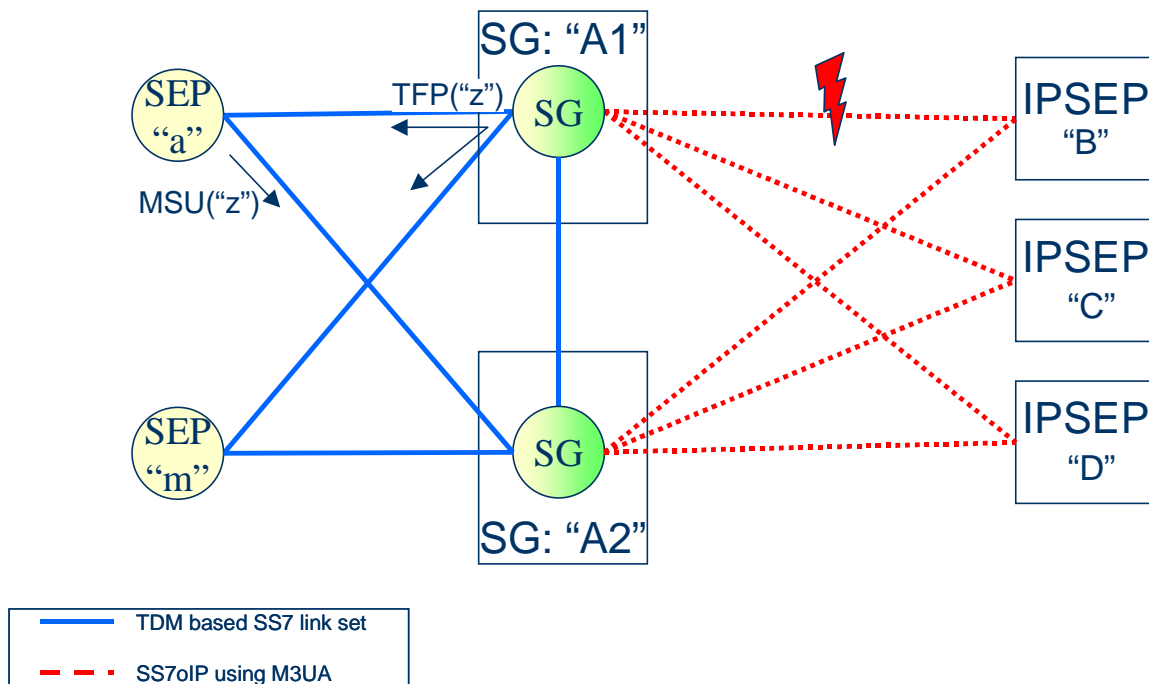

Figure 13: Migration in the SEP access area for quasi-associated signalling

4.2.2.4 Signalling Connection Control Part User Adaptation Layer (SUA)

The SUA protocol interferes with the SS7 stack at SCCP level, thus providing a means to convey SCCP messages only. Thus the node residing on the TDM/IP network edge could be considered as SCCP Relay Point providing seamless access to an SCCP subsystem located in the IP network. The ETSI endorsed SUA is contained in TS 102 143 [3]. Some optional functionality is not part of SUA according to the ETSI specifications.

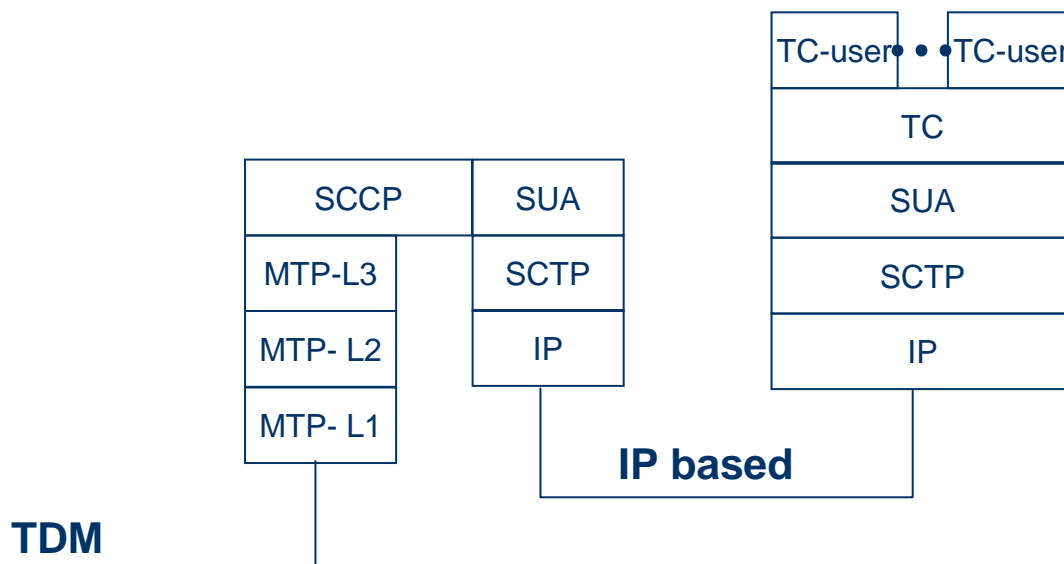

Figure 14: Positioning of SUA in the SS7 protocol stack

4.3 Architectural considerations STP network segment

The introduction of SS7oIP in the STP network segment is considered as a stepwise migration, starting e.g. at one node in the network, hence leaving others unaffected. This purely local introduction requires the use of "Signalling Gateways" (SG) as additional equipment in the SS7 backbone network. Due to the failure tolerant structure of a fully meshed SS7 backbone network, this introduction must not adversely influence the overall operation of the SS7 network. It also imposes no real constraints on the protocol to be used, as long as the transport of all SS7 Message Signal Units (MSUs) is assured.

In the figure shown below, this might be achieved using either:

- M2UA

The use of M2UA requires no SS7 point code at the SG. This solution is possible only as long as SS7oIP is introduced locally. Using M2UA it is not possible to migrate the whole STP network segment to SS7oIP as the SG continues to have TDM links on one side thus placing only a single STP into the IP network (designated STPG in the figure below, as this node retains some TDM links). All other STPs still remain TDM based.

- M2PA

Using M2PA requires the SG to have an SS7 point code assigned and the MTP3b has to be used on the SG and STPG. Using M2PA it is possible to migrate the whole STP network segment to SS7oIP.

- M3UA

Using M3UA according to TS 102 142 [2] requires the SG to have an SS7 point code of its own and the MTP3 functionality has to be present on the SG. Using M3UA it is possible to migrate the whole STP network segment to SS7oIP. Effectively a symmetrical SG-SG communication is used.

- Other solutions providing e.g. for transparent tunnelling of all SS7 Signal Units (SU) are possible, but they are mostly based on proprietary protocols. These solutions provide a sort of emulated "wire" over the IP signalling network. Using these solutions it is not possible to migrate the whole STP network segment to SS7oIP without continued use of SGs.

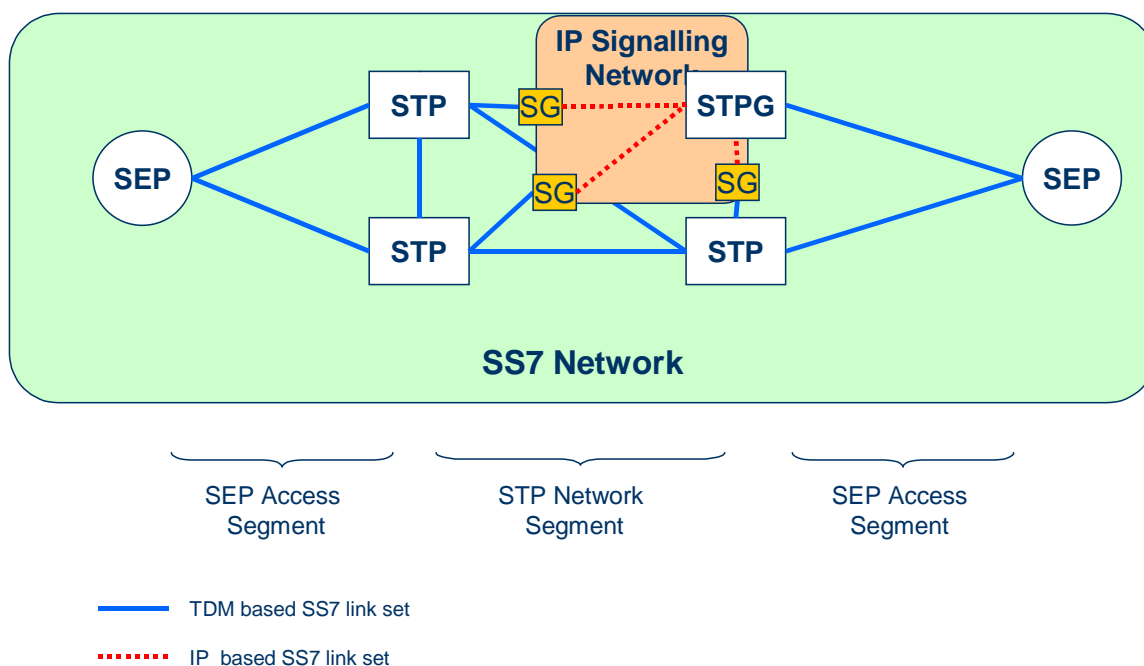

Figure 15: Local introduction of SS7oIP for STP interconnection

When considering a migration towards SS7oIP without introducing intermediate SG devices, the set of usable SIGTRAN protocols differs compared to a pure local introduction.

In figure 16, the following protocols could be used:

- M3UA using a symmetrical SG-SG communication;
- M2PA.

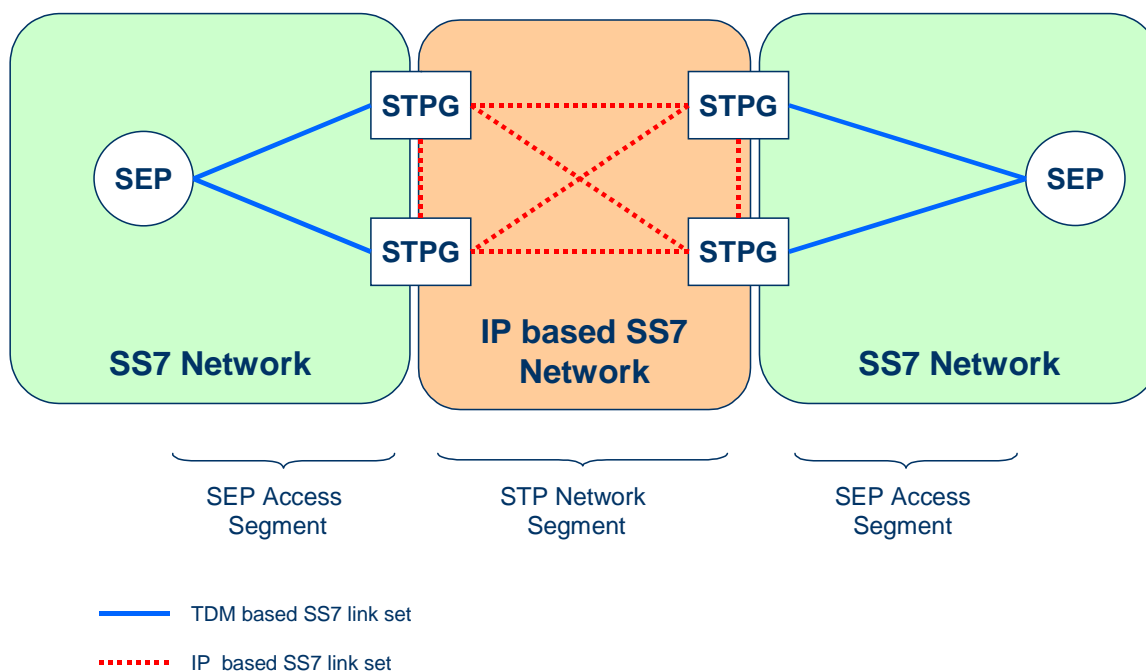

Figure 16: SS7oIP introduced for STP interconnection

Using M2PA for STP interconnection a peculiarity of M2PA has to be considered when deciding about the number of M2PA links between two adjacent SS7 nodes.

MTP L3 allows usage of up to 16 links in a link set and the SLS value is used to select the a link within the link set.

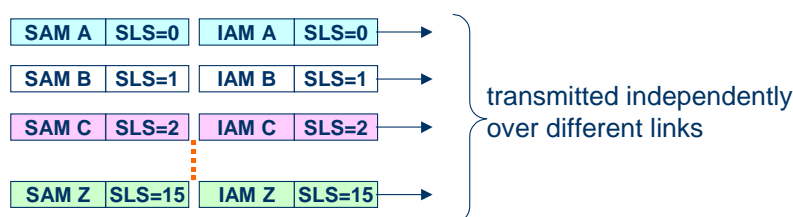

Figure 17: Sample MSU sequence on 16 parallel links forming one link set

In case there is only a single M2PA link in the link set, the messages formerly sent out in parallel over different links are now serialized over one communication channel, as M2PA makes no use of the "streams" concept provided by SCTP which in principle allows for independent communication channels within the same communication path.

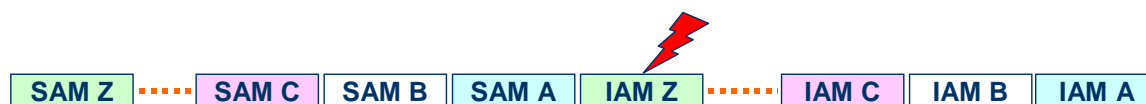

Figure 18: Sample MSU sequence from figure above on single M2PA link forming one link set

Therefore if e.g. the message containing "IAM Z" (shown with the flash above it) has to be retransmitted, all messages following this message are not delivered to the receiving M2PA. The resulting delay depends on the parameter setting of SCTP and the roundtrip delay of the used IP network. To avoid as far as possible inter link set changeover, more than one link using M2PA should be used to form an IP based SS7 link set. This results in having independent load-control mechanisms for every M2PA link, but also the traffic overhead caused by e.g. the heartbeat mechanism of SCTP. It should be kept in mind that implementations might use a very short heartbeat timer value to detect path failures as fast as possible.

A further issue related to network planning is the fact that M2PA requires the use of "extended changeover order" (XCO) and "extended changeover acknowledgement" (XCA) messages of MTP3b. In case a changeover to another link set is required, it has to be assured that the changeover procedure is using a route where all SS7 nodes are capable to transfer XCO/XCA messages.

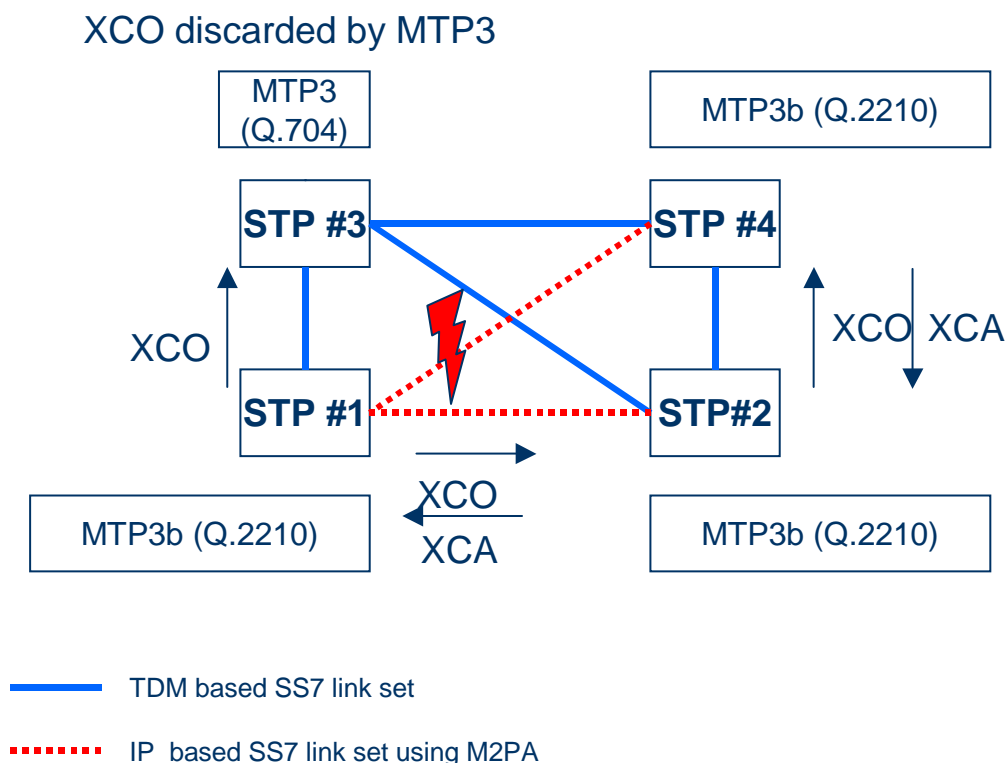

Figure 19: Inter-link set changeover procedure for M2PA

A route from STP#1 towards STP#4 via STP#3 will result in a time-controlled changeover procedure, as STP#3 provides only narrowband MTP3 functionality and is allowed to discard the unknown XCO/XCA messages. Instead of making use of M2PAs MSU retrieval capabilities, a message loss will occur.

Considering local introduction of SS7oIP in the STP network segment, as shown in the figure below, it apparently becomes clear that M2UA might be used as a first step to obtain experience with SS7oIP, but the following issues need to be considered:

- Bandwidth limitation, as there is still a one-to-one relation with the TDM link on one side.
- M2UA is specifically designed to allow for controlling the TDM side remotely from the IPSEP.
- Redundancy aspects requires to split an SS7 link set over several gateways.
- Due to the operation of M2UA that does not even allow the use of different SS7 point codes for the Signalling Gateway and the MGC, an integration of the Signalling Gateway into another SS7 network element, e.g. the STP, is not possible, as the IPSEP needs to have control over the SGs he is communication with.

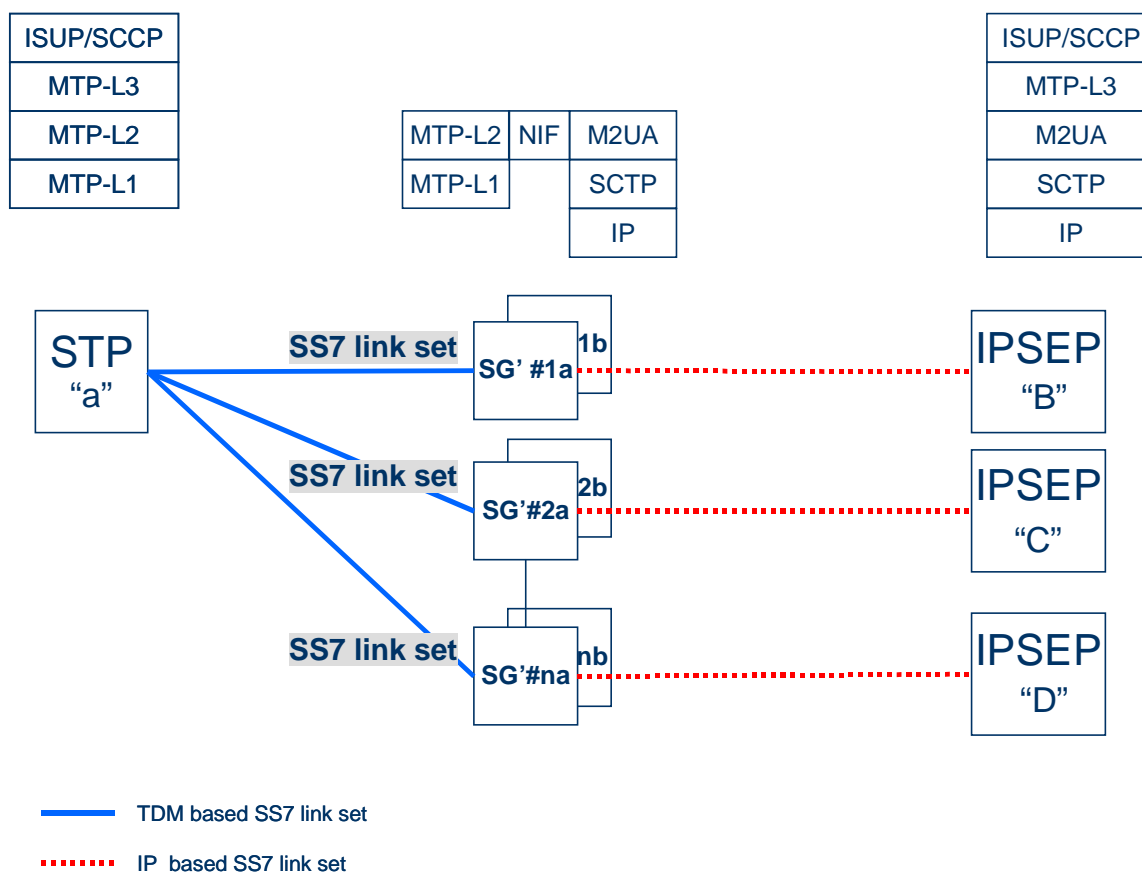

Figure 20: Using M2UA for local introduction of SS7oIP in case of STP interconnection

Reasons for not using SUA:

- MTP-L3 functionality is required in the Backbone Network Segment, use of SUA would not allow to transport e.g. ISUP messages, as SUA is designed specifically to handle SCCP only.

4.4 Architectural considerations SEP access segment

The introduction of SS7oIP in the SEP access segment could also be considered as a stepwise migration starting e.g. at the SEP, thus leaving other SS7 nodes unaffected. This purely local introduction requires the use of "Signalling Gateways" (SG) as additional equipment in the SS7 network. As any failure of this SG may result in interruption of the SS7 signalling relation, special attention has to be paid to possible failure scenarios. No constraints are put on the protocol to be used, as long as the reliable and in-sequence transport of all relevant SS7 Network Management messages and all User Part messages is assured.

In figure 21, this might be achieved using either:

- M2UA

Use of M2UA leaves the SS7 network unaware of the local migration towards SS7oIP.

- M2PA

Using M2PA requires the SG to have an SS7 point code assigned and the MTP3b functionality has to be present on the SG and IPSEP consequently changing associated signalling between SEPs into quasi-associated signalling.

- M3UA

Using M3UA according to TS 102 142 [2] requires the SG to have an SS7 point code of its own. Effectively there are now two or more point codes required, whereas there was only one previously.

- Other solutions providing e.g. for transparent tunnelling of all SS7 Signal Units (SU) are possible, but they are mostly based on proprietary protocols. These solutions provide sort of emulated "wire" over the IP signalling network. A corresponding SG is in turn necessary to perform the conversion back to TDM.

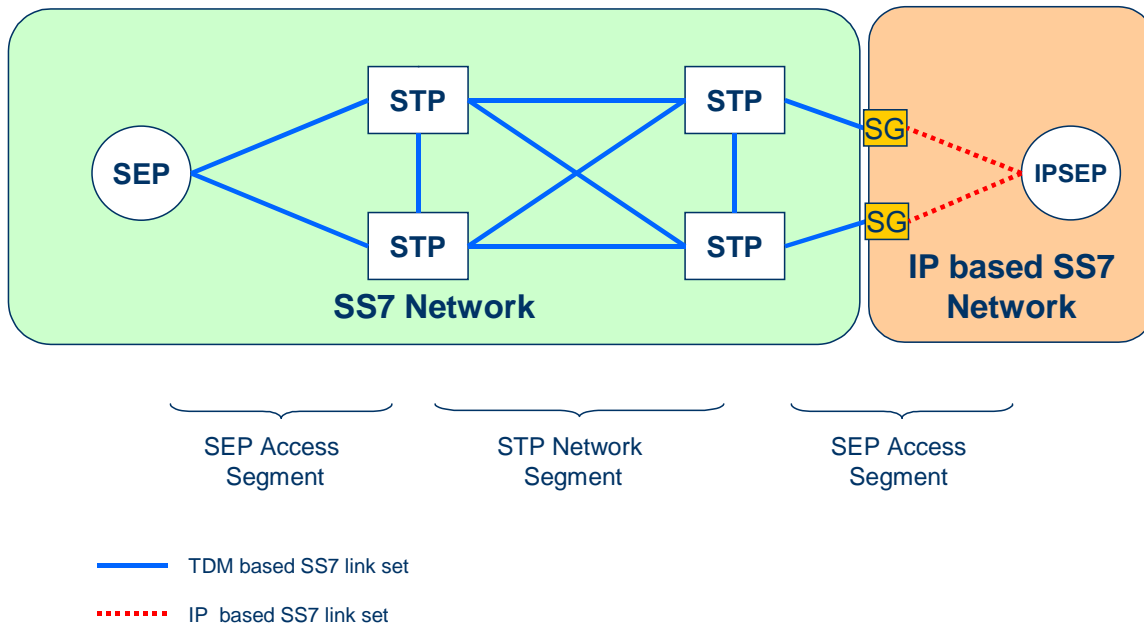

Figure 21: Local introduction of SS7oIP for STP/SEP connection

When considering a migration towards SS7oIP without introducing intermediate SG devices, a different set of usable SIGTRAN protocols needs to be considered.

In figure 22, the following protocols could be used:

- M3UA
 - Having an M3UA according to TS 102 142 [2] the integration of the signalling gateway into the STP removes the necessity to assign separate point codes for the SG.
- M2PA

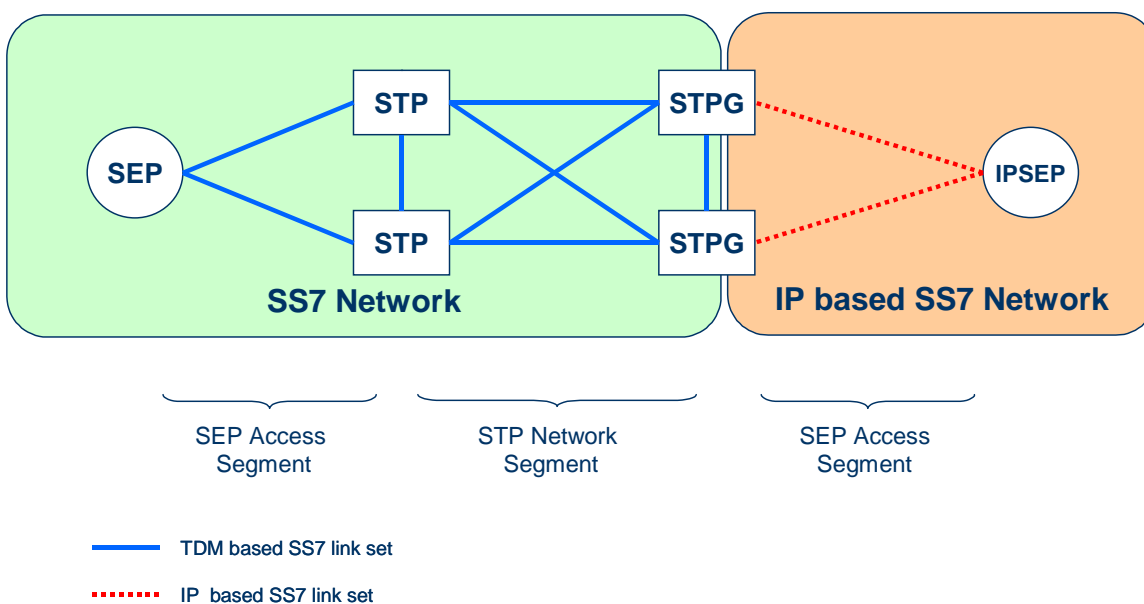

Figure 22: SS7oIP introduced for STP/SEP connection

Reasons for not using M2UA:

- The SG as shown in figure 21 could not be integrated into the adjacent STP due to the operation of M2UA, which therefore remains purely TDM based (see also the more detailed information given along with figure 20).

Reasons for not using SUA:

- It is required to transport all MTP3 user parts including MTP3 network management messages. SUA is designed specifically to handle SCCP only.

Even more complicated scenarios could be encountered and are discussed in the subsequent clauses.

4.4.1 Quasi-associated signalling

This clause attempts in providing more information regarding the possible combinations of protocols. The list is not expected to be exhaustive.

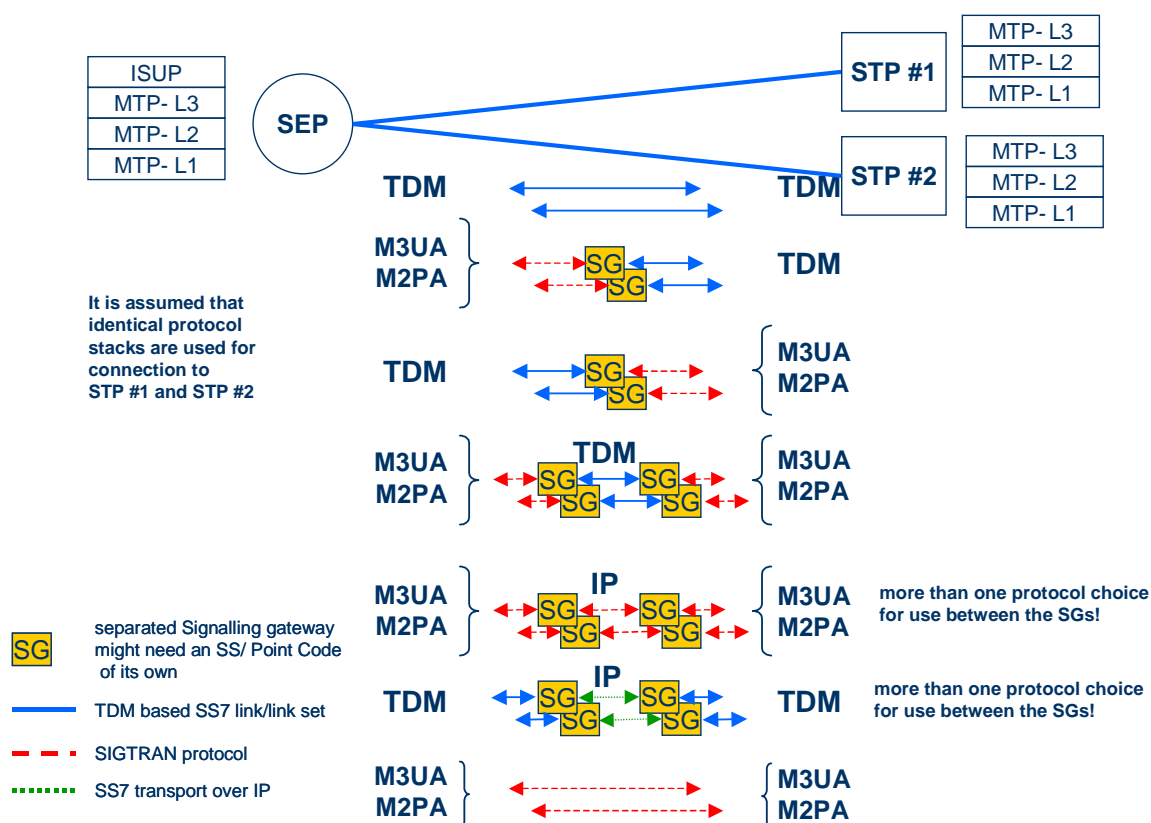

Figure 23: Migration in the SEP access area for quasi-associated signalling

Figure 23 uses a sort of "short hand" graphical representation to summarize the different protocol stack options that could be used either locally at the SEP or STP. Annex A explains the condensed representation to greater extent using M3UA between SEP and SG and TDM towards the STP.

NOTE: In case TDM-IP-TDM the two SGs connected "back-to-back" might use ANY protocol to transport SS7 signalling messages between them over the IP network. This possibility could also include a sort of "circuit emulation service" using proprietary protocols to either perform tunnelling of SUs or even transporting the SUs "bit-by-bit" using the same protocols as for transporting voice, except that the used codec (e.g. ITU-T Recommendation G.711 [26]) has to provide "clear-mode" capability.

Figure 23 does not even show all possibilities, as the separated gateways on the SEP side might be replaced by a single one. The usage of the same protocol towards both STPs is only assumed to put a limit on the number of combinations in the figure above. It might well be advisable to use different protocol stacks towards STP#1 and STP#2 to achieve resilience.

4.4.2 Associated signalling

This clause attempts in providing more information regarding the possible combinations of protocols. The information given is not considered to currently discuss all aspects.

Figure 24 shows the currently known possibilities. Some of the combinations above, especially those involving two external Signalling Gateways (SGs) might not even work, but have been found in the literature.

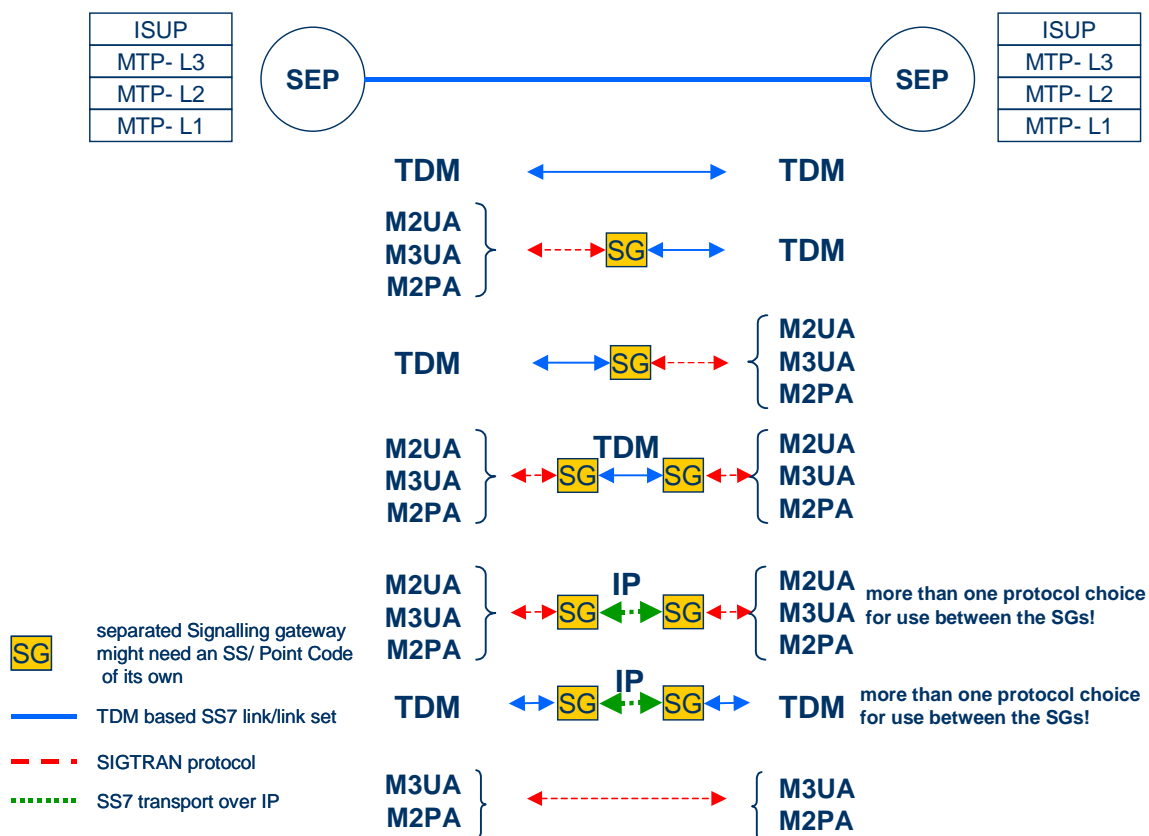

Figure 24: Migration in the access area for associated signalling

Figure 24 uses a sort of "short hand" graphical representation to summarize the different protocol stack options that could be used locally at the SEP. Annex A explains the condensed representation to greater extent using M3UA between SEP and SG and TDM towards the STP (previous clause on quasi-associated signalling).

NOTE: In case TDM-IP-TDM the two SGs connected "back-to-back" might use ANY protocol to transport SS7 signalling messages between them over the IP network. This possibility could also include a sort of "circuit emulation service" using proprietary protocols to either perform tunnelling of SUs or even transporting the SUs "bit-by-bit" using the same protocols as for transporting voice, except that the used codec (e.g. ITU-T Recommendation G.711 [26]) has to provide "clear-mode" capability.

A more detailed discussion on selected protocol choices is given on the next pages.

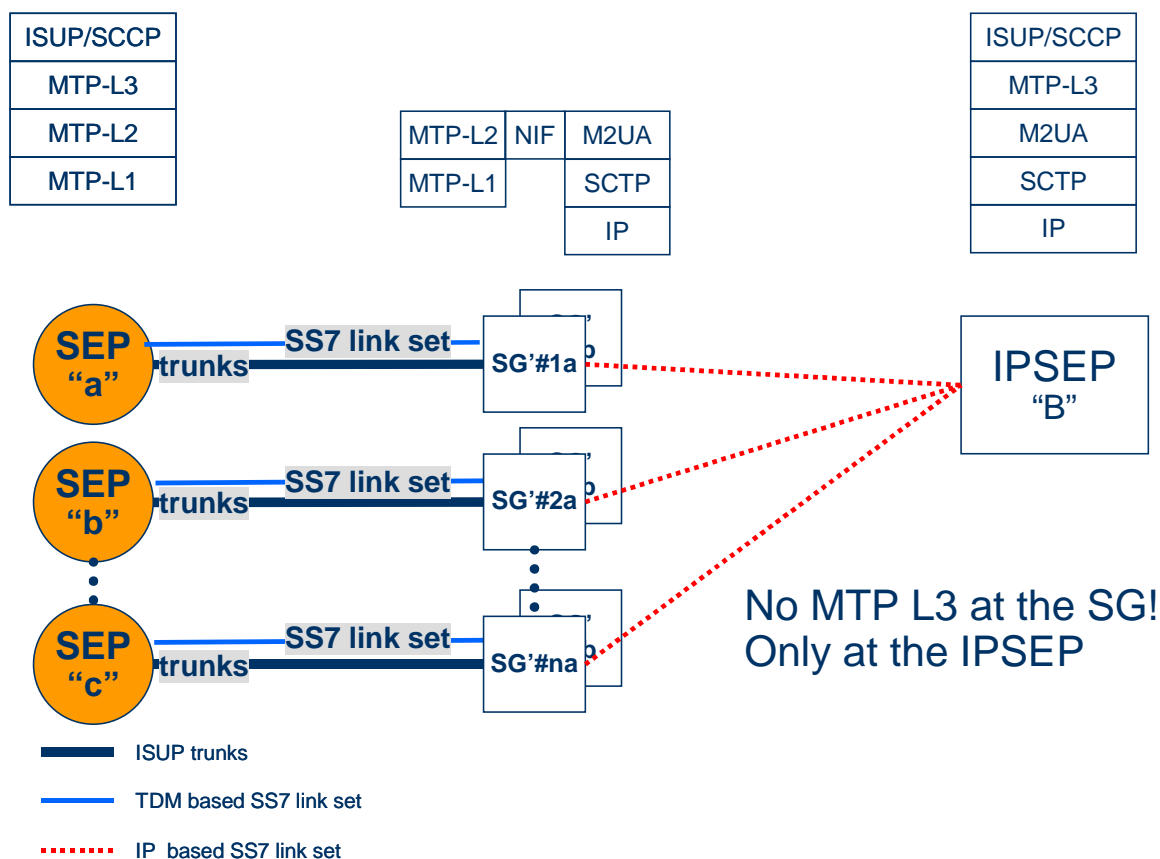

Figure 25: Migration using M2UA in the SEP Access area for associated signalling

The conversion from a TDM based to an IP based SS7 link at the SG'/MG remains invisible for the SS7 nodes in the TDM network, as the device at the TDM-IP network boundary has no SS7 point code of its own. In order to avoid a single point of failure, the use of more than one SG' per signalling relation is advisable, thus effectively distributing the SS7 link set over several independent devices.

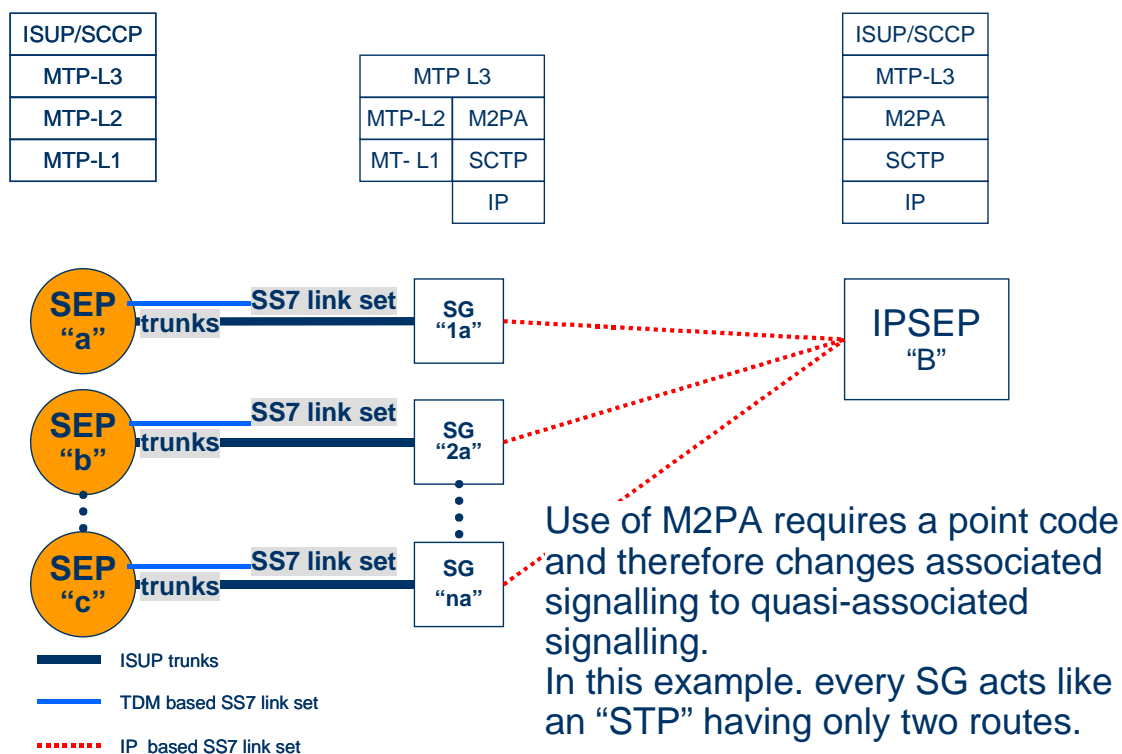

Figure 26: Migration using M2PA in the SEP Access area for associated signalling

The conversion from a TDM based to an IP based SS7 link at the SG' changes the nature of the signalling relation from associated to quasi-associated, as the device at the TDM-IP network boundary has an SS7 point code of its own. The introduction of a single point of failure might be avoided by:

- either using a redundant SG hardware; or
- effectively splitting the former single link set into at least two link sets when using multiple independent SGs; or
- using a distributed MTP-L3 that allows two or more SGs to act like a single MTP-L3.

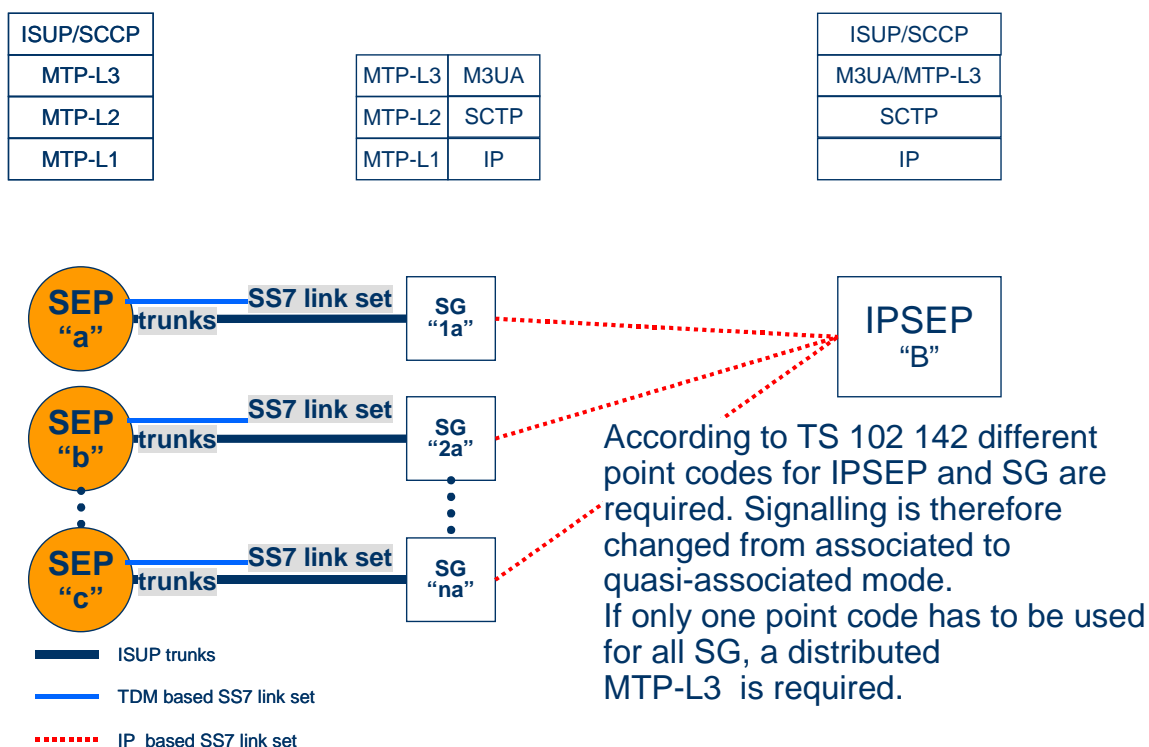

Figure 27: Migration using M3UA in the SEP Access area for associated signalling

The conversion from a TDM based to an IP based SS7 link at the SG changes the nature of the signalling relation from associated to quasi-associated, as the device at the TDM-IP network boundary has an SS7 point code of its own.

The introduction of a single point of failure might be avoided by:

- either using a redundant SG hardware; or
- effectively splitting the former single link set into at least two link sets when using multiple independent SGs; or
- using a distributed MTP-L3 that allows two or more SGs to act like a single MTP-L3.

4.5 Architectural considerations database segment

The introduction of SS7oIP in the database segment could be considered to some extent as comparable with the SEP network segment, starting with a purely local introduction of "Signalling Gateways" (SG) as additional equipment in database segment. The driving force behind introducing SS7oIP in the Database segment is, however, often the throughput limitation of the TDM based SS7 network. This bottleneck is not removed when local SGs are introduced, as these local devices still have a TDM connection to the STP network segment.

Figure 28 shown below, this might be achieved using either:

- M2UA

The use of M2UA requires no SS7 point code at the SG. This solution is possible only as long as SS7oIP is introduced locally. Any previously existing bandwidth problem is not solved as the connection to the STP network segment remains TDM based.

- M2PA

Using M2PA requires the SG to have an SS7 point code assigned and the MTP3 functionality has to be present on the SG.

- M3UA
Using M3UA according to TS 102 142 [2] requires the SG to have an SS7 point code of its own and the MTP-L3 functionality has to be present on the SG.
- SUA
Using SUA according to TS 102 143 [3]. Any previously existing bandwidth problem is not solved as the connection to the STP network segment remains TDM based.
- other solutions providing e.g. for transparent tunnelling of all SS7 Signal Units (SU) are possible, but they are mostly based on proprietary protocols. These solutions provide sort of emulated "wire" over the IP signalling network.

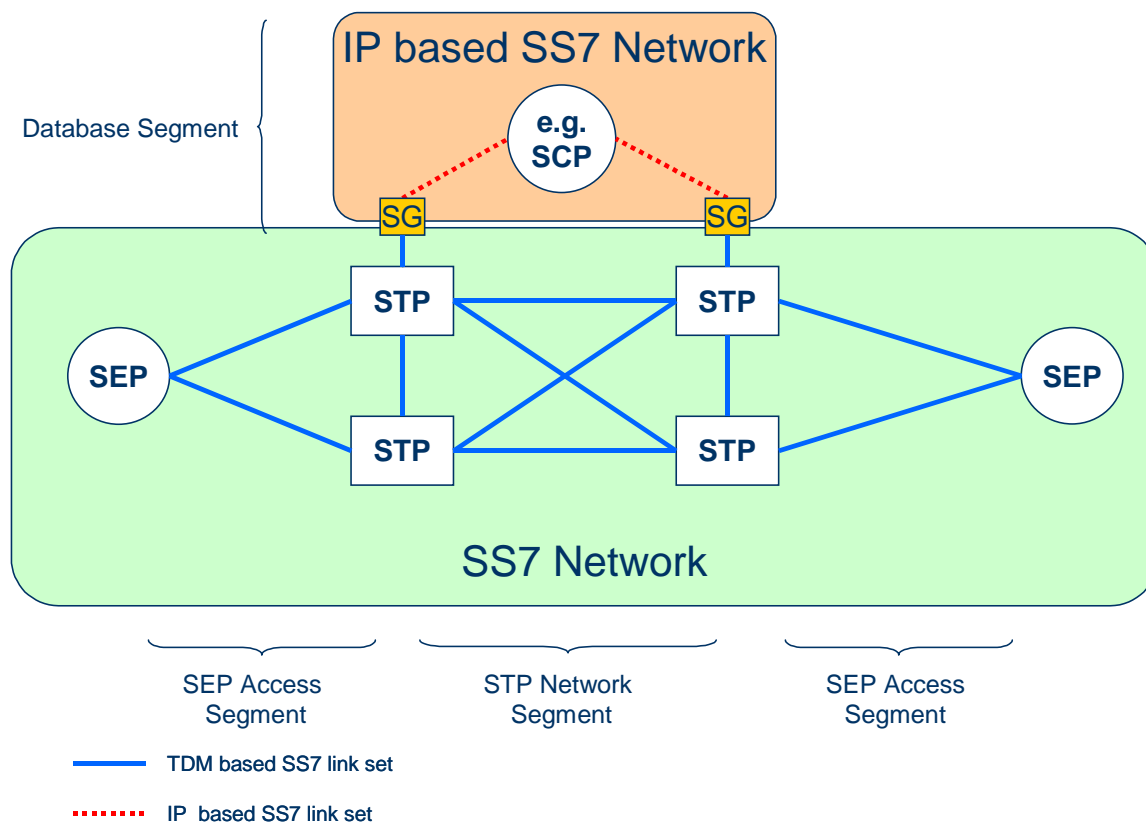

Figure 28: Local introduction of SS7oIP introduced for STP/SCP interconnection

The above mentioned bottleneck due to keeping the TDM connections to the STP network, could only be overcome by allowing the IP based SS7 network to include the STPs that provide access to the Database segment. This step again integrates the SG into the STP.

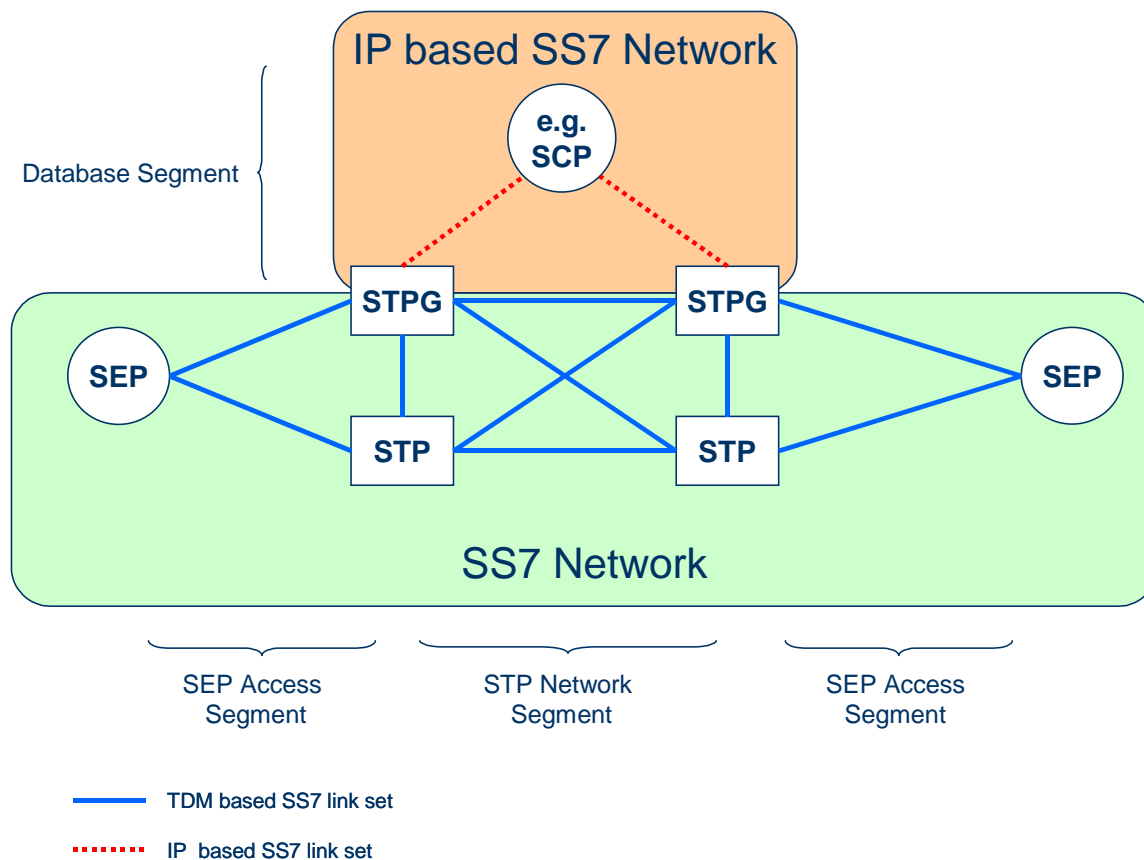

Figure 29: SS7oIP introduced for STP/SCP interconnection

Providing "SS7 over IP" between SCP and STP could be achieved using:

- M2PA;
- M3UA;
- SUA.

Reasons for not using M2UA:

- Reasons for not using M2UA are already given in previous clauses, they also apply here.

4.6 Security considerations

It is expected that security for the underlying IP network will be provided by some or all of the following techniques:

- physical access control;
- IPSec - see RFC 3554;
- TLS (Transport Layer Security) - see RFC 3436 [24].

The standardization of security measures is outside the scope of the present document, however if TLS is chosen, then the effect on the SCTP data payload should be taken into account.

The potential problems of IPsec compared with TLS are that:

- re-keying has the potential to cause interruption to service;
- management re-configuration requires potentially significant manpower.

These potential problems arise because each multi-homed SCTP association results in multiple security associations.

Annex A (informative): Graphical representation of interworking scenarios

This annex is to provide a guideline in how to interpret figure 23 and figure 24 as the detailed protocol stack is not shown there. As an example the first possibility of introducing the M3UA protocol on the SG side is shown to greater detail.

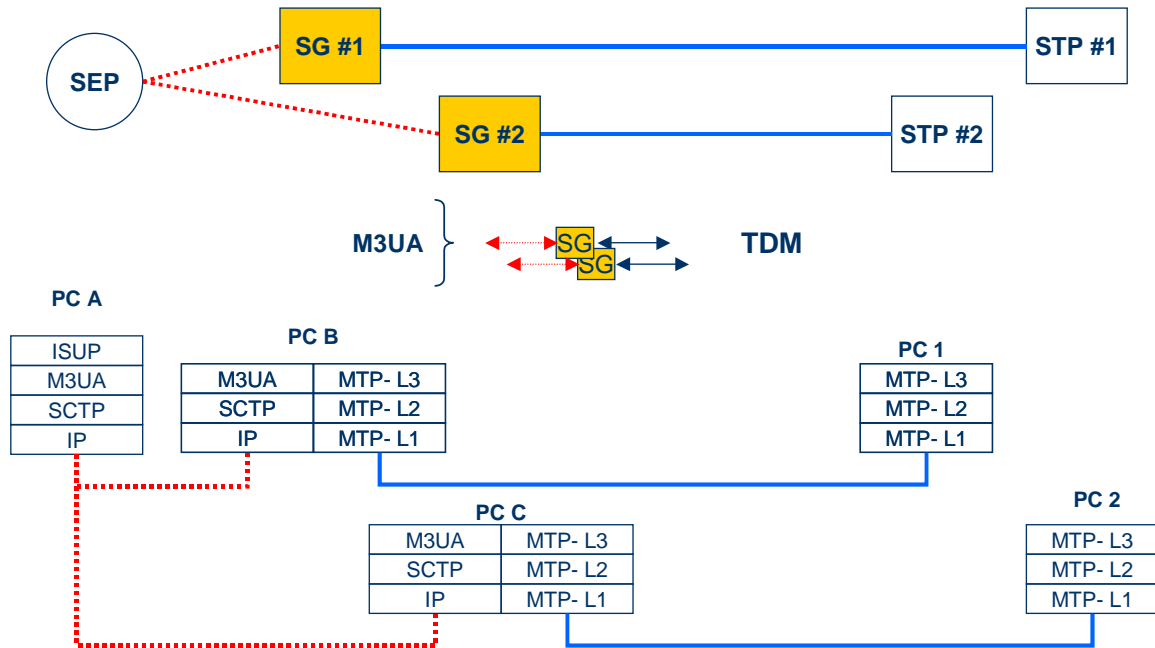

Figure A.1: Explanation for "short hand" notation used in figures of the present document

Annex B (informative): Bibliography

- IETF RFC 2719: "Framework Architecture for Signalling Transport".
- IETF RFC 2246: "The TLS Protocol, Version 1.0".
- IETF RFC 3554: "On the use of SCTP with IPsec".
- IETF RFC 3788: "Security Considerations for Signalling Transport (SIGTRAN) Protocols".
- IETF RFC 2401: "Security Architecture for the Internet Protocol".
- ETSI TS 102 144: "Services and Protocols for Advanced Networks (SPAN); MTP/SCCP/SSCOP and SIGTRAN (Transport of SS7 over IP); Stream Control Transmission Protocol (SCTP) [Endorsement of RFC 2960 and RFC 3309, modified]".

History

Document history		
V1.1.1	October 2004	Membership Approval Procedure MV 20041203: 2004-10-05 to 2004-12-03
V1.1.1	December 2004	Publication