

**Access and Terminals (AT);
Public Switched Telephone Network;
Support of legacy terminals
by Broadband IP networks and equipment;
Part 1: General (common part covering
both PSTN Analogue and ISDN TE)**



Reference

REG/AT-040005-01

Keywords

access, analogue, ISDN, broadband, IP,
multimedia, terminal, PSTN

ETSI

650 Route des Lucioles
F-06921 Sophia Antipolis Cedex - FRANCE

Tel.: +33 4 92 94 42 00 Fax: +33 4 93 65 47 16

Siret N° 348 623 562 00017 - NAF 742 C
Association à but non lucratif enregistrée à la
Sous-Préfecture de Grasse (06) N° 7803/88

Important notice

Individual copies of the present document can be downloaded from:

<http://www.etsi.org>

The present document may be made available in more than one electronic version or in print. In any case of existing or perceived difference in contents between such versions, the reference version is the Portable Document Format (PDF). In case of dispute, the reference shall be the printing on ETSI printers of the PDF version kept on a specific network drive within ETSI Secretariat.

Users of the present document should be aware that the document may be subject to revision or change of status. Information on the current status of this and other ETSI documents is available at

<http://portal.etsi.org/tb/status/status.asp>

If you find errors in the present document, please send your comment to one of the following services:

http://portal.etsi.org/chaicor/ETSI_support.asp

Copyright Notification

No part may be reproduced except as authorized by written permission.
The copyright and the foregoing restriction extend to reproduction in all media.

© European Telecommunications Standards Institute 2004.
All rights reserved.

DECTTM, **PLUGTESTS**TM and **UMTS**TM are Trade Marks of ETSI registered for the benefit of its Members.
TIPHONTM and the **TIPHON logo** are Trade Marks currently being registered by ETSI for the benefit of its Members.
3GPPTM is a Trade Mark of ETSI registered for the benefit of its Members and of the 3GPP Organizational Partners.

Contents

Intellectual Property Rights	7
Foreword.....	7
Introduction	7
1 Scope	8
2 References	8
3 Abbreviations	10
4 Overview	12
4.1 General Objectives	12
4.2 Geographical study area	13
5 Access Network.....	14
6 Examples of legacy terminal equipment	16
6.1 Analogue PSTN terminal equipment.....	16
6.2 ISDN Terminal Equipment.....	17
7 Features and functionality summary	17
7.1 Enhanced network functions	17
8 Supplementary Services	17
8.1 General	17
Annex A (informative): Power Failure	19
A.1 General	19
Annex B (informative): Supplementary Service Definitions	20
B.1 Abbreviated Address Services.....	20
B.1.1 Abbreviated Address (AA).....	20
B.1.2 Fixed Destination Call (FDC)	20
B.1.3 Repeat Last Call (RLC).....	20
B.2 Address Information Services	21
B.2.1 Direct Dialling In (DDI).....	21
B.2.2 Multiple Subscriber Number (MSN).....	21
B.2.3 SUB-addressing (SUB)	21
B.2.4 Automatic Personal Call (APC)	21
B.2.5 Distinctive Ringing (DR)	21
B.2.6 Distinctive Ringing/Call Waiting (DRCW)	21
B.2.7 Distinctive Ringing Called Number Dependent (DRCN)	22
B.3 Advice of Charge Services (AoC).....	22
B.3.1 Advice of Charge, Charging Information at Call Setup Time (AoC-S)	22
B.3.2 Advice of Charge, Charging Information During the Call (AoC-D).....	22
B.3.3 Advice of Charge, Charging Information at the End of the Call (AoC-E)	22
B.3.4 Advice of Charge: Charging information on user Request (AoC-R)	23
B.3.5 Subscriber Call Charge Meter	23
B.3.6 Automatic Verbal Announcement of Charges Applied.....	23
B.3.7 Printed Record on Duration and Charge of Calls	23
B.4 Call Booking Services	23
B.4.1 Alarm Call	23
B.4.2 Booked Call.....	23
B.4.3 Diary Service.....	24
B.5 Call Barring Services.....	24

B.5.1	Closed User Group (CUG)	24
B.5.2	Incoming Call Barring (ICB).....	24
B.5.3	Outgoing Call Barring: Fixed (OCB-F).....	24
B.5.4	Outgoing Call Barring: User Controlled (OCB-UC).....	25
B.5.5	Security Screening (SS).....	25
B.5.6	Inhibition of Incoming Forwarded Calls (IIFC)	25
B.5.7	Anonymous Call Rejection (ACR).....	25
B.5.8	Barring, Selective, Incoming Calls, all but 10 numbers barred (Code:932).....	25
B.5.9	Selective Call Rejection (SCR)	26
B.5.10	Address Screening (ADS)	26
B.6	Call Completion Services	26
B.6.1	Call Waiting (CW)	26
B.6.2	Completion of Calls to Busy Subscriber (CCBS).....	26
B.6.3	Queue Service (QS).....	26
B.6.4	Completion of Calls on No Reply (CCNR).....	27
B.6.5	Called Line Free Indication	27
B.6.6	Call Return	27
B.6.7	Call Back (CB)	27
B.7	Call Registration Services	27
B.7.1	Date and Time Call Record	27
B.7.2	Logging of Incoming Calls.....	27
B.7.3	Malicious Call Identification (MCID).....	28
B.7.4	Bulk Calling Line Identification (BCLID)	28
B.8	Changed Charging Services	28
B.8.1	FreePHone (FPH).....	28
B.8.2	REVerse charging at call Setup time (REV-S).....	28
B.8.3	REVerse charging Unconditional (REV-U).....	28
B.8.4	Transfer of Charge.....	29
B.8.5	Wide Area Service.....	29
B.8.6	Split Charging	29
B.8.7	Premium Rate	29
B.8.8	International [Premium Rate] services	29
B.8.9	International Freephone Service (IFS)	29
B.8.10	Home Country Direct	30
B.9	Diversion Services.....	30
B.9.1	Call Forwarding Unconditional (CFU).....	30
B.9.2	Call Forwarding Busy (CFB)	30
B.9.3	Call Forwarding No Reply (CFNR)	31
B.9.4	Call Deflection (CD)	31
B.9.5	Call Forwarding Unconditional to a Service Centre (CFU-S).....	31
B.9.6	Call Forwarding Busy to a Service Centre (CFB-S)	31
B.9.7	Call Forwarding No Reply to a Service Centre (CFNR-S)	31
B.9.8	Selective Call Forwarding (SCF)	32
B.9.9	Selective Call Forwarding Busy	32
B.9.10	Selective Call Forwarding No Reply	32
B.9.11	Sequence Calling (SC)	32
B.9.12	Call Forwarding Service.....	32
B.10	Help Services.....	33
B.10.1	Fault Reporting.....	33
B.10.2	General Deactivation (GD).....	33
B.10.3	Operator Access to and Control of Supplementary Services.....	33
B.10.4	Remote Control of Supplementary Services (RCSS)	33
B.10.5	Time Dependent Control of Supplementary Services	33
B.10.6	Screening List Editing (SLE)	33
B.11	Information Transfer Services.....	33
B.11.1	Delivery Confirmation (DC)	33
B.11.2	Packet Delivery Confirmation (PDC).....	34
B.11.3	User-to-User Signalling (UUS).....	34

B.11.4	Voice Mail (VM).....	34
B.11.5	Message Waiting Indication (MWI).....	34
B.12	Multiline Services	34
B.12.1	Centrex	34
B.12.2	Line Hunting (LH).....	34
B.12.3	Trunk Hunting (TH).....	35
B.12.4	Support of Private Numbering Plan (SPNP)	35
B.12.5	Multilocation Business Group (MBG)	35
B.13	Multiparty Calls.....	35
B.13.1	Call Hold (HOLD).....	35
B.13.2	Three-Party Service (3PTY).....	35
B.13.3	Call Transfer (CT).....	35
B.13.3.1	Normal Call Transfer (NCT)	35
B.13.3.2	Explicit Call Transfer (ECT)	36
B.13.3.3	Single Step Call Transfer (SSCT).....	36
B.13.4	CONFerence call, add-on (CONF).....	36
B.13.5	Meet-Me Conference (MMC)	36
B.13.6	Lecture Call	36
B.13.7	Preset Conference Calling service (PCC).....	37
B.13.8	Booked Add-On Conference	37
B.14	Identification Services	37
B.14.1	Calling Line Identification Presentation (CLIP).....	37
B.14.2	Calling Line Identification Restriction (CLIR)	37
B.14.3	Connected Line Identification Presentation (COLP).....	37
B.14.4	Connected Line Identification Restriction (COLR)	38
B.14.5	Calling Name Identification Presentation (CNIP).....	38
B.14.6	Calling Name Identification Restriction (CNIR).....	38
B.14.7	Calling Identity Delivery on Call Waiting (CIDCW).....	38
B.15	Numbering Services	38
B.15.1	Out of Area Line	38
B.15.2	Permanent Subscriber Number (PSN).....	38
B.15.3	Universal Access Number (UAN).....	39
B.15.4	Call DISTribution (CDIST).....	39
B.15.5	Call Volume Distribution (CVD)	39
B.15.6	User Defined Routing (UDR).....	39
B.15.7	Temporary Location for Outgoing Calls	39
B.15.8	Permanent Circuit (PC)	39
B.15.9	Permanent Virtual Circuit (PVC)	40
B.16	Payment Changing Services	40
B.16.1	Credit Card Calling (CRED)	40
B.16.2	Payphone	40
B.16.3	Automatic Credit Card Service (ACCS)	40
B.16.4	Account Card Calling (ACC)	40
B.16.5	Automatic Transferred Charge Call	40
B.16.6	Selective Accounting (SA).....	41
B.16.7	Charge Card Calling (CCC)	41
B.16.8	Virtual Card Calling (VCC)	41
B.17	Priority Services	41
B.17.1	PRiority (PRI)	41
B.17.2	Priority Selection (PS).....	41
B.17.3	MultiLevel Precedence and Pre-emption (MLPP)	41
B.18	Opinion Collecting Services	42
B.18.1	TeleVOTing (VOT).....	42
B.18.2	Teledialogue	42
B.18.3	Mass Calling.....	42
B.19	Miscellaneous Services	42
B.19.1	Alarm (Warning)	42

B.19.2	Changing of Service During an Established Call	42
B.19.3	Expediting of a Call in Progress	42
B.19.4	Interception of Calls	43
B.19.5	National Selection and Indication of Throughput Class	43
B.19.6	Terminal Portability (TP)	43
B.19.7	User Selection of PAD Parameter Settings	43
B.19.8	Call Diversion Override (CDO)	44
B.19.9	Incall Modification (IM)	44
B.19.10	Pick-up Facility	44
B.19.11	Message Relay (MR).....	44
Annex C (informative):	Bibliography	45
History		47

Intellectual Property Rights

IPRs essential or potentially essential to the present document may have been declared to ETSI. The information pertaining to these essential IPRs, if any, is publicly available for **ETSI members and non-members**, and can be found in ETSI SR 000 314: "*Intellectual Property Rights (IPRs); Essential, or potentially Essential, IPRs notified to ETSI in respect of ETSI standards*", which is available from the ETSI Secretariat. Latest updates are available on the ETSI Web server (<http://webapp.etsi.org/IPR/home.asp>).

Pursuant to the ETSI IPR Policy, no investigation, including IPR searches, has been carried out by ETSI. No guarantee can be given as to the existence of other IPRs not referenced in ETSI SR 000 314 (or the updates on the ETSI Web server) which are, or may be, or may become, essential to the present document.

Foreword

This ETSI Guide (EG) has been produced by ETSI Technical Committee Access and Terminals (AT), and is now submitted for the ETSI standards Membership Approval Procedure.

The present document is part 1 of a multi-part deliverable covering the support of legacy terminals by Broadband IP networks and equipment, as identified below:

Part 1: "**General (common part covering both PSTN Analogue and ISDN TE)**";

Part 2: "Analogue PSTN terminals";

Part 3: "ISDN terminals".

Introduction

The Telecommunications industry in Europe and surrounding regions has started to deploy broadband IP access networks using both wired and wireless access technologies, sometimes referred to as Next Generation Networks (NGN). The initial rollout of these Broadband networks has been focussed on supporting both data and interactive content, however, there is now an urgent need to support IP Voice (Telephony over IP) and other time critical multimedia services over these broadband networks. In particular there is a need to support legacy PSTN Analogue and ISDN Terminal Equipment, this fact is highlighted for example in TR 101 963 [4], clause 5 relating to MTA Requirements.

Consequently in order to support the development of broadband equipment with support for legacy PSTN Analogue and ISDN terminals, the key functions and features of these terminals need to be sufficiently defined.

All new systems, independent of their access technology, may enjoy the results of the present document.

1 Scope

The present document belongs to a set of documents which describes the functional technical characteristics supported by PSTNs across the wider European market, in order to provide guidance to developers of broadband equipment (e.g. IPCablecom MTA, FWA subscriber units) that support either PSTN analogue or ISDN terminal.

The present document is part 1 referring to the common aspects of PSTN Analogue and ISDN Terminals.

The present document does not include any Safety or EMC aspects or requirements.

2 References

The following documents contain provisions which, through reference in this text, constitute provisions of the present document.

- References are either specific (identified by date of publication and/or edition number or version number) or non-specific.
- For a specific reference, subsequent revisions do not apply.
- For a non-specific reference, the latest version applies.

Referenced documents which are not found to be publicly available in the expected location might be found at <http://docbox.etsi.org/Reference>.

- [1] ETSI EN 300 001: "Attachments to the Public Switched Telephone Network (PSTN); General technical requirements for equipment connected to an analogue subscriber interface in the PSTN".
- [2] ETSI ES 201 970: "Access and Terminals (AT); Public Switched Telephone Network (PSTN); Harmonized specification of physical and electrical characteristics at a 2-wire analogue presented Network Termination Point (NTP)".
- [3] ITU-T Recommendation Q.552: "Transmission characteristics at 2-wire analogue interfaces of digital exchanges".
- [4] ETSI TR 101 963: "Access and Terminals (AT); Report on the Requirements of European Cable Industry for Implementation of IPCablecom Technologies; Identification of high level requirements and establishment of priorities".
- [5] ETSI ETS 300 050: "Integrated Services Digital Network (ISDN); Multiple Subscriber Number (MSN) supplementary service; Service Description".
- [6] ETSI ETS 300 059: "Integrated Services Digital Network (ISDN); Subaddressing (SUB) supplementary service; Service Description".
- [7] ETSI ETS 300 062: "Integrated Services Digital Network (ISDN); Direct Dialling In (DDI) supplementary service; Service Description".
- [8] ETSI ETS 300 178: "Integrated Services Digital Network (ISDN); Advice of Charge: charging information at call set-up time (AOC-S) supplementary service; Service description".
- [9] ETSI ETS 300 179: "Integrated Services Digital Network (ISDN); Advice of Charge: charging information during the call (AOC-D) supplementary service; Service description".
- [10] ETSI ETS 300 180: "Integrated Services Digital Network (ISDN); Advice of Charge: charging information at the end of the call (AOC-E) supplementary service; Service description".
- [11] ETSI ETS 300 136: "Integrated Services Digital Network (ISDN); Closed User Group (CUG) supplementary service; Service description".

- [12] ETSI EN 301 001-1: "Integrated Services Digital Network (ISDN); Outgoing Call Barring (OCB) supplementary services; Digital Subscriber Signalling System No. one (DSS1) protocol; Part 1: Protocol specification".
- [13] ETSI ETS 300 056: "Integrated Services Digital Network (ISDN); Call Waiting (CW) supplementary service; Service description".
- [14] ETSI EN 300 357: "Integrated Services Digital Network (ISDN); Completion of Calls to Busy Subscriber (CCBS) supplementary service; Service description".
- [15] ETSI EN 301 065-1: "Integrated Services Digital Network (ISDN); Completion of Calls on No Reply (CCNR) supplementary service; Digital Subscriber Signalling System No. one (DSS1) protocol; Part 1: Protocol specification".
- [16] ETSI ETS 300 128: "Integrated Services Digital Network (ISDN); Malicious Call Identification (MCID) supplementary service; Service description".
- [17] ETSI ETS 300 208: "Integrated Services Digital Network (ISDN); Freephone (FPH) supplementary service; Service description".
- [18] ETSI ETS 300 200: "Integrated Services Digital Network (ISDN); Call Forwarding Unconditional (CFU) supplementary service; Service description".
- [19] ETSI EN 300 199: "Integrated Services Digital Network (ISDN); Call Forwarding Busy (CFB) supplementary service; Service description".
- [20] ETSI EN 300 201: "Integrated Services Digital Network (ISDN); Call Forwarding No Reply (CFNR) supplementary service; Service description".
- [21] ETSI ETS 300 202: "Integrated Services Digital Network (ISDN); Call Deflection (CD) supplementary service; Service description".
- [22] ETSI EN 301 133: "Integrated Services Digital Network (ISDN); Selective Call Forwarding (SCF) supplementary services (unconditional, busy and no reply); Service description".
- [23] ETSI ETS 300 284: "Integrated Services Digital Network (ISDN); User-to-User Signalling (UUS) supplementary service; Service description".
- [24] ETSI EN 300 650: "Integrated Services Digital Network (ISDN); Message Waiting Indication (MWI) supplementary service; Service description".
- [25] ETSI EN 301 479: "Integrated Services Digital Network (ISDN); Line Hunting (LH) supplementary service; Service description".
- [26] ETSI ETS 300 139: "Integrated Services Digital Network (ISDN); Call Hold (HOLD) supplementary service; Service description".
- [27] ETSI ETS 300 186: "Integrated Services Digital Network (ISDN); Three-Party (3PTY) supplementary service; Service description".
- [28] ETSI EN 300 367: "Integrated Services Digital Network (ISDN); Explicit Call Transfer (ECT) supplementary service; Service description".
- [29] ETSI ETS 300 183: "Integrated Services Digital Network (ISDN); Conference call, add-on (CONF) supplementary service; Service description".
- [30] ETSI ETS 300 164: "Integrated Services Digital Network (ISDN); Meet-Me Conference (MMC) supplementary service; Service description".
- [31] ETSI EN 300 089: "Integrated Services Digital Network (ISDN); Calling Line Identification Presentation (CLIP) supplementary service; Service description".
- [32] ETSI EN 300 090: "Integrated Services Digital Network (ISDN); Calling Line Identification Restriction (CLIR) supplementary service; Service description".

- [33] ETSI EN 300 094: "Integrated Services Digital Network (ISDN); Connected Line Identification Presentation (COLP) supplementary service; Service description".
- [34] ETSI ETS 300 095: "Integrated Services Digital Network (ISDN); Connected Line Identification Restriction (COLR) supplementary service; Service description".
- [35] ETSI ETS 300 710: "Integrated Services Digital Network (ISDN); Public Switched Telephone Network (PSTN); Universal Access Number (UAN) service; Service description".
- [36] ETSI ETS 300 048: "Integrated Services Digital Network (ISDN); ISDN Packet Mode Bearer Services (PMBS); ISDN Virtual Call (VC) and Permanent Virtual Circuit (PVC) bearer services provided by the B-channel of the user access - basic and primary rate".
- [37] ETSI ETS 300 711: "Integrated Services Digital Network (ISDN); Public Switched Telephone Network (PSTN); Virtual Card Calling (VCC); Service description".
- [38] ETSI ETS 300 713: "Integrated Services Digital Network (ISDN); Public Switched Telephone Network (PSTN); Televoting (VOT) service; Service description".
- [39] ETSI ETS 300 053: "Integrated Services Digital Network (ISDN); Terminal Portability (TP) supplementary service; Service Description".
- [40] ETSI EG 201 973-2: "Access and Terminals (AT); Public Switched Telephone Network; Support of legacy terminals by Broadband IP networks and equipment; Part 2: Legacy Analogue TE".
- [41] ETSI EG 201 973-3: "Access and Terminals (AT); Public Switched Telephone Network; Support of legacy terminals by Broadband IP networks and equipment; Part 3: Legacy ISDN TE".
- [42] ETSI TR 102 083: "Human Factors (HF); Supplementary service codes for use in public network services".
- [43] ETSI EG 202 306: "Transmission and Multiplexing (TM); Access networks for residential customers".

3 Abbreviations

For the purposes of the present document, the following abbreviations apply:

3PTY	Three ParTY service
AA	Abbreviated Address
AC	Automatic Call back
ACC	Account Card Calling
ACCS	Automatic Credit Card Service
ACR	Anonymous Call Rejection
ADS	ADdress Screening
AN	Access Network
AoC	Advice of Charge
AoC-D	Advice of Charge, charging information During the call
AoC-E	Advice of Charge, charging information at the End of the call
AoC-R	Advice of Charge, charging information on user Request
AoC-S	Advice of Charge, charging information at call Setup time
APC	Automatic Personal Call
AR	Automatic Recall
ATM	Asynchronous Transport Mode
BCLID	Bulk Calling Line Identification
CB	Call Back
CCBS	Completion of Calls to Busy Subscriber
CCC	Charge Card Calling
CCNR	Completion of Calls on No Reply
CD	Call Deflection
CDIST	Call DISTribution
CDO	Call Diversion Override

CFB	Call Forwarding Busy
CFB-S	Call Forwarding Busy to a Service centre
CFNR	Call Forwarding No Reply
CFNR-S	Call Forwarding No Reply to a Service centre
CFU	Call Forwarding Unconditional
CFU-S	Call Forwarding Unconditional to a Service centre
CIDCW	Calling Identity Delivery on Call Waiting
CL	Call Logging
CLIP	Calling Line Identification Presentation
CLIR	Calling Line Identification Restriction
CNAM	Calling NAME delivery
CND	Calling Number Delivery
CNIP	Calling Name Identification Presentation
CNIR	Calling Name Identification Restriction
COLP	COnnected Line identification Presentation
COLR	COnnected Line identification Restriction
CONF	CONFerence call, add on
COT	Customer Originated Trace
CPN	Customer Premises Network
CRED	CREDit card calling
CT	Call Transfer
CUG	Closed User Group
CVD	Call Volume Distribution
CW	Call Waiting
DC	Delivery Confirmation
DDI	Direct Dialling In
DR	Distinctive Ringing
DRCN	Distinctive Ringing Called Number dependent
DRCW	Distinctive Ringing/Call Waiting
DT	Dial Tone
DTMF	Dual Tone Modulation Frequency
DVB	Digital Video Broadcasting
ECT	Explicit Call Transfer
FDC	Fixed Destination Call
FPH	FreePHone
FTTH	Fibre To The Home
FWA	Fixed Wireless Access
GD	General Deactivation
HOLD	call HOLD
ICB	Incoming Call Barring
IFS	International Freephone Service
IIFC	Inhibition of Incoming Forwarded Calls
IM	Incall Modification
IODC	International Operator Direct Calling
IP	Internet Protocol
IPRS	International [Premium Rate] Service
LH	Line Hunting
MBG	Multi-location Business Group
MCID	Malicious Call IDentification
MLPP	MultiLevel Precedence and Pre-emption
MMC	Meet-Me Conference
MR	Message Relay
MSN	Multiple Subscriber Number
MTA	Media Terminal Adapter
MWI	Message Waiting Indication
NCT	Normal Call Transfer
NGN	Next Generation Network
NTP	Network Termination Point
OCB	Outgoing Call Barring
OCB-F	Outgoing Call Barring: Fixed
OCB-UC	Outgoing Call Barring: User Controlled
PABX	Private Automatic Branch eXchange

PBX	Private Branch eXchange
PC	Permanent Circuit
PCC	Preset Conference Calling service
PDC	Packet Delivery Confirmation
POTS	Plain Old Telephone Service
PRI	PRiority
PS	Priority Selection
PSN	Permanent Subscriber Number
PSTN	Public Switched Telephone Network
PVC	Permanent Virtual Circuit
RCSS	Remote Control of Supplementary Services
REV-S	REVerse charging at call Setup time
REV-U	REVerse charging Unconditional
RLC	Repeat Last Call
ROA	Recognized Operating Agency
SA	Selective Accounting
SC	Sequence Calling
SCA	Selective Call Acceptance
SCF	Selective Call Forwarding
SCR	Selective Call Rejection
SLE	Screening List Editing
SMS	Short Message Service
SNI	Service Node Interface
SPNP	Support of Private Numbering Plan
SS	Security Screening
SSCT	Single Step Call transfer
SUB	SUBaddressing
TE	Terminal Equipment
TH	Trunk Hunting
TP	Terminal Portability
UAN	Universal Access Number
UDR	User Defined Routing
UIFN	Universal International Freephone Numbers
UNI	User Network Interface
UUS	User-to-User Signalling
VCC	Virtual Card Calling
VM	Voice Mail
VMB	Voice Message Box
VOT	teleVOTing.

4 Overview

4.1 General Objectives

The general objectives of the study, and reflected in EG 201 973-2 [40] and EG 201 973-3 [41], was to:

- 1) Identify the various signalling aspects appropriate for supporting 2-wire analogue PSTN terminals in both OFF Hook and ON Hook state.
- 2) In the geographical study area, for legacy analogue TE:
 - a) Identify the various dialling characteristics supported by networks: DTMF and Loop Disconnect.
 - b) Identify the appropriate Ringing signals (including Frequency, Cadence, Distinctive Ringing).
 - c) Identify the appropriate Supplementary Services (e.g. CLI, SMS - Text Messaging, etc.).
 - d) Identify the appropriate Network Tones (e.g. Dial Tone (DT), Intermittent "Stutter" Dial Tone, Busy, etc.).

- e) Identify the appropriate call progress indication parameters (e.g. Answer, Clear, Sub_Release, etc.).
 - f) Identify specific functions relating to Register Recall, Network Service commands, Metering pulses.
- 3) In the geographical study area, for legacy ISDN TE:
- a) To reflect the use of ETSI harmonized standards for basic call control, also known as "Euro-ISDN"; incorporating both Basic and Primary Rate Access
 - b) Identify the appropriate Supplementary Services and develop a framework for the interactions between those services and broadband access call control elements
 - c) Identify any specific ISDN TE functions requiring support by broadband networks and equipment
- 4) Identify any other features or functionality appropriate to TE such that implementers of non-circuit switched broadband network technologies, may adequately understand the parameter types and signalling characteristics that are needed as the basis for supporting legacy analogue and ISDN TE.

4.2 Geographical study area

The present EG 201 973 series reflects the first phase study of European Union member states and other such information as is available from other non-EU countries. However, these non-EU countries may be subject to a later study.

It is intended that the countries identified in table 1 be captured within the scope of the present document as far as it is practical.

Table 1: Countries included or to be included within the study

Albania	Latvia
Armenia	Lithuania
Austria	Luxembourg
Azerbaijan	Malta
Belarus	Moldova
Belgium	Netherlands
Bosnia and Herzegovina	Norway
Bulgaria	Poland
Croatia	Portugal
Cyprus	Romania
Czech Republic	Russia
Denmark	Slovak Republic
Estonia	Slovenia
Finland	South Africa
France	Spain
Germany	Sweden
Georgia	Switzerland
Greece	Tajikistan
Hungary	Turkey
Iceland	Turkmenistan
Ireland	Ukraine
Italy	United Kingdom
Kazakhstan	Uzbekistan
Kyrgyz Republic	Yugoslavia

5 Access Network

EN 300 001 [1] provides a historical overview of the general technical requirements for equipment to be connected to an analogue subscriber interface in the PSTN (Public Switched Telephone Network); i.e. it gives requirements that terminal equipment had to satisfy at the UNI. The current harmonized specification of an analogue subscriber interface is given in ES 201 970 [2] and has been the basis of any comparisons provided in the present document. For analogue voice band services ITU-T Recommendation Q.552 [3] specifies the transmission characteristics at 2-wire analogue interfaces of digital exchanges. Strictly speaking it specifies the SNI, but if the AN is a simple twisted pair it can also be considered as a "U" type UNI specification.

For new access technologies like Fixed Wireless Access (FWA) and Fibre-to-the-Home (FTTH), the analogue subscriber UNI is more like an in-house T-interface.

The AN is the delivery mechanism from a Network Operators central site up to the Customer Premises Network (CPN) interface with appropriate transmission methods to support the service(s) required. The differentiation in the interface definition for a particular delivery mechanism is that of ownership i.e. public/Network Operator or private/customer. Consequently, that which is termed the NTP may be a regulatory or contractual break point for one service, e.g. POTS, it is not necessarily the UNI for other services.

NOTE: The source of figure 1 is from a study undertaken by ETSI TM (see EG 202 306 [43]).

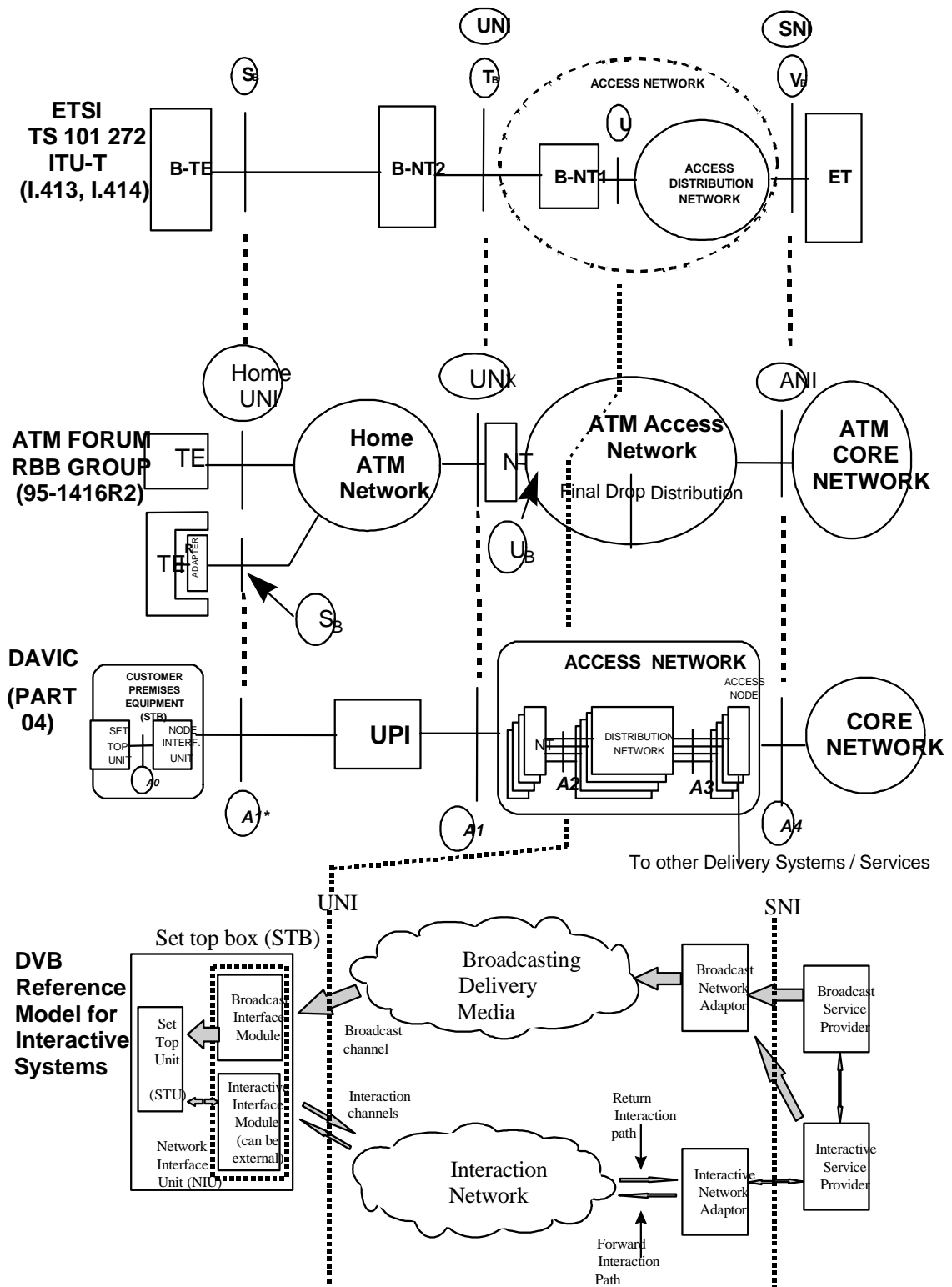

Figure 1: Alternative Access Network examples

6 Examples of legacy terminal equipment

6.1 Analogue PSTN terminal equipment

This is an informal market presentation of generic terminal (non-exhaustive list).

Table 2: Example list of analogue terminal equipment types

Equipment type	Description
PABX	Private Automatic Branch Exchange, a telephone exchange normally serving a business, allowing calls to be made between connected telephones without passing through the PSTN.
Key telephone system	Similar to a PABX, though normally smaller, and with each PSTN line connected to the system accessible by means of a separate key on each telephone.
Fax machine	Facsimile machines. Device for sending and receiving images of documents through the PSTN.
Voice band modems	Device for sending and receiving data through the PSTN.
Answering machines	Device for automatically answering an incoming call. Usually it plays a recorded message to the calling party and records a message left by the calling party.
Handset Telephone	Telephone where the user speaks and hears by means of a handset.
Hands Free Telephone	Telephone where the user speaks and hears by means of a microphone and speaker built into the telephone (see note).
Cordless Telephone (incl. DECT base station)	Telephone where the base station is connected directly to the PSTN, and communicates with the handset by radio, generally over a range not exceeding 100 m.
Remote control unit	Device for communicating remotely with a host system (for instance a voicemail server), typically employing DTMF signalling for sending control instructions.
Alarm system	System where an automatic call is made to a predefined number to indicate that an alarm (for instance an intruder alarm or a panic alarm) has been triggered.
Ringing Detector	Equipment that detects ringing signals and emits sounds or light in response, but cannot enter the off-hook state.
Metering and call detail recording equipment	Equipment connected in parallel to the main telephone, which detects meter pulses and possibly also dialling information, in order to record the destination, duration and cost of calls.
Recording and monitoring equipment	Equipment connected in parallel to the main telephone, so that the conversation can be recorded or monitored by another person.
Telemetry equipment	Equipment which transmits data signals reflecting the state of the apparatus it is monitoring.
EFTPOS Terminals, etc.	Equipment which sends and receives data regarding financial transactions (e.g. charges to credit cards).
Text Telephones	Equipment employing either in-band DTMF tones or a modem to transfer text messages for users with hearing disabilities.
NOTE: Loud speaking telephones may also include a handset.	

6.2 ISDN Terminal Equipment

This is an informal market presentation of generic terminal (non-exhaustive list).

Table 3: Example List of ISDN Terminal Equipment Types

Equipment Type	Description
PBX	Private Branch eXchange, a telephone exchange normally serving a business, allowing calls to be made between connected telephones without passing through the PSTN.
Key telephone system	Similar to a PABX, though normally smaller, and with each PSTN line connected to the system accessible by means of a separate key on each telephone.
Terminal Adapter	A communications adapter that allows non-ISDN equipment (e.g. Analogue telephone) to interconnect to an ISDN Network.
WAN/LAN Router/Bridge	A device used to interconnect data communications networks with different protocols i.e. IP to ISDN.
Voice Processing system	A device that receives speech from the ISDN, and performs a task as a result.
Fax machine	Facsimile machines. Device for sending and receiving images of documents via the ISDN.
Handset Telephone	Telephone where the user speaks and hears by means of a handset.
Hands Free Telephone	Telephone where the user speaks and hears by means of a microphone and speaker built into the telephone (see note).
Cordless Telephone (incl. DECT base station)	Telephone where the base station is connected directly to the ISDN, and communicates with the handset by radio, generally over a range not exceeding 100 m.
Videophone	Phone where the user's speech and image is transmitted.
NOTE:	Loud speaking telephones may also include a handset.

7 Features and functionality summary

7.1 Enhanced network functions

In some cases, Enhanced network functions (e.g. supplementary services and SMS) will require a variety of additional signalling arrangements beyond those necessary for a basic call.

Currently the majority of the service descriptions produced that are available within ETSI relate to ISDN, however, these may be of use when defining the support of enhanced network functions by Analogue TE within non-ISDN broadband networks. For more detailed information specific to legacy Analogue TE refer to EG 201 973-2 [40], and EG 201 973-3 [41] for legacy ISDN TE.

8 Supplementary Services

8.1 General

A variety of signalling is required to support calling features such as:

- Advice of Charge;
- Call Back;
- Call Waiting;
- Cancel Call Waiting;
- Call Forwarding (no-answer, busy, variable);
- Three-way Calling (3PTY);

- Voice mail Message Waiting Indicator;
- Calling Number Delivery;
- Calling Name Delivery;
- Calling Identity Delivery On Call Waiting;
- Calling Identity Delivery Blocking;
- Anonymous Call Rejection;
- Automatic Callback;
- Automatic Recall;
- Distinctive Ringing;
- Multiple Subscriber Number;
- Subaddressing;
- Customer Originated Trace.

Annex B lists the relevant supplementary service definitions.

Annex A (informative): Power Failure

A.1 General

From a regulatory standpoint throughout Europe, the requirements placed upon network operators to ensure voice communications are maintained during local power failure is achieved on an individual member state basis.

A number of concerns have been raised in relation to the provision of life line services in the event of local power failure on NGNs providing Analogue and ISDN voice connectivity (supporting legacy analogue PSTN TE and ISDN TE).

The current guidance on this matter is that broadband NTE should provide some means of powering at least one voice terminal in the event of power fail, such that emergency calls may still be made. However, the performance of such powering (e.g. standby time versus talk time) is a commercial issue and is not specified in the present document.

Manufacturers of such equipment should clearly indicate through suitable user warning statements; whether a specific TE port is to be powered in the event of power failure together with details of the period and under what conditions power will be supplied to the voice terminal.

NOTE: The OCG EMTEL requirements Special Report will need to be studied further in relation to any guidance provided in this clause.

Annex B (informative): Supplementary Service Definitions

The following list is intended to reflect the commonality of those supplementary service definitions used worldwide and the variation of names by which those services are also known.

A study by ETSI HF has produced TR 102 083 [42] that resulted from responses to a questionnaire regarding those supplementary services, using service codes, supported by various European networks. Further reference to that study should also be made by developers and implementers of NGNs.

The list given below is general and is not specific to the support of either analogue or ISDN TE. EG 201 973-2 [40] and EG 201 973-3 [41] list the specific services relevant to analogue and ISDN legacy terminals respectively.

Alternative definitions have been collated as part of the ETSI TEDDI database, reference to those variants should also be made for further understanding in this area: <http://portal.etsi.org/>.

Key to meanings:

Or. Origin of the text definition for a given service.
Other name(s) Variation of the stated supplementary service name.

NOTE 1: Where available a clause or page reference is provided for the given standard or specification.

NOTE 2: Additional references to be added to reflect supplementary service code/definition alignment of CEPT T/CAC and former CEPT SF Handbook (SFII) references to ETS 300 738 (and Finnish national guidance document GFI 9804 ed.3 7.5.2002)

B.1 Abbreviated Address Services

B.1.1 Abbreviated Address (AA)

The possibility for a subscriber to make a call by sending a short code instead of the full number.

Or.: T/CAC S 10.5, 1.1
Other name: Abbreviated dialling, SFII 1.1, 4 options
ETSI title Abbreviated dialling, 2 options registered

B.1.2 Fixed Destination Call (FDC)

The possibility for a subscriber to set up a call to a predetermined number, nominated by the subscriber, without having to send address signals to the network.

Or.: T/CAC S 10.5, 1.2
Other name: Hot Line SFII 1.2 3 options
ETSI title Fixed destination call, two options registered

B.1.3 Repeat Last Call (RLC)

The possibility for a subscriber to store the last number dialled and to be able to repeat that number by dialling a short code. The user may store the last number dialled either during the call or before releasing the call.

Or.: T/CAC S 10.5, 1.3
Other names: Number repetition, last number dialled SFII 6.2 3 options
 Automatic Callback (AC), CLASS service no. 3. TA-NWT-000215
 Repeat Dialling, CLASS service no. F
ETSI title Last number repetition, no options registered

B.2 Address Information Services

B.2.1 Direct Dialling In (DDI)

The Direct Dialling In (DDI) supplementary service enables a user to call directly via a public ISDN a user on a private ISDN by using the public ISDN numbering plan.

Or.: ETS 300 062 [7]
ITU-T Recommendation I.251.1, COM I-R 45, p 10
T/CAC S 10.5, 2.1; 10.7, 9
SFII 12.1

B.2.2 Multiple Subscriber Number (MSN)

The Multiple Subscriber Number (MSN) supplementary service provides the possibility for assigning multiple numbers to a single public or private access.

Or.: ETS 300 050 [5]
ITU-T Recommendation I.251.2, COM I-R 45, p 15
T/CAC S 10.5, 2.2; 10.7, 14

B.2.3 SUB-addressing (SUB)

The Subaddressing (SUB) supplementary service allows the called (served) user to expand his addressing capacity beyond the one given by the ISDN number.

Or.: ETS 300 059 [6]
ITU-T Recommendation I.251.8, COM I-R 45, p 41
T/CAC S 10.5, 2.3; 10.7, 18

B.2.4 Automatic Personal Call (APC)

With prior indication from a subscriber an operator may be associated with an automatically dialled call at the appropriate stage to determine if the wanted person is available.

Or.: SFII 6.8

B.2.5 Distinctive Ringing (DR)

The possibility for a customer to receive a distinctive ringing (call arrival indication) at his telephone when receiving calls from a set of numbers previously registered for this service.

Or.: SFII 14.9

B.2.6 Distinctive Ringing/Call Waiting (DRCW)

Distinctive Ringing/Call Waiting (DRCW) is an incoming call management service that allows the served user to designate special telephone number that may be identified by a distinctive alerting pattern that differs from standard power ring or call-waiting tone. The served user specifies the callers who are to special treatment by including their telephone numbers on a screening list. The structure of the list and the methods for updating its contents are described in the CLASSsm Feature: Screening List Editing.

Or.: CLASS service no. 12, TR-TSY-000219
Other name: Priority Ringing, CLASS service no. I

B.2.7 Distinctive Ringing Called Number Dependent (DRCN)

The Distinctive Ringing Called Number Dependent (DRCN) supplementary service enables the customer to have more directory numbers assigned to the same access, each with a different ringing sequence. With an incoming call, it can be immediately recognized acoustically which number has been called.

B.3 Advice of Charge Services (AoC)

B.3.1 Advice of Charge, Charging Information at Call Setup Time (AoC-S)

The AOC-S supplementary service provides the served user with information about the charging rates at call establishment. In addition, the served user shall be informed if a change in charging rates takes place during the call. The information can be sent for all calls, or on a per call basis. The charge information given shall relate to the charges incurred on the network to which the served user is attached.

NOTE: In some cases, e.g. due to off-line processing of charges, or timing considerations, the charge calculated by the user or the user's equipment may not precisely reflect the actual cost incurred.

Or.: ETS 300 178 [8]
 ITU-T Recommendation I.256.2a, COM 1-R 43, p 22
 T/CAC S 10.5, 3.1; 10.7, 1.1
 ETSI title Advice of charge, Call set-up

B.3.2 Advice of Charge, Charging Information During the Call (AoC-D)

The advice of charge, during call supplementary service provides the served user with cumulative (or incremental) charging information during the active phase of a call. Dependent on the option chosen at the time of subscription, the information can be sent for all calls, or on a per call basis. The charge information given relates to the charges incurred on the network to which the served user is attached.

Or.: ETS 300 179 [9]
 ITU-T Recommendation I.256.2b, COM 1-R 43, p 33
 T/CAC S 10.5, 3.2; 10.7, 1.2
 ETSI title Advice of charge, During call (two options described; cumulative or incremental)

B.3.3 Advice of Charge, Charging Information at the End of the Call (AoC-E)

The advice of charge, during call supplementary service provides the served user with incremental charging information during the active phase of a call. Dependent on the option chosen at the time of subscription, the information can be sent for all calls, or on a per call basis. The charge information given relates to the charges incurred on the network to which the served user is attached.

Or.: ETS 300 180 [10]
 ITU-T Recommendation I.256.2c, COM 1-R 43, p 42
 T/CAC S 10.5, 3.3; 10.7, 1.3
 ETSI title Advice of charge, End of call

B.3.4 Advice of Charge: Charging information on user Request (AoC-R)

The Advice of Charge: Charging information on user Request (AoC-R) supplementary service enables a user to receive information on the recorded charges, for a call, at the time of his own request during the active phase of this call.

Or.: Provision of Charging Information on Request, T/CAC S 10.5 3.4

B.3.5 Subscriber Call Charge Meter

The possibility for a subscriber to have a meter at his own premises, showing the number of call charge units debited.

Or.: SFII 7.1
ETSI title Home meter

B.3.6 Automatic Verbal Announcement of Charges Applied

The possibility for a user to request a verbal announcement of either the total or individual call charges.

Or.: SFII 7.2, 6 options
ETSI title Not in register of service codes

B.3.7 Printed Record on Duration and Charge of Calls

The possibility for a subscriber to get a specific printed record of called number, duration and charge of calls.

Or.: SFII 7.3, 8 options
ETSI title Not in register of service codes

B.4 Call Booking Services

B.4.1 Alarm Call

The possibility for a user to cause an alarm call to be made to his line at a time or times specified in advance by him and to receive an appropriate indication, when the call is answered.

Or.: T/CAC S 10.5 4.1
SFII 2.1 3 options
ETSI title Alarm call (three options described; Casual; Regular, number of days; Programme)

B.4.2 Booked Call

With prior information from a subscriber, a call may be made automatically from his termination to a particular number or services (excluding the Alarm Call Service) at a specified date and time.

Or.: T/CAC S 10.5 4.2
ETSI title Not in register of service codes

B.4.3 Diary Service

With prior indication from a subscriber, a call is made automatically to his telephone number at a specific date and time and when an answer condition is detected a recorded message is connected to his telephone termination to remind him of a particular event, e.g. the birthday of a relative.

Two versions of the service are envisaged:

- a) The recorded message is dictated to the recording equipment by the subscriber in each individual case,
- b) The recorded message is selected from a variety of pre-stored messages.

Or.: SFII 2.3

B.5 Call Barring Services

Other name: Call restriction services

B.5.1 Closed User Group (CUG)

This service enables users to form groups to and from which access is restricted. Members of a specific CUG can communicate among themselves, but not, in general, with users outside the group. Specific User group members can have additional capabilities that allow them to originate calls outside the group and/or to receive calls from outside the group.

Or.: ETS 300 136 [11]
 ITU-T Recommendation I.255.1, COM I-R 45, p 109
 T/CAC S 10.5, 5.1; 10.7 6.1
 SFII 3.3 3 options

B.5.2 Incoming Call Barring (ICB)

The Incoming Call Barring (ICB) supplementary service provides the user with the possibility to have certain categories of incoming calls barred from its termination. (The possibility for a fixed or mobile subscriber to prevent all or certain incoming calls to his telephone number. The service may be fully service provider controlled, or registered with a service provider but subscriber controlled, or barring category fully selected and controlled by the subscriber).

Or.: T/CAC S 10.5, 5.2
 Other name: Terminating Call Screening
 ETSI title: Barring, Incoming calls. The register describes other options.

B.5.3 Outgoing Call Barring: Fixed (OCB-F)

The Outgoing Call Barring: Fixed (OCB-F) supplementary service enables calls belonging to certain types to be rejected when they are originated by the served user. The served user's ability to receive incoming calls is unaffected by the OCB-F supplementary service. The OCB-F is fully service provider controlled.

Or.: EN 301 001-1 [12]
 ITU-T Recommendation I.255.5, COM I-R 45, p 122
 T/CAC S 10.7 6.2
 Other name: Service Restriction in the Outgoing Direction, SFII 3.1, 3 option
 Originating Call Screening
 ETSI title: Not in register. Currently does not use service code.

B.5.4 Outgoing Call Barring: User Controlled (OCB-UC)

The Outgoing Call Barring: User Controlled (OCB-UC) supplementary service enables calls belonging to certain types to be rejected when they are originated by the served user. The served user's ability to receive incoming calls is unaffected by the OCB-UC supplementary service. The served user can select the barring program, activate and later deactivate it. (This service provides the subscriber with the possibility to prevent all or certain types of outgoing calls and/or service control operations from his telephone line. When he applies the restriction the subscriber can select one or a number of types of restriction prescribed by the service provider.)

Or.: ITU-T Recommendation I.255.5, COM I-R 45, p 122
T/CAC S 10.7 6.2
Other name: Service Restriction in the Outgoing Direction, SFII 3.1, 3 options
Originating Call Screening
ETSI title Barring Outgoing calls, Subscriber selected. The register describes other options

B.5.5 Security Screening (SS)

The Security Screening supplementary service enables a network operator or service provider to screen attempts to access a network system, or an application.

A user must provide the correct identification code before access will be allowed. All attempts to access the network, the system or the application will be recorded whether successful or not.

Or.: T/CAC S 10.5, 5.4
ETSI title Not in register. Currently does not use service code.

B.5.6 Inhibition of Incoming Forwarded Calls (IIFC)

The Inhibition of Incoming Forwarded Calls (IIFC) supplementary service allows a user to prevent all forwarded calls, or just those associated with a specified basic service or class of basic services, from being offered to his access interface.

Or.: T/CAC S 10.5, 5.5
ETSI title Not in register. Currently does not use service code.

B.5.7 Anonymous Call Rejection (ACR)

Anonymous Call Rejection (ACR) is a service that allows the served user to reject calls from users who have a privacy service that prevents the delivery of their calling number to the served user.

Or.: CLASS service no. 1. TR-NWT-000567
ETSI title Call rejection for CLIR activation. A second option is rejection for no CLIP

B.5.8 Barring, Selective, Incoming Calls, all but 10 numbers barred (Code:932)

The possibility for a subscriber to bar all incoming calls except calls originating from up to 10 numbers selected by the subscriber.

Or.: SF 3.2.4, T/CAC S 10.5 5.2
Other name: CLASS service no. 14. TA-TSY-001034
Special Call Acceptance, CLASS service no. A

B.5.9 Selective Call Rejection (SCR)

Selective Call Rejection (SCR) is a service that allows served user to reject call attempts from a limited number of calling parties. The served user specifies the callers who are to be rejected by including their telephone numbers on a screening list. Incoming calls that are on the list will be rejected.

The structure of the list and the methods for updating its contents are described in the CLASSsm Feature: Screening List Editing.

Or.: CLASS service no. 16. TR-TSY-000218
 Other name: Call Screening, CLASS service no. E
 ETSI name: Barring, Selective, Outgoing Calls, up to 10 numbers barred (Code: 931)

B.5.10 ADdress Screening (ADS)

Address screening (ADS) is a supplementary service that can be provided in association to a data transfer service.

It provides restrictions on the user sending data units to certain destination users and/or the user receiving data units from certain source users.

Or.: ITU-T Recommendation I.259.1, COM 1-R 67 p61

B.6 Call Completion Services

B.6.1 Call Waiting (CW)

This service enables a busy user to be notified of an incoming call in a waiting position. The notification indicates that no information interface channel is available. The user then has the choice of accepting, rejecting or ignoring the waiting call making use of Switching Orders.

Or.: ETS 300 056 [13]
 ITU-T Recommendation I.253.1, Blue Book III.7 p.272
 T/CAC S 10.5, 6.1; 10.7, 2
 SFII 6.4, 4 options

B.6.2 Completion of Calls to Busy Subscriber (CCBS)

This service allows a calling user A, encountering a busy destination B, to have the call completed when the busy destination B becomes idle, without having to make a new attempt.

Or.: EN 300 357 [14]
 ITU-T Recommendation I.253.3, COM 1-R 67, p 21
 T/CAC S 10.5, 6.2; 10.7, 7
 SFII 6.1

B.6.3 Queue Service (QS)

The possibility for a subscriber to have incoming calls placed in a queue when all his lines are busy.

Or.: T/CAC S 10.5, 6.3
 SFII 6.9

B.6.4 Completion of Calls on No Reply (CCNR)

The Completion of Calls on No Reply supplementary service allows a calling user A, encountering a non-answering destination B, to be notified when the destination B becomes available.

Or.: EN 301 065-1 [15]
ITU-T Recommendation I.253.4, COM 1-R 67, p 42
T/CAC S 10.5, 6.4
SFII 6.1

B.6.5 Called Line Free Indication

At fixed intervals the exchange automatically checks whether a telephone number the service user has dialled before but found busy is still busy. As soon as the number is found free an indication is given to the service user, who then would have to repeat his call attempt.

Or.: SFII 6.6

B.6.6 Call Return

This service provides the possibility to activate an automatic call back to the last number which called and received ringing tone no reply.

Or.: SFII 6.10
CLASS service no. G
Other names: Automatic Recall (AR), CLASS service no. 4. TA-NWT-000227

B.6.7 Call Back (CB)

The Call Back service allows the called user (subscriber B) to generate, by means of an easy action, a call towards the incoming caller (subscriber A), that made the last correctly received call to the subscriber B, regardless whether that call was replied or not.

Other name: EURESCOM P403
Recall to the last incoming Caller

B.7 Call Registration Services

B.7.1 Date and Time Call Record

The possibility for a subscriber to have registered by the network the date and time at the start of each call.

Or.: T/CAC S 10.5, 7.1

B.7.2 Logging of Incoming Calls

The possibility for a subscriber to have registered details of all incoming calls to a particular termination, e.g.:

- Caller's number;
- Time ringing commenced;
- Time and answer or time of abandonment;
- Time of release;
- Advice on transferred charges.

Or.: T/CAC S 10.5, 7.2
SFII 4.2
Other name: Call Logging (CL), CLASS service no. 8. TA-NWT-001386

B.7.3 Malicious Call Identification (MCID)

The Malicious Call Identification (MCID) supplementary service enables a user to request that the source of an incoming call is identified and registered by the network.

Or.: ETS 300 128 [16]
ITU-T Recommendation I.251.7, COM I-R 45, p 32
T/CAC S 10.5, 7.3; 10.7, 13
SFII 14.2, 6 options
Other names: Customer Originated Trace (COT), CLASS service no. 11. TR-TSY-000216
Call Trace, CLASS service no. B

B.7.4 Bulk Calling Line Identification (BCLID)

Bulk Calling Line Identification (BCLID) is a service that allows Centrex, multi-line hunt group (MLHG), or Private Branch eXchange (PBX) user to receive call-related information on calls received by Centrex, MHLG, or PBX.

Or.: CLASS service no. 5. TR-NWT-000032

B.8 Changed Charging Services

B.8.1 FreePHone (FPH)

The FreePHone (FPH) supplementary service allows the served user having one or several installations to be reached from all or part of the country, or internationally as appropriate, with a FPH number and to be charged for this kind of calls.

Or.: ETS 300 208 [17]
T/CAC S 10.5, 8.1; 10.7, 11
SFII 7.5

B.8.2 REVerse charging at call Setup time (REV-S)

The REVerse charging at call Setup time (REV-S) supplementary service allows the served (called) user of a call to be charged for the entire call. Only usage-based charges can be charged to the called user. The REV-S supplementary service shall be requested by the calling user at call setup time.

Or.: ITU-T Recommendation I.256.3, COM I-R 45, p 128, + COM 1-R 23, p 90
T/CAC S 10.5, 8.2

B.8.3 REVerse charging Unconditional (REV-U)

The REVerse charging Unconditional (REV-U) supplementary service allows the served user to be charged for all incoming calls or all incoming calls for a predefined set of basic services. Only usage-based charges can be charged to the called user.

Or.: ITU-T Recommendation I.256.3, COM I-R 45, p 128, + COM 1-R 23, p 90
T/CAC S 10.5, 8.2

B.8.4 Transfer of Charge

The possibility for the automatic transfer of call charges either to some other subscriber or to a special account.

Or.: T/CAC S 10.5, 8.3
 Other name: Automatic Transferred Debiting of Call Charges, SFII 7.4
 Alternative Billing

B.8.5 Wide Area Service

For a flat rate charge a subscriber may make an unlimited number of calls within a prescribed area from a particular termination without the registration of call charges.

Or.: T/CAC S 10.5, 8.4
 SFII 7.6

B.8.6 Split Charging

The Split Charging supplementary service enables a network operator to distribute the charges for a call between the parties involved.

Or.: T/CAC S 10.5, 8.5

B.8.7 Premium Rate

The Premium Rate supplementary service allows a served user to provide value added services to calling users and to receive revenue from them. The calling user will be charged both for the transport and for the value added service. The revenue generated by the call except for the fraction devoted to transport shall be partly or wholly transferred to the served user. The rate to be applied to the calling user shall be determined by the network based on the dialled number.

Or.: T/CAC S 10.5, 8.6

B.8.8 International [Premium Rate] services

The International [Premium Rate] Service (IPRS) is a service whereby callers are offered the possibility to access a wide range of information and conversational services provided by service providers in other countries. The caller to the IPRS will be charged a "Premium Rate" for costs in connection with the services.

Access to the service is through national [Premium Rate] numbers in the country of origin. The caller dials a national number which is translated into a routing number and forwarded to the destination country.

Or.: ITU-T Draft E. prs COM 1-R 41, p 26

B.8.9 International Freephone Service (IFS)

The International Freephone Service (IFS) enables a customer in one country to be assigned one or more special telephone numbers in another country(ies) which allow callers in those countries to call the customer free of charge. All service and call-related charges are paid by the customer.

The international Freephone Service may be provided using:

- a) Access through national freephone number in the country of origin. An IFS number assigned to the customer from the available freephone numbers in each country from which the customer wishes to receive IFS calls. Due to variations in freephone number structure among countries, it is likely that the assigned number cannot be the same in each country. The caller dials a national freephone number, which is translated into a routing number and routed to the country of destination.

- b) Access to foreign domestic freephone numbers via international direct dialling. The IFS customer uses a single domestic freephone number to accept freephone calls from other countries. IFS callers can access the IFS customer by dialling the international prefix and the country code followed by the called IFS customer's national freephone number.
- c) Access via Universal International Freephone Numbers (UIFN). A universal international freephone number enables an IFS customer to be assigned a special IFS number that is the same throughout the world. It facilitates uniform global access to the IFS customer from all IFS service providers who choose to offer this feature. The UIFN should be portable, giving IFS customers the ability to retain their UIFNs when changing IFS service providers. The caller dials the international prefix followed by the UIFSN. This is translated into a routing number and routed to the country of destination.

Throughout this Recommendation, service provider A is the service provider which has the customer (the ROA of the destination of calls) and which is responsible for all relations with the customer. Service provider B is the ROA responsible for the establishment of the access to the international freephone number in its country. Figure 1/E.152 depicts the relationship of service providers A and B as regards the direction of call flow.

Or.: ITU-T Recommendation F.125, COM 1-R 41, p 7

B.8.10 Home Country Direct

Home Country Direct is an optional feature of the international telephone service which enables a caller in one country to access directly an ROA of another country for the purpose of placing a reverse, charge card, or credit card call to that country. This feature shall be provided on the basis of a bilateral agreement between the cooperating ROAs.

Or.: ITU-T Draft E.hcd COM 1-R 41, p 27
Other Name: International Operator Direct Calling (IODC).

B.9 Diversion Services

B.9.1 Call Forwarding Unconditional (CFU)

The Call Forwarding Unconditional (CFU) supplementary service enables a served user to have the network redirect to another user calls which are addressed to the served user's ISDN number. The CFU supplementary service may operate on all calls, or just those associated with specified basic services. The served user's ability to originate calls is unaffected by the CFU supplementary service. After the CFU supplementary service has been activated, calls are forwarded independent of the status of the termination of the served user.

Or.: ETS 300 200 [18]
ITU-T Recommendation I.252.4, COM I-R 62, p 25
T/CAC S 10.5, 9.1: 10.7, 10.1
Other names: Absent Subscriber Service, SFII 4.1, 12 options
Do not Disturb Service, SFII 5.1, 12 options

B.9.2 Call Forwarding Busy (CFB)

The Call Forwarding Busy (CFB) supplementary service enables a served user to have the network redirect to another user calls which are addressed to the served user's ISDN number and meet busy. The CFB supplementary service may operate on all calls, or just those associated with specified basic services. The served user's ability to originate calls is unaffected by the CFB supplementary service.

Or.: EN 300 199 [19]
ITU-T Recommendation I.252.2, COM 1-R 62, p 3
T/CAC S 10.5, 9.2; 10.7, 10.2
Other name: Diversion on busy, SFII 6.3 8 options

B.9.3 Call Forwarding No Reply (CFNR)

The Call Forwarding Unconditional (CFNR) supplementary service enables a served user to have the network redirect to another user calls which are addressed to the served user's ISDN number, and for which the connection is not established within a defined period of time. The CFNR supplementary service may operate on all calls, or just those associated with specified basic services. The served user's ability to originate calls is unaffected by the CFNR supplementary service.

Or.: EN 300 201 [20]
ITU-T Recommendation I.252.3, COM 1 R 62, p 14
T/CAC S 10.5, 9.3; 10.7, 10.3
Other name: Absent Subscriber Service, SFII 4.1, 12 options

B.9.4 Call Deflection (CD)

The Call Deflection (CD) supplementary service enables the served user to respond to an incoming call by requesting redirection of that call to another user. The CD supplementary services can only be invoked before the connection is established by the served user, i.e. in response to the offered call, or during the period that the served user is being informed of the call. The served user's ability to originate calls is unaffected by the CD supplementary services.

Or.: ETS 300 202 [21]
ITU-T Recommendation I.252.5, COM I-R 45, p. 82 + COM 1-R 23, p. 69
T/CAC S 10.5, 9.4; 10.7, 10.4

B.9.5 Call Forwarding Unconditional to a Service Centre (CFU-S)

The Call Forwarding Unconditional to a Service Centre (CFU-S) supplementary service enables a served user to have the network redirect to a service centre calls which are addressed to the served user's ISDN number. The CFU-S supplementary service may operate on all calls, or just those associated with specified basic services. The served user's ability to originate calls is unaffected by the CFU-S supplementary service. After the CFU-S supplementary service has been activated, calls are forwarded independent of the status of the termination of the served user.

Or.: T/CAC S 10.5, 9.5; 10.7, 10.5

B.9.6 Call Forwarding Busy to a Service Centre (CFB-S)

The Call Forwarding Busy to a Service Centre (CFB-S) supplementary service provides the user with the possibility of having incoming calls meeting busy forwarded to a service centre. During the registration phase the service centre has to accept the request from the user.

Or.: T/CAC S 10.5, 9.6; 10.7, 10.6

B.9.7 Call Forwarding No Reply to a Service Centre (CFNR-S)

The Call Forwarding No Reply to a Service Centre (CFNR-S) supplementary service provides the user with the possibility of having not replied incoming calls forwarded to a service centre. During the registration phase the service centre has to accept the request from the user.

Or.: T/CAC S 10.5, 9.7; 10.7, 10.7

B.9.8 Selective Call Forwarding (SCF)

The Selective Call Forwarding (SCF) supplementary service enables a served user to specify the forwarding of their incoming calls to a selected destination subject to certain conditions or circumstances e.g. Calling Line Identity of customer.

Or.: EN 301 133 [22]
T/CAC S 10.5, 9.8
CLASS service no. 15
Other names: Selective Diversion, SFII 5.2
Preferred Call Forwarding, CLASS service no. D

B.9.9 Selective Call Forwarding Busy

The Selective Call Forwarding Busy supplementary service enables the user to specify that incoming calls can be forwarded to a series of other addresses according to particular criteria, if the served user is busy.

The criteria which may be used to determine whether the call will be forwarded could include the calling line identity, the sub-address, and the time of day.

Or.: EN 301 133 [22]
T/CAC S 10.5, 9.9

B.9.10 Selective Call Forwarding No Reply

The Selective Call Forwarding No Reply supplementary service enables the user to specify that incoming calls can be forwarded to a series of other addresses, according to particular criteria, if they are not answered within a particular period of time.

The criteria which may be used to determine whether the call will be forwarded could include the calling line identity, the sub-address, and the time of day.

Or.: EN 301 133 [22]
T/CAC S 10.5, 9.10

B.9.11 Sequence Calling (SC)

Incoming calls may be diverted automatically to a series of numbers. Each of the numbers is called in turn until a call is set up or all the numbers have been tested.

Or.: T/CAC S 10.5, 9.11

B.9.12 Call Forwarding Service

The possibility for a subscriber to obtain a telephone number in a distant area and have all calls to that number automatically forwarded at his cost to a telephone number in his premises.

Or.: SFII 7.11

B.10 Help Services

B.10.1 Fault Reporting

A service which enables faults to be identified to the network operator. The fault information may originate either from the customer, or automatically from the customer's terminal or from the network.

Or.: T/CAC S 10.5, 10.1

B.10.2 General Deactivation (GD)

The possibility for a subscriber to deactivate all supplementary services activated on his line except Abbreviated Address and services requiring keywords.

Or.: T/CAC S 10.5, 10.2
SFII 14.8

B.10.3 Operator Access to and Control of Supplementary Services

The possibility for a network operator to be able to control supplementary services on behalf of customers.

Or.: T/CAC S 10.5, 10.3

B.10.4 Remote Control of Supplementary Services (RCSS)

The Remote Control (RC) service enables a user to control a supplementary service or a number of supplementary services associated with that user from another access.

Or.: T/CAC S 10.5, 10.4; 10.7, 17

B.10.5 Time Dependent Control of Supplementary Services

The possibility for a customer to activate certain supplementary services at predetermined discrete time periods.

Or.: SFII 2.4

B.10.6 Screening List Editing (SLE)

Screening List Editing (SLE) is a set of procedure that allows the served user to activate and deactivate services that use lists (Screening List Service - SLS), obtain a feature status report, create and modify lists of telephone number. The Screening List Services (SLS) are DRCW, SCA, SCF, SCR.

Or.: CLASS service no. 13. TA-NWT-000220
Other name: Visual Screening List Editing (VSLE), CLASS service no. 17. TA-NWT-001436

B.11 Information Transfer Services

B.11.1 Delivery Confirmation (DC)

The Delivery Confirmation supplementary service provides the originating party with the possibility to request that an explicit notification be returned to it when a submitted message has been successfully delivered to a receiving party.

Or.: T/CAC S 10.5, 11.1

B.11.2 Packet Delivery Confirmation (PDC)

A user facility which will provide information to the sending termination that the receipt of a given packet has been acknowledged by the nominated addressee(s).

Or.: T/CAC S 10.5, 11.2

B.11.3 User-to-User Signalling (UUS)

The User-to-User Signalling (UUS) supplementary service allows an ISDN user to send/receive a limited amount of information to/from another ISDN user over the signalling channel in association with a call to the other ISDN user.

Or.: ETS 300 284 [23]
ITU-T Recommendation I.257.1, COM I-R 45, p. 139 + COM 1-R 38, p. 64
T/CAC S 10.5, 11.3; 10.7, 21

B.11.4 Voice Mail (VM)

The fundamental ability of the Voice Mail (VM) service is to provide a public interface between originators and recipients of voice communication to enhance their means of communication, especially where there is no immediate or convenient direct telecommunication service available between subscribers' equipment, or the telecommunication service available are incompatible. This service may also provide features available for the preparation and the presentation of the messages.

Or.: ITU-T Recommendation F.440
T/CAC S 10.5, 11.4 (Voice Box)

B.11.5 Message Waiting Indication (MWI)

The Message Waiting Indication (MWI) supplementary service enables a voice box (VMB) user, to be indicated, that there are message in his/her voice mailbox, when the VMB user intends to make an outgoing call.

Or.: EN 300 650 [24]

B.12 Multiline Services

B.12.1 Centrex

The provision of customers by means of specially equipped public exchanges of services normally available only in PBXs, e.g. internal connections.

Or.: T/CAC S 10.5, 12.1

B.12.2 Line Hunting (LH)

The Line Hunting (LH) supplementary service enables calls to a single ISDN number to be offered to a free access in a group of accesses to which terminals are connected.

Or.: EN 301 479 [25]
ITU-T Recommendation I.252.6, Blue Book III.7 p. 267
T/CAC S 10.5, 12.2; 10.7, 12
SFII 12.2, 7 options

B.12.3 Trunk Hunting (TH)

The Trunk Hunting (TH) supplementary service enables calls to an ISDN number to be offered to a free access in a group of accesses to which a private ISDN is connected.

B.12.4 Support of Private Numbering Plan (SPNP)

The Support of Private Numbering Plan (SPNP) supplementary service enables a subscriber to define and use a Private Numbering Plan (PNP) for communication across one or more networks between nominated user access interfaces. A PNP provides a group of users the capability to place calls by using digit sequences having different structures and meanings than provided by the Public Numbering Plan.

Or.: ITU-T Recommendation I.255.2, COM 1-R 57, p. 36
 Other name: Private Numbering Plan (PNP)
 Or.: T/CAC S 10.5, 12.3; 10.7, 15

B.12.5 Multilocation Business Group (MBG)

The Multilocation Business Group (MBG) supplementary service is a grouping mechanism that allows users belonging to a customer but resident at more locations to subscribe to a variety of business services. The MBG supplementary service enables multilocation customers to coordinate their telecommunication services and to operate uniformly.

Or.: T/CAC S 10.5, 12.4

B.13 Multiparty Calls

B.13.1 Call Hold (HOLD)

The Call Hold (HOLD) supplementary service allows a user to interrupt communications on an existing call and the subsequently, if desired, re-establish communications.

Or.: ETS 300 139 [26]
 ITU-T Recommendation I.253.2, COM I-R 45, p. 91
 T/CAC S 10.5, 13.1; 10.7, 3
 Other name: Three Party Service, Hold for Enquiry, SFII 11.1.1

B.13.2 Three-Party Service (3PTY)

The Three-Party Service (3PTY) supplementary service enables a user to establish, participate in and control, a three-way conversation, i.e. a simultaneous communication involving the served user and two remote parties.

Or.: ETS 300 186 [27]
 ITU-T Recommendation I.254.2, COM I-R 45, p. 100
 T/CAC S 10.5, 13.2; 10.7, 20
 Other name: Three Party Service, Hold for Enquiry with 3-way Conversation, SFII 11.1.2

B.13.3 Call Transfer (CT)

B.13.3.1 Normal Call Transfer (NCT)

The Normal Call Transfer supplementary service enables a user to transfer an established (i.e. active) call to a third party. For the original call, the "served user" (see clause B.2.3) may have been either the calling or called party (i.e. the call may have been either incoming or outgoing).

Or.: ITU-T (CCITT) I.252.1, COM I-R 20, p. 23

B.13.3.2 Explicit Call Transfer (ECT)

The ECT supplementary service enables a user who has two calls, each of which can be an incoming or an outgoing call, to connect the other users in the two calls into one call.

Or.: EN 300 367 [28]
 ITU-T Recommendation I.252.7, COM 1-R 62, p. 36
 T/CAC S 10.5, 13.3.1; 10.7, 4.1
 Other name: Three Party Service, Hold for Enquiry with Transfer, SFII 11.1.3

B.13.3.3 Single Step Call Transfer (SSCT)

The Single Step Call Transfer (SSCT) supplementary service enables a user to transfer an answered call to a third party without having to set up a new call to the third party first.

Or.: T/CAC S 10.5, 13.3.2; 10.7, 4.2

NOTE: The Single Step Call Transfer supplementary service is deleted from the work programmes of ETSI and ITU-T.

B.13.4 CONFerence call, add-on (CONF)

The CONFerence call, add-on (CONF) supplementary service enables a user to participate in, and control, a simultaneous communication involving a number of users.

Or.: ETS 300 183 [29]
 ITU-T Recommendation I.254.1, COM I-R 20, p. 99
 T/CAC S 10.5, 13.4; 10.7, 8.1
 SFII 11.2, 6 Options
 Other name: Conference Calling (ITU-T)

B.13.5 Meet-Me Conference (MMC)

The Meet-Me Conference (MMC) supplementary service enables a user to arrange for a call between more the two participants. During the period the conference is active, participants use a special number to access the conference.

Or.: ETS 300 164 [30]
 ITU-T Recommendation I.254.5, COM 1-R 62, p 46
 T/CAC S 10.5, 13.5; 10.7, 8.2
 Other name: Conference Call, Meet-Me

B.13.6 Lecture Call

A lecture call is an established connection between a caller and two or more parties whereby information is passed unidirectional from the caller to the other connected parties. The call is set up by an automatic device programmed by the caller from his own terminal.

Or.: T/CAC S 10.5, 13.6
 SFII 11.3

B.13.7 Preset Conference Calling service (PCC)

The Preset Conference service allows the served user to quickly establish a conference call with a predetermined list of conferees that is stored in the network. This simultaneous communication is established in parallel when a user requests a Preset Conference from the network. The request is matched by the network with a previously defined list of subscribers. Once the request is validated and the previous defined list of subscribers is determined, call attempts are made in parallel (i.e. the service provider will initiate the call attempts to Preset conferees without waiting for resolution of previous conferee call attempts) to the Preset conferees. Once a call attempts are either completed or terminated by lack of response, the network establishes a Preset Conference call between the previously defined conferees and the originating user. The procedures for managing an established Preset Conference are described in the present document.

Other name: Predetermined Conference Call, T/CAC S 10.5, 13.7

B.13.8 Booked Add-On Conference

This supplementary service provides a user with the ability to have a multiconnection call, i.e. a simultaneous communication between more than two parties. The supplementary service shall include a per-booking facility enabling the served user to pre-book conferences and enter addresses of all conferees in advance.

B.14 Identification Services

B.14.1 Calling Line Identification Presentation (CLIP)

The Calling Line Identification Presentation (CLIP) supplementary service provides the called party with the possibility of receiving identification of the calling party.

Or.: EN 300 089 [31]
ITU-T Recommendation I.251.3, COM I-R 45, p. 18
T/CAC S 10.5, 14.1; 10.7, 5.1
SFII 14.3

Other names: Calling Number Delivery (CND), CLASS service no. 10. TR-TSY-000031
Caller ID, CLASS service no. H

B.14.2 Calling Line Identification Restriction (CLIR)

The Calling Line Identification Restriction (CLIR) supplementary service enables the calling party to prevent presentation of its ISDN number to the called party.

Or.: EN 300 090 [32]
ITU-T Recommendation I.251.4, COM I-R 45, p. 27
T/CAC S 10.5, 14.2; 10.7, 14.2

Other names: Calling Identity Delivery Blocking, CLASS services 6. TA-NWT-000391
Caller ID Blocking, CLASS service no. C

B.14.3 Connected Line Identification Presentation (COLP)

The Connected Line Identification Presentation (COLP) supplementary service provides the calling party with the possibility to receive identification of the connected party.

Or.: EN 300 094 [33]
ITU-T Recommendation I.251.5, COM I-R 34, p. 4
T/CAC S 10.5, 14.3; 10.7, 5.3

B.14.4 Connected Line Identification Restriction (COLR)

The Connected Line Identification Restriction (COLR) supplementary service enables the connected party to prevent presentation of its ISDN number to the calling party.

Or.: ETS 300 095 [34]
ITU-T Recommendation I.251.6, COM 1-R 34, p. 14
T/CAC S 10.5, 14.4; 10.7, 5.4

B.14.5 Calling Name Identification Presentation (CNIP)

Calling Name Identification Presentation is a terminating service that provides either the name associated with the calling party number or an indication of privacy or unavailability to the called party.

Or.: ITU-T Recommendation I.251.9, COM 1-R 67, p. 3
Other names: Calling Name Delivery (CNAM), CLASS service no. 9. TR-NWT-00118
Audible Name and Number (ANN), CLASS service no. 2. TA-NWT-00xyzw

B.14.6 Calling Name Identification Restriction (CNIR)

Calling Name Identification Restriction is an originating service that allows a user to alter the network stored or subscribed privacy status associated with the users calling name.

Or.: ITU-T Recommendation I.251.10, COM 1-R 67, p. 12

B.14.7 Calling Identity Delivery on Call Waiting (CIDCW)

Calling Identity Delivery on Call Waiting (CIDCW) is a service that allows served user, while off-hook on an existing call, to receive information (i.e. name or directory number, date and time) about a calling party on a waiting call. The transmission of the calling should take place after the first call waiting tone.

Or.: CLASS service no. 7. TA-NWT-000575

B.15 Numbering Services

B.15.1 Out of Area Line

The Out of Area Line supplementary service enables the user to be connected to a public exchange when he is not located within the area of that exchange.

Or.: T/CAC S 10.5, 15.1

B.15.2 Permanent Subscriber Number (PSN)

The Permanent Subscriber Number supplementary service enables a subscriber having moved from one location to another to retain his access number.

Or.: T/CAC S 10.5, 15.2

B.15.3 Universal Access Number (UAN)

The Universal Access Number (UAN) service allows the service subscriber having one or several installations to be reached from all or part of the network with a unique universal access number. Calls to the universal access number shall be routed to destinations defined by the service subscriber.

Or.: ETS 300 710 [35]
T/CAC S 10.5, 15.3
SFII 14.5

B.15.4 Call DISTribution (CDIST)

The Call DISTribution (CDIST) supplementary service enables a served user to have incoming calls distributed over several accesses, according to the availability of destination users to be able to accept the call.

Or.: T/CAC S 10.5, 15.4

B.15.5 Call Volume Distribution (CVD)

The Call Volume Distribution supplementary service enables a customer to have calls distributed over a number of locations using a defined mechanism.

Or.: T/CAC S 10.5, 15.5

B.15.6 User Defined Routing (UDR)

The User Defined Routing supplementary service enables users to specify the routing of their outgoing calls according to the following choices:

- a) The type of network to be used (e.g. PSTN, VPN, mobile).
- b) The desired network operator.
- c) The physical bearer (e.g. optical, satellite).
- d) The least cost routing (dependent upon time of day, etc.).
- e) Region of call (origination/destination).
- f) Proportional routing of traffic.

Or.: T/CAC S 10.5, 15.6

B.15.7 Temporary Location for Outgoing Calls

The Temporary Location for Outgoing Calls supplementary service enables a subscriber to register a location from which that user can originate calls and to make outgoing calls from that location. This can be for a series of calls or on a per call basis.

Or.: T/CAC S 10.5, 15.7

B.15.8 Permanent Circuit (PC)

The Permanent Circuit supplementary service provides the user with the possibility to communicate via the ISDN on a permanent basis. The network operator is responsible for the establishment of the connection. If the connection is interrupted, it is the responsibility of the network operator to re-establish the connection.

Or.: T/CAC S 10.5, 15.8

B.15.9 Permanent Virtual Circuit (PVC)

The Permanent Virtual Circuit Service is a supplementary service to packet switched services giving permanent association between two DTEs which is identical to the information transfer phase of a virtual call. No call setup or clearing procedure is possible or necessary.

Or.: ETS 300 048 [36]
T/CAC S 10.5, 15.9

B.16 Payment Changing Services

B.16.1 Credit Card Calling (CRED)

The Credit Card Calling (CRED) supplementary service enables payment of charges by placing a credit card in a specially adapted terminal.

Or.: T/CAC S 10.5, 16.1
ITU-T Recommendation I.256.1, COM I-R 13, p. 71. Deleted 09.94

B.16.2 Payphone

The Payphone supplementary service enables outgoing calls to be made by means of special equipment after insertion of adequate coin(s), token(s) or a coded card.

Outgoing calls to certain services (e.g. the emergency service) may be allowed without payment. Incoming calls may be received without payment.

Or.: T/CAC S 10.5, 16.2
SFII 7.8

B.16.3 Automatic Credit Card Service (ACCS)

Payment of call charges is made by placing a credit card in a specially adapted telephone.

Or.: SFII 7.7

B.16.4 Account Card Calling (ACC)

The Account Card Calling supplementary service enables the served user to make a call from any card reading terminal and to have the charges for the call automatically debited to a domestic or business account number as defined by the card content.

At the invocation of the Account Card Calling supplementary service, the served user enters its personal identification which is then validated and one or more calls can then be made.

Or.: T/CAC S 10.5, 16.3

B.16.5 Automatic Transferred Charge Call

With prior indication and mutual agreement between the two parties, the automatic debiting to a called subscriber's account of relevant charges for a call made to his telephone number.

Or.: SFII 7.9

B.16.6 Selective Accounting (SA)

A number of separate telephone accounts are associated with an ex change termination and the account to which charges for a particular call are to be debited is identified when making the call.

Or.: SFII 7.10

B.16.7 Charge Card Calling (CCC)

The Charge Card Calling (CCC) service allows the user to be automatically charged to the service subscriber's account (as defined by the card content), which is a telecommunications account subscribed with the network operator or may be optionally an account managed by some other commercial organization, for any outgoing call made from a card reading terminal (e.g. a terminal capable of accepting smart cards). The use of non-telecommunications accounts is dependant on agreements between the service provider and such commercial organizations.

B.16.8 Virtual Card Calling (VCC)

The Virtual Card Calling (VCC) service allows the user to be automatically charged to the service subscriber's account, which is a telecommunications account subscribed with the service provider or may be optionally an account managed by some other commercial organization, for any outgoing call. The use of non-telecommunications accounts is dependant on agreements between the service provider and such commercial organizations. The call shall be free of charge for the line the call originates from. After accessing the service, the user has to enter the card number, a PIN code and the called number.

Or.: ETS 300 711 [37]

B.17 Priority Services

B.17.1 PRiority (PRI)

The PRiority (PRI) supplementary service provides preferential treatment to calls originating from and/or addressed to certain numbers in order of path selection.

Or.: T/CAC S 10.5, 17.1; 10.7, 16
ITU-T Recommendation I.255.4, White Booklet
SFII 6.5

B.17.2 Priority Selection (PS)

The Priority Selection supplementary service enables a user to request preference for a call.

Or.: T/CAC S 10.5, 17.2

B.17.3 MultiLevel Precedence and Pre-emption (MLPP)

The MultiLevel Precedence and Pre-emption (MLPP) supplementary service gives priority in call handling. This service has two parts - precedence and pre-emption. Precedence involves assignments of a priority level to a call. Pre-emption involves the seizing of resources, which are in use by a call of a lower precedence by a higher level precedence call in the absence of idle resources.

Or.: ITU-T Recommendation I.255.3, White Booklet
T/CAC S 10.5, 17.3

B.18 Opinion Collecting Services

B.18.1 TeleVOTing (VOT)

The teleVOTing (VOT) service allows a service subscriber to know the number of calls placed to particular numbers during the time period of a televoting event (e.g. giving the service subscriber the capability to survey the opinion of the caller using the telephone network)

Or.: ETS 300 713 [38]
T/CAC S 10.5, 19.1

B.18.2 Teledialogue

The Teledialogue supplementary service allows bi-directional connections to be set up in the telephony services between callers and the called party who, while producing mass traffic, only inquires for it at its subscriber station(s) to a very limited extent. The traffic not susceptible to inquiry is routed to stand-by stations which are connected to announcement systems provided by the network operator at the network nodes.

Or.: T/CAC S 10.5, 19.2

B.18.3 Mass Calling

The Mass Calling supplementary service enables a user to have a single directory number allocated for a period time specified by the served user. Each time a call is made to this number during this time period, the calling user will be prompted for the input of a further digit to indicate a preference. The choice made will be recorded and count incremented. When the time period ends, the Mass Calling supplementary service will be deactivated, and the network operator will supply details of the total votes cast for each preference to the served user.

Or.: T/CAC S 10.5, 19.3

B.19 Miscellaneous Services

B.19.1 Alarm (Warning)

The Alarm (Warning) supplementary service enables a suitable signalling device (e.g. key or sensor device) at the customer's premises which when operated will cause the network to send information to identify the particular premises to a specified terminal, e.g. to the Police or to a security agency. Signals will be continuously exchanged between the network and the customers' premises to protect against faults or sabotage.

Or.: T/CAC S 10.5, 18.1

B.19.2 Changing of Service During an Established Call

The possibility for a user to change the service during an existing call without disconnecting the call.

Or.: T/CAC S 10.5, 18.2

B.19.3 Expediting of a Call in Progress

Intervention by an operator, interrupting a call in progress, in order to allow another incoming call to be offered.

Or.: T/CAC S 10.5, 18.3
SFII 6.7

B.19.4 Interception of Calls

Calls which cannot reach the wanted number for reasons such as those listed below may be intercepted and diverted to an operator, an answering machine giving a verbal or written announcement, or a tone to give the callers the appropriate information.

- Change of a particular number including advice of a new number.
- Re-numbering of a group of numbers or a change of dialling code.
- Wrong information in directory.
- Dialling on an unallocated code.
- Dialling of a number allowed by the numbering plan but not yet allocated or no longer in service.
- Route(s) out of order.
- Route(s) congested.
- Subscriber's line temporarily out of order.
- Suspension of service owing to non-payment.

Or.: T/CAC S 10.5, 18.4
SFII 13.1

B.19.5 National Selection and Indication of Throughput Class

The National Selection and Indication of Throughput Class supplementary service enables the calling and called terminals to indicate and negotiate a throughput class in bit/s that will not be exceeded on the virtual call.

Or.: T/CAC S 10.5, 18.5

B.19.6 Terminal Portability (TP)

The Terminal Portability (TP) supplementary service allows a user to move a terminal from one socket to another within one given basic access during the active state of a call. It also allows a user to move a call from one terminal to another terminal within one given basic access during the active phase of the call.

Or.: ETS 300 053 [39]
ITU-T Recommendation I.258.1, COM 1-R 38, p. 81
T/CAC S 10.5, 18.6; 10.7, 19

B.19.7 User Selection of PAD Parameter Settings

The User Selection of PAD Parameter Settings supplementary service enables both the non-packet mode DTE (Data Terminal Equipment) and the packet mode DTE, when communicating via a PAD (Packet Assembler/Disassembler), to select the values of certain PAD parameters. Values may be selected individually or en-bloc, when selecting a specified standard profile.

Or.: T/CAC S 10.5, 18.7

B.19.8 Call Diversion Override (CDO)

The Call Diversion Override supplementary service enables a calling user to override the call diversion supplementary service at the called destination.

An option can be foreseen where the Call Diversion Override supplementary service is restricted to the user-to-user information, permitting the call be diverted.

Or.: T/CAC S 10.5, 18.8

B.19.9 Incall Modification (IM)

The Incall Modification (IM) supplementary service provides the user with the ability to modify the type of his call on an established connection in terms of bearer, low- and high layer capabilities, without changing the end-to-end user relationship.

Or.: ITU-T Recommendation I.258.2, COM 1-R 34, p. 21
T/CAC S 10.5, 18.9

B.19.10 Pick-up Facility

A subscriber being away from his telephone can pick up a call on his line by dialling his own number and/or possibly a special code from any other telephone, after having been informed by means of a paging system that there is such a call.

Or.: SFII 10.2

B.19.11 Message Relay (MR)

A caller, whether a subscriber or not, may dictate a message into recording equipment and require that it is passed to a particular telephone number e.g. by the following morning.

Or.: SFII 14.7

Annex C (informative): Bibliography

ETSI TR 101 730: "Publication of interface specification under Directive 1995/5/EC; Guidelines for describing analogue interfaces".

ETSI TR 101 731: "Access and Terminals (AT); Digital access to the public telecommunications network; Publication of interface specification under Directive 1995/5/EC".

Directive 1999/5/EC of the European Parliament and of the Council of 9 March 1999 on radio equipment and telecommunications terminal equipment and the mutual recognition of their conformity (R&TTE Directive); OJ L 091 (1999).

Draft ETSI DES/TISPAN-01002-NGN: "TISPAN; NGN Basic Supplementary services; General aspects".

ITU-T Recommendation F.125: "Numbering plan for access to the mobile-satellite services of INMARSAT from the international telex service".

ITU-T Recommendation F.440: "Message handling services: The voice messaging service".

ITU-T Recommendation I.251.1: "Number identification supplementary services: Direct-dialling-In".

ITU-T Recommendation I.251.2: "Number identification supplementary services: Multiple Subscriber Number".

ITU-T Recommendation I.251.3: "Number identification supplementary services: Calling Line Identification Presentation".

ITU-T Recommendation I.251.4: "Number identification supplementary services: Calling Line Identification Restriction".

ITU-T Recommendation I.251.5: "Number identification supplementary services: Connected Line Identification Presentation (COLP)".

ITU-T Recommendation I.251.6: "Number identification supplementary services: Connected Line Identification Restriction (COLR)".

ITU-T Recommendation I.251.7: "Number identification supplementary services: Malicious call Identification".

ITU-T Recommendation I.251.8: "Number identification supplementary services: Sub-addressing supplementary service".

ITU-T Recommendation I.251.9: "Number identification supplementary services: Calling name identification presentation".

ITU-T Recommendation I.251.10: "Number identification supplementary services: Calling name identification restriction".

ITU-T Recommendation I.252.1: "Call offering supplementary services: Call Transfer".

ITU-T Recommendation I.252.2: "Call offering supplementary services: Call Forwarding Busy".

ITU-T Recommendation I.252.3: "Call offering supplementary services: Call Forwarding No Reply".

ITU-T Recommendation I.252.4: "Call offering supplementary services: Call Forwarding Unconditional".

ITU-T Recommendation I.252.5: "Call offering supplementary services: Call Deflection".

ITU-T Recommendation I.252.6: "Call offering supplementary services: Line Hunting (LH)".

ITU-T Recommendation I.252.7: "Call offering supplementary services: Explicit call transfer".

ITU-T Recommendation I.253.1: "Call completion supplementary services: Call waiting (CW) supplementary service".

ITU-T Recommendation I.253.2: "Call completion supplementary services: Call Hold".

ITU-T Recommendation I.253.3: "Call completion supplementary services: Completion of calls to busy subscribers".

ITU-T Recommendation I.253.4: "Call completion supplementary services: Completion of calls on no reply".

ITU-T Recommendation I.254.1: "Multiparty supplementary services: Conference calling (CONF)".

ITU-T Recommendation I.254.2: "Multiparty supplementary services: Three-Party Supplementary Service".

ITU-T Recommendation I.254.5: "Multiparty supplementary services: Meet-me conference".

ITU-T Recommendation I.255.1: "Community of interest supplementary services: Closed User Group".

ITU-T Recommendation I.255.2: "Community of interest supplementary services: Support of Private Numbering Plans".

ITU-T Recommendation I.255.3: "Community of interest supplementary services: Multi-level precedence and pre-emption service (MLPP)".

ITU-T Recommendation I.255.4: "Community of interest supplementary services: Priority service".

ITU-T Recommendation I.255.5: "Community of interest supplementary services: Outgoing call barring".

ITU-T Recommendation I.256.1: "Charging supplementary services: Credit Card Calling (CRED)".

ITU-T Recommendation I.256.2a: "Charging supplementary services: Advice of charge: charging information at call set-up time (AOC-S)".

ITU-T Recommendation I.256.2b: "Charging supplementary services: Advice of charge: charging information during the call (AOC-D)".

ITU-T Recommendation I.256.2c: "Charging supplementary services: Advice of charge: charging information at the end of the call (AOC-E)".

ITU-T Recommendation I.256.3: "Charging supplementary services: Reverse charging".

ITU-T Recommendation I.257.1: "Additional information transfer supplementary services: User-to-User Signalling (UUS)".

ITU-T Recommendation I.258.1: "Mobility and modification supplementary services: Terminal portability (TP)".

ITU-T Recommendation I.258.2: "Mobility and modification supplementary services: In-call modification (IM)".

ITU-T Recommendation I.259.1: "Screening supplementary services: Address screening (ADS)".

ETSI ETS 300 738: "Human Factors (HF); Minimum Man-Machine Interface (MMI) to public network based supplementary services".

ETSI TS 101 272: "Transmission and Multiplexing (TM); Optical Access Networks (OANs) for evolving services; ATM Passive Optical Networks (PONs) and the transport of ATM over digital subscriber lines".

History

Document history		
V1.1.1	December 2002	Publication as TR 101 973-1
V1.2.1	December 2004	Membership Approval Procedure MV 20050218: 2004-12-21 to 2005-02-18