

**Universal Mobile Telecommunications System (UMTS);  
Virtual Home Environment (VHE)  
in the Integrated Services Digital Network (ISDN);  
Evolved UMTS core network**

---



---

**Reference**

REG/SPAN-061311

---

**Keywords**

IN, ISDN, UMTS, VHE

**ETSI**

---

**Postal address**

F-06921 Sophia Antipolis Cedex - FRANCE

---

**Office address**

650 Route des Lucioles - Sophia Antipolis  
Valbonne - FRANCE  
Tel.: +33 4 92 94 42 00 Fax: +33 4 93 65 47 16  
Siret N° 348 623 562 00017 - NAF 742 C  
Association à but non lucratif enregistrée à la  
Sous-Préfecture de Grasse (06) N° 7803/88

---

**Internet**

secretariat@etsi.fr  
Individual copies of this ETSI deliverable  
can be downloaded from  
<http://www.etsi.org>  
If you find errors in the present document, send your  
comment to: editor@etsi.fr

---

**Important notice**

This ETSI deliverable may be made available in more than one electronic version or in print. In any case of existing or perceived difference in contents between such versions, the reference version is the Portable Document Format (PDF). In case of dispute, the reference shall be the printing on ETSI printers of the PDF version kept on a specific network drive within ETSI Secretariat.

---

**Copyright Notification**

No part may be reproduced except as authorized by written permission.  
The copyright and the foregoing restriction extend to reproduction in all media.

© European Telecommunications Standards Institute 2000.  
All rights reserved.

# Contents

Intellectual Property Rights .....	5
Foreword .....	5
1 Scope .....	6
2 References .....	6
3 Definitions and abbreviations .....	6
3.1 Definitions .....	6
3.2 Abbreviations .....	7
4 Description of VHE .....	8
4.1 Virtual Home Environment capabilities .....	8
4.2 Structure of the issues for mapping functional modularity .....	8
4.2.1 Applications .....	9
4.2.2 Application support .....	9
4.2.3 Transport and signalling capabilities .....	10
4.2.4 Fabric management and underlying protocols .....	10
4.2.5 Network access, network and server addressing, user identification and security .....	10
5 Architecture for VHE .....	11
5.1 Possible mechanisms to realize VHE .....	13
5.1.1 Service execution within the home network .....	13
5.1.2 Service execution within the USIM .....	14
5.1.3 Service execution within the mobile equipment .....	14
5.1.4 Service execution within the serving network .....	15
5.1.4.1 Downloading from the home network to the serving network .....	15
5.2 Mapping services onto VHE architecture .....	17
6 VHE service components .....	17
6.1 Services provided by VHE .....	17
6.1.1 User aspects .....	17
6.1.1.1 Networks and their supportable QoS .....	17
6.1.1.2 Service cost .....	17
6.1.1.3 Service selection .....	17
6.1.1.4 Service (profile) modification .....	17
6.1.1.5 Language preferences .....	18
6.1.1.6 Location information .....	18
6.1.1.7 Roaming .....	18
6.1.1.8 Call management .....	18
6.1.1.9 Outgoing calls including multimedia and conference calls .....	18
6.1.1.10 Incoming calls including multimedia and conference calls .....	18
6.1.1.11 VASP incentives and opportunities .....	18
6.1.1.12 Location services .....	18
6.1.1.13 Video-on-demand .....	18
6.1.1.14 Electronic banking .....	18
6.1.2 Network operator aspects .....	19
6.1.2.1 Support of VHE in non-UMTS networks .....	19
6.1.2.2 Remote programming of USIM applications .....	19
6.1.2.3 Remote programming of mobile equipment applications .....	19
6.1.2.4 Remote programming of serving network service applications and service data .....	19
6.2 Functions related to support VHE .....	19
6.3 VHE scenarios .....	20
7 Requirements on inter-network interfaces .....	21
7.1 VHE service procedure .....	21
7.2 Assumptions .....	21
7.3 Common procedure modules used .....	21

7.4	Information flow diagram.....	22
7.5	Information flows description.....	22
	Bibliography .....	23
	History .....	24

---

## Intellectual Property Rights

IPRs essential or potentially essential to the present document may have been declared to ETSI. The information pertaining to these essential IPRs, if any, is publicly available for **ETSI members and non-members**, and can be found in SR 000 314: *"Intellectual Property Rights (IPRs); Essential, or potentially Essential, IPRs notified to ETSI in respect of ETSI standards"*, which is available from the ETSI Secretariat. Latest updates are available on the ETSI Web server (<http://www.etsi.org/ipr>).

Pursuant to the ETSI IPR Policy, no investigation, including IPR searches, has been carried out by ETSI. No guarantee can be given as to the existence of other IPRs not referenced in SR 000 314 (or the updates on the ETSI Web server) which are, or may be, or may become, essential to the present document.

---

## Foreword

This ETSI Guide (EG) has been produced by ETSI Technical Committee Services and Protocols for Advanced Networks (SPAN).

---

# 1 Scope

The present document covers scenarios and procedures to support the UMTS Virtual Home Environment (VHE). The Virtual Home Environment is a capability for providing operator-specific services to end users with a consistent look and feel which is independent of location and serving network. It facilitates service adaptation to different network environments supporting directly connected, cordless and cellular access. The philosophy of VHE has been proposed by GSM MoU and implementation scenarios have been identified and studied by ITU-T for IMT-2000 work.

---

# 2 References

The following documents contain provisions which, through reference in this text, constitute provisions of the present document.

- References are either specific (identified by date of publication, edition number, version number, etc.) or non-specific.
- For a specific reference, subsequent revisions do not apply.
- For a non-specific reference, the latest version applies.
- A non-specific reference to an ETS shall also be taken to refer to later versions published as an EN with the same number.

- [1] TR 101 695: "Integrated Services Digital Network (ISDN); Universal Mobile Telecommunications System (UMTS); ISDN-UMTS Framework".
- [2] ITU-T Recommendation E.164 (1997): "The international public telecommunication numbering plan".
- [3] ITU-T Recommendation E.212 (1998): "The international identification plan for mobile terminals and mobile users".
- [4] ITU-T Recommendation E.191 (1996): "B-ISDN numbering and addressing".
- [5] ITU-T Recommendation Q.1701 (1999): "Framework for IMT-2000 Networks".
- [6] ITU-T Recommendation Q.1711 (1999): "Network functional model for IMT-2000".

---

# 3 Definitions and abbreviations

## 3.1 Definitions

For the purposes of the present document, the following terms and definition applies:

**Virtual Home Environment (VHE):** system concept for personalized service portability across network boundaries and between terminals. The concept of the VHE is such that UMTS users are consistently presented with the same personalized features, user interface capabilities and services in whatever network and whatever terminal, wherever the user may be located. The exact configuration available to the user at any instant will be dependent upon the capabilities of the USIM, Terminal Equipment and Network currently being used or on the subscription restriction (user roaming being restricted)

## 3.2 Abbreviations

For the purposes of the present document, the following abbreviations apply:

AAL	ATM Adaptation Layer
API	Application Programme Interface
API	Application Programming Interface
ATM	Abstract Test Method
CAMEL	Customized Application for Mobile Enhanced Logic
CoC	Communication Control
CORBA	Common Object Request Broker Architecture
DAT	Service-Profile/Data
EXE	Service Execution Environment
GPRS	General Packet Radio Service
HSCSD	High Speed Circuit Switched Data
IC	Integrated Circuit
INAP	IN Application Protocol
IP	Information Processing
ISDN	Integrated Services Digital Network
ME	Mobile Equipment
MEExE	Mobile application Execution Environment
MMI	Man Machine Interface
MMIC	MMI Control
PAD	Packet Assembly/Disassembly facility
PCMCIA	Personal Computer Memory Card International Association
PRG	Service Programme
Q.gft	Generic Functional Transport
Q.sig	Private Network Spelling
RPC	Remote Procedure Calls
SCF	Selective Call Forwarding
SDH	Synchronous Digital Hierarchy
SIM	Subscriber Identity Module
SMS	Service Management System
SONET	Synchronous Optical NETWORK
SS7	Signalling System N°7
SSF	Service Switching Function
UMTS	Universal Mobile Telecommunications System
UPT	Universal Personal Telecommunications
URL	User Requirements Language
USIM	UMTS Subscriber Identity Module
USIM	User Service Identity Module
VASP	Value Added Service Providers
VHE	Virtual Home Environment
WAP	Wireless Application Protocol

---

## 4 Description of VHE

### 4.1 Virtual Home Environment capabilities

The Virtual Home Environment supports:

- **service transparency:** between different IMT-2000 networks;
- **transparent execution:** of the "Virtual Home Environment" service features: the VHE service features are used by mobile operators to provide more functionality to mobile users than basic mobility. The services may be executed without necessary sharing of service and subscriber information with the visited mobile operator (except of roaming agreements);
- **customized services:** the means for network operators, service providers and users to define their own specific features/service;
- **a personalized service set:** with user personalization of features/services;
- **service level:** it is desirable that the roaming mobile end-users will experience the same service level as within their home networks (the Virtual Home Environment concept). Therefore, it is desirable that services are provided transparently by the visited networks;
- **provisioning of subscriber specific services:** mobile users may have custom demands for functionality from their home service providers. The Virtual Home Environment intends to make management access to customized services available to mobile users when roaming;
- **limited network load:** the current mobile networks already manage a considerable signalling load to handle a mobile call. This signalling is required to maintain the mobility information of the mobile subscriber up to date. Therefore, the signalling load of new features must be limited as far as possible to ensure that the mobile network's signalling capacity will not be overloaded;
- **activation of mobile related call events;**
- **perform charging activities:** the VHE may be able to exchange charging parameters between the Home Service Provider and Serving (Visited) Network. This exchange is required to have services such as Advice of Charge;
- **perform in-band user interaction:** the VHE shall provide the capabilities to order the playing of announcements and tones towards calling/called subscribers during the call-setup, call disconnection, unsuccessful call establishment, and incoming call procedures;
- **allow for subscriber interaction:** the subscriber should have control capabilities to activate/register/invoke supplementary services. The VHE should be able to add functionality to these supplementary service control mechanisms;
- **interaction with the supplementary services:** the mobile network provides a number of supplementary services; interaction with these services needs to be considered.

### 4.2 Structure of the issues for mapping functional modularity

The above categories will need to be structured into the following categories.



### 4.2.1 Applications

Applications by their nature are in the open competitive market and should not be standardized. However, a few widely used applications may benefit from standardization since significant performance advantages may be gained from features having a static distribution.

A basic level of standardization may be and has proven useful to made applications accessible to the marketplace and simpler to use: e.g. the layout of the telephone and typewriter/PC keyboard. Definition of examples is highly useful to understand the implied requirements on the lower layers.

### 4.2.2 Application support

A vast number of technologies are being pursued in this category some of which are being standardized: e.g. the ISO ECMA-script, based on JAVAscript. Other technologies are being pursued in industry fora: e.g. WTML in the WAP Forum. An initial list of the supporting technologies by which VHE is facilitated is included below:

- CAMEL (Customized Application for Mobile Enhanced Logic), INAP SSF-SCF interaction;
- SIM Toolkit/Smart Card applications;
- WAP (Wireless Application Protocol);
- MExE (Mobile application Execution Environment);
- Internet Protocols Service Negotiation;
- IP Media Controllers and Gateways;
- INAP CS3 SCF-SCF secure interaction;
- Software Agent technologies;
- Technologies for software download;
- Distributed Processing/CORBA.

It is clear that for these technologies to be transparently supported across networks whilst being recognized at the endpoints (terminals and servers) and in the network access points and gateways some standardization is required. It must be noted that that some of the above technologies aim at network independence but all of them are based on a network specific evolution. Some cases imply that the serving network supports knowledge on the service; e.g. CAMEL uses IN triggering.

The major challenge for the computing distributed processing based technologies is the efficiency and speed; it is unlikely that in a competitive world that distributed processing technologies like CORBA will be deployed to interwork throughout global networks. However the software architecture may be deployed on several endpoints (terminals and servers) with high speed links between these endpoints, thus divorcing the software platform from the underlying physical network.

Resource Control in such a scenario is a complex issue of the software requesting resources for handling multiple media streams without having direct control of knowledge of the configuration of where the resources may be sited. Service Mediation is required in an end-to-end sense when setting up the requested service, however negotiation and fall back procedures require definition where one endpoint fails to maintain the service or an intermediate transport network cannot support the required resource.

### 4.2.3 Transport and signalling capabilities

Transport and signalling capabilities are required and must be standardized to carry the VHE capabilities; some options exist, including:

- encapsulated signalling across SS7: Q.gft protocol; Q.sig;
- INAP CS3 SCF-SCF Service to Service encapsulation;
- INAP CS3 Terminal to SCF user to Service encapsulation;
- INAP CS3 SCF to Terminal Service to user encapsulation;
- session related Internet Protocols (including mobile IP);
- SS7 over IP;
- AAL2 or AAL5 Frame Relay;
- GSM GPRS;
- GSM HSCSD;
- dial-up modem capabilities.

NOTE: VHE may potentially be supported by a variety of transport systems so if these capabilities are to be successful either interworking is required, or ubiquitous deployment becomes necessary. Otherwise one network cannot interwork with another network for VHE.

### 4.2.4 Fabric management and underlying protocols

Generally, modern digital networks that exist support protocols that may be used and interconnected to support the above capabilities. Given that the world of data communication is using very high bandwidth transport mechanisms (SONET/SDH) and deploying IP switching or ATM multiplexing to support end-to-end connectivity across these networks. For relatively low speed services circuit switched technology may be used as a method of access, interworking or in some cases end-to-end transportation.

Interworking of analogue inband signalling, encapsulated signalling and frame based packet services is well developed and the options understood. A variety of modems, PADs and PCMCIA devices exists for this purpose.

Special bridging, replicating a merging resource will be required, which are requested by the higher layers. In initial implementations these resources may be deployed in servers and terminals. However, as more complex services justify the need, resources may need to be deployed within the network switches and multiplexers.

### 4.2.5 Network access, network and server addressing, user identification and security

The basic process used in GSM and UPT (Network Access, User Identification and Authentication) requires studying further, as new concepts are required for user security and deregulation.

Network access will be enhanced to support network selection and remote endpoint addressing, as deregulation and competition requires that users may select networks and address distinct servers (possibly incorporating new forms of addressing: i.e. ITU-T Recommendations E.164 [2], E.212 [3] and E.191 [4] (IP addresses and URLs)).

User identification and authentication will be enhanced to support mutual authentication allowing the user to authenticate the serving network and its connection to the remote endpoint. Service usage (non-repudiation) and remote server authentication may also be required by sharing secure signed tokens used for later verification during accounting and billing.

## 5 Architecture for VHE

Figure 1 provides an architecture derived from draft ITU-T Recommendation Q.1751 (see Bibliography) presenting the different functional elements and all the system parts (home, visited...) involved in the provision of VHE capabilities. The Functional Entities and networks shown are meant primarily for the purpose of NNI definition. The provision of VHE capabilities does not necessarily involve all of them.

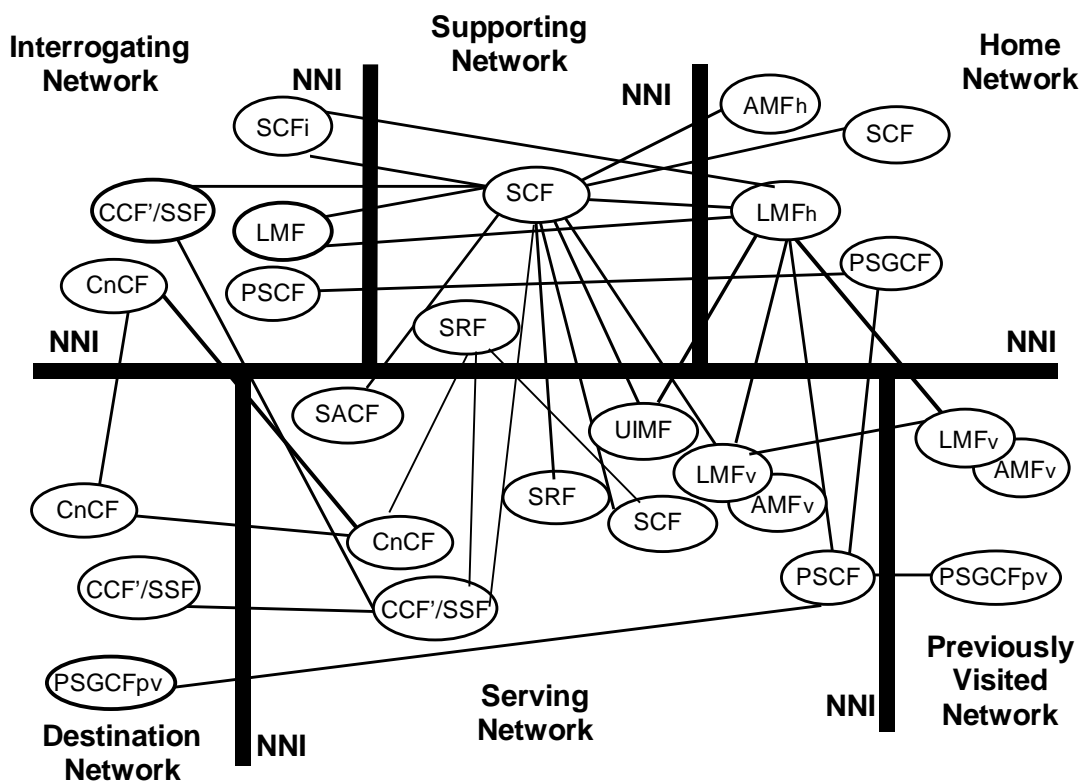
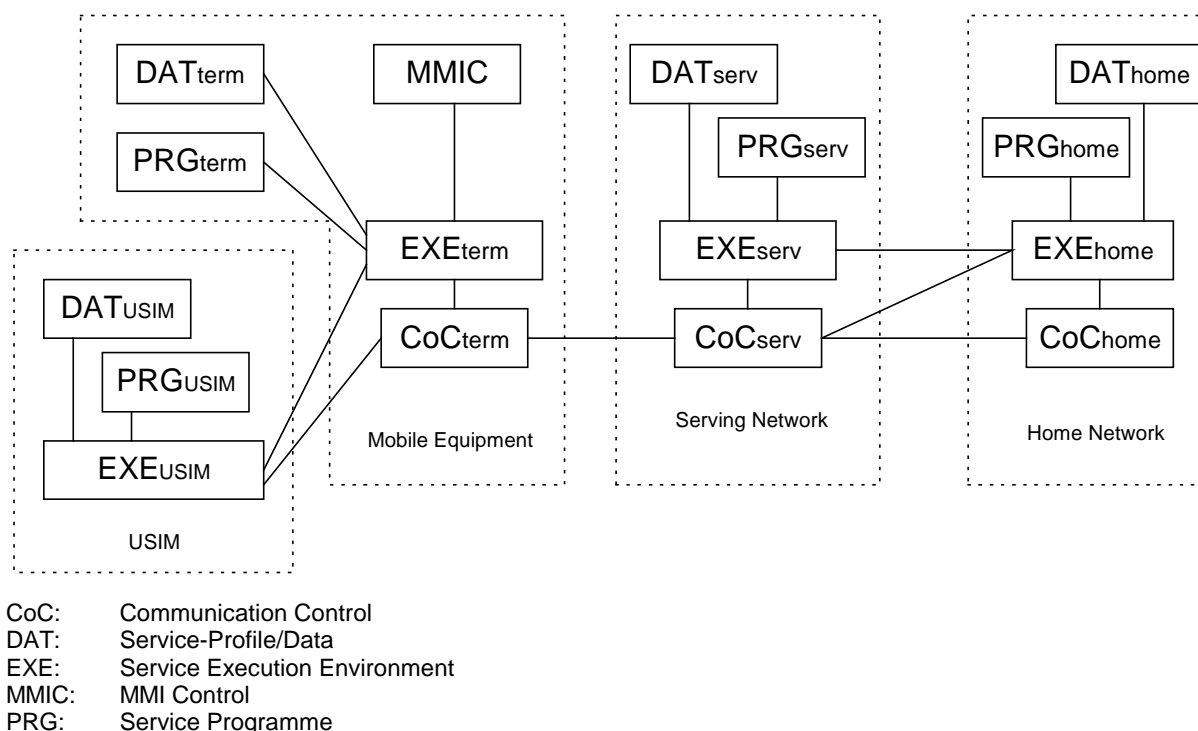

Figure 1: IMT-2000 Network Interconnection Model

This following presents a model to form the basis for development of VHE technical implementation options.



**Figure 2: Generic architecture for VHE**

The following **functional components** are introduced:

- the Service Programme **PRG** describes behaviour of a service and its corresponding service elements by means of (standardized) commands. The behaviour described by the PRG may be standardized, network- or even user-specific;
- the Service Execution Environment **EXE** provides (standardized) platform to execute a service programme and provides access to the communication resources. The service execution environment is accessed via (standardized) Application Programme Interfaces (APIs), e.g. Java-based. The execution environment also protects the communication control from unauthorized access;
- the Service Profile/Data **DAT** provides user- or network-specific input data to run a service programme;
- the Communication Control **CoC** handles actual communication (i.e. allocates bearers, handling of SMS, etc.);
- the MMI Control **MMIC** provides network/user-specific control of MMI (triggered by Execution Environment).

The corresponding **network components** are:

- the **ME** (Mobile Equipment) which provides CoC, EXE, DAT, PRG, MMIC;
- the **USIM** (User Service Identity Module), which may provide user-specific and probably also home network specific DAT and PRG as well as an EXE;
- the **Home Network**, which holds CoC, DAT, PRG as well as EXE;
- the **Serving or visited Network**, which holds similar to the home network CoC, EXE, PRG, DAT.

A key characteristic of the architecture model is that service data and service programmes may be stored in a distributed way in the UMTS network (e.g. home network, serving network, ME, USIM). The data and programme codes may be transferred in a flexible way in the network (either "downloaded" or "pushed", indicated by dotted arrows in the following figures) as required by the service provider and/or user. A flexible co-ordination and administration (e.g. validity, update procedures, location, etc) of the transferred programmes and data have to be defined to maintain the network.

## 5.1 Possible mechanisms to realize VHE

The following possible solutions for the realization of VHE have been identified, which differ in the "place" where the service execution (service control) is located:

- service execution in the Home Network;
- service execution in the USIM;
- service execution in the Mobile Equipment;
- service execution in the Serving Network.

The following subclauses will demonstrate how these identified possibilities could be fulfilled by existing GSM toolkits (e.g. CAMEL, SIM-Toolkit, MExE) and new techniques. They also show how the architecture model is used for the different scenarios and which components are involved.

### 5.1.1 Service execution within the home network

The service execution within the home network gives the subscriber the possibility to use his own VHE services ("service tunneling") although the serving network might not be able to support the desired service or the storage and execution of the appropriate data, e.g. when using some of the second generation systems for access to third generation services.

**Possible realization:** Evolved CAMEL/IN supports this mechanism by the use of remote procedure calls (RPC).

**Requirements:** The integration of packet and circuit switched service is one aspect of UMTS. Therefore in GPRS a CAMEL control is also needed. This integrates GPRS into the VHE concept.

**Uses:** Support of VHE in non-UMTS networks, of GSM CAMEL services in UMTS, of simple terminals and of supplementary services.

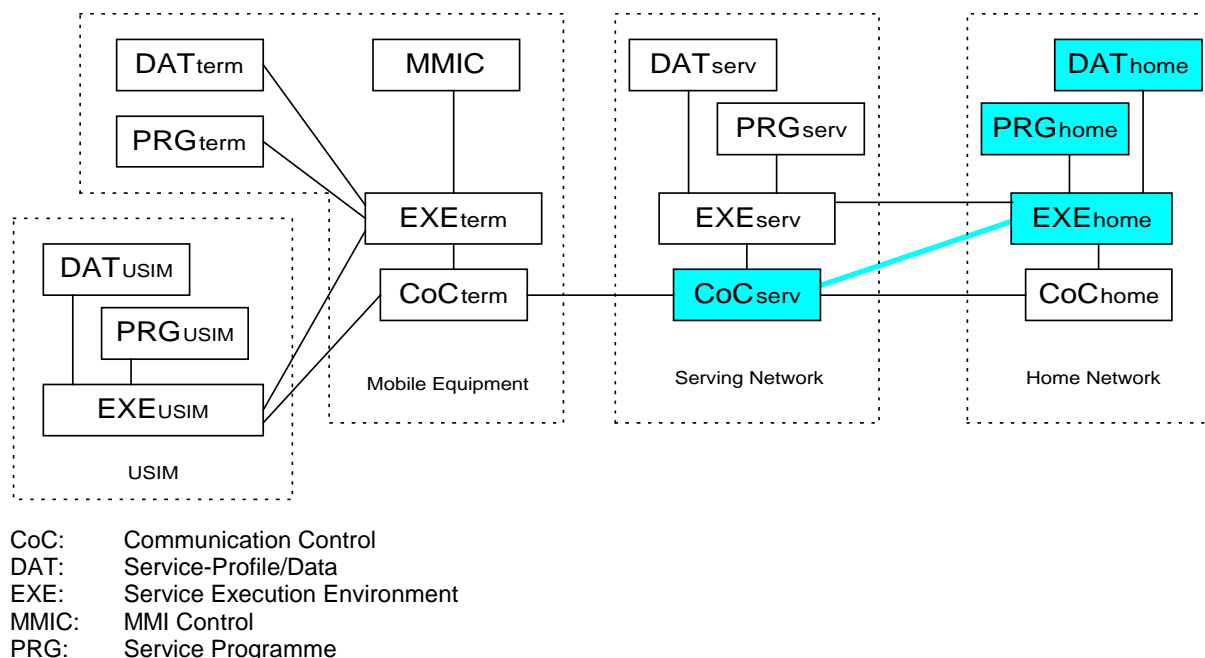

**Figure 3: Case 1 - Service execution in the home network**

The service control as specified in CAMEL would be described in terms of the architecture model in the following way: The execution environment of the home network directly interacts with the communication control in the serving network. The corresponding interface (API) of the communication control is either standardized (e.g. to one of the CAMEL phases) or bilaterally agreed between home and serving network. No service programme and service data needs to be transferred between home and visited network.

## 5.1.2 Service execution within the USIM

The support of the VHE can be realized by exchange of service-related data or service logic from the home network to the USIM. The software is then executed on the IC-Card.

**Possible Solutions:** Remote programming, (enhanced) SIM-toolkit, JavaCard.

**Requirements:** A secure and standardized execution environment and API within the USIM is needed. This requirement leads to an open USIM operating system. An electronic certification process by using hashing algorithms or encryption techniques can be used to guarantee the source and the quality of the downloaded software. In addition, the copyright question has to be solved.

**Uses:** This mechanism can be used for personalized MMI for operator specific services, banking application or update of subscriber data.

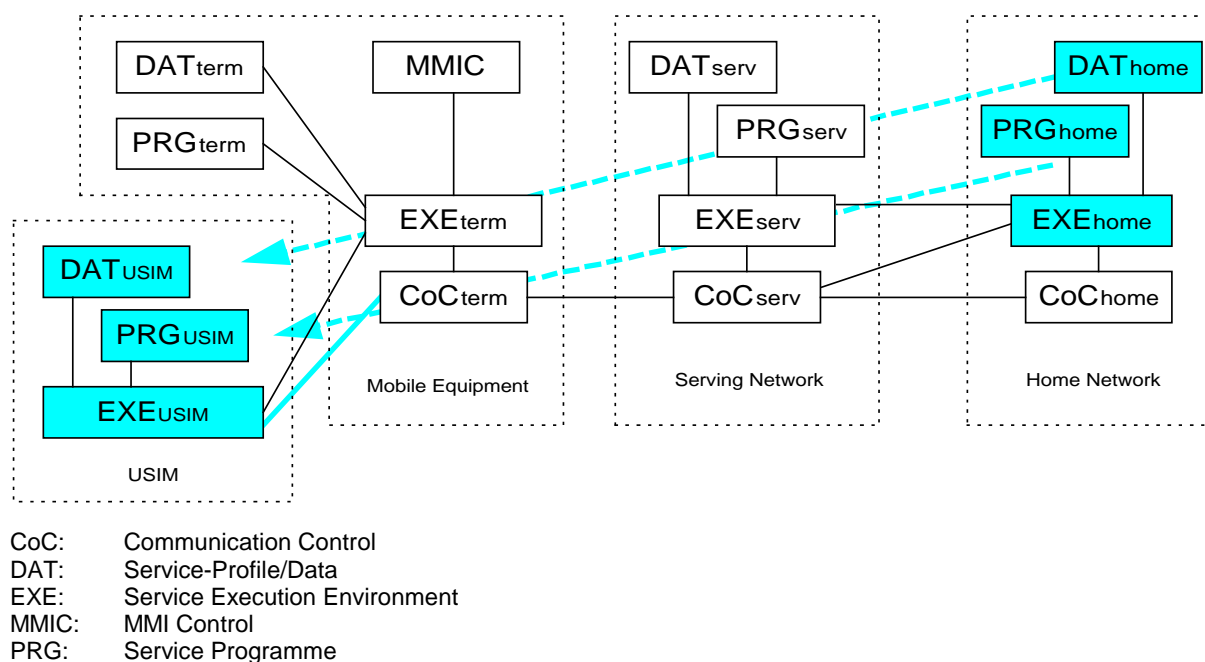

**Figure 4: Case 2 - Service execution in the USIM**

The case of the SIM-toolkit is covered by the capability of the USIM to store service data and programmes as well as to provide an execution environment, which interacts with the mobile terminal.

## 5.1.3 Service execution within the mobile equipment

Similar to the mechanism for the USIM a download of software into the mobile equipment (ME) can also support the VHE. The distinction between two execution environments with different levels of security may be useful: one for the UMTS service provider with larger functionality range and one for value added service providers (VASP) with less functionality but higher security. Functionality and security is meant mainly with respect to the UMTS network and should not limit the range services of the VASP.

**Possible solutions:** Remote programming, Mobile Station Execution Environment (MExE), Wireless Application Protocol (WAP), Sun's Java-Technology.

**Requirements:** Similar to the USIM a secure and standardized execution environment and API within the terminal is needed. This requirement leads to an open terminal operating system. Also similar to the USIM requirements an electronic certification process by using hash algorithms or encryption techniques can be used to guarantee the source and the quality of the downloaded software. Also the copyright question has to be solved.

In addition one new aspect has to be considered. ME software could exist which is only operating with a specific USIM enabling adaptation and personalization of ME functions which are related to a specific subscription and should not be available for another one. In contrast is the non-USIM related software e.g. codec updates.

**Uses:** Codec update, firmware update, download of announcements, enhancements of applications in general.

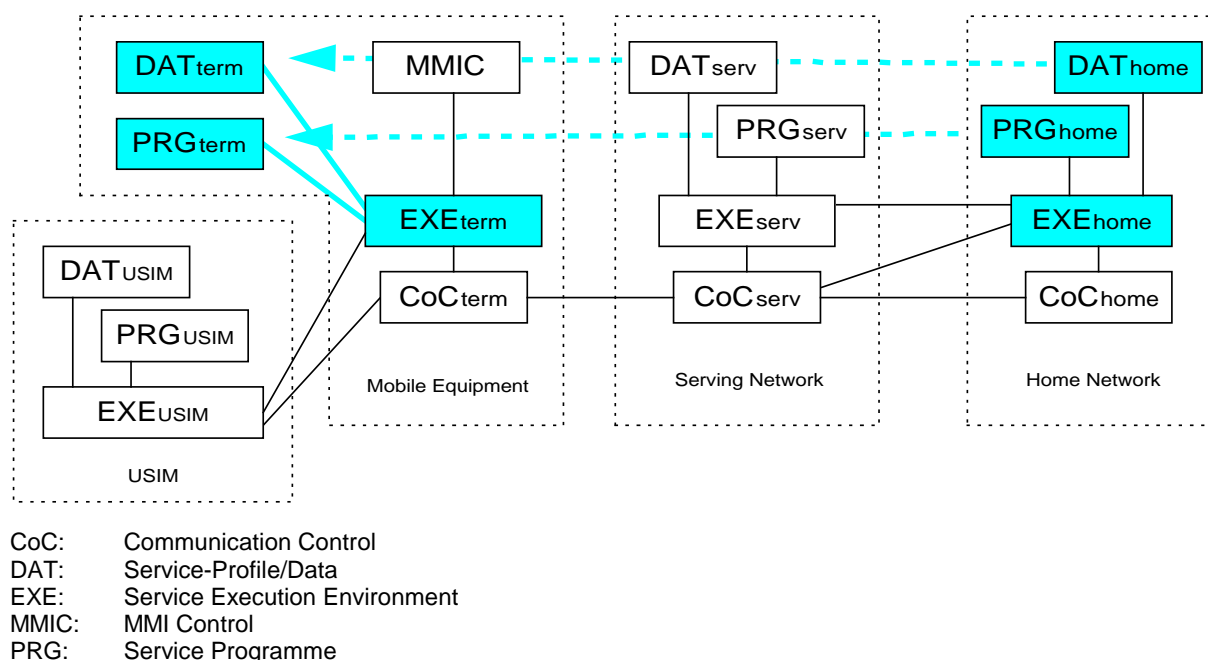

**Figure 5: Case 3 - Service execution in the mobile equipment**

The case of a **mobile station execution environment** is covered in the following way: the execution environment in the terminal would use service programmes and user specific data provided by the ME or the USIM to interact with the communication control and MMI control. The service programme and data may have been downloaded from the home or even serving network.

## 5.1.4 Service execution within the serving network

Download of software into the serving network.

**Possible solutions:** Remote programming.

**Requirements:** Secure and standardized execution environment within the serving network, open system, certification of software, copyrights, secure API. In addition, a standardized protocol is required for the secure and efficient transfer of the relevant service data across network boundaries.

**Uses:** Download of announcements, upload of user data (e.g. from the USIM) into the visited network e.g. the VLR.

It is not proposed to implement this scenario in the first phase of UMTS. This possibility to realize VHE is only included in the document for completeness and should only be investigated for further phases of UMTS.

### 5.1.4.1 Downloading from the home network to the serving network

The approach of **downloading of service programmes** (e.g. Java programmes) between networks would be described by a transfer of service programmes and associated service data or only the service programmes from the home to the serving network. The execution environment in the serving network uses these downloaded programme and data to interact with the communication control. The execution environment needs to be standardized.

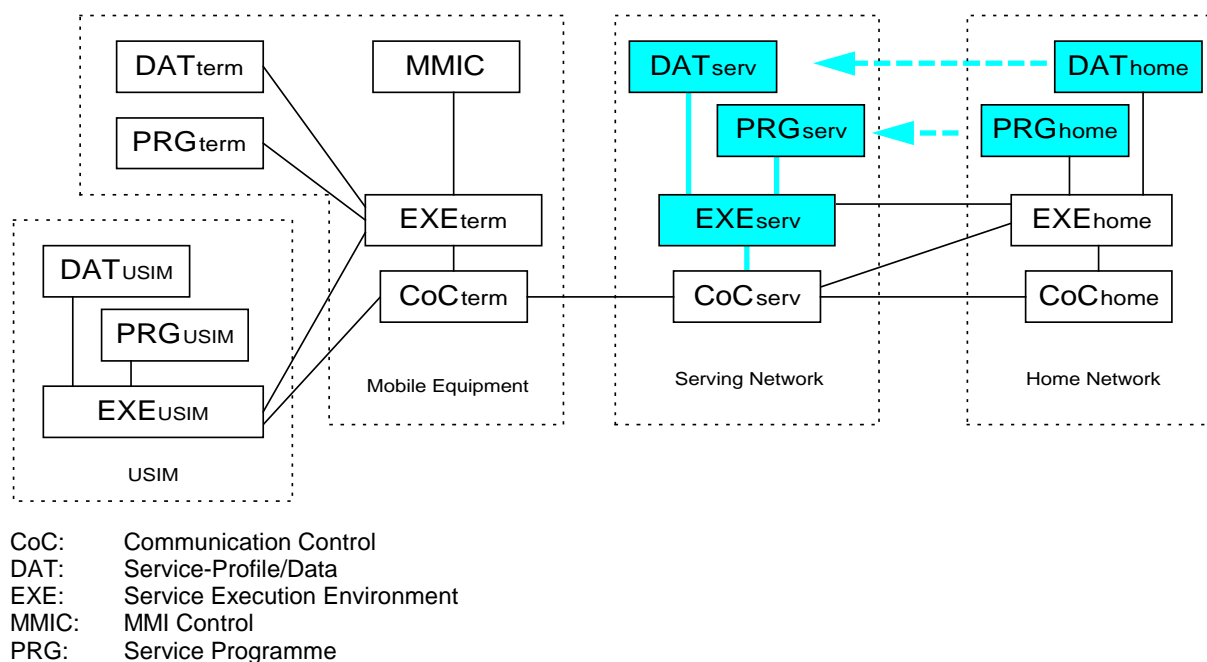

**Figure 6: Case 4a - Service execution by downloading of service programme and data from the home**

Another mechanism relies on interaction between execution environments of home and serving network, which may imply the download of user-specific service data from the home network to the serving network. The actual interaction with the communication control of the serving network will be carried out by the serving network. No programme code is exchanged, as the behaviour and input parameters of the services are either standardized or bilaterally agreed between home and serving network.

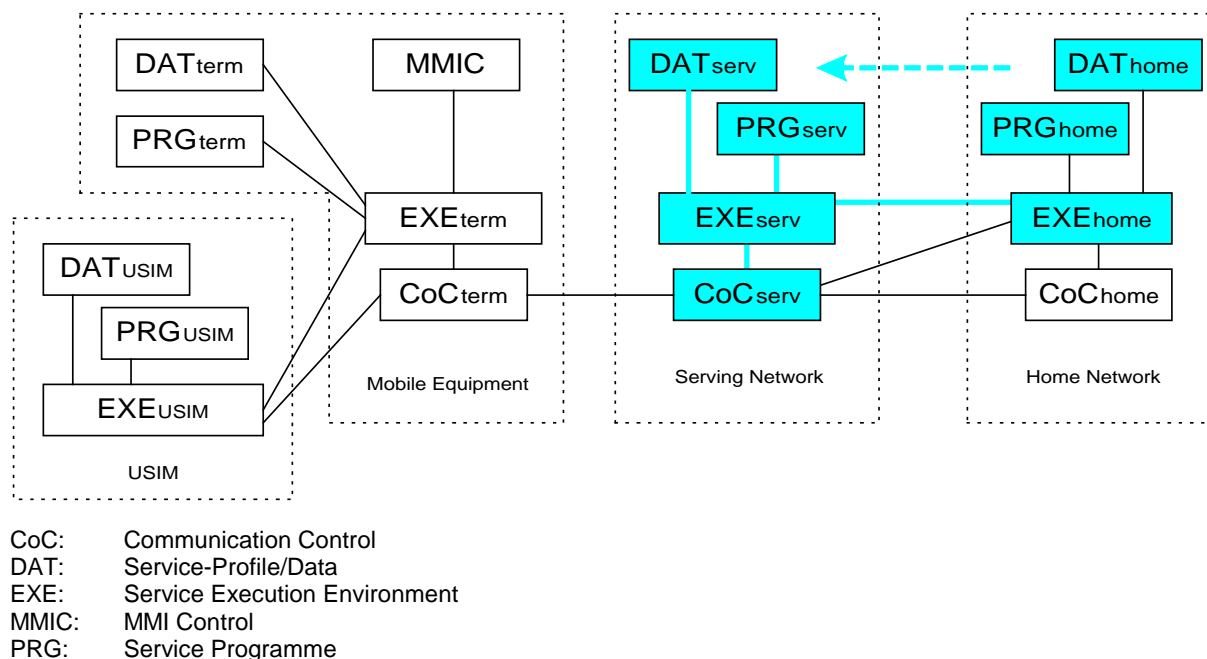

**Figure 7: Case 4b - Service execution by downloading of only data from the home network**



## 5.2 Mapping services onto VHE architecture

This subclause provides a mapping between proposed VHE service features and a VHE mechanism.

**Table 1: Proposed VHE Mechanisms**

Case	Description
1	Service execution in the home network
2	Service execution in the USIM
3	Service execution in the mobile equipment
4a	Service execution by downloading of service programme and data from the home
4b	Service execution by downloading of only data from the home network

**Table 2: Mapping between proposed VHE network aspects onto VHE mechanisms**

Service Feature - Network Operator Aspect	Proposed VHE Mechanism
Support of VHE in non UMTS networks	1
Remote programming of USIM applications	2
Remote programming of mobile equipment applications	3
Remote programming of serving network service applications and service data	4a, 4b

---

## 6 VHE service components

### 6.1 Services provided by VHE

This subclause contains example services and service presentation styles that are considered potential candidates for UMTS and may need to be delivered via VHE mechanisms.

#### 6.1.1 User aspects

This subclause lists requirements from a user perspective.

##### 6.1.1.1 Networks and their supportable QoS

The user can select how it wants the networks and QoS to be displayed for different types of calls and services.

##### 6.1.1.2 Service cost

The user is able to determine how much a call will cost, did cost or is costing (see advice of charge). The user can select how this information is displayed (tone, icon) globally and on a per call basis.

##### 6.1.1.3 Service selection

To indicate to the user of the services that are (un)available. The user is able to easily find out what services are available or not, particularly when roamed to another network. The user may elect to use a preferred network for outgoing calls of a particular type (can be overridden).

##### 6.1.1.4 Service (profile) modification

Can modify service characteristics from any terminal either globally or on a per call (override) basis.

#### 6.1.1.5 Language preferences

The user can specify language preference in which spoken announcements will be received, even when roaming in another country.

#### 6.1.1.6 Location information

This function keeps track of the user terminal's location. The user can permit release of location information on a per-call or global basis.

#### 6.1.1.7 Roaming

The user is able to roam to any network where commercial roaming agreements exist and is able to have access to all the personalized services which he used in the home environment. The VHE features need to be portable across networks.

#### 6.1.1.8 Call management

This includes, for example, the range of supplementary services e.g. call divert, call barring, call me free. The user is able to divert calls and also specify callers for which the divert is bypassed, is able to bar calls according to time of day, day of week, etc., is able to provide a free call service for specific people/number and is able to negotiate the charges for an incoming call while roaming.

#### 6.1.1.9 Outgoing calls including multimedia and conference calls

A call made by the user to a party/parties (person or machine) and the user can select terminal to use, can select called party or parties (person or machine) from a personal directory which is available from any terminal, can select the QoS required (may be default), may ask for QoS negotiation to take place and can select to pay for all/part/none of the call.

#### 6.1.1.10 Incoming calls including multimedia and conference calls

A call received by the user/person/machine which is made by an external party/parties, who can select the terminal to use, can select to bar/divert/deflect the call, can select to pay for all/part/none of the call and can select the QoS required.

#### 6.1.1.11 VASP incentives and opportunities

The user should be informed (in real time) about VASP incentives and opportunities (advertising, brokerage) by specifying preferences and should receive information about price changes and special offers.

#### 6.1.1.12 Location services

The user should be able to access personalized location based services. Customers need to allow the context provider to gain location information from the network operator on a per-call or global basis.

#### 6.1.1.13 Video-on-demand

The user should have access to favourite channels/programmes according to stated VHE preferences and should be able to view favourite programmes at most convenient time of day/day of year as specified by the user.

#### 6.1.1.14 Electronic banking

The user shall have access to banking applications over electronic media. Customer should deal directly with the bank and the context provider gives value added, personalized services.

The user can view his statements in real time, set alerts on specific transactions, bank balance etc., make payments for electronic transactions, has access to personalized banking services and can configure his personal preferences.

## 6.1.2 Network operator aspects

This subclause lists requirements from a network operator perspective.

### 6.1.2.1 Support of VHE in non-UMTS networks

The service execution within the home network gives the subscriber the possibility to use its own VHE services ("service tunneling") although the serving network might not be able to support the desired service or the storage and execution of the appropriate data, e.g. when using some of the second Generation systems for access to third generation services.

### 6.1.2.2 Remote programming of USIM applications

The support of the VHE can be realized by custom applications resident on the USIM. A mechanism is needed for the exchange of service-related data or service logic from the home network to the USIM. A secure and standardized execution environment and API within the USIM is needed.

### 6.1.2.3 Remote programming of mobile equipment applications

The support of the VHE can be realized by custom applications (codec, etc.) resident in the mobile equipment. A mechanism is needed for the exchange of service logic or service-related data from the home network to the mobile equipment. A secure and standardized execution environment and API within the terminal is needed.

### 6.1.2.4 Remote programming of serving network service applications and service data

The support of the VHE can be realized by service applications resident on a temporary basis in the serving network. A mechanism is needed for the exchange of service-related data or service logic to the serving network. Sources of this information may be the home network. A secure and standardized execution environment and API within the serving network is needed.

## 6.2 Functions related to support VHE

The VHE capability is an integrated network capability that provides operator specific services that are accessible to the user even when this user is roaming outside the home network (ITU-T Recommendation Q.1711 [6]).

The following functions are identified to support the provisioning of VHE supplementary services:

- provisioning of VHE specific service profiles: this function is required to ensure that the visited network receives the appropriate information to invoke the VHE supplementary services. The VHE service profiles are part of the IMT-2000 subscriber profiles. They contain the trigger information that has to be exchanged between the home network and the visited (serving) network;
- dynamic arming of triggers within the switching network: this function is required to activate the VHE triggers including the trigger profile (e.g. trigger conditions, information, etc.). The arming of these VHE triggers is requested to be activated by the home network or service provider;
- downloading VHE trigger profiles to the visited network: this function is required to reduce the unnecessary signalling between the home and visited network. The VHE trigger profile is downloaded towards the visited network together with the IMT-2000 subscriber profile;
- service logic execution (home network capability): this function requires an agreement between the home network and visited network for the home network to execute service logic from the home network to control the visited network resources. IN supported capabilities must be compatible between the two networks;
- service logic execution (visited network capability): this function requires an agreed upon application execution environment to execute distributed service logic from the home network within the visited network;

- service addressing (visited network capability): this function is required to allow the visited network to address specific service control functions. This is used to request the initiation of a VHE context between the visited network and the home network;
- security and screening functions (visited to home network): these functions are required to enable the networks to verify each other's identity and bind the context between the networks for the execution of the VHE services.

## 6.3 VHE scenarios

A description of VHE scenarios is proposed by ITU-T Recommendation Q.1711 [6].

**Direct Home Command:** This scenario (figure 8) calls for invocation of service logic to query for instruction/information to the SCFsn. In this scenario the pre-arrangement between the supporting and the home networks or between the supporting and the visited networks may need screening capabilities of triggering invocation.

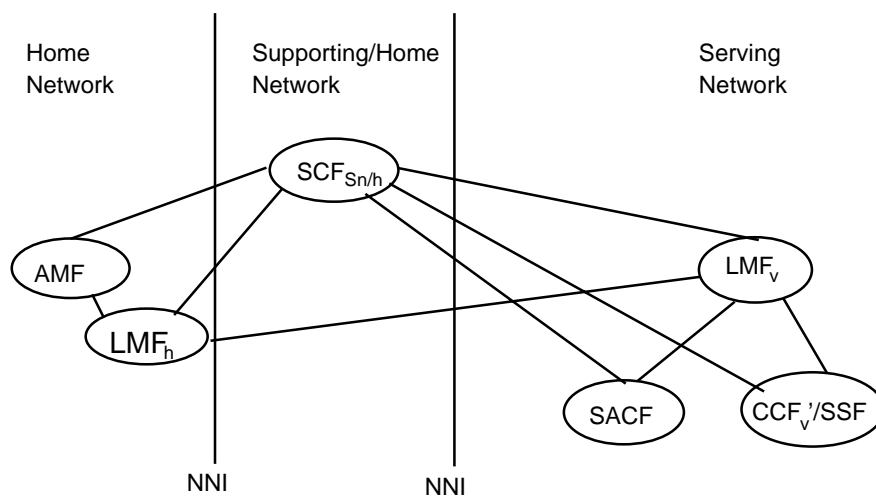

Figure 8: Direct home command

**Relay Service Control:** This scenario (figures 9 and 10) calls for the invocation of the service logic via the SCF<sub>h</sub> or the SCF<sub>v</sub> to query for instruction/information to the SCFsn. In this scenario the pre-arrangement between the supporting and the home networks or between the supporting and the visited networks ranges from relaying, security/screening capabilities to shared service logic.

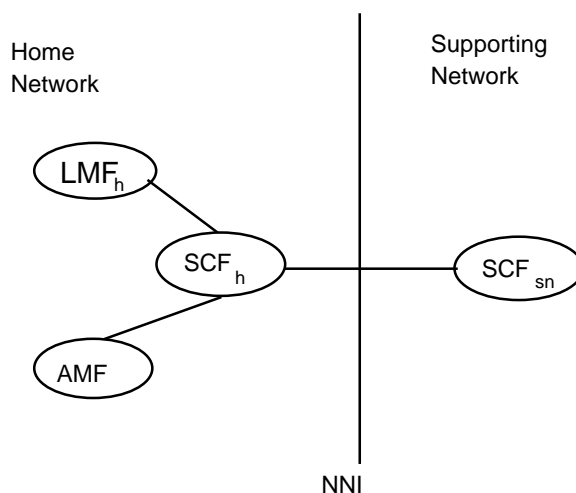
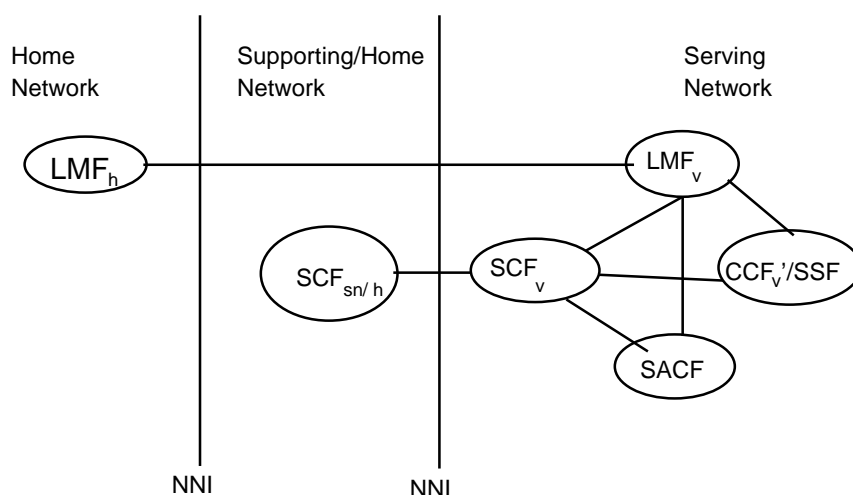

Figure 9: Relay service control mobility management triggers from home network



**Figure 10: Relay service control call related, call unrelated, and mobility management triggers from visited network**

## 7 Requirements on inter-network interfaces

The invocation of services including the VHE services occurs in the process of a call origination/termination from/to a user. The services are offered according to the information contained in the user service profile. This subclause addresses the "Direct Home Command" scenario. The Direct Home Command VHE scenario calls for the supporting (or home) network to provide service command/logic to the visited/serving network. It is to invoke the service logic in the supporting network via the triggering invocation capability of the visited network. In this scenario the pre-arrangement between the supporting and the home networks or between the supporting and the visited networks may be needed for screening capabilities of the triggering invocation.

### 7.1 VHE service procedure

In an end-to-end information flow scheme, this procedure consists of four components: call origination; VHE service invocation, call connect, and call routeing. This subclause addresses the information flows for the VHE service logic invocation part, and treats the information flows for the other three parts as common procedures within the context of the end-to-end information flow.

### 7.2 Assumptions

The following assumptions are made related to this information flow:

- in this scenario the pre-arrangement between the supporting and the home networks or between the supporting and the visited networks is needed for screening capabilities of triggering invocation;
- the serving/visited network has IN capability for triggering the required service logic.

### 7.3 Common procedure modules used

This scenario uses the following common procedures:

- 1) Call origination;
- 2) Call connect;
- 3) Call routeing.

## 7.4 Information flow diagram

Figure 11 presents the information flow diagram for the direct home command VHE scenario. The diagram includes only the call origination side of the flows, calling party A.

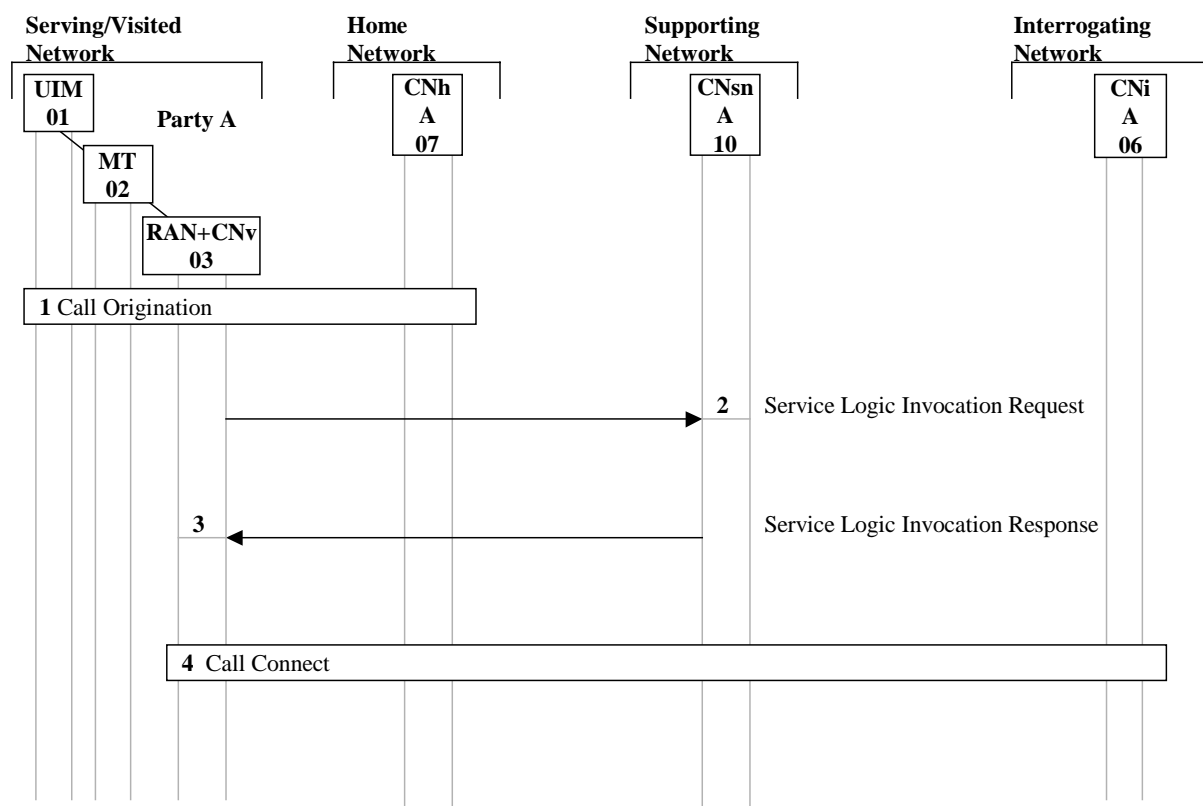

Figure 11: Information flow diagram for IMT-2000 VHE direct home command scenario

## 7.5 Information flows description

Information flows and functional group actions are described below in the same order as it is in figure 11.

- 1) **Call origination:** This common procedure is to originate a call by the calling party in a visited network (home or elsewhere). The information obtained from the home network will contain instructions to the serving network for the VHE service invocation (this information/instruction is inclusive of any user data obtained during MT registration).
- 2) **Service logic invocation request:** This flow is for the serving radio access network or core network to invoke VHE service logic/command per instruction and information contained in the user service profile, and from any active trigger detection point encountered during call processing.
- 3) **Service logic invocation response:** This flow is from the supporting (home service) network to the serving network for the service logic/command.
- 4) **Call connect:** This common procedure is employed to continue the process and to connect the call to the interrogating network.

---

## Bibliography

The following material, though not specifically referenced in the body of the present document (or not publicly available), gives supporting information.

- ITU-T Recommendation Q.1751: "Signalling requirement at network interface".

---

## History

<b>Document history</b>		
V1.4.1	September 1999	Membership Approval Procedure    MV 9945: 1999-09-07 to 1999-11-05
V1.4.2	November 1999	Publication
V1.4.3	January 2000	Publication