

**Intelligent Network (IN)
IN architecture and functionality for the support of
Cordless Terminal Mobility (CTM) phase 2**



Reference

DEG/NA-061303 (fpc00icq.PDF)

Keywords

CTM, IN, internet, supplementary services

ETSI

Postal address

F-06921 Sophia Antipolis Cedex - FRANCE

Office address

650 Route des Lucioles - Sophia Antipolis
Valbonne - FRANCE
Tel.: +33 4 92 94 42 00 Fax: +33 4 93 65 47 16
Siret N° 348 623 562 00017 - NAF 742 C
Association à but non lucratif enregistrée à la
Sous-Préfecture de Grasse (06) N° 7803/88

Internet

secretariat@etsi.fr
Individual copies of this ETSI deliverable
can be downloaded from
<http://www.etsi.org>
If you find errors in the present document, send your
comment to: editor@etsi.fr

Copyright Notification

No part may be reproduced except as authorized by written permission.
The copyright and the foregoing restriction extend to reproduction in all media.

© European Telecommunications Standards Institute 1999.
All rights reserved.

Contents

Intellectual Property Rights	5
Foreword	5
1 Scope.....	6
2 References.....	6
3 Abbreviations.....	7
4 Mobility management (core features).....	7
4.1 Handover	7
4.1.1 Reference Architecture.....	8
4.1.2 Scenario 1 - Inter-switch handover.....	9
4.1.2.1 Functional architecture - case 1	9
4.1.2.2 Handover execution procedure - case 1	10
4.1.2.3 Functional architecture - case 2	12
4.1.2.4 Handover execution procedure - case 2	13
4.1.3 Scenario 2 - Inter-switch handover.....	14
4.1.3.1 Functional architecture - case 1	14
4.1.3.2 Handover execution procedure - case 1	15
4.1.3.3 Handover execution procedure - case 2	17
4.1.4 Scenario 3 - Intra-switch handover.....	18
4.1.4.1 Functional architecture	18
4.1.4.2 Handover execution procedure	19
4.2 Enhanced Location Registration	20
4.2.1 Location registration when the user is already registered in the SDFmm.....	20
4.2.2 Location registration when the user is not already registered in the SDFmm (SCF-SCF).....	21
4.2.3 Location registration when the user is not already registered in the SDFmm (SCF-SDF)	23
4.3 Detach.....	24
4.4 Purge.....	25
5 Other Core Features	27
5.1 Message Waiting Indication (MWI)	27
5.1.1 MWIndicate - activation.....	28
5.1.2 MWIndicate - deactivation.....	29
5.1.3 Retrieval of messages	29
5.2 Emergency call without terminal authentication	29
5.2.1 Emergency call procedure initiated as normal outgoing call	29
5.2.2 CTM emergency call based on CAP feature	30
5.2.3 CTM emergency call based on CAP feature and IN triggering.....	30
6 CTM supplementary services	30
6.1 CTM incoming call scenario.....	31
6.2 CTM Call Forwarding on Not Reachable (CTM-CFNRC).....	31
6.2.1 CTM phase 1 solution (still valid).....	31
6.2.2 CTM phase 2 specific solution with mark detected in the home SDFsl	31
6.2.3 CTM phase 2 specific solution with mark detected in the visited SDFmm	32
6.2.3.1 Incoming call based on roaming number method and only SCF-SCF for internetwork functional interface	33
6.2.3.2 Incoming call based on roaming number method and CS2 SCF-SCF and SCF-SDF for internetwork functional interface.....	34
6.2.3.3 Incoming call based on routeing address method and CS2 SCF-SCF and SCF-SDF for internetwork functional interface.....	35
6.3 CTM Call Forwarding Unconditional (CTM-CFU).....	35
6.3.1 Geographic Number for CTM user	35
6.3.2 Non-Geographic CTM Number for CTM user.....	36
6.4 CTM Call Forwarding on Busy (CFB)	36
6.4.1 Geographic Number for CTM user	37

6.4.2	Non-Geographic CTM Number for CTM user.....	38
6.4.3	Information flows for CTM-CFB	39
6.5	CTM Call Forwarding on No Reply (CFNR)	39
6.5.1	Geographic Number for CTM user	40
6.5.2	Non-Geographic Number for CTM user	41
6.5.3	Information flows for CTM-CFNR	42
6.6	CTM Calling Line Identification Presentation (CTM-CLIP).....	42
6.7	CTM Calling Line Identification Restriction (CTM-CLIR).....	42
6.8	CTM Connected Line Identification Presentation (CTM-COLP).....	42
6.9	CTM Connected Line Identification Restriction (CTM-COLR).....	42
6.10	CTM Incoming Call Screening (CTM-ICS)	43
6.10.1	Geographic Number for CTM user	43
6.10.2	Non-Geographic Number for CTM user	44
6.11	CTM Outgoing Call Barring CTM-OCB).....	44
6.11.1	Generic Flow	45
6.11.2	Information Flows for OCB	46
7	Interaction with ISDN supplementary services	47
7.1	Interactions between the service of a calling of called CTM user and the service of the called user.....	47
7.1.1	Calling Line Information Presentation service for the called party and Calling Line Information Restriction service for the calling party	47
7.1.2	Connected Line Identification Presentation service for the called party and Connected Line Identification Restriction service for the calling party	47
7.2	Interactions when using a domestic base station.....	48
7.2.1	Call Forwarding on Busy (CFB)	48
	Annex A (informative): Information on DECT Handover	49
A.1	Presentation of the Information Flows on the DECT Air Interface (EN 300 175 and CAP).....	49
A.2	Handover mechanisms over the DECT air interface and involved DECT messages and Information Elements	50
A.2.1	Handover in DECT	51
	History.....	52

Intellectual Property Rights

IPRs essential or potentially essential to the present document may have been declared to ETSI. The information pertaining to these essential IPRs, if any, is publicly available for **ETSI members and non-members**, and can be found in SR 000 314: *"Intellectual Property Rights (IPRs); Essential, or potentially Essential, IPRs notified to ETSI in respect of ETSI standards"*, which is available **free of charge** from the ETSI Secretariat. Latest updates are available on the ETSI Web server (<http://www.etsi.org/ipr>).

Pursuant to the ETSI IPR Policy, no investigation, including IPR searches, has been carried out by ETSI. No guarantee can be given as to the existence of other IPRs not referenced in SR 000 314 (or the updates on the ETSI Web server) which are, or may be, or may become, essential to the present document.

Foreword

This ETSI Guide (EG) has been produced by ETSI Technical Committee Services and Protocol for Advanced Networks (SPAN), and is now submitted for the ETSI standards Membership Approval Procedure.

1 Scope

The present document describes the architecture and information flows for Stage 2 of Cordless Terminal Mobility (CTM) phase 2, and is based on the service description for CTM phase 2.

2 References

The following documents contain provisions which, through reference in this text, constitute provisions of the present document.

- References are either specific (identified by date of publication, edition number, version number, etc.) or non-specific.
- For a specific reference, subsequent revisions do not apply.
- For a non-specific reference, the latest version applies.
- A non-specific reference to an ETS shall also be taken to refer to later versions published as an EN with the same number.

- [1] EN 300 175-5: "Digital Enhanced Cordless Telecommunications (DECT); Common Interface (CI); Part 5: Network (NWK) layer".
- [2] EN 300 824: "Digital Enhanced Cordless Telecommunications (DECT); Cordless Terminal Mobility (CTM); CTM Access Profile (CAP)".
- [3] EN 301 273: "Cordless Terminal Mobility (CTM); Phase 2; Service description".
- [4] EG 201 096: "Intelligent Network (IN); Cordless Terminal Mobility (CTM); IN architecture and functionality for the support of CTM".
- [5] EN 300 745-1: "Integrated Services Digital Network (ISDN); Message Waiting Indication (MWI) supplementary service; Digital Subscriber Signalling System No. one (DSS1) protocol; Part 1: Protocol specification".
- [6] EN 300 196-1: "Integrated Services Digital Network (ISDN); Generic functional protocol for the support of supplementary services; Digital Subscriber Signalling System No. one (DSS1) protocol; Part 1: Protocol specification".
- [7] EN 300 444: "Digital Enhanced Cordless Telecommunications (DECT); Generic Access Profile (GAP)".
- [8] EN 300 175: "Digital Enhanced Cordless Telecommunications (DECT); Common Interface (CI)".

3 Abbreviations

For the purposes of the present document, the following abbreviations apply:

CAP	CTM Access Profile
CCF	Call Control Function
CI	Common Interface
CPH	Call Party Handling
CS1	Compatibility Set 1
CS2	Compatibility Set 2
CS3	Compatibility Set 3
CS4	Compatibility Set 4
CTM	Cordless Terminal Mobility
DECT	Digital Enhanced Cordless Telecommunications
DSS1	Digital Subscriber Signalling System No. one
FT1	File Transfer 1
FT2	File Transfer 2
GAP	Generic Access Profile
IN	Intelligent Network
ISDN	Integrated Services Digital Network
MWI	Message Waiting Indication
PT	Parallel Transmission
SSF1	Service Switching Function 1
SSF2	Service Switching Function 2

4 Mobility management (core features)

4.1 Handover

This clause presents functional architecture and information flows in order to carry out external handover in the network based on the external handover procedures as defined in EN 300 175-5 [1] and EN 300 824 [2].

The *handover candidate indication and retrieval procedures* are not described in the present document since it is assumed that the candidates for handover are provided to the Portable as described in the CAP procedures handover candidate indication, applied to call control messages during call establishment, or handover candidate retrieval.

The *handover reference indication and retrieval procedures* are not described in the present document since it is assumed that the 'network parameter' including the handover reference is provided to the Portable by the SCF as described in the CAP procedures handover reference indication, applied to call control messages during call establishment, or handover reference retrieval.

These information flows are CAP compliant which means that the messages used and the order in which they are used are compliant to the CAP.

Handover from one network to another is outside the scope of phase 2 of the CTM service (see EN 301 273 [3]).

All the messages whose backgrounds are grey are generic messages that need to be detailed in a protocol study.

4.1.1 Reference Architecture

When the handset moves within the same network there can be various handover scenarios that are represented below.

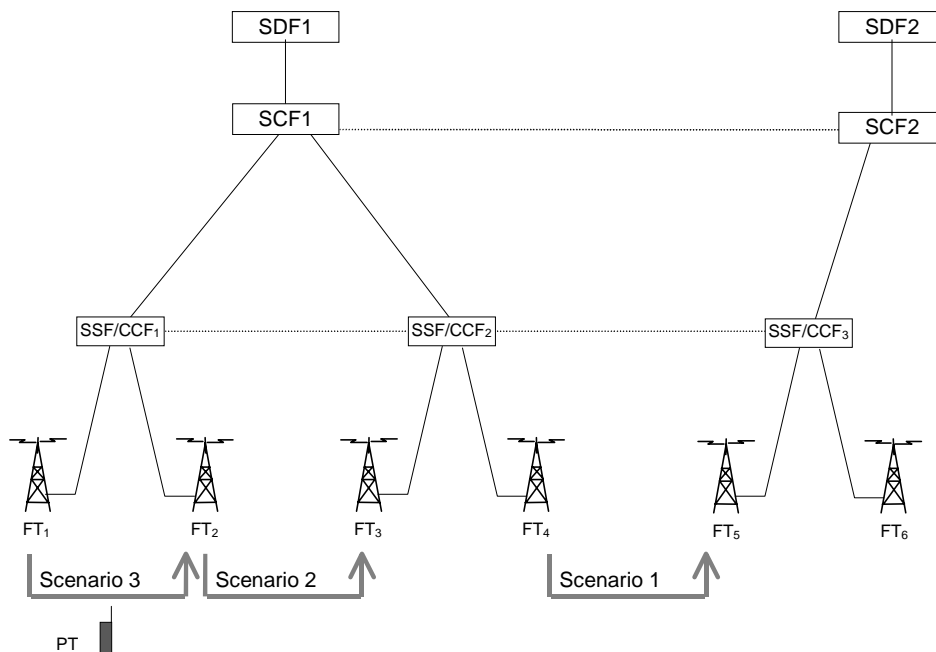

Figure 1: Handover scenarios

- Scenario 1 (Handover between FT₄ and FT₅): this is inter-switch handover with the SSF/CCF connected to different SCF/SDF.
- Scenario 2 (Handover between FT₂ and FT₃): this is inter-switch handover with both SSF/CCF connected to the same SCF/SDF.
- Scenario 3 (Handover between FT₁ and FT₂): this is intra-switch handover.

These scenarios are the basis for further study in the definition of requirements on IN CS3 and CS4. In the following subclauses, some descriptions are proposed for these scenarios, using more or less the mobility management service logic SCFmm (retrospectively for cases 1 & 2). They provide high level views and principles for the main steps for handover controlled by IN. However, from a stage 3 point of view, IN CS2 may not be sufficient; new functionalities, parameters or operations may be needed. They may be standardized in IN CS3 (for example through Call Party Handling (CPH) or IN CS4 (mobility procedures).

4.1.2 Scenario 1 - Inter-switch handover

4.1.2.1 Functional architecture - case 1

The following architecture is used to describe inter-switch handover:

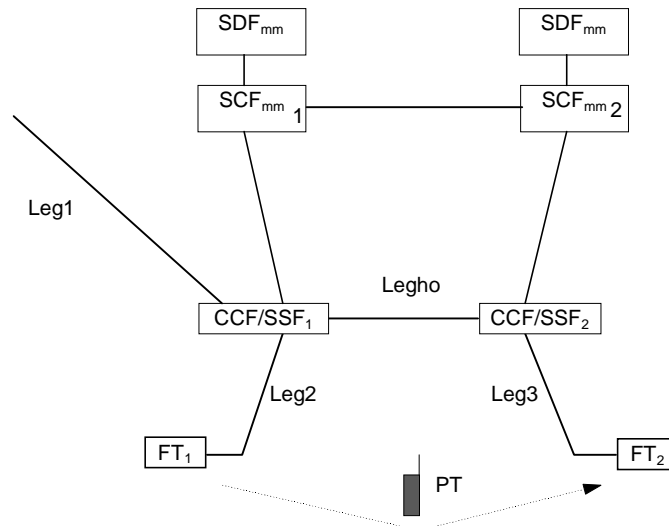

Figure 2: Inter-switch handover functional architecture

The PT involved in a call with a called/calling party (third party) moves from FT1 to FT2.

The leg between CCF/SSF1 and called/calling party is Leg1, the leg between FT1 and the CCF/SSF1 is Leg2, the leg between CCF/SSF1 and CCF/SSF2 is Legho and the leg between CCF/SSF2 and FT2 is Leg3.

It is assumed that the call control is always maintained by the SCF^{mm} that is associated to the switch where the user was roaming at the call set-up (SCF^{mm1}). In fact this SCF^{mm1} is the only SCF^{mm} that "knows" of the user and has all the information related to the call (e.g. if it is an incoming or outgoing call, the charging information, possible supplementary services activated by the user,...).

4.1.2.2 Handover execution procedure - case 1

The PP sends the CC-SETUP message containing all the information needed for the handover. Therefore, upon receiving the CC_SETUP message from the PT, FT2 routes the call towards the CCF/SSF2 it is connected to. Then the CCF/SSF 2 triggers to the SCF^{mm2}.

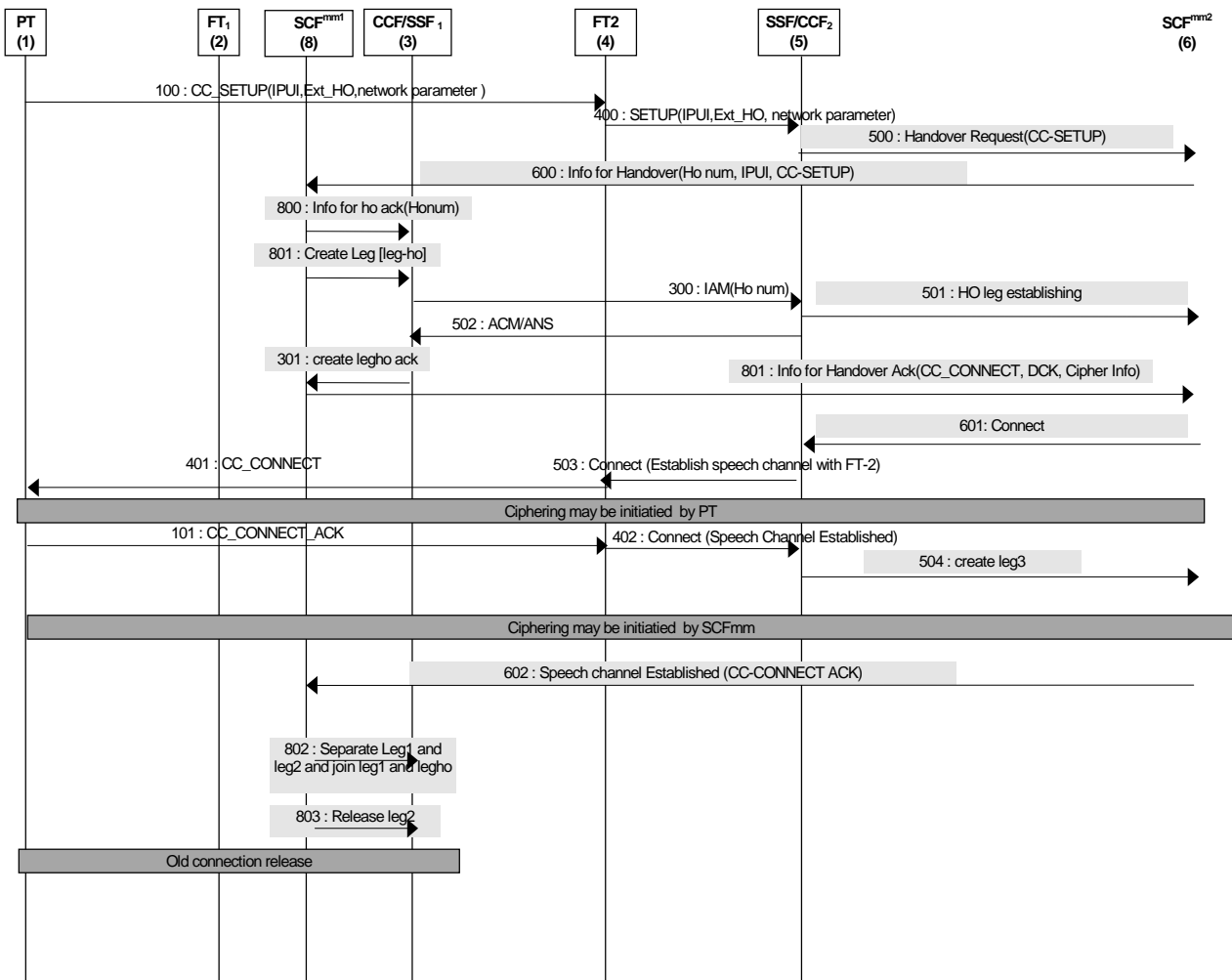

Figure 3: Information flows for inter-switch handover with handover number

Table 1: Message commentary - case 1

Msg	Remarks
100	The PT sends a CC_SETUP message to the FT2, with the Basic Service = Ext_Ho and the Network parameter including the HO_Reference and data field. In this data field could be contained a number identifying the SSF/CCF1.
400	The FT2, relays the SETUP message to the CCF/SSF 2.
500	The CCF/SSF2 recognizes an outgoing call request from a CTM user and triggers the SCFmm2.
600	The SCFmm2 recognizes an handover request and as the user is in an inter-switch handover, does not check if the user is registered in its SDFmm but uses the Handover_Reference information to relay the handover request to the SCFmm1. The information sent to the SCFmm1 includes the IPUI, all the data sent by the PT in the CC-SETUP message and an Handover Number that the SCFmm2 retrieves from itself to be used by the SCFmm1 to establish the handover speech channel towards the SSF/CCF2.
800	The SCFmm1 uses the handover information to request the CCF/SSF1 to establish a new leg (using the Handover Number) towards the CCF/SSF2.
300	The CCF/SSF1 sends the IAM message to the CCF/SSF2 using the Handover Number to route the call.
501	The CCF/SSF recognizes, based on the Handover Number, that the incoming leg is associated to the handover request and notifies this to the SCFmm2.
502	The SSF/SSF2 sends an address_complete message to SSF/CCF1 indicating that the connection has been established.
301	The CCF/SSF1 notifies the SCFmm1 that the speech channel for handover has been established.
801	The SCFmm1 sends information for handover_ack message to SCFmm2. This message should include the CC-CONNECT message to be sent to the mobile and DCK and cipher information known by the SCFmm1. If the old connection was ciphered also the new connection shall be ciphered.
601	The SCFmm2 orders the SSF/CCF to create a speech channel with the PT through the FT2.
503	The SSF/CCF2 sends a connect indication for the speech channel establishment to the FT2.
401	The FT2 sends a CC-CONNECT message to the PT to indicate the completion of the connection through the network (establishing speech channel). PT may start the Ciphering Procedure.
101	The PT acknowledges the speech channel establishment by sending a CC_CONNECT_ACK to the FT2.
402	The FT2 sends this acknowledgement to the CCF/SSF 2.
502	The SSF/CCF2 sends this acknowledgement to the SCFmm2. SCFmm may start the Ciphering Procedure.
602	The SCFmm2 orders the CCF/SSF2 to continue the call processing. A ciphering procedure (if required) may start now. It can be initiated either by the PT or by the SCFmm2.
802	The SCFmm1 orders the CCF/SSF1 to join Leg1 and Legho.
803	The SCFmm1 orders the CCF/SSF1 to release the connection on Leg2.
NOTE:	When the External Handover procedure is completed in compliance with CAP specification (EN 300 824 [2]) the PP performs a new Location Registration to the FT2. As a Location Registration implies the cancellation of user profile data in the SCFmm1 and the user profile data updating in the SCFmm2, this operation can cause some problems (e.g. release of the call). In order to avoid the problem, the Location Registration Request should be delayed until the call has been released (before sending of CC-RELEASE or CC-RELEASE COMPLETE).

4.1.2.3 Functional architecture - case 2

Although not completely stable in ITU-T, the general principles for inter-switch handover for IMT-2000 are summarized below:

- an anchor approach is used;
- the SSF is enhanced to include the handover control function (this needs confirmation but it seems that the split SSF/SCFmm is not used for handover in IMT-2000);
- the handover initiation starts from the current base station (and not the new one as in DECT).

This clause proposes a new and simplified description for CTM scenario 1 (inter-switch handover) that uses as little as possible the « new » SCFmm (the SCFmm1 controls the handover as the anchor); the check of the service profile is added.

The functional architecture and Information Flows for handover could be as follows:

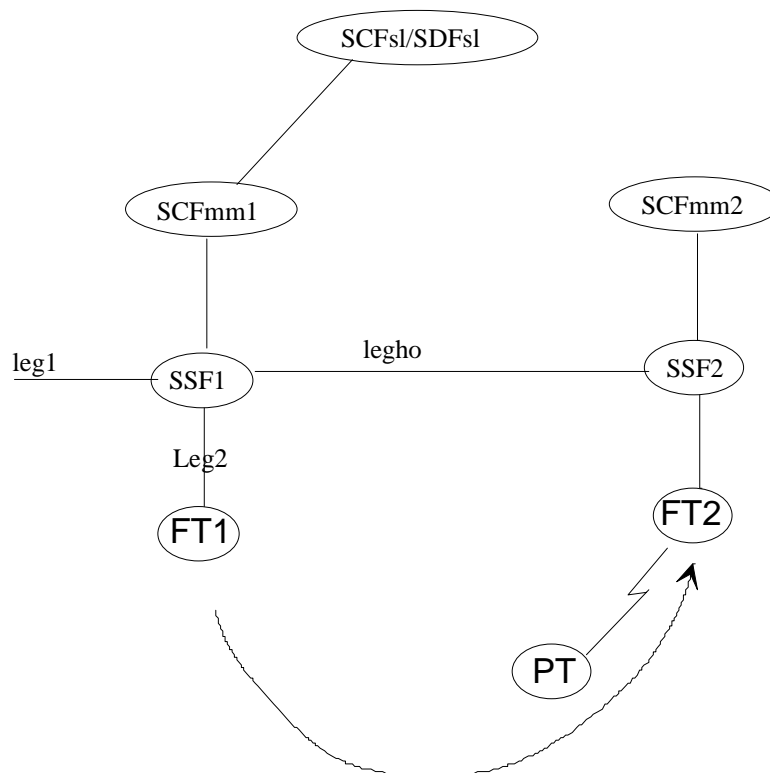

Figure 4: Handover functional architecture - case 2

4.1.2.4 Handover execution procedure - case 2

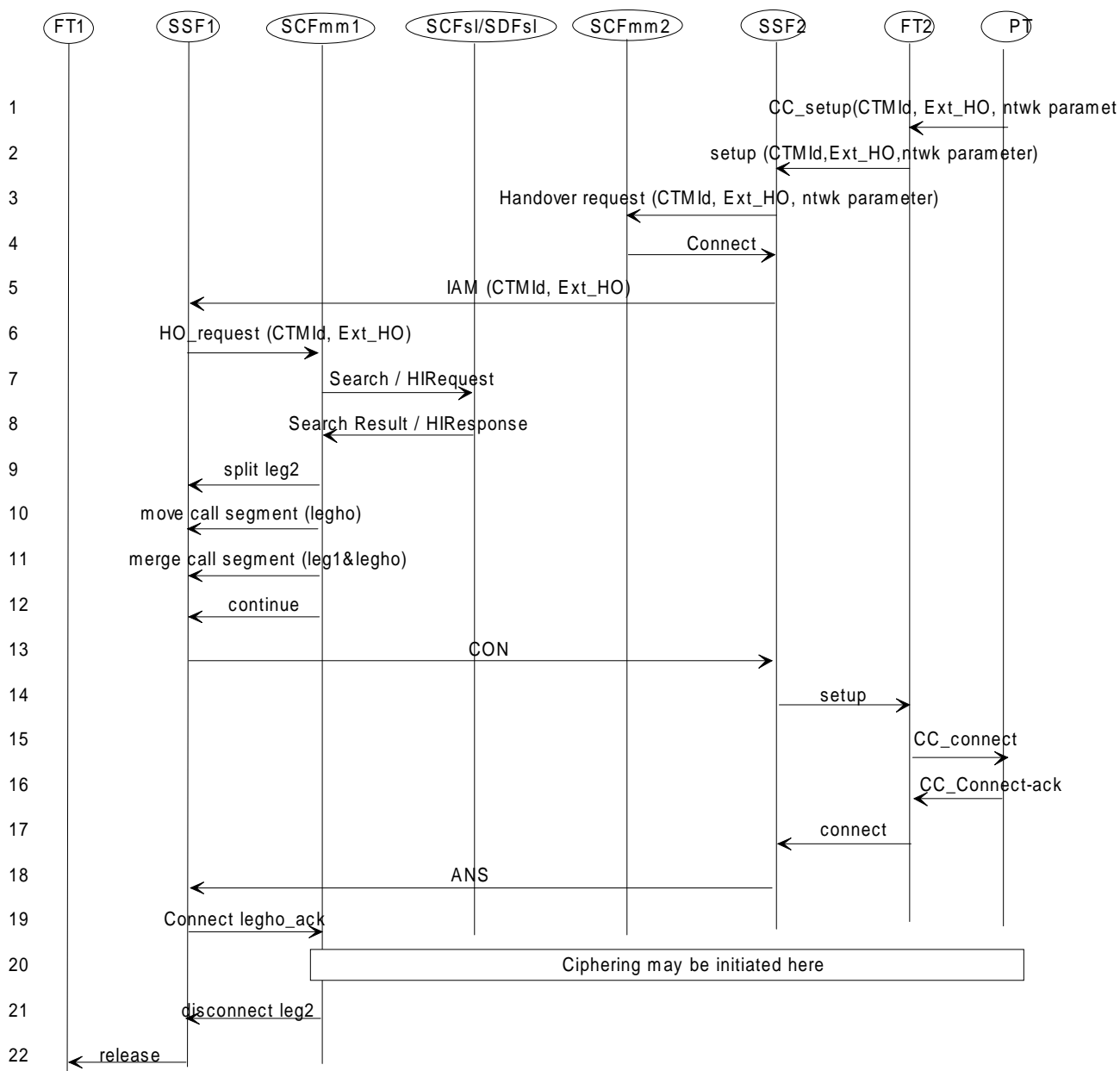

Figure 5: Handover execution procedure - case 2

Table 2: Message commentary - case 2

Msg	Remarks
1	The PT sends a CC_SETUP message to the FT2, with the Basic Service = Ext_Ho and the Network parameter including the HO_Reference and data field. In this data field could be contained a number identifying the SCFmm1.
2	The FT2 relays the SETUP message to the CCF/SSF2.
3	The CCF/SSF2 recognizes an outgoing call request from a CTM user and triggers the SCFmm2.
4	The SCFmm2 recognizes an inter-switch handover, does not check if the user is registered in its SDFmm but indicates the SSF1 that is to be contacted.
NOTE:	The need for flows 3 and 4 needs further consideration. Indeed, the SSF2 may be able to directly contact the SSF1, thanks to the network parameter (to be defined).
5	The CCF/SSF2 sends an IAM to the SSF1 for handover processing.
6	The SSF1 triggers the SCFmm1 (the triggering criteria could be Ext_HO parameter).
7-8	The SCFmm1 queries the service profile in order to check the handover rights.
9	The SCFmm1 asks the SSF1 to split the leg towards the FT1.
10-11	The SCFmm1 asks the SSF1 to link leg1 and legho.
12-13	The SCFmm1 sends a Continue, relayed by the CCF/SSF1 to the CCF/SSF2.
19	Upon reception of the connect acknowledgement, the SSF1 triggers the SCFmm1 to notify that the speech channel for handover has been established. At that time, ciphering may be processed.
21-22	The SCFmm1 orders CCF/SSF1 to disconnect the leg.

NOTE: This scenario may not be optimal, although more in line with IMT-2000 (a single anchor). Indeed, between "split leg2" and "merge call segment", the call may be suspended (during a short time but suspended however). This requires further study.

4.1.3 Scenario 2 - Inter-switch handover

4.1.3.1 Functional architecture - case 1

The following architecture is used to describe inter-switch handover:

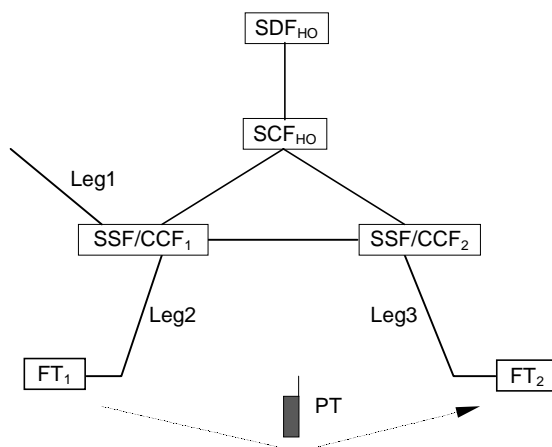

Figure 6: inter-switch handover functional architecture

The PT involved in a call with a third party moves from FT1 to FT2. These FTs are connected to two different SSFs but these ones remain controlled by the same SCF.

The leg between SSF and third party is Leg1, leg between FT1 and the first SSF is Leg2, leg between FT2 and the first SSF is Leg3.

We assume in the following procedures that the call and service controls are kept by the first SSF. This allows linking of handover between switches without any risk of tromboning and always with the possibility to provide services.

4.1.3.2 Handover execution procedure - case 1

In this situation, all the handover parameters (handover reference and handover candidate) are given to the PT when it is connected to the SSF/CCF1.

When the PT asks the new FT (FT2) for external handover procedure, the SCF, after HO_Reference retrieval, will be able to know that the corresponding call has been established on another switch and then, in order to have only one call control point, re-route the handover request to the right SSF.

Therefore, upon receiving the CC_SETUP message from the PT, the FT2 routes the calls towards the SSF it is connected to. The SSF then triggers the SCF (the DP should be the Ext_Ho parameter in the Setup message).

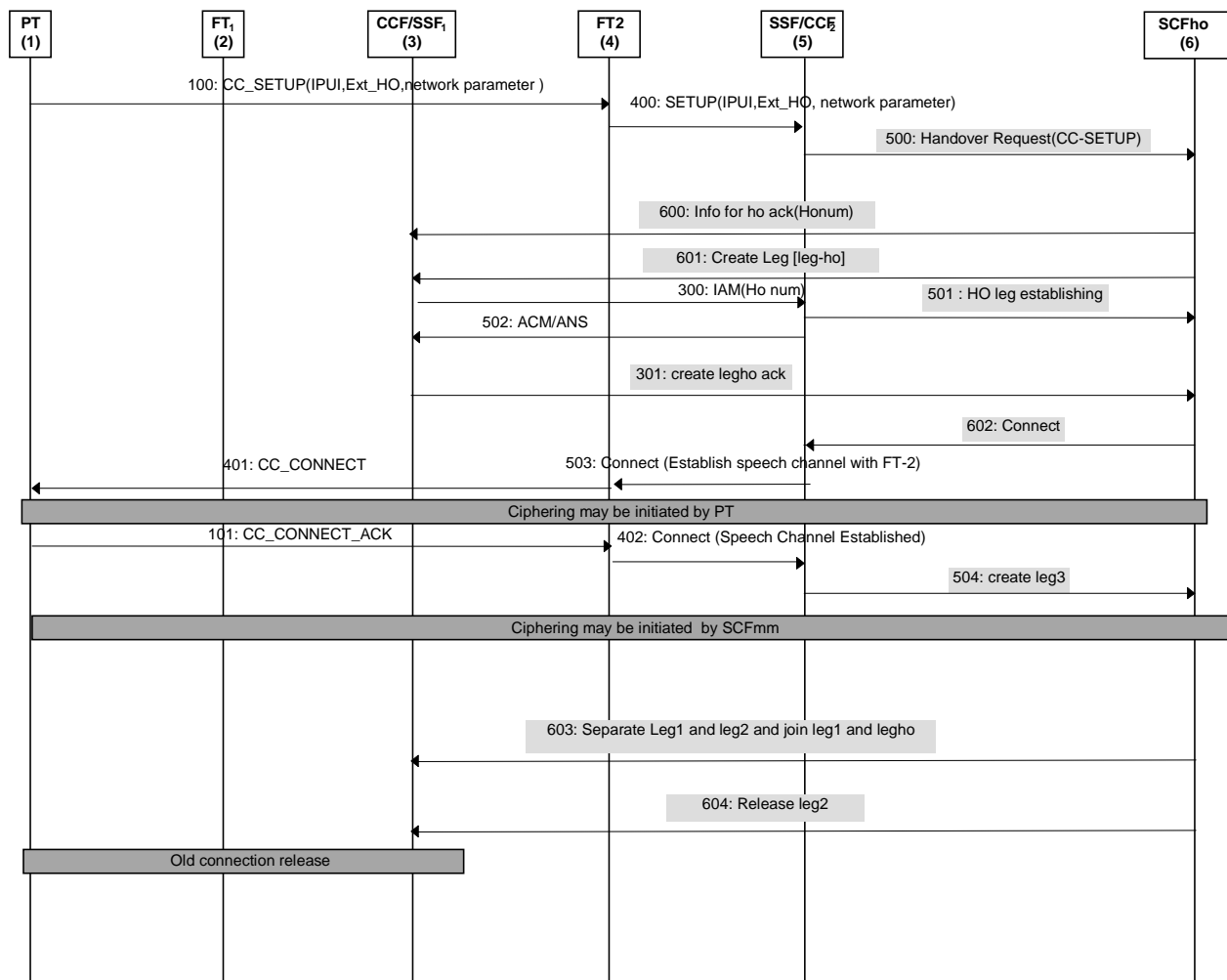

Figure 7: Information flows for inter-switch handover with handover number

Table 3: Handover execution procedure - case 1

Msg	Remarks
100	The PT sends a CC_SETUP message, with the Ext_Ho parameter to the FT2 including the HO_Reference.
400	The FT2, upon analysing the CC_SETUP message relays it to the SSF2.
500	The SSF2 triggers the SCFho.
600	The SCF upon analysing the HO_Request recognize that the SSF2 that has invoked service logic is not the first visited SSF in the call. The SCFho sends the handover (routeing) number to the SSF1.
601	The SCFho asks the SSF1 create Leg [legho]to the SSF2.
300	The first visited SSF sends an IAM containing the handover number to the SSF2.
502	The SSF2 acknowledges.
301	The SSF1 sends an acknowledgement to the SCFho.
602	The SCF issues the connect instruction to the SSF/CCF2.
503	The SSF/CCF2 sends a CONNECT message to the FT2.
401	FT2. connects to the PT.
401	The FT2 sends a CC_CONNECT message to the PT, establishing speech channel.
101	The PT acknowledges the speech channel establishment by sending a CC_CONNECT_ACK to the FT2.
402	The FT2 sends this acknowledgement to the SSF...
504	The SSF/CCF2 sends a create leg3 request.
6703	The SCF asks the SSF to separate the 2 first legs involved in the call and to join leg1 and leg3.
604	The SCF sends a disconnect message to SSF/CCF1.

4.1.3.3 Handover execution procedure - case 2

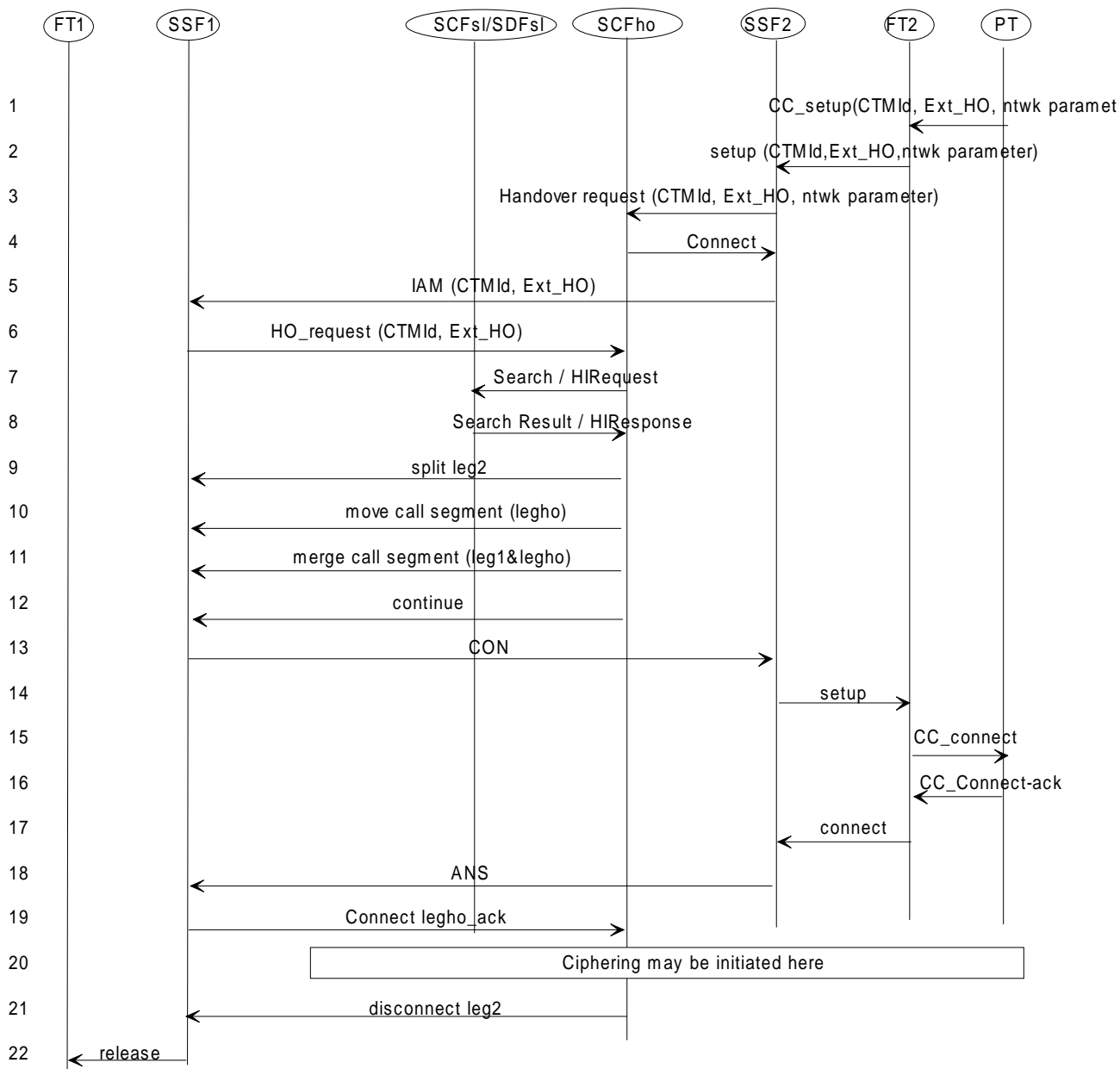

Figure 7A

Table 4: Handover execution procedure - case 2

Msg	Remarks
1	The PT sends a CC_SETUP message to the FT2, with the Basic Service = Ext_Ho and the Network parameter including the HO_Reference and data field. In this data field could be contained a number identifying the SCFho.
2	The FT2 relays the SETUP message to the CCF/SSF2.
3	The CCF/SSF2 recognizes an outgoing call request from a CTM user and triggers the SCFho.
4	The SCFho recognizes an inter-switch handover and the SSF1 that is to be contacted.
5	The CCF/SSF2 sends an IAM to the SSF1 for handover processing.
6	The SSF1 triggers the SCFho (the triggering criteria could be Ext_HO parameter).
7-8	The SCFho queries the service profile in order to check the handover rights.
9	The SCFho asks the SSF1 to split the leg towards the FT1.
10-11	The SCFho asks the SSF1 to link leg1 and leg2.
12-13	The SCFho sends a Continue, relayed by the CCF/SSF1 to the CCF/SSF2.
19	Upon reception of the connect acknowledgment, the SSF1 triggers the SCFho to notify that the speech channel for handover has been established. At that time, ciphering may be processed.
21-22	The SCFho orders CCF/SSF1 to disconnect leg2.

4.1.4 Scenario 3 - Intra-switch handover

4.1.4.1 Functional architecture

The following architecture will be used for the description of intra-switch handover.

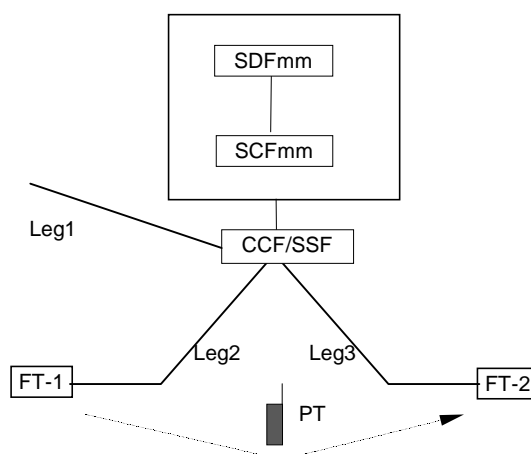

Figure 8: intra-switch handover functional architecture

4.1.4.2 Handover execution procedure

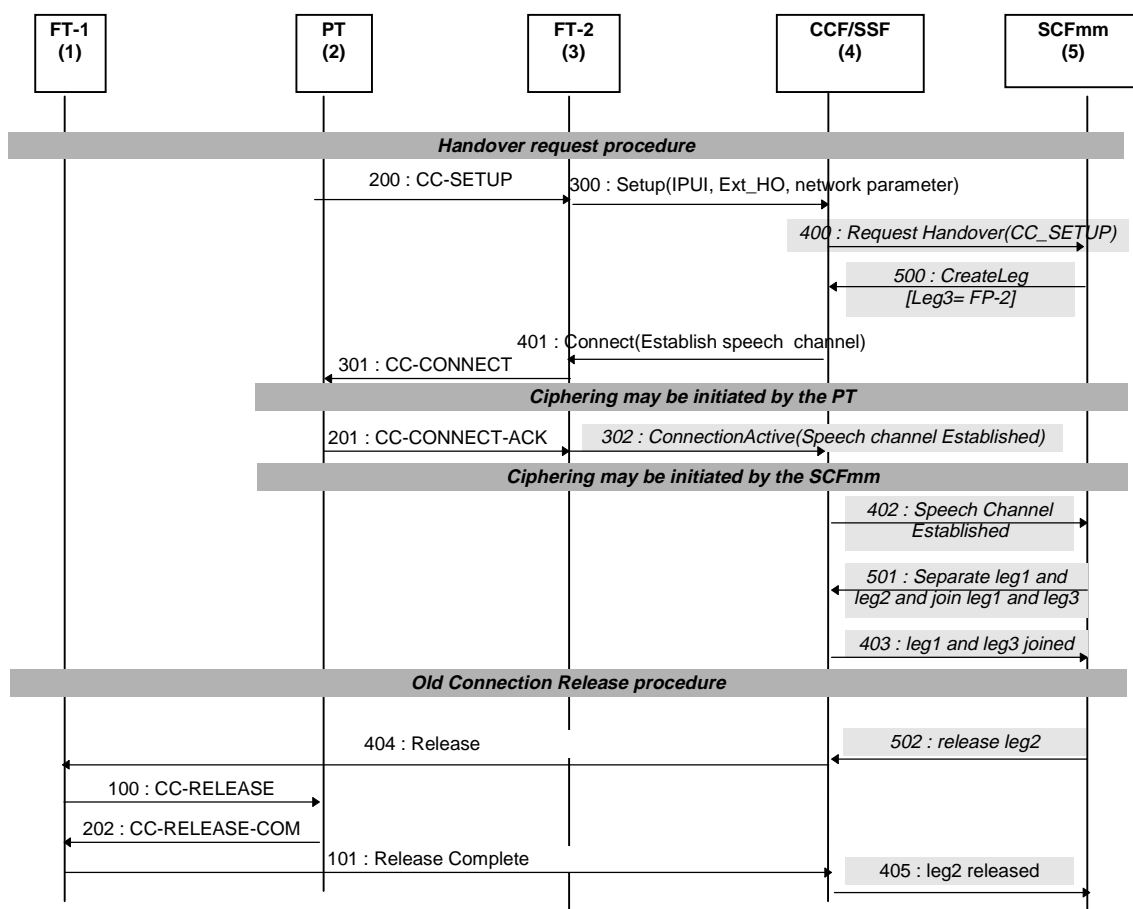

Figure 9: Information flows for intra-switch handover

Table 5: Intra-switch handover - messages

Msg	Remarks
200	The PT sends a CC-SETUP message to the FT2 including Basic Service= Ext_Ho and Network Parameter accordingly to the CAP specification.
300	The FT2 relays the SETUP message to the CCF/SSF, including the Network parameter containing the EXT_HO_Reference and additional data field.
400	the CCF/SSF recognizes an outgoing call request from the CTM user and triggers the SCFmm.
500	The SCFmm recognizes an inter switch handover request and asks the CCF/SSF to create a speech channel with the FT2 and the PT in order to inform the PT that the handover request has been accepted.
401	The CCF/SSF sends a CONNECT message to the FT2 for the speech channel establishment.
301	The FT2 sends a CC_CONNECT message to the PT in order to establish radio speech channel. PT may start the Ciphering Procedure.
201	The PT acknowledges the speech channel establishment with the CC-CONNECT-ACK to the FT2.
302	This acknowledgement is relayed from the FT2 to the CCF/SSF.
402	The CCF/SSF informs the SCFmm of speech channel establishment. The SCFmm may start the Cipher Procedure.
501	The SCFmm asks the CCF/SSF 1 to separate leg1 and leg2 and to join leg1 and leg3.
403	The CCF/SSF acknowledges the separation and the join.
502	The SCFmm asks the CCF/SSF 1 to release the call with FT1.
404	The CCF/SSF sends a disconnect message to FT1.
100	FT1 sends a CC_RELEASE message to the PT.
202	The PT acknowledges this release with a CC-RELEASE-COMplete.
101	The FT1 sends a Release Complete to the CCF/SSF.
405	The CCF/SSF informs the SCFmm that leg2 has been released.

4.2 Enhanced Location Registration

The periodic location registration is an enhancement of the CTM phase 1 location registration procedure as described in EG 201 096 [4].

Additional information indicating the duration of the registration is added in the location registration result towards the Portable. This duration parameter is optional and has some impact protocols (IN and DSS1+). The default value for this duration may be set via TMN which is outside the scope of the present document.

According to the location registration initiation rules as described in EN 301 273 [3], the Portable will periodically start the location registration procedure upon expiry of the time limits indicated in the duration information. In addition, the Portable will start the location registration procedure after losing synchronization with the system for the time defined by the lock limits indicated in the duration information.

4.2.1 Location registration when the user is already registered in the SDFmm

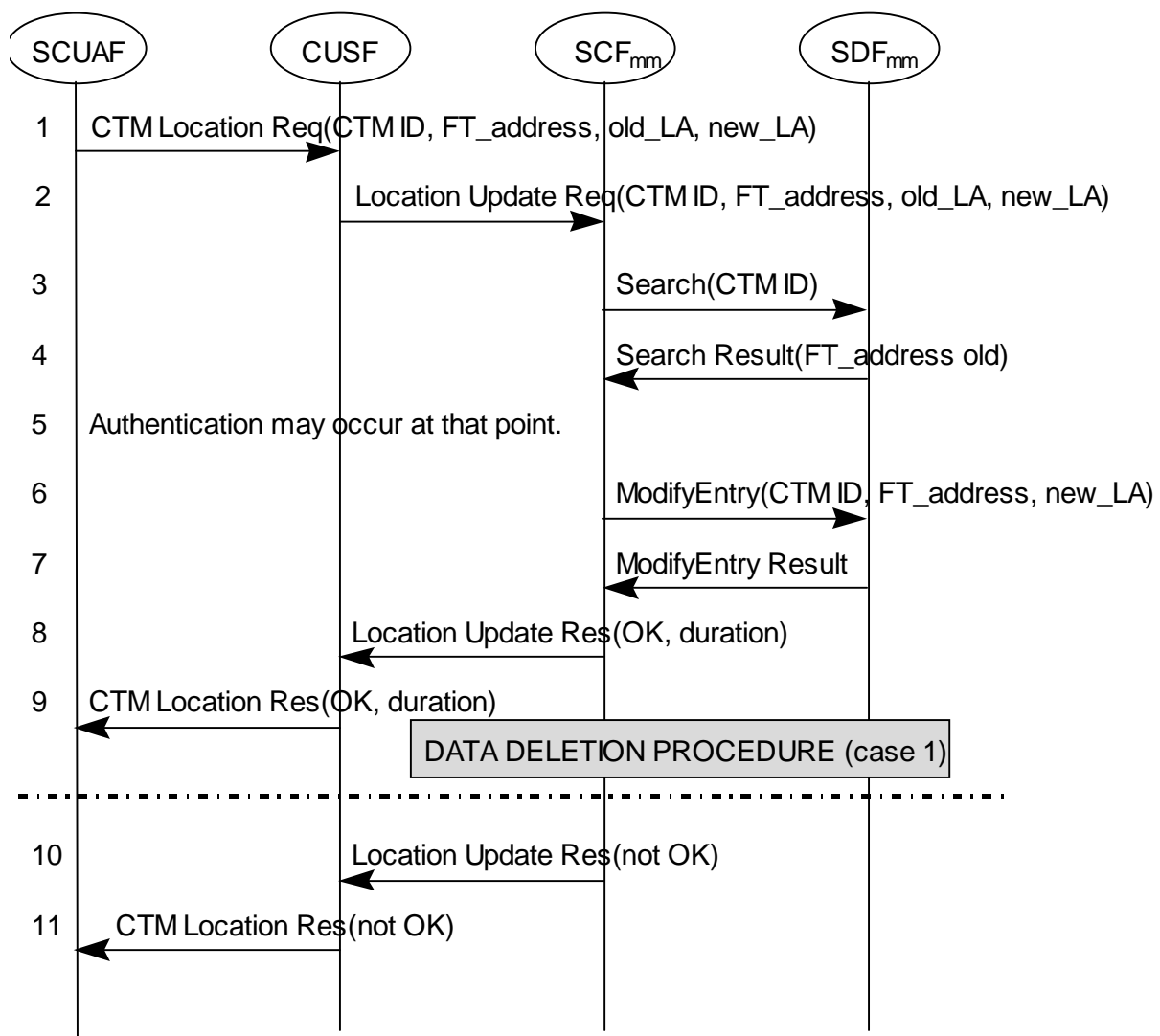

NOTE: Data deletion in the same mm area may start in parallel with data modification.

Figure 10: Location registration when the user is already registered in the SDFmm

Table 6: Location registration messages

Msg	Remarks
1	SCUAF detects the location registration message and sends a (call unrelated) message to the CUSF including the CTMid of the PT and the FT address.
2	On recognition of a CTM request, CUSF sends a call unrelated Location Update Request message to the SCFmm, including the CTMid of the PT and the FT address.
3,4	SCFmm checks if the PT is correctly registered in SDFmm in a Search request including CTMid. On the figure above, the PT is correctly registered and the old FT address is returned in the Search operation.
5	Authentication may occur at this stage. If authentication takes place and it is unsuccessful, go to 10. Data deletion procedure may also start at this stage and can be performed in parallel with data modification.
6,7	SCFmm stores the CTMid and the FT address in SDFmm with an Modify Entry message.
8,9	SCFmm sends back the location registration confirmation to SCUAF via CUSF and the duration allowed for registration on the FT. At the same time Data Deletion procedure may start.

4.2.2 Location registration when the user is not already registered in the SDFmm (SCF-SCF)

**Figure 11: Location registration when the user is not already registered in the SDFmm (SCF-SCF)**

Table 7: Location registration messages (SCF-SCF)

Msg	Remarks
1	SCUAF detects the location registration message and sends a call unrelated message to the CUSF including the CTMid of the PT and the FT address.
2	CUSF sends a call unrelated Update_Location Request message to the SCFmm, including the CTMid of the PT and the FT address.
3	The SCFmm checks if the PT is already registered in SDFmm in a Search request based on the CTMid.
4	The PT is not already registered in the current SDFmm and a negative result is returned in the Search operation.
5-6	The SCFmm accesses the SDFsl in the visited network to retrieve the home SCFsl address and the appropriate information is returned.
7-12	The SCFmm updates the location registration data in home SCFsl. It provides the new SCFmm address.
13-14	The SCFmm in the visited network stores the CTMid, the FT address and the CTMnumber in SDFmm with an Add Entry message.
15-16	SCFmm sends back the location registration confirmation to the PT, including the authorized duration for that FT.

4.2.3 Location registration when the user is not already registered in the SDFmm (SCF-SDF)

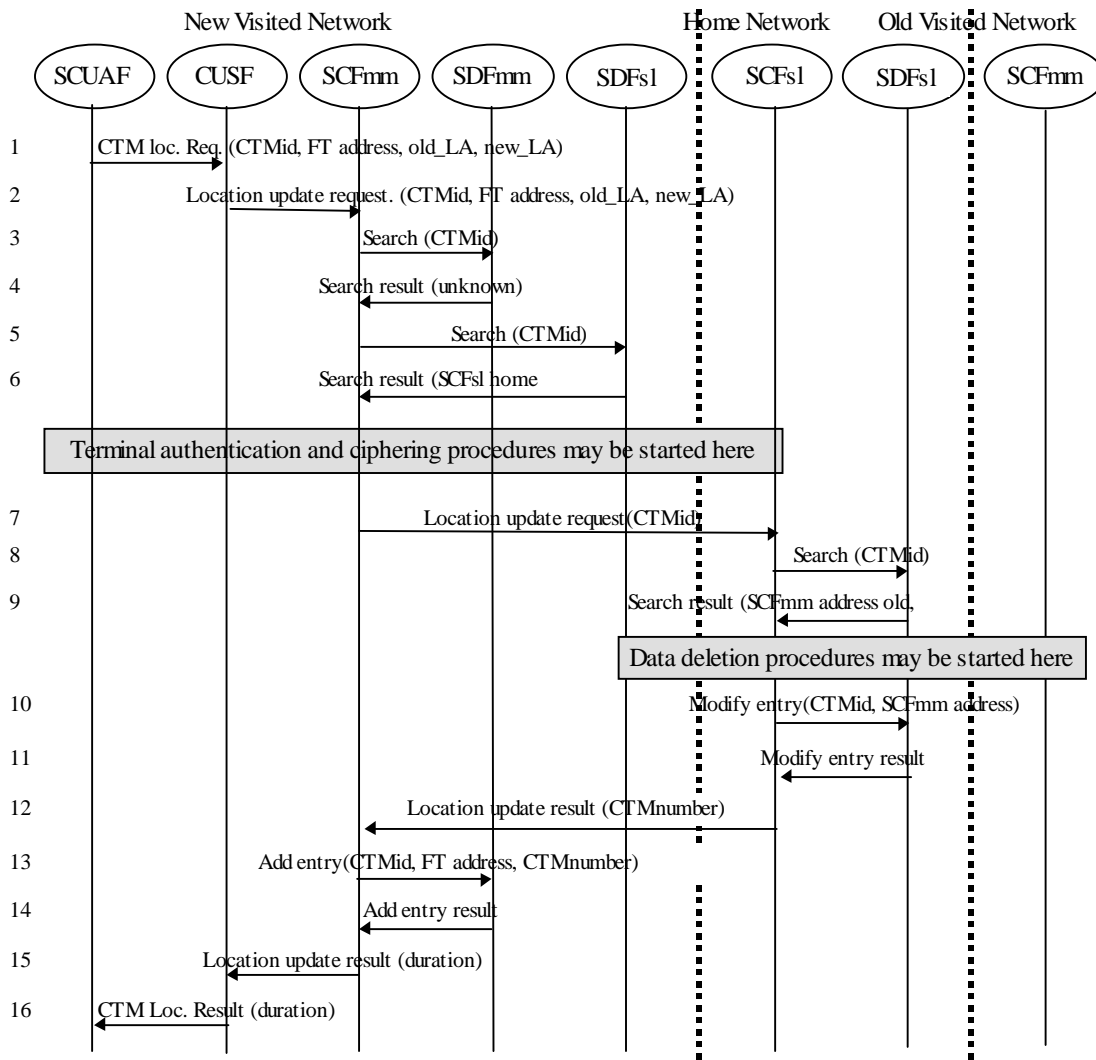
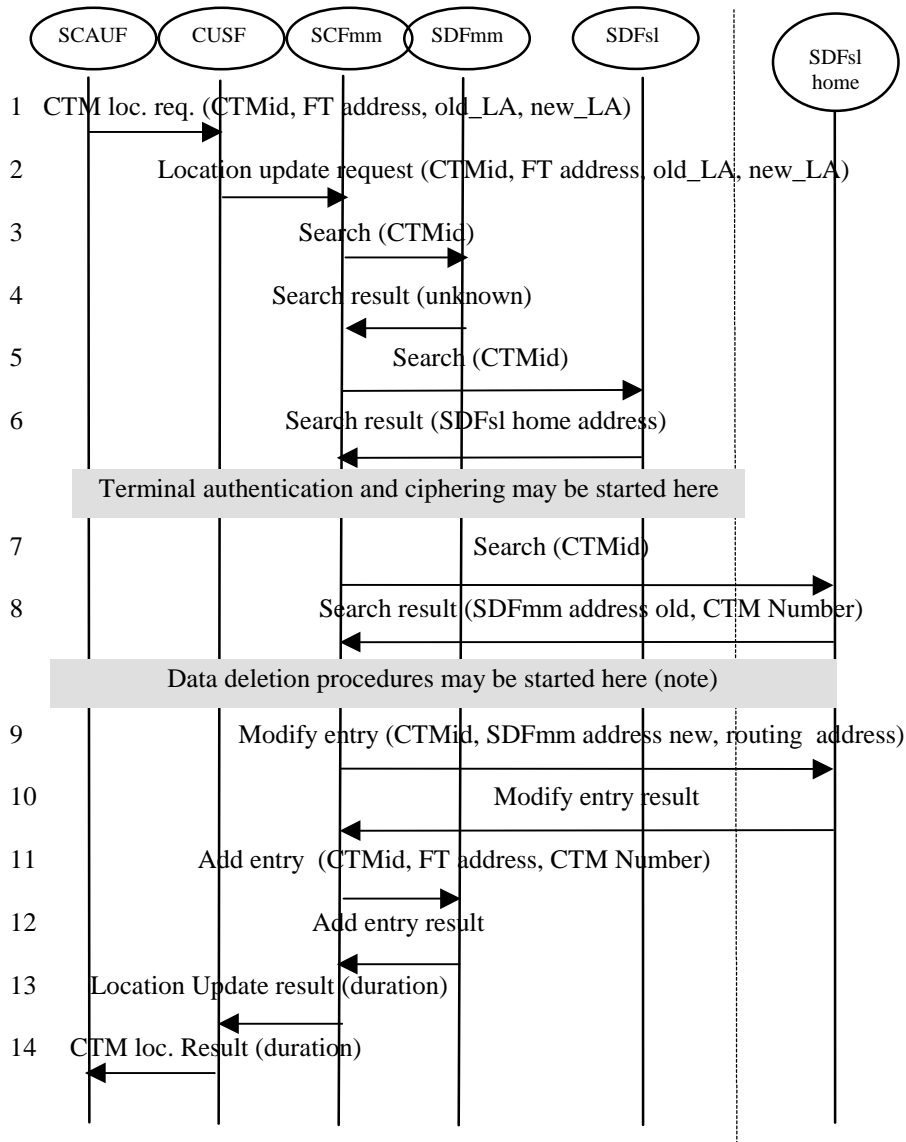

NOTE: Data deletion in the old network can start in parallel with data modification in the visited network.

Figure 12: Location registration when the user is not already registered in the SDFmm (SCF-SDF)

Table 8: Location registration messages (SCF-SDF)

Msg	Remarks
1	SCUAF detects the location registration message and sends a call unrelated message to the CUSF including the CTMid of the PT and the FT address.
2	CUSF sends a call unrelated Update_Location Request message to the SCFmm, including the CTMid of the PT and the FT address.
3	SCFmm checks if the PT is already registered in SDFmm in a Search request including CTMid.
4	The PT is not already registered in the current SDFmm and a negative result is returned in the Search operation.
5-6	The SCFmm accesses the SDFsl in the visited network to retrieve the home SDFsl address.
7-8	The SCFmm accesses the SDFsl in the home network to retrieve the SDFmm address of the previous visited network and the CTM Number.
9-10	The SCFmm updates location registration data in home SDFsl. It inserts the new SDFmm address, if roaming number method will apply for incoming call. The routing address is stored instead of the SDFmm address when the routing address method is used.
11-12	SCFmm stores the CTMid, the CTM Number and the FT address in SDFmm with an Add Entry message.
13-14	SCFmm sends back the location registration confirmation to the PT, including the duration authorized for that FT.
NOTE:	The SCFsl provides the information about the result of the authentication performed (here the authentication is assumed to be successfully completed).

4.3 Detach

The Portable performs the Detach procedure upon power -down.

Detach is the process whereby a Portable informs the network that it is no longer able to receive incoming calls.

Generic procedures:

According to the GSM approach, replacing:

- VLR with visited domain (SCF/SDF visited);
- HLR with home domain (SCF/SDF home) and in addition to cover both the intra-network and inter-network case specifying that;
- The visited domain may belong to the home network or a visited network, the textual definition may be applied to CTM environment and the generic procedures may be represented as following:

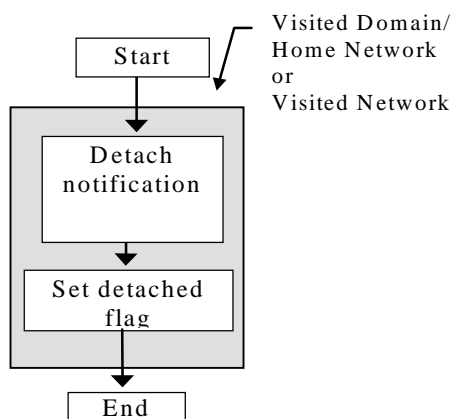

Figure 13: Detach procedure

A description is proposed in the figure below: The treatment is carried at the visited level (SCFmm). The CTMid is marked in the visited SDFmm when the incoming call is using the roaming number method, in the visited SDFmm or the home SDFsl when the incoming call is using the routing address method. It is then consistent with GSM and optimized for call routing.

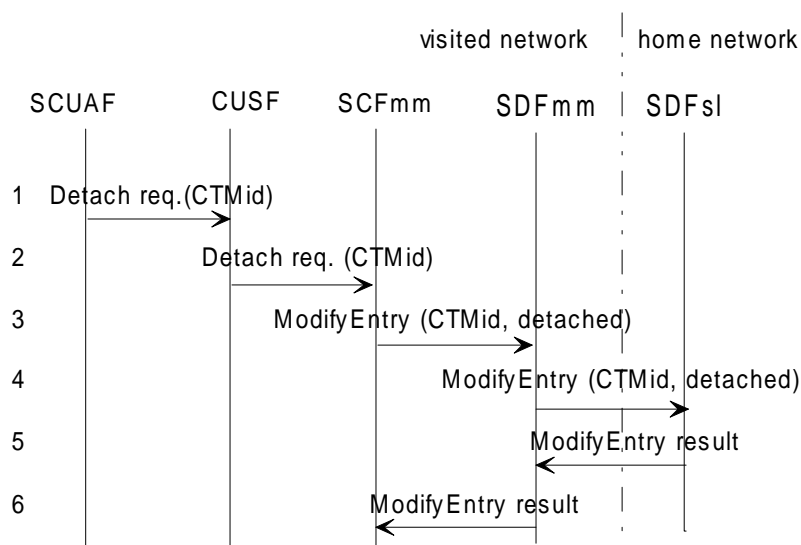

Figure 14: Information Flows for Detach procedure

Table 9: Detach messages

Msg	Remarks
1	SCUAF detects the request for Detach sent by the CTM terminal. It sends a call unrelated message to the CUSF indicating the CTMid of the PT.
2	CUSF send a call unrelated Detach request to the visited SCFmm, including the CTMid.
3	The SCFmm marks the CTMid in the SDFmm to indicate the new status of the CTM terminal.
4-5	When the routing number method is used for incoming calls, based on agreements between operators, the SDFmm can chain the Detach request to the home SDFsl where the CTMid is marked detached.
6	SCFmm sends back the Detach confirmation to the PT.

4.4 Purge

This service is used between the SCF/SDFmm and the SCF/SDFsl to cause the SCF/SDFsl to mark its data for a CTM terminal so that any request for routing information for a mobile terminated call or a mobile terminated short message will be treated as if the CTM terminal is not reachable. It is invoked when the subscriber record for the CTM terminal is to be deleted in the SCF/SDF^{mm}, either by MMI interaction or automatically, e.g. because the CTM terminal has been inactive for several days).

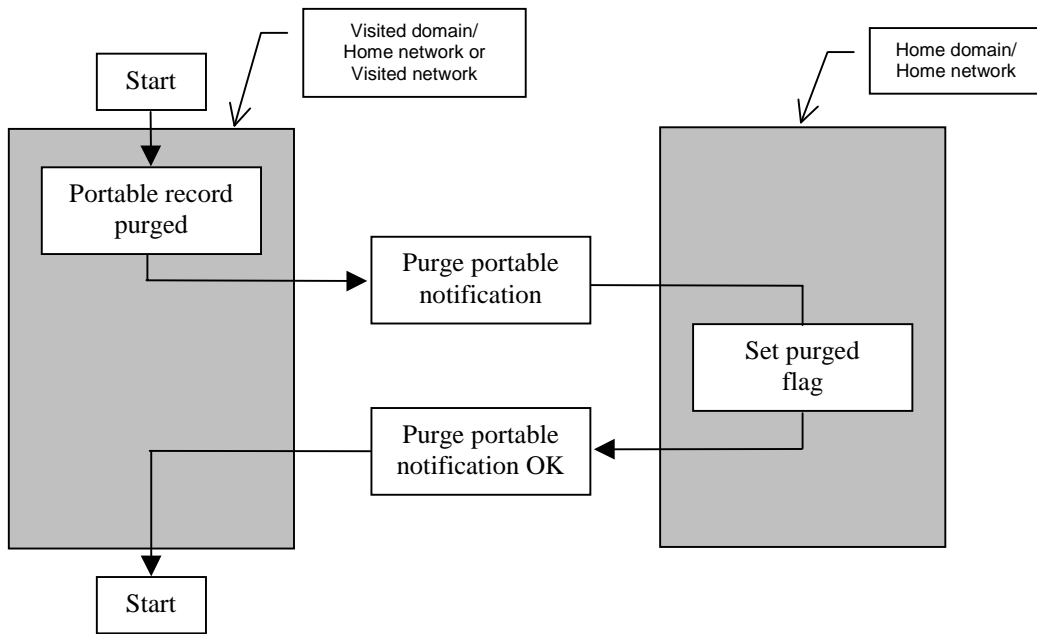

Figure 15: Purge procedure

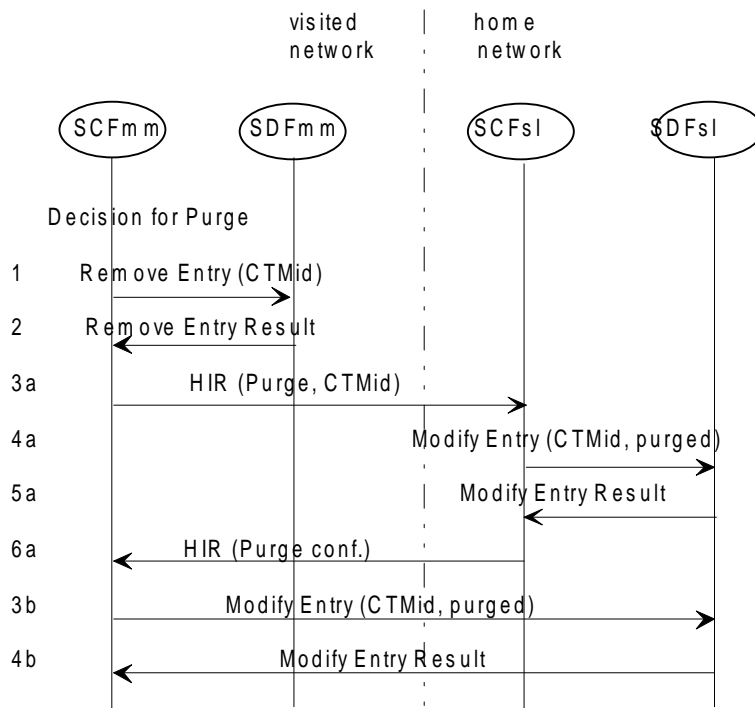

Figure 15A

Table 10: Purge messages

Msg	Remarks
1-2	The visited SCFmm decides to purge the record related to a given CTM user, identified by the CTMid. It then sends a Remove Entry message to its SDFmm.
2	CUSF send a call unrelated Detach request to the visited SCFmm, including the CTMid.
If the SCF-SCF interface is used between networks:	
3a	The visited SCFmm indicates the home SCFsl that Purge occurred for the identified CTM user.
4a-5a	The home SCFsl marks the CTMid in the home SDFsl to indicate the Purge status for the associated CTM user.
6a	The confirmation is sent back to the visited network.
If the SCF-SDF interface can be used between networks:	
3b-4b	The visited SCFmm marks the CTMid in the home SDFsl to indicate the Purge status for the associated CTM user.

5 Other Core Features

5.1 Message Waiting Indication (MWI)

All MWIndicate arguments defined in EN 300 745-1 [5] may be used. However, the following minimum requirements apply for the FP and the PP:

- the FP shall send the 'basic service' argument to indicate the kind of message; the 'basic service' element shall be coded as defined in EN 300 196-1 [6]. The PP shall support a separate MWI status for each of the following basic services values:
 - 1) voice messages shall be indicating using the "speech (1)" coding;
 - 2) text messages shall be indicating using the "teletext (33)" coding;
 - 3) other and unknown messages shall be indicating using the "all Services(0)" coding;

all other codings may optionally be understood by the PP;

- the FP may send the "controlling User Number" argument to indicate the party number of the corresponding message server. If the PP support this, then the PP shall store the number and may use this to call the message server and the minimum PP storing requirements for this number shall be 10 octets (20 digits);
- the PP shall support the "numberOf Messages" argument which may be used to indicate how many messages for the specific Basic Services are waiting. The PP shall be capable of handling values up to 127.

The principle is the following one: the network needs to indicate to the terminal/user that messages are available; it is controlled by the home SCF/SDFsl.

The information flows apply for both activation and deactivation.

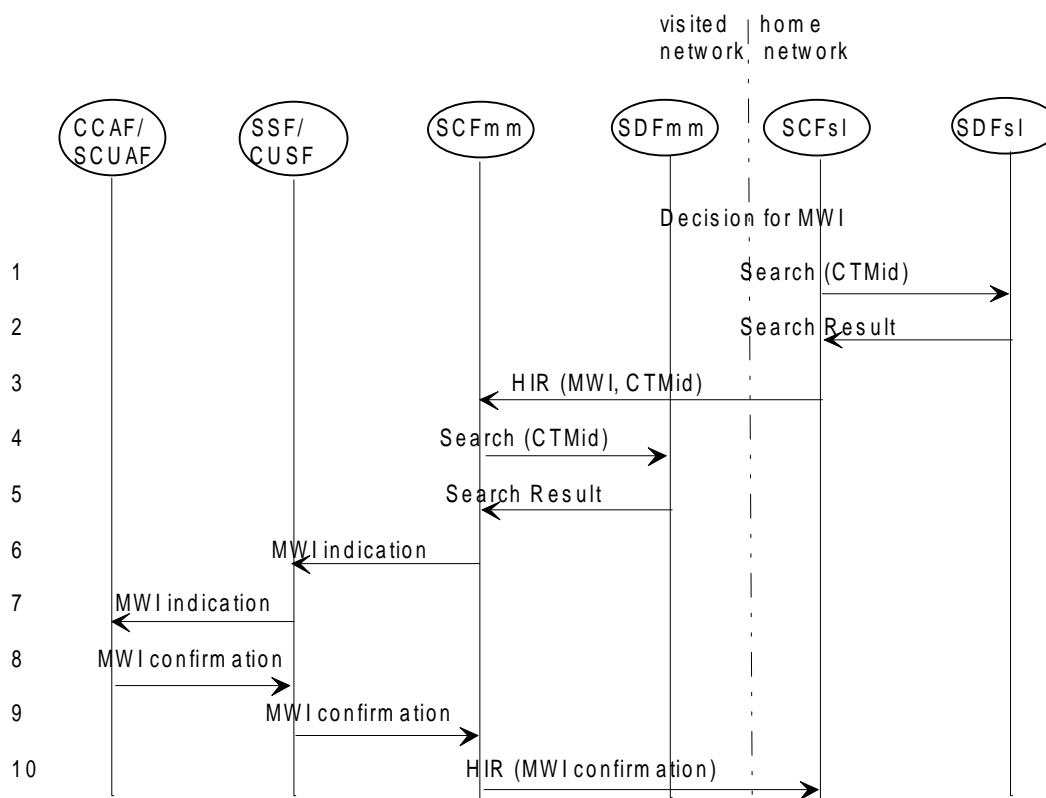

Figure 15B

Table 11: Message Waiting Indication (MWI) messages

Msg	Remarks
1-2	The home SCFsl decides to notify the terminal/user for MWI. It first retrieves from the home SDFsl the visited SCF/SDFmm location and optionally checks the user's service profile.
3	The home SCFsl sends the MWI notification to the visited SCFmm.
4-5	The visited SCFmm retrieves from the visited SDFmm the location of the terminal/user.
6-7	The visited SCFmm then sends the MWI to the access side. Facility messages are used.
8-10	When received by the terminal, the confirmation is sent back to the home SCFsl.

5.1.1 MWIndicate - activation

To activate the MWI status for a specific basic service, the FP shall send a 'FACILITY' message including a "Facility I.E." as defined in table 12.

Table 12: Values used within the FACILITY message for message waiting indication

Information element	Field within the information element	Standard values within the field/IE	Normative action/comment
"Facility"			Codings defined in EN 300 745-1 [5] and EN 300 196-1 [6]
	<Service discriminator>	17	Discriminator for supplementary services applications
	<Component Tag>	161	Component tag=Invoke
	<Invoke Identifier tag>	2	
	<Operation Value>		With regard to OBJECT IDENTIFIER for mWIndicate
	<ControllingUserNumber>	All	It is optional for the FP to include this information, it is optional for the PP to understand this information
	<basicService >	0,1,33	Unknown, speech, text messages
	<NumberOfMessages>	1..127	It is optional for the FP to include this information

5.1.2 MWIndicate - deactivation

To deactivate the indication of MWI for a specific basic service to the receiver user, the FP shall send a "Facility" Information element with the "numberOfMessages" argument for the specific basic service set to zero as defined in table 13.

Table 13: Values used within the FACILITY message for message waiting indication deactivation

Information element	Field within the information element	Standard values within the field/IE	Normative action/comment
"Facility"			Codings defined in EN 300 745-1 [5] and EN 300 196-1 [6]
	<Service discriminator>	17	Discriminator for supplementary services applications
	<Component Tag>	161	Component tag=Invoke
	<Invoke Identifier tag>	2	
	<Operation Value>		With regard to OBJECT IDENTIFIER for mWIndicate
	<basicService >	0,1,33	Unknown, speech, text messages
	<NumberOfMessages>	0	

5.1.3 Retrieval of messages

To call the message server, the PP shall use the outgoing call request as defined in subclause 8.2 of EN 300 444 [7], indicating "Normal call setup". The PP may apply the party number of the message server, if provided, within a 'CC-INFO' message as defined in EN 300 444 [7], subclause 8.10.

NOTE: If no number is received, The PP may also apply a locally stored address.

5.2 Emergency call without terminal authentication

5.2.1 Emergency call procedure initiated as normal outgoing call

The Emergency call procedure initiated as normal outgoing call is described in CTM phase 1 EG 201 096 [4]. In this case, as in a normal originating call, the emergency call number has to be dialled and only after the analysis of the received digit is the SCF visited able to recognize the call as an emergency one and ignore the result of the authentication, if previously invoked.

5.2.2 CTM emergency call based on CAP feature

Another possibility of working the emergency call not present in CTM PH1 is offered by CAP and is addressed below.

In this case, the outgoing call includes in the first set up message the indication that the basic service call class is emergency call instead of the normal call setup.

This indication can be used to avoid the initiation of the terminal authentication procedure.

No digits have to be requested from the user.

In addition the user may present itself to the network either with its CTM ID as part of his IPUI or with the IPEI (International Portable Equipment Identity).

CTM emergency call (based on CAP feature)

By the LE

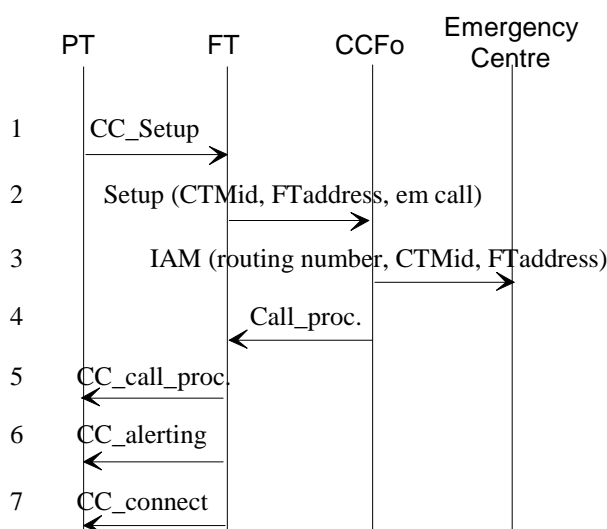

Figure 16: CTM emergency call (based on CAP feature)

In this case, the FT recognizes the request for an emergency call. It accepts the CC_setup without any checking and sends the call to the LE. The LE then analyses the Facility I.E., recognizes the request for an emergency call by virtue of the value of the Basic_Service IE and, e.g. according to the location of the calling party (provided by the FT), it routes with a routing number the call to an emergency line of the local emergency centre.

Note that the CTMId in the above figure can be:

- the IPUI if a subscription is attached to the CTM terminal;

or

- the IPEI if there is no subscription.

5.2.3 CTM emergency call based on CAP feature and IN triggering

A further option is when the IN is triggered between flows 2 and 3 (the CCF considers the call as a normal call, no check of Facility is needed).

6 CTM supplementary services

The generic procedures and the related information flows refer to the general inter-networking case. The intra-network case can be derived as a particular case of the more general one, where the originating, the home and the visited domains belong to the same network.

6.1 CTM incoming call scenario

The architecture for CTM phase 2 Incoming Call is the same as that for CTM phase 1 Incoming Call described in EG 201 096 [4].

6.2 CTM Call Forwarding on Not Reachable (CTM-CFNRc)

Although CTM-CFNRc is included in CTM phase 1, different scenarios have been identified as shown in the following.

6.2.1 CTM phase 1 solution (still valid)

No mark is detected in the SDFsl. The call is treated as a normal CTM incoming call, and released from the visited network.

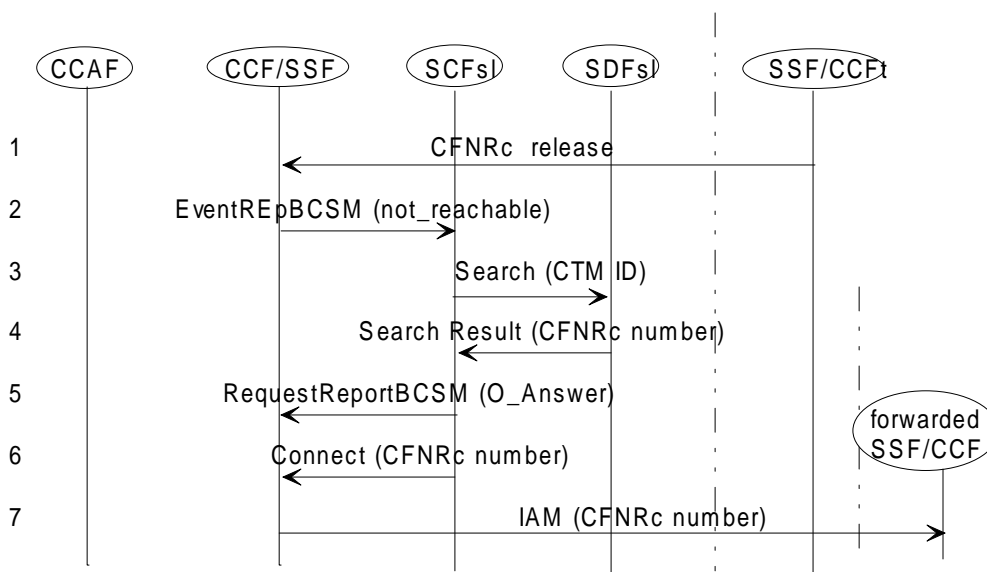

Figure 17: Information Flows for CTM Call Forwarding on Not Reachable

Preliminary, the call was routed to the visited side, paged and found not reachable.

Table 14: CTM phase 1 messages

Msg	Remarks
1	CCF/SSFt realizes that user has not answered and release the call back to CCFO.
2	CCF/SSFo reports appropriate cause (Not Reachable) to SCFsl.
3,4	SCFsl retrieves from SDFsl the routing number (CFNRc number).
5,6	SCFsl instructs to route the call towards the new destination and arms an EDP on O_Answer.
7	CCF/SSFo routes the call to new destination.

6.2.2 CTM phase 2 specific solution with mark detected in the home SDFsl

The mark detected in the SDFsl can be the mark for Purge (always set in the SDFsl) or the mark for Detach (the latter mark may be set in the SDFsl if the incoming call is based on routing address method). The call starts as any normal CTM incoming call.

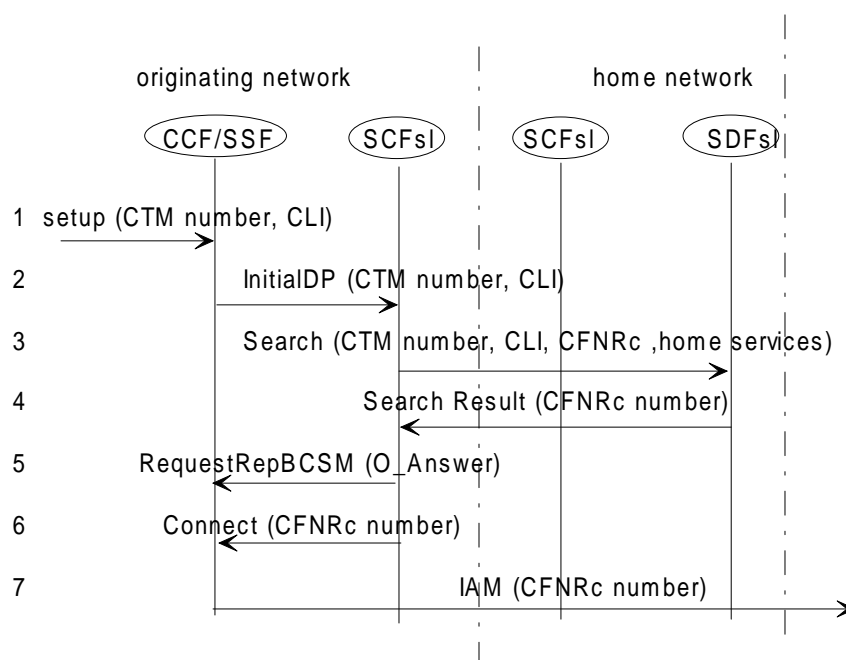

Figure 18: Information Flows for CTM Call Forwarding on Not Reachable

Table 15: CTM phase 2 SDFsl messages

Msg	Remarks
1	The calling party sends a set-up message, including the called number (CTM number) and its identity (CLI).
2	The SSFo recognizes the request as an incoming CTM call and sends an InitialDP to the SCFsl.
3	The SCFsl in the originating network requests information on home specific services to the SDFslhome. Also, the service profile is checked, in particular the possible Detach or Purge mark.
4	A CFNRc address/number is sent back by the home SDFsl because a mark for Detach or Purge was identified.
5	SCFsl orders SSFo to suspend call processing at given detection points.
6, 7	SCFsl orders SSFo to set up the call. The CFNRc number is included in the Connect operation.

6.2.3 CTM phase 2 specific solution with mark detected in the visited SDFmm

The mark detected in the SDFmm is a mark for Detach (the mark for Detach can be set in the SDFmm for any incoming call scenario).

6.2.3.1 Incoming call based on roaming number method and only SCF-SCF for internetwork functional interface

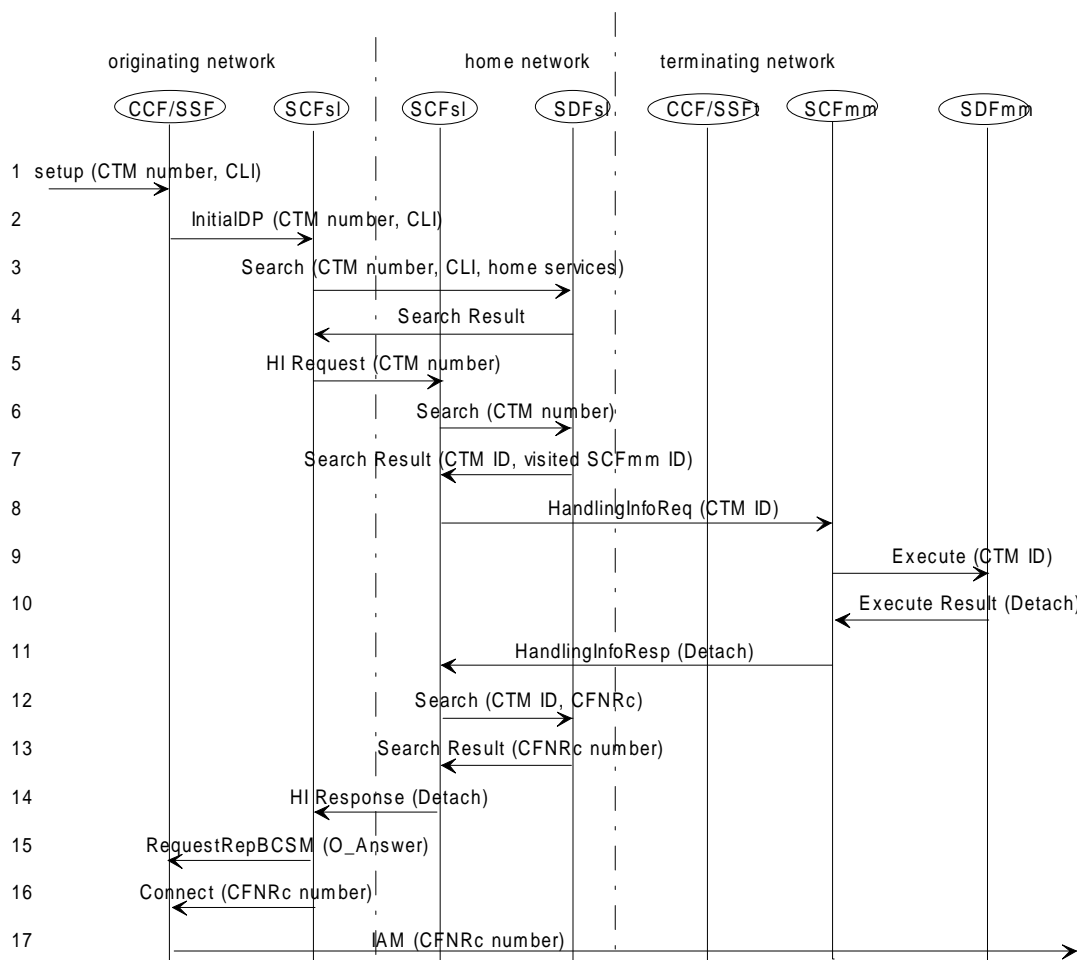

Figure 19: Information Flows for CTM Call Forwarding on Not Reachable

Table 16: CTM phase 2 SDFmm messages

Msg	Remarks
1	The calling user sends a Setup message, containing the CTM number (called CTM N°) of the called PT, to the CCF/SSFo.
2	The trigger DP is recognized by the CCF/SSFo which, on recognition of a CTM N°, sends a InitialDP message, containing the CTM N° and the Calling Line Identity, to the appropriate SCFsl. (The TDP criteria are on a per service base. The way used to route the query to the SCFsl is network operator dependant).
3, 4	The SCFsl in the originating network requests information on home specific services to the SDFslhome. In the same time, the service profile is checked.
5	the originating SCFsl request assistance from the home SCFsl in order to get a roaming number.
6, 7	The home SCFsl queries the home SDFsl in order to get the address of the visited SCFmm.
8	The home SCFsl requests assistance from the visited SCFmm to provide a roaming number (RN); SCFsl sends a Handling Information Request to SCFmm.
9, 10	Based on this request, the visited SCFmm checks the SDFmm for the RN (hence use of Execute) but detects the mark for Detach.
11	SCFmm responds to the home SCFsl with the Detach mark.
12, 13	The home SCFsl queries the home SDFsl in order to get a routing address. It receives a CFNRc number.
14	The CFNRc number is passed from the home SCFsl to the originating SCFsl.
15, 16	SCFsl answers to the CCF/SSFo InitialDP, providing the CFNRc number, placed in the destinationRoutingAddress IE of the Connect operation.
17	CCF/SSFo routes the call and provides the CFNRc number in an IAM message.

6.2.3.2 Incoming call based on roaming number method and CS2 SCF-SCF and SCF-SDF for internetwork functional interface

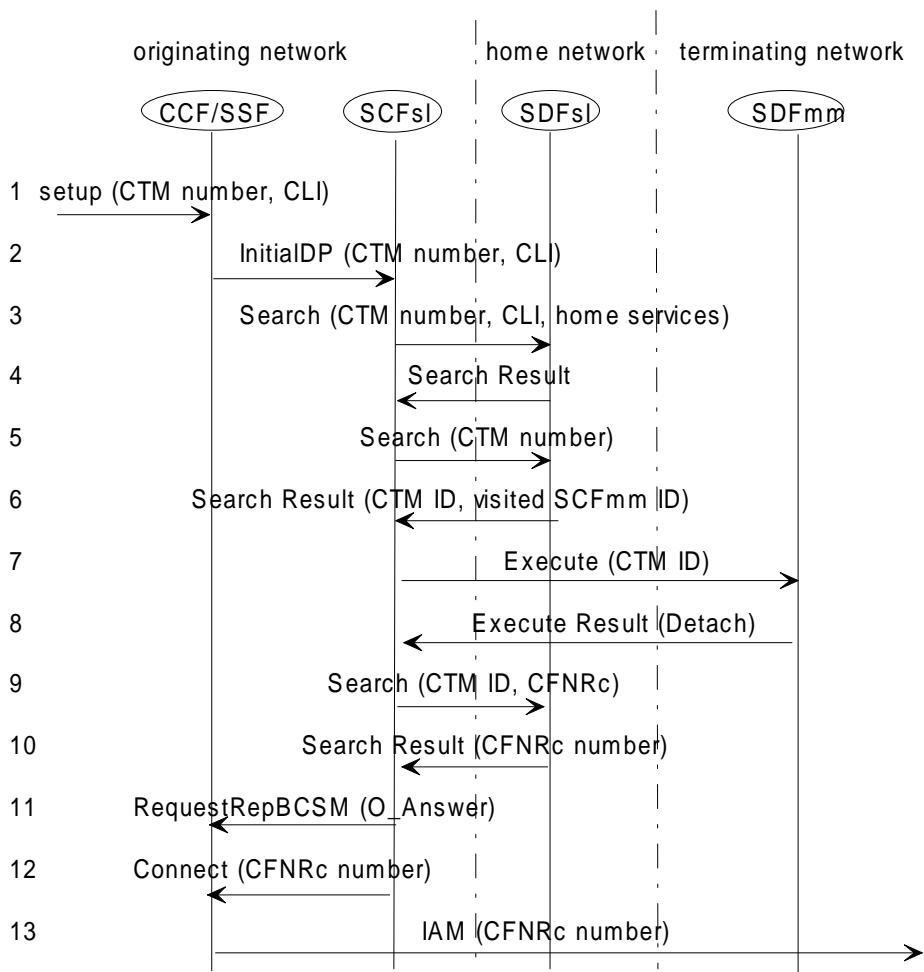

Figure 20: Information Flows for CTM Call Forwarding on Not Reachable

Table 17: CTM phase 2 messages

Msg	Remarks
1	The calling user sends a Setup message, containing the CTM number (called CTM N°) of the called PT, to the CCF/SSFo.
2	The trigger DP is recognized by the CCF/SSFo which, on recognition of a CTM N°, sends a InitialDP message, containing the CTM N° and the Calling Line Identity, to the appropriate SCFsl. (The TDP criteria are on a per service base. The way used to route the query to the SCFsl is network operator dependant).
3, 4	The SCFsl in the originating network requests information on home specific services to the SDFslhome. In the same time, the service profile is checked.
5; 6	The originating SCFsl queries the home SDFsl in order to get the address of the visited SDFmm.
7, 8	The originating SCFsl queries the visited SDFmm to get a roaming number for the user; the Detach mark is detected and the SCFsl receives back a CFNRc number.
9, 10	The originating SCFsl answers to the CCF/SSFo InitialDP, providing the CFNRc number, placed in the destinationRoutingAddress IE of the Connect operation.
11	CCF/SSFo routes the call to the CCF/SSFt and provides the CFNRc number in an IAM message.

6.2.3.3 Incoming call based on routing address method and CS2 SCF-SCF and SCF-SDF for internetwork functional interface

If the routing address is used to route the call to the visited CCF/SSF, the Detach mark is detected only when the visited SDFmm requests precise location of the called party to the visited SDFmm. It then releases the call and CFNRc occurs as in subclause 6.2.3.1.

6.3 CTM Call Forwarding Unconditional (CTM-CFU)

The User has roamed into a visited network and may or not have a call in progress. The originating network attempts to deliver the new incoming call. The CFU trigger is set and the call is unconditionally diverted to the pre-set destination. No action is required in the visited network.

Two cases are presented:

- Geographic Number for CTM user;
- Non-Geographic CTM Number for CTM user.

6.3.1 Geographic Number for CTM user

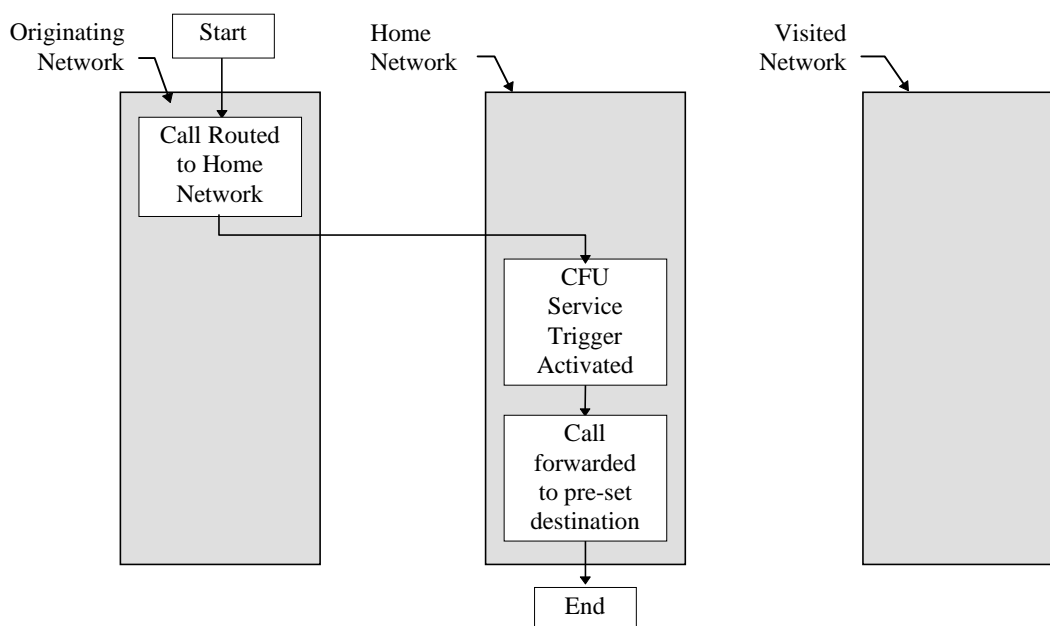

Figure 21: CTM Call Forwarding Unconditional (Geographic)

6.3.2 Non-Geographic CTM Number for CTM user

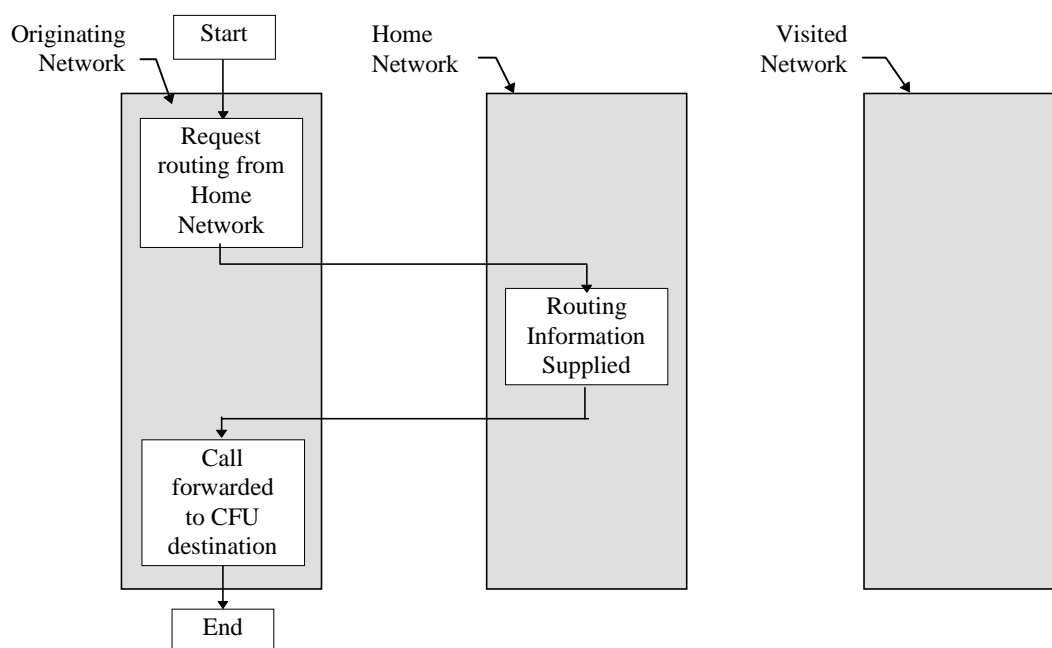

Figure 22: CTM Call Forwarding Unconditional (Non-geographic)

6.4 CTM Call Forwarding on Busy (CFB)

The CFNRc phase 1 description can be adapted for phase 2 CFB as described below.

The User has roamed into a visited network and has a call in progress. The visited network attempts to deliver the new incoming call. This combination of events satisfies the trigger criterion established for Call Forwarding on Busy.

Two cases are presented:

- Geographic Number for CTM user;
- Non-Geographic CTM Number for CTM user.

6.4.1 Geographic Number for CTM user

The new incoming call is released to the Home Network (Release Cause = Busy) for subsequent action.

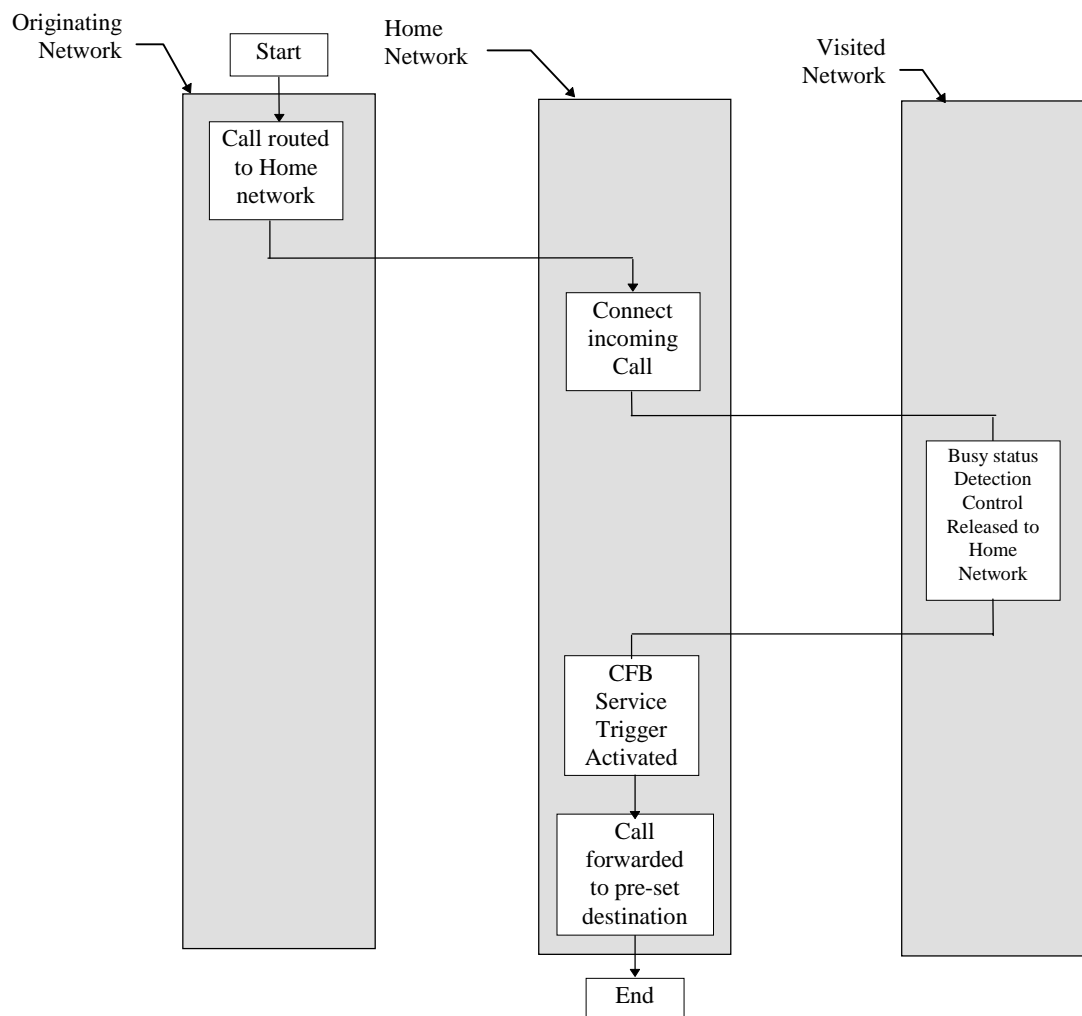

Figure 23: CTM Call Forwarding on Busy (Geographic)

6.4.2 Non-Geographic CTM Number for CTM user

The new incoming call is released to the Originating Network (Release Cause = Busy) for subsequent action.

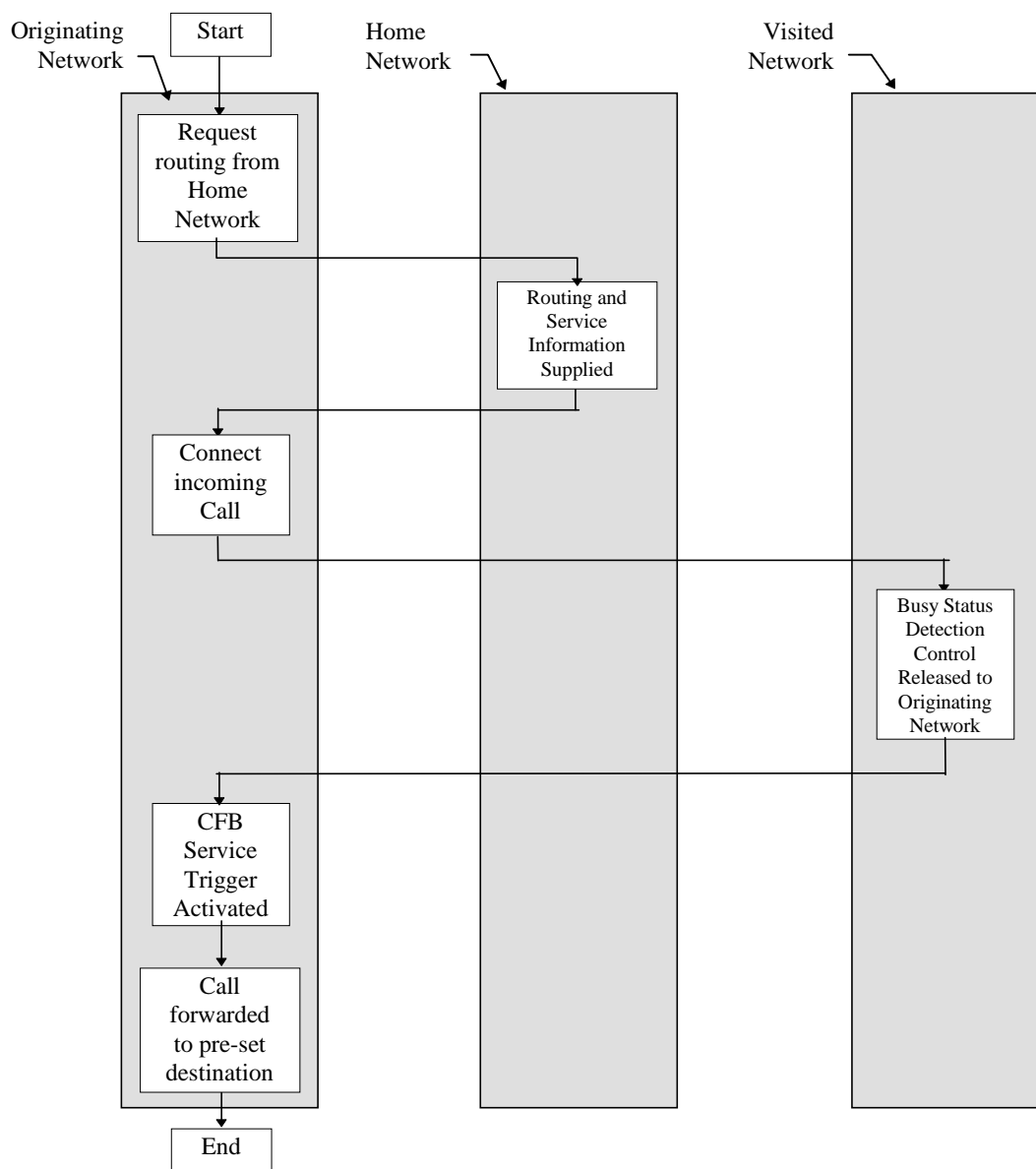

Figure 24: CTM Call Forwarding on Busy (Non-Geographic)

6.4.3 Information flows for CTM-CFB

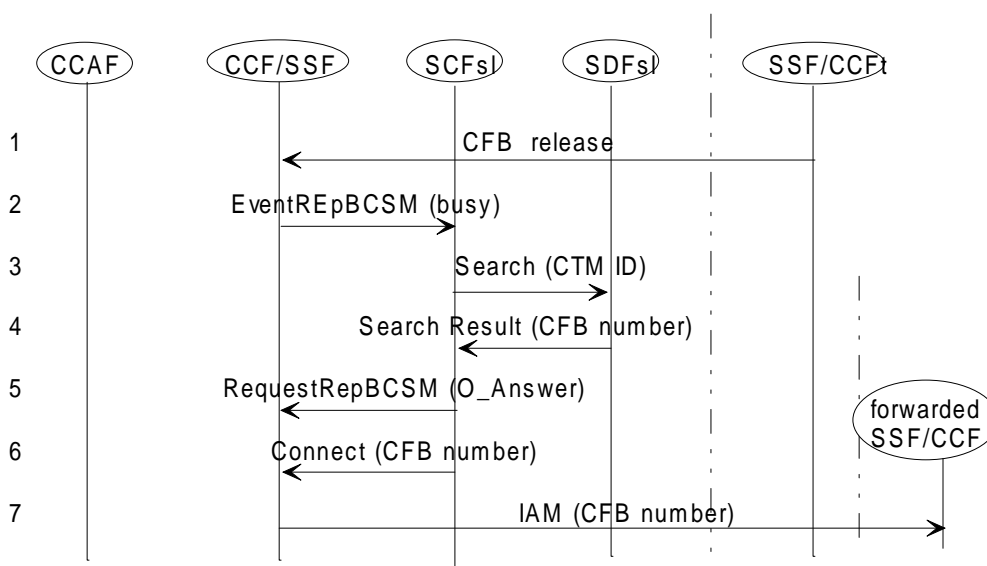

Figure 25: Information Flows for CTM-CFB

Preliminary, the call was routed to the visited side, paged and found busy.

Table 18: Information flows for CTM-CFB messages

Msg	Remarks
1	CCF/SSFt realizes that user is busy and releases the call back to CCFo.
2	CCF/SSFo reports appropriate EDP (Busy) to SCFsl.
3, 4	SCFsl retrieves from SDFsl the routing number (CFB number).
5, 6	SCFsl instructs to route the call towards the new destination and arms an EDP on O_Answer.
7	CCF/SSFo routes the call to new destination.

6.5 CTM Call Forwarding on No Reply (CFNR)

The CFNRc phase 1 description can be adapted for phase 2 CFNR as described below.

The User has roamed into a visited network and does not have a call in progress. The visited network attempts to deliver the new incoming call but is not answered after the expiration of a timer. This combination of events satisfies the trigger criterion established for Call Forwarding on No Reply.

Two cases are presented:

- Geographic Number for CTM user;
- Non-Geographic CTM Number for CTM user.

6.5.1 Geographic Number for CTM user

The new incoming call is released to the Home Network (Release Cause = No Reply) for subsequent action.

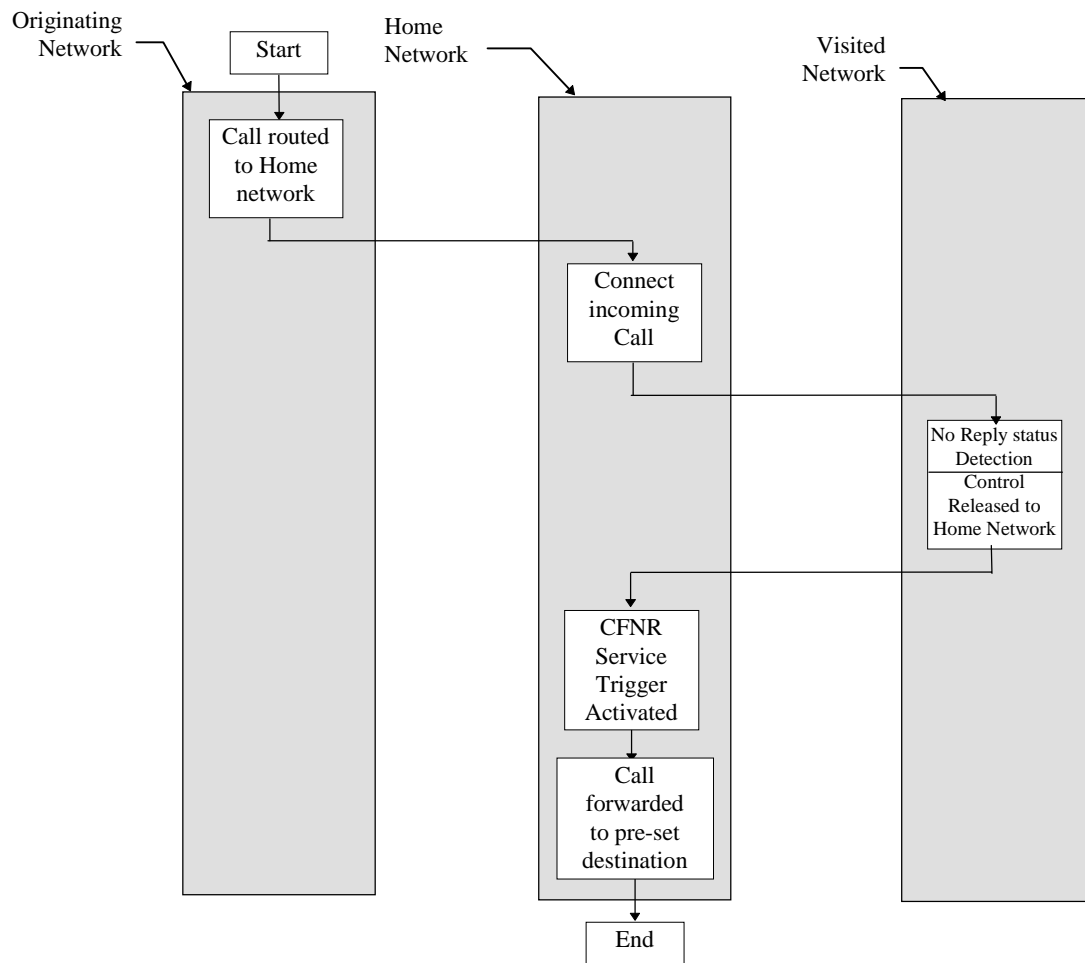

Figure 26: CTM Call Forwarding on No Reply (Geographic)

6.5.2 Non-Geographic Number for CTM user

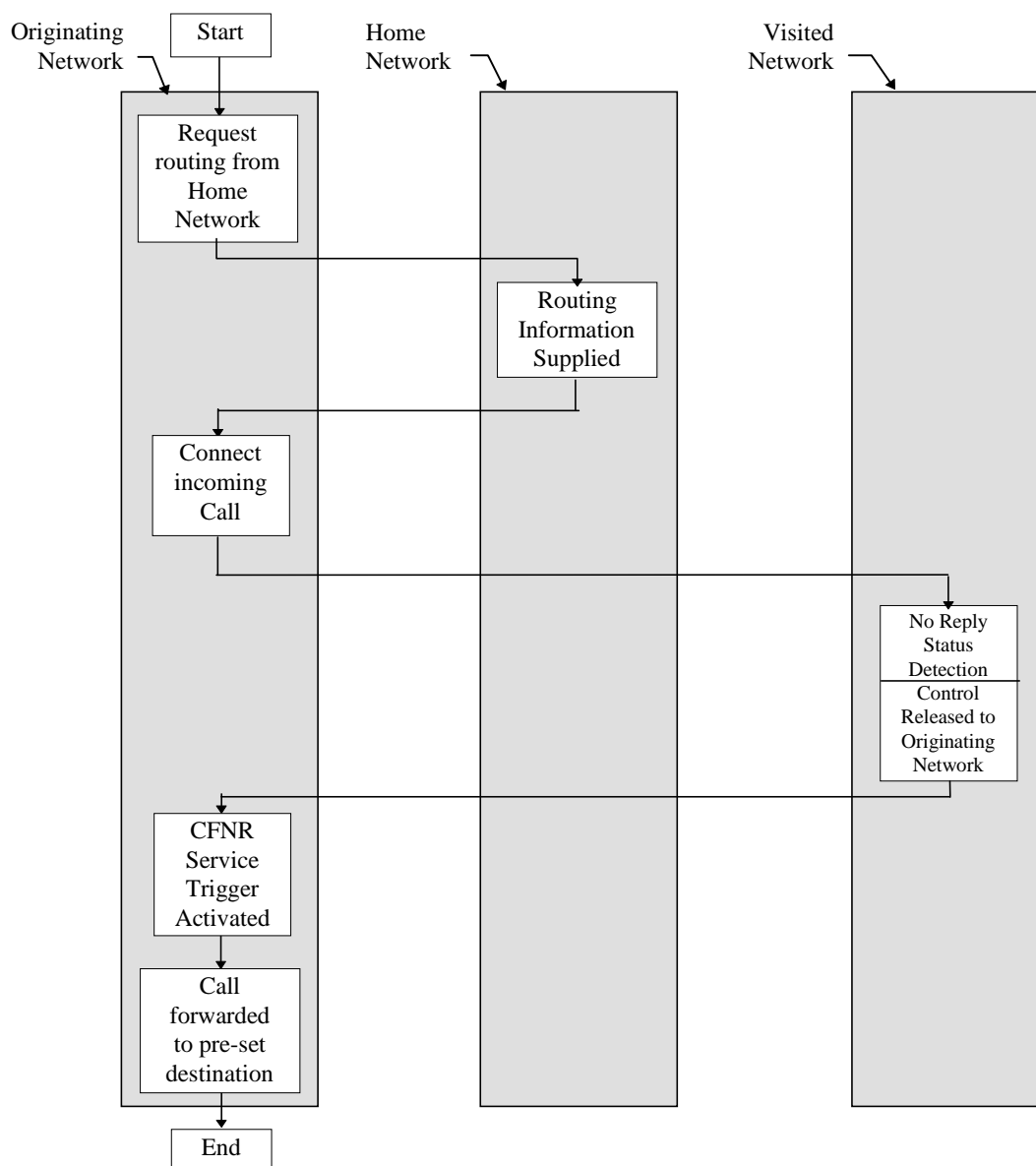

Figure 27: CTM Call Forwarding on No Reply

The new incoming call is released to the Originating Network (Release Cause = No Reply) for subsequent action.

6.5.3 Information flows for CTM-CFNR

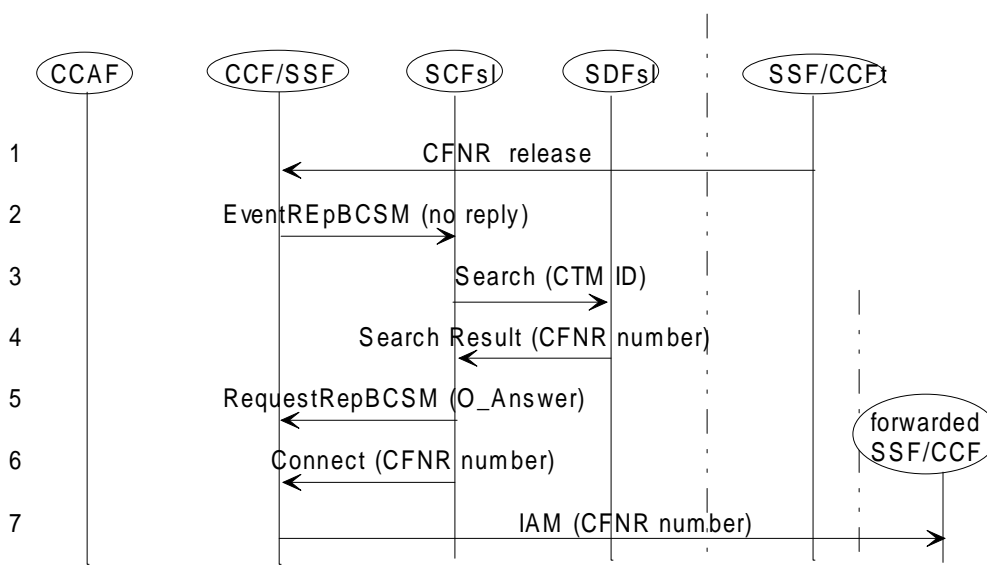

Figure 28: Information Flows for CTM-CFNR

Preliminary, the call was routed to the visited side, paged and found not replying.

Table 19: Information flows for CTM-CFNR messages

Msg	Remarks
1	CCF/SSFt realizes that user has not replied and release the call back to CCFo.
2	CCF/SSFo reports appropriate EDP (No Reply) to SCFsl.
3, 4	SCFsl retrieves from SDFsl the routing number (CFNR number).
5, 6	SCFsl instructs to route the call towards the new destination and arms an EDP on O_Answer.
7	CCF/SSFo routes the call to new destination.

6.6 CTM Calling Line Identification Presentation (CTM-CLIP)

It should be noted that all modes of CTM CLIR and COLR are permitted (i.e. Permanent, Temporary withhold with per call release and Per call withhold.)

6.7 CTM Calling Line Identification Restriction (CTM-CLIR)

It should be noted that all modes of CTM CLIR and COLR are permitted (i.e. Permanent, Temporary withhold with per call release and Per call withhold.)

6.8 CTM Connected Line Identification Presentation (CTM-COLP)

It should be noted that all modes of CTM CLIR and COLR are permitted (i.e. Permanent, Temporary withhold with per call release and Per call withhold.)

6.9 CTM Connected Line Identification Restriction (CTM-COLR)

It should be noted that all modes of CTM CLIR and COLR are permitted (i.e. Permanent, Temporary withhold with per call release and Per call withhold.)

6.10 CTM Incoming Call Screening (CTM-ICS)

This supplementary service provides the CTM user with the ability to restrict incoming calls. The screening criteria are recorded in the CTM service profile. The principles of the service operation are independent of the kind of incoming call screening set e.g. bar incoming call when roaming outside Home Network etc.

The User has roamed into a visited network and may or not have a call in progress. The visited network attempts to deliver the new incoming call. This combination of events satisfies the trigger criterion established for barring of All Incoming Calls.

Two cases are presented:

- Geographic Number for CTM user;
- Non-Geographic CTM Number for CTM user.

6.10.1 Geographic Number for CTM user

The new incoming call is retained in the Home Network for subsequent action.

No action is required in the visited network.

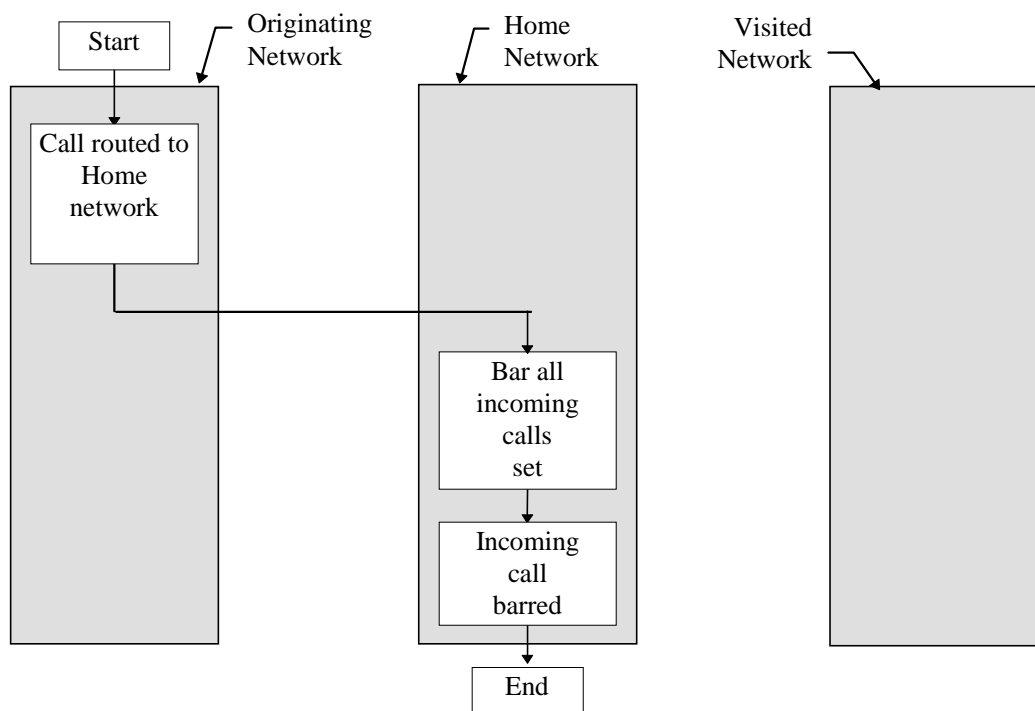

Figure 29: Screening of Incoming Calls (Geographic)

6.10.2 Non-Geographic Number for CTM user

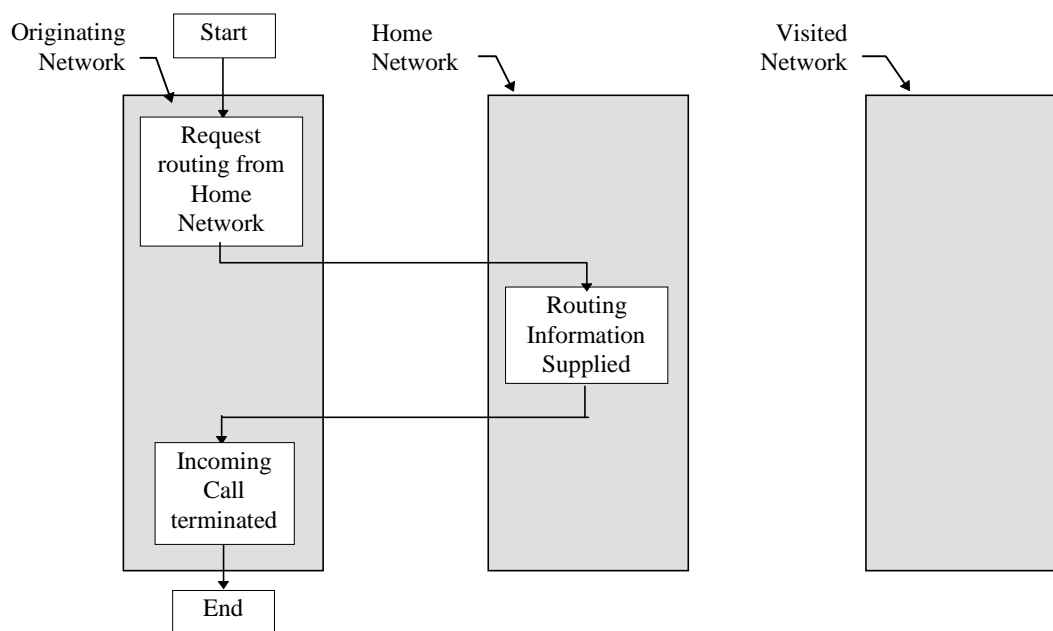

Figure 30: Screening of Incoming Calls (Non-Geographic)

The new incoming call is retained in the Originating Network for subsequent action.

6.11 CTM Outgoing Call Barring CTM-OCB)

This supplementary service provides the CTM user with the ability to restrict outgoing calls. The barring criteria are recorded in the CTM service profile and could include the kind of call barring supported by GSM.

The User has roamed into a visited network and attempts to make an outgoing call. The dialled digit sequence is passed to the Home Network with a request to provide OGC bar status. If this event satisfies the criterion established for Barring of the Outgoing Call, the Outgoing Call attempt is barred.

6.11.1 Generic Flow

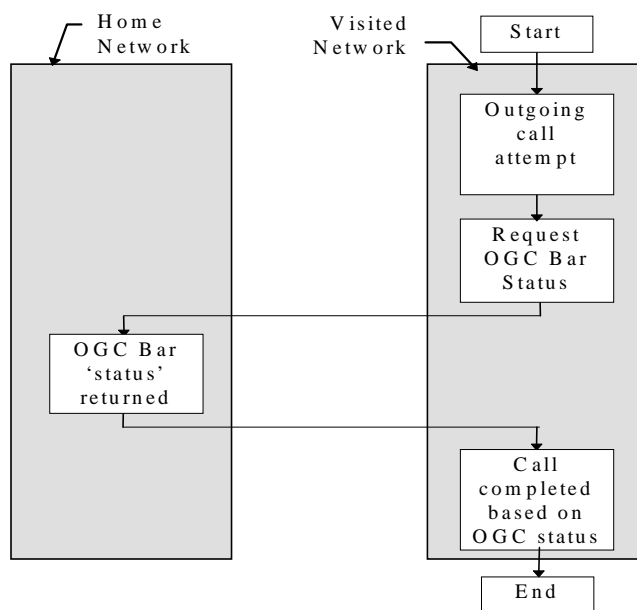
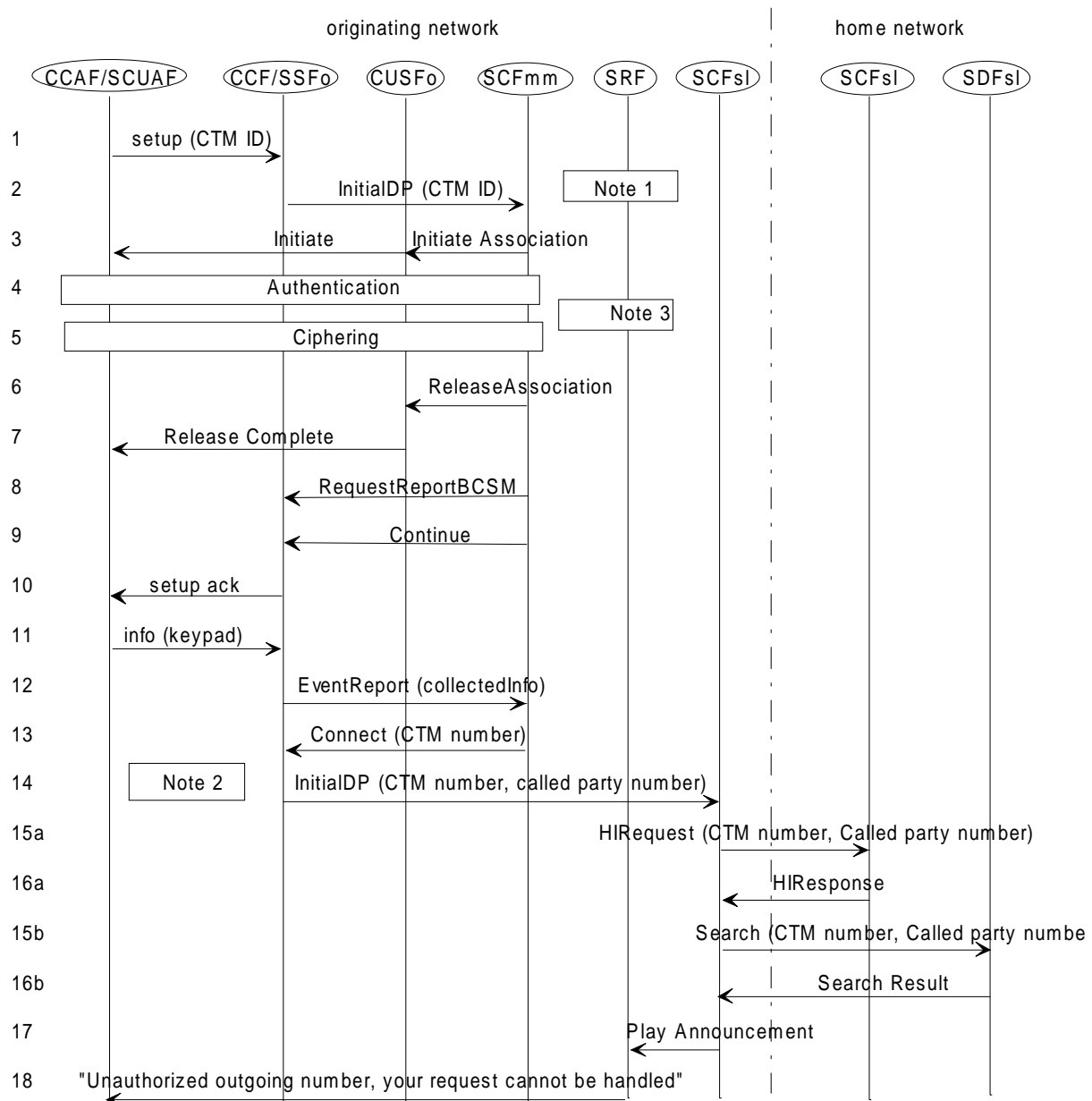

Figure 31: Barring of Outgoing Calls

The OCB procedure is based on the CTM phase 1 outgoing call description by the addition to phase 1 IFs to use an SRF in the originating network in order to inform the calling party.

6.11.2 Information Flows for OCB



NOTE 1: Authentication and ciphering may be processed in parallel with call set-up. If processed in sequence then it could be necessary to restart the set-up timer in FT and PT. Ciphering should be performed in order to protect user information across the user interface. It could be based on the old DCK.

NOTE 2: If it is an emergency call then the authentication result is ignored and the call continues without SCFsl triggering (flows from 14).

NOTE 3: The place for authentication and ciphering are pending on STF113 proposals at the next meeting.

Figure 32: Information flows for OCB

Table 20: Information flows for OCB messages

Msg	Remarks
1	FT sends a set-up message to the CCFo/SSFo, including CTMid of the calling PT.
2	The CCFo/SSFo recognizes the request as an outgoing CTM call and sends an InitialDP to the SCFmm.
NOTE:	If the call cannot be triggered in CCFo/SSFo, it is routed to the CCF/SSF to which the CTM user's subscription is associated and where triggering occurs.
3	SCFmm initiates an association with CUSF. Authentication and ciphering may start here.
6,7	The call unrelated association is released.
8	SCFmm request the report of the collected information event.
9	SCFmm orders the CCFo/SSFo to continue call setup.
10-11	The Setup message is acknowledged and the dialled digits are received.
12	The collected information is sent in an EventReport message to SCFmm.
13	SCFmm sends the CTM number to CCFo/SSFo in a Connect in order to enable the identification the calling CTM User.
14	The SSFo triggers the SCFsl to ask for services.
15a-16a	When incoming call is based on the roaming number scenario: the originating SCFsl queries the home SCFsl to check the service profile (e.g. restrictions on called party number) and get information on the support of home specific services.
15b-16b	When incoming call is based on the routeing address scenario: the originating SCFsl queries the home SDFsl to check the service profile (e.g. restrictions on called party number) and get information on the support of home specific services.
17-18	Upon response from the home network, the SCFsl in the originating network detects that the dialled number is not authorized for the calling party. It then requests from the SRFo the sending of a message in order to inform the CTM user. The call is released.

7 Interaction with ISDN supplementary services

7.1 Interactions between the service of a calling of called CTM user and the service of the called user

7.1.1 Calling Line Information Presentation service for the called party and Calling Line Information Restriction service for the calling party

In the case of the CLIP service for the called party and CLIR service for the calling party, the table 21 applies:

Table 21: Calling party's service

Type of Outgoing Call	CALLING PARTY'S SERVICE	
	NO CLIR	YES CLIR
CTM Outgoing Call [Line number NOT to be delivered]	CTM number WILL be delivered if called party has CLIP	CTM number WILL NOT be delivered even if called party has CLIP
Non-CTM Outgoing Call	Line number WILL be delivered if called party has CLIP	Line number WILL NOT be delivered even if called party has CLIP

7.1.2 Connected Line Identification Presentation service for the called party and Connected Line Identification Restriction service for the calling party

In the case of the COLP service for the called party and COLR service for the calling party, the table 22 applies:

Table 22: Called party's service

Type of Connected Call	CALLED PARTY'S SERVICE	
	NO COLR	YES COLR
CTM Incoming Call [Connected Line Number NOT to be Delivered]	CTM number WILL be delivered if calling party has COLP	CTM number will NOT be delivered even if calling party has COLP
Non CTM Incoming Call	Line number WILL be delivered if calling party has COLP	Line number will NOT be delivered even if calling party has COLP

7.2 Interactions when using a domestic base station

On a DSS1+ access (2B+D), the following configurations may interest CTM:

- only CTM domestic access;
- CTM domestic accesses and fixed line accesses.

7.2.1 Call Forwarding on Busy (CFB)

IF the line is busy with two conversations running (by the fixed line owners and/or the CTM users);

AND IF there is an incoming call (to the line owner or CTM user);

AND IF the called party (line owner or CTM user) has subscribed to CFB;

THEN the call is forwarded (by the LE for the line owner or by the CTM IN SCP for CTM user).

Type of Incoming Call	Called Party Subscribed to CFB	Called Party NOT Subscribed to CFB
Incoming call to line owner (independent of CTM user)	Forward call (by LE)	Calling party receives BUSY
Incoming call to CTM User (independent of line owner)	Forward call (by CTM SCP)	Calling party receives BUSY

Annex A (informative): Information on DECT Handover

A.1 Presentation of the Information Flows on the DECT Air Interface (EN 300 175 and CAP)

In DECT handover is very well defined. The type of the messages, the messages themselves, the information element and the fields within are defined. The following figure shows what message that are used and their order.

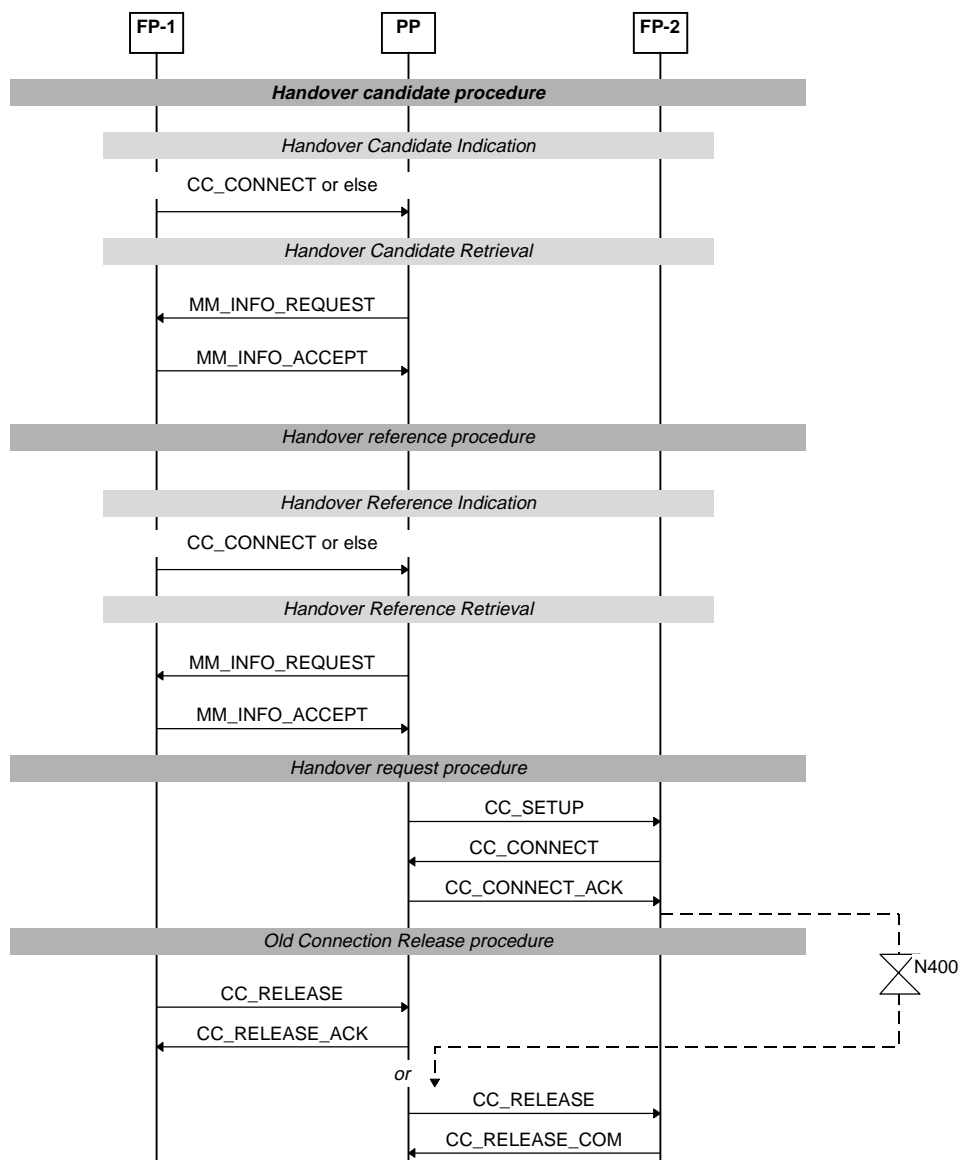

Figure A.1: External handover procedures compliant to EN 300 175 [8]

CTM phase 2 and DECT service should be based on CAP for the radio air interface. The CAP imposes a few constraints on the previous information flows. They are detailed below.

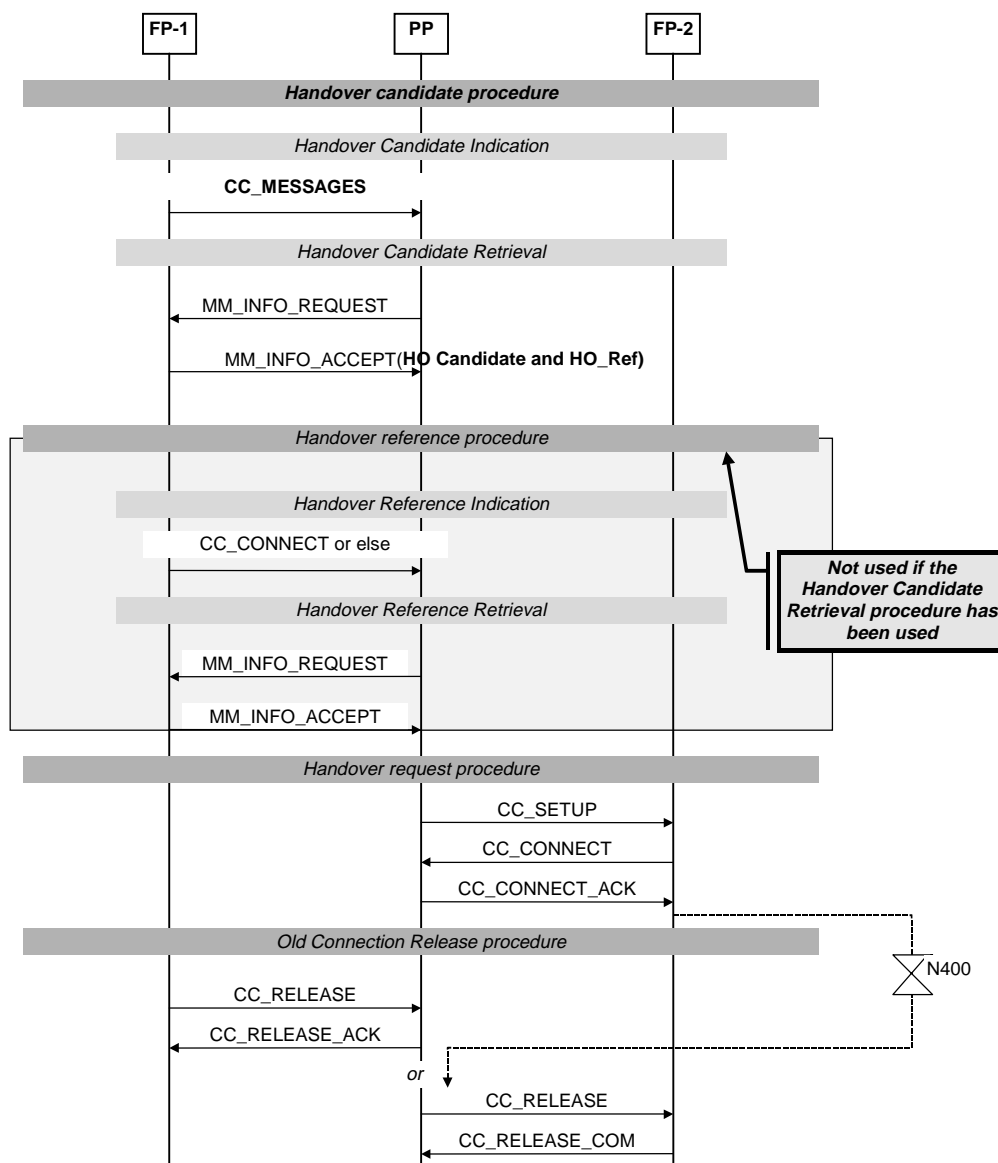

Figure A.2: External handover procedures compliant to CAP

This contribution only details the handover execution procedure. The other procedures will be detailed later as they are call-oriented.

Information flows are given for both intra and inter switch external handover. This contribution does not assume anything regarding functional entities (i.e. is the SCF for mobility management or for service control).

A.2 Handover mechanisms over the DECT air interface and involved DECT messages and Information Elements

The aim of this contribution is to clarify external handover procedures both specified in DECT standard EN 300 175-5 [1] and in CAP.

A.2.1 Handover in DECT

This subclause only refers to DECT standard (EN 300 175-5 [1]).

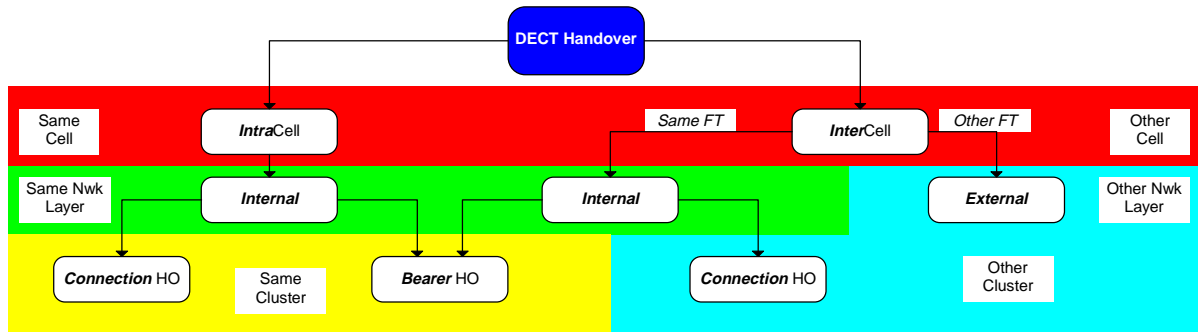

Figure A.3: Handover in DECT

There are three procedures that allow a PP to carry out an external handover for DECT. Figure A.4 explains the linking of these. For the first two procedures (Handover Candidate and Handover Reference) there are two options: Indication and Retrieval.

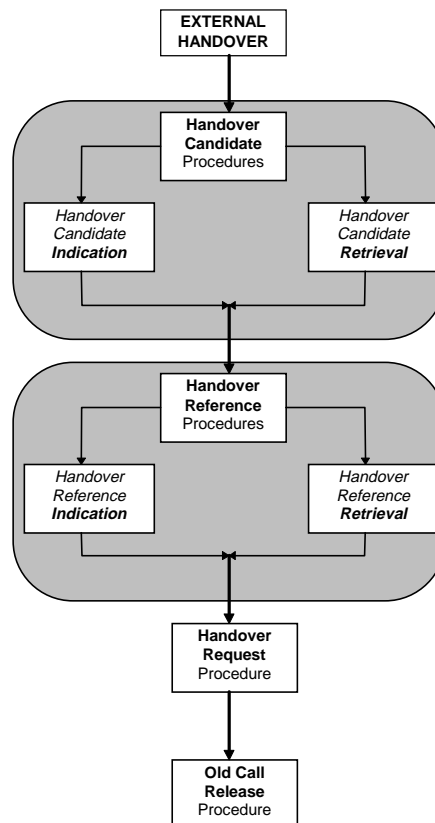

Figure A.4: External handover for DECT

The indication procedures are the ones where the necessary parameters are transmitted to the PP on the FP initiative (during locate or call establishment procedures).

The retrieval procedures are the ones where the necessary parameters are transmitted to the PP after it has sent a request to the FP for these (in call or out call procedures).

History

Document history		
V1.1.1	June 1999	Membership Approval Procedure MV 9935: 1999-06-29 to 1999-08-27