

ETSI EG 200 053 V1.4.1 (2002-04)

ETSI Guide

Electromagnetic compatibility and Radio spectrum Matters (ERM); Radio site engineering for radio equipment and systems

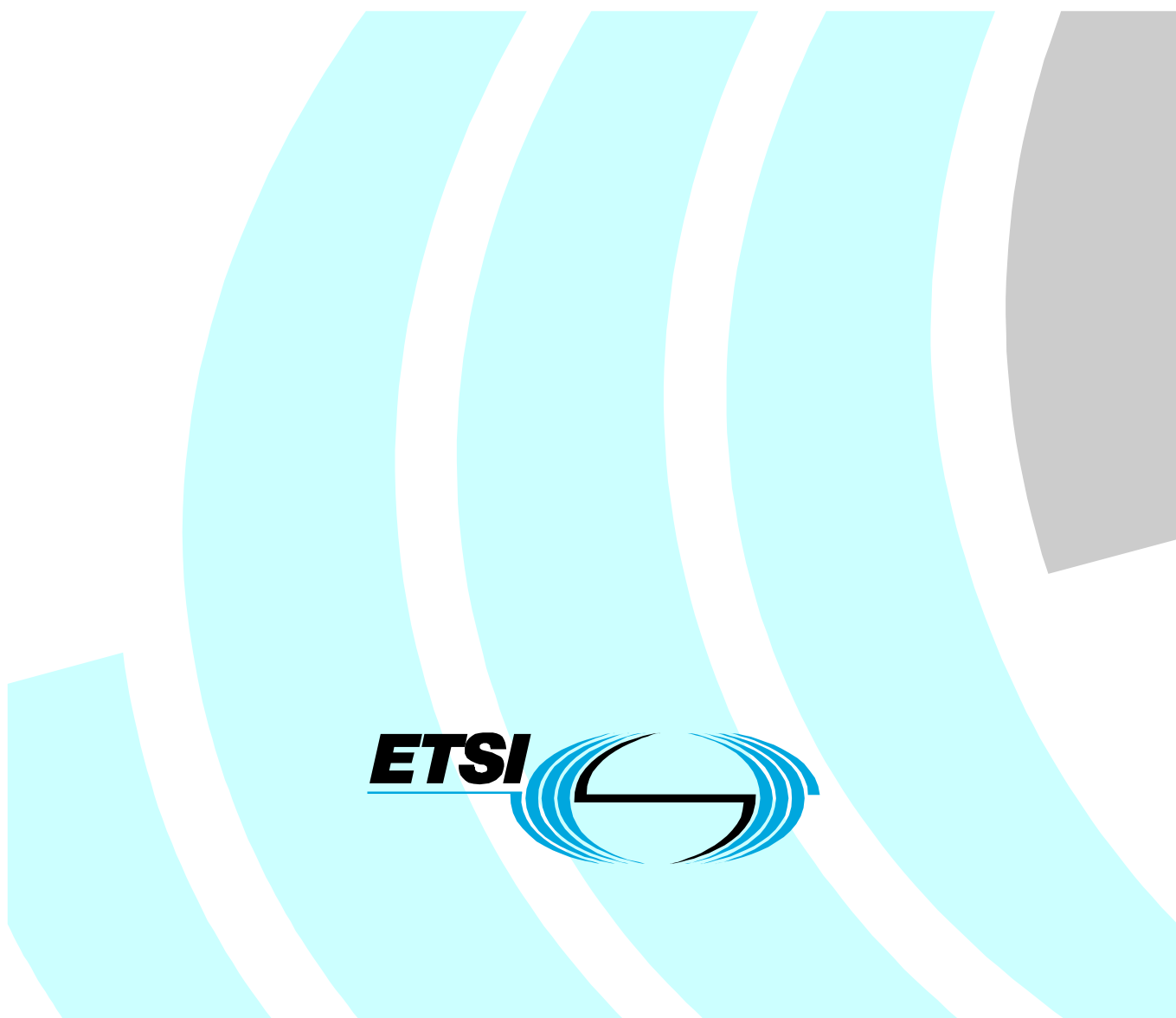

Reference

REG/ERM-TG27-003

Keywords

mobile, radio, site engineering

ETSI

650 Route des Lucioles
F-06921 Sophia Antipolis Cedex - FRANCE

Tel.: +33 4 92 94 42 00 Fax: +33 4 93 65 47 16

Siret N° 348 623 562 00017 - NAF 742 C
Association à but non lucratif enregistrée à la
Sous-Préfecture de Grasse (06) N° 7803/88

Important notice

Individual copies of the present document can be downloaded from:

<http://www.etsi.org>

The present document may be made available in more than one electronic version or in print. In any case of existing or perceived difference in contents between such versions, the reference version is the Portable Document Format (PDF). In case of dispute, the reference shall be the printing on ETSI printers of the PDF version kept on a specific network drive within ETSI Secretariat.

Users of the present document should be aware that the document may be subject to revision or change of status. Information on the current status of this and other ETSI documents is available at

<http://portal.etsi.org/tb/status/status.asp>

If you find errors in the present document, send your comment to:

editor@etsi.fr

Copyright Notification

No part may be reproduced except as authorized by written permission.
The copyright and the foregoing restriction extend to reproduction in all media.

© European Telecommunications Standards Institute 2002.
All rights reserved.

DECTTM, **PLUGTESTS**TM and **UMTS**TM are Trade Marks of ETSI registered for the benefit of its Members.
TIPHONTM and the **TIPHON logo** are Trade Marks currently being registered by ETSI for the benefit of its Members.
3GPPTM is a Trade Mark of ETSI registered for the benefit of its Members and of the 3GPP Organizational Partners.

Contents

Intellectual Property Rights	9
Foreword.....	9
Introduction	9
1 Scope	11
2 References	11
3 Definitions, symbols and abbreviations	12
3.1 Definitions	12
3.2 Symbols.....	13
3.3 Abbreviations	13
4 Choice of site.....	15
4.1 General	15
4.2 Radio site selection criteria	15
4.2.1 Location chosen by propagation analysis	16
4.2.2 Availability of capacity on existing sites	16
4.2.3 Compatibility	16
4.2.4 Environmental and planning considerations	17
5 System requirements	17
5.1 Private Mobile Radio (PMR).....	17
5.1.1 Introduction.....	17
5.1.2 Analogue PMR systems	18
5.1.2.1 Public Access Mobile Radio	18
5.1.3 Digital PMR systems	19
5.1.3.1 TETRA.....	20
5.1.3.2 Other Commercial Systems.....	20
5.1.3.3 Frequency planning - direct mode.....	21
5.1.3.4 Introduction of Trunked Radio Base stations onto Existing Radio Sites	21
5.1.4 Potential sources of interference	21
5.2 Paging.....	21
5.2.1 Introduction.....	21
5.2.2 On-site radio paging system.....	21
5.2.3 Wide area paging systems.....	21
5.2.4 Signalling systems	22
5.2.5 Coverage in confined spaces.....	22
5.3 Public radiotelephone	22
5.3.1 Introduction.....	22
5.3.2 Public radiotelephone (analogue)	23
5.3.2.1 Frequency re-use	23
5.3.2.2 Hand-over.....	23
5.3.3 Public radiotelephone (digital) - GSM/DCS 1 800.....	23
5.3.3.1 Databases	23
5.3.3.2 Radio	24
5.3.3.3 Traffic and signalling channel.....	24
5.3.4 Use of repeaters	25
5.4 Confined space engineering	25
5.4.1 Introduction.....	25
5.4.2 Characteristics of radiating cable	25
5.4.3 Confined space radiocommunication systems	25
5.4.3.1 Antenna characteristics	26
5.4.3.2 Recommendations for frequency range 150 kHz to 1 000 MHz.....	26
5.4.4 Installation and maintenance of radiating cables	26
5.5 Repeaters	27
5.5.1 Introduction.....	27
5.5.2 Types of repeater	27

5.5.3	Repeater characteristics	28
5.5.4	Installation recommendations	28
5.6	Fixed point-to-point radio links	29
5.6.1	Introduction.....	29
5.6.2	Use of fixed point-to-point radio links.....	29
5.6.3	Types of Fixed Links (including Frequency Allocations)	29
5.6.4	Physical Design Criteria for Fixed Links.....	29
5.6.5	Hardware for Fixed Links.....	30
5.7	Future systems.....	30
6	Installation recommendations.....	30
6.1	Support structure and mechanical considerations.....	30
6.1.1	Structural integrity	30
6.1.2	Wind loading	31
6.1.3	Protective coatings.....	31
6.1.4	Use of dissimilar metals.....	31
6.2	Equipment room	31
6.2.1	Equipment arrangements	32
6.2.2	Environment	32
6.3	Electrical supply, protection and lightning protection.....	32
6.3.1	Electrical supplies.....	32
6.3.2	Lightning effects, protection and responsibilities	33
6.3.3	Earthing of antenna support structures.....	33
6.3.4	Earthing of antennas, feeders and associated plant.....	34
6.3.5	Special Installations	34
6.4	Antennas and feeders.....	34
6.4.1	Choice of antenna type	34
6.4.2	Antenna specification	35
6.4.3	Location of antennas.....	36
6.4.4	Radiation pattern.....	36
6.4.5	Gain	36
6.4.6	Cross-polar performance.....	36
6.4.7	Voltage Standing Wave Ratio.....	37
6.4.8	Wind vibration	37
6.4.9	Degradation of antenna performance	37
6.4.10	Cables, cable routes and connectors	37
6.4.11	Feeder identification, terminations and earthing.....	38
6.4.12	Sealing	38
6.4.13	Inspection for moisture	38
7	Problems identified on site	39
7.1	Generation of unwanted products.....	39
7.1.1	Spurious emissions from transmitters	39
7.1.1.1	Noise considerations	40
7.1.1.2	Spurious considerations	41
7.1.2	Ambient RF noise levels.....	41
7.1.3	Intermodulation products between several source frequencies.....	41
7.1.4	Intermodulation products caused by external effects.....	43
7.2	Intermodulation and blocking effects in receiver systems.....	43
7.2.1	Intermodulation between received signals.....	43
7.2.2	Saturation of receiver front end	44
7.2.3	Selectivity of the receiver	44
7.2.4	Spurious response of the receiver	45
7.2.5	Receiver protection for low power equipment (EN 300 220 [9])	45
7.3	EMC issues.....	45
7.4	Technical responsibility of the site operator.....	45
8	Avoiding radio frequency problems.....	45
8.1	Antenna distribution networks	46
8.2	Receiver distribution networks.....	46
8.3	Filters and couplers	46
8.3.1	Control of unwanted products.....	46
8.3.2	The ferrite circulator	46

8.3.3	The cavity resonator.....	47
8.3.4	The spectrum dividing filter.....	47
8.3.5	Control of intermodulation, cross modulation and blocking effects in receiver systems by filter protection.....	47
9	Environmental effects.....	47
9.1	Standards.....	47
9.2	Corrosion and climatic effects.....	48
9.3	Ultraviolet degradation.....	48
10	Health and safety.....	48
10.1	Introduction.....	48
10.2	Physical safety.....	49
10.3	Electrical safety.....	49
10.4	Fire hazards.....	49
10.5	Radio Frequency hazards to personnel.....	49
11	Site administration.....	50
11.1	Site discipline.....	50
11.2	Site records.....	50
11.3	Orientation of support structure and antennas.....	51
11.4	Working arrangements.....	51
12	Maintenance recommendations.....	51
12.1	Support structure.....	51
12.2	Equipment room.....	51
12.3	Electrical supply and lightning protection.....	52
12.4	Antennas and feeders.....	53
12.5	Filters and couplers.....	54
13	Troubleshooting on radio sites.....	54
13.1	Method of approach.....	54
13.2	Case studies.....	55
13.2.1	Cases where the use of cavity resonators, bandpass filters or ferrite isolators provided a cure.....	55
13.2.2	Case where the problem is related to equipment alignment.....	57
13.2.3	Cases where the problems are related to broadcast transmitters.....	57
13.2.4	Cases where the problems are related to cables and connectors.....	58
13.2.5	Cases where the problems are related to site maintenance.....	58
13.2.6	Cases where the problems are related to faulty equipment.....	59
13.2.7	Case where the problem is related to site modifications.....	59
13.2.8	Case where the problem is related to equipment screening.....	59
13.2.9	Accidental operation of discarded equipment.....	60
13.2.10	Examples of lack of isolation between systems.....	60

Annex A (informative): Protection ratios and minimum field strengths required in the mobile services.....61

A.1	VHF and UHF land and maritime mobile services.....	61
A.1.1	Protection ratios based on internal noise and distortion in the receiver.....	61
A.1.2	Man-made noise.....	62
A.1.3	Noise Amplitude Distribution (NAD) determination of degradation.....	63
A.1.3.1	Definitions.....	63
A.1.3.1.1	Noise Amplitude Distribution.....	63
A.1.3.1.2	Spectrum amplitude.....	63
A.1.3.1.3	Impulse rate.....	63
A.1.3.1.4	Impulsive-noise tolerance.....	64
A.1.3.2	Determination of degradation.....	64
A.1.4	Minimum values of field strength to be protected.....	64

Annex B (informative): Spectral parameters.....68

B.1	Spectral parameters for TX-RX compatibility.....	68
B.2	Evaluation of spectral parameters.....	70
B.2.1	Spurious noise and sideband measurements - transmitters.....	70

B.2.2	Blocking effect of sideband noise	70
B.2.3	Estimation of sideband noise limits.....	71
Annex C (informative): Antennas and feeder systems		73
C.1	Common antenna configuration	73
C.2	Stacking and baying data.....	76
C.3	Isolation between antennas.....	78
C.4	Control of precipitation noise.....	79
C.5	Achieved Cross Polar Discrimination (XPD) for antennas mounted at an angle to precise horizontal and vertical frames of axes.....	80
C.6	Antennas and feeders.....	80
C.6.1	Calculation of system reflection performance.....	80
C.6.2	Points of note concerning the reflection performance of RF systems	81
C.6.3	Calculation procedure for system reflection performance.....	81
C.6.4	Reflection performance calculations for radio site designers	82
C.6.4.1	Voltage reflection coefficient method.....	82
C.6.4.2	Recommended procedure	82
C.6.4.3	Calculation example	82
C.6.5	Reflection performance calculations for radio site engineers.....	83
C.6.5.1	Return loss method	83
C.6.5.2	Recommended procedure	84
C.6.5.3	Example calculations	84
Annex D (informative): Noise power on typical radio sites		87
Annex E (informative): The position of metals in the galvanic series		88
Annex F (informative): Equipment arrangements.....		89
Annex G (informative): Typical example of good earthing practice.....		90
Annex H (informative): Equipment used to avoid radio frequency problems.....		91
H.1	Cavity resonators.....	91
H.1.1	Introduction	91
H.1.2	General	91
H.1.3	Typical applications	91
H.1.4	Cavity resonator construction.....	93
H.1.5	Alignment.....	94
H.2	Ferrite isolators and circulators	95
H.2.1	Introduction	95
H.2.2	General	95
H.2.3	Typical applications	96
H.2.4	Ferrite isolator construction.....	98
H.3	Characteristics of distribution amplifiers	99
H.3.1	Receiver distribution amplifier system.....	99
H.3.2	Receiver distribution amplifier in a 4 way multicoupler system	100
H.4	Typical filter system.....	101
H.5	Trunking combiner.....	104
H.5.1	Trunking combiner system.....	104
H.5.2	Specification of a TX/RX trunking combiner	105
Annex J (informative): Interference due to intermodulation products in the land mobile service between 25 MHz and 1 000 MHz.....		106
J.1	Introduction.....	106

J.2	Transmitters.....	106
J.2.1	Coupling loss A_C	106
J.2.2	Intermodulation conversion loss, A_I	107
J.3	External non-linear elements.....	108
J.4	Receivers	108
J.5	Reduction of intermodulation product levels in transmitters	109
J.5.1	Intermodulation conversion loss.....	109
J.5.2	Coupling loss.....	110
J.5.3	Identification of the source of an intermodulation product	112
J.6	Reduction of intermodulation products in receivers	113
J.7	Reduction of intermodulation interference by frequency arrangements	113
J.8	Reduction of intermodulation interference by other arrangements	113
Annex K (informative): Sources of unwanted signals in multiple base station sites in the land mobile service		114
K.1	Introduction	114
K.2	Simple frequency relationships	114
K.3	Complex frequency relationships.....	114
K.3.1	Generation of intermediate frequency and/or its derivatives.....	114
K.3.2	Generation of transmit/receive (TX/Rx) difference frequency.....	114
K.4	Intermodulation products	114
K.4.1	Generated external to the site	114
K.4.2	Intermodulation products generated on-site by non-linear junctions on the mast	115
K.4.3	Intermodulation products generated on-site by non-linearity in components of the system	115
K.5	Transmitter noise.....	115
K.6	External electrical noise	116
K.7	Summary	116
Annex L (informative): Intermodulation interference.....		117
L.1	Intermodulation spectrum.....	117
L.2	Products - combinations of two frequencies A and B excluding pure harmonics.....	118
L.3	Intermodulation products	121
Annex M (informative): Transmitter noise measurement.....		123
M.1	Introduction	123
M.2	Measurement system.....	123
M.3	Measurement accuracy.....	124
M.4	Results	124
M.5	Explanation of plots.....	127
M.6	Conclusions	127
Annex N (informative): Radiocommunications in confined spaces		128
N.1	Systems for radiocommunications in confined spaces.....	128
N.1.1	Design consideration.....	128
N.2	Typical characteristics of radiating cable.....	133
N.2.1	Environmental influences.....	133
N.2.2	Application example.....	133

N.3	Design example for confined space engineering.....	134
N.3.1	Design example	134
N.3.2	Conditions	134
N.3.3	Design procedure.....	134
N.3.4	Conclusions	135
Annex P (informative):	TETRA and Commercial System Parameters	136
Annex Q (informative):	Future Systems - Universal Mobile Telecommunications System (UMTS)	138
Q.1	Introduction	138
Q.2	UMTS Requirements.....	138
Q.3	Standardization.....	138
Q.4	Frequency Allocations.....	138
Q.5	Global Standards	139
Q.6	On Site Considerations.....	139
Annex R (informative):	Installations on High Voltage Electricity Towers - Guidelines.....	140
R.1	General	140
R.1.1	Antenna Positioning	140
R.1.2	Links.....	140
R.1.3	Cabling	140
R.1.4	Power Supply	141
R.1.5	Safety.....	141
History	142

Intellectual Property Rights

IPRs essential or potentially essential to the present document may have been declared to ETSI. The information pertaining to these essential IPRs, if any, is publicly available for **ETSI members and non-members**, and can be found in ETSI SR 000 314: "*Intellectual Property Rights (IPRs); Essential, or potentially Essential, IPRs notified to ETSI in respect of ETSI standards*", which is available from the ETSI Secretariat. Latest updates are available on the ETSI Web server (<http://webapp.etsi.org/IPR/home.asp>).

Pursuant to the ETSI IPR Policy, no investigation, including IPR searches, has been carried out by ETSI. No guarantee can be given as to the existence of other IPRs not referenced in ETSI SR 000 314 (or the updates on the ETSI Web server) which are, or may be, or may become, essential to the present document.

Foreword

This ETSI Guide (EG) has been produced by ETSI Technical Committee Electromagnetic compatibility and Radio spectrum Matters (ERM), and is now submitted for the ETSI standards Membership Approval Procedure.

Introduction

The growth of radio services has resulted in an increase in the number of radio sites required and in the number of users sharing their facilities.

The radio frequency spectrum is a finite natural resource for which there are many competing demands, therefore radio systems must be designed so that individual systems operate with minimum interference to other systems.

The aesthetic impact of radio structures provides an increasing constraint on the development of further radio sites. It is essential, therefore, to obtain the support of the community with regard to environmental issues. Consequently it is necessary to demonstrate that the optimum use will be made of the proposed installation.

In granting building permission for a radio structure, local authorities expect radio system users to operate the maximum number of systems from existing structures before giving consideration to an application for another structure in the same area.

The use of radio transmitters is subject to the radio license conditions of the relevant regulatory authority. The inclusion of any type of radio station in the present document does not mean its use will be permitted by the responsible administration.

Whilst the present document has been prepared to assist radio system designers to obtain optimum use of radio sites and the radio spectrum, it is also intended for the guidance of those site operators and maintenance organizations who do not have ready access to radio systems engineers.

The present document also addresses radio engineering installations which may cause potential problems with regard to interaction between transmitters and consequent interference to receivers.

Accordingly the present document sets out methods and design solutions which are achievable without extensive resources.

Radio equipment for the mobile and fixed services is built to standards which are directed to ensure the efficient use of the radio spectrum. These standards lay down appropriate performance parameters for transmitters that include frequency stability, frequency accuracy, spurious emissions, adjacent channel noise, intermodulation products generated by incoming transmissions etc. Similarly receiver performance parameters are defined including sensitivity, co-channel rejection, selectivity, intermodulation, blocking, frequency stability, frequency accuracy etc. Good installation design ensures that as far as possible the performance of a complete installation preserves the performance characteristics of the components, laying down the intended field strength in the designated area, avoiding the radiation of spurious emissions and preserving the sensitivity of receivers.

The objectives are as follows:

- a) to obtain the coverage required from the chosen site in a precise and well defined manner;
- b) to minimize spectrum pollution to other users on adjacent sites;
- c) to minimize interference to other co-sited users;
- d) to operate the system with the effective radiated power (erp) and optimum spectral efficiency compatible with providing the required service;
- e) to minimize the effects of lightning;
- f) to operate the site safely as required by relevant legislation.

To fulfill the requirements of all relevant legislation and recommendations, the above criteria should be met for the whole of the working life of the installation and should allow for future expansion. The quality of service is largely dependent on the planning of the system and considerable guidance on the topic is given in annex A.

The layout of the present document follows the logical approach that would be adopted in the provision of a new radio site, from the selection of a suitable geographic location to the installation and maintenance of radiocommunications equipment. It must be stressed that the order in which these subjects are discussed is not in order of importance. It is therefore essential to read the present document in its entirety after which it may be used as a reference document.

Preventive maintenance and repairs will be required to ensure that the installation continues to meet the performance criteria described; good engineering design will allow these activities to be carried out safely and with minimum loss of service.

1 Scope

The present document provides guidance for engineers concerned with the design, specification, installation, operation and maintenance of radio systems. It is particularly directed towards systems working in the Very High Frequency (VHF) and Ultra High Frequency (UHF) bands but encompassing a measurement range between 9 kHz and 56 GHz in respect of compatibility where co-sited operation of many different users' equipment has become common. It does not specifically cover the detailed technology associated with microwave systems, being frequencies above 3 GHz.

The present document examines the objectives of good design and the effects of common deficiencies. It provides recommendations designed to ensure that users avoid interactions which result in mutual interference, spectrum contamination, or danger to personnel or equipment. References and annexes are provided for further reading by engineers who are new to the field or are encountering the problems which are described for the first time.

The present document also includes information relating to the safety precautions required when dealing with non-ionising radiation.

The contents of the present document have been arranged to identify the source of the problems found on radio sites and recommendations are made for the control of these problems.

2 References

The following documents contain provisions which, through reference in this text, constitute provisions of the present document.

- References are either specific (identified by date of publication and/or edition number or version number) or non-specific.
- For a specific reference, subsequent revisions do not apply.
- For a non-specific reference, the latest version applies.

- [1] ITU-R Recommendation M.358-5: "Protection ratios and minimum field strengths required in the mobile services".
- [2] ITU-R Recommendation M.739-1: "Interference due to intermodulation products in the land mobile service between 25 MHz and 1 000 MHz".
- [3] CCIR Report 1019: "Sources of unwanted signals in multiple base station sites in the land mobile service".
- [4] CCIR Report 258-4: "Man made radio noise".
- [5] ETSI EN 300 086 (all parts): "EMC and Radio spectrum Matters (ERM); Land Mobile Service; Radio equipment with an internal or external RF connector intended primarily for analogue speech; Part 1: Technical characteristics and test conditions".
- [6] ETSI EN 300 113 (all parts): "EMC and Radio spectrum Matters(ERM); Land mobile service; Radio equipment intended for the transmission of data (and speech) and having an antenna connector; Part 1: Technical characteristics and methods of measurement".
- [7] ETSI EN 300 296 (all parts): "EMC and Radio spectrum Matters (ERM); Land mobile service Technical characteristics and test conditions for radio equipment using integral antennas intended primarily for analogue speech".
- [8] ETSI EN 300 390 (all parts): "EMC and Radio spectrum Matters (ERM) Land mobile service; Technical characteristics and test conditions for radio equipment intended for the transmission of data (and speech) and using an integral antenna".
- [9] ETSI EN 300 220 (all parts): "EMC and Radio spectrum Matters (ERM); Short range devices Technical characteristics and test methods for radio equipment to be used in the 25 MHz to 1 000 MHz frequency range with power levels ranging up to 500 mW".

- [10] ETSI EN 300 230: "EMC and Radio spectrum Matters (ERM); Land mobile service Binary Interchange of Information and Signalling (BIIS) at 1 200 bit/s (BIIS 1 200)".
- [11] ETSI ETS 300 577: "Digital cellular telecommunications system (Phase 2) (GSM); Radio transmission and reception (GSM 05.05 version 4.23.1)".
- [12] ETSI ETR 103: "European digital cellular telecommunications system (Phase 2); Radio network planning aspects (GSM 03.30)".
- [13] ETSI EN 300 339: "Electromagnetic compatibility and Radio spectrum Matters (ERM); General ElectroMagnetic Compatibility (EMC) for radio communications equipment".
- [14] Council Recommendation 1999/519/EC on limitation of exposure of the general public to electromagnetic fields 0 Hz-300 GHz..
- [15] ETSI TR 101 870 (V1.1.1): "Fixed radio transmitter sites; Exposure to Non-Ionising Electromagnetic Fields; Guidelines for Working Conditions".
- [16] ETSI ETR 300-1 Terrestrial Trunked Radio (TETRA); Voice plus Data (V+D); Designers' guide; Part 1: "Terrestrial Trunked Radio (TETRA); Voice plus Data (V+D); Designers' guide; Part 1: Overview, technical description and radio aspects".
- [17] ITU-R Recommendation SM. 329-9: "Spurious emissions".
- [18] ETSI ETS 300 086: "Radio Equipment and Systems (RES); Land mobile group; Technical characteristics and test conditions for radio equipment with an internal or external RF connector intended primarily for analogue speech".
- [19] ITU-R Recommendation M.2014: "Spectrum efficient digital land mobile systems for dispatch traffic".
- [20] ERC Report 052: "Methodology for the assessment of PMR systems in terms of spectrum efficiency, operation and implementation".
- [21] "Guidelines fo limiting exposure to time-varying electric, magnetic and electromagnetic fields (up to 300 GHz)", Health Physics April 1998, Volume 74, Number4: 494-522 - International Commission on Non-Ionizing Radiation Protection, www.icnirp.org.
- [22] "Mobile Phones and Health", Independent Expert Group on Mobile Phones, April 2000, www.iegmp.org.uk.
- [23] "Zmirou Report" to The French Health General Directorate, January 2001, www.sante.gouv.fr/htm/dossiers/index.htm.
- [24] "Mobile telephones; an evaluation of health effects", Health Council of the Netherlands, January 2002, www.gr.nl/engels/welcome/frameset.htm.

3 Definitions, symbols and abbreviations

3.1 Definitions

For the purposes of the present document, the following terms and definitions apply:

communal site: location at which there is more than one fixed transmitter

NOTE: There are two types of communal site; one having separate equipment and antennas but housed in a common equipment room, and the other having an engineered system employing common antenna working where the isolation between equipment's is determined by the filter system.

At all communal sites equipment installed on the site must meet the limits as specified in the relevant standards.

finial: metal spike or similar device mounted on the topmost part of a structure

NOTE: Usually for lightning protection in the context of the present document.

single fixed station: radio station where only one Radio Frequency (RF) carrier can be radiated at any one time

NOTE: Although the associated transmitter must meet all the specified performance parameters of the relevant standard, it is only the intermodulation characteristic that needs careful consideration in the site planning.

multiple fixed station: when two sites are in close proximity the decision governing when they should be classed as a single site or two sites shall be decided by the RF isolation between them

NOTE: The limiting minimum figure shall be 60 dB but this figure should ideally exceed 70 dB at all frequencies of operation. In any case any signal received from a neighbouring site should not exceed - 20 dBm and ideally - 30 dBm.

downlink: radio path for the transmission of signals from one Base Station (BS) to Mobile Stations (MS)

uplink: radio communication path for the transmission of signals from Mobile Stations (MS) to one Base Station (BS)

spurious emissions: emissions at frequencies other than those of the carrier and sidebands associated with normal modulation

3.2 Symbols

For the purposes of the present document, the following symbols apply:

ac	alternating current
C/I	Carrier to Interference ratio
C/N	Carrier to Noise ratio
dB	decibel
dBc	decibel relative to carrier
dBd	decibel relative to a half wave dipole
dB _i	decibel relative to an isotropic radiator
dBm	decibel relative to one mW
dc	direct current
GHz	GigaHertz
Hz	Hertz
Intermod	Intermodulation
kHz	kiloHertz
km	kilometre
kW	kiloWatt
m	metre
MHz	MegaHertz
mm	millimetre
mW	milliWatt
RX	Receiver
TX	Transmitter
V	Volt
W	Watt

3.3 Abbreviations

For the purposes of the present document, the following abbreviations apply:

3G	Third Generation (mobile systems)
3GPP	Third Generation Partnership Project
AF	Audio Frequency
AUC	Authentication Centre
BIIS	Binary Interchange of Information and Signalling
BPSK	BiPolar Shift Keying
BS	Base Station
BSC	Base Station Controller
BT	Bandwidth Time product

BTS	Base Transceiver Station
CBS	Common Base Station
DCS	Digital Communications System
DECT	Digital Enhanced Cordless Telecommunications
DMO	Direct Mode Operation
DQPSK	Differential Quadrature Phase Shift Keying
EC	European Commission
EIR	Equipment Identity Register
EMC	ElectroMagnetic Compatibility
e.m.f.	electro-motive force
EPIRB	Emergency Position Indication Radio Beacon
ERC	European Radiocommunications Committee
ERMES	Enhanced Radio MESSage System
erp	effective radiated power
ETACS	Extended Total Access Communications System
FDMA	Frequency Division Multiple Access
FPLMTS	Future Public Land Mobile Telecommunications System (now IMT 2000)
FM	Frequency Modulation
FSK	Frequency Shift Keying
GFSK	Gaussian Frequency Shift Keying
GMSK	Gaussian Minimum Shift Keying
GSM	Global System for Mobile communications
HF	High Frequency
HLR	Home Location Register
ICNIRP	International Commission fo Non-Ionising Radiation Protection
IF	Intermediate Frequency
IMT 2000	International Mobile Telecommunications 2000
ISDN	Integrated Services Digital Network
LMS	Land Mobile Service
MF	Medium Frequency
MS	Mobile Station
MSC	Mobile services Switching Centre
MSK	Minimum Shift Keying
MTBF	Mean Time Between Failure
NAD	Noise Amplitude Distribution
NRJ	Non-Reciprocal Junction
PA	Power Amplifier
PAMR	Public Access Mobile Radio
PDO	Packet Data Optimized
PIB	PolyIsoButylene
PMR	Private Mobile Radio
POCSAG	Post Office Code Standardization Advisory Group
PSK	Phase Shift Keying
PSTN	Public Switched Telephone Network
PVC	PolyVinylChloride
QPSK	Quadrature Phase Shift Keying
RCD	Residual Current Device
RF	Radio Frequency
RL	Return Loss
RIC	Radio Identity Code
SIM	Subscriber Identity Module
SMS	Short Message Service
TACS	Total Access Communications System
TDMA	Time Division Multiple Access
TETRA	Terrestrial Trunked Radio
UHF	Ultra High Frequency
UMTS	Universal Mobile Telecommunications System
VHF	Very High Frequency
VLR	Visitor Location Register
VSWR	Voltage Standing Wave Ratio
WARC	World Administrative Radio Conference (pre 1995)
XPD	Cross Polar Discrimination

4 Choice of site

4.1 General

For a proposed service, sites are chosen for their ability to provide coverage of the required service area. Buildings or other existing structures can be used providing a suitable antenna system can be erected. In deciding the suitability of sites, the effects on coverage of local physical obstructions must be taken into account. The final antenna height must be sufficient to clear obstructions if a good radiation pattern is to be achieved.

Preference is usually given to sites centrally located within the required service area so that maximum coverage is achieved with an omni-directional radiation pattern. In the event that no suitable locations can be found, it may be necessary to utilize sites on the periphery of the service area. In these circumstances directional antennas would normally be employed to limit radiation to the desired area.

The use of the highest available site is not always the best decision. As more users occupy the available radio spectrum there is an increasing need to share frequencies. The use of an unnecessarily high site may provide degraded service due to co-channel users. Modern systems are frequently designed on an interference limited, rather than a noise limited criteria.

When locations have been identified which meet the coverage requirements, the likelihood of sharing existing sites with other users should be considered. The site sharing decision will be influenced by the availability of sites, their coverage potential and whether RF compatibility exists with the other users' equipment.

If the construction of a new site is necessary the location should be carefully chosen both from the coverage and the environmental and planning aspects. Other radio users may be informed of the proposals as they may wish to expand their systems and share the new facility if it offers significant advantages.

It is essential that all potential users are taken into account in the initial planning of a site. There have been many cases in the past where a multitude of small sites have been erected in close proximity due to lack of early consultation. Co-operation to build a single large structure would mean users could share costs and all would benefit from increased performance of the facility.

To design installations which meet the user's expectations the requirements must be understood and interpreted with the propagation parameters of the frequencies to be used. In certain environments it may be extremely difficult to provide a clear path for the required radiation pattern. The choice of site may be a compromise between radio coverage requirements, technical considerations and economic or planning constraints.

The fundamentals to the choice of radio sites may be summarized as follows:

- a) examination of user requirements, service area, frequency, licence power limits, modes of operation;
- b) inspection of service area to identify preferred locations for sites;
- c) search for existing sites in the preferred areas;
- d) analyse suitability of existing sites and the feasibility of site sharing;
- e) formulate proposals for new sites where necessary.

The choice of sites is an iterative process that may have to be repeated several times to produce the optimum choice of sites. Where compromises are necessary it is essential that the user is given the opportunity to consider what effects coverage irregularities will have on the service.

4.2 Radio site selection criteria

Radio site selection criteria can be classified as follows:

- a) location chosen by propagation analysis;
- b) availability of capacity at existing sites;
- c) site compatibility;

- d) environmental and planning considerations;
- e) ability of site to be re-developed.

4.2.1 Location chosen by propagation analysis

Propagation analysis is necessary to decide in which areas to search for radio sites, to check the suitability of an existing site, or to decide the exact location for the construction of a new radio site.

Propagation information must be related not only to the site location but also to the power, frequency band, antenna type, antenna height and type of the system in use. It must account for the screening effects of terrain and clutter, e.g. buildings and trees. It must also consider the reception environment of the mobile station which may suffer from man made noise or multi-path fading due to signal reflections.

Propagation information can be obtained by several methods as follows:

- a) information from site operators based on their experience of existing sites;
- b) manual calculations by an experienced propagation engineer based on map information of terrain height and features;
- c) computer field strength predictions generated by evaluating radio path loss from a database of terrain height and feature data;
- d) radio survey by the establishment of a test station at the proposed location for the purpose of carrying out coverage measurements.

To identify the areas of search for radio sites, calculations from terrain details are the most appropriate. These may also be adequate to check the suitability of an existing site when they are examined along with the past experiences of other site users.

To decide the location of a new site computer predictions are strongly advised. These are available from a number of commercial organizations. The magnitude of the variations is dependent on the accuracy and resolution of the terrain database used to generate the predictions, and the quality of the propagation model.

The most reliable information is obtained by the establishment of a test station and measurement of signal strength across the area of interest. Such tests must be carefully executed to simulate the user's final operational conditions.

4.2.2 Availability of capacity on existing sites

When a suitable existing site has been located there are several options available to the new user and these are as follows:

- a) to share an information channel on an existing system;
- b) to share a frequency division filter system on an existing antenna;
- c) to share the equipment accommodation and install a new antenna on the structure;
- d) to provide separate equipment accommodation and install a new antenna on the structure.

Each possibility must be evaluated against the users' requirements. The proposals will be affected by various technical and economic limitations.

In the event that there are serious shortcomings in equipment room accommodation, antenna mounting positions or antenna structure load bearing capability, a complete site redevelopment may be required. It may be concluded that site sharing is not viable and that an alternative site should be sought.

4.2.3 Compatibility

For satisfactory performance of the installed system, radio site compatibility is essential. This covers all RF aspects which may cause interference to or from the proposed system. Compatibility with other users of the same or adjacent sites must be ensured.

Wherever possible, the location of a radio structure should be chosen with reference to its isolation from other radio transmission activity. It should preferably be at least 500 m from a busy road. This is to avoid the reception of vehicle ignition noise and to prevent interference from passing mobile radio transmitters.

The ambient noise level, particularly at urban sites in the lower VHF bands, will have a limiting effect on useable receiver sensitivity and therefore communication range and performance. Ambient RF noise includes atmospheric noise and man made electrical noise. Care should be taken to avoid areas of high level man made noise either from industrial or domestic sources. The increased processing speed and greater number of computing equipment's in recent years has proved to be a virulent source of radio noise in some cases even affecting the UHF bands. Annex A gives guidelines for ambient noise levels for various frequencies and environments.

The possibility of RF breakthrough into other electronic equipment should be considered. In the past cases of breakthrough to audio and video equipment have been reported due to the siting of radio installations in residential areas. It is important to realize that there are no actions that can be taken at the radio site to eliminate high ambient noise levels and RF breakthrough effects. These can only be reduced by measures which would also drastically affect the wanted coverage area.

Inability to achieve compatibility with local factors or with existing site users may cause the site to be rejected in favour of an alternative site offering better compatibility.

4.2.4 Environmental and planning considerations

Radio sites are prominent features of the landscape. It is therefore understandable that many building authorities pay particular attention to applications for new sites and for redevelopment of existing sites. There are also organizations and individuals who will raise objections to any application. Objections will be more numerous where the site is located in an environmentally sensitive area, such as a National Park, Area of Outstanding National Beauty or Area of High Landscape Value.

It is important that these aspects are carefully considered at the planning stage of any new site or redevelopment. Applications prepared without due consideration will result in refusal which may be impossible to overturn.

Whilst the site must have sufficient capacity for the foreseeable requirements, it should create the minimum impact on the environment. For example:

- a) relocating the site a small distance without changing the performance may drastically reduce the impact on the surroundings;
- b) minimization of the number of antennas, careful choice of antenna types and their arrangement in a symmetrical form, subject to a satisfactory RF performance, will provide a better appearance;
- c) an alternative type of support structure may present a more acceptable profile;
- d) varying materials, styles and colours for construction of equipment buildings may result in a more acceptable appearance;
- e) landscaping of the compound with the addition of trees and shrubs will improve the visual impact of the site.

5 System requirements

5.1 Private Mobile Radio (PMR)

5.1.1 Introduction

The most common use of private mobile radio (PMR) is to provide two way communication between a fixed site and a number of mobile units.

PMR systems operate in specifically allocated parts of the Very High Frequency (VHF) and Ultra High Frequency (UHF) bands. Each frequency band may be divided into a number of separate channels spaced at 5 kHz, 6,25 kHz, 12,5 kHz, 20 kHz or 25 kHz.

Most mobile radio services use Frequency Modulation (FM). In some cases phase modulation (PM) or FM with pre-emphasis is used to improve the received signal to noise ratio. Amplitude modulation (AM) is used in some of the VHF bands. An increasing number of modern mobile radio networks use digital modulation such as Phase Shift Keying (PSK) or Frequency Shift Keying (FSK). Single sideband or linear modulation techniques using narrow band channels may be introduced, with the aim of improving spectrum efficiency.

PMR equipment performance is covered by EN 300 086 [5] and/or EN 300 296 [7] for speech (analogue FM or PM systems) and EN 300 113 [6] and/or EN 300 390 [8] for the transmission of data (and speech). These ETSI standards apply to constant envelope angle modulation systems using the available bandwidth, operating on radio frequencies between 30 MHz and 1 GHz, with channel separations of 12,5 kHz, 20 kHz and 25 kHz depending on different national regulations.

5.1.2 Analogue PMR systems

The simplest form of PMR system is a single frequency simplex system. In this case the transmitters and receivers in the same system all operate on the same frequency. This mode of operation calls for a high degree of operational discipline on the part of the users. Single frequency channels may be assigned to low power and to handportable to handportable services.

Most PMR systems use two frequency channels. The base station transmits on one of these frequencies and the mobile stations in the same system transmit on the other frequency. This is known as two frequency simplex, or semi duplex operation. With the addition of suitable control apparatus, the base station transmitter may be operated in a full duplex, or repeater, mode. In this way communication may be established between mobile or portable users within range of the base station who may not otherwise be able to communicate directly between themselves. The repeater facility may be under the control of an operator.

Trunked PMR systems are often used to provide a service to a hundred or more mobile units. Several base stations are employed to provide the service. Using a control channel, a call to or from a mobile unit is allocated to whichever base station is unoccupied. This trunking procedure ensures efficient use of all the radio frequency channels allocated to the base stations. At least three base stations are required to realize the benefits of trunking. In addition to establishing calls to individual users, trunking systems can provide connection to pre-defined groups of users or to all users of the system. Additional facilities such as the connection of the base stations, comprising the radio terminal, to a private and (if permitted) the public telephone network and the provision of various data facilities such as short text messages may also be provided in a trunked PMR system.

In the case of PMR, there are self provided services in which the licensees own and operate their base stations. Most users operate a single base station with a few mobiles. Some private networks have many base stations and may have several thousand mobile units. These larger systems use various techniques to provide near contiguous coverage of large areas. These techniques include scanning mobiles, quasi-synchronous operation of all base station transmitters with receiver voting and more recently trunked radio systems. Other systems may use a single frequency with or without base stations for applications such as site security.

Shared PMR channels are used by several licensees, each with their own base station. In highly populated areas the coverage area of many channels can overlap each other such that several simultaneous transmissions can occur, with resulting interference. The use of access tone signalling systems can minimize the problem but does not offer a complete solution.

Common Base Station (CBS) systems are offered to subscribers by operators or service providers. CBS operators provide wide area coverage using a single or many radio channels from one or several base stations. Some networks can be built in a complex configuration in order to provide a good service and use coverage techniques such as simulcast, multi-channel configuration with sites linked by leased lines and voting systems. In some cases, networks can be dedicated to specific types of use, e.g. security, funds transportation, building or park keepers. Different user groups have to share a system. Sharing needs a signalling protocol based on audio tones or digital signalling (e.g. BIIS 1 200 [10]) resulting from the needs of users of the networks.

5.1.2.1 Public Access Mobile Radio

Public Access Mobile Radio (PAMR) operators offer regional or national coverage using trunked multiple channel systems. In a trunked system, subscribers share a pool of channels and are automatically allocated a vacant channel to make a call. Trunking has additional advantages in spectrum efficiency, operator simplicity, reliability, privacy and ease of expansion. Call set up processing is by use of digital signalling and communication may be by analogue speech, digital speech or data signals.

In a typical PAMR system, each radio station transmits a control signal on a radio channel. It also has a number of traffic channels at its disposal on which users of radio units communicate. When not in use, the radio unit is automatically tuned to the control signal and the unit's microprocessor can communicate with the system computer on this channel at any time.

When the user wishes to make a call, the unit transmits the request in the form of a data signal to the system computer. The computer finds the caller's desired correspondent and, by means of the control channel, checks for willingness to receive a call. When both called and calling parties are ready to communicate, the computer allocates the first available traffic channel.

When the call is terminated by either party, the radio unit sends a data signal releasing the channel.

Radio stations may be interconnected to increase the service area to provide any size of network, up to a national or international level.

Calls may also be made into other fixed line networks such as telephone systems.

Clause H.5 shows a configuration of equipment for a typical trunking installation.

5.1.3 Digital PMR systems

Many complete systems are known under their commercial designation. These are dedicated to different users such as mobile data, police systems and taxi networks. They can be operated on a local, regional, national or European coverage, using one or many frequencies. The protocols can be proprietary or public.

The digital systems can use different types of modulation, viz indirect (via the normal audio circuitry) for a rate of signalling not higher than 2 400 bit/s and direct frequency modulation for higher data rates (> 4 800 bit/s) or other modulation for data rates up to 36 kbits/s.

The most current modulation methods are:

- Minimum Shift Keying (MSK);
- Frequency Shift Keying (FSK);
- BiPolar Shift Keying (BPSK);
- Gaussian Minimum Shift Keying (GMSK);
- Gaussian Frequency Shift Keying (GFSK);
- FM 2 or 4 levels;
- $\pi/4$ QPSK (Quadrature Phase Shift Keying).

The access to the channels can be by Frequency Division Multiple Access (FDMA) or Time Division Multiple Access (TDMA) methods.

The general objectives of a spectrum efficient digital land mobile system, for despatch in either private or public systems, are to provide:

- systems that offer a higher spectrum efficiency, thereby accommodating more users within limited spectrum resources than analogue systems (see ERC Report 052 [20]);
- a higher average level of voice quality over the network and enciphered speech for privacy;
- users with a wide range of services and facilities, both voice and non-voice, that are compatible with those offered by the public fixed networks;
- users with a variety of applications to satisfy their requirements, ranging from handheld stations to vehicle mounted stations, with voice and data interfaces;
- mobiles and infrastructure equipment which use state of art technology to provide savings in weight, power consumption and cost.

The basic services offered by a digital dispatch traffic system can be divided into three types: teleservices, bearer services and supplementary services.

These systems, as opposed to public radiotelephones, use a fast call set up time and a short call re-establishment time.

Some categories of users, emergency and police services for example, need complex networks where the users apply different mode operations such as:

- Network mode where the mobile is within the coverage and control of the infrastructure (including trunking mode and open channel mode);
- direct mode where the mobile directly communicates with the other terminal in or outside the network coverage;
- repeater mode where the mobile communicates with the other terminal through a repeater.

All modes of operation are available for voice or for data. A detailed explanation may be found in ETR 300-1 [16].

5.1.3.1 TETRA

Terrestrial Trunked Radio (TETRA) is a standard developed by ETSI for professional digital trunked mobile radio systems. This standard is being adopted widely throughout Europe and in many other countries for public safety applications. It is also being deployed in commercial private regional networks and public access (PAMR) networks. The system has been supported by Recommendations issued by the European Radiocommunications Office for operation in the bands: 380 MHz to 400 MHz; 410 MHz to 430 MHz; 870 MHz to 876 MHz paired with 915 MHz to 921 MHz. It operates with 25kHz channel spacing. In addition, products are being developed in other bands to satisfy demand in specific market sectors.

The TETRA standard covers the following two formats:

- TETRA Voice + Data (V+D);
- TETRA Packet Data Optimized (PDO).

TETRA V+D provides voice services and both circuit switched and packet mode data services. A single TETRA base station can carry four speech channels, or a mixture of speech and data channels to occupy its 4 time slots. In addition a range of supplementary services are defined that provide additional useful functionality. TETRA (PDO) has been specifically designed for packet data applications.

TETRA is a TDMA technology (4 time slots) which uses $\pi/4$ DQPSK modulation. The speech coding rate is 4,8 kbit/s and the coding scheme is designed to minimize the effect of background noise on speech quality. In addition, authentication and encryption are used over the air interface. Group calls and broadcast calls are supported with fast call set-up times of less than 0,5 s. Point-to-point calls can be made privately between individuals and priority calls can be set up in emergency situations. Gateways into other systems are also supported such as PSTN and ISDN interconnect.

The standard supports both circuit switched and packet mode data services. A circuit switched mode data call can provide a data rate of 7,2 kbit/s from a single time-slot and these can be combined to provide up to 28,8 kbit/s when speech is not required.

Where no radio infrastructure is present, terminals may operate in direct mode operation (DMO) i.e. mobile to mobile. Repeaters and gateways are also specified for extending DMO range and for linking into the trunked infrastructure.

The main technical parameters for TETRA are given in table P.1.

5.1.3.2 Other Commercial Systems

Amongst commercial systems is TETRAPOL, which is standardized in the TETRAPOL FORUM. It was first developed for emergency services orientated applications, but can be implemented for other private applications in the VHF (68 MHz to 174 MHz) and UHF (380 MHz to 960 MHz) bands.

The main technical parameters for TETRAPOL are given in table P.2.

Other systems are described in ITU-R Report M.2014 [19].

5.1.3.3 Frequency planning - direct mode

As with all radio services it is necessary to ensure that they can co-exist with other services in adjacent bands in terms of not generating interference to or receiving interference from them.

The CEPT SE Group have published two compatibility studies on this subject:

- "Adjacent Band Compatibility of TETRA and TETRAPOL in the 380 MHz to 400 MHz frequency range - An Analysis Completed using a Monte Carlo based Simulation Tool"; and
- "Adjacent Band Compatibility of 400 MHz TETRA and Analogue FM PMR - An Analysis Completed using a Monte Carlo Based Simulation Tool".

5.1.3.4 Introduction of Trunked Radio Base stations onto Existing Radio Sites

Radio trunked systems use many channels assigned in a defined band. In many cases, digital systems use the same frequency bands as existing analogue systems, so the introduction of a new digital system on a existing radio site needs careful study to avoid interference between systems. If necessary, re-arrangement of antennas or addition of filters, as described in this document, may be needed to protect existing facilities. However it may prove necessary to reallocate frequencies on a local basis if these measures do not solve the problem.

5.1.4 Potential sources of interference

Mobile radio equipment can be affected by other sources of radiated products on the same site or in close proximity. General details are contained in clauses 7.1 and 7.2.

In order to minimize these effects, the use of filter systems and other related devices is strongly recommended. General details can be found in clause 8.

5.2 Paging

5.2.1 Introduction

Paging is a one way communication system for sending coded signals to personal receivers. Each receiver contains a unique Radio Identity Code (RIC) and when a transmission containing this code is received, the bearer is alerted by means of an audible tone, a light or a vibrator. The alert may be accompanied by a voice message, a numeric message or an alphanumeric message for display on the receiver.

Radio paging systems are described as either on-site or wide area paging systems.

5.2.2 On-site radio paging system

On-site radio paging systems are intended for the internal coverage of a premise or local site completely within the user's control.

On-site paging systems include High Frequency (HF), VHF and UHF systems and also induction loop systems using frequencies below 9 kHz. Some HF, VHF and UHF systems may be authorized to use outgoing speech facilities, but return speech may only be permitted for emergency services. With an induction loop system, outgoing and return speech is normally permitted although the return speech is typically in the VHF band.

5.2.3 Wide area paging systems

Paging systems where the radio coverage extends beyond a local site are classified as wide-area.

The reliable range of operation varies considerably depending on the base station location, and systems are designed to ensure a high probability of a user receiving a call whilst in the published coverage area. A network of base stations may be required for large regional or national systems. Where multiple base stations operate on the same frequency and their coverage areas overlap, then special attention is required to co-ordinate the frequency and modulation characteristics of these transmitters to ensure they operate in quasi-synchronous mode.

Wide area paging systems often use transmitters of higher power than those in normal PMR systems.

5.2.4 Signalling systems

Voice paging systems usually employ frequency or phase modulation techniques. The addressing of receivers is achieved by transmitting two or more audio tones sequentially. The receiver, on recognizing the correct tone sequence, activates and a voice message is received.

Numeric and alphanumeric display paging systems often use an open standard called Post Office Code Standardization Advisory Group (POCSAG) which was developed in the UK and accepted by CCIR as a No. 1 code for wide area paging. The air interface employs frequency shift keying techniques, and the carrier is modulated by a binary synchronous data stream. The maximum rate at which transitions may occur determines the bit rate, which for POCSAG systems may be 512 bits/s, 1 200 bits/s or 2 400 bits/s. The modulation is 2 level FSK with 4,0 kHz, 4,5 kHz or 5 kHz deviation.

A newer signalling system, the Enhanced Radio Message System (ERMES) developed as a European Standard, has been adopted by CCIR for paging use. This specification defines the complete interconnection of networks in addition to specifications of the air interface. ERMES transmissions are 4-level FSK transmissions, where each level represents the binary digits 00, 01, 10 or 11. This together with a higher signalling rate results in a bit rate of 6,125 kbit/s in a 25 kHz channel, giving the operator greater capacity than that offered by existing POCSAG systems. ERMES channels lie within the frequency range 169,4 MHz to 169,8 MHz, and as with all wide area systems, transmitters operate at high power. This frequency range lies close to existing PMR base receiver frequencies, and site operators must ensure that receivers operating in adjacent frequencies are protected from the ERMES transmissions. Two mechanisms by which interference at a site can be caused have been identified, viz. desensitization (blocking) and generation of intermodulation products. To minimize blocking, a notch filter in the receiver antenna downlead, designed to reject the unwanted transmission is recommended, although this becomes difficult if there are several unwanted ERMES transmissions. To minimize intermodulation, the use of ferrite isolators in each transmitter's antenna lead is recommended.

5.2.5 Coverage in confined spaces

Paging systems often use radiating cable techniques and repeaters when coverage is required in buildings and where screening prohibits the use of conventional antenna systems (see clause 5.4 for more details). Mixtures of radiating cables and conventional antennas are also often used in some system configurations, sometimes with the use of repeaters (see clause 5.5 for more details).

5.3 Public radiotelephone

5.3.1 Introduction

A public radiotelephone (cellular) system is designed as a network of contiguous radio cells, together providing a near complete coverage of the service area. Each cell has a Base Transceiver Station (BTS) operating on a dedicated set of radio channels which are different from the channels in adjacent cells. The primary function of the BTS is to provide radio transmission and reception. The BTS may contain one or more transceivers to provide the required capacity. A cell-site may be omni-directional or split into (typically three) directional cells.

A group of base stations is controlled by a Base Station Controller (BSC) for functions such as handover and power control. A group of BSCs is served by a Mobile services Switching Centre (MSC) which routes calls to and from the Public Switched Telephone Network (PSTN) or other services.

Two types of interference occur, namely co-channel and adjacent channel interference. As these sources of interference occur within the system they can be controlled by the designer.

Co-channel interference is controlled by selecting a geographical re-use pattern for frequencies which ensures that the same channels are not used in adjacent cells.

Adjacent channel interference is a possibility in systems using wide deviations for speech and data compared to the channel spacing. This can be tolerated if adjacent channels are not used in the same cell and if the frequency re-use distance ratio is increased.

Cell channel groups are selected to minimize co-site intermodulation products.

5.3.2 Public radiotelephone (analogue)

Each base station provides two types of radio channel: a duplex control channel to transfer information when a call is being set up and a duplex voice channel which is used for the telephone conversation. Adjacent radio base stations operate on different sets of channels to minimize interference, while non-adjacent base stations can re-use the same radio frequencies simultaneously (frequency re-use).

As with conventional telephone networks, data and information can be transmitted and received on the public radiotelephone systems by the use of appropriate modems.

5.3.2.1 Frequency re-use

Each cellular system is allocated a number of channels. Channels are grouped together in channel sets and allocated to patterns of cells that fit together to give continuous coverage. For each pattern there is a distance D that separates the base stations using the same channel set. When divided by the cell radius this is known as the re-use ratio. The smaller the re-use ratio, the fewer the channel groups that are required and for a given total number of channels, the higher the trunking efficiency. However, the potential for co-channel interference is increased as the re-use ratio is decreased, and the hand-over activity is also increased.

5.3.2.2 Hand-over

During a communication the base station monitors the level of received signals and messages are sent to the mobile to adjust its transmitter power as required. If the transmission quality falls below an acceptable level then the MSC checks the adjacent base stations to determine which can provide the best reception. The mobile is advised of the new channel to be used and the MSC connection is made to the new base station. This activity is known as hand-over and occurs automatically without the mobile user's knowledge or intervention and the call continues uninterrupted. Signal quality is not the only criteria used to determine whether hand-over is required. Distance or position measurement may be used alone or in conjunction with signal quality.

5.3.3 Public radiotelephone (digital) - GSM/DCS 1 800

The Global System for Mobile communications (GSM) provides a common standard for mobile phone operation. People can drive their cars, fitted with mobile phones, or travel to foreign destinations with their hand held phones retaining the facility to receive and make calls. This may be done without making special arrangements or additional subscription charge. GSM has been designed to be compatible with the Integrated Services Digital Network (ISDN) principles.

GSM is designed to use digital technology for performance and reliability. Phones may also be used for a wide variety of data services, including the Short Message Service (SMS), facsimile transmission and data communications to most common standards, at rates up to 9 600 bits/sec full duplex.

On GSM, subscription is on a Subscriber Identity Module (SIM) card which is a microcomputer with memory. Once plugged into a GSM phone all calls for that number are directed to it and all outgoing calls are charged to that subscriber.

Security is enhanced by the use of digital encryption, which is effective against unauthorized eavesdropping on conversations. This applies equally to data transmission.

GSM operates in the 900 MHz and 1 800 MHz frequency band but the same or similar protocols can be used at other frequencies.

5.3.3.1 Databases

The BSC database holds all the parameters for configuring the Base stations. The BSC downloads the data onto the Base Stations to set parameters which determine the coverage and frequency, as well as their traffic handling capabilities. The BSC also stores the parameters use to control the cell on which a mobile initiates a call and when it should handoff to another cell while the call is in progress. For these purposes data is passed to the mobile to allow it to assess the signal path.

Alarm data is set within the BSCs and MSCs to monitor equipment health and site access throughout the network. Equipment failure and other alarms are raised in central control rooms for immediate action.

A Home Location Register (HLR) carries information about subscription levels, supplementary services and the network/location currently, or most recently, in use by subscribers. Working in close association with the HLR is the Authentication Centre (AUC) which provides the information to authenticate all calls in order to guard against fraud, stolen subscriber cards or unpaid bills.

A Visitor Location Register (VLR) stores information about subscriber levels, supplementary services and location area for a subscriber currently, or most recently, in that (visited) area.

An Equipment Identity Register (EIR) stores information about the type of mobile in use and can bar a call if it considers the mobile is stolen, not type approved or has a fault which may disturb the network.

5.3.3.2 Radio

GSM uses Time Division Multiple Access (TDMA) with 8 time slots (i.e. any one call transmitting for one eighth of the time). Hence, one radio channel can support 8 "full rate" traffic channels, or 16 "half rate" traffic channels. A TDMA frame has a period of 4,615 ms (about 217 p/s). The radio channel separation is 200 kHz. The frequency band used is 890 MHz to 915 MHz for mobile transmit and 935 MHz to 960 MHz for base transmit. Hence there is a 45 MHz separation between transmit and receive channels.

The peak power of mobile stations depends on the "class". These were originally envisaged as being 20 W, 8 W, 5 W, 2 W and 0,8 W for classes 1 to 5. In practice, nearly all the market is occupied by 2 W mobiles (class 4). The mean power per user is one eighth (full rate channel of these figures). To minimize switching sidebands, the transmitted power is smoothly ramped up and down at the start of each burst, over a period of 28 ms. At any BTS one radio channel will be transmitting continuously, while additional transceivers will only transmit during timeslots occupied by active calls.

Power control (15 steps of 2 dB) is provided to avoid interference and increase battery life. Frequency hopping may be employed in order to avoid "deadspots" and mitigate the effects of interference. The hopping rate is one hop per TDMA frame.

The method of modulation used is Gaussian Minimum Shift Keying (GMSK), with a Bandwidth Time product (BT) value of 0,3 at a gross rate of 270 kbit/s. Thus it is seen that GSM is a digital radio system with a high data rate, so an equalizer must be employed, in particular to cope with a multipath environment with up to 16 ms dispersion. Most transmitted data is protected by error correcting codes. Phase and frequency synchronization must allow for Doppler shift for vehicle speeds of up to 250 km/h as well as for frequency standard drift. Timing advance must compensate for propagation delay due to round trips for paths, in cells up to 35 km radius.

All clock and timing frequencies required in a GSM system can be derived by division of a 13 MHz master oscillator.

5.3.3.3 Traffic and signalling channel

The information transmitted over the radio interface consists of a number of data streams, confusingly known as "channels". Information from all of these channels is sub-multiplexed into appropriate timeslots on the radio link. Traffic channels are defined for speech and for data at the rates of 9,6 kbit/s, 4,8 kbit/s and < 2,4 kbit/s.

In addition a number of logical signalling channels are specified. These operate at different rates with individual functions:

slow associated control channels	Control and supervisory signals associated with traffic channels;
fast associated control channels	Steal time slots from traffic allocations and use to control requirements such as handover;
dedicated control channels	Multiplexed on standard channels for registration, location updating, authentication and call set-up;
broadcast control channels	Downlink only, providing mobiles with data such as base station identity;
paging channel	Downlink only, informing mobiles that the network wants to make contact;
random access channel	Uplink only for mobiles wanting access to the network;

access grant channel	Downlink only, replying to random access and assigning a dedicated control channel for signalling;
cell broadcast channel	Downlink only, sending cell broadcast information.

5.3.4 Use of repeaters

Repeaters are used to extend the coverage range in areas of poor propagation or fill in "dead spots" within the normal coverage area. Further details are contained in clause 5.5.

The general description and planning aspects of repeaters specifically for use with GSM networks are described in EN 300 577 (GSM 05.05) [11] and ETR 103 (GSM 03.03) [12].

5.4 Confined space engineering

5.4.1 Introduction

In confined spaces such as tunnels, underground buildings, car parks and shopping precincts, standard techniques of radiocommunication involving antennas as radiation or pick-up devices have several disadvantages:

- due to multiple reflections and high absorption losses, the range for the antenna is reduced to a fraction of the range in free space;
- due to multiple reflections the points of in-phase and out-of-phase reflections would cause erratic communications, particularly whilst moving;
- for VHF, the size of a fixed antenna within a confined space, such as a tunnel, would be impracticable.

In order to provide reliable communications within a confined space, a specialized antenna system is used. The antenna system can consist of a radiating cable (see clause 5.4.2), a number of distributed antennas or a combination of both. The radiating cable functions as a continuous antenna so that multiple reflections are minimized.

5.4.2 Characteristics of radiating cable

A radiating cable is a form of transmission line and is typically a coaxial cable with slots or apertures that allows a controlled portion of a transmitted RF signal to radiate along the entire length of the cable. Conversely, a signal transmitted near to the cable will couple to the cable.

A single radiating cable is a broadband medium and can handle any number of communication systems in different frequency bands.

It is recommended that either continuously leaky coaxial cables or coaxial cables with periodic apertures are used in radiating cable systems.

See clause N.2 for typical characteristics of radiating cables.

5.4.3 Confined space radiocommunication systems

Radio coverage in confined spaces is difficult to engineer by use of an antenna solution at operating frequencies below approximately 500 MHz. At higher frequencies, radio coverage may be achieved by a combination of antennas and radiating cables.

A practicable combination of radiating cables, repeaters (see clause 5.5) and antennas can be arranged to optimize the propagation requirements of an installation whilst keeping installation costs to a minimum.

A practical method of obtaining the best possible coverage consists of terminating a radiating cable in an antenna which continues to provide coverage beyond the end of the radiating cable.

Systems for radiocommunications in confined spaces are described in clauses N.1 and N.3.

5.4.3.1 Antenna characteristics

The following antenna characteristics affect their use in confined spaces:

- for VHF, the size of antennas make them impracticable to use in confined space engineering applications;
- in tunnels, the dimensions of antennas could lead to fixing difficulties due to the loading gauge (e.g. the clearance distance between an antenna and a train or vehicle);
- antennas for frequencies below approximately 900 MHz have a limited life, even in a dry underground tunnel. It is advisable to replace such an antenna after 10 years;
- antennas for frequencies above approximately 900 MHz are smaller, have a more rugged boom, and the dipole and reflectors can be encapsulated, leading to a longer life;
- the radiated signal is attenuated due to the curvature of a tunnel;
- in the case of buildings, particularly car parks, terminals, bank vaults and underground storage, the use of antennas offer a practical solution;
- the frangibility (tendency to break) of the antenna system will determine whether the long term use of antennas would give the system security required;
- access for repair and maintenance is also a factor in determining the position of antennas particularly in large buildings;
- a faulty antenna sited in a restricted position could mean loss of service for a significant period of time until it is fixed.

5.4.3.2 Recommendations for frequency range 150 kHz to 1 000 MHz

Recommendations are made for the frequency range 150 kHz to 1 000 MHz as follows:

- 150 kHz to 150 MHz:
 - no consideration should be given to the use of antennas due to the size, weight and the practical difficulty of fixing;
 - for this frequency range, a radiating cable solution is more practicable and all of the bands in this part of the spectrum can be coupled by passive networks and radiating cables. It is fortunate that many radiating cables manufactured for higher frequencies (i.e. 500 MHz) will continue to operate in a satisfactory manner down to Medium Frequency (MF);
- 150 MHz to 500 MHz:
 - there may be a solution that is a compromise, using radiating cables in part and antennas in those locations that are practical for their mounting. In general however, antennas for operating frequencies less than 400 MHz are not recommended due to their dimensions and weight;
- 500 MHz to 1 000 MHz:
 - in general, the band 471 MHz to 854 MHz is used for UHF television but there may be occasional use for PMR in this band. In the frequency range 850 MHz to 960 MHz there are many services requiring coverage in confined spaces e.g. analogue or digital cellular;
 - whilst in general the radiating cable can also provide a working solution for this frequency band there are often cost limitations which make the alternative use of antennas an attractive option. At these frequencies the antenna is small enough to be manageable, unobtrusive and can be made very durable and long lasting.

5.4.4 Installation and maintenance of radiating cables

Radiating cable is routed wherever radiocommunications are required. When mounting radiating cable to concrete or conductive surfaces, or alongside mains or signal cables, it is recommended that stand off insulators of at least 65 mm be used in order to minimize attenuation in the cable. Their size will depend on the geometry of individual installations.

Radiating cables installed in underground tunnels should be kept dry and protected from water ingress to prevent undue increase in attenuation.

In some applications, radiating cable may be mounted under the ground but should be protected by an insulated tube. Cable installed in areas where vandalism or rodent damage could occur should also be protected by an insulated tube.

Radiating cable installed in road and rail tunnels could be affected by the effects of salt and chemicals used for de-icing, by carbon deposits from vehicle exhaust emissions and deposits from vehicle brake dust. The radiating cables should be inspected annually and any deposits should be minimized by cleaning the cable with water or steam.

See clause 6.3.4 for earthing details.

5.5 Repeaters

5.5.1 Introduction

A repeater is a device used to enhance radio signals between base and mobile stations in areas of poor propagation such as topographically shielded areas, buildings and tunnels.

There are many different types of repeaters which fall into three broad categories, those used in broadcasting, in cellular radio and those used in PMR systems.

Repeaters are usually purpose designed to meet a particular requirement and therefore there are a multiplicity of types in the above mentioned three categories. This mitigates against producing a standard specification for repeaters although ETSI has a standard for a specialized type of repeater used in GSM systems. However, like all radio equipment, repeaters should meet the requirements of the General Electro-Magnetic Compatibility (EMC) Standard for Radio Communications Equipment (EN 300 339) [13].

A repeater receives, amplifies and transmits simultaneously the radiated RF carrier generally in both the downlink direction (from the base station to the mobile) and in the uplink direction (from the mobile to the base station), and sometimes in the downlink direction only (e.g. paging).

A repeater used in a public mobile telephone system (cellular radio) is also referred to as a cell enhancer. Generally, a cell enhancer is the term used for a broadband repeater.

A repeater typically consists of amplifiers, bandpass filters, notch filters, attenuators and an automatic gain system but excludes a demodulator. Some repeaters include frequency changing circuits as part of the signal path in order to achieve adequate selectivity.

The power output level per channel of a repeater should be of the order of +20 dBm but in specialized applications, such as tunnels, higher or lower powers may be used.

5.5.2 Types of repeater

The following types of repeater are used for mobile radio systems, which include cellular and PMR. Most of such repeaters operate on a two frequency channel allocation and comprise two separate amplifier chains with a single receiving and separately a single transmitting antenna. However repeaters are capable of application to single frequency channel applications, in which case only one amplifier chain is used with again a single receiving and separately a single transmitting antenna. The term "on-frequency" indicates that the repeater receives and transmits on the same frequency for its one or two amplifier chains, although the frequency of each chain in the case of two frequency channel allocations will be different.

1) Single RF carrier on-frequency repeater:

- This applies to single or two frequency rf channel repeaters. Single carrier repeaters can provide enhancement of a single rf carrier, which in a traditional system will be associated with a single channel audio or data channel but for digital systems may be associated with 4 or more mixed audio and data channels.

- 2) Multi-channel narrowband RF carrier on-frequency repeater:
 - Multi-channel narrowband rf carrier repeaters can provide enhancement of several narrowband non-contiguous rf carriers within a particular frequency band;
- 3) Broadband on-frequency repeater:
 - A broadband repeater provides enhancement of rf signals over a wide band covering several rf channels;
- 4) Broadband frequency changing repeater:
 - In this type of repeater, the input signal frequencies are translated and transmitted in another frequency range.

5.5.3 Repeater characteristics

Repeaters should meet the minimum radio frequency performance of any relevant national specifications for repeaters, if they exist. There are no ETSI standards for repeaters except for GSM (see clause 5.3.4).

For analogue public mobile radio telephone (cellular radio) repeaters, the bandwidth of transmission through the repeater is often broadband to the extent of covering the entire band allocated to the service, e.g. in Total Access Communications System (TACS)/Extended Total Access Communications System (ETACS) the combined bandwidth is approximately 38 MHz in each signal path. In the case of repeaters used in PMR systems they will generally be narrowband, such as 12,5 kHz.

Regardless of the type of repeater or its application, it should be designed so that it only repeats the wanted signal(s). Any spurious emissions (including harmonics), intermodulation products and out of band noise should be at the low levels normally associated with base transmitters. The methods of measurement of those unwanted emissions should be those generally specified in ETSI standards applicable to any radio product.

5.5.4 Installation recommendations

The following recommendations are made regarding the installation of repeaters:

- a) A repeater requires two antennas, one a highly directional narrow beam antenna directed to the base station, the other is a radiating cable and/or omni-directional or directional antenna to cover the area in which the mobile stations are to be served.
- b) To maintain satisfactory operation of a repeater with adequate margin of stability, careful attention must be given to the coupling loss (isolation) between the two antennas.

The coupling loss is the attenuation between the exit from the receiving antenna connecting cable normally coupled to one repeater port, and the entry to the other antenna connecting cable normally coupled to the other repeater port. Every effort is necessary to maximize the coupling loss. For a repeater with its two antennas mounted on the same mast, tower or other structure the typical maximum achievable loss is 55 dB in the VHF, 60 dB in Band 3, 65 dB in the UHF and 70 dB in the 900 MHz bands.

When using a repeater in a tunnel for example, where one antenna is outside the tunnel and the other inside, a larger coupling loss is typically possible with figures up to 85 dB being achievable.

The greater the coupling loss the greater the usable gain of the repeater.

- c) The gain of the repeater should be at least 10 dB less than the coupling loss (isolation) between the two antennas of a repeater. The isolation should be measured before installation of the repeater.
- d) The output level per channel of a repeater should typically be 20 dBm (input level + gain = output level) but would not normally exceed 1 W.
- e) The noise output level (including spurious emission, intermodulation and out of band noise) of a repeater should be less than -36 dBm measured in an appropriate bandwidth up to 1000 MHz and less than -30 dBm measured in an appropriate bandwidth over 1000 MHz.
- f) The repeater antenna receiving signals from mobiles should have at least 70 dB isolation from the nearest mobile station. This is easily achieved when using a radiating cable but automatic gain control of the repeater may be provided as a protection measure against close mobile working causing system saturation.

- g) The physical locations of the antennas of the repeater should be chosen so that only the required areas of poor propagation are covered.
- h) For repeaters used in buildings where other communication systems operate in close vicinity (less than 5 m) of the repeater antennas, special care should be taken so that signals from other communication systems are not re-radiated from within the building by the repeater. When using repeaters with an antenna mounted on the outside of the building, the effect of any additional height should be considered. If the coverage of the other close coupled communication system is usually constrained within the building, it may be necessary to consider the impact of building penetration loss when planning the installation of the repeater.
- j) It is the operator's responsibility to ensure that the out-of-band gain of the repeater does not cause disruption to other existing co-located radiocommunication equipment. This can be done by careful choice of the repeater antennas and siting, or if necessary, the inclusion of in-line filters to attenuate the out-of-band signals from other systems operating in the close vicinity of the repeater.

5.6 Fixed point-to-point radio links

5.6.1 Introduction

This section is a simple introduction to a complex subject, covering the salient points which should be considered when planning to use fixed point to point radio links. Radio site designers should consult with the appropriate fixed link specialists within their organization for more detailed information and guidance.

5.6.2 Use of fixed point-to-point radio links

Fixed links are, as the title implies, used to provide radio communications between fixed locations, usually radio sites. There are also dedicated fixed link networks which provide trunked telecommunications services on a national and international basis. For the purpose of this document only fixed point to point radio links used in conjunction with radio systems will be considered.

The use of fixed links has increased in last few years because of the need to interconnect the large number of radio sites, particularly for the cellular operators, which have to be used at the higher frequencies designated for these i.e. GSM at 900 MHz, PCS at 1800 MHz and in the future, UMTS at 2 GHz. The use of fixed links for this purpose reduces the need for expensive landlines for interconnection between sites and to other services.

5.6.3 Types of Fixed Links (including Frequency Allocations)

National bodies usually require links to be licensed, to control erp, modulation, location and the path details. Main bands allocated for use in conjunction with radio systems are 1,4 GHz, 22 GHz, 25 GHz, 38 GHz, 55 GHz and 58 GHz. Some other bands in the 4 GHz to 58 GHz allocation are used exclusively for point to point telecommunications and TV links. The most commonly used bands for cellular operators' requirements are 22 GHz and 38 GHz.

5.6.4 Physical Design Criteria for Fixed Links

Detailed planning is required to ascertain whether a link can be set up between two locations. This planning consists of both theoretical and practical stages. The theoretical stage consists of plotting out the path on maps with detailed contour information to obtain a suitable path. Once this is done the path is drawn on special plotting paper which allows for the earth's curvature, so that a minimum ground clearance is obtained over the path. This minimum clearance is known as the "Fresnel zone" and is necessary to avoid reflected paths which could affect the signal levels and cause "fading". A calculation is also made to allow for the antenna characteristics e.g gain, feeder loss, input power at each end of the link, together with the path loss. In addition it is usual to carry out a practical test to back up the calculations. There may be some obstructions to the path, such as trees which do not show up on a map, but nevertheless will affect the path pattern. For short paths it may be possible to check using high power lights instead of a temporary link. In extreme cases a direct link may not be possible, so an intermediate relay site will need to be used. This will still require detailed calculations for both link paths. In some instances it may not be possible to carry out the practical check until the main radio installation has been built e.g. if the link antenna is to be on a mast which has not yet been erected.

5.6.5 Hardware for Fixed Links

The antennas used for links are generally dish type with diameters from 300 mm to 1 800 mm depending on the technical requirements for the link path. At the frequencies concerned there is a need for low loss cable or waveguides which require special measures for installation. The mounting arrangements require a minimum rigidity for the support structure to ensure that the antenna does not twist, as a very small movement could cause the link to fail. Some recommended mounting methods are shown in annex C. In addition it maybe that the system uses a masthead transmitter/receiver or amplifier, in which case this could lead to special maintenance procedures and additional training for staff.

5.7 Future systems

The continual and speedy growth of mobile telecommunications globally and other innovations, such as the demand for mobile Internet and mobile commerce services mean that additional systems will be needed to meet these increasing requirements from users in this millennium.

To this end, Third Generation (3G) systems are being developed to complement the existing First generation (e.g. analogue cellular as shown in annex Q) and Second Generation (e.g. GSM 900, GSM 1800, DECT) systems. The global standard, International Mobile Telecommunications 2000 (IMT-2000), will be matched in Europe by the Universal Mobile Telecommunications System (UMTS).

To harmonize all the 3G proposals, a Third Generation Partnership Project (3GPP) has been established on a global basis. The 3GPP objective is "to co-operate in the production of a globally applicable 3rd Generation Mobile system based on evolved GSM core networks". Members include ETSI and the regional standardization bodies from Japan, USA, Korea and China.

Work is continuing on the introduction of UMTS in Europe. Fuller details are contained in annex Q.

6 Installation recommendations

6.1 Support structure and mechanical considerations

During the design and construction of support structures the following processes will need to be considered. For each of these processes compliance with the relevant National Standards should be achieved:

- a) design of structural components;
- b) hot dip galvanizing of steel components;
- c) spin galvanizing of steel threads;
- d) use of lock nuts, spring washers and other locking devices;
- e) anodizing of aluminium components;
- f) use of protective paints.

NOTE: The anodizing on aluminium is likely to insulate the components and thus produce difficulties in terms of earthing and conductivity of the structure.

6.1.1 Structural integrity

The structural integrity of the mast or tower must be established by a competent structural engineer, the analysis must include the loads imposed by each antenna system.

6.1.2 Wind loading

The structural design should take into account the wind loading of all the components on the structure, e.g. antennas, feeders and associated hardware. Twist and tilt limitations for parabolic antennas may also have a bearing on design or reinforcement.

The design or selection of a suitable support must be by qualified structural engineers. The design of new structures should where possible take into account the probability of future development.

6.1.3 Protective coatings

The cutting or drilling of protective coated items should not be permitted during installation. On the occasions when cutting or drilling is unavoidable, consideration should be given to possible structural weakening, and the affected areas must be treated with a recommended protective coating. The painting of structures should be considered as an essential part of the post installation programme. A well defined schedule of time scale and of the exact process should form part of the design of the structure and must be implemented rigorously.

In the case of a galvanized structure there will be a recommended period after which a paint process should be applied.

6.1.4 Use of dissimilar metals

It should be carefully noted that wherever possible all metals used in contact with each other shall be in the yellow metal series, i.e. copper, brass, silver, nickel, or gold. The iron and steel part of the metals table should be avoided at all times as their oxides form nonlinear junctions and can cause intermodulation. The ideal combinations are silver/brass to copper using nickel plated nuts and bolts.

Structure design must take particular account of corrosion between dissimilar metals: electrolytic contact potentials between metals in contact in outdoor exposure must be less than 0,25 V, and in indoor situations should be less than 0,50 V. Annex E gives further information on the position of metals in the galvanic series and the potential differences that will exist.

6.2 Equipment room

There are several fundamental requirements for equipment rooms on radio sites which must be given full attention prior to the commissioning of the site. These are as follows:

- a) the construction of the installation must provide security against vandalism and casual attack by intruders;
- b) if services are to be provided on the site which warrant a high degree of security, then alarm systems must be fitted;
- c) the cables in and out of the equipment room must be hidden or protected in such a way that they cannot be easily damaged;
- d) the areas within the equipment room shall be divided off to allow access to individual parties as dictated by the requirements of the site;
- e) that a separate area is provided for the common services facility, e.g. mains power supply, filter multicouplers and incoming feeder cable assemblies;
- f) that cooling, heating and lighting be provided of a standard suitable for the environmental requirements of the site;
- g) that there is sufficient space within the enclosure to allow for reasonable expansion.

NOTE: The above criteria shall be judged when taking into account the climatic, access and future development conditions pertaining to each individual site. For some locations, e.g. mountain tops, it may not be possible to visit with normal vehicles during severe winter conditions. It will be necessary to provide standby and auxiliary mains power supplies for many sites where overhead power lines are provided.

6.2.1 Equipment arrangements

The equipment layouts given in annex F are based on the assumption that a choice of position for various items within the equipment room can be achieved.

Often, however, equipment rooms are already disposed in certain aspects, e.g. the power supply arrangements and emergency batteries may already be installed and occupy a critical position adjacent to the door.

There are some fundamental rules that should apply wherever possible and these are as follows:

- a) the filter couplers and associated signal distribution systems should be located in a separate area whenever possible and locked away from the transmitter and receiver equipment. This is to ensure that the filter parameters are not adjusted or interfered with by those who are not responsible for the filter performance;
- b) whenever batteries or emergency supplies are involved, these should ideally be housed in a separate cubicle and ventilated to the outside atmosphere. This is to ensure that no explosive gases or corrosive fumes are present within the equipment room;
- c) each frequency band will have its own cable feed and associated harness and therefore it is logical to present all the equipment in that band with adjacent racks and convenient to the cable tray;
- d) it is always advisable to keep receivers and transmitters as far apart as possible and this can be arranged in separate racks within the frequency band and its associated area;
- e) in some countries the common band allocations may be quite different from those shown in the diagrams given in annex F and therefore can be interpreted separately for that country.

6.2.2 Environment

Consideration should be given to ensuring that the equipment room is kept at an ambient condition which never allows the temperature to fall below the dew point and which keeps within the specified temperature range of the equipment, or at an acceptable working temperature for personnel.

It may be necessary to provide heating, ventilation or cooling to achieve this condition.

Precautions may be necessary to exclude pests and vermin from the equipment room.

6.3 Electrical supply, protection and lightning protection

6.3.1 Electrical supplies

The majority of sites will have ac power provided by the local Electricity Supply Authority. It is essential to arrange sufficiently large capacity for future expansion, and wherever possible a sub-division of the input circuits should be provided separately for each user function. This ensures that individual fuses or trips protecting sub-sections of the site installation cannot interrupt the supply of other users.

In many instances standby power supplies will be required and this should be based on the requirement of the service.

There are an increasing number of sites where dc supplies, in the form of large capacity batteries, are used to power equipment and these batteries are charged continuously by means of "float charge" systems. This has the dual advantage of automatic standby and "no-break" characteristics.

6.3.2 Lightning effects, protection and responsibilities

Radio sites can be particularly prone to lightning strikes by virtue of their normally exposed locations and the presence of relatively tall antenna support structures.

The effects of strikes on a site could comprise any or all of the following:

- a) death or injury to personnel;
- b) damage to equipment, or loss of service;
- c) damage to buildings and structures;
- d) loss or corruption of stored data.

It is not possible to provide and guarantee complete protection from these dangers. However, they can be considerably reduced by careful attention to earthing, protection devices and the layout of the site itself.

Understandably, site owners and users will be concerned with the protection of equipment to maintain the integrity of systems. However this concern must go alongside the prime consideration which is the safety of personnel.

Reference should also be made to various relevant publications. Where any site owner or site user is in doubt about the protection requirements for a particular location, the appropriate authority should be consulted.

The aims of any protection arrangements should be to provide a suitable path to earth for the lightning current, to ensure adequate bonding between structures, all metalwork on the site and the site common earthing system in order to reduce the side flashing, and to attempt to prevent the entry of flashes or surges into buildings.

Connections to site earthing systems (where corrosion may be unavoidable) should be made by means of a sacrificial anode of a material compatible with the structure being earthed.

All underground clamps on site earthing arrangements should be suitably protected by the use of non reactive, non setting pastes and tapes.

The resistance to earth should be kept to a minimum and a value of less than 10 Ω is recommended. The important feature is that the system should ideally be equipotential across the whole site.

Reference should generally be made to the appropriate National Standards for the protection of structures against lightning.

Certain authorities and service providers have their own particular practices which may have to be followed where applicable.

Arrangements will vary considerably from very simple sites to complicated sites with a multiplicity of buildings, antenna support structures and associated plant, and may involve integration with existing systems. Such systems may require upgrading.

Down conductors, bonding interconnections, earth rings and radial tapes should be of uninsulated solid copper tape of minimum cross sectional area 60 mm² with all connection clamps and supports protected by non reactive paste or tape (aluminium conductors may be acceptable).

Where the tape may be subject to chemical attack, e.g. when in close proximity to concrete, it should be protected by the use of non reactive paste or similar.

Protected test points should be included if appropriate and sacrificial earth lugs should be clearly marked and easily accessible for periodic inspection and replacement if necessary.

6.3.3 Earthing of antenna support structures

A structure will generally act as its own lightning conductor and will not therefore require a conducting tape from the apex to its base. A lightning finial may be required to extend the zone of protection to protect equipment mounted on the top of the structure. The finial should extend to at least 1 m above the highest equipment.

Ground mounted support structures should be connected at their base to an earth ring arrangement. This is normally by means of an anode usually in the form of a lug. Towers may require a connection from each leg.

Replacement of sacrificial anodes should be part of the site maintenance programme.

An earth ring may consist of copper tape with driven earth electrodes or radial tapes round the base of the structure as close to it as possible, buried to a depth of approximately 0,60 m where soil conditions allow.

The earth rings should be connected to the main building earth by the most direct route, buried as appropriate.

Roof mounted structures should be connected to the main building earth by the most direct route using sacrificial anodes and copper tapes as appropriate.

Mast guy wires should be directly bonded at their lowest point to a suitable earth electrode or connected to the site earth by the most direct route.

6.3.4 Earthing of antennas, feeders and associated plant

All antenna feeders should be bonded to the tower at the upper and lower ends and earthed at the point of entry into the building (see annex G). Weatherproof earthing kits are available from cable and connector manufacturers.

Fast acting gas filled surge arrestors can be used on some systems and may provide additional equipment protection, providing that Voltage Standing Wave Ratio (VSWR) degradation is acceptable.

In the case of radiating cables or RF cables in tunnels, the outer conductor is usually earthed at the point of entry into equipment rooms. There may be different practices between authorities regarding how earthing at intermediate points should be arranged. In general any metallic structures in tunnels should be earthed to a common point to avoid the possibility of electrocution.

All gantries, fuel tanks, pipes above and below ground, fences and other metalwork within 3 m of the support structure or building should be bonded to the earthing system by the most direct route using copper tape, buried where appropriate. This should include any reinforcing rods in foundations which are not already bonded to earth.

Ideally an earth ring should surround the building and be connected to the individual earths associated with the feeder entry, antenna support structure, building lightning conductor, equipment room, mains supply and other facilities. Each connection should be made by the most direct route to minimize interaction between the different earthing functions.

The earth ring should consist of copper tape with electrodes or radial tapes, buried to a depth of 0,60 m and at a distance from the building preferably not exceeding one metre.

Buildings may require lightning conductor terminals (finials) where they are not within the zone of another protected structure.

6.3.5 Special Installations

Whilst most radio sites have conventional layouts and characteristics, there are some which do not, particularly where space is at a premium. An example of this is the use of High Voltage Electricity Towers as the antenna support structure, particularly for cellular installations. Special precautions are necessary for this type of installation and associated equipment, and these measures are outlined in annex R.

6.4 Antennas and feeders

6.4.1 Choice of antenna type

The principle which governs the choice and siting of transmitting antennas is that only the minimum necessary erp must be radiated in each desired azimuth direction.

Omnidirectional antennas should be used only when necessary for the service requirements. The simplest examples of this class of antenna are top-mounted end-fed and coaxial dipoles, monopoles and collinear arrays. When omnidirectional characteristics are required of a side mounted array, a number of antenna elements must be placed around the supporting structures.

There are many satisfactory types of directional antennas: common examples are yagi arrays, corner reflector antennas and panel antennas.

Many antennas in common use fall between the omnidirectional and directional types described. They include simple dipoles side-mounted from support structures. Many of these antennas have ill-defined radiation pattern performance and are likely to give rise to radiation of intermodulation product frequencies originating from currents excited in the supporting structure. Their use is not recommended for multi-frequency applications.

6.4.2 Antenna specification

The following parameters must all be specified when procuring or selecting antennas.

- electrical:

a) gain;

Specified either in dB relative to an isotropic radiator (dBi) or a half-wave dipole (dBd).

b) VSWR;

Specify the maximum value compatible with the system being considered.

c) radiation pattern;

Specify the beamwidth in the azimuth and elevation planes, together with any necessary restrictions on side or rear lobe levels.

d) balance ratio;

This parameter defines the effectiveness of the balun fitted to balanced driven elements and consequently the acceptable level of currents on the outside surface of the feeder cable. A value of 20 dB should be considered as a minimum.

e) input power;

For combined transmitter outputs specify both the mean, and peak powers.

f) intermodulation performance:

The following specifications are desirable:

(i) for single frequency transmit and receiving applications:

-100 dBc;

(ii) for multiple frequency transmission:

-130 dBc;

(iii) for multiple frequency transmission and reception on a single antenna:

- 43 dBc;

The more severe specification will be met using all-welded construction and exceptional care in the encapsulation of antenna terminal arrangement;

g) bandwidth;

Specify the frequency band over which the antenna is to be used, over which all the parameters specified must be met. The practice of regarding the VSWR bandwidth as indicating the useable frequency band is unsound;

- mechanical:

a) structural design of antennas and supports must comply with relevant National Standards;

b) electrolytic contact potentials between dissimilar metals must be less than 0,25 V even for encapsulated assemblies;

c) conformity to a chosen environmental test specification.

6.4.3 Location of antennas

When determining the mounting positions for antennas each antenna must be mounted in a manner which does not impair its performance (see clauses C.1 and C.2). The spacing between antennas must be chosen to provide sufficient isolation to allow system intermodulation product targets to be met (see clause C.3).

6.4.4 Radiation pattern

As a general rule, the less directional the radiation pattern of an antenna, the greater the influence the mounting environment has on the pattern.

Highly directional antennas such as paraboloidal dishes and antennas with large mesh reflectors have high front/back ratio and may be regarded as largely independent of what lies behind them. Antennas of moderate front/back ratio such as yagis must be mounted with their rear elements at least one wavelength from the supporting tower if optimum performance is to be achieved.

Nominally omnidirectional antennas (dipoles, stacked dipole and collinear arrays) will only achieve genuine omnidirectional performance when mounted on top of the supporting structure. When side mounted, large currents flow in the supporting structure, causing distortion of the omnidirectional pattern and the probability of intermodulation product radiation due to non-linear joints between structure members or mast sections. In practice omnidirectional azimuth patterns can be obtained only by side mounting several antennas (usually 3 or 4) firing in equispaced radial directions. Radiation patterns may be most accurately predicted when the individual units of the antenna have a large front/back ratio. As such antennas are very expensive, their use is most attractive when a number of services can be multiplexed onto a single broadband antenna system.

6.4.5 Gain

The modification of the radiation pattern of an antenna, referred to above, also implies a change in its directivity and hence its gain. In general an antenna will lose forward gain when mounted too close to the supporting tower since the side and rear lobes will be increased. These changes result in reduced forward range and reduced protection against co-channel interference.

6.4.6 Cross-polar performance

The cross-polar performance of base station antennas for the mobile service has in the past been non-critical, as all stations used vertical polarization. An important change has taken place with the opening of services in Band III (174 MHz to 225 MHz) to the mobile radio service in some European countries as polarization protection is an important parameter in ensuring low interference levels caused to (and by) continuing overseas television transmissions in that band. Similar consideration will also apply in Band I (41,50 MHz to 67 MHz).

In bands used for fixed services the cross-polar protection provided by link antennas is an important factor in frequency planning and management. The geographical separation between stations using the same frequency can be reduced when orthogonal polarization is used. The Cross-Polar Discrimination (XPD) achieved by a practical antenna under test range conditions will lie between 20 dB, for a simple yagi or dipole of orthodox construction, and 40 dB, for a paraboloidal reflector illuminated by a well designed feed horn. The significance of the path to XPD must be considered.

Two commonly seen faults degrade the XPD of an installed antenna:

- a) if an antenna is installed in such a position that currents are induced into members of the supporting structure, these currents, flowing in arbitrary directions, will couple energy from the plane in which it was radiated into the orthogonal plane. This is a particular hazard for installations of yagi and similar antennas of moderate or low directivity;
- b) failure to erect antennas with the plane of polarization aligned exactly in the required direction produces a field component in the orthogonal plane. The XPD of an ideal linearly polarized antenna falls as misalignment increases, as shown in clause C.5.

6.4.7 Voltage Standing Wave Ratio

For a transmission line to deliver RF power efficiently to a load it is necessary for the load to behave as a pure resistance equal in value to the characteristic impedance of the line. Impedance discontinuities cause RF energy to be reflected back from the discontinuity towards the input of the line.

Reflections upset the uniform distribution of RF voltage and current on the line. Standing waves are established which cause voltage and current maxima and minima to exist at intervals along the length of the line. In severe cases Standing Waves may cause transmitter shutdown or the failure of system components.

There are two major causes of increased VSWR when an antenna system is mounted for use. In the VHF band, where antennas of low or moderate directivity are used, the proximity of structural or mounting components will change the antenna VSWR; this change will be of most significance when a very low antenna VSWR is needed. Above VHF (where more directive antennas are generally used) the main cause of degradation is reflection from connectors and from discontinuities in the line itself.

It should be noted that the attenuation of the antenna feeder has the effect of reducing the VSWR seen by the transmitter.

When designing or working on equipment at radio sites it is frequently necessary to calculate the reflection performance or matching condition of components in the RF system. It is often necessary for example to predict the matching condition at a certain point from specification or measurement data obtained else-where in the system.

Reflection calculations may be used to determine the worst-case VSWR which may occur with specified components, or to determine the component limits when the overall system performance is already determined.

Traditionally VSWR has been in common use to express the reflection performance of RF systems. In certain situations however, return loss and voltage reflection coefficient prove more useful.

Formulae for conversion between VSWR, return loss and voltage reflection coefficient and methods of calculation for reflection performance are dealt with in clause C.6.

6.4.8 Wind vibration

All antennas, mounting steelwork, feeders and ancillary equipment should be securely clamped to protect feeders and other semi flexible items from damage by vibration throughout the projected life of the installation.

Manufacturers' recommended feeder clamp spacings should be observed, with particular attention to exposed areas and transitions from antenna to tower, tower to gantries and gantries into buildings. Feeders should not be laid loose on gantries. Where necessary additional protection should be provided.

6.4.9 Degradation of antenna performance

It is important to appreciate that the performance of an antenna is very dependent on the environment in which it is mounted. This is particularly true of many antenna types commonly used in the VHF and UHF bands. The data quoted by manufacturers will generally relate to parameters measured on a test-range in which the antenna is erected clear of all obstructions, using the optimum mounting arrangement. Such an environment will not normally apply at a typical user's installation, and inferior performance may result unless particular care is taken.

Clause C.1 shows a number of common configurations and indicates their relative merits.

6.4.10 Cables, cable routes and connectors

It is recommended that wherever possible, solid, semi-rigid or double-screened cables should be used for all RF connections. This is to ensure maximum screening between adjacent cables and feeders and to reduce coupling between equipment. Solid outer conductor cables have superior passive intermodulation performance than braided screen cables. The use of single screened cable (e.g. UR67, UR43, RG58) should be avoided wherever possible and in particular, in cable runs where several of these conductors are brought close together.

The direct and shortest route is always the best for minimum radiation and minimum insertion loss. However, it is important that transmitter cables and receiver cables should be installed as far apart as possible. It is advisable that when they cross they should cross at right angles. Cable trays carrying transmitter cables should not also be used to carry receiver path cables and it is best if cables are insulated from each other at all times. It is normal to use cables with insulated outer jackets and the only points at which earth straps and earth bonding should be employed are those specifically chosen for the purpose.

It is often convenient to break down very large feeder cables to a more convenient size and there is a tendency to place connectors just inside the equipment room when reducing the main incoming feeder to a more manageable size. It is best, however, to take the main feeder as close as possible to the equipment to which it is to be connected before interrupting its outer conductor.

The only exception to this rule is to provide an earth connection for lightning conductor purposes. This should be carried out by means of an external clamp on the outer copper conductor and this should be taken via the most direct route.

Incoming feeders must not be interconnected by a "patch panel", traditionally used in the past. The "patch panel" is a source of earth current coupling and intermodulation and should be avoided.

It is also recommended that high quality connectors be used and a minimum standard would be type N, preferably with a silver-plated finish. The use of such connectors produces maximum screening effect and gives the best RF connection between the various components of the system. Connectors such as type "UHF" have been the cause of many problems and their use should be avoided. With increased use by the cellular industry, the higher specification 7/16 DIN connectors are now often cheaper than N-type connectors for solid outer conductor cables. All connectors must be fitted in conformity with manufacturers' instructions to ensure proper sealing and electrical uniformity and should be tightened to the manufacturer's recommended torque settings.

6.4.11 Feeder identification, terminations and earthing

Feeder cables should be uniquely and permanently identified at each end and at the point of exit from the structure. More frequent identification may be advisable when cables are buried in a duct.

Connectors and earthing kits should be fitted in accordance with manufacturers' instructions. Connector fitting should be carried out in dry surroundings wherever possible and feeders should be lifted in accordance with manufacturers' recommendations, with connectors already fitted to their upper ends and suitably protected from water ingress.

6.4.12 Sealing

On completion, connectors should be wrapped with PolyIsoButylene (PIB) self-amalgamating tape. Over-wrapping with petroleum jelly impregnated waterproof tape should be avoided since PIB is attacked and gradually dissolved by petroleum based products. Where PolyVinylChloride (PVC) covers are provided for connectors, they should be removed and the connectors taped as described.

Feeder and cable entries, external cable or feeder terminations, and earth connections to feeders on towers or gantries should be suitably sealed or protected against the ingress of moisture using non setting pastes, self amalgamating tapes, neoprene paints as appropriate and in accordance with manufacturers instructions. Particular attention should be paid to the shedding of surface water.

6.4.13 Inspection for moisture

In cases where the mast is exposed and there is a possibility of moisture gathering at the outer jacket of the copper case of the incoming cables, it is wise to remove the outer insulating jacket at a point well inside the equipment room where it can be inspected for traces of moisture.

7 Problems identified on site

The rapid development of mobile radio, particularly within large cities in Europe, produced a wide range of technical and operational problems as a direct result of hurried and badly thought out arrangements on radio sites.

A particularly significant factor was the almost total disregard for technical co-ordination between users on radio sites, and indeed many installations were provided without thought for adjacent systems.

There was also the primitive instinct to provide the highest possible antenna position for each and every system and a separate antenna for every transmitter. These antennas were often fed by poor quality and badly arranged feeder cables which were terminated in a careless way using cheap connectors.

The results merited a great deal of rectification in the 1980s' and one of the major factors that brought about improvements was the proliferation of interference causing loss of service in nearly all the mobile radio bands. The present document highlights the sources of interference and offers solutions that are practical and effective.

7.1 Generation of unwanted products

Three main sources of radiated products are capable of disturbing other equipment on the same site or on another in close proximity:

- a) broadband noise and spurious products of transmitters;
- b) intermodulation products between several source frequencies;
- c) intermodulation products caused by external effects.

The apparent nature of the disturbance may be:

- 1) unwanted received signals which do not result from transmissions on that frequency by the intended user or any other operator sharing the frequency. The signals may or may not contain modulation although in many cases they are overmodulated (distorted) and they may contain a composite of the modulation from several sources; or
- 2) an increased level of noise which degrades the useable sensitivity of receivers.

Disturbances of type 1) may be identified with relative ease since the unwanted signals are heard in between wanted transmissions or they are of sufficient magnitude that wanted signals are occasionally obliterated.

Disturbances of type 2) are more insidious since they cannot be heard by the operator. The effect causes a degradation of receiver sensitivity and a reduction in effective range. The operator may not notice the change or he may mistakenly blame poor propagation conditions.

All these problems show the importance of having adequate isolation between equipment and sites. The ultimate design aim is to preserve the quality of service from the site by eliminating, or at least minimizing, receiver disturbance.

It is usual to decide a system target figure for the sensitivity degradation of the base station receiver which is acceptable when caused by the operation of co-located or neighbouring transmitters. For example, it may be decided that a 1 dB sensitivity degradation is acceptable for any one transmitter operating alone, or 3 dB for the worst multiple transmitter combination.

7.1.1 Spurious emissions from transmitters

All practical transmitters generate unwanted outputs generally described as spurious emissions. A spurious emission is defined as:

- Emission on a frequency, or frequencies, which is outside the necessary bandwidth and the level of which may be reduced without affecting the corresponding transmission of information. Spurious emissions include harmonic emissions, parasitic emissions, intermodulation products and frequency conversion products but exclude out-of-band emissions.

An out-of-band emission, which is excluded from the above definition is defined as:

- Emission on a frequency or frequencies immediately outside the necessary bandwidth which results from the modulation process, but excluding spurious emissions.

Both spurious emissions and out-of-band emissions may occur at a discrete frequency or be broadband noise occupying a significant bandwidth.

Harmonics of the wanted carrier frequency are commonly occurring spurious emissions and may occur at the harmonic frequencies $2f_c$, $3f_c$, $4f_c$, etc., where f_c is the fundamental carrier frequency.

Frequencies which are not harmonically related may be affected by spurious emissions from some transmitter designs. For transmitters which generate the final carrier frequency (f_c) by frequency multiplication of a lower fundamental frequency (f_x), the frequencies $f_c + f_x$ and $f_c - f_x$ are particularly at risk.

As a condition of the operating licence permitting the operation of a transmitter, minimum standards are legally enforced for the permissible level of spurious and out-of-band emissions. In Europe these are typically -36 dBm for spurious emissions up to 1 000 MHz and -30 dBm above.

At radio sites where several transmitters and receivers are co-located with associated antennas in close proximity, it is necessary to analyse the spurious and out-of-band emissions in relation to the receivers' operating frequencies to see what additional measures are necessary to avoid degradation of the receivers performance.

The minimum isolation required between transmitters and receivers on the same radio site is calculated by relating the transmitters' spurious and out-of-band emissions with the useable sensitivity and noise floor of the receivers.

Attention is drawn to the ITU-R Recommendation SM. 329-9 [17] giving full details of methods of measurement of spurious and out-of-band emissions and the different categories of permitted levels for several different classes of radio communications equipment

The clauses that follow give examples of calculations that may be made to establish the minimum isolation between transmitters and receivers on a shared radio site (see annex B for more detail).

7.1.1.1 Noise considerations

In considering the effects of noise, receiver bandwidth must be taken into account. For the equipment in use for mobile radio, the worst degradation of sensitivity is obtained for the 12,50 kHz channel spacing standard having a useable bandwidth of 7,50 kHz.

Typical modern receivers for the 12,50 kHz channel spacing standard have a useable sensitivity of -110 dBm, corresponding to a signal to noise ratio of 10 dB and a noise floor of -120 dBm.

Additional noise power from external sources of -120 dBm in the 7,50 kHz bandwidth will degrade the receiver sensitivity by 3 dB.

For 1 dB degradation of sensitivity the noise power from external sources cannot exceed -126 dBm in 7,50 kHz.

The noise floor of the present generation of transmitters may be expected to be approximately -140 dBc/Hz within 1 % of f_c and -150 dBc/Hz elsewhere.

The Transmitter (TX) power relative to carrier in the useable bandwidth of 7,50 kHz (+39 dB relative to 1 Hz) therefore approximates to $-140 + 39 = -101$ dBc within 1 % of f_c or $-150 + 39 = -111$ dBc elsewhere.

Assuming the maximum power of transmitters to be +43 dBm (20 W) the noise power generated by a single transmitter, measured in the 7,50 kHz Receiver (RX) bandwidth, may be expected to be $-101 + 43 = -58$ dBm within 1 % of f_c or -68 dBm elsewhere.

It follows that to safeguard a receiver from a single transmitter by ensuring that the sensitivity degradation during transmission is less than 1 dB, where the frequency separation is within 1 % of f_c , requires a minimum isolation of $-126 - (-58) = 68$ dB.

For multiple transmitters the noise power is additive therefore the noise power of N identical transmitters at the same frequency spacing from the carrier is greater by a factor of $10 \log(N)$ dB (e.g. the noise power from four 20 W

transmitters within 1 % of f_c is $-58 + 6 = -52$ dBm and the minimum isolation required in the above example would then be 74 dB). For an example of transmitter noise measurement, see annex M.

7.1.1.2 Spurious considerations

Where the disturbance to a receiver is a discrete signal such as in the case of a spurious emission, the required RF carrier to interference ratio for satisfactory operation is 14 dB.

For the typical 12,50 kHz channel spacing receiver previously described, having a useable sensitivity of -110 dBm, this equates to an unwanted input signal level of -124 dBm.

The limits defined by EN 300 086 [5] state maximum levels for transmitter spurious emissions of -36 dBm in the frequency range up to 1 GHz and -30 dBm above that frequency.

Assuming the above receiver is operating at a frequency below 1 GHz, the minimum isolation required from a transmitter having an on channel spurious emission at the maximum allowable level is $-36 - (-124) = 88$ dB.

The design of radio equipment is generally such that direct degradation of the receiver by a companion transmitter is avoided when a moderate amount of antenna isolation is provided and if a sensible frequency separation is chosen during frequency planning. For a single fixed station it is usually only necessary to check the isolation from neighbouring sites.

For multiple fixed stations it is necessary to check the isolation from both co-sited transmitters and from those of neighbouring sites. In this case the use of combining systems to communal antennas, offering 10 dB to 15 dB minimum isolation improvement by filtering, gives total isolations in the region of 70 dB. This figure is generally adequate to avoid spurious problems and allow the simultaneous transmission of 10 to 20 signals each at a power of +43 dBm.

7.1.2 Ambient RF noise levels

It is recognized that any ambient RF noise measurement is only an approximate indication, since it is strictly applicable to the antenna employed and the noise conditions at the time. The ambient noise level particularly at urban sites in the lower VHF bands, has a major influence on system range and performance.

Precipitation static noise, caused by the exchange of static charges between raindrops and the antenna system, is a significant source of noise at frequencies below 150 MHz. It may be controlled by the fitting of insulating shrouds to antenna elements (see clause C.4).

Ambient RF noise includes atmospheric, sky noise and man made electrical noise. In general this is beyond the control of the site operator (see annex D).

On a remote green field site it may be possible to operate receivers in the VHF band at levels below -110 dBm. However more realistically the minimum useable signal will be typically -107 dBm.

7.1.3 Intermodulation products between several source frequencies

These products are caused by the mixing of two or more source frequencies which produce well defined signals which may be of a high level. They are usually the result of inadequate isolation between transmitter output stages, which allows coupling of RF energy between them and the generation of products by a mixing process.

The intermodulation factor has been adopted as a standard by which the immunity to these effects may be judged. It may be considered to be the ratio in dB between the unwanted coupled signal level and the level of the third order intermodulation products which are produced by the mixing process.

The intermodulation factor facilitates a simple calculation method to determine the level of third order intermodulation products which can be obtained as a result of transmitter coupling.

If:

- W = wanted RX signal;
- XT = Isolation, TX - TX;
- XR = Isolation, TX - RX;

- Y = Equipment intermodulation factor;
- Z = TX power in dBm.

Then:

- $(Z - XT) - Y$ = 3rd order intermodulation product power level = P ;
- $P - XR$ = disturbing signal level at the RX = D ;
- $W - D$ = protection ratio in dB.

Design targets:

- PMR = 10 dB;
- analogue cellular = 18 dB;
- digital cellular = 9 dB.

The protection ratio can be improved by increasing XT , XR or Y as appropriate to the type of service involved.

The applicable limits for intermodulation factor result from the interpretation of existing standards for fixed stations.

For PMR, the applicable standard is EN 300 086 [5] and the limits are set according to the intended use of the equipment which may fall into one of two categories:

- a) normal - use as a single base station operating alone, for which the intermodulation factor is a minimum of 10 dB;
- b) special - use at communal sites where many units may be co-located, for which the intermodulation factor is a minimum of 40 dB.

EXAMPLE: Two transmitters each having a power output of +43 dBm are operated on neighbouring sites with a total port to port isolation of 70 dB. The output stage of each therefore receives an unwanted signal of $+43 - 70 = -27$ dBm.

The level of the resulting third order intermodulation products is therefore:

- for "normal" intermodulation factor: $-27 - 10 = -37$ dBm;
- for "special" intermodulation factor: $-27 - 40 = -67$ dBm.

Assuming that a receiver exists in the vicinity, tuned to the frequency of one of these products, and if the antenna isolation between the transmitter and receiver is also 70 dB:

- the "normal" transmitters give a disturbing product of $-37 - 70 = -107$ dBm;
- the "special" transmitters give a disturbing product of $-67 - 70 = -137$ dBm.

Comparing these levels with a receiver having a useable sensitivity of -110 dBm for 10 dB RF signal/noise ratio it is evident that the product of the "normal" transmitters will exceed low level wanted signals on that frequency and will give unacceptable disturbance. The products of the "special" transmitters are well below the receiver noise floor and will have no discernible effect.

This short calculation, which has been applied to identical signal levels, can also be applied to transmissions of any signal level. It shows the importance of intermodulation problems which must be carefully examined when determining frequency planning.

EXAMPLE (for GSM): Two transmitters each having a power output of $Z = 43$ dBm are operated on the same site with a total port to port isolation of $XT = 30$ dB. The output stage of each, therefore, receives an unwanted signal of $43 - 30 = 13$ dBm.

The value of the equipment intermodulation factor $Y = 40$ dB. The level of the resulting third order intermodulation power, P , is therefore equal to $13 - 40 = -27$ dBm.

The limit sensitivity of a GSM receiver, W , is about -104 dBm and the protection ratio is 9 dB. Thus, the disturbing signal level, D , should be less than $-104 - 9 = -113$ dBm at the receiver. This leaves a requirement for XR of greater than 86 dB. However, isolation between transmit and receive antennas can be as low as 30 dB. Therefore additional transmitter filtration of greater than 56 dB is necessary for transmitted intermodulation falling on the receive frequency.

7.1.4 Intermodulation products caused by external effects

The metallic contacts in masts and antenna hardware can be a source of problems when high field strengths occur on the site and cause them to radiate intermodulation products which disturb equipment at the same site, or at a neighbouring site.

No standards exist that are able to specify reasonable limits for such effects. The intermodulation factors used to make these calculations are affected by many parameters and they also depend on electrical resonances in the components which make up the mast and antenna arrays.

The only way to minimize these problems is to follow the guidelines presented elsewhere in the present document and should problems occur, to make measurements to locate the origin and establish the necessary modifications to effect a cure.

7.2 Intermodulation and blocking effects in receiver systems

These problems are usually a result of large signals at the input of a receiving system which cause non-linearity. There are four different sources:

- a) intermodulation between received signals;
- b) saturation of receiver front end;
- c) inadequate receiver selectivity;
- d) receiver spurious responses.

Although all operational parameters for receivers are well defined by existing ENs used in the Land Mobile Service (LMS), the effect of receiver distribution amplifiers must be considered in addition to these traditional standards since the amplifiers often operate in a hostile RF environment on densely utilized sites.

There is a need to define two bandwidths in the receiving system:

- 1) the useable bandwidth of the receiver when properly aligned on the allocated channel;
- 2) the RF front end bandwidth of the receiver system whether this is the preselector filter of the receiver RF amplifier or the input filter of an RX distribution system.

7.2.1 Intermodulation between received signals

The reception of high level signals, within the bandwidth of the first RF filter, is the worst case of intermodulation in a receiver system. The bandwidth and out of band attenuation of this filter is therefore very important.

On a communal site, a high performance preselector filter is generally placed at the antenna input to the distribution amplifier to define the operational frequency band.

For angle modulation systems, receiver intermodulation performance is defined by the existing standard EN 300 086 [5] as a ratio between an on-frequency wanted test signal of -107 dBm and two off-frequency unwanted signals at 70 dB above this level displaced to cause a third order intermodulation product on the wanted channel. Under these conditions an audio output approximately equivalent to a 7 dB RF carrier to interference ratio at the receiver input must be obtained. This definition therefore accepts that in the presence of the off-frequency signals, the receiver sensitivity required by standards may be degraded by 3 dB.

The practical result of this definition is that for unwanted input signals at third order related frequencies, the receiver which just meets intermodulation standards experiences a 3 dB sensitivity degradation when the unwanted signals exceed $-107 + 70 = -37$ dBm. This represents a minimum isolation from other 20 W ($+43$ dBm) transmitters of 80 dB.

In the case of receivers which exceed the minimum sensitivity required by standards, the degradation caused by intermodulation may be much higher. For example, a receiver with a sensitivity of -110 dBm which just meets the intermodulation standard at -107 dBm, has in fact been degraded by approximately 6 dB.

Considering the RF level of the product as a signal at the receiver input, the 7 dB carrier to interference ratio relative to a -110 dBm wanted signal represents an equivalent interfering signal level of -117 dBm.

Since the receiver encounters an intermodulation product as a discrete frequency and not as simple wideband noise, the required RF carrier to interference ratio for a 1 dB degradation of sensitivity is identical to the case of transmitter spurious and must be 14 dB or greater, dictating a maximum equivalent interfering signal of $-110 - 14 = -124$ dBm.

For a design aim of 1 dB sensitivity degradation due to intermodulation, to a receiver of sensitivity -110 dBm, the equivalent interfering signal level suggested by standards is too high by 10 dB.

Due to the cubic power law of intermodulation products, the level of the actual unwanted signals is therefore too high by at least $10/3$ or 3.33 dB, requiring isolation from the culprit transmitters of $80 + 4 = 84$ dB when rounded to the nearest dB.

When considering transmitters on the same site, appropriate frequency planning in conjunction with filtering can achieve the isolation figures required by the design aim.

The isolation figure is also achievable from mobiles when sites are situated away from busy roads or other areas having a high concentration of mobile transmitters.

Difficulties may arise when considering isolation from other sites if the physical separation or the frequency planning of neighbouring sites are inadequately co-ordinated.

This results in the necessity for critical attention to the bandwidth of the receiver systems at radio sites. Receiver distribution amplifiers must be arranged with precisely defined bandwidths and they must have an intermodulation performance at least 10 dB better than that required by standards. For example, two input signals of -30 dBm produce third order intermodulation products of -120 dBm equivalent to a third order input intercept point of +15 dBm for a unity gain system.

The design aim in receiver distribution systems should always be that the performance is limited by the performance of the receivers themselves rather than the distribution amplifier.

Fulfilling the above criteria should ensure that intermodulation problems do not originate in the site receiver system but probably in the neighbouring transmitters themselves. Careful frequency planning and site engineering, if applied to all sites, should minimize these difficulties.

7.2.2 Saturation of receiver front end

The consequence of very high level received signals will be that the front end active devices of the receiver will have a gain reduction resulting in a degradation of sensitivity.

This situation is generally qualified in the existing standards by the blocking performance. The acceptable limits are defined in the same way as for intermodulation which means that the limit stated corresponds to a received signal of -23 dBm or an isolation of at least 66 dB between source and receiver (assumes +43 dBm source).

Although this problem is basically independent of frequency great care should be taken to identify all critical signals within the response of the front end filtering of the equipment by monitoring.

7.2.3 Selectivity of the receiver

This parameter defines the ability of a receiver to reject signals at unwanted frequencies. The selectivity figure not only depends on the characteristic of the intermediate frequency filter but also on the spectral performance of the local oscillator.

The existing standards define a two signal method of measurement taking all these problems into account by looking at sensitivity degradation. The limits refer also to a wanted signal of -07 dBm and are 60 dB above for the worst case (12,50 kHz channel spacing). This means that great care should be taken with the frequency planning to avoid having signal levels higher than -47 dBm on adjacent channels in this case and -37 dBm in a close frequency proximity (up to $5 \times$ channel spacing).

These limits should be reduced by at least 3 dB in the case of using the full sensitivity performance of a site (i.e. -50 dBm on adjacent channels and -40 dBm in close frequency proximity).

7.2.4 Spurious response of the receiver

All receivers have their own frequency conversion plan which can be in either upper or lower mode. The result of this process added to the RF filtering response and to the possible spurious signals of the local oscillators used may be the source of other spurious responses at the RF input, resulting from the complex mixing of signals. The latest ETSI standards give well defined methods of measurement for these spurious responses and the calculation of frequencies at which they can occur (including duplex mode) by taking into account all local oscillator sources.

The limits considered are referred to a -107 dBm wanted signal and 70 dB above. They are identical to intermodulation limits and the same comments should apply regarding suitable response of all RF filters.

7.2.5 Receiver protection for low power equipment (EN 300 220 [9])

Low power equipment is commonly used for short range data collection and in some administrations is operated on an unlicensed (deregulated) basis.

No requirements are currently specified for receiver protection and the deregulated nature of implementation increases the probability of operation in proximity to other higher powered VHF/UHF services.

It is therefore particularly important that performance is checked at the intended site and that suitable filtering arrangements are provided if necessary.

7.3 EMC issues

It should be noted that current ElectroMagnetic Compatibility (EMC) approval for non-radio equipment does not guarantee sufficient protection to base station receivers when used on a radio site. In such circumstances the site operator may require additional EMC suppression before giving approval to the installation of suspect equipment.

7.4 Technical responsibility of the site operator

It is essential that the site operator is able to quantify any unwanted products which give rise to unreasonable degradation of service to co-sited installations. This is a continual activity and a number of compatibility studies have been carried out by various agencies with particular reference to Third Generation systems. Amongst these, the UK Radiocommunications Agency has completed a number of these studies. Further information can be found on their website at <http://www.radio.gov.uk/> under the heading of "Research and Development".

Some solutions to the problems arising from unwanted products are offered in clause 8. There is a need for further procedures to control the lack of co-ordination that often exists between the site operator, the users and the licensing authority.

8 Avoiding radio frequency problems

In considering the need to produce this report the urgent priorities were to avoid new systems having the deficiencies already identified in earlier installations, and to identify the sources of problems and to offer remedies.

This clause clearly identifies items which can cause difficulty and offers components that are practical and economically available to solve the problems.

Practical solutions and experience on sites have been taken as the basis of these recommendations and the principles of use are not theoretical or academic but are well tried and proven in the field.

8.1 Antenna distribution networks

In the case of a filter system, combining network, or receiver distribution network, it is important that the cables are treated with care and that the distribution network should be mounted away from the transmitters and receivers whenever possible. Ideally the filter or distribution network should be mounted on the wall adjacent to the antenna incoming feeders and the transmitter section should be connected as far away from the receiver section as possible.

It should be noted that overloading of a receiver distribution network could affect many other users on the same system.

The power supply associated with such amplifiers can operate either from mains supply or batteries which are becoming increasingly common on remote hilltop sites. Again it must be stressed that the reliability of the supply is essential for the maintenance of the service and it is usual to provide back-up in the event of mains failure (see clause H.3 for further details of distribution amplifiers).

8.2 Receiver distribution networks

There are many instances where many receiver systems in the same frequency band are required to be installed at the same radio site. It may therefore be appropriate to fit a receiver distribution network comprising one antenna input feeding a suitable bandpass filter, followed by a low noise amplifier which then distributes its output, usually by a passive network, to the receivers in that band.

The low noise amplifier is carefully chosen to have a very good signal to noise performance to minimize degradation of the overall system signal to noise performance whilst feeding up to typically 16 receivers in the same band. The amplifier needs also to be chosen for large signal handling capability together with an inherent protection against damage by transient impulse voltages.

The use of a high quality semiconductor device operated at a small fraction of its rated dissipation will meet these requirements and provide a Mean Time Between Failure (MTBF) typically in excess of 100 000 hours. It is essential to appreciate that the design objectives for the receiver distribution network will determine the failure rate of the subsequent systems involved.

8.3 Filters and couplers

8.3.1 Control of unwanted products

The origins of unwanted products are related to mixing processes that take place in any non-linear component of the complete system (see annexes J, K and L). The simple guidelines of increasing the isolation between the components of the mixing process will result in the reduction of the intermodulation product level.

8.3.2 The ferrite circulator

The ferrite circulator is a practical component which can be utilized to provide directional isolation at the output stage of the transmitter.

A ferrite circulator has directional properties that typically result in additional isolation of between 20 dB and 40 dB. The isolation parameter has to be considered in conjunction with the insertion loss and bandwidth, all parameters being considered in the system design.

For isolation in excess of 40 dB, a dual circulator version may be fitted.

The third port of the ferrite circulator is terminated in a matched load, the power rating of which is intended to withstand the maximum return power that is envisaged in the worst fault condition that can arise on the system (see clause H.2).

8.3.3 The cavity resonator

The cavity resonator is a bandpass circuit, having a centre resonance frequency related to its physical dimensions. The unloaded Q of such a device depends on its physical volume and at VHF it ranges between 2 000 and 10 000. The loaded Q is normally arranged to be between 500 and 1 500 according to the insertion loss and isolation required.

A system using a cavity resonator gives protection to co-sited receivers by reducing the radiation of wide-band noise.

Cavity resonators may be connected together to provide additional isolation when used to combine several transmitters to a single antenna.

When used in conjunction with ferrite isolators, cavity resonators provide the necessary isolation to combine several transmitters into a single antenna configuration. This system employs several cavity resonators coupled together with a precisely dimensioned cable harness to allow single antenna working with insertion losses of typically 2 dB with a relative frequency separation of 1 %. With high performance cavities the separation can be reduced to 0,25 % and still give isolations greater than 20 dB. When used in conjunction with a ferrite isolator it is typically possible to attain 50 dB isolation between adjacent transmitters when coupled to a single antenna (see clause H.1 for details).

8.3.4 The spectrum dividing filter

When the outputs of several transmitters are to be considered as a combined signal it is convenient that each antenna shall have the frequency spectrum coupled to it defined by a filter having a comparatively broad, flat topped response. This enables any transmitter to be operated within the specified band without excessive filter insertion loss and ensures the attenuation of signals outside the defined frequency band.

This system defines the band edges, controls spurious emissions and is therefore given the title "spectrum dividing filter".

Spectrum dividing filters can be coupled together by means of a precisely dimensioned cable harness to other similar filters, to provide duplex and combiner facilities for multiple bands to a single antenna system (see clauses H.4 and H.5 for further details).

8.3.5 Control of intermodulation, cross modulation and blocking effects in receiver systems by filter protection

A common source of receiver problems is that incoming signals outside the band of interest arrive at the receiver front end at an amplitude which can cause blocking, inter-modulation and distortion of the wanted signals. This situation is most likely to occur when the receiver is connected to an antenna which may be in close proximity to other antennas on a communal site. An improvement in this situation can be obtained by positioning the receiver antenna well away from any other installation and in particular from other transmit antennas. On shared sites this is often not possible.

An alternative procedure is to connect bandpass filters between the antenna and the receiver input. These filters need to have the necessary shape factor to limit the bandwidth to that which is required for the receiver system.

A single small cavity resonator providing 20 dB isolation at the offending frequency will often provide a solution to receiver interference problems but in those cases where the interfering signal is closer than ± 1 % of the centre frequency of resonance to the wanted signal then multiple section filters or large cavity resonators may be required. The typical responses for such filters are given in clause H.4.

9 Environmental effects

9.1 Standards

It should be recognized that corrosion and climatic effects cannot be eliminated. However, the effects can normally be contained by careful design and selection of materials, high quality manufacturing, high standards of installation and a maintenance programme planned for the life of an installation.

9.2 Corrosion and climatic effects

The materials which are used in the construction of antennas and their support structures are prone to corrosion. The European environment combines wet and humid conditions with mild temperatures; industrial pollutants and coastal conditions accelerate corrosion in many locations. With one of the windiest climates in the world, ice and snow, and the incidence of ultra-violet radiation to degrade paints and plastics, UK designers of outdoor installations must understand the problems which can arise and recognize the practices which have proved adequate to overcome them.

Deterioration will take the following forms:

- a) corrosion of metallic components, causing structural weakening of antenna elements and mountings. Corrosion will be accelerated at bi-metallic contacts and will give rise to non-linear conduction with consequent generation of intermodulation products. A rise in contact resistance at connections will increase ohmic losses and reduce antenna gain;
- b) water ingress into insulating materials will cause changes in permittivity (giving rise to VSWR changes) and will increase dielectric losses, especially if the water is polluted or has run off metallic components;
- c) water ingress into feeders and connectors produces mismatch and increases loss;
- d) wind-induced vibration causes antenna elements to break by fatigue failure and accelerates corrosion at element clamps;
- e) snow and ice cause temporary increases in VSWR and losses of gain and polarization purity. These effects will become permanent if the weight or wind load is large enough to cause permanent distortion. Freezing splits components into which water has penetrated. Falling ice can cause damage, distorting elements or even breaking off complete antennas;
- f) wind-induced vibration and falling ice cause damage to badly mounted feeders. Damage is often in the form of complete annular cracks in the outer conductor of corrugated semi-flexible cables; these produce intermittent faults with high VSWR and severe non-linearity.

The problems listed above result not only in a degraded service for the user of the antenna and feeder concerned, but by loss of directivity, polarization discrimination and linearity may result in problems for other users, whether co-sited or not.

The management of these problems lies in the care with which an installation is designed, carried out and maintained.

9.3 Ultraviolet degradation

Products liable to degradation by ultraviolet light should not be used in external situations where there is an acceptable alternative. Where the life of an item is known to be limited, its periodic replacement should be included in the site maintenance programme. Replacement only on failure is not generally acceptable.

10 Health and safety

10.1 Introduction

The safety of the working environment on, and in the vicinity of radio sites must always remain a consideration of high importance to site operators and engineers. This clause is not intended as a comprehensive guide to all of those health and safety aspects, but is intended as a precis of health and safety issues that will need to be considered by existing and potential site operators.

Health and safety issues in EC countries and some other non-EC European countries subject to national legislation. This legislation has been introduced for the protection of employers, employees and the public. It is therefore essential that in the construction and operation of radio sites professional advice is obtained on the legislative requirements that prevail in each individual country.

10.2 Physical safety

In most cases common sense is the best guide to the physical safety on radio sites.

A working policy should be in force for all staff, especially those engaged on work external to the equipment room. In many cases the wearing of a hard hat is a legal requirement when work is undertaken on the antenna support structure and the dangers of falling objects makes their use essential.

Only qualified personnel should be allowed to climb the antenna support structures. They should have had training on all aspects of climbing procedures, particularly the emergency procedures pertaining to these activities.

A consideration that is sometimes overlooked is the danger of falling ice in colder climates during winter months. The structure design and site layout should take into account the icing which could reasonably be expected to occur on structures and antennas in a particular location and the danger of falling ice in relation to personnel and damage to buildings, equipment, antennas and feeders.

Inside the equipment room care should be taken to ensure that sharp projections are avoided and that the common walkways remain clear and unhindered. This is particularly important when additional services are added and equipment rooms become crowded.

Where lead acid battery power supplies are installed the first aid aspect of acid splashes must be considered and in particular the requirement for eye wash solution in first aid cabinets.

Where soldering irons are in use care should be taken such that hot irons are not left unprotected, but are placed in suitable holders.

High power devices commonly found on radio sites often contain beryllium, usually in the form of an oxide. Where work is undertaken on such equipment the safety hazards of this substance must be made clear. Beryllium is a toxic substance particularly in its oxide form and is suspected of inducing cancer. In its mildest form, the inhalation of Beryllium dust can cause inflammation of the nose, throat and chest. If a beryllium device is broken then the utmost care should be taken in removing the fragments and dust from the site. It is recommended that professional advice be obtained in all cases before removal of the substance is attempted.

Other substances which are commonly found at radio sites and which may cause health hazards include:

- insulating oil from transformers and capacitors (fire hazard and believed to be carcinogenic after prolonged use);
- teflon from insulators (gives off toxic vapours when heated above 205°C).

10.3 Electrical safety

Accidents that are related to the electrical installation are amongst the most common occurrences. The design and construction of the electrical installation has already been amply illustrated in the present document, but emphasis should be placed on the importance of electrical safety and correct earthing procedures on radio sites. The minimum requirement as far as the user is concerned is the use of Residual Current Devices (RCD). In particular, it is desirable that anyone who regularly works in a radio site environment should be aware of the procedures for the first aid treatment of personnel suffering electric shock. The design requirements for individual sites are governed by local or national rules.

10.4 Fire hazards

Once again, the requirements for the prevention and extinguishing of fires is often governed by legislation. In particular the storage of paper, cardboard boxes, paint and other inflammable goods is not desirable. The number and type of extinguishers that are required at a site should be decided in consultation with the appropriate fire authority.

10.5 Radio Frequency hazards to personnel

Radio sites need to be designed and operated to limit the exposure of both the General Public and Workers to RF emissions. More details are provided in TR 101 870 [15].

At a communal site a common approach to RF exposure compliance is required to ensure that technical communication between operators, site providers, local authorities and the general public is consistent and sound.

Whilst research in this area is continuing, the World Health Organisation (WHO) does not recommend the application of guidelines more restrictive than those of the International Commission on Non-Ionizing Radiation Protection (ICNIRP) [21].

RF exposure guidelines may contain two separate sets of exposure limits, one applicable for the General Public and one applicable for Workers and the appropriate set of limits should be used. In the absence of national exposure limits for Workers, it is recommended that the ICNIRP Occupational limits should be used rather than the national exposure limits for the General Public. EC Recommendation 1999/519/EC of 12 July 1999 [14] contains details of the reference levels for the General Public exposure.

A number of scientific expert reviews [22], [23] and [24] conclude that for human exposure below these guidelines there are no established adverse health effects.

11 Site administration

11.1 Site discipline

A common problem is caused by mobile transmitters, without power control, having the ability to come within a very short distance of the receiving site, e.g. 25 m, in which case signals typically in excess of +10 dBm can arrive at the receiver within the wanted frequency band; this is a source of non-linearity. On a communal site where there is a multiplicity of users, it is likely there will be several potential users in the same band able to visit the site using their mobile transmitters. This problem can be avoided by strict discipline on this topic or a complete ban on the use of mobile transmitters, without power control, on the site.

A further cause of interference on base station receivers can be distant mobiles using their transmitters when on elevated locations or during conditions of enhanced propagation.

These problems can be minimized by co-operation with the distant user, the use of signalling systems, the choice of site and assignment of frequencies in association with the appropriate authority.

11.2 Site records

The efficient administration of complex radio sites relies on precise details of physical facilities, users and emissions. Information should be kept centrally, and displayed in a useful form on site, where appropriate, and where security considerations allow. A common practice is to maintain a master outline of each structure, referring to detailed drawings of mounting arrangements, feeder routes and other relevant information.

On multiple user sites, records should be kept of each user with contact details for both the owner and maintenance contractor for the equipment.

Physical information should include:

- a) antenna types;
- b) feeder lengths and types;
- c) connector types and sex;
- d) distribution harness details;
- e) details of mounting hardware.

Electrical information established at systems commissioning provides a useful reference for the diagnosis of later problems. Data recorded for each antenna system should include:

- a) VSWR, insulation and attenuation of feeder cable for the appropriate frequency band;

- b) VSWR measurements on complete antenna systems, bench measurements of power division networks for the appropriate frequency band;
- c) power output of each transmitter at the transmitter output port;
- d) calculated erp of each transmitter.

11.3 Orientation of support structure and antennas

Orientation should be based on an agreed reference, e.g. True North, although it may be preferred that a statement of magnetic bearing, variation and date is also kept on records. A clear method for referring to the legs and faces of the structure should be observed.

11.4 Working arrangements

Operations on site must follow safe working practice. Only one user or contractor must work on the structure at any time and arrangements for lifting equipment past working antennas must be agreed with the Site Manager.

12 Maintenance recommendations

Maintenance on the basis of remedial action only is a dangerous practice.

12.1 Support structure

The installation of the mast or tower will have been carried out to the specifications required of the authorities in the region concerned and should therefore include all the basic earthing, lightning protection and other parameters which are defined elsewhere in the present document.

It is essential that at certain intervals (and annually would be regarded as the norm,) the structural installation is inspected for condition, protection against rust, tension in guy assemblies and general deterioration of the surface.

If any defects are found, they should be recorded and reported immediately so that corrective action can be taken. The adjustable screws or tensioners for a guy system should be well greased and protected and all mechanical parts should be examined for corrosion beneath the external surface.

Any corrosion should be scraped clean and the material of the structure then prepared for protective coating.

Particular note should be taken of earth bonding, lugs, straps or connections that these are free from corrosion.

All painted surfaces should be given an undercoat and a topcoat of a suitable protective layer and micaceous oxide is regarded as a suitable ingredient. The use of red lead has been severely curtailed on account of its toxic properties and hazard to health.

Agreement should be obtained between the mast owner and the contractor that the surface coating meets with the required specifications.

On completion of the work a full inspection should be undertaken to ensure that surfaces that are normally lubricated have not been painted and that the standard of painting is such that a further year of protection is guaranteed.

12.2 Equipment room

The following notes are the basis for keeping radio sites in good working order over a period of many years.

Some of the points raised might be regarded as stating the obvious, but if they are written down and complied with, then the results obtained will be commensurably better than currently pertaining on many radio sites.

Cleaning:

- the site should be regularly inspected and cleaned of all fragments of cable, braid and other rubbish which tends to accumulate after modifications to wiring or termination of new equipment etc.;
- these items should not be brushed but removed with a vacuum cleaner, the contents of which are removed completely from the site;
- it should be stressed that no dust should be raised, particularly from concrete floors, as the resulting floating debris can be injurious to relays and contact assemblies etc.;
- for plastic surfaces, a moist cloth is best, or alternatively a suction cleaner, but for metal surfaces an approved polish can be applied sparingly;
- it should be noted that the generation of charges must be avoided and therefore manufacturers' recommendations should apply to all cleaning products.

Tidiness:

- it is essential that no superfluous materials, cables, connectors etc. are allowed to clutter up radio equipment rooms. A particular danger exists when faulty or unreliable assemblies for cables and connectors may be left on site and cause further problems in due course. All doubtful components should be removed from radio sites. A minimum of spares should be held on a radio site and these should be located in locked cupboards and clearly identified. There is no purpose in having equipment on a site which does not relate specifically to equipment in use at that location;
- a tidy site will also encourage others to be equally tidy and leave the equipment room in pristine condition.

Examination of feeders, connectors, and terminations:

- all terminations should be examined for corrosion, general cleanliness and tidiness and appropriate action taken if problems are encountered;
- the report on difficulties encountered should be made at the earliest possible time to the equipment suppliers or users and the cause of the problem identified in order to avoid repetition;

NOTE: Connectors should not be opened or removed unless a specific fault is found and the operators of the equipment should be informed and the equipment switched off where appropriate before disconnection.

- at regular intervals or after intervals agreed with suppliers or contractors, measurements should be taken of the feeder and antenna parameters, but before disconnecting the feeder, the appropriate warning actions should be taken;
- the results of any measurements taken should be noted in a log book;
- any filters or multicouplers on the site should be examined for condition and if necessary, test measurements taken to ensure that the parameters are as defined. No adjustments should be undertaken, nor any connections broken without authority and with the appropriate test equipment;
- if there is obvious physical damage, e.g. resulting from a lightning strike, flood or fire, then spare filter equipment should be made available before any work is undertaken;
- when routine or restorative maintenance is carried out on radio equipment, it may be appropriate to make simple checks on the overall performance of the radio site. These checks can then be noted in a log book and compared with the results obtained on previous visits.

The overall performance of the radio site is only as good as the performance of those engineers visiting and maintaining the installation. A good and efficient radio site looks immaculate, is clean, well lit and bears the evidence of careful treatment and high technical standards.

12.3 Electrical supply and lightning protection

There have been many instances in the past where fire and damage has been caused on radio sites due to overloaded electrical circuits.

It is essential that the rating of the cables, fuses, trips and ancillaries are all within the loading placed upon them and a very simple check on all the electrical system can be the temperature rise in the cables and connections. This can be easily detected with a small temperature probe and any part of the installation running at 10 °C above ambient is in danger of being overrun and could become dangerous. These remarks apply particularly to PVC covered copper cable.

A slightly more sophisticated method of checking would be to use a tong-test current meter to check every cable and connection in the system and record the results in the site logbook.

A physical examination of the installation for untidy wiring or badly connected tails is also well worth carrying out.

The voltage should be checked at various agreed points within the system and should be within 5 % of the nominal figure.

In some countries there is a legal limit on the maximum excursion from the stipulated voltage and any severe reduction in voltage can adversely affect the equipment and is an indication of overloading.

With regard to the earth system, it is essential to check that this is still intact and that the earth impedance has not risen to an unreasonable figure.

In many installations the earth mat connections or spike terminations are contained within pits and can be easily removed for checking.

The standard earth test should be applied, both for absolute figure of impedance and also for current carrying capacity if there are no trips operated by earth leakage. In the latter case, earth trip can be checked by passing the nominal current from live to the earth connection, at which current the trip should come out.

This test can only be conducted, however, in the presence of radio engineers who will ensure that no adverse effect on any of the equipment on site will be produced.

On no account should the mains supply be broken if there are emergency services present on the site, except with their authority.

12.4 Antennas and feeders

The maintenance of antennas and feeders can be split into two parts:

a) 1 year intervals:

- antenna elements should be inspected for signs of corrosion. Where pitting of the surface metal is evident complete replacement is recommended;
- plastic encapsulation forming antenna terminations or balun networks are liable to degradation and splitting subsequently admitting water and should, therefore, be examined in detail for hairline cracks;
- fixing clamps should be checked for rigidity and signs of corrosion paying particular attention to threaded components which should be treated with non setting bituminous paint;
- feeder trays and securing cleats should be checked for tightness and earthing straps must be checked for electrical integrity. Cables should be inspected for physical damage which can be caused by inexperienced riggers climbing on existing cable trays.

b) 5 year intervals:

- far field performance for all antennas on a given site should be measured and compared to gain and radiation pattern measurements recorded at installation. Any antenna showing substantial deviation should then be further examined to deduce the cause which includes connectors, feeder and balun if fitted;
- PIB and petroleum based tapes used as wrapping over in line connectors should be checked and replaced as necessary;
- in general, on sites in a coastal environment, it is recommended that antennas are replaced at intervals not exceeding 5 years due to the accelerated rate of corrosion of aluminium based components.

12.5 Filters and couplers

The installation of filters and couplers, particularly on those sites having a separate multicoupler room, is easily kept under strict control and records can be maintained in the equipment room as well as being returned to the site managers office.

These records should include forward and reflected powers taken at the appropriate points in the system and it is suggested that these are as follows:

- a) at the antenna port;
- b) at the output of the transmitter couplers;
- c) at the transmitter output or the multicoupler input.

There should be a set of predetermined levels which are agreeable between the supplier, manufacturer, installer and operator and there should be a nominal tolerance on these figures which is both practical and realizable. The accuracy of field test equipment must be considered, particularly for the measurement of absolute RF power using broadband instruments.

It is recommended that the figures are checked at not less than annual intervals, but in the case of public service operators, they may need to be checked at quarterly or even monthly intervals.

In the event of discrepancies being found in the test figures, a careful analysis and interpretation of the results should be carried out before any adjustments or physical investigation of the filter coupling system is undertaken.

In the case of a completely passive network, the most likely event to cause a disruption of the parameters is damage to the antenna and therefore a peculiarity in the reflected power figures throughout the coupling system.

It must be remembered that a passive band pass filter system has a transparency to return loss and that therefore a problem at the antenna can be sent back through the system and cause very confusing results.

It can be generally stated that passive filter coupling systems should be left alone unless there is evidence of severe deterioration either visually on casual inspection, or by analysis of the test parameters.

The typical life of a passive filter system should exceed 10 years and would normally be 15 to 20 years without any adjustment.

In very severe environments, e.g. maritime or marine installations, where there may be an element of vibration, corrosive salts and corrosive atmosphere, then the visual inspection can be a guide to the internal condition of the components.

Where there are power amplifiers, these should be examined separately and their parameters checked at perhaps annual intervals.

It should also be remembered that in general terms, unless there are moving parts, e.g. ventilating fan or relays, the MTBF of such devices probably exceeds 100 000 hours.

Most of the difficulties encountered on multicoupled sites are caused by anomalies in the transmitters, e.g. spurious emissions or failure of the output stage and, of course damage to the antenna.

A summary of the position regarding multicoupler installations is that they are best left alone unless there is evidence of a technical problem.

13 Troubleshooting on radio sites

13.1 Method of approach

In the case of interference being detected, then a logical sequence of steps should be followed to identify the cause of the problem:

- a) Check that the receiver front end is not being overloaded; a notch filter tuned to the interfering signal installed at the antenna input to the receiver will normally solve an overload problem.
- b) Check that mixing is not taking place in the front end of the receiver; if the unwanted received signals are within ± 1 % of the unwanted frequency then follow step a), however, normally a bandpass filter installed at the antenna input to the receiver will solve this problem.
- c) If the interference is not generated in the receiver then the direction of the interference may be traced by using an antenna, with directional properties, connected to a receiver with signal level indication.
- d) When interference has been traced back to a site, and the signals causing the interference have been identified, it will be necessary to determine where the mix is occurring.
- e) DO NOT tamper with any equipment on site unless the owners prior permission has been obtained. If it is necessary to disconnect the antenna feeder from the transmitter output, ensure that the transmitter cannot be keyed.
- f) It should be noted that when making measurements with sensitive measuring instruments, particularly when tracing intermodulation products in the transmitter output, that appropriate precautions are taken (such as stop or notch filters, attenuators or directional couplers to protect the input stages of sensitive equipment).
- g) Mixing can occur in a transmitter output stage, due to the carrier frequency mixing with another signal being fed back via the antenna feeder. This problem can normally be solved by fitting an isolator or bandpass filter in the antenna feeder close to the transmitter output.
- h) If interference is still present then mixing is most likely taking place either on the transmitter or receiver mast structure. It may be possible to overcome the problem by increasing the horizontal or preferably the vertical separation between the antenna on the existing mast.

Alternatively if the radiating source on the mast can be located, it may be possible to carry out the necessary maintenance.

- j) In extreme cases it may be necessary for one of the users to change sites, to overcome the interference problems.

13.2 Case studies

The following cases contained in this section are typical examples of interference cases which could have been prevented if the guidelines contained in this code had been followed.

Case 23 is included as a reminder that the cause of the problem may be in the users own equipment, therefore it should be ensured that the equipment is regularly maintained.

13.2.1 Cases where the use of cavity resonators, bandpass filters or ferrite isolators provided a cure

Case 1: a high power 150 MHz band transmitter was causing interference to a co-sited 160 MHz marine band receiver by desensitizing the receiver and causing blocking. The transmitter already had an isolator and bandpass filter fitted to the output antenna feeder. The problem was solved by inserting a bandpass cavity resonator into the antenna feeder to the marine receiver.

Case 2: interference was being received on a police VHF base station receiver. It was suspected that a high power radiophone transmitter, located approximately 500 m away, was overloading the front end of the receiver. A bandpass filter was inserted into the antenna feeder of the receiver, and although the level of interference was reduced, a significant signal level was still present.

Further tests showed that the RF signal from the Radiophone transmitter was getting into the output stage of the police transmitter, co-sited with the receiver. The mix between the two carriers produced a resultant product on the police receive frequency. An additional band pass filter was inserted in the output feeder of the police transmitter. The interference problem was solved by placing bandpass filters in both the police transmitter and receiver antenna feeders.

Case 3: interference was being received on several base station receivers, located on a communal site. During tests at the site, it was noted that the interference ceased when one particular co-sited transmitter was keyed. The transmitter used a semiconductor output stage, which was still active even when the drive had been removed, i.e. the transmitter

was in the standby mode. The problem was caused when co-sited transmitters were keyed, causing the output stage of the offending transmitter to go unstable and radiate spurious noise.

By installing a bandpass filter and isolator at the output of the transmitter the problem was solved.

Case 4: interference was being caused to a 141 MHz FM base station receiver from a co-sited 138 MHz AM base station transmitter.

It was suspected that the 138 MHz transmitter was overloading the FM receiver. An additional bandpass cavity filter was installed in series with the existing high-Q bandpass filter which is normally fitted to the receiver input, but produced no improvement. A notch filter tuned to the interfering carrier was then tried in the receiver, again no improvement was noted.

A spectrum analyser was used to observe the transmitted spectrum, which showed a number of low level spurious signals, one of them falling directly onto the FM channel. By fitting a bandpass filter at the transmitter output and retaining the single bandpass cavity at the receiver, the interference was cured.

Case 5: co-channel interference was being caused to a police base station receiver which was located near to a communal base station site approximately 500 m away, with some 10 PMR transmitters on site. None of the transmitters had filters or isolators fitted to their outputs, therefore a large number of intermodulation products were being generated over a wide band. The problem was solved by fitting isolators and filters to the outputs of the offending transmitters.

Case 6: co-channel interference was received on a 141 MHz band base station receiver. The source of the interference was traced to a spurious signal being radiated from a 145 MHz amateur band repeater. The repeater transmitter used a local oscillator with a times 36 multiplying stage to obtain the required carrier frequency. A spurious signal, which was due to the 35th harmonic of the local oscillator, was being radiated.

The problem was solved by inserting an additional bandpass filter at the transmitter output.

Case 7: a third order intermodulation product was traced to a communal site. The two transmitters were identified, which already had isolators and filters fitted to their outputs. On further investigation the interference was traced to a receiver antenna which was radiating the antenna intermodulation product. When the antenna feeder was disconnected from the associated receiver, the interference disappeared. To solve the problem a band pass filter was installed at the input to the receiver.

Case 8: a high band user was complaining of interference on his channel; the system (system A) was using free running talk through. The frequency separation between the transmit and receive on a high band channel is 4,80 MHz. A nearby transmitter (system B) operating on a channel 2,40 MHz above system A produced a radiated third order intermod which fell on the receive frequency of system A. Due to the intermod product system A would remain on whilst system B was transmitting even when the mobiles of system A ceased transmitting.

Case 9: use of multiple common base stations on a communal site exhibits the same problem as any talk through stations, that is the generation of transmitter/receiver difference frequencies.

A classic case is that of two VHF high band talk through base stations having standard TX/RX spacing (i.e. 4,80 MHz) in an urban environment where the mobiles of one system have regular access within 70 dB of the communal site, the transmitter not being fitted with an isolator. The level of the received mobile frequency can be in the order of several milliVolts, and mixing with its own transmitter produces a difference frequency equal to the TX/RX spacing. If now the second base station is keyed, its own receiver will be disturbed by the resultant of the mix from the first base station, and so will any subsequent VHF high band transmitters keyed on the site.

In many cases of this type the disturbance to the second system is that of an extremely over-modulated signal carrying the modulation of the first base station.

The solution to this problem would be the fitting of suitable ferrite isolators and/or bandpass filters to the offending transmitters.

Case 10: interference was being received on a private mobile radio base station receiver tuned to 172,80 MHz. The receiver employed a local oscillator running at 162,10 MHz (i.e. 172,80 MHz - 10,70 MHz). The interference occurred when a nearby transmitter operating at 167,45 MHz was keyed. This transmit frequency (167,45 MHz) was exactly 5,35 MHz (half 10,70 MHz) lower than the wanted signal. The difference between twice the local oscillator and twice the unwanted signal (i.e. 324,20 MHz and 334,90 MHz respectively) produced an Intermediate Frequency (IF) of 10,70 MHz. The receiver thus responded to the unwanted signal. The installation of a cavity resonator before the

receiver allowed only the wanted signal to pass. (Alternatively a notch filter installed before the receiver would have rejected the unwanted signal).

It should be noted that even with receivers that meet existing ETS requirements this problem can occur.

13.2.2 Case where the problem is related to equipment alignment

Case 11: a high band VHF transmitter was set up at the repair depot before being reinstalled on site. The transmitter when installed on the communal site was connected to the antenna via a high-Q filter. When the transmitter was keyed high level spurious signals were emitted causing interference to other co-sited systems. The problem was solved by retuning the transmitter RF stages to match the filter system.

NOTE: A transmitter should be set up in the workshop into an accurate 50 Ω dummy load.

13.2.3 Cases where the problems are related to broadcast transmitters

Case 12: programmes from a VHF FM broadcast transmitter were received on a police base station receiver. Intermodulation products were generated in the structure of the mast on which the police antennas were mounted, due to the high powered broadcast transmitter.

This problem was solved by removing the receiving antenna to a position above the mast structure using a vertically stacked dipole on a 3 m pole. This succeeded in removing the receiving antenna away from the field of interference caused by the mast structure.

Case 13: interference was received on a public utility base station receiver operating on 106 MHz. Co-sited was a 4 kW local radio broadcast transmitter on 96 MHz and also an automobile club transmitter on 86,525 MHz. No 3rd order intermodulation products were detected from the broadcast transmitter, however, by using a loop antenna connected to an analyser the intermodulation product was traced to the broadcast antenna. The antenna was checked but no fault could be found.

Some reduction in level was obtained by changing the public utility collinear antenna for two dipoles. Additional reduction was obtained by replacing the antennas further down the mast, i.e. increasing the vertical separation.

Case 14: a fire brigade base station receiver was receiving an FM broadcast programme. The co-channel interference was traced to a nearby communal base station site. The broadcast transmission was being picked up on the antenna feeder, which provided a path to the power amplifier stage of a PMR transmitter where the mixing occurred. The broadcast transmitter was several kilometres from the communal site. The problem was solved by earthing the antenna feeder, the cable ducts and equipment racks.

Case 15: a 50 kW erp transmitter operating on 96,70 MHz was radiating spurious signals at a frequency of 97,483 MHz and 95,917 MHz. Both spurious signals were noted to be 783 kHz from the wanted carrier.

A 20 kW transmitter operating on 783 kHz was located at a distance of 7 km from this site. It was thought that this transmitter could be associated with the problem.

The 783 kHz transmitter was switched off and the spurious emissions ceased. The problem was solved by inserting a low pass filter at the input of the FM transmitter exciter stage. It should be noted that the problem was one of breakthrough into an audio frequency stage. By suppressing the 783 kHz transmissions at this Audio Frequency (AF) stage the RF spurious emissions were removed.

Case 16: interference was being received on 121,50 MHz and it was known to be caused by a broadcast transmitting station.

The broadcast transmitter was operating on 102,50 MHz with an output of 500 W erp. The distance between the two stations was 30 km.

Spectral analysis of the broadcast transmitter station showed several spurious emissions including 121,50 MHz.

Measuring the incident and reflected power of the transmitter showed that the reflected power was approximately 25 % of the incident power. The antenna feeder was checked and found to contain water. The problem was solved by changing the coaxial cable and connectors. The transmitter was then retuned to match the new feeder.

Case 17: interference was being received on manually tuned aeroplane receivers when tuned to a radio beacon on 371 kHz. The problem was found to be caused by intermodulation between two medium wave broadcast transmitter stations.

One station used a 135 kW erp transmitter on 666 kHz and the other a 120 kW erp transmitter on 1 035 kHz. The transmitters were 12 km apart.

The intermodulation product was found to be a mixing problem with the 1 035 kHz transmitter (1 035 kHz - 666 kHz = 369 kHz).

The interference problem was solved by installing a bandpass filter into the antenna feeder of the 1 035 kHz transmitter.

Case 18: interference was being received on 118,20 MHz and was found to be caused by two FM broadcast transmitter stations located on the same site. One transmitter was operating on 104,30 MHz with an output of 40 kW erp. The other transmitter was operating on 90,40 MHz with an output of 1 kW erp. This case is a typical 3rd order intermodulation problem. The intermodulation product is given by:

$$(2 \times 104,3 \text{ MHz}) - 90,4 \text{ MHz} = 118,2 \text{ MHz}$$

The level of the second harmonic of the 104,30 MHz transmitter was measured as -72 dBc. The intermodulation product disappeared when the output power of this transmitter was reduced by 6 dB.

This problem was solved by replacing the 90,40 MHz transmitter until the correct cavity resonator could be obtained and inserted into its antenna feeder.

13.2.4 Cases where the problems are related to cables and connectors

Case 19: a telephone company were experiencing on site problems from their radiophone and paging transmitters which were causing breakthrough on the radiophone receivers. After a considerable amount of work on the site, breakthrough was still being experienced. The problem was finally solved by replacing the existing feeders with double screen cables and using high quality connectors.

Case 20: the operator of a trunked radio system was experiencing a high proportion of lost calls during peak traffic periods. The problem was confined to a certain site of his multi site system.

The radio and combining equipment was tested with all ten channels operating into a high power load and isolating cable connected to the combiner antenna access. No problems were observed. When testing into the antenna, intermodulation products were observed in the receive band whenever seven or more transmitters were operating.

Inspection of the antenna system feeders at the affected sites revealed the connectors to be the culprit. the type used relied on a spring fingering for the centre contact to the inner conductor of the coaxial cable. The peak power of seven or more transmitters caused this connection to generate intermodulation.

Replacement of the connectors by the soldered and clamped variety effected a complete cure.

13.2.5 Cases where the problems are related to site maintenance

Case 21: an on air intermodulation product was traced to a communal site. Work had recently taken place at the site on the mast and in the equipment room. The problem was traced to an intermodulation product which was being picked up by a feeder cable and radiated from the attached antenna. The feeder cable and antenna were no longer being used at the site. When the feeder cable and antenna were removed the problem was resolved. It should be noted that all unwanted equipment should be removed from mast structures and equipment rooms.

Case 22: there have been numerous cases of moisture within antennas and feeder cables causing a deterioration of transmission characteristics. In extreme cases severe corrosion takes place at the lower connector of the feeder run, where the moisture gathers behind the connector. The source of the problems are numerous, the main points of entry being:

- a) the drain holes in antennas and antenna structures;
- b) the connectors and interfaces;
- c) cracks and orifices in the outer casing of the antenna feeder cables.

Due to atmospheric changes in temperature and pressure there is a tendency for feeder systems to "breathe" and in extreme wind conditions the "Venturi effect" may be produced sucking moisture into the system.

The solution to these problems are mainly inspection and maintenance, since complete abandonment of drain holes in antennas can lead to other problems due to ingress of water in the upper part of the antenna, and excessive use of sealants and wrapping of connector assemblies can produce adverse effects of a secondary nature.

It is possible to provide drip loops and examination points within the equipment room by removing a short section of the outer casing of the feeder cable. This provides a means of detecting any moisture that may be trapped between the outer coaxial tube and the casing. The real solution is to provide annual inspection and regular maintenance of the system.

13.2.6 Cases where the problems are related to faulty equipment

Case 23: interference was being caused to a 141 MHz base station receiver whenever a co-sited 139 MHz base station transmitter was keyed.

A bandpass filter was fitted to the receiver which reduced the level of interference. However, the wanted signal was still unworkable, even at this reduced level of interference. As a result of using a spectrum analyser it was found that the receiver front end was oscillating at around 140 MHz. When the 139 MHz transmitter was keyed, mixing occurred to produce a 3rd order intermodulation product which fell on to the receiver channel. No fault was suspected on the receiver since good signals were received from the mobile. The receiver was repaired which cured the interference problem.

Case 24: a radiated interference signal was traced to a communal site. The actual source, however could not easily be identified, therefore with the owners permission equipment was switched off to try and eliminate the source. With all known equipment off, the interference was still present. The source was traced to the system master crystal oscillator, which was still running.

Case 25: the symptoms of this case were identical to those in case 24. However, the feeder and connector system had been checked and eliminated from the investigation. In this case antenna substitution effected a cure.

On inspection of the faulty antenna, a loose connection was found at the junction of the driven element and the feeder tail. The joint was dismantled, cleaned and tightened and the antenna returned to service. No further problems were encountered.

In this case, and in case 24 the onset of intermodulation was well defined. Until a certain number of transmitters was reached no intermodulation occurred. Once started, the effects remained until the number of active transmitters approximately halved.

13.2.7 Case where the problem is related to site modifications

Case 26: intermodulation was being received on a high density radio telephone network employing a number of different VHF and UHF systems. The antenna systems comprized a number of tubular masts employing interlocking push-fit sections. These masts were aligned along the top of a building. One of the UHF networks was receiving high level intermodulation products.

The only alteration that had been recently undertaken was the removal of an unused VHF antenna on an adjacent mast. On inspection it was confirmed that the antenna clamp had provided a good bond between two sections of the mast. The removal of the clamp had resulted in a poor contact between the sections and created intermodulation. The mast sections were bonded by a continuous earthing strip along the length of the mast and the intermodulation ceased.

13.2.8 Case where the problem is related to equipment screening

Case 27: a police system comprising four transmitters and receivers coupled to a single antenna was radiating intermodulation products which caused interference to other installations.

The system was checked into a dummy load and isolating cable. All products were found to be -70 dBc which would be incapable of causing the interference observed.

The system was reconnected to the antenna and the tests for intermodulation were repeated using a line sampler in the main feeder cable. The intermodulation products were now observed to be only -25 dBc (the antenna was known to be well matched and in good condition).

While testing it was observed that the intermodulation products were variable, depending on position of cabinet doors, engineers in the room, etc.

The site was located in the lift motor room of a tall office building with antennas mounted above the roof on a short stub mast. It was concluded that the intermodulation mechanism was the direct radiation of energy from the antenna into the transmitters and associated wiring.

The provision of a screened rack for the radio equipment completely eliminated the problem.

13.2.9 Accidental operation of discarded equipment

Case 28: interference was being received on 121,50 MHz and was caused by a signal generating the usual emergency tone signal.

The interfering transmitter was located some kilometres away and was found to be a discarded Emergency Position Indicating Radio Beacon (EPIRB). This EPIRB was located in a scrap yard and proved very difficult to find.

13.2.10 Examples of lack of isolation between systems

Case 29: a VHF trunked radio system was installed at a rooftop site on a city centre building. The system employed ten duplex transmitters and receivers multicoupled to a single antenna connection using isolators, cavity resonators and bandpass filters.

Intermittent severe interference was received on all channels having calls in progress. The modulation of the interference was observed to be severely distorted and only occurred if the companion transmitter was on. The interference also coincided with strong signals received within the base receive frequency band. The level of these received transmissions indicated that they must be originating close to the site. Tests showed that mixing in the base station transmitters was not the source of interference.

The cause was finally traced to the re-radiation of mixing products generated in the nearby mobile transmitter. These mixing products radiated back into the antenna system to disturb the receivers of other channels. No modifications were possible without affecting the coverage of the site.

The problem was solved by restricting the use of mobile transmitters in close proximity to the site.

Annex A (informative): Protection ratios and minimum field strengths required in the mobile services

ITU-R (ex CCIR) REPORT 358-5

(Question 1/8)

(1966-1970-1974-1978-1982-1986)

A.1 VHF and UHF land and maritime mobile services

A.1.1 Protection ratios based on internal noise and distortion in the receiver

The World Administrative Radio Conference, Geneva, 1979, defined the protection ratio as the minimum value of the wanted-to-unwanted signal ratio, usually expressed in decibels, at the receiver input determined under specified conditions such that a specified reception quality of the wanted signal is achieved at the receiver output (*RR No. 164*). For further information on the definition see Report 525. This ratio may have different values, according to the type of service desired.

However, in the absence of information submitted to Study Group 8 on subjective measurements made in the VHF and UHF land and maritime mobile services several administrations submitted the results of laboratory measurements, using appropriate test signals, of the degradation of the signal-to-noise ratio of the wanted test signal, when a co-channel interfering signal is superimposed on the latter. A degradation of the initial signal-to-noise ratio of 20 dB to a signal-to-noise + interference ratio of 14 dB is taken as the criterion. For some systems this grade of service is acceptable.

In the tests described by the various administrations, the frequency deviations are 70 % or 60 % of the maximum specified frequency deviations, and for amplitude modulation the modulation percentages are 70 % or 60 %, for both wanted and unwanted signals. From a study of the documents submitted, it may be deduced that the slight differences in measurement conditions and in the characteristics of the receivers used in the different tests, may result in differences in the measured receiver protection ratios, of up to about ± 3 dB.

One administration performed tests to determine the protection ratio for the case where the wanted narrowband G3E signal is interfered by a direct-printing F2B signal (see Recommendation 476) [CCIR, 1978-82]. The e.m.f. of the wanted signal at the receiver input was 2 μ V. In these tests the level of the interfering co-channel F2B signal was so adjusted that the subjective effect on the wanted signal was the same as that of an interfering co-channel narrowband G3E signal attenuated by the protection ratio of 8 dB laid down in Table I for this case. The peak frequency deviations used for the F2B signal were ± 1 kHz, ± 3 kHz and ± 5 kHz respectively. The sub-carrier was 1 500 Hz and the frequency shift 170 Hz. 12 dB was found to be a suitable representative value for the protection ratio and is therefore included in table A.1.

Although the ability of the receiver to receive the wanted signal is dependent on the passband characteristics of the receiver, the frequency difference between the co-channel wanted and unwanted signals, the frequency deviation, etc., the receiver protection ratios in table A.1 may be used as the basis for the calculation of system protection ratios for mobile systems for a minimum grade of service. Additional protection should be provided to allow for the effects of multipath propagation, man-made noise, terrain irregularities, and in the case of very closely spaced assignments, adjacent-channel interference (see Report 319).

When using frequency modulation, "capture effect" is enhanced as the frequency deviation of the wanted signal is increased; therefore, a wideband F3E, G3E system requires less protection than a narrowband F3E, G3E system for the same type of interfering source.

If a higher grade of service is required a higher protection ratio should be adopted, particularly in the case of amplitude-modulated wanted emissions.

A.1.2 Man-made noise

Man-made noise degrades the performance of a mobile system. To maintain a desired grade of service in the presence of man-made noise, it is necessary to increase the level of the field strength of the wanted signal. Motor vehicles have been shown, by measurements [US Advisory Committee, 1967], to be the primary source of man-made noise for frequencies above 30 MHz. Other noise sources are fewer in number and usually radiate from fixed locations.

Table A.1: Typical receiver protection ratios, for use in calculating system protection ratios

Wanted emission (Note 1)		Unwanted emission (Note 1)		Receiver protection ratio (dB)
Wideband	F3E, G3E	Wideband	F3E, G3E	See Report 319
Narrowband	F3E, G3E	Narrowband	F3E, G3E	See Report 319
Wideband	F3E, G3E		A3E	8
Narrowband	F3E, G3E		A3E	10
Narrowband	F3E, G3E	Direct printing	F2B	12
	A3E	Wideband	F3E, G3E	8 - 17 (note 2)
	A3E	Narrowband	F3E, G3E	8 - 17 (note 2)
	A3E		A3E	17

NOTE 1: Wideband F3E, G3E systems normally employ frequency deviations with a maximum value in the range ± 12 to ± 15 kHz.

The narrowband F3E, G3E systems considered here normally employ frequency deviations with maximum values of either ± 4 or ± 5 kHz.

The value of the F2B case is with a peak frequency deviation of ± 5 kHz. Frequency deviations of ± 3 and ± 1 kHz do not significantly decrease this value.

NOTE 2: The receiver protection ratio may vary within the range shown dependent upon the difference in frequency between the carriers of the wanted and unwanted emissions and the frequency deviation of the unwanted emission. In general, it will tend towards the higher figure as the frequency deviation of the unwanted emission decreases.

For convenience in evaluating the degradation of performance of a base receiver, the following classifications of noise sources are provided:

- high noise locations - traffic density of 100 vehicles/km² at any given instant of time;
- moderate noise locations - traffic density of 10 vehicles/km² at any given instant of time;
- low noise locations - traffic density of 1 vehicle/km² at any given instant of time;
- concentrated noise sources (hot spots): noise radiated from individual sources or closely spaced multiple sources which are usually located within 500 m of the receiving antenna, such as a high concentration of vehicles, manufacturing plants and defective power transmission lines.

Noise data for base stations at high, moderate and low noise locations are presented by a noise amplitude distribution (NAD) (the number of pulses per second equal to or greater than the value shown as ordinate) and are illustrated in figure A.1. The amplitude (A) (in dB(μ V/MHz)) of noise pulses at a rate of 10 pps (pulse-per-second) is expressed as follows:

$$A = C + 10 \log V - 28 \log f$$

where:

C : constant (tentative value: 106 dB(μ V/MHz))

V : traffic density vehicles/km²

f : channel frequency, MHz

Noise data for hot spots can also be presented in the form of a noise amplitude distribution. However, due to a wide variety of noise sources, it is not yet practical to provide a classified list.

The constant C is a function of the electrical noise suppression applied to vehicles and may also vary according to the relative proportion of goods and passenger vehicles if the level of suppression is not the same for both categories. A tentative value of 106 dB(μ V/MHz) is shown and this may be revised as more information becomes available.

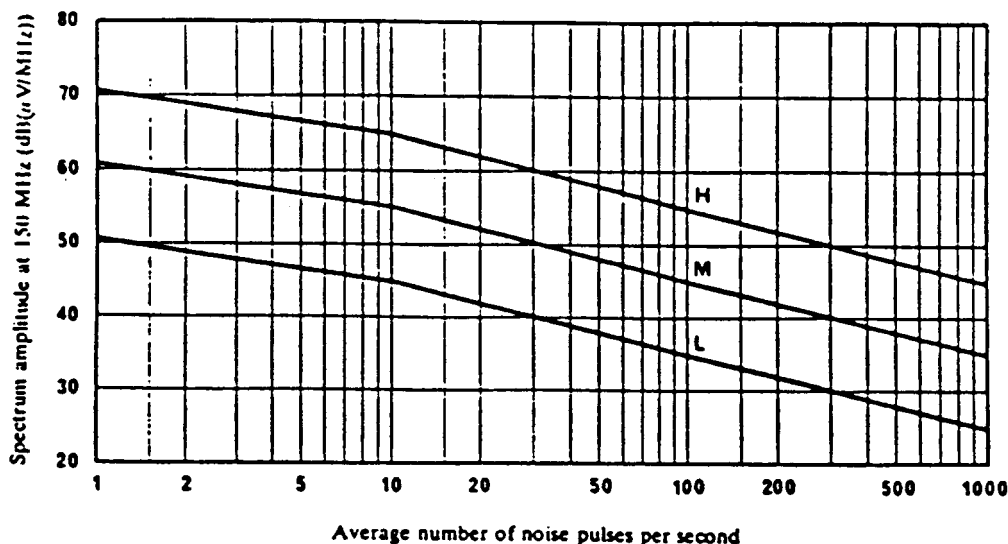

Figure A.1: Noise amplitude distribution at base station (150 MHz)

For frequencies other than 150 MHz, raise or lower curves H, M and L in accordance with the formula below.

$$A = C + 10 \log V - 28 \log f$$

where A = dB (μ V/MHz) at 10 pps

Curve H: high noise location ($V = 100$)

Curve M: moderate noise location ($V = 10$)

Curve L: low noise location ($V = 1$)

A.1.3 Noise Amplitude Distribution (NAD) determination of degradation

A.1.3.1 Definitions

A.1.3.1.1 Noise Amplitude Distribution

A presentation of impulsive noise data in terms of its basic parameters of spectrum amplitude and impulse rate.

A.1.3.1.2 Spectrum amplitude

The vector sum of the voltages produced by an impulse in a given bandwidth, divided by the bandwidth.

A.1.3.1.3 Impulse rate

The number of impulses that exceed a given spectrum amplitude in a given period of time.

A.1.3.1.4 Impulsive-noise tolerance

The spectrum amplitude of impulses at a given pulse-repetition frequency at which the receiver, with an input signal applied at specific levels, produces standard signal-to-noise ratios at the output terminals.

A.1.3.2 Determination of degradation

Degradation of receivers can be determined as follows:

- 1) Measure the impulsive noise tolerance of the receiving equipment in accordance with applicable IEC standards;
- 2) Measure NAD in accordance with applicable IEC standards;
- 3) Superimpose the graphs for the receiver impulse noise tolerance and the NAD. An example is shown in figure A.1.

A.1.4 Minimum values of field strength to be protected

The minimum values of field strength to be protected in the land mobile service at frequencies above 30 MHz are determined by internal noise generated in the receiver, man-made noise usually in the form of radiation from ignition systems of motor vehicles and the effects of multipath propagation to and from moving vehicles. Some information on the effects of traffic density is now available. In the maritime mobile service, the level of man-made noise depends on the number and nature of high level sources of noise on the ship.

A convenient measure of the threshold of performance for narrowband receivers is a specified value of:

$$\frac{S + N + D}{N + D}$$

ratio; the conventionally accepted value being 12 dB (see Recommendation 331).

This defines the minimum useable field strength for any particular installation, in the absence of man-made noise.

The sensitivity of typical receivers is such that an input signal of 0,7 μ V e.m.f. (assuming a receiver input impedance of 50 Ω) would result in a 12 dB.

$$\frac{S + N + D}{N + D}$$

ratio at the output. A mobile service is characterized by large variations of field strength as a function of location and time. These variations may be represented by a log-normal distribution for which standard deviations of 8 dB at VHF and 10 dB at UHF are appropriate for terrain irregularities of 50 m (see Recommendation 370). To determine the minimum value of median field strength to be protected, it is necessary to specify the percentage of time for which the minimum useable field strength should be exceeded for different grades of service. For land mobile radiotelephony, a high grade of service would require that the value be exceeded for 99 % of the time, but, for a lower (or normal) grade of service, for 90 % of the time.

The minimum values of field strength to be protected can be determined subjectively, taking into account man-made noise and multipath propagation. Ignition systems of motor vehicles are usually the most prevalent source of man-made noise. Field strength cancellations due to multipath propagation produce an annoyance somewhat similar to that created by ignition systems. When a mobile unit is in motion, both of these annoyances occur at the same time. Only the effects of receiver noise and man-made noise remain when the mobile unit is stationary. The separation of motor vehicles is generally less with slow-moving or stationary traffic, and under these circumstances, particularly at the lower frequencies, the degradation experienced in a stationary mobile unit is greater than when it is in motion.

Figures 3 and 4 can be used to determine the combined degradation effects of man-made noise and multipath propagation for the case of vehicles in motion. These figures are based on subjective testing under traffic conditions commonly experienced by most mobile vehicles [FCC, 1973]. Specifically, these traffic conditions are the following: in motion while in a low noise area, in motion in traffic surrounded by other vehicles and stationary surrounded by other stationary or moving vehicles.

The tendency for the curves of Figures. 3 and 4 to merge at the higher frequencies is due to the almost constant multipath degradation effect with frequency and the fact that the degradation effect of man-made noise decreases with frequency.

Degradation is defined as the increase of level necessary in the desired input signal to maintain the receiving signal at the degree of quality obtainable when by receiver noise only.

Definitions of signal quality are as follows:

Grade	Interfering effect
5	Almost nil
4	Noticeable
3	Annoying
2	Very annoying
1	So bad that the presence of speech is barely discernible

} Speech understandable but with increasing effort as the grade decreases

Some information on field strengths can be derived from Recommendation 370. Additional information can be found in CCIR, [1966-69], and in the article of Okumura *et al.* (1968).

Information on protection ratios and minimum field strengths may also be found in the "Special Agreement between the Administrations of Belgium, the Netherlands, and the Federal Republic of Germany relating to the use of metric and decimetric waves for fixed and mobile services in border areas, Brussels, 1963", and in the Final Acts of the Special Regional Conference, Geneva, 1960. Similar information may be found in the Agreement between the Telecommunications Administrations of Austria, the Federal Republic of Germany, Italy and Switzerland, Vienna, 1969.

CCIR, [1963-66], deals with the above questions for signal-to-noise ratios of 30 dB and 40 dB at the receiver output.

Until values based on man-made noise and multipath effects are available, the calculated values of minimum and median values of field strength shown in figure A.2 may be used for hand-portable stations.

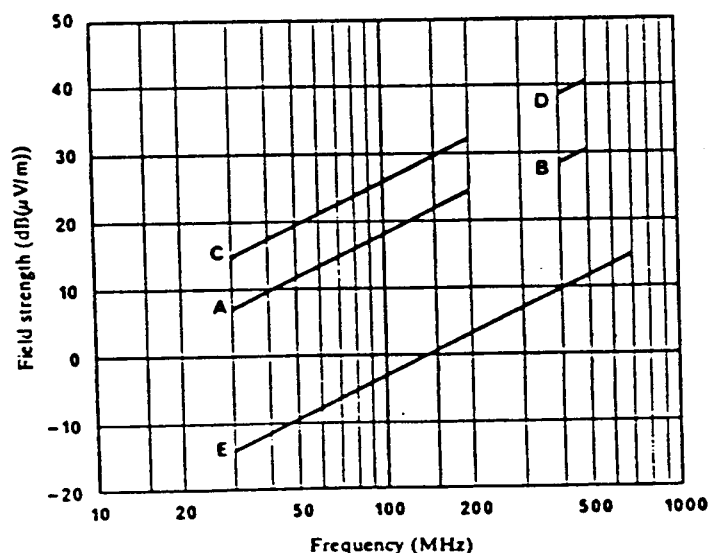

Figure A.2: Minimum useable and medium field strengths for typical hand-portable stations based on minimum useable input of 0,7 μ V e.m.f., in the absence of man-made noise

Characteristics assumed: antenna gain $\begin{cases} \text{A and C: } -9 \text{ dB} \\ \text{B and D: } -6 \text{ dB} \end{cases}$

A, B: median, normal grade

C, D: median, high grade

E: minimum useable field strength (dipole antenna)

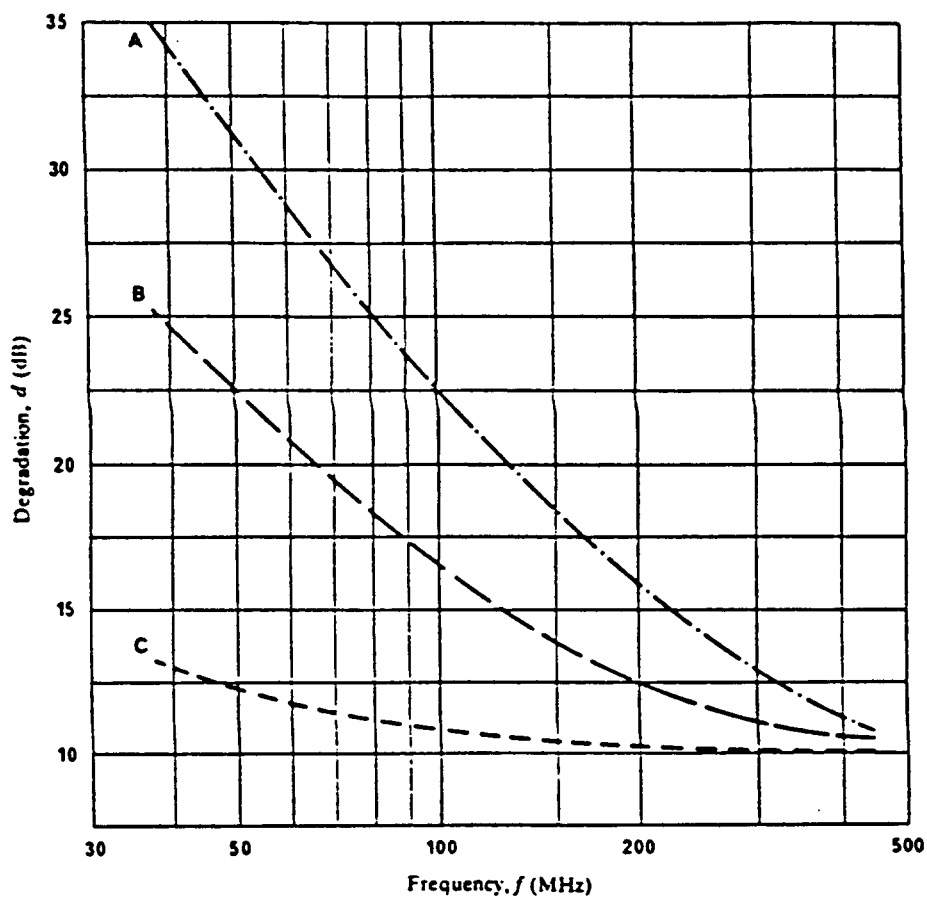

Figure A.3: Variation of degradation of mobile reception and minimum values of field strength to be protected for signal quality grade 4 and receiver sensitivity of 0,7 μ V e.m.f.

$$\text{Field strength} = -41 + d + 20 \log f \text{ dB}(\mu\text{V}/\text{m})$$

- A: mobile vehicle stationary within a high noise area
- B: mobile vehicle in motion within a high noise area
- C: mobile vehicle in motion within a low noise area

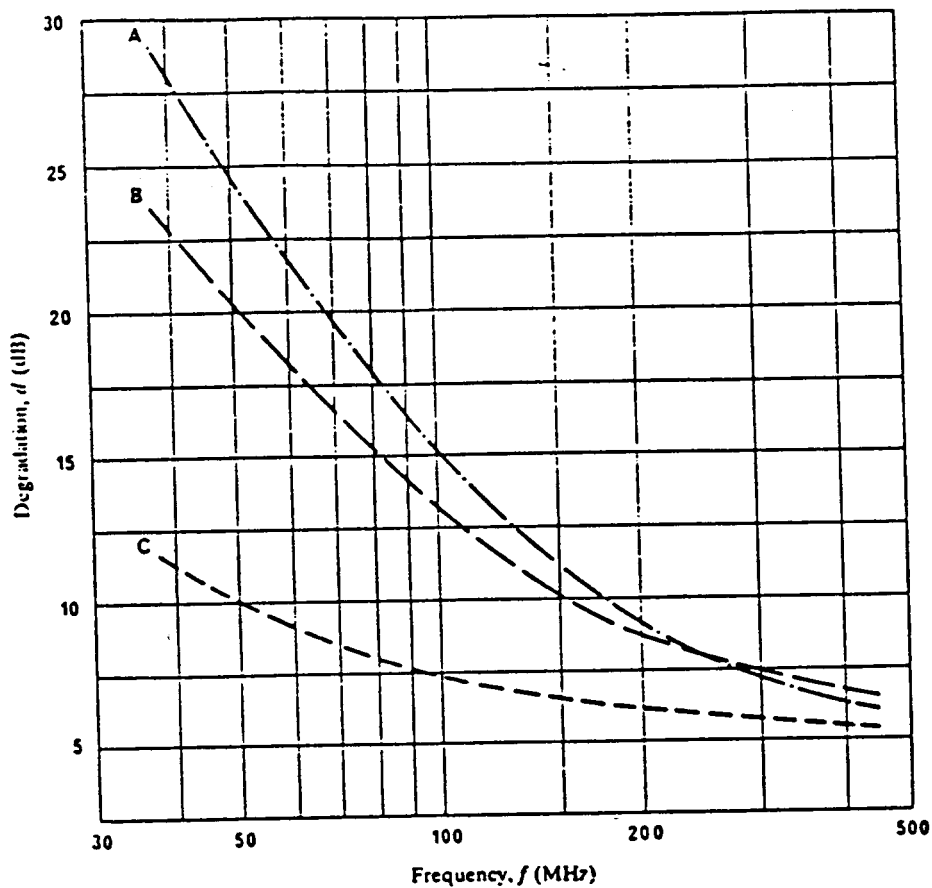

Figure A.4: Variation of degradation of mobile reception and minimum values of field strength to be protected for signal quality grade 3 and receiver sensitivity of 0,7 μ V e.m.f.

$$\text{Field strength} = -41 + d + 20 \log f \text{ dB}(\mu\text{V}/\text{m})$$

- A: mobile vehicle stationary within a high noise area.
- B: mobile vehicle in motion within a high noise area.
- C: mobile vehicle in motion within a low noise area.

Annex B (informative): Spectral parameters

B.1 Spectral parameters for TX-RX compatibility

Figure B.1 shows a typical arrangement of a TX-RX system.

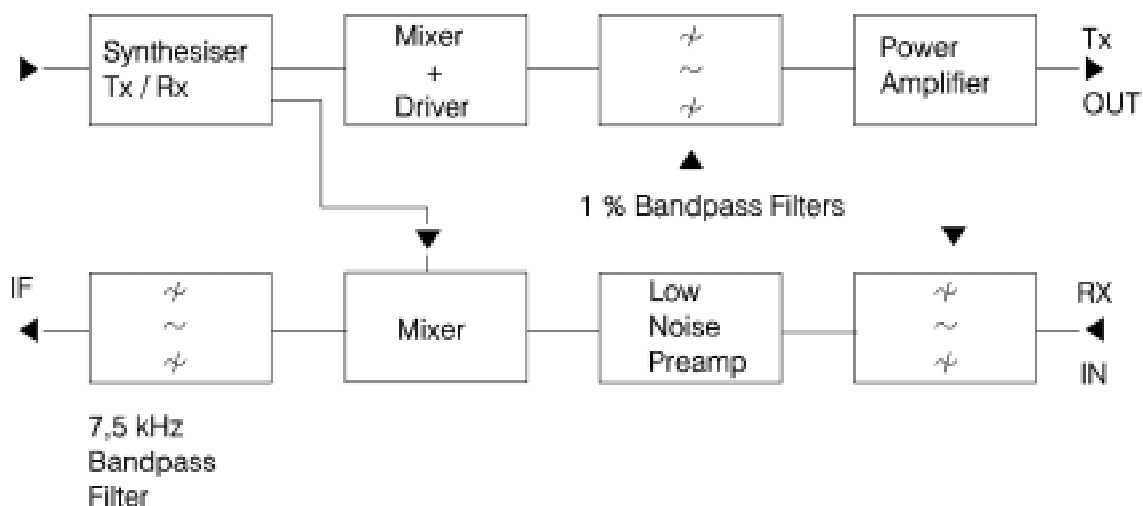

Figure B.1: A typical arrangement of a TX-RX system

The following figures are taken from a transmitter of current design having a noise figure of 23 dB. The typical driver output for such a device would be +3 dBm. To derive the broadband noise we take the source noise (kTB) as being -174 dBm/Hz, (since B = 1 Hz). Now add the driver level to the noise figure and the noise source level we get:

$$\text{Broadband noise} = -(3 + 174 - 23) = -154 \text{ dBc/Hz}$$

For a typical 12,50 kHz channel spacing the effective bandwidth of the channel will be 7,5 kHz (see EN 300 086 [5]). The optimum IF filter for a 12,50 kHz channel therefore has an effective noise bandwidth of 7,50 kHz.

Taking the carrier power as C = + 43 dBm, and N = the noise in a 7,50 kHz bandwidth,

$$10 \log 7\,500 = 39$$

and so C/N = -154 + 39 = -115 dB (or -72 dBm at TX output).

The driver noise is assumed to have a better noise figure (15 dB) for a lower output from the mixer (-20 dBm). (Typical value of noise figure for -20 dBm driver = 15 dB):

$$-(-20 + 174 - 15 - 39) = -100 \text{ dBc}$$

This limit applies to ± 1 % of the carrier frequency and the characteristics of the filtering is at least 12 dB/octave above.

The calculated noise floor for a receiver having a 15 dB noise figure (input figure included) is:

$$-174 + 15 + 39 = -120 \text{ dBm corresponding to } -110 \text{ dBm sensitivity (C/N = 10 dB)}.$$

At the duplex distance from the transmitter frequency

Assume a 3 dB degradation on sensitivity as being the worst case (see EN 300 086 [5]).

The isolation for a 3 dB degradation on sensitivity means an addition of the same noise power and 48 dB is therefore required (-120 dBm \pm 72 dBm).

For a 1 dB degradation the requirement is between 7 dB and 10 dB tighter which results in an isolation requirement of 55 dB to 58 dB.

The preceding case has assumed duplex spacings of greater than 2 %. For the case where the duplex distance is less than 2 % it can be seen from the plot that an additional 15 dB of isolation is required.

This is valid for a single channel, single base station situation. On multiple sites with different characteristics the calculation must be performed for each base station.

If further base stations are added to the site the isolation between them is increased by

$$10 \log(n + 1) \text{ dB (where } n = \text{the number of additional base stations)}$$

This assumes that all additional base stations have similar characteristics and are within the same frequency band.

It should be noted that additional isolation will need to be applied to the original base station as well as the additional ones.

For a four base station installation the isolation requirement is increased by $10 \log(3 + 1) = 6 \text{ dB}$.

This means an isolation of 61 - 64 dB will be required between each base station.

If we now consider a duplex TX/RX spacing of 1 % of f_0 and a permitted degradation of 1 dB then the required isolation will be at least 76 - 80 dB (i.e. 15 dB more).

To derive the starting point for the plot we must consider the adjacent channel effect on the noise level. Taking a typical receiver having a 12,50 kHz channel spacing we find that the IF selectivity is typically 0,015 % at 80 MHz and 0,014 % at 900 MHz. This results in a typical 7,50 kHz bandwidth based on a worst case degradation of 5 dB below the stated limit.

RX blocking performance

The limit is stated in ETSI standards at -23 dBm which means that for a transmitter having +43 dBm output a 66 dB isolation is required to protect the associated receiver.

Again this is only valid for a single channel, single base station situation.

Spurious and intermodulation

For the case of a single transmitter and receiver there will be no difficulty with spurious and intermodulation, but when multiple installations are brought together on a site, additional filtering will be required to ensure that the levels shown in the attached plot are obtained.

If a site has been engineered with TX-RX isolations which are adequate to protect the receivers from desensitization by transmitter Power Amplifier (PA) noise (at a typical level of -72 dBm), then taking the limits for spurious from EN 300 086 [5] of -36 dBm, it can be seen that should a spurious output fall on or close to a receiver frequency, additional TX filtering in the order of 36 dB would be necessary.

Intermodulation at the receiver input between a local TX signal and a strong external signal with a frequency which gives a third order product at the exact RX frequency is the worst case to consider for interference and desensitization of receivers.

If sites are designed with a TX to RX isolation which is sufficient to meet the RX blocking limits (-23 dBm from EN 300 086 [5]) then protection of the receivers to their intermodulation limit (-37 dBm from EN 300 086 [5]) requires 14 dB of additional filtering at the RX input.

B.2 Evaluation of spectral parameters

Most of the previous discussion in clause B.1 applies to analogue systems where there are existing comprehensive standards clearly specifying limits for spurious radiations in their current modulation bandwidths. With the introduction of digital systems into common use, wideband noise needs to be considered more closely to allow limits and appropriate bandwidths to be specified to ensure complete compatibility between all types of mobile radios. These limits must consider a balanced impact on the quality of a call, either from the transmitted noise or from the blocking performance of the receiver, both effects having the same degradation origin.

B.2.1 Spurious noise and sideband measurements - transmitters

All methods of measurement for sideband spurious noise are based on a power analysis at fixed offsets of frequency from the transmitter unmodulated carrier. The analysis bandwidth is usually compatible with the modulation applied e.g. for analogue transmissions with channel separations of 12,5 kHz or 25 kHz, the analysis bandwidths are typically 7,5 kHz and 15 kHz respectively, and 30 kHz and 100 kHz for digital transmission with a separation of 200 kHz (GSM) depending on the offset considered.

These methods do not separate noise from spurious emissions even though the impact may differ dependent on the type of communication being considered.

For example: a so-called spurious emission occupying 400 kHz with a power of -27 dBm will be found in a 100 kHz bandwidth at a level of -33 dBm, and would be considered unsatisfactory for 2 adjacent GSM channels. Similarly in a narrowband analogue 12,5 kHz channel separation (8 kHz bandwidth) it will produce a level in the 32 adjacent channels of $-27 + 10 \log(8/400)$ i.e. -44 dB. This level would be fully acceptable for each channel, however the same "narrowband spurious" could disturb a single GSM or analogue channel if it occupies less than 8 kHz.

To occupy a spurious effect as "narrow" or "wideband" the influence of the measuring bandwidth on its "displayed" power must be analysed. When increasing the bandwidth has no further effect on the "displayed" power levels, this indicates that the maximum "occupation" spectrum of the considerable spurious emission has been reached, and this result can be recorded.

B.2.2 Blocking effect of sideband noise

The quality of a call depends on the Signal to Noise (S/N) characteristic seen at the input of the demodulator of a receiver. Any addition of noise at this level will result in a significant degradation of this quality. This addition can come from the sideband noise of a transmission directly received on the tuned channel or it can result from the mixing of the intermediate frequency with a strong unwanted signal at a fixed offset of this channel, and the wideband noise of the local oscillator of the receiver at the same offset.

When performing a measurement of the blocking immunity of a receiver, it is not possible to differentiate between the reduction (usually by a compression of the gain in the front end modules) of the wanted signal (S_w) or an increase of the power supply to the active part of receivers' front ends or by better filtering, the most critical source of blocking problems is the adjacent noise performances of all oscillators.

Consider the case of a GSM receiver which requires a blocking protection of -23 dBm at a fixed offset of its tuned frequency. The sensitivity of the receiver is -104 dBm, with a usual value of -105 dBm and this is degraded by 3 dBm to -101 dBm if the natural noise floor (N_f) of the receiver has the same power level as the unwanted noise (N_u) "mixed" to the intermediate frequency (IF) by any signal received directly or through the local oscillator.

The difference between the blocking protection, taking the minimum unwanted signal level (S_u) as -23 dBm, and the final sensitivity for the wanted signal (S_w) as -101 dBm is 78 dB. At the IF the minimum Signal/Interference noise required is about 8 dB so that $N_u = N_f = (N - 3) = (S - 11)$ dB.

Considering the spectrum of the unwanted mixed signal at the fixed offset (S_u/N_u) this means that the receiver has to accept the equivalent of noise in its antenna port of ($S_w - 11$) dB so that $S_u/N_u = +78 + 11$ i.e. 89 dBc in the modulation bandwidth of the GSM signals (270 kHz). For a 1 kHz bandwidth this means $89 + 10 \log 270\,000 = 89 + 54,3 = 143,3$ dBc/Hz.

The limit applies to wideband spurious performance if the Su/Nu is transmitted by another GSM signal. However if Su/Nu is mixed with the IF through a local oscillator assumed to have worse spectral performance than the unwanted signal, the limit applies to this local oscillator.

GSM standards specify the widest bandwidth measurement to be 100 kHz, so the calculated limit has to be corrected by $10 \log (270/100)$ i.e. 4,3 dB. Thus the requirement for the transmitted S/N of any GSM signal at the fixed frequency offset has to be better than $(89 + 4,3)$ dB i.e. 93,3 dB.

GSM recommendations call for transmitted spurious to be 65 dBc to 75 dBc, so these expected limits are 18,3 dBc to 28,3 dBc below the specified figures. Thus it can be considered that either the blocking requirement of the receivers is so tight that it will never affect a call, or that GSM transmitted spurious noise is not strictly dependent on the sideband noise of the unmodulated sources in use but also on other modulation effects.

For a typical analogue transmission as specified in EN 300 086 [5] for 12,5 kHz channel separation (7,5 kHz modulation bandwidth), the same calculation can be performed. In this case the blocking requirement for unwanted to wanted signals is 87 dB, the minimum S/N at IF for reception is 10 dB, giving $N_u = N_f = (N - 3) = (S - 13)$ dB. Thus Su/Nu is $(87 + 13)$ dB i.e. 100 dBc in a 7,5 kHz bandwidth or referring to a 1 kHz bandwidth $100 + 10 \log (7\ 500)$ i.e. 138,7 dBc/Hz.

B.2.3 Estimation of sideband noise limits

It can be seen that by considering the compatibility between blocking effects of receivers and sideband noise performance of oscillators, both GSM and analogue equipment need to have similar spectral characteristics close to 140 dBc/Hz. However, the spurious specifications of GSM transmitters are not so tight because of the ability in cellular applications to escape from a degraded situation into a neighbouring cell. In PMR, where such a possibility does not exist, these performances are more critical.

Comparing these calculated results to the sideband noise curves plotted in figure B.2, the difference looks marginal and it has been proven by physical measurements that such performances were achievable by many transmitters. These curves show three levels for sideband noise:

- a) the oscillator noise up to an offset of 0,1 %;
- b) the effect of filtering in the driver of the PA showing a first noise floor within its bandwidth for an offset of 0,1 % to 1 %;
- c) the extreme noise floor from the PA for offsets greater than 1 %.

The cases analysed in this annex can be considered to be in the first noise floor region.

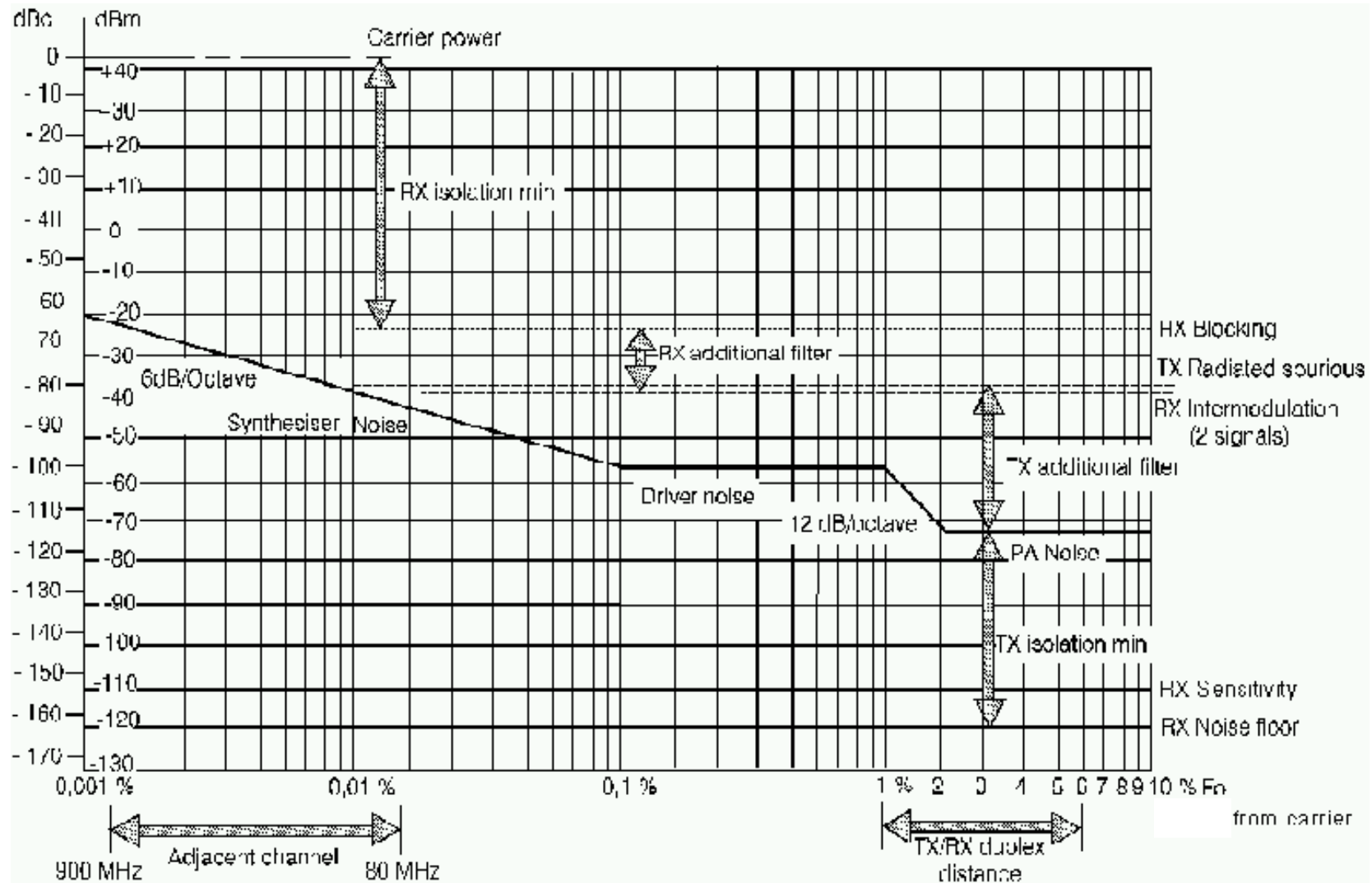

Figure B.2: TX and RX base station compatibility

Annex C (informative): Antennas and feeder systems

C.1 Common antenna configuration

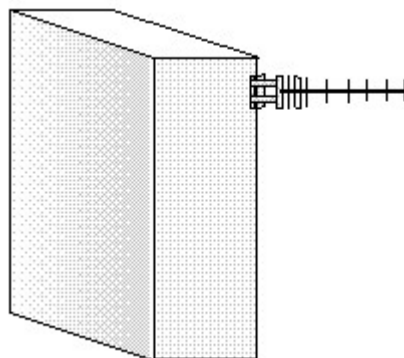

Figure C.1: Solid Structure characteristics as C.2

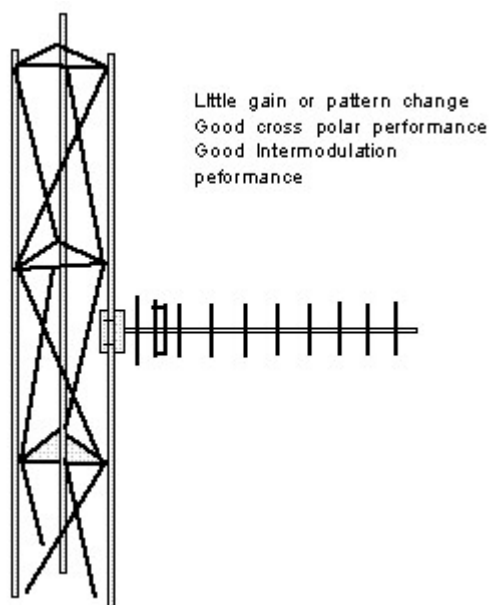
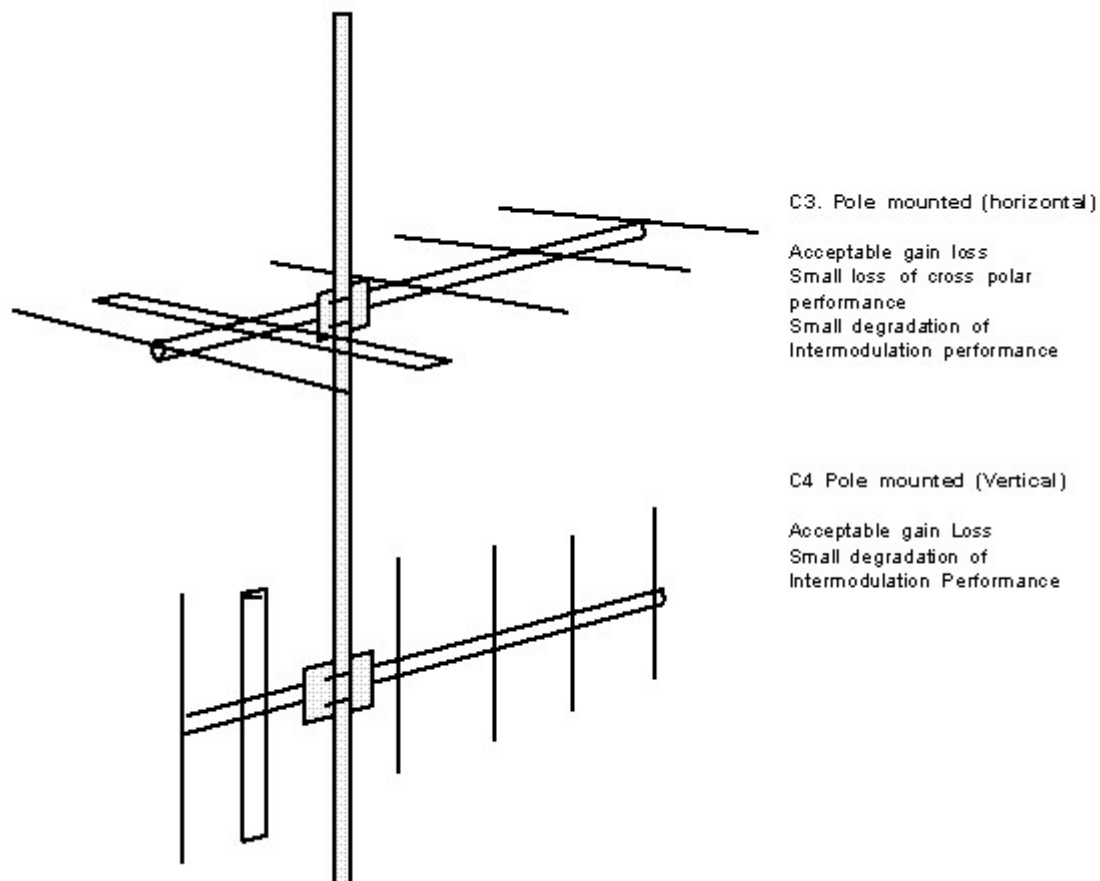
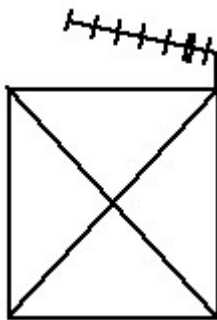

Figure C.2: Triangular metal mast



Figures C.3 and C.4



Loss of directivity dubious cross polar performance

Figure C.5: Square section mast

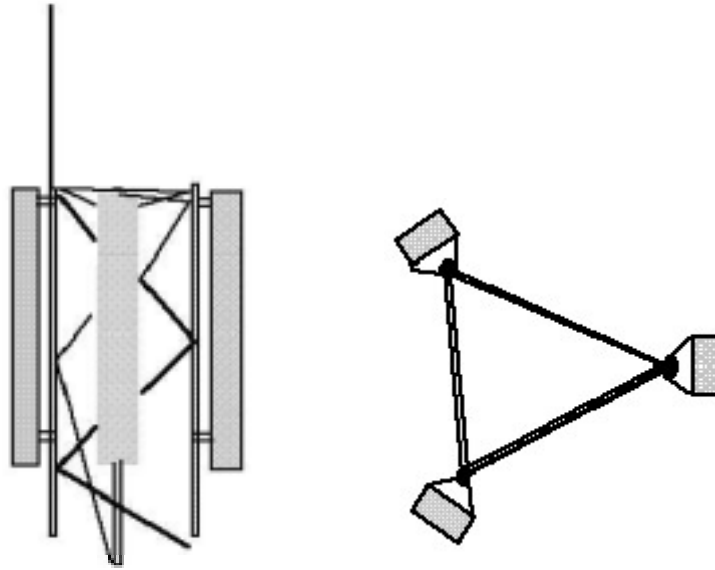

Figure C.6: Typical arrangement of sectored antennas for GSM application (note lightning finial)

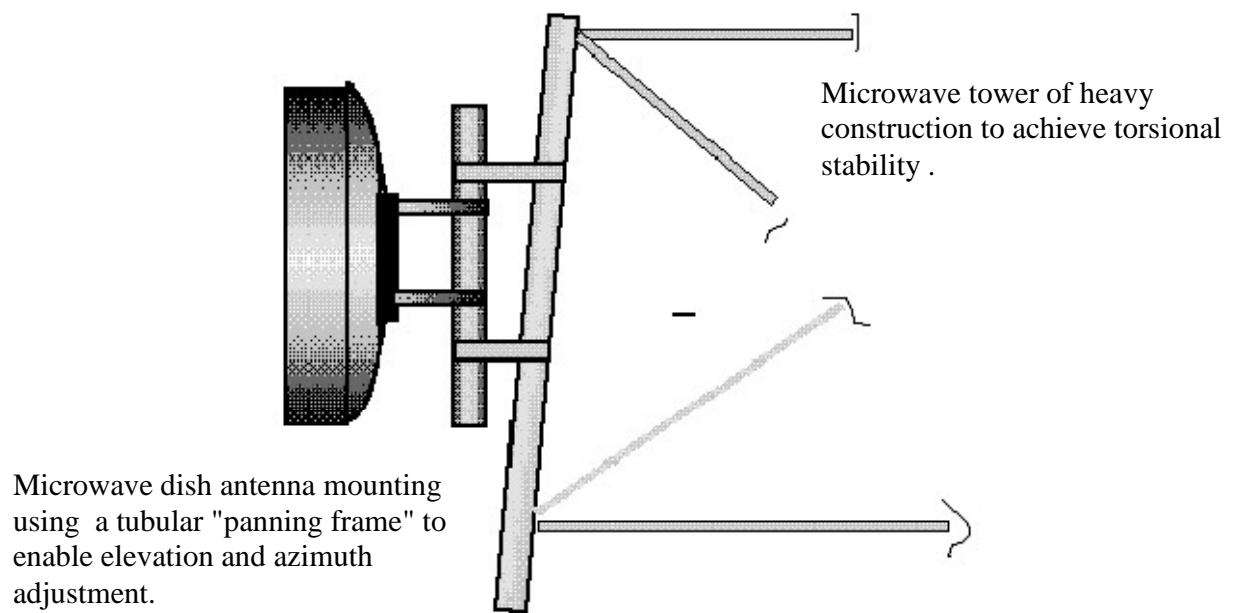

Figure C.7: Typical microwave antenna arrangement

C.2 Stacking and baying data

Table C.1

Frequency MHz	Dimensions (in metres)	
	D	S
35	0,90	3,40
80	0,75	2,70
100	0,60	2,40
125	0,50	1,80
140	0,40	1,70
180	0,40	1,40
400	0,14	0,53
430	0,133	0,48
460	0,127	0,43

NOTE 1: When antennas are stacked, correct phasing is essential. The installer must ensure that all dipoles are mounted on the same side of the booms when erected.

NOTE 2: Dimensions "D" above is a minimum figure for a 51 mm diameter mast. The required polar diagram will determine the actual spacing used. For general purposes, a spacing of $\lambda/4$ is recommended. These points refer also to the installation of a single VHF/UHF antenna.

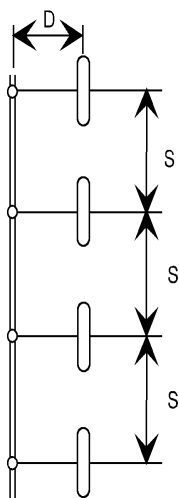

Figure C.8: Side-mounted dipoles stacking data

Yagi antennas
Stacking and baying data

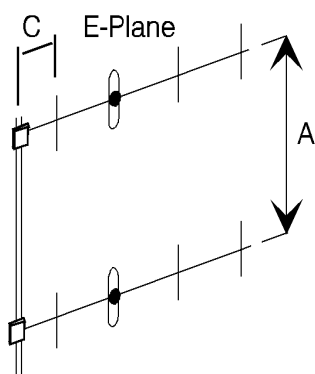

Figure C.9: Vertically polarized (stacked)

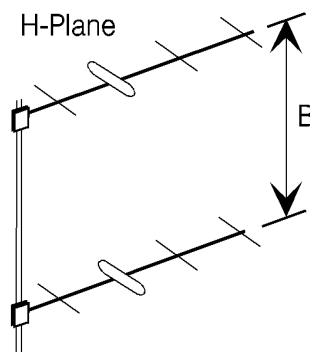

Figure C.10: Horizontally polarized (stacked)

Table C.2

Number of elements	D I M	Frequency (MHz)				
		80	120	160	400	460
2	A	2,30 m	1,50 m	1,20 m		
	B	3,10 m	2,00 m	1,50 m		
3	A	3,00 m	2,00 m	1,10 m		
	B	3,90 m	2,60 m	1,90 m		
4	A	3,80 m	2,20 m	1,70 m		
	B	4,00 m	3,40 m	2,30 m		
6	A		3,20 m	2,30 m		
	B		2,80 m	2,60 m		
8	A			2,80 m		
	B			3,00 m		
9	A				0,70 m	0,60 m
	B				0,70 m	0,60 m
12	A				1,10 m	1,00 m
	B				1,10 m	1,00 m
All types	C	0,40 m	0,25 m	0,20 m	0,08 m	0,06 m

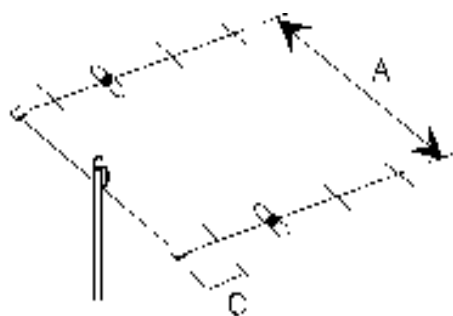

Figure C.11: Horizontally polarized (baying)

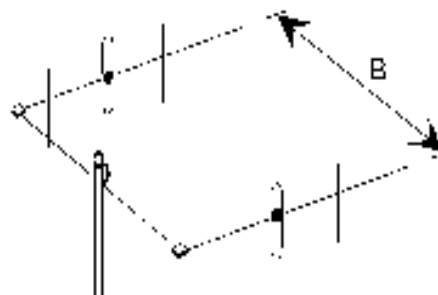

Figure C.12: Vertically polarized (bayed)

C.3 Isolation between antennas

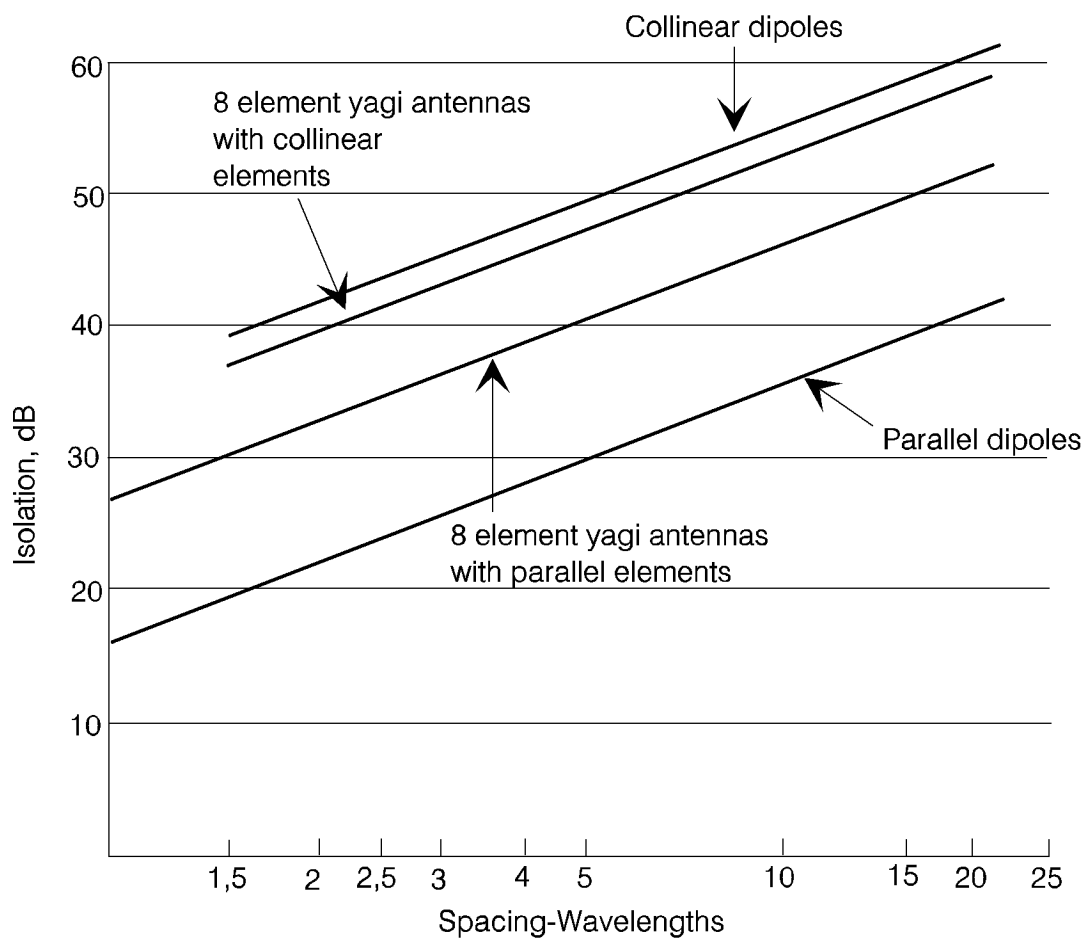

Figure C.13: Typical isolation between antennas

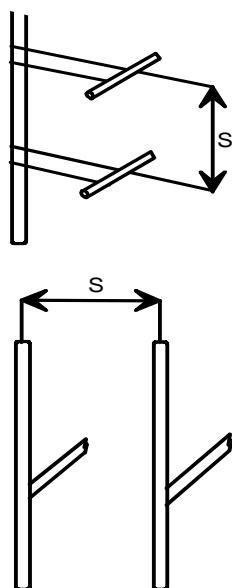

Figure C.14: Parallel elements

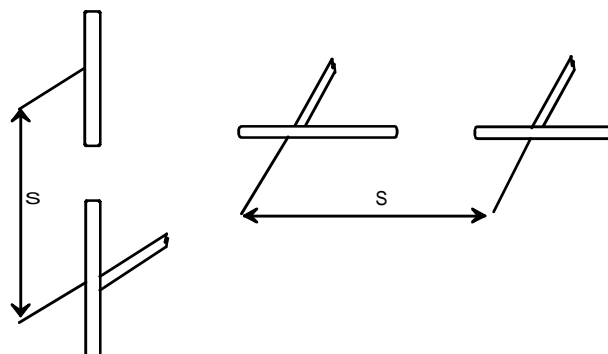

Figure C.15: Collinear elements

C.4 Control of precipitation noise

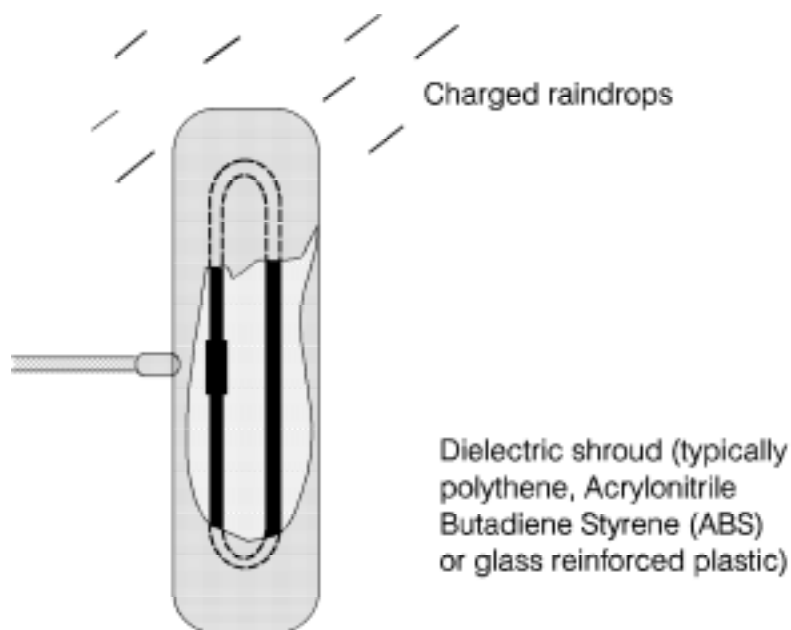

Figure C.16: Folded dipole with a dielectric shroud

Raindrops, sleet and snow particles which fall in highly convective conditions (not only during thunderstorms) often carry electrostatic charges.

When such precipitation falls on antenna elements the transfer of electrostatic charges injects noise impulses into the associated receiver. The effect is particularly troublesome at the lower VHF frequencies where all but the strongest wanted signals may be obliterated.

An insulated shroud may be fitted to the antenna to prevent the direct discharge on the elements. The discharging process on the wetted surface of the shroud still radiates some energy but with a shroud providing 25 mm to 50 mm radial clearance around the elements, the noise power coupled to the receiver is much reduced.

For VHF Yagi antennas, shrouds are usually fitted only to the driven elements.

Yagi antennas operating in the higher UHF bands are often completely encapsulated for protection of their delicate elements rather than for the elimination of precipitation noise.

C.5 Achieved Cross Polar Discrimination (XPD) for antennas mounted at an angle to precise horizontal and vertical frames of axes

Table C.3

Angle of plane of polarization from nominal (degrees)	Achieved XPD for various test range values (dB)			
	Ideal antenna	40	30	20
0° (Correctly aligned)	∞	40	30	20
0,1°	55	38,6	29,6	19,6
0,5°	41	34,6	27,9	19,3
1,0°	35	31,2	26,1	18,6
2,0°	29	27,0	23,5	17,4
5,0°	21	20,2	18,5	14,5

Table C.3 indicates the XPD which is achieved between two antennas mounted with its polarization plane exactly horizontal and the other one exactly vertical, and an antenna mounted with a small angular error. As an example two antennas providing 40 dB XPD when correctly mounted provide a XPD of 27 dB if mounted with an alignment error of 2°.

The table emphasizes the importance of accurate mounting; the achievement of a XPD of 30 dB or more requires especial care at frequencies at which the antenna elements are small or inaccessible. In such cases it is necessary to optimize cross polar performance by electrical measurements.

C.6 Antennas and feeders

C.6.1 Calculation of system reflection performance

For a transmission line to deliver RF power efficiently to a load it is necessary for the load to behave as a pure resistance equal in value to the characteristic impedance of the line. Impedance discontinuities cause RF energy to be reflected back from the discontinuity towards the input of the line.

Reflections upset the uniform distribution of RF voltage and current on the line. Standing waves are established which cause voltage and current maxima and minima to exist at intervals along the length of the line. In severe cases standing waves may cause transmitter shutdown or the failure of system components.

In an RF system having several discontinuities, multiple reflections arrive at the system input with random phase relationships. In the worst case, if the reflections are in phase, voltage addition will occur. The in phase condition will almost certainly exist in a broadband system over some part of the operating frequency band.

Traditionally, Voltage Standing Wave Ratio (VSWR) has been in common use to express the reflection performance of RF systems. In certain situations however, return loss and voltage reflection coefficient prove more useful. The three terms are related by the following formulae:

To convert from VSWR (σ) to voltage reflection coefficient (ρ):

$$\rho = \frac{\sigma - 1}{\sigma + 1}$$

and conversely:

$$\sigma = \frac{1 + \rho}{1 - \rho}$$

Note that ρ is always less than 1 for a passive system; when ρ is expressed as a percentage it must first be rewritten in standard form, e.g. 7 % = 0,07.

Return loss (A_R) is expressed in dB and is given by:

$$A_R = -20 \log_{10}(\rho)$$

or:

$$\rho = 10^{\frac{-A_R}{20}}$$

The return loss measured at the input end of a cable is always greater than that at the load end owing to the attenuation of the cable. The input VSWR is correspondingly lower than that of the load alone. For a cable with an attenuation of 2 dB, the input return loss (A_{in}) is related to the return loss at the load (A_e) by:

$$A_{in} = A_e + 2$$

C.6.2 Points of note concerning the reflection performance of RF systems

- the measurement of VSWR below 1,2:1 (20 dB return loss) is unreliable and meaningless. Return losses, and to a lesser degree reflection coefficients are measurable and meaningful over a far greater range;
- if a transmitter is connected via a transmission line of the correct characteristic impedance to a mismatched load, the return loss at the transmitter $L_{r,in}$ is always greater than that at the load $L_{r,load}$ owing to the attenuation of the cable. For a cable of attenuation (A)dB:

$$L_{r,in} = L_{r,load} + 2A$$

- manufacturers of transmission lines generally guarantee the reflection performance which may be achieved from an installed cable with both connectors fitted and one end terminated in a high quality matched load;

No allowance can be made for cable attenuation in respect of these figures since they are only guaranteed to be measurable at the cable input.

In practice, long cables are more likely to suffer discontinuities along their length. However the increased attenuation inherent in longer cables limits the degradation of reflection performance.

- in an RF system having several discontinuities, multiple reflections arrive at the system input with random phase relationships. In the worst case, if the reflections are in phase, voltage addition will occur. The in phase condition will almost certainly exist in a broadband system over some part of the operating frequency band.

C.6.3 Calculation procedure for system reflection performance

The radio site designer and of the on-site engineer have different needs for a reflection performance calculation method. The calculations of the Radio Site designer should account for the effects of all possible sources of mismatch or reflection and they should be able to predict the range of values which may be expected at any point in the system in the best and in the worst case.

The on site engineer has need of a rapid calculation method which can give a good indication of the performance to be expected even though this may overlook the detailed effects of certain minor reflection sources.

C.6.4 Reflection performance calculations for radio site designers

C.6.4.1 Voltage reflection coefficient method

Detailed calculations of reflection performance should be carried out using voltage ratios and reflection coefficients throughout. The adoption of this method enables the effects of multiple reflections, cable attenuations etc. to be reconciled in a single calculation.

C.6.4.2 Recommended procedure

- all reflection performance values should be expressed as voltage reflection coefficients either by direct measurement or by conversion from VSWR and return loss using the standard formulae or conversion tables. The coefficients should be listed against the system configuration;
- the system RF Attenuations should be converted to voltage ratios and listed in order against the system configuration;
- the voltage reflection coefficient at the input to each stage of the system may be calculated by the application of the formula:

$$\rho_{in} = L_{dev}^2 \times \rho_{out} \pm \rho_{dev}$$

where:

ρ_{in} is the voltage reflection coefficient at the input to the stage in question;

ρ_{out} is the voltage reflection coefficient of the load to the stage in question;

ρ_{dev} is the voltage reflection coefficient at the input to the stage when it is perfectly matched at the output;

L_{dev} is the loss of the stage expressed as a voltage ratio.

NOTE: The sign of the calculation allows the best case and the worst case values to be found.

- the formula is applied systematically working from the output back towards the input thereby obtaining the voltage reflection coefficients existing at the input to each device in the system.

The calculated reflection coefficient values may be converted back to VSWR or return loss values using the conversion formulae or conversion tables as required.

C.6.4.3 Calculation example

An antenna with VSWR of 1,3 is connected via a flexible tail having a 1 dB loss and manufacturer's reflection coefficient 0,07 to a main feeder having a 3 dB loss and manufacturers reflection coefficient 0,01. Calculate the return loss and VSWR to be expected in the best and in the worst case at the input to the main feeder.

- Convert all parameters to Voltage Ratios and Reflection Coefficients

Antenna	VSWR	= 1,30:1
	Reflection Coefficient	$\rho_A = 0,13$
Antenna Tail	Loss	1 dB
	Voltage Ratio	$L_T = 0,89$
	Reflection Coefficient	$\rho_T = 0,07$
Main Feeder	Loss	3 dB
	Voltage Ratio	$L_F = 0,707$

Reflection Coefficient

$$\rho_F = 0,01$$

b) Calculate ρ at the input to the antenna tail

$$\begin{aligned}\rho_{in} &= 0,89^2 \times 0,13 \pm 0,070 \\ &= 0,173 \text{ Worst Case} \\ &= 0,033 \text{ Best Case}\end{aligned}$$

c) Calculate ρ at the input to the main feeder

In the worst case

$$\begin{aligned}\rho_{in} &= 0,707^2 \times 0,173 + 0,1 \\ &= 0,186 \text{ 5}\end{aligned}$$

In the best case

$$\begin{aligned}\rho_{in} &= 0,707^2 \times 0,033 - 0,1 \\ &= 0,083 \text{ 5}\end{aligned}$$

d) Convert to VSWR

$$1 + 0,186 \text{ 5} = 1,46:1 \text{ Worst Case}$$

$$1 - 0,186 \text{ 5}$$

$$1 + 0,083 \text{ 5} = 1,18:1 \text{ Best Case}$$

$$1 - 0,083 \text{ 5}$$

e) Convert to return loss

$$-20 \log_{10} (0,186 \text{ 5}) = 14,6 \text{ dB Worst Case}$$

$$-20 \log_{10} (0,083 \text{ 5}) = 21,6 \text{ dB Best Case}$$

C.6.5 Reflection performance calculations for radio site engineers

C.6.5.1 Return loss method

The matching condition or reflection performance of RF systems may be rapidly evaluated by calculation of the return loss to be expected throughout the system.

The method is simple and effective and it lends itself to mental calculation so that an experienced engineer will have expected values for any measurements he may make on site. This is a considerable advantage in recognizing problems and diagnosing their cause.

The method is based upon the fact that Return Loss (RL) (dB) of a load is modified by any intervening attenuation A (dB) according to the formula:

$$RL_{in} = RL_{load} + 2A$$

and therefore conversely:

$$RL_{load} = RL_{in} - 2A$$

It is therefore possible to calculate return loss at the distant end of an RF system from a local return loss measurement providing the system attenuation is known.

C.6.5.2 Recommended procedure

The following procedure should be followed:

- all reflection performance values should be expressed as return loss (dB) either by direct measurement or by conversion from VSWR and reflection coefficient using the standard formulae or conversion tables;
- the known system return loss values and RF attenuations should be listed in order against the system configuration;
- the formula should be applied systematically to calculate the return loss at different stages of the system.

NOTE: It is not usually possible to calculate the effects of multiple reflection sources using this method, however a rule of thumb assessment is possible using the fact that if two reflections present identical return losses at a point when considered in isolation the resultant return loss when they act together could be up to 6 dB worse.

In most cases one reflection source dominates (has substantially lower return loss) and the effects of the minor reflection are ignored.

C.6.5.3 Example calculations

- A faulty antenna is connected to a feeder having an attenuation of 6 dB. What is the return loss and VSWR to be expected in the equipment room?

RL of open circuit antenna = 0 dB (assumed)

$$RL_{(in)} = 0 + (2 \times 6)$$

$$= 12 \text{ dB}$$

$$VSWR = 1,67:1$$

- An antenna having a VSWR of 1,50: 1 is fed by a flexible feeder tail of 0,5 dB loss and then via a main feeder of 3 dB to the equipment room. What is the expected return loss and VSWR when measured at the equipment room connector?

Antenna VSWR 1,5: 1 = Return Loss 14 dB

Return Loss at Main Feeder (top) = 14 + (2 × 0,50)

$$= 15 \text{ dB}$$

Return Loss at Main Feeder (bottom) = 15 + (2 × 3)

$$= 21 \text{ dB}$$

Return Loss 21 dB

VSWR 1,20:1

- The feeder of b) above becomes damaged and when terminated with a known good 50 Ω load (having return loss > 30 dB) exhibits a return loss of 20 dB at the equipment room. If the cable attenuation is unchanged what return loss and VSWR could be expected when the antenna is connected?

Assuming that the reflections are in phase:

RL approximately 14 dB or VSWR = 1,50:

If the reflection is in perfect antiphase the cancellation occurs and the match appears to be perfect:

RL > 30 dB+ VSWR < 1,06:1

Table C.4 is included for ease of reference.

Table C.4: Conversion table

VSWR	Return loss (dB)	Transmission loss (dB)	Voltage reflection coefficient (ρ)
1,00		0,000	0,00
1,01	46,1	0,000	0,00
1,02	40,1	0,000	0,01
1,03	36,6	0,001	0,01
1,04	34,2	0,002	0,02
1,05	32,3	0,003	0,02
1,06	30,7	0,004	0,03
1,07	29,4	0,005	0,03
1,08	28,3	0,006	0,04
1,09	27,3	0,008	0,04
1,10	26,4	0,010	0,05
1,11	25,7	0,012	0,05
1,12	24,9	0,014	0,06
1,13	24,3	0,016	0,06
1,14	23,7	0,019	0,07
1,15	23,1	0,021	0,07
1,16	22,6	0,024	0,07
1,17	22,1	0,027	0,08
1,18	21,7	0,030	0,08
1,19	21,2	0,033	0,09
1,20	20,8	0,036	0,09
1,21	20,4	0,039	0,10
1,22	20,1	0,043	0,10
1,23	19,7	0,046	0,10
1,24	19,4	0,050	0,11
1,25	19,1	0,054	0,11
1,26	18,8	0,058	0,12
1,27	18,5	0,062	0,12
1,28	18,2	0,066	0,12
1,29	17,9	0,070	0,13
1,30	17,7	0,075	0,13
1,32	17,2	0,083	0,14
1,34	16,8	0,093	0,15
1,36	16,3	0,102	0,15
1,38	15,9	0,112	0,16
1,40	15,6	0,122	0,17
1,42	15,2	0,133	0,17
1,44	14,9	0,144	0,18
1,46	14,6	0,155	0,19
1,48	14,3	0,166	0,19
1,50	14,0	0,177	0,20
1,52	13,7	0,189	0,21
1,54	13,4	0,201	0,21
1,56	13,2	0,213	0,22
1,58	13,0	0,225	0,22
1,60	12,7	0,238	0,23
1,62	12,5	0,250	0,24
1,64	12,3	0,263	0,24
1,65	12,1	0,276	0,25
1,68	11,9	0,289	0,25
1,70	11,7	0,302	0,26
1,72	11,5	0,315	0,26
1,74	11,4	0,329	0,27
1,76	11,2	0,342	0,28
1,78	11,0	0,356	0,28
1,80	10,9	0,370	0,29
1,82	10,7	0,384	0,29

VSWR	Return loss (dB)	Transmission loss (dB)	Voltage reflection coefficient (ρ)
1,84	10,6	0,398	0,30
1,86	10,4	0,412	0,30
1,88	10,3	0,426	0,31
1,90	10,2	0,440	0,31
1,92	10,0	0,454	0,32
1,94	9,9	0,468	0,32
1,96	9,8	0,483	0,32
1,98	9,7	0,497	0,33
2,00	9,5	0,512	0,33
2,50	7,4	0,881	0,43
3,00	6,0	1,249	0,50
3,50	5,1	1,603	0,56
4,00	4,4	1,938	0,6
4,50	3,9	2,255	0,64
5,00	3,5	2,553	0,67
5,50	3,2	2,834	0,69
6,00	2,9	3,100	0,71
6,50	2,7	3,351	0,73
7,00	2,5	3,590	0,75
7,50	2,3	3,817	0,76
8,00	2,2	4,033	0,78
8,50	2,1	4,240	0,79
9,00	1,9	4,437	0,8
9,50	1,8	4,626	0,81
10,00	1,7	4,807	0,82
11,00	1,6	5,149	0,83
12,00	1,5	5,466	0,85
13,00	1,3	5,762	0,86
14,00	1,2	6,040	0,87
15,00	1,2	6,301	0,88
16,00	1,1	6,547	0,88
17,00	1,0	6,780	0,89
18,00	1,0	7,002	0,89
19,00	0,9	7,212	0,90
20,00	0,9	7,413	0,90
25,00	0,7	8,299	0,92
30,00	0,6	9,035	0,94

Annex D (informative): Noise power on typical radio sites

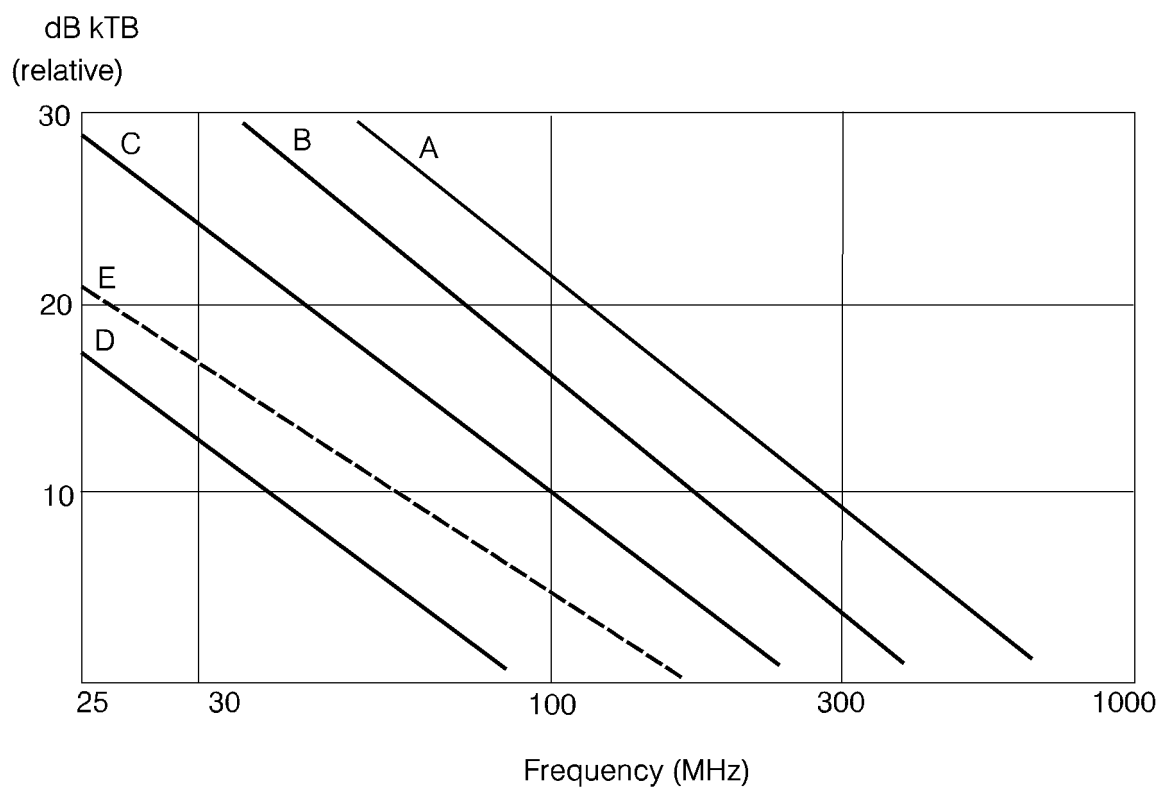

Environmental category:

- A: business
- B: residential
- C: rural
- D: quiet rural
- E: galactic

Figure D.1: Mean values of man-made noise for a short vertical lossless grounded monopole antenna

The above graph has been taken from CCIR Report 258-4 [4], and has been expanded from 25 MHz to 1 000 MHz for ease of reference to the Land Mobile Service.

Annex E (informative): The position of metals in the galvanic series

The use of dissimilar metals in an antenna support structure can cause considerable trouble due to electrolytic corrosion.

Unless metals of similar potential are used, or the appropriate protective paints applied, corrosion will occur at the point of contact even when care has been taken to exclude moisture.

The various metals may be arranged in groups according to their electro-potentials. Metals from the same group may be used together with little risk. However, metals from different groups will suffer corrosive effects.

Data is available detailing the electro-potentials of various metals. The data is normally expressed as the potential difference of the metal relative to a Hydrogen electrode as given in table E.1.

Table E.1: Galvanic series (Potential between metal and a hydrogen electrode)

METAL	POTENTIAL (Volt)
Magnesium	+ 2,40
Aluminium	+ 1,70
Duraluminium	+ 1,1
Zinc	+ 0,762
Chromium	+ 0,557
Chromium/Iron Alloys	+ 0,51
Iron (Fe ³⁺)	+ 0,441
Cadmium	+ 0,401
Chromium/Nickel/Iron	+ 0,231
Nickel	+ 0,19
Tin	+ 0,136
Lead	+ 0,122
Iron (Fe ²⁺)	+ 0,045
Brasses	-0,1 to 0
Bronzes	- 0,1 to -0,2
Nickel/Copper	- 0,2
Copper (CU ²⁺)	- 0,344
Copper (CU ⁺)	- 0,470
Silver	- 0,798
Lead	- 0,80
Platinum	- 0,863
Gold (AU ⁴⁺)	- 1,360
Gold (AU ⁺)	- 1,50

Annex F (informative): Equipment arrangements

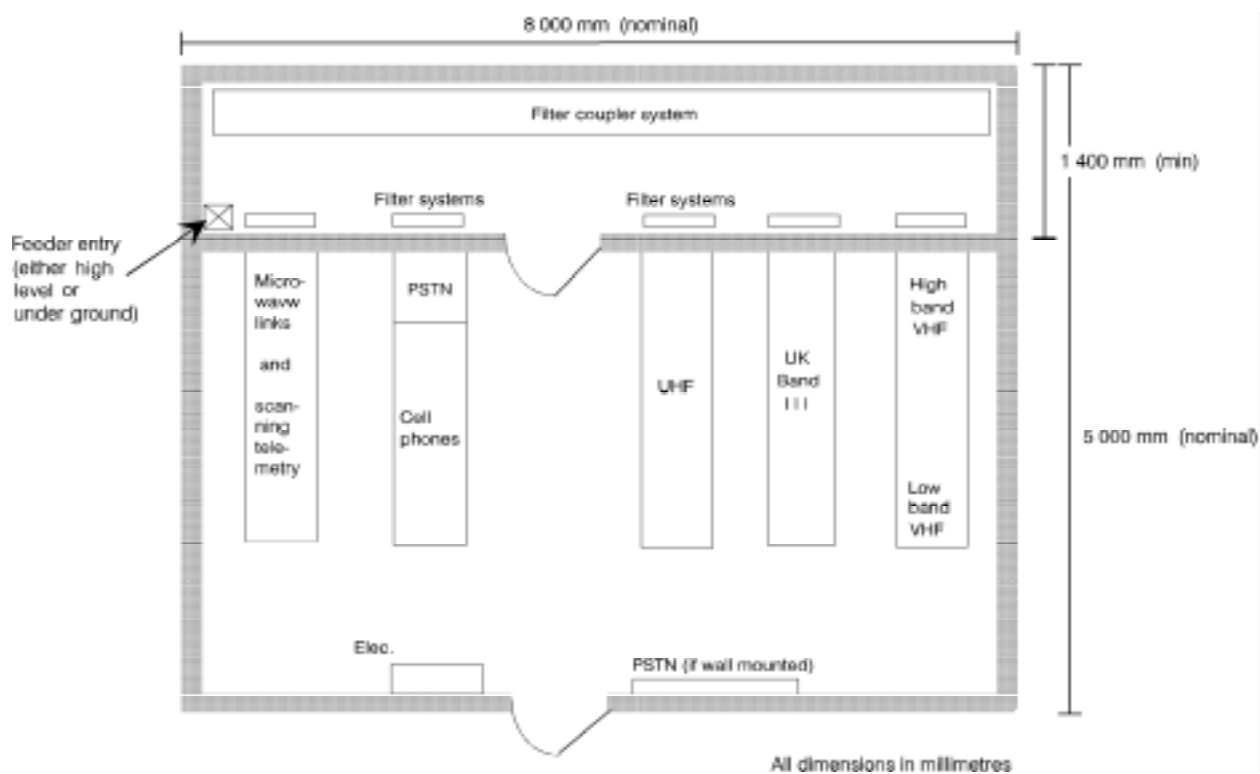

Figure F.1

Annex G (informative): Typical example of good earthing practice

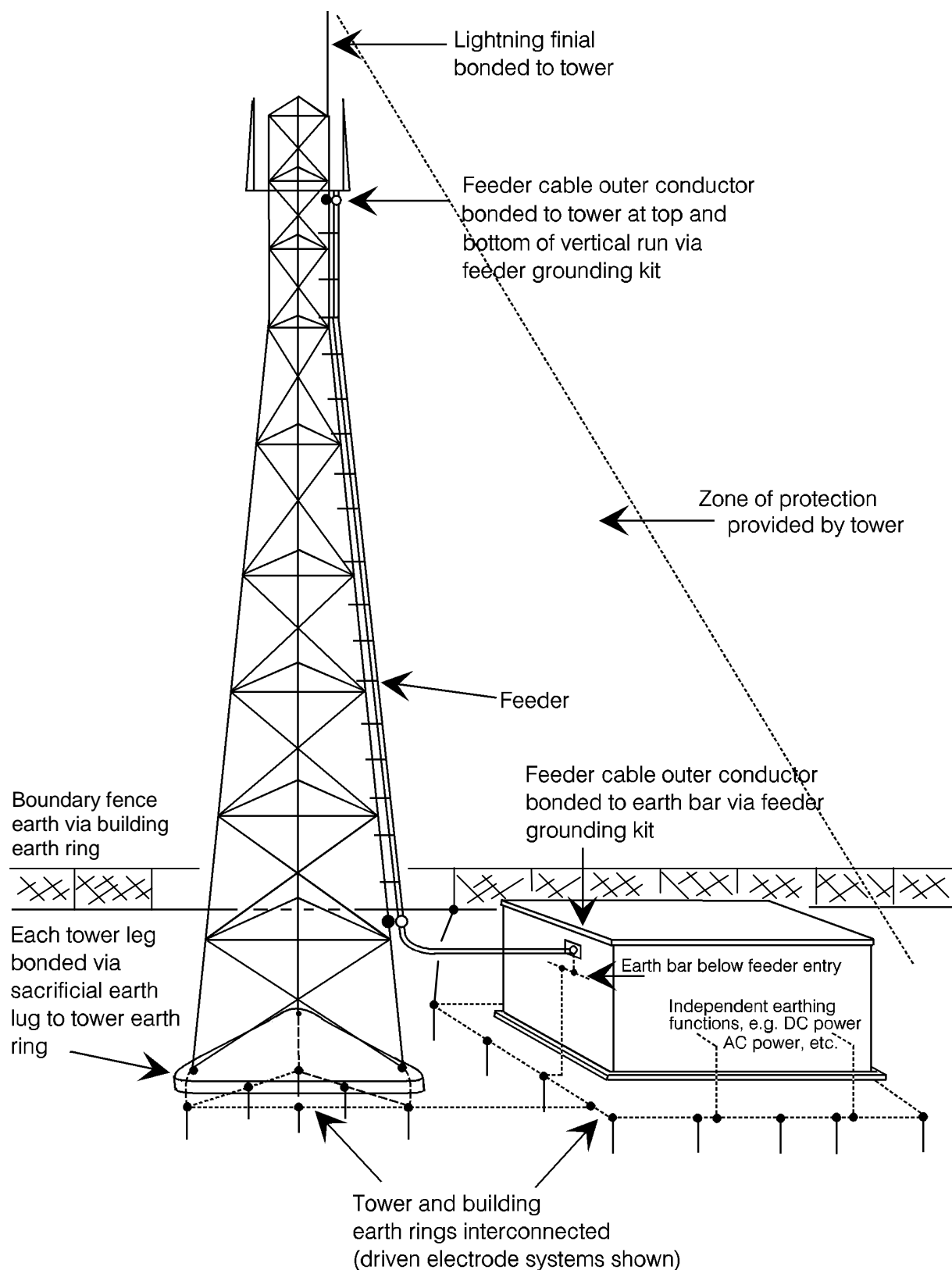

Figure G.1

Annex H (informative): Equipment used to avoid radio frequency problems

H.1 Cavity resonators

H.1.1 Introduction

Throughout this annex many references have made to the use of cavity resonators. This clause has been included for the benefit of those encountering cavity resonators for the first time.

H.1.2 General

The main characteristic of cavity resonators is their high selectivity. They can be used to protect receiver inputs from strong off frequency signals which can generate interference and they can also provide isolation between transmitters and reduce spurious emissions. The selectivity curve of a typical high-band cavity resonator is shown in figure H.1.

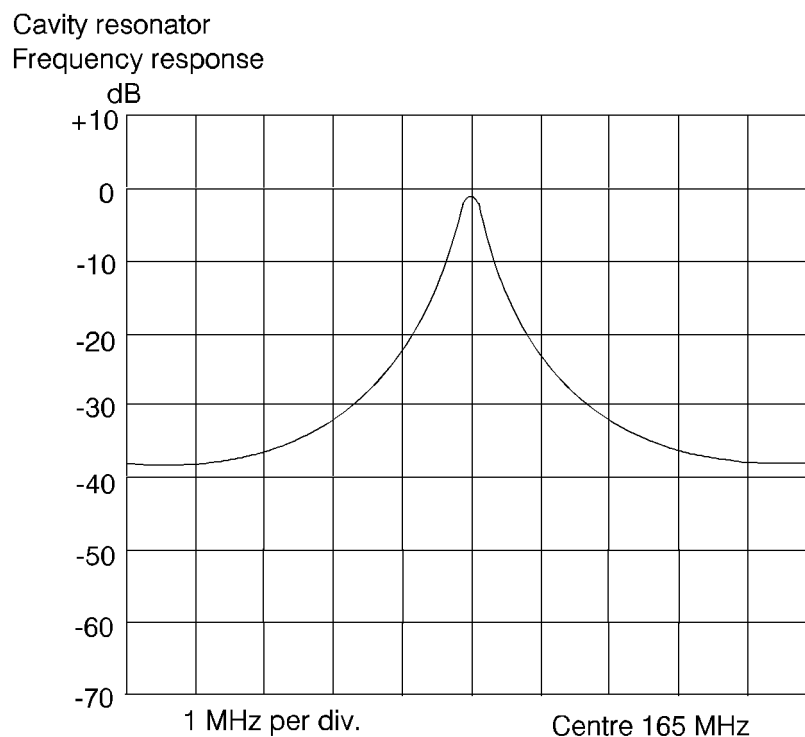

Figure H.1: Cavity resonator frequency response

H.1.3 Typical applications

A cavity resonator can be employed when analysing interference problems, particularly those which occur at radio sites. Receiver deficiencies can be identified by inserting the cavity resonator in the lead between the aerial and the receiver. If this cures the interference it indicates that the receiver has a spurious response or is overloaded by off frequency signals. Note that although the selectivity of the cavity resonator is very high the pass-band will include several 12,5 kHz spaced channels.

When monitoring close to radio sites problems can be encountered in the form of breakthrough into receiving equipment. A cavity filter can often help in this situation. To be effective, the cavity resonator must be used ahead of any active stages in the signal path, such as pre-amplifiers and converters. The slight reduction in the signal to noise ratio, caused by the insertion loss of the cavity resonator, does not usually cause a problem.

When investigating intermodulation problems with a spectrum analyser care should be taken to ensure that signals displayed on the screen are not internally generated. Figure H.2 shows the display of a spectrum analyser used without a cavity resonator. Signal C is observed only when signals A and B are present simultaneously. The difference in level between signals A and B and the third order intermodulation product (signal C) is greater than the dynamic range of the analyser. Note that signals which could cause the analyser to be overloaded can fall outside the part of the spectrum being displayed.

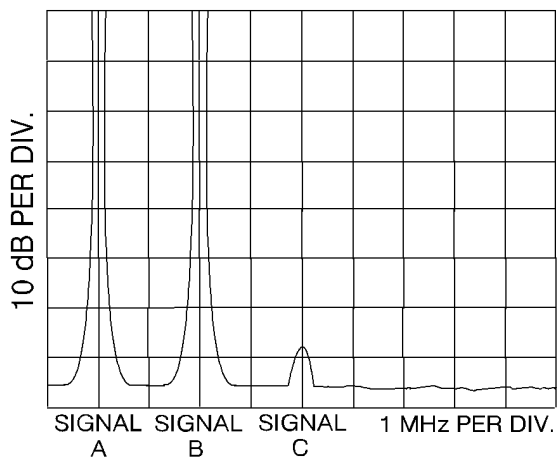

Figure H.2

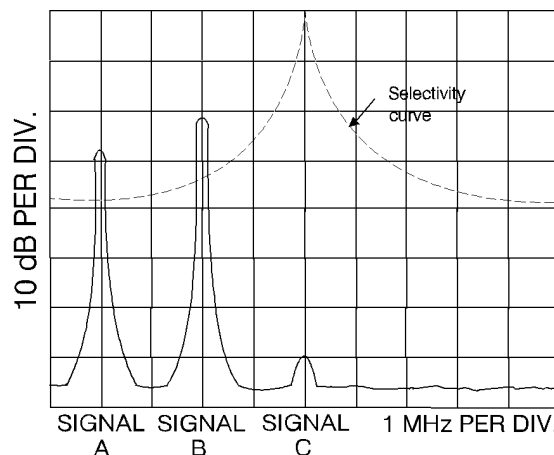

Figure H.3

In figure H.3 the analyser is used with a cavity resonator. The selectivity curve is shown dotted. Signals A and B are attenuated so that they are within the dynamic range of the analyser. In this particular case signal C remains, thus proving that it is being received and not generated within the analyser.

Cavity resonators are used to provide transmitter isolation on multicoupled sites. A typical installation is shown in figure H.4.

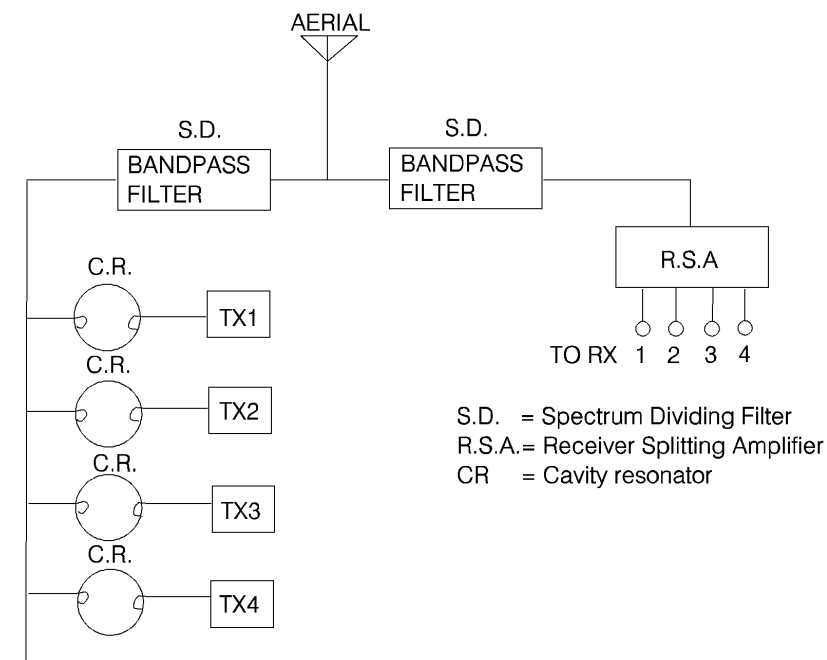

Figure H.4

H.1.4 Cavity resonator construction

A cavity resonator is formed when conducting walls surround a space. They are often made cylindrical in shape and the electrical resonant frequency of the cavity is dependent on the physical dimensions and the mode of operation. The electrical behaviour of the cavity resonator is similar to a capacitor and inductor combination. A common form of construction is shown in figure H.5.

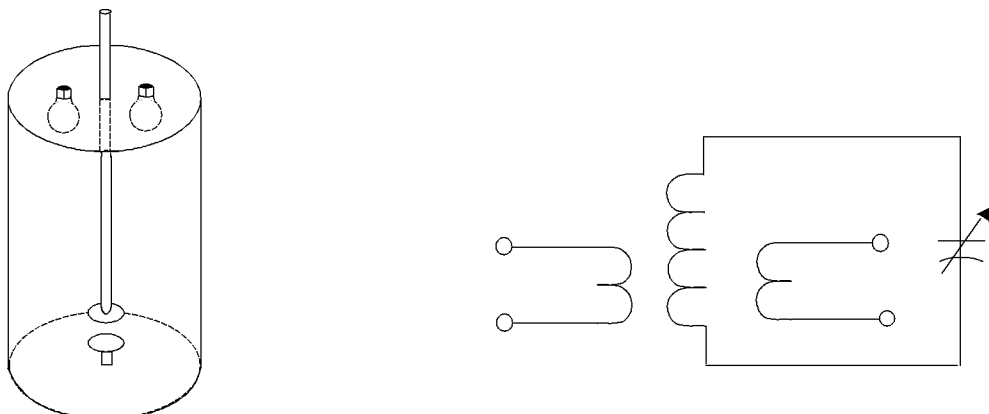

Figure H.5

Figure H.6 gives a simplified explanation of how a cavity resonator is derived from a tuned circuit with lumped components. Progressively lower inductances are used to tune a fixed capacitor to higher frequencies. In figure H.6b, the coil is reduced to a single hairpin loop. In figure H.6c, two loops are connected to the same capacitor and the inductance is halved. Further loops are added in figure H.6d. The cavity shown in figure H.6e is, in effect, an infinite number of loops in parallel.

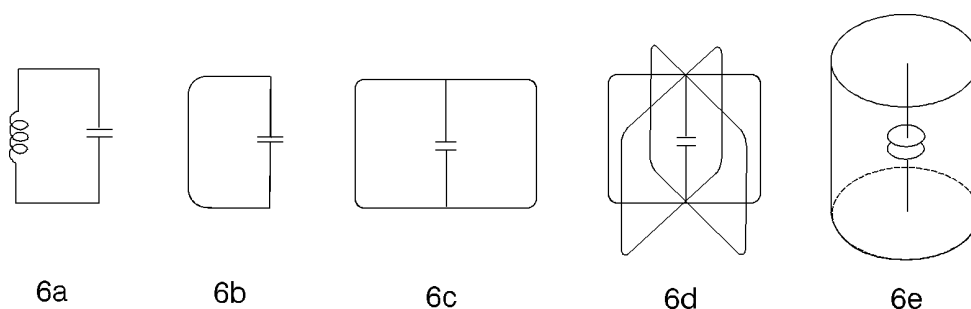

Figure H.6

The coaxial construction of the cavity resonator is similar to a quarter-wave section of transmission line that is open at one end. Like a quarter wave stub, the cavity possesses additional resonances on odd-harmonic frequencies. These resonances can be used to extend the useful frequency range but make the cavity resonator unsuitable for use as a transmitter harmonic filter.

The factor "Q" is used as a measure of the selectivity of a tuned circuit. It can be found from:

$$Q = \frac{f}{b}$$

where:

- Q = loaded Q;
- f = centre frequency (Hz);
- b = bandwidth to 3 dB points (Hz).

A typical cavity resonator would have a frequency range of 145 MHz to 180 MHz, with a power rating of 100 W, possess a Q in the order of 1 000 with an insertion loss of about 1 dB. One of the coupling loops is normally adjustable and its purpose is to provide fine adjustment of the input matching. The cavity resonators are normally supplied with these loops locked in the maximum coupling position. A greater Q can be achieved at the expense of insertion loss, but this involves changing the loop size. This should not be attempted.

H.1.5 Alignment

To align the cavity resonator a signal generator is used in conjunction with a spectrum analyser as shown in figure H.7.

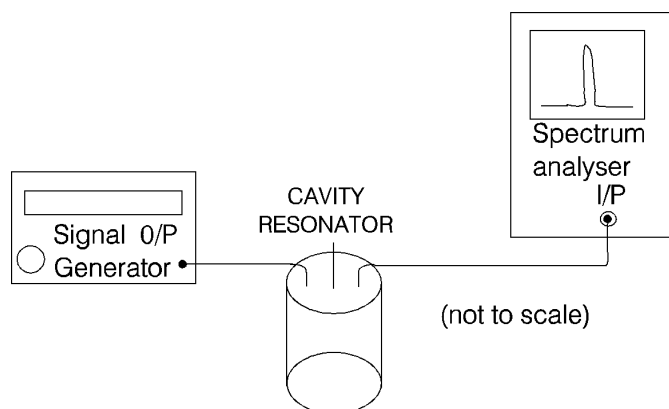

Figure H.7

With the locking screw loosened, the central tuning rod is moved in or out until the position for minimum loss (maximum signal) is found. Moving the tuning rod inwards lowers the frequency and vice versa. This provides a coarse method of tuning.

Fine tuning is normally achieved by means of an adjusting nut. It is usually positioned on the tuning rod so that it is in contact with the collar at the top of the cavity resonator and then tightened to the rod by means of a screw. Rotation of the nut clockwise or anti-clockwise now provides fine tuning HF or LF respectively. Because there is not usually a return spring, it is necessary to apply a manual pressure to the tuning rod towards the cavity whilst adjusting the nut. Once the final tuning point has been found the tuning rod locking screw can be tightened. Check that this final tightening does not alter the tuning. The adjusting nut can now be removed from the tuning rod.

If the cavity resonator is to be used on the output of a transmitter, as in a multi-coupled system, a more suitable method of alignment is shown in figure H.8. A power meter is inserted in the lead between the transmitter and the cavity resonator and the tuning rod is adjusted for minimum reflected power. This method has the advantage of not requiring the power meter to be inserted on the output side of the cavity resonator where the output cable may be acting as a phasing line. Although rotation of the adjustable coupling loop might improve the matching still further there is a possibility that this would compensate for poor positioning of the tuning rod and result in excessive insertion loss. The coupling loop should therefore be left in the position as supplied by the manufacturers.

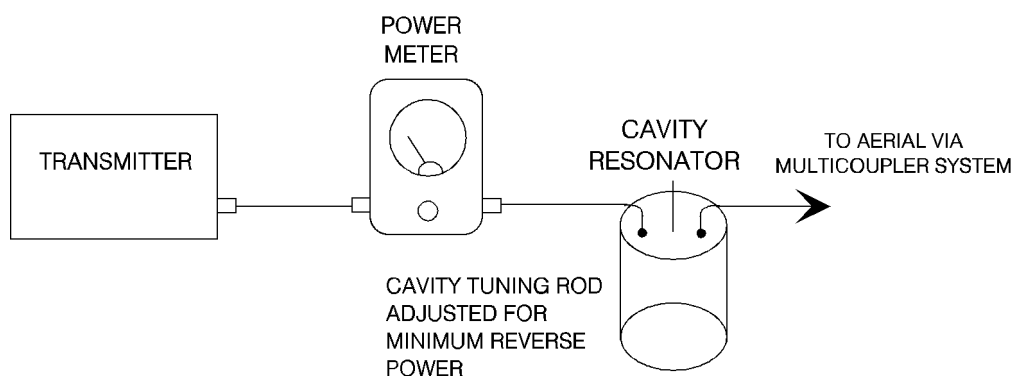

Figure H.8

Cavity resonators that are primarily designed as bandpass filters can also be used as a notch filter. As shown in figure H.9, the cavity resonator is used in conjunction with a quarter wave section of cable which is "T"ed into the transmission line. The quarter wave section of cable transforms the high impedance at resonance at the cavity terminal to a low impedance at the "T", which attenuates the unwanted signal. Because the coupling loop within the cavity acts as an extension of the quarter wave section of cable, the physical length of the section needs only to be about 1/8 wavelength. Typical cavity resonators only produce about 10 dB notch when used in this manner (although it is often very sharp). Modification to the loop to obtain a more useful notch should not be attempted.

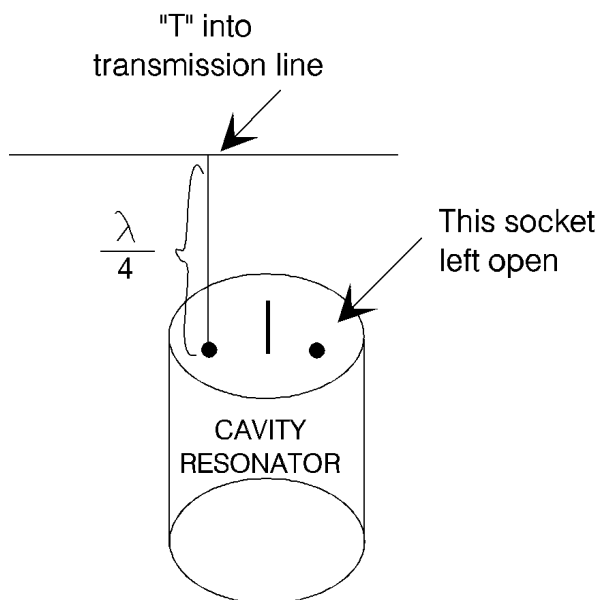

Figure H.9

Although not specifically designed for the purpose, the cavity resonator can be used in a third-harmonic resonance mode, thus extending their frequency range with reduced performance.

H.2 Ferrite isolators and circulators

H.2.1 Introduction

Throughout this ETR many references have been made to the use of ferrite isolators and circulators. This clause has been included for the benefit of those meeting the devices for the first time.

H.2.2 General

The ferrite isolator is a device which allows RF power to flow in only one direction. Power entering at the "IN" port will go to the "OUT" port with a small loss (< 1 dB typical). Power entering the "OUT" port will go to the "LOAD" port to be dissipated in a termination, thus providing isolation (> 25 dB typical). With the load removed from the third port the device can be used as a circulator.

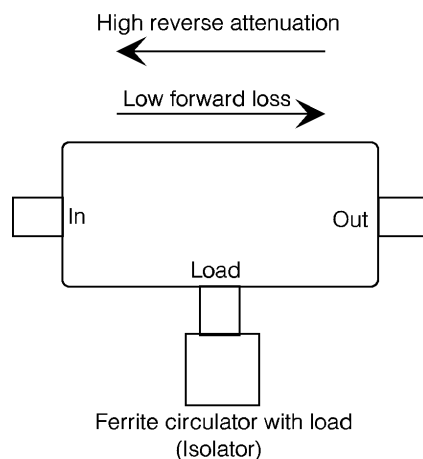

Figure H.10

H.2.3 Typical applications

The non-reciprocal property of the isolator can often be used to reduce or eliminate intermodulation between co-sited transmitters. A common situation where intermodulation occurs is shown in figure H.11. Because of the close proximity of the two aerials, the RF power from transmitter 2 finds its way into the power amplifier (PA) stage of transmitter 1. Non-linearity in the PA stage causes the two carrier frequencies to mix and unwanted intermodulation products are radiated via the antenna. Similarly, the RF from transmitter 1 can find its way into the PA of transmitter 2, where the same effect occurs.

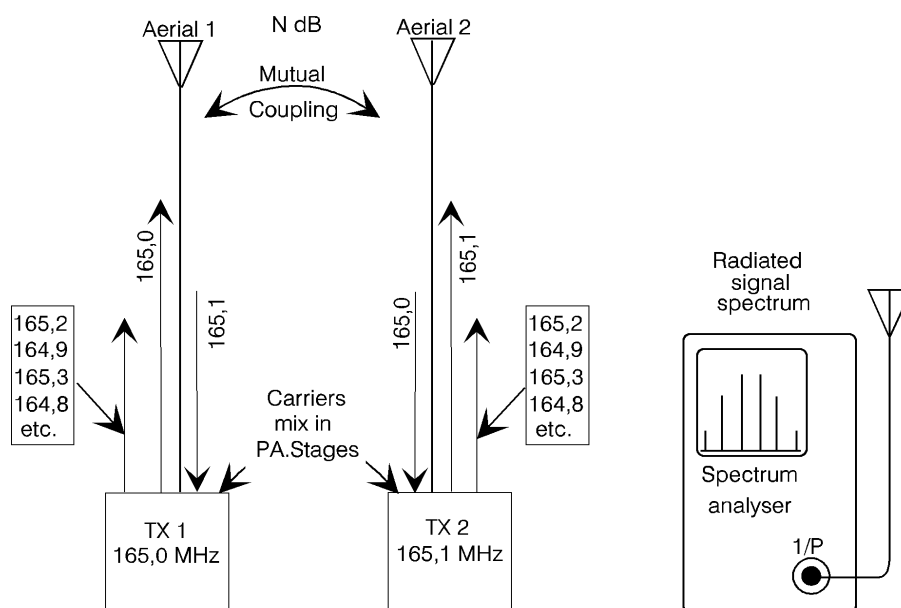

Figure H.11

These unwanted frequencies exist as radiated signals and can sometimes be radiated a considerable distance. No amount of filtering at the receiver can eliminate those that fall within the receiver passband.

One solution to this problem is shown in figure H.12, where isolators are inserted in the output lead of each transmitter and the unwanted RF energy is absorbed in the load associated with each isolator.

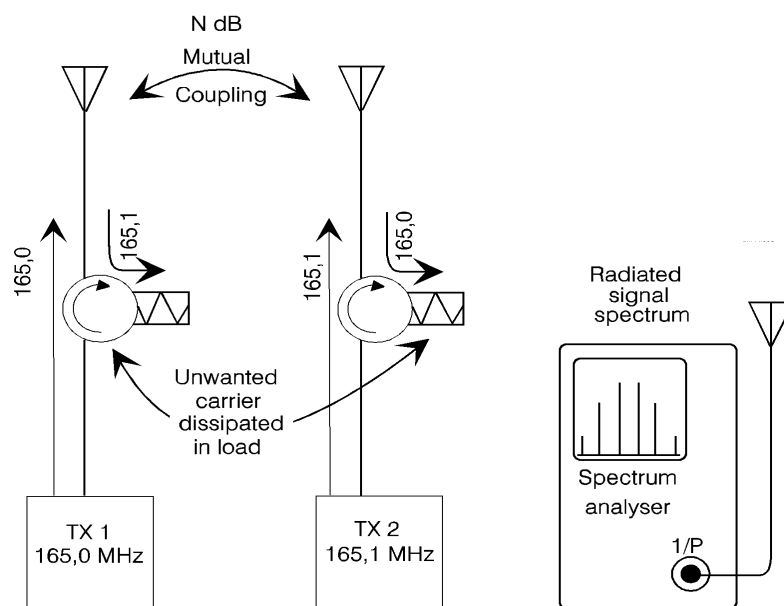

Figure H.12

The isolator also protects the transmitter against a high VSWR should the aerial or cable become faulty, as the transmitter power is then diverted to the load. Under such fault conditions the load needs to be capable of handling the full transmitter power.

As a general rule it is better to make sure that the intermodulation problem is not due to a faulty transmitter or antenna system before fitting an isolator as these devices can clear a problem by masking the actual fault. Note that the isolator cannot be fitted in a feeder carrying both transmit and receive signals.

The useful bandwidth over which the non-reciprocal effect occurs is about 1,5 % of the centre frequency. A plot of the forward and reverse attenuation is shown in figure H.13. It can be seen that the isolator is suitable for "close-in" intermodulation problems. If the frequency spacing of the transmitters is greater than the isolator bandwidth it is likely that a bandpass filter will provide better isolation.

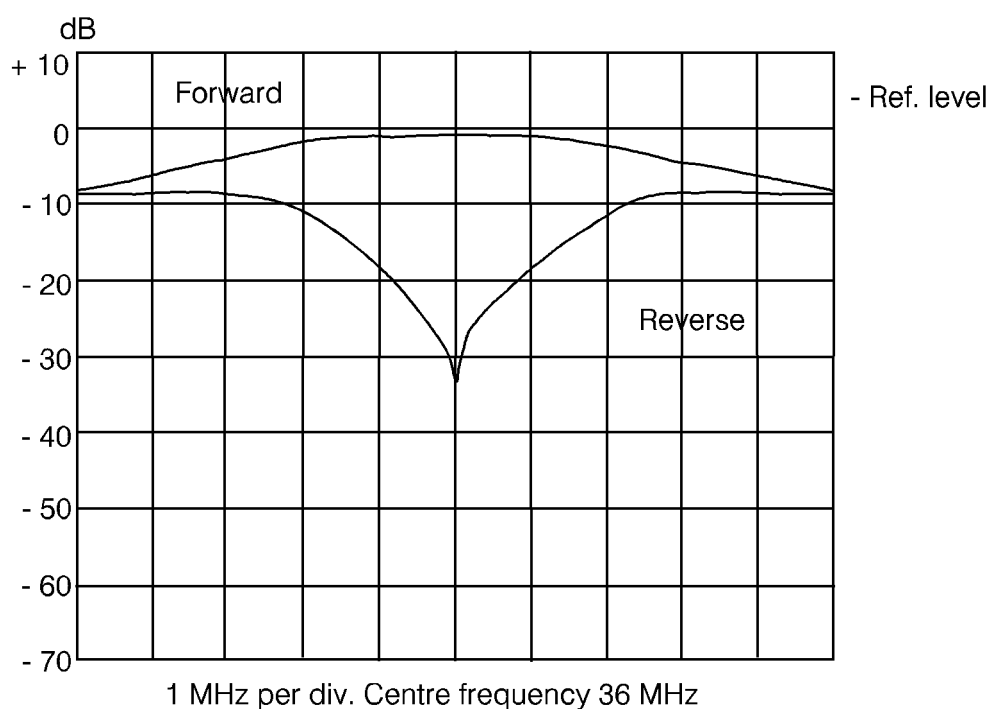

Figure H.13

As a circulator, the device can be used to split transmit and receive paths for duplex operation, see figure H.14.

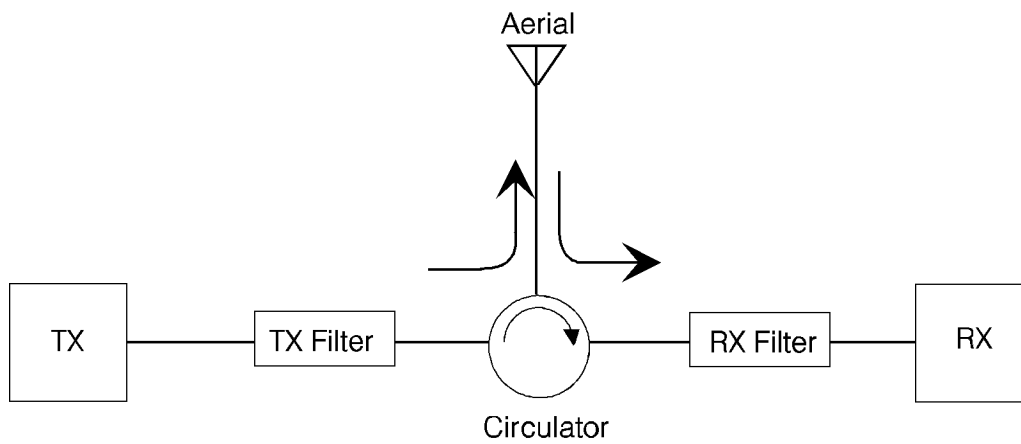

Figure H.14

H.2.4 Ferrite isolator construction

The ferrite isolator consists of a central element called variously a hexalator, isoductor, gyator, Non-Reciprocal Junction (NRJ) according to the manufacturer. Each of the three terminals of this device has associated with it a matching circuit, as in figures H.15 and H.16.

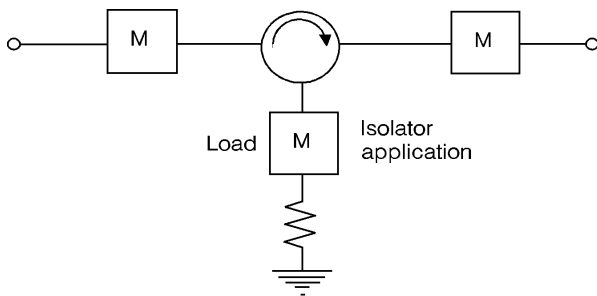

Figure H.15

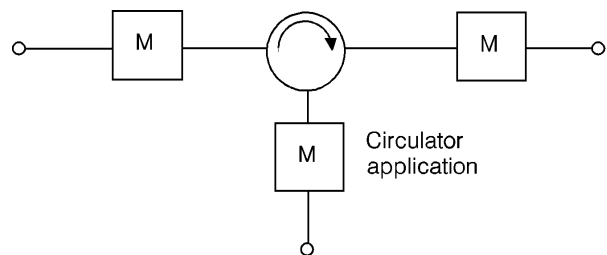

Figure H.16

Ferrite isolators are normally supplied factory tuned. If the problem under investigation involves frequencies outside of this alignment it may be necessary to re-align the circulator. The maximum through power rating is typically 30 W.

H.3 Characteristics of distribution amplifiers

H.3.1 Receiver distribution amplifier system

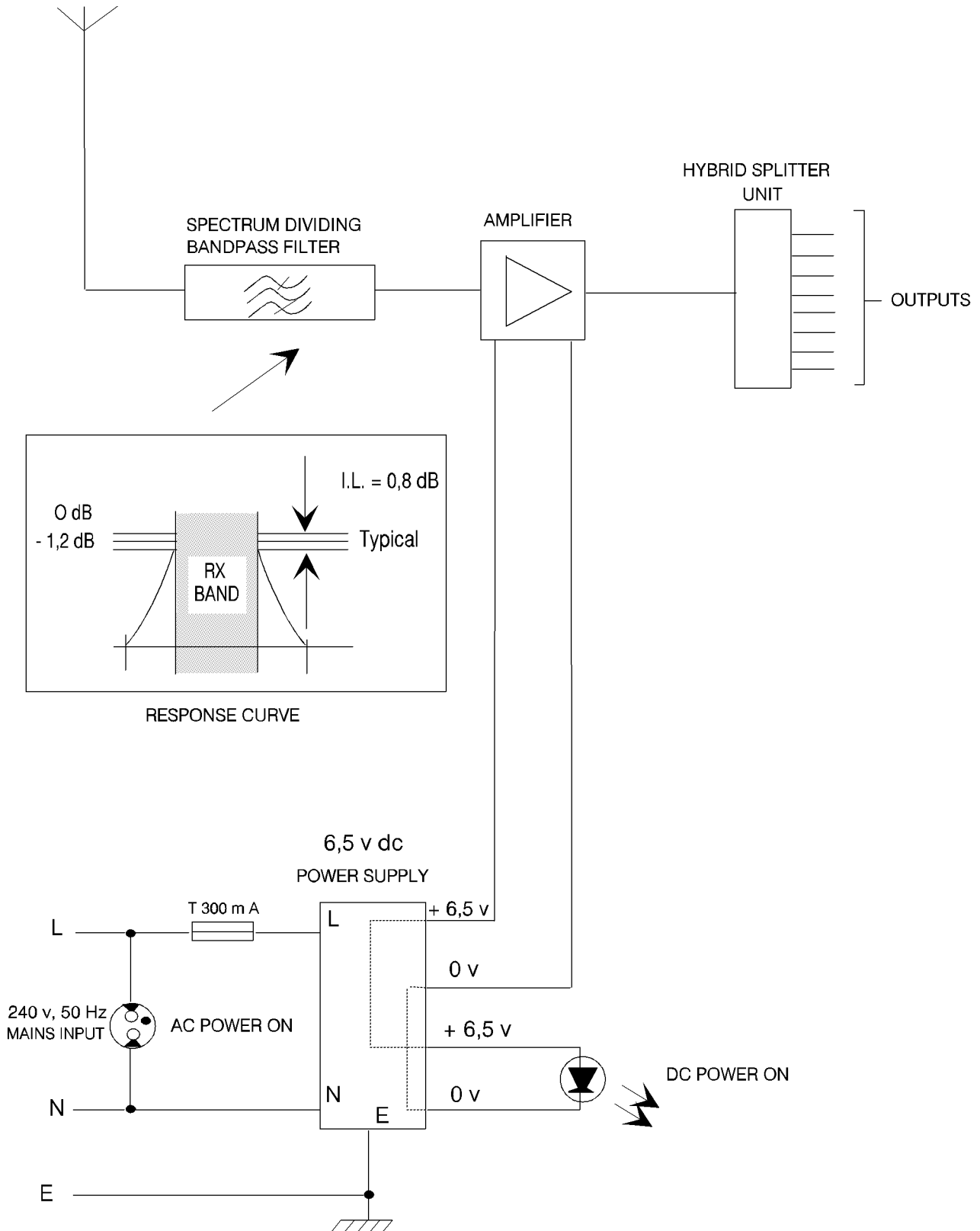

Figure H.17

H.3.2 Receiver distribution amplifier in a 4 way multicoupler system

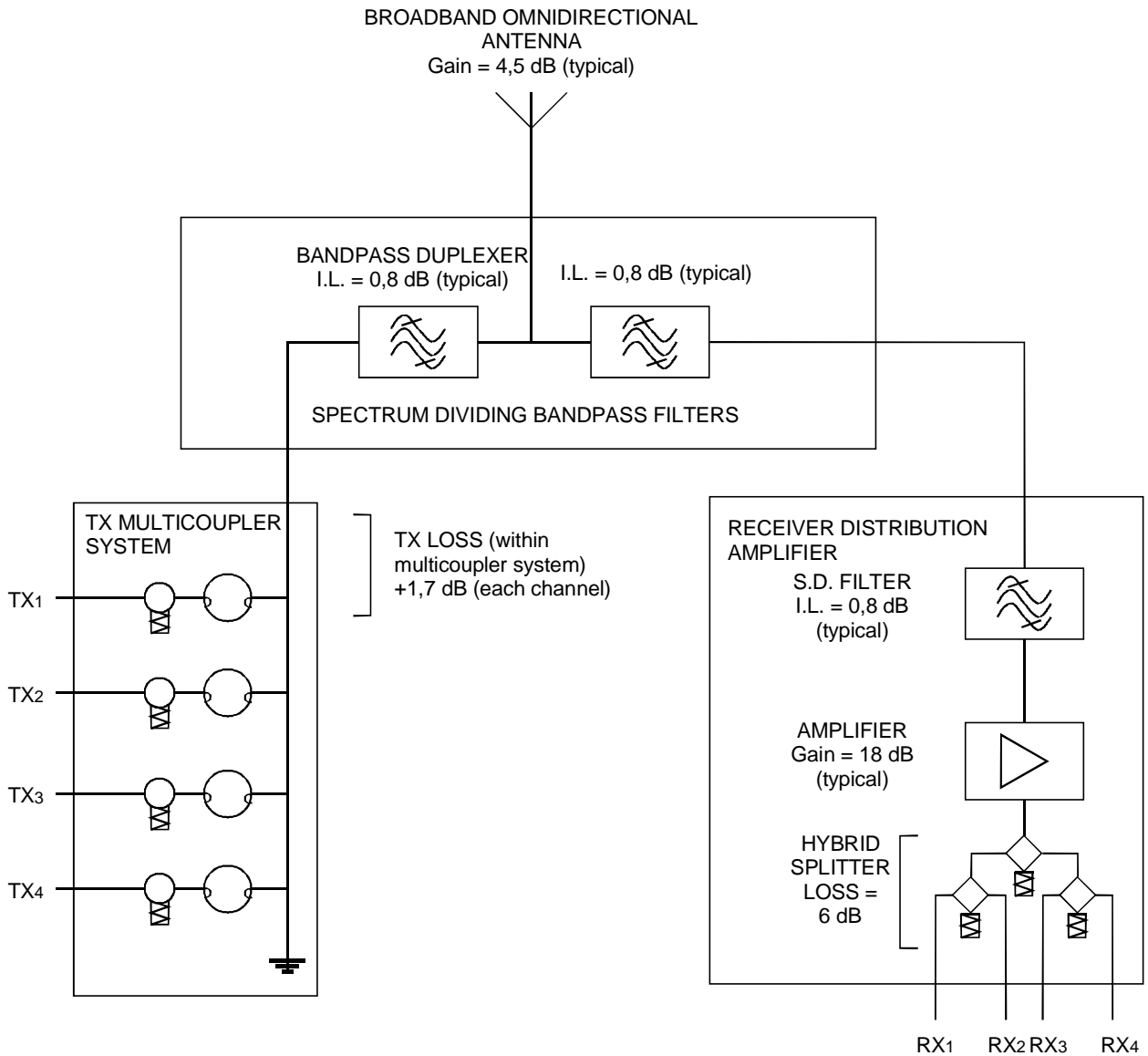

Figure H.18

H.4 Typical filter system

This clause gives details of typical filter systems employed within the UK. The principles involved are equally valid throughout Europe providing the frequencies used in these examples are exchanged for those available in the respective countries.

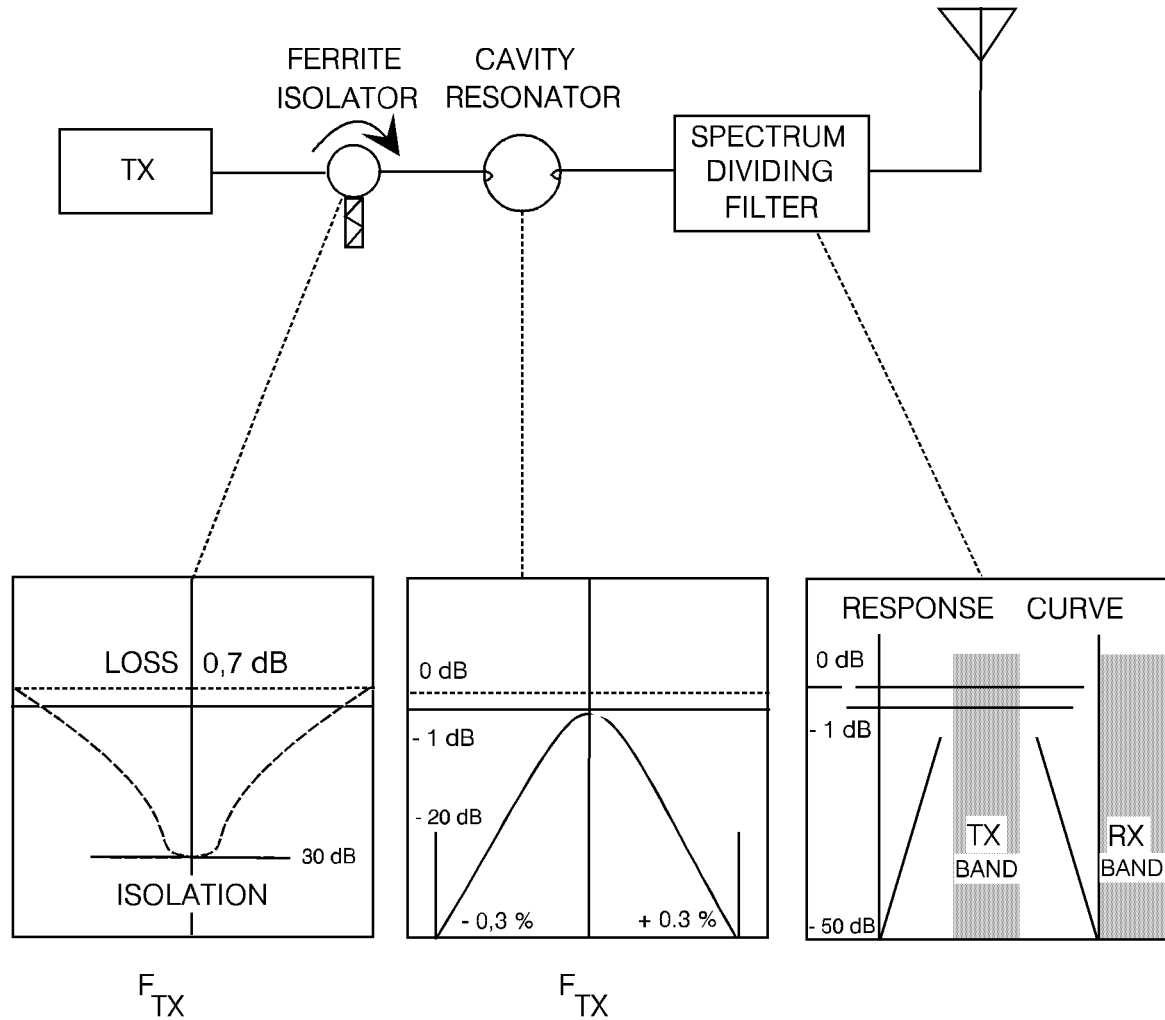

Figure H.19: Typical TX filter system for talkthrough operation (VHF 150 MHz to 160 MHz)

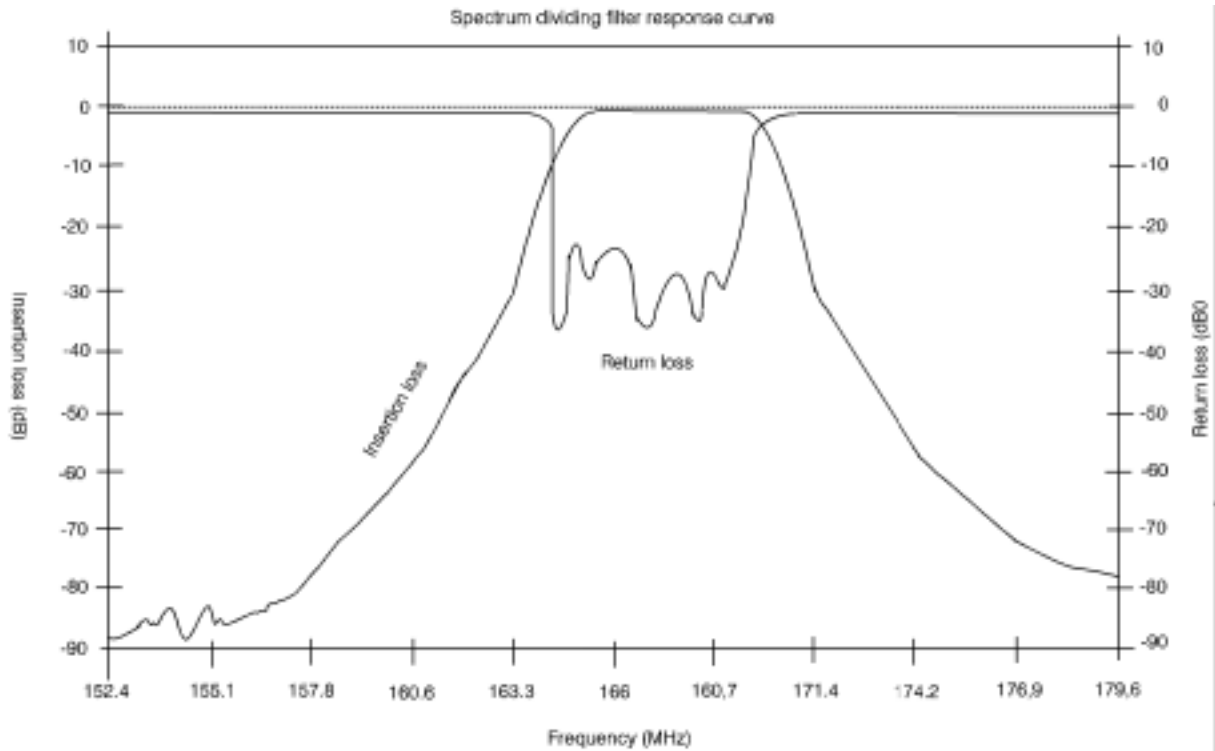

Figure H.20: Insertion loss

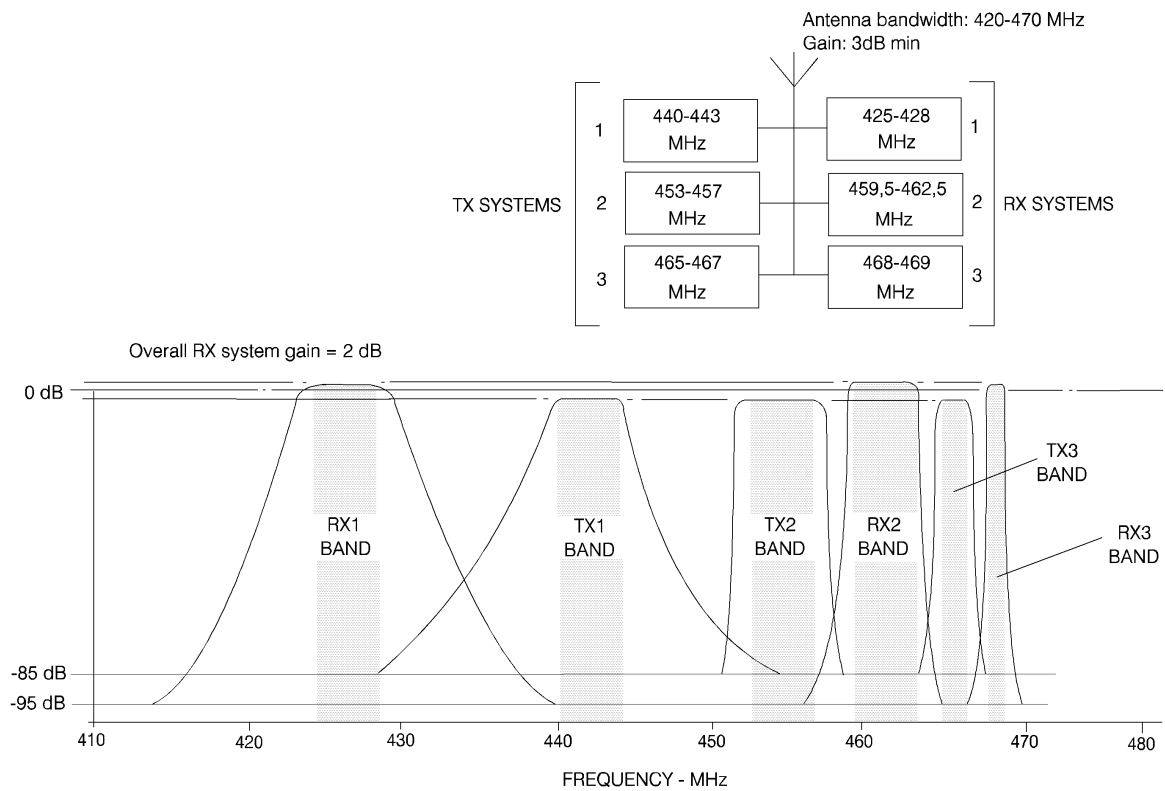

Figure H.21: Single antenna UHF system

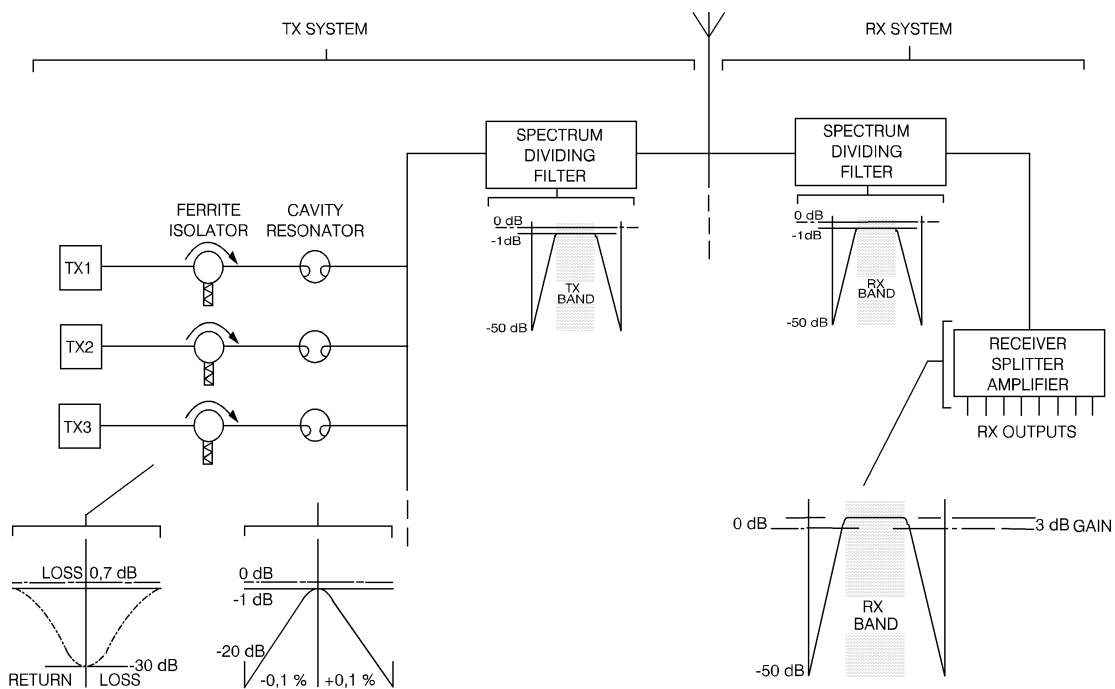

Figure H.22: Typical sub-band TX/RX system

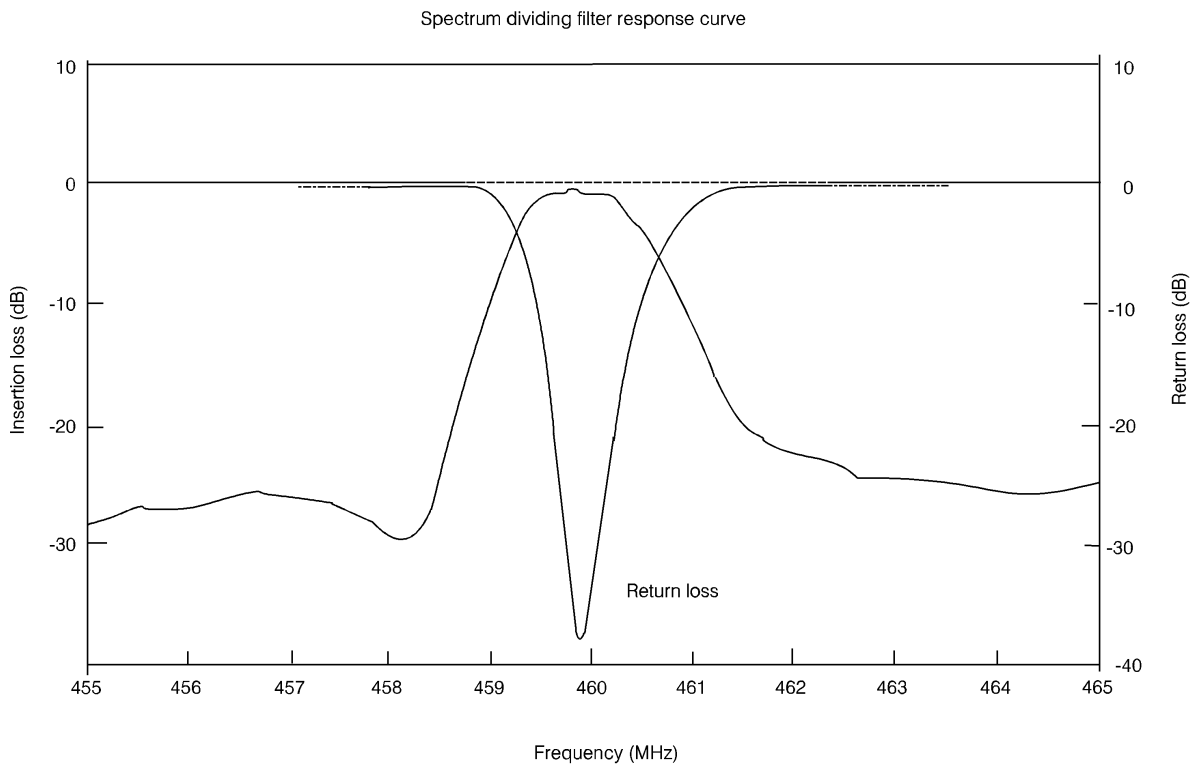

Figure H.23: Spectrum dividing filter response curve

H.5 Trunking combiner

H.5.1 Trunking combiner system

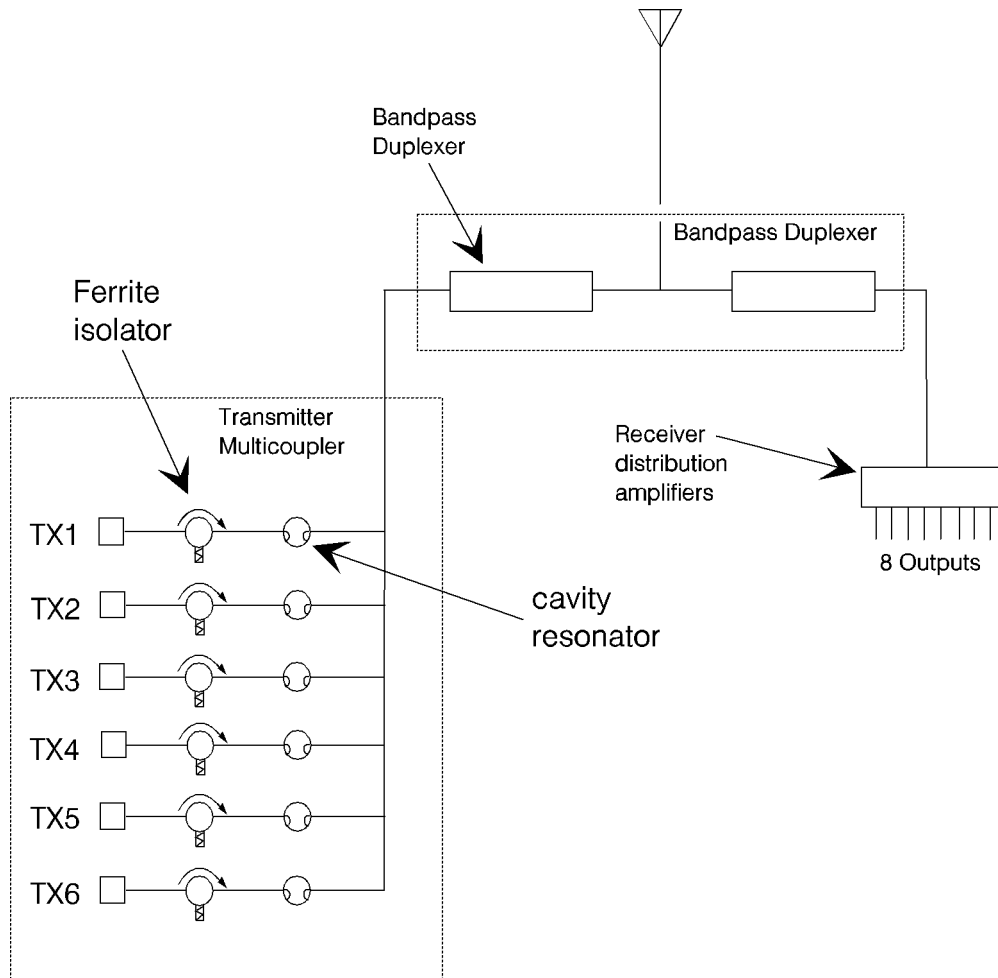

Figure H.24: Typical trunking combiner system

This system is designed to allow single antenna working for a multi-channel trunking installation.

The equipment is configured such that it can operate over various bandwidths (range 1 MHz to 10 MHz).

The system can accommodate up to 16 channels in VHF or UHF.

H.5.2 Specification of a TX/RX trunking combiner

The following specification relates to an 8 channel combiner.

Table H.1: TX/RX trunking combiner specification - TX path

Insertion Loss (from input to antenna port):	Typically 2,80 dB
TX to TX Isolation:	> 55 dB
Minimum Frequency Spacing between Transmitters:	120 kHz
Input VSWR:	Better than 1,10:1 (Return loss 26 dB)
Output VSWR:	Better than 1,20:1 (Return loss 21 dB)
Power handling (each channel):	60 W (17 dBW) 100 W version available)
5th Order Intermodulation (for 17 dBW inputs):	Better than - 154 dBW
TX to RX isolation:	> 90 dB
Number of channels:	5, 8, 10 or 16

Table H.2: TX/RX trunking combiner specification - RX path

Overall Gain:	Typically + 3 dB (can be adjusted up to 6 dB)
Input VSWR:	Better than 1,20:1 (Return Loss 21 dB)
Output VSWR:	Better than 1,20:1 (Return Loss 21 dB)
RX to TX Isolation:	> 90 dB
Noise Figure:	5 dB typical
Third Order Intercept:	+25 dBm typical
RX to RX Isolation:	25 dB typical

Annex J (informative): Interference due to intermodulation products in the land mobile service between 25 MHz and 1 000 MHz

J.1 Introduction

Intermodulation causes a degradation to radio services when:

- unwanted emissions are generated in transmitters;
- unwanted emissions are generated in non-linear elements external to the transmitters; or
- in-band intermodulation products are generated in the radio-frequency stages of receivers.

These cases occur with varying probability and varying severity. They may be reduced by equipment design or careful choice of channels, but solutions of the latter type to one case of intermodulation may increase another.

J.2 Transmitters

The last active stage of a transmitter is usually an amplifier. The current in this stage will be repeatedly swept from zero amplitude to a maximum and the impedance of the output active device is liable to contain a small amount of non-linearity.

If any other signal from another emission is also present at the output of this stage, the non-linearity will give rise to a number of products having frequencies with specific frequency relationships to the frequency of both the wanted and unwanted signals. These products are called intermodulation products, and their frequencies may be expressed as:

$$f_i = C_1 \cdot f_1 + C_2 \cdot f_2 + \dots + C_n \cdot f_n \quad (1)$$

where the sum $|C_1| + |C_2| + \dots + |C_n|$ is the order of the product.

The odd-order intermodulation products may be relatively close in frequency to the wanted signal frequency and thus coupled via the output circuit to the antenna with minimal attenuation.

In order to be able to calculate the effects of these products, it is necessary to establish certain terms.

J.2.1 Coupling loss A_c

The coupling loss A_c , in dB, is the ratio of the power emitted from one transmitter to the power level of that emission at the output of another transmitter which may produce the unwanted intermodulation product.

Typical values for the coupling loss on a common site are of the order of 30 dB.

J.2.2 Intermodulation conversion loss, A_I

The intermodulation conversion loss A_I , in dB, is the ratio of power levels of the interfering signal from an external source and the intermodulation product, both measured at the output of the transmitter.

Without any special precautions, typical values for semi-conductor transmitters are to be found in a range of 5 to 20 dB and for valve transmitters, in the range of 10 to 30 dB, in respect of the 3rd order product ($2f_1 - f_2$).

The overall loss between a transmitter providing the unwanted emission giving rise to the intermodulation product and a receiver operating at the frequency of the product is:

$$A = A_c + A_I + A_p \quad (2)$$

where A_p , in dB, is the propagation loss of the intermodulation product between the relevant transmitter output and the receiver input.

Note that the power level of the transmitter in which the intermodulation is produced is not included in formula but this level may have an effect on the value of the intermodulation conversion loss A_I .

Example:

Signal frequency of transmitter producing intermodulation product:	f_1
Signal frequency of transmitter whose emission is coupled into transmitter (f_1):	f_2
Power level of transmitter (f_2):	+10 dBW
Assumed coupling loss A_c :	30 dB
Assumed conversion loss A_I :	15 dB
Assumed receiver threshold signal level:	-150 dBW

Overall path loss is equal to 10 dBW - (-150 dBW) = 160 dB.

If $A_c + A_I = 45$ dB, then the required value of A_p is 115 dB.

Figure J.1 gives an example of propagation path losses at 100 MHz and, under free space conditions, a very large distance is required between the "product producing" transmitter and the receiver. If the receiver is a mobile condition, this distance is considerably reduced. It may be concluded therefore that 2-frequency operation provides better conditions for the reduction of the effects of inter-transmitter intermodulation if the base receive frequency band is remote from the transmit frequency band.

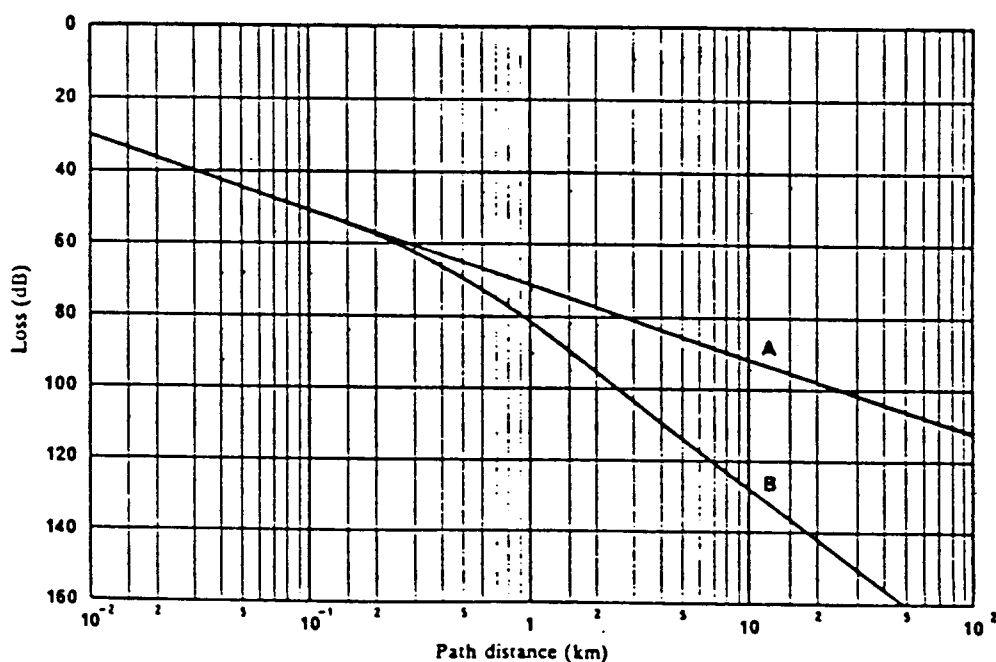

Figure J.1: Short range path loss at 100 MHz ($\frac{1}{2}$ dipoles assumed)

Curves A: Free space
 B: Recommendations 370-3: $h_1 = 37,5$ m $h_2 = 2$ m

The intermodulation caused by two or more mobile transmitters will be worse when the mobiles are closest together and when the desired signal originates at a mobile at the edge of the service area, an event which is associated with some (perhaps small) probability. The mobile being interfered with will be received at its base as a signal of widely varying level (due to fades and shadows) which will be independent of the IM interference. These wide and independent variations can allow the IM to reach harmful values for periods of time, even when its average value is much less than that of the signal.

J.3 External non-linear elements

On most sites, external non-linear elements will be at junctions in masts, feeders, and other antennas which are closely coupled to the radiating elements of nearby transmitters.

It would be useful to determine conversion losses for masts, etc., of various qualities in terms of isotropic loss between transmitters and the masts, etc. It would then be possible to establish specific values as good engineering practice.

J.4 Receivers

An intermodulation response is a response at the output of a receiver from an in-band signal generated in the RF stages of the receiver. This in-band signal is generated by the presence of two (or more) high-level signals in a non-linear section of the RF stages. As with transmitters, the two (or more) unwanted signals must have specific frequencies such that the intermodulation product lies within the frequency band accepted by the receiver.

This receiver characteristic is normally recorded as a signal measurement with the level of the unwanted signals equal and is given as a single ratio which is:

the ratio of the level of these two equal signals

to

the apparent level of the intermodulation product at the input to the receiver.

Figure J.2 gives examples (3 theoretical and 1 measured) of the overall third order intermodulation characteristic of receivers. It shows that intermodulation may easily be a problem when one of the unwanted signals is not excessively high. Such curves can be used to calculate other intermodulation product levels when the unwanted signals do not have values equal to those plotted.

For a product with a frequency relationship of the form $(2f_1 - f_2)$, the level will be proportional to the level of the signal at frequency f_2 , but will vary as the square of the level of the signal f_1 ; i.e. the product will have an amplitude of the form $k \times V_1^2 \times V_2$, where V_1 , V_2 are the amplitudes of the signals at frequencies f_1 and f_2 respectively.

When a mobile receiver is used in a multi-channel system it will be subject to an intermodulation response due to many equally spaced high level signals. The following relationship has been suggested by the People's Republic of China to relate the maximum permissible signal level with the intermodulation response rejection ratio of the receiver [CCIR, 1982-86A]:

$$E_S + 3E_M \geq 3E_{I_{max}} + B + k(n,p)$$

where:

- E_S : wanted signal level (dB) above sensitivity;
- $E_{I_{max}}$: maximum interference signal level (dB) above sensitivity;
- E_M : receiver's third-order intermodulation rejection ratio (dB) (for two signals);
- B : RF protection ratio (dB);
- $k(n,p)$: a constant dependent on the number of channels n and channel sequence p .

The derivation of this formula and the calculation of $k(n,p)$ are given in annex I.

J.5 Reduction of intermodulation product levels in transmitters

J.5.1 Intermodulation conversion loss

It is obvious that a reduction of the non-linearity, particularly of the odd-numbered orders, will improve the overall performance and increase the value of the intermodulation conversion loss A_I .

From the example in clause J.2, it is evident that a considerable improvement is necessary before the relevant path loss reduces to manageable values.

J.5.2 Coupling loss

The coupling loss can obviously be increased by increasing the distance between the relevant transmitters but it may not always be possible to do so effectively at a particular site.

Ferrite isolators could be used in the output circuits of the transmitter in which the product is generated but present production units do not provide much more than 25 dB additional loss and the use of the multiple units is inhibited by the inherent non-linearity of the isolators themselves. To suppress undesirable products filters may be required after such isolators. These isolators are equally effective irrespective of the frequency spacing between f_1 and f_2 .

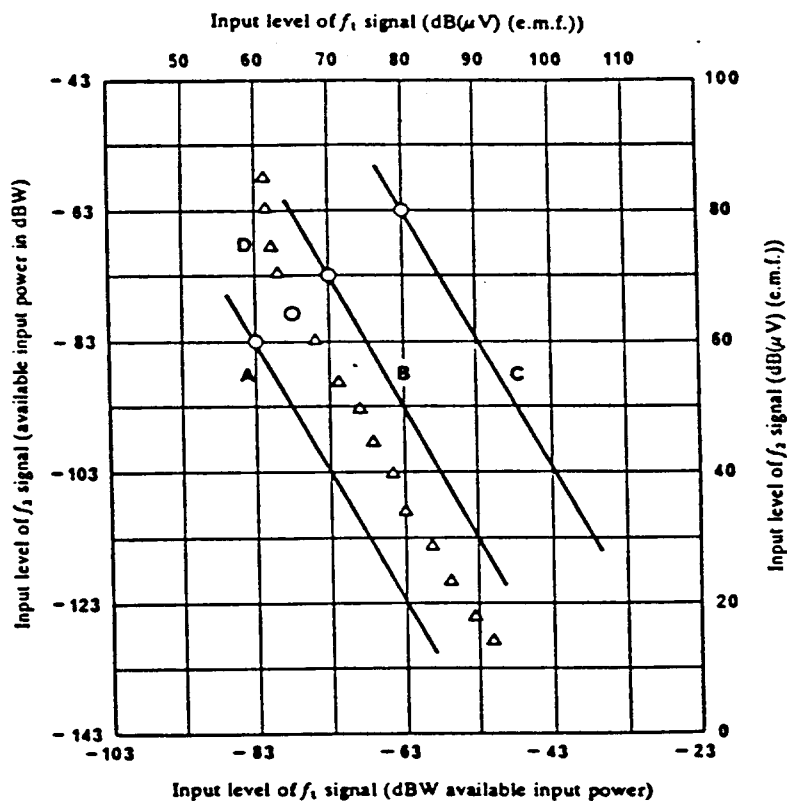

Levels of unwanted input signals which together produce a constant product level.

Curves A, B and C: derived characteristics based on a single recorded value of the receiver's third order intermodulation characteristic, i.e. for $(2f_1 - f_2)$.

Curves A: based on a single value, with both input levels at a level of 60 dB(μ V) (e.m.f. to 50 Ω).

B: based on a single value, with both input levels at a level of 70 dB(μ V) (e.m.f. to 50 Ω).

C: based on a single value, with both input levels at a level of 80 dB(μ V) (e.m.f. to 50 Ω).

D: measured values for a receiver for which the specified criterion is achieved with equal input signal levels of 65,5 dB(μ V) (e.m.f. to 50 Ω).

Figure J.2: Receiver intermodulation characteristic

Cavity filters can also be used and examples of their theoretical responses are given in figure J.3. They may be used in cascade or in more complex series-parallel combinations but in all cases, their performance is dependent on the frequency spacing between f_1 and f_2 . They have the advantage that they will also attenuate the product level at the input to the antenna or transmission line and thus increase A_I .

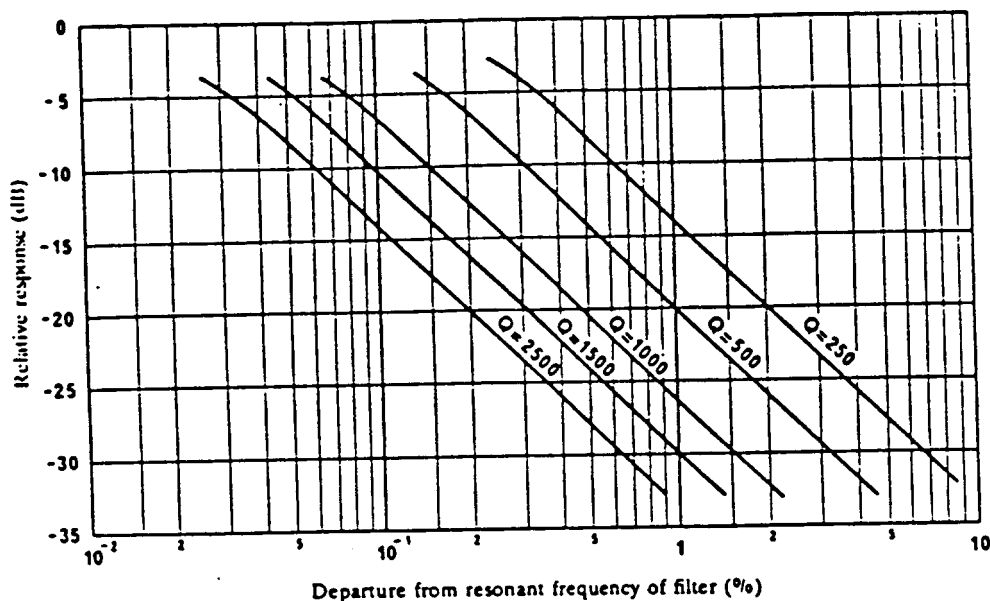

NOTE 1: For values of loaded Q of 250 - 2 500.

NOTE 2: The unloaded Q should be at least 5 times the loaded Q and preferably 10 times.

Figure J.3: Theoretical response of cavity band-pass filters

An economic and efficient filter is the coaxial cavity resonator, either in its pure quarter-wavelength form or with varying degrees of modification to reduce the overall length and improve the value of the loaded Q . The resonator should be robust, simple to tune, highly efficient in terms of transmission loss, and provide a high degree of isolation at the required frequencies. Resonators for use with transmitters should have a low temperature coefficient and good thermal conductivity, so that their performance is not affected by changes in ambient temperature or through being heated by transmission losses. Temperature compensation can be employed to maintain the length of the centre conductors. Physical robustness is necessary to avoid changes in technical parameters from being caused by mechanical shock or deformation. The physical and mechanical design should also prevent the formation of electrical discharges or corona. Adjustable telescopic centre conductor assemblies permit a variation of resonant frequency of, typically, $\pm 15\%$ of the centre frequency.

Reliable and economical resonators can be manufactured from high-conductivity aluminium for the larger units, and silver-plated copper or brass for smaller units. Practical limitations of mechanical engineering govern the upper limits of Q obtainable with a cavity resonator. As the diameter is increased, the value of the unloaded Q is increased but the sensitivity of tuning and the temperature coefficient become more critical. Practical and satisfactory resonators with a power handling capacity of up to 250 W can, however, be made for the band 150 MHz to 170 MHz, for example, having an unloaded Q as large as 18 000, with a diameter of 0,58 m, and length 0,63 m giving 35 dB discrimination at a frequency 1 % removed from the resonant frequency.

It is not usual to employ cavity resonators for values of Q below 1 000 since there are more satisfactory techniques, e.g. helical resonators, which can be coupled together to form smaller but relatively efficient filter units. Tables I and II give the choice of types of filter and their relative costs.

Table J.1: Relative sizes and costs of resonators (150-174 MHz)

1	2	3	4	5	6
Reference	Q_0	Q_L	Attenuation at 1 % F_0 (dB)	Diameter (m)	Relative cost of practical resonators
A	920	100	7	0,03	1,0
B	2 300	250	14	0,07	1,7
C	4 600	500	21	0,14	2,8
D	6 900	750	24	0,21	3,3
E	9 200	1 000	26	0,29	3,9
F	11 700	1 250	28	0,37	4,6
G	13 800	1 500	30	0,46	5,3
H	16 100	1 750	32	0,53	6,8
I	18 400	2 000	35	0,58	7,1

Table J.2: Relative costs of practical resonators for other frequencies

Resonant frequency (MHz)	Cavity height (m)	Unloaded Q					
		920	2 300	4 600	6 900	9 200	13 800
50 - 60	1,55	*	*	8,7	12,0	14,7	+
60 - 80	1,15	*	*	5,5	7,3	10,6	14,9
95 - 110	0,85	*	3,3	4,1	5,2	6,4	10,7
120 - 150	0,68	*	2,6	3,3	4,2	5,0	8,9
150 - 174	0,63	1,0	1,7	2,8	3,3	3,9	5,3
160 - 180	0,52	0,9	1,5	2,4	2,9	3,4	4,6
400 - 500	0,24	0,8	1,0	1,5	2,0	2,2	3,0

NOTE: Items not tabulated are identified as follows:
 * Helical resonator superior
 + Single cavity large and somewhat uneconomic.

Compared with the total cost of the radio equipment at a base station, cavity resonator filters are an economical and efficient means of reducing spurious emissions and preventing or minimizing interference.

J.5.3 Identification of the source of an intermodulation product

The frequency of the third order intermodulation resulting from the interaction of two transmitters may be expressed as either $2f_1 - f_2$ or $2f_2 - f_1$.

If the product is $2f_1 - f_2$, the mixing is occurring within or close to the transmitter operating on f_1 .

Conversely, if the product is $2f_2 - f_1$, the mixing is occurring within or close to the transmitter operating on f_2 .

In the case of FM or PM emissions, the deviation caused by modulation is doubled when a second harmonic is generated. So if the modulation on one of the intermodulation products appears to be excessive, this modulation is probably transferred from the f_1 signal of a $2f_1 - f_2$ mixing.

J.6 Reduction of intermodulation products in receivers

As with transmitters, a reduction in the non-linearity of a receiver will improve the performance.

Attenuation at the input of the receiver may be used to reduce the level of an intermodulation product. The levels of these products are related to the levels of the signals that produce them, in such a way that the attenuation (in dB) of each " n^{th} " order product will, in most cases, be n times the attenuation (in dB) of the wanted signal.

For example, a 3 dB attenuator will reduce a third order product by 9 dB while reducing the wanted signal by 3 dB. This may also be used as a test device to prove that the intermodulation product is being generated in the receiver.

Cavity filters can be used, either as rejection filters to f_1 and/or f_2 , or as band-pass filters to the wanted signal. Again the effectiveness of these filters depends on the frequency spacings involved.

J.7 Reduction of intermodulation interference by frequency arrangements

The frequencies to be used can be arranged so that no receiver on the product frequency is required to operate in an area where the unwanted signals may produce an intermodulation product of sufficient level to disturb the service. If this level is at the maximum sensitivity level of the receiver; it will mean receivers cannot be used for distances up to 2 km from the sites of the base station operating at f_1 and f_2 stations are separated by several kilometres and thus implies that the base station on the product channel must be sited outside the service area of stations operating on f_1 and f_2 . This leads to very poor use of the frequency spectrum.

In systems that operate a number of frequency channels, most cases of harmful base transmitter and mobile receiver intermodulation within the system can be alleviated by the choice of even channel sets at the base stations. This means that the channels of each base station are evenly distributed at a constant frequency separation. In a service area the intermodulation products within the band used will in that case coincide with channels of the set, and the ratio of the desired signal to the intermodulation product in a mobile receiver is independent of the distance and propagation characteristics.

J.8 Reduction of intermodulation interference by other arrangements

If continuous tone signalling is used, the receiver will operate only in the presence of this signalling tone and it is then necessary only to ensure that the wanted signal on the product channel exceeds the level of an unwanted product of f_1 and f_2 by an amount in excess of the required protection ratio. This can be best assured by siting the product channel base transmitter at the same, or near to, the site of stations operating on f_1 and f_2 . Under these conditions, the need for filters or other devices in the transmitter or receiver is reduced.

Annex K (informative): Sources of unwanted signals in multiple base station sites in the land mobile service

K.1 Introduction

The greatly increased use of land mobile services has resulted in a dramatic increase in the number of base stations on any one site, particularly on those sites strategically placed to serve large built-up areas. This has led to instances of severe interference due to unwanted signals being generated at the site. This report is not intended to examine every possible type of interference but rather to indicate the more commonly occurring sources. It should be particularly noted that transmitters of other services may be involved.

K.2 Simple frequency relationships

As land mobile frequency bands are used throughout the VHF/UHF spectrum there may be harmonic relationships between frequencies in the various bands. The equipment cabinet, the power supply cabling and land-line cabling can contribute to the level of these unwanted harmonic signals.

Other interfering signals can be caused by simple mixes either in transmitter output stages or at the antenna mast. As an example, if the signal from a VHF broadcasting transmitter at 93 MHz mixes with a signal of the mobile service at 170,5 MHz, a difference signal of 77,5 MHz can be produced. This can cause a problem if it is a receive frequency of the mobile service.

K.3 Complex frequency relationships

K.3.1 Generation of intermediate frequency and/or its derivatives

Interference can be caused in a receiver where signals are received from two transmitters whose frequencies are separated by an amount equal to the IF, or a submultiple of the IF, of the receiver.

K.3.2 Generation of transmit/receive (TX/Rx) difference frequency

This problem arises on sites where there are several base stations having "repeater" or "talk-through" facilities, i.e. the transmitters and receivers are in use simultaneously. If the TX/Rx spacing is constant (D), an incoming signal from a mobile station will produce in the base station transmitter output stage a difference frequency, D. Any other base station transmitter may now mix with D to produce its own receiver frequency in the same band.

K.4 Intermodulation products

K.4.1 Generated external to the site

Under this heading, products arise from stations on adjacent sites, and, in particular, the third order product i.e. $2f_1 - f_2$, which is prevalent in large built-up areas. In some instances significant intermodulation products up to and including the seventh order have been noted and in exceptional cases the interference has been traced to the nineteenth order.

K.4.2 Intermodulation products generated on-site by non-linear junctions on the mast

More study is required to verify the mechanism and levels of such interference, which certainly exists in the land mobile bands. However, at lower radiated powers, the significance of these products is reduced, compared with other forms of non-linearity, e.g. clauses K.4.1 and K.4.3.

K.4.3 Intermodulation products generated on-site by non-linearity in components of the system

Junctions between dissimilar metals cause non-linearity, and therefore intermodulation products, when subjected to radio frequency currents, and recent work has highlighted such products up to the eleventh order at VHF caused by connectors, cables and dissimilar junctions in what might be regarded as otherwise innocuous components.

For the long-term development of the land mobile radio industry, it may be necessary to define the non-linearity of passive components in the system.

K.5 Transmitter noise

All transmitters on base station sites generate wide band noise at frequencies up to several megahertz from the carrier frequency, in addition to other discrete spurious emissions and noise on the adjacent channel produced by the modulation process.

The level of wide band noise is inherent in the design of the transmitter and the designer will normally take reasonable steps to minimize the level. However the standards to which transmitters have to be certified, such as the European ENs, may not stipulate any measurements or limits for wide band noise.

Transmitter wide band noise can degrade the performance of a receiver or receivers operating on the same site. However provided the receiving frequency or frequencies are more than 1 % of the transmitter frequency above or below that frequency, the receivers can be protected by fitting one or more cavity filters at the offending transmitter output.

Annex H describes how cavity resonators can be used to protect receiver inputs from strong off frequency signals. In this context transmitter wide band noise can be considered as an interfering off frequency signal.

Figures K.1 and K.2 give the graphical results of measurements made in the United Kingdom of noise from VHF transmitters for the VHF "high band" (150 MHz to 170 MHz) and VHF "low band" (71,5 MHz to 87,9 MHz).

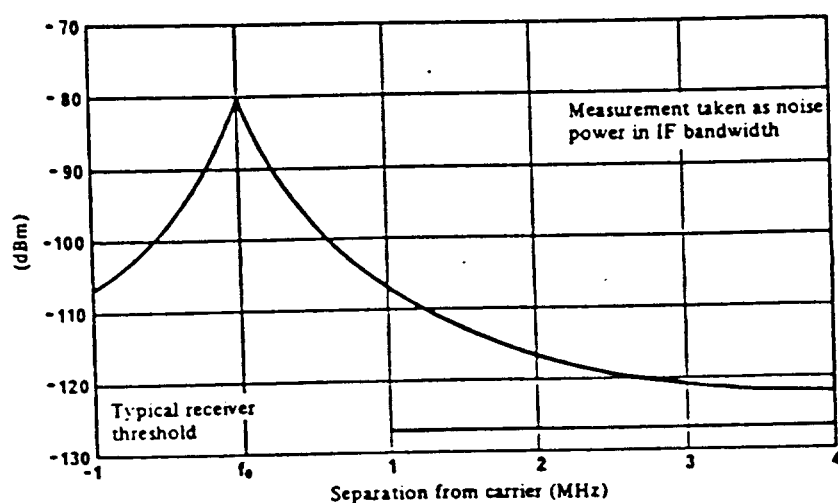

Figure K.1: Typical transmitter noise VHF high band (150 MHz to 170 MHz): solid-state output stage

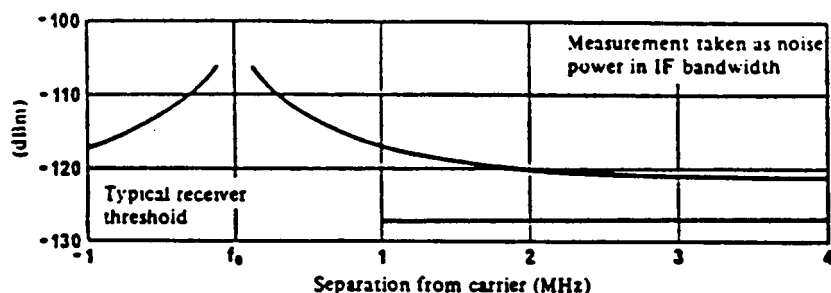

Figure K.2: Typical transmitter noise VHF low band (71,5 MHz to 87,9 MHz): solid-state output stage

K.6 External electrical noise

Apart from ignition noise, there are the well-known sources of radio interference, which continue to proliferate, particularly from industrial users, i.e. RF heating, microwave ovens, X-ray and medical equipment. These normally provide a broad spectrum of noise which tends to vary in frequency.

Screening or suppression of the interfering equipment normally reduces the problem to an acceptable level.

There is however, a new family of sources, namely computers and computer peripherals, which are currently causing problems with broadband noise over the VHF spectrum.

K.7 Summary

There are instances where the present engineering practices in multiple transmitter sites have allowed the generation of excessive unwanted signals. With the increased use of land mobile radio it is desirable to perfect techniques to reduce interference effects in the future. There is a need for better site engineering in order to establish "quiet" base station sites for trunking networks and cellular radio.

The following should be considered:

- spurious emissions from transmitters;
- filtering of transmitter outputs to reduce spurious emissions and noise at frequencies near the carrier;
- use of directive isolators in transmitter output stages;
- additional filtering to provide protection at adjacent frequency bands;
- non-linear effects at all points in the system.

Annex L (informative): Intermodulation interference

L.1 Intermodulation spectrum

At the output of a transmitter of frequency B, the level of the interfering signal due to a transmitter on frequency A will be attenuated by the isolation between the transmitters. In this case the amplitudes of the intermodulation products of the same order will not be equal. (ITU-R (Ex-CCIR) Report 739-1 [2]).

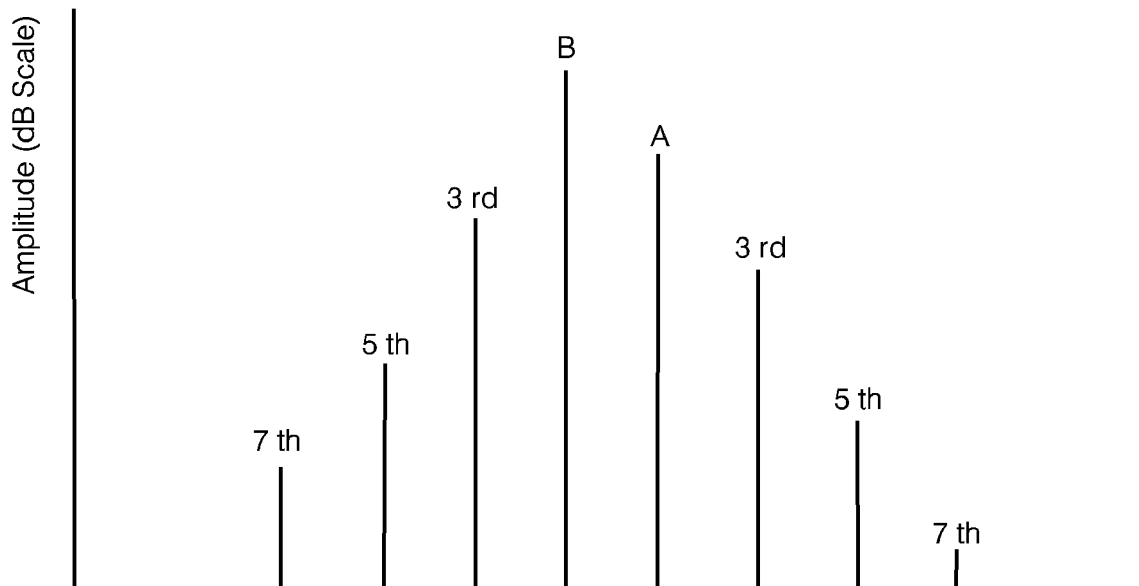
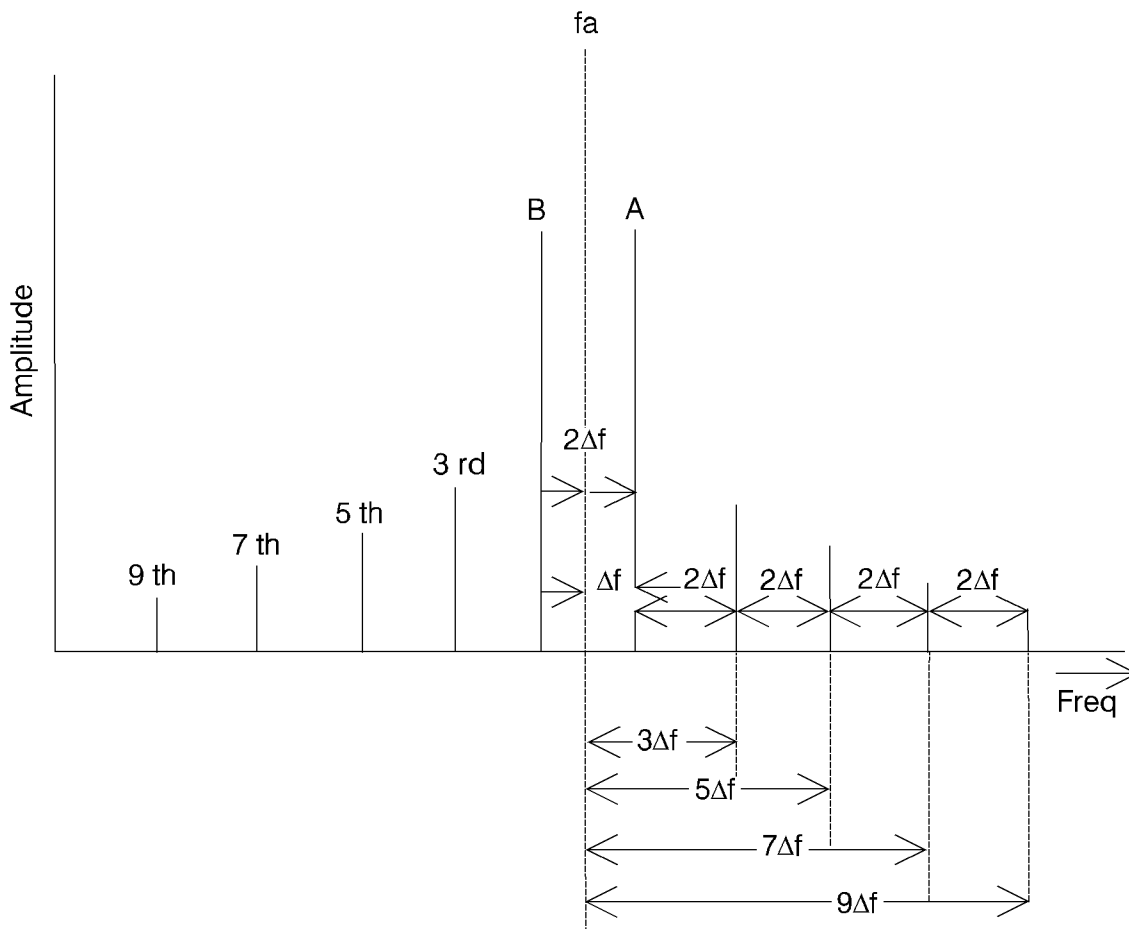

Figure L.1: Intermodulation spectrum (at the output of transmitter frequency B, interfering signal frequency A)

L.2 Products - combinations of two frequencies A and B excluding pure harmonics



NOTE: Correct for 2 signals only - not drawn to scale.

Figure L.2: Intermodulation spectrum for A and B (simultaneous inputs of equal amplitude)

Let:

$$A = f_a + \Delta f$$

$$B = f_a - \Delta f$$

where:

$$f_a = \frac{A+B}{2}$$

$$\Delta f = \frac{A-B}{2}$$

2nd order products (quantity 2):

- $A + B = 2f_a$;
- $A - B = 2\Delta f$.

3rd order products (quantity 4):

- $2A + B = 3f_a + \Delta f$;

- $*2A - B = fa + 3\Delta f$;
- $2B + A = 3fa - \Delta f$;
- $*2B - A = fa - 3\Delta f$.

4th order products (quantity 7):

- $2A + 2B = 4fa$;
- $2A - 2B = 4\Delta f$;
- $2B - 2A = -4\Delta f$;
- $3A + B = 4fa + 2\Delta f$;
- $3A - B = 2fa + 4\Delta f$;
- $3B - A = 2fa - 4\Delta f$;
- $3B - A = 4fa - 2\Delta f$.

5th order products (quantity 8):

- $3A + 2B = 4fa + \Delta f$;
- $3B + 2A = 4fa - \Delta f$;
- $*3A - 2B = fa + 5\Delta f$;
- $*3B - 2A = fa - 5\Delta f$;
- $4B + A = 5fa - 3\Delta f$;
- $4A + B = 5fa + 3\Delta f$;
- $4A - B = 3fa + 5\Delta f$;
- $4B - A = 3fa - 5\Delta f$.

6th order products (quantity 11):

- $5A + B = 6fa + 4\Delta f$;
- $5B + A = 6fa - 4\Delta f$;
- $5A - B = 4fa + 6\Delta f$;
- $5B - A = 4fa - 6\Delta f$;
- $4B + 2A = 6fa - 2\Delta f$;
- $4A + 2B = 6fa + 2\Delta f$;
- $4B - 2A = 2fa - 6\Delta f$;
- $4B - 2B = 2fa + 6\Delta f$;
- $3A + 3B = 6fa$;
- $3A - 3B = +6\Delta f$;
- $3B - 3A = -6\Delta f$.

7th order products (quantity 12):

- $4A + 3B = 7fa + \Delta f$;

- $4B + 3A = 7fa - \Delta f$;
- $*4A - 3B = fa + 7\Delta f$;
- $*4B - 3A = fa - 7\Delta f$;
- $5A + 2B = 7fa + 3\Delta f$;
- $5B + 2A = 7fa - 3\Delta f$;
- $5A - 2B = 3fa + 8\Delta f$;
- $5B - 2A = 3fa - 7\Delta f$;
- $6A + B = 8fa + 5\Delta f$;
- $6B + A = 7fa + 5\Delta f$;
- $6A - B = 5fa + 8\Delta f$;
- $6B - A = 5fa - 7\Delta f$.

8th order products (quantity 15):

- $5A + 3B = 8fa + 2\Delta f$;
- $5B + 3A = 8fa - 2\Delta f$;
- $5A - 3B = 2fa + 8\Delta f$;
- $5B - 3A = 2fa - 8\Delta f$;
- $6A + 2B = 8fa + 4\Delta f$;
- $6B + 2A = 8fa - 4\Delta f$;
- $6A - 2B = 4fa + 8\Delta f$;
- $6B - 2A = 4fa - 8\Delta f$;
- $7A + B = 8fa + 6\Delta f$;
- $7B + A = 8fa - 6\Delta f$;
- $7A - B = 6fa + 8\Delta f$;
- $7B - A = 6fa - 8\Delta f$;
- $4A + 4B = 8fa$;
- $4A - 4B = 8fa + 8\Delta f$;
- $4B - 4A = 8fa - 8\Delta f$.

9th order products (quantity 16):

- $5A + 4B = 9fa + \Delta f$;
- $5B + 4A = 9fa + \Delta f$;
- $*5A - 4B = fa + 9\Delta f$;
- $*5B - 4A = fa - 9\Delta f$;
- $6A + 3B = 9fa + 3\Delta f$;
- $6B - 3A = 9fa - 3\Delta f$;

- $6A - 3B = 3fa + 9\Delta f$;
- $6B - 3A = 3fa - 9\Delta f$;
- $7A + 2B = 9fa + 5\Delta f$;
- $7B + 2A = 9fa - 5\Delta f$;
- $7A - 2B = 5fa + 9\Delta f$;
- $7B - 2A = 5fa - 9\Delta f$;
- $8A - B = 9fa + 7\Delta f$;
- $8B + A = 9fa - 7\Delta f$;
- $8A + B = 7fa + 9\Delta f$;
- $8B - A = 7fa - 9\Delta f$.

NOTE: * = Inband.

L.3 Intermodulation products

Intermodulation between frequencies of channels allocated in a bandwidth B Hz will be spread over the spectrum from DC to n times the highest frequency used (where n is the order of the non-linearity producing the intermodulation). Of particular interest are those products which fall back within and around the band B. This group will extend over a range of $n \times B$ Hz, the distribution within this being dependent on the initial distribution within B. In addition the modulation of the generating carriers will cause each individual product to be spread over n times the occupied bandwidth.

For example if the band B were 2 MHz wide from 154 to 156 MHz then 9th order intermodulation products would extend from 146 MHz to 164 MHz and each product would cover a band of 72 kHz if the occupied bandwidth is taken as ± 4 kHz.

The number of such products is given in table L.1.

Table L.1: Number of intermodulation products

Non-linearity order number number of channels	3rd	5th	7th	9th
2	2	2	2	2
3	9	15	21	27
4	24	64	124	204
5	50	200	525	1 095
6	90	510	1 770	4 626
7	147	1 127		

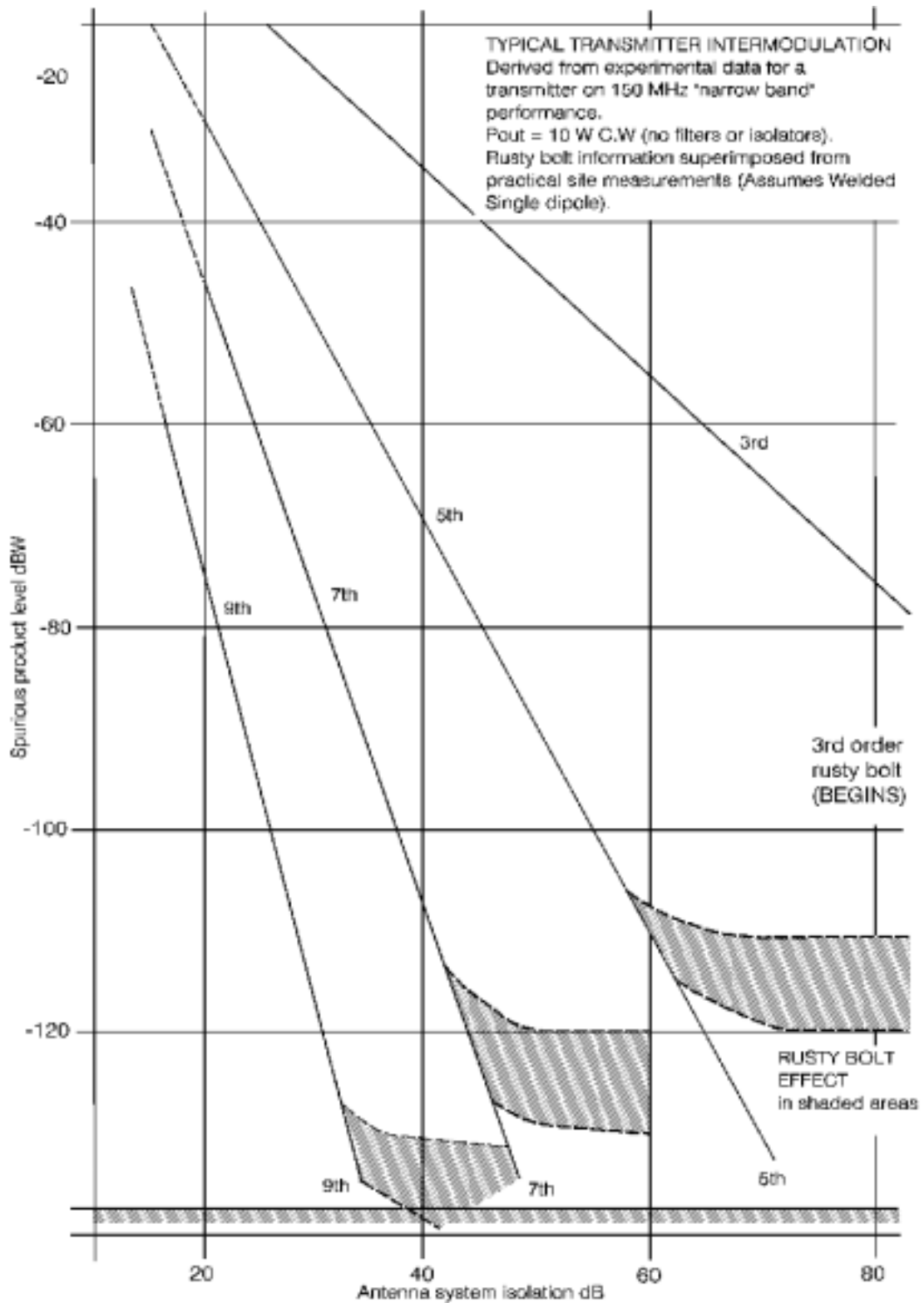

Figure L.3

Annex M (informative): Transmitter noise measurement

M.1 Introduction

As a result of work carried out in the preparation of the radio site engineering report it became very evident that one of the main sources of interference on radio sites was transmitter noise.

There are many complex equipment on the market which are able to examine spectral pollution, but in general terms there is always the difficulty of carrier power being several orders of magnitude in excess of the acceptable level at the input stage of such equipment (typically -20 dBm).

A test method was therefore necessary which could be applied to transmitters in the base station frequency range employed on radio sites, and having a dynamic range of test measurements down to the level of receiver sensitivities associated with such systems. This means in general terms from +55 dBm down to -117 dBm (i.e. 172 dBc).

It is also essential that the components of the test system are practical, easy to use, and readily available in the context of the mobile radio industry. The prime components to enable such a system to work effectively are a notch reject filter system at the frequency of the transmitter and a low noise amplifier to feed the detector system. The transmitter is unmodulated.

The spectrum analyser described in this paper is a well known industry standard and could be replaced by a wide variety of alternatives having similar parameters.

M.2 Measurement system

The layout consists of the equipment under test, followed by a conventional through line power meter suitably calibrated to ensure the accuracy of the experiments.

In order to guarantee a reasonable match to the transmitter under test, an isolating cable comprising in this case approximately 70 m of RG214AU was used between the wattmeter and the carrier notch reject assembly.

The reject filters comprise four sections of high Q cavity resonators suitably coupled to the through-line by quarter wave sections. The rejection capability of this filter system was in excess of 80 dB whilst its insertion loss was less than 1 dB.

Following on the filter system is a low noise amplifier with a gain of approximately 22 dB, a noise figure of 3 dB, and a third order intercept of +42 dBm.

The detector used was a spectrum analyser which was set to 0 dB input attenuation and the bandwidth setting was selected at 100 kHz. The secondary attenuator, which is for the IF section of the analyser, was adjusted to bring the trace to a convenient reference level at the top of the screen.

It should be noted that this second adjustment does not affect the RF performance of the spectrum analyser. A check of the noise figure of the spectrum analyser without the pre-amplifier produced a figure of 29 dB.

At no time was the input level to the spectrum analyser allowed to rise above -20 dBm. The resolution bandwidth of 100 kHz was chosen for observable convenience.

When setting up the test method, a signal generator was used at an appropriate level to check the precise tuning of the notch filters before the TX was connected. This was in order to ensure that no excessive power was applied to the detector circuit (-20 dBm).

M.3 Measurement accuracy

The absolute calibration of the system is carried out very simply by substituting an accurate signal generator for the TX under test, and calibrating the whole system at each frequency under consideration.

By taking into account the measurement of the notch rejection and by adding the carefully measured amplifier gain, it was possible to produce a system calibration figure at each frequency.

The absolute accuracy of the spectrum analyser is $\pm 1,50$ dB but this can also be overcome by absolute measurement from a reference source level, which was done.

For overall system level calculations an absolute standard was available in the form of a power meter with an absolute accuracy $\pm 0,01$ dBm.

The absolute level therefore of all these measurements can be clearly stated as being within 1 dB, bearing in mind that the important measurements in these experiments are 100 dB below carrier. It can be easily seen that the absolute accuracy of the system is well within reasonable limits for the purpose of the exercise.

M.4 Results

It will be seen from the following plots that a wide variety of spectral outputs were obtained and several transmitters were tested, each of different frequency band and manufacture.

The reference level at the top of the screen was in each case referred to a convenient absolute power in order that the visual dynamic range on the screen could be maximized.

The absolute noise level of the test system was at -107 dBm and this was checked by injecting a -101 dBm signal which was found to be in the correct corresponding position, i.e. 6 dB above the noise.

The test set-up was calibrated before, and after each, measurement in order to ensure that none of the fundamental parameters in the system had changed.

The following graphic results are self-explanatory.

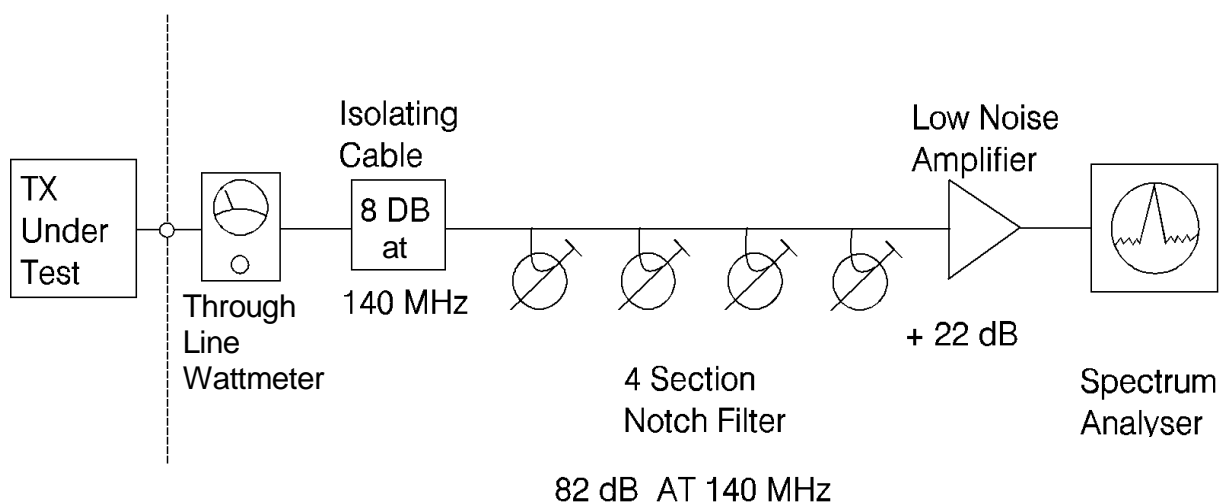

Figure M.1: Transmitter noise measurement - test set-up

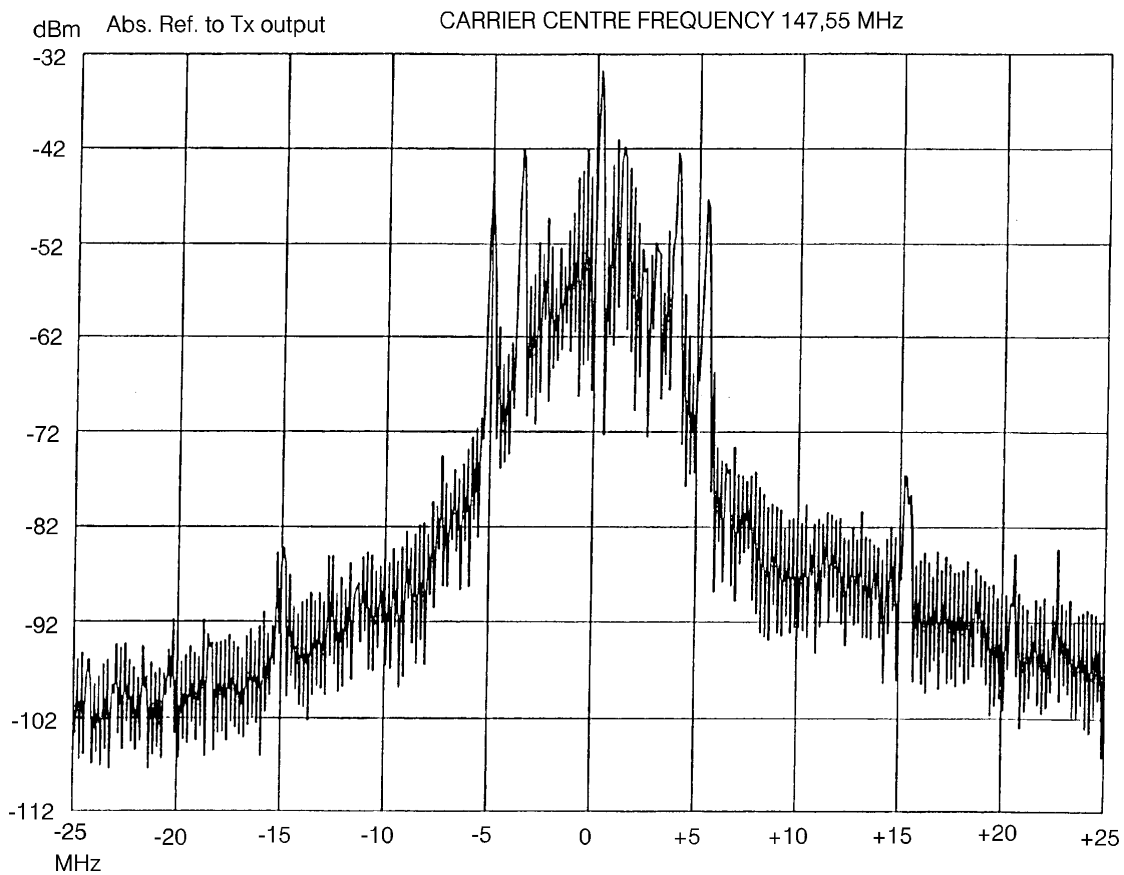

Figure M.2: Plot 1/Tx1

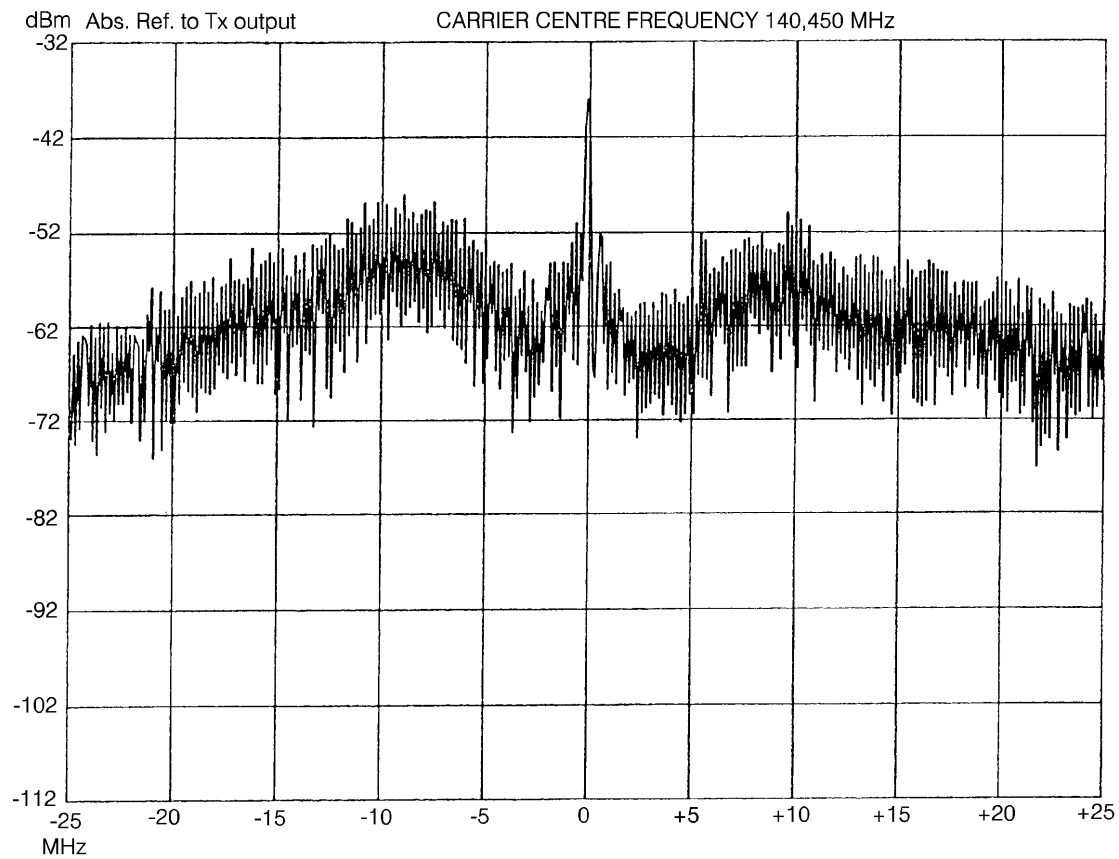

Figure M.3: Plot 2/Tx2

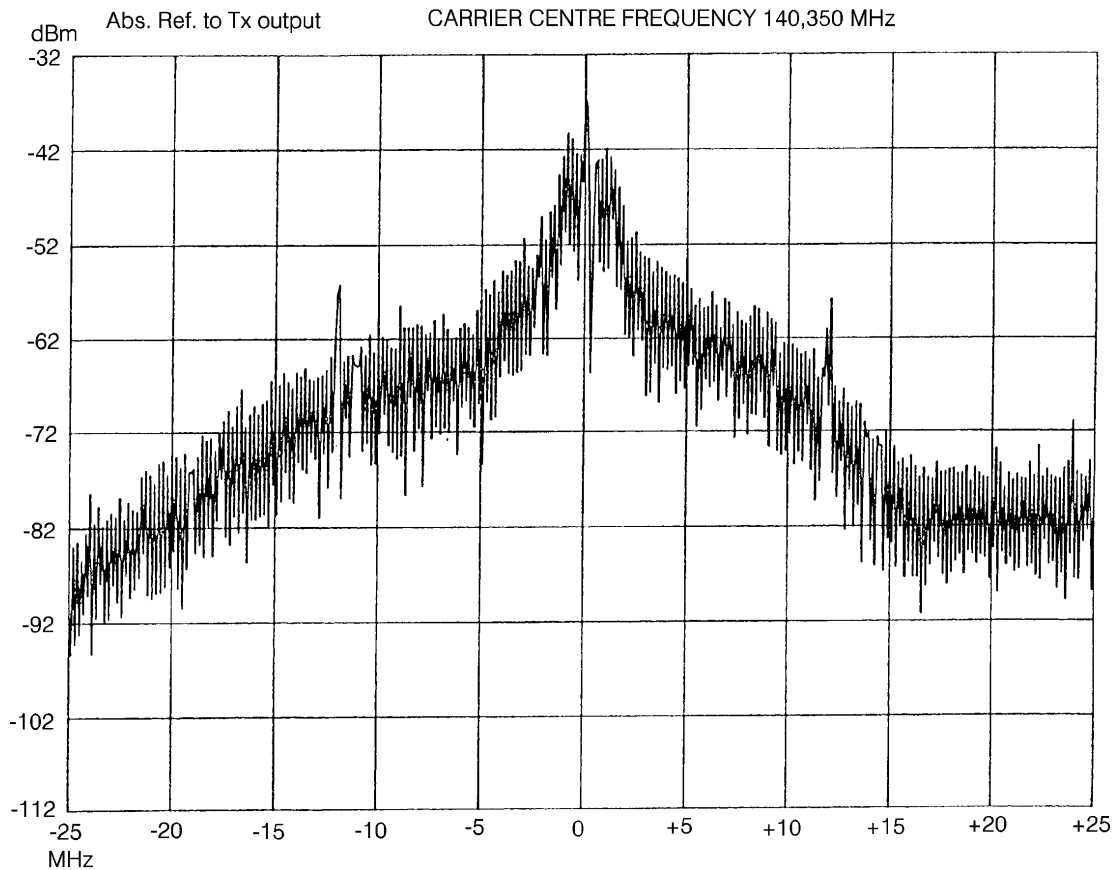

Figure M.4: Plot 3/Tx3

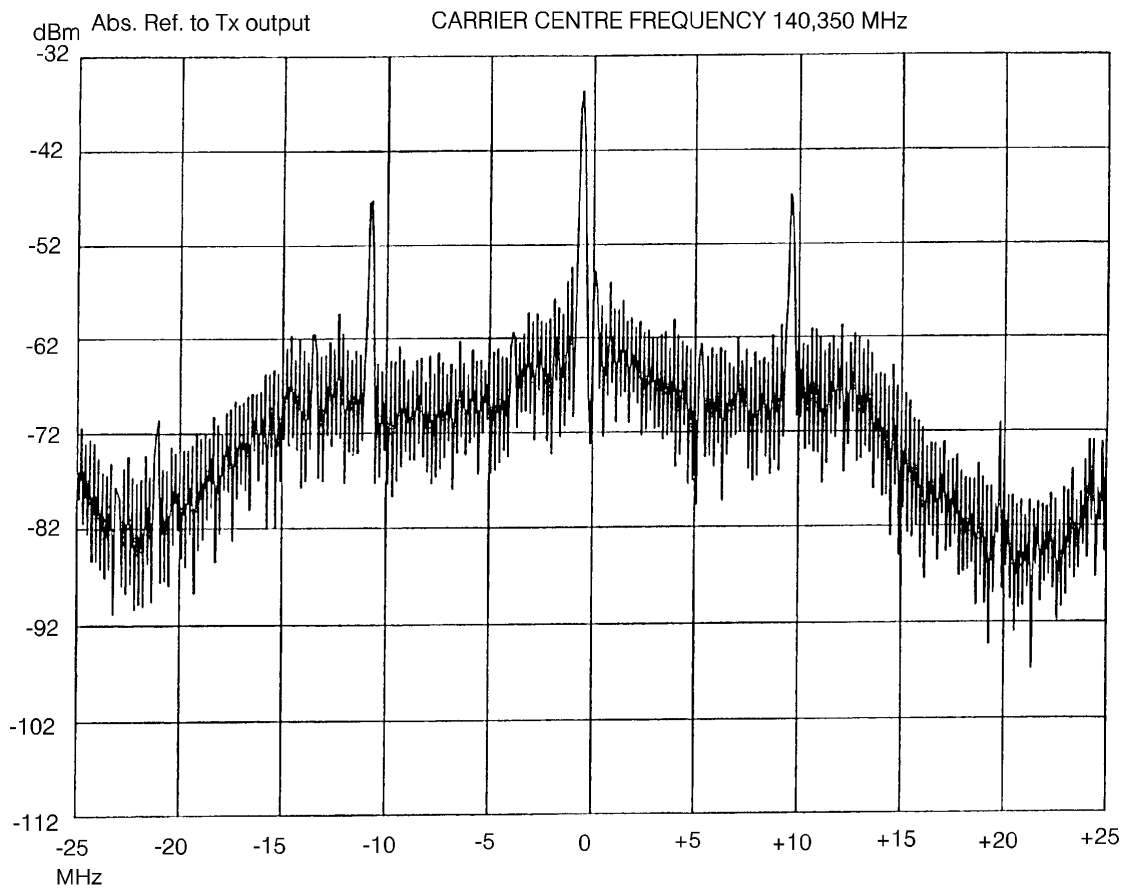

Figure M.5: Plot 4/Tx4

M.5 Explanation of plots

The stop notch on the transmitter frequency was carefully measured for each experiment and the depth of the notch was no less than -82 dB in VHF and -72 dB at 450 MHz. The difference being simply that for convenience a slightly different configuration of filters was utilized at UHF. This was still adequate to demonstrate the outband noise levels in absolute terms.

The top of the graticule on the display was set for convenience in the VHF cases to -32 dBm and at UHF to -25 dBm. These levels were chosen simply to obtain maximum use of the screen to keep the absolute noise level of the system below the bottom line.

It should be noted that the total dynamic range of the plotting system gives 162 dBc for +55 dBm input and for the 25 W case, i.e. +43 dBm, the dynamic range of -150 dBc.

M.6 Conclusions

It can be seen from the results that a wide variety of noise levels can be generated from various transmitters, but there is conclusive evidence that at frequencies between 1 MHz and 5 MHz away from carrier the noise levels can be as high as -80 dBc and down to -130 dBc in a 100 kHz bandwidth.

All of these levels are quite large signals in terms of receiver performance, and it becomes extremely important to ensure that when a multiplicity of transmitters are to be located on the same site as the associated filters that account has been taken of the noise possibilities and the appropriate filters added in the transmitter outputs.

Annex N (informative): Radiocommunications in confined spaces

N.1 Systems for radiocommunications in confined spaces

In designing a confined space communications system a series of calculations have to be made. The results of the calculation will be the confirmation that successful two-way communications will be achieved.

In order to illustrate the calculations required an example of a passive system is given. The example is a tunnel 2 km in length with two lengths of radiating cable installed in it. For convenience the radiating cables are fed at the mid point of the tunnel. Each length of radiating cable is 1 000 m. The base station equipment is installed at the surface above the tunnel, and the RF signals are connected to the radiating cable with low-loss feeder cable. A convenient ventilation shaft is used to install the feeder cable. The general arrangement is shown in figure N.1.

N.1.1 Design consideration

The calculations to be performed are a summation of the gains and losses in the circuit at the frequency of interest for both the uplink and downlink directions. A separate calculation is performed for each frequency band to be used in the system. Generally the highest frequency to be used will dictate the type of radiating cable to be used. Typical parameters for radiating cables are given in clause N.2.

The calculations are made for the worst possible case that may exist. Typically this is for a portable user, using the highest frequency band, located at the extreme end of the radiating cable, with his transceiver antenna shielded by his body from the cable. In order that a call to this user is successfully initiated these losses must be initially overcome. Once a call has been established the user may well operate the transceiver in a position that is more favourable for RF propagation.

The calculations take account of the various factors affecting the transmission path. These may be broken down into four main areas: base station parameters, cable losses, environmental losses and the mobile or portable parameters.

Tables N.1 and N.2 show the calculated RF power signal levels for the following cases typical of PMR applications:

- VHF Vehicle mounted, 10 W mobile transceiver, four channel system.
- UHF Hand held, 1 W portable unit, two channel system.

Downlink refers to the signal path from the base station to the users and uplink to the return p.

Table N.1: Downlink

Frequency	150 MHz VHF	450 MHz UHF	Unit
Base station output power	+40	+40	dBm
Combining loss	-9,0	-5,5	dB
Connecting cable and all connections	-0,8	-1,5	dB
Tunnel splitter loss	-3,5	-3,5	dB
Radiating cable (1¼ inch diam.) longitudinal loss	-10,6	-20	dB
Radiating cable median coupling loss (at 2 m)	-70	-70	dB
Cable installation variability	-10	-10	dB
Radiating efficiency	0	-5	dB
Signal level at the receiver input	-63,9	-80,5	dBm
Receiver threshold	-110	-110	dBm
Operating signal margin	46,1	34,5	dB

Table N.2: Uplink

Frequency	150 MHz VHF	450 MHz UHF	Unit
Portable output power	+40	+30	dBm
Radiating efficiency	0	-5	dB
Radiating cable median coupling loss (at 2 m)	-70	-70	dB
Cable installation variability	-10	-10	dB
Radiating cable (1¼ inch diam.) longitudinal loss	-10,6	-20	dB
Tunnel splitter loss	-3,5	-3,5	dB
Connecting cable and all connections	-0,8	-1,5	dB
Signal level at the receiver input	-54,9	-85,0	dBm
Receiver threshold	-112	-112	dBm
Operating signal margin	57,1	32	dB

In order to balance the system (to give the same operating signal margin for the uplink and the downlink) either the base station transmitter power should be reduced, or the base station receiver sensitivity should be increased.

In the case of higher frequency applications typical of public telephony such as GSM using 900 MHz and DCS at 1 800 MHz, using the foregoing example with 1 000 metre cable lengths results in an unworkable system.

For completeness an example of a tunnel using only a single 500 m length of 1½ inch diameter radiating cable is given in tables N.3 and N.4.

Table N.3: Downlink

Frequency	900 MHz GSM	1 800 MHz DCS	Unit
Base station output power	+40	+40	dBm
Combining loss	-8,0	-5,0	dB
Connecting cable and all connections	-2,0	-2,5	dB
Radiating cable (1½ inch diam.) longitudinal loss	-13,5	-28	dB
Radiating cable median coupling loss (at 2 m)	-70	-64	dB
Cable installation variability	-10	-10	dB
Radiating efficiency	-6	-6	dB
Signal level at the receiver input	-69,5	-75,5	dBm
Receiver threshold	-102	-100	dBm
Operating signal margin	32,5	24,5	dB

Table N.4: Uplink

Frequency	900 MHz GSM	1800 MHz DCS	Unit
Portable output power	+33	+30	dBm
Radiating efficiency	-6	-6	dB
Radiating cable median coupling loss (at 2 metres)	-70	-64	dB
Cable installation variability	-10	-10	dB
Radiating cable (1½ inch diam.) longitudinal loss	-13,5	-28	dB
Connecting cable and all connections	-2,0	-2,5	dB
Signal level at the receiver input	-68,5	-80,5	dBm
Receiver threshold	-104	-104	dBm
Operating signal margin	35,5	23,5	dB

It should be noted that a suitable allowance should be made for other, application specific, losses. For example a system used for public telephony in an underground railway, should consider the screening effects of the railway carriage, and the position in which the radiating cable is mounted relative to the carriage windows.

The foregoing calculations show that at the highest frequencies, the practical length of cable run is quite small when compared to the tunnel lengths that frequently occur.

Figure N.2 shows the arrangement of a typical multi-band RF combiner used to feed a radiating cable in a public service tunnel. The following services are combined into a single cable:

- FM (Band II) broadcast;
- VHF high band PMR;
- ERMES paging;
- UHF PMR in two sub-bands;
- UHF paging;
- GSM public mobile telephony;
- DCS public mobile telephony.

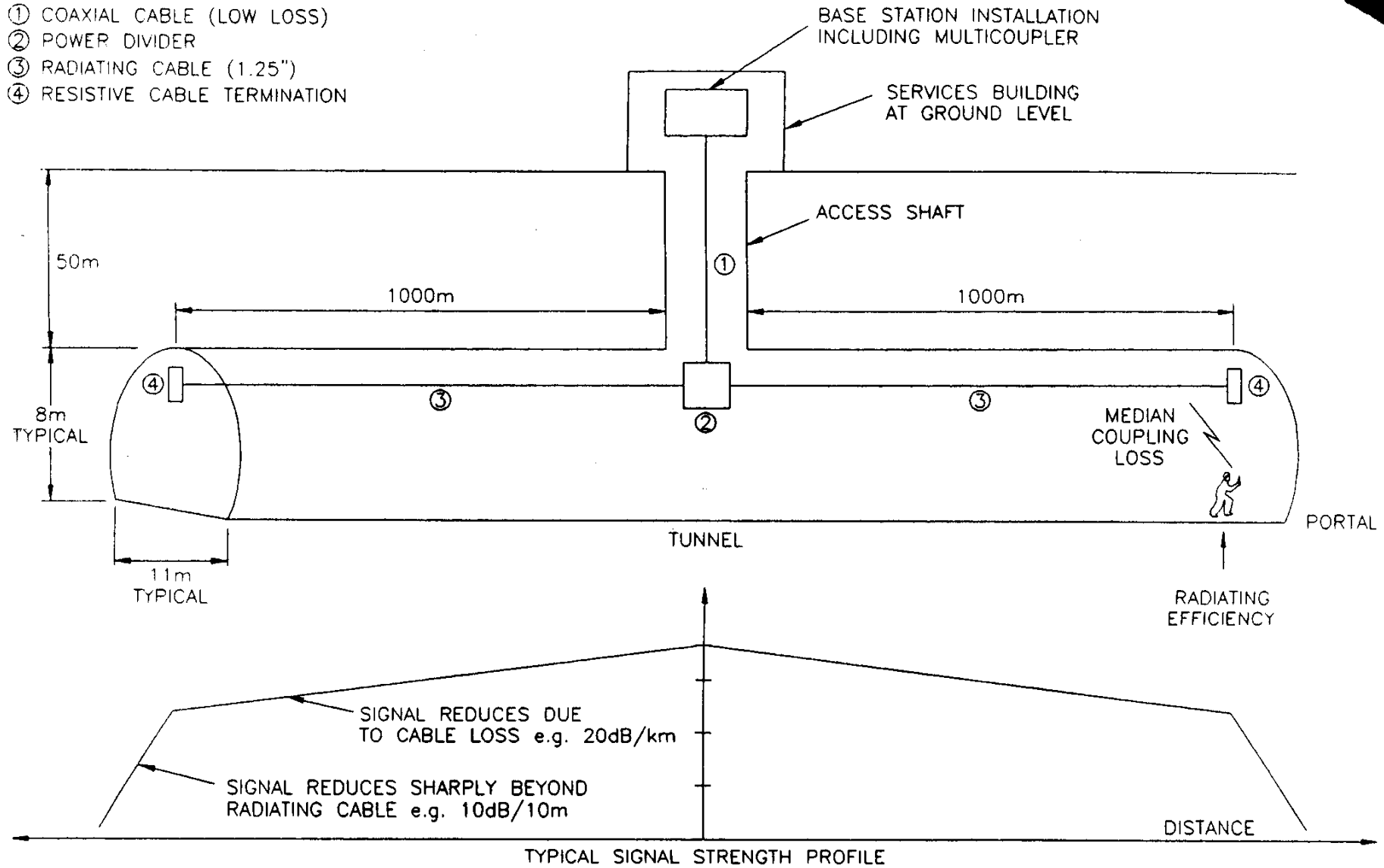

Figure N.1: Typical confined space R.F. system

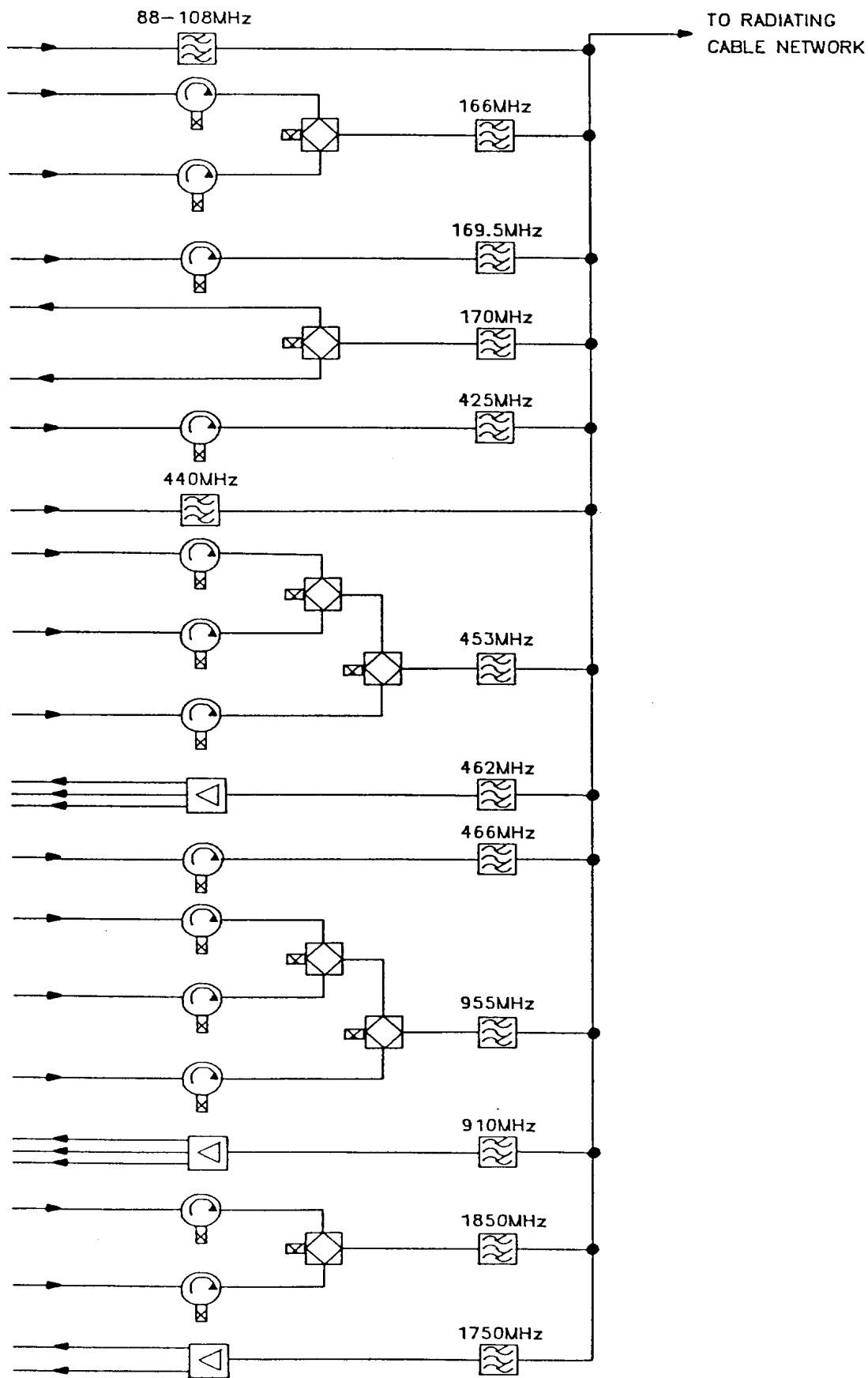

Figure N.2: Typical Multi-Band R.F. Combiner Network for use in public service tunnels

N.2 Typical characteristics of radiating cable

Radiating cables are manufactured by a number of companies. The figures given in this annex are illustrative only for the more popular size of cable; for specific types of cable for specific purposes reference should be made to the appropriate manufacturer's catalogue.

For general purpose use, most systems require fire retardent cable to be used, so this annex is based on typical mid range specifications for fire retardent cable.

Table N.5

Cable Type mm (")	13 (½")	22 (⅞")	32 (1¼")	41 (1⅝")
Overall diameter (mm)	15	29	39	48
Min. bending radius (mm)	150	350	500	700
Weight - kg (m)	0,34	0,77	1,16	1,5
Impedance Ω	50	50	50	50
Propogation Velocity (%)	88	88	88	88
Longitudinal attenuation (dB/100 m) (note 1)				
75 MHz	2,1	1,1	0,71	0,6
150 MHz	3,1	1,6	1,06	0,88
450 MHz	5,6	3,0	2,0	1,7
900 MHz	8,3	4,7	3,2	2,7
1800 MHz	23,3	20,8	8,2	5,6
Coupling loss (dB) (free space) (note 2)				
75 MHz	70	60	66	68
150 MHz	70	62	70	73
450 MHz	75	65	70	75
900 MHz	75	65	68	70
1800 MHz	54	54	62	64
NOTE 1: Longitudinal loss: the values are representative for cables mostly working at the coupling mode. Cables at the radiating mode show an increase of longitudinal losses above their cut-off frequency accompanied by a decrease of coupling loss.				
NOTE 2: Coupling loss: the values are the median coupling loss (50 %) for cables working in the coupling mode. The measurement procedure for free space is standardized by IEC sub-committee 46A, 1993. The variation of coupling loss from the median (50 %) X dB, is for 95 % cover X+12 dB, and for 5 % cover X-5 dB, where X also has a tolerance of ±10 dB to take account of different antenna orientations and measurement uncertainties.				

These typical catalogue values are for illustrative purposes only. They are based on the standardized measurement procedure developed in SC IEC 46A, 1993. For a good reproducibility, the cables should be mounted on stand offs approximately 65 mm from the mounting surface. For special applications the manufacturer should be consulted.

N.2.1 Environmental influences

Cable characteristics can be affected seriously by their environment; the amount depends on the cable type.

Continuously slotted cable is more affected by humidity than cables with large spaces between slots.

Wall standoffs less than half a wavelength lead to an increase of the longitudinal loss; the amount depends on frequency.

The coupling loss is affected mostly by reflections from surrounding walls. Interference leads to variations of free space measurement values. For rectangular tunnels variations of ±5 dB in the cross section have to be considered. In tunnels of cylindrical shape the conditions can be worse.

N.2.2 Application example

A 7/8" cable is required to supply a 500 m tunnel at 900 MHz. Coverage required is 95 %.

System loss = Longitudinal loss + coupling loss

Longitudinal loss: $4,7 \text{ dB}/100 \text{ m} \times 500 \text{ m} = 23,5 \text{ dB}$

Coupling loss: 65 dB for 50 %

65 dB + 12 dB for 95 % = 77,0 dB

System loss: $23,5 + 77 \text{ dB} = 100,5 \text{ dB} (\pm 10 \text{ dB})$

N.3 Design example for confined space engineering

N.3.1 Design example

A radio system has to supply four services from 150 MHz to 1 800 MHz in a tunnel at a coverage of 95 %. The system for each service consists of three cascaded repeaters feeding radiating cables of 1¼" diameter. The system has to be analysed and the maximum trunk lengths of each service band have to be computed under the same conditions and assumptions.

N.3.2 Conditions

Each repeater is of the same type. The gain compensates the actual cable losses of the appropriate cable sections only. It is assumed that for downlink, the first repeater has a gain of 30 dB.

N.3.3 Design procedure

The design procedure can be demonstrated by the trunk sketch in figure N.3.

The worst cases have been considered where 5 carriers have been transmitted the same time in up- and downlink. The requirements of maximum third order intermodulation product levels meet the GSM specifications. The minimum reception level along the cable has to be greater than -95 dBm while generally an additional screening loss of cabin windows is assumed to be 6 dB, location 1. In uplink the worst case is further characterized by locations of minimum coupling loss nearby the input of repeaters outside trains, location 2.

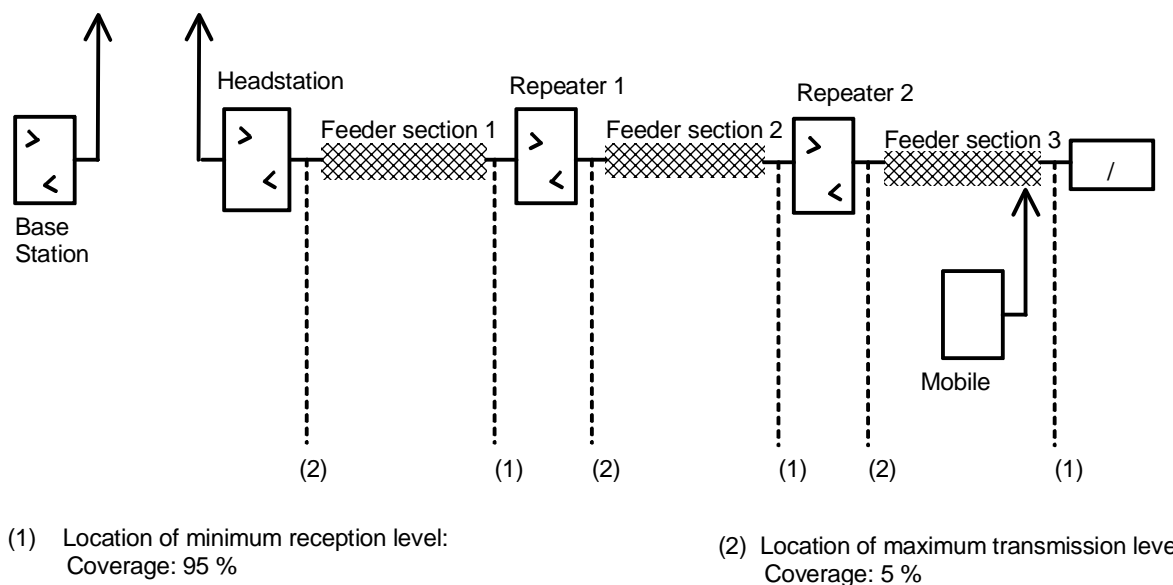

Figure N.3: Sketch of up- and downlink conditions

N.3.4 Conclusions

This example demonstrates that broadband repeater systems are well suited for confined areas applying radiating cables. Distortions due to noise and intermodulations can be limited to GSM specifications even in worst case situations. The dynamic ranges are determined by the system losses and the screening loss. For GSM and DCS 1 800 systems the feature of power control can reduce these ranges in uplink without suppressing the weakest signal.

Table N.6: Summary of computations

Service	Rescue	Train - Radio	GSM	DCS 1800
General conditions:				
Minimum reception level (dB/95 %)	-95	-95	-95	-95
Maximum spurious emissions (dBm)	-36	-36	-36	-36
Number of carriers	5	5	5	5
Screening losses (dB)	6	6	6	6
Repeater ICP3 (dBm)	50	50	50	50
Repeater noise figure (dB)	6	6	6	6
Channel bandwidth (kHz)	12,5	12,5	200	200
Cable type, diameter (mm) (inch) (1)	32 (1¼)	32 (1¼)	32 (1¼)	32 (1¼)
Mobile output level (dBm)	30	30	30	30
Downlink:				
Frequency range (MHz)	140 to 145	440 to 445	890 to 905	1 760 to 1 770
Maximum section length (m)	2 254	1 145	778	365
Maximum carrier level (dBm)	15	15	15	15
Repeater gain (dB)	24	23	25	30
Dynamic range (dB)	45	45	47	53
Maximum IM level (dBm)	-38	-38	-38	-38
C/I (dB)	53	53	53	53
C/N (dB) (on the cable)	134	133	122	125
C/D (dB)	53	53	53	53
Uplink:				
Frequency range (MHz)	150 to 155	450 to 455	935 to 950	1 855 to 1 865
Min. repeater output level (dBm)	-56	-57	-55	-50
Max. repeater output level (dBm)	-11	12	-8	3
Maximum IM level (dBm)	-116	-119	-107	-74
C/I (dB)	60	62	52	24
C/N (dB)	42	42	30	30
C/D (dB)	42	42	30	23,5
Maximum trunk length (m)	6 762	3 435	2 334	1 095
NOTE: The computations in table N.6 are based on a commercially available cable. The application of other types of the same diameter can lead to different results.				

Annex P (informative): TETRA and Commercial System Parameters

Tables P.1 and P.2 give the main technical parameters for TETRA (table P.1) and for the commercial system TETRAPOL (table P.2).

Table P.1: TETRA Parameters (From Report ITU-R M2014)

Frequency bands	380-470 MHz (870-888/915-933 MHz)
RFC carrier spacing (kHz)	25 kHz
Duplex separation (in Europe)	10 MHz in 380-470 MHz and 45 in 900 MHz
Modulation	$\pi/4$ QPSK
Access method	TDMA
Maximum base station ERP (W)	25W
Nominal mobile stations transmit power(W°)	
- Mobile	10 W
- Handheld	1.2W or 2W
Receiver sensitivity	for C/I 19 dB, with fading
Mobile stations	-103 dBm
Base stations	-106 dBm
Cell radius (km)	3,8 - 17.5 km
- Handheld/ suburban	3,8 km
- Mobile/rural	17,5 km (to take into account time advance)
Area coverage technique	Cellular channel reuse
Quasi synchronous (Simulcast)	
Time sharing transmission	
Diversity receivers	
Delay spread equalization capability(μ s)	Class A (single transmitter operation): No
equalization needed	
Class B (single transmitter operation):	55,5 μ s
Class Q (quasi synchronous operation):	111,1 μ s
Direct mode	Yes
Repeater mode	Yes
	P-1

Table P.2: Commercial System (TETRAPOL) Parameters (from ITU-R Recommendation M.2014 [19])

Frequency bands (870-888/915-933MHz)	68-88 MHz/150-174 MHz/380-470 MHz
RF carrier spacing	12,5 kHz and 10kHz
Duplex separation	As necessary in 68-174 MHz, 10 MHz in 380-470 MHz and 45 in 900 MHz
Modulation	GMSK
Access method	FDMA
Maximum base station ERP (W)	25W
Nominal mobile stations transmit power (W°)	
- Mobile	1/2/10 W
- Handheld	1 or 2 W
Receiver sensitivity	for C/I 15dB, with fading
Mobile stations	-111dBm
Base stations	-113 dBm
Cell radius (km)	
- Handheld/suburban	8-28 km
- Mobile/rural	28km (to more than 60km, no problem of time advance)
Area coverage technique	Cellular channel reuse
Simulcast	
Diversity receiver (time sharing transmission)	
Delay spread equalization capability (μ s)	No equalization needed
Direct mode	Yes
Repeater mode	Yes

Annex Q (informative): Future Systems - Universal Mobile Telecommunications System (UMTS)

Q.1 Introduction

The Universal Mobile Telecommunications System (UMTS), which is the subject of standardization work within ETSI, has been adopted as the new 3rd Generation (3G) system for Europe.

UMTS is to be compatible with the International Mobile Telecommunications 2000 (IMT - 2000), formerly known as Future Public Land Mobile Telecommunications System (FPLMTS), being developed on a world wide level, and will use the frequencies identified for IMT-2000 at WARC 92 taking into account the ITU recommendations. Consequently the minimum requirements of IMT-2000 as approved by the ITU, i.e. 144 kbit/s wide area coverage, 384 kbit/s local area coverage, 2 Mbit/s indoor coverage and 9,6 kbit/s satellite coverage, will be met by UMTS.

Q.2 UMTS Requirements

It is envisaged that UMTS will:

- a. have a spectrum environment able to respond to long-term 21st century evolution and growth of services and applications;
- b. bring about fixed and mobile, public and private, network convergence;
- c. effectively integrate access to cellular, cordless, paging, data, pmr, satellite, etc., systems through a single hand-held terminal;
- d. support a multiplicity of operators, service providers and applications;
- e. plan for a European-wide roll-out of new mobile, broadband, multi-media and information services;
- f. expect mobile terminal transmission needs to vary between and during calls;
- g. assume multi-mode terminals of widely differing capabilities.

Q.3 Standardization

The standardization work started in 1991, and the relevant standards have been or are in the process of being finalized. The timescale for implementation of UMTS is for a global system outline by 2000, a pilot scheme introduction starting in 2002 with mass commercial introduction by 2005.

Q.4 Frequency Allocations

A European Radiocommunications Committee (ERC) decision (ERC/DEC/97(07) of 30 June 1997, which came into force on 1 October 1997, has designated the frequency bands 1 900 MHz to 1 980 MHz, 2 010 MHz to 2 025 MHz and 2 110 MHz to 2 170 MHz to terrestrial UMTS, and will accommodate the UMTS satellite component applications within the bands 1 980 MHz to 2 010 MHz and 2 170 to 2 200 MHz. The ERC further decided that at least two 40 MHz blocks in the bands 1 900 MHz to 1 980 MHz and 2 110 MHz to 2 170 MHz shall be made available for UMTS by 1 January 2002 and further spectrum in the terrestrial allocations could be made available by 1 January 2005 subject to market demand.

Q.5 Global Standards

The 155 MHz of spectrum currently allocated to UMTS is split into the "paired" band (2×60 MHz) for frequency division duplex (FDD) operation and "unpaired" bands (separate 20 MHz and 15 MHz allocations) for time division duplex (TDD) operation, where one carrier is switched in time between uplink and downlink transmissions. Further work has been done on an international basis to harmonize key operating parameters. This has resulted in three main modes of operation for UMTS, based on UMTS Terrestrial Radio Access (UTRA) group's proposals together with submissions from the USA. The modes of operation are:

- a. CDMA-DS (CDMA- Direct Sequence), based on UTRA FDD.
- b. CDMA-MC (CDMA- Multi Carrier), based on cdma2000 (USA System IS-95).
- c. CDMA-TDD, based on UTRA TDD.

The adoption of the above criteria will allow interoperability and interworking between UTRA and cdma2000.

Q.6 On Site Considerations

With the expected wide use of UMTS, the co-siting of this system with the existing 2nd Generation systems will require careful planning, if interference between systems is to be avoided. There have been some initial theoretical CEPT studies, which indicate there could be problems regarding compatibility with DECT systems, but that these can be minimized by careful site engineering. Further studies are needed to assess the compatibility of UMTS, GSM 900, GSM 1800, TETRA and PMR systems when they are co located or co sited. It is likely that some form of filtering will be required to minimize the risks of interference. A practical study in UK found no interference from GSM 900, GSM 1800, TETRA and PMR in the UMTS band adjacent to a number of communal sites. However there was no UMTS equipment on these sites, so further work will be required when UMTS enters service.

Annex R (informative): Installations on High Voltage Electricity Towers - Guidelines

R.1 General

This annex details the general implications of installing antenna equipment (particularly cellular system antennas) on High Voltage Electricity Towers. These guidelines cover towers with cables operating at voltage levels of between 132 kV and 400 kV.

The tower owner/operator is referred to in this annex as the Grid Operator.

It must be noted that practices covering such installations will vary dependant on the National and Regional rules and regulations in place, particularly regarding personnel safety. Thus the guidelines in this annex are not definitive and are provided for general information purposes only.

Detailed personnel safety guidelines are not included in this annex.

R.1.1 Antenna Positioning

The following conditions apply to antenna positioning on towers:

1. Omnidirectional colinear array antennas may only be installed above the top tower cross-arm.
2. All antennas must be DC grounded.
3. All antennas must remain within the lightning cone of protection of the tower i.e. all antennas must lie within an imaginary cone of angle 35 degrees to the vertical with the apex at the tower earth wire ("top wire").
4. Antennas and any associated bracketry and cabling must not impede normal access to the tower. All climbing bolts/ladders must be left completely clear.
5. The tower cross arms form a radio frequency block. Antennas should not be mounted where cross arms impede the line of sight to the intended coverage area.
6. Antennas may not be mounted on any part of the cross arm outside the main tower body.

R.1.2 Links

Microwave link equipment may be tower mounted with similar restrictions on cabling and positioning as the other antennas.

Landline fibre links must incorporate a length of non-metallic content fibre to the base station equipment fibre termination point (typically greater than 50 metres distant from the Base Station Equipment). Where link equipment is within a Grid sub-station, fibre runs must have no metallic content within the boundaries of that sub-station. Metallic content includes the fibre cable armouring.

R.1.3 Cabling

All tower cabling (RF, Control and Power) must be fully screened. All screens must be solidly earthed to the tower structure at each end of the tower cable run and at least at 20 metre intervals along that run. Special attention must be made to ensure that all earth bonds are electrically secure and that electrolytic corrosion cannot occur.

R.1.4 Power Supply

Power supplies must incorporate additional protection to safeguard against Grid malfunction and/or lightning strikes. These include:

1. Incoming mains cables must incorporate an overall mains earth screen earthed only to the supply source, as stipulated by the Grid Operator.
2. Mains supply earth and tower earth must be isolated.
3. An isolating transformer must be provided to isolate "mains-side" and "equipment-side" supplies.
4. Surge arrestors must be provided in all "mains-side" wires to prevent over-voltage conditions due to lightning and switching surges.
5. Surge arrestors must be provided in "equipment-side" wires to prevent uncontrolled surges damaging the transformer and BTS equipment.
6. All extended lengths of cabling (greater than 5 metres) connected to the mains termination equipment must be housed in plastic conduit.
7. All on-site cabinet equipment must be earthed to a common point. This point must be earthed directly to the tower.

R.1.5 Safety

Where Live Line Working is permitted, it is expected that the following minimum guidelines will apply:

1. Tower access will be severely restricted. Typically all climbing works may only be carried out by the Grid Operator.
2. The Grid Operator will have the right to remove/disable tower equipment at any time.
3. The site and tower must be cleared of all non-permanent items (e.g. installation materials, cable drums etc.) when unattended.
4. Installations must be designed so that any mechanical failure will minimize incursion within the distance limit to live conductors and insulators.
5. Any vehicles attending the site must conform to site size (especially height) and weight restrictions and must keep to authorized vehicle roadways.
6. Restrictions will be placed on site tools and materials (e.g. metal ladders, steel re-inforced or electrically conductive rules or measures may not be used).

NOTE: Personnel safety guidelines have not been included in this annex as these will vary greatly according to local rules and regulations.

History

Document history		
Edition 1	November 1992	Publication as ETR 053
Edition 2	September 1996	Publication as ETR 053
Corrigendum 1	March 1997	Corrigendum 1 to 2 nd Edition of ETR 053
V1.3.1	August 1998	Publication as TR 100 053
V1.4.1	April 2002	Membership Approval Procedure MV 20020621: 2002-04-23 to 2002-06-21