

ETSI TS 138 106 V19.2.0 (2026-02)



TECHNICAL SPECIFICATION

5G; NR repeater radio transmission and reception (3GPP TS 38.106 version 19.2.0 Release 19)



Reference

RTS/TSGR-0438106vj20

Keywords

5G

ETSI

650 Route des Lucioles
F-06921 Sophia Antipolis Cedex - FRANCE

Tel.: +33 4 92 94 42 00 Fax: +33 4 93 65 47 16

Siret N° 348 623 562 00017 - APE 7112B
Association à but non lucratif enregistrée à la
Sous-Préfecture de Grasse (06) N° w061004871

Important notice

The present document can be downloaded from the
[ETSI Search & Browse Standards](#) application.

The present document may be made available in electronic versions and/or in print. The content of any electronic and/or print versions of the present document shall not be modified without the prior written authorization of ETSI. In case of any existing or perceived difference in contents between such versions and/or in print, the prevailing version of an ETSI deliverable is the one made publicly available in PDF format on [ETSI deliver](#) repository.

Users should be aware that the present document may be revised or have its status changed, this information is available in the [Milestones listing](#).

If you find errors in the present document, please send your comments to the relevant service listed under [Committee Support Staff](#).

If you find a security vulnerability in the present document, please report it through our [Coordinated Vulnerability Disclosure \(CVD\)](#) program.

Notice of disclaimer & limitation of liability

The information provided in the present deliverable is directed solely to professionals who have the appropriate degree of experience to understand and interpret its content in accordance with generally accepted engineering or other professional standard and applicable regulations.

No recommendation as to products and services or vendors is made or should be implied.

No representation or warranty is made that this deliverable is technically accurate or sufficient or conforms to any law and/or governmental rule and/or regulation and further, no representation or warranty is made of merchantability or fitness for any particular purpose or against infringement of intellectual property rights.

In no event shall ETSI be held liable for loss of profits or any other incidental or consequential damages.

Any software contained in this deliverable is provided "AS IS" with no warranties, express or implied, including but not limited to, the warranties of merchantability, fitness for a particular purpose and non-infringement of intellectual property rights and ETSI shall not be held liable in any event for any damages whatsoever (including, without limitation, damages for loss of profits, business interruption, loss of information, or any other pecuniary loss) arising out of or related to the use of or inability to use the software.

Copyright Notification

No part may be reproduced or utilized in any form or by any means, electronic or mechanical, including photocopying and microfilm except as authorized by written permission of ETSI.

The content of the PDF version shall not be modified without the written authorization of ETSI.

The copyright and the foregoing restriction extend to reproduction in all media.

© ETSI 2026.
All rights reserved.

Intellectual Property Rights

Essential patents

IPRs essential or potentially essential to normative deliverables may have been declared to ETSI. The declarations pertaining to these essential IPRs, if any, are publicly available for **ETSI members and non-members**, and can be found in ETSI SR 000 314: "*Intellectual Property Rights (IPRs); Essential, or potentially Essential, IPRs notified to ETSI in respect of ETSI standards*", which is available from the ETSI Secretariat. Latest updates are available on the [ETSI IPR online database](#).

Pursuant to the ETSI Directives including the ETSI IPR Policy, no investigation regarding the essentiality of IPRs, including IPR searches, has been carried out by ETSI. No guarantee can be given as to the existence of other IPRs not referenced in ETSI SR 000 314 (or the updates on the ETSI Web server) which are, or may be, or may become, essential to the present document.

Trademarks

The present document may include trademarks and/or tradenames which are asserted and/or registered by their owners. ETSI claims no ownership of these except for any which are indicated as being the property of ETSI, and conveys no right to use or reproduce any trademark and/or tradename. Mention of those trademarks in the present document does not constitute an endorsement by ETSI of products, services or organizations associated with those trademarks.

DECT™, **PLUGTESTS™**, **UMTS™** and the ETSI logo are trademarks of ETSI registered for the benefit of its Members. **3GPP™**, **LTE™** and **5G™** logo are trademarks of ETSI registered for the benefit of its Members and of the 3GPP Organizational Partners. **oneM2M™** logo is a trademark of ETSI registered for the benefit of its Members and of the oneM2M Partners. **GSM®** and the GSM logo are trademarks registered and owned by the GSM Association.

Legal Notice

This Technical Specification (TS) has been produced by ETSI 3rd Generation Partnership Project (3GPP).

The present document may refer to technical specifications or reports using their 3GPP identities. These shall be interpreted as being references to the corresponding ETSI deliverables.

The cross reference between 3GPP and ETSI identities can be found at [3GPP to ETSI numbering cross-referencing](#).

Modal verbs terminology

In the present document "**shall**", "**shall not**", "**should**", "**should not**", "**may**", "**need not**", "**will**", "**will not**", "**can**" and "**cannot**" are to be interpreted as described in clause 3.2 of the [ETSI Drafting Rules](#) (Verbal forms for the expression of provisions).

"**must**" and "**must not**" are **NOT** allowed in ETSI deliverables except when used in direct citation.

Contents

Intellectual Property Rights	2
Legal Notice	2
Modal verbs terminology.....	2
Foreword.....	14
1 Scope	16
2 References	16
3 Definitions of terms, symbols and abbreviations	17
3.1 Terms.....	17
3.2 Symbols.....	19
3.3 Abbreviations	20
4 General	21
4.1 Relationship between Minimum Requirements and Test Requirements	21
4.2 Conducted and radiated requirement reference points	21
4.2.1 RF repeater type 1-C.....	21
4.2.1A NCR type 1-C	22
4.2.1B Network controlled Repeater type 1-H	23
4.2.2 Repeater type 2-O	23
4.2.2A Network controlled Repeater type 2-O	24
4.3 Repeater classes.....	25
4.3.1 Repeater class for downlink.....	25
4.3.2 Repeater class for uplink.....	26
4.3A Network controlled repeater classes	26
4.3A.1 Network controlled repeater class for downlink	26
4.3A.2 Network controlled repeater class for uplink and MT	26
4.4 Regional requirements.....	26
4.5 Applicability of requirements.....	27
4.6 Requirements for contiguous and non-contiguous spectrum.....	29
4.7 Requirements for repeater capable of multi-band operation	29
5 Operating bands.....	29
5.1 General	29
5.2 Operating bands.....	30
5.3 Channel arrangement.....	30
5.3.1 Channel raster	30
5.3.1.1 NR-ARFCN and channel raster.....	30
5.3.1.2 Channel raster entries for each operating band	30
5.3.1.3 Channel raster to resource element mapping.....	30
5.3.2 Synchronization raster	30
5.3.2.1 Synchronization raster and numbering.....	30
5.3.2.2 Synchronization raster entries for each operating band.....	30
5.3.2.3 Synchronization raster to synchronization block resource element mapping.....	30
5.3.3 Channel spacing.....	31
5.3.4 TX–RX frequency separation	31
5.4 NCR-MT channel bandwidth	32
5.4.1 General.....	32
5.4.2 Transmission bandwidth configuration.....	32
5.4.3 Minimum guardband and transmission bandwidth configuration.....	32
5.4.4 RB alignment	32
5.4.5 NCR-MT channel bandwidth per operating band	33
6 Conducted characteristics.....	33
6.1 General	33
6.2 Repeater output power.....	33
6.2.1 General.....	33

6.2.2	Minimum requirement for RF repeater	34
6.2.3	Minimum requirement for NCR	35
6.2.3.1	Minimum requirement for NCR-Fwd	35
6.2.3.1.1	Minimum requirement for NCR-Fwd type 1-C	35
6.2.3.1.2	Minimum requirement for NCR-Fwd type 1-H	35
6.2.3.2	Minimum requirement for NCR-MT	35
6.2.3.2.1	General	35
6.2.3.2.2	Minimum requirement for NCR-MT type 1-C and NCR-MT type 1-H	36
6.3	Frequency stability	36
6.3.1	General	36
6.3.2	Minimum requirement for RF repeater	36
6.3.3	Minimum requirement for NCR	36
6.3.3.1	Minimum requirement for NCR-Fwd	36
6.3.3.1.1	Minimum requirement for NCR-Fwd type 1-C	36
6.3.3.1.2	Minimum requirement for NCR-Fwd type 1-H	36
6.4	Out of band gain	36
6.4.1	General	36
6.4.2	Minimum requirement for RF repeater	37
6.4.3	Minimum requirement for NCR	37
6.4.3.1	Minimum requirement for NCR-Fwd	37
6.4.3.1.1	Minimum requirement for NCR-Fwd type 1-C	37
6.4.3.1.2	Minimum requirement for NCR-Fwd type 1-H	37
6.5	Unwanted emissions	37
6.5.1	General	37
6.5.2	Adjacent Channel Leakage Power Ratio	38
6.5.2.1	General	38
6.5.2.2	Limits and basic limits	39
6.5.2.3	Minimum requirement for RF repeater	44
6.5.2.4	Minimum requirement for NCR	44
6.5.2.4.1	Minimum requirements for NCR-Fwd	44
6.5.2.4.2	Minimum requirement for NCR-MT	45
6.5.3	Operating band unwanted emissions	45
6.5.3.1	General	45
6.5.3.2	Basic limits	47
6.5.3.2.1	basic limits for Wide Area repeater type 1-C (Category A)	47
6.5.3.2.2	Basic limit for Wide Area repeater type 1-C (Category B)	48
6.5.3.2.3	Basic limits for Medium Range repeater type 1-C (Category A and B) for DL	50
6.5.3.2.4	Basic limits for Local Area repeater type 1-C (Category A and B)	52
6.5.3.2.5	Additional basic limits	53
6.5.3.2.6	Basic limit inside passband with no UL input signal	53
6.5.3.3	Minimum requirement for NCR	54
6.5.3.3.1	Minimum requirement for NCR-Fwd	54
6.5.3.3.2	Minimum requirement for NCR-MT	55
6.5.4	Transmitter spurious emissions	55
6.5.4.1	General	55
6.5.4.2	Basic limits	56
6.5.4.2.1	General transmitter spurious emissions basic limits	56
6.5.4.2.2	Additional spurious emissions basic limits	57
6.5.4.2.3	Co-location with base stations and repeater Nodes	68
6.5.4.3	Minimum requirement for RF repeater	75
6.5.4.4	Minimum requirement for NCR	75
6.5.4.4.1	Minimum requirement for NCR-Fwd	75
6.5.4.4.2	Minimum requirement for NCR-MT	76
6.5.5	Receiver spurious emissions	76
6.5.5.1	General	76
6.5.5.2	Basic limits	76
6.5.5.3	Minimum requirement for RF repeater	77
6.5.5.4	Minimum requirement for NCR	77
6.5.5.4.1	Minimum requirement for NCR-Fwd	77
6.6	Repeater Error Vector Magnitude	78
6.6.1	Downlink repeater error vector magnitude	78
6.6.1.1	General	78

6.6.1.2	Minimum requirement for RF repeater	78
6.6.1.2A	Minimum requirement for NCR.....	78
6.6.1.2A.1	Minimum requirement for NCR-Fwd.....	78
6.6.1.3	Repeater EVM frame structure for measurement.....	79
6.6.2	Uplink repeater error vector magnitude	79
6.6.2.1	General	79
6.6.2.2	Minimum requirement for RF repeater	79
6.6.2.3	Minimum requirement for NCR.....	79
6.6.2.3.1	Minimum requirement for NCR-Fwd.....	79
6.7	Input intermodulation	80
6.7.1	General requirement	80
6.7.1.1	General	80
6.7.1.2	Minimum requirement for RF repeater	80
6.7.1.3	Minimum requirement for NCR.....	80
6.7.1.3.1	Minimum requirement for NCR-Fwd.....	80
6.7.2	Co-location with BS/repeater in other systems.....	81
6.7.2.1	General	81
6.7.2.2	Minimum requirement for RF repeater	81
6.7.2.3	Minimum requirement for NCR.....	82
6.7.2.3.1	Minimum requirement for NCR-Fwd.....	82
6.7.3	Co-existence with other systems.....	82
6.7.3.1	General	82
6.7.3.2	Minimum requirement for RF repeater	82
6.7.3.3	Minimum requirement for NCR.....	83
6.7.3.3.1	Minimum requirement for NCR-Fwd.....	83
6.8	Output intermodulation	83
6.8.3	Minimum requirements for NCR.....	84
6.8.3.1	Minimum requirements for NCR-Fwd.....	84
6.8.3.1.1	Minimum requirements for NCR-Fwd type 1-C	84
6.8.3.1.2	Additional requirements for NCR-Fwd type 1-C	85
6.8.3.1.3	Minimum requirements for NCR-Fwd type 1-H	85
6.8.3.1.4	Additional requirements for NCR-Fwd type 1-H.....	85
6.9	Adjacent Channel Rejection Ratio (ACRR).....	85
6.9.1	General.....	85
6.9.2	Minimum Requirements for RF repeater	85
6.9.3	Minimum Requirements for NCR	86
6.9.3.1	Minimum requirements for NCR-Fwd.....	86
6.9.3.1.1	Minimum requirements for NCR-Fwd type 1-C	86
6.9.3.1.2	Minimum Requirements for NCR-Fwd type 1-H.....	87
6.10	Transmit ON/OFF power	87
6.10.1	Transmitter OFF power	87
6.10.1.1	General	87
6.10.1.2	Minimum requirement for RF repeater	87
6.10.1.3	Minimum requirement for NCR.....	87
6.10.1.3.1	Minimum requirement for NCR Fwd	87
6.10.2	Transmitter transient period.....	88
6.10.2.1	General	88
6.10.2.2	Minimum requirement for RF repeater	88
6.10.2.3	Minimum requirement for NCR.....	88
6.10.2.3.1	Minimum requirement for NCR-Fwd.....	88
6.11	Output power dynamics for NCR-MT.....	89
6.11.1	General.....	89
6.11.2	Transmit OFF power for NCR-MT.....	89
6.11.3	Transmit ON/OFF time mask for NCR-MT	89
6.11.4	Power control for NCR-MT	89
6.12	Transmit signal quality for NCR-MT.....	89
6.12.1	General.....	89
6.12.2	Frequency error requirements for NCR-MT	89
6.12.3	Transmit modulation quality.....	89
6.13	Transmit intermodulation for NCR-MT	90
6.13.1	General.....	90
6.13.2	Minimum requirements for NCR-MT.....	90

6.14	Void.....	90
6.15	Diversity characteristics for NCR-MT	90
6.16	Reference sensitivity for NCR-MT	90
6.16.1	NCR-MT reference sensitivity level.....	90
6.16.1.1	General.....	90
6.16.1.2	Minimum requirements for NCR-MT type 1-C and 1-H.....	90
6.17	Maximum input level for NCR-MT	91
6.18	Adjacent channel selectivity for NCR-MT.....	91
6.18.1	Adjacent Channel Selectivity (ACS)	91
6.18.1.1	General.....	91
6.18.1.2	Minimum requirement for NCR-MT type 1-C and 1-H.....	91
6.18.1.3	Void.....	92
6.19	Blocking characteristics for NCR-MT	92
6.19.1	General.....	92
6.19.2	Minimum requirement for NCR-MT type 1-C and 1-H	92
6.19.3	Void.....	92
6.20	Transmitter spurious response for NCR-MT.....	92
6.20.1	General.....	92
6.20.2	Minimum requirements for NCR-MT type 1-C and NCR-MT type 1-H.....	92
6.21	Receiver intermodulation characteristics for NCR-MT.....	92
6.21.1	General.....	92
6.21.2	Minimum requirement for NCR-MT type 1-C and 1-H	92
6.21.3	Void	93
6.22	Receiver spurious emissions for NCR-MT	93
6.22.1	General.....	93
6.22.2	Minimum requirements for NCR-MT type 1-C and type 1-H.....	93
7	Radiated characteristics.....	94
7.1	General	94
7.2	OTA output power.....	94
7.2.1	General.....	94
7.2.2	Minimum requirement for RF repeater.....	95
7.2.3	Minimum requirement for NCR	96
7.2.3.1	Minimum requirement for NCR-MT	96
7.2.3.1.1	Minimum requirement for NCR-MT type 1-H	96
7.2.3.1.2	Minimum requirement for NCR-MT type 2-O	96
7.2.3.2	Minimum requirement for NCR-Fwd	96
7.2.3.2.1	Minimum requirement for NCR-Fwd type 2-O.....	96
7.3	OTA frequency stability.....	96
7.3.1	General.....	96
7.3.2	Minimum requirement for RF repeater.....	97
7.3.3	Minimum requirement for NCR	97
7.3.3.1	Minimum requirement for NCR-Fwd	97
7.3.3.1.1	Minimum requirement for NCR-Fwd type 2-O.....	97
7.4	OTA out of band gain.....	97
7.4.1	General.....	97
7.4.2	Minimum requirement for RF repeater.....	97
7.4.3	Minimum requirement for NCR	97
7.4.3.1	Minimum requirement for NCR-Fwd	97
7.4.3.1.1	Minimum requirement for NCR-Fwd type 2-O.....	97
7.5	OTA unwanted emissions	98
7.5.1	General.....	98
7.5.2	OTA Adjacent Channel Leakage Power Ratio (ACLR)	98
7.5.2.1	General	98
7.5.2.2	Minimum requirement for RF repeater	98
7.5.2.3	Minimum requirement for NCR.....	102
7.5.2.3.1	Minimum requirement for NCR-Fwd.....	102
7.5.2.3.2	Minimum requirement for NCR-MT.....	102
7.5.3	OTA operating band unwanted emissions	102
7.5.3.1	General	102
7.5.3.2	Minimum requirement for RF repeater	102
7.5.3.2.1	General	102

7.5.3.2.2	OTA operating band unwanted emission limits (Category A)	103
7.5.3.2.3	OTA operating band unwanted emission limits (Category B).....	104
7.5.3.2.4	Additional OTA operating band unwanted emission requirements	104
7.5.3.3	Minimum requirement for NCR.....	105
7.5.3.3.1	Minimum requirement for NCR-Fwd.....	105
7.5.3.3.2	Minimum requirement for NCR-MT	105
7.5.4	OTA transmitter spurious emissions.....	105
7.5.4.1	General	105
7.5.4.2	Minimum requirement for RF repeater	105
7.5.4.2.1	General	105
7.5.4.2.2	General OTA transmitter spurious emissions requirements	106
7.5.4.2.3	Additional OTA transmitter spurious emissions requirements.....	107
7.5.4.3	Minimum requirement for NCR.....	107
7.5.4.3.1	Minimum requirement for NCR-Fwd.....	107
7.5.4.3.2	Minimum requirement for NCR-MT.....	107
7.5.5	OTA receiver spurious emissions	107
7.5.5.1	General	107
7.5.5.2	Minimum requirement for RF repeater	108
7.5.5.3	Minimum requirement for NCR.....	108
7.5.5.3.1	Minimum requirement for NCR-Fwd.....	108
7.6	OTA Repeater Error Vector Magnitude	109
7.6.1	Downlink repeater error vector magnitude	109
7.6.1.1	General	109
7.6.1.2	Minimum requirement for repeater	109
7.6.1.2A	Minimum requirement for NCR.....	110
7.6.1.2A.1	Minimum requirement for NCR-Fwd.....	110
7.6.1.3	Repeater EVM frame structure for measurement.....	110
7.6.2	Uplink repeater error vector magnitude	110
7.6.2.1	General	110
7.6.2.2	Minimum requirement for RF repeater	111
7.6.2.3	Minimum requirement for NCR.....	111
7.6.2.3.1	Minimum requirement for NCR-Fwd.....	111
7.7	OTA input intermodulation	111
7.7.1	General.....	111
7.7.2	Minimum requirement for RF repeater.....	111
7.7.3	Minimum requirement for NCR	112
7.7.3.1	Minimum requirement for NCR-Fwd	112
7.7.3.1.1	Minimum requirement for NCR-Fwd type 2-O.....	112
7.8	OTA Adjacent Channel Rejection Ratio (ACRR).....	112
7.8.1	General.....	112
7.8.2	Minimum Requirements for RF repeater	112
7.8.3	Minimum Requirements for NCR	113
7.8.3.1	Minimum Requirements for NCR-Fwd	113
7.8.3.1.1	Minimum Requirements for NCR-Fwd type 2-O.....	113
7.9	OTA transmit ON/OFF power.....	114
7.9.1	General.....	114
7.9.2	OTA transmitter OFF power.....	114
7.9.2.1	General	114
7.9.2.2	Minimum requirement for RF repeater	114
7.9.2.3	Minimum requirement for NCR.....	114
7.9.2.3.1	Minimum requirement for NCR-Fwd.....	114
7.9.2.3.2	Minimum requirement for NCR-MT	114
7.9.3	OTA transient period	115
7.9.3.1	General	115
7.9.3.2	Minimum requirement for RF repeater	115
7.9.3.3	Minimum requirement for NCR.....	116
7.9.3.3.1	Minimum requirement for NCR-Fwd.....	116
7.9.3.3.2	Minimum requirement for NCR-MT	116
7.10	OTA output power dynamics for NCR-MT	116
7.10.1	General.....	116
7.10.2	Minimum requirement for NCR-MT	116
7.11	OTA transmit signal quality for NCR-MT	116

7.11.1	General.....	116
7.11.2	Frequency error requirements for NCR-MT	116
7.11.2.1	Minimum requirement for NCR-MT type 2-O	116
7.11.3	Transmit modulation quality.....	116
7.11.3.1	Minimum requirement for NCR-MT type 2-O	116
7.12	Diversity characteristics for NCR-MT	117
7.12.1	General.....	117
7.12.2	Minimum requirement for NCR-MT	117
7.13	OTA reference sensitivity for NCR-MT	117
7.13.1	General.....	117
7.13.2	Minimum requirement for NCR-MT type 2-O	117
7.14	OTA maximum input level for NCR-MT.....	117
7.14.1	General.....	117
7.14.2	Minimum requirement for NCR-MT type 2-O	117
7.15	OTA adjacent channel selectivity for NCR-MT.....	117
7.15.1	General.....	117
7.15.1	Minimum requirement for NCR-MT type 2-O	117
7.16	OTA blocking characteristics for NCR-MT	118
7.16.1	General.....	118
7.16.2	Minimum requirement for NCR-MT type 2-O	118
7.17	OTA receiver spurious emissions for NCR-MT.....	118
7.17.1	General.....	118
7.17.2	Minimum requirement for NCR-MT type 2-O	118
7.18	OTA spatial emission	118
7.18.1	General.....	118
7.18.2	Protection of FSS UL.....	118
7.18.2.1	General	118
7.18.2.2	Minimum requirement for NCR type 1-H.....	119
8	Conducted performance requirements.....	119
8.1	General	119
8.2	Demodulation performance requirements	120
8.2.1	Performance requirements for PDSCH.....	120
8.2.1.1	2Rx requirements	120
8.2.1.1.1	FDD	120
8.2.1.1.2	TDD.....	121
8.2.1.2	4Rx requirements	122
8.2.1.2.1	FDD	122
8.2.1.2.2	TDD.....	123
8.2.2	Performance requirements for PDCCCH	124
8.2.2.1	2Rx requirements	124
8.2.2.1.1	FDD	124
8.2.2.1.2	TDD.....	125
8.2.2.2	4Rx requirements	126
8.2.2.2.1	FDD	126
8.2.2.2.2	TDD.....	127
8.2.3	Channel Quality Indicator (CQI) reporting requirements	128
8.2.3.1	General	128
8.2.3.2	2Rx requiremnets	128
8.2.3.2.1	FDD	128
8.2.3.2.2	TDD.....	130
8.2.3.3	4Rx requiremnets	131
8.2.3.3.1	FDD	131
8.2.3.3.2	TDD.....	132
9	Radiated performance requirements.....	133
9.1	General	133
9.2	OTA demodulation branches.....	133
9.3	Demodulation performance requirements	134
9.3.1	Performance requirements for NCR type 2-O	134
9.3.1.1	Performance requirements for PDSCH	134
9.3.1.1.1	General	134

9.3.1.1.2	Minimum requirements	134
9.3.1.2	Performance requirements for PDCCH.....	135
9.3.1.2.1	General	135
9.3.1.2.2	Minimum requirements	135
9.4	CSI reporting requirements	136
9.4.1	Performance requirements for NCR-MT type 2-O	136
9.4.1.1	General	136
9.4.1.2	Common test parameters	136
9.4.1.3	Reporting of Channel Quality Indicator (CQI)	138
9.4.1.3.1	General	138
9.4.1.3.2	Minimum requirements	138
10	NCR-MT RRC_CONNECTED state mobility	139
10.1	RRC Connection Mobility Control for NCR-MT	139
10.1.1	SA: RRC Re-establishment	139
10.1.1.1	Introduction.....	139
10.1.1.2	Requirements	139
10.1.1.2.1	NCR-MT Re-establishment delay requirement	139
10.1.2	Random access.....	141
10.1.2.1	Introduction.....	141
10.1.2.2	Requirements for 4-step RA type.....	141
10.1.2.2.1	Contention based random access	141
10.1.2.2.2	Non-Contention based random access.....	142
10.2	Timing	143
10.2.1	NCR-MT transmit timing	143
10.2.1.1	Introduction.....	143
10.2.1.2	Requirements	143
10.2.1.2.1	Gradual timing adjustment	144
10.2.2.1	Introduction.....	145
10.2.2.2	Requirements	145
10.2.3	NCR-MT timing advance	145
10.2.3.1	Introduction.....	145
10.2.3.2	Requirements	145
10.2.3.2.1	Timing Advance adjustment delay	145
10.2.3.2.2	Timing Advance adjustment accuracy.....	145
10.3	Signalling Characteristics for NCR-MT	146
10.3.1	Radio Link Monitoring	146
10.3.1.1	Introduction.....	146
10.3.1.2	Requirements for SSB based radio link monitoring.....	147
10.3.1.2.1	Introduction	147
10.3.1.2.2	Minimum requirement.....	147
10.3.1.2.3	Measurement restrictions for SSB based RLM	148
10.3.1.3	Requirements for CSI-RS based radio link monitoring.....	149
10.3.1.3.1	Introduction	149
10.3.1.3.2	Minimum requirement.....	149
10.3.1.3.3	Measurement restrictions for CSI-RS based RLM	150
10.3.1.4	Minimum requirement for NCR-MT turning off the transmitter	151
10.3.1.5	Minimum requirement for L1 indication.....	151
10.3.1.6	Scheduling availability of NCR-MT during radio link monitoring.....	152
10.3.1.6.1	Scheduling availability of NCR-MT performing radio link monitoring with a same subcarrier spacing as PDSCH/PDCCH on FR1.....	152
10.3.1.6.2	Scheduling availability of NCR-MT performing radio link monitoring with a different subcarrier spacing than PDSCH/PDCCH on FR1	152
10.3.1.6.3	Scheduling availability of NCR-MT performing radio link monitoring on FR2-1.....	152
10.3.2	Link Recovery Procedure	152
10.3.2.1	Introduction.....	152
10.3.2.2	Requirements for SSB based beam failure detection	153
10.3.2.2.1	Introduction	153
10.3.2.2.2	Minimum requirement.....	154
10.3.2.2.3	Measurement restriction for SSB based beam failure detection	154
10.3.2.3	Requirements for CSI-RS based beam failure detection.....	155
10.3.2.3.1	Introduction	155

10.3.2.3.2	Minimum requirement.....	155
10.3.2.3.3	Measurement restrictions for CSI-RS based beam failure detection	156
10.3.2.4	Minimum requirement for L1 indication.....	157
10.3.2.5	Requirements for SSB based candidate beam detection	157
10.3.2.5.1	Introduction	157
10.3.2.5.2	Minimum requirement.....	157
10.3.2.5.3	Measurement restriction for SSB based candidate beam detection	158
10.3.2.6	Requirements for CSI-RS based candidate beam detection	159
10.3.2.6.1	Introduction	159
10.3.2.6.2	Minimum requirement.....	159
10.3.2.6.3	Measurement restriction for CSI-RS based candidate beam detection.....	160
10.3.2.7	Scheduling availability of NCR-MT during beam failure detection	160
10.3.2.7.1	Scheduling availability of NCR-MT performing beam failure detection with a same subcarrier spacing as PDSCH/PDCCH on FR1	160
10.3.2.7.2	Scheduling availability of NCR-MT performing beam failure detection with a different subcarrier spacing than PDSCH/PDCCH on FR1	160
10.3.2.7.3	Scheduling availability of NCR-MT performing beam failure detection on FR2-1	160
10.3.2.8	Scheduling availability of NCR-MT during candidate beam detection	161
10.3.2.8.1	Scheduling availability of NCR-MT performing L1-RSRP measurement with a same subcarrier spacing as PDSCH/PDCCH on FR1	161
10.3.2.8.2	Scheduling availability of NCR-MT performing L1-RSRP measurement with a different subcarrier spacing than PDSCH/PDCCH on FR1	161
10.3.2.8.3	Scheduling availability of NCR-MT performing L1-RSRP measurement on FR2-1	161
Annex A:	Void.....	163
Annex B (normative):	NCR-MT Reference measurement channels.....	164
B.1	NCR-MT Demodulation Performance Fixed Reference Channels	164
B.1.1	Fixed Reference Channels for PDSCH performance requirements.....	164
B.1.2	Fixed Reference Channels for PDCCH performance requirements	165
B.1.3	Fixed Reference Channels for CSI reporting performance	165
B.2	Fixed Reference Channels for reference sensitivity level, ACS, in-band blocking, out-of-band blocking and receiver intermodulation (QPSK, R=1/3).....	167
Annex C (normative):	Propagation conditions.....	168
C.1	Static propagation condition.....	168
C.1.1	NCR-MT receiver with 2RX	168
C.1.2	NCR-MT Receiver with 4Rx.....	168
C.2	Multi-path fading propagation conditions	168
C.2.1	General	168
C.2.2	Delay profiles	169
C.2.2.1	General.....	169
C.2.2.2	Delay profiles for FR1	170
C.2.3	Combinations of channel model parameters	171
C.2.4	MIMO channel correlation matrices.....	171
C.2.4.1	General.....	171
C.2.4.2	MIMO correlation matrices using Uniform Linear Array	172
C.2.4.2.1	General	172
C.2.4.2.2	Definition of MIMO correlation matrices	172
C.2.4.2.3	MIMO correlation matrices at high, medium and low level	173
C.2.4.3	Multi-antenna channel models using cross polarized antennas.....	174
C.2.4.3.1	General	174
C.2.4.3.2	Definition of MIMO correlation matrices using cross polarized antennas.....	175
C.2.4.3.3	Spatial correlation matrices at NCR-MT and gNB sides	175
C.2.4.3.3.1	Spatial correlation matrices at NCR-MT side.....	175
C.2.4.3.3.2	Spatial correlation matrices at gNB side	176
C.2.4.3.4	MIMO correlation matrices using cross polarized antennas	176
C.2.4.3.5	Beam steering approach	176
C.3	Physical signals, channels mapping and precoding.....	177

C.3.1	General	177
Annex D:	Void	178
Annex E:	Void	178
Annex F:	Void	178
Annex G (normative):	NCR-MT RRM Testing	178
G.1	NCR-MT RRM test configurations	180
G.1.1	Reference measurement channels	180
G.1.1.1	PDSCH	180
G.1.1.1.1	TDD	180
G.1.1.1.2	FDD	183
G.1.1.2	CORESET for RMSI scheduling	184
G.1.1.2.1	TDD	184
G.1.1.2.2	FDD	187
G.1.1.3	CORESET for RMC scheduling	188
G.1.1.3.1	TDD	188
G.1.1.3.2	FDD	189
G.1.2	OFDMA channel noise generator (OCNG)	190
G.1.2.1	Generic OFDMA Channel Noise Generator (OCNG)	190
G.1.2.1.1	OCNG pattern 1: Generic OCNG pattern for all unused REs	190
G.1.2.1.2	OCNG pattern 2: Generic OCNG pattern for all unused REs for 2AoA setup	190
G.1.2.1.3	OCNG pattern 3: Generic OCNG pattern for unused REs in the same bandwidth as PDSCH RMC	191
G.1.2.1.4	OCNG pattern 4: Generic OCNG pattern for all unused REs outside SSB slot(s)	191
G.1.3	Antenna configurations	191
G.1.3.1	Antenna configurations for FR1	191
G.1.3.1.1	Antenna connection for 4 Rx capable NCR-MT	191
G.1.3.1.1.1	Introduction	191
G.1.3.1.1.2	Principle of testing	192
G.1.3.2	Antenna configurations for FR2	193
G.1.4	BWP configurations	193
G.1.4.1	Introduction	193
G.1.4.2	Downlink BWP configurations	193
G.1.4.2.1	Initial BWP	193
G.1.4.2.2	Dedicated BWP	193
G.1.4.3	Uplink BWP configurations	194
G.1.4.3.1	Initial BWP	194
G.1.4.3.2	Dedicated BWP	194
G.1.5	SSB Configurations	194
G.1.5.1	SSB Configurations for FR1	194
G.1.5.1.1	SSB pattern 1 in FR1: SSB allocation for SSB SCS=15 kHz	194
G.1.5.1.2	SSB pattern 2 in FR1: SSB allocation for SSB SCS=30 kHz	195
G.1.5.1.3	SSB pattern 3 in FR1: SSB allocation for SSB SCS=15 kHz	195
G.1.5.1.4	SSB pattern 4 in FR1: SSB allocation for SSB SCS=30 kHz	196
G.1.5.1.5	SSB pattern 5 in FR1: SSB allocation for SSB SCS=15 kHz starting from odd SFN	196
G.1.5.1.6	SSB pattern 6 in FR1: SSB allocation for SSB SCS=30 kHz starting from odd SFN	197
G.1.5.2	SSB Configurations for FR2	197
G.1.5.2.1	SSB pattern 1 in FR2: SSB allocation for SSB SCS=120 kHz	197
G.1.5.2.2	SSB pattern 2 in FR2: SSB allocation for SSB SCS=240 kHz	198
G.1.5.2.3	SSB pattern 3 in FR2: SSB allocation for SSB SCS=120 kHz	198
G.1.5.2.4	SSB pattern 4 in FR2: SSB allocation for SSB SCS=240 kHz	198
G.1.5.2.5	SSB pattern 5 in FR2: SSB allocation for SSB SCS=120 kHz	199
G.1.5.2.6	SSB pattern 6 in FR2: SSB allocation for SSB SCS=240 kHz	199
G.1.5.2.7	SSB pattern 7 in FR2: SSB allocation for SSB SCS=120 kHz	199
G.1.5.2.8	SSB pattern 8 in FR2: SSB allocation for SSB SCS=240 kHz	200
G.1.6	SMTC Configurations	200
G.1.6.1	SMTC pattern 1: SMTC period = 20 ms with SMTC duration = 1 ms	200
G.1.6.2	SMTC pattern 2: SMTC period = 20 ms with SMTC duration = 5 ms	200

G.1.6.3	SMTC pattern 3: SMTC period = 160 ms with SMTC duration = 1 ms.....	200
G.1.6.4	SMTC pattern 4: SMTC period = 20 ms with SMTC duration = 1 ms.....	201
G.1.6.5	SMTC pattern 5: SMTC period = 20 ms with SMTC duration = 5 ms.....	201
G.1.7	CSI-RS configurations	202
G.1.7.1	TDD.....	202
.1.7.2	FDD.....	204
G.1.8	Angle of Arrival (AoA) for FR2 RRM test cases.....	205
G.1.8.1	Setup 1: Single AoA	205
G.1.8.2	Setup 2: 2 AoAs.....	205
G.1.9	TCI State Configuration	205
G.1.9.1	Introduction.....	205
G.1.9.2	TCI states.....	206
G.1.10	Configurations of CSI-RS for tracking.....	206
G.1.10.1	Configuration of CSI-RS for tracking for FR1	206
G.1.10.1.2	TDD	206
G.1.10.1.3	FDD.....	207
G.1.10.2	Configuration of CSI-RS for tracking for FR2.....	208
G.1.10.2.1	TDD	208
G.2	NCR-MT RRM test cases.....	209
G.2.1	RRC_CONNECTED state mobility for NCR-MTs	209
G.2.1.1	RRC Connection Mobility Control.....	209
G.2.1.1.2	RRC Re-establishment for LA NCR-MT.....	209
G.2.1.1.1.1	Inter-frequency RRC Re-establishment in FR1 for LA NCR-MT	209
G.2.1.1.1.2	Intra-frequency RRC Re-establishment in FR1 without serving cell timing for LA NCR-MT.....	212
G.2.1.1.1.3	Inter-frequency RRC Re-establishment in FR2-1 for LA NCR-MT	215
G.2.1.1.1.4	Intra-frequency RRC Re-establishment in FR2-1 without serving cell timing for LA NCR-MT	218
G.2.2	Timing	220
G.2.2.1	Transmit timing	220
G.2.2.1.1	NR NCR-MT Transmit Timing Test for FR1	220
G.2.2.1.1.1	Test Purpose and environment	220
G.2.2.1.1.2	Test requirements	222
G.2.2.1.2	NR NCR-MT Transmit Timing Test for FR2-1	223
G.2.2.1.2.1	Test Purpose and environment	223
G.2.2.1.2.2	Test requirements	225
G.2.3	Signalling Characteristics for NCR MTs.....	226
G.2.3.1	Radio link Monitoring	226
G.2.3.1.1	Radio Link Monitoring Out-of-sync Test for FR1 PCell configured with SSB-based RLM RS in non-DRX mode	226
G.2.3.1.1.1	Test Purpose and Environment.....	226
G.2.3.1.1.2	Test Requirements	228
G.2.3.1.2	Radio Link Monitoring In-sync Test for FR1 PCell configured with SSB-based RLM RS in non-DRX mode	229
G.2.3.1.2.1	Test Purpose and Environment.....	229
G.2.3.1.2.2	Test Requirements	233
G.2.3.1.3	Radio Link Monitoring Out-of-sync Test for FR2-1 PCell configured with SSB-based RLM RS in non-DRX mode	233
G.2.3.1.3.1	Test Purpose and Environment.....	233
G.2.3.1.3.2	Test Requirements	236
G.2.3.1.4	Radio Link Monitoring In-sync Test for FR2-1 PCell configured with SSB-based RLM RS in non-DRX mode	236
G.2.3.1.4.1	Test Purpose and Environment.....	236
G.2.3.1.4.2	Test Requirements	239
G.2.3.1.5	Radio Link Monitoring Out-of-sync Test for FR1 PCell configured with CSI-RS-based RLM in non-DRX mode	240
G.2.3.1.5.1	Test Purpose and Environment.....	240
G.2.3.1.5.2	Test Requirements	242
G.2.3.1.6	Radio Link Monitoring In-sync Test for FR1 PCell configured with CSI-RS-based RLM in non-DRX mode	243
G.2.3.1.6.1	Test Purpose and Environment.....	243
G.2.3.1.6.2	Test Requirements	245

G.2.3.1.7	Radio Link Monitoring Out-of-sync Test for FR2-1 PCell configured with CSI-RS-based RLM in non-DRX mode	246
G.2.3.1.7.1	Test Purpose and Environment.....	246
G.2.3.1.7.2	Test Requirements	248
G.2.3.1.8	Radio Link Monitoring In-sync Test for FR2-1 PCell configured with CSI-RS-based RLM in non-DRX mode	249
G.2.3.1.8.1	Test Purpose and Environment.....	249
G.2.3.1.8.2	Test Requirements	251
G.2.3.2	Beam Failure Detection and Link Recovery Procedure.....	252
G.2.3.2.1	Beam Failure Detection and Link Recovery Test for FR1 PCell configured with SSB-based BFD and LR.....	252
G.2.3.2.1.1	Test Purpose and Environment.....	252
G.2.3.2.1.2	Test Requirements	256
G.2.3.2.2	Beam Failure Detection and Link Recovery Test for FR2 PCell configured with SSB-based BFD and LR.....	256
G.2.3.2.2.1	Test Purpose and Environment.....	256
G.2.3.2.2.2	Test Requirements	261
G.2.3.2.3	Beam Failure Detection and Link Recovery Test for FR1 PCell configured with CSI-RS-based BFD and LR.....	262
G.2.3.2.3.1	Test Purpose and Environment.....	262
G.2.3.2.3.2	Test Requirements	266
G.2.3.2.4	Beam Failure Detection and Link Recovery Test for FR2 PCell configured with CSI-RS-based BFD and LR in non-DRX mode	266
G.2.3.2.4.1	Test Purpose and Environment.....	266
G.2.3.2.4.2	Test Requirements	271
Annex H (informative):	Change history	272
History		275

Foreword

This Technical Specification has been produced by the 3rd Generation Partnership Project (3GPP).

The contents of the present document are subject to continuing work within the TSG and may change following formal TSG approval. Should the TSG modify the contents of the present document, it will be re-released by the TSG with an identifying change of release date and an increase in version number as follows:

Version x.y.z

where:

- x the first digit:
 - 1 presented to TSG for information;
 - 2 presented to TSG for approval;
 - 3 or greater indicates TSG approved document under change control.
- y the second digit is incremented for all changes of substance, i.e. technical enhancements, corrections, updates, etc.
- z the third digit is incremented when editorial only changes have been incorporated in the document.

In the present document, modal verbs have the following meanings:

- shall** indicates a mandatory requirement to do something
- shall not** indicates an interdiction (prohibition) to do something

The constructions "shall" and "shall not" are confined to the context of normative provisions, and do not appear in Technical Reports.

The constructions "must" and "must not" are not used as substitutes for "shall" and "shall not". Their use is avoided insofar as possible, and they are not used in a normative context except in a direct citation from an external, referenced, non-3GPP document, or so as to maintain continuity of style when extending or modifying the provisions of such a referenced document.

- should** indicates a recommendation to do something
- should not** indicates a recommendation not to do something
- may** indicates permission to do something
- need not** indicates permission not to do something

The construction "may not" is ambiguous and is not used in normative elements. The unambiguous constructions "might not" or "shall not" are used instead, depending upon the meaning intended.

- can** indicates that something is possible
- cannot** indicates that something is impossible

The constructions "can" and "cannot" are not substitutes for "may" and "need not".

- will** indicates that something is certain or expected to happen as a result of action taken by an agency the behaviour of which is outside the scope of the present document
- will not** indicates that something is certain or expected not to happen as a result of action taken by an agency the behaviour of which is outside the scope of the present document
- might** indicates a likelihood that something will happen as a result of action taken by some agency the behaviour of which is outside the scope of the present document

might not indicates a likelihood that something will not happen as a result of action taken by some agency the behaviour of which is outside the scope of the present document

In addition:

is (or any other verb in the indicative mood) indicates a statement of fact

is not (or any other negative verb in the indicative mood) indicates a statement of fact

The constructions "is" and "is not" do not indicate requirements.

1 Scope

The present document establishes the minimum RF characteristics of RF repeater and network controlled repeater. For network controlled repeater (NCR), requirements for NCR-Fwd and NCR-MT apply. In this version of the specification mixed type NCR are not considered.

2 References

The following documents contain provisions which, through reference in this text, constitute provisions of the present document.

- References are either specific (identified by date of publication, edition number, version number, etc.) or non-specific.
- For a specific reference, subsequent revisions do not apply.
- For a non-specific reference, the latest version applies. In the case of a reference to a 3GPP document (including a GSM document), a non-specific reference implicitly refers to the latest version of that document *in the same Release as the present document*.

- [1] 3GPP TR 21.905: "Vocabulary for 3GPP Specifications".
- [2] 3GPP TS 38.104: "NR; Base Station (BS) radio transmission and reception".
- [3] 3GPP TR 25.942: "RF system scenarios".
- [4] Recommendation ITU-R SM.328: "Spectra and bandwidth of emissions".
- [5] ITU-R Recommendation SM.329: "Unwanted emissions in the spurious domain".
- [6] ITU-R Recommendation M.1545: "Measurement uncertainty as it applies to test limits for the terrestrial component of International Mobile Telecommunications – 2000".
- [7] 3GPP TS 38.115-1: "NR; Repeater conformance testing - Part 1: Conducted conformance testing".
- [8] 3GPP TS 38.115-2: "NR; Repeater conformance testing - Part 2: Radiated conformance testing".
- [9] ERC Recommendation 74-01, "Unwanted emissions in the spurious domain".
- [10] "Title 47 of the Code of Federal Regulations (CFR)", Federal Communications Commission.
- [11] Void
- [12] Void
- [13] 3GPP TS 38.101-1: "NR User Equipment (UE) radio transmission and reception; Part 1: Range 1 Standalone".
- [14] 3GPP TS 38.101-2: "NR User Equipment (UE) radio transmission and reception: Part 2: Range 2 Standalone".
- [15] Void
- [16] Void
- [17] Void
- [18] Void
- [19] Void
- [20] 3GPP TS 36.104: "Evolved Universal Terrestrial Radio Access (E-UTRA); Base Station (BS) radio transmission and reception"

- [21] Void
- [22] 3GPP TS 38.174: "NR; Integrated Access and Backhaul (IAB) radio transmission and reception".
- [23] 3GPP TS 38.331: "NR; Radio Resource Control (RRC); Protocol specification".
- [24] 3GPP TS 38.213: "NR; Physical layer procedures for control".
- [25] 3GPP TS 38.321: "NR; Medium Access Control (MAC) protocol specification".
- [26] 3GPP TS 38.211: "NR; Physical channels and modulation".
- [27] 3GPP TS 38.306: "NR; User Equipment (UE) radio access capabilities".
- [28] 3GPP TS 38.214: "NR; Physical layer procedures for data".
- [29] 3GPP TR 38.901: "Study on channel model for frequencies from 0.5 to 100 GHz"
- [30] 3GPP TR 38.101-4: " NR; User Equipment (UE) radio transmission and reception; Part 4: Performance requirements"
- [31] Commission Implementing Decision (EU) 2020/590 of 24 April 2020 amending Decision (EU) 2019/784 as regards an update of relevant technical conditions applicable to the 24,25-27,5 GHz frequency band.
- [32] ITU World Radiocommunication Conference 2023 (WRC-23) Final Acts, Resolution 220

3 Definitions of terms, symbols and abbreviations

3.1 Terms

For the purposes of the present document, the terms given in 3GPP TR 21.905 [1] and the following apply. A term defined in the present document takes precedence over the definition of the same term, if any, in 3GPP TR 21.905 [1].

Antenna connector: connector at the conducted interface of the *repeater type 1-C*

Beam: beam (of the antenna) is the main lobe of the radiation pattern of an *antenna array*

Beam centre direction: direction equal to the geometric centre of the half-power contour of the beam

Beam direction pair: data set consisting of the *beam centre direction* and the related *beam peak direction*

Beam peak direction: direction where the maximum EIRP is found

Beamwidth: beam which has a half-power contour that is essentially elliptical, the half-power beamwidths in the two pattern cuts that respectively contain the major and minor axis of the ellipse

directional requirement: requirement which is applied in a specific direction within the *OTA coverage range*.

Equivalent isotropic radiated power: equivalent power radiated from an isotropic directivity device producing the same field intensity at a point of observation as the field intensity radiated in the direction of the same point of observation by the discussed device

Fractional bandwidth: *fractional bandwidth* FBW is defined as $FBW = 200 \cdot \frac{F_{FBW\ high} - F_{FBW\ low}}{F_{FBW\ high} + F_{FBW\ low}} \%$

gap between passbands: frequency gap between two consecutive passbands that belong to the same *operating band*, where the RF requirements in the gap are based on co-existence for un-coordinated operation

Inter-passband gap: The frequency gap between two supported consecutive *passbands* that belong to different operating bands.

Maximum passband output power: mean power level measured per *passband* at the *antenna connector*, during the *transmitter ON state* in a specified reference condition

Maximum passband TRP output power: mean power level measured per passband during the *transmitter ON state* in a specified reference condition and corresponding to the declared *rated passband TRP output power* ($P_{\text{rated,p.,TRP}}$)

Measurement bandwidth: RF bandwidth in which an emission level is specified

multi-band connector: *Antenna Connector* for a *Multi-band repeater*.

Multi-band repeater: *Repeater Type 1-C* whose *antenna connector* is associated with a transmitter and/or receiver that is characterized by the ability to process two or more *passband(s)* in common active RF components simultaneously, where at least one *passband* is configured at a different operating band than the other *passband(s)* and where this different operating band is not a sub-band or superseding-band of another supported operating band

NCR type 1-C: NCR-MT or NCR-Fwd at FR1 with a *requirement set* consisting only of conducted requirements defined at individual antenna connectors.

NCR type 1-H: NCR-MT or NCR-Fwd operating at FR1 with a *requirement set* consisting of conducted requirements defined at individual TAB connectors and OTA requirements defined at RIB.

NCR type 2-O: NCR-MT or NCR-Fwd operating at FR2 with a *requirement set* consisting only of OTA requirements defined at the RIB.

Nominal channel bandwidth: Bandwidth calculated as $\min(100\text{MHz}, BW_{\text{passband}})$ in FR1 or $\min(400\text{MHz}, BW_{\text{passband}})$ in FR2. If this bandwidth is not defined for BS channel bandwidth for the operating band, *nominal channel bandwidth* shall be defined as the widest BS channel bandwidth for the operating band which is narrower than BW_{passband} .

Non-contiguous spectrum: spectrum consisting of two or more *passbands* separated by *inter-passband gap(s)*.

Operating band: frequency range in which NR operates (paired or unpaired), that is defined with a specific set of technical requirements

OTA coverage range: a common range of directions within which OTA requirements that are neither specified in the *OTA peak directions sets* nor as *TRP requirements* are intended to be met

OTA peak directions set: set(s) of *beam peak directions* within which certain OTA requirements are intended to be met, where all *OTA peak directions set(s)* are subsets of the *OTA coverage range*

Passband: The frequency range in which the repeater operates in with operational configuration, this frequency range can correspond to one or several consecutive nominal channels, if they are not consecutive each subset of channels shall be considered as an individual *passband*, a repeater can have one or several *passbands*, all channels within the *passband(s)* shall belong to a single operator or collaborating operators.

passband edge: Frequency at the edge of the passband

Radiated interface boundary: *operating band* specific radiated requirements reference where the radiated requirements apply

Rated beam EIRP: For a declared beam and *beam direction pair*, the *rated beam EIRP* level is the maximum power that the repeater is declared to radiate at the associated *beam peak direction* during the *transmitter ON state*

Rated passband output power: mean power level associated with a *passband* the manufacturer has declared to be available at the *antenna connector*, during the *transmitter ON state* in a specified reference condition

Rated passband TRP output power: mean power level declared by the manufacturer per passband, that the manufacturer has declared to be available at the RIB during the *transmitter ON state*

Rated total output power: mean power level associated with a particular *operating band* the manufacturer has declared to be available at the *antenna connector*, during the *transmitter ON state* in a specified reference condition

Rated total TRP output power: mean power level associated with a particular *operating band*, that the manufacturer has declared to be available at the RIB during the *transmitter ON state* in a specified reference condition

Reference beam direction pair: Beam direction pair in the reference direction declared by the manufacturer.

RF repeater type 1-C (RFR type 1-C): Repeater operating at FR1 with a requirement set consisting only of conducted requirements defined at individual *antenna connectors*.

RF repeater type 2-O (RFR type 2-O): Repeater operating at FR2 with a requirement set consisting only of OTA requirements defined at the RIB

Requirement set: one of the NR requirements set as defined for *repeater*

single-band connector: *Repeater type 1-C antenna connector* supporting operation either in a single *operating band* only, or in multiple *operating bands* but does not meet the conditions for a *multi-band connector*.

Sub-band: A *sub-band* of an operating band contains a part of the uplink and downlink frequency range of the operating band.

sub-block: one contiguous allocated block of spectrum for transmission and reception by the repeater.

Superseding-band: A *superseding-band* of an operating band includes the whole of the uplink and downlink frequency range of the operating band.

Total radiated power: is the total power radiated by the antenna

NOTE: The total radiated power is the power radiating in all direction for two orthogonal polarizations. Total radiated power is defined in both the near-field region and the far-field region

Transmitter OFF state: Time period during which the repeater downlink or uplink is not allowed to transmit in the corresponding direction.

Transmitter ON state: Time period during which the repeater is transmitting downlink or uplink signals in the corresponding direction.

Transmitter transient period: Time period during which the repeater is changing from the OFF state to the ON state or vice versa.

3.2 Symbols

For the purposes of the present document, the following symbols apply:

BW_{Config}	Transmission bandwidth configuration, where $BW_{\text{Config}} = N_{\text{RB}} \times \text{SCS} \times 12$
BW_{Nominal}	Nominal channel bandwidth
BW_{Passband}	Passband bandwidth
Δf	Separation between the <i>passband edge</i> frequency and the nominal -3 dB point of the measuring filter closest to the carrier frequency
Δf_{max}	$f_{\text{offsetmax}}$ minus half of the bandwidth of the measuring filter
Δf_{OBUE}	Maximum offset of the <i>operating band</i> unwanted emissions mask from the <i>operating band</i> edge
$F_{\text{DL,low}}$	The lowest frequency of the downlink <i>operating band</i>
$F_{\text{DL,high}}$	The highest frequency of the downlink <i>operating band</i>
F_{FBWhigh}	Highest supported frequency within supported operating band, for which <i>fractional bandwidth</i> support was declared
F_{FBWlow}	Lowest supported frequency within supported operating band, for which <i>fractional bandwidth</i> support was declared
F_{filter}	Filter centre frequency
$F_{\text{offset,high}}$	Frequency offset from $F_{\text{C,high}}$ to the upper <i>passband edge</i>
$F_{\text{offset,low}}$	Frequency offset from $F_{\text{C,low}}$ to the lower <i>passband edge</i>
f_{offset}	Separation between the <i>passband edge</i> frequency and the centre of the measuring
$f_{\text{offsetmax}}$	The offset to the frequency Δf_{OBUE} outside the <i>operating band</i>
$F_{\text{step,X}}$	Frequency steps for the OTA transmitter spurious emissions (Category B)
$F_{\text{UL,low}}$	The lowest frequency of the uplink <i>operating band</i>
$F_{\text{UL,high}}$	The highest frequency of the uplink <i>operating band</i>
$P_{\text{EM,n50/n75,ind}}$	Declared emission level for Band n50/n75; ind = a, b
$P_{\text{EM,n54,ind}}$	Declared emission level for Band n54; ind = a, b, c, d, e, f
$P_{\text{max,c,AC}}$	Maximum carrier output power measured per antenna connector
$P_{\text{rated,c,AC}}$	The rated carrier output power per antenna connector
$P_{\text{rated,c,sys}}$	The sum of $P_{\text{rated,c,TABC}}$ for all TAB connectors for a single carrier
$P_{\text{rated,c,TABC}}$	The rated carrier output power per TAB connector

$P_{\text{rated,p,AC}}$	Rated passband output power per antenna connector
$P_{\text{rated,p,TABC}}$	The <i>rated passband output power per TAB connector</i>
$P_{\text{rated,t,AC}}$	Rated total output power declared per antenna connector
$P_{\text{rated,t,TABC}}$	The <i>rated total output power declared at TAB connector</i>
$P_{\text{rated,p,TRP}}$	Rated passband TRP output power declared per RIB
$P_{\text{rated,t,TRP}}$	Rated total TRP output power declared per RIB
$P_{\text{in,p,AC}}$	Input power intended to produce the maximum rated output power ($P_{\text{rated,p,AC}}$) at the <i>antenna connector</i>
$P_{\text{in,p,TABC}}$	Input power intended to produce the maximum rated output power ($P_{\text{rated,p,TABC}}$) at the <i>TAB connector</i>
$P_{\text{in,p,EIRP}}$	Input power intended to produce the maximum rated output power ($P_{\text{rated,p,TRP}}$) at the RIB
$P_{\text{rated,out,FBWhigh}}$	The rated output EIRP for the higher supported frequency range within supported <i>operating band</i> , for which <i>fractional bandwidth</i> support was declared
$P_{\text{rated,out,FBWlow}}$	The rated output EIRP for the lower supported frequency range within supported <i>operating band</i> , for which <i>fractional bandwidth</i> support was declared
$P_{\text{max,p,AC}}$	<i>Maximum passband output power measured per antenna connector</i>
$P_{\text{max,p,TABC}}$	<i>The maximum passband output power per TAB connector</i>
$P_{\text{max,p,EIRP}}$	<i>Maximum passband EIRP output power when repeater is configured at the rated passband TRP output power ($P_{\text{rated,p,TRP}}$)</i>
$P_{\text{max,p,TRP}}$	<i>Maximum passband TRP output power measured per RIB</i>
W_{gap}	<i>Inter passband Bandwidth gap size</i>

3.3 Abbreviations

For the purposes of the present document, the abbreviations given in 3GPP TR 21.905 [1] and the following apply. An abbreviation defined in the present document takes precedence over the definition of the same abbreviation, if any, in 3GPP TR 21.905 [1].

ACLR	Adjacent Channel Leakage Ratio
AoA	Angle of Arrival
BFD	Beam Failure Detection
BW	Bandwidth
BWP	Bandwidth Part
CACLR	Cumulative ACLR
CBD	Candidate Beam Detection
CP-OFDM	Cyclic Prefix-OFDM
CSI-RS	Channel State Information - Reference Signal
DFT-s-OFDM	Discrete Fourier Transform-spread-OFDM
DL	Downlink
DMRS	Demodulation Reference Signal
EIRP	Effective Isotropic Radiated Power
EEIRP	Expected EIRP
EVM	Error Vector Magnitude
FBW	Fractional Bandwidth
FR	Frequency Range
FSS	Fixed Satellite Service
ITU-R	Radiocommunication Sector of the International Telecommunication Union
LA	Local Area
MR	Medium Range
NCR	Network Controlled Repeater
NCR-MT	NCR Mobile Termination
NCR-Fwd	NCR Forward
NR	New Radio
OBUE	Operating Band Unwanted Emissions
OOB	Out-of-band
OTA	Over-The-Air
QAM	Quadrature Amplitude Modulation
QCL	Quasi Co-Location
RF	Radio Frequency
RFR	RF repeater
RIB	Radiated Interface Boundary

RLM	Radio Link Monitoring
RLM-RS	Reference Signal for RLM
RMSI	Remaining Minimum System Information
RSRP	Reference Signal Received Power
RX	Receiver
SA	Standalone operation mode
SCS	Sub-Carrier Spacing
SMTC	SSB-based Measurement Timing configurationSS-RSRP Synchronization Signal based Reference Signal Received Power
SSB	Synchronization Signal Block
SSS	Secondary Synchronization Signal
TCI	Transmission Configuration Indicator
TRS	Tracking Reference Signal
TX	Transmitter
TRP	Total Radiated Power
UL	Uplink
WA	Wide Area

4 General

4.1 Relationship between Minimum Requirements and Test Requirements

Conformance to the present specification is demonstrated by fulfilling the test requirements specified in the conformance specification TS 38.115-1 [7] or TS 38.115-2 [8].

The minimum requirements given in this specification make no allowance for measurement uncertainty. The test specifications TS 38.115-1 [7] and TS 38.115-2 [8] define test tolerances. These test tolerances are individually calculated for each test. The test tolerances are used to relax the minimum requirements in this specification to create test requirements. For some requirements, including regulatory requirements, the test tolerance is set to zero.

The measurement results returned by the test system are compared - without any modification - against the test requirements as defined by the shared risk principle.

The shared risk principle is defined in recommendation ITU-R M.1545 [6].

4.2 Conducted and radiated requirement reference points

4.2.1 RF repeater type 1-C

For *RF Repeater type 1-C*, the requirements are applied at the repeater *antenna connector* (BS-side connector or UE-side connector) for downlink or uplink for the configuration in normal operating conditions.

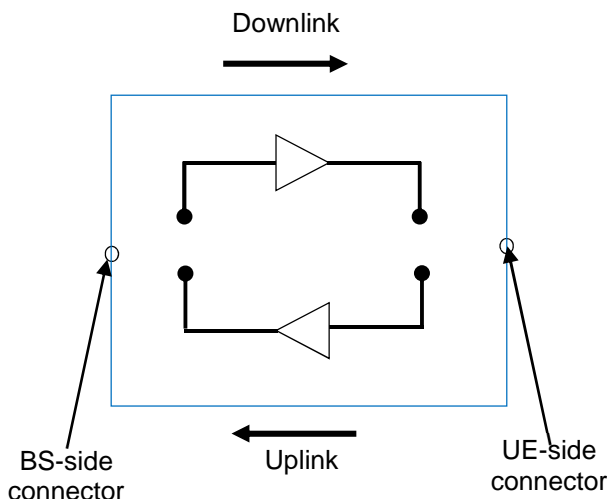

Figure 4.2.1-1: RF repeater type 1-C downlink and uplink interface

4.2.1A NCR type 1-C

For *NCR type 1-C*, the NCR-Fwd RF requirements are applied at the NCR antenna connector (BS-side connector or UE-side connector) for downlink or uplink for the configuration in normal operating conditions.

For *NCR type 1-C*, the NCR-MT RF requirements are applied at the NCR antenna connector (BS-side connector) for the configuration in normal operating conditions.

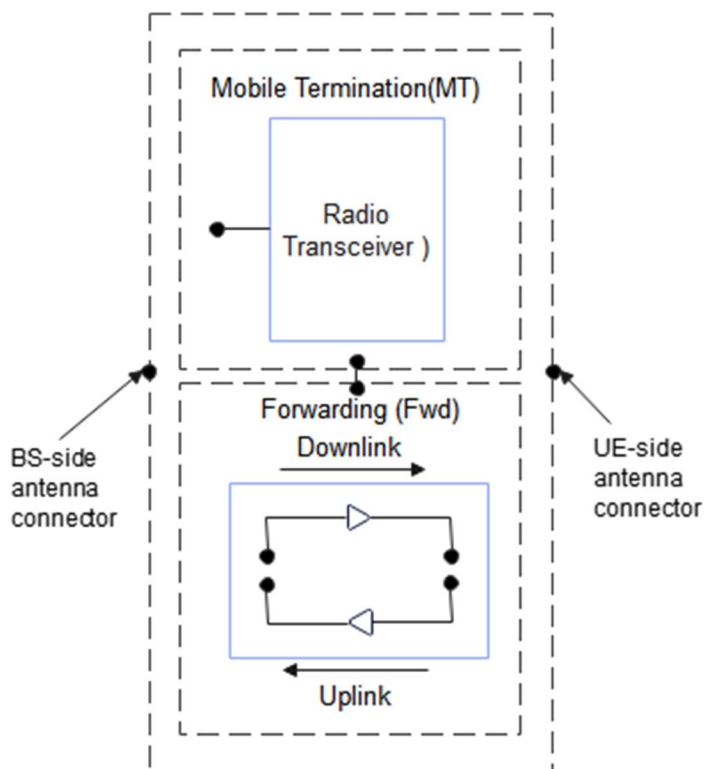

Figure 4.2.1-1A: Network controlled Repeater type 1-C downlink and uplink interface

NOTE 1: the NCR-MT and NCR-Fwd may have the same or separate antenna connectors.

4.2.1B Network controlled Repeater type 1-H

For *NCR type 1-H*, the requirements are defined for two points of reference, signified by radiated requirements and conducted requirements.

For *NCR type 1-H*, the NCR-Fwd conducted RF requirements are applied at the NCR individual or groups of *TAB connectors* at the *transceiver array boundary* (BS-side TAB connector or UE-side TAB connector) for downlink or uplink for the configuration in normal operating conditions.

For *NCR type 1-H*, the NCR-MT conducted RF requirements are applied at the NCR individual or groups of *TAB connectors* at the *transceiver array boundary* (BS-side TAB connector) for the configuration in normal operating conditions.

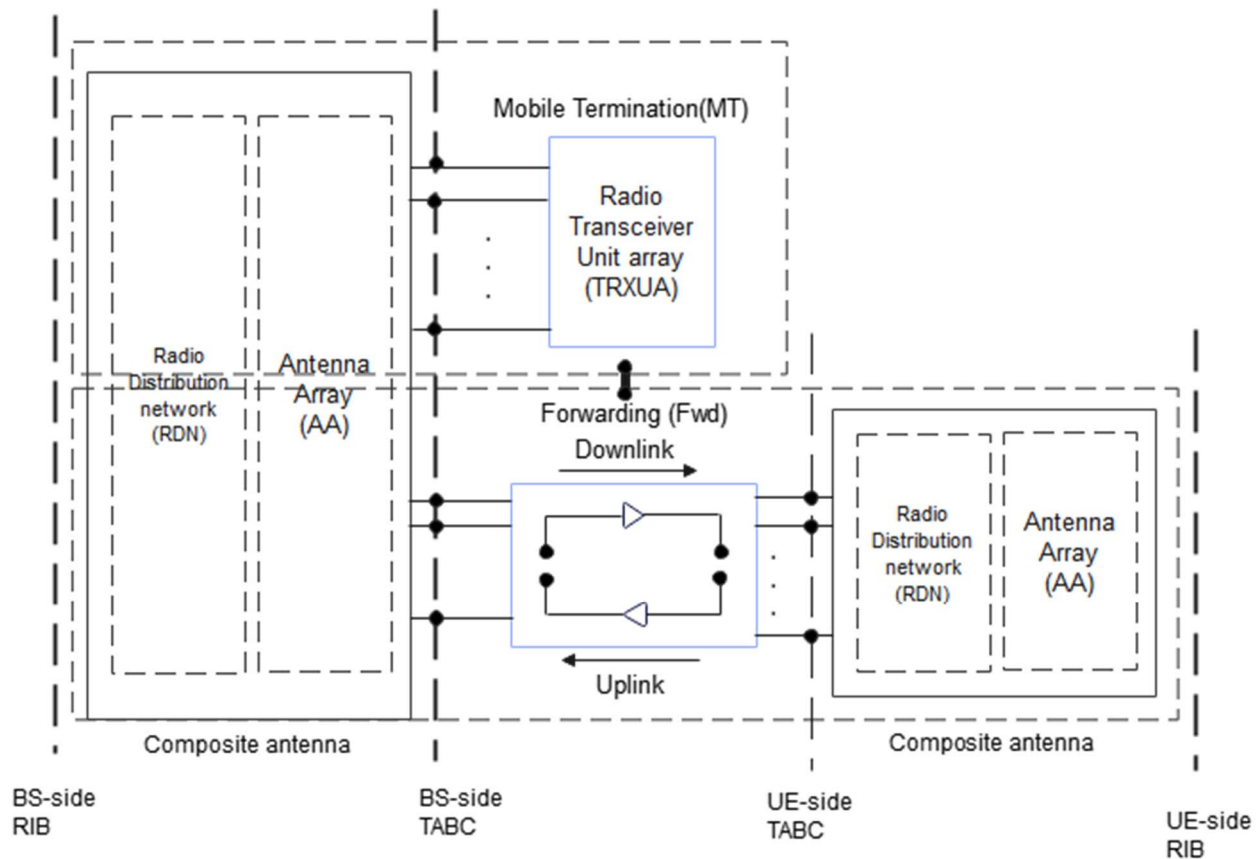

Figure 4.2.1-1B: Network controlled Repeater type 1-H downlink and uplink interface

NOTE 1: The NCR-MT and NCR-Fwd may have the same or separate TAB connectors.

4.2.2 Repeater type 2-O

For *RF repeater type 2-O*, the radiated characteristics are defined over the air (OTA), where the operating band specific radiated interface is referred to as the Radiated Interface Boundary (RIB). Radiated requirements are also referred to as OTA requirements. The (spatial) characteristics in which the OTA requirements apply are detailed for each requirement.

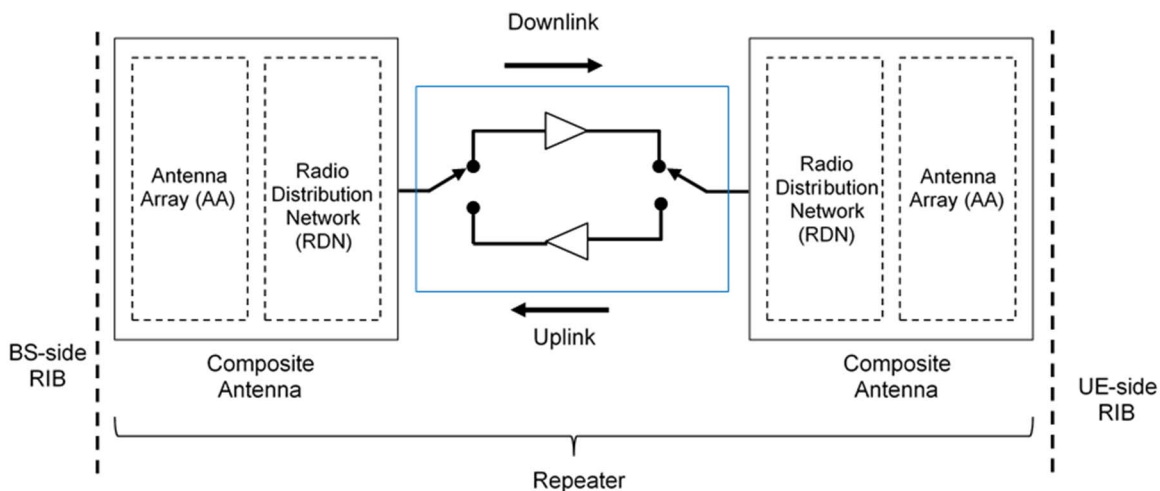

Figure 4.2.2-1: Radiated reference points for RF repeater type 2-O

4.2.2A Network controlled Repeater type 2-O

For *NCR type 2-O*, the radiated characteristics for NCR-Fwd and NCR-MT are defined over the air (OTA), where the operating band specific radiated interface is referred to as the Radiated Interface Boundary (RIB). Radiated requirements are also referred to as OTA requirements. The (spatial) characteristics in which the OTA requirements apply are detailed for each requirement.

For *NCR type 2-O*, the NCR-MT conducted RF requirements are applied at the BS side RIB for the configuration in normal operating conditions.

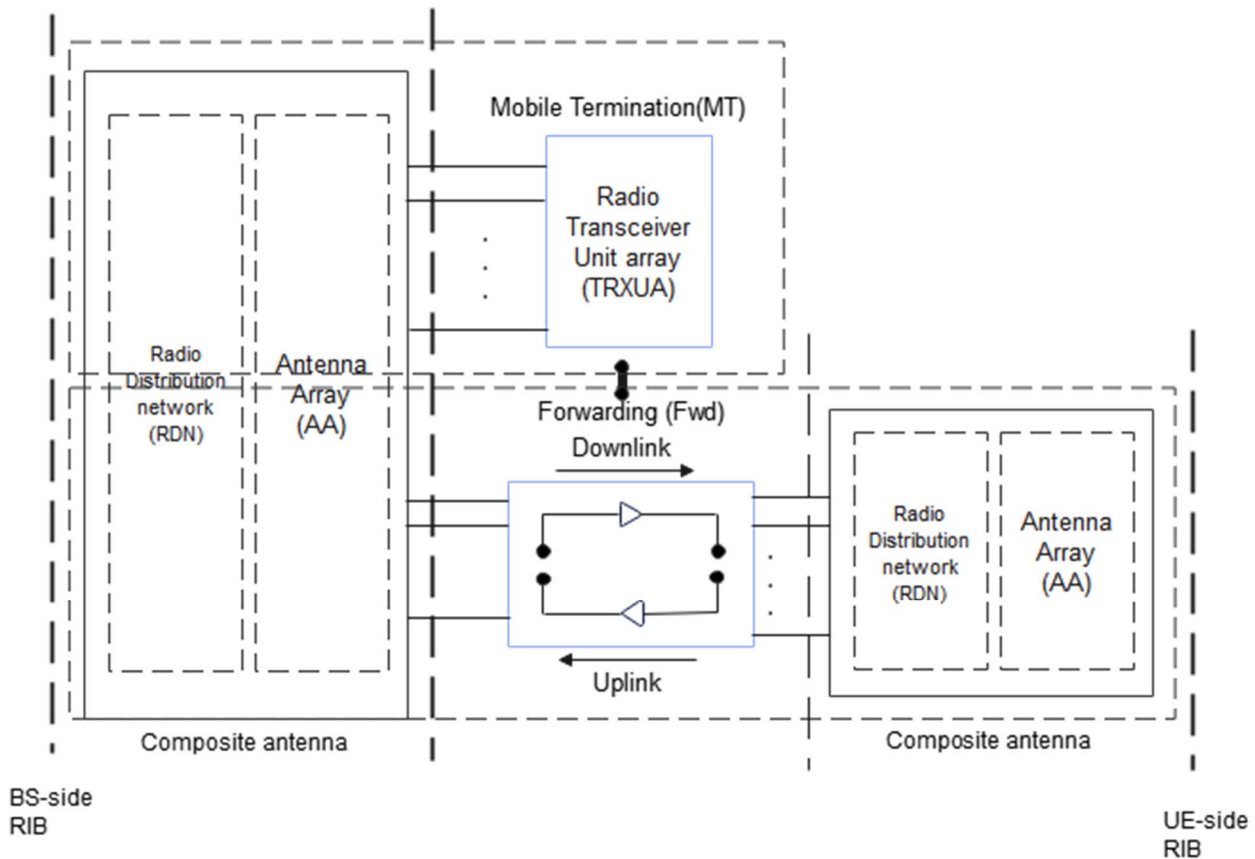

Figure 4.2.2-1A: Radiated reference points for *network controlled repeater type 2-O*

NOTE 1: the NCR-MT and NCR-Fwd may have the same or separate RIB

4.3 Repeater classes

4.3.1 Repeater class for downlink

The requirements in this specification apply to downlink Wide Area repeaters, downlink Medium Range repeaters and downlink Local Area repeaters unless otherwise stated. The associated deployment scenarios for each class are exactly the same for repeater with and without connectors.

For *RF repeater type 1-C* and *type 2-O*, repeater downlink classes are defined as indicated below:

- Wide Area repeaters are characterised by requirements derived from Macro Cell scenarios with a repeater to UE minimum distance along the ground equal to 35 m.
- Medium Range repeaters are characterised by requirements derived from Micro Cell scenarios with a repeater to UE minimum distance along the ground equal to 5 m.
- Local Area repeaters are characterised by requirements derived from Pico Cell scenarios with a repeater to UE minimum distance along the ground equal to 2 m or from Femto Cell scenarios.
- Note: The requirements in this specification for LA 1-C repeaters apply to 1-C repeaters with declared output power less than or equal to LA rated output power limits as in table 6.2.1-1.

4.3.2 Repeater class for uplink

The requirements in this specification apply to uplink Wide Area repeaters and uplink Local Area repeaters unless otherwise stated. The associated deployment scenarios for each class are exactly the same for repeater with and without connectors.

For *RF repeater type 1-C* and *type 2-O*, repeater uplink classes are defined as indicated below:

- Wide Area repeaters are characterised by requirements derived from Macro Cell and/or Micro Cell scenarios.
- Local Area repeaters are characterised by requirements derived from Pico Cell and/or Micro Cell scenarios.

4.3A Network controlled repeater classes

4.3A.1 Network controlled repeater class for downlink

The requirements in this specification apply to downlink Wide Area NCR, downlink Medium Range NCR and downlink Local Area NCR unless otherwise stated. The associated deployment scenarios for each class are exactly the same for NCR with and without connectors.

For *NCR type 1-C*, *type 1-H* and *type 2-O*, NCR downlink classes are defined as indicated below:

- Wide Area NCR are characterised by requirements derived from Macro Cell scenarios with a NCR to UE minimum distance along the ground equal to 35 m.
- Medium Range NCR are characterised by requirements derived from Micro Cell scenarios with a NCR to UE minimum distance along the ground equal to 5 m.
- Local Area NCR are characterised by requirements derived from Pico Cell scenarios with a NCR to UE minimum distance along the ground equal to 2 m or from Femto Cell scenarios.
- Note: The requirements in this specification for LA NCR type 1-C apply to NCR type 1-C with declared output power less than or equal to LA rated output power limits as in table 6.2.1-1.

4.3A.2 Network controlled repeater class for uplink and MT

The requirements in this specification apply to uplink Wide Area NCR and uplink Local Area NCR unless otherwise stated. The associated deployment scenarios for each class are exactly the same for NCR with and without connectors.

For *NCR type 1-C*, *type 1-H* and *type 2-O*, NCR uplink classes and MT classes are defined as indicated below:

- Wide Area NCR are characterised by requirements derived from Macro Cell and/or Micro Cell scenarios.
- Local Area NCR are characterised by requirements derived from Pico Cell and/or Micro Cell scenarios.

4.4 Regional requirements

Some requirements in the present document may only apply in certain regions either as optional requirements, or as mandatory requirements set by local and regional regulation. It is normally not stated in the 3GPP specifications under what exact circumstances the regional requirements apply, since this is defined by local or regional regulation.

Table 4.4-1 lists all requirements in the present specification that may be applied differently in different regions.

Table 4.4-1: List of regional requirements

Clause number	Requirement	Comments
5.2	<i>Operating bands</i>	Some NR <i>operating bands</i> may be applied regionally.
6.2	Repeater output power	For Band n41 and n90 operation in Japan, additional output power limits shall be applied.
6.2.4, 7.3.4	Repeater output power, OTA repeater output power: Additional requirements	These requirements may be applied regionally as additional repeater output power requirements.
6.5.2	Adjacent Channel Leakage Power Ratio	For Band n41 and n90 operation in Japan, absolute ACLR limits shall be applied to the sum of the absolute ACLR power over all <i>antenna connectors</i> for <i>repeater type 1-C</i> .
6.5.3.2, 7.5.3.2	Operating band unwanted emission, OTA operating band unwanted emissions	Category A or Category B operating band unwanted emissions limits may be applied regionally.
6.5.3.2.5.1	Operating band unwanted emission	The repeater may have to comply with the additional requirements, when deployed in regions where those limits are applied, and under the conditions declared by the manufacturer.
6.5.3.2.5.2	Operating band unwanted emission	The repeater operating in Band n20 may have to comply with the additional requirements for protection of DTT, when deployed in certain regions.
6.5.3.2	Operating band unwanted emissions	For Band n41 and n90 operation in Japan, the operating band unwanted emissions limits shall be applied to the sum of the emission power over all <i>antenna connectors</i> for <i>repeater type 1-C</i> .
6.5.4.2.1, 7.5.4.2	Tx spurious emissions, OTA Tx spurious emissions	Category A or Category B spurious emission limits, as defined in ITU-R Recommendation SM.329 [5], may apply regionally.
6.5.4.2.2, 7.5.4.2.3	Tx spurious emissions: additional requirements, OTA Tx spurious emissions: additional requirements	These requirements may be applied for the protection of system operating in frequency ranges other than the repeater <i>operating band</i> .
6.5.4.2	Transmitter spurious emissions	For Band n41 and n90 operation in Japan, the sum of the spurious emissions over all <i>antenna connectors</i> for <i>repeater type 1-C</i> shall not exceed the <i>basic limits</i> .
6.5.5.1	Receiver spurious emissions	For Band n41 and n90 operation in Japan, the sum of receiver spurious emissions requirements over all <i>antenna connectors</i> for <i>repeater type 1-C</i> shall not exceed <i>minimum requirements</i> defined in clause 6.5.5.2.
6.7.2	Input intermodulation	Interfering signal positions that are partially or completely outside of any downlink <i>operating band</i> of the repeater are not excluded from the requirement in Japan in Band n77, n78, n79.
6.8	Output intermodulation	For Band n41 and n90 operation in Japan, the repeater may have to comply with the additional requirements, when deployed in certain regions.

4.5 Applicability of requirements

In Table 4.5-1, the requirement applicability for each requirement set is defined. For each requirement, the applicable requirement clause in the specification is identified. Requirements not included in a requirement set is marked not applicable (NA).

Table 4.5-1: Requirement set applicability

Requirement	Requirement set				
	RFR type 1-C, NCR-Fwd type 1-C	NCR-Fwd type 1-H	NCR-MT type 1-C	NCR-MT type 1-H	RFR type 2-O, NCR- Fwd type 2-O
Repeater output power	6.2	6.2			
Frequency stability	6.3	6.3			
Out of band gain	6.4	6.4			
Unwanted emissions	6.5	6.5			
Repeater Error Vector Magnitude	6.6	6.6	NA	NA	NA
Input intermodulation	6.7	6.7			
Output intermodulation	6.8	6.8			
Adjacent Channel Rejection Ratio (ACRR)	6.9	6.9			
Transmit ON/OFF power	6.10	6.10			
Repeater output power for NCR-MT			6.2.3.2	6.2.3.2	
Output power dynamics for NCR-MT			6.11	6.11	
Transmit signal quality for NCR-MT			6.12	6.12	
Unwanted emissions for NCR-MT			6.5	6.5	NA
Transmit intermodulation for NCR-MT		NA	6.13	6.13	
Diversity characteristics for NCR-MT			6.15	6.15	
Reference sensitivity for NCR-MT			6.16	6.16	
Maximum input level for NCR-MT			6.17	6.17	
Adjacent channel selectivity for NCR-MT			6.18	6.18	
Blocking characteristics for NCR-MT			6.19	6.19	
Spurious response for NCR-MT			6.20	6.20	
Receiver intermodulation characteristics for NCR-MT			6.21	6.21	
Receiver spurious emissions for NCR-MT			6.22	6.22	
Performance requirements for NCR-MT			8	8	
OTA Repeater output power		7.2			7.2
OTA frequency stability					7.3
OTA out of band gain					7.4
OTA unwanted emissions					7.5
OTA Repeater Error Vector Magnitude	NA			NA	7.6
OTA input intermodulation					7.7
OTA Adjacent Channel Rejection Ratio (ACRR)					7.8
OTA transmit ON/OFF power					7.9
OTA repeater output power for NCR-MT		NA	NA	7.2	7.2
OTA output power dynamics for NCR-MT					7.10
OTA transmit signal quality for NCR-MT					7.11
OTA unwanted emissions for NCR-MT					7.5
OTA diversity characteristics for NCR-MT					7.12
OTA reference sensitivity for NCR-MT				NA	7.13
OTA maximum input level for NCR-MT					7.14
OTA adjacent channel selectivity for NCR-MT					7.15
OTA blocking characteristics for NCR-MT					7.16
OTA receiver spurious emissions for NCR-MT					7.17
OTA spatial emission		7.18		7.18	NA
Radiated performance requirements for NCR-MT					9

Table 4.5-1a: Void

Table 4.5-1b: Void

4.6 Requirements for contiguous and non-contiguous spectrum

A spectrum allocation where a repeater operates can either be contiguous or non-contiguous. Unless otherwise stated, the requirements in the present specification apply for repeater configured for both contiguous spectrum operation and non-contiguous spectrum operation.

For repeater operation in non-contiguous spectrum, some requirements apply at the repeater *passband* edges. For each such requirement, it is stated how the limits apply relative to the repeater *gap between passbands* and the *Inter-passband gap* respectively.

For NCR operation in non-contiguous spectrum, some requirements apply at the NCR-Fwd *passband* edges or NCR-MT carrier edges. For each such requirement, it is stated how the limits apply relative to the NCR *gap between passbands* and the *Inter-passband gap* respectively.

4.7 Requirements for repeater capable of multi-band operation

For multi-band connector or multi-band RIB, the RF requirements in clauses 6 and 7 apply separately to each supported operating band unless otherwise stated. For some requirements, it is explicitly stated that specific additions or exclusions to the requirement apply at multi-band connector(s), and multi-band RIB(s) as detailed in the requirement clause. For repeater or NCR capable of multi-band operation, various structures in terms of combinations of different downlink and uplink implementations (multi-band or single band) with mapping to one or more *antenna connectors* for *repeater type 1-C*, *NCR type 1-C*, *type 1-H* in different ways are possible. For multi-band connector(s) the exclusions or provisions for multi-band apply. For single-band connector(s), the following applies:

- Single-band transmitter spurious emissions, *operating band* unwanted emissions, ACLR, output intermodulation, ACRR and receiver spurious emissions requirements apply to this *connector* that is mapped to single-band.
- If the repeater or NCR is configured for single-band operation, single-band requirements shall apply to this *antenna connector* configured for single-band operation and no exclusions or provisions for multi-band capable repeater or NCR are applicable. Single-band requirements are tested separately at the *antenna connector* configured for single-band operation, with all other *antenna connectors* terminated.

5 Operating bands

5.1 General

The channel arrangements presented in this clause are based on the *operating bands* defined in the present release of specifications.

NOTE: Other *operating bands* may be considered in future releases.

Requirements throughout the RF specifications are in many cases defined separately for different frequency ranges (FR). The frequency ranges in which NR can operate according to the present version of the specification are identified as described in table 5.1-1.

Table 5.1-1: Definition of frequency ranges

Frequency range designation		Corresponding frequency range
FR1		410 MHz – 7125 MHz
FR2	FR2-1	24250 MHz – 52600 MHz
	FR2-2	52600 MHz – 71000 MHz

Whenever FR2 is referred, both FR2-1 and FR2-2 frequency sub-ranges shall be applied, unless otherwise stated.

5.2 Operating bands

Repeater is designed to operate in the *operating bands* in FR1 and FR2-1 defined in TS 38.104 [2] except the operating bands n46, n96 and n102.

5.3 Channel arrangement

5.3.1 Channel raster

5.3.1.1 NR-ARFCN and channel raster

For repeater and NCR-Fwd, the NR-ARFCN and channel raster is the same as specified for BS in TS 38.104 [2], subclause 5.4.2.1.

For NCR-MT, the NR-ARFCN and channel raster is the same as specified for UE in TS 38.101-1 [13] for FR1 in subclause 5.4.2.1 and in TS 38.101-2 [14] for FR2-1 in subclause 5.4.2.1.

5.3.1.2 Channel raster entries for each operating band

For repeater and NCR-Fwd, the channel raster entries for NR bands for FR1 and FR2-1 defined in TS 38.104 [2] are the same as specified for BS in TS38.104 [2], clause 5.4.2.3.

For NCR-MT, the channel raster entries for NR bands for FR1 are the same as specified for UE in TS 38.101-1 [13] in subclause 5.4.2.3 and for NR bands for FR2-1 are the same as specified for UE in TS 38.101-2 [14] in subclause 5.4.2.3.

5.3.1.3 Channel raster to resource element mapping

For NCR-MT, the channel raster to resource element mapping is the same as specified for UE in TS 38.101-1 [13] for FR1 in subclause 5.4.2.2 and in TS 38.101-2 [14] for FR2 in subclause 5.4.2.2.

5.3.2 Synchronization raster

5.3.2.1 Synchronization raster and numbering

For repeater and NCR-Fwd, the synchronization raster and numbering are the same as specified for BS in TS38.104 [2], clause 5.4.3.1.

For NCR-MT, the synchronization raster and numbering are the same as specified for UE in subclause 5.4.3.1 in TS 38.101-1 [13] for FR1 in subclause 5.4.3.1 and in subclause 5.4.3.1 in TS 38.101-2 [14] for FR2-1 in subclause 5.4.3.1.

5.3.2.2 Synchronization raster entries for each operating band

For repeater and NCR-Fwd, the synchronization raster entries for NR bands for FR1 and FR2-1 defined in TS38.104 [2] are the same as specified for BS in TS38.104 [2], clause 5.4.3.3.

For NCR-MT, the synchronization raster entries for NR bands for FR1 in Table 5.2-1 are the same as specified for UE in TS 38.101-1 [13] in subclause 5.4.3.3 and for NR bands for FR2-1 are the same as specified for UE in TS 38.101-2 [14] in subclause 5.4.3.3.

5.3.2.3 Synchronization raster to synchronization block resource element mapping

For NCR-MT, the synchronization raster to synchronization block resource element mapping is the same as specified for UE in TS 38.101-1 [13] for FR1 in subclause 5.4.3.2 and in TS 38.101-2 [14] for FR2-1 in subclause 5.4.3.2.

5.3.3 Channel spacing

For NCR-MT, the channel spacing is the same as specified for UE in TS 38.101-1 [13] for FR1 in subclause 5.4.1 and in TS 38.101-2 [14] for FR2-1 in subclause 5.4.1.

5.3.4 TX–RX frequency separation

The default TX channel (carrier centre frequency) to RX channel (carrier centre frequency) separation for operating bands is specified in Table 5.3.4-1.

Table 5.3.4-1: NCR-MT TX-RX frequency separation

NR Operating Band	TX – RX carrier centre frequency separation
n1	190 MHz
n2	80 MHz
n3	95 MHz
n5	45 MHz
n7	120 MHz
n8	45 MHz
n12	30 MHz
n13	-31 MHz
n14	-30 MHz
n18	45 MHz
n20	-41 MHz
n24	-101.5, -120.5 MHz
n25	80 MHz
n26	45 MHz
n28	55 MHz
n30	45 MHz
n65	190 MHz
n66	400 MHz
n68	55 MHz
n70	300 MHz
n71	-46 MHz
n74	48 MHz
n85	30 MHz
n87	10MHz
n88	10MHz
n91	570 MHz – 595 MHz (NOTE 2)
n92	575 MHz – 680 MHz ($\mu = 0$) 580 MHz – 675 MHz ($\mu = 1$) (NOTE 2)
n93	517 MHz – 547 MHz (NOTE 2)
n94	522 MHz – 632 MHz ($\mu = 0$) 527 MHz – 627 MHz ($\mu = 1$) (NOTE 2)
n100	45 MHz
n105	-51 MHz
n110	42 MHz
NOTE 1: Void	
NOTE 2: The range of TX-RX frequency separation given paired UL and DL channel bandwidths BW_{UL} and BW_{DL} is given by the respective lower and upper limit $F_{DL_low} - F_{UL_high} + 0.5(BW_{DL} + BW_{UL})$ and $F_{DL_high} - F_{UL_low} - 0.5(BW_{DL} + BW_{UL})$. The UL and DL channel bandwidth combinations specified in Clause 5.4 depend on the subcarrier spacing configuration μ [21].	

5.4 NCR-MT channel bandwidth

5.4.1 General

The NCR-MT supports a single NR RF carrier per passband in the uplink or downlink in this release. From a BS perspective, different NCR-MT channel bandwidths may be supported within the same spectrum for transmitting to and receiving from NCR-MT connected to the BS. Transmission of multiple carriers to different NCR-MT within the BS channel bandwidth can be supported.

NOTE: 7 MHz channel bandwidth is not supported in the present version of the specification.

From a NCR-MT perspective, the NCR-MT per passband is configured with one carrier and NCR-MT is configured with one or more BWPs. The NCR-MT does not need to be aware of the BS channel bandwidth or how the BS allocates bandwidth to different NCR-MT.

The placement of the NCR-MT channel bandwidth is flexible but can only be completely within the BS channel bandwidth.

The relationship between the NCR-MT channel bandwidth, the guardband and the transmission bandwidth configuration is shown in Figure 5.4.1-1.

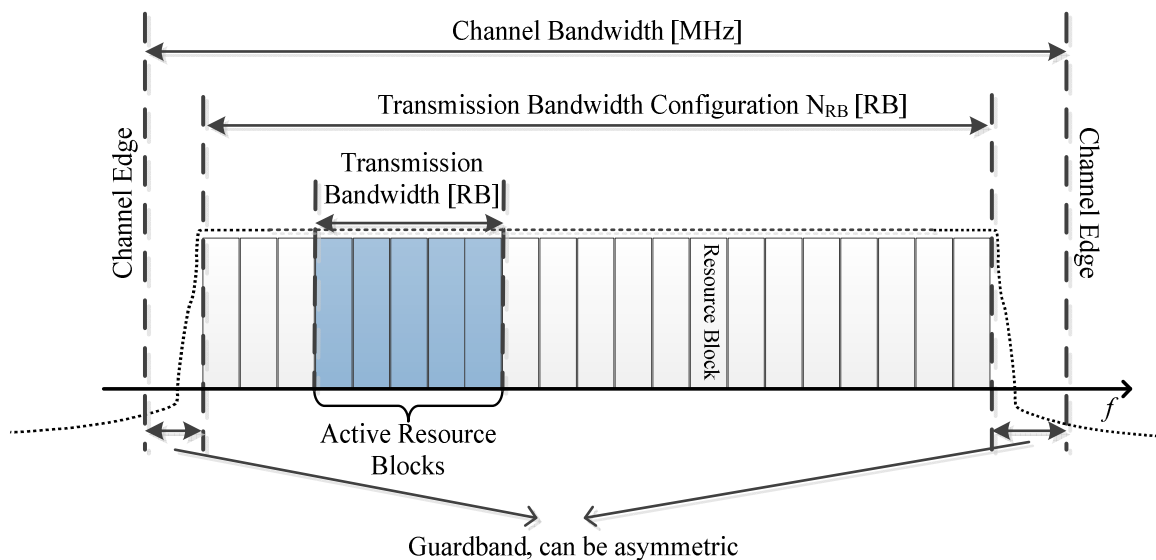

Figure 5.4.1-1: Definition of channel bandwidth and transmission bandwidth configuration for one NR channel

5.4.2 Transmission bandwidth configuration

For NCR-MT, the transmission bandwidth configuration is the same as specified for UE in TS 38.101-1 [13] for FR1 in subclause 5.3.2 and in TS 38.101-2 [14] for FR2-1 in subclause 5.3.2.

5.4.3 Minimum guardband and transmission bandwidth configuration

For NCR-MT, the minimum guardband and transmission bandwidth configuration is the same as specified for UE in TS38.101-1 [13] for FR1 and in TS 38.101-2 [14] for FR2-1 in subclause 5.3.3.

5.4.4 RB alignment

For NCR-MT, the RB alignment is the same as specified for UE in TS38.101-1 [13] for FR1 in subclause 5.3.4 and in TS 38.101-2 [14] for FR2-1 in subclause 5.3.4

5.4.5 NCR-MT channel bandwidth per operating band

For NCR-MT, the channel bandwidth for NR bands for FR1 in Table 5.2-1 is the same as specified for UE in TS38.101-1 [13] in subclause 5.3.5 and is the same as specified for UE in TS38.101-2 [14] in subclause 5.3.5.

6 Conducted characteristics

6.1 General

Clause 6 includes the conducted characteristics for both transmitter and receiver.

For conducted transmitter characteristics:

Unless otherwise stated, the conducted transmitter characteristics are specified at:

- Antenna connector for repeater type 1-C and *NCR type 1-C* (including Fwd and MT interfaces) configuration,
- *TAB connector* for *NCR type 1-H* (including Fwd and MT interfaces) in normal operating conditions.

Requirements apply in both DL and UL unless otherwise stated or declared.

For the DL the *antenna connector* or the *TAB connector* on the BS side is the input and the *antenna connector* or the *TAB connector* on the UE side is the output.

For the UL the *antenna connector* or the *TAB connector* on the UE side is the input and the *antenna connector* or the *TAB connector* on the BS side is the output.

All requirements are defined for normal conditions, unless otherwise stated.

For conducted receiver characteristics:

Conducted receiver characteristics are specified at *antenna connector* for *NCR type 1-C* and *TAB connector* for *NCR type 1-H*, with full complement of transceivers for the configuration in normal operating condition.

Unless otherwise stated, the following arrangements apply for conducted receiver characteristics requirements in clause 6:

- Requirements apply during the receive period.
- Requirements shall be met for any transmitter setting.
- Throughput requirements defined for the conducted receiver characteristics do not assume HARQ retransmissions.
- For ACS, blocking and intermodulation characteristics, the negative offsets of the interfering signal apply relative to the lower *passband* edge or *inter-passband gap*, and the positive offsets of the interfering signal apply relative to the upper *passband* edge or *inter-passband gap*.

NOTE: In normal operating condition the NCR-MT in TDD operation is configured to TX OFF power during receive period.

6.2 Repeater output power

6.2.1 General

The repeater conducted output power requirement is at the *antenna connector*.

The *rated passband output power* of the *RF repeater type 1-C* and *NCR-Fwd type 1-C* shall be as specified in table 6.2.1-1 and table 6.2.1-2.

Table 6.2.1-1: RF repeater type 1-C and NCR-FWD type 1-C DL transmission classes rated output power limits for repeater classes

Repeater class	$P_{\text{rated,p,AC}}$
Wide Area repeater	Note 1
Medium Range repeater	$\leq 38 \text{ dBm} + X$, Note 2
Local Area repeater	$\leq 24 \text{ dBm} + X$, Note 2
NOTE 1: There is no upper limit for the $P_{\text{rated,p,AC}}$ <i>rated passband output power</i> of the Wide Area repeater	
NOTE 2: $X = 10 \cdot \log(\text{ceil}(\text{passband bandwidth}/20\text{MHz}))$	

Table 6.2.1-2: RF repeater type 1-C and NCR-Fwd type 1-C UL transmission classes rated output power limits for repeater classes

Repeater class	$P_{\text{rated,p,AC}}$
Wide Area repeater	Note 1
Local Area repeater	$\leq 24 \text{ dBm} + X$, Note 2
NOTE 1: There is no upper limit for the $P_{\text{rated,p,AC}}$ <i>rated passband output power</i> of the Wide Area repeater.	
NOTE 2: $X = 10 \cdot \log(\text{ceil}(\text{passband bandwidth}/20\text{MHz}))$	

The *rated passband output power* of the *NCR-Fwd 1-H* shall be as specified in table 6.2.1-3 and table 6.2.1-4.

Table 6.2.1-3: NCR-Fwd 1-H DL rated output power limits for NCR classes

Repeater class	$P_{\text{rated,c,sys}}$	$P_{\text{rated,c,TABC}}$
Wide Area NCR	(Note 1)	(Note 1)
Medium Range NCR	$\leq 38 \text{ dBm} + 10\log(N_{\text{TXU,counted}}) + X$ (NOTE 2)	$\leq 38 \text{ dBm} + X$ (NOTE 2)
Local Area NCR	$\leq 24 \text{ dBm} + 10\log(N_{\text{TXU,counted}}) + X$ (NOTE 2)	$\leq 24 \text{ dBm} + X$ (NOTE 2)
NOTE 1: There is no upper limit for the $P_{\text{rated,c,sys}}$ or $P_{\text{rated,c,TABC}}$ of the Wide Area NCR-Fwd.		
NOTE 2: $X = 10 \cdot \log(\text{ceil}(\text{passband bandwidth}/20\text{MHz}))$		

Table 6.2.1-4: NCR-Fwd 1-H UL rated output power limits for NCR classes

Repeater class	$P_{\text{rated,c,sys}}$	$P_{\text{rated,c,TABC}}$
Wide Area NCR	(Note 1)	(Note 1)
Local Area NCR	$\leq 24 \text{ dBm} + 10\log(N_{\text{TXU,counted}}) + X$ (NOTE 2, 3)	$\leq 24 \text{ dBm} + X$ (NOTE 2)
NOTE 1: There is no upper limit for the $P_{\text{rated,c,sys}}$ or $P_{\text{rated,c,TABC}}$ of the Wide Area NCR.		
NOTE 2: $X = 10 \cdot \log(\text{ceil}(\text{passband bandwidth}/20\text{MHz}))$		
NOTE 3: For joint transmission of NCR-Fwd and NCR-MT, $P_{\text{rated,c,sys}}$ shall apply to the total power of NCR-Fwd and NCR-MT.		

6.2.2 Minimum requirement for RF repeater

The requirements shall apply with NR signals in the *passband* of the repeater at:

The lowest input power ($P_{\text{in,p,AC}}$) that produces the *rated passband output power* ($P_{\text{rated,p,AC}}$).

Up to:

The lowest input power ($P_{\text{in,p,AC}}$) that produces the *rated passband output power* ($P_{\text{rated,p,AC}}$), plus 10dB

In normal conditions, the measured output power, $P_{\text{max,p,AC}}$ shall remain within +2 dB and -2 dB of the *rated passband output power* $P_{\text{rated,p,AC}}$, declared by the manufacturer.

In extreme conditions, the measured output power, $P_{\max,p,AC}$ shall remain within +2.5 dB and -2.5 dB of the *rated passband output power* $P_{\text{rated},p,AC}$, declared by the manufacturer.

6.2.3 Minimum requirement for NCR

6.2.3.1 Minimum requirement for NCR-Fwd

6.2.3.1.1 Minimum requirement for NCR-Fwd type 1-C

The requirements shall apply with NR signals in the *passband* of the NCR-Fwd at:

The lowest input power ($P_{\text{in},p,AC}$) that produces the *rated passband output power* ($P_{\text{rated},p,AC}$).

Up to:

The lowest input power ($P_{\text{in},p,AC}$) that produces the *rated passband output power* ($P_{\text{rated},p,AC}$), plus 10dB

In normal conditions, the measured output power, $P_{\max,p,AC}$ shall remain within +2 dB and -2 dB of the *rated passband output power* $P_{\text{rated},p,AC}$, declared by the manufacturer.

In extreme conditions, the measured output power, $P_{\max,p,AC}$ shall remain within +2.5 dB and -2.5 dB of the *rated passband output power* $P_{\text{rated},p,AC}$, declared by the manufacturer.

6.2.3.1.2 Minimum requirement for NCR-Fwd type 1-H

The requirements shall apply with NR signals in the *passband* of the NCR-Fwd at:

The lowest input power ($P_{\text{in},p,TABC}$) that produces the *rated passband output power* ($P_{\text{rated},p,TABC}$).

Up to:

The lowest input power ($P_{\text{in},p,TABC}$) that produces the *rated passband output power* ($P_{\text{rated},p,TABC}$), plus 10dB

In normal conditions, the measured output power, $P_{\max,p,TABC}$ shall remain within +2 dB and -2 dB of the *rated passband output power* $P_{\text{rated},p,TABC}$, declared by the manufacturer.

In extreme conditions, the measured output power, $P_{\max,p,TABC}$ shall remain within +2.5 dB and -2.5 dB of the *rated passband output power* $P_{\text{rated},p,TABC}$, declared by the manufacturer.

6.2.3.2 Minimum requirement for NCR-MT

6.2.3.2.1 General

The NCR-MT conducted output power requirement is at *antenna connector* for *NCR-MT type 1-C*, or at *TAB connector* for *NCR-MT type 1-H*.

The *rated carrier output power* of the *NCR-MT type 1-C* shall be as specified in table 6.2.3.2.1-1.

Table 6.2.3.2.1-1: NCR-MT type 1-C UL transmission classes rated output power limits

Repeater class	$P_{\text{rated},c,AC}$
Wide Area NCR-MT	(Note)
Local Area NCR-MT	≤ 24 dBm
NOTE: There is no upper limit for the $P_{\text{rated},c,AC}$ <i>rated output power</i> of the Wide Area NCR-MT.	

The *rated carrier output power* of the *NCR-MT type 1-H* shall be as specified in table 6.2.3.2.1-2.

Table 6.2.3.2.1-2: NCR-MT type 1-H UL transmission classes rated output power limits

Repeater class	$P_{\text{rated,c,sys}}$	$P_{\text{rated,c,TABC}}$
Wide Area NCR-MT	(Note 1)	(Note 1)
Local Area NCR-MT ^{2,3}	$\leq 24 \text{ dBm} + 10\log(N_{\text{TXU,counted}})$	$\leq 24 \text{ dBm}$
NOTE 1: There is no upper limit for the $P_{\text{rated,c,AC}}$ <i>rated output power</i> of the Wide Area NCR-MT.		
NOTE 2: LA MT cannot exceed highest power class for that band as specified in TS 38.101-1.		
NOTE 3: $N_{\text{TXU,counted}} = \min(N_{\text{TXU,active}}, 4)$		

6.2.3.2.2 Minimum requirement for NCR-MT type 1-C and NCR-MT type 1-H

In normal conditions, $P_{\text{max,c,AC}}$ shall remain within +2 dB and -2 dB of the *rated carrier output power* $P_{\text{rated,c,AC}}$, declared by the manufacturer.

In extreme conditions, $P_{\text{max,c,AC}}$ shall remain within +2.5 dB and -2.5 dB of the *rated carrier output power* $P_{\text{rated,c,AC}}$, declared by the manufacturer.

6.3 Frequency stability

6.3.1 General

Frequency stability is the ability to maintain the same frequency on the output signal with respect to the input signal.

6.3.2 Minimum requirement for RF repeater

The frequency deviation of the output signal with respect to the input signal shall be no more than $\pm 0,01$ PPM.

6.3.3 Minimum requirement for NCR

6.3.3.1 Minimum requirement for NCR-Fwd

6.3.3.1.1 Minimum requirement for NCR-Fwd type 1-C

The frequency deviation of the output signal with respect to the input signal shall be no more than $\pm 0,01$ PPM.

6.3.3.1.2 Minimum requirement for NCR-Fwd type 1-H

The frequency deviation of the output signal with respect to the input signal between corresponding input/output TAB connectors shall be no more than $\pm 0,01$ PPM.

6.4 Out of band gain

6.4.1 General

Out of band gain refers to the gain of the repeater outside the *passband*.

The intended use of a repeater in a system is to amplify the in-band signals and not to amplify signals outside of the *passband*.

In the intended application of the repeater, the out of band gain is less than lowest expected the coupling loss to the nearest source of emissions.

6.4.2 Minimum requirement for RF repeater

The gain outside the *passband* shall not exceed the maximum level specified in table 6.4.2-1 or table 6.4.2-2, where:

- $f_{\text{offset_CW}}$ is the offset between the outer channel edge frequency of the outer channel in the *passband* and a CW signal.

Table 6.4.2-1: Out of band gain limits 1 for bands below 2496 MHz

Frequency offset, $f_{\text{offset_CW}}$	Maximum gain
$0,2 \leq f_{\text{offset_CW}} < 1,0$ MHz	60 dB
$1,0 \leq f_{\text{offset_CW}} < 5,0$ MHz	45 dB
$5,0 \leq f_{\text{offset_CW}} < 10,0$ MHz	45 dB
$10,0$ MHz $\leq f_{\text{offset_CW}}$	35 dB

Table 6.4.2-2: Out of band gain limits 1 for bands above 2496 MHz

Frequency offset, $f_{\text{offset_CW}}$	Maximum gain
$[0,2] < f_{\text{offset_CW}} < 4,0$ MHz	60 dB
$4,0 < f_{\text{offset_CW}} < 15,0$ MHz	45 dB
$15,0$ MHz $< f_{\text{offset_CW}}$	35 dB

6.4.3 Minimum requirement for NCR

6.4.3.1 Minimum requirement for NCR-Fwd

6.4.3.1.1 Minimum requirement for NCR-Fwd type 1-C

The gain between the input antenna connector and output antenna connector outside the *passband* shall not exceed the maximum level specified in table 6.4.2-1 or table 6.4.2-2

6.4.3.1.2 Minimum requirement for NCR-Fwd type 1-H

The gain defined between corresponding input/output TAB connectors outside the *passband* shall not exceed the maximum level specified in table 6.4.2-1 or table 6.4.2-2.

6.5 Unwanted emissions

6.5.1 General

Unwanted emissions consist of out-of-band emissions and spurious emissions according to ITU definitions [5]. In ITU terminology, out of band emissions are unwanted emissions immediately outside the channel bandwidth resulting from the modulation process and non-linearity in the transmitter but excluding spurious emissions. Spurious emissions are emissions which are caused by unwanted transmitter effects such as harmonics emission, parasitic emission, intermodulation products and frequency conversion products, but exclude out of band emissions.

The out-of-band emissions requirement for the Repeater transmitter is specified both in terms of Adjacent Channel Leakage power Ratio (ACLR) and *operating band* unwanted emissions (OBUE).

The maximum offset of the *operating band* unwanted emissions mask from the *operating band* edge is Δf_{OBUE} . The Operating band unwanted emissions define all unwanted emissions in each supported downlink *operating band* of *repeater type 1-C* DL and uplink *operating band* of *repeater type 1-C* UL, plus the frequency ranges Δf_{OBUE} above and Δf_{OBUE} below each band. Unwanted emissions outside of this frequency range are limited by a spurious emissions requirement.

The values of Δf_{OBUE} are defined in tables 6.5.1-1 and 6.5.1-2 for the NR *operating bands*.

Table 6.5.1-1: Maximum offset of OBUE outside the downlink *operating band* of *repeater type 1-C, NCR-Fwd type 1-C and NCR-Fwd type 1-H DL*

Repeater or NCR type	Operating band characteristics	Δf_{OBUE} (MHz)
NCR-Fwd type 1-H	$F_{DL,high} - F_{DL,low} < 100$ MHz	10
	$100 \text{ MHz} \leq F_{DL,high} - F_{DL,low} \leq 900$ MHz	40
Repeater type 1-C and NCR-Fwd type 1-C	$F_{DL,high} - F_{DL,low} \leq 200$ MHz	10
	$200 \text{ MHz} < F_{DL,high} - F_{DL,low} \leq 900$ MHz	40

Table 6.5.1-2: Maximum offset of OBUE outside the uplink *operating band* of *repeater 1-C UL*

Repeater or NCR type	Operating band characteristics	Δf_{OBUE} (MHz)
NCR-Fwd type 1-H	$F_{DL,high} - F_{DL,low} < 100$ MHz	10
	$100 \text{ MHz} \leq F_{DL,high} - F_{DL,low} \leq 900$ MHz	40
Repeater type 1-C and NCR-Fwd type 1-C	$F_{DL,high} - F_{DL,low} \leq 200$ MHz	10
	$200 \text{ MHz} < F_{DL,high} - F_{DL,low} \leq 900$ MHz	40

For *NCR-Fwd type 1-H* the unwanted emission requirements are applied per the *TAB connector TX min cell groups* for all the configurations supported by the repeater. The *basic limits* and corresponding emissions scaling are defined in each relevant clause.

There is no co-location unwanted emission requirement for LA NCR-Fwd type 1-C and repeaters type 1-C deployed in Femto cell scenario.

6.5.2 Adjacent Channel Leakage Power Ratio

6.5.2.1 General

Adjacent Channel Leakage power Ratio (ACLR) is the ratio of the filtered mean power centred on the assigned channel frequency to the filtered mean power centred on an adjacent channel frequency.

The requirements shall apply outside the *repeater type 1-C passband* whatever the type of transmitter considered (single carrier or multi-carrier) and for all transmission modes foreseen by the manufacturer's specification.

For a *repeater* operating in *non-contiguous spectrum*, the ACLR requirement in clause 6.5.2.2 shall apply in *Gaps between passbands* for the frequency ranges defined in table 6.5.2.2-3, while the CACLR requirement in clause 6.5.2.2 shall apply in *gaps between passbands* for the frequency ranges defined in table 6.5.2.2-4.

For a *multi-band connector*, the ACLR requirement in clause 6.5.2.2 shall apply in *inter-passband gaps* for the frequency ranges defined in table 6.5.2.2-3, while the CACLR requirement in clause 6.5.2.2 shall apply in *inter-passband gaps* for the frequency ranges defined in table 6.5.2.2-4.

The requirement shall apply during the *transmitter ON state*.

6.5.2.2 Limits and basic limits

The ACLR is defined with a square filter of bandwidth equal to the transmission bandwidth configuration of the transmitted signal (BW_{Config}) centred on the assigned channel frequency and a filter centred on the adjacent channel frequency according to the tables below.

For DL (all repeater classes), and for UL for WA class, either the ACLR (CACLR) absolute *basic limits* in table 6.5.2.2-2, 6.5.2.2-5 or else the relevant the ACLR (CACLR) *limits* in table 6.5.2.2-1, 6.5.2.2-3 or 6.5.2.2-4, whichever is less stringent, shall apply for each *antenna connector*. For UL for LA class, the ACLR (CACLR) and *basic limits* in table 6.5.2.2-1a, 6.5.2.2-3 or 6.5.2.2-4a shall apply.

Table 6.5.2.2-1: ACLR limit for DL (all repeater classes) and for UL for Wide Area class

nominal channel bandwidth BW_{Nominal} (MHz) (NOTE 5)	Repeater type 1-C adjacent channel centre frequency offset below or above the passband edge	Assumed adjacent channel carrier (informative)	Filter on the adjacent channel frequency and corresponding filter bandwidth	ACLR limit
5, 10, 15, 20, 25, 30, 35, 40, 45, 50, 60, 70, 80, 90, 100	$BW_{\text{Nominal}}/2$	NR of same BW (Note 2)	Square (BW_{Config})	45 dB 38 dB (Note 4)
	$1.5 \times BW_{\text{Nominal}}$	NR of same BW (Note 2)	Square (BW_{Config})	45 dB 38 dB (Note 4)
	2.5 MHz	5 MHz E-UTRA	Square (4.5 MHz)	45 dB (Note 3)
	7.5 MHz	5 MHz E-UTRA	Square (4.5 MHz)	45 dB (Note 3)
<p>NOTE 1: BW_{Nominal} is the <i>nominal channel bandwidth</i>. BW_{Config} is the <i>transmission bandwidth configuration</i> assumed for the adjacent channel.</p> <p>NOTE 2: With SCS that provides largest <i>transmission bandwidth configuration</i> (BW_{Config}).</p> <p>NOTE 3: The requirements are applicable when the band is also defined for E-UTRA or UTRA.</p> <p>NOTE 4: For repeater operating in band n104, ACLR requirement 38 dB applies. For repeater operating in other bands, ACLR requirement 45 dB applies.</p> <p>NOTE 5: For simultaneous NCR-Fwd and NCR-MT transmission, if the NCR-MT carrier is within the passband then the nominal channel bandwidth shall be calculated based on the the bandwidth between the lower edge of the passband and the lower edge of the NCR-MT carrier for lower side, or between the upper edge of the passband and the upper edge of the NCR-MT carrier for upper side. If the NCT-MT carrier is adjacent to the passband then ACLR requirement for NCR-MT based on NCR-MT channel bandwidth shall be applied for the NCR-MT carrier side and the nominal channel bandwidth calculated with the passband bandwidth shall be used for the passband side. If the NCR-MT carrier is not adjacent to the passband then CACLR shall be applied in the gap between the passband and the NCR-MT carrier.</p>				

Table 6.5.2.2-1a: ACLR limit for UL for Local Area

nominal channel bandwidth BW_{Nominal} (MHz) (NOTE 4)	Repeater type 1-C adjacent channel centre frequency offset below or above the passband edge	Assumed adjacent channel carrier (informative)	Filter on the adjacent channel frequency and corresponding filter bandwidth	ACLR limit
5, 10, 15, 20, 25, 30, 35, 40, 45, 50, 60, 70, 80, 90, 100	$BW_{\text{Nominal}}/2$	NR of same BW (Note 2)	Square (BW_{Config})	31 dB
	$1.5 \times BW_{\text{Nominal}}$	NR of same BW (Note 2)	Square (BW_{Config})	31 dB
	2.5 MHz	5 MHz E-UTRA	Square (4.5 MHz)	31 dB
	7.5 MHz	5 MHz E-UTRA	Square (4.5 MHz)	31 dB
<p>NOTE 1: BW_{Nominal} is the <i>nominal channel bandwidth</i>. BW_{Config} is the <i>transmission bandwidth configuration</i> assumed for the adjacent channel.</p> <p>NOTE 2: With SCS that provides the largest <i>transmission bandwidth configuration</i> (BW_{Config}).</p> <p>NOTE 3: The requirements are applicable when the band is also defined for E-UTRA or UTRA.</p> <p>NOTE 4: For simultaneous NCR-Fwd and NCR-MT transmission, if the NCR-MT carrier is within the passband then the nominal channel bandwidth shall be calculated based on the the bandwidth between the lower edge of the passband and the lower edge of the NCR-MT carrier for lower side, or between the upper edge of the passband and the upper edge of the NCR-MT carrier for upper side. If the NCT-MT carrier is adjacent to the passband then ACLR requirement for NCR-MT based on NCR-MT channel bandwidth shall be applied for the NCR-MT carrier side and the nominal channel bandwidth calculated with the passband bandwidth shall be used for the passband side. If the NCR-MT carrier is not adjacent to the passband then CAACLR shall be applied in the gap between the passband and the NCR-MT carrier.</p>				

The ACLR absolute *basic limit* is specified in table 6.5.2.2-2 and is applicable for both contiguous spectrum, non-contiguous spectrum and multiple bands

Table 6.5.2.2-2: ACLR absolute *basic* limits for DL and UL for WA class, for DL for MR class and for DL for LA class

Repeater category / class	ACLR absolute <i>basic limit</i>
Category A Wide Area DL and UL	-13 dBm/MHz
Category B Wide Area DL and UL	-15 dBm/MHz
Medium Range DL	-25 dBm/MHz
Local Area DL	-32 dBm/MHz

Table 6.5.2.2-3: ACLR limit in non-contiguous spectrum or multiple bands for DL (all repeater classes) and for UL for Wide Area class

nominal channel bandwidth BW_{Nominal} (MHz) (NOTE 6)	Gap between passbands or inter-passband gap size (W_{gap}) where the limit applies (MHz)	Repeater type 1-C adjacent channel centre frequency offset below or above the passband edge (inside the gap)	Assumed adjacent channel carrier	Filter on the adjacent channel frequency and corresponding filter bandwidth	ACLR limit
5, 10, 15, 20	$W_{\text{gap}} \geq 15$ (Note 3) $W_{\text{gap}} \geq 45$ (Note 4)	2.5 MHz	5 MHz NR (Note 2)	Square (BW_{Config})	45 dB 38 dB (Note 5)
	$W_{\text{gap}} \geq 20$ (Note 3) $W_{\text{gap}} \geq 50$ (Note 4)	7.5 MHz	5 MHz NR (Note 2)	Square (BW_{Config})	45 dB 38 dB (Note 5)
25, 30, 35, 40, 45, 50, 60, 70, 80, 90, 100	$W_{\text{gap}} \geq 60$ (Note 4) $W_{\text{gap}} \geq 30$ (Note 3)	10 MHz	20 MHz NR (Note 2)	Square (BW_{Config})	45 dB 38 dB (Note 5)
	$W_{\text{gap}} \geq 80$ (Note 4) $W_{\text{gap}} \geq 50$ (Note 3)	30 MHz	20 MHz NR (Note 2)	Square (BW_{Config})	45 dB 38 dB (Note 5)
<p>NOTE 1: BW_{Nominal} is the <i>nominal channel bandwidth</i>. BW_{Config} is the <i>transmission bandwidth configuration</i> assumed for the adjacent channel.</p> <p>NOTE 2: With SCS that provides the largest <i>transmission bandwidth configuration</i> (BW_{Config}).</p> <p>NOTE 3: Applicable in case the <i>repeater type 1-C nominal channel bandwidth</i> at the other edge of the gap is ≤ 20 MHz.</p> <p>NOTE 4: Applicable in case the <i>repeater type 1-C nominal channel bandwidth</i> at the other edge of the gap is > 20 MHz.</p> <p>NOTE 5: For repeater operating in band n104, ACLR requirement 38 dB applies. For repeater operating in other bands, ACLR requirement 45 dB applies.</p> <p>NOTE 6: For simultaneous NCR-Fwd and NCR-MT transmission, if the NCR-MT carrier is within the passband then the nominal channel bandwidth shall be calculated based on the the bandwidth between the lower edge of the passband and the lower edge of the NCR-MT carrier for lower side, or between the upper edge of the passband and the upper edge of the NCR-MT carrier for upper side. If the NCT-MT carrier is adjacent to the passband then ACLR requirement for NCR-MT based on NCR-MT channel bandwidth shall be applied for the NCR-MT carrier side and the nominal channel bandwidth calculated with the passband bandwidth shall be used for the passband side. If the NCR-MT carrier is not adjacent to the passband then CACLR shall be applied in the gap between the passband and the NCR-MT carrier.</p>					

Table 6.5.2.2-3a: ACLR limit in non-contiguous spectrum or multiple bands for UL for Local Area class

nominal channel bandwidth BW_{Nominal} (MHz) (NOTE 5)	Sub-block or inter-passband gap size (W_{gap}) where the limit applies (MHz)	Repeater type 1-C adjacent channel centre frequency offset below or above the passband edge (inside the gap)	Assumed adjacent channel carrier	Filter on the adjacent channel frequency and corresponding filter bandwidth	ACLR limit
5, 10, 15, 20	$W_{\text{gap}} \geq 15$ (Note 3) $W_{\text{gap}} \geq 45$ (Note 4)	2.5 MHz	5 MHz NR (Note 2)	Square (BW_{Config})	31 dB
	$W_{\text{gap}} \geq 20$ (Note 3) $W_{\text{gap}} \geq 50$ (Note 4)	7.5 MHz	5 MHz NR (Note 2)	Square (BW_{Config})	31 dB
25, 30, 35, 40, 45, 50, 60, 70, 80, 90, 100	$W_{\text{gap}} \geq 60$ (Note 4) $W_{\text{gap}} \geq 30$ (Note 3)	10 MHz	20 MHz NR (Note 2)	Square (BW_{Config})	31 dB
	$W_{\text{gap}} \geq 80$ (Note 4) $W_{\text{gap}} \geq 50$ (Note 3)	30 MHz	20 MHz NR (Note 2)	Square (BW_{Config})	31 dB

NOTE 1: BW_{Config} is the *transmission bandwidth configuration* assumed for the adjacent channel.
NOTE 2: With SCS that provides the largest *transmission bandwidth configuration* (BW_{Config}).
NOTE 3: Applicable in case the *repeater type 1-C nominal channel bandwidth* at the other edge of the gap is ≤ 20 MHz.
NOTE 4: Applicable in case the *repeater type 1-C nominal channel bandwidth* at the other edge of the gap is > 20 MHz.
NOTE 5: For simultaneous NCR-Fwd and NCR-MT transmission, if the NCR-MT carrier is within the passband then the nominal channel bandwidth shall be calculated based on the the bandwidth between the lower edge of the passband and the lower edge of the NCR-MT carrier for lower side, or between the upper edge of the passband and the upper edge of the NCR-MT carrier for upper side. If the NCT-MT carrier is adjacent to the passband then ACLR requirement for NCR-MT based on NCR-MT channel bandwidth shall be applied for the NCR-MT carrier side and the nominal channel bandwidth calculated with the passband bandwidth shall be used for the passband side. If the NCR-MT carrier is not adjacent to the passband then CACLR shall be applied in the gap between the passband and the NCR-MT carrier.

The Cumulative Adjacent Channel Leakage power Ratio (CACLR) in a *gap between passbands* or the *inter-passband gap* is the ratio of:

- the sum of the filtered mean power centred on the assigned channel frequencies for the two carriers adjacent to each side of the *gap between passbands* or the *inter-passband gap*, and
- the filtered mean power centred on a frequency channel adjacent to one of the respective *repeater type 1-C passband edges*.

The assumed filter for the adjacent channel frequency is defined in table 6.5.3.2-4 and the filters on the assigned channels are defined in table 6.5.2.2-6.

CACLR shall also be applied in case NCR-Fwd and NCR-MT transmit simultaneously in uplink and the NCR-Fwd passband and NCR-MT carrier are not contiguous. In this case, the gap between the NCR-Fwd passband and the NCR-MT carrier shall be considered in the same manner as a *gap between passbands*.

For operation in *non-contiguous spectrum* or multiple bands, the CACLR for NR carriers located on either side of the *gap between passbands* or the *inter-passband gap* shall be higher than the value specified in table 6.5.2.2-4.

Table 6.5.2.2-4: CACLR limit for DL (all repeater classes) and for UL for Wide Area class

nominal channel bandwidth BW_{Nominal} (MHz)	Gap between passbands or inter-passband gap size (W_{gap}) where the limit applies (MHz)	adjacent channel centre frequency offset below or above the passband edge (inside the gap)	Assumed adjacent channel carrier	Filter on the adjacent channel frequency and corresponding filter bandwidth	CACLR limit
5, 10, 15, 20	$5 \leq W_{\text{gap}} < 15$ (Note 3) $5 \leq W_{\text{gap}} < 45$ (Note 4)	2.5 MHz	5 MHz NR (Note 2)	Square (BW_{Config})	45 dB 38 dB (Note 5)
	$10 < W_{\text{gap}} < 20$ (Note 3) $10 \leq W_{\text{gap}} < 50$ (Note 4)	7.5 MHz	5 MHz NR (Note 2)	Square (BW_{Config})	45 dB 38 dB (Note 5)
25, 30, 35, 40, 45, 50, 60, 70, 80, 90, 100	$20 \leq W_{\text{gap}} < 60$ (Note 4) $20 \leq W_{\text{gap}} < 30$ (Note 3)	10 MHz	20 MHz NR (Note 2)	Square (BW_{Config})	45 dB 38 dB (Note 5)
	$40 < W_{\text{gap}} < 80$ (Note 4) $40 \leq W_{\text{gap}} < 50$ (Note 3)	30 MHz	20 MHz NR (Note 2)	Square (BW_{Config})	45 dB 38 dB (Note 5)

NOTE 1: BW_{Config} is the *transmission bandwidth configuration* assumed for the adjacent channel.
NOTE 2: With SCS that provides the largest *transmission bandwidth configuration* (BW_{Config}).
NOTE 3: Applicable in case the *nominal channel bandwidth* at the other edge of the gap is ≤ 20 MHz.
NOTE 4: Applicable in case the *nominal channel bandwidth* at the other edge of the gap is > 20 MHz.
NOTE 5: For repeater operating in band n104, ACLR requirement 38 dB applies. For repeater operating in other bands, ACLR requirement 45 dB applies.

The CACLR shall be higher than the value specified in table 6.5.2.2-4a for UL Local Area.

Table 6.5.2.2-4a: CACLR limit for UL for Local Area

nominal channel bandwidth BW_{Nominal} (MHz)	Gap between passbands or inter-passband gap size (W_{gap}) where the limit applies (MHz)	adjacent channel centre frequency offset below or above the passband edge (inside the gap)	Assumed adjacent channel carrier	Filter on the adjacent channel frequency and corresponding filter bandwidth	CACLR limit
5, 10, 15, 20	$5 \leq W_{\text{gap}} < 15$ (Note 3) $5 \leq W_{\text{gap}} < 45$ (Note 4)	2.5 MHz	5 MHz NR (Note 2)	Square (BW_{Config})	31 dB
	$10 < W_{\text{gap}} < 20$ (Note 3) $10 \leq W_{\text{gap}} < 50$ (Note 4)	7.5 MHz	5 MHz NR (Note 2)	Square (BW_{Config})	31 dB
25, 30, 35, 40, 45, 50, 60, 70, 80, 90, 100	$20 \leq W_{\text{gap}} < 60$ (Note 4) $20 \leq W_{\text{gap}} < 30$ (Note 3)	10 MHz	20 MHz NR (Note 2)	Square (BW_{Config})	31 dB
	$40 < W_{\text{gap}} < 80$ (Note 4) $40 \leq W_{\text{gap}} < 50$ (Note 3)	30 MHz	20 MHz NR (Note 2)	Square (BW_{Config})	31 dB

NOTE 1: BW_{Config} is the *transmission bandwidth configuration* assumed for the adjacent channel.
NOTE 2: With SCS that provides the largest *transmission bandwidth configuration* (BW_{Config}).
NOTE 3: Applicable in case the *nominal channel bandwidth* at the other edge of the gap is ≤ 20 MHz.
NOTE 4: Applicable in case the *nominal channel bandwidth* at the other edge of the gap is > 20 MHz.

The CACLR absolute *minimum requirement* is specified in table 6.5.2.2-5.

Table 6.5.2.2-5: CACLR absolute basic *limit* for DL and UL for WA class, for DL for MR class and for DL for LA class

Repeater category / class	CACLR absolute basic <i>limit</i>
Category A Wide Area DL and UL	-13 dBm/MHz
Category B Wide Area DL and UL	-15 dBm/MHz
Medium Range DL	-25 dBm/MHz
Local Area DL	-32 dBm/MHz

Table 6.5.2.2-6: Filter parameters for the assigned channel

RAT of the carrier adjacent to the <i>gap between passbands or inter-passband gap</i>	Filter on the assigned channel frequency and corresponding filter bandwidth
NR	NR of same BW with SCS that provides largest <i>transmission bandwidth configuration</i>

6.5.2.3 Minimum requirement for RF repeater

The ACLR (CACLR) absolute *basic limits* or the ACLR (CACLR) *limits*, whichever is less stringent, shall apply for each *antenna connector*.

For Band n41 and n90 operation in Japan, absolute ACLR limits shall be applied to the sum of the absolute ACLR power over all *antenna connectors* for *repeater type 1-C*.

6.5.2.4 Minimum requirement for NCR

6.5.2.4.1 Minimum requirements for NCR-Fwd

6.5.2.4.1.1 Minimum requirements for NCR-Fwd type 1-C

The ACLR (CACLR) absolute *basic limits* or the ACLR (CACLR) *limits*, whichever is less stringent, shall apply for each *antenna connector*.

For Band n41 and n90 operation in Japan, absolute ACLR limits shall be applied to the sum of the absolute ACLR power over all *antenna connectors* for *NCR-Fwd type 1-C*.

6.5.2.4.1.2 Minimum requirement for NCR-Fwd type 1-H

The ACLR (CACLR) absolute *basic limits* + X (where $X = 10\log_{10}(N_{\text{TXU, counted per cell}})$ for DL and for WA UL and $X=0$ for LA UL) or the ACLR (CACLR) *limits*, whichever is less stringent, shall apply for each *TAB connector TX min cell group*. For joint transmission of NCR-Fwd and NCR-MT in uplink, the limits shall apply to the sum of emissions from both NCR-Fwd and NCR-MT.

NOTE: Conformance to the NCR-Fwd type 1-H ACLR requirement can be demonstrated by meeting at least one of the following criteria as determined by the manufacturer:

- 1) The ratio of the sum of the filtered mean power measured on each *TAB connector* in the *TAB connector TX min cell group* at the assigned channel frequency to the sum of the filtered mean power measured on each *TAB connector* in the *TAB connector TX min cell group* at the adjacent channel frequency shall be greater than or equal to the ACLR *basic limit* of the NCR-Fwd. This shall apply for each *TAB connector TX min cell group*.

Or

- 2) The ratio of the filtered mean power at the *TAB connector* centred on the assigned channel frequency to the filtered mean power at this *TAB connector* centred on the adjacent channel frequency shall be greater than or equal to the ACLR *basic limit* of the NCR-Fwd for every *TAB connector* in the *TAB connector TX min cell group*, for each *TAB connector TX min cell group*.

In case the ACLR (CACLR) absolute *basic limit* of NCR-Fwd type 1-H are applied, the conformance can be demonstrated by meeting at least one of the following criteria as determined by the manufacturer:

- 1) The sum of the filtered mean power measured on each *TAB connector* in the *TAB connector TX min cell group* at the adjacent channel frequency shall be less than or equal to the ACLR (CACLR) absolute *basic limit* + X of the NCR-Fwd. This shall apply to each *TAB connector TX min cell group*.

Or

- 2) The filtered mean power at each *TAB connector* centred on the adjacent channel frequency shall be less than or equal to the ACLR (CACLR) absolute *basic limit* + X of the NCR-Fwd scaled by $X - 10\log_{10}(n)$ for every *TAB connector* in the *TAB connector TX min cell group*, for each *TAB connector TX min cell group*, where n is the number of *TAB connectors* in the *TAB connector TX min cell group*.

6.5.2.4.2 Minimum requirement for NCR-MT

6.5.2.4.2.1 Minimum requirements for NCR-MT type 1-C

For WA NCR-MT type 1-C, the BS ACLR basic requirements specified in clause 6.6.3 and 6.6.4 in TS 38.104 apply.

For LA NCR-MT type 1-C, the UE ACLR requirements specified in clause 6.5.2.5 in TS 38.101-1 apply.

For simultaneous transmission the limits apply for sum of NCR-MT transmission and NCR-Fwd transmission

6.5.2.4.2.2 Minimum requirements for NCR-MT type 1-H

Limits for NCR-MT type 1-H apply to the sum of emissions across all TAB connectors.

For WA NCR-MT type 1-H, the repeater relative ACLR requirements specified in clause 6.6.3 and 6.6.4 in TS 38.104 apply. For Absolute ACLR requirements, the following scaling factor should be added on top of NCR-MT type 1-C basic limit requirements.

$$10\log(N_{\text{TXU,counted}}), \text{ where } N_{\text{TXU,counted}} = \min(N_{\text{TXU,active}}, 8)$$

For LA NCR-MT type 1-H, the UE ACLR requirements specified in clause 6.5.2.5 in TS 38.101-1 apply.

For simultaneous transmission the limits apply for sum of NCR-MT transmission and NCR-Fwd transmission.

6.5.3 Operating band unwanted emissions

6.5.3.1 General

Unless otherwise stated, the operating band unwanted emission (OBUE) *basic limits* for DL are defined from Δf_{OBUE} below the lowest frequency of each supported downlink *operating band* up to Δf_{OBUE} above the highest frequency of each supported downlink *operating band*. The values of Δf_{OBUE} are defined in table 6.5.1-1 for the NR *operating bands*.

Unless otherwise stated, the operating band unwanted emission (OBUE) *basic limits* for UL are defined from Δf_{OBUE} below the lowest frequency of each supported uplink *operating band* up to Δf_{OBUE} above the highest frequency of each supported uplink *operating band*. The values of Δf_{OBUE} are defined in table 6.5.1-2 for the NR *operating bands*.

The requirements shall apply whatever the type of transmitter considered and for all transmission modes foreseen by the manufacturer's specification. In addition, for *repeater* operating in *non-contiguous spectrum*, the *basic limits* apply inside any *gap between passbands*. In addition, for a *repeater* operating in multiple bands, the *basic limits* apply inside any *inter-passband gap*.

Basic Limits are specified in the tables below, where:

- Δf is the separation between the *passband edge* frequency and the nominal -3dB point of the measuring filter closest to the carrier frequency.
- f_{offset} is the separation between the *passband edge* frequency and the centre of the measuring filter.

- $f_{\text{offset_max}}$ is the offset to the frequency Δf_{OBUE} outside the downlink *operating band* of *repeater type 1-C DL* and uplink *operating band* of *repeater type 1-C UL*, where Δf_{OBUE} is defined in tables 6.5.1-1 and 6.5.1-2.
- Δf_{max} is equal to $f_{\text{offset_max}}$ minus half of the bandwidth of the measuring filter.

For a *multi-band connector* of UL, the operating band unwanted emission basic limits apply also in a supported uplink *operating band* without any carrier transmitted, in the case where there are carrier(s) transmitted in another supported uplink *operating band*. In this case, no cumulative *basic limit* is applied in the *inter-band gap* between a supported uplink *operating band* with carrier(s) transmitted and a supported uplink *operating band* without any carrier transmitted and

- Δf is the separation between the *repeater type 1-C passband edge* frequency and the nominal -3 dB point of the measuring filter closest to the *repeater type 1-C passband edge*.
- f_{offset} is the separation from the *repeater type 1-C passband edge* frequency to the centre of the measuring filter.
- $f_{\text{offset_max}}$ is equal to the *inter-passband gap* minus half of the bandwidth of the measuring filter.
- Δf_{max} is equal to $f_{\text{offset_max}}$ minus half of the bandwidth of the measuring filter.

For a *multi-band connector* of DL, the operating band unwanted emission basic limits apply also in a supported downlink *operating band* without any carrier transmitted, in the case where there are carrier(s) transmitted in another supported downlink *operating band*. In this case, no cumulative *basic limit* is applied in the *inter-band gap* between a supported downlink *operating band* with carrier(s) transmitted and a supported downlink *operating band* without any carrier transmitted and

- In case the *inter-band gap* between a supported downlink *operating band* with carrier(s) transmitted and a supported downlink *operating band* without any carrier transmitted is less than $2 * \Delta f_{\text{OBUE}}$, $f_{\text{offset_max}}$ shall be the offset to the frequency Δf_{OBUE} MHz outside the outermost edges of the two supported downlink *operating bands* and the operating band unwanted emission minimum requirement of the band where there are carriers transmitted, as defined in the tables of the present clause, shall apply across both downlink bands.
- In other cases, the operating band unwanted emission *basic limit* of the band where there are carriers transmitted, as defined in the tables of the present clause for the largest frequency offset (Δf_{max}), shall apply from Δf_{OBUE} MHz below the lowest frequency, up to Δf_{OBUE} MHz above the highest frequency of the supported downlink *operating band* without any carrier transmitted.

For a *multi-band connector* of UL, the operating band unwanted emission limits apply also in a supported uplink *operating band* without any carrier transmitted, in the case where there are carrier(s) transmitted in another supported uplink *operating band*. In this case, no cumulative *basic limit* is applied in the *inter-band gap* between a supported uplink *operating band* with carrier(s) transmitted and a supported uplink *operating band* without any carrier transmitted and

- In case the *inter-band gap* between a supported uplink *operating band* with carrier(s) transmitted and a supported uplink *operating band* without any carrier transmitted is less than $2 * \Delta f_{\text{OBUE}}$, $f_{\text{offset_max}}$ shall be the offset to the frequency Δf_{OBUE} MHz outside the outermost edges of the two supported uplink *operating bands* and the operating band unwanted emission *basic limit* of the band where there are carriers transmitted, as defined in the tables of the present clause, shall apply across both uplink bands.
- In other cases, the operating band unwanted emission basic limits of the band where there are carriers transmitted, as defined in the tables of the present clause for the largest frequency offset (Δf_{max}), shall apply from Δf_{OBUE} MHz below the lowest frequency, up to Δf_{OBUE} MHz above the highest frequency of the supported uplink *operating band* without any carrier transmitted.

In addition, inside any *gap between passbands* for a *single-band connector* operating in *non-contiguous spectrum*, a combined basic limit shall be applied which is the cumulative sum of the basic limit specified for the adjacent *sub-blocks* on each side of the *gap between passbands*. The basic limit for each *sub-block* is specified in clauses 6.5.3.2.1 to 6.5.3.2.4 below, where in this case:

- Δf is the separation between the *sub-block edge* frequency and the nominal -3 dB point of the measuring filter closest to the *sub-block edge*.
- f_{offset} is the separation between the *sub-block edge* frequency and the centre of the measuring filter.

- $f_{\text{offset}_{\text{max}}}$ is equal to the *gap between passbands* bandwidth minus half of the bandwidth of the measuring filter.
- Δf_{max} is equal to $f_{\text{offset}_{\text{max}}}$ minus half of the bandwidth of the measuring filter.

For Wide Area *repeater type 1-C*, the basic limits of either clause 6.5.3.2.1 (Category A limits) or clause 6.5.3.2.2 (Category B limits) shall apply.

For Medium Range *repeater type 1-C*, the basic limits in clause 6.5.3.2.3 shall apply (Category A and B).

For Local Area *repeater type 1-C*, the basic limits of clause 6.5.3.2.4 shall apply (Category A and B).

The application of either Category A or Category B basic limits shall be the same as for Transmitter spurious emissions in clause 6.5.4.

In addition to, for the part of passband where there is no input signal at DL input port, the basic limits in Table 6.5.2.2-2 shall apply. In addition to, for the part of passband where there is no input signal at UL input port, the basic limits in clause 6.5.3.2.6 shall apply.

6.5.3.2 Basic limits

6.5.3.2.1 basic limits for Wide Area repeater type 1-C (Category A)

For repeater operating in Bands n5, n8, n12, n13, n14, n18, n26, n28, n29, n31, n68, n71, n72, n85, n87, n88, basic limits are specified in table 6.5.3.2.1-1.

Table 6.5.3.2.1-1: Wide Area operating band unwanted emission basic limits (NR bands below 1 GHz) for Category A

Frequency offset of measurement filter -3dB point, Δf	Frequency offset of measurement filter centre frequency, f_{offset}	Basic limits (Notes 1, 2)	Measurement bandwidth
$0 \text{ MHz} \leq \Delta f < 5 \text{ MHz}$	$0.05 \text{ MHz} \leq f_{\text{offset}} < 5.05 \text{ MHz}$	$-7 \text{ dBm} - \frac{7}{5} \cdot \left(\frac{f_{\text{offset}}}{\text{MHz}} - 0.05 \right) \text{ dB}$	100 kHz
$5 \text{ MHz} \leq \Delta f < \min(10 \text{ MHz}, \Delta f_{\text{max}})$	$5.05 \text{ MHz} \leq f_{\text{offset}} < \min(10.05 \text{ MHz}, f_{\text{offset}_{\text{max}}})$	-14 dBm	100 kHz
$10 \text{ MHz} \leq \Delta f \leq \Delta f_{\text{max}}$	$10.05 \text{ MHz} \leq f_{\text{offset}} < f_{\text{offset}_{\text{max}}}$	-13 dBm (Note 3)	100 kHz
NOTE 1: For a <i>repeater</i> supporting <i>non-contiguous spectrum</i> operation within any <i>operating band</i> , the emission basic limits within <i>gaps between passbands</i> is calculated as a cumulative sum of contributions from adjacent <i>sub-blocks</i> on each side of the <i>gap between passbands</i> . Exception is $\Delta f \geq 10 \text{ MHz}$ from both adjacent <i>sub-blocks</i> on each side of the <i>gap between passbands</i> , where the emission limits within <i>gaps between passbands</i> shall be -13 dBm/1 MHz.			
NOTE 2: For a <i>multi-band connector</i> with <i>inter-passband gap</i> $< 2 \cdot \Delta f_{\text{OBUe}}$ the emission basic limits within the <i>inter-passband gaps</i> is calculated as a cumulative sum of contributions from adjacent <i>sub-blocks</i> or <i>passband</i> on each side of the <i>inter-passband gap</i> , where the contribution from the far-end <i>sub-block</i> or <i>passband</i> shall be scaled according to the <i>measurement bandwidth</i> of the near-end <i>sub-block</i> or <i>passband</i> .			
NOTE 3: The basic limit is not applicable when $\Delta f_{\text{max}} < 10 \text{ MHz}$.			

For repeater operating in Bands n1, n2, n3, n7, n24, n25, n30, n34, n38, n39, n40, n41, n48, n50, n54, n65, n66, n70, n74, n75, n77, n78, n79, n90, n92, n94, n109, n110 basic limits are specified in table 6.5.3.2.1-2.

Table 6.5.3.2.1-2: Wide Area *operating band* unwanted emission basic limits (NR bands above 1 GHz) for Category A

Frequency offset of measurement filter -3dB point, Δf	Frequency offset of measurement filter centre frequency, f_{offset}	Basic limit (Notes 1, 2)	Measurement bandwidth
$0 \text{ MHz} \leq \Delta f < 5 \text{ MHz}$	$0.05 \text{ MHz} \leq f_{\text{offset}} < 5.05 \text{ MHz}$	$-7 \text{ dBm} - \frac{7}{5} \cdot \left(\frac{f_{\text{offset}}}{\text{MHz}} - 0.05 \right) \text{ dB}$	100 kHz
$5 \text{ MHz} \leq \Delta f < \min(10 \text{ MHz}, \Delta f_{\text{max}})$	$5.05 \text{ MHz} \leq f_{\text{offset}} < \min(10.05 \text{ MHz}, f_{\text{offset}_{\text{max}}})$	-14 dBm	100 kHz
$10 \text{ MHz} \leq \Delta f \leq \Delta f_{\text{max}}$	$10.5 \text{ MHz} \leq f_{\text{offset}} < f_{\text{offset}_{\text{max}}}$	-13 dBm (Note 3)	1MHz
<p>NOTE 1: For a <i>repeater</i> supporting <i>non-contiguous spectrum</i> operation within any <i>operating band</i>, the emission basic limits within <i>gaps between passbands</i> is calculated as a cumulative sum of contributions from adjacent <i>sub-blocks</i> on each side of the <i>gap between passbands</i>, where the contribution from the far-end <i>sub-block</i> shall be scaled according to the <i>measurement bandwidth</i> of the near-end <i>sub-block</i>. Exception is $\Delta f \geq 10\text{MHz}$ from both adjacent <i>sub-blocks</i> on each side of the <i>gap between passbands</i>, where the emission basic limits within <i>gaps between passbands</i> shall be -13 dBm/1 MHz.</p> <p>NOTE 2: For a <i>multi-band connector</i> with <i>inter-passband gap</i> $< 2 \cdot \Delta f_{\text{OBUe}}$ the emission basic limits within the <i>inter-passband gaps</i> is calculated as a cumulative sum of contributions from adjacent <i>sub-blocks</i> or <i>passband</i> on each side of the <i>inter-passband gap</i>, where the contribution from the far-end <i>sub-block</i> or <i>passband</i> shall be scaled according to the <i>measurement bandwidth</i> of the near-end <i>sub-block</i> or <i>passband</i>.</p> <p>NOTE 3: The basic limit is not applicable when $\Delta f_{\text{max}} < 10 \text{ MHz}$.</p>			

6.5.3.2.2 Basic limit for Wide Area repeater type 1-C (Category B)

For Category B Operating band unwanted emissions, there are two options for the *basic limits* that may be applied regionally. Either the *basic limits* in clause 6.5.3.2.2.1 or clause 6.5.3.2.2.2 shall be applied.

6.5.3.2.2.1 Category B basic limits (Option 1)

For *repeater type 1-C* operating in Bands n5, n8, n12, n20, n26, n28, n29, n31, n67, n68, n71, n72, n85, n87, n88, the basic limits are specified in table 6.5.3.2.2.1-1:

Table 6.5.3.2.2.1-1: Wide Area operating band unwanted emission *basic limits* (NR bands below 1 GHz) for Category B

Frequency offset of measurement filter -3dB point, Δf	Frequency offset of measurement filter centre frequency, f_{offset}	Basic limit (Notes 1, 2)	Measurement bandwidth
$0 \text{ MHz} \leq \Delta f < 5 \text{ MHz}$	$0.05 \text{ MHz} \leq f_{\text{offset}} < 5.05 \text{ MHz}$	$-7 \text{ dBm} - \frac{7}{5} \cdot \left(\frac{f_{\text{offset}}}{\text{MHz}} - 0.05 \right) \text{ dB}$	100 kHz
$5 \text{ MHz} \leq \Delta f < \min(10 \text{ MHz}, \Delta f_{\text{max}})$	$5.05 \text{ MHz} \leq f_{\text{offset}} < \min(10.05 \text{ MHz}, f_{\text{offset}_{\text{max}}})$	-14 dBm	100 kHz
$10 \text{ MHz} \leq \Delta f \leq \Delta f_{\text{max}}$	$10.05 \text{ MHz} \leq f_{\text{offset}} < f_{\text{offset}_{\text{max}}}$	-16 dBm (Note 3)	100 kHz
<p>NOTE 1: For a <i>repeater</i> supporting <i>non-contiguous spectrum</i> operation within any <i>operating band</i>, the emission basic limits within <i>gaps between passbands</i> is calculated as a cumulative sum of contributions from adjacent <i>sub-blocks</i> on each side of the <i>gap between passbands</i>. Exception is $\Delta f \geq 10\text{MHz}$ from both adjacent <i>sub-blocks</i> on each side of the <i>gap between passbands</i>, where the emission basic limits within <i>gaps between passbands</i> shall be -15 dBm/1 MHz.</p> <p>NOTE 2: For a <i>multi-band connector</i> with <i>inter-passband gap</i> $< 2 \cdot \Delta f_{\text{OBUe}}$ the emission basic limits within the <i>inter-passband gaps</i> is calculated as a cumulative sum of contributions from adjacent <i>sub-blocks</i> or <i>passband</i> on each side of the <i>inter-passband gap</i>.</p> <p>NOTE 3: The <i>basic limit</i> is not applicable when $\Delta f_{\text{max}} < 10 \text{ MHz}$.</p>			

For *repeater* operating in Bands n1, n2, n3, n7, n25, n34, n38, n39, n40, n41, n48, n50, n65, n66, n70, n75, n77, n78, n79, n90, n92, n94, n109 basic limits are specified in table 6.5.3.2.2.1-2.

Table 6.5.3.2.2.1-2: Wide Area repeater type 1-C operating band unwanted emission basic limits for Category B

Frequency offset of measurement filter -3dB point, Δf	Frequency offset of measurement filter centre frequency, f_{offset}	Basic limits (Notes 1, 2)	Measurement bandwidth
$0 \text{ MHz} \leq \Delta f < 5 \text{ MHz}$	$0.05 \text{ MHz} \leq f_{\text{offset}} < 5.05 \text{ MHz}$	$-7 \text{ dBm} - \frac{7}{5} \cdot \left(\frac{f_{\text{offset}}}{\text{MHz}} - 0.05 \right) \text{ dB}$	100 kHz
$5 \text{ MHz} \leq \Delta f < \min(10 \text{ MHz}, \Delta f_{\text{max}})$	$5.05 \text{ MHz} \leq f_{\text{offset}} < \min(10.05 \text{ MHz}, f_{\text{offset}_{\text{max}}})$	-14 dBm	100 kHz
$10 \text{ MHz} \leq \Delta f \leq \Delta f_{\text{max}}$	$10.5 \text{ MHz} \leq f_{\text{offset}} < f_{\text{offset}_{\text{max}}}$	-15 dBm (Note 3)	1MHz
<p>NOTE 1: For a <i>repeater</i> supporting <i>non-contiguous spectrum</i> operation within any <i>operating band</i>, the emission basic limits within <i>gaps between passbands</i> is calculated as a cumulative sum of contributions from adjacent <i>sub-blocks</i> on each side of the <i>gap between passbands</i>, where the contribution from the far-end <i>sub-block</i> shall be scaled according to the <i>measurement bandwidth</i> of the near-end <i>sub-block</i>. Exception is $\Delta f \geq 10 \text{ MHz}$ from both adjacent <i>sub-blocks</i> on each side of the <i>gap between passbands</i>, where the emission basic limits within <i>gaps between passbands</i> shall be -15 dBm/1 MHz.</p> <p>NOTE 2: For a <i>multi-band connector</i> with <i>inter-passband gap</i> $< 2 \cdot \Delta f_{\text{OBU E}}$ the emission basic limits within the <i>inter-passband gaps</i> is calculated as a cumulative sum of contributions from adjacent <i>sub-blocks</i> or <i>passband</i> on each side of the <i>inter-passband gap</i>, where the contribution from the far-end <i>sub-block</i> or <i>passband</i> shall be scaled according to the <i>measurement bandwidth</i> of the near-end <i>sub-block</i> or <i>passband</i>.</p> <p>NOTE 3: The basic limit is not applicable when $\Delta f_{\text{max}} < 10 \text{ MHz}$.</p>			

For *repeater type 1-C* operating in Band n104, the *basic limits* are specified in tables 6.5.3.2.2.1-2a:

Table 6.5.3.2.2.1-2a: Wide Area operating band unwanted emission basic limits for band n104 for Category B

Frequency offset of measurement filter -3dB point, Δf	Frequency offset of measurement filter centre frequency, f_{offset}	Basic limits	Measurement bandwidth
$0 \text{ MHz} \leq \Delta f < 20 \text{ MHz}$	$0.05 \text{ MHz} \leq f_{\text{offset}} < 20.05 \text{ MHz}$	$-7 \text{ dBm} - \frac{7}{20} \left(\frac{f_{\text{offset}}}{\text{MHz}} - 0.05 \right)$	100 kHz
$20 \text{ MHz} \leq \Delta f < \min(40 \text{ MHz}, \Delta f_{\text{max}})$	$20.05 \text{ MHz} \leq f_{\text{offset}} < \min(40.05 \text{ MHz}, f_{\text{offset}_{\text{max}}})$	-14 dBm	100 kHz
$40 \text{ MHz} \leq \Delta f \leq \Delta f_{\text{max}}$	$40.5 \text{ MHz} \leq f_{\text{offset}} < f_{\text{offset}_{\text{max}}}$	-15 dBm (Note 3)	1MHz
<p>NOTE 1: For a <i>repeater</i> supporting <i>non-contiguous spectrum</i> operation within any <i>operating band</i>, the emission basic limits within <i>gaps between passbands</i> is calculated as a cumulative sum of contributions from adjacent <i>sub-blocks</i> on each side of the <i>gap between passband</i>, where the contribution from the far-end <i>sub-block</i> shall be scaled according to the <i>measurement bandwidth</i> of the near-end <i>sub-block</i>. Exception is $\Delta f \geq 40 \text{ MHz}$ from both adjacent <i>sub-blocks</i> on each side of the <i>gap between passband</i>, where the emission basic limits within <i>gaps between passbands</i> shall be -15 dBm/1 MHz.</p> <p>NOTE 2: For a <i>multi-band connector</i> with <i>inter-passband gap</i> $< 2 \cdot \Delta f_{\text{OBU E}}$ the emission basic limits within the <i>inter-passband gaps</i> is calculated as a cumulative sum of contributions from adjacent <i>sub-blocks</i> or <i>passband</i> on each side of the <i>inter-passband gap</i>, where the contribution from the far-end <i>sub-block</i> or <i>passband</i> shall be scaled according to the <i>measurement bandwidth</i> of the near-end <i>sub-block</i> or <i>passband</i>.</p> <p>NOTE 3: The <i>basic limit</i> is not applicable when $\Delta f_{\text{max}} < 40 \text{ MHz}$.</p>			

6.5.3.2.2.2 Category B basic limits (Option 2)

The basic limits in this clause are intended for Europe and may be applied regionally for *repeater type 1-C* operating in bands n1, n3, n7, n8, n38, n65.

For a *repeater type 1-C* operating in bands n1, n3, n7, n8, n38 or n65, *basic limits* are specified in Table 6.5.3.2.2.2-1:

Table 6.5.3.2.2-1: For a *repeater type 1-C* operating in bands n1, n3, n7, n8, n38 or n65, basic limits are specified in Table 6.5.3.2.2.2-1:

Frequency offset of measurement filter -3dB point, Δf	Frequency offset of measurement filter centre frequency, f_{offset}	Basic limits (Notes 1, 2)	Measurement bandwidth
$0 \text{ MHz} \leq \Delta f < 0.2 \text{ MHz}$	$0.015 \text{ MHz} \leq f_{offset} < 0.215 \text{ MHz}$	-14 dBm	30 kHz
$0.2 \text{ MHz} \leq \Delta f < 1 \text{ MHz}$	$0.215 \text{ MHz} \leq f_{offset} < 1.015 \text{ MHz}$	$-14\text{dBm} - 15 \cdot \left(\frac{f_{offset}}{\text{MHz}} - 0.215 \right) \text{dB}$	30 kHz
(Note 4)	$1.015 \text{ MHz} \leq f_{offset} < 1.5 \text{ MHz}$	-26 dBm	30 kHz
$1 \text{ MHz} \leq \Delta f \leq \min(10 \text{ MHz}, \Delta f_{max})$	$1.5 \text{ MHz} \leq f_{offset} < \min(10.5 \text{ MHz}, f_{offset_{max}})$	-13 dBm	1 MHz
$10 \text{ MHz} \leq \Delta f \leq \Delta f_{max}$	$10.5 \text{ MHz} \leq f_{offset} < f_{offset_{max}}$	-15 dBm (Note 3)	1 MHz
<p>NOTE 1: For a <i>repeater</i> supporting <i>non-contiguous spectrum</i> operation within any <i>operating band</i>, the emission basic limits within <i>gaps between passbands</i> is calculated as a cumulative sum of contributions from adjacent <i>sub-blocks</i> on each side of the <i>gap between passbands</i>, where the contribution from the far-end <i>sub-block</i> shall be scaled according to the <i>measurement bandwidth</i> of the near-end <i>sub-block</i>. Exception is $\Delta f \geq 10\text{MHz}$ from both adjacent <i>sub-blocks</i> on each side of the <i>gap between passbands</i>, where the emission basic limits within <i>gaps between passbands</i> shall be -15 dBm/1 MHz.</p> <p>NOTE 2: For a <i>multi-band connector</i> with <i>inter-passband gap</i> $< 2 \cdot \Delta f_{\text{OBUe}}$ the emission limits within the <i>inter-passband gaps</i> is calculated as a cumulative sum of contributions from adjacent <i>sub-blocks</i> or <i>passband</i> on each side of the <i>inter-passband gap</i>, where the contribution from the far-end <i>sub-block</i> or <i>passband</i> shall be scaled according to the <i>measurement bandwidth</i> of the near-end <i>sub-block</i> or <i>passband</i>.</p> <p>NOTE 3: The <i>basic limit</i> is not applicable when $\Delta f_{max} < 10 \text{ MHz}$.</p> <p>NOTE 4: This frequency range ensures that the range of values of f_{offset} is continuous.</p>			

6.5.3.2.3 Basic limits for Medium Range repeater type 1-C (Category A and B) for DL

For Medium Range *repeater* for DL, *basic limits* are specified in table 6.5.3.2.3-1 and table 6.5.3.2.3-2.

For the tables in this clause for *repeater*, $P_{\text{rated},x} = P_{\text{rated},p,AC} - 10 \cdot \log(\text{ceil}(\text{BW}_{\text{Passband}}/20\text{MHz}))$

Table 6.5.3.2.3-1: Medium Range *repeater operating band* unwanted emission basic limits, $31 < P_{\text{rated},x} \leq 38 \text{ dBm}$

Frequency offset of measurement filter -3dB point, Δf	Frequency offset of measurement filter centre frequency, f_{offset}	Basic limits (Notes 1, 2)	Measurement bandwidth
$0 \text{ MHz} \leq \Delta f < 5 \text{ MHz}$	$0.05 \text{ MHz} \leq f_{offset} < 5.05 \text{ MHz}$	$P_{\text{rated},x} - 53\text{dB} - \frac{7}{5} \left(\frac{f_{offset}}{\text{MHz}} - 0.05 \right) \text{dB}$	100 kHz
$5 \text{ MHz} \leq \Delta f < \min(10 \text{ MHz}, \Delta f_{max})$	$5.05 \text{ MHz} \leq f_{offset} < \min(10.05 \text{ MHz}, f_{offset_{max}})$	$P_{\text{rated},x} - 60\text{dB}$	100 kHz
$10 \text{ MHz} \leq \Delta f \leq \Delta f_{max}$	$10.05 \text{ MHz} \leq f_{offset} < f_{offset_{max}}$	$\text{Min}(P_{\text{rated},x} - 60\text{dB}, -25\text{dBm})$ (Note 3)	100 kHz
<p>NOTE 1: For a <i>repeater</i> DL supporting <i>non-contiguous spectrum</i> operation within any <i>operating band</i> the emission basic limits within <i>gaps between passbands</i> is calculated as a cumulative sum of contributions from adjacent <i>sub-blocks</i> on each side of the <i>gap between passbands</i>. Exception is $\Delta f \geq 10\text{MHz}$ from both adjacent <i>sub-blocks</i> on each side of the <i>gap between passbands</i>, where the emission basic limits within <i>gaps between passbands</i> shall be $\text{Min}(P_{\text{rated},x} - 60\text{dB}, -25\text{dBm})/100\text{kHz}$.</p> <p>NOTE 2: For a <i>multi-band connector</i> with <i>inter-passband gap</i> $< 2 \cdot \Delta f_{\text{OBUe}}$ the emission basic limits within the <i>inter-passband gaps</i> is calculated as a cumulative sum of contributions from adjacent <i>sub-blocks</i> or <i>passband</i> on each side of the <i>inter-passband gap</i>.</p> <p>NOTE 3: The <i>basic limit</i> is not applicable when $\Delta f_{max} < 10 \text{ MHz}$.</p>			

For *repeater* operating in Band n104, the limits are specified in Table 6.5.3.2.3-1a and Table 6.5.3.2.3-2a.

Table 6.5.3.2.3-1a. Medium Range *repeater operating band* unwanted emission *basic limits* for band n104, $31 < P_{\text{rated},x} \leq 38$ dBm

Frequency offset of measurement filter -3dB point, Δf	Frequency offset of measurement filter centre frequency, f_{offset}	<i>Basic limits</i> (Notes 1, 2)	<i>Measurement bandwidth</i>
$0 \text{ MHz} \leq \Delta f < 20 \text{ MHz}$	$0.05 \text{ MHz} \leq f_{\text{offset}} < 20.05 \text{ MHz}$	$P_{\text{rated},x} - 53\text{dB} - \frac{7}{20} \left(\frac{f_{\text{offset}}}{\text{MHz}} - 0.05 \right)$	100 kHz
$20 \text{ MHz} \leq \Delta f < \min(40 \text{ MHz}, \Delta f_{\text{max}})$	$20.05 \text{ MHz} \leq f_{\text{offset}} < \min(40.05 \text{ MHz}, f_{\text{offset}_{\text{max}}})$	$P_{\text{rated},x} - 60\text{dB}$	100 kHz
$40 \text{ MHz} \leq \Delta f \leq \Delta f_{\text{max}}$	$40.05 \text{ MHz} \leq f_{\text{offset}} < f_{\text{offset}_{\text{max}}}$	$\text{Min}(P_{\text{rated},x} - 60\text{dB}, -25\text{dBm})$ (Note 3)	100 kHz
NOTE 1: For a <i>repeater</i> DL supporting <i>non-contiguous spectrum</i> operation within any <i>operating band</i> the emission basic limits within <i>gaps between passbands</i> is calculated as a cumulative sum of contributions from adjacent <i>sub-blocks</i> on each side of the <i>gap between passbands</i> . Exception is $\Delta f \geq 40\text{MHz}$ from both adjacent <i>sub-blocks</i> on each side of the <i>gap between passbands</i> , where the emission basic limits within <i>gaps between passbands</i> shall be $\text{Min}(P_{\text{rated},x} - 60\text{dB}, -25\text{dBm})/100\text{kHz}$.			
NOTE 2: For a <i>multi-band connector</i> with <i>inter-passband gap</i> $< 2 * \Delta f_{\text{OBUe}}$ the emission basic limits within the <i>inter-passband gaps</i> is calculated as a cumulative sum of contributions from adjacent <i>sub-blocks</i> or <i>passband</i> on each side of the <i>inter-passband gap</i> .			
NOTE 3: The <i>basic limit</i> is not applicable when $\Delta f_{\text{max}} < 40 \text{ MHz}$.			

Table 6.5.3.2.3-2: Medium Range *repeater operating band* unwanted emission *basic limits*, $P_{\text{rated},x} \leq 31$ dBm

Frequency offset of measurement filter -3dB point, Δf	Frequency offset of measurement filter centre frequency, f_{offset}	<i>Basic limits</i> (Notes 1, 2)	<i>Measurement bandwidth</i>
$0 \text{ MHz} \leq \Delta f < 5 \text{ MHz}$	$0.05 \text{ MHz} \leq f_{\text{offset}} < 5.05 \text{ MHz}$	$-22\text{dBm} - \frac{7}{5} \left(\frac{f_{\text{offset}}}{\text{MHz}} - 0.05 \right) \text{dB}$	100 kHz
$5 \text{ MHz} \leq \Delta f < \min(10 \text{ MHz}, \Delta f_{\text{max}})$	$5.05 \text{ MHz} \leq f_{\text{offset}} < \min(10.05 \text{ MHz}, f_{\text{offset}_{\text{max}}})$	-29 dBm	100 kHz
$10 \text{ MHz} \leq \Delta f \leq \Delta f_{\text{max}}$	$10.05 \text{ MHz} \leq f_{\text{offset}} < f_{\text{offset}_{\text{max}}}$	-29 dBm (Note 3)	100 kHz
NOTE 1: For a <i>repeater</i> DL supporting <i>non-contiguous spectrum</i> operation within any <i>operating band</i> the emission basic limits within <i>gaps between passbands</i> is calculated as a cumulative sum of contributions from adjacent <i>sub-blocks</i> on each side of the <i>gap between passbands</i> . Exception is $\Delta f \geq 10\text{MHz}$ from both adjacent <i>sub-blocks</i> on each side of the <i>gap between passbands</i> , where the emission basic limits within <i>gaps between passbands</i> shall be $-29\text{dBm}/100\text{kHz}$.			
NOTE 2: For a <i>multi-band connector</i> with <i>inter-passband gap</i> $< 2 * \Delta f_{\text{OBUe}}$ the emission basic limits within the <i>inter-passband gaps</i> is calculated as a cumulative sum of contributions from adjacent <i>sub-blocks</i> or <i>passband</i> on each side of the <i>inter-passband gap</i> .			
NOTE 3: The <i>basic limit</i> is not applicable when $\Delta f_{\text{max}} < 10 \text{ MHz}$.			

Table 6.5.3.2.3-2a. Medium Range repeater operating band unwanted emission basic limits for band 104, $P_{\text{rated},x} \leq 31$ dBm

Frequency offset of measurement filter -3dB point, Δf	Frequency offset of measurement filter centre frequency, f_{offset}	basic limits (Notes 1, 2)	Measurement bandwidth
$0 \text{ MHz} \leq \Delta f < 20 \text{ MHz}$	$0.05 \text{ MHz} \leq f_{\text{offset}} < 20.05 \text{ MHz}$	$-22 \text{ dBm} - \frac{7}{20} \left(\frac{f_{\text{offset}}}{\text{MHz}} - 0.05 \right)$	100 kHz
$20 \text{ MHz} \leq \Delta f < \min(40 \text{ MHz}, \Delta f_{\text{max}})$	$20.05 \text{ MHz} \leq f_{\text{offset}} < \min(40.05 \text{ MHz}, f_{\text{offset}_{\text{max}}})$	-29 dBm	100 kHz
$40 \text{ MHz} \leq \Delta f \leq \Delta f_{\text{max}}$	$40.05 \text{ MHz} \leq f_{\text{offset}} < f_{\text{offset}_{\text{max}}}$	-29 dBm	100 kHz
<p>NOTE 1: For a repeater DL supporting <i>non-contiguous spectrum</i> operation within any <i>operating band</i> the emission basic limits within <i>gaps between passbands</i> is calculated as a cumulative sum of contributions from adjacent <i>sub-blocks</i> on each side of the <i>gap between passband</i>. Exception is $f \geq 40 \text{ MHz}$ from both adjacent <i>sub-blocks</i> on each side of the <i>gap between passband</i>, where the emission basic limits within <i>gaps between passbands</i> shall be -29dBm/100kHz.</p> <p>NOTE 2: For a <i>multi-band connector</i> with <i>inter-passband gap</i> $< 2 \cdot \Delta f_{\text{OBUe}}$ the emission basic limits within the <i>inter-passband gaps</i> is calculated as a cumulative sum of contributions from adjacent <i>sub-blocks</i> or <i>passband</i> on each side of the <i>inter-passband gap</i>.</p> <p>NOTE 3: The <i>basic limit</i> is not applicable when $\Delta f_{\text{max}} < 40 \text{ MHz}$.</p>			

6.5.3.2.4 Basic limits for Local Area repeater type 1-C (Category A and B)

For Local Area, *basic limits* are specified in table 6.5.3.2.4-1.

Table 6.5.3.2.4-1: Local Area repeater operating band unwanted emission basic limits

Frequency offset of measurement filter -3dB point, Δf	Frequency offset of measurement filter centre frequency, f_{offset}	Basic limits (Notes 1, 2)	Measurement bandwidth
$0 \text{ MHz} \leq \Delta f < 5 \text{ MHz}$	$0.05 \text{ MHz} \leq f_{\text{offset}} < 5.05 \text{ MHz}$	$-30 \text{ dBm} - \frac{7}{5} \left(\frac{f_{\text{offset}}}{\text{MHz}} - 0.05 \right) \text{ dB}$	100 kHz
$5 \text{ MHz} \leq \Delta f < \min(10 \text{ MHz}, \Delta f_{\text{max}})$	$5.05 \text{ MHz} \leq f_{\text{offset}} < \min(10.05 \text{ MHz}, f_{\text{offset}_{\text{max}}})$	-37 dBm	100 kHz
$10 \text{ MHz} \leq \Delta f \leq \Delta f_{\text{max}}$	$10.05 \text{ MHz} \leq f_{\text{offset}} < f_{\text{offset}_{\text{max}}}$	-37 dBm (Note 10)	100 kHz
<p>NOTE 1: For a repeater supporting <i>non-contiguous spectrum</i> operation within any <i>operating band</i> the emission basic limits within <i>gaps between passbands</i> is calculated as a cumulative sum of contributions from adjacent <i>sub-blocks</i> on each side of the <i>gap between passbands</i>. Exception is $f \geq 10 \text{ MHz}$ from both adjacent <i>sub-blocks</i> on each side of the <i>gap between passbands</i>, where the emission basic limits within <i>gaps between passbands</i> shall be -37dBm/100kHz.</p> <p>NOTE 2: For a <i>multi-band connector</i> with <i>inter-passband gap</i> $< 2 \cdot \Delta f_{\text{OBUe}}$ the emission basic limits within the <i>inter-passband gaps</i> is calculated as a cumulative sum of contributions from adjacent <i>sub-blocks</i> or <i>passband</i> on each side of the <i>inter-passband gap</i>.</p> <p>NOTE 3: The basic limit is not applicable when $\Delta f_{\text{max}} < 10 \text{ MHz}$.</p>			

For repeater operating in Band n104, *basic limits* are specified in Table 6.5.3.2.4-1a.

Table 6.5.3.2.4-1a. Local Area repeater operating band unwanted emission basic limits for band n104

Frequency offset of measurement filter -3dB point, Δf	Frequency offset of measurement filter centre frequency, f_{offset}	Basic limits (Notes 1, 2)	Measurement bandwidth
$0 \text{ MHz} \leq \Delta f < 20 \text{ MHz}$	$0.05 \text{ MHz} \leq f_{\text{offset}} < 20.05 \text{ MHz}$	$-30\text{dBm} - \frac{7}{20} \left(\frac{f_{\text{offset}}}{\text{MHz}} - 0.05 \right)$	100 kHz
$20 \text{ MHz} \leq \Delta f < \min(40 \text{ MHz}, \Delta f_{\text{max}})$	$20.05 \text{ MHz} \leq f_{\text{offset}} < \min(40.05 \text{ MHz}, f_{\text{offset}_{\text{max}}})$	-37 dBm	100 kHz
$40 \text{ MHz} \leq \Delta f \leq \Delta f_{\text{max}}$	$40.05 \text{ MHz} \leq f_{\text{offset}} < f_{\text{offset}_{\text{max}}}$	-37 dBm	100 kHz
<p>NOTE 1: For a repeater supporting <i>non-contiguous spectrum</i> operation within any <i>operating band</i> the emission basic limits within <i>sub-block gaps</i> is calculated as a cumulative sum of contributions from adjacent <i>sub-blocks</i> on each side of the <i>sub-block gap</i>. Exception is $\Delta f \geq 40\text{MHz}$ from both adjacent <i>sub-blocks</i> on each side of the <i>sub-block gap</i>, where the emission basic limits within <i>sub-block gaps</i> shall be -37dBm/100kHz.</p> <p>NOTE 2: For a <i>multi-band connector</i> with <i>Inter RF Bandwidth gap</i> $< 2 \cdot \Delta f_{\text{OBUe}}$ the emission basic limits within the <i>Inter RF Bandwidth gaps</i> is calculated as a cumulative sum of contributions from adjacent <i>sub-blocks</i> or RF Bandwidth on each side of the <i>Inter RF Bandwidth gap</i></p> <p>NOTE 3: The basic limit is not applicable when $\Delta f_{\text{max}} < 40 \text{ MHz}$.</p>			

6.5.3.2.5 Additional basic limits

6.5.3.2.5.1 Limits in FCC Title 47

In addition to the basic limits in clauses 6.5.3.2.1, 6.5.3.2.2, 6.5.3.2.3 and 6.5.3.2.4, the *repeater type I-C* may have to comply with the applicable emission basic limits established by FCC Title 47 [10], when deployed in regions where those limits are applied, and under the conditions declared by the manufacturer.

6.5.3.2.5.2 Protection of DTT

In certain regions the following basic limit may apply for protection of DTT. For *repeater type I-C* operating in Band n20, the level of emissions in the band 470-790 MHz, measured in an 8 MHz filter bandwidth on centre frequencies F_{filter} according to table 6.5.3.2.5.2-1, a basic limit $P_{\text{EM,N}}$ is declared by the manufacturer. This basic limit applies in the frequency range 470-790 MHz even though part of the range falls in the spurious domain.

Table 6.5.3.2.5.2-1: Declared emissions basic limit for protection of DTT

Filter centre frequency, F_{filter}	Measurement bandwidth	Declared emission basic limit (dBm)
$F_{\text{filter}} = 8 \cdot N + 306 \text{ (MHz)}$; $21 \leq N \leq 60$	8 MHz	$P_{\text{EM,N}}$

Note: The regional requirement is defined in terms of EIRP (effective isotropic radiated power), which is dependent on both the repeater emissions at the *antenna connector* and the deployment (including antenna gain and feeder loss). The requirement defined above provides the characteristics of the repeater needed to verify compliance with the regional requirement. Compliance with the regional requirement can be determined using the method outlined in TS 36.104 [20], annex F.

6.5.3.2.6 Basic limit inside passband with no UL input signal

The requirement is defined as a function of frequency offset from the edge of some part of passband with non-zero input signal. The requirement is measured as the ratio of the repeater output power in a zero-input basic unit to the repeater output power in a non-zero input basic unit. Basic unit equal to 360KHz.

The average of the basic limits over 10 sub-frames shall not exceed the values specified in Table 6.5.3.2.6-1.

Table 6.5.3.2.6-1: Basic limits inside passband with no UL input signal

Parameter description	Unit	Basic Limit (NOTE 1)		Applicable Frequencies
General	dB	$\max\{-25 - 10 \cdot \log_{10}(N_{RB}/L_{CRB}), 20 \cdot \log_{10} EVM - 3 - 5 \cdot (\Delta_{RB} - 1)/L_{CRB}, -57\text{dBm} + 10 \log_{10}(SCS/15\text{kHz}) - \overline{P_{RB}}\}$		Any zero-input basic unit (NOTE 2)
IQ Image	dB	-28	Image frequencies when output power > 10 dBm	Image frequencies (NOTES 2, 3)
		-25	Image frequencies when output power ≤ 10 dBm	
Carrier leakage	dBc	-28	Output power > 10 dBm	Carrier leakage frequency (NOTES 4, 5)
		-25	0 dBm ≤ Output power ≤ 10 dBm	
		-20	-30 dBm ≤ Output power < 0 dBm	
		-10	-40 dBm ≤ Output power < -30 dBm	
<p>NOTE 1: requirement is evaluated in each zero-input basic unit. For each such basic unit, the minimum requirement is calculated as the higher of $\overline{P_{RB}} - 30$ dB and the power sum of all limit values (General, IQ Image or Carrier leakage) that apply. $\overline{P_{RB}}$ is defined in NOTE 10.</p> <p>NOTE 2: The measurement bandwidth is one basic unit and the limit is expressed as a ratio of measured power in one zero-input basic unit to the measured average power per non-zero input basic unit, where the averaging is done across all non-zero input parts of the passband.</p> <p>NOTE 3: The applicable frequencies for this limit are those that are enclosed in the reflection of the non-zero input part of passband, based on symmetry with respect to the carrier leakage frequency, but excluding any non-zero input basic units.</p> <p>NOTE 4: The measurement bandwidth is 1 basic unit and the limit is expressed as a ratio of measured power in one zero-input basic unit to the measured total power in all non-zero input basic units</p> <p>NOTE 5: The applicable frequencies are those that are enclosed either in the basic unit containing the carrier leakage frequency, or in the two basic units immediately adjacent to the carrier leakage frequency but excluding any non-zero input basic units.</p> <p>NOTE 6: L_{CRB} is the $\text{floor}\left(\frac{BW_{\text{passband}}}{\text{basic unit}}\right)$.</p> <p>NOTE 7: N_{RB} is the $\text{floor}\left(\frac{\text{bandwidth of non-zero input signal}}{\text{basic unit}}\right)$.</p> <p>NOTE 8: EVM is the limit specified in Table 6.6.2.2-1 for the modulation format used in the non-zero input basic units..</p> <p>NOTE 9: Δ_{RB} is the starting frequency offset between the end of nearest non-zero input basic unit and the measured zero-input basic unit (e.g. $\Delta_{RB} = 1$ or $\Delta_{RB} = -1$ for the first zero-input basic unit outside of the non-zero input part of passband).</p> <p>NOTE 10: $\overline{P_{RB}}$ is an average of the transmitted power over 10 sub-frames normalized by the number of non-zero input basic units, measured in dBm.</p>				

6.5.3.3 Minimum requirement for NCR

6.5.3.3.1 Minimum requirement for NCR-Fwd

6.5.3.3.1.1 Minimum requirement for NCR-Fwd type 1-C

The operating band unwanted emissions for *NCR-Fwd type 1-C* for each *antenna connector* shall be below the applicable *basic limits* defined in clause 6.5.3.2.

For Band n41 and n90 operation in Japan, the operating band unwanted emissions limits shall be applied to the sum of the emission power over all *antenna connectors* for *NCR-Fwd type 1-C*.

For joint transmission of NCR-Fwd and NCR-MT in the uplink, the operating band unwanted emissions limits shall apply to the total emissions from both the NCR-Fwd and NCR-MT.

6.5.3.3.1.2 Minimum requirement for NCR-Fwd type 1-H

The operating band unwanted emissions requirements for *NCR-Fwd type 1-H* are that for each *TAB connector TX min cell group* and each applicable *basic limit* in clause 6.5.3.2, the power summation emissions at the *TAB connectors* of

the *TAB connector TX min cell group* shall not exceed a limit specified as the *basic limit + X*, where $X = 10\log_{10}(N_{\text{TXU,countedpercell}})$ for DL and for UL WA and $X=0$ for UL LA.

For joint transmission of NCR-Fwd and NCR-MT in the uplink, the operating band unwanted emissions limits shall apply to the total emissions from both the NCR-Fwd and NCR-MT.

NOTE: Conformance to the NCR-Fwd type 1-H spurious emission requirement can be demonstrated by meeting at least one of the following criteria as determined by the manufacturer:

1) The sum of the emissions power measured on each *TAB connector* in the *TAB connector TX min cell group* shall be less than or equal to the limit as defined in this clause for the respective frequency span.

Or

2) The unwanted emissions power at each *TAB connector* shall be less than or equal to the *NCR-Fwd type 1-H* limit as defined in this clause for the respective frequency span, scaled by $-10\log_{10}(n)$, where n is the number of *TAB connectors* in the *TAB connector TX min cell group*.

6.5.3.3.2 Minimum requirement for NCR-MT

6.5.3.3.2.1 Minimum requirements for NCR-MT type 1-C

For LA NCR-MT type 1-C, regardless of simultaneous transmission with NCR- Fwd is transmitting, the UE spectrum emission mask requirements specified in clause 6.5.2 in TS 38.101-1 applies .

For WA NCR-MT type 1-C, regardless of simultaneous transmission between NCR-MT and NCR-Fwd, the BS requirements specified in clause 6.6.4 in TS 38.104 apply.

For simultaneous transmission the limits apply for sum of NCR-MT transmission and NCR-Fwd transmission.

6.5.3.3.2.2 Minimum requirements for NCR-MT type 1-H

Limits for NCR-MT type 1-H apply to the sum of emissions across all TAB connectors.

For LA NCR-MT type 1-H, regardless of simultaneous transmission with NCR- Fwd is transmitting, the UE spectrum emission mask requirements specified in clause 6.5.2 in TS 38.101-1 applies without scaling factor allowed.

For WA NCR-MT type 1-H, the repeater basic requirements specified in clause 6.6.4 in TS 38.104 relaxed with following scaling factor apply.

$$10\log(N_{\text{TXU,counted}}), \text{ where } N_{\text{TXU,counted}} = \min(N_{\text{TXU,active}}, 8)$$

For simultaneous transmission the limits apply for sum of NCR-MT transmission and NCR-Fwd transmission.

6.5.4 Transmitter spurious emissions

6.5.4.1 General

The transmitter spurious emission limits shall apply from 9 kHz to 12.75 GHz, excluding

- the frequency range from Δf_{OBUE} below the lowest frequency of each supported downlink *operating band*, up to Δf_{OBUE} above the highest frequency of each supported downlink *operating band*, where the Δf_{OBUE} is defined in table 6.5.1-1 for downlink, or
- the frequency range from Δf_{OBUE} below the lowest frequency of each supported uplink *operating band*, up to Δf_{OBUE} above the highest frequency of each supported uplink *operating band*, where the Δf_{OBUE} is defined in table 6.5.1-2 for uplink

For some *operating bands*, the upper limit is higher than 12.75 GHz in order to comply with the 5th harmonic limit of the downlink *operating band*, as specified in ITU-R recommendation SM.329 [5].

For a *multi-band connector*, for each supported *operating band* together with Δf_{OBUE} around the band is excluded from the transmitter spurious emissions requirement.

The requirements shall apply whatever the type of transmitter considered (single carrier or multi-carrier). It applies for all transmission modes foreseen by the manufacturer's specification.

Unless otherwise stated, all requirements are measured as mean power (RMS).

For Band n41 and n90 operation in Japan, the sum of the spurious emissions over all *antenna connectors* for *Repeater type 1-C* shall not exceed the *minimum requirements* defined in clause 6.5.5.2.

6.5.4.2 Basic limits

6.5.4.2.1 General transmitter spurious emissions basic limits

The *basic limits* of either table 6.5.4.2.1-1, table 6.5.4.2.1-2 (Category A limits) or table 6.5.4.2.1-3 (Category B limits) shall apply. The application of either Category A or Category B limits shall be the same as for operating band unwanted emissions in clause 6.5.3.

Table 6.5.4.2.1-1: General transmitter spurious emission *basic limits* for DL in FR1, Category A

Spurious frequency range	Basic limit	Measurement bandwidth	Notes
9 kHz – 150 kHz	-13 dBm	1 kHz	Note 1
150 kHz – 30 MHz		10 kHz	Note 1
30 MHz – 1 GHz		100 kHz	Note 1
1 GHz – 12.75 GHz		1 MHz	Note 1, Note 2
12.75 GHz – 5 th harmonic of the upper frequency edge of the DL <i>operating band</i> in GHz		1 MHz	Note 1, Note 2, Note 3
NOTE 1: <i>Measurement bandwidths</i> as in ITU-R SM.329 [5], s4.1.			
NOTE 2: Upper frequency as in ITU-R SM.329 [5], s2.5 table 1.			
NOTE 3: For DL, this spurious frequency range applies only for <i>operating bands</i> for which the 5 th harmonic of the upper frequency edge of the DL <i>operating band</i> is reaching beyond 12.75 GHz.			

Table 6.5.4.2.1-2: General transmitter spurious emission *basic limits* for UL in FR1, Category A

Spurious frequency range	Basic limits	Measurement bandwidth	Notes
9 kHz – 150 kHz	-36 dBm	1 kHz	Note 1
150 kHz – 30 MHz		10 kHz	Note 1
30 MHz – 1 GHz		100 kHz	Note 1
1 GHz – 12.75 GHz	-30 dBm	1 MHz	Note 1, Note 2
12.75 GHz – 5 th harmonic of the upper frequency edge of the UL <i>operating band</i> in GHz		1 MHz	Note 1, Note 2, Note 3
NOTE 1: <i>Measurement bandwidths</i> as in ITU-R SM.329 [5], s4.1.			
NOTE 2: Upper frequency as in ITU-R SM.329 [5], s2.5 table 1.			
NOTE 3: For UL, this spurious frequency range applies only for <i>operating bands</i> for which the 5 th harmonic of the upper frequency edge of the UL <i>operating band</i> is reaching beyond 12.75 GHz.			

Table 6.5.4.2.1-3: General transmitter spurious emission *basic limits* in FR1, Category B

Spurious frequency range	<i>basic limits</i>	<i>Measurement bandwidth</i>	Notes
9 kHz – 150 kHz	-36 dBm	1 kHz	Note 1
150 kHz – 30 MHz		10 kHz	Note 1
30 MHz – 1 GHz		100 kHz	Note 1
1 GHz – 12.75 GHz	-30 dBm	1 MHz	Note 1, Note 2
12.75 GHz – 5 th harmonic of the upper frequency edge of the <i>operating band</i> in GHz		1 MHz	Note 1, Note 2, Note 3
NOTE 1: <i>Measurement bandwidths</i> as in ITU-R SM.329 [5], s4.1. NOTE 2: Upper frequency as in ITU-R SM.329 [5], s2.5 table 1. NOTE 3: For DL, this spurious frequency range applies only for <i>operating bands</i> for which the 5 th harmonic of the upper frequency edge of the DL <i>operating band</i> is reaching beyond 12.75 GHz. For UL, this spurious frequency range applies only for <i>operating bands</i> for which the 5 th harmonic of the upper frequency edge of the UL <i>operating band</i> is reaching beyond 12.75 GHz.			

6.5.4.2.2 Additional spurious emissions basic limits

These *basic limits* may be applied for the protection of system operating in other frequency ranges. The limits may apply as an optional protection of such systems that are deployed in the same geographical area as the repeater-Node, or they may be set by local or regional regulation as a mandatory requirement for an NR *operating band*. It is in some cases not stated in the present document whether a requirement is mandatory or under what exact circumstances that a limit applies, since this is set by local or regional regulation. An overview of regional requirements in the present document is given in clause 4.5.

Some requirements may apply for the protection of specific equipment (UE, MS and/or BS) or equipment operating in specific systems (GSM, CDMA, UTRA, E-UTRA, NR, etc.) as listed below.

The spurious emission *basic limits* are provided in table 6.5.4.2.2-1 where requirements for co-existence with the system listed in the first column apply for *repeater type 1-C*. For a *multi-band connector*, the exclusions and conditions in the Note column of table 6.5.4.2.2-1 apply for each supported *operating band*.

Table 6.5.4.2.2-1: Repeater type 1-C spurious emissions basic limits for co-existence with systems operating in other frequency bands

System type to co-exist with	Frequency range for co-existence requirement	basic limits	Measurement bandwidth	Note
GSM900	921 – 960 MHz	-57 dBm	100 kHz	This basic limit does not apply to repeater operating in band n8
	876 – 915 MHz	-61 dBm	100 kHz	For the frequency range 880-915 MHz, this basic limit does not apply to repeater operating in band n8, since it is already covered by the basic limit in clause 6.5.5.2.2.
DCS1800	1805 – 1880 MHz	-47 dBm	100 kHz	This basic limit does not apply to repeater operating in band n3.
	1710 – 1785 MHz	-61 dBm	100 kHz	This basic limit does not apply to repeater operating in band n3, since it is already covered by the basic limit in clause 6.5.5.2.2.
PCS1900	1930 – 1990 MHz	-47 dBm	100 kHz	This basic limit does not apply to repeater operating in band n2, n25 or band n70.
	1850 – 1910 MHz	-61 dBm	100 kHz	This basic limit does not apply to repeater operating in band n2 or n25 since it is already covered by the basic limit in clause 6.6.5.2.2.
GSM850 or CDMA850	869 – 894 MHz	-57 dBm	100 kHz	This basic limit does not apply to repeater operating in band n5 or n26.
	824 – 849 MHz	-61 dBm	100 kHz	This basic limit does not apply to repeater operating in band n5 or n26, since it is already covered by the basic limit in clause 6.6.5.2.2.
UTRA FDD Band I or E-UTRA Band 1 or NR Band n1	2110 – 2170 MHz	-52 dBm	1 MHz	This basic limit does not apply to repeater operating in band n1 or n65
	1920 – 1980 MHz	-49 dBm	1 MHz	This basic limit does not apply to repeater operating in band n1 or n65, since it is already covered by the basic limit in clause 6.6.5.2.2.
UTRA FDD Band II or E-UTRA Band 2 or NR Band n2	1930 – 1990 MHz	-52 dBm	1 MHz	This basic limit does not apply to repeater operating in band n2 or n70.
	1850 – 1910 MHz	-49 dBm	1 MHz	This basic limit does not apply to repeater operating in band n2, since it is already covered by the basic limit in clause 6.6.5.2.2.
UTRA FDD Band III or E-UTRA Band 3 or NR Band n3	1805 – 1880 MHz	-52 dBm	1 MHz	This basic limit does not apply to repeater operating in band n3.
	1710 – 1785 MHz	-49 dBm	1 MHz	This basic limit does not apply to repeater operating in band n3, since it is already covered by the basic limit in clause 6.6.5.2.2.
UTRA FDD Band IV or E-UTRA Band 4	2110 – 2155 MHz	-52 dBm	1 MHz	This basic limit does not apply to repeater operating in band n66
	1710 – 1755 MHz	-49 dBm	1 MHz	This basic limit does not apply to repeater operating in band n66, since it is already covered by the basic limit in clause 6.6.5.2.2.
UTRA FDD Band V or E-UTRA Band 5 or NR Band n5	869 – 894 MHz	-52 dBm	1 MHz	This basic limit does not apply to repeater operating in band n5 or n26.
	824 – 849 MHz	-49 dBm	1 MHz	This basic limit does not apply to repeater operating in band n5 or n26, since it is already covered by the basic limit in clause 6.6.5.2.2.
UTRA FDD Band VI, XIX or E-UTRA Band 6, 18, 19 or NR Band n18	860 – 890 MHz	-52 dBm	1 MHz	This basic limit does not apply to repeater operating in band n18.
	815 – 830 MHz	-49 dBm	1 MHz	This basic limit does not apply to repeater operating in band n18, since it is already covered by the basic limit in clause 6.6.5.2.2.
	830 – 845 MHz	-49 dBm	1 MHz	

UTRA FDD Band VII or E-UTRA Band 7 or NR Band n7	2620 – 2690 MHz	-52 dBm	1 MHz	This basic limit does not apply to repeater operating in band n7.
	2500 – 2570 MHz	-49 dBm	1 MHz	This basic limit does not apply to repeater operating in band n7, since it is already covered by the basic limit in clause 6.6.5.2.2.
UTRA FDD Band VIII or E-UTRA Band 8 or NR Band n8	925 – 960 MHz	-52 dBm	1 MHz	This basic limit does not apply to repeater operating in band n8.
	880 – 915 MHz	-49 dBm	1 MHz	This basic limit does not apply to repeater operating in band n8, since it is already covered by the basic limit in clause 6.6.5.2.2.
UTRA FDD Band IX or E-UTRA Band 9	1844.9 – 1879.9 MHz	-52 dBm	1 MHz	This basic limit does not apply to repeater operating in band n3.
	1749.9 – 1784.9 MHz	-49 dBm	1 MHz	This basic limit does not apply to repeater operating in band n3, since it is already covered by the basic limit in clause 6.6.5.2.2.
UTRA FDD Band X or E-UTRA Band 10	2110 – 2170 MHz	-52 dBm	1 MHz	This basic limit does not apply to repeater operating in band n66
	1710 – 1770 MHz	-49 dBm	1 MHz	This basic limit does not apply to repeater operating in band n66, since it is already covered by the basic limit in clause 6.6.5.2.2.
UTRA FDD Band XI or XXI or E-UTRA Band 11 or 21	1475.9 – 1510.9 MHz	-52 dBm	1 MHz	This basic limit does not apply to repeater operating in band n50, n74, n75, n92, n94 or n109.
	1427.9 – 1447.9 MHz	-49 dBm	1 MHz	This basic limit does not apply to repeater operating in band n50, n51, n74, n75, n76, n91, n92, n93, n94 or n109.
	1447.9 – 1462.9 MHz	-49 dBm	1 MHz	This basic limit does not apply to repeater operating in band n50, n74, n75, n92, n94 or n109.
UTRA FDD Band XII or E-UTRA Band 12 or NR Band n12	729 – 746 MHz	-52 dBm	1 MHz	This basic limit does not apply to repeater operating in band n12 or n85.
	699 – 716 MHz	-49 dBm	1 MHz	This basic limit does not apply to repeater operating in band n12 or n85, since it is already covered by the basic limit in clause 6.6.5.2.2. For repeater operating in n29, it applies 1 MHz below the Band n29 downlink operating band (Note 5).
UTRA FDD Band XIII or E-UTRA Band 13	746 – 756 MHz	-52 dBm	1 MHz	This basic limit does not apply to repeater operating in band n13.
	777 – 787 MHz	-49 dBm	1 MHz	This basic limit does not apply to repeater operating in band n13, since it is already covered by the basic limit in clause 6.6.5.2.2.
UTRA FDD Band XIV or E-UTRA Band 14 or NR band n14	758 – 768 MHz	-52 dBm	1 MHz	This basic limit does not apply to repeater operating in band n14.
	788 – 798 MHz	-49 dBm	1 MHz	This basic limit does not apply to repeater operating in band n14, since it is already covered by the basic limit in clause 6.6.5.2.2.
E-UTRA Band 17	734 – 746 MHz	-52 dBm	1 MHz	

	704 – 716 MHz	-49 dBm	1 MHz	For repeater operating in n29, it applies 1 MHz below the Band n29 downlink operating band (Note 5).
UTRA FDD Band XX or E-UTRA Band 20 or NR Band n20	791 – 821 MHz	-52 dBm	1 MHz	This basic limit does not apply to repeater operating in band n20 or n28.
	832 – 862 MHz	-49 dBm	1 MHz	This basic limit does not apply to repeater operating in band n20, since it is already covered by the basic limit in clause 6.6.5.2.2.
UTRA FDD Band XXII or E-UTRA Band 22	3510 – 3590 MHz	-52 dBm	1 MHz	This basic limit does not apply to repeater operating in band n48, n77 or n78.
	3410 – 3490 MHz	-49 dBm	1 MHz	This basic limit does not apply to repeater operating in band n77 or n78.
E-UTRA Band 24	1525 – 1559 MHz	-52 dBm	1 MHz	This basic limit does not apply to repeater operating in band n24.
	1626.5 – 1660.5 MHz	-49 dBm	1 MHz	This basic limit does not apply to repeater operating in band n24, since it is already covered by the basic limit in clause 6.6.5.2.2.
UTRA FDD Band XXV or E-UTRA Band 25 or NR band n25	1930 – 1995 MHz	-52 dBm	1 MHz	This basic limit does not apply to repeater operating in band n2, n25 or n70.
	1850 – 1915 MHz	-49 dBm	1 MHz	This basic limit does not apply to repeater operating in band n25 since it is already covered by the basic limit in clause 6.6.5.2.2. For repeater operating in Band n2, it applies for 1910 MHz to 1915 MHz, while the rest is covered in clause 6.6.5.2.2.
UTRA FDD Band XXVI or E-UTRA Band 26 or NR Band n26	859 – 894 MHz	-52 dBm	1 MHz	This basic limit does not apply to repeater operating in band n5 or n26.
	814 – 849 MHz	-49 dBm	1 MHz	This basic limit does not apply to repeater operating in band n26 since it is already covered by the basic limit in clause 6.6.5.2.2. For repeater operating in Band n5, it applies for 814 MHz to 824 MHz, while the rest is covered in clause 6.6.5.2.2.
E-UTRA Band 27	852 – 869 MHz	-52 dBm	1 MHz	This basic limit does not apply to repeater operating in Band n5.
	807 – 824 MHz	-49 dBm	1 MHz	This basic limit also applies to repeater operating in Band n28, starting 4 MHz above the Band n28 downlink operating band (Note 4).
E-UTRA Band 28 or NR Band n28	758 – 803 MHz	-52 dBm	1 MHz	This basic limit does not apply to repeater operating in band n20, n67, n68 or n28.
	703 – 748 MHz	-49 dBm	1 MHz	This basic limit does not apply to repeater operating in band n28, since it is already covered by the basic limit in clause 6.6.5.2.2. For repeater operating in band n67, it applies for 703 MHz to 736 MHz. For repeater operating in Band n68, it applies for 728 MHz to 733 MHz.
E-UTRA Band 29 or NR Band n29	717 – 728 MHz	-52 dBm	1 MHz	This basic limit does not apply to repeater operating in Band n29 or n85
E-UTRA Band 30 or NR Band n30	2350 – 2360 MHz	-52 dBm	1 MHz	This basic limit does not apply to repeater operating in band n30
	2305 – 2315 MHz	-49 dBm	1 MHz	This basic limit does not apply to repeater operating in band n30, since it is already covered by the basic limit in clause 6.6.5.2.2.
E-UTRA Band 31 or NR Band n31	462.5 – 467.5 MHz	-52 dBm	1 MHz	This basic limit does not apply to repeater operating in band n31 or n72.

	452.5 – 457.5 MHz	-49 dBm	1 MHz	This basic limit does not apply to repeater operating in band n31, since it is already covered by the basic limit in clause 6.6.5.2.2. This basic limit does not apply to repeater operating in band n72.
UTRA FDD band XXXII or E-UTRA band 32	1452 – 1496 MHz	-52 dBm	1 MHz	This basic limit does not apply to repeater operating in band n50, n74, n75, n92, n94 or n109.
UTRA TDD Band a) or E-UTRA Band 33	1900 – 1920 MHz	-52 dBm	1 MHz	
UTRA TDD Band a) or E-UTRA Band 34 or NR band n34	2010 – 2025 MHz	-52 dBm	1 MHz	This basic limit does not apply to repeater operating in Band n34.
UTRA TDD Band b) or E-UTRA Band 35	1850 – 1910 MHz	-52 dBm	1 MHz	
UTRA TDD Band b) or E-UTRA Band 36	1930 – 1990 MHz	-52 dBm	1 MHz	This basic limit does not apply to repeater operating in Band n2 or n25.
UTRA TDD Band c) or E-UTRA Band 37	1910 – 1930 MHz	-52 dBm	1 MHz	
UTRA TDD Band d) or E-UTRA Band 38 or NR Band n38	2570 – 2620 MHz	-52 dBm	1 MHz	This basic limit does not apply to repeater operating in Band n38.
UTRA TDD Band f) or E-UTRA Band 39 or NR band n39	1880 – 1920MHz	-52 dBm	1 MHz	This basic limit does not apply to repeater operating in Band n39.
UTRA TDD Band e) or E-UTRA Band 40 or NR Band n40	2300 – 2400MHz	-52 dBm	1 MHz	This basic limit does not apply to repeater operating in Band n30 or n40.
E-UTRA Band 41 or NR Band n41, n90	2496 – 2690 MHz	-52 dBm	1 MHz	This is not applicable to repeater operating in Band n41, n53 or [n90].
E-UTRA Band 42	3400 – 3600 MHz	-52 dBm	1 MHz	This is not applicable to repeater operating in Band n48, n77 or n78.
E-UTRA Band 43	3600 – 3800 MHz	-52 dBm	1 MHz	This is not applicable to repeater operating in Band n48, n77 or n78.
E-UTRA Band 44	703 – 803 MHz	-52 dBm	1 MHz	This is not applicable to repeater operating in Band n28.
E-UTRA Band 45	1447 – 1467 MHz	-52 dBm	1 MHz	
E-UTRA Band 46	5150 – 5925 MHz	-52 dBm	1 MHz	
E-UTRA Band 47	5855 – 5925 MHz	-52 dBm	1 MHz	
E-UTRA Band 48 or NR Band n48	3550 – 3700 MHz	-52 dBm	1 MHz	This is not applicable to repeater operating in Band n48, n77 or n78.
E-UTRA Band 50 or NR band n50	1432 – 1517 MHz	-52 dBm	1 MHz	This basic limit does not apply to repeater operating in Band n50, n51, n74, n75, n76, n91, n92, n93, n94, n109 or n110.
E-UTRA Band 51 or NR Band n51	1427 – 1432 MHz	-52 dBm	1 MHz	This basic limit does not apply to repeater operating in Band n50, n51, n75, n76, n91, n92, n93, n94, n109, or n110.
E-UTRA Band 53 or NR Band n53	2483.5 - 2495 MHz	-52 dBm	1 MHz	This basic limit does not apply to repeater operating in Band n41, n53 or n90.

E-UTRA Band 54 or NR Band n54	1670 – 1675 MHz	-52 dBm	1 MHz	This basic limit does not apply to repeater operating in Band n54
E-UTRA Band 65 or NR Band n65	2110 – 2200 MHz	-52 dBm	1 MHz	This basic limit does not apply to repeater operating in band n1 or n65.
	1920 – 2010 MHz	-49 dBm	1 MHz	For repeater operating in Band n1, it applies for 1980 MHz to 2010 MHz, while the rest is covered in clause 6.6.5.2.2. This basic limit does not apply to repeater operating in band n65, since it is already covered by the basic limit in clause 6.6.5.2.2.
E-UTRA Band 66 or NR Band n66	2110 – 2200 MHz	-52 dBm	1 MHz	This basic limit does not apply to repeater operating in band n66.
	1710 – 1780 MHz	-49 dBm	1 MHz	This basic limit does not apply to repeater operating in band n66, since it is already covered by the basic limit in clause 6.6.5.2.2.
E-UTRA Band 67	738 – 758 MHz	-52 dBm	1 MHz	This basic limit does not apply to repeater operating in Band n28 or n67.
E-UTRA Band 68 or NR Band n68	753 -783 MHz	-52 dBm	1 MHz	This basic limit does not apply to repeater operating in band n28 or n68.
	698-728 MHz	-49 dBm	1 MHz	This basic limit does not apply to repeater operating in band n68, since it is already covered by the basic limit in clause 6.6.5.2.2. For repeater operating in Band n28, this basic limit applies between 698 MHz and 703 MHz, while the rest is covered in clause 6.6.5.2.2.
E-UTRA Band 69	2570 – 2620 MHz	-52 dBm	1 MHz	This basic limit does not apply to repeater operating in Band n38.
E-UTRA Band 70 or NR Band n70	1995 – 2020 MHz	-52 dBm	1 MHz	This basic limit does not apply to repeater operating in band n2, n25 or n70
	1695 – 1710 MHz	-49 dBm	1 MHz	This basic limit does not apply to repeater operating in band n70, since it is already covered by the basic limit in clause 6.6.5.2.2.
E-UTRA Band 71 or NR Band n71	617 – 652 MHz	-52 dBm	1 MHz	This basic limit does not apply to repeater operating in band n71 or n105
	663 – 698 MHz	-49 dBm	1 MHz	This basic limit does not apply to repeater operating in band n71 or n105, since it is already covered by the basic limit in clause 6.6.5.2.2.
E-UTRA Band 72 or NR Band n72	461 – 466 MHz	-52 dBm	1 MHz	This basic limit does not apply to repeater operating in band n31 or n72.
	451 – 456 MHz	-49 dBm	1 MHz	This basic limit does not apply to repeater operating in band n72, since it is already covered by the basic limit in clause 6.6.5.2.2. This basic limit does not apply to repeater operating in band n31.
E-UTRA Band 74 or NR Band n74	1475 – 1518 MHz	-52 dBm	1 MHz	This basic limit does not apply to repeater operating in band n50, n74, n75, n92, n94 or n109.
	1427 – 1470 MHz	-49 dBm	1MHz	This basic limit does not apply to repeater operating in band n50, n51, n74, n75, n76, n91, n92, n93, n94 or n109.
E-UTRA Band 75 or NR Band n75	1432 – 1517 MHz	-52 dBm	1 MHz	This basic limit does not apply to repeater operating in Band n50, n51, n74, n75, n76, n91, n92, n93, n94, n109 or n110.
E-UTRA Band 76 or NR Band n76	1427 – 1432 MHz	-52 dBm	1 MHz	This basic limit does not apply to repeater operating in Band n50, n51, n75, n76, n91, n92, n93, n94, n109 or n110.
NR Band n77	3.3 – 4.2 GHz	-52 dBm	1 MHz	This basic limit does not apply to repeater operating in Band n48, n77 or n78
NR Band n78	3.3 – 3.8 GHz	-52 dBm	1 MHz	This basic limit does not apply to repeater operating in Band n48, n77 or n78
NR Band n79	4.4 – 5.0 GHz	-52 dBm	1 MHz	This basic limit does not apply to repeater operating in Band n79

NR Band n80	1710 – 1785 MHz	-49 dBm	1 MHz	This basic limit does not apply to repeater operating in band n3, since it is already covered by the basic limit in clause 6.6.5.2.2.
NR Band n81	880 – 915 MHz	-49 dBm	1 MHz	This basic limit does not apply to repeater operating in band n8, since it is already covered by the basic limit in clause 6.6.5.2.2.
NR Band n82	832 – 862 MHz	-49 dBm	1 MHz	This basic limit does not apply to repeater operating in band n20, since it is already covered by the basic limit in clause 6.6.5.2.2.
NR Band n83	703 – 748 MHz	-49 dBm	1 MHz	This basic limit does not apply to repeater operating in band n28, since it is already covered by the basic limit in clause 6.6.5.2.2. For repeater operating in Band n67, it applies for 703 MHz to 736 MHz. For repeater operating in Band n68, it applies for 728 MHz to 733 MHz.
NR Band n84	1920 – 1980 MHz	-49 dBm	1 MHz	This basic limit does not apply to repeater operating in band n1, since it is already covered by the basic limit in clause 6.6.5.2.2.
E-UTRA Band 85 and NR Band n85	728 – 746 MHz	-52 dBm	1 MHz	This basic limit does not apply to repeater operating in band n12, n29 or n85.
	698 – 716 MHz	-49 dBm	1 MHz	This basic limit does not apply to repeater operating in band n12 or n85, since it is already covered by the basic limit in clause 6.6.5.2.2. For NR repeater operating in n29, it applies 1 MHz below the Band n29 downlink operating band (Note 5).
NR Band n86	1710 – 1780 MHz	-49 dBm	1 MHz	This basic limit does not apply to repeater operating in band n66, since it is already covered by the basic limit in clause 6.6.5.2.2.
E-UTRA Band 87 or NR Band n87	420 - 425 MHz	-52 dBm	1 MHz	This basic limit does not apply to repeater operating in band n87 or n88.
	410 - 415 MHz	-49 dBm	1 MHz	This basic limit does not apply to repeater operating in band n87, since it is already covered by the basic limit in clause 6.6.5.2.2.
E-UTRA Band 88 or NR Band n88	422 - 427 MHz	-52 dBm	1 MHz	This basic limit does not apply to repeater operating in band n87 or n88.
	412 - 417 MHz	-49 dBm	1 MHz	This basic limit does not apply to repeater operating in band n88, since it is already covered by the basic limit in clause 6.6.5.2.2. This basic limit does not apply to repeater operating in band n87.
NR Band n89	824 – 849 MHz	-49 dBm	1 MHz	This basic limit does not apply to repeater operating in band n5, since it is already covered by the basic limit in clause 6.6.5.2.2.
NR Band n91	1427 – 1432 MHz	-52 dBm	1 MHz	This basic limit does not apply to repeater operating in Band n50, n51, n75, n76, n109 or n110.
	832 – 862 MHz	-49 dBm	1 MHz	This basic limit does not apply to repeater operating in band n20, since it is already covered by the basic limit in clause 6.6.5.1.2.
NR Band n92	1432 – 1517 MHz	-52 dBm	1 MHz	This basic limit does not apply to repeater operating in Band n50, n51, n74, n75, n76, n109 or n110.
	832 – 862 MHz	-49 dBm	1 MHz	This basic limit does not apply to repeater operating in band n20, since it is already covered by the basic limit in clause 6.6.5.1.2.
NR Band n93	1427 – 1432 MHz	-52 dBm	1 MHz	This basic limit does not apply to repeater operating in Band n50, n51, n75, n76, n109 or n110.
	880 – 915 MHz	-49 dBm	1 MHz	This basic limit does not apply to repeater operating in band n8, since it is already covered by the basic limit in clause 6.6.5.1.2.
NR Band n94	1432 – 1517 MHz	-52 dBm	1 MHz	This basic limit does not apply to repeater operating in Band n50, n51, n74, n75, n76, n109 or n110.
	880 – 915 MHz	-49 dBm	1 MHz	This basic limit does not apply to repeater operating in band n8, since it is already covered by the basic limit in clause 6.6.5.1.2.
NR Band n95	2010 – 2025 MHz	-52 dBm	1 MHz	
NR Band n96	5925 – 7125 MHz	-52 dBm	1 MHz	

NR Band n97	2300 – 2400MHz	-52 dBm	1 MHz	
NR Band n98	1880 – 1920MHz	-52 dBm	1 MHz	
NR Band n99	1626.5 – 1660.5 MHz	-49 dBm	1 MHz	This basic limit does not apply to repeater operating in band n24, since it is already covered by the basic limit in clause 6.5.5.2.2.
NR band n101	1900 – 1910 MHz	-52 dBm	1 MHz	This basic limit does not apply to repeater operating in Band n101.
NR Band n102	5925 – 6425 MHz	-52 dBm	1 MHz	
E-UTRA Band 103	757 – 758 MHz	-52 dBm	1 MHz	
	787 – 788 MHz	-49 dBm	1 MHz	
NR Band n104	6425 – 7125 MHz	-52 dBm	1 MHz	This basic limit does not apply to repeater operating in Band n104
NR band n105	612 – 652 MHz	-52 dBm	1 MHz	This basic limit does not apply to repeater operating in band n71 or n105
	663 – 703 MHz	-49 dBm	1 MHz	This basic limit does not apply to repeater operating in band n105, since it is already covered by the basic limit in clause 6.6.5.2.2.
E-UTRA Band 106	935 - 940 MHz	-52 dBm	1 MHz	
	896 – 901 MHz	-49 dBm	1 MHz	
NR band n109	1432 – 1517 MHz	-52 dBm	1 MHz	This basic limit does not apply to repeater operating in Band n50, n51, n74, n75, n76, n91, n92, n93, n94, n109 or n110.
	703 – 733 MHz	-49 dBm	1 MHz	This basic limit does not apply to repeater operating in band n109, since it is already covered by the basic limit in clause 6.6.6.5.2.4. For repeater operating in band n68, it applies for 728 MHz to 733 MHz.
NR Band n110	1432 – 1435 MHz	-52 dBm	1 MHz	This requirement does not apply to repeater operating in Band n50, n51, n75, n76, n91, n92, n93, n94, n109 or n110.
	1390 – 1395 MHz	-49 dBm	1 MHz	This requirement does not apply to repeater operating in band n110, since it is already covered by the requirement in clause 6.6.6.5.2.4.
E-UTRA Band 111	1820 – 1830 MHz	-52 dBm	1 MHz	This basic limit does not apply to repeater operating in Band n3
	1800 – 1810 MHz	-49 dBm	1 MHz	

NOTE 1: As defined in the scope for spurious emissions in this clause, except for the cases where the noted basic limits apply to a repeater operating in Band n28, the co-existence requirements in table 6.5.4.2.3 -1 do not apply for the Δf_{OBUE} frequency range immediately outside the downlink operating band (see table 5.2-1). Emission limits for this excluded frequency range may be covered by local or regional requirements.

NOTE 2: Table 6.5.5.2.3 -1 assumes that two operating bands, where the frequency ranges in table 5.2-1 would be overlapping, are not deployed in the same geographical area. For such a case of operation with overlapping frequency arrangements in the same geographical area, special co-existence requirements may apply that are not covered by the 3GPP specifications.

NOTE 3: For unsynchronized operation, special co-existence requirements may apply that are not covered by the 3GPP specifications.

NOTE 4: For NR Band n28 repeater, specific solutions may be required to fulfil the spurious emissions limits for repeater for co-existence with E-UTRA Band 27 UL operating band.

NOTE 5: For NR Band n29 repeater, specific solutions may be required to fulfil the spurious emissions limits for repeater for co-existence with UTRA Band XII, E-UTRA Band 12 or NR Band n12 UL operating band, E-UTRA Band 17 UL operating band or E-UTRA Band 85 UL or NR Band n85 UL operating band.

The following requirement may be applied for the protection of PHS. This requirement is also applicable at specified frequencies falling between Δf_{OBUE} below the lowest repeater transmitter frequency of the downlink *operating band* and Δf_{OBUE} above the highest repeater transmitter frequency of the downlink *operating band*. Δf_{OBUE} is defined in clause 6.5.1.

The spurious emission *basic limit* for this requirement are:

Table 6.5.4.2.3-2: Repeater spurious emissions basic limit for repeater for co-existence with PHS for DL

Frequency range	<i>basic limit</i>	<i>Measurement Bandwidth</i>	Note
1884.5 – 1915.7 MHz	-41 dBm	300 kHz	Applicable when co-existence with PHS system operating in 1884.5 – 1915.7 MHz

In certain regions, the following requirement may apply to repeater operating in Band n50 and n75 within the 1432 – 1452 MHz, and in Band n51 and Band n76. The *basic limit* are specified in Table 6.5.4.2.3-4. This requirement is also applicable at the frequency range from Δf_{OBUE} below the lowest frequency of the repeater downlink *operating band* up to Δf_{OBUE} above the highest frequency of the repeater downlink *operating band*.

Table 6.5.4.2.3-4: Additional operating band unwanted emission basic limit for repeater operating in Band n50 and n75 within 1432 – 1452 MHz, and in Band n51 and n76

Filter centre frequency, F_{filter}	<i>basic limit</i>	<i>Measurement Bandwidth</i>
$F_{\text{filter}} = 1413.5$ MHz	-42 dBm	27 MHz

In certain regions, the following requirement may apply to repeater operating in NR Band n50 and n75 within 1492-1517 MHz and in Band n74 within 1492-1518 MHz. The maximum level of emissions, measured on centre frequencies F_{filter} with filter bandwidth according to Table 6.5.4.2.3-5, shall be defined according to the *basic limits* $P_{\text{EM},n50/n75,a}$ nor $P_{\text{EM},n50/n75,b}$ declared by the manufacturer.

Table 6.5.4.2.3-5: Operating band n50, n74 and n75 declared emission above 1518 MHz

Filter centre frequency, F_{filter}	Declared <i>basic limits</i> (dBm)	<i>Measurement bandwidth</i>
$1518.5 \text{ MHz} \leq F_{\text{filter}} \leq 1519.5 \text{ MHz}$	$P_{\text{EM},n50/n75,a}$	1 MHz
$1520.5 \text{ MHz} \leq F_{\text{filter}} \leq 1558.5 \text{ MHz}$	$P_{\text{EM},n50/n75,b}$	1 MHz

In certain regions, the following requirement shall be applied to repeater operating in Band n13 and n14 to ensure that appropriate interference protection is provided to 700 MHz public safety operations. This requirement is also applicable at the frequency range from 10 MHz below the lowest frequency of the repeater downlink operating band up to 10 MHz above the highest frequency of the repeater downlink operating band.

The power of any spurious emission shall not exceed:

Table 6.5.4.2.3-6: Repeater spurious emissions basic limits for protection of 700 MHz public safety operations

Operating Band	Frequency range	<i>Basic limit</i>	<i>Measurement Bandwidth</i>
n13	763 - 775 MHz	-46 dBm	6.25 kHz
n13	793 - 805 MHz	-46 dBm	6.25 kHz
n14	769 - 775 MHz	-46 dBm	6.25 kHz
n14	799 - 805 MHz	-46 dBm	6.25 kHz

In certain regions, the following requirement may apply to repeater operating in Band n30. This requirement is also applicable at the frequency range from 10 MHz below the lowest frequency of the repeater downlink operating band up to 10 MHz above the highest frequency of the repeater downlink operating band.

The power of any spurious emission shall not exceed:

Table 6.5.4.2.3-7: Additional repeater spurious emissions basic limits for Band n30

Frequency range	<i>basic limits</i>	<i>Measurement Bandwidth</i>	Note
2200 – 2345 MHz	-45 dBm	1 MHz	
2362.5 – 2365 MHz	-25 dBm	1 MHz	
2365 – 2367.5 MHz	-40 dBm	1 MHz	
2367.5 – 2370 MHz	-42 dBm	1 MHz	
2370 – 2395 MHz	-45 dBm	1 MHz	

The following requirement may apply to repeater operating in Band n48 in certain regions. The power of any spurious emission shall not exceed:

Table 6.5.4.2.3-8: Additional repeater spurious emissions basic limits for Band n48

Frequency range	<i>Basic limits</i>	<i>Measurement Bandwidth (NOTE)</i>	Note
3530 MHz – 3720 MHz	-25 dBm	1 MHz	Applicable 10 MHz from the assigned <i>passband edge</i>
3100 MHz – 3530 MHz 3720 MHz – 4200 MHz	-40 dBm	1 MHz	

NOTE: The resolution bandwidth of the measuring equipment should be equal to the measurement bandwidth. However, to improve measurement accuracy, sensitivity and efficiency, the resolution bandwidth may be smaller than the measurement bandwidth. When the resolution bandwidth is smaller than the measurement bandwidth, the result should be integrated over the measurement bandwidth in order to obtain the equivalent noise bandwidth of the measurement bandwidth.

NOTE: The regional requirement, included in [12], is defined in terms of EIRP, which is dependent on both the repeater emissions at the antenna connector and the deployment (including antenna gain and feeder loss). The requirement defined above provides the characteristics of the base station needed to verify compliance with the regional requirement. The assessment of the EIRP level is described in Annex F.

The following requirement shall be applied to repeater operating in Band n26 to ensure that appropriate interference protection is provided to 800 MHz public safety operations. This requirement is also applicable at the frequency range from 10 MHz below the lowest frequency of the repeater downlink operating band up to 10 MHz above the highest frequency of the repeater downlink operating band.

The power of any spurious emission shall not exceed:

Table 6.5.4.2.3-9: Repeater spurious emissions basic limits for protection of 800 MHz public safety operations

Operating Band	Frequency range	<i>Basic limit</i>	<i>Measurement Bandwidth</i>	Note
n26	851 - 859 MHz	-13 dBm	100 kHz	Applicable for offsets > 37.5kHz from the <i>passband edge</i>

The following requirement may apply to Repeater for Band n41 and n90 operation in Japan. This requirement is also applicable at the frequency range from Δf_{OBUE} below the lowest frequency of the Repeater downlink operating band up to Δf_{OBUE} above the highest frequency of the Repeater downlink operating band.

The power of any spurious emission shall not exceed:

Table 6.5.4.2.3-10: Additional repeater spurious emissions basic limit for Band n41 and n90

Frequency range	Basic limit	Measurement Bandwidth
2505 MHz – 2535 MHz	-42 dBm	1 MHz
NOTE: This requirement applies for carriers allocated within 2545-2645 MHz.		

The following requirement may apply to repeater operating in 3.45-3.55 GHz in Band n77 in certain regions. Basic limits are specified in table 6.5.4.2.3-11.

Table 6.5.4.2.3-11: Additional repeater spurious emissions basic limits for Band n77

Channel bandwidth [MHz]	Frequency range [MHz]	Filter centre frequency, F_{filter} [MHz]	Basic limit [dBm]	Measurement bandwidth [MHz]
All	3430 – 3440 3560 – 3570	$3430.5 \leq F_{\text{filter}} < 3439.5$ $3560.5 \leq F_{\text{filter}} < 3569.5$	-25	1
All	≤ 3430 > 3570	$F_{\text{filter}} < 3429.5$ $3570.5 \leq F_{\text{filter}}$	-40	1

NOTE: The resolution bandwidth of the measuring equipment should be equal to the measurement bandwidth. However, to improve measurement accuracy, sensitivity and efficiency, the resolution bandwidth may be smaller than the measurement bandwidth. When the resolution bandwidth is smaller than the measurement bandwidth, the result should be integrated over the measurement bandwidth in order to obtain the equivalent noise bandwidth of the measurement bandwidth.

The following requirement may also apply to repeater operating in Band n54 in certain regions. The level of emissions in the 1541 – 1650 MHz band, measured in measurement bandwidth according to Table 6.5.4.2.3-12 shall not exceed the maximum emission levels $P_{EM,n54,a}$, $P_{EM,n54,b}$, $P_{EM,n54,c}$, $P_{EM,n54,d}$, $P_{EM,n54,e}$ and $P_{EM,n54,f}$ declared by the manufacturer.

Table 6.5.4.2.3-12: Declared Band n54 emissions basic limits for protection of the 1541-1650 MHz band

Operating Band	Frequency range	Declared emission level (dBW) (Measurement bandwidth = 1 MHz)	Declared emission level (dBW) of discrete emissions of less than 700 Hz bandwidth (Measurement bandwidth = 1 kHz)	Declared emission level (dBW) of discrete emissions of less than 2 kHz bandwidth (Measurement bandwidth = 1 kHz)
n54	1541 - 1559 MHz	$P_{EM,n54,a}$		$P_{EM,n54,f}$
	1559 - 1610 MHz	$P_{EM,n54,b}$	$P_{EM,n54,d}$	
	1610 - 1650 MHz	$P_{EM,n54,c}$	$P_{EM,n54,e}$	

Note: The regional requirements specified in attachment to the FCC reference document, 0007135419 are defined in terms of EIRP (effective isotropic radiated power), which is dependent on both the repeater emissions at the antenna connector and the deployment (including antenna gain and feeder loss). The EIRP level is calculated using: $P_{EIRP} = P_E + G_{\text{ant}}$ where P_E denotes the repeater unwanted emission level at the antenna connector, G_{ant} equals the repeater antenna gain minus feeder loss. The requirement defined above provides the characteristics of the base station needed to verify compliance with the regional requirement.

6.5.4.2.3 Co-location with base stations and repeater Nodes

These requirements may be applied for the protection of other BS, IAB-DU, IAB-MT and repeater receivers when GSM900, DCS1800, PCS1900, GSM850, CDMA850, UTRA FDD, UTRA TDD, E-UTRA, NR BS, IAB-DU, IAB-MT, or repeater are co-located.

The requirements assume a 30 dB coupling loss between transmitter and receiver and are based on co-location with same class.

The *basic limits* are in table 6.5.4.2.3-1. Requirements for co-location with a system listed in the first column apply, depending on the declared class. For a *multi-band connector*, the exclusions and conditions in the Note column of table 6.5.4.2.3-1 shall apply for each supported *operating band*.

Table 6.5.4.2.3-1: Spurious emissions minimum requirements for co-location with BS, IAB-Node or repeater-Node

Type of co-located BS	Frequency range for co-location requirement	Basic limits			Measurement bandwidth	Note
		WA repeater	MR repeater	LA repeater		
GSM900	876 – 915 MHz	-98 dBm	-91 dBm	-70 dBm	100 kHz	
DCS1800	1710 – 1785 MHz	-98 dBm	-91 dBm	-80 dBm	100 kHz	
PCS1900	1850 – 1910 MHz	-98 dBm	-91 dBm	-80 dBm	100 kHz	
GSM850 or CDMA850	824 – 849 MHz	-98 dBm	-91 dBm	-70 dBm	100 kHz	
UTRA FDD Band I or E-UTRA Band 1 or NR Band n1	1920 – 1980 MHz	-96 dBm	-91 dBm	-88 dBm	100 kHz	
UTRA FDD Band II or E-UTRA Band 2 or NR Band n2	1850 – 1910 MHz	-96 dBm	-91 dBm	-88 dBm	100 kHz	
UTRA FDD Band III or E-UTRA Band 3 or NR Band n3	1710 – 1785 MHz	-96 dBm	-91 dBm	-88 dBm	100 kHz	
UTRA FDD Band IV or E-UTRA Band 4	1710 – 1755 MHz	-96 dBm	-91 dBm	-88 dBm	100 kHz	
UTRA FDD Band V or E-UTRA Band 5 or NR Band n5	824 – 849 MHz	-96 dBm	-91 dBm	-88 dBm	100 kHz	
UTRA FDD Band VI, XIX or E-UTRA Band 6, 19	830 – 845 MHz	-96 dBm	-91 dBm	-88 dBm	100 kHz	
UTRA FDD Band VII or E-UTRA Band 7 or NR Band n7	2500 – 2570 MHz	-96 dBm	-91 dBm	-88 dBm	100 kHz	
UTRA FDD Band VIII or E-UTRA Band 8 or NR Band n8	880 – 915 MHz	-96 dBm	-91 dBm	-88 dBm	100 kHz	
UTRA FDD Band IX or E-UTRA Band 9	1749.9 – 1784.9 MHz	-96 dBm	-91 dBm	-88 dBm	100 kHz	
UTRA FDD Band X or E-UTRA Band 10	1710 – 1770 MHz	-96 dBm	-91 dBm	-88 dBm	100 kHz	
UTRA FDD Band XI or E-UTRA Band 11	1427.9 – 1447.9 MHz	-96 dBm	-91 dBm	-88 dBm	100 kHz	This is not applicable to repeater operating in Band n50, n75, n91, n92, n93 or n94
UTRA FDD Band XII or E-UTRA Band 12 or NR Band n12	699 – 716 MHz	-96 dBm	-91 dBm	-88 dBm	100 kHz	
UTRA FDD Band XIII or E-UTRA Band 13 or NR Band n13	777 – 787 MHz	-96 dBm	-91 dBm	-88 dBm	100 kHz	
UTRA FDD Band XIV or E-UTRA Band 14 or NR Band n14	788 – 798 MHz	-96 dBm	-91 dBm	-88 dBm	100 kHz	
E-UTRA Band 17	704 – 716 MHz	-96 dBm	-91 dBm	-88 dBm	100 kHz	
E-UTRA Band 18 or NR Band n18	815 – 830 MHz	-96 dBm	-91 dBm	-88 dBm	100 kHz	
UTRA FDD Band XX or E-UTRA Band 20 or NR Band n20	832 – 862 MHz	-96 dBm	-91 dBm	-88 dBm	100 kHz	
UTRA FDD Band XXI or E-UTRA Band 21	1447.9 – 1462.9 MHz	-96 dBm	-91 dBm	-88 dBm	100 kHz	This is not applicable to repeater operating in Band n50, n75, n92 or n94

UTRA FDD Band XXII or E-UTRA Band 22	3410 – 3490 MHz	-96 dBm	-91 dBm	-88 dBm	100 kHz	This is not applicable to repeater operating in Band n48, n77 or n78
E-UTRA Band 24 or NR Band n24	1626.5 – 1660.5 MHz	-96 dBm	-91 dBm	-88 dBm	100 kHz	
UTRA FDD Band XXV or E-UTRA Band 25 or NR Band n25	1850 – 1915 MHz	-96 dBm	-91 dBm	-88 dBm	100 kHz	
UTRA FDD Band XXVI or E-UTRA Band 26 or NR Band n26	814 – 849 MHz	-96 dBm	-91 dBm	-88 dBm	100 kHz	
E-UTRA Band 27	807 – 824 MHz	-96 dBm	-91 dBm	-88 dBm	100 kHz	
E-UTRA Band 28 or NR Band n28	703 – 748 MHz	-96 dBm	-91 dBm	-88 dBm	100 kHz	
E-UTRA Band 30 or NR Band n30	2305 – 2315 MHz	-96 dBm	-91 dBm	-88 dBm	100 kHz	
E-UTRA Band 31 or NR Band n31	452.5 – 457.5 MHz	-96 dBm	-91 dBm	-88 dBm	100 kHz	
UTRA TDD Band a) or E-UTRA Band 33	1900 – 1920 MHz	-96 dBm	-91 dBm	-88 dBm	100 kHz	
UTRA TDD Band a) or E-UTRA Band 34 or NR band n34	2010 – 2025 MHz	-96 dBm	-91 dBm	-88 dBm	100 kHz	This is not applicable to repeater operating in Band n34
UTRA TDD Band b) or E-UTRA Band 35	1850 – 1910 MHz	-96 dBm	-91 dBm	-88 dBm	100 kHz	
UTRA TDD Band b) or E-UTRA Band 36	1930 – 1990 MHz	-96 dBm	-91 dBm	-88 dBm	100 kHz	This is not applicable to repeater operating in Band n2 or band n25
UTRA TDD Band c) or E-UTRA Band 37	1910 – 1930 MHz	-96 dBm	-91 dBm	-88 dBm	100 kHz	
UTRA TDD Band d) or E-UTRA Band 38 or NR Band n38	2570 – 2620 MHz	-96 dBm	-91 dBm	-88 dBm	100 kHz	This is not applicable to repeater operating in Band n38.
UTRA TDD Band f) or E-UTRA Band 39 or NR band n39	1880 – 1920MHz	-96 dBm	-91 dBm	-88 dBm	100 kHz	This is not applicable to repeater operating in Band n39
UTRA TDD Band e) or E-UTRA Band 40 or NR Band n40	2300 – 2400MHz	-96 dBm	-91 dBm	-88 dBm	100 kHz	This is not applicable to repeater operating in Band n30 or n40.
E-UTRA Band 41 or NR Band n41, n90	2496 – 2690 MHz	-96 dBm	-91 dBm	-88 dBm	100 kHz	This is not applicable to repeater operating in Band n41, n53 or [n90]
E-UTRA Band 42	3400 – 3600 MHz	-96 dBm	-91 dBm	-88 dBm	100 kHz	This is not applicable to repeater operating in Band n48, n77 or n78

E-UTRA Band 43	3600 – 3800 MHz	-96 dBm	-91 dBm	-88 dBm	100 kHz	This is not applicable to repeater operating in Band n48, n77 or n78
E-UTRA Band 44	703 – 803 MHz	-96 dBm	-91 dBm	-88 dBm	100 kHz	This is not applicable to repeater operating in Band n28
E-UTRA Band 45	1447 – 1467 MHz	-96 dBm	-91 dBm	-88 dBm	100 kHz	
E-UTRA Band 46 or NR Band n46	5150 – 5925 MHz	N/A	-91 dBm	-88 dBm	100 kHz	
E-UTRA Band 48 or NR Band n48	3550 – 3700 MHz	-96 dBm	-91 dBm	-88 dBm	100 kHz	This is not applicable to repeater operating in Band n48, n77 or n78
E-UTRA Band 50 or NR Band n50	1432 – 1517 MHz	-96 dBm	-91 dBm	-88 dBm	100 kHz	This is not applicable to repeater operating in Band n51, n74, n75, n91, n92, n93, n94 or n110
E-UTRA Band 51 or NR Band n51	1427 – 1432 MHz	N/A	N/A	-88 dBm	100 kHz	This is not applicable to repeater operating in Band n50, n74, n75, n76, n91, n92, n93, n94 or n110
E-UTRA Band 53 or NR Band n53	2483.5 – 2495 MHz	N/A	-91 dBm	-88 dBm	100 kHz	This is not applicable to repeater operating in Band n41, n53 or n90
E-UTRA Band 54 or NR Band n54	1670 – 1675 MHz	-96 dBm	-91 dBm	-88 dBm	100 kHz	This is not applicable to repeater operating in Band n54
E-UTRA Band 65 or NR Band n65	1920 – 2010 MHz	-96 dBm	-91 dBm	-88 dBm	100 kHz	
E-UTRA Band 66 or NR Band n66	1710 – 1780 MHz	-96 dBm	-91 dBm	-88 dBm	100 kHz	
E-UTRA Band 68 or NR Band n68	698 – 728 MHz	-96 dBm	-91 dBm	-88 dBm	100 kHz	
E-UTRA Band 70 or NR Band n70	1695 – 1710 MHz	-96 dBm	-91 dBm	-88 dBm	100 kHz	
E-UTRA Band 71 or NR Band n71	663 – 698 MHz	-96 dBm	-91 dBm	-88 dBm	100 kHz	
E-UTRA Band 72 or NR Band n72	451 – 456 MHz	-96 dBm	-91 dBm	-88 dBm	100 kHz	
E-UTRA Band 74 or NR Band n74	1427 – 1470 MHz	-96 dBm	-91 dBm	-88 dBm	100 kHz	This is not applicable to repeater operating in Band n50, n51, n91, n92, n93, n94 or n110

NR Band n77	3.3 – 4.2 GHz	-96 dBm	-91 dBm	-88 dBm	100 kHz	This is not applicable to repeater operating in Band n48, n77 or n78
NR Band n78	3.3 – 3.8 GHz	-96 dBm	-91 dBm	-88 dBm	100 kHz	This is not applicable to repeater operating in Band n48, n77 or n78
NR Band n79	4.4 – 5.0 GHz	-96 dBm	-91 dBm	-88 dBm	100 kHz	
NR Band n80	1710 – 1785 MHz	-96 dBm	-91 dBm	-88 dBm	100 kHz	
NR Band n81	880 – 915 MHz	-96 dBm	-91 dBm	-88 dBm	100 kHz	
NR Band n82	832 – 862 MHz	-96 dBm	-91 dBm	-88 dBm	100 kHz	
NR Band n83	703 – 748 MHz	-96 dBm	-91 dBm	-88 dBm	100 kHz	
NR Band n84	1920 – 1980 MHz	-96 dBm	-91 dBm	-88 dBm	100 kHz	
E-UTRA Band 85 or NR Band n85	698 – 716 MHz	-96 dBm	-91 dBm	-88 dBm	100 kHz	
NR Band n86	1710 – 1780 MHz	-96 dBm	-91 dBm	-88 dBm	100 kHz	
E-UTRA Band 87 or NR Band n87	410 – 415 MHz	-96 dBm	-91 dBm	-88 dBm	100 kHz	
E-UTRA Band 88 or NR Band n88	412 – 417 MHz	-96 dBm	-91 dBm	-88 dBm	100 kHz	
NR Band n89	824 – 849 MHz	-96 dBm	-91 dBm	-88 dBm	100 kHz	
NR Band n91	832 – 862 MHz	N/A	N/A	-88 dBm	100 kHz	
NR Band n92	832 – 862 MHz	-96 dBm	-91 dBm	-88 dBm	100 kHz	
NR Band n93	880 – 915 MHz	N/A	N/A	-88 dBm	100 kHz	
NR Band n94	880 – 915 MHz	-96 dBm	-91 dBm	-88 dBm	100 kHz	
NR Band n95	2010 – 2025 MHz	-96 dBm	-91 dBm	-88 dBm	100 kHz	
NR Band n96	5925 – 7125 MHz	N/A	-90 dBm	-87 dBm	100 kHz	
NR Band n97	2300 – 2400MHz	-96 dBm	-91 dBm	-88 dBm	100 kHz	
NR Band n98	1880 – 1920MHz	-96 dBm	-91 dBm	-88 dBm	100 kHz	
NR Band n99	1626.5 – 1660.5 MHz	-96 dBm	-91 dBm	-88 dBm	100 kHz	
NR Band n101	1900 – 1910 MHz	-96 dBm	NA	NA	100 kHz	
NR Band n102	5925 – 6425 MHz	N/A	-90 dBm	-87 dBm	100 kHz	
E-UTRA Band 103	787 – 788 MHz	-96 dBm	-91 dBm	-88 dBm	100 kHz	
NR Band n104	6425 – 7125 MHz	-95 dBm	-90 dBm	-87 dBm	100 kHz	This requirement does not apply to repeater operating in Band n104.
NR Band n105	663 – 703 MHz	-96 dBm	-91 dBm	-88 dBm	100 kHz	
E-UTRA Band 106	896 – 901 MHz	-96 dBm	-91 dBm	-88 dBm	100 kHz	

NR Band n109	703 – 733 MHz	-96 dBm	-91 dBm	-88 dBm	100 kHz	
NR Band n110	1390 – 1395 MHz	-96 dBm	-91 dBm	-88 dBm	100 kHz	
E-UTRA Band 111	1800 – 1810 MHz	-96 dBm	-91 dBm	-88 dBm	100 kHz	

NOTE 1: As defined in the scope for spurious emissions in this clause, the co-location requirements in table 6.5.4.2.4-1 do not apply for the frequency range extending Δf_{OBUe} immediately outside the transmit frequency range. The current state-of-the-art technology does not allow a single generic solution for co-location with other system on adjacent frequencies for 30dB antenna to antenna minimum coupling loss. However, there are certain site-engineering solutions that can be used. These techniques are addressed in TR 25.942 [3].

NOTE 2: Table 6.5.4.2.3-1 assumes that two operating bands, where the corresponding transmit and receive frequency ranges in table 5.2-1 would be overlapping, are not deployed in the same geographical area. For such a case of operation with overlapping frequency arrangements in the same geographical area, special co-location requirements may apply that are not covered by the 3GPP specifications.

6.5.4.3 Minimum requirement for RF repeater

The Tx spurious emissions for *repeater type 1-C* for each *antenna connector* shall not exceed the *basic limits* specified in clause 6.5.4.2.

For Band n41 and n90 operation in Japan, the sum of the spurious emissions over all *antenna connectors* for *repeater type 1-C* shall not exceed the *basic limits* defined in clause 6.6.4.2.

6.5.4.4 Minimum requirement for NCR

6.5.4.4.1 Minimum requirement for NCR-Fwd

6.5.4.4.1.1 Minimum requirement for NCR-Fwd type 1-C

The Tx spurious emissions for *NCR-Fwd type 1-C* for each *antenna connector* shall not exceed the *basic limits* specified in clause 6.5.4.2.

For Band n41 and n90 operation in Japan, the sum of the spurious emissions over all *antenna connectors* for *NCR-Fwd type 1-C* shall not exceed the *basic limits* defined in clause 6.6.5.2.

For joint transmission of NCR-Fwd and NCR-MT in the uplink, the spurious emissions limits shall apply to the total emissions from both the NCR-Fwd and NCR-MT.

6.5.4.4.1.2 Minimum requirement for NCR-Fwd type 1-H

The Tx spurious emissions requirements for *NCR-Fwd type 1-H* are that for each *TAB connector TX min cell group* and each applicable *basic limit* in clause 6.5.4.2, the power summation emissions at the *TAB connectors* of the *TAB connectors* of the *TAB connector TX min cell group* shall not exceed a limit specified as the *basic limit* + X, where $X = 10\log_{10}(N_{\text{TXU, counted per cell}})$ for DL and for WA UL and $X=0$ for LA UL, unless stated differently in regional regulation.

NOTE: Conformance to the NCR-Fwd type 1-H spurious emission requirement can be demonstrated by meeting at least one of the following criteria as determined by the manufacturer:

1) The sum of the emissions power measured on each TAB connector in the TAB connector TX min cell group shall be less than or equal to the limit as defined in this clause for the respective frequency span.

Or

2) The unwanted emissions power at each TAB connector shall be less than or equal to the NCR-Fwd type 1-H limit as defined in this clause for the respective frequency span, scaled by $-10\log_{10}(n)$, where n is the number of TAB connectors in the TAB connector TX min cell group.

For joint transmission of NCR-Fwd and NCR-MT in the uplink, the spurious emissions limits shall apply to the total emissions from both the NCR-Fwd and NCR-MT.

6.5.4.4.2 Minimum requirement for NCR-MT

6.5.4.4.2.1 Minimum requirements for NCR-MT type 1-C

When NCR-MT and NCR-Fwd are not transmitting simultaneously, the requirements in clause 6.6.4 of TS 38.104 applies for WA NCR-MT type 1-C and the requirements in clause 6.5.3 in TS 38.101-1 applies for LA NCR-MT type 1-C.

When NCR-MT and NCR-Fwd are transmitting simultaneously, the requirements in clause 6.5.3 in TS 38.101-1 applies for LA NCR-MT type 1-C for sum of NCR-MT transmission and NCR-Fwd transmission.

6.5.4.4.2.2 Minimum requirements for NCR-MT type 1-H

Limits for NCR-MT type 1-H apply to the sum of emissions across all TAB connectors.

When WA NCR-MT and NCR-Fwd are not transmitting simultaneously, the requirements in clause 6.6.4 of TS 38.104 relaxed with the following scaling factor applies for WA NCR-MT type 1-H.

$$10\log(N_{\text{TXU,counted}}), \text{ where } N_{\text{TXU,counted}} = \min(N_{\text{TXU,active}}, 8)$$

When WA NCR-MT and NCR-Fwd are transmitting simultaneously, the requirements in clause 6.6.4 of TS 38.104 relaxed with the following scaling factor applies for the sum of NCR-MT transmission and NCR-Fwd transmission.

When LA NCR-MT and NCR-Fwd are not transmitting simultaneously, the requirements in clause 6.5.3 in TS 38.101-1 applies for LA NCR-MT type 1-H without scaling factor allowed for the sum of the spurious emissions.

When NCR-MT and NCR-Fwd are transmitting simultaneously, the requirements in clause 6.5.3 in TS 38.101-1 applies for sum of NCR-MT transmission and NCR-Fwd transmission.

6.5.5 Receiver spurious emissions

6.5.5.1 General

The receiver spurious emissions power is the power of emissions generated or amplified in a receiver unit that appear at the *antenna connector*. The requirements only apply to *repeater type 1-C* for TDD operation.

For each *antenna connectors* on BS-side and UE-side supporting both RX and TX in TDD, the requirements apply during the *transmitter OFF state*. For *antenna connectors* both BS-side and UE-side in FDD, the RX spurious emissions requirements are superseded by the TX spurious emissions requirements, as specified in clause 6.5.4.

For *multi-band connectors* that both transmit and receive in *operating band* supporting TDD, RX spurious emissions requirements are applicable during the *TX OFF state*, and are subject to exclusion zones in each supported *operating band*.

For Band n41 and n90 operation in Japan, the sum of receiver spurious emissions requirements over all *antenna connectors* for *repeater type 1-C* shall not exceed *minimum requirements* defined in clause 6.5.5.2.

6.5.5.2 Basic limits

The receiver spurious emissions requirements, *basic limits* are provided in table 6.5.5.2-1.

Table 6.5.5.2-1: Repeater receiver spurious emissions basic limits

Spurious frequency range	Basic limits	Measurement bandwidth	Note
30 MHz – 1 GHz	-57 dBm	100 kHz	Note 1
1 GHz – 12.75 GHz	-47 dBm	1 MHz	Note 1, Note 2
12.75 GHz – 5 th harmonic of the upper frequency edge of the UL operating band in GHz	-47 dBm	1 MHz	Note 1, Note 2, Note 3, Note 5
12.75 GHz - 26 GHz	-47 dBm	1 MHz	Note 1, Note 2, Note 6
NOTE 1: Measurement bandwidths as in ITU-R SM.329 [5], s4.1.			
NOTE 2: Upper frequency as in ITU-R SM.329 [5], s2.5 table 1.			
NOTE 3: This spurious frequency range applies only for operating bands for which the 5 th harmonic of the upper frequency edge of the UL operating band is reaching beyond 12.75 GHz.			
NOTE 4: The frequency range from Δf_{OBUE} below the lowest frequency of the repeater transmitter operating band to Δf_{OBUE} above the highest frequency of the repeater transmitter operating band may be excluded from the requirement. Δf_{OBUE} is defined in clause 6.5.1. For multi-band connectors, the exclusion applies for all supported operating bands.			
NOTE 5: Does not apply for band n104.			
NOTE 6: Applies only for band n104.			

6.5.5.3 Minimum requirement for RF repeater

The RX spurious emissions requirements for *repeater type 1-C* are that for each *antenna connector*, the power of emissions shall not exceed *basic limits* specified in table 6.5.5.2-1.

For Band n41 and n90 operation in Japan, the sum of RX spurious emissions requirements over all *antenna connectors* for *repeater type 1-C* shall not exceed *basic limits* specified in table 6.5.5.2-1.

6.5.5.4 Minimum requirement for NCR

6.5.5.4.1 Minimum requirement for NCR-Fwd

6.5.5.4.1.1 Minimum requirement for NCR-Fwd type 1-C

The RX spurious emissions requirements for *NCR-Fwd type 1-C* are that for each *antenna connector*, the power of emissions shall not exceed *basic limits* specified in table 6.5.5.2-1.

For Band n41 and n90 operation in Japan, the sum of RX spurious emissions requirements over all *antenna connectors* for *NCR-Fwd type 1-C* shall not exceed *basic limits* specified in table 6.5.5.2-1.

For joint reception of NCR-Fwd and NCR-MT in the uplink, the receiver spurious emissions limits shall apply to the total emissions from both the NCR-Fwd and NCR-MT.

6.5.5.4.1.2 Minimum requirement for NCR-Fwd type 1-H

The RX spurious emissions requirements for *NCR-Fwd type 1-H* are that for each applicable *basic limit* specified in table 7.6.2-1 for each *TAB connector RX min cell group*, the power sum of emissions at respective *TAB connectors* shall not exceed the limits specified as the *basic limits* + X, where $X = 10\log_{10}(N_{\text{RXU, counted per cell}})$ for DL and for WA UL and X=0 for LA UL, unless stated differently in regional regulation.

The RX spurious emission requirements are applied per the *TAB connector RX min cell group* for all the configurations supported by the repeater.

NOTE: Conformance to the repeater receiver spurious emissions requirement can be demonstrated by meeting at least one of the following criteria as determined by the manufacturer:

- 1) The sum of the spurious emissions power measured on each TAB connector in the TAB connector RX min cell group shall be less than or equal to the limit above for the respective frequency span.

Or

- 2) The spurious emissions power at each TAB connector shall be less than or equal to the limit as defined above for the respective frequency span, scaled by $-10\log_{10}(n)$, where n is the number of TAB connectors in the TAB connector RX min cell group.

For joint reception of NCR-Fwd and NCR-MT in the uplink, the receiver spurious emissions limits shall apply to the total emissions from both the NCR-Fwd and NCR-MT.

6.6 Repeater Error Vector Magnitude

6.6.1 Downlink repeater error vector magnitude

6.6.1.1 General

The Repeater Error Vector Magnitude (EVM) is a measure of the difference between the symbols provided at the input of repeater and the measured signal symbols at the output of the repeater after the equalization by the measurement equipment. This difference is called the error vector. Details about how the repeater EVM is determined are the same as specified in TS 38.104 [2] Annex B for FR1. The repeater EVM result is defined as the square root of the ratio of the mean error vector power to the mean reference power expressed in percent.

The repeater EVM requirement is applicable for a repeater operating at an input power in the range from what is required to reach the maximum output power to the minimum power level in table 6.6.1.1-1.

Table 6.6.1.1-1: Minimum input power for repeater EVM

Repeater DL class	Minimum input power spectral density (dBm/MHz)	
	QPSK, 16 QAM, 64QAM	256QAM ¹
WA	-82	-75
MR	-77	-70
LA	-74	-67

Note 1: support of 256QAM is based on the declaration

6.6.1.2 Minimum requirement for RF repeater

The repeater EVM levels for different modulation schemes outlined in table 6.6.1.2-1 shall be met using the frame structure described in clause 6.6.1.3.

Table 6.6.1.2-1: Repeater EVM requirements

Parameter	Required repeater EVM
QPSK, 16QAM, 64QAM	8 %
256QAM	3.5 % ¹

Note 1: support of 256QAM is based on the declaration.

6.6.1.2A Minimum requirement for NCR

6.6.1.2A.1 Minimum requirement for NCR-Fwd

6.6.1.2A.1.1 Minimum requirement for NCR-Fwd type 1-C

The NCR-Fwd EVM levels for different modulation schemes outlined in table 6.6.1.2-1 shall be met using the frame structure described in clause 6.6.1.3.

6.6.1.2A.1.2 Minimum requirement for NCR-Fwd type 1-H

The NCR-Fwd EVM levels for different modulation schemes outlined in table 6.6.1.2-1 shall be met using the frame structure described in clause 6.6.1.3 between corresponding input/output TAB connectors.

6.6.1.3 Repeater EVM frame structure for measurement

The input signals for the repeater EVM requirement shall have the same frame structure as defined for the BS in TS 38.104 [2].

6.6.2 Uplink repeater error vector magnitude

6.6.2.1 General

The Repeater Error Vector Magnitude is a measure of the difference between the reference waveform provided at the input of repeater and the measured waveform at the output of the repeater. This difference is called the error vector. Details about how the repeater EVM is determined are the same as specified in TS 38.101-1 [13] Annex F for FR1. Before calculating the repeater EVM the measured waveform is corrected by the sample timing offset and RF frequency offset. Then the carrier leakage shall be removed from the measured waveform before calculating the repeater EVM.

The measured waveform is further equalised using the channel estimates subjected to the repeater EVM equaliser spectrum flatness requirement specified in TS 38.101-1 [13] clause 6.4.2.4. For DFT-s-OFDM waveforms, the repeater EVM result is defined after the front-end FFT and IDFT as the square root of the ratio of the mean error vector power to the mean reference power expressed as a %. For CP-OFDM waveforms, the repeater EVM result is defined after the front-end FFT as the square root of the ratio of the mean error vector power to the mean reference power expressed as a %.

The basic repeater EVM measurement interval in one slot in the time domain. The repeater EVM measurement interval is reduced by any symbols that contains an allowable power transient in the measurement interval, as defined in TS 38.101-1 [13] clause 6.3.3 for EVM for UE.

The repeater EVM requirement is applicable for a repeater operating at an input power in the range from what is required to reach the maximum output power to the minimum power level in table 6.6.2.1-1.

Table 6.6.2.1-1: Minimum input power for repeater EVM

Repeater UL class	Minimum input power spectral density (dBm/MHz)	
	QPSK, 16 QAM, 64QAM	256QAM ¹
WA	-82	-75
LA	-74	-67
Note 1: support of 256QAM is based on the declaration		

6.6.2.2 Minimum requirement for RF repeater

The RMS average of the basic repeater EVM measurements over 10 subframes for the average repeater EVM case for the different modulation schemes shall not exceed the values specified in Table 6.6.2.2-1.

Table 6.6.2.2-1: Requirements for Repeater Error Vector Magnitude

Parameter	Unit	Average Repeater EVM Level
QPSK, 16 QAM, 64QAM	%	8
256 QAM	%	3.5 ¹
Note 1: support of 256QAM is based on the declaration.		

6.6.2.3 Minimum requirement for NCR

6.6.2.3.1 Minimum requirement for NCR-Fwd

6.6.2.3.1.1 Minimum requirement for NCR-Fwd type 1-C

The RMS average of the basic NCR-Fwd EVM measurements over 10 subframes for the average NCR-Fwd EVM case for the different modulation schemes shall not exceed the values specified in Table 6.6.2.2-1.

6.6.2.3.1.2 Minimum requirement for NCR-Fwd type 1-H

The RMS average of the basic NCR-Fwd EVM measurements over 10 subframes for the average NCR-Fwd EVM case for the different modulation schemes shall not exceed the values specified in Table 6.6.2.2-1 between corresponding input/output TAB connectors.

6.7 Input intermodulation

6.7.1 General requirement

6.7.1.1 General

The input intermodulation is a measure of the capability of the repeater to inhibit the generation of interference in the *passband*, in the presence of interfering signals on frequencies other than the *passband*.

The following requirement applies for interfering signals depending on the repeaters *passband*.

This requirement applies to the uplink and downlink of the repeater during the *transmitter ON state*.

There is no co-location input intermodulation requirement for LA 1-C repeaters deployed in Femto cell scenario.

6.7.1.2 Minimum requirement for RF repeater

For the parameters specified in table 6.7.1.2-1, the power in the *passband* shall not increase with more than 10 dB at the output of the repeater as measured with 1 MHz measurement bandwidth, compared to the level obtained without interfering signals applied.

The core requirement is applicable for all frequency separation possibilities between the two interfering signals that cause the 3rd order intermodulation product to fall into the *passband*.

Table 6.7.1.2-1 specifies the parameters for two interfering signals, where:

- f_1 offset is the offset from the channel edge frequency of the first or last channel in the *passband* of the closer carrier.

Table 6.7.1.2-1: Input intermodulation requirement

f_1 offset	Interfering Signal Levels	Type of signals	Measurement bandwidth
1 MHz	-40 dBm	2 CW carriers	1 MHz

6.7.1.3 Minimum requirement for NCR

6.7.1.3.1 Minimum requirement for NCR-Fwd

6.7.1.3.1.1 Minimum requirement for NCR-Fwd type 1-C

For the parameters specified in table 6.7.1.1-1, the power in the *passband* shall not increase with more than 10 dB at the output of the NCR-Fwd as measured with 1 MHz measurement bandwidth, compared to the level obtained without interfering signals applied.

The core requirement is applicable for all frequency separation possibilities between the two interfering signals that cause the 3rd order intermodulation product to fall into the *passband*.

Table 6.7.1.2-1 specifies the parameters for two interfering signals.

6.7.1.3.1.2 Minimum requirement for NCR-Fwd type 1-H

For the parameters specified in table 6.7.1.1-1, considering corresponding input/output TAB connectors, the power in the *passband* shall not increase with more than 10 dB at the output of the NCR-Fwd as measured with 1 MHz measurement bandwidth, compared to the level obtained without interfering signals applied.

The core requirement is applicable for all frequency separation possibilities between the two interfering signals that cause the 3rd order intermodulation product to fall into the *passband*.

Table 6.7.1.2-1 specifies the parameters for two interfering signals.

6.7.2 Co-location with BS/repeater in other systems

6.7.2.1 General

This additional input intermodulation requirement may be applied for the protection of repeater receivers when GSM, CDMA, UTRA, E-UTRA, NR BS or repeater operating in a different frequency band are co-located with a repeater.

The following requirement applies for interfering signals depending on the repeaters *passband*.

This requirement applies to the uplink and downlink of the repeater. If the BS side is declared to meet co-location requirements, then it should meet input intermodulation co-location requirements for the downlink. If the UE side is declared to meet co-location requirements, then it should meet input intermodulation co-location requirements for the uplink.

6.7.2.2 Minimum requirement for RF repeater

For the parameters specified in table 6.7.2.2-1 for DL and 6.7.2.2-2 for UL, the power in the *passband* shall not increase with more than 10 dB at the output of the repeater as measured with 1MHz measurement bandwidth, compared to the level obtained without interfering signals applied.

The core requirement is applicable for all frequency separation possibilities between the two interfering signals that cause the 3rd order intermodulation product to fall into the *passband*.

Table 6.7.2.2-1: input intermodulation requirement for RF repeater DL when co-located with BS/repeater in other frequency bands.

Frequency range of interfering signal	Interfering signal mean power for repeater with WA UE side (dBm)	Interfering signal mean power for repeater with MR UE side(dBm)	Interfering signal mean power for repeater with LA UE side(dBm)	Type of interfering signals
Frequency range of co-located BS's downlink operating band or located repeater's <i>passband</i>	+16	+8	x (Note 1)	2 CW carriers
NOTE 1: x = -7 dBm for RF repeater co-located with Pico GSM850 or Pico CDMA850 x = -4 dBm for RF repeater co-located with Pico DCS1800 or Pico PCS1900 x = -6 dBm for RF repeater co-located with UTRA bands or E-UTRA bands or NR bands NOTE 2: The requirement does not apply when the interfering signal falls within the <i>passband</i> . NOTE 3: For unsynchronized base stations (except in band n46, n96, and n102) or repeaters, special co-location requirements may apply that are not covered by the 3GPP specifications.				

Table 6.7.2.2-2: input intermodulation requirement for RF Repeater UL when co-located with BS/repeater in other frequency bands.

Frequency range of interfering signal	Interfering signal mean power for repeater with WA BS side(dBm)	Interfering signal mean power for repeater with LA BS side(dBm)	Type of interfering signals
Frequency range of co-located BS's downlink operating band or located repeater's <i>passband</i>	+16	$P_{\text{rated,p,AC}} - 30$	2 CW carriers
NOTE 1: The requirement does not apply when the interfering signal falls within the <i>passband</i> .			
NOTE 2: For unsynchronized base stations (except in band n46, n96, and n102) or repeaters, special co-location requirements may apply that are not covered by the 3GPP specifications.			

6.7.2.3 Minimum requirement for NCR

6.7.2.3.1 Minimum requirement for NCR-Fwd

6.7.2.3.1.1 Minimum requirement for NCR-Fwd type 1-C

For the parameters specified in table 6.7.2.2-1 for DL and 6.7.2.2-2 for UL, the power in the *passband* shall not increase with more than 10 dB at the output of the NCR-Fwd as measured with 1MHz measurement bandwidth, compared to the level obtained without interfering signals applied.

The core requirement is applicable for all frequency separation possibilities between the two interfering signals that cause the 3rd order intermodulation product to fall into the *passband*.

6.7.2.3.1.2 Minimum requirement for NCR-Fwd type 1-H

For the parameters specified in table 6.7.2.2-1 for DL and 6.7.2.2-2 for UL, considering corresponding input/output TAB connectors, the power in the *passband* shall not increase with more than 10 dB at the output of the NCR-Fwd as measured with 1MHz measurement bandwidth, compared to the level obtained without interfering signals applied.

The core requirement is applicable for all frequency separation possibilities between the two interfering signals that cause the 3rd order intermodulation product to fall into the *passband*.

6.7.3 Co-existence with other systems

6.7.3.1 General

This input intermodulation existence requirement may be applied for the protection of RF repeater receivers when GSM, CDMA, UTRA, E-UTRA, NR BS or repeater operating in another frequency band co-exist with a RF repeater.

6.7.3.2 Minimum requirement for RF repeater

For the parameters specified in table 6.7.3.2-1, the power in the *passband* shall not increase with more than 10 dB at the output of the repeater as measured with 1MHz measurement bandwidth, compared to the level obtained without interfering signals applied.

The core requirement is applicable for all frequency separation possibilities between the two interfering signals that cause the 3rd order intermodulation product to fall into the *passband*.

Table 6.7.3.2-1: input intermodulation requirement for RF repeater when co-exist with BS/repeater in other non-overlapping frequency bands

Frequency range of interfering signal	Interfering signal mean power (dBm)	Type of interfering signals	Measurement bandwidth
Frequency range of co-existence system operating band	-15	2 CW carriers	1MHz
NOTE 1: All the interfering signals should be limited into the frequency ranges that are either X MHz higher than $F_{UL,high}$ or X MHz lower than $F_{UL,low}$, where X equals to 20MHz when $F_{UL,high} - F_{UL,low}$ is not larger than 200MHz, otherwise X equals to 60MHz			

6.7.3.3 Minimum requirement for NCR

6.7.3.3.1 Minimum requirement for NCR-Fwd

6.7.3.3.1.1 Minimum requirement for NCR-Fwd type 1-C

For the parameters specified in table 6.7.3.2-1, the power in the *passband* shall not increase with more than 10 dB at the output of the NCR-Fwd as measured with 1MHz measurement bandwidth, compared to the level obtained without interfering signals applied.

The core requirement is applicable for all frequency separation possibilities between the two interfering signals that cause the 3rd order intermodulation product to fall into the *passband*.

6.7.3.3.1.2 Minimum requirement for NCR-Fwd type 1-H

For the parameters specified in table 6.7.3.2-1, considering corresponding input/output TAB connectors, the power in the *passband* shall not increase with more than 10 dB at the output of the NCR-Fwd as measured with 1MHz measurement bandwidth, compared to the level obtained without interfering signals applied.

The core requirement is applicable for all frequency separation possibilities between the two interfering signals that cause the 3rd order intermodulation product to fall into the *passband*.

6.8 Output intermodulation

6.8.1 General

The output intermodulation requirement is a measure of the capability of the repeater to inhibit the generation of signals in its non-linear elements caused by presence of the wanted signal and an interfering signal reaching the repeater via the output port. The requirement shall apply during the *transmitter ON state* and the *transmitter transient period*.

The requirement shall apply to the uplink and downlink of the Repeater.

The output intermodulation level is the power of the intermodulation products when an interfering signal is injected into the *antenna connector*.

6.8.2 Minimum requirements for *RF repeater*

6.8.2.1 Minimum requirements

The output intermodulation level is the power of the intermodulation products when an interfering signal is injected into the output port. The wanted signal *passband* shall be the maximum bandwidth supported by the repeater.

For *repeater type 1-C*, the wanted signal and interfering signal centre frequency is specified in table 6.8.2.1-1, where interfering signal level is *rated total output power* ($P_{rated,t,AC}$) at *antenna connector* in the *passband* – 30 dB.

The unwanted emission with output intermodulation applied shall not exceed the corresponding uplink and downlink unwanted emission limits in clause 6.5 in the presence of an interfering signal according to table 6.8.2.1-1. The

measurement may be limited to frequencies on which third and fifth order intermodulation products appear, considering the width of these products.

Table 6.8.2.1-1: Interfering and wanted signals for the output intermodulation requirement

Parameter	Value
Wanted signal type	NR signal, filling all supported <i>passbands</i> in the operating band and with sufficient carriers to fill each <i>passband</i> . Minimum defined SCS for the operating band
Interfering signal type	NR signal, with the minimum SCS and channel bandwidth defined in the operating band in [2]
Interfering signal level	<i>Rated total output power</i> ($P_{\text{rated,t,AC}}$) in the <i>passband</i> – 30 dB
Interfering signal centre frequency offset from the lower/upper edge of the wanted signal or edge of <i>sub-block</i> inside a <i>sub-block gap</i>	$f_{\text{offset}} = \pm \text{minimum pass band} \left(n - \frac{1}{2} \right)$, for $n=1, 2$ and 3
NOTE 1: Interfering signal positions that are partially or completely outside of any downlink operating band of the repeater are excluded from the requirement, unless the interfering signal positions fall within the frequency range of adjacent downlink operating bands in the same geographical area. In case that none of the interfering signal positions fall completely within the frequency range of the downlink operating band, TS 38.115-1 [7] provides further guidance regarding appropriate test requirements.	
NOTE 2: In Japan, NOTE 1 is not applied in Band n77, n78, n79.	

6.8.2.2 Additional requirements

For repeater supporting Band n41 and n90 operation in Japan, the sum of output intermodulation level over all *antenna connectors* shall not exceed the unwanted emission limits in clauses 6.5 in the presence of an NR interfering signal according to table 6.8.2.2-1.

Table 6.8.2.2-1 Interfering and wanted signals for the additional output intermodulation requirement for Band n41 and n90

Parameter	Value
Wanted signal	NR single (NOTE)
Interfering signal type	NR signal of 10 MHz <i>passband bandwidth</i>
Interfering signal level	<i>Rated total output power</i> ($P_{\text{rated,t,AC}}$) in the <i>passband</i> – 30 dB
Interfering signal centre frequency offset from the lower/upper <i>passband</i> centre frequency of the wanted signal	± 5 MHz ± 15 MHz ± 25 MHz
NOTE: This requirement applies for <i>passband</i> allocated within 2545-2645 MHz.	

6.8.3 Minimum requirements for NCR

6.8.3.1 Minimum requirements for NCR-Fwd

6.8.3.1.1 Minimum requirements for NCR-Fwd type 1-C

The output intermodulation level is the power of the intermodulation products when an interfering signal is injected into the output port. The wanted signal *passband* shall be the maximum bandwidth supported by the NCR-Fwd.

For *NCR-Fwd type 1-C*, the wanted signal and interfering signal centre frequency is specified in table 6.8.2.1-1, where interfering signal level is *rated total output power* ($P_{\text{rated,t,AC}}$) at *antenna connector* in the *passband* – 30 dB.

The unwanted emission with output intermodulation applied shall not exceed the corresponding uplink and downlink unwanted emission limits in clause 6.5 in the presence of an interfering signal according to table 6.8.2.1-1. The measurement may be limited to frequencies on which third and fifth order intermodulation products appear, considering the width of these products.

6.8.3.1.2 Additional requirements for NCR-Fwd type 1-C

For NCR supporting Band n41 and n90 operation in Japan, the sum of output intermodulation level over all *antenna connectors* shall not exceed the unwanted emission limits in clauses 6.5 in the presence of an NR interfering signal according to table 6.8.2.2-1.

6.8.3.1.3 Minimum requirements for NCR-Fwd type 1-H

The output intermodulation level is the power of the intermodulation products when an interfering signal is injected into the output port. The wanted signal *passband* shall be the maximum bandwidth supported by the NCR-Fwd.

For *NCR-Fwd type 1-H*, the wanted signal and interfering signal centre frequency is specified in table 6.8.2.1-1, where interfering signal level is *rated total output power* ($P_{\text{rated,t,TABC}}$) at *TAB connector* in the *passband* – 30 dB.

The unwanted emission with output intermodulation applied shall not exceed the corresponding uplink and downlink unwanted emission limits in clause 6.5 in the presence of an interfering signal according to table 6.8.2.1-1. The measurement may be limited to frequencies on which third and fifth order intermodulation products appear, considering the width of these products.

6.8.3.1.4 Additional requirements for NCR-Fwd type 1-H

For NCR supporting Band n41 and n90 operation in Japan, the sum of output intermodulation level over all *TAB connectors* shall not exceed the unwanted emission limits in clauses 6.5 in the presence of an NR interfering signal according to table 6.8.2.2-1.

6.9 Adjacent Channel Rejection Ratio (ACRR)

6.9.1 General

Adjacent Channel Rejection Ratio (ACRR) is the ratio of the average gain over a carrier of the repeater in the *passband* to the average gain of the repeater over an adjacent channel outside the repeater *passband*. The carrier in the *passband* and in the adjacent channel shall be of the same type (reference carrier) with bandwidths as defined by *nominal channel bandwidth*.

The requirement shall apply to the uplink and downlink of the Repeater, where the donor link is maintained via antennas (wireless Repeater).

The requirement is differentiated between uplink and downlink.

The requirement shall apply during the *transmitter ON state*.

6.9.2 Minimum Requirements for RF repeater

For a repeater operating at *passband* below 2496 MHz, the ACRR requirements in table 6.9.2-1 shall apply in downlink. ACRR for downlink shall be higher than the value specified in the Table 6.9.2-1.

Table 6.9.2-1: Repeater Downlink ACRR below 2496MHz

Co-existence with other systems	Repeater Class	Channel offset from frequency edge of <i>passband</i> (MHz)	ACRR limit
UTRA, E-UTRA, NR	Wide Area repeater	$BW_{\text{Nominal}}/2$	45
	Medium Range repeater	$BW_{\text{Nominal}}/2$	45
	Local Area repeater	$BW_{\text{Nominal}}/2$	33 (Note 1)
NOTE 1: This requirement does not applicable if the <i>passband</i> occupies the entire <i>operating band</i> .			

For a repeater operating at *passband* above 2496 MHz, the ACRR requirements in table 6.9.2-1a shall apply in downlink. ACRR for downlink shall be higher than the value specified in the Table 6.9.2-1a.

Table 6.9.2-1a: Repeater Downlink ACRR above 2496 MHz

Co-existence with other systems	Repeater Class	Channel offset from frequency edge of <i>passband</i> (MHz)	ACRR limit
UTRA, E-UTRA, NR	Wide Area repeater	$BW_{Nominal}/2$	33dB
	Medium Range repeater	$BW_{Nominal}/2$	33dB
	Local Area repeater	$BW_{Nominal}/2$	33dB (Note 1)
NOTE 1: This requirement does not applicable if the <i>passband</i> occupies the entire <i>operating band</i> .			

For a repeater operating at *passband* below 2496 MHz, the ACRR requirements in table 6.9.2-2 shall apply in uplink. ACRR for uplink shall be higher than the value specified in the Table 6.9.2-2.

Table 6.9.2-2: Repeater Uplink ACRR below 2496 MHz

Co-existence with other systems	Repeater Class	Channel offset from frequency edge of <i>passband</i> (MHz)	ACRR limit
UTRA, E-UTRA, NR	Wide Area repeater	$BW_{Nominal}/2$	33dB
	Local Area repeater	$BW_{Nominal}/2$	33dB (Note 1)
NOTE 1: This requirement does not applicable if the <i>passband</i> occupies the entire <i>operating band</i> .			

For a repeater operating at *passband* above 2496 MHz, the ACRR requirements in table 6.9.2-2a shall apply in uplink. ACRR for uplink shall be higher than the value specified in the Table 6.9.2-2a.

Table 6.9.2-2a: Repeater Uplink ACRR above 2496 MHz

Co-existence with other systems	Repeater Class	Channel offset from frequency edge of <i>passband</i> (MHz)	ACRR limit
UTRA, E-UTRA, NR	Wide Area repeater	$BW_{Nominal}/2$	33dB
	Local Area repeater	5MHz	20dBc (Note 1, Note 2)
		$BW_{Nominal}/2$	33dBc (Note 1)
NOTE 1: This requirement does not applicable if the <i>passband</i> occupies the entire <i>operating band</i> .			
NOTE 2: In this case, the channel within the <i>passband</i> and the adjacent channel are assumed to have a bandwidth of 10 MHz.			

6.9.3 Minimum Requirements for NCR

6.9.3.1 Minimum requirements for NCR-Fwd

6.9.3.1.1 Minimum requirements for NCR-Fwd type 1-C

For a NCR-Fwd operating at *passband* below 2496 MHz, the ACRR requirements in table 6.9.2-1 shall apply in downlink. In normal conditions the ACRR for downlink shall be higher than the value specified in the Table 6.9.2-1.

For a NCR-Fwd operating at *passband* above 2496 MHz, the ACRR requirements in table 6.9.2-1a shall apply in downlink. In normal conditions the ACRR for downlink shall be higher than the value specified in the Table 6.9.2-1a.

For a NCR-Fwd operating at *passband* below 2496 MHz, the ACRR requirements in table 6.9.2-2 shall apply in uplink. In normal conditions the ACRR for uplink shall be higher than the value specified in the Table 6.9.2-2.

For a NCR-Fwd operating at *passband* above 2496 MHz, the ACRR requirements in table 6.9.2-2a shall apply in uplink. In normal conditions the ACRR for uplink shall be higher than the value specified in the Table 6.9.2-2a.

6.9.3.1.2 Minimum Requirements for NCR-Fwd type 1-H

For a NCR-Fwd operating at *passband* below 2496 MHz, the ACRR requirements in table 6.9.2-1 shall apply in downlink. In normal conditions the ACRR for downlink between corresponding input/output TAB connectors shall be higher than the value specified in the Table 6.9.2-1.

For a NCR-Fwd operating at *passband* above 2496 MHz, the ACRR requirements in table 6.9.2-1a shall apply in downlink. In normal conditions the ACRR for downlink between corresponding input/output TAB connectors shall be higher than the value specified in the Table 6.9.2-1a.

For a NCR-Fwd operating at *passband* below 2496 MHz, the ACRR requirements in table 6.9.2-2 shall apply in uplink. In normal conditions the ACRR for uplink between corresponding input/output TAB connectors shall be higher than the value specified in the Table 6.9.2-2.

For a NCR-Fwd operating at *passband* above 2496 MHz, the ACRR requirements in table 6.9.2-2a shall apply in uplink. In normal conditions the ACRR for uplink between corresponding input/output TAB connectors shall be higher than the value specified in the Table 6.9.2-2a.

6.10 Transmit ON/OFF power

6.10.1 Transmitter OFF power

6.10.1.1 General

Transmit OFF power requirements apply only to TDD operation of the repeater. The requirement applies to both downlink and uplink of the repeater.

Transmitter OFF power is defined as the mean power measured over $70/N$ us filtered with a square filter of bandwidth equal to the *passband bandwidth* of the repeater (BW_{passband}) centred on the assigned channel frequency during the *transmitter OFF state*. $N = \text{SCS}/15$, where SCS is Sub Carrier Spacing in kHz of the input signal.

For *multi-band connectors* and for *single band connectors* supporting transmission in multiple *operating bands*, the requirement is only applicable during the *transmitter OFF state* in all supported *operating bands*.

6.10.1.2 Minimum requirement for RF repeater

For *repeater type 1-C downlink*, the requirements for transmitter OFF power spectral density shall be less than -85 dBm/MHz per *antenna connector*.

For *repeater type 1-C uplink*, the requirements for transmitter OFF power spectral density shall be less than -50dBm / $(\text{SCS} \cdot (12 \cdot N_{\text{RB}} + 1) / 1000)$ MHz per *antenna connector*, where SCS is Sub Carrier Spacing in kHz.

6.10.1.3 Minimum requirement for NCR

6.10.1.3.1 Minimum requirement for NCR Fwd

6.10.1.3.1.1 Minimum requirement for NCR-Fwd type 1-C

For *NCR-Fwd type 1-C downlink*, the requirements for transmitter OFF power spectral density shall be less than -85 dBm/MHz per *antenna connector*.

For *NCR-Fwd type 1-C uplink*, the requirements for transmitter OFF power spectral density shall be less than -50dBm / $(\text{SCS} \cdot (12 \cdot N_{\text{RB}} + 1) / 1000)$ MHz per *antenna connector*, where SCS is Sub Carrier Spacing in kHz.

6.10.1.3.1.2 Minimum requirement for NCR-Fwd type 1-H

For *NCR-Fwd type 1-H downlink*, the requirements for transmitter OFF power spectral density shall be less than -85 dBm/MHz per *TAB connector*.

For *NCR-Fwd type 1-H uplink*, the requirements for transmitter OFF power spectral density shall be less than $-50\text{dBm} / (\text{SCS} \cdot (12 \cdot N_{\text{RB}} + 1) / 1000)$ MHz per *TAB connector*, where SCS is Sub Carrier Spacing in kHz.

6.10.2 Transmitter transient period

6.10.2.1 General

Transmitter transient period requirements apply only to TDD operation of the repeater. The requirement applies to both downlink and uplink of the repeater.

The *transmitter transient period* is the time period during which the transmitter is changing from the *transmitter OFF state* to the *transmitter ON state* or vice versa. The *transmitter transient period* is illustrated in figure 6.10.2.1-1.

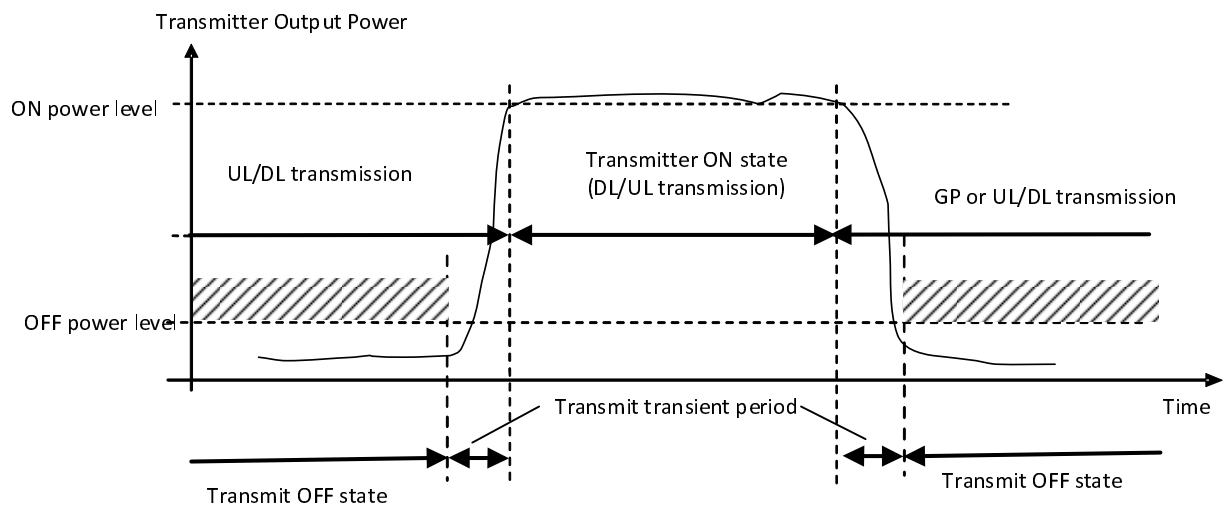

Figure 6.10.2.1-1: Example of relations between transmitter ON state, transmitter OFF state and transmitter transient period

For *repeater type 1-C* this requirement shall be applied at the *antenna connector* supporting transmission in the *operating band*. The beginning and end point of downlink and uplink bursts are referenced to the slot timing at the input.

6.10.2.2 Minimum requirement for RF repeater

For *repeater type 1-C*, the *transmitter transient period* shall be shorter than the values listed in the minimum requirement table 6.10.2.2-1.

Table 6.10.2.2-1: Minimum requirement for the transmitter transient period for repeater type 1-C

Transition	Transient period length (µs)
OFF to ON	10
ON to OFF	10

6.10.2.3 Minimum requirement for NCR

6.10.2.3.1 Minimum requirement for NCR-Fwd

6.10.2.3.1.1 Minimum requirement for NCR-Fwd type 1-C

For *NCR-Fwd type 1-C* this requirement shall be applied at the *antenna connector* supporting transmission in the *operating band*. The beginning and end point of downlink and uplink bursts are referenced to the slot timing at the input.

For *NCR-Fwd type 1-C*, the *transmitter transient period* shall be shorter than the values listed in the minimum requirement table 6.10.2.2-1.

6.10.2.3.1.2 Minimum requirement for NCR-Fwd type 1-H

For *NCR-Fwd type 1-H* this requirement shall be applied at the *TAB connector* supporting transmission in the *operating band*. The beginning and end point of downlink and uplink bursts are referenced to the slot timing at the input.

For *NCR-Fwd type 1-H*, the *transmitter transient period* shall be shorter than the values listed in the minimum requirement table 6.10.2.2-1.

6.11 Output power dynamics for NCR-MT

6.11.1 General

Output power dynamics is specified in terms of: OFF power, ON/OFF time mask and power control requirements.

6.11.2 Transmit OFF power for NCR-MT

For WA NCR-MT type 1-C and NCR-MT type 1-H, the BS requirements specified in clause 6.4.1.2 in TS 38.104 [2] applies.

For LA NCR-MT type 1-C and NCR-MT type 1-H, the UE requirement specified in clause 6.3.2 in TS 38.101-1 [13] applies.

6.11.3 Transmit ON/OFF time mask for NCR-MT

For WA NCR-MT type 1-C and NCR-MT type 1-H, the BS requirements specified in clause 6.4.2.2 in TS 38.104 [2] applies.

For LA NCR-MT type 1-C and NCR-MT type 1-H, the UE requirements specified in clause 6.3.3 in TS 38.101-1 [13] applies.

6.11.4 Power control for NCR-MT

For WA NCR-MT, The IAB-MT requirements specified in clause 6.3.2 output dynamic range requirement, 6.3.3.1 relative power tolerance and 6.3.3.2 aggregated power tolerance requirements in TS 38.174 [22] applies.

For LA NCR-MT, The UE requirements specified in clause 6.3.4.3 of relative power tolerance and clause 6.3.4.4 of aggregate power tolerance in TS 38.101-1 [13] applies.

6.12 Transmit signal quality for NCR-MT

6.12.1 General

Transmit signal quality is specified in terms of: frequency error and transmit modulation quality requirements.

6.12.2 Frequency error requirements for NCR-MT

The IAB-MT requirements specified in clause 6.5.1.2 in TS 38.174 [22] apply to both NCR-MT type 1-C and NCR-MT type 1-H.

6.12.3 Transmit modulation quality

The IAB-MT requirements specified in clause 6.5.2.2 in TS 38.174 [22] apply to both NCR-MT type 1-C and NCR-MT type 1-H.

6.13 Transmit intermodulation for NCR-MT

6.13.1 General

The transmit intermodulation performance is a measure of the capability of the transmitter to inhibit the generation of signals in its non linear elements caused by presence of the wanted signal and an interfering signal reaching the transmitter via the antenna.

NCR-MT transmit intermodulation is defined by the ratio of the mean power of the wanted signal to the mean power of the intermodulation product when an interfering signal is added at a level below the wanted signal at each transmitter antenna port with the other antenna port(s) if any terminated.

6.13.2 Minimum requirements for NCR-MT

The Tx IMD requirement for IAB-MT specified in clause 6.7 of Rel-16 TS 38.174 [22] apply for WA and LA NCR-MT. The IM interference level is based on NCR-Fwd link.

6.14 Void

6.15 Diversity characteristics for NCR-MT

The Local Area NCR-MT is required to be equipped with a minimum of two Rx antenna ports in all operating bands except for the bands n7, n38, n41, n48, n77, n78, n79, n104 where the NCR-MT is required to be equipped with a minimum of four Rx antenna ports. This requirement applies when the band is used as a standalone band or as part of a band combination.

For the single carrier REFSSENS requirements in Clause 6.16, the Local Area NCR-MT shall be verified with two Rx antenna ports in all supported frequency bands, additional requirements for four Rx ports shall be verified in operating bands where the NCR-MT is equipped with four Rx antenna ports.

For Rx requirements other than single carrier REFSSENS in Clause 6.16, the NCR-MT shall be verified with four Rx antenna ports and skip two Rx antenna ports requirements in operating bands where the NCR-MT is equipped with four Rx antenna ports, otherwise, the NCR-MT shall be verified with two Rx antenna ports.

6.16 Reference sensitivity for NCR-MT

6.16.1 NCR-MT reference sensitivity level

6.16.1.1 General

The reference sensitivity power level P_{REFSENS} is the minimum mean power received at the antenna connector for *NCR-MT type 1-C* or *TAB connector for NCR-MT type 1-H* at which a throughput requirement shall be met for a specified reference measurement channel.

6.16.1.2 Minimum requirements for NCR-MT type 1-C and 1-H

The throughput shall be $\geq 95\%$ of the maximum throughput of the reference measurement channel as specified in annex B.1.5.

The Wide Area NCR-MT reference sensitivity level is specified in table 6.16.1.2-1.

Table 6.16.1.2-1: Wide Area NCR-MT reference sensitivity levels

NCR-MT channel bandwidth (MHz)	Sub-carrier spacing (kHz)	Reference measurement channel	Reference sensitivity power level, P_{REFSENS} (dBm)
5,10,15	15	G-FR1-A1-27 (Note 1)	-101.5
10, 15	30	G-FR1-A1-22 (Note 1)	-102.0
10, 15	60	G-FR1-A1-23 (Note 1)	-99.0
20, 25, 30, 35, 40, 45, 50	15	G-FR1-A1-24 (Note 1)	-95.2
20, 25, 30, 40, 50, 60, 70, 80, 90, 100	30	G-FR1-A1-25 (Note 1)	-95.4
20, 25, 30, 40, 50, 60, 70, 80, 90, 100	60	G-FR1-A1-26 (Note 1)	-95.6
NOTE 1: P_{REFSENS} is the power level of a single instance of the reference measurement channel. This requirement shall be met for each consecutive application of a single instance of the reference measurement channel mapped to disjoint frequency ranges with a width corresponding to the number of resource blocks of the reference measurement channel each, except for one instance that might overlap one other instance to cover the full <i>NCR-MT channel bandwidth</i> .			

The Local Area NCR-MT reference sensitivity level is specified the same as specified in TS 38.101-1 [13] clause 7.3.

Referenced requirements applying to NB IoT are not applicable to the NCR-MT.

6.17 Maximum input level for NCR-MT

Maximum input level is defined as the maximum mean power received at the Local Area NCR-MT antenna port, at which the specified relative throughput shall meet or exceed the minimum requirements for the specified reference measurement channel. For Local Area NCR-MT, the throughput shall be $\geq 95\%$ of the maximum throughput of the reference measurement channels as specified in 38.101-1 [13] Annex A.3.2 and Annex A.3.3 (with one sided dynamic OCNG Pattern OP.1 FDD/TDD as described in Annex A.5.1.1/A.5.2.1) with parameters specified in TS 38.101-1 [13] in Table 7.4-1.

6.18 Adjacent channel selectivity for NCR-MT

6.18.1 Adjacent Channel Selectivity (ACS)

6.18.1.1 General

Adjacent channel selectivity (ACS) is a measure of the receiver's ability to receive a wanted signal at its assigned channel frequency at the antenna connector for *NCR-MT type 1-C* or *TAB connector for NCR-MT type 1-H* in the presence of an adjacent channel signal with a specified centre frequency offset of the interfering signal to the band edge of a victim system.

6.18.1.2 Minimum requirement for NCR-MT type 1-C and 1-H

The throughput shall be $\geq 95\%$ of the maximum throughput of the reference measurement channel as specified in annex B.1.5. For *Wide Area NCR-MT type 1-C* and *type 1-H*, the requirement formulation and interferer levels for minimum requirement are the same as specified for *Wide Area BS type 1-C* and *type 1-H* in TS 38.104 [2], clause 7.4.1.2. The P_{REFSENS} used for wanted signal mean power in TS 38.104 [2] is specified in table 6.16.1.2-1 of TS 38.106.

For Local Area *NCR-MT type 1-C* and *type 1-H*, minimum requirement is the same as specified in TS 38.101-1 [13], clause 7.3.2.

6.18.1.3 Void

6.19 Blocking characteristics for NCR-MT

6.19.1 General

The in-band blocking characteristics is a measure of the receiver's ability to receive a wanted signal at its assigned channel at the *TAB connector* for *NCR-MT type 1-C* and *NCR-MT type 1-H* in the presence of an unwanted interferer, which is an NR signal for general blocking or an NR signal with one resource block for narrowband blocking.

6.19.2 Minimum requirement for NCR-MT type 1-C and 1-H

The throughput shall be $\geq 95\%$ of the maximum throughput of the reference measurement channel as specified in annex B.1.5. For Wide Area *NCR-MT type 1-C* and *type 1-H*, the requirement formulation and interferer levels for minimum requirement are the same as specified for Wide Area BS *type 1-C* and *type 1-H* in TS 38.104 [2], clause 7.4.2.2. The P_{REFSENS} used for wanted signal mean power in TS 38.104 [2] is specified in table 6.16.1.2-1 of TS 38.106.

For Local Area *NCR-MT type 1-C* and *Type 1-H*, minimum requirement is the same as specified in TS 38.101-1 [13] clause 7.6.2.

6.19.3 Void

6.20 Transmitter spurious response for NCR-MT

6.20.1 General

Third and higher order mixing of the two interfering RF signals can produce an interfering signal in the band of the desired channel. Intermodulation response rejection is a measure of the capability of the receiver to receive a wanted signal on its assigned channel frequency at the *antenna connector* for *NCR-MT type 1-C* or *TAB connector* for *NCR-MT type 1-H* in the presence of two interfering signals which have a specific frequency relationship to the wanted signal.

6.20.2 Minimum requirements for NCR-MT type 1-C and NCR-MT type 1-H

For Local Area *NCR-MT type 1-C* and *NCR-MT type 1-H*, minimum requirements are the same as specified in TS 38.101-1 [13], clause 7.7.

6.21 Receiver intermodulation characteristics for NCR-MT

6.21.1 General

Third and higher order mixing of the two interfering RF signals can produce an interfering signal in the band of the desired channel. Intermodulation response rejection is a measure of the capability of the receiver to receive a wanted signal on its assigned channel frequency at the *antenna connector* for *NCR-MT type 1-C* or *TAB connector* for *NCR-MT type 1-H* in the presence of two interfering signals which have a specific frequency relationship to the wanted signal.

6.21.2 Minimum requirement for NCR-MT type 1-C and 1-H

The throughput shall be $\geq 95\%$ of the maximum throughput of the reference measurement channel as specified in annex B.1.5. For Wide Area *NCR-MT type 1-C* and *type 1-H*, the requirement formulation and interferer levels for minimum requirement are the same as specified for Wide Area BS *type 1-C* and *type 1-H* in TS 38.104 [2], clause 7.7.2. The P_{REFSENS} used for wanted signal mean power in TS 38.104 [2] is specified in table 6.16.1.2-1 of TS 38.106.

For Local Area *NCR-MT type 1-C* and *Type 1-H*, minimum requirement at antenna connector is the same as specified in TS 38.101-1 [13], clause 7.8.2.

6.21.3 Void

6.22 Receiver spurious emissions for NCR-MT

6.22.1 General

The receiver spurious emissions power is the power of emissions generated or amplified in a receiver unit that appear at the *antenna connector for NCR-MT type 1-C* and at the *TAB connector for NCR-MT type 1-H*. The requirements apply to all NCR-MT with separate RX and TX *TAB connectors*.

For *TAB connectors* supporting both RX and TX in TDD, the requirements apply during the *transmitter OFF period*.

For RX-only *multi-band connectors*, the spurious emissions requirements are subject to exclusion zones in each supported *operating band*. For *multi-band connectors* that both transmit and receive in *operating band* supporting TDD, RX spurious emissions requirements are applicable during the *TX OFF period*, and are subject to exclusion zones in each supported *operating band*.

For *NCR-MT type 1-H* manufacturer shall declare *TAB connector RX min cell groups*. Every *TAB connector of -NCR-MT type 1-H* supporting reception in an *operating band* shall map to one *TAB connector RX min cell group*, where mapping of *TAB connectors* to cells/beams is implementation dependent.

The number of active receiver units that are considered when calculating the conducted RX spurious emission limits ($N_{\text{RXU, counted}}$) for Wide Area *NCR-MT type 1-H* is calculated as follows:

$$N_{\text{RXU, counted}} = \min(N_{\text{RXU, active}}, 8)$$

NOTE: $N_{\text{RXU, active}}$ is the number of actually active receiver units.

6.22.2 Minimum requirements for NCR-MT type 1-C and type 1-H

The receiver spurious emissions requirements for *NCR-MT type 1-C at the antenna connector* and *NCR-MT type 1-H* are that for each *TAB connector*, the power of emissions shall not exceed the value specified in table 6.22.2-1.

Table 6.22.2-1: NCR-MT type 1-C and type 1-H receiver spurious emissions minimum requirements

Spurious frequency range	Basic requirements	Measurement bandwidth	Note
30 MHz – 1 GHz	-57 dBm	100 kHz	Note 1
1 GHz – 12.75 GHz	-47 dBm	1 MHz	Note 1, Note 2
12.75 GHz – 5 th harmonic of the upper frequency edge of the UL <i>operating band</i> in GHz	-47 dBm	1 MHz	Note 1, Note 2, Note 3, Note 5
12.75 GHz - 26 GHz	-47 dBm	1 MHz	Note 1, Note 2, Note 6
NOTE 1: <i>Measurement bandwidths</i> as in ITU-R SM.329 [5], s4.1.			
NOTE 2: Upper frequency as in ITU-R SM.329 [5], s2.5 table 1.			
NOTE 3: This spurious frequency range applies only for <i>operating bands</i> for which the 5 th harmonic of the upper frequency edge of the UL <i>operating band</i> is reaching beyond 12.75 GHz.			
NOTE 4: The frequency range from Δf_{OBUE} below the lowest frequency of the repeater transmitter <i>operating band</i> to Δf_{OBUE} above the highest frequency of the repeater transmitter <i>operating band</i> may be excluded from the requirement. Δf_{OBUE} is defined in clause 6.5.1. For <i>multi-band connectors</i> , the exclusion applies for all supported <i>operating bands</i> .			
NOTE 5: Does not apply for band n104.			
NOTE 6: Applies only for band n104.			

7 Radiated characteristics

7.1 General

Clause 7 includes the radiated characteristics for both transmitter and receiver.

For radiated transmitter characteristics:

Radiated transmitter characteristics are specified at RIB for *repeater type 2-O*, *NCR- type 1-H* (including Fwd and MT interfaces), and *NCR type 2-O* (including Fwd and MT interfaces) including all its functional components active and for all foreseen modes of operation unless otherwise stated.

For radiated receiver characteristics:

Radiated receiver characteristics are specified at RIB for *NCR type 1-H* or *NCR type 2-O*, with full complement of transceivers for the configuration in normal operating condition.

Unless otherwise stated, the following arrangements apply for radiated receiver characteristics requirements in clause 7:

- Requirements apply during the receive period.
- Requirements shall be met for any transmitter setting.
- Throughput requirements defined for the conducted receiver characteristics do not assume HARQ retransmissions.
- For ACS, blocking and intermodulation characteristics, the negative offsets of the interfering signal apply relative to the lower *passband* edge or *inter-passband gap*, and the positive offsets of the interfering signal apply relative to the upper *passband* edge or *inter-passband gap*.

NOTE 1: In normal operating condition the NCR-MT in TDD operation is configured to TX OFF power during receive period.

All requirements are defined for normal conditions, unless otherwise stated.

7.2 OTA output power

7.2.1 General

Repeater type 2-O, *NCR-Fwd type 2-O* are declared to support one or more beams, as per manufacturer's declarations specified in TS 38.115-2 [8]. Radiated transmit power is defined as the EIRP level for a declared beam at a specific *beam peak direction*.

For each beam, the requirement is based on declaration of a beam identity, *reference beam direction pair*, beamwidth, *rated beam EIRP*, *OTA peak directions set*, the *beam direction pairs* at the maximum steering directions and their associated *rated beam EIRP* and beamwidth(s).

For a declared beam and *beam direction pair*, the *rated beam EIRP* level is the maximum power that the repeater is declared to radiate at the associated *beam peak direction*.

For each *beam peak direction* associated with a *beam direction pair* within the *OTA peak directions set*, a specific *rated beam EIRP* level may be claimed. Any claimed value shall be met within the accuracy requirement as described below. *Rated beam EIRP* is only required to be declared for the *beam direction pairs* subject to conformance testing as detailed in TS 38.115-2 [8].

NOTE 1: OTA peak directions set is set of beam peak directions for which the EIRP accuracy requirement is intended to be met. The beam peak directions are related to a corresponding contiguous range or discrete list of beam centre directions by the beam direction pairs included in the set.

NOTE 2: A beam direction pair is data set consisting of the beam centre direction and the related beam peak direction.

NOTE 3: A declared EIRP value is a value provided by the manufacturer for verification according to the conformance specification declaration requirements, whereas a claimed EIRP value is provided by the manufacturer to the equipment user for normal operation of the equipment and is not subject to formal conformance testing.

For *pass bands* where the supported *fractional bandwidth* (FBW) is larger than 6%, two rated beam EIRP may be declared by manufacturer:

- $P_{\text{rated,out,FBWlow}}$ for lower supported frequency range, and
- $P_{\text{rated,out,FBWhigh}}$ for higher supported frequency range.

For frequencies in between F_{FBWlow} and F_{FBWhigh} the rated beam EIRP is:

- $P_{\text{rated,out,FBWlow}}$, for the output whose frequency is within frequency range $F_{\text{FBWlow}} \leq f < (F_{\text{FBWlow}} + F_{\text{FBWhigh}}) / 2$,
- $P_{\text{rated,out,FBWhigh}}$, for the output whose frequency is within frequency range $(F_{\text{FBWlow}} + F_{\text{FBWhigh}}) / 2 \leq f \leq F_{\text{FBWhigh}}$.

For *repeater type 2-O*, *NCR-Fwd type 2-O*, OTA repeater output power is also declared as a TRP radiated requirement, with the output power accuracy requirement defined at the RIB. TRP does not change with beamforming settings as long as the *beam peak direction* is within the *OTA peak directions set*. Thus, the TRP accuracy requirement shall be met for any beamforming setting for which the *beam peak direction* is within the *OTA peak directions set*.

There is no upper limit for the *rated TRP output power* and the *rated beam EIRP output power* of *repeater type 2-O* DL transmission.

The *repeater rated TRP output power* and the *rated beam EIRP output power* for *repeater type 2-O* UL transmission shall be within limits as specified in table 7.2.1-1.

Table 7.2.1-1: Repeater *rated TRP output power* limits and *rated EIRP output power* limits for *repeater type 2-O* UL transmission

Repeater class	$P_{\text{rated,p,TRP}}$	$P_{\text{rated,p,EIRP}}$
Wide Area	(note 1)	(note 1)
Local Area	$\leq + 35 + X$ dBm (Note 2)	$\leq + 55 + X$ dBm (Note 2)
NOTE1: There is no upper limit for the $P_{\text{rated,p,TRP}}$ or $P_{\text{rated,p,EIRP}}$ of the <i>repeater type 2-O</i> UL transmission.		
NOTE2: $X = 10 \cdot \log(\text{ceil}(\text{passband bandwidth}/100\text{MHz}))$		

There is no upper limit for the *rated TRP output power* and the *rated beam EIRP output power* of *NCR-Fwd type 2-O* DL transmission.

The *repeater rated TRP output power* and the *rated beam EIRP output power* for *NCR-Fwd type 2-O* UL transmission shall be within limits as specified in table 7.2.1-2.

Table 7.2.1-2: *Rated TRP output power* limits and *rated beam EIRP output power* limits for *NCR-Fwd type 2-O* UL transmission

NCR-Fwd class	$P_{\text{rated,p,TRP}}$	$P_{\text{rated,p,EIRP}}$
Wide Area	(note 1)	(note 1)
Local Area	$\leq + 35 + X$ dBm (Note 2)	$\leq + 55 + X$ dBm (Note 2)
NOTE1: There is no upper limit for the $P_{\text{rated,p,TRP}}$ or $P_{\text{rated,p,EIRP}}$ of the <i>NCR type 2-O</i> UL transmission.		
NOTE2: $X = 10 \cdot \log(\text{ceil}(\text{passband bandwidth}/100\text{MHz}))$		

7.2.2 Minimum requirement for RF repeater

The AoA of the input signal shall be the same as the reference direction for the *OTA peak directions set* when operating in the opposite DL/UL direction.

The requirements shall apply with NR signals in the *passband* of the repeater at:

The lowest input power ($P_{p,in,EIRP}$) that produces the *rated passband TRP output power* ($P_{rated,p,TRP}$)

Up to:

The lowest input power ($P_{p,in,EIRP}$) that produces the *rated passband TRP output power* ($P_{rated,p,TRP}$), plus 10dB

In normal conditions, the measured output power, $P_{max,p,EIRP}$ shall remain within +3.4 dB and -3.4 dB of the *rated beam EIRP output power* $P_{rated,p,EIRP}$, declared by the manufacturer.

In extreme conditions, the measured output power, $P_{max,p,EIRP}$ shall remain within +4.5 dB and -4.5 dB of the *rated beam EIRP output power* $P_{rated,p,EIRP}$, declared by the manufacturer.

In normal conditions, the *repeater type 2-O maximum passband TRP output power*, $P_{max,p,TRP}$ measured at the RIB shall remain within ± 3 dB of the *rated passband TRP output power* $P_{rated,p,TRP}$, as declared by the manufacturer.

7.2.3 Minimum requirement for NCR

7.2.3.1 Minimum requirement for NCR-MT

7.2.3.1.1 Minimum requirement for NCR-MT type 1-H

For NCR-MT type 1-H, the IAB requirement specified in clause 9.2.2 in TS 38.174 [22] apply.

7.2.3.1.2 Minimum requirement for NCR-MT type 2-O

For NCR-MT type 2-O, the IAB requirement specified in clause 9.2.3 in TS 38.174 [22] apply.

7.2.3.2 Minimum requirement for NCR-Fwd

7.2.3.2.1 Minimum requirement for NCR-Fwd type 2-O

The AoA of the input signal shall be within the *Gain REFSENS RoAoA*.

The requirements shall apply with NR signals in the *passband* of the NCR-Fwd at:

- The lowest input power ($P_{p,in,EIRP}$) that produces the *rated passband TRP output power* ($P_{rated,p,TRP}$)

Up to:

- The lowest input power ($P_{p,in,EIRP}$) that produces the *rated passband TRP output power* ($P_{rated,p,TRP}$), plus 10dB

In normal conditions, the measured output power, $P_{max,p,EIRP}$ shall remain within +3.4 dB and -3.4 dB of the *rated beam EIRP output power* $P_{rated,p,EIRP}$, declared by the manufacturer.

In extreme conditions, the measured output power, $P_{max,p,EIRP}$ shall remain within +4.5 dB and -4.5 dB of the *rated beam EIRP output power* $P_{rated,p,EIRP}$, declared by the manufacturer.

In normal conditions, the *repeater type 2-O maximum passband TRP output power*, $P_{max,p,TRP}$ measured at the RIB shall remain within ± 3 dB of the *rated passband TRP output power* $P_{rated,p,TRP}$, as declared by the manufacturer.

7.3 OTA frequency stability

7.3.1 General

Frequency stability is the ability to maintain the same frequency on the output signal with respect to the input signal.

OTA frequency stability requirement is defined as a *directional requirement* at the RIB and shall be met within the *OTA coverage range*.

7.3.2 Minimum requirement for RF repeater

The frequency deviation of the output signal with respect to the input signal shall be no more than $\pm 0,01$ PPM.

7.3.3 Minimum requirement for NCR

7.3.3.1 Minimum requirement for NCR-Fwd

7.3.3.1.1 Minimum requirement for NCR-Fwd type 2-O

The frequency deviation of the output signal with respect to the input signal shall be no more than $\pm 0,01$ PPM.

7.4 OTA out of band gain

7.4.1 General

Out of band gain refers to the gain of the repeater outside the *passband*.

The requirement is based on the ratio of TRP output power to directional input power.

The intended use of a repeater in a system is to amplify the in-band signals and not to amplify signals outside of the *passband*.

In the intended application of the repeater, the out of band gain is less than lowest expected the coupling loss to the nearest source of emissions.

7.4.2 Minimum requirement for RF repeater

The gain outside the *passband* shall not exceed the maximum level specified in table 7.4.2-1, where:

- $f_{\text{offset_CW}}$ is the offset between the outer channel edge frequency of the outer channel in the *passband* and a CW signal.

Table 7.4.2-1: Out of band gain limits 1

Frequency offset, $f_{\text{offset_CW}}$	Maximum gain
$0.1 * \text{Minimum} \{400\text{MHz}, \text{passband BW}\} \leq f_{\text{offset_CW}} < 150$ MHz	68 dB
$150 \text{ MHz} \leq f_{\text{offset_CW}} < 400 \text{ MHz}$	55 dB
$400 \text{ MHz} \leq f_{\text{offset_CW}} < f_{\text{offset_max}}$	35 dB

7.4.3 Minimum requirement for NCR

7.4.3.1 Minimum requirement for NCR-Fwd

7.4.3.1.1 Minimum requirement for NCR-Fwd type 2-O

The gain outside the *passband* shall not exceed the maximum level specified in Table 7.4.2-1.

7.5 OTA unwanted emissions

7.5.1 General

Unwanted emissions consist of so-called out-of-band emissions and spurious emissions according to ITU definitions ITU-R SM.329 [5]. In ITU terminology, out of band emissions are unwanted emissions immediately outside the *passband* resulting from the modulation process and non-linearity in the transmitter but excluding spurious emissions. Spurious emissions are emissions which are caused by unwanted transmitter effects such as harmonics emission, parasitic emission, intermodulation products and frequency conversion products, but exclude out of band emissions.

The OTA out-of-band emissions requirement for the *repeater type 2-O* transmitter is specified both in terms of Adjacent Channel Leakage power Ratio (ACLR) and operating band unwanted emissions (OBUE). OTA Unwanted emissions outside of this frequency range are limited by an OTA spurious emissions requirement.

The maximum offset of the operating band unwanted emissions mask from the *operating band* edge is Δf_{OBUE} . The value of Δf_{OBUE} are defined in table 7.5.1-1 and 7.5.1-2 for *repeater type 2-O* for NR *operating bands*.

Table 7.5.1-1: Maximum offset Δf_{OBUE} outside the downlink operating band for repeater type 2-O and NCR-Fwd type 2-O DL

Repeater type	Operating band characteristics	Δf_{OBUE} (MHz)
Repeater type 2-O NCR-Fwd type 2-O	$F_{\text{DL,high}} - F_{\text{DL,low}} \leq 4000$ MHz	1500

Table 7.5.1-2: Maximum offset Δf_{OBUE} outside the downlink operating band for repeater type 2-O and NCR-Fwd type 2-O UL

Repeater type	Operating band characteristics	Δf_{OBUE} (MHz)
Repeater type 2-O, NCR-Fwd type 2-O	$F_{\text{UL,high}} - F_{\text{UL,low}} \leq 4000$ MHz	1500

The unwanted emission requirements are applied per cell for all the configurations. Requirements for OTA unwanted emissions are captured using TRP, *directional requirements* or co-location requirements as described per requirement.

If the NCR supports simultaneous NCR-MT and NCR-Fwd transmission, then the unwanted emissions requirements should be defined on the total emissions from NCR-MT and NCR-Fwd.

7.5.2 OTA Adjacent Channel Leakage Power Ratio (ACLR)

7.5.2.1 General

OTA Adjacent Channel Leakage power Ratio (ACLR) is the ratio of the filtered mean power centred on the assigned channel frequency to the filtered mean power centred on an adjacent channel frequency. The measured power is TRP.

The requirement shall be applied per RIB during the *transmitter ON state*.

7.5.2.2 Minimum requirement for RF repeater

The OTA ACLR limit is specified in table 7.5.2.2-1 for DL and UL for Wide Area class and DL for Local Area class.

The OTA ACLR limit is specified in table 7.5.2.2-1a for UL for Local Area class.

The OTA ACLR absolute limit is specified in table 7.5.2.2-2.

Either the OTA ACLR (CACLR) absolute limit in table 7.5.2.2-2 or 7.5.2.2-5 or the relevant ACLR (CACLR) limit in table 7.5.2.2-1, 7.5.2.2-1a, 7.5.2.2-3, 7.5.2.2-3a, 7.5.2.2-4 or 7.5.2.2-4a, whichever is less stringent, shall apply.

For a RIB operating in *non-contiguous spectrum*, the OTA ACLR requirement in table 7.5.2.2-3 shall apply in *gaps between passbands* for the frequency ranges defined in the table, while the OTA CACLR requirement in table 7.5.2.2-4 shall apply in *gaps between passbands* for the frequency ranges defined in the table.

The CA CLR in a *gap between passbands* is the ratio of:

- a) the sum of the filtered mean power centred on the assigned channel frequencies for the two carriers adjacent to each side of the *gap between passbands*, and
- b) the filtered mean power centred on a frequency channel adjacent to one of the respective *passband* edges.

The assumed filter for the adjacent channel frequency is defined in table 7.5.2.2-4 and the filters on the assigned channels are defined in table 7.5.2.2-6.

For operation in *non-contiguous spectrum*, the CA CLR for NR carriers located on either side of the *gap between passbands* shall be higher than the value specified in table 7.5.2.2-4.

Table 7.5.2.2-1: Repeater type 2-O ACLR limit for DL and UL for WA class and DL for LA class

Repeater nominal channel bandwidth BW_{Nominal} (MHz)	Repeater adjacent channel centre frequency offset below or above the passband edge	Assumed adjacent channel carrier	Filter on the adjacent channel frequency and corresponding filter bandwidth	ACLR limit (dB)
50, 100, 200, 400	$BW_{\text{Nominal}}/2$	NR of same BW (Note 2)	Square (BW_{Config})	28 (Note 3) 26 (Note 4)
NOTE 1: BW_{Nominal} is the <i>nominal channel bandwidth</i> . BW_{Config} is the <i>transmission bandwidth configuration</i> assumed for the adjacent channel. NOTE 2: With SCS that provides the largest <i>transmission bandwidth configuration</i> (BW_{Config}). NOTE 3: Applicable to bands defined within the frequency spectrum range of 24.25 – 33.4 GHz NOTE 4: Applicable to bands defined within the frequency spectrum range of 37 – 52.6 GHz NOTE 5: For simultaneous NCR-Fwd and NCR-MT transmission, if the NCR-MT carrier is within the passband then the nominal channel bandwidth shall be calculated based on the the bandwidth between the lower edge of the passband and the lower edge of the NCR-MT carrier for lower side, or between the upper edge of the passband and the upper edge of the NCR-MT carrier for upper side. If the NCT-MT carrier is adjacent to the passband then ACLR requirement for NCR-MT based on NCR-MT channel bandwidth shall be applied for the NCR-MT carrier side and the nominal channel bandwidth calculated with the passband bandwidth shall be used for the passband side. If the NCR-MT carrier is not adjacent to the passband then CA CLR shall be applied in the gap between the passband and the NCR-MT carrier.				

Table 7.5.2.2-1a: Repeater type 2-O ACLR limit for UL LA class

Repeater nominal channel bandwidth BW_{Nominal} (MHz)	Repeater adjacent channel centre frequency offset below or above the passband edge	Assumed adjacent channel carrier	Filter on the adjacent channel frequency and corresponding filter bandwidth	ACLR limit (dB)
50, 100, 200, 400	$BW_{\text{Nominal}}/2$	NR of same BW (Note 2)	Square (BW_{Config})	17 (Note 3) 16 (Note 4)
NOTE 1: BW_{Nominal} is the <i>nominal channel bandwidth</i> . BW_{Config} is the <i>transmission bandwidth configuration</i> assumed for the adjacent channel. NOTE 2: With SCS that provides the largest <i>transmission bandwidth configuration</i> (BW_{Config}). NOTE 3: Applicable to bands defined within the frequency spectrum range of 24.25 – 33.4 GHz NOTE 4: Applicable to bands defined within the frequency spectrum range of 37 – 52.6 GHz NOTE 5: For simultaneous NCR-Fwd and NCR-MT transmission, if the NCR-MT carrier is within the passband then the nominal channel bandwidth shall be calculated based on the the bandwidth between the lower edge of the passband and the lower edge of the NCR-MT carrier for lower side, or between the upper edge of the passband and the upper edge of the NCR-MT carrier for upper side. If the NCT-MT carrier is adjacent to the passband then ACLR requirement for NCR-MT based on NCR-MT channel bandwidth shall be applied for the NCR-MT carrier side and the nominal channel bandwidth calculated with the passband bandwidth shall be used for the passband side. If the NCR-MT carrier is not adjacent to the passband then CA CLR shall be applied in the gap between the passband and the NCR-MT carrier.				

Table 7.5.2.2-2: Repeater type 2-O ACLR absolute limit

Repeater class	ACLR absolute limit
Wide area DL and UL	-13 dBm/MHz
Medium range DL	-20 dBm/MHz
Local area DL	-20 dBm/MHz

Table 7.5.2.2-3: Repeater type 2-O ACLR limit in non-contiguous spectrum for DL and UL for WA class and DL for LA class

Repeater nominal channel bandwidth BW_{Nominal} (MHz)	Gap between passbands size (W_{gap}) where the limit applies (MHz)	Repeater adjacent channel centre frequency offset below or above the passband edge (inside the gap)	Assumed adjacent channel carrier	Filter on the adjacent channel frequency and corresponding filter bandwidth	ACLR limit
50, 100, 200, 400	$W_{\text{gap}} \geq 100$ (Note 5) $W_{\text{gap}} \geq 250$ (Note 6)	25 MHz	50 MHz NR (Note 2)	Square (BW_{Config})	28 (Note 3) 26 (Note 4)
50, 100, 200, 400	$W_{\text{gap}} \geq 400$ (Note 6) $W_{\text{gap}} \geq 250$ (Note 5)	100 MHz	200 MHz NR (Note 2)	Square (BW_{Config})	28 (Note 3) 26 (Note 4)

NOTE 1: BW_{Nominal} is the *nominal channel bandwidth*. BW_{Config} is the *transmission bandwidth configuration* assumed for the adjacent channel.
NOTE 2: With SCS that provides the largest *transmission bandwidth configuration* (BW_{Config}).
NOTE 3: Applicable to bands defined within the frequency spectrum range of 24.25 – 33.4 GHz.
NOTE 4: Applicable to bands defined within the frequency spectrum range of 37 – 52.6 GHz.
NOTE 5: Applicable in case the *repeater type 2-O nominal channel bandwidth* at the other edge of the gap is ≤ 100 MHz.
NOTE 6: Applicable in case the *repeater type 2-O nominal channel bandwidth* at the other edge of the gap is > 100 MHz.

Table 7.5.2.2-3a: Repeater type 2-O ACLR limit in non-contiguous spectrum for UL for LA class

Repeater nominal channel bandwidth BW_{Nominal} (MHz)	Gap between passbands size (W_{gap}) where the limit applies (MHz)	Repeater adjacent channel centre frequency offset below or above the passband edge (inside the gap)	Assumed adjacent channel carrier	Filter on the adjacent channel frequency and corresponding filter bandwidth	ACLR limit
50, 100, 200, 400	$W_{\text{gap}} \geq 100$ (Note 5) $W_{\text{gap}} \geq 250$ (Note 6)	25 MHz	50 MHz NR (Note 2)	Square (BW_{Config})	17 (Note 3) 16 (Note 4)
50, 100, 200, 400	$W_{\text{gap}} \geq 400$ (Note 6) $W_{\text{gap}} \geq 250$ (Note 5)	100 MHz	200 MHz NR (Note 2)	Square (BW_{Config})	17 (Note 3) 16 (Note 4)

NOTE 1: BW_{Config} is the *transmission bandwidth configuration* assumed for the adjacent channel.
NOTE 2: With SCS that provides the largest *transmission bandwidth configuration* (BW_{Config}).
NOTE 3: Applicable to bands defined within the frequency spectrum range of 24.25 – 33.4 GHz.
NOTE 4: Applicable to bands defined within the frequency spectrum range of 37 – 52.6 GHz.
NOTE 5: Applicable in case the *repeater type 2-O nominal channel bandwidth* at the other edge of the gap is ≤ 100 MHz.
NOTE 6: Applicable in case the *repeater type 2-O nominal channel bandwidth* at the other edge of the gap is > 100 MHz.

Table 7.5.2.2-4: Repeater type 2-O CACLR limit in non-contiguous spectrum for DL and UL for WA class and DL for LA class

Repeater nominal channel bandwidth BW_{Nominal} (MHz)	Gap between passbands size (W_{gap}) where the limit applies (MHz)	Repeater adjacent channel centre frequency offset below or above the passband edge (inside the gap)	Assumed adjacent channel carrier	Filter on the adjacent channel frequency and corresponding filter bandwidth	CACLR limit
50, 100, 200, 400	$50 \leq W_{\text{gap}} < 100$ (Note 5) $50 \leq W_{\text{gap}} < 250$ (Note 6)	25 MHz	50 MHz NR (Note 2)	Square (BW_{Config})	28 (Note 3) 26 (Note 4)
50, 100, 200, 400	$200 \leq W_{\text{gap}} < 400$ (Note 6) $200 \leq W_{\text{gap}} < 250$ (Note 5)	100 MHz	200 MHz NR (Note 2)	Square (BW_{Config})	28 (Note 3) 26 (Note 4)

NOTE 1: BW_{Config} is the *transmission bandwidth configuration* assumed for the adjacent channel.
NOTE 2: With SCS that provides the largest *transmission bandwidth configuration* (BW_{Config}).
NOTE 3: Applicable to bands defined within the frequency spectrum range of 24.25 – 33.4 GHz.
NOTE 4: Applicable to bands defined within the frequency spectrum range of 37 – 52.6 GHz.
NOTE 5: Applicable in case the *repeater type 2-O nominal channel bandwidth* at the other edge of the gap is ≤ 100 MHz.
NOTE 6: Applicable in case the *repeater type 2-O nominal channel bandwidth* at the other edge of the gap is > 100 MHz.

Table 7.5.2.2-4a: Repeater type 2-O CACLR limit in non-contiguous spectrum for UL for LA class

Repeater nominal channel bandwidth BW_{Nominal} (MHz)	Gap between passbands size (W_{gap}) where the limit applies (MHz)	Repeater adjacent channel centre frequency offset below or above the passband edge (inside the gap)	Assumed adjacent channel carrier	Filter on the adjacent channel frequency and corresponding filter bandwidth	CACLR limit
50, 100, 200, 400	$50 \leq W_{\text{gap}} < 100$ (Note 5) $50 \leq W_{\text{gap}} < 250$ (Note 6)	25 MHz	50 MHz NR (Note 2)	Square (BW_{Config})	17 (Note 3) 16 (Note 4)
50, 100, 200, 400	$200 \leq W_{\text{gap}} < 400$ (Note 6) $200 \leq W_{\text{gap}} < 250$ (Note 5)	100 MHz	200 MHz NR (Note 2)	Square (BW_{Config})	17 (Note 3) 16 (Note 4)

NOTE 1: BW_{Config} is the *transmission bandwidth configuration* assumed for the adjacent channel.
NOTE 2: With SCS that provides the largest *transmission bandwidth configuration* (BW_{Config}).
NOTE 3: Applicable to bands defined within the frequency spectrum range of 24.25 – 33.4 GHz.
NOTE 4: Applicable to bands defined within the frequency spectrum range of 37 – 52.6 GHz.
NOTE 5: Applicable in case the *repeater type 2-O nominal channel bandwidth* at the other edge of the gap is ≤ 100 MHz.
NOTE 6: Applicable in case the *repeater type 2-O nominal channel bandwidth* at the other edge of the gap is > 100 MHz.

Table 7.5.2.2-5: Repeater type 2-O CACLR absolute limit

Repeater class	CACLR absolute limit
Wide area DL and UL	-13 dBm/MHz
Medium range DL	-20 dBm/MHz
Local area DL	-20 dBm/MHz

Table 7.5.2.2-6: Filter parameters for the assigned channel

RAT of the carrier adjacent to the <i>gap between passbands</i>	Filter on the assigned channel frequency and corresponding filter bandwidth
NR	NR of same BW with SCS that provides largest <i>transmission bandwidth configuration</i>

7.5.2.3 Minimum requirement for NCR

7.5.2.3.1 Minimum requirement for NCR-Fwd

7.5.2.3.1.1 Minimum requirement for NCR-Fwd type 2-O

The requirements in clause 7.5.2.2 apply for NCR-Fwd type 2-O. The limits apply to the sum of emissions from NCR-MT and NCR-FWD when transmitting simultaneously.

7.5.2.3.2 Minimum requirement for NCR-MT

7.5.2.3.2.1 Minimum requirement for NCR-MT type 2-O

For WA NCR-MT type 2-O, the BS ACLR requirements specified in clause 9.7.3.3 in TS 38.104 apply.

For LA NCR-MT type 2-O, the UE ACLR requirements specified in clause 6.5.2.3 in TS 38.101-2 apply.

For simultaneous transmission the limits apply for sum of NCR-MT transmission and NCR-Fwd transmission

7.5.3 OTA operating band unwanted emissions

7.5.3.1 General

The OTA limits for operating band unwanted emissions are specified as TRP per RIB unless otherwise stated.

In addition to, for the part of passband where there is no input signal, -13dBm/MHz shall apply for all classes DL and UL.

7.5.3.2 Minimum requirement for RF repeater

7.5.3.2.1 General

The requirements of either clause 7.5.3.2.2 (Category A limits) or clause 7.5.3.2.3 (Category B limits) shall apply. The application of either Category A or Category B limits shall be the same as for General OTA transmitter spurious emissions requirements (*repeater type 2-O*) in clause 7.5.3.3.2. In addition, the limits in clause 7.5.3.2.4 may also apply.

Out-of-band emissions in FR2 are limited by OTA operating band unwanted emission limits.

For *repeater type 2-O*, unless otherwise stated, the OTA operating band unwanted emission limits in FR2 are defined from Δf_{OBUE} below the lowest frequency of each supported downlink *operating band* up to Δf_{OBUE} above the highest frequency of each supported downlink *operating band*.

The values of Δf_{OBUE} are defined in table 7.5.1-1 and 7.5.1-2 for the NR *operating bands*.

The requirements shall apply whatever the type of transmitter considered and for all transmission modes foreseen by the manufacturer's specification. For a *RIB* operating in contiguous CA, the requirements apply to the frequencies (Δf_{OBUE}) starting from the edge of the *passband*. In addition, for a *RIB* operating in *non-contiguous spectrum*, the requirements apply inside any *gap between passbands*.

Emissions shall not exceed the maximum levels specified in the tables below, where:

- Δf is the separation between the *passband* edge frequency and the nominal -3dB point of the measuring filter closest to the *passband* edge.
- f_{offset} is the separation between the *passband* edge frequency and the centre of the measuring filter.
- $f_{\text{offset}_{\text{max}}}$ is the offset to the frequency Δf_{OBUE} outside the downlink *operating band*, where Δf_{OBUE} is defined in table 7.5.1-1 and 7.5.1-2.

- Δf_{\max} is equal to $f_{\text{offset}_{\max}}$ minus half of the bandwidth of the measuring filter.

In addition, inside any *gap between passbands* for a *RIB* operating in *non-contiguous spectrum*, emissions shall not exceed the cumulative sum of the limits specified for the adjacent *sub-blocks* on each side of the *gap between passbands*. The limit for each *sub-block* is specified in clauses 7.5.3.2.2 and 7.5.3.2.3 below, where in this case:

- Δf is the separation between the *sub-block* edge frequency and the nominal -3 dB point of the measuring filter closest to the *sub-block* edge.
- f_{offset} is the separation between the *sub-block* edge frequency and the centre of the measuring filter.
- $f_{\text{offset}_{\max}}$ is equal to the *gap between passbands* bandwidth minus half of the bandwidth of the measuring filter.
- Δf_{\max} is equal to $f_{\text{offset}_{\max}}$ minus half of the bandwidth of the measuring filter.

7.5.3.2.2 OTA operating band unwanted emission limits (Category A)

Repeater type 2-O unwanted emissions shall not exceed the maximum levels specified in tables 7.5.3.2.2-1 and 7.5.3.2.2-2.

Table 7.5.3.2.2-1: OBUE limits applicable in the frequency range 24.25 – 33.4 GHz

Frequency offset of measurement filter -3B point, Δf	Frequency offset of measurement filter centre frequency, f_{offset}	Limit	Measurement bandwidth
$0 \text{ MHz} \leq \Delta f < 0.1 * \text{BW}_{\text{contiguous}}$	$0.5 \text{ MHz} \leq f_{\text{offset}} < 0.1 * \text{BW}_{\text{contiguous}} + 0.5 \text{ MHz}$	Min(-5 dBm, Max($P_{\text{rated,t,TRP}} - 35 \text{ dB}$, -12 dBm))	1 MHz
$0.1 * \text{BW}_{\text{contiguous}} \leq \Delta f < \Delta f_{\max}$	$0.1 * \text{BW}_{\text{contiguous}} + 0.5 \text{ MHz} \leq f_{\text{offset}} < f_{\text{offset}_{\max}}$	Min(-13 dBm, Max($P_{\text{rated,t,TRP}} - 43 \text{ dB}$, -20 dBm))	1 MHz
NOTE 1: For <i>non-contiguous spectrum</i> operation within any <i>operating band</i> the limit within <i>gaps between passbands</i> is calculated as a cumulative sum of contributions from adjacent <i>sub-blocks</i> on each side of the <i>gap between passbands</i> .			

Table 7.5.3.2.2-2: OBUE limits applicable in the frequency range 37 – 52.6 GHz

Frequency offset of measurement filter -3B point, Δf	Frequency offset of measurement filter centre frequency, f_{offset}	Limit	Measurement bandwidth
$0 \text{ MHz} \leq \Delta f < 0.1 * \text{BW}_{\text{contiguous}}$	$0.5 \text{ MHz} \leq f_{\text{offset}} < 0.1 * \text{BW}_{\text{contiguous}} + 0.5 \text{ MHz}$	Min(-5 dBm, Max($P_{\text{rated,t,TRP}} - 33 \text{ dB}$, -12 dBm))	1 MHz
$0.1 * \text{BW}_{\text{contiguous}} \leq \Delta f < \Delta f_{\max}$	$0.1 * \text{BW}_{\text{contiguous}} + 0.5 \text{ MHz} \leq f_{\text{offset}} < f_{\text{offset}_{\max}}$	Min(-13 dBm, Max($P_{\text{rated,t,TRP}} - 41 \text{ dB}$, -20 dBm))	1 MHz
NOTE 1: For <i>non-contiguous spectrum</i> operation within any <i>operating band</i> the limit within <i>gaps between passbands</i> is calculated as a cumulative sum of contributions from adjacent <i>sub-blocks</i> on each side of the <i>gap between passbands</i> .			

7.5.3.2.3 OTA operating band unwanted emission limits (Category B)

Repeater type 2-O unwanted emissions shall not exceed the maximum levels specified in table 7.5.3.2.3-1 or 7.5.3.2.3-2.

Table 7.5.3.2.3-1: OBUE limits applicable in the frequency range 24.25 – 33.4 GHz

Frequency offset of measurement filter -3 dB point, Δf	Frequency offset of measurement filter centre frequency, f_{offset}	Limit	Measurement bandwidth
$0 \text{ MHz} \leq \Delta f < 0.1 * BW_{\text{contiguous}}$	$0.5 \text{ MHz} \leq f_{\text{offset}} < 0.1 * BW_{\text{contiguous}} + 0.5 \text{ MHz}$	Min(-5 dBm, Max($P_{\text{rated,t,TRP}} - 35 \text{ dB}$, -12 dBm))	1 MHz
$0.1 * BW_{\text{contiguous}} \leq \Delta f < \Delta f_{\text{B}}$	$0.1 * BW_{\text{contiguous}} + 0.5 \text{ MHz} \leq f_{\text{offset}} < \Delta f_{\text{B}} + 0.5 \text{ MHz}$	Min(-13 dBm, Max($P_{\text{rated,t,TRP}} - 43 \text{ dB}$, -20 dBm))	1 MHz
$\Delta f_{\text{B}} \leq \Delta f < \Delta f_{\text{max}}$	$\Delta f_{\text{B}} + 5 \text{ MHz} \leq f_{\text{offset}} < f_{\text{offset}_{\text{max}}}$	Min(-5 dBm, Max($P_{\text{rated,t,TRP}} - 33 \text{ dB}$, -10 dBm))	10 MHz
NOTE 1: For non-contiguous spectrum operation within any <i>operating band</i> the limit within gaps between <i>passbands</i> is calculated as a cumulative sum of contributions from adjacent sub-blocks on each side of the gap between <i>passbands</i> .			
NOTE 2: $\Delta f_{\text{B}} = 2 * BW_{\text{contiguous}}$ when $BW_{\text{contiguous}} \leq 500 \text{ MHz}$, otherwise $\Delta f_{\text{B}} = BW_{\text{contiguous}} + 500 \text{ MHz}$.			

Table 7.5.3.2.3-2: OBUE limits applicable in the frequency range 37 – 52.6 GHz

Frequency offset of measurement filter -3 dB point, Δf	Frequency offset of measurement filter centre frequency, f_{offset}	Limit	Measurement bandwidth
$0 \text{ MHz} \leq \Delta f < 0.1 * BW_{\text{contiguous}}$	$0.5 \text{ MHz} \leq f_{\text{offset}} < 0.1 * BW_{\text{contiguous}} + 0.5 \text{ MHz}$	Min(-5 dBm, Max($P_{\text{rated,t,TRP}} - 33 \text{ dB}$, -12 dBm))	1 MHz
$0.1 * BW_{\text{contiguous}} \leq \Delta f < \Delta f_{\text{B}}$	$0.1 * BW_{\text{contiguous}} + 0.5 \text{ MHz} \leq f_{\text{offset}} < \Delta f_{\text{B}} + 0.5 \text{ MHz}$	Min(-13 dBm, Max($P_{\text{rated,t,TRP}} - 41 \text{ dB}$, -20 dBm))	1 MHz
$\Delta f_{\text{B}} \leq \Delta f < \Delta f_{\text{max}}$	$\Delta f_{\text{B}} + 5 \text{ MHz} \leq f_{\text{offset}} < f_{\text{offset}_{\text{max}}}$	Min(-5 dBm, Max($P_{\text{rated,t,TRP}} - 31 \text{ dB}$, -10 dBm))	10 MHz
NOTE 1: For non-contiguous spectrum operation within any <i>operating band</i> the limit within gaps between <i>passbands</i> is calculated as a cumulative sum of contributions from adjacent sub-blocks on each side of the gap between <i>passbands</i> .			
NOTE 2: $\Delta f_{\text{B}} = 2 * BW_{\text{contiguous}}$ when $BW_{\text{contiguous}} \leq 500 \text{ MHz}$, otherwise $\Delta f_{\text{B}} = BW_{\text{contiguous}} + 500 \text{ MHz}$.			

7.5.3.2.4 Additional OTA operating band unwanted emission requirements

7.5.3.2.4.1 Protection of Earth Exploration Satellite Service

For repeater operating in the frequency range 24.25 – 27.5 GHz, the power of unwanted emission shall not exceed the limits in table 7.5.3.2.4.1-1 for DL and in table 7.5.3.2.4.1-2.

Table 7.5.3.2.4.1-1: OBUE limits for protection of Earth Exploration Satellite Service for DL

Frequency range	Limit	Measurement Bandwidth
23.6 – 24 GHz	-3 dBm (Note 1)	200 MHz
23.6 – 24 GHz	-9 dBm (Note 2)	200 MHz
NOTE 1: This limit applies to repeater brought into use on or before 1 September 2027 in countries not adopting EU Decision 2020/590 [31].		
NOTE 2: This limit applies to repeater brought into use after 1 September 2027 or to repeater in countries adopting EU Decision 2020/590 [31].		

Table 7.5.3.2.4.1-2: OBUE limits for protection of Earth Exploration Satellite Service for UL

Frequency range	Limit	Measurement Bandwidth
23.6 – 24 GHz	1 dBm	200 MHz

7.5.3.3 Minimum requirement for NCR

7.5.3.3.1 Minimum requirement for NCR-Fwd

7.5.3.3.1.1 Minimum requirement for NCR-Fwd type 2-O

The requirements in clause 7.5.3.2 apply for NCR-Fwd type 2-O. The limits apply to the sum of emissions from NCR-MT and NCR-Fwd when transmitting simultaneously.

7.5.3.3.2 Minimum requirement for NCR-MT

7.5.3.3.2.1 Minimum requirement for NCR-MT type 2-O

For Wide Area *NCR-MT type 2-O*, the BS OBUE requirements specified in clause 9.7.4.3 in TS 38.104 [2] apply.

For Local Area *NCR-MT type 2-O*, the UE SEM requirements specified in clause 6.5.2.1 in TS 38.101-2 [14] apply.

7.5.4 OTA transmitter spurious emissions

7.5.4.1 General

Unless otherwise stated, all requirements are measured as mean power.

The OTA spurious emissions limits are specified as TRP per RIB unless otherwise stated.

7.5.4.2 Minimum requirement for RF repeater

7.5.4.2.1 General

For *repeater type 2-O*, the OTA transmitter spurious emission limits apply from 30 MHz to 2nd harmonic of the upper frequency edge of the downlink *operating band*, excluding the frequency range from Δf_{OBUE} below the lowest frequency of the downlink *operating band*, up to Δf_{OBUE} above the highest frequency of the downlink *operating band*, where the Δf_{OBUE} is defined in table 7.5.1-1 and 7.5.1-2.

7.5.4.2.2 General OTA transmitter spurious emissions requirements

7.5.4.2.2.1 General

The requirements of either clause 7.5.4.2.2.2 (Category A limits) or clause 7.5.4.2.2.3 (Category B limits) shall apply. The application of either Category A or Category B limits shall be the same as for Operating band unwanted emissions in clause 7.5.3.

7.5.4.2.2.2 OTA transmitter spurious emissions (Category A)

The power of any spurious emission shall not exceed the limits in table 7.5.4.2.2.2-1.

Table 7.5.4.2.2.2-1: Repeater radiated Tx spurious emission limits in FR2

Frequency range	Limit	Measurement Bandwidth	Note
30 MHz – 1 GHz	-13 dBm	100 kHz	Note 1
1 GHz – 2 nd harmonic of the upper frequency edge of the <i>operating band</i>		1 MHz	Note 1, Note 2
NOTE 1: Bandwidth as in ITU-R SM.329 [5], s4.1			
NOTE 2: Upper frequency as in ITU-R SM.329 [5], s2.5 table 1.			

7.5.4.2.2.3 OTA transmitter spurious emissions (Category B)

The power of any spurious emission shall not exceed the limits in table 7.5.4.2.2.3-1.

Table 7.5.4.2.2.3-1: Repeater radiated Tx spurious emission limits in FR2 (Category B)

Frequency range (Note 4)	Limit	Measurement Bandwidth	Note
30 MHz ↔ 1 GHz	-36 dBm	100 kHz	Note 1
1 GHz ↔ 18 GHz	-30 dBm	1 MHz	Note 1
18 GHz ↔ $F_{\text{step},1}$	-20 dBm	10 MHz	Note 2
$F_{\text{step},1}$ ↔ $F_{\text{step},2}$	-15 dBm	10 MHz	Note 2
$F_{\text{step},2}$ ↔ $F_{\text{step},3}$	-10 dBm	10 MHz	Note 2
$F_{\text{step},4}$ ↔ $F_{\text{step},5}$	-10 dBm	10 MHz	Note 2
$F_{\text{step},5}$ ↔ $F_{\text{step},6}$	-15 dBm	10 MHz	Note 2
$F_{\text{step},6}$ ↔ 2 nd harmonic of the upper frequency edge of the <i>operating band</i>	-20 dBm	10 MHz	Note 2, Note 3
NOTE 1: Bandwidth as in ITU-R SM.329 [5], s4.1			
NOTE 2: Limit and bandwidth as in ERC Recommendation 74-01 [9], Annex 2.			
NOTE 3: Upper frequency as in ITU-R SM.329 [5], s2.5 table 1.			
NOTE 4: The step frequencies $F_{\text{step},X}$ are defined in Table 7.5.4.2.2.3-2.			

Table 7.5.4.2.2.3-2: Step frequencies for defining the Repeater radiated Tx spurious emission limits in FR2 (Category B)

Operating band	$F_{\text{step},1}$ (GHz)	$F_{\text{step},2}$ (GHz)	$F_{\text{step},3}$ (GHz) (Note 2)	$F_{\text{step},4}$ (GHz) (Note 2)	$F_{\text{step},5}$ (GHz)	$F_{\text{step},6}$ (GHz)
n257	18	23.5	25	31	32.5	41.5
n258	18	21	22.75	29	30.75	40.5
n259	23.5	35.5	38	45	47.5	59.5
n263	18	43	53.5	74.5	85	127
NOTE 1: $F_{\text{step},X}$ are based on ERC Recommendation 74-01 [9], Annex 2.						
NOTE 2: $F_{\text{step},3}$ and $F_{\text{step},4}$ are aligned with the values for Δf_{OBUE} in table 7.5.1-1.						

7.5.4.2.3 Additional OTA transmitter spurious emissions requirements

These requirements may be applied for the protection of systems operating in frequency ranges other than the repeater-Node. The limits may apply as an optional protection of such systems that are deployed in the same geographical area as the repeater-Node, or they may be set by local or regional regulation as a mandatory requirement for an NR *operating band*. It is in some cases not stated in the present document whether a requirement is mandatory or under what exact circumstances that a limit applies, since this is set by local or regional regulation. An overview of regional requirements in the present document is given in clause 4.4.

7.5.4.2.3.1 Limits for protection of Earth Exploration Satellite Service

For repeater operating in the frequency range 23.6 – 24 GHz, the power of any spurious emissions shall not exceed the limits in Table 7.5.4.2.3.1-1 and Table 7.5.4.2.3.1-2.

Table 7.5.4.2.3.1-1: Limits for protection of Earth Exploration Satellite Service for DL

Frequency range	Limit	Measurement Bandwidth	Note
23.6 – 24 GHz	-3 dBm	200 MHz	Note 1
23.6 – 24 GHz	-9 dBm	200 MHz	Note 2
NOTE 1: This limit applies to Repeater brought into use on or before 1 September 2027 in countries not adopting EU Decision 2020/590 [31].			
NOTE 2: This limit applies to Repeater brought into use after 1 September 2027 or to repeater in countries adopting EU Decision 2020/590 [31].			

Table 7.5.4.2.3.1-2: OBUE limits for protection of Earth Exploration Satellite Service for UL

Frequency range	Limit	Measurement Bandwidth
23.6 – 24 GHz	1 dBm	200 MHz

7.5.4.3 Minimum requirement for NCR

7.5.4.3.1 Minimum requirement for NCR-Fwd

7.5.4.3.1.1 Minimum requirement for NCR-Fwd type 2-O

The requirements in clause 7.5.4.2 apply. The limits apply to the sum of emissions from NCR-MT and NCR-Fwd when transmitting simultaneously.

7.5.4.3.2 Minimum requirement for NCR-MT

7.5.4.3.2.1 Minimum requirement for NCR-MT Type 2-O

For Wide Area *NCR-MT type 2-O*, the OTA TX spurious emission requirements are as defined in clause 7.5.4.2.

For Local Area *NCR-MT type 2-O*, the OTA TX spurious emission requirements defined for NR UE in clause 6.5.3 in TS 38.101-2 [14] apply.

7.5.5 OTA receiver spurious emissions

7.5.5.1 General

The OTA RX spurious emission is the power of the emissions radiated from the antenna array from a receiver unit.

The metric used to capture OTA receiver spurious emissions is *total radiated power* (TRP), with the requirement defined at the RIB.

For a RIB operating in FDD, OTA RX spurious emissions requirement do not apply as they are superseded by the OTA TX spurious emissions requirement. This is due to the fact that TX and RX spurious emissions cannot be distinguished in OTA domain.

For a RIB operating in TDD, the OTA RX spurious emissions requirement shall apply during the *transmitter OFF state* only.

For *multi-band RIB*, the OTA RX spurious emissions requirements are subject to exclusion zones in each supported *operating band*.

7.5.5.2 Minimum requirement for RF repeater

For the *Repeater type 2-O*, the power of any RX spurious emission shall not exceed the limits in table 7.5.5.2-1.

7.5.5.2-1: OTA receiver spurious emission limits for Repeater type 2-O

Spurious frequency range (Note 4)	Limit (Note 5)	Measurement Bandwidth	Note
30 MHz ↔ 1 GHz	-36 dBm	100 kHz	Note 1
1 GHz ↔ 18 GHz	-30 dBm	1 MHz	Note 1
18 GHz ↔ $F_{\text{step},1}$	-20 dBm	10 MHz	Note 2
$F_{\text{step},1}$ ↔ $F_{\text{step},2}$	-15 dBm	10 MHz	Note 2
$F_{\text{step},2}$ ↔ $F_{\text{step},3}$	-10 dBm	10 MHz	Note 2
$F_{\text{step},4}$ ↔ $F_{\text{step},5}$	-10 dBm	10 MHz	Note 2
$F_{\text{step},5}$ ↔ $F_{\text{step},6}$	-15 dBm	10 MHz	Note 2
$F_{\text{step},6}$ ↔ 2 nd harmonic of the upper frequency edge of the UL <i>operating band</i>	-20 dBm	10 MHz	Note 2, Note 3

NOTE 1: Bandwidth as in ITU-R SM.329 [5], s4.1.
 NOTE 2: Limit and bandwidth as in ERC Recommendation 74-01 [9], Annex 2.
 NOTE 3: Upper frequency as in ITU-R SM.329 [5], s2.5 table 1.
 NOTE 4: The step frequencies $F_{\text{step},X}$ are defined in table 7.5.5.3-2.
 NOTE 5: Additional limits may apply regionally.

Table 7.5.5.2-2: Step frequencies for defining the OTA receiver spurious emission limits for Repeater type 2-O

Operating band	$F_{\text{step},1}$ (GHz)	$F_{\text{step},2}$ (GHz)	$F_{\text{step},3}$ (GHz)	$F_{\text{step},4}$ (GHz)	$F_{\text{step},5}$ (GHz)	$F_{\text{step},6}$ (GHz)
n257	18	23.5	25	31	32.5	41.5
n258	18	21	22.75	29	30.75	40.5
n259	23.5	35.5	38	45	47.5	59.5
n260	25	34	35.5	41.5	43	52
n261	18	25.5	26.0	29.85	30.35	38.35
n262	37.2	45.2	45.7	49.7	50.2	58.2
n263	18	43	53.5	74.5	85	127

In addition to the requirements in Table 7.5.5.2-1, the requirement for protection of EESS for *RF repeater* operating in frequency range 24.25 – 27.5 GHz in clause 7.5.4.2.3.1 may be applied.

7.5.5.3 Minimum requirement for NCR

7.5.5.3.1 Minimum requirement for NCR-Fwd

7.5.5.3.1.1 Minimum requirement for NCR-Fwd type 2-O

The requirements in clause 7.5.5.2 apply.

The receiver spurious emissions limits shall apply to the total emissions from both the NCR-Fwd and NCR-MT.

7.6 OTA Repeater Error Vector Magnitude

7.6.1 Downlink repeater error vector magnitude

7.6.1.1 General

The Repeater Error Vector Magnitude (EVM) is a measure of the difference between the symbols provided at the input of the repeater and the measured signal symbols at the output of the repeater after the equalization by the measurement equipment. This difference is called the error vector. Details about how the repeater EVM is determined are same as specified in TS 38.104 [2] Annex C for FR2. The repeater EVM result is defined as the square root of the ratio of the mean error vector power to the mean reference power expressed in percent.

For repeater type 2-O, OTA modulation quality requirement is defined as a *directional requirement* at the RIB and shall be met within the *OTA coverage range* on the transmit side and the AoA of the incident wave of the received signal is in the reference direction at the receive side.

For NCR-Fwd type 2-O, OTA modulation quality requirement is defined as a directional requirement at the RIB and shall be met within the OTA coverage range on the transmit side and the AoA of the incident wave of the received signal is within the OTA REFSSENS RoAoA at the receive side.

The repeater EVM requirement is applicable when the repeater is operating with an input power level within the range from what is required to reach the rated beam EIRP output power ($P_{\text{rated,p,EIRP}}$) to the minimum power levels in table 7.6.1.1-1.

Table 7.6.1.1-1: Minimum input power for repeater EVM for repeater type 2-O and NCR-Fwd type 2-O

Repeater class	Minimum input power (dBm/MHz)					
	24.25 – 33.4 GHz			37 – 52.6 GHz		
WA, MR, LA	Up to 16 QAM -77- $G_{\text{RX_ANT}}$	64QAM ¹ -73- $G_{\text{RX_ANT}}$	256QAM ² -66- $G_{\text{RX_ANT}}$	Up to 16 QAM -75- $G_{\text{RX_ANT}}$	64QAM ¹ -71- $G_{\text{RX_ANT}}$	256QAM ² -64- $G_{\text{RX_ANT}}$
Note 1:	support of 64QAM is based on the declaration					
Note 2:	support of 256QAM is based on the declaration					

Where $G_{\text{RX_ANT}}$ is the gain of the receive side antennas and is estimated based on the 3dB gain RoAoA and a formula, $G_{\text{RX_ANT}} = 44.1 - 10 \cdot \log_{10}(\text{Be}W_{\theta, \text{REFSENS}} \cdot \text{Be}W_{\phi, \text{REFSENS}})$ dB.

7.6.1.2 Minimum requirement for repeater

The repeater EVM levels for different modulation schemes outlined in table 7.6.1.2-1 shall be met using the frame structure described in clause 7.6.1.3.

Table 7.6.1.2-1: Repeater EVM requirements

Parameter	Required repeater EVM
Up to 16QAM	12.5%
64QAM	8 % ¹
256QAM	3.5 % ²
Note 1:	support of 64QAM is based on the declaration
Note 2:	support of 256QAM is based on the declaration.

7.6.1.2A Minimum requirement for NCR

7.6.1.2A.1 Minimum requirement for NCR-Fwd

7.6.1.2A.1.1 Minimum requirement for NCR-Fwd type 2-O

The requirements in clause 7.6.1.2 apply for NCR-Fwd type 2-O.

7.6.1.3 Repeater EVM frame structure for measurement

The input signals for the repeater EVM requirement shall have the same frame structure as defined for the BS in TS 38.104 [2].

7.6.2 Uplink repeater error vector magnitude

7.6.2.1 General

The Repeater Error Vector Magnitude is a measure of the difference between the reference waveform provided at the input of the repeater and the measured waveform at the output of the repeater. This difference is called the error vector. Details about how the repeater EVM is determined are the same as specified in TS 38.101-2 [14] Annex F for FR2. Before calculating the repeater EVM, the measured waveform is corrected by the sample timing offset and RF frequency offset. Then the carrier leakage shall be removed from the measured waveform before calculating the repeater EVM.

The measured waveform is further equalised using the channel estimates subjected to the EVM equaliser spectrum flatness requirement specified in TS 38.101-2 [14] clauses 6.4.2.4 and 6.4.2.5. For DFT-s-OFDM waveforms, the repeater EVM result is defined after the front-end FFT and IDFT as the square root of the ratio of the mean error vector power to the mean reference power expressed as a %. For CP-OFDM waveforms, the repeater EVM result is defined after the front-end FFT as the square root of the ratio of the mean error vector power to the mean reference power expressed as a %.

The basic repeater EVM measurement interval is one slot in the time domain. The repeater EVM measurement interval is reduced by any symbols that contains an allowable power transient in the measurement interval as defined in TS 38.101-2 [14] clause 6.3.3.

All the parameters defined in clause 7.6.2 are defined using the measurement methodology specified in TS 38.101-2 [14] Annex F.

For *repeater type 2-O*, OTA modulation quality requirement is defined as a *directional requirement* at the RIB and shall be met within the *OTA coverage range* on the transmit side and the AoA of the incident wave of the received signal is in the reference direction at the receive side.

For *NCR-Fwd type 2-O*, OTA modulation quality requirement is defined as a directional requirement at the RIB and shall be met within the OTA coverage range on the transmit side and the AoA of the incident wave of the received signal is within the OTA REFSSENS RoAoA at the receive side.

The repeater EVM requirement is applicable when the repeater is operating with an input power level within the range from what is required to reach the rated beam EIRP output power ($P_{\text{rated,p,EIRP}}$) to the minimum input power levels in table 7.6.2.1-1.

Table 7.6.2.1-1: Minimum input power for repeater EVM for repeater type 2-O and NCR-Fwd type 2-O

Repeater class	Minimum input power (dBm/MHz)			
	24.25 – 33.4 GHz		37 – 52.6 GHz	
	Up to 16 QAM	64QAM ¹	Up to 16 QAM	64QAM ¹
WA, LA	-77- G _{RX_ANT}	-73- G _{RX_ANT}	-75- G _{RX_ANT}	-71- G _{RX_ANT}

Note 1: support of 64QAM is based on the declaration

Where G_{RX_ANT} is the gain of the receive side antennas and is estimated based on the 3dB gain RoAoA and a formula, $G_{RX_ANT} = 44.1 - 10 \cdot \log_{10}(BeW_{\phi, RESENS} \cdot BeW_{\phi, RESENS})$ dB.

7.6.2.2 Minimum requirement for RF repeater

The RMS average of the basic repeater EVM measurements over 10 subframes for the average repeater EVM case, for the different modulation schemes shall not exceed the values specified in Table 7.6.2.2-1.

Table 7.6.2.2-1: Minimum requirements for repeater error vector magnitude

Parameter	Unit	Average repeater EVM level
Up to 16 QAM	%	12.5
64 QAM	%	8 ¹
Note 1: support of 64QAM is based on the declaration		

7.6.2.3 Minimum requirement for NCR

7.6.2.3.1 Minimum requirement for NCR-Fwd

7.6.2.3.1.1 Minimum requirement for NCR-Fwd type 2-O

The requirements in clause 7.6.2.2 apply for *NCR-Fwd type 2-O*.

7.7 OTA input intermodulation

7.7.1 General

The input intermodulation is a measure of the capability of the repeater to inhibit the generation of interference in the *passband*, in the presence of interfering signals on frequencies other than the *passband*. The requirement is defined as a directional requirement.

The requirement shall apply at the RIB when the AoA of the incident wave of a received signal and the interfering signal are from the same direction:

The interfering signals apply to each supported polarization, under the assumption of polarization match.

The following requirement applies for interfering signals depending on the repeaters *passband*.

This requirement applies to the uplink and downlink of the repeater during the *transmitter ON state*.

When GSM, CDMA, UTRA, E-UTRA, NR BS or repeater operating in a different frequency band are co-located with a NCR, additional input intermodulation co-location requirement may be applied for the protection of RF repeater or NCR receivers. This requirement applies to the uplink and downlink of the repeater. If the BS side is declared to meet co-location requirements, then it should meet input intermodulation co-location requirements for the downlink. If the UE side is declared to meet co-location requirements, then it should meet input intermodulation co-location requirements for the uplink.

When GSM, CDMA, UTRA, E-UTRA, NR BS or repeater operating in another frequency band co-exist with a NCR, additional input intermodulation co-existence requirement may be applied for the protection of NR repeater or NCR receivers.

7.7.2 Minimum requirement for RF repeater

For the parameters specified in table 7.7.2-1, the power in the *passband* shall not increase with more than 10 dB at the output of the repeater as measured with 1 MHz measurement bandwidth, compared to the level obtained without interfering signals applied.

The core requirement is applicable for all frequency separation possibilities between the two interfering signals that cause the 3rd order intermodulation product to fall into the whole *passband*.

Table 7.7.2-1 specifies the parameters for two interfering signals, where:

- f_1 offset is the offset from the channel edge frequency of the first or last channel in the *passband* of the closer carrier.
- G_{RX_ANT} is the gain of the receive side antennas and is calculated from EIRP and TRP declaration.

Table 7.7.2-1: Input intermodulation requirement

f_1 offset	Interfering Signal Levels	Type of signals	Measurement bandwidth
1 MHz	-53dBm – G_{RX_ANT}	2 CW carriers	1 MHz

7.7.3 Minimum requirement for NCR

7.7.3.1 Minimum requirement for NCR-Fwd

7.7.3.1.1 Minimum requirement for NCR-Fwd type 2-O

The requirements in clause 7.7.2 apply for NCR-Fwd type 2-O.

7.8 OTA Adjacent Channel Rejection Ratio (ACRR)

7.8.1 General

OTA Adjacent Channel Rejection Ratio (ACRR) is the ratio of the average gain over a carrier of the repeater in the *passband* to the average gain of the repeater over an adjacent channel outside the repeater *passband*. The requirement shall apply to the uplink and downlink of the Repeater. The bandwidth of the channel inside the *passband* and the adjacent channel shall be of the same type (reference carrier) with bandwidths as defined by *nominal channel bandwidth*.

The requirement is differentiated between downlink and uplink.

The requirement shall apply during the *transmitter ON state*.

The ACRR is a ratio of gain in the adjacent channel to gain in the wanted channel. The gain in each case is defined as the ratio of TRP output power to directional input power.

7.8.2 Minimum Requirements for RF repeater

The requirement shall apply at the RIB when the AoA of the incident wave of a received signal in the *passband* and a received signal on an adjacent channel outside repeater *passband* is from the same direction and are the same as the TX reference direction for the opposite DL/UL setting.

For a repeater operating at *passband* operating in FR2, the ACRR requirements in table 7.8.2-1 shall apply in downlink. ACRR for downlink shall be higher than the value specified in the Table 7.8.2-1.

Table 7.8.2-1: Repeater Downlink ACRR

Co-existence with other systems	Repeater Class	Channel offset from frequency edge of <i>passband</i> (MHz)	ACRR limit (dB)
NR	Wide Area repeater	$BW_{Nominal}/2$	28 (Note 2) 26 (Note 3)
	Medium Range repeater	$BW_{Nominal}/2$	28 (Note 2) 26 (Note 3)
	Local Area repeater	$BW_{Nominal}/2$	28 (Notes 1, 2) 26 (Note 1, 3)
NOTE 1: This requirement does not applicable if the <i>passband</i> occupies the entire <i>operating band</i> .			
NOTE 2: Applicable to bands defined within the frequency spectrum range of 24.25 – 33.4 GHz.			
NOTE 3: Applicable to bands defined within the frequency spectrum range of 37 – 52.6 GHz			

For a repeater operating at *passband* operating in FR2, the ACRR requirements in table 7.8.2-2 shall apply in uplink. ACRR for uplink shall be higher than the value specified in the Table 7.8.2-2.

Table 7.8.2-2: Repeater Uplink ACRR

Co-existence with other systems	Repeater Class	Channel offset from frequency edge of <i>passband</i> (MHz)	ACRR limit (dB)
NR	Wide Area repeater	$BW_{Nominal}/2$	28 (Note 2) 26 (Note 3)
	Local Area repeater	$BW_{Nominal}/2$	17 (Note 1, 2) 16 (Note 1, 3)
NOTE 1: This requirement does not applicable if the <i>passband</i> occupies the entire <i>operating band</i> .			
NOTE 2: Applicable to bands defined within the frequency spectrum range of 24.25 – 33.4 GHz.			
NOTE 3: Applicable to bands defined within the frequency spectrum range of 37 – 52.6 GHz			

7.8.3 Minimum Requirements for NCR

7.8.3.1 Minimum Requirements for NCR-Fwd

7.8.3.1.1 Minimum Requirements for NCR-Fwd type 2-O

The requirement shall apply at the RIB when the AoA of the incident wave of a received signal in the *passband* and a received signal on an adjacent channel outside repeater *passband* is from the same direction and are the same as the TX reference direction for the opposite DL/UL setting.

For *NCR-Fwd type 2-O* operating at *passband* operating in FR2, the ACRR requirements in table 7.8.3.1.1-1 shall apply in downlink. In normal conditions the ACRR for downlink shall be higher than the value specified in the Table 7.8.3.1.1-1.

Table 7.8.3.1.1-1: NCR-Fwd type 2-O Downlink ACRR

Co-existence with other systems	Repeater Class	Channel offset from frequency edge of <i>passband</i> (MHz)	ACRR limit (dB)
NR	Wide Area repeater	$BW_{Nominal}/2$	28 (Note 2) 26 (Note 3)
	Medium Range repeater	$BW_{Nominal}/2$	28 (Note 2) 26 (Note 3)
	Local Area repeater	$BW_{Nominal}/2$	28 (Notes 1, 2) 26 (Note 1, 3)
NOTE 1: This requirement is not applicable if the <i>passband</i> occupies the entire <i>operating band</i> .			
NOTE 2: Applicable to bands defined within the frequency spectrum range of 24.25 – 33.4 GHz.			
NOTE 3: Applicable to bands defined within the frequency spectrum range of 37 – 52.6 GHz			

For *NCR-Fwd type 2-O* operating at *passband* operating in FR2, the ACRR requirements in table 7.8.3.1.1-2 shall apply in uplink. In normal conditions the ACRR for uplink shall be higher than the value specified in the Table 7.8.3.1.1-2.

Table 7.8.3.1.1-2: NCR-Fwd type 2-O Uplink ACRR

Co-existence with other systems	Repeater Class	Channel offset from frequency edge of <i>passband</i> (MHz)	ACRR limit (dB)
NR	Wide Area repeater	$BW_{Nominal}/2$	28 (Note 2) 26 (Note 3)
	Local Area repeater	$BW_{Nominal}/2$	17 (Note 1, 2) 16 (Note 1, 3)
NOTE 1: This requirement is not applicable if the <i>passband</i> occupies the entire <i>operating band</i> .			
NOTE 2: Applicable to bands defined within the frequency spectrum range of 24.25 – 33.4 GHz.			
NOTE 3: Applicable to bands defined within the frequency spectrum range of 37 – 52.6 GHz			

7.9 OTA transmit ON/OFF power

7.9.1 General

OTA transmit ON/OFF power requirements apply only to TDD operation of repeater. The requirements apply to both downlink and uplink of the repeater.

7.9.2 OTA transmitter OFF power

7.9.2.1 General

OTA transmitter OFF power is defined as the mean power measured over $70/N$ μ s filtered with a square filter of bandwidth equal to the *passband bandwidth* of the repeater ($BW_{passband}$) centred on the assigned channel frequency during the *transmitter OFF state*. $N = SCS/15$, where SCS is Sub Carrier Spacing in kHz of the input signal. For *repeater type 2-O* and *NCR-Fwd type 2-O*, the OTA transmitter OFF power is defined as TRP.

7.9.2.2 Minimum requirement for RF repeater

The OTA transmitter OFF TRP spectral density for *repeater type 2-O* shall be less than -36 dBm/MHz.

7.9.2.3 Minimum requirement for NCR

7.9.2.3.1 Minimum requirement for NCR-Fwd

7.9.2.3.1.1 Minimum requirement for NCR-Fwd type 2-O

The requirements in clause 7.9.2.2 apply for NCR-Fwd type 2-O.

7.9.2.3.2 Minimum requirement for NCR-MT

7.9.2.3.2.1 Minimum requirement for NCR-MT type 2-O

For Wide Area NCR-MT type 2-O, the OTA transmitter OFF TRP spectral density shall be less than -36 dBm/MHz. For Local Area *NCR-MT type 2-O*, the transmit OFF power shall not exceed the values specified in Tables 7.9.2.3.2.1-1 for each operating band supported. The requirement is verified with the test metric of TRP (Link=TX beam peak direction, Meas=TRP grid).

Table 7.9.2.3.2.1-1: Transmit OFF power for FR2-1

Operating band	Channel bandwidth / Transmit OFF power (dBm) / measurement bandwidth			
	50 MHz	100 MHz	200 MHz	400 MHz
n257, n258, n259, n260, n261, n262	-35	-35	-35	-35
	47.58 MHz	95.16 MHz	190.20 MHz	380.28 MHz

7.9.3 OTA transient period

7.9.3.1 General

The OTA *transmitter transient period* is the time period during which the transmitter is changing from the *transmitter OFF state* to the *transmitter ON state* or vice versa. The *transmitter transient period* is illustrated in figure 7.9.3.1-1.

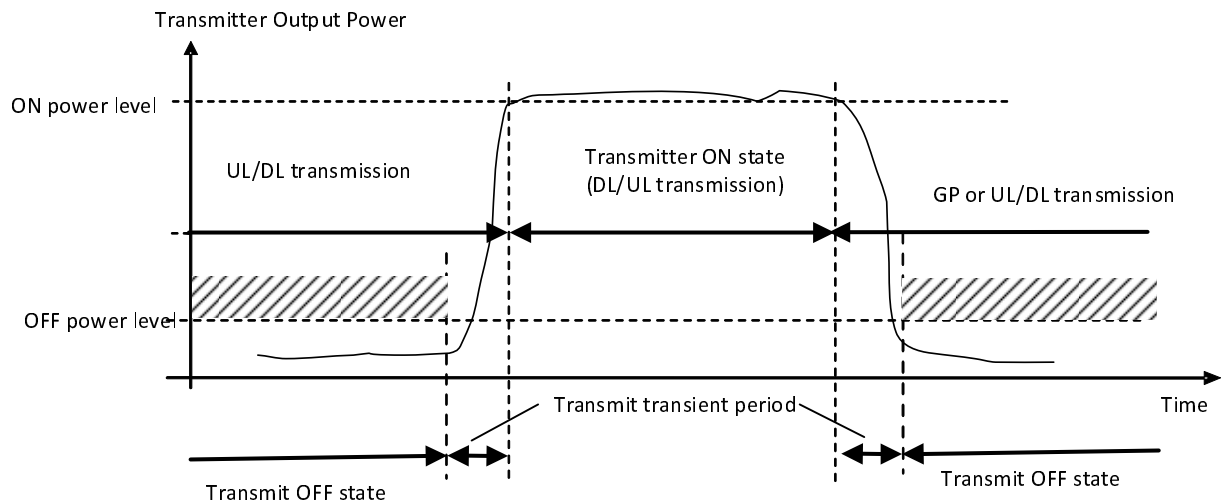

Figure 7.9.3.1-1: Example of relations between transmitter ON state, transmitter OFF state and transmitter transient period

This requirement shall be applied at each RIB supporting transmission in the *operating band*. The beginning and end point of downlink and uplink bursts are referenced to the slot timing at the input.

7.9.3.2 Minimum requirement for RF repeater

For *repeater type 2-O*, the OTA *transmitter transient period* shall be shorter than the values listed in the minimum requirement table 7.9.3.2-1.

Table 7.9.3.2-1: Minimum requirement for the OTA transmitter transient period for repeater type 2-O

Transition	Transient period length (µs)
OFF to ON	3
ON to OFF	3

7.9.3.3 Minimum requirement for NCR

7.9.3.3.1 Minimum requirement for NCR-Fwd

7.9.3.3.1.1 Minimum requirement for NCR-Fwd type 2-O

The requirements in clause 7.9.3.2 apply for NCR-Fwd type 2-O.

7.9.3.3.2 Minimum requirement for NCR-MT

7.9.3.3.2.1 Minimum requirement for NCR-MT type 2-O

For Wide Area NCR-MT type 2-O, the OTA transmitter transient period shall be shorter than the values listed in the minimum requirement table 7.9.3.3.2.1-1.

Table 7.9.3.3.2.1-1: Minimum requirement for the OTA transmitter transient period for Wide Area NCR-MT type 2-O

Transition	Transient period length (μ s)
OFF to ON	3
ON to OFF	3

For Local Area NCR-MT type 2-O, the requirement from TS 38.101-2 section 6.3.3.2 applies.

7.10 OTA output power dynamics for NCR-MT

7.10.1 General

7.10.2 Minimum requirement for NCR-MT

7.11 OTA transmit signal quality for NCR-MT

7.11.1 General

Transmit signal quality is specified in terms of: frequency error and transmit modulation quality requirements.

7.11.2 Frequency error requirements for NCR-MT

7.11.2.1 Minimum requirement for NCR-MT type 2-O

For NCR-MT type 2-O, the requirements specified in clause 9.6.1.2.3 in TS 38.174 applies.

7.11.3 Transmit modulation quality

7.11.3.1 Minimum requirement for NCR-MT type 2-O

For NCR-MT type 2-O, the requirements specified in clause 9.6.2.2.3 in TS 38.174 applies.

7.12 Diversity characteristics for NCR-MT

7.12.1 General

7.12.2 Minimum requirement for NCR-MT

The OTA diversity characteristic is specified the same as conducted diversity characteristic for FR1 NCR type 1-C, 1-H in sub-clause 6.13.

7.13 OTA reference sensitivity for NCR-MT

7.13.1 General

The reference sensitivity power level REFSENS is defined as the EIS level at the centre of the quiet zone in the RX beam peak direction, at which the throughput shall meet or exceed the requirements for the specified reference measurement channel.

7.13.2 Minimum requirement for NCR-MT type 2-O

The wide area NCR-MT reference sensitivity level is specified the same as the Wide Area IAB-MT reference sensitivity level requirement in TS 38.174 [22], subclause 10.3.3.3.

The local area NCR-MT reference sensitivity level is specified the same as reference sensitivity power level for power class 3 in TS 38.101-2 [14], subclause 7.3.2.3.

7.14 OTA maximum input level for NCR-MT

7.14.1 General

The maximum input level is defined as the maximum mean power, for which the throughput shall meet or exceed the minimum requirements for the specified reference measurement channel.

7.14.2 Minimum requirement for NCR-MT type 2-O

The local area NCR-MT maximum input power is specified the same as maximum input power in TS 38.101-2 [14], subclause 7.4.

7.15 OTA adjacent channel selectivity for NCR-MT

7.15.1 General

Adjacent Channel Selectivity (ACS) is a measure of a receiver's ability to receive a NR signal at its assigned channel frequency in the presence of an adjacent channel signal at a given frequency offset from the centre frequency of the assigned channel. ACS is the ratio of the receive filter attenuation on the assigned channel frequency to the receive filter attenuation on the adjacent channel(s).

7.15.1 Minimum requirement for NCR-MT type 2-O

The wide area NCR-MT ACS requirement is specified the same as the Wide Area IAB-MT ACS requirement in TS 38.174 [22], subclause 10.5.1.4.

The local area NCR-MT reference sensitivity level is specified the same as ACS requirement in TS 38.101-2 [14], subclause 7.5.

7.16 OTA blocking characteristics for NCR-MT

7.16.1 General

The blocking characteristic is a measure of the receiver's ability to receive a wanted signal at its assigned channel frequency in the presence of an unwanted interferer on frequencies other than those of the spurious response or the adjacent channels, without this unwanted input signal causing a degradation of the performance of the receiver beyond a specified limit. The blocking performance shall apply at all frequencies except those at which a spurious response occurs.

7.16.2 Minimum requirement for NCR-MT type 2-O

The wide area NCR-MT blocking requirement is specified the same as the Wide Area IAB-MT blocking requirement in TS 38.174 [22], subclause 10.5.2.4.

The local area NCR-MT blocking requirement is specified the same as blocking requirement in TS 38.101-2 [14], subclause 7.6.

7.17 OTA receiver spurious emissions for NCR-MT

7.17.1 General

The receiver spurious emissions power is the power of emissions generated or amplified in a receiver. The receiver spurious emissions power level is measured as TRP.

7.17.2 Minimum requirement for NCR-MT type 2-O

The wide area NCR-MT receiver spurious emission requirement is specified the same as the Wide Area IAB-MT receiver spurious emission requirement in TS 38.174 [22], subclause 10.7.3.2.

The local area NCR-MT receiver spurious emission requirement is specified the same as receiver spurious emission requirement in TS 38.101-2 [14], subclause 7.9.

7.18 OTA spatial emission

7.18.1 General

OTA spatial emission requirements are defined to set upper limits on radiated power in specific directions.

7.18.2 Protection of FSS UL

7.18.2.1 General

This requirement shall be applied to NCR operating in band n104 to protect FSS (Earth-to-space) satellite receiver.

The expected EIRP (EEIRP) is defined as the average value of the EIRP, with the averaging being performed:

- over azimuth angles from -180° to $+180^\circ$ with reference to NCR horizontal boresight and over the specified range of angles $\theta_{HLi} \leq \theta < \theta_{HHi}$, above the horizon as defined in Table 7.18.2.2-1, and
- over the supported beam directions.

Note: The requirement is defined based on [32].

7.18.2.2 Minimum requirement for NCR type 1-H

For NCR type 1-H operating in band n104, the Expected EIRP (EEIRP) in the frequency range 6425 – 7075 MHz, shall not exceed the limits specified in table 7.18.2.2-1.

Table 7.18.2.2-1: EEIRP limits as function of elevation above horizon

Bin number i	Elevation angular range $\theta_{HLi} \leq \theta < \theta_{HHi}$ (Degrees)	EEIRP limit (dBm/MHz)
1	$0 \leq \theta < 5$	27
2	$5 \leq \theta < 10$	23
3	$10 \leq \theta < 15$	19
4	$15 \leq \theta < 20$	18
5	$20 \leq \theta < 30$	16
6	$30 \leq \theta < 60$	15
7	$60 \leq \theta < 90$	15

NOTE: The requirement shall apply to all supported mechanical tilts.

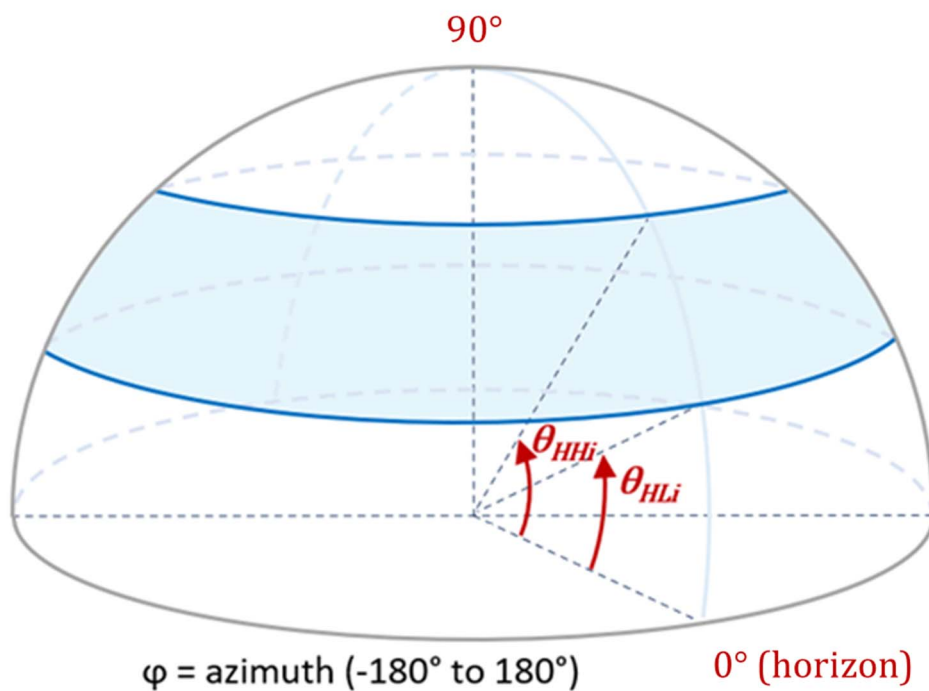

Figure 7.18.2.2-1: Definitions of θ_{HLi} and θ_{HHi} angles.

8 Conducted performance requirements

8.1 General

Conducted performance requirements specify the ability of the *NCR-MT type 1-C* to correctly demodulate signals in various conditions and configurations. Conducted performance requirements are specified at the *TAB connector(s)* (for *NCR-MT type 1-C*).

Conducted performance requirements for the NCR-MT are specified for the fixed reference channels defined in Annex B and the propagation conditions in Annex C. The requirements only apply to those FRCs that are supported by the NCR-MT.

The SNR used in this clause is specified based on a single carrier and defined as:

$$\text{SNR} = S / N$$

Where:

S is the total signal energy in the slot on a single *TAB connector* (for *NCR-MT type 1-C*).

N is the noise energy in a bandwidth corresponding to the transmission bandwidth over the duration of a slot on a single *TAB connector* (for *NCR-MT type 1-C*).

8.2 Demodulation performance requirements

8.2.1 Performance requirements for PDSCH

8.2.1.1 2Rx requirements

8.2.1.1.1 FDD

The performance requirements are specified in Table 8.2.1.1.1-1 and Table 8.2.1.1.1-2, with the addition of test parameters in Table 8.2.1.1.1-1.

The required throughput is expressed as a fraction of maximum throughput for the FRCs listed in Annex B.

Table: 8.2.1.1.1-1 Test parameters for testing PDSCH

Parameter		Value
Cyclic prefix		Normal
Duplex mode		FDD
HARQ	Maximum number of HARQ transmissions	4 for Test 1-1 and 1-2 1 for Test 2-1 and 2-2
	RV sequence	0, 2, 3, 1
DM-RS	DM-RS configuration type	1
	DM-RS duration	single-symbol DM-RS
	DM-RS position (l_0)	2
	Additional DM-RS position	pos1
	Number of DM-RS CDM group(s) without data	1
	DM-RS port(s)	{1000}
Time domain resource assignment	DM-RS sequence generation	$N_{ID}^0=0$
	PDSCH mapping type	A
	Start symbol	2
Frequency domain resource assignment	Allocation length	12
	RB assignment	Full applicable test bandwidth
PT-RS configuration		Not configured
PRB bundling size		2
VRB-to-PRB mapping type		Not interleaved
PDSCH & PDSCH DMRS Precoding configuration		Single Panel Type I, Random precoder selection updated per slot, with equal probability of each applicable i_1, i_2 combination, and with PRB bundling granularity

8.2.1.1.1.1 Minimum requirements

Table 8.2.1.1.1.1-1: Minimum requirements for PDSCH Type A with Rank 1

Test number	FRC (Annex B)	Bandwidth (MHz) / Subcarrier spacing (kHz)	Propagation conditions (Annex C)	Antenna configuration	Fraction of maximum throughput (%)	SNR (dB)
1-1	M-FR1-NCR.1.1-1	10/15	TDLA30-10	2x2, ULA Low	70	-0.9
1-2	M-FR1-NCR.1.1-3	10/15	TDLA30-10	2x2, ULA Low	70	6.8

Table 8.2.1.1.1.1-2: Minimum requirements for PDSCH Type A with Rank 1

Test number	FRC (Annex B)	Bandwidth (MHz) / Subcarrier spacing (kHz)	Propagation conditions (Annex C)	Antenna configuration	Fraction of maximum BLER (%)	SNR (dB)
2-1	M-FR1-NCR.1.1-1	10/15	TDLA30-10	2x2, ULA Low	1	5.0
2-2	M-FR1-NCR.1.1-3	10/15	TDLA30-10	2x2, ULA Low	1	13.0

8.2.1.1.2 TDD

The performance requirements are specified in Table 8.2.1.1.2.1-1 and Table 8.2.1.1.2.1-2, with the addition of test parameters in Table 8.2.1.1.1-1.

The required throughput is expressed as a fraction of maximum throughput for the FRCs listed in Annex B.

Table: 8.2.1.1.1-1 Test parameters for testing PDSCH

Parameter		Value
Cyclic prefix		Normal
Default TDD UL-DL pattern (Note 1)		7D1S2U, S=6D:4G:4U
HARQ	Maximum number of HARQ transmissions	4 for Test 1-1 and 1-2 1 for Test 2-1 and 2-2
	RV sequence	0, 2, 3, 1
DM-RS	DM-RS configuration type	1
	DM-RS duration	single-symbol DM-RS
	DM-RS position (l_0)	2
	Additional DM-RS position	pos1
	Number of DM-RS CDM group(s) without data	1
	DM-RS port(s)	{1000}
Time domain resource assignment	DM-RS sequence generation	$N_{ID}^0=0$
	PDSCH mapping type	A
	Start symbol	2
Frequency domain resource assignment	Allocation length	12
	RB assignment	Full applicable test bandwidth
PT-RS configuration		Not configured
PRB bundling size		2
VRB-to-PRB mapping type		Not interleaved
PDSCH & PDSCH DMRS Precoding configuration		Single Panel Type I, Random precoder selection updated per slot, with equal probability of each applicable i_1, i_2 combination, and with PRB bundling granularity
Note 1: The same requirements are applicable to TDD with different UL-DL patterns.		

8.2.1.1.2.1 Minimum requirements

Table 8.2.1.1.2.1-1: Minimum requirements for PDSCH Type A with Rank 1

Test number	FRC (Annex B)	Bandwidth (MHz) / Subcarrier spacing (kHz)	Propagation conditions (Annex C)	Antenna configuration	Fraction of maximum throughput (%)	SNR (dB)
1-1	M-FR1-NCR.1.1-2	40/30	TDLA30-10	2x2, ULA Low	70	-1.0
1-2	M-FR1-NCR.1.1-4	40/30	TDLA30-10	2x2, ULA Low	70	6.8

Table 8.2.1.1.2.1-2: Minimum requirements for PDSCH Type A with Rank 1

Test number	FRC (Annex B)	Bandwidth (MHz) / Subcarrier spacing (kHz)	Propagation conditions (Annex C)	Antenna configuration	Fraction of maximum BLER (%)	SNR (dB)
2-1	M-FR1-NCR.1.1-2	40/30	TDLA30-10	2x2, ULA Low	1	4.3
2-2	M-FR1-NCR.1.1-4	40/30	TDLA30-10	2x2, ULA Low	1	12

8.2.1.2 4Rx requirements

8.2.1.2.1 FDD

The performance requirements are specified in Table 8.2.1.2.1.1-1 and Table 8.2.1.2.1.1-2, with the addition of test parameters in Table 8.2.1.2.1-1.

The required throughput is expressed as a fraction of maximum throughput for the FRCs listed in Annex B.

Table: 8.2.1.2.1-1 Test parameters for testing PDSCH

Parameter		Value
Cyclic prefix		Normal
Duplex mode		FDD
HARQ	Maximum number of HARQ transmissions	4 for Test 1-1 and 1-2 1 for Test 2-1 and 2-2
	RV sequence	0, 2, 3, 1
DM-RS	DM-RS configuration type	1
	DM-RS duration	single-symbol DM-RS
	DM-RS position (l_0)	2
	Additional DM-RS position	pos1
	Number of DM-RS CDM group(s) without data	1
	DM-RS port(s)	{1000}
	DM-RS sequence generation	$N_{ID}^0=0$
Time domain resource assignment	PDSCH mapping type	A
	Start symbol	2
	Allocation length	12
Frequency domain resource assignment	RB assignment	Full applicable test bandwidth
PT-RS configuration		Not configured
PRB bundling size		2
VRB-to-PRB mapping type		Not interleaved
PDSCH & PDSCH DMRS Precoding configuration		Single Panel Type I, Random precoder selection updated per slot, with equal probability of each applicable i_1, i_2 combination, and with PRB bundling granularity

8.2.1.2.1.1 Minimum requirements

Table 8.2.1.2.1.1-1: Minimum requirements for PDSCH Type A with Rank 1

Test number	FRC (Annex B)	Bandwidth (MHz) / Subcarrier spacing (kHz)	Propagation conditions (Annex C)	Antenna configuration	Fraction of maximum throughput (%)	SNR (dB)
1-1	M-FR1-NCR.1.1-1	10/15	TDLA30-10	2x4, ULA Low	70	-3.9
1-2	M-FR1-NCR.1.1-3	10/15	TDLA30-10	2x4, ULA Low	70	3.5

Table 8.2.1.2.1.1-2: Minimum requirements for PDSCH Type A with Rank 1

Test number	FRC (Annex B)	Bandwidth (MHz) / Subcarrier spacing (kHz)	Propagation conditions (Annex C)	Antenna configuration	Fraction of maximum BLER (%)	SNR (dB)
2-1	M-FR1-NCR.1.1-1	10/15	TDLA30-10	2x4, ULA Low	1	0.2
2-2	M-FR1-NCR.1.1-3	10/15	TDLA30-10	2x4, ULA Low	1	7.7

8.2.1.2.2 TDD

The performance requirements are specified in Table 8.2.1.2.2.1-1 and Table 8.2.1.2.2.1-2, with the addition of test parameters in Table 8.2.1.2.2-1.

The required throughput is expressed as a fraction of maximum throughput for the FRCs listed in annex B.

Table: 8.2.1.2.2-1 Test parameters for testing PDSCH

Parameter		Value
Cyclic prefix		Normal
Default TDD UL-DL pattern (Note 1)		7D1S2U, S=6D:4G:4U
HARQ	Maximum number of HARQ transmissions	4 for Test 1-1 and 1-2 1 for Test 2-1 and 2-2
	RV sequence	0, 2, 3, 1
DM-RS	DM-RS configuration type	1
	DM-RS duration	single-symbol DM-RS
	DM-RS position (l_0)	2
	Additional DM-RS position	pos1
	Number of DM-RS CDM group(s) without data	1
	DM-RS port(s)	{1000} for Rank 1 tests
Time domain resource assignment	DM-RS sequence generation	$N_{ID}^0=0$
	PDSCH mapping type	A
	Start symbol	2
Frequency domain resource assignment	Allocation length	12
	RB assignment	Full applicable test bandwidth
PT-RS configuration		Not configured
PRB bundling size		2
VRB-to-PRB mapping type		Not interleaved
PDSCH & PDSCH DMRS Precoding configuration		Single Panel Type I, Random precoder selection updated per slot, with equal probability of each applicable i_1, i_2 combination, and with PRB bundling granularity
Note 1: The same requirements are applicable to TDD with different UL-DL patterns.		

8.2.1.2.2.1 Minimum requirements

Table 8.2.1.2.2.1-1: Minimum requirements for PDSCH Type A with Rank 1

Test number	FRC (Annex B)	Bandwidth (MHz) / Subcarrier spacing (kHz)	Propagation conditions (Annex C)	Antenna configuration	Fraction of maximum throughput (%)	SNR (dB)
1-1	M-FR1-NCR.1.1-2	40/30	TDLA30-10	2x4, ULA Low	70	-3.9
1-2	M-FR1-NCR.1.1-4	40/30	TDLA30-10	2x4, ULA Low	70	3.6

Table 8.2.1.2.2.1-2: Minimum requirements for PDSCH Type A with Rank 1

Test number	FRC (Annex B)	Bandwidth (MHz) / Subcarrier spacing (kHz)	Propagation conditions (Annex C)	Antenna configuration	Fraction of maximum BLER (%)	SNR (dB)
2-1	M-FR1-NCR.1.1-2	40/30	TDLA30-10	2x4, ULA Low	1	-0.5
2-2	M-FR1-NCR.1.1-4	40/30	TDLA30-10	2x4, ULA Low	1	7.1

8.2.2 Performance requirements for PDCCH

The receiver characteristics of the PDCCH are determined by the probability of miss-detection of the Downlink Scheduling Grant (Pm-dsg).

8.2.2.1 2Rx requirements

8.2.2.1.1 FDD

The parameters specified in Table 8.2.2.1.1-1 are valid for all FDD tests unless otherwise stated.

Table: 8.2.2.1.1-1 Test parameters for testing PDCCH

Parameter	Value
Cyclic prefix	Normal
DM-RS sequence generation	NID=0
Frequency domain resource allocation for CORESET	Start from RB = 0 with contiguous RB allocation
CCE to REG mapping type	Not-Interleaved
Interleaver size	3
REG bundle size	6 for test with 1Tx and 2Tx
Shift Index	0
Slots for PDCCH monitoring	Each slot
Number of PDCCH candidates for the tested aggregation level	1
PDCCH Precoding configuration	Single Panel Type I, Random precoder selection updated per slot, with equal probability of each applicable i1, i2 combination with REG bundling granularity for number of Tx larger than 1

8.2.2.1.1.1 1Tx requirements

For the parameters specified in Table 8.2.2.1.1-1, the average probability of a missed downlink scheduling grant (Pm-dsg) shall be below the specified value in Table 8.2.2.1.1.1-1.

Table 8.2.2.1.1.1-1: Minimum performance for PDCCH with 15 kHz SCS

Test number	Bandwidth (MHz)	CORE SET RB	CORESET duration	Aggregation level	Reference Channel	Propagation Condition	Antenna configuration and correlation Matrix	Reference value	
								Pm-dsg (%)	SNR (dB)
1-1	10	24	2	2	M-FR1-NCR.1.2-1	TDLA30-10	1x2 Low	1	8.1
1-2	10	48	2	4	M-FR1-NCR.1.2-2	TDLA30-10	1x2 Low	1	5.5

8.2.2.1.1.2 2Tx requirements

For the parameters specified in Table 8.2.2.1.1-1, the average probability of a missed downlink scheduling grant (Pm-dsg) shall be below the specified value in Table 8.2.2.1.1.2-1.

Table 8.2.2.1.1.2-1: Minimum performance for PDCCH with 15 kHz SCS

Test number	Bandwidth (MHz)	CORE SET RB	CORESET duration	Aggregation level	Reference Channel	Propagation Condition	Antenna configuration and correlation Matrix	Reference value	
								Pm-dsg (%)	SNR (dB)
1-1	10	48	1	8	M-FR1-NCR.1.2-3	TDLA30-10	2x2 Low	1	-0.2

8.2.2.1.2 TDD

The parameters specified in Table 8.2.2.1.2-1 are valid for all TDD tests unless otherwise stated.

Table: 8.2.2.1.2-1 Test parameters for testing PDCCH

Parameter	Value
Cyclic prefix	Normal
Default TDD UL-DL pattern (Note 1)	7D1S2U, S=6D:4G:4U
DM-RS sequence generation	$N_{ID}=0$
Frequency domain resource allocation for CORESET	Start from RB = 0 with contiguous RB allocation
CCE to REG mapping type	Interleaved
Interleaver size	3
REG bundle size	2 for test with 1Tx 6 for test with 2Tx
Shift Index	0
Slots for PDCCH monitoring	Each slot
Number of PDCCH candidates for the tested aggregation level	1
PDCCH Precoding configuration	Single Panel Type I, Random precoder selection updated per slot, with equal probability of each applicable i_1, i_2 combination with REG bundling granularity for number of Tx larger than 1
Note 1: The same requirements are applicable to TDD with different UL-DL patterns.	

8.2.2.1.2.1 1Tx requirements

For the parameters specified in Table 8.2.2.1.2-1, the average probability of a missed downlink scheduling grant (Pm-dsg) shall be below the specified value in Table 8.2.2.1.2.1-1.

Table 8.2.2.1.2.1-1: Minimum performance for PDCCH with 30 kHz SCS

Test number	Bandwidth (MHz)	CORE SET RB	CORESET duration	Aggregation level	Reference Channel	Propagation Condition	Antenna configuration and correlation Matrix	Reference value	
								Pm-dsg (%)	SNR (dB)
1-1	40	102	1	2	M-FR1-NCR.1.2-4	TDLA30-10	1x2 Low	1	7.0
1-2	40	102	1	4	M-FR1-NCR.1.2-5	TDLA30-10	1x2 Low	1	4.9

8.2.2.1.2.2 2Tx requirements

For the parameters specified in Table 8.2.2.1.2-1, the average probability of a missed downlink scheduling grant (Pm-dsg) shall be below the specified value in Table 8.2.2.1.2.2-1.

Table 8.2.2.1.2.2-1: Minimum performance for PDCCH with 30 kHz SCS

Test number	Bandwidth (MHz)	CORE SET RB	CORESET duration	Aggregation level	Reference Channel	Propagation Condition	Antenna configuration and correlation Matrix	Reference value	
								Pm-dsg (%)	SNR (dB)
1-1	40	90	1	8	M-FR1-NCR.1.2-6	TDLA30-10	2x2 Low	1	-0.7

8.2.2.2 4Rx requirements

8.2.2.2.1 FDD

The parameters specified in Table 8.2.2.2.1-1 are valid for all FDD tests unless otherwise stated.

Table: 8.2.2.2.1-1 Test parameters for testing PDCCH

Parameter	Value
Cyclic prefix	Normal
DM-RS sequence generation	NID=0
Frequency domain resource allocation for CORESET	Start from RB = 0 with contiguous RB allocation
CCE to REG mapping type	Not-Interleaved
Interleaver size	3
REG bundle size	6 for test with 1Tx and 2Tx
Shift Index	0
Slots for PDCCH monitoring	Each slot
Number of PDCCH candidates for the tested aggregation level	1
PDCCH Precoding configuration	Single Panel Type I, Random precoder selection updated per slot, with equal probability of each applicable i1, i2 combination with REG bundling granularity for number of Tx larger than 1

8.2.2.2.1.1 1Tx requirements

For the parameters specified in Table 8.2.2.2.1-1, the average probability of a missed downlink scheduling grant (Pm-dsg) shall be below the specified value in Table 8.2.2.2.1.1-1.

Table 8.2.2.2.1.1-1: Minimum performance for PDCCH with 15 kHz SCS

Test number	Bandwidth (MHz)	CORE SET RB	CORESET duration	Aggregation level	Reference Channel	Propagation Condition	Antenna configuration and correlation Matrix	Reference value	
								Pm-dsg (%)	SNR (dB)
1-1	10	24	2	2	M-FR1-NCR.1.2-1	TDLA30-10	1x4 Low	1	2.2
1-2	10	48	2	4	M-FR1-NCR.1.2-2	TDLA30-10	1x4 Low	1	0.2

8.2.2.2.1.2 2Tx requirements

For the parameters specified in Table 8.2.2.2.1-1, the average probability of a missed downlink scheduling grant (Pm-dsg) shall be below the specified value in Table 8.2.2.2.1.2-1.

Table 8.2.2.2.1.2-1: Minimum performance for PDCCH with 15 kHz SCS

Test number	Bandwidth (MHz)	CORE SET RB	CORESET duration	Aggregation level	Reference Channel	Propagation Condition	Antenna configuration and correlation Matrix	Reference value	
								Pm-dsg (%)	SNR (dB)
1-1	10	48	2	8	M-FR1-NCR.1.2-3	TDLA30-10	2x4 Low	1	-2.5

8.2.2.2.2 TDD

The parameters specified in Table 8.2.2.2.2-1 are valid for all TDD tests unless otherwise stated.

Table: 8.2.2.2.2-1 Test parameters for testing PDCCH

Parameter	Value
Cyclic prefix	Normal
Default TDD UL-DL pattern (Note 1)	7D1S2U, S=6D:4G:4U
DM-RS sequence generation	$N_{ID}=0$
Frequency domain resource allocation for CORESET	Start from RB = 0 with contiguous RB allocation
CCE to REG mapping type	Interleaved
Interleaver size	3
REG bundle size	2 for test with 1Tx 6 for test with 2Tx
Shift Index	0
Slots for PDCCH monitoring	Each slot
Number of PDCCH candidates for the tested aggregation level	1
PDCCH Precoding configuration	Single Panel Type I, Random precoder selection updated per slot, with equal probability of each applicable i_1, i_2 combination with REG bundling granularity for number of Tx larger than 1
Note 1:	The same requirements are applicable to TDD with different UL-DL patterns.

8.2.2.2.2.1 1Tx requirements

For the parameters specified in Table 8.2.2.2.2-1, the average probability of a missed downlink scheduling grant (Pm-dsg) shall be below the specified value in Table 8.2.2.2.2.1-1.

Table 8.2.2.2.1-1: Minimum performance for PDCCH with 30 kHz SCS

Test number	Bandwidth (MHz)	CORE SET RB	CORE SET duration	Aggregation level	Reference Channel	Propagation Condition	Antenna configuration and correlation Matrix	Reference value	
								Pm-dsg (%)	SNR (dB)
1-1	40	102	1	2	M-FR1-NCR.1.2-4	TDLA30-10	1x4 Low	1	2.1
1-2	40	102	1	4	M-FR1-NCR.1.2-5	TDLA30-10	1x4 Low	1	0.7

8.2.2.2.2.2 2Tx requirements

For the parameters specified in Table 8.2.2.2.1, the average probability of a missed downlink scheduling grant (Pm-dsg) shall be below the specified value in Table 8.2.2.2.2-1.

Table 8.2.2.2.2-1: Minimum performance for PDCCH with 30 kHz SCS

Test number	Bandwidth (MHz)	CORE SET RB	CORE SET duration	Aggregation level	Reference Channel	Propagation Condition	Antenna configuration and correlation Matrix	Reference value	
								Pm-dsg (%)	SNR (dB)
1-1	40	90	1	8	M-FR1-NCR.1.2-6	TDLA30-10	2x4 Low	1	-4.1

8.2.3 Channel Quality Indicator (CQI) reporting requirements

8.2.3.1 General

This clause includes conducted requirements for the reporting of channel quality indicator (CQI).

The reporting accuracy of the channel quality indicator (CQI) under frequency non-selective conditions is determined by the reporting variance and the BLER performance using the transport format indicated by the reported CQI median. The purpose is to verify that the reported CQI values are in accordance with the CQI definition given in TS 38.214 [28]. To account for sensitivity of the input SNR the reporting definition is considered to be verified if the reporting accuracy is met for at least one of two SNR levels separated by an offset of 1 dB.

8.2.3.2 2Rx requirements

8.2.3.2.1 FDD

8.2.3.2.1.1 Test parameters

Parameters specified in Table 8.2.3.2.1-1 are applied for all test cases in clause 8.2.3.2.1 unless otherwise stated.

Table 8.2.3.2.1.1-1: Test parameters for testing CQI reporting

Parameter		Unit	Test 1		Test 2	
Bandwidth		MHz	10			
Duplex Mode			FDD			
Subcarrier spacing		kHz	15			
SNR		dB	8	9	14	15
Propagation channel			AWGN			
Antenna configuration			2x2 with static channel specified in Annex C			
Beamforming Model			TBD			
NZIP CSI-RS for CSI acquisition	CSI-RS resource Type		Periodic			
	Number of CSI-RS ports (X)		2			
	CDM Type		FD-CDM2			
	Density (ρ)		1			
	First subcarrier index in the PRB used for CSI-RS (k_0)		Row 3,(6)			
	First OFDM symbol in the PRB used for CSI-RS (l_0)		13			
	NZIP CSI-RS-timeConfig periodicity and offset	slot	5/1			
ReportConfigType			Periodic			
CQI-table			Table 2			
reportQuantity			cri-RI-PMI-CQI			
timeRestrictionForChannelMeasurements			Not configured			
timeRestrictionForInterferenceMeasurements			Not configured			
cqi-FormatIndicator			Wideband			
pmi-FormatIndicator			Wideband			
Sub-band Size		RB	8			
Csi-ReportingBand			1111111			
CSI-Report periodicity and offset		slot	5/0			
aperiodicTriggeringOffset			Not configured			
Codebook configuration	Codebook Type		type1-SinglePanel			
	Codebook Mode		1			
	(CodebookConfig-N1,CodebookConfig-N2)		Not configured			
	CodebookSubsetRestriction		010000			
	RI Restriction		N/A			
Physical channel for CSI report			PUCCH			
CQI/RI/PMI delay		ms	8			
Maximum number of HARQ transmission			1			
Measurement channel			M-FR1-NCR.1.3-1			

8.2.3.2.1.2 Minimum requirements

For the parameters specified in Table 8.2.3.2.1.1-1, the minimum requirements are specified by the following:

- The reported CQI value according to the reference channel shall be in the range of ± 1 of the reported median more than 90% of the time.
- If the PDSCH BLER using the transport format indicated by median CQI is less than or equal to 0.1, then the BLER using the transport format indicated by the (median CQI+1) shall be greater than 0.1. If the PDSCH BLER using the transport format indicated by the median CQI is greater than 0.1, then the BLER using transport format indicated by (median CQI-1) shall be less than or equal to 0.1.

8.2.3.2.2 TDD

8.2.3.2.2.1 Test parameters

Parameters specified in Table 8.2.3.2.2.1-1 are applied for all test cases in clause 8.2.3.2.2.1 unless otherwise stated.

Table 8.2.3.2.2.1-1: Test parameters for testing CQI reporting

Parameter		Unit	Test 1		Test 2	
Bandwidth		MHz	40			
Subcarrier spacing		kHz	30			
Duplex Mode			TDD			
TDD UL-DL pattern (Note 1)			7D1S2U, S=6D:4G:4U			
SNR		dB	8	9	14	15
Propagation channel			AWGN			
Antenna configuration			2x2 with static channel specified in Annex C			
Beamforming Model			TBD			
N郑 CSI-RS for CSI acquisition	CSI-RS resource Type		Periodic			
	Number of CSI-RS ports (X)		2			
	CDM Type		FD-CDM2			
	Density (ρ)		1			
	First subcarrier index in the PRB used for CSI-RS (k ₀)		Row 3,(6,-)			
	First OFDM symbol in the PRB used for CSI-RS (l ₀)		13			
	N郑 CSI-RS-timeConfig periodicity and offset	slot	10/1			
ReportConfigType			Periodic			
CQI-table			Table 2			
reportQuantity			cri-RI-PMI-CQI			
timeRestrictionForChannelMeasurements			Not configured			
timeRestrictionForInterferenceMeasurements			Not configured			
cqi-FormatIndicator			Wideband			
pmi-FormatIndicator			Wideband			
Sub-band Size		RB	16			
Csi-ReportingBand			1111111			
CSI-Report periodicity and offset		slot	10/9			
aperiodicTriggeringOffset			Not configured			
Codebook configuration	Codebook Type		typel-SinglePanel			
	Codebook Mode		1			
	(CodebookConfig-N1,CodebookConfig-N2)		Not configured			
	CodebookSubsetRestriction		010000			
	RI Restriction		N/A			
Physical channel for CSI report			PUCCH			
CQI/RI/PMI delay		ms	9.5			
Maximum number of HARQ transmission			1			
Measurement channel			M-FR1-NCR.1.3-2			
Note 1: The same requirements are applicable for TDD with different UL-DL pattern.						
Note 2: SSB, TRS, CSI-RS, and/or other unspecified test parameters with respect to TS 38.101-4 [30] are left up to test implementation, if transmitted or needed.						

8.2.3.2.2.2 Minimum requirements

For the parameters specified in Table 8.2.3.2.2.1-1, the minimum requirements are specified by the following:

- a) The reported CQI value according to the reference channel shall be in the range of ±1 of the reported median more than 90% of the time.
- b) If the PDSCH BLER using the transport format indicated by median CQI is less than or equal to 0.1, then the BLER using the transport format indicated by the (median CQI+1) shall be greater than 0.1. If the PDSCH BLER using the transport format indicated by the median CQI is greater than 0.1, then the BLER using transport format indicated by (median CQI-1) shall be less than or equal to 0.1.

8.2.3.3 4Rx requirements

8.2.3.3.1 FDD

8.2.3.3.1.1 Test parameters

Parameters specified in Table 8.2.3.3.1.1-1 are applied for all test cases in clause 8.2.3.3.1.1 unless otherwise stated.

Table 8.2.3.3.1.1-1: Test parameters for testing CQI reporting

Parameter		Unit	Test 1		Test 2	
Bandwidth		MHz	10			
Subcarrier spacing		kHz	15			
Duplex Mode			FDD			
SNR		dB	5	6	11	12
Propagation channel			AWGN			
Antenna configuration			2x4 with static channel specified in Annex C			
Beamforming Model			TBD			
NZP CSI-RS for CSI acquisition	CSI-RS resource Type		Periodic			
	Number of CSI-RS ports (X)		2			
	CDM Type		FD-CDM2			
	Density (ρ)		1			
	First subcarrier index in the PRB used for CSI-RS (k_0)		Row 3,(6)			
	First OFDM symbol in the PRB used for CSI-RS (l_0)		13			
NZP CSI-RS-timeConfig periodicity and offset		slot	5/1			
ReportConfigType			Periodic			
CQI-table			Table 2			
reportQuantity			cri-RI-PMI-CQI			
timeRestrictionForChannelMeasurements			Not configured			
timeRestrictionForInterferenceMeasurements			Not configured			
cqi-FormatIndicator			Wideband			
pmi-FormatIndicator			Wideband			
Sub-band Size		RB	8			
csi-ReportingBand			1111111			
CSI-Report periodicity and offset		slot	5/0			
aperiodicTriggeringOffset			Not configured			
Codebook configuration	Codebook Type		type1-SinglePanel			
	Codebook Mode (CodebookConfig-N1,CodebookConfig-N2)		1			
	CodebookSubsetRestriction		Not configured			
	RI Restriction		010000			
Physical channel for CSI report			PUCCH			
CQI/RI/PMI delay		ms	8			
Maximum number of HARQ transmission			1			
Measurement channel			M-FR1-NCR.1.3-1			

8.2.3.3.1.2 Minimum requirements

For the parameters specified in Table 8.2.3.3.1.1-1, the minimum requirements are specified by the following:

- The reported CQI value according to the reference channel shall be in the range of ± 1 of the reported median more than 90 % of the time.

- b) If the PDSCH BLER using the transport format indicated by median CQI is less than or equal to 0.1, then the BLER using the transport format indicated by the (median CQI+1) shall be greater than 0.1. If the PDSCH BLER using the transport format indicated by the median CQI is greater than 0.1, then the BLER using transport format indicated by (median CQI-1) shall be less than or equal to 0.1.

8.2.3.3.2 TDD

8.2.3.3.2.1 Test parameters

Parameters specified in Table 8.2.3.3.2.1 -1 are applied for all test cases in clause 8.2.3.3.2.1 unless otherwise stated.

Table 8.2.3.3.2.1 -1: Test parameters for testing CQI reporting

Parameter		Unit	Test 1		Test 2	
Bandwidth		MHz	40			
Subcarrier spacing		kHz	30			
Duplex Mode			TDD			
TDD UL-DL pattern (Note 1)			7D1S2U, S=6D:4G:4U			
SNR		dB	5	6	11	12
Propagation channel			AWGN			
Antenna configuration			2x4 with static channel specified in Annex C			
Beamforming Model			TBD			
NZIP CSI-RS for CSI acquisition	CSI-RS resource Type		Periodic			
	Number of CSI-RS ports (X)		2			
	CDM Type		FD-CDM2			
	Density (ρ)		1			
	First subcarrier index in the PRB used for CSI-RS (k ₀)		Row 3,(6,-)			
	First OFDM symbol in the PRB used for CSI-RS (l ₀)		13			
	NZIP CSI-RS-timeConfig periodicity and offset	slot	10/1			
ReportConfigType			Periodic			
CQI-table			Table 2			
reportQuantity			cri-RI-PMI-CQI			
timeRestrictionForChannelMeasurements			Not configured			
timeRestrictionForInterferenceMeasurements			Not configured			
cqi-FormatIndicator			Wideband			
pmi-FormatIndicator			Wideband			
Sub-band Size		RB	16			
Csi-ReportingBand			1111111			
CSI-Report periodicity and offset		slot	10/9			
aperiodicTriggeringOffset			Not configured			
Codebook configuration	Codebook Type		type1-SinglePanel			
	Codebook Mode		1			
	(CodebookConfig-N1,CodebookConfig-N2)		Not configured			
	CodebookSubsetRestriction		010000			
			RI Restriction			
			N/A			
Physical channel for CSI report			PUCCH			
CQI/RI/PMI delay		ms	9.5			
Maximum number of HARQ transmission			1			
Measurement channel			M-FR1-NCR.1.3-2			
Note 1: The same requirements are applicable for TDD with different UL-DL pattern.						
Note 2: SSB, TRS, CSI-RS, and/or other unspecified test parameters with respect to TS 38.101-4 [30] are left up to test implementation, if transmitted or needed.						

8.2.3.3.2.2 Minimum requirements

For the parameters specified in Table 8.2.3.3.2.1 -1-1, the minimum requirements are specified by the following:

- a) The reported CQI value according to the reference channel shall be in the range of ± 1 of the reported median more than 90% of the time.
- b) If the PDSCH BLER using the transport format indicated by median CQI is less than or equal to 0.1, then the BLER using the transport format indicated by the (median CQI+1) shall be greater than 0.1. If the PDSCH BLER using the transport format indicated by the median CQI is greater than 0.1, then the BLER using transport format indicated by (median CQI-1) shall be less than or equal to 0.1.

9 Radiated performance requirements

9.1 General

Radiated performance requirements specify the ability of the *NCR-MT type 2-O* to correctly demodulate radiated signals in various conditions and configurations. Radiated performance requirements are specified at the RIB.

Radiated performance requirements for the *NCR-MT* are specified for the fixed reference channels defined in annex B and the propagation conditions in annex C.

The radiated performance requirements for the *NCR-MT type 2-O* are limited to two *OTA demodulation branches* as described in clause 9.2. Conformance requirements can only be tested for 1 or 2 *demodulation branches* depending on the number of polarizations supported by the *NCR-MT*, with the required SNR applied separately per polarization.

NOTE 1: The *NCR-MT* can support more than 2 demodulation branches, however OTA conformance testing can only be performed for 1 or 2 demodulation branches.

Radiated performance requirements apply for a single carrier only.

Whenever the "RX antennas" term is used for the radiated performance requirements description, it shall refer to the *demodulation branches* (i.e. not physical antennas of the antenna array).

The SNR used in this clause is specified based on a single carrier and defined as:

$$\text{SNR} = S / N$$

Where:

S is the total signal energy in a slot on a RIB.

N is the noise energy in a bandwidth corresponding to the *transmission bandwidth* over the duration of a slot on a RIB

Radiated performance requirements are only specified for up to 2 *demodulation branches*.

9.2 OTA demodulation branches

If the *NCR-MT type 2-O* uses polarization diversity and has the ability to maintain isolation between the signals for each of the *demodulation branches*, then radiated performance requirements can be tested for up to two *demodulation branches* (i.e. 1RX or 2RX test setups). When tested for two *demodulation branches*, each demodulation branch maps to one polarization.

If the *NCR-MT type 2-O* does not use polarization diversity then radiated performance requirements can only be tested for a single *demodulation branch* (i.e. 1RX test setup).

9.3 Demodulation performance requirements

9.3.1 Performance requirements for NCR type 2-O

9.3.1.1 Performance requirements for PDSCH

9.3.1.1.1 General

The performance requirement of PDSCH is determined by (i) a minimum required throughput for a given SNR and (ii) a minimum SNR at which 1% first transmission BLER is achieved. The required throughput is expressed as a fraction of maximum throughput for the FRCs listed in annex B. The throughput requirements assume HARQ retransmissions whereas the 1% BLER requirements are based on the first transmission only.

Table: 9.3.1.1.1-1 Test parameters for PDSCH testing

Parameter		Value
Cyclic prefix		Normal
Default TDD UL-DL pattern (Note 1)		3D1S1U, S=10D:2G:2U
HARQ	Maximum number of HARQ transmissions	4
	RV sequence	0, 2, 3, 1
DM-RS	DM-RS configuration type	1
	DM-RS duration	single-symbol DM-RS
	DM-RS position (l_0)	2
	Additional DM-RS position	pos1
	Number of DM-RS CDM group(s) without data	1
	DM-RS port(s)	{1000} for Rank 1 tests {1000-1001} for Rank 2 tests
	DM-RS sequence generation	$N_{ID}^0=0$
Time domain resource assignment	PDSCH mapping type	A
	Start symbol	1
	Allocation length	13
Frequency domain resource assignment	RB assignment	Full applicable test bandwidth
PT-RS configuration	Frequency density (K_{PT-RS})	2
	Time density (L_{PT-RS})	1
PRB bundling size		2
VRB-to-PRB mapping type		Not interleaved
PDSCH & PDSCH DMRS Precoding configuration		Single Panel Type I, Random precoder selection updated per slot, with equal probability of each applicable i_1, i_2 combination, and with PRB bundling granularity
Note 1: The same requirements are applicable to TDD with different UL-DL patterns.		
Note 2: SSB, TRS, CSI-RS, and/or other unspecified test parameters with respect to TS 38.101-4 [30] are left up to test implementation, if transmitted or needed.		

9.3.1.1.2 Minimum requirements

The throughput shall be equal to or larger than the fraction of maximum throughput, and also meet the 1st transmission BLER 1% for the FRCs stated in table 9.3.1.1.2-1 at the given respective SNR with the test parameters stated in Tabl9.3.1.1.1-1.

Table 9.3.1.2-1: Minimum requirements for PDSCH with 100 MHz Channel Bandwidth, 120 kHz SCS

Case number	Bandwidth (MHz)	FRC	SCS (kHz)	Propagation condition	Antenna configuration	70% throughput (dB)	1% BLER (dB)
1	100	M-FR2-B.1.1-1	120	TDLA30-75	2x2	-0.9	2.8

9.3.1.2 Performance requirements for PDCCH

9.3.1.2.1 General

The receiver characteristics of the PDCCH are determined by the probability of miss-detection of the Downlink Scheduling Grant (Pm-dsg).

Table: 9.3.1.2.1-1 Test parameters for testing PDCCH

Parameter	Value
Cyclic prefix	Normal
Default TDD UL-DL pattern (Note 1)	3D1S1U, S=10D:2G:2U
DM-RS sequence generation	NID=0
Frequency domain resource allocation for CORESET	Start from RB = 0 with contiguous RB allocation
CCE to REG mapping type	Interleaved
Interleaver size	2 for test with Aggregation level 4 3 for others
REG bundle size	6 for test with Aggregation level 4 2 for others
Shift Index	0
Slots for PDCCH monitoring	Each slot
Number of PDCCH candidates for the tested aggregation level	1
PDCCH Precoding configuration	Single Panel Type I, Random precoder selection updated per slot, with equal probability of each applicable i_1, i_2 combination with REG bundling granularity for number of Tx larger than 1
Note 1:	The same requirements are applicable to TDD with different UL-DL patterns.
Note 2:	SSB, TRS, CSI-RS, and/or other unspecified test parameters with respect to TS 38.101-4 [30] are left up to test implementation, if transmitted or needed

9.3.1.2.2 Minimum requirements

The Pm-dsg shall be equal to or smaller than 1%, for the cases stated in Table 9.3.1.2.2-1 at the given SNR with the test parameters stated in Table 9.3.1.2.1-1.

Table 9.3.1.2.2-1: Minimum requirements for PDCCH, 100 MHz Channel Bandwidth, 120 kHz SCS

Antenna configuration	CORESET RB	CORESET duration	Aggregation level	FRC (Annex A)	Propagation conditions and correlation matrix (Annex I)	Pm-dsg (%)	SNR (dB)
1x2	60	1	2	M-FR2-NCR.1.2-1	TDLA30-75, ULA Low	1	6.4
1x2	60	1	4	M-FR2-NCR.1.2-2	TDLA30-75, ULA Low	1	2.9
2x2	60	1	8	M-FR2-NCR.1.2-3	TDLA30-75, ULA Low	1	0.1

9.4 CSI reporting requirements

9.4.1 Performance requirements for NCR-MT type 2-O

9.4.1.1 General

This clause includes radiated requirements for the reporting of channel state information (CSI).

9.4.1.2 Common test parameters

Parameters specified in Table 9.4.1.2-1 are applied for all test cases in this clause unless otherwise stated.

Table 9.4.1.2-1: Test parameters for CSI test cases

Parameter		Unit	Value
PDSCH transmission scheme			Transmission scheme 1
Duplex Mode			TDD
PTRS <i>epr</i> -Ratio			0
Actual carrier configuration	Offset between Point A and the lowest usable subcarrier on this carrier (Note 3)	RBs	0
	Subcarrier spacing	kHz	120
DL BWP configuration #1	Cyclic prefix		Normal
	RB offset	RBs	0
	Number of contiguous PRB	PRBs	Maximum transmission bandwidth configuration as specified in clause 5.3.2 of TS 38.101-2 [4] for tested channel bandwidth and subcarrier spacing
Active DL BWP index			1
PDSCH configuration	Mapping type		Type A
	<i>k₀</i>		0
	Starting symbol (S)		2
	Length (L)		12
	PDSCH aggregation factor		1
	PRB bundling type		Static
	PRB bundling size		2
	Resource allocation type		Type 0
	RBG size		Config2
	VRB-to-PRB mapping type		Non-interleaved
PDSCH DMRS configuration	VRB-to-PRB mapping interleaver bundle size		N/A
	DMRS Type		Type 1
	Number of additional DMRS		1
	DMRS ports indexes		{1000} for Rank1 {1000,1001} for Rank2
	Maximum number of OFDM symbols for DL front loaded DMRS		1
PTRS configuration	Number of PDSCH DMRS CDM group(s) without data		2
	Frequency density (K_{PT-RS})		2
	Time density (L_{PT-RS})		1
N/ZP CSI-RS for CSI acquisition	Resource Element Offset		2
	Frequency Occupation		Start PRB 0 Number of PRB = BWP size
Redundancy version coding sequence			{0,2,3,1}
Physical signals, channels mapping and precoding			As specified in Annex C.3.1
Note 1:	PDSCH is scheduled only on full DL slots without CSI-RS resource and TRS allocated.		
Note 2:	Point A coincides with minimum guard band as specified in Table 5.3.3-1 from TS 38.101-2 [4] for tested channel bandwidth and subcarrier spacing.		

9.4.1.3 Reporting of Channel Quality Indicator (CQI)

9.4.1.3.1 General

The reporting accuracy of the channel quality indicator (CQI) under frequency non-selective conditions is determined by the reporting variance and the BLER performance using the transport format indicated by the reported CQI median. The purpose is to verify that the reported CQI values are in accordance with the CQI definition given in TS 38.214 [11]. To account for sensitivity of the input SNR the reporting definition is considered to be verified if the reporting accuracy is met for at least one of two SNR levels separated by an offset of 1 dB.

Table 9.4.1.3.1-1: Test parameters

Parameter		Unit	Test 1				Test 2			
Bandwidth		MHz	100							
Subcarrier spacing		kHz	120							
Duplex Mode			TDD							
Default TDD UL-DL pattern (Note 1)			3D1S1U							
Special Slot Configuration			10D+2G+2U							
SNR _{BB}		dB	8	9	14	15				
Propagation channel			AWGN							
Antenna configuration			2x2 with static channel specified in Annex I.1							
Beamforming Model			As specified in Annex I.3.1							
NZP CSI-RS for CSI acquisition	CSI-RS resource Type		Periodic							
	Number of CSI-RS ports (X)		2							
	CDM Type		fd-CDM2							
	Density (ρ)		1							
	First subcarrier index in the PRB used for CSI-RS (k_0, k_1)		6							
	First OFDM symbol in the PRB used for CSI-RS (l_0, l_1)		13							
	NZP CSI-RS-timeConfig periodicity and offset	slot	5/1							
ReportConfigType			Periodic							
CQI-table			Table 1							
reportQuantity			cri-RI-PMI-CQI							
cqi-FormatIndicator			Wideband							
pmi-FormatIndicator			Wideband							
Sub-band Size		RB	8							
csi-ReportingBand			111111111							
CSI-Report periodicity and offset		slot	5/4							
Codebook configuration	Codebook Type		type1-SinglePanel							
	Codebook Mode		1							
	(CodebookConfig-N1, CodebookConfig-N2)		Not configured							
	CodebookSubsetRestriction		010000							
	RI Restriction		N/A							
CQI/RI/PMI delay		ms	1.75							
Maximum number of HARQ transmission			1							
Measurement channel			M-FR2-NCR.1.3-1							
<p>Note 1: The same requirements are applicable to with different UL-DL patterns.</p> <p>Note 2: SSB, TRS, CSI-RS, and/or other unspecified test parameters with respect to TS 38.101-4 [30] are left up to test implementation, if transmitted or needed.</p> <p>Note 3: If the NCR-MT reports in an available uplink reporting instance at slot #n based on CQI estimation at a downlink slot not later than slot#(n-4), this reported CQI cannot be applied at the gNB downlink before slot#(n+4).</p>										

9.4.1.3.2 Minimum requirements

For the parameters specified in Table 9.4.1.3.-1, and using the downlink physical channels specified in Annex B, the minimum requirements are specified by the following:

- a) The reported CQI value according to the reference channel shall be in the range of ± 1 of the reported median more than 90% of the time.
- b) If the PDSCH BLER using the transport format indicated by median CQI is less than or equal to 0.1, then the BLER using the transport format indicated by the (median CQI+1) shall be greater than 0.1. If the PDSCH BLER using the transport format indicated by the median CQI is greater than 0.1, then the BLER using transport format indicated by (median CQI-1) shall be less than or equal to 0.1.

10 NCR-MT RRC_CONNECTED state mobility

10.1 RRC Connection Mobility Control for NCR-MT

10.1.1 SA: RRC Re-establishment

10.1.1.1 Introduction

This clause contains requirements on the NCR-MT regarding RRC connection re-establishment procedure. The requirements in this clause are applicable only for local area (LA) NCR-MT.

RRC connection re-establishment is initiated when an NCR-MT in RRC_CONNECTED state loses RRC connection due to any of failure cases, including radio link failure, handover failure, and RRC connection reconfiguration failure. The RRC connection re-establishment procedure is specified in clause 5.3.7 of TS 38.331 [23].

The requirements in this clause are applicable for RRC connection re-establishment to NR cell.

10.1.1.2 Requirements

In RRC_CONNECTED state the NCR-MT shall be capable of sending *RRCReestablishmentRequest* message within $T_{re-establish_delay}$ seconds from the moment it detects a loss in RRC connection. The total RRC connection delay ($T_{re-establish_delay}$) shall be less than:

$$T_{re-establish_delay} = T_{NCR-MT_re-establish_delay} + T_{UL_grant}$$

T_{UL_grant} : It is the time required to acquire and process uplink grant from the target PCell. The uplink grant is required to transmit *RRCReestablishmentRequest* message.

The NCR-MT re-establishment delay ($T_{NCR-MT_re-establish_delay}$) is specified in clause 10.1.1.2.1.

10.1.1.2.1 NCR-MT Re-establishment delay requirement

The NCR-MT re-establishment delay ($T_{NCR-MT_re-establish_delay}$) is the time between the moments when any of the conditions requiring RRC re-establishment as defined in clause 5.3.7 in TS 38.331 [23] is detected by the NCR-MT and when the NCR-MT sends PRACH to the target PCell. The NCR-MT re-establishment delay ($T_{NCR-MT_re-establish_delay}$) requirement shall be less than:

$$T_{NCR-MT_re-establish_delay} = 400 \text{ ms} + T_{identify_intra_NR} + \sum_{i=1}^{N_{freq}-1} T_{identify_inter_NR,i} + T_{SI-NR} + T_{PRACH}$$

The intra-frequency target NR cell shall be considered detectable if each relevant SSB can satisfy that:

- the conditions of SSB_RP and SSB \hat{E}_s/I_{ot} according to Annex TBD for the LA NCR-MT class and NCR type are fulfilled.

The inter-frequency target NR cell shall be considered detectable when for each relevant SSB:

- the conditions of SSB_RP and SSB \hat{E}_s/I_{ot} according to Annex TBD for the LA NCR-MT class and NCR type are fulfilled.

$T_{\text{identify_intra_NR}}$: It is the time to identify the target intra-frequency NR cell and it depends on whether the target NR cell is known cell or unknown cell and on the frequency range (FR) of the target NR cell. If the NCR-MT is not configured with intra-frequency NR carrier for RRC re-establishment then $T_{\text{identify_intra_NR}}=0$; otherwise $T_{\text{identify_intra_NR}}$ shall not exceed the values defined in Table 10.1.1.2.1-1.

$T_{\text{identify_inter_NR},i}$: It is the time to identify the target inter-frequency NR cell on inter-frequency carrier i configured for RRC re-establishment and it depends on whether the target NR cell is known cell or unknown cell and on the frequency range (FR) of the target NR cell. $T_{\text{identify_inter_NR},i}$ shall not exceed the values defined in Table 10.1.1.2.1-2.

T_{SMTC} : It is the periodicity of the SMTC occasion configured for the intra-frequency carrier. If the NCR-MT has been provided with higher layer signaling of *smtc2* [23] then T_{SMTC} follows *smtc1* or *smtc2* according to the physical cell ID of the target cell.

$T_{\text{SMTC},i}$: It is the periodicity of the SMTC occasion configured for the inter-frequency carrier i . If the NCR-MT is not provided with SMTC configuration then the NCR-MT may assume that the target SSB periodicity is no larger than 20 ms.

$T_{\text{SI-NR}}$: It is the time required for receiving all the relevant system information according to the reception procedure and the RRC procedure delay of system information blocks defined in TS 38.331 [23] for the target NR cell.

T_{PRACH} : It is the delay uncertainty in acquiring the first available PRACH occasion in the target NR cell. T_{PRACH} can be up to the summation of SSB to PRACH occasion association period and 10 ms. SSB to PRACH occasion associated period is defined in clause 14 of TS 38.213 [24].

N_{freq} : It is the total number of NR frequencies to be monitored for RRC re-establishment; $N_{\text{freq}} = 1$ if the target intra-frequency NR cell is known, else $N_{\text{freq}} = 2$ and $T_{\text{identify_intra_NR}} = 0$ if the target inter-frequency NR cell is known.

There is no requirement if the target cell does not contain the NCR-MT context or if the SSB transmission periodicity is larger than 20 ms.

In the requirement defined in the below tables, the target FR1 cell is known if it has been meeting the relevant cell identification requirement during the last 5 seconds otherwise it is unknown.

Table 10.1.1.2.1-1: Time to identify target NR cell for RRC connection re-establishment to NR intra-frequency cell

Serving cell SSB \hat{E}_s/lot (dB)	Frequency range (FR) of target NR cell	$T_{\text{identify_intra_NR}}$ [ms]	
		Known NR cell	Unknown NR cell
≥ -8	FR1	MAX (1600 ms, $40 \times T_{\text{SMTC}}$)	MAX (6400 ms, $80 \times T_{\text{SMTC}}$)
≥ -8	FR2-1	N/A	MAX (8000 ms, $640 \times T_{\text{SMTC}}$)
< -8	FR1	N/A	6400 ^{Note1}
< -8	FR2-1	N/A	28160 ^{Note1}

Note 1: The NCR-MT is not required to successfully identify a cell on any NR frequency layer when $T_{\text{SMTC}} > 20$ ms and serving cell SSB $\hat{E}_s/\text{lot} < -8$ dB.

Table 10.1.1.2.1-2: Time to identify target NR cell for RRC connection re-establishment to NR inter-frequency cell

Serving cell SSB \hat{E}_s/lot (dB)	Frequency range (FR) of target NR cell	$T_{\text{identify_inter_NR},i}$ [ms]	
		Known NR cell	Unknown NR cell
≥ -8	FR1	MAX (1600 ms, $48 \times T_{\text{SMTC},i}$)	MAX (6400 ms, $104 \times T_{\text{SMTC},i}$)
≥ -8	FR2-1	N/A	MAX (8000 ms, $832 \times T_{\text{SMTC},i}$)
< -8	FR1	N/A	6400 ^{Note1}
< -8	FR2-1	N/A	32000 ^{Note1}

Note 1: The NCR-MT is not required to successfully identify a cell on any NR frequency layer when $T_{\text{SMTC},i} > 20$ ms and serving cell SSB $\hat{E}_s/\text{lot} < -8$ dB.

10.1.2 Random access

10.1.2.1 Introduction

This clause contains requirements on the NCR-MT regarding random access procedure. The random access procedure is initiated to establish uplink time synchronization for a NCR-MT which either has not acquired or has lost its uplink synchronization, or to convey NCR-MT's request Other SI, or for beam failure recovery. The random access is specified in clause 8 of TS 38.213 [24] and the control of the RACH transmission is specified in clause 5.1 of TS 38.321 [25].

The requirements in this clause apply for LA NCR-MT.

10.1.2.2 Requirements for 4-step RA type

The NCR-MT shall have capability to calculate PRACH transmission power according to the PRACH power formula defined in clause 7.4 of TS 38.213 [24] and apply this power level at the first preamble or additional preambles. The absolute power applied to the first preamble shall have an accuracy as specified in Table TBA for FR1 and in Table TBA for FR2-1. The relative power applied to additional preambles shall have an accuracy as specified in Table TBA for FR1 and clause TBA for FR2-1.

The NCR-MT shall indicate a random access problem to upper layers if the maximum number of preamble transmission counter has been reached for the random access procedure on PCell as specified in clause 5.1.4 in TS 38.321 [25].

The requirements in this clause apply for NCR-MT in SA operation mode.

10.1.2.2.1 Contention based random access

10.1.2.2.1.1 Correct behaviour when transmitting Random Access Preamble

With the NCR-MT selected SSB with SS-RSRP above $rsrp-ThresholdSSB$, NCR-MT shall have the capability to select a Random Access Preamble randomly with equal probability from the Random Access Preambles associated with the selected SSB if the association between Random Access Preambles and SSB is configured, as specified in clause 5.1.2 in TS 38.321 [25].

With the NCR-MT selected SSB with SS-RSRP above $rsrp-ThresholdSSB$, NCR-MT shall have the capability to transmit Random Access Preamble on the next available PRACH occasion from the PRACH occasions corresponding to the selected SSB permitted by the restrictions given by the $ra-ssb-OccasionMaskIndex$ if configured, if the association between PRACH occasions and SSBs is configured, and PRACH occasion shall be randomly selected with equal probability amongst the selected SSB associated PRACH occasions occurring simultaneously but on different subcarriers, as specified in clause 5.1.2 in TS 38.321 [25].

10.1.2.2.1.2 Correct behaviour when receiving Random Access Response

The NCR-MT may stop monitoring for Random Access Response(s) and shall transmit the msg3 if the Random Access Response contains a Random Access Preamble identifier corresponding to the transmitted Random Access Preamble.

The NCR-MT shall again perform the Random Access Resource selection procedure defined in clause 5.1.2 in TS 38.321 [25], and transmit with the calculated PRACH transmission power when the backoff time expires if all received Random Access Responses contain Random Access Preamble identifiers that do not match the transmitted Random Access Preamble.

10.1.2.2.1.3 Correct behaviour when not receiving Random Access Response

The NCR-MT shall again perform the Random Access Resource selection procedure defined in clause 5.1.2 in TS 38.321 [25], and transmit with the calculated PRACH transmission power when the backoff time expires if no Random Access Response is received within the RA Response window defined in clause 5.1.4 in TS 38.321 [25].

10.1.2.2.1.4 Correct behaviour when receiving an UL grant for msg3 retransmission

The NCR-MT shall re-transmit the msg3 upon the reception of an UL grant for msg3 retransmission.

10.1.2.2.1.5 SA: Correct behaviour when receiving a message over Temporary C-RNTI

The NCR-MT shall send ACK if the Contention Resolution is successful.

The NCR-MT shall again perform the Random Access Resource selection procedure defined in clause 5.1.2 in TS 38.321 [25], and transmit with the calculated PRACH transmission power when the backoff time expires unless the received message includes a NCR-MT Contention Resolution Identity MAC control element and the NCR-MT Contention Resolution Identity included in the MAC control element matches the CCCH SDU transmitted in the uplink message.

10.1.2.2.1.6 Correct behaviour when contention Resolution timer expires

The NCR-MT shall re-select a preamble and transmit with the calculated PRACH transmission power when the backoff time expires if the Contention Resolution Timer expires.

10.1.2.2.2 Non-Contention based random access

10.1.2.2.2.1 Correct behaviour when transmitting Random Access Preamble

If the contention-free Random Access Resources and the contention-free PRACH occasions associated with SSBs is configured, with the NCR-MT selected SSB with SS-RSRP above *rsrp-ThresholdSSB* amongst the associated SSBs, NCR-MT shall have the capability to select the Random Access Preamble corresponding to the selected SSB, and to transmit Random Access Preamble on the next available PRACH occasion from the PRACH occasions corresponding to the selected SSB permitted by the restrictions given by the *ra-ssb-OccasionMaskIndex* if configured, and PRACH occasion shall be randomly selected with equal probability amongst the selected SSB associated PRACH occasions occurring simultaneously but on different subcarriers, as specified in clause 5.1.2 in TS 38.321 [25].

If the contention-free Random Access Resources and the contention-free PRACH occasions associated with CSI-RSs is configured, with the NCR-MT selected CSI-RS with CSI-RSRP above *rsrp-ThresholdCSI-RS* amongst the associated CSI-RSs, NCR-MT shall have the capability to select the Random Access Preamble corresponding to the selected CSI-RS, and to transmit Random Access Preamble on the next available PRACH occasion from the PRACH occasions in *ra-OccasionList* corresponding to the selected CSI-RS, and PRACH occasion shall be randomly selected with equal probability amongst the selected CSI-RS associated PRACH occasions occurring simultaneously but on different subcarriers, as specified in clause 5.1.2 in TS 38.321 [25].

If the random access procedure is initialized for beam failure recovery and if the contention-free Random Access Resources and the contention-free PRACH occasions for beam failure recovery request associated with any of the SSBs and/or CSI-RSs is configured, NCR-MT shall have the capability to select the Random Access Preamble corresponding to the selected SSB with SS-RSRP above *rsrp-ThresholdSSB* amongst the associated SSBs or the selected CSI-RS with CSI-RSRP above *rsrp-ThresholdCSI-RS* amongst the associated CSI-RSs, and to transmit Random Access Preamble on the next available PRACH occasion from the PRACH occasions corresponding to the selected SSB permitted by the restrictions given by the *ra-ssb-OccasionMaskIndex* if configured, or from the PRACH occasions in *ra-OccasionList* corresponding to the selected CSI-RS, and PRACH occasion shall be randomly selected with equal probability amongst the selected SSB associated PRACH occasions or the selected CSI-RS associated PRACH occasions occurring simultaneously but on different subcarriers, as specified in clause 5.1.2 in TS 38.321 [25].

10.1.2.2.2.2 Correct behaviour when receiving Random Access Response

The NCR-MT may stop monitoring for Random Access Response(s), if the Random Access Response contains a Random Access Preamble identifier corresponding to the transmitted Random Access Preamble, unless the random access procedure is initialized for Other SI request from NCR-MT.

The NCR-MT may stop monitoring for Random Access Response(s) and shall monitor the Other SI transmission if the Random Access Response only contains a Random Access Preamble identifier which is corresponding to the transmitted Random Access Preamble and the random access procedure is initialized for SI request from NCR-MT, as specified in clause 5.1.4 in TS 38.321 [25].

The NCR-MT may stop monitoring for Random Access Response(s), if the contention-free Random Access Preamble for beam failure recovery request was transmitted and if the PDCCH addressed to NCR-MT's C-RNTI is received, as specified in clause 5.1.4 in TS 38.321 [25].

The NCR-MT shall again perform the Random Access Resource selection procedure defined in clause 5.1.2 in TS 38.321 [25] for the next available PRACH occasion, and transmit the preamble with the calculated PRACH transmission power if all received Random Access Responses contain Random Access Preamble identifiers that do not match the transmitted Random Access Preamble.

10.1.2.2.3 Correct behaviour when not receiving Random Access Response

The NCR-MT shall again perform the Random Access Resource selection procedure defined in clause 5.1.2 in TS 38.321 [25] for the next available PRACH occasion, and transmit the preamble with the calculated PRACH transmission power, if no Random Access Response is received within the RA Response window configured in *RACH-ConfigCommon* or if no PDCCH addressed to NCR-MT's C-RNTI is received within the RA Response window configured in *BeamFailureRecoveryConfig*, as defined in clause 5.1.4 in TS 38.321 [25].

10.2 Timing

10.2.1 NCR-MT transmit timing

10.2.1.1 Introduction

The NCR-MT shall have capability to follow the frame timing change of the reference cell in connected state. The uplink frame transmission takes place $(N_{TA} + N_{TA\ offset}) \times T_c$ before the reception of the first detected path (in time) of the corresponding downlink frame from the reference cell. NCR-MT shall use the PCell as the reference cell for deriving the NCR-MT transmit timing. NCR-MT initial transmit timing accuracy, gradual timing adjustment requirements are defined in the following requirements.

10.2.1.2 Requirements

The requirements in clause 10.2.1.2 apply for both wide area and local area NCR-MT as defined in clause 4.3A.2.

The NCR-MT initial transmission timing error shall be less than or equal to $\pm T_e$ where the timing error limit value T_e is specified in Table 10.2.1.2-1. This requirement applies for PUCCH, PUSCH and SRS or it is the PRACH transmission.

The NCR-MT shall meet the T_e requirement for an initial transmission provided that at least one SSB is available at the NCR-MT during the last 160 ms. The reference point for the NCR-MT initial transmit timing control requirement shall be the downlink timing of the reference cell minus $(N_{TA} + N_{TA\ offset}) \times T_c$. The downlink timing is defined as the time when the first path (in time) of the corresponding downlink frame used by the NCR-MT to determine downlink timing is received from the reference cell at the NCR-MT antenna. N_{TA} for PRACH is defined as 0.

$(N_{TA} + N_{TA\ offset}) \times T_c$ (in T_c units) for other channels is the difference between NCR-MT transmission timing and the downlink timing immediately after when the last timing advance in clause 10.2.2 was applied. N_{TA} for other channels is not changed until next timing advance is received. The value of $N_{TA\ offset}$ depends on the duplex mode of the cell in which the uplink transmission takes place and the frequency range (FR). $N_{TA\ offset}$ is defined in Table 10.2.1.2-2.

Table 10.2.1.2-1: T_e Timing Error Limit

Frequency Range	SCS of SSB signals (kHz)	SCS of uplink signals (kHz)	T_e
1	15	15	$12 \cdot 64 \cdot T_c$
		30	$10 \cdot 64 \cdot T_c$
		60	$10 \cdot 64 \cdot T_c$
	30	15	$8 \cdot 64 \cdot T_c$
		30	$8 \cdot 64 \cdot T_c$
		60	$7 \cdot 64 \cdot T_c$
2-1	120	60	$3.5 \cdot 64 \cdot T_c$
		120	$3.5 \cdot 64 \cdot T_c$
	240	60	$3 \cdot 64 \cdot T_c$
		120	$3 \cdot 64 \cdot T_c$
Note 1: T_c is the basic timing unit defined in TS 38.211 [26]			

Table 10.2.1.2-2: The Value of $N_{TA\ offset}$

Frequency range and band of cell used for uplink transmission	$N_{TA\ offset}$ (Unit: T_c)
FR1 TDD band without LTE-NR coexistence case	25600 (Note 1)
FR1 TDD band with LTE-NR coexistence case	39936 (Note 1)
FR2-1	13792
Note 1: The NCR-MT identifies $N_{TA\ offset}$ based on the information n-TimingAdvanceOffset as specified in TS 38.331 [23]. If NCR-MT is not provided with the information n-TimingAdvanceOffset, the default value of $N_{TA\ offset}$ is set as 25600 for FR1 band.	

When it is the transmission for PUCCH, PUSCH and SRS transmission, the NCR-MT shall be capable of changing the transmission timing according to the received downlink frame of the reference cell except when the timing advance in clause 10.2.3 is applied.

10.2.1.2.1 Gradual timing adjustment

The requirements in this clause apply for NCR-MT belonging to local area NCR-MT class as defined in clause 4.3A.2.

When the transmission timing error between the NCR-MT and the reference timing exceeds $\pm T_e$ then the NCR-MT is required to adjust its timing to within $\pm T_e$. The reference timing shall be $(N_{TA} + N_{TA\ offset}) \times T_c$ before the downlink timing of the reference cell. All adjustments made to the NCR-MT uplink timing shall follow these rules:

- 1) The maximum amount of the magnitude of the timing change in one adjustment shall be T_q .
- 2) The minimum aggregate adjustment rate shall be T_p per second.
- 3) The maximum aggregate adjustment rate shall be T_q per 200 ms.

where the maximum autonomous time adjustment step T_q and the aggregate adjustment rate T_p are specified in Table 10.2.1.2.1-1.

Table 10.2.1.2.1-1: T_q Maximum Autonomous Time Adjustment Step and T_p Minimum Aggregate Adjustment rate

Frequency Range	SCS of uplink signals (kHz)	T_q	T_p
1	15	$5.5 \cdot 64 \cdot T_c$	$5.5 \cdot 64 \cdot T_c$
	30	$5.5 \cdot 64 \cdot T_c$	$5.5 \cdot 64 \cdot T_c$
	60	$5.5 \cdot 64 \cdot T_c$	$5.5 \cdot 64 \cdot T_c$
2-1	60	$2.5 \cdot 64 \cdot T_c$	$2.5 \cdot 64 \cdot T_c$
	120	$2.5 \cdot 64 \cdot T_c$	$2.5 \cdot 64 \cdot T_c$
NOTE: T_c is the basic timing unit defined in TS 38.211 [26].			

10.2.2 NCR-MT timer accuracy

10.2.2.1 Introduction

NCR-MT timers are used in different protocol entities to control the NCR-MT behaviour.

The requirements in clause 10.2.2 apply for NCR-MT belonging to local area NCR-MT class as defined in clause 4.3A.2.

10.2.2.2 Requirements

For NCR-MT timers specified in TS 38.331 [23], the NCR-MT shall comply with the timer accuracies according to Table 10.2.2.2-1.

The requirements are only related to the actual timing measurements internally in the NCR-MT. They do not include the following:

- Inaccuracy in the start and stop conditions of a timer (e.g. NCR-MT reaction time to detect that start and stop conditions of a timer is fulfilled), or
- Inaccuracies due to restrictions in observability of start and stop conditions of an NCR-MT timer (e.g. slot alignment when NCR-MT sends messages at timer expiry).

Table 10.2.2.2-1

Timer value [s]	Accuracy
timer value < 4	± 0.1s
timer value ≥ 4	± 2.5%

10.2.3 NCR-MT timing advance

10.2.3.1 Introduction

The timing advance is initiated from gNB to NCR-MT, with MAC message that implies the adjustment of the timing advance, as defined in clause 5.2 of TS 38.321 [25]. The time advance adjustment requirement for both wide area and local area NCR-MT as defined in clause 4.3A.2.

10.2.3.2 Requirements

10.2.3.2.1 Timing Advance adjustment delay

NCR-MT shall adjust the timing of its uplink transmission timing at time slot $n+k+1$ for a timing advance command received in time slot n , and the value of k is defined in clause 4.2 in TS 38.213 [24]. The same requirement applies also when NCR-MT is not able to transmit a configured uplink transmission due to the channel assessment procedure.

10.2.3.2.2 Timing Advance adjustment accuracy

The NCR-MT shall adjust the timing of its transmissions with a relative accuracy better than or equal to the NCR-MT Timing Advance adjustment accuracy requirement in Table 10.2.3.2.2-1, to the signalled timing advance value compared to the timing of preceding uplink transmission. The timing advance command step is defined in TS 38.213 [24].

Table 10.2.3.2-1: NCR-MT Timing Advance adjustment accuracy

UL Sub Carrier Spacing(kHz)	15	30	60	120
NCR-MT Timing Advance adjustment accuracy	$\pm 256 T_c$	$\pm 256 T_c$	$\pm 128 T_c$	$\pm 32 T_c$
NOTE: T_c is the basic timing unit defined in TS 38.211 [26].				

10.3 Signalling Characteristics for NCR-MT

10.3.1 Radio Link Monitoring

10.3.1.1 Introduction

The requirements in clause 10.3.1 apply for radio link monitoring of local area NCR-MT class as defined in clause 4.3A.2 on:

- PCell in SA NR,

The NCR-MT shall monitor the downlink radio link quality based on the reference signal configured as RLM-RS resource(s) in order to detect the downlink radio link quality of the PCell as specified in TS 38.213 [24]. The configured RLM-RS resources can be all SSBs, or all CSI-RSs, or a mix of SSBs and CSI-RSs. NCR-MT is not required to perform RLM outside the active DL BWP.

On each RLM-RS resource, the NCR-MT shall estimate the downlink radio link quality and compare it to the thresholds Q_{out} and Q_{in} for the purpose of monitoring downlink radio link quality of the cell.

The threshold Q_{out} is defined as the level at which the downlink radio link cannot be reliably received and shall correspond to the out-of-sync block error rate ($BLER_{out}$) as defined in Table 10.3.1-1. For SSB based radio link monitoring, Q_{out_SSB} is derived based on the hypothetical PDCCH transmission parameters listed in Table 10.3.1.2.1-1. For CSI-RS based radio link monitoring, Q_{out_CSI-RS} is derived based on the hypothetical PDCCH transmission parameters listed in Table 10.3.1.3.1-1.

The threshold Q_{in} is defined as the level at which the downlink radio link quality can be received with significantly higher reliability than at Q_{out} and shall correspond to the in-sync block error rate ($BLER_{in}$) as defined in Table 10.3.1-1. For SSB based radio link monitoring, Q_{in_SSB} is derived based on the hypothetical PDCCH transmission parameters listed in Table 10.3.1.2.1-2. For CSI-RS based radio link monitoring, Q_{in_CSI-RS} is derived based on the hypothetical PDCCH transmission parameters listed in Table 10.3.1.3.1-2.

The out-of-sync block error rate ($BLER_{out}$) and in-sync block error rate ($BLER_{in}$) are determined from the network configuration via parameter *rlmInSyncOutOfSyncThreshold* signalled by higher layers. When NCR-MT is not configured with *rlmInSyncOutOfSyncThreshold* from the network, NCR-MT determines out-of-sync and in-sync block error rates from Configuration #0 in Table 10.3.1-1 by default. All requirements in clause 10.3.1 are applicable for BLER Configuration #0 in Table 10.3.1-1.

Table 10.3.1-1: Out-of-sync and in-sync block error rates

Configuration	$BLER_{out}$	$BLER_{in}$
0	10%	2%

NCR-MT shall be able to monitor up to N_{RLM} RLM-RS resources of the same or different types in each corresponding carrier frequency range, depending on a maximum number L_{max} of SSBs per half frame according to TS 38.213 [24], where N_{RLM} is specified in Table 10.3.1-2 according TS 38.213 [24], and meet the requirements as specified in clause 10.3.1. NCR-MT is not required to meet the requirements in clause 10.3.1 if RLM-RS is not configured and no TCI state for PDCCH is activated.

Table 10.3.1-2: Maximum number of RLM-RS resources N_{RLM}

Carrier frequency range of PCell	L_{max}	Maximum number of RLM-RS resources, N_{RLM}
FR1, ≤ 3 GHz ^{Note}	4	2
FR1, > 3 GHz ^{Note}	8	4
FR2-1	64	8

10.3.1.2 Requirements for SSB based radio link monitoring

10.3.1.2.1 Introduction

The requirements in this clause apply for each SSB based RLM-RS resource configured for PCell, provided that the SSB configured for RLM is actually transmitted within NCR-MT active DL BWP during the entire evaluation period specified in clause 10.3.1.2.2.

Table 10.3.1.2.1-1: PDCCH transmission parameters for out-of-sync evaluation

Attribute	Value for BLER Configuration #0
DCI format	1-0
Number of control OFDM symbols	2
Aggregation level (CCE)	8
Ratio of hypothetical PDCCH RE energy to average SSS RE energy	4dB
Ratio of hypothetical PDCCH DMRS energy to average SSS RE energy	4dB
Bandwidth (PRBs)	24
Sub-carrier spacing (kHz)	SCS of the active DL BWP
DMRS precoder granularity	REG bundle size
REG bundle size	6
CP length	Normal
Mapping from REG to CCE	Distributed

Table 10.3.1.2.1-2: PDCCH transmission parameters for in-sync evaluation

Attribute	Value for BLER Configuration #0
DCI payload size	1-0
Number of control OFDM symbols	2
Aggregation level (CCE)	4
Ratio of hypothetical PDCCH RE energy to average SSS RE energy	0dB
Ratio of hypothetical PDCCH DMRS energy to average SSS RE energy	0dB
Bandwidth (PRBs)	24
Sub-carrier spacing (kHz)	SCS of the active DL BWP
DMRS precoder granularity	REG bundle size
REG bundle size	6
CP length	Normal
Mapping from REG to CCE	Distributed

10.3.1.2.2 Minimum requirement

NCR-MT shall be able to evaluate whether the downlink radio link quality on the configured RLM-RS resource estimated over the last $T_{Evaluate_out_SSB}$ [ms] period becomes worse than the threshold Q_{out_SSB} within $T_{Evaluate_out_SSB}$ [ms] evaluation period.

NCR-MT shall be able to evaluate whether the downlink radio link quality on the configured RLM-RS resource estimated over the last $T_{\text{Evaluate_in_SSB}}$ [ms] period becomes better than the threshold $Q_{\text{in_SSB}}$ within $T_{\text{Evaluate_in_SSB}}$ [ms] evaluation period.

$T_{\text{Evaluate_out_SSB}}$ and $T_{\text{Evaluate_in_SSB}}$ are defined in Table 10.3.1.2.2-1 for FR1 with scaling factor $K_1 = 5$.

$T_{\text{Evaluate_out_SSB}}$ and $T_{\text{Evaluate_in_SSB}}$ are defined in Table 10.3.1.2.2-2 for FR2-1 with scaling factor $N=8$ and $K_2 = 3$.

For FR1,

- $P = 1$

For FR2-1,

- $P=1$, when the RLM-RS resource is not overlapped with SMTC occasion.
- $P = \frac{1}{1 - \frac{T_{\text{SSB}}}{T_{\text{SMTCperiod}}}}$, when the RLM-RS resource is partially overlapped with SMTC occasion ($T_{\text{SSB}} < T_{\text{SMTCperiod}}$).
- $P = 3$, when RLM-RS resource is fully overlapped with SMTC period ($T_{\text{SSB}} = T_{\text{SMTCperiod}}$).

If the high layer in TS 38.331 [23] signaling of smtc_2 is present, $T_{\text{SMTCperiod}}$ follows smtc_2 ; Otherwise $T_{\text{SMTCperiod}}$ follow smtc_1 .

Longer evaluation period would be expected if the combination of RLM-RS resource and SMTC occasion configurations does not meet previous conditions.

Table 10.3.1.2.2-1: Evaluation period $T_{\text{Evaluate_out_SSB}}$ and $T_{\text{Evaluate_in_SSB}}$ for FR1

Configuration	$T_{\text{Evaluate_out_SSB}}$ (ms)	$T_{\text{Evaluate_in_SSB}}$ (ms)
no DRX	$\text{Max}(200 \times K_1, \text{Ceil}(10 \times P \times K_1) \times T_{\text{SSB}})$	$\text{Max}(100 \times K_1, \text{Ceil}(5 \times P \times K_1) \times T_{\text{SSB}})$
NOTE: T_{SSB} is the periodicity of the SSB configured for RLM.		

Table 10.3.1.2.2-2: Evaluation period $T_{\text{Evaluate_out_SSB}}$ and $T_{\text{Evaluate_in_SSB}}$ for FR2-1

Configuration	$T_{\text{Evaluate_out_SSB}}$ (ms)	$T_{\text{Evaluate_in_SSB}}$ (ms)
no DRX	$\text{Max}(200 \times K_2, \text{Ceil}(10 \times P \times N \times K_2) \times T_{\text{SSB}})$	$\text{Max}(100 \times K_2, \text{Ceil}(5 \times P \times N \times K_2) \times T_{\text{SSB}})$
NOTE: T_{SSB} is the periodicity of the SSB configured for RLM.		

10.3.1.2.3 Measurement restrictions for SSB based RLM

The NCR-MT is required to be capable of measuring SSB for RLM without measurement gaps. The NCR-MT is required to perform the SSB measurements with measurement restrictions as described in the following scenarios.

For FR1, when the SSB for RLM is in the same OFDM symbol as CSI-RS for RLM, BFD, CBD or L1-RSRP measurement,

- If SSB and CSI-RS have same SCS, NCR-MT shall be able to measure the SSB for RLM without any restriction;
- If SSB and CSI-RS have different SCS,
 - If NCR-MT supports *simultaneousRxDataSSB-DiffNumerology*, NCR-MT shall be able to measure the SSB for RLM without any restriction;
 - If NCR-MT does not support *simultaneousRxDataSSB-DiffNumerology*, NCR-MT is required to measure one of but not both SSB for RLM and CSI-RS. Longer measurement period for SSB based RLM is expected, and no requirements are defined.

For FR2-1, when the SSB for RLM measurement on one CC is in the same OFDM symbol as CSI-RS for RLM, BFD, CBD or L1-RSRP measurement on the same CC or different CCs in the same band, NCR-MT is required to measure

one of but not both SSB for RLM and CSI-RS. Longer measurement period for SSB based RLM is expected, and no requirements are defined.

10.3.1.3 Requirements for CSI-RS based radio link monitoring

10.3.1.3.1 Introduction

The requirements in this clause apply for each CSI-RS based RLM-RS resource configured for PCell, provided that the CSI-RS configured for RLM is actually transmitted within NCR-MT active DL BWP during the entire evaluation period specified in clause 10.3.1.3.2. NCR-MT is not expected to perform radio link monitoring measurements on the CSI-RS configured as RLM-RS if the CSI-RS is not in the active TCI state of any CORESET configured in the NCR-MT active BWP.

Table 10.3.1.3.1-1: PDCCH transmission parameters for out-of-sync evaluation

Attribute	Value for BLER Configuration #0
DCI format	1-0
Number of control OFDM symbols	2
Aggregation level (CCE)	8
Ratio of hypothetical PDCCH RE energy to average CSI-RS RE energy	4dB
Ratio of hypothetical PDCCH DMRS energy to average CSI-RS RE energy	4dB
Bandwidth (PRBs)	48
Sub-carrier spacing (kHz)	SCS of the active DL BWP
DMRS precoder granularity	REG bundle size
REG bundle size	6
CP length	Normal
Mapping from REG to CCE	Distributed

Table 10.3.1.3.1-2: PDCCH transmission parameters for in-sync evaluation

Attribute	Value for BLER Configuration #0
DCI payload size	1-0
Number of control OFDM symbols	2
Aggregation level (CCE)	4
Ratio of hypothetical PDCCH RE energy to average CSI-RS RE energy	0dB
Ratio of hypothetical PDCCH DMRS energy to average CSI-RS RE energy	0dB
Bandwidth (PRBs)	48
Sub-carrier spacing (kHz)	SCS of the active DL BWP
DMRS precoder granularity	REG bundle size
REG bundle size	6
CP length	Normal
Mapping from REG to CCE	Distributed

10.3.1.3.2 Minimum requirement

NCR-MT shall be able to evaluate whether the downlink radio link quality on the configured RLM-RS resource estimated over the last $T_{\text{Evaluate_out_CSI-RS}}$ [ms] period becomes worse than the threshold $Q_{\text{out_CSI-RS}}$ within $T_{\text{Evaluate_out_CSI-RS}}$ [ms] evaluation period.

NCR-MT shall be able to evaluate whether the downlink radio link quality on the configured RLM-RS resource estimated over the last $T_{\text{Evaluate_in_CSI-RS}}$ [ms] period becomes better than the threshold $Q_{\text{in_CSI-RS}}$ within $T_{\text{Evaluate_in_CSI-RS}}$ [ms] evaluation period.

- $T_{\text{Evaluate_out_CSI-RS}}$ and $T_{\text{Evaluate_in_CSI-RS}}$ are defined in Table 10.3.1.3.2-1 for FR1 with scaling factor $K_1 = 5$.
- $T_{\text{Evaluate_out_CSI-RS}}$ and $T_{\text{Evaluate_in_CSI-RS}}$ are defined in Table 10.3.1.3.2-2 for FR2-1 with scaling factor $K_2 = 3$.

The requirements of $T_{\text{Evaluate_out_CSI-RS}}$ and $T_{\text{Evaluate_in_CSI-RS}}$ apply provided that the CSI-RS for RLM is not in a resource set configured with repetition ON. The requirements do not apply when the CSI-RS resource in the active TCI state of CORESET is the same CSI-RS resource for RLM and the TCI state information of the CSI-RS resource is not given, wherein the TCI state information means QCL Type-D to SSB for L1-RSRP or CSI-RS with repetition ON.

For FR1,

- $P=1$.

For FR2-1,

- $P=1$, when the RLM-RS resource is not overlapped with SMTC occasion.
- $P = \frac{1}{1 - \frac{T_{\text{CSI-RS}}}{T_{\text{SMTCperiod}}}}$, when the RLM-RS resource is partially overlapped with SMTC occasion ($T_{\text{CSI-RS}} < T_{\text{SMTCperiod}}$).
- $P = 3$, when the RLM-RS resource is fully overlapped with SMTC occasion ($T_{\text{CSI-RS}} = T_{\text{SMTCperiod}}$).

If the high layer in TS 38.331 [23] signaling of smtc_2 is present, $T_{\text{SMTCperiod}}$ follows smtc_2 ; Otherwise $T_{\text{SMTCperiod}}$ follow smtc_1 .

NOTE: The overlap between CSI-RS for RLM and SMTC means that CSI-RS based RLM is within the SMTC window duration.

Longer evaluation period would be expected if the combination of RLM-RS resource and SMTC occasion configurations does not meet previous conditions.

The values of M_{out} and M_{in} used in Table 10.3.1.3.2-1 and Table 10.3.1.3.2-2 are defined as:

- $M_{\text{out}} = 20$ and $M_{\text{in}} = 10$, if the CSI-RS resource configured for RLM is transmitted with higher layer CSI-RS parameter *density* [8, clause 7.4.1] set to 3 and over the bandwidth ≥ 24 PRBs.

Table 10.3.1.3.2-1: Evaluation period $T_{\text{Evaluate_out_CSI-RS}}$ and $T_{\text{Evaluate_in_CSI-RS}}$ for FR1

Configuration	$T_{\text{Evaluate_out_CSI-RS}}$ (ms)	$T_{\text{Evaluate_in_CSI-RS}}$ (ms)
no DRX	$\text{Max}(200 \times K_1, \text{Ceil}(M_{\text{out}} \times P \times K_1) \times T_{\text{CSI-RS}})$	$\text{Max}(100 \times K_1, \text{Ceil}(M_{\text{in}} \times P \times K_1) \times T_{\text{CSI-RS}})$
NOTE: $T_{\text{CSI-RS}}$ is the periodicity of the CSI-RS resource configured for RLM. The requirements in this table apply for $T_{\text{CSI-RS}}$ equal to 5 ms, 10ms, 20 ms or 40 ms.		

Table 10.3.1.3.2-2: Evaluation period $T_{\text{Evaluate_out_CSI-RS}}$ and $T_{\text{Evaluate_in_CSI-RS}}$ for FR2-1

Configuration	$T_{\text{Evaluate_out_CSI-RS}}$ (ms)	$T_{\text{Evaluate_in_CSI-RS}}$ (ms)
no DRX	$\text{Max}(200 \times K_2, \text{Ceil}(M_{\text{out}} \times P \times K_2) \times T_{\text{CSI-RS}})$	$\text{Max}(100 \times K_2, \text{Ceil}(M_{\text{in}} \times P \times K_2) \times T_{\text{CSI-RS}})$
NOTE: $T_{\text{CSI-RS}}$ is the periodicity of the CSI-RS resource configured for RLM. The requirements in this table apply for $T_{\text{CSI-RS}}$ equal to 5 ms, 10 ms, 20 ms or 40 ms.		

10.3.1.3.3 Measurement restrictions for CSI-RS based RLM

The NCR-MT is required to be capable of measuring CSI-RS for RLM without measurement gaps. The NCR-MT is required to perform the CSI-RS measurements with measurement restrictions as described in the following clauses.

For both FR1 and FR2-1, when the CSI-RS for RLM is in the same OFDM symbol as SSB for RLM, BFD, CBD or L1-RSRP measurement, NCR-MT is not required to receive CSI-RS for RLM in the PRBs that overlap with an SSB.

For FR1, when the SSB for RLM, BFD, CBD, or L1-RSRP measurement is within the active BWP and has same SCS than CSI-RS for RLM, the NCR-MT shall be able to perform CSI-RS measurement without restrictions.

For FR1, when the SSB for RLM, BFD, CBD or L1-RSRP measurement is within the active BWP and has different SCS than CSI-RS for RLM, the NCR-MT shall be able to perform CSI-RS measurement with restrictions according to its capabilities:

- If the NCR-MT supports *simultaneousRxDataSSB-DiffNumerology* the NCR-MT shall be able to perform CSI-RS for RLM measurement without restrictions.
- If the NCR-MT does not support *simultaneousRxDataSSB-DiffNumerology*, NCR-MT is required to measure one of but not both CSI-RS for RLM and SSB. Longer measurement period for CSI-RS based RLM is expected, and no requirements are defined.

For FR1, when the CSI-RS for RLM is in the same OFDM symbol as another CSI-RS for RLM, BFD, CBD or L1-RSRP measurement, NCR-MT shall be able to measure the CSI-RS for RLM without any restriction.

For FR2-1, when the CSI-RS for RLM measurement on one CC is in the same OFDM symbol as SSB for RLM, BFD, or L1-RSRP measurement on the same CC or different CCs in the same band, or in the same symbol as SSB for CBD measurement on the same CC or different CCs in the same band when beam failure is detected, NCR-MT is required to measure one of but not both CSI-RS for RLM and SSB. Longer measurement period for CSI-RS based RLM is expected, and no requirements are defined.

For FR2-1, when the CSI-RS for RLM measurement on one CC is in the same OFDM symbol as another CSI-RS for RLM, BFD, CBD or L1-RSRP measurement on the same CC or different CCs in the same band,

- In the following cases, NCR-MT is required to measure one of but not both CSI-RS for RLM and the other CSI-RS. Longer measurement period for CSI-RS based RLM is expected, and no requirements are defined.
 - The CSI-RS for RLM or the other CSI-RS in a resource set configured with repetition ON, or
 - The other CSI-RS is configured in q1 and beam failure is detected, or
 - The two CSI-RS-es are not QCL-ed w.r.t. QCL-TypeD, or the QCL information is not known to NCR-MT,
- Otherwise, NCR-MT shall be able to measure the CSI-RS for RLM without any restriction.

10.3.1.4 Minimum requirement for NCR-MT turning off the transmitter

The transmitter power of the NCR-MT in the monitored cell shall be turned off within 40ms after expiry of T310 timer as specified in TS 38.331 [23].

10.3.1.5 Minimum requirement for L1 indication

When the downlink radio link quality on all the configured RLM-RS resources is worse than $Q_{out, layer 1}$ of the NCR-MT shall send an out-of-sync indication for the cell to the higher layers. A layer 3 filter shall be applied to the out-of-sync indications as specified in TS 38.331 [23].

When the downlink radio link quality on at least one of the configured RLM-RS resources is better than $Q_{in, layer 1}$ of the NCR-MT shall send an in-sync indication for the cell to the higher layers. A layer 3 filter shall be applied to the in-sync indications as specified in TS 38.331 [23].

The out-of-sync and in-sync evaluations for the configured RLM-RS resources shall be performed as specified in clause 5 [25]. Two successive indications from layer 1 shall be separated by at least $T_{Indication_interval}$.

$T_{Indication_interval}$ is $\max(10ms, T_{RLM-RS,M})$, where $T_{RLM-RS,M}$ is the shortest periodicity of all configured RLM-RS resources for the monitored cell, which corresponds to T_{SSB} specified in clause 10.3.1.2 if the RLM-RS resource is SSB, or T_{CSI-RS} specified in clause 10.3.1.3 if the RLM-RS resource is CSI-RS.

10.3.1.6 Scheduling availability of NCR-MT during radio link monitoring

When the reference signal to be measured for RLM has different subcarrier spacing than PDSCH/PDCCH or is on frequency range 2, there are restrictions on the scheduling availability as described in the following clauses.

10.3.1.6.1 Scheduling availability of NCR-MT performing radio link monitoring with a same subcarrier spacing as PDSCH/PDCCH on FR1

There are no scheduling restrictions due to radio link monitoring performed with a same subcarrier spacing as PDSCH/PDCCH on FR1.

10.3.1.6.2 Scheduling availability of NCR-MT performing radio link monitoring with a different subcarrier spacing than PDSCH/PDCCH on FR1

For NCR-MTs which support *simultaneousRxDataSSB-DiffNumerology* [27] there are no restrictions on scheduling availability due to radio link monitoring based on SSB as RLM-RS. For NCR-MTs which do not support *simultaneousRxDataSSB-DiffNumerology* [27] the following restrictions apply due to radio link monitoring based on SSB as RLM-RS.

- The NCR-MT is not expected to transmit PUCCH, PUSCH or SRS or receive PDCCH, PDSCH or CSI-RS for tracking or CSI-RS for CQI on SSB symbols to be measured for radio link monitoring.

10.3.1.6.3 Scheduling availability of NCR-MT performing radio link monitoring on FR2-1

The following scheduling restriction applies due to radio link monitoring on an FR2-1 serving PCell .

- If the RLM-RS is CSI-RS which is type-D QCLed with active TCI state for PDCCH or PDSCH, and the CSI-RS is not in a CSI-RS resource set with repetition ON,
 - There are no scheduling restrictions due to radio link monitoring based on the CSI-RS.
- Otherwise
 - The NCR-MT is not expected to transmit PUCCH, PUSCH or SRS or receive PDCCH, PDSCH or CSI-RS for tracking or CSI-RS for CQI on RLM-RS symbols to be measured for radio link monitoring.

For FR2-1, if following conditions are met,

- NCR-MT has been notified about system information update through paging,
- The gap between NCR-MT's reception of PDCCH that NCR-MT monitors in the Type2-PDCCH CSS set and that notifies system information update, and the PDCCH that NCR-MT monitors in the Type0-PDCCH CSS set, is greater than 2 slots,

For the SSB for RLM and CORESET for RMSI scheduling multiplexing patterns 3, NCR-MT is expected to receive the PDCCH that NCR-MT monitors in the Type0-PDCCH CSS set, and the corresponding PDSCH, on SSB symbols to be measured for RLM; and

For the SSB for RLM and CORESET for RMSI scheduling multiplexing patterns 2, NCR-MT is expected to receive PDSCH that corresponds to the PDCCH that NCR-MT monitors in the Type0-PDCCH CSS set, on SSB symbols to be measured for RLM.

10.3.2 Link Recovery Procedure

10.3.2.1 Introduction

The local area NCR-MT as defined in clause 4.3A.2 shall assess the downlink radio link quality of a serving cell based on the reference signal in the set \bar{Q}_0 as specified in TS 38.213 [24] in order to detect beam failure on:

- PCell in SA NR,

The RS resource configurations in the set \bar{q}_0 on PCell can be periodic CSI-RS resources and/or SSBs. RS resource configuration in the set \bar{q}_0 on SCell shall be periodic CSI-RS. NCR-MT is not required to perform beam failure detection outside the active DL BWP. NCR-MT is not required to meet the requirements in clause 10.3.2.2 and 10.3.2.3 if NCR-MT does not have set \bar{q}_0 .

On each RS resource configuration in the set \bar{q}_0 , the NCR-MT shall estimate the radio link quality and compare it to the threshold $Q_{\text{out_LR}}$ for the purpose of accessing downlink radio link quality of the serving cell beams.

The threshold $Q_{\text{out_LR}}$ is defined as the level at which the downlink radio level link of a given resource configuration on set \bar{q}_0 cannot be reliably received and shall correspond to the $\text{BLER}_{\text{out}} = 10\%$ block error rate of a hypothetical PDCCH transmission. For SSB based beam failure detection, $Q_{\text{out_LR_SSB}}$ is derived based on the hypothetical PDCCH transmission parameters listed in Table 10.3.2.2.1. For CSI-RS based beam failure detection, $Q_{\text{out_LR_CSI-RS}}$ is derived based on the hypothetical PDCCH transmission parameters listed in Table 10.3.2.3.1-1.

Upon request the NCR-MT shall deliver configuration indexes from the set \bar{q}_1 as specified in TS 38.213 [24], to higher layers, and the corresponding L1-RSRP measurement provided that the measured L1-RSRP is equal to or better than the threshold $Q_{\text{in_LR}}$, which is indicated by higher layer parameter *rsrp-ThresholdSSB*. The NCR-MT applies the $Q_{\text{in_LR}}$ threshold to the L1-RSRP measurement obtained from an SSB. The NCR-MT applies the $Q_{\text{in_LR}}$ threshold to the L1-RSRP measurement obtained for a CSI-RS resource after scaling a respective CSI-RS reception power with a value provided by higher layer parameter *powerControlOffsetSS*. The RS resource configurations in the set \bar{q}_1 can be periodic CSI-RS resources or SSBs or both SSB and CSI-RS resources. NCR-MT is not required to perform candidate beam detection outside the active DL BWP.

10.3.2.2 Requirements for SSB based beam failure detection

10.3.2.2.1 Introduction

The requirements in this clause apply for each SSB resource in the set \bar{q}_1 configured for a serving cell, provided that the SSB configured for beam failure detection is actually transmitted within the NCR-MT active DL BWP during the entire evaluation period specified in clause 10.3.2.2.2. The requirements in this clause could not be applicable if NCR-MT is required to perform beam failure detection on more than 1 serving cell per band.

Table 10.3.2.2.1-1: PDCCH transmission parameters for beam failure instance

Attribute	Value for BLER
DCI format	1-0
Number of control OFDM symbols	2
Aggregation level (CCE)	8
Ratio of hypothetical PDCCH RE energy to average SSS RE energy	0dB
Ratio of hypothetical PDCCH DMRS energy to average SSS RE energy	0dB
Bandwidth (PRBs)	24
Sub-carrier spacing (kHz)	Same as the SCS of RMSI CORESET
DMRS precoder granularity	REG bundle size
REG bundle size	6
CP length	Normal
Mapping from REG to CCE	Distributed

10.3.2.2.2 Minimum requirement

NCR-MT shall be able to evaluate whether the downlink radio link quality on the configured SSB resource in set \bar{q}_0 estimated over the last $T_{\text{Evaluate_BFD_SSB}}$ ms period becomes worse than the threshold $Q_{\text{out_LR_SSB}}$ within $T_{\text{Evaluate_BFD_SSB}}$ ms period.

The value of $T_{\text{Evaluate_BFD_SSB}}$ is defined in Table 10.3.2.2.2-1 for FR1.

The value of $T_{\text{Evaluate_BFD_SSB}}$ is defined in Table 10.3.2.2.2-2 for FR2-1 with scaling factor $N=8$.

For FR1,

- $P=1$.

For FR2-1,

- $P=1$, when the BFD-RS resource is not overlapped with SMTC occasion.
- $P = \frac{1}{1 - \frac{T_{\text{SSB}}}{T_{\text{SMTCperiod}}}}$, when the BFD-RS resource is partially overlapped with SMTC occasion ($T_{\text{SSB}} < T_{\text{SMTCperiod}}$).
- $P = 3$, when the BFD-RS resource is fully overlapped with SMTC period ($T_{\text{SSB}} = T_{\text{SMTCperiod}}$).

If the high layer in TS 38.331 [23] signaling of smtc_2 is present, $T_{\text{SMTCperiod}}$ follows smtc_2 ; Otherwise $T_{\text{SMTCperiod}}$ follow smtc_1 .

Longer evaluation period would be expected if the combination of BFD-RS resource and SMTC occasion does not meet pervious conditions.

Table 10.3.2.2.2-1: Evaluation period $T_{\text{Evaluate_BFD_SSB}}$ for FR1

Configuration	$T_{\text{Evaluate_BFD_SSB}}$ (ms)
no DRX	$\text{Max}(50, \text{Ceil}(5 \times P) \times T_{\text{SSB}})$
Note:	T_{SSB} is the periodicity of SSB in the set \bar{q}_0 .

Table 10.3.2.2.2-2: Evaluation period $T_{\text{Evaluate_BFD_SSB}}$ for FR2-1

Configuration	$T_{\text{Evaluate_BFD_SSB}}$ (ms)
no DRX	$\text{Max}(50, \text{Ceil}(5 \times P \times N) \times T_{\text{SSB}})$
Note:	T_{SSB} is the periodicity of SSB in the set \bar{q}_0 .

10.3.2.2.3 Measurement restriction for SSB based beam failure detection

The NCR-MT is required to be capable of measuring SSB for BFD without measurement gaps. The NCR-MT is required to perform the SSB measurements with measurement restrictions as described in the following scenarios.

For FR1, when the SSB for BFD measurement is in the same OFDM symbol as CSI-RS for RLM, BFD, CBD or L1-RSRP measurement,

- If SSB and CSI-RS have same SCS, NCR-MT shall be able to measure the SSB for BFD measurement without any restriction;
- If SSB and CSI-RS have different SCS,
 - If NCR-MT supports *simultaneousRxDataSSB-DiffNumerology*, NCR-MT shall be able to measure the SSB for BFD measurement without any restriction;
 - If NCR-MT does not support *simultaneousRxDataSSB-DiffNumerology*, NCR-MT is required to measure one of but not both SSB for BFD measurement and CSI-RS. Longer measurement period for SSB based BFD measurement is expected, and no requirements are defined.

For FR2-1, when the SSB for BFD measurement on one CC is in the same OFDM symbol as CSI-RS for RLM, BFD, CBD or L1-RSRP measurement on the same CC in the same band, NCR-MT is required to measure one of but not both SSB for BFD measurement and CSI-RS. Longer measurement period for SSB based BFD measurement is expected, and no requirements are defined.

10.3.2.3 Requirements for CSI-RS based beam failure detection

10.3.2.3.1 Introduction

The requirements in this clause apply for each CSI-RS resource in the set \bar{q}_0 of resource configurations for a serving cell, provided that the CSI-RS resource(s) in set \bar{q}_0 for beam failure detection are actually transmitted within the NCR-MT active DL BWP during the entire evaluation period specified in clause 10.3.2.3.2. NCR-MT is not expected to perform beam failure detection measurements on the CSI-RS configured for BFD if the CSI-RS is not QCL-ed, with QCL-TypeD when applicable, with the RS in the active TCI state of any CORESET configured in the NCR-MT active BWP. The requirements in this clause apply when NCR-MT is required to perform beam failure detection on no more than 1 serving cell per band.

Table 10.3.2.3.1-1: PDCCH transmission parameters for beam failure instance

Attribute	Value for BLER
DCI format	1-0
Number of control OFDM symbols	2
Aggregation level (CCE)	8
Ratio of hypothetical PDCCH RE energy to average CSI-RS RE energy	0dB
Ratio of hypothetical PDCCH DMRS energy to average CSI-RS RE energy	0dB
Bandwidth (PRBs)	48
Sub-carrier spacing (kHz)	SCS of the active DL BWP
DMRS precoder granularity	REG bundle size
REG bundle size	6
CP length	Normal
Mapping from REG to CCE	Distributed

10.3.2.3.2 Minimum requirement

NCR-MT shall be able to evaluate whether the downlink radio link quality on the CSI-RS resource in set \bar{q}_0 estimated over the last $T_{\text{Evaluate_BFD_CSI-RS}}$ ms period becomes worse than the threshold $Q_{\text{out_LR_CSI-RS}}$ within $T_{\text{Evaluate_BFD_CSI-RS}}$ ms period.

The value of $T_{\text{Evaluate_BFD_CSI-RS}}$ is defined in Table 10.3.2.3.2-1 for FR1.

The value of $T_{\text{Evaluate_BFD_CSI-RS}}$ is defined in Table 10.3.2.3.2-2 for FR2-1 with $N=1$.

The requirements of $T_{\text{Evaluate_BFD_CSI-RS}}$ apply provided that the CSI-RS for BFD is not in a resource set configured with repetition ON. The requirements shall not apply when the CSI-RS resource in the active TCI state of CORESET is the same CSI-RS resource for BFD and the TCI state information of the CSI-RS resource is not given, wherein the TCI state information means QCL Type-D to SSB for L1-RSRP or CSI-RS with repetition ON.

For FR1,

- $P = 1$.

For FR2-1,

- $P = 1$, when the BFD-RS resource is not overlapped with SMTC occasion.

- $P = \frac{1}{1 - \frac{T_{\text{CSI-RS}}}{T_{\text{SMTCperiod}}}}$, when the BFD-RS resource is partially overlapped with SMTC occasion ($T_{\text{CSI-RS}} < T_{\text{SMTCperiod}}$).
- $P = P_{\text{sharing factor}}$, when BFD-RS resource is fully overlapped with SMTC occasion ($T_{\text{CSI-RS}} = T_{\text{SMTCperiod}}$).
- $P_{\text{sharing factor}} = 3$.

If the high layer in TS 38.331 [23] signaling of smtc_2 is present, $T_{\text{SMTCperiod}}$ follows smtc_2 ; Otherwise $T_{\text{SMTCperiod}}$ follow smtc_1 .

NOTE: The overlap between CSI-RS for BFD and SMTC means that CSI-RS for BFD is within the SMTC window duration.

Longer evaluation period would be expected if the combination of the BFD-RS resource and SMTC occasion configurations does not meet pervious conditions.

The values of M_{BFD} used in Table 10.3.2.3.2-1 and Table 10.3.2.3.2-2 are defined as

- $M_{\text{BFD}} = 10$, if the CSI-RS resource(s) in set \bar{q}_0 used for BFD is transmitted with Density = 3.

Table 10.3.2.3.2-1: Evaluation period $T_{\text{Evaluate_BFD_CSI-RS}}$ for FR1

Configuration	$T_{\text{Evaluate_BFD_CSI-RS}}$ (ms)
no DRX	$\text{Max}(50, [M_{\text{BFD}} \times P] \times T_{\text{CSI-RS}})$
Note:	$T_{\text{CSI-RS}}$ is the periodicity of CSI-RS resource in the set \bar{q}_0 .

Table 10.3.2.3.2-2: Evaluation period $T_{\text{Evaluate_BFD_CSI-RS}}$ for FR2-1

Configuration	$T_{\text{Evaluate_BFD_CSI-RS}}$ (ms)
no DRX	$\text{Max}(50, [M_{\text{BFD}} \times P \times N] \times T_{\text{CSI-RS}})$
Note:	$T_{\text{CSI-RS}}$ is the periodicity of CSI-RS resource in the set \bar{q}_0 .

10.3.2.3.3 Measurement restrictions for CSI-RS based beam failure detection

The NCR-MT is required to be capable of measuring CSI-RS for BFD without measurement gaps. The NCR-MT is required to perform the CSI-RS measurements with measurement restrictions as described in the following scenarios.

For both FR1 and FR2-1, when the CSI-RS for BFD measurement is in the same OFDM symbol as SSB for RLM, BFD, CBD or L1-RSRP measurement, NCR-MT is not required to receive CSI-RS for BFD measurement in the PRBs that overlap with an SSB.

For FR1, when the SSB for RLM, BFD, CBD or L1-RSRP measurement is within the active BWP and has same SCS than CSI-RS for BFD measurement, the NCR-MT shall be able to perform CSI-RS measurement without restrictions.

For FR1, when the SSB for RLM, BFD, CBD or L1-RSRP measurement is within the active BWP and has different SCS than CSI-RS for BFD measurement, the NCR-MT shall be able to perform CSI-RS measurement with restrictions according to its capabilities:

- If the NCR-MT supports *simultaneousRxDataSSB-DiffNumerology* the NCR-MT shall be able to perform CSI-RS measurement without restrictions.
- If the NCR-MT does not support *simultaneousRxDataSSB-DiffNumerology*, NCR-MT is required to measure one of but not both CSI-RS for BFD measurement and SSB. Longer measurement period for CSI-RS based BFD measurement is expected, and no requirements are defined.

For FR1, when the CSI-RS for BFD measurement is in the same OFDM symbol as another CSI-RS for RLM, BFD, CBD or L1-RSRP measurement, NCR-MT shall be able to measure the CSI-RS for BFD measurement without any restriction.

For FR2-1, when the CSI-RS for BFD measurement on one CC is in the same OFDM symbol as SSB for RLM, BFD or L1-RSRP measurement on the same CC in the same band, or in the same symbol as SSB for CBD measurement on the same CC in the same band when beam failure is detected, NCR-MT is required to measure one of but not both CSI-RS for BFD measurement and SSB. Longer measurement period for CSI-RS based BFD measurement is expected, and no requirements are defined.

For FR2-1, when the CSI-RS for BFD measurement on one CC is in the same OFDM symbol as another CSI-RS for RLM, BFD, CBD or L1-RSRP measurement on the same CC in the same band,

- In the following cases, NCR-MT is required to measure one of but not both CSI-RS for BFD measurement and the other CSI-RS. Longer measurement period for CSI-RS based BFD measurement is expected, and no requirements are defined.
 - The CSI-RS for BFD measurement or the other CSI-RS in a resource set configured with repetition ON, or
 - The other CSI-RS is configured in set \bar{q}_1 and beam failure is detected, or
 - The two CSI-RS-es are not QCL-ed w.r.t. QCL-TypeD, or the QCL information is not known to NCR-MT,
- Otherwise, NCR-MT shall be able to measure the CSI-RS for BFD measurement without any restriction.

10.3.2.4 Minimum requirement for L1 indication

When the radio link quality on all the RS resources in set \bar{q}_0 is worse than $Q_{\text{out_LR, layer 1}}$ of the NCR-MT shall send a beam failure instance indication to the higher layers. A layer 3 filter may be applied to the beam failure instance indications as specified in TS 38.331 [23].

The beam failure instance evaluation for the RS resources in set \bar{q}_0 shall be performed as specified in clause 6 in TS 38.213 [24]. Two successive indications from layer 1 shall be separated by at least $T_{\text{Indication_interval_BFD}}$.

$T_{\text{Indication_interval_BFD}}$ is $\max(2\text{ms}, T_{\text{SSB-RS,M}})$ or $\max(2\text{ms}, T_{\text{CSI-RS,M}})$, where $T_{\text{SSB-RS,M}}$ and $T_{\text{CSI-RS,M}}$ is the shortest periodicity of all RS resources in set \bar{q}_0 for the accessed cell, corresponding to either the shortest periodicity of the SSB in the set \bar{q}_0 or CSI-RS resource in the set \bar{q}_0 .

10.3.2.5 Requirements for SSB based candidate beam detection

10.3.2.5.1 Introduction

The requirements in this clause apply for each SSB resource in the set \bar{q}_1 configured for a serving cell, provided that the SSBs configured for candidate beam detection are actually transmitted within NCR-MT active DL BWP during the entire evaluation period specified in clause 10.3.2.5.2.

10.3.2.5.2 Minimum requirement

Upon request the NCR-MT shall be able to evaluate whether the L1-RSRP measured on the configured SSB resource in set \bar{q}_1 estimated over the last $T_{\text{Evaluate_CBD_SSB}}$ ms period becomes better than the threshold $Q_{\text{in_LR}}$ provided SSB_{RP} and SSB \hat{E}_s/I_{ot} are according to Annex Table in B.2.4.1 [23] for a corresponding band.

The NCR-MT shall monitor the configured SSB resources using the evaluation period in table 10.3.2.5.2-1 and 10.3.2.5.2-2 which is applicable to the non-DRX mode only.

The value of $T_{\text{Evaluate_CBD_SSB}}$ is defined in Table 10.3.2.5.2-1 for FR1.

The value of $T_{\text{Evaluate_CBD_SSB}}$ is defined in Table 10.3.2.5.2-2 for FR2-1 with scaling factor $N=8$.

Where,

For FR1,

- $P = 1$.

For FR2-1,

- $P=1$, when the candidate beam detection RS resource is not overlapped with SMTC occasion.
- $P = \frac{1}{1 - \frac{T_{SSB}}{T_{SMTCperiod}}}$, when candidate beam detection RS is partially overlapped with SMTC occasion ($T_{SSB} < T_{SMTCperiod}$).
- $P = 3$, when candidate beam detection RS is fully overlapped with SMTC period ($T_{SSB} = T_{SMTCperiod}$).

If the high layer in TS 38.331 [23] signaling of $smtc_2$ is present, $T_{SMTCperiod}$ follows $smtc_2$; Otherwise $T_{SMTCperiod}$ follow $smtc_1$.

Longer evaluation period would be expected if the combination of CBD-RS resource and SMTC occasion configurations does not meet pervious conditions.

Table 10.3.2.5.2-1: Evaluation period $T_{Evaluate_CBD_SSB}$ for FR1

Configuration	$T_{Evaluate_CBD_SSB}$ (ms)
non-DRX	$Ceil(3 \times P) \times T_{SSB}$
Note: T_{SSB} is the periodicity of SSB in the set \bar{q}_i .	

Table 10.3.2.5.2-2: Evaluation period $T_{Evaluate_CBD_SSB}$ for FR2-1

Configuration	$T_{Evaluate_CBD_SSB}$ (ms)
non-DRX	$Ceil(3 \times P \times N) \times T_{SSB}$
Note: T_{SSB} is the periodicity of SSB in the set \bar{q}_i .	

10.3.2.5.3 Measurement restriction for SSB based candidate beam detection

For FR1, when the SSB for CBD measurement is in the same OFDM symbol as CSI-RS for RLM, BFD, CBD or L1-RSRP measurement,

- If SSB and CSI-RS have same SCS, NCR-MT shall be able to measure the SSB for CBD measurement without any restrictions;
- If SSB and CSI-RS have different SCS-es,
 - If NCR-MT supports *simultaneousRxDataSSB-DiffNumerology*, NCR-MT shall be able to measure the SSB for CBD measurement without any restriction;
 - If NCR-MT does not support *simultaneousRxDataSSB-DiffNumerology*, NCR-MT is required to measure one of but not both SSB for CBD measurement and CSI-RS. Longer measurement period for SSB based CBD measurement is expected, and no requirements are defined.

For FR2-1, when the SSB for CBD measurement on one CC is in the same OFDM symbol as CSI-RS for RLM, BFD, CBD or L1-RSRP measurement on the same CC in the same band, NCR-MT is required to measure one of but not both SSB for CBD measurement and CSI-RS. Longer measurement period for SSB based CBD measurement is expected, and no requirements are defined.

10.3.2.6 Requirements for CSI-RS based candidate beam detection

10.3.2.6.1 Introduction

The requirements in this clause apply for each CSI-RS resource in the set \bar{q}_1 configured for a serving cell, provided that the CSI-RS resources configured for candidate beam detection are actually transmitted within NCR-MT active DL BWP during the entire evaluation period specified in clause 10.3.2.6.2.

10.3.2.6.2 Minimum requirement

Upon request the NCR-MT shall be able to evaluate whether the L1-RSRP measured on the configured CSI-RS resource in set \bar{q}_1 estimated over the last $T_{\text{Evaluate_CBD_CSI-RS}}$ [ms] period becomes better than the threshold $Q_{\text{in_LR}}$ within $T_{\text{Evaluate_CBD_CSI-RS}}$ [ms] period provided CSI-RS \hat{E}_s/Iot is according to Annex Table in B.2.4.2 [23] for a corresponding band.

The NCR-MT shall monitor the configured CSI-RS resources using the evaluation period in table 10.3.2.6.2-1 and 10.3.2.6.2-2 which is applicable to the non-DRX mode only.

The value of $T_{\text{Evaluate_CBD_CSI-RS}}$ is defined in Table 10.3.2.6.2-1 for FR1.

The value of $T_{\text{Evaluate_CBD_CSI-RS}}$ is defined in Table 10.3.2.6.2-2 for FR2-1 with scaling factor $N=8$.

For FR1,

- $P = 1$.

For FR2-1,

- $P = 1$, when candidate beam detection RS is not overlapped with SMTC occasion.
- $P = \frac{1}{1 - \frac{T_{\text{CSI-RS}}}{T_{\text{SMTCperiod}}}}$, when candidate beam detection RS is partially overlapped with SMTC occasion ($T_{\text{CSI-RS}} < T_{\text{SMTCperiod}}$).
- $P = 3$, when candidate beam detection RS is fully overlapped with SMTC occasion ($T_{\text{CSI-RS}} = T_{\text{SMTCperiod}}$).

If the high layer in TS 38.331 [23] signaling of smtc_2 is present, $T_{\text{SMTCperiod}}$ follows smtc_2 ; Otherwise $T_{\text{SMTCperiod}}$ follow smtc_1 .

Longer evaluation period would be expected if the CSI-RS is on the same OFDM symbols with RLM, BFD, BM-RS, or other CBD-RS, according to the measurement restrictions defined in clause 10.3.2.6.3.

The values of M_{CBD} used in Table 10.3.2.6.2-1 and Table 10.3.2.6.2-2 are defined as

- $M_{\text{CBD}} = 3$, if the CSI-RS resource configured in the set \bar{q}_1 is transmitted with Density = 3.

Table 10.3.2.6.2-1: Evaluation period $T_{\text{Evaluate_CBD_CSI-RS}}$ for FR1

Configuration	$T_{\text{Evaluate_CBD_CSI-RS}}$ (ms)
non-DRX	$\text{Max}(25, \text{Ceil}(M_{\text{CBD}} \times P) \times T_{\text{CSI-RS}})$
Note:	$T_{\text{CSI-RS}}$ is the periodicity of CSI-RS resource in the set \bar{q}_1 .

Table 10.3.2.6.2-2: Evaluation period $T_{\text{Evaluate_CBD_CSI-RS}}$ for FR2-1

Configuration	$T_{\text{Evaluate_CBD_CSI-RS}}$ (ms)
non-DRX	$\text{Max}(25, \text{Ceil}(M_{\text{CBD}} \times P \times N) \times T_{\text{CSI-RS}})$
Note:	$T_{\text{CSI-RS}}$ is the periodicity of CSI-RS resource in the set \bar{q}_1 .

10.3.2.6.3 Measurement restriction for CSI-RS based candidate beam detection

For both FR1 and FR2-1, when the CSI-RS for CBD measurement is in the same OFDM symbol as SSB for RLM, BFD, CBD or L1-RSRP measurement, NCR-MT is not required to receive CSI-RS for CBD measurement in the PRBs that overlap with an SSB.

For FR1, when the SSB for RLM, BFD, CBD or L1-RSRP measurement is within the active BWP and has same SCS than CSI-RS for CBD measurement, the NCR-MT shall be able to perform CSI-RS based CBD measurement without restrictions.

For FR1, when the SSB for RLM, BFD, CBD or L1-RSRP measurement is within the active BWP and has different SCS than CSI-RS for CBD measurement, the NCR-MT shall be able to perform CSI-RS based CBD measurement with restrictions according to its capabilities:

- If the NCR-MT supports *simultaneousRxDataSSB-DiffNumerology* the NCR-MT shall be able to perform CSI-RS based CBD measurement for without restrictions.
- If the NCR-MT does not support *simultaneousRxDataSSB-DiffNumerology*, NCR-MT is required to measure one of but not both CSI-RS for CBD measurement and SSB. Longer measurement period for CSI-RS based CBD measurement is expected, and no requirements are defined.

For FR1, when the CSI-RS for CBD measurement is in the same OFDM symbol as another CSI-RS for RLM, BFD, CBD or L1-RSRP measurement, NCR-MT shall be able to measure the CSI-RS for CBD measurement without any restriction.

For FR2-1, when the CSI-RS for CBD measurement on one CC is in the same OFDM symbol as SSB for RLM, BFD, CBD or L1-RSRP measurement on the same CC in the same band, NCR-MT is required to measure one of but not both CSI-RS for CBD measurement and SSB. Longer evaluation period for CSI-RS based CBD measurement is expected, and no requirements are defined.

For FR2-1, when the CSI-RS for CBD measurement on one CC is in the same OFDM symbol as another CSI-RS for RLM, BFD, CBD or L1-RSRP measurement on the same CC in the same band, NCR-MT is required to measure one of but not both CSI-RS for CBD measurement and the other CSI-RS. Longer evaluation period for CSI-RS based CBD measurement is expected, and no requirements are defined.

10.3.2.7 Scheduling availability of NCR-MT during beam failure detection

Scheduling availability restrictions when the NCR-MT is performing beam failure detection are described in the following clauses.

10.3.2.7.1 Scheduling availability of NCR-MT performing beam failure detection with a same subcarrier spacing as PDSCH/PDCCH on FR1

There are no scheduling restrictions due to beam failure detection performed on SSB and CSI-RS configured for BFD with the same SCS as PDSCH or PDCCH in FR1.

10.3.2.7.2 Scheduling availability of NCR-MT performing beam failure detection with a different subcarrier spacing than PDSCH/PDCCH on FR1

For NCR-MTs which support *simultaneousRxDataSSB-DiffNumerology* [27] there are no restrictions on scheduling availability due to beam failure detection when SSB is configured as BFD. For NCR-MTs which do not support *simultaneousRxDataSSB-DiffNumerology* [27] the following restrictions apply due to beam failure detection when SSB is configured as BFD.

- The NCR-MT is not expected to transmit PUCCH, PUSCH or SRS or receive PDCCH, PDSCH or CSI-RS for tracking or CSI-RS for CQI on SSB symbols to be measured for beam failure detection.

10.3.2.7.3 Scheduling availability of NCR-MT performing beam failure detection on FR2-1

The following scheduling restriction applies due to beam failure detection.

- For the case where no RSs are provided for BFD, or when CSI-RS is configured for BFD is explicitly configured and is type-D QCLed with active TCI state for PDCCH or PDSCH, and the CSI-RS is not in a CSI-RS resource set with repetition ON.
 - There are no scheduling restrictions due to beam failure detection performed based on the CSI-RS.
- Otherwise
 - The NCR-MT is not expected to transmit PUCCH, PUSCH or SRS or receive PDCCH, PDSCH or CSI-RS for tracking or CSI-RS for CQI on BFD-RS resource symbols to be measured for beam failure detection.

For FR2-1, if following conditions are met,

- NCR-MT has been notified about system information update through paging,
- The gap between NCR-MT's reception of PDCCH that NCR-MT monitors in the Type2-PDCCH CSS set and that notifies system information update, and the PDCCH that NCR-MT monitors in the Type0-PDCCH CSS set, is greater than 2 slots,

For the SSB and CORESET for RMSI scheduling multiplexing patterns 3, NCR-MT is expected to receive the PDCCH that NCR-MT monitors in the Type0-PDCCH CSS set, and the corresponding PDSCH, on SSB symbols to be measured for BFD measurement; and

For the SSB and CORESET for RMSI scheduling multiplexing patterns 2, NCR-MT is expected to receive PDSCH that corresponds to the PDCCH that NCR-MT monitors in the Type0-PDCCH CSS set, on SSB symbols to be measured for BFD measurement.

10.3.2.8 Scheduling availability of NCR-MT during candidate beam detection

Scheduling availability restrictions when the NCR-MT is performing L1-RSRP measurement for candidate beam detection are described in the following clauses.

10.3.2.8.1 Scheduling availability of NCR-MT performing L1-RSRP measurement with a same subcarrier spacing as PDSCH/PDCCH on FR1

There are no scheduling restrictions due to L1-RSRP measurement performed on SSB and CSI-RS configured as link recovery detection resource with the same SCS as PDSCH or PDCCH in FR1.

10.3.2.8.2 Scheduling availability of NCR-MT performing L1-RSRP measurement with a different subcarrier spacing than PDSCH/PDCCH on FR1

For NCR-MTs which support *simultaneousRxDataSSB-DiffNumerology* [27] there are no restrictions on scheduling availability due to L1-RSRP measurement based on SSB as link recovery detection resource. For NCR-MTs which do not support *simultaneousRxDataSSB-DiffNumerology* [27] the following restrictions apply due to L1-RSRP measurement based on SSB configured as link recovery detection resource.

- The NCR-MT is not expected to transmit PUCCH, PUSCH or SRS or receive PDCCH, PDSCH, TRS, CSI-RS for tracking or CSI-RS for CQI on SSB symbols to be measured for L1-RSRP.

10.3.2.8.3 Scheduling availability of NCR-MT performing L1-RSRP measurement on FR2-1

The following scheduling restriction applies due to candidate beam detection

- The NCR-MT is not expected to transmit PUCCH, PUSCH or SRS or receive PDCCH, PDSCH, CSI-RS for tracking or CSI-RS for CQI on reference symbols to be measured for candidate beam detection.

For FR2-1, if following conditions are met,

- NCR-MT has been notified about system information update through paging,

- The gap between NCR-MT's reception of PDCCH that NCR-MT monitors in the Type2-PDCCH CSS set and that notifies system information update, and the PDCCH that NCR-MT monitors in the Type0-PDCCH CSS set, is greater than 2 slots,

For the SSB and CORESET for RMSI scheduling multiplexing patterns 3, NCR-MT is expected to receive the PDCCH that NCR-MT monitors in the Type0-PDCCH CSS set, and the corresponding PDSCH, on SSB symbols to be measured for CBD measurement; and

For the SSB and CORESET for RMSI scheduling multiplexing patterns 2, NCR-MT is expected to receive PDSCH that corresponds to the PDCCH that NCR-MT monitors in the Type0-PDCCH CSS set, on SSB symbols to be measured for CBD measurement.

Annex A: Void

Annex B (normative): NCR-MT Reference measurement channels

B.1 NCR-MT Demodulation Performance Fixed Reference Channels

B.1.1 Fixed Reference Channels for PDSCH performance requirements

The parameters for the reference measurement channels are specified in table B.1.1-1 for FR1 PDSCH performance requirements.

The parameters for the reference measurement channels are specified in table B.1.1-2 for FR2-1 PDSCH performance requirements.

Table B.1.1-1: FRC parameters for FR1 PDSCH performance requirements, 1 transmission layer

Parameter	Unit	Value			
		M-FR1-NCR.1.1-1	M-FR1-NCR.1.1-2	M-FR1-NCR.1.1-3	M-FR1-NCR.1.1-4
Reference channel					
Channel bandwidth	MHz	10	40	10	40
Subcarrier spacing	kHz	15	30	15	30
Allocated resource blocks	PRBs	52	106	52	106
Number of consecutive PDSCH symbols		12	12	12	12
MCS table		64QAM	64QAM	64QAM	64QAM
MCS index		4	4	13	13
Modulation		QPSK	QPSK	16QAM	16QAM
Target Coding Rate		0.30	0.30	0.48	0.48
Number of MIMO layers		1	1	1	1
Number of DMRS REs		12	12	12	12
Overhead for TBS determination		0	0	0	0
Information Bit Payload per Slot		4096	8456	13064	26632
Transport block CRC per Slot		24	24	24	24
Number of Code Blocks per Slot		1	2	2	4
Binary Channel Bits Per Slot		13728	27984	27456	55968

Table B.1.1-2: FRC parameters for FR2-1 PDSCH performance requirements, 1 transmission layer

Parameter	Unit	Value
Reference channel		M-FR2-NCR.1.1-1
Channel bandwidth	MHz	100
Subcarrier spacing	kHz	120
Allocated resource blocks	PRBs	66
Number of consecutive PDSCH symbols		13
MCS table		64QAM
MCS index		4
Modulation		QPSK
Target Coding Rate		0.30
Number of MIMO layers		1
Number of DMRS REs		12
Overhead for TBS determination		6
Information Bit Payload per Slot		5504
Transport block CRC per Slot		24
Number of Code Blocks per Slot		1
Binary Channel Bits Per Slot		18282

B.1.2 Fixed Reference Channels for PDCCH performance requirements

The parameters for the reference measurement channels are specified in table B.1.2-1 for FR1 PDCCH performance requirements.

The parameters for the reference measurement channels are specified in table B.1.2-2 for FR2-1 PDCCH performance requirements.

Table B.1.2-1: FR1 PDCCH Reference Channels

Parameter	Unit	Value					
		M-FR1-NCR.1.2-1	M-FR1-NCR.1.2-2	M-FR1-NCR.1.2-3	M-FR1-NCR.1.2-4	M-FR1-NCR.1.2-5	M-FR1-NCR.1.2-6
Reference channel							
Subcarrier spacing	kHz	15	15	15	30	30	30
CORESET frequency domain allocation		24	48	48	102	102	90
CORESET time domain allocation		2	2	1	1	1	1
Aggregation level		2	4	8	2	4	8
DCI Format		1_0	1_1	1_1	1_0	1_1	1_1
Payload (without CRC)	Bits	39	52	52	41	53	53

Table B.1.2-2: FR2-1 PDCCH Reference Channels

Parameter	Unit	Value		
		M-FR2-NCR.1.2-1	M-FR2-NCR.1.2-2	M-FR2-NCR.1.2-3
Reference channel				
Subcarrier spacing	kHz	120	120	120
CORESET frequency domain allocation		60	60	60
CORESET time domain allocation		1	1	1
Aggregation level		2	4	8
DCI Format		1_0	1_1	1_1
Payload (without CRC)	Bits	40	56	56

B.1.3 Fixed Reference Channels for CSI reporting performance

This clause defines the DL signal applicable to the reporting of channel status information.

Tables in this clause specifies the mapping of CQI index to Information Bit payload, which complies with the CQI definition specified in clause 5.2.2.1 of TS 38.214 [11] and with MCS definition specified in clause 5.1.3 of TS 38.214 [11].

Table B.1.3-1: Fixed Reference Channels for FR1 CSI reporting with CQI table 2 and MCS table 2

Reference channel				M-FR1-NCR.1.3-1	M-FR1-NCR.1.3-2
Number of allocated PDSCH resource blocks				52	106
Number of consecutive PDSCH symbols				12	12
Number of PDSCH MIMO layers				1	2
Number of DMRS REs (Note 1)				24	24
Overhead for TBS determination				0	0
Available RE-s for PDSCH				6240	12720
CQI index	Spectral efficiency	MCS index	Modulation	Information Bit Payload per Slot	
0	0OR	0OR	0OR	N/A	N/A
1	0.1523	0	QPSK	1480	2976
2	0.3770	1		2408	4744
3	0.8770	3		5504	11016
4	1.4766	5	16QAM	9224	18960
5	1.9141	7		12040	24576
6	2.4063	9		15112	30728
7	2.7305	11	64QAM	16896	34816
8	3.3223	13		20496	42016
9	3.9023	15		24576	49176
10	4.5234	17		28168	57376
11	5.1152	19	256QAM	31752	65576
12	5.5547	21		34816	69672
13	6.2266	23		38936	79896
14	6.9141	25		43032	88064
15	7.4063	27		46104	94248
NOTE 1: Number of DMRS REs includes the overhead of the DM-RS CDM groups without data					
NOTE 2: PDSCH is only scheduled on slots which are full DL					

Table B.1.3-2: Fixed Reference Channels for FR2-1 CSI reporting with CQI table 1 and MCS table 1

Reference channel				M-FR2-NCR.1.3-1
Number of allocated PDSCH resource blocks				66
Number of consecutive PDSCH symbols				12
Number of PDSCH MIMO layers				1
Number of DMRS REs (Note 1)				24
Overhead for TBS determination				6
Available RE-s for PDSCH				7590
CQI index	Spectral efficiency	MCS index	Modulation	Information Bit Payload per Slot
0	0OR	0OR	0OR	N/A
1	0.1523	0	QPSK	1800
2	0.2344	0		1800
3	0.3770	2		2856
4	0.6016	4		4480
5	0.8770	6		6528
6	1.1758	8		8712
7	1.4766	11	16QAM	11016
8	1.9141	13		14343
9	2.4063	15		17928
10	2.7305	18	64QAM	20496
11	3.3223	20		25104
12	3.9023	22		29192
13	4.5234	24		33816
14	5.1152	26		38936
15	5.5547	28		42016
NOTE 1: Number of DMRS REs includes the overhead of the DM-RS CDM groups without data				
NOTE 2: PDSCH is only scheduled on slots which are full DL				

B.2 Fixed Reference Channels for reference sensitivity level, ACS, in-band blocking, out-of-band blocking and receiver intermodulation (QPSK, R=1/3)

The parameters for the FR1 WA NCR-MT reference measurement channels are specified in tables B.2-1 for FR1 reference sensitivity level, ACS, in-band blocking, out-of-band blocking, receiver intermodulation.

Table B.2-1: FRC parameters for FR1 reference sensitivity level for FR1 WA NCR-MT

Reference channel	G-FR1-A1-22	G-FR1-A1-23	G-FR1-A1-24	G-FR1-A1-25	G-FR1-A1-26	G-FR1-A1-27
Subcarrier spacing (kHz)	30	60	15	30	60	15
Allocated resource blocks	11	11	106	51	24	25
CP-OFDM Symbols per slot (Note 1)	9	9	9	9	9	9
Modulation	QPSK	QPSK	QPSK	QPSK	QPSK	QPSK
Code rate (Note 2)	1/3	1/3	1/3	1/3	1/3	1/3
NOTE 1: <i>DL-DMRS-config-type</i> = 1 with <i>DL-DMRS-max-len</i> = 1, <i>DL-DMRS-add-pos</i> = pos2 with $l_0 = 2$, $l = 6$ and 9 as per Table 7.4.1.1.2-3 of TS 38.211 [3].						
NOTE 2: MCS index 4 and target coding rate = 308/1024 are adopted to calculate payload size for receiver sensitivity						

Annex C (normative): Propagation conditions

C.1 Static propagation condition

The propagation for the static performance measurement is an Additive White Gaussian Noise (AWGN) environment. No fading or multi-paths exist for this propagation model.

C.1.1 NCR-MT receiver with 2RX

For 1 port transmission the channel matrix is defined in the frequency domain by:

$$\mathbf{H} = \begin{pmatrix} 1 \\ 1 \end{pmatrix}.$$

For 2 port transmission the channel matrix is defined in the frequency domain by:

$$\mathbf{H} = \begin{pmatrix} 1 & j \\ 1 & -j \end{pmatrix}.$$

C.1.2 NCR-MT Receiver with 4Rx

For 1 port transmission the channel matrix is defined in the frequency domain by

$$\mathbf{H} = \begin{bmatrix} 1 \\ 1 \\ 1 \\ 1 \end{bmatrix}.$$

For 2 port transmission the channel matrix is defined in the frequency domain by

$$\mathbf{H} = \begin{bmatrix} 1 & j \\ 1 & -j \\ 1 & j \\ 1 & -j \end{bmatrix}.$$

C.2 Multi-path fading propagation conditions

C.2.1 General

The multipath propagation conditions consist of several parts:

- A delay profile in the form of a "tapped delay-line", characterized by a number of taps at fixed positions on a sampling grid. The profile can be further characterized by the r.m.s. delay spread and the maximum delay spanned by the taps.
- A combination of channel model parameters that include the Delay profile and the Doppler spectrum that is characterized by a classical spectrum shape and a maximum Doppler frequency.
- Different models are used for FR1 (410 MHz - 7.125 GHz) and FR2 (24.25 GHz – 52.6 GHz).

C.2.2 Delay profiles

C.2.2.1 General

The delay profiles are simplified from the TR 38.901 [29] TDL models. The simplification steps are shown below for information. These steps are only used when new delay profiles are created. Otherwise, the delay profiles specified in C.2.2.1 can be used as such.

- Step 1: Use the original TDL model from TR 38.901 [29].
- Step 2: Re-order the taps in ascending delays.
- Step 3: Perform delay scaling according to the procedure described in clause 7.7.3 in TR 38.901 [29].
- Step 4: Apply the quantization to the delay resolution 5 ns. This is done simply by rounding the tap delays to the nearest multiple of the delay resolution.
- Step 5: If multiple taps are rounded to the same delay bin, merge them by calculating their linear power sum.
- Step 6: If there are more than 12 taps in the quantized model, merge the taps as follows:
 - Find the weakest tap from all taps (both merged and unmerged taps are considered):
 - If there are two or more taps having the same value and are the weakest, select the tap with the smallest delay as the weakest tap.
 - When the weakest tap is the first delay tap, merge taps as follows:
 - Update the power of the first delay tap as the linear power sum of the weakest tap and the second delay tap.
 - Remove the second delay tap.
 - When the weakest tap is the last delay tap, merge taps as follows:
 - Update the power of the last delay tap as the linear power sum of the second-to-last tap and the last tap.
 - Remove the second-to-last tap.
 - Otherwise:
 - For each side of the weakest tap, identify the neighbour tap that has the smaller delay difference to the weakest tap.
 - When the delay difference between the weakest tap and the identified neighbour tap on one side equals the delay difference between the weakest tap and the identified neighbour tap on the other side.
 - Select the neighbour tap that is weaker in power for merging.
 - Otherwise, select the neighbour tap that has smaller delay difference for merging.
 - To merge, the power of the merged tap is the linear sum of the power of the weakest tap and the selected tap.
 - When the selected tap is the first tap, the location of the merged tap is the location of the first tap. The weakest tap is removed.

- When the selected tap is the last tap, the location of the merged tap is the location of the last tap. The weakest tap is removed.
- Otherwise, the location of the merged tap is based on the average delay of the weakest tap and selected tap. If the average delay is on the sampling grid, the location of the merged tap is the average delay. Otherwise, the location of the merged tap is rounded towards the direction of the selected tap (e.g. 10 ns & 20 ns → 15 ns, 10 ns & 25 ns → 20 ns, if 25 ns had higher or equal power; 15 ns, if 10 ns had higher power). The weakest tap and the selected tap are removed.
- Repeat step 6 until the final number of taps is 12.
- Step 7: Round the amplitudes of taps to one decimal (e.g. -8.78 dB → -8.8 dB)
- Step 8: If the delay spread has slightly changed due to the tap merge, adjust the final delay spread by increasing or decreasing the power of the last tap so that the delay spread is corrected.
- Step 9: Re-normalize the highest tap to 0 dB.

NOTE 1: Some values of the delay profile created by the simplification steps may differ from the values in tables C.2.2.2-2, C.2.2.2-3, and C.2.1.1-4 for the corresponding model.

NOTE 2: For Step 5 and Step 6, the power values are expressed in the linear domain using 6 digits of precision. The operations are in the linear domain.

C.2.2.2 Delay profiles for FR1

The delay profiles for FR1 are selected to be representative of low, medium and high delay spread environment. The resulting model parameters are specified in C.2.2.2-1 and the tapped delay line models are specified in tables C.2.2.2-2 ~ table C.2.2.2-4.

Table C.2.2.2-1: Delay profiles for NR channel models

Model	Number of channel taps	Delay spread (r.m.s.)	Maximum excess tap delay (span)	Delay resolution
TDLA30	12	30 ns	290 ns	5 ns
TDLB100	12	100 ns	480 ns	5 ns
TDLC300	12	300 ns	2595 ns	5 ns

Table C.2.2.2-2: TDLA30 (DS = 30 ns)

Tap #	Delay (ns)	Power (dB)	Fading distribution
1	0	-15.5	Rayleigh
2	10	0	
3	15	-5.1	
4	20	-5.1	
5	25	-9.6	
6	50	-8.2	
7	65	-13.1	
8	75	-11.5	
9	105	-11.0	
10	135	-16.2	
11	150	-16.6	
12	290	-26.2	

Table C.2.2.2-3: TDLB100 (DS = 100ns)

Tap #	Delay (ns)	Power (dB)	Fading distribution
1	0	0	Rayleigh
2	10	-2.2	
3	20	-0.6	
4	30	-0.6	
5	35	-0.3	
6	45	-1.2	
7	55	-5.9	
8	120	-2.2	
9	170	-0.8	
10	245	-6.3	
11	330	-7.5	
12	480	-7.1	

Table C.2.2.2-4: TDLC300 (DS = 300 ns)

Tap #	Delay (ns)	Power (dB)	Fading distribution
1	0	-6.9	Rayleigh
2	65	0	
3	70	-7.7	
4	190	-2.5	
5	195	-2.4	
6	200	-9.9	
7	240	-8.0	
8	325	-6.6	
9	520	-7.1	
10	1045	-13.0	
11	1510	-14.2	
12	2595	-16.0	

C.2.3 Combinations of channel model parameters

The propagation conditions used for the performance measurements in multi-path fading environment are indicated as a combination of a channel model name and a maximum Doppler frequency, i.e., TDLA<DS>-<Doppler>, TDLB<DS>-<Doppler> or TDLC<DS>-<Doppler> where '<DS>' indicates the desired delay spread and '<Doppler>' indicates the maximum Doppler frequency (Hz).

Table C.2.3-1 show the propagation conditions that are used for the performance measurements in multi-path fading environment for low, medium and high Doppler frequencies for FR1.

Table C.2.3-1: Channel model parameters for FR1

Combination name	Model	Maximum Doppler frequency
TDLA30-5	TDLA30	5 Hz
TDLA30-10	TDLA30	10 Hz
TDLB100-400	TDLB100	400 Hz
TDLC300-100	TDLC300	100 Hz

C.2.4 MIMO channel correlation matrices

C.2.4.1 General

The MIMO channel correlation matrices defined in annex C.2.4 apply for the antenna configuration using uniform linear arrays at both gNB and NCR-MT and for the antenna configuration using cross polarized antennas.

C.2.4.2 MIMO correlation matrices using Uniform Linear Array

C.2.4.2.1 General

The MIMO channel correlation matrices defined in annex C.2.4.2 apply for the antenna configuration using uniform linear array (ULA) at both gNB and NCR-MT.

C.2.4.2.2 Definition of MIMO correlation matrices

Table C.2.4.2.2-1 defines the correlation matrix for the gNB.

Table C.2.4.2.2-1: gNB correlation matrix

gNB correlation	
One antenna	$R_{gNB} = 1$
Two antennas	$R_{gNB} = \begin{pmatrix} 1 & \alpha \\ \alpha^* & 1 \end{pmatrix}$
NOTE: The matrix applies to the gNB for NCR-MT requirements.	

Table C.2.4.2.2-2 defines the correlation matrix for the NCR-MT:

Table C.2.4.2.2-2: NCR-MT correlation matrix

NCR-MT correlation	
Two antennas	$R_{UE} = \begin{pmatrix} 1 & \beta \\ \beta^* & 1 \end{pmatrix}$
Four antennas	$R_{UE} = \begin{pmatrix} 1 & \beta^{1/9} & \beta^{4/9} & \beta \\ \beta^{1/9*} & 1 & \beta^{1/9} & \beta^{4/9} \\ \beta^{4/9*} & \beta^{1/9*} & 1 & \beta^{1/9} \\ \beta^* & \beta^{4/9*} & \beta^{1/9*} & 1 \end{pmatrix}$
NOTE: The correlation matrix R_{UE} applies to NCR-MT for NCR-MT requirements	

Table C.2.4.2.2-3 defines the channel spatial correlation matrix R_{yx} . The parameters, α and β in table C.2.4.2.2-3 defines the spatial correlation between the antennas at the gNB and NCR-MT respectively.

Table C.2.4.2.2-3: R_{spat} correlation matrices

1x2 case	$R_{spat} = R_{UE} = \begin{bmatrix} 1 & \beta \\ \beta^* & 1 \end{bmatrix}$
1x4 case	$R_{spat} = R_{UE} = \begin{bmatrix} 1 & \beta^{1/9} & \beta^{4/9} & \beta \\ \beta^{1/9*} & 1 & \beta^{1/9} & \beta^{4/9} \\ \beta^{4/9*} & \beta^{1/9*} & 1 & \beta^{1/9} \\ \beta^* & \beta^{4/9*} & \beta^{1/9*} & 1 \end{bmatrix}$
2x2 case	$R_{spat} = R_{gNB} \otimes R_{UE} = \begin{bmatrix} 1 & \alpha \\ \alpha^* & 1 \end{bmatrix} \otimes \begin{bmatrix} 1 & \beta \\ \beta^* & 1 \end{bmatrix} = \begin{bmatrix} 1 & \beta & \alpha & \alpha\beta \\ \beta^* & 1 & \alpha\beta^* & \alpha \\ \alpha^* & \alpha^*\beta & 1 & \beta \\ \alpha^*\beta^* & \alpha^* & \beta^* & 1 \end{bmatrix}$
2x4 case	$R_{spat} = R_{gNB} \otimes R_{UE} = \begin{bmatrix} 1 & \alpha \\ \alpha^* & 1 \end{bmatrix} \otimes \begin{bmatrix} 1 & \beta^{1/9} & \beta^{4/9} & \beta \\ \beta^{1/9*} & 1 & \beta^{1/9} & \beta^{4/9} \\ \beta^{4/9*} & \beta^{1/9*} & 1 & \beta^{1/9} \\ \beta^* & \beta^{4/9*} & \beta^{1/9*} & 1 \end{bmatrix}$
NOTE 1: R_{gNB} refers to the correlation matrix of gNB for NCR-MT requirements. NOTE 2: R_{UE} refers to the correlation matrix of NCR-MT for NCR-MT requirements	

For cases with more antennas at either gNB or NCR-MT or both, the channel spatial correlation matrix can still be expressed as the Kronecker product of R_{gNB} and R_{UE} according to $R_{spat} = R_{gNB} \otimes R_{UE}$.

C.2.4.2.3 MIMO correlation matrices at high, medium and low level

The α and β for different correlation types are given in table C.2.4.2.3-1.

Table C.2.4.2.3-1: Correlation for high, medium and low level

Low correlation		Medium correlation		High correlation	
α	β	α	β	α	β
0	0	0.3	0.9	0.9	0.9

The correlation matrices for high, medium and low correlation are defined in table C.2.4.2.3-2, C.2.4.2.3-3 and C.2.4.2.3-4 as below.

The values in table C.2.4.2.3-2 have been adjusted for the 2x4 high correlation case to ensure the correlation matrix is positive semi-definite after round-off to 4 digit precision. This is done using the equation:

$$\mathbf{R}_{high} = [\mathbf{R}_{spatial} + a\mathbf{I}_n] / (1 + a)$$

Where the value "a" is a scaling factor such that the smallest value is used to obtain a positive semi-definite result. For the 2x4 high correlation case, a = 0.00010.

Table C.2.4.2.3-2: MIMO correlation matrices for high correlation

1x2 case	$R_{high} = \begin{pmatrix} 1 & 0.9 \\ 0.9 & 1 \end{pmatrix}$
2x2 case	$R_{high} = \begin{pmatrix} 1 & 0.9 & 0.9 & 0.81 \\ 0.9 & 1 & 0.81 & 0.9 \\ 0.9 & 0.81 & 1 & 0.9 \\ 0.81 & 0.9 & 0.9 & 1 \end{pmatrix}$
2x4 case	$R_{high} = \begin{bmatrix} 1.0000 & 0.9883 & 0.9542 & 0.8999 & 0.8999 & 0.8894 & 0.8587 & 0.8099 \\ 0.9883 & 1.0000 & 0.9883 & 0.9542 & 0.8894 & 0.8999 & 0.8894 & 0.8587 \\ 0.9542 & 0.9883 & 1.0000 & 0.9883 & 0.8587 & 0.8894 & 0.8999 & 0.8894 \\ 0.8999 & 0.9542 & 0.9883 & 1.0000 & 0.8099 & 0.8587 & 0.8894 & 0.8999 \\ 0.8999 & 0.8894 & 0.8587 & 0.8099 & 1.0000 & 0.9883 & 0.9542 & 0.8999 \\ 0.8894 & 0.8999 & 0.8894 & 0.8587 & 0.9883 & 1.0000 & 0.9883 & 0.9542 \\ 0.8587 & 0.8894 & 0.8999 & 0.8894 & 0.9542 & 0.9883 & 1.0000 & 0.9883 \\ 0.8099 & 0.8587 & 0.8894 & 0.8999 & 0.8999 & 0.9542 & 0.9883 & 1.0000 \end{bmatrix}$

Table C.2.4.2.3-3: MIMO correlation matrices for medium correlation

1x2 case	[N/A]
2x2 case	$R_{medium} = \begin{pmatrix} 1.0000 & 0.9000 & 0.3000 & 0.2700 \\ 0.9000 & 1.0000 & 0.2700 & 0.3000 \\ 0.3000 & 0.2700 & 1.0000 & 0.9000 \\ 0.2700 & 0.3000 & 0.9000 & 1.0000 \end{pmatrix}$
2x4 case	$R_{medium} = \begin{pmatrix} 1.0000 & 0.9884 & 0.9543 & 0.9000 & 0.3000 & 0.2965 & 0.2863 & 0.2700 \\ 0.9884 & 1.0000 & 0.9884 & 0.9543 & 0.2965 & 0.3000 & 0.2965 & 0.2863 \\ 0.9543 & 0.9884 & 1.0000 & 0.9884 & 0.2863 & 0.2965 & 0.3000 & 0.2965 \\ 0.9000 & 0.9543 & 0.9884 & 1.0000 & 0.2700 & 0.2863 & 0.2965 & 0.3000 \\ 0.3000 & 0.2965 & 0.2863 & 0.2700 & 1.0000 & 0.9884 & 0.9543 & 0.9000 \\ 0.2965 & 0.3000 & 0.2965 & 0.2863 & 0.9884 & 1.0000 & 0.9884 & 0.9543 \\ 0.2863 & 0.2965 & 0.3000 & 0.2965 & 0.9543 & 0.9884 & 1.0000 & 0.9884 \\ 0.2700 & 0.2863 & 0.2965 & 0.3000 & 0.9000 & 0.9543 & 0.9884 & 1.0000 \end{pmatrix}$

Table C.2.4.2.3-4: MIMO correlation matrices for low correlation

1x2 case	$R_{low} = \mathbf{I}_2$
1x4 case	$R_{low} = \mathbf{I}_4$
2x2 case	$R_{low} = \mathbf{I}_4$
2x4 case	$R_{low} = \mathbf{I}_8$

In table C.2.4.2.3-4, \mathbf{I}_d is a $d \times d$ identity matrix.

NOTE: For completeness, the correlation matrices were defined for high, medium and low correlation but performance requirements exist only for low correlation.

C.2.4.3 Multi-antenna channel models using cross polarized antennas

C.2.4.3.1 General

The MIMO channel correlation matrices defined in annex C.2.4.3 apply to two cases as presented below:

- One TX antenna and multiple RX antennas case, with cross polarized antennas used at gNB
- Multiple TX antennas and multiple RX antennas case, with cross polarized antennas used at both NCR-MT and gNB

The cross-polarized antenna elements with +/-45 degrees polarization slant angles are deployed at gNB. For one TX antenna case, antenna element with +90 degree polarization slant angle is deployed at NCR-MT. For multiple TX antennas case, cross-polarized antenna elements with +90/0 degrees polarization slant angles are deployed at NCR-MT.

For the cross-polarized antennas, the N antennas are labelled such that antennas for one polarization are listed from 1 to N/2 and antennas for the other polarization are listed from N/2+1 to N, where N is the number of TX or RX antennas.

C.2.4.3.2 Definition of MIMO correlation matrices using cross polarized antennas

For the channel spatial correlation matrix, the following is used:

$$R_{spat} = P_{UL} (R_{UE} \otimes \Gamma_{UL} \otimes R_{gNB}) P_{UL}^T$$

Where

- R_{UE} is the spatial correlation matrix at the NCR-MT (NCR-MT requirements) with same polarization,
- R_{gNB} is the spatial correlation matrix at the gNB (NCR-MT requirements) with same polarization,
- Γ_{UL} is a polarization correlation matrix,
- P_{UL} is a permutation matrix, and
- $(\bullet)^T$ denotes transpose.

Table C.2.4.3.2-1 defines the polarization correlation matrix.

Table C.2.4.3.2-1: Polarization correlation matrix

	One TX antenna	Multiple TX antennas
Polarization correlation matrix	$\Gamma_{UL} = \begin{bmatrix} 1 & -\gamma \\ -\gamma & 1 \end{bmatrix}$	$\Gamma_{UL} = \begin{bmatrix} 1 & -\gamma & 0 & 0 \\ -\gamma & 1 & 0 & 0 \\ 0 & 0 & 1 & \gamma \\ 0 & 0 & \gamma & 1 \end{bmatrix}$

The matrix P_{UL} is defined as

$$P_{UL}(a,b) = \begin{cases} 1 & \text{for } a = (j-1)Nr + i \text{ and } b = 2(j-1)Nr + i, & i = 1, \dots, Nr, j = 1, \dots, \lceil Nt/2 \rceil \\ 1 & \text{for } a = (j-1)Nr + i \text{ and } b = 2(j - Nt/2)Nr - Nr + i, & i = 1, \dots, Nr, j = \lceil Nt/2 \rceil + 1, \dots, Nt \\ 0 & \text{otherwise} \end{cases}$$

where Nt and Nr is the number of TX and RX antennas respectively, and $\lceil \bullet \rceil$ is the ceiling operator.

The matrix P_{UL} is used to map the spatial correlation coefficients in accordance with the antenna element labelling system described in C.2.4.3.

C.2.4.3.3 Spatial correlation matrices at NCR-MT and gNB sides

C.2.4.3.3.1 Spatial correlation matrices at NCR-MT side

In this subclause, R_{UE} refers to an NCR-MT for NCR-MT requirements.

For 2-antenna receiver using one pair of cross-polarized antenna elements, $R_{UE} = 1$.

For 4-antenna receiver using two pairs of cross-polarized antenna elements, $R_{UE} = \begin{pmatrix} 1 & \beta \\ \beta^* & 1 \end{pmatrix}$.

C.2.4.3.3.2 Spatial correlation matrices at gNB side

In this subclause, R_{gNB} refers to a gNB for NCR-MT requirements.

For 1-antenna transmitter, $R_{gNB} = 1$.

For 2-antenna transmitter using one pair of cross-polarized antenna elements, $R_{gNB} = 1$.

C.2.4.3.4 MIMO correlation matrices using cross polarized antennas

The values for parameters α , β and γ for low spatial correlation are given in table C.2.4.3.4-1.

Table C.2.4.3.4-1: Values for parameters α , β and γ

Low spatial correlation		
α	β	γ
0	0	0
NOTE 1: Value of α applies when more than one pair of cross-polarized antenna elements at gNB side. NOTE 2: Value of β applies when more than one pair of cross-polarized antenna elements at NCR-MT side.		

C.2.4.3.5 Beam steering approach

For the 2D cross-polarized antenna array at gNB, given the channel spatial correlation matrix in C.2.4.3.2, C.2.4.3.3 and C.2.4.3.4, the corresponding random channel matrix H can be calculated. The signal model for the k -th slot is denoted as

$$y = HD_{\theta_{k,1}, \theta_{k,2}} Wx + n$$

And the steering matrix is further expressed as following:

$$D_{\theta_{k,1}, \theta_{k,2}} = \begin{bmatrix} 1 & 0 \\ 0 & 1 \end{bmatrix} \otimes (D_{\theta_{k,1}}(N_1) \otimes D_{\theta_{k,2}}(N_2))$$

where

- H is the $N_r \times N_t$ channel matrix per subcarrier.
- $D_{\theta_{k,1}, \theta_{k,2}}$ is the steering matrix,
- $D_{\theta_{k,1}}(N_1)$ is the steering matrix in first dimension with same polarization,
- $D_{\theta_{k,2}}(N_2)$ is the steering matrix in second dimension with same polarization,
- N_1 is the number of antenna elements in first dimension with same polarization,
- N_2 is the number of antenna elements in second dimension with same polarization,
- For antenna array with only one direction, number of antenna element in second direction N_2 equals 1.

For 1 antenna element with the same polarization in one direction,

$$D_{\theta_{k,i}}(1) = 1$$

For 2 antenna elements with the same polarization in one direction,

$$D_{\theta_{k,i}}(2) = \begin{bmatrix} 1 & 0 \\ 0 & e^{j3\theta_{k,i}} \end{bmatrix}$$

where the index $i=1,2$ stands for first dimension and second dimension respectively.

- $\theta_{k,i}$ controls the phase variation in first dimension and second dimension respectively, and the phase for k-th subframe is denoted by $\theta_{k,i} = \theta_{0,i} + \Delta\theta k$, where $\theta_{0,i}$ is the random start value with the uniform distribution, i.e., $\theta_{0,i} \in [0, 2\pi]$, $\Delta\theta$ is the step of phase variation, which is defined in Table C.2.4.3.5-1, and k is the linear increment of $2^{-\mu}$ for every slot throughout the simulation, the index $i=1,2$ stands for first dimension and second dimension respectively.
- W is the precoding matrix for N_t transmission antennas,
- y is the received signal, x is the transmitted signal, and n is AWGN.
- μ corresponds to subcarrier spacing configuration, $\Delta f = 2^{\mu} \cdot 15$ [kHz]

For the 1D cross-polarized antenna array at gNB, the corresponding random channel matrix H can be calculated by letting $N_2=1$, i.e.,

$$D_{\theta_{k,i}} = \begin{bmatrix} 1 & 0 \\ 0 & 1 \end{bmatrix} \otimes D_{\theta_{k,i}}(N_1)$$

Table C.2.4.3.5-1: The step of phase variation

Variation Step	Value (rad/ms)
$\Delta\theta$	1.2566×10^{-3}

C.3 Physical signals, channels mapping and precoding

C.3.1 General

Unless otherwise stated, the transmission on antenna port(s) $p = p_0, p_0 + 1, \dots, p_0 + N_p - 1$ is defined by using a precoder matrix $W(i)$ of size $N_{ANT} \times N_p$, where N_{ANT} is the number of physical transmit antenna elements configured per test, N_p is the number of ports for a reference signal or physical channel configured per test, and p_0 is the first port for that reference signal or physical channel as defined in clauses 7.3 and 7.4 in TS 38.211 [21]. This precoder takes as an input a block of signals for antenna port(s) $p = p_0, p_0 + 1, \dots, p_0 + N_p - 1$, $y^{(p)}(i) =$

$[y^{(p_0)}(i) \ y^{(p_0+1)}(i) \ \dots \ y^{(p_0+N_p-1)}(i)]^T$, $i = 0, 1, \dots, M_{\text{symb}}^{\text{ap}} - 1$, with $M_{\text{symb}}^{\text{ap}}$ being the number of modulation symbols

per antenna port including the reference signal symbols, and generates a block of signals $y_{bf}^{(q)}(i) =$

$[y_{bf}^{(0)}(i) \ y_{bf}^{(1)}(i) \ \dots \ y_{bf}^{(N_{ANT}-1)}(i)]^T$ the elements of which are to be mapped onto the frequency-time index pair (k, l) as per the test configuration but transmitted on different physical antenna elements:

$$y_{bf}^{(q)}(i) = W(i)y^{(p)}(i)$$

For Clause 8.2.3 and 9.4.1, the transmission of PDCCH and PDCCH DMRS on antenna port $p = p_0$ is defined by using a precoder matrix $W(i)$ of size 2×1 . This precoder takes as an input a block of signals for antenna port(s) $p = p_0$,

$y^{(p)}(i) = y^{(p_0)}(i)$ and generates a block of signals $y_{bf}^{(q)}(i) = \left[y_{bf}^{(0)}(i) \ y_{bf}^{(\frac{N_{ANT}}{2})}(i) \right]^T$ the elements of which are to be

mapped onto the frequency-time index pair (k, l) as per the test configuration but transmitted on different physical antenna elements:

$$y_{bf}^{(q)}(i) = W(i)y^{(p)}(i)$$

The precoder matrix $W(i)$ is specific to the test case configuration. $W(i)$ is defined in Clause 5.2.2.2 of TS 38.214 [28].

The transmission on PT-RS antenna port is associated (using same precoder) with the lowest indexed DM-RS antenna port among the DM-RS antenna ports assigned for the PDSCH.

The physical antenna elements are identified by indices $j = 0, 1, \dots, N_{ANT} - 1$, where N_{ANT} is the number of physical antenna elements configured per test.

Modulation symbols $y^{(p)}(i)$ with $p \in \{4000\}$ (i.e. PSS, SSS, PBCH and DM-RS for PBCH) are directly mapped to first physical antenna element.

Modulation symbols $a_{k,l}$ for CSI-RS resources which configured for tracking with one port are directly mapped to first physical antenna element.

Modulation symbols $a_{k,l}$ for CSI-RS resources which configured for beam refinement with one port are directly mapped to first physical antenna element.

Modulation symbols $a_{k,l}^{(p)}$ for NZP CSI-RS which configured for CSI acquisition with

$p \in \{p_0, p_0 + 1, \dots, p_0 + N_{CSI} - 1\}$ are mapped to the physical antenna index $j = p - p_0$ where N_{CSI} is the number of NZP CSI-RS ports configured per test.

Annex D: Void

Annex E: Void

Annex F: Void

Annex G (normative): NCR-MT RRM Testing

The test cases defined in this Annex are to verify the minimum requirements defined in clause 12. The conducted tests are performed for NCR type 1-H, and the over the air (OTA) tests are performed for NCR type 2-O, where the conducted and radiated reference points and the NCR type are defined in clause 4.3. For the test cases for NCR-MT, the DU part is disabled during the testing. The test cases apply for Local-area NCR-MT classes, where the NCR-MT classes are defined in clause 4.4.

The test configurations and procedures are defined in following clauses and in each test cases. The test requirements are derived using the corresponding configuration parameters as example. The actual NCR-MT RRM test can be conducted by any set of configuration parameters which are left to implementations and manufacturer declarations and the corresponding test requirements shall be based on the actual configuration parameters used in the test. For example, TDD pattern and related configurations shall be configurable and left for implementation and declaration including:

- DL/UL scheduling related configuration
- PRACH configuration
- SRS configuration
- SSB configuration
- CSI-RS configuration
- BWP configuration
- SMTC configuration
- TCI state configuration
- Antenna configuration
- AoA configuration

G.1 NCR-MT RRM test configurations

G.1.1 Reference measurement channels

G.1.1.1 PDSCH

G.1.1.1.1 TDD

Table G.1.1.1.1-1: PDSCH Reference Measurement Channels for SCS=15kHz

Parameter	Unit	Value						
Reference channel		SR.1.1 TDD						
Channel bandwidth	MHz	10						
Number of transmitter antennas		1						
Allocated resource blocks for PDSCH ^{Note 1}		24						
Allocated slots per Radio Frame								
Radio frame containing SSB	slots	Note 5						
Radio frame not containing SSB	slots	4						
MCS table		64QAM						
MCS index		4						
Modulation		QPSK						
Target Coding Rate		1/3						
Number of control symbols		2						
PDSCH mapping type		Type A						
Information Bit Payload								
For slots with RMSI ^{Note 2}	bits	1608						
For slots without RMSI	bits	1864						
Number of Code Blocks per slot		1						
Binary Channel Bits Per slot								
For slots with RMSI ^{Note 2, Note 4}	bits	5184						
For slots without RMSI ^{Note 6}	bits	6048						
<p>Note 1: Allocated outside the SMTC duration in time and in resource blocks which do not overlap with the resource blocks allocated for SS/PBCH block.</p> <p>Note 2: PDSCH is scheduled on the slots with RMSI.</p> <p>Note 3: If necessary the information bit payload size can be adjusted to facilitate the test implementation. The payload sizes are defined in TS 38.213 [3].</p> <p>Note 4: Derived based on the PDSCH DMRS assumption: dmrs-TypeA-Position=2, dmrs-Type=1, dmrs-AdditionalPositions=2, maxLength=1, Antenna port index: 1000, and Number of PDSCH DMRS CDM group(s) without data: 2.</p> <p>Note 5: PDSCH is not scheduled in slots containing SSB according to the SSB configuration used in the test. SSB configurations are defined in clause G.1.5.</p> <p>Note 6: Derived based on the PDSCH DMRS assumption: dmrs-TypeA-Position=2, dmrs-Type=1, dmrs-AdditionalPositions=2, maxLength=1, Antenna port index: 1000, and Number of PDSCH DMRS CDM group(s) without data: 1.</p>								

Table G.1.1.1.1-2: PDSCH Reference Measurement Channels for SCS=30kHz

Parameter	Unit	Value					
Reference channel		SR.2.1 TDD					
Channel bandwidth	MHz	40					
Number of transmitter antennas		1					
Allocated resource blocks for PDSCH ^{Note 1}		24					
Allocated slots per Radio Frame							
Radio frame containing SSB	slots	Note 5					
Radio frame not containing SSB	slots	10					
MCS table		64QAM					
MCS index		4					
Modulation		QPSK					
Target Coding Rate		1/3					
Number of control symbols		2					
PDSCH mapping type		Type A					
Information Bit Payload							
For slots with RMSI ^{Note 2}	bits	1608					
For slots without RMSI	bits	1864					
Number of Code Blocks per slot		1					
Binary Channel Bits Per slot							
For slots with RMSI ^{Note 2, Note 4}	bits	5184					
For slots without RMSI ^{Note 6}	bits	6048					
<p>Note 1: Allocated outside the SMTC duration in time and in resource blocks which do not overlap with the resource blocks allocated for SS/PBCH block.</p> <p>Note 2: PDSCH is scheduled on the slots with RMSI.</p> <p>Note 3: If necessary the information bit payload size can be adjusted to facilitate the test implementation. The payload sizes are defined in TS 38.213 [3].</p> <p>Note 4: Derived based on the PDSCH DMRS assumption: dmrs-TypeA-Position=2, dmrs-Type=1, dmrs-AdditionalPositions=2, maxLength=1, Antenna port index: 1000, and Number of PDSCH DMRS CDM group(s) without data: 2.</p> <p>Note 5: PDSCH is not scheduled in slots containing SSB according to the SSB configuration used in the test. SSB configurations are defined in clause G.1.5.</p> <p>Note 6: Derived based on the PDSCH DMRS assumption: dmrs-TypeA-Position=2, dmrs-Type=1, dmrs-AdditionalPositions=2, maxLength=1, Antenna port index: 1000, and Number of PDSCH DMRS CDM group(s) without data: 1.</p>							

Table G.1.1.1.1-3: PDSCH Reference Measurement Channels for SCS=120kHz

Parameter	Unit	Value					
Reference channel		SR.3.1 TDD					
Channel bandwidth	MHz	100					
Number of transmitter antennas		1					
Allocated resource blocks for PDSCH ^{Note 1}		24					
Allocated slots per Radio Frame							
Radio frame containing SSB	slots	Note 5					
Radio frame not containing SSB	slots	48					
MCS table		64QAM					
MCS index		4					
Modulation		QPSK					
Target Coding Rate		1/3					
Number of control symbols		2					
PDSCH mapping type		Type A					
Information Bit Payload							
For slots with RMSI ^{Note 2}	bits	1608					
For slots without RMSI	bits	1864					
Number of Code Blocks per slot		1					
Binary Channel Bits Per slot							
For slots with RMSI ^{Note 2, Note 4}	bits	5184					
For slots without RMSI ^{Note 6}	bits	6048					
<p>Note 1: Allocated outside the SMTC duration in time and in resource blocks which do not overlap with the resource blocks allocated for SS/PBCH block</p> <p>Note 2: PDSCH is scheduled on the slots with RMSI.</p> <p>Note 3: If necessary the information bit payload size can be adjusted to facilitate the test implementation. The payload sizes are defined in TS 38.213 [3].</p> <p>Note 4: Derived based on the PDSCH DMRS assumption: dmrs-TypeA-Position=2, dmrs-Type=1, dmrs-AdditionalPositions=2, maxLength=1, Antenna port index: 1000, and Number of PDSCH DMRS CDM group(s) without data: 2.</p> <p>Note 5: PDSCH is not scheduled in slots containing SSB according to the SSB configuration used in the test. SSB configurations are defined in clause G.1.5.</p> <p>Note 6: Derived based on the PDSCH DMRS assumption: dmrs-TypeA-Position=2, dmrs-Type=1, dmrs-AdditionalPositions=2, maxLength=1, Antenna port index: 1000, and Number of PDSCH DMRS CDM group(s) without data: 1.</p>							

G.1.1.1.2 FDD

Table G.1.1.1.2-1: PDSCH Reference Measurement Channels for SCS=15kHz

Parameter	Unit	Value						
Reference channel		SR.1.1 FDD						
Channel bandwidth	MHz	10						
Number of transmitter antennas		1						
Allocated resource blocks for PDSCH ^{Note 1}		24						
Allocated slots per Radio Frame		10						
Radio frame containing SSB	slots	Note 5						
Radio frame not containing SSB	slots	10						
MCS index		4						
Modulation		QPSK						
Target Coding Rate		1/3						
Number of control symbols		2						
PDSCH mapping type		Type A						
Information Bit Payload								
For slots with RMSI ^{Note 2}	bits	1864						
Number of Code Blocks per slot		1						
Binary Channel Bits Per slot								
For slots with RMSI ^{Note 2, Note 4}	bits	6048						
<p>Note 1: Allocated outside the SMTC duration in time and in resource blocks which do not overlap with the resource blocks allocated for SS/PBCH block.</p> <p>Note 2: PDSCH is scheduled on the slots with RMSI.</p> <p>Note 3: If necessary the information bit payload size can be adjusted to facilitate the test implementation. The payload sizes are defined in TS 38.213 [3].</p> <p>Note 4: Derived based on the PDSCH DMRS assumption: dmrs-TypeA-Position=2, dmrs-Type=1, dmrs-AdditionalPositions=2, maxLength=1, Antenna port index: 1000, and Number of PDSCH DMRS CDM group(s) without data: 1.</p> <p>Note 5: PDSCH is not scheduled in slots containing SSB according to the SSB configuration used in the test. SSB configurations are defined in clause A.3.10.</p>								

G.1.1.2 CORESET for RMSI scheduling

G.1.1.2.1 TDD

Table G.1.1.2.1-1: RMSI CORESET Reference Channel for TDD with SCS=15KHz

Parameter	Unit	Value					
Reference channel		CR.1.1 TDD					
Channel bandwidth	MHz	10					
Subcarrier spacing	kHz	15					
Allocated resource blocks for RMSI CORESET ^{Note 7}		24					
SSB and RMSI CORESET multiplexing configuration ^{Note 7}		Pattern 1					
Offset between SSB and RMSI CORESET ^{Note 3, 7}	RB	0 (Note 8)					
Configuration of PDCCH monitoring occasions for RMSI CORESET ^{Note 4}		Index 4					
Number of transmitter antennas		1					
Duration of RMSI CORESET ^{Note 7}	symbols	2					
DCI Format ^{Note 1}		Note 2					
Aggregation level	CCE	8					
DMRS precoder granularity		6					
REG bundle size		6					
Mapping from REG to CCE		Distributed					
Cell ID		Note 5					
Payload (without CRC)	bits	Note 6					
<p>Note 1: DCI formats are defined in TS 38.212.</p> <p>Note 2: DCI format shall depend upon the test configuration.</p> <p>Note 3: The offset is defined with respect to the subcarrier spacing of the CORESET from the smallest RB index of RMSI CORESET to the smallest RB index of the common RB overlapping with the first RB of the SS/PBCH block.</p> <p>Note 4: The configuration of PDCCH monitoring occasions for RMSI CORESET is defined in Table 13-11 in TS 38.213 [3].</p> <p>Note 5: Cell ID shall depend upon the test configuration.</p> <p>Note 6: Payload size shall depend upon the test configuration.</p> <p>Note 7: The configuration of set of resource blocks and slot symbols of control resource set for Type0-PDCCH search space corresponds to index 0 in Table 13-1 in TS 38.213 [3].</p> <p>Note 8: Other values can be used to align with GSCN [13] as long as SSB does not overlap the RMC.</p>							

Table G.1.1.2.1-2: RMSI CORESET Reference Channel for TDD with SCS=30KHz

Parameter	Unit	Value					
Reference channel		CR.2.1 TDD					
Channel bandwidth	MHz	40					
Subcarrier spacing	kHz	30					
Allocated resource blocks for RMSI CORESET ^{Note 7}		24					
SSB and RMSI CORESET multiplexing configuration ^{Note 7}		Pattern 1					
Offset between SSB and RMSI CORESET ^{Note 3, 7}	RB	0 (Note 8)					
Configuration of PDCCH monitoring occasions for RMSI CORESET ^{Note 4}		Index 4					
Number of transmitter antennas		1					
Duration of RMSI CORESET ^{Note 7}	symbols	2					
DCI Format ^{Note 1}		Note 2					
Aggregation level	CCE	8					
DMRS precoder granularity		6					
REG bundle size		6					
Mapping from REG to CCE		Distributed					
Cell ID		Note 5					
Payload (without CRC)	bits	Note 6					
<p>Note 1: DCI formats are defined in TS 38.212.</p> <p>Note 2: DCI format shall depend upon the test configuration.</p> <p>Note 3: The offset is defined with respect to the subcarrier spacing of the CORESET from the smallest RB index of RMSI CORESET to the smallest RB index of the common RB overlapping with the first RB of the SS/PBCH block.</p> <p>Note 4: The configuration of PDCCH monitoring occasions for RMSI CORESET is defined in Table 13-11 in TS 38.213 [3].</p> <p>Note 5: Cell ID shall depend upon the test configuration.</p> <p>Note 6: Payload size shall depend upon the test configuration.</p> <p>Note 7: The configuration of set of resource blocks and slot symbols of control resource set for Type0-PDCCH search space corresponds to index 0 in Table 13-6 in TS 38.213 [3].</p> <p>Note 8: Other values can be used to align with GSCN [13] as long as SSB does not overlap the RMC.</p>							

Table G.1.1.2.1-3: RMSI CORESET Reference Channel for TDD with SCS=120KHz

Parameter	Unit	Value					
Reference channel		CR.3.1 TDD					
Channel bandwidth	MHz	100					
Subcarrier spacing	kHz	120					
Allocated resource blocks for RMSI CORESET ^{Note 7}		24					
SSB and RMSI CORESET multiplexing configuration ^{Note 7}		Pattern 1					
Offset between SSB and RMSI CORESET ^{Note 3, 7}	RB	0 (Note 8)					
Configuration of PDCCH monitoring occasions for RMSI CORESET ^{Note 4}		Index 4					
Number of transmitter antennas		1					
Duration of RMSI CORESET ^{Note 7}	symbols	2					
DCI Format ^{Note 1}		Note 2					
Aggregation level	CCE	8					
DMRS precoder granularity		6					
REG bundle size		6					
Mapping from REG to CCE		Distributed					
Cell ID		Note 5					
Payload (without CRC)	bits	Note 6					
<p>Note 1: DCI formats are defined in TS 38.212.</p> <p>Note 2: DCI format shall depend upon the test configuration.</p> <p>Note 3: The offset is defined with respect to the subcarrier spacing of the CORESET from the smallest RB index of RMSI CORESET to the smallest RB index of the common RB overlapping with the first RB of the SS/PBCH block.</p> <p>Note 4: The configuration of PDCCH monitoring occasions for RMSI CORESET is defined in Table 13-12 in TS 38.213 [3].</p> <p>Note 5: Cell ID shall depend upon the test configuration.</p> <p>Note 6: Payload size shall depend upon the test configuration.</p> <p>Note 7: The configuration of set of resource blocks and slot symbols of control resource set for Type0-PDCCH search space corresponds to index 0 in Table 13-8 in TS 38.213 [3].</p> <p>Note 8: Other values can be used to align with GSCN [13] as long as SSB does not overlap the RMC.</p>							

G.1.1.2.2 FDD

Table G.1.1.2.2-1: RMSI CORESET Reference Channel for FDD with SCS=15KHz

Parameter	Unit	Value					
Reference channel		CR.1.1 FDD					
Channel bandwidth	MHz	10					
Subcarrier spacing for RMSI CORESET	kHz	15					
Allocated resource blocks for RMSI CORESET ^{Note 7}		24					
Subcarrier spacing for SSB	kHz	15					
SSB and RMSI CORESET multiplexing configuration ^{Note 7}		Pattern 1					
Offset between SSB and RMSI CORESET ^{Note 3, 7}	RB	0 (Note8)					
Configuration of PDCCH monitoring occasions for RMSI CORESET ^{Note 4}		Index 4					
Number of transmitter antennas		1					
Duration of RMSI CORESET ^{Note 7}	symbols	2					
DCI Format ^{Note 1}		Note 2					
Aggregation level	CCE	8					
DMRS precoder granularity		6					
REG bundle size		6					
Mapping from REG to CCE		Distributed					
Cell ID		Note 5					
Payload (without CRC)	bits	Note 6					
<p>Note 1: DCI formats are defined in TS 38.212.</p> <p>Note 2: DCI format shall depend upon the test configuration.</p> <p>Note 3: The offset is defined with respect to the subcarrier spacing of the CORESET from the smallest RB index of RMSI CORESET to the smallest RB index of the common RB overlapping with the first RB of the SS/PBCH block.</p> <p>Note 4: The configuration of PDCCH monitoring occasions for RMSI CORESET is defined in Table 13-11 in TS 38.213 [3].</p> <p>Note 5: Cell ID shall depend upon the test configuration.</p> <p>Note 6: Payload size shall depend upon the test configuration.</p> <p>Note 7: The configuration of set of resource blocks and slot symbols of control resource set for Type0-PDCCH search space corresponds to index 0 in Table 13-1 in TS 38.213 [3]</p> <p>Note 8: Other values can be used to align with GSCN [13] as long as SSB does not overlap the RMC.</p>							

G.1.1.3 CORESET for RMC scheduling

G.1.1.3.1 TDD

Table G.1.1.3.1-1: Control Channel RMC for TDD with SCS=15KHz

Parameter	Unit	Value					
Reference channel		CCR.1.1 TDD	CCR.1.2 TDD				
Subcarrier spacing	kHz	15	15				
Allocated resource blocks for CORESET ^{Note 3}		24	18				
Number of transmitter antennas		1	1				
Duration of CORESET	symbols	2	2				
REG bundle size		6	6				
DMRS precoder granularity		Same as REG bundle size	Same as REG bundle size				
CCE to REG mapping		Interleaved	Interleaved				
Interleave n_shift		0	0				
Interleave size		2	2				
Beamforming Pre-Coder		N/A	N/A				
Aggregation level	CCE	8	4				
DCI formats		Note 1	Note 1				
Payload size (without CRC)	bits	Note 2	Note 2				
Note 1: DCI format shall depend upon the test configuration. Note 2: Payload size shall depend upon the test configuration Note 3: Allocated in the resource blocks where the associated RMC is scheduled.							

Table G.1.1.3.1-2: Control Channel RMC for TDD with SCS=30KHz

Parameter	Unit	Value					
Reference channel		CCR.2.1 TDD					
Subcarrier spacing	kHz	30					
Allocated resource blocks for CORESET ^{Note 3}		24					
Number of transmitter antennas		1					
Duration of CORESET	symbols	2					
REG bundle size		6					
DMRS precoder granularity		Same as REG bundle size					
CCE to REG mapping		Interleaved					
Interleave n_shift		0					
Interleave size		2					
Beamforming Pre-Coder		N/A					
Aggregation level	CCE	8					
DCI formats		Note 1					
Payload size (without CRC)	bits	Note 2					
Note 1: DCI format shall depend upon the test configuration. Note 2: Payload size shall depend upon the test configuration. Note 3: Allocated in the same resource blocks where the associated RMC is scheduled.							

Table G.1.1.3.1-3: Control Channel RMC for TDD with SCS=120KHz

Parameter	Unit	Value					
		CCR.3.1 TDD	CCR.3.2 TDD	CCR.3.3 TDD			
Reference channel		CCR.3.1 TDD	CCR.3.2 TDD	CCR.3.3 TDD			
Subcarrier spacing	kHz	120	120	120			
Allocated resource blocks for CORESET <small>Note 3</small>		24	24	24			
Number of transmitter antennas		1	1	1			
monitoringSlotPeriodicityAndOffset		sl160 0	sl160 0	sl160 80			
monitoringSymbolsWithinSlot		1100000 0000000	0011000 0000000	1100000 0000000			
Duration of CORESET	slot	1	1	1			
REG bundle size		6	6	6			
DMRS precoder granularity		Same as REG bundle size	Same as REG bundle size	Same as REG bundle size			
CCE to REG mapping		Interleaved	Interleaved	Interleaved			
Interleave n_shift		0	0	0			
Interleave size		2	2	2			
Beamforming Pre-Coder		N/A	N/A	N/A			
Aggregation level	CCE	8	8	8			
DCI formats		Note 1	Note 1	Note 1			
Payload size (without CRC)	bits	Note 2	Note 2	Note 2			
Note 1: DCI format shall depend upon the test configuration. Note 2: Payload size shall depend upon the test configuration. Note 3: Allocated in the same resource blocks where the associated PDSCH RMC is scheduled.							

G.1.1.3.2 FDD**Table G.1.1.3.2-1: Control Channel RMC for FDD with SCS=15KHz**

Parameter	Unit	Value					
		CCR.1.1 FDD	CCR.1.2 FDD				
Reference channel		CCR.1.1 FDD	CCR.1.2 FDD				
Channel bandwidth	MHz	10	10				
Subcarrier spacing	kHz	15	15				
Allocated resource blocks for CORESET <small>Note 3</small>		24	18				
Number of transmitter antennas		1	1				
Duration of CORESET	symbols	2	2				
REG bundle size		6	6				
DMRS precoder granularity		Same as REG bundle size	Same as REG bundle size				
CCE to REG mapping		Interleaved	Interleaved				
Interleave n_shift		0	0				
Interleave size		2	2				
Beamforming Pre-Coder		N/A	N/A				
Aggregation level	CCE	4	2				
DCI formats		Note 1	Note 1				
Payload size (without CRC)	bits	Note 2	Note 2				
Note 1: DCI format shall depend upon the test configuration. Note 2: Payload size shall depend upon the test configuration Note 3: Allocated in the resource blocks where the associated RMC is scheduled.							

G.1.2 OFDMA channel noise generator (OCNG)

G.1.2.1 Generic OFDMA Channel Noise Generator (OCNG)

The OCNG pattern is used in a test for modelling allocations of unused resources in the channel bandwidth to virtual NCR-MTs (which are not under test). The OCNG pattern comprises PDCCH and PDSCH transmissions to the virtual NCR-MTs.

G.1.2.1.1 OCNG pattern 1: Generic OCNG pattern for all unused REs

Table G.1.2.1.1-1: OP.1: Generic OCNG pattern for all unused REs

OCNG Parameters	Control Region	Data Region
Resource allocation	Unused REs (Note 1)	Unused REs (Note 2)
Channel	PDCCH	PDSCH
Contents	Virtual NCR-MT IDs	Uncorrelated pseudo random QPSK modulated data
Antenna transmission scheme	Same as used in PDCCH RMC	Same as used in PDSCH RMC
Subcarrier spacing	Same as used in PDCCH RMC	Same as used in PDSCH RMC
Aggregation level	Same as used in PDCCH RMC	N/A
Code rate	Same as used in PDCCH RMC	Same as used in PDSCH RMC
Transmit Power	Same as used in PDCCH RMC	Same as used in PDSCH RMC
CP length	Same as used in PDCCH RMC	Same as used in PDSCH RMC
Note 1:	REs not used in the active CORESETs where PDCCH is scheduled for the NCR-MT under test.	
Note 2:	REs not allocated to any physical channels, CORESET, SSB or any other reference signal within the channel bandwidth of the cell.	

G.1.2.1.2 OCNG pattern 2: Generic OCNG pattern for all unused REs for 2AoA setup

Table G.1.2.1.2-1: OP.2: Generic OCNG pattern for all unused REs for 2AoA setup

OCNG Parameters	Control Region	Data Region
Probe	Transmitting the serving beam	
Resource allocation	Unused REs (Note 1) in the symbols where SSB/CSI-RS are not transmitted from both the serving beam probe and non-serving beam probe.	Unused REs (Note 2) in the symbols where SSB/CSI-RS are not transmitted from both the serving beam probe and non-serving beam probe.
Channel	PDCCH	PDSCH
Contents	Virtual NCR-MT IDs	Uncorrelated pseudo random QPSK modulated data
Antenna transmission scheme	Same as used in PDCCH RMC	Same as used in PDSCH RMC
Subcarrier spacing	Same as used in PDCCH RMC	Same as used in PDSCH RMC
Aggregation level	Same as used in PDCCH RMC	N/A
Code rate	Same as used in PDCCH RMC	Same as used in PDSCH RMC
Transmit Power	Same as used in PDCCH RMC	Same as used in PDSCH RMC
CP length	Same as used in PDCCH RMC	Same as used in PDSCH RMC
Note 1:	REs not used in the active CORESETs where PDCCH is scheduled for the NCR-MT under test.	
Note 2:	REs not allocated to any physical channels, CORESET, SSB or any other reference signal within the channel bandwidth of the cell.	
Note 3:	No OCNG is transmitted from the probe transmitting non-serving beam.	

G.1.2.1.3 OCNG pattern 3: Generic OCNG pattern for unused REs in the same bandwidth as PDSCH RMC

Table G.1.2.1.3-1: OP.3: Generic OCNG pattern for unused REs in the same BW as RMC

OCNG Parameters	Control Region	Data Region
Resource allocation	Unused REs (Note 1)	Unused REs (Note 2)
Channel	PDCCH	PDSCH
Contents	Virtual NCR-MT IDs	Uncorrelated pseudo random QPSK modulated data
Antenna transmission scheme	Same as used in PDCCH RMC	Same as used in PDSCH RMC
Subcarrier spacing	Same as used in PDCCH RMC	Same as used in PDSCH RMC
Aggregation level	Same as used in PDCCH RMC	N/A
Code rate	Same as used in PDCCH RMC	Same as used in PDSCH RMC
Transmit Power	Same as used in PDCCH RMC	Same as used in PDSCH RMC
CP length	Same as used in PDCCH RMC	Same as used in PDSCH RMC
Note 1:	REs not used in the active CORESETs where PDCCH is scheduled for the NCR-MT under test. REs for OCNG shall not be allocated outside the allocated bandwidth of the PDSCH RMC of the serving cell.	
Note 2:	REs not allocated to any physical channels, CORESET, SSB or any other reference signal within the allocated bandwidth of the PDSCH RMC of the serving cell. REs for OCNG shall not be allocated outside the allocated bandwidth of the PDSCH RMC of the serving cell.	

G.1.2.1.4 OCNG pattern 4: Generic OCNG pattern for all unused REs outside SSB slot(s)

Table G.1.2.1.4-1: OP.4: Generic OCNG pattern for all unused REs outside SSB slot(s)

OCNG Parameters	Control Region	Data Region
Resource allocation	Unused REs (Note 1)	Unused REs (Note 2)
Channel	PDCCH	PDSCH
Contents	Virtual NCR-MT IDs	Uncorrelated pseudo random QPSK modulated data
Antenna transmission scheme	Same as used in PDCCH RMC	Same as used in PDSCH RMC
Subcarrier spacing	Same as used in PDCCH RMC	Same as used in PDSCH RMC
Aggregation level	Same as used in PDCCH RMC	N/A
Code rate	Same as used in PDCCH RMC	Same as used in PDSCH RMC
Transmit Power	Same as used in PDCCH RMC	Same as used in PDSCH RMC
CP length	Same as used in PDCCH RMC	Same as used in PDSCH RMC
Note 1:	REs not used in the active CORESETs where PDCCH is scheduled for the NCR-MT under test. REs for OCNG shall not be allocated in the slot(s) containing SSB of the respective cell.	
Note 2:	REs not allocated to any physical channels, CORESET, SSB or any other reference signal within the channel bandwidth of the cell. REs for OCNG shall not be allocated in the slot(s) containing SSB of the respective cell.	

G.1.3 Antenna configurations

G.1.3.1 Antenna configurations for FR1

Unless otherwise specified, NR TDD cells in all RRM Test cases in AWGN propagation condition are configured with Antenna Configuration [1x2].

G.1.3.1.1 Antenna connection for 4 Rx capable NCR-MT

G.1.3.1.1.1 Introduction

All tests for FR1 are specified for NCR-MTs supporting 2RX. In this clause, the antenna connection method for applying 2RX tests to NCR-MTs supporting 4RX antenna ports is specified. No tests are currently specified for FR1

which are applicable only to 4RX antenna ports, so 4RX capable NCR-MTs are always tested by reusing tests which were originally specified for 2RX NCR-MTs.

G.1.3.1.1.2 Principle of testing

G.1.3.1.1.2.1 Single carrier tests

For 4RX capable NCR-MTs supporting at least one 2RX band, the, all single carrier tests specified for FR1 except those in G.2.3 shall be tested on any band where 2RX is supported with the antenna connection specified in clause G.1.3.1.1.2.2.

For 4RX capable NCR-MT which do not support any 2RX band, all tests specified for FR1 shall be tested using the antenna connection specified in clause G.1.3.1.1.2.3. For radio link monitoring tests, the SNR levels are modified according to table G.1.3.1.1.2.1-1 and table G.1.3.1.1.2.1-2. For beam failure detection and link recovery tests, the SNR levels are modified according to table G.1.3.1.1.2.1-3.

Table G.1.3.1.1.2.1-1: Modified parameters for RLM out of sync testing with 4 RX antenna connection

Test case	SNR during T3 (dB)			
	Test 1	Test 2	Test 3	Test 4
G.2.3.1.1	-18	N/A	N/A	N/A
G.2.3.1.3	-18	N/A	N/A	N/A
G.2.3.1.5	-18	N/A	N/A	N/A
G.2.3.1.7	-18	N/A	N/A	N/A

Table G.1.3.1.1.2.1-2: Modified parameters for RLM in sync single carrier testing with 4 RX antenna connection

Test case	SNR during T3 (dB)		SNR during T4 (dB)	
	Test 1	Test 2	Test 1	Test 2
G.2.3.1.2	-18	N/A	-8	N/A
G.2.3.1.4	-18	N/A	-8	N/A
G.2.3.1.6	-18	N/A	-8	N/A
G.2.3.1.8	-18	N/A	-8	N/A

Table G.1.3.1.1.2.1-3: Modified parameters for Beam Failure Detection and Link Recovery testing with 4 RX antenna connection

Test case	SNR for RS in set q_0 during T3, T4 and T5 (dB)
	Test 1
G.2.3.2.1	-15
G.2.3.2.2	-15
G.2.3.2.3	-15
G.2.3.2.4	-15

G.1.3.1.1.2.2 Antenna connection for bands where 2RX is supported

For bands where 2RX is supported, it is left to declaration and AP configuration to decide which 2 of the 4 Rx ports are connected with data source from tester. The remaining 2 Rx ports shall be connected with zero input. No test parameters or requirements are modified.

G.1.3.1.1.2.3 Antenna connection for bands where 4RX is supported

For bands where 4RX is supported, all 4 RX antennas are connected with data source from tester. The Tester provide independent noise and fading (low correlation) for each antenna port. Except for the modifications to radio link monitoring thresholds described in clauses G.1.3.1.1.2.1 and G.1.3.1.1.2.2, no test parameters or requirements are modified.

G.1.3.2 Antenna configurations for FR2

Unless otherwise specified, the default Downlink Antenna Configuration for NR FR2 cells is 1x2.

In case of Downlink Antenna Configuration 2x2 for NR FR2 cells, unless otherwise specified, the downlink signal is transmitted over the two polarizations (V and H) of the dual polarized antenna of the test equipment.

G.1.4 BWP configurations

G.1.4.1 Introduction

This clause provides the typical BWP configurations used for RRM test cases defined in Annex G. For downlink BWP, both initial BWP and dedicated BWP configurations are specified in clause G.1.4.2 and for uplink BWP, both initial BWP and dedicated BWP configurations are specified in clause G.1.4.3.

G.1.4.2 Downlink BWP configurations

G.1.4.2.1 Initial BWP

Table G.1.4.2.1-1: Downlink BWP patterns for initial BWP configuration

BWP Parameters	Unit	Values		
		DLBWP.0.1	DLBWP.0.2	
Reference BWP		DLBWP.0.1	DLBWP.0.2	
Starting PRB index		0	RB _a ^{Note 1}	
Bandwidth	RB	Same as RF channel defined in each test	same as RMSI CORESET (CORESET #0) defined in each test	
Note 1: RB _a is the lowest PRB index to guarantee the BWP including SSB PRB index (RB _J , RB _{J+1} ,..., RB _{J+19}) which is defined in Clause G.1.5.				

G.1.4.2.2 Dedicated BWP

Table G.1.4.2.2-1: Downlink BWP patterns for dedicated BWP configuration

BWP Parameters	Unit	Values		
		DLBWP.1.1	DLBWP.1.2	DLBWP.1.3
Reference BWP		DLBWP.1.1	DLBWP.1.2	DLBWP.1.3
Starting PRB index		0	RB _b ^{Note 1}	RB _a ^{Note 2}
Bandwidth	RB	Same as RF channel defined in each test	25 for SCS = 15KHz, 51 for SCS = 30KHz, 32 for SCS = 120KHz	25 for SCS = 15KHz, 51 for SCS = 30KHz, 32 for SCS = 120KHz
Note 1: RB _b is the lowest PRB index to guarantee the BWP not fully overlapped with SSB PRB index (RB _J , RB _{J+1} ,..., RB _{J+19}) which is defined in Clause G.1.5.				
Note 2: RB _a is the lowest PRB index to guarantee the BWP including SSB PRB index (RB _J , RB _{J+1} ,..., RB _{J+19}) which is defined in Clause G.1.5.				

G.1.4.3 Uplink BWP configurations

G.1.4.3.1 Initial BWP

Table G.1.4.3.1-1: Uplink BWP patterns for initial BWP configuration

BWP Parameters	Unit	Values		
Reference BWP		ULBWP.0.1	ULBWP.0.2	
Starting PRB index		0	RB _a ^{Note 1}	
Bandwidth	RB	Same as RF channel defined in each test	same as RMSI CORESET (CORESET #0) defined in each test	
Note 1: RB _a is same as RB _a for DLBWP.0.2 as defined in Table G.1.4.2.1-1.				

G.1.4.3.2 Dedicated BWP

Table G.1.4.3.2-1: Uplink BWP patterns for dedicated BWP configuration

BWP Parameters	Unit	Values		
Reference BWP		ULBWP.1.1	ULBWP.1.2	ULBWP.1.3
Starting PRB index		0	RB _b ^{Note 1}	RB _a ^{Note 2}
Bandwidth	RB	Same as RF channel defined in each test	25 for SCS = 15KHz, 51 for SCS = 30KHz, 32 for SCS = 120KHz	25 for SCS = 15KHz, 51 for SCS = 30KHz, 32 for SCS = 120KHz
Note 1: RB _b is same as RB _b for DLBWP.1.2 as defined in Table G.1.4.2.2-1.				
Note 2: RB _a is same as RB _a for DLBWP.1.3 as defined in Table G.1.4.2.2-1.				

G.1.5 SSB Configurations

G.1.5.1 SSB Configurations for FR1

G.1.5.1.1 SSB pattern 1 in FR1: SSB allocation for SSB SCS=15 kHz

Table G.1.5.1.1-1: SSB.1 FR1: SSB Pattern 1 for SSB SCS=15 kHz in 10 MHz channel

SSB Parameters	Values
SSB SCS	15 kHz
SSB periodicity (T _{SSB})	20 ms
Number of SSBs per SS-burst	1
SS/PBCH block index	0
Symbol numbers containing SSB ^{Note 2}	2-5
Slot numbers containing SSB ^{Note 2}	0
SFN containing SSB	SFN mod (max(T _{SSB} , 10ms)/10ms) = 0
RB numbers containing SSB within channel BW	(RB _J , RB _{J+1} , ..., RB _{J+19}) ^{Note 1}
Note 1: RBs containing SSB can be configured in any frequency location within the cell bandwidth according to the allowed synchronization raster defined in clause 5.4.3	
Note 2: These values have been derived from other parameters for information purposes (as per TS 38.213 [3]). They are not settable parameters themselves.	

G.1.5.1.2 SSB pattern 2 in FR1: SSB allocation for SSB SCS=30 kHz

Table G.1.5.1.2-1: SSB.2 FR1: SSB Pattern 2 for SSB SCS=30 kHz

SSB Parameters	Values
SSB SCS	30 kHz
SSB periodicity (T_{SSB})	20 ms
Number of SSBs per SS-burst	1
SS/PBCH block index	0
Symbol numbers containing SSB ^{Note 3}	4-7 or 2-5 ^{Note 2}
Slot numbers containing SSB ^{Note 3}	0
SFN containing SSB	SFN mod ($\max(T_{SSB}, 10\text{ms})/10\text{ms}$) = 0
RB numbers containing SSB within channel BW	($RB_J, RB_{J+1}, \dots, RB_{J+19}$) ^{Note 1}
Note 1:	RBs containing SSB can be configured in any frequency location within the cell bandwidth according to the allowed synchronization raster defined in clause 5.4.3
Note 2:	Symbols 4-7 is chosen, if the SSB pattern Case B should be used for the current band as define in clause 5.4.3; Otherwise, symbol 2-5 is chosen.
Note 3:	These values have been derived from other parameters for information purposes (as per TS 38.213 [3]). They are not settable parameters themselves

G.1.5.1.3 SSB pattern 3 in FR1: SSB allocation for SSB SCS=15 kHz

Table G.1.5.1.3-1: SSB.3 FR1: SSB Pattern 3 for SSB SCS=15 kHz

SSB Parameters	Values	
SSB SCS	15 kHz	
SSB periodicity (T_{SSB})	20 ms	
Number of SSBs per SS-burst	2	
SS/PBCH block index	0	1
Symbol numbers containing SSB ^{Note 2}	2-5	8-11
Slot numbers containing SSB ^{Note 2}	0	0
SFN containing SSB	SFN mod ($\max(T_{SSB}, 10\text{ms})/10\text{ms}$) = 0	
RB numbers containing SSB within channel BW	($RB_J, RB_{J+1}, \dots, RB_{J+19}$) ^{Note 1}	
Note 1:	RBs containing SSB can be configured in any frequency location within the cell bandwidth according to the allowed synchronization raster defined in clause 5.4.3	
Note 2:	These values have been derived from other parameters for information purposes (as per TS 38.213 [3]). They are not settable parameters themselves.	

G.1.5.1.4 SSB pattern 4 in FR1: SSB allocation for SSB SCS=30 kHz

Table G.1.5.1.4-1: SSB.4 FR1: SSB Pattern 4 for SSB SCS=30 kHz

SSB Parameters	Values	
SSB SCS	30 kHz	
SSB periodicity (T_{SSB})	20 ms	
Number of SSBs per SS-burst	2	
SS/PBCH block index	0	1
Symbol numbers containing SSB ^{Note 3}	4-7 or 2-5 ^{Note 2}	8-11
Slot numbers containing SSB ^{Note 3}	0	0
SFN containing SSB	SFN mod ($\max(T_{SSB}, 10\text{ms})/10\text{ms}$) = 0	
RB numbers containing SSB within channel BW	$(RB_J, RB_{J+1}, \dots, RB_{J+19})$ ^{Note 1}	
Note 1:	RBs containing SSB can be configured in any frequency location within the cell bandwidth according to the allowed synchronization raster defined in clause 5.4.3.	
Note 2:	Symbols 4-7 is chosen, if the SSB pattern Case B should be used for the current band as defined in clause 5.4.3; Otherwise, symbol 2-5 is chosen.	
Note 3:	These values have been derived from other parameters for information purposes (as per TS 38.213 [3]). They are not settable parameters themselves.	

G.1.5.1.5 SSB pattern 5 in FR1: SSB allocation for SSB SCS=15 kHz starting from odd SFN

Table G.1.5.1.5-1: SSB.5 FR1: SSB Pattern 5 for SSB SCS=15 kHz

SSB Parameters	Values
SSB SCS	15 kHz
SSB periodicity (T_{SSB})	20 ms
Number of SSBs per SS-burst	1
SS/PBCH block index	0
Symbol numbers containing SSB ^{Note 2}	2-5
Slot numbers containing SSB ^{Note 2}	0
SFN containing SSB	SFN mod ($\max(T_{SSB}, 10\text{ms})/10\text{ms}$) = 1
RB numbers containing SSB within channel BW	$(RB_J, RB_{J+1}, \dots, RB_{J+19})$ ^{Note 1}
Note 1:	RBs containing SSB can be configured in any frequency location within the cell bandwidth according to the allowed synchronization raster defined in clause 5.4.3.
Note 2:	These values have been derived from other parameters for information purposes (as per TS 38.213 [3]). They are not settable parameters themselves.

G.1.5.1.6 SSB pattern 6 in FR1: SSB allocation for SSB SCS=30 kHz starting from odd SFN

Table G.1.5.1.6-1: SSB.6 FR1: SSB Pattern 6 for SSB SCS=30 kHz

SSB Parameters	Values
SSB SCS	30 kHz
SSB periodicity (T_{SSB})	20 ms
Number of SSBs per SS-burst	1
SS/PBCH block index	0
Symbol numbers containing SSB ^{Note 3}	4-7 or 2-5 ^{Note 2}
Slot numbers containing SSB ^{Note 3}	0
SFN containing SSB	SFN mod $(\max(T_{SSB}, 10\text{ms})/10\text{ms}) = 1$
RB numbers containing SSB within channel BW	$(RB_J, RB_{J+1}, \dots, RB_{J+19})^{\text{Note 1}}$
Note 1:	RBs containing SSB can be configured in any frequency location within the cell bandwidth according to the allowed synchronization raster defined in clause 5.4.3
Note 2:	Symbols 4-7 is chosen, if the SSB pattern Case B should be used for the current band as defined in clause 5.4.3; Otherwise, symbol 2-5 is chosen.
Note 3:	These values have been derived from other parameters for information purposes (as per TS 38.213 [3]). They are not settable parameters themselves.

G.1.5.2 SSB Configurations for FR2

G.1.5.2.1 SSB pattern 1 in FR2: SSB allocation for SSB SCS=120 kHz

Table G.1.5.2.1-1: SSB.1 FR2: SSB Pattern 1 for SSB SCS = 120 kHz with 2 SSBs per SS-burst

SSB Parameters	Values	
SSB SCS	120 kHz	
SSB periodicity (T_{SSB})	20 ms	
Number of SSBs per SS-burst	2	
SS/PBCH block index	0	1
Symbol numbers containing SSBs ^{Note 2}	4-7	8-11
Slot numbers containing SSB ^{Note 2}	0	0
SFN containing SSB	SFN mod $(\max(T_{SSB}, 10\text{ms})/10\text{ms}) = 0$	
RB numbers containing SSBs within channel BW	$(RB_J, RB_{J+1}, \dots, RB_{J+19})^{\text{Note 1}}$	
Note 1:	RBs containing SSB can be configured in any frequency location within the cell bandwidth according to the allowed synchronization raster defined in clause 5.4.3.	
Note 2:	These values have been derived from other parameters for information purposes (as per TS 38.213 [3]). They are not settable parameters themselves.	

G.1.5.2.2 SSB pattern 2 in FR2: SSB allocation for SSB SCS=240 kHz

Table G.1.5.2.2-1: SSB.2 FR2: SSB Pattern 2 for SSB SCS = 240 kHz with 2 SSBs per SS-burst

SSB Parameters	Values	
SSB SCS	240 kHz	
SSB periodicity (T_{SSB})	20 ms	
Number of SSBs per SS-burst	2	
SS/PBCH block index	0	1
Symbol numbers containing SSBs ^{Note 2}	8-11	12-13, 0-1
Slot numbers containing SSB ^{Note 2}	0	0, 1
SFN containing SSB	SFN mod ($\max(T_{SSB}, 10\text{ms})/10\text{ms}$) = 0	
RB numbers containing SSBs within channel BW	$(RB_J, RB_{J+1}, \dots, RB_{J+39})$ ^{Note 1}	
Note 1: RBs containing SSB can be configured in any frequency location within the cell bandwidth according to the allowed synchronization raster defined in clause 5.4.3.		
Note 2: These values have been derived from other parameters for information purposes (as per TS 38.213 [3]). They are not settable parameters themselves.		

G.1.5.2.3 SSB pattern 3 in FR2: SSB allocation for SSB SCS=120 kHz

Table G.1.5.2.3-1: SSB.3 FR2: SSB Pattern 3 for SSB SCS = 120 kHz with 1 SSB per SS-burst

SSB Parameters	Values	
SSB SCS	120 kHz	
SSB periodicity (T_{SSB})	20 ms	
Number of SSBs per SS-burst	1	
SS/PBCH block index	0	
Symbol numbers containing SSBs ^{Note 2}	4-7	
Slot numbers containing SSB ^{Note 2}	0	
SFN containing SSB	SFN mod ($\max(T_{SSB}, 10\text{ms})/10\text{ms}$) = 0	
RB numbers containing SSBs within channel BW	$(RB_J, RB_{J+1}, \dots, RB_{J+19})$ ^{Note 1}	
Note 1: RBs containing SSB can be configured in any frequency location within the cell bandwidth according to the allowed synchronization raster defined in clause 5.4.3.		
Note 2: These values have been derived from other parameters for information purposes (as per TS 38.213 [3]). They are not settable parameters themselves.		

G.1.5.2.4 SSB pattern 4 in FR2: SSB allocation for SSB SCS=240 kHz

Table G.1.5.2.4-1: SSB.4 FR2: SSB Pattern 4 for SSB SCS = 240 kHz with 1 SSB per SS-burst

SSB Parameters	Values	
SSB SCS	240 kHz	
SSB periodicity (T_{SSB})	20 ms	
Number of SSBs per SS-burst	1	
SS/PBCH block index	0	
Symbol numbers containing SSBs ^{Note 2}	8-11	
Slot numbers containing SSB ^{Note 2}	0	
SFN containing SSB	SFN mod ($\max(T_{SSB}, 10\text{ms})/10\text{ms}$) = 0	
RB numbers containing SSBs within channel BW	$(RB_J, RB_{J+1}, \dots, RB_{J+39})$ ^{Note 1}	
Note 1: RBs containing SSB can be configured in any frequency location within the cell bandwidth according to the allowed synchronization raster defined in clause 5.4.3.		
Note 2: These values have been derived from other parameters for information purposes (as per TS 38.213 [3]). They are not settable parameters themselves.		

G.1.5.2.5 SSB pattern 5 in FR2: SSB allocation for SSB SCS=120 kHz

Table G.1.5.2.5-1: SSB.5 FR2: SSB Pattern 5 for SSB SCS = 120 kHz with 2 SSBs per SS-burst

SSB Parameters	Values	
SSB SCS	120 kHz	
SSB periodicity (T_{SSB})	20 ms	
Number of SSBs per SS-burst	2	
SS/PBCH block index	2	3
Symbol numbers containing SSBs ^{Note 2}	2-5	6-9
Slot numbers containing SSB ^{Note 2}	1	1
SFN containing SSB	SFN mod ($\max(T_{SSB}, 10\text{ms})/10\text{ms}$) = 0	
RB numbers containing SSBs within channel BW	$(RB_J, RB_{J+1}, \dots, RB_{J+19})$ ^{Note 1}	
Note 1: RBs containing SSB can be configured in any frequency location within the cell bandwidth according to the allowed synchronization raster defined in clause 5.4.3.		
Note 2: These values have been derived from other parameters for information purposes (as per TS 38.213 [3]). They are not settable parameters themselves.		

G.1.5.2.6 SSB pattern 6 in FR2: SSB allocation for SSB SCS=240 kHz

Table G.1.5.2.6-1: SSB.6 FR2: SSB Pattern 6 for SSB SCS = 240 kHz with 2 SSBs per SS-burst

SSB Parameters	Values	
SSB SCS	240 kHz	
SSB periodicity (T_{SSB})	20 ms	
Number of SSBs per SS-burst	2	
SS/PBCH block index	2	3
Symbol numbers containing SSBs ^{Note 2}	2-5	6-9
Slot numbers containing SSB ^{Note 2}	1	1
SFN containing SSB	SFN mod ($\max(T_{SSB}, 10\text{ms})/10\text{ms}$) = 0	
RB numbers containing SSBs within channel BW	$(RB_J, RB_{J+1}, \dots, RB_{J+39})$ ^{Note 1}	
Note 1: RBs containing SSB can be configured in any frequency location within the cell bandwidth according to the allowed synchronization raster defined in clause 5.4.3.		
Note 2: These values have been derived from other parameters for information purposes (as per TS 38.213 [3]). They are not settable parameters themselves.		

G.1.5.2.7 SSB pattern 7 in FR2: SSB allocation for SSB SCS=120 kHz

Table G.1.5.2.7-1: SSB.7 FR2: SSB Pattern 7 for SSB SCS = 120 kHz with 1 SSB per SS-burst

SSB Parameters	Values	
SSB SCS	120 kHz	
SSB periodicity (T_{SSB})	20 ms	
Number of SSBs per SS-burst	1	
SS/PBCH block index	1	
Symbol numbers containing SSBs ^{Note 2}	8-11	
Slot numbers containing SSB ^{Note 2}	0	
SFN containing SSB	SFN mod ($\max(T_{SSB}, 10\text{ms})/10\text{ms}$) = 0	
RB numbers containing SSBs within channel BW	$(RB_J, RB_{J+1}, \dots, RB_{J+19})$ ^{Note 1}	
Note 1: RBs containing SSB can be configured in any frequency location within the cell bandwidth according to the allowed synchronization raster defined in clause 5.4.3.		
Note 2: These values have been derived from other parameters for information purposes (as per TS 38.213 [3]). They are not settable parameters themselves.		

G.1.5.2.8 SSB pattern 8 in FR2: SSB allocation for SSB SCS=240 kHz

Table G.1.5.2.8-1: SSB.8 FR2: SSB Pattern 8 for SSB SCS = 240 kHz with 1 SSB per SS-burst

SSB Parameters	Values	
SSB SCS	240 kHz	
SSB periodicity (T_{SSB})	20 ms	
Number of SSBs per SS-burst	1	
SS/PBCH block index	1	
Symbol numbers containing SSBs ^{Note 2}	12-13	0-1
Slot numbers containing SSB ^{Note 2}	0	1
SFN containing SSB	SFN mod ($\max(T_{SSB}, 10\text{ms})/10\text{ms}$) = 0	
RB numbers containing SSBs within channel BW	$(RB_J, RB_{J+1}, \dots, RB_{J+39})$ ^{Note 1}	
Note 1: RBs containing SSB can be configured in any frequency location within the cell bandwidth according to the allowed synchronization raster defined in clause 5.4.3.		
Note 2: These values have been derived from other parameters for information purposes (as per TS 38.213 [3]). They are not settable parameters themselves.		

G.1.6 SMTC Configurations

G.1.6.1 SMTC pattern 1: SMTC period = 20 ms with SMTC duration = 1 ms

Table G.1.6.1-1: SMTC.1: SMTC Pattern 1 for SMTC period = 20 ms and duration = 1 ms

SMTC Parameters	Values
SMTC periodicity	20 ms
SMTC offset	0 ms
SMTC duration	1 ms

G.1.6.2 SMTC pattern 2: SMTC period = 20 ms with SMTC duration = 5 ms

Table G.1.6.2-1: SMTC.2: SMTC Pattern 2 for SMTC period = 20 ms and duration = 5 ms

SMTC Parameters	Values
SMTC periodicity	20 ms
SMTC offset	0 ms
SMTC duration	5 ms

G.1.6.3 SMTC pattern 3: SMTC period = 160 ms with SMTC duration = 1 ms

Table G.1.6.3-1: SMTC.3: SMTC Pattern 3 for SMTC period = 20 ms and duration = 5 ms

SMTC Parameters	Values
SMTC periodicity	160 ms
SMTC offset	0 ms
SMTC duration	1 ms

G.1.6.4 SMTC pattern 4: SMTC period = 20 ms with SMTC duration = 1 ms

Table G.1.6.4-1: SMTC.4: SMTC Pattern 4 for SMTC period = 20 ms and duration = 1 ms

SMTC Parameters	Values
SMTC periodicity	20 ms
SMTC offset	10 ms
SMTC duration	1 ms

G.1.6.5 SMTC pattern 5: SMTC period = 20 ms with SMTC duration = 5 ms

Table G.1.6.4-1: SMTC.5: SMTC Pattern 5 for SMTC period = 20 ms and duration = 5 ms

SMTC Parameters	Values
SMTC periodicity	20 ms
SMTC offset	10 ms
SMTC duration	5 ms

G.1.7 CSI-RS configurations

G.1.7.1 TDD

Table G.1.7.1-1: CSI-RS Reference Measurement Channels for SCS=15kHz

	CSI-RS.1.1 TDD	CSI-RS.1.2 TDD	CSI-RS.1.3 TDD	CSI-RS.1.4 TDD
Resource Type	periodic	periodic	aperiodic	aperiodic
Resource Set Config				
nzp-CSI-ResourceSetId	0	0	0	0
repetition	n.a.	off	off	on
aperiodicTriggeringOffset	n.a.	n.a.	0	0
trs-Info	n.a.	n.a.	n.a.	n.a.
Resource Config				
nzp-CSI-RS-ResourceId	0 for resource #0	10 for resource #0	20 for resource #0	0 for resource #0
				1 for resource #1
				2 for resource #2
				3 for resource #3
		11 for resource #1	21 for resource #1	4 for resource #4
				5 for resource #5
				6 for resource #6
		7 for resource #7		
powerControlOffset	0	0	0	0
powerControlOffsetSS	db0	db0	db0	db0
scramblingID	0	0	0	0
Period (slots)	slot5	slot10	n.a.	n.a.
qcl-InfoPeriodicCSI-RS	TCI.State.0	TCI.State.0	n.a.	n.a.
		TCI.State.1		
frequencyDomainAllocation	000001	000001	000001	000001
nrofPorts	2	1	1	1
firstOFDMSymbolInTimeDomain	4 for resource #0	6 for resource #0	6 for resource #0	0 for resource #0
				1 for resource #1
				2 for resource #2
				3 for resource #3
		10 for resource #1	10 for resource #1	4 for resource #4
				5 for resource #5
				6 for resource #6
		7 for resource #7		
cdm-Type	FD-CDM2	noCDM	noCDM	noCDM
density	1	3	3	3
startingRB	0	0	0	0
nrofRBs	276 (Note 1)	276 (Note 1)	276 (Note 1)	276 (Note 1)
Note 1:	If the configured value of PRBs is larger than the width of the corresponding BWP relevant for the test case, the Test Equipment shall implement CSI-RS only in the width of that BWP.			

Table G.1.7.1-2: CSI-RS Reference Measurement Channels for SCS=30kHz

	CSI-RS.2.1 TDD	CSI-RS.2.2 TDD	CSI-RS.2.3 TDD	CSI-RS.2.4 TDD
Resource Type	periodic	periodic	aperiodic	aperiodic
Resource Set Config				
nzp-CSI-ResourceSetId	0	0	0	0
repetition	n.a.	off	off	on
aperiodicTriggeringOffset	n.a.	n.a.	0	0
trs-Info	n.a.	n.a.	n.a.	n.a.
Resource Config				
nzp-CSI-RS-ResourceId	0 for resource #0	10 for resource #0	20 for resource #0	0 for resource #0
				1 for resource #1
				2 for resource #2
				3 for resource #3
		11 for resource #1	21 for resource #1	4 for resource #4
				5 for resource #5
				6 for resource #6
		7 for resource #7		
powerControlOffset	0	0	0	0
powerControlOffsetSS	db0	db0	db0	db0
scramblingID	0	0	0	0
Period (slots)	slot10	slot20	n.a.	n.a.
qcl-InfoPeriodicCSI-RS	TCI.State.0	TCI.State.0	n.a.	n.a.
		TCI.State.1		
frequencyDomainAllocation	000001	000001	000001	000001
nrofPorts	2	1	1	1
firstOFDMSymbolInTimeDomain	4 for resource #0	6 for resource #0	6 for resource #0	0 for resource #0
				1 for resource #1
				2 for resource #2
				3 for resource #3
		10 for resource #1	10 for resource #1	4 for resource #4
				5 for resource #5
				6 for resource #6
		7 for resource #7		
cdm-Type	FD-CDM2	noCDM	noCDM	noCDM
density	1	3	3	3
startingRB	0	0	0	0
nrofRBs	276 (Note 1)	276 (Note 1)	276 (Note 1)	276 (Note 1)
Note 1: If the configured value of PRBs is larger than the width of the corresponding BWP relevant for the test case, the Test Equipment shall implement CSI-RS only in the width of that BWP.				

Table G.1.7.1-3: CSI-RS Reference Measurement Channels for SCS=120kHz

Resource Type	CSI-RS.3.1 TDD	CSI-RS.3.2 TDD	CSI-RS.3.3 TDD	CSI-RS.3.4 TDD
Resource Set Config	periodic	periodic	aperiodic	aperiodic
nzp-CSI-ResourceSetId	0	0	0	0
repetition	n.a.	off	off	on
aperiodicTriggeringOffset	n.a.	n.a.	4	4
trs-Info	n.a.	n.a.	n.a.	n.a.
Resource Config				
nzp-CSI-RS-ResourceId	0 for resource #0	10 for resource #0	20 for resource #0	0 for resource #0
				1 for resource #1
				2 for resource #2
				3 for resource #3
		11 for resource #1	21 for resource #1	4 for resource #4
				5 for resource #5
				6 for resource #6
			7 for resource #7	
powerControlOffset	0	0	0	0
powerControlOffsetSS	db0	db0	db0	db0
scramblingID	0	0	0	0
Period (slots)	slot40	slot80	n.a.	n.a.
qcl-InfoPeriodicCSI-RS	TCI.State.0	TCI.State.0	n.a.	n.a.
		TCI.State.1		
frequencyDomainAllocation	000001	000001	000001	000001
nrofPorts	1	1	1	1
firstOFDMSymbolInTimeDomain	4 for resource #0	6 for resource #0	6 for resource #0	0 for resource #0
				1 for resource #1
				2 for resource #2
				3 for resource #3
		10 for resource #1	10 for resource #1	4 for resource #4
				5 for resource #5
				6 for resource #6
			7 for resource #7	
cdm-Type	FD-CDM2	noCDM	noCDM	noCDM
density	1	3	3	3
startingRB	0	0	0	0
nrofRBs	276 (Note 1)	276 (Note 1)	276 (Note 1)	276 (Note 1)
Note 1: If the configured value of PRBs is larger than the width of the corresponding BWP relevant for the test case, the Test Equipment shall implement CSI-RS only in the width of that BWP.				

1.7.2 FDD

Table G.1.7.2-1: CSI-RS Reference Measurement Channels for SCS=15kHz

Resource Type	CSI-RS.1.1 FDD	CSI-RS.1.2 FDD	CSI-RS.1.3 FDD	CSI-RS.1.4 FDD	
Resource Set Config	periodic	periodic	aperiodic	aperiodic	
nzp-CSI-ResourceSetId	0	0	0	0	
repetition	n.a.	off	off	on	
aperiodicTriggeringOffset	n.a.	n.a.	6	6	
trs-Info	n.a.	n.a.	n.a.	n.a.	
Resource Config					
nzp-CSI-RS-ResourceId	0 for resource #0	10 for resource #0	20 for resource #0	30 for resource #0	
					31 for resource #1
					32 for resource #2
		11 for resource #1	21 for resource #1	33 for resource #3	
					34 for resource #4
			35 for resource #5		

				36 for resource #6
				37 for resource #7
powerControlOffset	0	0	0	0
powerControlOffsetSS	db0	db0	db0	db0
scramblingID	0	0	0	0
Period (slots)	slot5	slot10	n.a.	n.a.
Offset	1	1	n.a.	n.a.
qcl-InfoPeriodicCSI-RS	TCI.State.0	TCI.State.0	n.a.	n.a.
		TCI.State.1		
frequencyDomainAllocation	000001	000001	000001	000001
nrofPorts	2	1	1	1
firstOFDMSymbolInTimeDomain	5 for resource #0	6 for resource #0	6 for resource #0	0 for resource #0
				1 for resource #1
				2 for resource #2
		10 for resource #1	10 for resource #1	3 for resource #3
				4 for resource #4
				5 for resource #5
				6 for resource #6
				7 for resource #7
cdm-Type	FD-CDM2	noCDM	noCDM	noCDM
density	1	3	3	3
startingRB	0	0	0	0
nrofRBs	276	276	276	276

G.1.8 Angle of Arrival (AoA) for FR2 RRM test cases

This clause specifies the AoA setups for FR2 RRM test cases. The applicable AoA setup is defined in each test case.

G.1.8.1 Setup 1: Single AoA

There is only one active probe in the test. The DL signals, and noise if applicable, transmitted from the probe, are aligned to AoA based upon the declaration.

G.1.8.2 Setup 2: 2 AoAs

There are 2 active probes in the test. The DL signals, and noise if applicable, transmitted from the two active probes, align to AoAs based upon the declaration.

G.1.9 TCI State Configuration

G.1.9.1 Introduction

This clause provides the configurations for TCI states towards either SSB or CSI-RS. The TCI states defined in this clause are configured in each test when applicable to indicate that certain DL signals are QCL'ed with the referenceSignal configured in the TCI states.

G.1.9.2 TCI states

Table G.1.9.2-1: TCI States

Parameter	TCI.State.0	TCI.State.1	TCI.State.2	TCI.State.3
tcid-StateId	Id0	Id1	Id2	Id3
qcl-Type1	typeC	typeC	typeA	typeA
qcl-Type2 ^{Note1}	typeD	typeD	typeD	typeD
referenceSignal	SSB0	SSB1	Resource #4 in TRS resource set 1 ^{Note3}	Resource #4 in TRS resource set 2 ^{Note3}
Note 1: qcl-Type2 of typeD only where applicable. For RRM test cases, this will be only in FR2 Note 2: referenceSignal configurations towards which the TCI states are configured are defined in a test-specific manner. Note 3: Reference TRS resource sets are defined in G.1.10, and the applicable TRS resource set(s) are specified in each test case. When a single TRS resource set is configured in a test case, it is considered as resource set 1.				

G.1.10 Configurations of CSI-RS for tracking

G.1.10.1 Configuration of CSI-RS for tracking for FR1

G.1.10.1.2 TDD

Table G.1.10.1.2-1: CSI-RS for tracking for SCS=15kHz

Parameter	Unit	Value
Reference channel		TRS.1.1 TDD
Bandwidth		BW of Active BWP ^{Note 1}
SCS	kHz	15
First subcarrier index in the PRB used for CSI-RS		$k_0=0$ for CSI-RS resource 1,2,3,4
First OFDM symbol in the slot used for CSI-RS		$l_0 = 5$ for CSI-RS resource 1 and 3 $l_0 = 9$ for CSI-RS resource 2 and 4
Number of CSI-RS ports (X)		1 for CSI-RS resource 1,2,3,4
CDM Type		'No CDM' for CSI-RS resource 1,2,3,4
Density (ρ)		3 for CSI-RS resource 1,2,3,4
CSI-RS periodicity	slots	20 for CSI-RS resource 1,2,3,4
EPRE ratio to SSS	dB	-3 ^{Note 2}
TCI state		TCI.State.0
Note: BW of TRS is configured same as the BW size of NCR-MT active BWP in the RRM test cases		

Table G.1.10.1.2-2: CSI-RS for tracking for SCS=30kHz

Parameter	Unit	Value
Reference channel		TRS.1.2 TDD
Bandwidth		BW of Active BWP ^{Note 1}
SCS	kHz	30
First subcarrier index in the PRB used for CSI-RS		$k_0=0$ for CSI-RS resource 1,2,3,4
First OFDM symbol in the slot used for CSI-RS		$l_0 = 5$ for CSI-RS resource 1 and 3 $l_0 = 9$ for CSI-RS resource 2 and 4
Number of CSI-RS ports (X)		1 for CSI-RS resource 1,2,3,4
CDM Type		'No CDM' for CSI-RS resource 1,2,3,4
Density (ρ)		3 for CSI-RS resource 1,2,3,4
CSI-RS periodicity	slots	40 for CSI-RS resource 1,2,3,4
EPRE ratio to SSS	dB	-3 ^{Note 2}
TCI state		TCI.State.0
Note 1: BW of TRS is configured same as the BW size of NCR-MT active BWP in the RRM test cases		
Note 2: Unless otherwise specified in the test case		

G.1.10.1.3 FDD

Table G.1.10.1.3-1: CSI-RS for tracking for SCS=15kHz

Parameter	Unit	Value
Reference channel		TRS.1.1 FDD
Bandwidth		BW of Active BWP ^{Note 1}
SCS	kHz	15
First subcarrier index in the PRB used for CSI-RS		$k_0=0$ for CSI-RS resource 1,2,3,4
First OFDM symbol in the slot used for CSI-RS		$l_0 = 5$ for CSI-RS resource 1 and 3 $l_0 = 9$ for CSI-RS resource 2 and 4
Number of CSI-RS ports (X)		1 for CSI-RS resource 1,2,3,4
CDM Type		'No CDM' for CSI-RS resource 1,2,3,4
Density (ρ)		3 for CSI-RS resource 1,2,3,4
CSI-RS periodicity	slots	20 for CSI-RS resource 1,2,3,4
CSI-RS offset	slots	10 for CSI-RS resource 1 and 2 11 for CSI-RS resource 3 and 4
EPRE ratio to SSS	dB	-3 ^{Note 2}
TCI state		TCI.State.0
Note 1: BW of TRS is configured same as the BW size of UE active BWP in the RRM test cases		
Note 2: Unless otherwise specified in the test case		

Table G.1.10.1.3-2: CSI-RS for tracking for SCS=30kHz

Parameter	Unit	Value
Reference channel		TRS.1.2 FDD
Bandwidth		BW of Active BWP ^{Note 1}
SCS	kHz	30
First subcarrier index in the PRB used for CSI-RS		$k_0=0$ for CSI-RS resource 1,2,3,4
First OFDM symbol in the slot used for CSI-RS		$l_0 = 5$ for CSI-RS resource 1 and 3 $l_0 = 9$ for CSI-RS resource 2 and 4
Number of CSI-RS ports (X)		1 for CSI-RS resource 1,2,3,4
CDM Type		'No CDM' for CSI-RS resource 1,2,3,4
Density (ρ)		3 for CSI-RS resource 1,2,3,4
CSI-RS periodicity	slots	40 for CSI-RS resource 1,2,3,4
CSI-RS offset	slots	20 for CSI-RS resource 1 and 2 21 for CSI-RS resource 3 and 4
EPRE ratio to SSS	dB	-3 ^{Note 2}
TCI state		TCI.State.0
Note 1: BW of TRS is configured same as the BW size of UE active BWP in the RRM test cases		
Note 2: Unless otherwise specified in the test case		

G.1.10.2 Configuration of CSI-RS for tracking for FR2

G.1.10.2.1 TDD

Table G.1.10.2.1-1: CSI-RS for tracking for SCS=120kHz Set 1

Parameter	Unit	Value
Reference channel		TRS.2.1 TDD
Bandwidth		BW of Active BWP ^{Note 1,3}
SCS	kHz	120
First subcarrier index in the PRB used for CSI-RS		$k_0=0$ for CSI-RS resource 1,2,3,4
First OFDM symbol in the slot used for CSI-RS		$l_0 = 1$ for CSI-RS resource 1 and 3 $l_0 = 5$ for CSI-RS resource 2 and 4
Number of CSI-RS ports (X)		1 for CSI-RS resource 1,2,3,4
CDM Type		'No CDM' for CSI-RS resource 1,2,3,4
Density (ρ)		3 for CSI-RS resource 1,2,3,4
CSI-RS periodicity	slots	80 for CSI-RS resource 1,2,3,4
EPRE ratio to SSS	dB	-3 ^{Note 2}
TCI state		TCI.State.0
Note 1: BW of TRS is configured same as the BW size of NCR-MT active BWP in the RRM test cases Note 2: Unless otherwise specified in the test case Note 3: If active BWP is larger than 52RBs, BW of TRS is configured as 52RBs. Otherwise, same as active BWP size.		

Table G.1.10.2.1-2: CSI-RS for tracking for SCS=120kHz Set 2

Parameter	Unit	Value
Reference channel		TRS.2.2 TDD
Bandwidth		BW of Active BWP ^{Note 1,3}
SCS	kHz	120
First subcarrier index in the PRB used for CSI-RS		$k_0=0$ for CSI-RS resource 1,2,3,4
First OFDM symbol in the slot used for CSI-RS		$l_0 = 2$ for CSI-RS resource 1 and 3 $l_0 = 6$ for CSI-RS resource 2 and 4
Number of CSI-RS ports (X)		1 for CSI-RS resource 1,2,3,4
CDM Type		'No CDM' for CSI-RS resource 1,2,3,4
Density (ρ)		3 for CSI-RS resource 1,2,3,4
CSI-RS periodicity	slots	80 for CSI-RS resource 1,2,3,4
EPRE ratio to SSS	dB	-3 ^{Note 2}
TCI state		TCI.State.1
Note 1: BW of TRS is configured same as the BW size of NCR-MT active BWP in the RRM test cases Note 2: Unless otherwise specified in the test case Note 3: If active BWP is larger than 52RBs, BW of TRS is configured as 52RBs. Otherwise, same as active BWP size.		

G.2 NCR-MT RRM test cases

G.2.1 RRC_CONNECTED state mobility for NCR-MTs

G.2.1.1 RRC Connection Mobility Control

G.2.1.1.2 RRC Re-establishment for LA NCR-MT

G.2.1.1.1.1 Inter-frequency RRC Re-establishment in FR1 for LA NCR-MT

G.2.1.1.1.1.1 Test Purpose and Environment

The purpose is to verify that the NR inter-frequency RRC re-establishment delay in FR1 to an unknown target cell is within the specified limits. These tests will verify the requirements in clause 10.1.1. This test case is applicable only for local area NCR-MT and for NCR type 1-H.

The test parameters are given in table G.2.1.1.1.1.1-1, table G.2.1.1.1.1.1-2 and table G.2.1.1.1.1.1-3 below. The test consists of 3 successive time periods, with time duration of T1, T2 and T3 respectively. At the start of time period T2, cell 1, which is the active cell, becomes inactive. The time period T3 starts after the occurrence of the radio link failure. During T1, the NCR-MT shall be configured with the carrier frequency of cell 2 (with RF Channel Number #2) to ensure that the NCR-MT has the context of the carrier frequency of cell 2 by the end of T1.

Table G.2.1.1.1.1.1-1: Supported test configurations

Configuration	Description of serving cell	Description of target cell
1	15 kHz SSB SCS, 10 MHz bandwidth, TDD duplex mode	15 kHz SSB SCS, 10 MHz bandwidth, TDD duplex mode
2	30 kHz SSB SCS, 40 MHz bandwidth, TDD duplex mode	30 kHz SSB SCS, 40 MHz bandwidth, TDD duplex mode
3	15 kHz SSB SCS, 10 MHz bandwidth, FDD duplex mode	15 kHz SSB SCS, 10 MHz bandwidth, FDD duplex mode
Note: The NCR-MT is only required to be tested in one of the supported test configurations.		

Table G.2.1.1.1.1-2: General test parameters for NR inter-frequency RRC Re-establishment test case in FR1

Parameter		Unit	Test configuration	Value	Comment
Initial condition	Active cell		1, 2	Cell1	
	Neighbour cells		1, 2	Cell2	
Final condition	Active cell		1, 2	Cell2	
RF Channel Number			1, 2	1, 2	
Time offset between cells			1, 2	3 μ s	Synchronous cells
N310		-	1, 2	1	Maximum consecutive out-of-sync indications from lower layers
N311		-	1, 2	1	Minimum consecutive in-sync indications from lower layers
T310		ms	1, 2	0	Radio link failure timer; T310 is disabled
T311		ms	1, 2	30000	RRC re-establishment timer
Access Barring Information		-	1, 2	Not Sent	No additional delays in random access procedure.
SSB configuration			1	SSB.1 FR1	
			2	SSB.2 FR1	
SMTC configuration			1	SMTC pattern 1	
			2	SMTC pattern 1	
DRX cycle length		s	1, 2	OFF	
PRACH configuration			1, 2	FR1 PRACH configuration 1	TBD
T1		s	1, 2	20	
T2		ms	1, 2	1000	Time for the NCR-MT to detect RLF
T3		s	1, 2	20	

Table G.2.1.1.1.1-3: Cell specific test parameters for NR inter-frequency RRC Re-establishment test case in FR1

Parameter	Unit	Test configuration	Cell 1			Cell 2		
			T1	T2	T3	T1	T2	T3
RF Channel Number		1, 2	1			2		
TDD configuration		1	TDDConf.1.1			TDDConf.1.1		
		2	TDDConf.2.1			TDDConf.2.1		
PDSCH RMC configuration		1	SR.1.1 FDD			N/A		
		2	SR.1.1 TDD					
		3	SR.1.1 FDD					
RMSI CORESET RMC configuration		1	CR.1.1 TDD			CR.1.1 TDD		
		2	CR.2.1 TDD			CR.2.1 TDD		
		3	CR.1.1 FDD			CR.1.1 FDD		
Dedicated CORESET RMC configuration		1	CCR.1.1 TDD			CCR.1.1 TDD		
		2	CCR.2.1 TDD			CCR.2.1 TDD		
		3	CCR.1.1 FDD			CCR.1.1 FDD		
OCNG Pattern		1, 2	OP.1 defined in TBD			OP.1 defined in TBD		
TRS configuration		1	TRS.1.1 TDD			N/A		
		2	TRS.1.2 TDD					
		3	TRS.1.1 FDD					
Initial DL BWP configuration		1, 2	DLBWP.0			DLBWP.0		
Initial UL BWP configuration		1, 2	ULBWP.0			ULBWP.0		
Active DL BWP configuration		1, 2	DLBWP.1.1	N/A	N/A	N/A	N/A	DLBWP.1.1
Active UL BWP configuration		1, 2	ULBWP.1.1	N/A	N/A	N/A	N/A	ULBWP.1.1
RLM-RS		1, 2	SSB			SSB		
\hat{E}_s / I_{ot}	dB	1, 2	4	-infinity	-infinity	-infinity	-infinity	7
N_{oc} <small>Note2</small>	dBm/SCS	1	-98					
		2	-95					
N_{oc} <small>Note2</small>	dBm/15 kHz	1, 2	-98					
\hat{E}_s / N_{oc}	dB	1, 2	4	-infinity	-infinity	-infinity	-infinity	7
SS-RSRP <small>Note3</small>	dBm/SCS	1	-94	-infinity	-infinity	-infinity	-infinity	-91
		2	-91	-infinity	-infinity	-infinity	-infinity	-88
Io	dBm/9.36 MHz	1	-64.59	-70.05	-70.05	-70.05	-70.05	-62.26
	dBm/38.16 MHz	2	-58.50	-63.94	-63.94	-63.94	-63.94	-56.15
Propagation Condition		1, 2	AWGN					
<p>Note 1: OCNG shall be used such that both cells are fully allocated and a constant total transmitted power spectral density is achieved for all OFDM symbols.</p> <p>Note 2: Interference from other cells and noise sources not specified in the test is assumed to be constant over subcarriers and time and shall be modelled as AWGN of appropriate power for N_{oc} to be fulfilled.</p> <p>Note 3: SS-RSRP levels have been derived from other parameters for information purposes. They are not settable parameters themselves.</p>								

G.2.1.1.1.1.2 Test Requirements

The RRC re-establishment delay is defined as the time from the start of time period T3, to the moment when the NCR-MT starts to send PRACH preambles to cell 2 for sending the *RRCReestablishmentRequest* message to cell 2.

The RRC re-establishment delay to an unknown NR inter frequency cell shall be less than 14.5 s.

The rate of correct RRC re-establishments observed during repeated tests shall be at least 90%.

NOTE: The RRC re-establishment delay in the test is derived from the following expression:

$$T_{re-establish_delay} = T_{NCR-MT_re-establish_delay} + T_{UL_grant}$$

Where:

T_{UL_grant} = It is the time required to acquire and process uplink grant from the target cell. The PRACH reception is used as a trigger for the completion of the test; hence T_{UL_grant} is not used.

$$T_{NCR-MT_re-establish_delay} = 400 \text{ ms} + T_{identify_intra_NR} + \sum_{i=1}^{N_{freq}-1} T_{identify_inter_NR,i} + T_{SI-NR} + T_{PRACH}$$

$$N_{freq} = 2$$

$$T_{identify_intra_NR} = 6400 \text{ ms}$$

$$T_{identify_inter_NR} = 6400 \text{ ms}$$

$T_{SI-NR} = 1280 \text{ ms}$; it is the time required for receiving all the relevant system information as defined in TS 38.331 for the target inter-frequency NR cell.

$T_{PRACH} = 15 \text{ ms}$; it is the additional delay caused by the random access procedure.

This gives a total of 14495 ms, allow 14.5 s in the test case.

G.2.1.1.1.2 Intra-frequency RRC Re-establishment in FR1 without serving cell timing for LA NCR-MT

G.2.1.1.1.2.1 Test Purpose and Environment

The purpose is to verify that the NR intra-frequency RRC re-establishment delay in FR1 without serving cell timing is within the specified limits. These tests will verify the requirements in clause 10.1.1. This test case is applicable only for local area NCR-MT and for NCR type 1-H.

The test parameters are given in table G.2.1.1.1.2.1-1, table G.2.1.1.1.2.1-2 and table G.2.1.1.1.2.1-3 below. The test consists of 3 successive time periods, with time duration of T1, T2 and T3 respectively. At the start of time period T2, cell 1, which is the active cell, is deactivated. The time period T3 starts after the occurrence of the radio link failure.

Table G.2.1.1.1.2.1-1: Supported test configurations

Configuration	Description
1	15 kHz SSB SCS, 10 MHz bandwidth, TDD duplex mode
2	30 kHz SSB SCS, 40 MHz bandwidth, TDD duplex mode
3	15 kHz SSB SCS, 10 MHz bandwidth, FDD duplex mode
Note:	The NCR-MT is only required to be tested in one of the supported test configurations.

Table G.2.1.1.2.1-2: General test parameters for NR intra-frequency RRC Re-establishment test case in FR1

Parameter		Unit	Test configuration	Value	Comment
Initial condition	Active cell		1, 2	Cell1	
	Neighbour cells		1, 2	Cell2	
Final condition	Active cell		1, 2	Cell2	
RF Channel Number			1, 2	1, 2	
Time offset between cells			1, 2	3 μ s	Synchronous cells
N310		-	1, 2	1	Maximum consecutive out-of-sync indications from lower layers
N311		-	1, 2	1	Minimum consecutive in-sync indications from lower layers
T310		ms	1, 2	6000	Radio link failure timer configured by <i>RLF-TimersAndConstants</i>
T311		ms	1, 2	15000	RRC re-establishment timer
Access Barring Information		-	1, 2	Not Sent	No additional delays in random access procedure.
SSB configuration			1	SSB.1 FR1	
			2	SSB.2 FR1	
SMTC configuration			1	SMTC pattern 1	
			2	SMTC pattern 1	
DRX cycle length		s	1, 2	OFF	
PRACH configuration			1, 2	FR1 PRACH configuration 1	TBD
T1		s	1, 2	10	
T2		s	1, 2	7	Time for the NCR-MT to detect RLF
T3		s	1, 2	10	

Table G.2.1.1.2.1-3: Cell specific test parameters for NR intra-frequency RRC Re-establishment test case in FR1

Parameter	Unit	Test configuration	Cell 1			Cell 2		
			T1	T2	T3	T1	T2	T3
TDD configuration		1	TDDConf.1.1			TDDConf.1.1		
		2	TDDConf.2.1			TDDConf.2.1		
PDSCH RMC configuration		1	SR.1.1 TDD			N/A		
		2	SR.2.1 TDD					
		3	SR.1.1 FDD					
RMSI CORESET RMC configuration		1	CR.1.1 TDD			CR.1.1 TDD		
		2	CR.2.1 TDD			CR.2.1 TDD		
		3	CR.1.1 FDD			CR.1.1 FDD		
Dedicated CORESET RMC configuration		1	CCR.1.1 TDD			CCR.1.1 TDD		
		2	CCR.2.1 TDD			CCR.2.1 TDD		
		3	CCR.1.1 FDD			CCR.1.1 FDD		
OCNG Pattern		1, 2	OP.1 defined in TBD			OP.1 defined in TBD		
Initial DL BWP configuration		1, 2	DLBWP.0.1			DLBWP.0.1		
Initial UL BWP configuration		1, 2	ULBWP.0.1			ULBWP.0.1		
RLM-RS		1, 2	SSB			SSB		
\hat{E}_s / I_{ot}	dB	1, 2	4	-infinity	-infinity	-infinity	-infinity	4
N_{oc} ^{Note2}	dBm/SCS	1	-98					
		2	-95					
N_{oc} ^{Note2}	dBm/15 kHz	1, 2	-98					
\hat{E}_s / N_{oc}	dB	1, 2	4	-infinity	-infinity	-infinity	-infinity	4
SS-RSRP ^{Note3}	dBm/SCS	1	-94	-infinity	-infinity	-infinity	-infinity	-94
		2	-91	-infinity	-infinity	-infinity	-infinity	-91
Io	dBm/9.36 MHz	1	-64.59	-infinity	-infinity	-infinity	-infinity	-64.59
	dBm/9.36 MHz	2	-58.50	-infinity	-infinity	-infinity	-infinity	-58.50
Propagation Condition		1, 2	AWGN					
Note 1: OCNG shall be used such that both cells are fully allocated and a constant total transmitted power spectral density is achieved for all OFDM symbols.								
Note 2: Interference from other cells and noise sources not specified in the test is assumed to be constant over subcarriers and time and shall be modelled as AWGN of appropriate power for N_{oc} to be fulfilled.								
Note 3: SS-RSRP levels have been derived from other parameters for information purposes. They are not settable parameters themselves.								

G.2.1.1.2.2 Test Requirements

The RRC re-establishment delay is defined as the time from the start of time period T3, to the moment when the NCR-MT starts to send PRACH preambles to cell 2 for sending the *RRCReestablishmentRequest* message to cell 2.

The RRC re-establishment delay to an unknown NR intra frequency cell without serving cell timing shall be less than 8.1 s.

The rate of correct RRC re-establishments observed during repeated tests shall be at least 90%.

NOTE: The RRC re-establishment delay in the test is derived from the following expression:

$$T_{re-establish_delay} = T_{NCR-MT_re-establish_delay} + T_{UL_grant}$$

Where:

T_{UL_grant} = It is the time required to acquire and process uplink grant from the target cell. The PRACH reception is used as a trigger for the completion of the test; hence T_{UL_grant} is not used.

$$T_{NCR-MT_re-establish_delay} = 400 \text{ ms} + T_{identify_intra_NR} + \sum_{i=1}^{N_{freq}-1} T_{identify_inter_NR,i} + T_{SI-NR} + T_{PRACH}$$

$$N_{freq} = 1$$

$$T_{identify_intra_NR} = 6400 \text{ ms}$$

$T_{SI-NR} = 1280 \text{ ms}$; it is the time required for receiving all the relevant system information as defined in TS 38.331 [2] for the target intra-frequency NR cell.

$T_{PRACH} = 15 \text{ ms}$; it is the additional delay caused by the random access procedure.

This gives a total of 8095 ms, allow 8.1 s in the test case.

G.2.1.1.1.3 Inter-frequency RRC Re-establishment in FR2-1 for LA NCR-MT

G.2.1.1.1.3.1 Test Purpose and Environment

The purpose is to verify that the NR inter-frequency RRC re-establishment delay in FR2-1 without known target cell is within the specified limits. These tests will verify the requirements in clause 10.1.1. This test case is applicable only for local area NCR-MT and for NCR type 2-O.

The test parameters are given in table G.2.1.1.1.3.1-1, table G.2.1.1.1.3.1-2 and table G.2.1.1.1.3.1-3 below. The test consists of 3 successive time periods, with time duration of T1, T2 and T3 respectively. At the start of time period T2, cell 1, which is the active cell, becomes inactive. The time period T3 starts after the occurrence of the radio link failure. During T1, the NCR-MT shall be configured with the carrier frequency of cell 2 (with RF Channel Number #2) to ensure that the NCR-MT has the context of the carrier frequency of cell 2 by the end of T1.

Table G.2.1.1.1.3.1-1: Supported test configurations

Configuration	Description
1	NR 120 kHz SSB SCS, 100 MHz bandwidth, TDD duplex mode

Table G.2.1.1.1.3.1-2: General test parameters for NR inter-frequency RRC Re-establishment test case in FR2-1

Parameter		Unit	Test configuration	Value	Comment
Initial condition	Active cell		1	Cell1	
	Neighbour cells		1	Cell2	
Final condition	Active cell		1	Cell2	
RF Channel Number			1	1, 2	
Time offset between cells			1	3 μ s	Synchronous cells
N310		-	1	1	Maximum consecutive out-of-sync indications from lower layers
N311		-	1	1	Minimum consecutive in-sync indications from lower layers
T310		ms	1	0	Radio link failure timer; T310 is disabled
T311		ms	1	30000	RRC re-establishment timer
Access Barring Information		-	1	Not Sent	No additional delays in random access procedure.
SSB configuration			1	SSB.1 FR2-1	
			1	SMTC pattern 1	
DRX cycle length		s	1	OFF	
PRACH configuration			1	FR2-1 PRACH configuration 1	Table TBD
T1		s	1	10	
T2		ms	1	4800	Time for the NCR-MT to detect RLF
T3		s	1	20	

Table G.2.1.1.3.1-3: Cell specific test parameters for NR inter-frequency RRC Re-establishment test case in FR2-1

Parameter	Unit	Test configuration	Cell 1			Cell 2		
			T1	T2	T3	T1	T2	T3
AoA setup		1	Setup 2 as specified in clause G.1.8.2					
TDD configuration		1	TDDConf.3.1			TDDConf.3.1		
PDSCH RMC configuration		1	SR.3.1 TDD			N/A		
RMSI CORESET RMC configuration		1	CR.3.1 TDD			CR.3.1 TDD		
Dedicated CORESET RMC configuration		1	CCR.3.1 TDD			CCR.3.1 TDD		
TRS configuration		1	TRS.2.1 TDD			N/A		
PDSCH/PDCCH TCI state		1	TCI.State.2			N/A		
OCNG Pattern		1	OP.1 defined in TBD			OP.1 defined in TBD		
Initial DL BWP configuration		1	DLBWP.0.1			DLBWP.0.1		
Initial UL BWP configuration		1	ULBWP.0.1			ULBWP.0.1		
RLM-RS		1	SSB			SSB		
\hat{E}_s / I_{ot}	dB	1	5	-infinity	-infinity	-infinity	-infinity	8
N_{oc} ^{Note2}	dBm/15 kHz	1	-98					
N_{oc} ^{Note2}	dBm/SCS	1	-89					
\hat{E}_s / N_{oc}	dB	1	5	-infinity	-infinity	-infinity	-infinity	8
SS-RSRP ^{Note3}	dBm/SCS	1	-84	-infinity	-infinity	-infinity	-infinity	-81
Io	dBm/95.04 MHz	1	-53.82	-infinity	-infinity	-infinity	-infinity	-51.37
Propagation Condition		1	AWGN					
<p>Note 1: OCNG shall be used such that both cells are fully allocated and a constant total transmitted power spectral density is achieved for all OFDM symbols.</p> <p>Note 2: Interference from other cells and noise sources not specified in the test is assumed to be constant over subcarriers and time and shall be modelled as AWGN of appropriate power for N_{oc} to be fulfilled.</p> <p>Note 3: SS-RSRP levels have been derived from other parameters for information purposes. They are not settable parameters themselves.</p> <p>Note 4: Void</p>								

G.2.1.1.3.2 Test Requirements

The RRC re-establishment delay is defined as the time from the start of time period T3, to the moment when the NCR-MT starts to send PRACH preambles to cell 2 for sending the *RRCReestablishmentRequest* message to cell 2.

The RRC re-establishment delay to an unknown NR inter frequency cell shall be less than 18 s.

The rate of correct RRC re-establishments observed during repeated tests shall be at least 90%.

NOTE: The RRC re-establishment delay in the test is derived from the following expression:

$$T_{re-establish_delay} = T_{NCR-MT_re-establish_delay} + T_{UL_grant}$$

Where:

T_{UL_grant} = It is the time required to acquire and process uplink grant from the target cell. The PRACH reception is used as a trigger for the completion of the test; hence T_{UL_grant} is not used.

$$T_{NCR-MT_re-establish_delay} = 400 \text{ ms} + T_{identify_intra_NR} + \sum_{i=1}^{N_{freq}-1} T_{identify_inter_NR,i} + T_{SI-NR} + T_{PRACH}$$

$$N_{freq} = 2$$

$$T_{\text{identify_intra_NR}} = 8000 \text{ ms}$$

$$T_{\text{identify_inter_NR}} = 8000 \text{ ms}$$

$T_{SI-NR} = 1280 \text{ ms}$; it is the time required for receiving all the relevant system information as defined in TS 38.331 for the target inter-frequency NR cell.

$T_{\text{PRACH}} = 15 \text{ ms}$; it is the additional delay caused by the random access procedure.

This gives a total of 17695 ms, allow 18 s in the test case.

G.2.1.1.1.4 Intra-frequency RRC Re-establishment in FR2-1 without serving cell timing for LA NCR-MT

G.2.1.1.1.4.1 Test Purpose and Environment

The purpose is to verify that the NR intra-frequency RRC re-establishment delay in FR2-1 without serving cell timing is within the specified limits. These tests will verify the requirements in clause 10.1.1. This test case is applicable only for local area NCR-MT and for NCR type 2-O.

The test parameters are given in table G.2.1.1.1.4.1-1, table G.2.1.1.1.4.1-2 and table G.2.1.1.1.4.1-3 below. The test consists of 3 successive time periods, with time duration of T1, T2 and T3 respectively. At the start of time period T2, cell 1, which is the active cell, is deactivated. The time period T3 starts after the occurrence of the radio link failure.

Table G.2.1.1.1.4.1-1: Supported test configurations

Configuration	Description
1	120 kHz SSB SCS, 100 MHz bandwidth, TDD duplex mode

Table G.2.1.1.1.4.1-2: General test parameters for NR intra-frequency RRC Re-establishment test case in FR2-1

Parameter		Unit	Test configuration	Value	Comment
Initial condition	Active cell		1	Cell1	
	Neighbour cells		1	Cell2	
Final condition	Active cell		1	Cell2	
RF Channel Number			1	1	
Time offset between cells			1	3 μs	Synchronous cells
N310		-	1	1	Maximum consecutive out-of-sync indications from lower layers
N311		-	1	1	Minimum consecutive in-sync indications from lower layers
T310		ms	1	6000	Radio link failure timer configured by <i>RLF-TimersAndConstants</i>
T311		ms	1	30000	RRC re-establishment timer
Access Barring Information		-	1	Not Sent	No additional delays in random access procedure.
SSB configuration			1	SSB.1 FR2-1	
SMTC configuration			1	SMTC pattern 1	
DRX cycle length		s	1	OFF	
PRACH configuration			1	FR2-1 PRACH configuration 1	Table TBD
T1		s	1	10	
T2		s	1	10800	Time for the NCR-MT to detect RLF
T3		s	1	30	

Table G.2.1.1.4.1-3: Cell specific test parameters for NR intra-frequency RRC Re-establishment test case in FR2-1

Parameter	Unit	Test configuration	Cell 1			Cell 2		
			T1	T2	T3	T1	T2	T3
AoA setup		1	Setup 2 as specified in clause G.1.8.2					
TDD configuration		1	TDDConf.3.1			TDDConf.3.1		
		1	SR.3.1 TDD			N/A		
RMSI CORESET RMC configuration		1	CR.3.1 FDD			CR.3.1 FDD		
Dedicated CORESET RMC configuration		1	CCR.3.1 FDD			CCR.3.1 FDD		
TRS configuration		1	TRS.2.1 TDD			N/A		
TCI state		1	CSI-RS.Config.0			N/A		
OCNG Pattern		1	OP.1 defined in TBD			OP.1 defined in TBD		
Initial DL BWP configuration		1	DLBWP.0.1			DLBWP.0.1		
Initial UL BWP configuration		1	ULBWP.0.1			ULBWP.0.1		
RLM-RS		1	SSB			SSB		
AoA setup		1	Setup 1 defined in TBD			Setup 1 defined in TBD		
\hat{E}_s / I_{ot}	dB	1	5	-infinity	-infinity	-infinity	-infinity	5
N_{oc} Note2	dBm/SCS	1	-98					
N_{oc} Note2	dBm/15 kHz	1	-89					
\hat{E}_s / N_{oc}	dB	1	5	-infinity	-infinity	-infinity	-infinity	5
SS-RSRP Note3	dBm/SCS	1	-93	-infinity	-infinity	-infinity	-infinity	-93
Io	dBm/95.04 MHz	1	-62.82	-infinity	-infinity	-infinity	-infinity	-62.82
Propagation Condition		1	AWGN					
<p>Note 1: OCNG shall be used such that both cells are fully allocated and a constant total transmitted power spectral density is achieved for all OFDM symbols.</p> <p>Note 2: Interference from other cells and noise sources not specified in the test is assumed to be constant over subcarriers and time and shall be modelled as AWGN of appropriate power for N_{oc} to be fulfilled.</p> <p>Note 3: SS-RSRP levels have been derived from other parameters for information purposes. They are not settable parameters themselves.</p> <p>Note 4: Void</p>								

G.2.1.1.4.2 Test Requirements

The RRC re-establishment delay is defined as the time from the start of time period T3, to the moment when the NCR-MT starts to send PRACH preambles to cell 2 for sending the *RRCReestablishmentRequest* message to cell 2.

The RRC re-establishment delay to an unknown NR intra frequency cell without serving cell timing shall be less than 30 s.

The rate of correct RRC re-establishments observed during repeated tests shall be at least 90%.

NOTE: The RRC re-establishment delay in the test is derived from the following expression:

$$T_{re-establish_delay} = T_{NCR-MT_re-establish_delay} + T_{UL_grant}$$

Where:

T_{UL_grant} = It is the time required to acquire and process uplink grant from the target cell. The PRACH reception is used as a trigger for the completion of the test; hence T_{UL_grant} is not used.

$$T_{NCR-MT_re-establish_delay} = 400 \text{ ms} + T_{identify_intra_NR} + \sum_{i=1}^{N_{freq}-1} T_{identify_inter_NR,i} + T_{SI-NR} + T_{PRACH}$$

$$N_{freq} = 1$$

$T_{\text{identify_intra_NR}} = 28160$ ms

$T_{SI-NR} = 1280$ ms; it is the time required for receiving all the relevant system information as defined in TS 38.331 [2] for the target intra-frequency NR cell.

$T_{\text{PRACH}} = 15$ ms; it is the additional delay caused by the random access procedure.

This gives a total of 29855 ms, allow 30 s in the test case.

G.2.2 Timing

G.2.2.1 Transmit timing

G.2.2.1.1 NR NCR-MT Transmit Timing Test for FR1

G.2.2.1.1.1 Test Purpose and environment

The purpose of this test is to verify that the NCR-MT can follow frame timing change of the connected gNodeB and that the NCR-MT initial transmit timing accuracy, maximum amount of timing change in one adjustment, minimum and maximum adjustment rate are within the specified limits. This test will verify the requirements in clause 10.2.1.2. Local area NCR-MT type 1-C and type 1-H shall be tested with this test.

Supported test configurations are shown in Table G.2.2.1.1.1-1.

Table G.2.2.1.1.1-1: Supported test configurations for FR1 PCell

Configuration	Description
1	NR TDD, SSB SCS 15 kHz, data SCS 15 kHz, BW 10 MHz
2	NR TDD, SSB SCS 30 kHz, data SCS 30 kHz, BW 40 MHz
Note:	The NCR-MT is only required to be tested in one of the supported test configurations

For this test a single NR cell (Cell 1) is used. Table G.2.2.1.1.1-2 defines the parameters to be configured and strength of the transmitted signals. The transmit timing is verified by the NCR-MT transmitting SRS using the configuration defined in Table G.2.2.1.1.1-3.

Table G.2.2.1.1-2: Cell Specific Test Parameters for UL Transmit Timing test

Parameter	Unit	Config	Test1
SSB ARFCN		1,2,3	1
TDD configuration		1	TDDConf.1.1
		2	TDDConf.1.2
BW _{channel}	MHz	1	10: N _{RB,c} = 52
		2	10: N _{RB,c} = 52
		3	40: N _{RB,c} = 106
Initial BWP Configuration		1,2,3	DLBWP.0.1 ULBWP.0.1
Dedicated BWP Configuration		1,2,3	DLBWP.1.1 ULBWP.1.1
DRX Cycle	ms		N/A
PDSCH Reference measurement channel		1	SR.1.1 TDD
		2	SR.2.1 TDD
RMSI CORESET Reference Channel		1	CR.1.1 TDD
		2	CR.2.1 TDD
Dedicated CORESET Reference Channel		1	CCR.1.1 TDD
		2	CCR.2.1 TDD
OCNG Patterns		1,2,3	OP.1
SSB configuration		1,2	SSB.1 FR1
		3	SSB.2 FR1
SMTC Configuration		1,2	SMTC.1
		3	SMTC.2
TRS configuration		1	TRS.1.1 TDD
		2	TRS.1.2 TDD
EPRE ratio of PSS to SSS	dB	1,2,3	0
EPRE ratio of PBCH DMRS to SSS			
EPRE ratio of PBCH to PBCH DMRS			
EPRE ratio of PDCCH DMRS to SSS			
EPRE ratio of PDCCH to PDCCH DMRS			
EPRE ratio of PDSCH DMRS to SSS			
EPRE ratio of PDSCH to PDSCH			
EPRE ratio of OCNG DMRS to SSS(Note 1)			
EPRE ratio of OCNG to OCNG DMRS (Note 1)			
N_{oc} ^{Note2}			
N_{oc} ^{Note2}	dBm/SCS	1,2	-98
		3	-95
\hat{E}_s / I_{ot}		1,2,3	3
\hat{E}_s / N_{oc}		1,2,3	3
SS-RSRP ^{Note3}	dBm/SCS	1,2	-95
		3	-92
I _o ^{Note3}	dBm/9.36MHz	1,2	-65.2
	dBm/38.1MHz	3	-59.2
Propagation condition		1,2,3	AWGN
SRS Config		1,2	SRSCConf.1 ^{Note5}
		3	SRSCConf.1 ^{Note5}

Note 1:	OCNG shall be used such that the resources in Cell 1 are fully allocated and a constant total transmitted power spectral density is achieved for all OFDM symbols.
Note 2:	Interference from other cells and noise sources not specified in the test is assumed to be constant over subcarriers and time and shall be modelled as AWGN of appropriate power for N_{oc} to be fulfilled.
Note 3:	SS-RSRP and I_0 levels have been derived from other parameters for information purposes. They are not settable parameters themselves.
Note 4:	SS-RSRP minimum requirements are specified assuming independent interference and noise at each receiver antenna port.
Note 5:	SRS configs are given in Table G.2.2.1.1.1-3

Table G.2.2.1.1.1-3: SRS Configuration for Timing Accuracy Test

	Field	SRSCConf.1	Comments
SRS-ResourceSet	srs-ResourceSetId	0	
	srs-ResourceIdList	0	
	resourceType	Periodic	
SRS-Resource	Usage	Codebook	
	SRS-ResourceId	0	
	nrofSRS-Ports	Port1	
	transmissionComb	n2	
	combOffset-n2	0	
	cyclicShift-n2	0	
	resourceMapping	0	
	startPosition		
	resourceMapping	n1	
	nrofSymbols		
	resourceMapping	n1	
	repetitionFactor		
	freqDomainPosition	0	
	freqDomainShift	0	
	freqHopping	14 for test	Matches $N_{RB,c}$
	c-SRS	configuration 1,2	
		25 for test	
	configuration 3		
freqHopping	0		
b-SRS			
freqHopping	0		
b-hop			
groupOrSequenceHopping	Neither		
resourceType	Periodic		
periodicityAndOffset-p	s1, 0		
sequenceId	0	Any 10 bit number	

G.2.2.1.1.2 Test requirements

The test sequence shall be carried out in RRC_CONNECTED for every test case.

Following will be the test sequence for this test

- 1) Setup NR PCell according to parameters given in Table G.2.2.1.1.1-1.
- 2) After connection set up with the cell, the test equipment will verify that the timing of the NR cell is within $(N_{TA} + N_{TA_offset}) \times T_c \pm T_e$ of the first path (in time) of DL SSB used by the NCR-MT to determine downlink timing is received from the reference cell at the NCR-MT antenna.
 - a. The N_{TA} offset value (in T_c units) is 25600
 - b. The T_e values depend on the DL and UL SCS for which the test is being run and are given in Table 10.2.1.2-1
- 3) The test system shall adjust the timing of the DL path by values given in Table G.2.2.1.1.2-1

Table G.2.2.1.1.2-1: Adjustment Value for DL Timing

SCS of SSB signals (KHz)	Adjustment Value
15	Test1 $+64 \cdot 64 T_c$
30	$+32 \cdot 64 T_c$

- 4) The test system shall verify that the adjustment step size and the adjustment rate shall be according to requirements specified in clause 10.2.1.2 Table 10.2.1.2.1-1 until the NCR-MT transmit timing offset is within $(N_{TA} + N_{TA_offset}) \times T_c \pm T_e$ respective to the first path (in time) of DL SSB used by the NCR-MT to determine downlink timing is received from the reference cell at the NCR-MT antenna.
- 5) The test system shall verify that the NCR-MT transmit timing offset stays within $(N_{TA} + N_{TA_offset}) \times T_c \pm T_e$ of the first path (in time) of DL SSB used by the NCR-MT to determine downlink timing is received from the reference cell at the NCR-MT antenna.

G.2.2.1.2 NR NCR-MT Transmit Timing Test for FR2-1

G.2.2.1.2.1 Test Purpose and environment

The purpose of this test is to verify that the NCR-MT can follow frame timing change of the connected gNodeB and that the NCR-MT initial transmit timing accuracy, maximum amount of timing change in one adjustment, minimum and maximum adjustment rate are within the specified limits. This test will verify the requirements in clause 10.2.1.2. Local area NCR-MT type 2-O shall be tested with this test.

Supported test configurations are shown in Table G.2.2.1.2.1-1.

Table G.2.2.1.2.1-1: Supported test configurations for FR2-1 PCell

Configuration	Description
1	NR TDD, SSB SCS 240 kHz, data SCS 120 kHz, BW 100 MHz

For this test a single NR cell is used. Tables G.2.2.1.2.1-2 and Tables G.2.2.1.2.1-2A define the parameters to be configured and strength of the transmitted signals. The transmit timing is verified by the NCR-MT transmitting SRS using the configuration defined in Table G.2.2.1.2.1-3.

Table G.2.2.1.2.1-2: Cell Specific Test Parameters for UL Transmit Timing test

Parameter	Unit	Config	Test1	Test2
SSB ARFCN		1	Freq1	Freq1
$BW_{channel}$	MHz	1	100: $N_{RB,c} = 66$	
Initial BWP Configuration		1	DLBWP.0.1 ULBWP.0.1	
Dedicated BWP Configuration		1	DLBWP.1.1 ULBWP.1.1	
TRS Configuration		1	TRS.2.1 TDD	
TCI State		1	CSI-RS.Config.0	
DRx Cycle	ms		N/A	
PDSCH Reference measurement channel		1	SR.3.1 TDD	
RMSI CORESET Reference Channel		1	CR.3.1 TDD	
Dedicated CORESET Reference Channel		1	CCR.3.1 TDD	
OCNG Patterns		1	OP.1	
SSB Configuration		1	SSB.4 FR2-1	
SMTC Configuration		1	SMTC.1	
EPRE ratio of PSS to SSS	dB	1	0	0
EPRE ratio of PBCH DMRS to SSS				
EPRE ratio of PBCH to PBCH DMRS				
EPRE ratio of PDCCH DMRS to SSS				
EPRE ratio of PDCCH to PDCCH DMRS				
EPRE ratio of PDSCH DMRS to SSS				
EPRE ratio of PDSCH to PDSCH				
EPRE ratio of OCNG DMRS to SSS(Note 1)				
EPRE ratio of OCNG to OCNG DMRS (Note 1)				
Propagation condition				
SRS Config		1	SRSCConf.1 ^{Note5}	SRSCConf.2 ^{Note5}
Note 1:	OCNG shall be used such that both cells are fully allocated and a constant total transmitted power spectral density is achieved for all OFDM symbols.			
Note 2:	Interference from other cells and noise sources not specified in the test is assumed to be constant over subcarriers and time and shall be modelled as AWGN of appropriate power for N_{oc} to be fulfilled.			
Note 3:	SS-RSRP and I_o levels have been derived from other parameters for information purposes. They are not settable parameters themselves.			
Note 4:	SS-RSRP minimum requirements are specified assuming independent interference and noise at each receiver antenna port.			
Note 5:	SRS configs are given in Table G.2.2.1.2.1-3			

Table G.2.2.1.2.1-2A: OTA related test parameters

Parameter	Unit	Test 1	Test 2
Angle of arrival configuration		Setup 1 according to clause G.1.8	
N_{oc} ^{Note1}	dBm/15kHz ^{Note4}	-112	
N_{oc} ^{Note1}	dBm/SCS ^{Note3}	-103	
\hat{E}_s / N_{oc}	dB	4	
SS-RSRP ^{Note2}	dBm/SCS ^{Note4}	-99	
\hat{E}_s / I_{ot}	dB	4	
I_o ^{Note2}	dBm/95.04 MHz ^{Note4}	-68.5	
Note 1:	Interference from other cells and noise sources not specified in the test is assumed to be constant over subcarriers and time and shall be modelled as AWGN of appropriate power for N_{oc} to be fulfilled.		
Note 2:	SS-RSRP and I_o levels have been derived from other parameters for information purposes. They are not settable parameters themselves.		
Note 3:	SS-RSRP minimum requirements are specified assuming independent interference and noise at each receiver antenna port.		
Note 4:	Equivalent power received by an antenna with 0dBi gain at the centre of the quiet zone		
Note 5:	As observed with 0dBi gain antenna at the centre of the quiet zone		

Table G.2.2.1.2.1-3: SRS Configuration for Timing Accuracy Test

	Field	SRSCConf.1	SRSCConf.2	Comments
SRS-ResourceSet	srs-ResourceSetId	0	0	
	srs-ResourceIdList	0	0	
	resourceType	Periodic	Periodic	
	Usage	Codebook	Codebook	
SRS-Resource	SRS-ResourceId	0	0	
	nrofSRS-Ports	Port1	Port1	
	transmissionComb	n2	n2	
	combOffset-n2	0	0	
	cyclicShift-n2	0	0	
	resourceMapping startPosition	0	0	
	resourceMapping nrofSymbols	n1	n1	
	resourceMapping repetitionFactor	n1	n1	
	freqDomainPosition	0	0	
	freqDomainShift	0	0	
	freqHopping c-SRS	17	17	Matches $N_{RB,c}$
	freqHopping b-SRS	0	0	
	freqHopping b-hop	0	0	
	groupOrSequenceHopping	Neither	Neither	
	resourceType	Periodic	Periodic	
periodicityAndOffset-p	sl1, 0	sl2560, 4		
sequenceId	0	0	Any 10 bit number	

G.2.2.1.2.2 Test requirements

The test sequence shall be carried out in RRC_CONNECTED for every test case.

Following will be the test sequence for this test:

- 1) Setup NR PCell according to parameters given in Table G.2.2.1.2.1-1.

- 2) After connection set up with the cell, the test equipment will verify that the timing of the NR cell is within $(N_{TA} + N_{TA_offset}) \times T_c \pm T_e$ of the first path (in time) of DL SSB used by the NCR-MT to determine downlink timing is received from the reference cell at the NCR-MT antenna.
 - a. The N_{TA} offset value (in T_c units) is 13792
 - b. The T_e values depend on the DL and UL SCS for which the test is being run and are given in Table 10.2.1.2-1
- 3) The test system shall adjust the timing of the DL path by values given in Table G.2.2.1.2.2-1

Table G.2.2.1.2.2-1: Adjustment Value for DL Timing

SCS of SSB signals (kHz)	Adjustment Value	
	Test1	Test2
240	$+8*64T_c$	$+4*64T_c$

- 4) The test system shall verify that the adjustment step size and the adjustment rate shall be according to requirements specified in clause 10.2.1.2 Table 10.2.1.2.1-1 until the NCR-MT transmit timing offset is within $(N_{TA} + N_{TA_offset}) \times T_c \pm T_e$ respective to the first path (in time) of DL SSB used by the NCR-MT to determine downlink timing is received from the reference cell at the NCR-MT antenna.
- 5) The test system shall verify that the NCR-MT transmit timing offset stays within $(N_{TA} + N_{TA_offset}) \times T_c \pm T_e$ of the first path (in time) of DL SSB used by the NCR-MT to determine downlink timing is received from the reference cell at the NCR-MT antenna.

G.2.3 Signalling Characteristics for NCR MTs

G.2.3.1 Radio link Monitoring

G.2.3.1.1 Radio Link Monitoring Out-of-sync Test for FR1 PCell configured with SSB-based RLM RS in non-DRX mode

G.2.3.1.1.1 Test Purpose and Environment

The purpose of this test is to verify that the NCR-MT properly detects the out of sync and in sync for the purpose of monitoring downlink radio link quality of the PCell. This test will partly verify the FR1 radio link monitoring requirements in clause 12.3.1.

In the test, NCR-MT is configured to perform RLM on SSB, with *detectionResource* included in *RadioLinkMonitoringRS* set to SSB#0 and SSB#1, and *purpose* set to 'rlf'. Supported test configurations are shown in table G.2.3.1.1.1-1. The test parameters are given in Tables G.2.3.1.1-2 and G.2.3.1.1-3 below. There is one cell (Cell 1), which is the active NR cell, in the test. The test consists of three successive time periods, with time duration of T1, T2 and T3 respectively. Figure G.2.3.1.1.1-1 shows the variation of the downlink SNR in the active cell to emulate out-of-sync and in-sync states. Prior to the start of the time duration T1, the NCR-MT shall be fully synchronized to Cell 1. The NCR-MT shall be configured for periodic CSI reporting with a reporting periodicity of 5 ms.

Table G.2.3.1.1.1-1: Supported test configurations for FR1 PCell

Configuration	Description
1	TDD, SSB SCS 15 kHz, data SCS 15 kHz, BW 10 MHz
2	TDD, SSB SCS 30 kHz, data SCS 30 kHz, BW 40 MHz
Note:	The NCR-MT is only required to pass in one of the supported test configurations in FR1

Table G.2.3.1.1-2: General test parameters for FR1 out-of-sync testing in non-DRX mode

Parameter		Unit	Value
			Test 1
Active PCell			Cell 1
RF Channel Number			1
Duplex mode	Config 1,2		TDD
BWchannel	Config 1	MHz	10: NRB,c = 52
	Config 2		40: NRB,c = 106
DL initial BWP configuration	Config 1, 2		DLBWP.0.1
DL dedicated BWP configuration	Config 1, 2		DLBWP.1.1
UL initial BWP configuration	Config 1, 2		ULBWP.0.1
UL dedicated BWP configuration	Config 1, 2		ULBWP.1.1
TDD Configuration	Config 1		TDDConf.1.1
	Config 2		TDDConf.2.1
CORESET	Config 1		CR.1.1 TDD
Reference Channel	Config 2		CR.2.1 TDD
SSB Configuration	Config 1		SSB.1 FR1
	Config 2		SSB.2 FR1
SMTTC Configuration	Config 1		SMTTC.1
	Config 2		SMTTC.1
PDSCH/PDCCH subcarrier spacing	Config 1		15 kHz
	Config 2		30 kHz
PRACH Configuration	Config 1		TBD
	Config 2		TBD
SSB index assigned as RLM RS			0
OCNG parameters			OP.1
CP length			Normal
Correlation Matrix and Antenna Configuration			2x2 Low
Out of sync transmission parameters	DCI format		1-0
	Number of Control OFDM symbols		2
	Aggregation level	CCE	8
	Ratio of hypothetical PDCCH RE energy to average SSS RE energy	dB	4
	Ratio of hypothetical PDCCH DMRS energy to average SSS RE energy	dB	4
	DMRS precoder granularity		REG bundle size
	REG bundle size		6
DRX			OFF
Layer 3 filtering			Enabled
T310 timer		ms	0
T311 timer		ms	1000
N310			1
N311			1
CSI-RS configuration for CSI reporting	Config 1		CSI-RS.1.1 TDD
	Config 2		CSI-RS.2.1 TDD
CSI-RS for tracking	Config 1		TRS.1.1 TDD
	Config 2		TRS.1.2 TDD
T1		s	0.2
T2		s	1.08
T3		s	1.08
D1		s	1.04
Note 1: All configurations are assigned to the NCR-MT prior to the start of time period T1.			
Note 2: NCR-MT-specific PDCCH is not transmitted after T1 starts.			

Table G.2.3.1.1.1-3: Cell specific test parameters for FR1 (Cell 1) for out-of-sync radio link monitoring tests in non-DRX mode

Parameter		Unit	Test 1		
			T1	T2	T3
EPRE ratio of PDCCH DMRS to SSS		dB	4		
EPRE ratio of PDCCH to PDCCH DMRS			0		
EPRE ratio of PBCH DMRS to SSS			0		
EPRE ratio of PBCH to PBCH DMRS					
EPRE ratio of PSS to SSS					
EPRE ratio of PDSCH DMRS to SSS					
EPRE ratio of PDSCH to PDSCH DMRS					
EPRE ratio of OCNG DMRS to SSS					
EPRE ratio of OCNG to OCNG DMRS					
SNR on RLM-RS	Config 1	dB	1	-7	-15
	Config 2		1	-7	-15
	Config 3		1	-7	-15
SNR on other channels and signals	Config 1, 2, 3	dB	1		
N_{oc}	Config 1		-98		
	Config 2	dBm/SCS	-95		
Propagation condition			TDL-C 300ns 100Hz		
<p>Note 1: OCNG shall be used such that the resources in Cell 1 are fully allocated and a constant total transmitted power spectral density is achieved for all OFDM symbols.</p> <p>Note 2: The signal contains PDCCH for NCR-MTs other than the device under test as part of OCNG.</p> <p>Note 3: SNR levels correspond to the signal to noise ratio over the SSS REs.</p> <p>Note 4: The SNR in time periods T1, T2 and T3 is denoted as SNR1, SNR2 and SNR3 respectively in Figure G.2.3.1.1.1-1.</p> <p>Note 5: The SNR values are specified for testing an NCR-MT which supports 2RX on at least one band. For testing of an NCR-MT which supports 4RX on all bands, the SNR during T3 is defined in clause G.1.3</p>					

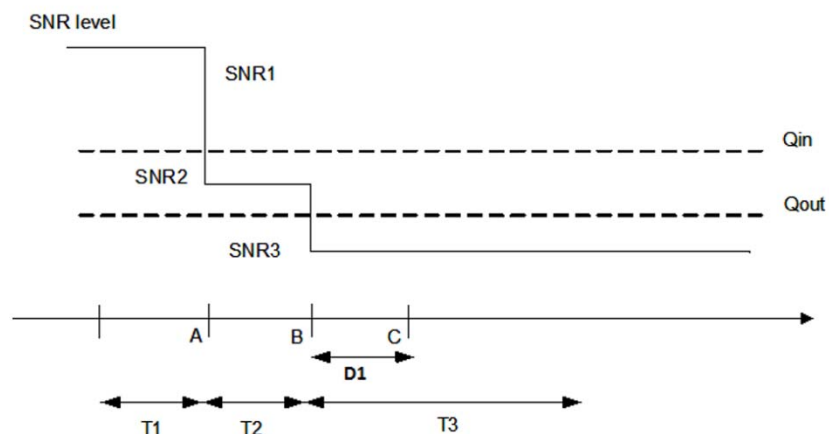

Figure G.2.3.1.1.1-1: SNR variation for out-of-sync testing

G.2.3.1.1.2 Test Requirements

The NCR-MT behaviour in each test during time durations T1, T2 and T3 shall be as follows:

During the period from time point A to time point B the NCR-MT shall transmit uplink signal at least in all uplink slots configured for CSI transmission according to the configured periodic CSI reporting.

The NCR-MT shall stop transmitting uplink signal no later than time point C (D1 second after the start of the time duration T3).

The rate of correct events observed during repeated tests shall be at least 90%.

G.2.3.1.2 Radio Link Monitoring In-sync Test for FR1 PCell configured with SSB-based RLM RS in non-DRX mode

G.2.3.1.2.1 Test Purpose and Environment

The purpose of this test is to verify that the NCR-MT properly detects the out of sync and in sync for the purpose of monitoring downlink radio link quality of the PCell. This test will partly verify the FR1 radio link monitoring requirements in clause 12.3.1.

In the test, NCR-MT is configured to perform RLM on SSB, with *detectionResource* included in *RadioLinkMonitoringRS* set to SSB#0 and SSB#1, and *purpose* set to 'rlf'. Supported test configurations are shown in table G.2.3.1.2.1-1. The test parameters are given in Tables G.2.3.1.2.1-2, and G.2.3.1.2.1-3 below. There is one cell (Cell 1), which is the active cell, in the test. The test consists of five successive time periods, with time duration of T1, T2, T3, T4 and T5 respectively. Figure G.2.3.1.2.1-1 shows the variation of the downlink SNR in the active cell to emulate out-of-sync and in-sync states. Prior to the start of the time duration T1, the NCR-MT shall be fully synchronized to Cell 1. Prior to the start of the time duration T1, the NCR-MT shall be fully synchronized to Cell 1. The NCR-MT shall be configured for periodic CSI reporting with a reporting periodicity of 5 ms.

Table G.2.3.1.2.1-1: Supported test configurations for FR1 PCell

Configuration	Description
1	TDD, SSB SCS 15 kHz, data SCS 15 kHz, BW 10 MHz
2	TDD, SSB SCS 30 kHz, data SCS 30 kHz, BW 40 MHz
Note:	The NCR-MT is only required to pass in one of the supported test configurations in FR1

Table G.2.3.1.2.1-2: General test parameters for FR1 in-sync testing in non-DRX mode

Parameter		Unit	Value
			Test 1
Active PCell			Cell 1
RF Channel Number			1
Duplex mode	Config 1, 2		TDD
BW _{channel}	Config 1	MHz	10: N _{RB,c} = 52
	Config 2		40: N _{RB,c} = 106
DL initial BWP configuration	Config 1, 2		DLBWP.0.1
DL dedicated BWP configuration	Config 1, 2		DLBWP.1.1
UL initial BWP configuration	Config 1, 2		ULBWP.0.1
UL dedicated BWP configuration	Config 1, 2		ULBWP.1.1
TDD Configuration	Config 1		TDDConf.1.1
	Config 2		TDDConf.2.1
CORESET Reference Channel	Config 1		CR.1.1 TDD
	Config 2		CR.2.1 TDD
SSB Configuration	Config 1		SSB.1 FR1
	Config 2		SSB.2 FR1
SMTC Configuration	Config 1,2		SMTC.1
PDSCH/PDCCH subcarrier spacing	Config 1		15 kHz
	Config 2		30 kHz
PRACH Configuration	Config 1		TBD
	Config 2		TBD
SSB index assigned as RLM RS			0
OCNG parameters			OP.1
CP length			Normal
Correlation Matrix and Antenna Configuration			2x2 Low
In sync transmission parameters	DCI format		1-0
	Number of Control OFDM symbols		2
	Aggregation level	CCE	4
	Ratio of hypothetical PDCCH RE energy to average SSS RE energy	dB	0
	Ratio of hypothetical PDCCH DMRS energy to average SSS RE energy	dB	0
	DMRS precoder granularity		REG bundle size
	REG bundle size		6
Out of sync transmission parameters	DCI format		1-0
	Number of Control OFDM symbols		2
	Aggregation level	CCE	8
	Ratio of hypothetical PDCCH RE energy to average SSS RE energy	dB	4
	Ratio of hypothetical PDCCH DMRS energy to average SSS RE energy	dB	4
	DMRS precoder granularity		REG bundle size
	REG bundle size		6
DRX			OFF
Layer 3 filtering			Enabled
T310 timer		ms	1000
T311 timer		ms	1000

N310		1
N311		1
CSI-RS configuration for CSI reporting	Config 1	CSI-RS.1.1 TDD
	Config 2	CSI-RS.2.1 TDD
CSI-RS for tracking	Config 1	TRS.1.1 TDD
	Config 2	TRS.1.2 TDD
T1	s	0.2
T2	s	0.2
T3	s	1.04
T4	s	0.2
T5	s	2.02
D1	s	1.98
Note 1: All configurations are assigned to the NCR-MT prior to the start of time period T1.		
Note 2: NCR-MT-specific PDCCH is not transmitted after T1 starts.		

Table G.2.3.1.2.1-3: Cell specific test parameters for FR1 (Cell 1) for in-sync radio link monitoring tests in non-DRX mode

Parameter	Unit	Test 1					
		T1	T2	T3	T4	T5	
EPRE ratio of PDCCH DMRS to SSS	dB	4					
EPRE ratio of PDCCH to PDCCH DMRS	dB	0					
EPRE ratio of PBCH DMRS to SSS	dB	0					
EPRE ratio of PBCH to PBCH DMRS	dB						
EPRE ratio of PSS to SSS	dB						
EPRE ratio of PDSCH DMRS to SSS	dB						
EPRE ratio of PDSCH to PDSCH DMRS	dB						
EPRE ratio of OCNG DMRS to SSS	dB						
EPRE ratio of OCNG to OCNG DMRS	dB						
SNR on RLM-RS	Config 1						dB
	Config 2		1	-7	-15	-4.5	1
	Config 3		1	-7	-15	-4.5	1
SNR on other channels and signals	Config 1, 2, 3	dB	1				
N_{oc}	Config 1	dBm/SCS	-98				
	Config 2		-95				
Propagation condition			TDL-C 300ns 100Hz				
Note 1: OCNG shall be used such that the resources in Cell 1 are fully allocated and a constant total transmitted power spectral density is achieved for all OFDM symbols.							
Note 2: The signal contains PDCCH for NCR-MTs other than the device under test as part of OCNG.							
Note 3: SNR levels correspond to the signal to noise ratio over the SSS REs.							
Note 4: The SNR in time periods T1, T2, T3, T4 and T5 is denoted as SNR1, SNR2, SNR3, SNR4 and SNR5 respectively in Figure G.2.3.1.2.1-1.							
Note 5: The SNR values are specified for testing an NCR-MT which supports 2RX on at least one band. For testing of an NCR-MT which supports 4RX on all bands, the SNR during T3 and T4 is modified as specified in clause G.1.3.							

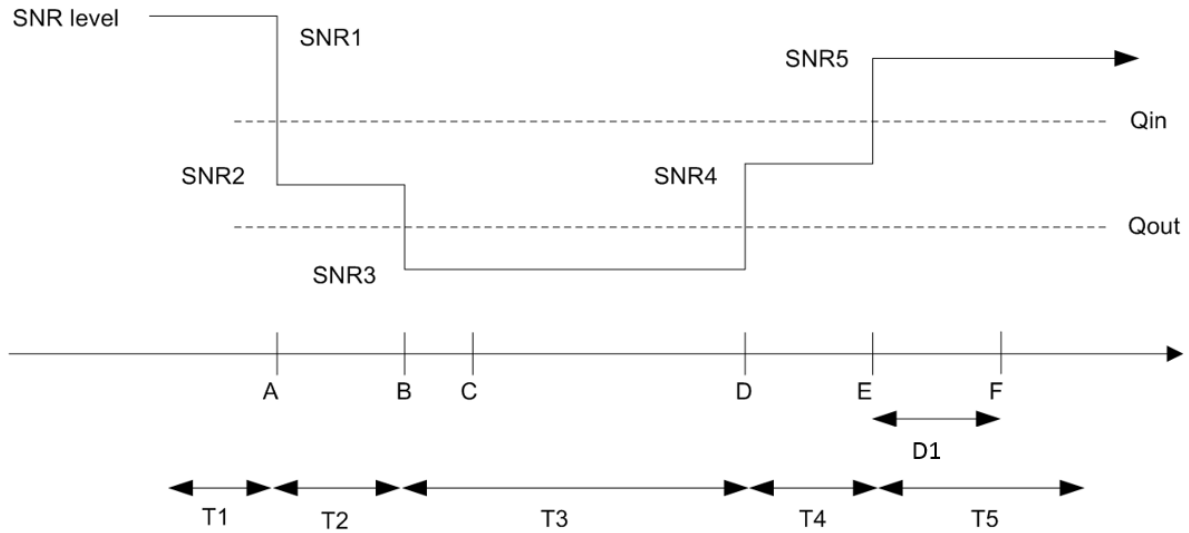

Figure G.2.3.1.2.1-1: SNR variation for in-sync testing

G.2.3.1.2.2 Test Requirements

The NCR-MT behaviour in each test during time durations T1, T2, T3, T4 and T5 shall be as follows:

During the period from time point A to time point F (D1 second after the start of time duration T5) the NCR-MT shall transmit uplink signal at least in all uplink slots configured for CSI transmission according to the configured periodic CSI reporting.

The rate of correct events observed during repeated tests shall be at least 90%.

G.2.3.1.3 Radio Link Monitoring Out-of-sync Test for FR2-1 PCell configured with SSB-based RLM RS in non-DRX mode

G.2.3.1.3.1 Test Purpose and Environment

The purpose of this test is to verify that the NCR-MT properly detects the out of sync and in sync for the purpose of monitoring downlink radio link quality of the PCell. This test will partly verify the FR2-1 radio link monitoring requirements in clause 12.3.1.

In the test, NCR-MT is configured to perform RLM on SSB, with *detectionResource* included in *RadioLinkMonitoringRS* set to SSB#0 and SSB#1, and *purpose* set to 'rlf'. Supported test configurations are shown in table G.2.3.1.3.1-1. The test parameters are given in Tables G.2.3.1.3.1-2 and G.2.3.1.3.1-3 below. There is one cell (Cell 1), which is the active NR cell, in the test. The test consists of three successive time periods, with time duration of T1, T2 and T3 respectively. Figure G.2.3.1.3.1-1 shows the variation of the downlink SNR in the active cell to emulate out-of-sync and in-sync states, and Figure G.2.3.1.3.1-2 shows the Time multiplexed downlink transmissions from each Angle of Arrival. Prior to the start of the time duration T1, the NCR-MT shall be fully synchronized to Cell 1. The NCR-MT shall be configured for periodic CSI reporting with a reporting periodicity of 5 ms.

Table G.2.3.1.3.1-1: Supported test configurations for FR2-1 PCell

Configuration	Description
1	TDD, SSB SCS 120 KHz, data SCS 120KHz, BW 100 MHz

Table G.2.3.1.3.1-2: General test parameters for FR2-1 out-of-sync testing in non-DRX mode

Parameter		Unit	Value
			Test 1
Active PCell			Cell 1
RF Channel Number			1
Duplex mode	Config 1		TDD
BW_{channel}	Config 1		100: $N_{RB,c} = 66$
DL initial BWP configuration	Config 1		DLBWP.0.1
DL dedicated BWP configuration	Config 1		DLBWP.1.1
UL initial BWP configuration	Config 1		ULBWP.0.1
UL dedicated BWP configuration	Config 1		ULBWP.1.1
TDD Configuration	Config 1		TDDConf.3.1
CORESET Reference Channel	Config 1		CR.3.1 TDD
SSB Configuration	Config 1		SSB.1 FR2
SMTTC Configuration	Config 1		SMTTC.1
PDSCH/PDCCH subcarrier spacing	Config 1		120 KHz
PRACH Configuration	Config 1		TBD
SSB index assigned as RLM RS	Config 1		0,1
OCNG parameters			OP.2
CP length			Normal
Out of sync transmission parameters	DCI format		1-0
	Number of Control OFDM symbols		2
	Aggregation level	CCE	8
	Ratio of hypothetical PDCCH RE energy to average SSS RE energy	dB	4
	Ratio of hypothetical PDCCH DMRS energy to average SSS RE energy	dB	4
	DMRS precoder granularity		REG bundle size
REG bundle size			6
DRX			OFF
Layer 3 filtering			<i>Enabled</i>
T310 timer		ms	0
T311 timer		ms	1000
N310			1
N311			1
CSI-RS for CSI reporting	Config 1		CSI-RS.3.1 TDD
TCI states for PDCCH/PDSCH			TCI.State.2
CSI-RS for tracking	Config 1		TRS.2.1 TDD
T1		s	0.2
T2		s	4.88
T3		s	4.88
D1		s	4.84
Note 1:		All configurations are assigned to the NCR-MT prior to the start of time period T1.	
Note 2:		NCR-MT-specific PDCCH is not transmitted after T1 starts.	

Table G.2.3.1.3.1-3: OTA related cell specific test parameters for FR2-1 (Cell 1) for out-of-sync radio link monitoring tests in non-DRX mode

Parameter		Unit	Test 1					
			T1	T2	T3	T1	T2	T3
AoA setup			Setup 2 as specified in clause G.1.8.2					
			AoA1			AoA2		
EPRE ratio of PDCCH DMRS to SSS		dB	4			Not sent		
EPRE ratio of PDCCH to PDCCH DMRS		dB	0					
EPRE ratio of PBCH DMRS to SSS		dB						
EPRE ratio of PBCH to PBCH DMRS		dB						
EPRE ratio of PSS to SSS		dB						
EPRE ratio of PDSCH DMRS to SSS		dB						
EPRE ratio of PDSCH to PDSCH DMRS		dB						
EPRE ratio of OCNG DMRS to SSS		dB						
EPRE ratio of OCNG to OCNG DMRS		dB						
ssb-Index 0 SNR	Config 1	dB	2 ^{Note 6}	-6 ^{Note 6}	-15			
ssb-Index 1 SNR	Config 1		Not sent			2 ^{Note 6}	-15	-15
SNR on other channels and signals	Config 1	dB	2 ^{Note 6}			N/A		
N_{oc}	Config 1	dBm/15kHz	-92.1			-92.1		
Time multiplexing of the downlink transmissions from each AoA			Defined in Figure G.2.3.1.3.1-2					
Propagation condition			TDL-A 30ns 75Hz			TDL-A 30ns 75Hz		
<p>Note 1: OCNG shall be used such that the resources in Cell 1 are fully allocated and a constant total transmitted power spectral density is achieved for all OFDM symbols.</p> <p>Note 2: The signal contains PDCCH for NCR-MTs other than the device under test as part of OCNG.</p> <p>Note 3: SNR levels correspond to the signal to noise ratio over the SSS REs.</p> <p>Note 4: The SNR values are specified for testing an NCR-MT which supports 2RX on at least one band. For testing of an NCR-MT which supports 4RX on all bands, the SNR during T3 is defined in clause G.1.3.</p> <p>Note 5: Void</p> <p>Note 6: This value allows up to 1dB degradation from applied SNR to NCR-MT baseband.</p>								

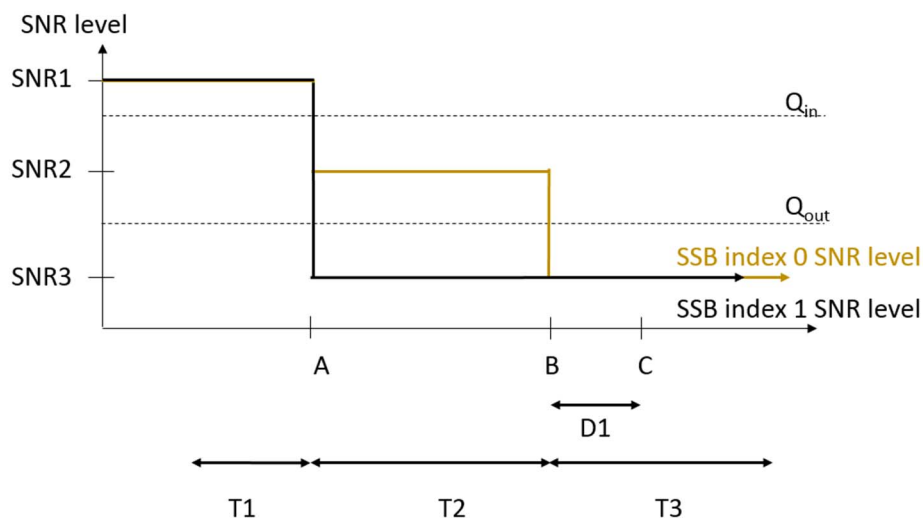

Figure G.2.3.1.3.1-1: SNR variation for out-of-sync testing

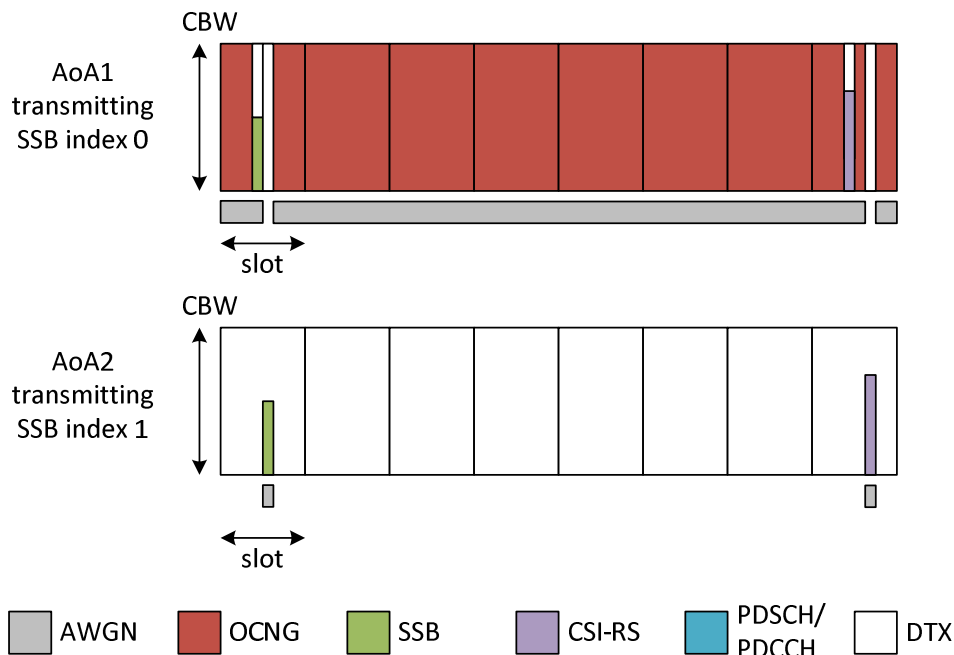

Figure G.2.3.1.3.1-2: Time multiplexed downlink transmissions

G.2.3.1.3.2 Test Requirements

The NCR-MT behavior in each test during time durations T1, T2 and T3 shall be as follows:

During the period from time point A to time point B the NCR-MT shall transmit uplink signal at least in all uplink slots configured for CSI transmission according to the configured periodic CSI reporting.

The NCR-MT shall stop transmitting uplink signal no later than time point C (D1 second after the start of the time duration T3).

The rate of correct events observed during repeated tests shall be at least 90%.

G.2.3.1.4 Radio Link Monitoring In-sync Test for FR2-1 PCell configured with SSB-based RLM RS in non-DRX mode

G.2.3.1.4.1 Test Purpose and Environment

The purpose of this test is to verify that the NCR-MT properly detects the out of sync and in sync for the purpose of monitoring downlink radio link quality of the PCell. This test will partly verify the FR2-1 radio link monitoring requirements in clause 12.3.1.

In the test, NCR-MT is configured to perform RLM on SSB, with *detectionResource* included in *RadioLinkMonitoringRS* set to SSB#0 and SSB#1, and *purpose* set to 'rlf'. Supported test configurations are shown in table G.2.3.1.4.1-1. The test parameters are given in Tables G.2.3.1.4.1-2, and G.2.3.1.4.1-3 below. There is one cell (Cell 1), which is the active cell, in the test. The test consists of five successive time periods, with time duration of T1, T2, T3, T4 and T5 respectively. Figure G.2.3.1.4.1-1 shows the variation of the downlink SNR in the active cell to emulate out-of-sync and in-sync states, and Figure G.2.3.1.4.1-2 shows the Time multiplexed downlink transmissions from each Angle of Arrival. Prior to the start of the time duration T1, the NCR-MT shall be fully synchronized to Cell 1. Prior to the start of the time duration T1, the NCR-MT shall be fully synchronized to Cell 1. The NCR-MT shall be configured for periodic CSI reporting with a reporting periodicity of 5 ms.

Table G.2.3.1.4.1-1: Supported test configurations for FR2-1 PCell

Configuration	Description
1	TDD, SSB SCS 120 KHz, data SCS 120KHz, BW 100 MHz

Table G.2.3.1.4.1-2: General test parameters for FR2-1 in-sync testing in non-DRX mode

Parameter		Unit	Value
			Test 1
Active PCell			Cell 1
RF Channel Number			1
Duplex mode	Config 1		TDD
BW _{channel}	Config 1		100: N _{RB,c} = 66
DL initial BWP configuration	Config 1		DLBWP.0.1
DL dedicated BWP configuration	Config 1		DLBWP.1.1
UL initial BWP configuration	Config 1		ULBWP.0.1
UL dedicated BWP configuration	Config 1		ULBWP.1.1
TDD Configuration	Config 1		TDDConf.3.1
CORESET Reference Channel	Config 1		CR.3.1 TDD
SSB Configuration	Config 1		SSB.1 FR2-1
SMTC Configuration	Config 1		SMTC.3
PDSCH/PDCCH subcarrier spacing	Config 1		120 KHz
PRACH Configuration	Config 1		TBD
SSB index assigned as RLM RS	Config 1		0,1
OCNG parameters			OP.2
CP length			Normal
In sync transmission parameters	DCI format		1-0
	Number of Control OFDM symbols		2
	Aggregation level	CCE	4
	Ratio of hypothetical PDCCH RE energy to average SSS RE energy	dB	0
	Ratio of hypothetical PDCCH DMRS energy to average SSS RE energy	dB	0
	DMRS precoder granularity		REG bundle size
	REG bundle size		6
Out of sync transmission parameters	DCI format		1-0
	Number of Control OFDM symbols		2
	Aggregation level	CCE	8
	Ratio of hypothetical PDCCH RE energy to average SSS RE energy	dB	4
	Ratio of hypothetical PDCCH DMRS energy to average SSS RE energy	dB	4
	DMRS precoder granularity		REG bundle size
	REG bundle size		6
DRX			OFF
Layer 3 filtering			<i>Enabled</i>
T310 timer		ms	4000
T311 timer		ms	1000
N310			1
N311			1
CSI-RS for CSI reporting	Config 1		CSI-RS.3.1 TDD
TCI states for PDCCH/PDSCH			TCI.State.2
CSI-RS for tracking	Config 1		TRS.2.1 TDD
T1		s	0.2
T2		s	0.2
T3		s	4.84
T4		s	0.2
T5		s	7.84
D1		s	7.8
Note 1: All configurations are assigned to the NCR-MT prior to the start of time period T1.			
Note 2: NCR-MT-specific PDCCH is not transmitted after T1 starts.			

Table G.2.3.1.4.1-3: OTA related cell specific test parameters for FR2-1 (Cell 1) for in-sync radio link monitoring tests in non-DRX mode

Parameter		Unit	Test 1									
			T1	T2	T3	T4	T5	T1	T2	T3	T4	T5
AoA setup			Setup 2 as specified in clause G.1.8.2									
			AoA1					AoA2				
EPRE ratio of PDCCH DMRS to SSS		dB	4					Not sent				
EPRE ratio of PDCCH to PDCCH DMRS		dB	0									
EPRE ratio of PBCH DMRS to SSS		dB										
EPRE ratio of PBCH to PBCH DMRS		dB										
EPRE ratio of PSS to SSS		dB										
EPRE ratio of PDSCH DMRS to SSS		dB										
EPRE ratio of PDSCH to PDSCH DMRS		dB										
EPRE ratio of OCNG DMRS to SSS		dB										
EPRE ratio of OCNG to OCNG DMRS		dB										
ssb-Index 0 SNR	Config 1	dB	² Note 6	⁻⁶ Note 6	-15	-4.5	² Note 6					
ssb-Index 1 SNR	Config 1		Not sent					² Note 6	-15	-15	-15	-15
SNR on other channels and signals	Config 1	dB	² Note 6					N/A				
N_{oc}	Config 1	dBm/15kHz	-92.1					-92.1				
Time multiplexing of the downlink transmissions from each AoA			Defined in Figure G.2.3.1.4.1-2									
Propagation condition			TDL-A 30ns 75Hz					TDL-A 30ns 75Hz				
Note 1: OCNG shall be used such that the resources in Cell 1 are fully allocated and a constant total transmitted power spectral density is achieved for all OFDM symbols. Note 2: The signal contains PDCCH for NCR-MTs other than the device under test as part of OCNG. Note 3: SNR levels correspond to the signal to noise ratio over the SSS REs. Note 4: The SNR values are specified for testing an NCR-MT which supports 2RX on at least one band. For testing of an NCR-MT which supports 4RX on all bands, the SNR during T3 is defined in clause G.1.3. Note 5: Void. Note 6: This value allows up to 1dB degradation from applied SNR to NCR-MT baseband												

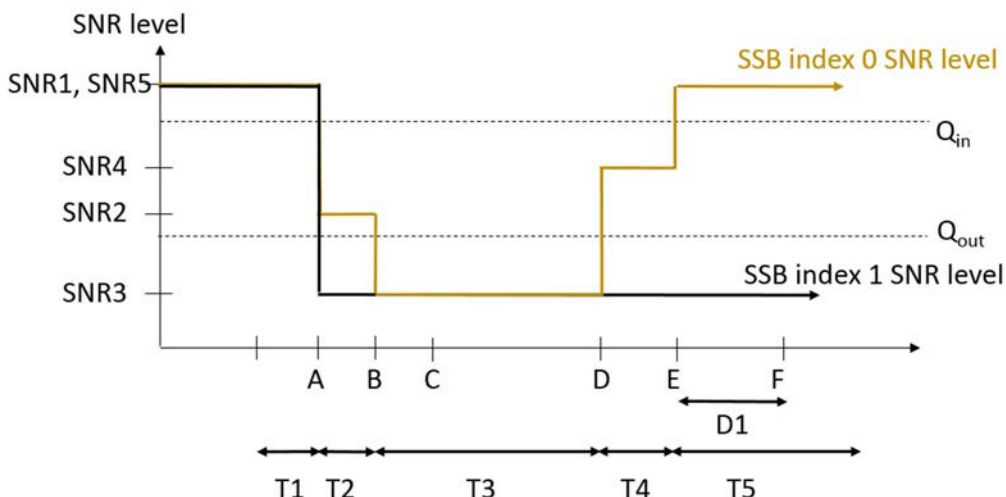

Figure G.2.3.1.4.1-1: SNR variation for in-sync testing

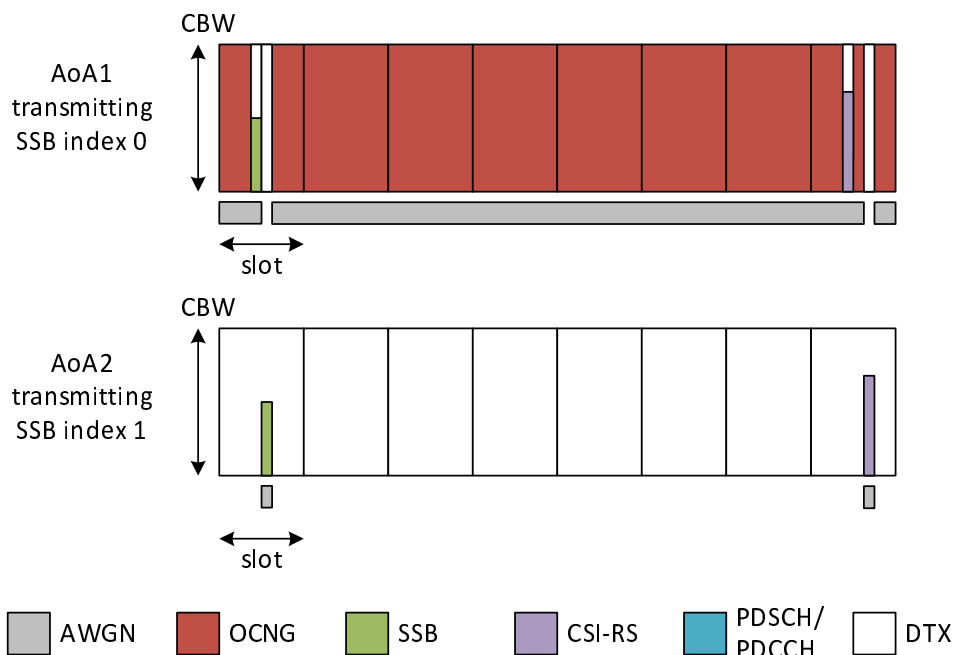

Figure G.2.3.1.4.1-2: Time multiplexed downlink transmissions

G.2.3.1.4.2 Test Requirements

The NCR-MT behaviour in each test during time durations T1, T2, T3, T4 and T5 shall be as follows:

During the period from time point A to time point F (D1 second after the start of time duration T5) the NCR-MT shall transmit uplink signal at least in all uplink slots configured for CSI transmission according to the configured periodic CSI reporting.

The rate of correct events observed during repeated tests shall be at least 90%.

G.2.3.1.5 Radio Link Monitoring Out-of-sync Test for FR1 PCell configured with CSI-RS-based RLM in non-DRX mode

G.2.3.1.5.1 Test Purpose and Environment

The purpose of this test is to verify that the NCR-MT properly detects the out of sync for the purpose of monitoring downlink CSI-RS based radio link quality of the PCell. This test will partly verify the FR1 PCell CSI-RS Out-of-sync radio link monitoring requirements in clause 12.3.1.3. This test case is applicable only for local area NCR-MT and for NCR type 1-H.

The test parameters are given in Tables G.2.3.1.5.1-1, G.2.3.1.5.1-2 and G.2.3.1.5.1-3 below. There is one cell, cell 1 which is the PCell, in the test. The test consists of three successive time periods, with time duration of T1, T2 and T3 respectively. Figure G.2.3.1.5.1-1 shows the variation of the downlink SNR in the PCell to emulate out-of-sync and in-sync states. Prior to the start of the time duration T1, the NCR-MT shall be fully synchronized to cell 1. The NCR-MT shall be configured for periodic CSI reporting with a reporting periodicity defined in CSI-RS configuration. In the test, SSB0 is configured as the BFD-RS.

Table G.2.3.1.5.1-1: Supported test configurations for FR1 PCell

Configuration	Description
1	TDD duplex mode, 15 kHz SSB SCS, 10 MHz bandwidth
2	TDD duplex mode, 30 kHz SSB SCS, 40 MHz bandwidth
Note:	The NCR-MT is only required to pass in one of the supported test configurations in FR1

Table G.2.3.1.5.1-2: General test parameters for FR1 PCell for CSI-RS out-of-sync testing in non-DRX

Parameter		Unit	NCR-MT Test 1
Active PCell			Cell 1
RF Channel Number			1
Duplex mode	Config 1, 2		TDD
TDD Configuration	Config 1		TDDConf.1.1
	Config 2		TDDConf.2.1
DL initial BWP configuration	Config 1, 2		DLBWP.0.1
DL dedicated BWP configuration	Config 1, 2		DLBWP.1.1
UL initial BWP configuration	Config 1, 2		ULBWP.0.1
UL dedicated BWP configuration	Config 1, 2		ULBWP.1.1
CORESET Reference Channel	Config 1		CR.1.1 TDD
	Config 2		CR.2.1 TDD
SSB Configuration	Config 1		SSB.1 FR1
	Config 2		SSB.2 FR1
SMTC Configuration	Config 1		SMTC.1
	Config 2		SMTC.1
PDSCH/PDCCH subcarrier spacing	Config 1		15 kHz
	Config 2		30 kHz
TRS configuration	Config 1		TRS.1.1 TDD
	Config 2		TRS.1.2 TDD
CSI-RS for RLM	Config 1		Resource #4 in TRS.1.1 TDD
	Config 2		Resource #4 in TRS.1.2 TDD
TCI configuration for PDCCH/PDSCH			TCI.State.2
OCNG parameters			OP.1
CP length			Normal
Correlation Matrix and Antenna Configuration			2x2 Low
Out of sync transmission parameters	DCI format		1-0
	Number of Control OFDM symbols		2
	Aggregation level	CCE	8
	Ratio of hypothetical PDCCH RE energy to average CSI-RS RE energy	dB	4
	Ratio of hypothetical PDCCH DMRS energy to average CSI-RS RE energy	dB	4
	DMRS precoder granularity		REG bundle size
	REG bundle size		6
Layer 3 filtering			<i>Enabled</i>
T310 timer		ms	0
T311 timer		ms	1000
N310			1
N311			1
CSI-RS configuration for CSI reporting	Config 1		CSI-RS.1.1 TDD
	Config 2		CSI-RS.2.1 TDD
T1		s	0.2
T2		s	48
T3		s	0.48
D1		s	0.44
Note 1: NCR-MT-specific PDCCH is not transmitted after T1 starts.			

Table G.2.3.1.5.1-3: Cell specific test parameters for FR1 for CSI-RS out-of-sync radio link monitoring in non-DRX

Parameter		Unit	Test 1		
			T1	T2	T3
PDCCH_beta		dB	4		
PDCCH_DMRS_beta		dB	4		
PBCH_beta		dB	0		
PSS_beta		dB			
SSS_beta		dB			
PDSCH_beta		dB			
OCNG_beta		dB			
SNR on RLM-RS	Config 1, 2	dB	1	-7	-15
SNR on other channels and signals	Config 1, 2	dB	1		
N_{oc}	Config 1, 2	dBm/15kHz	-98		
Propagation condition			TDL-C 300ns 100Hz		
Note 1: OCNG shall be used such that the resources in Cell 1 are fully allocated and a constant total transmitted power spectral density is achieved for all OFDM symbols. Note 2: The uplink resources for CSI reporting are assigned to the NCR-MT prior to the start of time period T1. Note 3: NZP CSI-RS resource set configuration for CSI reporting are assigned to the NCR-MT prior to the start of time period T1. Note 4: The timers and layer 3 filtering related parameters are configured prior to the start of time period T1. Note 5: The signal contains PDCCH for NCR-MTs other than the device under test as part of OCNG. Note 6: SNR levels correspond to the signal to noise ratio over the SSS REs. Note 7: The SNR in time periods T1, T2 and T3 is denoted as SNR1, SNR2 and SNR3 respectively in figure G.2.3.1.5.1-1. Note 8: The SNR NCR-MTs are specified for testing a NCR-MT which supports 2RX on at least one band. For testing of NCR-MT which supports 4RX on all bands, the SNR during T3 is specified in clause G.1.3.1.1.					

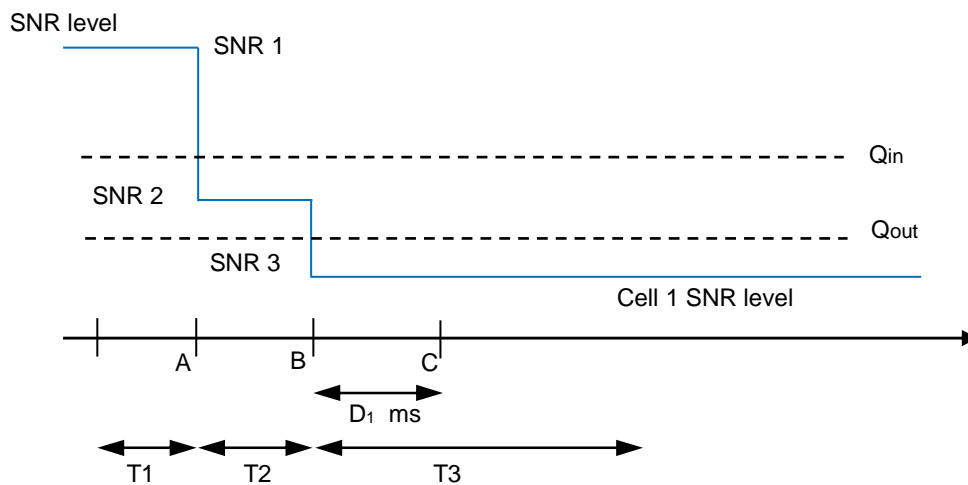

Figure G.2.3.1.5.1-1: SNR variation for CSI-RS out-of-sync testing

G.2.3.1.5.2 Test Requirements

The NCR-MT behaviour during time durations T1, T2, and T3 shall be as follows:

During time durations T1, T2 and T3, the NCR-MT shall transmit uplink signal at least in all subframes configured for CSI transmission on Cell 1.

During the period from time point A to time point B the NCR-MT shall transmit uplink signal in Cell 1 at least in all uplink slots configured for CSI transmission according to the configured periodic CSI reporting for Cell 1.

The NCR-MT shall stop transmitting uplink signal in Cell 1 no later than time point C (D_1 ms after the start of the time duration T3) on the PCell.

The rate of correct events observed during repeated tests shall be at least 90%.

G.2.3.1.6 Radio Link Monitoring In-sync Test for FR1 PCell configured with CSI-RS-based RLM in non-DRX mode

G.2.3.1.6.1 Test Purpose and Environment

The purpose of this test is to verify that the NCR-MT properly detects the in sync for the purpose of monitoring downlink CSI-RS based radio link quality of the PCell. This test will partly verify the FR1 PCell CSI-RS In-sync radio link monitoring requirements in clause 12.3.1.3. This test case is applicable only for local area NCR-MT and for NCR type 1-H.

The test parameters are given in Tables G.2.3.1.6.1-1, G.2.3.1.6.1-2, and G.2.3.1.6.1-3 below. There is one cells, cell 1 which is the PCell, in the test. The test consists of five successive time periods, with time duration of T1, T2, T3, T4 and T5 respectively. Figure G.2.3.1.6.1-1 shows the variation of the downlink SNR in the PCell to emulate out-of-sync and in-sync states. Prior to the start of the time duration T1, the NCR-MT shall be fully synchronized to cell 1. The NCR-MT shall be configured for periodic CSI reporting with a reporting periodicity defined in CSI-RS configuration. In the test, SSB0 is configured as the BFD-RS.

Table G.2.3.1.6.1-1: Supported test configurations for FR1 PCell

Configuration	Description
1	TDD duplex mode, 15 kHz SSB SCS, 10 MHz bandwidth
2	TDD duplex mode, 30kHz SSB SCS, 40 MHz bandwidth
Note:	The NCR-MT is only required to pass in one of the supported test configurations in FR1

Table G.2.3.1.6.1-2: General test parameters for FR1 PCell for CSI-RS in-sync testing in non-DRX

Parameter		Unit	NCR-MT
			Test 1
Active PCell			Cell 1
RF Channel Number			1
Duplex mode	Config 1, 2		TDD
TDD Configuration	Config 1		TDDConf.1.1
	Config 2		TDDConf.2.1
DL initial BWP configuration	Config 1, 2		DLBWP.0.1
DL dedicated BWP configuration	Config 1, 2		DLBWP.1.1
UL initial BWP configuration	Config 1, 2		ULBWP.0.1
UL dedicated BWP configuration	Config 1, 2		ULBWP.1.1
CORESET Reference Channel	Config 1		CR.1.1 TDD
	Config 2		CR.2.1 TDD
SSB Configuration	Config 1		SSB.1 FR1
	Config 2		SSB.2 FR1
SMTC Configuration	Config 1, 2		SMTC.1
PDSCH/PDCCH subcarrier spacing	Config 1		15 kHz
	Config 2		30 kHz
TRS configuration	Config 1		TRS.1.1 TDD
	Config 2		TRS.1.2 TDD
CSI-RS for RLM	Config 1		Resource #4 in TRS.1.1 TDD
	Config 2		Resource #4 in TRS.1.2 TDD
TCI configuration for PDCCH/PDSCH			TCI.State.2
OCNG parameters			OP.1
CP length			Normal
Correlation Matrix and Antenna Configuration			2x2 Low
Out of sync transmission parameters	DCI format		1-0
	Number of Control OFDM symbols		2
	Aggregation level	CCE	8
	Ratio of hypothetical PDCCH RE energy to average CSI-RS RE energy	dB	4
	Ratio of hypothetical PDCCH DMRS energy to average CSI-RS RE energy	dB	4
	DMRS precoder granularity		REG bundle size
	REG bundle size		6
In sync transmission parameters	DCI format		1-0
	Number of Control OFDM symbols		2
	Aggregation level	CCE	4
	Ratio of hypothetical PDCCH RE energy to average CSI-RS RE energy	dB	0
	Ratio of hypothetical PDCCH DMRS energy to average CSI-RS RE energy	dB	0
	DMRS precoder granularity		REG bundle size
	REG bundle size		6
Layer 3 filtering			<i>Enabled</i>
T310 timer		ms	1000
T311 timer		ms	1000
N310			1
N311			1
CSI-RS configuration for CSI reporting	Config 1		CSI-RS.1.1 TDD
	Config 2		CSI-RS.2.1 TDD
T1		s	0.2
T2		s	0.2
T3		s	0.44
T4		s	0.2
T5		s	0.88
T6		s	0.84

Note 1: NCR-MT-specific PDCCH is not transmitted after T1 starts.

Table G.2.3.1.6.1-3: Cell specific test parameters for FR1 for CSI-RS in-sync radio link monitoring in non-DRX

Parameter		Unit	Test 1				
			T1	T2	T3	T4	T5
PDCCH_beta		dB	4				
PDCCH_DMRS_beta		dB	4				
PBCH_beta		dB	0				
PSS_beta		dB					
SSS_beta		dB					
PDSCH_beta		dB					
OCNG_beta		dB					
SNR on RLM-RS		dB					
SNR on other channels and signals		dB	1				
N_{oc}		dBm/15kHz	-98				
Propagation condition			TDL-C 300ns 100Hz				
<p>Note 1: OCNG shall be used such that the resources in Cell 1 are fully allocated and a constant total transmitted power spectral density is achieved for all OFDM symbols.</p> <p>Note 2: The uplink resources for CSI reporting are assigned to the NCR-MT prior to the start of time period T1.</p> <p>Note 3: NZP CSI-RS resource set configuration for CSI reporting are assigned to the NCR-MT prior to the start of time period T1.</p> <p>Note 4: The timers and layer 3 filtering related parameters are configured prior to the start of time period T1.</p> <p>Note 5: The signal contains PDCCH for NCR-MTs other than the device under test as part of OCNG.</p> <p>Note 6: SNR levels correspond to the signal to noise ratio over the SSS REs.</p> <p>Note 7: The SNR in time periods T1, T2, T3, T4 and T5 is denoted as SNR1, SNR2, SNR3, SNR4 and SNR5 respectively in figure G.2.3.1.6.1-1.</p> <p>Note 8: The SNR NCR-MTs are specified for testing a NCR-MT which supports 2RX on at least one band. For testing of NCR-MT which supports 4RX on all bands, the SNR during T3 is specified in clause G.1.3.1.1.</p>							

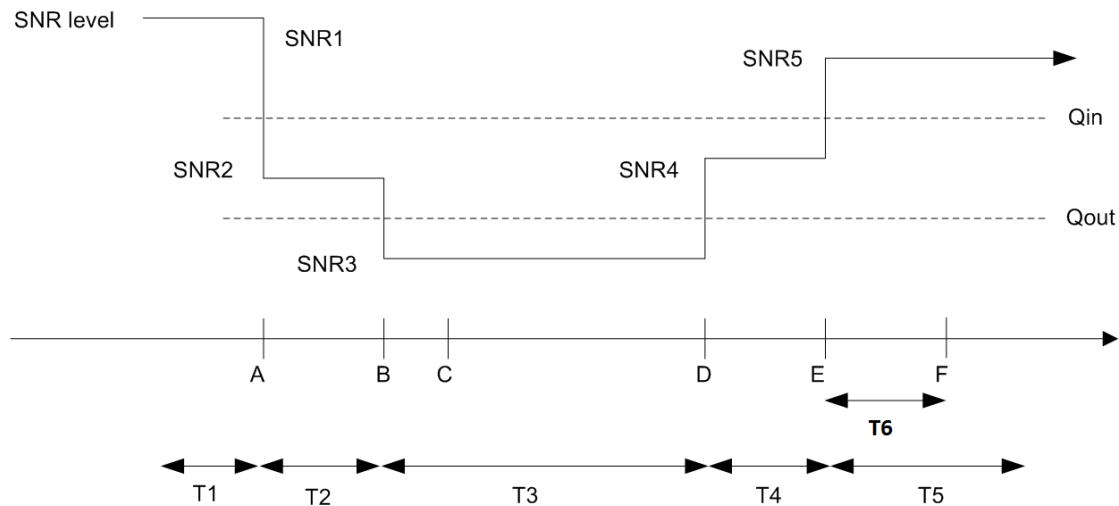

Figure G.2.3.1.6.1-1: SNR variation for CSI-RS in-sync testing

G.2.3.1.6.2 Test Requirements

The NCR-MT behaviour in each test during time durations T1, T2, T3, T4 and T5 shall be as follows:

During the period from time point A to time point F (T6 second after the start of time duration T5) the NCR-MT shall transmit uplink signal at least in all uplink slots configured for CSI transmission according to the configured periodic CSI reporting on the PCell.

The rate of correct events observed during repeated tests shall be at least 90%.

G.2.3.1.7 Radio Link Monitoring Out-of-sync Test for FR2-1 PCell configured with CSI-RS-based RLM in non-DRX mode

G.2.3.1.7.1 Test Purpose and Environment

The purpose of this test is to verify that the NCR-MT properly detects the out of sync for the purpose of monitoring downlink CSI-RS based radio link quality of the PCell. This test will partly verify the FR2-1 PCell CSI-RS Out-of-sync radio link monitoring requirements in clause 12.3.1.3. This test case is applicable only for local area NCR-MT and for NCR type 2-0.

The test parameters are given in Tables G.2.3.1.7.1-1, G.2.3.1.7.1-2 and G.2.3.1.7.1-3 below. There is one cell, cell 1 which is the PCell, in the test. The test consists of three successive time periods, with time duration of T1, T2 and T3 respectively. Figure G.2.3.1.7.1-1 shows the variation of the downlink SNR in the PCell to emulate out-of-sync and in-sync states. Prior to the start of the time duration T1, the NCR-MT shall be fully synchronized to cell 1. The NCR-MT shall be configured for periodic CSI reporting with a reporting periodicity of 10 ms. In the test, SSB0 and SSB1 are configured as BFD-RS.

Table G.2.3.1.7.1-1: Supported test configurations for FR2-1 PCell

Configuration	Description
1	TDD duplex mode, 120 kHz SSB SCS, 100 MHz bandwidth

Table G.2.3.1.7.1-2: General test parameters for FR2-1 PCell for CSI-RS out-of-sync testing in non-DRX

Parameter		Unit	NCR-MT
			Test 1
Active PCell			Cell 1
RF Channel Number			1
Duplex mode	Config 1		TDD
TDD Configuration	Config 1		TDDConf.3.1
DL initial BWP configuration	Config 1		DLBWP.0.1
DL dedicated BWP configuration	Config 1		DLBWP.1.1
UL initial BWP configuration	Config 1		ULBWP.0.1
UL dedicated BWP configuration	Config 1		ULBWP.1.1
CORESET Reference Channel	Config 1		CCR.3.1 TDD CCR.3.3 TDD
SSB Configuration	Config 1		SSB.1 FR2-1
SMTC Configuration	Config 1		SMTC.1
PDSCH/PDCCH subcarrier spacing	Config 1		120 KHz
CSI-RS for RLM	Config 1		Resource #4 in TRS.2.1 TDD Resource #4 in TRS.2.2 TDD
TRS configuration			TRS.2.1 TDD TRS.2.2 TDD
TCI configuration for PDCCH#1/PDSCH			TCI.State.2
TCI configuration for PDCCH#2			TCI.State.3
OCNG parameters			OP.1
CP length			Normal
Out of sync transmission parameters	DCI format		1-0
	Number of Control OFDM symbols		2
	Aggregation level	CCE	8
	Ratio of hypothetical PDCCH RE energy to average CSI-RS RE energy	dB	4
	Ratio of hypothetical PDCCH DMRS energy to average CSI-RS RE energy	dB	4
	DMRS precoder granularity		REG bundle size
	REG bundle size		6
Layer 3 filtering			<i>Enabled</i>
T310 timer		ms	0
T311 timer		ms	1000
N310			1
N311			1
CSI-RS for CSI reporting	Config 1		CSI-RS.3.1 TDD
T1		s	0.2
T2		s	0.35
T3		s	0.35
D1		s	0.31
Note 1: NCR-MT-specific PDCCH is not transmitted after T1 starts.			

Table G.2.3.1.7.1-3: Cell specific test parameters for FR2-1 for CSI-RS out-of-sync radio link monitoring in non-DRX

Parameter		Unit	Test 1					
			T1	T2	T3	T1	T2	T3
AoA setup			AoA setup as defined in clause G.1.8					
			AoA1			AoA2		
Assumption for NCR-MT beams ^{Note 8}			Rough			Rough		
PDCCH_beta		dB	4			Not sent		
PDCCH_DMRS_beta		dB	4					
PBCH_beta		dB	0					
PSS_beta		dB						
SSS_beta		dB						
PDSCH_beta		dB						
OCNG_beta		dB						
SNR on RLM-RS1	Config 1	dB	2 ^{Note 9}	-6 ^{Note 9}	-15			
SNR on RLM-RS2	Config 1		Not sent			2 ^{Note 9}	-14	-15
SNR on other channels and signals	Config 1	dB	2 ^{Note 9}			N/A		
N_{oc}	Config 1	dBm/15kHz	-92.1			-92.1		
Propagation condition			TDL-C 300ns 100Hz			TDL-C 300ns 100Hz		
<p>Note 1: OCNG shall be used such that the resources in Cell 1 are fully allocated and a constant total transmitted power spectral density is achieved for all OFDM symbols.</p> <p>Note 2: The uplink resources for CSI reporting are assigned to the NCR-MT prior to the start of time period T1.</p> <p>Note 3: NZP CSI-RS resource set configuration for CSI reporting are assigned to the NCR-MT prior to the start of time period T1.</p> <p>Note 4: The timers and layer 3 filtering related parameters are configured prior to the start of time period T1.</p> <p>Note 5: The signal contains PDCCH for NCR-MTs other than the device under test as part of OCNG.</p> <p>Note 6: SNR levels correspond to the signal to noise ratio over the SSS REs.</p> <p>Note 7: The SNR in time periods T1, T2 and T3 is denoted as SNR1, SNR2 and SNR3 respectively in figure G.2.3.1.7.1-1.</p> <p>Note 8: Information about types of NCR-MT beam does not limit NCR-MT implementation or test system implementation.</p> <p>Note 9: This NCR-MT allows up to 1dB degradation from applied SNR to NCR-MT baseband</p>								

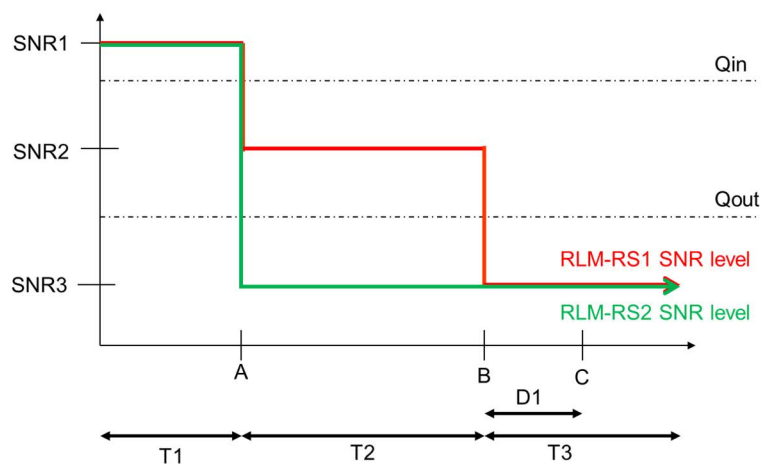

Figure G.2.3.1.7.1-1: SNR variation for CSI-RS out-of-sync testing

G.2.3.1.7.2 Test Requirements

The NCR-MT behaviour during time durations T1, T2, and T3 shall be as follows:

During time durations T1, T2 and T3, the NCR-MT shall transmit uplink signal at least in all subframes configured for CSI transmission on Cell 1.

During the period from time point A to time point B the NCR-MT shall transmit uplink signal in Cell 1 at least in all uplink slots configured for CSI transmission according to the configured periodic CSI reporting for Cell 1.

The NCR-MT shall stop transmitting uplink signal in Cell 1 no later than time point C (D_1 second after the start of the time duration T3) on the PCell.

The rate of correct events observed during repeated tests shall be at least 90%.

G.2.3.1.8 Radio Link Monitoring In-sync Test for FR2-1 PCell configured with CSI-RS-based RLM in non-DRX mode

G.2.3.1.8.1 Test Purpose and Environment

The purpose of this test is to verify that the NCR-MT properly detects the in sync for the purpose of monitoring downlink CSI-RS based radio link quality of the PCell. This test will partly verify the FR2 PCell CSI-RS In-sync radio link monitoring requirements in clause 12.3.1.3. This test case is applicable only for local area NCR-MT and for NCR type 2-O.

The test parameters are given in Tables G.2.3.1.8.1-1, G.2.3.1.8.1-2 and G.2.3.1.8.1-3 below. There is one cells, cell 1 which is the PCell, in the test. The test consists of five successive time periods, with time duration of T1, T2, T3, T4 and T5 respectively. Figure G.2.3.1.8.1-1 shows the variation of the downlink SNR in the PCell to emulate out-of-sync and in-sync states. Prior to the start of the time duration T1, the NCR-MT shall be fully synchronized to cell 1. The NCR-MT shall be configured for periodic CSI reporting with a reporting periodicity of 10 ms. In the test, SSB0 and SSB1 are configured as BFD-RS.

Table G.2.3.1.8.1-1: Supported test configurations for FR2-1 PCell

Configuration	Description
1	TDD duplex mode, 120 kHz SSB SCS, 100 MHz bandwidth

Table G.2.3.1.8.1-2: General test parameters for FR2-1 PCell for CSI-RS in-sync testing in non-DRX

Parameter		Unit	NCR-MT
			Test 1
Active PCell			Cell 1
RF Channel Number			1
Duplex mode	Config 1		TDD
TDD Configuration	Config 1		TDDConf.3.1
DL initial BWP configuration	Config 1		DLBWP.0.1
DL dedicated BWP configuration	Config 1		DLBWP.1.1
UL initial BWP configuration	Config 1		ULBWP.0.1
UL dedicated BWP configuration	Config 1		ULBWP.1.1
CORESET Reference Channel	Config 1		CCR.3.1 TDD CCR.3.3 TDD
SSB Configuration	Config 1		SSB.1 FR2-1
SMTC Configuration	Config 1		SMTC.1
PDSCH/PDCCH subcarrier spacing	Config 1		120 KHz
CSI-RS for RLM	Config 1		Resource #4 in TRS.2.1 TDD Resource #4 in TRS.2.2 TDD
TRS configuration			TRS.2.1 TDD TRS.2.2 TDD
TCI configuration for PDCCH#1/PDSCH			TCI.State.2
TCI configuration for PDCCH#2			TCI.State.3
OCNG parameters			OP.1
CP length			Normal
Out of sync transmission parameters	DCI format		1-0
	Number of Control OFDM symbols		2
	Aggregation level	CCE	8
	Ratio of hypothetical PDCCH RE energy to average CSI-RS RE energy	dB	4
	Ratio of hypothetical PDCCH DMRS energy to average CSI-RS RE energy	dB	4
	DMRS precoder granularity		REG bundle size
	REG bundle size		6
In sync transmission parameters	DCI format		1-0
	Number of Control OFDM symbols		2
	Aggregation level	CCE	4
	Ratio of hypothetical PDCCH RE energy to average CSI-RS RE energy	dB	0
	Ratio of hypothetical PDCCH DMRS energy to average CSI-RS RE energy	dB	0
	DMRS precoder granularity		REG bundle size
	REG bundle size		6
Layer 3 filtering			<i>Enabled</i>
T310 timer		ms	1000
T311 timer		ms	1000
N310			1
N311			1
CSI-RS for CSI reporting	Config 1		CSI-RS.3.1 TDD
T1		s	0.2
T2		s	0.2
T3		s	0.24
T4		s	0.2
T5		s	0.88
D1		s	0.84
Note 1: NCR-MT-specific PDCCH is not transmitted after T1 starts.			

Table G.2.3.1.8.1-3: Cell specific test parameters for FR2-1 for CSI-RS in-sync radio link monitoring in non-DRX

Parameter		Unit	Test 1									
			T1	T2	T3	T4	T5	T1	T2	T3	T4	T5
AoA setup			AoA setup as defined in clause G.1.8									
			AoA1					AoA2				
Assumption for NCR-MT beams ^{Note 8}			Rough					Rough				
PDCCH_beta		dB	4					Not sent				
PDCCH_DMRS_beta		dB	4									
PBCH_beta		dB	0									
PSS_beta		dB										
SSS_beta		dB										
PDSCH_beta		dB										
OCNG_beta		dB										
SNR on RLM-RS1	Config 1	dB	2 ^{Note 9}	-6 ^{Note 9}	-15	-4.5	2 ^{Note 9}					
SNR on RLM-RS2	Config 1		Not sent					2 ^{Note 9}	-14	-15	-15	-14
SNR on other channels and signals	Config 1	dB	2 ^{Note 10}					N/A				
N_{oc}	Config 1	dBm/15KHz	-92.1					-92.1				
Propagation condition			TDL-C 300ns 100Hz					TDL-C 300ns 100Hz				
<p>Note 1: OCNG shall be used such that the resources in Cell 1 are fully allocated and a constant total transmitted power spectral density is achieved for all OFDM symbols.</p> <p>Note 2: The uplink resources for CSI reporting are assigned to the NCR-MT prior to the start of time period T1.</p> <p>Note 3: NZP CSI-RS resource set configuration for CSI reporting are assigned to the NCR-MT prior to the start of time period T1.</p> <p>Note 4: The timers and layer 3 filtering related parameters are configured prior to the start of time period T1.</p> <p>Note 5: The signal contains PDCCH for NCR-MTs other than the device under test as part of OCNG.</p> <p>Note 6: SNR levels correspond to the signal to noise ratio over the SSS REs.</p> <p>Note 7: The SNR in time periods T1, T2, T3, T4 and T5 is denoted as SNR1, SNR2, SNR3, SNR4 and SNR5 respectively in figure G.2.3.1.8.1-1.</p> <p>Note 8: Information about types of NCR-MT beam does not limit NCR-MT implementation or test system implementation.</p> <p>Note 9: This NCR-MT allows up to 1dB degradation from applied SNR to NCR-MT baseband.</p>												

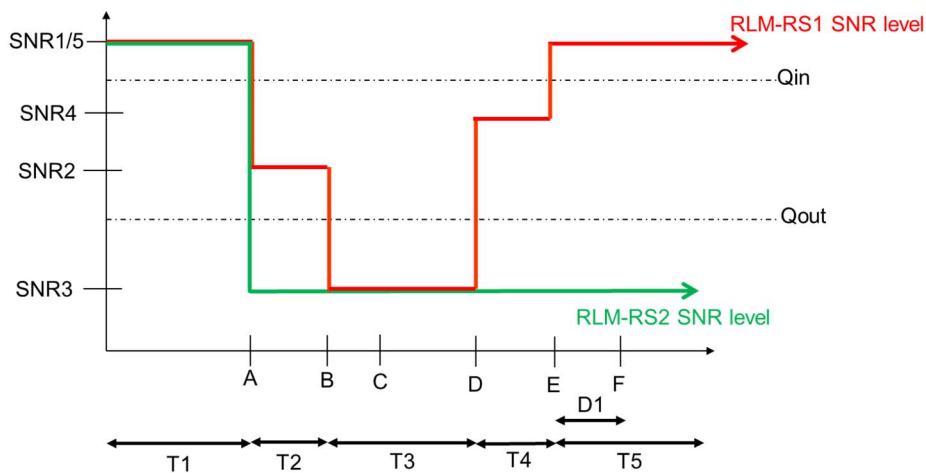

Figure G.2.3.1.8.1-1: SNR variation for CSI-RS in-sync testing

G.2.3.1.8.2 Test Requirements

The NCR-MT behaviour in each test during time durations T1, T2, T3, T4 and T5 shall be as follows:

During the period from time point A to time point F (D1 second after the start of time duration T5) the NCR-MT shall transmit uplink signal at least in all uplink slots configured for CSI transmission according to the configured periodic CSI reporting on the PCell.

The rate of correct events observed during repeated tests shall be at least 90%.

G.2.3.2 Beam Failure Detection and Link Recovery Procedure

G.2.3.2.1 Beam Failure Detection and Link Recovery Test for FR1 PCell configured with SSB-based BFD and LR

G.2.3.2.1.1 Test Purpose and Environment

The purpose of this test is to verify that the NCR-MT properly detects SSB-based beam failure in the set q_0 configured for a serving cell and that the NCR-MT performs correct SSB-based link recovery based on beam candidate set q_1 . The purpose is to test the downlink monitoring for beam failure detection within the NCR-MT's active DL BWP, during the evaluation period, and link recovery. This test will partly verify the SSB based beam failure detection and link recovery for an FR1 serving cell requirements in clause 12.3.2.

The test parameters are given in Tables G.2.3.2.1.1-1, G.2.3.2.1.1-2 and G.2.3.2.1.1-3 below. There is one cell, cell 1 which is the active cell, in the test. The test consists of five successive time periods, with time duration of T1, T2, T3, T4 and T5 respectively. Figure G.2.3.2.1.1-1 shows the variation of the downlink SNR of the SSB in set q_0 in the active cell to emulate SSB based beam failure. Figure G.2.3.2.1.1-1 additionally shows the variation of the downlink L1-RSRP of the SSB in set q_1 of the candidate beam used for link recovery. Prior to the start of the time duration T1, the NCR-MT shall be fully synchronized to cell 1. The NCR-MT shall be configured for periodic CSI reporting with a reporting periodicity of 2 ms. The NCR-MT is configured to perform inter-frequency measurements using GP ID #0 (40ms) in test 1.

Table G.2.3.2.1.1-1: Supported test configurations for FR1 PCell

Configuration	Description
1	TDD duplex mode, 15 kHz SSB SCS, 10 MHz bandwidth
2	TDD duplex mode, 30 kHz SSB SCS, 40 MHz bandwidth
3	FDD duplex mode, 15 kHz SSB SCS, 10 MHz bandwidth
Note: The NCR-MT is only required to pass in one of the supported test configurations in FR1	

Table G.2.3.2.1.1-2: General test parameters for FR1 PCell for SSB-based beam failure detection and link recovery testing

Parameter		Unit	Value	Comment
			Test 1	
Active PSCell			Cell 1	
RF Channel Number			1	
Duplex mode	Config 1, 2		TDD	
	Config 3		FDD	
BWchannel	Config 1	MHz	10: NRB,c = 52	
	Config 2		40: NRB,c = 106	
DL initial BWP configuration	Config 1, 2		DLBWP.0.1	
DL dedicated BWP configuration	Config 1, 2		DLBWP.1.1	
UL initial BWP configuration	Config 1, 2		ULBWP.0.1	
UL dedicated BWP configuration	Config 1, 2		ULBWP.1.1	
CORESET Reference Channel	Config 1		CR.1.1 TDD	
	Config 2		CR.2.1 TDD	
	Config 3		CR.1.1 FDD	
SSB Configuration	Config 1		SSB.3 FR1	
	Config 2		SSB.4 FR1	
SMTC Configuration	Config 1		SMTC.1	
	Config 2		SMTC.1	
PDSCH/PDCCH subcarrier spacing	Config 1		15 KHz	
	Config 2		30 KHz	
PRACH Configuration	Config 1		Table G.X	
	Config 2		Table G.X	
SSB Index assigned as BFD RS (q_0)			0	
SSB Index assigned as CBD RS (q_1)			1	
OCNG parameters			OP.1	
CP length			Normal	
Correlation Matrix and Antenna Configuration			2x2 Low	
Beam failure detection transmission parameters	DCI format		1-0	
	Number of Control OFDM symbols		2	
	Aggregation level	CCE	8	
	Ratio of hypothetical PDCCH RE energy to average CSI-RS RE energy	dB	0	
	Ratio of hypothetical PDCCH DMRS energy to average CSI-RS RE energy	dB	0	
	DMRS precoder granularity		REG bundle size	
	REG bundle size		6	
rlmInSyncOutOfSyncThreshold			absent	When the field is absent, the NCR-MT applies the value 0. (Table 8.1.1-1 of TS 38.133).
rsrp-ThresholdSSB	Config 1	dBm/SC S kHz	-98	Threshold used for $Q_{in_LR_SSB}$
	Config 2		-95	
powerControlOffsetSS			db0	Used for deriving $rsrp-ThresholdCSI-RS$
beamFailureInstanceMaxCount			n1	see clause 5.17 of TS 38.321 [14]
beamFailureDetectionTimer			pbfd4	see clause 5.17 of TS 38.321 [14]
CSI-RS configuration for CSI reporting	Config 1		CSI-RS.1.1 TDD	
	Config 2		CSI-RS.2.1 TDD	
	Config 3		CSI-RS.1.1 FDD	
CSI-RS for tracking	Config 1		TRS.1.1 TDD	
	Config 2		TRS.1.2 TDD	
	Config 3		TRS.1.1 FDD	
SSB Index assigned as RLM RS		0, 1		
T310 Timer	ms	1000		
N310		2		

Parameter	Unit	Value	Comment
		Test 1	
T1	s	0.2	During this time the the NCR-MT shall be fully synchronized to cell 1
T2	s	0.37	
T3	s	0.24	
T4	s	0	
T5	s	0.17	
D1	s	0.13	
Note 1: All configurations are assigned to the NCR-MT prior to the start of time period T1.			
Note 2: NCR-MT-specific PDCCH is not transmitted after T1 starts.			

Table G.2.3.2.1.1-3: Cell specific test parameters for FR1 PCell for SSB-based beam failure detection and link recovery testing

Parameter		Unit	Test 1				
			T1	T2	T3	T4	T5
EPRE ratio of PDCCH DMRS to SSS		dB	0				
EPRE ratio of PDCCH to PDCCH DMRS							
EPRE ratio of PBCH DMRS to SSS							
EPRE ratio of PBCH to PBCH DMRS							
EPRE ratio of PSS to SSS							
EPRE ratio of PDSCH DMRS to SSS							
EPRE ratio of PDSCH to PDSCH DMRS							
EPRE ratio of OCNG DMRS to SSS							
EPRE ratio of OCNG to OCNG DMRS							
SNR_SSB of set q ₀	Config 1	dB	5	-3	-12	-12	-12
	Config 2		5	-3	-12	-12	-12
SNR_SSB of set q ₁	Config 1	dB	-10	-10	10	10	10
	Config 2		-10	-10	10	10	10
SSB_RP of set q ₁	Config 1	dBm/S CS kHz	-108	-108	-88	-88	-88
	Config 2		-105	-105	-85	-85	-85
N _{oc}	Config 1	dBm/15 KHz	-98				
	Config 2		-98				
Propagation condition			TDL-C 300ns 100Hz				
<p>Note 1: OCNG shall be used such that the resources in Cell 1 are fully allocated and a constant total transmitted power spectral density is achieved for all OFDM symbols.</p> <p>Note 2: The uplink resources for CSI reporting are assigned to the NCR-MT prior to the start of time period T1.</p> <p>Note 3: NZP CSI-RS resource set configuration for CSI reporting are assigned to the NCR-MT prior to the start of time period T1.</p> <p>Note 4: Void.</p> <p>Note 5: The timers and layer 3 filtering related parameters are configured prior to the start of time period T1.</p> <p>Note 6: The signal contains PDCCH for NCR-MTs other than the device under test as part of OCNG.</p> <p>Note 7: SNR levels correspond to the signal to noise ratio over the SSS REs.</p> <p>Note 8: The SNR in time periods T1, T2, T3, T4 and T5 is denoted as SNR1, SNR2 and SNR3 respectively in figure G.2.3.2.1.1-1.</p> <p>Note 9: The SNR values are specified for testing a NCR-MT which supports 2RX on at least one band. For testing of a NCR-MT which supports 4RX on all bands, the SNR during T3 is modified as specified in clause G.1.3.</p>							

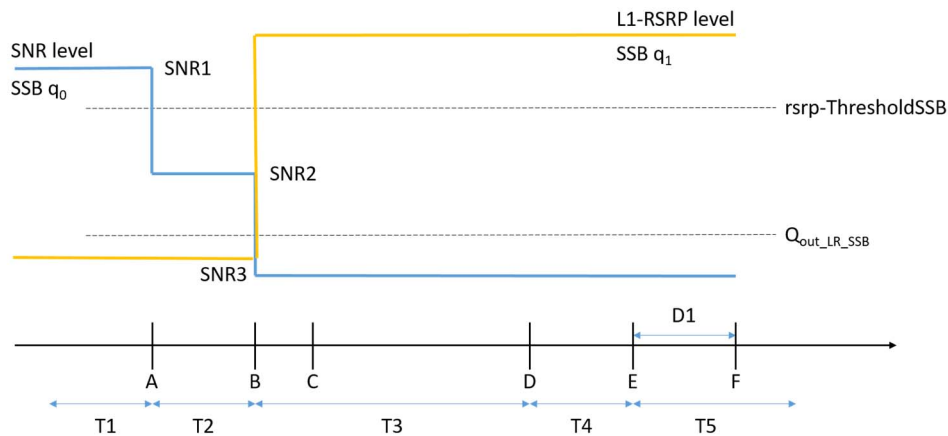

Figure G.2.3.2.1.1-1: SNR and L1-RSRP variation SSB for SSB-based beam failure detection and link recovery testing

G.2.3.2.1.2 Test Requirements

The NCR-MT behaviour during time durations T1, T2, T3, T4 and T5 shall be as follows:

During the time duration T1 and T2, the NCR-MT shall transmit uplink signal at least in all subframes configured for CSI transmission on Cell 1.

During the period from time point A to time point B the NCR-MT shall transmit uplink signal in Cell 1 in all uplink slots configured for CSI transmission according to the configured periodic CSI reporting for Cell 1.

During T3 the NCR-MT shall detect beam failure and initiate link recovery. During T4 and T5 the NCR-MT measures and evaluate beam candidate from beam candidate set q_1 .

No later than time point F occurring no later than $D1 = 120 + 10$ ms after the start of T5, the NCR-MT shall transmit preamble on a beam associated with the candidate beam set q_1 . The NCR-MT shall not transmit preamble on a beam associated with the candidate beam set q_1 earlier than time point B.

Test is concluded once the test equipment has received the initial preamble transmission from the NCR-MT. The rate of correct events observed during repeated tests shall be at least 90%.

G.2.3.2.2 Beam Failure Detection and Link Recovery Test for FR2 PCell configured with SSB-based BFD and LR

G.2.3.2.2.1 Test Purpose and Environment

The purpose of this test is to verify that the NCR-MT properly detects SSB-based beam failure in the set q_0 configured for a serving cell and that the NCR-MT performs correct SSB-based link recovery based on beam candidate set q_1 . The purpose is to test the downlink monitoring for beam failure detection within the NCR-MT active DL BWP, during the evaluation period, and link recovery, when no DRX is used. This test will partly verify the SSB based beam failure detection and link recovery for an FR2 serving cell requirements in clause 12.3.2.2.

The test parameters are given in Tables G.2.3.2.2.1-1, G.2.3.2.2.1-2 and G.2.3.2.2.1-3 below. There is one cell, cell 1 which is the active cell, in the test. The test consists of five successive time periods, with time duration of T1, T2, T3, T4 and T5 respectively. Figure G.2.3.2.2.1-1 shows the variation of the downlink SNR of the SSB in set q_0 in the active cell to emulate SSB based beam failure. Figure G.2.3.2.2.1-1 additionally shows the variation of the downlink L1-RSRP of the SSB in set q_1 of the candidate beam used for link recovery. Prior to the start of the time duration T1, the NCR-MT shall be fully synchronized to cell 1. The NCR-MT shall be configured for periodic CSI reporting with a reporting periodicity of 2 ms. In the test, DRX configuration is not enabled.

Table G.2.3.2.1-1: Supported test configurations for FR2 PCell

Configuration	Description
1	TDD duplex mode, 120 kHz SSB SCS, 100 MHz bandwidth
2	TDD duplex mode, 240 kHz SSB SCS, 100 MHz bandwidth
Note:	The NCR-MT is only required to pass in one of the supported test configurations in FR2

Table G.2.3.2.2.1-2: General test parameters for FR2 PCell for SSB-based beam failure detection and link recovery testing

Parameter		Unit	Value	Comment
			Test 1	
Active PCell			Cell 1	
RF Channel Number			1	
Duplex mode	Config 1, 2		TDD	
BW _{channel}	Config 1, 2		100: N _{RB,c} = 66	
DL initial BWP configuration	Config 1, 2		DLBWP.0.1	
DL dedicated BWP configuration	Config 1, 2		DLBWP.1.1	
UL initial BWP configuration	Config 1, 2		ULBWP.0.1	
UL dedicated BWP configuration	Config 1, 2		ULBWP.1.1	
CORESET Reference Channel	Config 1, 2		CR. 3.1 TDD	
SSB Configuration	Config 1		SSB.1 FR2	
	Config 2		SSB.2 FR2	
SMTC Configuration	Config 1, 2		SMTC.3	
PDSCH/PDCCH subcarrier spacing	Config 1, 2		120 KHz	
SSB index assigned as BFD RS (q ₀)			0	
SSB index assigned as CBD RS (q ₁)			1	
OCNG parameters			OP.1	
CP length			Normal	
Beam failure detection transmission parameters	DCI format		1-0	
	Number of Control OFDM symbols		2	
	Aggregation level	CCE	8	
	Ratio of hypothetical PDCCH RE energy to average CSI-RS RE energy	dB	0	
	Ratio of hypothetical PDCCH DMRS energy to average CSI-RS RE energy	dB	0	
	DMRS precoder granularity		REG bundle size	
	REG bundle size		6	
DRX			OFF	
rlmInSyncOutOfSyncThreshold			absent	When the field is absent, the NCR-MT applies the value 0. (Table 8.1.1-1 in TS 38.133 [6]).

Parameter		Unit	Value	Comment
			Test 1	
rsrp-ThresholdSSB	Config 1	dBm/SSB SCS	-94.5	Threshold used for $Q_{in_LR_SSB}$
	Config 2		-91.5	
powerControlOffsetSS			db0	Used for deriving rsrp-ThresholdCSI-RS
beamFailureInstanceMaxCount			n1	see clause 5.17 of TS 38.321 [7]
beamFailureDetectionTimer			pbfd4	see clause 5.17 of TS 38.321 [7]
CSI-RS configuration for CSI reporting	Config 1, 2		CSI-RS.3.1 TDD	
TCI states			TCI.State.0	
CSI-RS for tracking	Config 1, 2		TRS.2.1 TDD	
SSB index assigned as RLM RS			0, 1	
T310 Timer		ms	1000	
N310			2	
T1		s	1	During this time the the NCR-MT shall be fully synchronized to cell 1
T2		s	2.61	
T3		s	1.64	
T4		s	0	
T5		s	1.01	
D1		s	0.97	
Note 1: All configurations are assigned to the NCR-MT prior to the start of time period T1.				
Note 2: NCR-MT-specific PDCCH is not transmitted after T1 starts.				

Editor's note: An additional RS for RLM, different from BFD-RS at constant high SNR shall be configured as part of the test configuration.

Table G.2.3.2.2.1-3: Cell specific test parameters for FR2 PCell for SSB-based beam failure detection and link recovery testing

Parameter		Unit	Test 1				
			T1	T2	T3	T4	T5
AoA setup			Setup 1 defined in G.1.18				
EPRE ratio of PDCCH DMRS to SSS		dB	0				
EPRE ratio of PDCCH to PDCCH DMRS		dB					
EPRE ratio of PBCH DMRS to SSS		dB					
EPRE ratio of PBCH to PBCH DMRS		dB					
EPRE ratio of PSS to SSS		dB					
EPRE ratio of PDSCH DMRS to SSS		dB					
EPRE ratio of PDSCH to PDSCH DMRS		dB					
EPRE ratio of OCNB DMRS to SSS		dB					
EPRE ratio of OCNB to OCNB DMRS		dB					
SNR_SSB of set q_0	Config 1	dB					
	Config 2	dB	5	-3	-12	-12	-12
SNR_SSB of set q_1	Config 1	dB	0.2	0.2	20.2	20.2	20.2
	Config 2	dB	0.2	0.2	20.2	20.2	20.2
SSB_RP of set q_1	Config 1	dBm/SSB	-104.5	-104.5	-84.5	-84.5	-84.5
	Config 2	SCS	-101.5	-101.5	-81.5	-81.5	-81.5
N_{oc}	Config 1	dBm/120 KHz	-104.7				
	Config 2	dBm/120 KHz	-104.7				
Propagation condition			TDL-A 30ns 75Hz				
Note 1: OCNB shall be used such that the resources in Cell 1 are fully allocated and a constant total transmitted power spectral density is achieved for all OFDM symbols. Note 2: The uplink resources for CSI reporting are assigned to the NCR-MT prior to the start of time period T1. Note 3: NZP CSI-RS resource set configuration for CSI reporting are assigned to the NCR-MT prior to the start of time period T1. Note 4: Void Note 5: The timers and layer 3 filtering related parameters are configured prior to the start of time period T1. Note 6: The signal contains PDCCH for NCR-MTs other than the device under test as part of OCNB. Note 7: SNR levels correspond to the signal to noise ratio over the SSS REs. Note 8: The SNR in time periods T1, T2, T3, T4 and T5 is denoted as SNR1, SNR2 and SNR3 respectively in figure G.2.3.2.X.1-1. Note 9: The SNR values are specified for testing an NCR-MT which supports 2RX on at least one band.							

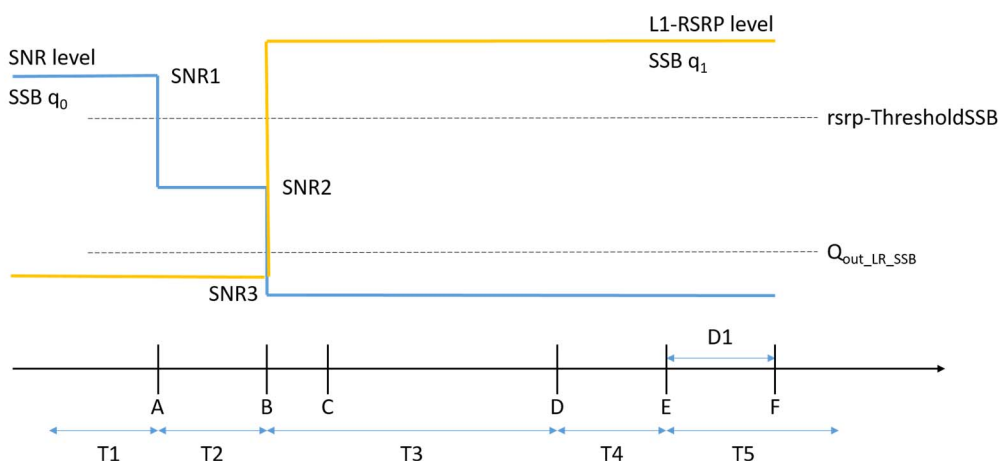

Figure G.2.3.2.2.1-1: SNR and L1-RSRP variation SSB for SSB-based beam failure detection and link recovery testing in non-DRX mode

G.2.3.2.2.2 Test Requirements

The NCR-MT behaviour during time durations T1, T2, T3, T4 and T5 shall be as follows:

During the time duration T1 and T2, the NCR-MT shall transmit uplink signal at least in all subframes configured for CSI transmission on Cell 1.

During the period from time point A to time point B the NCR-MT shall transmit uplink signal in Cell 1 in all uplink slots configured for CSI transmission according to the configured periodic CSI reporting for Cell 1.

During T3 the NCR-MT shall detect beam failure and initiate link recovery. During T4 and T5 the NCR-MT measures and evaluate beam candidate from beam candidate set q_1 .

No later than time point F occurring no later than $D1 = 560+650$ ms after the start of T5, the NCR-MT shall transmit preamble on a beam associated with the candidate beam set q_1 . The NCR-MT shall not transmit preamble on a beam associated with the candidate beam set q_1 earlier than time point B.

Test is concluded once the test equipment has received the initial preamble transmission from the NCR-MT. The rate of correct events observed during repeated tests shall be at least 90%.

G.2.3.2.3 Beam Failure Detection and Link Recovery Test for FR1 PCell configured with CSI-RS-based BFD and LR

G.2.3.2.3.1 Test Purpose and Environment

The purpose of this test is to verify that the NCR-MT properly detects CSI-RS-based beam failure in the set q_0 configured for a serving cell and that the NCR-MT performs correct CSI-RS-based link recovery based on beam candidate set q_1 . The purpose is to test the downlink monitoring for beam failure detection within the NCR-MT's active DL BWP, during the evaluation period, and link recovery. This test will partly verify the CSI-RS based beam failure detection and link recovery for an FR1 serving cell requirements in clause 12.3.2.

The test parameters are given in Tables G.2.3.2.3.1-1, G.2.3.2.3.1-2 and G.2.3.2.3.1-3 below. There is one cell, cell 1 which is the active cell, in the test. The test consists of five successive time periods, with time duration of T1, T2, T3, T4 and T5 respectively. Figure G.2.3.2.3.1-1 shows the variation of the downlink SNR of the CSI-RS in set q_0 in the active cell to emulate CSI-RS based beam failure. Figure G.2.3.2.3.1-1 additionally shows the variation of the downlink L1-RSRP of the CSI-RS in set q_1 of the candidate beam used for link recovery. Prior to the start of the time duration T1, the NCR-MT shall be fully synchronized to cell 1. The NCR-MT shall be configured for periodic CSI reporting with a reporting periodicity of 2 ms.

Table G.2.3.2.3.1-1: Supported test configurations for FR1 PCell

Configuration	Description
1	TDD duplex mode, 15 kHz SSB SCS, 10 MHz bandwidth
2	TDD duplex mode, 30 kHz SSB SCS, 40 MHz bandwidth
3	FDD duplex mode, 15 kHz SSB SCS, 10 MHz bandwidth
Note:	The NCR-MT is only required to pass in one of the supported test configurations in FR1

Table G.2.3.2.3.1-2: General test parameters for FR1 PCell for CSI-RS-based beam failure detection and link recovery testing

Parameter		Unit	Value	Comment
			Test 1	
Active PCell			Cell 1	
RF Channel Number			1	
Duplex mode	Config 1, 2		TDD	
	Config 3		FDD	
CORESET Reference Channel	Config 1		CR.1.1 TDD	
	Config 2		CR.2.1 TDD	
	Config 3		CR.1.1 FDD	
SSB Configuration	Config 1		SSB.1 FR1	
	Config 2		SSB.2 FR1	
SMTTC Configuration	Config 1		SMTTC.1	G.1.6
	Config 2		SMTTC.1	
PDSCH/PDCCH subcarrier spacing	Config 1		15 KHz	
	Config 2		30 KHz	
csi-RS-Index assigned as beam failure detection RS in set q_0			0	
OCNG parameters			OP.1	G.1.2.1
CP length			Normal	
Correlation Matrix and Antenna Configuration			2x2 Low	
Beam failure detection transmission parameters	DCI format		1-0	
	Number of Control OFDM symbols		2	
	Aggregation level	CCE	8	
	Ratio of hypothetical PDCCH RE energy to average CSI-RS RE energy	dB	0	
	Ratio of hypothetical PDCCH DMRS energy to average CSI-RS RE energy	dB	0	
	DMRS precoder granularity		REG bundle size	
REG bundle size			6	
csi-RS-Index assigned as candidate beam detection RS in set q_1			1	
rmlnSyncOutOfSyncThreshold			absent	When the field is absent, the NCR-MT applies the value 0. (Table 8.1.1-1of TS 38.133).
rsrp-ThresholdSSB	Config 1	dBm/S CS kHz	-98	Threshold used for $Q_{in_LR_SSB}$
	Config 2		-95	
powerControlOffsetSS			db0	Used for deriving rsrp-ThresholdCSI-RS
beamFailureInstanceMaxCount			n1	see clause 5.17 of TS 38.321 [14]
beamFailureDetectionTimer			pbfd4	see clause 5.17 of TS 38.321 [14]
CSI-RS configuration for q_0 and q_1	Config 1		CSI-RS.1.2 TDD	
	Config 2		CSI-RS.2.2 TDD	
	Config 3		CSI-RS.1.2 FDD	
CSI-RS configuration for CSI reporting	Config 1		CSI-RS.1.1 TDD	
	Config 2		CSI-RS.2.1 TDD	
	Config 3		CSI-RS.1.1 FDD	
TRS configuration	Config 1		TRS.1.1 TDD	
	Config 2		TRS.1.2 TDD	
	Config 2		TRS.1.1 FDD	
CSI-RS-Index assigned as RLM RS	Config 1		CSI-RS.1.2 TDD	
	Config 2		CSI-RS.2.2 TDD	
	Config 13		CSI-RS.1.2 FDD	
T310 Timer		ms	1000	
N310			2	
T1		s	0.2	During this time the the NCR-MT shall be fully synchronized to cell 1
T2		s	0.18	
T3		s	0.14	
T4		s	0	

Parameter	Unit	Value	Comment
		Test 1	
T5	s	0.08	
D1	s	0.04	

Note 1: NCR-MT-specific PDCCH is not transmitted after T1 starts.

Table G.2.3.2.3.1-3: Cell specific test parameters for FR1 PCell for CSI-RS-based beam failure detection and link recovery testing

Parameter		Unit	Test 1				
			T1	T2	T3	T4	T5
EPRE ratio of PDCCH DMRS to SSS		dB	0				
EPRE ratio of PDCCH to PDCCH DMRS		dB					
EPRE ratio of PBCH DMRS to SSS		dB					
EPRE ratio of PBCH to PBCH DMRS		dB					
EPRE ratio of PSS to SSS		dB					
EPRE ratio of PDSCH DMRS to SSS		dB					
EPRE ratio of PDSCH to PDSCH DMRS		dB					
EPRE ratio of OCNG DMRS to SSS		dB					
EPRE ratio of OCNG to OCNG DMRS		dB					
SNR_CSI-RS of set q_0	Config 1	dB	5	-3	-12	-12	-12
	Config 2		5	-3	-12	-12	-12
SNR_CSI-RS of set q_1	Config 1	dB	-10	-10	10	10	10
	Config 2		-10	-10	10	10	10
CSI-RS_RP of set q_1	Config 1	dBm/S CS kHz	-108	-108	-88	-88	-88
	Config 2		-105	-105	-85	-85	-85
N_{oc}	Config 1	dBm/15 KHz	-98				
	Config 2		-98				
Propagation condition			TDL-C 300ns 100Hz				
<p>Note 1: OCNG shall be used such that the resources in Cell 1 are fully allocated and a constant total transmitted power spectral density is achieved for all OFDM symbols.</p> <p>Note 2: The uplink resources for CSI reporting are assigned to the NCR-MT prior to the start of time period T1.</p> <p>Note 3: NZP CSI-RS resource set configuration for CSI reporting are assigned to the NCR-MT prior to the start of time period T1.</p> <p>Note 4: Void</p> <p>Note 5: The timers and layer 3 filtering related parameters are configured prior to the start of time period T1.</p> <p>Note 6: The signal contains PDCCH for NCR-MTs other than the device under test as part of OCNG.</p> <p>Note 7: SNR levels correspond to the signal to noise ratio over the REs carrying CSI-RS.</p> <p>Note 8: The SNR in time periods T1, T2, T3, T4 and T5 is denoted as SNR1, SNR2 and SNR3 respectively in figure G.2.3.2.2.1-1.</p> <p>Note 9: The SNR values are specified for testing a NCR-MT which supports 2RX on at least one band. For testing of a NCR-MT which supports 4RX on all bands, the SNR during T3 is modified as specified in clause G.1.3.</p>							

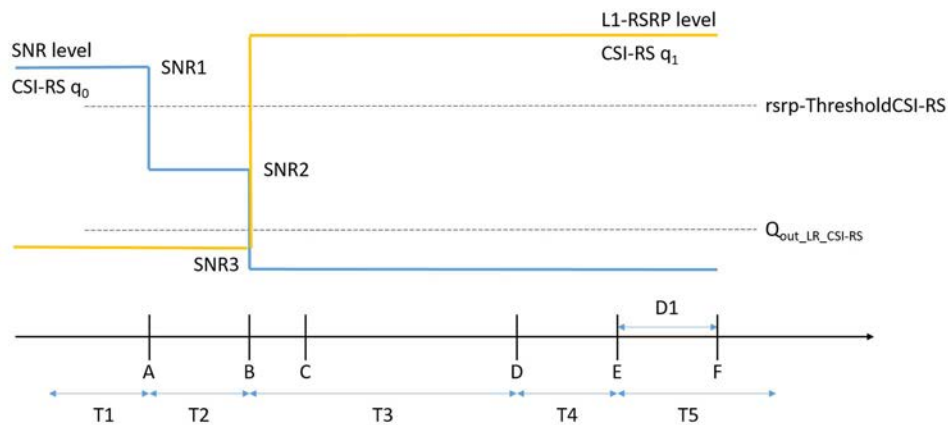

Figure G.2.3.2.3.1-1: SNR and L1-RSRP variation for CSI-RS-based beam failure detection and link recovery testing

G.2.3.2.3.2 Test Requirements

The NCR-MT behaviour during time durations T1, T2, T3, T4 and T5 shall be as follows:

During the time duration T1 and T2, the NCR-MT shall transmit uplink signal at least in all subframes configured for CSI transmission on Cell 1.

During the period from time point A to time point B the NCR-MT shall transmit uplink signal in Cell 1 in all uplink slots configured for CSI transmission according to the configured periodic CSI reporting for Cell 1.

During T3 the shall detect beam failure and initial link recovery. During T4 and T5 the NCR-MT measures and evaluate beam candidate from beam candidate set q_1 .

No later than time point F occurring no later than $D1 = 30+10$ ms after the start of T5, the NCR-MT shall transmit preamble on a beam associated with the candidate beam set q_1 . The NCR-MT shall not transmit preamble on a beam associated with the candidate beam set q_1 earlier than time point B.

Test is concluded once the test equipment has received the initial preamble transmission from the NCR-MT. The rate of correct events observed during repeated tests shall be at least 90%.

G.2.3.2.4 Beam Failure Detection and Link Recovery Test for FR2 PCell configured with CSI-RS-based BFD and LR in non-DRX mode

G.2.3.2.4.1 Test Purpose and Environment

The purpose of this test is to verify that the NCR-MT properly detects CSI-RS-based beam failure in the set q_0 configured for a serving cell and that the NCR-MT performs correct CSI-RS-based link recovery based on beam candidate set q_1 . The purpose is to test the downlink monitoring for beam failure detection within the NCR-MT's active DL BWP, during the evaluation period, and link recovery, when no DRX is used. This test will partly verify the CSI-RS based beam failure detection and link recovery for an FR2 serving cell requirements in clause 12.3.2.

The test parameters are given in Tables G.2.3.2.4.1-1, G.2.3.2.4.1-2, and G.2.3.2.4.1-3 below. There is one cell, cell 1 which is the active cell, in the test. The test consists of five successive time periods, with time duration of T1, T2, T3, T4 and T5 respectively. Figure G.2.3.2.4.1-1 shows the variation of the downlink SNR of the CSI-RS in set q_0 in the active cell to emulate CSI-RS based beam failure. Figure G.2.3.2.4.1-1 additionally shows the variation of the downlink L1-RSRP of the CSI-RS in set q_1 of the candidate beam used for link recovery. Prior to the start of the time duration T1, the NCR-MT shall be fully synchronized to cell 1. The NCR-MT shall be configured for periodic CSI reporting with a reporting periodicity of 2 ms. In the test, DRX configuration is not enabled.

Table G.2.3.2.4.1-1: Supported test configurations for FR2 PCell

Configuration	Description
1	TDD duplex mode, 120 kHz SSB SCS, 100 MHz bandwidth

Table G.2.3.2.4.1-2: General test parameters for FR2 PCell for CSI-RS based beam failure detection and link recovery testing in non-DRX mode

Parameter		Unit	Value	Comment
			Test 1	
Active PCell			Cell 1	
RF Channel Number			1	
Duplex mode	Config 1		TDD	
TDD Configuration	Config 1		TBD	
CORESET Reference Channel	Config 1		CR.3.1 TDD	G.1.1.2
SSB Configuration	Config 1		SSB.3 FR2	G.1.5
SMTC Configuration	Config 1		SMTC.3	G.1.6
PDSCH/PDCCH subcarrier spacing	Config 1		120KHz	
csi-RS-Index assigned as beam failure detection RS in set q_0			0	
TRS configuration			TRS.2.1 TDD	G.1.10.2
TCI configuration			TBD	
OCNG parameters			OP.1	G.1.2.1
CP length			Normal	
Beam failure detection transmission parameters	DCI format		1-0	
	Number of Control OFDM symbols		2	
	Aggregation level	CCE	8	
	Ratio of hypothetical PDCCH RE energy to average CSI-RS RE energy	dB	0	
	Ratio of hypothetical PDCCH DMRS energy to average CSI-RS RE energy	dB	0	
	DMRS precoder granularity		REG bundle size	
	REG bundle size		6	
DRX			OFF	
csi-RS-Index assigned as candidate beam detection RS in set q_1			1	
rlmInSyncOutOfSyncThreshold			absent	When the field is absent, the NCR-MT applies the value 0. (Table 8.1.1-1 in TS 38.133 [6]).
rsrp-ThresholdSSB		dBm/S CS kHz	-94.5	Threshold used for $Q_{in_LR_SSB}$
powerControlOffsetSS			db0	Used for deriving rsrp-ThresholdCSI-RS
beamFailureInstanceMaxCount			n1	see clause 5.17 of TS 38.321 [14]
beamFailureDetectionTimer			pbfd4	see clause 5.17 of TS 38.321 [14]
CSI-RS configuration for q_0 and q_1	Config 1		CSI-RS.3.2 TDD	G.1.7.1
CSI-RS configuration for CSI reporting	Config 1		CSI-RS.3.1 TDD	G.1.7.1
csi-RS-Index assigned as RLM RS			0, 1	G.1.7.1
T310 Timer		ms	1000	
N310			2	
T1		s	0.2	During this time the the NCR-MT shall be fully synchronized to cell 1
T2		s	0.18	

Parameter	Unit	Value	Comment
		Test 1	
T3	s	0.14	
T4	s	0	
T5	s	0.08	
D1	s	0.04	
Note 1: NCR-MT-specific PDCCH is not transmitted after T1 starts.			

Table G.2.3.2.4.1-3: Cell specific test parameters for FR2 PCell for CSI-RS based beam failure detection and link recovery testing in non-DRX mode

Parameter		Unit	Test 1				
			T1	T2	T3	T4	T5
AoA setup			Setup 1 defined in G.1.8				
EPRE ratio of PDCCH DMRS to SSS		dB	0				
EPRE ratio of PDCCH to PDCCH DMRS		dB					
EPRE ratio of PBCH DMRS to SSS		dB					
EPRE ratio of PBCH to PBCH DMRS		dB					
EPRE ratio of PSS to SSS		dB					
EPRE ratio of PDSCH DMRS to SSS		dB					
EPRE ratio of PDSCH to PDSCH DMRS		dB					
EPRE ratio of OCNG DMRS to SSS		dB					
EPRE ratio of OCNG to OCNG DMRS		dB					
SNR_CSI-RS of set q ₀	Config 1	dB	5	-3	-12	-12	-12
SNR_CSI-RS of set q ₁	Config 1	dB	0.2	0.2	20.2	20.2	20.2
CSI-RS_RP of set q ₁	Config 1	dBm/S CS kHz	-104.5	-104.5	-84.5	-84.5	-84.5
N_{oc}	Config 1	dBm/15 KHz	-104.7				
Propagation condition			TDL-A 30ns 75Hz				
Note 1:		OCNG shall be used such that the resources in Cell 1 are fully allocated and a constant total transmitted power spectral density is achieved for all OFDM symbols.					
Note 2:		The uplink resources for CSI reporting are assigned to the NCR-MT prior to the start of time period T1.					
Note 3:		NZP CSI-RS resource set configuration for CSI reporting are assigned to the NCR-MT prior to the start of time period T1.					
Note 4:		Void					
Note 5:		The timers and layer 3 filtering related parameters are configured prior to the start of time period T1.					
Note 6:		The signal contains PDCCH for UEs other than the device under test as part of OCNG.					
Note 7:		SNR levels correspond to the signal to noise ratio over the REs carrying CSI-RS.					
Note 8:		The SNR in time periods T1, T2, T3, T4 and T5 is denoted as SNR1, SNR2 and SNR3 respectively in figure G.2.3.2.x-1-1.					
Note 9:		The SNR values are specified for testing an NCR-MT which supports 2RX on at least one band. For testing of an NCR-MT which supports 4RX on all bands, the SNR during T3 is modified as specified in clause G.1.3.2.					

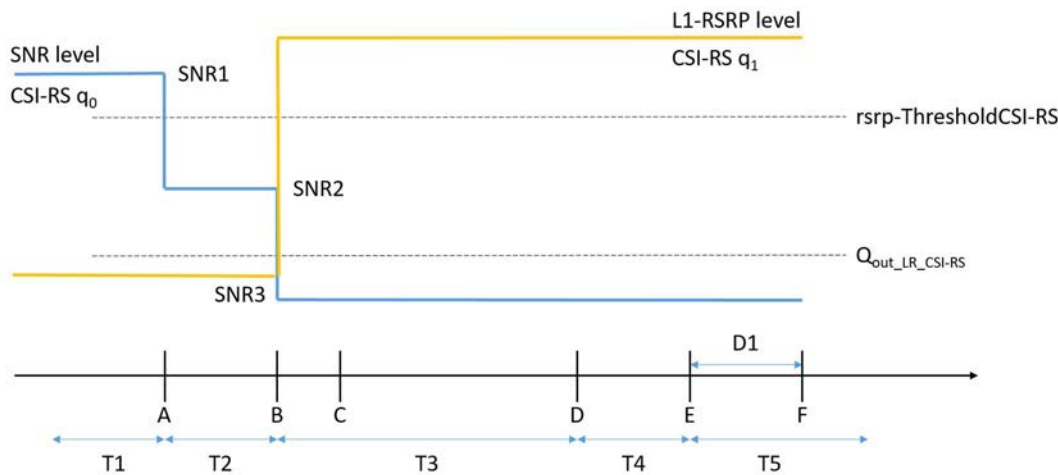

Figure G.2.3.2.4.1-1: SNR and L1-RSRP variation for CSI-RS based beam failure detection and link recovery testing in non-DRX mode

G.2.3.2.4.2 Test Requirements

The NCR-MT behaviour during time durations T1, T2, T3, T4 and T5 shall be as follows:

During the time duration T1 and T2, the NCR-MT shall transmit uplink signal at least in all subframes configured for CSI transmission on Cell 1.

During the period from time point A to time point B the NCR-MT shall transmit uplink signal in Cell 1 in all uplink slots configured for CSI transmission according to the configured periodic CSI reporting for Cell 1.

During T3 the shall detect beam failure and initial link recovery. During T4 and T5 the NCR-MT measures and evaluate beam candidate from beam candidate set q_1 .

No later than time point F occurring no later than $D1 = [560+650 \text{ ms}]$ after the start of T5, the NCR-MT shall transmit preamble on a beam associated with the candidate beam set q_1 . The NCR-MT shall not transmit preamble on a beam associated with the candidate beam set q_1 earlier than time point B.

Test is concluded once the test equipment has received the initial preamble transmission from the NCR-MT. The rate of correct events observed during repeated tests shall be at least 90%.

Annex H (informative): Change history

Change history							
Date	TSG #	TSG Doc.	CR	Rev	Subject/Comment	Old	New
2022-03	RAN#95e	RP-220790			NR Repeater Radio Transmission and Reception		1.0.0

Change history							
Date	Meeting	TDoc	CR	Rev	Cat	Subject/Comment	New version
2022-03	RAN#95					Approved by plenary – Rel-17 spec under change control	17.0.0
2022-06	RAN#96	RP-221681	0002	1	F	CR to 38.106: TDD off power radiated requirement correction	17.1.0
2022-06	RAN#96	RP-221681	0003	1	F	CR to 38.106: Corections to definitons, symbols and abbreviations	17.1.0
2022-06	RAN#96	RP-221681	0004	1	F	CR to 38.106: Output power definitions for NR repeaters	17.1.0
2022-06	RAN#96	RP-221681	0006	1	F	CR for TS 38.106 R17: clean up of clause 4	17.1.0
2022-06	RAN#96	RP-221681	0007	1	F	CR for TS 38.106 R17: clean up of clause 6	17.1.0
2022-06	RAN#96	RP-221681	0008	1	F	CR for TS 38.106 R17: clean up of clause 7	17.1.0
2022-06	RAN#96	RP-221681	0009	1	F	CR to TS38.106: clarification on the supported operating bands for NR repeater	17.1.0
2022-06	RAN#96	RP-221681	0011	1	F	CR to TS 38.106 with corrections to repeater core specification	17.1.0
2022-06	RAN#96	RP-221681	0012		F	BIG CR to 38.106 maintenance	17.1.0
2022-09	RAN#97	RP-222034	0013		F	CR to 38.106: NR repeater ACLR requirements	17.2.0
2022-09	RAN#97	RP-222034	0015	1	F	CR to 38.106: NR repeater receiver spurious emissions requirements	17.2.0
2022-09	RAN#97	RP-222034	0016		F	CR to 38.106: Removal of unlicensed bands for NR repeaters	17.2.0
2022-09	RAN#97	RP-222034	0017	1	F	CR to 38.106: Correction of LA ACLR requirements	17.2.0
2022-09	RAN#97	RP-222034	0018		F	CR to 38.106: Correction of LA ACLR requirements	17.2.0
2022-09	RAN#97	RP-222034	0019	1	F	CR to TS 38.106 with updates and corrections for conductive part	17.2.0
2022-09	RAN#97	RP-222034	0020		F	CR to TS 38.106 with updates and corrections for radiated part	17.2.0
2022-09	RAN#97	RP-222034	0021		F	Big CR for TS 38.106 Maintenance (Rel-17, CAT F)	17.2.0
2022-12	RAN#98-e	RP-223310	0026	1	F	CR to 38.106: ACLR requirements	17.3.0
2022-12	RAN#98-e	RP-223310	0027	1	F	CR to 38.106: EVM requirements	17.3.0
2022-12	RAN#98-e	RP-223310	0028	1	F	CR to 38.106: ACRR requirements	17.3.0
2023-03	RAN#99	RP-230518	0029	1	F	CR for TS 38.106: Correction of some errors in 3.2	17.4.0

Change history							
Date	Meeting	TDoc	CR	Rev	Cat	Subject/Comment	New version
2023-03	RAN#99	RP-230535	0030	1	B	CR to 38.106 on introduction of Band n54	18.0.0
2023-03	RAN#99	RP-230533	0032		B	CR to TS38.106 the introduction of APT600MHz	18.0.0
2023-06	RAN#100	RP-231339	0036		A	CR to 38.106: Corrections on repeater OTA output power requirements (Rel-18)	18.1.0
2023-09	RAN#101	RP-232496	0037		D	CR to 38.106: Editorial correction in transmitter transient period for NR repeaters	18.2.0
2023-09	RAN#101	RP-232496	0039		A	[NR_repeater] CR to 38.106: Input intermodulation	18.2.0
2023-12	RAN#102	RP-233366	0041		B	CR to TS38.106: introduction of NR bands n31 and n72	18.3.0
2023-12	RAN#102	RP-233366	0042		B	CR to TS 38.106 - Introduction of band n109	18.3.0
2023-12	RAN#102	RP-233350	0044		A	CR to 38.106: Correction of terminologies for NR repeaters (Rel-18)	18.3.0
2023-12	RAN#102	RP-233350	0047	1	F	CR to TS 38.106 with correction of co-existence and co-location requirements	18.3.0
2023-12	RAN#102	RP-233361	0049	1	B	Big CR to TS 38.106 on RRM core requirements for NR network-controlled repeaters	18.3.0
2023-12	RAN#102	RP-233361	0050		B	Big CR to TS 38.106 Introduction of NCR	18.3.0
2024-03	RAN#103	RP-240588	0055	1	F	CR to TS 38.106 on correction of requirement set applicability for NCR-MT	18.4.0
2024-03	RAN#103	RP-240588	0057	1	F	CR for TS 38.106 updating reference measurement channels	18.4.0
2024-03	RAN#103	RP-240588	0058	1	F	(NR_netcon_repeater-Core) CR to TS 38.106 with corrections to NCR part	18.4.0
2024-03	RAN#103	RP-240588	0061		F	CR to 38.106: NCR-MT channel bandwidth	18.4.0
2024-03	RAN#103	RP-240574	0064	1	F	CR to 38.106: NR repeater transmitter spurious emissions requirements (rel-18)	18.4.0
2024-03	RAN#103	RP-240588	0065		B	Draft CR for TS38.106 on conducted performance requirements for NCR-MT	18.4.0
2024-03	RAN#103	RP-240588	0066		F	Big CR on Core maintenance for NR Network-controlled Repeaters	18.4.0
2024-06	RAN#104	RP-241468	0067		F	CR for TS 38.106, Correction on ACLR requirement for NCR	18.5.0
2024-06	RAN#104	RP-241468	0068		F	CR for TS 38.106, Correction on ACRR requirement for NCR	18.5.0
2024-06	RAN#104	RP-241468	0069	1	F	CR for TS 38.106, Correction on conducted receiver general requirement	18.5.0
2024-06	RAN#104	RP-241468	0070	1	F	CR to 38.106: Correction of requirement set applicability table	18.5.0
2024-06	RAN#104	RP-241468	0073	2	F	CR to 38.106: Correction on clause titles for NCR-MT requirements	18.5.0
2024-06	RAN#104	RP-241468	0075		F	CR to TS 38.106: maintenance corrections	18.5.0
2024-06	RAN#104	RP-241468	0076		D	CR to TS 38.106: NCR-Fwd editorials maintenance	18.5.0
2024-06	RAN#104	RP-241422	0077		F	CR on FRCs of NCR MT Demodulation Performance in 38.106	18.5.0
2024-06	RAN#104	RP-241422	0078		F	CR on Propagation Condition of NCR-MT for 38.106	18.5.0
2024-06	RAN#104	RP-241468	0080		A	CR to TS 38.106: removal of environmental annex	18.5.0
2024-06	RAN#104	RP-241422	0081	1	B	Big CR to TS 38.106: the introduction of NCR RRM test case	18.5.0
2024-09	RAN#105	RP-242172	0082	1	F	CR for TS 38.106, Correction on spurious emission requirements for NCR	18.6.0
2024-09	RAN#105	RP-242172	0083	1	F	CR for TS 38.106, Correction on general requirements for NCR	18.6.0
2024-09	RAN#105	RP-242172	0084	1	F	CR for TS 38.106, Correction on antenna connector and TAB connector related symbols for NCR	18.6.0
2024-09	RAN#105	RP-242172	0085	1	F	(NR_netcon_repeater-Core)CR for TS 38.106, Correction on network controlled repeater classes for NCR	18.6.0
2024-09	RAN#105	RP-242172	0086	1	F	(NR_netcon_repeater-Core)CR for TS 38.106, Correction on requirement for 5MHz channel bandwidth for NCR MT	18.6.0
2024-09	RAN#105	RP-242172	0089	1	F	CR to 38.106: Requirement set applicability	18.6.0
2024-09	RAN#105	RP-242172	0090	1	F	CR on 38.106 for NCR requirements	18.6.0
2024-09	RAN#105	RP-242186	0093	1	F	Clarification on extreme conditions	18.6.0
2024-12	RAN#106	RP-243030	0096		A	(LTE410_Europe_PPDR-Core) CR to Rel-18 38.106: Add missing LTE band 87 and band 88	18.7.0
2024-12	RAN#106	RP-243053	0097	1	F	CR on Correlation Matrix of NCR Demodulation in 38.106	18.7.0
2024-12	RAN#106	RP-243053	0098	1	F	CR to 38.106: ACLR requirements for NCR	18.7.0
2024-12	RAN#106	RP-243053	0100	1	F	CR to TS 38.106 with terminology alignment for Rel-18	18.7.0
2024-12	RAN#106	RP-243063	0101		A	(NR_repeater-Core) CR on TS38.106 on mmWave EESS protection for NCR for R18	18.7.0
2025-03	RAN#107	RP-250611	0106		F	(TEI18) CR to 38.106 on corrections to co-existence table [bands_coex_req]	18.8.0
2025-03	RAN#107	RP-250592	0108		F	CR on NCR-MT Correlation Matrix in 38.106	18.8.0

Change history							
Date	Meeting	TDoc	CR	Rev	Cat	Subject/Comment	New version
2025-03	RAN#107	RP-250618	0102		B	CR related to Introduction of new LTE FDD Band 111	19.0.0
2025-03	RAN#107	RP-250621	0103		B	CR to TS38.106 on introduction of NR bands n87 and n88	19.0.0
2025-03	RAN#107	RP-250622	0104		B	CR to TS38.106 on introduction of NR band n68	19.0.0
2025-03	RAN#107	RP-250627	0107		B	CR to TS 38.106 on introduction of Band n110	19.0.0
2025-06	RAN#108	RP-250923	0111		F	(LTE410_Europe_PPDR-Core)CR to Rel-19 TS38.106 to add missing LTE bands 87 and 88	19.1.0
2025-06	RAN#108	RP-250944	0112	2	B	CR to TS 38.106 for introduction of expected EIRP mask core requirement for NCR	19.1.0
2025-06	RAN#108	RP-250929	0114		A	CR on NCR Mimo Correlation Matrices in 38.106	19.1.0
2025-09	RAN#109	RP-252420	0116		B	CR to TS 38106 - 7 MHz channel BW clarification	19.2.0

History

Document history		
V19.2.0	February 2026	Publication