

# ETSI TS 136 181 V19.2.0 (2026-02)



TECHNICAL SPECIFICATION

**LTE;  
Evolved Universal Terrestrial Radio Access (E-UTRA);  
Satellite Access Node conformance testing  
(3GPP TS 36.181 version 19.2.0 Release 19)**



---

**Reference**

RTS/TSGR-0436181 vj20

---

**Keywords**

LTE

**ETSI**

---

650 Route des Lucioles  
F-06921 Sophia Antipolis Cedex - FRANCE

Tel.: +33 4 92 94 42 00 Fax: +33 4 93 65 47 16

Siret N° 348 623 562 00017 - APE 7112B  
Association à but non lucratif enregistrée à la  
Sous-Préfecture de Grasse (06) N° w061004871

---

**Important notice**

The present document can be downloaded from the  
[ETSI Search & Browse Standards](#) application.

The present document may be made available in electronic versions and/or in print. The content of any electronic and/or print versions of the present document shall not be modified without the prior written authorization of ETSI. In case of any existing or perceived difference in contents between such versions and/or in print, the prevailing version of an ETSI deliverable is the one made publicly available in PDF format on [ETSI deliver](#) repository.

Users should be aware that the present document may be revised or have its status changed,  
this information is available in the [Milestones listing](#).

If you find errors in the present document, please send your comments to  
the relevant service listed under [Committee Support Staff](#).

If you find a security vulnerability in the present document, please report it through our  
[Coordinated Vulnerability Disclosure \(CVD\)](#) program.

---

**Notice of disclaimer & limitation of liability**

The information provided in the present deliverable is directed solely to professionals who have the appropriate degree of experience to understand and interpret its content in accordance with generally accepted engineering or other professional standard and applicable regulations.

No recommendation as to products and services or vendors is made or should be implied.

No representation or warranty is made that this deliverable is technically accurate or sufficient or conforms to any law and/or governmental rule and/or regulation and further, no representation or warranty is made of merchantability or fitness for any particular purpose or against infringement of intellectual property rights.

In no event shall ETSI be held liable for loss of profits or any other incidental or consequential damages.

Any software contained in this deliverable is provided "AS IS" with no warranties, express or implied, including but not limited to, the warranties of merchantability, fitness for a particular purpose and non-infringement of intellectual property rights and ETSI shall not be held liable in any event for any damages whatsoever (including, without limitation, damages for loss of profits, business interruption, loss of information, or any other pecuniary loss) arising out of or related to the use of or inability to use the software.

---

**Copyright Notification**

No part may be reproduced or utilized in any form or by any means, electronic or mechanical, including photocopying and microfilm except as authorized by written permission of ETSI.

The content of the PDF version shall not be modified without the written authorization of ETSI.

The copyright and the foregoing restriction extend to reproduction in all media.

© ETSI 2026.  
All rights reserved.

---

# Intellectual Property Rights

## Essential patents

IPRs essential or potentially essential to normative deliverables may have been declared to ETSI. The declarations pertaining to these essential IPRs, if any, are publicly available for **ETSI members and non-members**, and can be found in ETSI SR 000 314: "*Intellectual Property Rights (IPRs); Essential, or potentially Essential, IPRs notified to ETSI in respect of ETSI standards*", which is available from the ETSI Secretariat. Latest updates are available on the [ETSI IPR online database](#).

Pursuant to the ETSI Directives including the ETSI IPR Policy, no investigation regarding the essentiality of IPRs, including IPR searches, has been carried out by ETSI. No guarantee can be given as to the existence of other IPRs not referenced in ETSI SR 000 314 (or the updates on the ETSI Web server) which are, or may be, or may become, essential to the present document.

## Trademarks

The present document may include trademarks and/or tradenames which are asserted and/or registered by their owners. ETSI claims no ownership of these except for any which are indicated as being the property of ETSI, and conveys no right to use or reproduce any trademark and/or tradename. Mention of those trademarks in the present document does not constitute an endorsement by ETSI of products, services or organizations associated with those trademarks.

**DECT™**, **PLUGTESTS™**, **UMTS™** and the ETSI logo are trademarks of ETSI registered for the benefit of its Members. **3GPP™**, **LTE™** and **5G™** logo are trademarks of ETSI registered for the benefit of its Members and of the 3GPP Organizational Partners. **oneM2M™** logo is a trademark of ETSI registered for the benefit of its Members and of the oneM2M Partners. **GSM®** and the GSM logo are trademarks registered and owned by the GSM Association.

---

# Legal Notice

This Technical Specification (TS) has been produced by ETSI 3rd Generation Partnership Project (3GPP).

The present document may refer to technical specifications or reports using their 3GPP identities. These shall be interpreted as being references to the corresponding ETSI deliverables.

The cross reference between 3GPP and ETSI identities can be found at [3GPP to ETSI numbering cross-referencing](#).

---

# Modal verbs terminology

In the present document "**shall**", "**shall not**", "**should**", "**should not**", "**may**", "**need not**", "**will**", "**will not**", "**can**" and "**cannot**" are to be interpreted as described in clause 3.2 of the [ETSI Drafting Rules](#) (Verbal forms for the expression of provisions).

"**must**" and "**must not**" are **NOT** allowed in ETSI deliverables except when used in direct citation.

# Contents

Intellectual Property Rights .....	2
Legal Notice .....	2
Modal verbs terminology.....	2
Foreword.....	12
1 Scope .....	14
2 References .....	14
3 Definitions of terms, symbols and abbreviations .....	15
3.1 Terms.....	15
3.2 Symbols.....	18
3.3 Abbreviations .....	19
4 General test conditions and declarations .....	21
4.1 Measurement uncertainties and test requirements .....	21
4.1.1 General.....	21
4.1.2 Acceptable uncertainty of Test System.....	22
4.1.2.1 General .....	22
4.1.2.2 Measurement of transmitter .....	22
4.1.2.3 Measurement of receiver .....	23
4.1.2.3 Measurement of performance requirement .....	27
4.1.3 Interpretation of measurement results.....	28
4.2 Requirement reference points.....	28
4.2.1 SAN type 1-H .....	28
4.2.2 SAN type 1-O .....	29
4.3 Satellite Access Node classes.....	29
4.4 Regional requirements.....	30
4.5 SAN configurations .....	30
4.5.1 SAN type 1-H transmit configurations .....	30
4.5.2 SAN type 1-H receive configurations .....	31
4.5.3 SAN type 1-H and 1-O transmit configurations .....	31
4.5.4 SAN type 1-H and 1-O receive configurations.....	31
4.5.5 Power supply options.....	32
4.6 Manufacturer declarations .....	32
4.7 Test configurations .....	40
4.7.1 General.....	40
4.7.2 Test signal used to build Test Configurations.....	40
4.7.3 ETC1: Contiguous spectrum operation.....	40
4.7.3.1 ETC1 generation .....	40
4.7.3.2 ETC1 power allocation .....	41
4.7.4 ETC6: Contiguous spectrum operation.....	41
4.7.4.1 ETC6 generation .....	41
4.7.4.2 ETC6 power allocation .....	41
4.8 Applicability of requirements.....	41
4.8.1 General.....	41
4.8.2 Requirement set applicability .....	41
4.8.3 Applicability of test configurations for single-band operation .....	42
4.9 RF channels and test models .....	43
4.9.1 RF channels .....	43
4.9.2 Test models .....	44
4.9.2.1 General .....	44
4.9.2.2 Test models for E-UTRA .....	44
4.9.2.2.1 E-UTRA Test Model 1.1 (E-SAN-TM1.1).....	44
4.9.2.2.2 E-UTRA Test Model 1.2 (E-SAN-TM1.2).....	44
4.9.2.2.3 E-UTRA Test Model 2 (E-SAN-TM2).....	45
4.9.2.2.4 E-UTRA Test Model 3.1 (E-SAN-TM3.1).....	45
4.9.2.2.5 E-UTRA Test Model 3.2 (E-SAN-TM3.2).....	45

4.9.2.2.6	E-UTRA Test Model 3.3 (E-SAN-TM3.3).....	45
4.9.2.3	Test Model for NB-IoT .....	46
4.9.2.4	Data content of Physical channels and Signals for N-TM.....	46
4.9.2.4.1	Reference signals.....	46
4.9.2.4.2	Synchronization signals.....	47
4.9.2.4.3	NPBCH.....	47
4.9.2.4.4	NPDCCH.....	47
4.9.2.4.5	NPDSCH .....	47
4.10	Requirements for contiguous and non-contiguous spectrum.....	47
4.11	Requirements for SAN capable of multi-band operation .....	47
4.12	Reference coordinate system.....	48
4.13	Format and interpretation of tests.....	48
5	Operating bands and channel arrangement.....	50
6	Conducted transmitter characteristics .....	51
6.1	General .....	51
6.2	Satellite Access Node output power.....	51
6.2.1	Definition and applicability .....	51
6.2.2	Minimum requirement .....	51
6.2.3	Test purpose.....	51
6.2.4	Method of test.....	51
6.2.4.1	Initial conditions .....	51
6.2.4.2	Procedure .....	52
6.2.5	Test requirement .....	52
6.3	Output power dynamics.....	52
6.3.1	General.....	52
6.3.2	RE power control dynamic range .....	52
6.3.2.1	Definition and applicability.....	52
6.3.2.2	Minimum requirement .....	52
6.3.2.3	Method of test .....	52
6.3.3	Total power dynamic range .....	53
6.3.3.1	Definition and applicability.....	53
6.3.3.2	Minimum requirement .....	53
6.3.3.3	Test purpose .....	53
6.3.3.4	Method of test .....	53
6.3.3.4.1	Initial conditions.....	53
6.3.3.4.2	Procedure.....	53
6.3.3.5	Test requirements.....	54
6.4	Transmit ON/OFF power .....	54
6.5	Transmitted signal quality .....	54
6.5.1	General.....	54
6.5.2	Frequency error.....	54
6.5.2.1	Definition and applicability.....	54
6.5.2.2	Minimum Requirement .....	54
6.5.2.3	Test purpose .....	55
6.5.2.4	Method of test .....	55
6.5.2.5	Test Requirements.....	55
6.5.3	Modulation quality.....	55
6.5.3.1	Definition and applicability.....	55
6.5.3.2	Minimum Requirement .....	55
6.5.3.3	Test purpose .....	55
6.5.3.4	Method of test .....	55
6.5.3.4.1	Initial conditions.....	55
6.5.3.4.2	Procedure.....	55
6.5.3.5	Test requirements.....	56
6.5.4	Time alignment error .....	57
6.5.5	DL RS power .....	57
6.5.5.1	Definition and applicability.....	57
6.5.5.2	Minimum Requirement .....	57
6.5.5.3	Test purpose .....	57
6.5.5.4	Method of test .....	57

6.5.5.4.1	Initial conditions .....	57
6.5.5.4.2	Procedure .....	57
6.5.5.5	Test requirements .....	58
6.6	Unwanted emissions .....	58
6.6.1	General .....	58
6.6.2	Occupied bandwidth .....	58
6.6.2.1	Definition and applicability .....	58
6.6.2.2	Minimum requirements .....	58
6.6.2.3	Test purpose .....	58
6.6.2.4	Method of test .....	59
6.6.2.4.1	Initial conditions .....	59
6.6.2.4.2	Procedure .....	59
6.6.2.5	Test requirements .....	59
6.6.3	Adjacent Channel Leakage Power Ratio (ACLR) .....	59
6.6.3.1	Definition and applicability .....	59
6.6.3.2	Minimum requirement .....	60
6.6.3.3	Test purpose .....	60
6.6.3.4	Method of test .....	60
6.6.3.4.1	Initial conditions .....	60
6.6.3.4.2	Procedure .....	60
6.6.3.5	Test requirements .....	60
6.6.4	Out-of-band emissions .....	62
6.6.4.1	Definition and applicability .....	62
6.6.4.2	Minimum requirement .....	62
6.6.4.3	Test purpose .....	62
6.6.4.4	Method of test .....	62
6.6.4.4.1	Initial conditions .....	62
6.6.4.4.2	Procedure .....	62
6.6.4.5	Test requirements .....	63
6.6.5	Transmitter spurious emissions .....	63
6.6.5.1	Definition and applicability .....	63
6.6.5.2	Minimum requirement .....	64
6.6.5.3	Test purpose .....	64
6.6.5.4	Method of test .....	64
6.6.5.4.1	Initial conditions .....	64
6.6.5.4.2	Procedure .....	64
6.6.5.5	Test requirements .....	65
6.6.5.6	Protection of the own Satellite Access Node receiver .....	65
6.6.5.7	Additional spurious emissions requirements .....	65
6.7	Transmitter intermodulation .....	65
7	Conducted receiver characteristics .....	66
7.1	General .....	66
7.2	Reference sensitivity level .....	66
7.2.1	Definition and applicability .....	66
7.2.2	Minimum requirement .....	66
7.2.3	Test purpose .....	66
7.2.4	Method of test .....	66
7.2.4.1	Initial conditions .....	66
7.2.4.2	Procedure .....	67
7.2.5	Test requirements .....	67
7.3	Dynamic range .....	68
7.3.1	Definition and applicability .....	68
7.3.2	Minimum requirement .....	68
7.3.3	Test purpose .....	68
7.3.4	Method of test .....	68
7.3.4.1	Initial conditions .....	68
7.3.4.2	Procedure .....	68
7.3.5	Test requirements .....	69
7.4	In-band sensitivity and blocking .....	69
7.4.1	Adjacent Channel Selectivity (ACS) .....	69
7.4.1.1	Definition and applicability .....	69

7.4.1.2	Minimum requirement .....	69
7.4.1.3	Test purpose .....	70
7.4.1.4	Method of test .....	70
7.4.1.4.1	Initial conditions .....	70
7.4.1.4.2	Procedure .....	70
7.4.1.5	Test requirements .....	70
7.4.2	In-band blocking .....	71
7.5	Out-of-band blocking .....	71
7.5.1	Definition and applicability .....	71
7.5.2	Minimum requirement .....	71
7.5.3	Test purpose .....	71
7.5.4	Method of test .....	72
7.5.4.1	Initial conditions .....	72
7.5.4.2	Procedure .....	72
7.5.5	Test requirements .....	72
7.6	Receiver spurious emission .....	73
7.7	Receiver intermodulation .....	73
7.8	In-channel selectivity .....	73
7.8.1	Definition and applicability .....	73
7.8.2	Minimum requirement .....	73
7.8.3	Test purpose .....	73
7.8.4	Method of test .....	73
7.8.4.1	Initial conditions .....	73
7.8.4.2	Procedure .....	73
7.8.5	Test requirements .....	74
8	Conducted performance characteristics .....	75
8.1	General .....	75
8.2	Performance requirements for PUSCH .....	75
8.2.1	Performance requirements of PUSCH in multipath fading propagation conditions transmission on single antenna port for coverage enhancement .....	75
8.2.1.1	Definition and applicability .....	75
8.2.1.2	Minimum Requirement .....	75
8.2.1.3	Test Purpose .....	75
8.2.1.4	Method of test .....	75
8.2.1.4.1	Initial conditions .....	75
8.2.1.4.2	Procedure .....	76
8.2.1.5	Test Requirement .....	77
8.3	Performance requirements for PUCCH .....	77
8.3.1	ACK missed detection for PUCCH format 1a transmission on single antenna port for coverage enhancement .....	77
8.3.1.1	Definition and applicability .....	77
8.3.1.2	Minimum Requirement .....	77
8.3.1.3	Test purpose .....	78
8.3.1.4	Method of test .....	78
8.3.1.4.1	Initial Conditions .....	78
8.3.1.4.2	Procedure .....	78
8.3.1.5	Test Requirement .....	79
8.4	Performance requirements for PRACH .....	79
8.4.1	PRACH false alarm probability and missed detection .....	79
8.4.1.1	Definition and applicability .....	79
8.4.1.2	Minimum Requirement .....	79
8.4.1.3	Test purpose .....	79
8.4.1.4	Method of test .....	80
8.4.1.4.1	Initial Conditions .....	80
8.4.1.4.2	Procedure .....	80
8.4.1.5	Test Requirement .....	80
8.5.2	ACK missed detection for NPUSCH format 2 .....	83
8.5.2.1	Definition and applicability .....	83
8.5.2.2	Minimum Requirement .....	83
8.5.2.3	Test purpose .....	83
8.5.2.4	Method of test .....	84

8.5.2.4.1	Initial Conditions .....	84
8.5.2.4.2	Procedure .....	84
8.5.2.5	Test Requirement .....	85
8.5.3	Performance requirements for NPRACH .....	85
8.5.3.1	Definition and applicability .....	85
8.5.3.2	Minimum Requirement .....	86
8.5.3.3	Test purpose .....	86
8.5.3.4	Method of test .....	86
8.5.3.4.1	Initial Conditions .....	86
8.5.3.4.2	Procedure .....	86
8.5.3.5	Test Requirement .....	87
9	Radiated transmitter characteristics .....	88
9.1	General .....	88
9.2	Radiated transmit power .....	88
9.2.1	Definition and applicability .....	88
9.2.2	Minimum requirement .....	88
9.2.3	Test purpose .....	88
9.2.4	Method of test .....	88
9.2.4.1	Initial conditions .....	88
9.2.4.2	Procedure .....	89
9.2.5	Test requirement .....	89
9.3	OTA SAN output power .....	89
9.3.1	Definition and applicability .....	89
9.3.2	Minimum requirement .....	89
9.3.3	Test purpose .....	90
9.3.4	Method of test .....	90
9.3.4.1	Initial conditions .....	90
9.3.4.2	Procedure .....	90
9.3.5	Test requirement .....	90
9.4	OTA output power dynamics .....	91
9.4.1	General .....	91
9.4.2	OTA RE power control dynamic range .....	91
9.4.2.1	Definition and applicability .....	91
9.4.2.2	Minimum requirement .....	91
9.4.2.3	Test purpose .....	91
9.4.3	OTA total power dynamic range .....	91
9.4.3.1	Definition and applicability .....	91
9.4.3.2	Minimum requirement .....	91
9.4.3.3	Test purpose .....	91
9.4.3.4	Method of test .....	91
9.4.3.4.1	Initial conditions .....	91
9.4.3.4.2	Procedure .....	92
9.4.3.5	Test requirement .....	92
9.5	OTA transmit ON/OFF power .....	92
9.6	OTA transmitted signal quality .....	93
9.6.1	General .....	93
9.6.2	OTA frequency error .....	93
9.6.2.1	Definition and applicability .....	93
9.6.2.2	Minimum Requirement .....	93
9.6.2.3	Test purpose .....	93
9.6.2.4	Method of test .....	93
9.6.2.4.1	General .....	93
9.6.2.4.2	Initial conditions .....	93
9.6.2.5	Test Requirements .....	93
9.6.3	OTA modulation quality .....	93
9.6.3.1	Definition and applicability .....	93
9.6.3.2	Minimum Requirement .....	93
9.6.3.3	Test purpose .....	94
9.6.3.4	Method of test .....	94
9.6.3.4.1	Initial conditions .....	94
9.6.3.4.2	Procedure .....	94

9.6.3.5	Test requirements .....	95
9.6.4	OTA time alignment error .....	95
9.6.5	OTA DL RS power .....	95
9.6.5.1	Definition and applicability .....	95
9.6.5.2	Minimum Requirement .....	95
9.6.5.3	Test purpose .....	95
9.6.5.4	Method of test .....	95
9.6.5.4.1	Initial conditions .....	95
9.6.5.4.2	Procedure .....	95
9.6.5.5	Test requirements .....	96
9.7	OTA unwanted emissions .....	96
9.7.1	General .....	96
9.7.2	OTA occupied bandwidth .....	96
9.7.2.1	General .....	96
9.7.2.2	Minimum requirement .....	96
9.7.2.3	Test purpose .....	97
9.7.2.4	Method of test .....	97
9.7.2.4.1	Initial conditions .....	97
9.7.2.4.2	Procedure .....	97
9.7.2.5	Test requirement .....	98
9.7.3	OTA Adjacent Channel Leakage Power Ratio (ACLR) .....	98
9.7.3.1	Definition and applicability .....	98
9.7.3.2	Minimum requirement .....	98
9.7.3.3	Test purpose .....	98
9.7.3.4	Method of test .....	98
9.7.3.4.1	Initial conditions .....	98
9.7.3.4.2	Procedure .....	98
9.7.3.5	Test requirements .....	99
9.7.4	OTA out-of-band emissions .....	100
9.7.4.1	Definition and applicability .....	100
9.7.4.2	Minimum requirement .....	101
9.7.4.3	Test purpose .....	101
9.7.4.4	Method of test .....	101
9.7.4.4.1	Initial conditions .....	101
9.7.4.4.2	Procedure .....	101
9.7.4.5	Test requirements .....	102
9.7.5	OTA transmitter spurious emissions .....	102
9.7.5.1	Definition and applicability .....	102
9.7.5.2	Minimum requirement .....	103
9.7.5.3	Test purpose .....	103
9.7.5.4	Method of test .....	103
9.7.5.4.1	Initial conditions .....	103
9.7.5.4.2	Procedure .....	103
9.7.5.5	Test requirement .....	104
9.7.5.6	Protection of the SAN receiver .....	104
9.7.5.7	Additional spurious emissions requirements .....	104
9.8	OTA transmitter intermodulation .....	104
10	Radiated receiver characteristic .....	105
10.1	General .....	105
10.2	OTA sensitivity .....	105
10.2.1	Definition and applicability .....	105
10.2.2	Minimum requirement .....	106
10.2.3	Test Purpose .....	106
10.2.4	Method of test .....	106
10.2.4.1	Initial conditions .....	106
10.2.4.2	Procedure .....	106
10.2.5	Test requirements .....	107
10.3	OTA reference sensitivity level .....	108
10.3.1	Definition and applicability .....	108
10.3.2	Minimum requirement .....	108
10.3.3	Test Purpose .....	108

10.3.4	Method of test .....	108
10.3.4.1	Initial conditions .....	108
10.3.4.2	Procedure .....	108
10.3.5	Test requirements.....	109
10.4	OTA dynamic range .....	109
10.4.1	Definition and applicability .....	109
10.4.2	Minimum requirement .....	110
10.4.3	Test purpose.....	110
10.4.4	Method of test .....	110
10.4.4.1	Initial conditions .....	110
10.4.4.2	Procedure .....	110
10.4.5	Test requirement .....	111
10.4.5.1	General .....	111
10.4.5.2	Test requirements for <i>SAN type I-O</i> .....	111
10.5	OTA in-band selectivity and blocking.....	112
10.5.1	OTA adjacent channel selectivity .....	112
10.5.1.1	Definition and applicability.....	112
10.5.1.2	Minimum requirement .....	112
10.5.1.3	Test purpose .....	112
10.5.1.4	Method of test .....	112
10.5.1.4.1	Initial conditions .....	112
10.5.1.4.2	Procedure.....	112
10.5.1.5	Test requirement .....	113
10.5.2	OTA in-band blocking .....	113
10.6	OTA out-of-band blocking .....	114
10.6.1	Definition and applicability .....	114
10.6.2	Minimum requirement .....	114
10.6.3	Test purpose.....	114
10.6.4	Method of test .....	114
10.6.4.1	Initial conditions .....	114
10.6.4.2	Procedure .....	114
10.6.5	Test requirements.....	115
10.7	OTA receiver spurious emissions.....	115
10.8	OTA receiver intermodulation .....	115
10.9	OTA in-channel selectivity.....	116
10.9.1	Definition and applicability .....	116
10.9.2	Minimum requirement .....	116
10.9.3	Test purpose.....	116
10.9.4	Method of test .....	116
10.9.4.1	Initial conditions .....	116
10.9.4.2	Procedure .....	116
10.9.5	Test requirement .....	117
11	Radiated performance requirements.....	118
11.1	General .....	118
11.1.0	Scope and definitions.....	118
11.1.1	Demodulation branches .....	118
11.2	Radiated performance requirements for PUSCH .....	119
11.2.1	Performance requirements of PUSCH in multipath fading propagation conditions transmission on single antenna port for coverage enhancement .....	119
11.2.1.1	Definition and applicability.....	119
11.2.1.2	Minimum Requirement .....	119
11.2.1.3	Test Purpose .....	119
11.2.1.4	Method of test .....	119
11.2.1.4.1	Initial Conditions .....	119
11.2.1.4.2	Procedure.....	119
11.2.1.5	Test Requirement .....	120
11.3	OTA performance requirements for PUCCH .....	121
11.3.1	Performance requirements for PUCCH format 1A.....	121
11.3.1.2	ACK missed detection.....	121
11.3.1.2.1	Definition and applicability .....	121
11.3.1.2.2	Minimum Requirement .....	121

11.3.1.2.3	Test purpose .....	121
11.3.1.2.4	Method of test.....	121
11.3.1.2.5	Test Requirement.....	123
11.4	OTA performance requirements for PRACH .....	123
11.4.1	PRACH false alarm probability and missed detection.....	123
11.4.1.1	Definition and applicability.....	123
11.4.1.2	Minimum requirement .....	123
11.4.1.3	Test purpose .....	123
11.4.1.4	Method of test .....	124
11.4.1.4.1	Initial conditions .....	124
11.4.1.4.2	Procedure.....	124
11.4.1.5	Test requirement .....	124
11.5	Performance requirements for Narrowband IoT.....	125
11.5.1	Performance requirements for NPUSCH format 1 .....	125
11.5.1.1	Definition and applicability.....	125
11.5.1.2	Minimum Requirement .....	125
11.5.1.3	Test Purpose .....	125
11.5.1.4	Method of test .....	125
11.5.1.4.1	Initial Conditions .....	125
11.5.1.4.2	Procedure.....	125
11.5.1.5	Test Requirement .....	127
11.5.2	ACK missed detection for NPUSCH format 2 .....	128
11.5.2.1	Definition and applicability.....	128
11.5.2.2	Minimum Requirement .....	128
11.5.2.3	Test purpose .....	128
11.5.2.4	Method of test .....	128
11.5.2.4.1	Initial Conditions .....	128
11.5.2.4.2	Procedure.....	128
11.5.2.5	Test Requirement.....	129
11.5.3	Performance requirements for NPRACH .....	130
11.5.3.1	Definition and applicability.....	130
11.5.3.2	Minimum Requirement .....	131
11.5.3.3	Test purpose .....	131
11.5.3.4	Method of test .....	131
11.5.3.4.1	Initial Conditions .....	131
11.5.3.4.2	Procedure.....	131
11.5.3.5	Test Requirement .....	132
<b>Annex A (normative): Reference measurement channel.....</b>		<b>133</b>
A.1	Fixed Reference Channels for reference sensitivity and in-channel selectivity (QPSK, R=1/3) .....	134
A.2	Fixed Reference Channels for dynamic range (16QAM, R=2/3).....	135
A.5	Fixed Reference Channels for performance requirements (QPSK 1/3) .....	135
A.6	PRACH Test preambles .....	135
A.14	Fixed Reference Channels for NB-IOT reference sensitivity ( $\pi/2$ BPSK, R=1/3).....	136
A.15	Fixed Reference Channels for NB-IoT dynamic range ( $\pi/4$ QPSK, R=2/3).....	136
A.16	Fixed Reference Channels for NB-IoT NPUSCH format 1 .....	138
<b>Annex B (informative): Environmental requirements for SAN equipment.....</b>		<b>139</b>
<b>Annex C (informative): Test tolerances and derivation of test requirements.....</b>		<b>140</b>
C.1	Measurement of transmitter.....	141
C.2	Measurement of receiver .....	142
C.3	Measurement of performance requirements.....	143
<b>Annex D (informative): Measurement system set-up.....</b>		<b>144</b>

D.1	SAN type 1-H transmitter.....	144
D.1.1	SAN output power, output power dynamics, frequency error, EVM, unwanted emissions for SAN type 1-H.....	144
D.1.2	Transmitter intermodulation for SAN type 1-H .....	145
D.1.3	Transmitter spurious emissions for SAN type 1-H.....	145
D.1.4	Time alignment error for <i>SAN type 1-H</i> .....	146
D.2	SAN type 1-H receiver .....	146
D.2.1	Reference sensitivity level for SAN type 1-H .....	146
D.2.2	Receiver dynamic range for SAN type 1-H.....	147
D.2.3	Receiver adjacent channel selectivity for SAN type 1-H .....	147
D.2.4	Receiver spurious emissions.....	147
D.2.5	Receiver In-channel selectivity for SAN type 1-H.....	148
D.2.6	Receiver intermodulation for SAN type 1-H.....	148
D.3	SAN type 1-H and type 1-O transmitter.....	148
D.3.1	Radiated transmit power, OTA output power, OTA output power dynamics, OTA transmitted signal quality, OTA unwanted emissions, OTA transmitter spurious emissions .....	149
D.4	SAN type 1-H and type 1-O receiver .....	149
D.4.1	OTA sensitivity and OTA reference sensitivity level.....	150
D.4.2	OTA dynamic range, OTA adjacent channel selectivity .....	150
D.4.3	OTA out-of-band blocking .....	151
D.5	SAN type 1-H performance requirements .....	151
D.5.1	Performance requirements for PUSCH, single user PUCCH, PRACH on single antenna port in multipath fading conditions .....	151
D.5.2	Performance requirements for PUSCH and PRACH in static conditions .....	152
D.5.3	Performance requirements for UL timing adjustment .....	153
<b>Annex E (normative): Characteristics of the interfering signals.....</b>		<b>154</b>
<b>Annex F (normative): Propagation conditions.....</b>		<b>155</b>
F.1	Static propagation condition.....	155
F.2	Multi-path fading propagation conditions .....	155
F.2.1	Delay profiles .....	155
F.2.1.1	Delay profiles.....	155
F.2.2	Combinations of channel model parameters .....	156
<b>Annex G (normative): In-channel Tx test .....</b>		<b>157</b>
G.1	General .....	157
G.2	Basic principle.....	157
G.2.2	Output signal of the TX under test .....	157
G.2.3	Reference signal .....	157
G.2.4	Measurement results.....	157
G.2.5	Measurement points .....	158
G.3	Pre-FFT minimization process .....	158
G.4	Timing of the FFT window .....	159
G.5	Resource Element TX power .....	159
G.6	Post FFT equalisation.....	160
G.7	EVM.....	161
G.7.1	General .....	161
G.7.2	Averaged EVM .....	162
G.7.3	Averaged EVM (TDD).....	162
<b>Annex H (informative): Change history .....</b>		<b>164</b>
History .....		165

---

# Foreword

This Technical Specification has been produced by the 3rd Generation Partnership Project (3GPP).

The contents of the present document are subject to continuing work within the TSG and may change following formal TSG approval. Should the TSG modify the contents of the present document, it will be re-released by the TSG with an identifying change of release date and an increase in version number as follows:

Version x.y.z

where:

- x the first digit:
  - 1 presented to TSG for information;
  - 2 presented to TSG for approval;
  - 3 or greater indicates TSG approved document under change control.
- y the second digit is incremented for all changes of substance, i.e. technical enhancements, corrections, updates, etc.
- z the third digit is incremented when editorial only changes have been incorporated in the document.

In the present document, modal verbs have the following meanings:

- shall** indicates a mandatory requirement to do something
- shall not** indicates an interdiction (prohibition) to do something

The constructions "shall" and "shall not" are confined to the context of normative provisions, and do not appear in Technical Reports.

The constructions "must" and "must not" are not used as substitutes for "shall" and "shall not". Their use is avoided insofar as possible, and they are not used in a normative context except in a direct citation from an external, referenced, non-3GPP document, or so as to maintain continuity of style when extending or modifying the provisions of such a referenced document.

- should** indicates a recommendation to do something
- should not** indicates a recommendation not to do something
- may** indicates permission to do something
- need not** indicates permission not to do something

The construction "may not" is ambiguous and is not used in normative elements. The unambiguous constructions "might not" or "shall not" are used instead, depending upon the meaning intended.

- can** indicates that something is possible
- cannot** indicates that something is impossible

The constructions "can" and "cannot" are not substitutes for "may" and "need not".

- will** indicates that something is certain or expected to happen as a result of action taken by an agency the behaviour of which is outside the scope of the present document
- will not** indicates that something is certain or expected not to happen as a result of action taken by an agency the behaviour of which is outside the scope of the present document
- might** indicates a likelihood that something will happen as a result of action taken by some agency the behaviour of which is outside the scope of the present document

**might not** indicates a likelihood that something will not happen as a result of action taken by some agency the behaviour of which is outside the scope of the present document

In addition:

**is** (or any other verb in the indicative mood) indicates a statement of fact

**is not** (or any other negative verb in the indicative mood) indicates a statement of fact

The constructions "is" and "is not" do not indicate requirements.

---

# 1 Scope

The present document specifies the Radio Frequency (RF) test methods and conformance requirements for Satellite Access Node (SAN) type 1-H and *SAN type 1-O*, supporting standalone NB-IoT operation or E-UTRA or NB-IoT operation in NTN NR in-band. These have been derived from and are consistent with the conducted requirements for *SAN type 1-H*, and radiated requirement for *SAN type 1-H* and *SAN type 1-O* in SAN specification defined in TS 36.108 [2].

---

# 2 References

The following documents contain provisions which, through reference in this text, constitute provisions of the present document.

- References are either specific (identified by date of publication, edition number, version number, etc.) or non-specific.
- For a specific reference, subsequent revisions do not apply.
- For a non-specific reference, the latest version applies. In the case of a reference to a 3GPP document (including a GSM document), a non-specific reference implicitly refers to the latest version of that document *in the same Release as the present document*.

- [1] 3GPP TR 21.905: "Vocabulary for 3GPP Specifications".
- [2] 3GPP TS 36.108: "Evolved Universal Terrestrial Radio Access (E-UTRA); Satellite Access Node radio transmission and reception"
- [3] ITU-R Recommendation SM.329: "Unwanted emissions in the spurious domain".
- [4] ITU-R Recommendation M.1545: "Measurement uncertainty as it applies to test limits for the terrestrial component of International Mobile Telecommunications-2000".
- [5] 3GPP TR 37.941: "Radio Frequency (RF) conformance testing background for radiated Base Station (BS) requirements"
- [6] 3GPP TS 38.181: "NR; Satellite Access Node (SAN) conformance testing"
- [7] 3GPP TS 36.211: "Evolved Universal Terrestrial Radio Access (E-UTRA); Physical Channels and Modulation"
- [8] 3GPP TS 36.213: "Evolved Universal Terrestrial Radio Access (E-UTRA); Physical layer procedures"
- [9] 3GPP 38.141-2: "NR; Base Station (BS) conformance testing Part 2: Radiated conformance testing"
- [10] 3GPP TS 36.141: "Evolved Universal Terrestrial Radio Access (E-UTRA); Base Station (BS) conformance testing"
- [11] ITU-R Recommendation SM.328: "Spectra and bandwidth of emissions".
- [12] 3GPP TS 36.211: "Evolved Universal Terrestrial Radio Access (E-UTRA); Physical channels and modulation"
- [13] 3GPP TR 38.811: "Study on New Radio (NR) to support non-terrestrial networks".
- [14] 3GPP TS 38 108: "Space Access Node (SAN) radio transmission and reception".
- [15] ITU-R Recommendation SM.1541-6: "Unwanted emissions in the out-of-band domain".

## 3 Definitions of terms, symbols and abbreviations

### 3.1 Terms

For the purposes of the present document, the terms given in TR 21.905 [1] and the following apply. A term defined in the present document takes precedence over the definition of the same term, if any, in TR 21.905 [1].

**SAN RF Bandwidth:** RF bandwidth in which a SAN transmits and/or receives single or multiple carrier(s) within a supported *operating band*.

NOTE: In single carrier operation, the *SAN RF Bandwidth* is equal to the *SAN channel bandwidth*.

**SAN RF Bandwidth edge:** frequency of one of the edges of the *SAN RF Bandwidth*.

**basic limit:** emissions limit relating to the power supplied by a single transmitter to a single antenna transmission line in ITU-R SM.329 [3] used for the formulation of unwanted emission requirements.

**beam:** beam (of the antenna) is the main lobe of the radiation pattern of an *antenna array*.

NOTE: For certain *antenna array*, there may be more than one beam.

**beam centre direction:** direction equal to the geometric centre of the half-power contour of the beam.

**beam direction pair:** data set consisting of the *beam centre direction* and the related *beam peak direction*.

**beam peak direction:** direction where the maximum EIRP is found.

**beamwidth:** beam which has a half-power contour that is essentially elliptical, the half-power beamwidths in the two pattern cuts that respectively contain the major and minor axis of the ellipse.

**Channel edge:** lowest or highest frequency of the E-UTRA carrier, separated by the *SAN channel bandwidth*.

**directional requirement:** requirement which is applied in a specific direction within the *OTA coverage range* for the Tx and when the AoA of the incident wave of a received signal is within the *OTA REFSENS RoAoA* or the *minSENS RoAoA* as appropriate for the receiver.

**equivalent isotropic radiated power:** equivalent power radiated from an isotropic directivity device producing the same field intensity at a point of observation as the field intensity radiated in the direction of the same point of observation by the discussed device.

NOTE: Isotropic directivity is equal in all directions (i.e. 0 dBi).

**equivalent isotropic sensitivity:** sensitivity for an isotropic directivity device equivalent to the sensitivity of the discussed device exposed to an incoming wave from a defined AoA.

NOTE 1: The sensitivity is the minimum received power level at which specific requirement is met.

NOTE 2: Isotropic directivity is equal in all directions (i.e. 0 dBi).

**feeder link:** Wireless link between satellite-gateway and satellite.

**Geostationary Earth Orbit:** Circular orbit at 35,786 km above the Earth's equator and following the direction of the Earth's rotation. An object in such an orbit has an orbital period equal to the Earth's rotational period and thus appears motionless, at a fixed position in the sky, to ground observers.

**Low Earth Orbit:** Orbit around the Earth with an altitude between 300 and 1500 km.

**Highest Carrier:** The carrier with the highest carrier frequency transmitted/received in a specified frequency band.

**Lowest Carrier:** The carrier with the lowest carrier frequency transmitted/received in a specified frequency band.

**maximum carrier output power:** mean power level measured per carrier at the indicated interface, during the *transmitter ON period* in a specified reference condition.

**maximum carrier TRP output power:** mean power level measured per RIB during the *transmitter ON period* for a specific carrier in a specified reference condition and corresponding to the declared *rated carrier TRP output power* ( $P_{\text{rated,c,TRP}}$ ).

**maximum total output power:** mean power level measured within the *operating band* at the indicated interface, during the *transmitter ON period* in a specified reference condition.

**maximum total TRP output power:** mean power level measured per RIB during the *transmitter ON period* in a specified reference condition and corresponding to the declared *rated total TRP output power* ( $P_{\text{rated,t,TRP}}$ ).

**measurement bandwidth:** RF bandwidth in which an emission level is specified.

**minSENS:** the lowest declared EIS value for the OSDD's declared for OTA sensitivity requirement.

**minSENS RoAoA:** The *reference RoAoA* associated with the OSDD with the lowest declared EIS.

**minimum elevation angle:** Minimum angle under which the satellite can be seen by a UE.

**NB-IoT operation in NTN NR in-band:** NB-IoT is operating in-band when it utilizes the resource block(s) within a normal NTN NR carrier.

**NB-IoT operation in NTN NR guard band:** NB-IoT is operating in guard band when it utilizes the unused resource block(s) within a NTN NR carrier's guard-band.

**NB-IoT standalone operation:** NTN NB-IoT is operating standalone when it utilizes its own spectrum.

**necessary bandwidth:** The width of the frequency band which is just sufficient to ensure the transmission of information at the rate and with the quality required under specified conditions.

**non-terrestrial networks:** Networks, or segments of networks, using an airborne or space-borne vehicle to embark a transmission equipment relay node or SAN.

**satellite-gateway:** An earth station or gateway is located at the surface of Earth, and providing sufficient RF power and RF sensitivity for accessing to the satellite.

**operating band:** frequency range in which E-UTRA operates (paired or unpaired), that is defined with a specific set of technical requirements.

NOTE: The *operating band(s)* for a SAN is declared by the manufacturer according to the designations in TS 36.108 [2], tables 5.2-1 and 5.2-2.

**OTA coverage range:** a common range of directions within which TX OTA requirements that are neither specified in the *OTA peak directions sets* nor as *TRP requirement* are intended to be met.

**OTA peak directions set:** set(s) of *beam peak directions* within which certain TX OTA requirements are intended to be met, where all *OTA peak directions set(s)* are subsets of the *OTA coverage range*.

NOTE: The *beam peak directions* are related to a corresponding contiguous range or discrete list of *beam centre directions* by the *beam direction pairs* included in the set.

**OTA REFSENS RoAoA:** the RoAoA determined by the contour defined by the points at which the achieved EIS is 3dB higher than the achieved EIS in the reference direction assuming that for any AoA, the receiver gain is optimized for that AoA.

NOTE: This contour will be related to the average element/sub-array radiation pattern 3 dB beamwidth.

**OTA sensitivity directions declaration:** set of manufacturer declarations comprising at least one set of declared minimum EIS values (with *SAN channel bandwidth*), and related directions over which the EIS applies.

NOTE: All the directions apply to all the EIS values in an OSDD.

**polarization match:** condition that exists when a plane wave, incident upon an antenna from a given direction, has a polarization that is the same as the receiving polarization of the antenna in that direction.

**radiated interface boundary:** *operating band* specific radiated requirements reference where the radiated requirements apply.

NOTE: For requirements based on EIRP/EIS, the *radiated interface boundary* is associated to the far-field region.

**Radio Bandwidth:** frequency difference between the upper edge of the highest used carrier and the lower edge of the lowest used carrier.

**rated beam EIRP:** For a declared beam and *beam direction pair*, the *rated beam EIRP* level is the maximum power that the SAN is declared to radiate at the associated *beam peak direction* during the *transmitter ON period*.

**rated carrier output power:** mean power level associated with a particular carrier the manufacturer has declared to be available at the indicated interface, during the *transmitter ON period* in a specified reference condition.

**rated carrier TRP output power:** mean power level declared by the manufacturer per carrier, for SAN operating in single carrier, multi-carrier, or carrier aggregation configurations that the manufacturer has declared to be available at the RIB during the *transmitter ON period*.

**rated total output power:** mean power level associated with a particular *operating band* the manufacturer has declared to be available at the indicated interface, during the *transmitter ON period* in a specified reference condition.

**rated total TRP output power:** mean power level declared by the manufacturer, that the manufacturer has declared to be available at the RIB during the *transmitter ON period*.

**reference beam direction pair:** declared *beam direction pair*, including reference *beam centre direction* and reference *beam peak direction* where the reference *beam peak direction* is the direction for the intended maximum EIRP within the *OTA peak directions set*.

**receiver target:** AoA in which reception is performed by *SAN types 1-H* or *SAN type 1-O*.

**receiver target redirection range:** union of all the *sensitivity RoAoA* achievable through redirecting the *receiver target* related to particular OSDD.

**receiver target reference direction:** direction inside the *OTA sensitivity directions declaration* declared by the manufacturer for conformance testing. For an OSDD without *receiver target redirection range*, this is a direction inside the *sensitivity RoAoA*.

**reference RoAoA:** the *sensitivity RoAoA* associated with the *receiver target reference direction* for each OSDD.

**requirement set:** one of the E-UTRA SAN requirement's set as defined for *SAN type 1-H*, *SAN type 1-O*.

**SAN channel bandwidth:** RF bandwidth supporting a single E-UTRA RF carrier with the *transmission bandwidth* configured in the uplink or downlink.

NOTE 1: The *SAN channel bandwidth* is measured in MHz and is used as a reference for transmitter and receiver RF requirements.

NOTE 2: It is possible for the SAN to transmit to and/or receive from one or more satellite UE bandwidth parts that are smaller than or equal to the *SAN transmission bandwidth configuration*, in any part of the *SAN transmission bandwidth configuration*.

**SAN transmission bandwidth configuration:** set of resource blocks located within the *SAN channel bandwidth* which may be used for transmitting or receiving by the SAN.

**SAN transponder bandwidth:** Total bandwidth of the carrier(s) in operation by one SAN transponder.

NOTE: When the SAN transponder operates one carrier only, the SAN transponder bandwidth is equal to the SAN channel bandwidth of this carrier.

**SAN transponder:** part of the SAN permitting to receive, channelize and transmit signals within an allocated bandwidth.

**SAN type 1-H:** Satellite Access Node operating at FR1 with a requirement set consisting of conducted requirements defined at individual *TAB connectors* and OTA requirements defined at RIB.

**SAN type 1-O:** Satellite Access Node operating at FR1 with a requirement set consisting only of OTA requirements defined at the RIB.

**satellite:** A space-borne vehicle embarking a transparent payload or a regenerative payload telecommunication transmitter, placed into Low-Earth Orbit (LEO) or Geostationary Earth Orbit (GEO).

**Satellite Access Node:** node providing E-UTRA user plane and control plane protocol terminations towards NTN satellite capable UE and connected via the S1 interface to the EPC. It encompasses a transparent payload on board an NTN platform, with satellite-gateway and eNB functions.

**satellite-gateway:** An earth station or gateway is located at the surface of Earth and providing sufficient RF power and RF sensitivity for accessing to the satellite.

**sensitivity RoAoA:** RoAoA within the *OTA sensitivity directions declaration*, within which the declared EIS(s) of an OSDD is intended to be achieved at any instance of time for a specific SAN direction setting.

**TAB connector:** *transceiver array boundary* connector.

**total radiated power:** is the total power radiated by the antenna.

NOTE: The *total radiated power* is the power radiating in all direction for two orthogonal polarizations. *Total radiated power* is defined in both the near-field region and the far-field region.

**transceiver array boundary:** conducted interface between the transceiver unit array and the composite antenna.

**transmission bandwidth:** RF Bandwidth of an instantaneous transmission from a satellite UE or SAN, measured in resource block units.

## 3.2 Symbols

For the purposes of the present document, the following symbols apply:

$\beta$	Percentage of the mean transmitted power emitted outside the occupied bandwidth on the assigned channel
$BeW_{\theta,REFSENS}$	Beamwidth equivalent to the <i>OTA REFSENS RoAoA</i> in the $\theta$ -axis in degrees
$BeW_{\varphi,REFSENS}$	Beamwidth equivalent to the <i>OTA REFSENS RoAoA</i> in the $\varphi$ -axis in degrees
$BW_{Channel}$	<i>SAN channel bandwidth</i> .
$BW_{Config}$	<i>Transmission bandwidth configuration</i> , where $BW_{Config} = E-UTRA_B \times SCS \times 12$
$BW_{Contiguous}$	Contiguous <i>transmission bandwidth</i> , i.e. <i>SAN channel bandwidth</i> for single carrier
$BW_{SAN}$	The <i>SAN transponder bandwidth</i>
$\Delta f$	Separation between the <i>channel edge</i> frequency and the nominal -3 dB point of the measuring filter closest to the carrier frequency
$\Delta f_{max}$	$f_{offset_{max}}$ minus half of the bandwidth of the measuring filter
$\Delta f_{OOB}$	Maximum offset of the out-of-band boundary from the uplink <i>operating band edge</i>
$\Delta_{minSENS}$	Difference between conducted reference sensitivity and <i>minSENS</i>
$\Delta_{OTA REFSENS}$	Difference between conducted reference sensitivity and <i>OTA REFSENS</i>
$EIS_{minSENS}$	The EIS declared for the <i>minSENS RoAoA</i>
$EIS_{REFSENS}$	<i>OTA REFSENS</i> EIS value
$F_C$	<i>RF reference frequency</i> on the channel raster, given in TS 36.108 [2], table 5.4
$F_{C,low}$	The $F_C$ of the <i>lowest carrier</i> , expressed in MHz
$F_{C,high}$	The $F_C$ of the <i>highest carrier</i> , expressed in MHz
$F_{DL,low}$	The lowest frequency of the downlink <i>operating band</i>
$F_{DL,high}$	The highest frequency of the downlink <i>operating band</i>
$F_{filter}$	Filter centre frequency
$F_{offset,high}$	Frequency offset from $F_{C,high}$ to the upper <i>SAN RF Bandwidth edge</i>
$F_{offset,low}$	Frequency offset from $F_{C,low}$ to the lower <i>SAN RF Bandwidth edge</i>
$f_{offset}$	Separation between the <i>channel edge</i> frequency and the centre of the measuring filter
$F_{UL,low}$	The lowest frequency of the uplink <i>operating band</i>
$F_{UL,high}$	The highest frequency of the uplink <i>operating band</i>
$GB_{Channel}$	Minimum guard band defined in TS 36.108 [2], clause 5.3
$n_{PRB}$	Physical resource block number
$M_{DL}$	Offset of NB-IoT Downlink channel number to Downlink EARFCN
$M_{UL}$	Offset of NB-IoT Uplink channel number to Uplink EARFCN
$N_{DL}$	Downlink EARFCN
$N_{Offs-DL}$	Offset used for calculating downlink EARFCN

$N_{\text{Offs-UL}}$	Offset used for calculating uplink EARFCN
$N_{\text{RB}}$	<i>Transmission bandwidth configuration</i> , expressed in resource blocks
$N_{\text{UL}}$	Uplink EARFCN
$P_{\text{EIRP},N}$	EIRP level for channel N
$P_{\text{max},c,\text{TABC}}$	The <i>maximum carrier output power per TAB connector</i> .
$P_{\text{max},c,\text{TRP}}$	<i>Maximum carrier TRP output power</i> measured at the RIB(s), and corresponding to the declared <i>rated carrier TRP output power</i> ( $P_{\text{rated},c,\text{TRP}}$ )
$P_{\text{max},c,\text{EIRP}}$	The maximum carrier EIRP when the SAN is configured at the maximum rated carrier output TRP ( $P_{\text{rated},c,\text{TRP}}$ ).
$P_{\text{rated},c,\text{sys}}$	$P_{\text{rated},c,\text{sys},\text{GEO}}$ for SAN GEO class or $P_{\text{rated},c,\text{sys},\text{LEO}}$ for SAN LEO class
$P_{\text{rated},c,\text{TRP}}$	<i>Rated carrier TRP output power</i> declared per RIB
$P_{\text{rated},c,\text{sys},\text{GEO}}$	The sum of $P_{\text{rated},c,\text{TABC}}$ for all <i>TAB connectors</i> for a single carrier of the SAN GEO class
$P_{\text{rated},c,\text{sys},\text{LEO}}$	The sum of $P_{\text{rated},c,\text{TABC}}$ for all <i>TAB connectors</i> for a single carrier of the SAN LEO class
$P_{\text{rated},c,\text{TABC}}$	$P_{\text{rated},c,\text{TABC},\text{GEO}}$ for SAN GEO class or $P_{\text{rated},c,\text{TABC},\text{LEO}}$ for SAN LEO class
$P_{\text{rated},c,\text{TABC},\text{GEO}}$	The <i>rated carrier output power per TAB connector</i> of the SAN GEO class
$P_{\text{rated},c,\text{TABC},\text{LEO}}$	The <i>rated carrier output power per TAB connector</i> of the SAN LEO class
$P_{\text{rated},t,\text{TABC}}$	The <i>rated total output power</i> declared at <i>TAB connector</i>
$P_{\text{rated},t,\text{TRP}}$	<i>Rated total TRP output power</i> declared per RIB
$P_{\text{rated},t,\text{sys}}$	The sum of $P_{\text{rated},t,\text{TABC}}$ for all <i>TAB connectors</i>
$P_{\text{REFSENS}}$	Conducted Reference Sensitivity power level

### 3.3 Abbreviations

For the purposes of the present document, the abbreviations given in TR 21.905 [1] and the following apply. An abbreviation defined in the present document takes precedence over the definition of the same abbreviation, if any, in TR 21.905 [1].

AA	Antenna Array
AAS	Active Antenna System
ACLR	Adjacent Channel Leakage Ratio
ACS	Adjacent Channel Selectivity
AoA	Angle of Arrival
AWGN	Additive White Gaussian Noise
BW	Bandwidth
CA	Carrier Aggregation
CP-OFDM	Cyclic Prefix-OFDM
CW	Continuous Wave
DFT-s-OFDM	Discrete Fourier Transform-spread-OFDM
EARFCN	E-UTRA Absolute Radio Frequency Channel Number
EIRP	Equivalent Isotropic Radiated Power
EIS	Equivalent Isotropic Sensitivity
EVM	Error Vector Magnitude
E-UTRA	Evolved UTRA
FR	Frequency Range
FRC	Fixed Reference Channel
GEO	Geostationary Earth Orbiting
ICS	In-Channel Selectivity
LEO	Low Earth Orbiting
MCS	Modulation and Coding Scheme
N-TM	NB-IoT Test Model
NB-IoT	Narrowband – Internet of Things
NTN	Non-Terrestrial Network
OOB	Out-of-band
OOBE	Out-of-band Emissions
OSDD	OTA Sensitivity Directions Declaration
OTA	Over-The-Air
PRB	Physical Resource Block
QAM	Quadrature Amplitude Modulation
RB	Resource Block
RDN	Radio Distribution Network
RE	Resource Element

REFSENS	Reference Sensitivity
RF	Radio Frequency
RIB	Radiated Interface Boundary
RMS	Root Mean Square (value)
RoAoA	Range of Angles of Arrival
RX	Receiver
SAN	Satellite Access Node
SCS	Sub-Carrier Spacing
SPRF	Satellite Payload RF
TAB	Transceiver Array Boundary
TRP	Total Radiated Power
TX	Transmitter

## 4 General test conditions and declarations

### 4.1 Measurement uncertainties and test requirements

#### 4.1.1 General

The requirements of this clause apply to all applicable tests in TS 36.181 (the present document), i.e. to all conducted tests defined for *SAN type 1-H* and radiated tests defined for *SAN type 1-H* and *SAN type 1-O*.

The minimum requirements are given in TS 36.108 [2]. Test Tolerances for the conducted test requirements (TT) and test Tolerances for the radiated test requirements (TT<sub>OTA</sub>) explicitly stated in the present document are given in annex C of the present document.

The test tolerances for the radiated test requirements (TT<sub>OTA</sub>) for SAN were reused from TR 37.941 [5]. Reuse of TR 37.941 [5] TT<sub>OTA</sub> values for SAN LEO radiated conformance testing is subject to the following conditions:

- EUT suitability to fit OTA chambers considered in TR 37.941 [5], and
- Environmental test conditions assumed for BS testing in TR 37.941 [5].

Reuse of TR 37.941 [5] TT<sub>OTA</sub> values for SAN GEO radiated conformance testing may not be justified for some products due to too large SAN GEO antenna array dimensions, and required OTA RF chamber size.

Test Tolerances are individually calculated for each test. Test Tolerances are used to relax the minimum requirements to create test requirements.

When a test requirement differs from the corresponding minimum requirement, then the Test Tolerance applied for the test is non-zero. The Test Tolerance for the test and the explanation of how the minimum requirement has been relaxed by the Test Tolerance are given in annex C.

The radiated requirements are classified according to spatial characteristics as shown in table 4.1.1-1 and table 4.1.1-2.

**Table 4.1.1-1: Overview of radiated Tx requirements**

Tx requirement	Classification	Coverage range	Number of conformance directions
Radiated transmit power	Directional	OTA peak directions set	5
OTA SAN output power	TRP	N/A	NOTE 2
OTA output power dynamics	Directional	OTA peak directions set	1
OTA frequency error	Directional	OTA coverage range	1
OTA modulation quality	Directional	OTA coverage range	5
OTA DL RS power	Directional	OTA coverage range	1
OTA occupied bandwidth	Directional	OTA coverage range	1
OTA ACLR	TRP	N/A	NOTE 2
OTA operating band unwanted emission	TRP	N/A	NOTE 2
OTA transmitter spurious emission: General requirement	TRP	N/A	NOTE 2

NOTE 1: Directional requirement does not imply one compliance direction only. The directional requirement applies to a single direction at a time.

NOTE 2: For the number of conformance test directions for the TRP measurement procedure, refer to TS 38.141-2 [9], annex I.

Table 4.1.1-2: Overview of radiated Rx requirements

Rx requirement	Classification	Applicability levels	Coverage range	Number of conformance directions
OTA sensitivity	Directional	Minimum EIS	OSDD	5
OTA reference sensitivity level	Directional	OTA REFSSENS	OTA REFSSENS RoAoA	5
OTA dynamic range	Directional	OTA REFSSENS	OTA REFSSENS RoAoA	1
OTA adjacent channel selectivity	Directional	minSENS	minSENS RoAoA	1
OTA out-of-band blocking: General requirement	Directional	minSENS	minSENS RoAoA	1
OTA in-channel selectivity	Directional	minSENS	minSENS RoAoA	1
NOTE: Directional requirement does not imply one compliance direction only. The directional requirement applies to a single direction at a time.				

## 4.1.2 Acceptable uncertainty of Test System

### 4.1.2.1 General

The maximum acceptable uncertainty of the Conducted Test System and OTA Test System are specified below for each test defined explicitly in the present specification, where appropriate. The maximum acceptable uncertainty of the Test System for test requirements included by reference is defined in the respective referred test specification.

The Test System shall enable the stimulus signals in the test case to be adjusted to within the specified tolerance and the equipment under test to be measured with an uncertainty not exceeding the specified values. All tolerances and uncertainties are absolute values, and are valid for a confidence level of 95 %, unless otherwise stated.

A confidence level of 95 % is the measurement uncertainty tolerance interval for a specific measurement that contains 95 % of the performance of a population of test equipment.

For conducted RF tests, it should be noted that the uncertainties in clause 4.1.2 apply to the Test System operating into a nominal 50 ohm load and do not include system effects due to mismatch between the EUT and the Test System.

For details on measurement uncertainty budget calculation, measurement methodology description (including calibration and measurement stage for each test range), MU budget format and its contributions, refer to TR 37.941 [5], where MU analyses for the BS radiated testing were captured. The maximum OTA Test System uncertainty for OTA transmitter and receiver tests in table 4.1.2.2-2 and 4.1.2.3-2 were reused from BS MU budgets in TR 37.941 [5]. Reuse of TR 37.941 [5] MU values for SAN LEO radiated conformance testing is subject to the following conditions:

- EUT suitability to fit OTA chambers considered in TR 37.941 [5], and
- Environmental test conditions assumed for BS testing in TR 37.941 [5].

Reuse of TR 37.941 [5]  $TT_{OTA}$  values for SAN GEO radiated conformance testing may not be justified for some products due to too large SAN GEO antenna array dimensions, and required OTA RF chamber size.

### 4.1.2.2 Measurement of transmitter

The maximum conducted Test System uncertainty for conducted transmitter tests minimum requirements is given in table 4.1.2.2-1. And the maximum OTA Test System uncertainty for OTA transmitter tests minimum requirements is given in table 4.1.2.2-2.

**Table 4.1.2.2-1: Maximum Test System uncertainty for conducted transmitter tests**

clause	Maximum Test System Uncertainty
6.2 SAN output power	$\pm 0.7$ dB for E-UTRA, $f \leq 3$ GHz $\pm 1$ dB for standalone NB-IoT
6.3 Output power dynamics	$\pm 0.4$ dB
6.5.2 Frequency error	$\pm 12$ Hz
6.5.3 EVM	$\pm 1\%$
6.5.5 DL RS power	$\pm 0.8$ dB, $f \leq 3$ GHz
6.6.2 Occupied bandwidth	1.4 MHz channel BW: 30 kHz
6.6.3 Adjacent Channel Leakage power Ratio (ACLR)	$\pm 0.8$ dB
6.6.4 Operating band unwanted emissions	$\pm 1.5$ dB, $f \leq 3$ GHz
6.6.5.5 TX spurious emissions: General requirements	9 kHz < $f \leq 4$ GHz: $\pm 2$ dB 4 GHz < $f \leq 15$ GHz: $\pm 4$ dB
6.6.5.6 TX spurious emissions: Protection of SAN receiver	$\pm 3$ dB
NOTE 1: Test system uncertainty values are applicable for normal condition unless otherwise stated.	
NOTE 2: Measurement testing system uncertainty requirements for SAN output power, frequency error, EVM and DL RS requirement are identical for NB-IoT standalone mode and NB-IoT operation in NTN NR in-band.	

**Table 4.1.2.2-2: Maximum OTA Test System uncertainty for OTA transmitter tests**

clause	Maximum OTA Test System uncertainty
9.2 Radiated transmit power	$\pm 1.1$ dB for E-UTRA, $f \leq 3$ GHz $\pm 1.4$ dB for standalone NB-IoT
9.3 OTA SAN output power	$\pm 1.4$ dB, $f \leq 3$ GHz
9.4.3 OTA total power dynamic range	$\pm 0.4$ dB
9.6.2 OTA frequency error	$\pm 12$ Hz
9.6.3 OTA EVM	$\pm 1\%$
9.6.5 OTA DL RS power	$\pm 1.1$ dB
9.7.2 OTA occupied bandwidth	1.4 MHz channel BW: 30 kHz
9.7.3 OTA ACLR	$\pm 1$ dB, $f \leq 3$ GHz
9.7.4 OTA operating band unwanted emissions	Absolute power: $\pm 1.8$ dB, $f \leq 3$ GHz
9.7.5.5 OTA TX spurious emissions: General requirements	$\pm 2.3$ dB, 30 MHz < $f \leq 6$ GHz $\pm 4.2$ dB, 6 GHz < $f \leq 15$ GHz
NOTE 1: Test system uncertainty values are applicable for normal condition unless otherwise stated.	
NOTE 2: Measurement testing system uncertainty requirements for radiated transmit power, OTA SAN output power, OTA frequency error, OTA EVM and OTA DL RS requirement are identical for NB-IoT standalone mode and NB-IoT operation in NTN NR in-band.	

#### 4.1.2.3 Measurement of receiver

The maximum conducted Test System uncertainty for conducted receiver tests minimum requirements are given in table 4.1.2.3-1, and the maximum OTA Test System uncertainty for OTA receiver tests minimum requirements are given in table 4.1.2.3-2.

**Table 4.1.2.3-1: Maximum Test System Uncertainty for conducted receiver tests**

clause	Maximum Test System Uncertainty	Derivation of Test System Uncertainty
7.2 Reference sensitivity level	For E-UTRA: $\pm 0.7$ dB, $f \leq 3$ GHz For standalone NB-IoT: $\pm 1$ dB, $f \leq 3$ GHz	
7.3 Dynamic range	$\pm 0.3$ dB	Overall system uncertainty for static conditions is equal to signal-to-noise ratio uncertainty. Signal-to-noise ratio uncertainty $\pm 0.3$ dB Definitions of signal-to-noise ratio, AWGN and related constraints are given in table 4.1.2-3.
7.4.1 Adjacent channel selectivity	$\pm 1.4$ dB, $f \leq 3$ GHz	Overall system uncertainty comprises three quantities: 1. Wanted signal level error 2. Interferer signal level error 3. Additional impact of interferer ACLR Items 1 and 2 are assumed to be uncorrelated so can be root sum squared to provide the ratio error of the two signals. The interferer ACLR effect is systematic, and is added arithmetically. Test System uncertainty = $\text{SQRT}(\text{wanted\_level\_error}^2 + \text{interferer\_level\_error}^2) + \text{ACLR effect.}$ $f \leq 3$ GHz Wanted signal level $\pm 0.7$ dB Interferer signal level $\pm 0.7$ dB
7.5 Out-of-band blocking	$f_{\text{wanted}} \leq 3\text{GHz}$ $1 \text{ MHz} < f_{\text{interferer}} \leq 3 \text{ GHz}$ : $\pm 1.3$ dB $3 \text{ GHz} < f_{\text{interferer}} \leq 4.2 \text{ GHz}$ : $\pm 1.5$ dB $4.2\text{GHz} < f_{\text{interferer}} \leq 12.75 \text{ GHz}$ : $\pm 3.2$ dB	Overall system uncertainty can have these contributions: 1. Wanted signal level error 2. Interferer signal level error 3. Interferer ACLR 4. Interferer broadband noise Items 1 and 2 are assumed to be uncorrelated so can be root sum squared to provide the ratio error of the two signals. The Interferer ACLR or Broadband noise effect is systematic, and is added arithmetically. Test System uncertainty = $\text{SQRT}(\text{wanted\_level\_error}^2 + \text{interferer\_level\_error}^2) + \text{ACLR effect} + \text{Broadband noise effect.}$  Out of band blocking, using CW interferer: Wanted signal level: $\pm 0.7$ dB $f \leq 3$ GHz Interferer signal level: $\pm 1.0$ dB up to 3 GHz Interferer ACLR not applicable. Impact of interferer Broadband noise 0.1 dB.
7.8 In-channel selectivity	$\pm 1.4$ dB, $f \leq 3$ GHz	Overall system uncertainty comprises three quantities: 1. Wanted signal level error 2. Interferer signal level error 3. Additional impact of interferer leakage Items 1 and 2 are assumed to be uncorrelated so can be root sum squared to provide the ratio error of the two signals. The interferer leakage effect is systematic, and is added arithmetically. Test System uncertainty = $\text{SQRT}(\text{wanted\_level\_error}^2 + \text{interferer\_level\_error}^2) + \text{leakage effect.}$ $f \leq 3$ GHz: Wanted signal level $\pm 0.7$ dB Interferer signal level $\pm 0.7$ dB

NOTE 1: Unless otherwise noted, only the Test System stimulus error is considered here. The effect of errors in the throughput measurements due to finite test duration is not considered.

NOTE 2: The Test equipment ACLR requirement for a specified uncertainty contribution is calculated as below:  
 a) The wanted signal to noise ratio for Reference sensitivity is calculated based on a 5 dB noise figure  
 b) The same wanted signal to (noise + interference) ratio is then assumed at the desensitisation level according to the ACS test conditions  
 c) The noise is subtracted from the total (noise + interference) to compute the allowable SAN adjacent channel interference. From this an equivalent SAN ACS figure can be obtained  
 d) The contribution from the Test equipment ACLR is calculated to give a 0.4 dB additional rise in interference. This corresponds to a Test equipment ACLR which is 10.2 dB better than the SAN ACS  
 e) This leads to the following Test equipment ACLR requirements for the interfering signal:  
 Adjacent channel Selectivity  
 E-UTRA 1.4 MHz channel bandwidth: 56 dB  
 Standalone NB-IoT 200 kHz channel bandwidth: 56 dB

NOTE 3: Measurement testing system uncertainty requirements for Reference sensitivity level, dynamic range, adjacent channel selectivity, out-of-band blocking are identical for NB-IoT standalone mode and NB-IoT operation in NTN NR in-band .

**Table 4.1.2.3-2: Maximum OTA Test System uncertainty for OTA receiver tests**

clause	Maximum OTA Test System uncertainty
10.2 OTA sensitivity	±1.3 dB for E-UTRA, $f \leq 3$ GHz ±1.6 dB for standalone NB-IoT
10.3 OTA reference sensitivity level	±1.3 dB for E-UTRA, $f \leq 3$ GHz ±1.6 dB for standalone NB-IoT
10.4 OTA dynamic range	±0.3 dB
10.5.1 OTA adjacent channel selectivity	±1.7 dB, $f \leq 3$ GHz
10.6 OTA out-of-band blocking	$f_{\text{wanted}} \leq 3$ GHz: ±2 dB, $f_{\text{interferer}} \leq 3$ GHz ±2.1 dB, $3 \text{ GHz} < f_{\text{interferer}} \leq 6$ GHz ±3.5 dB, $6 \text{ GHz} < f_{\text{interferer}} \leq 12.75$ GHz
10.9 OTA in-channel selectivity	±1.7 dB, $f \leq 3$ GHz
NOTE 1: Test system uncertainty values are applicable for normal condition unless otherwise stated.	
NOTE 2: Measurement testing system uncertainty requirements for OTA sensitivity, OTA reference sensitivity level, OTA dynamic range, OTA adjacent channel selectivity, OTA out-of-band blocking are identical for NB-IoT standalone mode and NB-IoT operation in NTN NR in-band .	

## 4.1.2.3 Measurement of performance requirement

**Table 4.1.2.3-1: Maximum Test System Uncertainty for Performance Requirements**

Clause	Maximum Test System Uncertainty (NOTE)	Derivation of Test System Uncertainty
8.2.1 Performance requirements for NPUSCH format 1	$\pm 0.6$ dB	Signal-to-noise ratio uncertainty $\pm 0.3$ dB Fading profile power uncertainty $\pm 0.5$ dB
8.2.2 ACK missed detection for NPUSCH format 2	$\pm 0.6$ dB	Signal-to-noise ratio uncertainty $\pm 0.3$ dB Fading profile power uncertainty $\pm 0.5$ dB
8.2.3 Performance requirements for NPRACH	$\pm 0.6$ dB	Signal-to-noise ratio uncertainty $\pm 0.3$ dB Fading profile power uncertainty $\pm 0.5$ dB
In addition, the following Test System uncertainties and related constraints apply:		
AWGN Bandwidth	$\geq 1.08$ MHz; $N_{RB} \times 180$ kHz according to $BW_{Config}$	
AWGN absolute power uncertainty, averaged over $BW_{Config}$	$\pm 1.5$ dB	
AWGN flatness and signal flatness, max deviation for any resource block, relative to average over $BW_{Config}$	$\pm 2$ dB	
AWGN flatness over $BW_{Channel}$ , max deviation for any resource block, relative to average over $BW_{Config}$	$+2$ dB	
AWGN flatness and signal flatness, max difference between adjacent resource blocks	$\pm 0.5$ dB	
AWGN peak to average ratio	$\geq 10$ dB @0.001%	
Signal-to noise ratio uncertainty, averaged over uplink transmission Bandwidth	$\pm 0.3$ dB	
Fading profile power uncertainty	Test-specific	
Fading profile delay uncertainty, relative to frame timing	$\pm 5$ ns (excludes absolute errors related to baseband timing)	
NOTE: Only the overall stimulus error is considered here. The effect of errors in the throughput measurements due to finite test duration is not considered.		

**Table 4.1.2.3-2: Maximum Test System Uncertainty for Performance Requirements (FR1 OTA performance tests)**

Clause	Maximum Test System Uncertainty (NOTE)	Derivation of Test System Uncertainty
11.2.1 Performance requirements for NPUSCH format 1	$\pm 0.6$ dB	Signal-to-noise ratio uncertainty $\pm 0.3$ dB Fading profile power uncertainty $\pm 0.5$ dB
11.2.2 ACK missed detection for NPUSCH format 2	$\pm 0.6$ dB	Signal-to-noise ratio uncertainty $\pm 0.3$ dB Fading profile power uncertainty $\pm 0.5$ dB
11.2.3 Performance requirements for NPRACH	$\pm 0.6$ dB	Signal-to-noise ratio uncertainty $\pm 0.3$ dB Fading profile power uncertainty $\pm 0.5$ dB
In addition, the following Test System uncertainties and related constraints apply:		
AWGN Bandwidth	$\geq 1.08$ MHz; $N_{RB} \times 180$ kHz according to $BW_{Config}$	
AWGN absolute power uncertainty, averaged over $BW_{Config}$	$\pm 1.5$ dB	
AWGN flatness and signal flatness, max deviation for any resource block, relative to average over $BW_{Config}$	$\pm 2$ dB	
AWGN flatness over $BW_{Channel}$ , max deviation for any resource block, relative to average over $BW_{Config}$	$+2$ dB	
AWGN flatness and signal flatness, max difference between adjacent resource blocks	$\pm 0.5$ dB	
AWGN peak to average ratio	$\geq 10$ dB @0.001%	
Signal-to noise ratio uncertainty, averaged over uplink transmission Bandwidth	$\pm 0.3$ dB	
Fading profile power uncertainty	Test-specific	
Fading profile delay uncertainty, relative to frame timing	$\pm 5$ ns (excludes absolute errors related to baseband timing)	
NOTE: Only the overall stimulus error is considered here. The effect of errors in the throughput measurements due to finite test duration is not considered.		

### 4.1.3 Interpretation of measurement results

The measurement results returned by the Test System are compared - without any modification - against the test requirements as defined by the Shared Risk principle.

The Shared Risk principle is defined in Recommendation ITU-R M.1545 [4].

The actual measurement uncertainty of the Test System for the measurement of each parameter shall be included in the test report.

The recorded value for the Test System uncertainty shall be, for each measurement, equal to or lower than the appropriate figure in clause 4.1.2 of the present document.

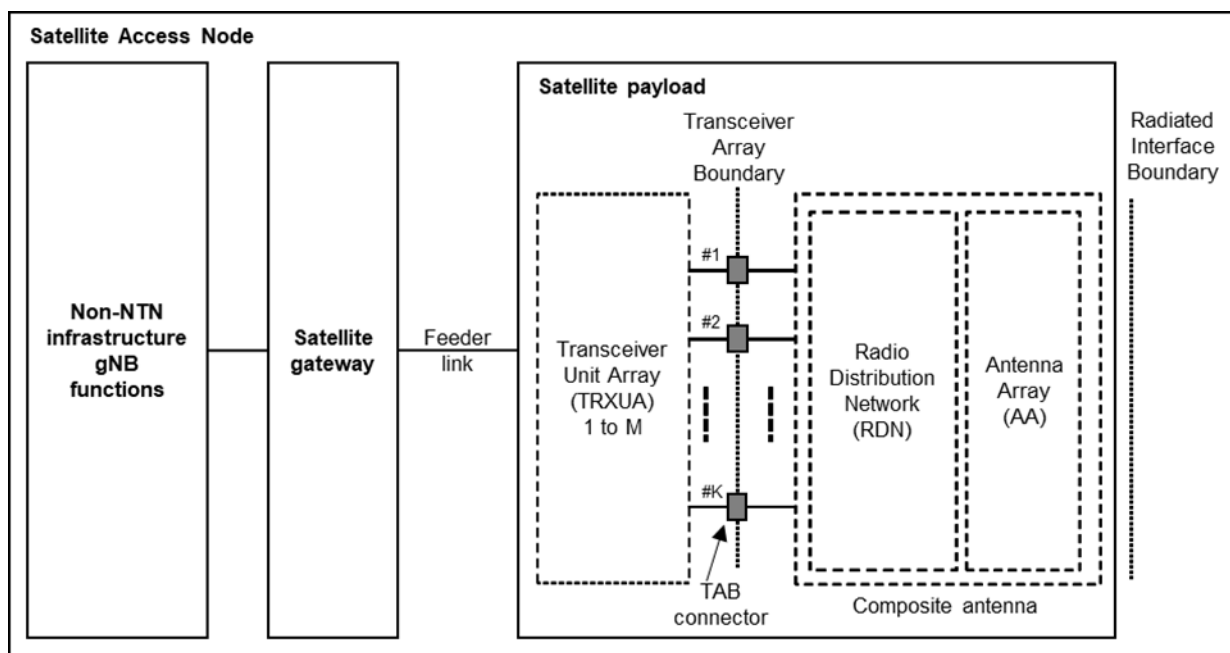
If the Test System for a test is known to have a measurement uncertainty greater than that specified in clause 4.1.2, it is still permitted to use this apparatus provided that an adjustment is made as follows.

Any additional uncertainty in the Test System over and above that specified in clause 4.1.2 shall be used to tighten the test requirement, making the test harder to pass. For some tests e.g. receiver tests, this may require modification of stimulus signals. This procedure will ensure that a Test System not compliant with clause 4.1.2 does not increase the chance of passing a device under test where that device would otherwise have failed the test if a Test System compliant with clause 4.1.2 had been used.

## 4.2 Requirement reference points

### 4.2.1 SAN type 1-H

For *SAN type 1-H*, the requirements are defined for two points of reference, signified by radiated requirements and conducted requirements.



**Figure 4.2.1-1: Radiated and conducted reference points for SAN type 1-H**

Radiated characteristics are defined over the air (OTA), where the radiated interface is referred to as the *Radiated Interface Boundary* (RIB). Radiated requirements are also referred to as OTA requirements. The (spatial) characteristics in which the OTA requirements apply are detailed for each requirement.

Conducted characteristics are defined at individual or groups of *TAB connectors* at the *transceiver array boundary*, which is the conducted interface between the transceiver unit array and the composite antenna.

The transceiver unit array is part of the composite transceiver functionality receiving and transmitting modulated signal to ensure radio links with users.

The satellite payload is composed by a transceiver unit array and a composite antenna array. The transceiver unit array contains an implementation specific number of transmitter units and an implementation specific number of receiver units.

The composite antenna contains a radio distribution network (RDN) and an antenna array. The RDN is a linear passive network which distributes the RF power generated by the transceiver unit array to the antenna array, and/or distributes the radio signals collected by the antenna array to the transceiver unit array, in an implementation specific way.

How a conducted requirement is applied to the *transceiver array boundary* is detailed in the respective requirement clause.

### 4.2.2 SAN type 1-O

For *SAN type 1-O*, the radiated characteristics are defined over the air (OTA), where the *operating band* specific radiated interface is referred to as the *Radiated Interface Boundary* (RIB). Radiated requirements are also referred to as OTA requirements. The (spatial) characteristics in which the OTA requirements apply are detailed for each requirement.

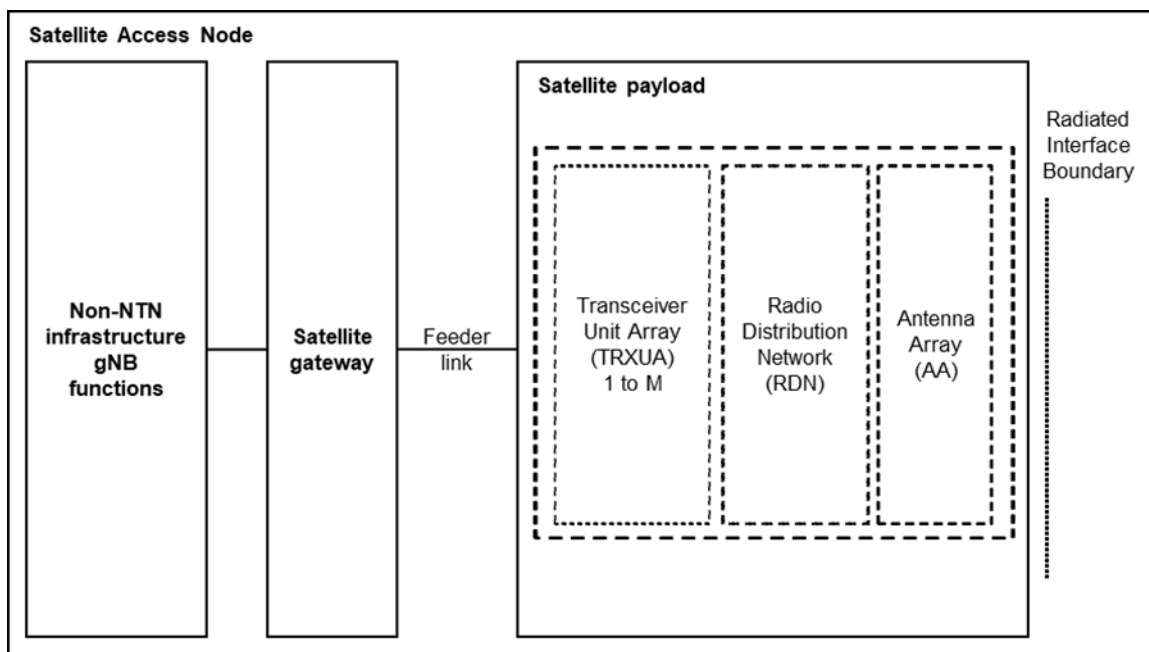


Figure 4.2.2-1: Radiated reference points for *SAN type 1-O*

Transmitter units and receiver units may be combined into transceiver units. The transmitter/receiver units have the ability to transmit/receive parallel independent modulated symbol streams.

## 4.3 Satellite Access Node classes

The requirements in this specification apply to Satellite Access Node unless otherwise stated. The associated deployment scenarios are exactly the same for SAN with and without connectors.

For *SAN type 1-O* and *SAN type 1-H*, two SAN classes (LEO and GEO) are currently defined in table 4.3-1.

Table 4.3-1 SAN classes

SAN Class	Satellite constellation
GEO class	GEO satellite
LEO class	LEO 600 km satellite LEO 1200 km satellite

## 4.4 Regional requirements

Some requirements in the present document may only apply in certain regions either as optional requirements, or as mandatory requirements set by local and regional regulation. It is normally not stated in the 3GPP specifications under what exact circumstances the regional requirements apply, since this is defined by local or regional regulation.

Table 4.4-1 lists all requirements in the present specification that may be applied differently in different regions.

Table 4.4-1: List of regional requirements

clause number	Requirement	Comments
5	<i>Operating bands</i>	Satellite <i>operating bands</i> may be applied regionally.
6.6.4, 9.7.4	Out-of-band emissions, OTA out-of-band emissions	For band 252 and n255 operation in US, Limits in FCC Title 47 apply.
6.6.5, 9.7.5	Tx spurious emissions, OTA Tx spurious emissions	For band 252 and n255 operation in US, Limits in FCC Title 47 apply.

## 4.5 SAN configurations

### 4.5.1 SAN type 1-H transmit configurations

Unless otherwise stated, the conducted transmitter characteristics in clause 6 are specified at the *transceiver array boundary* at the *TAB connector(s)* with a full complement of transceiver units for the configuration in normal operating conditions.

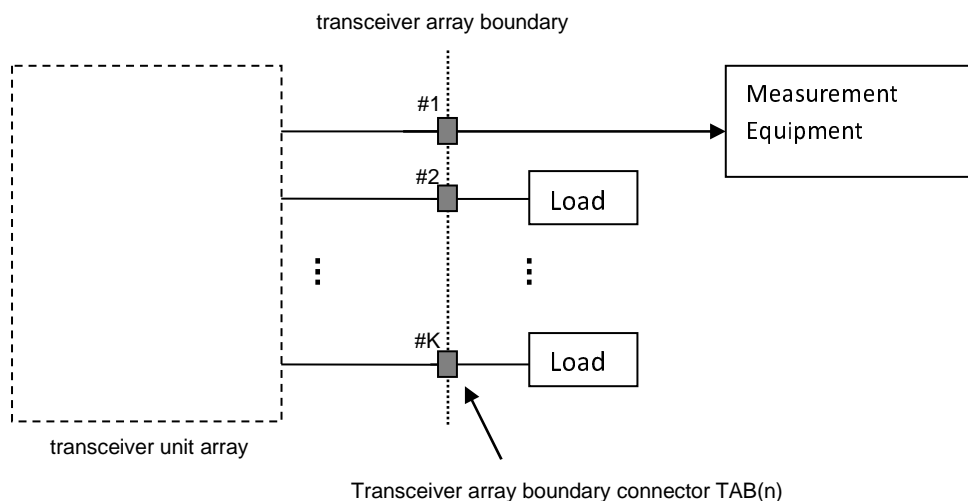
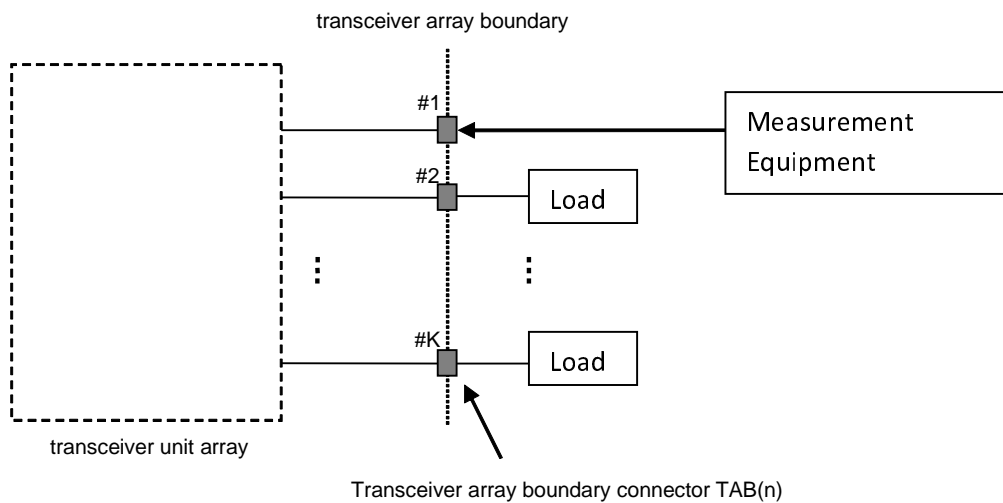


Figure 4.5.1-1: SAN type 1-H transmitter test ports

Unless otherwise stated, for the tests in clause 6 of the present document, the requirement applies for each transmit *TAB connector*.

### 4.5.2 SAN type 1-H receive configurations

Unless otherwise stated, the conducted receiver characteristics in clause 7 are specified at the *TAB connector* with a full complement of transceiver units for the configuration in normal operating conditions.



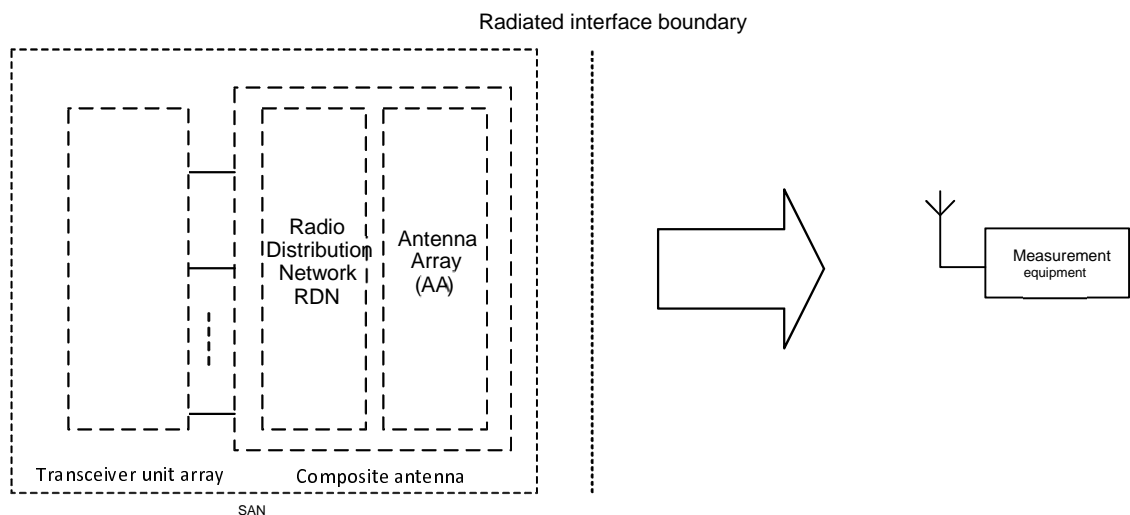
**Figure 4.5.2-1: Receiver test ports**

For the tests in clause 7 of the present document, the requirement applies at each receive *TAB connector*.

Conducted receive requirements are tested at the *TAB connector*, with the remaining receiver unit(s) disabled or their *TAB connector(s)* being terminated.

### 4.5.3 SAN type 1-H and 1-O transmit configurations

Unless otherwise stated, the radiated transmitter characteristics in clause 9 are specified at RIB, with a full complement of transceiver units for the configuration in normal operating conditions.



**Figure 4.5.3-1: SAN type 1-O transmitter test interfaces**

### 4.5.4 SAN type 1-H and 1-O receive configurations

Unless otherwise stated, the radiated receiver characteristics in clause 10 are specified at RIB, with a full complement of transceiver units for the configuration in normal operating conditions.

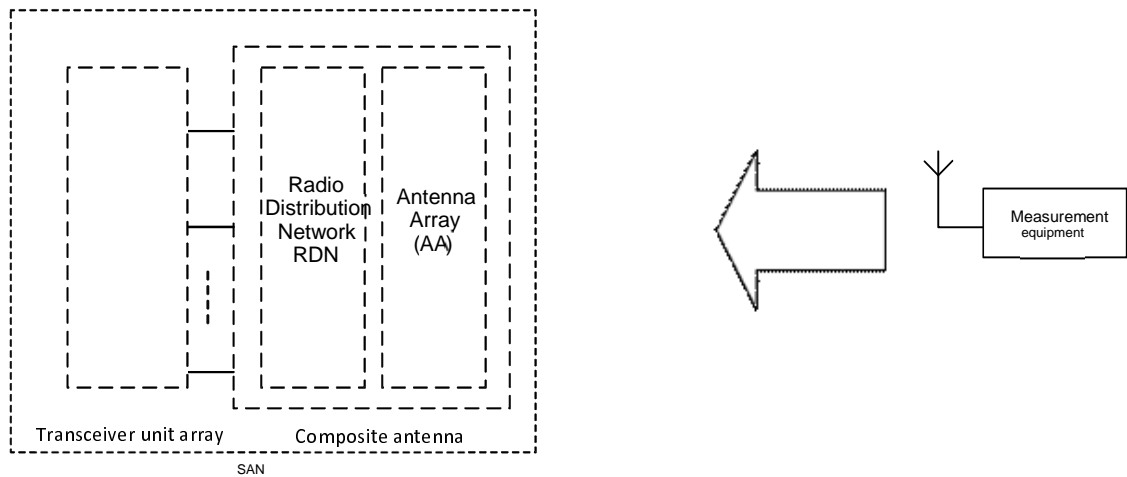


Figure 4.5.4-1: SAN type 1-O receiver test interfaces

### 4.5.5 Power supply options

If the SAN is supplied with a number of different power supply configurations, it may not be necessary to test RF parameters for each of the power supply options, provided that it can be demonstrated that the range of conditions over which the equipment is tested is at least as great as the range of conditions due to any of the power supply configurations.

## 4.6 Manufacturer declarations

The following SAN declarations listed in table 4.6-1, when applicable to the SAN under test, are required to be provided by the manufacturer for the conducted requirements testing of the SAN type 1-H, and radiated requirements testing of SAN type 1-H and SAN type 1-O.

**Table 4.6-1 Manufacturers declarations for *SAN type 1-H* conducted test requirements, and for *SAN type 1-H and SAN type 1-O* radiated test requirements**

Declaration identifier	Declaration	Description	Applicability (Note 1)	
			SAN type 1-H (Note 2)	SAN type 1-O
D.1	Coordinate system reference point	Location of coordinated system reference point in reference to an identifiable physical feature of the SAN enclosure.	x	x
D.2	Coordinate system orientation	Orientation of the coordinate system in reference to an identifiable physical feature of the SAN enclosure.	x	x
D.3	Beam identifier	<p>A unique title to identify a beam, e.g. a, b, c or 1, 2, 3. The vendor may declare any number of beams with unique identifiers. The minimum set to declare for conformance, corresponds to the beams at the reference beam direction with the highest intended EIRP, and covering the properties listed below:</p> <ol style="list-style-type: none"> <li>1) A beam with the narrowest intended <math>BeW_{\theta}</math> and narrowest intended <math>BeW_{\phi}</math> possible when narrowest intended <math>BeW_{\theta}</math> is used.</li> <li>2) A beam with the narrowest intended <math>BeW_{\phi}</math> and narrowest intended <math>BeW_{\theta}</math> possible when narrowest intended <math>BeW_{\phi}</math> is used.</li> <li>3) A beam with the widest intended <math>BeW_{\theta}</math> and widest intended <math>BeW_{\phi}</math> possible when widest intended <math>BeW_{\theta}</math> is used.</li> <li>4) A beam with the widest intended <math>BeW_{\phi}</math> and widest intended <math>BeW_{\theta}</math> possible when widest intended <math>BeW_{\phi}</math> is used.</li> <li>5) A beam which provides the highest intended EIRP of all possible beams.</li> </ol> <p>When selecting the above five beam widths for declaration, all beams that the SAN is intended to produce shall be considered, including beams that during operation may be identified by any kind of cell or UE specific reference signals, with the exception of any type of beam that is created from a group of transmitters that are not all phase synchronised. (Note 3)</p>	x	x
D.4	<i>Operating bands and frequency ranges</i>	List of <i>operating band(s)</i> supported by the SAN and if applicable, frequency range(s) within the <i>operating band(s)</i> that the SAN can operate in. Supported bands declared for every beam for <i>SAN type 1-O</i> (D.3), or every <i>TAB connector</i> for <i>SAN type 1-H</i> . (Note 4)	c	x
D.5	SAN requirements set	Declaration of one of the satellite access node <i>requirements set</i> as defined for <i>SAN type 1-H</i> , or <i>SAN type 1-O</i> .	c	x
D.6	SAN class	Declared as GEO SAN, or LEO SAN.	c	x
D.7	E-UTRA or standalone NB-IoT support	E-UTRA or standalone NB-IoT support. Declared for each beam for <i>SAN type 1-O</i> (D.3) or each <i>TAB connector</i> for <i>SAN type 1-H</i> , and each <i>operating band</i> (D.4).	c	x
D.8	<i>OTA peak directions set reference beam direction pair</i>	The beam direction pair, describing the reference beam peak direction and the reference beam centre direction. Declared for every beam (D.3).	x	x
D.9	<i>OTA peak directions set</i>	The OTA peak directions set for each beam. Declared for every beam (D.3).	x	x

Declaration identifier	Declaration	Description	Applicability (Note 1)	
			SAN type 1-H (Note 2)	SAN type 1-O
D.10	OTA peak directions set maximum steering direction(s)	The <i>beam direction pair(s)</i> corresponding to the following points: 1) The beam peak direction corresponding to the maximum steering from the reference beam centre direction in the positive $\Phi$ direction, while the $\theta$ value being the closest possible to the reference beam centre direction. 2) The beam peak direction corresponding to the maximum steering from the reference beam centre direction in the negative $\Phi$ direction, while the $\theta$ value being the closest possible to the reference beam centre direction. 3) The beam peak direction corresponding to the maximum steering from the reference beam centre direction in the positive $\theta$ direction, while the $\Phi$ value being the closest possible to the reference beam centre direction. 4) The beam peak direction corresponding to the maximum steering from the reference beam centre direction in the negative $\theta$ direction, while the $\Phi$ value being the closest possible to the reference beam centre direction. The maximum steering direction(s) may coincide with <i>the reference beam centre direction</i> . Declared for every beam (D.3).	x	x
D.11	Rated beam EIRP ( $P_{\text{rated,c,EIRP}}$ )	The rated EIRP level per carrier ( $P_{\text{rated,c,EIRP}}$ ) at the <i>beam peak direction</i> associated with a particular <i>beam direction pair</i> for each of the declared maximum steering directions (D.10), as well as the reference <i>beam direction pair</i> (D.8). Declared for every beam (D.3). (Note 11)	x	x
D.12	Beamwidth	The <i>beamwidth</i> for the reference <i>beam direction pair</i> and the four maximum steering directions. Declared for every beam (D.3).	x	x
D.13	Equivalent beams	List of beams which are declared to be equivalent. Equivalent beams imply that the beams are expected to have identical <i>OTA peak directions sets</i> and intended to have identical spatial properties at all steering directions within the <i>OTA peak directions set</i> when presented with identical signals. All declarations (D.4 – D.12) made for the beams are identical and the transmitter unit, RDN and antenna array responsible for generating the beam are of identical design.	x	x
D.14	Parallel beams	List of beams which have been declared equivalent (D.13) and can be generated in parallel using independent RF power resources. Independent power resources mean that the beams are transmitted from mutually exclusive transmitter units.	x	x
D.15	Number of carriers at maximum TRP	The number of carriers per operating band the SAN is capable of generating at maximum TRP declared for every beam (D.3).	n/a	x
D.16	Maximum Satellite Access Node RF Bandwidth	Maximum <i>Satellite Access Node RF Bandwidth</i> in the <i>operating band</i> , declared for each supported operating band for each beam for SAN type 1-O, or for each TAB connector for SAN type 1-H (D.4). (Note 10)	c	x

Declaration identifier	Declaration	Description	Applicability (Note 1)	
			SAN type 1-H (Note 2)	SAN type 1-O
D.17	Total RF bandwidth ( $BW_{tot}$ )	Total RF bandwidth $BW_{tot}$ of transmitter and receiver, declared per the band combinations (D.42).	c	x
D.18	Contiguous spectrum operation support	Ability of SAN to support contiguous frequency distribution of carriers when operating multi-carrier in an operating band. Declared for each <i>single-band RIB</i> for SAN type 1-O or each <i>single-band connector</i> for SAN type 1-H, for each <i>operating band</i> .	c	x
D.19	OSDD identifier	A unique identifier for the OSDD.	x	x
D.20	OSDD operating band support	Operating band supported by the OSDD, declared for every OSDD (D.19). (Note 5)	x	x
D.22	Redirection of receiver target support	Ability to redirect the receiver target related to the OSDD.	x	x
D.23	Minimum EIS ( $EIS_{minSENS}$ )	The minimum $EIS_{minSENS}$ requirement (i.e. maximum allowable EIS value) applicable to all sensitivity RoAoA per OSDD. Declared per supported channel BW for the OSDD (D.19). The lowest EIS value for all the declared OSDD's is called <i>minSENS</i> , while its related range of angles of arrival is called <i>minSENS RoAoA</i> . (Note 6)	x	x
D.24	Receiver target reference direction Sensitivity Range of Angle of Arrival	The sensitivity RoAoA associated with the receiver target reference direction (D.26) for each OSDD.	x	x
D.25	Receiver target redirection range	For each OSDD the associated union of all the sensitivity RoAoA achievable through redirecting the receiver target related to the OSDD.	x	x
D.26	Receiver target reference direction	For each OSDD an associated direction inside the receiver target redirection range (D.25). (Note 7)	x	x
D.27	Conformance test directions sensitivity RoAoA	For each OSDD that includes a receiver target redirection range, four sensitivity RoAoA comprising the conformance test directions (D.28).	x	x

Declaration identifier	Declaration	Description	Applicability (Note 1)	
			SAN type 1-H (Note 2)	SAN type 1-O
D.28	Conformance test directions	<p>For each OSDD four conformance test directions.</p> <p>If the OSDD includes a receiver target redirection range the following four directions shall be declared:</p> <ol style="list-style-type: none"> <li>1) The direction determined by the maximum <math>\phi</math> value achievable inside the receiver target redirection range, while <math>\theta</math> value being the closest possible to the receiver target reference direction.</li> <li>2) The direction determined by the minimum <math>\phi</math> value achievable inside the receiver target redirection range, while <math>\theta</math> value being the closest possible to the receiver target reference direction.</li> <li>3) The direction determined by the maximum <math>\theta</math> value achievable inside the receiver target redirection range, while <math>\phi</math> value being the closest possible to the receiver target reference direction.</li> <li>4) The direction determined by the minimum <math>\theta</math> value achievable inside the receiver target redirection range, while <math>\phi</math> value being the closest possible to the receiver target reference direction.</li> </ol> <p>If an OSDD does not include a receiver target redirection range the following 4 directions shall be declared:</p> <ol style="list-style-type: none"> <li>1) The direction determined by the maximum <math>\phi</math> value achievable inside the sensitivity RoAoA, while <math>\theta</math> value being the closest possible to the receiver target reference direction.</li> <li>2) The direction determined by the minimum <math>\phi</math> value achievable inside the sensitivity RoAoA, while <math>\theta</math> value being the closest possible to the receiver target reference direction.</li> <li>3) The direction determined by the maximum <math>\theta</math> value achievable inside the sensitivity RoAoA, while <math>\phi</math> value being the closest possible to the receiver target reference direction.</li> <li>4) The direction determined by the minimum <math>\theta</math> value achievable inside the sensitivity RoAoA, while <math>\phi</math> value being the closest possible to the receiver target reference direction.</li> </ol>	x	x
D.29	OTA coverage range	Declared as a single range of directions within which selected TX OTA requirements are intended to be met. (Note 8)	x	x
D.30	OTA coverage range reference direction	The direction describing the reference direction of the OTA coverage range (D.29). (Note 9)	x	x

Declaration identifier	Declaration	Description	Applicability (Note 1)	
			SAN type 1-H (Note 2)	SAN type 1-O
D.31	OTA coverage range maximum directions	The directions corresponding to the following points: 1) The direction determined by the maximum $\varphi$ value achievable inside the <i>OTA coverage range</i> , while $\theta$ value being the closest possible to the <i>OTA coverage range</i> reference direction. 2) The direction determined by the minimum $\varphi$ value achievable inside the <i>OTA coverage range</i> , while $\theta$ value being the closest possible to the <i>OTA coverage range</i> reference direction. 3) The direction determined by the maximum $\theta$ value achievable inside the <i>OTA coverage range</i> , while $\varphi$ value being the closest possible to the <i>OTA coverage range</i> reference direction. 4) The direction determined by the minimum $\theta$ value achievable inside the <i>OTA coverage range</i> , while $\varphi$ value being the closest possible to the <i>OTA coverage range</i> reference direction.	x	x
D.32	The rated carrier OTA SAN power, $P_{\text{rated,c,TRP}}$	$P_{\text{rated,c,TRP}}$ is declared as TRP OTA power per carrier, declared per supported operating band. (Note 11)	n/a	x
D.33	Rated transmitter TRP, $P_{\text{rated,t,TRP}}$	Rated total radiated output power. Declared per supported <i>operating band</i> . (Note 11)	n/a	x
D.34	Rated carrier output power ( $P_{\text{rated,c,TABC}}$ )	Conducted rated carrier output power, per <i>single band connector</i> . Declared per supported <i>operating band</i> , per <i>TAB connector</i> for <i>SAN type 1-H</i> . (Note 11)	c	n/a
D.35	Rated total output power ( $P_{\text{rated,t,TABC}}$ )	Conducted total rated output power. Declared per supported <i>operating band</i> , per <i>TAB connector</i> for <i>SAN type 1-H</i> . (Note 11)	c	n/a
D.36	Single band connector	List of single-band connector for the supported operating bands (D.4).	c	n/a
D.37	Equivalent connectors	List of <i>TAB connector</i> of <i>SAN type 1-H</i> , which have been declared equivalent. Equivalent connectors imply that the <i>TAB connector</i> of <i>SAN type 1-H</i> , are expected to behave in the same way when presented with identical signals under the same operating conditions. All declarations made for the <i>TAB connector</i> of <i>SAN type 1-H</i> are identical and the transmitter unit and/or receiver unit driving <i>TAB connector</i> of <i>SAN type 1-H</i> are of identical design.	c	n/a
D.38	Single-band RIB	List of single-band RIB for the supported operating bands (D.4).	n/a	x
D.39	Single or multiple carrier	SAN capability to operate with a single carrier (only) or multiple carriers. Declared per supported <i>operating band</i> , per <i>RIB</i> for <i>SAN type 1-O</i> or per <i>TAB connector</i> for <i>SAN type 1-H</i> .	c	x
D.40	Maximum number of supported carriers per <i>operating band</i>	Maximum number of supported carriers. Declared per supported <i>operating band</i> , per <i>RIB</i> for <i>SAN type 1-O</i> or per <i>TAB connector</i> for <i>SAN type 1-H</i> . (Note 10)	c	x
D.41	Maximum supported power difference between carriers	Maximum supported power difference between carriers in each supported <i>operating band</i> . Declared per <i>operating band</i> (D.4), per <i>RIB</i> for <i>SAN type 1-O</i> or per <i>TAB connector</i> for <i>SAN type 1-H</i> .	c	x

Declaration identifier	Declaration	Description	Applicability (Note 1)	
			SAN type 1-H (Note 2)	SAN type 1-O
D.42	Operating band combination support	List of <i>operating bands</i> combinations supported by <i>single-band RIB(s)</i> of <i>SAN type 1-O</i> , or <i>single-band connector(s)</i> of <i>SAN type 1-H</i> .	c	x
D.43	OTA REFSSENS RoAoA	Range of angles of arrival associated with the OTA REFSSENS.	n/a	x
D.44	OTA REFSSENS receiver target reference direction	Reference direction inside the OTA REFSSENS RoAoA (D.43).	n/a	x
D.45	OTA REFSSENS conformance test directions	The following four OTA REFSSENS conformance test directions shall be declared: 1) The direction determined by the maximum $\varphi$ value achievable inside the OTA REFSSENS RoAoA, while $\theta$ value being the closest possible to the OTA REFSSENS receiver target reference direction. 2) The direction determined by the minimum $\varphi$ value achievable inside the OTA REFSSENS RoAoA, while $\theta$ value being the closest possible to the OTA REFSSENS receiver target reference direction. 3) The direction determined by the maximum $\theta$ value achievable inside the OTA REFSSENS RoAoA, while $\varphi$ value being the closest possible to the OTA REFSSENS receiver target reference direction. 4) The direction determined by the minimum $\theta$ value achievable inside the OTA REFSSENS RoAoA, while $\varphi$ value being the closest possible to the OTA REFSSENS receiver target reference direction.	n/a	x
D.46	Relation between supported maximum RF bandwidth, number of carriers and Rated maximum TRP	If the rated transmitter TRP and total number of supported carriers are not simultaneously supported, the manufacturer shall declare the following additional parameters: - The reduced number of supported carriers at the rated transmitter TRP; - The reduced total output power at the maximum number of supported carriers.	n/a	x
D.47	Relation between supported maximum RF bandwidth, number of carriers and Rated total output power	If the rated total output power and total number of supported carriers are not simultaneously supported, the manufacturer shall declare the following additional parameters: - The reduced number of supported carriers at the rated total output power; - The reduced total output power at the maximum number of supported carriers.	c	n/a
D.48	<i>TAB connectors</i> used for performance requirement testing	To reduce test complexity, declaration of a representative (sub)set of <i>TAB connectors</i> to be used for performance requirement test purposes. At least one <i>TAB connector</i> mapped to each <i>demodulation branch</i> is declared.	c	n/a
D.49	$P_{\text{rated,c,sys,GEO}}$	The sum of $P_{\text{rated,c,TABC}}$ for all <i>TAB connectors</i> for a single carrier of the SAN GEO class.	c	n/a
D.50	$P_{\text{rated,c,TABC,GEO}}$	The <i>rated carrier output power per TAB connector</i> of the SAN GEO class.	c	n/a
D.51	$P_{\text{rated,c,sys,LEO}}$	The sum of $P_{\text{rated,c,TABC}}$ for all <i>TAB connectors</i> for a single carrier of the SAN LEO class.	c	n/a
D.52	$P_{\text{rated,c,TABC,LEO}}$	The <i>rated carrier output power per TAB connector</i> of the SAN LEO class.	c	n/a

Declaration identifier	Declaration	Description	Applicability (Note 1)	
			SAN type 1-H (Note 2)	SAN type 1-O
NOTE 1: Manufacturer declarations applicable per SAN <i>requirement set</i> were marked as "x" or "c". Manufacturer declarations not applicable per SAN <i>requirement set</i> were marked as "n/a".				
NOTE 2: For <i>SAN type 1-H</i> , the only radiated declarations are related to EIRP and EIS requirements. For declarations marked as 'c', related conducted declarations apply, and for declarations marked as 'x', related radiated declarations apply.				
NOTE 3: Depending on the capability of the system some of these beams may be the same. For those same beams, testing is not repeated.				
NOTE 4: These <i>operating bands</i> are related to their respective single-band RIBs, or single-band TAB connectors.				
NOTE 5: As each identified OSDD has a declared minimum EIS value (D.23), multiple operating band can only be declared if they have the same minimum EIS declaration.				
NOTE 6: If the <i>SAN type 1-H</i> or <i>SAN type 1-O</i> is not capable of redirecting the receiver target related to the OSDD then there is only one RoAoA applicable to the OSDD.				
NOTE 7: For an OSDD without receiver target redirection range, this is a direction inside the sensitivity RoAoA.				
NOTE 8: <i>OTA coverage range</i> is used for conformance testing of such TX OTA requirements as occupied bandwidth, frequency error or EVM.				
NOTE 9: The <i>OTA coverage reference</i> direction may be the same as the Reference beam direction pair (D.8) but does not have to be.				
NOTE 10: Parameters for contiguous spectrum operation in the operating band are assumed to be the same unless they are separately declared. When separately declared, they shall still use the same declaration identifier.				
NOTE 11: If a SAN is capable of 64QAM DL operation then up to two rated output power declarations may be made. One declaration is applicable when configured for 64QAM transmissions, and the other declaration is applicable when not configured for 64QAM transmissions.				

## 4.7 Test configurations

### 4.7.1 General

The test configurations shall be constructed using the methods defined below, subject to the parameters declared by the manufacturer for the supported RF configurations as listed in clause 4.6.8. The test configurations to use for conformance testing are defined for each supported RF configuration in clause 4.11.

The applicable test models for generation of the carrier transmit test signal are defined in clause 6.1.1.

### 4.7.2 Test signal used to build Test Configurations

### 4.7.3 ETC1: Contiguous spectrum operation

The purpose of test configuration ETC1 is to test all SAN requirements excluding CA occupied bandwidth.

For ETC1 used in receiver tests only the two outermost carriers within each supported operating band need to be generated by the test equipment.

#### 4.7.3.1 ETC1 generation

ETC1 shall be constructed on a per band basis using the following method:

- Declared maximum *SAN RF Bandwidth* supported for contiguous spectrum operation shall be used;
- Place 1.4 MHz carrier adjacent to the lower *SAN RF Bandwidth edge* and place a 1.4 MHz carrier adjacent to the upper *SAN RF Bandwidth edge*.
- For transmitter tests, select as many 1.4 MHz carriers that the SAN supports within a band and fit in the rest of the declared maximum *SAN RF Bandwidth*. Place the carriers adjacent to each other starting from the upper *SAN RF Bandwidth edge*. The nominal carrier spacing defined in clause 5.7 shall apply;

All configured component carriers are transmitted simultaneously in the tests where the transmitter should be on.

#### 4.7.3.2 ETC1 power allocation

Set the power of each carrier to the same level so that the sum of the carrier powers equals the rated total output power  $P_{\text{rated},t}$  according to the manufacturer's declaration in clause 4.6.8.

#### 4.7.4 ETC6: Contiguous spectrum operation.

The purpose of the ETC6 is to test NB-IoT standalone multi-carrier aspects.

##### 4.7.4.1 ETC6 generation

ETC6 is constructed using the following method:

- The *SAN RF Bandwidth* shall be the declared maximum *SAN RF Bandwidth*.
- Place a NB-IoT carrier at the upper edge and a NB-IoT carrier at the lower edge of *SAN RF Bandwidth*.
- For transmitter tests, add NB-IoT carriers at the edges using [600 kHz] spacing until no more NB-IoT carriers are supported or no more NB-IoT carriers fit.

##### 4.7.4.2 ETC6 power allocation

Set the power of each carrier to the same level so that the sum of the carrier powers equals the rated total output power  $P_{\text{rated},t}$  according to the manufacturer's declaration in clause 4.6.8.

### 4.8 Applicability of requirements

#### 4.8.1 General

#### 4.8.2 Requirement set applicability

In table 4.8.2-1, the requirement applicability for each *requirement set* is defined. For each requirement, the applicable requirement clause in the specification is identified. Requirements not included in a *requirement set* is marked not applicable (NA).

Table 4.8.2-1: Requirement set applicability

Requirement	Requirement set		
	SAN type 1-H	SAN type 1-O	
Satellite Access Network output power	6.2	NA	
Output power dynamics	6.3		
Transmit ON/OFF power	NA		
Frequency error	6.5.1		
Modulation quality	6.5.2		
Time alignment error	NA		
Occupied bandwidth	6.6.2		
ACLR	6.6.3		
Out-of-band emissions	6.6.4		
Transmitter spurious emissions	6.6.5		
Transmitter intermodulation	NA		
Reference sensitivity level	7.2		
Dynamic range	7.3		
ACS	7.4.1		
In-band blocking	NA		
Out-of-band blocking	7.5		
Receiver spurious emissions	NA		
Receiver intermodulation	NA		
In-channel selectivity	7.8		
Performance requirements	8		
Radiated transmit power	9.2	9.2	
OTA Satellite Access Network output power	NA	9.3	
OTA output power dynamics		9.4	
OTA transmit ON/OFF power		NA	
OTA frequency error		9.6.1	
OTA modulation quality		9.6.2	
OTA time alignment error		NA	
OTA occupied bandwidth		9.7.2	
OTA ACLR		9.7.3	
OTA out-of-band emission		9.7.4	
OTA transmitter spurious emission		9.7.5	
OTA transmitter intermodulation		NA	
OTA sensitivity		10.2	10.2
OTA reference sensitivity level		NA	10.3
OTA dynamic range			10.4
OTA ACS	10.5.1		
OTA in-band blocking	NA		
OTA out-of-band blocking	10.6		
OTA receiver spurious emission	NA		
OTA receiver intermodulation	NA		
OTA in-channel selectivity	10.9		
Radiated performance requirements		11	

### 4.8.3 Applicability of test configurations for single-band operation

The applicable test configurations are specified in the tables below for each the supported RF configuration, which shall be declared according to clause 4.6. The generation and power allocation for each test configuration is defined in clause 4.7. This clause contains the test configurations for a SAN capable of single carrier, multi-carrier operation in contiguous spectrum in single band.

For a SAN declared to be capable of single carrier operation only (D.39), a single carrier (SC) shall be used for testing.

For conducted test, for a SAN declared to support multi-carrier operation in contiguous spectrum within a single band (D.39) with *single band connector*, the test configurations in the second column of table 4.8.3-1 shall be used for testing.

For OTA test, for a SAN declared to support multi-carrier operation in contiguous spectrum within a single band (D.39) with *single band RIB*, the test configurations in the second column of table 4.8.3-2 shall be used for testing.

Unless otherwise stated, single carrier configuration (SC) tests shall be performed using signal with narrowest supported channel bandwidth and the smallest supported sub-carrier spacing.

**Table 4.8.3-1: Test configurations for a *single-band connector***

<b>SAN test case</b>	<b>Contiguous spectrum capable SAN</b>
Base station output power	ETC1
RE Power control dynamic range	Tested with Error Vector Magnitude
Total power dynamic range	SC
Frequency error	Tested with Error Vector Magnitude
Error Vector Magnitude	ETC1
Occupied bandwidth	SC
Adjacent Channel Leakage power Ratio (ACLR)	ETC1
Out-of-band emissions	ETC1, SC (Note)
Transmitter spurious emissions	ETC1
Reference sensitivity level	SC
Dynamic range	SC
Adjacent Channel Selectivity (ACS)	ETC1
Out-of-band blocking	ETC1
In-channel selectivity	SC
NOTE: OOB SC shall be tested using the widest supported channel bandwidth and the highest supported sub-carrier spacing.	

**Table 4.8.3-2: Test configurations for a *single-band RIB***

<b>SAN test case</b>	<b>Contiguous spectrum capable SAN</b>
Radiated transmit power	ETC1
OTA base station maximum output power	ETC1
OTA RE Power control dynamic range	Tested with Error Vector Magnitude
OTA total power dynamic range	SC
OTA frequency error	Tested with Error Vector Magnitude
OTA error Vector Magnitude	ETC1
OTA Occupied bandwidth	SC
OTA ACLR	ETC1
OTA Out-of-band emissions	ETC1, SC (Note)
OTA transmitter spurious emissions	ETC1
OTA sensitivity	SC
OTA reference sensitivity level	SC
OTA dynamic range	SC
OTA adjacent channel selectivity	ETC1
OTA out-of-band blocking	ETC1
OTA in-channel selectivity	SC
NOTE: OOB SC shall be tested using the widest supported channel bandwidth and the highest supported subcarrier spacing.	

## 4.9 RF channels and test models

### 4.9.1 RF channels

For the single carrier testing many tests in this TS are performed with appropriate frequencies in the bottom, middle and top channels of the supported frequency range of the SAN. These are denoted as RF channels B (bottom), M (middle) and T (top).

Unless otherwise stated, the test shall be performed with a single carrier at each of the RF channels B, M and T.

Many tests in this TS are performed with the maximum *SAN RF Bandwidth* located at the bottom, middle and top of the supported frequency range in the operating band. These are denoted as  $B_{RFBW}$  (bottom),  $M_{RFBW}$  (middle) and  $T_{RFBW}$  (top).

Unless otherwise stated, the test shall be performed at  $B_{RFBW}$ ,  $M_{RFBW}$  and  $T_{RFBW}$  defined as following:

- $B_{\text{RFBW}}$ : maximum *SAN RF Bandwidth* located at the bottom of the supported frequency range in the operating band.
- $M_{\text{RFBW}}$ : maximum *SAN RF Bandwidth* located in the middle of the supported frequency range in the operating band.
- $T_{\text{RFBW}}$ : maximum *SAN RF Bandwidth* located at the top of the supported frequency range in the operating band.

When a test is performed by a test laboratory, the position of B, M and T for single carrier,  $B_{\text{RFBW}}$ ,  $M_{\text{RFBW}}$  and  $T_{\text{RFBW}}$  for single band operation shall be specified by the laboratory. The laboratory may consult with operators, the manufacturer or other bodies.

## 4.9.2 Test models

### 4.9.2.1 General

The following clauses will describe the SAN test models needed for *SAN type 1-H* and *SAN type 1-O*.

#### 4.9.2.2 Test models for E-UTRA

The set-up of physical channels for transmitter tests shall be according to one of the E-UTRA test models (E-TM) below. A reference to the applicable test model is made within each test.

The following general parameters are used by all E-UTRA test models:

- The test models are defined for a single antenna port (using  $p = 0$ ); 1 code word ( $q = 0$ ), 1 layer, precoding is not used; unless specified otherwise
- Duration is 10 subframes (10 ms)
- Normal CP
- Virtual resource blocks of localized type, no intra-subframe hopping for PDSCH
- UE-specific reference signals are not used

Power settings of physical channels are defined by physical channel EPRE relative to the EPRE of the RS. The relative accuracy of the physical channel EPRE as referred to the EPRE of the RS shall have a tolerance of  $\pm 0.5$  dB.

##### 4.9.2.2.1 E-UTRA Test Model 1.1 (E-SAN-TM1.1)

The test model E-TM1.1 in TS 36.141 [10] apply for E-SAN-TM1.1 and carrier bandwidth is only limited to 1.4 MHz.

This model shall be used for tests on:

- SAN output power
- Unwanted emissions
  - Occupied bandwidth
  - ACLR
  - Operating band unwanted emissions
  - Transmitter spurious emissions

##### 4.9.2.2.2 E-UTRA Test Model 1.2 (E-SAN-TM1.2)

The test model in E-TM1.2 in TS 36.141 [10] apply for E-SAN-TM1.2 and carrier bandwidth is only limited to 1.4 MHz.

This model shall be used for tests on:

- Unwanted emissions
- ACLR
- Operating band unwanted emissions

#### 4.9.2.2.3 E-UTRA Test Model 2 (E-SAN-TM2)

The test model in E-SAN-TM2 in TS 36.141 [10] apply for E-SAN-TM2 and carrier bandwidth is only limited to 1.4 MHz.

This model shall be used for tests on:

- Total power dynamic range (lower OFDM symbol power limit at min power),
- EVM of single 64QAM PRB allocation (at min power)
- Frequency error (at min power)

#### 4.9.2.2.4 E-UTRA Test Model 3.1 (E-SAN-TM3.1)

The test model in E-TM3.1 in TS 36.141 [10] apply for E-SAN-TM3.1 and carrier bandwidth is only limited to 1.4 MHz.

This model shall be used for tests on:

- Output power dynamics
- Total power dynamic range (upper OFDM symbol power limit at max power with all 64QAM PRBs allocated)
- Transmitted signal quality
- Frequency error
- EVM for 64QAM modulation (at max power)

#### 4.9.2.2.5 E-UTRA Test Model 3.2 (E-SAN-TM3.2)

The test model in E-TM3.2 in TS 36.141 [10] apply for E-SAN-TM3.2 and carrier bandwidth is only limited to 1.4 MHz.

This model shall be used for tests on:

- Transmitted signal quality
- Frequency error
- EVM for 16QAM modulation

#### 4.9.2.2.6 E-UTRA Test Model 3.3 (E-SAN-TM3.3)

The test model in E-TM3.3 in TS 36.141 [10] apply for E-SAN-TM3.3 and carrier bandwidth is only limited to 1.4 MHz.

This model shall be used for tests on:

- Transmitted signal quality
- Frequency error
- EVM for QPSK modulation

#### 4.9.2.3 Test Model for NB-IoT

The set-up of physical channels for transmitter tests shall be according to the NB-IoT Test Model (N-TM) below.

The following general parameters are used:

- The test models are defined for a single antenna port (using  $p = 1000$ );
- Duration is 10 subframes (10 ms)
- Normal CP

The following physical channel parameters are used:

- The ratio of synchronisation signal EPRE and NRS EPRE is 0 dB
- NPDCCH format 1

The test model for NB-IoT are identical for NB-IoT standalone mode and NB-IoT operation in NTN NR in-band.

#### 4.9.2.4 Data content of Physical channels and Signals for N-TM

Data content of physical channels and signals for NB-IoT should be fully aligned the specification statement in TS 36.211 [7]. Detail configuration for the transmitter characteristic tests are used as follows,

In case multiple NB-IoT carriers are configured with N-TMs, the  $N_{ID}^{cell}$  for the  $n^{\text{th}}$  configured NB-IoT carrier shall be equal to  $97+6*n+\max(0,m-1)$ , where  $m$  is equal to 0 for stand-alone NB-IoT carrier or equal to the Cell ID of the E-UTRA carrier containing the in-band/guard-band NB-IoT carrier.

Initialization of the scrambler and RE-mappers as defined in TS 36.211 [7] use the following additional parameters:

- $n_f = 0$
- The N-TM shall start when  $n_s = 0$
- $p = 1000$  shall be used for the generation of the N-TM data
- $N_{ID}^{cell} = 103$  for the lowest configured stand-alone NB-IoT carrier or in-band/guard-band NB-IoT carrier(s) within the lowest E-UTRA carrier,  $N_{ID}^{cell} = 109$  for the 2<sup>nd</sup> lowest configured NB-IoT stand-alone carrier or 110 for the in-band/guard-band NB-IoT carrier(s) within the 2<sup>nd</sup> lowest E-UTRA carrier, ...,  $N_{ID}^{cell} = 97+6*n+\max(0,m-1)$  for the  $n^{\text{th}}$  configured NB-IoT stand-alone carrier or in-band/guard-band NB-IoT carrier(s) within the  $m^{\text{th}}$  E-UTRA carrier.

The data content of physical channels and signals for N-TM are identical for NB-IoT standalone mode and NB-IoT operation in NTN NR in-band.

##### 4.9.2.4.1 Reference signals

Sequence generation, modulation and mapping to REs according to TS 36.211 [7], clause 10.2.6.

#### 4.9.2.4.2 Synchronization signals

Sequence generation, modulation and mapping to REs according to TS 36.211 [7], clause 10.2.7.

#### 4.9.2.4.3 NPBCH

- 100 REs (200 bits) are available for NPBCH for the duration of the NB-IoT test model (1 frame, 10 ms)
- Generate 200 bits of 'all 0' data
- Initialize scrambling generator for each invocation of the N-TM, i.e. set always  $n_f = 0$
- Perform scrambling according to TS 36.211 [7], clause 10.2.4.1
- Perform modulation according to TS 36.211 [7], clause 10.2.4.2
- Perform mapping to REs according to TS 36.211 [7], clause 10.2.4.4

#### 4.9.2.4.4 NPDCCH

- NPDCCH is on the first of all available subframes which not transmit synchronization signals and NPBCH in the duration of the NB-IoT test model. The number of available bits (304 bits for stand-alone and guard band operation, or 200 bits for in-band operation) for NPDCCH is depended on the higher layer parameter *operationModeInfo* according to TS 36.213 [8], clause 16.6.1.
- Generate the amount of NPDCCH bits according to 'all 0' data
- Perform NPDCCH scrambling according to TS 36.211 [7], clause 10.2.5.2
- Perform modulation according to TS 36.211 [7], clause 10.2.5.3
- Perform mapping to REs according to TS 36.211 [7], clause 10.2.5.5

#### 4.9.2.4.5 NPDSCH

- NPDSCH is on the rest of subframes in the duration of NB-IoT test model. The number of available bits (304 bits for stand-alone and guard band operation or 200 bits for in-band operation for QPSK PRBs; the number of bits is doubled for 16QAM PRBs) in each subframe for NPDSCH is depended on the higher layer parameter *operationModeInfo* according to TS 36.213 [8], clause 16.6.1. Unless otherwise stated, QPSK PRBs shall be used.
- Generate the required amount of bits according to 'all 0' data
- N-TM utilize 1 user NPDSCH transmissions indicated by  $n_{\text{RNTI}}=1000$
- Perform user specific scrambling according to TS 36.211 [7], clause 10.2.3.1. This makes use of  $n_{\text{RNTI}}$ .
- Perform modulation of the scrambled bits with the modulation scheme defined for each user according to TS 36.211 [7], clause 10.2.3.2.
- Perform mapping of the complex-valued symbols to PRBs according to TS 36.211 [7], clause 10.2.3.4.

## 4.10 Requirements for contiguous and non-contiguous spectrum

Requirements for non-contiguous spectrum operation are not applicable in this version of specification.

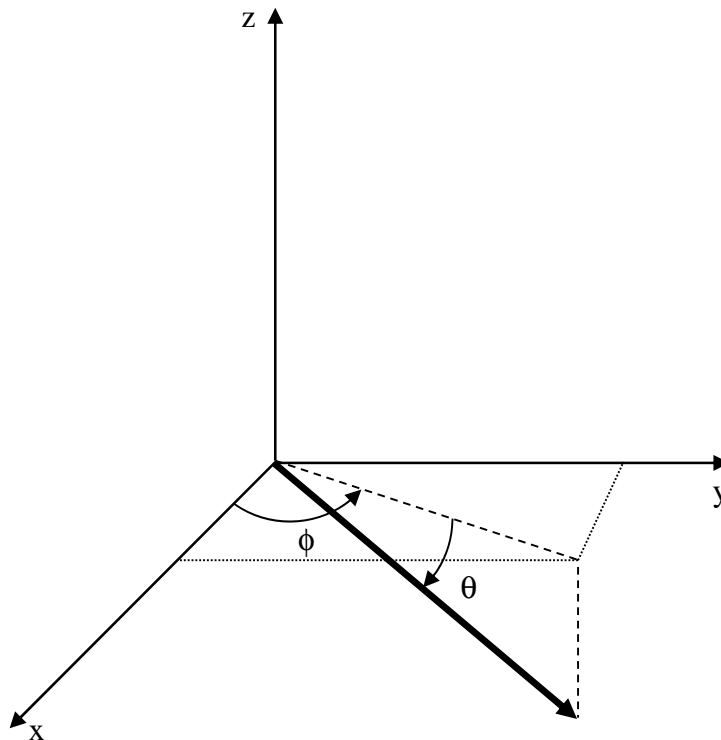
## 4.11 Requirements for SAN capable of multi-band operation

Requirements for multi-band operation are not applicable in this version of specification.

## 4.12 Reference coordinate system

Radiated requirements are stated in terms of electromagnetic characteristics (e.g. EIRP and EIS) at certain angles with respect to the SAN. To be able to declare radiated characteristics part of radiated requirements a reference coordinate system is required. The reference coordinate system should be associated to an identifiable physical feature on the SAN enclosure. The location of the origin and the orientation of the reference coordinate system are for the SAN manufacturer to declare.

The reference coordinate system is created of a Cartesian coordinate system with rectangular axis (x, y, z) and spherical angles ( $\theta$ ,  $\phi$ ) as showed in figure 4.12-1.



**Figure 4.12-1: Reference coordinate system**

$\phi$  is the angle in the x/y plane, between the x-axis and the projection of the radiating vector onto the x/y plane and is defined between  $-180^\circ$  and  $+180^\circ$ , inclusive.  $\theta$  is the angle between the projection of the vector in the x/y plane and the radiating vector and is defined between  $-90^\circ$  and  $+90^\circ$ , inclusive. Note that  $\theta$  is defined as positive along the down-tilt angle.

## 4.13 Format and interpretation of tests

Each test has a standard format:

### **X Title**

All tests are applicable to all equipment within the scope of the present document, unless otherwise stated.

### **X.1 Definition and applicability**

This clause gives the general definition of the parameter under consideration and specifies whether the test is applicable to all equipment or only to a certain subset. Required manufacturer declarations may be included here.

### **X.2 Minimum requirement**

This clause contains the reference to the clause to the 3GPP reference (or core) specification which defines the minimum requirement.

### **X.3 Test purpose**

This clause defines the purpose of the test.

### **X.4 Method of test**

#### **X.4.1 General**

In some cases there are alternative test procedures or initial conditions. In such cases, guidance for which initial conditions and test procedures can be applied are stated here. In the case only one test procedure is applicable, that is stated here.

#### **X.4.2 First test method**

##### **X.4.2.1 Initial conditions**

This clause defines the initial conditions for each test, including the test environment, the RF channels to be tested and the basic measurement set-up.

##### **X.4.2.2 Procedure**

This clause describes the steps necessary to perform the test and provides further details of the test definition like domain (e.g. frequency-span), range, weighting (e.g. bandwidth), and algorithms (e.g. averaging). The procedure may comprise data processing of the measurement result before comparison with the test requirement (e.g. average result from several measurement positions).

##### **X.4.2a Alternative test method (if any)**

If there are alternative test methods, each is described with its initial conditions and procedures.

### **X.5 Test requirement**

This clause defines the pass/fail criteria for the equipment under test, see clause 4.1.3 (Interpretation of measurement results). Test requirements for every minimum requirement referred in clause X.2 are listed here. Cases where minimum requirements do not apply need not be mentioned.

---

## 5 Operating bands and channel arrangement

For the operating bands specification, their channel bandwidth configurations, channel spacing and raster, as well as synchronization raster specification, refer to TS 36.108 [2], clause 5 and its relevant clauses.

## 6 Conducted transmitter characteristics

### 6.1 General

General test conditions for conducted transmitter tests are given in clause 4, including interpretation of measurement results and configurations for testing. SAN configurations for the tests are defined in clause 4.5.

If a number of *single-band connectors* have been declared equivalent (D.37), only a representative one is necessary to be tested to demonstrate conformance.

The conformance testing procedure and testing requirement for SAN output power, frequency error, EVM and DL RS requirement are identical for NB-IoT standalone mode and NB-IoT operation in NTN NR in-band, for other conformance testing procedure and testing requirements for NB-IoT operation in NTN NR in-band are defined in TS 38.181 [6].

### 6.2 Satellite Access Node output power

#### 6.2.1 Definition and applicability

The conducted SAN output power requirements are specified at *single-band connector*.

The *rated carrier output power* of the *SAN type 1-H* shall be as specified in table 6.2.1-1.

**Table 6.2.1-1: SAN type 1-H rated output power limits for SAN classes**

SAN class	$P_{\text{rated,c,sys}}$ (NOTE)	$P_{\text{rated,c,TABC}}$ (NOTE)
SAN GEO	$P_{\text{rated,c,sys,GEO}}$	$P_{\text{rated,c,TABC,GEO}}$
SAN LEO	$P_{\text{rated,c,sys,LEO}}$	$P_{\text{rated,c,TABC,LEO}}$
NOTE: $P_{\text{rated,c,sys}}$ Or $P_{\text{rated,c,TABC}}$ of SAN shall be based on manufacturer declaration and comply with regulation requirement.		

The output power limit for the respective SAN classes in table 6.2.1-1 shall be compared to the rated output power and the declared SAN class. It is not subject to testing.

#### 6.2.2 Minimum requirement

The minimum requirement applies per *single-band connector* supporting transmission in the *operating band*.

The minimum requirement for *SAN type 1-H* is defined in TS 36.108 [2], clause 6.2.2.

#### 6.2.3 Test purpose

The test purpose is to verify the accuracy of the *maximum carrier output power* across the frequency range and under normal conditions.

#### 6.2.4 Method of test

##### 6.2.4.1 Initial conditions

Test environment: Normal, see annex B.

RF channels to be tested for single carrier: B, M and T; see clause 4.9.1.

*SAN RF Bandwidth* positions to be tested for multi-carrier:  $B_{\text{RFBW}}$ ,  $M_{\text{RFBW}}$  and  $T_{\text{RFBW}}$  for *single-band connector(s)*, see clause 4.9.1.

### 6.2.4.2 Procedure

For *SAN type 1-H* where there may be multiple *TAB connectors*, they may be tested one at a time or multiple *TAB connectors* may be tested in parallel as shown in annex D.1.1. Whichever method is used the procedure is repeated until all *TAB connectors* necessary to demonstrate conformance have been tested.

- 1) Connect the power measuring equipment to *single-band connector(s)* under test as shown in annex D.1.1 for *SAN type 1-H*. All connectors not under test shall be terminated.
- 2) For single carrier set the connector under test to transmit according to the applicable test configuration in clause 4.8 using the corresponding test models or set of physical channels in clause 4.9.2 at *rated carrier output power*  $P_{\text{rated,c,TABC}}$  for *SAN type 1-H* (D.34).

For a connector under test declared to be capable of multi-carrier (D.39) set the connector under test to transmit on all carriers configured using the applicable test configuration and corresponding power setting specified in clauses 4.7 and 4.8 using the corresponding test models or set of physical channels in clause 4.9.2.

- 3) Measure the *maximum carrier output power* ( $P_{\text{max,c,TABC}}$  for *SAN type 1-H*) for each carrier at each connector under test.

### 6.2.5 Test requirement

For each *single-band connector* under test, the power measured in clause 6.2.4.2 in step 3 shall remain within the values provided in table 6.2.5-1 for normal test environments, relative to the manufacturer's declared  $P_{\text{rated,c,TABC}}$  for *SAN type 1-H* (D.34):

**Table 6.2.5-1: Test requirement for conducted SAN output power**

SAN type	Normal test environment
<i>SAN type 1-H</i>	$f \leq 3$ GHz: $\pm 2.7$ dB for E-UTRA $\pm 3.0$ dB for standalone NB-IoT

## 6.3 Output power dynamics

### 6.3.1 General

The requirements in clause 6.3 apply during the *transmitter ON period*. Transmit signal quality requirements (as specified in clause 6.5) shall be maintained for the output power dynamics requirements of this clause.

### 6.3.2 RE power control dynamic range

#### 6.3.2.1 Definition and applicability

The RE power control dynamic range is the difference between the power of an RE and the average RE power for a SAN at *maximum carrier output power* ( $P_{\text{max,c,TABC}}$ ) for a specified reference condition.

#### 6.3.2.2 Minimum requirement

The minimum requirement applies per *single-band connector* in the *operating band*.

The minimum requirement for *SAN type 1-H* is defined in TS 36.108 [2], clause 6.3.2.

#### 6.3.2.3 Method of test

No specific test or test requirements are defined for conducted RE power control dynamic range. The Error Vector Magnitude (EVM) test, as described in clause 6.5.3 provides sufficient test coverage for this requirement.

## 6.3.3 Total power dynamic range

### 6.3.3.1 Definition and applicability

The total power dynamic range is the difference between the maximum and the minimum transmit power of an OFDM symbol for a specified reference condition.

NOTE: The upper limit of the dynamic range is the OFDM symbol power for a SAN at maximum output power. The lower limit of the dynamic range is the OFDM symbol power for a SAN when one resource block is transmitted. The OFDM symbol shall carry PDSCH and not contain RS, PBCH or synchronisation signals.

### 6.3.3.2 Minimum requirement

The minimum requirement applies per *single-band connector*.

The minimum requirement for *SAN type 1-H* is in TS 36.108 [2], clause 6.3.3.2.

### 6.3.3.3 Test purpose

The test purpose is to verify that the total power dynamic range is within the limits specified by the minimum requirement.

### 6.3.3.4 Method of test

#### 6.3.3.4.1 Initial conditions

Test environment: Normal, see annex B.

RF channels to be tested: M; see clause 4.9.1.

Set the channel set-up of the connector under as shown in annex D.1 for *SAN type 1-H*.

#### 6.3.3.4.2 Procedure

For *SAN type 1-H* where there may be multiple *TAB connectors*, they may be tested one at a time or multiple *TAB connectors* may be tested in parallel as shown in annex D.1.1. Whichever method is used the procedure is repeated until all *TAB connectors* necessary to demonstrate conformance have been tested.

- 1) Connect the *single-band connector(s)* under test as shown in annex D.1.1 for *SAN type 1-H*. All connectors not under test shall be terminated.
- 2) Set each connector under test to transmit according to the applicable test configuration in clause 4.8 using the corresponding test models in clause 4.9.2 at rated carrier output power  $P_{\text{rated,c,TABC}}$  for *SAN type 1-H* (D.34).
- 3) For *SAN type 1-H* supporting E-UTRA, set the SAN to transmit a signal according to:
  - Set-up SAN transmission at maximum total power as declared by the manufacturer.
  - Channel set-up shall be according to
    - E-SAN-TM3.1 if 64QAM is supported by SAN without power back off, or
    - E-SAN-TM3.1 with all 64QAM PDSCH PRBs replaced by 16QAM PDSCH PRBs if 64QAM is supported by SAN with power back off, or
    - E-SAN-TM3.1 with all 64QAM PDSCH PRBs replaced by 16QAM PDSCH PRBs if 64QAM is not supported by SAN but 16QAM is supported by SAN, or
    - E-SAN-TM3.1 with all 64QAM PDSCH PRBs replaced by QPSK PDSCH PRBs if 64QAM and 16QAM are both not supported by SAN.

- 4) Measure the average OFDM symbol power as defined in annex F.
- 5) For *SAN type I-H* supporting E-UTRA, set the SAN to transmit a signal according to:
  - E-SAN-TM2 if 64QAM is supported by SAN, or
  - E-SAN-TM2 with all 64QAM PDSCH PRBs replaced by 16QAM PDSCH PRBs if 64QAM is not supported by SAN and 16QAM is supported;
  - E-SAN-TM2 with all 64QAM PDSCH PRBs replaced by QPSK PDSCH PRBs if 64QAM and 16QAM are both not supported;
- 6) Measure the average OFDM symbol power as defined in annex F. The measured OFDM symbols shall not contain RS, PBCH or synchronisation signals.

### 6.3.3.5 Test requirements

The downlink (DL) total power dynamic range for each SAN carrier shall be larger than or equal to the level in table 6.3.3.5-1. There are no requirements specified for NB-IoT.

**Table 6.3.3.5-1: Total power dynamic range**

SAN channel bandwidth (MHz)	Total power dynamic range (dB)
1.4	7.3

NOTE: Additional test requirements for the EVM at the lower limit of the dynamic range are defined in clause 6.5.3.

## 6.4 Transmit ON/OFF power

The requirement is not applicable in this version of the specification.

## 6.5 Transmitted signal quality

### 6.5.1 General

The requirements in clause 6.5 apply during the *transmitter ON period*.

### 6.5.2 Frequency error

#### 6.5.2.1 Definition and applicability

Frequency error is the measure of the difference between the actual SAN transmit frequency and the assigned frequency. The same source shall be used for RF frequency and data clock generation.

It is not possible to verify by testing that the data clock is derived from the same frequency source as used for RF generation. This may be confirmed by the manufacturer's declaration.

For *SAN type I-H* this requirement shall be applied at each *TAB connector* supporting transmission in the *operating band*.

#### 6.5.2.2 Minimum Requirement

The minimum requirement is in TS 36.108 [2], clause 6.5.1.1.

### 6.5.2.3 Test purpose

The test purpose is to verify that frequency error is within the limit specified by the minimum requirement.

### 6.5.2.4 Method of test

Requirement is tested together with modulation quality test, as described in clause 6.5.3.

### 6.5.2.5 Test Requirements

The modulated carrier frequency of each carrier configured by the SAN shall be accurate to within 0.05 ppm + 12 Hz (tolerance) observed over 1 ms.

## 6.5.3 Modulation quality

### 6.5.3.1 Definition and applicability

Modulation quality is defined by the difference between the measured carrier signal and an ideal signal. Modulation quality can e.g. be expressed as Error Vector Magnitude (EVM). The Error Vector Magnitude is a measure of the difference between the ideal symbols and the measured symbols after the equalization. This difference is called the error vector.

For *SAN type I-H* this requirement shall be applied at each *TAB connector* supporting transmission in the *operating band*.

### 6.5.3.2 Minimum Requirement

The minimum requirement is in TS 36.108 [2], clause 6.5.2.2.

### 6.5.3.3 Test purpose

The test purpose is to verify that modulation quality is within the limit specified by the minimum requirement.

### 6.5.3.4 Method of test

#### 6.5.3.4.1 Initial conditions

Test environment: Normal; see annex B.

RF channels to be tested for single carrier: B, M and T; see clause 4.9.1.

RF bandwidth positions to be tested for multi-carrier:  $B_{RFBW}$ ,  $M_{RFBW}$  and  $T_{RFBW}$  in single-band operation, see clause 4.9.1.

#### 6.5.3.4.2 Procedure

The minimum requirement is applied to all *TAB connectors*, they may be tested one at a time or multiple *TAB connectors* may be tested in parallel as shown in annex D.1.1 for *SAN type I-H*. Whichever method is used the procedure is repeated until all *TAB connectors* necessary to demonstrate conformance have been tested.

- 1) For a *TAB connector* declared to be capable of single carrier operation only (D.39), set the *TAB connector* under test to transmit a signal according to the applicable test configuration in clause 4.8 using the corresponding test models:
  - E-SAN-TM3.1 if 64QAM is supported by SAN without power back off, or
  - E-SAN-TM3.1 at manufacturer's declared rated output power if 64QAM is supported by SAN with power back off, and E-SAN-TM3.2 at maximum power, or
  - E-SAN-TM3.2 if highest modulation order supported by SAN is 16QAM, or

- E-SAN-TM3.3 if highest modulation order supported by SAN is QPSK.

For *TAB connector* declared to be capable of multi-carrier operation, set the *TAB connector* under test to transmit according to the applicable test configuration and corresponding power setting specified in clauses 4.7 and 4.8 using the corresponding test models on all carriers configured:

- E-SAN-TM3.1 if 64QAM is supported by SAN without power back off, or
- E-SAN-TM3.1 at manufacturer's declared rated output power if 64QAM is supported by SAN with power back off, and E-SAN-TM3.2 at maximum power, or
- E-SAN-TM3.2 if highest modulation order supported by SAN is 16QAM, or
- E-SAN-TM3.3 if highest modulation order supported by SAN is QPSK.

For E-SAN-TM3.1, power back-off shall be applied if it is declared.

- 2) Measure the EVM and frequency error as defined in annex H.

### 6.5.3.5 Test requirements

The EVM of each E-UTRA carrier for different modulation schemes on PDSCH shall be less than the limits in table 6.5.3.5-1.

**Table 6.5.3.5-1 EVM requirements for E-UTRA carrier**

Modulation scheme for PDSCH or sPDSCH	Required EVM (%)
QPSK	18.5
16QAM	13.5
64QAM (NOTE)	9
NOTE: EVM requirement for 64QAM is optional.	

The EVM of each NB-IoT carrier on NB-PDSCH shall be less than the limits in table 6.5.2.5-2:

**Table 6.5.3.5-2 EVM requirements for NB-IoT carrier**

Modulation scheme for NB-PDSCH	Required EVM (%)
QPSK	18.5
16QAM	13.5

The EVM requirement shall be applicable within a time period around the centre of the CP therefore the EVM requirement is tested against the maximum of the RMS average of 10 subframes at the two window *W* extremities.

Table 6.5.2.5-3 and table 6.5.2.5-4 specify EVM window length (*W*) for normal CP, the cyclic prefix length  $N_{cp}$  is 160 for symbols 0 and 144 for symbols 1-6.

**Table 6.5.2.5-3 EVM window length for normal CP for E-UTRA**

Channel Bandwidth MHz	FFT size	Cyclic prefix length for symbols 0 in FFT samples	Cyclic prefix length for symbols 1-6 in FFT samples	EVM window length <i>W</i>	Ratio of <i>W</i> to total CP for symbols 1-6 (NOTE) (%)
1.4	128	10	9	5	55.6
NOTE: These percentages are informative and apply to symbols 1 through 6. Symbol 0 has a longer CP and therefore a lower percentage.					

Table 6.5.2.5-4 EVM window length for normal CP for NB-IoT

FFT size	Cyclic prefix length for symbols 0 in FFT samples	Cyclic prefix length for symbols 1-6 in FFT samples	EVM window length W	Ratio of W to total CP for symbols 1-6 (NOTE) (%)
128	10	9	3	33.3
NOTE: These percentages are informative and apply to symbols 1 through 6. Symbol 0 has a longer CP and therefore a lower percentage.				

## 6.5.4 Time alignment error

The requirement is not applicable in this version of the specification.

## 6.5.5 DL RS power

### 6.5.5.1 Definition and applicability

For E-UTRA, DL RS power is the resource element power of Downlink Reference Symbol.

The absolute DL RS power is indicated on the DL-SCH. The absolute accuracy is defined as the maximum deviation between the DL RS power indicated on the DL-SCH and the DL RS power of each E-UTRA carrier at the SAN TAB connector.

For NB-IoT, DL NRS power is the resource element power of the Downlink Narrow-band Reference Signal.

The absolute DL NRS power is indicated on the DL-SCH. The absolute accuracy is defined as the maximum deviation between the DL NRS power indicated on the DL-SCH and the DL NRS power of each NB-IoT carrier at the SAN TAB connector.

### 6.5.5.2 Minimum Requirement

The minimum requirement is in TS 36.108 [2] clause 6.5.4.

### 6.5.5.3 Test purpose

The test purpose is to verify that the DL RS/NRS power is within the limit specified by the minimum requirement.

### 6.5.5.4 Method of test

#### 6.5.5.4.1 Initial conditions

Test environment: Normal; see annex B.

RF channels to be tested for single carrier: B, M and T; see clause 4.7.

Connect the signal analyser to the TAB connector as shown in annex D.1.1.

#### 6.5.5.4.2 Procedure

For E-UTRA, setup SAN transmission at manufacturer's declared rated output power. Channel setup shall be according to E-SAN-TM 1.1.

For NB-IoT, setup SAN transmission at manufacturer's declared rated output power. Channel setup shall be according to N-TM.

Measure the RS transmitted power according to annex D.1.1.

### 6.5.5.5 Test requirements

For E-UTRA, DL RS power of each E-UTRA carrier shall be within  $\pm 2.9$  dB of the DL RS power indicated on the DL-SCH for carrier frequency  $f \leq 3$  GHz.

For NB-IoT, DL NRS power of each NB-IoT carrier shall be within  $\pm 2.9$  dB of the DL NRS power indicated on the DL-SCH for carrier frequency  $f \leq 3$  GHz.

## 6.6 Unwanted emissions

### 6.6.1 General

Unwanted emissions consist of out-of-band emissions and spurious emissions according to ITU definitions in SM.329 [3]. In ITU terminology, out of band emissions are unwanted emissions immediately outside the *SAN channel bandwidth* resulting from the modulation process and non-linearity in the transmitter but excluding spurious emissions. Spurious emissions are emissions which are caused by unwanted transmitter effects such as harmonics emission, parasitic emission, intermodulation products and frequency conversion products, but exclude out of band emissions.

The out-of-band emissions requirement for the SAN transmitter is specified both in terms of Adjacent Channel Leakage power Ratio (ACLR) and out-of-band emissions (OOBE).

#### Table 6.6.1-1: Void

There is in addition a requirement for occupied bandwidth.

### 6.6.2 Occupied bandwidth

#### 6.6.2.1 Definition and applicability

The occupied bandwidth is the width of a frequency band such that, below the lower and above the upper frequency limits, the mean powers emitted are each equal to a specified percentage  $\beta/2$  of the total mean transmitted power. See also Recommendation ITU-R SM.328 [11].

The value of  $\beta/2$  shall be taken as 0.5%.

The minimum requirement below may be applied regionally. There may also be regional requirements to declare the occupied bandwidth according to the definition in the present clause.

For SAN *type 1-H* this requirement shall be applied at each *TAB connector* supporting transmission in the *operating band*.

#### 6.6.2.2 Minimum requirements

The minimum requirement for SAN *type 1-H* is defined in TS 36.108 [2] clause 6.6.2.

#### 6.6.2.3 Test purpose

The test purpose is to verify that the emission at the *TAB connector* does not occupy an excessive bandwidth for the service to be provided and is, therefore, not likely to create interference to other users of the spectrum beyond undue limits.

## 6.6.2.4 Method of test

### 6.6.2.4.1 Initial conditions

Test environment: Normal; see annex B.

RF channels to be tested for single carrier: M; see clause 4.9.1.

- 1 Connect the measurement device to the *TAB connector* as shown in annex D.1.1 for *SAN type I-H*.
- 2 For a SAN declared to be capable of single carrier operation (D.39), start transmission according to the applicable test configuration in clause 4.8 using the corresponding test model E-SAN-TM1.1 at manufacturer's declared *rated carrier output power per TAB connector* ( $P_{\text{rated,c,TABC}}$ , D.34).

### 6.6.2.4.2 Procedure

- 1 Measure the spectrum emission of the transmitted signal using at least the number of measurement points, and across a span, as listed in table 6.6.2.4.2-1. The selected resolution bandwidth (RBW) filter of the analyser shall be 30 kHz or less.

**Table 6.6.2.4.2-1: Span and number of measurement points for OBW measurements**

Bandwidth	SAN channel bandwidth BW <sub>Channel</sub> (MHz)	
	0.2	1.4
Span (MHz)	0.4	10
Minimum number of measurement points	400	1429

NOTE: The detection mode of the spectrum analyzer will not have any effect on the result if the statistical properties of the out-of-OBW power are the same as those of the inside-OBW power. Both are expected to have the Rayleigh distribution of the amplitude of Gaussian noise. In any case where the statistics are not the same, though, the detection mode must be power responding. The analyser may be set to respond to the average of the power (root-mean-square of the voltage) across the measurement cell.

- 2) Compute the total of the power, P<sub>0</sub>, (in power units, not decibel units) of all the measurement cells in the measurement span. Compute P<sub>1</sub>, the power outside the occupied bandwidth on each side. P<sub>1</sub> is half of the total power outside the bandwidth. P<sub>1</sub> is half of (100 % - (occupied percentage)) of P<sub>0</sub>. For the occupied percentage of 99 %, P<sub>1</sub> is 0.005 times P<sub>0</sub>.
- 3) Determine the lowest frequency, f<sub>1</sub>, for which the sum of all power in the measurement cells from the beginning of the span to f<sub>1</sub> exceeds P<sub>1</sub>.
- 4) Determine the highest frequency, f<sub>2</sub>, for which the sum of all power in the measurement cells from f<sub>2</sub> to the end of the span exceeds P<sub>1</sub>.
- 5) Compute the occupied bandwidth as f<sub>2</sub> - f<sub>1</sub>.

### 6.6.2.5 Test requirements

For E-UTRA, the occupied bandwidth for each carrier shall be less than the channel bandwidth as defined in TS 36.108 [2], clause 5.3A.

For NB-IoT standalone operation, the occupied bandwidth for carrier shall be less than the channel bandwidth as defined in TS 36.108 [2], clause 5.3B.

## 6.6.3 Adjacent Channel Leakage Power Ratio (ACLR)

### 6.6.3.1 Definition and applicability

Adjacent Channel Leakage Power Ratio (ACLR) is the ratio of the filtered mean power centred on the assigned channel frequency to the filtered mean power centred on an adjacent channel frequency.

The requirements shall apply outside the Satellite Access Node RF Bandwidth or Radio Bandwidth whatever the type of transmitter considered (e.g. single carrier or multi-carrier) and for all transmission modes foreseen by the manufacturer's specification.

### 6.6.3.2 Minimum requirement

The minimum requirement applies per *single-band connector* supporting transmission in the *operating band*.

The minimum requirement for *SAN type 1-H* is defined in TS 36.108 [2], clause 6.6.3.2.

### 6.6.3.3 Test purpose

To verify that the adjacent channel leakage power ratio requirement shall be met as specified by the minimum requirement.

### 6.6.3.4 Method of test

#### 6.6.3.4.1 Initial conditions

Test environment: Normal; see annex B.

RF channels to be tested for single carrier: B, M and T; see clause 4.9.1.

*Satellite Access Node RF Bandwidth* positions to be tested for multi-carrier:  $B_{RFBW}$ ,  $M_{RFBW}$  and  $T_{RFBW}$  in single-band operation; see clause 4.9.1.

#### 6.6.3.4.2 Procedure

For *SAN type 1-H* where there may be multiple *TAB connectors*, they may be tested one at a time or multiple *TAB connectors* may be tested in parallel as shown in annex D.1.1 for *SAN type 1-H*. Whichever method is used the procedure is repeated until all *TAB connectors* necessary to demonstrate conformance have been tested.

- 1 Connect the *single-band connector* or *multi-band connector* under test to measurement equipment as shown in annex D.1.1 for *SAN type 1-H*. All connectors not under test shall be terminated.

The measurement device characteristics shall be:

- Measurement filter bandwidth: defined in clause 6.6.3.5.
- Detection mode: true RMS voltage or true average power.

- 2 For a connectors declared to be capable of single carrier operation only (D.39), set the representative connectors under test to transmit according to the applicable test configuration in clause 4.8 using the corresponding test models E-SAN-TM1.1 in clause 4.9.2 at *rated carrier output power*  $P_{rated,c,TABC}$  for *SAN type 1-H* (D.34).

For a connector under test declared to be capable of multi-carrier operation set the connector under test to transmit on all carriers configured using the applicable test configuration and corresponding power setting specified in clauses 4.7 and 4.8 using the corresponding test models or set of physical channels in clause 4.9.2.

- 1 Measure ACLR for the frequency offsets both side of channel frequency as specified in table 6.6.3.5-1 and in table 6.6.3.5-2. In multiple carrier case only offset frequencies below the lowest and above the highest carrier frequency used shall be measured.
- 2 Repeat the test with the channel set-up according to E-SAN-TM1.2 in clause 4.9.2.

### 6.6.3.5 Test requirements

The ACLR is defined with a square filter of bandwidth equal to the transmission bandwidth configuration of the transmitted signal ( $BW_{Config}$ ) centred on the assigned channel frequency and a filter centred on the adjacent channel frequency according to the tables below.

The ACLR shall be higher than the value specified in table 6.6.3.5-1 and table 6.6.3.5-2.

Table 6.6.3.5-1: SAN ACLR limit for GEO class

SAN channel bandwidth of lowest/highest carrier transmitted $BW_{\text{Channel}}$ (MHz)	SAN adjacent channel centre frequency offset below the lowest or above the highest carrier centre frequency transmitted	Assumed adjacent channel carrier (informative)	Filter on the adjacent channel frequency and corresponding filter bandwidth	ACLR limit (dB)
1.4	$BW_{\text{Channel}}$	E-UTRA of same BW	Square ( $BW_{\text{Config}}$ ) (NOTE)	13.2
	$2 \times BW_{\text{Channel}}$	E-UTRA of same BW	Square ( $BW_{\text{Config}}$ ) (NOTE)	13.2
NOTE: $BW_{\text{Channel}}$ and $BW_{\text{Config}}$ are the SAN channel bandwidth and transmission bandwidth configuration of the lowest/highest carrier transmitted on the assigned channel frequency.				

Table 6.6.3.5-2: SAN ACLR limit for LEO class

SAN channel bandwidth of lowest/highest carrier transmitted $BW_{\text{Channel}}$ (MHz)	SAN adjacent channel centre frequency offset below the lowest or above the highest carrier centre frequency transmitted	Assumed adjacent channel carrier (informative)	Filter on the adjacent channel frequency and corresponding filter bandwidth	ACLR limit (dB)
1.4	$BW_{\text{Channel}}$	E-UTRA of same BW	Square ( $BW_{\text{Config}}$ ) (NOTE)	23.2
	$2 \times BW_{\text{Channel}}$	E-UTRA of same BW	Square ( $BW_{\text{Config}}$ ) (NOTE)	23.2
NOTE: $BW_{\text{Channel}}$ and $BW_{\text{Config}}$ are the SAN channel bandwidth and transmission bandwidth configuration of the lowest/highest carrier transmitted on the assigned channel frequency.				

For SAN supporting standalone NB-IoT operation in paired spectrum, the ACLR shall be higher than the value specified in table 6.6.3.5-3 and table 6.6.3.5-4.

Table 6.6.3.5-3: ACLR limit of SAN supporting standalone NB-IoT operation for GEO class

Channel bandwidth of NB-IoT lowest/highest carrier transmitted $BW_{\text{Channel}}$ (kHz)	SAN adjacent channel centre frequency offset below the lowest or above the highest carrier centre frequency transmitted	Assumed adjacent channel carrier (informative)	Filter on the adjacent channel frequency and corresponding filter bandwidth	ACLR limit (dB)
200	[200 kHz]	Standalone NB-IoT	Square (180 kHz)	13.2
	[400 kHz]	Standalone NB-IoT	Square (180 kHz)	13.2

Table 6.6.3.5-4: ACLR limit of SAN supporting standalone NB-IoT operation for LEO class

Channel bandwidth of NB-IoT lowest/highest carrier transmitted $BW_{\text{Channel}}$ (kHz)	SAN adjacent channel centre frequency offset below the lowest or above the highest carrier centre frequency transmitted	Assumed adjacent channel carrier (informative)	Filter on the adjacent channel frequency and corresponding filter bandwidth	ACLR limit (dB)
200	[200 kHz]	Standalone NB-IoT	Square (180 kHz)	23.2
	[400 kHz]	Standalone NB-IoT	Square (180 kHz)	23.2

## 6.6.4 Out-of-band emissions

### 6.6.4.1 Definition and applicability

Unless otherwise stated, the out-of-band emissions (OOBE) limits for SAN are defined from  $BW_{SAN}$  channel edge up to frequencies separated from the  $BW_{SAN}$  channel edge by 200% of the *necessary bandwidth*, where the *necessary bandwidth* is  $BW_{SAN}$ .

The requirements shall apply whatever the type of transmitter considered and for all transmission modes foreseen by the manufacturer's specification.

*Basic limits* are specified in the tables below, where:

- $\Delta f$  is the separation between the *channel edge* frequency and the nominal -3 dB point of the measuring filter closest to the carrier frequency.
- $f_{offset}$  is the separation between the *channel edge* frequency and the centre of the measuring filter.
- $PSD_{SAN}$  represents the Power Spectral Density of the channel(s) operating in  $BW_{SAN}$
- $BW_{SAN}$  is the considered SAN transponder bandwidth.
- $\Delta_{Sat\_Class}$  is the *SAN class parameter* in dB identified to characterize different SAN classes.

For a multi-carrier *single-band connector* the definitions above apply to the lower edge of the carrier transmitted at the *lowest carrier* frequency and the upper edge of the carrier transmitted at the *highest carrier* frequency within a specified frequency band.

- The operating band unwanted emission basic limits of the band where there are carriers transmitted, as defined in the tables of the present clause for the largest frequency offset ( $\Delta f_{max}$ ), shall apply from channel edge up to frequencies separated from the channel edge by 200% of the necessary bandwidth.

### 6.6.4.2 Minimum requirement

The minimum requirement applies per *single-band connector* supporting transmission in the *operating band*.

The minimum requirement for *SAN type 1-H* is defined in TS 36.108 [2], clause 6.6.4.2.

### 6.6.4.3 Test purpose

This test measures the emissions close to the assigned channel bandwidth of the wanted signal, while the transmitter is in operation.

### 6.6.4.4 Method of test

#### 6.6.4.4.1 Initial conditions

Test environment: Normal; see annex B.

RF channels to be tested for single carrier: B, M and T; see clause 4.9.1.

*SAN RF Bandwidth* positions to be tested for multi-carrier:  $B_{RFBW}$ ,  $M_{RFBW}$  and  $T_{RFBW}$  in single-band operation; see clause 4.9.1.

#### 6.6.4.4.2 Procedure

For *SAN type 1-H* where there may be multiple *TAB connectors*, they may be tested one at a time or multiple *TAB connectors* may be tested in parallel as shown in annex D.1.1. Whichever method is used the procedure is repeated until all *TAB connectors* necessary to demonstrate conformance have been tested.

- 1) Connect the *single-band connector* under test to measurement equipment as shown in annex D.1.1. All connectors not under test shall be terminated.

As a general rule, the resolution bandwidth of the measuring equipment should be equal to the measurement bandwidth. However, to improve measurement accuracy, sensitivity, efficiency and avoiding e.g. carrier leakage, the resolution bandwidth may be smaller than the measurement bandwidth. When the resolution bandwidth is smaller than the measurement bandwidth, the result should be integrated over the measurement bandwidth in order to obtain the equivalent noise bandwidth of the measurement bandwidth.

The measurement device characteristics shall be: Detection mode: True RMS.

The emission power should be averaged over an appropriate time duration to ensure the measurement is within the measurement uncertainty in table 4.1.2.2-1.

- 2) For a connectors declared to be capable of single carrier operation only, set the representative connectors under test to transmit according to the applicable test configuration in clause 4.8 at manufacturer's declared *rated carrier output power per TAB connector* ( $P_{rated,c,TABC}$ , D.34). Channel set-up shall be according to E-SAN-TM1.1.

For connectors under test declared to be capable of multi-carrier operation set the connectors under test to transmit on all carriers configured using the applicable test configuration and corresponding power setting specified in clauses 4.7 and 4.8 using the corresponding test models or set of physical channels in clause 4.9.2.

- 3) Step the centre frequency of the measurement filter in contiguous steps and measure the emission within the specified frequency ranges with the specified measurement bandwidth.
- 4) Repeat the test for the remaining test cases, with the channel set-up according to E-SAN-TM1.2.

#### 6.6.4.5 Test requirements

For SAN operating in bands defined in TS 36.108 [2] clause 5.2, the out-of-band emissions (OOBE) requirements for GEO and LEO classes are defined as described in table 6.6.4.5-1, in line with annex 5 of ITU recommendation SM.1541-6 [15].

**Table 6.6.4.5-1: SAN OOBE basic limits**

Frequency offset of measurement filter -3 dB point, $\Delta f$	Frequency offset of measurement filter centre frequency, $f_{offset}$	Basic limits (dBm)	Measurement bandwidth
$0 \text{ MHz} \leq \Delta f < 2 \times BW_{SAN}$	$0.002 \text{ MHz} \leq f_{offset} < 2 \times BW_{SAN} + 0.002 \text{ MHz}$	$\left[ \max \left( SE \text{ limit}, P_{rated,t,sys} - 10 \log_{10}(BW_{SAN}) - 24 - \Delta_{Sat,Class} - 40 \times \log_{10} \left( \frac{f_{offset} - 0.002}{BW_{SAN}} \times 2 + 1 \right) \right) \right]$	4 kHz
NOTE 1: $BW_{SAN}$ is in the unit of MHz. NOTE 2: SE limit is spurious emission limit specified in spurious emission clause 6.6.5. NOTE 3: PSD attenuation as in ITU-R SM.1541-6 [15], annex 5 OoB domain emission limits for space services. NOTE 4: $\Delta_{Sat,Class} = 0 \text{ dB}$ for GEO class and $\Delta_{Sat,Class} = 3 \text{ dB}$ for LEO class.			

### 6.6.5 Transmitter spurious emissions

#### 6.6.5.1 Definition and applicability

The transmitter spurious emission limits shall apply from 30 MHz to 11 GHz, excluding the *SAN transponder bandwidth*  $BW_{SAN}$  and the frequency range where the out-of-band emissions apply.

The lower limit and upper limit are as per ITU-R recommendation SM.329 [3], table 1: For systems operating within 600 MHz and 5.2 GHz, the lower limit is 30 MHz and the upper limit is the 5<sup>th</sup> harmonic of the higher frequency.

The lower limit of 30 MHz can be replaced as per ITU-R SM.329 [3]: Systems having an integral antenna incorporating a waveguide section, or with an antenna connection in such form, and of unperturbed length equal to at least twice the cut-off wavelength, do not require spurious domain emission measurements below 0.7 times the waveguide cut-off frequency.

The requirements shall apply whatever the type of transmitter considered (e.g. single carrier or multi-carrier). It applies for all transmission modes foreseen by the manufacturer's specification.

Unless otherwise stated, all requirements are measured as mean power (RMS).

### 6.6.5.2 Minimum requirement

The minimum requirement applies per *single-band connector* supporting transmission in the *operating band*.

The minimum requirement for *SAN type 1-H* is defined in table 6.6.5.5-1.

### 6.6.5.3 Test purpose

This test measures conducted spurious emissions while the transmitter is in operation.

### 6.6.5.4 Method of test

#### 6.6.5.4.1 Initial conditions

Test environment: Normal; see annex B.

RF channels to be tested for single carrier:

- B when testing the spurious emissions below the lower frequency edge of the *SAN transponder bandwidth* minus 2 times  $BW_{SAN}$ ,
- T when testing the spurious emissions above the upper frequency edge of the *SAN transponder bandwidth* plus 2 times  $BW_{SAN}$ ; see clause 4.9.1.

*SAN RF Bandwidth* positions to be tested for multi-carrier:

- $B_{RFBW}$  when testing the spurious frequencies below the lower frequency edge of the *SAN transponder bandwidth* minus 2 times  $BW_{SAN}$ ;
- $T_{RFBW}$  when testing the spurious frequencies above the upper frequency edge of the *SAN transponder bandwidth* plus 2 times  $BW_{SAN}$  in single-band operation; see clause 4.9.1.

#### 6.6.5.4.2 Procedure

For *SAN type 1-H* where there may be multiple *TAB connectors*, they may be tested one at a time or multiple *TAB connectors* may be tested in parallel as shown in annex D.1.1. Whichever method is used the procedure is repeated until all *TAB connectors* necessary to demonstrate conformance have been tested.

- 1) Connect the *single-band connector* under test to measurement equipment as shown in annex D.1.1 for *SAN type 1-H*. All connectors not under test shall be terminated with a matched load.
- 2) Measurements shall use a measurement bandwidth in accordance to the conditions in clause 6.6.5.5.

The measurement device characteristics shall be: Detection mode: True RMS.

The emission power should be averaged over an appropriate time duration to ensure the measurement is within the measurement uncertainty in table 4.1.2.2-1.

- 3) For a connectors declared to be capable of single carrier operation only (D.39), set the representative connectors under test to transmit according to the applicable test configuration in clause 4.8 at *rated carrier output power* ( $P_{rated,c,TABC}$ , D.34). Channel set-up shall be according to E-SAN-TM1.1.

For a connector under test declared to be capable of multi-carrier operation (D.39) set the connector under test to transmit on all carriers configured using the applicable test configuration and corresponding power setting specified in clauses 4.7 and 4.8 using the corresponding test models or set of physical channels in clause 4.9.2.

- 4) Measure the emission at the specified frequencies with specified measurement bandwidth.

### 6.6.5.5 Test requirements

The limits of table 6.6.5.5-1 shall apply.

**Table 6.6.5.5-1: General SAN transmitter spurious emission limits**

Spurious frequency range	$P_{\text{rated,t,sys}}$ (dBm)	Basic limit (dBm)	Measurement bandwidth (kHz)	Notes
30 MHz – 5 <sup>th</sup> harmonic of the upper frequency edge of the DL operating band	$\leq 47$	-13	4	NOTE 1, NOTE 2, NOTE 3
	$> 47$	$P_{\text{rated,t,sys}} - 60$ dB		
NOTE 1: <i>Measurement bandwidths</i> as in ITU-R SM.329 [3], s4.1.				
NOTE 2: Upper frequency as in ITU-R SM.329 [3], s2.5 table 1.				
NOTE 3: The lower frequency limit is replaced by 0.7 times the waveguide cut-off frequency, according to ITU-R SM.329 [3], for systems having an integral antenna incorporating a waveguide section, or with an antenna connection in such form, and of unperturbed length equal to at least twice the cut-off.				

### 6.6.5.6 Protection of the own Satellite Access Node receiver

This requirement shall be applied for FDD operation in order to prevent the receivers of the SAN being de-sensitized by emissions from its own SAN transmitter. It is measured at the *TAB connector* for *SAN type 1-H* for any type of SAN which has common or separate Tx/Rx *TAB connectors*.

The spurious emission *basic limits* are provided in table 6.6.5.6-1.

**Table 6.6.5.6-1: SAN spurious emissions *basic limits* for protection of the SAN receiver**

Frequency range	Basic limits	Measurement bandwidth
$F_{UL,low} - F_{UL,high}$	-96 dBm	100 kHz

### 6.6.5.7 Additional spurious emissions requirements

The additional spurious emissions requirement is not applicable for SAN.

## 6.7 Transmitter intermodulation

The requirement is not applicable in this version of the specification.

## 7 Conducted receiver characteristics

### 7.1 General

Conducted receiver characteristics are specified at the *TAB connector* for *SAN type I-H*, with full complement of transceivers for the configuration in normal operating condition.

Unless otherwise stated, the following arrangements apply for conducted receiver characteristics requirements in clause 7:

- Requirements shall be met for any transmitter setting.
- The requirements shall be met with the transmitter unit(s) ON.
- Throughput requirements do not assume HARQ retransmissions.
- When SAN is configured to receive multiple carriers, all the throughput requirements are applicable for each received carrier.
- For ACS and blocking characteristics, the negative offsets of the interfering signal apply relative to the lower *SAN RF Bandwidth edge*, and the positive offsets of the interfering signal apply relative to the upper *SAN RF Bandwidth edge*.

NOTE: In normal operating condition the SAN is configured to transmit and receive at the same time.

For *SAN type I-H* if a number of *TAB connectors* have been declared equivalent (D.37), only a representative one is necessary to demonstrate conformance.

The conformance testing procedures and testing requirement for Reference sensitivity level are identical for NB-IoT standalone mode and NB-IoT operation in NTN NR in-band, for other conformance testing procedure and testing requirements for NB-IoT operation in NTN NR in-band are defined in TS 38.181 [6].

### 7.2 Reference sensitivity level

#### 7.2.1 Definition and applicability

The reference sensitivity power level  $P_{\text{REFSENS}}$  is the minimum mean power received at the *TAB connector* for *SAN type I-H* at which a throughput requirement shall be met for a specified reference measurement channel.

#### 7.2.2 Minimum requirement

The minimum requirement for *SAN type I-H* is in TS 36.108 [2], clause 7.2.2.

#### 7.2.3 Test purpose

To verify that for the *SAN type I-H* receiver at the reference sensitivity level the throughput requirement shall be met for a specified reference measurement channel.

#### 7.2.4 Method of test

##### 7.2.4.1 Initial conditions

Test environment: Normal; see annex B.

RF channels to be tested for single carrier: B, M and T; see clause 4.9.1.

### 7.2.4.2 Procedure

The minimum requirement is applied to all connectors under test.

For *SAN type 1-H* the procedure is repeated until all *TAB connectors* necessary to demonstrate conformance have been tested; see clause 7.1.

- 1) Connect the connector under test to measurement equipment as shown in annex D.2.1 for *SAN type 1-H*.
- 2) Set the SAN to transmit a signal using the applicable test configuration and corresponding power setting specified in clauses 4.7 and 4.8 using the corresponding test models or set of physical channels in clause 4.9.2, for *SAN type 1-H* set the *TAB connector* to the manufacturers declared *rated carrier output power* ( $P_{\text{rated,c,TABC}}$ , D.34).
- 3) Start the signal generator for the wanted signal to transmit the Fixed Reference Channels for reference sensitivity according to annex A.1.
- 4) Set the signal generator for the wanted signal power as specified in clause 7.2.5.
- 5) Measure the throughput according to annex A.1.

### 7.2.5 Test requirements

For SAN supporting E-UTRA, the throughput shall be  $\geq 95\%$  of the maximum throughput of the reference measurement channel as specified in annex A.1 with parameters specified in table 7.2.5-1 and 7.2.5-2 for *SAN type 1-H* in all operating bands.

**Table 7.2.5-1: Reference sensitivity levels of SAN supporting E-UTRA (GEO class payload)**

SAN channel bandwidth (MHz)	Sub-carrier spacing (kHz)	Reference measurement channel (NOTE)	Reference sensitivity power level, $P_{\text{REFSENS}}$ (dBm)
1.4	15	FRC A1-1 in annex A.1	-103.7
NOTE: $P_{\text{REFSENS}}$ is the power level of a single instance of the reference measurement channel.			

**Table 7.2.5-2: Reference sensitivity levels of SAN supporting E-UTRA (LEO class payload)**

SAN channel bandwidth (MHz)	Sub-carrier spacing (kHz)	Reference measurement channel (NOTE)	Reference sensitivity power level, $P_{\text{REFSENS}}$ (dBm)
1.4	15	FRC A1-1 in annex A.1	-106.8
NOTE: $P_{\text{REFSENS}}$ is the power level of a single instance of the reference measurement channel.			

For SAN supporting standalone NB-IoT operation or NB-IoT operation in NTN NR in-band, the throughput shall be  $\geq 95\%$  of the maximum throughput of the reference measurement channel as specified in annex A.1 with parameters specified in table 7.2.2-3 and 7.2.2-4 for *SAN type 1-H* in all operating bands.

**Table 7.2.5-3: Reference sensitivity levels of SAN supporting standalone NB-IoT operation and NB-IoT operation in NTN NR in-band (GEO class payload)**

SAN channel bandwidth (kHz)	Sub-carrier spacing (kHz)	Reference measurement channel	Reference sensitivity power level, $P_{\text{REFSENS}}$ (dBm)
200	15	FRC A14-1 in annex A.14	-123.9
200	3.75	FRC A14-2 in annex A.14	-129.9

**Table 7.2.5-4: Reference sensitivity levels of SAN supporting standalone NB-IoT operation and NB-IoT operation in NTN NR in-band (LEO class payload)**

SAN channel bandwidth (kHz)	Sub-carrier spacing (kHz)	Reference measurement channel	Reference sensitivity power level, $P_{\text{REFSENS}}$ (dBm)
200	15	FRC A14-1 in annex A.14	-127.0
200	3.75	FRC A14-2 in annex A.14	-133.0

## 7.3 Dynamic range

### 7.3.1 Definition and applicability

The dynamic range is specified as a measure of the capability of the receiver to receive a wanted signal in the presence of an interfering signal at the *TAB connector* for *SAN type I-H* inside the received *SAN channel bandwidth*. In this condition, a throughput requirement shall be met for a specified reference measurement channel. The interfering signal for the dynamic range requirement is an AWGN signal.

### 7.3.2 Minimum requirement

The minimum requirement for *SAN type I-H* is in TS 36.108 [2], clause 7.3.2.

### 7.3.3 Test purpose

To verify that the each *SAN type I-H TAB connector* receiver dynamic range, the relative throughput shall fulfil the specified limit.

### 7.3.4 Method of test

#### 7.3.4.1 Initial conditions

Test environment: Normal; see annex B.

RF channels to be tested for single carrier: M; see clause 4.9.1.

#### 7.3.4.2 Procedure

The minimum requirement is applied to all connectors under test.

For *SAN type I-H* supporting E-UTRA or standalone NB-IoT, the procedure is repeated until all *TAB connectors* necessary to demonstrate conformance have been tested; see clause 7.1.

- 1) Connect the connector under test to measurement equipment as shown in annex D.2.2 for *SAN type I-H*.
- 2) Set the signal generator for the wanted signal to transmit as specified in table 7.3.5-1 for SAN LEO class supporting E-UTRA, in table 7.3.5-2 for SAN GEO class supporting standalone NB-IoT and in table 7.3.5-3 for SAN LEO class supporting standalone NB-IoT.
- 3) Set the Signal generator for the AWGN interfering signal at the same frequency as the wanted signal to transmit as specified in table 7.3.5-1 for LEO SAN supporting E-UTRA in table 7.3.5-1 for SAN LEO class supporting E-UTRA, in table 7.3.5-2 for SAN GEO class supporting standalone NB-IoT and in table 7.3.5-3 for SAN LEO class supporting standalone NB-IoT.
- 4) Measure the throughput according to annex A.2.

## 7.3.5 Test requirements

For SAN supporting E-UTRA, the throughput shall be  $\geq 95\%$  of the maximum throughput of the reference measurement channel as specified in annex A.2 with parameters specified in table 7.3.5-1 for SAN LEO class.

**Table 7.3.5-1: Dynamic range of SAN supporting E-UTRA (LEO class payload)**

SAN channel bandwidth (MHz)	Reference measurement channel	Wanted signal mean power (dBm)	Interfering signal mean power (dBm) / $BW_{Config}$	Type of interfering signal
1.4	FRC A2-1 in annex A.2	-81.7	-94.4	AWGN
NOTE: The wanted signal mean power is the power level of a single instance of the reference measurement channel.				

For SAN supporting standalone NB-IoT operation, the throughput shall be  $\geq 95\%$  of the maximum throughput of the reference measurement channel as specified in annex A.2 with parameters specified in table 7.3.5-2 and 7.3.5-3.

**Table 7.3.5-2: Dynamic range of SAN supporting standalone NB-IoT operation (GEO class payload)**

SAN channel bandwidth (kHz)	Reference measurement channel	Wanted signal mean power (dBm)	Interfering signal mean power (dBm) / $BW_{Channel}$	Type of interfering signal
200	FRC A15-1 in annex A.15	-97.0	-93.6	AWGN
200	FRC A15-2 in annex A.15	-102.9	-93.6	AWGN

**Table 7.5.2-3: Dynamic range of SAN supporting standalone NB-IoT operation (LEO class payload)**

SAN channel bandwidth (kHz)	Reference measurement channel	Wanted signal mean power (dBm)	Interfering signal mean power (dBm) / $BW_{Channel}$	Type of interfering signal
200	FRC A15-1 in annex A.15	-89.1	-85.7	AWGN
200	FRC A15-2 in annex A.15	-95.0	-85.7	AWGN

## 7.4 In-band sensitivity and blocking

### 7.4.1 Adjacent Channel Selectivity (ACS)

#### 7.4.1.1 Definition and applicability

Adjacent channel selectivity (ACS) is a measure of the receiver's ability to receive a wanted signal at its assigned channel frequency at *TAB connector* for *SAN type 1-H* in the presence of an adjacent channel signal with a specified centre frequency offset of the interfering signal to the band edge of a victim system.

#### 7.4.1.2 Minimum requirement

The minimum requirement for *SAN type 1-H* is in TS 36.108 [2], clause 7.4.1.2.

### 7.4.1.3 Test purpose

The test purpose is to verify the ability of the SAN receiver filter to suppress interfering signals in the channels adjacent to the wanted channel.

### 7.4.1.4 Method of test

#### 7.4.1.4.1 Initial conditions

Test environment: Normal; see annex B.

RF channels to be tested for single carrier (SC): M; see clause 4.9.1.

*SAN RF Bandwidth* positions to be tested for multi-carrier (MC):  $M_{\text{RFBW}}$  for *single-band connector(s)*, see clause 4.9.1.

#### 7.4.1.4.2 Procedure

The minimum requirement is applied to all connectors under test.

For *SAN type 1-H* the procedure is repeated until all *TAB connectors* necessary to demonstrate conformance have been tested; see clause 7.1.

- 1) Connect the connector under test to measurement equipment as shown in annex D.2.3 for *SAN type 1-H*.
- 2) For FDD operation, set the SAN to transmit:
  - For single carrier operation set the connector under test to transmit at manufacturers declared *rated carrier output power* ( $P_{\text{rated,c,TABC}}$ , D.34).
  - For a connector under test declared to be capable of multi-carrier operation (D.39) set the connector under test to transmit on all carriers configured using the applicable test configuration and corresponding power setting specified in clauses 4.7 and 4.8 using the corresponding test models or set of physical channels in clause 4.9.2.
- 3) Set the signal generator for the wanted signal to transmit as specified in table 7.4.1.5-1 for SAN supporting E-UTRA, table 7.4.1.5-2 for SAN supporting standalone NB-IoT.
- 4) Set the signal generator for the interfering signal to transmit at the frequency offset and as specified in table 7.4.1.5-1 for SAN supporting E-UTRA, table 7.4.1.5-2 for SAN supporting standalone NB-IoT.

### 7.4.1.5 Test requirements

The throughput shall be  $\geq 95\%$  of the maximum throughput of the reference measurement channel.

For SAN supporting E-UTRA, the wanted and the interfering signal coupled to the *SAN type 1-H TAB connector* are specified in table 7.4.1.5-1. The reference measurement channel for the wanted signal is identified in table 7.2.2-1 for each *SAN channel bandwidth* in any operating band and further specified in annex A.1. The characteristics of the interfering signal is further specified in annex E.

For SAN supporting standalone NB-IoT operation, the wanted and the interfering signal coupled to the *SAN type 1-H TAB connector* are specified in table 7.4.1.5-2. The reference measurement channel for the wanted signal is identified in table 7.2.2-1 for each *SAN channel bandwidth* in any operating band and further specified in annex A.1. The characteristics of the interfering signal is further specified in annex E.

The ACS requirement is applicable outside the *SAN RF Bandwidth* or *Radio Bandwidth*. The interfering signal offset is defined relative to the *SAN RF Bandwidth* edges or *Radio Bandwidth* edges.

Minimum conducted requirement is defined at the *TAB connector* for *SAN type 1-H*.

Table 7.4.1.5-1: ACS requirement of SAN supporting E-UTRA

SAN channel bandwidth of the lowest/highest carrier received (MHz)	Wanted signal mean power (dBm)	Interfering signal mean power (dBm)	Interfering signal centre frequency offset from the lower/upper SAN RF Bandwidth edge or sub-block edge inside a sub-block gap (MHz)	Type of interfering signal
1.4	$P_{\text{REFSENS}} + 11$ dB (NOTE)	GEO SAN class: -57.6 LEO SAN class: -60.7	$\pm 0.7025$	1.4 MHz E-UTRA signal
NOTE: $P_{\text{REFSENS}}$ depends on the channel bandwidth as specified in table 7.2.2-1 and table 7.2.2-2.				

Table 7.4.1.5-2: ACS requirement of SAN supporting standalone NB-IoT operation

SAN channel bandwidth of the lowest/highest carrier received (kHz)	Wanted signal mean power (dBm)	Interfering signal mean power (dBm)	Interfering signal centre frequency offset to the lower/upper SAN RF Bandwidth edge or sub-block edge inside a sub-block gap (kHz)	Type of interfering signal
200	$P_{\text{REFSENS}} + 19.5$ dB (NOTE)	GEO SAN class: -56.6 LEO SAN class: -59.7	$\pm 100$	180 kHz NB-IoT signal
NOTE: $P_{\text{REFSENS}}$ depends on the sub-carrier spacing as specified in table 7.2.2-3 and table 7.2.2-4.				

## 7.4.2 In-band blocking

The requirement is not applicable in this version of the specification.

## 7.5 Out-of-band blocking

### 7.5.1 Definition and applicability

The out-of-band blocking characteristics is a measure of the receiver ability to receive a wanted signal at its assigned channel at the *TAB connector* for SAN type 1-H in the presence of an unwanted interferer out of the *operating band*, which is a CW signal for out-of-band blocking.

### 7.5.2 Minimum requirement

The minimum requirements for SAN type 1-H are defined in TS 36.108 [2], clause 7.5.2.

### 7.5.3 Test purpose

The test stresses the ability of the receiver unit associated with the *TAB connector* under test to withstand high-level interference from unwanted signals at specified frequency bands, without undue degradation of its sensitivity.

## 7.5.4 Method of test

### 7.5.4.1 Initial conditions

Test environment: Normal; see annex B.

RF channels to be tested for single carrier (SC): M; see clause 4.9.1.

*SAN RF bandwidth* positions to be tested for multi-carrier (MC):  $M_{\text{RFBW}}$  for *single-band connector(s)*, see clause 4.9.1.

### 7.5.4.2 Procedure

The minimum requirement is applied to all *TAB connectors* under test. For *SAN type 1-H* the procedure is repeated until all *TAB connectors* necessary to demonstrate conformance have been tested; see clause 7.1.

- 1) Connect the connector under test to measurement equipment as shown in annex D.2.3.
- 2) For FDD operation, set the *SAN* to transmit a signal according to clause 4.9.2, connector under test to transmit on all carriers configured using the applicable test configuration and corresponding power setting specified in clauses 4.7 and 4.8.

The transmitter may be turned OFF for the out-of-band blocker tests when the frequency of the blocker is such that no IM2 or IM3 products fall inside the bandwidth of the wanted signal.

- 3) Set the signal generator for the wanted signal as defined in clause 7.5.5 to transmit as specified in table 7.5.5-1.
- 4) Set the signal generator for the interfering signal to transmit at the frequency offset and as specified in table 7.5.5-1. The CW interfering signal shall be swept with a step size of 1 MHz over than range 1 MHz to  $(F_{\text{UL,low}} - \Delta f_{\text{OOB}})$  MHz and  $(F_{\text{UL,high}} + \Delta f_{\text{OOB}})$  MHz to 12750 MHz.

- 5) Measure the throughput according to annex A.1.

## 7.5.5 Test requirements

The throughput shall be  $\geq 95\%$  of the maximum throughput of the reference measurement channel, with a wanted and an interfering signal coupled to *SAN type 1-H TAB connector* using the parameters in table 7.5.5-1.

The reference measurement channel for the wanted signal is identified in clause 7.2.2 for each *SAN channel bandwidth* and further specified in annex A.1.

The out-of-band blocking requirement apply from 1 MHz to  $F_{\text{UL,low}} - \Delta f_{\text{OOB}}$  and from  $F_{\text{UL,high}} + \Delta f_{\text{OOB}}$  up to 12750 MHz, including the downlink frequency range of the *FDD operating band* for *SAN*. The  $\Delta f_{\text{OOB}}$  for *SAN type 1-H* is defined in table 7.5.5-2.

Minimum conducted requirement is defined at the *TAB connector* for *SAN type 1-H*.

**Table 7.5.5-1: Out-of-band blocking requirement for SAN supporting E-UTRA or standalone NB-IoT operation**

Wanted signal mean power (dBm)	Interfering signal mean power (dBm)	Type of interfering signal
$P_{\text{REFSENS}} + 6$ dB (NOTE 1)	-44	CW carrier
NOTE 1: For <i>SAN</i> , $P_{\text{REFSENS}}$ depends on the <i>SAN channel bandwidth</i> . NOTE 2: [For <i>SAN</i> supporting standalone NB-IoT, up to 24 exceptions are allowed for spurious response frequencies in each wanted signal frequency when measured using a 1 MHz step size. For these exceptions the above throughput requirement shall be met when the blocking signal is set to a level of -46 dBm for 3.75 kHz subcarrier spacing. In addition, each group of exceptions shall not exceed three contiguous measurements using a 1 MHz step size.]		

**Table 7.5.5-2:  $\Delta f_{\text{OoB}}$  offset for E-UTRA operating bands**

<b>SAN type</b>	<b>Operating band characteristics</b>	<b><math>\Delta f_{\text{OoB}}</math> (MHz)</b>
<i>SAN type 1-H</i>	$F_{\text{UL,high}} - F_{\text{UL,low}} < 100$ MHz	20

## 7.6 Receiver spurious emission

The requirement is not applicable in this version of the specification.

## 7.7 Receiver intermodulation

The requirement is not applicable in this version of the specification.

## 7.8 In-channel selectivity

### 7.8.1 Definition and applicability

In-channel selectivity (ICS) is a measure of the receiver ability to receive a wanted signal at its assigned resource block locations at the *TAB connector* for *SAN type 1-H* in the presence of an interfering signal received at a larger power spectral density. In this condition a throughput requirement shall be met for a specified reference measurement channel. The interfering signal shall be an E-UTRA signal which is time aligned with the wanted signal.

### 7.8.2 Minimum requirement

The minimum requirements for *SAN type 1-H* are in TS 36.108 [2], clause 7.8.2.

### 7.8.3 Test purpose

The purpose of this test is to verify the SAN receiver ability to suppress the IQ leakage.

### 7.8.4 Method of test

#### 7.8.4.1 Initial conditions

Test environment: Normal; see annex B.

RF channels to be tested for single carrier: M; see clause 4.9.1.

#### 7.8.4.2 Procedure

The minimum requirement is applied to all connectors under test.

For *SAN type 1-H* the procedure is repeated until all *TAB connectors* necessary to demonstrate conformance have been tested; see clause 7.1.

- 1) Set the signal generator for the wanted signal to transmit as specified from table 7.8.5-1 and 7.8.5-2.
- 2) Set the signal generator for the interfering signal to transmit at the frequency offset and as specified from table 7.8.5-1 and 7.8.5-2.
- 3) Measure the throughput according to annex A.1.

## 7.8.5 Test requirements

For SAN supporting E-UTRA, the throughput shall be  $\geq 95\%$  of the maximum throughput of the reference measurement channel as specified in annex A.1 with parameters specified in table 7.8.5-1 for GEO SAN, in table 7.8.5-2 for LEO SAN. The characteristics of the interfering signal is further specified in annex E.

**Table 7.8.5-1 In-channel selectivity of SAN supporting E-UTRA (GEO class payload)**

SAN channel bandwidth (MHz)	Reference measurement channel	Wanted signal mean power (dBm)	Interfering signal mean power (dBm)	Type of interfering signal
1.4	A1-4	-103.1	-97.6	1.4 MHz E-UTRA signal, 3 RBs

**Table 7.8.5-2 In-channel selectivity of SAN supporting E-UTRA (LEO class payload)**

SAN channel bandwidth (MHz)	Reference measurement channel	Wanted signal mean power (dBm)	Interfering signal mean power (dBm)	Type of interfering signal
1.4	A1-4	-106.2	-88.7	1.4 MHz E-UTRA signal, 3 RBs

---

## 8 Conducted performance characteristics

### 8.1 General

Performance requirements are specified for a number of test environments and multipath channel classes.

Unless stated otherwise, performance requirements apply for a single carrier only. Performance requirements for a SAN supporting carrier aggregation are defined in terms of single carrier requirements. The requirements only apply to those measurement channels that are supported by the SAN.

For SAN with receiver antenna diversity the required SNR shall be applied separately at each antenna port.

In tests performed with signal generators a synchronization signal may be provided, from the SAN to the signal generator, to enable correct timing of the wanted signal.

For tests in clause 8 the transmitter may be OFF.

Unless stated otherwise performance requirements, for a SAN supporting different numbers of *TAB connectors*, the tests with low MIMO correlation level shall apply only for the highest number of supported connectors, and the specific connectors used for testing are based on manufacturer declaration. If performance requirement is not specified for the highest number of supported connectors, the tests shall be done by using performance requirement for the closest number of connectors lower than this highest number of supported connectors.

### 8.2 Performance requirements for PUSCH

#### 8.2.1 Performance requirements of PUSCH in multipath fading propagation conditions transmission on single antenna port for coverage enhancement

##### 8.2.1.1 Definition and applicability

The performance requirement of PUSCH is determined by a minimum required throughput for a given SNR. The required throughput is expressed as a fraction of maximum throughput for the FRCs listed in annex A. The performance requirements assume HARQ re-transmissions.

The tests for CEModeA defined in clause 8.2.1 are applicable only to the space access nodes supporting coverage enhancement configured with CEModeA. The tests for CEModeB defined in clause 8.2.1 are applicable only to the space access nodes supporting coverage enhancement configured with CEModeB.

A test for a specific channel bandwidth is only applicable if the SAN supports it. For a SAN supporting FDD multiple channel bandwidths, only the tests for the lowest and the highest FDD channel bandwidths supported by the SAN are applicable.

##### 8.2.1.2 Minimum Requirement

The minimum requirement is in TS 36.108 [2] clause 8.2.1.

##### 8.2.1.3 Test Purpose

The test shall verify the receiver's ability to achieve throughput under multipath fading propagation conditions for a given SNR.

##### 8.2.1.4 Method of test

###### 8.2.1.4.1 Initial conditions

Test environment: Normal, see annex B.

RF channels to be tested: M; see clause 4.7.

- 1) Connect the SAN tester generating the wanted signal, multipath fading simulators and AWGN generators to all SAN TAB connectors for diversity reception via a combining network as shown in annex D.5.

#### 8.2.1.4.2 Procedure

- 1) Adjust the AWGN generator, according to the channel bandwidth, defined in table 8.2.1.4.2-1.

**Table 8.2.1.4.2-1: AWGN power level at the SAN input**

Channel bandwidth (MHz)	AWGN power level
1.4	-92.7dBm / 1.08MHz

- 2) The characteristics of the wanted signal shall be configured according to the corresponding UL reference measurement channel defined in annex A and the test parameters in table 8.2.1.4.2-2. The index of the narrowband is set to 0. For reference channels using resource blocks less than 6, the resource blocks shall be allocated from the lowest number within the indicated narrowband.

**Table 8.2.1.4.2-2: Test parameters for testing PUSCH**

Parameter	CEMode A	CEMode B
Maximum number of HARQ transmissions	4	2
RV sequences	0, 2, 3, 1, 0, 2, 3, 1	FDD: 0, 0, 0, 0, 2, 2, 2, 2, 3, 3, 3, 3, 1, 1, 1, 1
Duration of PUSCH segment transmission ( $N_{segment}^{precompensation}$ )	8ms	256ms
No. Repetitions	8	256
Frequency hopping	OFF	OFF
NOTE: Guard period shall be created according to TS 36.211, clause 5.2.5 [12].		

- 3) The multipath fading emulators shall be configured according to the corresponding channel model defined in annex F.
- 4) Adjust the equipment so that required SNR specified in table 8.2.1.5-1 to 8.2.1.5-2 is achieved at the SAN input.
- 5) The test signal generator sends frames, and the receiver tries to demodulate the content. The frames are sent with certain frequency offsets as described below in table 8.2.1.4.2-3 as well as certain timing offsets as described below in table 8.2.1.4.2-4.

**Table 8.2.1.4.2-3: Frequency Offsets for testing PUSCH**

Channel	Frequency Offset (Hz)
CEmode A	4
CEmode B	128

**Table 8.2.1.4.2-4: Timing Offsets for testing PUSCH**

Channel	Step size $\Delta t$
CEmode A	0.01 $\mu$ s per subframe
CEmode B	0.01 $\mu$ s per subframe

- 6) For each of the reference channels in table 8.2.1.5-1 to 8.2.1.5-2 applicable for the access node, measure the throughput, according to annex A.

### 8.2.1.5 Test Requirement

The throughput measured according to clause 8.2.1.4.2 shall not be below the limits for the SNR levels specified in table 8.2.1.5-1 for CEMode A tests and not be below the limits for the SNR levels specified in table 8.2.1.5-2 for CEMode B tests.

**Table 8.2.1.5-1 Minimum requirements for PUSCH, 1.4 MHz channel bandwidth for Mode A, 1Tx**

Number of TX antennas	Number of RX antennas	CE Mode	Propagation conditions (annex F)	FRC (annex A)	Fraction of maximum throughput	SNR (dB)
1	1	Mode A	NTN-TDLA100-5	A5-2	70%	-2.5
1	1	Mode A	NTN-TDLC5-5	A5-2	70%	-2.8
1	2	Mode A	NTN-TDLA100-5	A5-2	70%	-6.7
1	2	Mode A	NTN-TDLC5-5	A5-2	70%	-6.7

**Table 8.2.1.5-2 Minimum requirements for PUSCH, 1.4 MHz channel bandwidth for Mode B, 1Tx**

Number of TX antennas	Number of RX antennas	CE Mode	Propagation conditions (annex F)	FRC (annex A)	Fraction of maximum throughput	SNR (dB)
1	1	Mode B	NTN-TDLA100-5	A5-1	70%	-11.0
1	1	Mode B	NTN-TDLC5-5	A5-1	70%	-12.7
1	2	Mode B	NTN-TDLA100-5	A5-1	70%	-13.9
1	2	Mode B	NTN-TDLC5-5	A5-1	70%	-14.9

NOTE: If the above Test Requirement differs from the Minimum Requirement then the Test Tolerance applied for this test is non-zero. The Test Tolerance for this test and the explanation of how the Minimum Requirement has been relaxed by the Test Tolerance is given in annex C.

## 8.3 Performance requirements for PUCCH

### 8.3.1 ACK missed detection for PUCCH format 1a transmission on single antenna port for coverage enhancement

#### 8.3.1.1 Definition and applicability

The performance requirement of PUCCH for ACK missed detection is determined by the two parameters: probability of false detection of the ACK and the probability of detection of ACK. The performance is measured by the required SNR at probability of detection equal to 0.99. The probability of false detection of the ACK shall be 0.01 or less.

The probability of false detection of the ACK is defined as a conditional probability of erroneous detection of the ACK for the configured PUCCH transmission repetitions when input is only noise.

The probability of detection of ACK is defined as conditional probability of detection of the ACK for the configured PUCCH transmission repetitions when the signal is present.

The test is applicable only to space access nodes supporting coverage enhancement. A test for a specific channel bandwidth is only applicable if the SAN supports it.

#### 8.3.1.2 Minimum Requirement

The minimum requirement is in TS 36.108 [2] clause 8.3.9.1 and 8.3.9.2.

### 8.3.1.3 Test purpose

The test shall verify the receiver’s ability to detect ACK under multipath fading propagation conditions for a given SNR.

### 8.3.1.4 Method of test

#### 8.3.1.4.1 Initial Conditions

Test environment: Normal, see annex B.

RF channels to be tested: M; see clause 4.7.

- 1) Connect the SAN tester generating the wanted signal, multipath fading simulators and AWGN generators to all SAN TAB connectors for diversity reception via a combining network as shown in annex D.5.

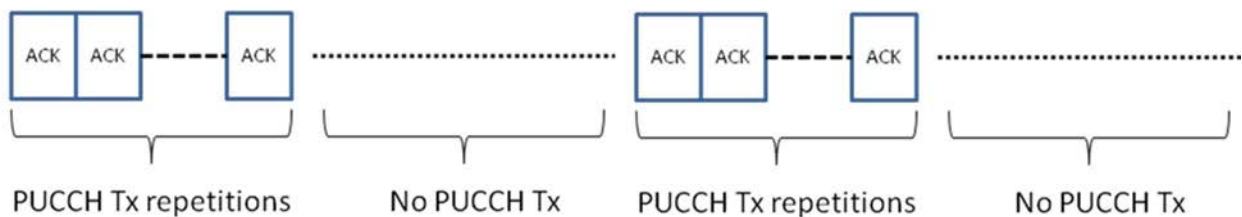
#### 8.3.1.4.2 Procedure

- 1) Adjust the AWGN generator, according to the channel bandwidth defined in table 8.3.1.4.2-1.

**Table 8.3.1.4.2-1: AWGN power level at the SAN input**

Channel bandwidth (MHz)	AWGN power level
1.4	-89.7 dBm / 1.08MHz

- 2) The characteristics of the wanted signal shall be configured according to TS 36.211 [12].
- 3) The multipath fading emulators shall be configured according to the corresponding channel model defined in annex F.
- 4) Adjust the equipment so that the SNR specified in table 8.3.1.4.2-1 is achieved at the SAN input during the ACK transmissions.
- 5) The signal generator sends a test pattern with the pattern outlined in figure 8.3.1.4.2-1. The PUCCH signals are sent with certain timing and frequency offsets as described below. The following statistics are kept: the number of ACKs detected in the idle periods and the number of missed ACKs.



**Figure 8.3.1.4.2-1: Test signal pattern for PUCCH format 1a demodulation tests**

PUCCH test signals are sent with a frequency offset as described below in table 8.3.1.4.2-2 as well as a timing offset as described below in table 8.3.1.4.2-3.

**Table 8.3.1.4.2-2: Frequency Offsets for testing PUCCH**

Channel	Duration of PUCCH segment transmission ( $N_{segment}^{precompensation}$ )	Frequency offset (Hz)
PUCCH format 1a	8 ms	4

**Table 8.3.1.4.2-3: Timing Offsets for testing PUCCH**

Channel	Duration of PUCCH segment transmission ( $N_{segment}^{precompensation}$ )	Step size $\Delta t$
PUCCH format 1a	8 ms	0.01 $\mu$ s per subframe

### 8.3.1.5 Test Requirement

The fraction of falsely detected ACKs shall be less than 1% and the fraction of correctly detected ACKs shall be larger than 99% for the SNR listed in table 8.3.1.2.1-1.

**Table 8.3.1.2.1-1 Minimum requirements for single user PUCCH format 1a, 1Tx**

Number of TX antennas	Number of RX antennas	Channel bandwidth	Cyclic Prefix	Propagation conditions (annex F)	Repetitions	SNR (dB)
1	1	1.4 MHz	Normal	NTN-TDLA100-5	8	-2.0
1	2	1.4 MHz	Normal	NTN-TDLA100-5	8	-7.6

NOTE 1: Frequency Hopping: OFF  
NOTE 2: Guard period shall be created according to TS 36.211 [12], clause 5.2.5.

NOTE: If the above Test Requirement differs from the Minimum Requirement then the Test Tolerance applied for this test is non-zero. The Test Tolerance for this test and the explanation of how the Minimum Requirement has been relaxed by the Test Tolerance is given in annex C.

## 8.4 Performance requirements for PRACH

### 8.4.1 PRACH false alarm probability and missed detection

#### 8.4.1.1 Definition and applicability

The performance requirement of PRACH for preamble detection is determined by the two parameters: total probability of false detection of the preamble (Pfa) and the probability of detection of preamble (Pd). The performance is measured by the required SNR at probability of detection, Pd of 99%. Pfa shall be 0.1% or less.

Pfa is defined as a conditional total probability of erroneous detection of the preamble (i.e. erroneous detection from any detector) when input is only noise.

The probability of detection is the conditional probability of correct detection of the preamble when the signal is present. There are several error cases – detecting different preamble than the one that was sent, not detecting a preamble at all or correct preamble detection but with the wrong timing estimation. For NTN-TDLA100-5, a timing estimation error occurs if the estimation error of the timing of the strongest path is larger than 2.08  $\mu$ s. The strongest path for the timing estimation error refers to the strongest path (i.e. average of the delay of all paths having the same highest gain = 310 ns for ETU) in the power delay profile.

The test preambles for normal mode are listed in table A.6-1.8.5

#### 8.4.1.2 Minimum Requirement

The minimum requirement is in TS 36.108 [2] clause 8.4.1.1 and 8.4.2.1.

#### 8.4.1.3 Test purpose

The test shall verify the receiver's ability to detect PRACH preamble under multipath fading propagation conditions for a given SNR.

8.4.1.4 Method of test

8.4.1.4.1 Initial Conditions

Test environment: Normal, see annex B.

RF channels to be tested: M; see clause 4.7.

- 1) Connect the SAN tester generating the wanted signal, multipath fading simulators and AWGN generators to all SAN TAB connectors for diversity reception via a combining network as shown in annex I.3.1 or annex D.5 as applicable.

8.4.1.4.2 Procedure

- 1) Adjust the AWGN generator, according to the channel bandwidth.

**Table 8.4.1.4.2-1: AWGN power level at the SAN input**

Channel bandwidth (MHz)	AWGN power level
1.4	-89.7 dBm / 1.08MHz

- 2) The characteristics of the wanted signal shall be configured according to the corresponding UL reference measurement channel defined in annex A.
- 3) The multipath fading emulators shall be configured according to the corresponding channel model defined in annex F.
- 4) Adjust the frequency offset of the test signal according to table 8.4.1.5-1.
- 5) Adjust the equipment so that the SNR specified in table 8.4.1.5-1 is achieved at the SAN input during the PRACH preambles.
- 6) The test signal generator sends a preamble and the receiver tries to detect the preamble. This pattern is repeated as illustrated in figure 8.4.1.4.2-1. The preambles are sent with certain timing estimation errors as described below. The following statistics are kept: the number of preambles detected in the idle period and the number of missed preambles.



**Figure 8.4.1.4.2-1: PRACH preamble test pattern**

PRACH preambles are sent with a timing estimation error of 2.08 us.

8.4.1.5 Test Requirement

Pfa shall not exceed 0.1%. Pd shall not be below 99% for the SNRs in table 8.4.1.5-1.

**Table 8.4.1.5-1: PRACH missed detection requirements for coverage enhancement (PRACH frequency hopping OFF)**

Number of TX antennas	Number of RX antennas	Propagation conditions (annex F)	Frequency offset	Number of Repetitions	SNR (dB)			
					Burst format 0	Burst format 1	Burst format 2	Burst format 3
1	1	NTN-TDLA100-5	270 Hz	8	-10.4	-10.0	-	-
				16	-	-	-15.5	-15.5
	2	NTN-TDLA100-5	270 Hz	8	-15.7	-15.5	-	-
				16	-	-	-19.5	-19.5

NOTE: Under fading channels, the PRACH detection performance may be significantly different with different PRACH Configuration Indexes. The requirements in this table are defined based on the simulation results with PRACH Configuration Indexes (3, 19, 35, 51) for Format 0, Format 1, Format 2, and Format 3 respectively.

## 8.5 Performance requirements for Narrowband IoT

### 8.5.1 Performance requirements for NPUSCH format 1

#### 8.5.1.1 Definition and applicability

The performance requirement of NPUSCH format 1 is determined by a minimum required throughput for a given SNR. The required throughput is expressed as a fraction of maximum throughput for the FRCs listed in annex A. The performance requirements assume HARQ re-transmissions.

The tests for 3.75 kHz subcarrier spacing are applicable to the base stations supporting 3.75 kHz subcarrier spacing requirements. The tests for single-subcarrier/multi-subcarrier of 15 kHz subcarrier spacing are applicable to the base stations supporting the number of subcarriers of 15 kHz subcarrier spacing requirements.

#### 8.5.1.2 Minimum Requirement

The minimum requirement is in TS 36.108 [2] clause 8.5.1.

#### 8.5.1.3 Test Purpose

The test shall verify the receiver's ability to achieve the throughput under multipath fading propagation conditions for a given SNR.

#### 8.5.1.4 Method of test

##### 8.5.1.4.1 Initial Conditions

Test environment: Normal, see annex B.

RF channels to be tested: M; see clause 4.9.1.

- 1) Connect the SAN tester generating the wanted signal, multipath fading simulators and AWGN generators to all SAN TAB connectors for diversity reception via a combining network as shown in annex D.5.

##### 8.5.1.4.2 Procedure

- 1) Adjust the AWGN generator, according to the channel bandwidth, defined in table 8.5.1.4.2-1.

**Table 8.5.1.4.2-1: AWGN power level at the SAN input**

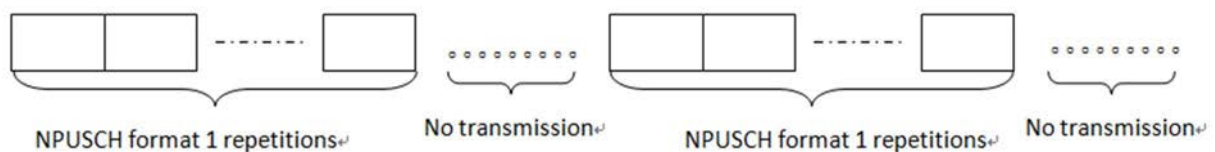
Channel bandwidth (kHz)	AWGN power level
200	-100.5dBm /180kHz

- 2) The characteristics of the wanted signal shall be configured according to the corresponding UL reference measurement channel defined in annex A and the test parameters in table 8.5.1.4.2-2.

**Table 8.5.1.4.2-2: Test parameters for testing NPUSCH format 1**

Parameter	unit	Value
Maximum number of HARQ transmissions		4
RV sequences		RV0, RV2
Duration of NPUSCH format 1 segment transmission ( $N_{segment}^{precompensation}$ )	ms	256 for 3.75kHz SCS, 16 for 15kHz SCS
Repetition		4 for 3.75kHz SCS, 16 for 15kHz SCS

- 3) The multipath fading emulators shall be configured according to the corresponding channel model defined in annex F.
- 4) Adjust the equipment so that required SNR specified in tables 8.5.1.5-1 to 8.5.1.5-3 is achieved at the SAN input.
- 5) The signal generator sends a test pattern with the pattern outlined in Figure 8.5.1.4.2-1. The test signal generator sends frames, and the receiver tries to demodulate the content. The frames are sent with certain frequency and gradual time offset per segment as described below in table 8.5.1.4.2-3 and table 8.5.1.4.2-4. The time offset is reset back to zero between segments.



**Figure 8.5.1.4.2-1: Test signal pattern for NPUSCH format 1 demodulation tests**

**Table 8.5.1.4.2-3: Frequency Offsets for testing NPUSCH format 1**

Cases	Accumulated Frequency Offset
Table 8.5.1.5-1	128 Hz
Table 8.5.1.5-2	8 Hz

**Table 8.5.1.4.2-4: Timing Offsets for testing NPUSCH format 1**

Cases	Step size $\Delta t$
Table 8.5.1.5-1	0.32 us per RU
Table 8.5.1.5-2	0.01 us per RU

- 6) For each of the reference channels in table 8.5.1.5-1 to 8.5.1.5-2 applicable for the base station, measure the throughput.

### 8.5.1.5 Test Requirement

The throughput measured according to clause 8.5.1.4.2 shall not be below the limits for the SNR levels specified in table 8.5.1.5-1 for 3.75 kHz subcarrier spacing tests and not be below the limits for the SNR levels specified in table 8.5.1.5-2 for 15kHz subcarrier spacing with the supported number of subcarrier tests.

**Table 8.5.1.5-1 Required SNR for NPUSCH format 1 test, 200 kHz channel bandwidth, 3.75 kHz subcarrier spacing, 1Tx**

Number of TX antennas	Number of RX antennas	Subcarrier spacing	Number of allocated subcarriers	Propagation conditions (annex F)	FRC (annex A)	Repetition number	Fraction of maximum throughput	SNR (dB)
1	1	3.75 kHz	1	NTN-TDLA100-1	A16-1	4	70%	-1.4
1	1	3.75 kHz	1	NTN-TDLC5-1	A16-1	4	70%	-3.0
1	2	3.75 kHz	1	NTN-TDLA100-1	A16-1	4	70%	-4.8
1	2	3.75 kHz	1	NTN-TDLC5-1	A16-1	4	70%	-5.9

**Table 8.5.1.5-2 Required SNR for NPUSCH format 1 test, 200 kHz channel bandwidth, 15 kHz SCS, multiple subcarriers, 1Tx**

Number of TX antennas	Number of RX antennas	Subcarrier spacing	Number of allocated subcarriers	Propagation conditions (Annex F)	FRC (annex A)	Repetition number	Fraction of maximum throughput	SNR (dB)
1	1	15kHz	12	NTN-TDLA100-1	A16-2	16	70%	-2.6
1	1	15kHz	12	NTN-TDLC5-1	A16-2	16	70%	-3.4
1	2	15kHz	12	NTN-TDLA100-1	A16-2	16	70%	-6.5
1	2	15kHz	12	NTN-TDLC5-1	A16-2	16	70%	-7.2

NOTE: If the above Test Requirement differs from the Minimum Requirement then the Test Tolerance applied for this test is non-zero. The Test Tolerance for this test and the explanation of how the Minimum Requirement has been relaxed by the Test Tolerance is given in annex C.

## 8.5.2 ACK missed detection for NPUSCH format 2

### 8.5.2.1 Definition and applicability

The performance requirement of NPUSCH format 2 for ACK missed detection is determined by the two parameters: probability of false detection of the ACK and the probability of detection of ACK. The performance is measured by the required SNR at probability of detection equal to 0.99. The probability of false detection of the ACK shall be 0.01 or less.

The probability of false detection of the ACK is defined as a conditional probability of erroneous detection of the ACK when input is only noise.

The probability of detection of ACK is defined as conditional probability of detection of the ACK when the ACK was sent per NPUSCH format 2 transmission when the signal is present.

The tests for 3.75 kHz subcarrier spacing are applicable to the base stations supporting 3.75 kHz subcarrier spacing requirements. The tests for 15 kHz subcarrier spacing are applicable to the base stations supporting 15 kHz subcarrier spacing requirements.

### 8.5.2.2 Minimum Requirement

The minimum requirement is in TS 36.108 [2] clause 8.5.2.1 and 8.5.2.2.

### 8.5.2.3 Test purpose

The test shall verify the receiver's ability to detect ACK under multipath fading propagation conditions for a given SNR.

### 8.5.2.4 Method of test

#### 8.5.2.4.1 Initial Conditions

Test environment: Normal, see annex B.

RF channels to be tested: M; see clause 4.9.1.

- 1) Connect the SAN tester generating the wanted signal, multipath fading simulators and AWGN generators to all SAN TAB connectors for diversity reception via a combining network as shown in annex D.5.

#### 8.5.2.4.2 Procedure

- 1) Adjust the AWGN generator, according to the channel bandwidth defined in table 8.5.2.4.2-1.

**Table 8.5.2.4.2-1: AWGN power level at the SAN input**

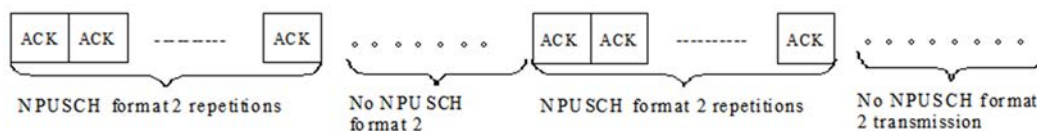
Channel bandwidth (kHz)	AWGN power level
200	-100.5dBm /180kHz

- 2) The characteristics of the wanted signal shall be configured according to TS 36.211 [12] and the test parameters in table 8.5.2.4.2-2.

**Table 8.5.2.4.2-2: Test parameters for testing NPUSCH format 2**

Parameter	unit	Value
Duration of NPUSCH format 2 segment transmission ( $N_{segment}^{precompensation}$ )	ms	128 for 3.75 kHz SCS, 32 for 15kHz SCS
Repetition		16

- 3) The multipath fading emulators shall be configured according to the corresponding channel model defined in annex F.
- 4) Adjust the equipment so that the SNR specified in tables 8.5.2.5-1 to 8.5.2.5-2 is achieved at the SAN input during the ACK transmissions.
- 5) The signal generator sends a test pattern with the pattern outlined in figure 8.5.2.4.2-1. The following statistics are kept: the number of ACKs falsely detected in the idle periods and the number of missed ACKs. Each falsely detected ACK transmission in the idle periods is accounted as one error for the statistics of false ACK detection, and each missed ACK transmission per NPUSCH format 2 transmission is accounted as one error for the statistics of missed ACK detection. The frames are sent with certain frequency and time offsets per segment as described below in table 8.5.2.4.2-3 and table 8.5.2.4.2-4. The time offset is reset back to zero between segments.



**Figure 8.5.2.4.2-1: Test signal pattern for NPUSCH format 2 demodulation tests**

**Table 8.5.2.4.2-3: Frequency Offsets for testing NPUSCH format 2**

Cases	Accumulated Frequency Offset
Table 8.5.2.5-1	64 Hz
Table 8.5.2.5-2	16 Hz

**Table 8.5.2.4.2-4: Timing Offsets for testing NPUSCH format 2**

Cases	Step size $\Delta t$
Table 8.5.2.5-1	0.08 us per RU
Table 8.5.2.5-2	0.02 us per RU

## 8.5.2.5 Test Requirement

The fraction of falsely detected ACKs shall be less than 1% and the fraction of correctly detected ACKs shall be larger than 99% for the SNR listed in table 8.5.2.5-1 and table 8.5.2.5-2.

**Table 8.5.2.5-1 Required SNR for NPUSCH format 2 test, 200 kHz channel bandwidth, 3.75 kHz subcarrier spacing, 1Tx**

Number of TX antennas	Number of RX antennas	Propagation conditions (annex F)	Number of allocated subcarriers	Subcarrier spacing	Repetition number	SNR (dB)
1	1	NTN-TDLA100-1	1	3.75kHz	16	2.4
1	2	NTN-TDLA100-1	1	3.75 kHz	16	-3.3

**Table 8.5.2.5-2 Required SNR for NPUSCH format 2 test, 200 kHz channel bandwidth, 15 kHz subcarrier spacing, 1Tx**

Number of TX antennas	Number of RX antennas	Propagation conditions (annex F)	Number of allocated subcarriers	Subcarrier spacing	Repetition number	SNR (dB)
1	1	NTN-TDLA100-1	1	15kHz	16	5.7
1	2	NTN-TDLA100-1	1	15kHz	16	-2.7

NOTE: If the above Test Requirement differs from the Minimum Requirement then the Test Tolerance applied for this test is non-zero. The Test Tolerance for this test and the explanation of how the Minimum Requirement has been relaxed by the Test Tolerance is given in annex C.

## 8.5.3 Performance requirements for NPRACH

### 8.5.3.1 Definition and applicability

The performance requirement of NPRACH for preamble detection is determined by two parameters: the total probability of false detection of the preamble ( $P_{fa}$ ) and the probability of detection of the preamble ( $P_d$ ). The performance is measured for the required SNR

- at probability of  $P_d$  which shall not be smaller than 99% and
- at probability of  $P_{fa}$  which shall not be larger than 0.1%.

P<sub>fa</sub> is defined as a conditional total probability of erroneous detection of the preamble (i.e. erroneous detection from any detector) when input is only noise.

P<sub>d</sub> is defined as conditional probability of detection of the preamble when the signal is present. The erroneous detection consists of several error cases – detecting different preamble than the one that was sent, not detecting a preamble at all or correct preamble detection but with the wrong timing estimation. A timing estimation error occurs if the estimation error of the timing of the strongest path is larger than 3.646 us. The strongest path for the timing estimation error refers to the strongest path in the power delay profile.

The performance requirements for TDD are optional and only valid for base stations supporting TDD.

The parameters of NPRACH test preambles are listed in table 8.5.3.1-1.

**Table 8.5.3.1-1 NPRACH Test Parameters**

Parameter	Value	Value
Narrowband physical layer cell identity	0	0
nprach-Periodicity (ms)	80	160
nprach-SubcarrierOffset	0	0
nprach-NumSubcarriers	12	12
numRepetitionsPerPreambleAttempt	8	16

### 8.5.3.2 Minimum Requirement

The minimum requirement is in TS 36.108 [2] clause 8.5.3.1.1 and 8.5.3.2.1.

### 8.5.3.3 Test purpose

The test shall verify the receiver's ability to detect NPRACH preamble under multipath fading propagation conditions for a given SNR.

### 8.5.3.4 Method of test

#### 8.5.3.4.1 Initial Conditions

Test environment: Normal, see annex B.

RF channels to be tested: M; see clause 4.9.1.

- 1) Connect the SAN tester generating the wanted signal, multipath fading simulators and AWGN generators to all SAN TAB connectors for diversity reception via a combining network as shown in annex D.5.

#### 8.5.3.4.2 Procedure

- 1) Adjust the AWGN generator, according to the channel bandwidth.

**Table 8.5.3.4.2-1: AWGN power level at the SAN input**

Channel bandwidth [kHz]	AWGN power level
200	-100.5dBm /180kHz

- 2) The characteristics of the wanted signal shall be configured according to the corresponding UL reference measurement channel defined in annex A.
- 3) The multipath fading emulators shall be configured according to the corresponding channel model defined in annex F.
- 4) Adjust the frequency offset of the test signal according to table 8.5.3.5-1.

- 5) Adjust the equipment so that the SNR specified in table 8.5.3.5-1 is achieved at the SAN input during the NPRACH preambles.
- 6) The test signal generator sends a preamble with repetitions and the receiver tries to detect the preamble. This pattern is repeated as illustrated in figure 8.5.3.4.2-1. The preambles are sent with a fixed timing offset of  $0.5T_{CP}$  during the test, where  $T_{CP}$  is NPRACH cyclic prefix of length as defined in TS 36.211 [12]. The following statistics are kept: the number of preambles detected in the idle period and the number of missed preambles.



**Figure 8.5.3.4.2-1: NPRACH preamble test pattern**

### 8.5.3.5 Test Requirement

$P_{fa}$  shall not exceed 0.1% and  $P_{md}$  shall not exceed 1% for the SNRs in table 8.5.3.5-1.

**Table 8.5.3.5-1: NPRACH missed detection test requirements for FDD**

Number of TX antennas	Number of RX antennas	Repetition number	Propagation conditions (annex F)	Frequency offset [Hz]	SNR(dB)	
					Preamble format 0	Preamble format 1
1	1	8	NTN-TDLA100-1	200	13.9	14.3
1	2	8	NTN-TDLA100-1	200	6.6	6.7
1	1	16	NTN-TDLA100-1	200	10.4	10.2
1	2	16	NTN-TDLA100-1	200	2.2	2.3

NOTE: If the above Test Requirement differs from the Minimum Requirement then the Test Tolerance applied for this test is non-zero. The Test Tolerance for this test and the explanation of how the Minimum Requirement has been relaxed by the Test Tolerance is given in annex C.

## 9 Radiated transmitter characteristics

### 9.1 General

General test conditions for transmitter tests are given in clause 4, including interpretation of measurement results and configurations for testing. SAN configurations for the tests are defined in clause 4.5.

If beams have been declared equivalent and parallel (D.13, D.14), only a representative beam is necessary to be tested to demonstrate conformance.

NOTE: The conformance testing procedure and testing requirement for radiated transmit power, OTA SAN output power, OTA frequency error, OTA EVM and OTA DL RS requirement are identical for NB-IoT standalone mode and NB-IoT operation in NTN NR in-band, for other conformance testing procedure and testing requirements for NB-IoT operation in NTN NR in-band are defined in TS 38.181 [6].

### 9.2 Radiated transmit power

#### 9.2.1 Definition and applicability

Radiated transmit power is defined as the EIRP level for a declared beam at a specific *beam peak direction*.

For each declared beam, the requirement is based on declarations given in clause 4.6 for a beam identifier (D.3), *reference beam direction pair* (D.8), *rated beam EIRP* (D.11) at the beam's reference direction pair, *OTA peak directions set* (D.9), the *beam direction pairs* at the maximum steering directions (D.10) and their associated *rated beam EIRP* and *beam width(s)* for reference *beam direction pair* and maximum steering directions (D.12).

For a declared beam identifier and *beam direction pair*, the *rated beam EIRP* level is the maximum power that the SAN is declared to radiate at the associated *beam peak direction*.

For each *beam peak direction* associated with a *beam direction pair* within the *OTA peak directions set*, a specific *rated beam EIRP* level may be claimed. Any claimed value shall be met within the accuracy requirement as described below. *Rated beam EIRP* is only required to be declared for the *beam direction pairs* subject to conformance testing as detailed in clause 9.2.4.1.

NOTE 1: The *OTA peak directions set* for a beam is the complete continuous or discrete set of all *beam direction* for which the EIRP requirement is achieved for the beam.

NOTE 2: A beam direction pair consists of a beam centre direction and an associated beam peak direction.

Radiated transmit power is directional requirement applicable to *SAN type 1-H* and *SAN type 1-O*.

#### 9.2.2 Minimum requirement

Radiated transmit power minimum requirement for *SAN type 1-H* and *SAN type 1-O* is defined in TS 36.108 [2], clause 9.2.2.

#### 9.2.3 Test purpose

The test purpose is to verify the ability to accurately generate and direct radiated power per beam, across the frequency range and under normal conditions, for all declared beams of the *SAN type 1-H* and *SAN type 1-O*.

#### 9.2.4 Method of test

##### 9.2.4.1 Initial conditions

Test environment: Normal.

RF channels to be tested for single carrier: B, M, T; see clause 4.9.1.

Directions to be tested:

- OTA peak directions set reference beam direction pair (D.8), and
- OTA peak directions set maximum steering directions (D.10).

Beams to be tested: A representative number of beams shall be chosen to demonstrate the SAN conformance to radiated power requirements.

### 9.2.4.2 Procedure

The test procedure is as follows:

- 1) Place the satellite on the positioner.
- 2) Align the manufacturer declared coordinate system orientation (D.2) of the satellite with the test system.
- 3) Orient the positioner and satellite in order that the direction to be tested aligns with the test antenna.
- 4) Configure the *beam peak direction* of the satellite according to the declared *beam direction pair*.
- 5) Set the SAN to transmit according to the applicable test configuration in clause 4.8 using the corresponding test model(s) in clause 4.9.2.

For a SAN declared to be capable of multi-carrier operation use the applicable test signal configuration and corresponding power setting specified in clauses [4.7.2] and 4.8 using the corresponding test model(s) in clause 4.9.2 on all carriers configured.

- 6) Measure EIRP for any two orthogonal polarizations (denoted p1 and p2) and calculate total radiated transmit power for particular *beam direction pair* as  $EIRP = EIRP_{p1} + EIRP_{p2}$ .
- 7) Test steps 3 to 6 are repeated for all declared beams (D.3) and their reference *beam direction pairs* and *maximum steering directions* (D.8 and D.10).

For multi-band capable SAN and single band tests, repeat the steps above per involved *operating band* where single band test configurations and test models shall apply with no carriers activated in the other band.

### 9.2.5 Test requirement

For each declared conformance *beam direction pair*, the EIRP measurement results in clause 9.2.4.2 shall remain within the values provided in table 9.2.5-1, relative to the manufacturer's declared rated beam EIRP (D.11) value:

**Table 9.2.5-1: Test requirement for radiated transmit power**

SAN type	Normal test environment
<i>SAN type 1-H, SAN type 1-O</i>	f ≤ 3 GHz: ± 3.3 dB for E-UTRA ± 3.6 dB for standalone NB-IoT

## 9.3 OTA SAN output power

### 9.3.1 Definition and applicability

OTA SAN output power is declared as rated carrier TRP.

### 9.3.2 Minimum requirement

The minimum requirement for *SAN type 1-O* is specified in TS 36.108 [2], clause 9.3.

### 9.3.3 Test purpose

The test purpose is to measure the *maximum carrier TRP* ( $P_{\max,c,TRP}$ ) across the frequency range for all *RIBs*.

### 9.3.4 Method of test

#### 9.3.4.1 Initial conditions

Test environment: Normal.

RF channels to be tested for single carrier: B, M, T; see clause 4.9.1.

*SAN RF Bandwidth* positions to be tested for multi-carrier:  $B_{RFBW}$ ,  $M_{RFBW}$  and  $T_{RFBW}$  in single band operation; see clause 4.9.1.

Beams to be tested: As the requirement is TRP the beam pattern(s) may be set up to optimise the TRP measurement procedure as long as the required TRP level is achieved.

#### 9.3.4.2 Procedure

The following procedure for measuring TRP is based on the directional power measurements.

- 1) Place the satellite on the positioner.
- 2) Align the manufacturer declared coordinate system orientation (D.2) of the satellite with the test system.
- 3) Configure the satellite such that the beam peak direction(s) applied during the power measurement step 6 are consistent with the grid and measurement approach for the TRP test.
- 4) Set the SAN to transmit according to the applicable test configuration in clause 4.8 using the corresponding test model(s) in clause 4.9.2.

For a SAN declared to be capable of multi-carrier operation use the applicable test signal configuration and corresponding power setting specified in clauses [4.7.2] and 4.8 using the corresponding test model(s) in clause 4.9.2 on all carriers configured.

- 5) Orient the positioner and satellite in order that the direction to be tested aligns with the test antenna such that measurements to determine TRP can be performed.
- 6) Measure the radiated power for any two orthogonal polarizations (denoted p1 and p2) and calculate total radiated transmit power for particular beam direction pair as  $EIRP = EIRP_{p1} + EIRP_{p2}$ .
- 7) Repeat step 6-7 for all directions in the appropriated TRP measurement grid needed for full TRP estimation
- 8) Calculate TRP using the EIRP measurements.

For single band tests, repeat the steps above per involved band where single band test configurations and test models shall apply with no carriers activated in the other band.

### 9.3.5 Test requirement

For E-UTRA, the final TRP measurement result in clause 9.3.4.2 shall remain within +3.4 dB and -3.4 dB of the manufacturer's declared *rated carrier TRP*  $P_{\text{rated},c,TRP}$  carrier frequency  $f \leq 3$  GHz.

For standalone NB-IoT: the final TRP measurement result in clause 9.3.4.2 shall remain within +3.7 dB and -3.7 dB of the manufacturer's declared *rated carrier TRP*  $P_{\text{rated},c,TRP}$  carrier frequency  $f \leq 3$  GHz.

## 9.4 OTA output power dynamics

### 9.4.1 General

The requirements in clause 9.4 apply during the *transmitter ON period*. Transmit signal quality (as specified in clause 9.6) shall be maintained for the output power dynamics requirements.

The OTA output power requirements are single direction requirements and apply to the beam peak directions over the OTA peak directions set.

### 9.4.2 OTA RE power control dynamic range

#### 9.4.2.1 Definition and applicability

The OTA RE power control dynamic range is the difference between the power of an RE and the average RE power for a SAN at maximum output power ( $P_{\max,c,EIRP}$ ) for a specified reference condition.

This requirement shall apply at each RIB supporting transmission in the *operating band*.

#### 9.4.2.2 Minimum requirement

The minimum requirement for *SAN type I-O* is in TS 36.108 [2], clause 9.4.2.2.

#### 9.4.2.3 Test purpose

No specific test or test requirements are defined for RE power control dynamic range. The Error Vector Magnitude test, as described in clause 9.6.3 provides sufficient test coverage for this requirement.

### 9.4.3 OTA total power dynamic range

#### 9.4.3.1 Definition and applicability

The OTA total power dynamic range is the difference between the maximum and the minimum transmit power of an OFDM symbol for a specified reference condition.

This requirement shall apply at each RIB supporting transmission in the *operating band*.

NOTE: The upper limit of the dynamic range is the OFDM symbol power for a BS at maximum output power. The lower limit of the dynamic range is the OFDM symbol power for a BS when one resource block is transmitted. The OFDM symbol shall carry PDSCH and not contain RS, PBCH or synchronisation signals.

#### 9.4.3.2 Minimum requirement

The minimum requirement for *SAN type I-O* is in TS 36.108 [2], clause 9.4.3.2.

#### 9.4.3.3 Test purpose

The test purpose is to verify that the total power dynamic range is within the limits specified by the minimum requirement.

#### 9.4.3.4 Method of test

##### 9.4.3.4.1 Initial conditions

Test environment: Normal, see annex B.

RF channels to be tested for single carrier: M; see clause 4.9.1.

Beams to be tested: Declared beam with the highest intended EIRP for the narrowest intended beam corresponding to the smallest  $BeW\theta$ , or for the narrowest intended beam corresponding to the smallest  $BeW\phi$  (D.3, D.11).

Directions to be tested: The OTA peak directions set reference beam direction pair (D.8).

#### 9.4.3.4.2 Procedure

- 1 Place the SAN at the positioner.
- 2 Align the manufacturer declared coordinate system orientation (D.2) of the SAN with the test system.
- 3 Orient the positioner (and SAN) in order that the direction to be tested aligns with the test antenna.
- 4 Configure the beam peak direction of the SAN according to the declared beam direction pair.
- 5 For *SAN type I-O*, set the SAN to transmit a signal according to the applicable test configuration in clause 4.8 using the corresponding test models:
  - E-SAN-TM3.1 if 64QAM is supported by SAN without power back off, or
  - E-SAN-TM3.1 with all 64QAM PDSCH PRBs replaced by 16QAM PDSCH PRBs if 64QAM is supported by SAN with power back off, or
  - E-SAN-TM3.1 with all 64QAM PDSCH PRBs replaced by 16QAM PDSCH PRBs if 64QAM is not supported by SAN but 16QAM is supported by SAN, or
  - E-SAN-TM3.1 with all 64QAM PDSCH PRBs replaced by QPSK PDSCH PRBs if 16QAM is not supported by SAN.
- 6 Measure the average OFDM symbol power as defined in annex F.
- 7 For *SAN type I-O*, set the SAN to transmit a signal according to the applicable test configuration in clause 4.8 using the corresponding test models:
  - E-SAN--TM2 if 64QAM is supported by SAN, or
  - E-SAN-TM2 with all 64QAM PDSCH PRBs replaced by 16QAM PDSCH PRBs if 64QAM is not supported by SAN and 16QAM is supported, or
  - E-SAN-TM2 with all 64QAM PDSCH PRBs replaced by QPSK PDSCH PRBs if 64QAM and 16QAM are both not supported.
- 8 Measure the average OFDM symbol power as defined in annex F. The measured OFDM symbols shall not contain RS, PBCH or synchronisation signals.

#### 9.4.3.5 Test requirement

The downlink (DL) total power dynamic range for each SAN carrier shall be larger than or equal to the level in table 9.4.3.5-1. There are no requirements specified for NB-IoT.

**Table 9.4.3.5-1: Total power dynamic range**

SAN channel bandwidth (MHz)	Total power dynamic range (dB)
1.4	7.3

NOTE: Additional test requirements for the EVM at the lower limit of the dynamic range are defined in clause 9.5.3.

## 9.5 OTA transmit ON/OFF power

The requirement is not applicable in this version of the specification.

## 9.6 OTA transmitted signal quality

### 9.6.1 General

The requirements in clause 9.6 apply during the *transmitter ON period*.

### 9.6.2 OTA frequency error

#### 9.6.2.1 Definition and applicability

OTA frequency error is the measure of the difference between the actual SAN transmit frequency and the assigned frequency. The same source shall be used for RF frequency and data clock generation.

OTA frequency error requirement is defined as a *directional requirement* at the RIB and shall be met within the *OTA coverage range*.

#### 9.6.2.2 Minimum Requirement

The minimum requirement for *SAN type I-O* is in TS 36.108 [2], clause 9.6.1.2.

#### 9.6.2.3 Test purpose

The test purpose is to verify that OTA frequency error is within the limit specified by the minimum requirement.

#### 9.6.2.4 Method of test

##### 9.6.2.4.1 General

Requirement is tested together with OTA modulation quality test, as described in clause 9.6.3.

##### 9.6.2.4.2 Initial conditions

Directions to be tested: OTA coverage range reference direction (D.30).

#### 9.6.2.5 Test Requirements

The modulated carrier frequency of each carrier configured by the SAN shall be accurate to within 0.05 ppm + 12 Hz (tolerance) observed over 1 ms.

## 9.6.3 OTA modulation quality

### 9.6.3.1 Definition and applicability

OTA modulation quality is defined by the difference between the measured carrier signal and an ideal signal. Modulation quality can e.g. be expressed as Error Vector Magnitude (EVM). The Error Vector Magnitude is a measure of the difference between the ideal symbols and the measured symbols after the equalization. This difference is called the error vector.

OTA modulation quality requirement is defined as a directional requirement at the RIB and shall be met within the *OTA coverage range*.

### 9.6.3.2 Minimum Requirement

The minimum requirement for *SAN type I-O*, is in TS 36.108 [2], clause 9.6.2.2.

### 9.6.3.3 Test purpose

The test purpose is to verify that OTA modulation quality is within the limit specified by the minimum requirement.

### 9.6.3.4 Method of test

#### 9.6.3.4.1 Initial conditions

Test environment: Normal; see annex B.

RF channels to be tested for single carrier: B and T; see clause 4.9.1.

*SAN RF bandwidth* positions to be tested for multi-carrier:  $B_{RFBW}$  and  $T_{RFBW}$  in single-band operation, see clause 4.9.1;

Directions to be tested:

- The OTA coverage range reference direction (D.30).
- The OTA coverage range maximum directions (D.31).

Polarizations to be tested: For dual polarized systems the requirement shall be tested and met for both polarizations.

#### 9.6.3.4.2 Procedure

- 1) Place the SAN at the positioner.
- 2) Align the manufacturer declared coordinate system orientation (D.2) of the SAN with the test system.
- 3) Orient the positioner (and SAN) in order that the direction to be tested aligns with the test antenna.
- 4) Configure the beamforming settings of the SAN according to the direction to be tested.
- 5) Set the SAN to output according to the applicable test configuration in clause 4.8 using the corresponding test models or set of physical channels in clause 4.9.2.

For *SAN type I-O* declared to be capable of single carrier operation only, set the SAN to transmit a signal according to:

- E-SAN-TM3.1 if 64QAM is supported by SAN without power back off, or
- E-SAN-TM3.1 at manufacturer's declared rated output power if 64QAM is supported by SAN with power back off, and E-SAN-TM3.2 at maximum power, or
- E-SAN-TM3.2 if highest modulation order supported by SAN is 16QAM, or
- E-SAN-TM3.3 if highest modulation order supported by SAN is QPSK.

For *SAN type I-O* declared to be capable of multi-carrier operation, set the SAN to transmit according to the applicable test signal configuration and corresponding power setting specified in clauses [4.7.2] and 4.8 using the corresponding test models on all carriers configured:

- E-SAN-TM3.1 if 64QAM is supported by SAN without power back off, or
- E-SAN-TM3.1 at manufacturer's declared rated output power if 64QAM is supported by SAN with power back off, and E-SAN-TM3.2 at maximum power, or
- E-SAN-TM3.2 if highest modulation order supported by SAN is 16QAM, or
- E-SAN-TM3.3 if highest modulation order supported by SAN is QPSK.

For E-SAN-TM3.1, power back-off shall be applied if it is declared.

- 6) For each carrier, measure the EVM and frequency error as defined in annex F.

### 9.6.3.5 Test requirements

For *SAN type I-O*, the same EVM test requirement as in clause 6.5.3.5 applies.

### 9.6.4 OTA time alignment error

The requirement is not applicable in this version of the specification.

### 9.6.5 OTA DL RS power

#### 9.6.5.1 Definition and applicability

For E-UTRA, OTA DL RS power is the resource element power of Downlink Reference Symbol.

The absolute OTA DL RS power is indicated on the DL-SCH. The absolute accuracy is defined as the maximum deviation between the OTA DL RS power indicated on the DL-SCH and the OTA DL RS power of each E-UTRA carrier at the RIB.

For NB-IoT, OTA DL NRS power is the resource element power of the Downlink Narrow-band Reference Signal.

The absolute OTA DL NRS power is indicated on the DL-SCH. The absolute accuracy is defined as the maximum deviation between the OTA DL NRS power indicated on the DL-SCH and the OTA DL NRS power of each NB-IoT carrier at the RIB.

#### 9.6.5.2 Minimum Requirement

The minimum requirement is in TS 36.108 [2] clause 9.6.4.

#### 9.6.5.3 Test purpose

The test purpose is to verify that the OTA DL RS/NRS power is within the limit specified by the minimum requirement.

#### 9.6.5.4 Method of test

##### 9.6.5.4.1 Initial conditions

Test environment: Normal; see annex B.

RF channels to be tested for single carrier: B, M and T; see clause 4.7.

Directions to be tested:

- The OTA coverage range reference direction (D.30).
- The OTA coverage range maximum directions (D.31).

Polarizations to be tested: For dual polarized systems the requirement shall be tested and met for both polarizations.

##### 9.6.5.4.2 Procedure

- 1) Place the SAN at the positioner.
- 2) Align the manufacturer declared coordinate system orientation (D.2) of the SAN with the test system.
- 3) Orient the positioner (and SAN) in order that the direction to be tested aligns with the test antenna.
- 4) Configure the beamforming settings of the SAN according to the direction to be tested.
- 5) Set the SAN to output according to the applicable test configuration in clause 4.8 using the corresponding test models or set of physical channels in clause 4.9.2.

For E-UTRA, setup SAN transmission at manufacturer's declared rated output power. Channel setup shall be according to E-SAN-TM 1.1.

For NB-IoT, setup SAN transmission at manufacturer's declared rated output power. Channel setup shall be according to N-TM.

- 6) Measure the OTA RS transmitted power according to annex D.1.1.

### 9.6.5.5 Test requirements

For E-UTRA, OTA DL RS power of each E-UTRA carrier shall be within  $\pm 3.2$  dB of the OTA DL RS power indicated on the DL-SCH for carrier frequency  $f \leq 3$  GHz.

For NB-IoT, OTA DL NRS power of each NB-IoT carrier shall be within  $\pm 3.2$  dB of the OTA DL NRS power indicated on the DL-SCH for carrier frequency  $f \leq 3$  GHz.

## 9.7 OTA unwanted emissions

### 9.7.1 General

Unwanted emissions consist of so-called out-of-band emissions and spurious emissions according to ITU definitions ITU-R SM.329 [3]. In ITU terminology, out of band emissions are unwanted emissions immediately outside the *SAN channel bandwidth* resulting from the modulation process and non-linearity in the transmitter but excluding spurious emissions. Spurious emissions are emissions which are caused by unwanted transmitter effects such as harmonics emission, parasitic emission, intermodulation products and frequency conversion products, but exclude out of band emissions.

The OTA out-of-band emissions requirement for the SAN type 1-O is specified both in terms of Adjacent Channel Leakage power Ratio (ACLR) and out-of-band emissions (OOBE).

#### Table 9.7.1-1: Void

The unwanted emission requirements are applied per cell for all the configurations. Requirements for OTA unwanted emissions are captured using TRP, or *directional requirements* as described per requirement.

For the OTA TRP measurement procedures, refer to TS 38.141-2 [9], annex I.

There is in addition a requirement for occupied bandwidth.

### 9.7.2 OTA occupied bandwidth

#### 9.7.2.1 General

The OTA occupied bandwidth is the width of a frequency band such that, below the lower and above the upper frequency limits, the mean powers emitted are each equal to a specified percentage  $\beta/2$  of the total mean transmitted power. See also recommendation ITU-R SM.328 [11].

The value of  $\beta/2$  shall be taken as 0.5%.

The minimum requirement below may be applied regionally. There may also be regional requirements to declare the OTA occupied bandwidth according to the definition in the present clause.

The OTA occupied bandwidth is defined as a *directional requirement* and shall be met in the manufacturer's declared *OTA coverage range* at the RIB.

#### 9.7.2.2 Minimum requirement

The minimum requirement for *SAN type 1-O* is defined in TS 36.108 [2], clause 9.7.2.2.

### 9.7.2.3 Test purpose

The test purpose is to verify that the emission at the *RIB* does not occupy an excessive bandwidth for the service to be provided and is, therefore, not likely to create interference to other users of the spectrum beyond undue limits.

### 9.7.2.4 Method of test

#### 9.7.2.4.1 Initial conditions

Test environment: Normal, see annex B.

RF channels to be tested for single carrier: M; see clause 4.9.1.

Directions to be tested: OTA coverage range reference direction (D.30).

Beams to be tested: Declared beam with the highest intended EIRP for the narrowest intended beam corresponding to the smallest  $BeW\theta$ , or for the narrowest intended beam corresponding to the smallest  $BeW\phi$  (D.3, D.11).

For SAN declared to be capable of single carrier operation, start transmission according to the applicable test configuration in clause 4.8 using the corresponding test model E-SAN-TM1.1 for *SAN type 1-O* in clause 4.9.2 at manufacturers declared rated carrier EIRP ( $P_{rated,c,EIRP}$ , D.11).

#### 9.7.2.4.2 Procedure

- 1) Place the SAN at the positioner.
- 2) Align the manufacturer declared coordinate system orientation (D.2) of the SAN with the test system.
- 3) Orient the positioner (and SAN) in order that the direction to be tested aligns with the test antenna.
- 4) Configure the beam peak direction of the SAN according to the declared beam direction pair.
- 5) Set the SAN to transmit signal.
- 6) Measure the spectrum emission of the transmitted signal using at least the number of measurement points, and across a span, as listed in table 9.7.2.4.2-1. The selected resolution bandwidth (RBW) filter of the analyser shall be 30 kHz or less.

NOTE: The detection mode of the spectrum analyzer will not have any effect on the result if the statistical properties of the out-of-OBW power are the same as those of the inside-OBW power. Both are expected to have the Rayleigh distribution of the amplitude of Gaussian noise. In any case where the statistics are not the same, though, the detection mode is power responding. There are at least two ways to be power responding. The spectrum analyser can be set to "sample" detection, with its video bandwidth setting at least three times its RBW setting. Or the analyser may be set to respond to the average of the power (root-mean-square of the voltage) across the measurement cell.

**Table 9.7.2.4.2-1: Span and number of measurement points for OBW measurements**

Bandwidth	SAN channel bandwidth $BW_{Channel}$ (MHz)	
	0.2	1.4
Span (MHz)	0.4	10
Minimum number of measurement points	400	1429

- 7) Compute the total of the EIRP,  $P_0$ , (in power units, not decibel units) of all the measurement cells in the measurement span. Compute  $P_1$ , the EIRP outside the occupied bandwidth on each side.  $P_1$  is half of the total EIRP outside the bandwidth.  $P_1$  is half of (100 % - (occupied percentage)) of  $P_0$ . Measure the EIRP for any two orthogonal polarizations (denoted  $p_1$  and  $p_2$ ) and calculate total radiated transmit power for particular *beam direction pair* as  $EIRP = EIRP_{p_1} + EIRP_{p_2}$ .
- 8) Determine the lowest frequency,  $f_1$ , for which the sum of all EIRP in the measurement cells from the beginning of the span to  $f_1$  exceeds  $P_1$ .

- 9) Determine the highest frequency,  $f_2$ , for which the sum of all EIRP in the measurement cells from the end of the span to  $f_2$  exceeds  $P_1$ .
- 10) Compute the OTA occupied bandwidth as  $f_2 - f_1$ .

### 9.7.2.5 Test requirement

For E-UTRA, the occupied bandwidth for each carrier shall be less than the channel bandwidth as defined in TS 36.108 [2], clause 5.3A.

For NB-IoT standalone operation, the occupied bandwidth for carrier shall be less than the channel bandwidth as defined in TS 36.108 [2], clause 5.3B.

## 9.7.3 OTA Adjacent Channel Leakage Power Ratio (ACLR)

### 9.7.3.1 Definition and applicability

OTA Adjacent Channel Leakage Power Ratio (ACLR) is the ratio of the filtered mean power centred on the assigned channel frequency to the filtered mean power centred on an adjacent channel frequency. The measured power is TRP.

The requirement shall be applied per RIB.

For a *RIB* operating in multi-carrier, the OTA ACLR requirements in clause 9.7.3.2 apply to *SAN channel bandwidths* of the outermost carrier.

### 9.7.3.2 Minimum requirement

The minimum requirement for *SAN type 1-O* is in TS 36.108 [2], clause 9.7.3.2.

### 9.7.3.3 Test purpose

To verify that the OTA adjacent channel leakage ratio requirement shall be met as specified by the minimum requirement.

### 9.7.3.4 Method of test

#### 9.7.3.4.1 Initial conditions

Test environment: normal; see annex B.

RF channels to be tested for single carrier: B and T; see clause 4.9.1.

*SAN RF bandwidth* positions to be tested for multi-carrier:  $B_{RFBW}$  and  $T_{RFBW}$  in single-band operation, see clause 4.9.1.

Directions to be tested: As the requirement is TRP the beam pattern(s) may be set up to optimise the TRP measurement procedure (see TS 38.141-2 [9], annex I) as long as the required TRP level is achieved.

#### 9.7.3.4.2 Procedure

The following procedure for measuring TRP is based on the directional power measurements as described in TS 38.141-2 [9], annex I. An alternative method to measure TRP is to use a characterized and calibrated reverberation chamber if so follow steps 1, 3, 4, 6, 8, 9, 10, and 11.

- 1) Place the SAN at the positioner.
- 2) Align the manufacturer declared coordinate system orientation (D.2) of the SAN with the test system.
- 3) The measurement devices characteristics shall be:
  - Measurement filter bandwidth: defined in clause 9.7.3.5.
  - Detection mode: true RMS voltage or true power averaging.

- The emission power should be averaged over an appropriate time duration to ensure the measurement is within the measurement uncertainty in table 4.1.2.2-2.

- 4) For single carrier operation, set the SAN to transmit according to the applicable test configuration in clause 4.8 using the corresponding test model(s) in clause 4.9.2 at manufacturers declared *rated carrier TRP output power* declared per RIB ( $P_{\text{rated,c,TRP}}$ ).

For SAN declared to be capable of multi-carrier operation use the applicable test signal configuration and corresponding power setting specified in clauses 4.7 and 4.8 using the corresponding test model(s) in clause 4.9.2 on all carriers configured.

- 5) Orient the positioner (and SAN) in order that the direction to be tested aligns with the test antenna such that measurements to determine TRP can be performed (see TS 38.141-2 [9], annex I).
- 6) Measure the absolute power of the assigned channel frequency and the (adjacent channel frequency).
- 7) Repeat step 5-6 for all directions in the appropriated TRP measurement grid needed for  $\text{TRP}_{\text{Estimate}}$  (see TS 38.141-2 [9], annex I).
- 8) Calculate  $\text{TRP}_{\text{Estimate}}$  for the absolute total radiated power of the wanted channel and the adjacent channel using the measurements made in step 7.
- 9) Calculate relative ACLR estimate.

NOTE 1: ACLR is calculated by the ratio of the absolute TRP of the assigned channel frequency and the absolute TRP of the adjacent frequency channel.

NOTE 2: For the measurement uncertainty of the reverberation chamber for the relative ACLR is higher than the measurement uncertainty in clause 4.1.2 the test requirements in table 9.7.3.5-1 and table 9.7.3.5-2 shall be tightened following the procedure in clause 4.1.3.

- 10) Measure OTA ACLR for the frequency offsets both side of channel frequency as specified in table 9.7.3.5-1 and table 9.7.3.5-2 for *SAN type I-O*. In multiple carrier case only offset frequencies below the lowest and above the highest carrier frequency used shall be measured.
- 11) Repeat the test with the channel set-up using E-SAN-TM1.2.

### 9.7.3.5 Test requirements

The OTA ACLR limit specified in table 9.7.3.5-1 for SAN GEO class and 9.7.3.5-2 for SAN LEO class shall apply.

**Table 9.7.3.5-1: OTA ACLR limit for GEO class**

SAN channel bandwidth of lowest/highest carrier transmitted $\text{BW}_{\text{Channel}}$ (MHz)	SAN adjacent channel centre frequency offset below the lowest or above the highest carrier centre frequency transmitted	Assumed adjacent channel carrier (informative)	Filter on the adjacent channel frequency and corresponding filter bandwidth	ACLR limit (dB)
1.4	$\text{BW}_{\text{Channel}}$	E-UTRA of same BW	Square ( $\text{BW}_{\text{Config}}$ ) (NOTE)	13
	$2 \times \text{BW}_{\text{Channel}}$	E-UTRA of same BW	Square ( $\text{BW}_{\text{Config}}$ ) (NOTE)	13
NOTE: $\text{BW}_{\text{Channel}}$ and $\text{BW}_{\text{Config}}$ are the <i>SAN channel bandwidth</i> and <i>transmission bandwidth configuration</i> of the lowest/highest carrier transmitted on the assigned channel frequency.				

Table 9.7.3.5-2: OTA ACLR limit for LEO class

SAN channel bandwidth of lowest/highest carrier transmitted $BW_{\text{Channel}}$ (MHz)	SAN adjacent channel centre frequency offset below the lowest or above the highest carrier centre frequency transmitted	Assumed adjacent channel carrier (informative)	Filter on the adjacent channel frequency and corresponding filter bandwidth	ACLR limit (dB)
1.4	$BW_{\text{Channel}}$	E-UTRA of same BW	Square ( $BW_{\text{Config}}$ ) (NOTE)	23
	$2 \times BW_{\text{Channel}}$	E-UTRA of same BW	Square ( $BW_{\text{Config}}$ ) (NOTE)	23
NOTE: $BW_{\text{Channel}}$ and $BW_{\text{Config}}$ are the SAN channel bandwidth and transmission bandwidth configuration of the lowest/highest carrier transmitted on the assigned channel frequency.				

For SAN supporting standalone NB-IoT operation in paired spectrum, the ACLR shall be higher than the value specified in table 9.7.3.5-3 and table 9.7.3.5-4.

Table 9.7.3.5-3: ACLR limit of SAN supporting standalone NB-IoT operation for GEO class

Channel bandwidth of NB-IoT lowest/highest carrier transmitted $BW_{\text{Channel}}$ (kHz)	SAN adjacent channel centre frequency offset below the lowest or above the highest carrier centre frequency transmitted	Assumed adjacent channel carrier (informative)	Filter on the adjacent channel frequency and corresponding filter bandwidth	ACLR limit (dB)
200	[200 kHz]	Standalone NB-IoT	Square (180 kHz)	13
	[400 kHz]	Standalone NB-IoT	Square (180 kHz)	13

Table 9.7.3.5-4: ACLR limit of SAN supporting standalone NB-IoT operation for LEO class

Channel bandwidth of NB-IoT lowest/highest carrier transmitted $BW_{\text{Channel}}$ (kHz)	SAN adjacent channel centre frequency offset below the lowest or above the highest carrier centre frequency transmitted	Assumed adjacent channel carrier (informative)	Filter on the adjacent channel frequency and corresponding filter bandwidth	ACLR limit (dB)
200	[200 kHz]	Standalone NB-IoT	Square (180 kHz)	23
	[400 kHz]	Standalone NB-IoT	Square (180 kHz)	23

## 9.7.4 OTA out-of-band emissions

### 9.7.4.1 Definition and applicability

The OTA limits for out-of-band emissions are specified as TRP per RIB unless otherwise stated.

Unless otherwise stated, the out-of-band emission (OOBE) limits for SAN are defined from  $BW_{\text{SAN}}$  channel edge up to frequencies separated from the  $BW_{\text{SAN}}$  channel edge by 200% of the *necessary bandwidth*, where the *necessary bandwidth* is  $BW_{\text{SAN}}$ .

The requirements shall apply whatever the type of transmitter considered and for all transmission modes foreseen by the manufacturer's specification.

*Basic limits* are specified in the tables below, where:

- $\Delta f$  is the separation between the  $BW_{\text{SAN}}$  channel edge frequency and the nominal -3 dB point of the measuring filter closest to the carrier frequency.
- $f_{\text{offset}}$  is the separation between the channel edge frequency and the centre of the measuring filter.
- $PSD_{\text{SAN}}$  represents the Power Spectral Density of the channel(s) operating in  $BW_{\text{SAN}}$

- $BW_{SAN}$  is the considered SAN transponder bandwidth.
- $\Delta_{Sat\_class}$  is the *SAN class parameter* in dB identified to characterize different SAN classes.

For a multi-carrier *single-band RIB* the definitions above apply to the lower edge of the carrier transmitted at the *lowest carrier* frequency and the upper edge of the carrier transmitted at the *highest carrier* frequency within a specified frequency band.

- The operating band unwanted emission basic limits of the band where there are carriers transmitted, as defined in the tables of the present clause for the largest frequency offset ( $\Delta f_{max}$ ), shall apply from channel edge up to frequencies separated from the channel edge by 200% of the necessary bandwidth.

#### 9.7.4.2 Minimum requirement

The minimum requirement for *SAN type I-O* is defined in TS 36.108 [2], clause 9.7.4.2.

#### 9.7.4.3 Test purpose

This test measures the emissions of the SAN, close to the assigned channel bandwidth of the wanted signal, while the SAN is in operation.

#### 9.7.4.4 Method of test

##### 9.7.4.4.1 Initial conditions

Test environment: normal; see annex B.

RF channels to be tested for single carrier: B, M and T; see clause 4.9.1.

*SAN RF bandwidth* positions to be tested for multi-carrier:  $B_{RFBW}$ ,  $M_{RFBW}$  and  $T_{RFBW}$  in single-band operation, see clause 4.9.1.

Directions to be tested: As the requirement is TRP the beam pattern(s) may be set up to optimise the TRP measurement procedure (see TS 38.141-2 [9], annex I) as long as the required TRP level is achieved.

##### 9.7.4.4.2 Procedure

The following procedure for measuring TRP is based on the directional power measurements as described in TS 38.141-2 [9], annex I. An alternative method to measure TRP is to use a characterized and calibrated reverberation chamber if so follow steps 1, 3, 4, 6.

- 1) Place the SAN at the positioner.
- 2) Align the manufacturer declared coordinate system orientation (D.2) of the SAN with the test system.
- 3) The measurement devices characteristics shall be:
  - Measurement filter bandwidth: as defined in clause 9.7.4.5.
  - Detection mode: true RMS voltage or true power averaging.

As a general rule, the resolution bandwidth of the measuring equipment should be equal to the measurement bandwidth. However, to improve measurement accuracy, sensitivity, efficiency and avoiding e.g. carrier leakage, the resolution bandwidth may be smaller than the measurement bandwidth. When the resolution bandwidth is smaller than the measurement bandwidth, the result should be integrated over the measurement bandwidth in order to obtain the equivalent noise bandwidth of the measurement bandwidth.

The emission power should be averaged over an appropriate time duration to ensure the measurement is within the measurement uncertainty in table 4.1.2.2-2.

- 4) For single carrier operation, set the SAN to transmit according to the applicable test configuration in clause 4.8 using the corresponding test model(s) in clause 4.9.2 at manufacturers declared *rated carrier TRP output power* declared per RIB ( $P_{rated,c,TRP}$ ).

For a SAN declared to be capable of multi-carrier operation, use the applicable test signal configuration and corresponding power setting specified in clause 4.7.2 and 4.8 using the corresponding test model(s) in clause 4.9.2 on all carriers configured.

- 5) Orient the positioner (and SAN) in order that the direction to be tested aligns with the test antenna such that measurements to determine TRP can be performed (see TS 38.141-2 [9], annex I).
- 6) Sweep the centre frequency of the measurement filter in contiguous steps and measure emission power within the specified frequency ranges with the specified measurement bandwidth.
- 7) Repeat step 5-6 for all directions in the appropriated TRP measurement grid needed for  $TRP_{Estimate}$  (see TS 38.141-2 [9], annex I).
- 8) Calculate  $TRP_{Estimate}$  using the measurements made in step 6.

### 9.7.4.5 Test requirements

The OTA out-of-band emission requirement for *SAN type I-O* shall not exceed the limit in table 9.7.4.5-1.

**Table 9.7.4.5-1: SAN LEO and GEO operating band unwanted emission limits**

Frequency offset of measurement filter -3dB point, $\Delta f$	Frequency offset of measurement filter centre frequency, $f_{offset}$	Basic Limits (dBm)	Measurement bandwidth
$0 \text{ MHz} \leq \Delta f < 2 \times BW_{SAN}$	$0.002 \text{ MHz} \leq f_{offset} < 2 \times BW_{SAN} + 0.002 \text{ MHz}$	$\left[ \max \left( SE \text{ limit}, P_{rated,t,sys} - 10 \log_{10}(BW_{SAN}) - 24 - \Delta_{Sat\_Class} - 40 \times \log_{10} \left( \frac{f_{offset} - 0.002}{BW_{SAN}} \times 2 + 1 \right) \right) \right]$	4 kHz
NOTE 1: $BW_{SAN}$ is in the unit of MHz .			
NOTE 2: SE limit is spurious emission limit specified in spurious emission clause 6.6.5.			
NOTE 3: PSD attenuation as in ITU-R SM.1541-6 [15], annex 5 OoB domain emission limits for space services.			
NOTE 4: $\Delta_{Sat\_Class}=0$ dB for GEO class and $\Delta_{Sat\_Class}=3$ dB for LEO class.			

## 9.7.5 OTA transmitter spurious emissions

### 9.7.5.1 Definition and applicability

Unless otherwise stated, all requirements are measured as mean power.

The OTA transmitter spurious emissions limits are specified as TRP per RIB, unless otherwise stated.

The OTA transmitter spurious emission limits shall apply from 30 MHz to 11 GHz, excluding the *SAN transponder bandwidth*  $BW_{SAN}$  and the frequency where the out-of-band emissions apply..

The lower limit and upper limit are as per ITU-R recommendation SM.329 [3], table 1: For systems operating within 600 MHz and 5.2 GHz, the lower limit is 30 MHz and the upper limit is the 5<sup>th</sup> harmonic of the higher frequency.

The lower limit of 30 MHz can be replaced as per ITU-R SM.329 [3]: Systems having an integral antenna incorporating a waveguide section, or with an antenna connection in such form, and of unperturbed length equal to at least twice the cut-off wavelength, do not require spurious domain emission measurements below 0.7 times the waveguide cut-off frequency.

The requirements shall apply whatever the type of transmitter considered (single carrier or multi-carrier). It applies for all transmission modes foreseen by the manufacturer's specification.

*SAN type I-O* requirements consists of OTA transmitter spurious emission requirements based on TRP.

The general OTA transmitter spurious emissions requirements are specified as TRP per RIB, per cell, unless otherwise specified.

### 9.7.5.2 Minimum requirement

The minimum requirement for *SAN type I-O* is specified in TS 36.108 [2], clause 9.7.5.2.2.

### 9.7.5.3 Test purpose

The test purpose is to verify if the radiated spurious emissions from the SAN at the RIB are within the specified minimum requirements.

### 9.7.5.4 Method of test

#### 9.7.5.4.1 Initial conditions

Test environment: Normal; see annex B.

RF channels to be tested for single carrier, see clause 4.9.1:

- B when testing from 30 MHz to the lower frequency edge of the *SAN transponder bandwidth* minus 2 times  $BW_{SAN}$
- T when testing from the upper frequency edge of the *SAN transponder bandwidth* plus 2 times  $BW_{SAN}$  to 5<sup>th</sup> harmonic

RF bandwidth positions to be tested in single-band multi-carrier operation, see clause 4.9.1:

- $B_{RFBW}$  when testing from 30 MHz to the lower frequency edge of the *SAN transponder bandwidth* minus 2 times  $BW_{SAN}$
- $T_{RFBW}$  when testing from the upper frequency edge of the *SAN transponder bandwidth* plus 2 times  $BW_{SAN}$  to 5<sup>th</sup> harmonic

Directions to be tested: As the requirement is TRP the beam pattern(s) may be set up to optimise the TRP measurement procedure (see TS 38.141-2 [9], annex I) as long as the required TRP level is achieved.

#### 9.7.5.4.2 Procedure

The following procedure for measuring TRP is based on directional power measurements as described in TS 38.141-2 [9], annex I. An alternative method to measure TRP is to use a characterized and calibrated reverberation chamber if so follow steps 1, 3, 4, 5, 7.

- 1) Place the SAN at the positioner.
- 2) Align the manufacturer declared coordinate system orientation (D.2) of the SAN with the test system.
- 3) Measurements shall use a measurement bandwidth in accordance to the conditions in clause 9.7.5.5.
- 4) The measurement device characteristics shall be:
  - Detection mode: True RMS.
  - The emission power should be averaged over an appropriate time duration to ensure the measurement is within the measurement uncertainty in table 4.1.2.2-2.
- 5) Set the SAN to transmit:
  - For RIB declared to be capable of single carrier operation only, set the RIB to transmit a signal according to the applicable test configuration in clause 4.8 using the corresponding test model in clause 4.9.2 (i.e. E-SAN-TM1.1 for *SAN type I-O*), at manufacturer's declared rated output power  $P_{rated,c,TRP}$ .
  - For a RIB declared to be capable of multi-carrier operation, set the RIB to transmit according to the corresponding test model in clause 4.9.2 on all carriers configured using the applicable test configuration and corresponding power setting specified in clause [4.7.2] and 4.8.

- 6) Orient the positioner (and SAN) in order that the direction to be tested aligns with the test antenna such that measurements to determine TRP can be performed (see TS 38.141-2 [9], annex I).
- 7) Measure the emission at the specified frequencies with specified measurement bandwidth.
- 8) Repeat step 6-7 for all directions in the appropriated TRP measurement grid needed for full TRP estimation (see TS 38.141-2 [9], annex I).

NOTE 1: The TRP measurement grid may not be the same for all measurement frequencies.

NOTE 2: The frequency sweep or the TRP measurement grid sweep may be done in any order.

- 9) Calculate TRP at each specified frequency using the directional measurements.

### 9.7.5.5 Test requirement

For a SAN type 1-O, the TRP of any spurious emission shall not exceed the limits in table 9.7.5.5-1.

**Table 9.7.5.5-1: General OTA SAN transmitter spurious emission limits for SAN type 1-O**

Spurious frequency range	$P_{\text{rated,t,TRP}}$ (dBm)	Basic limit (dBm)	Measurement bandwidth (kHz)	Notes
30 MHz – 5 <sup>th</sup> harmonic of the upper frequency edge of the DL operating band	$\leq 47$	-13	4	NOTE 1, NOTE 2, NOTE 3
	$> 47$	$P_{\text{rated,t,TRP}} - 60$ dB		
NOTE 1: <i>Measurement bandwidths</i> as in ITU-R SM.329 [3], s4.1.				
NOTE 2: Upper frequency as in ITU-R SM.329 [3], s2.5 table 1.				
NOTE 3: The lower frequency limit is replaced by 0.7 times the waveguide cut-off frequency, according to ITU-R SM.329 [3], for systems having an integral antenna incorporating a waveguide section, or with an antenna connection in such form, and of unperturbed length equal to at least twice the cut-off.				

### 9.7.5.6 Protection of the SAN receiver

The co-location requirement is not applicable for SAN in this version of the specification.

### 9.7.5.7 Additional spurious emissions requirements

The additional spurious emissions requirement is not applicable for SAN.

## 9.8 OTA transmitter intermodulation

The requirement is not applicable in this version of the specification.

## 10 Radiated receiver characteristic

### 10.1 General

General test conditions for receiver tests are given in clause 4, including interpretation of measurement results and configurations for testing. SAN configurations for the tests are defined in clause 4.5.

Radiated receiver characteristics are specified at RIB for *SAN type 1-H* or *SAN type 1-O*, with full complement of transceivers for the configuration in normal operating condition.

Unless otherwise stated, the following arrangements apply for the radiated receiver characteristics requirements in clause 10:

- Requirements shall be met for any transmitter setting.
- The requirements shall be met with the transmitter unit(s) ON.
- Throughput requirements defined for the radiated receiver characteristics do not assume HARQ retransmissions.
- When SAN is configured to receive multiple carriers, all the throughput requirements are applicable for each received carrier.
- For ACS and blocking characteristics, the negative offsets of the interfering signal apply relative to the lower *SAN RF Bandwidth edge*, and the positive offsets of the interfering signal apply relative to the upper *SAN RF Bandwidth edge*.
- Each requirement shall be met over the RoAoA specified.

NOTE: In normal operating condition the SAN in FDD operation is configured to transmit and receive at the same time.

For requirements which are to be met over the *OTA REFSENS RoAoA* absolute requirement values are offset by the following term:

$$\Delta_{\text{OTAREFSENS}} = 44.1 - 10 \cdot \log_{10}(\text{BeW}_{\theta, \text{REFSENS}} \cdot \text{BeW}_{\phi, \text{REFSENS}}) \text{ dB for the reference direction}$$

and

$$\Delta_{\text{OTAREFSENS}} = 41.1 - 10 \cdot \log_{10}(\text{BeW}_{\theta, \text{REFSENS}} \cdot \text{BeW}_{\phi, \text{REFSENS}}) \text{ dB for all other directions}$$

For requirements which are to be met over the *minSENS RoAoA* absolute requirement values are offset by the following term:

$$\Delta_{\text{minSENS}} = P_{\text{REFSENS}} - \text{EIS}_{\text{minSENS}} \text{ (dB)}$$

NOTE: The conformance testing procedures and testing requirement for OTA sensitivity and OTA Reference sensitivity level are identical for NB-IoT standalone mode and NB-IoT operation in NTN NR in-band, for other conformance testing procedure and testing requirements for NB-IoT operation in NTN NR in-band are defined in TS 38.181 [6].

### 10.2 OTA sensitivity

#### 10.2.1 Definition and applicability

The OTA sensitivity requirement is a *directional requirement* based upon the declaration of one or more *OTA sensitivity direction declarations* (OSDD), related to a *SAN type 1-H* and *SAN type 1-O* receiver.

The *SAN type 1-H* and *SAN type 1-O* may optionally be capable of redirecting/changing the *receiver target* by means of adjusting SAN settings resulting in multiple *sensitivity RoAoA*. The *sensitivity RoAoA* resulting from the current SAN settings is the active *sensitivity RoAoA*.

If the SAN is capable of redirecting the *receiver target* related to the OSDD then the OSDD shall include:

- *SAN channel bandwidth* and declared minimum EIS level applicable to any active *sensitivity RoAoA* inside the *receiver target redirection range* in the OSDD.
- A declared *receiver target redirection range*, describing all the angles of arrival that can be addressed for the OSDD through alternative settings in the SAN.
- Five declared *sensitivity RoAoA* comprising the conformance testing directions as detailed in TR 37. 941 [5].
- The *receiver target reference direction*.

NOTE 1: Some of the declared *sensitivity RoAoA* may coincide depending on the redirection capability.

NOTE 2: In addition to the declared *sensitivity RoAoA*, several *sensitivity RoAoA* may be implicitly defined by the *receiver target redirection range* without being explicitly declared in the OSDD.

If the SAN is not capable of redirecting the *receiver target* related to the OSDD, then the OSDD includes only:

- The set(s) of RAT, *SAN channel bandwidth* and declared minimum EIS level applicable to the *sensitivity RoAoA* in the OSDD.
- One declared active *sensitivity RoAoA*.
- The *receiver target reference direction*.

NOTE 3: For SAN without target redirection capability, the declared (fixed) *sensitivity RoAoA* is always the active *sensitivity RoAoA*.

The OTA sensitivity EIS level declaration shall apply to each supported polarization, under the assumption of *polarization match*.

## 10.2.2 Minimum requirement

For a received signal whose AoA of the incident wave is within the active *sensitivity RoAoA* of an OSDD, the error rate criterion as described in TS 36.108 [2] clause 10.2.2 shall be met when the level of the arriving signal is equal to the minimum EIS level in the respective declared set of EIS level and *SAN channel bandwidth*.

### 10.2.3 Test Purpose

The test purpose is to verify that the SAN can meet the throughput requirement for a specified measurement channel at the EIS level and the range of angles of arrival declared in the OSDD.

## 10.2.4 Method of test

### 10.2.4.1 Initial conditions

Test environment: Normal, see annex B.

RF channels to be tested for single carrier: M; see clause 4.9.1.

Directions to be tested:

- Receiver target reference direction (D.26),
- Conformance test directions (D.28).

### 10.2.4.2 Procedure

- 1) Place the SAN with its manufacturer declared coordinate system reference point in the same place as calibrated point in the test system, as shown in annex D.4.1.
- 2) Align the manufacturer declared coordinate system orientation of the SAN with the test system.
- 3) Align the SAN with the test antenna in the declared direction to be tested.

- 4) Ensure the polarization is accounted for such that all the power from the test antenna is captured by the SAN under test.
- 5) Configure the beam peak direction for the transmitter according to the declared reference beam direction pair for the appropriate beam identifier.
- 6) For FDD operation, set the SAN to transmit beam(s) of the same operational band as the OSDD being tested according to the appropriate test configuration in clauses 4.7 and 4.8.
- 7) Start the signal generator for the wanted signal to transmit:
  - The test signal as specified in clause 10.2.5.
- 8) Set the test signal mean power so the calibrated radiated power at the SAN Antenna Array coordinate system reference point is as specified in clause 10.2.5.
- 9) Measure the throughput according to annex A.1 for each supported polarization.
- 10) Repeat steps 3 to 9 for all OSDD(s) declared for the SAN (D.19), and supported polarizations.

## 10.2.5 Test requirements

The minimum EIS level is a declared figure (D.23) for each OSDD (D.19). The test requirement is calculated from the declared value offset by the EIS Test Tolerance specified in clause 4.1.

For each measured carrier, the throughput measured in step 9 of clause 10.2.4.2 shall be  $\geq 95\%$  of the maximum throughput of the reference measurement channel as specified in annex A.1 with parameters specified in table 10.2.5-1 for E-UTRA, and in table 10.2.5-2 for standalone NB-IoT or NB-IoT operation in NTN NR in-band.

**Table 10.2.5-1: SAN GEO and SAN LEO class EIS levels for E-UTRA operation**

SAN channel bandwidth	Sub-carrier spacing (kHz)	Reference measurement channel (NOTE)	OTA sensitivity level, EIS (dBm)
1.4 MHz	15	A1-1 in annex A.1	Declared minimum EIS + 1.3
NOTE: EIS is the power level of a single instance of the reference measurement channel. This requirement shall be met for each consecutive application of a single instance of the reference measurement channel mapped to disjoint frequency ranges with a width corresponding to the number of resource blocks of the reference measurement channel each, except for one instance that might overlap one other instance to cover the full <i>SAN channel bandwidth</i> .			

**Table 10.2.5-2: SAN GEO and SAN LEO class EIS levels for standalone NB-IoT operation and NB-IoT operation in NTN NR in-band**

SAN channel bandwidth	Sub-carrier spacing (kHz)	Reference measurement channel (NOTE)	OTA sensitivity level, EIS (dBm)
200 kHz	15	A14-1 in annex A.14	Declared minimum EIS + 1.6
200 kHz	3.75	A14-2 in annex A.14	
NOTE: EIS is the power level of a single instance of the reference measurement channel. This requirement shall be met for each consecutive application of a single instance of the reference measurement channel mapped to disjoint frequency ranges with a width corresponding to the number of resource blocks of the reference measurement channel each, except for one instance that might overlap one other instance to cover the full <i>SAN channel bandwidth</i> .			

## 10.3 OTA reference sensitivity level

### 10.3.1 Definition and applicability

The OTA REFSENS requirement is a *directional requirement* and is intended to ensure the minimum OTA reference sensitivity level for a declared *OTA REFSENS RoAoA*. The OTA reference sensitivity power level  $EIS_{REFSENS}$  is the minimum mean power received at the RIB at which a reference performance requirement shall be met for a specified reference measurement channel.

The OTA REFSENS requirement shall apply to each supported polarization, under the assumption of *polarization match*.

### 10.3.2 Minimum requirement

For SAN *type 1-O* the minimum requirement is in TS 36.108 [2], clause 10.3.2.

### 10.3.3 Test Purpose

The test purpose is to verify that the SAN receiver can meet the throughput requirement for a specified measurement channel at the  $EIS_{REFSENS}$  level and the range of angles of arrival within the *OTA REFSENS RoAoA*.

### 10.3.4 Method of test

#### 10.3.4.1 Initial conditions

Test environment: Normal, see annex B.

RF channels to be tested for single carrier: B, M and T; see clause 4.9.1.

Directions to be tested:

- OTA REFSENS receiver target reference direction (D.44),
- OTA REFSENS conformance test directions (D.45)

#### 10.3.4.2 Procedure

- 1) Place the SAN with its manufacturer declared coordinate system reference point in the same place as calibrated point in the test system, as shown in annex D.4.1.
- 2) Align the manufacturer declared coordinate system orientation of the SAN with the test system.
- 3) Align the SAN with the test antenna in the declared direction to be tested.
- 4) Ensure the polarization is accounted for such that all the power from the test antenna is captured by the SAN under test.
- 5) Configure the beam peak direction for the transmitter according to the declared reference beam direction pair for the appropriate beam identifier.
- 6) Set the SAN to transmit beam(s) of the same operational band as the *OTA REFSENS RoAoA* being tested according to the appropriate test configuration in clauses 4.7 and 4.8.
- 7) Start the signal generator for the wanted signal to transmit: The test signal as specified in clause 10.3.5.
- 8) Set the test signal mean power so the calibrated radiated power at the SAN Antenna Array coordinate system reference point is as specified in clause 10.3.5.
- 9) Measure the throughput according to annex A.1 for each supported polarization.

10) Repeat steps 3 to 9 for all OTA REFSENS conformance test directions of the SAN (D.45) and supported polarizations.

### 10.3.5 Test requirements

The  $EIS_{REFSENS}$  level is the conducted REFSENS requirement value offset by  $\Delta_{OTAREFSNS}$ . The test requirement is calculated from the  $EIS_{REFSENS}$  level offset by the  $EIS_{REFSENS}$  Test Tolerance specified in clause 4.1.

For SAN supporting E-UTRA, the throughput shall be  $\geq 95\%$  of the maximum throughput of the reference measurement channel as specified in annex A.1 with parameter specified in table 10.3.5-1 and table 10.3.5-2 when the OTA test signal is at the corresponding  $EIS_{REFSENS}$  level and arrives from any direction within the *OTA REFSENS RoAoA*.

**Table 10.3.5-1: Reference sensitivity levels of SAN supporting E-UTRA (GEO class payload)**

SAN channel bandwidth (MHz)	Sub-carrier spacing (kHz)	Reference measurement channel (NOTE)	Reference sensitivity power level, $EIS_{REFSENS}$ (dBm)
1.4	15	A1-1 in annex A.1	$-103.1 - \Delta_{OTAREFSNS}$
NOTE: $P_{REFSENS}$ is the power level of a single instance of the reference measurement channel.			

**Table 10.3.5-2: Reference sensitivity levels of SAN supporting E-UTRA (LEO class payload)**

SAN channel bandwidth (MHz)	Sub-carrier spacing (kHz)	Reference measurement channel (NOTE)	Reference sensitivity power level, $EIS_{REFSENS}$ (dBm)
1.4	15	A1-1 in annex A.1	$-106.2 - \Delta_{OTAREFSNS}$
NOTE: $P_{REFSENS}$ is the power level of a single instance of the reference measurement channel.			

For SAN supporting standalone NB-IoT operation or NB-IoT operation in NTN NR in-band, the throughput shall be  $\geq 95\%$  of the maximum throughput of the reference measurement channel as specified in annex A.1 with parameter specified in table 10.3.5-3 and table 10.3.5-4 when the OTA test signal is at the corresponding  $EIS_{REFSENS}$  level and arrives from any direction within the *OTA REFSENS RoAoA*.

**Table 10.3.5-3: Reference sensitivity levels of SAN supporting standalone NB-IoT operation and NB-IoT operation in NTN NR in-band (GEO class payload)**

SAN channel bandwidth (kHz)	Sub-carrier spacing (kHz)	Reference measurement channel	Reference sensitivity power level, $EIS_{REFSENS}$ (dBm)
200	15	FRC A14-1 in annex A.14	$-123.6 - \Delta_{OTAREFSNS}$
200	3.75	FRC A14-2 in annex A.14	$-129.6 - \Delta_{OTAREFSNS}$

**Table 10.3.5-4: Reference sensitivity levels of SAN supporting standalone NB-IoT operation and NB-IoT operation in NTN NR in-band (LEO class payload)**

SAN channel bandwidth (kHz)	Sub-carrier spacing (kHz)	Reference measurement channel	Reference sensitivity power level, $EIS_{REFSENS}$ (dBm)
200	15	FRC A14-1 in annex A.14	$-126.7 - \Delta_{OTAREFSNS}$
200	3.75	FRC A14-2 in annex A.14	$-132.7 - \Delta_{OTAREFSNS}$

## 10.4 OTA dynamic range

### 10.4.1 Definition and applicability

The OTA dynamic range is a measure of the capability of the receiver unit to receive a wanted signal in the presence of an interfering signal inside the received *SAN channel bandwidth*.

The requirement shall apply at the RIB when the AoA of the incident wave of a received signal and the interfering signal are from the same direction and are within the *OTA REFSENS RoAoA*.

The wanted and interfering signals apply to each supported polarization, under the assumption of *polarization match*.

## 10.4.2 Minimum requirement

For *SAN type I-O*, the minimum requirement is in TS 36.108 [2], clause 10.4.2.

## 10.4.3 Test purpose

The test purpose is to verify that at the SAN receiver dynamic range, the relative throughput shall fulfil the specified limit.

## 10.4.4 Method of test

### 10.4.4.1 Initial conditions

Test environment: Normal: see annex B.

RF channels to be tested for single carrier: M; see clause 4.9.1.

Directions to be tested: *OTA REFSENS* receiver target reference direction (D.44).

### 10.4.4.2 Procedure

- 1) Place the SAN with its manufacturer declared coordinate system reference point in the same place as calibrated point in the test system, as shown in annex D.4.2.
- 2) Align the manufacturer declared coordinate system orientation of the SAN with the test system.
- 3) Align the SAN with the test antenna in the declared direction to be tested.
- 4) Ensure the polarization is accounted for such that all the power from the test antenna is captured by the SAN under test.
- 5) Configure the beam peak direction for the transmitter according to the declared reference beam direction pair for the appropriate beam identifier.
- 6) For FDD operation, set the SAN to transmit beam(s) of the same operational band as the *OTA REFSENS RoAoA* being tested according to the appropriate test configuration in clauses 4.7 and 4.8.
- 7) Set the test signal mean power so that the calibrated radiated power at the SAN Antenna Array coordinate system reference point is as follows:
  - a) Set the signal generator for the wanted signal to transmit as specified in table 10.4.5.2-1 for SAN LEO class supporting E-UTRA, table 10.4.5.2-2 for SAN GEO class supporting standalone NB-IoT and table 10.4.5.2-3 for SAN LEO class supporting standalone NB-IoT.
  - b) Set the signal generator for the AWGN interfering signal at the same frequency as the wanted signal to transmit as specified in table 10.4.5.2-1 for SAN LEO class supporting E-UTRA, table 10.4.5.2-2 for SAN GEO class supporting standalone NB-IoT and table 10.4.5.2-3 for SAN LEO class supporting standalone NB-IoT.
- 8) Measure the throughput according to annex A.2 for each supported polarization.

## 10.4.5 Test requirement

### 10.4.5.1 General

The test requirement is calculated from the OTA wanted signal mean power level offset by the OTA dynamic range Test Tolerance specified in clause 4.1.

### 10.4.5.2 Test requirements for SAN type 1-0

For SAN supporting E-UTRA, the throughput shall be  $\geq 95\%$  of the maximum throughput of the reference measurement channel as specified in annex A.2 with parameters specified in table 10.4.5.2-1 for LEO SAN.

**Table 10.4.5.2-1: Dynamic range of SAN supporting E-UTRA (LEO class payload)**

SAN channel bandwidth (MHz)	Reference measurement channel	Wanted signal mean power (dBm)	Interfering signal mean power (dBm) / $BW_{Config}$	Type of interfering signal
1.4	FRC A2-1 in annex A.2	-81.7 - $\Delta_{OTAREFSENS}$	-94.4 - $\Delta_{OTAREFSENS}$	AWGN
NOTE: The wanted signal mean power is the power level of a single instance of the reference measurement channel. This requirement shall be met for each consecutive application of a single instance of FRC A2-3 mapped to disjoint frequency ranges with a width of 25 resource blocks each.				

For SAN supporting standalone NB-IoT, the throughput shall be  $\geq 95\%$  of the maximum throughput of the reference measurement channel as specified in annex A.2 with parameters specified in table 10.4.5.2-2 for GEO SAN and table 10.4.5.2-3 for LEO SAN.

**Table 10.4.5.2-2: Dynamic range of SAN supporting standalone NB-IoT operation (GEO class payload)**

SAN channel bandwidth (kHz)	Reference measurement channel	Wanted signal mean power (dBm)	Interfering signal mean power (dBm) / $BW_{Channel}$	Type of interfering signal
200	FRC A15-1 in annex A.15	-97 - $\Delta_{OTAREFSENS}$	-93.6 - $\Delta_{OTAREFSENS}$	AWGN
200	FRC A15-2 in annex A.15	-102.9 - $\Delta_{OTAREFSENS}$	-93.6 - $\Delta_{OTAREFSENS}$	AWGN

**Table 10.4.5.2-3: Dynamic range of SAN supporting standalone NB-IoT operation (LEO class payload)**

SAN channel bandwidth (kHz)	Reference measurement channel	Wanted signal mean power (dBm)	Interfering signal mean power (dBm) / $BW_{Channel}$	Type of interfering signal
200	FRC A15-1 in annex A.15	-89.1 - $\Delta_{OTAREFSENS}$	-85.7 - $\Delta_{OTAREFSENS}$	AWGN
200	FRC A15-2 in annex A.15	-95 - $\Delta_{OTAREFSENS}$	-85.7 - $\Delta_{OTAREFSENS}$	AWGN

## 10.5 OTA in-band selectivity and blocking

### 10.5.1 OTA adjacent channel selectivity

#### 10.5.1.1 Definition and applicability

OTA Adjacent channel selectivity (ACS) is a measure of the receiver's ability to receive an OTA wanted signal at its assigned channel frequency in the presence of an OTA adjacent channel signal with a specified centre frequency offset of the interfering signal to the band edge of a victim system. The wanted and interfering signals apply to each supported polarization, under the assumption of polarization match.

#### 10.5.1.2 Minimum requirement

For *SAN type I-O*, the minimum requirement is in TS 36.108 [2], clause 10.5.1.2.

#### 10.5.1.3 Test purpose

The test purpose is to verify the ability of the SAN receiver filter to suppress interfering signals in the channels adjacent to the wanted channel.

#### 10.5.1.4 Method of test

##### 10.5.1.4.1 Initial conditions

Test environment: Normal, see annex B.

RF channels to be tested for single carrier: M; see clause 4.9.1.

*SAN RF Bandwidth edge* position to be tested for multi-carrier:  $M_{\text{RFBW}}$  in single-band operation, see clause 4.9.1.

Directions to be tested: For *SAN type I-O*, receiver target reference direction (D.26).

##### 10.5.1.4.2 Procedure

- 1) Place the SAN with its manufacturer declared coordinate system reference point in the same place as calibrated point in the test system, as shown in annex D.4.2.
- 2) Align the manufacturer declared coordinate system orientation of the SAN with the test system.
- 3) Align the SAN with the test antenna in the declared direction to be tested.
- 4) Align the SAN so that the wanted signal and interferer signal is *polarization matched* with the test antenna(s).
- 5) Configure the beam peak direction for the transmitter according to the declared reference beam direction pair for the appropriate beam identifier.
- 6) For FDD operation, set the SAN to transmit beam(s) of the same operational band as the OSDD or *OTA REFSENS RoAoA* being tested according to the appropriate test configuration in clauses 4.7 and 4.8.
- 7) Set the test signal mean power so that the calibrated radiated power at the SAN Antenna Array coordinate system reference point is as follows:
  - a) Set the signal generator for the wanted signal to transmit as specified in table 10.5.1.5-1 for SAN supporting E-UTRA and table 10.5.1.5-2 for SAN supporting standalone NB-IoT.
  - b) Set the signal generator for the interfering signal at the adjacent channel frequency of the wanted signal to transmit as specified in table 10.5.1.5-1 for SAN supporting E-UTRA and table 10.5.1.5-2 for SAN supporting standalone NB-IoT.

- 8) Measure throughput according to annex A.1 for each supported polarization, for multi-carrier operation the throughput shall be measured for relevant carriers specified by the test configuration specified in clauses 4.7.2 and 4.8.

### 10.5.1.5 Test requirement

The requirement shall apply at the RIB when the AoA of the incident wave of a received signal and the interfering signal are from the same direction and are within the *minSENS RoAoA*.

The wanted and interfering signals apply to each supported polarization, under the assumption of *polarization match*.

The throughput shall be  $\geq 95\%$  of the maximum throughput of the reference measurement channel.

For SAN supporting E-UTRA, the OTA wanted signal and the interfering signal are specified in table 10.5.1.5-1 for OTA ACS. The reference measurement channel for the OTA wanted signal is further specified in annex A.1. The characteristic of the interfering signal is further specified in annex C.

For SAN supporting standalone NB-IoT operation, the OTA wanted signal and the interfering signal are specified in table 10.5.1.5-2 for OTA ACS. The reference measurement channel for the OTA wanted signal is further specified in annex A.1. The characteristic of the interfering signal is further specified in annex C.

The OTA ACS requirement is applicable outside the *SAN RF Bandwidth* or *Radio Bandwidth*. The OTA interfering signal offset is defined relative to the *SAN RF Bandwidth edges* or *Radio Bandwidth edges*.

**Table 10.5.1.5-1: ACS requirement of SAN supporting E-UTRA**

SAN channel bandwidth of the lowest/highest carrier received (MHz)	Wanted signal mean power (dBm)	Interfering signal mean power (dBm)	Interfering signal centre frequency offset from the lower/upper <i>SAN RF Bandwidth edge</i> or sub-block edge inside a sub-block gap (MHz)	Type of interfering signal
1.4	$P_{\text{REFSENS}} + 11 \text{ dB} - \Delta_{\text{OTAREFSSENS}}$ (NOTE)	GEO SAN class: $-57.6 - \Delta_{\text{OTAREFSSENS}}$ LEO SAN class: $-60.7 - \Delta_{\text{OTAREFSSENS}}$	$\pm 0.7025$	1.4 MHz E-UTRA signal
NOTE: $P_{\text{REFSENS}}$ depends on the channel bandwidth as specified in table 7.2.2-1 and table 7.2.2-2.				

**Table 10.5.1.5-2: ACS requirement of SAN supporting standalone NB-IoT operation**

SAN channel bandwidth of the lowest/highest carrier received (kHz)	Wanted signal mean power (dBm)	Interfering signal mean power (dBm)	Interfering signal centre frequency offset to the lower/upper <i>SAN RF Bandwidth edge</i> or sub-block edge inside a sub-block gap (kHz)	Type of interfering signal
200	$P_{\text{REFSENS}} + 19.5 \text{ dB} - \Delta_{\text{OTAREFSSENS}}$ (NOTE)	GEO SAN class: $-56.6 - \Delta_{\text{OTAREFSSENS}}$ LEO SAN class: $-59.7 - \Delta_{\text{OTAREFSSENS}}$	$\pm 100$	180 kHz NB-IoT signal
NOTE: $P_{\text{REFSENS}}$ depends on the sub-carrier spacing as specified in table 7.2.2-3 and table 7.2.2-4.				

### 10.5.2 OTA in-band blocking

The requirement is not applicable in this version of the specification.

## 10.6 OTA out-of-band blocking

### 10.6.1 Definition and applicability

The OTA out-of-band blocking characteristics are a measure of the receiver unit ability to receive a wanted signal at the *RIB* at its assigned channel in the presence of an unwanted interferer.

For the general OTA out-of-band blocking the requirement applies to the wanted signal for each supported polarization, under the assumption of *polarization match*. The interferer shall be polarization matched for in-band frequencies and the polarization maintained for out-of-band frequencies.

### 10.6.2 Minimum requirement

The minimum requirement for *SAN type I-O* is defined in TS 36.108 [2], clause 10.6.2.

### 10.6.3 Test purpose

The test stresses the ability of the receiver unit associated with the *RIB* under test to withstand high-level interference from unwanted signals at specified frequency bands, without undue degradation of its sensitivity.

### 10.6.4 Method of test

#### 10.6.4.1 Initial conditions

Test environment: Normal; see annex B.

RF channels to be tested for single carrier (SC): M; see clause 4.9.1.

*SAN RF bandwidth* positions to be tested for multi-carrier (MC):  $M_{\text{RFBW}}$  in *single-band RIB*, see clause 4.9.1.

Directions to be tested: For *SAN type I-O*, receiver target reference direction (D.26).

#### 10.6.4.2 Procedure

- 1) Place *SAN* and the test antenna(s) according to annex D.4.3.
- 2) Align the *SAN* and test antenna(s) according to the directions to be tested.
- 3) Connect test antenna(s) to the measurement equipment as shown in annex D.4.3.
- 4) The test antenna(s) shall be dual (or single) polarized covering the same frequency ranges as the *SAN* and the blocking frequencies. If the test antenna does not cover both the wanted and interfering signal frequencies, separate test antennas for the wanted and interfering signal are required.
- 5) The OTA blocking interferer is injected into the test antenna, with the blocking interferer producing specified interferer field strength level for each supported polarization. The interferer shall be *polarization matched* in-band and the polarization maintained for out-of-band frequencies.
- 6) Generate the wanted signal in receiver target reference direction, according to the applicable test configuration (see clause 4.8) using applicable reference measurement channel to the *RIB*, according to annex A.1.
- 7) For FDD operation, configure the beam peak direction for the transmitter units associated with the *RIB* under test according to the declared reference beam direction pair for the appropriate beam identifier with the carrier set-up and power allocation according to the applicable test configuration(s) (see clause 4.8). The transmitter may be turned OFF for the out-of-band blocker tests when the frequency of the blocker is such that no IM2 or IM3 products fall inside the bandwidth of the wanted signal.
- 8) Adjust the signal generators to the type of interfering signals, levels and the frequency offsets as specified for general test requirements in table 10.6.5-1. The distance between the test object and test antenna injecting the interferer signal is adjusted when necessary to ensure specified interferer signal level to be received.

- 9) The CW interfering signal shall be swept with a step size of 1 MHz within the frequency range specified in clause 10.6.5.
- 10) Measure the performance of the wanted signal at the receiver unit associated with the RIB, as defined in the clause 10.6.5, for the relevant carriers specified by the test configuration in clause 4.7 and 4.8.
- 11) Repeat for all supported polarizations.

## 10.6.5 Test requirements

The requirement shall apply at the RIB when the AoA of the incident wave of the received signal and the interfering signal are from the same direction and are within the *minSENS RoAoA*.

The wanted signal applies to each supported polarization, under the assumption of *polarization match*.

For OTA wanted and OTA interfering signals provided at the RIB using the parameters in table 10.6.5-1, the following requirements shall be met:

- The throughput shall be  $\geq 95\%$  of the maximum throughput of the reference measurement channel. The reference measurement channel for the OTA wanted signal is identified in clause 10.3.2 for each *SAN channel bandwidth* and further specified in annex A.1.

For *SAN type 1-O* the OTA out-of-band blocking requirement apply from 30 MHz to  $F_{UL,low} - \Delta f_{OOB}$  and from  $F_{UL,high} + \Delta f_{OOB}$  up to 12750 MHz, including the downlink frequency range of the *SAN operating band*. The  $\Delta f_{OOB}$  for *SAN type 1-O* is defined in table 10.6.5-2.

**Table 10.6.5-1: OTA out-of-band blocking performance requirement for SAN supporting E-UTRA or standalone NB-IoT operation**

Wanted signal mean power (dBm)	Interfering signal RMS field-strength (V/m)	Type of interfering Signal
$EIS_{minSENS} + 6$ dB (NOTE 1)	0.0129 (NOTE 2)	CW carrier
NOTE 1: $EIS_{minSENS}$ depends on the <i>channel bandwidth</i> as specified in clause 10.2. NOTE 2: The RMS field-strength level in V/m is related to the interferer EIRP level at a distance described as $E = \frac{\sqrt{30 EIRP}}{r}$ , where EIRP is in W and r is in m. NOTE 3: [For SAN supporting standalone NB-IoT operation, up to 24 exceptions are allowed for spurious response frequencies in each wanted signal frequency when measured using a 1 MHz step size. For these exceptions the above throughput requirement shall be met when the blocking signal is set to a level of 0.0103 V/m for 3.75 kHz subcarrier spacing. In addition, each group of exceptions shall not exceed three contiguous measurements using a 1 MHz step size.]		

**Table 10.6.5-2:  $\Delta f_{OOB}$  offset for satellite operating bands**

SAN type	Operating band characteristics	$\Delta f_{OOB}$ (MHz)
<i>SAN type 1-O</i>	$F_{UL,high} - F_{UL,low} < 100$ MHz	20

## 10.7 OTA receiver spurious emissions

The requirement is not applicable in this version of the specification.

## 10.8 OTA receiver intermodulation

The requirement is not applicable in this version of the specification.

## 10.9 OTA in-channel selectivity

### 10.9.1 Definition and applicability

In-channel selectivity (ICS) is a measure of the receiver ability to receive a wanted signal at its assigned resource block locations in the presence of an interfering signal received at a larger power spectral density. In this condition a throughput requirement shall be met for a specified reference measurement channel. The interfering signal shall be an E-UTRA signal as specified in annex A.1 and shall be time aligned with the wanted signal.

### 10.9.2 Minimum requirement

The minimum requirement for *SAN type I-O* is in TS 36.108 [2], clause 10.9.2.

### 10.9.3 Test purpose

The purpose of this test is to verify the SAN receiver ability to suppress the IQ leakage.

### 10.9.4 Method of test

#### 10.9.4.1 Initial conditions

Test environment: Normal, see annex B.

RF channels to be tested for single carrier: *M*; see clause 4.9.1.

Directions to be tested: For *SAN type I-O*, receiver target reference direction (D.26).

#### 10.9.4.2 Procedure

- 1) Place the SAN with its manufacturer declared coordinate system reference point in the same place as calibrated point in the test system, as shown in annex D.2.5.
- 2) Align the manufacturer declared coordinate system orientation of the SAN with the test system.
- 3) Align the SAN with the test antenna in the declared direction to be tested.
- 4) Align the SAN to that the wanted signal and interferer signal is *polarization matched* with the test antenna(s).
- 5) Configure the beam peak direction for the transmitter according to the declared reference beam direction pair for the appropriate beam identifier.
- 6) For FDD operation, set the SAN to transmit beam(s) of the same operational band as the *OTA REFSENS RoAoA* or OSDD being tested according to the appropriate test configuration in clauses 4.7 and 4.8.
- 7) Set the test signal mean power so the calibrated radiated power at the SAN Antenna Array coordinate system reference point is as specified as follows:
  - a) Adjust the signal generator for the wanted signal as specified in:
 

For *SAN type I-O*, table 10.9.5-1 for SAN GEO class, in table 10.9.5-2 for SAN LEO class on one side of the  $F_C$ .
  - b) Adjust the signal generator for the interfering signal as specified in:
 

For *SAN type I-O*, table 10.9.5-1 for SAN GEO class, in table 10.9.5-2 for SAN LEO class at opposite side of the  $F_C$  and adjacent to the wanted signal.
- 8) Measure throughput according to annex A.1 for each supported polarization.
- 9) Repeat the measurement with the wanted signal on the other side of the  $F_C$ , and the interfering signal at opposite side of the  $F_C$  and adjacent to the wanted signal.

10) Repeat for all the specified measurement directions and supported polarizations.

## 10.9.5 Test requirement

The requirement shall apply at the RIB when the AoA of the incident wave of the received signal and the interfering signal are the same direction and are within the *minSENS RoAoA*.

The wanted and interfering signals applies to each supported polarization, under the assumption of *polarization match*.

For a wanted and an interfering signal coupled to the RIB, the following requirements shall be met:

- For SAN supporting E-UTRA, the throughput shall be  $\geq 95\%$  of the maximum throughput of the reference measurement channel as specified in annex A.1 with parameters specified in table 10.9.5-1 for SAN GEO class, in table 10.9.5-2 for SAN LEO class.

**Table 10.9.5-1: In-channel selectivity of SAN supporting E-UTRA (GEO class payload)**

SAN channel bandwidth (MHz)	Reference measurement channel	Wanted signal mean power (dBm)	Interfering signal mean power (dBm)	Type of interfering signal
1.4	FRC A1-4 in annex A.1	$-102.8 - \Delta_{\min\text{SENS}}$	$-97.6 - \Delta_{\min\text{SENS}}$	1.4 MHz E-UTRA signal, 3 RBs

**Table 10.9.5-2: In-channel selectivity of SAN supporting E-UTRA (LEO class payload)**

SAN channel bandwidth (MHz)	Reference measurement channel	Wanted signal mean power (dBm)	Interfering signal mean power (dBm)	Type of interfering signal
1.4	FRC A1-4 in annex A.1	$-105.9 - \Delta_{\min\text{SENS}}$	$-88.7 - \Delta_{\min\text{SENS}}$	1.4 MHz E-UTRA signal, 3 RBs

# 11 Radiated performance requirements

## 11.1 General

### 11.1.0 Scope and definitions

Radiated performance requirements are specified for a number of test environments and multipath channel classes.

Unless stated otherwise, performance requirements apply for a single carrier only. Radiated performance requirements for a SAN supporting carrier aggregation are defined in terms of single carrier requirements. The requirements only apply to those measurement channels that are supported by the SAN.

The radiated performance requirements for *SAN* are limited to two *demodulation branches* as described in clause 11.1.1. Conformance requirements can only be tested for 1 or 2 *demodulation branches* depending on the number of polarizations supported by the SAN, with the required SNR applied separately per polarization.

NOTE 1: SAN can support more than 2 *demodulation branches*, however radiated conformance testing can only be performed for 1 or 2 *demodulation branches*.

For tests in clause 11 the transmitter may be off.

In tests performed with signal generators a synchronization signal may be provided, from the SAN to the signal generator, to enable correct timing of the wanted signal.

For radiated performance requirements the SNR used in this clause is specified based on a single carrier and defined as:

$$\text{SNR} = S / N$$

Where:

*S* is the total signal energy in the subframe on a RIB.

*N* is the noise energy in a bandwidth corresponding to the *transmission bandwidth* over the same duration where signal energy exists.

Radiated performance requirements are specified at the RIB, based on one or two *demodulation branches*.

Unless stated otherwise performance requirements, for a SAN supporting different numbers of *demodulation branches*, the tests with low MIMO correlation level shall apply only for the highest number of supported *demodulation branches*, and the specific *demodulation branches* used for testing are based on manufacturer declaration. If performance requirement is not specified for the highest number of supported *demodulation branches*, the tests shall be done by using performance requirement for the closest number of *demodulation branches* lower than this highest number of supported *demodulation branches*.

#### 11.1.1 Demodulation branches

Radiated performance requirements are only specified for up to 2 *demodulation branches*.

If the SAN uses polarization diversity and has the ability to maintain isolation between the signals for each of the demodulation branches, then radiated performance requirements can be tested for up to two demodulation branches (i.e. 1RX or 2RX test setups). When tested for two demodulation branches, each demodulation branch maps to one polarization.

If the SAN does not use polarization diversity then radiated performance requirements can only be tested for one demodulation branch (i.e. 1RX test setup).

## 11.2 Radiated performance requirements for PUSCH

### 11.2.1 Performance requirements of PUSCH in multipath fading propagation conditions transmission on single antenna port for coverage enhancement

#### 11.2.1.1 Definition and applicability

The performance requirement of PUSCH is determined by a minimum required throughput for a given SNR. The required throughput is expressed as a fraction of maximum throughput for the FRCs listed in annex A. The performance requirements assume HARQ re-transmissions.

The tests for CEModeA defined in clause 8.2.1 are applicable only to the space access nodes supporting coverage enhancement configured with CEModeA. The tests for CEModeB defined in clause 8.2.1 are applicable only to the the space access nodes supporting coverage enhancement configured with CEModeB.

A test for a specific channel bandwidth is only applicable if the SAN supports it. For a SAN supporting FDD multiple channel bandwidths, only the tests for the lowest and the highest FDD channel bandwidths supported by the SAN are applicable.

#### 11.2.1.2 Minimum Requirement

The minimum requirement is in TS 36.108 [2] clause 8.2.1.

#### 11.2.1.3 Test Purpose

The test shall verify the receiver's ability to achieve throughput under multipath fading propagation conditions emulated in OTA test chamber, for a given SNR.

#### 11.2.1.4 Method of test

##### 11.2.1.4.1 Initial Conditions

Test environment: Normal, see annex B.

RF channels to be tested for single carrier: M; see clause 4.9.1.

Direction to be tested: OTA REFSENS *receiver target reference direction* (see D.44 in table 4.6-1).

##### 11.2.1.4.2 Procedure

- 1) Place the SAN with its manufacturer declared coordinate system reference point in the same place as calibrated point in the test system, as shown in annex [E.3].
- 2) Align the manufacturer declared coordinate system orientation of the SAN with the test system.
- 3) Set the SAN in the declared direction to be tested.
- 4) Connect the SAN tester generating the wanted signal, multipath fading simulators and AWGN generators to a test antenna via a combining network in OTA test setup, as shown in annex [E.3]. Each of the demodulation branch signals should be transmitted on one polarization of the test antenna(s).
- 5) The characteristics of the wanted signal shall be configured according to the corresponding UL reference measurement channel defined in annex A and the test parameters in table 11.2.1.4.2-2. The index of the narrowband is set to 0. For reference channels using resource blocks less than 6, the resource blocks shall be allocated from the lowest number within the indicated narrowband.

**Table 11.2.1.4.2-2: Test parameters for testing PUSCH**

Parameter	CE Mode A	CE Mode B
Maximum number of HARQ transmissions	4	2
RV sequences	0, 2, 3, 1, 0, 2, 3, 1	FDD: 0, 0, 0, 0, 2, 2, 2, 2, 3, 3, 3, 3, 1, 1, 1, 1
Duration of PUSCH segment transmission ( $N_{segment}^{precompensation}$ )	Same duration as repetition length	Same duration as repetition length
No. Repetitions	8	256
Frequency hopping	OFF	OFF
NOTE:	Guard period shall be created according to TS36.211, 5.2.5 [12]	

- 6) The multipath fading emulators shall be configured according to the corresponding channel model defined in annex J.
- 7) Adjust the test signal mean power so the calibrated radiated SNR value at the SAN receiver is as specified in clause 11.2.1.5.1 and 11.2.1.5.2 for SAN respectively, and that the SNR at the SAN receiver is not impacted by the noise floor.

The power level for the transmission may be set such that the AWGN level at the RIB is equal to the AWGN level in table 11.2.1.4.2-1.

**Table 11.2.1.4.2-1: AWGN power level at the SAN input**

Channel bandwidth (MHz)	AWGN power level
1.4	$-92.7 - \Delta_{OTAREFSENS}$ [dBm] / 1.08 MHz

- 9) If RX diversity is not supported, ensure the *polarisation match* is achieved among test antenna(s) and the SAN under test, in order to maximize the power at the SAN receiver.
- 10) For reference channels applicable to the SAN, measure the throughput.

### 11.2.1.5 Test Requirement

The throughput measured according to clause 8.2.1.4.2 shall not be below the limits for the SNR levels specified in table 11.2.1.5-1 for CE Mode A tests and not be below the limits for the SNR levels specified in table 11.2.1.5-2 for CE Mode B tests.

**Table 11.2.1.5-1 Minimum requirements for PUSCH, 1.4 MHz channel bandwidth for Mode A, 1Tx**

Number of TX antennas	Number of demodulation branches	CE Mode	Propagation conditions (annex F)	FRC (annex A)	Fraction of maximum throughput	SNR (dB)
1	1	Mode A	NTN-TDLA100-5	A5-2	70%	-2.5
1	1	Mode A	NTN-TDLC5-5	A5-2	70%	-2.8
1	2	Mode A	NTN-TDLA100-5	A5-2	70%	-6.7
1	2	Mode A	NTN-TDLC5-5	A5-2	70%	-6.7

**Table 11.2.1.5-2 Minimum requirements for PUSCH, 1.4 MHz channel bandwidth for Mode B, 1Tx**

Number of TX antennas	Number of demodulation branches	CE Mode	Propagation conditions (annex F)	FRC (annex A)	Fraction of maximum throughput	SNR (dB)
1	1	Mode B	NTN-TDLA100-5	A5-1	70%	-11.0
1	1	Mode B	NTN-TDLC5-5	A5-1	70%	-12.7
1	2	Mode B	NTN-TDLA100-5	A5-1	70%	-13.9
1	2	Mode B	NTN-TDLC5-5	A5-1	70%	-14.9

NOTE: If the above Test Requirement differs from the Minimum Requirement then the Test Tolerance applied for this test is non-zero. The Test Tolerance for this test and the explanation of how the Minimum Requirement has been relaxed by the Test Tolerance is given in annex C.

## 11.3 OTA performance requirements for PUCCH

### 11.3.1 Performance requirements for PUCCH format 1A

#### 11.3.1.2 ACK missed detection

##### 11.3.1.2.1 Definition and applicability

The performance requirement of PUCCH format 1 for ACK missed detection is determined by the two parameters: probability of false detection of the ACK and the probability of detection of ACK. The performance is measured by the required SNR at probability of detection equal to 0.99. The probability of false detection of the ACK shall be 0.01 or less.

The probability of false detection of the ACK is defined as a conditional probability of erroneous detection of the ACK when input is only noise.

The probability of detection of ACK is defined as conditional probability of detection of the ACK when the signal is present.

The test is applicable only to space access nodes supporting coverage enhancement. A test for a specific channel bandwidth is only applicable if the SAN supports it.

##### 11.3.1.2.2 Minimum Requirement

The minimum requirement is in TS 36.108 [2] clause 8.3.1.1 and 8.3.1.2.

##### 11.3.1.2.3 Test purpose

The test shall verify the receiver's ability to detect ACK bits under multipath fading propagation conditions for a given SNR.

##### 11.3.1.2.4 Method of test

###### 11.3.1.2.4.1 Initial Conditions

Test environment: Normal, see annex B.

RF channels to be tested for single carrier: M; see clause 4.9.1

Direction to be tested: OTA REFSENS receiver target reference direction (see [D.44 in table 4.6-1]).

###### 11.3.1.2.4.2 Procedure

- 1) Place the SAN with its manufacturer declared coordinate system reference point in the same place as calibrated point in the test system, as shown in [annex D.7].
- 2) Align the manufacturer declared coordinate system orientation of the SAN with the test system.
- 3) Set the SAN in the declared direction to be tested.
- 4) Connect the SAN tester generating the wanted signal, multipath fading simulators and AWGN generators to a test antenna via a combining network in OTA test setup, as shown in annex [D.7]. Each of the demodulation branch signals should be transmitted on one polarization of the test antenna(s).
- 5) The characteristics of the wanted signal shall be configured according to TS 36.211 [12], and according to additional test parameters listed in table 11.3.1.2.4.2-1.

**Table 11.3.1.2.4.2-1: Test Parameters**

Parameter	Value
Number of information bits	2
Number of PRBs	1
Number of symbols	14
First PRB prior to frequency hopping	0
Intra-slot frequency hopping	enabled
First PRB after frequency hopping	The largest PRB index – (nrofPRBS – 1)
Group and sequence hopping	neither
Hopping ID	0
Initial cyclic shift	0
First symbol	0
Index of orthogonal cover code ( <i>timeDomainOCC</i> )	0

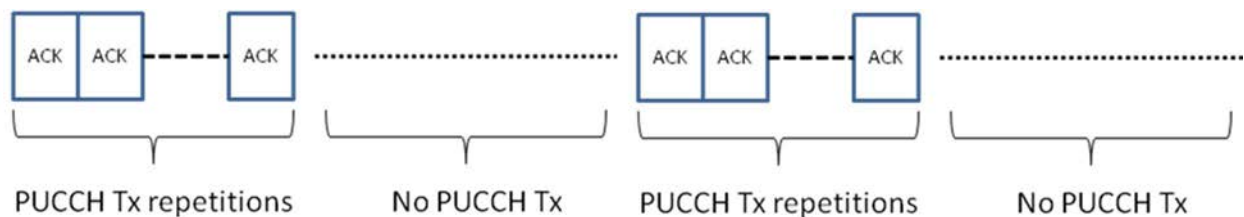
- 6) The multipath fading emulators shall be configured according to the corresponding channel model defined in [annex G.2].
- 7) Adjust the test signal mean power so the calibrated radiated SNR value at the SAN receiver is as specified in clause 11.3.1.2.5.1, and that the SNR at the SAN receiver is not impacted by the noise floor.

The power level for the transmission may be set such that the AWGN level at the RIB is equal to the AWGN level in table 11.3.1.2.4.2-2.

**Table 11.3.1.2.4.2-2: AWGN power level at the SAN input**

Subcarrier spacing (kHz)	Channel bandwidth (MHz)	AWGN power level
15 kHz	1.4	-89.7 – $\Delta_{OTAREFSENS}$ dBm / 1.08 MHz
NOTE 1: $\Delta_{OTAREFSENS}$ as declared in [D.43 in table 4.6-1] and clause [10.1].		
NOTE 2: The AWGN power level contains an AWGN offset of 16dB by default. If needed for test purposes, the AWGN level can be reduced from the default by any value in the range 0dB to 16dB. Changing the AWGN level does not impact the validity of the test, as it reduces the effective base band SNR level.		

- 8) The signal generator sends a test pattern with the pattern outlined in figure 11.3.1.2.4.2-1. The PUCCH signals are sent with certain timing and frequency offsets as described below. The following statistics are kept: the number of ACKs detected in the idle periods and the number of missed ACKs.



**Figure 11.3.1.2.4.2-1: Test signal pattern for PUCCH format 1a demodulation tests**

PUCCH test signals are sent with a frequency offset as described below in table 11.3.1.2.4.2-3 as well as a timing offset as described below in 11.3.1.2.4.2-4.

**Table 11.3.1.2.4.2-3: Frequency Offsets for testing PUCCH**

Channel	Duration of PUCCH segment transmission ( $N_{segment}^{precompensation}$ )	Frequency offset (Hz)
PUCCH format 1a	8 ms	4

**Table 11.3.1.2.4.2-4: Timing Offsets for testing PUCCH**

Channel	Duration of PUCCH segment transmission ( $N_{segment}^{precompensation}$ )	Step size $\Delta t$
PUCCH format 1a	8 ms	0.01 $\mu$ s per subframe

### 11.3.1.2.5 Test Requirement

The fraction of falsely detected ACK bits shall be less than 1% and the fraction of correctly detected ACK bits shall be larger than 99% for the SNR listed in table 11.3.1.2.5-1.

**Table 11.3.1.2.5.1-1: Required SNR for PUCCH format 1a, 1Tx**

Number of TX antennas	Number of demodulation branches	Channel bandwidth	Cyclic Prefix	Propagation conditions and correlation matrix (annex F)	Repetitions	SNR (dB)
1	1	1.4 MHz	Normal	NTN-TDLA100-5	8	-2.0
1	2	1.4 MHz	Normal	NTN-TDLA100-5	8	-7.6

NOTE 1: Frequency Hopping: OFF  
NOTE 2: Guard period shall be created according to TS36.211 [12], 5.2.5.

NOTE: If the above Test Requirement differs from the Minimum Requirement then the Test Tolerance applied for this test is non-zero. The Test Tolerance for this test and the explanation of how the Minimum Requirement has been relaxed by the Test Tolerance is given in annex C.

## 11.4 OTA performance requirements for PRACH

### 11.4.1 PRACH false alarm probability and missed detection

#### 11.4.1.1 Definition and applicability

The performance requirement of PRACH for preamble detection is determined by the two parameters: total probability of false detection of the preamble (Pfa) and the probability of detection of preamble (Pd). The performance is measured by the required SNR at probability of detection, Pd of 99%. Pfa shall be 0.1% or less.

Pfa is defined as a conditional total probability of erroneous detection of the preamble (i.e. erroneous detection from any detector) when input is only noise.

The probability of detection is the conditional probability of correct detection of the preamble when the signal is present. There are several error cases – detecting different preamble than the one that was sent, not detecting a preamble at all or correct preamble detection but with the wrong timing estimation. For NTN-TDLA100-5, a timing estimation error occurs if the estimation error of the timing of the strongest path is larger than 2.08 $\mu$ s. The strongest path for the timing estimation error refers to the strongest path (i.e. average of the delay of all paths having the same highest gain = 310ns for ETU) in the power delay profile.

The test preambles for normal mode are listed in table A.6-1.

#### 11.4.1.2 Minimum requirement

The minimum requirement is in TS 36.108 [2] clause 8.4.1.1 and 8.4.2.1.

#### 11.4.1.3 Test purpose

The test shall verify the receiver's ability to detect PRACH preamble under static conditions and multipath fading propagation conditions for a given SNR.

### 11.4.1.4 Method of test

#### 11.4.1.4.1 Initial conditions

Test environment: Normal, see annex B.

RF channels to be tested for single carrier: M, see clause 4.9.1.

Direction to be tested: OTA REFSENS *receiver target reference direction* (see [D.44 in table 4.6-1]).

#### 11.4.1.4.2 Procedure

- 1) Place the SAN with its manufacturer declared coordinate system reference point in the same place as calibrated point in the test system, as shown in annex [D.7].
- 2) Align the manufacturer declared coordinate system orientation of the SAN with the test system.
- 3) Set the SAN in the declared direction to be tested.
- 4) Connect the SAN tester generating the wanted signal, multipath fading simulators and AWGN generators to a test antenna via a combining network in OTA test setup, as shown in annex [D.7]. Each of the demodulation branch signals should be transmitted on one polarization of the test antenna(s).
- 5) The characteristics of the wanted signal shall be configured according to the corresponding UL reference measurement channel defined in annex A and the test parameter *msg1-FrequencyStart* is set to 0.
- 6) The multipath fading emulators shall be configured according to the corresponding channel model defined in annex G.
- 7) Adjust the AWGN generator, according to the SCS and channel bandwidth. The power level for the transmission may be set such that the AWGN level at the RIB is equal to the AWGN level in table 11.4.1.4.2-1.

**Table 11.4.1.4.2-1: AWGN power level at the SAN input**

Channel bandwidth (MHz)	AWGN power level
1.4	-89.7 - Δ <sub>OTAREFSENS</sub> dBm / 1.08MHz
NOTE 1: Δ <sub>OTAREFSENS</sub> as declared in D.43 in table 4.6-1 and clause 10.1.	
NOTE 2: The AWGN power level contains an AWGN offset of 16dB by default. If needed for test purposes, the AWGN level can be reduced from the default by any value in the range 0dB to 16dB. Changing the AWGN level does not impact the validity of the test, as it reduces the effective base band SNR level.	

- 8) Adjust the frequency offset of the test signal according to table 11.4.1.5-1.
- 9) Adjust the equipment so that the SNR specified in table 11.4.1.5-1 is achieved at the SAN input during the PRACH preambles.
- 10) The test signal generator sends a preamble and the receiver tries to detect the preamble. This pattern is repeated as illustrated in figure 11.4.1.4.2-1. The preambles are sent with certain timing offsets as described below. The following statistics are kept: the number of preambles detected in the idle period and the number of missed preambles.



**Figure 11.4.1.4.2-1: PRACH preamble test pattern**

PRACH prambles are sent with a timing estimation error of 2.08us

#### 11.4.1.5 Test requirement

P<sub>fa</sub> shall not exceed 0.1%. P<sub>d</sub> shall not be below 99% for the SNRs in table 11.4.1.5-1.

**Table 11.4.1.5-1: PRACH missed detection requirements for coverage enhancement (PRACH frequency hopping OFF)**

Number of TX antennas	Number of demodulation branches	Propagation conditions and correlation matrix (annex F)	Frequency offset	Number of Repetitions	SNR (dB)			
					Burst format 0	Burst format 1	Burst format 2	Burst format 3
1	1	NTN-TDLA100-5	270 Hz	8	-10.4	-10.0	-	-
				16	-	-	-15.5	-15.5
	2	NTN-TDLA100-5	270 Hz	8	-15.7	-15.5	-	-
				16	-	-	-19.5	-19.5

NOTE: Under fading channels, the PRACH detection performance may be significantly different with different PRACH Configuration Indexes. The requirements in this table are defined based on the simulation results with PRACH Configuration Indexes (3, 19, 35, 51) for Format 0, Format 1, Format 2, and Format 3 respectively.

## 11.5 Performance requirements for Narrowband IoT

### 11.5.1 Performance requirements for NPUSCH format 1

#### 11.5.1.1 Definition and applicability

The performance requirement of NPUSCH format 1 is determined by a minimum required throughput for a given SNR. The required throughput is expressed as a fraction of maximum throughput for the FRCs listed in annex A. The performance requirements assume HARQ re-transmissions.

The tests for 3.75 kHz subcarrier spacing are applicable to the base stations supporting 3.75 kHz subcarrier spacing requirements. The tests for single-subcarrier/multi-subcarrier of 15 kHz subcarrier spacing are applicable to the base stations supporting the number of subcarriers of 15 kHz subcarrier spacing requirements.

#### 11.5.1.2 Minimum Requirement

For *SAN type I-O*, the minimum requirement is in TS 36.102 [2] clause 11.1.1.

#### 11.5.1.3 Test Purpose

The test shall verify the receiver's ability to achieve the throughput under multipath fading propagation conditions for a given SNR.

#### 11.5.1.4 Method of test

##### 11.5.1.4.1 Initial Conditions

Test environment: Normal, see annex B.

RF channels to be tested for single carrier: M; see clause 4.9.1.

Direction to be tested: OTA REFSSENS *receiver target reference direction* (see D.44 in table 4.6-1).

##### 11.5.1.4.2 Procedure

- 1) Place the SAN with its manufacturer declared coordinate system reference point in the same place as calibrated point in the test system, as shown in annex D.7.
- 2) Align the manufacturer declared coordinate system orientation of the SAN with the test system.

- 3) Set the SAN in the declared direction to be tested.
- 4) Connect the SAN tester generating the wanted signal, multipath fading simulators and AWGN generators to a test antenna via a combining network in OTA test setup, as shown in annex D.7. Each of the demodulation branch signals should be transmitted on one polarization of the test antenna(s).
- 5) The characteristics of the wanted signal shall be configured according to the corresponding UL reference measurement channel defined in annex A, and according to additional test parameters listed in table 11.5.1.4.2-1.

**Table 11.5.1.4.2-1: Test parameters for testing NPUSCH format 1**

Parameter	unit	Value
Maximum number of HARQ transmissions		4
RV sequences		RV0, RV2
Duration of NPUSCH format 1 segment transmission ( $N_{segment}^{precompensation}$ )	ms	256 for 3.75 kHz SCS, 16 for 15kHz SCS
Repetition		4 for 3.75 kHz SCS, 16 for 15kHz SCS

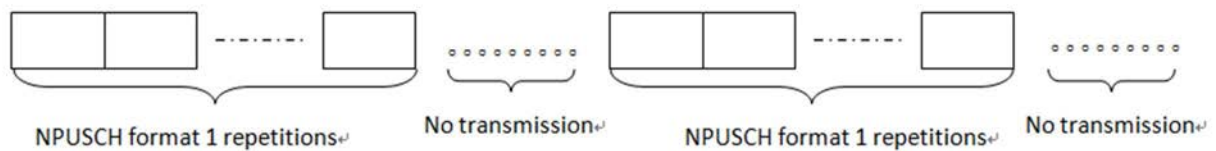
- 6) The multipath fading emulators shall be configured according to the corresponding channel model defined in annex G.
- 7) Adjust the test signal mean power so the calibrated radiated SNR value at the SAN receiver is as specified in clause 11.5.1.5 for SAN type 1-O, and that the SNR at the SAN receiver is not impacted by the noise floor.

The power level for the transmission may be set such that the AWGN level at the RIB is equal to the AWGN level in table 11.5.1.4.2-2.

**Table 11.5.1.4.2-2: AWGN power level at the SAN input**

Channel bandwidth (kHz)	AWGN power level
200	-100.5dBm - $\Delta_{OTAREFSNS}$ dBm /180kHz
NOTE 1: $\Delta_{OTAREFSNS}$ as declared in D.43 in table 4.6-1 and clause 10.1	
NOTE 2: The AWGN power level contains an AWGN offset of 16dB by default. If needed for test purposes, the AWGN level can be reduced from the default by any value in the range 0dB to 16dB. Changing the AWGN level does not impact the validity of the test, as it reduces the effective base band SNR level.	

- 8) The signal generator sends a test pattern with the pattern outlined in Figure 11.5.1.4.2-1. The test signal generator sends frames, and the receiver tries to demodulate the content. The frames are sent with certain frequency and gradual time offset per segment as described below in table 11.5.1.4.2-2 and table 11.5.1.4.2-3. The time offset is reset back to zero between segments.



**Figure 11.5.1.4.2-1: Test signal pattern for NPUSCH format 1 demodulation tests**

**Table 11.5.1.4.2-2: Frequency Offsets for testing NPUSCH format 1**

Cases	Accumulated Frequency Offset
Table 11.5.1.5-1	128 Hz
Table 11.5.1.5-2	8 Hz

**Table 11.5.1.4.2-3: Timing Offsets for testing NPUSCH format 1**

Cases	Step size $\Delta t$
Table 11.5.1.5-1	0.32 us per RU
Table 11.5.1.5-2	0.01 us per RU

- 8) For each of the reference channels in table 11.5.1.5-1 to 11.5.1.5-3 applicable for the SAN, measure the throughput, according to annex E.

### 11.5.1.5 Test Requirement

The throughput measured according to clause 11.5.1.4.2 shall not be below the limits for the SNR levels specified in table 11.5.1.5-1 for 3.75 kHz subcarrier spacing tests and not be below the limits for the SNR levels specified in table 11.5.1.5-2 for 15 kHz subcarrier spacing with the supported number of subcarrier tests.

**Table 11.5.1.5-1 Required SNR for NPUSCH format 1 test, 200 kHz channel bandwidth, 3.75 kHz subcarrier spacing, 1Tx**

Number of TX antennas	Number of demodulation branches	Subcarrier spacing	Number of allocated subcarriers	Propagation conditions and correlation matrix (Annex F)	FRC (annex A)	Repetition number	Fraction of maximum throughput	SNR (dB)
1	1	3.75 kHz	1	NTN-TDL100-1	A16-1	4	70%	-1.4
1	1	3.75 kHz	1	NTN-TDLC5-1	A16-1	4	70%	-3.0
1	2	3.75kHz	1	NTN-TDL100-1	A16-1	4	70%	-4.8
1	2	3.75kHz	1	NTN-TDLC5-1	A16-1	4	70%	-5.9

**Table 11.5.1.5-2 Required SNR for NPUSCH format 1 test, 200 kHz channel bandwidth, 15 kHz subcarrier spacing, multiple subcarriers, 1Tx**

Number of TX antennas	Number of demodulation branches	Subcarrier spacing	Number of allocated subcarriers	Propagation conditions and correlation matrix (Annex F)	FRC (annex A)	Repetition number	Fraction of maximum throughput	SNR (dB)
1	1	15 kHz	12	NTN-TDL100-1	A16-2	16	70%	-2.6
1	1	15 kHz	12	NTN-TDLC5-1	A16-2	16	70%	-3.4
1	2	15 kHz	12	NTN-TDL100-1	A16-2	16	70%	-6.5
1	2	15 kHz	12	NTN-TDLC5-1	A16-2	16	70%	-7.2

NOTE: If the above Test Requirement differs from the Minimum Requirement then the Test Tolerance applied for this test is non-zero. The Test Tolerance for this test and the explanation of how the Minimum Requirement has been relaxed by the Test Tolerance is given in annex C.

## 11.5.2 ACK missed detection for NPUSCH format 2

### 11.5.2.1 Definition and applicability

The performance requirement of NPUSCH format 2 for ACK missed detection is determined by the two parameters: probability of false detection of the ACK and the probability of detection of ACK. The performance is measured by the required SNR at probability of detection equal to 0.99. The probability of false detection of the ACK shall be 0.01 or less.

The probability of false detection of the ACK is defined as a conditional probability of erroneous detection of the ACK when input is only noise.

The probability of detection of ACK is defined as conditional probability of detection of the ACK when the ACK was sent per NPUSCH format 2 transmission when the signal is present.

The tests for 3.75 kHz subcarrier spacing are applicable to the base stations supporting 3.75 kHz subcarrier spacing requirements. The tests for 15 kHz subcarrier spacing are applicable to the base stations supporting 15 kHz subcarrier spacing requirements.

### 11.5.2.2 Minimum Requirement

For *SAN type I-O*, the minimum requirement is in TS 36.102 [2] clause 11.5.2.1 and 11.5.2.2.

### 11.5.2.3 Test purpose

The test shall verify the receiver's ability to detect ACK under multipath fading propagation conditions for a given SNR.

### 11.5.2.4 Method of test

#### 11.5.2.4.1 Initial Conditions

Test environment: Normal, see annex B.

RF channels to be tested for single carrier: M; see clause 4.9.1.

Direction to be tested: OTA REFSENS *receiver target reference direction* (see D.44 in table 4.6-1).

#### 11.5.2.4.2 Procedure

- 1) Place the SAN with its manufacturer declared coordinate system reference point in the same place as calibrated point in the test system, as shown in annex D.7.
- 2) Align the manufacturer declared coordinate system orientation of the SAN with the test system.
- 3) Set the SAN in the declared direction to be tested.
- 4) Connect the SAN tester generating the wanted signal, multipath fading simulators and AWGN generators to a test antenna via a combining network in OTA test setup, as shown in annex D.7. Each of the demodulation branch signals should be transmitted on one polarization of the test antenna(s).
- 5) The characteristics of the wanted signal shall be configured according to TS 38.211 [8], and according to additional test parameters listed in table 11.5.1.4.2-1.

**Table 11.5.1.4.2-1: Test parameters for testing NPUSCH format 2**

Parameter	unit	Value
Duration of NPUSCH format 2 segment transmission ( $N_{segment}^{precompensation}$ )	ms	128 for 3.75 kHz SCS, 32 for 15kHz SCS
Repetition		16

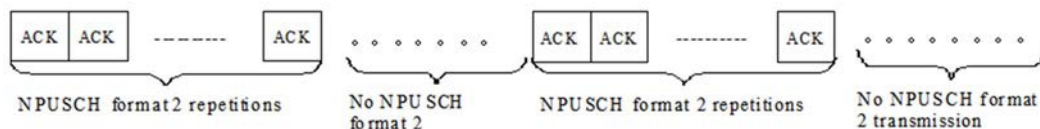
- 6) The multipath fading emulators shall be configured according to the corresponding channel model defined in annex G.2.
- 7) Adjust the test signal mean power so the calibrated radiated SNR value at the SAN receiver is as specified in clause 11.5.1.5.1, and that the SNR at the SAN receiver is not impacted by the noise floor.

The power level for the transmission may be set such that the AWGN level at the RIB is equal to the AWGN level quoted in table 11.5.1.4.2-2.

**Table 11.5.2.4.2-2: AWGN power level at the SAN input**

Channel bandwidth (kHz)	AWGN power level
200	-100.5dBm /180kHz
NOTE 1: $\Delta OTAREFSENS$ as declared in D.43 in table 4.6-1 and clause 10.1	
NOTE 2: The AWGN power level contains an AWGN offset of 16dB by default. If needed for test purposes, the AWGN level can be reduced from the default by any value in the range 0dB to 16dB. Changing the AWGN level does not impact the validity of the test, as it reduces the effective base band SNR level.	

- 8) The signal generator sends a test pattern with the pattern outlined in figure 11.5.2.4.2-1. The following statistics are kept: the number of ACKs falsely detected in the idle periods and the number of missed ACKs. Each falsely detected ACK transmission in the idle periods is accounted as one error for the statistics of false ACK detection, and each missed ACK transmission per NPUSCH format 2 transmission is accounted as one error for the statistics of missed ACK detection. The frames are sent with certain frequency and time offsets per segment as described below in Figure 11.5.2.4.2-3 and table 11.5.2.4.2-4. The time offset is reset back to zero between segments.



**Figure 11.5.2.4.2-1: Test signal pattern for NPUSCH format 2 demodulation tests**

**Table 11.5.2.4.2-3: Frequency Offsets for testing NPUSCH format 2**

Cases	Accumulated Frequency Offset
Table 11.5.2.5-1	64 Hz
Table 11.5.2.5-2	16 Hz

**Table 11.5.2.4.2-4: Timing Offsets for testing NPUSCH format 2**

Cases	Step size $\Delta t$
Table 11.5.2.5-1	0.08 us per RU
Table 11.5.2.5-2	0.02 us per RU

**11.5.2.5 Test Requirement**

The fraction of falsely detected ACKs shall be less than 1% and the fraction of correctly detected ACKs shall be larger than 99% for the SNR listed in table 11.5.2.5-1 and table 11.5.2.5-2.

**Table 11.5.2.5-1 Required SNR for NPUSCH format 2 test, 200 kHz channel bandwidth, 3.75 kHz subcarrier spacing, 1Tx**

Number of TX antennas	Number of demodulation branches	Propagation conditions and correlation matrix (annex F)	Number of allocated subcarriers	Subcarrier spacing	Repetition number	SNR (dB)
1	1	NTN-TDLA100-1	1	3.75kHz	16	2.4
1	2	NTN-TDLA100-1	1	3.75 kHz	16	-3.3

**Table 11.5.2.5-2 Required SNR for NPUSCH format 2 test, 200 kHz channel bandwidth, 15 kHz subcarrier spacing, 1Tx**

Number of TX antennas	Number of demodulation branches	Propagation conditions and correlation matrix (annex F)	Number of allocated subcarriers	Subcarrier spacing	Repetition number	SNR (dB)
1	1	NTN-TDLA100-1	1	15kHz	16	5.7
1	2	NTN-TDLA100-1	1	15kHz	16	-2.7

NOTE: If the above Test Requirement differs from the Minimum Requirement then the Test Tolerance applied for this test is non-zero. The Test Tolerance for this test and the explanation of how the Minimum Requirement has been relaxed by the Test Tolerance is given in annex C.

### 11.5.3 Performance requirements for NPRACH

#### 11.5.3.1 Definition and applicability

The performance requirement of NPRACH for preamble detection is determined by two parameters: the total probability of false detection of the preamble ( $P_{fa}$ ) and the probability of detection of the preamble ( $P_d$ ). The performance is measured for the required SNR

- at probability of  $P_d$  which shall not be smaller than 99% and
- at probability of  $P_{fa}$  which shall not be larger than 0.1%.

$P_{fa}$  is defined as a conditional total probability of erroneous detection of the preamble (i.e. erroneous detection from any detector) when input is only noise.

$P_d$  is defined as conditional probability of detection of the preamble when the signal is present. The erroneous detection consists of several error cases – detecting different preamble than the one that was sent, not detecting a preamble at all or correct preamble detection but with the wrong timing estimation. A timing estimation error occurs if the estimation error of the timing of the strongest path is larger than 3.646  $\mu$ s. The strongest path for the timing estimation error refers to the strongest path in the power delay profile.

The performance requirements for TDD are optional and only valid for base stations supporting TDD.

The parameters of NPRACH test preambles are listed in table 11.5.3.1-1.

**Table 11.5.3.1-1 NPRACH Test Parameters**

Parameter	Value	Value
Narrowband physical layer cell identity	0	0
nprach-Periodicity (ms)	80	160
nprach-SubcarrierOffset	0	0
nprach-NumSubcarriers	12	12
numRepetitionsPerPreambleAttempt	8	16

### 11.5.3.2 Minimum Requirement

For SAN type I-O, the minimum requirement is in TS 36.102 [2] clause 11.5.3.1.1 and 11.5.3.2.1.

### 11.5.3.3 Test purpose

The test shall verify the receiver’s ability to detect NPRACH preamble under multipath fading propagation conditions for a given SNR.

### 11.5.3.4 Method of test

#### 11.5.3.4.1 Initial Conditions

Test environment: Normal, see annex B.

RF channels to be tested for single carrier: M; see clause 4.9.1.

Direction to be tested: OTA REFSENS receiver target reference direction (see D.44 in table 4.6-1).

#### 11.5.3.4.2 Procedure

- 1) Place the SAN with its manufacturer declared coordinate system reference point in the same place as calibrated point in the test system, as shown in annex D.7.
- 2) Align the manufacturer declared coordinate system orientation of the SAN with the test system.
- 3) Set the SAN in the declared direction to be tested.
- 4) Connect the SAN tester generating the wanted signal, multipath fading simulators and AWGN generators to a test antenna via a combining network in OTA test setup, as shown in annex D.7. Each of the demodulation branch signals should be transmitted on one polarization of the test antenna(s).
- 5) The characteristics of the wanted signal shall be configured according to the corresponding UL reference measurement channel defined in annex A and the test parameter msg1-FrequencyStart is set to 0.
- 6) The multipath fading emulators shall be configured according to the corresponding channel model defined in annex G.
- 7) Adjust the AWGN generator, according to the SCS and channel bandwidth. The power level for the transmission may be set such that the AWGN level at the RIB is equal to the AWGN level in table 11.5.3.4.2-1.

**Table 11.5.3.4.2-1: AWGN power level at the SAN input**

Channel bandwidth (kHz)	AWGN power level
200	-100.5dBm /180kHz
NOTE 1: $\Delta_{OTAREFSENS}$ as declared in D.43 in table 4.6-1 and clause 10.1.	
NOTE 2: The AWGN power level contains an AWGN offset of 16dB by default. If needed for test purposes, the AWGN level can be reduced from the default by any value in the range 0dB to 16dB. Changing the AWGN level does not impact the validity of the test, as it reduces the effective base band SNR level.	

- 8) The test signal generator sends a preamble with repetitions and the receiver tries to detect the preamble. This pattern is repeated as illustrated in Figure 11.5.3.4.2-1. The preambles are sent with a fixed timing offset of  $0.5T_{CP}$  during the test, where  $T_{CP}$  is NPRACH cyclic prefix of length as defined in TS 36.211 [12]. The following statistics are kept: the number of preambles detected in the idle period and the number of missed preambles.



**Figure 11.5.3.4.2-1: NPRACH preamble test pattern**

### 11.5.3.5 Test Requirement

Pfa shall not exceed 0.1% and Pmd shall not exceed 1% for the SNRs in table 11.5.3.5-1.

**Table 11.5.3.5-1: NPRACH missed detection test requirements for FDD**

Number of TX antennas	Number of demodulation branches	Repetition number	Propagation conditions and correlation matrix (annex F)	Frequency offset [Hz]	SNR(dB)	
					Preamble format 0	Preamble format 1
1	1	8	NTN-TDLA100-1	200	13.9	14.3
1	2	8	NTN-TDLA100-1	200	6.6	6.7
1	1	16	NTN-TDLA100-1	200	10.4	10.2
1	2	16	NTN-TDLA100-1	200	2.2	2.3

NOTE: If the above Test Requirement differs from the Minimum Requirement then the Test Tolerance applied for this test is non-zero. The Test Tolerance for this test and the explanation of how the Minimum Requirement has been relaxed by the Test Tolerance is given in annex C.

# Annex A (normative): Reference measurement channel

The parameters for the reference measurement channels are specified in clause A.1 for E-UTRA reference sensitivity and in-channel selectivity and in clause A.2 for dynamic range.

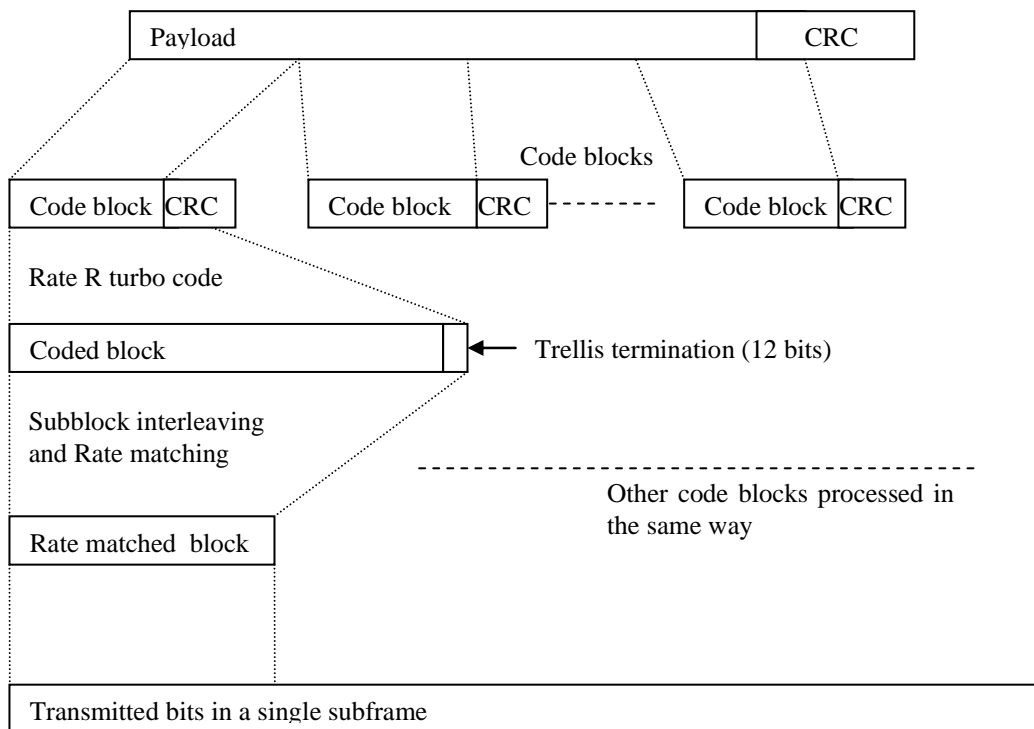
A schematic overview of the encoding process for the E-UTRA reference measurement channels is provided in Figure A-1.

E-UTRA receiver requirements in the present document are defined with a throughput stated relative to the Maximum throughput of the FRC. The Maximum throughput for an FRC equals the Payload size \* the Number of uplink subframes per second. For FDD, 1000 uplink sub-frames per second are used.

The parameters for the reference measurement channels are specified in clause A.14 for NB-IoT reference sensitivity and in clause A.15 for dynamic range.

A schematic overview of the encoding process for the NB-IoT reference measurement channels is provided in Figure A-2.

NB-IoT receiver requirements in the present document are defined with a throughput stated relative to the Maximum throughput of the FRC. The Maximum throughput for an FRC equals the Payload size / (Number of Resource Unit \* time to send one Resource Unit).



**Figure A-1. Schematic overview of the encoding process**

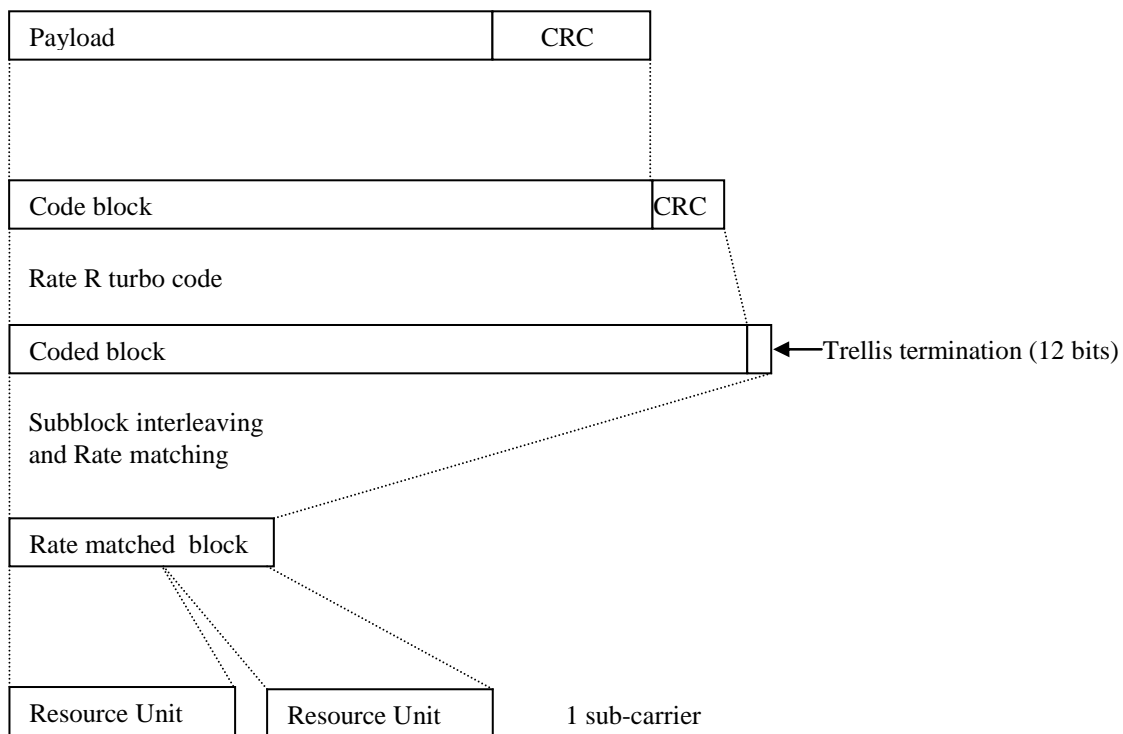


Figure A-2. Schematic overview of the encoding process for NB-IoT

## A.1 Fixed Reference Channels for reference sensitivity and in-channel selectivity (QPSK, R=1/3)

Note: Fixed reference channels A1-2, A1-3, and A1-5 to A1-9 are not used in this specification.

The parameters for the reference measurement channels are specified in table A.1-1 for reference sensitivity and in-channel selectivity.

Table A.1-1 FRC parameters for reference sensitivity and in-channel selectivity

Reference channel	A1-1	A1-2	A1-3	A1-4	A1-5	A1-6	A1-7	A1-8	A1-9
Allocated resource blocks	6	15	25	3	9	12	24	10 <sup>1</sup>	10 <sup>2</sup>
DFT-OFDM Symbols per subframe	12	12	12	12	12	12	12	12	12
Modulation	QPSK	QPSK	QPSK	QPSK	QPSK	QPSK	QPSK	QPSK	QPSK
Code rate	1/3	1/3	1/3	1/3	1/3	1/3	1/3	1/3	1/3
Payload size (bits)	600	1544	2216	256	936	1224	2088	1032	1032
Transport block CRC (bits)	24	24	24	24	24	24	24	24	24
Code block CRC size (bits)	0	0	0	0	0	0	0	0	0
Number of code blocks - C	1	1	1	1	1	1	1	1	1
Coded block size including 12bits trellis termination (bits)	1884	4716	6732	852	2892	3756	6348	3180	3180
Total number of bits per sub-frame	1728	4320	7200	864	2592	3456	6912	2880	2880
Total symbols per sub-frame	864	2160	3600	432	1296	1728	3456	1440	1440
NOTE 1: For reference channel A1-8, the allocated RB's are uniformly spaced over the channel bandwidth at RB index N, N+5, N+10, ..., N+45 where N = {0, 1, 2, 3, 4}.									
NOTE 2: For reference channel A1-9, the allocated RB's are uniformly spaced over the channel bandwidth at RB index N, N+10, N+20, ..., N+90 where N = {0, 1, 2, ... 9}.									

## A.2 Fixed Reference Channels for dynamic range (16QAM, R=2/3)

Note: Fixed reference channels A2-2 to A2-5 are not used in this specification.

The parameters for the reference measurement channels are specified in table A.2-1 for dynamic range.

**Table A.2-1 FRC parameters for dynamic range**

Reference channel	A2-1	A2-2	A2-3	A2-4	A2-5
Allocated resource blocks	6	15	25	10 <sup>1</sup>	10 <sup>2</sup>
DFT-OFDM Symbols per subframe	12	12	12	12	12
Modulation	16QAM	16QAM	16QAM	16QAM	16QAM
Code rate	2/3	2/3	2/3	2/3	2/3
Payload size (bits)	2344	5992	9912	4008	4008
Transport block CRC (bits)	24	24	24	24	24
Code block CRC size (bits)	0	0	24	0	0
Number of code blocks - C	1	1	2	1	1
Coded block size including 12bits trellis termination (bits)	7116	18060	14988	12108	12108
Total number of bits per sub-frame	3456	8640	14400	5760	5760
Total symbols per sub-frame	864	2160	3600	1440	1440
NOTE 1: For reference channel A2-4, the allocated RB's are uniformly spaced over the channel bandwidth at RB index N, N+5, N+10, ..., N+45 where N = {0, 1, 2, 3, 4}.					
NOTE 2: For reference channel A2-5, the allocated RB's are uniformly spaced over the channel bandwidth at RB index N, N+10, N+20, ..., N+90 where N = {0, 1, 2, ..., 9}.					

## A.5 Fixed Reference Channels for performance requirements (QPSK 1/3)

**Table A.5-1 FRC parameters for performance requirements (QPSK 1/3)**

Reference channel	A5-1	A5-2
Allocated resource blocks	1	6
DFT-OFDM Symbols per subframe	12	12
Modulation	QPSK	QPSK
Code rate	1/3	1/3
Payload size (bits)	104	600
Transport block CRC (bits)	24	24
Code block CRC size (bits)	0	0
Number of code blocks - C	1	1
Coded block size including 12bits trellis termination (bits)	396	1884
Total number of bits per sub-frame	288	1728
Total symbols per sub-frame	144	864

## A.6 PRACH Test preambles

**Table A.6-1 Test preambles for coverage enhancement**

Burst format	Ncs	Logical sequence index	v
0	13	22	32
1	167	22	2
2	167	22	0
3	0	22	0

---

## A.14 Fixed Reference Channels for NB-IOT reference sensitivity ( $\pi/2$ BPSK, R=1/3)

The parameters for the reference measurement channels are specified in table A.14-1 for reference sensitivity.

**Table A.14-1 FRC parameters for reference sensitivity and in-channel selectivity**

Reference channel	A14-1	A14-2
Sub-carrier spacing (kHz)	15	3.75
Number of tone	1	1
Diversity	No	No
Modulation	$\pi/2$ BPSK	$\pi/2$ BPSK
Frequency offset	0	0
Channel estimation length (ms) (NOTE)	4	16
Number of NPUSCH repetition	1	1
IMCS / TBS	0 / 0	0 / 0
Payload size (bits)	32	32
Allocated resource unit	2	2
Code rate (target)	1/3	1/3
Code rate (effective)	0.29	0.29
Transport block CRC (bits)	24	24
Code block CRC size (bits)	0	0
Number of code blocks - C	1	1
Total number of bits per resource unit	96	96
Total symbols per resource unit	96	96
Tx time (ms)	16	64
NOTE: Channel estimation lengths are included in the table for information only.		

---

## A.15 Fixed Reference Channels for NB-IoT dynamic range ( $\pi/4$ QPSK, R=2/3)

The parameters for the reference measurement channels are specified in table A.15-1 for NB-IoT dynamic range.

Table A.15-1 FRC parameters for NB-IoT dynamic range

Reference channel	A15-1	A15-2
Sub carrier spacing (kHz)	15	3.75
Number of tone	1	1
Modulation	$\pi/4$ QPSK	$\pi/4$ QPSK
Diversity	No	No
Frequency offset	0	0
IMCS / ITBS	7 / 7	7 / 7
Payload size (bits)	104	104
Allocated resource units	1	1
Transport block CRC (bits)	24	24
Coding rate (target)	2/3	2/3
Coding Rate	0.67	0.67
Code block CRC size (bits)	0	0
Number of code blocks – C	1	1
Total symbols per resource unit	96	96
Total number of bits per resource unit	192	192
Tx time (ms)	8	32
Frequency offset	0	0
Channel estimation length (ms) (NOTE)	4	16
NOTE: Channel estimation lengths are included in the table for information only.		

## A.16 Fixed Reference Channels for NB-IoT NPUSCH format 1

**Table A.16-1: FRC parameters for NB-IoT NPUSCH format 1**

Reference channel	A16-1	A16-2
Subcarrier spacing (kHz)	3.75	15
Number of allocated subcarriers	1	12
Diversity	No	No
Modulation	BPSK	QPSK
$I_{TBS} / I_{RU}$	0 / 1	9 / 0
Payload size (bits)	32	136
Allocated resource unit	2	1
Code rate (target)	1/3	2/3
Code rate (effective)	0.29	0.56
Transport block CRC (bits)	24	24
Code block CRC size (bits)	0	0
Number of code blocks - C	1	1
Total number of bits per resource unit	96	288
Total symbols per resource unit	96	144
Channel estimation length (ms) (NOTE)	16	
NOTE: Channel estimation lengths are included in the table for information only.		

---

## Annex B (informative): Environmental requirements for SAN equipment

For each test in the present document, the environmental conditions under which the SAN is to be tested are to be defined, considering two categories of SAN equipment:

- Equipment deployed in space as part of Satellite Payload RF (SPRF)
- Equipment deployed on the ground (SAN terrestrial equipment).

Normal test environment for SAN is defined in TS 38.181 [6], annex B.2.

When vibration conditions are specified for a test, the test shall be performed while the equipment is subjected to a vibration sequence as defined by the manufacturer's declaration for the equipment under test. Vibration conditions for SAN are defined in TS 38.181 [6], annex B.4.

The measurement accuracy of the test environments are defined in TS 38.181 [6], annex B.5.

---

## Annex C (informative): Test tolerances and derivation of test requirements

The test requirements explicitly defined in this specification have been calculated by relaxing the minimum requirements of the core specification TS 36.108 [2] using the test tolerances (TT) defined here. When the TT value is zero, the test requirement will be the same as the minimum requirement. When the TT value is non-zero, the test requirements will differ from the minimum requirements, and the formula used for this relaxation is given in the following tables.

The  $TT_{OTA}$  values are derived from OTA Test System uncertainties, regulatory requirements and criticality to system performance. As a result, the  $TT_{OTA}$  values may sometimes be set to zero.

The  $TT_{OTA}$  values should not be modified for any reason e.g. to take account of commonly known OTA Test System errors (such as mismatch, cable loss, etc.).

Note that a formula for applying  $TT_{OTA}$  values is provided for all OTA tests, even those with a test tolerance of zero. This is necessary in the case where the OTA Test System uncertainty is greater than that allowed in clause 4.1.2. In this event, the excess error shall be subtracted from the defined  $TT_{OTA}$  value in order to generate the correct tightened test requirements as defined in this annex.

## C.1 Measurement of transmitter

**Table C.1-1: Derivation of test requirements for conducted transmitter tests**

Test	Minimum requirement in TS 36.108 [2]	Test Tolerance (TT)	Test requirement in the present document
6.2 SAN output power	clause 6.2	0.7 dB for E-UTRA 1 dB for standalone NB-IoT	Formula: Upper limit + TT, Lower limit - TT
6.3.3 Total power dynamic range	clause 6.3.3	0.4 dB	Formula: Total power dynamic range - TT
6.5.2 Frequency error	clause 6.5.1	12 Hz	Formula: Frequency Error limit + TT
6.5.3 EVM	clause 6.5.2	1%	Formula: EVM limit + TT
6.5.5 DL RS power	clause 6.5.4	0.8 dB, $f \leq 3$ GHz	Formula: Upper limit + TT Lower limit - TT DL RS power shall be within $\pm 2.9$ dB, $f \leq 3$ GHz
6.6.2 Occupied bandwidth	clause 6.6.2	0 Hz	Formula: Minimum Requirement + TT
6.6.3 Adjacent Channel Leakage power Ratio (ACLR)	clause 6.6.3	BW $\leq 20$ MHz: 0.8 dB	Formula: ACLR Minimum Requirement - TT
6.6.4 Operating band unwanted emissions	clause 6.6.4	Offsets < 10 MHz: 1.5 dB, $f \leq 3$ GHz  Offsets $\geq 10$ MHz: 0 dB	Formula: Minimum Requirement + TT
6.6.5.5 TX spurious emissions: General requirements	clause 6.6.5.2.1	0 dB	Formula: Minimum Requirement + TT
6.6.5.6 TX spurious emissions: Protection of SAN receiver	clause 6.6.5.2.2	0 dB	Formula: Minimum Requirement + TT
NOTE: TT values are applicable for normal condition unless otherwise stated.			

**Table C.1-2: Derivation of test requirements for OTA transmitter tests**

Test	Minimum requirement in TS 36.108 [2]	Test Tolerance (TT <sub>OTA</sub> )	Test requirement in the present document
9.2 Radiated transmit power	clause 9.2	E-UTRA: 1.1 dB Standalone NB-IoT: 1.4 dB	Formula: Upper limit + TT, Lower limit - TT
9.3 OTA SAN output power	clause 9.3	E-UTRA: 1.4 dB Standalone NB-IoT: 1.7 dB	Formula: Upper limit + TT, Lower limit - TT
9.4.3 OTA total power dynamic range	clause 9.4.3	0.4 dB	Formula: Total power dynamic range - TT
9.6.2 OTA frequency error	clause 9.6.1	12 Hz	Formula: Frequency Error limit + TT
9.6.3 OTA EVM	clause 9.6.2	1%	Formula: EVM limit + TT
9.6.5 OTA DL RS power	clause 9.6.4	3.2 dB	Formula: limit + TT
9.7.2 OTA occupied bandwidth	clause 9.7.2	0 Hz	Formula: Minimum Requirement + TT
9.7.3 OTA ACLR	clause 9.7.3	1 dB, $f \leq 3$ GHz	Formula: Relative limit - TT
9.7.4 OTA operating band unwanted emissions	clause 9.7.4	Offsets < 10 MHz: 1.8 dB Offsets $\geq 10$ MHz: 0 dB	Formula: Minimum Requirement + TT
9.7.5.5 OTA TX spurious emissions: General requirements	clause 9.7.5.2.2	0 dB	Formula: Minimum Requirement + TT
NOTE: TT values are applicable for normal condition unless otherwise stated.			

## C.2 Measurement of receiver

**Table C.2-1: Derivation of test requirements for conducted receiver tests**

Test	Minimum requirement in TS 36.108 [2]	Test Tolerance (TT)	Test requirement in the present document
7.2 Reference sensitivity level	clause 7.2	E-UTRA: 0.7 dB, $f \leq 3$ GHz Standalone NB-IoT: 1 dB	Formula: Reference sensitivity power level + TT
7.3 Dynamic range	clause 7.3	0.3 dB	Formula: Wanted signal power + TT
7.4.1 Adjacent Channel Selectivity (ACS)	clause 7.4	0 dB	Formula: Wanted signal power + TT
7.5 Out-of-band blocking	clause 7.5	0 dB	Formula: Wanted signal power + TT
7.8 In-channel selectivity	clause 7.8	1.4 dB	Formula: Wanted signal power + TT

NOTE: TT values are applicable for normal condition unless otherwise stated.

**Table C.2-2: Derivation of test requirements for OTA receiver tests**

Test	Minimum requirement in TS 36.108 [2]	Test Tolerance (TT <sub>OTA</sub> )	Test requirement in the present document
10.2 OTA sensitivity	clause 10.2	E-UTRA: 1.3 dB Standalone NB-IoT: 1.6 dB	Formula: Declared Minimum EIS + TT
10.3 OTA reference sensitivity level	clause 10.3	E-UTRA: 1.3 dB Standalone NB-IoT: 1.6 dB	Formula: EIS <sub>REFSENS</sub> + TT
10.4 OTA dynamic range	clause 10.4	0.3 dB	Formula: Wanted signal power + TT Interferer signal power unchanged.
10.5.1 OTA adjacent channel selectivity	clause 10.5.1	0 dB	Formula: Wanted signal power + TT Interferer signal power unchanged.
10.6 OTA out-of-band blocking	clause 10.6	0 dB	Formula: Wanted signal power + TT Interferer signal power unchanged.
10.9 OTA in-channel selectivity	clause 10.9	1.7 dB	Formula: Wanted signal power + TT Interferer signal power unchanged

NOTE: TT values are applicable for normal condition unless otherwise stated.

## C.3 Measurement of performance requirements

**Table G.3-1: Derivation of Test Requirements (Performance tests)**

Test	Minimum Requirement in TS 36.102 [x]	Test Tolerance (TT)	Test Requirement in TS 36.181
8.2.1 Performance requirements for NPUSCH format 1	SINRs as specified	0.6 dB	Formula: SINR + TT T-put limit unchanged
8.2.2 ACK missed detection for NPUSCH format 2	SINRs as specified	0.6 dB	Formula: SNR + TT False ACK limit unchanged Correct ACK limit unchanged
8.2.3 Performance requirements for NPRACH	SNRs as specified	0.6 dB	Formula: SNR + TT NPRACH False detection limit unchanged NPRACH detection limit unchanged

**Table C.3-2: Derivation of Test Requirements (OTA performance tests)**

Test	Minimum Requirement in TS 36.102 [x]	Test Tolerance (TT)	Test Requirement in TS 36.181
11.5.1 Performance requirements for NPUSCH format 1	SINRs as specified	0.6 dB	Formula: SINR + TT <sub>OTA</sub> T-put limit unchanged
11.5.2 ACK missed detection for NPUSCH format 2	SINRs as specified	0.6 dB	Formula: SNR + TT <sub>OTA</sub> False ACK limit unchanged Correct ACK limit unchanged
11.5.3 Performance requirements for NPRACH	SNRs as specified	0.6 dB	Formula: SNR + TT <sub>OTA</sub> NPRACH False detection limit unchanged NPRACH detection limit unchanged

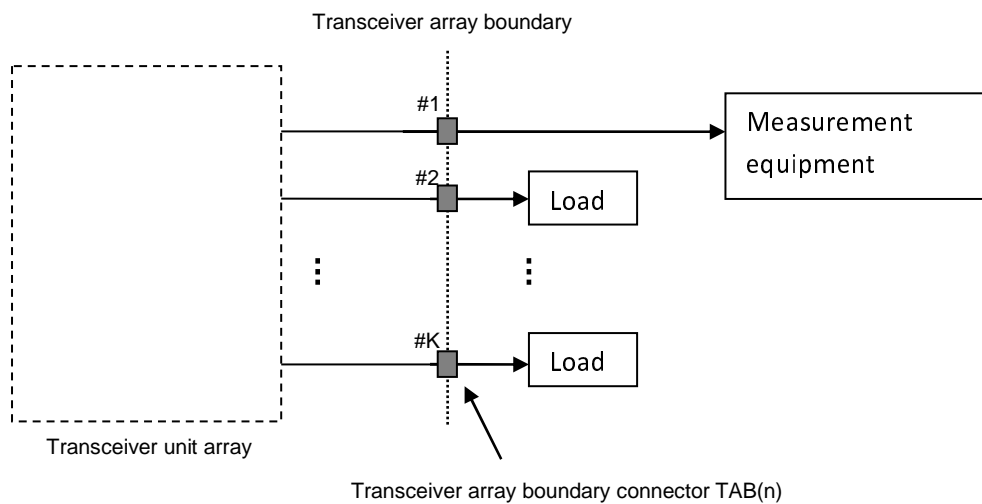
## Annex D (informative): Measurement system set-up

### D.1 SAN type 1-H transmitter

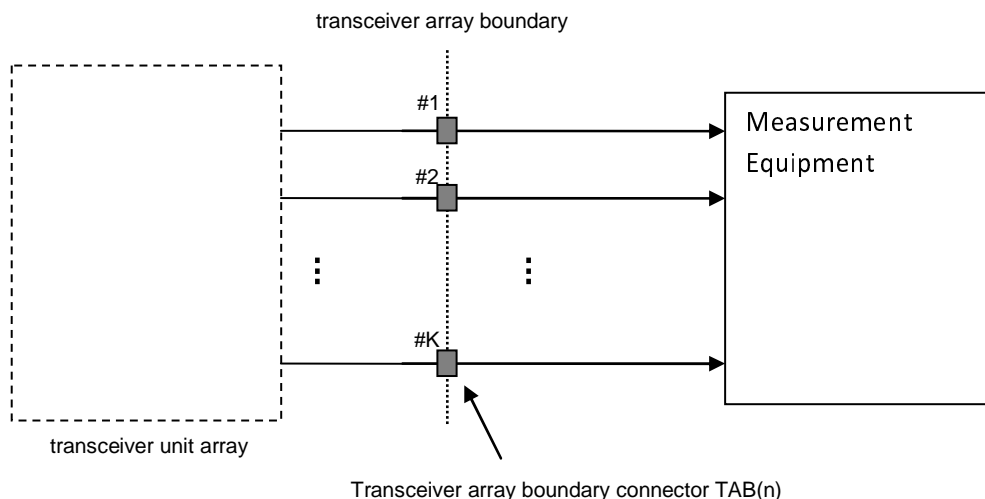
#### D.1.1 SAN output power, output power dynamics, frequency error, EVM, unwanted emissions for SAN type 1-H

*TAB connectors* may be connected to the measurement equipment singularly and tested one at a time (figure D.1.1-1), or may be tested simultaneously in groups (figure D.1.1-2) where the group size may range from two to all the *TAB connectors* which are subject to particular transmitter test in this test setup.

In all cases the measurement is per *TAB connector* but the measurement may be done in parallel.



**Figure D.1.1-1: Measuring system set-up for SAN type 1-H output power, output power dynamics, frequency error, EVM, unwanted emissions for a single TAB connector**



**Figure D.1.1-2: Measuring system set-up for SAN type 1-H output power, output power dynamics, frequency error, EVM, unwanted emissions for multiple TAB connectors**

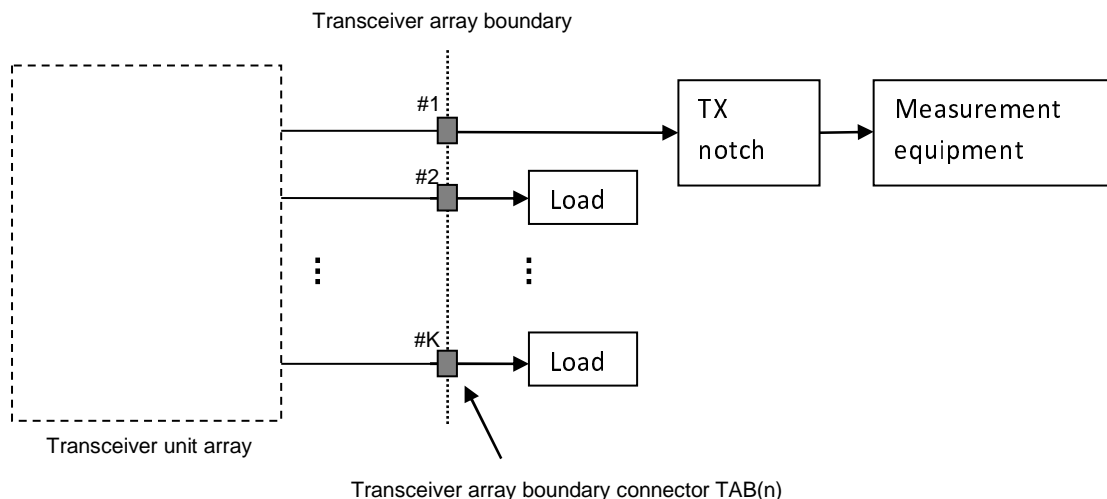
### D.1.2 Transmitter intermodulation for SAN type 1-H

The requirement and the measuring system set-up are not applicable in this version of the specification.

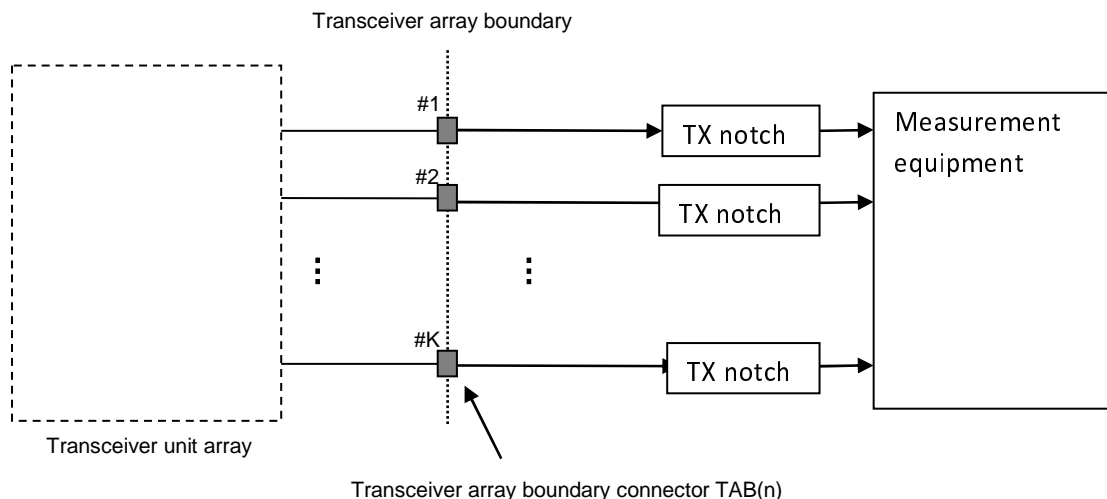
### D.1.3 Transmitter spurious emissions for SAN type 1-H

TAB connectors may be connected to the measurement equipment singularly and tested one at a time (figure D.1.3-1), or may be tested simultaneously in groups (figure D.1.3-2) where the group size may range from two to all the TAB connectors which are subject to transmitter spurious emissions test.

In all cases the measurement is per TAB connector but the measurement may be done in parallel.



**Figure D.1.3-1: Measuring system set-up for transmitter spurious emissions for a single TAB connector**



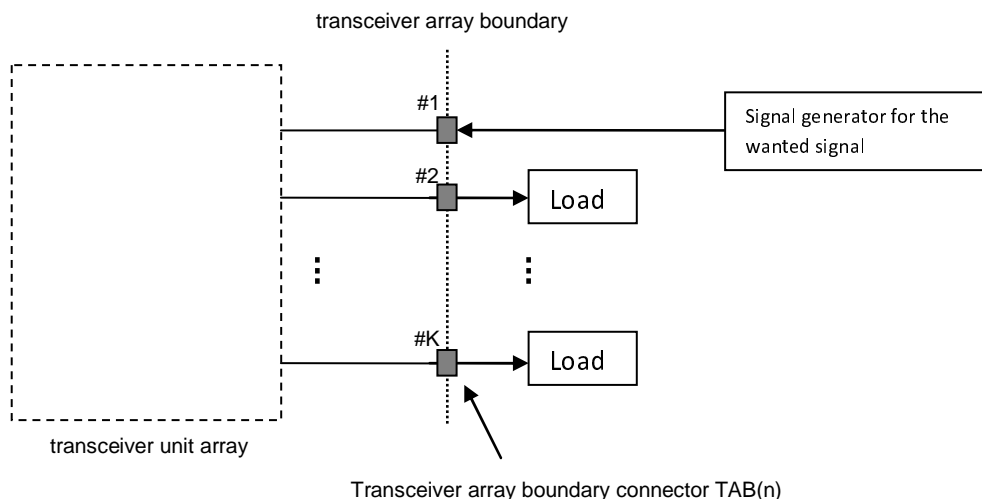
**Figure D.1.3-2: Measuring system set-up for transmitter spurious emissions for multiple TAB connectors in parallel test**

### D.1.4 Time alignment error for SAN type 1-H

The requirement and the measuring system set-up are not applicable in this version of the specification.

## D.2 SAN type 1-H receiver

### D.2.1 Reference sensitivity level for SAN type 1-H



**Figure D.2.1-1: Measuring system set-up for SAN type 1-H reference sensitivity level test**

### D.2.2 Receiver dynamic range for SAN type 1-H

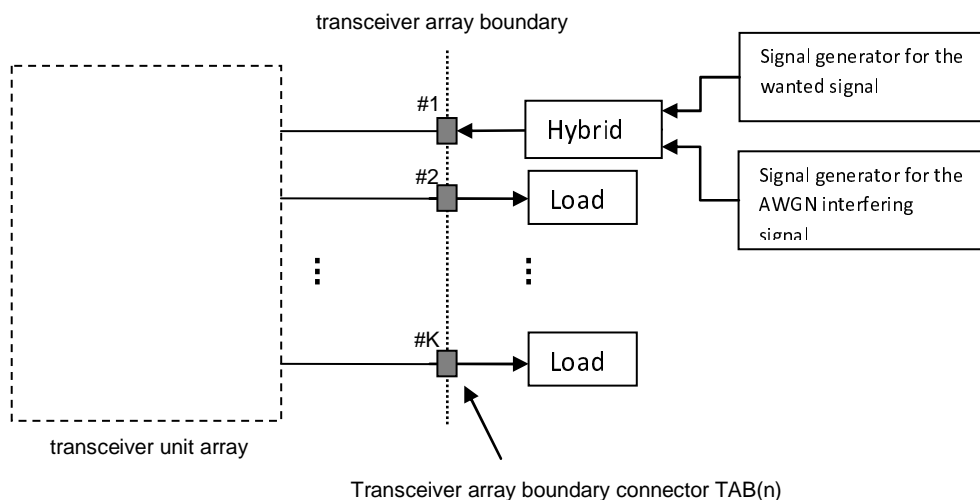


Figure D.2.2-1: Measuring system set-up for SAN type 1-H dynamic range test

### D.2.3 Receiver adjacent channel selectivity for SAN type 1-H

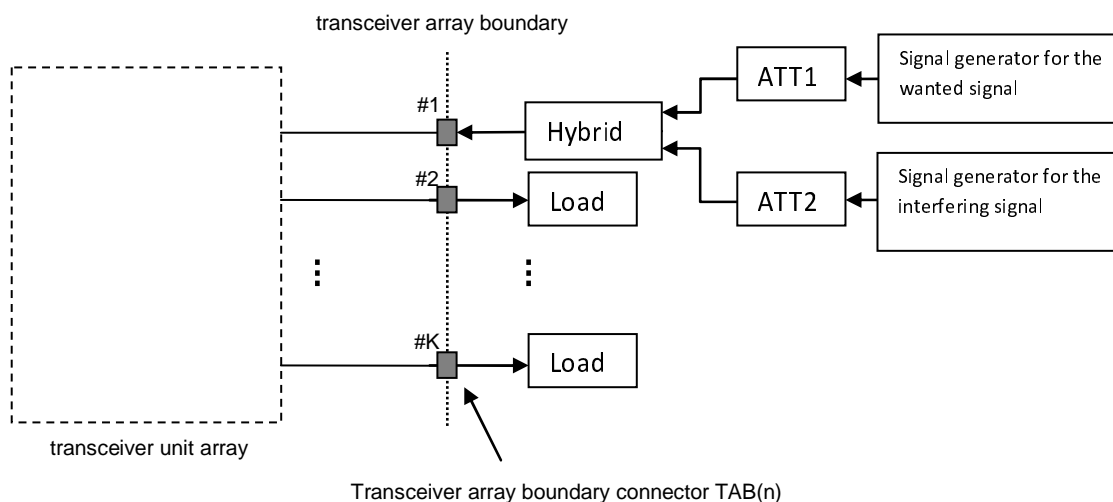


Figure D.2.3-1: Measuring system set-up for SAN type 1-H adjacent channel selectivity and narrowband blocking test

### D.2.4 Receiver spurious emissions

The requirement and the measuring system set-up are not applicable in this version of the specification.

## D.2.5 Receiver In-channel selectivity for SAN type 1-H

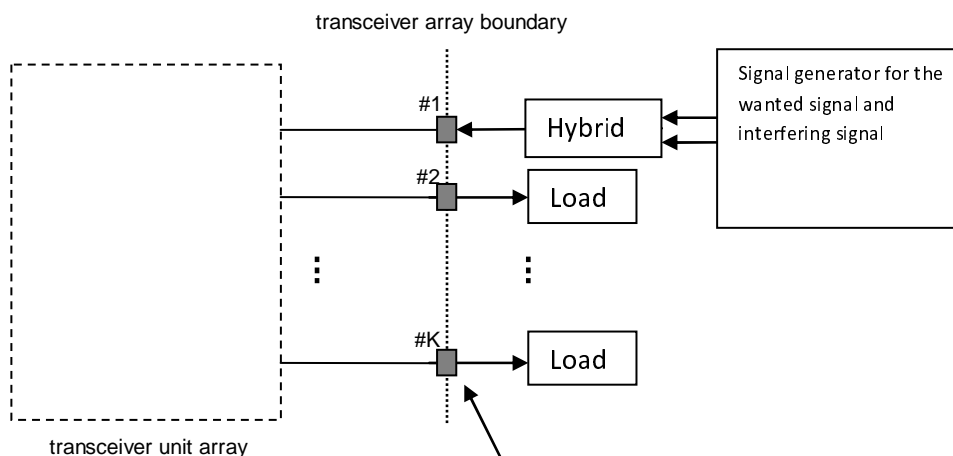


Figure D.2.5-1: Measuring system set-up for SAN type 1-H in-channel selectivity test

## D.2.6 Receiver intermodulation for SAN type 1-H

The requirement and the measuring system set-up are not applicable in this version of the specification.

## D.3 SAN type 1-H and type 1-O transmitter

The OTA chamber configuration shown in this section is intended to be generic and may represent any suitable OTA chamber (e.g. far field anechoic chamber, Compact Antenna Test Range (CATR), near field chamber, Reverberation chamber).

The link between the satellite and the Gateway is made in conducted mode. The Gateway equipment (modems, RF chain, commands, telemetries, etc.) may be partially or completely located outside the chamber.

### D.3.1 Radiated transmit power, OTA output power, OTA output power dynamics, OTA transmitted signal quality, OTA unwanted emissions, OTA transmitter spurious emissions

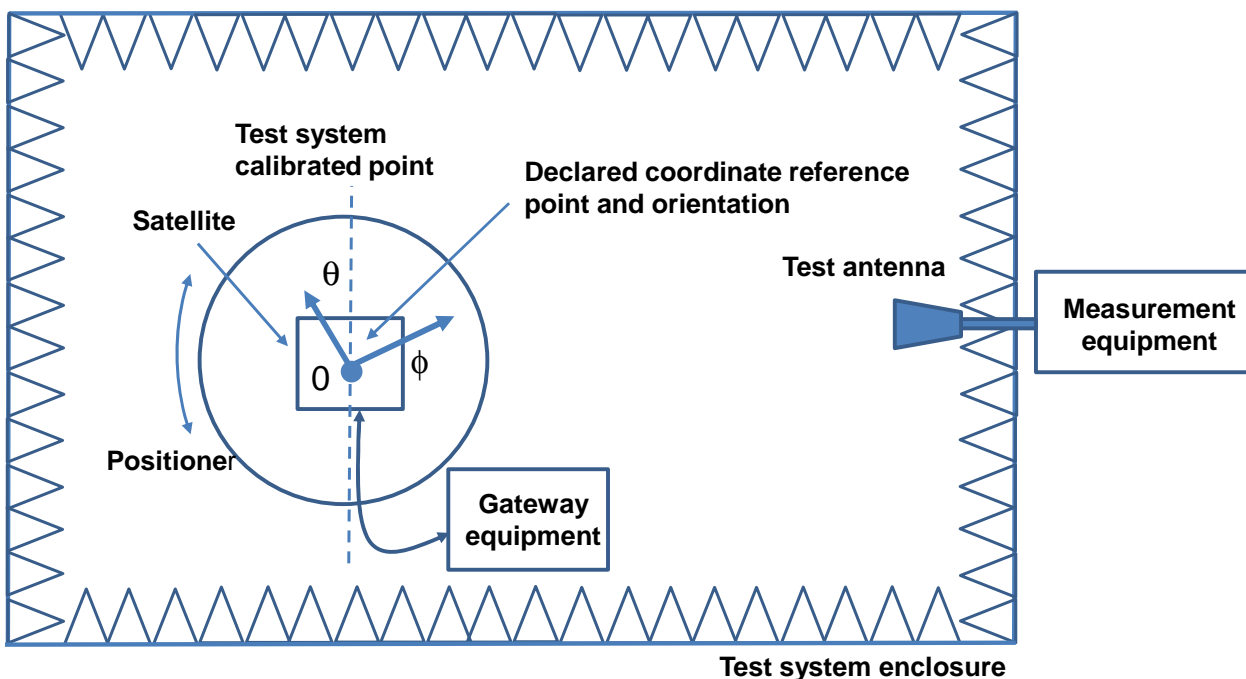


Figure D.3.1-1: Measurement set up for radiated transmit power, OTA output power dynamics and OTA transmitted signal quality (SAN type 1-O)

## D.4 SAN type 1-H and type 1-O receiver

The OTA chamber configurations shown in this section are intended to be generic and may represent any suitable OTA chamber (e.g. Far field anechoic chamber, Compact Antenna Test Range (CATR), Near field chamber).

The link between the satellite and the Gateway is made in conducted mode. The Gateway equipment (modems, RF chain, commands, telemetries, etc.) may be partially or completely located outside the chamber.

### D.4.1 OTA sensitivity and OTA reference sensitivity level

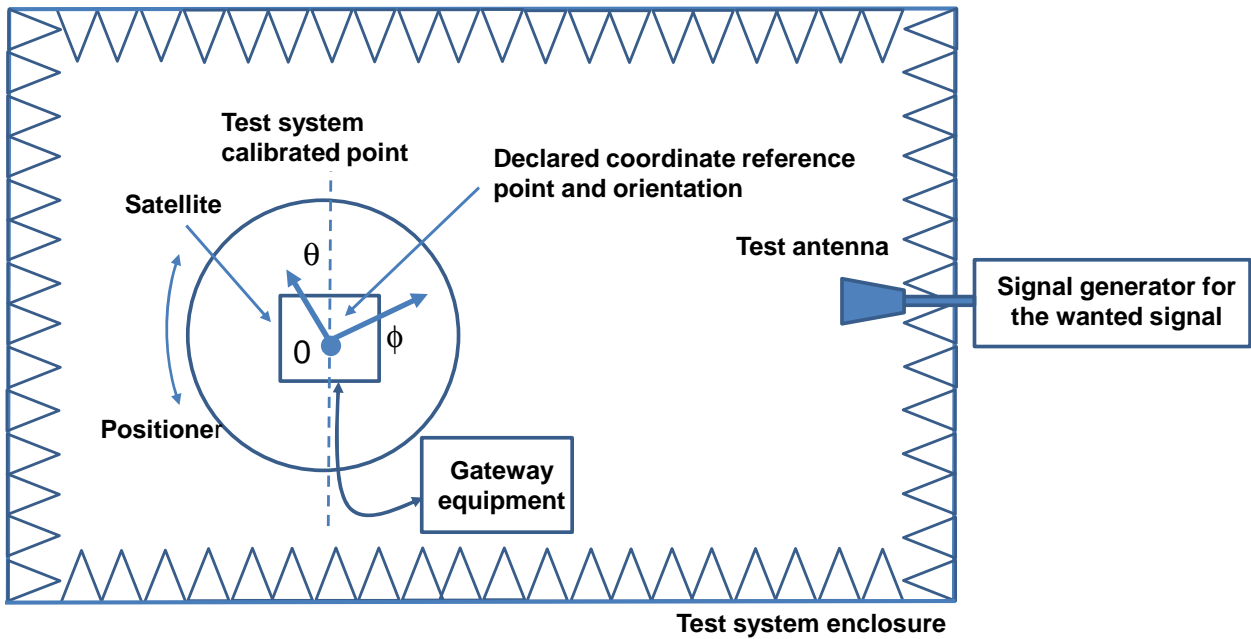


Figure D.4.1-1: Measurement set up for OTA sensitivity and OTA reference sensitivity level

### D.4.2 OTA dynamic range, OTA adjacent channel selectivity

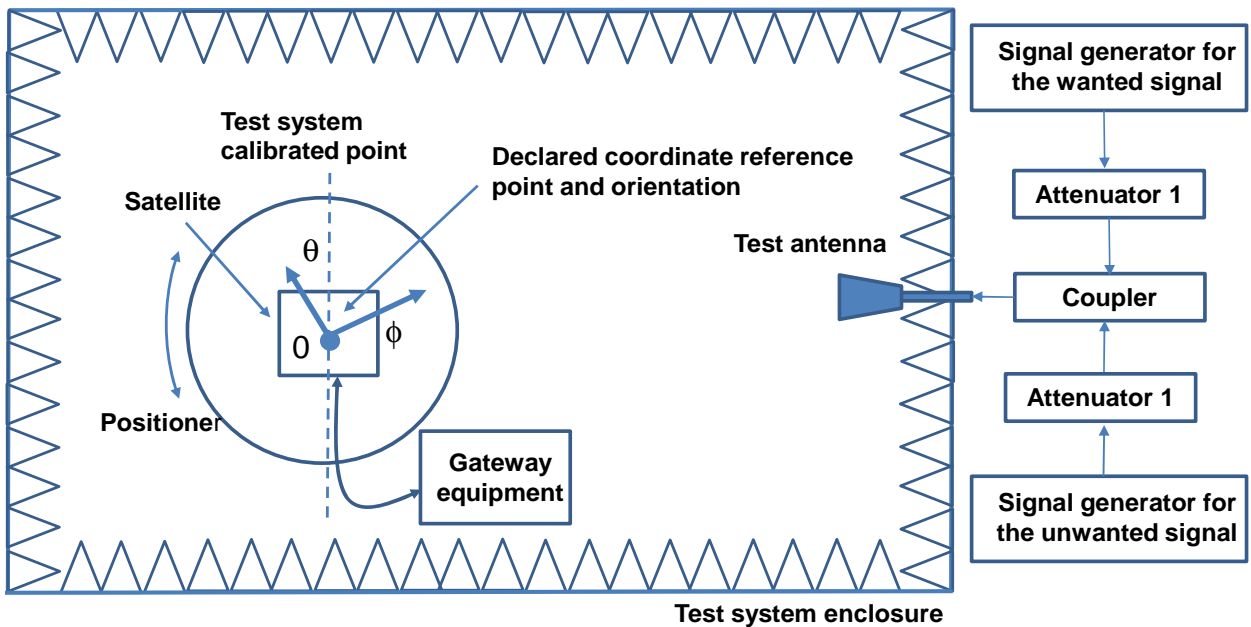


Figure D.4.2-1: Measurement set up for OTA dynamic range

### D.4.3 OTA out-of-band blocking

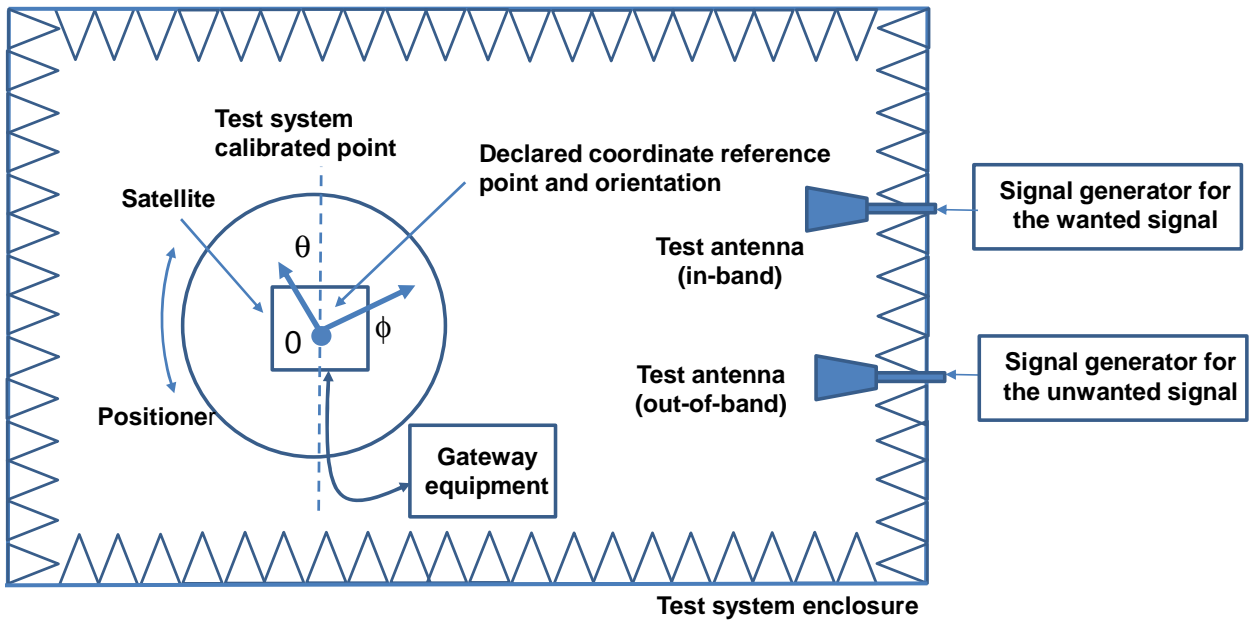


Figure D.4.3-1: Measurement set up for general OTA out-of-band blocking

## D.5 SAN type 1-H performance requirements

### D.5.1 Performance requirements for PUSCH, single user PUCCH, PRACH on single antenna port in multipath fading conditions

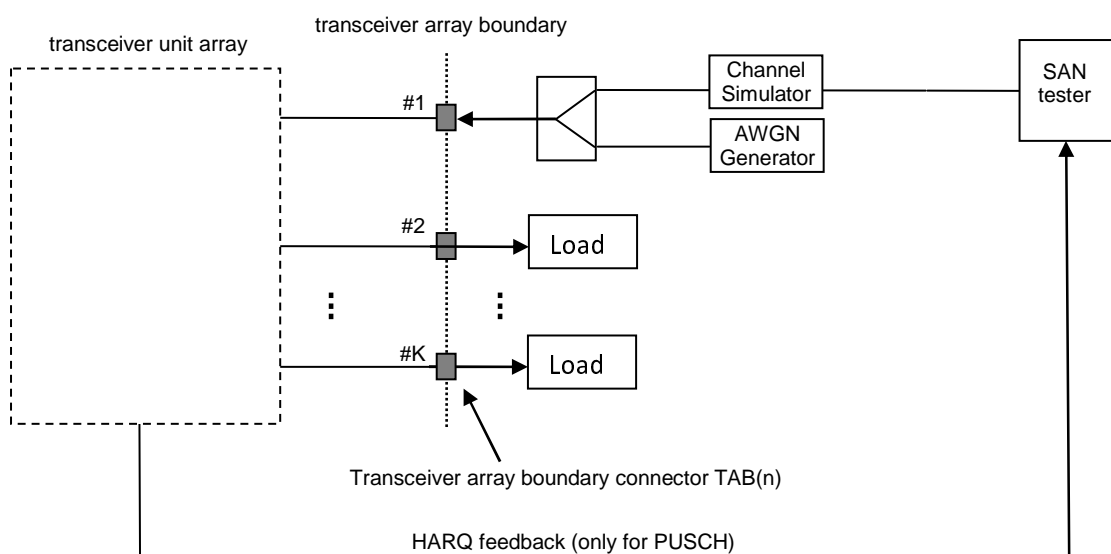
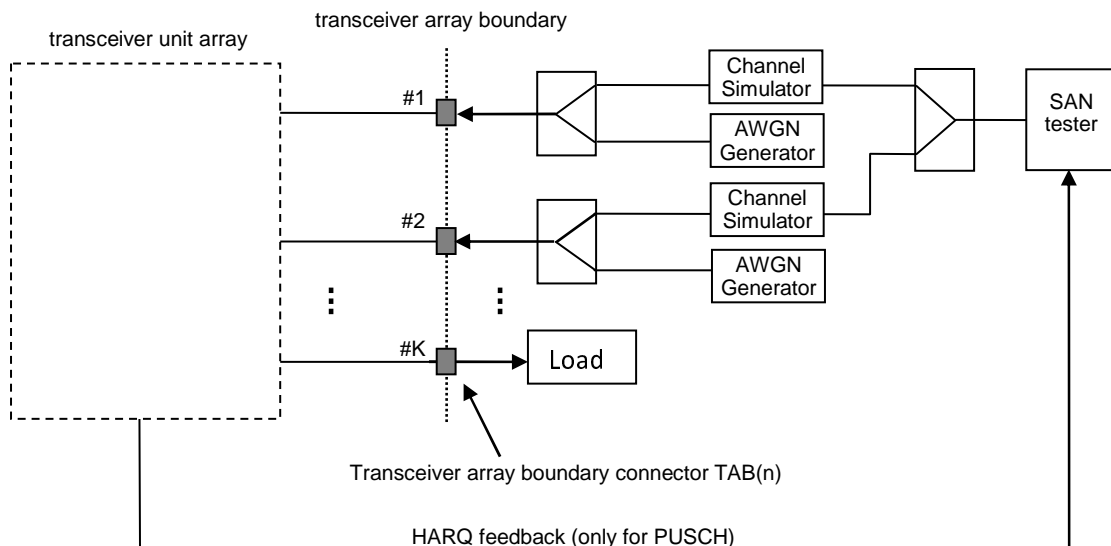


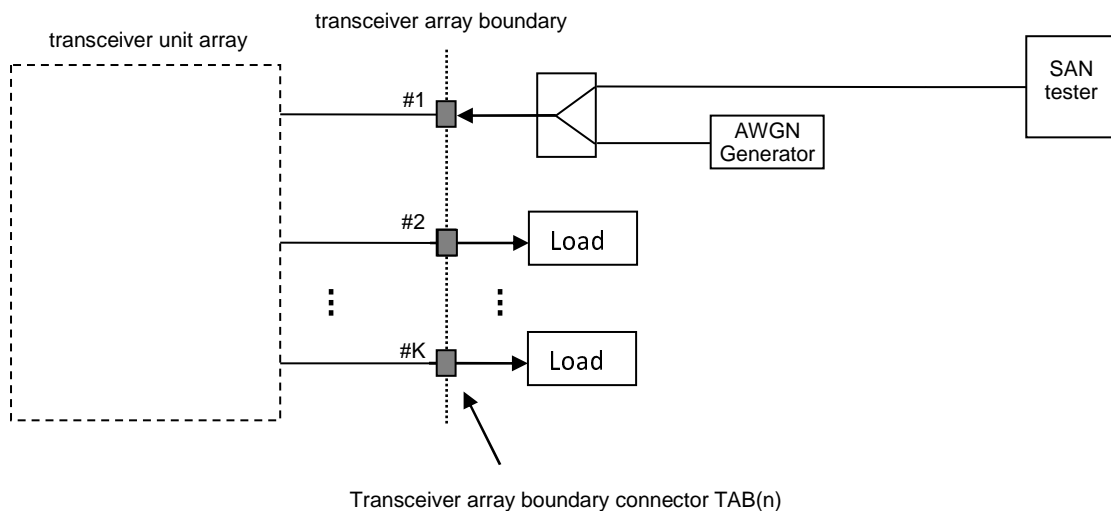
Figure D.5.1-1: Functional set-up for performance requirements for PUSCH, single user PUCCH, PRACH on single antenna port in multipath fading conditions for SAN with 1Rx



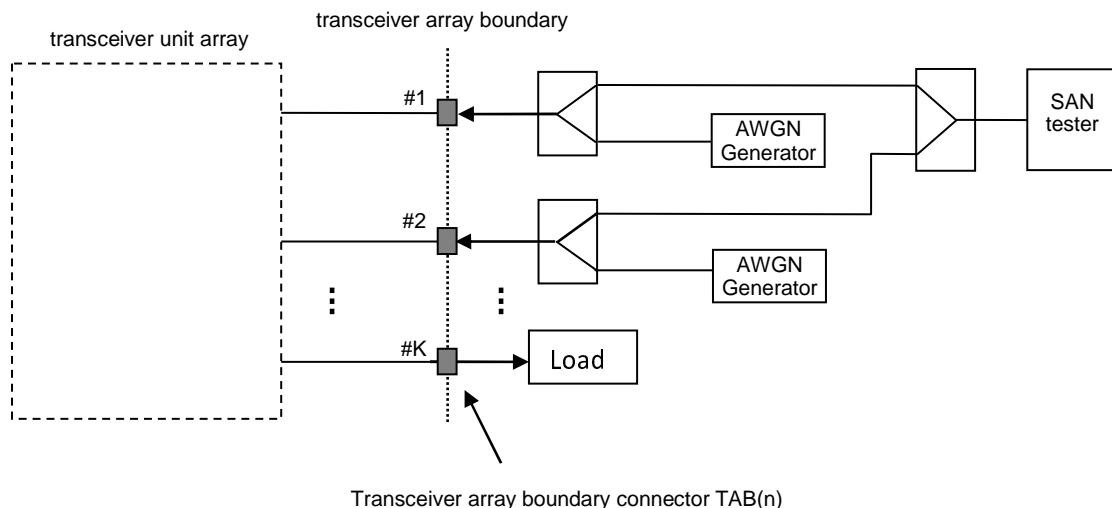
**Figure D.5.1-2: Functional set-up for performance requirements for PUSCH, single user PUCCH, PRACH on single antenna port in multipath fading conditions for SAN with Rx diversity (2 Rx case shown)**

NOTE: The HARQ Feedback could be done as an RF feedback or as a digital feedback. The HARQ Feedback should be error free.

### D.5.2 Performance requirements for PUSCH and PRACH in static conditions

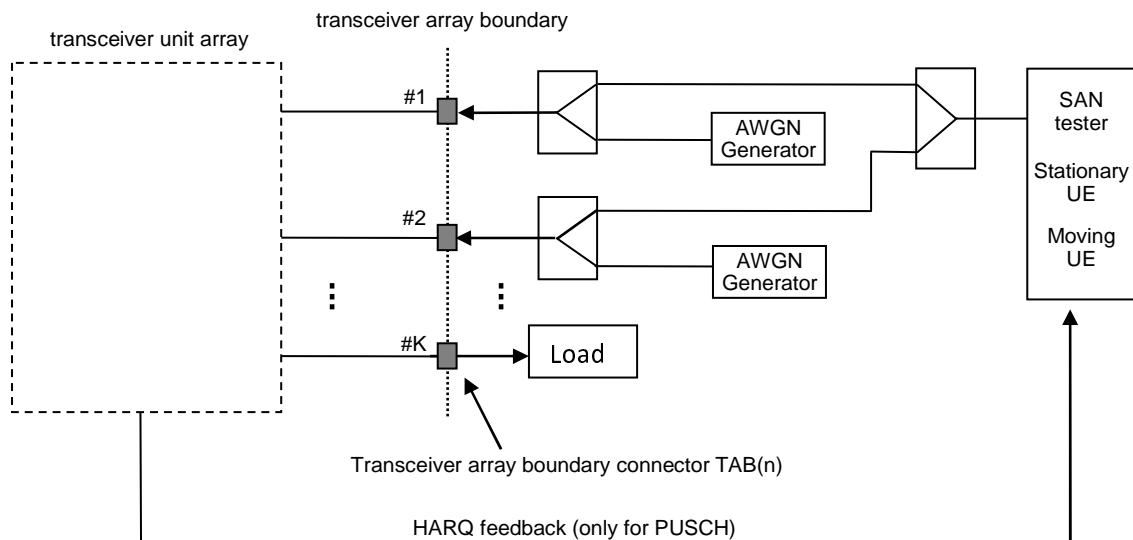


**Figure D.5.2-1: Functional set-up for performance requirements for PUSCH and PRACH in static conditions for SAN with 1Rx case shown**



**Figure D.5.2-2: Functional set-up for performance requirements for PUSCH and PRACH in static conditions for SAN with Rx diversity (2 Rx case shown)**

### D.5.3 Performance requirements for UL timing adjustment



**Figure D.5.3-1: Functional set-up for performance requirement for UL timing adjustment**

NOTE: The HARQ feedback and TA commands could be done as an RF feedback or as a digital feedback. The HARQ feedback and TA commands should be error free.

---

## Annex E (normative): Characteristics of the interfering signals

For E-UTRA SAN, the interfering signal shall be a PUSCH containing data and reference symbols. Normal cyclic prefix is used. The data content shall be uncorrelated to the wanted signal and modulated according to clause 5 of TS 36.211 [7]. Mapping of PUSCH modulation to receiver requirement are specified in table E-1.

**Table E-1: Modulation of the interfering signal for E-UTRA**

Receiver requirement	Modulation
In-channel selectivity	16QAM
Adjacent channel selectivity	QPSK

For standalone NB-IoT standalone SAN, the interfering signal shall be a NPUSCH containing data and reference symbols. Normal cyclic prefix is used. The data content shall be uncorrelated to the wanted signal and modulated according to clause 10.1 of TS 36.211 [7]. Mapping of NPUSCH modulation to receiver requirement are specified in table E-2.

**Table E-2: Modulation of the interfering signal for standalone NB-IoT**

Receiver requirement	Modulation
Adjacent channel selectivity	$\pi/4$ QPSK

## Annex F (normative): Propagation conditions

### F.1 Static propagation condition

The propagation for the static performance measurement is an Additive White Gaussian Noise (AWGN) environment. No fading or multi-paths exist for this propagation model.

### F.2 Multi-path fading propagation conditions

The multipath propagation conditions consist of several parts:

- A delay profile in the form of a "tapped delay-line", characterized by a number of taps at fixed positions on a sampling grid. The profile can be further characterized by the r.m.s. delay spread and the maximum delay spanned by the taps.
- A combination of channel model parameters that include the Delay profile and the Doppler spectrum that is characterized by a classical spectrum shape and a maximum Doppler frequency.

#### F.2.1 Delay profiles

The delay profiles are simplified from the TR 38.811 [13] TDL models. The simplification steps are described in TS 38.108 annex D.2 [14].

##### F.2.1.1 Delay profiles

The delay profiles are selected to be representative of low, medium and high delay spread environment. The resulting model parameters are specified in table F.2.1.1-1 and the tapped delay line models are specified in tables F.2.1.1-2 ~ F.2.1.1-4.

**Table F.2.1.1-1: Delay profiles for NR channel models**

Model	Number of channel taps	Delay spread (r.m.s.)	Maximum excess tap delay (span)	Delay resolution
NTN-TDLA100	3	100 ns	285	5ns
NTN-TDLC5	2	5 ns	60	5ns

**Table F.2.1.1-2: NTN-TDLA100 (DS = 100 ns)**

Tap #	Delay (ns)	Power (dB)	Fading distribution
1	0	0	Rayleigh
2	110	-4.7	Rayleigh
3	285	-6.5	Rayleigh

**Table F.2.1.1-3: NTN-TDLC5 (DS = 5 ns)**

Tap #	Delay (ns)	Power (dB)	Fading distribution
1	0	-0.6	LOS path
	0	-8.9	Rayleigh
2	60	-21.5	Rayleigh

## F.2.2 Combinations of channel model parameters

The propagation conditions used for the performance measurements in multi-path fading environment are indicated as a combination of a channel model name and a maximum Doppler frequency, i.e., NTN-TDLA<DS>-<Doppler> or NTN-TDLC<DS>-<Doppler> where '<DS>' indicates the desired delay spread and '<Doppler>' indicates the maximum Doppler frequency (Hz).

Table F.2.2-1 show the propagation conditions that are used for the performance measurements in multi-path fading environment.

**Table F.2.2-1: Channel model parameters**

<b>Combination name</b>	<b>Tapped delay line model</b>	<b>Maximum Doppler frequency</b>
NTN-TDLA100-5	NTN-TDLA100	5 Hz
NTN-TDLC5-5	NTN-TDLC5	5 Hz
NTN-TDLA100-1	NTN-TDLA100	1 Hz
NTN-TDLC5-1	NTN-TDLC5	1 Hz

---

# Annex G (normative): In-channel Tx test

## G.1 General

The global in-channel Tx test enables the measurement of all relevant parameters that describe the in-channel quality of the output signal of the TX under test in a single measurement process.

The parameters describing the in-channel quality of a transmitter, however, are not necessarily independent. The algorithm chosen for description inside this annex places particular emphasis on the exclusion of all interdependencies among the parameters.

---

## G.2 Basic principle

The process is based on the comparison of the actual output signal of the TX under test, received by an ideal receiver, with a reference signal, that is generated by the measuring equipment and represents an ideal error free received signal. All signals are represented as equivalent (generally complex) baseband signals.

The description below uses numbers and illustrations as examples. These numbers are taken from frame structure 1 with normal CP length and a transmission bandwidth configuration of  $N_{RB} = 100$ . The application of the text below, however, is not restricted to this parameterset.

### G.2.2 Output signal of the TX under test

The output signal of the TX under test is acquired by the measuring equipment and stored for further processing. It is sampled at a sampling rate of 30.72 Msps and it is named  $z(v)$ . In the time domain it comprises at least 1 frame::  $z(v)$ . It is modelled as a signal with the following parameters: demodulated data content, carrier frequency, amplitude and phase for each subcarrier.

### G.2.3 Reference signal

Two types of reference signal are defined:

The reference signal  $i_1(v)$  is constructed by the measuring equipment according to the relevant TX specifications, using the following parameters: demodulated data content, nominal carrier frequency, nominal amplitude and phase for each subcarrier. It is represented as a sequence of samples at a sampling rate of 30.72 Msps in the time domain. The structure of the signal is described in the testmodells.

The reference signal  $i_2(v)$  is constructed by the measuring equipment according to the relevant TX specifications, using the following parameters: restricted data content: nominal Reference Symbols and the Primary Synchronisation Channel, (all other modulation symbols are set to 0 V), nominal carrier frequency, nominal amplitude and phase for each applicable subcarrier, nominal timing. It is represented as a sequence of samples at a sampling rate of 30.72 Msps in the time domain.

### G.2.4 Measurement results

The measurement results, achieved by the global in channel TX test are the following:

- Carrier Frequency error
- EVM (Error Vector Magnitude)
- Resource Element TX power
  - RS TX power (RSTP)

- OFDM Symbol TX power (OSTP)

Other side results are: residual amplitude- and phase response of the TX chain after equalisation.

## G.2.5 Measurement points

Resource element TX power is measured after the FFT as described below. EVM is calculated after the Equalizer (Ampl./ Phase correction). The result of the frequency synchronisation is the frequency offset. It is performed in the pre- and/or post-FFT domain. The FFT window of 2048 samples out of 2194 samples (data +CP) in the time domain is selected in the box CP removal.

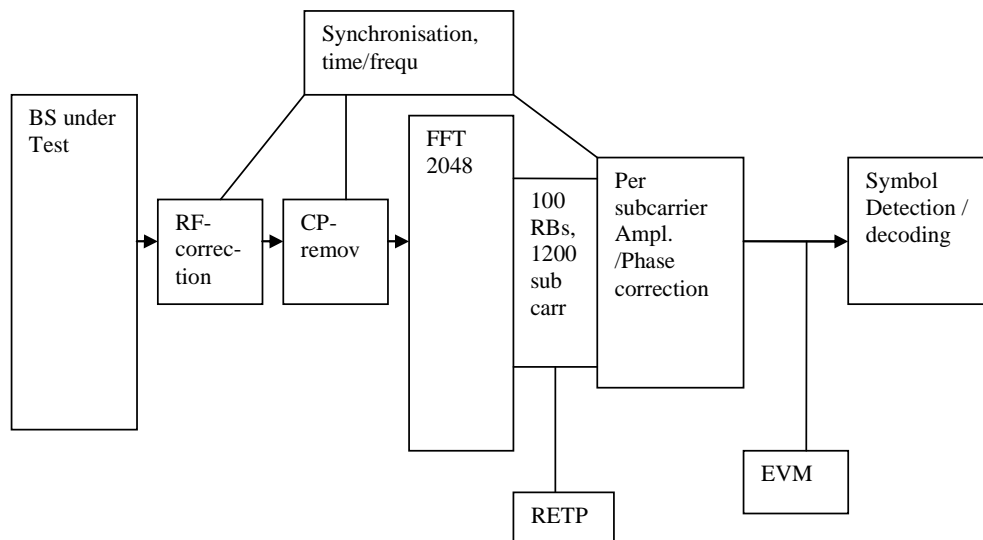


Figure G.2.5-1: Measurement points

## G.3 Pre-FFT minimization process

Sample Timing, Carrier Frequency in  $z(v)$  are varied in order to minimise the difference between  $z(v)$  and  $i_1(v)$ , after the amplitude ratio of  $z(v)$  and  $i_1(v)$  has been scaled. Best fit (minimum difference) is achieved when the RMS difference value between  $z(v)$  and  $i(v)$  is an absolute minimum.

The carrier frequency variation is the measurement result: Carrier Frequency Error.

From the acquired samples one carrier frequency error can be derived.

NOTE 1: The minimisation process, to derive the RF error can be supported by Post FFT operations. However the minimisation process defined in the pre FFT domain comprises all acquired samples (i.e. it does not exclude the samples inbetween the FFT widths and it does not exclude the bandwidth outside the transmission bandwidth configuration).

NOTE 2: The algorithm would allow to derive Carrier Frequency error and Sample Frequency error of the TX under test separately. However there are no requirements for Sample Frequency error. Hence the algorithm models the RF and the sample frequency commonly (not independently). It returns one error and does not distinguish between both.

After this process the samples  $z(v)$  are called  $z^0(v)$ .

## G.4 Timing of the FFT window

The FFT window length is 2048 samples per OFDM symbol. 140 FFTs (286720 samples) cover less than the acquired number of samples (307200 samples in 10 subframes). The position in time for FFT must be determined.

In an ideal signal, the FFT may start at any instant within the cyclic prefix without causing an error. The TX filter, however, reduces the window. The EVM requirements shall be met within a window  $W < CP$ . There are three different instants for FFT:

Centre of the reduced window, called  $\Delta\tilde{c}$ ,  $\Delta C - W/2$  and  $\Delta C + W/2$ ,

The SAN shall transmit a signal according to the Test models, intended for EVM. The primary synchronisation signal and the reference signal shall be used to find the centre of the FFT window.

The timing of the measured signal is determined in the pre FFT domain as follows, using  $z^0(v)$  and  $i_2(v)$ :

1. The measured signal is delay spread by the TX filter. Hence the distinct borders between the OFDM symbols and between Data and CP are also spread and the timing is not obvious.
2. In the Reference Signal  $i_2(v)$  the timing is known.

Correlation between (1) and (2) will result in a correlation peak. The meaning of the correlation peak is approx. the “impulse response” of the TX filter.

3. The meaning of “impulse response” assumes that the autocorrelation of the reference signal  $i_2(v)$  is a Dirac peak and that the correlation between the reference signal  $i_2(v)$  and the data in the measured signal is 0. The correlation peak, (the highest, or in case of more than one highest, the earliest) indicates the timing in the measured signal.

The number of samples, used for FFT is reduced compared to  $z^0(v)$ . This subset of samples is called  $z'(v)$ .

From the acquired samples one timing can be derived.

The timing of the centre  $\Delta\tilde{c}$  with respect to the different CP length in a slot is as follows: (Frame structure 1, normal CP length)

$\Delta\tilde{c}$  is on  $T_{f=72}$  within the CP of length 144 (in OFDM symbol 1 to 6)

$\Delta\tilde{c}$  is on  $T_{f=88}$  (=160-72) within the CP of length 160 (in OFDM symbol 0).

## G.5 Resource Element TX power

Perform FFT ( $z'(v)$ ) with the FFT window timing  $\Delta\tilde{c}$

The result is called  $Z'(t,f)$ . The RE TX power is then defined as:

$$RETP = |Z'(t, f)|^2 \cdot 15 \text{ KHz}$$

From this the Reference Signal Transmit power (RSTP) is derived as follows:

$$RSTP = \frac{1}{n_{RSRElocations \text{ within subframe}}} \sum RETP,$$

It is an average power and accumulates the powers of the reference symbols within a sub frame divided by n, the number of reference symbols within a sub frame.

From RETP the OFDM Symbol TX power (OSTP) is derived as follows:

$$OSTP = \sum_{\substack{\text{all } N_{RB}^{DL} N_{sc}^{RB} \text{ RE locations} \\ \text{of 4th symbol within subframe}}} RETP$$

It accumulates all sub carrier powers of the 4th OFDM symbol. The 4th (out of 14 OFDM symbols within a subframe (in case of frame type 1, normal CP length)) contains exclusively PDSCH.

From the acquired samples 10 values for each RSTP and OSTP can be derived.

## G.6 Post FFT equalisation

Perform 140 FFTs on  $z'(v)$ , one for each OFDM symbol comprising the full frame with the FFT window timing  $\Delta\tilde{C}$ . (in case of frame type 1, normal CP length) The result is an array of samples, 140 in the time axis  $t$  times 2048 in the frequency axis  $G$ .

The equalizer coefficients  $\tilde{a}(f)$  and  $\tilde{\varphi}(f)$  are determined as follows:

1. Calculate the complex ratios (amplitude and phase) of the post-FFT acquired signal  $Z'(t, f)$  and the post-FFT Ideal signal  $I_2(t, f)$ , for each reference symbol, over 10 subframes. This process creates a set of complex ratios:

$$a(t, f) \cdot e^{j\varphi(t, f)} = \frac{Z'(t, f)}{I_2(t, f)}$$

2. Perform time averaging at each reference signal subcarrier of the complex ratios, the time-averaging length is 10 subframes. Prior to the averaging of the phases  $\phi(t_i, f)$  an unwrap operation must be performed according to the following definition: The unwrap operation corrects the radian phase angles of  $\phi(t_i, f)$  by adding multiples of  $2\pi$  when absolute phase jumps between consecutive time instances  $t_i$  are greater than or equal to the jump tolerance of  $\pi$  radians. This process creates an average amplitude and phase for each reference signal subcarrier (i.e. every third subcarrier with the exception of the reference subcarrier spacing across the DC subcarrier).

$$a(f) = \frac{\sum_{i=1}^N a(t_i, f)}{N}$$

$$\varphi(f) = \frac{\sum_{i=1}^N \varphi(t_i, f)}{N}$$

Where  $N$  is the number of reference symbol time-domain locations  $t_i$  from  $Z'(f, t)$  for each reference signal subcarrier  $f$ .

3. The equalizer coefficients for amplitude and phase  $\hat{a}(f)$  and  $\hat{\varphi}(f)$  at the reference signal subcarriers are obtained by computing the moving average in the frequency domain of the time-averaged reference signal subcarriers, i.e. every third subcarrier. The moving average window size is 19. For reference subcarriers at or near the edge of the channel the window size is reduced accordingly as per figure G.6.
4. Perform linear interpolation from the equalizer coefficients  $\hat{a}(f)$  and  $\hat{\varphi}(f)$  to compute coefficients  $\tilde{a}(f)$ ,  $\tilde{\varphi}(f)$  for each subcarrier.

The equalized samples are called  $Z'_{eq}(f, t)$ .

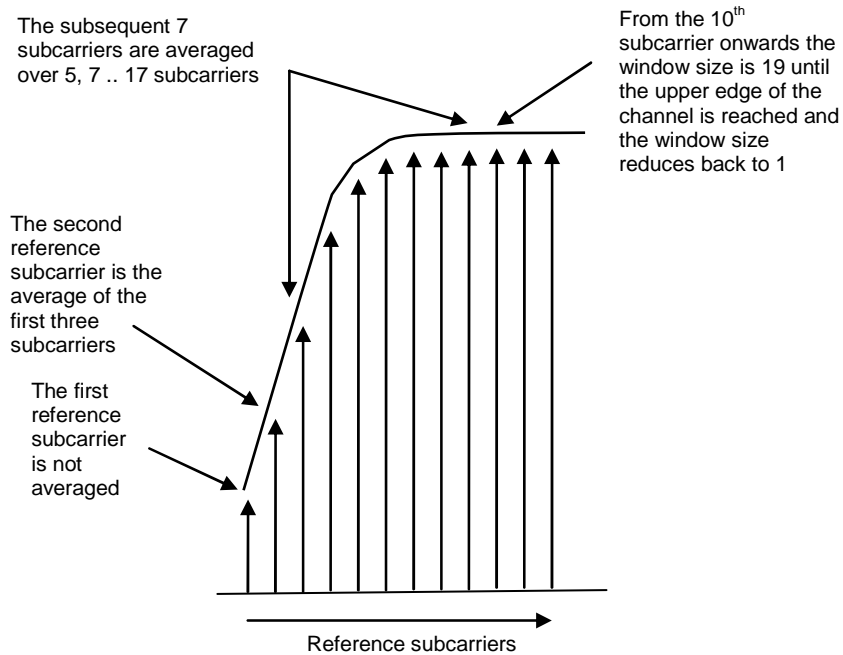


Figure G.6-1: Reference subcarrier smoothing in the frequency domain

## G.7 EVM

### G.7.1 General

For EVM create two sets of  $Z'_{eq}(f,t)$ , according to the timing " $\Delta C - W/2$  and  $\Delta C + W/2$ ", using the equalizer coefficients from G.3.4.

The equivalent ideal samples are calculated from  $i_1(v)$  (clause G.2.3) and are called  $I(f,t)$ .

The EVM is the difference between the ideal waveform and the measured and equalized waveform.

$$EVM = \sqrt{\frac{\sum_{t \in T} \sum_{f \in F(t)} |Z'_{eq}(f,t) - I(f,t)|^2}{\sum_{t \in T} \sum_{f \in F(t)} |I(f,t)|^2}}$$

where

$T$  is the set of symbols with the considered modulation scheme being active within the subframe or within the sTTI,

$F(t)$  is the set of subcarriers within the  $N_{SC}^{RB}$  resource blocks with the considered modulation scheme being active in symbol  $t$ ,

$I(t,f)$  is the ideal signal reconstructed by the measurement equipment in accordance with relevant Test models,

$Z'_{eq}(t,f)$  is the equalized signal under test.

NOTE 1: Although the basic unit of measurement is one subframe or one sTTI, the equalizer is calculated over the entire 10 subframes measurement period to reduce the impact of noise in the reference symbols.

NOTE 2: Applicability of EVM calculation:

One EVM value is associated to 12 subcarriers times 1 subframe = pair of 2 RBs = 168 resource elements. For sTTI, one EVM value is associated to 12 subcarriers times 1 slot or 84 resource elements (slot TTI) or times 1 subslot or 24/36 resource elements (subslot TTI).

But only a reduced number of REs in this pair of 2 RBs contribute to EVM. Those are the PDSCH or sPDSCH REs, containing the considered modulation scheme. Only those pairs of 2 RBs are evaluated with respect to EVM, which contain the maximum number of PDSCH or sPDSCH REs. (EVM-relevant location in the time/frequency grid) The others are not evaluated.

In specific:

- For bandwidth 1.4 MHz:
  - Only the pairs of 2 RBs containing 138 PDSCH REs are used for EVM. Only those 138 REs contribute to EVM
  - All pairs of 2 RBs, which contain less than 138 PDSCH REs, are not evaluated with respect to EVM.
- For all other Bandwidths:
  - Only the pairs of 2 RBs containing 150 PDSCH REs are used for EVM. Only those 150 REs contribute to EVM
  - All pairs of 2 RBs, which contain less than 150 PDSCH REs, are not evaluated with respect to EVM.
- For sTTI and all bandwidths:
  - Only when EVM value could be evaluated over [84] sPDSCH REs for slot TTI or [24 or 36] sPDSCH REs for subslot TTI, value is considered for EVM.
  - When there are less than [84] REs for slot TTI or [24 or 36] REs for subslot TTI value is not considered with respect to EVM.

This restriction serves to avoid weighted averaging in G.7.2.

## G.7.2 Averaged EVM

EVM is averaged over all allocated EVM relevant locations in the frequency domain, and 10 consecutive downlink subframes (10 ms):

$\overline{EVM}$  is derived by: square the EVM results in G.7.1, sum the squares over all EVM relevant locations in the time/frequency grid, divide the sum by the number of EVM relevant locations, square-root the quotient.

The EVM requirements should be tested against the maximum of the average EVM at the window W extremities of the EVM measurements:

Thus  $\overline{EVM}_l$  is calculated using  $\Delta\tilde{t} = \Delta\tilde{t}_l$  in the expressions above and  $\overline{EVM}_h$  is calculated using  $\Delta\tilde{t} = \Delta\tilde{t}_h$ . (l and h, low and high. Where l is the timing  $\Delta C - W/2$  and high is the timing  $\Delta C + W/2$ )

Thus we get:

$$EVM_{final} = \max(\overline{EVM}_l, \overline{EVM}_h)$$

For TDD special fields (DwPTS and GP) are not included in the averaging.

## G.7.3 Averaged EVM (TDD)

For TDD the averaging in the time domain can be calculated from subframes or slots (for slot TTI) of different frames and should have a minimum of 10 subframes averaging length. TDD special fields (DwPTS and GP) are not included in the averaging.

$\overline{EVM}_{frame}$  is derived by: Square the EVM results in a frame. Relevant for EVM are subframes or slots (for slot TTI) in a frame, which are active in the DL,  $N_{dl}$ . Within these subframes or slots, those RBs are relevant, that carry the maximum number of PDSCH REs (same as FDD) or sPDSCH REs (slot TTI). Sum the squares, divide the sum by the number of EVM relevant locations, square-root the quotient. (RMS)

The  $EVM_{frame}$  is calculated, using the maximum of  $\overline{EVM}_{frame}$  at the window  $W$  extremities. Thus  $\overline{EVM}_{frame,l}$  is calculated using  $\Delta\tilde{t} = \Delta\tilde{t}_l$  and  $\overline{EVM}_{frame,h}$  is calculated using  $\Delta\tilde{t} = \Delta\tilde{t}_h$ . (l and h, low and high. Where l is the timing  $\Delta C - W/2$  and and high is the timing  $\Delta C + W/2$ )

$$EVM_{frame} = \max(\overline{EVM}_{frame,l}, \overline{EVM}_{frame,h})$$

In order to unite at least 10 subframes, consider the minimum integer number of radio frames, containing at least 10 EVM relevant subframes. Unite by RMS.

$$\overline{EVM} = \sqrt{\frac{1}{N_{frame}} \sum_{k=1}^{N_{frame}} EVM_{frame,k}^2}, \quad N_{frame} = \left\lceil \frac{10}{N_{dl}} \right\rceil$$

The result,  $\overline{EVM}$ , is compared against the limit.

## Annex H (informative): Change history

Change history							
Date	Meeting	TDoc	CR	Rev	Cat	Subject/Comment	New version
2023-03	RAN4#106	R4-2302451				First version of the skeleton	0.0.1
2023-04	RAN4#106bis-e	R4-2305949				First version of the specification	0.1.0
2023-05	RAN4#107	R4-2309902				TS 36.181 specification	0.2.0
2023-06	RAN#100	RP-231436				TS 36.181 provided for 1-step approval to RAN #100	1.0.0
2023-06	RAN#100					First version of Release 18	18.0.0
2023-09	RAN#101	RP-232510	0001	1	F	[LTE_NBIoT_eMTC_NTN_req] CR on TS 36.181 for SAN Demodulation on PUSCH	18.1.0
2023-09	RAN#101	RP-232510	0004	1	F	CR to 36.181: Test model correction for total power dynamic range requirements	18.1.0
2023-09	RAN#101	RP-232510	0006	1	F	[LTE_NBIoT_eMTC_NTN_req-Perf] CR on IOT NTN demodulation performance requirements (TS36.181, Rel-18)	18.1.0
2023-12	RAN#102	RP-233357	0008	1	F	CR on Unwanted emission requirement for IoT NTN	18.2.0
2024-03	RAN#103	RP-240582	0011		F	(LTE_NBIoT_eMTC_NTN_req-Perf) CR on IOT NTN demodulation performance requirements (TS36.181, Rel-18)	18.3.0
2024-03	RAN#103	RP-240578	0012		B	CR to TS36.181 Introduction of the extended L-band	18.3.0
2024-03	RAN#103	RP-240579	0013		B	CR to TS36.181 Introduction of a new FDD band (L+S band) for IoT NTN operation	18.3.0
2024-06	RAN#104	RP-241411	0016		F	[LTE_NBIoT_eMTC_NTN_req-Perf] CR on TS 36.181 for SAN Demodulation	18.4.0
2024-06	RAN#104	RP-241411	0017		F	(LTE_NBIoT_eMTC_NTN_req-Perf)CR for TS 36.181, Correction on antenna connector for demodulation requirements	18.4.0
2024-06	RAN#104	RP-241411	0018		F	(LTE_NBIoT_eMTC_NTN_req-Perf)CR for TS 36.181, Correction on general SAN transmitter spurious emission limits	18.4.0
2024-06	RAN#104	RP-241411	0020	1	F	CR to TS 36.181: Band-agnostic OBUE requirement	18.4.0
2024-09	RAN105	RP-242151	0021		F	(LTE_NBIoT_eMTC_NTN_req-Perf)CR for TS36.181, Correction on Number of RX antennas in header row of tables for radiated demodulation test requirements	18.5.0
2024-09	RAN105	RP-242151	0022		F	(LTE_NBIoT_eMTC_NTN_req) Collection of IoT-NTN SAN demodulation conformance requirements	18.5.0
2025-03	RAN#107	RP-250600	0023	2	F	(LTE_NBIoT_eMTC_NTN_req-Perf) CR for TS36.181, Correction on non-regenerative payload and gateway for IoT NTN	18.6.0
2025-03	RAN#107	RP-250611	0024	1	B	(TEI18) CR to 36.181 NB-IoT In-band operation with NTN NR [NTNBIoT_inbandNTNRR]	18.6.0
2025-06	RAN#108	RP-250937	0025		B	CR to TS 36.181: Introduction of IoT-NTN band 252	19.0.0
2025-09	RAN#109	RP-252390	0028		A	Missing Correlation Matrix info (8.2 TC; 36.181; Rel 19)	19.1.0
2025-09	RAN#109	RP-252390	0030		A	Channel Model Parameters Annex F update for 36.181 TC 8.5 - Rel 19	19.1.0
2025-12	RAN#110	RP-253668	0033		A	(LTE_NBIoT_eMTC_NTN_req-Perf)Correction CR on IoT NTN requirement in 36.181	19.2.0

---

## History

<b>Version</b>	<b>Date</b>	<b>Status</b>
V19.1.0	October 2025	Publication
V19.2.0	February 2026	Publication