

ETSI TS 129 392 V19.2.0 (2026-07)



TECHNICAL SPECIFICATION

**5G;
Application layer support for MMTel;
MMTel Enabler Server Services;
stage 3
(3GPP TS 29.392 version 19.2.0 Release 19)**



Reference

RTS/TSGC-0329392vj20

Keywords

5G

ETSI

650 Route des Lucioles
F-06921 Sophia Antipolis Cedex - FRANCE

Tel.: +33 4 92 94 42 00 Fax: +33 4 93 65 47 16

Siret N° 348 623 562 00017 - APE 7112B
Association à but non lucratif enregistrée à la
Sous-Préfecture de Grasse (06) N° w061004871

Important notice

The present document can be downloaded from the
[ETSI Search & Browse Standards](#) application.

The present document may be made available in electronic versions and/or in print. The content of any electronic and/or print versions of the present document shall not be modified without the prior written authorization of ETSI. In case of any existing or perceived difference in contents between such versions and/or in print, the prevailing version of an ETSI deliverable is the one made publicly available in PDF format on [ETSI deliver](#) repository.

Users should be aware that the present document may be revised or have its status changed,
this information is available in the [Milestones listing](#).

If you find errors in the present document, please send your comments to
the relevant service listed under [Committee Support Staff](#).

If you find a security vulnerability in the present document, please report it through our
[Coordinated Vulnerability Disclosure \(CVD\)](#) program.

Notice of disclaimer & limitation of liability

The information provided in the present deliverable is directed solely to professionals who have the appropriate degree of experience to understand and interpret its content in accordance with generally accepted engineering or other professional standard and applicable regulations.

No recommendation as to products and services or vendors is made or should be implied.

No representation or warranty is made that this deliverable is technically accurate or sufficient or conforms to any law and/or governmental rule and/or regulation and further, no representation or warranty is made of merchantability or fitness for any particular purpose or against infringement of intellectual property rights.

In no event shall ETSI be held liable for loss of profits or any other incidental or consequential damages.

Any software contained in this deliverable is provided "AS IS" with no warranties, express or implied, including but not limited to, the warranties of merchantability, fitness for a particular purpose and non-infringement of intellectual property rights and ETSI shall not be held liable in any event for any damages whatsoever (including, without limitation, damages for loss of profits, business interruption, loss of information, or any other pecuniary loss) arising out of or related to the use of or inability to use the software.

Copyright Notification

No part of this document may be reproduced in any form, by any means and in any media, without the prior written authorization of ETSI and except as expressly permitted below.

By way of exception and when the document is a normative deliverable (European Standard (EN), Technical Specification (TS), Group Specification (GS) or ETSI Standard (ES)), ETSI authorizes to reproduce and incorporate into products, services and technical documentation only those extracts (e.g. templates) that are strictly necessary for the technical implementation of the normative deliverable, to ensure compliance with the latter. Nothing in this notice shall be construed as limiting any mandatory exceptions to copyright provided by applicable law.

© ETSI 2026.
All rights reserved.

Intellectual Property Rights

Essential patents

IPRs essential or potentially essential to normative deliverables (European Standard (EN), Technical Specification (TS), Group Specification (GS) or ETSI Standard (ES)) may have been declared to ETSI. The declarations pertaining to these essential IPRs, if any, are publicly available for **ETSI members and non-members**, and can be found in ETSI SR 000 314: *"Intellectual Property Rights (IPRs); Essential, or potentially Essential, IPRs notified to ETSI in respect of ETSI standards"*, which is available from the ETSI Secretariat. Latest updates are available on the [ETSI IPR online database](#).

Pursuant to the ETSI Directives including the ETSI IPR Policy, no investigation regarding the essentiality of IPRs, including IPR searches, has been carried out by ETSI. No guarantee can be given as to the existence of other IPRs not referenced in ETSI SR 000 314 (or the updates on the ETSI Web server) which are, or may be, or may become, essential to the present document.

Trademarks

The present document may include trademarks and/or tradenames which are asserted and/or registered by their owners. ETSI claims no ownership of these except for any which are indicated as being the property of ETSI, and conveys no right to use or reproduce any trademark and/or tradename. Mention of those trademarks in the present document does not constitute an endorsement by ETSI of products, services or organizations associated with those trademarks.

DECT™, **PLUGTESTS™**, **UMTS™** and the ETSI logo are trademarks of ETSI registered for the benefit of its Members. **3GPP™**, **LTE™** and **5G™** logo are trademarks of ETSI registered for the benefit of its Members and of the 3GPP Organizational Partners. **oneM2M™** logo is a trademark of ETSI registered for the benefit of its Members and of the oneM2M Partners. **GSM®** and the GSM logo are trademarks registered and owned by the GSM Association.

BLUETOOTH® is a trademark registered and owned by Bluetooth SIG, Inc.

Legal Notice

This Technical Specification (TS) has been produced by ETSI 3rd Generation Partnership Project (3GPP).

The present document may refer to technical specifications or reports using their 3GPP identities. These shall be interpreted as being references to the corresponding ETSI deliverables.

The cross reference between 3GPP and ETSI identities can be found at [3GPP to ETSI numbering cross-referencing](#).

Modal verbs terminology

In the present document "**shall**", "**shall not**", "**should**", "**should not**", "**may**", "**need not**", "**will**", "**will not**", "**can**" and "**cannot**" are to be interpreted as described in clause 3.2 of the [ETSI Drafting Rules](#) (Verbal forms for the expression of provisions).

"**must**" and "**must not**" are **NOT** allowed in ETSI deliverables except when used in direct citation.

Contents

Intellectual Property Rights	2
Legal Notice	2
Modal verbs terminology.....	2
Foreword.....	8
1 Scope	10
2 References	10
3 Definitions of terms, symbols and abbreviations	11
3.1 Definitions	11
3.2 Symbols.....	11
3.3 Abbreviations	11
4 Overview	11
5 Services offered by the MMTel Enabler Server.....	13
5.1 Introduction	13
5.2 MMTel_DCAppManagement Service	13
5.2.1 Service Description.....	13
5.2.2 Service Operations.....	13
5.2.2.1 Introduction.....	13
5.2.2.2 MMTel_DCAppManagement_Configure	14
5.2.2.2.1 General	14
5.2.2.2.2 DC Application and Profile Configuration.....	14
5.2.2.3 MMTel_DCAppManagement_Update.....	15
5.2.2.3.1 General	15
5.2.2.3.2 DC Application and Profile Update.....	15
5.2.2.4 MMTel_DCAppManagement_Delete.....	15
5.2.2.4.1 General	15
5.2.2.4.2 DC Application and Profile Deletion	15
5.2.2.5 MMTel_DCAppManagement_Retrieval.....	16
5.2.2.5.1 General	16
5.2.2.5.2 DC Application and Profile Retrieval.....	16
5.3 MMTel_DCAppCall Service.....	18
5.3.1 Service Description.....	18
5.3.2 Service Operations.....	18
5.3.2.1 Introduction.....	18
5.3.2.2 MMTel_DCAppCall_DCCallReq.....	18
5.3.2.2.1 General	18
5.3.2.2.2 DC Call Establishment	18
5.3.2.3 MMTel_DCAppCall_UpdateDCMedia.....	19
5.3.2.3.1 General	19
5.3.2.3.2 DC Media Update.....	19
5.3.2.4 MMTel_DCAppCall_Notify	20
5.3.2.4.1 General	20
5.3.2.4.2 DC Media Notification	20
5.4 MMTel_CallEvent Service.....	21
5.4.1 Service Description.....	21
5.4.2 Service Operations.....	21
5.4.2.1 Introduction.....	21
5.4.2.1A Void.....	21
5.4.2.2 MMTel_CallEvent_Notify	21
5.4.2.2.1 General	21
5.4.2.2.2 Session Event Notification	21
5.5 MMTel_CallControl Service.....	22
5.5.1 Service Description.....	22
5.5.2 Service Operations.....	22

5.5.2.1	Introduction	22
5.5.2.2	MMTel_CallControl_Create	22
5.5.2.2.1	General	22
5.5.2.2.2	IMS session Creation.....	22
5.5.2.3	MMTel_CallControl_Update	23
5.5.2.3.1	General	23
5.5.2.3.2	IMS session Update.....	23
5.5.2.3.3	Void.....	24
5.5.2.4	MMTel_CallControl_Delete	24
5.5.2.4.1	General	24
5.5.2.4.2	IMS session Deletion.....	24
5.5.2.5	MMTel_CallControl_Notify	25
5.5.2.5.1	General	25
5.5.2.5.2	IMS Session Notification.....	25
6	API Definitions	26
6.1	MMTel_DCAppManagement API.....	26
6.1.1	Introduction.....	26
6.1.2	Usage of HTTP and common API related aspects.....	26
6.1.3	Resources.....	26
6.1.3.1	Overview.....	26
6.1.3.2	Resource: DC APP.....	27
6.1.3.2.1	Description	27
6.1.3.2.2	Resource Definition.....	27
6.1.3.2.3	Resource Standard Methods	27
6.1.3.2.4	Resource Custom Operations	28
6.1.4	Custom Operations without associated resources.....	31
6.1.5	Notifications	31
6.1.6	Data Model	31
6.1.6.1	General.....	31
6.1.6.2	Structured data types.....	32
6.1.6.2.1	Introduction	32
6.1.6.2.2	Type: DcAppConfigReq.....	33
6.1.6.2.3	Type: DcAppConfigParameters.....	34
6.1.6.2.4	Type: DcAppConfigResp	35
6.1.6.2.5	Type: DcAppConfigResponseParameters	35
6.1.6.2.6	Type: DcAppUpdateReq	35
6.1.6.2.7	Type: DcAppUpdateParameters	36
6.1.6.2.8	Type: DcAppStatResp	37
6.1.6.2.9	Type: DcAppResponseParameters	37
6.1.6.2.10	Type: DcAppIdReq	37
6.1.6.2.11	Type: DcAppIdResp.....	37
6.1.6.3	Simple data types and enumerations	38
6.1.6.3.1	Introduction	38
6.1.6.3.2	Simple data types.....	38
6.1.6.3.3	Enumeration: AppLoadPhase	38
6.1.6.3.4	Enumeration: SupportScenario.....	38
6.1.6.3.5	Enumeration: Status.....	38
6.1.6.3.6	Enumeration: Condition	38
6.1.7	Error Handling.....	39
6.1.7.1	General.....	39
6.1.7.2	Protocol Errors	39
6.1.7.3	Application Errors.....	39
6.1.8	Feature negotiation	39
6.1.9	Security.....	39
6.2	MMTel_DCAppCall API.....	40
6.2.1	Introduction.....	40
6.2.2	Usage of HTTP and common API related aspects.....	40
6.2.3	Resources.....	40
6.2.4	Custom Operations without associated resources.....	40
6.2.4.1	Overview.....	40
6.2.4.2	Operation: DcMediaUpdateRequest	41

6.2.4.2.1	Description	41
6.2.4.2.2	Operation Definition.....	41
6.2.4.3	Operation: DcCallRequest	42
6.2.4.3.1	Description	42
6.2.4.3.2	Operation Definition.....	42
6.2.5	Notifications	43
6.2.5.1	DC Media Notification.....	43
6.2.5.1.1	Description	43
6.2.5.1.2	Target URI.....	43
6.2.5.1.3	Standard Methods	43
6.2.6	Data Model	44
6.2.6.1	General	44
6.2.6.2	Structured data types	45
6.2.6.2.1	Introduction	45
6.2.6.2.2	Type: DcCallReq	46
6.2.6.2.3	Type: DcCallResp	46
6.2.6.2.4	Type: DcMediaUpdateReq	47
6.2.6.2.5	Type: DcMediaUpdateResp	47
6.2.6.2.6	Type: DcMediaNotifyReq	47
6.2.6.2.7	Type: DcMediaNotifyResp.....	47
6.2.6.3	Simple data types and enumerations	47
6.2.6.3.1	Introduction	47
6.2.6.3.2	Simple data types.....	47
6.2.6.3.3	Enumeration: AdcType	48
6.2.6.3.4	Enumeration: CallType	48
6.2.6.4	Data types describing alternative data types or combinations of data types	48
6.2.6.5	Binary data	48
6.2.6.5.1	Binary Data Types	48
6.2.7	Error Handling	48
6.2.7.1	General	48
6.2.7.2	Protocol Errors	49
6.2.7.3	Application Errors.....	49
6.2.8	Feature negotiation	49
6.2.9	Security	49
6.3	MMTel_CallEvent Service API	50
6.3.1	Introduction.....	50
6.3.2	Usage of HTTP and common API related aspects.....	50
6.3.3	Resources.....	50
6.3.4	Custom Operations without associated resources	50
6.3.5	Notifications	50
6.3.5.1	General	50
6.3.5.2	Session Event Notification.....	51
6.3.5.2.1	Description	51
6.3.5.2.2	Target URI.....	51
6.3.5.2.3	Standard Methods	51
6.3.6	Data Model	52
6.3.6.1	General	52
6.3.6.2	Structured data types	52
6.3.6.2.1	Introduction	52
6.3.6.3	Simple data types and enumerations	52
6.3.6.3.1	Introduction	52
6.3.6.3.2	Simple data types.....	52
6.3.6.4	Data types describing alternative data types or combinations of data types	53
6.3.6.5	Binary data	53
6.3.6.5.1	Binary Data Types	53
6.3.7	Error Handling	53
6.3.7.1	General	53
6.3.7.2	Protocol Errors	53
6.3.7.3	Application Errors.....	53
6.3.8	Feature negotiation	53
6.3.9	Security	54
6.4	MMTel_CallControl API	54

6.4.1	Introduction.....	54
6.4.2	Usage of HTTP and common API related aspects.....	54
6.4.3	Resources.....	54
6.4.3.1	Overview.....	54
6.4.3.2	Resource: IMS Sessions.....	55
6.4.3.2.1	Description.....	55
6.4.3.2.2	Resource Definition.....	55
6.4.3.2.3	Resource Standard Methods.....	55
6.4.3.2.4	Resource Custom Operations.....	56
6.4.3.3	Resource: Individual IMS Session.....	56
6.4.3.3.1	Description.....	56
6.4.3.3.2	Resource Definition.....	56
6.4.3.3.3	Resource Standard Methods.....	57
6.4.3.3.4	Resource Custom Operations.....	60
6.4.4	Custom Operations without associated resources.....	60
6.4.5	Notifications.....	60
6.4.5.1	General.....	60
6.4.5.2	IMS Session Notification.....	61
6.4.5.2.1	Description.....	61
6.4.5.2.2	Target URI.....	61
6.4.5.2.3	Operation Definition.....	61
6.4.6	Data Model.....	62
6.4.6.1	General.....	62
6.4.6.2	Structured data types.....	63
6.4.6.2.1	Introduction.....	63
6.4.6.3	Simple data types and enumerations.....	63
6.4.6.3.1	Introduction.....	63
6.4.6.3.2	Simple data types.....	63
6.4.6.4	Data types describing alternative data types or combinations of data types.....	63
6.4.6.5	Binary data.....	63
6.4.6.5.1	Binary Data Types.....	63
6.4.7	Error Handling.....	63
6.4.7.1	General.....	63
6.4.7.2	Protocol Errors.....	64
6.4.7.3	Application Errors.....	64
6.4.8	Feature negotiation.....	64
6.4.9	Security.....	64
7	Using Common API Framework.....	65
7.1	General.....	65
7.2	Security.....	65
Annex A (normative): OpenAPI specification.....		66
A.1	General.....	66
A.2	MMTel_DCAppManagement API.....	67
A.3	MMTel_DCAppCall API.....	74
A.4	MMTel_CallEvent API.....	79
A.5	MMTel_CallControl API.....	80
Annex B (informative): Withdrawn API versions.....		84
B.1	General.....	84
B.2	MMTel_DCAppManagement API.....	84
B.3	MMTel_DCAppCall API.....	84
B.4	MMTel_CallEvent API.....	84
B.5	MMTel_CallControl API.....	84

Annex C (informative): Change history85
History86

Foreword

This Technical Specification has been produced by the 3rd Generation Partnership Project (3GPP).

The contents of the present document are subject to continuing work within the TSG and may change following formal TSG approval. Should the TSG modify the contents of the present document, it will be re-released by the TSG with an identifying change of release date and an increase in version number as follows:

Version x.y.z

where:

- x the first digit:
 - 1 presented to TSG for information;
 - 2 presented to TSG for approval;
 - 3 or greater indicates TSG approved document under change control.
- y the second digit is incremented for all changes of substance, i.e. technical enhancements, corrections, updates, etc.
- z the third digit is incremented when editorial only changes have been incorporated in the document.

In the present document, modal verbs have the following meanings:

- shall** indicates a mandatory requirement to do something
- shall not** indicates an interdiction (prohibition) to do something

The constructions "shall" and "shall not" are confined to the context of normative provisions, and do not appear in Technical Reports.

The constructions "must" and "must not" are not used as substitutes for "shall" and "shall not". Their use is avoided insofar as possible, and they are not used in a normative context except in a direct citation from an external, referenced, non-3GPP document, or so as to maintain continuity of style when extending or modifying the provisions of such a referenced document.

- should** indicates a recommendation to do something
- should not** indicates a recommendation not to do something
- may** indicates permission to do something
- need not** indicates permission not to do something

The construction "may not" is ambiguous and is not used in normative elements. The unambiguous constructions "might not" or "shall not" are used instead, depending upon the meaning intended.

- can** indicates that something is possible
- cannot** indicates that something is impossible

The constructions "can" and "cannot" are not substitutes for "may" and "need not".

- will** indicates that something is certain or expected to happen as a result of action taken by an agency the behaviour of which is outside the scope of the present document
- will not** indicates that something is certain or expected not to happen as a result of action taken by an agency the behaviour of which is outside the scope of the present document
- might** indicates a likelihood that something will happen as a result of action taken by some agency the behaviour of which is outside the scope of the present document

might not indicates a likelihood that something will not happen as a result of action taken by some agency the behaviour of which is outside the scope of the present document

In addition:

is (or any other verb in the indicative mood) indicates a statement of fact

is not (or any other negative verb in the indicative mood) indicates a statement of fact

The constructions "is" and "is not" do not indicate requirements.

1 Scope

The present document specifies the stage 3 Protocol and data model for the MMTel Enabler Server services, enabling the support of MMTel applications and services over 3GPP networks. It provides stage 3 protocol definitions and message flows, and specifies the API of each service offered by the MMTel Enabler Server over the MMTel-2/3 interface. The stage 2 application layer architecture, functional requirements, procedures and information flows necessary for MMTel Service are contained in 3GPP TS 23.392 [2].

The stage 2 application layer architecture for MMTel, functional requirements, procedures and information flows necessary for enabling MMTel applications over 3GPP networks are specified in 3GPP TS 23.392 [6].

The common protocol and interface aspects for API definition are specified in clause 5.2 of 3GPP TS 29.122 [2].

2 References

The following documents contain provisions which, through reference in this text, constitute provisions of the present document.

- References are either specific (identified by date of publication, edition number, version number, etc.) or non-specific.
- For a specific reference, subsequent revisions do not apply.
- For a non-specific reference, the latest version applies. In the case of a reference to a 3GPP document (including a GSM document), a non-specific reference implicitly refers to the latest version of that document *in the same Release as the present document*.

- [1] 3GPP TR 21.905: "Vocabulary for 3GPP Specifications".
- [2] 3GPP TS 29.122: "T8 reference point for Northbound Application Programming Interfaces (APIs)".
- [3] 3GPP TS 29.501: "5G System; Principles and Guidelines for Services Definition; Stage 3".
- [4] OpenAPI: "OpenAPI Specification Version 3.0.0", <https://spec.openapis.org/oas/v3.0.0>.
- [5] 3GPP TR 21.900: "Technical Specification Group working methods".
- [6] 3GPP TS 23.392: "Application enablement aspects for MMTel".
- [7] 3GPP TS 29.571: "5G System; Common Data Types for Service Based Interfaces; Stage 3".
- [8] 3GPP TS 23.222: "Common API Framework for 3GPP Northbound APIs; Stage 2".
- [9] 3GPP TS 29.222: "Common API Framework for 3GPP Northbound APIs; Stage 3".
- [10] 3GPP TS 33.122: "Security aspects of Common API Framework (CAPIF) for 3GPP northbound APIs".
- [11] IETF RFC 6749: "The OAuth 2.0 Authorization Framework".
- [12] 3GPP TS 29.500: "5G System; Technical Realization of Service Based Architecture; Stage 3".
- [13] 3GPP TS 29.175: "IP Multimedia Subsystem (IMS) Application Server (AS) Services Stage 3".
- [14] 3GPP TS 29.522: "5G System; Network Exposure Function Northbound APIs; Stage 3".
- [15] OMA-TS-REST_NetAPI_ThirdPartyCall-V1_0-20130212-C: "RESTful Network API Framework for Third Party Call".

3 Definitions of terms, symbols and abbreviations

3.1 Definitions

For the purposes of the present document, the terms and definitions given in 3GPP TR 21.905 [1] and the following apply. A term defined in the present document takes precedence over the definition of the same term, if any, in 3GPP TR 21.905 [1].

For the purpose of the present document, the terms and definitions given in clause 3 of 3GPP TS 23.392 [6] also apply, including the ones referencing other specifications.

3.2 Symbols

Void

3.3 Abbreviations

For the purposes of the present document, the abbreviations given in 3GPP TR 21.905 [1] and the following apply. An abbreviation defined in the present document takes precedence over the definition of the same abbreviation, if any, in 3GPP TR 21.905 [1].

4 Overview

3GPP TS 23.392 [6] has specified the application layer architecture, architectural requirements, procedures, information flows, in order to support the Application enablement for MMTel Service, mainly including DC Application management, DC Application downloading control, MMTel service usage and Multiple call control handling.

The present document specifies the APIs needed to support MMTel Services for interworking between the MMTel Enabler Server and the Controlling Application Server or Application Server, including the following functionalities:

1. Server-side functionality with the DC application configuration, update, deletion and information query, provided by the MMTel Enabler Server over the MMTel-2 interface.
2. Server-side functionality to provide capabilities to application providers/Vertical service providers to use MMTel services over the MMTel-3 interface.

Figure 4-1 shows the reference model of the MMTel Application Enabler Layer, with a focus on the MMTel Enabler Server:

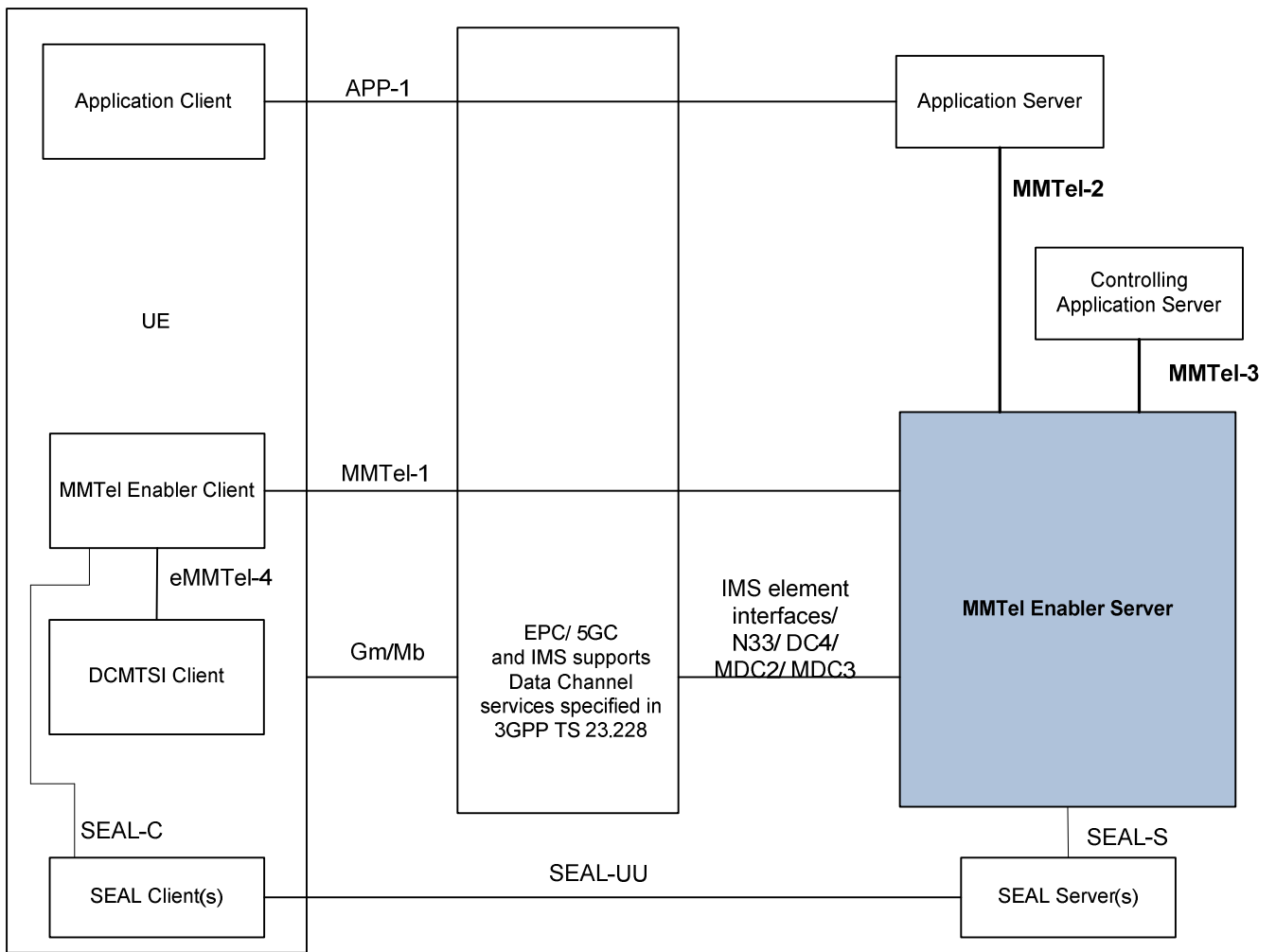

Figure 4-1: MMTel Application Enabler Layer functional model

5 Services offered by the MMTel Enabler Server

5.1 Introduction

Table 5.1-1 summarizes the corresponding APIs defined for this specification.

Table 5.1-1: API Descriptions

Service Name	Clause	Description	OpenAPI Specification File	API Name	Annex
MMTel_DCAppManagement Service	6.1	MMTel DC Application Management Service	TS29392_MMTel_DCAppManagement.yaml	mmtel-dcappmgmt	A.2
MMTel_DCAppCall Service	6.2	MMTel DC Application Call Service	TS29392_MMTel_DCAppCall.yaml	mmtel-dcappcall	A.3
MMTel_CallEvent Service	6.3	MMTel Enabler Server Call Event Service.	TS29392_MMTel_CallEvent.yaml	mmtel-callevent	A.4
MMTel_CallControl Service	6.4	MMTel Call Control Service	TS29392_MMTel_CallControl.yaml	mmtel-callcontrol	A.5

NOTE: When 3GPP TS 29.122 [2] is referenced for the common protocol and interface aspects for API definition in this document, the MMTel Server) takes the role of the SCEF and the service consumer takes the role of the SCS/AS.

5.2 MMTel_DCAppManagement Service

5.2.1 Service Description

The MMTel_DCAppManagement Service as defined in clause 8.2 in 3GPP TS 23.392 [6], is provided by the MMTel Enabler Server.

This service:

- allows Controlling Application Server invokes services provided by a MMTel Enabler Server to config DC application and profile to the MMTel Enabler Server;
- allows Controlling Application Server invokes services provided by a MMTel Enabler Server to update DC application and profile to the MMTel Enabler Server.
- allows Controlling Application Server invokes services provided by a MMTel Enabler Server to delete DC application.
- allows Controlling Application Server invokes services provided by a MMTel Enabler Server to obtain detail DC application profile information on the MMTel Enabler Server.

5.2.2 Service Operations

5.2.2.1 Introduction

The service operations defined for MMTel_DCAppManagement Service is shown in the table 5.2.2.1-1

Table 5.2.2.1-1: Operations of the MMTel_DCAppManagement Service

Service operation name	Description	Initiated by
MMTel_DCAppManagement_Configure	This service operation is used by the service consumer to configure DC application and profile to the MMTel Enabler Server.	e.g., Controlling Application Server
MMTel_DCAppManagement_Update	This service operation is used by Controlling Application Server to update an existing DC application profile information or DC application.	e.g., Controlling Application Server
MMTel_DCAppManagement_Delete	This service operation is used by the service consumer to delete an existing DC application.	e.g., Controlling Application Server
MMTel_DCAppManagement_Retrieve	This service operation is used by the service consumer to retrieve the details of an existing DC application profile information.	e.g., Controlling Application Server

5.2.2.2 MMTel_DCAppManagement_Configure

5.2.2.2.1 General

This service operation is used by the service consumer to configure DC application and profile to the MMTel Enabler Server.

The following procedures are supported by the "MMTel_DCAppManagement_Configure" service operation:

- DC Application and Profile Configuration.

5.2.2.2.2 DC Application and Profile Configuration

Figure 5.2.2.2.2-1 depicts a scenario where a Controlling Application Server sends a request to the MMTel Enabler Server to configure DC application and profile (see also clause 8.2.2 of 3GPP TS 23.392 [6]).

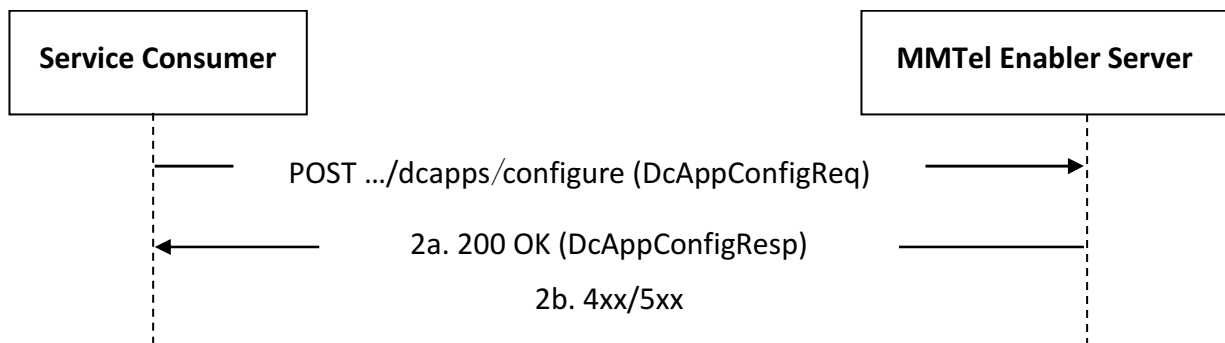
**Figure 5.2.2.2.2-1: Procedure for DC Application and Profile Configuration**

1. In order to configure DC application and profile, the Controlling Application Server shall send an HTTP POST request (i.e., resource custom operation "Configure") to the MMTel Enabler Server targeting the "DC APP" collection resource, with the request body including the DcAppConfigReq data structure.
- 2a. Upon success, the MMTel Enabler Server shall respond with an HTTP "200 OK" status code with the response body containing the DC application and profile configuration response information within the DcAppConfigResp data structure.
- 2b. On failure, the appropriate HTTP status code indicating the error shall be returned and appropriate additional error information should be returned in the HTTP POST response body, as specified in clause 6.1.7.

5.2.2.3 MMTel_DCAppManagement_Update

5.2.2.3.1 General

This service operation is used by Controlling Application Server to update an existing DC application profile information or DC application at the MMTel Enabler Server.

The following procedures are supported by the "MMTel_DCAppManagement_Configure" service operation:

- DC Application and Profile Update.

5.2.2.3.2 DC Application and Profile Update

Figure 5.2.2.3.2-1 depicts a scenario where a Controlling Application Server sends a request to the MMTel Enabler Server to update existing DC application and profile (see also clause 8.2.3 of 3GPP TS 23.392 [6]).

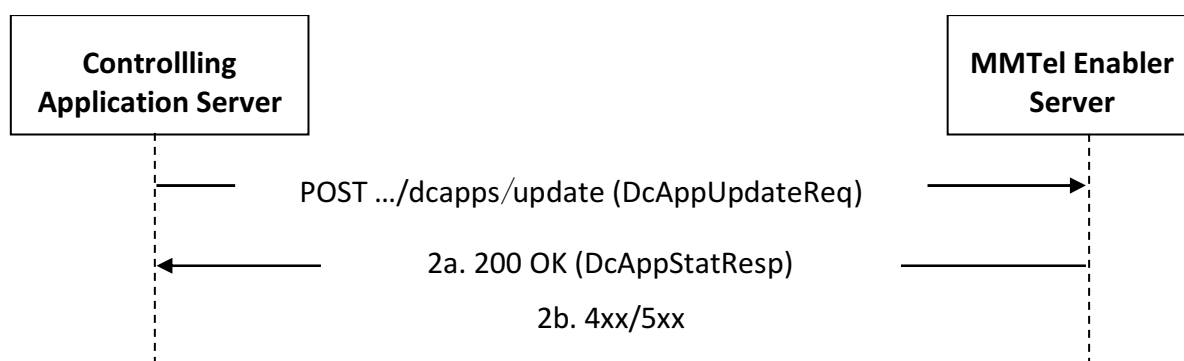

Figure 5.2.2.3.2-1: Procedure for DC Application and Profile Update

1. In order to update existing DC application or DC application profile related information, the Controlling Application Server shall send an HTTP POST request (i.e., custom operation "Update") to the MMTel Enabler Server targeting the corresponding "DC APP" resource, with the request body including the DcAppUpdateReq data structure.
- 2a. Upon success, the MMTel Enabler Server shall respond with an HTTP "200 OK" status code with the response body containing a representation of the updated "DC APP" resource within the DcAppStatResp data structure.
- 2b. On failure, the appropriate HTTP status code indicating the error shall be returned and appropriate additional error information should be returned in the HTTP POST response body, as specified in clause 6.1.7.

5.2.2.4 MMTel_DCAppManagement_Delete

5.2.2.4.1 General

This service operation is used by the service consumer to delete an existing DC application at the MMTel Enabler Server.

The following procedures are supported by the "MMTel_DCAppManagement_Configure" service operation:

- DC Application and Profile Deletion.

5.2.2.4.2 DC Application and Profile Deletion

Figure 5.2.2.4.2-1 depicts a scenario where a Controlling Application Server sends a request to the MMTel Enabler Server to delete existing DC application and profile (see also clause 8.2.4 of 3GPP TS 23.392 [6]).

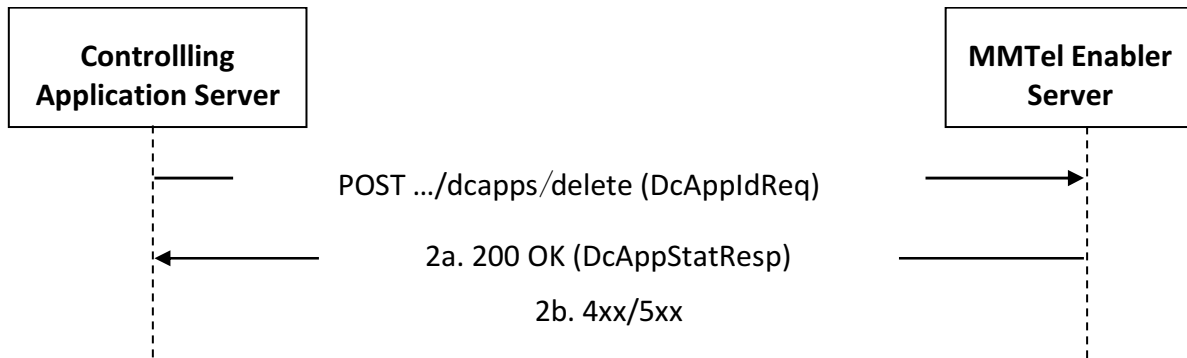

Figure 5.2.2.4.2-1: Procedure for DC Application and Profile Deletion

1. In order to configure DC application and profile, the Controlling Application Server shall send an HTTP POST request (i.e., custom operation "Delete") to the MMTel Enabler Server targeting the "DC APP" collection resource, with the request body including the DcAppIdReq data structure;
2. Upon success, the MMTel Enabler Server shall respond with an HTTP "200 OK" status code with the response body containing a representation of the updated "DC APP" resource within the DcAppStatResp data structure.
3. On failure, the appropriate HTTP status code indicating the error shall be returned and appropriate additional error information should be returned in the HTTP POST response body, as specified in clause 6.1.7.

5.2.2.5 MMTel_DCAppManagement_Retrieval

5.2.2.5.1 General

This service operation is used by the service consumer to retrieve the details of an existing DC application profile information at the MMTel Enabler Server.

The following procedures are supported by the "MMTel_DCAppManagement_Configure" service operation:

- DC Application and Profile Retrieval.

5.2.2.5.2 DC Application and Profile Retrieval

Figure 5.2.2.5.2-1 depicts a scenario where a Controlling Application Server sends a request to the MMTel Enabler Server to retrieve DC application profile related information (see also clause 8.2.5 of 3GPP TS 23.392 [6]).

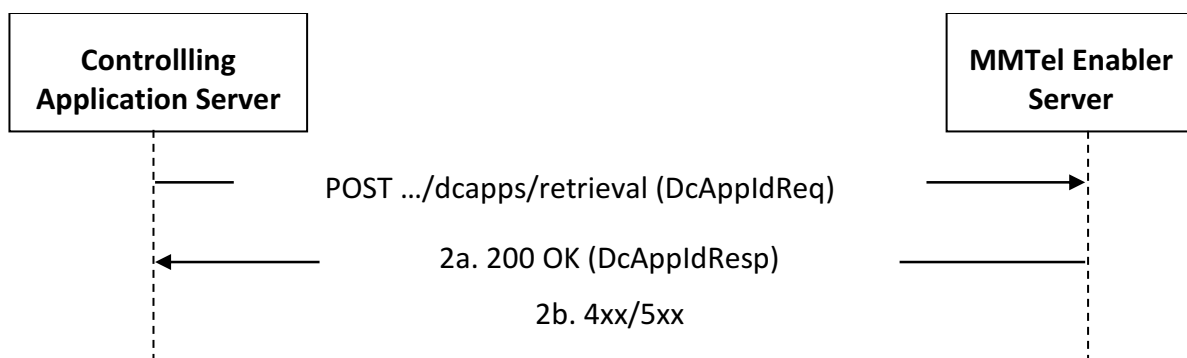

Figure 5.2.2.5.2-1: Procedure for DC Application and Profile Retrieval

1. In order to retrieve existing DC application profile related information, the Controlling Application Server shall send an HTTP POST request (i.e., custom operation "Retrieval") to the MMTel Enabler Server targeting the "DC APP" collection resource, with the request body including the DcAppIdReq data structure.
2. Upon success, the MMTel Enabler Server shall respond with an HTTP "200 OK" status code with the response body containing a representation of the retrieved "DC APP" resource within the DcAppIdResp data structure.

3. On failure, the appropriate HTTP status code indicating the error shall be returned and appropriate additional error information should be returned in the HTTP GET response body, as specified in clause 6.1.7.

5.3 MMTel_DCAppCall Service

5.3.1 Service Description

The MMTel_DCAppCall Service as defined in clause 8.4 of 3GPP TS 23.392 [2], is provided by the MMTel Enabler Server.

This service allows:

- the service consumer (e.g., Application Server) to invoke the service provided by a MMTel Enabler Server to establish a Third-Party Call with Data Channel capability;
- the service consumer (e.g., Application Server) to invoke services provided by a MMTel Enabler Server to add an A2P Data Channel to an existing IMS session for establishment of an Application Call with Data Channel capability; and
- the MMTel Enabler Server to notify the service consumer (e.g., Application Server) about DC resource information.

5.3.2 Service Operations

5.3.2.1 Introduction

The service operations defined for MMTel_DCAppCall API are shown in table 5.3.2.1-1.

Table 5.3.2.1-1: Operations of the MMTel_DCAppCall API

Service operation name	Description	Initiated by
MMTel_DCAppCall_DCCallReq	The service operation is used by the service consumer to request to establish a Third-Party Call with Data Channel capability.	e.g., Application Server
MMTel_DCAppCall_UpdateDCMedia	The service operation is used by the service consumer to request to add an A2P Data Channel media to an existing IMS session.	e.g., Application Server
MMTel_DCAppCall_Notify	The service operation is used by the MMTel Enabler Server to notify the service consumer about any update of DC resource information.	MMTel Enabler Server

5.3.2.2 MMTel_DCAppCall_DCCallReq

5.3.2.2.1 General

This service operation is used by the service consumer to request the MMTel Enabler Server to establish a call with Data Channel capability. It supports two scenarios:

- Application Call Scenario: A non-IMS application initiates a call with a single UE, specified in 3GPP TS 23.392 [6] clause 8.4.2.
- Third-Party Call Scenario: Application Server triggers a call between two UEs, specified in 3GPP TS 23.392 [6] clause 8.4.3.

The following procedures are supported by the "MMTel_DCAppCall_DCCallReq" service operation:

- DC Call Establishment.

5.3.2.2.2 DC Call Establishment

Figure 5.3.2.2.2-1 depicts a scenario where an service consumer sends a request to the MMTel Enabler Server to establish a Data Channel capability enabled call (see also clauses 8.4.2 and 8.4.3 of 3GPP TS 23.392 [6]).

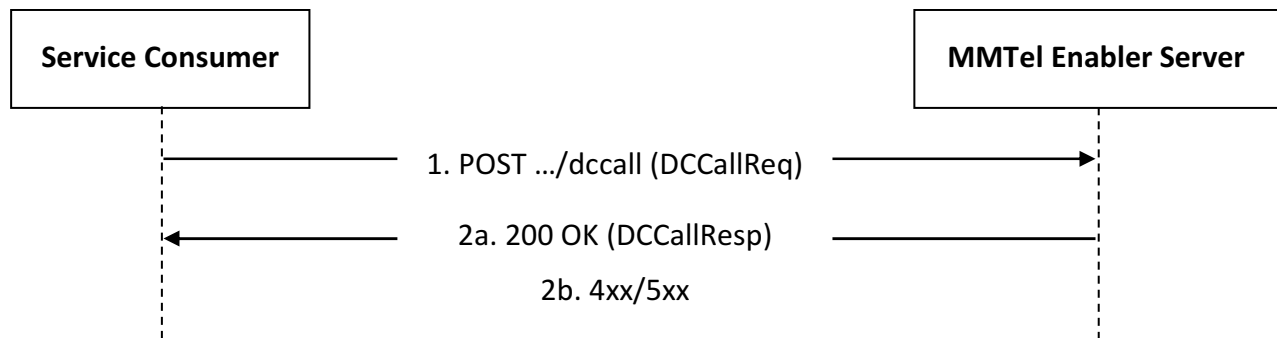

Figure 5.3.2.2-1: Procedure for DC Call Establishment

1. In order to establish a call with Data Channel capability, the service consumer shall send an HTTP POST request to the MMTel Enabler Server targeting the URI of the corresponding custom operation (i.e., "DcCallRequest"), with the request body including the DCCallReq data structure.
- 2a. Upon success, the MMTel Enabler Server shall respond with an HTTP "200 OK " status code with the response body including the requested DC Call information within the DCCallResp data structure.
- 2b. On failure, the appropriate HTTP status code indicating the error shall be returned and appropriate additional error information should be returned in the HTTP POST response body, as specified in clause 6.2.7

5.3.2.3 MMTel_DCAppCall_UpdateDCMedia

5.3.2.3.1 General

This service operation is used by the service consumer to request the MMTel Enabler Server to add an A2P Data Channel media to an existing IMS session.

The following procedures are supported by the "MMTel_DCAppCall_UpdateDCMedia " service operation:

- DC Media Update.

5.3.2.3.2 DC Media Update

Figure 5.3.2.3.2-1 depicts the scenario where a service consumer sends a request to the MMTel Enabler Server to add an A2P Data Channel media to an existing IMS session (see also clauses 8.4.4 of 3GPP TS 23.392 [6]).

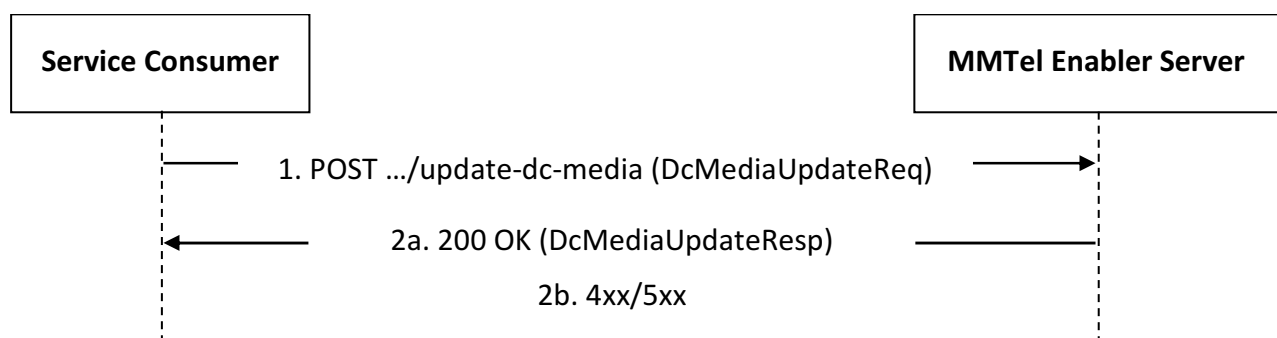

Figure 5.3.2.3.2-1: Procedure for DC Media Update

1. In order to add an A2P Data Channel media, the service consumer shall send an HTTP POST request to the MMTel Enabler Server targeting the URI of the corresponding custom operation (i.e., "DcMediaUpdateRequest"), with the request body including the DcMediaUpdateReq data structure.
- 2a. Upon success, the MMTel Enabler Server shall respond with an HTTP "200 OK" status code with the response body including the requested DC Media update information within the DcMediaUpdateResp data structure.

- 2b. On failure, the appropriate HTTP status code indicating the error shall be returned and appropriate additional error information should be returned in the HTTP POST response body, as specified in clause 6.2.7.

5.3.2.4 MMTel_DCAppCall_Notify

5.3.2.4.1 General

This service operation is used by the MMTel Enabler Server to notify the service consumer about DC media information updates.

The following procedures are supported by the "MMTel_DCAppCall_Notify" service operation:

- DC Media Notification.

5.3.2.4.2 DC Media Notification

Figure 5.3.2.4.2-1 depicts a scenario where the MMTel Enabler Server sends a notification to the service consumer about DC resource information (see also clause 8.4.4 of 3GPP TS 23.392 [6]).

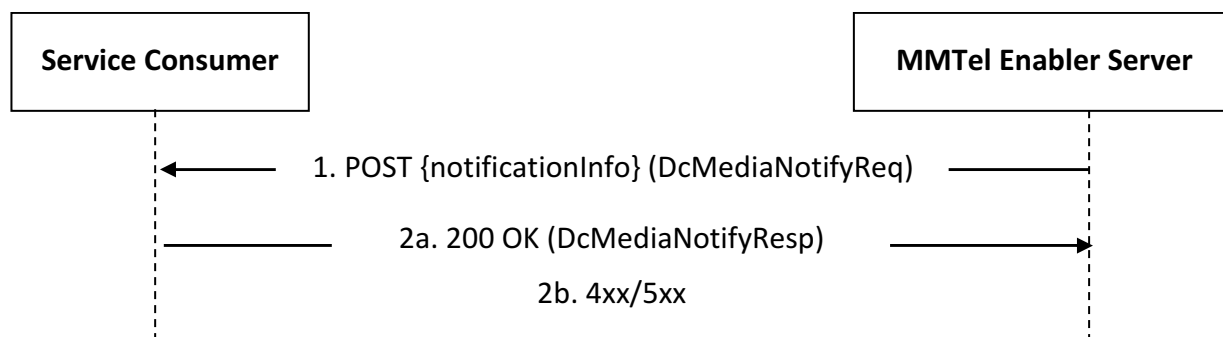

Figure 5.3.2.4.2-1: Procedure for DC Media Notification

1. In order to notify a previously subscribed service consumer on DC media information changes, the MMTel Enabler Server shall send an HTTP POST request to the service consumer with the request URI set to "{notificationInfo}", where the "notificationInfo" variable is set to the value received from the service consumer during the corresponding DC Call Establishment or DC Media Update using the procedures defined in clauses 5.3.2.2 and 5.3.2.3, and the request body including the DcMediaNotifyReq data structure.
- 2a. Upon success, the service consumer shall respond with an HTTP "200 OK" status code with the response body including DC Media notification related information within the DcMediaNotifyResp data structure.
- 2b. On failure, the appropriate HTTP status code indicating the error shall be returned and appropriate additional error information should be returned in the HTTP POST response body, as specified in clause 6.2.7.

5.4 MMTel_CallEvent Service

5.4.1 Service Description

The MMTel_CallEvent service enables the MMTel Enabler Server to notify a previously subscribed service consumer (e.g., Application Server) on session events when served IMS subscribers take part in IMS sessions as defined in 3GPP TS 23.392 [6].

5.4.2 Service Operations

5.4.2.1 Introduction

The service operation defined for MMTel_CallControl API is shown in the Table 5.5.2.1-1.

Table 5.5.2.1-1: Operations of the MMTel_CallControl API

Service operation name	Description	Initiated by
MMTel_CallEvent_Notify	Enables the MMTel Enabler Server to notify about IMS session event(s).	MMTel Enabler Server

NOTE: Explicit subscription to receive session events is another service operation defined in 3GPP TS 23.228[15] which has not been specified in this Release. In this Release of the specification, an implicit subscription is assumed where the MMTel Enabler Server notifies a configured or discovered service consumer (e.g., Application Server) of a call event through a Notification.

5.4.2.1A Void

5.4.2.2 MMTel_CallEvent_Notify

5.4.2.2.1 General

This service operation is used by the MMTel Enabler Server to notify a previously subscribed service consumer on IMS session event(s).

The following procedures are supported by the "MMTel_CallEvent_Notify" service operation:

- Session Event Notification.

5.4.2.2.2 Session Event Notification

Figure 5.4.2.2.2-1 depicts a scenario where the MMTel Enabler Server sends a notification to the service consumer on IMS session event(s) (see also clause 8.5 of 3GPP TS 23.392 [6]).

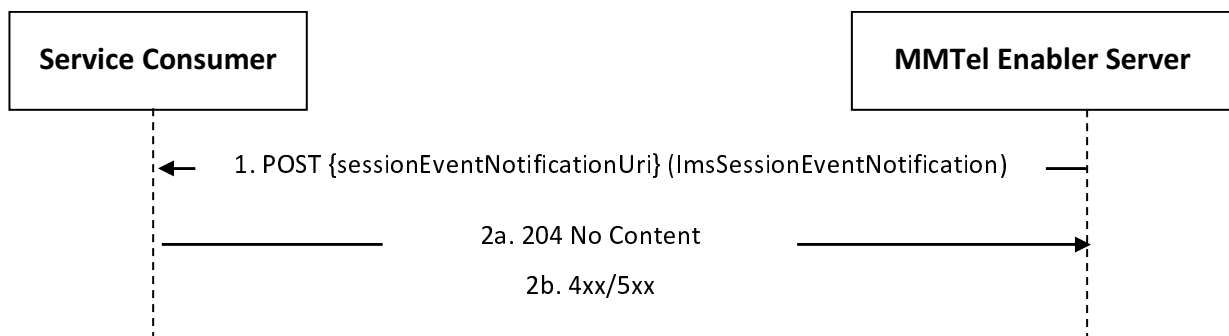

Figure 5.4.2.2.2-1: Procedure for Session Event Notification

1. If the MMTel Enabler Server receives the IMS session control events of a specific IMS Session and determines that the events need to be notified to a service consumer, the MMTel Enabler Server shall send an HTTP POST request to the service consumer with the request URI set to "{sessionEventNotificationUri}", where the "notificationInfo" variable is pre-configured at or pre-discovered by the MMTel Enabler Server, and the request body including the ImsSessionEventNotification data structure.
- 2a. Upon success, the service consumer shall respond with an HTTP "204 No Content" status code to acknowledge the successful reception of the notification.
- 2b. On failure, the appropriate HTTP status code indicating the error shall be returned and appropriate additional error information should be returned in the HTTP POST response body, as specified in clause 6.3.7.

5.5 MMTel_CallControl Service

5.5.1 Service Description

The MMTel_CallControl service enables a service consumer (e.g., Application Server) to request the MMTel Enabler Server to handle the specific call control logic (e.g., create new call session, terminate call session or call control, etc.) or enables the MMTel Enabler Server to notify the call control results to the service consumer.

5.5.2 Service Operations

5.5.2.1 Introduction

The service operations defined for MMTel_CallControl API are shown in the Table 5.5.2.1-1.

Table 5.5.2.1-1: Operations of the MMTel_CallControl API

Service operation name	Description	Initiated by
MMTel_CallControl_Create	This service operation is used by the service consumer to request call control to the MMTel Enabler Server to create an IMS session.	e.g., Application Server
MMTel_CallControl_Update	This service operation is used by the service consumer to request call control to the MMTel Enabler Server to update an IMS session, e.g., modify the media of the IMS session.	e.g., Application Server
MMTel_CallControl_Delete	This service operation is used by the service consumer to request call control to the MMTel Enabler Server to delete an IMS session.	e.g., Application Server
MMTel_CallControl_Notify	This service operation is used by the MMTel Enabler Server to notify the call control results to the service consumer.	MMTel Enabler Server

5.5.2.2 MMTel_CallControl_Create

5.5.2.2.1 General

This service operation is used by the service consumer to request IMS session creation at the MMTel Enabler Server.

The following procedures are supported by the "MMTel_CallControl_Create" service operation:

- IMS session Creation.

5.5.2.2.2 IMS session Creation

Figure 5.5.2.2.2-1 depicts a scenario where a service consumer sends a request to the MMTel Enabler Server to request the creation of an IMS Session (see also clauses 8.4 of 3GPP TS 23.392 [6]).

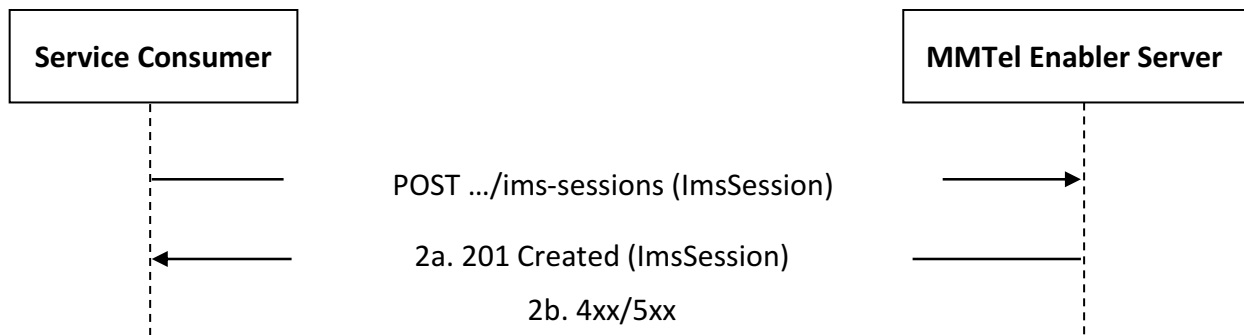

Figure 5.5.2.2-1: Procedure for IMS Session Creation

1. In order to create a new IMS Session, the service consumer shall send an HTTP POST request to the MMTel Enabler Server targeting the URI of the "IMS Sessions" collection resource, with the request body including the ImsSession data structure.
- 2a. Upon success, the MMTel Enabler Server shall respond with an HTTP "201 Created" status code with the response body containing a representation of the created "Individual IMS Session" resource within the ImsSession data structure, and an HTTP "Location" header field containing the URI of the created resource.
- 2b. On failure, the appropriate HTTP status code indicating the error shall be returned and appropriate additional error information should be returned in the HTTP POST response body, as specified in clause 6.4.7. In particular:
 - if the service consumer is not authorized to perform this operation, the MMTel Enabler Server shall reject the request with an HTTP "403 Forbidden" status code with the response body including the ProblemDetails data structure containing the "cause" attribute set to the "AF_NOT_AUTHORIZED" application error.

5.5.2.3 MMTel_CallControl_Update

5.5.2.3.1 General

This service operation is used by the service consumer to update an existing IMS session at the MMTel Enabler Server.

The following procedures are supported by the "MMTel_CallControl_Update" service operation:

- IMS session Update.

5.5.2.3.2 IMS session Update

Figure 5.5.2.3.2-1 depicts a scenario where a service consumer sends a request to the MMTel Enabler Server to request the update of an existing IMS Session (see also clauses 8.4 of 3GPP TS 23.392 [6]).

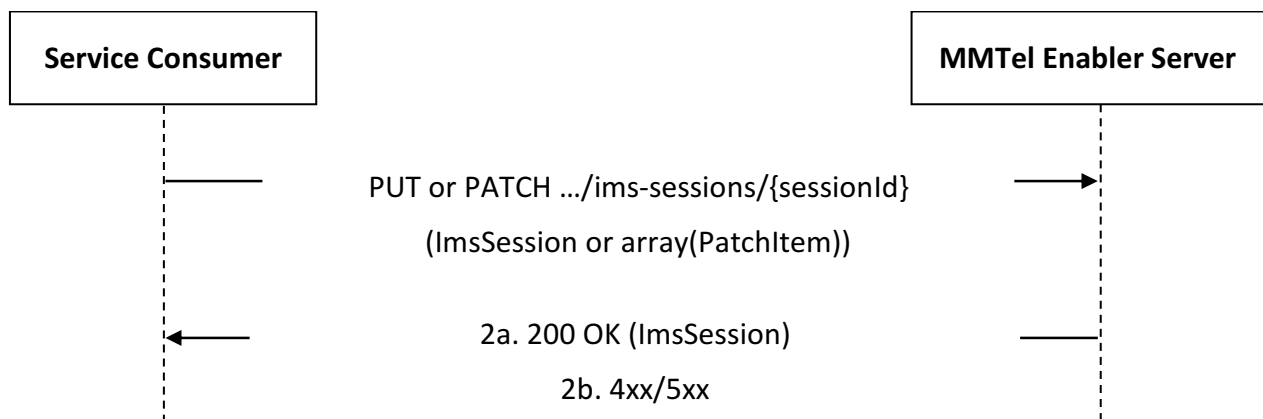

Figure 5.5.2.3.2-1: Procedure for IMS Session Update

1. In order to update an existing IMS Session, the service consumer shall send an HTTP PUT/PATCH request to the MMTel Enabler Server, targeting the URI of the corresponding "Individual IMS Session" resource, with the request body including either:
 - the updated representation of the resource within the ImsSession data structure, in case the HTTP PUT method is used; or
 - the requested modifications to the resource within one or several instances of the PatchItem data structure, in case the HTTP PATCH method is used.
- 2a. Upon success, the MMTel Enabler Server shall update the targeted "Individual IMS Session" resource accordingly and respond with either:
 - an HTTP "200 OK" status code with the response body containing a representation of the updated "Individual IMS Session" resource within the ImsSession data structure; or
 - an HTTP "204 No Content" status code.
- 2b. On failure, the appropriate HTTP status code indicating the error shall be returned and appropriate additional error information should be returned in the HTTP PUT/PATCH response body, as specified in clause 6.4.7. In particular:
 - if the service consumer is not authorized to perform this operation, the MMTel Enabler Server shall reject the request with an HTTP "403 Forbidden" status code with the response body including the ProblemDetails data structure containing the "cause" attribute set to the "AF_NOT_AUTHORIZED" application error.

5.5.2.3.3 Void

5.5.2.4 MMTel_CallControl_Delete

5.5.2.4.1 General

This service operation is used by the service consumer to delete an existing IMS session at the MMTel Enabler Server.

The following procedures are supported by the "MMTel_CallControl_Delete" service operation:

- IMS session Deletion.

5.5.2.4.2 IMS session Deletion

Figure 5.5.2.4.2-1 depicts a scenario where a service consumer sends a request to the MMTel Enabler Server to request the deletion of an existing IMS Session (see also clauses 8.4 of 3GPP TS 23.392 [6]).

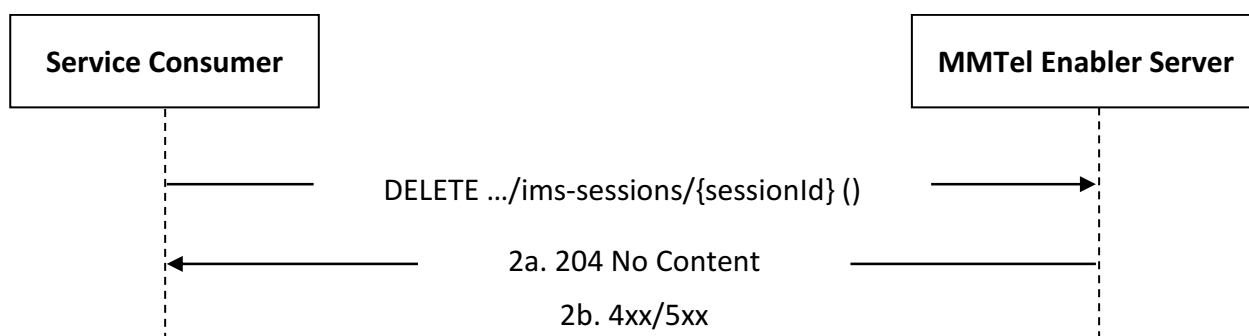

Figure 5.5.2.4.2-1: Procedure for IMS Session Deletion

1. In order to request the deletion of an existing IMS Session, the service consumer shall send an HTTP DELETE request to the MMTel Enabler Server targeting the URI of the corresponding "Individual IMS Session" resource.
- 2a. Upon success, the MMTel Enabler Server shall respond with an HTTP "204 No Content" status code.

2b. On failure, the appropriate HTTP status code indicating the error shall be returned and appropriate additional error information should be returned in the HTTP DELETE response body, as specified in clause 6.4.7. In particular:

- if the service consumer is not authorized to perform this operation, the MMTel Enabler Server shall reject the request with an HTTP "403 Forbidden" status code with the response body including the ProblemDetails data structure containing the "cause" attribute set to the "AF_NOT_AUTHORIZED" application error.

5.5.2.5 MMTel_CallControl_Notify

5.5.2.5.1 General

This service operation is used by the MMTel Enabler Server to notify the service consumers of session events related to call control result.

The following procedures are supported by the "MMTel_CallControl_Notify" service operation:

- IMS Session Notification.

5.5.2.5.2 IMS Session Notification

Figure 5.5.2.5.2-1 depicts a scenario where the MMTel Enabler Server notifies a previously subscribed service consumer on IMS Session event(s) (see also clauses 8.4 of 3GPP TS 23.392 [6]).

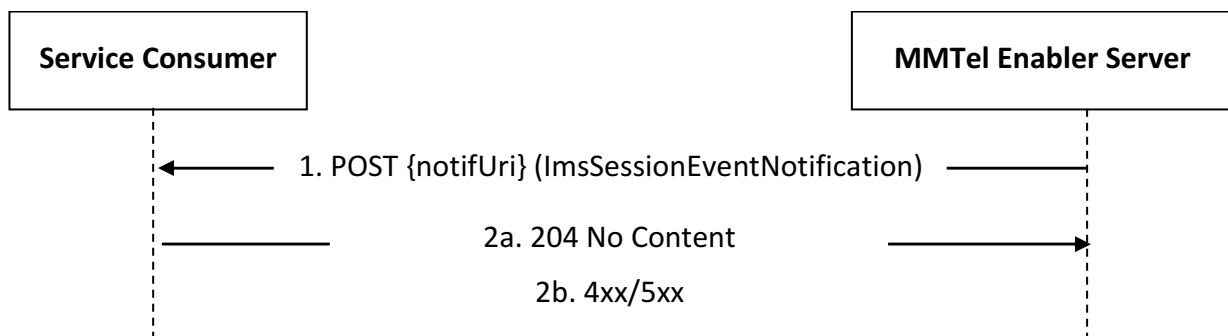

Figure 5.5.2.5.2-1: Procedure for IMS Session Notification

1. In order to notify a previously subscribed service consumer on IMS Session event(s), the MMTel Enabler Server shall send an HTTP POST request to the service consumer with the request URI set to "{notifUri}", where the "notificationInfo" variable is set to the value received from the service consumer during the corresponding IMS Session Creation/Update procedures defined in clauses 5.5.2.2 and 5.5.2.3, and the request body including the ImsSessionEventNotification data structure.
2. Upon success, the service consumer shall respond with an HTTP "204 No Content" status code to acknowledge the successful reception and processing of the notification.
3. On failure, the appropriate HTTP status code indicating the error shall be returned and appropriate additional error information should be returned in the HTTP POST response body, as specified in clause 6.4.7.

6 API Definitions

6.1 MMTel_DCAppManagement API

6.1.1 Introduction

The MMTel_DCAppManagement shall use the MMTel_DCAppManagement API.

The API URI of the MMTel_DCAppManagement shall be:

{apiRoot}/<apiName>/<apiVersion>

The request URIs used in HTTP requests shall have the Resource URI structure defined in clause 5.2.4 of 3GPP TS 29.122 [2], i.e.:

{apiRoot}/<apiName>/<apiVersion>/<apiSpecificSuffixes>

with the following components:

- The {apiRoot} shall be set as described in clause 5.2.4 of 3GPP TS 29.122 [2].
- The <apiName> shall be "mmtel-dcappmgmt".
- The <apiVersion> shall be "v1".
- The <apiSpecificSuffixes> shall be set as described in clause 5.2.4 of 3GPP TS 29.122 [2].

NOTE: When 3GPP TS 29.122 [2] is referenced for the common protocol and interface aspects for API definition in the clauses under clause 6.1, the MMTel Enabler Server takes the role of the SCEF and the service consumer takes the role of the SCS/AS.

6.1.2 Usage of HTTP and common API related aspects

The provisions of clause 5.2.2 of 3GPP TS 29.122 [2] shall apply for the MMTel_DCAppManagement API.

6.1.3 Resources

6.1.3.1 Overview

This clause describes the structure for the Resource URIs and the resources and methods used for the service.

Figure 6.1.3.1-1 depicts the resource URIs structure for the MMTel_DCAppManagement API.

{apiRoot}/mmtel-dcappmgmt/<apiVersion>

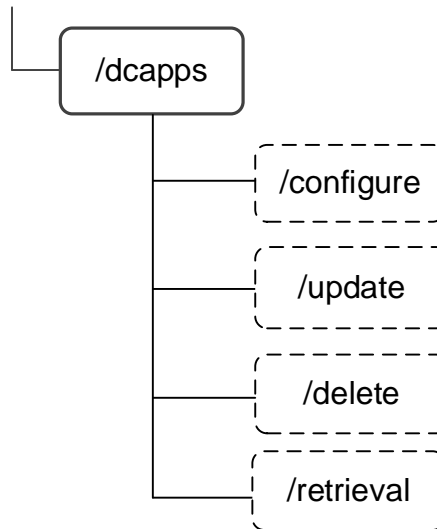

Figure 6.1.3.1-1: Resource URI structure of the MMTel_DCAppManagement API

Table 6.1.3.1-1 provides an overview of the resources and applicable HTTP methods.

Table 6.1.3.1-1: Resources and methods overview

Resource name	Resource URI	HTTP method or custom operation	Description
DC APP	/dcapps/configure	POST	Configure DC application and DC application profile.
	/dcapps/update	POST	Update existing DC application and DC application profile.
	/dcapps/delete	POST	Delete existing DC application
	/dcapps/retrieval	POST	Obtain the DC APP profile related information according to the APPID

6.1.3.2 Resource: DC APP

6.1.3.2.1 Description

6.1.3.2.2 Resource Definition

Resource URI: {apiRoot}/mmtel-dcappmgmt/<apiVersion>/dcapps

This resource shall support the resource URI variables defined in table 6.1.3.2.2-1.

Table 6.1.3.2.2-1: Resource URI variables for this resource

Name	Data type	Definition
apiRoot	string	See clause 6.1.1

6.1.3.2.3 Resource Standard Methods

None in current release of specification.

6.1.3.2.4 Resource Custom Operations

6.1.3.2.4.1 Overview

Table 6.1.3.2.4.1-1: Custom operations

Operation name	Custom operation URI	Mapped HTTP method	Description
Configure	/dcapps/configure	POST	Enables to configure DC application and DC application profile.
Update	/dcapps/update	POST	Enables to update existing DC application and DC application profile.
Delete	/dcapps/delete	POST	Enables to delete existing DC application and DC application profile.
Retrieval	/dcapps/retrieval	POST	Enables to retrieval existing DC application and DC application profile.

6.1.3.2.4.2 Operation: Configure

This custom operation enables to configure DC application and DC application profile.

This operation shall support the request data structures specified in table 6.1.3.2.4.2-1 and the response data structure and response codes specified in table 6.1.3.2.4.2-2.

Table 6.1.3.2.4.2-1: Data structures supported by the POST Request Body on this resource

Data type	P	Cardinality	Description
DcAppConfigReq	M	1	Represents the DC application and DC application profile configuration information.

Table 6.1.3.2.4.2-2: Data structures supported by the POST Response Body on this resource

Data type	P	Cardinality	Response codes	Description
DcAppConfigResp	M	1	200 OK	Indicates the successfully configured list of APPID.
n/a			307 Temporary Redirect	Temporary redirection. The response shall include a Location header field containing an alternative URI of the resource located in an alternative MMTel Enabler Server. Redirection handling is described in clause 5.2.10 of 3GPP TS 29.122 [2].
n/a			308 Permanent Redirect	Permanent redirection. The response shall include a Location header field containing an alternative URI of the resource located in an alternative MMTel Enabler Server. Redirection handling is described in clause 5.2.10 of 3GPP TS 29.122 [2].

NOTE: The mandatory HTTP error status code for the HTTP POST method listed in table 5.2.6-1 of 3GPP TS 29.122 [2] shall also apply.

Table 6.1.3.2.4.2-3: Headers supported by the 307 Response Code on this resource

Name	Data type	P	Cardinality	Description
Location	string	M	1	An alternative URI of the resource located in an alternative MMTel Enabler Server.

Table 6.1.3.2.4.2-4: Headers supported by the 308 Response Code on this resource

Name	Data type	P	Cardinality	Description
Location	string	M	1	An alternative URI of the resource located in an alternative MMTel Enabler Server.

6.1.3.2.4.3 Operation: Update

This custom operation enables to update existing DC application and DC application profile.

This operation shall support the request data structures specified in table 6.1.3.2.4.3-1 and the response data structure and response codes specified in table 6.1.3.2.4.3-2.

Table 6.1.3.2.4.3-1: Data structures supported by the POST Request Body on this resource

Data type	P	Cardinality	Description
DcAppUpdateReq	M	1	Represents the DC application and DC application profile information that shall be updated.

Table 6.1.3.2.4.3-2: Data structures supported by the POST Response Body on this resource

Data type	P	Cardinality	Response codes	Description
DcAppStatResp	M	1	200 OK	Indicates the successfully updated list of APPID.
n/a			307 Temporary Redirect	Temporary redirection. The response shall include a Location header field containing an alternative URI of the resource located in an alternative MMTel Enabler Server. Redirection handling is described in clause 5.2.10 of 3GPP TS 29.122 [2].
n/a			308 Permanent Redirect	Permanent redirection. The response shall include a Location header field containing an alternative URI of the resource located in an alternative MMTel Enabler Server. Redirection handling is described in clause 5.2.10 of 3GPP TS 29.122 [2].
NOTE: The mandatory HTTP error status codes for the POST method listed in table 5.2.6-1 of 3GPP TS 29.122 [3] shall also apply.				

Table 6.1.3.2.4.3-3: Headers supported by the 307 Response Code on this resource

Name	Data type	P	Cardinality	Description
Location	string	M	1	An alternative URI of the resource located in an alternative MMTel Enabler Server.

Table 6.1.3.2.4.3-4: Headers supported by the 308 Response Code on this resource

Name	Data type	P	Cardinality	Description
Location	string	M	1	An alternative URI of the resource located in an alternative MMTel Enabler Server.

6.1.3.2.4.4 Operation: Delete

This custom operation enables to delete existing DC application.

This operation shall support the request data structures specified in table 6.1.3.2.4.4-1 and the response data structure and response codes specified in table 6.1.3.2.4.4-2.

Table 6.1.3.2.4.4-1: Data structures supported by the POST Request Body on this resource

Data type	P	Cardinality	Description
DcAppldReq	M	1	Represents the DC application and DC application that shall be deleted.

Table 6.1.3.2.4.4-2: Data structures supported by the POST Response Body on this resource

Data type	P	Cardinality	Response codes	Description
DcAppldResp	M	1	200 OK	Indicates the successfully deleted list of APPID.
n/a			307 Temporary Redirect	Temporary redirection. The response shall include a Location header field containing an alternative URI of the resource located in an alternative MMTel Enabler Server. Redirection handling is described in clause 5.2.10 of 3GPP TS 29.122 [2].
n/a			308 Permanent Redirect	Permanent redirection. The response shall include a Location header field containing an alternative URI of the resource located in an alternative MMTel Enabler Server. Redirection handling is described in clause 5.2.10 of 3GPP TS 29.122 [2].
NOTE: The mandatory HTTP error status codes for the POST method listed in table 5.2.6-1 of 3GPP TS 29.122 [2] shall also apply.				

Table 6.1.3.2.4.4-3: Headers supported by the 307 Response Code on this resource

Name	Data type	P	Cardinality	Description
Location	string	M	1	An alternative URI of the resource located in an alternative MMTel Enabler Server.

Table 6.1.3.2.4.4-4: Headers supported by the 308 Response Code on this resource

Name	Data type	P	Cardinality	Description
Location	string	M	1	An alternative URI of the resource located in an alternative MMTel Enabler Server.

6.1.3.2.4.5 Operation: Retrieval

This custom operation enables to retrieval existing DC application.

This operation shall support the request data structures specified in table 6.1.3.2.4.5-1 and the response data structure and response codes specified in table 6.1.3.2.4.5-2.

Table 6.1.3.2.4.5-1: Data structures supported by the POST Request Body on this resource

Data type	P	Cardinality	Description
DcAppldReq	M	1	Represents the requested DC application information.

Table 6.1.3.2.4.5-2: Data structures supported by the POST Response Body on this resource

Data type	P	Cardinality	Response codes	Description
DcAppIdResp	M	1	200 OK	The requested DC application profile related information is returned
n/a			307 Temporary Redirect	Temporary redirection. The response shall include a Location header field containing an alternative URI of the resource located in an alternative MMTel Enabler Server. Redirection handling is described in clause 5.2.10 of 3GPP TS 29.122 [2].
n/a			308 Permanent Redirect	Permanent redirection. The response shall include a Location header field containing an alternative URI of the resource located in an alternative MMTel Enabler Server. Redirection handling is described in clause 5.2.10 of 3GPP TS 29.122 [2].
NOTE: The mandatory HTTP error status codes for the POST method listed in table 5.2.6-1 of 3GPP TS 29.122 [2] shall also apply.				

Table 6.1.3.2.4.5-3: Headers supported by the 307 Response Code on this resource

Name	Data type	P	Cardinality	Description
Location	string	M	1	An alternative URI of the resource located in an alternative MMTel Enabler Server.

Table 6.1.3.2.4.5-4: Headers supported by the 308 Response Code on this resource

Name	Data type	P	Cardinality	Description
Location	string	M	1	An alternative URI of the resource located in an alternative MMTel Enabler Server.

6.1.4 Custom Operations without associated resources

There are no custom operations without associated resources defined for this API in this release of the specification.

6.1.5 Notifications

There are no custom operations without associated resources defined for this API in this release of the specification.

6.1.6 Data Model

6.1.6.1 General

This clause specifies the application data model supported by the API.

Table 6.1.6.1-1 specifies the data types defined specifically for the MMTel_DCAppManagement API service.

Table 6.1.6.1-1: MMTel_DCAppManagement API specific Data Types

Data type	Section defined	Description	Applicability
AppLoadPhase	6.1.6.3.3	Represents the load phase of the DC application	
Condition	6.1.6.3.6	Represents the conditions used by the DC application	
DcAppConfigParameters	6.1.6.2.3	Represents the parameters of single-DC applicaion in the configuration request	
DcAppConfigReq	6.1.6.2.2	Represents the DC application and profile configuration request	
DcAppConfigResp	6.1.6.2.4	Represents the DC application and profile configuration response	
DcAppConfigResponseParameters	6.2.6.2.5	Represents the parameters of single-DC applicaion in the configuration response	
DcAppIdReq	6.1.6.2.10	Represents the DC application delete request and DC application information retrieval request	
DcAppIdResp	6.1.6.2.11	Represents the DC application profile information retrieval response	
DcAppResponseParameters	6.1.6.2.9	Represents the parameters of single-DC applicaion in the DC application and profile update response and DC application delete response	
DcAppStatResp	6.1.6.2.8	Represents the DC application and profile update response or DC application delete response	
DcAppUpdateReq	6.1.6.2.6	Represents the DC application and profile update request	
DcAppUpdateParameters	6.1.6.2.7	Represents the parameters of single-DC applicaion in the update response	
Status	6.1.6.3.5	Represents the request return status	
SupportScenario	6.1.6.3.4	Represents the support scenario of the DC application	

Table 6.1.6.1-2 specifies data types re-used by theMMTel_DCAppManagement API service.

Table 6.1.6.1-2: Re-used Data Types

Data type	Reference	Comments	Applicability
Binary	3GPP TS 29.122 [3]	Used to represent binary values.	
DateTime	3GPP TS 29.122 [3]	Used to represent the subscription duration.	
Uri	3GPP TS 29.122 [3]	Used to indicate the notification URI.	

6.1.6.2 Structured data types

6.1.6.2.1 Introduction

This clause defines the structures to be used in resource representations.

6.1.6.2.2 Type: DcAppConfigReq

Table 6.1.6.2.2-1: Definition of type DcAppConfigReq

Attribute name	Data type	P	Cardinality	Description	Applicability
reqId	string	M	1	The identity of the DC Application provider	
secCred	string	O	0..1	Security information required by the MMTel Enabler Server.	
dcAppNum	integer	M	1	Indicates the total number of DC Application.	
dcAppConfigParamList	array(DcAppConfigParameters)	M	1..N	The list of DC application configuration parameters.	

6.1.6.2.3 Type: DcAppConfigParameters

Table 6.1.6.2.3-1: Definition of type DcAppConfigParameters

Attribute name	Data type	P	Cardinality	Description	Applicability
appIndex	string	M	1	The index of the DC Application configuration parameter.	
appName	string	O	0..1	The name of the Data Channel Application.	
svcType	string	O	0..1	The service type of the Data Channel Application.	
applconUrl	Uri	O	0..1	The url of the Data Channel Application icon.	
appVer	string	O	0..1	The latest version of the DC application in UE.	
appVal	DateTime	O	0..1	The latest validity of the DC application.	
appLoadPh	AppLoadPhase	O	0..1	Indicates the phase when this Data Channel Application is allowed to be used.	
autoload	boolean	O	0..1	Indicates whether this Data Channel Application is needed to be load to the UE automatically. Set to "true" if this Data Channel Application is needed to be load to the UE automatically. otherwise set to "false". Default value is "false".	
autolaunch	boolean	O	0..1	Indicates whether this Data Channel Application is needed to be downloaded to the UE and run automatically. Set to "true" if this Data Channel Application is needed to be downloaded to the UE and run automatically. otherwise set to "false". Default value is "false".	
peerDcReq	boolean	O	0..1	Indicates whether this Data Channel Application can be used if Data Channel is not supported by the other party of the call. Set to "true" if this Data Channel Application can be used if Data Channel is not supported by the other party of the call. otherwise set to "false". Default value is "false".	
suppScnr	SupportScenario	O	0..1	Indicates supported media type required for this Data Channel Application.	
cond	Condition	O	0..1	Indicates whether this Data Channel Application can be used if under the conditions	
qosReq	string	O	0..1	Indicates the QoS requirement of this Data Channel Application.	
persDataColl	boolean	O	0..1	Indicates whether this Data Channel Application will collect the user personal data. Set to "true" if this Data Channel Application will collect the user personal data. otherwise set to "false". Default value is "false".	
persDataCollInfoUrl	Uri	O	0..1	The url of the purpose description of mandatory and optional personal data to be collected.	
appPkg	Binary	O	0..1	The package of the Data Channel Application.	

6.1.6.2.4 Type: DcAppConfigResp

Table 6.1.6.2.4-1: Definition of type DcAppConfigResp

Attribute name	Data type	P	Cardinality	Description	Applicability
dcAppConfigRespList	array(DcAppConfigResponseParameters)	M	1..N	The list of DC application configuration response parameters.	

6.1.6.2.5 Type: DcAppConfigResponseParameters

Table 6.1.6.2.5-1: Definition of type DcAppConfigResponseParameters

Attribute name	Data type	P	Cardinality	Description	Applicability
applIndex	string	M	1	The index of the DC Application configuration parameter.	
status	Status	M	1	Indicates the success or failure of the request.	
applId	string	O	0..1	The unique identifier of the Data Channel Application assigned by the MMTel Enabler Server. May only be present if the status sets to "SUCCESS".	
failureCause	string	O	0..1	The failure reason the DC Application configuration. May only be present if the status sets to "FAILED".	

6.1.6.2.6 Type: DcAppUpdateReq

Table 6.1.6.2.6-1: Definition of type DcAppUpdateReq

Attribute name	Data type	P	Cardinality	Description	Applicability
reqId	string	M	1	The identity of the DC Application provider	
secCred	string	O	0..1	Security information required by the MMTel Enabler Server.	
dcAppNum	integer	M	1	Indicates the total number of DC Application.	
dcAppUpdateParametersList	array(DcAppUpdateParameters)	M	1..N	The list of DC application update parameters.	

6.1.6.2.7 Type: DcAppUpdateParameters

Table 6.1.6.2.7-1: Definition of type DcAppUpdateParameters

Attribute name	Data type	P	Cardinality	Description	Applicability
appld	string	M	1	The unique identifier of the Data Channel Application assigned by the MMTel Enabler Server.	
appName	string	O	0..1	The name of the Data Channel Application.	
svcType	string	O	0..1	The service type of the Data Channel Application.	
applconUrl	Uri	O	0..1	The url of the Data Channel Application icon.	
appVer	string	O	0..1	The latest version of the DC application in UE.	
appVal	DateTime	O	0..1	The latest validity of the DC application.	
appLoadPh	AppLoadPhase	O	0..1	Indicates the phase when this Data Channel Application is allowed to be used.	
autoload	boolean	O	0..1	Indicates whether this Data Channel Application is needed to be load to the UE automatically. Set to "true" if this Data Channel Application is needed to be load to the UE automatically. otherwise set to "false". Default value is "false".	
autolaunch	boolean	O	0..1	Indicates whether this Data Channel Application is needed to be downloaded to the UE and run automatically. Set to "true" if this Data Channel Application is needed to be downloaded to the UE and run automatically. otherwise set to "false". Default value is "false".	
peerDcReq	boolean	O	0..1	Indicates whether this Data Channel Application can be used if Data Channel is not supported by the other party of the call. Set to "true" if this Data Channel Application can be used if Data Channel is not supported by the other party of the call. otherwise set to "false". Default value is "false".	
suppScnr	SupportScenario	O	0..1	Indicates supported media type required for this Data Channel Application.	
cond	Condition	O	0..1	Indicates whether this Data Channel Application can be used if under this condition	
qosReq	string	O	0..1	Indicates the QoS requirement of this Data Channel Application.	
persDataColl	boolean	O	0..1	Indicates whether this Data Channel Application will collect the user personal data. Set to "true" if this Data Channel Application will collect the user personal data. otherwise set to "false". Default value is "false".	
persDataCollInfoUrl	Uri	O	0..1	The url of the purpose description of mandatory and optional personal data to be collected.	
appPkg	Binary	O	0..1	The package of the Data Channel Application.	

6.1.6.2.8 Type: DcAppStatResp

Table 6.1.6.2.8-1: Definition of type DcAppStatResp

Attribute name	Data type	P	Cardinality	Description	Applicability
dcAppStatRespList	array(DcAppResponseParameters)	M	1..N	The list of DC application update response parameters.	

6.1.6.2.9 Type: DcAppResponseParameters

Table 6.1.6.2.9-1: Definition of type DcAppResponseParameters

Attribute name	Data type	P	Cardinality	Description	Applicability
appld	string	M	1	The unique identifier of the Data Channel Application assigned by the MMTel Enabler Server.	
status	Status	M	1	Indicates the success or failure of the request.	
failureCause	string	O	0..1	The failure reason the DC Application configuration. May only be present if the status sets to "FAILED".	

6.1.6.2.10 Type: DcAppIdReq

Table 6.1.6.2.10-1: Definition of type DcAppIdReq

Attribute name	Data type	P	Cardinality	Description	Applicability
reqId	string	M	1	The identity of the DC Application provider	
dcAppNum	integer	M	1	Indicates the total number of DC Application.	
appldList	array(string)	M	1..N	The list of appld.	

6.1.6.2.11 Type: DcAppIdResp

Table 6.1.6.2.11-1: Definition of type DcAppIdResp

Attribute name	Data type	P	Cardinality	Description	Applicability
status	Status	M	1	Indicates the success or failure of the request.	
dcAppInfoList	array(DcAppUpdateParameters)	O	1..N	The list of DC application profile information. May only be present if the status sets to "SUCCESS".	
failureCause	string	O	0..1	The failure reason the DC Application configuration. May only be present if the status sets to "FAILED".	
NOTE: The "appPkg" attribute within the DcAppUpdateParameters data type provided within this attribute is not applicable and shall not be present.					

6.1.6.3 Simple data types and enumerations

6.1.6.3.1 Introduction

This clause defines simple data types and enumerations that can be referenced from data structures defined in the previous clauses.

6.1.6.3.2 Simple data types

None.

6.1.6.3.3 Enumeration: AppLoadPhase

Table 6.1.6.3.3-1: Enumeration AppLoadPhase

Enumeration value	Description	Applicability
PRECALL_ONLY	The Data Channel Application is allowed to be used before the MMTel call session is established.	
INCALL	The Data Channel Application is allowed to be used after the MMTel call session is established.	
PRECALL_AND_INCALL	The Data Channel Application is allowed to be used during the entire Pre-call and in-call.	

6.1.6.3.4 Enumeration: SupportScenario

Table 6.1.6.3.4-1: Enumeration SupportScenario

Enumeration value	Description	Applicability
VOICE_CALL_ONLY	The Data Channel Application can be used if and only if the corresponding call is a voice call.	
VIDEO_CALL_ONLY	The Data Channel Application can be used if and only if the corresponding call is a video call.	
VOICE_AND_VIDEO_CALL	The Data Channel Application can be used in both voice call and video call.	

6.1.6.3.5 Enumeration: Status

Table 6.1.6.3.5-1: Enumeration Status

Enumeration value	Description	Applicability
SUCCESS	Indicates that the request is processed successfully.	
FAILED	Indicates that the request fails to be processed.	

6.1.6.3.6 Enumeration: Condition

Table 6.1.6.3.6-1: Definition of type Condition

Enumeration value	Description	Applicability
CONDTY	The Data Channel Application is allowed to be used in this condition, e.g. Service area	
CONDVA	The value of the CONFTY.	

6.1.7 Error Handling

6.1.7.1 General

For the MMTel_DCAppManagement API, HTTP error responses shall be supported as specified in clause 5.2.6 of 3GPP TS 29.122 [2]. Protocol errors and application errors specified in clause 5.2.6 of 3GPP TS 29.122 [2] shall be supported for the HTTP status codes specified in table 5.2.6-1 of 3GPP TS 29.122 [2].

In addition, the requirements in the following clauses are applicable for the MMTel_DCAppManagement API.

6.1.7.2 Protocol Errors

No specific protocol errors for the MMTel_DCAppManagement API are specified.

6.1.7.3 Application Errors

The application errors defined for the MMTel_DCAppManagement API are listed in Table 6.1.7.3-1.

Table 6.1.7.3-1: Application errors

Application Error	HTTP status code	Description

6.1.8 Feature negotiation

The optional features in table 6.1.8-1 are defined for the MMTel_DCAppManagement API. They shall be negotiated using the extensibility mechanism defined in clause 5.2.7 of 3GPP TS 29.122 [2].

Table 6.1.8-1: Supported Features

Feature number	Feature Name	Description

6.1.9 Security

The provisions of clause 6 of 3GPP TS 29.122 [2] shall apply for the MMTel_DCAppManagement API.

6.2 MMTel_DCAppCall API

6.2.1 Introduction

The MMTel_DCAppCall shall use the MMTel_DCAppCall API.

The API URI of the MMTel_DCAppCall shall be:

{apiRoot}/<apiName>/<apiVersion>

The request URIs used in HTTP requests shall have the Resource URI structure defined in clause 5.2.4 of 3GPP TS 29.122 [2], i.e.:

{apiRoot}/<apiName>/<apiVersion>/<apiSpecificSuffixes>

with the following components:

- The {apiRoot} shall be set as described in clause 5.2.4 of 3GPP TS 29.122 [2].
- The <apiName> shall be "mmtel-dcappcall".
- The <apiVersion> shall be "v1".
- The <apiSpecificSuffixes> shall be set as described in clause 5.2.4 of 3GPP TS 29.122 [2].

NOTE: When 3GPP TS 29.122 [2] is referenced for the common protocol and interface aspects for API definition in the clauses under clause 6.2, the MMTel Enabler Server takes the role of the SCEF and the service consumer takes the role of the SCS/AS.

6.2.2 Usage of HTTP and common API related aspects

The provisions of clause 5.2.2 of 3GPP TS 29.122 [2] shall apply for the MMTel_DCAppCall API.

6.2.3 Resources

There are no resources defined for this API in this release of the specification.

6.2.4 Custom Operations without associated resources

6.2.4.1 Overview

The structure of the custom operation URIs of the MMTel_DCAppCall API is shown in Figure 6.2.4.1-1.

{apiRoot}/mmtel-dcappcall/<apiVersion>

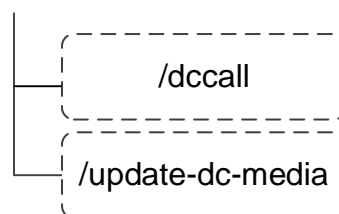

Figure 6.2.4.1-1: Custom operation URI structure of the MMTel_DCAppCall API

Table 6.2.4.1-1 provides an overview of the custom operations and applicable HTTP methods defined for the MMTel_DCAppCall API.

Table 6.2.4.1-1: Custom operations without associated resources

Operation name	Custom operation URI	Mapped HTTP method	Description
DcCallRequest	/dccall	POST	Request to establish a DC capability enabled call to a given MMTel Enabler Server.
DcMediaUpdateRequest	/update-dc-media	POST	Request to update DC media of an application call to a given MMTel Enabler Server.

6.2.4.2 Operation: DcMediaUpdateRequest

6.2.4.2.1 Description

The custom operation is used by the service consumer to request a DC media update to a given MMTel Enabler Server.

6.2.4.2.2 Operation Definition

This operation shall support the response data structures and response codes specified in Table 6.2.4.2.2-1 and Table 6.2.4.2.2-2.

Table 6.2.4.2.2-1: Data structures supported by the POST Request Body on this resource

Data type	P	Cardinality	Description
DCMediaUpdateReq	M	1	Represents the requested DC media update information.

Table 6.2.4.2.2-2: Data structures supported by the POST Response Body on this resource

Data type	P	Cardinality	Response codes	Description
DCMediaUpdateResp	M	1	200 OK	Successful case. The requested update information of DC media is returned.
n/a			307 Temporary Redirect	Temporary redirection. The response shall include a Location header field containing an alternative URI of the resource located in an alternative MMTel Enabler Server. Redirection handling is described in clause 5.2.10 of 3GPP TS 29.122 [2].
n/a			308 Permanent Redirect	Permanent redirection. The response shall include a Location header field containing an alternative URI of the resource located in an alternative MMTel Enabler Server. Redirection handling is described in clause 5.2.10 of 3GPP TS 29.122 [2].

NOTE: The mandatory HTTP error status codes for the HTTP POST method listed in table 5.2.6-1 of 3GPP TS 29.122 [2] shall also apply.

Table 6.2.4.2.2-: Headers supported by the 307 method on this resource

Name	Data type	P	Cardinality	Description
Location	string	M	1	Contains an alternative target URI located in an alternative MMTel Enabler Server.

Table 6.2.4.2.2-5: Headers supported by the 308 response code on this resource

Name	Data type	P	Cardinality	Description
Location	string	M	1	Contains an alternative URI located in an alternative MMTel Enabler Server.

6.2.4.3 Operation: DcCallRequest

6.2.4.3.1 Description

The custom operation is used by the service consumer to request a call enabled by DC capabilities to a given MMTel Enabler Server.

6.2.4.3.2 Operation Definition

This operation shall support the response data structures and response codes specified in Table 6.2.4.3.2-1 and Table 6.2.4.3.2-2.

Table 6.2.4.3.2-1: Data structures supported by the POST Request Body on this resource

Data type	P	Cardinality	Description
DcCallReq	M	1	Represents the requested DC Call.

Table 6.2.4.3.2-2: Data structures supported by the POST Response Body on this resource

Data type	P	Cardinality	Response codes	Description
DcCallResp	M	1	200 OK	Successful case. The requested DC Call information is returned.
n/a			307 Temporary Redirect	Temporary redirection. The response shall include a Location header field containing an alternative URI of the resource located in an alternative MMTel Enabler Server. Redirection handling is described in clause 5.2.10 of 3GPP TS 29.122 [2].
n/a			308 Permanent Redirect	Permanent redirection. The response shall include a Location header field containing an alternative URI of the resource located in an alternative MMTel Enabler Server. Redirection handling is described in clause 5.2.10 of 3GPP TS 29.122 [2].
NOTE: The mandatory HTTP error status codes for the HTTP POST method listed in table 5.2.6-1 of 3GPP TS 29.122 [2] shall also apply.				

Table 6.2.4.3.2-3: Headers supported by the 307 method on this resource

Name	Data type	P	Cardinality	Description
Location	string	M	1	Contains an alternative target URI located in an alternative MMTel Enabler Server.

Table 6.2.4.3.2-5: Headers supported by the 308 response code on this resource

Name	Data type	P	Cardinality	Description
Location	string	M	1	Contains an alternative target URI located in an alternative MMTel Enabler Server.

6.2.5 Notifications

Notifications shall comply to clause 5.2.5 of 3GPP TS 29.122 [2].

Table 6.2.5.1-1: Notifications overview

Notification	Callback URI	HTTP method or custom operation	Description (service operation)
DC Media Notification	{notificationInfo}	POST	Notify about DC Media changes from MMTel Enabler Server.

6.2.5.1 DC Media Notification

6.2.5.1.1 Description

The DC Media Notification is used by the MMTel Enabler Server to notify a previously subscribed service consumer on DC Media changes.

6.2.5.1.2 Target URI

The Callback URI "{notificationInfo}" shall be used with the callback URI variables defined in table 6.2.5.1.2-1.

Table 6.2.5.1.2-1: Callback URI variables

Name	Definition
notificationInfo	Represents the callback URI encoded as a string formatted as a URI.

6.2.5.1.3 Standard Methods

6.2.5.1.3.1 POST

This method shall support the request data structures specified in table 6.2.5.1.3.1-1 and the response data structures and response codes specified in table 6.2.5.1.3.1-2.

Table 6.2.5.1.3.1-1: Data structures supported by the POST Request Body

Data type	P	Cardinality	Description
DcMediaNotifyReq	M	1	Represents the subscribed DC Media Notification.

Table 6.2.5.1.3.1-2: Data structures supported by the POST Response Body

Data type	P	Cardinality	Response codes	Description
DcMediaNotifyResp	M	1	200 OK	Successful case. The Notification is successfully received and DC Media notification related information is returned in the response body.
n/a			307 Temporary Redirect	Temporary redirection. The response shall include a Location header field containing an alternative URI representing the end point of an alternative service consumer towards which the notification should be sent. Redirection handling is described in clause 5.2.10 of 3GPP TS 29.122 [2].
n/a			308 Permanent Redirect	Permanent redirection. The response shall include a Location header field containing an alternative URI representing the end point of an alternative service consumer towards which the notification should be sent. Redirection handling is described in clause 5.2.10 of 3GPP TS 29.122 [2].
NOTE: The mandatory HTTP error status codes for the HTTP POST method listed in Table 5.2.6-1 of 3GPP TS 29.122 [24] shall also apply.				

Table 6.2.5.1.3.1-3: Headers supported by the 307 Response Code on this resource

Name	Data type	P	Cardinality	Description
Location	string	M	1	Contains an alternative URI representing the end point of an alternative service consumer towards which the notification should be redirected.

Table 6.2.5.1.3.1-4: Headers supported by the 308 Response Code on this resource

Name	Data type	P	Cardinality	Description
Location	string	M	1	Contains an alternative URI representing the end point of an alternative service consumer towards which the notification should be redirected.

6.2.6 Data Model

6.2.6.1 General

This clause specifies the application data model supported by the API.

Table 6.2.6.1-1 specifies the data types defined specifically for the MMTel_DCAAppCall API service.

Table 6.2.6.1-1: MMTel_DCAppCall API specific Data Types

Data type	Section defined	Description	Applicability
AdcType	6.2.6.3.3	Represents the type of DC communication.	
CallType	6.2.6.3.4	Represents the call is established as A2P or P2P call.	
DcCallReq	6.2.6.2.2	Represents the DC Call establishment request.	
DcCallResp	6.2.6.2.3	Represents the DC Call establishment response.	
DcMediaUpdateReq	6.2.6.2.4	Represents the DC media update request.	
DcMediaUpdateResp	6.2.6.2.5	Represents the DC media update response.	
DcMediaNotifyReq	6.2.6.2.6	Represents the DC media update notification request.	
DcMediaNotifyResp	6.2.6.2.6	Represents the DC media update notification response.	

Table 6.2.6.1-2 specifies data types re-used by the MMTel_DCAppCall API service.

Table 6.2.6.1-2: Re-used Data Types

Data type	Reference	Comments	Applicability
DcAppUpdateParameters	Clause 6.1.6.2.7	Represents parameters of DC application profile.	
Status	Clause 6.1.6.3.5	Represents the status.	
Uri	3GPP TS 29.571 [7]	Represents a URI.	

6.2.6.2 Structured data types

6.2.6.2.1 Introduction

This clause defines the structures to be used in resource representations.

6.2.6.2.2 Type: DcCallReq

Table 6.2.6.2.2: Definition of type DcCallReq

Attribute name	Data type	P	Cardinality	Description	Applicability
originatingId	Uri	C	0..1	The identifier of the caller, corresponding to participant address in OMA Third Party Call API [15], which could be 'sip' URI, 'tel' URI or 'acr' URI. (NOTE)	
terminatingId	Uri	M	1	The identifier of the callee, corresponding to participant address in OMA Third Party Call API [15], which could be 'sip' URI, 'tel' URI or 'acr' URI.	
mediaInfo	array(string)	O	1..N	Identifier of one or more media type(s), corresponding to the mediaInfo of Call	
dcMediaInfo	boolean	O	0..1	Identifier of whether DC media is expected to be used.	
appProfileRequested	DcAppUpdateParameters	O	0..1	The DC application profile expected to be used.	
notificationInfo	Uri	M	1	The address where call related notification is sent, corresponding to callbackReference in OMA Third Party Call API.	
callType	CallType	M	1	Indicate if the call is established as A2P or P2P call. (NOTE)	

NOTE: The "originatingId" attribute shall be present if the "callType" attribute is set to "P2P".

6.2.6.2.3 Type: DcCallResp

Table 6.2.6.2.3-1: Definition of type DcCallResp

Attribute name	Data type	P	Cardinality	Description	Applicability
callResult	Status	M	1	Indication if the Call establishment is success or failure.	
sessionId	string	O	0..1	The identifier of the call session, corresponding to callSessionId in OMA Third Party Call API	
failureCause	string	O	0..1	The reason for failure, corresponding to callSessionId in OMA Third Party Call API	
originatingId	Uri	C	0..1	The identifier of the caller, corresponding to participant address in OMA Third Party Call API [15], which could be 'sip' URI, 'tel' URI or 'acr' URI. (NOTE)	
terminatingId	Uri	M	1	The identifier of the callee, corresponding to participant address in OMA Third Party Call API [15], which could be 'sip' URI, 'tel' URI or 'acr' URI.	
mediaInfo	array(string)	O	1..N	Identifier of one or more media type(s)	
dcMediaInfo	string	O	0..1	Identifier of whether DC media is expected to be used	
appProfileRequested	DcAppUpdateParameters	O	0..1	The DC application profile expected to be used	
callType	CallType	M	1	Indicate if the call is established as A2P or P2P call. (NOTE)	

NOTE: The "originatingId" attribute shall be present if the "callType" attribute is set to "P2P".

6.2.6.2.4 Type: DcMediaUpdateReq

Table 6.2.6.2.4-1: Definition of type DcMediaUpdateReq

Attribute name	Data type	P	Cardinality	Description	Applicability
dcAppId	string	M	1	The identifier of the DC application	
sessionId	string	M	1	The session identifier for media update	
mediaResourceInfo	object	O	0..1	The media information to be passed via the Data Channel	
appProfileRequested	DcAppUpdateParameters	O	0..1	The DC application profile expected to be used	
notificationInfo	Uri	M	1	The address where call related notification is sent to	
mediaDirection	AdcType	O	0..1	Type of DC communication, e.g. A2P or P2A.	

6.2.6.2.5 Type: DcMediaUpdateResp

Table 6.2.6.2.5-1: Definition of type DcMediaUpdateResp

Attribute name	Data type	P	Cardinality	Description	Applicability
sessionId	string	M	1	The session identifier of the session	
result	Status	M	1	Indicates if the request was successful or failed.	
cause	string	O	0..1	Indicates the cause of request failure	

6.2.6.2.6 Type: DcMediaNotifyReq

Table 6.2.6.2.6-1: Definition of type DcMediaNotifyReq

Attribute name	Data type	P	Cardinality	Description	Applicability
sessionId	string	M	1	The session identifier of the session	
mediaResourceInfo	object	M	1	The media information to be passed via the Data Channel	
mediaDirection	AdcType	O	0..1	Type of DC communication, e.g. A2P or P2A.	

6.2.6.2.7 Type: DcMediaNotifyResp

Table 6.2.6.2.7-1: Definition of type DcMediaNotifyResp

Attribute name	Data type	P	Cardinality	Description	Applicability
sessionId	string	M	1	The session identifier of the session	
result	Status	M	1	Indicates if the request was successful or failed.	
cause	string	O	0..1	Indicates the cause of request failure	

6.2.6.3 Simple data types and enumerations

6.2.6.3.1 Introduction

This clause defines simple data types and enumerations that can be referenced from data structures defined in the previous clauses.

6.2.6.3.2 Simple data types

The simple data types defined in table 6.2.6.3.2-1 shall be supported.

Table 6.2.6.3.2-1: Simple data types

Type Name	Type Definition	Description	Applicability

6.2.6.3.3 Enumeration: AdcType

The enumeration AdcType represents the type of the data channel media direction. It shall comply with the provisions defined in table 6.2.6.3.3-1.

Table 6.2.6.3.3-1: Enumeration AdcType

Enumeration value	Description
A2P	Indicates that the type of the data channel media direction is a Data Channel initiated by the Application.
P2A	Indicates that the type of the data channel media direction is a Data Channel initiated by the UE.

6.2.6.3.4 Enumeration: CallType

The enumeration CallType represents the established call type. It shall comply with the provisions defined in table 6.2.6.3.4-1.

Table 6.2.6.3.4-1: Enumeration CallType

Enumeration value	Description
A2P	Indicates that the established call type is an Application call initiated by the Application towards the UE.
P2P	Indicates that the established call type is a Third Party call established between two UEs.

6.2.6.4 Data types describing alternative data types or combinations of data types

There are no data types describing alternative data types or combinations of data types defined for this API in this release of the specification.

6.2.6.5 Binary data

6.2.6.5.1 Binary Data Types

Table 6.2.6.5.1-1: Binary Data Types

Name	Clause defined	Content type

6.2.7 Error Handling

6.2.7.1 General

For the MMTel_DCAppCall API, HTTP error responses shall be supported as specified in clause 5.2.6 of 3GPP TS 29.122 [2]. Protocol errors and application errors specified in clause 5.2.6 of 3GPP TS 29.122 [2] shall be supported for the HTTP status codes specified in table 5.2.6-1 of 3GPP TS 29.122 [2].

In addition, the requirements in the following clauses are applicable for the MMTel_DCAppCall API.

6.2.7.2 Protocol Errors

No specific protocol errors for the MMTel_DCAppCall API are specified.

6.2.7.3 Application Errors

The application errors defined for the MMTel_DCAppCall API are listed in Table 6.2.7.3-1.

Table 6.2.7.3-1: Application errors

Application Error	HTTP status code	Description

6.2.8 Feature negotiation

The optional features in table 6.2.8-1 are defined for the MMTel_DCAppCall API. They shall be negotiated using the extensibility mechanism defined in clause 5.2.7 of 3GPP TS 29.122 [2].

Table 6.2.8-1: Supported Features

Feature number	Feature Name	Description

6.2.9 Security

The provisions of clause 6 of 3GPP TS 29.122 [2] shall apply for the MMTel_DCAppCall API.

6.3 MMTel_CallEvent Service API

6.3.1 Introduction

The MMTel_CallEvent service shall use the MMTel_CallEvent API.

The API URI of the MMTel_CallEvent API shall be:

{apiRoot}/<apiName>/<apiVersion>

The request URIs used in HTTP requests shall have the Resource URI structure defined in clause 5.2.4 of 3GPP TS 29.122 [2], i.e.:

{apiRoot}/<apiName>/<apiVersion>/<apiSpecificResourceUriPart>

with the following components:

- The {apiRoot} shall be set as described in clause 5.2.4 of 3GPP TS 29.122 [2].
- The <apiName> shall be "mmtel-callevent".
- The <apiVersion> shall be "v1".
- The <apiSpecificResourceUriPart> shall be set as described in clause 6.3.3 and 6.3.4.

NOTE: When 3GPP TS 29.122 [2] is referenced for the common protocol and interface aspects for API definition in the clauses under clause 6.3, the MMTel Enabler Server takes the role of the SCEF and the service consumer takes the role of the SCS/AS.

6.3.2 Usage of HTTP and common API related aspects

The provisions of clause 5.2.2 of 3GPP TS 29.122 [2] shall apply for the MMTel_CallEvent API.

6.3.3 Resources

There are no resources defined for this API in this release of the specification.

6.3.4 Custom Operations without associated resources

There are no custom operations without associated resources defined for this API in this release of the specification.

6.3.5 Notifications

6.3.5.1 General

Notifications shall comply to clause 5.2.5 of 3GPP TS 29.122 [2].

Table 6.3.5.1-1: Notifications overview

Notification	Callback URI	HTTP method or custom operation	Description (service operation)
Session Event Notification	{sessionEventNotificationUri}	POST	Report the session event received.

6.3.5.2 Session Event Notification

6.3.5.2.1 Description

The Session Event Notification is used by the MMTel Enabler Server to report the received session event to a service consumer.

6.3.5.2.2 Target URI

The Callback URI "{sessionEventNotificationUri}" shall be used with the callback URI variables defined in table 6.3.5.2.2-1.

Table 6.3.5.2.2-1: Callback URI variables

Name	Definition
sessionEventNotificationUri	Represents the callback URI encoded as a string formatted as a URI. In this release, the "sessionEventNotificationUri" of the service consumer is locally pre-configured or pre-discovered at the MMTel Enabler Server.

6.3.5.2.3 Standard Methods

6.3.5.2.3.1 POST

This method shall support the request data structures specified in table 6.3.5.2.3.1-1 and the response data structures and response codes specified in table 6.3.5.2.3.1-1.

Table 6.3.5.2.3.1-1: Data structures supported by the POST Request Body

Data type	P	Cardinality	Description
ImsSessionEventNotification	M	1	Represents the Session Event Notification.

Table 6.3.5.2.3.1-2: Data structures supported by the POST Response Body

Data type	P	Cardinality	Response codes	Description
n/a			204 No Content	Successful case. The Session Event notification is successfully received and acknowledged.
n/a			307 Temporary Redirect	Temporary redirection. The response shall include a Location header field containing an alternative URI representing the end point of an alternative service consumer towards which the notification should be sent. Redirection handling is described in clause 5.2.10 of 3GPP TS 29.122 [2].
n/a			308 Permanent Redirect	Permanent redirection. The response shall include a Location header field containing an alternative URI representing the end point of an alternative service consumer towards which the notification should be sent. Redirection handling is described in clause 5.2.10 of 3GPP TS 29.122 [2].
ProblemDetails	O	0..1	404 Not Found	(NOTE 2)
NOTE 1: The mandatory HTTP error status codes for the HTTP POST method listed in Table 5.2.6-1 of 3GPP TS 29.122 [2] shall also apply.				
NOTE 2: Failure causes are described in clause 6.3.7.				

Table 6.3.5.2.3-3: Headers supported by the 307 Response Code on this endpoint

Name	Data type	P	Cardinality	Description
Location	string	M	1	Contains an alternative URI representing the end point of an alternative service consumer towards which the notification should be redirected.

Table 6.3.5.2.3-4: Headers supported by the 308 Response Code on this endpoint

Name	Data type	P	Cardinality	Description
Location	string	M	1	Contains an alternative URI representing the end point of an alternative service consumer towards which the notification should be redirected.

6.3.6 Data Model

6.3.6.1 General

This clause specifies the application data model supported by the API.

Table 6.3.6.1-1 specifies the data types defined for the MMTel_CallEvent API.

Table 6.3.6.1-1: MMTel_CallEvent specific Data Types

Data type	Clause defined	Description

Table 6.3.6.1-2 specifies data types re-used by the MMTel_CallEvent API from other specifications, including a reference to their respective specifications and when needed, a short description of their use within the MMTel_CallEvent API.

Table 6.3.6.1-2: MMTel_CallEvent re-used Data Types

Data type	Reference	Comments
ImsSessionEventNotification	3GPP TS 29.175 [13]	Represents the IMS Session Notification.

6.3.6.2 Structured data types

6.3.6.2.1 Introduction

This clause defines the data structures to be used in resource representations.

There are no data structures defined for this API in this release of the specification.

6.3.6.3 Simple data types and enumerations

6.3.6.3.1 Introduction

This clause defines simple data types and enumerations that can be referenced from data structures defined in the previous clauses.

6.3.6.3.2 Simple data types

The simple data types defined in table 6.3.6.3.2-1 shall be supported.

Table 6.3.6.3.2-1: Simple data types

Type name	Description

6.3.6.4 Data types describing alternative data types or combinations of data types

There are no data types describing alternative data types or combinations of data types defined for this API in this release of the specification.

6.3.6.5 Binary data

6.3.6.5.1 Binary Data Types

Table 6.3.6.5.1-1: Binary Data Types

Name	Clause defined	Content type

6.3.7 Error Handling

6.3.7.1 General

For the MMTel_CallEvent API, HTTP error responses shall be supported as specified in clause 5.2.6 of 3GPP TS 29.122 [2]. Protocol errors and application errors specified in clause 5.2.6 of 3GPP TS 29.122 [2] shall be supported for the HTTP status codes specified in table 5.2.6-1 of 3GPP TS 29.122 [2].

In addition, the requirements in the following clauses are applicable for the MMTel_CallEvent API.

6.3.7.2 Protocol Errors

No specific protocol errors for the MMTel_CallEvent API are specified.

6.3.7.3 Application Errors

The application errors defined for the MMTel_CallEvent API are listed in Table 6.3.7.3-1.

Table 6.3.7.3-1: Application errors

Application Error	HTTP status code	Description	Applicability
USER_NOT_FOUND	404 Not Found	Indicates that the Session Event Notification request failed because the service consumer (e.g., Application Server) does not serve this service user.	
NOTIFICATION_URI_NOT_FOUND	404 Not Found	Indicates that the Session Event Notification request failed because the notification URI is not recognized.	

6.3.8 Feature negotiation

The optional features in table 6.3.8-1 are defined for the MMTel_CallEvent API. They shall be negotiated using the extensibility mechanism defined in clause 5.2.7 of 3GPP TS 29.122 [2].

Table 6.3.8-1: Supported Features

Feature number	Feature Name	Description

6.3.9 Security

The provisions of clause 6 of 3GPP TS 29.122 [2] shall apply for the MMTel_CallEvent API.

6.4 MMTel_CallControl API

6.4.1 Introduction

The Nnef_MMTel_CallControl service shall use the MMTel_CallControl API.

The API URI of the MMTel_CallControl API shall be:

{apiRoot}/<apiName>/<apiVersion>

The request URIs used in HTTP requests shall have the Resource URI structure defined in clause 5.2.4 of 3GPP TS 29.122 [2], i.e.:

{apiRoot}/<apiName>/<apiVersion>/<apiSpecificResourceUriPart>

with the following components:

- The {apiRoot} shall be set as described in clause 5.2.4 of 3GPP TS 29.222 [9].
- The <apiName> shall be "mmtel-callcontrol".
- The <apiVersion> shall be "v1".
- The <apiSpecificResourceUriPart> shall be set as described in clause 5.2.4 of 3GPP TS 29.122 [2].

NOTE: When 3GPP TS 29.122 [2] is referenced for the common protocol and interface aspects for API definition in the clauses under clause 6.4, the MMTel Enabler Server takes the role of the SCEF and the service consumer takes the role of the SCS/AS.

6.4.2 Usage of HTTP and common API related aspects

The provisions of clause 5.2.2 of 3GPP TS 29.122 [2] shall apply for the MMTel_CallControl API.

6.4.3 Resources

6.4.3.1 Overview

This clause describes the structure for the Resource URIs as shown in figure 6.4.3.1-1 and the resources and HTTP methods used for the MMTel_CallControl API.

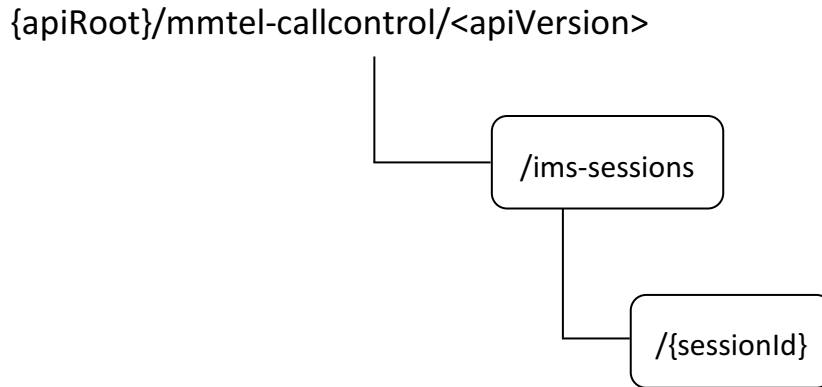

Figure 6.4.3.1-1: Resource URI structure of the MMTel_CallControl API

Table 6.4.3.1-1 provides an overview of the resources and applicable HTTP methods for the MMTel_CallControl API.

Table 6.4.3.1-1: Resources and methods overview

Resource name	Resource URI (relative path after API URI)	HTTP method or custom operation	Description (service operation)
IMS Sessions	/ims-sessions	POST	Create a new IMS Session at the MMTel Enabler Server.
Individual IMS Session	/ims-sessions/{sessionId}	PUT	Update an existing "Individual IMS Session" resource.
		PATCH	Modify an existing "Individual IMS Session" resource.
		DELETE	Delete an existing "Individual IMS Session" resource.

6.4.3.2 Resource: IMS Sessions

6.4.3.2.1 Description

This resource represents the collection of IMS Sessions managed by the MMTel Enabler Server.

The resource is modelled with the Collection resource archetype (see clause C.2 of 3GPP TS 29.501 [3]).

6.4.3.2.2 Resource Definition

Resource URI: **{apiRoot}/mmtel-callcontrol/<apiVersion>/ims-sessions**

This resource shall support the resource URI variables defined in table 6.4.3.2.2-1.

Table 6.4.3.2.2-1: Resource URI variables for this resource

Name	Data type	Definition
apiRoot	string	See clause 6.4.1.

6.4.3.2.3 Resource Standard Methods

6.4.3.2.3.1 POST

The HTTP POST method enables a service consumer to request the creation of a new IMS Session at the MMTel Enabler Server.

This method shall support the URI query parameters specified in table 6.4.3.2.3.1-1.

Table 6.4.3.2.3.1-1: URI query parameters supported by the POST method on this resource

Name	Data type	P	Cardinality	Description	Applicability
n/a					

This method shall support the request data structures specified in table 6.4.3.2.3.1-2 and the response data structures and response codes specified in table 6.4.3.2.3.1-3.

Table 6.4.3.2.3.1-2: Data structures supported by the POST Request Body on this resource

Data type	P	Cardinality	Description
ImsSession	M	1	Contains the parameters to request the creation of a new IMS Session.

Table 6.4.3.2.3.1-3: Data structures supported by the POST Response Body on this resource

Data type	P	Cardinality	Response codes	Description
ImsSession	M	1	201 Created	Successful response. The "Individual IMS Session" resource is successfully created and a representation of the created resource is returned in the response body. The URI of the created resource shall be returned in an HTTP "Location" header.
ProblemDetails	O	0..1	403 Forbidden	(NOTE 2)
NOTE 1: The mandatory HTTP error status codes for the HTTP POST method listed in table 5.2.6-1 of 3GPP TS 29.122 [2] shall also apply.				
NOTE 2: Failure cases are described in clause 6.4.7.				

Table 6.4.3.2.3.1-4: Headers supported by the 201 response code on this resource

Name	Data type	P	Cardinality	Description
Location	string	M	1	Contains the URI of the newly created resource, according to the structure: {apiRoot}/mmtel-callcontrol/<apiVersion>/ims-sessions/{sessionId}

6.4.3.2.4 Resource Custom Operations

There are no resource custom operations defined for this resource in this release of the specification.

6.4.3.3 Resource: Individual IMS Session

6.4.3.3.1 Description

This resource represents an "Individual IMS Session" resource managed by the MMTel Enabler Server.

This resource is modelled with the Document resource archetype (see clause C.1 of 3GPP TS 29.501 [3]).

6.4.3.3.2 Resource Definition

Resource URI: {apiRoot}/mmtel-callcontrol/<apiVersion>/ims-sessions/{sessionId}

This resource shall support the resource URI variables defined in table 6.4.3.3.2-1.

Table 6.4.3.3.2-1: Resource URI variables for this resource

Name	Data type	Definition
apiRoot	string	See clause 6.4.1.
sessionId	string	Represents the identifier of the "Individual IMS Session" resource.

6.4.3.3.3 Resource Standard Methods

6.4.3.3.3.1 PUT

The HTTP PUT method enables a service consumer to request the update of an existing "Individual IMS Session" resource at the MMTel Enabler Server.

This method shall support the URI query parameters specified in table 6.4.3.3.3.1-1.

Table 6.4.3.3.3.1-1: URI query parameters supported by the PUT method on this resource

Name	Data type	P	Cardinality	Description	Applicability
n/a					

This method shall support the request data structures specified in table 6.4.3.3.3.1-2 and the response data structures and response codes specified in table 6.4.3.3.3.1-3.

Table 6.4.3.3.3.1-2: Data structures supported by the PUT Request Body on this resource

Data type	P	Cardinality	Description
ImsSession	M	1	Represents the updated "Individual IMS Session" resource representation.

Table 6.4.3.3.3.1-3: Data structures supported by the PUT Response Body on this resource

Data type	P	Cardinality	Response codes	Description
ImsSession	M	1	200 OK	Successful response. The "Individual IMS Session" resource is successfully updated and a representation of the updated resource is returned in the response body.
n/a			204 No Content	Successful response. The "Individual IMS Session" resource is successfully updated and no content is returned in the response body.
n/a			307 Temporary Redirect	Temporary redirection. The response shall include a Location header field containing an alternative target URI of the resource located in an alternative MMTel Enabler Server. Redirection handling is described in clause 5.2.10 of 3GPP TS 29.122 [2].
n/a			308 Permanent Redirect	Permanent redirection. The response shall include a Location header field containing an alternative target URI of the resource located in an alternative MMTel Enabler Server. Redirection handling is described in clause 5.2.10 of 3GPP TS 29.122 [2].
ProblemDetails	O	0..1	403 Forbidden	(NOTE 2)
NOTE 1: The mandatory HTTP error status codes for the HTTP PUT method listed in Table 5.2.6-1 of 3GPP TS 29.122 [2] shall also apply.				
NOTE 2: Failure cases are described in clause 6.4.7.				

Table 6.4.3.3.3.1-4: Headers supported by the 307 Response Code on this resource

Name	Data type	P	Cardinality	Description
Location	string	M	1	Contains an alternative target URI of the resource located in an alternative MMTel Enabler Server.

Table 6.4.3.3.3.1-5: Headers supported by the 308 Response Code on this resource

Name	Data type	P	Cardinality	Description
Location	string	M	1	Contains an alternative target URI of the resource located in an alternative MMTel Enabler Server.

6.4.3.3.3.2 PATCH

The HTTP PATCH method enables a service consumer to request the modification of an existing "Individual IMS Session" resource at the MMTel Enabler Server.

This method shall support the URI query parameters specified in table 6.4.3.3.3.2-1.

Table 6.4.3.3.3.2-1: URI query parameters supported by the PATCH method on this resource

Name	Data type	P	Cardinality	Description	Applicability
n/a					

This method shall support the request data structures specified in table 6.4.3.3.3.2-2 and the response data structures and response codes specified in table 6.4.3.3.3.2-3.

Table 6.4.3.3.3.2-2: Data structures supported by the PATCH Request Body on this resource

Data type	P	Cardinality	Description
array(PatchItem)	M	1..N	Represents the list of modifications to be applied to the concerned existing Individual IMS Session resource, as specified in clause 4.6.1.1.3.2 of 3GPP TS 29.501 [3].

Table 6.4.3.3.2-3: Data structures supported by the PATCH Response Body on this resource

Data type	P	Cardinality	Response codes	Description
ImsSession	M	1	200 OK	Successful response. The "Individual IMS Session" resource is successfully modified and a representation of the updated resource is returned in the response body.
n/a			204 No Content	Successful response. The "Individual IMS Session" resource is successfully modified and no content is returned in the response body.
n/a			307 Temporary Redirect	Temporary redirection. The response shall include a Location header field containing an alternative target URI of the resource located in an alternative MMTel Enabler Server. Redirection handling is described in clause 5.2.10 of 3GPP TS 29.122 [2].
n/a			308 Permanent Redirect	Permanent redirection. The response shall include a Location header field containing an alternative target URI of the resource located in an alternative MMTel Enabler Server. Redirection handling is described in clause 5.2.10 of 3GPP TS 29.122 [2].
ProblemDetails	O	0..1	403 Forbidden	(NOTE 2)
NOTE 1: The mandatory HTTP error status codes for the HTTP PATCH method listed in table 5.2.6-1 of 3GPP TS 29.122 [2] shall also apply.				
NOTE 2: Failure cases are described in clause 6.4.7.				

Table 6.4.3.3.2-4: Headers supported by the 307 Response Code on this resource

Name	Data type	P	Cardinality	Description
Location	string	M	1	Contains an alternative URI of the resource located on an alternative MMTel Enabler Server.

Table 6.4.3.3.2-5: Headers supported by the 308 Response Code on this resource

Name	Data type	P	Cardinality	Description
Location	string	M	1	Contains an alternative URI of the resource located on an alternative MMTel Enabler Server.

6.4.3.3.3.3 DELETE

The HTTP DELETE method enables a service consumer to request the deletion of an existing "Individual IMS Session" resource at the MMTel Enabler Server.

This method shall support the URI query parameters specified in table 6.4.3.3.3.3-1.

Table 6.4.3.3.3.3-1: URI query parameters supported by the DELETE method on this resource

Name	Data type	P	Cardinality	Description	Applicability
n/a					

This method shall support the request data structures specified in table 6.4.3.3.3.3-2 and the response data structures and response codes specified in table 6.4.3.3.3.3-3.

Table 6.4.3.3.3.3-2: Data structures supported by the DELETE Request Body on this resource

Data type	P	Cardinality	Description
n/a			

Table 6.4.3.3.3.3-3: Data structures supported by the DELETE Response Body on this resource

Data type	P	Cardinality	Response codes	Description
n/a			204 No content	Successful response. The "Individual IMS Session" resource is successfully deleted.
n/a			307 Temporary Redirect	Temporary redirection. The response shall include a Location header field containing an alternative target URI of the resource located in an alternative MMTel Enabler Server. Redirection handling is described in clause 5.2.10 of 3GPP TS 29.122 [2].
n/a			308 Permanent Redirect	Permanent redirection. The response shall include a Location header field containing an alternative target URI of the resource located in an alternative MMTel Enabler Server. Redirection handling is described in clause 5.2.10 of 3GPP TS 29.122 [2].
ProblemDetails	O	0..1	403 Forbidden	(NOTE 2)
NOTE 1: The mandatory HTTP error status codes for the HTTP DELETE method listed in table 5.2.6-1 of 3GPP TS 29.122 [2] shall also apply.				
NOTE 2: Failure cases are described in clause 6.4.7.				

Table 6.4.3.3.3.3-4: Headers supported by the 307 Response Code on this resource

Name	Data type	P	Cardinality	Description
Location	string	M	1	Contains an alternative URI of the resource located on an alternative MMTel Enabler Server.

Table 6.4.3.3.3.3-5: Headers supported by the 308 Response Code on this resource

Name	Data type	P	Cardinality	Description
Location	string	M	1	Contains an alternative URI of the resource located on an alternative MMTel Enabler Server.

6.4.3.3.4 Resource Custom Operations

There are no resource custom operations defined for this resource in this release of the specification.

6.4.4 Custom Operations without associated resources

There are no resource custom operations defined for this resource in this release of the specification.

6.4.5 Notifications

6.4.5.1 General

Notifications shall comply to clause 5.2.5 of 3GPP TS 29.122 [2].

Table 6.4.5.1-1: Notifications overview

Notification	Callback URI	HTTP method or custom operation	Description (service operation)
IMS Session Notification	{notifUri}	POST	Enables the MMTel Enabler Server to notify a previously subscribed service consumer on IMS Session related event(s).

6.4.5.2 IMS Session Notification

6.4.5.2.1 Description

The IMS Session Notification is used by the MMTel Enabler Server to report IMS session related event(s) to a previously subscribed service consumer.

6.4.5.2.2 Target URI

The Callback URI "{notifUri}" shall be used with the callback URI variables defined in table 6.4.5.2.2-1.

Table 6.4.5.2.2-1: Callback URI variables

Name	Definition
notifUri	Represents the callback URI encoded as a string formatted as a URI.

6.4.5.2.3 Operation Definition

This method shall support the request data structures specified in table 6.4.5.2.3-1 and the response data structures and response codes specified in table 6.4.5.2.3-2.

Table 6.4.5.2.3-1: Data structures supported by the POST Request Body on this resource

Data type	P	Cardinality	Description
ImsSessionEvent Notification	M	1	Contains the IMS Session Notification.

Table 6.4.5.2.3-2: Data structures supported by the POST Response Body on this resource

Data type	P	Cardinality	Response codes	Description
n/a			204 No Content	Successful case. The IMS Session Notification is successfully received and acknowledged.
n/a			307 Temporary Redirect	Temporary redirection. The response shall include a Location header field containing an alternative URI representing the end point of an alternative AF towards which the notification should be sent. Redirection handling is described in clause 5.2.10 of 3GPP TS 29.122 [2].
n/a			308 Permanent Redirect	Permanent redirection. The response shall include a Location header field containing an alternative URI representing the end point of an alternative AF towards which the notification should be sent. Redirection handling is described in clause 5.2.10 of 3GPP TS 29.122 [2].
NOTE: The mandatory HTTP error status codes for the HTTP POST method listed in table 5.2.6-1 of 3GPP TS 29.122 [2] shall also apply.				

Table 6.4.5.2.3-3: Headers supported by the 307 Response Code on this resource

Name	Data type	P	Cardinality	Description
Location	string	M	1	Contains an alternative URI representing the end point of an alternative service consumer towards which the notification should be redirected.

Table 6.4.5.2.3-4: Headers supported by the 308 Response Code on this resource

Name	Data type	P	Cardinality	Description
Location	string	M	1	Contains an alternative URI representing the end point of an alternative service consumer towards which the notification should be redirected.

6.4.6 Data Model

6.4.6.1 General

This clause specifies the application data model supported by the API.

Table 6.4.6.1-1 specifies the data types defined for the MMTel_CallControl service-based interface protocol.

Table 6.4.6.1-1: MMTel_CallControl API specific Data Types

Data type	Clause defined	Description	Applicability

Table 6.4.6.1-2 specifies data types re-used by the MMTel_CallControl API from other specifications, including a reference to their respective specifications and when needed, a short description of their use within the MMTel_CallControl API.

Table 6.4.6.1-2: MMTel_CallControl API re-used Data Types

Data type	Reference	Comments	Applicability
ImsSessionEventNotification	3GPP TS 29.175 [13]	Represents the IMS Session Notification.	
ImsSession	3GPP TS 29.522 [14]	Represent an IMS Session.	
PatchItem	3GPP TS 29.571 [7]	Represents the requested modifications to an IMS Session.	

6.4.6.2 Structured data types

6.4.6.2.1 Introduction

This clause defines the structured data types to be used in resource representations.

There are no data structures defined for this API in this release of the specification.

6.4.6.3 Simple data types and enumerations

6.4.6.3.1 Introduction

This clause defines simple data types and enumerations that can be referenced from data structures defined in the previous clauses.

6.4.6.3.2 Simple data types

The simple data types defined in table 6.4.6.3.2-1 shall be supported.

Table 6.4.6.3.2-1: Simple data types

Type Name	Type Definition	Description	Applicability

6.4.6.4 Data types describing alternative data types or combinations of data types

There are no data types describing alternative data types or combinations of data types defined for this API in this release of the specification.

6.4.6.5 Binary data

6.4.6.5.1 Binary Data Types

Table 6.4.6.5.1-1: Binary Data Types

Name	Clause defined	Content type

6.4.7 Error Handling

6.4.7.1 General

For the MMTel_CallControl API, HTTP error responses shall be supported as specified in clause 5.2.6 of 3GPP TS 29.122 [2]. Protocol errors and application errors specified in clause 5.2.6 of 3GPP TS 29.122 [2] shall be supported for the HTTP status codes specified in table 5.2.6-1 of 3GPP TS 29.122 [2].

In addition, the requirements in the following clauses are applicable for the MMTel_CallControl API.

6.4.7.2 Protocol Errors

No specific protocol errors for the MMTel_CallControl API are specified.

6.4.7.3 Application Errors

The application errors defined for the MMTel_CallControl API are listed in Table 6.4.7.3-1.

Table 6.3.7.3-1: Application errors

Application Error	HTTP status code	Description	Applicability
AF_NOT_AUTHORIZED	403 Forbidden	The IMS session creation/update/modification/deletion request is rejected because the service consumer is not authorized.	

6.4.8 Feature negotiation

The optional features listed in table 6.4.8-1 are defined for the MMTel_CallControl API. They shall be negotiated using the extensibility mechanism defined in clause 5.2.7 of 3GPP TS 29.122 [2].

Table 6.4.8-1: Supported Features

Feature number	Feature Name	Description

6.4.9 Security

The provisions of clause 6 of 3GPP TS 29.122 [2] shall apply for the MMTel_CallEvent API.

7 Using Common API Framework

7.1 General

When CAPIF is used with a MMTel Enabler Server service, the MMTel Enabler Server shall support the following functionalities as defined in 3GPP TS 29.222 [9]:

- the API Exposing Function and the related APIs over CAPIF-2/2e and CAPIF-3/3e reference points;
- the API Publishing Function and the related APIs over CAPIF-4/4e reference point;
- the API Management Function and the related APIs over CAPIF-5/5e reference point; and
- at least one of the security methods for authentication and authorization, and the related security mechanisms.

In a centralized deployment as defined in 3GPP TS 23.222 [8], where the CAPIF Core Function and the API Provider domain functions are co-located, the interactions between the CAPIF Core Function and the API Provider domain functions may be independent of the CAPIF-3/3e, CAPIF-4/4e and CAPIF-5/5e reference points.

When CAPIF is used with a MMTel Enabler Server service, the MMTel Enabler Server shall register all the northbound APIs features in the CAPIF Core Function.

7.2 Security

When CAPIF is used for managing the exposure of the MMTel Enabler Server APIs, before invoking an API exposed by the MMTel Enabler Server, the service consumer (e.g., Application Server), acting as an API Invoker, shall negotiate the security method (PKI, TLS-PSK or OAuth 2.0) with the CAPIF Core Function and ensure that the MMTel Enabler Server has enough credentials to authenticate the service consumer, as defined in clauses 5.6.2.2 and 6.2.2.2 of 3GPP TS 29.222 [9].

If PKI or TLS-PSK is selected as the security method to be used between the service consumer and the MMTel Enabler Server, upon API invocation, the MMTel Enabler Server shall retrieve the authorization information from the CAPIF Core Function as described in clause 5.6.2.4 of 3GPP TS 29.222 [9].

As indicated in 3GPP TS 33.122 [10], the access to the MMTel Enabler Server APIs may be authorized by means of the OAuth 2.0 protocol (see IETF RFC 6749 [11]), where the CAPIF Core Function (see 3GPP TS 29.222 [9]) plays the role of the authorization server.

If OAuth 2.0 is selected as the security method to be used between the service consumer and the MMTel Enabler Server, the service consumer shall, prior to consuming the services offered by the MMTel Enabler Server APIs, obtain a "token" from the authorization server, by invoking the Obtain_Authorization service operation as described in clause 5.6.2.3.2 of 3GPP TS 29.222 [9].

The MMTel Enabler Server APIs do not define any scopes for OAuth 2.0 authorization in the present specification. For the definition and handling of scopes for OAuth2 authorization in CAPIF, see 3GPP TS 29.222 [9].

It is the MMTel Enabler Server responsibility to check whether the service consumer is authorized to use an API based on the provided "token". Once the MMTel Enabler Server verifies the "token", it shall check whether the MMTel Enabler Server identifier in the "token" matches its own published identifier, whether the API name in the "token" matches its own published API name and whether the granted scope (see 3GPP TS 29.222 [9]) in the "token" is authorized. If those checks are passed, the service consumer has full authority to access any resource(s) and/or operation(s) provided by the invoked service API and that are within the limits of the granted scope in the "token".

NOTE: For the aforementioned security methods, the MMTel Enabler Server needs to apply admission control according to access control policies after performing the authorization checks.

Annex A (normative): OpenAPI specification

A.1 General

This Annex specifies the formal definition of the API(s) defined in the present specification. It consists of OpenAPI specifications in YAML format.

This Annex takes precedence when being discrepant to other parts of the specification with respect to the encoding of information elements and methods within the API(s).

NOTE 1: The semantics and procedures, as well as conditions, e.g. for the applicability and allowed combinations of attributes or values, not expressed in the OpenAPI definitions but defined in other parts of the specification also apply.

Informative copies of the OpenAPI specification files contained in this 3GPP Technical Specification are available on a Git-based repository that uses the GitLab software version control system (see clause 5.3.1 of 3GPP TS 29.501 [3] and clause 5B of 3GPP TR 21.900 [5]).

A.2 MMTel_DCAppManagement API

openapi: 3.0.0

info:

```
title: MMTel DC Application Management Service
version: 1.0.1
description: |
  MMTel DC Application Management Service.
  © 2026, 3GPP Organizational Partners (ARIB, ATIS, CCSA, ETSI, TSDSI, TTA, TTC).
  All rights reserved.
```

externalDocs:

```
description: >
  3GPP TS 29.392 V19.1.0;
  Application layer support for MMTel;
  MMTel Enabler Server Services;Stage 3.
url: http://www.3gpp.org/ftp/Specs/archive/29_series/29.392/
```

servers:

```
- url: '{apiRoot}/mmtel-dcappmgmt/v1'
  variables:
    apiRoot:
      default: https://example.com
      description: apiRoot as defined in clause 5.2.4 of 3GPP TS 29.122
```

security:

```
- {}
- oAuth2ClientCredentials: []
```

paths:

```
/dcapps/configure:
  post:
    summary: Request the creation of a new DC application management configuration.
    operationId: CreatedCAppMgmt
    tags:
      - DC Application Management Configurations
    requestBody:
      required: true
      content:
        application/json:
          schema:
            $ref: '#/components/schemas/DcAppConfigReq'
    responses:
      '200':
        description: >
          OK. The DC application and DC application profile configuration is successfully
          processed and DC application and profile Configuration shall be returned in the response
```

body.

```
content:
  application/json:
    schema:
      $ref: '#/components/schemas/DcAppConfigResp'
'307':
  $ref: 'TS29122_CommonData.yaml#/components/responses/307'
'308':
  $ref: 'TS29122_CommonData.yaml#/components/responses/308'
'400':
  $ref: 'TS29122_CommonData.yaml#/components/responses/400'
'401':
  $ref: 'TS29122_CommonData.yaml#/components/responses/401'
'403':
  $ref: 'TS29122_CommonData.yaml#/components/responses/403'
'404':
  $ref: 'TS29122_CommonData.yaml#/components/responses/404'
'411':
  $ref: 'TS29122_CommonData.yaml#/components/responses/411'
'413':
  $ref: 'TS29122_CommonData.yaml#/components/responses/413'
'415':
  $ref: 'TS29122_CommonData.yaml#/components/responses/415'
'429':
  $ref: 'TS29122_CommonData.yaml#/components/responses/429'
'500':
  $ref: 'TS29122_CommonData.yaml#/components/responses/500'
'503':
  $ref: 'TS29122_CommonData.yaml#/components/responses/503'
```

```

    default:
      $ref: 'TS29122_CommonData.yaml#/components/responses/default'

/dcappps/update:
  post:
    summary: Request the update of a DC application management configuration.
    operationId: UpdateDCAppMgmt
    tags:
      - DC Application Management Configurations Update
    requestBody:
      required: true
      content:
        application/json:
          schema:
            $ref: '#/components/schemas/DcAppUpdateReq'
    responses:
      '200':
        description: >
          Updated. The DC application and DC application profile configuration is successfully
          updated.
        content:
          application/json:
            schema:
              $ref: '#/components/schemas/DcAppStatResp'
      '307':
        $ref: 'TS29122_CommonData.yaml#/components/responses/307'
      '308':
        $ref: 'TS29122_CommonData.yaml#/components/responses/308'
      '400':
        $ref: 'TS29122_CommonData.yaml#/components/responses/400'
      '401':
        $ref: 'TS29122_CommonData.yaml#/components/responses/401'
      '403':
        $ref: 'TS29122_CommonData.yaml#/components/responses/403'
      '404':
        $ref: 'TS29122_CommonData.yaml#/components/responses/404'
      '411':
        $ref: 'TS29122_CommonData.yaml#/components/responses/411'
      '413':
        $ref: 'TS29122_CommonData.yaml#/components/responses/413'
      '415':
        $ref: 'TS29122_CommonData.yaml#/components/responses/415'
      '429':
        $ref: 'TS29122_CommonData.yaml#/components/responses/429'
      '500':
        $ref: 'TS29122_CommonData.yaml#/components/responses/500'
      '503':
        $ref: 'TS29122_CommonData.yaml#/components/responses/503'
    default:
      $ref: 'TS29122_CommonData.yaml#/components/responses/default'

/dcappps/delete:
  post:
    summary: Request the delete of a DC application management configuration.
    operationId: DeleteDCAppMgmt
    tags:
      - DC Application Management Configurations Delete
    requestBody:
      required: true
      content:
        application/json:
          schema:
            $ref: '#/components/schemas/DcAppIdReq'
    responses:
      '200':
        description: >
          Deleted. The DC application and DC application profile configuration is successfully
          deleted.
        content:
          application/json:
            schema:
              $ref: '#/components/schemas/DcAppIdResp'
      '307':
        $ref: 'TS29122_CommonData.yaml#/components/responses/307'
      '308':
        $ref: 'TS29122_CommonData.yaml#/components/responses/308'
      '400':
        $ref: 'TS29122_CommonData.yaml#/components/responses/400'

```

```

'401':
  $ref: 'TS29122_CommonData.yaml#/components/responses/401'
'403':
  $ref: 'TS29122_CommonData.yaml#/components/responses/403'
'404':
  $ref: 'TS29122_CommonData.yaml#/components/responses/404'
'411':
  $ref: 'TS29122_CommonData.yaml#/components/responses/411'
'413':
  $ref: 'TS29122_CommonData.yaml#/components/responses/413'
'415':
  $ref: 'TS29122_CommonData.yaml#/components/responses/415'
'429':
  $ref: 'TS29122_CommonData.yaml#/components/responses/429'
'500':
  $ref: 'TS29122_CommonData.yaml#/components/responses/500'
'503':
  $ref: 'TS29122_CommonData.yaml#/components/responses/503'
default:
  $ref: 'TS29122_CommonData.yaml#/components/responses/default'

```

/dcapps/retrieval:

```

post:
  summary: Request the retrieval of a DC application management configuration.
  operationId: RetrievalDCAppMgmt
  tags:
    - DC Application Management Configurations Retrieval
  requestBody:
    required: true
    content:
      application/json:
        schema:
          $ref: '#/components/schemas/DcAppIdReq'
  responses:
    '200':
      description: >
        The requested DC application profile related information is returned.
      content:
        application/json:
          schema:
            $ref: '#/components/schemas/DcAppIdResp'
    '307':
      $ref: 'TS29122_CommonData.yaml#/components/responses/307'
    '308':
      $ref: 'TS29122_CommonData.yaml#/components/responses/308'
    '400':
      $ref: 'TS29122_CommonData.yaml#/components/responses/400'
    '401':
      $ref: 'TS29122_CommonData.yaml#/components/responses/401'
    '403':
      $ref: 'TS29122_CommonData.yaml#/components/responses/403'
    '404':
      $ref: 'TS29122_CommonData.yaml#/components/responses/404'
    '411':
      $ref: 'TS29122_CommonData.yaml#/components/responses/411'
    '413':
      $ref: 'TS29122_CommonData.yaml#/components/responses/413'
    '415':
      $ref: 'TS29122_CommonData.yaml#/components/responses/415'
    '429':
      $ref: 'TS29122_CommonData.yaml#/components/responses/429'
    '500':
      $ref: 'TS29122_CommonData.yaml#/components/responses/500'
    '503':
      $ref: 'TS29122_CommonData.yaml#/components/responses/503'
  default:
    $ref: 'TS29122_CommonData.yaml#/components/responses/default'

```

components:

```

securitySchemes:
  oAuth2ClientCredentials:
    type: oauth2
    flows:
      clientCredentials:
        tokenUrl: '{tokenUrl}'
        scopes: {}

```

schemas:

STRUCTURED DATA TYPES
#

```

DcAppConfigReq:
  description: >
    Represents the DC application and profile configuration request.
  type: object
  properties:
    reqId:
      type: string
    secCred:
      type: string
    dcAppNum:
      type: integer
    dcAppConfigParamList:
      type: array
      items:
        $ref: '#/components/schemas/DcAppConfigParameters'
      minItems: 1
  required:
    - reqId
    - dcAppNum
    - dcAppConfigParamList

DcAppConfigParameters:
  description: >
    Represents the parameters of single-DC applicaion in the configuration request.
  type: object
  properties:
    appIndex:
      type: string
    appName:
      type: string
    svcType:
      type: string
    appIconUrl:
      $ref: 'TS29122_CommonData.yaml#/components/schemas/Uri'
    appVer:
      type: string
    appVal:
      $ref: 'TS29122_CommonData.yaml#/components/schemas/DateTime'
    appLoadPh:
      $ref: '#/components/schemas/AppLoadPhase'
    autoload:
      type: boolean
    autolaunch:
      type: boolean
    peerDcReq:
      type: boolean
    suppScnr:
      $ref: '#/components/schemas/SupportScenario'
    cond:
      $ref: '#/components/schemas/Condition'
    qosReq:
      type: string
    persDataColl:
      type: boolean
    persDataCollInfoUrl:
      $ref: 'TS29122_CommonData.yaml#/components/schemas/Uri'
    appPkg:
      $ref: 'TS29122_CommonData.yaml#/components/schemas/Binary'
  required:
    - appIndex

DcAppConfigResp:
  description: >
    Represents the DC application and profile configuration response.
  type: object
  properties:
    dcAppConfigRespList:
      type: array
      items:
        $ref: '#/components/schemas/DcAppConfigResponseParameters'
      minItems: 1
  required:

```

```

- dcAppConfigRespList

DcAppConfigResponseParameters:
description: >
  Represents the parameters of single-DC applicaion in the configuration response.
type: object
properties:
  appIndex:
    type: string
  status:
    $ref: '#/components/schemas/Status'
  appId:
    type: string
  failureCause:
    type: string
required:
- appIndex
- status

DcAppUpdateReq:
description: >
  Represents the DC application and profile update request.
type: object
properties:
  reqId:
    type: string
  secCred:
    type: string
  dcAppNum:
    type: integer
  dcAppUpdateParamList:
    type: array
    items:
      $ref: '#/components/schemas/DcAppUpdateParameters'
    minItems: 1
required:
- reqId
- dcAppNum
- dcAppUpdateParamList

DcAppUpdateParameters:
description: >
  Represents the parameters of single-DC applicaion in the update response.
  appId:
    type: string
  appName:
    type: string
  svcType:
    type: string
  appIconUrl:
    $ref: 'TS29122_CommonData.yaml#/components/schemas/Uri'
  appVer:
    type: string
  appVal:
    $ref: 'TS29122_CommonData.yaml#/components/schemas/DateTime'
  appLoadPh:
    $ref: '#/components/schemas/AppLoadPhase'
  autoload:
    type: boolean
  autolaunch:
    type: boolean
  peerDcReq:
    type: boolean
  suppScnr:
    $ref: '#/components/schemas/SupportScenario'
  cond:
    $ref: '#/components/schemas/Condition'
  qosReq:
    type: string
  persDataColl:
    type: boolean
  persDataCollInfoUrl:
    $ref: 'TS29122_CommonData.yaml#/components/schemas/Uri'
  appPkg:
    $ref: 'TS29122_CommonData.yaml#/components/schemas/Binary'
required:
- appId

```

```

DcAppStatResp:
  description: >
    Represents the DC application and profile update response or DC application delete response.
  type: object
  properties:
    dcAppStatRespList:
      type: array
      items:
        $ref: '#/components/schemas/DcAppResponseParameters'
      minItems: 1
    required:
      - dcAppStatRespList

DcAppResponseParameters:
  description: >
    Represents the parameters of single-DC applicaion in the DC application and
    profile update response and DC application delete response.
  type: object
  properties:
    appId:
      type: string
    status:
      $ref: '#/components/schemas/Status'
    failureCause:
      type: string
    required:
      - appId
      - status

DcAppIdReq:
  description: >
    Represents the DC application delete request and DC application information
    retrieval request.
  type: object
  properties:
    reqId:
      type: string
    dcAppNum:
      type: integer
    appIdList:
      type: array
      items:
        type: string
      minItems: 1
    required:
      - reqId
      - dcAppNum
      - appIdList

DcAppIdResp:
  description: >
    Represents the DC application profile information retrieval response.
  type: object
  properties:
    status:
      $ref: '#/components/schemas/Status'
    dcAppInfoList:
      type: array
      items:
        $ref: '#/components/schemas/DcAppUpdateParameters'
      minItems: 1
    failureCause:
      type: string
    required:
      - status

# SIMPLE DATA TYPES
#

#
# ENUMERATIONS
#

AppLoadPhase:
  anyOf:
    - type: string

```

```

enum:
  - PRECALL_ONLY
  - INCALL
  - PRECALL_AND_INCALL
- type: string
  description: >
    This string provides forward-compatibility with future extensions to the enumeration but
    is not used to encode content defined in the present version of this API.
description: |
  Represents the load phase of the DC application.
  It complies with the provisions defined in Table 6.1.6.3.3-1 of 3GPP TS 29.392.
  Possible values are:
  - PRECALL_ONLY: Indicates the Data Channel Application is allowed to be used before
    the MMTel call session is established.
  - INCALL: Indicates that the Data Channel Application is allowed to be used after
    the MMTel call session is established.
  - PRECALL_AND_INCALL: Indicates that the Data Channel Application is allowed to be
    used during the entire Precall and incall.

SupportScenario:
  anyOf:
  - type: string
    enum:
      - VOICE_CALL_ONLY
      - VIDEO_CALL_ONLY
      - VOICE_AND_VIDEO_CALL
  - type: string
    description: >
      This string provides forward-compatibility with future extensions to the enumeration but
      is not used to encode content defined in the present version of this API.
description: |
  Represents the support scenario of the DC application.
  It complies with the provisions defined in Table 6.1.6.3.4-1 of 3GPP TS 29.392.
  Possible values are:
  - VOICE_CALL_ONLY: Indicates the Data Channel Application can be used if and only
    if the corresponding call is a voice call.
  - VIDEO_CALL_ONLY: Indicates that the Data Channel Application can be used if
    and only if the corresponding call is a video call.
  - VOICE_AND_VIDEO_CALL: Indicates that the Data Channel Application can be used
    in both voice call and video call.

Status:
  anyOf:
  - type: string
    enum:
      - SUCCESS
      - FAILED
  - type: string
    description: >
      This string provides forward-compatibility with future extensions to the enumeration but
      is not used to encode content defined in the present version of this API.
description: |
  Represents the request return status.
  It complies with the provisions defined in Table 6.1.6.3.5-1 of 3GPP TS 29.392.
  Possible values are:
  - SUCCESS: Indicates that the request is processed successfully.
  - FAILED: Indicates that the request fails to be processed.

Condition:
  anyOf:
  - type: string
    enum:
      - CONDTY
      - CONDVA
  - type: string
    description: >
      This string provides forward-compatibility with future extensions to the enumeration but
      is not used to encode content defined in the present version of this API.
description: |
  Represents the conditions used by the DC application.
  It complies with the provisions defined in Table 6.1.6.3.6-1 of 3GPP TS 29.392.
  Possible values are:
  - CONDTY: Indicates the Data Channel Application is allowed to be used in this
    condition, e.g. Service area.
  - CONDVA: Indicates the value of the CONFTY.

```

A.3 MMTel_DCAppCall API

openapi: 3.0.0

info:

```
title: MMTel_DCAppCall API
version: 1.0.1
description: |
  MMTel Enabler Server DC Application Call Service.
  © 2026, 3GPP Organizational Partners (ARIB, ATIS, CCSA, ETSI, TSDSI, TTA, TTC).
  All rights reserved.
```

externalDocs:

```
description: |
  3GPP TS 29.392 V19.1.0;
  Application layer support for MMTel; MMTel Enabler Server Services; Stage 3.
url: https://www.3gpp.org/ftp/Specs/archive/29_series/29.392/
```

servers:

```
- url: '{apiRoot}/mmtel-dcappcall/v1'
  variables:
    apiRoot:
      default: https://example.com
      description: apiRoot as defined in clause 5.2.4 of 3GPP TS 29.122
```

security:

```
- {}
- oAuth2ClientCredentials: []
```

paths:

```
/dccall:
  post:
    summary: Request to Establish a call with DC capability.
    operationId: DcCallRequest
    tags:
      - DC Call Establishment Request
    requestBody:
      required: true
      content:
        application/json:
          schema:
            $ref: '#/components/schemas/DcCallReq'
    responses:
      '200':
        description: >
          OK. The requested DC Call information is returned.
        content:
          application/json:
            schema:
              $ref: '#/components/schemas/DcCallResp'
      '307':
        $ref: 'TS29122_CommonData.yaml#/components/responses/307'
      '308':
        $ref: 'TS29122_CommonData.yaml#/components/responses/308'
      '400':
        $ref: 'TS29122_CommonData.yaml#/components/responses/400'
      '401':
        $ref: 'TS29122_CommonData.yaml#/components/responses/401'
      '403':
        $ref: 'TS29122_CommonData.yaml#/components/responses/403'
      '404':
        $ref: 'TS29122_CommonData.yaml#/components/responses/404'
      '409':
        $ref: 'TS29122_CommonData.yaml#/components/responses/409'
      '411':
        $ref: 'TS29122_CommonData.yaml#/components/responses/411'
      '413':
        $ref: 'TS29122_CommonData.yaml#/components/responses/413'
      '415':
        $ref: 'TS29122_CommonData.yaml#/components/responses/415'
      '429':
        $ref: 'TS29122_CommonData.yaml#/components/responses/429'
      '500':
        $ref: 'TS29122_CommonData.yaml#/components/responses/500'
      '503':
        $ref: 'TS29122_CommonData.yaml#/components/responses/503'
    default:
```

```

    $ref: 'TS29122_CommonData.yaml#/components/responses/default'
  callbacks:
    DcMediaNotification:
      '{$request.body#/notificationInfo}':
        post:
          requestBody:
            required: true
            content:
              application/json:
                schema:
                  $ref: '#/components/schemas/DcMediaNotifyReq'
          responses:
            '200':
              description: >
                OK. The DC Media Notification is successfully received and DC Media related
                information is returned in the response body.
              content:
                application/json:
                  schema:
                    $ref: '#/components/schemas/DcMediaNotifyResp'
            '307':
              $ref: 'TS29122_CommonData.yaml#/components/responses/307'
            '308':
              $ref: 'TS29122_CommonData.yaml#/components/responses/308'
            '400':
              $ref: 'TS29122_CommonData.yaml#/components/responses/400'
            '401':
              $ref: 'TS29122_CommonData.yaml#/components/responses/401'
            '403':
              $ref: 'TS29122_CommonData.yaml#/components/responses/403'
            '404':
              $ref: 'TS29122_CommonData.yaml#/components/responses/404'
            '411':
              $ref: 'TS29122_CommonData.yaml#/components/responses/411'
            '413':
              $ref: 'TS29122_CommonData.yaml#/components/responses/413'
            '415':
              $ref: 'TS29122_CommonData.yaml#/components/responses/415'
            '429':
              $ref: 'TS29122_CommonData.yaml#/components/responses/429'
            '500':
              $ref: 'TS29122_CommonData.yaml#/components/responses/500'
            '503':
              $ref: 'TS29122_CommonData.yaml#/components/responses/503'
          default:
            $ref: 'TS29122_CommonData.yaml#/components/responses/default'

/update-dc-media:
  post:
    summary: Update DC media of an existing session.
    operationId: DcMediaUpdateRequest
    tags:
      - DC Media Update Request
    requestBody:
      required: true
      content:
        application/json:
          schema:
            $ref: '#/components/schemas/DcMediaUpdateReq'
    responses:
      '200':
        description: >
          OK. The requested DC Media update information is successfully returned.
        content:
          application/json:
            schema:
              $ref: '#/components/schemas/DcMediaUpdateResp'
      '307':
        $ref: 'TS29122_CommonData.yaml#/components/responses/307'
      '308':
        $ref: 'TS29122_CommonData.yaml#/components/responses/308'
      '400':
        $ref: 'TS29122_CommonData.yaml#/components/responses/400'
      '401':
        $ref: 'TS29122_CommonData.yaml#/components/responses/401'
      '403':
        $ref: 'TS29122_CommonData.yaml#/components/responses/403'
      '404':

```

```

    $ref: 'TS29122_CommonData.yaml#/components/responses/404'
  '409':
    $ref: 'TS29122_CommonData.yaml#/components/responses/409'
  '411':
    $ref: 'TS29122_CommonData.yaml#/components/responses/411'
  '413':
    $ref: 'TS29122_CommonData.yaml#/components/responses/413'
  '415':
    $ref: 'TS29122_CommonData.yaml#/components/responses/415'
  '429':
    $ref: 'TS29122_CommonData.yaml#/components/responses/429'
  '500':
    $ref: 'TS29122_CommonData.yaml#/components/responses/500'
  '503':
    $ref: 'TS29122_CommonData.yaml#/components/responses/503'
  default:
    $ref: 'TS29122_CommonData.yaml#/components/responses/default'

```

```

components:
  securitySchemes:
    oAuth2ClientCredentials:
      type: oauth2
      flows:
        clientCredentials:
          tokenUrl: '{tokenUrl}'
          scopes: {}

  schemas:

    DcCallReq:
      type: object
      properties:
        originatingId:
          $ref: 'TS29122_CommonData.yaml#/components/schemas/Uri'
        terminatingId:
          $ref: 'TS29122_CommonData.yaml#/components/schemas/Uri'
        mediaInfo:
          type: array
          items:
            type: string
            minItems: 1
        dcMediaInfo:
          type: boolean
          description: Indicates whether the DC Media is expected to be used or not.
            true indicates that the DC Media is expected to be used.
            false (default) indicates that the DC Media is not expected to be used.
        appProfileRequested:
          $ref: 'TS29392_MMTel_DCAppManagement.yaml#/components/schemas/DcAppUpdateParameters'
        notificationInfo:
          $ref: 'TS29122_CommonData.yaml#/components/schemas/Uri'
        callType:
          $ref: '#/components/schemas/CallType'
      required:
        - terminatingId
        - notificationInfo
        - callType

    DcCallResp:
      type: object
      properties:
        callResult:
          $ref: 'TS29392_MMTel_DCAppManagement.yaml#/components/schemas/Status'
        sessionId:
          type: string
          description: Call session identifier, maps to callSessionId in OMA Third Party Call API
        failureCause:
          type: string
          description: Cause of call establishment failure
        originatingId:
          $ref: 'TS29122_CommonData.yaml#/components/schemas/Uri'
        terminatingId:
          $ref: 'TS29122_CommonData.yaml#/components/schemas/Uri'
        mediaInfo:
          type: array
          items:
            type: string
          description: Negotiated media types
          minItems: 1

```

```

dcMediaInfo:
  type: string
  description: DC media activation status
appProfileRequested:
  $ref: 'TS29392_MMTel_DCAppManagement.yaml#/components/schemas/DcAppUpdateParameters'
callType:
  $ref: '#/components/schemas/CallType'
required:
- callResult
- terminatingId
- callType
DcMediaUpdateReq:
  type: object
  properties:
    dcAppId:
      type: string
      description: Unique identifier of the DC application
    sessionId:
      type: string
      description: Identifier of the session to be updated
    mediaResourceInfo:
      type: object
      description: Media information to be transmitted via the Data Channel
    appProfileRequested:
      $ref: 'TS29392_MMTel_DCAppManagement.yaml#/components/schemas/DcAppUpdateParameters'
    notificationInfo:
      $ref: 'TS29122_CommonData.yaml#/components/schemas/Uri'
    mediaDirection:
      $ref: '#/components/schemas/AdcType'
  required:
- dcAppId
- sessionId
- notificationInfo
DcMediaUpdateResp:
  type: object
  properties:
    sessionId:
      type: string
      description: Session identifier
    result:
      $ref: 'TS29392_MMTel_DCAppManagement.yaml#/components/schemas/Status'
    cause:
      type: string
      description: Cause of update request failure
  required:
- sessionId
- result
DcMediaNotifyReq:
  type: object
  properties:
    sessionId:
      type: string
      description: Session identifier
    mediaResourceInfo:
      type: object
      description: Media information transmitted via the Data Channel
    mediaDirection:
      $ref: '#/components/schemas/AdcType'
  required:
- sessionId
- mediaResourceInfo
DcMediaNotifyResp:
  type: object
  properties:
    sessionId:
      type: string
      description: Session identifier
    result:
      $ref: 'TS29392_MMTel_DCAppManagement.yaml#/components/schemas/Status'
    cause:
      type: string
      description: Cause of notification processing failure
  required:
- sessionId
- result

```

```

#
# SIMPLE DATA TYPES

```

```
#
#
# ENUMERATIONS
#

AdcType:
  anyOf:
    - type: string
      enum:
        - A2P
        - P2A
    - type: string
      description: >
        This string provides forward-compatibility with future extensions to the enumeration
        and is not used to encode content defined in the present version of this API.
  description: |
    Represents the type of the data channel media direction.
    Possible values are:
    - A2P: Indicates that the type of the data channel media direction is a Data Channel
      initiated by the Application.
    - P2P: Indicates that the type of the data channel media direction is a Data Channel
      initiated by the UE.

CallType:
  anyOf:
    - type: string
      enum:
        - A2P
        - P2P
    - type: string
      description: >
        This string provides forward-compatibility with future extensions to the enumeration
        and is not used to encode content defined in the present version of this API.
  description: |
    Represents the established call type.
    Possible values are:
    - A2P: Indicates that the established call type is an Application call initiated by the
      Application towards the UE.
    - P2P: Indicates that the established call type is a Third Party call established between
      two UEs.
```

A.4 MMTel_CallEvent API

openapi: 3.0.0

info:

```
title: MMTel_CallEvent API
version: 1.0.1
description: |
  MMTel Enabler Server Call Event Service.
  © 2026, 3GPP Organizational Partners (ARIB, ATIS, CCSA, ETSI, TSDSI, TTA, TTC).
  All rights reserved.
```

externalDocs:

```
description: >
  3GPP TS 29.392 V19.1.0;
  Application layer support for MMTel; MMTel Enabler Server Services; Stage 3.
url: https://www.3gpp.org/ftp/Specs/archive/29_series/29.392/
```

servers:

```
- url: '{apiRoot}/mmtel-callevent/v1'
  variables:
    apiRoot:
      default: https://example.com
      description: apiRoot as defined in clause 5.2.4 of 3GPP TS 29.122
```

security:

```
- {}
- oAuth2ClientCredentials: []
```

paths:

```
/session-event-subscriptions:
  # This is a dummy resource that is not needed and not used. It is defined for the sole purpose
  of enabling the definition of the below ImsSessionEventNotification callback.
  post:
    # This is a dummy service operation, service consumers (e.g., Application Server) shall NOT
    invoke this method on this resource! It is defined only for the purpose of defining the below
    ImsSessionEventNotification callback.
    summary: Pseudo dummy operation
    tags:
      - Session Event Subscriptions (Collection)
    operationId: DummySubscribe
    requestBody:
      required: true
      content:
        application/json:
          # Unspecified schema for the JSON body, since this is not used by consumer or producer.
          schema: {}
    responses:
      default:
        $ref: 'TS29571_CommonData.yaml#/components/responses/default'
    callbacks:
      ImsSessionEventNotification:
        '{sessionEventNotificationUri}':
          post:
            requestBody:
              required: true
              content:
                application/json:
                  schema:
                    $ref:
' TS29175_Nimsas_ImsSessionManagement.yaml#/components/schemas/ImsSessionEventNotification'
      responses:
        '204':
          description: No Content, notification was successfully received.
        '307':
          $ref: 'TS29571_CommonData.yaml#/components/responses/307'
        '308':
          $ref: 'TS29571_CommonData.yaml#/components/responses/308'
        '400':
          $ref: 'TS29571_CommonData.yaml#/components/responses/400'
        '401':
          $ref: 'TS29571_CommonData.yaml#/components/responses/401'
        '403':
          $ref: 'TS29571_CommonData.yaml#/components/responses/403'
        '404':
          $ref: 'TS29571_CommonData.yaml#/components/responses/404'
        '411':
```

```

    $ref: 'TS29571_CommonData.yaml#/components/responses/411'
  '413':
    $ref: 'TS29571_CommonData.yaml#/components/responses/413'
  '415':
    $ref: 'TS29571_CommonData.yaml#/components/responses/415'
  '429':
    $ref: 'TS29571_CommonData.yaml#/components/responses/429'
  '500':
    $ref: 'TS29571_CommonData.yaml#/components/responses/500'
  '502':
    $ref: 'TS29571_CommonData.yaml#/components/responses/502'
  '503':
    $ref: 'TS29571_CommonData.yaml#/components/responses/503'
  default:
    $ref: 'TS29571_CommonData.yaml#/components/responses/default'

```

components:

```

securitySchemes:
  oAuth2ClientCredentials:
    type: oauth2
    flows:
      clientCredentials:
        tokenUrl: '{tokenUrl}'
        scopes: {}

```

A.5 MMTel_CallControl API

openapi: 3.0.0

info:

```

title: MMTel_CallControl API
version: 1.0.1
description: |
  API for MMTel Enabler Server Call Control Service.
  © 2026, 3GPP Organizational Partners (ARIB, ATIS, CCSA, ETSI, TSDSI, TTA, TTC).
  All rights reserved.

```

externalDocs:

```

description: >
  3GPP TS 29.392 V19.1.0;
  Application layer support for MMTel; MMTel Enabler Server Services; Stage 3.
url: https://www.3gpp.org/ftp/Specs/archive/29_series/29.392/

```

servers:

```

- url: '{apiRoot}/mmtel-callcontrol/v1'
  variables:
    apiRoot:
      default: https://example.com
      description: apiRoot as defined in clause 5.2.4 of 3GPP TS 29.122

```

security:

```

- {}
- oAuth2ClientCredentials: []

```

paths:

```

/ims-sessions:
  post:
    summary: Create a new IMS Session
    operationId: ImsSessionCreate
    tags:
      - IMS Sessions (Collection)
    requestBody:
      required: true
      content:
        application/json:
          schema:
            $ref: 'TS29522_ImsSessionManagement.yaml#/components/schemas/ImsSession'
    responses:
      '201':
        description: >
          Created. The Individual IMS Session resource is successfully created and
          a representation of the created resource is returned in the response body.
        content:
          application/json:

```

```

    schema:
      $ref: 'TS29522_ImsSessionManagement.yaml#/components/schemas/ImsSession'
  headers:
    Location:
      description: >
        The URI of the newly created resource.
      schema:
        type: string
  '400':
    $ref: 'TS29571_CommonData.yaml#/components/responses/400'
  '401':
    $ref: 'TS29571_CommonData.yaml#/components/responses/401'
  '403':
    $ref: 'TS29571_CommonData.yaml#/components/responses/403'
  '404':
    $ref: 'TS29571_CommonData.yaml#/components/responses/404'
  '406':
    $ref: 'TS29571_CommonData.yaml#/components/responses/406'
  '411':
    $ref: 'TS29571_CommonData.yaml#/components/responses/411'
  '413':
    $ref: 'TS29571_CommonData.yaml#/components/responses/413'
  '415':
    $ref: 'TS29571_CommonData.yaml#/components/responses/415'
  '429':
    $ref: 'TS29571_CommonData.yaml#/components/responses/429'
  '500':
    $ref: 'TS29571_CommonData.yaml#/components/responses/500'
  '501':
    $ref: 'TS29571_CommonData.yaml#/components/responses/501'
  '503':
    $ref: 'TS29571_CommonData.yaml#/components/responses/503'
  default:
    $ref: 'TS29571_CommonData.yaml#/components/responses/default'
  callbacks:
    ImsSessionEventNotification:
      '{$request.body#/notifUri}':
        post:
          requestBody:
            required: true
            content:
              application/json:
                schema:
                  $ref:
'TS29175_Nimsas_ImsSessionManagement.yaml#/components/schemas/ImsSessionEventNotification'
      responses:
        '204':
          description: >
            No Content. The IMS session notification is successfully
            received and acknowledged.
        '307':
          $ref: 'TS29122_CommonData.yaml#/components/responses/307'
        '308':
          $ref: 'TS29122_CommonData.yaml#/components/responses/308'
        '400':
          $ref: 'TS29122_CommonData.yaml#/components/responses/400'
        '401':
          $ref: 'TS29122_CommonData.yaml#/components/responses/401'
        '403':
          $ref: 'TS29122_CommonData.yaml#/components/responses/403'
        '404':
          $ref: 'TS29122_CommonData.yaml#/components/responses/404'
        '411':
          $ref: 'TS29122_CommonData.yaml#/components/responses/411'
        '413':
          $ref: 'TS29122_CommonData.yaml#/components/responses/413'
        '415':
          $ref: 'TS29122_CommonData.yaml#/components/responses/415'
        '429':
          $ref: 'TS29122_CommonData.yaml#/components/responses/429'
        '500':
          $ref: 'TS29122_CommonData.yaml#/components/responses/500'
        '503':
          $ref: 'TS29122_CommonData.yaml#/components/responses/503'
        default:
          $ref: 'TS29122_CommonData.yaml#/components/responses/default'

/ims-sessions/{sessionId}:

```

```

parameters:
  - name: sessionId
    in: path
    description: Represents the identifier of the "Individual IMS session" resource.
    required: true
    schema:
      type: string

put:
  summary: Update an existing Individual IMS Session resource.
  operationId: ImsSessionUpdate
  tags:
    - Individual IMS Session (Document)
  requestBody:
    required: true
    content:
      application/json:
        schema:
          $ref: 'TS29522_ImsSessionManagement.yaml#/components/schemas/ImsSession'
  responses:
    '200':
      description: >
        OK. The Individual IMS Session resource is successfully updated and a representation
        of the updated resource is returned in the response body.
      content:
        application/json:
          schema:
            $ref: 'TS29522_ImsSessionManagement.yaml#/components/schemas/ImsSession'
    '204':
      description: >
        No Content. The Individual IMS Session Management resource is
        successfully updated and no content is returned in the response body.
    '307':
      $ref: 'TS29122_CommonData.yaml#/components/responses/307'
    '308':
      $ref: 'TS29122_CommonData.yaml#/components/responses/308'
    '400':
      $ref: 'TS29122_CommonData.yaml#/components/responses/400'
    '401':
      $ref: 'TS29122_CommonData.yaml#/components/responses/401'
    '403':
      $ref: 'TS29122_CommonData.yaml#/components/responses/403'
    '404':
      $ref: 'TS29122_CommonData.yaml#/components/responses/404'
    '409':
      $ref: 'TS29122_CommonData.yaml#/components/responses/409'
    '411':
      $ref: 'TS29122_CommonData.yaml#/components/responses/411'
    '413':
      $ref: 'TS29122_CommonData.yaml#/components/responses/413'
    '415':
      $ref: 'TS29122_CommonData.yaml#/components/responses/415'
    '429':
      $ref: 'TS29122_CommonData.yaml#/components/responses/429'
    '500':
      $ref: 'TS29122_CommonData.yaml#/components/responses/500'
    '503':
      $ref: 'TS29122_CommonData.yaml#/components/responses/503'
    default:
      $ref: 'TS29122_CommonData.yaml#/components/responses/default'

patch:
  summary: Modify an existing Individual IMS Session resource.
  operationId: ImsSessionPatch
  tags:
    - Individual IMS Session (Document)
  requestBody:
    required: true
    content:
      application/json-patch+json:
        schema:
          type: array
          items:
            $ref: 'TS29571_CommonData.yaml#/components/schemas/PatchItem'
          minItems: 1
  responses:
    '200':
      description: >

```

```

    OK. The "Individual IMS Session" resource is successfully modified and a
    representation of the updated resource is returned in the response body.
  content:
    application/json:
      schema:
        $ref: 'TS29522_ImsSessionManagement.yaml#/components/schemas/ImsSession'
  '204':
    description: >
      No Content. The "Individual IMS Session" resource is successfully modified
      and no content is returned in the response body.
  '307':
    $ref: 'TS29122_CommonData.yaml#/components/responses/307'
  '308':
    $ref: 'TS29122_CommonData.yaml#/components/responses/308'
  '400':
    $ref: 'TS29122_CommonData.yaml#/components/responses/400'
  '401':
    $ref: 'TS29122_CommonData.yaml#/components/responses/401'
  '403':
    $ref: 'TS29122_CommonData.yaml#/components/responses/403'
  '404':
    $ref: 'TS29122_CommonData.yaml#/components/responses/404'
  '411':
    $ref: 'TS29122_CommonData.yaml#/components/responses/411'
  '413':
    $ref: 'TS29122_CommonData.yaml#/components/responses/413'
  '415':
    $ref: 'TS29122_CommonData.yaml#/components/responses/415'
  '429':
    $ref: 'TS29122_CommonData.yaml#/components/responses/429'
  '500':
    $ref: 'TS29122_CommonData.yaml#/components/responses/500'
  '503':
    $ref: 'TS29122_CommonData.yaml#/components/responses/503'
  default:
    $ref: 'TS29122_CommonData.yaml#/components/responses/default'

```

delete:

```

  summary: Delete an existing Individual IMS Session resource.
  operationId: ImsSessionDelete
  tags:
    - Individual IMS Session (Document)
  responses:
    '204':
      description: No content, successful delete of the resource identified by sessionId.
    '307':
      $ref: 'TS29571_CommonData.yaml#/components/responses/307'
    '308':
      $ref: 'TS29571_CommonData.yaml#/components/responses/308'
    '400':
      $ref: 'TS29571_CommonData.yaml#/components/responses/400'
    '401':
      $ref: 'TS29571_CommonData.yaml#/components/responses/401'
    '403':
      $ref: 'TS29571_CommonData.yaml#/components/responses/403'
    '404':
      $ref: 'TS29571_CommonData.yaml#/components/responses/404'
    '429':
      $ref: 'TS29571_CommonData.yaml#/components/responses/429'
    '500':
      $ref: 'TS29571_CommonData.yaml#/components/responses/500'
    '502':
      $ref: 'TS29571_CommonData.yaml#/components/responses/502'
    '503':
      $ref: 'TS29571_CommonData.yaml#/components/responses/503'
  default:
    $ref: 'TS29571_CommonData.yaml#/components/responses/default'

```

components:

```

  securitySchemes:
    oAuth2ClientCredentials:
      type: oauth2
      flows:
        clientCredentials:
          tokenUrl: '{tokenUrl}'
          scopes: {}

```

Annex B (informative): Withdrawn API versions

B.1 General

This Annex lists withdrawn API versions of the APIs defined in the present specification. 3GPP TS 29.501 [5] clause 4.3.1.6 describes the withdrawal of API versions.

B.2 MMTel_DCAppManagement API

The API versions listed in table B.2-1 are withdrawn for the MMTel_DCAppManagement API.

Table B.2-1: Withdrawn API versions of the MMTel_DCAppManagement service

API version number	Remarks

B.3 MMTel_DCAppCall API

The API versions listed in table B.3-1 are withdrawn for the MMTel_DCAppCall API.

Table B.3-1: Withdrawn API versions of the MMTel_DCAppCall service

API version number	Remarks

B.4 MMTel_CallEvent API

The API versions listed in table B.4-1 are withdrawn for the MMTel_CallEvent API.

Table B.4-1: Withdrawn API versions of the MMTel_CallEvent service

API version number	Remarks

B.5 MMTel_CallControl API

The API versions listed in table B.5-1 are withdrawn for the MMTel_CallControl API.

Table B.5-1: Withdrawn API versions of the MMTel_CallControl service

API version number	Remarks

Annex C (informative): Change history

Change history							
Date	Meeting	TDoc	CR	Rev	Cat	Subject/Comment	New version
2025-04	CT3#140	C3-251619				Based on the skeleton for the new MMTel Enabler Server Services TS (C3-251557). Incorporates agreed pCRs C3-251558, C3-251559, C3-251560, C3-251561, C3-251562. Editorial changes and corrections from the rapporteur.	0.1.0
2025-09	CT3#142	C3-253654				Incorporates agreed pCRs C3-253338, C3-253455, C3-253456, C3-253457, C3-253458, C3-253604, C3-253704. Editorial changes and corrections from the rapporteur.	0.2.0
2025-09	CT#109	CP-252069				Presentation to TSG CT for information	1.0.0
2025-11	CT3#144	C3-255664				Incorporates agreed pCRs C3-255436, C3-255437, C3-255438, C3-255439, C3-255440, C3-255441, C3-255625. Editorial changes and corrections from the rapporteur.	1.1.0
2025-12	CT#110	CP-253017				Presentation to TSG CT for approval	2.0.0
2025-12	CT#110	CP-253017				Approved by TSG CT	19.0.0
2026-03	CT#111	CP-260074	0001	1	F	Corrections to the MMTel_DCAppManagement_Configure service operation	19.1.0
2026-03	CT#111	CP-260074	0002	1	F	Corrections to the service description clauses of the MMTel_DCAppCall API	19.1.0
2026-03	CT#111	CP-260074	0003	1	F	Corrections to the API definition clauses of the MMTel_DCAppCall API	19.1.0
2026-03	CT#111	CP-260074	0004	2	F	Corrections to the OpenAPI description of the MMTel_DCAppCall API	19.1.0
2026-03	CT#111	CP-260074	0005		F	Corrections to the service description clauses of the MMTel_CallEvent API	19.1.0
2026-03	CT#111	CP-260074	0006		F	Corrections to the API definition clauses of the MMTel_CallEvent API	19.1.0
2026-03	CT#111	CP-260074	0007		F	Corrections to the OpenAPI description of the MMTel_CallEvent API	19.1.0
2026-03	CT#111	CP-260074	0008		F	Corrections to the service description clauses of the MMTel_CallControl API	19.1.0
2026-03	CT#111	CP-260074	0009		F	Corrections to the API definition clauses of the MMTel_CallControl API	19.1.0
2026-03	CT#111	CP-260074	0010		F	Corrections to the OpenAPI description of the MMTel_CallControl API	19.1.0
2026-03	CT#111	CP-260074	0011	1	F	Corrections to the CAPIF related provisions	19.1.0
2026-03	CT#111	CP-260074	0012		F	Corrections to the cond attribute of the DcAppConfigParameters data type	19.1.0
2026-03	CT#111	CP-260074	0013	2	F	Corrections to presence conditions for the data model of the MMTel_DCAppManagement API	19.1.0
2026-03	CT#111	CP-260074	0014		F	Corrections to the API definition clauses of the MMTel_DCAppManagement API	19.1.0
2026-03	CT#111	CP-260081	0015		F	Update of info and externalDocs fields	19.1.0
2026-06	CT#112	CP-261224	0016		F	Corrections to the AF_NOT_AUTHORIZED application error case	19.2.0

History

Version	Date	Status
V19.0.0	February 2026	Publication
V19.1.0	March 2026	Publication
V19.2.0	July 2026	Publication