

# ETSI TS 123 503 V19.7.0 (2026-03)



TECHNICAL SPECIFICATION

**5G;**  
**Policy and charging control framework**  
**for the 5G System (5GS);**  
**Stage 2**  
**(3GPP TS 23.503 version 19.7.0 Release 19)**



---

**Reference**

RTS/TSGS-0223503vj70

---

**Keywords**

5G

**ETSI**

650 Route des Lucioles  
F-06921 Sophia Antipolis Cedex - FRANCE

---

Tel.: +33 4 92 94 42 00 Fax: +33 4 93 65 47 16

Siret N° 348 623 562 00017 - APE 7112B  
Association à but non lucratif enregistrée à la  
Sous-Préfecture de Grasse (06) N° w061004871

---

**Important notice**

The present document can be downloaded from the  
[ETSI Search & Browse Standards](#) application.

The present document may be made available in electronic versions and/or in print. The content of any electronic and/or print versions of the present document shall not be modified without the prior written authorization of ETSI. In case of any existing or perceived difference in contents between such versions and/or in print, the prevailing version of an ETSI deliverable is the one made publicly available in PDF format on [ETSI deliver](#) repository.

Users should be aware that the present document may be revised or have its status changed, this information is available in the [Milestones listing](#).

If you find errors in the present document, please send your comments to the relevant service listed under [Committee Support Staff](#).

If you find a security vulnerability in the present document, please report it through our [Coordinated Vulnerability Disclosure \(CVD\)](#) program.

---

**Notice of disclaimer & limitation of liability**

The information provided in the present deliverable is directed solely to professionals who have the appropriate degree of experience to understand and interpret its content in accordance with generally accepted engineering or other professional standard and applicable regulations.

No recommendation as to products and services or vendors is made or should be implied.

No representation or warranty is made that this deliverable is technically accurate or sufficient or conforms to any law and/or governmental rule and/or regulation and further, no representation or warranty is made of merchantability or fitness for any particular purpose or against infringement of intellectual property rights.

In no event shall ETSI be held liable for loss of profits or any other incidental or consequential damages.

Any software contained in this deliverable is provided "AS IS" with no warranties, express or implied, including but not limited to, the warranties of merchantability, fitness for a particular purpose and non-infringement of intellectual property rights and ETSI shall not be held liable in any event for any damages whatsoever (including, without limitation, damages for loss of profits, business interruption, loss of information, or any other pecuniary loss) arising out of or related to the use of or inability to use the software.

---

**Copyright Notification**

No part may be reproduced or utilized in any form or by any means, electronic or mechanical, including photocopying and microfilm except as authorized by written permission of ETSI.

The content of the PDF version shall not be modified without the written authorization of ETSI.

The copyright and the foregoing restriction extend to reproduction in all media.

© ETSI 2026.  
All rights reserved.

---

# Intellectual Property Rights

## Essential patents

IPRs essential or potentially essential to normative deliverables may have been declared to ETSI. The declarations pertaining to these essential IPRs, if any, are publicly available for **ETSI members and non-members**, and can be found in ETSI SR 000 314: "*Intellectual Property Rights (IPRs); Essential, or potentially Essential, IPRs notified to ETSI in respect of ETSI standards*", which is available from the ETSI Secretariat. Latest updates are available on the [ETSI IPR online database](#).

Pursuant to the ETSI Directives including the ETSI IPR Policy, no investigation regarding the essentiality of IPRs, including IPR searches, has been carried out by ETSI. No guarantee can be given as to the existence of other IPRs not referenced in ETSI SR 000 314 (or the updates on the ETSI Web server) which are, or may be, or may become, essential to the present document.

## Trademarks

The present document may include trademarks and/or tradenames which are asserted and/or registered by their owners. ETSI claims no ownership of these except for any which are indicated as being the property of ETSI, and conveys no right to use or reproduce any trademark and/or tradename. Mention of those trademarks in the present document does not constitute an endorsement by ETSI of products, services or organizations associated with those trademarks.

**DECT™**, **PLUGTESTS™**, **UMTS™** and the ETSI logo are trademarks of ETSI registered for the benefit of its Members. **3GPP™**, **LTE™** and **5G™** logo are trademarks of ETSI registered for the benefit of its Members and of the 3GPP Organizational Partners. **oneM2M™** logo is a trademark of ETSI registered for the benefit of its Members and of the oneM2M Partners. **GSM®** and the GSM logo are trademarks registered and owned by the GSM Association.

---

# Legal Notice

This Technical Specification (TS) has been produced by ETSI 3rd Generation Partnership Project (3GPP).

The present document may refer to technical specifications or reports using their 3GPP identities. These shall be interpreted as being references to the corresponding ETSI deliverables.

The cross reference between 3GPP and ETSI identities can be found at [3GPP to ETSI numbering cross-referencing](#).

---

# Modal verbs terminology

In the present document "**shall**", "**shall not**", "**should**", "**should not**", "**may**", "**need not**", "**will**", "**will not**", "**can**" and "**cannot**" are to be interpreted as described in clause 3.2 of the [ETSI Drafting Rules](#) (Verbal forms for the expression of provisions).

"**must**" and "**must not**" are **NOT** allowed in ETSI deliverables except when used in direct citation.

# Contents

Intellectual Property Rights .....	2
Legal Notice .....	2
Modal verbs terminology.....	2
Foreword.....	7
Introduction .....	7
1 Scope .....	8
2 References .....	8
3 Definitions and abbreviations.....	10
3.1 Definitions .....	10
3.2 Abbreviations .....	13
4 High level architectural requirements .....	13
4.1 General requirements .....	13
4.2 Non-session management related policy control requirements .....	14
4.2.1 Access and mobility related policy control requirements .....	14
4.2.2 UE policy control requirements .....	14
4.2.3 Network analytics information requirements.....	14
4.2.4 Management of packet flow descriptions .....	14
4.2.5 SMF selection management related policy control requirements .....	15
4.2.6 Support for non-session management related network capability exposure .....	15
4.2.7 Slice replacement related policy control requirements .....	15
4.3 Session management related policy control requirements.....	16
4.3.1 General requirements.....	16
4.3.2 Charging related requirements.....	16
4.3.2.1 General .....	16
4.3.2.2 Charging models .....	16
4.3.2.3 Charging requirements .....	17
4.3.2.4 Examples of Service Data Flow Charging .....	17
4.3.3 Policy control requirements .....	17
4.3.3.1 Gating control requirements.....	17
4.3.3.2 QoS control requirements .....	18
4.3.3.2.1 QoS control at service data flow level.....	18
4.3.3.2.2 QoS control at QoS Flow level.....	18
4.3.3.2.3 QoS control at PDU Session level.....	18
4.3.3.3 Subscriber spending limits requirements .....	18
4.3.4 Usage monitoring control requirements.....	19
4.3.5 Application detection and control requirements .....	19
4.3.6 Support for session management related network capability exposure .....	19
4.3.7 Traffic steering control .....	20
4.3.8 Handling of Payload Headers .....	20
4.4 Network slice related policy control requirements.....	20
5 Architecture model and reference points.....	20
5.1 General .....	20
5.2 Reference architecture .....	21
5.2.1 Non-roaming architecture .....	21
5.2.2 Roaming architecture.....	22
5.2.3 Void .....	24
5.3 Service-based interfaces and reference points.....	25
5.3.1 Interactions between PCF and AF .....	25
5.3.2 Interactions between PCF and SMF .....	25
5.3.3 Interactions between PCF and AMF.....	26
5.3.4 Interactions between V-PCF and H-PCF .....	26
5.3.5 Interactions between PCF and UDR .....	26

5.3.6	Interactions between SMF and CHF .....	26
5.3.7	Void .....	27
5.3.8	Interactions between PCF and CHF .....	27
5.3.9	Interactions between SMF and NEF .....	27
5.3.10	Interactions between NEF and PCF .....	27
5.3.11	Interactions between NWDAF and PCF .....	28
5.3.12	Interactions between PCF for the UE and PCF for the PDU Session .....	28
5.3.13	Interactions between PCF and TSCTSF .....	28
5.3.14	Interactions between NWDAF and NEF (PFDF) .....	28
6	Functional description .....	28
6.1	Overall description .....	28
6.1.1	General .....	28
6.1.1.1	PCF Discovery and Selection .....	28
6.1.1.2	Binding an AF request targeting an UE address to the relevant PCF .....	29
6.1.1.2.1	General .....	29
6.1.1.2.2	The Binding Support Function (BSF) .....	29
6.1.1.2a	Binding an NF request targeting a UE to the relevant PCF for the UE .....	31
6.1.1.3	Policy decisions based on network analytics .....	31
6.1.1.4	Policy decisions based on spending limits .....	37
6.1.1.5	Policy control decisions based on awareness of URSP rule enforcement .....	38
6.1.1.5.1	General .....	38
6.1.1.5.2	Policy control decisions based on awareness of URSP rule enforcement with UE assistance .....	39
6.1.1.5.3	Policy control decisions based on awareness of URSP rule enforcement without UE assistance .....	39
6.1.2	Non-session management related policy control .....	39
6.1.2.1	Access and mobility related policy control .....	39
6.1.2.1.1	General .....	39
6.1.2.1.2	Handling of the AM Policy Association .....	42
6.1.2.2	UE policy control .....	43
6.1.2.2.1	General .....	43
6.1.2.2.2	Distribution of the policies to UE .....	45
6.1.2.2.3	URSP rule provisioning in EPS .....	48
6.1.2.2.4	Distribution of VPLMN specific URSP rules to the UE .....	49
6.1.2.2.5	Handling of the UE Policy Association .....	50
6.1.2.3	Management of packet flow descriptions .....	50
6.1.2.3.1	PFD management .....	50
6.1.2.3.2	Packet Flow Description .....	52
6.1.2.4	Negotiation for future background data transfer .....	53
6.1.2.5	Policy Control Request Triggers relevant for AMF .....	55
6.1.2.6	AF influence on Access and Mobility related policy control .....	59
6.1.2.6.0	General .....	59
6.1.2.6.1	AF request Access and Mobility related Policy Control for a UE .....	59
6.1.2.6.2	AF request to influence on Access and Mobility related Policy Control .....	60
6.1.2.7	Negotiation for planned data transfer with QoS requirements .....	61
6.1.3	Session management related policy control .....	62
6.1.3.1	General .....	62
6.1.3.2	Binding mechanism .....	62
6.1.3.2.1	General .....	62
6.1.3.2.2	Session binding .....	63
6.1.3.2.3	PCC rule authorization .....	63
6.1.3.2.4	QoS Flow binding .....	63
6.1.3.3	Reporting .....	65
6.1.3.4	Credit management .....	66
6.1.3.5	Policy Control Request Triggers relevant for SMF .....	66
6.1.3.6	Policy control .....	76
6.1.3.7	Service (data flow) prioritization and conflict handling .....	77
6.1.3.8	Termination action .....	78
6.1.3.9	Handling of packet filters provided to the UE by SMF .....	78
6.1.3.10	IMS emergency session support .....	78
6.1.3.11	Multimedia Priority Service support .....	79
6.1.3.12	Redirection .....	81

6.1.3.13	Resource sharing for different AF sessions.....	81
6.1.3.14	Traffic steering control.....	82
6.1.3.15	Resource reservation for services sharing priority .....	82
6.1.3.16	3GPP PS Data Off.....	83
6.1.3.17	Policy decisions based on spending limits .....	85
6.1.3.18	Event reporting from the PCF .....	85
6.1.3.19	Mission Critical Services support .....	92
6.1.3.20	Access Traffic Steering, Switching and Splitting.....	93
6.1.3.21	QoS Monitoring control .....	96
6.1.3.22	AF session with required QoS.....	98
6.1.3.23	Support of integration with Time Sensitive Networking.....	100
6.1.3.23a	Support of Time Sensitive Communication and Time Synchronization .....	101
6.1.3.23b	Support of IETF Deterministic Networking.....	101
6.1.3.24	Policy control for redundant PDU Sessions .....	103
6.1.3.25	User Plane Remote Provisioning of UE SNPN Credentials in Onboarding Network .....	103
6.1.3.26	Packet Delay Variation monitoring and reporting.....	104
6.1.3.27	Support of eXtended Reality and Interactive Media Services.....	104
6.1.3.27.1	Exposure of network information .....	104
6.1.3.27.2	UL/DL policy control based on round-trip latency requirement .....	105
6.1.3.27.3	Support for delivery of multi-modal services .....	105
6.1.3.27.4	PDU Set based handling .....	106
6.1.3.27.5	Data Burst Based Handling .....	107
6.1.3.27.6	Traffic Parameter Information and Traffic Parameter Measurement .....	107
6.1.3.27.7	Traffic identification and differentiated QoS for multiplexed media flows .....	108
6.1.3.27.8	Support of transferring media related information over N6 .....	108
6.1.3.27.9	Expedited Data Transfer with Reflective QoS .....	108
6.1.3.27.10	Support of RAN-controlled UL bitrate recommendation .....	109
6.1.3.28	AF requested QoS for a UE or group of UEs not identified by a UE address.....	109
6.1.3.29	Network Slice replacement for a PDU Session.....	110
6.1.3.30	Handling of Payload Headers Control.....	111
6.1.3.31	Policy control for non-3GPP devices connecting behind a UE.....	111
6.1.4	Network slice related policy control .....	111
6.1.4.1	General .....	111
6.1.4.2	Limitation of data rate per network slice with assistance of the NWDAF.....	112
6.1.4.3	Limitation of data rate per network slice with PCF based monitoring.....	112
6.1.5	Group related policy control .....	113
6.1.6	Void .....	113
6.2	Network functions and entities.....	113
6.2.1	Policy Control Function (PCF).....	113
6.2.1.1	General .....	113
6.2.1.1.1	Session management related functionality .....	113
6.2.1.1.2	Non-session management related functionality .....	115
6.2.1.1.3	Network slice related functionality.....	115
6.2.1.1.4	Group related functionality.....	115
6.2.1.2	Input for PCC decisions .....	116
6.2.1.3	Policy control subscription information management.....	116
6.2.1.4	V-PCF .....	121
6.2.1.5	H-PCF .....	121
6.2.1.6	Application specific policy information management.....	121
6.2.1.7	Usage monitoring .....	122
6.2.1.8	Sponsored data connectivity.....	123
6.2.1.9	Monitoring the data rate per Network Slice for a UE .....	123
6.2.1.10	Monitoring the data rate per Network Slice .....	123
6.2.1.10.1	General .....	123
6.2.1.10.2	Monitoring the data rate per Network Slice by using QoS parameters.....	124
6.2.1.11	Monitoring the data rate per Group.....	124
6.2.1.11.1	General .....	124
6.2.1.11.2	Monitoring the data rate per Group by using QoS parameters .....	124
6.2.1.12	VPLMN Specific Offloading Policy .....	125
6.2.1.13	Local Offloading Management Policy .....	125
6.2.2	Session Management Function (SMF).....	125
6.2.2.1	General .....	125

6.2.2.2	Service data flow detection .....	127
6.2.2.3	Measurement .....	127
6.2.2.4	QoS control .....	129
6.2.2.5	Application detection .....	130
6.2.2.6	Traffic steering .....	130
6.2.2.7	Access Traffic Steering, Switching and Splitting .....	130
6.2.2.8	Network Slice Replacement .....	130
6.2.3	Application Function (AF) .....	130
6.2.4	Unified Data Repository (UDR) .....	131
6.2.5	Charging Function (CHF) .....	132
6.2.6	Void .....	132
6.2.7	Network Exposure Function (NEF) .....	132
6.2.8	Access and Mobility Management Function (AMF) .....	132
6.2.9	Network Data Analytics Function (NWDAF) .....	132
6.2.10	Void .....	132
6.2.11	Time Sensitive Communication and Time Synchronization Function (TSCTSF) .....	132
6.3	Policy and charging control rule .....	132
6.3.1	General .....	132
6.3.2	Policy and charging control rule operations .....	149
6.4	PDU Session related policy information .....	150
6.5	Access and mobility related policy information .....	156
6.6	UE policy information .....	159
6.6.1	Access Network Discovery & Selection Policy Information .....	159
6.6.1.1	General .....	159
6.6.1.2	UE selecting a WLANSP rule .....	160
6.6.1.3	UE procedure for selecting a WLAN access based on WLANSP rules .....	160
6.6.2	UE Route Selection Policy information .....	161
6.6.2.1	Structure Description .....	161
6.6.2.2	Configuration and Provision of URSP .....	167
6.6.2.2.1	General .....	167
6.6.2.2.2	URSP rules for an SNPN-enabled UE .....	167
6.6.2.2.3	Void .....	168
6.6.2.3	UE procedure for associating applications to PDU Sessions based on URSP .....	168
6.6.2.4	Support of URSP rule enforcement reporting .....	171
6.6.3	V2X Policy information .....	172
6.6.4	ProSe Policy information .....	172
6.6.5	Ranging/Sidelink Positioning Policy information .....	172
6.6.6	A2X Policy information .....	172
6.6.7	UE Policy Association supplementary information .....	173
<b>Annex A (informative): URSP rules example .....</b>		<b>174</b>
<b>Annex B (informative): Deployment option to support of BSF and DRA coexistence due to network migration .....</b>		<b>177</b>
<b>Annex C (Normative): Support for Application Functions supporting Rx interface .....</b>		<b>178</b>
<b>Annex D (informative): PCC usage for sponsored data connectivity .....</b>		<b>180</b>
D.1	General .....	180
D.2	Reporting for sponsored data connectivity .....	181
<b>Annex E (informative): Change history .....</b>		<b>182</b>
History .....		195

---

# Foreword

This Technical Specification has been produced by the 3rd Generation Partnership Project (3GPP).

The contents of the present document are subject to continuing work within the TSG and may change following formal TSG approval. Should the TSG modify the contents of the present document, it will be re-released by the TSG with an identifying change of release date and an increase in version number as follows:

Version x.y.z

where:

- x the first digit:
  - 1 presented to TSG for information;
  - 2 presented to TSG for approval;
  - 3 or greater indicates TSG approved document under change control.
- y the second digit is incremented for all changes of substance, i.e. technical enhancements, corrections, updates, etc.
- z the third digit is incremented when editorial only changes have been incorporated in the document.

---

# Introduction

For references to TS 23.203 [4] made in this document,

- the IP-CAN session of TS 23.203 [4] maps to the PDU Session in 5GC.
- the APN of TS 23.203 [4] maps to DNN in 5GC.
- the IP-CAN bearer of TS 23.203 [4] maps to the QoS Flow in 5GC.
- The PCRF of TS 23.203 [4] maps to the PCF in 5GC.
- The PCEF of TS 23.203 [4] maps to the combination of SMF and UPF in 5GC.
- The BBF shall be considered as being located in the PCEF.
- TDF related description does not apply.
- NBIFOM related description does not apply.

---

# 1 Scope

The present document defines the Stage 2 policy and charging control framework for the 5G System specified in TS 23.501 [2] and TS 23.502 [3].

The policy and charging control framework encompasses the following high level functions:

- Flow Based Charging for network usage, including charging control and online credit control, for service data flows;
- Policy control for session management and service data flows (e.g. gating control, QoS control, etc.);
- Management for access and mobility related policies;
- Management of UE policy information.

Interworking with E-UTRAN connected to EPC is described in TS 23.501 [2].

TS 23.502 [3] contains the stage 2 procedures and flows for the policy and charging control framework and it is a companion specification to this specification.

TS 32.255 [21] contains the functional description of the converged offline and online charging functionality for the 5G System.

---

# 2 References

The following documents contain provisions which, through reference in this text, constitute provisions of the present document.

- References are either specific (identified by date of publication, edition number, version number, etc.) or non-specific.
- For a specific reference, subsequent revisions do not apply.
- For a non-specific reference, the latest version applies. In the case of a reference to a 3GPP document (including a GSM document), a non-specific reference implicitly refers to the latest version of that document *in the same Release as the present document*.

- [1] 3GPP TR 21.905: "Vocabulary for 3GPP Specifications".
- [2] 3GPP TS 23.501: "Technical Specification Group Services and System Aspects; System Architecture for the 5G System".
- [3] 3GPP TS 23.502: "Procedures for the 5G System; Stage 2".
- [4] 3GPP TS 23.203: "Policies and Charging control architecture; Stage 2".
- [5] 3GPP TS 23.228: "IP Multimedia Subsystem (IMS); Stage 2".
- [6] 3GPP TS 23.179: "Functional architecture and information flows to support mission-critical communication service; Stage 2".
- [7] Void.
- [8] 3GPP TS 32.240: "Charging management; Charging architecture and principles".
- [9] 3GPP TS 23.402: "Architecture enhancements for non-3GPP accesses".
- [10] 3GPP TS 23.161: "Network-Based IP Flow Mobility (NBIFOM); Stage 2".
- [11] 3GPP TS 23.261: "IP flow mobility and seamless Wireless Local Area Network (WLAN) offload; Stage 2".

- [12] 3GPP TS 23.167: "3rd Generation Partnership Project; Technical Specification Group Services and Systems Aspects; IP Multimedia Subsystem (IMS) emergency sessions".
- [13] 3GPP TS 29.507: "Access and Mobility Policy Control Service; Stage 3".
- [14] Void.
- [15] 3GPP TS 22.011: "Service Accessibility".
- [16] 3GPP TS 23.221: "Architectural requirements".
- [17] 3GPP TS 29.551: "5G System; Packet Flow Description Management Service; Stage 3".
- [18] 3GPP TS 32.421: "Telecommunication management; Subscriber and equipment trace; Trace concepts and requirements".
- [19] 3GPP TS 24.526: "UE Equipment (UE) policies for 5G System (5GS); Stage 3".
- [20] 3GPP TS 32.291: "Charging management; 5G system, Charging service; stage 3".
- [21] 3GPP TS 32.255: "Telecommunication management; Charging management; 5G Data connectivity domain charging; Stage 2".
- [22] 3GPP TS 24.501: "Non-Access-Stratum (NAS) protocol for 5G System (5GS); Stage 3".
- [23] 3GPP TS 23.280: "Common functional architecture to support mission critical services; Stage 2".
- [24] 3GPP TS 23.288: "Architecture enhancements for 5G System (5GS) to support network data analytics services".
- [25] 3GPP TS 23.216: "Single Radio Voice Call Continuity (SRVCC); Stage 2".
- [26] 3GPP TS 23.272: "Circuit Switched (CS) fallback in Evolved Packet System (EPS); Stage 2".
- [27] 3GPP TS 23.316: "Wireless and wireline convergence access support for the 5G System (5GS)".
- [28] 3GPP TS 23.287: "Architecture enhancements for 5G System (5GS) to support Vehicle-to-Everything (V2X) services".
- [29] 3GPP TS 24.229: "IP multimedia call control protocol based on Session Initiation Protocol (SIP) and Session Description Protocol (SDP); Stage 3".
- [30] 3GPP TS 24.237: "IP Multimedia (IM) Core Network (CN) subsystem IP Multimedia Subsystem (IMS) Service Continuity; Stage 3".
- [31] 3GPP TS 26.114: "IP Multimedia Subsystem (IMS); Multimedia telephony; Media handling and interaction".
- [32] 3GPP TS 29.510: "5G System; Network Function Repository Services; Stage 3".
- [33] 3GPP TS 23.548: "5G System Enhancements for Edge Computing; Stage 2".
- [34] 3GPP TS 23.304: "Proximity based Services (ProSe) in the 5G System (5GS)".
- [35] 3GPP TS 29.500: "5G System; Technical Realization of Service Based Architecture; Stage 3".
- [36] 3GPP TS 29.514: "Policy Authorization Service; Stage 3".
- [37] IETF RFC 9633: "Deterministic Networking (DetNet) YANG Model".
- [38] IETF RFC 5279: "A Uniform Resource Name (URN) Namespace for the 3rd Generation Partnership Project (3GPP)".
- [39] GSMA PRD NG.141, Version 3.0: ""Guidelines for URSP.
- [40] 3GPP TS 26.522: "5G Real-time Media Transport Protocol Configurations".

- [41] 3GPP TS 23.586: "Architectural Enhancements to support Ranging based services and Sidelink Positioning".
- [42] IETF RFC 8939: "Deterministic Networking (DetNet) Data Plane: IP".
- [43] 3GPP TS 23.256: "Support of Uncrewed Aerial Systems (UAS) connectivity, identification and tracking; Stage 2".
- [44] 3GPP TS 29.512: "Session Management Policy Control Service; Stage 3".
- [45] 3GPP TS 23.204: "Support of Short Message Service (SMS) over generic Internet Protocol (IP) access; Stage 2".
- [46] IETF draft-ietf-moq-transport: "Media over QUIC Transport".

---

## 3 Definitions and abbreviations

### 3.1 Definitions

For the purposes of the present document, the terms and definitions given in TR 21.905 [1], TS 23.501 [2], TS 23.502 [3] and the following apply. A term defined in the present document takes precedence over the definition of the same term, if any, in TR 21.905 [1].

**AM Policy Association:** Access and Mobility management Policy Association. An association between the AMF and the PCF (i.e. the PCF for the UE) for performing access and mobility related policy control for a UE.

**Application detection filter:** A logic used to detect packets generated by an application based on extended inspection of these packets, e.g. header and/or payload information, as well as dynamics of packet flows. The logic is entirely internal to a UPF, and is out of scope of this specification.

**Application identifier:** An identifier referring to a specific application detection filter.

**Application service provider:** A business entity responsible for the application that is being / will be used by a UE, which may be either an AF operator or has an association with the AF operator.

**Authorised QoS:** The maximum QoS that is authorised for a service data flow. In the case of an aggregation of multiple service data flows within one QoS Flow, the combination of the "Authorised QoS" information of the individual service data flows is the "Authorised QoS" for the QoS Flow. It contains the 5QI and the data rate.

**Binding:** The association between a service data flow and the QoS Flow transporting that service data flow.

**Binding mechanism:** The method for creating, modifying and deleting bindings.

**Charging control:** The process of associating packets, belonging to a service data flow, to a charging key and applying online charging and/or offline charging, as appropriate.

**Charging key:** Information used by the CHF for rating purposes.

**Detected application traffic:** An aggregate set of packet flows that are generated by a given application and detected by an application detection filter.

**Dynamic PCC Rule:** a PCC rule, for which the definition is provided to the SMF by the PCF.

**Flow Description:** information describing the characteristics of a packet flow for the purpose of detection, e.g. the combination of protocol (Protocol ID of the protocol above IP), source and destination IP address, source and destination port number, and optionally, ToS (IPv4) or TC (IPv6) value.

**Gating control:** The process of blocking or allowing packets, belonging to a service data flow / detected application's traffic, to pass through to the UPF.

**Media flow:** One or more packet flows that are used for the transfer of a single media of a specific Media Type (defined in clause 5.6.3.3 of TS 29.514 [36]) in an AF session. This definition replaces the definition of media flow in

TS 23.228 [5] for the description of functionality in the 5GS related specifications (as this definition is covering more than IP based packet flows). A media flow describes a service data flow from the perspective of the AF.

**Monitoring key:** information used by the SMF and PCF for usage monitoring control purposes as a reference to a given set of service data flows or application (s), that all share a common allowed usage on a per UE and DNN basis.

**Multi-modal service:** A multi-modal service is a communication service that consists of several data flows that relate to each other and are subject to application coordination. The data flows can transfer different types of data (for example audio, video, positioning, haptic data) and may come from different sources (e.g. a single UE, a single device or multiple devices connected to the single UE, or multiple UEs).

**Non-3GPP access network selection information:** It consists of ePDG identifier configuration, N3IWF identification and non-3GPP access node selection information, as defined in clause 6.3.6.1 in TS 23.501 [2].

**Non-Seamless Offload:** A capability of the UE to access the data networks via non-3GPP access (e.g. WLAN radio access) outside of a PDU Session.

**Operator-controlled service:** A service for which complete PCC rule information, including service data flow filter information, is available in the PCF through configuration and/or dynamic interaction with an AF.

**Operating System (OS):** Collection of UE software that provides common services for applications.

**Operating System Identifier (OSId):** An identifier identifying the operating system.

**OS specific Application Identifier (OSAppId):** An identifier associated with a given application and uniquely identifying the application within the UE for a given operating system.

**Packet flow:** A specific flow of user data packets from and/or to the UE.

**Packet Flow Description (PFD):** A set of information enabling the detection of application traffic provided by a 3rd party service provider.

**PCC decision:** A PCF decision for policy and charging control provided to the SMF (consisting of PCC rules and PDU Session related attributes), a PCF decision for access and mobility related policy control provided to the AMF, a PCF decision for UE policy information provided to the UE or a PCF decision for service related policy (e.g. background data transfer policy) provided to the AF.

**PCC rule:** A set of information enabling the detection of a service data flow and providing parameters for policy control and/or charging control and/or other control or support information. The possible information is described in clause 6.3.1.

**PCF for the PDU Session:** A PCF providing session management policy control for a PDU Session of a UE.

**PCF for the UE:** A PCF providing non-session management policy control for a UE, i.e. access and mobility related policy control and/or UE policy control.

**Policy control:** The process whereby the PCF indicates to the SMF how to control the QoS Flow. Policy control includes QoS control and/or gating control.

**Policy Control Request trigger report:** a notification, possibly containing additional information, of an event which occurs that corresponds with a Policy Control Request trigger.

**Policy Control Request trigger:** defines a condition when the SMF shall interact again with the PCF.

**Policy counter:** A mechanism within the CHF to track spending applicable to a subscriber.

**Policy counter identifier:** A reference to a policy counter in the CHF for a subscriber.

**Policy counter status:** A label whose values are not standardized and that is associated with a policy counter's value relative to the spending limit(s) (the number of possible policy counter status values for a policy counter is one greater than the number of thresholds associated with that policy counter, i.e. policy counter status values describe the status around the thresholds). This is used to convey information relating to subscriber spending from CHF to PCF. Specific labels are configured jointly in CHF and PCF.

**Policy Section:** A Policy Section is identified by a Policy Section Identifier and consists of one or multiple URSP rule(s) or one or multiple WLANSF rule(s) or non-3GPP access network selection information or a combination of WLANSF rule(s) and non-3GPP access network selection information.

**Predefined PCC Rule:** a PCC rule that has been provisioned directly into the SMF by the operator.

**Redirection:** Redirect the detected service traffic to an application server (e.g. redirect to a top-up / service provisioning page).

**Service data flow:** An aggregate set of packet flows carried through the UPF that matches a service data flow template.

**Service data flow filter:** A set of packet flow header parameter values/ranges used to identify one or more of the packet flows in the UPF. The possible service data flow filters are defined in clause 6.2.2.2.

**Service data flow filter identifier:** A scalar that is unique for a specific service data flow (SDF) filter within a PDU Session.

**Service data flow template:** The set of service data flow filters in a PCC Rule or an application identifier in a PCC rule referring to an application detection filter in the SMF or in the UPF, required for defining a service data flow.

**Service identifier:** An identifier for a service. The service identifier provides the most detailed identification, specified for flow based charging, of a service data flow. A concrete instance of a service may be identified if additional AF information is available (further details to be found in clause 6.3.1).

**Session based service:** An end user service requiring application level signalling, which is separated from service rendering.

**Spending limit:** A spending limit is the usage limit of a policy counter (e.g. monetary, volume, duration) that a subscriber is allowed to consume.

**SM Policy Association:** Session Management Policy Association. An association between the SMF and the PCF (i.e. the PCF for the PDU Session) for performing session management policy control for a PDU Session of a UE.

**Spending limit report:** a notification, containing the current policy counter status generated from the CHF to the PCF.

**Subscribed guaranteed bandwidth QoS:** The per subscriber, authorized cumulative guaranteed bandwidth QoS which is provided by the UDR to the PCF.

**Subscriber category:** is a means to group the subscribers into different classes, e.g. gold user, silver user and bronze user.

**UE Local Configuration:** Information about the association of an application to either a PDU Session or to non-seamless Offload is configured in the Mobile Termination (MT) and in the Terminal Equipment (TE). For example, UE Local Configuration can include operator specific configuration (e.g. operator provided S-NSSAI(s)), or application specific parameters to set up a PDU Session or end user configuration for specific applications.

**UE Policy Association:** An association between the AMF and the PCF (i.e. the PCF for the UE) for providing UE policy information from the PCF to the UE.

**UE policy information:** Policy information preconfigured in the UE and/or provisioned to the UE for access selection (i.e. ANDSP), PDU Session selection (i.e. URSP), V2X communications (i.e. V2XP), ProSe operations (i.e. ProSeP), A2X communications (i.e. A2XP) and/or Ranging/Sidelink Positioning operations (i.e. RSLPP).

**Uplink binding verification:** The network enforcement of terminal compliance with the negotiated uplink traffic mapping to QoS Flows.

**User Preferences On Non-3GPP Access Selection:** The list of configuration parameters provided by a layer (e.g. application) above NAS and used by the UE for access network discovery and selection.

**VPLMN specific URSP Rules:** A VPLMN specific URSP Rule is applicable when the UE is registered in that VPLMN or its equivalent PLMNs. A VPLMN specific URSP Rule may be used to route traffic to the VPLMN, if the V-PCF provides a local DNN to the AMF, using the PCRT on SMF selection management. A VPLMN specific URSP Rule may be used to route traffic to the Home PLMN if the HPLMN operator wants to provide a different list of RSDs for the same Traffic Descriptor for a VPLMN and for the HPLMN. When provided, the Time and Location criteria in the RSD(s) contain values that are based on agreements with the VPLMN or service parameters that were received from the VPLMN.

## 3.2 Abbreviations

For the purposes of the present document, the abbreviations given in TR 21.905 [1], TS 23.501 [2], TS 23.502 [3], TS 23.316 [27] and the following apply. An abbreviation defined in the present document takes precedence over the definition of the same abbreviation, if any, in TR 21.905 [1].

5G DDNMF	5G Direct Discovery Name Management Function
A2XP	A2X Policy
AMBR	Aggregate Maximum Bitrate
ANDSP	Access Network Discovery & Selection Policy
ARP	Allocation and Retention Priority
ASP	Application Service Provider
BDT	Background Data Transfer
BSF	Binding Support Function
CHF	CHarging Function
DCCF	Data Collection Coordination Function
H-PCF	A PCF in the HPLMN
H-UDR	A UDR in the HPLMN
HR-SBO	Home Routed with Session Breakout in VPLMN
MPS	Multimedia Priority Service
NBIFOM	Network-based IP flow mobility
NSWO	Non-Seamless WLAN Offload
NWDAF	Network Data Analytics Function
OAM	Operation Administration and Maintenance
OCS	Online Charging System
PCC	Policy and Charging Control
PDTQ	Planned Data Transfer with QoS
PDUID	ProSe Discovery UE ID
PDV	Packet Delay Variation
PFD	Packet Flow Description
PFDF	Packet Flow Description Function
PRA	Presence Reporting Area
ProSe	Proximity based Services
ProSeP	ProSe Policy
RAN	Radio Access Network
RSLPP	Ranging/Sidelink Positioning Policy
SNPN	Stand-alone Non-Public Network
URSP	UE Route Selection Policy
V2XP	V2X Policy
V-PCF	A PCF in the VPLMN
V-UDR	A UDR in the VPLMN
vSRVCC	video Single Radio Voice Call Continuity
WLANSF	WLAN Selection Policy

---

## 4 High level architectural requirements

### 4.1 General requirements

It shall be possible to apply policy and charging control to any kind of 3GPP and non-3GPP accesses defined in TS 23.501 [2].

The policy and charging control framework shall support the roaming scenarios defined in TS 23.501 [2].

The policy and charging control shall be enabled on a per slice instance, per DNN, or per both slice instance and DNN basis.

**NOTE:** In single PCF deployment, the PCF will provide all mobility, UE access selection and PDU Session related policies that it is responsible for. In deployments where different PCFs support N15 and N7 respectively, the standardized interface between them supports policy alignment and exchange of relevant information.

The policy and charging control framework shall fulfil non-session management related requirements as defined in clause 4.2, session management related requirements as defined in clause 4.3 and network slice related requirements as defined in clause 4.4.

## 4.2 Non-session management related policy control requirements

### 4.2.1 Access and mobility related policy control requirements

The policy framework shall provide following functionality for the access and mobility enforcement:

- Policy Control Function (PCF) shall support interactions with the access and mobility policy enforcement in the AMF, through service-based interfaces.
- The PCF shall be able to provide Access and Mobility Management related policies to the AMF.
- The PCF shall be able to evaluate operator policies that are triggered by events.
- The AF may influence Access and Mobility related policy control performed by the PCF.

### 4.2.2 UE policy control requirements

The 5GC shall be able to provide policy information from the PCF to the UE. Such UE policy information includes:

- Access Network Discovery & Selection Policy (ANDSP): It is used by the UE for selecting non-3GPP accesses network.
- UE Route Selection Policy (URSP): This policy is used by the UE to determine how to route outgoing traffic. Traffic can be routed to an established PDU Session, can be offloaded to non-3GPP access outside a PDU Session, can be routed via a ProSe Layer-3 UE-to-Network Relay outside a PDU session, or can trigger the establishment of a new PDU Session.
- V2X Policy (V2XP): This policy provides configuration parameters to the UE for V2X communication over PC5 reference point or over Uu reference point or both. V2X Policies are defined in TS 23.287 [28].
- ProSe Policy (ProSeP): This policy provides configuration parameters to the UE for ProSe features as defined in clause 5.1 of TS 23.304 [34].
- Ranging/Sidelink Positioning Policy (RSLPP): This policy provides configuration parameters to the UE for Ranging/Sidelink Positioning control. Ranging/Sidelink Positioning Policies are defined in TS 23.586 [41].
- A2X Policy (A2XP): This policy provides configuration parameters to the UE for A2X communication over PC5 reference point or over Uu reference point or both. A2X Policies are defined in TS 23.256 [43].

### 4.2.3 Network analytics information requirements

The PCF shall be able to collect network analytic information from the NWDAF directly or via DCCF, if deployed. The NWDAF provides network data analytics (e.g. load level information on a network slice level) to PCF. The PCF shall be able to use those data in its policy decisions. The details are defined in clause 6.1.1.3.

### 4.2.4 Management of packet flow descriptions

Management of Packet Flow Descriptions (PFDs) refers to the capability to create, update or remove PFDs in the NEF (PFDF) and the distribution from the NEF (PFDF) to the SMF and finally to the UPF. This feature may be used when the UPF is configured to detect a particular application provided by an ASP.

NOTE 1: A possible scenario for the management of PFDs in the SMF is when an application, identified by an application detection filter in the UPF, deploys a new server or a reconfiguration occurs in the ASP network which impacts the application detection filters of that particular application.

NOTE 2: The management of application detection filters in the SMF can still be performed by using operation and maintenance procedures.

NOTE 3: This feature aims for both: to enable accurate application detection at the UPF and to minimize storage requirements for the UPF and the SMF.

The management of PFDs is supported in non-roaming and home-routed scenarios for those ASPs that have a business relation with the home operator.

## 4.2.5 SMF selection management related policy control requirements

The policy framework may provide following functionality for the SMF selection management for a PDU Session:

- The Policy Control Function (PCF) may support interactions with the SMF selection functionality in the AMF and the PCF may provide SMF selection management related policies to the AMF;
- The PCF may provide a policy to the AMF to contact PCF for performing DNN replacement of specific DNNs;
- The PCF may provide a policy to the AMF to contact PCF for performing DNN replacement for an unsupported DNN.

## 4.2.6 Support for non-session management related network capability exposure

Support for network capability exposure enables an AF (e.g. an external ASP) to request the following non-session management related policy control functionality from the NEF:

- Management of PFDs as defined in clause 6.1.2.3 and in clause 4.18 of TS 23.502 [3];
- Negotiations for future background data transfer as defined in clause 6.1.2.4 and in clause 4.16.7 of TS 23.502 [3];
- Applying a previously negotiated background data transfer policy to a UE or group of UEs as defined in clause 6.1.2.4 and in clause 4.15.6.8 of TS 23.502 [3];
- Service specific parameter provisioning for V2X communication (see clause 5.20 of TS 23.501 [2] and clause 4.15.6.7 of TS 23.502 [3]);
- 5G VN group management (see clause 5.29 of TS 23.501 [2] and clause 4.15.6 of TS 23.502 [3]);
- Service specific parameter provisioning for ProSe Direct Discovery, ProSe Direct Communication, ProSe Relay Discovery and ProSe Relay Communications (see clause 5.20 of TS 23.501 [2] and clause 4.15.6.7 of TS 23.502 [3]);
- Service specific parameter provisioning for Ranging/Sidelink Positioning control (see clause 5.20 of TS 23.501 [2] and clause 4.15.6.7 of TS 23.502 [3]);
- Service specific parameter provisioning for time synchronization service (see clause 5.27.1.8 of TS 23.501 [2] and clause 4.15.9 of TS 23.502 [3]);
- Negotiations for planned data transfer with QoS requirements as defined in clause 6.1.2.7 and in clause 5.2.5.9 of TS 23.502 [3];
- Service specific parameter provisioning for A2X communication (see clause 5.20 of TS 23.501 [2] and clause 4.15.6.7 of TS 23.502 [3]).

## 4.2.7 Slice replacement related policy control requirements

The policy framework may provide following functionality for the slice replacement:

- The Policy Control Function (PCF) may support interactions with the slice replacement functionality in the AMF and the PCF may provide slice replacement related policies to the AMF.

## 4.3 Session management related policy control requirements

### 4.3.1 General requirements

It shall be possible for the PCC framework to base decisions upon subscription information, Access Type and the RAT Type.

The PCC framework shall perform Gating Control and discard packets that don't match any service data flow of the active PCC rules. It shall also be possible for the operator to define PCC rules, with wild-carded service data flow filters, to allow sending or receiving packets that do not match any service data flow template of any other active PCC rules.

The PCC framework shall allow the charging control to be applied on a per service data flow and on a per application basis, independent of the policy control.

The PCC framework shall have a binding method that allows the unique association between service data flows and specific QoS Flow.

A single service data flow detection shall suffice for the purpose of both policy control and flow based charging.

A PCC rule may be predefined or dynamically provisioned at establishment and during the lifetime of a PDU Session. The latter is referred to as a dynamic PCC rule.

It shall be possible to take a PCC rule into service, and out of service, at a specific time of day, without any PCC interaction at that point in time.

It shall be possible to take DNN-related policy information into service, and out of service, once validity conditions specified as part of the DNN-related policy information are fulfilled or not fulfilled anymore, respectively, without any PCC interaction at that point in time.

PCC shall be enabled on a per DNN basis at the SMF. It shall be possible for the operator to configure the PCC framework to perform charging control, policy control or both for a DNN access.

The PCC framework shall allow the resolution of conflicts which would otherwise cause a subscriber's Subscribed Guaranteed Bandwidth QoS to be exceeded.

It should be possible to use PCC framework for handling IMS-based emergency service.

It shall be possible with the PCC framework, in real-time, to monitor the overall amount of resources that are consumed by a user and to control usage independently from charging mechanisms, the so-called usage monitoring control.

It shall be possible for the PCC framework to provide application awareness even when there is no explicit service level signalling.

The PCC framework shall support making policy decisions based on subscriber spending limits.

The PCC framework shall support making policy decisions for N6 traffic steering.

### 4.3.2 Charging related requirements

#### 4.3.2.1 General

In order to allow for charging control on service data flow, the information in the PCC rule identifies the service data flow and specifies the parameters for charging control.

For the purpose of charging correlation between service data flow level and application level (e.g. IMS) as well as on-line charging support at the application level, applicable charging identifiers and Access Type identifiers shall be passed from the PCF to the AF, if such identifiers are available.

#### 4.3.2.2 Charging models

The PCC charging shall support the following charging models for charging performed by SMF:

- Volume based charging;
- Time based charging;
- Volume and time based charging;
- Event based charging;
- No charging.

NOTE: The charging model - "No charging" implies that charging control is not applicable, and no charging records are generated.

### 4.3.2.3 Charging requirements

It shall be possible to apply different rates and charging models depending on a UE's roaming status.

It shall be possible to apply different rates based on the location of a UE.

It shall be possible to apply different rates for specific part of a service, e.g. allow the UE to download a certain volume for one rate, and after this volume has been reached continue with a different rate.

It shall be possible to apply different rates based on the time of day.

It shall be possible to enforce per service data flow, identified by PCC Rule, usage limits on a per UE basis.

It shall be possible to apply different rates depending on the access used to carry a Service Data Flow

It shall be possible to apply an online charging action upon Application Start/Stop events.

It shall be possible to indicate to the SMF that interactions with the CHF are not required for a PCC rule, i.e. to not perform accounting, credit control or recording of usage for the service data flow, in this case no charging information is generated.

### 4.3.2.4 Examples of Service Data Flow Charging

There are many different services that may be used within a network, including both user-user and user-network services. Service data flows from these services may be identified and charged in many different ways. A number of examples of configuring PCC rules for different service data flows are described below.

EXAMPLE 1: A network server provides an FTP service. The FTP server supports both the active (separate ports for control and data) and passive modes of operation. A PCC rule is configured for the service data flows associated with the FTP server for the user. The PCC rule uses a filter specification for the uplink that identifies packets sent to port 20 or 21 of the IP address of the server, and the origination information is wildcarded. In the downlink direction, the filter specification identifies packets sent from port 20 or 21 of the IP address of the server.

EXAMPLE 2: A network server provides a "web" service. A PCC rule is configured for the service data flows associated with the HTTP server for the user. The PCC rule uses a filter specification for the uplink that identifies packets sent to port 80 of the IP address of the server, and the origination information is wildcarded. In the downlink direction, the filter specification identifies packets sent from port 80 of the IP address of the server.

EXAMPLE 3: An operator has a specific charging rate for user-user VoIP traffic over the IMS. A PCC rule is established for this service data flow. The filter information to identify the specific service data flow for the user-user traffic is provided by the P-CSCF (AF).

## 4.3.3 Policy control requirements

### 4.3.3.1 Gating control requirements

Gating control shall be applied by the UPF on a per service data flow basis.

To enable the PCF gating control decisions, the AF shall report session events (e.g. session termination, modification) to the PCF. For example, session termination, in gating control, may trigger the blocking of packets or "closing the gate".

Gating Control applies for service data flows of IP type.

### 4.3.3.2 QoS control requirements

#### 4.3.3.2.1 QoS control at service data flow level

It shall be possible to apply QoS control on a per service data flow basis in the SMF, applicable for service data flows of both IP type and Ethernet type.

QoS control per service data flow allows the PCC framework to provide the SMF with the authorized QoS to be enforced for each specific service data flow. Criteria such as the QoS subscription information may be used together with policy rules such as, service-based, subscription-based, or predefined PCF internal policies to derive the authorized QoS to be enforced for a service data flow.

It shall be possible to apply multiple PCC rules, without application provided information, using different authorised QoS within a single PDU Session and within the limits of the Subscribed QoS profile.

#### 4.3.3.2.2 QoS control at QoS Flow level

It shall be possible for the PCC framework to support control of QoS reservation procedures (UE-initiated or network-initiated). It shall be possible to determine the QoS to be applied in QoS reservation procedures (QoS control) based on the authorised QoS of the service data flows that are applicable to the QoS Flow and on criteria such as the QoS subscription information, service based policies, and/or predefined PCF internal policies.

It shall be possible for the SMF to determine the authorized QoS of a QoS Flow using the PCC rules associated to the QoS Flow, and the SMF shall be able to notify the PCF if the QoS Flow is removed or the GFBR of a QoS Flow can no longer (or can again) be guaranteed.

It shall be possible for the PCC framework to support control of QoS for the packet traffic of the PDU Session.

The PCC framework shall be able to provide policy control in the presence of NAT devices. This may be accomplished by providing appropriate address and port information to the PCF.

The enforcement of the control for QoS reservation procedures for a QoS Flow shall allow for a downgrading or an upgrading of the requested QoS as part of a UE-initiated QoS Flow establishment and modification. The PCC framework shall be able to provide a mechanism to initiate QoS Flow establishment and modification as part of the QoS control.

The PCC framework shall be able to handle QoS Flows that require a guaranteed bitrate (GBR bearers) and QoS Flows for which there is no guaranteed bitrate (non-GBR bearers).

#### 4.3.3.2.3 QoS control at PDU Session level

It shall be possible for the PCF to provide the authorized Session-AMBR values, default 5QI/ARP combination for PDU Session of IP type, Ethernet type and unstructured type unconditionally or conditionally, i.e. per PDU Session type and/or RAT type.

It shall be possible for the PCF to request a change of the unconditional or conditional authorized Session-AMBR value(s) at a specific point in time.

### 4.3.3.3 Subscriber spending limits requirements

It shall be possible to enforce policies based on subscriber spending limits. The CHF shall maintain policy counter(s) to track spending for a subscription. These policy counters must be available in the CHF prior to their use over the N28 interface.

NOTE: The mechanism for provisioning the policy counters in the CHF is out of scope of this document.

The PCF shall request information regarding the subscriber's spending from the CHF, to be used as input for dynamic policy decisions for the subscriber, using subscriptions to spending limit reports. The CHF shall make information regarding the subscriber's spending available to the PCF using spending limit reports.

#### 4.3.4 Usage monitoring control requirements

The requirements to monitor, both volume and time usage, and report the accumulated usage of network resources apply for PDU Sessions of type IP and Ethernet.

It shall be possible to apply usage monitoring for the accumulated usage of network resources on a per Session and user basis. This capability is required for enforcing dynamic policy decisions based on the total network usage in real-time.

The PCF that uses usage monitoring for making dynamic policy decisions shall set and send the applicable thresholds to the SMF for monitoring. The usage monitoring thresholds shall be based either on time, or on volume. The PCF may send both thresholds to the SMF. The SMF shall notify the PCF when a threshold is reached and report the accumulated usage since the last report for usage monitoring. If both time and volume thresholds were provided to the SMF, the accumulated usage since last report shall be reported when either the time or the volume thresholds are reached.

NOTE: There are reasons other than reaching a threshold that can cause the SMF to report accumulated usage to the PCF as defined in clauses 6.2.2.3.

The usage monitoring capability shall be possible for an individual or a group of service data flow(s), or for all traffic of a PDU Session in the SMF. When usage monitoring for all traffic of a PDU Session is enabled, it shall be possible to exclude an individual SDF or a group of service data flow(s) from the usage monitoring for all traffic of this PDU Session. It shall be possible to activate usage monitoring both to service data flows associated with predefined PCC rules and dynamic PCC rules, including rules with deferred activation and/or deactivation times while those rules are active.

If service data flow(s) need to be excluded from PDU Session level usage monitoring and PDU Session level usage monitoring is enabled, the PCF shall be able to provide the indication of exclusion from session level monitoring associated with the respective PCC rule(s).

It shall be possible to apply different usage monitoring depending on the access used to carry a Service Data Flow.

#### 4.3.5 Application detection and control requirements

The application detection and control feature comprise the request to detect the specified application traffic, report to the PCF on the start or stop of application traffic and to apply the specified enforcement and charging actions.

The PCF shall instruct the SMF on which applications to detect and whether to report start or stop event to the PCF by activating the appropriate PCC rules in the SMF. Reporting notifications of start and stop of application detection to the PCF may be muted.

The report to the PCF shall include the report is for start or stop, the detected application identifier and, if deducible, the service data flow descriptions for the detected application traffic.

Upon receiving the report from SMF, the PCF may make policy decisions based on the information received and may send the corresponding updated or new PCC rules to the SMF.

The PCF may have to further notify the AF on the detection of application start or stop event if the AF, may be via NEF, has subscribed this event from the PCF.

In this Release of the specification Application Detection and Control applies only to the IP PDU Session types.

#### 4.3.6 Support for session management related network capability exposure

Support for network capability exposure enables an AF (e.g. an external ASP) to request the following session management related policy control functionality from the NEF:

- Set or change a chargeable party at AF session setup (see clause 4.15.6.4 and 4.15.6.5 of TS 23.502 [3]);
- Set up an AF session with required QoS (see clause 4.15.6.6 of TS 23.502 [3] and clause 6.1.3.22);

- Request QoS, traffic characteristics provisioning and performance monitoring for an individual UE or a group of UEs (see clause 4.15.6.14 of TS 23.502 [3]);
- Transfer of traffic characteristics of Time Sensitive Communication from the TSN AF (see clause 6.1.3.23) or from the TSCTSF (see clause 6.1.3.23a);
- Set up a time synchronization service from the TSCTSF (see clause 5.27.1.8 of TS 23.501 [2], clause 4.15.9 of TS 23.502 [3] and clause 6.1.3.23a);
- Application Function influence on traffic routing, as defined in clauses 4.3.7 and 6.1.3.14, as well as in clause 5.6.7 of TS 23.501 [2];
- Application Function influence on Service Function Chaining, as defined in clauses 4.3.7 and 6.1.3.14, as well as in clause 5.6.16 of TS 23.501 [2].
- Application Function influence on Handling of Payload Headers as defined in clauses 4.3.8 and 6.1.3.30, as well as in clause 5.6.17 of TS 23.501 [2].

### 4.3.7 Traffic steering control

Traffic Steering Control refers to the capability to activate/deactivate traffic steering policies from the PCF in the SMF for the purpose of:

- steering the subscriber's traffic to appropriate operator or 3rd party service functions (e.g. NAT, antimalware, parental control, DDoS protection) in the N6-LAN or 5G-LAN type of services according to operator policy, or Application Function influence on Service Function Chaining as described in clause 5.6.16 of TS 23.501 [2]. This is supported in non-roaming and home-routed scenarios only.
- Application Function influence on traffic routing which enables the routing of the user traffic matching the traffic filters provided in the PCC rule to a local Data Network identified by the DNAI per AF request. This is supported in non-roaming, LBO and HR-SBO scenarios only, as described in clause 5.6.7 of TS 23.501 [2].

### 4.3.8 Handling of Payload Headers

Handling of Payload Headers refers to the capability to provide Header Handling Control information according to Application Function influence on Handling of Payload Headers as described in clause 5.6.17 of TS 23.501 [2]. This is only supported in non-roaming and home-routed scenarios.

## 4.4 Network slice related policy control requirements

The network slice related policy control requirements include:

- Limitation of the data rate per network slice.

---

## 5 Architecture model and reference points

### 5.1 General

This specification describes the policy and charging control framework for the 5G system. The interaction between network functions is represented in two ways:

- A service-based representation, where network functions enable other authorized network functions to access their services. This representation also includes point-to-point reference points where necessary;
- A reference point representation, which shows that interactions exist between those network functions for which a reference point is depicted between them.

## 5.2 Reference architecture

### 5.2.1 Non-roaming architecture

The reference architecture of policy and charging control framework for the 5G System is comprised by the functions of the Policy Control Function (PCF), the Session Management Function (SMF), the User Plane Function (UPF), the Access and Mobility Management Function (AMF), the Network Exposure Functionality (NEF), the Network Data Analytics Function (NWDAF), the Charging Function (CHF), the Application Function (AF) and UDR (Unified Data Repository).

Figure 5.2.1-1 shows the service based representation and Figure 5.2.1-1a shows the reference point representation of the reference architecture of policy and charging control framework for the 5G System.

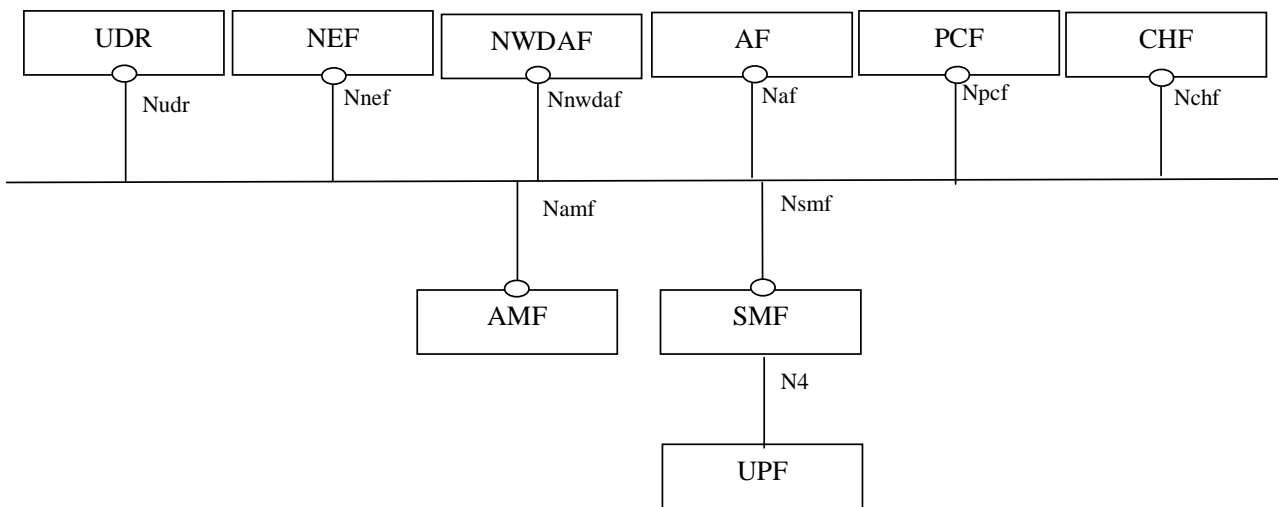

**Figure 5.2.1-1: Overall non-roaming reference architecture of policy and charging control framework for the 5G System (service based representation)**

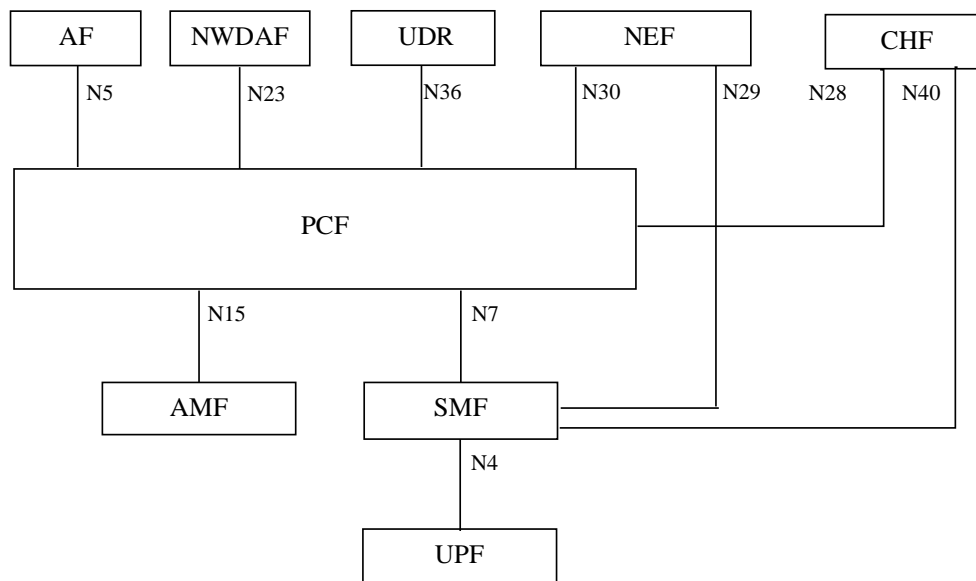

**Figure 5.2.1-1a: Overall non-roaming reference architecture of policy and charging control framework for the 5G System (reference point representation)**

NOTE 1: The N4 reference point is not part of the 5G Policy Framework architecture but shown in the figures for completeness. See TS 23.501 [2] for N4 reference point definition.

NOTE 2: How the PCF/NEF stores/retrieves information related with policy subscription data or with application data is defined in TS 23.501 [2].

NOTE 3: The 5G DDNMF to PCF reference point is not depicted in the point-to-point reference architecture diagrams and the 5G DDNMF is not shown in the service-based architecture diagrams. The 5G DDNMF is included in the ProSe architecture depicted in TS 23.304 [34].

NOTE 4: For clarity, the DCCF and its connections with PCF are not depicted in the point-to-point and service-based architecture diagrams. For more information on network data analytics architecture using DCCF refer to TS 23.288 [24].

The Nchf service for online and offline charging consumed by the SMF is defined in TS 32.240 [8].

The Nchf service for Spending Limit Control consumed by the PCF is defined in TS 23.502 [3].

The PCF providing session management policy control for a UE (i.e. PCF for the PDU Session) and the PCF providing non-session management policy control for that UE (i.e. PCF for the UE) may be different PCF instances. For the case that there are different PCF instances, the PCF for the PDU Session does not support the N15 reference point while the PCF for the UE does not support the N7 reference point. The N43 reference point enables communication between the PCF for the UE and the PCF for the PDU Session.

### 5.2.2 Roaming architecture

Figure 5.2.2-1 shows the local breakout roaming architecture of the policy and charging control framework for the 5G System:

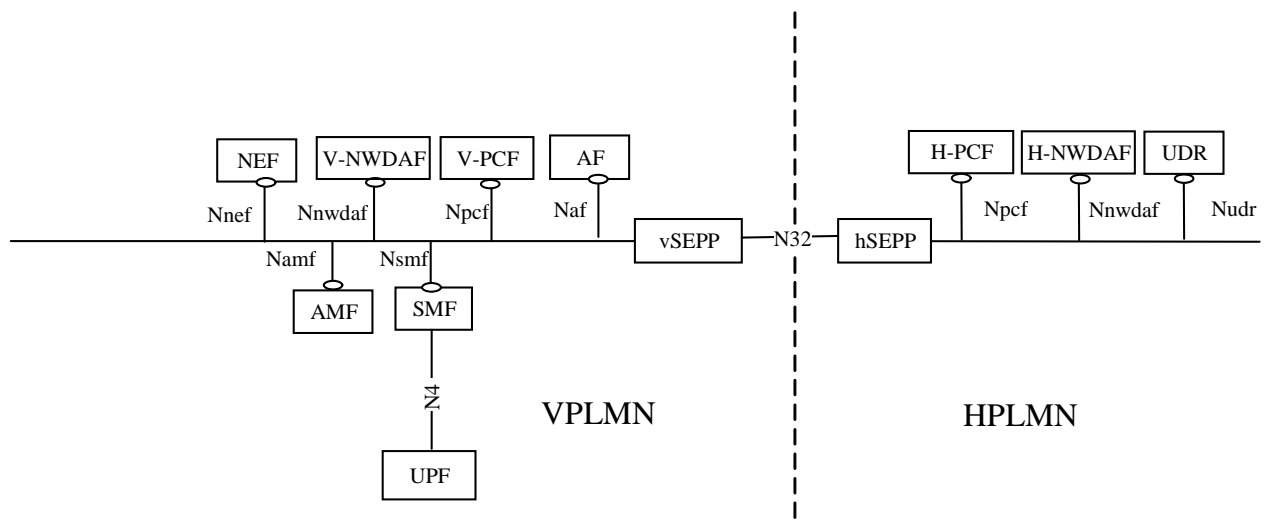
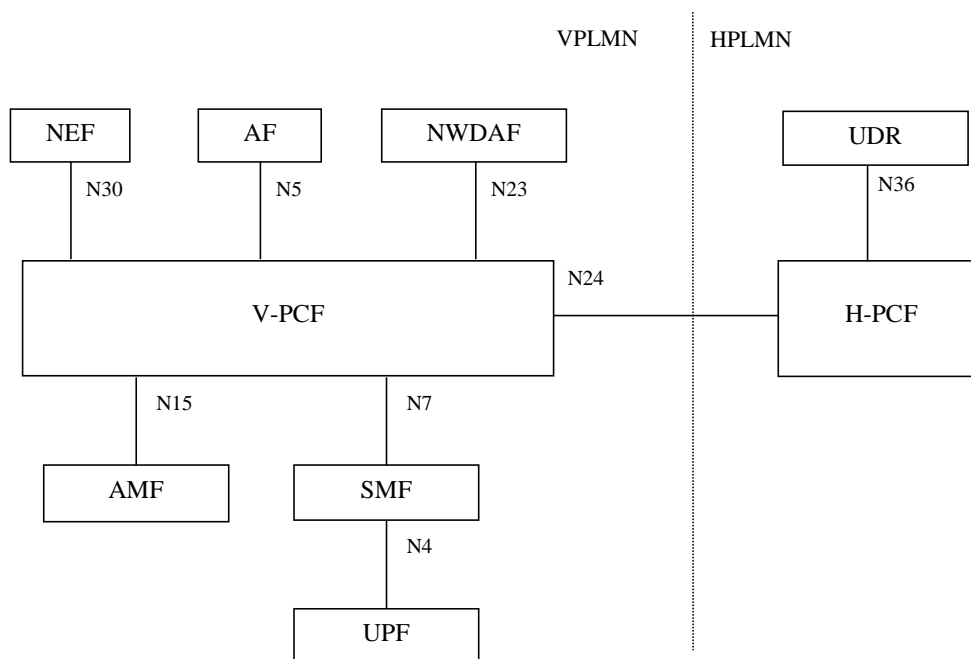

Figure 5.2.2-1: Overall roaming reference architecture of policy and charging control framework for the 5G System - local breakout scenario



**Figure 5.2.2-1a: Overall roaming reference architecture of policy and charging control framework for the 5G System - local breakout scenario (reference point representation)**

- NOTE 1: In the LBO architecture, the PCF in the VPLMN may interact with the AF in order to generate PCC Rules for services delivered via the VPLMN. The PCF in the VPLMN uses locally configured policies according to the roaming agreement with the HPLMN operator as input for PCC Rule generation. The PCF in VPLMN has no access to subscriber policy information from the HPLMN for PCC Rule generation.
- NOTE 2: In the LBO architecture, N24 can be used to deliver UE policy information from the PCF in the HPLMN to the PCF in the VPLMN. The PCF in the VPLMN can provide access and motility policy information without contacting the PCF in the HPLMN.
- NOTE 3: In the LBO architecture, AF requests providing routing information for roamers targeting a DNN and S-NSSAI (targeting all roamers) or an External-Group-Identifier (identifying a group of roamers) are stored as Application Data in the UDR (in the VPLMN) by the NEF (in the VPLMN).
- NOTE 4: In the LBO architecture, AF requests influencing AM policy for roamers targeting any inbound roaming UEs together with combination (s) of DNN and S-NSSAI or External Application Identifier(s) are stored as Application Data in the UDR (in the VPLMN) by the NEF (in the VPLMN). The inbound roamers are identified by their home PLMN ID(s).
- NOTE 5: For the sake of clarity, SEPPs (see definition in clause 6.2.17 of TS 23.501 [2]) are not depicted in the roaming reference point architecture figures.

Figure 5.2.2-2 shows the home routed roaming architecture of the policy and charging control framework for the 5G System:

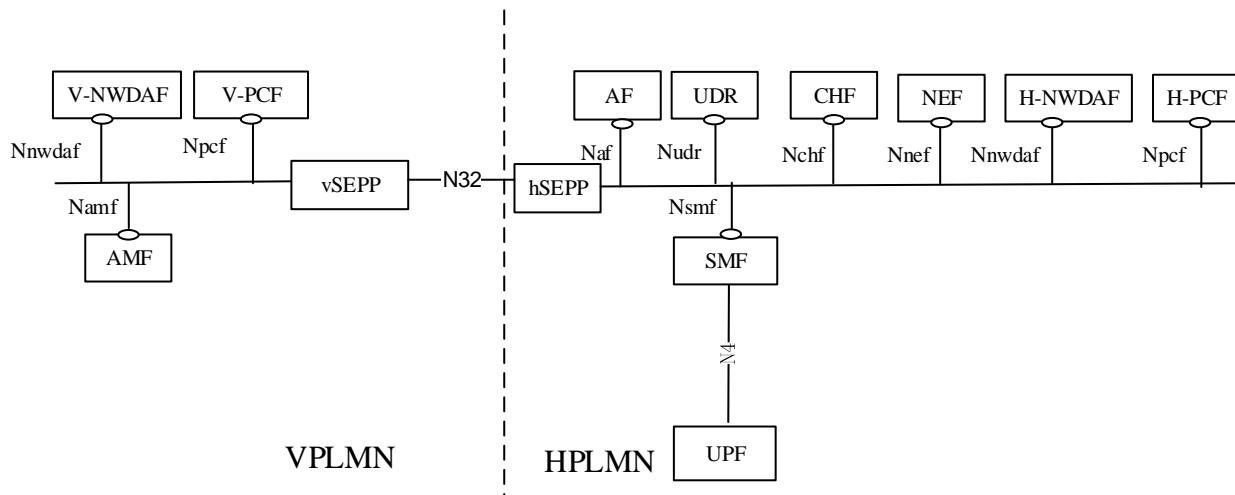

**Figure 5.2.2-2: Overall roaming reference architecture of policy and charging control framework for the 5G System - home routed scenario**

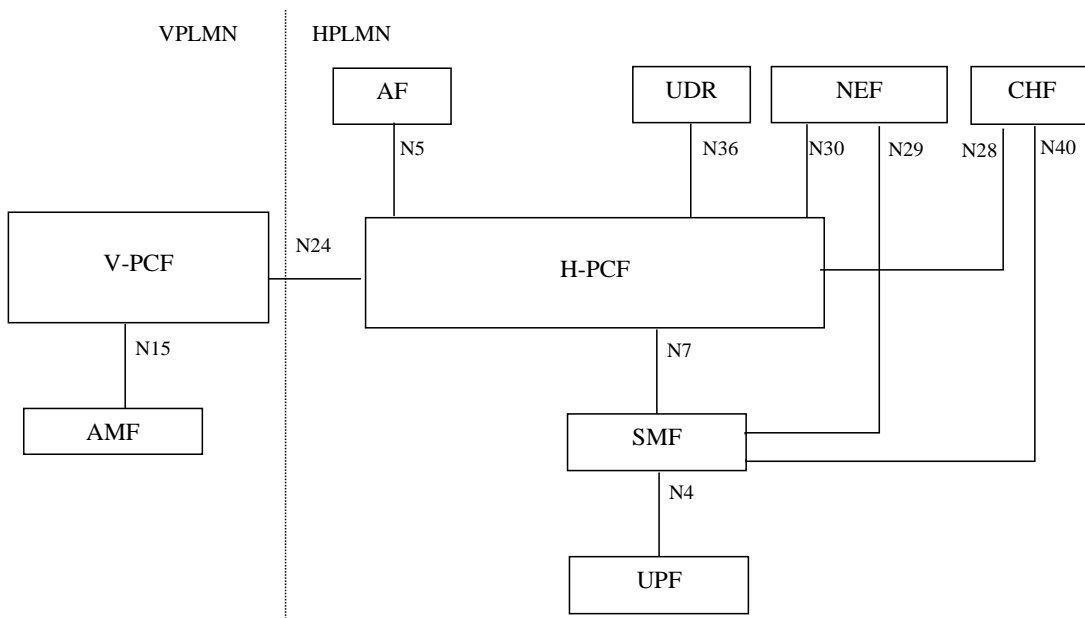

**Figure 5.2.2-2a: Overall roaming reference architecture of policy and charging control framework for the 5G System - home routed scenario (reference point representation)**

NOTE 5: All functional entities as described in Figure 5.2.1-1 non-roaming scenario applies also to the HPLMN in the home routed scenario above.

NOTE 6: For the sake of clarity, SEPPs (see definition in clause 6.2.17 of TS 23.501 [2]) are not depicted in the roaming reference point architecture figures.

NOTE 7: For HR roaming scenarios (including HR-SBO PDU Session defined in TS 23.548 [33]), there is no PCF for the PDU Session in the VPLMN.

### 5.2.3 Void

## 5.3 Service-based interfaces and reference points

### 5.3.1 Interactions between PCF and AF

Npcf and Naf enable transport of application level session information and Ethernet/IP port management information from AF to PCF. Such information includes, but is not limited to:

- IP filter information or Ethernet packet filter information to identify the service data flow for policy control and/or differentiated charging;
- media/application bandwidth requirements for QoS control;
- In addition, for sponsored data connectivity:
  - the sponsor's identification;
  - optionally, a usage threshold and whether the PCF reports these events to the AF;
  - information identifying the application service provider and application (e.g. SDFs, application identifier, etc.);
- information required to enable Application Function influence on traffic routing as defined in clause 5.6.7 of TS 23.501 [2];
- information required to enable Application Function influence on Service Function Chaining as defined in clause 5.6.16 of TS 23.501 [2];
- information required to enable Application Function influence on Handling of Payload Headers as defined in clause 5.6.17 of TS 23.501 [2];
- information required to enable setting up an AF session with required QoS as defined in clause 6.1.3.22;
- information required to enable setting up an AF session with support for Time Sensitive Networking (TSN) as defined in clause 6.1.3.23.
- information required to enable setting up an AF session with support for Time Sensitive Communication as defined in clause 6.1.3.23a.
- information required to enable setting up an AF session with support for Deterministic Networking (DetNet) as defined in clause 6.1.3.23b.
- information required to enable setting up an AF session with support for eXtended Reality and Interactive Media Services (XRM) as defined in clause 6.1.3.27.

Npcf also enables the AF to request to influence Access and Mobility related policies for a UE and enables the AF to provide guidance for UE URSP rule determination. Npcf and Naf enable the AF subscription to notifications on PDU Session events, i.e. the events requested by the AF as described in clause 6.1.3.18 and the change of DNAI as defined in clause 5.6.7 of TS 23.501 [2].

The N5 reference point is defined for the interactions between PCF and AF in the reference point representation.

### 5.3.2 Interactions between PCF and SMF

Npcf and Nsmf enable the PCF to have dynamic control over the policy and charging behaviour at a SMF.

Npcf and Nsmf enable the signalling of policy and charging control decisions and support the following functionality:

- Creation of a SM Policy Association as defined in clause 4.16 of TS 23.502 [3];
- Request for policy and charging control decision from the SMF to the PCF when a Policy Control Request Trigger related to Session Management has been met;
- Provision of policy and charging control decision from the PCF to the SMF;
- Deletion of a SM Policy Association as defined in clause 4.16 of TS 23.502 [3];

- Forwarding of UE reporting of URSP rule enforcement by SMF to PCF as defined in clause 6.6.2.4.

The N7 reference point is defined for the interactions between PCF and SMF in the reference point representation.

### 5.3.3 Interactions between PCF and AMF

Npcf and Namf enable the PCF to provide Access and Mobility related policy information to the AMF as well as to provide UE policy information to the UE via the AMF and support the following functionality:

- Creation and Deletion of an AM Policy Association as defined in clause 4.16 of TS 23.502 [3];
- Creation and Deletion of an UE Policy Association as defined in clause 4.16 of TS 23.502 [3];
- Request for access and mobility related policy information from the AMF to the PCF when a Policy Control Request Trigger related to Access and Mobility Management, UE access selection or PDU Session selection has been met as defined in clause 6.1.2.5;
- Provision of access and mobility management related policy information from the PCF to the AMF as defined in clause 6.5;
- Handling of transparent delivery of UE policy information from the PCF to the UE via the AMF.

The N15 reference point is defined for the interactions between PCF and AMF in the reference point representation.

### 5.3.4 Interactions between V-PCF and H-PCF

For roaming scenario, the interactions between V-PCF and H-PCF through Npcf enables:

- Creation of an UE Policy Association as defined in clause 4.16 of TS 23.502 [3];
- Relay of notification of changes from the V-PCF in the VPLMN to the H-PCF as defined in clause 4.16 of TS 23.502 [3];
- Provision of UE policy information to the V-PCF in the VPLMN;
- Deletion of an UE Policy Association as defined in clause 4.16 of TS 23.502 [3];
- Provision of Service Parameters of the VPLMN to the H-PCF in the HPLMN.

The N24 reference point is defined for the interactions between V-PCF and H-PCF in the reference point representation.

### 5.3.5 Interactions between PCF and UDR

The Nudr enables the PCF to access policy control related subscription information and application specific information stored in the UDR. The Nudr interface supports the following functions:

- request for policy control related subscription information and application specific information from the UDR;
- provisioning of policy control related subscription information and application specific information to the UDR;
- notifications from the UDR on changes in the policy control related subscription information;
- subscription to the UDR for the update of application data;
- notifications from the UDR on the update of application data.

The N36 reference point is defined for the interactions between PCF and UDR in the reference point representation.

### 5.3.6 Interactions between SMF and CHF

The interactions between SMF and CHF enable online and offline charging.

The N40 reference point is defined for the interactions between SMF and CHF in the reference point representation.

Since the N40 reference point resides between the SMF and CHF in the HPLMN, home routed roaming and non-roaming scenarios are supported in the same manner.

NOTE: The functionality of this interface/reference point is defined in TS 32.240 [8].

### 5.3.7 Void

### 5.3.8 Interactions between PCF and CHF

The Nchf enables the PCF to access policy counter status information relating to subscriber spending from CHF and support the following functionality:

- Request for reporting of policy counter status information from PCF to CHF and subscribe to or unsubscribe from spending limit reports (i.e. notifications of policy counter status changes);
- Report of policy counter status information upon a PCF request from CHF to PCF;
- Notification of spending limit reports from CHF to PCF;
- Cancellation of spending limit reporting from PCF to CHF.

The N28 reference point is defined for the interactions between PCF and CHF in the reference point representation.

Since the N28 reference point resides between the PCF and CHF in the HPLMN, home routed roaming and non-roaming scenarios are supported in the same manner.

NOTE: In this Release of the specification, there is no support by the Nchf\_SpendingLimitControl service between the PCF in VPLMN and the CHF in the HPLMN.

### 5.3.9 Interactions between SMF and NEF

Nsmf and Nnef enable transport of PFDs from the NEF (PFDF) to the SMF for a particular application identifier or for a set of application identifiers. It is achieved with the support of the following functionality:

- Creation, updating and removal of individual or the whole set of PFDs from the NEF (PFDF) to the SMF;
- Confirmation of creation, updating and removal of PFDs from the SMF to the NEF (PFDF).

NOTE: The interactions between the SMF and the NEF (PFDF) for transporting PFDs are not related to any PDU Session.

The N29 reference point is defined for the interactions between SMF and NEF (PFDF) in the reference point representation.

### 5.3.10 Interactions between NEF and PCF

Npcf and Nnef enable the negotiation of policy and charging control behaviour between PCF and NEF by supporting the following functionality:

- service specific policy and charging control;
- sponsor data connectivity including usage monitoring;
- Application Function influence on traffic routing;
- Application Function influence on Service Function Chaining;
- Application Function influence on Handling of Payload Headers;
- subscription and reporting of events for the event exposure;
- negotiations for future background data transfer;

- negotiation of planned data transfer with QoS requirements.

The N30 reference point is defined for the interactions between PCF and NEF in the reference point representation.

NOTE: For HR-SBO roaming case, there is no PCF for the PDU Session in the VPLMN.

### 5.3.11 Interactions between NWDAF and PCF

The NnwdaF enables the PCF to request or subscribe to and be notified on analytics specified in clause 6 of TS 23.288 [24]. The specific list of analytics and how these analytics can be used by the PCF is described in clause 6.1.1.3.

The N23 reference point is defined for the interactions between NWDAF and PCF in the reference point representation.

### 5.3.12 Interactions between PCF for the UE and PCF for the PDU Session

Npcf services enable reporting of PDU Session related events detected by the PCF for the PDU Session to the PCF for the UE. Such events are described in clause 6.1.3.18, e.g. reporting the start and stop of application traffic detection and UE reporting of URSP rule enforcement.

### 5.3.13 Interactions between PCF and TSCTSF

Npcf enables transport of application level session information from TSCTSF to PCF and Ethernet or IP port management information between PCF and TSCTSF. Such information includes, but is not limited to:

- information required to enable setting up an AF session with support for Time Sensitive Communication and Time Synchronization as defined in clause 6.1.3.23a.
- information required to enable setting up an AF session with support for Deterministic Networking as defined in clause 6.1.3.23b.

Npcf enables the TSCTSF subscription to notifications on PDU Session events, i.e. the events requested by the TSCTSF as described in clause 6.1.3.18.

The N84 reference point is defined for the interactions between PCF and TSCTSF in the reference point representation.

### 5.3.14 Interactions between NWDAF and NEF (PFDF)

The NnwdaF enables the NEF (PFDF) to request or to subscribe to and to be notified of the PFD Determination analytics as specified in TS 23.288 [24].

NOTE: How PFD Determination analytics can be used by the NEF (PFDF) is described in clause 6.1.2.3.1.

---

## 6 Functional description

### 6.1 Overall description

#### 6.1.1 General

##### 6.1.1.1 PCF Discovery and Selection

The procedures for PCF Discovery and Selection by the AMF and by the SMF are described in TS 23.501 [2].

The procedure to ensure that a consumer NF (e.g. an AF, NEF or PCF for the UE) reaches the PCF selected for a PDU Session is described in clause 6.1.1.2.

The procedure to ensure that a consumer NF (e.g. an AF) reaches the PCF selected for a UE is described in clause 6.1.1.2a.

## 6.1.1.2 Binding an AF request targeting an UE address to the relevant PCF

### 6.1.1.2.1 General

When multiple and separately addressable PCFs have been deployed, a network functionality is required in order to ensure that a consumer NF (e.g. AF) needing to send policies about UE traffic identified by an UE address can reach over N5 the PCF holding the corresponding PDU Session information. This network functionality has the following characteristics:

- It has information about the user identity, the DNN, the UE (IP or MAC) address(es), the S-NSSAI and the selected PCF address for a certain PDU Session.
- For IP PDU Session type, it shall receive information when an IP address is allocated or released for a PDU Session.
- If integration with TSN applies (see clause 5.28 of TS 23.501 [2]), it shall receive the DS-TT port MAC address.
- For Ethernet PDU Sessions supporting binding of AF request based on MAC address, it shall receive information when a MAC address is detected as being used by the UE over the PDU Session (this detection takes place at the UPF under control of SMF and is defined in clause 5.8.2 of TS 23.501 [2]). In addition, it receives the DS-TT port MAC address in the case of support of time sensitive communication and time synchronization (as described in clause 5.28.3.2 of TS 23.501 [2]).
- The functionality determines the PCF address and if available the associated PCF instance ID and PCF set ID, selected by the PCF discovery and selection function described in TS 23.501 [2].

A private IPv4 address may be allocated to different PDU Sessions, e.g.:

- The same UE IPv4 address is allocated to different PDU Sessions to the same DNN and different S-NSSAI;
- The same UE IPv4 address is allocated to different PDU Sessions to the same S-NSSAI and different DNN.

In the case of private IPv4 address being used for the UE, the AF or the NEF may send DNN S-NSSAI, in addition, in Npcf\_PolicyAuthorization\_Create request and Nbsf\_Management\_Discovery request. The DNN and S-NSSAI can be used by the PCF for session binding, and they can be also used to help selecting the correct PCF.

### 6.1.1.2.2 The Binding Support Function (BSF)

The BSF has the following characteristics:

- The BSF stores internally information about the corresponding selected PCF:
  - For a certain PDU Session, the BSF stores internally information about the user identity, the DNN, the UE (IP or MAC) address(es), the S-NSSAI, the selected PCF address and if available the associated PCF instance ID, PCF set ID and the level of binding (see clause 6.3.1.0 of TS 23.501 [2]).
  - For a certain UE, the BSF stores internally information about the user identity, the selected PCF address and if available the associated PCF instance ID, PCF set ID and the level of binding (see clause 6.3.1.0 of TS 23.501 [2]).

NOTE 1: Only NF instance or NF set Level of Binding indication are supported at the BSF.

- The PCF registers, updates and removes the stored information in the BSF using the Nbsf management service operations defined in TS 23.502 [3]:
  - For a PDU Session, the PCF ensures that it is updated each time an IP address is allocated or de-allocated to the PDU Session or, for Ethernet PDU Sessions supporting binding of AF request based on MAC address, each time it has been detected that a MAC address is used or no more used by the UE in the PDU Session.
  - For a UE, the PCF ensures that it is updated each time the AMF selects a new PCF.
  - Based on operator's policies and configuration, the PCF determines whether the same PCF shall be selected for the SM Policy Associations to the same UE ID, S-NSSAI and DNN combination in the non-roaming or home-routed scenario.

NOTE 2: This applies to usage monitoring.

- Based on operator's policies and configuration, the PCF determines whether the same PCF shall be selected for the SM Policy Associations to the same UE ID and S-NSSAI combination in the non-roaming or home-routed scenario.

NOTE 3: This applies to network slice related policy control.

- The selected PCF (if needed) downloads the user profile from the UDR as described in clause 4.16.4 step 2 of TS 23.502 [3]. If usage monitoring is enabled for the user, and based on operator's policies, the PCF checks if the BSF has already existing PCF serving the combination of SUPI, S-NSSAI and DNN:
  - If no such PCF is found the PCF shall register itself to the BSF as described above in this clause.
  - Else if an existing PCF is found for the above combination, the PCF shall return to the SMF the available information about the existing PCF and a redirection indication.

NOTE 4: The assumption is that for DNN, S-NSSAI combinations where usage monitoring be applied, the same BSF instance or the same BSF SET is selected for all UE PDU Sessions to the same DNN, S-NSSAI.

- The BSF verifies whether to provide the address of a PCF for the PDU Session or a PCF for the UE according to the information provided by the consumer NF (e.g. the AF, the NEF, or the PCF for the UE). If the consumer NF provides the user identity and neither a UE address nor a (DNN, S-NSSAI) tuple, the BSF shall provide the address of the PCF for the UE. If the consumer NF (e.g. the PCF for the UE) provides the user identity (e.g. SUPI or GPSI) and the tuple (DNN, S-NSSAI), the BSF shall provide the address of a PCF for the PDU Session for this UE. If the consumer NF (e.g. the AF or the NEF) provides the UE address, the BSF shall provide the address of a PCF for the PDU Session.

NOTE 5: It is up to stage3 to ensure an unambiguous error proof way for the BSF to differentiate between PCF for the PDU Session and PCF for the UE. This might or might not require providing the BSF additional parameter(s) when a PCF registers itself with the BSF and/or when a consumer attempts to discover a PCF via discovery or subscription.

- For retrieval binding information, any NF, such as NEF or AF, that needs to discover the selected PCF address(es), and if available, the associated PCF instance ID, PCF set ID and level of binding (see clause 6.3.1.0 of TS 23.501 [2]) for the tuple (UE address, DNN, S-NSSAI, SUPI, GPSI) (or for a subset of this Tuple) uses the Nbsf management service discovery service operation defined in TS 23.502 [3].
- The NF may discover the BSF via NRF or based on local configuration. When registering the NF profile in NRF, the Range(s) of UE IPv4 addresses, Range(s) of UE IPv6 prefixes supported by the BSF and optionally, the DNN list, S-NSSAI(s) or IP domain list as described in TS 29.510 [32], may be provided to NRF.
- If the NF received a PCF set ID or a PCF instance ID with an indication of level of binding as result of the Nbsf management service discovery service operation, it should use that information as NF set level or NF instance level Binding Indication to route requests to the PCF as defined in clause 6.3.1.0 of TS 23.501 [2] and according to the following provisions:
  - For the NF set level of binding, the NF will receive a PCF set ID but no PCF instance ID. If an NF is not able to reach the received PCF address(es) and applies direct discovery, it should query the NRF for PCF instances within the PCF set and select another instance.
  - For the NF instance level of binding, the NF will receive a PCF set ID and a PCF instance ID. If an NF is not able to reach the received PCF address(es) and applies direct discovery, it should query the NRF for PCF service instances within the PCF and select another instance.
  - The NF should provide a Routing Binding Indication based on the received PCF set ID, level of binding and possible PCF instance ID in requests it sends to the PCF.
- For an ongoing NF service session, the PCF may provide Binding indication to the NF (see clause 6.3.1.0 of TS 23.501 [2]). This Binding indication shall then be used instead of any PCF information received from the BSF.
- If a new PCF instance is selected, the new PCF should invoke Nbsf\_Management\_Update service operation to update the binding information in BSF.

The BSF may be deployed standalone or may be collocated with other network functions, such as PCF, UDR, NRF and SMF.

NOTE 6: Collocation allows combined implementation.

A consumer may subscribe to the BSF to be notified when a PCF for the PDU Session for a certain SUPI is registered in the BSF. The subscription may include an expiration time. When the subscription expires, if the NF Service Consumer wants to keep receiving notifications, it shall create a new subscription in the BSF.

### 6.1.1.2a Binding an NF request targeting a UE to the relevant PCF for the UE

When multiple and separately addressable PCFs have been deployed, a network functionality is required in order to ensure that a consumer NF (e.g. AF, 5G DDNMF) reaches the PCF serving the UE. This network functionality is provided by the BSF (described in clause 6.1.1.2.2) and has the following characteristics:

- It has information about the user identity, and the selected PCF address for a certain UE.
- The functionality determines the PCF address and if available the associated PCF instance ID and PCF set ID, selected by the PCF discovery and selection function described in TS 23.501 [2].

NOTE: The above is required e.g. for dynamic control of access and mobility related policy control functionality or for reporting events for a UE to a consumer such as 5G DDNMF.

A consumer may subscribe to the BSF to be notified when a PCF for the UE is registered in the BSF for a certain SUPI or GPSI. The subscription may include an expiration time. When the subscription expires, if the NF Service Consumer wants to keep receiving notifications, it shall create a new subscription in the BSF.

### 6.1.1.3 Policy decisions based on network analytics

Policy decisions based on network analytics allow PCF to perform policy decisions taking into account analytics information defined for Analytics IDs listed in TS 23.288 [24]. The analytics information may be provided by NWDAF directly or via DCCF, depending on the deployment of NWDAF or DCCF. Local configuration in the PCF indicates if one or multiple or all Analytics ID(s) are retrieved either from NWDAF directly or using DCCF. The PCF uses the DCCF services and DCCF service operations to fetch, subscribe and unsubscribe to the Analytics IDs as described in clause 6.1.4 and clause 8 in TS 23.288 [24].

The PCF performs discovery and selection of NWDAF and DCCF as defined in TS 23.501 [2] and subscribes/unsubscribes to Analytics information as defined in TS 23.288 [24]. In addition, the AMF and/or SMF may include, in the AM/SM Policy Association establishment or modification procedures, the list of NWDAF instance IDs used for the UE or the PDU Session and their associated Analytics ID(s) consumed by the AMF or SMF respectively. The PCF may select those NWDAF instances as the ones to subscribe for their associated Analytics ID(s) for the UE for which those AM/SM Policy Associations are related to or may perform NWDAF discovery if the NWDAF for an Analytics ID not provided by the AMF or SMF is needed.

The following Analytics IDs are relevant for Policy decisions: "Load level information", "Service Experience", "Network Performance", "Abnormal behaviour", "UE Mobility", "UE Communication", "User Data Congestion", "Data Dispersion", "Session Management Congestion Control Experience", "DN Performance", "WLAN performance", "Redundant Transmission Experience" and "QoS and policy assistance". The PCF may subscribe to NWDAF as described below or alternatively, the PCF may use `Ndccf_DataManagement_Subscribe` including the "Analytics Specification" with the same information as provided in the `Nnwdaf_AnalyticsSubscription_Subscribe`, and optionally the PCF may include the NWDAF ID, e.g. if provided by AMF or SMF:

- The PCF may subscribe to notifications of network analytics related to "Load Level Information" using the `Nnwdaf_AnalyticsSubscription_Subscribe` service operation including the Analytics ID "Load level information", the Analytics Filter "S-NSSAI" and the Analytics Reporting Information set to a load level threshold value. The PCF is notified when the load level of the Network Slice Instance reaches the threshold.

The NWDAF service to retrieve the Load Level Information is described in clause 6.3 of TS 23.288 [24].

- The PCF may subscribe to notifications of network analytics related to "Service Experience" using the `Nnwdaf_AnalyticsSubscription_Subscribe` service operation including the Analytics ID "Service Experience", the Target of Analytics Reporting "SUPI", "Internal Group Id" or "any UE", the Analytics Filter including one or more Application Identifier(s), one or more or "any" RAT Type(s) or Frequency value(s), one or more list(s) of

combination of (S-NSSAI, DNN, PDU Session type and SSC Mode) optionally per Access Type and the Analytics Reporting Information set to service experience threshold value(s) for the RAT Type(s) and/or Frequency value(s). The PCF is notified on the Service Experience statistics or predictions including, for each Application Identifier, the list of SUPIs for which Service Experience is provided and the list of RAT Types and/or Frequency values for which the Service Experience applies. In addition, the list of SUPIs for which Service Experience is provided is also added when the Target of Analytics Reporting is "Internal Group Id" or "any UE". Both spatial and time validity may be provided as well as the confidence of the prediction.

The NWDAF service to retrieve the service experience (i.e. the average observed Service MoS) is described in clause 6.4 of TS 23.288 [24].

- The PCF may subscribe to notifications of network analytics related to "Network Performance" using the Nnwdaf\_AnalyticsSubscription\_Subscribe service operation including the Analytics ID "Network Performance", the Target of Analytics Reporting "Internal Group Id" and the Analytics Filter including the Area of Interest. The PCF is notified on the Network Performance statistics or predictions including the Area of Interest. In addition, the confidence of the prediction may be provided.

The NWDAF services to retrieve "Network Performance" as described in clause 6.6 of TS 23.288 [24].

- The PCF may subscribe to notifications of network analytics related to "Abnormal behaviour" using the Nnwdaf\_AnalyticsSubscription\_Subscribe service operation including the Analytics ID "Abnormal behaviour", the Target of Analytics Reporting "SUPI", "Internal Group Id" or "any UE" and the Analytics Filter including the expected analytics type or the list of Exceptions IDs and per each Exception Id a possible threshold and other Analytics Filter Information if needed. The list of Exception IDs is specified in TS 23.288 [24].

The NWDAF services to retrieve "Abnormal behaviour" analytics are described in clause 6.7.5 of TS 23.288 [24].

- The PCF may subscribe to notifications of network analytics related to "UE Mobility" using NWDAF\_AnalyticsSubscription\_Subscribe service operation including the Analytics ID "UE Mobility", the Target of Analytics Reporting "SUPI", "Internal Group Id" and the Analytics Filter may include one or more "Area(s) of Interest". The PCF is notified on the UE Mobility statistics or predictions as defined clause 6.7.2 of TS 23.288 [24].

The NWDAF services to retrieve "UE Mobility" analytics are described in clause 6.7.2 of TS 23.288 [24].

- The PCF may subscribe to notifications of network analytics related to "UE Communication" using NWDAF\_AnalyticsSubscription\_Subscribe service operation including the Analytics ID "UE communication", the Target of Analytics Reporting "SUPI", "Internal Group Id" and the Analytics Filter may include one or more "Application Identifier(s)". The PCF is notified on the UE communication statistics or predictions including list of application(s) in use and corresponding characteristics, e.g. start time and duration time. In addition, the confidence of the prediction may be provided.

The NWDAF services to retrieve "UE Communication" analytics are described in clause 6.7.3 of TS 23.288 [24].

- The PCF may subscribe to notifications of network analytics related to "User Data Congestion" using NWDAF\_AnalyticsSubscription\_Subscribe service operation including the Analytics ID "User Data Congestion", the Target of Analytics Reporting containing a SUPI, indication requesting the identifiers of the applications that contribute the most to the traffic and the Analytics Filter may include Area of Interest, reporting threshold and maximum number of applications to be reported. The PCF is notified when the congestion level reaches the threshold. The notification can include the identifiers of the applications that contribute the most to the traffic.

The NWDAF services to retrieve "User Data Congestion" analytics are described in clause 6.8 of TS 23.288 [24].

- The PCF may subscribe to notifications of network analytics related to "Data Dispersion" using NWDAF\_AnalyticsSubscription\_Subscribe service operation including the Analytics ID "UE Dispersion Analytics" and the dispersion analytic (DA) type, i.e. Data or Transactions. The Target of Analytics Reporting containing "SUPI", "Internal Group Id" or "any UE", and the Analytics Filter may include a list of TA(s) or an Area of Interest, or a list of Cells, or an S-NSSAI or top heavy users. With the Data Volume Dispersion Analytics type, the PCF may calculate the average data rate in the network slice by subscribing to notifications

of network analytics related to Data Volume Dispersion in the network slice for a duration of interest when it sets the Target of Analytics Reporting as "any UE" and the Analytics Filter as the S-NSSAI.

The NWDAF services to retrieve "Data Dispersion" analytics are described in clause 6.10 of TS 23.288 [24].

- The PCF may subscribe to notifications of network analytics related to "WLAN performance" using the Nnwdaf\_AnalyticsSubscription\_Subscribe service operation including the Analytics ID "WLAN performance", the Target of Analytics Reporting "SUPI", "Internal Group Id" or "any UE" and the Analytics Filter including the Area of Interest, SSID(s), or BSSID(s). The PCF is notified on the WLAN performance statistics or predictions. In addition, the confidence of the prediction may be provided.

The NWDAF services to retrieve "WLAN performance" analytics are described in clause 6.11 of TS 23.288 [24].

- The PCF may subscribe to notifications of network analytics related to "Session Management Congestion Control Experience" using the Nnwdaf\_AnalyticsSubscription\_Subscribe service operation including the Analytics ID "Session Management Congestion Control Experience", the Target of Analytics Reporting containing "SUPI" and the Analytics Filter may include DNN and/or S-NSSAI. The PCF is notified on the Session Management Congestion Control Experience statistics including the DNN and/or S-NSSAI.

The NWDAF services to retrieve "Session Management Congestion Control Experience" analytics are described in clause 6.12 of TS 23.288 [24].

- The PCF may subscribe to notifications of network analytics related to "DN Performance" using the Nnwdaf\_AnalyticsSubscription\_Subscribe service operation including the Analytics ID "DN Performance", the Target of Analytics Reporting containing "SUPI", "Internal Group Id" or "any UE", and the Analytics Filter may include Application ID(s). The PCF is notified on the DN Performance statistics or predictions including Application ID(s). In addition, the confidence of the prediction may be provided.

The NWDAF services to retrieve "DN Performance" analytics are described in clause 6.14 of TS 23.288 [24].

- The PCF may subscribe to notifications of network analytics related to "Redundant Transmission Experience" using the Nnwdaf\_AnalyticsSubscription\_Subscribe service operation including the Analytics ID "Redundant Transmission Experience", the Target of Analytics Reporting "SUPI", "Internal Group Id" or "any UE" and the Analytics Filter including the Area of Interest, DNN, or S-NSSAI. The PCF is notified on the Redundant Transmission Experience statistics or predictions.

The NWDAF services to retrieve "Redundant Transmission Experience" analytics are described in clause 6.13 of TS 23.288 [24].

- The PCF may subscribe to notifications of network analytics related to "QoS and policy assistance" using the Nnwdaf\_AnalyticsSubscription\_Subscribe service operation including the Analytics ID "QoS and policy assistance", the Target of Analytics Reporting "SUPI", "Internal Group Id" or "any UE", a list of one or more QoS parameter set(s) with the corresponding value(s), the Application ID or SDF template, an optional requested QoE and the Analytics Filter according to clause 6.23.1 of TS 23.288 [24] (e.g. DNN, Area of Interest, S-NSSAI, RAT Type, Frequency, list of analytics subsets that are requested). The PCF is notified on the QoS and policy assistance predictions of the provided QoS parameter set(s). If the requested QoE is provided to the NWDAF, the PCF is only notified on the QoS and policy assistance predictions for the QoS parameter set(s) for which the predicted QoE is equal to or higher than the requested QoE.

The NWDAF services to retrieve "QoS and policy assistance" analytics are described in clause 6.23 of TS 23.288 [24].

In the Analytic filter information of Analytics ID = "Service Experience" in Table 6.4.1-1 of TS 23.288 [24], some of the information is equal to the RSCs in URSP rules, for example, DNN, S-NSSAI, PDU session type, Access type and S-NSSAI. So, the PCF can request the analytic of different combinations of RSC values to NWDAF, and these RSC values can be listed in Analytics Filter Information of Analytics request/subscribe towards NWDAF. And the NWDAF can provide the analytic of these combinations of RSCs to PCF. For example, if the PCF subscribes the Analytics ID = "Service Experience" with analytic filter {DNN1, SSC mode 1}, the NWDAF can provide the analytic of RSC combination of DNN1 + SSC mode 1 to PCF. The PCF can know the performance of each of the RSC combination.

NOTE 1: Care needs to be taken with regards to signalling and processing load caused when requesting analytics targeting "Any UE". A PCF preferably limits the analytics requests to a smaller UE set to reduce the load.

Possible triggers for the PCF to subscribe to analytics information from the NWDAF may include:

- Requests from AF/NEF;
- AM Policy Association establishment or modification request from the AMF;
- UE Policy Association establishment or modification;
- SM Policy Association establishment or modification request from the SMF;
- Notifications received from UDR or CHF on UE subscription change;
- Analytics information received.

The trigger conditions may depend on operator and implementation policy in the PCF. When a trigger condition happens, the PCF may check local configuration or evaluate operator policy to decide if any analytics information is needed and if so, initiate a subscription to the analytics information from the NWDAF directly or via DCCF, if deployed.

The PCF may, upon a request from AF/NEF for negotiation for future background data transfer, subscribe to the network analytics related to "Network Performance" from the NWDAF directly or via DCCF, if deployed to assist in determination of BDT policies as described in clause 6.1.2.4.

The PCF shall, upon a request from AF/NEF for negotiation for Planned Data Transfer with QoS requirements (PDTQ), subscribe to the network analytics related to "Network Performance" or "DN Performance" from the NWDAF directly or via DCCF, if deployed to assist in determination of PDTQ policies as described in clause 6.1.2.7.

The PCF may, upon AM or UE or SM Policy Association establishment or modification request from the AMF or SMF, or based on notifications received from UDR or CHF on UE subscription change, decide that network analytics related to "Abnormal behaviour", "UE Mobility" or "UE Communication" of the UE, "Session Management Congestion Control Experience", "DN Performance", "User Data Congestion" is needed for policy decision and therefore subscribe to notifications of those network analytics from the NWDAF.

The PCF may, upon reception of analytics information, subscribe to other analytics information from the NWDAF directly or via DCCF, if deployed.

The PCF may use the network analytics information as input to its policy decision to apply operator defined actions for session management related policy control (as described in clauses 6.1.3), non-session management related policy control (as described in clause 6.1.2) and network slice related policy control (as described in clause 6.1.4).

In roaming scenarios, the H-PCF may make policy decisions for the outbound roaming UEs based on network analytics provided by the V-NWDAF. The H-PCF performs discovery and selection of an H-NWDAF with roaming exchange capability (i.e. RE-NWDAF) as defined in TS 23.502 [3] and subscribes/unsubscribes to Analytics information from the V-NWDAF via the H-NWDAF as defined in TS 23.288 [24]. The H-PCF may request or subscribe to network analytics related to "Service Experience" or "Load Level Information" of the VPLMN. Based on these analytics, the H-PCF may update the URSP on Network Slice Selection Policy for the UE.

The PCF may, at AM Policy Association establishment or modification, subscribe to network analytics related to "Load Level Congestion" to request load information for the Allowed NSSAI.

Examples of operator policies including network analytics information as inputs for policy decisions included below:

- Based on the "Load Level Information" statistics or predictions of the Network Slice Instance, the PCF may verify if the RFSP index value needs to be modified for a SUPI for which an AM Policy Association is created; this is based on operator policies in the PCF, as defined in clause 6.1.2.1.
- Based on the "Service Experience" statistics or predictions, the PCF may check the 5QI values assigned to the Application, and may use this as input to calculate and update the authorized QoS for a service data flow template.
- The PCF may use the network analytics related to "Network Performance" as input to calculate the background data transfer policies that are negotiated with the ASP, as defined in clause 6.1.2.4.
- The PCF may use the network analytics related to "Network Performance" or "DN Performance", as input to calculate the planned data transfer with QoS requirements policies that are negotiated with the ASP, as defined in clause 6.1.2.7.

- Based on the UE mobility statistics or predictions, the PCF may adjust Service Area Restriction as defined in clause 6.1.2.1.
- The PCF may use the network analytics related to "Unexpected UE location" as input to determine the Service Area Restrictions defined in clause 6.1.2.1, "Suspicion of DDoS attack" or "Too frequent Service Access" to request the SMF to terminate the PDU Session as defined in clause 6.1.3.6, "Wrong destination address" to perform gating of a service data flow as defined in clause 6.1.3.6 and "Unexpected long-live/large rate flows" to perform QoS related policies such as gating or policing as defined in clause 6.2.1.1. Consequently, based on operator policies (that indicate that the PCF should store the subscriber status in the UE/AM/SM context), the PCF may store a Restricted Status for the subscriber in the Data Set "Policy Data" and Data Subset "UE context policy control data" or/and Data Subset "Access and Mobility policy control data" or/and Data Subset "PDU Session policy control data" in the UDR. The Restricted Status contains the reason for that status (i.e. Exception IDs listed in Table 6.7.5.3-3 of TS 23.288 [24]) and the time stamp set to the current time.

NOTE 2: This will allow the PCF for the UE to keep UE/AM context in case of AMF relocation with new PCF or/and in case of a new registration. This will allow the PCF for the PDU Session to keep the SM context in case of a PDU session establishment request. For example, if one or more exceptions (e.g. "Unexpected UE location" or "Suspicion of DDoS attack") are being reported by NWDAF for an individual UE, the current PCF can store a Restricted Status for the subscriber in the UDR along with the reason(s) and a Time stamp. A new PCF after AMF relocation or after a new registration, can automatically restrict the UE accordingly or/and immediately subscribe for the related analytics type at the NWDAF.

Based on operator policies, network conditions and additional reports from NWDAF (e.g. UE moves out of Restricted service area), the PCF may remove the Restricted Status for the subscriber in the UDR for any of the Data Subsets listed above.

- Based on the WLAN performance statistics or predictions, the PCF may update WLANSF as defined in clause 6.1.2.2.1.
- Based on the "User Data Congestion" statistics or predictions including the list of applications contributing the most to the traffic the PCF may perform SM Policy Association modifications to update policies in the SMF for the PDU sessions handling traffic from those applications.
- The PCF may use the network analytics on "Service Experience" for an Application Identifier, "any RAT type" and/or "any Frequency value" to determine the RFSP Index value for running this application, as described in clause 6.1.2.1.
- The PCF may also use the network analytics as input to its policy decision to apply operator defined actions for example for the UE context(s) or PDU Session(s).
- Based on the "Load Level Information" statistics or predictions for network slice(s), the PCF may give priority to consider the network slice(s) with lowest load for an application, and the PCF may update URSP on Network Slice Selection Policy.
- Based on the "Load Level Information" statistics or predictions for network slice(s), the PCF may update the "S-NSSAI availability information" specified in clause 6.5, to indicate that an S-NSSAI is not available and to provide an Alternative S-NSSAI to replace with, this occurs when the Load Level Information reaches a threshold provided by the PCF.
- Based on the "Load Level Information" statistics or predictions for network slice(s), the PCF may update the "S-NSSAI availability information" specified in clause 6.5, to indicate that an S-NSSAI is available again, and to indicate that replacement with the Alternative S-NSSAI does not apply any longer, this occurs when the Load Level Information goes below a threshold provided by the PCF.
- Based on the "UE communication" statistics or predictions, the PCF may consider the DNN in Traffic characterization and associated Traffic Volume, Spatial validity and inactivity time, and the PCF may update URSP on DNN Selection Policy for associated UEs.
- Based on the "Dispersion Analytics" statistics or predictions for Data Volume Dispersion in network slice(s), the PCF may calculate the average data rate in the network slice, and the PCF may update URSP on Network Slice Selection Policy for the associated UEs.
- Based on the "Session Management Congestion Control Experience" statistics for PDU Session(s) associated with corresponding S-NSSAI(s) or DNN for a UE, PCF may give priority to consider the S-NSSAI or the DNN

will be likely to that provide the lowest experience level of Session Management Congestion Control, and then the PCF may update URSP on Network Slice Selection Policy and/or DNN Selection Policy for the UE.

- Based on the "Network Performance" statistics or predictions on gNB status information, gNB resource usage, communication performance and mobility performance in an Area of Interest, the PCF may consider to offload the traffic to non-3GPP access for the number of UEs that are located in that Area of Interest, and the PCF may update URSP on Non-Seamless Offload Policy for associated UEs.
- Based on the "User Data Congestion" statistics or predictions including the list of applications contributing the most to the traffic, the PCF may consider to offload the traffic to non-3GPP access for those applications, and the PCF may update URSP on Non-Seamless Offload Policy for those applications.
- Based on the "DN Performance" statistics or predictions for user plane performance for an application, the PCF may consider the DNN with higher performance, and the PCF may update URSP on DNN Selection Policy for the application.
- Based on the "Redundant Transmission Experience" statistics or predictions, the PCF may update URSP for redundant PDU Sessions as described in clause 5.33.2.1 of TS 23.501 [2], e.g. by modifying the URSP rule for Network Slice Selection and DNN Selection.
- Based on the "Service Experience" statistics or predictions, the PCF may select one or a combination of following: the network slice, the DNN, the PDU Session type, the SSC Mode, the Access Type, as one RSC or a combination of RSCs in URSP rule for an application, and the PCF may also adjust the RSD precedence in URSP in terms of statistics or predictions of the whole RSD (a combination of RSCs) and then the PCF may update URSP on one or several of Network Slice Selection Policy, DNN Selection Policy, PDU Session Type Policy, SSC Mode Selection Policy, Access Type preference and the priority of each RSD.
- The PCF may use the network analytics related to "QoS and policy assistance" as input to determine the QoS parameters to apply for an application or service data flow. The PCF first determines the list of candidate QoS parameters sets and the corresponding value(s) for an application or service flow based on e.g. configuration or operator policies, and then subscribes to QoS and policy assistance information including such list of QoS parameters sets. The NWDAF then provides analytics result including assistance information for every QoS parameters set in the list, including the predicted QoE for every QoS parameter set in the request. The PCF may use this information as input to determine the final set of QoS parameters to apply for an application or service flow, based on operator policies.

Examples of operator policies including combination of multiple network analytics as inputs for policy decisions are included below:

- Based on the notification of application(s) in use, provided by "UE Communication" analytics, the PCF may request the "Service Experience" analytics (optionally per RAT Type and/or per Frequency) for each application in use as defined in the list of examples of operator policies that may include network analytics as input for a policy decision.
- Based on the "User Data Congestion" statistics or predictions, the PCF may further request the NWDAF directly or via DCCF, if deployed, to report the "Data Dispersion Analytics" of either a UE or just the Top Heavy UEs located at the congested area of interest. To mitigate the reported or predicted congestion at the area of interest, the PCF may perform:
  - AM Policy Association modification to update UE-AMBR, RFSP index and/or service area restriction, for those UEs reported as heavy users.
  - SM Policy Association modification to update the policies in the SMF for those UEs reported as heavy users.
  - UE Policy Association establishment/modification: Based on the "Load level information", "Service Experience", "Network Performance", "Abnormal behaviour", "UE Mobility", "UE Communication", "User Data Congestion", "Data Dispersion", "Session Management Congestion Control Experience", "DN Performance", "User Data Congestion" and "WLAN performance" statistics or predictions, the PCF uses analytics results from NWDAF to select proper values of URSP rules provided to UEs.
- Based on the notification of Spatial validity for application(s) in use, provided by "UE Communication" analytics, the PCF may request the "WLAN performance" analytics for the Area of Interest derived from the Spatial validity of "UE Communication" analytics, and the PCF may update URSP on Non-Seamless Offload Policy for associated UEs.

- Based on the "Observed Service Experience" statistics or predictions for an application, and when the PCF determines that the application SLA is not satisfied with the current QoS parameters, the PCF may request the "QoS and policy assistance" to use it as input for the determination of new or updated QoS Parameters to be applied for the application, based on operator policies.

The PCF may, upon UE Policy Association establishment or modification request from the AMF or based on notifications received from UDR or CHF on UE subscription change, subscribe to the analytics ID(s) listed in Table 6.1.1.3-1 from the NWDAF directly or via DCCF, if deployed, to adjust the fields (i.e. RSCs) and the RSD precedence in URSP rules.

**Table 6.1.1.3-1: Network analytics available for generation of each URSP field at the PCF**

URSP field	Analytics ID(s)
<b>Route Selection Components</b>	
S-NSSAI	"Service Experience", "Load level information", "Dispersion Analytics", "Session Management Congestion Control Experience", "Redundant Transmission Experience".
DNN	"Service Experience", "UE Communication", "Session Management Congestion Control Experience", "DN Performance", "Redundant Transmission Experience".
Non-Seamless Offload Indication	"UE Communication", "WLAN performance", "Load level information", "Network Performance", "User Data Congestion".
SSC Mode	"Service Experience".
PDU Session type	"Service Experience".
Access Type Preference	"Service Experience", "WLAN Performance".
<b>Route Selection Validation Criteria</b>	
Time Window	Based on the validity period and spatial validity provided in the Analytics ID(s) used for RSD generation.
Location Criteria	Based on the validity period and spatial validity provided in the Analytics ID(s) used for RSD generation.

#### 6.1.1.4 Policy decisions based on spending limits

Policy decisions based on spending limits is a functionality that allows PCF taking actions related to the status of policy counters that are maintained in the CHF. The CHF in the non-roaming case or the H-CHF in the Home Routed roaming case provides policy counters for spending limits to the (H-)PCF for the PDU Session. The CHF in the non-roaming case or the H-CHF in the roaming case provides policy counters for spending limits to the (H-)PCF for the UE.

In the non-roaming case this functionality is applicable to session management related policy control, access and mobility management related policy control and UE policy control. In the Home Routed roaming case this functionality is applicable only to session management related policies and UE policies. In the local breakout roaming case this functionality is applicable only to UE policies. The PCF determines to enforce SM, UE and/or AM policy based on subscriber spending limits as indicated by Subscriber spending limits control as described in clause 6.2.1.3, respectively.

NOTE: In the context of the above function, UE policy control refers to URSP only.

The PCF for the PDU Session and the PCF for the UE use the CHF selection mechanism defined in TS 23.501 [2] to select the CHF that provides policy counters for spending limits.

If the home operator policies indicate that the same CHF shall be selected by the SMF and the (H-)PCF, the (H-)PCF for the PDU Session shall also provide the selected CHF address(es) and if available, the associated CHF instance ID(s) and/or CHF set ID(s) to the SMF in the PDU Session related policy information, otherwise the PCF for the PDU Session does not provide the selected CHF information to the SMF and the SMF applies the CHF selection mechanisms defined in TS 23.501 [2].

If the home operator policies indicate that the same CHF shall be selected by the PCF for the UE and the AMF, then the PCF for the UE shall also provide the selected CHF address(es) and if available, the associated CHF instance ID(s) and/or CHF set ID(s) to the AMF:

- In the non-roaming case, the access and mobility management related policy information or the UE Policy Association supplementary information is used for passing the above information between the PCF for the UE and the AMF.

- In the roaming case, the UE Policy Association supplementary information is used for passing the above information between the H-PCF for the UE and the AMF via the V-PCF for the UE.

If there is no home operator policy indicating that the same CHF shall be selected by the PCF for the UE and the AMF, then the (H-)PCF for the UE does not provide the selected (H-)CHF information to the AMF and the AMF applies the (H-)CHF selection mechanism defined in TS 23.501 [2].

The identifiers of the policy counters that are relevant for a policy decision in the PCF may be stored in the PCF or possibly in UDR. The PCF is configured with the actions associated with the policy counter status that is received from CHF.

The PCF may retrieve the status of policy counters in the CHF using the Initial or Intermediate Spending Limit Report Retrieval Procedure. The CHF provides the current status of the policy counters to the PCF. The CHF may in addition provide one or more pending statuses for a policy counter together with the time they have to be applied. The PCF shall immediately apply the current status of a policy counter. A pending status of a policy counter shall autonomously become the current status of a policy counter at the PCF when the indicated corresponding time is reached. Subsequently provided information for pending statuses of a policy counter shall overwrite the previously received information.

The PCF may subscribe to spending limit reporting for policy counters from the CHF using the Initial or Intermediate Spending Limit Report Retrieval procedure. If spending limit reporting for a policy counter is enabled, the CHF shall notify the PCF of changes in the status of this policy counter (e.g. daily spending limit of \$2 reached or monthly spending limit of \$60 is reached) and optionally pending statuses of this policy counter together with their activation time (e.g. due to a billing period that will expire at midnight). The PCF may cancel spending limit reporting for specific policy counter(s) using the Intermediate Spending Limit Report Retrieval procedure, or for all policy counter(s) using the Final Spending Limit Report Retrieval procedure.

The PCF uses the status of each relevant policy counter, and optional pending policy counter statuses if known, as input to its policy decision to apply operator defined actions, e.g.:

- change the QoS (e.g. downgrade or upgrade Session-AMBR or UE-AMBR), modify the PCC Rules to apply or remove gating or change charging conditions;
- change the URSP rule (e.g. remove or add an RSD that allows the UE to use a dedicated S-NSSAI and DNN).

The CHF may report to the PCF the removal of the subscriber from the CHF system, and the PCF shall remove all the policy counters of the subscriber accordingly.

If an operator policy indicates that a policy counter and its status should be available for a policy decision before the PCF retrieves the status of the policy counter from the CHF, the PCF stores the policy counter and its status in the UDR at termination of the respective UE Policy Association, AM Policy Association or SM Policy Association, as defined in TS 23.502 [3].

### 6.1.1.5 Policy control decisions based on awareness of URSP rule enforcement

#### 6.1.1.5.1 General

Based on operator policy, the PCF may, together with any other input for PCC decisions (see clause 6.2.1.2), make policy control decisions based on awareness of URSP rule enforcement for an application by using the following mechanisms:

- Policy control decisions based on awareness of URSP rule enforcement with UE assistance: PCF may make policy control decisions based on UE reported Connection Capabilities as illustrated in clause 6.1.1.5.2.
- Policy control decisions based on awareness of URSP rule enforcement without UE assistance: PCF may make policy control decisions without involving UE based on application detection as illustrated in clause 6.1.1.5.3.

The PCF for the UE may adjust the URSP rules when needed, based on the notified URSP rule enforcement information, which may include UE reported Connection Capabilities if available, PDU Session parameters if available, and detected application event if applicable.

The PCF for the PDU Session may generate PCC rules under consideration of the traffic descriptor corresponding to the UE reported Connection Capabilities.

#### 6.1.1.5.2 Policy control decisions based on awareness of URSP rule enforcement with UE assistance

The PCF may obtain UE reporting of URSP rule enforcement as described in clause 6.6.2.4.

Based on the received URSP rule enforcement information, the PCF for the PDU Session may interact with the PCF for the UE as described in clause 4.16.16 of TS 23.502 [3]. The PCF for the UE may adjust the URSP rules based on the notification from the PCF for the PDU Session e.g. when the PCF for the UE determines that the UE does not have up-to-date URSP rules.

NOTE: The PCF can combine UE reporting of URSP rule enforcement with analytics information (see clause 6.1.1.5.3).

#### 6.1.1.5.3 Policy control decisions based on awareness of URSP rule enforcement without UE assistance

The PCF for the UE may subscribe to Analytics ID "PDU Session traffic analytics" described in TS 23.288 [24] for traffic monitoring of known traffic in order to verify the traffic according to provisioned URSP rule(s). If the PCF for the UE is notified by the NWDAF about traffic which is not expected according to any of the URSP rules, the PCF for the UE may adjust the URSP rule(s) related to the unexpected application.

In detail, the PCF for the UE generate the input parameters as described in clause 6.20.1 of TS 23.288 [24] and the NWDAF notifies the unmatched traffic as described in clause 6.20.3 of TS 23.288 [24].

During the request of Analytics ID "PDU Session traffic analytics", the PCF for the UE includes the Traffic Descriptor of the URSP rule(s) in the request of the analytic for the PDU Session(s) of the UE. The PCF sets Analytics Filter Information per Traffic Descriptor of the URSP rules as following:

- Area of Interest as the location of the UE where URSP rule enforcement is monitored;
- S-NSSAI corresponding to a Route Selection Descriptor of the URSP rule;
- DNN corresponding to a Route Selection Descriptor of the URSP rule.

NOTE: It is recommended that the PCF for the UE only subscribes to Analytics ID "PDU Session traffic analytics" for the combinations of DNN and S-NSSAI for which awareness of URSP rule enforcement is required. For all URSP rules which contain such a combination of DNN and S-NSSAI, it is expected that the PCF provides all their traffic descriptors of type IP Descriptor, Domain Descriptor or Application Descriptor (i.e. the Application Identifier corresponding to the Application Descriptor) so that the NWDAF can generate the output based on the information about all available URSP rules for that combination of DNN and S-NSSAI.

### 6.1.2 Non-session management related policy control

#### 6.1.2.1 Access and mobility related policy control

##### 6.1.2.1.1 General

The access and mobility related policy control encompasses the management of service area restrictions, the management of the RFSP Index, the management of the UE-AMBR, the management of the UE Slice-MBR, the slice replacement management and the management of the SMF selection. This clause defines the management of service area restrictions and RFSP Index for a UE registered over 3GPP access. The management of service area restrictions for a 5G-RG or a FN-CRG using W-5GAN are specified in TS 23.316 [27].

The management of service area restrictions enables the PCF of the serving PLMN (e.g. V-PCF in roaming case) to modify the service area restrictions used by AMF as described in clause 5.3.4 of TS 23.501 [2].

A UE's subscription may contain service area restrictions, which may be further modified by PCF based on operator defined policies at any time, either by expanding a list of allowed TAIs or by reducing a non-allowed TAIs or by increasing the maximum number of allowed TAIs. Operator defined policies in the PCF may depend on input data such as UE location, time of day, information provided by other NFs such as an AF request to change the service coverage, network analytics from NWDAF, etc.

The AMF may report the subscribed service area restrictions received from UDM during Registration procedure or when the AMF changed, the conditions for reporting are that local policies in the AMF indicate that access and mobility related policy control is enabled. The AMF reports the subscribed service area restrictions to the PCF also when the policy control request trigger for service area restrictions changes, as described in clause 6.1.2.5, is met. The AMF receives the modified service area restrictions from the PCF. The AMF stores them and then uses it to determine mobility restriction for a UE. The PCF may indicate to the AMF that there is an unlimited service area.

The service area restrictions consist of a list of allowed TAI(s) or a list of non-allowed TAI(s) and optionally the maximum number of allowed TAIs.

NOTE 1: The enforcement of the service area restrictions is performed by the UE, when the UE is in CM-IDLE state or in CM-CONNECTED state when in RRC Inactive, and in the RAN/AMF when the UE is in CM-CONNECTED state.

The management of the RFSP Index enables the PCF to modify the RFSP Index used by the AMF to perform radio resource management functionality as described in clause 5.3.4 of TS 23.501 [2]. The PCF may determine to modify the RFSP Index at any time based on operator policies that take into consideration e.g. accumulated usage, load level information per network slice instance, the indication that high throughput is desired for a specific application traffic or independently of the application in use and other information described in clause 6.1.1.3. If the modified RFSP index value indicates that EPC/E-UTRAN access is prioritized over the 5G access for the UE, the PCF may, based on operator policy, include a RFSP Index in Use Validity Time of the RFSP Index.

The determination of the RFSP Index value requires to configure the PCF with the mapping of RAT Type and/or Frequency value to the RFSP Index that will be sent to RAN.

Operator policies in the PCF may modify the RFSP index based on the Allowed NSSAI, Target NSSAI, Partially Allowed NSSAI, S-NSSAI(s) rejected partially in the RA, rejected S-NSSAI(s) for the RA, Alternative S-NSSAI(s) mapped to some Replaced S-NSSAI(s) or Pending NSSAI as defined in clause 5.15 of TS 23.501 [2].

Operator policies in the PCF may determine that the access and mobility related policy information (e.g. RFSP index value or service area restrictions) can change at the start and stop of an application traffic detection, at the start and stop of a SM Policy Association to a DNN and S-NSSAI, or immediately. In the former case, the PCF subscribes to the SMF for application traffic detection as described in clause 6.2.2.5. In addition, when the PCF evaluates that the access and mobility related policy information need any changes, the PCF reports it to the AF if the AF has subscribed to the notification on outcome of service area coverage change as defined in clause 6.1.3.18.

Operator policies in the PCF may determine that the access and mobility related policy information (e.g. RFSP index value or service area restrictions) can change based on the Spending Limits information from CHF as defined in clause 6.1.1.4.

Operator policies in the PCF may determine that the access and mobility related policy information can change based on the Energy Saving Indicator received from the AMF as described in clause 5.51.6 of TS 23.501 [2].

For radio resource management, the AMF may report the subscribed RFSP Index received from UDM during the Registration procedure or when the AMF changed. The conditions for reporting are that local policies in the AMF indicate that access and mobility related policy control is enabled. The AMF reports the subscribed RFSP Index to the PCF when the subscription to the RFSP Index change to the PCF is met. The AMF receives the modified RFSP Index from the PCF.

NOTE 2: The enforcement of the RFSP Index is performed in the RAN.

Upon change of AMF, the source AMF informs the PCF that the UE context was removed in the AMF in the case of inter-PLMN mobility.

The management of UE-AMBR enables the PCF to provide the UE-AMBR information to the AMF based on serving network policy. The AMF may report the subscribed UE-AMBR received from UDM. The conditions for reporting are that the PCF provided Policy Control Request Triggers the AMF to report subscribed UE-AMBR. The AMF receives the modified UE-AMBR from the PCF. The AMF provides a UE-AMBR value of the serving network to the RAN as specified in clause 5.7.2.6 of TS 23.501 [2].

The management of the SMF selection enables the PCF to instruct the AMF to contact the PCF during the PDU Session Establishment procedure to perform a DNN replacement, as specified in clause 5.6.1 of TS 23.501 [2]. To indicate the conditions to check whether to contact the PCF at PDU Session establishment (as specified in clause 6.1.2.5), the PCF provides the Policy Control Request Triggers SMF selection management and, if necessary Change of the Allowed

NSSAI, together with SMF selection management related policy information (see clause 6.5) during UE Registration procedure and at establishment of the AM Policy Association.

The PCF may update the SMF selection management information based on a PCF local decision or upon being informed about a new Allowed NSSAI. The AMF applies the updated SMF selection management information to new PDU Sessions only, i.e. already established PDU Sessions are not affected.

The management of the slice replacement enables the PCF to instruct the AMF to contact the PCF to provide the Alternative S-NSSAI for each S-NSSAI that requires slice replacement as specified in clause 5.15.19 of TS 23.501 [2]. The AMF reports S-NSSAI(s) of the serving network that requires slice replacement. The conditions for reporting are defined in clause 6.1.2.5. The PCF returns the Alternative S-NSSAI for the S-NSSAI of the serving network received from the AMF. The AMF receives the Alternative S-NSSAI for each S-NSSAI that requires slice replacement for which it has provided to the PCF.

If the AMF has indicated support of the Network Slice Replacement for the UE and the PCF detects the change in the availability of the S-NSSAI in the Allowed NSSAI or Partially Allowed NSSAI (i.e. the S-NSSAI becomes unavailable or available) based on a PCF local decision (e.g. based on OAM or NWDAF analytics output), the PCF notifies the S-NSSAI availability information (see clause 6.5) based on the implicit subscription from the AMF. The AMF may also interact with the PCF to determine the Alternative S-NSSAI for S-NSSAI to be replaced based on Policy Control Request Triggers as defined in clause 6.1.2.5.

The PCF may receive AF triggered network slice replacement requirement from the AF, NEF, or UDR including the Replaced S-NSSAI and the corresponding Alternative S-NSSAI and optional policy duration parameter that indicates when to terminate the network slice replacement. Based on the implicit subscription from the AMF, the PCF notifies the AMF with the Slice replacement management information policy including the Replaced S-NSSAI, the corresponding Alternative S-NSSAI and a Network Slice Replacement Type with the Type set to AF initiated (see clause 6.5 and clause 5.15.5.2.2a of TS 23.501 [2]). Similarly, the PCF may receive AF request to terminate the network slice replacement to use the Replaced S-NSSAI instead of the Alternative S-NSSAI for a UE again. The PCF triggers the termination of the network slice replacement for the UE from the Alternative S-NSSAI back to the Replaced S-NSSAI, including a Network Slice Replacement Type, to the AMF (see clause 5.15.5.2.2a of TS 23.501 [2]).

The optional management of UE-Slice-MBR enables the PCF to modify the value in the list of Subscribed UE-Slice-MBR assigned to a SUPI based on serving network policies, if the HPLMN permits based on roaming agreement. The AMF reports the Subscribed UE-Slice-MBR for each S-NSSAI of the serving network. The S-NSSAI of the VPLMN is derived from the Subscribed S-NSSAI by the AMF and provided to the PCF. The AMF may provide the Subscribed S-NSSAI together with the S-NSSAI of the VPLMN. The conditions for reporting are defined in clause 6.1.2.5. The PCF returns the authorized UE-Slice-MBR for the S-NSSAI of the serving network. The AMF receives the authorized list of UE-Slice-MBR value for each S-NSSAI for which it has provided the Subscribed UE-Slice-MBR from the PCF. Then the AMF provides the authorized list of UE-Slice-MBR for the S-NSSAIs in the Allowed S-NSSAI to the RAN as specified in clause 5.7.1.10 of TS 23.501 [2].

The optional management of 5G access stratum time distribution enables the PCF for the UE to instruct the AMF about the 5G access stratum time distribution parameters, i.e. 5G access stratum time distribution indication (enable, disable). Optionally, when 5G access stratum time distribution or (g)PTP time synchronization is enabled, the PCF for the UE instructs the AMF about the Uu Time synchronization error budget. Optionally, when 5G access stratum time distribution is enabled, the PCF for UE instructs the AMF about the clock quality reporting control information (clock quality detail level, clock quality acceptance criteria).

In the case that the PCF for the UE (providing the access and mobility related policy information) and the PCF for the PDU Session of this UE (providing the Session Management related policies) are separate PCF instances, the following applies:

- If the PCF for the UE determines that the access and mobility related policy information can change at the start and stop of an application traffic detection, the following applies:
  - The PCF for the UE may subscribe to be notified when a PCF for the PDU Session is serving a DNN and S-NSSAI for a SUPI, this is achieved by either:
    - a subscription request to be notified about the PCF binding information when a PCF for the PDU Session (of this UE) registers in the BSF, the PCF for the UE includes the SUPI, DNN, S-NSSAI in the subscription request to BSF. The DNN, S-NSSAI is either provided by the AF or locally configured in the PCF for certain Application Identifier(s).

- Or the PCF for the PDU Session of this UE is to request the AMF to send to the PCF for the PDU Session of the DNN, S-NSSAI, via SMF, the PCF binding information (i.e. address(es) of PCF for the UE, instance id of PCF for the UE). In detail, the PCF for the UE provides its PCF binding information to the AMF together with DNN, S-NSSAI and Request for notification of SM Policy Association establishment and termination and the AMF will then forward the PCF binding to the SMF for every PDU Session with this DNN and S-NSSAI. In this case, the PCF for the PDU Session shall be notified via Request for reporting the PCF binding information Policy Control Request Trigger as described in clause 6.1.3.5.

In both cases above, the DNN, S-NSSAI is either provided by the AF or locally configured in the PCF for certain Application Identifier(s).

- When the PCF for the UE is notified that PCF for the PDU Session is registered, either via the BSF that provides the UE address, DNN and the PCF address, PCF instance Id and PCF set id if available or via PCF for the PDU Session when it received PCF binding information from the SMF. The PCF for the UE may subscribe to the "start/stop of application traffic detection" event defined in clause 6.1.3.18 or trigger a policy decision if there is a SM Policy Association to the DNN, S-NSSAI.
- The reporting of "start/stop of application traffic detection" to the PCF for the UE is used as input for a policy decision to change the access and mobility related policy information.

NOTE 3: The PCF for the UE may subscribe to the notifications of newly registered PCF for the PDU Session and subscribe to the "start/stop of application traffic detection" events for multiple applications with different application identifiers. When PCF receives the notifications for multiple applications, the PCF for the UE can determine which access and mobility related policy information to apply based on local configuration and operator policy.

- If the PCF for the UE determines that the access and mobility related policy information can change at the establishment and termination of a SM Policy Association to a DNN and S-NSSAI base on the notification sent by the BSF, the PCF may indicate to the BSF to report the registration of a PCF for the PDU Session when the first SM Policy Association is established and the deregistration of the PCF for the PDU Session when the last SM Policy Association is terminated for a DNN, S-NSSAI.
- The PCF for the UE checks if an AF is subscribed to be notified on outcome of service area coverage change, using the related event defined in clause 6.1.3.18.

#### 6.1.2.1.2 Handling of the AM Policy Association

In the non-roaming scenario, the establishment of the AM Policy Association is determined as follows. First, the AMF checks the AM Policy Association indicator received from UDM and establishes the AM Policy Association if its value is "enabled" and do not establish the AM Policy Association if its value is "disabled". If no AM Policy Association indicator is received from the UDM then the AMF determines whether to establish the AM Policy Association or not according to local configuration.

In the roaming scenario, only the AMF local configuration is considered for the determination of the establishment of the AM Policy Association.

NOTE 1: In roaming, the AMF does not consider the value of the AM Policy Association indicator, if received.

The AM Policy Association indicator for a SUPI is part of Access and Mobility Subscription data in UDM as described in clause 5.2.3.3.1 of TS 23.502 [3] and can be set by the operator to "enabled" or "disabled".

NOTE 2: The operator can set the AM Policy Association indicator to "enabled" when it is required to provide AM Policies to the AMF or to "disabled" when there is no AM Policies to be provided to the AMF.

NOTE 3: A possible reason to set the AM Policy Association indicator to "enabled" is that either there are "AM influence information" for e.g. a SUPI in UDR or AM Policies are available for e.g. a SUPI provisioned in the PCF. The "AM influence information" is not provided to the AMF when the AM Policy Association Indicator is set to "disabled".

## 6.1.2.2 UE policy control

### 6.1.2.2.1 General

The 5GC shall be able to provide policy information from the PCF to the UE. Such UE policy information includes:

- 1) Access Network Discovery & Selection Policy (ANDSP): It is used by the UE for selecting non-3GPP accesses and for selection of the N3IWF in the PLMN. The structure and the content of this policy are specified in clause 6.6.1.
- 2) UE Route Selection Policy (URSP): This policy is used by the UE to determine if a detected application or a PIN:
  - can be associated to an established PDU Session; or
  - can be offloaded to non-3GPP access outside a PDU Session; or
  - can be routed via a ProSe Layer-3 UE-to-Network Relay outside a PDU session; or
  - multi-path communication via 5G ProSe Layer-3 UE-to-Network Relay outside of a PDU session and over Uu reference point or either path; or
  - can trigger the establishment of a new PDU Session.

The structure and the content of this policy are specified in clause 6.6.2. A URSP rule includes one Traffic descriptor that specifies the matching criteria and one or more of the following components:

2a) SSC Mode Selection Policy (SSCMSP): This is used by the UE to associate the matching application/PIN with SSC modes.

2b) Network Slice Selection Policy (NSSP): This is used by the UE to associate the matching application/PIN with S-NSSAI.

2c) DNN Selection Policy: This is used by the UE to associate the matching application/PIN with DNN.

2d) PDU Session Type Policy: This is used by the UE to associate the matching application/PIN with a PDU Session Type.

2e) Non-Seamless Offload Policy: This is used by the UE to determine that the matching application/Connectivity Group should be non-seamlessly offloaded to non-3GPP access (i.e. outside of a PDU Session).

2f) Access Type preference: If the UE needs to establish a PDU Session for the matching application/PIN, this indicates the preferred Access Type (3GPP or non-3GPP or Multi-Access).

NOTE 1: The Access Type of 3GPP also includes the use of ProSe UE-to-Network Relay access as defined in TS 23.304 [34].

2g) ProSe Layer-3 UE-to-Network Relay Offload Policy: This is used by the UE to determine if the matching application should be routed via a ProSe Layer-3 UE-to-Network Relay outside of a PDU Session. If this indication is not present the traffic shall not be routed via a ProSe Layer-3 UE-to-Network Relay outside of a PDU Session.

2h) PDU Session Pair ID: If the UE needs to establish a PDU Session for the matching application, this indicates PDU Sessions with same PDU Session Pair ID are paired for redundant transmission.

2i) RSN: If the UE needs to establish a PDU Session for the matching application, this indicates RSN for redundant transmission.

2j) ProSe Multi-path Preference: It indicates to UE whether a matching application is preferred to be routed via multipath (i.e. via a PDU Session over Uu reference point and via ProSe Layer-3 UE-to-Network Relay outside of a PDU Session).

3) V2X Policy (V2XP): This policy provides configuration parameters to the UE for V2X communication over PC5 reference point or over Uu reference point or both. V2X Policies are defined in clause 5.1.2.1 and clause 5.1.3.1 of TS 23.287 [28].

- 4) ProSe Policy (ProSeP): This policy provides configuration parameters to the UE for ProSe features as defined in clauses 5.1 of TS 23.304 [34].
- 5) Ranging/Sidelink Positioning Policy (RSLPP): This policy provides configuration parameters to the UE for Ranging/Sidelink Positioning control. Ranging/Sidelink Positioning Policies are defined in clause 5.1 of TS 23.586 [41].
- 6) A2X Policy (A2XP): This policy provides configuration parameters to the UE for A2X communication over PC5 reference point or over Uu reference point or both. A2X Policies are defined in clauses 6.2.1.2.1 and 6.2.1.3.1 of TS 23.256 [43].

The ANDSP and URSP may be pre-configured in the UE or may be provisioned to UE from PCF. The pre-configured policy shall be applied by the UE only when it has not received the same type of policy from PCF.

The methods of configuring V2XP to the UE, including (pre-) configuration and provisioning, and the priority of the same type of parameters acquired from different sources are defined in clause 5.1.1 of TS 23.287 [28].

The methods of configuring ProSeP to the UE, including (pre-)configuration and provisioning, and the priority of the same type of parameters acquired from different sources are defined in clause 5.1.1 of TS 23.304 [34].

The methods of configuring A2XP to the UE, including (pre-) configuration and provisioning, and the priority of the same type of parameters acquired from different sources are defined in clause 4.2.1.2.2 of TS 23.256 [43].

The methods of configuring RSLPP to the UE, including (pre-) configuration and provisioning, and the priority of the same type of parameters acquired from different sources are defined in clause 5.1.1 of TS 23.586 [41].

The ANDSP policy, V2X Policy, ProSe Policy (ProSeP), A2X Policy (A2XP) and Ranging/Sidelink Positioning Policy (RSLPP) are not applicable to any of 5G-RG, FN-RG and AUN3 devices. The ProSe Layer-3 UE-to-Network Relay Offload Policy, PDU Session Pair ID, RSN and ProSe Multi-path Preference components of the Route Selection descriptor are not applicable to 5G-RG, FN-RG and AUN3 devices.

The PCF selects the UE policy information applicable for each UE based on local configuration, operator policies taking into consideration the information defined in clause 6.2.1.2 and the PCF determines the URSP Rules for the UE using input from NWDAF as one of the inputs.

In the case of a roaming UE, the V-PCF may retrieve UE policy information from the H-PCF over N24/Npcf. When the UE is roaming and the UE has valid rules from both HPLMN and VPLMN, the UE gives priority to the valid ANDSP rules from the VPLMN.

In the case of a roaming UE, the V-PCF or UDR may provide the application guidance on VPLMN specific URSP determination to the H-PCF as defined in clause 4.15.6.10 of TS 23.502 [3] and clause 6.1.2.2.4. The H-PCF is required to generate VPLMN specific URSP rule(s) and provide the URSP rules to the UE. This can be triggered by the UE's registration in the VPLMN or it can happen before UE roams into the VPLMN. The URSP Rules received by UE for a VPLMN are only applicable when the UE is registered in that VPLMN or its equivalent VPLMNs. If a UE does not indicate support for VPLMN specific URSP rules, the H-PCF may still trigger an update of the UE's URSP Rules, which may be based on the application guidance from the VPLMN or HPLMN, upon receiving a notification that the UE has registered in the VPLMN.

The UE policy information shall be provided from the PCF to the AMF via N15/Namf interface and then from AMF to the UE via the N1 interface as described in clause 4.2.4.3 of TS 23.502 [3]. The AMF shall not change the UE policy information provided by PCF.

The PCF is responsible for delivery of UE policy. If the PCF is notified about UE policy information delivery failure (e.g. because of UE unreachable), the PCF may provide a new trigger "Connectivity state changes" in Policy Control Request Trigger of UE Policy Association to AMF as defined in clause 4.16.12.2 of TS 23.502 [3]. After reception of the Notify message indicating that the UE enters the CM-Connected state, the PCF may retry to deliver the UE policy information.

NOTE 2: For backward compatibility the PCF may subscribe the "Connectivity state changes (IDLE or CONNECTED)" event in Rel-15 AMF as defined in clause 5.2.2.3 of TS 23.502 [3].

If due to UE Local Configurations, a UE application requests a network connection using Non-Seamless Offload or ProSe Layer-3 UE-to-Network Relay Offload, the UE shall use Non-Seamless Offload for this application without evaluating the URSP rules. Otherwise, the UE shall select the PDU Session or Non-Seamless Offload in the following order:

- If the UE has an URSP rule (except the URSP rule with the "match all" Traffic descriptor) that matches the application as defined in clause 6.6.2.3, the UE shall perform the association of the application to the corresponding PDU Session or to Non-Seamless Offload or ProSe Layer-3 UE-to-Network Relay Offload according to this rule; Otherwise,
- If no URSP rule is applicable for the application (except the URSP rule with the "match all" Traffic descriptor), the UE shall perform the association of the application to a PDU Session according to the applicable UE Local Configurations, if any. If the UE attempts to establish a new PDU Session according to the UE Local Configurations and this PDU Session Establishment request is rejected by the network, then the UE shall perform the association of the application to a PDU Session or to Non-Seamless Offload or ProSe Layer-3 UE-to-Network Relay Offload according to the URSP rule with the "match all" Traffic descriptor; Otherwise,

NOTE 3: It is assumed that the S-NSSAI(s) in the UE Local Configurations are operator-provided S-NSSAI(s). The provision of the S-NSSAI(s) is not specified.

NOTE 4: The application layer is not allowed to set the S-NSSAI when the UE establishes a PDU Session based on the UE Local Configurations.

NOTE 5: Any missing information in the UE Local Configurations needed to build the PDU Session Establishment request can be the appropriate corresponding component from the URSP rule with the "match all" Traffic descriptor.

- If neither the UE Local Configurations nor the URSP rules are applicable for the application (except the URSP rule with the "match all" Traffic descriptor), the UE shall perform the association of the application to a PDU Session or to Non-Seamless Offload or ProSe Layer-3 UE-to-Network Relay Offload according to the URSP rule with the "match all" Traffic descriptor.

NOTE 6: The UE evaluates both VPLMN and non-VPLMN specific URSP Rules as defined in clause 6.6.2.3.

For the existing PDU Session(s), the UE shall examine the URSP rules within the UE policy information in order to determine whether the existing PDU Session(s) (if any) are maintained or not. If not, then the UE may initiate a PDU Session release procedure for the PDU Session(s) that cannot be maintained.

If there are multiple IPv6 prefixes within the PDU Session, then the IPv6 multi-homed routing rules, described in clause 5.8.2.2.2 in TS 23.501 [2], on the UE shall be used to select which IPv6 prefix to route the traffic of the application.

NOTE 7: For the case that an application cannot be associated to any PDU Session, the UE can inform the application that association of the application to PDU Session fails.

The PCF may subscribe to analytics on "WLAN performance" from NWDAF following the procedures and services described in TS 23.288 [24]. When the PCF gets a notification from the NWDAF, the PCF may try to update WLANSF rules.

The PCF may use Spending Limits information from the CHF to decide whether to install, update or delete URSP rules, as defined in clause 6.1.1.4.

The definition of UE policy control for 5G-RG, FN-RG and AUN3 devices is specified in TS 23.316 [27]

#### 6.1.2.2.2 Distribution of the policies to UE

The UE policy control enables the PCF to provide UE access selection related policy information, PDU Session related policy information, V2X Policy information, ProSe Policy information, A2X Policy information and Ranging/Sidelink Positioning Policy information to the UE, i.e. UE policies, that includes Access network discovery & selection policy (ANDSP) or UE Route Selection Policy (URSP) or V2X Policy (V2XP) or ProSe Policy (ProSeP) or A2X Policy (A2XP) or Ranging/Sidelink Positioning Policy (RSLPP) or their combinations using Npcf and Namf service operations.

The PCF may be triggered to provide the UE policy information during UE Policy Association Establishment and UE Policy Association Modification procedures as defined in clause 4.16.11 and clause 4.16.12 of TS 23.502 [3].

NOTE 1: The PCF can install a PCC Rule and activate start and stop of application detection in the SMF. When the same PCF is selected for SM Policy Association control and UE Policy Association control, the reporting of start and stop of an application can trigger the installation or update of a URSP rule in the UE to send the application traffic to the PDU Session as defined in the URSP rule.

NOTE 2: The PCF can subscribe to the UDR on service specific information change, which will be taken into consideration by the PCF to determine the updated V2XP, ProSeP, A2XP and RSLPP as defined in clause 4.15.6.7 of TS 23.502 [3].

Operator defined policies in the PCF may depend on input data such as UE location, time of day, information provided by other NFs, etc. as defined in clause 6.2.1.2.

The PCF includes the UE policy information delivered to the UE into a Policy Section identified by a Policy Section Identifier (PSI). The PCF may divide the UE policy information into different Policy Sections, each one identified by a PSI. Each Policy Section provides a list of self-contained UE policy information to the UE, via AMF. The PCF ensures that a Policy Section is under a predefined size limit, known by the PCF.

NOTE 3: The size limit to allow the policy information to be delivered using NAS transport is specified in TS 29.507 [13]. The size limit is configured in the PCF.

A list of self-contained UE policy information implies that:

- when the PCF delivers URSP rules to the UE, the PCF provides the list of URSP rules in the order of precedence and without splitting a URSP rule across Policy Sections;
- when the PCF delivers V2XP to the UE, the PCF provides the list of V2XP in the order of precedence and without splitting a V2XP across Policy Sections;
- when the PCF delivers ProSeP to the UE, the PCF provides the list of ProSeP in the order of precedence and without splitting a ProSeP across Policy Sections;
- when the PCF delivers A2XP to the UE, the PCF provides the list of A2XP in the order of precedence and without splitting a A2XP across Policy Sections;
- when the PCF delivers RSLPP to the UE, the PCF provides the list of RSLPP in the order of precedence and without splitting a RSLPP across Policy Sections;
- when the PCF delivers WLANSP rules, the list of WLANSP rules are provided in the order of priority and without splitting a WLANSP rule across Policy Sections;
- when the PCF delivers the non-3GPP access network selection information, the whole list of non-3GPP access network selection information (as defined in clause 6.6.1.1) is provided in one Policy Section.

It is up to PCF decision how to divide the UE policy information into Policy Sections as long as the requirements for the predefined size limit and the self-contained content (described above) are fulfilled.

NOTE 4: The Policy Section list can be different per user. One PSI and its corresponding content can be the same for one or more users.

NOTE 5: The PCF may, for example, assign the URSP as one whole Policy Section, or it may subdivide the information in the URSP into multiple Policy Sections by assigning one or several URSP rules to each Policy Section.

The PLMN ID is provided to the UE together with UE policy information and it is used to indicate which PLMN a Policy Section list belongs to.

NOTE 6: If an operator uses multiple PLMN IDs then it is assumed that the above PLMN ID matches the SUPI of the UE.

The AMF forwards the UE policy information transparently to the UE. If the (H-)PCF decides to split the UE policies to be sent to the UE, the PCF provides multiple Policy Sections separately to the AMF and then AMF uses UE configuration Update procedure for transparent UE policies delivery procedure to deliver the policies to the UE, this is defined in clauses 4.2.4.3 and 4.16 of TS 23.502 [3].

NOTE 7: The AMF does not need to understand the content of the UE policy, rather send them to the UE for storage.

The UE shall update the stored UE policy information with the one provided by the PCF as follows (details are specified in TS 24.501 [22]):

- If the UE has no Policy Sections with the same PSI, the UE stores the Policy Section;
- If the UE has an existing Policy Section with the same PSI, the UE replaces the stored Policy Section with the received information;
- The UE removes the stored Policy Section if the received information contains only the PSI.

The UE keeps the received UE policies stored even when registering in another PLMN. The number of UE policies to be kept stored in the UE for PLMNs other than the HPLMN is up to UE implementation. If necessary, e.g. the number of UE policies stored in UE for PLMNs exceeds the maximum value, the UE may remove earlier stored UE policy in UE.

NOTE 8: For aspects related to URSP rules for an SNPN-enabled UE, please refer to clause 6.6.2.2.2.

The ANDSP for VPLMN, if provided within the UE policy in the UE Configuration Update procedure described in clause 4.2.4.3 of TS 23.502 [3], applies to the equivalent PLMN(s) indicated in the last received list of equivalent PLMNs in Registration Accept.

At Initial Registration or the Registration to 5GS when the UE moves from EPS to 5GS, the UE provides the UE Policy Container including one or more of the following information:

- The UE provides the list of stored PSIs which identify the Policy Sections associated to the home PLMN and the visited PLMN (if the UE is roaming) that are currently stored in the UE. If USIM is changed, the UE does not provide any PSI. If no policies are stored in the UE for the home PLMN, the UE does not provide any PSI associated to the home PLMN. If the UE is roaming and has policies for the home PLMN but no associated policies for the visited PLMN the UE includes only the list of PSIs associated to the home PLMN.
- UE may indicate its ANDSP support to the PCF. If it is received, the PCF shall take it into account for the determination on whether to provide the ANDSP to the UE. The PCF does not provide ANDSP rules to the UE if the UE does not indicate support for ANDSP.

NOTE 9: In the roaming scenario, during AMF relocation with V-PCF change, if the H-PCF does not provide the Indication of UE support for ANDSP, then the behaviour of V-PCF to determine whether to provide ANDSP rules to the UE is implementation specific.

- The UE may also provide the OSId.
- The UE may indicate whether it supports the URSP Provisioning when attached in EPS. The PCF for the UE stores it at the UDR, see clause 6.2.1.3.
- UE may indicate its capability of reporting URSP rule enforcement to network to the PCF. If it is received, the PCF shall take it into account as described in clause 6.6.2.4.
- The UE may indicate whether it supports VPLMN specific URSP rules.

The UE may trigger an Initial registration with the list of stored PSIs to request a synchronization for example if the UE powers up without USIM being changed.

During Initial Registration, the (H-)PCF retrieves the list of PSIs and its content stored in the (H-)UDR for this SUPI while the V-PCF (in the roaming scenario) retrieves the list of PSIs and its content stored in the V-UDR for the PLMN ID of this UE (alternatively, the V-PCF can have this information configured locally).

NOTE 10: The PSI list and content stored/configured for a PLMN ID can be structured according to e.g. location areas (e.g. TAs, PRAs). The V-PCF can then provide PSIs and its content only if they correspond to the current UE location.

In the roaming scenario, the V-PCF shall also forward any UE provided PSIs that are associated to the home PLMN to the H-PCF.

When the PCF (i.e. the (H-)PCF as well as the V-PCF) receives a list of PSIs associated to the PLMN of the PCF from the UE, the PCF compares the list of PSIs provided by the UE and the list of PSIs retrieved from the UDR. In addition, the PCF checks whether the list of PSIs provided by the UE or its content needs to be updated according to operator policies, e.g. change of Location and/or time. If the two lists of PSIs are different or an update is necessary according to

operator policies (which includes the case that the UE did not provide a list of PSIs associated to the PLMN of the PCF), the PCF provides the changes in the list of PSIs or the corresponding content to the AMF which forwards them to the UE.

The (H-)PCF maintains the latest list of PSIs delivered to each UE as part of the information related to the UE Policy Association until the UE Policy Association termination request is received from the AMF. Then the (H-)PCF stores the latest list of PSIs and its contents in the (H-)UDR using the Nudr\_DM\_Update including DataSet "Policy Data" and Data Subset "Policy Set Entry".

The (H-)PCF may use the PEI provided by the AMF and/or the OSId provided by the UE, to determine the operating system of the UE.

If the PEI, the OSId or the indication of UE support for ANDSP is available to the (H-)PCF, the (H-)PCF stores them in the (H-)UDR using Nudr\_DM\_Create including DataSet "Policy Data" and Data Subset "UE context policy control data" when such information is received from the UE in the UE Policy Container.

If the (H-)PCF is not able to determine the operating system of the UE, and if the (H-)PCF requires to deliver URSP rules that contain Application descriptors as Traffic Descriptors, then the Traffic Descriptors of such URSP rules include multiple instances of Application descriptors each associated to supported UE operating systems by the network operator implementation.

If the (H-)PCF determines the operating system of the UE and if the (H-)PCF requires to deliver URSP rules that contain Application descriptors as Traffic Descriptors, then the Traffic Descriptors of such URSP rules include the Application descriptors associated with the operating system determined by the PCF.

NOTE 11: If the PCF does not take into account the received PEI and/or OSId then the PCF can send URSP rules containing application traffic descriptors associated to multiple operating systems.

When the PCF determines to provision VPLMN specific URSP rules to the UE (as described in clause 6.1.2.2.4) the PCF provides the URSP rules to be applied in VPLMN in specific Policy Section(s) identified by corresponding PSIs. Such Policy Section(s) do not include any non-VPLMN specific URSP rules. The PCF also provides to the UE the tuple (PLMN ID, list of PSIs of the Policy Sections containing URSP rules to be applied at specific VPLMN). The PCF may indicate the UE to add a new tuple(s), to update a stored tuple(s) or to remove a stored tuple(s), then the UE stores, updates, or removes the tuples as requested by the PCF (details are specified in TS 24.501 [22]). In roaming scenarios, the H-PCF provides this information via V-PCF. The PCF may provide, at any time, the full list of tuples (VPLMN ID(s), list of PSIs associated with the VPLMN ID) to the UE, and then the UE replaces any stored list of tuples with the new list of tuples provided by the PCF.

After Registration procedure, the UE may perform UE triggered V2X Policy Provisioning procedure to request V2XP from the PCF as specified in clause 6.2.4 of TS 23.287 [28].

After Registration procedure, the UE may perform UE triggered 5G ProSe Policy Provisioning procedure to request ProSeP from the PCF as specified in clause 6.2.4 of TS 23.304 [34].

After Registration procedure, the UE may perform UE triggered A2X Policy Provisioning procedure to request A2XP from the PCF as specified in clause 6.3.2.3 of TS 23.256 [43].

After Registration procedure, the UE may perform UE triggered Ranging/Sidelink Positioning Policy Provisioning procedure to request RSLPP from the PCF as specified in clause 6.2.4 of TS 23.586 [41].

### 6.1.2.2.3 URSP rule provisioning in EPS

When a UE attaches initially in EPS and PDN connectivity request message is sent together with initial attach request, or the UE requested PDN connectivity procedure is performed for the first PDN connection or when the UE handovers from 5GS to EPS, PCF for the UE may need to update the URSP rules in the UE:

- During Initial attach procedure in EPS due to for example:
  - New application guidance on URSP determination request applicable to the UE was sent by an AF (see clause 4.15.6.10 of TS 23.502 [3]) while the UE is deregistered and prior to the EPC attach procedure, so the corresponding URSP rules were not delivered yet to the UE.
  - Operator policies configured with time, location or any other condition are met when the UE attaches to EPC, implying new or updated URSP rules apply under those conditions.

- Operator policies for determining URSP rules were updated by the operator while the UE is deregistered and prior to the EPC attach procedure, so the corresponding URSP rules were not delivered yet to the UE.
- At any time a URSP rule is changed while the UE is registered in EPC (coming from EPS initial attachment or after handover from 5GS) due to for example:
  - New application guidance on URSP determination request applicable to the UE is sent by an AF (see clause 4.15.6.10 of TS 23.502 [3]).
  - Due to time, location change or other network condition the PCF for the UE determines that an operator policy configured for the operator for URSP determination applies in the new network conditions, implying new or updated URSP rules apply to the UE.

How the UE associates application traffic to PDN Connections is described in clause 4.4.2 of TS 24.526 [19]. When the UE is attached to EPS, only the non-VPLMN specific URSP Rules are used to associate applications to PDN Connections at the UE.

#### 6.1.2.2.4 Distribution of VPLMN specific URSP rules to the UE

The H-PCF may provision VPLMN specific URSP Rules to UE for the purpose of routing traffic to the VPLMN. The H-PCF provides VPLMN specific URSP Rules. The Network Slice Selection Policies of the VPLMN specific URSP Rules contain values that are associated with the HPLMN. The DNN Selection Policies of the VPLMN specific URSP Rules contain DNN values from the list of subscribed DNNs that have LBO Roaming set to allowed in the UE Policy Context Subscription Data in the UDR. When Time and Location criteria are included in the RSD(s), the Time and Location criteria contain values that are based on agreements with the VPLMN or service parameters that were received from the VPLMN.

The H-PCF may use application guidance on URSP determination, received from the V-PCF or retrieved from UDR at the HPLMN, as input to generate new or update existing VPLMN specific URSP Rules, as well as other input data as described in clause 6.2.1.1. The list of parameters provided for application guidance on URSP Rule determination is defined in clause 4.15.6.10 of TS 23.502 [3] and the procedures are specified in clause 4.15.6.7 of TS 23.502 [3].

The AF may provide application guidance on URSP Rule determination to the VPLMN or to the HPLMN.

When the AF provides application guidance on URSP Rule determination to the VPLMN, it will target "PLMN ID(s) of inbound roamers", the NEF in the VPLMN authorizes requests based on local configuration using e.g. the AF identifier before storing them in UDR, as defined in clause 4.15.6.7 of TS 23.502 [3]. The NEF in the VPLMN rejects any request for a GPSI or an External-Group-ID of a different PLMN. The UDR in the VPLMN notifies the V-PCF(s) that has subscribed to the reception of application guidance on URSP determination.

When the AF provides application guidance on URSP Rule determination to the HPLMN, it will target either a GPSI or an External-Group-ID or "any UE" of the HPLMN. The NEF in the HPLMN, may, based on the HPLMN operator local policy, authorize any request for a GPSI or an External-Group-ID and maps it into a SUPI or an Internal-Group-ID via UDM, before storing them in UDR as Application Data. The UDR notifies the H-PCF(s) that has subscribed to the reception of application guidance on URSP determination. The Application guidance on traffic routing may contain the VPLMN ID(s) where the Service Parameters apply.

When the UE Policy Association is established or the V-PCF receives updates on application guidance on URSP determination with target PLMN ID(s) containing the HPLMN ID of a SUPI that has a UE Policy Association established, the V-PCF checks whether application guidance on URSP determination exists and applies for HPLMN ID of the SUPI. If yes, then the V-PCF:

- maps the S-NSSAI of the VPLMN into the S-NSSAI of the HPLMN, using the Configured NSSAI for the Serving PLMN and mapping of each S-NSSAI of the Configured NSSAI to corresponding HPLMN S-NSSAI values provided by the AMF and stored in PCF. Then the V-PCF sends the mapped application guidance on URSP determination including the HPLMN S-NSSAI values to the H-PCF;
- subscribes to the result of the delivery of UE Policies if it was requested by the AF to the H-PCF, using the event reporting on "Notification on outcome of UE Policies delivery" described in clause 6.1.3.18; and
- checks whether the requested application guidance are included in HPLMN subscription by checking the LBO Information (i.e. DNN(s) and/or S-NSSAI(s) that are allowed for LBO Session in VPLMN, which is part of SMF Selection Data) if the V-PCF received the LBO Information from the AMF. If LBO Information is not available

at V-PCF in VPLMN or if the V-PCF needs to be made aware of any changes in the LBO Information, the V-PCF may send the PCRT for reporting the LBO Information.

NOTE 1: The AMF performs SMF selection to select the SMF in VPLMN for LBO case as described in clause 6.3.2 of TS 23.501 [2].

The H-PCF generates new or updated URSP Rules using the application guidance on URSP Rule determination. The VPLMN ID included in the Service Parameters of the application guidance from the AF to indicates that this URSP Rule applies when the UE is registered in the VPLMN. The H-PCF provides RSD values in the URSP Rules that are within the subscribed values defined in the S-NSSAI subscription information defined in Table 6.2.1.3-1. The H-PCF provides the list of PSIs applicable per VPLMN ID(s) to the UE. The VPLMN ID(s) corresponds to the VPLMN ID(s) included in the Service Parameters provided by the AF in application guidance. The VPLMN ID provided by the H-PCF may contain one or more specific values for the MCC and MNC and/or one or more wildcarded values for MCC and/or MNC. The H-PCF should set the precedence in the URSP Rules to ensure that the UE checks the VPLMN ID(s) that contain one or more specific values for the MCC and MNC before any URSP Rule related the VPLMN ID(s) that contain wildcarded values for MCC and/or MNC. The H-PCF should also set the precedence in the URSP Rules to ensure that the UE checks any URSP Rule related to VPLMN ID(s) that contain wildcarded values for MCC and/or MNC before any non-VPLMN specific URSP Rules.

NOTE 2: The H-PCF sets the precedence in URSP Rules based on operator policies.

How the UE associates applications to PDU Sessions based on URSP Rules follows the same procedure as described in clause 6.6.2.3.

#### 6.1.2.2.5 Handling of the UE Policy Association

In the non-roaming scenario, the establishment of the UE Policy Association is determined as follows. First, the AMF checks the UE Policy Association indicator received from UDM and establishes the UE Policy Association if its value is "enabled" and do not establish the UE Policy Association if its value is "disabled". If no UE Policy Association indicator is received from the UDM then the AMF establishes the UE Policy Association when the UE Policy Container is received from the UE. If no UE Policy Association indicator is received from the UDM and no UE Policy Container is received from the UE, then the AMF determines whether to establish the UE Policy Association or not as indicated by the local configuration.

In the roaming scenario, the AMF local configuration is considered first for the determination of the establishment of the UE Policy Association then the remaining parameters described above are applied.

NOTE 1: It is assumed that the AMF local configuration is based on agreement between operators about whether UE policies can be delivered in the roaming scenario.

The UE Policy Association indicator for a SUPI is part of Access and Mobility Subscription data in UDM as described in clause 5.2.3.3.1 of TS 23.502 [3] and can be set by the operator to "enabled" or "disabled".

NOTE 2: The operator can set the UE Policy Association indicator to "enabled" when it is required to provision UE Policies to the UE or to "disabled" when the UE is no longer subscribed to any service that requires sending UE policies to the UE.

NOTE 3: A possible reason to set the UE Policy Association indicator to "enabled" is that either there are service specific parameters for e.g. a SUPI in UDR or UE Policies are available for e.g. a SUPI provisioned in the PCF. Before setting the indicator to "disabled", the operator needs to ensure that there are no UE Policies stored for any of these services in the UE, by revoking the authorization for the service specific information, for Service Type "AF guidance for URSP", for all of the AFs with active authorizations, as defined in clause 4.15.6.7a of TS 23.502 [3] and by triggering the PCF to remove the UE Policies in the UE if any or both.

#### 6.1.2.3 Management of packet flow descriptions

##### 6.1.2.3.1 PFD management

The Management of Packet Flow Descriptions enables the UPF to perform accurate application detection when PFD(s) are provided by an ASP and then to apply enforcement actions as instructed in the PCC Rule.

The operator is able to configure pre-defined PCC Rules in the SMF or dynamic PCC Rules in the PCF that include at least an application identifier for service data flow detection, charging control information, i.e. charging key and optionally the Sponsor identifier or the ASP identifier or both. Depending on the service level agreements between the operator and the Application Server Provider, it may be possible for the ASP to provide individual PFDs or the full set of PFDs for each application identifier maintained by the ASP to the SMF via the PFD Management service in the NEF (PFDF). The PFDs become part of the application detection filters in the SMF/UPF and therefore are used as part of the logic to detect traffic generated by an application. The ASP may remove or modify some or all of the PFDs which have been provided previously for one or more application identifiers. The SMF may report the application stop to the PCF for an application instance identifier as defined in clause 5.8.2.8.4 of TS 23.501 [2] if the removed/modified PFD in SMF/UPF results in that the stop of the application instance is not being able to be detected.

NOTE 1: PFD management is optionally supported in the NEF and the SMF.

The ASP manages (provision, update, delete) the PFDs through the NEF (PFDF). The PFD(s) are transferred to the SMF through the NEF (PFDF). The PFDF is a logical functionality in the NEF which receives PFD(s) from the ASP through the NEF, stores the PFD(s) in the UDR and provides the PFD(s) to the SMF(s) either on the request from ASP PFD management through NEF (PFDF) (push mode) or on the request from SMF (pull mode). The PFDF functionality is a service provided by the NEF.

The ASP may provide/update/remove PFDs with an allowed delay to the NEF (PFDF). Upon reception of the request from the ASP, the NEF (PFDF) shall check if the ASP is authorized to provide/update/remove those PFD(s) and request the allowed delay. The NEF (PFDF) may be configured with a minimum allowed delay based on SLA to authorize the allowed delay provided by the ASP. When ASP and requested allowed delay are successfully authorized, the NEF (PFDF) shall translate each external application identifier to the corresponding application identifier known in the core network. The NEF (PFDF) stores the PFD(s) into the UDR setting "AF" as the source NF type (which is defined in clause 5.2.12.2.1 of TS 23.502 [3]).

NOTE 2: The Allowed Delay is an optional parameter. If the Allowed Delay is included, it indicates that the requested PFD(s) should be deployed within the time interval indicated by the Allowed Delay.

The PFDs may be retrieved by SMF from NEF (PFDF) in "pull" mode or may be provisioned from NEF (PFDF) to the SMF in "push" mode.

When the "push" mode is used, the NEF (PFDF) retrieves from the UDR the PFDs for each application identifier and distributes them to those SMFs that enable access to those applications. There are three methods to provision PFD(s) from the NEF (PFDF) to the SMF:

- a) Push of whole PFD(s) that can be accessed by the NEF (PFDF) according to operator configuration in NEF (PFDF) (e.g. provision per day according to operator configuration);
- b) Selective push of an ASP change in the PFD set (i.e. ASP changes the PFD set while operator configuration defines when to push);
- c) Selective push of an ASP change in the PFD set according to ASP request (i.e. ASP indicates to push changes in a PFD set within the time interval indicated by the Allowed Delay).

When the "pull" mode is used, at the time a PCC Rule with an application identifier for which PFDs are not available is activated or provisioned, the SMF requests all PFDs for that application identifier from the NEF (PFDF), and NEF (PFDF) retrieves them from the UDR. The PFD(s) retrieved for an application identifier from the NEF (PFDF) are cached in the SMF, and the SMF maintains a caching timer associated to the PFD(s) to control how long the PFD(s) are valid. When the caching timer expires:

- If there are still active PCC rules that refer to the corresponding application identifier, the SMF reloads the PFD(s) from the NEF (PFDF) and provides it to the UPF over N4;
- If there's no active PCC rule that refers to the corresponding application identifier or the SMF removes the last PCC rule that refers to the corresponding application identifier, the SMF removes the PFD(s) identified by the application identifier and informs the UPF to remove the PFD(s) identified by the application identifier over N4.

NOTE 3: It is assumed that all SMF(s) and PFD (s) in an operator network are configured with the same default caching time value to be applied for all application identifiers.

When the "pull" mode is used, the NEF (PFDF) may provide to the SMF a caching time value per application identifier. The SMF receives the caching time value together with the PFD(s) from the NEF (PFDF) over N29 and applies this

value for the application identifier instead of the configured default caching time value. If no caching time value is received from NEF (PFDF), the SMF uses the configured default caching time value.

NOTE 4: The configuration of a caching time value per application identifier in NEF (PFDF) is based on the SLA between the operator and the ASP.

When only "pull" mode is used in one PLMN for an application identifier, if the Allowed Delay is shorter than the caching time value stored for this application identifier, or shorter than the default caching time if no application-specific caching time is stored, the NEF (PFDF) may still store the PFD(s) to the UDR. The NEF (PFDF) shall provide an indication that the PFD(s) were stored and the caching time value to the ASP when informing that the Allowed Delay could not be met.

When either "pull" mode or "push" mode is used, if there's any update of the PFD(s) received and there are still active application detection rules in the UPF for the application identifier, the SMF shall provision the updated PFD set corresponding to the application identifier to the UPF.

NOTE 5: SMF should assure not to overload N4 signalling while managing PFD(s) to the UPF, e.g. forwarding the PFD(s) to the right UPF where the PFD(s) is enforced.

When the UPF receives the updated PFD(s) from either the same or different SMF for the same application identifier, the latest received PFD(s) shall overwrite any existing PFD(s) stored in the UPF.

If the PFDs are managed by local O&M procedures, PFD retrieval is not used; otherwise, the PFDs retrieved from NEF (PFDF) overrides any PFDs pre-configured in the SMF. The SMF shall manage the pre-configured PFDs and PFDs provided by the NEF (PFDF) at the UPF as defined in clause 5.8.2.8.4 of TS 23.501 [2]. The SMF may differentiate the need for PFD retrieval based on operator configuration in the SMF.

The AF requests including an application identifier may trigger the activation or provisioning of a PCC Rule in the SMF by the PCF based on operator policies.

The NEF (PFDF) may subscribe to "PFD Determination" analytics from the NWDAF for an application identifier to assist determination of PFDs for known application identifiers as specified in TS 23.288 [24]. Based on the "PFD Determination" analytics received from the NWDAF, the NEF (PFDF) may determine to create PFD(s) for that application identifier, and then stores these PFD(s) in the UDR setting "NWDAF" as the source NF type (which is defined in clause 5.2.12.2.1 of TS 23.502 [3]). The NEF (PFDF) may also determine to modify or delete PFD(s) for that application identifier. The NEF(PFDF) shall only modify or delete PFD(s) if they contain "NWDAF" as the source NF type (i.e. they have been previously created based on "PFD Determination" analytics from the NWDAF) unless it has been agreed with the service provider owning the AF that changes to the PFDs provided by the AF are also permitted. The NEF (PFDF) then interacts with the UDR to modify or delete the corresponding PFD(s). If the NEF (PFDF) unsubscribes from "PFD Determination" analytics, the NEF (PFDF) should identify all PFDs for that application identifier which contain "NWDAF" as the source NF type (i.e. they have been previously created based on "PFD Determination" analytics from the NWDAF) and interact with the UDR to delete these PFD(s). The distribution of PFD updates triggered by NWDAF analytics shall be performed in the same way as PFD updates triggered by ASP requests, i.e. using the "push" and "pull" methods described above.

### 6.1.2.3.2 Packet Flow Description

PFD (Packet Flow Description) is a set of information enabling the detection of application traffic.

Each PFD may be identified by a PFD id. A PFD id is unique in the scope of a particular application identifier. Conditions for when PFD ID is included in the PFD is described in TS 29.551 [17]. There may be different PFD types associated to an application identifier.

A PFD include the following information:

- PFD id; and
- one or more of the following:
  - 3-tuple(s) including protocol, server side IP address and port number;
  - the significant parts of the URL to be matched, e.g. host name;
  - a Domain name matching criteria and information about applicable protocol(s).

NOTE 1: Based on the agreement between AF and mobile operator, the PFD can be designed to convey proprietary extension for proprietary application traffic detection mechanisms.

NOTE 2: How the PFD(s) are used in service flow detection is specified in clause 6.2.2.2.

#### 6.1.2.4 Negotiation for future background data transfer

The AF may contact the PCF via the NEF (and Npcf\_BDTPolicyControl\_Create service operation) to request a time window and related conditions for future background data transfer (BDT).

NOTE 1: The NEF may contact any PCF in the operator network.

The AF request shall contain an ASP identifier, the volume of data to be transferred per UE, the expected amount of UEs, the desired time window, the External Group Identifier and optionally, Network Area Information, MAC address or IP 3-tuple to identify the Application server, request for notification and the Energy indicator. The AF provides as Network Area Information either a geographical area (e.g. a civic address or shapes), or an area of interest that includes a list of TAs or list of NG-RAN nodes and/or a list of cell identifiers. When the AF provides a geographical area, then the NEF maps it based on local configuration into of a short list of TAs and/or NG-RAN nodes and/or cells identifiers that is provided to the PCF. The NEF may map the ASP identifier based on local configuration to a DNN and S-NSSAI that is in addition provided to the PCF. The MAC address or IP 3-tuple to identify the Application server may be provided by the AF or may be locally configured at the PCF and it is used for the generation of a URSP rule for the application as well as a PCC rule for the application traffic. The request for notification is an indication that the ASP accepts that the BDT policy can be re-negotiated using the BDT warning notification procedure described in clause 4.16.7.3 of TS 23.502 [3]. The Energy indicator is an indication that the AF is interested in transferring data in time windows that consume lower energy.

NOTE 2: A 3rd party application server is typically not able to provide any specific network area information and if so, the AF request is for the whole operator network.

The PCF shall first retrieve all existing BDT policies stored for any ASP from the UDR. The PCF may retrieve analytics on "Network Performance" from NWDAF following the procedure and services described in TS 23.288 [24]. Afterwards, the PCF shall determine, based on the information provided by the AF, the analytics on "Network Performance" if available and other available information (e.g. network policy, existing BDT policies or Energy indicator) one or more BDT policies. The PCF may be configured to map the ASP identifier to a target DNN and S-NSSAI if the NEF did not provide the DNN, S-NSSAI to the PCF.

A BDT policy consists of a recommended time window for the background data transfer, a reference to a charging rate for this time window and optionally maximum aggregated bitrate (indicating that the charging according to the referenced charging rate is only applicable for the aggregated traffic of all involved UEs that stays below this value). Finally, the PCF shall provide the candidate list of BDT policies to the AF via NEF together with the Background Data Transfer Reference ID. If the AF received more than one BDT policy, the AF shall select one of them and inform the PCF about the selected BDT policy.

NOTE 3: The maximum aggregated bitrate (optionally provided in a BDT policy) is not enforced in the network. The operator may apply offline CDRs processing (e.g. combining the accounted volume of the involved UEs for the time window) to determine whether the maximum aggregated bitrate for the set of UEs was exceeded by the ASP and charge the excess traffic differently.

NOTE 4: It is assumed that the 3rd party application server is configured to understand the reference to a charging rate based on the agreement with the operator.

The selected BDT policy together with the Background Data Transfer Reference ID, the network area information, the volume of data to be transferred per UE, the expected amount of UEs, the Energy indicator, the ASP identifier, MAC address or IP 3-tuple to identify the Application server, the one or more route selection component (DNN, S-NSSAI), the desired time window and whether the AF accepts BDT policy re-negotiation or not is stored by the PCF in the UDR as Data Set "Policy Data" and Data Subset "Background Data Transfer data". The same or a different PCF can retrieve this BDT policy and the corresponding related information from the UDR and take them into account for future decisions about BDT policies related to the same or other ASPs.

When the AF wants to apply the Background Data Transfer Policy to an existing session, then the AF will, at the time the BDT is about to start, provide, for each UE, the Background Data Transfer Reference ID together with the AF session information to the PCF (via the N5 interface). The PCF retrieves the corresponding BDT policy from Policy Data Set in the UDR and derives the PCC rule for the BDT according to this transfer policy.

When the AF wants to apply the Background Data Transfer Policy to a future session, then the AF provides, to the NEF, the Background Data Transfer Reference ID together with the External Identifier (i.e. GPSI) or External Group Identifier of the UE(s) that are subject to the policy. The NEF translates the External Group Identifier into the Internal Group Identifier or the External Identifier into a SUPI. The NEF stores the Background Data Transfer Reference ID, in the UDR as Application Data Set and Background Data transfer data Subset for an Internal Group Identifier or a SUPI and the ASP identifier requesting to apply the Background Data transfer Policy to a future session for the UE(s). A PCF that serves the UE(s) (i.e. the PCF that serves the UE for UE Policies) may retrieve the Background Data Transfer Reference ID by retrieving the UE's Application Data from the UDR or by subscribing to notifications of changes to the UEs' Application Data in the UDR. Furthermore, the PCF retrieves the specific Background Data Transfer Policy and the corresponding network area information and the MAC address or IP 3-tuple to identify the Application server based on the received Background Data Transfer Reference ID stored as Policy Data Set from the UDR.

When the PCF determines to send a URSP rule related to the Background Data Transfer Policy to the UE, the PCF creates the URSP rule using the MAC address or IP 3-tuple (to identify the Application server) as Traffic descriptor. The RSD part of the URSP rule is populated with the S-NSSAI and DNN associated with the ASP identifier. The Route Selection Validation Criteria of the URSP rule (see clause 6.6.2.1) is populated with the Time Window set to the recommended time window of the BDT policy and, if the BDT policy is not applicable for the whole network, the Location Criteria is set to the network area information of the BDT policy. The PCF will store the URSP rule in the UDR as part of the UE's Policy Set Entry. The PCF will use the associated S-NSSAI and DNN associated with the ASP identifier stored in the Application Data to store the Background Data Transfer Reference ID in the UE's PDU Session policy control subscription information (see clause 6.2.1.3).

The PCF uses local policies to decide when the URSP rule related to the Background Data Transfer Policy is going to be sent to the UE. The PCF may, based on operator configuration, trigger the UE Configuration Update procedure when the AF request to apply the BDT policy to a future session is received, or the PCF may wait until receiving a notification from the AMF that the UE has entered the Tracking Area or Presence Area where the BDT policy applies, and/or the PCF may wait until the time window when the BDT policy applies is approaching.

The UE uses the Route Selection Validation Criteria to determine whether or not a PDU Session should be established. The Time Window and Location Criteria are not required to be checked again during the lifetime of the PDU Session. The UE's support of the Validation Criteria in a URSP rule is optional.

NOTE 5: If a non-supporting UE receives Validation Criteria, it ignores the URSP rule.

When the PDU Session is established, the PCF that serves the PDU Session will use the Background Data Transfer Reference ID in the UE's PDU Session policy control subscription information (see clause 6.2.1.3) to retrieve the corresponding BDT policy and the related information from the UDR and derives the PCC rule for the BDT according to this information.

NOTE 6: The AF will typically contact the PCF for the individual UEs to request sponsored connectivity for the BDT.

NOTE 7: A transfer policy is only valid until the end of its time window. The removal of outdated transfer policies from the UDR is up to implementation.

The PCF may reject the establishment of an SM Policy Association, (described in clause 4.16.4 of TS 23.502 [3]), if the S-NSSAI and DNN corresponding to a BDT policy and the Validation Criteria are not fulfilled. And based on this feedback, SMF will reject the PDU Session establishment.

After successful PDU Session setup, PCF may trigger PDU Session release when Validation Criteria are no longer fulfilled.

The PCF may subscribe to analytics on "Network Performance" from NWDAF for the area of interest and time window of a BDT policy following the procedure and services described in TS 23.288 [24] indicating a Reporting Threshold in the Analytics Reporting information. The value for the Reporting Threshold is set by the PCF based on operator configuration. When the NWDAF determines that the network performance goes below the threshold, the NWDAF notifies the PCF with the network performance analytics in the area of interest and time window. When the PCF gets the notification from the NWDAF, the PCF may try to re-negotiate the affected BDT policies with AFs that accepted BDT policy re-negotiation. To do this, the PCF retrieves all the BDT policies together with their additionally stored AF provided information (e.g. their corresponding desired time window) from the UDR, identifies the BDT policies that are not desirable anymore due to the degradation of the network performance and tries to calculate new candidate BDT policies for the ASP(s) to select from. If the PCF does not find any new candidate BDT policy or the related AF did not accept BDT policy re-negotiation, the previously negotiated BDT policy shall be kept and no interaction with the ASP

shall occur. If the PCF finds one or more new candidate BDT policies, the PCF notifies the related ASP(s) on both the BDT policy that is not valid any longer and the candidate BDT policies via NEF.

The PCF invalidates the BDT policy stored in the UDR for the corresponding BDT reference ID while the BDT policy re-negotiation is ongoing. The PCF shall reject a PDU Session request corresponding to an invalid BDT policy.

When the AF receives the notification, the AF may select one of the BDT policies included in the candidate list, and then inform the PCF about the selected BDT policy. The PCF stores the newly selected BDT policy into the UDR for the corresponding Background Data Transfer Reference ID and removes the BDT policy that is no longer valid. The PCF is also updating the URSP rule corresponding to the BDT policy with the new Validation Criteria in the Policy Set Entry of all UEs. As a consequence, the PCF identifies the UEs for which the BDT policy was already provided and updates the URSP rule corresponding to the BDT policy using the procedure described in clause 4.16.12.2 of TS 23.502 [3].

NOTE 8: A PCF can subscribe to notifications on changes in BDT policy in UDR.

If the AF does not select one of the BDT policies included in the candidate list, the PCF removes the BDT policy stored in the UDR together with the corresponding Background Data Transfer Reference ID and all related information as well as the URSP rule corresponding to the BDT policy in the Policy Set Entry of all UEs. As a consequence, the PCF identifies the UEs for which the URSP rule corresponding to the BDT policy was already provided and removes the URSP rule corresponding to the BDT policy using the procedure described in clause 4.16.12.2 of TS 23.502 [3].

NOTE 9: The PCF can also remove the no longer valid BDT policy after an operator configurable time for the case that the AF does not respond.

#### 6.1.2.5 Policy Control Request Triggers relevant for AMF

The Policy Control Request Triggers relevant for AMF are listed in the tables below and define the conditions when the AMF shall interact again with PCF after the AM Policy Association Establishment or UE Policy Association Establishment.

The PCF provides Policy Control Request Triggers to the AMF indicating a specific UE (i.e. SUPI or PEI) in the Policy Association establishment and modification procedures defined in the TS 23.502 [3]. The Policy Control Request Triggers are transferred from the old AMF to the new AMF when the AMF changes.

The Policy Control Request Triggers are not applicable any longer at termination of the AM Policy Association or termination of UE Policy Association.

**Table 6.1.2.5-1: Policy Control Request Triggers relevant for AMF and 3GPP access type**

<b>Policy Control Request Trigger</b>	<b>Description</b>	<b>Condition for reporting</b>
Location change (tracking area)	The tracking area of the UE has changed.	PCF (AM Policy Association, UE Policy Association)
Change of UE presence in Presence Reporting Area	The UE is entering/leaving a Presence Reporting Area.	PCF (AM Policy Association, UE Policy Association)
Service Area restriction change	The subscribed service area restriction information has changed.	PCF (AM Policy Association)
RFSP index change	The subscribed RFSP index has changed.	PCF (AM Policy Association)
Change of the Allowed NSSAI	The Allowed NSSAI has changed.	PCF (AM Policy Association)
Generation of Target NSSAI	The Target NSSAI has been generated.	PCF (AM Policy Association)
Change of Partially Allowed NSSAI	The Partially Allowed NSSAI has changed.	PCF (AM Policy Association)
Change of S-NSSAI(s) rejected partially in the RA	The S-NSSAI(s) rejected partially in the RA has changed.	PCF (AM Policy Association)
Change of rejected S-NSSAI(s) for the RA	The rejected S-NSSAI(s) for the RA has changed.	PCF (AM Policy Association)
Change of Pending NSSAI	The Pending NSSAI has changed.	PCF (AM Policy Association)
UE-Slice-MBR change	The subscribed UE-Slice-MBR has changed.	PCF (AM Policy Association)
PLMN change	The UE has moved to another operators' domain.	PCF (UE Policy Association)
Slice replacement management	The AMF cannot determine the Alternative S-NSSAI for an S-NSSAI or, the AMF has determined/changed the Alternative S-NSSAI for an S-NSSAI after received the Alternative S-NSSAI from OAM or network slice availability notification from NSSF.	PCF (AM Policy Association)
Connectivity state changes	The connectivity state of UE is changed.	PCF (UE Policy Association)
NWDAF info change	The NWDAF instance IDs used for the UE or associated Analytics IDs used for the UE and available in the AMF have changed.	PCF (AM Policy Association)
Satellite backhaul category change	Satellite backhaul category changes between different types of satellite backhaul, or between satellite backhaul and non-satellite backhaul.	PCF (UE Policy Association)
LBO Information change	LBO Information (i.e. DNN(s) and/or S-NSSAI(s) that are allowed for LBO in VPLMN in SMF Selection Data) has changed.	PCF (UE Policy Association)
Notification of Network Slice Replacement Outcome	The AMF reports the outcome of Network Slice Replacement request.	PCF (AM Policy Association)
Energy Saving Indicator change	The subscribed Energy Saving Indicator has changed.	PCF (AM Policy Association)

**Table 6.1.2.5-1a: Policy Control Request Triggers relevant for AMF and both 3GPP and Non 3GPP access type**

<b>Policy Control Request Trigger</b>	<b>Description</b>	<b>Condition for reporting</b>
Access Type change (NOTE 1) (NOTE 2)	The Access Type or RAT Type or both Access Type and RAT Type changed, added, or removed.	PCF (AM Policy Association, UE Policy Association)
UE-AMBR change	The subscribed UE-AMBR has changed.	PCF (AM Policy Association)
SMF selection management	UE request for an unsupported DNN or UE request for a DNN within the list of DNN candidates for replacement per S-NSSAI.	PCF (AM Policy Association)
Configured NSSAI change	The Configured NSSAI has changed.	PCF (UE Policy Association)
NOTE 1: RAT Type change is applicable only for AM Policy.		
NOTE 2: Corresponding triggers are defined for this PCRT at stage 3.		

**Table 6.1.2.5-2: Policy Control Request Triggers relevant for AMF and Non 3GPP access type**

Policy Control Request Trigger	Description	Condition for reporting
wrong non-3GPP access	UE has connected to a wrong non-3GPP access that does not match its subscribed S-NSSAI(s).	Always report

NOTE 1: In the following description of the Policy Control Request Triggers relevant for AMF, the term trigger is used instead of Policy Control Request Trigger where appropriate.

If the Location change trigger are armed, the AMF shall activate the relevant procedure which reports any changes in location as explained in clause 5.6.11 of TS 23.501 [2] by subscribing with the Npcf\_AMPolicyAssociation service or Npcf\_UEPolicyAssociation service. The reporting is requested to the level indicated by the trigger (i.e. Tracking Area). The AMF reports that the Location change trigger was met and the Tracking Area identifier.

If the Change of UE presence in Presence Reporting Area trigger is armed, i.e. the PCF subscribed to reporting change of UE presence in a Presence Reporting Area, including a list of PRA ids. In addition, for "UE-dedicated Presence Reporting Area" a short list of TAs and/or NG-RAN nodes and/or cells identifiers is included. Then, the AMF shall activate the relevant procedure which reports any Change of UE presence in Area of Interest as explained in clause 5.6.11 of TS 23.501 [2]. The reporting is requested for the specific condition when target UE moved into a specified PRA. The AMF reports the PRA Identifier(s) and indication(s) whether the UE is inside or outside the Presence Reporting Area(s) to the PCF.

The Service Area restriction change trigger and the RFSP index change trigger shall trigger the AMF to interact with the PCF for all changes in the Service Area restriction or RFSP index data received in AMF from UDM. The reporting includes that the trigger is met and the subscribed Service Area restriction or the subscribed RFSP index provided to AMF by UDM, as described in clause 6.1.2.1.

The Change of the Allowed NSSAI trigger shall trigger the AMF to interact with the PCF if the Allowed NSSAI has been changed. The reporting includes that the trigger is met and the new Allowed NSSAI. The PCF may update RFSP index and/or SMF selection management related policy information (described in clause 6.5) and/or S-NSSAI availability information (described in clause 6.5) in the AMF based on the Allowed NSSAI.

The Generation of a Target NSSAI trigger shall trigger the AMF to interact with the PCF. The reporting includes that the trigger is met and the generated Target NSSAI. The PCF may generate RFSP index associated with the Target NSSAI.

The Change of the Partially Allowed NSSAI trigger shall trigger the AMF to interact with the PCF if the Partially Allowed NSSAI has been changed. The reporting includes that the trigger is met and the new Partially Allowed NSSAI. The PCF may update RFSP index related policy information (described in clause 6.5) and/or S-NSSAI availability information (described in clause 6.5) in the AMF based on the Partially Allowed NSSAI.

The Change of the S-NSSAI(s) rejected partially in the RA shall trigger the AMF to interact with the PCF if the S-NSSAI(s) rejected partially in the RA has been changed. The reporting includes that the trigger is met and the new S-NSSAI(s) rejected partially in the RA. The PCF may update RFSP index related policy information (described in clause 6.5) in the AMF based on the S-NSSAI(s) rejected partially in the RA.

The Change of the rejected S-NSSAI(s) for the RA shall trigger the AMF to interact with the PCF if the rejected S-NSSAI(s) for the RA has been changed. The reporting includes that the trigger is met and the new rejected S-NSSAI(s) in the RA. The PCF may update RFSP index related policy information (described in clause 6.5) in the AMF based on the rejected S-NSSAI(s) for the RA.

The Change of the Pending NSSAI trigger shall trigger the AMF to interact with the PCF if the Pending NSSAI has been changed. The reporting includes that the trigger is met and the new Pending NSSAI. The PCF may update RFSP index related policy information (described in clause 6.5) in the AMF based on the Pending NSSAI.

If the Configured NSSAI change trigger is armed, the AMF shall report the Configured NSSAI and mapping of each S-NSSAI of the Configured NSSAI to corresponding HPLMN S-NSSAI values as defined in clause 5.15.4.1.1 of TS 23.501 [2] to the PCF. The V-PCF sends the HPLMN S-NSSAI to the H-PCF after mapping the S-NSSAI of the VPLMN into the S-NSSAI of the HPLMN as described in clause 4.15.6.7 of TS 23.502 [3]. The H-PCF may take this into account to update UE Policy as defined in clause 6.1.2.2. When the UE is connected to a non-3GPP access, the PCF may take this into account to update UE Policy e.g. ANDSP as defined in clause 6.1.2.2.

The UE-AMBR change trigger shall trigger the AMF to interact with the PCF for all changes in the subscribed UE-AMBR data received in AMF from UDM. The reporting includes that the trigger is met and the subscribed UE-AMBR provided to AMF by UDM, as described in clause 6.1.2.1.

The Slice-UE-MBR change trigger shall trigger the AMF to interact with the PCF for all changes in the Subscribed UE-Slice-MBR for each subscribed S-NSSAI in the NSSAI with a Subscribed UE-Slice-MBR received at the AMF from UDM. The reporting includes that the trigger is met, as described in clause 6.1.2.1.

If the PLMN change trigger is armed, the AMF shall report it to the PCF to trigger the update of V2X service authorization parameters to the UE as defined in clause 6.2.2 of TS 23.287 [28], to trigger the update of ProSe authorization parameters to the UE as defined in clause 6.2.2 of TS 23.304 [34], to trigger the update of A2X service authorization parameters to the UE as defined in clause 6.3.2.2 of TS 23.256 [43] and to trigger the update of Ranging/Sidelink Positioning authorization parameters to the UE as defined in clause 6.2.2 of TS 23.586 [41]. The reporting includes the event with the serving PLMN ID.

If the SMF selection management trigger is set, then the AMF shall contact the PCF when the AMF detects that the UE requested an unsupported DNN and the PCF indicated DNN replacement of unsupported DNNs in the Access and mobility related policy information (see clause 6.5). The PCF shall select a DNN and provide the selected DNN to the AMF.

If the SMF selection management trigger is set, then the AMF shall contact the PCF when the UE requested a DNN within the list of DNN candidates for replacement for the S-NSSAI indicated in the Access and mobility related policy information (see clause 6.5). The PCF shall select the DNN and provide the selected DNN to the AMF.

If the slice replacement management trigger is set, the AMF shall contact the PCF:

- in Case i) when AMF cannot determine the Alternative S-NSSAI for the S-NSSAI(s), e.g. NSSF doesn't provide Alternative S-NSSAI and there is no Alternative S-NSSAI in the AMF local configuration. The reporting includes that the trigger is met, the S-NSSAI(s) that requires slice replacement, as described in clause 6.1.2.1.
- in Case ii) if the AMF can determine the Alternative S-NSSAI for the S-NSSAI(s) when network slice replacement applies for some S-NSSAIs, or if the AMF determines to stop the network slice replacement for some S-NSSAI(s) after receiving the Alternative S-NSSAI from OAM or network slice availability notification from NSSF. The reporting includes the trigger is met and S-NSSAI(s) that requires slice replacement and the corresponding Alternative S-NSSAI. If no corresponding Alternative S-NSSAI is provided, the PCF is informed no Alternative S-NSSAI is mapped to the replaced S-NSSAI(s) any longer.

NOTE 2: The Alternative S-NSSAI does not have to be a Subscribed S-NSSAIs.

NOTE 3: AMF receiving network slice replacement notification from the PCF is not a trigger for the AMF to update the PCF with the mapping information between Alternative S-NSSAI and replaced S-NSSAI.

If the Connectivity state changes trigger is set, then the AMF shall notify the PCF when the UE connectivity state is changed e.g. from IDLE to CONNECTED. The AMF then reset the trigger.

The NWDAF info change trigger shall trigger the AMF to interact with the PCF when the list of NWDAF Instance IDs used for the UE or associated Analytics IDs used for the UE at the AMF are changed in the AMF.

If the Satellite backhaul category change trigger is armed, the AMF shall report the Satellite backhaul category to indicate the change between different types of satellite backhaul, or the change between satellite backhaul and non-satellite backhaul (as specified in clause 5.43.4 of TS 23.501 [2]) to the PCF. The PCF may take this into account to update UE Policy as defined in clause 6.1.2.2.

The AMF indicates a PCRT corresponding to wrong non-3GPP access when the UE has connected to a non-3GPP access that is not supporting the configured NSSAI. The AMF also indicates whether it is for untrusted or trusted non-3GPP access. This triggers the PCF to update the relevant policies on the UE e.g. WLANSF or Non-3GPP access network selection information.

If the LBO Information change is armed, the AMF shall report the LBO Information (i.e. DNN(s) and/or S-NSSAI(s) that are allowed in VPLMN for LBO roaming in SMF Selection Data) to the PCF when there is change in the LBO Information.

If the Access Type change trigger is met, the AMF reports the changed, the added or the removed Access Type and/or the changed RAT Type to the PCF.

The AMF reports to PCF the outcome of AF triggered network slice replacement type as specified in clause 5.15.5.2.2a of TS 23.501 [2].

If the Energy Saving Indicator change is armed, the AMF shall send the changed Energy Saving Indicator to the PCF. The PCF may take this into account to update AM Policy as defined in clause 6.1.2.1.

## 6.1.2.6 AF influence on Access and Mobility related policy control

### 6.1.2.6.0 General

The AF influence on Access and Mobility related policy control refers to the AF capability to request a service area coverage or the indication that high throughput is desired for a UE.

Two methods enable the AF to influence Access and Mobility related policy control (see clause 4.15.6.9 of TS 23.502 [3] for the related procedures):

- The AF requests a service area coverage for the UE and/or indicates that high throughput is desired, knowing that certain conditions are met, i.e. the application traffic needs a change of service area coverage or high throughput, as defined in clause 6.1.2.6.1.
- The AF provides the service area coverage and/or the indication that high throughput is desired for one or multiple UEs that may or may not already be registered or fulfil certain conditions related to application traffic. This is considered when the AM Policy Association is established or via a modification of an AM Policy Association, as defined in clause 6.1.2.6.2.

The AF may also support to influence on Access and Mobility related policy to request network slice replacement for target UE, as defined in clauses 6.1.2.6.1 and 6.1.2.6.2.

### 6.1.2.6.1 AF request Access and Mobility related Policy Control for a UE

This clause applies to non-roaming, i.e. cases where the PCF, AF, AMF and SMF belong to the serving PLMN, or the AF belongs to a third party with which the Serving PLMN has an agreement. AF influence on Access and Mobility related policy control does not apply in the case of Home Routed or Local breakout roaming cases.

The AF may subscribe to notifications when a PCF for the UE is registered in the BSF for a certain SUPI or GPSI.

The AF may contact, either directly or via NEF, the PCF for the UE to request notifications on the outcome of a service area coverage change (represented as a geographical area or a list of TA(s)) or the indication that high throughput is desired for UE traffic or both, for a SUPI or a GPSI. The request applies until the AF requests to terminate the request, or the AF request expires (according to relevant input provided by the AF), or the AM Policy Association is terminated. The AF may subscribe to notifications on the outcome of the service area coverage change to the PCF, according to the events described in clause 6.1.3.18. At the time the AF request expires, the PCF removes the context provided by the AF and then checks if the Access and Mobility related policy information needs to be updated at the AMF.

NOTE: The assumption is that the AF also removes the context at the time the AF request expires.

When the AF contacts the NEF then the following mappings are performed by the NEF:

- 1) The geographical area (e.g. a civic address or shapes) is mapped into a list of TAs determined by local configuration.
- 2) The GPSI, if provided, is mapped to a SUPI according to the subscription information received from UDM.

The PCF takes the list of TAs as input for policy decisions, considering the list of TAs provided by the AF as allowed TAIs for the UE when calculating the service area restrictions, then checking operator policies to determine whether the service area restrictions need to be updated.

The PCF reports the outcome of a service area coverage change, including the list of allowed TAIs (that is mapped to a geographical area if the requests goes via NEF) and any changes to the AF, according to the events described in clause 6.1.3.18.

The PCF checks if the RFSP value index for a UE needs to be changed, as described in clause 6.1.2.1, using the indication that high throughput is desired. The PCF reports to the AF that the request was executed, but without reporting anything related to actually applied RFSP or throughput changes.

The AF may request either directly or via NEF network slice replacement for target UE. The AF Request may include the Replaced S-NSSAI and the Alternative S-NSSAI. If the AF requests the Network Slice replacement via a NEF, the AF provides slice replacement requirement defined by a pair (Replaced AF-Service-Identifier, Alternative AF-Service-Identifier) to the NEF and the NEF maps the AF-Service-Identifiers to Replaced S-NSSAI and Alternative S-NSSAI. The AF request may also include the policy duration parameter to indicate when to terminate the network slice replacement. The PCF triggers the network slice replacement as described in clause 6.1.2.1. The AF is notified of the outcome of network slice replacement request. The PCF reports to the AF the outcome of the network slice replacement by means of the Npcf\_EventExposure\_Notify service after it receives the outcome from the AMF.

After a successful slice replacement by the AF, the AF may request to terminate the network slice replacement and to use the Replaced S-NSSAI instead of the Alternative S-NSSAI. In this case, the PCF triggers the termination of the network slice replacement as described in clause 6.1.2.1. The PCF reports to the AF the outcome of the termination of the network slice replacement after it receives the outcome from the AMF, according to the event "Notification on outcome Network Slice Replacement" described in clause 6.1.3.18.

#### 6.1.2.6.2 AF request to influence on Access and Mobility related Policy Control

This clause applies to non-roaming and LBO roaming i.e. to cases where the involved entities (AF, PCF, SMF, AMF) belong to the Serving PLMN, or the AF belongs to a third party with which the Serving PLMN has an agreement. In LBO roaming, the AF request targets any inbound roaming UEs (identified by their home PLMN ID(s)) combined with DNN/S-NSSAI or External Application Identifier(s). AF influence on Access and Mobility related policy control does not apply in the case of Home Routed case.

The PCF for the UE may subscribe at UDR to notifications on change of "Application Data" and "AM influence information", e.g. when the AM Policy Association is established.

The AF may request notifications on outcome of service area coverage change, represented by a geographical area, may indicate that high throughput is desired for one or multiple target UEs, which may be associated to an Application Identifier(s) or to a (DNN,S-NSSAI) combination (if no Application Identifier(s) or (DNN,S-NSSAI) combination is provided, the request applies independently of the application traffic), the AF transaction identifier (allowing the AF to update or remove the AM influence data), a policy expiration time, and the Notification Correlation Id, then the NEF performs the following mappings where needed:

- 1) The geographical area(s) are mapped into a list of TAs determined by local configuration.
- 2) The GPSI, if provided, is mapped to a SUPI according to the subscription information received from UDM.
- 3) External Group Identifier(s) are mapped to Internal Group Identifier(s).

The NEF stores the AF request in the UDR as Data Set "Application Data" and Data Subset "AM influence information".

The PCF calculates the service area restrictions as defined in clause 6.1.2.6.1, including the notification to the AF on the service area coverage as described in clause 6.1.3.18, in this case it is implicit subscription, to the AF using the Notification Correlation Id.

The PCF calculates the RFSP index value as defined in clause 6.1.2.6.1.

When the expiration time of the policy is reached or when the PCF receives a notification from the UDR that the policy has been deleted, the PCF re-evaluates the policies without consideration of the AM influence data of the expired policy and applies policies as defined in clause 6.1.2.1.

The AF may request a network slice replacement for target UE via a NEF. The NEF stores the AF Request in the UDR which include the replaced S-NSSAI and the Alternative S-NSSAI, The AF requests the network slice replacement via a NEF by providing a slice replacement requirement defined by a pair (Replaced AF-Service-Identifier, Alternative AF-Service-Identifier) to the NEF and the NEF maps the AF-Service-Identifiers into Replaced S-NSSAI and Alternative S-NSSAI respectively prior to storing them in the UDR. The PCF receives notification from the UDR of updated "AM influence information" and the PCF triggers the network slice replacement based on the indication that slice replacement is requested, as described in clause 6.1.2.1. The AF is notified of the outcome of network slice replacement request. The PCF reports to the AF the outcome of the network slice replacement by means of the Npcf\_EventExposure\_Notify service after it receives the outcome from the AMF.

### 6.1.2.7 Negotiation for planned data transfer with QoS requirements

The AF may contact the PCF via the NEF by invoking `Npcf_PDTQPolicyControl_Create` service operation to request a time window for planned data transfer with QoS requirements (PDTQ).

NOTE 1: The NEF may contact any PCF in the operator network.

The AF request shall contain an ASP identifier, either a QoS Reference or individual QoS parameters, the Number of UEs, the list of Desired time windows and, if the AF can adjust to different QoS parameter combinations, the AF may, in addition, provide Alternative Service Requirements in a prioritized order as defined in clause 6.1.3.22, Network Area Information, and Request for notification. As Network Area Information, the AF may provide either a geographical area (e.g. a civic address or shapes), or an area of interest that includes a list of TAs and/or a list of NG-RAN nodes or a list of cell identifiers. When the AF provides a geographical area, the NEF maps it, based on local configuration, into an area of interest (i.e. a list of TAs or NG-RAN nodes list or cells identifiers list) and provides it to the PCF. The Request for notification can be included in the AF request to indicate that the ASP accepts that the PDTQ policy can be re-negotiated using the PDTQ warning notification procedures described in clause 4.16.15.2 of TS 23.502 [3].

NOTE 2: A third party application server is typically not able to provide any specific Network Area Information and if so, the AF request is for the whole operator network.

The PCF shall firstly retrieve all existing PDTQ policies stored for any ASP from the UDR. Then the PCF subscribes to "Network Performance" analytics or "DN Performance" analytics from NWDAF following the procedures and services described in TS 23.288 [24]. The PCF may request threshold reporting or periodic reporting. Afterwards, the PCF shall determine one or more PDTQ policies, based on the information provided by the AF, the analytics on "Network Performance" or "DN Performance" and other available information (e.g. network policy and existing PDTQ policies).

NOTE 3: Whether the PCF subscribes to "Network Performance" analytics or "DN Performance" analytics is based on PCF configuration. PCF implementation has to ensure that analytics information is available for the list of desired time windows and Network Area Information requested by the AF.

A PDTQ policy consists of a recommended time window for the traffic transfer for each of the AF sessions for each of the UEs involved.

Finally, the PCF shall provide the candidate list of PDTQ policies to the AF via NEF together with the PDTQ Reference ID. If the AF received more than one PDTQ policy, the AF shall select one of them and inform the PCF about the selected PDTQ policy and corresponding PDTQ Reference ID. The selected PDTQ policy together with the PDTQ Reference ID, the Network Area Information (if provided by the AF), ASP identifier, the list of desired time windows, the QoS Reference or individual QoS parameters, the Alternative Service Requirements in a prioritized order (if provided by the AF), the Number of UEs and the Request for notification of PDTQ policy re-negotiation (if provided by the AF) are stored by the PCF in the UDR as Data Set "Policy Data" and Data Subset "Planned Data Transfer with QoS requirements data". The same or a different PCF can retrieve this PDTQ policy and the corresponding related information from the UDR and take them into account for future decisions about PDTQ policies related to the same or other ASPs.

When the recommended time window in the selected PDTQ policy is about to start, and the AF needs to make use of the PDTQ policy for existing or new sessions, the AF invokes the `Nnef_AFsessionWithQoS_Create/Npcf_PolicyAuthorization_Create` in order to set up the AF session with the required QoS.

NOTE 4: It is expected that the AF requests the same QoS (or at least a similar one) that has been provided during the PDTQ policy negotiation as otherwise, the time window recommendation in the negotiated PDTQ policy loses the baseline on which it has been derived.

The PCF may subscribe to analytics on "Network Performance" or "DN Performance" from NWDAF for the area of interest and time window of a PDTQ policy following the procedure and services described in TS 23.288 [24] indicating a Reporting Threshold or periodic reporting in the Analytics Reporting information. The value for the Reporting Threshold is set by the PCF based on operator configuration. When the NWDAF determines that the Network Performance or DN Performance reaches the Reporting Threshold, the NWDAF notifies the PCF with the Network Performance analytics or DN Performance analytics for the requested area of interest and time window. When the PCF gets the notification from the NWDAF, the PCF may try to re-negotiate the affected PDTQ policies with AFs that accept PDTQ policy re-negotiation. If periodic reporting is received, the PCF shall determine, based on the latest analytics information and previously selected PDTQ policy, whether the PDTQ policy should be updated or not. If the PCF determines to update the PDTQ policy, the PCF may try to re-negotiate the affected PDTQ policies with AFs that accepted PDTQ policy re-negotiation. To do this, the PCF retrieves all the PDTQ policies together with the

corresponding AF provided information (e.g. the corresponding list of Desired time windows) from the UDR, identifies the PDTQ policies that are not desirable anymore due to the degradation of the Network Performance or DN Performance and calculates new candidate PDTQ policies for the ASP(s). If the PCF cannot determine any new candidate PDTQ policy or the related AF has indicated it does not accept PDTQ policy re-negotiation, the previously negotiated PDTQ policy shall be kept and no interaction with the ASP shall occur. If the PCF determines one or more new candidate PDTQ policies, the PCF notifies the related ASP(s) of the candidate PDTQ policies and corresponding PDTQ reference ID via NEF.

When the AF receives the notification, the AF may select one of the PDTQ policies included in the candidate list, and then inform the PCF about the selected PDTQ policy and corresponding PDTQ Reference ID. The PCF stores the newly selected PDTQ policy into the UDR for the corresponding PDTQ Reference ID and removes the PDTQ policy that is no longer valid.

If the AF does not select any of the PDTQ policies included in the candidate list, the previously negotiated PDTQ policy shall be kept.

## 6.1.3 Session management related policy control

### 6.1.3.1 General

The session management related policy control functionality of the Policy and Charging control framework for the 5G system provides the functions for policy and charging control as well as event reporting for service data flows.

The PCF evaluates operator policies that are triggered by events received from the AF directly or indirectly via an NEF, from the SMF, from the AMF and from the CHF as well as changes in User subscription Profile.

NOTE 1: The details for credit management and reporting are defined in SA WG5 specification.

NOTE 2: In single PCF deployment, the PCF will provide all mobility, access and session related policies that it is responsible for. In deployments where different PCFs support N15 and N7 respectively, the standardized interface between them supports policy alignment and exchange of relevant information.

NOTE 3: Policy control in multiple administrative areas is not defined in this release.

NOTE 4: Events received from the AF include changes in global policy related instructions (as described in clause 5.6.7 of TS 23.501 [2]).

The following clauses describe the most relevant session management related functionality in detail.

### 6.1.3.2 Binding mechanism

#### 6.1.3.2.1 General

The binding mechanism is the procedure that associates a service data flow (defined in a PCC rule by means of the SDF template), to the QoS Flow deemed to transport the service data flow. For service data flows belonging to AF sessions, the binding mechanism shall also associate the AF session information with the QoS Flow that is selected to carry the service data flow.

NOTE 1: The relation between AF sessions and rules depends only on the operator configuration. An AF session can be covered by one or more PCC rules, if applicable (e.g. one rule per media component of an IMS session).

NOTE 2: The PCF may authorize dynamic PCC rules for service data flows without a corresponding AF session.

The binding mechanism includes three steps:

1. Session binding;
2. PCC rule authorization; and
3. QoS Flow binding.

### 6.1.3.2.2 Session binding

Session binding is the association of the AF session information to one and only one PDU Session. The PCF shall perform the session binding, which may take the following PDU Session parameters into account:

- a) For an IP type PDU Session, the UE IPv4 address and/or IPv6 prefix as specified in TS 23.501 [2], in addition when using W-5GAN the specification in TS 23.316 [27] applies. For IPv6 prefix delegation, the assigned IPv6 network prefix is shorter than /64;

For an Ethernet type PDU Session, the UE MAC address(es);

- b) The UE identity (e.g. SUPI), if present;
- c) The information about the Data Network (DN) the user is accessing, i.e. DNN, if present, or DNN and S-NSSAI, if present.

NOTE: The AF is not aware of the Network Slice Replacement functionality (as described in clause 5.15.19 of TS 23.501 [2]), therefore the (replaced) S-NSSAI stored as part of the Session Management context is used for session binding.

Once it has determined the impacted PDU Session, the PCF shall identify the PCC rules affected by the AF session information, including new PCC rules to be installed and existing PCC rules to be modified or removed.

Session Binding applies for PDU Sessions of IP type. It may also apply to Ethernet PDU Session type but only when especially allowed by PCC related Policy Control Request triggers.

### 6.1.3.2.3 PCC rule authorization

PCC Rule authorization is the selection of the 5G QoS parameters, described in clause 5.7.2 of TS 23.501 [2], for the PCC rules.

The PCF shall perform the PCC rule authorization for dynamic PCC rules belonging to AF sessions that have been selected in step 1, as described in clause 6.1.3.2.2, as well as for PCC rules without corresponding AF sessions.

For the authorization of a PCC rule the PCF shall consider any 5GC specific restrictions, subscription information and other information available to the PCF. Each PCC rule receives a set of QoS parameters that are supported by the specific Access Network.

The authorization of a PCC rule associated with an emergency service shall be supported without subscription information. The PCF shall apply local policies configured for the emergency service.

The authorization of a PCC rule used for provisioning the UE SNPN credentials via User Plane Remote Provisioning shall be supported without subscription information in the case of Onboarding SNPN (or shall be supported with subscription information in the cases other than Onboarding SNPN). The PCF shall apply policies for support of User Plane Remote Provisioning of UE SNPN Credentials as described in clause 6.1.3.25.

### 6.1.3.2.4 QoS Flow binding

QoS Flow binding is the association of a PCC rule to a QoS Flow within a PDU Session. The binding is performed using the following binding parameters:

- 5QI;
- ARP;
- QNC (if available in the PCC rule);
- Priority Level (if available in the PCC rule);
- Averaging Window (if available in the PCC rule);
- Maximum Data Burst Volume (if available in the PCC rule).

When the PCF provisions a PCC Rule, the SMF shall evaluate whether a QoS Flow with QoS parameters identical to the binding parameters exists unless the PCF requests to bind the PCC rule to the QoS Flow associated with the default

QoS rule. If no such QoS Flow exists, the SMF derives the QoS parameters, using the parameters in the PCC Rule, for a new QoS Flow, binds the PCC Rule to the QoS Flow and then proceeds as described in clause 5.7.1.5 of TS 23.501 [2] to establish the new QoS Flow. If a QoS Flow with QoS parameters identical to the binding parameters exists, the SMF binds the PCC Rule to this QoS Flow and proceeds as described in clause 5.7.1.5 of TS 23.501 [2] to modify the QoS Flow unless local policies or the below mentioned conditions (which QoS Flow binding shall ensure), require the establishment of a new QoS Flow following the actions described above.

NOTE 1: For PCC rules containing a delay critical GBR 5QI value, the SMF can bind PCC Rules with the same binding parameters to different QoS Flows to ensure that the GFBR of the QoS Flow can be achieved with the Maximum Data Burst Volume of the QoS Flow.

The SMF shall identify the QoS Flow associated with the default QoS rule based on the fact that the PCC rule(s) bound to this QoS Flow contain:

- 5QI and ARP values that are identical to the PDU Session related information Authorized default 5QI/ARP; or
- a Bind to QoS Flow associated with the default QoS rule and apply PCC rule parameters Indication.

NOTE 2: The Bind to QoS Flow associated with the default QoS rule and apply PCC rule parameters Indication has to be used whenever the PDU Session related information Authorized default 5QI/ARP (as described in clause 6.3.1) cannot be directly used as the QoS parameters of the QoS Flow associated with the default QoS rule, for example when a GBR 5QI is used or the 5QI priority level has to be changed.

When a QoS Flow associated with the default QoS rule exists, the PCF can request that a PCC rule is bound to this QoS Flow by including the Bind to QoS Flow associated with the default QoS rule Indication in a dynamic PCC rule. In this case, the SMF shall bind the dynamic PCC rule to the QoS Flow associated with the default QoS rule (i.e. ignoring the binding parameters) and keep the binding as long as this indication remains set. When the PCF removes the association of a PCC rule to the QoS Flow associated with the default QoS rule, a new binding may need to be created between this PCC rule and a QoS Flow based on the binding mechanism described above.

The binding created between a PCC Rule and a QoS Flow causes the downlink part of the service data flow to be directed to the associated QoS Flow at the UPF (as described in clause 5.7.1 of TS 23.501 [2]). In the UE, the QoS rule associated with the QoS Flow (which is generated by the SMF and explicitly signalled to the UE as described in clause 5.7.1 of TS 23.501 [2]) instructs the UE to direct the uplink part of the service data flow to the QoS Flow in the binding.

Whenever the binding parameters of a PCC rule changes, the binding of this PCC rule shall be re-evaluated, i.e. the binding mechanism described above is performed again. The re-evaluation may, for a PCC rule, result in a new binding with another QoS Flow. If the PCF requests the same change of the binding parameter value(s) for all PCC rules that are bound to the same QoS Flow, the SMF should not re-evaluate the binding of these PCC rules and instead, modify the QoS parameter value(s) of the QoS Flow accordingly.

NOTE 3: A QoS change of the PDU Session related information Authorized default 5QI/ARP values doesn't cause the QoS Flow rebinding for PCC rules with the Bind to QoS Flow associated with the default QoS rule Indication set.

When the PCF removes a PCC Rule, the SMF shall remove the association of the PCC Rule to the QoS Flow. If the last PCC rule that is bound to a QoS Flow is removed, the SMF shall delete the QoS Flow.

When a QoS Flow is removed, the SMF shall remove the PCC rules bound to this QoS Flow and report to the PCF that the PCC Rules bound to a QoS Flow are removed.

The QoS Flow binding shall also ensure that:

- when the PCF provisions a PCC rule, and if the PCC rule contains a TSC Assistance Container, the PCC rule is bound to a new QoS Flow and no other PCC rule is bound to this QoS Flow. Whenever the TSC Assistance Container of an existing PCC rule is changed, the binding of this PCC rule shall not be re-evaluated.
- if a dynamic value for the Core Network Packet Delay Budget (defined in clause 5.7.3.4 of TS 23.501 [2]) is used, PCC rules with the same above binding parameters but different PDU Session anchors (i.e. the corresponding service data flows which have different CN PDBs) are not bound to the same QoS Flow.

NOTE 4: Different PDU Session anchors can exist if the DNAI parameter of PCC rules contains multiple DNAIs.

- For MA PDU Session, PCC rules for GBR or delay critical GBR service data flows allowed on different access are not bound to the same QoS Flow even if the PCC rules contain the same binding parameters.

NOTE 5: For MA PDU Session, the GBR or delay critical GBR resource for a service data flow is allocated only in one access (as described in clause 5.32.4 of TS 23.501 [2]).

- When the PCF provisions a PCC rule with Alternative QoS parameter Set(s), the PCC rule is bound to a new QoS Flow and no other PCC rule is bound to this QoS Flow.
- The SMF should not bind the PCC rule(s) for the service data flow(s) with enabled ECN marking for L4S and the PCC rule(s) for the service data flow(s) without enabled ECN marking for L4S to the same QoS Flow.

NOTE 6: The SMF can also, based on local configuration in the PCF and the SMF, bind a PCC Rule that does not include Indication of ECN marking for L4S to a new QoS Flow that supports ECN marking for L4S.

- When the PCF provisions a PCC rule with QoS Monitoring Policy, the PCC rule is bound to a new QoS Flow and no other PCC rule is bound to this QoS Flow.

NOTE 7: The binding of PCC rule with QoS Monitoring policy to a new QoS Flow is not applicable to the QoS Monitoring of packet delay when per GTP-U path level measurement (as described in clause 5.33.3.3 of TS 23.501 [2]) is used.

- When the PCF provisions a PCC rule with Traffic Parameter Information, the PCC rule is bound to a new QoS Flow and no other PCC rule is bound to this QoS Flow.
- When the PCF provisions a PCC rule with PDU Set Control Information, the PCC rule is bound to a new QoS Flow and no other PCC rule is bound to this QoS Flow. Whenever the PDU Set Control Information of an existing PCC rule is changed, the binding of this PCC rule shall not be re-evaluated.
- When the PCF provisions a PCC rule with Data Burst Handling Information, the PCC rule is bound to a new QoS Flow and no other PCC rule is bound to this QoS Flow.
- When the PCF provisions a PCC rule with a Multi-modal Service ID, the PCC rule is bound to a new QoS Flow or to an existing QoS Flow under the following conditions. Only PCC rules with the same Multi-modal Service ID can be bound to the same QoS Flow if the binding parameters and conditions described in this clause allow for this.
- When the PCF provisions a PCC rule with RAN-Controlled UL Bitrate Recommendation Indication, the PCC rule is bound to a new QoS Flow and no other PCC rule is bound to this QoS Flow.

### 6.1.3.3 Reporting

Reporting refers to the differentiated PDU Session resource usage information (measured at the UPF) being reported by the SMF to the CHF.

NOTE 1: Reporting usage information to the CHF is distinct from credit management. Hence multiple PCC rules may share the same charging key for which one credit is assigned whereas reporting may be at higher granularity if serviced identifier level reporting is used.

The SMF shall report usage information for online and offline charging.

The SMF shall report usage information for each charging key value.

For service data flow charging, for the case of sponsored data connectivity, the reports for offline charging shall report usage for each charging key, Sponsor Identity and Application Service Provider Identity combination if Sponsor Identity and Application Service Provider Identifier have been provided in the PCC rules.

NOTE 2: Usage reports for online charging that include Sponsor Identity and Application Service Provider Identity is not within scope of the specification in this release. Online charging for sponsored data connectivity can be based on charging key as described in Annex X.

The SMF shall report usage information for each charging key/service identifier combination if service identifier level reporting is requested in the PCC rule.

NOTE 3: For reporting purposes when charging is performed by the SMF:

- a) the charging key value identifies a service data flow if the charging key value is unique for that particular service data flow, and
- b) if the service identifier level reporting is present then the service identifier value of the PCC rule together with the charging key identify the service data flow.

Charging information shall be reported based on the result from the service data flow detection and measurement on a per PDU Session basis.

A report may contain multiple containers, each container associated with a charging key, charging key and Sponsor Identity (in the case of sponsored connectivity) or charging key/service identifier.

#### 6.1.3.4 Credit management

The credit management applies only for service data flow with online charging method and shall operate on a per charging key basis. The SMF should initiate one charging session with the CHF for each PDU Session subject to charging, in order to perform credit management within the charging session.

NOTE 1: Independent credit control for an individual service/application may be achieved by assigning a unique charging key value in the corresponding PCC rule.

The SMF shall request a credit for each charging key occurring in a PCC rule. It shall be up to operator configuration whether the SMF shall request credit in conjunction with the PCC rule being activated or when the first packet corresponding to the service is detected. The CHF may either grant or deny the request for credit. The CHF shall strictly control the rating decisions.

NOTE 2: The term 'credit' as used here does not imply actual monetary credit, but an abstract measure of resources available to the user. The relationship between this abstract measure, actual money, and actual network resources or data transfer, is controlled by the CHF.

During PDU Session establishment and modification, the SMF shall request credit using the information after applying policy enforcement action (e.g. upgraded or downgraded QoS information), if applicable, even though the SMF has not signalled this information to the AMF or RAN.

The events trigger information which may be received from the CHF, causing the SMF to perform a usage reporting and credit request to CHF when the event occurs are specified in TS 32.255 [21].

The CHF may subscribe to Change of UE presence in Presence Reporting Area at any time during the life time of the charging session as described in TS 32.255 [21].

If the PCF set the Out of credit event trigger (see clause 6.1.3.5), the SMF shall inform the PCF about the PCC rules for which credit is no longer available together with the applied termination action.

#### 6.1.3.5 Policy Control Request Triggers relevant for SMF

The Policy Control Request Triggers relevant for SMF define the conditions when the SMF shall interact again with PCF after a PDU Session establishment as defined in the Session Management Policy Establishment and Session Management Policy Modification procedure as defined in TS 23.502 [3].

The PCR triggers are not applicable any longer at termination of the SM Policy Association.

The access independent Policy Control Request Triggers relevant for SMF are listed in table 6.1.3.5-1.

The differences with table 6.2 and table A.4.3-2 in TS 23.203 [4] are shown, either "none" means that the parameter applies in 5GS or "removed" meaning that the parameter does not apply in 5GS, this is due to the lack of support in the 5GS for this feature or "modified" meaning that the parameter applies with some modifications defined in the parameter.

**Table 6.1.3.5-1: Access independent Policy Control Request Triggers relevant for SMF**

Policy Control Request Trigger	Description	Difference compared with table 6.2 and table A.4.3-2 in TS 23.203 [4]	Conditions for reporting	Motivation
PLMN change	The UE has moved to another operators' domain.	None	PCF	
QoS change	The QoS parameters of the QoS Flow has changed.	Removed		Only applicable when binding of bearers was done in PCRF.
QoS change exceeding authorization	The QoS parameters of the QoS Flow has changed and exceeds the authorized QoS.	Removed		Only applicable when binding of bearers was done in PCRF.
Traffic mapping information change	The traffic mapping information of the QoS profile has changed.	Removed		Only applicable when binding of bearers was done in PCRF.
Resource modification request	A request for resource modification has been received by the SMF.	None	SMF always reports to PCF	
Routing information change	The IP flow mobility routing information has changed (when IP flow mobility as specified in TS 23.261 [11] applies) or the PCEF has received Routing Rules from the UE (when NBIFOM as specified in TS 23.161 [10] applies).	Removed		Not in 5GS yet.
Change in Access Type (NOTE 8) (NOTE 11)	The Access Type or RAT Type or both Access Type and RAT Type of the PDU Session changed.	None	PCF	
EPS Fallback	EPS fallback is initiated	Added	PCF	
Loss/recovery of transmission resources	The Access type transmission resources are no longer usable/again usable.	Removed		Not in 5GS yet.
Location change (serving cell) (NOTE 6)	The serving cell of the UE has changed.	None	PCF	
Location change (serving area) (NOTE 2)	The serving area of the UE has changed.	None	PCF	
Location change (serving CN node) (NOTE 3)	The serving core network node of the UE has changed.	None	PCF	
Change of UE presence in Presence Reporting Area (see NOTE 1)	The UE is entering/leaving a Presence Reporting Area.	None	PCF	Only applicable to PCF
Out of credit	Credit is no longer available.	None	PCF	
Reallocation of credit	Credit has been reallocated after the former Out of credit indication.	Added	PCF	
Enforced PCC rule request	SMF is performing a PCC rules request as instructed by the PCF.	None	PCF	
Enforced ADC rule request	TDF is performing an ADC rules request as instructed by the PCRF.	Removed		ADC Rules are not applicable.

Policy Control Request Trigger	Description	Difference compared with table 6.2 and table A.4.3-2 in TS 23.203 [4]	Conditions for reporting	Motivation
UE IP address change	A UE IP address has been allocated/released.	None	SMF always reports allocated or released UE IP addresses	
UE MAC address change	A new UE MAC address is detected or a used UE MAC address is inactive for a specific period.	New	PCF	
Access Network Charging Correlation Information	Access Network Charging Correlation Information has been assigned.	None	PCF	
Usage report (NOTE 4)	The PDU Session or the Monitoring key specific resources consumed by a UE either reached the threshold or needs to be reported for other reasons.	None	PCF	
Start of application traffic detection and Stop of application traffic detection (NOTE 5)	The start or the stop of application traffic has been detected.	None	PCF	
SRVCC CS to PS handover	A CS to PS handover has been detected.	Removed		No support in 5GS yet
Access Network Information report	Access information as specified in the Access Network Information Reporting part of a PCC rule.	None	PCF	
Credit management session failure	Transient/Permanent failure as specified by the CHF.	None	PCF	
Addition / removal of an access to an IP-CAN session	The PCEF reports when an access is added or removed.	Removed		No support in 5GS yet
Change of usability of an access	The PCEF reports that an access becomes unusable or usable again.	Removed		No support in 5GS yet
3GPP PS Data Off status change	The SMF reports when the 3GPP PS Data Off status changes.	None	SMF always reports to PCF	
Session AMBR change	The Session-AMBR has changed.	Added	SMF always reports to PCF	
Default QoS change	The subscribed QoS has changed.	Added	SMF always reports to PCF	
Removal of PCC rule	The SMF reports when the PCC rule is removed.	Added	SMF always reports to PCF	
Successful resource allocation	The SMF reports to the PCF that the resources for a PCC rule have been successfully allocated.	Added	PCF	
GFBP of the QoS Flow can no longer (or can again) be guaranteed	The SMF notifies the PCF when receiving notifications from RAN that GFBP of the QoS Flow can no longer (or can again) be guaranteed.	Added		
UE resumed from suspend state	The SMF reports to the PCF when it detects that the UE is resumed from suspend state.	None	PCF	Only applicable to EPC IWK

Policy Control Request Trigger	Description	Difference compared with table 6.2 and table A.4.3-2 in TS 23.203 [4]	Conditions for reporting	Motivation
Change of DN Authorization Profile Index	The DN Authorization Profile Index received from DN-AAA has changed.	Added	SMF always reports to PCF	
5GS Bridge/Router information available	SMF has detected new 5GS Bridge/Router information, which may contain, user-plane Node ID, UE-DS-TT residence time and Ethernet port (port number and MAC address) or IP address for the PDU Session, MTU size for IPv4 or MTU size for IPv6 and/or PMIC and/or UMIC.	Added	PCF	
QoS Monitoring	The SMF notifies the PCF of the QoS Monitoring reports (as defined in clause 5.45 of TS 23.501 [2]).	Added	PCF	
DDN Failure event Subscription with Traffic Descriptor	The SMF requests PCF to provide or remove policies if it received an event subscription or cancellation for DDN Failure event including traffic descriptors. The SMF provides the traffic descriptors to the PCF for policy evaluation.	Added	PCF	
DDD Status event Subscription with Traffic Descriptor	The SMF requests PCF to provide or remove policies if it received an event subscription or cancellation for DDD Status event including traffic descriptors. The SMF provides the traffic descriptors and the requested type(s) of notifications (notifications about downlink packets being buffered, and/or discarded) to the PCF for policy evaluation.	Added	PCF	
QoS constraints change	The QoS constraints in the VPLMN have been provided or changed.	Added	SMF always reports to PCF	
Satellite backhaul category change	The backhaul is changed between different types of satellite backhaul, or between satellite backhaul and non-satellite backhaul.	Added	PCF	
NWDAF info change	The NWDAF instance IDs used for the PDU Session or associated Analytics IDs used for the PDU Session and available in the SMF have changed.	Added	PCF	
Request for reporting the PCF binding information (NOTE 9)	The SMF reports the updated PCF binding information of the PCF for the UE.	Added	SMF always reports to PCF	
Notification on BAT offset	The SMF reports the BAT offset and optionally the adjusted periodicity provided by the RAN.	Added	PCF	

<b>Policy Control Request Trigger</b>	<b>Description</b>	<b>Difference compared with table 6.2 and table A.4.3-2 in TS 23.203 [4]</b>	<b>Conditions for reporting</b>	<b>Motivation</b>
UE reporting Connection Capabilities from associated URSP rule (NOTE 10)	The SMF has received from the UE reporting from an associated URSP rule via a PDU Session establishment or PDU Session modification request.	Added	SMF always reports to PCF	

Policy Control Request Trigger	Description	Difference compared with table 6.2 and table A.4.3-2 in TS 23.203 [4]	Conditions for reporting	Motivation
UE Policy Container received or delivery failure for UE Policy Container delivery via EPS	The SMF reports that a UE Policy Container has been received from the UE or a delivery failure for UE Policy Container delivery via EPS.	Added	SMF always reports to PCF	
Change of HR-SBO support indication	The HR-SBO support indication has changed.	Added		
Network Slice Replacement	The SMF reports the event of change between S-NSSAI and Alternative S-NSSAI to PCF when the SMF determines that the PDU Session and SM Policy Association can be retained.	Added	PCF	
ECN marking for L4S can no longer (or can again) be performed	The SMF notifies the PCF when ECN marking for L4S can no longer (or can again) be performed.	Added	PCF	
QoS Monitoring can no longer (or can again) be performed	The SMF notifies the PCF when QoS Monitoring can no longer (or can again) be performed.	Added	PCF	
UE reachability status change	The SMF reports to the PCF when it receives an indication of a change of the UE reachability status.	Added	PCF	
Non-3GPP Device Identifier received	The SMF reports to the PCF when a Non-3GPP Device Identifier is received.	Added	SMF always reports to PCF	
<p>NOTE 1: The maximum number of PRA(s) per UE per PDU Session is configured in the PCF. The PCF may have independent configuration of the maximum number for Core Network pre-configured PRAs and UE-dedicated PRAs. The exact number(s) should be determined by operator in deployment.</p> <p>NOTE 2: This trigger reports change of Tracking Area in both 5GS and EPC interworking, or reports change of Routing Area for GERAN/UTRAN access (see Annex G of TS 23.502 [3]).</p> <p>NOTE 3: This trigger reports change of AMF in 5GC, change between ePDG and Serving GW in EPC, change between Serving GWs in EPC, change between EPC and 5GC, change between Serving Gateway and SGSN in GERAN/UTRAN from/to E-UTRAN mobility, or change between SGSNs in the case of GERAN/UTRAN access. In HR roaming case, if the AMF change is unknown by the H-SMF, then the AMF change is not reported.</p> <p>NOTE 4: Usage is defined as either volume or time of user plane traffic.</p> <p>NOTE 5: The start and stop of application traffic detection are separate event triggers, but received under the same subscription from the PCF.</p> <p>NOTE 6: Location change of serving cell can increase signalling load on multiple interfaces. Hence it is recommended that any such serving cell changes only applied for a limited number of subscribers avoiding extra signalling load. It also is applicable for GERAN/UTRAN access.</p> <p>NOTE 7: Void.</p> <p>NOTE 8: For 3GPP access the RAT type may refer to NR, E-UTRAN, and, when the SMF+PGW-C enhancements to support GERAN/UTRAN access via Gn/Gp interface as specified in Annex L of TS 23.501 [2] apply, to UTRAN or GERAN. For MA PDU Session this trigger reports the current used Access Type(s) and RAT type(s) upon any change of Access Type and RAT type.</p> <p>NOTE 9: The PCF for the PDU Session knows the change of the PCF for the UE by this Policy Control Request Trigger based on the associated binding information of and notifies the PCF for the UE as described in clause 6.1.3.18.</p> <p>NOTE 10: See clause 6.6.2.4.</p> <p>NOTE 11: Multiple triggers are described in TS 29.512 [44] for this event.</p>				

NOTE 1: In the following description of the access independent Policy Control Request Triggers relevant for SMF, the term trigger is used instead of Policy Control Request Trigger where appropriate.

When the EPS Fallback trigger is armed by the PCF, the SMF shall report the event to the PCF when a QoS Flow with 5QI=1 is rejected due to EPS Fallback.

When the Location change trigger is armed, the SMF shall subscribe to the AMF for reports on changes in location to the level indicated by the trigger. If credit-authorization triggers and Policy Control Request Triggers require different levels of reporting of location change for a single UE, the location to be reported should be changed to the highest level of detail required. However, there should be no request being triggered for PCC rules update to the PCF if the report received is more detailed than requested by the PCF.

NOTE 2: The access network may be configured to report location changes only when transmission resources are established in the radio access network.

The Resource modification request trigger shall trigger the PCF interaction for all resource modification requests not tied to a specific QoS Flow received by SMF. The resource modification request received by SMF may include request for guaranteed bit rate changes for a traffic aggregate and/or the association/disassociation of the traffic aggregate with a 5QI and/or a modification of the traffic aggregate.

The enforced PCC rule request trigger shall trigger a SMF interaction to request PCC rules from the PCF for an established PDU Session. This SMF interaction shall take place within the Revalidation time limit set by the PCF in the PDU Session related policy information. The SMF reports that the enforced PCC rule request trigger was met and the enforced PCC Rules.

NOTE 3: The enforced PCC rule request trigger can be used to avoid signalling overload situations e.g. due to time of day based PCC rule changes.

The UE IP address change trigger shall trigger a SMF interaction with the PCF if a UE IP address is allocated or released during the lifetime of the PDU Session. The SMF reports that the UE IP address change trigger was met and the new or released UE IP address.

The UE MAC address change trigger shall trigger a SMF interaction with the PCF if a new UE MAC address is detected or a used UE MAC address is inactive for a specific period during the lifetime of the Ethernet type PDU Session. The SMF reports that the UE MAC address change trigger was met and the new or released UE MAC address.

NOTE 4: The SMF instructs the UPF to detect new UE MAC addresses or used UE MAC address is inactive for a specific period as described in TS 23.501 [2].

The Access Network Charging Correlation Information trigger shall trigger the SMF to report the assigned access network charging identifier for the PCC rules that are accompanied with a request for this trigger at activation. The SMF reports that the Access Network Charging Correlation Information trigger was met and the Access Network Charging Correlation Information.

If the Usage report trigger is set and the volume or the time thresholds, earlier provided by the PCF, are reached, the SMF shall report this situation to the PCF. If both volume and time thresholds were provided and the thresholds, for one of the measurements, are reached, the SMF shall report this situation to the PCF and the accumulated usage since last report shall be reported for both measurements.

The management of the Presence Reporting Area (PRA) functionality enables the PCF to subscribe to reporting change of UE presence in a particular Presence Reporting Area.

NOTE 5: PCF decides whether to subscribe to AMF or to SMF for those triggers that are present in both tables 6.1.2.5-2 and 6.1.3.5-1. If the Change of UE presence in Presence Reporting Area trigger is available on both AMF and SMF, PCF should not subscribe to both AMF and SMF simultaneously.

Upon every interaction with the SMF, the PCF may activate / deactivate reporting changes of UE presence in Presence Reporting Area by setting / unsetting the corresponding trigger by providing the PRA Identifier(s) and additionally the list(s) of elements comprising the Presence Reporting Area for UE-dedicated Presence Reporting Area(s).

The SMF shall subscribe to the UE Location Change notification from the AMF by providing an area of interest containing the PRA Identifier(s) and additionally the list(s) of elements provided by the PCF as specified in clause 5.6.11 of TS 23.501 [2] and in clause 5.2.2.3.1 of TS 23.502 [3].

When the Change of UE presence in Presence Reporting Area trigger is armed, i.e. when the PCF subscribes to reporting change of UE presence in a particular Presence Reporting Area and the reporting change of UE presence in this Presence Reporting Area was not activated before, the SMF subscribes to the UE mobility event notification service provided by the AMF for reporting of UE presence in Area of Interest which reports when the UE enters or leaves a Presence Reporting Area (an initial report is received when the PDU Session specific procedure is activated). The SMF reports the PRA Identifier(s) and indication(s) whether the UE is inside or outside the Presence Reporting Area(s), and indication(s) if the corresponding Presence Reporting Area(s) is set to inactive by the AMF to the PCF.

NOTE 6: The serving node (i.e. AMF in 5GC or MME in EPC/EUTRAN) can activate the reporting for the PRAs which are inactive as described in the TS 23.501 [2].

When PCF modifies the list of PRA id(s) to change of UE presence in Presence Reporting Area for a particular Presence Reporting Area(s), the SMF removes or adds the PRA id(s) provided in the UE mobility event notification service provided by AMF for reporting of UE presence in Area Of Interest. When the PCF unsubscribes to reporting change of UE presence in Presence reporting Area, the SMF unsubscribes to the UE mobility event notification service provided by AMF for reporting of UE presence in Area Of Interest, unless subscriptions to AMF remains due to other triggers.

The SMF stores PCF subscription to reporting for changes of UE presence in Presence Reporting Area and notifies the PCF with the PRA Identifier(s) and indication(s) whether the UE is inside or outside the Presence Reporting Area(s) based on UE location change notification in area of interest received from the serving node according to the corresponding subscription.

NOTE 7: The SMF can also be triggered by the CHF to subscribe to notification of UE presence in PRA from the AMF, and notifies the CHF when receiving reporting of UE presence in PRA from the AMF, referring to TS 32.291 [20].

If PCF is configured with a PRA identifier referring to the list of PRA Identifier(s) within a Set of Core Network predefined Presence Reporting Areas as defined in TS 23.501 [2], it activates the reporting of UE entering/leaving each individual PRA in the Set of Core Network predefined Presence Reporting Areas, without providing the complete set of individual PRAs.

When a PRA set identified by a PRA Identifier was subscribed to report changes of UE presence in Presence Reporting Area by the PCF, the SMF additionally receives the PRA Identifier of the PRA set from the AMF, along with the individual PRA Identifier(s) belonging to the PRA set and indication(s) of whether the UE is inside or outside the individual Presence Reporting Area(s), as described in TS 23.501 [2].

When the Out of credit detection trigger is set, the SMF shall inform the PCF about the PCC rules for which credit is no longer available together with the applied termination action.

When the Reallocation of credit detection trigger is set, the SMF shall inform the PCF about the PCC rules for which credit has been reallocated after credit was no longer available and the termination action was applied.

The Start of application traffic detection and Stop of application traffic detection triggers shall trigger an interaction with PCF once the requested application traffic is detected (i.e. Start of application traffic detection) or the end of the requested application traffic is detected (i.e. Stop of application traffic detection) unless it is requested within a specific PCC Rule to mute such interaction for solicited application reporting or unconditionally in the case of unsolicited application reporting. The application identifier and service data flow descriptions, if deducible, shall also be included in the report. An application instance identifier shall be included in the report both for Start and for Stop of application traffic detection when service data flow descriptions are deducible. This is done to unambiguously match the Start and the Stop events.

At PCC rule activation, modification and deactivation the SMF shall send, as specified in the PCC rule, the User Location Report and/or UE Timezone Report and/or Satellite Identifier Report to the PCF.

NOTE 8: At PCC rule deactivation the User Location Report includes information on when the UE was last known to be in that location.

If the trigger for Access Network Information reporting is set, the SMF shall check the need for access network information reporting after successful installation/modification or removal of a PCC rule or upon termination of the PDU Session. The SMF shall check the Access Network Information report parameters (User Location Report, UE Timezone Report, Satellite Identifier Report) of the PCC rules and report the access network information to the PCF. The SMF shall not report any subsequent access network information updates received from the PDU Session without any previous updates of related PCC rule unless the associated QoS Flow or PDU Session has been released.

If the SMF receives a request to install/modify or remove a PCC rule with Access Network Information report parameters (User Location Report, UE Timezone Report, Satellite Identifier Report) set the SMF shall initiate a PDU Session modification to retrieve the current access network information of the UE and forward it to the PCF afterwards.

If the Access Network Information report parameter for the User Location Report is set and the user location (e.g. cell) is not available to the SMF, the SMF shall provide the serving PLMN identifier to the PCF.

The Credit management session failure trigger shall trigger a SMF interaction with the PCF to inform about a credit management session failure and to indicate the failure reason, and the affected PCC rules.

NOTE 9: As a result, the PCF may decide about e.g. PDU Session termination, perform gating of services, switch to offline charging, change rating group, etc.

NOTE 10: The Credit management session failure trigger applies to situations wherein the PDU Session is not terminated by the SMF due to the credit management session failure.

The default QoS change triggers shall trigger the PCF interaction for all changes in the default QoS data received in SMF from the UDM.

The Session AMBR change trigger shall trigger the SMF to provide the Session-AMBR to the PCF containing the DN authorised Session AMBR if received from the DN-AAA, or the Subscribed Session-AMBR received from the UDM as described in clause 5.6.6 of TS 23.501 [2].

The default QoS change trigger reports a change in the default 5QI/ARP retrieved by SMF from UDM, as explained in clause 5.7.2.7 of TS 23.501 [2].

If the PCC Rules bound to a QoS Flow are removed when the corresponding QoS Flow is removed or the PCC rules are failed to be enforced, the SMF shall report this situation to the PCF and may provide the reason for failure, if the reason for failure is that the UE is temporarily unreachable, the SMF may also provide the maximum waiting time to the PCF, in this case the PCF does not provide the same or updated PCC Rules for the established PDU Session before the maximum waiting time expires, the PCF may also subscribe to PCRT on change of UE reachability. In other failure scenarios, the PCF may then provide the same or updated PCC rules for the established PDU Session.

NOTE 11: The PCF can decide to provide PCC Rules when the maximum waiting time expires or send them later depending on implementation.

If the trigger for successful resource allocation is set and the PCF has also provided an indication that a specific PCC rule is subject to this trigger, the SMF shall report to the PCF when the resources associated to this PCC rule have been successfully allocated. The SMF shall report resource allocation failure always to the PCF, independently of this trigger. If the SMF reports resource allocation failure for a PCC rule containing MA PDU Session Control information with Redundant as Steering Mode (see clause 5.32.4 of TS 23.501 [2]), the SMF shall also indicate the respective Access Type.

If the GFBR of the QoS Flow can no longer (or can again) be guaranteed trigger is armed, the SMF shall check the need for reporting to the PCF when the SMF receives an explicit notification from (R)AN indicating that GFBR of the QoS Flow can no longer (or can again) be guaranteed or when the condition described in clause 5.7.2.4 of TS 23.501 [2] is met during the handover. The SMF shall report that GFBR of the QoS Flow can no longer (or can again) be guaranteed accordingly to the PCF for those PCC rules which are bound to the affected QoS Flow and have the QoS Notification Control (QNC) parameter set. If the SMF receives a direction information together with the notification from (R)AN (as described in clause 5.7.2.4.1a of TS 23.501 [2] for the case of a GBR QoS Flow), the SMF shall also forward the direction information to the PCF. If other information is received together with the notification from NG-RAN (see clause 5.7.2.4 of TS 23.501 [2]), the SMF shall also provide to the PCF the reference to the Alternative QoS parameter set corresponding to the Alternative QoS Profile referenced by NG-RAN. If NG-RAN has indicated that the lowest priority Alternative QoS Profile cannot be fulfilled, the SMF shall indicate to the PCF that the lowest priority Alternative QoS parameter set cannot be fulfilled.

In an interworking scenario between 5GS and EPC/E-UTRAN, as explained in clause 4.3 of TS 23.501 [2], the PCF may subscribe via the SMF also to the Policy Control Request Triggers described in clause 6.1.2.5 when the UE is served by the EPC/E-UTRAN.

The change of DN Authorization Profile Index shall trigger a SMF interaction to send DN Authorization Profile Index to retrieve a list of PCC Rules (as defined in clause 6.3) and/or PDU Session related policy (as defined in clause 6.4) for an established PDU Session.

If the trigger for 5GS Bridge/Router information available is armed, the SMF shall report the 5GS Bridge/Router information when the SMF has determined or updated the 5GS Bridge/Router information, e.g. when SMF has detected an Ethernet port which supports exchange of Ethernet Port Management Information Containers or received User plane node Management Information Container or Port Management Information Container. If a new manageable Ethernet DS-TT port is detected, the SMF provides User plane node ID, the port number and optionally MAC address of the related port of the related PDU Session to the PCF. If the SMF has received UE-DS-TT Residence Time then the SMF also provides UE-DS-TT Residence Time to the PCF. If the SMF has received the User plane node Management

Information Container from NW-TT or Port Management Information Container from NW-TT or DS-TT, the SMF also provides User plane node Management Information Container or Port Management Information Container and related port number to the PCF. In the case of Deterministic Networking, the SMF may also provide the MTU size for IPv4 or the MTU size for IPv6.

When the QoS Monitoring trigger is set, the SMF shall, upon receiving the QoS Monitoring report from the UPF, send the measurement report to the PCF.

If the Policy Control Request Trigger "DDN Failure event subscription with Traffic Descriptor" or "DDD Status event subscription with Traffic Descriptor" is set, the SMF shall request policies if it received a subscription or cancellation of notifications for availability after DDN Failure event with traffic descriptor or DDD Status event with traffic descriptor, respectively. The SMF indicates whether it is a subscription or cancellation event and provides the received Traffic Descriptor as well as the requested type(s) of notifications (notifications about downlink packets being buffered, and/or discarded) to the PCF. When the SMF indicates a subscription event, the PCF checks whether an installed PCC rule exists for the received Traffic Descriptor and if so, the PCF sets the Downlink Data Notification Control information of that PCC rule according to the requested type(s) of notifications. Otherwise, the PCF provides a new PCC Rule with the received Traffic Descriptor in the SDF Template, the Downlink Data Notification Control information set according to the requested type(s) of notifications and other PCC Rule information set to the same values as in the existing PCC rule that previously matched the traffic. When the new PCC rule has to be bound to the QoS Flow associated with the default QoS rules, the PCF sets the "Bind to QoS Flow associated with the default QoS rule" parameter. From now on, the PCF needs to keep the PCC rule for the DDD event detection fully synchronized with the existing PCC rule that previously matched the traffic for all other policy and charging control settings to ensure the same user experience and traffic treatment according to the operator policy. When the SMF indicates a cancellation event, the PCF removes the Downlink Data Notification Control information in the installed PCC Rule or removes the PCC Rule if a new PCC rule has been provided during the subscription event and this PCC rule is no longer necessary for any other policy enforcement.

NOTE 12: Downlink Data Delivery (DDD) status event and DDN Failure event are specified in clause 4.15.3 of TS 23.502 [3].

The QoS constraints change trigger shall trigger a SMF interaction with the PCF if QoS constraints are received by the SMF during the lifetime of the PDU Session. The SMF reports that the QoS constraints change trigger was met and the new QoS constraints.

When the Satellite backhaul category change trigger is armed, the SMF reports to the PCF that the Satellite backhaul category change was met and the new Satellite backhaul category (including satellite backhaul is no longer used) when it becomes aware that there is a change of the backhaul which is used for the PDU Session between different types of satellite backhaul, or between satellite backhaul and a non-satellite backhaul. The SMF determines whether or not a satellite backhaul is used and whether there is a change of backhaul based on signalling from the AMF as specified in TS 23.501 [2].

NOTE 13: As specified in clause 5.43.4 of TS 23.501 [2], Satellite backhaul category refers to the type of the satellite (or non-satellite) used in the backhaul. Only a single backhaul category can be indicated.

The NWDAF info change trigger shall trigger the SMF to interact with the PCF when the list of NWDAF Instance IDs used for the PDU Session or associated Analytics IDs used for the PDU Session are changed in the SMF.

The Request for reporting the PCF binding information indicates to the SMF to report to the PCF both the updated PCF binding information (of the PCF for the UE), if it is received from the AMF together with Request for notification of SM Policy Association establishment and termination if both are received from the AMF.

When the Notification on BAT offset trigger is set, the SMF shall, upon receiving a BAT offset and optionally an adjusted periodicity from the RAN (in a notification that GFBR of the QoS Flow can no longer be guaranteed as defined in clause 5.27.2.5.3 of TS 23.501 [2]), report the BAT offset and optionally the adjusted periodicity to the PCF for the PCC rule which is bound to the QoS Flow for which the notification from RAN was received.

The UE reporting Connection Capabilities from associated URSP rule trigger indicates to the SMF that when a UE includes Connection Capabilities in the PDU Session Establishment Request or PDU Session Modification Request, the SMF shall forward this information to the PCF as described in clause 6.6.2.4.

The UE Policy Container received or delivery failure for UE Policy Container delivery via EPS trigger shall trigger a SMF interaction with the PCF, if a UE Policy Container is received from the UE via EPS or in case of a delivery failure for UE Policy Container delivery via EPS (with appropriate reason, e.g. UE is not reachable), as described in clause 4.11.0a.2a.10 of TS 23.502 [3].

NOTE 14: The UE Policy Container can include a list of provisioned PSIs and/or UE capabilities (e.g. indication of supporting URSP rules over EPS) or the result of the delivery of the UE Policy Container as well as the result of processing the content of the UE Policy Container by the UE.

When the Change of HR-SBO support indication trigger is armed, the H-SMF reports to the H-PCF that the HR-SBO support indication change was met. The H-SMF determines whether there is a change of HR-SBO support indication based on HR-SBO Request Indication from the V-SMF and/or the SM subscription data from UDM as described in clause 6.7.2.2 of TS 23.548 [33].

The Network Slice Replacement trigger shall trigger a SMF interaction with the PCF to notify change between S-NSSAI and Alternative S-NSSAI when the SMF determines that the existing PDU Session and existing SM Policy Association can be retained as described in clause 5.15.19 of TS 23.501 [2]. The SMF provides Alternative S-NSSAI if the PDU Session is transferred from a S-NSSAI to its Alternative S-NSSAI. The SMF indicates to the PCF that the PDU Session is transferred from the Alternative S-NSSAI back to the replaced S-NSSAI with no additional information, when the replaced S-NSSAI is available again and the PDU Session is transferred to the replaced S-NSSAI.

NOTE 15: The SMF reports to the PCF a PDU session transfer anytime when the PDU Session is transferred from one S-NSSAI to another S-NSSAI.

If the "ECN marking for L4S can no longer (or can again) be performed" trigger is armed, the SMF shall report to the PCF for those PCC rules which have enabled ECN marking for L4S (explicitly or implicitly as described in clause 6.1.3.22) if neither 5G-AN nor UPF PSA ECN marking for L4S can be enabled on the affected QoS Flows, and when ECN marking for L4S can be enabled on the affected QoS Flows (again).

If the "QoS Monitoring can no longer (or can again) be performed trigger" is armed, the SMF shall report to the PCF for those PCC rules with QoS Monitoring Policy when the support for QoS monitoring is not possible or has changed for the respective QoS Monitoring parameter, i.e. from QoS monitoring is possible to QoS monitoring is not possible or vice versa. The SMF determines whether QoS monitoring is possible or not as described in clause 5.45.1 of TS 23.501 [2] and indicates the affected QoS Monitoring parameter(s) to the PCF.

When the UE reachability status change is armed, the SMF subscribes to event of "UE reachability status" by using the `Namf_EventExposure_Subscribe` defined in clause 5.2.2.3.1 of TS 23.502 [3]. The SMF reports a change of the UE reachability status to the PCF.

When SMF receives a Non-3GPP Device Identifier, the SMF reports, to the PCF, the Non-3GPP Device Identifier and corresponding user plane address information (if included) as described in clause 5.52 of TS 23.501 [2] and Annex C of TS 23.316 [27].

### 6.1.3.6 Policy control

QoS control refers to the authorization and enforcement of the maximum QoS that is authorized for a service data flow, for a QoS Flow or for the PDU Session. A service data flow may be either of IP type or of Ethernet type. PDU Sessions may be of IP type or Ethernet type or unstructured.

The PCF, in a dynamic PCC Rule, associates a service data flow template to an authorized QoS that is provided in a PCC Rule to the SMF. The PCF may also activate a pre-defined PCC Rule that contains that association.

The authorized QoS for a service data flow template shall include a 5QI and the ARP and may include a 5QI Priority Level. For a 5QI of GBR or Delay-critical GBR resource type, the authorized QoS shall also include the MBR, GBR and may include the QoS Notification Control parameter (for notifications when authorized GFBR can no longer (or can again) be fulfilled). For 5QI of Non-GBR resource type, the authorized QoS may include the MBR and the Reflective QoS Control parameter. The 5QI value can be standardized (i.e. referring to QoS characteristics as defined in clause 5.7.3 of TS 23.501 [2]), pre-configured (i.e. referring to QoS characteristics configured in the RAN) or dynamically assigned (i.e. referring to QoS characteristics provided by the PCF as Explicitly signalled QoS Characteristics in the PDU Session related policy information described in clause 6.4).

NOTE 1: Further details, special cases and additional parameters are described in clause 6.3.1.

QoS control also refers to the authorization and enforcement of the Session-AMBR, default 5QI/ARP combination and 5QI Priority Level, if applicable. The PCF may provide the Authorized Session-AMBR, the Authorized default 5QI and ARP combination and the 5QI Priority Level as part of the PDU Session information for the PDU Session to the SMF. The Authorized Session-AMBR, Authorized default 5QI/ARP and if available, 5QI Priority Level values take precedence over other values locally configured or received at the SMF.

In home routed roaming, the H-SMF may provide the QoS constraints (defined in clause 5.7.1.11 of TS 23.501 [2]) received from the VPLMN (according to clause 4.3.2.2.2 of TS 23.502 [3]) to the H-PCF. The H-PCF ensures that the Authorized Session-AMBR value does not exceed the Session-AMBR value provided by the VPLMN, that the Authorized default 5QI/ARP contains a 5QI and ARP value supported by the VPLMN and if available, the applicable 5QI Priority Level is supported by the VPLMN. If no QoS constraints are provided the H-PCF considers that no QoS constraints apply unless operator policies define any. The PCF shall also consider the QoS constraints for the setting of the Subsequent Authorized default 5QI/ARP, if available, the applicable 5QI Priority Level and Subsequent Authorized Session-AMBR.

For policy control, the AF interacts with the PCF and the PCF interacts with the SMF as instructed by the AF. For certain events related to policy control, the AF shall be able to give instructions to the PCF to act on its own, i.e. based on the service information currently available. The following events are subject to instructions from the AF:

- The authorization of the service based on incomplete service information;

NOTE 2: The QoS authorization based on incomplete service information is required for e.g. IMS session setup scenarios with available resources on originating side and a need for resource reservation on terminating side.

- The immediate authorization of the service;
- The gate control (i.e. whether there is a common gate handling per AF session or an individual gate handling per AF session component required);
- The forwarding of QoS Flow level information or events (see clause 6.1.3.18).

The UE and the AF shall provide all available Flow Description information (e.g. source and destination IP address and port numbers and the protocol information) to enable the binding functionality and the generation or selection of the service data flow filter(s) in the PCC rules. The AF may also provide a ToS (IPv4) or TC (IPv6) value that is set by the application as part of the Flow Description information. The PCF generates a PCC Rule with service data flow filter(s) (either as IP Packet Filter set as defined in clause 5.7.6.2 of TS 23.501 [2] or as Ethernet Packet Filter set as defined in clause 5.7.6.3 of TS 23.501 [2]) derived from the Flow Description information.

NOTE 3: A ToS/TC value can be useful when another packet filter attribute is needed to differentiate between packet flows. For example, packet flows encapsulated and encrypted by a tunnelling protocol can be differentiated by the ToS/TC value of the outer header if appropriately set by the application. To use ToS/TC for service data flow detection, network configuration by the operator (and additionally by the 3rd party Service Provider when the transport network is not fully within the operator control) needs to ensure there is no ToS/TC re-marking applied along the path from the application to the PSA UPF and the specific ToS/TC values are managed properly to avoid potential collision with other usage (e.g. paging policy differentiation). An example that the transport network is not fully within operator control is the Edge Hosting Environment according to TS 23.548 [33].

The AF may provide an AF Application Identifier, i.e. an identifier that refers to the application the AF session belongs to, containing either an AF identifier, an external application identifier (if the NEF is involved and performs the mapping to the application identifier) or an application identifier (if the AF is configured accordingly).

NOTE 4: Either Flow Description information or an (external) application identifier for application detection control can be provided.

If SMF indicates that a PDU Session is carried over NR satellite access or satellite backhaul, the PCF may take this information into account for the policy decision, e.g. together with any delay requirements provided by the AF.

When SMF indicates that the dynamic satellite backhaul is used to serve the PDU Session, the PCF, based on local policy, may use QoS monitoring (as described in clause 6.1.3.21) to get reports for the packet delay (defined in clause 5.45.2 of TS 23.501 [2]). The PCF may take this reported packet delay information into account for the policy decision along with other criteria, such as the AF requested QoS requirements.

### 6.1.3.7 Service (data flow) prioritization and conflict handling

Service pre-emption priority enables the PCF to resolve conflicts where the activation of all requested active PCC rules for services would result in a cumulative authorized QoS which exceeds the Subscribed Guaranteed bandwidth QoS.

NOTE 1: For example, the PCF may use the pre-emption priority of a service, the activation of which would cause the subscriber's authorized QoS to be exceeded. If this pre-emption priority is greater than that of any one or more active PCC rules, the PCF can determine whether the deactivation of any one or more such rules would allow the higher pre-emption priority PCC rule to be activated whilst ensuring the resulting cumulative QoS does not exceed a subscriber's Subscribed Guaranteed Bandwidth QoS.

If such a determination can be made, the PCF may resolve the conflict by deactivating those selected PCC rules with lower pre-emption priorities and accepting the higher priority service information from the AF. If such a determination cannot be made, the PCF may reject the service information from the AF.

NOTE 2: Normative PCF requirements for conflict handling are not defined. Alternative procedures may use a combination of pre-emption priority and AF provided priority indicator.

### 6.1.3.8 Termination action

The termination action indicates the action which the SMF instructs the UPF to perform for all PCC rules of a Charging key for which credit is no longer available. The functional description for termination actions is described in TS 32.255 [21].

The SMF shall revert the termination action related instructions for the UPF for all PCC rules of a Charging key when credit is available again.

### 6.1.3.9 Handling of packet filters provided to the UE by SMF

Traffic mapping information is signalled to the UE by the SMF in the Packet Filter Sets of QoS rules as defined in TS 23.501 [2].

The network shall ensure that the traffic mapping information signalled to UE reflects the QoS Flow binding of PCC rules, except for those extending the inspection beyond what can be signalled to the UE. The PCC rules may restrict what traffic is allowed compared to what is explicitly signalled to the UE. The PCF may, per service data flow filter, indicate that the SMF is required to explicitly signal the corresponding traffic mapping information to the UE, e.g. for the purpose of IMS precondition handling at the UE. In absence of that indication, it is an SMF decision whether to signal the traffic mapping information that is redundant from a traffic mapping point of view.

For QoS Flow for services with no uplink IP flows, there is no need to provide any UL filter to the UE that effectively disallows any useful packet flows in uplink direction.

The default QoS rule will either contain a Packet Filter Set that allows all UL packets or a Packet Filter Set that is generated from the UL SDF filters (and from the DL SDF filters if they are available) which have an indication to signal corresponding traffic mapping information to the UE.

NOTE: If multiple PCC rules with an indication to signal corresponding traffic mapping information to the UE are bound to the QoS Flow associated with the default QoS rule, it is up to SMF implementation which one will be chosen to generate the default QoS rule. If the PCC rule that is chosen to generate the default QoS rule is removed/deactivated, another PCC rule bound to the QoS Flow associated with the default QoS rule will be used instead and the default QoS rule would be updated accordingly.

In the case of interworking with E-UTRAN connected to EPC, the specific aspects of the handling of packet filters at the SMF are described in clause 4.11.1 of TS 23.502 [3].

### 6.1.3.10 IMS emergency session support

PDU Sessions for IMS Emergency services are provided by the serving network to support IMS emergency when the serving network is configured to support emergency services. The serving network may be either a PLMN or a SNPN. Emergency services are network services provided through an Emergency DNN and may not require a subscription depending on operator policies and local regulatory requirements. For emergency services, the architecture for the non-roaming case is the only applicable architecture model.

For emergency services, the N36 reference point does not apply. Emergency services are handled locally in the serving network.

For a PDU Session serving an IMS emergency session, the PCF makes authorization and policy decisions that restrict the traffic to emergency destinations, IMS signalling and the traffic to retrieve user location information (in the user

plane) for emergency services. A PDU Session serving an IMS emergency session shall not serve any other service and shall not be converted to/from any PDU Session serving other services. The PCF shall determine based on the DNN if a PDU Session concerns an IMS emergency session.

The PCC Rule Authorization function selects QoS parameters that allow prioritization of IMS Emergency sessions. If an IMS Emergency session is prioritized the QoS parameters in the PCC Rule shall contain an ARP value that is reserved for intra-operator use of IMS Emergency services. The PCF does not perform subscription check; instead it utilizes the locally configured operator policies to make authorization and policy decisions.

NOTE 1: Reserved value range for intra-operator use is defined in TS 23.501 [2].

For an emergency DNN, the PCF does not perform subscription check; instead it utilizes the locally configured operator policies to make authorization and policy decisions.

It shall be possible for the PCF to verify that the IMS service information is associated with a UE IP address belonging to an emergency DNN. If the IMS service information does not contain an emergency related indication and the UE IP address is associated with an emergency DNN, the PCF shall reject the IMS service information provided by the P-CSCF (and thus to trigger the release of the associated IMS session), see TS 23.167 [12].

In addition, the PCF shall provide the PEI and the subscriber identifiers (SUPI, GPSI) (if available), received from the SMF at PDU Session establishment, if so requested by the P-CSCF. The SUPI contains an IMSI or a network-specific identifier in the form of a NAI as defined in clauses 5.9.2 and 5.30.2.3 of TS 23.501 [2]. If the PCF removes all PCC Rules with a 5QI other than the default 5QI and the 5QI used for IMS signalling, the SMF shall start a configurable inactivity timer (e.g. to enable PSAP Callback session). When the configured period of time expires the SMF shall terminate the PDU Session serving the IMS Emergency session as defined in TS 23.502 [3]. If the SMF receives new PCC rule(s) with a 5QI other than the default 5QI and the 5QI used for IMS signalling for the PDU Session serving the IMS Emergency session, the SMF shall cancel the inactivity timer.

### 6.1.3.11 Multimedia Priority Service support

Multimedia Priority Services (MPS) is defined in TS 23.501 [2], TS 23.502 [3] and in TS 23.228 [5], utilising the architecture defined for 5GS.

Subscription data for MPS is provided to PCF through the N36/Nudr. To support MPS service, the PCF shall subscribe to changes in the MPS subscription data for Priority PDU connectivity service. Dynamic invocation for MPS provided from an AF using the Priority indicator over N5 takes precedence over the MPS subscription. Dynamic invocation for Data Transport Service is provided by sending an MPS for Data Transport Service request to the PCF over N5. Dynamic invocation for MPS for Messaging Service may be supported by sending an MPS for Messaging request to the PCF over N5.

ARP and/or 5QI may be modified. It shall be possible to override the default Priority Level associated with the standardized 5QI.

For dynamic invocation of MPS service, the PCF shall generate the corresponding PCC rule(s) with the ARP and 5QI parameters as appropriate for the prioritized service, as defined in TS 23.501 [2].

Whenever one or more AF sessions of an MPS service are active within the same PDU Session, the PCF shall ensure that the ARP priority level of the QoS Flow for signalling as well as the QoS Flow associated with the default QoS rule is at least as high as the highest ARP priority level used by any authorized PCC rule belonging to an MPS service. If the ARP pre-emption capability is enabled for any of the authorized PCC rules belonging to an MPS service, the PCF shall also enable the ARP pre-emption capability for the QoS Flow for signalling as well as the QoS Flow associated with the default QoS rule.

In the case of IMS MPS, in addition to the above, the following QoS Flow handling applies:

- At reception of the indication from subscription information that the IMS Signalling Priority is set for the PDU Session or at reception of service authorization from the P-CSCF (AF) including an MPS session indication and the service priority level as defined in TS 23.228 [5], the PCF shall (under consideration of the requirement described in clauses 5.16.5 and 5.22.3 in TS 23.501 [2]) modify the ARP in all the PCC rules that describe the IMS signalling traffic to the value appropriate for IMS Multimedia Priority Services, if upgrade of the QoS Flow carrying IMS Signalling is required. To modify the ARP of the QoS Flow associated with the default QoS rule the PCF shall modify the Authorized default 5QI/ARP.

- When the PCF detects that the P-CSCF (AF) released all the MPS sessions and the IMS Signalling Priority is not set for the PDU Session the PCF shall consider changes of the requirement described in clauses 5.16.5 and 5.22.3 in TS 23.501 [2] and modify the ARP in all PCC rules that describe the IMS signalling traffic to an appropriate value according to PCF decision. The PCC rules bound to the QoS Flow associated with the default QoS rule have to be changed accordingly.

NOTE 1: To keep the PCC rules bound to the QoS Flow associated with the default QoS Rule, the PCF can either modify the ARP of these PCC rules accordingly or set the Bind to QoS Flow associated with the default QoS rule.

The Priority PDU connectivity service targets the ARP and/or 5QI of the QoS Flows, enabling the prioritization of all traffic on the same QoS Flow.

For non-MPS service, the PCF shall generate the corresponding PCC rule(s) as per normal procedures (i.e. without consideration whether the MPS Priority PDU connectivity service is active or not), and shall upgrade the ARP/5QI values suitable for MPS when the Priority PDU connectivity service is invoked. When the Priority PDU connectivity service is revoked, the PCF shall change the ARP/5QI values modified for the Priority PDU connectivity service to appropriate values according to PCF decision.

The PCF shall, at the activation of the Priority PDU connectivity service:

- modify the ARP of PCC rules installed before the activation of the Priority PDU connectivity service to the ARP as appropriate for the Priority PDU connectivity service under consideration of the requirement described in clause 5.16.5 of TS 23.501 [2]; and
- if modification of the 5QI of the PCC rule(s) is required, modify the 5QI of the PCC rules installed before the activation of the Priority PDU connectivity service to the 5QI as appropriate for this service.

The PCF shall, at the deactivation of the Priority PDU connectivity service modify any 5QI and ARP value to the value according to the PCF policy decision.

For PCC rules modified due to the activation of Priority PDU connectivity service:

- modify the ARP to an appropriate value according to PCF decision under consideration of the requirement described in clauses 5.16.5 and 5.22.3 in TS 23.501 [2]; and
- if modification of the 5QI of PCC rule(s) is required, modify the 5QI to an appropriate value according to PCF decision.

MPS for Data Transport Service enables the prioritization of all traffic on the QoS Flow associated with the default QoS rule and other QoS Flows upon AF request. The QoS modification to the QoS Flow associated with the default QoS rule and other QoS Flows is done based on operator policy and regulatory rules by means of local PCF configuration.

NOTE 2: If no configuration is provided, MPS for Data Transport Service applies only to the QoS Flow associated with the default QoS rule.

Upon receipt of an MPS for Data Transport Service invocation/revocation request from the UE, the AF or the PCF authorizes the request. If the UE has an MPS subscription, MPS for Data Transport Service is authorized by the AF or the PCF, based on AF decision. If the Service User is using a UE that does not have an MPS subscription, the AF authorizes MPS for Data Transport Service:

- In the case that the AF authorizes the MPS for Data Transport Service request, after successful authorization, the AF sends the MPS for Data Transport Service request to the PCF over N5/Npcf for QoS Flow modifications, including an indication that PCF authorization is not needed. In this case, the PCF shall not perform any MPS subscription check for the MPS for Data Transport Service request. The AF also indicates to the PCF whether the request is for invoking or revoking MPS for Data Transport Service.
- In the case that the AF does not authorize the MPS for Data Transport Service request, the AF sends the request to the PCF over N5/Npcf for authorization and QoS Flow modifications, including an indication that PCF authorization is needed. In this case, the PCF shall perform an MPS subscription check for the MPS for Data Transport Service request. The AF also indicates whether the request is for invoking or revoking MPS for Data Transport Service. The PCF will inform the AF when the UE does not have an MPS subscription associated with the request.

After successful authorization by either AF or PCF as described above, the PCF shall, at the invocation/revocation of MPS for Data Transport Service, perform the same steps for QoS modifications as described above for the activation/deactivation of the Priority PDU connectivity service.

NOTE 3: To keep the PCC rules bound to the QoS Flow associated with the default QoS Rule, the PCF can either modify the ARP/5QI of these PCC rules accordingly or set the PCC rule attribute Bind to QoS Flow associated with the default QoS rule.

The PCF shall inform the AF of the success or failure of the MPS for Data Transport Service invocation/revocation request. If the PDU Session is deactivated for other reasons than an AF request, the PCF shall notify the AF by deleting the N5 session context.

For MPS for Data Transport Service, the AF may also request an SDF for priority signalling between the UE and the AF, where the AF includes the Priority indicator over N5/Npcf, in order to enable the PCF to set appropriate QoS values for the QoS Flow.

MPS for Messaging (specified in clauses 5.16.5 and 5.22.3 of TS 23.501 [2]) requires MPS priority on the QoS Flow for IMS signalling traffic, including messages delivered via SMS over IP (TS 23.204 [45]) and via IMS Messaging (clause 5.16 of TS 23.228 [5]). IMS Session-based Messaging also requires MPS priority for media flow(s).

When the P-CSCF obtains MPS for Messaging indication, as specified in TS 23.228 [5], the P-CSCF may send an MPS for Messaging indication to the PCF over the N5 interface to request the PCF to modify the QoS Flow for IMS signalling traffic for MPS for Messaging. If the QoS Flow for IMS signalling traffic does not already receive MPS priority treatment, for example based on a prior request for MPS Service that upgraded the QoS Flow for IMS signalling traffic, or based on the IMS Signalling Priority attribute in the UDR, the PCF shall also:

- modify the ARP, 5QI, and optionally, the Priority Level in all the PCC rules that describe the IMS signalling traffic to values appropriate for MPS for Messaging Service.

When the PCF receives an MPS for Messaging clearing (disabling) indication via N5, the PCF shall, while considering other services simultaneously requiring priority treatment of the QoS Flow for IMS signalling traffic:

- modify the ARP, 5QI and, optionally, the Priority Level in all the PCC rules that describe the IMS signalling traffic to appropriate values according to PCF decision.

NOTE 4: To keep the PCC rules bound to the QoS Flow associated with the default QoS Rule, the PCF can either modify the ARP/5QI of these PCC rules accordingly or set the PCC rule attribute Bind to QoS Flow associated with the default QoS rule.

### 6.1.3.12 Redirection

Redirection of uplink application traffic is an option applicable in SMF or in UPF.

PCF may control redirection by provisioning and modifying dynamic PCC rules over the N7 interface, or activate/deactivate the predefined redirection policies in SMF. The PCF may enable/disable redirection and set a redirect destination for every dynamic PCC rule. Redirect information (redirection enabled/disabled and redirect destination) within a PCC Rule instructs the SMF whether or not to perform redirection towards a specific redirect destination. The redirect destination may be provided as part of the dynamic PCC Rule, or may be preconfigured in the SMF or UPF. A redirect destination provided in a dynamic PCC Rule overrides the redirect destination preconfigured in the SMF or UPF for this PCC Rule.

### 6.1.3.13 Resource sharing for different AF sessions

The P-CSCF (i.e. AF) may indicate to the PCF that media of an AF session may share resources with media belonging to other AF sessions according to TS 23.228 [5]. For every media flow, the P-CSCF may indicate that the media flow may share resources in both directions or in one direction only (UL or DL).

The PCF makes authorization and policy decisions for the affected AF sessions individually and generates a PCC rule for every media flow in any AF session.

If the PCF received identical indication(s) for resource sharing for multiple AF sessions, the PCF may request the SMF to realize resource sharing for the corresponding set of PCC rules. The PCF provides a DL and/or UL sharing indication with the same value for those PCC rules that are candidate to share resources according to the direction of resource sharing indicated by the AF.

For each direction, the SMF shall take the highest GBR value from each set of PCC rules related with the same sharing indication for this direction and bound to the same QoS Flow and uses that value as input for calculating the GFBR of the QoS Flow. For each direction, the SMF may take the MBR value of the most demanding PCC rule included in each set of PCC rules related with the same sharing indication for this direction and bound to the same QoS Flow and uses that as input for calculating the MFBR of the QoS Flow.

The AF session termination or modification procedure that removes media flows triggers the removal of the corresponding PCC rules from the SMF. The SMF shall recalculate the GFBR (and MFBR) value of the QoS Flow whenever a set of PCC rules with the same sharing indication changes.

Resource sharing is applied as long as there are at least two active PCC rules with the same sharing indication bound to the same QoS Flow.

Resource sharing for different AF sessions is possible only if the P-CSCF, the PCF and the SMF support it.

NOTE: This procedure assumes that applications/service logic must do the necessary coordination, e.g. pause sending or employ gating, to avoid service data flows interfering and to ensure that multiple flows comply with the combined QoS parameters.

#### 6.1.3.14 Traffic steering control

Traffic steering control is triggered by the PCF initiated request and consists of steering the detected service data flows matching application detection filters or service data flow filter(s) in PCC Rules. The traffic steering control consists in one or both of the following:

- Application Function influence on traffic routing: diverting (at DNAI(s) provided in PCC rules) traffic matching traffic filters provided by the PCF, as described in clause 5.6.7 of TS 23.501 [2].
- N6-LAN Traffic Steering (also called Service Function Chaining): applying a specific N6 traffic steering policy for the purpose of steering the subscriber's traffic to appropriated N6 service functions deployed by the operator or a 3rd party service provider according to operator policy or Application Function influence on Service Function Chaining as described in clause 5.6.16 of TS 23.501 [2].

The PCF uses one or more pieces of information such as network operator's policies, user subscription, user's current RAT, network load status, application identifier, time of day, UE location, DNN, related to the subscriber session and the application traffic, as well as information provided by the AF (if applicable), as input for selecting a traffic steering policy.

In the case of Application Function influence on a Service Function Chaining, the PCF takes the AF provided SFC ID and Metadata (if provided by the AF) into account when generating the traffic steering control information for N6-LAN Traffic Steering in the PCC rule.

The PCF controls traffic steering by provisioning and modifying traffic steering control information in PCC rules. Traffic steering control information consists of a traffic description and in the case of N6-LAN Traffic Steering, a reference to a traffic steering policy that is configured in the SMF or, in the case of Application Function influence on traffic routing, per DNAI a reference to a traffic steering policy that is configured in the SMF and/or N6 traffic routing information as well as other parameters described in clause 6.3.1.

The SMF instructs the UPF to perform necessary actions to enforce the traffic steering policy referenced by the PCF. The actual traffic steering applies at the UPF. The details and constraints for the SMF and the UPF are described in clause 5.6.7 of TS 23.501 [2] for Application Function influence on traffic routing and in clause 5.6.16 of TS 23.501 [2] for N6-LAN Traffic Steering.

#### 6.1.3.15 Resource reservation for services sharing priority

An AF may indicate to the PCF that a media flow of an AF session is allowed to use the same priority as media flows belonging to other AF sessions (instead of the service priority provided for this media flow). In this case, the AF will provide a priority sharing indicator in addition to the application identifier and the service priority. For MCPTT, the service priority and the priority sharing indicator are defined in TS 23.179 [6]. The priority sharing indicator is used to indicate what media flows are allowed to share priority.

The PCF makes authorization and policy decisions for the affected AF sessions individually and generates a PCC rule for every media flow as specified in clause 6.1.1.3. The application identifier and the service priority are used to

calculate the ARP priority. The AF may also provide suggested pre-emption capability and vulnerability values per media flow to the PCF. The ARP pre-emption capability and the ARP pre-emption vulnerability are set according to operator policies and regulatory requirements, also taking into consideration the application identifier and suggested values, when provided by the AF. The priority sharing indicator is stored for later use.

For PCC rules with the same 5QI assigned and having an associated priority sharing indicator, the PCF shall try to make authorization and policy decisions taking the priority sharing indicator into account and modify the ARP of these PCC rules as follows, (the original ARP values are stored for later use):

- The modified ARP priority is set to the highest of the original priority among all the PCC rules that include the priority sharing indicator;
- The modified ARP pre-emption capability is set if any of the original PCC rules have the ARP pre-emption capability set;
- The modified ARP pre-emption vulnerability is set if all the original PCC rules have the ARP pre-emption vulnerability set.

If the PCF receives an indication that a PCC rule provisioning or modification failed (due to resource reservation failure) then, the PCF may apply pre-emption and remove active PCC rules from the SMF and then retry the PCC rule provisioning or modification. If the PCF does not apply pre-emption, the AF is notified using existing procedures that the resource reservation for the new media flow failed.

The AF may optionally provide pre-emption control information, including pre-emption capability and vulnerability values, in addition to the priority sharing indicator to the PCF. If so, the PCF shall apply pre-emption and remove active PCC rules according to this information when receiving an indication that a PCC rule provisioning or modification failed. The pre-emption control information indicates:

- whether media flows sharing priority are candidates to being pre-empted taking into account pre-emption capability and vulnerability values;
- how to perform pre-emption among multiple potential media flow candidates of same priority: most recently added media flow, least recently added media flow, media flow with highest requested bandwidth in the AF request.

### 6.1.3.16 3GPP PS Data Off

This feature, when activated by the user, prevents traffics via 3GPP access except for 3GPP PS Data Off Exempt Services. The 3GPP PS Data Off Exempt Services are a set of operator services, defined in TS 22.011 [15] and TS 23.221 [16], that are the only allowed services in both downlink and uplink direction when the 3GPP PS Data Off feature has been activated by the user.

When PCF is deployed, it shall be able to configure the list(s) of 3GPP PS Data Off Exempt Services for 3GPP access, and the Policy Control Request Trigger of 3GPP PS Data Off status change used to inform the PCF from SMF about every change of the 3GPP PS Data Off status.

NOTE 1: The PCF can be configured with a list(s) of 3GPP PS Data Off Exempt Services per DNN. The list(s) of 3GPP PS Data Off Exempt Services for an DNN can also be empty, or can allow for any service within that DNN, according to operator policy.

NOTE 2: For the PDU Session used for IMS services, the 3GPP Data Off Exempt Services are enforced in the IMS domain as specified TS 23.228 [5]. Policies configured in the PCF need to ensure that IMS services are allowed when the 3GPP Data Off status of the UE is set to "activated", e.g. by treating any service within a well-known IMS DNN as 3GPP PS Data Off Exempt Services.

When the PCF is informed about the activation of 3GPP PS Data Off, it shall update the PCC rules in such a way that for 3GPP access only packets for services belonging to the list(s) of 3GPP PS Data Off Exempt Services are forwarded while all other packets are discarded. Packets sent over non-3GPP access are not affected, and in the case of MA PDU Session, this is ensured by the MA PDU Session Control policy, e.g. for packets not belonging to the 3GPP Data Off Exempt Services, PCF provides PCC rule containing Steering Mode "Active-Standby" with active access as non-3GPP access and no standby access for downlink and uplink direction.

NOTE 3: For non MA PDU Sessions, in order for the SMF/UPF to prevent the services that do not belong to the list(s) of 3GPP PS Data Off Exempted Services, if the services are controlled by dynamic PCC rules, the PCF could modify the PCC rules by setting the gate status to "closed" for downlink and optionally uplink direction in all active dynamic PCC rules or remove those dynamic PCC rules. If the services are controlled by predefined PCC rules, the PCF can deactivate those predefined PCC rules. PCC rule with wild-carded service data flow filters can be among the PCC rules that are modified, removed or deactivated in that manner. In this case, it can be necessary that the PCF at the same time installs or activates PCC rules for data-off exempt services.

NOTE 4: For example, for non MA PDU Sessions, four PCC rules (A, B, C, D) are active for a PDU Session with PCC rule A representing a 3GPP PS Data Off Exempt Service. When 3GPP PS Data Off is activated, the PCF could either modify PCC rules B, C and D if they are dynamic PCC rules by closing the gate in downlink and optionally uplink direction or remove/deactivate PCC rules B, C and D if they are predefined PCC rules. PCC rule A does not need to be changed as it represents 3GPP PS Data Off Exempt Service. Assuming that PCC rule B contained wild-carded service data flow filters which has enabled some 3GPP PS Data Off Exempt Service is removed or deactivated, an additional PCC rule E can be installed or activated as well to enable downlink and optionally uplink traffic for that 3GPP PS Data Off Exempt Service.

NOTE 5: The network configuration can ensure that at least one PCC Rule is activated for the PDU Session when Data Off is activated in order to avoid deletion of an existing PDU Session or in order not to fail a PDU Session establishment.

When the PCF receives service information from the AF, in addition to what is specified in clause 6.2.1, PCF shall check if the requested service information belongs to the 3GPP PS Data Off Exempt Services. If the requested service belongs to 3GPP PS Data Off Exempt Services or if the service traffic can be sent over non-3GPP access, PCF shall continue as specified in clause 6.2.1. If the requested service doesn't belong to the 3GPP PS Data Off Exempt Services and the PDU Session is established only over 3GPP access, PCF shall reject the service request.

When the PCF is informed about the deactivation of 3GPP PS Data Off, it shall perform policy control decision as specified in clause 6.2.1 and perform PCC rule operations as specified in clause 6.3.2 to make sure that the services are allowed according to user's subscription and operator policy (irrespective of whether they belong to the list(s) of 3GPP PS Data Off Exempt Services).

When PCF is not deployed, predefined PCC rules, can be configured in the SMF, on a per DNN basis, to ensure the following:

- when the SMF is informed about activation of 3GPP PS Data Off, the SMF shall update the predefined PCC rule in a way that for 3GPP access only downlink and optionally uplink packets for services belonging to the list(s) of 3GPP PS Data Off Exempt Services are forwarded while all other downlink and uplink packets are discarded. Packets sent over non-3GPP access are not affected, and in the case of MA PDU Session, this is ensured by the MA PDU Session Control policy, e.g. for packets not belonging to the 3GPP Data Off Exempt Services, the SMF applies predefined PCC rule containing Steering Mode "Active-Standby" with active access as non-3GPP access and no standby access for downlink and uplink direction; and
- When SMF is informed about deactivation of 3GPP PS Data Off, the SMF ensures in UPF downlink and uplink packets are forwarded according to the operator policy for the subscriber.

NOTE 6: For example, for non MA PDU Sessions the SMF can be configured with two sets of predefined PCC rules: one set for UE 3GPP PS Data Off status "inactive" and another set for UE 3GPP PS Data Off status "active". The set of predefined PCC rules for UE 3GPP PS Data Off status "active" can be equivalent to the set of predefined PCC rules for UE with 3GPP PS Data Off status "inactive" with the following two differences: All services belonging to the list(s) of 3GPP PS Data Off Exempt Services can be represented by PCC rule(s) which allows the traffic to pass while in all other PCC rules (not belonging to the list(s) of 3GPP PS Data Off Exempt Services) the gate status can be "closed" for downlink and optionally uplink direction. When the SMF is informed about the change of UE 3GPP PS Data Off status, it can replace the currently active set of predefined PCC rules with the other set of predefined PCC rules.

When the UE 3GPP PS Data Off status is "active" and a handover from one access-system to another occurs, the PCF or the SMF when PCF is not deployed performs the above operations so that the downlink and optionally uplink traffic for services not belonging to the list(s) of 3GPP PS Data Off Exempt Services is only prevented via the 3GPP access.

### 6.1.3.17 Policy decisions based on spending limits

An extended description of this clause is defined in clause 6.1.1.4.

### 6.1.3.18 Event reporting from the PCF

The AF may subscribe/unsubscribe to notifications of events from the PCF for the PDU Session to which the AF session is bound. The AF can either subscribe/unsubscribe directly at the PCF or indirectly via an NEF or a TSCTSF.

The PCF for the UE may subscribe/unsubscribe to notifications of events from the PCF for the PDU Session. Other NFs may subscribe/unsubscribe to notifications of events from the PCF for the PDU Session or from the PCF for the UE.

The events that can be subscribed by the AF and by other NFs are listed in Table 6.1.3.18-1.

Table 6.1.3.18-1: Events relevant for reporting from the PCF

Event	Description	NF that can subscribe for reporting	Availability for Rx PDU Session (NOTE 2)	Availability for N5 per PDU Session	Availability for Bulk Subscription (NOTE 1)	Availability for N43 per SUPI, DNN, S-NSSAI	Availability for N5 per UE (NOTE 6)	Availability for N24 per UE (NOTE 6)
PLMN Identifier Notification (NOTE 5)	The PLMN identifier or SNPN identifier where the UE is currently located.	AF, PCF	Yes	Yes	Yes	No	No	Yes
Change of Access Type	The Access Type and, if applicable, the RAT Type of the PDU Session has changed.	AF	Yes	Yes	Yes	No	No	No
EPS fallback	EPS fallback is initiated	AF	Yes	Yes	No	No	No	No
Signalling path status	The status of the resources related to the signalling traffic of the AF session.	AF	Yes	Yes	No	No	No	No
Access Network Charging Correlation Information	The Access Network Charging Correlation Information of the resources allocated for the AF session.	AF	Yes	Yes	No	No	No	No
Access Network Information Notification	The user location and/or timezone and/or identifier of the serving satellite of the UE when the PDU Session has changed in relation to the AF session.	AF	Yes	Yes	No	No	No	No
Reporting Usage for Sponsored Data Connectivity	The usage threshold provided by the AF has been reached; or the AF session is terminated.	AF	Yes	Yes	No	No	No	No
Service Data Flow deactivation	The resources related to the AF session are released.	AF, TSCTSF	Yes	Yes	No	No	No	No
Resource allocation outcome	The outcome of the resource allocation related to the AF session.	AF, TSCTSF	Yes	Yes	No	No	No	No
QoS targets can no longer (or can again) be fulfilled	The QoS targets can no longer (or can again) be fulfilled by the network for (a part of) the AF session.	AF	No	Yes	No	No	No	No
QoS Monitoring parameters	The QoS Monitoring parameter(s) (as defined in clause 5.45 of TS 23.501 [2]) are reported to the AF according to the subscription based on QoS Monitoring reports received from the SMF.	AF	No	Yes	No	No	No	No
Network support for QoS Monitoring	The QoS Monitoring can no longer (or can again) be performed by the network for the service data flow.	AF	No	Yes	No	No	No	No
Packet Delay Variation	Monitoring and reporting of 5GS Packet Delay Variation based on packet delay measured between UE and PSA UPF.	AF	No	Yes	No	No	No	No
Round-trip delay measurement over two service data flows	Measurements of round-trip delay considering the UL direction of a service data flow and the DL direction of another service data flow. It is derived from measurements of packet delay between UE and PSA UPF.	AF	No	Yes	No	No	No	No
Network support for ECN marking for L4S (NOTE 8)	The ECN marking for L4S can no longer (or can again) be performed by the network for the service data flow.	AF	No	Yes	No	No	No	No
Out of credit	Credit is no longer available.	AF	Yes	Yes	No	No	No	No
Reallocation of credit	Credit has been reallocated after the former Out of credit indication.	AF	Yes	Yes	No	No	No	No

Event	Description	NF that can subscribe for reporting	Availability for Rx PDU Session (NOTE 2)	Availability for N5 per PDU Session	Availability for Bulk Subscription (NOTE 1)	Availability for N43 per SUPI, DNN, S-NSSAI	Availability for N5 per UE (NOTE 6)	Availability for N24 per UE (NOTE 6)
5GS Bridge/Router information Notification (NOTE 3)	5GS Bridge/Router information that the PCF has received from the SMF.	TSN AF, TSCTSF	No	Yes	No	No	No	No
Notification on outcome of service area coverage change	The outcome of the request of service area coverage change.	AF	No	No	Yes	No	Yes	No
Notification on outcome of UE Policies delivery	The outcome of the request for UE policies delivery due to service specific parameter provisioning procedure.	AF	No	No	No	No	No	Yes
Start of application traffic detection and Stop of application traffic detection	The start or the stop of application traffic has been detected.	PCF, AF	No	No	Yes	Yes (NOTE 4)	No	No
UE reporting Connection Capabilities from associated URSP rule	The Connection Capability received from the UE during PDU Session Establishment or Modification, see clause 6.6.2.4.	PCF	No	No	No	Yes	No	Yes
Satellite backhaul category change	The backhaul has changed between different types of satellite backhaul, or the backhaul has changed between satellite backhaul and non-satellite backhaul.	AF	No	Yes	Yes	No	No	No
Change of PDUID	The PDUID assigned to a UE has changed.	5G DDNMF	No	No	No	No	Yes	No
SM Policy Association established or terminated	The establishment or termination of a SM Policy Association is reported.	PCF	No	No	No	Yes (NOTE 7)	No	No
Reporting of extra UE addresses	Reporting of the extra IP addresses or address ranges allocated for the given PDU Session resulting from framed routes or IPv6 prefix delegation.	TSCTSF	No	Yes	No	No	No	

Event	Description	NF that can subscribe for reporting	Availability for Rx PDU Session (NOTE 2)	Availability for N5 per PDU Session	Availability for Bulk Subscription (NOTE 1)	Availability for N43 per SUPI, DNN, S-NSSAI	Availability for N5 per UE (NOTE 6)	Availability for N24 per UE (NOTE 6)
Notification on BAT offset	The PCF reports the BAT offset and optionally the adjusted periodicity that has been received from the SMF.	TSCTSF	No	Yes	No	No	No	
UE reachability status change	The PCF reports when it receives an indication of a change of the UE reachability status.	AF	No	Yes	No	No	No	No
Result of UE Policy Container delivery via EPS	The PCF reports the result of UE policies delivery via EPS.	PCF	No	No	No	Yes (NOTE 9)	No	No
Notification on outcome Network Slice Replacement	The PCF reports the outcome of Network Slice Replacement.	AF	No	No	No	No	Yes	No
Data Rate Limitation Information for the Non-GBR service data flow	The PCF reports the uplink and downlink maximum bitrate authorized for the Non-GBR service data flow and any change of it.	AF	No	Yes	No	No	No	No
Data Rate Limitation Information for the PDU Session	The PCF reports the uplink and downlink Authorized Session-AMBR of the PDU Session and any change of it.	AF	No	No	Yes	No	No	No
<p>NOTE 1: Additional parameters for the subscription as well as reporting related to these events are described in TS 23.502 [3].</p> <p>NOTE 2: Applicability of Rx is described in Annex C.</p> <p>NOTE 3: 5GS Bridge/Router information is described in clause 6.1.3.5.</p> <p>NOTE 4: Bulk subscription is implicit. NOTE 1 does not apply.</p> <p>NOTE 5: For a PDU Session established over a SNPN, the combination of the PLMN id and the NID identifies the SNPN.</p> <p>NOTE 6: This column contains also UE context related events that are reported to other consumers such as 5G DDMNF via other reference points than N5. The Conditions for reporting column indicates the respective consumer.</p> <p>NOTE 7: The PCF for the UE subscribes to this Event indirectly via AMF and SMF.</p> <p>NOTE 8: Subscription to this event is performed implicitly when AF provides the ECN marking for L4S support indication.</p> <p>NOTE 9: The PCF for the UE subscribes to this Event to PCF for the PDU Session.</p>								

If an AF requests the PCF to report the PLMN identifier where the UE is currently located, then the PCF shall provide the PLMN identifier or the SNPN identifier to the AF if available. Otherwise, the PCF shall provision the corresponding PCC rules, and the Policy Control Request Trigger to report PLMN change to the SMF. The PCF shall, upon receiving the PLMN identifier or the SNPN identifier from the SMF forward this information to the AF, including the PLMN Id and if available the NID. If the H-PCF requests to report the PLMN identifier where the UE is currently located, the V-PCF provisions the PCRT on "PLMN change" to the AMF as described in clause 6.1.2.5 and then forwards the PLMN ID received from the AMF to the H-PCF.

If an AF requests the PCF to report on the change of Access Type, the PCF shall provide the corresponding Policy Control Request Trigger to the SMF to enable the report of the Change in Access Type to the PCF. The PCF shall, upon reception of information about the Access Type the user is currently using and upon indication of change of Access Type, notify the AF on changes of the Access Type and forward the information received from the SMF to the AF. The change of the RAT Type shall also be reported to the AF, even if the Access Type is unchanged. For MA PDU Session the Access Type information may include two Access Type information that the user is currently using.

If an AF requests the PCF to report on the signalling path status, for the AF session, the PCF shall, upon indication of removal of PCC Rules identifying signalling traffic from the SMF report it to the AF.

If an AF requests the PCF to report Access Network Charging Correlation Information, the PCF shall provide to the AF the Access Network Charging Correlation Information, which allows to identify the usage reports that include measurements for the Service Data Flow(s), once the Access Network Charging Correlation Information is known at the PCF.

If an AF requests the PCF to report Access Network Information (i.e. the User Location Report and/or the UE Timezone Report and/or the Satellite Identifier Report) at AF session establishment, modification or termination, the PCF shall set the Access Network Information report parameters in the corresponding PCC rule(s) and provision them together with the corresponding Policy Control Request Trigger to the SMF. For those PCC rule(s) based on preliminary service information the PCF may assign the 5QI and ARP of the QoS Flow associated with the default QoS rule to avoid signalling to the UE.

NOTE 1: The PCF can also use the dynamic or pre-defined PCC Rules related to the IMS signalling to request Access Network Information reporting. This can be used to support e.g. regulatory requirements for SMS over IP, where the IMS network (i.e. P-CSCF) needs to retrieve the user location and/or UE Time Zone information. Note that due to regulatory requirements, the Access Network Information can be requested for SMS over IP, impacting a large number of PDU Sessions, that can lead to significant increase in signalling load when the Access Network Information is requested from AMF.

The PCF shall, upon receiving an Access Network Information report corresponding to the AF session from the SMF, forward the Access Network Information as requested by the AF (if the SMF only reported the serving PLMN identifier or the SNPN identifier to the PCF, as described in clause 6.1.3.5, the PCF shall forward it to the AF). For AF session termination the communication between the AF and the PCF shall be kept alive until the PCF report is received.

If an AF requests the PCF to report the Usage for Sponsored Data Connectivity, the PCF shall provision the corresponding PCC rules, and the Policy Control Request Trigger to the SMF. If the usage threshold provided by the AF has been reached or the AF session is terminated, the PCF forwards such information to the AF.

If an AF or TSCTSFS requests the PCF to report the Service Data Flow deactivation, the PCF shall report the release of resources corresponding to the AF session. The PCF shall, upon being notified of the removal of PCC Rules corresponding to the AF session from the SMF, forward this information to the AF. The PCF shall also forward, if available, the reason why the resources are released, the user location information and the UE Timezone.

If an AF or TSCTSFS requests the PCF to report the Resource allocation outcome, the PCF shall report the outcome of the resource allocation of the Service Data Flow(s) related to the AF session. The AF or TSCTSFS may request to be notified about successful or failed resource allocation. In this case, the PCF shall instruct the SMF to report the successful resource allocation trigger (see clause 6.1.3.5). If the SMF has notified the PCF that the resource allocation of a Service Data Flow is successful and the currently fulfilled QoS matches an Alternative QoS parameter set (as described in clause 6.2.2.1), the PCF shall also provide to the AF the QoS Reference parameter or the Requested Alternative QoS Parameter Set which corresponds to the Alternative QoS parameter set referenced by the SMF. If the SMF has notified the PCF about resource allocation failure together with an Access Type (as described in clause 6.1.3.5), the PCF shall only notify the AF when the PCC rule is removed and without forwarding any Access Type information. If the SMF has notified the PCF about resource allocation failure due to UE temporary unreachable together with a maximum waiting time, if available, (as described in clause 6.1.3.5), the PCF shall notify the AF on resource allocation failure and provide the UE temporary unreachable and the maximum waiting time, if available.

If an AF requests the PCF to report when the QoS targets can no longer (or can again) be fulfilled for a particular media flow, the PCF shall set the QNC indication in the corresponding PCC rule(s) that includes a GBR or delay critical GBR 5QI value and provision them together with the corresponding Policy Control Request Trigger to the SMF. At the time, the SMF notifies that GFBR can no longer (or can again) be guaranteed for a QoS Flow to which those PCC Rule(s) are bound, the PCF shall report to the AF the affected media flow and provides the indication that QoS targets can no longer (or can again) be fulfilled. If the PCF receives a direction information together with the notification from the SMF, the PCF shall also forward the direction information to the AF. If other information is received together with the notification from SMF (see clause 5.7.2.4 of TS 23.501 [2]), the PCF shall also provide to the AF the QoS Reference parameter or the Requested Alternative QoS Parameter Set which corresponds to the Alternative QoS parameter set referenced by the SMF. If the SMF has indicated that the lowest priority Alternative QoS parameter set cannot be fulfilled, the PCF shall indicate to the AF that the lowest priority QoS Reference or the lowest priority set of Requested Alternative QoS Parameters of the Alternative Service Requirements cannot be fulfilled.

If the AF subscribes to be notified of the QoS Monitoring reports, the PCF decides about the path for the QoS Monitoring reports and sets the QoS Monitoring Policy Control Request Trigger accordingly, as described in clause 6.1.3.21. The PCF sends the QoS Monitoring reports to AF based on the QoS Monitoring reports that it receives from the SMF, according to AF subscription and PCF selected notification path e.g. PCF does not report to AF if AF will receive the QoS Monitoring reports directly from the UPF.

NOTE 2: The QoS Monitoring report received by the PCF and the information sent to the AF can be different. The QoS Monitoring report (e.g. packet delay) may be used by PCF to calculate the requested QoS parameter (e.g. packet delay variation).

NOTE 3: This event can only be subscribed as part of an AF session with required QoS (described in clause 6.1.3.22) and as part of AF requested QoS for a UE or group of UEs not identified by a UE address (described in clause 6.1.3.28).

NOTE 4: If the service data flow is mapped to two QoS Flows (i.e. the UL traffic and DL traffic of the service data flow are separated into two QoS Flows respectively) in the same PDU Session, the PCF triggers QoS Monitoring for each direction packet delay of the individual QoS Flows respectively and generates the QoS Monitoring reports for the AF based on the packet delay monitored on the QoS Flow for each direction (as described in clause 5.37.4 of TS 23.501 [2]).

If the AF subscribes to be notified of Packet Delay Variation reports (the variation of UL/DL packet delay between UE and PSA UPF), the PCF triggers the QoS monitoring procedure, derives the 5GS Packet Delay Variation and reports the value to the AF, as described in clause 6.1.3.26.

NOTE 5: This event can only be subscribed as part of an AF session with required QoS (described in clause 6.1.3.22).

If the AF subscribes to Round-trip delay measurement over two service data flows considering the UL direction of a service data flows and the DL direction of another service data flow, PCF triggers the QoS monitoring procedure to derive the Round-Trip delay measurement for delay measurements on the individual QoS Flows respectively (as described in clause 6.1.3.27.1 and in clause 5.37.4 of TS 23.501 [2]). The PCF derives the Round-Trip delay based on the packet delay measurement reports of the QoS Flows of each direction and reports the results to the AF. PCF sets QoS Monitoring Policies for each of the individual service data flows and QoS Monitoring Policy Control Request Trigger as described in clause 6.1.3.21.

NOTE 6: This event can only be subscribed as part of an AF session with required QoS (described in clause 6.1.3.22).

If the AF subscribes to the event Network support for QoS Monitoring, the PCF sets the QoS Monitoring can no longer (or can again) be performed Policy Control Request Trigger in the SMF, if not done before. The PCF shall notify the AF that QoS Monitoring can no longer (or can again) be performed by the network based on the last notification from the SMF that QoS Monitoring can no longer (or can again) be performed but only if the QoS monitoring parameter for which the AF subscription relates to is affected.

NOTE 7: AF QoS monitoring subscription can require implicit support of QoS monitoring parameters not directly associated with the functionality requested by the AF, e.g. PDV monitoring requires the support of packet delay monitoring. In that case the PCF will also report whether QoS monitoring can no longer (or can again) be performed.

If the AF indicates ECN marking for L4S support by the application, PCF authorizes the request and sets the ECN marking for L4S can no longer (or can again) be performed trigger accordingly. PCF shall further send the notification

it receives from the SMF to AF on whether the network can not (or can again) perform ECN marking for L4S, for example, if due to user mobility neither target 5G-AN nor UPF PSA support ECN marking for L4S.

If an AF requests the PCF to report on the Out of credit event for the associated service data flow(s), the PCF shall inform the AF (when it gets informed by the SMF) that credit is no longer available for the services data flow(s) related to the AF session together with the applied termination action.

If an AF requests the PCF to report on the Reallocation of credit event for the associated service data flow(s), the PCF shall inform the AF (when it gets informed by the SMF) that credit has been reallocated after credit was no longer available and the termination action was applied for the service data flow(s) related to the AF session.

The PCF can arm the trigger of 5GS Bridge/Router information available to SMF based on local policy (i.e. without an AF request) or based on subscription request from TSCTSF. The PCF shall, upon reception of the 5GS Bridge/Router information (refer to clauses 6.1.3.23, 6.1.3.23a, 6.1.3.23b) from the SMF, forward this information to the TSN AF or the TSCTSF. When the PCF has received the User plane node Management Information Container or Port Management Information Container and related port number from SMF, the PCF also provides User plane node Management Information Container or Port Management Information Container and related port number to the TSN AF or TSCTSF. When SMF has reported the 5GS Bridge/Router information and no AF session exists, the PCF forward this information to a pre-configured TSN AF, or to a pre-configured TSCTSF or a TSCTSF discovered and selected via NRF. In the case of private IPv4 address being used for IP type PDU Session, the PCF shall additionally report DNN and S-NSSAI of the PDU Session to TSCTSF.

If the AF requests the PCF to report on the outcome of the service area coverage change, the PCF reports the outcome of the service area coverage change to the AF and notifies the current service area coverage to the AF. The outcome is the result of the execution of the request of service coverage change at the PCF; the outcome is successful if the request was executed, and includes the current service area coverage that may be the same or different from the service area coverage provided by the AF. The subscription may also be implicit. In this case there may be bulk subscription, either for an Internal-Group-Id or for any UE. In order to prevent massive notifications to the AF, the request for any UE is associated to a specific Application Identifier or DNN, S-NSSAI. For bulk subscription, when the AF request includes an expiration time, the PCF stops reporting to the AF when the expiration time is reached.

If the AF requests the (H-)PCF, via V-PCF when roaming, to report on the outcome of the UE Policies delivery due to service specific parameter provisioning procedure, the (H-)PCF reports the outcome of the related UE Policies provisioning procedure for the related traffic descriptor for the UE to the AF, via V-PCF when roaming. The outcome of the UE Policies provisioning procedure includes the success, the failure with an appropriate cause, including failure reported by the UE as described in TS 24.501 [22] or failure detected by the network e.g. service parameters provided by the AF are not authorized for a SUPI, or the interim status report such as the UE is temporarily unreachable or that URSP Rules have not yet been delivered by the H-PCF (see clauses 4.15.6.7 and 5.2.5.7 of TS 23.502 [3]). The PCF reports the outcome of the UE Policy provisioning procedure for each of the UEs that were included as Target UEs in the service specific information Data Subset in UDR. When the AF requested the PCF for the UE to report on the outcome of the UE Policies delivery due to service specific parameter provisioning procedure targeting a single UE, the Result of UE Policy Container delivery via EPS event trigger shall be subscribed.

NOTE 8: An example reason for sending an interim status report that indicates that "URSP Rules have not yet been delivered by the H-PCF" may be that the UE does not support the VPLMN Specific URSP Rules feature and is not registered in the PLMN where the service parameters apply.

A request to report Start of application traffic detection and Stop of application traffic detection triggers the reporting when the PCF receives start of application traffic detection event or stop of application traffic detection event from SMF. The reception of a subscription to this event triggers the setting of the corresponding Policy Control Request Trigger to SMF, if not already subscribed.

A request to forward UE reporting Connection Capabilities from an associated URSP rule triggers the reporting when the PCF receives UE reporting of URSP rule enforcement information from the SMF matching specific Connection Capabilities (see clause 6.6.2.4). The request may include SUPI(s), DNN(s) and/or S-NSSAI(s) to which the request applies. The PCF reports the received Connection Capabilities and PDU Session information including the SUPI, UE requested DNN, Selected DNN, S-NSSAI, SSC Mode, PDU Session Type.

If an AF requests the PCF to report Start of application traffic detection and Stop of application traffic detection via bulk subscription, the AF shall provide the application identifier together with the S-NSSAI and DNN. The PCF provides a PCC rule for the application identifier together with the corresponding Policy Control Request Trigger to the SMF for every PDU Session to this S-NSSAI and DNN. When the PCF receives start of application traffic detection event or stop of application traffic detection event for the PCC rule in a PDU Session, the PCF forwards the event to the AF together with the UE identifier and optionally the IP address of the PDU Session corresponding to this PCC rule.

When the AF removes bulk subscription for this application identifier, then the PCF removes the Policy Control Request Trigger from the SMF for every PDU Session to this S-NSSAN and DNN, if it is not used for other purpose.

NOTE 9: The restriction of the bulk subscription to a specific combination of S-NSSAI and DNN avoids excessive signalling load.

If an AF requests the PCF to report on the change between different types of satellite backhaul or the change between satellite backhaul and non-satellite backhaul (as specified in clause 5.43.4 of TS 23.501 [2]), the PCF shall provide the corresponding Policy Control Request Trigger to the SMF to enable the report of satellite backhaul category change (see clause 6.1.3.5) to the PCF. The PCF shall, upon reception of information about the change of Satellite backhaul category, notify the AF on the Satellite backhaul category change event was met and forward the current Satellite backhaul category received from the SMF to the AF. When the satellite backhaul is no longer used, the Satellite backhaul category indicates that a non-satellite backhaul is used.

If 5G DDNMF requests the PCF to report on the Change of PDUID, the PCF shall notify whenever a new PDUID is allocated. Further details on how the 5G DDNMF retrieves and subscribes to notifications on Change of PDUID are defined in TS 23.304 [34].

A request to report SM Policy Association established or terminated triggers an implicit subscription and the reporting to the PCF for the UE when the PCF for the PDU Session receives PCF binding information together with Request for notification of SM Policy Association establishment and termination from the SMF. The PCF for the PDU Session derives the PCF for the UE from the PCF binding information and then notifies the PCF for the UE on this event, including the PCF binding information of the PCF for the PDU Session.

If the TSCTSF requests the PCF notifications for reporting of extra UE addresses, the PCF shall provide the extra UE addresses allocated to the PDU Session due to Framed Routes or IPv6 prefix delegation. The report shall include the actual list of IPv4 address masks or a list of IPv6 prefixes as currently allocated.

If the AF provides the Capability for BAT adaptation or BAT Window and subscribes to PCF for Notification on BAT offset, the PCF will trigger the subscription to SMF for Notification on BAT offset defined in clause 6.1.3.5. When the Notification on BAT offset trigger is set and the PCF receives a BAT offset and optionally an adjusted periodicity from the SMF, the PCF identifies the affected AF session (based on the PCC rule indicated by the SMF) and forwards the BAT offset and optionally the adjusted periodicity for this AF session to the TSCTSF.

A request to report Result of UE Policy Container delivery via EPS triggers the reporting when the PCF for the PDU Session receives the UE Policy Container from the UE during UE Policy Container delivery via EPS, or a delivery failure result for UE Policy Container delivery via EPS with appropriate reason from the SMF. The reception of a subscription to this event triggers the setting of the corresponding Policy Control Request Trigger to SMF, if not already subscribed.

If an AF requests the PCF to report on the UE reachability status change, the PCF shall provide the corresponding Policy Control Request Trigger to the SMF to enable the report of the UE reachability status change to the PCF, if not already subscribed. The PCF shall, upon indication of change of reachability status, notify the AF and forward the information received from the SMF to the AF.

If an AF requests the PCF to report on the change between S-NSSAI and Alternative S-NSSAI, the PCF reports the outcome of the network slice replacement to the AF.

If an AF requests the PCF to report the Data Rate Limitation Information for the Non-GBR service data flow, the PCF reports the uplink and downlink maximum bitrate authorized for the service data flow to the AF and any change of it. Further details are described in clause 6.1.3.27.1.

If an AF requests the PCF to report the Data Rate Limitation Information report for the PDU Session, the PCF reports the uplink and downlink Authorized Session-AMBR for the PDU Session to the AF and any change of it. Further details are described in clause 6.1.3.27.1.

### 6.1.3.19 Mission Critical Services support

Mission Critical Services are defined in TS 23.501 [2], TS 23.502 [3] and in TS 23.280 [23], utilising the architecture defined for 5GS.

Subscription data for MCX services are provided to PCF through the N36/Nudr. To support MCX services, the PCF shall subscribe to changes in the MCX services subscription data for Priority PDU connectivity service. Dynamic

invocation for MCX services provided from an AF using the Priority indicator over N5/Npcf takes precedence over the MCX services subscription.

For MCX services the session management relate policy control functionality of the Policy and Charging control framework for the 5G system is as defined in clause 6.1.3.11 for Multimedia Priority Service.

### 6.1.3.20 Access Traffic Steering, Switching and Splitting

As specified in TS 23.501 [2], the Access Traffic Steering, Switching and Splitting (ATSSS) feature is an optional feature that may be supported by the UE and the 5GC network.

The ATSSS feature enables a multi-access PDU Connectivity Service, which can exchange PDUs between the UE and a data network by simultaneously using one 3GPP access network and one non-3GPP access network (both connected to 5GC) when both accesses are allowed for the same S-NSSAI. The multi-access PDU Connectivity Service also supports the exchange of PDUs between the UE and a data network by simultaneously using one 3GPP access network in EPC and one non-3GPP access network in 5GC, or one 3GPP access network in 5GC and one non-3GPP access network in EPC, as described in TS 23.501 [2]. This enables a scenario where a MA PDU Session can simultaneously be associated with user-plane resources on 3GPP access network connected to 5GC or EPC and non-3GPP access network connected to 5GC, or with user-plane resources on 3GPP access network connected to 5GC and non-3GPP access network connected to EPC.

The PCF is informed of the ATSSS capabilities of a MA PDU Session by the SMF, as defined in clause 5.32.2 of TS 23.501 [2]. The ATSSS capabilities are both the Steering Mode and the Steering Functionality.

The PCF control of Access Traffic Steering, Switching and Splitting for a detected service data flow (SDF) is enabled by including Multi-Access PDU (MA PDU) Session Control information in the PCC rule. This allows the PCF to control:

- The Steering Mode that is used to steer/switch/split the detected SDF. The available Steering Modes are defined in TS 23.501 [2].
- The Steering Functionality that is used for the detected SDF, e.g. the MPTCP functionality, the ATSSS-LL functionality, the MPQUIC-UDP functionality, the MPQUIC-IP functionality, or the MPQUIC-E functionality defined in TS 23.501 [2].
- The Steering Mode Indicator authorized for the detected SDF.
- The Threshold values for RTT and Packet Loss Rate authorized for the detected SDF.
- The Charging information depending on what Access Type is used for a detected SDF.
- The Usage Monitoring information depending on what Access Type is used for a detected SDF.
- Transport Mode that is used for the detected SDF. The available Transport Modes are defined in TS 23.501 [2].

The rest of the information in the PCC Rule apply to the SDF as such and are not dependent on what Access Type is used for a packet.

The MA PDU Session Control information in the PCC rules is used by the SMF in order to create applicable N4 rules for the UPF and ATSSS rules for the UE, as described in TS 23.501 [2]. The ATSSS rules are sent to UE via NAS when the MA PDU Session is created or updated by the SMF/PCF, as described in TS 23.501 [2] and TS 23.502 [3].

When MA PDU Session Control Information is provided to the SMF within a PCC Rule, the (H-)PCF provides both the Service Data Flow templates to identify a Service Data Flow in the UPF and if the Service Data Flow template includes an application identifier, then the corresponding Application descriptors to identify the application traffic in the UE is also included.

The (H-) PCF may use the OSid stored in the UDR as DataSet "Policy Data" and Data Subset "UE context policy control data" to determine the OSAppId supported by the OSid. The (H-)PCF may also provide multiple Application descriptors to identify application traffic in the UE, this is determined by the (H-)PCF local policies that indicates e.g. the operating system supported by the UE. If no OSid is available in the UDR, the (H-)PCF may use the PEI to determine the OSid supported by the UE.

NOTE 1: If the (H-)PCF does not take into account the received PEI and/or OSid then the (H-)PCF can send PCC rules containing application traffic descriptors associated to multiple operating systems.

The Traffic Descriptor in the ATSSS rule is generated by the SMF from the SDF template of the PCC rule. If the SDF template contains SDF filters, the SMF uses the UL SDF filters for the generation of the IP descriptors or Non-IP descriptors, respectively. If the SDF template contains an application identifier, the SMF includes the Application descriptors received from the PCF as part of the MA PDU Session information in the PCC Rule within the Traffic Descriptors in the ATSSS rule.

For the Load-Balancing steering mode with fixed split percentages (i.e. without the Autonomous load-balance indicator or UE-assistance indicator), the PCF may provide one or more threshold values together with the split percentages. For the Priority-based steering mode, the PCF may provide one or more threshold values together with the priority of the accesses. For the Redundant steering mode, the PCF may provide one threshold value and/or a primary access. For the Load-Balancing and the Priority-based steering mode, one threshold value for the Round Trip Time (RTT) and/or one threshold value for the Packet Loss Rate (PLR) may be included in a PCC Rule. For the Redundant steering mode, either one threshold value for the Round Trip Time (RTT) or one threshold value for the Packet Loss Rate (PLR) may be included in a PCC Rule based on local configuration or QoS requirements received from AF as specified in clause 4.15.6.6 or clause 4.15.6.6a of TS 23.502 [3]. The threshold values are not dependent on what Access Type is used for a packet, i.e. a given threshold value is applicable to both accesses. The threshold values are applied by the UE and UPF as described in TS 23.501 [2].

NOTE 2: The Round Trip Time (RTT) threshold value can be determined based on the PDB of the 5QI authorized for the SDF, and the Packet Loss Rate (PLR) threshold value can be determined based on the PER of the 5QI authorized for the SDF.

The MA PDU Session Control information in a PCC rule may contain only one of the following Steering Mode Indicators:

- Autonomous load-balance indicator: This indicator may be included only when the Steering Mode is Load-Balancing and indicates whether autonomous load-balance operation is allowed. Further details are specified in clause 5.32.8 of TS 23.501 [2].
- UE-assistance indicator: It indicates that the UE can decide how to distribute the UL traffic based on its internal state (e.g. battery level), and that the UE can request from UPF to apply the same distribution for the DL traffic. Further details are specified in clause 5.32.8 of TS 23.501 [2].

The PCF may also provide URSP rules to the UE for instructing the UE to establish a MA PDU Session, as described in clause 6.6.2.

The PCF control of PDU Session level Usage Monitoring depending on what access type is used to carry the traffic is enabled by providing Usage Monitoring control related information per access in the PDU Session related policy control information (as described in clause 6.4).

The Transport Mode may be included in a PCC rule that is used for the detected SDF only when the Steering functionality is the MPQUIC-UDP functionality, the MPQUIC-IP functionality, or the MPQUIC-E functionality.

NOTE 3: The MPQUIC-UDP functionality, the MPQUIC-IP functionality and the MPTCP functionality are only applied for IP MA PDU Session.

NOTE 4: The MPQUIC-E functionality is only applied for Ethernet MA PDU Session.

If the MA PDU Session is capable of supporting one of the following:

- MPTCP and ATSSS-LL with any Steering Mode (i.e. any Steering Mode allowed for ATSSS-LL) in the downlink and MPTCP and ATSSS-LL with Active-Standby in the uplink;
- MPQUIC-UDP and ATSSS-LL with any Steering Mode (i.e. any Steering Mode allowed for ATSSS-LL) in the downlink and MPQUIC-UDP and ATSSS-LL with Active-Standby in the uplink;
- MPTCP, MPQUIC-UDP and ATSSS-LL with any Steering Mode (i.e. any Steering Mode allowed for ATSSS-LL) in the downlink and MPTCP, MPQUIC-UDP and ATSSS-LL with Active-Standby in the uplink;

then the PCF shall provide a PCC Rule for "match all" traffic. This PCC Rule contains a "match all" SDF template, the lowest precedence, the Steering Functionality set to "ATSSS-LL" and the Steering Mode set to "Active-Standby" for the uplink direction, and the Steering Functionality set to "ATSSS-LL" and the Steering Mode set to any supported steering mode (i.e. any Steering Mode allowed for ATSSS-LL) for the downlink direction.

If the MA PDU Session is capable of supporting one of the following:

- MPTCP with any Steering Mode in the downlink, ATSSS-LL with any steering mode except Smallest Delay steering mode and Redundant steering mode in the downlink, and MPTCP and ATSSS-LL with Active-Standby in the uplink;
- MPQUIC-UDP with any Steering Mode in the downlink, ATSSS-LL with any steering mode except Smallest Delay steering mode and Redundant steering mode in the downlink, and MPQUIC-UDP and ATSSS-LL with Active-Standby in the uplink;
- Both MPTCP and MPQUIC-UDP with any Steering Mode in the downlink, ATSSS-LL with any steering mode except Smallest Delay steering mode and Redundant steering mode in the downlink, and MPTCP, MPQUIC-UDP and ATSSS-LL with Active-Standby in the uplink;

then the PCF shall provide a PCC Rule for "match all" traffic. This PCC Rule contains a "match all" SDF template, the lowest precedence, the Steering Functionality set to "ATSSS-LL" and the Steering Mode set to "Active-Standby" for the uplink direction, and the Steering Functionality set to "ATSSS-LL" and the Steering Mode set to any supported steering mode except Smallest Delay steering mode and Redundant steering mode for the downlink direction.

If the MA PDU Session is capable of supporting one of the following:

- MPTCP and ATSSS-LL with Active-Standby in the uplink and downlink;
- MPQUIC-UDP and ATSSS-LL with Active-Standby in the uplink and downlink;
- MPTCP, MPQUIC-UDP and ATSSS-LL with Active-Standby in the uplink and downlink;

then the PCF shall provide a PCC Rule for "match all" traffic. This PCC Rule contains a "match all" SDF template, the lowest precedence, the Steering Functionality set to "ATSSS-LL" and the Steering Mode set to "Active-Standby" for the uplink direction and the downlink direction.

If the MA PDU Session is capable of supporting one of the following:

- MPTCP and ATSSS-LL with any Steering Mode (i.e. any Steering Mode allowed for ATSSS-LL) in the uplink and downlink;
- MPQUIC-UDP and ATSSS-LL with any Steering Mode (i.e. any Steering Mode allowed for ATSSS-LL) in the uplink and downlink;
- MPTCP, MPQUIC-UDP and ATSSS-LL with any Steering Mode (i.e. any Steering Mode allowed for ATSSS-LL) in the uplink and downlink;

then the PCF shall provide a PCC Rule for "match all" traffic. This PCC Rule may contain a "match all" SDF template, the lowest precedence, the Steering Functionality set to "ATSSS-LL" and the Steering Mode set to any supported steering mode for the uplink direction and for the downlink direction (i.e. any Steering Mode allowed for ATSSS-LL).

If MA PDU Session is capable of supporting both MPQUIC-E and ATSSS-LL functionalities in the uplink and downlink; then the PCF either sets the Steering Functionality to MPQUIC-E for all the PCC rules, or sets the Steering Functionality to ATSSS-LL for all the PCC rules, but not both.

For other cases, the PCF shall provide a PCC rule for "match all" traffic, as follows:

- If the MA PDU Session is capable of supporting MPQUIC-IP functionality (and zero or more other steering functionalities), the PCC Rule for "match all" traffic may contain a "match all" SDF template, the lowest precedence and the Steering Functionality set to "MPQUIC-IP" and the Steering Mode set to any supported steering mode for the uplink direction and for the downlink direction.
- If the MA PDU Session is capable of supporting MPQUIC-E functionality (and zero or more other steering functionalities), the PCC Rule for "match all" traffic may contain a "match all" SDF template, the lowest precedence and the Steering Functionality set to "MPQUIC-E" and the Steering Mode set to any supported steering mode for the uplink direction and for the downlink direction.
- If the MA PDU Session is capable of supporting ATSSS-LL functionality with any steering mode (and zero or more other steering functionalities), the PCF PCC Rule for "match all" traffic may contain a "match all" SDF template, the lowest precedence and the Steering Functionality set to "ATSSS-LL" and Steering Mode set to any supported steering mode (i.e. any Steering Mode allowed for ATSSS-LL) for the uplink direction and for the downlink direction.

- If the MA PDU Session is capable of supporting ATSSS-LL functionality with Active Standby steering mode, the PCC Rule for "match all" traffic may contain a "match all" SDF template, the lowest precedence and the Steering Functionality set to "ATSSS-LL" and the Steering Mode set to "Active-Standby".

The Steering functionality "ATSSS-LL" shall not be provided together with Steering Mode "Redundant".

These PCC Rules are used by the SMF to generate an ATSSS rule for the UE and an N4 rule for the UPF to route the "match all" traffic of the MA PDU Session in the uplink and downlink direction respectively.

NOTE 5: The PCF can also use the ATSSS capability of the MA PDU Session to provide PCC Rules containing SDF template for some specific non-MPTCP traffic or non-MPQUIC traffic other than the PCC Rule containing a "match all" SDF template. This allows the operator to apply different policies e.g. charging key to non-MPTCP traffic or non-MPQUIC traffic other than the non-MPTCP traffic or non-MPQUIC matching the "match all" PCC Rule.

When the Redundant steering mode is used and resources are not available in one access, the SMF will notify the PCF about the resource allocation failure and indicate the respective Access Type (as described in clause 6.1.3.5). The PCF can then determine by implementation specific means how to proceed with such a GBR SDF for which redundant traffic transmission is no longer possible.

NOTE 6: The PCF can e.g. provide the PCC rule again in order to trigger another resource allocation, modify the MA PDU Session Control information in the PCC rule or remove the PCC rule (and inform the AF accordingly).

#### 6.1.3.21 QoS Monitoring control

The QoS Monitoring control refers to the enabling of real-time measurements of QoS Monitoring parameters for a service data flow.

An AF may request measurements for one or more of the QoS Monitoring parameters defined in clause 5.45 of TS 23.501 [2].

NOTE 1: The QoS Monitoring parameters which can be measured are parameters which describe the QoS experienced in the 5GS by the application, i.e. they are not restricted to the 5G QoS Parameters.

The AF may also request measurements for the following QoS Monitoring parameters (see clause 6.1.3.18) that are derived by PCF:

- Packet Delay Variation, as described in clause 6.1.3.26.
- Round-trip delay for two service data flows, as described in clause 5.37.4 of TS 23.501 [2].

In addition, the following AF requested QoS requirements may trigger QoS monitoring for service data flow(s):

- Round-trip latency requirement, see clause 5.37.6 of TS 23.501 [2] and clause 6.1.3.27.2.

The PCF generates the authorized QoS Monitoring policy for the service data flow based on local policy and/or AF request, including the QoS Monitoring request if received from the AF (as specified in clause 6.1.3.22 and in TS 23.502 [3]) and AF subscription requests for other QoS Monitoring parameter measurements as listed above.

Based on operator policy, the PCF may not generate an authorized QoS Monitoring policy for a QoS Monitoring request received from the AF that applies to an ongoing service data flow that has been established without a QoS Monitoring policy. If so, the PCF indicates that the QoS Monitoring request cannot be fulfilled when responding to the QoS Monitoring request received from the AF.

NOTE 2: Adding a QoS Monitoring policy to an ongoing service data flow that has been established without a QoS Monitoring policy could in some cases require a QoS Flow rebinding of the corresponding PCC rule (or other PCC rules) as described in clause 6.1.3.2.4 and such QoS Flow rebinding could lead to service interruption or even service termination.

The QoS Monitoring policy includes the following:

- QoS Monitoring parameters as defined in clause 5.45 of TS 23.501 [2];
- Reporting frequency (event triggered, periodic):

- if the reporting frequency is event triggered:
  - the corresponding reporting threshold to each QoS Monitoring parameter;
  - minimum waiting time between subsequent reports;
- the reporting period;
- optionally, Target of reporting (i.e. the NEF, the AF or the Local NEF, indicated as Notification Target Address + Notification Correlation ID);
- optionally, an indication of direct event notification (to request the UPF to directly send QoS Monitoring reports to the Local NEF or the AF as described in clause 5.8.2.18 of TS 23.501 [2]).

When multiple QoS Monitoring parameters are required to be measured for a given service data flow, multiple QoS Monitoring policies may be included within one PCC rule. At a given time, the PCC Rule only has one authorized QoS Monitoring policy enabling the measurement of each QoS Monitoring parameter.

NOTE 2: Within a PCC rule, each QoS Monitoring parameter can only be requested in one QoS Monitoring Policy. As an example, if a new QoS Monitoring Policy is provided for a QoS Monitoring parameter, the existing QoS Monitoring Policy for same QoS Monitoring parameter (if any) will be replaced.

NOTE 3: The AF requested QoS Monitoring parameters and the PCF requested QoS Monitoring parameters based on the AF request can be different, e.g. Packet Delay Variation and packet delay, as described in clause 6.1.3.26.

If the AF did not provide an indication of direct event notification in the request and the PCF may decide that it does not want to receive the QoS Monitoring reports. If so, the PCF forwards the Target of reporting parameter in the QoS Monitoring policy and the SMF shall then send the QoS Monitoring reports directly to the NF indicated by the Target of reporting parameter. If the PCF decides that it wants to receive the QoS Monitoring reports, e.g. when the AF request includes measurements that are derived by PCF, the PCF shall not forward the Target of reporting parameter in the QoS Monitoring policy and instead subscribe to receive QoS Monitoring reports from SMF by setting the QoS Monitoring Policy Control Request Trigger.

If the AF provided an indication of direct event notification in the request and PCF determines that the QoS Monitoring reports can be notified directly (i.e. the AF request does not include QoS Monitoring parameter measurements that are derived by PCF), the PCF forwards the Target of reporting parameter in the QoS Monitoring policy and sets the indication of direct event notification to indicate that QoS Monitoring reports have to be sent by the UPF directly to the NF indicated by the Target of reporting. The PCF may also subscribe to receive QoS Monitoring reports, by setting the QoS Monitoring Policy Control Request Trigger. In that case, the UPF is asked to duplicate the reports and the QoS Monitoring reports will be sent by the UPF to both, the NF indicated by the Target of reporting and to the SMF (which then forwards the report to the PCF).

If the AF provided an indication of direct event notification and PCF determines that the QoS Monitoring reports cannot be notified directly (i.e. the AF request includes QoS Monitoring parameter measurements that are derived by PCF), the PCF generates a successful response to AF and indicates that direct event notification is not possible. The PCF shall neither forward the Target of reporting parameter nor the indication of direct event notification in the QoS Monitoring policy and instead subscribe to receive QoS Monitoring reports from SMF by setting the QoS Monitoring Policy Control Request Trigger.

NOTE 4: If there are multiple QoS rules containing a QoS Monitoring policy, the PCF will receive the QoS Monitoring reports for all of them when the QoS Monitoring Policy Control Request Trigger is set.

The PCF includes the authorized QoS Monitoring policy in the PCC rule and provides it to the SMF. The SMF determines the configuration for the measurement of the QoS Monitoring parameters (e.g. the QoS Monitoring parameter(s) requested) from the QoS Monitoring policy in the PCC rule and requests the RAN (if necessary) and the UPF to perform the measurement of the QoS Monitoring parameters defined in clause 5.45 of TS 23.501 [2] as needed and as defined in clause 5.8.2.18 of TS 23.501 [2] and in clause 4.3.3.2 of TS 23.502 [3].

The PCF can be configured to include in the QoS Monitoring policy of the PCC rule a `DataCollection_ApplicationIdentifier` determined based on the AF request or local configuration. The `DataCollection_ApplicationIdentifier` is provided to assist the SMF when it needs to decide whether this PCC Rule corresponds to an event exposure subscription (see clause 4.15.4.5.1 of TS 23.502 [3]).

NOTE 5: The SMF selects the PCC Rules whose DataCollection\_ApplicationIdentifier matches the Application Identifier received in the event exposure subscription, e.g. a subscription for QoS Monitoring event for data collection that includes an Application Identifier.

NOTE 6: The PCF can also include the DataCollection\_ApplicationIdentifier when the SDF template of the PCC rule contains a list of service data flow filters.

### 6.1.3.22 AF session with required QoS

The AF may request that a data session to a UE is set up with a specific QoS (e.g. low latency or PDV) and priority handling. The AF can request the network to provide QoS for the AF session based on the service requirements with the help of a QoS Reference parameter that refers to pre-defined QoS information. Instead of the QoS Reference, the AF may provide individual QoS parameters associated to the Flow Description.

a) When the AF provides only a QoS Reference to determine the QoS parameters but no individual QoS parameters:

- When the PCF authorizes the service information from the AF, it derives the QoS parameters of the PCC rule based on the service information and the indicated QoS Reference.

NOTE 1: An SLA has to be in place between the operator and the ASP defining the possible QoS levels and their charging rates. For each of the possible pre-defined QoS information sets, the PCF needs to be configured with the corresponding QoS parameters and their values as well as the appropriate Charging key (or receive this information from the UDR).

- The AF may change the QoS by providing a different QoS Reference while the AF session is ongoing. If this happens, the PCF shall update the related QoS parameter sets in the PCC rule accordingly.

b) When the AF provides individual QoS parameters instead of a QoS Reference:

- The AF provides one or more of the following individual QoS parameters, i.e. Requested Priority, Maximum Burst Size, Requested 5GS Delay, Requested Maximum Bitrate, Requested Guaranteed Bitrate and Requested Packet Error Rate.

NOTE 2: Different combinations of individual QoS parameters with specific parameter names exist and they are described in TS 23.501 [2] (for Time Sensitive Communication), in clause 6.1.3.23 (for integration with Time Sensitive Networking) and in TS 29.514 [36].

- If the AF request for QoS is sent via the TSCTSF and the request contains a Requested 5GS Delay, the TSCTSF determines a Requested PDB considering the UE-DS-TT Residence Time (either provided by the PCF or pre-configured).
- When the PCF authorizes the service information from the AF, it derives the QoS parameters of the PCC rule based on the service information and the individual QoS parameters received from the AF and TSCTSF. The PCF should select a standardized, pre-configured or existing dynamically assigned 5QI that matches the individual QoS parameters. If no 5QI exists that matches the individual QoS parameters, the PCF generates a new dynamically assigned 5QI based on the individual QoS parameters.
- The AF may change the QoS by providing different values for the individual QoS parameters while the AF session is ongoing. If this happens, the PCF shall update the related QoS parameter sets in the PCC rule accordingly.
- The PCF may reject the individual QoS parameters received from the AF based on operator policy or impossibility to support the requested values of the individual QoS parameters. If this happens, the PCF may provide in the response to the AF one or more combinations of individual QoS parameters that can be supported. The PCF may indicate in the response to the AF that the request is not authorized because the applicable QoS parameters are not supported in the PLMN where the UE is registered, then the AF may retry the request when the UE moves to a different PLMN.

In addition to the QoS Reference or the individual QoS parameters described above, the AF may provide further parameters associated with the Flow Description, e.g. parameters that describe traffic characteristics as described in clause 6.1.3.23 or 6.1.3.23a.

The PCF generates a PCC Rule with service data flow filter (including IP Packet Filter set as in clause 5.7.6.2 of TS 23.501 [2]) or Ethernet Packet Filter set as in clause 5.7.6.3 of TS 23.501 [2]) derived from the Flow Descriptions provided by the AF, the derived PCC rule QoS parameters such as 5QI, ARP, GBR and MBR (see clause 6.3.1 for all possible PCC rule QoS parameters) and the associated TSC Assistance Container as received from the TSN AF or TSCTSF.

For TSC QoS, the PCF derives the 5QI value as defined in clause 5.27.3 of TS 23.501 [2], the PCF derives the MBR using the Requested Maximum Bitrate provided by the AF and sets the GBR equal to the MBR unless the AF provides a Requested Guaranteed Bitrate, in which case the MBR and GBR are set separately.

If the PCF gets informed about Policy Control Request Triggers relevant for the AF session, the PCF shall inform the AF about it as defined in clause 6.1.3.18.

If an AF session can adjust to different QoS parameter combinations, the AF may provide Alternative Service Requirements in a prioritized order (indicating the preference of the QoS requirements with which the service can operate) in addition to the QoS Reference or individual QoS parameters. Alternative Service Requirements contain:

- When the AF requests the network to provide QoS with a QoS Reference, one or more QoS Reference parameters in a prioritized order.
- When the AF requests the network to provide QoS with individual QoS parameters, one or more Requested Alternative QoS Parameter Set(s) in a prioritized order. Each Requested Alternative QoS Parameter Set is comprised of the following individual parameters: Requested 5GS Delay, Requested Guaranteed Flow Bitrate, Requested Packet Error Rate and optionally, a Requested Averaging Window. Each requested Alternative QoS Parameter Set may also include a Maximum Burst Size parameter.

If the AF request is sent via the TSCTSF, the TSCTSF determines a Requested PDB considering the Requested 5GS Delay and the UE-DS-TT Residence Time.

An AF that provides Alternative Service Requirements shall also subscribe to receive notifications from the PCF for successful resource allocation and when the QoS targets can no longer (or can again) be fulfilled as described in clause 6.1.3.18.

When the PCF authorizes the service information from the AF and generates a PCC rule, it shall also derive Alternative QoS Parameter Sets for this PCC rule based on the QoS Reference parameters or the Requested Alternative QoS Parameter Sets in the Alternative Service Requirements. If the AF provided Requested Alternative QoS Parameter Sets in the request, the PCF may reject any of the Requested Alternative QoS Parameter Sets it has received based on operator policy or impossibility to support the requested values of the individual parameters. If this happens, the PCF may provide in the response to the AF one or more Requested Alternative QoS Parameters Sets that can be supported.

The PCF shall enable QoS Notification Control and include the derived Alternative QoS parameter sets (in the same prioritized order indicated by the AF) in the PCC rule sent to the SMF. When the PCF notifies the AF that QoS targets can no longer be fulfilled, the PCF shall include the QoS Reference parameter or the set of Requested Alternative QoS Parameters corresponding to the Alternative QoS parameter set referenced by the SMF, or an indication that the lowest priority QoS Reference or the lowest priority set of Requested Alternative QoS Parameters of the Alternative Service Requirements cannot be fulfilled (as described in clause 6.1.3.18).

NOTE 3: The AF behaviour is out of the scope of this TS but can include adaptation to the change of QoS (e.g. rate adaptation) as well as application layer signalling with the UE.

The AF may change the Alternative Service Requirements while the AF session is ongoing. If this happens, the PCF shall update the Alternative QoS parameter sets in the PCC rule accordingly.

The AF may indicate to the PCF that the UE does not need to be informed about changes related to Alternative QoS Profiles. With this indication received from the AF, the PCF decides whether to disable the notifications to the UE when changes related to the Alternative QoS Profiles occur and sets the Disable UE notifications at changes related to Alternative QoS Profiles parameter in the PCC rule accordingly.

The AF may also provide the PCF with QoS duration and QoS inactivity interval. The requested QoS is applied to each QoS duration interval. Once the PCF receives the request from the AF, the PCF provides a PCC Rule with the QoS parameters to SMF to allocate resources. The PCF may allocate resources at the beginning of each QoS duration interval and release the resources at the end of the corresponding QoS duration interval. This process is repeated until the AF session is revoked. If the AF has subscribed to the PCF and resource allocation for any of the QoS duration interval fails, the PCF informs the AF of the resource allocation failure.

NOTE 4: When leveraging the QoS duration and the QoS inactivity interval, both are expected to be in the order of minutes to avoid too frequent signalling between RAN, AF and 5GC/PCF.

The PCF may generate policies to request to monitor the Traffic Parameter (i.e. N6 jitter range associated with DL Periodicity) and include it into a PCC rule based local policy. Based on the received PCC rule or local configuration, the SMF indicates UPF to monitor and report the requested traffic characteristics as described in clause 5.37.8.2 of TS 23.501 [2] and in clause 6.1.3.27.6.

The AF may also request measurements of QoS Monitoring parameters for the AF session (as described in clause 6.1.3.21).

### 6.1.3.23 Support of integration with Time Sensitive Networking

Time Sensitive Networking (TSN) support is defined in TS 23.501 [2], where the 5GS represents logical TSN bridge(s) based on the defined granularity model. The TSN AF and PCF interact to perform QoS mapping as described in clause 5.28.4 of TS 23.501 [2].

The PCF provides the following parameters to the TSN AF:

- 5GS user-plane Node information:
  - 5GS Bridge ID;
  - UE-DS-TT Residence time;
  - port number of the Ethernet port of DS-TT;
  - MAC address of the Ethernet port of DS-TT (i.e. DS-TT port MAC address).
- Port Management Information Container and the related port number.
- User plane node Management Information Container.

The TSN AF may use this information to construct IEEE 802.1 managed objects, to interwork with IEEE 802.1 TSN networks, as described in TS 23.501 [2] and TS 23.502 [3].

The TSN AF may use the PTP Port state of NW-TT and DS-TT in the Port/User plane node Management Information Container to determine the Port Pairs that will be used for (g)PTP delivery. Based on this the TSN AF may request appropriate QoS treatment for the (g)PTP flows from PCF.

The TSN AF request related to TSN configuration or gPTP flow delay requirement is sent on the AF session associated with the DS-TT port MAC address. The TSN AF decides the TSN QoS information (i.e. priority, delay, maximum TSC Burst Size and Maximum Flow Bitrate) and TSC Assistance Container based on the received configuration information of 5GS Bridge from the CNC as defined in clause 5.28.2 of TS 23.501 [2], the bridge delay information at the TSN AF and the UE-DS-TT Residence time.

NOTE: TSC burst size can represent the maximum burst size of the TSN streams that have been aggregated.

The TSN AF provides the Flow Descriptions (including Ethernet Packet Filters), TSC Assistance Container (as described in clause 5.27.2.2 of TS 23.501 [2]), and the related QoS information to the PCF by setting up an AF session with required QoS as described in clause 6.1.3.22. In addition, the TSN AF may provide the following parameters to the PCF:

- Port Management Information Container and related Port number as applicable;
- User plane node Management Information Container;
- optionally, Notification Target Address for PMIC/UMIC UPF event and Correlation ID for PMIC/UMIC UPF event.

The PCF provides the SMF the parameters received from the TSN AF (as specified in TS 23.502 [3]). The SMF indicates the UPF to report the TSC management information as defined in clause 5.8.5.14 of TS 23.501 [2] if the PCF forwards the Target of reporting parameter.

The PCF assigns the ARP to a value preconfigured for TSN services.

### 6.1.3.23a Support of Time Sensitive Communication and Time Synchronization

Enablers for Time Sensitive Communication and Time Synchronization are defined in TS 23.501 [2] clause 5.27.

When the PCF has the 5GS Bridge/Router information for the PDU Session received from SMF and has a subscription for the 5GS Bridge/Router information Notification from the TSCTSF or the PCF determines that the PDU Session is potentially impacted by (g)PTP based time synchronization service based on a local policy, if integration with IEEE TSN does not apply, the PCF provides the following parameters to the TSCTSF:

- 5GS user-plane Node information:
  - User-plane Node ID;
  - UE-DS-TT Residence time;
  - port number of the DS-TT;
  - MAC address of the Ethernet port of DS-TT (i.e. DS-TT port MAC address) (for Ethernet type PDU Session), or IP address of the UE (for IP type PDU Session, additionally DNN and S-NSSAI of IP type PDU Session in the case of private IPv4 address being used for the PDU Session);
  - Port Management Information Container and the related port number;
  - User plane node Management Information Container.

Upon reception of the above information, if the TSCTSF does not have a corresponding AF session, the TSCTSF shall create an AF session with the PCF.

The TSCTSF may receive a request from an AF that a data session to a UE is to be set up for Time Sensitive Communication with a specific QoS and parameters that describe the traffic characteristics. If so, the TSCTSF provides the Flow Descriptions, the TSC Assistance Container (as described in clause 5.27.2.3 of TS 23.501 [2]), and the related QoS information to the PCF by setting up an AF session with required QoS as described in clause 6.1.3.22. In addition, the TSCTSF may provide the following parameters to the PCF:

- Port Management Information Container and related Port number as applicable.
- User plane node Management Information Container.
- optionally, Notification Target Address for PMIC/UMIC UPF event and Correlation ID for PMIC/UMIC UPF event.

The TSCTSF may use the PTP Port state of NW-TT and DS-TT in the Port/User plane node Management Information Container to determine the Port Pairs that will be used for (g)PTP delivery. Based on this the TSCTSF may request appropriate QoS treatment for the (g)PTP flows from PCF.

The AF may include the Capability for BAT adaptation or a BAT Window or Periodicity Range in the request (as described in clause 5.27.2.3 of TS 23.501 [2]), if so the TSCTSF subscribes to Notification on BAT offset defined in clause 6.1.3.18. The PCF sends the BAT offset received from the SMF to the AF and the AF adjusts the burst sending time according to the indicated BAT offset. If the PCF additionally sends the adjusted periodicity received from the SMF to the AF, the AF adjusts the periodicity in addition to the burst sending time according to the indicated adjusted periodicity.

The AF may subscribe to requested 5G access stratum time synchronization service or (g)PTP time synchronization service status update notifications for target UE(s) from TSCTSF. The TSCTSF may determine whether the clock quality acceptance criteria requested by AF can be met or not, and performs behaviours per acceptance criteria result as described in clause 5.27.1.12 of TS 23.501 [2].

**NOTE:** For the adjustment of burst sending time and periodicity in UL direction it is expected that the AF interacts with the application in the UE or devices behind the UE based on application layer signalling.

### 6.1.3.23b Support of IETF Deterministic Networking

Enablers for the support of IETF Deterministic Networking are defined in clauses 4.4.8.4 and 5.28.5 of TS 23.501 [2].

When the PCF has received the 5GS Bridge/Router information for the PDU Session from SMF and has a subscription for the 5GS Bridge/Router information Notification from the TSCTSF or based on a local policy, if integration with IETF Deterministic Networking applies, the PCF provides the following information to the TSCTSF for device side ports:

- user-plane node ID;
- port number;
- IP address or IPv6 prefix allocated to the PDU Session;
- MTU size for IPv4 or MTU size for IPv6 (optional).

Upon reception of the above information, if the TSCTSF does not have a corresponding AF session, the TSCTSF shall create an AF session with the PCF.

The TSCTSF shall subscribe for notifications from the PCF for reporting of extra UE addresses for the same PDU Session. As a result, the TSCTSF shall be notified of any extra address or address range that is allocated for the given PDU Session as a result of Framed Routes or IPv6 Prefix delegation.

When the TSCTSF is first notified about a 5GS DetNet router identified by the user-plane node ID, the TSCTSF may subscribe with the NW-TT for receiving user plane node management information changes for the 5GS router, as described in clause 5.28.3.1 of TS 23.501 [2].

After receiving a User plane node Management Information Container (UMIC) containing the NW-TT port numbers, the TSCTSF may subscribe with the NW-TT for receiving NW-TT port management information changes for the NW-TT port indicated by each of the NW-TT port numbers as described in clause 5.28.3.1 of TS 23.501 [2]. For network side ports, the Port Management Information Container may contain information to be exposed to the DetNet controller (see Information for deterministic networking in Table K.1-1 of TS 23.501 [2]).

The TSCTSF may receive DetNet YANG configuration as described in IETF RFC 9633 [37] from a DetNet Controller that describe the traffic characteristics and requirements.

When both the TSCTSF and the DetNet controller support 3GPP extensions to the IETF RFC 9633 [37], the DetNet controller may provide the 5GS-node-max-latency and 5GS-node-max-loss specific to the 5GS system.

NOTE 1: The 3GPP extension to the IETF RFC 9633 [37] is defined in 3GPP as a YANG model which imports IETF RFC 9633 [37] and adds the 3GPP specific parameters. The 3GPP defined YANG model uses the 3GPP namespace as defined in RFC 5279 [38].

NOTE 2: If the DetNet YANG configuration neither includes 5GS specific 5GS-node-max-latency nor the end-to-end Max-latency, the TSCTSF can derive the Requested 5GS Delay or the PCF can derive the PDB. Similarly, if the DetNet YANG configuration neither includes 5GS specific 5GS-node-max-loss nor the end-to-end Max-loss, the TSCTSF can derive the Requested Packet Error Rate or the PCF can derive the PER. This derivation is not further specified.

The TSCTSF provides the Flow Descriptions, the TSC Assistance Container (as described in clause 5.27.2.3 of TS 23.501 [2]), and the related QoS information to the PCF as specified in the AF session with required QoS procedure for the signalling between the TSCTSF and the PCF described in clause 4.15.6.6 of TS 23.502 [3]. The TSCTSF can set up an AF session on behalf of DetNet controller with required QoS as described in clause 6.1.3.22. The TSCTSF maps the DetNet configuration as follows before interacting with the PCF.

- 5GS-node-max-latency to Requested 5GS Delay.
- Min-bandwidth to Requested Guaranteed Bitrate.
- 5GS-node-max-loss to Requested Packet Error Rate.
- Max-consecutive-loss-tolerance to Survival time (see clause 5.27.2.1 of TS 23.501 [2]) - when such mapping is possible, such as when there is only a single packet per interval.
- Interval to Periodicity.
- $\text{max-pkts-per-interval} * (\text{max-payload-size} + \text{protocol header size})$  to Maximum Burst Size.
- $\text{max-pkts-per-interval} * (\text{max-payload-size} + \text{protocol header size}) / \text{Interval}$  to Requested Maximum Bitrate.

- DetNet flow specification is mapped to the Flow Description information. The DetNet flow specification is based on the following header fields: IP source and destination address, IPv4 protocol or IPv6 next header, IPv4 type of service or IPv6 traffic class, IPv6 flow label, TCP or UDP source or destination ports, IPsec SPI as defined in clause 5.1 of IETF RFC 8939 [42], which are mapped to the corresponding fields in the Flow Description information.

If the DetNet YANG configuration includes the Max-latency and Max-loss only for the end-to-end flow and not the 5GS specific requirement, the TSCTSF determines the requirements applicable to 5GS (5GS-node-max-latency and 5GS-node-max-loss) based on a pre-configured mapping for the given deployment.

Based on the mapping, the TSCTSF provides the Flow Descriptions, the TSC Assistance Container (as described in clause 5.27.2.3 of TS 23.501 [2]), and the related QoS information to the PCF by setting up an AF session with required QoS as described in clause 6.1.3.22.

The TSCTSF shall subscribe to the Resource allocation outcome and Service Data Flow deactivation events at the PCF, so that TSCTSF gets notified when the DetNet requirements are not satisfied. In that case, the DetNet controller shall be notified.

#### 6.1.3.24 Policy control for redundant PDU Sessions

As specified in clause 5.33.2.1 of TS 23.501 [2], in order to support highly reliable URLLC services, two redundant PDU Sessions over the 5G network may be established such that the 5GS sets up the user plane paths of the two redundant PDU Sessions to be disjoint. The policy control for redundant PDU Session specifies that the PCF may request traffic redundancy for the PDU Session (e.g. when some of the allowed services require redundancy).

The PCF provides to the SMF the indication that the PDU Session is a redundant PDU Session based on operator policies. The SMF follows the procedure defined in TS 23.501 [2] to establish redundant PDU Sessions depending on the indication from the PCF.

#### 6.1.3.25 User Plane Remote Provisioning of UE SNPN Credentials in Onboarding Network

User Plane Remote Provisioning of UE SNPN Credentials in Onboarding Network is specified in clause 5.30.2.10.4 of TS 23.501 [2].

User Plane Remote Provisioning of UE SNPN Credentials is provided through a DNN and S-NSSAI used for onboarding.

For a PDU Session with a DNN and S-NSSAI used for onboarding, the PCF may make authorization and policy decisions that restrict the use of the PDU Session, e.g. by restricting the traffic to/from Provisioning Server address(es) and DNS server address(es) only.

For a PDU Session established to the DNN and S-NSSAI used for onboarding, the SMF provides the Onboarding Indication to the PCF if the Onboarding Network is an ON-SNPN or the SMF does not provide any Onboarding Indication to the PCF if the Onboarding Network is a PLMN or an SNPN. When the Onboarding Indication is provided, the PCF does not perform a subscription check. Instead, the PCF uses the locally stored Onboarding Configuration Data for this DNN and S-NSSAI combination to make authorization and policy decisions. When the Onboarding Indication is not provided, the PCF retrieves policy control subscription profile for this SUPI, DNN, S-NSSAI from UDR that includes the list of allowed services. If the list of allowed services includes both PVS and DNS services, then the PCF has local policies that define the PVS and DNS addresses(es) to be used in the SDF template of the PCC Rule(s) and allow traffic to/from these destinations.

If the Onboarding Indication is provided by the SMF, the PCF sets the SDF template of the PCC rule(s) according to the Onboarding Configuration Data for this DNN and S-NSSAI combination that may include the Provisioning Server address(es) and DNS server address(es). If the PCF receives Provisioning Server address(es) from SMF, then PCF creates the SDF templates in the PCC rule using the received Provisioning Server address(es) instead of using the Provisioning Server address(es) stored locally as part of the Onboarding Configuration Data. The Provisioning Server address(es) provided by SMF may include IP address(es) and FQDN(s).

**NOTE:** How the PCF can resolve a PVS FQDN to an IP address or IP address range other than using local configuration is not specified in this release of the specification.

The PCC Rule Authorization function selects QoS parameters applicable to the User Plane Remote Provisioning. Then, the PCF installs these PCC Rules at the SMF to enable traffic to/from the dedicated IP addresses (i.e. Provisioning Server address(es) and DNS server address(es)) with the associated QoS. The DNS server address(es) are locally configured at the PCF.

The PCC Rules provided by the PCF take precedence over the locally stored policy used for the PDU Session used for User Plane Remote Provisioning at the SMF.

### 6.1.3.26 Packet Delay Variation monitoring and reporting

The AF may send a request to PCF for Packet Delay Variation (i.e. between UE and PSA UPF) monitoring and reporting, together with the request for packet delay monitoring and reporting. The PCF may generate the authorized QoS Monitoring policy for the service data flow based on both, Packet Delay Variation monitoring request and the QoS Monitoring request for packet delay.

The Packet Delay Variation monitoring request includes the following:

- Packet Delay Variation (UL, DL or RT packet delay variation);
- frequency of reporting (event triggered or periodic):
  - if the reporting frequency is event triggered:
    - the corresponding reporting thresholds;
    - minimum waiting time between subsequent reports.

NOTE 1: The reporting period for the Packet Delay Variation monitoring is the same as the reporting period of the packet delay monitoring.

Based on the above Packet Delay Variation monitoring request, the QoS Monitoring request for packet delay received from the AF and any other AF requirements related to QoS monitoring, the PCF generates the authorized QoS Monitoring policy for packet delay monitoring. The PCF shall subscribe to receive QoS Monitoring reports from SMF by setting the QoS Monitoring Policy Control Request Trigger. Then, the SMF reports the measured packet delay values to the PCF, the PCF derives the Packet Delay Variation and reports to the AF both, the packet delay measurements and Packet Delay Variation results under consideration of the respective thresholds and minimum waiting times (if they are applicable).

NOTE 2: If event triggered reporting is used for packet delay monitoring and Packet Delay Variation monitoring, the PCF report can contain only packet delay measurements or Packet Delay Variation.

If the Reporting frequency indicates "event triggered", PCF shall send a report when the measurement result matches or exceeds the indicated Reporting threshold. Subsequent reports shall not be sent during the Minimum waiting time. After the Minimum waiting time is over, the PCF shall report if measurement results are produced that match or exceed the indicated Reporting threshold.

### 6.1.3.27 Support of eXtended Reality and Interactive Media Services

#### 6.1.3.27.1 Exposure of network information

For support of real-time media codec/traffic adaptation to the network conditions, the AF may subscribe for exposure of 5GS network information.

When the AF requests the network to provide QoS for the AF session (as described in clause 6.1.3.22), the AF may also provide the subscription to the following information based on QoS monitoring (as described in clause 5.37.4 of TS 23.501 [2]): the UL and/or DL congestion information, UL and/or DL packet delay, the round-trip delay over one or two service data flows, the UL and/or DL Available Bitrate for the service data flow, the UL and/or DL data rate for the service data flow as described in clause 6.1.3.21. The PCF may generate QoS Monitoring policies for the above network information in the PCC rule of the service data flow as described in clause 6.1.3.21.

If the AF provides an explicit indication (i.e. Indication of ECN marking for L4S support) that the UL and/or DL of the service data flow supports ECN marking for L4S or the PCF decides, based on local configuration, that the service data flow supports ECN marking for L4S, then the PCF may explicitly, or implicitly (based on PCF/SMF local

configuration), indicate to the SMF to enable for ECN marking for L4S. ECN marking for L4S may be also enabled based on dynamic detection of L4S traffic, either upon SMF decision (as described in clause 5.37.3.1 of TS 23.501 [2]) or when the PCF receives an application detection report from the SMF (see clause 6.2.2.5) for a PCC rule with an application identifier that is detecting L4S traffic on the QoS Flow associated with the default QoS rule (see clause 5.37.3.1 of TS 23.501 [2] for the detection criteria).

The PCF shall ensure that only one of QoS monitoring for UL and/or DL congestion information or ECN marking for L4S is activated for the same service data flow (due to the limitation described in clause 5.45.3 of TS 23.501 [2]).

For subscription of UL and/or DL Available Bitrate of a GBR service data flow, the AF also provides a list of thresholds per direction, containing the bitrate values of interest to the AF including one value equal to the Requested Guaranteed Bitrate and one value equal to the Requested Maximum Bitrate (in case it is different). The list of thresholds per direction is to be provided with an increasing order of bitrate values. The PCF then includes the list(s) of thresholds in the QoS Monitoring policy of the corresponding PCC rule (see also clause 5.45.6 of TS 23.501 [2]).

The AF may also provide the value for Averaging Window using AF session with required QoS as described in clause 6.1.3.22.

The AF may subscribe the Data Rate Limitation Information report for a Non-GBR service data flow as described in clauses 6.1.3.18 and 6.1.3.22 (see also clause 5.37.4 of TS 23.501 [2]). The PCF reports the uplink and downlink maximum bitrate authorized for the service data flow to the AF and any change of it.

**NOTE:** The PCF derives the uplink and downlink maximum bitrate authorized for the service data flow to be reported to the AF under consideration of the uplink and downlink Authorized Session-AMBR, based on local PCF configuration and operator policies.

The AF may subscribe the Data Rate Limitation Information report for a PDU Session as described in clause 6.1.3.18 (see also clause 5.37.4 of TS 23.501 [2]). The PCF reports the uplink and downlink Authorized Session-AMBR to the AF and any change of it by means of the Npcf\_EventExposure service.

#### 6.1.3.27.2 UL/DL policy control based on round-trip latency requirement

The AF may provide a round-trip (RT) latency indication together with a single direction delay requirement between the UE and the PSA UPF expressed as the QoS Reference or the individual QoS parameters (as described in clause 6.1.3.22). The RT latency indication indicates the need to meet the RT latency requirement of the service data flow, i.e. doubling of the single direction delay requirement between the UE and the PSA UPF.

Based on the RT latency requirement received from the AF or locally configured in the PCF, the PCF authorizes the AF request and can split the RT latency requirement into two PDBs of two PCC rules, used for the UL QoS Flow and DL QoS Flow to carry the UL and DL traffics of the service respectively. The two PDBs can be unequal, but their sum shall not exceed the RT latency requirement.

Based on the RT latency requirements, the PCF shall generate UL and DL QoS monitoring policies in the PCC rules associated to the two correlated QoS Flows respectively to enable RT latency tracking. The uplink and downlink delay for the two QoS Flows shall be tracked by PCF independently.

When the QoS monitoring results are reported to PCF, the PCF can derive and track the RT latency by combining the QoS monitoring reports for the UL and the DL packet delay. Based on the QoS monitoring results, the PCF may adjust the PDBs of one or both PCC rules under the consideration of the RT latency requirement using SM Policy Association Modification procedure described in clause 4.16.5.2 of TS 23.502 [3] to better fit the new situation.

**NOTE:** How the PCF derives the round-trip latency and takes policy decisions is up to implementation.

If the UL and DL traffic of the service have different QoS requirements (e.g. different one-way delay), the AF may provide the QoS requirements with RT latency indication in the AF Session with required QoS request for UL and DL Flow Descriptions. The PCF then identifies the UL and DL service data flows with RT latency indicator for RT latency control. In this case, the RT latency requirement of the service is described by the sum of the UL and DL delay requirements.

#### 6.1.3.27.3 Support for delivery of multi-modal services

Enablers to support interactive media services that require high data rate and low latency communication, e.g. cloud gaming, AR/VR/XR services and tactile/multi-modal communication services are defined in TS 23.501 [2] clause 5.37.2.

For the delivery of a multi-modal service, the AF may request to the PCF directly (or indirectly via an NEF) multiple data flows for a single UE via single PDU Session or for multiple UEs (via multiple PDU Sessions and a separate request per PDU Session), to be setup or modified with specific QoS requirements, using the AF session with required QoS procedure described in clause 6.1.3.22.

NOTE 1: The term "data flow" used in this clause describes a service data flow from the perspective of the AF.

The following additional attributes are supported where the AF provides specific information for the multi-modal service:

- Multi-modal Service ID: an identifier that refers to the multi-modal communication service. Data flows belonging to the same multi-modal service share the same Multi-modal Service ID.

The following existing attributes are applicable to multi-modal services and may be provided by the AF for every data flow of the multi-modal service in the Multi-modal Service Requirements information:

- QoS monitoring requirements for each data flow.
- QoS information and service requirements for each data flow, that consist of: Flow description information of the data flow and individual QoS parameters/QoS Reference as described in clause 6.1.3.22.

NOTE 2: The attributes for multiple data flows can be provided via a single or multiple AF requests.

The PCF determines whether the request from the NEF or AF is authorized, derives a PCC rule for each data flow based on the above information provided by the AF (in the same way it is described in clause 6.1.3.22) and provisions the determined PCC rules to the SMF for the affected PDU Session. If the PCF authorization fails, the PCF rejects the request received from the AF (in the same way it is described in clause 6.1.3.22).

The AF may provide QoS monitoring requirements for each data flow associated with the same Multi-modal Service ID. If the PCF has received the QoS monitoring requirements from the AF, the PCF generates the QoS monitoring policy for the PCC rule corresponding to the data flow.

When the PCF receives a further AF request with the same Multi-modal Service ID and PCF authorization fails, the PCF rejects the AF request (in the same way it is described in clause 6.1.3.22). The application decides how to deal with the data flows with already authorized AF request with the same Multi-modal Service ID (e.g. stop them, adjust the AF request).

#### 6.1.3.27.4 PDU Set based handling

PDU Set based handling support is defined in clause 5.37.5 of TS 23.501 [2]. The AF may provide the Protocol Description (UL and/or DL) and/or On-path N6 Signalling Information as described in TS 23.501 [2].

The PCF shall, based on local configuration or on information received from the AF, include the UL and/or DL Protocol Description (see clause 5.37.5 of TS 23.501 [2] and TS 26.522 [40]) and/or On-path N6 Signalling Information (see clause 5.37.9 of TS 23.501 [2]) in the PCC Rule.

The PCF may also, based on local configuration or on information received from the AF, generate PDU Set Control Information and include it in the PCC rule. The PDU Set Control Information includes the PDU Set QoS Parameters (see clause 5.7.7 of TS 23.501 [2]). The PCF may in addition, based on local configuration or on information received from the AF, generate Alternative QoS Parameter sets containing PDU Set QoS parameters. Based on the PDU Set QoS parameters received in the PCC rule or a pre-configured PCC rule, the SMF provides 5G-AN with the PDU Set QoS Parameters and optionally Alternative PDU Set QoS parameters (as described in clause 5.37.5 of TS 23.501 [2]). If the PCC rule includes the Protocol Description and/or On-path N6 Signalling Information, it is used for PDU Set identification (as described in clauses 5.37.5 and 5.37.9 of TS 23.501 [2]).

When the AF requests that a data session to a UE (including the case of 5G-RG) is set up with a specific QoS (as described in clause 6.1.3.22), the AF may also provide Requested PDU Set Delay Budget (UL and/or DL), Requested PDU Set Error Rate (UL and/or DL) and/or Requested PDU Set Integrated Handling Information (UL and/or DL) to describe the requirements for the PDU Set based QoS handling (both the Requested PDU Set Delay Budget and Requested PDU Set Error Rate in one direction shall be provided together when they are provided by the AF) and the PCF generates the corresponding PDU Set QoS parameters (described in clause of 5.7.7 of TS 23.501 [2]) in the PCC rule. If Alternative Service Requirements are provided by the AF (described in clause 6.1.3.22), the AF is expected to also provide Requested PDU Set Delay Budget (UL and/or DL) and Requested PDU Set Error Rate (UL and/or DL) in

the Alternative Service Requirements and the PCF generates the corresponding PDU Set QoS parameters in the Alternative QoS Parameter Sets in the PCC rule.

The PCF may also, based on local configuration or on information received from the AF, generate the parameter PDU Set Importance for N6-unmarked PDUs and include it in the PCC rule (in the PDU Set Control Information, see clause 6.3.1).

#### 6.1.3.27.5 Data Burst Based Handling

The Data Burst Based Handling includes the detection and marking of End of Data Burst, the identification and marking of time to next Data Burst and the identification and marking of Data Burst Size.

The detection and marking of End of Data Burst is defined in clause 5.37.8.3 of TS 23.501 [2]. Based on the AF provided:

- DL Protocol Description (see clause 5.37.5 of TS 23.501 [2] and TS 26.522 [40]); and/or
- On-path N6 Signalling Information (see clause 5.37.9 of TS 23.501 [2]); and/or
- local configuration,

the PCF generates the End of Data Burst Marking Indication (see clause 5.37.8.3 of TS 23.501 [2]) and provides it and the DL Protocol Description and/or the On-path N6 Signalling Information in the PCC rule to the SMF.

The identification and marking of Data Burst size is defined in clause 5.37.10.1 of TS 23.501 [2]. Based on the AF provided:

- Data Burst Size Marking Support Indication (which indicates that the Data Burst size is supported and marked in the header of the protocol identified by the DL Protocol Description);
- DL Protocol Description (see clause 5.37.5 of TS 23.501 [2] and TS 26.522 [40]);
- On-path N6 Signalling Information (see clause 5.37.9 of TS 23.501 [2]); and
- operator policy,

the PCF provides the Data Burst Size Marking Indication (see clause 5.37.10.1 of TS 23.501 [2]), the DL Protocol Description and/or the On-path N6 Signalling Information in the PCC rule to the SMF.

The identification and marking of time to next Data Burst is defined in clause 5.37.10.2 of TS 23.501 [2]. Based on the AF provided:

- Time to Next Burst Marking Support Indication (which indicates that the time to next Data Burst is supported and marked in the header of the protocol identified by the DL Protocol Description);
- DL Protocol Description (see clause 5.37.5 of TS 23.501 [2] and TS 26.522 [40]);
- On-path N6 Signalling Information (see clause 5.37.9 of TS 23.501 [2]); and
- operator policy,

the PCF provides the Time to Next Burst Marking Indication (see clause 5.37.10.2 of TS 23.501 [2]), the DL Protocol Description and/or the On-path N6 Signalling Information in the PCC rule to the SMF.

The identification and marking of time to next Data Burst is only used when the deployment is such that the time to next Burst is sufficiently accurate i.e. the jitter (e.g. the N6 jitter) is sufficiently limited without impact to the accuracy of time to next Data Burst.

NOTE: It is assumed the PCF can take the above information to determine to provide the Time to Next Burst Marking Indication in the PCC rule or not.

#### 6.1.3.27.6 Traffic Parameter Information and Traffic Parameter Measurement

The Traffic Parameter Information and Traffic Parameter Measurement apply to the UE power saving as specified in clause 5.37.8 of TS 23.501 [2].

The PCF may, based on the AF provided periodicity information, generate a PCC Rule with Traffic Parameter Information and Traffic Parameter Measurement, see clause 6.3.1.

The Traffic Parameter Information includes the UL and/or DL Periodicity and the Traffic Parameter Measurement indicates the Traffic Parameters to be measured and reporting conditions.

#### 6.1.3.27.7 Traffic identification and differentiated QoS for multiplexed media flows

Traffic identification and differentiated QoS for multiplexed media flows is as defined in clause 5.37.11 of TS 23.501 [2] and enables differentiated QoS handling for (S)RTP media flows that are multiplexed on the same end-to-end transport layer connection.

When the UE indicates the support for (S)RTP Multiplexed Media Identification Information in IP Packet Filters to SMF at PDU Session establishment, the SMF provides this UE capability information to PCF.

In order to request differentiated QoS for multiplexed media flows from the PCF, the AF has to provide per media flow the (S)RTP Multiplexed Media Identification Information (see clause 5.7.6.2 of TS 23.501 [2]) in the Flow Description and the specific QoS requirements (described in clause 6.1.3.22).

The PCF determines the PCC Rules and QoS parameters for the multiplexed (S)RTP media flows as follows:

- When the AF request includes uplink direction and the UE capability information indicates support for (S)RTP Multiplexed Media Identification Information in IP Packet Filters, or the AF request is for the downlink direction only, the PCF generates a separate PCC rule for every media flow in the same way it is described in clause 6.1.3.22. Each PCC Rule includes the QoS parameters of the corresponding media flow and its (S)RTP Multiplexed Media Identification Information in the IP Packet Filter set.
- When the AF request includes media flows with an uplink direction and the UE has not indicated support for (S)RTP Multiplexed Media Identification Information in IP Packet Filters, the PCF may, based on operator configuration, reject the AF request indicating lack of UE support for (S)RTP Multiplexed Media Identification or generate PCC rules and notify the AF that the differentiated QoS handling for multiplexed media flows is not supported by the UE.

NOTE: It is assumed the PSA UPF supports the IP Packet Filter with (S)RTP Multiplexed Media Identification Information.

#### 6.1.3.27.8 Support of transferring media related information over N6

Support of transferring media related information over N6 is defined in clause 5.37.9 of TS 23.501 [2].

If the media traffic is transferred using connect-UDP, the AF provides On-path N6 Signalling Information for connect-UDP and the PCF generates PCC rules including this On-path N6 Signalling Information, as specified in clause 6.3.1, based on local policy (see clause 5.37.9.3 of TS 23.501 [2]). The AF may additionally provide a Protocol Description for DL traffic indicating the use of UDP-option and then, the PCF will include the Protocol Description in the PCC Rules, depending on local policy (see clause 5.37.9.4 of TS 23.501 [2]).

If the media traffic is transferred using Media over QUIC Transport (specified in IETF draft-ietf-moq-transport [46]), the AF indicates that in the Protocol Description and the PCF includes it in the PCC Rules, depending on local policy (see clause 5.37.9.2 of TS 23.501 [2]).

#### 6.1.3.27.9 Expedited Data Transfer with Reflective QoS

The AF may request Expedited Data Transfer with reflective QoS to expedite the transfer of larger payloads for XR applications by requesting two media flows that contain the same SDF filter with different QoS requirements, and the information for transmission of media related information over N6 as described in clause 5.37.9 of TS 23.501 [2], or in TS 26.522 [40] for RTP header extension. An Expedited Transfer Indication is set to TRUE in one of the media flows and to FALSE in the other media flow.

If reflective QoS is supported by the UE, based on the AF request the PCF generates a PCC Rule for each media flow, applies reflective QoS for the flow for which the AF has set the Expedited Transfer Indication to TRUE and may apply reflective QoS for the media flow with Expedited Transfer Indication set to FALSE based on operator configuration. If the PCF does not enable Reflective QoS control in the PCC rule with Expedited Transfer Indication set to FALSE, then

the PCF shall set the precedence of the PCC rule to a value higher than the reserved range for PCC rules subject to Reflective QoS as specified in TS 24.501 [22] clause 6.2.5.1.1.3.

NOTE: It is assumed that the application does not send DL data packets in the media flow with Expedited Transfer Indication set to FALSE simultaneously with DL data packets in the media flow with Expedited Transfer Indication set to TRUE.

If reflective QoS is not supported by the UE, the PCF rejects the AF request with an indication that the expedited transfer is not supported by the UE.

#### 6.1.3.27.10 Support of RAN-controlled UL bitrate recommendation

The AF may provide a RAN-Controlled UL Bitrate Recommendation Indication for a media flow (see clause 5.37.12 of TS 23.501 [2]) within the AF session with required QoS procedure (as specified in clause 6.1.3.22). The PCF, based on the information received from AF and local operator policies, may then provide the RAN-Controlled UL Bitrate Recommendation Indication within the PCC rule to the SMF.

#### 6.1.3.28 AF requested QoS for a UE or group of UEs not identified by a UE address

The AF may request that the data session(s) for a UE (identified by a GPSI) or a group of UEs (identified by an External Group ID) for a specific DNN and S-NSSAI are set up with a specific QoS (e.g. low latency or PDV) and priority handling. The request from the AF may also include parameters for QoS monitoring and parameters that describe the traffic characteristics.

According to the QoS parameters for AF session with QoS as described in clause 6.1.3.22, the parameters that describe the traffic characteristics for AF session with QoS as described in clause 6.1.3.23a, and the parameters to subscribe to be notified of the QoS Monitoring reports as described in clause 6.1.3.21, the AF request information may include:

- DNN and S-NSSAI;
- Information about target UEs: External Group Identifier or GPSI;
- Flow Descriptions as described in clause 6.1.3.6;

NOTE 1: At the time of providing Flow Description from AF, the AF can only provide the server side information as Flow Description, e.g. 3-tuple(s) including protocol, server side IP address and port number. At the time of applying the Flow Description for generation of PCC rules, the PCF can supplement the UE side information, e.g. UE IP address and port.

- Traffic characteristics as described in clause 6.1.3.23 or clause 6.1.3.23a;
- QoS parameters (e.g. QoS Reference or individual QoS parameters or Alternative QoS Parameter Set) as defined in clause 6.1.3.22;
- QoS parameters for monitoring as defined in clause 6.1.3.21;

NOTE 2: The AF can support monitoring of specific performance characteristic by requesting the Notification control with Alternative QoS Profiles as defined in clause 5.7.2.4.1b of TS 23.501 [2] and deriving the specific degraded QoS characteristic (e.g. GFBR, PDB or PER) and the way it is degraded with the "GFBR can no longer be guaranteed" notifications and indications to Alternative QoS Profile.

- Temporal invalidity condition (start-time, end-time), indicate the time period when there will be no user payload for the DNN/S-NSSAI and Flow Descriptions provided with the request (e.g. at night or on weekends);
- Subscription to events as defined in clause 6.1.3.18.

The NEF determines whether or not to invoke the TSCTSF in the same way as for AF session with required QoS procedure, as described in step 2 of clause 4.15.6.6 in TS 23.502 [3].

In case the TSCTSF is not used, the NEF stores the AF request on UDR. The PCF receives the AF requested QoS information from the UDR as described in clause 4.15.6.14 of TS 23.502 [3]. If the AF requested QoS information contains temporal invalidity condition, the PCF activates, modifies, or removes PCC rules corresponding to the QoS information as needed based on the invalidity conditions.

In the case that the TSCTSF is used, the TSCTSF receives the AF requested QoS information from the NEF. The TSCTSF applies the AF requested QoS information as described in clause 5.20c of TS 23.501 [2] and clause 4.15.6.14 of TS 23.502 [3].

### 6.1.3.29 Network Slice replacement for a PDU Session

The Network Slice Replacement is specified in clause 5.15.19 of TS 23.501 [2].

The PCF may set the Network Slice Replacement trigger event in the SMF as defined in clause 6.1.3.5.

When a new PDU Session is established and the SMF receives both an S-NSSAI and an Alternative S-NSSAI, the SMF includes both the replaced S-NSSAI and the Alternative S-NSSAI in SM Policy Association establishment request to PCF. The PCF may retrieve PDU Session policy control subscription information using both the replaced S-NSSAI and the Alternative S-NSSAI. The PCF makes policy decision by combining subscription information of the replaced S-NSSAI and the Alternative S-NSSAI based on the principle that if there is common information present for both S-NSSAIs, the PCF chooses the data of the replaced S-NSSAI. The PCF maintains both the S-NSSAI and the Alternative S-NSSAI in the Session Management context. The PCF registers the replaced S-NSSAI in the BSF.

When the existing PDU Session is transferred from S-NSSAI to Alternative S-NSSAI, if the SMF determines that the existing PDU Session and existing SM Policy Association can be retained (e.g. if the SMF determines that same PCF can be used for the Alternative S-NSSAI) and the PCF set the Network Slice Replacement PCRT to request the SMF to report as defined in clause 6.1.3.5, then the SMF includes the Alternative S-NSSAI in SM Policy Association modification request to PCF to update the S-NSSAI of the PDU Session. The PCF may request subscription information associated with the Alternative S-NSSAI from the UDR. Then the PCF makes policy decision by combining subscription information of the replaced S-NSSAI and the Alternative S-NSSAI based on the principle that if there is common information present for both S-NSSAIs, the PCF chooses the data of the replaced S-NSSAI and may provide updated PCC rules to SMF. The PCF does not update the binding information in the BSF. When the existing PDU Session is transferred from Alternative S-NSSAI to the replaced S-NSSAI, if the SMF determines that the existing PDU Session and existing SM Policy Association can be retained (e.g. if the SMF determines that same PCF can be used for the Alternative S-NSSAI) and the PCF set the Network Slice Replacement PCRT to request the SMF to report as defined in clause 6.1.3.5, then the SMF removes the Alternative S-NSSAI in SM Policy Association modification request to PCF to update the S-NSSAI of the PDU Session. The PCF requests subscription information associated with the replaced S-NSSAI from the UDR, if not already available. Then the PCF makes policy decision based on the replaced S-NSSAI and may provide updated PCC rules to SMF. The PCF does not update the binding information in the BSF. If the SMF determines that the existing PDU Session and existing SM Policy Association is not retained (e.g. if the SMF determines that PCF discovery and selection for the Alternative S-NSSAI is to be performed), then the SMF terminates the existing SM Policy Association, and the PCF removes the SUPI to S-NSSAI association from the BSF. Then the SMF establishes a new SM Policy Association.

When existing PDU Session is transferred back to the replaced S-NSSAI, the SMF sends SM Policy Association modification request to PCF to update the S-NSSAI of the PDU Session. Then the PCF makes policy decision based on the replaced S-NSSAI and may provide updated PCC rules to the SMF.

When the PCF receives the SM Policy Association establishment (or modification) request message including the S-NSSAI and the Alternative S-NSSAI, the PCF checks if the PDU Session of a SUPI for a DNN and a S-NSSAI that has been replaced by an Alternative S-NSSAI is subject of usage monitoring control and PCF determines based on operator policy to perform usage monitoring related information per DNN and Alternative S-NSSAI combination instead of per DNN and replaced S-NSSAI combination, if so, the PCF terminates the usage monitoring for the replaced S-NSSAI, both on PDU Session and per PCC Rule level and updates the remaining allowed usage for the replaced S-NSSAI, as it is not currently in use, as described in clause 6.2.1.7. The PCF initiates usage monitoring for the Alternative S-NSSAI, as such retrieves usage monitoring related information per DNN and Alternative S-NSSAI combination for a SUPI from the UDR if available, then performs usage monitoring control as described in clause 6.2.1.7. When the Alternative S-NSSAI is no longer in use, the PCF terminates the usage monitoring control for the Alternative S-NSSAI, both on PDU Session level and per PCC Rule, and updating the remaining allowed usage for the Alternative S-NSSAI, as it is not currently in use, as described in clause 6.2.1.7. The usage monitoring control may continue for the replaced S-NSSAI as per current procedures in clause 6.2.1.7.

The PCRTs provided to the SMF are still reported to the PCF, when the PDU Session is established or has been replaced by an Alternative S-NSSAI.

### 6.1.3.30 Handling of Payload Headers Control

The Handling of Payload Headers is defined in clause 5.6.17 of TS 23.501 [2]. When AF provides Header Handling Control information in a request, the PCF determines whether AF influence on Handling of Payload Headers is allowed considering the Handling of Payload Headers indication in the PDU Session policy control subscription information. The PCF forwards the Header Handling Control information in the PCC rule(s) related to the AF request as defined in clause 6.3.1.

The SMF instructs the UPF to perform Handling of Payload Headers according to the Header Handling Control information provided by the PCF in the PCC Rule as described in clause 5.6.17 of TS 23.501 [2].

### 6.1.3.31 Policy control for non-3GPP devices connecting behind a UE

The support of QoS differentiation for non-3GPP devices connecting behind a UE using a Non-3GPP Device Identifier is specified in clause 5.52 of TS 23.501 [2].

The SMF may receive, from the UE, the Non-3GPP Device Identifier(s) and the corresponding user plane address(es) in the UE initiated PDU session modification procedure, as specified in clauses 4.3.3.2 and 4.3.3.3 of TS 23.502 [3]. The SMF sends the Non-3GPP Device Identifier(s) and the user plane address(es) of the non-3GPP device(s) to the PCF. For the Non-3GPP Device Identifier(s) and the corresponding user plane address(es) received from the SMF, the PCF creates and/or updates PCC rule(s) accordingly. The PCF determines QoS parameters in the PCC rule(s) based on the Non-3GPP Device Identifier Information retrieved from the UDR and/or based on operator policy. The PCF subscribes to the modification of the Non-3GPP Device Identifier Information in the UDR. The PCF provides the PCC rule(s) to the SMF to enable differentiated QoS handling of the traffic to/from the non-3GPP device(s) behind the UE. Based on operator policy and during interworking from 5GS to EPS, the PCF may update the PCC rule(s) so that the PCC rule(s) are not based on Non-3GPP Device Identifier Information.

The SMF may receive, from the UE, the Non-3GPP Device Identifier(s) and no corresponding user plane address(es) in the UE initiated PDU Session Modification procedure, as specified in clauses 4.3.3.2 and 4.3.3.3 of TS 23.502 [3]. The SMF sends the Non-3GPP Device Identifier(s) with no associated user plane address information to the PCF. If a Non-3GPP Device Identifier is received from the SMF without corresponding user plane address information, the PCF, without contacting the UDR, responds to the SMF with the PCC rules to disable differentiated QoS handling of the traffic to/from those non-3GPP Device Identifier(s).

If any of the Non-3GPP Device Identifiers received in a PDU Session Modification Request is not present within the Non-3GPP Device Identifier Information as specified in clause 5.2.12.2.1 of TS 23.502 [3] for the UE, the PCF indicates to the SMF that one or more of the Non-3GPP Device Identifier(s) is not available for the UE. In such a case, the PCF shall reject the SM Policy Association Modification and based on the rejection received, the SMF shall reject the PDU Session Modification with a cause code to notify the UE that at least one of the Non-3GPP Device Identifier is not present for the UE.

When the Non-3GPP Device Identifier Information is updated/removed in the UDR for one or more Non-3GPP Device Identifiers, the UDR notifies the PCF, via the Nudr\_DM\_Notify service, of the update/removal of Non-3GPP Device Identifier Information (as defined in clauses 4.15.6.7.2 and 4.15.6.15 of TS 23.502 [3]). If there are PCC rule(s) associated to the traffic associated with the updated/removed Non-3GPP Device Identifier in a PDU session, the PCF shall remove or update the PCC rule(s) and start a PCF initiated SM Policy Association Modification, in which case the SMF removes/updates the corresponding QoS and N4 rule(s).

## 6.1.4 Network slice related policy control

### 6.1.4.1 General

Network slice related policy control supports limitation of the data rate per network slice.

A Maximum Slice Data Rate can be configured for an S-NSSAI (indicating the network slice subject to network slice data rate limitation control) by the operator (e.g. based on an SLA related to the network slice). The Maximum Slice Data Rate has an UL and a DL value.

The Maximum Slice Data Rate defines the maximum allowed aggregate data rate across all GBR and Non-GBR QoS Flows within the network slice identified by an S-NSSAI.

NOTE 1: The maximum data rate of the Non-GBR QoS Flows is controlled via the authorized Session-AMBR while the maximum data rate of the GBR QoS Flows is controlled via the authorized MBR value in the PCC rules of GBR service data flows.

The PCF monitors the data rate of the network slice and ensures that it does not exceed the Maximum Slice Data Rate for that network slice by e.g. rejecting new SM Policy Associations, rejecting new GBR service data flows with high GBR requirements, changing the Authorized Session-AMBR values (if allowed by the HPLMN), changing the MBR values in PCC rules belonging to GBR service data flows or other actions depending on operator policies. When the PCF rejects the SM Policy Association Establishment procedure to the SMF due to the Maximum Slice Data Rate for that network slice is exceeded, then the SMF rejects the establishment of the PDU Session.

NOTE 2: It is recommended to avoid frequent policy decisions which trigger a signalling with the UE (like change of Authorized Session-AMBR or change of MBR in a PCC rule belonging to a GBR service data flow).

NOTE 3: Based on operator policy it is also possible to accept the exceeding of the Maximum Slice Data Rate by new PDU Sessions or PCC rules belonging to GBR service data flows and to apply a different charging for them.

NOTE 4: Subject to operator policy and national/regional regulations, prioritised services and emergency services may be exempted from the limitation of data rate per network slice.

NOTE 5: A single PCF can be used for the monitoring and limitation of the data rate per network slice. To enable this, the SMF has to select the same PCF instance for all PDU Sessions of the UE to the S-NSSAI. This is achieved as described in clause 6.3.7.1 of TS 23.501 [2], for example by using local operator policies in the SMF, SUPI ranges, explicit indication (i.e. Same PCF Selection Indication) from the AMF to select the PCF selected for the UE, or the PCF redirects to a PCF service provided by another PCF.

#### 6.1.4.2 Limitation of data rate per network slice with assistance of the NWDAF

If the NWDAF is used for network slice data rate analysis, the PCF consumes the analytics from the NWDAF and receives the Data Volume Dispersion Analytics statistics outputs for all UEs of the network slice as defined in TS 23.288 [24]. The PCF subscribes to the NWDAF for periodic reporting when it becomes responsible for the first PDU Session of a slice (subject to limitation of data rate per network slice) and cancels the subscription when it stops to handle the last PDU Session of that slice.

NOTE 1: It is recommended to configure the NWDAF in such a way that a too frequent notification is avoided.

The NWDAF periodically provides the analytics output to the PCF. The PCF calculates the utilized data rate of the network slice by using the statistics output Data volume dispersed and Duration. When the utilized data rate of the network slice is getting close to or is exceeding the Maximum Slice Data Rate for this S-NSSAI obtained from the UDR, based on operator policy, the PCF may apply a policy decision to strengthen the traffic restrictions for individual PDU Sessions or PCC rules (see clause 6.1.4.1). When the utilized data rate of the network slice falls below the Maximum Slice Data Rate, the PCF may relax the traffic restrictions for individual PDU Sessions or PCC rules.

When multiple PCFs for the same S-NSSAI are deployed, each PCF subscribes to the analytics from the NWDAF separately.

NOTE 2: When multiple PCFs are active for the slice, the NWDAF notification will trigger all of them but their policy decisions can be different.

#### 6.1.4.3 Limitation of data rate per network slice with PCF based monitoring

If the NWDAF is not deployed or is not to be used for network slice data rate analysis, the UDR maintains the Remaining Maximum Slice Data Rate per S-NSSAI and the PCF interacts with the UDR to deduct the value of the authorized Session-AMBR and the MBR of every GBR SDF from the Remaining Maximum Slice Data Rate per S-NSSAI for every PDU Session of this slice. When the Remaining Maximum Slice Data Rate for that S-NSSAI is close to zero, the PCF may, based on operator policies, apply a policy decision to strengthen the traffic restrictions for individual PDU Sessions or PCC rules (see clause 6.1.4.1). When the Remaining Maximum Slice Data Rate for that S-NSSAI increases again, the PCF may relax the traffic restrictions for individual PDU Sessions or PCC rules.

NOTE 1: Multiple PCFs responsible for PDU Sessions of UEs to the same S-NSSAI can read and update the Remaining Maximum Slice Data Rate for the S-NSSAI in the UDR using the conditional requests with preconditions for the update of the Remaining Maximum Slice Data Rate, this mechanism using Etags is defined in Table 5.2.2.2-2 of TS 29.500 [35] to ensure a proper update of UDR data in case of simultaneous access from different PCFs.

The details on monitoring the data rate per network slice by the PCF are described in clause 6.2.1.10.

NOTE 2: While the Remaining Maximum Slice Data Rate is relatively high, the PCF can be configured to maintain a local Remaining Maximum Slice Data Rate and to only interact with the UDR to update the Remaining Maximum Slice Data Rate when a certain threshold is reached, or a certain time window has passed. The higher the configured values are the lower the chances for an accurate limitation of the slice data rate becomes. When multiple PCFs for the same S-NSSAI are deployed, each PCF can also subscribe to the change of the Network slice specific policy control information in the UDR. The UDR will then send a notification to each subscribed PCF on the change of the Remaining Maximum Slice Data Rate per S-NSSAI.

## 6.1.5 Group related policy control

Group related policy control supports limitation of the data rate per group and is only applicable to 5G VN groups, as described in clause 5.29.2 of TS 23.501 [2].

The Maximum Group Data Rate defines the maximum allowed aggregate data rate across all GBR and Non-GBR QoS Flows within the 5G VN group.

A Maximum Group Data Rate can be configured for a 5G VN group by the operator or provided by an AF. The Maximum Group Data Rate has an UL and a DL value.

The PCF monitors the data rate of the 5G VN group and ensures that it does not exceed the Maximum Group Data Rate for that group. The method of PCF to realize the above functions is the same as limitation of the data rate per network slice as defined in clauses 6.1.4.1 and 6.1.4.3 with the following differences:

- Instead of handling Maximum Slice Data Rate per S-NSSAI, the UDR and PCF handles the Maximum Group Data Rate per 5G VN group.
- Instead of deducting the value of the authorized Session-AMBR and the MBR of every GBR SDF for every PDU Session of the slice, the PCF deducts such value for every PDU Session accessing to the 5G VN group.

The PCF may receive the Maximum Group Data Rate as part of the 5G VN group data (within the subscription data set), as described in clause 5.29 of TS 23.501 [2]. The PCF(s) that have subscribed to modifications of 5G VN group data receive(s) a Nudr\_DM\_Notify notification in case the 5G VN group data has changed in UDR. In both cases, if the values of the Maximum Group Data Rate in 5G VN group data and 5G VN Group specific policy control information are different, the PCF shall update the Maximum Group Data Rate in the 5G VN Group specific policy control information and adjust the Remaining Maximum Group Data Rate in the 5G VN Group specific policy control information accordingly.

## 6.1.6 Void

# 6.2 Network functions and entities

## 6.2.1 Policy Control Function (PCF)

### 6.2.1.1 General

#### 6.2.1.1.1 Session management related functionality

The PCF provides the following session management related functionality:

- Policy and charging control for a service data flows;
- PDU Session related policy control;
- PDU Session event reporting to the AF.

The PCF provides authorized QoS for a service data flow and other network control regarding service data flow detection, gating, QoS and charging (except credit management) towards the SMF.

The PCF uses the service information received from the AF (e.g. SDP information or other available application information) and/or the subscription information received from the UDR to calculate the proper QoS authorization (QoS class identifier, bitrates). The PCF may also take into account the requested QoS received from the SMF and the analytics information (e.g. analytics related to "Service Experience" and "QoS and policy assistance") received from the NWDAF.

NOTE 1: The PCF provides always the maximum values for the authorized QoS even if the requested QoS is lower than what can be authorized.

The PCF may check that the service information provided by the AF is consistent with both the operator defined policies and the related subscription information as received from the UDR during PDU Session establishment before storing the service information. The PCF may reject the request received from the AF when the service information is not consistent with either the related subscription information or the operator defined policies and may indicate, in the response to the AF, the service information that can be accepted by the PCF (e.g. the acceptable bandwidth). In the absence of other policy control mechanisms outside the scope of PCC, it is recommended that the PCF include this information in the response.

In this Release, the PCF supports only the interaction with a single AF for each AF session.

The Authorization of QoS shall be based on complete service information unless the PCF is required to perform the authorization of QoS based on preliminary service information. The PCF shall after receiving the complete service information, update the affected PCC rules accordingly.

At reception of the service information from the AF if configured through policy and taking into account information defined in TS 26.114 [31], the PCF determines the Maximum Packet Loss Rate for UL and DL based on the service information and sends it to SMF along with the PCC rule.

NOTE 2: Based on local configuration, the PCF sets the Maximum Packet Loss Rate (UL, DL) corresponding to either the most robust codec configuration (e.g. codec, mode, redundancy) or the least robust codec configuration of the negotiated set in each direction.

NOTE 3: Details for setting the Maximum Packet Loss Rate are specified by SA4.

The PCF supports usage monitoring control as described in clause 6.2.1.7.

The PCF supports sponsored data connectivity for a service as described in clause 6.2.1.8.

The PCF uses the information relating to subscriber spending available in the CHF as input for policy decisions related to e.g. QoS control, gating or charging conditions. Details for policy decisions based on spending limits are described in clause 6.1.3.17.

The PCF uses one or more pieces of information defined in the clause 6.2.1.2 as input for the selection of traffic steering policies used to control the steering of the subscriber's traffic as described in clause 6.1.3.14.

The PCF reports PDU Session events, e.g. Access Type, RAT Type (if applicable), Access Network Information, PLMN identifier where the UE is located, as described in clause 6.1.3.18.

The subscription and reporting of events when the target for reporting is an Internal Group Identifier or any UE accessing a combination of (DNN, S-NSSAI), is described in clause 5.2.5.7 of TS 23.502 [3]. The events that can be reported by the PCF are described in clause 6.1.3.18.

The subscription and reporting of events targeting an individual UE IP address (IPv4 address or IPv6 prefix) and optionally the DN information are described below. The events that can be reported by the PCF are described in clause 6.1.3.18.

The PCF shall ensure that the sum of the packet filters used by all PCC rules which trigger the generation of signalled QoS rules does not exceed the number of supported packet filters for signalled QoS rules indicated by the UE for the PDU Session, if this information is provided by the SMF (as defined in clause 6.2.1.2).

For EPC IWK, when PCF receives from the SMF of the report on UE resumed from suspend state, the PCF may provision PCC Rules to the SMF to trigger an IP-CAN Session modification procedure.

The PCF may provide the IP index as the PDU Session related policy to the SMF for IP address/Prefix allocation at SM Policy Association Establishment. If PCF receives from the SMF an allocated IP address/Prefix for the PDU Session, it shall not include IP Index into the PDU Session related policy.

On receiving the DN Authorization Profile Index provided by the SMF at the establishment or modification of the SM Policy Association for a PDU Session, the PCF takes the DN Authorization Profile Index as input for a policy decision and then obtains the list of PCC Rules (as defined in clause 6.3) and/or PDU Session related policy (as defined in clause 6.4) and provides them to the SMF as part of the Session Management Policy Control Data for enforcement.

On receiving the Session-AMBR provided by the SMF at the establishment or modification of the SM Policy Association for a PDU Session under the conditions defined in clause 5.6.6 of TS 23.501 [2], the PCF provides the Authorized Session-AMBR as part of the PDU Session policy control information defined in clause 6.4.

The PCF provides DNAI(s) in the PCC rule(s) to the SMF, taking into account the AF request and the Local routing indication from the PDU Session policy control subscription information.

When the PCF detects that all PCC rules related to an AF session are removed, or the PCF detects that the SM Policy Association is terminated, the PCF shall request the AF to terminate the AF session. If the SMF indicated that the PCC rules were removed or that the SM Policy Association is terminated due to PS to CS handover, the PCF shall indicate PS to CS handover as cause within the request to terminate the AF session.

When PCF receives from the SMF the report on UE reachability status change, if the UE is reachable as defined in clause 6.1.3.5, the PCF stops the Maximum Waiting time if available, and it may provision PCC Rules to the SMF.

The PCF supports functionality for Network Slice Replacement, as described in clause 6.1.3.29.

NOTE 4: For 5G-SRVCC (i.e. SRVCC from NG-RAN to UTRAN) as specified in TS 23.216 [25]), the SM Policy Association is terminated by the SMF. For SRVCC (i.e. SRVCC from E-UTRAN to GERAN/UTRAN) as specified in TS 23.216 [25], the SMF indicates that PCC rules are removed.

#### 6.2.1.1.2 Non-session management related functionality

The PCF provides the following non-session management related functionality:

- Access and mobility related policy control (as described in clause 6.1.2.1);
- UE policy information control (as described in clause 6.1.2.2);
- Negotiation for future BDT (as described in clause 6.1.2.4);
- Negotiation for planned data transfer with QoS requirements (as described in clause 6.1.2.7).

#### 6.2.1.1.3 Network slice related functionality

The PCF provides the following network slice related functionality:

- Limitation of the data rate per network slice (as described in clause 6.1.4).

#### 6.2.1.1.4 Group related functionality

The PCF provides the following group related functionality:

- Limitation of the data rate per 5G VN group (as described in clause 6.1.5).

### 6.2.1.2 Input for PCC decisions

The listed information below is not intended to be complete and describes only examples of the information that can be provided by the respective NF.

The PCF shall accept input for PCC decision-making from the SMF, the AMF, the CHF, the NWDAF if present, the UDR and if the AF is involved, from the AF, as well as the PCF may use its own predefined information. These different NFs should provide as much information as possible to the PCF. Depending on the particular scenario all the information may not be available or is already provided to the PCF.

The AMF may provide information related to the UE as defined in clauses 5.2.5.2 and 5.2.5.6 of TS 23.502 [3] (Npcf\_AMPolicyControl service and Npcf\_UEPolicyControl service).

The UE may provide information as defined in step 1 of clause 4.2.2.2.2 of TS 23.502 [3] (General Registration) and in clause 5.2.5.6 of TS 23.502 [3] (Npcf\_UEPolicyControl service).

The SMF may provide information related to the PDU Session as defined in clause 5.2.5.4 of TS 23.502 [3] (Npcf\_SMPolicyControl service).

The UDR may provide the information for a subscriber connecting to a specific DNN and S-NSSAI, as described in the clause 6.2.1.3.

The UDR may provide policy information related to an ASP as defined in clause 5.2.12.2 of TS 23.502 [3] (Nudr\_DataManagement (DM) service).

NOTE 1: The information related with AF influence on traffic routing may be provided by UDR when the UDR serving the NEF is deployed and stores the application request.

The UDR may provide the service specific information as defined in clause 4.15.6.7 of TS 23.502 [3] (Service specific parameter provisioning procedure).

The AF, if involved, may provide application session related information as defined in clause 5.2.5.3 of TS 23.502 [3] (Npcf\_PolicyAuthorization Service) directly or via NEF, e.g. based on SIP and SDP.

NOTE 2: The information related with QoS monitoring may be provided by UDR when the UDR serving the NEF is deployed and stores the application request.

The AF may provide BDT related information as defined in clause 5.2.5.5 of TS 23.502 [3] (Npcf\_BDTPolicyControl Service) via NEF.

The CHF, if involved, may provide information for a subscriber as defined in clause 5.2.17.2 of TS 23.502 [3] (Nchf\_SpendingLimitControl service).

The NWDAF, if involved, may provide analytics information as described in clause 6.1.1.3.

In addition, the predefined information in the PCF may contain additional rules based on charging policies in the network, whether the subscriber is in its home network or roaming, depending on the QoS Flow attributes.

The 5QIs (see clause 5.7.4 of TS 23.501 [2]) in the PCC rule is derived by the PCF from AF or UDR interaction if available. The input can be SDP information or other available application information, in line with operator policy.

The Allocation and Retention Priority in the PCC Rule is derived by the PCF from AF or UDR interaction if available, in line with operator policy.

### 6.2.1.3 Policy control subscription information management

The PCF may request subscription information at PDU Session establishment, PDU Session modification, during AM Policy Association Establishment procedure and during the UE Policy Association Establishment procedure.

The PCF may receive notifications on changes in the subscription information. Upon reception of a notification, the PCF shall make the policy control decisions necessary to accommodate the change in the subscription and shall update the SMF and/or the AMF if needed.

NOTE 1: How the PCF provisions/retrieves information related with policy control subscription data is defined in TS 23.501 [2].

The policy control subscription profile information provided by the UDR during the UE Policy Association Establishment procedure using Nudr service for Data Set "Policy Data" and Data Subset "UE context policy control data" is described in Table 6.2.1.3-1:

**Table 6.2.1.3-1: UE context policy control subscription information**

Information name	Description	Category
Subscriber categories	List of category identifiers associated with the subscriber	Optional
Tracing Requirements	Tracing requirements as defined in TS 32.421 [18]	Optional
PEI	The Permanent Equipment Identifier of the UE.	Optional
OSId	Identifies the operating system supported by UE.	Optional
Indication of UE support for ANDSP	Indicates the UE support for ANDSP.	Optional
Indication of URSP Provisioning Support in EPS	Indicates the UE support for URSP Provisioning in EPS.	Optional
S-NSSAI subscription information	Contains the list of subscribed S-NSSAIs, its associated subscribed DNNs. For each DNN, it includes the Allowed PDU Session types, the Allowed SSC modes, LBO roaming allowed indication and the ATSSS information (NOTE 1).	Optional
Subscriber spending limits control	Indicates whether the PCF must enforce UE policies based on subscriber spending limits.	Optional
Subscriber spending limits information	List of policy counter identifiers and statuses of these policy counters relevant for UE policy control.	Optional
CHF address	The address of the Charging Function and optionally the associated CHF instance ID and/or CHF set ID (see clause 6.3.1.0 of TS 23.501 [2]).	Optional
CHF group ID	The CHF Group ID for the UE (see clause 6.3.1.0 of TS 23.501 [2]).	Optional
Restricted Status	Indicates that the UE has a status of Restricted, lists its accompanying reason(s) and the Time stamp of when this status was stored (NOTE 2).	Optional
Indication of UE capability of reporting URSP rule enforcement to network	Indicates the UE support for reporting URSP rule enforcement to network.	Optional
Indication of VPLMN specific URSP rule support	Indicates the UE support of VPLMN specific URSP rules.	Optional
NOTE 1: ATSSS information is defined in Table 5.2.3.3.1-1 of TS 23.502 [3] and Indicates whether MA PDU Session establishment is allowed.		
NOTE 2: Accompanying reason is according to Exception IDs defined in Table 6.7.5.1-1 of TS 23.288 [24]. For example, Unexpected UE location.		

NOTE 2: S-NSSAI subscription information can be part of UE context policy control subscription information and Session Management Subscription data/Slice Selection Subscription data. UDR implementation and the provisioning system are responsible for keeping the consistency of this information when both Data Sets are stored in the same UDR. The provisioning system is responsible for keeping the consistency of this information when both Data Sets are stored in different UDRs.

The policy control subscription profile information provided by the UDR at PDU Session establishment, using Nudr service for Data Set "Policy Data" and Data Subset "PDU Session policy control data" is described in Table 6.2.1.3-2.

Table 6.2.1.3-2: PDU Session policy control subscription information

Information name	Description	Category
Allowed services	List of subscriber's allowed service identifiers.	Optional
Subscriber categories	List of category identifiers associated with the subscriber.	Optional
Subscribed GBR	Maximum aggregate bitrate that can be provided across all GBR QoS Flows for the DNN and S-NSSAI.	Optional
ADC support	Indicates whether application detection and control can be enabled for a subscriber.	Optional
Subscriber spending limits control	Indicates whether the PCF must enforce session management related policies based on subscriber spending limits.	Optional
Subscriber spending limits information	List of policy counter identifiers and statuses of the policy counters relevant for session management related policy control.	Optional
IP index information	Information that identifies the IP Address allocation method during PDU Session establishment.	Optional
Background Data Transfer Reference ID(s)	Reference ID(s) for Background Data Transfer Policies that apply to the UE.	Optional
Local routing indication	Indication on whether AF influence on traffic routing is allowed or not allowed.	Optional
Service Function Chaining influence indication	Indication on whether AF influence on Service Function Chaining is allowed or not allowed.	Optional
Subscribed UE-Slice-MBR(s)	List of maximum aggregated uplink and downlink MBRs to be shared across all GBR and Non-GBR QoS Flows related to the same S-NSSAI according to the subscription of the user. There is a single uplink and a single downlink value per S-NSSAI.	Conditional (NOTE 2)
Restricted Status	Indicates that the UE has a status of Restricted, lists its accompanying reason(s) and the Time stamp of when this status was stored (NOTE 3).	Optional
Handling of Payload Headers indication	Indication on whether AF influence on Handling of Payload Headers is allowed or not allowed.	Optional
<b>Charging related information</b>	This part defines the charging related information in the policy control subscription profile.	
Default charging method	Default charging method for the PDU Session (online / offline).	Optional
CHF address	The address of the Charging Function and optionally the associated CHF instance ID and/or CHF set ID (see clause 6.3.1.0 of TS 23.501 [2]).	Optional
CHF group ID	The CHF Group ID for the PDU Session (see clause 6.3.1.0 of TS 23.501 [2]).	Optional
<b>Usage monitoring related information</b>	This part includes a list of usage monitoring profiles associated with the subscriber. Each usage monitoring profile is logically associated with a particular operator offer, and includes the following elements.	
Monitoring key	An identifier to a usage monitoring control instance that includes one or more PCC rules.	Conditional (NOTE 1)
Usage monitoring level	Indicates the scope of the usage monitoring instance (PDU Session level or per Service).	Optional
Start date	Start date and time when the usage monitoring profile applies.	Optional
End date	End date and time when the usage monitoring profile applies.	Optional
Volume limit	Maximum allowed traffic volume.	Optional
Time limit	Maximum allowed resource time usage.	Optional
Reset period	Time period to reset the remaining allowed consumed usage for periodic usage monitoring control (postpaid subscriptions).	Optional
<b>MPS subscription data</b>	This part defines the MPS subscription information in the policy control subscription profile.	
MPS priority	Indicates subscription to MPS priority service; priority applies to all traffic on the PDU Session.	Conditional (NOTE 1)
IMS signalling priority	Indicates subscription to IMS signalling priority service; priority only applies to IMS signalling traffic.	Conditional (NOTE 1)

Information name	Description	Category
MPS priority level	Relative priority level for multimedia priority services.	Conditional (NOTE 1)
MCS priority	Indicates subscription to MCS priority service; priority applies to all traffic on the PDU Session.	Conditional (NOTE 1)
MCS priority level	Relative priority level for MCS services.	Conditional (NOTE 1)
NOTE 1: The information is mandatory if the specific part is included in the subscription information (e.g. the monitoring key is mandatory if the usage monitoring information part is included).		
NOTE 2: The information is used in PCF as described in clause 6.2.1.9 when the monitoring of the UE-Slice-MBR for an S-NSSAI is performed at the PCF. There may be a UE-Slice-MBR value for each S-NSSAI, if applicable.		
NOTE 3: Accompanying reason is according to Exception IDs defined in Table 6.7.5.1-1 of TS 23.288 [24]. For example, Unexpected UE location.		

NOTE 3: Subscribed UE-Slice-MBR can be part of the Access and Mobility Subscription data as described in clause 5.2.3.3.1 of TS 23.502 [3] and can be part of the PDU Session policy control subscription information as described in Table 6.2.1.3-2. UDR implementation and the provisioning system are responsible for keeping the consistency of this information when both Data Sets are stored in the same UDR. The provisioning system is responsible for keeping the consistency of this information when both Data Sets are stored in different UDRs.

**Table 6.2.1.3-3: Remaining allowed usage subscription information**

Information name	Description	Category
<b>Remaining allowed usage related information</b>	<i>This part includes a list of Remaining allowed usage associated with the subscriber.</i>	
Monitoring key	An identifier to a usage monitoring control included one or more PCC rules.	Conditional (NOTE 1)
Usage monitoring level	Indicates the scope of the usage monitoring (PDU Session level or service level).	Optional
Volume usage	Remaining allowed traffic volume.	Optional
Time usage	Remaining allowed resource time usage.	Optional
NOTE 1: The information is mandatory if the specific part is included in the subscription information (e.g. the monitoring key is mandatory if the usage monitoring information part is included).		

The *Allowed services* may comprise any number of service identifiers allowed for the subscriber in the PDU Session. The PCF maps those service identifiers into PCC rules according to local configuration and operator policies.

The *Subscriber category* may comprise any number of identifiers associated with the subscriber (e.g. gold, silver, etc.). Each identifier associates operator defined policies to the subscriber that belong to that category.

The *Usage monitoring related information* may comprise any number of usage monitoring control instances associated with the subscriber. In each usage monitoring control instance is mandatory to include the *Monitoring key*. The *Reset period* only applies to usage monitoring control instances that periodically reset the allowed usage (e.g. daily, monthly, etc.). If the Reset period is not specified, the usage monitoring control instance ends when the allowed data is consumed or when the *End date* is reached. The usage monitoring related information is used by the PCF instead of the respective information for the subscriber category.

The policy subscription profile may be extended with operator-specific information. Operator-specific extensions may be added both to any specific part of the policy control subscription information (e.g. to the subscriber category part), or as a new optional information block.

Handling of operator specific policy data by the PCF is out of scope of this specification in this release.

The latest list of PSIs and list of PSIs for the VPLMN ID(s) and its content delivered to the UE provided by the UDR during the UE Policy Association Establishment procedure using Nudr service for Data Set "Policy Data" and Data Subset "Policy Set Entry" is described in Table 6.2.1.3-4.

**Table 6.2.1.3-4: Policy Set Entry**

Information name	Description	Category
Policy Set Entry	List of PSIs and content for each PSI. Content may be Access Network Discovery & Selection Policy Information or UE Route Selection Policy information or both. The list of tuples (PLMN ID, list of PSIs associated with the PLMN ID) may also be included.	Optional

The network slice specific policy control information is per S-NSSAI information stored by the UDR and updated by the PCF during PDU Session Establishment or Modification procedure using Nudr service for Data Set "Policy Data" and Data Subset "Network Slice Specific Control Data" is described in Table 6.2.1.3-5:

**Table 6.2.1.3-5: Network slice specific policy control information**

Information name	Description	Category
Maximum Slice Data Rate for UL (per S-NSSAI)	The maximum uplink data rate for the specific network slice.	Optional (NOTE 2)
Maximum Slice Data Rate for DL (per S-NSSAI)	The maximum downlink data rate for the specific network slice.	Optional (NOTE 2)
Remaining Maximum Slice Data Rate for UL (per S-NSSAI)	The remaining maximum uplink data rate for the specific network slice (NOTE 1).	Optional (NOTE 3)
Remaining Maximum Slice Data Rate for DL (per S-NSSAI)	The remaining maximum downlink data rate limited for the specific network slice (NOTE 1).	Optional (NOTE 3)
NOTE 1: The initial value is set to the Maximum Slice Data Rate for UL/DL value.		
NOTE 2: The information is only used for limitation of data rate per network slice with assistance of the NWDAF.		
NOTE 3: The information is only used for limitation of data rate per network slice with PCF based monitoring.		

The policy control subscription profile information is per SUPI information, provided by the UDR using Nudr service for Data Set "Policy Data" and Data Subset "Access and Mobility policy control data" is described in Table 6.2.1.3-6:

**Table 6.2.1.3-6: Access and Mobility policy control subscription information**

Information name	Description	Category
Subscriber spending limits control	Indicates whether the PCF must enforce Access and Mobility management related policies based on subscriber spending limits.	Optional
Subscriber spending limits information	List of policy counter identifiers and statuses of these policy counters relevant for access and mobility related policy control.	Optional
CHF address	The address of the Charging Function and optionally the associated CHF instance ID and/or CHF set ID (see clause 6.3.1.0 of TS 23.501 [2]).	Optional
CHF group ID	The CHF Group ID for the UE (see clause 6.3.1.0 of TS 23.501 [2]).	Optional
Restricted Status	Indicates that the UE has a status of Restricted, lists its accompanying reason(s) and the Time stamp of when this status was stored (NOTE 1).	Optional
NOTE 1: Accompanying reason is according to Exception IDs defined in Table 6.7.5.1-1 of TS 23.288 [24]. For example, Unexpected UE location.		

The 5G VN group specific policy control information is per group information stored by the UDR and updated by the PCF during PDU Session Establishment or Modification procedure using Nudr service for Data Set "Policy Data" and Data Subset "5G VN Group Specific Control Data" is described in Table 6.2.1.3-7:

**Table 6.2.1.3-7: 5G VN Group specific policy control information**

Information name	Description	Category
Maximum Group Data Rate for UL	The maximum uplink data rate for the specific 5G VN group (see clause 6.1.5). (NOTE 1)	Optional
Maximum Group Data Rate for DL	The maximum downlink data rate for the specific 5G VN group (see clause 6.1.5). (NOTE 1)	Optional
Remaining Maximum Group Data Rate for UL	The remaining maximum uplink data rate for the specific 5G VN group (NOTE 1).	Optional
Remaining Maximum Group Data Rate for DL	The remaining maximum downlink data rate for the specific 5G VN group (NOTE 1).	Optional
NOTE 1: The initial value is set to the Maximum Group Data Rate for UL/DL value (as part of the 5G VN group data stored at the UDR subscription data) as described in clause 6.1.5 and/or operator policies.		

#### 6.2.1.4 V-PCF

The V-PCF is a functional element that encompasses policy control decision functionalities in the VPLMN.

For session management related policy control, the V-PCF only includes functionality for local breakout roaming scenario based on roaming agreements.

For UE policy control, the V-PCF receives the UE policy from the H-PCF and forwards it to the UE via the AMF. The V-PCF may provide service parameters to the H-PCF. The V-PCF can send additional UE policy information (i.e. ANDSP policies) to the UE which is different from the one from H-PCF.

For Access and mobility related policy control, the V-PCF generates the values for RFSP Index, UE-AMBR, UE-Slice-MBR, Service Area Restriction, SMF selection management and Network Slice Replacement.

#### 6.2.1.5 H-PCF

The H-PCF is a functional element that encompasses policy control decision functionalities in the HPLMN.

For session management related policy control, the H-PCF only includes functionality for home routed roaming scenario and provides the same functionality as the PCF in the non-roaming case.

For UE policy control, H-PCF generates the UE policy based on subscription data, service parameters from the V-PCF or application guidance on URSP determination from the UDR as described in clause 4.15.6.7 of TS 23.502 [3] and optionally network analytics as described in clause 6.1.1.3 and transfers the UE policy to the UE via the AMF, or via the V-PCF in the roaming case.

#### 6.2.1.6 Application specific policy information management

The application specific information used for policy control includes:

- Negotiation of BDT information stored in the UDR as Data Set "Policy Data" and Data Subset "Background Data Transfer data": It contains an ASP identifier, Non-IP information or IP 3-tuple to identify the Application server, a transfer policy together with the Background Data Transfer Reference ID, the volume of data to be transferred per UE, the expected amount of UEs and optionally, the subscription to notifications when the BDT policy needs to renegotiated;
- Sponsored data connectivity profile information stored in the UDR as Data Set "Policy Data" and Data Subset "Sponsored data connectivity profile data": It contains a list of ASP identifiers and their applications per sponsor identity;
- Application Function request information for multiple UEs (per group of UEs or all UEs) stored in the UDR as Data Set "Application Data" and Data Subset "AF request information for multiple UEs";
- PDTQ information stored in the UDR as Data Set "Policy Data" and Data Subset "Planned Data Transfer with QoS requirements data". It contains an ASP identifier, a PDTQ policy together with the PDTQ Reference ID, the requested QoS Reference or individual QoS parameters, optionally Alternative Service Requirements, the list of

Desired time windows, the Number of UEs, the Network Area Information provided by the AF (mapped by NEF) and the subscription to notifications of PDTQ policy re-negotiation.

The application specific policy information may be requested/updated by the PCF per AF request.

The management of Application Function request information for multiple UEs is defined in clause 6.3.7.2 of TS 23.501 [2], the management of policies for the negotiation of BDT is defined in clause 6.1.2.4, the management of policies for the negotiation of PDTQ is defined in clause 6.1.2.7 and the provision and usage of sponsored data connectivity profile is defined in clause 6.2.1.1.

### 6.2.1.7 Usage monitoring

The PCF supports usage monitoring control for a PDU Session or per Monitoring Key. Usage is defined as either volume or time of user plane traffic.

The PCF may receive usage monitoring related information per DNN and S-NSSAI combination and UE from the UDR, i.e. the overall amount of allowed resources (based either on traffic volume and/or traffic time) that are to be monitored for the PDU Sessions of a user, together with the corresponding remaining allowed usage related information. In addition, usage monitoring related information for Monitoring key(s) per DNN and S-NSSAI combination and UE may also be received from the UDR, together with the corresponding remaining allowed usage related information. For the purpose of usage monitoring per access type, the PCF receives an individual Monitoring key per access type from UDR. Details about the usage monitoring related information and the remaining allowed usage related information provided by the UDR are described in clause 6.2.1.3.

For the purpose of usage monitoring control the PCF shall request the Usage report trigger and provide the necessary usage threshold(s), either volume threshold, time threshold, or both volume threshold and time threshold, upon which the SMF shall report to the PCF. The PCF shall decide if and when to activate usage monitoring to the SMF.

The PCF may provide a Monitoring time to the SMF for the Monitoring keys(s) and optionally specify a subsequent threshold value for the usage after the Monitoring time.

If the SMF reports usage before the Monitoring time is reached, the Monitoring time is not retained by the SMF. Therefore, the PCF may again provide a Monitoring time and optionally the subsequent threshold value for the usage after the Monitoring time in the response.

It shall be possible for the PCF to request a usage report from the SMF.

**NOTE 1:** The PCF ensures that the number of requests/following policy decisions provided to the SMF do not cause excessive signalling load by e.g. assigning the same time for the report only for a preconfigured number of PDU Sessions.

Once the PCF receives a usage report from the SMF the PCF shall deduct the value of the usage report from the remaining allowed usage for that DNN and S-NSSAI combination and UE (if usage per PDU Session is reported). If usage is reported from the SMF, the PCF shall deduct the value of the usage report from the remaining allowed usage for individual Monitoring key(s) for that DNN and S-NSSAI combination and UE (if usage for one or several Monitoring keys is reported).

**NOTE 2:** The PCF maintains usage thresholds for each Monitoring key and PDU Session that is active for a certain DNN and S-NSSAI combination and UE. Updating the remaining allowed usage after the SMF reporting, minimizes the risk of exceeding the usage allowance.

If the remaining allowed usage reaches a value of zero (or below zero), the PCF may apply other policy decisions and interact with the SMF accordingly.

If the SMF reports usage for a certain Monitoring key and if monitoring shall continue for that Monitoring key then the PCF shall provide new threshold value(s) in the response to the SMF respectively. If Monitoring time and subsequent threshold value are used then the PCF provides them to the SMF as well.

The PCF may provide a new volume threshold and/or a new time threshold to the SMF, the new threshold values overrides the existing threshold values in the SMF.

If monitoring shall no longer continue for that Monitoring key, then the PCF shall not provide a new threshold in the response to the SMF.

If the last PDU Session of a user for a DNN and S-NSSAI combination is terminated, the PCF shall store the remaining allowed usage, i.e. the information about the remaining overall amount of resources, in the UDR.

If the End date of the usage monitoring related information (see clause 6.2.1.3 for details) is reached, the PCF shall reset the remaining allowed usage to the value(s) indicated in the usage monitoring related information and shall then interact with the SMF to undo any previously applied policy decisions related to remaining allowed usage of zero (or below zero).

### 6.2.1.8 Sponsored data connectivity

The PCF may authorise an application service provider to request specific PCC decisions (e.g. authorisation to request sponsored IP flows, authorisation to request QoS resources) based on sponsored data connectivity profile from the UDR. For sponsored data connectivity, the PCF may receive a usage threshold from the AF. If the AF specifies a usage threshold, the PCF shall use the Sponsor Identity to construct a Monitoring key for monitoring the volume, time, or both volume and time of user plane traffic, and invoke usage monitoring on the SMF. The PCF shall notify the AF when the SMF reports that a usage threshold for the Monitoring key is reached provided that the AF requests to be notified for this event, as described in clause 6.1.3.18. If the usage threshold is reached, the AF may terminate the AF session or provide a new usage threshold to the PCF. Alternatively, the AF may allow the session to continue without specifying a usage threshold. If the AF decides to allow the session to continue without specifying a usage threshold, then monitoring in the SMF shall be discontinued for that monitoring key by the PCF, unless there are other reasons for continuing the monitoring.

If the H-PCF detects that the UE is in a home-routed roaming scenario when sponsored data connectivity is requested by an AF, it may allow the sponsored data connectivity in the service authorization request, reject the service authorization request, or initiate the AF session termination based on home operator policy.

NOTE: Sponsored data connectivity is not supported in the roaming with local breakout scenario in this Release.

If the AF revokes the service information and the AF has notified previously a usage threshold to the PCF, the PCF shall report the usage up to the time of the revocation of service authorization.

If the PDU Session terminates and the AF has specified a usage threshold then the PCF shall notify the AF of the accumulated usage (i.e. either volume, or time, or both volume and time) of user plane traffic since the last usage report.

### 6.2.1.9 Monitoring the data rate per Network Slice for a UE

A PCF may support monitoring of data rate per S-NSSAI for a UE. The monitoring is performed by aggregating the Session-AMBR values and the MBR values allocated to each PCC Rule (belonging to a GBR service data flow) in all PDU Sessions established for a UE in that S-NSSAI. To enable this monitoring, the SMF selects the same PCF instance for all PDU Sessions of the UE to the S-NSSAI that is subject to this monitoring, this is achieved as described in clause 6.3.7.1 of TS 23.501 [2], for example by using local operator policies in the SMF, SUPI ranges or explicit indication from the AMF to select the PCF selected for the UE.

If the monitored data rate per S-NSSAI for a UE reaches a certain percentage of the Subscribed UE-Slice-MBR value for that S-NSSAI (detected via operator defined thresholds), the PCF may apply a policy decision to strengthen the traffic restrictions for individual PDU Sessions or PCC rules (e.g. to change Session-AMBR value (if allowed by the HPLMN) or update PCC Rule(s) to change QoS or charging keys(s)) and interact with the SMF accordingly. When the data rate per S-NSSAI for a UE falls below that percentage of the Subscribed UE-Slice-MBR value, the PCF may relax the traffic restrictions for individual PDU Sessions or PCC rules.

NOTE 1: It is recommended to avoid frequent policy decisions which trigger a signalling with the UE (like change of Session-AMBR or change of MBR in a PCC rule belonging to a GBR service data flow).

NOTE 2: At the same time the UE-Slice-MBR may be enforced in the NG-RAN, as described in clause 5.15.13 of TS 23.501 [2].

### 6.2.1.10 Monitoring the data rate per Network Slice

#### 6.2.1.10.1 General

The PCF supports monitoring and limitation of the data rate per S-NSSAI.

If the S-NSSAI is subject to network slice data rate limitation the Remaining Maximum Slice Data rate per S-NSSAI is stored in the UDR as Data Set "Policy Data" and Data Subset "Network Slice Specific Policy Control Data" as defined in clause 6.2.1.3.

The PCF interacts with the UDR to update the network slice specific policy control information per S-NSSAI in the UDR, i.e. the Remaining Maximum Slice Data Rate per S-NSSAI, so that the usage of multiple PCFs for the same S-NSSAI is enabled.

#### 6.2.1.10.2 Monitoring the data rate per Network Slice by using QoS parameters

For the purpose of monitoring the data rate per S-NSSAI, the PCF shall perform the following for an SM Policy Association with an S-NSSAI subject to data rate limitation:

- At the establishment of a SM Policy Association, the PCF shall check whether the Remaining Maximum Slice Data Rate is higher than the Authorized Session-AMBR. If so, the PCF shall deduct the value of the Authorized Session-AMBR allocated to the PDU Session from the Remaining Maximum Slice Data Rate for that S-NSSAI in the UDR. If the Remaining Maximum Slice Data Rate is not sufficient, the PCF shall reject the establishment of the SM Policy Association.
- At the time a PCC Rule of a GBR service data flow is installed, modified or activated in the SMF, the PCF requests reporting "Successful resource allocation" with the corresponding Policy Control Request Trigger. When the SMF reports that the resources are successfully allocated, the PCF shall deduct the value of the MBR authorized for the GBR service data flow from the Remaining Maximum Slice Data Rate for that S-NSSAI in the UDR.
- At the time a change of Authorized Session-AMBR occurs or a PCC Rule containing a GBR value is removed or modified, the PCF shall update the Remaining Maximum Slice Data Rate for that S-NSSAI in the UDR accordingly.
- If the Remaining Maximum Slice Data Rate for that S-NSSAI reaches a (operator defined) threshold that indicates that it is closer to zero, the PCF may apply a policy decision to strengthen the traffic restrictions for individual PDU Sessions or PCC rules (see clause 6.1.4.1) and interact with the SMF accordingly. When the Remaining Maximum Slice Data Rate for that S-NSSAI increases again, the PCF may relax the traffic restrictions for individual PDU Sessions or PCC rules.
- At the time the SM Policy Association for an S-NSSAI subject to data rate limitation is terminated, the PCF shall add the value of the Authorized Session-AMBR allocated to the PDU Session to the Remaining Maximum Slice Data Rate for that S-NSSAI in the UDR.

#### 6.2.1.11 Monitoring the data rate per Group

##### 6.2.1.11.1 General

The PCF supports monitoring and limitation of the data rate per 5G VN group.

If the group is subject to data rate limitation the Maximum Group Data Rate for the group is stored in the UDR as defined in clause 5.29.2 of TS 23.501 [2].

The PCF interacts with the UDR to update the Maximum Group Data Rate specific policy control information per group in the UDR, i.e. the Remaining Maximum Group Data Rate per group, so that the usage of multiple PCFs for the same group is enabled.

##### 6.2.1.11.2 Monitoring the data rate per Group by using QoS parameters

For the purpose of monitoring the data rate per group, the PCF shall perform the same operations as for the monitoring of the data rate per network slice described in clause 6.2.1.10.2 with the following differences:

- Instead of handling Maximum Slice Data Rate per S-NSSAI, the UDR and PCF handles the Maximum Group Data Rate per group identified by DNN and S-NSSAI.
- Instead of deducting the value of the authorized Session-AMBR and the MBR of every GBR SDF for every PDU Session of the network slice, the PCF deducts such value for every PDU Session accessing to the 5G VN group.

### 6.2.1.12 VPLMN Specific Offloading Policy

For Home Routing roaming scenario, the PCF for the PDU Session in HPLMN may provide the VPLMN Specific Offloading Policy for the local part of the DN in VPLMN for the HR-SBO PDU Session (see the clause 6.7 of TS 23.548 [33]).

If the PCF receives over the SM Policy Association a Serving Network identifier indicating the current VPLMN and an HR-SBO support indication, the PCF may provide VPLMN Specific Offloading Policy and (if available) corresponding Offload Identifier in HPLMN. The detailed attributes of this policy are specified under PDU Session related policy information specified in the clause 6.4.

NOTE: VPLMN Specific Offloading Policy can be provisioned in HPLMN per each VPLMN based on the service level agreement between HPLMN and VPLMN.

### 6.2.1.13 Local Offloading Management Policy

In the non-roaming scenario if the PCF receives over the SM Policy Association a Local Offloading Policy indication (see the clause 6.10 of TS 23.548 [33]), the PCF may provide the Local Offloading Management Policy or (if available) the associated Offload Identifier to the SMF. The Offload Identifier is unique within the PLMN. The details of the attributes are specified under PDU Session related policy information as described in clause 6.4.

## 6.2.2 Session Management Function (SMF)

### 6.2.2.1 General

The SMF is responsible for the enforcement of the policy decisions related to service data flow detection, authorized QoS, charging, gating, traffic usage reporting, packet routing and forwarding and traffic steering. The SMF controls the policy and charging enforcement which includes the binding of service data flows to QoS Flows (as described in clause 6.1.3.2.4) as well as the interaction with the CHF. The SMF interacts with the UPF(s), the RAN and the UE to achieve the appropriate treatment of the user plane traffic.

The SMF control of the UPF(s) is described in TS 23.501 [2] as well as the interaction principles between SMF and RAN and between SMF and UE. The procedures for the interaction between SMF and UPF, SMF and RAN as well as SMF and UE are described in TS 23.502 [3].

The SMF is enforcing the Policy Control as indicated by the PCF in two different ways:

- Gate enforcement. The SMF shall instruct the UPF to allow a service data flow, which is subject to policy control, to pass through the UPF if and only if the corresponding gate is open;
- QoS enforcement:
  - 5QI corresponding with 5G QoS Characteristics. The SMF shall be able to convert a 5QI value to 5G QoS Characteristics values.
  - PCC rule QoS enforcement. The SMF shall instruct the UPF to enforce the authorized QoS of a service data flow according to the active PCC rule (e.g. to enforce DSCP marking).
  - QoS Flow QoS enforcement. The SMF controls the QoS that is provided to a combined set of service data flows. The policy enforcement function ensures that the resources which can be used by an authorized set of service data flows are within the "authorized resources" specified by the PCF. The authorized QoS provides an upper bound on the resources that can be reserved (GFBR) or allocated (MFBR) for the QoS Flow. During QoS Flow QoS enforcement, if packet filters are provided to the UE, the SMF shall provide packet filters with the same content as that in the SDF template filters received from the PCF.

The SMF is enforcing the charging control in the following way:

- For a service data flow (defined by an active PCC rule) that is subject to charging control, the SMF shall allow the service data flow to pass through the UPF if and only if there is a corresponding active PCC rule with and, for online charging, the CHF has authorized credit for the charging key. The SMF may let a service data flow pass through the UPF during the course of the credit re-authorization procedure.

For a service data flow (defined by an active PCC rule) that is subject to both Policy Control and Charging Control, the SMF shall allow the service data flow to pass through the UPF if and only if the right conditions from both policy control and charging control happen. i.e. the corresponding gate is open and in the case of online charging the CHF has authorized credit for its charging key.

For a service data flow (defined by an active PCC rule) that is subject to policy control only and not charging control, the SMF shall allow the service data flow to pass through the UPF if and only if the conditions for policy control are met.

A SMF may be served by one or more PCF nodes. The SMF shall contact the appropriate PCF as described in clause 6.3.7.1 of TS 23.501 [2].

The operator may configure an indicator in UDM which is delivered to the SMF within the Charging Characteristics and used by the SMF to not establish the SM Policy Association during the PDU Session establishment procedure.

NOTE 1: The decision to not establish the SM Policy Association applies for the life time of the PDU Session.

NOTE 2: The indicator in the UDM is operator specific, therefore its value is understood within the HPLMN and can be used in both non-roaming or home routed roaming cases.

The SMF shall, on request from the PCF, modify a PCC rule, using the equivalent SMF behaviour as the removal of the old and the activation of the new (modified) PCC rule. The SMF shall modify a PCC rule as an atomic operation. The SMF shall not modify a predefined PCC rule on request from the PCF.

The SMF should support predefined PCC rules.

The SMF shall gather and report QoS Flow usage information according to clause 6.1.3.3. The SMF may have a pre-configured Default charging method. Upon the initial interaction with the PCF, the SMF shall provide pre-configured Default charging method if available.

At PDU Session establishment the SMF shall initiate the SM Policy Association Establishment procedure. If no PCC rule was activated for the PDU Session, the SMF shall reject the PDU Session establishment.

If there is no PCC rule active for a successfully established PDU Session at any later point in time, e.g. through a PCF initiated SM Policy Association Modification, the SMF shall initiate a PDU Session termination procedure. If the PCF terminates the SM Policy Association, the SMF shall initiate a PDU Session termination procedure.

If there is no PCC rule active for a successfully established QoS Flow at any later point in time, e.g. through a PCF triggered SM Policy Association Modification, the SMF shall initiate a PDU Session Modification procedure and terminate the QoS Flow.

If the PDU Session is modified, e.g. by changing the characteristics for an QoS Flow, the SMF shall first use the Policy Control Request Trigger to determine whether to request the PCC rules for the modified PDU Session from the PCF; afterwards, the SMF shall use the re-authorisation triggers, if available, in order to determine whether to require re-authorisation for the PCC rules that were either unaffected or modified. If the SMF receives an unsolicited update of the PCC rules from the PCF, the PCC rules shall be activated, modified or removed as indicated by the PCF.

The SMF shall inform the PCF about the outcome of a PCC rule operation. If a QoS Flow cannot be established or modified to satisfy the QoS Flow binding, then the SMF shall reject the activation of a PCC rule. If the SMF is requested to notify the PCF about a successful resource allocation (see clause 6.1.3.5) and the currently fulfilled QoS of an established or modified QoS Flow matches an Alternative QoS Profile (as described in clause 5.7.2.4.3 of TS 23.501 [2]), the SMF shall also provide to the PCF the reference to the Alternative QoS parameter set corresponding to the Alternative QoS Profile referenced by the RAN.

The SMF shall inform the PCF about any removal of a PCC rule, that the PCF has activated, that occurs without explicit instruction from the PCF.

When QoS Flow resources are released, i.e. at SM Policy Association termination or SMF-initiated SM Policy Association modification notifying that PCC Rules are removed, the SMF shall also provide, if available, the reason why resources are released, i.e. RAN/NAS Release Cause.

NOTE 3: In the case of a rejection of a PCC rule activation the PCF may e.g. modify the attempted PCC rule, deactivate or modify other PCC rules and retry activation or abort the activation attempt and, if applicable, inform the AF that transmission resources are not available.

The SMF forwards the Maximum Packet Loss Rate for UL and DL, if received from PCF for the PCC rule bound to a 5QI=1 QoS Flow. In the case multiple PCC Rules share one 5QI=1 QoS Flow and the SMF received multiple Maximum Packet Loss Rates, the SMF chooses the lowest value per direction related to these PCC rules.

When the PCF provides updated PCC rules for the PDU Session to the SMF, and the PCC rules were not enforced due to that the UE is in suspend state, e.g. due to SRVCC to GERAN without DTM support as specified in clause 6.2.2.1 in the TS 23.216 [25] or CSFB to UTRAN without PS Handover as specified in clause 6.5 in the TS 23.272 [26], the SMF shall indicate to the PCF that the PCC Rules were not enforced with the reason that the UE is in suspend state. Upon reception of the failure indication, the PCF may subscribe to UE resumed from suspend state event trigger.

NOTE 4: This above description applies in the case of EPC interworking.

When the PCF provides updated PCC rules for the PDU Session to the SMF, and the PCC rules were not enforced due to that the UE is not reachable, e.g. the UE using extended idle mode DRX as specified in clause 4.2.3 of TS 23.502 [3], the SMF shall indicate to the PCF that the resource allocation failure with the reason that the UE is unreachable and may provide a maximum waiting time, that is based on the Estimated Maximum Wait time provided by the AMF to the SMF. Upon reception of the failure indication, the PCF waits for the maximum waiting time to expire and may subscribe to change of UE reachability status to the SMF, as defined in clause 6.1.3.5.

### 6.2.2.2 Service data flow detection

The Service Data Flow detection uses the service data flow template included in a PCC Rule provide by the PCF. The service data flow template defines the data for the service data flow detection as a set of service data flow filters or an application identifier referring to an application detection filter. The SMF maps the service data flow template in the PCC Rule into the detection information in a Packet Detection Rules to the UPF as described in TS 23.501 [2].

The application detection filters provided to the SMF may be extended with the PFDs provided by the NEF (PFDF). How the SMF uses the service data flow detection capabilities in the UPF is described in clause 5.8.2 of TS 23.501 [2].

For IP PDU Session type and Ethernet PDU Session type, the service data flow filters that may apply for traffic on a PDU Session are defined in clause 5.7.6 of TS 23.501 [2]. The following specifics apply:

- Each service data flow template may contain any number of service data flow filters;
- Each service data flow filter is applicable uplink, downlink or both uplink and downlink;

NOTE 1: Service data flow filters that apply in both uplink and downlink should be used whenever possible.

- Each service data flow filter may contain information about whether the explicit signalling of the corresponding traffic mapping information to the UE is required.

NOTE 2: This information enables e.g. the generation/removal of traffic mapping information for the UE as well as the usage of PCC rules with specific service data flow filters on the QoS Flow associated with the default QoS rule without the need to generate traffic mapping information.

### 6.2.2.3 Measurement

The SMF shall ensure that the UPF supports data volume, duration, combined volume/duration and event based measurement for charging. The Measurement method indicates what measurement type is applicable to the PCC rule.

NOTE 1: Event based charging is only applicable to predefined PCC rules and PCC rules using an application detection filter (i.e. with an application identifier).

The SMF shall ensure that the UPF measurement measures all the user plane traffic, except traffic that PCC causes to be discarded.

The SMF shall ensure that the UPF maintains a measurement per QoS Flow, and Charging Key combination.

If Service identifier level reporting is mandated in a PCC rule, the SMF shall ensure that the UPF maintains a measurement for that Charging Key and Service Identifier combination, for the QoS Flow.

NOTE 2: In addition, the SMF may instruct the UPF to maintain QoS Flow level measurement if required by the operator.

For usage monitoring, the SMF shall ensure that the UPF supports volume and time measurement for a PDU Session and maintains a measurement for each PDU Session for which the PCF has requested the Usage report trigger and provided threshold values on a PDU Session level. The SMF shall ensure that the UPF is able to support volume and time measurements simultaneously for a given PDU Session.

The SMF shall ensure that the UPF supports volume and time measurement per Monitoring key and maintain a measurement for each Monitoring key if the PCF has requested the Usage report trigger and provided threshold values on Monitoring key level. The SMF shall ensure that the UPF is able to support volume and time measurements simultaneously for a given Monitoring Key.

The SMF shall ensure that the UPF supports simultaneous volume and time measurement for usage monitoring on PDU Session level and Monitoring key level for the same PDU Session.

Volume and time measurements for usage monitoring purposes on PDU Session level and on Monitoring key level shall be performed independently of each other. If the PCC rule is associated with an indication of exclusion from session level monitoring, the SMF shall ensure that the UPF does not consider the corresponding service data flow for the volume and time measurement on PDU Session level.

If the Usage report reached Policy Control Request Trigger is set and a volume or a time threshold is reached, the SMF shall report this event to the PCF. The SMF shall continue to perform volume or time measurement after the threshold is reached and before a new threshold is provided by the PCF. At PDU Session termination or if the conditions defined in clause 6.4 for continued monitoring are no longer met, or if the PCF explicitly requests a usage report, the SMF shall inform the PCF about the resources that have been consumed by the user since the last usage report for the affected Monitoring keys, including the resources consumed before and after the Monitoring time was reached, if provided according to clause 6.2.1.1.

If combined volume and time measurements are requested by the PCF, then the reporting shall be done for both together. For example, if the volume threshold is reached, the consumed time shall be reported as well and, in order to continue combined volume and time measurements, the PCF shall provide a new time threshold along with a new volume threshold. The SMF shall continue to instruct the UPF to perform volume and time measurement after the threshold is reached and before a new threshold is provided by the PCF. If new threshold is provided only for time or volume, then the measurements shall continue only for that provided type and the SMF shall ensure that the accumulated usage for the non provided type is discarded by the UPF.

When the PCF requests to report usage, the SMF shall report the accumulated usage to the PCF according to the provided usage threshold, i.e. the SMF reports accumulated volume when the volume threshold was provided by the PCF, accumulated time when the time threshold was provided by the PCF and both accumulated volume and accumulated time when volume threshold and time threshold were provided by the PCF.

If the Usage thresholds for a Monitoring key are not provided to the SMF in the acknowledgement of a PDU Session modification where its usage was reported, then the usage monitoring shall not continue in the SMF for that Monitoring key.

When the Monitoring time occurs, the accumulated volume and/or time usage shall be recorded by the UPF and reported to the SMF, and:

- If the subsequent usage threshold value is provided, the usage threshold shall be reset to this value by the SMF.
- Otherwise, the usage threshold shall be set by the SMF to the remaining value of the threshold previously sent by the PCF (i.e. excluding the accumulated usage).

The first usage report after the Monitoring Time was reached shall indicate the usage up to the Monitoring time and usage after the Monitoring time.

In order to support time based usage monitoring, the PCF may optionally indicate to the SMF, along with other usage monitoring information provided, the Inactivity Detection Time. This value represents the time interval after which the time measurement shall stop for the Monitoring key, if no packets are received belonging to the corresponding Monitoring Key during that time period. Time measurement shall resume on receipt of a further packet belonging to the Monitoring key.

Time measurement for a Monitoring key shall also be stopped when time based usage monitoring is disabled, if this happens before the Inactivity Detection Time is reached.

If an Inactivity Detection Time value of zero is provided, or if no Inactivity Detection Time is present within the usage monitoring information provided by the PCF, the time measurement shall be performed continuously from the point at which it was started until time based usage monitoring is disabled.

The SMF instructs the UPF to provide usage reports to the SMF as described in TS 23.501, clause 5.8.2.6.

#### 6.2.2.4 QoS control

The SMF receives the authorized QoS for a service data flow in the PCC rule. The SMF derives the QoS parameters for a QoS Flow (other than the QoS Flow associated with the default QoS rule) based on the PCC rule information of the PCC rule(s) bound to this QoS Flow:

- The SMF shall set the QoS Flow parameters 5QI and ARP to the values of the corresponding PCC rule parameters.
- For the QoS Flow parameters QNC, Priority Level, Averaging Window and Maximum Data Burst Volume, the SMF shall use the corresponding PCC rule parameters if they are available in the PCC rule.
- The SMF shall set the PDU Set Delay Budget, the PDU Set Error Rate and the PDU Set Integrated Handling Information for QoS Flow based on the corresponding parameter in the PDU Set Control Information if available in the PCC rule.
- For GBR QoS Flows, the SMF should set the GFBR to the sum of the GBRs of all PCC rules that are active and bound to that QoS Flow and the MFBR to the sum of the MBRs of all PCC rules that are active and bound to that GBR QoS Flow. If a set of PCC Rules is subject to resource sharing as specified in clause 6.1.3.13 the SMF should use, for each applicable direction, the highest GBR from the set of PCC Rules sharing resources as input for calculating the GFBR and may use, for each applicable direction, the highest MBR from the set of PCC Rules as input for calculating the MFBR.
- For GBR QoS Flows, the SMF shall set the QoS Flow parameter Maximum Packet Loss Rate for UL and DL if the corresponding PCC rule parameters are available in the PCC rule. In the case multiple PCC Rules are bound to the QoS Flow and the SMF received multiple Maximum Packet Loss Rates, the SMF chooses the lowest value per direction in all these PCC rules.
- If the PCC rule contains a non-standardized 5QI, the SMF shall also provide the corresponding 5G QoS characteristics parameters (as received in the PDU Session related information Explicitly signalled QoS Characteristics) for the QoS Flow.
- If the PCC rule contains Alternative QoS Parameter Sets, the SMF shall provide their attributes as Alternative QoS Profile(s) (see clause 5.7.1.2a of TS 23.501 [2]) in the same prioritized order (in which they occur in the PCC rule) in addition to the QoS parameters for the QoS Flow.

The SMF shall set the QoS parameters of the QoS Flow associated with the default QoS rule to:

- the PCC rule parameters contained in the PCC rule that is bound to this QoS Flow (in the way it is described above) if the PCC rule attribute Bind to QoS Flow associated with the default QoS rule and apply PCC rule parameters is present; or otherwise
- the Authorized default 5QI/ARP received in the PDU Session related information. If the Authorized default 5QI contains a non-standardized 5QI, the SMF shall also provide the corresponding 5G QoS characteristics parameters (as received in the PDU Session related information Explicitly signalled QoS Characteristics) for the QoS Flow associated with the default QoS rule.

The SMF receives the Authorized Session-AMBR in the PDU Session related information. The SMF ensures that the Authorized Session-AMBR for a PDU Session is enforced for bandwidth policing at the UPF(s) as described in clause 5.7.1 of TS 23.501 [2].

The SMF generates QoS rule(s) as described in TS 23.501 [2]. For a PDU Session of unstructured type, only one PCC Rule allowing all packets is to be activated in the SMF and only the QoS Flow associated with the default QoS rule exists as described in clause 5.7.1 of TS 23.501 [2].

### 6.2.2.5 Application detection

The SMF shall instruct the UPF to detect the Start and Stop of the application traffic for the PCC rules used for application detection (i.e. with application identifier) that the PCF has activated at the SMF.

If the PCF has subscribed to the event and notification is not muted for the specific PCC Rule, the SMF shall also instruct the UPF to report the Start/Stop of application, as described in the TS 23.501 [2].

When receiving the application detection report from UPF, the SMF shall forward the application identifier, the start/stop indication and, when service data flow descriptions were deduced, the application instance identifier(s) and the service data flow description(s), to the PCF.

NOTE: The PCF can make policy decision when receiving the application detection report.

### 6.2.2.6 Traffic steering

The SMF shall support traffic steering control as defined in clause 6.1.3.14.

The SMF may be configured with the traffic steering policy IDs related to the mechanism enabling traffic steering to the N6-LAN, DN and/or DNAIs associated with N6 traffic routing requirements.

Upon receiving a PCC rule which contains the traffic steering control information, the SMF shall provide the information to the UPF for the enforcement.

In the case of Application Function influence on traffic routing, the traffic steering control information in the PCC rule may include a set of DNAI(s) and for each DNAI a traffic steering policy identifier and/or N6 traffic routing information dynamically provided by the AF. Based on the received traffic steering policy identifier(s), the UPF may remove or insert VLAN tags on N6 interface for downlink and uplink frames, respectively. The details of the scenario are defined in clause 5.6.10.2 of TS 23.501 [2].

NOTE: The UPF can, for example, perform marking packets in order to indicate a certain type of traffic to the DN side of the N6 reference point which enables those packets to be steered in the DN. As another example the UPF can forward, i.e. offload, traffic identified by the traffic descriptor to a local tunnel.

### 6.2.2.7 Access Traffic Steering, Switching and Splitting

The SMF may support functionality for traffic steering, switching and splitting within a MA PDU Session, as described in TS 23.501 [2].

Upon receiving a PCC rule which contains the MA PDU Session Control information, the SMF shall instruct the UPF accordingly and shall also create and provide applicable ATSSS rules to the UE (the details for both SMF actions are described in TS 23.501 [2]).

### 6.2.2.8 Network Slice Replacement

The SMF may support functionality for Network Slice Replacement, as described in clause 6.1.3.29 and in clause 5.15.19 of TS 23.501 [2].

## 6.2.3 Application Function (AF)

The Application Function (AF) is an element offering applications that require dynamic policy and/or charging control over the user plane behaviour and/or an element requesting non-session based network capability exposure. In this specification, the functionality of the AF is only defined with respect to the interaction with the 5G Core Network.

An AF may contact the PCF via the NEF for network capability exposure as defined in clause 4.3.6. Based on operator deployment, an AF considered to be trusted by the operator can be allowed to interact directly with the PCF. AFs not allowed by the operator to directly interact with the PCF shall use the network capability exposure framework (see clause 7.3 of TS 23.501 [2]) to interact with the PCF via the NEF.

An AF may communicate with multiple PCFs. The mechanism for an AF to select the PCF associated to a PDU Session based on the UE address is described in clause 6.1.1.2.

The AF shall communicate with the PCF to transfer dynamic session information, required for PCF decisions as well as to receive access network specific information and notifications about events related to the PDU Session or the QoS Flow transferring the application traffic. One example of an AF is the P-CSCF of the IM CN subsystem.

The AF may receive an indication that the service information is not accepted by the PCF together with service information that the PCF would accept. In that case, the AF rejects the service establishment towards the UE. If possible, the AF forwards the service information to the UE that the PCF would accept.

For certain events related to policy control, the AF shall be able to give instructions to the PCF to act on its own, i.e. based on the service information currently available as described in clause 6.1.3.6.

NOTE 1: The QoS authorization based on incomplete service information is required for e.g. IMS session setup scenarios with available resources on originating side and a need for resource reservation on terminating side.

The AF may request the PCF to report events related to the PDU Session or the QoS Flow transferring the application traffic as defined in clause 6.1.3.18. The AF may use the access network specific information and notifications about events in the AF session signalling or to adjust the event reporting related to the PDU Session or the QoS Flow transferring the application traffic.

The AF may contact the PCF to request a time window and related conditions for future BDT. Details of the AF behaviour to support future BDT are defined in clause 6.1.2.4.

The AF may contact the PCF via the NEF to request a time window for PDTQ. Details of the AF behaviour to support PDTQ are defined in clause 6.1.2.7.

To support sponsored data connectivity the AF may provide the PCF with the sponsored data connectivity information, including optionally a usage threshold, as specified in clause 6.2.1.1. The AF may request the PCF to report events related to sponsored data connectivity.

NOTE 2: Annex D describes the scenario for sponsored data connectivity.

The AF may receive a request to terminate an AF session. The PCF may include an indication that the transmission resources are lost due to PS to CS handover.

NOTE 3: The AF action upon reception of the indication that the transmission resources are lost due to PS to CS handover is application specific. The IMS uses the indication to prevent a termination of an ongoing session as specified in TS 24.229 [29] and TS 24.237 [30].

The AF may send guidance to PCF for the determination of proper URSP rules for the UE. Details of the application guidance are described in clause 6.6 of TS 23.548 [33] and in clause 4.15.6.10 of TS 23.502 [3].

For Time Sensitive Communication and Time synchronization as specified in clause 5.27 of TS 23.501 [2] and in clause 6.1.3.23a, the AF interacts with the TSCTSF (directly or via NEF) and the TSCTSF is interacting with the PCF. Based on operator deployment, an AF considered to be trusted by the operator can be allowed to interact directly with the TSCTSF. AFs not allowed by the operator to directly interact with the TSCTSF shall use the network capability exposure framework (see clause 7.3 of TS 23.501 [2]) to interact with the TSCTSF via the NEF.

The AF may request measurements of QoS parameters by subscribing to events (e.g. QoS Monitoring parameters, see clause 6.1.3.18) as part of an AF session with required QoS defined in clause 6.1.3.22.

The AF may send the UL and/or DL Periodicity as defined in clause 5.37.8.2 of TS 23.501 [2].

The AF may receive a report that resource allocation failure due to UE temporary unreachable together with a maximum waiting time, if available (as described in clause 6.1.3.5). The AF may subscribe to UE reachability status change to receive an indication that the UE is reachable again, the AF stops the maximum waiting timer and may request resource allocation to the PCF.

## 6.2.4 Unified Data Repository (UDR)

The Unified Data Repository (UDR) is defined in TS 23.501 [2].

## 6.2.5 Charging Function (CHF)

The Charging Function is specified in TS 32.240 [8].

## 6.2.6 Void

## 6.2.7 Network Exposure Function (NEF)

The Network Exposure Function (NEF) is defined in TS 23.501 [2] and additionally supports the following policy related functionalities:

- Service specific policy and charging control;
- Management of packet flow descriptions;
- Sponsor data connectivity including usage monitoring (as defined in clause 6.2.1.1);
- Negotiations for future BDT;
- Negotiations for PDTQ.

## 6.2.8 Access and Mobility Management Function (AMF)

The Access and Mobility Management Function (AMF) is defined in TS 23.501 [2] and additionally supports the following policy related functionalities:

- Enforcement of access and mobility related policies received from the PCF;
- Transfers of UE policy information received from the PCF to the UE via N1 interface;
- Reporting of events to the PCF that the PCF has subscribed to.

## 6.2.9 Network Data Analytics Function (NWDAF)

The Network Data Analytics Function (NWDAF) is defined in TS 23.288 [24].

## 6.2.10 Void

## 6.2.11 Time Sensitive Communication and Time Synchronization Function (TSCTSF)

The Time Sensitive Communication and Time Synchronization Function (TSCTSF) is defined in TS 23.501 [2].

# 6.3 Policy and charging control rule

## 6.3.1 General

The Policy and charging control rule (PCC rule) comprises the information that is required to enable the user plane detection of, the policy control and proper charging for a service data flow. The packets detected by applying the service data flow template of a PCC rule form a service data flow.

Two different types of PCC rules exist: Dynamic rules and predefined rules. The dynamic PCC rules are provisioned by the PCF to the SMF, while the predefined PCC rules are configured into the SMF, as described in TS 23.501 [2], and only referenced by the PCF.

NOTE 1: The procedure for provisioning predefined PCC rules is out of scope for this specification.

The operator defines the PCC rules.

Table 6.3.1 lists the information contained in a PCC rule, including the information name, the description and whether the PCF may modify this information in a dynamic PCC rule which is active in the SMF. The Category field indicates if a certain piece of information is mandatory or not for the construction of a PCC rule, i.e. if it is possible to construct a PCC rule without it.

The differences with table 6.3 in TS 23.203 [4] are shown, either "none" means that the IE applies in 5GS or "removed" meaning that the IE does not apply in 5GS, this is due to the lack of support in the 5GS for this feature or "modified" meaning that the IE applies with some modifications defined in the IE.

**Table 6.3.1: The PCC rule information in 5GC**

Information name	Description	Category	PCF permitted to modify for a dynamic PCC rule in the SMF	Differences compared with table 6.3. in TS 23.203 [4]
Rule identifier	Uniquely identifies the PCC rule, within a PDU Session. It is used between PCF and SMF for referencing PCC rules.	Mandatory	No	None
<b>Service data flow detection</b>	<i>This part defines the method for detecting packets belonging to a service data flow.</i>			
Precedence	Determines the order, in which the service data flow templates are applied at service data flow detection, enforcement and charging. (NOTE 1).	Conditional (NOTE 2)	Yes	None
Service data flow template	For IP PDU traffic: Either a list of service data flow filters or an application identifier that references the corresponding application detection filter for the detection of the service data flow. For Ethernet PDU traffic: Combination of traffic patterns of the Ethernet PDU traffic. It is defined in clause 5.7.6.3 of TS 23.501 [2].	Mandatory (NOTE 3)	Conditional (NOTE 4)	Modified (packet filters for Ethernet PDU traffic added)
Mute for notification	Defines whether application's start or stop notification is to be muted.	Conditional (NOTE 5)	No	None
Expedited Transfer Indication	Defines if Expedite Data Transfer of larger payload for XR application is set or not.		No	Added
<b>Charging</b>	<i>This part defines identities and instructions for charging and accounting that is required for an access point where flow based charging is configured</i>			
Charging key (NOTE 22)	The charging system (CHF) uses the charging key to determine the tariff to apply to the service data flow.		Yes	None
Service identifier	The identity of the service or service component the service data flow in a rule relates to.		Yes	None
Sponsor Identifier	An identifier, provided from the AF which identifies the Sponsor, used for sponsored flows to correlate measurements from different users for accounting purposes.	Conditional (NOTE 6)	Yes	None

Information name	Description	Category	PCF permitted to modify for a dynamic PCC rule in the SMF	Differences compared with table 6.3. in TS 23.203 [4]
Application Service Provider Identifier	An identifier, provided from the AF which identifies the Application Service Provider, used for sponsored flows to correlate measurements from different users for accounting purposes.	Conditional (NOTE 6)	Yes	None
Charging method	Indicates the required charging method for the PCC rule. Values: online or offline or neither.	Conditional (NOTE 7)	No	None
Service Data flow handling while requesting credit	Indicates whether the service data flow is allowed to start while the SMF is waiting for the response to the credit request. Only applicable for charging method online. Values: blocking or non-blocking		No	New
Measurement method	Indicates whether the service data flow data volume, duration, combined volume/duration or event shall be measured. This is applicable to reporting, if the charging method is online or offline. Note: Event based charging is only applicable to predefined PCC rules and PCC rules used for application detection filter (i.e. with an application identifier).		Yes	None
Application Function Record Information	An identifier, provided from the AF, correlating the measurement for the Charging key/Service identifier values in this PCC rule with application level reports.		No	None
Service Identifier Level Reporting	Indicates that separate usage reports shall be generated for this Service Identifier. Values: mandated or not required		Yes	None
<b>Policy control</b>	<i>This part defines how to apply policy control for the service data flow.</i>			
Gate status	The gate status indicates whether the service data flow, detected by the service data flow template, may pass (Gate is open) or shall be discarded (Gate is closed).		Yes	None
5G QoS Identifier (5QI)	The 5QI authorized for the service data flow.	Conditional (NOTE 10)	Yes	Modified (corresponds to QCI in TS 23.203 [4])
QoS Notification Control (QNC)	Indicates whether notifications are requested from 3GPP RAN when the GBR can no longer (or can again) be guaranteed for a QoS Flow during the lifetime of the QoS Flow.	Conditional (NOTE 15)	Yes	Added
Reflective QoS Control	Indicates to apply reflective QoS for the SDF.		Yes	Added
UL-maximum bitrate	The uplink maximum bitrate authorized for the service data flow		Yes	None

Information name	Description	Category	PCF permitted to modify for a dynamic PCC rule in the SMF	Differences compared with table 6.3. in TS 23.203 [4]
DL-maximum bitrate	The downlink maximum bitrate authorized for the service data flow		Yes	None
UL-guaranteed bitrate	The uplink guaranteed bitrate authorized for the service data flow		Yes	None
DL-guaranteed bitrate	The downlink guaranteed bitrate authorized for the service data flow		Yes	None
UL sharing indication	Indicates resource sharing in uplink direction with service data flows having the same value in their PCC rule		No	None
DL sharing indication	Indicates resource sharing in downlink direction with service data flows having the same value in their PCC rule		No	None
Redirect	Redirect state of the service data flow (enabled/disabled)	Conditional (NOTE 8)	Yes	None
Redirect Destination	Controlled Address to which the service data flow is redirected when redirect is enabled	Conditional (NOTE 9)	Yes	None
ARP	The Allocation and Retention Priority for the service data flow consisting of the priority level, the pre-emption capability and the pre-emption vulnerability	Conditional (NOTE 10)	Yes	None
Bind to QoS Flow associated with the default QoS rule	Indicates that the dynamic PCC rule shall always have its binding with the QoS Flow associated with the default QoS rule (NOTE 11).		Yes	Modified (corresponds to bind to the default bearer in TS 23.203 [4])
Bind to QoS Flow associated with the default QoS rule and apply PCC rule parameters	Indicates that the dynamic PCC rule shall always have its binding with the QoS Flow associated with the default QoS rule. It also indicates that the that the QoS related attributes of the PCC rule shall be applied to derive the QoS parameters of the QoS Flow associated with the default QoS rule instead of the PDU Session related parameters Authorized default 5QI/ARP.	Conditional (NOTE 17)	Yes	Added
PS to CS session continuity	Indicates whether the service data flow is a candidate for vSRVCC.			Removed
Priority Level	Indicates a priority in scheduling resources among QoS Flows (NOTE 14).		Yes	Added
Averaging Window	Represents the duration over which the guaranteed and maximum bitrate shall be calculated (NOTE 14).		Yes	Added
Maximum Data Burst Volume (MDBV)	Denotes the largest amount of data that is required to be transferred within a period of 5G-AN PDB (NOTE 14).		Yes	Added

Information name	Description	Category	PCF permitted to modify for a dynamic PCC rule in the SMF	Differences compared with table 6.3. in TS 23.203 [4]
Disable UE notifications at changes related to Alternative QoS Profiles	Indicates to disable QoS Flow parameters signalling to the UE when the SMF is notified by the NG-RAN of changes in the fulfilled QoS situation. The fulfilled situation is either the QoS profile or an Alternative QoS Profile.	Conditional (NOTE 25)	Yes	Added
Precedence for TFT packet filter allocation	Determines the order of TFT packet filter allocation for PCC rules	Conditional (NOTE 28)	Yes	Added
ECN marking for L4S (NOTE 32)	The ECN marking for L4S indicates the UL and/or DL of the service data flow, detected by the service data flow template, supports ECN marking for L4S and to enable ECN marking for L4S for the service data flow.	Conditional	Yes	Added
Multi-modal Service ID	The Multi-modal Service ID indicates the multi-modal service that the service data flow is related to.	Conditional	Yes	Added
RAN-controlled UL Bitrate Recommendation Indication	Indicates that the RAN-controlled UL Bitrate Recommendation is supported by this service data flow.	Optional	Yes	Added
<b>Access Network Information Reporting</b>	<i>This part describes access network information to be reported for the PCC rule when the corresponding QoS Flow is established, modified or terminated.</i>			
User Location Report	The serving cell of the UE is to be reported. When the corresponding QoS Flow is deactivated, and if available, information on when the UE was last known to be in that location is also to be reported.		Yes	None
UE Timezone Report	The time zone of the UE is to be reported.		Yes	None
Satellite Identifier Report	The identifier of the serving satellite of the UE is to be reported if the UE access is over a gNB onboard the satellite.		Yes	New
<b>Usage Monitoring Control</b>	<i>This part describes identities required for Usage Monitoring Control.</i>			None
Monitoring key (NOTE 23)	The PCF uses the monitoring key to group services that share a common allowed usage.		Yes	None
Indication of exclusion from session level monitoring	Indicates that the service data flow shall be excluded from PDU Session usage monitoring		Yes	None
<b>N6-LAN Traffic Steering Enforcement Control (NOTE 18)</b>	<i>This part describes information required for N6-LAN Traffic Steering.</i>			
Traffic steering policy identifier(s)	Reference to a pre-configured traffic steering policy at the SMF (NOTE 12).		Yes	None

Information name	Description	Category	PCF permitted to modify for a dynamic PCC rule in the SMF	Differences compared with table 6.3. in TS 23.203 [4]
Metadata	Data provided by AF and included by UPF when forwarding traffic to N6-LAN.		Yes	Added
<b>Application Function influence on traffic routing Enforcement Control (NOTE 18)</b>	<i>This part describes information required for Application Function influence on traffic routing.</i>			
Data Network Access Identifier	Identifier(s) of the target Data Network Access (DNAI). It is defined in clause 5.6.7 of TS 23.501 [2].		Yes	Added
Per DNAI: Traffic steering policy identifier	Reference to a pre-configured traffic steering policy at the SMF (NOTE 19).		Yes	Added
Per DNAI: N6 traffic routing information	Describes the information necessary for traffic steering to the DNAI. It is described in clause 5.6.7 of TS 23.501 [2] (NOTE 19).		Yes	Added
Information on AF subscription to UP change events	Indicates whether notifications in the case of change of UP path are requested and optionally indicates whether acknowledgment to the notifications shall be expected (as defined in clause 5.6.7 of TS 23.501 [2]).		Yes	Added
Indication of UE IP address preservation	Indicates UE IP address should be preserved. It is defined in clause 5.6.7 of TS 23.501 [2].		Yes	Added
Indication of traffic correlation (NOTE 29)	Indicates that the target PDU Sessions should be correlated via a common DNAI in the user plane. It is described in clause 5.6.7 of TS 23.501 [2].		Yes	Added
Information on User Plane Latency requirements	Indicates the user plane latency requirements. It is defined in clause 6.3.6 of TS 23.548 [33].		Yes	Added
Indication for Simultaneous Connectivity at Edge Relocation	Indicates request for simultaneous connectivity over source and target PSA from the AF (see clause 5.6.7 of TS 23.501 [2]).		Yes	Added
Information for EAS IP Replacement in 5GC	Indicates the Source EAS identifier and Target EAS identifier, (i.e. IP addresses and port numbers of the source and target EAS). (see clause 5.6.7 of TS 23.501 [2]).		Yes	Added
EAS Correlation indication	Indicates selecting a common EAS for the application identified by Service data flow template accessed by the UEs with the same Traffic Correlation ID.		Yes	Added
Traffic Correlation ID	Identification of a set of UEs accessing the application identified by the Service data flow template (see clause 5.6.7 of TS 23.501 [2]).		Yes	Added

Information name	Description	Category	PCF permitted to modify for a dynamic PCC rule in the SMF	Differences compared with table 6.3. in TS 23.203 [4]
Common EAS IP address	IP address of the common EAS for the application identified by the Traffic Description for the UEs the AF request aims at (as defined in clause 5.6.7 of TS 23.501 [2]).		Yes	Added
Common DNAI	Common DNAI applicable to the set of UEs identified by a traffic correlation ID.		Yes	Added
FQDN(s)	FQDN(s) for the application indicated in the PCC rule (see clause 5.6.7 of TS 23.501 [2]).		Yes	Added
Indication of considering N6 delay	Indicates to consider the N6 delay measurement.		Yes	Added
NEF information	Notification Endpoint of NEF subscription to be notified with information related to UE members of the set of UEs identified by traffic correlation ID.		Yes	Added
<b>Handling of Payload Headers Control (NOTE 18)</b>	<i>This part describes information required for Handling of Payload Headers Control.</i>			
Header Handling Control information	Information required for Handling of Payload Headers (see clause 5.6.17 of TS 23.501 [2])		Yes	Added
<b>NBIFOM related control Information</b>	<i>This part describes PCC rule information related with NBIFOM.</i>			
Allowed Access Type	The access to be used for traffic identified by the PCC rule.			Removed
<b>RAN support information</b>	<i>This part defines information supporting the RAN for e.g. handover threshold decision.</i>			
UL Maximum Packet Loss Rate	The maximum rate for lost packets that can be tolerated in the uplink direction for the service data flow. It is defined in clause 5.7.2.8 of TS 23.501 [2].	Conditional (NOTE 13)	Yes	None
DL Maximum Packet Loss Rate	The maximum rate for lost packets that can be tolerated in the downlink direction for the service data flow. It is defined in clause 5.7.2.8 of TS 23.501 [2].	Conditional (NOTE 13)	Yes	None
<b>MA PDU Session Control (NOTE 20)</b>	<i>This part defines information supporting control of MA PDU Sessions</i>		Yes	New
Application descriptors	Identifies the application traffic for which MA PDU Session control is required based on the Steering Functionality, the Steering Mode, Steering Mode Indicator and Threshold Values. It is described in clause 5.32.8 of TS 23.501 [2].	Conditional (NOTE 27)	Yes	New
Steering Functionality	Indicates the applicable traffic steering functionality.	Conditional (NOTE 21, NOTE 31)	Yes	New
Steering Mode	Indicates the rule for distributing traffic between accesses together with associated steering parameters (if any).	Conditional (NOTE 21, NOTE 31)	Yes	New

Information name	Description	Category	PCF permitted to modify for a dynamic PCC rule in the SMF	Differences compared with table 6.3. in TS 23.203 [4]
Steering Mode Indicator	Indicates either autonomous load-balance operation or UE-assistance operation, if the Steering Mode is set to "Load Balancing", as defined in TS 23.501 [2].		Yes	New
Threshold Values (NOTE 30)	A Maximum RTT or a Maximum Packet Loss Rate or both.		Yes	New
Transport Mode (NOTE 33)	Indicates the transport mode that should be used for the matching traffic, as defined in TS 23.501 [2].		Yes	New
Charging key for Non-3GPP access (NOTE 22)	Indicates the Charging key used for charging packets carried via Non-3GPP access for a MA PDU Session.		Yes	New
Monitoring key for Non-3GPP access (NOTE 23)	Indicates the Monitoring key used to monitor usage of the packets carried via Non-3GPP access for a MA PDU Session.		Yes	New
<b>QoS Monitoring</b>	<i>This part describes PCC rule information related with QoS Monitoring.</i>			
QoS Monitoring parameter(s)	Indicates the QoS Monitoring parameter(s) for which QoS Monitoring can be enabled as defined in clause 5.45 of TS 23.501 [2].		Yes	Added
Reporting frequency	Defines the frequency for the reporting, such as event triggered, periodic.		Yes	Added
Target of reporting	Defines the target of the QoS Monitoring reports, it can be the NEF, the AF or the Local NEF.		Yes	Added
Indication of direct event notification	Indicates that the QoS Monitoring event shall be reported by the UPF directly to the NF indicated by the Target of reporting.		Yes	Added
<b>DataCollection_ApplicationIdentifier</b>	Identifier used in SMF to decide whether this PCC Rule corresponds to an event exposure subscription (see clause 4.15.4.5.1 of TS 23.502 [3]).		No	Added
<b>Alternative QoS Parameter Sets (NOTE 24) (NOTE 26)</b>	<i>This part defines Alternative QoS Parameter Sets for the service data flow.</i>			
Packet Delay Budget	The Packet Delay Budget in this Alternative QoS Parameter Set.		Yes	Added
Packet Error Rate	The Packet Error Rate in this Alternative QoS Parameter Set.		Yes	Added
UL-guaranteed bitrate	The uplink guaranteed bitrate in this Alternative QoS Parameter Set.		Yes	Added
DL-guaranteed bitrate	The downlink guaranteed bitrate in this Alternative QoS Parameter Set.		Yes	Added
Maximum Data Burst Volume (MDBV)	The Maximum Data Burst Volume (MDBV) in this Alternative QoS Parameter Set.		Yes	Added
Averaging Window	The Averaging Window in this Alternative QoS Parameter Set		Yes	Added

Information name	Description	Category	PCF permitted to modify for a dynamic PCC rule in the SMF	Differences compared with table 6.3. in TS 23.203 [4]
UL-PDU Set Delay Budget	The uplink PDU Set Delay Budget (PSDB) in this Alternative QoS Parameter Set (see clause 5.7.7.2 of TS 23.501 [2]).		Yes	Added
DL-PDU Set Delay Budget	The downlink PDU Set Delay Budget (PSDB) in this Alternative QoS Parameter Set (see clause 5.7.7.2 of TS 23.501 [2]).		Yes	Added
UL-PDU Set Error Rate	The uplink PDU Set Error Rate (PSER) in this Alternative QoS Parameter Set (see clause 5.7.7.3 of TS 23.501 [2]).		Yes	Added
DL-PDU Set Error Rate	The downlink PDU Set Error Rate (PSER) in this Alternative QoS Parameter Set (see clause 5.7.7.3 of TS 23.501 [2]).		Yes	Added
<b>TSC Assistance Container</b>	<i>This part defines parameters provided by TSN AF or TSCTSF. The parameters are defined in clause 5.27.2 of TS 23.501 [2].</i>		No	Added
<b>Traffic Parameter Information</b>	<i>This part describes PCC rule information related with Traffic Parameter Information for power saving as specified in clause 5.37.8 of TS 23.501 [2].</i>			
Periodicity	Indicates the time period between start of two data bursts in UL and/or DL direction.		Yes	Added
<b>Traffic Parameter Measurement</b>	<i>This part describes PCC rule information related with Traffic Parameter Measurement for power saving as specified in clause 5.37.8 of TS 23.501 [2].</i>			
Traffic Parameter to be measured	Indicates to measure the N6 jitter range associated with DL Periodicity and optionally, the UL/DL periodicity.		Yes	Added
Reporting condition	Defines the condition for the reporting, such as event triggered or periodic, frequency.		Yes	Added
<b>Downlink Data Notification Control</b>	<i>This part describes information required for controlling the sending of Downlink data delivery status event and DDN Failure event notifications as specified in clause 4.15.3 of TS 23.502 [3].</i>			
Notification control for DDD status	Indicates that notifications of downlink data delivery status are required and the requested type of such notifications.		Yes	Added
Notification Control for DDN Failure	Indicates that notifications of DDN Failure are required.		Yes	Added
<b>PDU Set Control Information</b>	Information needed to support the delivery of PDU Sets of a service data flow.			
PDU Set QoS Parameters (UL/DL)	See clause 5.7.7 of TS 23.501 [2].		Yes	Added
PDU Set Importance for N6-unmarked PDUs	Indicates the PDU Set Importance to be used for PDUs that do not belong to a PDU Set, see clause 5.37.5.1 of TS 23.501 [2].		Yes	Added
<b>Data Burst Handling Information</b>	<i>This part describes Data Burst Handling Information</i>			

Information name	Description	Category	PCF permitted to modify for a dynamic PCC rule in the SMF	Differences compared with table 6.3. in TS 23.203 [4]
End of Data Burst Marking Indication	Indicates to detect last PDU of the data burst and to mark End of Data Burst Indication (See clause 5.37.8 of TS 23.501 [2]) on the last PDU.		Yes	Added
Data Burst Size Marking Indication	Indicates to identify the size of Data Burst and mark Data Burst Size (See clause 5.37.10.1 of TS 23.501 [2]).		Yes	Added
Time to Next Burst Marking Indication	Indicates to identify the time to next Data Burst and mark Time to Next Burst (See clause 5.37.10.2 of TS 23.501 [2]).		Yes	Added
<b>Protocol Description Information</b>	Information needed to support identifying PDU Set Information for packets, size of a Data Burst, the time to next Data Burst and/or last packet of a Data Burst.			
Protocol Description (UL/DL)	Indicates the protocol, e.g. which is used to detect PDU Set Information of packets, size of a Data Burst, the time to next Data Burst and/or last packet of the Data Burst (see clauses 5.37.5, 5.37.8, 5.37.10.1 and 5.37.10.2 of TS 23.501 [2] and TS 26.522 [40]), or the use of UDP-option or Media over QUIC for retrieving media related information from DL traffic (see clause 5.37.9 of TS 23.501 [2]).		No	Added
<b>On-path N6 Signalling</b>	Information needed to use On-path signalling for retrieving media related information.			

Information name	Description	Category	PCF permitted to modify for a dynamic PCC rule in the SMF	Differences compared with table 6.3. in TS 23.203 [4]
On-path N6 Signalling Information	Indicates the method and provides the AS proxy address for On-path N6 signalling (see TS 23.501 [2] clause 5.37.9)			
<p>NOTE 1: For PCC rules based on an application detection filter, the precedence is only relevant for the enforcement, i.e. when multiple PCC rules overlap, only the enforcement, reporting of application starts and stops, monitoring, and charging actions of the PCC rule with the highest precedence shall be applied.</p> <p>NOTE 2: The Precedence is mandatory for PCC rules with SDF template containing SDF filter(s). For dynamic PCC rules with SDF template containing an application identifier, the precedence is either preconfigured in SMF or provided in the PCC rule from PCF.</p> <p>NOTE 3: Either service data flow filter(s) or application identifier shall be defined per each rule.</p> <p>NOTE 4: YES, if the service data flow template consists of a set of service data flow filters. NO if the service data flow template consists of an application identifier</p> <p>NOTE 5: Optional and applicable only if application identifier exists within the rule.</p> <p>NOTE 6: Applicable to sponsored data connectivity.</p> <p>NOTE 7: Mandatory if there is no default charging method for the PDU Session.</p> <p>NOTE 8: Optional and applicable only if application identifier exists within the rule.</p> <p>NOTE 9: If Redirect is enabled.</p> <p>NOTE 10: Mandatory when Bind to QoS Flow associated with the default QoS rule is not present.</p> <p>NOTE 11: The presence of this attribute causes the 5QI/ARP/QNC/Priority Level/Averaging Window/Maximum Data Burst Volume of the rule to be ignored for the QoS Flow binding.</p> <p>NOTE 12: The Traffic steering policy identifier can be different for uplink and downlink direction. If two Traffic steering policy identifiers are provided, then one is for uplink direction, while the other one is for downlink direction.</p> <p>NOTE 13: Optional and applicable only for voice service data flow in this release.</p> <p>NOTE 14: Optional and applicable only when a value different from the standardized value for this 5QI in Table 5.7.4-1 TS 23.501 [2] is required.</p> <p>NOTE 15: Optional and applicable only for GBR service data flow.</p> <p>NOTE 16: Usage of the charging information is described in TS 32.255 [21].</p> <p>NOTE 17: Only one PCC rule can contain this attribute and this PCC rule shall not contain the attribute Bind to QoS Flow associated with the default QoS rule.</p> <p>NOTE 18: None, one, multiple or all of these control information may be present in a PCC rule.</p> <p>NOTE 19: Per DNAI, a Traffic steering policy identifier and/or N6 traffic routing information can be provided. If the pre-configured traffic steering policy (that is referenced by the Traffic steering policy identifier) contains information that is overlapping with the N6 traffic routing information, the N6 traffic routing information shall take precedence.</p> <p>NOTE 20: Only applicable to a PCC Rules provided to a MA PDU Session.</p> <p>NOTE 21: Mandatory when MA PDU Session Control information is provided.</p> <p>NOTE 22: When a Charging key for Non-3GPP access is provided, the parameters in the Charging Section (other than the Charging key) apply to both accesses and the Charging key (in the Charging Section) shall be used for charging packets carried via the 3GPP access.</p> <p>NOTE 23: When a Monitoring key for Non-3GPP access is provided, the Monitoring key (in the Usage Monitoring Control Section) shall be used to monitor usage of the packets carried via the 3GPP access.</p> <p>NOTE 24: Optional and applicable only for GBR service data flow with QoS Notification Control enabled.</p> <p>NOTE 25: Optional and applicable only for GBR service data flow for which Alternative QoS Parameter Set(s) are provided.</p> <p>NOTE 26: One or more Alternative QoS Parameter Sets can be provided in a prioritized order starting with the Alternative QoS Parameter Set that has the highest priority.</p> <p>NOTE 27: Mandatory in MA PDU Session Control information only when there is application identifier in the service data flow template.</p> <p>NOTE 28: If this parameter is used, it has to be present in every PCC rule of the PDU Session.</p> <p>NOTE 29: The use of traffic correlation is defined in TS 23.501 [2], clauses 5.6.7.1 and 5.29.</p> <p>NOTE 30: If Steering Mode is set to "Redundant", either a Maximum RTT or a Maximum Packet Loss Rate may be provided, but not both.</p> <p>NOTE 31: The Steering functionality "ATSSS-LL" shall not be provided together with Steering Mode "Redundant".</p> <p>NOTE 32: This parameter is only provided when the PCF is configured to provide an explicit indicator to the SMF to enable ECN marking for L4S for the traffic identified by the SDF template.</p> <p>NOTE 33: The Transport Mode may be included when the Steering Functionality is the MPQUIC-IP functionality,, the MPQUIC-UDP functionality,, or the MPQUIC-E functionality.</p>				

The Rule identifier shall be unique for a PCC rule within a PDU Session. A dynamically provided PCC rule that has the same Rule identifier value as a predefined PCC rule shall replace the predefined rule within the same PDU Session.

The Precedence defines in what order the activated PCC rules within the same PDU Session shall be applied at the UPF for service data flow detection. When a dynamic PCC rule and a predefined PCC rule have the same precedence, the dynamic PCC rule takes precedence.

NOTE 2: The operator shall ensure that overlap between the predefined PCC rules can be resolved based on precedence of each predefined PCC rule in the SMF. The PCF shall ensure that overlap between the dynamically allocated PCC rules can be resolved based on precedence of each dynamically allocated PCC rule.

For downlink packets all the service data flow templates, activated for the PDU Session shall be applied for service data flow detection and for the mapping to the correct QoS Flow. For uplink packets the service data flow templates activated on their QoS Flow shall be applied for service data flow detection (further details are provided in clause 6.2.2.2).

The *Service data flow template* may comprise any number of *Service data flow filters* or an *application identifier* as is defined in table 6.3.1.

NOTE 3: Predefined PCC rules may include service data flow templates, which support extended capabilities, including enhanced capabilities to identify events associated with application protocols.

A Service data flow filter contains information for matching user plane packets for IP PDU traffic or Ethernet PDU traffic. All Service data flow filters of a Service data flow template shall be of the same type, i.e. either Packet Filters for IP or Ethernet PDU traffic (defined in clause 5.7.6 of TS 23.501 [2]). The Service data flow template information within an activated PCC rule is applied by the SMF to instruct the UPF to identify the packets belonging to a particular service data flow.

For the IP PDU Session type only, the Service data flow template may consist of an application identifier that references an application detection filter that is used for matching user plane packets. The application identifier is also identifying the application, for which the rule applies. The same application identifier value can occur in a dynamic PCC rule and one or multiple predefined PCC rules. If so, the PCF shall ensure that there is at most one PCC rule active per application identifier value at any time.

The *Mute for notification* defines whether notification to the PCF of application's starts or stops shall be muted. Absence of this parameter means that start/stop notifications shall be sent.

The *Expedited Transfer Indication* defines whether Expedite Data Transfer of larger payload for XR application is set or not. It takes values "TRUE" or "FALSE".

The *Charging key* is the reference to the tariff for the service data flow. Any number of PCC Rules may share the same charging key value. The Charging key values for each service shall be operator configurable.

NOTE 4: Assigning the same Charging key for several service data flows implies that the charging does not require the credit management to be handled separately.

The *Service identifier* identifies the service. PCC Rules may share the same service identifier value. The service identifier provides the most detailed identification, specified for flow-based charging, of a service data flow.

NOTE 5: The PCC rule service identifier need not have any relationship to service identifiers used on the AF level, i.e. is an operator policy option.

The *Sponsor Identifier* indicates the (3rd) party organization willing to pay for the operator's charge for connectivity required to deliver a service to the end user.

The *Application Service Provider Identifier* indicates the (3rd) party organization delivering a service to the end user.

The *Charging method* indicates whether online charging or offline charging is required, or the service data flow is not subject to any end user charging. If the charging method identifies that the service data flow is not subject to any end user charging, a Charging key shall not be included in the PCC rule for that service data flow, along with other charging related parameters. If the charging method is omitted the SMF shall apply the default charging method provided within the PDU Session related policy information (see clause 6.4). The Charging method is mandatory if there is no default charging method for the PDU Session.

NOTE 6: With converged charging architecture for 5GC, online charging method also includes usage reporting from the SMF to the CHF. Hence, setting the charging method to online will also result in usage reports and thus allow for offline charging being performed by the CHF.

The *Service Data Flow handling while requesting credit* indicates either "blocking" if a credit for the Charging Key needs to be granted as a condition for the PCC Rule to be active or "non-blocking" if a credit for the Charging Key has been requested as a condition for the PCC Rule to be active.

The *Measurement method* indicates what measurements apply to charging for a PCC rule.

The *Service Identifier Level Reporting* indicates whether the SMF shall generate reports per Service Identifier. The SMF shall accumulate the measurements from all PCC rules with the same combination of Charging key/Service Identifier values in a single report.

The *Application Function Record Information* identifies an instance of service usage. A subsequently generated usage report (i.e. CDR), generated as a result of the PCC rule by the SMF, may include the Application Function Record Information, if available. The Application Function Record Information may contain the AF Charging Identifier and/or the Flow identifiers. If exclusive charging information related to the Application function record information is required, the PCF shall provide a service identifier, not used by any other PCC rule of the PDU Session at this point in time, for the AF session.

NOTE 7: For example, the PCF may be configured to maintain a range of service identifier values for each service which require exclusive per instance charging information. Whenever a separate counting or credit management for an AF session is required, the PCF shall select a value, which is not used at this point in time, within that range. The uniqueness of the service identifier in the SMF ensures a separate accounting/credit management while the AF record information identifies the instance of the service.

The *Gate* indicates whether the SMF shall instruct the UPF to let a packet identified by the PCC rule pass through (gate is open) to discard the packet (gate is closed).

NOTE 8: A packet, matching a PCC Rule with an open gate, may be discarded due to credit management reasons.

The *5G QoS Identifier*, 5QI, represents the QoS parameters for the service data flow. The 5G QoS identifier is scalar and accommodates the need for differentiating QoS in both 3GPP and non-3GPP access type.

The *bitrates* indicate the authorized bitrates at the IP packet level of the SDF, i.e. the bitrates of the IP packets before any access specific compression or encapsulation.

The *UL maximum-bitrate* indicates the authorized maximum bitrate for the uplink component of the service data flow.

The *DL maximum-bitrate* indicates the authorized maximum bitrate for the downlink component of the service data flow.

The *UL guaranteed-bitrate* indicates the authorized guaranteed bitrate for the uplink component of the service data flow.

The *DL guaranteed-bitrate* indicates the authorized guaranteed bitrate for the downlink component of the service data flow.

The 'Maximum bitrate' is used for enforcement of the maximum bit rate that the SDF may consume, while the 'Guaranteed bitrate' is used by the SMF to determine resource allocation demands.

The *UL sharing indication* indicates that resource sharing in uplink direction for service data flows with the same value in their PCC rule shall be applied by the SMF as described in clause 6.2.2.4.

The *DL sharing indication* indicates that resource sharing in downlink direction for service data flows with the same value in their PCC rule shall be applied by the SMF as described in clause 6.2.2.4.

The *Allocation and Retention Priority* indicates the allocation, retention and priority of the service data flow. The ARP contains information about the priority level, the pre-emption capability and the pre-emption vulnerability. The Allocation and Retention Priority resolves conflicts of demands for network resources.

The *Priority Level* is signalled together with the 5QI to the (R)AN and UPF, only when a value different from the standardized value in the QoS characteristics Table 5.7.4-1 in TS 23.501 [2] is required.

The *Averaging Window* is signalled together with the 5QI to the (R)AN and UPF, only when a value different from the standardized value in the QoS characteristics Table 5.7.4-1 in TS 23.501 [2] is required.

The *Maximum Data Burst Volume*, MDBV, is signalled together with the 5QI to the (R)AN, only when a value different from the standardized value in the QoS characteristics Table 5.7.4-1 in TS 23.501 [2] is required.

The *Bind to QoS Flow associated with the default QoS rule* indicates that the SDF shall be bound to the QoS Flow associated with the default QoS rule. The presence of this parameter attribute causes the 5QI/ARP of the rule to be ignored by the SMF during the QoS Flow binding.

The *Bind to QoS Flow associated with the default QoS rule and apply PCC rule parameters* indicates that the SDF shall be bound to the QoS Flow associated with the default QoS rule and that the QoS related attributes of the PCC rule shall be applied by the SMF to derive the QoS parameters of the QoS Flow associated with the default QoS rule instead of the PDU Session related information Authorized default 5QI/ARP.

NOTE 9: The Bind to QoS Flow associated with the default QoS rule and apply PCC rule parameters Indication has to be used whenever the PDU Session related information Authorized default 5QI/ARP (as described in clause 6.3.1) cannot be directly used as the QoS parameters of the QoS Flow associated with the default QoS rule, for example when a GBR 5QI is used or the 5QI priority level has to be changed.

The *QoS Notification Control, QNC*, indicates whether notifications are requested from the access network (i.e. 3GPP RAN) when the GFBR can no longer (or can again) be guaranteed for a QoS Flow during the lifetime of the QoS Flow. If it is set and the GFBR can no longer (or can again) be guaranteed, the access network (i.e. 3GPP RAN) sends a notification towards the SMF, which then notifies the PCF.

The *Disable UE notifications at changes related to Alternative QoS Profiles* parameter indicates to disable QoS Flow parameters signalling to the UE when the SMF is notified by the NG-RAN of changes in the fulfilled QoS situation. The fulfilled situation is either the QoS profile or an Alternative QoS Profile.

The *Precedence for TFT packet filter allocation* parameter determines the order in which TFT packet filters are allocated for PCC rules. The PCF may include this parameter if there is a possibility to run into a restriction regarding the number of TFT packet filters that can be allocated for the PDU Session and interworking with EPS with N26 deployment is supported (see also clause 4.11.1 of TS 23.502 [3]).

NOTE 10: PCF can know that interworking with EPS with N26 is supported based on DNN and S-NSSAI of the PDU Session.

The *Reflective QoS Control* indicates to apply reflective QoS for the service data flow. The indication is used to control the RQI marking in the DL packets of the service data flow and may trigger the sending of the RQA parameter for the QoS Flow the service data flow is bound to. Reflective QoS is defined in clause 5.7.5 of TS 23.501 [2].

NOTE 11: While the UE applies a standardized value for the precedence of all UE derived QoS rules, PCC rules require different precedence values and PCF configuration has to ensure that there is a large enough value range for the precedence of PCC rules corresponding to UE derived QoS rules. To avoid that the precedence of network provided QoS rules need to be changed when Reflective QoS is activated and filters are overlapping, the PCF will take the standardized value for the precedence of UE derived QoS rules into account when setting the precedence value of PCC rules subject to Reflective QoS.

The *Reflective QoS Control* parameter shall not be used for the PCC rule with match-all SDF template. If PCC rule with match-all SDF template is present, the *Reflective QoS Control* parameter shall not be used for PCC rules which contain the *Bind to QoS Flow of the default QoS rule* parameter, either.

The *N6-LAN Traffic Steering Enforcement Control* contains *Traffic steering policy identifier(s)* for steering traffic onto N6-LAN to the appropriate N6 service functions deployed by the operator or a third party, and optional Metadata if received from AF due to Application Function influence on Service Function Chaining as described in clause 5.6.16 of TS 23.501 [2].

The content of the *Header Handling Control information* is defined in clause 5.6.17 of TS 23.501 [2].

The *ECN marking for L4S* indicates that the service data flow supports ECN marking for L4S to be performed.

The *Multi-modal Service ID* indicates the multi-modal service that the service data flow is related to.

The *RAN-controlled UL Bitrate Recommendation Indication* indicates that the service data flow supports the RAN-controlled UL bit rate recommendation, as described in clause 5.37.12 of TS 23.501 [2].

The access network information reporting parameters (*User Location Report, UE Timezone Report, Satellite Identifier Report*) instruct the SMF about what information to forward to the PCF when the PCC rule is activated, modified or removed.

The *Monitoring Key* is the reference to a resource threshold. Any number of PCC Rules may share the same monitoring key value. The monitoring key values for each service shall be operator configurable.

The *Indication of exclusion from session level monitoring* indicates that the service data flow shall be excluded from the PDU Session usage monitoring.

The *Application Function influence on traffic routing Enforcement Control* may contain:

- a *set of DNAI(s)* (i.e. a reference to the DNAI(s) the SMF needs to consider for UPF selection/reselection), an optional *Indication of traffic correlation* and, per DNAI, a corresponding *Traffic steering policy identifier* (i.e. a reference to a pre-configured traffic steering policy at the SMF), and/or a corresponding *N6 traffic routing information* (when the N6 traffic routing information is provided explicitly as part of the AF request, as described in clause 5.6.7 of TS 23.501 [2]), or;
- an *AF subscription to UP change events* parameter which contains subscription information defined in clause 5.2.8.3 of TS 23.502 [3] for the change of UP path Event Id i.e. an *Indication of early and/or late notification* and information on where to provide the corresponding notifications (Notification Target Address + Notification Correlation ID as specified in clause 4.15.1 of TS 23.502 [3]) and optionally an indication of "AF acknowledgment to be expected" to the corresponding notifications as described in clause 5.6.7 of TS 23.501 [2].
- a *user plane latency requirements* parameter which contains AF requested information on the requirements for user plane latency defined in TS 23.548 [33].
- an *indication for Simultaneous Connectivity at Edge Relocation*, which includes *Keep existing PSA* indication to provide guidance to the network on whether to provide simultaneous connectivity over source and target PSA at edge relocation; also, optionally a related *Keep existing PSA timer* that indicates the minimum time interval to be considered for inactivity for the traffic described before the connectivity over the source PSA may be removed, as defined in TS 23.548 [33].
- an *EAS Correlation indication*, which indicates selecting a common EAS for a set of UEs identified by Traffic Correlation ID and accessing the application identified by Service data flow template or FQDN(s).
- a *Traffic Correlation ID*, identifying a set of UEs accessing the application identified by the Service data flow template or FQDN(s). See more in clause 5.6.7 of TS 23.501 [2].
- a *Common EAS IP address*, IP address of the common EAS accessed by the UEs with the same Traffic Correlation ID, for the application identified by the Service data flow template.
- *FQDN(s)*, FQDN(s) for the application traffic identified by the Service data flow template, and used for influencing EASDF-based DNS query procedure as defined in TS 23.548 [33].
- *NEF Information*, Notification Endpoint of the NEF responsible of the set of UEs associated with the Traffic correlation ID.
- *Indication of considering N6 delay* which indicates to consider the N6 delay measurement between UPF(s) and EAS(es). See more in clause 6.9 of TS 23.548 [33].

The *Traffic Steering Enforcement Control* may contain *Indication of UE IP address preservation*. The SMF takes this indication into account when determining whether to reselect PSA UPF, as specified in clause 5.6.7 of TS 23.501 [2].

The *Redirect* indicates whether the uplink part of the service data flow should be redirected to a controlled address.

The *Redirect Destination* indicates the target redirect address when *Redirect* is enabled.

The *UL Maximum Packet Loss Rate* indicates the maximum rate for lost packets that can be tolerated in the uplink direction.

The *DL Maximum Packet Loss Rate* indicates the maximum rate for lost packets that can be tolerated in the downlink direction.

The *Application descriptors* provides one or several instances of the OSId and OSAppId combination. It is used by the UE to identify the application traffic for which steering is required based on the Steering Functionality, the Steering Mode, the Steering Mode Indicator and the Threshold Values.

The *Steering Functionality* indicates the method for how traffic matching the SDF template in the UPF or a Traffic descriptor in the UE is sent over the MA PDU Session. The method ATSSS\_LL indicates that the traffic matching the

SDF template is sent over the MA PDU Session without additional tunnelling, e.g. with IP flow switching. The method MPTCP indicates that the traffic matching the SDF template is sent over the MA PDU Session using MPTCP. The methods MPQUIC-UDP, MPQUIC-IP, or MPQUIC-E indicate that traffic matching the SDF template is sent over the MA PDU Session using MPQUIC based on the CONNECT-UDP, CONNECT-IP, or CONNECT-Ethernet proxy methods, respectively.

The *Steering Mode* indicates the rule for distributing downlink SDFs in the UPF or uplink traffic in the UE between accesses, together with the associated steering parameters. The PCF may indicate separate values for uplink and downlink directions. The available Steering Modes are defined in TS 23.501 [2].

The *Steering Mode Indicator* indicates that the UE or the UPF or both may change the steering parameters provided in the Steering Mode and may adjust the traffic steering based on their own decisions, as further defined in TS 23.501 [2]. When the PCF selects the Load-Balancing Steering Mode for both the uplink and the downlink, and the PCF provides a *Steering Mode Indicator* for the uplink equal to UE-assistance operation, then the PCF shall provide the same *Steering Mode Indicator* for the downlink.

The *Threshold Values* indicate the authorized RTT or Packet Loss Rate for a SDF. Depending on the Steering Mode value, the PCF may include, per SDF, one threshold value for RTT or one threshold value for Packet Loss Rate, or both. The PCF may indicate separate values for uplink and downlink directions. The Steering Modes that may use the threshold values and how the UE and UPF enforces them are defined in TS 23.501 [2].

The *Transport Mode* indicates one of the Transport Modes as defined in TS 23.501 [2] that should be applied for transmitting a UDP flow between UE and UPF. The Transport Mode may be included when the MPQUIC-UDP functionality, the MPQUIC-IP functionality, or the MPQUIC-E functionality is selected as the Steering Functionality.

The *Charging key for Non-3GPP access* indicates the Charging key that shall be used for charging the detected service data flow traffic carried via Non-3GPP access. The other charging related parameters apply for both accesses.

The *Monitoring key for Non-3GPP access* indicates the Monitoring key that shall be used for monitoring the usage of the detected service data flow traffic carried via Non-3GPP access.

The *QoS Monitoring parameter(s)* indicates the QoS Monitoring parameter(s) for which QoS Monitoring can be enabled for a service data flow as defined in clause 5.45 of TS 23.501 [2], e.g. the UL packet delay, DL packet delay or round trip packet delay between the UE and the UPF.

The *Reporting frequency* indicates the frequency for the reporting, such as event triggered, periodic. The following applies:

- If the *Reporting frequency* indicates "periodic", the *reporting period* shall also be included in the PCC rule.
- The *reporting period* shall also be used for reporting measurement failure in any of the *Reporting frequency* modes "periodic" or "event triggered".

NOTE 12: The indication of a measurement failure is not possible or not supported for some *QoS Monitoring parameter(s)* (as described in the respective clauses of clause 5.45 of TS 23.501 [2]).

- If the *Reporting frequency* indicates "event triggered", the *reporting period*, *Reporting threshold(s)* and the *minimum waiting time* shall also be included in the PCC rule. The *Reporting threshold(s)* indicates the measurement threshold for each of the included *QoS Monitoring parameter(s)*. The *minimum waiting time* indicates the minimum time interval between subsequent reports. In the case of monitoring of the UL and/or DL Available Bitrate for the service data flow, a list of Reporting threshold(s) shall be included for the respective direction(s) as described in clause 6.1.3.27.1 and clause 5.45.6 of TS 23.501 [2].

The *Target of reporting* indicates the target for the QoS Monitoring reports sent as notifications. It can be either the NEF, the AF or the Local NEF, indicated as Notification Target Address + Notification Correlation ID.

The *Indication of direct event notification* indicates that the QoS Monitoring reports shall be sent by the UPF directly to the NF indicated by the Target of reporting (i.e. to the Local NEF or the AF as described in clause 5.8.2.18 of TS 23.501 [2]).

The *DataCollection\_ApplicationIdentifier* is provided to assist the SMF when it needs to decide whether this PCC Rule corresponds to an event exposure subscription (see clause 4.15.4.5.1 of TS 23.502 [3]).

The *Alternative QoS Parameter Set(s)* define alternative set(s) of QoS parameters for the service data flow. Every set consists of a PER, a PDB, an UL and a DL guaranteed bitrate QoS parameter, optionally, an Averaging Window and

optionally, a PSDB and PSER for UL and/or a DL direction. For delay-critical service data flow, every Alternative QoS Parameter Set may also include a Maximum Data Burst Volume (MDBV).

The content of the *TSC Assistance Container* is defined in clause 5.27.2 of TS 23.501 [2].

The *Traffic Parameter Information* applies to the UE power saving as specified in clause 5.37.8 of TS 23.501 [2]. The following parameters are included:

- *Periodicity*:
  - indicates the time period between start of two data bursts in UL and/or DL direction.
  - this parameter is only included when PCF receives the periodicity information from AF.

The *Traffic Parameter Measurement* applies to the UE power saving as specified in clause 5.37.8 of TS 23.501 [2]. The following parameters are included:

- *Traffic Parameter to be measured*:
  - UL and/or DL periodicity. This parameter is only included when PCF does not receive the periodicity information from AF.
  - N6 jitter range associated with DL Periodicity.
- *reporting condition* can be optionally included to define the condition for the reporting, such as event triggered or periodic, frequency.

The *Downlink Data Notification Control* applies to the control of subscription to Downlink Data Delivery status event notifications and DDN Failure event notifications as specified in clause 4.15.3 of TS 23.502 [3]. The following parameters are included:

- The *Notification control for DDD status* applies as described in clause 4.15.3.2.8 of TS 23.502 [3] and contains the following parameters:
  - indication that notifications of Downlink Data Delivery status are required; and
  - the requested type of such notifications (notifications about downlink packets being buffered, and/or discarded).
- The *Notification Control for DDN Failure* applies as described in clause 4.15.3.2.9 of TS 23.502 [3] and contains the following parameters:
  - indication that notifications of DDN Failure are required.

NOTE 13: Downlink Data Notification Control information is provided to assist the SMF in the generation/update of N4 information. The PCF will not be notified about the Downlink data delivery status events or the DDN Failure events.

The *PDU Set Control Information* is needed to support the delivery of PDU Sets for a service data flow. The PDU Set QoS Parameter values for UL and DL may be different (see clause 5.7.7 of TS 23.501 [2]). The *PDU Set Control Information* may also contain the parameter PDU Set Importance for N6-unmarked PDUs.

The *Protocol Description Information* is needed to support identifying PDU Set Information for DL/UL packets, size of a DL Data Burst, time to next Data Burst and/or last packet of a DL Data Burst. The Protocol Descriptions for UL and DL may be different (see clause 5.37.5 of TS 23.501 [2]). It may also indicate whether Media over QUIC or UDP-option is used to carry media related information, see clause 5.37.9 of TS 23.501 [2].

The *On-path N6 Signalling Information* is used to receive media related information using On-path N6 signalling, see clause 5.37.9.3 and clause 5.37.9.4 of TS 23.501 [2].

The *Data Burst Handling Information* is needed for the following:

- to support detecting last PDU of the Data Burst and marking End of Data Burst Indication on the last packet of the Data Burst (see clause 5.37.8 of TS 23.501 [2]);
- to support identifying the size of a DL Data Burst and marking Data Burst Size as defined in clause 5.37.10.1 of TS 23.501 [2];

- to support identifying the time to next Data Burst and marking Time to Next Burst as defined in clause 5.37.10.2 of TS 23.501 [2].

### 6.3.2 Policy and charging control rule operations

Policy and Charging Rule operations consist of activation, modification and de-activation of PCC rules. The PCF may activate, modify and deactivate a PCC rule at any time. However, the modification is applicable to dynamic PCC rules only.

Activation of a dynamic PCC rule provides the PCC rule information to the SMF. Activation of a predefined PCC rule provides an identifier of the relevant PCC rule to the SMF.

Each PCC rule shall be installed for a single QoS Flow only (for further details about predefined PCC rules see below).

An active PCC rule means that:

- the service data flow template shall be used for service data flow detection;
- the service data flow template shall be used for mapping of downlink packets to the QoS Flow determined by the QoS Flow binding;
- the service data flow template shall be used for service data flow detection of uplink packets on the PDU Session determined by the QoS Flow binding;
- usage data for the service data flow shall be recorded;
- policies associated with the PCC rule, if any, shall be invoked;
- for service data flow detection with an application detection filter, the start or the stop of the application traffic is reported to the PCF, if applicable and requested by the PCF. In that case, the notification for start may include service data flow filters, (if possible to provide) and the application instance identifier associated with the service data flow filters.
- Either one of the conditions below:
  - a credit has been granted for the service data flow. Applicable when the Charging method is set to "online" and the Service Data Flow handling while requesting credit is set to "blocking"; or
  - a credit has been requested for the service data flow. Applicable when the Charging method is set to "online" and the Service Data Flow handling while requesting credit is set to "non-blocking".

A predefined PCC rule is known at least, within the scope of one PDU Session.

NOTE 1: The same predefined PCC rule can be activated for multiple QoS Flows in multiple PDU Sessions.

A predefined PCC rule is bound to one and only one QoS Flow per PDU Session. For a predefined PCC rule whose service data flow cannot be fully reflected for the uplink direction in terms of traffic mapping information sent to the UE, the SMF may request the UPF to apply the uplink service data flow detection at additional QoS Flows with non-GBR 5QI of the same PDU Session. The deactivation of such a predefined PCC rule ceases its service data flow detection for the whole PDU Session.

The PCF may, at any time, deactivate an active PCC rule in the SMF. At QoS Flow termination all active PCC rules on that QoS Flow are deactivated without explicit instructions from the PCF to do so.

Policy and charging control rule operations can be also performed in a deferred mode. A PCC rule may have either a single deferred activation time, or a single deferred deactivation time or both.

A PCC rule with only a deferred activation time shall be inactive until that time. A PCC rule with only a deferred deactivation time shall be active until that time. When the rule activation time occurs prior to the rule deactivation time, the rule is inactive until the activation and remains active until the deactivation time occurs. When the rule deactivation time occurs prior to the rule activation time, the rule is initially active until the deactivation time, then remains inactive until the activation time, and then becomes active again. An inactive PCC rule, that has not been activated yet, is still considered to be installed, and may be removed by the PCF. When modifying a dynamic PCC rule by setting, modifying or clearing its deferred activation and/or deactivation time or by changing any other attribute of a PCC rule

having a deferred activation and/or deactivation time, the PCF shall provide all attributes of that PCC rule, including attributes that have not changed.

NOTE 2: In this case, the PCF omission of an attribute that has a prior value will erase that attribute from the rule.

Deferred activation and deactivation of PCC rules can only be used for PCC rules that belong to the QoS Flow associated with the default QoS rule that allows all UL packets.

Deferred modification of PCC rules shall not be applied for changes of the QoS or service data flow filter information of PCC rules.

NOTE 3: This limitation prevents dependencies on the signalling of changed traffic mapping information towards the UE.

## 6.4 PDU Session related policy information

The purpose of the PDU Session related policy information is to provide policy and charging control related information that is applicable to a single Monitoring key or the whole PDU Session respectively. The PCF may provide PDU Session related policy information to the SMF together with PCC rules or separately.

Table 6.4-1 includes the PDU Session related policy information.

The differences with table 6.4 and table 6.6 in TS 23.203 [4] are shown, either "none" means that the IE applies in 5GS or "removed" meaning that the IE does not apply in 5GS, this is due to the lack of support in the 5GS for this feature or "modified" meaning that the IE applies with some modifications defined in the IE.

**Table 6.4-1: PDU Session related policy information**

Attribute	Description	PCF permitted to modify for dynamically provided information	Scope	Differences compared with table 6.4. and 6.6 in TS 23.203 [4]
Charging information	Defines the containing CHF address and optionally the associated CHF instance ID and/or CHF set ID.	No	PDU Session	None (NOTE 18)
CHF group ID	The CHF Group ID for the PDU Session.	No	PDU Session	Added
Default charging method	Defines the default charging method for the PDU Session.	No	PDU Session	None
PDU Session with offline charging only	Indicates that the "online" charging method is never used for PCC rules in the PDU Session.	No	PDU Session	Added
Policy control request trigger	Defines the event(s) that shall cause a re-request of PCC rules for the PDU Session.	Yes	PDU Session	Explicitly subscribed by invoking Npcf_SMPolicyControl service operation
Authorized QoS per bearer (UE-initiated IP-CAN bearer activation/modification)	Defines the authorised QoS for the IP-CAN bearer (QCI, GBR, MBR).	Yes	IP-CAN bearer	Removed
Authorized MBR per QCI (network initiated IP-CAN bearer activation/modification)	Defines the authorised MBR per QCI.	Yes	IP-CAN session	Removed
Revalidation time limit	Defines the time period within which the SMF shall perform a PCC rules request.	Yes	PDU Session	None

Attribute	Description	PCF permitted to modify for dynamically provided information	Scope	Differences compared with table 6.4. and 6.6 in TS 23.203 [4]
PRA Identifier(s)	Defines the Presence Reporting Area(s) to monitor for the UE with respect to entering/leaving	Yes	PDU Session	None but only applicable to PCF
List(s) of Presence Reporting Area elements (NOTE 14)	Defines the elements of the Presence Reporting Area(s)	Yes	PDU Session	None but only applicable to PCF
Default NBIFOM access	The access to be used for all traffic that does not match any existing Routing Rule	Yes (only at the addition of an access to the IP-CAN session)	IP-CAN session	Removed
IP Index (NOTE 11)	Provided to SMF to assist in determining the IP Address allocation method (e.g. which IP pool to assign from) when a PDU Session requires an IP address – as defined in clause 5.8.2.2.1 of TS 23.501 [2].	No	PDU Session	Added
Redundant PDU Session	Indicates that the PDU Session is a redundant PDU Session	No	PDU Session	New
Explicitly signalled QoS Characteristics (NOTE 1)	Defines a dynamically assigned 5QI value (from the non-standardized value range) and the associated 5G QoS characteristics as defined in clause 5.7.3 of TS 23.501 [2].	No	PDU Session	Added
Reflective QoS Timer	Defines the lifetime of a UE derived QoS rule belonging to the PDU Session.	No	PDU Session	Added
Authorized Session-AMBR (NOTE 2) (NOTE 3)	Defines the Aggregate Maximum Bit Rate for the Non-GBR QoS Flows of the PDU Session.	Yes	PDU Session	Modified
Authorized default 5QI/ARP (NOTE 3) (NOTE 10)	Defines the default 5QI and ARP of the QoS Flow associated with the default QoS rule.	Yes	PDU Session	Modified
Time Condition (NOTE 4)	Defines the time at which the corresponding Subsequent Authorized Session-AMBR or Subsequent Authorized default 5QI/ARP shall be applied.	No (NOTE 5)	PDU Session	Modified
Subsequent Authorized Session-AMBR (NOTE 4) (NOTE 2)	Defines the Aggregate Maximum Bit Rate for the Non-GBR QoS Flows of the PDU Session when the Time Condition is reached.	No (NOTE 5)	PDU Session	Modified
Subsequent Authorized default 5QI/ARP (NOTE 4) (NOTE 10)	Defines the default 5QI and ARP when the Time Condition is reached.	No (NOTE 5)	PDU Session	Modified
PDU Session Inactivity Timer value (NOTE 16)	Defines the inactivity timer value for a PDU Session before releasing the PDU Session due to slice usage control.	Yes	PDU Session	New
<b>Usage Monitoring Control related information (NOTE 12) (NOTE 13)</b>	Defines the information that is required to enable user plane monitoring of resources for individual applications/services, groups of applications/services, for a PDU Session.			

Attribute	Description	PCF permitted to modify for dynamically provided information	Scope	Differences compared with table 6.4. and 6.6 in TS 23.203 [4]
Monitoring key	The PCF uses the monitoring key to group services that share a common allowed usage.	No	PDU Session (NOTE 12)	None
Volume threshold (NOTE 7)	Defines the traffic volume value after which the SMF shall report usage to the PCF for this monitoring key.	Yes	Monitoring key	None
Time threshold (NOTE 7)	Defines the resource time usage after which the SMF shall report usage to the PCF.	Yes	Monitoring key	None
Monitoring time	Defines the time at which the SMF shall reapply the Volume and/or Time Threshold.	No (NOTE 6)	Monitoring Key	None
Subsequent Volume threshold (NOTE 9)	Defines the traffic volume value after which the SMF shall report usage to the PCF for this Monitoring key for the period after the Monitoring time.	No (NOTE 6)	Monitoring Key	None
Subsequent Time threshold (NOTE 9)	Defines resource time usage after which the SMF shall report usage to the PCF for this Monitoring key for the period after the Monitoring time.	No (NOTE 6)	Monitoring Key	None
Inactivity Detection Time (NOTE 8)	Defines the period of time after which the time measurement shall stop, if no packets are received.	Yes	Monitoring Key	None
<b>Ethernet or IP port management related</b>				
Port number	Port number for which Port Management Information Container is provided.	Yes	PDU Session	New
Port Management Information Container	Includes Ethernet/IP port management information.	Yes	PDU Session	New
User plane node Management Information Container	Includes User plane node management information.	Yes		New
Target of reporting	Target of reporting (indicated as Notification Target Address + Notification Correlation ID).	Yes	PDU Session	New
PDU Slice Inactivity Timer value (NOTE 16)	Defines the Slice inactivity timer value before releasing the PDU Session.			
<b>VPLMN Specific Offloading Policy</b>	HR-SBO policy for the local part of DN in VPLMN.			
IP range(s)	IP address range(s) allowed to be routed to the local part of DN in VPLMN.	Yes	PDU Session (NOTE 15)	New
FQDN(s)	FQDN(s) allowed to be routed to the local part of DN in VPLMN.	Yes	PDU Session (NOTE 15)	New

Attribute	Description	PCF permitted to modify for dynamically provided information	Scope	Differences compared with table 6.4. and 6.6 in TS 23.203 [4]
Authorized DL Session AMBR for Offloading	Defines the DL Aggregate Maximum Bit Rate for the Non-GBR QoS Flows of the PDU Session authorized for offloading to the local part of DN in VPLMN.	Yes	PDU Session (NOTE 15)	New
Offload Identifier	Identifies a certain VPLMN Specific Offloading Information to be generated based on this VPLMN Specific Offloading Policy.	Yes	PDU Session (NOTE 15)	New
<b>Local Offloading Management Policy</b>	Local Offloading Policy for the local part of DN when Local Offloading Management applies.			
IP range(s)	IP address range(s) allowed to be routed to the local part of DN.	Yes	PDU Session (NOTE 17)	New
FQDN(s)	FQDN(s) allowed to be routed to the local part of DN.	Yes	PDU Session (NOTE 17)	New
Offload Identifier	Identifies the corresponding Local Offloading Management Policy.	Yes	PDU Session (NOTE 17)	New
<p>NOTE 1: Multiple Non-standardized QoS Characteristics can be provided by the PCF. Operator configuration is assumed to ensure that the non-standardized 5QI to QoS characteristic relation is unique within the PLMN.</p> <p>NOTE 2: The Authorized Session-AMBR and the Subsequent Authorized Session-AMBR may be provided together with a list of Access Types possibly complemented by RAT types.</p> <p>NOTE 3: There is always an unconditional value for the Authorized Session-AMBR and Authorized default 5QI/ARP available at the SMF. The initial value is received as Subscribed Session-AMBR/Subscribed default 5QI/ARP, and the PCF can overwrite it with these parameters.</p> <p>NOTE 4: The Time Condition and Subsequent Authorized Session-AMBR/ Subsequent Authorized default 5QI/ARP are used together. The PCF may provide up to four instances of them. When multiple instances are provided, the values of the associated Time Condition have to be different.</p> <p>NOTE 5: The PCF may replace all instances that have been provided previously with a new instruction. A previously provided Time Condition and Subsequent Authorized Session-AMBR/ Subsequent Authorized default 5QI/ARP pair cannot be individually modified.</p> <p>NOTE 6: The PCF may replace all instances that have been provided previously with a new instruction. A previously provided Volume threshold/Time threshold and Monitoring Time pair cannot be individually modified.</p> <p>NOTE 7: This attribute is also used by the SMF, e.g. during PDU Session termination, to inform the PCF about the resources that have been consumed by the UE.</p> <p>NOTE 8: This attribute is applicable in presence of Time threshold only.</p> <p>NOTE 9: This attribute is applicable in presence of Monitoring Time only.</p> <p>NOTE 10: The Authorized default 5QI and the Subsequent Authorized default 5QI shall be of Non-GBR Resource Type.</p> <p>NOTE 11: This attribute is applicable only when no IP address/Prefix for the PDU Session is received from the SMF.</p> <p>NOTE 12: A Monitoring Key can either be used to monitor the traffic of a PDU Session, the traffic of a PDU Session per access (for a MA PDU Session) or the traffic of specific SDF(s) in the PCC Rule(s) that share the same Monitoring Key.</p> <p>NOTE 13: For a MA PDU Session, the PDU Session level Usage Monitoring shall be possible per access (i.e. 3GPP and/or Non-3GPP) and irrespective of the access.</p> <p>NOTE 14: The list of PRA elements shall be a short list of elements.</p> <p>NOTE 15: This attribute is applicable only for the PDU Session supporting HR-SBO. This attribute is applied only to the current serving VPLMN. This attributed shall not be forwarded to RAN or UE.</p> <p>NOTE 16: Included if the PDU Session Slice Inactivity Timer value is set by PCF.</p> <p>NOTE 17: This attribute is applicable only for Local Offloading Management.</p> <p>NOTE 18: Only OFCS and OCS addresses are present in TS 23.203 [4].</p>				

Upon the initial interaction with the SMF, the PCF may provide the following attributes to the SMF:

The *Charging information* contains addresses of the CHF that manages charging for the PDU Session and optionally the associated CHF instance ID and/or CHF set ID (see clause 6.3.1.0 of TS 23.501 [2]). If received, the SMF shall apply it as defined in clause 6.3.11 of TS 23.501 [2].

The *CHF group ID* contains the CHF Group ID of the CHFs that manages charging for the PDU Session and when received, the SMF shall apply it as defined in clause 6.3.11 of TS 23.501 [2].

The *Default charging method* indicates what charging method shall be used in the PDU Session for every PCC rule where the charging method identifier is omitted, including predefined PCC rules that are activated by the SMF. If received by the SMF, it supersedes the *Default charging method* in the charging characteristics profile.

The *PDU Session with offline charging only* can be assigned to a PDU Session by the PCF to indicate that the online charging method is never set for any of the PCC Rules activated during the lifetime of the PDU Session nor provided as Default charging method.

NOTE 1: If this parameter is provided by the PCF or configured in the SMF charging characteristics the SMF can use the *Nchf\_OfflineOnlyCharging* service instead of the *Nchf\_ConvergedCharging* service for a PDU Session as defined in TS 32.255 [21].

NOTE 2: When the "PDU Session with offline charging only" indication is provisioned by the PCF, the PCF can set the charging method for a PCC rule within this PDU Session to either "offline" or "neither".

The *IP Index* indicates the IP Address/Prefix allocation method which is used by the SMF for IP Address/Prefix allocation during PDU Session Establishment procedure as defined in clause 5.8.2.2.1 of TS 23.501 [2].

Upon every interaction with the SMF, the PCF may provide the following attributes to the SMF:

The *Revalidation time limit* defines the time period within which the SMF shall trigger a request for PCC rules for an established PDU Session.

The *Reflective QoS Timer* defines the lifetime of a UE derived QoS rule belonging to the PDU Session. It is used in the UE as defined in clause 5.7.5.3 of TS 23.501 [2].

NOTE 3: The Reflective QoS Timer that is sent to the UE has to be in alignment with the corresponding timer configured in the UPF (defined in clause 5.7.5.3 of TS 23.501 [2]).

The *Authorized Session-AMBR* defines the UL/DL Aggregate Maximum Bit Rate for the Non-GBR QoS Flows of the PDU Session, which is enforced in the UPF as defined in clause 5.7.1 of TS 23.501 [2]. The PCF may provide the *Authorized Session-AMBR* in every interaction with the SMF. When the SMF receives it from the PDU Session policy, it is provided to the UPF over N4 interface for the enforcement.

The *Authorized default 5QI/ARP* defines the 5QI and ARP values of the QoS Flow associated with the default QoS rule as described in clause 6.2.2.4. The PCF may provide a 5QI Priority Level according to clause 5.7.3.3 of TS 23.501 [2] together with the Authorized default 5QI, when a 5QI Priority Level value different from the standardized Default Priority Level value in the QoS characteristics Table 5.7.4-1 of TS 23.501 [2] is required. The SMF applies the *Authorized default 5QI/ARP* also for the QoS Flow binding as described in clause 6.1.3.2.4.

The *Time Condition* and *Subsequent Authorized Session-AMBR / Subsequent Authorized default 5QI/ARP* are used together and up to four instances with different values of the *Time Condition* parameter may be provided by the PCF. *Time Condition* indicates that the associated *Subsequent Authorized Session-AMBR / Subsequent Authorized default 5QI/ARP* is only applied when the time defined by this attribute is met. The PCF may provide a 5QI Priority Level according to clause 5.7.3.3 of TS 23.501 [2] together with the Subsequent Authorized default 5QI, when a 5QI Priority Level value different from the standardized Default Priority Level value in the QoS characteristics Table 5.7.4-1 of TS 23.501 [2] is required. When the SMF receives a *Time Condition* and *Subsequent Authorized Session-AMBR / Subsequent Authorized default 5QI/ARP* pair, it stores it locally. The SMF shall discard any previously received *Subsequent Authorized Session-AMBR / Subsequent Authorized default 5QI/ARP* instances on explicit instruction as well as whenever the PCF provides a new instruction for one or more *Subsequent Authorized Session-AMBR / Subsequent Authorized default 5QI/ARP*. When the time defined by the *Time Condition* parameter is reached, the SMF shall apply (or instruct the UPF to apply) *Subsequent Authorized Session-AMBR / Subsequent Authorized default 5QI/ARP*.

NOTE 4: In order to reduce the risk for signalling overload, the PCF should avoid simultaneous provisioning of the *Subsequent Authorized Session-AMBR / Subsequent Authorized default 5QI/ARP* for many UEs (e.g. by spreading over time).

NOTE 5: In order to provide further *Subsequent Authorized Session-AMBR/ Subsequent Authorized default 5QI/ARP* in a timely fashion the PCF can use its own clock to issue the desired changes or use the Revalidation time limit parameter to trigger an SMF request for a policy decision.

NOTE 6: For services that depend on specific Session-AMBR and/or default 5QI/ARP (e.g. MPS session) the PCF is responsible to ensure that no *Subsequent Authorized Session-AMBR* or *Subsequent Authorized default 5QI/ARP* interfere with the service, e.g. by removing the *Subsequent Authorized Session-AMBR* or *Subsequent Authorized default 5QI/ARP* before the respective change time is reached.

The *Monitoring Key* is the reference to a resource threshold. Any number of PCC Rules may share the same monitoring key value. The monitoring key values for each service shall be operator configurable.

It shall also be possible for an operator to use the *Monitoring Key* parameter to indicate usage monitoring on an PDU Session level or, in the case of an MA PDU Session, to indicate usage monitoring on PDU Session level for the 3GPP access and/or the Non-3GPP access.

Usage monitoring on PDU Session level is active when a PDU Session is active when a *Monitoring Key* for the PDU Session and a corresponding volume and/or time threshold value have been provided to the SMF. Usage monitoring on Monitoring key level is active when a volume and/or time threshold has been provided for a *Monitoring Key* to the SMF and there is at least one PCC rule active for the PDU Session that is associated with that *Monitoring Key*.

The *Volume threshold* indicates the overall user traffic volume value after which the SMF shall report the Usage threshold reached trigger to the PCF.

The *Time threshold* indicates the overall resource time usage after which the SMF shall report the Usage threshold reached trigger to the PCF.

The *Monitoring time* indicates the time at which the SMF shall store the accumulated usage information.

The *Subsequent Volume threshold* indicates the overall user traffic volume value measured after Monitoring time, after which the SMF shall report the Usage threshold reached trigger to the PCF.

The *Subsequent Time threshold* indicates the overall resource time usage measured after Monitoring time, after which the SMF shall report the Usage threshold reached trigger to the PCF.

The *Inactivity Detection Time* indicates the period of time after which the time measurement shall stop, if no packets are received during that time period.

The *Port Management Information Container* carries Ethernet or IP port management information for an Ethernet/IP port located in DS-TT or NW-TT. The port for which the container is provided is identified by the port number.

The *User plane node Management Information Container* carries User plane node management information for a 5GS Bridge or Router.

The *VPLMN specific offloading policy* contains the attributes for the traffic to be offloaded to the local part of DN in VPLMN. The following attributes under this policy is applicable only for the serving VPLMN. When the H-SMF receives it from PCF and HR-SBO is authorized, H-SMF shall generate VPLMN Specific Offloading Information based on this policy to the V-SMF as described in clause 6.7.2.2 of TS 23.548 [33]. The V-SMF may use this information to configure V-EASDF, ULCL/BP UPF and Local UPF.

The *IP range(s)* indicates one or more IPv4/IPv6 address range(s) that are allowed to be offloaded to the local part of the DN in VPLMN when the PDU Session is authorized for HR-SBO.

The *FQDN(s)* indicates one or more FQDN or FQDN range expressed by regular expression that are allowed to be offloaded to the local part of the DN in VPLMN when the PDU Session is authorized for HR-SBO.

The *Authorized DL Session AMBR for Offloading* defines the DL Aggregate Maximum Bit Rate for the Non-GBR QoS Flows applicable for the local traffic offloaded to the local part of DN in VPLMN of the PDU Session for HR-SBO.

The *Offload Identifier* is used to identify a certain VPLMN Specific Offloading Information to be generated based on this VPLMN Specific Offloading Policy and can be used in any subsequent HR-SBO PDU Sessions between V-SMF(s) and H-SMF(s), see details in clause 6.7.2 of TS 23.548 [33].

The *Local Offloading Management Policy* contains the attributes for the traffic to be offloaded to the local part of DN via the local PSA UPF under the control of I-SMF when Local Offloading Management of Edge Computing is supported for the non-roaming PDU Session.

The *IP range(s)* indicates one or more IPv4/IPv6 address range(s) that are allowed to be offloaded to the local part of the DN via the local PSA UPF under the control of I-SMF.

The *FQDN(s)* indicates one or more FQDN(s) or FQDN range(s) expressed by regular expression that are allowed to be offloaded to the local part of the DN via the local PSA UPF under the control of I-SMF.

The *Offload Identifier* refers to a Local Offloading Management Policy tagged with this Offload Identifier, which can be preconfigured in the SMF and I-SMF or assigned by PCF, see details in clause 6.10 of TS 23.548 [33].

## 6.5 Access and mobility related policy information

To enable the enforcement in the 5GC system of the access and mobility policy decisions made by the PCF for the control as described in clause 6.1.2.1, the 5GC system may provide the Access and mobility related policy information from the PCF to the AMF.

Table 6.5-1 lists the AMF access and mobility related policy information.

**Table 6.5-1: Access and mobility related policy information**

Information name	Description	Category	PCF permitted to modify in a UE context in the AMF	Scope
<b>Aggregate maximum bit rate</b>	<i>This part defines the aggregate maximum bit rate</i>			
UE-AMBR	This defines the UE-AMBR value that applies for a UE	Conditional (NOTE 5)	Yes	UE context
List of UE-Slice-MBR	This defines the List of UE-Slice-MBR (UL/DL) that each applies to the network slice of the UE.	Conditional (NOTE 8)	Yes	UE context
<b>Service Area Restrictions</b>	<i>This part defines the service area restrictions</i>			
List of allowed TAIs.	List of allowed TAIs (NOTE 3) (NOTE 4).	Conditional (NOTE 1)	Yes	UE context
List of non-allowed TAIs.	List of non-allowed TAIs (NOTE 3).	Conditional (NOTE 1)	Yes	UE context
Maximum number of allowed TAIs	The maximum number of allowed TAIs. (NOTE 4)	Conditional (NOTE 1)	Yes	UE context
<b>RFSP Index</b>	<i>This part defines the RFSP index related information</i>			
RFSP Index for Allowed NSSAI	Defines the RFSP Index associated with Allowed NSSAI that applies for a UE	Conditional (NOTE 2)	Yes	UE context
RFSP Index for Target NSSAI	Defines the RFSP Index associated with Target NSSAI that applies for a UE	Conditional (NOTE 2)	Yes	UE context
RFSP Index in Use Validity Time	Defines the time by which the RFSP Index will be used in MME after 5GS to EPS mobility.	Conditional (NOTE 2, NOTE 11)	Yes	UE context
<b>5G access stratum time distribution</b>	<i>This part defines the 5G access stratum time distribution</i>			
5G access stratum time distribution indication	Defines if 5G access stratum time distribution via Uu reference point is enabled or disabled	Conditional (NOTE 9)	Yes	UE context
Uu interface time synchronization error budget	Indicates the Uu Time Synchronization error budget for 5G access stratum time distribution	Conditional (NOTE 10)	Yes	UE context

Information name	Description	Category	PCF permitted to modify in a UE context in the AMF	Scope
Clock quality detail level	Defines which clock quality information (clock quality metrics or acceptable/not acceptable indication) to report to the UE as defined in clause 5.27.1.12 of TS 23.501 [2]	Conditional (NOTE 9)	Yes	UE context
Clock quality acceptance criteria	Indicates the acceptable criteria as defined in clause 5.27.1.12 of TS 23.501 [2]	Conditional (NOTE 9)	Yes	UE context
<b>SMF selection management</b>	This part defines the SMF selection management instructions			
DNN replacement of unsupported DNNs	Defines if a UE requested unsupported DNN is requested for replacement by PCF	Conditional (NOTE 6)	Yes	UE context
List of S-NSSAIs	Defines the list of S-NSSAIs containing DNN candidates for replacement by PCF	Conditional (NOTE 6) (NOTE 7)	Yes	UE context
Per S-NSSAI: List of DNNs	Defines UE requested DNN candidates for replacement by PCF	Conditional (NOTE 6)	Yes	UE context
<b>Slice replacement management</b>	Defines slice replacement management		Yes	UE context
S-NSSAI availability information	Defines the S-NSSAI availability and/or alternative S-NSSAI for S-NSSAI	Conditional (NOTE 12)	Yes	UE context
Network Slice Replacement Type	Define the type of Network Slice Replacement.	Conditional (NOTE 12)	Yes	UE context
<b>Slice Related Restrictions</b>	Defines network policies for Slices subject to network control			
List of S-NSSAIs	Defines the List of S-NSSAIs that are on demand	Conditional (NOTE 13)	No	UE context
Per S-NSSAI: Deregistration Inactivity Timer value	Defines the S-NSSAI deregistration inactivity timer value before removing the S-NSSAI from the Allowed Slices	(NOTE 14)	No	UE context
<b>Charging related information</b>	Defines information related to Charging			
Charging information	Defines the containing CHF address and optionally the associated CHF instance ID and/or CHF set ID	Conditional (NOTE 15)	Yes	UE context
CHF group ID	The CHF Group ID for the UE	Conditional (NOTE 15)	Yes	UE context

Information name	Description	Category	PCF permitted to modify in a UE context in the AMF	Scope
	NOTE 1: If management of service area restrictions by PCF is enabled. NOTE 2: If management of RFSP index by PCF is enabled. NOTE 3: Either the list of allowed TAIs or the list of non-allowed TAIs are provided by the PCF. NOTE 4: Both the maximum number of allowed TAIs and the list of allowed TAIs may be sent by PCF. NOTE 5: If management of UE-AMBR by PCF is enabled. NOTE 6: If SMF selection management by PCF is enabled. NOTE 7: The List of S-NSSAIs contains S-NSSAIs, valid in the serving network, of the Allowed NSSAI. NOTE 8: If management of UE-Slice-MBR by PCF is enabled. NOTE 9: If management of 5G access stratum time distribution is enabled. NOTE 10: If 5G access stratum time distribution or (g)PTP time synchronization is enabled. NOTE 11: If required based on operator policy when the RFSP index provided by the PCF indicates a change in priority from 5G access to E-UTRAN access. NOTE 12: If slice replacement management by PCF is enabled. NOTE 13: Includes only the list of subscribed slices with network restriction policies for slice use by the UE. The list is empty if there are no S-NSSAIs that are on demand or the timer value are not set by the PCF. NOTE 14: The S-NSSAI deregistration timer is mandatory for every S-NSSAI in the list of S-NSSAIs that are on demand S-NSSAI. NOTE 15: Shall be included if the home operator policies indicates that the same CHF is selected by the PCF for the UE and the AMF, otherwise optional.			

The *list of allowed TAIs* indicates the TAIs where the UE is allowed to be registered, see clause 5.3.4 of TS 23.501 [2] for the description on how AMF uses this information.

The *list of non-allowed TAIs* indicates the TAIs where the UE is not allowed to be registered, see clause 5.3.4 of TS 23.501 [2] for the description on how AMF uses this information.

The *Maximum number of allowed TAs* indicates the maximum number of allowed Tracking Areas, the list of TAI is defined in the AMF and not explicitly provided by the PCF.

The *RFSP Index for Allowed NSSAI* and *RFSP Index for Target NSSAI* defines the RFSP Index for radio resource management functionality.

*RFSP Index in Use Validity Time* defines the time for which the RFSP Index in use will be used in MME after 5GS to EPS mobility as specified in clause 5.17.2.2 of TS 23.501 [2].

The *UE-AMBR* limits the aggregated bit rate across all Non-GBR QoS Flows of a UE in the serving network.

The *list of UE-Slice-MBR* defines the list of authorized UE-Slice-MBR allocated for a UE, how it is enforced is described in clause 5.7.1.10 of TS 23.501 [2].

The *DNN replacement of unsupported DNNs* indicates that the AMF shall contact the PCF for replacement of an unsupported DNN requested by the UE.

The *List of S-NSSAIs* defines the S-NSSAIs, valid in the serving network, of the Allowed NSSAI that contain DNN candidates for replacement by PCF.

The *List of DNNs* defines the DNN candidates for which the AMF shall contact the PCF for replacement if such a DNN is requested by a UE.

The *5G access stratum time distribution* indicates the 5G access stratum time distribution parameters to be indicated to the NG-RAN via AMF.

The *S-NSSAI availability information* indicates whether the S-NSSAI is not available or is available, and/or an alternative S-NSSAI that the S-NSSAI can be replaced with.

The *Network Slice Replacement Type* indicates the Type of Network Slice Replacement. This is described in detail in clause 5.15.5.2.2a of TS 23.501 [2]

The *Charging information* includes CHF address(es) and if available, the associated CHF instance ID(s) and/or CHF set ID(s). The *CHF group ID* contains CHF Group ID of the CHF. This is described in detail in clause 6.3.11 of TS 23.501 [2] and in clause 6.1.1.4.

## 6.6 UE policy information

### 6.6.1 Access Network Discovery & Selection Policy Information

#### 6.6.1.1 General

The Access Network Discovery & Selection policy is an optional policy that may be provided to UE by the network.

In this release of the specification, the Access Network Discovery & Selection policy shall contain only rules that aid the UE in selecting a WLAN access network. Rules for selecting other types of non-3GPP access networks are not specified.

The WLAN access network selected by the UE with the use of Access Network Discovery & Selection policy may be used for direct traffic offload (i.e. sending traffic to the WLAN outside of a PDU Session) and for registering to 5GC using the non-3GPP access network selection information.

If the UE supports non-3GPP access to 5GC, it shall support ANDSP.

The procedure for WLAN access network selection is defined in clause 6.6.1.3, the procedure for N3IWF selection is defined in clause 6.3.6.1 of TS 23.501 [2].

The Access Network Discovery & Selection policy shall contain one or more WLAN Selection Policy (WLANSPP) rules defined in clause 4.8.2.1.6 of TS 23.402 [9].

The Access Network Discovery & Selection policy may contain information to select ePDG or N3IWF by the UE as specified in TS 23.501 [2]

**Table 6.6.1.1-1: Access Network Discovery & Selection Policy**

Information name	Description	Category	PCF permitted to modify in a UE context	Scope
WLANSPP rules	1 or more WLANSPP rules as specified in 4.8.2.1.6 of TS 23.402 [9].	Mandatory	Yes	UE context
Extended WLANSPP information for network slice	Information to support TNGF selection based on the S-NSSAI(s) needed by the UE.	Optional	Yes	UE context
ePDG identifier configuration	The UE uses this information to select ePDG as defined in clause 6.3.6.1 of TS 23.501 [2].	Optional	Yes	UE context
N3IWF identifier configuration	The UE uses this information to select N3IWF as defined in clause 6.3.6.1 of TS 23.501 [2].	Optional	Yes	UE context
Extended Home N3IWF identifier configuration	The UE uses this information to select N3IWF based on the slices that the UE intends to access as defined in clause 6.3.6.1 of TS 23.501 [2].	Optional	Yes	UE context
Non-3GPP access node (N3AN) selection information	The UE uses this information to select ePDG or N3IWF as defined in clause 6.3.6.1 of TS 23.501 [2].	Optional	Yes	UE context
Slice-specific N3IWF prefix configuration	The UE uses this information to determine the prefix to be used for the Prefixed N3IWF OI or TA FQDNs as defined in clause 6.3.6.1 and clause 6.3.6.3 of TS 23.501 [2].	Optional	Yes	UE context

The extended WLANSPP information for network slice contains the association of the set of slices that the UE is allowed to access to with SSID(s) and TNGF ID(s).

NOTE: The details of extended WLANSF rule will be specified by CT WG1.

### 6.6.1.2 UE selecting a WLANSF rule

The UE, when not operating in SNPN access mode, may be provisioned with multiple valid WLANSF rules (by the HPLMN and by the VPLMN when the UE is roaming). A WLANSF rule is valid if it meets the validity conditions included in the WLANSF rule (if provided).

When the UE is in the home the UE uses the valid WLANSF rules from the home PLMN to select an available WLAN. When the UE is roaming and the UE has valid rules from both HPLMN and VPLMN the UE gives priority to the valid WLANSF rules from the VPLMN.

The SNPN-enabled UE may be provisioned with one or multiple valid WLANSF policy by the subscribed SNPN or by the registered SNPN or by the Credential Holder to be used when operating in SNPN access mode. Based on implementation specific procedure the UE selects the WLANSF corresponding to the Credential Holder or the SNPN to which the UE wants to connect to. If the UE is registered to a non-subscribed SNPN and the UE has valid rules from both CH or subscribed SNPN and the registered SNPN, the UE gives priority to the valid WLANSF rules from the registered SNPN. A WLANSF rule is valid if it meets the validity conditions included in the WLANSF rule (if provided).

NOTE: A PLMN or an SNPN when operating as a CH (see clause 5.30.2.9 of TS 23.501 [2]) does not provide PCF functionality i.e. the PCF of this network cannot provision WLANSF rules to the UE when the UE is accessing an SNPN using CH credentials from this network operating as a CH. If the UE is in a non-subscribed SNPN using credentials from the Credential Holder and the UE selects WLANSF rules of the PLMN or SNPN of which the CH is part of, those WLANSF rules were provisioned (signalled) when the UE was registered in the PLMN or SNPN of which the CH is part of.

The N5CW device may be provisioned with multiple valid WLANSF policy (e.g. if they have been received via 3GPP access or via any other implementation specific means).

### 6.6.1.3 UE procedure for selecting a WLAN access based on WLANSF rules

The UE (or N5CW device) shall apply the procedure in this clause when the UE (or N5CW device) is provisioned with WLANSF rules and:

- a) when the UE initiates untrusted non-3GPP access to 5GC and attempts to select a WLAN access network; or
- b) when the UE initiates trusted non-3GPP access to 5GC by executing the Access Network Selection Procedure specified in clause 6.3.12.2 of TS 23.501 [2] and attempts to select a WLAN access network; or
- c) when the N5CW device initiates access to 5GC by executing the Access Network Selection Procedure specified in clause 6.3.12a.2 for access to PLMN or clause 5.30.2.15 of TS 23.501 [2] for access to SNPN and attempts to select a WLAN access network.

The procedure in this clause applies to both UE operating in SNPN access mode and UE not operating in SNPN access mode, except where stated otherwise. The procedure in this clause also applies to N5CW devices when accessing a PLMN or an SNPN.

When the UE or N5WC device has valid 3GPP subscription credentials (i.e. a valid USIM or valid SNPN credentials) and WLANSF rules, the UE or N5CW device shall perform WLAN selection based on these rules, the applicable User Preferences On Non-3GPP Access Selection and the corresponding procedures specified in this document. User Preferences On Non-3GPP Access Selection take precedence over the WLANSF rules.

The UE or N5CW device determines the most preferred WLAN access network using WLANSF rules when a WLAN access network cannot be selected based on User Preferences On Non-3GPP Access Selection (e.g. when there are no User Preferences On Non-3GPP Access Selection or when there is no user-preferred WLAN access network available).

The UE or N5CW device constructs a prioritized list of the available WLANs by discovering the available WLANs and comparing their attributes / capabilities against the groups of selection criteria in the valid WLANSF rule(s). When there are multiple valid WLANSF rules the UE evaluates the valid WLANSF rules in priority order. The UE evaluates first if an available WLAN access meets the criteria of the highest priority valid WLANSF rule. The UE then evaluates if an available WLAN access meets the selection criteria of the next priority valid WLANSF rule.

Within a valid WLANSF rule, the WLAN(s) that match the group of selection criteria with the highest priority are considered as the most preferred WLANs, the WLAN(s) that match the group of selection criteria with the second highest priority are considered as the second most preferred WLANs, etc.

When a group of selection criteria includes the HomeNetwork attribute and is set, then the UE or N5CW device (a) shall create a list of available WLANs that directly interwork with the home operator (as specified in clause 4.8.2.1.6 of TS 23.402 [9]) and (b) shall apply the group of selection criteria to all the WLANs in this list. Otherwise, when the HomeNetwork attribute is not set or is not present, the UE or N5CW device shall apply the group of selection criteria to all available WLANs. The UE or N5CW device may need to perform ANQP procedures (as specified in the HS2.0 Rel-2 specification [ref]) or other procedures in order to discover the attributes / capabilities of the available WLANs.

When the UE is roaming (this implies that it is not operating in SNPN access mode and is not an N5CW device) the UE may have valid WLANSF rules from both the VPLMN and the HPLMN. In such a case the UE gives priority to the valid WLANSF rules from the VPLMN. The UE constructs a prioritised list of the available WLANs when the available WLAN accesses meet the selection criteria of the valid rules from the VPLMN and the valid rules from the HPLMN. The prioritised WLAN accesses based on the WLANSF rules from the HPLMN will have lower priority from the prioritised list of WLAN access based on the WLANSF rules of the VPLMN.

## 6.6.2 UE Route Selection Policy information

### 6.6.2.1 Structure Description

The UE Route Selection Policy (URSP) includes a prioritized list of URSP rules.

**Table 6.6.2.1-1: UE Route Selection Policy**

Information name	Description	Category	PCF permitted to modify in a URSP	Scope
URSP rules	1 or more URSP rules as specified in table 6.6.2.1-2	Mandatory	Yes	UE context

The structure of the URSP rules is described in Table 6.6.2.1-2 and Table 6.6.2.1-3.

Table 6.6.2.1-2: UE Route Selection Policy Rule

Information name	Description	Category	PCF permitted to modify in a UE context	Scope
Rule Precedence	Determines the order the URSP rule is enforced in the UE.	Mandatory (NOTE 1)	Yes	UE context
Indication for reporting URSP rule enforcement	Determines the need for reporting the URSP rule enforcement in the UE. (NOTE 10)	Optional	Yes	UE context
<b>Traffic descriptor</b>	<i>This part defines the Traffic descriptor components for the URSP rule.</i>	Mandatory (NOTE 3)		
Application descriptors	It consists of OSId and OSAppId(s) (NOTE 2, NOTE 8).	Optional	Yes	UE context
IP descriptors (NOTE 6)	Destination IP 3 tuple(s) (IP address or IPv6 network prefix, port number, protocol ID of the protocol above IP) (NOTE 8, NOTE 12).	Optional	Yes	UE context
Domain descriptors	FQDN(s) or a regular expression which are used as a domain name matching criteria (NOTE 7, NOTE 8).	Optional	Yes	UE context
Non-IP descriptors (NOTE 6)	Descriptor(s) for destination information of non-IP traffic (NOTE 8, NOTE 12).	Optional	Yes	UE context
DNN	This is matched against the DNN information provided by the application (NOTE 8).	Optional	Yes	UE context
Connection Capabilities	This is matched against the information provided by a UE application when it requests a network connection with certain capabilities (NOTE 4, NOTE 8) or traffic categories (NOTE 5).	Optional	Yes	UE context
PIN ID	Matched against a PIN ID for a specific PIN configured in the PEGC (NOTE 9).	Optional	Yes	UE context
Connectivity Group ID	Matched against a Connectivity Group ID for a specific Connectivity Group configured in the 5G-RG (NOTE 11).	Optional	Yes	UE context

Information name	Description	Category	PCF permitted to modify in a UE context	Scope
<b>List of Route Selection Descriptors</b>	A list of Route Selection Descriptors. The components of a Route Selection Descriptor are described in table 6.6.2.1-3.	Mandatory		
<p>NOTE 1: Rules in a URSP shall have different precedence values.</p> <p>NOTE 2: The information is used to identify the Application(s) that is(are) running on the UE's OS. The OSId does not include an OS version number. The OSAppId does not include a version number for the application.</p> <p>NOTE 3: At least one of the Traffic descriptor components shall be present.</p> <p>NOTE 4: The format and some values of Connection Capabilities, e.g. "ims", "mms", "internet", etc. are defined in TS 24.526 [19]. More than one Connection Capabilities value can be provided.</p> <p>NOTE 5: The format and values of Connection Capabilities Traffic Descriptor to match against standardized traffic categories are defined in TS 24.526 [19] according to the requirements in GSMA PRD NG.141 [39]. The reserved values of Connection Capabilities to match operator-specific traffic categories are specified in TS 24.526 [19]. Traffic categories requested by the UE application are independent from the UE's Operating System. Operator-specific traffic categories values are out of scope of 3GPP specifications. Details on how UE applications indicate traffic categories to the UE's Operating System are out of scope of 3GPP specifications.</p> <p>NOTE 6: A URSP rule cannot contain the combination of the Traffic descriptor components IP descriptors and Non-IP descriptors.</p> <p>NOTE 7: The match of this Traffic descriptor does not require successful DNS resolution of the FQDN provided by the UE Application.</p> <p>NOTE 8: Not applicable for PINE traffic.</p> <p>NOTE 9: The PCF delivers Traffic descriptor with PIN ID based on S-NSSAI/DNN as specified in clause 6.2.1.3. PIN ID only applies to traffic to/from PINs. PIN ID and other Traffic descriptor components are mutually exclusive, i.e. if PIN ID is included in a URSP rule, then no other Traffic descriptor components are supported in the same URSP rule.</p> <p>NOTE 10: A URSP rule can contain this indication only if the URSP rule includes a Connection Capabilities Traffic descriptor.</p> <p>NOTE 11: Only applies to traffic to/from NAUN3 devices behind the 5G-RG (as defined in TS 23.316 [27]) and may only be combined with IP descriptors and/or non-IP descriptors in the same URSP rule.</p> <p>NOTE 12: May also be applied for traffic from NAUN3 devices behind the 5G-RG (as defined in TS 23.316 [27]).</p>				

Table 6.6.2.1-3: Route Selection Descriptor

Information name	Description	Category	PCF permitted to modify in URSP	Scope
Route Selection Descriptor Precedence	Determines the order in which the Route Selection Descriptors are to be applied.	Mandatory (NOTE 1)	Yes	UE context
<b>Route selection components</b>	<i>This part defines the route selection components</i>	Mandatory (NOTE 2)		
SSC Mode Selection	One single value of SSC mode. (NOTE 5)	Optional	Yes	UE context
Network Slice Selection	Either a single value or a list of values of S-NSSAI(s).	Optional (NOTE 3)	Yes	UE context
DNN Selection	Either a single value or a list of values of DNN(s).	Optional	Yes	UE context
PDU Session Type Selection	One single value of PDU Session Type	Conditional (NOTE 8)	Yes	UE context
Non-Seamless Offload indication	Indicates if the traffic of the matching application is to be offloaded to non-3GPP access outside of a PDU Session.	Optional (NOTE 4) (NOTE 10)	Yes	UE context
ProSe Layer-3 UE-to-Network Relay Offload indication	Indicates if the traffic of the matching application is to be sent via a ProSe Layer-3 UE-to-Network Relay outside of a PDU Session.	Optional (NOTE 4) (NOTE 10)	Yes	UE context
ProSe Multi-path Preference	Indicates if the traffic of the matching application is preferred to be sent via a PDU Session over the Uu reference point and a ProSe Layer-3 UE-to-Network Relay outside of a PDU Session.	Optional (NOTE 9) (NOTE 10)	Yes	UE context
Access Type preference	Indicates the preferred Access Type (3GPP or non-3GPP or Multi-Access) when the UE establishes a PDU Session for the matching application.	Optional	Yes	UE context
PDU Session Pair ID	An indication shared by redundant PDU Sessions as described in clause 5.33.2.1 of TS 23.501 [2].	Optional (NOTE 10)	Yes	UE context
RSN	The RSN as described in clause 5.33.2.1 of TS 23.501 [2].	Optional (NOTE 10)	Yes	UE context
<b>Route Selection Validation Criteria</b> (NOTE 6, NOTE 7)	<i>This part defines the Route Validation Criteria components</i>	Optional		

Information name	Description	Category	PCF permitted to modify in URSP	Scope
Time Window	The time window when the matching traffic is allowed. The RSD is not considered to be valid if the current time is not in the time window.	Optional	Yes	UE context
Location Criteria	The UE location where the matching traffic is allowed. The RSD rule is not considered to be valid if the UE location does not match the location criteria.	Optional	Yes	UE context
<p>NOTE 1: Every Route Selection Descriptor in the list shall have a different precedence value.</p> <p>NOTE 2: At least one of the route selection components shall be present.</p> <p>NOTE 3: When the Subscription Information contains only one S-NSSAI in UDR, the PCF needs not provision the UE with S-NSSAI in the Network Slice Selection information. The "match all" URSP rule has one S-NSSAI at most.</p> <p>NOTE 4: If this indication is present in a Route Selection Descriptor, no other components shall be included in the Route Selection Descriptor.</p> <p>NOTE 5: The SSC Mode 3 shall only be used when the PDU Session Type is IP.</p> <p>NOTE 6: The Route Selection Descriptor is not considered valid unless all the provided Validation Criteria are met.</p> <p>NOTE 7: To support VPLMN specific URSP rules, Location Criteria in the Route Selection Descriptor may contain VPLMN specific values.</p> <p>NOTE 8: This component shall be present when the Route Selection Component does neither include the "Non-Seamless Offload indication" nor "ProSe Layer-3 UE-to-Network Relay Offload indication".</p> <p>NOTE 9: If this indication is present in a Route Selection Descriptor, ProSe Layer-3 UE-to-Network Relay Offload indication shall not be included in the Route Selection Descriptor.</p> <p>NOTE 10: This indication is not applicable for PIN.</p>				

Each URSP rule contains a Traffic descriptor (containing one or more components described in Table 6.6.2.1-2) that determines when the rule is applicable. A URSP rule is determined to be applicable when every component in the Traffic descriptor (for Traffic descriptor components other than the PIN ID) matches the corresponding information from the application, matches the information configured for a PIN (if the URSP rule contains a PIN ID Traffic descriptor component) or matches the information configured for a Connectivity Group (if the URSP rule contains a Connectivity Group ID Traffic descriptor). A URSP rule is determined not to be applicable when for any given component in the Traffic descriptor:

- No corresponding information from the application/for a PIN/for a Connectivity Group is available; or
- The corresponding information from the application/for a PIN/for a Connectivity Group does not match any of the values in the Traffic descriptor component.

NOTE 1: It is recommended to avoid listing more than two components in the Traffic descriptor of a URSP rule.

If a URSP rule is provided that contains a Traffic descriptor with two or more components, it is recommended to also provide URSP rule(s) with lower precedence and a Traffic descriptor with less components, in order to increase the likelihood of URSP rule matching for a particular application.

Each URSP rule contains a list of Route Selection Descriptors containing one or multiple Route Selection Descriptors each having a different Route Selection Descriptor Precedence value. A Route Selection Descriptor contains one or more of the following components:

- Session and Service Continuity (SSC) Mode: Indicates that the traffic of the matching application/PIN shall be routed via a PDU Session supporting the included SSC Mode.
- Network Slice Selection: Indicates that the traffic of the matching application/PIN shall be routed via a PDU Session supporting any of the included S-NSSAIs, see clause 5.15.4 in TS 23.501 [2]. It includes one or more S-NSSAI(s).
- DNN Selection: Indicates that the traffic of the matching application/PIN shall be routed via a PDU Session supporting any of the included DNNs. It includes one or more DNN(s). If a DNN Selection component is provided in the Route Selection Descriptor then the UE shall use any of the DNNs of the DNN Selection component, instead of the DNN requested by the application for the PDU Session that is used to route the traffic of the matching application. If there is no DNN Selection component in the Route Selection Descriptor, then the

UE shall use the DNN requested by the application for the PDU Session that is used to route the traffic of the matching application.

NOTE 2: To provide uniform service experience for UEs from earlier Releases, when a USRP rule with a DNN in both, Traffic descriptor and Route Selection Descriptor, is provided to the UEs, the DNN(s) used in the Traffic descriptor would also need to be included in the policy for DNN replacement in the network. In addition, a lower priority Route Selection Descriptor without a DNN would also need to be provided to the UEs.

- PDU Session Type Selection: Indicates that the traffic of matching application/PIN shall be routed via a PDU Session supporting the included PDU Session Type. The possible PDU Session Types are defined in clause 5.6.10 in TS 23.501 [2].
- Non-Seamless Offload indication: Indicates that traffic of the matching application is to be offloaded to non-3GPP access outside of a PDU Session when the rule is applied. If this component is present in a Route Selection Descriptor, no other components shall be included in the Route Selection Descriptor.
- ProSe Layer-3 UE-to-Network Relay Offload indication: Indicates that the traffic of the matching application is to be sent via a ProSe Layer-3 UE-to-Network Relay outside of a PDU Session when the rule is applied. If this indication is absent and the ProSe Multipath Preference indication is absent then the traffic matching the URSP rule shall not be sent via a ProSe Layer-3 UE-to-Network Relay outside of a PDU Session. If this component is present in a Route Selection Descriptor, no other components shall be included in the Route Selection Descriptor.
- ProSe Multipath Preference indication: Indicates that the traffic of the matching application is preferred to be sent via a PDU Session over the Uu reference point and a ProSe Layer-3 UE-to-Network Relay without N3IWF outside of a PDU Session. The traffic of the matching application may be sent via a PDU Session over Uu reference point or via ProSe Layer-3 UE-to-Network Relay outside of a PDU Session when e.g. one of the paths is not available. If this indication is absent and the ProSe Layer-3 UE-to-Network Relay Offload indication is absent then the traffic matching of the URSP rule shall not be sent via a ProSe Layer-3 UE-to-Network Relay outside of a PDU Session. If this component is present in a Route Selection Descriptor, other components can be included in the Route Selection Descriptor to determine the PDU Session over the Uu reference point.
- Access Type Preference: If the UE needs to establish a PDU Session when the rule is applied, this indicates the Access Type (3GPP or non-3GPP or multi-access) on which the PDU Session should be established. The type "Multi-Access" indicates that the PDU Session should be established as a MA PDU Session, using both 3GPP access and non-3GPP access.

NOTE 3: The Access Type of 3GPP also includes the use of 5G ProSe Layer-2 UE-to-Network Relay access as defined in TS 23.304 [34]. The Access Type of non-3GPP also includes the use of 5G ProSe Layer-3 UE-to-Network Relay with N3IWF as defined in TS 23.304 [34].

- PDU Session Pair ID: An indication shared by redundant PDU Sessions as described in clause 5.33.2.1 of TS 23.501 [2].
- RSN: The RSN for redundant PDU Sessions as described in clause 5.33.2.1 of TS 23.501 [2].

NOTE 4: For backward compatibility, PCF may provide a RSD with PDU Session Pair ID and RSN and a RSD without PDU Session Pair ID and RSN in the URSP rule. In this case, the RSD with PDU Session Pair ID and RSN has a lower precedence value (i.e. higher prioritised) than the one without PDU Session Pair ID. If a non-supporting UE receives the RSD containing PDU Session Pair ID, it ignores this RSD.

NOTE 5: The UE may also set the PDU Session Pair ID and RSN parameters based on UE implementation as described in clause 5.33.2.1 of TS 23.501 [2].

- Time Window: The Route Selection Descriptor is not be considered valid unless the UE is in the time window.
- Location Criteria: The Route Selection Descriptor is not be considered valid unless the UE's location matches the Location Criteria.

NOTE 6: The structure of the URSP does not define how the PCF splits the URSP when URSP cannot be delivered to the UE in a single NAS message.

NOTE 7: It is expected that UE applications will not be able to change or override the PDU Session parameters in the URSP rules. A UE application can express preferences when it requests a network connection (e.g. certain Connection Capabilities), which can be mapped into specific PDU Session parameters by the URSP rules.

NOTE 8: A Route Selection Descriptor can include a Time Window and/or a Location Criteria or neither a Time Window nor a Location Criteria. A URSP rule can include RSDs with or without validation criteria at the same time.

In the case of network rejection of the PDU Session Establishment Request, the UE may trigger a new PDU Session establishment based on the rejection cause and the URSP policy.

When the PCF provisions URSP rules to the UE, one URSP rule with a "match all" Traffic descriptor may be included.

NOTE 9: When URSP rules containing NSSP are available to the UE and the URSP rule with the "match all" Traffic descriptor is not part of them, a UE application that has no matching URSP rule and no UE Local Configuration cannot request a network connection.

The URSP rule with the "match all" Traffic descriptor is used to route the traffic of applications which do not match any other URSP rules and shall therefore be evaluated as the last URSP rule, i.e. with lowest priority. There shall be only one Route Selection Descriptor in this URSP rule. The Route Selection Descriptor in this URSP rule includes at most one value for each Route Selection Component.

NOTE 10: How to set the URSP rule with the "match all" Traffic descriptor as the URSP rule with lowest priority is defined in TS 24.526 [19].

NOTE 11: The URSP rule with the "match all" Traffic descriptor is not applicable to PINE traffic.

If a URSP rule is provided with an Indication for reporting URSP rule enforcement, the UE follows the procedures specified in clause 6.6.2.4.

## 6.6.2.2 Configuration and Provision of URSP

### 6.6.2.2.1 General

The UE may be provisioned (signalled) with URSP rules by PCF of the HPLMN. When the UE is roaming, the PCF in the HPLMN may update both the non-VPLMN specific and VPLMN specific URSP rules in the UE. For URSP rules, the UE shall support the provisioning (signalling) from the PCF in the HPLMN, as specified in TS 24.501 [22]. In addition, the UE may be also pre-configured with URSP rules (e.g. by the operator).

Only the URSP rules provisioned (signalled) by the PCF are used by the UE, if both URSP rules provisioned (signalled) by the PCF and pre-configured URSP rules are present. If no URSP rule is provisioned (signalled) by the PCF, and the UE has pre-configured rules configured in both the USIM and ME, then only the pre-configured URSP rules configured in the USIM is used.

If the PCF receives application guidance for URSP determination that may apply to a given UE from UDR or from V-PCF as specified in clause 4.15.6.7 of TS 23.502 [3], the PCF may verify the requested parameters (which are described in clauses 4.15.6.7 and 4.15.6.10 of TS 23.502 [3]) with regards to the existing URSP rules and (re-)compose the URSP rules for the UE as described in clause 6.6 of TS 23.548 [33].

### 6.6.2.2.2 URSP rules for an SNPN-enabled UE

An SNPN-enabled UE, while registered in an SNPN, may be provisioned (signalled) with URSP rules by the PCF of the SNPN. For URSP rules, the UE shall support the provisioning (signalling) from the PCF in the SNPN as specified in TS 24.501 [22]. In addition, the UE may be also pre-configured with URSP rules for the SNPN (e.g. by the operator of the SNPN).

When an SNPN-enabled UE accesses an SNPN using credentials from a Credentials Holder (CH), the UE may also be provisioned (signalled) with URSP rules for the SNPN by the PCF of the SNPN. However, the UE may be required to not accept URSP rules signalled by any SNPN that the UE accesses using CH credentials from a CH as specified in TS 24.501 [22], as follows:

- by (pre-)configuration by the PLMN or SNPN of which the CH is part of (when applicable); or

- by provisioning (signalling) by the PLMN or SNPN of which the CH is part of, when the UE is registered in that PLMN or SNPN.

NOTE 1: A network (PLMN or SNPN) when operating as a CH (see clause 5.30.2.9 of TS 23.501 [2]) does not provide PCF functionality i.e. the PCF of this network cannot provision (signal) URSP rules to the UE when the UE is accessing an SNPN using CH credentials from this network operating as a CH. If the UE is in a non-subscribed SNPN using credentials from the Credential Holder and the UE selects URSP rules of the PLMN or SNPN of which the CH is part of, those URSP rules were provisioned (signalled) when the UE was registered in the PLMN or SNPN of which the CH is part of.

If a UE accesses an SNPN using credentials from a CH, the UE applies URSP rules as follows:

- The UE first evaluates (in precedence order) the URSP rules, if any, provisioned (signalled) by the PCF of this SNPN, except the URSP rule with the "match all" Traffic descriptor, following the procedure described in clause 6.6.2.3.
- If none of the above URSP rules received from this SNPN match, or if there is no URSP rules except the URSP rule with the "match all" Traffic descriptor received from this SNPN (or if the UE is required to not accept any URSP rules from any SNPN), then the UE evaluates (in precedence order) the URSP rules, if any, provisioned (signalled) by the PCF of the network (HPLMN or SNPN) holding the credentials when previously registered in the network holding the credentials, except the URSP rule with the "match all" Traffic descriptor, following the procedure described in clause 6.6.2.3.
- If there is no matching URSP rules according to the above, the UE uses UE Local Configuration if any.
- If no UE Local Configuration matches or there is no UE Local Configuration, the UE applies the URSP rule with the "match all" Traffic descriptor as follows:
  - The UE first uses the URSP rule with the "match all" Traffic descriptor, if any, provisioned (signalled) by the PCF of this SNPN, following the procedure described in clause 6.6.2.3.
  - If there is no URSP rule with the "match all" Traffic descriptor from provisioned (signalled) by the PCF of this SNPN, then the UE uses the URSP rule with the "match all" Traffic descriptor, if any, provisioned (signalled) by the PCF of the network (HPLMN or SNPN) holding the credentials when previously registered in the network holding the credentials, following the procedure described in clause 6.6.2.3.

The UE keeps the received UE policies stored even when registering in another SNPN. The number of UE policies to be kept stored in the UE for SNPNS other than the subscribed SNPN is up to UE implementation. If necessary, the UE may remove earlier stored UE policy in UE.

If the UE is in an SNPN, at Initial Registration:

- The UE provides the list of stored PSIs which identify the Policy Sections associated to the serving SNPN that are currently stored in the UE. If USIM is changed or the selected entry of "list of subscriber data" is updated, the UE does not provide any PSI. If no policies are stored in the UE for the serving SNPN, the UE does not provide any PSI associated to the serving SNPN.

The PCF of the serving SNPN retrieves the list of PSIs and its content stored in the UDR of the serving SNPN for the UEs subscribed to the SNPN; for other UEs, the PCF of the serving SNPN has this information locally configured.

NOTE 2: The PSI list and content stored/configured for a SNPN ID can be structured according to e.g. location areas (e.g. TAs, PRAs). If the UE is in an SNPN, the PCF of the serving SNPN can then provide PSIs and its content only if they correspond to the current UE location.

#### 6.6.2.2.3 Void

### 6.6.2.3 UE procedure for associating applications to PDU Sessions based on URSP

For every newly detected application/PIN the UE evaluates the URSP rules in the order of Rule Precedence and determines if the application/PIN is matching the Traffic descriptor of any URSP rule. When a URSP rule is determined to be applicable for a given application/PIN (see clause 6.6.2.1), the UE shall select a Route Selection Descriptor within this URSP rule in the order of the Route Selection Descriptor Precedence.

When a valid Route Selection Descriptor is found, the UE determines if there is an existing PDU Session that matches all components in the selected Route Selection Descriptor. The UE compares the components of the selected Route Selection Descriptor with the existing PDU Session(s) as follows:

- For a component which only contains one value (e.g. SSC mode), the value of the PDU Session has to be identical to the value specified in the Route Selection Descriptor.
- For a component which contains a list of values (e.g. Network Slice Selection), the value of the PDU Session has to be identical to one of the values specified in the Route Selection Descriptor.
- When some component(s) is not present in the Route Selection Descriptor, a PDU Session is considered matching only if it was established without including the missing component(s) in the PDU Session Establishment Request.
- When the Route Selection Descriptor includes a Time Window or a Location Criteria, the PDU Session is considered matching only if the PDU Session is associated with an RSD that has the same Time Window or a Location Criteria Validity Conditions.

When a matching PDU Session exists the UE associates the application/PIN to the existing PDU Session, i.e. route the traffic of the detected application/PIN on this PDU Session.

If the UE determines that there is more than one existing PDU Session which matches (e.g. the selected Route Selection Descriptor only specifies the Network Slice Selection, while there are multiple existing PDU Sessions matching the Network Slice Selection with different DNNs), it is up to UE implementation to select one of them to use.

NOTE 1: When more than one PDU Sessions of SSC mode 3 to the same DNN and S-NSSAI exist due to PDU Session anchor change procedure as described in clause 4.3.5.2 of TS 23.502 [3], the UE can take the PDU Session Address Lifetime value into account when selecting the PDU Session.

If none of the existing PDU Sessions matches, the UE tries to establish a new PDU Session using the values specified by the selected Route Selection Descriptor. If the PDU Session Establishment Request is accepted, the UE associates the application/PIN to this new PDU Session. If the PDU Session Establishment Request is rejected, based on the rejection cause, the UE selects another combination of values in the currently selected Route Selection Descriptor if any other value for the rejected component in the same Route Selection Descriptor can be used. Otherwise, the UE selects the next Route Selection Descriptor, which contains a combination of component value which is not rejected by network, in the order of the Route Selection Descriptor Precedence, if any. If the UE fails to establish a PDU Session with any of the Route Selection Descriptors, it tries other URSP rules in the order of Rule Precedence with matching Traffic descriptors, except the URSP rule with the "match-all" Traffic descriptor, if any. The UE shall not use the UE Local Configuration in this case.

NOTE 2: An application can match the Traffic descriptor of different URSP rules and be associated with different PDU Sessions simultaneously.

If a UE receives tuple(s) (PLMN ID, list of PSIs associated with the PLMN ID), the UE uses the URSP rules associated with the PSIs indicated in the tuple(s) as VPLMN specific URSP rules and the UE uses the URSP rules associated with the PSI not indicated in the tuple(s) as non-VPLMN specific URSP rules.

If a UE receives VPLMN specific URSP rules and non-VPLMN specific URSP rules (i.e. the URSP rules which are applicable to both HPLMN and VPLMN), the VPLMN specific URSP rules take precedence over the non-VPLMN specific URSP rules and Local UE Configuration and any other URSP rules provided to the UE. The UE determines VPLMN specific URSP rules to be used taking serving PLMN ID into consideration. If the UE does not find a match to the VPLMN specific URSP rules associated to serving PLMN ID, then the UE uses the VPLMN specific URSP rules associated to the equivalent serving PLMN ID, if any. Otherwise, the UE uses the non-VPLMN specific URSP rules.

The UE receives the updated URSP rules and (re-)evaluates their validities in a timely manner when certain conditions are met, for example:

- the URSP is updated by the PCF;
- the UE moves from EPC to 5GC;
- change of Allowed NSSAI or Configured NSSAI;
- change of LADN DNN availability;

- change of PLMN;
- UE registers over 3GPP or non-3GPP access;
- UE establishes a connection with a ProSe Layer-3 UE-to-Network Relay;
- UE establishes connection to a WLAN access.

Details of the conditions are defined by TS 24.526 [19].

NOTE 3: When providing the updated URSP rules to the UE with a new DNN, the PCF can set the SMF selection management trigger in the AMF to contact the PCF at PDU Session establishment (as specified in clause 6.1.2.5) if the old DNN is requested by the UE.

The Route Selection Descriptor of a URSP rule shall be only considered valid if all of the following conditions are fulfilled:

- 1) If any S-NSSAI(s) is present, the S-NSSAI(s) is in the Allowed NSSAI or in the Partially Allowed NSSAI for the non-roaming case and in the mapping of the Allowed NSSAI (or of the Partially Allowed NSSAI) to HPLMN S-NSSAI(s) for the roaming case.
- 2) If any DNN is present and the DNN is an LADN DNN, the UE is in the area of availability of this LADN.
- 3) If Access Type preference is present and set to Multi-Access, the UE supports ATSSS.
- 4) If a Time Window is present and the time matches what is indicated in the Time Window.
- 5) If a Location Criteria is present and the UE location matches what is indicated in the Location Criteria.
- 6) If ProSe Layer-3 UE-to-Network Relay Offload indication is present and the UE supports the ProSe capability of 5G ProSe Layer-3 Remote UE.
- 7) If ProSe Multipath Preference indication is present and the UE supports the ProSe capability of 5G ProSe Layer-3 Remote UE.

If none of the conditions in bullet 1) are met for all the S-NSSAI(s) in the RSD during the validation of the route selection descriptor, the UE shall attempt to meet the condition by requesting any of the S-NSSAI(s) in the RSD through a Mobility Registration Update procedure to attempt to add the S-NSSAI(s) to the Allowed NSSAI (or to the Partially Allowed NSSAI), as specified in clause 5.15.5.2.2 of TS 23.501 [2]. The UE attempts the Mobility Registration Update for a S-NSSAI only if the S-NSSAI is in the Configured NSSAI or, in the roaming case, in the mapping of the S-NSSAI of the Configured NSSAI for the VPLMN to the corresponding S-NSSAI values of the HPLMN, and any other restrictions to prevent triggering Mobility Registration Update as defined in TS 24.501 [22].

If a matching URSP rule has no valid RSD, the UE tries other URSP rules in the order of Rule Precedence with matching Traffic descriptors, except the URSP rule with "match-all" Traffic descriptor. The UE shall not use the UE Local Configuration in this case.

When URSP rules are updated or their validity according to the conditions above change, the association of existing applications/PINs to PDU Sessions may need to be re-evaluated. The UE may also re-evaluate the application/PIN to PDU Session association due to the following reasons:

- periodic re-evaluation based on UE implementation;
- an existing PDU Session that is used for routing traffic of an application/PIN based on a URSP rule is released;
- The expiration of Time Window in Route Selection Validation Criteria, i.e. the expiration of Time Window, or UE's location no longer matches the Location Criteria.
- change of PLMN.

NOTE 4: It is up to UE implementation to avoid frequent re-evaluation due to location change.

If the re-evaluation leads to a change of the application/PIN to PDU Session association, e.g. the application/PIN is to be associated with another PDU Session or a new PDU Session needs to be established, the UE may enforce such changes in a timely manner based on implementation, e.g. immediately or when UE enters CM-IDLE state.

If the selected Route Selection Descriptor contains a Non-Seamless Offload indication and the UE has established a connection to a WLAN access, the UE routes the traffic matching the Traffic descriptor of the URSP rule via the WLAN access outside of a PDU Session.

If the selected Route Selection Descriptor contains a ProSe Layer-3 UE-to-Network Relay Offload indication and the UE has established a connection with a ProSe Layer-3 UE-to-Network Relay, the UE routes the traffic matching the Traffic descriptor of the URSP rule (including the URSP rule with the "match-all" Traffic descriptor) via the ProSe Layer-3 UE-to-Network Relay outside of a PDU Session.

The 5G-RG and FN-RG procedure for associating applications to PDU Sessions based on URSP is defined in clause 9.5.2 of TS 23.316 [27].

#### 6.6.2.4 Support of URSP rule enforcement reporting

The UE may report URSP rule enforcement to PCF, so that PCF will be made aware about the URSP rule enforcement when a given UE enforces specific URSP rule(s) and the PCF may trigger an action upon the reception of such reporting.

In order to activate the URSP rule enforcement reporting for a URSP rule (containing Connection Capabilities in the Traffic descriptor, see clause 6.6.2.1), for a UE indicating the capability of reporting URSP rule enforcement to network (see clause 4.2.2.2 of TS 23.502 [3]), the PCF sets the Indication for reporting URSP rule enforcement in a URSP rule sent to the UE (see clause 6.6.2.1).

NOTE 1: The format and values of the Traffic descriptor component type identifier are defined in clause 5.2 of TS 24.526 [19].

A UE supporting URSP rule enforcement reporting shall send a URSP rule enforcement report to the SMF for a URSP rule which includes an Indication for reporting URSP rule enforcement as well as Connection Capabilities in the Traffic descriptor (see clause 6.6.2.1). The UE shall send a URSP rule enforcement report, i.e. all Connection Capabilities contained in the Traffic descriptor of the associated URSP rule, to the SMF when:

- the UE associates a newly detected application to a new PDU Session (based on URSP evaluation result (see clause 6.6.2.3) for such a URSP rule), by including the URSP rule enforcement report in the PDU Session Establishment Request (see clause 4.3.2.2.1 of TS 23.502 [3]); or
- the UE associates a newly detected application to an existing PDU Session (based on URSP evaluation result (see clause 6.6.2.3) for such a URSP rule), by sending the PDU Session Modification Request (see clause 4.3.3.2 of TS 23.502 [3]) including the URSP rule enforcement report; or
- the UE changes the association of an application to a PDU Session (based on the URSP re-evaluation result (see clause 6.6.2.3) for such a URSP rule), by including the URSP rule enforcement report in a PDU Session Establishment (see clause 4.3.2.2.1 of TS 23.502 [3]) or by sending a PDU Session Modification Request (see clause 4.3.3.2 of TS 23.502 [3]) including the URSP rule enforcement report; or
- the UE has the association of an application to a PDN Connection/PDU Session in EPC (based on the URSP evaluation result (see clause 6.6.2.3) for such a URSP rule) and the UE moves from EPS to 5GS, by including the URSP rule enforcement report in a PDU Session Establishment Request (for the case without N26, see the step 9 of Figure 4.11.2.3-1 of TS 23.502 [3]) or by sending a PDU Session Modification Request (for the case with N26, see clause 4.3.3.2 of TS 23.502 [3]) including the URSP rule enforcement report.

NOTE 2: UE reporting of URSP rule enforcement can increase the amount of signalling in the network. Use of this feature is recommended to be restricted to URSP rules for specific application traffic on specific UEs based on the deployment choices of the operator.

If the UE enforces several URSP rules for multiple applications, and these multiple applications are all associated to the same established PDU Session, in order to reduce the number of uplink NAS messages, the UE may include more than one URSP rule enforcement report in the PDU Session Modification Request (see clause 4.3.3.2 of TS 23.502 [3]) and each URSP rule enforcement report includes all Connection Capabilities contained in the Traffic descriptor of the associated URSP rule.

The PCF receives the URSP rule enforcement report for a given UE via SM Policy Association Establishment procedure or via SM Policy Association Modification procedure according to the Policy Control Request Trigger "UE reporting Connection Capabilities from associated URSP rule" (see clause 6.1.3.5).

When the PCF serving a given UE is configured to use UE reporting of URSP rule enforcement for this UE and the configuration does not guarantee that the PCF serving the PDU Session is the same as the (H-)PCF serving the UE, then the (H-)PCF serving the UE subscribes to the PCF serving the PDU Session to receive the URSP rule enforcement report for the UE via PCF event reporting (see clause 6.1.3.18 and the related procedure in clause 4.16.16.2 of TS 23.502 [3]).

For LBO roaming session case, the H-PCF for the UE requests to forward UE reporting Connection Capabilities from an associated URSP rule to the V-PCF for the UE to receive the URSP rule enforcement report via PCF event reporting (see clause 6.1.3.18) during the UE Policy Association Establishment or Modification (see clause 4.16.16.3 of TS 23.502 [3]).

The PCF for the UE may check whether the URSP rule enforcement report and the relate PDU Session parameters (e.g. DNN/S-NSSAI) are compliant to the corresponding URSP rule of the UE. The PCF may perform the following actions:

- To identify at least one of the URSP rule sent to the UE, the PCF compares the value of the URSP rule enforcement with the Connection Capabilities in all the URSP Rules, that includes "the Indication for reporting URSP rule enforcement" set and are provisioned to the UE.
- To identify the RSD in the URSP rule used for the establishment/modification of the PDU Session, the PCF compares the PDU Session parameters with the Route Selection Components of each RSD in the identified URSP rule as follows: the Requested DNN and the S-NSSAI of the HPLMN in the PDU Session parameters is compared with the DNN included in the DNN selection and the list of S-NSSAI(s) in the Network Slice Selection, if any. The SSC mode and the PDU Session type in the PDU Session parameters with the SSC Mode and PDU Session type selection in the Route Selection Component.

If the PCF for the UE found an inconsistency in the PDU Session parameters, e.g., the Requested S-NSSAI are not matching the any Route Selection Component in an RSD of the identified URSP Rule, the PCF for the UE may perform additional check (e.g. check the Selected S-NSSAI) and may perform appropriate actions (e.g. initiating slice replacement procedure).

NOTE 3: The identification of the URSP rule sent to the UE using the URSP rule enforcement information by the PCF can fail if the same list of Connection Capabilities is included in more that one URSP Rule with the Indication for reporting URSP rule enforcement. The possible actions at the PCF are implementation specific.

NOTE 4: The PCF cannot check the Route Selection Validation Criteria, given that the UE can delay the reporting of the URSP Rule to reduce the amount of generated signalling.

Policy control decisions based on awareness of URSP rule enforcement are described in clause 6.1.1.5.

The USRP rule enforcement reporting is not supported by 5G-RG and FN-RG.

### 6.6.3 V2X Policy information

The V2X Policy information (V2XP) is defined in TS 23.287 [28].

### 6.6.4 ProSe Policy information

The ProSe Policy information (ProSeP) is defined in TS 23.304 [34].

### 6.6.5 Ranging/Sidelink Positioning Policy information

The Ranging/Sidelink Positioning Policy information (RSLPP) is defined in TS 23.586 [41].

### 6.6.6 A2X Policy information

The A2X Policy information (A2XP) is defined in TS 23.256 [43].

## 6.6.7 UE Policy Association supplementary information

To enable the (H-)PCF to provide the V-PCF/AMF information that is related to UE Policy, but is to be consumed by the AMF itself (e.g. address information of CHF), the 5GC system may provide the UE Policy Association supplementary information from the (H-)PCF to the V-PCF/AMF.

Table 6.6.7-1 lists the UE Policy Association supplementary information.

**Table 6.6.7-1: UE Policy Association supplementary information**

Information name	Description	Category	PCF permitted to modify in a UE context in the AMF/V-PCF	Scope
<b>Charging information</b>	<i>Information related to charging</i>			
Charging information	Defines the CHF address and optionally the associated CHF instance ID and/or CHF set ID.	Conditional (NOTE 1)	Yes	UE context
CHF group ID	The CHF Group ID for the UE.	Optional	Yes	UE context
NOTE 1: Shall be included if the home operator policies indicate that the same CHF is selected by the PCF for the UE and the AMF, otherwise optional.				

The *Charging information* includes CHF address(es) and, if available, the associated CHF instance ID(s) and/or CHF set ID(s). The *CHF group ID* contains the CHF Group ID of the CHF. This is described in detail in clause 6.3.11 of TS 23.501 [2] and in clause 6.1.1.4.

## Annex A (informative): URSP rules example

As an example, the URSP rules provisioned in the UE may include the following rules:

**Table A-1: Example of URSP rules**

Example URSP rules		Comments
Rule Precedence =1  Traffic Descriptor: Application descriptor=App1	Route Selection Descriptor Precedence=1 Network Slice Selection: S-NSSAI-a SSC Mode Selection: SSC Mode 3 DNN Selection: internet Access Type preference: 3GPP access	This URSP rule associates the traffic of application "App1" with S-NSSAI-a, SSC Mode 3, 3GPP access and the "internet" DNN.  It enforces the following routing policy: The traffic of App1 should be transferred on a PDU Session supporting S-NSSAI-a, SSC Mode 3 and DNN=internet over 3GPP access. If this PDU Session is not established, the UE shall attempt to establish a PDU Session with S-NSSAI-a, SSC Mode 3 and the "internet" DNN over 3GPP access.
Rule Precedence =2  Traffic Descriptor: Application descriptor=App2	Route Selection Descriptor Precedence =1 Network Slice Selection: S-NSSAI-a Access Type preference: Non-3GPP access	This URSP rule associates the traffic of application "App2" with S-NSSAI-a and Non-3GPP access.  It enforces the following routing policy: The traffic of application App2 should be transferred on.  a PDU Session supporting S-NSSAI-a using a Non-3GPP access. If this PDU Session is not established, the UE shall attempt to establish a PDU Session with S-NSSAI-a over Access Type=non-3GPP access.
	Route Selection Descriptor Precedence =2 Non-seamless Offload indication: Permitted (WLAN SSID-a)	If the PDU Session cannot be established, the traffic of App2 shall be directly offloaded to WLAN, if the UE is connected to a WLAN with SSID-a (based on the 2nd RSD)
Rule Precedence =3  Traffic Descriptor: DNN=DNN_1	Route Selection Descriptor Precedence =1 Network Slice Selection: S-NSSAI-a Access Type preference: Non-3GPP access	This URSP rule associates the traffic of applications that are configured to use DNN_1 with DNN_1, S-NSSAI-a over Non-3GPP access.  It enforces the following routing policy: The traffic of application(s) that are configured to use DNN_1 should be transferred on a PDU Session supporting S-NSSAI-a over Non-3GPP access. If this PDU Session is not established, the UE shall attempt to establish the PDU Session with S-NSSAI-a over Non-3GPP access.
Rule Precedence =4  Traffic Descriptor: Application descriptor=App1  Connection Capabilities="internet", "supl"	Route Selection Descriptor Precedence =1 Network Slice Selection: S-NSSAI-a DNN Selection: DNN_1 Access Type preference: Non-3GPP access	This URSP rule associates the application "App1" and the Connection Capabilities "internet" and "supl" with DNN_1, S-NSSAI-a over Non-3GPP access.  It enforces the following routing policy without UE reporting the URSP rule enforcement as specified in clause 6.6.2.4: When the "App1" requests a network connection with Connection Capability "internet" or "supl", the UE establishes (if not already established) a PDU Session with DNN_1 and S-NSSAI-a over Non-3GPP access. After that, the UE routes the traffic of "App1" over this PDU Session.

Example URSP rules		Comments
<p>Rule Precedence =5</p> <p>Traffic Descriptor: Application descriptor=App3</p> <p>Connection Capabilities="ims"</p>	<p>Route Selection Descriptor Precedence =1</p> <p>Network Slice Selection: S-NSSAI-c DNN Selection: DNN_1</p> <p>Access Type preference: Multi- Access</p>	<p>This URSP rule associates the application "App3" and the Connection Capability "ims" with DNN_1, S-NSSAI-c and multi-access connectivity.</p> <p>It enforces the following routing policy without UE reporting the URSP rule enforcement as specified in clause 6.6.2.4: When the "App3" requests a network connection with Connection Capability "ims", the UE establishes (if not already established) a MA PDU Session with DNN_1 and S-NSSAI-c. After that, the UE routes the traffic of "App3" over this MA PDU Session by using the received ATSSS rules.</p>
<p>Rule Precedence =6</p> <p>Traffic Descriptor: Application descriptor=App1</p>	<p>Route Selection Descriptor Precedence =1</p> <p>DNN Selection: DNN_1</p> <p>Network Slice Selection: S-NSSAI-a</p> <p>Access Type preference: Multi Access</p>	<p>This URSP rule associates App 1 with DNN_1, S-NSSAI-a with Multi Access connectivity.</p> <p>It enforces the following routing policy: The traffic of Application 1 should be transferred on a PDU Session supporting S-NSSAI-a and DNN_1 according to the received ATSSS rules. After that the UE routes the traffic of any other application according to the ATSSS rule with match all packet filters if available.</p>
<p>Rule Precedence =7</p> <p>Traffic Descriptor: Connection Capabilities="Real time interactive"</p>	<p>Route Selection Descriptor Precedence =1</p> <p>Network Slice Selection: S-NSSAI-d</p> <p>Access Type preference: 3GPP- Access</p>	<p>This URSP rule associates the Connection Capability "Real time interactive" with S-NSSAI-d and 3GPP-access connectivity.</p> <p>It enforces the following routing policy and: When any application requests a network connection with Connection Capability "Real time interactive", the UE establishes (if not already established) a PDU Session with S-NSSAI-d over 3GPP access. After that, the UE routes the traffic from the requesting application over this PDU Session.</p>
<p>Rule Precedence =8</p> <p>Traffic Descriptor: Connection Capabilities="Real time interactive"</p> <p>Indication for reporting of URSP rule enforcement = "Y"</p> <p>UE supports reporting of URSP rule enforcement conditions (see clause 6.6.2.4)</p>	<p>Route Selection Descriptor Precedence =1</p> <p>Network Slice Selection: S-NSSAI-d</p> <p>Access Type preference: 3GPP- Access</p>	<p>Since indication for reporting of URSP rule enforcement is included, if UE reporting of URSP rule enforcement conditions are met (see clause 6.6.2.4), same as in example with Rule Precedence=7, with the difference that the UE enforces the routing policy and additionally, the UE reports the URSP rule enforcement as specified in clause 6.6.2.4. Otherwise, same as in example with Rule Precedence=7.</p>
<p>Rule Precedence =9</p> <p>Traffic Descriptor: PIN ID=PIN1</p>	<p>Route Selection Descriptor Precedence =1</p> <p>DNN Selection: DNN_p1</p> <p>Network Slice Selection: S-NSSAI-p1</p> <p>Access Type preference: 3GPP access</p>	<p>This URSP rule associates PIN 1 with DNN_p1, S-NSSAI-p1 with 3GPP Access connectivity.</p> <p>It enforces the following routing policy: The traffic of PIN 1 should be transferred on a PDU Session supporting S-NSSAI-p1 and DNN_p1 over 3GPP access. If this PDU Session is not established, the UE shall attempt to establish a PDU Session with S-NSSAI-p1 and DNN_p1 over 3GPP access.</p>

Example URSP rules		Comments
<p>Rule Precedence =10</p> <p>Traffic Descriptor: IP descriptor=IP Address of PIN Server of PIN1</p>	<p>Route Selection Descriptor Precedence =1 DNN Selection: DNN_p2 Network Slice Selection: S-NSSAI-p2 Access Type preference: 3GPP access</p>	<p>This URSP rule associates traffic towards the PIN Server of PIN 1 with DNN_p2, S-NSSAI-p2 with 3GPP Access connectivity.</p> <p>It enforces the following routing policy: The traffic that targets the PIN 1 Server should be transferred on a PDU Session supporting S-NSSAI-p2 and DNN_p2 over 3GPP access. If this PDU Session is not established, the UE shall attempt to establish a PDU Session with S-NSSAI-p2 and DNN_p2 over 3GPP access.</p> <p>In a deployment, DNN_p1 and DNN_p2 may be configured to the same value. Also, S-NSSAI-p1 and S-NSSAI-p2 may be configured to the same value.</p>
<p>Rule Precedence = lowest priority</p> <p>Traffic Descriptor: *</p>	<p>Route Selection Descriptor Precedence =1 Network Slice Selection: S-NSSAI-b SSC Mode Selection: SSC Mode 3 DNN Selection: internet</p>	<p>This URSP rule associates all traffic not matching any prior rule a PDU Session with S-NSSAI-b, SSC Mode 3 and the "internet" DNN.</p> <p>It enforces the following routing policy: All traffic not matching any prior rule should be transferred on a PDU Session supporting S-NSSAI-b, SSC Mode 3 and DNN=internet with no access network preference.</p>

---

## Annex B (informative): Deployment option to support of BSF and DRA coexistence due to network migration

During the network migration, DRA and BSF may coexist in operator's network. The DRA can be a consumer of Nbsf services and the BSF can provide binding functionality for different subscribers. When the AF using Rx, such as P-CSCF, sends Rx request to the DRA, if the DRA has no binding information for the subscriber, based on configuration or via NRF, it selects the BSF. Then the DRA can query the BSF by invoking Nbsf\_Management discovery service operation, to get the relevant PCF address, based on which the DRA routes the Rx request to the selected PCF.

NOTE: The DRA decides to select a BSF based on user IP address range.

## Annex C (Normative): Support for Application Functions supporting Rx interface

To allow the 5G system to interwork with AFs related to existing services, e.g. IMS based services as described in TS 23.228 [5], Mission Critical Push To Talk services as described in TS 23.179 [6], the PCF shall support the corresponding IMS procedures defined in the main body of this TS via Rx interface. This facilitates the migration from EPC to 5GC without requiring these AFs to upgrade to support the Npcf\_PolicyAuthorization services in Rel-16.

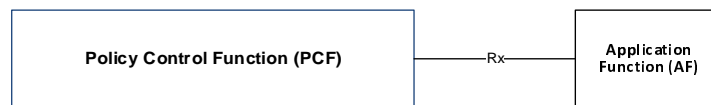

**Figure C-1: Interworking between 5G Policy framework and AFs supporting Rx interface**

Session Binding applies for PDU Sessions of IP type only.

The functionality described for Multimedia Priority Services (clause 6.1.3.11) and Mission Critical service (clause 6.1.3.19) applies via Rx interface.

In order to support IMS Emergency services over Rx interface, in addition to the functional description in clause 6.1.3.10, the following applies: The PCF shall provide the IMEI and the subscriber identifiers (IMSI, MSISDN) (if available), received from the SMF at PDU Session establishment, if so requested by the P-CSCF. The PCF derives the IMEI from the PEI, the IMSI from the SUPI and the MSISDN from the GPSI.

NOTE 1: TS 23.501 [2] defines both 5G identifiers, SUPI, PEI and GPSI and then how they are allocated to allow interworking with functional entities not supporting 5G identifiers such as P-CSCF.

Any AF using Rx, such as P-CSCF, the BSF determines the selected PCF address according to the information included in the incoming Rx requests and the information stored at the BSF. The BSF is able to proxy or redirect Rx requests targeting an IP address of a UE to the selected PCF.

The following event reporting is supported over Rx interface:

**Table C-1: Events relevant for reporting from the PCF**

<b>Event</b>	<b>Description</b>	<b>Availability for Rx Session</b>
PLMN Identifier Notification	The PLMN identifier where the UE is currently located.	Yes
Change of Access Type	The Access Type and, if applicable, the RAT Type of the PDU Session has changed.	Yes
EPS fallback	EPS fallback is initiated	Yes
Signalling path status	The status of the resources related to the signalling traffic of the AF session.	Yes
Access Network Charging Correlation Information	The Access Network Charging Correlation Information of the resources allocated for the AF session.	Yes
Access Network Information Notification	The user location and/or timezone and/or identifier of the serving satellite of the UE when the PDU Session has changed in relation to the AF session.	Yes
Reporting Usage for Sponsored Data Connectivity	The usage threshold provided by the AF has been reached; or the AF session is terminated.	Yes
Resource allocation status	The status of the resources related to the AF session (established/released).	Yes
QoS targets can no longer (or can again) be fulfilled	The QoS targets can no longer (or can again) be fulfilled by the network for (a part of) the AF session.	No
Out of credit	Credit is no longer available.	Yes

## Annex D (informative): PCC usage for sponsored data connectivity

### D.1 General

With sponsored data connectivity, the Sponsor has a business relationship with the operator and the Sponsor reimburses the operator for the user's data connectivity in order to allow the user access to an associated Application Service Provider's (ASP) services. Alternatively, the user pays for the connectivity with a transaction which is separate from the subscriber's charging. It is assumed the user already has a subscription with the operator.

A possible deployment configuration for sponsored data connectivity in the non-roaming case is illustrated in Figure D.1-1.

NOTE 1: Sponsored data connectivity is not supported in the roaming with visited access scenario in this Release.

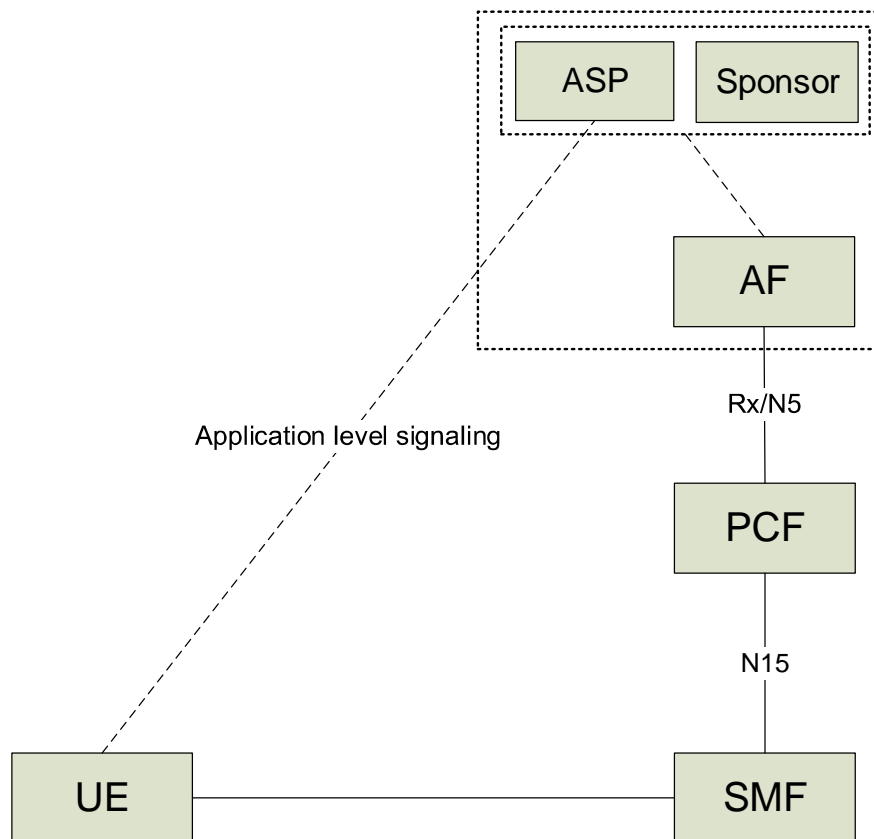

**Figure D.1-1: Deployment for sponsored data connectivity**

The relationship between the AF and Sponsor and between the Sponsor and ASP is out of scope of this specification. A single AF can serve multiple ASPs and multiple sponsors.

NOTE 2: An ASP can also be a sponsor.

The sponsor may choose to supply the PCF (via the AF) with the usage thresholds that it expects the SMF to enforce. Alternatively, the Sponsor can allow the ASP to enforce such control over the sponsored data connectivity.

The information required for the detection of sponsored HTTP traffic (i.e. server host name) can be verified with the corresponding server IP address/prefix of the IP packets by the SMF. The SMF uses implementation specific logic to perform this verification.

---

## D.2 Reporting for sponsored data connectivity

There are two deployment scenarios for usage reporting for sponsored data connectivity. The Sponsor Identifier and Application Service Provider Identifier are provided for sponsored services to the PCF from the AF over the Rx/N5 interface.

In the first scenario the PCF assigns a service specific Charging Key for a sponsored IP flow. The Charging key is used by the SMF to generate separate accounting records for offline charging and and/or usage data records for online charging for the sponsored flows. Correlation of accounting records and usage data records from multiple users per sponsor and/or application service provider is then performed using the charging key.

In a second scenario the Sponsor Identifier and Application Service Provider Identity is included in PCC rules from the PCF to the SMF as defined in clause 6.3.1. For this scenario the same Charging Key may be used both for IP flows that are sponsored and for flows that are not sponsored. Accounting records generated by the SMF for offline charging include the Sponsor Identity and the Application Service Provider Identity. Correlation of accounting records from multiple users per sponsor and/or application service provider can then be based on Sponsor Identity and Application Service Provider Identity instead of the Charging Key. Usage reporting for online charging including Sponsor Identity and Application Service Provider Identity has not been specified in this release of the specification. PCC rules that include a Sponsor Identity and an Application Service Provider Identity should include a Charging Method that indicates offline charging.

## Annex E (informative): Change history

Change history							
Date	Meeting	TDoc	CR	R ev	Cat	Subject/Comment	New version
2017-12	SP-78	SP-170933	-	-	-	MCC Editorial update for presentation to TSG SA#78 for approval	1.0.0
2017-12	SP-78	-	-	-	-	MCC Editorial update after TSG SA#78 Approval	15.0.0
2018-03	SP-79	SP-180107	0001	-	F	Clarification on PCF interaction	15.1.0
2018-03	SP-79	SP-180092	0002	3	F	Remove EN related with Session binding	15.1.0
2018-03	SP-79	SP-180107	0003	1	F	Correction for background data transfer for TS 23.503	15.1.0
2018-03	SP-79	SP-180093	0004	-	F	Correction on Notification control for GBR QoS flow	15.1.0
2018-03	SP-79	SP-180093	0005	1	F	Addition of Reflective QoS Timer in PDU session related policy information	15.1.0
2018-03	SP-79	SP-180107	0006	2	F	Removal of editor's notes and addition of references to empty sections	15.1.0
2018-03	SP-79	SP-180107	0007	1	F	Influence of additional non-standardized QoS parameters on QoS Flow Binding	15.1.0
2018-03	SP-79	SP-180107	0008	1	F	Description of components in URSP	15.1.0
2018-03	SP-79	SP-180107	0010	1	F	QoS rule generation	15.1.0
2018-03	SP-79	SP-180093	0011	2	F	UE policies granularity and UE assistance for policy evaluation	15.1.0
2018-03	SP-79	SP-180091	0012	1	F	Resource reservation for services sharing priority	15.1.0
2018-03	SP-79	SP-180093	0013	2	F	Add Nchf service in service base representation architecture	15.1.0
2018-03	SP-79	SP-180107	0014	-	F	Traffic mapping information that disallows UL packets	15.1.0
2018-03	SP-79	SP-180091	0016	1	F	Moving NWDAF to 23.501	15.1.0
2018-03	SP-79	SP-180107	0017	3	F	Default URSP Rule	15.1.0
2018-03	SP-79	SP-180107	0018	2	F	UE selects a PDU Session based on URSP	15.1.0
2018-03	SP-79	SP-180107	0020	2	F	Clarification on the handling of event triggers	15.1.0
2018-03	SP-79	SP-180107	0021	3	F	Update of UDR policy related subscription	15.1.0
2018-03	SP-79	SP-180107	0022	1	F	Remove EN related with EPC IWK	15.1.0
2018-03	SP-79	SP-180107	0023	-	F	Remove some ENs	15.1.0
2018-03	SP-79	SP-180107	0024	3	F	AF subscription to AMF and SMF events and events reporting	15.1.0
2018-03	SP-79	SP-180107	0025	1	F	Corrections to description of session management related policy enforcement	15.1.0
2018-03	SP-79	SP-180095	0028	2	B	Supporting 3GPP PS Data Off in 5GS	15.1.0
2018-03	SP-79	SP-180107	0031	2	F	Session Binding Mechanism for non-IP PDU Session	15.1.0
2018-03	SP-79	SP-180107	0032	2	F	Clarification on enforcement of Application Detection Control	15.1.0
2018-03	SP-79	SP-180092	0033	2	F	Resolve the Editor's Note on Presence Reporting Area	15.1.0
2018-03	SP-79	SP-180107	0034	2	F	Update of event trigger section	15.1.0
2018-03	SP-79	SP-180107	0035	5	F	Clarification on AF using legacy Rx binding with relevant PCF	15.1.0
2018-03	SP-79	SP-180125	0036	1	B	Addition of PDU Session type IPv4v6	15.1.0
2018-06	SP-80	SP-180478	0019	7	B	Additional PDU Session Type in Route Selection Descriptor	15.2.0
2018-06	SP-80	SP-180483	0037	1	F	Correction to URSP and UE preferences for NSSP and SSCMSP	15.2.0
2018-06	SP-80	SP-180481	0043	7	F	Clarification on using PSI	15.2.0
2018-06	SP-80	SP-180481	0044	7	F	Clarification on UE policy configuration	15.2.0
2018-06	SP-80	SP-180483	0046	1	F	Correction on Policy Control Request Triggers	15.2.0
2018-06	SP-80	SP-180480	0049	2	F	Clarification on match all URSP rule	15.2.0
2018-06	SP-80	SP-180480	0050	2	F	Clarification on policy provision in roaming case	15.2.0
2018-06	SP-80	SP-180478	0051	2	F	Alignment with the definition of PCF-AMF and PCF-SMF interfaces	15.2.0
2018-06	SP-80	SP-180482	0053	1	F	Cleanups on the support of session binding for Ethernet PDU session Type	15.2.0
2018-06	SP-80	SP-180486	0054	2	F	NEF and UDR in LBO architecture for AF influence on traffic routing	15.2.0
2018-06	SP-80	SP-180486	0055	5	F	Network slicing information for binding the AF request to the relevant PCF	15.2.0
2018-06	SP-80	SP-180489	0058	4	F	Support use of DNN for URSP traffic descriptor	15.2.0
2018-06	SP-80	SP-180490	0060	1	F	TS23.503 Clarification on Access and mobility related policy	15.2.0
2018-06	SP-80	SP-180490	0061	2	F	TS23.503 Clarification on BSF	15.2.0
2018-06	SP-80	SP-180490	0062	2	F	TS23.503 ePDG/N3IWF selection information	15.2.0
2018-06	SP-80	SP-180483	0063	2	F	Correction to the UE Policy Section 6.1.2.2.1	15.2.0
2018-06	SP-80	SP-180489	0064	-	F	The interaction between PCF and AF	15.2.0
2018-06	SP-80	SP-180484	0067	-	F	Corrections to PFD management descriptions	15.2.0
2018-06	SP-80	SP-180487	0068	1	F	Protocol criteria for domain name matching	15.2.0
2018-06	SP-80	SP-180484	0071	3	F	Delivery of UE policies	15.2.0
2018-06	SP-80	SP-180485	0073	2	F	How to differentiate the PSIs in different PLMNs	15.2.0
2018-06	SP-80	SP-180477	0079	-	D	Corrected the name of a PCF service operation in clause 6.1.2.2.2	15.2.0
2018-06	SP-80	SP-180485	0081	2	F	Handling of Configured NSSAIs in Roaming Scenarios - 23.503	15.2.0
2018-06	SP-80	SP-180478	0082	2	F	Alignment for policy control application specific information	15.2.0
2018-06	SP-80	SP-180490	0084	2	F	Update for usage monitoring support	15.2.0

Change history							
Date	Meeting	TDoc	CR	R ev	Cat	Subject/Comment	New version
2018-06	SP-80	SP-180490	0085	2	F	Update for sponsored data connectivity support	15.2.0
2018-06	SP-80	SP-180487	0087	5	F	Provisioning of ANDSP via signalling	15.2.0
2018-06	SP-80	SP-180483	0088	4	F	Provisioning of ANDSP via signalling	15.2.0
2018-06	SP-80	SP-180487	0089	2	F	QoS flow binding for URLLC services	15.2.0
2018-06	SP-80	SP-180487	0093	1	F	Removal of editor's notes	15.2.0
2018-09	SP-81	SP-180723	0097	1	F	PDU Session selection	15.3.0
2018-09	SP-81	SP-180723	0098	1	F	UE Policy Delivery in case of UE not reachable	15.3.0
2018-09	SP-81	SP-180724	0099	3	B	Support of tracing in 5GS signalling: PCF related data	15.3.0
2018-09	SP-81	SP-180723	0103	3	F	Number of packet filters supported by UE	15.3.0
2018-09	SP-81	SP-180723	0107	3	F	Policy Control Request triggers for updating the AM Policy Association	15.3.0
2018-09	SP-81	SP-180723	0108	2	F	N28 session termination	15.3.0
2018-09	SP-81	SP-180723	0109	2	F	URSP updates and Application to PDU session association re-evaluation	15.3.0
2018-09	SP-81	SP-180723	0111	3	F	Clarification on initial UE policy provisioning	15.3.0
2018-09	SP-81	SP-180723	0112	3	F	Notification Control applicability	15.3.0
2018-09	SP-81	SP-180723	0117	-	F	Change OCS to CHF in TS23.503	15.3.0
2018-09	SP-81	SP-180723	0119	4	F	Clarification of URSP update trigger	15.3.0
2018-09	SP-81	SP-180723	0121	3	F	BDT: clarification on network area information and ASP identifier	15.3.0
2018-09	SP-81	SP-180723	0123	1	F	Correction on UE policy delivery	15.3.0
2018-09	SP-81	SP-180723	0125	3	F	Corrections to URSP rules	15.3.0
2018-09	SP-81	SP-180723	0128	-	F	Clarification on Application identifier	15.3.0
2018-09	SP-81	SP-180723	0129	3	F	Alignment with 23502 for SBI friendly UE policy distribution	15.3.0
2018-09	SP-81	SP-180723	0131	2	F	Corrections to AF influence (5.6.7) based on CT WG3 LS on AF influence on traffic routing	15.3.0
2018-09	SP-81	SP-180723	0132	2	F	Application detection report when the PFDs are removed	15.3.0
2018-09	SP-81	SP-180723	0133	3	F	Correction on PRA	15.3.0
2018-09	SP-81	SP-180723	0135	-	F	Reference to TS 24.526	15.3.0
2018-09	SP-81	SP-180723	0138	1	F	Storage of UE Policy in VPLMN	15.3.0
2018-09	SP-81	SP-180723	0139	1	F	Binding information storage	15.3.0
2018-09	SP-81	SP-180723	0141	1	F	Update of input parameters for PCC decisions	15.3.0
2018-12	SP-82	SP-181086	0146	2	F	Clarification on UE policy distribution	15.4.0
2018-12	SP-82	SP-181084	0149	4	F	Bulk subscription to events provided by PCF	15.4.0
2018-12	SP-82	SP-181090	0150	4	F	Selection of the CHF for charging and spending limit control for the PDU session	15.4.0
2018-12	SP-82	SP-181089	0151	4	F	Extending Charging Control Data in a PCC Rule	15.4.0
2018-12	SP-82	SP-181091	0152	5	F	UE policy service update	15.4.0
2018-12	SP-82	SP-181084	0153	-	F	Alignment with 23.501 for N36	15.4.0
2018-12	SP-82	SP-181090	0154	2	F	Removing Subscribed GBR from PDU Session policy control subscription information	15.4.0
2018-12	SP-82	SP-181084	0158	5	F	AF subscribed events	15.4.0
2018-12	SP-82	SP-181218	0159	10	F	Correction on SSCMSP	15.4.0
2018-12	SP-82	SP-181086	0160	1	F	Control of QoS parameters for default QoS Flow	15.4.0
2018-12	SP-82	SP-181086	0161	-	F	Consistent usage of Policy Control Request Trigger GFR of QoS Flow cannot be guaranteed	15.4.0
2018-12	SP-82	SP-181087	0162	5	F	Correction for URSP rule parameter traffic descriptor	15.4.0
2018-12	SP-82	SP-181087	0163	2	F	Clarification on URSP rule and UE local configuration association	15.4.0
2018-12	SP-82	SP-181087	0164	11	F	Clarification on user preference and URSP	15.4.0
2018-12	SP-82	SP-181088	0165	6	F	Efficient delivery of UE Policies	15.4.0
2018-12	SP-82	SP-181085	0166	1	F	Clarification on inclusion of list of PSIs in Initial Registration	15.4.0
2018-12	SP-82	SP-181087	0167	4	F	Correction to traffic steering control	15.4.0
2018-12	SP-82	SP-181091	0171	2	F	Updates to SMF Policy Control Request Triggers	15.4.0
2018-12	SP-82	SP-181089	0172	2	F	Location change triggers	15.4.0
2018-12	SP-82	SP-181085	0177	1	F	Clarification of the OSId and OSAppId	15.4.0
2018-12	SP-82	SP-181085	0178	2	F	Clarification of IP descriptors in URSP	15.4.0
2018-12	SP-82	SP-181089	0181	1	F	OSID storage	15.4.0
2018-12	SP-82	SP-181085	0182	2	F	Clarification on packet filter handling	15.4.0
2018-12	SP-82	SP-181090	0183	1	F	Subscriber IP index provisioning	15.4.0
2019-03	SP-83	SP-190160	0180	7	F	Indication of ANDSP (non-3GPP) support	15.5.0
2019-03	SP-83	SP-190160	0188	1	F	Correction to traffic steering control	15.5.0
2019-03	SP-83	SP-190160	0190	-	F	SEPPs in roaming architecture	15.5.0
2019-03	SP-83	SP-190160	0191	2	F	PSI list corrections	15.5.0
2019-03	SP-83	SP-190160	0193	-	F	PSI list corrections	15.5.0
2019-03	SP-83	SP-190160	0194	2	F	PSI list corrections	15.5.0
2019-03	SP-83	SP-190160	0196	2	F	Packet filters to the UE	15.5.0
2019-03	SP-83	SP-190160	0197	1	F	Alignment on UE policy delivery trigger	15.5.0
2019-03	SP-83	SP-190160	0198	1	F	UE Policy related corrections	15.5.0
2019-03	SP-83	SP-190160	0201	3	F	Clarification on URSP rule validation check	15.5.0
2019-03	SP-83	SP-190160	0202	6	F	Policy Control using DN authorization profile index	15.5.0

Change history							
Date	Meeting	TDoc	CR	R ev	Cat	Subject/Comment	New version
2019-03	SP-83	SP-190160	0203	1	F	Clarification on condition of including UE Policy Container in RR message	15.5.0
2019-03	SP-83	SP-190160	0204	3	F	Clarification for UE policy distribution	15.5.0
2019-03	SP-83	SP-190160	0207	2	F	PCC support for MCS	15.5.0
2019-03	SP-83	SP-190160	0210	2	F	Clarification on associating applications to PDU Sessions	15.5.0
2019-03	SP-83	SP-190160	0212	-	F	Corrections on routing rule	15.5.0
2019-03	SP-83	SP-190160	0221	-	F	Change OCS to CHF in TS 23.503	15.5.0
2019-03	SP-83	SP-190160	0222	1	F	Clarification on when PCF allocates a PSI	15.5.0
2019-03	SP-83	SP-190173	0185	4	B	PCC support for traffic switching, steering and splitting	16.0.0
2019-03	SP-83	SP-190173	0187	3	B	Support of ATSSS rules and URSP rules for MA-PDU Sessions	16.0.0
2019-03	SP-83	SP-190169	0199	4	B	N6-based traffic routing for 5G-LAN type of services	16.0.0
2019-03	SP-83	SP-190172	0205	2	B	Update of TS 23.503 for Rel.16 BDT Notification	16.0.0
2019-03	SP-83	SP-190172	0206	2	B	Use of analytics for background data transfer	16.0.0
2019-03	SP-83	SP-190173	0208	2	B	Support for Multi-Access PDU Session in URSP and PDU session selection	16.0.0
2019-03	SP-83	SP-190171	0209	-	B	Update 23.503 to support solution 13 in 23.725	16.0.0
2019-03	SP-83	SP-190236	0219	4	F	Replacing references to TS 23.203 with text in clauses 6.3 and 6.4	16.0.0
2019-03	SP-83	SP-190175	0220	2	F	Terminology alignments and editorial corrections	16.0.0
2019-03	SP-83	SP-190172	0224	1	C	Aligning specification with eNA TS 23.288	16.0.0
2019-06	SP-84	SP-190427	0215	4	F	Replacing references to TS 23.203 with context in clause 6.1.3.5	16.1.0
2019-06	SP-84	SP-190427	0217	4	F	Replacing references to TS 23.203 with text in clause 6.2.2	16.1.0
2019-06	SP-84	SP-190430	0228	1	F	Removal of Editor's note related to N6 routing	16.1.0
2019-06	SP-84	SP-190414	0229	-	F	QoS Flow for which the deferred activation/deactivation of PCC rule can only be used	16.1.0
2019-06	SP-84	SP-190414	0230	3	F	Replacing references to TS 23.203 with text for clause 6.1.3.9	16.1.0
2019-06	SP-84	SP-190402	0232	2	A	Alignment with stage 3 on multiple values for a PFD attribute	16.1.0
2019-06	SP-84	SP-190414	0235	1	C	Charging requirements and functional description	16.1.0
2019-06	SP-84	SP-190415	0236	2	B	Access and mobility related policy information for 5G-RG	16.1.0
2019-06	SP-84	SP-190415	0237	1	B	Session binding information in wireline access	16.1.0
2019-06	SP-84	SP-190419	0238	5	B	Support for IMS functionality using Npcf services	16.1.0
2019-06	SP-84	SP-190427	0240	2	F	Clarification for the association between application and PDU session	16.1.0
2019-06	SP-84	SP-190398	0242	6	B	Adding Support for Delivering Background Data Transfer Policies to the UE	16.1.0
2019-06	SP-84	SP-190412	0243	2	C	Explicit indication of AF response to be expected for runtime coordination with AF	16.1.0
2019-06	SP-84	SP-190420	0246	2	B	Input for PCC decision from NWDAF	16.1.0
2019-06	SP-84	SP-190402	0250	1	A	Clarify on the condition of setting PDU Session Type in URSP	16.1.0
2019-06	SP-84	SP-190402	0252	1	A	Clarification the condition of URSP rule validity on S-NSSAI for roaming case	16.1.0
2019-06	SP-84	SP-190414	0255	3	F	Replace the reference to 23.203 to the clause in 23.503 in 6.2.7	16.1.0
2019-06	SP-84	SP-190420	0256	-	B	Removal of Editor's note for BDT warning notification and define send for notification in TS23.503	16.1.0
2019-06	SP-84	SP-190402	0261	2	A	Alignment with 23501 on Policy Control Request Triggers relevant for SMF	16.1.0
2019-06	SP-84	SP-190402	0263	2	C	23.503-23203 endorsement	16.1.0
2019-06	SP-84	SP-190427	0264	2	C	Serving network policy control	16.1.0
2019-06	SP-84	SP-190414	0265	2	B	23.503 part of PCF selection for PDU sessions with same DNN and S-NSSAI	16.1.0
2019-06	SP-84	SP-190406	0267	-	C	PCC support for MCS Priority Levels	16.1.0
2019-06	SP-84	SP-190414	0269	2	F	Replace the TS 23.203 reference with the texts for PCF description in 6.2.1.1	16.1.0
2019-06	SP-84	SP-190431	0271	2	B	PDU session management for Background Data Transfer	16.1.0
2019-06	SP-84	SP-190402	0273	2	A	PCR trigger on serving node change	16.1.0
2019-06	SP-84	SP-190427	0274	1	F	Replacing references to TS 23.203 with text for clauses 4.3.4, 5 and 6	16.1.0
2019-06	SP-84	SP-190427	0275	1	F	Replacing references to TS 23.203 with text for general policy control features	16.1.0
2019-06	SP-84	SP-190427	0276	1	F	Replacing references to TS 23.203 with text in Annex X	16.1.0
2019-06	SP-84	SP-190427	0277	-	F	Replacing references to TS 23.203 with text in scope and abbreviation	16.1.0
2019-06	SP-84	SP-190427	0278	1	F	Replacing references to TS 23.203 with text in definitions section	16.1.0
2019-06	SP-84	SP-190402	0282	2	A	Adding the input from AF via NEF for PCC decisions	16.1.0
2019-06	SP-84	SP-190423	0285	2	C	New UE Policy Control Request Trigger for V2X	16.1.0
2019-09	SP-85	SP-190608	0227	7	B	QoS Monitoring to assist URLLC Service	16.2.0
2019-09	SP-85	SP-190621	0258	7	C	DNN replacement	16.2.0
2019-09	SP-85	SP-190610	0279	2	F	Update of policy framework extensions for ATSSS	16.2.0
2019-09	SP-85	SP-190618	0288	2	C	Introducing support for Ethernet port management	16.2.0
2019-09	SP-85	SP-190601	0292	1	A	Clarifications on Location change reporting to PCF	16.2.0

Change history							
Date	Meeting	TDoc	CR	R ev	Cat	Subject/Comment	New version
2019-09	SP-85	SP-190621	0295	-	F	Add missing NOTE number for PDU Session Type in RSD table	16.2.0
2019-09	SP-85	SP-190622	0297	1	F	Clarification of the use of URSP validation criteria	16.2.0
2019-09	SP-85	SP-190601	0299	-	A	Correction on the architecture	16.2.0
2019-09	SP-85	SP-190621	0300	1	F	Missing description on AF request trigger	16.2.0
2019-09	SP-85	SP-190619	0303	2	F	xBDT negotiation and BDT policy retrieval	16.2.0
2019-09	SP-85	SP-190622	0304	2	F	Alignment with SA5 on the support of offline only charging	16.2.0
2019-09	SP-85	SP-190615	0305	3	B	QoS Handling for V2X Communication Over Uu Reference Point	16.2.0
2019-09	SP-85	SP-190618	0308	3	B	TSN Support in TS 23.503	16.2.0
2019-09	SP-85	SP-190618	0309	1	F	Adding NID as input for policy decisions	16.2.0
2019-09	SP-85	SP-190618	0310	4	B	Update to Policy Framework for TSC	16.2.0
2019-09	SP-85	SP-190608	0313	1	B	QoS Monitoring parameter(s) sent to the AF	16.2.0
2019-09	SP-85	SP-190621	0315	1	F	Clarification on applicability of UE policy to PLMNs	16.2.0
2019-12	SP-86	SP-191080	0290	5	F	BDT renegotiation upon expected network performance change	16.3.0
2019-12	SP-86	SP-191089	0316	-	F	MBR of Non-GBR type 5QI	16.3.0
2019-12	SP-86	SP-191073	0320	3	C	Correction on Policy Control information to support QoS Monitoring	16.3.0
2019-12	SP-86	SP-191093	0321	6	F	DNN and slicing for xBDT	16.3.0
2019-12	SP-86	SP-191075	0322	1	F	AMF change notification	16.3.0
2019-12	SP-86	SP-191092	0325	3	F	QoS mapping for uplink TSC communication	16.3.0
2019-12	SP-86	SP-191064	0326	7	F	Correction of PCF discovery via BSF to consider eSBA binding principles	16.3.0
2019-12	SP-86	SP-191089	0327	1	F	Correction on PCC description	16.3.0
2019-12	SP-86	SP-191089	0329	3	F	23.503:PCF provides local traffic routing policy to SMF based on AF request	16.3.0
2019-12	SP-86	SP-191080	0330	1	F	Corrections for analytics	16.3.0
2019-12	SP-86	SP-191084	0331	2	F	Corrections to handling of Alternative QoS Profiles	16.3.0
2019-12	SP-86	SP-191077	0334	7	F	Selection of the preferred access type for non-MPTCP traffic in a MA PDU session	16.3.0
2019-12	SP-86	SP-191092	0336	1	F	Implement traffic correlation indication of AF influence	16.3.0
2019-12	SP-86	SP-191089	0339	1	F	Aligning TS 23.503 with the CHEM feature of SA4	16.3.0
2019-12	SP-86	SP-191072	0342	6	F	SR-VCC with PS to CS handover indication	16.3.0
2019-12	SP-86	SP-191089	0348	3	F	Clarification for pre-configured URSP	16.3.0
2019-12	SP-86	SP-191075	0349	2	A	Addition of Reallocation Of Credit missing Policy Control Request Trigger	16.3.0
2019-12	SP-86	SP-191089	0354	2	F	List of NSSAIs parameter update in DNN Replacement triggers	16.3.0
2019-12	SP-86	SP-191089	0362	3	F	Clarification on Policy Control Request Triggers	16.3.0
2019-12	SP-86	SP-191075	0368	1	A	Location Change related triggers	16.3.0
2019-12	SP-86	SP-191075	0375	2	F	Clarifications on policy control related interface and functionality for MCS support	16.3.0
2019-12	SP-86	SP-191071	0376	-	F	Correction of CHF discovery to consider eSBA binding principles	16.3.0
2020-03	SP-87E	SP-200077	0344	5	F	TSN parameters	16.4.0
2020-03	SP-87E	SP-200060	0352	3	A	Location Change (Serving CN node), alignment with stage 3	16.4.0
2020-03	SP-87E	SP-200069	0361	2	F	Clarification on Access type for ATSSS	16.4.0
2020-03	SP-87E	SP-200077	372	3	F	MDBV mapping and configuration for TSC QoS Flow	16.4.0
2020-03	SP-87E	SP-200080	0381	1	F	Domain descriptors in URSP	16.4.0
2020-03	SP-87E	SP-200080	0382	1	F	SRVCC with PS to CS handover	16.4.0
2020-03	SP-87E	SP-200080	0384	2	F	Reporting event of EPS FB initiated	16.4.0
2020-03	SP-87E	SP-200065	0385	3	F	Correction of PCF discovery via BSF to consider eSBA binding principles - AF/NEF/SCP re-selection functionality (23.503)	16.4.0
2020-03	SP-87E	SP-200067	0388	1	F	Alignment on the packet delay measurement failure for the QoS monitoring support	16.4.0
2020-03	SP-87E	SP-200070	0389	2	F	Clarification of the BDT policy re-negotiation descriptions	16.4.0
2020-03	SP-87E	SP-200080	0390	3	F	Correction on the binding mechanism	16.4.0
2020-03	SP-87E	SP-200080	0391	-	F	Corrections for authorized QoS description	16.4.0
2020-03	SP-87E	SP-200080	0392	-	F	Correction about the DN Information	16.4.0
2020-03	SP-87E	SP-200077	0394	5	F	QoS flow binding for TSN streams with same periodicity	16.4.0
2020-03	SP-87E	SP-200080	0397	4	F	Clarification on support of UE policies by the UE	16.4.0
2020-03	SP-87E	SP-200070	0398	2	F	Correction on policy decision based on UE related analytics	16.4.0
2020-03	SP-87E	SP-200080	0400	4	F	Replace the reference to 23.203 to the clause in 23.503 in 4.3.6	16.4.0
2020-03	SP-87E	SP-200080	0401	4	F	Replace the reference to 23.203 to the clause in 23.503 in 6.2.3	16.4.0
2020-03	SP-87E	SP-200070	0408	1	F	Policy decisions based on Analytics	16.4.0
2020-03	SP-87E	SP-200080	0417	1	F	Correction on QoS Flow Binding for QoS Flow Behaviour	16.4.0
2020-03	SP-87E	SP-200080	0419	1	F	Corrections for event reporting from the PCF	16.4.0
2020-03	SP-87E	SP-200069	0420	1	F	Correction on QoS Flow Binding about ATSSS	16.4.0
2020-03	SP-87E	SP-200080	0423	1	F	Policy update on DNN replacement	16.4.0
2020-03	SP-87E	SP-200069	0424	1	F	Clarification on PS Data Off	16.4.0
2020-03	SP-87E	SP-200067	0429	1	F	UE notification due to Alternative QoS Profile	16.4.0
2020-04	SP-87E	SP-200077	0344	5	F	TSN parameters (MCC re-implementation of missing parts of the CR)	16.4.1
2020-07	SP-88E	SP-200425	0416	2	F	Correction on QoS Flow Binding for CN PDB	16.5.0

Change history							
Date	Meeting	TDoc	CR	R ev	Cat	Subject/Comment	New version
2020-07	SP-88E	SP-200422	0431	1	F	PCC control for DDD status and availability after DDN failure events	16.5.0
2020-07	SP-88E	SP-200439	0433	1	F	Clarification of SDF generation	16.5.0
2020-07	SP-88E	SP-200551	0434	1	F	Reallocation of credit reporting to the AF	16.5.0
2020-07	SP-88E	SP-200428	0435	1	F	Providing OSid and OSAppId in the MA PDU Session Control Information	16.5.0
2020-07	SP-88E	SP-200439	0436	-	F	QoS parameter mapping for TSN	16.5.0
2020-07	SP-88E	SP-200552	0438	-	F	Completion of description in general PCF clause	16.5.0
2020-07	SP-88E	SP-200439	0441	1	F	QoS container vs. TSCAI input container	16.5.0
2020-07	SP-88E	SP-200428	0442	1	F	Clarification on Access Type Preference in RSD of URSP rule	16.5.0
2020-07	SP-88E	SP-200551	0443	-	F	Correct the wrong placement of UE-AMBR	16.5.0
2020-07	SP-88E	SP-200434	0444	-	F	Correction on V2X Policy related description	16.5.0
2020-07	SP-88E	SP-200551	0447	1	F	The clarification for PDU session establishment based on URSP rule	16.5.0
2020-07	SP-88E	SP-200431	0448	1	F	Clarifications on policy decisions based on network analytics	16.5.0
2020-07	SP-88E	SP-200434	0449	1	F	Correction on QoS Flow Binding for general SMF behaviour and Alternative QoS Parameter Sets	16.5.0
2020-07	SP-88E	SP-200594	0451	2	F	URSP info provision for xBDT	16.5.0
2020-07	SP-88E	SP-200552	0452	1	F	PCC handling for MPTCP and ATSSS-LL with any Steering Mode	16.5.0
2020-07	SP-88E	SP-200428	0453	1	F	PS data off for MA PDU session when PCC is not deployed	16.5.0
2020-07	SP-88E	SP-200428	0454	-	F	Corrections for MA PDU session capabilities	16.5.0
2020-07	SP-88E	SP-200439	0455	1	F	Adding TSN AF decides the TSN QoS container	16.5.0
2020-07	SP-88E	SP-200551	0456	1	F	Use of DNN replacement when updating URSP rules	16.5.0
2020-07	SP-88E	SP-200424	0458	1	F	Routing binding indication generated by AF	16.5.0
2020-07	SP-88E	SP-200551	0459	1	F	Update to Reporting and Credit management	16.5.0
2020-07	SP-88E	SP-200439	0461	2	F	Correction to session binding for TSN	16.5.0
2020-07	SP-88E	SP-200439	0464	2	F	Updating Session Binding rule	16.5.0
2020-07	SP-88E	SP-200552	0465	1	F	Clarification on the of online charging and offline charging indication on N7 interface	16.5.0
2020-07	SP-88E	SP-200551	0466	-	F	Clarification of PCF behaviour to honour UE provided maximum packet filter support	16.5.0
2020-07	SP-88E	SP-200439	0468	-	F	Clarification of ETH Filters	16.5.0
2020-08	SP-88E	SP-200425	0472	-	F	Replacement of noted CR0472R1 with CR0472: Update about Alternative QoS Profile	16.5.1
2020-09	SP-89E	SP-200688	0475	-	F	Supplement for TSN QoS information	16.6.0
2020-09	SP-89E	SP-200688	0477	1	F	Clarification of the delay parameter for TSN QoS	16.6.0
2020-09	SP-89E	SP-200682	0478	1	F	QoS Flow establishment based on AQP	16.6.0
2020-09	SP-89E	SP-200679	0479	1	F	Alignment of BDT policy negotiation description with the procedures in TS 23.502	16.6.0
2020-09	SP-89E	SP-200679	0480	1	F	Re-ordering of interactions in the BDT policy re-negotiation description	16.6.0
2020-09	SP-89E	SP-200688	0482	1	F	Clarification on BSF behaviour for TSN service	16.6.0
2020-09	SP-89E	SP-200688	0484	1	F	Adding BMIC information to TSN part.	16.6.0
2020-09	SP-89E	SP-200682	0486	1	F	V2X Policy Control	16.6.0
2020-09	SP-89E	SP-200688	0488	-	F	23.503 - Resolution of open items related to IEEE LS	16.6.0
2020-09	SP-89E	SP-200673	0489	1	F	PCC control for DDD status and availability after DDN failure events	16.6.0
2020-12	SP-90E	SP-200951	0483	2	F	Policy control for redundant PDU Session for URLLC	16.7.0
2020-12	SP-90E	SP-200959	0491	1	F	Location change (serving cell) for Policy Control Request Trigger	16.7.0
2020-12	SP-90E	SP-200953	0494	1	F	Correction to TSN Bridge Information on N7	16.7.0
2020-12	SP-90E	SP-200955	0495	1	F	Policy subscription information extension to include ATSSS information	16.7.0
2020-12	SP-90E	SP-200959	0496	1	F	Correction on the QoS Flow binding with Alternative QoS Parameter Set(s)	16.7.0
2020-12	SP-90E	SP-200950	0499	1	F	PCC rule resource allocation outcome and its usage in AQP-based QoS Flow establishment	16.7.0
2020-12	SP-90E	SP-200954	0502	1	F	Clarification on the UE procedure for selecting a WLAN access based on WLANSP rules	16.7.0
2020-12	SP-90E	SP-200959	0503	1	F	General cleanup of specification	16.7.0
2021-03	SP-91E	SP-210053	0514	1	A	Adding DNN, S-NSSAI, IP domain to the parameters provided by BSF registration to NRF	16.8.0
2021-03	SP-91E	SP-210082	0516	1	F	QoS control in the VPLMN	16.8.0
2021-03	SP-91E	SP-210055	0522	-	F	DDN failure and DDD status events handling with V-SMF and I-SMF	16.8.0
2021-03	SP-91E	SP-210243	0523	-	F	Remove the NEF pre-configuration option for PFD push and correct the handling of Allowed Delay	16.8.0
2021-03	SP-91E	SP-210069	0504	1	B	Support of AF guidance to PCF determination of proper URSP rules	17.0.0
2021-03	SP-91E	SP-210069	0535	1	B	Edge relocation considering user plane latency requirement	17.0.0
2021-03	SP-91E	SP-210073	0505	1	B	PCF Management Considering Various NWDAF Analytics Output	17.0.0

Change history							
Date	Meeting	TDoc	CR	R ev	Cat	Subject/Comment	New version
2021-03	SP-91E	SP-210088	0506	1	B	BSF enhancement on PCF Discovery for dynamic AM policy	17.0.0
2021-03	SP-91E	SP-210088	0520	1	B	Access and mobility policy control functionality to enable dynamic change of AM Policies	17.0.0
2021-03	SP-91E	SP-210085	0507	1	B	Multimedia Priority Service (MPS) Phase 2 support for Data Transport Service	17.0.0
2021-03	SP-91E	SP-210065	0508	1	C	Handling of long delays for satellite access and backhaul	17.0.0
2021-03	SP-91E	SP-210065	0539	1	B	Policy control based on satellite backhaul information	17.0.0
2021-03	SP-91E	SP-210068	0509	1	B	MA PDU sessions with connectivity over E-UTRAN/EPC and non-3GPP access to 5GC	17.0.0
2021-03	SP-91E	SP-210068	0524	1	B	Introducing steering mode threshold conditions	17.0.0
2021-03	SP-91E	SP-210068	0538	1	B	Load-Balancing steering mode extension	17.0.0
2021-03	SP-91E	SP-210084	0510	1	B	KI#5-1: Impact due to Survival Time	17.0.0
2021-03	SP-91E	SP-210084	0530	1	B	KI#1, adding BMCA impacts to 23.503	17.0.0
2021-03	SP-91E	SP-210074	0518	1	B	Support of IMS voice service for SNPN	17.0.0
2021-03	SP-91E	SP-210074	0519	-	B	Support of IMS Emergency service for SNPN	17.0.0
2021-03	SP-91E	SP-210089	0536	1	B	PCC to support Advanced Interactive Service	17.0.0
2021-03	SP-91E	SP-210064	0533	-	B	ProSe Policy	17.0.0
2021-03	SP-91E	SP-210064	0541	1	C	Extending the usage of PLMN change AMF PCRT for ProSe based services	17.0.0
2021-03	SP-91E	SP-210064	0542	1	C	Extending UE policy control for ProSe based services	17.0.0
2021-06	SP-92E	SP-210356	0543	3	B	KI#5 - Total bandwidth per S-NSSAI	17.1.0
2021-06	SP-92E	SP-210356	0544	4	B	KI#3 - Slice Maximum Bit Rate (Slice-MBR)	17.1.0
2021-06	SP-92E	SP-210345	0545	1	C	Applicability of thresholds to steering modes	17.1.0
2021-06	SP-92E	SP-210347	0547	1	B	Support of AF guidance to PCF determination of proper URSP rules	17.1.0
2021-06	SP-92E	SP-210324	0550	-	A	Delete NSI ID via N7 interface	17.1.0
2021-06	SP-92E	SP-210356	0552	3	B	Policy control of data rate per network slice	17.1.0
2021-06	SP-92E	SP-210372	0553	3	B	AF Influence enhancement for EAS IP replacement	17.1.0
2021-06	SP-92E	SP-210342	0554	2	F	Corrections and clarification on satellite backhaul	17.1.0
2021-06	SP-92E	SP-210363	0559	1	B	Enhancement for GERAN/UTRAN access	17.1.0
2021-06	SP-92E	SP-210337	0563	2	F	TSC Assistance Container Determination by the PCF in the trusted domain	17.1.0
2021-06	SP-92E	SP-210354	0565	3	B	KI#4-T3, Enabling restricted PDU Session for remote provisioning of UE using User Plane	17.1.0
2021-06	SP-92E	SP-210359	0566	1	B	Terminology on the TSC MIC and Bridge ID	17.1.0
2021-06	SP-92E	SP-210340	0567	2	C	UE policy control to support ProSe U2N relay	17.1.0
2021-06	SP-92E	SP-210361	0568	1	F	Multimedia Priority Service (MPS) Phase 2 support for Data Transport Service	17.1.0
2021-06	SP-92E	SP-210340	0569	2	B	URSP enhancement for the 5G ProSe UE-to-Network Relay support	17.1.0
2021-06	SP-92E	SP-210324	0572	1	A	Application Identifier in the PCC Rule	17.1.0
2021-06	SP-92E	SP-210340	0573	1	B	Reporting Change of PDUID by the PCF	17.1.0
2021-06	SP-92E	SP-210356	0574	1	B	Retrieval of Subscribed UE-Slice-MBR to the PCF	17.1.0
2021-06	SP-92E	SP-210347	0575	-	B	Notification on the outcome of UE Policies delivery due to service specific parameter provisioning	17.1.0
2021-06	SP-92E	SP-210352	0576	1	C	Providing information on NWDAF for UE related Analytics to PCF	17.1.0
2021-06	SP-92E	SP-210329	0582	-	A	Updates to support QoS Monitoring control for service data flows	17.1.0
2021-06	SP-92E	SP-210359	0585	1	C	Exposure of Time synchronization as a service - policy	17.1.0
2021-06	SP-92E	SP-210341	0586	1	F	Clean-up for AF related identifier	17.1.0
2021-06	SP-92E	SP-210347	0587	1	B	Policy control enhancement for local notification	17.1.0
2021-06	SP-92E	SP-210333	0589	1	A	Clarify the BDT warning description with degraded Network performance	17.1.0
2021-06	SP-92E	SP-210356	0592	1	B	eNS_503_KI#5_Update of Network Analytics	17.1.0
2021-06	SP-92E	SP-210363	0595	1	B	UE providing PDU Session Pair ID based on URSP rules	17.1.0
2021-06	SP-92E	SP-210341	0596	1	F	Clarification on handling of URSP Traffic Descriptor Component Domain Descriptors	17.1.0
2021-06	SP-92E	SP-210359	0599	1	C	Requested 5GS delay and UE-DS-TT residence time	17.1.0
2021-06	SP-92E	SP-210341	0600	1	F	Clarification on association of applications to PDU sessions	17.1.0
2021-06	SP-92E	SP-210342	0601	1	C	Determination of 5QI for satellite backhaul	17.1.0
2021-06	SP-92E	SP-210361	0602	1	B	Additional authorization functionality in support of MPS for Data Transport Service	17.1.0
2021-09	SP-93E	SP-210937	0606	1	F	Notification of SM Policy Association Establishment	17.2.0
2021-09	SP-93E	SP-210936	0607	1	C	DNN in URSP Traffic Descriptor and Route Selection Descriptor	17.2.0
2021-09	SP-93E	SP-210926	0608	1	B	KI#5 - Monitoring Remaining Data Rate per S-NSSAI	17.2.0
2021-09	SP-93E	SP-210922	0609	-	F	User data Congestion analytic including list of most contributing applications	17.2.0
2021-09	SP-93E	SP-210920	0611	1	F	AF Request for Simultaneous Connectivity at Edge Relocation	17.2.0
2021-09	SP-93E	SP-210930	0615	1	F	Updates for TSC text - policy specification	17.2.0
2021-09	SP-93E	SP-210920	0617	1	F	Corrections for User Plane Latency Requirement	17.2.0

Change history							
Date	Meeting	TDoc	CR	R ev	Cat	Subject/Comment	New version
2021-09	SP-93E	SP-210916	0618	1	F	Clarification on SMF determines satellite backhaul and PCF reports satellite backhaul category change event	17.2.0
2021-09	SP-93E	SP-210936	0619	1	F	Corrections on the AF related identifier	17.2.0
2021-09	SP-93E	SP-210937	0620	1	F	Clarifications on Nnef_AMPolicyAuthorization input parameters	17.2.0
2021-09	SP-93E	SP-210937	0621	1	F	Clarifications on AM influence requests for multiple applications	17.2.0
2021-09	SP-93E	SP-210926	0622	1	F	Change of the Target NSSAI	17.2.0
2021-09	SP-93E	SP-210914	0623	1	F	Clarification on L3 U2N Relay Offload indication in URSP	17.2.0
2021-09	SP-93E	SP-210930	0625	1	C	Control of the 5G reference time distribution	17.2.0
2021-09	SP-93E	SP-210926	0626	-	F	KI#3 Subscribed UE-Slice-MBR in PDU Session policy control subscription	17.2.0
2021-09	SP-93E	SP-210926	0629	1	B	KI#5-Policy control for data rate per network slice with assistance of the NWDAF	17.2.0
2021-09	SP-93E	SP-210914	0631	1	B	IP prefix delegation for ProSe	17.2.0
2021-09	SP-93E	SP-210936	0632	1	F	URSP rule generation based on BDT policy and related information	17.2.0
2021-09	SP-93E	SP-210926	0633	1	F	Clarifications for slice related policy control	17.2.0
2021-09	SP-93E	SP-210911	0637	1	A	Clarification on 5GS Bridge Information Notification when no AF Session exists	17.2.0
2021-09	SP-93E	SP-210920	0638	1	F	Update with AF guidance	17.2.0
2021-09	SP-93E	SP-210930	0640	1	B	KI#3, clarification on the TSC Assistance Container provider, AF functionality and PCF report	17.2.0
2021-09	SP-93E	SP-210930	0641	1	B	KI#3, clarification on the TSCTSF provides the Qos and traffic information	17.2.0
2021-09	SP-93E	SP-210918	0642	-	F	Clarification on threshold values	17.2.0
2021-12	SP-94E	SP-211300	0634	4	F	QoS parameter handling for TSC	17.3.0
2021-12	SP-94E	SP-211291	0639	2	F	Clarifications on offline charging only indication	17.3.0
2021-12	SP-94E	SP-211305	0650	-	F	Reporting the outcome of the AM Policy request from the AF	17.3.0
2021-12	SP-94E	SP-211305	0651	-	F	Access and Mobility related Policy Authorization for a UE	17.3.0
2021-12	SP-94E	SP-211295	0652	3	F	Selection of the PCF for Network Slice Related Policy Control	17.3.0
2021-12	SP-94E	SP-211293	0653	1	F	Retrieval of analytics using DCCF	17.3.0
2021-12	SP-94E	SP-211288	0654	4	F	Extending MA PDU Session Control information in the PCC Rule	17.3.0
2021-12	SP-94E	SP-211305	0655	-	F	Consistent usage of the term service area coverage throughout the TS	17.3.0
2021-12	SP-94E	SP-211293	0656	-	F	Clarification on PCF behaviour based on OSE analytics	17.3.0
2021-12	SP-94E	SP-211293	0657	-	F	Correction on geographic zone	17.3.0
2021-12	SP-94E	SP-211300	0658	1	F	Alternative QoS and TSC fixes	17.3.0
2021-12	SP-94E	SP-211284	0659	3	F	Editorial correction in TS 23.503	17.3.0
2021-12	SP-94E	SP-211294	0661	2	F	Clarification for PVS address formats	17.3.0
2021-12	SP-94E	SP-211305	0662	1	F	Correction to AF-triggered change of AM policies	17.3.0
2021-12	SP-94E	SP-211293	0664	1	F	Miscellaneous correction for eNA_Ph2 on TS 23.503	17.3.0
2021-12	SP-94E	SP-211279	0672	1	A	Access network info request without PCC rules	17.3.0
2021-12	SP-94E	SP-211300	0675	1	F	Fixes for AF session with required QoS update procedure	17.3.0
2021-12	SP-94E	SP-211300	0680	1	F	Correction on 5G access stratum time distribution parameters	17.3.0
2021-12	SP-94E	SP-211300	0681	1	F	Clarifications on the use of DS-TT port MAC address	17.3.0
2021-12	SP-94E	SP-211300	0682	1	F	Clarifications on Policy for AF	17.3.0
2021-12	SP-94E	SP-211279	0684	-	A	Clarifications on Support for Application Functions supporting Rx interface	17.3.0
2021-12	SP-94E	SP-211304	0685	-	D	Alignment of PCC input parameter documentation	17.3.0
2021-12	SP-94E	SP-211300	0689	1	F	Clarification on bridge information notification	17.3.0
2022-03	SP-95E	SP-220067	0662	3	F	Correction to AF-triggered dynamically changing AM policies	17.4.0
2022-03	SP-95E	SP-220056	0692	1	F	Correction on Analytics ID on Service Experience	17.4.0
2022-03	SP-95E	SP-220057	0694	1	F	Correction for remote provisioning	17.4.0
2022-03	SP-95E	SP-220055	0695	1	F	AF guides URSP policy determination via Npcf	17.4.0
2022-03	SP-95E	SP-220060	0698	1	F	Clarification on Application Function	17.4.0
2022-03	SP-95E	SP-220058	0702	-	F	SM Policy association establishment rejected due to NW slice monitoring	17.4.0
2022-03	SP-95E	SP-220058	0703	1	B	Clarification on UE-Slice-MBR	17.4.0
2022-03	SP-95E	SP-220060	0704	1	F	Fixes for AF session with required QoS update procedure	17.4.0
2022-03	SP-95E	SP-220060	0705	1	F	Updates for TSCTSF functionality within 23.503 specification	17.4.0
2022-03	SP-95E	SP-220055	0706	-	F	Correction to the UE Policies delivery notification	17.4.0
2022-03	SP-95E	SP-220057	0707	-	F	eNPN: URSP provisioning when UE accesses an SNPN using CH credentials	17.4.0
2022-06	SP-96	SP-220398	0708	1	F	Outcome of UE Policies delivery procedure	17.5.0
2022-06	SP-96	SP-220401	0709	1	F	Corrections to the UE-Slice-MBR	17.5.0
2022-06	SP-96	SP-220410	0712	2	F	Number of TFT filters exceeding allowed limit for 5GS to EPS interworking	17.5.0
2022-06	SP-96	SP-220404	0714	-	F	corrections for 5GS Bridge Information reporting and subscription	17.5.0
2022-06	SP-96	SP-220400	0716	1	F	Clarifications for eNPN related description	17.5.0
2022-06	SP-96	SP-220404	0717	-	F	PCF response when rejecting an AF session with required QoS	17.5.0

Change history							
Date	Meeting	TDoc	CR	R ev	Cat	Subject/Comment	New version
2022-06	SP-96	SP-220404	0718	1	F	Alignment of description for support of Time Sensitive Communication and Time Synchronization	17.5.0
2022-06	SP-96	SP-220400	0719	1	F	eNPN: Correction to URSP provisioning when UE accesses an SNPN using CH credentials	17.5.0
2022-06	SP-96	SP-220410	0724	1	F	Traffic identification based on AF provided ToS/TC	17.5.0
2022-06	SP-96	SP-220410	0725	1	F	Clarifications for traffic steering	17.5.0
2022-06	SP-96	SP-220410	0726	1	F	Replacement of AM policy terminology	17.5.0
2022-09	SP-97E	SP-220789	0697	3	F	Clarification of PCC input parameter AF application identifier	17.6.0
2022-09	SP-97E	SP-220783	0735	1	F	Alignment of IIoT related parameter description	17.6.0
2022-12	SP-98E	SP-221079	0732	2	F	Correction related to traffic correlation in PCC rule	17.7.0
2022-12	SP-98E	SP-221071	0753	1	F	The list of PSIs associated to an SNPN	17.7.0
2022-12	SP-98E	SP-221079	0760	2	F	Traffic Identification using ToS/TC for 5G Media Streaming	17.7.0
2022-12	SP-98E	SP-221061	0767	4	A	Fix for Packet Delay Failure Threshold	17.7.0
2022-12	SP-98E	SP-221079	0786	4	F	Clarification on storage and retrieval of list of PSIs and its content delivered to the UE	17.7.0
2022-12	SP-98E	SP-221348	0751	4	F	Clarifications for QoS monitoring control	17.7.0
2022-12	SP-98E	SP-221085	0739	1	B	New timer from PCF along with RFSP Index to direct a UE to 4G	18.0.0
2022-12	SP-98E	SP-221084	0741	-	B	N3IWF selection enhancement for support of S-NSSAI needed by UE	18.0.0
2022-12	SP-98E	SP-221087	0745	3	B	Support of Non-3GPP access for SNPN	18.0.0
2022-12	SP-98E	SP-221092	0754	1	B	Support AF Request of PER for QoS and Alt-QoS	18.0.0
2022-12	SP-98E	SP-221092	0755	4	B	RAN feedback for burst sending time adjustment	18.0.0
2022-12	SP-98E	SP-221096	0764	3	B	Negotiation of the time window for Application Data Transfer	18.0.0
2022-12	SP-98E	SP-221139	0769	4	B	NWDAF- assisted URSPs introduced in policy decision	18.0.0
2022-12	SP-98E	SP-221086	0776	2	B	KI#4 23.503 PCC rule for common EAS, DNAI selection	18.0.0
2022-12	SP-98E	SP-221083	0779	1	B	Support of Satellite Edge Computing via UPF deployed on satellite	18.0.0
2022-12	SP-98E	SP-221139	0783	3	B	PFDF consume Application Detection analytics from NWDAF	18.0.0
2022-12	SP-98E	SP-221083	0788	1	B	Policy control for dynamic satellite backhaul	18.0.0
2023-03	SP-99	SP-230075	0740	2	B	Basic description of Service Function Chaining	18.1.0
2023-03	SP-99	SP-230075	0756	2	B	Application Function influence SFC support	18.1.0
2023-03	SP-99	SP-230059	0763	5	C	Introducing selection of more granular set of UEs	18.1.0
2023-03	SP-99	SP-230048	0775	3	B	Multi-Path transmission	18.1.0
2023-03	SP-99	SP-230115	0781	2	B	PCF support of 5GS Packet Delay Variation value monitoring based on QoS monitoring mechanism and exposed to AF	18.1.0
2023-03	SP-99	SP-230050	0787	3	B	Exposure of satellite backhaul information	18.1.0
2023-03	SP-99	SP-230063	0795	2	B	N5CW device access to SNPN services	18.1.0
2023-03	SP-99	SP-230054	0799	7	B	DN Performance Analytics usage in PDTQ policy	18.1.0
2023-03	SP-99	SP-230034	0803	1	A	PDU Session Type Selection in the URSP Rule	18.1.0
2023-03	SP-99	SP-230081	0805	1	B	23.503 - Spending Limits for AM and UE Policies in the 5GC	18.1.0
2023-03	SP-99	SP-230057	0806	6	B	Support of integration with IETF Deterministic Networking	18.1.0
2023-03	SP-99	SP-230036	0809	-	A	Removal of ProSe policy request during registration procedure	18.1.0
2023-03	SP-99	SP-230081	0810	1	B	IPv6 prefix delegation in 5GS	18.1.0
2023-03	SP-99	SP-230055	0813	1	F	Removing ENs on PCF awareness of IWK	18.1.0
2023-03	SP-99	SP-230065	0814	1	B	New value of Connection Capability	18.1.0
2023-03	SP-99	SP-230050	0816	-	C	Re-using existing QoS monitoring for satellite backhaul	18.1.0
2023-03	SP-99	SP-230068	0819	1	B	Exposure of traffic characteristics and performance monitoring for a group of UEs, using new NEF service	18.1.0
2023-03	SP-99	SP-230044	0822	-	A	Removal of V2X policy request during registration procedure	18.1.0
2023-03	SP-99	SP-230247	0825	3	B	Introduction of Power Saving requirements for XRM service	18.1.0
2023-03	SP-99	SP-230062	0827	-	F	Correction and clarification on NWDAF assisted URSP	18.1.0
2023-03	SP-99	SP-230052	0829	4	B	Corrections for the description of coverage area support for time synchronization service KI6	18.1.0
2023-03	SP-99	SP-230081	0831	4	B	Adding application detection event exposure from PCF	18.1.0
2023-03	SP-99	SP-230247	0835	7	B	Policy update to support policy control enhancements for multi-modal services	18.1.0
2023-03	SP-99	SP-230065	0839	1	B	Support URSP provisioning in EPS	18.1.0
2023-03	SP-99	SP-230068	0841	1	B	GMEC KI1 TS23.503 CR Update for Group MBR	18.1.0
2023-03	SP-99	SP-230053	0843	1	B	ANDSP extension to support TNGF selection for S-NSSAI needed by UE	18.1.0
2023-03	SP-99	SP-230062	0847	4	B	NWDAF assisted decision on E2E redundant transmission	18.1.0
2023-03	SP-99	SP-230056	0848	1	B	MA PDU Session between 5GC and EPC	18.1.0
2023-03	SP-99	SP-230052	0853	4	B	RAN feedback for burst sending time and periodicity adjustment	18.1.0
2023-03	SP-99	SP-230050	0858	-	B	Add Satellite backhaul category information as input for PCC decisions	18.1.0
2023-03	SP-99	SP-230059	0859	4	B	KI#4 23.503 PCC rule for common EAS, DNAI selection	18.1.0
2023-03	SP-99	SP-230056	0870	1	B	Introducing Redundant Steering Mode	18.1.0
2023-03	SP-99	SP-230077	0871	1	B	Updates on PDU session related policy information	18.1.0
2023-03	SP-99	SP-230114	0873	4	A	Corrections to use of RSD validation criteria in URSP rules	18.1.0
2023-03	SP-99	SP-230062	0875	5	B	Update on NWDAF-assisted URSP	18.1.0

Change history							
Date	Meeting	TDoc	CR	R ev	Cat	Subject/Comment	New version
2023-03	SP-99	SP-230248	0877	8	B	5GS Information Exposure	18.1.0
2023-03	SP-99	SP-230247	0878	9	B	Support of UL/DL transmission coordination to meet RT latency requirements	18.1.0
2023-03	SP-99	SP-230062	0880	1	B	Remove EN about NWDAF assisted URSP in TS23.503	18.1.0
2023-03	SP-99	SP-230080	0881	1	F	Generalization of QoS monitoring control description	18.1.0
2023-03	SP-99	SP-230033	0882	1	A	Removal of unspecified QoS monitoring control options	18.1.0
2023-03	SP-99	SP-230065	0893	1	B	Support standardized and operator-specific traffic categories in URSP	18.1.0
2023-03	SP-99	SP-230065	0901	4	B	UE reporting implementing conclusions for KI#2 from TR 23.700-85	18.1.0
2023-03	SP-99	SP-230065	0905	3	B	Slice mapping for the Service Parameters from VPLMN	18.1.0
2023-03	SP-99	SP-230065	0906	2	B	URSP Re-evaluation Upon PLMN Change	18.1.0
2023-03	SP-99	SP-230048	0908	2	B	5G ProSe Remote UE traffic handling for multipath transmission via UE-to-Network Relay	18.1.0
2023-03	SP-99	SP-230065	0910	4	B	KI#1 - Provision of URSP to route traffic to the VPLMN	18.1.0
2023-03	SP-99	SP-230073	0915	2	C	URSP handling for PIN	18.1.0
2023-03	SP-99	SP-230059	0925	2	B	VPLMN Specific Offloading Policy for HR-SBO	18.1.0
2023-03	SP-99	SP-230065	0927	4	B	Support for URSP awareness	18.1.0
2023-03	SP-99	SP-230062	0928	2	C	NWDAF-assisted PFD management	18.1.0
2023-06	SP-100	SP-230490	0757	2	F	Support for 5QI Priority Level in QoS constraints	18.2.0
2023-06	SP-100	SP-230498	0891	3	B	KI#5: Support for PDU Set QoS Framework	18.2.0
2023-06	SP-100	SP-230498	0897	2	B	Policy Control for L4S	18.2.0
2023-06	SP-100	SP-230469	0926	6	B	Using network analytics for roaming scenarios	18.2.0
2023-06	SP-100	SP-230493	0929	7	B	Support of time synchronization status reporting	18.2.0
2023-06	SP-100	SP-230485	0930	1	B	Updates to support Ranging/Sidelink Positioning	18.2.0
2023-06	SP-100	SP-230477	0945	7	B	Ki#1 - Removal of Editors Notes	18.2.0
2023-06	SP-100	SP-230477	0946	3	B	Ki#3 - UE Policy new PCRT	18.2.0
2023-06	SP-100	SP-230477	0947	9	B	Forwarding of UE reporting of URSP rule enforcement between SM-PCF and UE-PCF	18.2.0
2023-06	SP-100	SP-230486	0949	1	C	Policy subscription data for service function chaining	18.2.0
2023-06	SP-100	SP-230460	0952	1	F	Updates to 5GS DetNet integration	18.2.0
2023-06	SP-100	SP-230450	0953	1	F	KI#5: Update related to EN resolution in TS 23.304 for term of multi-path via Uu and via U2N Relay	18.2.0
2023-06	SP-100	SP-230498	0955	-	B	Policy control support for Packet Delay Variation monitoring and reporting	18.2.0
2023-06	SP-100	SP-230477	0957	6	B	KI#1 - Provision of URSP to route traffic to wild-carded VPLMN	18.2.0
2023-06	SP-100	SP-230477	0961	1	C	Clarification on provisioning tuple (PLMN ID, list of PSIs associated with the PLMN ID) within UE policies	18.2.0
2023-06	SP-100	SP-230460	0966	1	F	Text alignment for 3gpp extension for DetNet YANG	18.2.0
2023-06	SP-100	SP-230498	0967	6	B	QoS monitoring enhancement	18.2.0
2023-06	SP-100	SP-230478	0970	4	C	KI#3 address the ENs about restructuring and the scenario without TSCTSF	18.2.0
2023-06	SP-100	SP-230493	0971	-	F	KI#6 Clarify the AF adjustment for BAT offset and adjusted periodicity on the UL direction	18.2.0
2023-06	SP-100	SP-230456	0973	5	B	URSP for authenticable and non-authenticable non-3GPP (AUN3/NAUN3) devices connected behind a 5G-RG	18.2.0
2023-06	SP-100	SP-230456	0974	1	B	AMF/PCF Policy Control Trigger for TNGF/N3IWF selection enhancement based on support of S-NSSAI needed by UE	18.2.0
2023-06	SP-100	SP-230498	0975	2	C	Correction on Jitter and Alignment with PDV	18.2.0
2023-06	SP-100	SP-230477	0978	1	B	Update of the provision of URSP to route traffic to the VPLMN	18.2.0
2023-06	SP-100	SP-230472	0981	-	A	Correction on UE-Slice-MBR	18.2.0
2023-06	SP-100	SP-230452	0986	1	F	Clarification on Satellite backhaul category change of Policy Control Request Triggers	18.2.0
2023-06	SP-100	SP-230474	0991	1	B	Support of determining alternative S-NSSAI	18.2.0
2023-06	SP-100	SP-230462	0992	1	B	KI#1 Resolve ENs on EAS Discovery for HR-SBO	18.2.0
2023-06	SP-100	SP-230498	0995	1	B	Periodicity measurement and reporting for power saving	18.2.0
2023-06	SP-100	SP-230495	0997	1	B	Updates on TSCTSF parameters	18.2.0
2023-06	SP-100	SP-230491	1003	5	B	23.503 -Supporting DCAMP in LBO roaming scenario	18.2.0
2023-06	SP-100	SP-230484	1004	1	F	Clarification on URSP for PIN	18.2.0
2023-06	SP-100	SP-230452	1005	1	F	Clarification of QoS monitoring for satellite backhaul	18.2.0
2023-06	SP-100	SP-230478	1006	1	F	Clarifications for monitoring the data rate per group	18.2.0
2023-06	SP-100	SP-230486	1007	-	F	Corrections and alignments of SFC terminology	18.2.0
2023-06	SP-100	SP-230458	1009	4	B	Updates on PDTQ policy	18.2.0
2023-06	SP-100	SP-230459	1010	1	B	Support of MPQUIC Steering Mode	18.2.0
2023-06	SP-100	SP-230494	1012	3	B	Provisioning of A2X policy to UE	18.2.0
2023-06	SP-100	SP-230495	1013	1	B	QoS monitoring exposure by UPF to NWDAF aligned with TS 23.502	18.2.0
2023-06	SP-100	SP-230462	1014	4	C	HR-SBO Session AMBR in VPLMN Specific Offloading Policy	18.2.0
2023-06	SP-100	SP-230477	1017	5	F	Update of Provision of URSP to route traffic to the VPLMN	18.2.0
2023-06	SP-100	SP-230474	1023	1	B	SM policy for network slice replacement	18.2.0

Change history							
Date	Meeting	TDoc	CR	R ev	Cat	Subject/Comment	New version
2023-06	SP-100	SP-230469	1028	1	C	Clarification on NWDAF-assisted PFD management in TS23.503	18.2.0
2023-06	SP-100	SP-230450	1029	1	C	General description updates for Supporting UE-to-UE Relay	18.2.0
2023-06	SP-100	SP-230452	1032	-	F	Correction in 6.1.3.5 to align with 23.501	18.2.0
2023-06	SP-100	SP-230477	1036	1	C	Adding a Support Indication for VPLMN Specific URSP Rules	18.2.0
2023-06	SP-100	SP-230477	1040	2	F	Clarifications in the Definition of VPLMN Specific URSP Rules	18.2.0
2023-06	SP-100	SP-230477	1041	1	C	Validation Criteria in Roaming scenarios	18.2.0
2023-06	SP-100	SP-230474	1042	2	B	KI#6: PCF Configuration Support for Network Control of UE Use of network slices	18.2.0
2023-06	SP-100	SP-230484	1051	4	C	UE policy related PIN subscription	18.2.0
2023-06	SP-100	SP-230492	1052	-	B	23.503 - CHF selection in Spending Limits for AM and UE Policies in the 5GC	18.2.0
2023-06	SP-100	SP-230477	1053	3	B	Provisioning tuple (PLMN ID, list of PSIs associated with the PLMN ID) within UE policies	18.2.0
2023-06	SP-100	SP-230458	1054	2	B	R18 AIMLsys_KI6_23503 CR for adding timing info for AF QoS	18.2.0
2023-06	SP-100	SP-230484	1056	3	C	Further update on the usage of URSP for PIN	18.2.0
2023-06	SP-100	SP-230477	1062	2	C	Remove the EN for PCC rule generation	18.2.0
2023-06	SP-100	SP-230474	1064	3	C	Alternative S-NSSAI related Policy control	18.2.0
2023-06	SP-100	SP-230474	1065	3	C	Partially support S-NSSAI related RFSP	18.2.0
2023-06	SP-100	SP-230492	1067	1	F	Correction for SLAMUP on UE-Slice-MBR	18.2.0
2023-06	SP-100	SP-230469	1068	-	B	Update on NWDAF-assisted URSP	18.2.0
2023-06	SP-100	SP-230477	1069	4	C	Update to the Reporting the Outcome of the UE Policies Provisioning procedure to account for VPLMN Specific URSP Rules	18.2.0
2023-06	SP-100	SP-230477	1073	1	B	PCRT for UE reporting of URSP rule enforcement for LBO roaming	18.2.0
2023-06	SP-100	SP-230477	1077	2	B	Using LBO info for authorizing the application guidance request for URSP determination in VPLMN	18.2.0
2023-06	SP-100	SP-230462	1082	2	B	Common EAS/DNAI determination for a set of UEs	18.2.0
2023-09	SP-101	SP-230858	1048	3	F	Notification of ECN marking for L4S support flows	18.3.0
2023-09	SP-101	SP-230844	1083	2	F	Updates to AI/ML functionality descriptions related to policies	18.3.0
2023-09	SP-101	SP-230838	1087	1	A	Same UE Policy Association shared by 3GPP and non-3GPP accesses	18.3.0
2023-09	SP-101	SP-230851	1089	3	F	Provision VPLMN specific URSP rules	18.3.0
2023-09	SP-101	SP-230851	1090	2	F	Corrections related to KI#1 and KI#4	18.3.0
2023-09	SP-101	SP-230851	1094	4	F	Clarification on UE applying URSP rules when registering to a VPLMN	18.3.0
2023-09	SP-101	SP-230851	1106	3	F	The clarifications for the usage of VPLMN specific URSP rules	18.3.0
2023-09	SP-101	SP-230851	1114	2	F	Corrections related to LBO Information as part of SMF Selection Data	18.3.0
2023-09	SP-101	SP-230851	1115	2	F	Minor corrections related to VPLMN ID details	18.3.0
2023-09	SP-101	SP-230849	1123	2	F	Update of Network Slice Replacement event report	18.3.0
2023-09	SP-101	SP-230859	1126	1	D	Clarification for clause 6.2.1.2	18.3.0
2023-09	SP-101	SP-230847	1127	2	F	Clarifications on NWDAF-assisted PFD management	18.3.0
2023-09	SP-101	SP-230858	1140	2	F	XRM corrections in various sections	18.3.0
2023-09	SP-101	SP-230847	1148	-	F	Correction on NEF for PFD Determination	18.3.0
2023-09	SP-101	SP-230842	1150	3	F	Update QoS policy control for supporting satellite backhaul	18.3.0
2023-09	SP-101	SP-230844	1152	3	F	Corrections on Planned Data Transfer with QoS (PDTQ) Policy	18.3.0
2023-12	SP-102	SP-231277	1049	3	F	Support for delivery of multi-modal services	18.4.0
2023-12	SP-102	SP-231261	1093	9	F	Clarification on handling of URSPs for on demand network slices	18.4.0
2023-12	SP-102	SP-231277	1104	3	F	Update for UE power saving management	18.4.0
2023-12	SP-102	SP-231269	1109	2	F	URSP parameters applicable for PIN	18.4.0
2023-12	SP-102	SP-231261	1118	1	F	S-NSSAIs used to determine RFSP	18.4.0
2023-12	SP-102	SP-231259	1119	4	F	Provisioning of WLANSP rules to SNPN-enabled UE	18.4.0
2023-12	SP-102	SP-231253	1151	4	F	Corrections on timing info for AF QoS	18.4.0
2023-12	SP-102	SP-231274	1156	-	F	Fixing referred clauses for A2XP	18.4.0
2023-12	SP-102	SP-231255	1158	1	D	Support of IETF Deterministic Networking	18.4.0
2023-12	SP-102	SP-231243	1160	1	F	Maximum Slice Data Rate	18.4.0
2023-12	SP-102	SP-231250	1161	2	F	Clarification on dynamic satellite backhaul indication	18.4.0
2023-12	SP-102	SP-231264	1164	3	F	Clarification on group specific policy control information	18.4.0
2023-12	SP-102	SP-231277	1174	3	F	Update on support of coordinated UL and DL transmission	18.4.0
2023-12	SP-102	SP-231277	1179	4	F	Support of extra traffic characteristics for alternative QoS profile	18.4.0
2023-12	SP-102	SP-231277	1180	7	F	Clarification of QoS flow reporting for event triggered case 23.503	18.4.0
2023-12	SP-102	SP-231263	1189	3	F	URSP delivery via EPS	18.4.0
2023-12	SP-102	SP-231277	1192	2	F	Provisioning separate DL and UL PDU Set QoS Parameters to PCF/NEF	18.4.0
2023-12	SP-102	SP-231253	1193	3	F	Miscellaneous corrections on PDTQ	18.4.0
2023-12	SP-102	SP-231248	1196	3	F	Dynamically store identifiers and statuses of the policy counters in UDR	18.4.0
2023-12	SP-102	SP-231258	1200	2	F	PCF stores Forbidden Status in UDR based on NWDAF input	18.4.0

Change history							
Date	Meeting	TDoc	CR	R ev	Cat	Subject/Comment	New version
2023-12	SP-102	SP-231263	1203	1	F	Correction of URSP rule provision in EPS according to LS from CT1	18.4.0
2023-12	SP-102	SP-231248	1210	1	F	Spending Limits for AM and UE Policies in the 5GC	18.4.0
2023-12	SP-102	SP-231269	1212	2	F	Handling of Traffic from UEs that host PIN Management Clients and PIN Gateway Clients (Alternative #2)	18.4.0
2023-12	SP-102	SP-231261	1213	3	F	Correction to network slice replacement	18.4.0
2023-12	SP-102	SP-231361	1217	4	F	Clarification on Network Slice Replacement	18.4.0
2023-12	SP-102	SP-231254	1218	1	F	Clarifications on redundant steering mode for GBR QoS Flow	18.4.0
2023-12	SP-102	SP-231258	1219	1	F	Clarify handling of PFDs created based on NWDAF analytics	18.4.0
2023-12	SP-102	SP-231263	1236	2	F	Clarification on UE reporting URSP rule enforcement	18.4.0
2024-03	SP-103	SP-240114	1101	4	F	Update for QoS monitoring and network exposure	18.5.0
2024-03	SP-103	SP-240103	1110	4	F	Correction to Policy control decisions based on awareness of URSP rule enforcement	18.5.0
2024-03	SP-103	SP-240103	1116	3	F	Interaction between SM-PCF and UE-PCF for PCC rule generation	18.5.0
2024-03	SP-103	SP-240103	1120	3	F	Not reporting URSP rule enforcement other then connection capability	18.5.0
2024-03	SP-103	SP-240097	1171	4	F	Clarification on information transferred between TSCTS and PCF for DetNet	18.5.0
2024-03	SP-103	SP-240098	1201	2	F	Roaming procedures with a distinction to HR-SBO scenario	18.5.0
2024-03	SP-103	SP-240103	1205	2	F	Add missing indication of UE capability of reporting URSP rule enforcement in Table 6.2-1	18.5.0
2024-03	SP-103	SP-240103	1206	1	D	Clarification on UE Capability of reporting URSP rule enforcement	18.5.0
2024-03	SP-103	SP-240101	1208	1	F	Correction on RFSP index generation	18.5.0
2024-03	SP-103	SP-240103	1214	1	F	URSP Rule enforcing reporting to the PCF	18.5.0
2024-03	SP-103	SP-240115	1223	4	F	RAT Type Change in the same Access Type	18.5.0
2024-03	SP-103	SP-240103	1224	1	F	Clarification to URSP rule enforcement reporting.	18.5.0
2024-03	SP-103	SP-240098	1226	2	F	KI#1 Corrections on Offload Identifier and misalignments in services	18.5.0
2024-03	SP-103	SP-240103	1240	1	F	KI#1 - Provisioning of new, updated and removed tuples for VPS URSP Rules to the UE	18.5.0
2024-03	SP-103	SP-240091	1241	1	F	Clarification on satellite backhaul category change indication	18.5.0
2024-03	SP-103	SP-240094	1242	1	F	Clarification on the PDTQ policy	18.5.0
2024-03	SP-103	SP-240103	1243	4	F	Correction on URSP rule enforcement reporting	18.5.0
2024-03	SP-103	SP-240104	1244	1	F	Handling of updated Maximum Group Data Rate	18.5.0
2024-03	SP-103	SP-240114	1245	1	F	Protocol Description for UL and DL traffic	18.5.0
2024-03	SP-103	SP-240136	1246	1	F	A fix for Spending Limits for AM and UE Policies in the 5GC	18.5.0
2024-03	SP-103	SP-240108	1248	-	F	Ranging/SL Positioning policy information	18.5.0
2024-03	SP-103	SP-240101	1249	1	F	Clarification on subscription retrieval during slice replacement	18.5.0
2024-03	SP-103	SP-240136	1252	-	F	Corrections for spending limit information stored in UDR	18.5.0
2024-03	SP-103	SP-240093	1253	1	F	AMF/PCF Policy Control Trigger for UE policy update in non-3GPP access	18.5.0
2024-03	SP-103	SP-240094	1254	1	F	R18 AIMLsys_KI5_23503_CR for clarification on PDTQ procedures	18.5.0
2024-03	SP-103	SP-240103	1255	1	F	Clarification on UE reporting URSP rule enforcement	18.5.0
2024-03	SP-103	SP-240114	1256	1	F	Clarification on AF providing Periodicity and PCF behavior	18.5.0
2024-03	SP-103	SP-240101	1257	4	F	PCF related corrections to Network Slice Replacement	18.5.0
2024-03	SP-103	SP-240114	1258	1	F	Update for UE power saving management	18.5.0
2024-03	SP-103	SP-240114	1261	1	F	Correction of UPF reporting of QoS Monitoring packet delay	18.5.0
2024-03	SP-103	SP-240093	1262	1	F	URSP for 5G-RG and FN-RG	18.5.0
2024-03	SP-103	SP-240103	1269	2	F	Interaction between SM-PCF and UE-PCF for PCC rule generation	18.5.0
2024-03	SP-103	SP-240115	1270	2	F	Reporting UE temporarily unreachable and reachable again	18.5.0
2024-03	SP-103	SP-240103	1271	2	F	Forwarding of URSP Rule Enforcement Information for LBO roaming	18.5.0
2024-03	SP-103	SP-240103	1272	2	F	Conditions of URSP rule enforcement reporting	18.5.0
2024-03	SP-103	SP-240103	1275	3	F	Wildcarding H-PLMN ID in URSP rules	18.5.0
2024-03	SP-103	SP-240409	1278	5	F	Clarifications for UE Policy Container delivery via EPS	18.5.0
2024-06	SP-104	SP-240606	1284	2	F	PCF retrieves policy counters and statuses from UDR before CHF association	18.6.0
2024-06	SP-104	SP-240597	1285	6	F	Clarification on Alternative S-NSSAI related Policy control	18.6.0
2024-06	SP-104	SP-240597	1289	3	F	Usage monitoring control and network slice data rate monitoring	18.6.0
2024-06	SP-104	SP-240602	1290	2	F	RAT Type Change in the same Access Type from AMF to PCF	18.6.0
2024-06	SP-104	SP-240602	1299	2	D	Cleanup CR for TS 23.503	18.6.0
2024-06	SP-104	SP-240607	1288	4	B	Minimize number of UE and AM Policy Associations	19.0.0
2024-06	SP-104	SP-240607	1296	3	B	Spending Limits for UE Policies in Roaming scenario	19.0.0
2024-06	SP-104	SP-240607	1300	2	C	Support of QoS monitoring capability configuration and transfer within 5GC	19.0.0
2024-09	SP-105	SP-241246	1305	1	A	Restrictions to use VPLMN specific URSP Rules in EPS	19.1.0
2024-09	SP-105	SP-241278	1307	1	A	The PCF indicates QoS authorization failure due to roaming in a non-supported PLMN	19.1.0

Change history							
Date	Meeting	TDoc	CR	R ev	Cat	Subject/Comment	New version
2024-09	SP-105	SP-241272	1308	1	F	Corrections to the handling of the UE and the AM Policy association	19.1.0
2024-09	SP-105	SP-241272	1309	-	F	Misalignment text in AM and UE policy association with respect to local configuration	19.1.0
2024-09	SP-105	SP-241246	1318	1	A	Add missing VPLMN specific URSP support indication	19.1.0
2024-09	SP-105	SP-241246	1320	1	A	Clarification on URSP rule enforcement	19.1.0
2024-09	SP-105	SP-241278	1331	1	A	Alignment of QoS monitoring as defined in TS 23.501	19.1.0
2024-09	SP-105	SP-241266	1343	3	B	Support of MPS priority for Messaging	19.1.0
2024-09	SP-105	SP-241265	1348	3	B	Local Offloading Policy to support Local Handling of Edge Computing	19.1.0
2024-09	SP-105	SP-241278	1356	1	A	Addition of definitions	19.1.0
2024-09	SP-105	SP-241254	1369	1	A	Correction on the traffic parameter measurement	19.1.0
2024-12	SP-106	SP-241494	1310	15	B	PCC enhancements for support of identified non-3GPP devices	19.2.0
2024-12	SP-106	SP-241497	1324	10	B	KI#5, Support of Data Burst related	19.2.0
2024-12	SP-106	SP-241487	1325	5	B	PCC rule enhancement to support N6 delay measurement	19.2.0
2024-12	SP-106	SP-241495	1329	5	B	Support of Handling of Headers	19.2.0
2024-12	SP-106	SP-241475	1339	4	A	Correction on the misalignment on Policy control based on URSP awareness	19.2.0
2024-12	SP-106	SP-241494	1344	7	B	Ericsson, Deutsche Telekom	19.2.0
2024-12	SP-106	SP-241497	1360	4	B	XRM_Ph2 KI#6 L4S support in non-3GPP access	19.2.0
2024-12	SP-106	SP-241489	1362	11	B	Updates of the PCC rules, ATSSS rules and N4 rules of the MPQUIC-IP/MPQUIC-UDP/MPQUIC-E functionalities	19.2.0
2024-12	SP-106	SP-241497	1364	2	B	PDU Set handling in non-3GPP accesses	19.2.0
2024-12	SP-106	SP-241481	1368	4	A	Correction on the PDU Set QoS handling	19.2.0
2024-12	SP-106	SP-241481	1387	-	A	Align ECN marking indication	19.2.0
2024-12	SP-106	SP-241484	1392	2	F	WLANSP and URSP rules provided by the HPLMN	19.2.0
2024-12	SP-106	SP-241487	1401	7	B	KI#1 Clarification on Local Offloading Policy	19.2.0
2024-12	SP-106	SP-241481	1408	1	A	Fix the descriptions on QoS information for PDU Set QoS Parameters AF provisions	19.2.0
2024-12	SP-106	SP-241488	1420	5	B	BDT Energy Criteria	19.2.0
2024-12	SP-106	SP-241489	1423	8	B	Support of enabling correct header compression to be performed by NG-RAN	19.2.0
2024-12	SP-106	SP-241490	1437	2	F	Corrections for MPS priority for Messaging	19.2.0
2024-12	SP-106	SP-241503	1438	3	B	Support of network slice replacement based on AF request	19.2.0
2025-03	SP-107	SP-250042	1303	4	B	PCF use of QoS and policy assistance information analytic	19.3.0
2025-03	SP-107	SP-250046	1315	3	A	Correction to Awareness of URSP Rule Enforcement - 23.503	19.3.0
2025-03	SP-107	SP-250033	1375	3	A	Correction on DCAMP	19.3.0
2025-03	SP-107	SP-250064	1378	4	B	KI#1, Support the PDU Set Information Marking Support Indication	19.3.0
2025-03	SP-107	SP-250064	1381	9	B	KI#9, Support of Rate limitation	19.3.0
2025-03	SP-107	SP-250064	1388	13	B	Traffic detection and QoS handling of multiplexed data flows	19.3.0
2025-03	SP-107	SP-250064	1394	9	B	PDU Set Information Identification for end-to-end encrypted traffic using connect-UDP - PCC part	19.3.0
2025-03	SP-107	SP-250064	1419	6	B	Support of available data rate exposure	19.3.0
2025-03	SP-107	SP-250040	1429	4	B	Procedure update for UE-Satellite-UE communication	19.3.0
2025-03	SP-107	SP-250053	1440	2	A	Averaging Window in Alternative QoS Parameter Set	19.3.0
2025-03	SP-107	SP-250064	1441	5	B	PDU Set support in QoS Notification Control and Alternative QoS	19.3.0
2025-03	SP-107	SP-250064	1448	10	B	Enhancements for AF/AS triggered expedite data transfer	19.3.0
2025-03	SP-107	SP-250053	1452	-	A	Clarification on multi-modal service	19.3.0
2025-03	SP-107	SP-250064	1457	4	B	Support of providing MMSID from 5GC to NG-RAN through NGAP	19.3.0
2025-03	SP-107	SP-250059	1459	4	F	Update to 23.503 Support of network slice replacement based on AF request	19.3.0
2025-03	SP-107	SP-250037	1463	-	F	Reporting PCF authorization failure to the AF	19.3.0
2025-03	SP-107	SP-250061	1467	-	F	PCC enhancements for support of identified non-3GPP devices	19.3.0
2025-03	SP-107	SP-250035	1474	-	A	Updated reference for DetNet RFC	19.3.0
2025-03	SP-107	SP-250061	1480	1	F	PCC enhancements for support of identified non-3GPP devices	19.3.0
2025-03	SP-107	SP-250046	1484	-	A	URSP Guidelines updates of GSMA	19.3.0
2025-03	SP-107	SP-250055	1485	-	D	Editorial changes on provisioning PCC rule for ATSSS	19.3.0
2025-03	SP-107	SP-250054	1486	9	F	Policy control with energy saving consideration.	19.3.0
2025-03	SP-107	SP-250037	1500	3	F	Clarifications for activation of QoS monitoring	19.3.0
2025-03	SP-107	SP-250061	1503	1	F	Corrections to PCR trigger and SM policy modification for Non-3GPP device identifier	19.3.0
2025-03	SP-107	SP-250055	1504	1	F	Clarification for PCF behaviour for generating Match All PCC rules for MA PDU Session	19.3.0
2025-03	SP-107	SP-250059	1507	2	F	Fixing the QoS monitoring capability notification mechanism	19.3.0
2025-03	SP-107	SP-250037	1509	2	C	Extending charging support in 5GC	19.3.0
2025-06	SP-108	SP-250462	1357	7	F	Clarifications for multi-modal services	19.4.0
2025-06	SP-108	SP-250469	1492	7	F	Corrections for energy saving related AF input on BDT policy negotiation	19.4.0

Change history							
Date	Meeting	TDoc	CR	R ev	Cat	Subject/Comment	New version
2025-06	SP-108	SP-250458	1516	2	A	Clarifications and corrections for ECN marking for L4S and congestion monitoring	19.4.0
2025-06	SP-108	SP-250451	1527	1	A	Update network slice replacement PCRT	19.4.0
2025-06	SP-108	SP-250474	1530	-	F	Adding a Reference to the Home Routed Roaming PDU Session Modification Procedure	19.4.0
2025-06	SP-108	SP-250478	1532	3	F	Clarification on AF requested network slice replacement	19.4.0
2025-06	SP-108	SP-250477	1533	2	F	Correction concerning presence of PDU Set Control information without a Protocol Description	19.4.0
2025-06	SP-108	SP-250471	1537	1	D	Terminology alignment for steering functionality(ies)	19.4.0
2025-06	SP-108	SP-250462	1541	-	D	Simplification of clause 6.2.1.2	19.4.0
2025-06	SP-108	SP-250477	1545	1	F	Clarifications for available bitrate exposure	19.4.0
2025-06	SP-108	SP-250477	1547	8	F	Clarifications for rate limitation exposure	19.4.0
2025-06	SP-108	SP-250477	1548	3	F	Clarifications for QoS Notification Control with direction information	19.4.0
2025-06	SP-108	SP-250462	1550	2	F	Activation of QoS monitoring for the GBR service data flow	19.4.0
2025-06	SP-108	SP-250474	1551	4	F	Clarification on supporting multiple non-3GPP device identifiers	19.4.0
2025-06	SP-108	SP-250478	1552	1	F	Clarification on notifying the outcome of network slice replacement to AF	19.4.0
2025-06	SP-108	SP-250451	1557	2	A	BSF subscription validity time	19.4.0
2025-06	SP-108	SP-250462	1558	3	F	Clarification of Note related to CHF Group ID and CHF Set ID	19.4.0
2025-06	SP-108	SP-250462	1561	2	F	Update of definitions clause	19.4.0
2025-09	SP-109	SP-250958	1564	1	F	Clarification of Note related to CHF Group ID and CHF Set ID for AM	19.5.0
2025-09	SP-109	SP-250954	1568	1	D	UIA_ARC Corrections	19.5.0
2025-12	SP-110	SP-251338	1531	9	B	23.503 Support of uplink rate control for QoS flows at RAN	19.6.0
2025-12	SP-110	SP-251338	1534	3	F	MoQ missing from the Protocol Description	19.6.0
2025-12	SP-110	SP-251337	1570	5	F	Policy modifications for Suspending QoS differentiation for Non-3GPP Devices	19.6.0
2025-12	SP-110	SP-251338	1574	6	F	Corrections for PCF involvement in ECN marking for L4S	19.6.0
2025-12	SP-110	SP-251338	1575	3	F	Clarification of PCF configuration for SDF data rate limitation exposure	19.6.0
2025-12	SP-110	SP-251326	1578	-	F	Enhancement of Rx Interface for UE-Satellite-UE Communication in TS 23.503	19.6.0
2025-12	SP-110	SP-251334	1581	-	F	Correction related to storage of CHF set ID	19.6.0
2025-12	SP-110	SP-251322	1584	1	A	Partially Allowed NSSAI handling for network slice replacement	19.6.0
2025-12	SP-110	SP-251335	1585	2	F	Further clarification on AF triggered slice replacement	19.6.0
2025-12	SP-110	SP-251337	1586	1	D	Clarification to Policy control for non-3GPP devices connecting behind a UE	19.6.0
2025-12	SP-110	SP-251338	1589	-	F	Correcting XRM related typos in TS 23.503	19.6.0
2026-03	SP-111	SP-260087	1603	2	F	Interworking for UIA_ARC	19.7.0
2026-03	SP-111	SP-260081	1608	1	F	Correction on QoS and policy assistance analytics	19.7.0
2026-03	SP-111	SP-260088	1623	1	C	PSI for N6 unmarked PDUs	19.7.0

---

## History

<b>Version</b>	<b>Date</b>	<b>Status</b>
V19.5.0	January 2026	Publication
V19.6.0	January 2026	Publication
V19.7.0	March 2026	Publication