

**Access and Terminals (AT);
POTS requirements applicable to ADSL modems
when connected to an analogue presented PSTN line**



Reference

DES/AT-010110

Keywords

ADSL, analogue, POTS, PSTN, terminal

ETSI

650 Route des Lucioles
F-06921 Sophia Antipolis Cedex - FRANCE

Tel.: +33 4 92 94 42 00 Fax: +33 4 93 65 47 16

Siret N° 348 623 562 00017 - NAF 742 C
Association à but non lucratif enregistrée à la
Sous-Préfecture de Grasse (06) N° 7803/88

Important notice

Individual copies of the present document can be downloaded from:

<http://www.etsi.org>

The present document may be made available in more than one electronic version or in print. In any case of existing or perceived difference in contents between such versions, the reference version is the Portable Document Format (PDF). In case of dispute, the reference shall be the printing on ETSI printers of the PDF version kept on a specific network drive within ETSI Secretariat.

Users of the present document should be aware that the document may be subject to revision or change of status. Information on the current status of this and other ETSI documents is available at

<http://portal.etsi.org/tb/status/status.asp>

If you find errors in the present document, send your comment to:

editor@etsi.org

Copyright Notification

No part may be reproduced except as authorized by written permission.
The copyright and the foregoing restriction extend to reproduction in all media.

© European Telecommunications Standards Institute 2003.
All rights reserved.

DECTTM, **PLUGTESTS**TM and **UMTS**TM are Trade Marks of ETSI registered for the benefit of its Members.
TIPHONTM and the **TIPHON logo** are Trade Marks currently being registered by ETSI for the benefit of its Members.
3GPPTM is a Trade Mark of ETSI registered for the benefit of its Members and of the 3GPP Organizational Partners.

Contents

Intellectual Property Rights	4
Foreword.....	4
Introduction	4
1 Scope	5
2 References	5
3 Definitions and abbreviations.....	6
3.1 Definitions	6
3.2 Abbreviations	6
4 General aspects - Rationale for requirements.....	6
4.1 Polarity	8
4.2 DC resistance.....	8
4.3 Ringing impedance	8
4.4 Transient response to ringing signals	8
4.5 DC current during ringing	8
4.6 Impedance unbalance about earth	8
4.7 DC resistance to earth.....	9
4.8 Impedance for PSTN voice band and metering signals.....	9
4.8.1 Voice band (200 Hz - 4 000 Hz).....	9
4.8.2 Frequencies used for metering pulses (12 kHz and 16 kHz).....	10
History	11

Intellectual Property Rights

IPRs essential or potentially essential to the present document may have been declared to ETSI. The information pertaining to these essential IPRs, if any, is publicly available for **ETSI members and non-members**, and can be found in ETSI SR 000 314: "*Intellectual Property Rights (IPRs); Essential, or potentially Essential, IPRs notified to ETSI in respect of ETSI standards*", which is available from the ETSI Secretariat. Latest updates are available on the ETSI Web server (<http://webapp.etsi.org/IPR/home.asp>).

All published ETSI deliverables shall include information which directs the reader to the above source of information.

Foreword

This ETSI Standard (ES) has been produced by ETSI Technical Committee Access and Terminals (AT).

Introduction

ADSL modems are often installed in parallel with PSTN analogue terminal equipment. They may be indirectly connected to line via an ADSL splitter, or directly connected when using distributed filters with the existing POTS terminals. Often the ADSL splitter at the customer's premises does not contain a DC blocking component, therefore there is a DC path between ADSL modem and the PSTN line. Arising from this TR 101 954 [2] was produced to study what requirements would need to be met by the line interface of the ADSL modem in order not to degrade the PSTN service.

1 Scope

The present document specifies the requirements normally applying to analogue presented PSTN terminal equipment to ensure correct interworking with PSTN network interfaces that would also apply to ADSL modems when connected to the PSTN using distributed filters or ADSL splitters without a DC blocking function.

The requirements of the present document do not apply in cases where the modem is only intended for use with splitters that include blocking capacitors.

The present document considers that the ADSL modem may be connected with up to 4 PSTN terminals.

2 References

The following documents contain provisions which, through reference in this text, constitute provisions of the present document.

- References are either specific (identified by date of publication and/or edition number or version number) or non-specific.
- For a specific reference, subsequent revisions do not apply.
- For a non-specific reference, the latest version applies.

Referenced documents which are not found to be publicly available in the expected location might be found at <http://docbox.etsi.org/Reference>.

- [1] ETSI TBR 021: "Terminal Equipment (TE); Attachment requirements for pan-European approval for connection to the analogue Public Switched Telephone Networks (PSTNs) of TE (excluding TE supporting the voice telephony service) in which network addressing, if provided, is by means of Dual Tone Multi Frequency (DTMF) signalling".
- [2] ETSI TR 101 954: "Access and Terminals (AT); A study on POTS requirements applicable to ADSL modems when connected to an analogue presented PSTN line".
- [3] ETSI EG 201 120: "Public Switched Telephone Network (PSTN); Method of rating terminal equipment so that it can be connected in series and/or in parallel to a Network Termination Point (NTP)".
- [4] Council Directive 91/263/EEC of 29 April 1991 on the approximation of the laws of the Member States concerning telecommunications terminal equipment, including the mutual recognition of their conformity.
- [5] Directive 98/13/EC of the European Parliament and of the Council of 12 February 1998 relating to telecommunications terminal equipment and satellite earth station equipment, including the mutual recognition of their conformity.

3 Definitions and abbreviations

3.1 Definitions

For the purposes of the present document, the following terms and definitions apply:

TBR: Technical Basis for Regulation

NOTE: Former European Regulation under the no longer applicable EU Directives 91/263/EEC [4] and 98/13/EC [5]. In general equivalent to deliverables of the series EN 301 4xx when mandated by CEC under the cited earlier Directives.

POTS terminal: terminal intended for connection to the analogue presented PSTN network

Distributed filter: splitter implementation that is valid only at the customer end of the loop

NOTE: It is a low pass filter that is added in series with each of the parallel connected POTS TE. Each of these parallel connected filters is known as a distributed filter. These filters are also known as In-line filters or microfilters.

3.2 Abbreviations

For the purposes of the present document, the following abbreviations apply:

AC	Alternating Current
ADSL	Asymmetric Digital Subscriber Line
DC	Direct Current
NTP	Network Termination Point (user interface)
POTS	Plain Old Telephone System
PSTN	Public Switched Telephone Networks
TBR	Technical Basis for Regulation
TE	Terminal Equipment

4 General aspects - Rationale for requirements

Analogue presented PSTN requirements have been specified in TBR 021 [1] for the case of a single terminal connected to the line. EG 201 120 [3] is an ETSI guide that assists the manufacturer in the design of terminals capable of sharing the resources available at the NTP with other terminals in the installation. The present document assumes that the ADSL modem will share the line with up to 4 PSTN TEs. This assumes that the ADSL modem has a Loading Factor of 20 as described in EG 201 120 [3].

There are two scenarios that need to be considered:

- 1) The ADSL modem is connected to the line via a splitter that does not contain a DC blocking function as shown in figure 1. In the majority of cases the ADSL port of the splitter is electrically the same as the line port, the ADSL port is no more than a convenient connection point (in parallel with the line port) in these cases.

NOTE: There may be a common mode choke between the line port and the ADSL port, however the requirements specified in the present document still apply.

- 2) The ADSL modem is connected directly to the line and there is a micro-filter inserted in front of each item of POTS TE as shown in figure 2.

For each scenario some POTS requirements will apply to the ADSL modem.

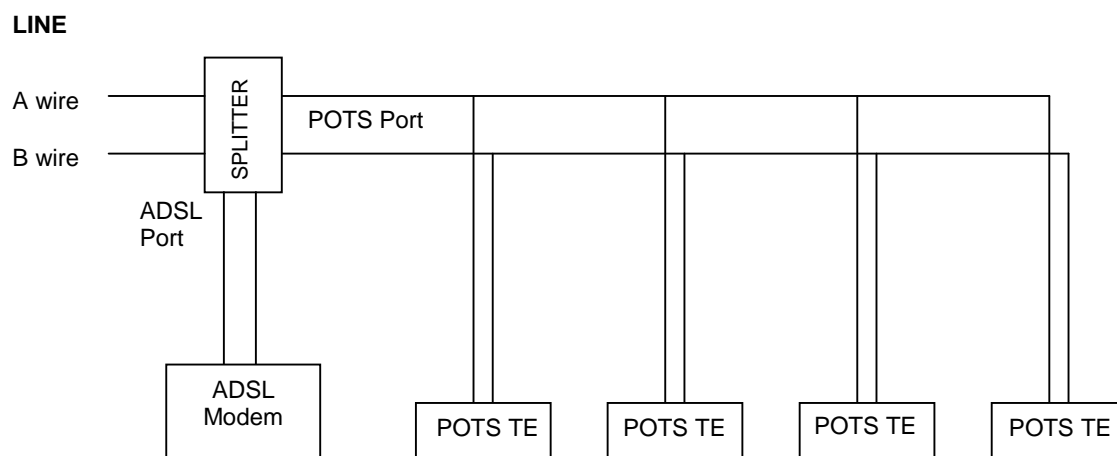

Figure 1: Scenario 1: installation using a central splitter

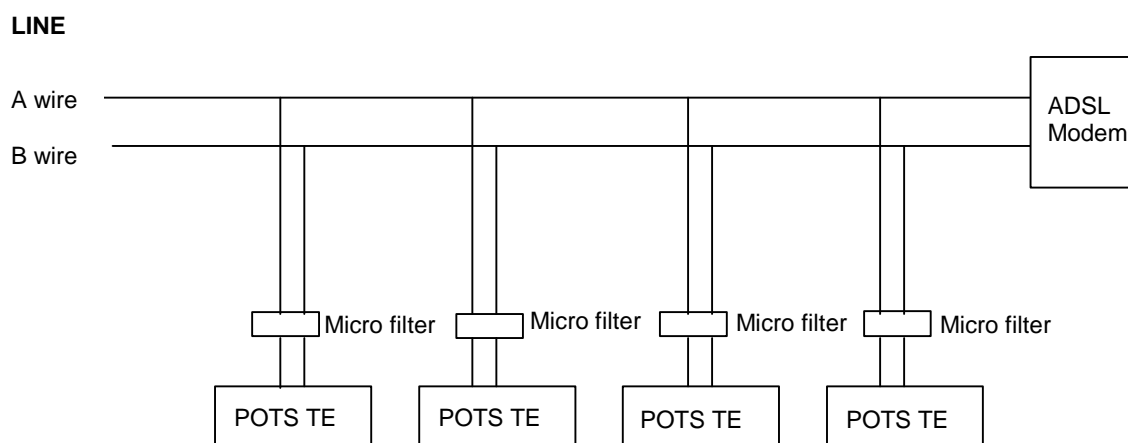

Figure 2: Scenario 2: installation using distributed filters

POTS TE requirements are applicable to ADSL modems for each of these scenarios as outlined in table 1. These requirements are applicable when the modem is both powered or un-powered.

Table 1: Overview of applicable PSTN requirements for ADSL modems

Requirement	Clause in the present document	TBR 021 [1], clause	EG 201 120 [3], clause	Scenario 1	Scenario 2
Polarity	4.1	4.3.1	Not applicable	X	X
DC Resistance	4.2	4.4.1	6.2	X	X
Ringling impedance	4.3	4.4.2.1	6.2	X	X
Quiescent State Transient Response	4.4	4.4.2.2	Not applicable	X	X
DC current during ringling	4.5	4.4.2.3	6.2	X	X
Impedance unbalance about earth	4.6	4.4.3	6.2	X	X
DC resistance to earth	4.7	4.4.4	6.2	X	X
Impedance	4.8	Not applicable	6.2	X	X

4.1 Polarity

The PSTN line typically has 40 V to 70 V DC powering the POTS service, in each requirement the DC excitation is specified. When the POTS terminal is off hook the voltage appearing across the ADSL modem input will normally be lower depending on the characteristics of the terminal and the line length. Reversals in polarity are used for signalling purposes, the ADSL modem shall not significantly affect these polarity reversals preventing them from performing their intended function.

4.2 DC resistance

The DC current drawn by the ADSL modem when connected to a source of:

- 100 V DC
- 50 V DC
- 25 V DC

shall not exceed that which would be drawn by a 5 M Ω resistor replacing the modem. This requirement applies 30 s after the voltage is applied. The test method is described in TBR 021 [1], clause A.4.4.1.

4.3 Ringing impedance

The impedance of the ADSL modem at frequencies of 25 Hz and 50 Hz shall not be less than 100 k Ω , when tested at 30 V rms. The test method is described in TBR 021 [1], clause A.4.4.2.1.

4.4 Transient response to ringing signals

When ringing signals are applied to the ADSL modem, the resulting current shall not cause the public exchange to detect a loop state. This can be verified by a DC excitation of 60 V with a source resistance of 200 Ω applied to the modem. The current shall be equal to or less than 25 mA 1 ms after commencement of the excitation, and equal to or less than 10 mA 6 ms after commencement. The test method is described in TBR 021 [1], clause A.4.4.2.2.

4.5 DC current during ringing

The resulting DC current drawn by the ADSL modem during the ringing signal, tested with a 25 Hz and 50 Hz AC signal at a voltage of 90 V rms superimposed on a DC voltage of 60 V, shall be less than 0,6 mA. The test method is described in TBR 021 [1], clause A.4.4.2.3.

4.6 Impedance unbalance about earth

The longitudinal conversion loss when the AC termination of the ADSL modem is 600 Ω shall be at least the values given in table 2.

Table 2: Longitudinal conversion loss, minimum values

Frequency range	Minimum value
50 Hz to 600 Hz	54 dB
600 Hz to 3 400 Hz	60 dB
3 400 Hz to 3 800 Hz	54 dB

The test method is described in TBR 021 [1], clause A.4.4.3.

4.7 DC resistance to earth

Where the supplier's instructions state that a connection to earth is intended, the DC resistance between each line terminal of the ADSL modem and earth when tested at 100 V DC shall be not less than 50 M Ω .

The test method is described in TBR 021 [1], clause A.4.4.4.

4.8 Impedance for PSTN voice band and metering signals

The impedance of the ADSL modem for PSTN voice band and metering frequencies shall meet the following requirements.

This parameter could be tested by the following test method:

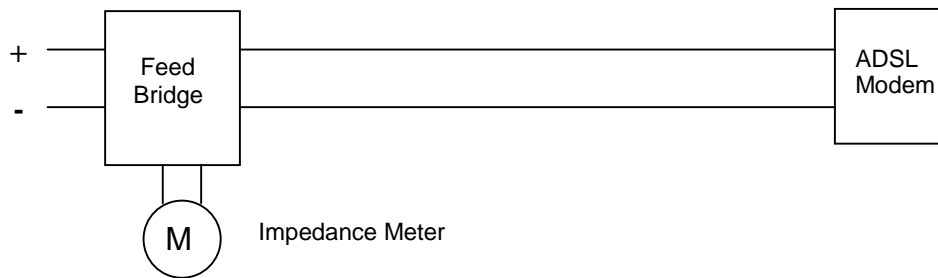

NOTE 1: The feeding bridge shown in figure 3 is considered to be ideal, actual implementation of the test setup is a matter for the test laboratory.

NOTE 2: The feed voltage used should simulate the DC voltage likely to be present when the POTS terminal is off hook and not the on hook or quiescent state DC voltage.

NOTE 3: The minimum impedance specified in clauses 4.8.1 and 4.8.2 is equivalent to the impedance presented by a capacitance of 35 nF.

Figure 3: Impedance test setup

4.8.1 Voice band (200 Hz - 4 000 Hz)

The modulus of the input impedance of the ADSL modem shall be greater than or equal to the impedance defined in table 3 and figure 4.

Table 3: Minimum impedance requirements in the voice band

Frequency (Hz)	Impedance (Ω)
200	10 000
455	10 000
4 000	1 137

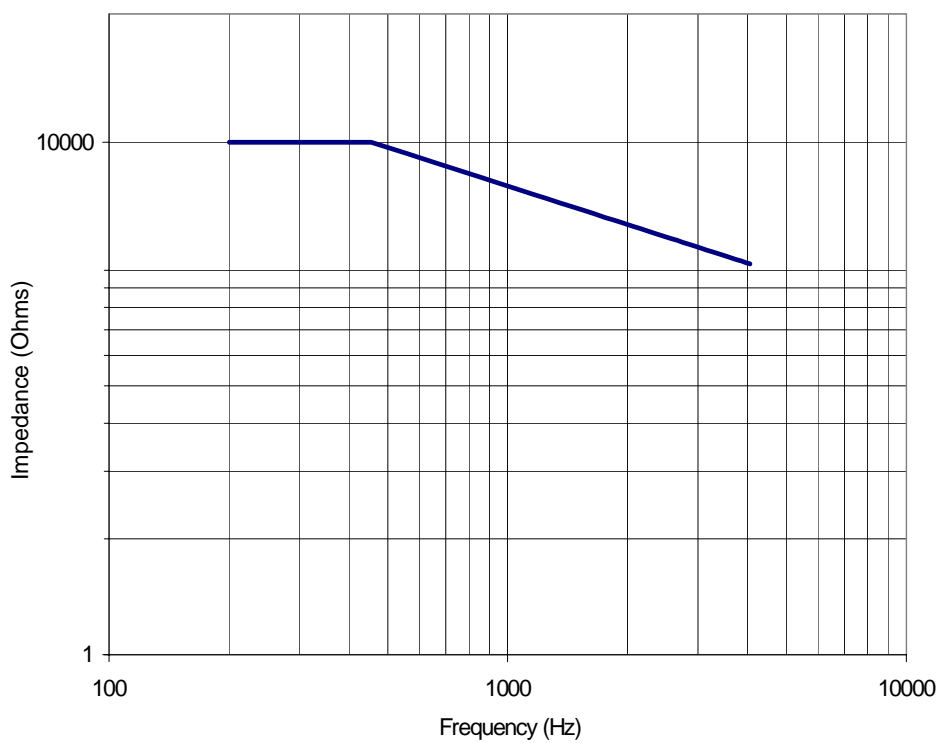

Figure 4: Minimum impedance in the voice band

4.8.2 Frequencies used for metering pulses (12 kHz and 16 kHz)

At 12 kHz the input impedance of the ADSL modem shall be greater than or equal to 379 Ω .

At 16 kHz the input impedance of the ADSL modem shall be greater than or equal to 284 Ω .

History

Document history		
V1.1.1	November 2002	Publication as TS 102 913
V1.1.1	January 2003	Publication