

**Speech Processing, Transmission and Quality Aspects (STQ);
Harmonized Pan-European/North-American approach to loss
and level planning for voice gateways to IP based networks**

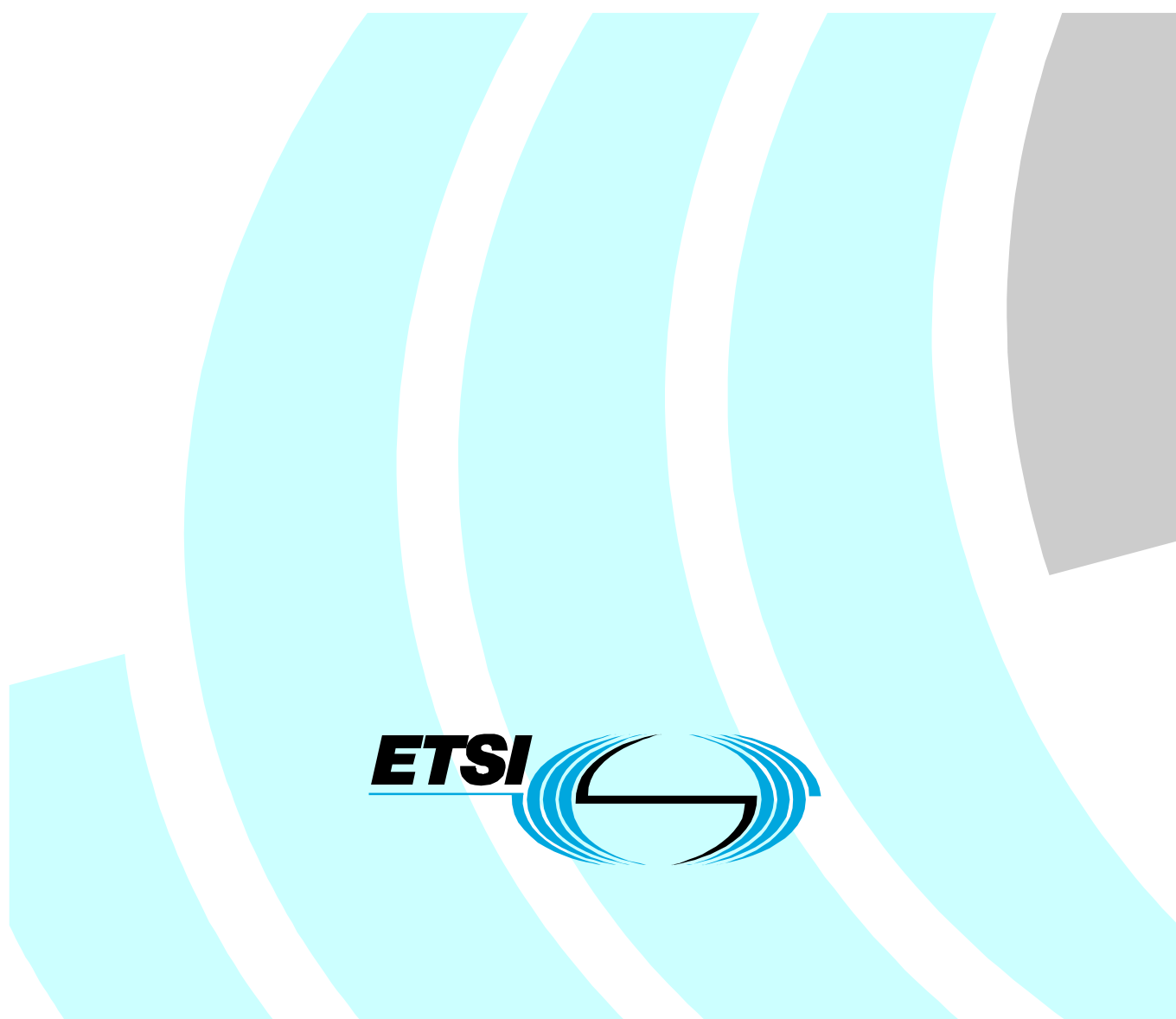

Reference

RES/STQ-00106

Keywords

QoS, quality, speech, transmission, voice

ETSI

650 Route des Lucioles
F-06921 Sophia Antipolis Cedex - FRANCE

Tel.: +33 4 92 94 42 00 Fax: +33 4 93 65 47 16

Siret N° 348 623 562 00017 - NAF 742 C
Association à but non lucratif enregistrée à la
Sous-Préfecture de Grasse (06) N° 7803/88

Important notice

Individual copies of the present document can be downloaded from:

<http://www.etsi.org>

The present document may be made available in more than one electronic version or in print. In any case of existing or perceived difference in contents between such versions, the reference version is the Portable Document Format (PDF). In case of dispute, the reference shall be the printing on ETSI printers of the PDF version kept on a specific network drive within ETSI Secretariat.

Users of the present document should be aware that the document may be subject to revision or change of status. Information on the current status of this and other ETSI documents is available at

<http://portal.etsi.org/tb/status/status.asp>

If you find errors in the present document, please send your comment to one of the following services:

http://portal.etsi.org/chaicor/ETSI_support.asp

Copyright Notification

No part may be reproduced except as authorized by written permission.
The copyright and the foregoing restriction extend to reproduction in all media.

© European Telecommunications Standards Institute 2007.
All rights reserved.

DECTTM, **PLUGTESTS**TM and **UMTS**TM are Trade Marks of ETSI registered for the benefit of its Members.
TIPHONTM and the **TIPHON logo** are Trade Marks currently being registered by ETSI for the benefit of its Members.
3GPPTM is a Trade Mark of ETSI registered for the benefit of its Members and of the 3GPP Organizational Partners.

Contents

| | |
|--|-----------|
| Intellectual Property Rights | 4 |
| Foreword..... | 4 |
| 1 Scope | 5 |
| 2 References | 6 |
| 3 Definitions and abbreviations..... | 6 |
| 3.1 Definitions | 6 |
| 3.2 Abbreviations | 7 |
| 4 Loss and level planning | 8 |
| 4.1 Overview | 8 |
| 4.2 Half-channel loss and level plans | 8 |
| 4.3 Loudness rating definitions | 8 |
| 4.3.1 Loudness rating..... | 8 |
| 4.3.2 Relationship between loudness ratings and loss plans | 9 |
| 4.4 0 dBr Reference level point | 11 |
| 4.5 Reference level | 11 |
| 4.5.1 Network level changes..... | 11 |
| 4.6 Harmonized half-channel loss and level plans | 11 |
| 4.7 Regional full-channel loss and level plans | 12 |
| 5 Requirements for the harmonized half-channel loss and level plan..... | 12 |
| 5.1 The Pan-European half-channel loss plan | 12 |
| 5.1.1 Voice Gateway connections..... | 12 |
| 5.1.2 Interface descriptions..... | 13 |
| 5.1.3 Voice Gateway half-channel loss plan..... | 14 |
| 5.2 The North American half-channel loss plan | 15 |
| 5.2.1 Voice Gateway connections..... | 15 |
| 5.2.2 Port descriptions | 16 |
| 5.2.3 Voice Gateway half-channel loss plan..... | 17 |
| Annex A (informative): Loss and level planning and loudness ratings | 19 |
| A.1 Introduction | 19 |
| A.2 Send and receive levels | 19 |
| A.3 Telephone equipment loudness ratings | 20 |
| A.4 Interface-to-interface loss allocation | 22 |
| Annex B (informative): The Pan-European loss and level plan..... | 24 |
| B.1 Overview | 24 |
| B.2 The Pan-European LR and loss plan derivations | 24 |
| B.3 The Pan-European full-channel loss plan..... | 25 |
| B.4 Calculation spreadsheet..... | 26 |
| Annex C (informative): The North American loss and level plan..... | 27 |
| C.1 Overview | 27 |
| C.2 The North American full-channel loss plan | 27 |
| Annex D (informative): Relationship of channel based loss plans to Q.551..... | 29 |
| Annex E (informative): Bibliography..... | 30 |
| History | 31 |

Intellectual Property Rights

IPRs essential or potentially essential to the present document may have been declared to ETSI. The information pertaining to these essential IPRs, if any, is publicly available for **ETSI members and non-members**, and can be found in ETSI SR 000 314: "*Intellectual Property Rights (IPRs); Essential, or potentially Essential, IPRs notified to ETSI in respect of ETSI standards*", which is available from the ETSI Secretariat. Latest updates are available on the ETSI Web server (<http://webapp.etsi.org/IPR/home.asp>).

Pursuant to the ETSI IPR Policy, no investigation, including IPR searches, has been carried out by ETSI. No guarantee can be given as to the existence of other IPRs not referenced in ETSI SR 000 314 (or the updates on the ETSI Web server) which are, or may be, or may become, essential to the present document.

Foreword

This ETSI Standard (ES) has been produced by ETSI Technical Committee Speech Processing, Transmission and Quality Aspects (STQ), and is now submitted for the ETSI standards Membership Approval Procedure.

The North American version of this joint work is the "Voice Gateway Transmission Requirements" standard. Within TIA it has the number ANSI/TIA-912-B [1].

1 Scope

The purpose of the present document is the harmonization of loss and level planning between the Pan-European and the North American regions, with a global view and the intent that the present document may be subject to adoption by other regions, in future. An equivalent standard has been published by the North American Telecommunications Industries Association (ANSI/TIA-912-B [1]).

The objective of the present document is to specify a loss plan for IP based networks particularly suitable for use by voice gateway manufacturers operating in Europe.

The recommended loss values are based on:

- Pan-European analogue telephone sets as specified in TBR 038 [3];
- digital sets as specified in ITU-T Recommendation P.310 [7]; and
- typical European public network losses.

These loss values may not provide optimum performance in conjunction with network operators whose telephone set loudness ratings or network losses differ significantly from the values used in the present document. Manufacturers may need to modify their loss plans accordingly, but the principles described in the present document provide guidance on how to derive suitable loss values. A spreadsheet is also provided as an annex to assist manufacturers in determining the correct loss values.

The PBX ports referred to in the present document are as defined in ES 201 168 [2] or ANSI/TIA-912-B [1].

NOTE: The present document introduces two variants of the L2 interfaces for transmission planning purposes.

The present document applies to all kind of voice services, irrespective whether they provide:

- real time conversational telecommunication between human subjects; or
- listening-only telecommunication from a machine interface (stored speech) to a human subject; or
- speaking-only telecommunication from a human subject to a machine interface.

The present document is initially limited to voice gateways interfacing to IP telephony networks. For the purposes of the present document, a voice gateway is considered to be a device that performs routing functions between:

- telephones (analogue, digital, IP);
- public and private network trunks;
- IP based networks.

The present document may apply also to loss planning in any purely digital transmission network which may include:

- circuit switched networks;
- frame relay or ATM networks;
- mobile networks.

While the present document does not apply to other services, which may be carried over the same infrastructure, e.g. Voiceband Data or Fax; nevertheless, complying with the present document will, in general, be advantageous for such other services.

2 References

The following documents contain provisions which, through reference in this text, constitute provisions of the present document.

- References are either specific (identified by date of publication and/or edition number or version number) or non-specific.
- For a specific reference, subsequent revisions do not apply.
- For a non-specific reference, the latest version applies.

Referenced documents which are not found to be publicly available in the expected location might be found at <http://docbox.etsi.org/Reference>.

NOTE: While any hyperlinks included in this clause were valid at the time of publication ETSI cannot guarantee their long term validity.

- [1] ANSI/TIA-912-B-2007: "Telecommunications - IP Telephony Equipment - Voice Gateway Transmission Requirements".
- [2] ETSI ES 201 168 (V1.2.1): "Speech processing, Transmission and Quality aspects (STQ); Transmission characteristics of digital Private Branch eXchanges (PBXs) for interconnection to private networks, to the public switched network or to IP gateways".
- [3] ETSI TBR 038 (1998): "Public Switched Telephone Network (PSTN); Attachment requirements for a terminal equipment incorporating an analogue handset function capable of supporting the justified case service when connected to the analogue interface of the PSTN in Europe".
- [4] ITU-T Recommendation G.100: "Definitions used in Recommendations on general characteristics of international telephone connections and circuits".
- [5] ITU-T Recommendation G.101: "The transmission plan".
- [6] ITU-T Recommendation G.107: "The E-Model, a computational model for use in transmission planning".
- [7] ITU-T Recommendation P.310: "Transmission characteristics for telephone band (300-3 400 Hz) digital telephones".
- [8] ITU-T Recommendation G.111: "Loudness ratings (LRs) in an international connection".
- [9] ITU-T Recommendation G.121: "Loudness ratings (LRs) of national systems".

3 Definitions and abbreviations

3.1 Definitions

For the purposes of the present document, the following terms and definitions apply:

decoding: digital-to-analogue conversion

encoding: analogue-to-digital conversion

full-channel loss plan: loss plan where each loss is defined for a complete path between two acoustical interfaces

half-channel loss plan: loss plan where each loss is defined for a path between an acoustical interface and an (electrical) standard reference point, the 0 dBr point

half-channel receive loudness rating: RLR_{HC} is defined as the RLR at the 0 dBr point

half-channel send loudness rating: SLR_{HC} is defined as the SLR at the 0 dBr point

interface: Pan-European term for the input or output circuit connections

loudness rating: send and receive loudness ratings are collectively referred to as the loudness rating

port: North American term for the input or output circuit connections

receive loudness rating: electrical/acoustic conversion characteristic of the terminating equipment

reference level: half-channel send loudness rating of 8 dB

reference level point: VG-to-IP network connection point (also termed the 0 dBr or zero-level point)

send loudness rating: acoustic/electrical conversion characteristic of the originating equipment

telephony terminal: terms telephone, terminal equipment, and end point are equivalent, and refer to the device that performs the acoustic/electrical conversion

NOTE: The terms interface and port are used interchangeably in the present document.

transcoding: transcoding refers to the conversion from one voice coding algorithm to another

NOTE: E.g. ITU-T Recommendations G.711 to G.729A (see bibliography).

voice gateway: device which routes packetized voice from one end-point to another, and provides other voice related functions that a data gateway would not provide

NOTE: It may provide interfaces to analogue and digital voice terminals and access to public and private switched telephone networks and WANs.

3.2 Abbreviations

For the purposes of the present document, the following abbreviations apply:

| | |
|--------|--|
| AAL | Analogue Access Line (Analogue Interface at DEO) |
| AAL(D) | Analogue Access Line (Digital Interface at PBX) |
| ATM | Asynchronous Transfer Modus |
| ATT | Analogue Tie Trunk |
| CATV | CABle TV |
| CB | Channel Bank |
| DAL | Digital Access Line |
| dB SPL | Sound Pressure Level in dB |
| DC | Direct Current |
| DEO | Digital End Office |
| DGS | DiGital Station |
| DT | Digital Trunk |
| DTMF | Dual Tone Multi Frequency |
| FXD | Foreign eXchange Digital |
| FXO | Foreign eXchange Office |
| FXS | Foreign eXchange Station |
| IAD | Integrated Access Device |
| IP | Internet Protocol |
| LAN | Local Area Network |
| LD | Loss Distortion |
| LR | Loudness Rating |
| MRP | Mouth Reference Point (according to ITU-T Recommendation P.64) |
| MTA | Multimedia Terminal Adaptor |
| OLR | Overall Loudness Rating |
| ONS | On Premise Station |
| OPS | Off Premise Staion |
| PAL | Packet Access Line |
| PBX | Private Branch eXchange |
| PBX | Private Branch eXchanges |
| PSTN | Public Switched Telephone Network |
| RLR | Receive Loudness Rating |

| | |
|-------------------|--------------------------------------|
| RLR _{HC} | Half-Channel Receive Loudness Rating |
| RLR _T | Telephone Receive Loudness Rating |
| SLR | Send Loudness Rating |
| SLR _{HC} | Half-Channel Send Loudness Rating |
| SLR _T | Telephone Send Loudness Rating |
| TDM | Time Division Multiplex |
| TEL _R | Talker Echo Loudness Rating |
| VG | Voice Gateway |
| WAN | Wide Area Network |

4 Loss and level planning

4.1 Overview

Developing a loss plan can be a complex process, as the objective is to ensure a satisfactory overall loudness rating for all connections types. To do this the loudness ratings of the end points (telephones) and the transmission loss between the end points, for each connection type must be known.

This is a trivial exercise in a purely IP telephony environment, if one assumes that the end points are digital telephone sets with an LR of 8 dB and 2 dB (in line with the ITU-T Recommendation G.101 [5]), and that no gains or losses are introduced in the digital transmission path. In this case the OLR for any digital telephone set-to-set connection world-wide is 10 dB, which is the ITU-T objective.

The complexity is introduced when the IP telephony network connects to analogue telephones and trunks. In this case the LRs of the telephones and trunks vary, although a loss-less digital transmission path can be maintained.

A half-channel loss plan for national and international IP telephony networks can be implemented based on the premise that only the LRs vary, and that the IP network does not introduce any additional gain or loss.

VGs can also connect to existing analogue and TDM based digital networks. In North America these connections require losses to be defined on a port-to-port basis for technical and sometimes regulatory reasons, and full-channel loss plans are required for VGs.

4.2 Half-channel loss and level plans

The basic concept in the half-channel loss plan is to adjust all send levels on an IP telephony network to the optimum SLR_{HC} of 8 dB. Digital telephone sets provide the reference SLR of 8 dB by definition. This is not an original concept, as it is the basis of the European dBr reference system. The recent move to standardize the North American digital telephone set LRs to the ITU-T recommended levels now makes this practical for IP telephony networks.

NOTE: Clause 5 of the present document describes the half-channel loss implementation in more detail.

The same basic concept could be applied to the current non-IP PSTN and private networks, but existing industry standards and regulatory requirements may make it difficult to implement.

4.3 Loudness rating definitions

4.3.1 Loudness rating

Loudness ratings are a function of the acoustic/electrical conversion characteristics of the originating and terminating equipment (typically telephones). These ratings are determined by measuring the conversion characteristics over the telephony frequency band and by applying a weighting factor for each 1/3 octave band. See ITU-T Recommendation G.100 [4].

These loudness ratings are defined as the Send Loudness Rating (SLR) and Receive Loudness Rating (RLR), and the sum of these ratings (plus any circuit gain or loss) is defined as the Overall Loudness Rating (OLR).

To compensate for this, the VG loss pads, as specified in table 1 and shown in figure2, have 3 dB more loss for the L21 interface compared to the L22 interface. These combinations of set loudness ratings and VG loss pads provide the optimum SLR_{HC} and RLR_{HC} of 8 dB and 2 dB respectively for both interfaces, which produces the optimum OLR of 10 dB in both directions.

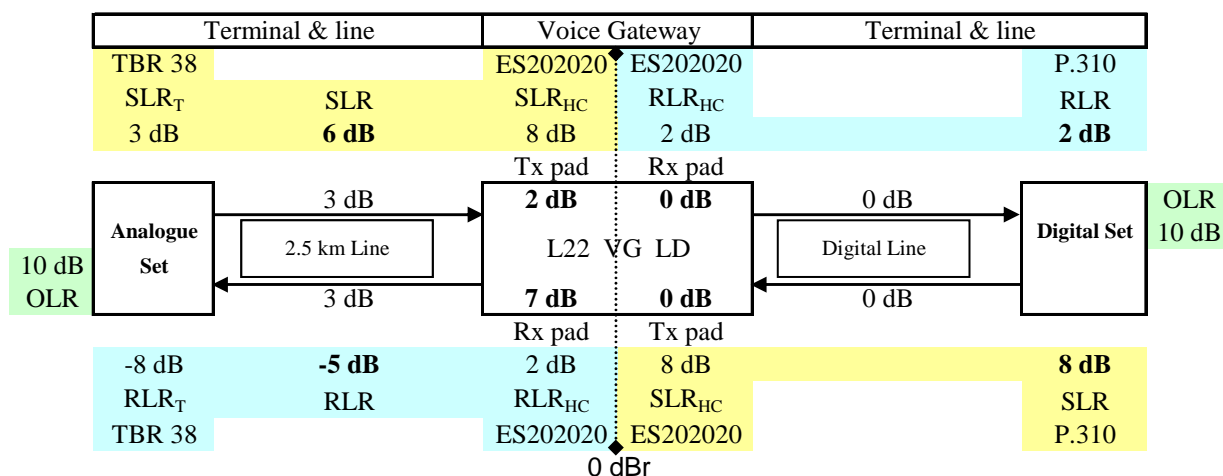

Figure 2: Scenario 2: Analogue Set-VG-Analogue Set

Figure 3 combines Scenarios 1 and 2 with an analogue set on a 3 dB line connected to the L22 interface of the VG and a digital set connected to the LD interface on the VG. Again these combinations of set loudness ratings and VG loss plans provide the optimum SLR_{HC} and RLR_{HC} of 8 dB and 2 dB respectively, which produces the optimum OLR of 10 dB in both directions. However, Scenario 3 illustrates the idea that any half-channel interface can be combined with any other half-channel interface to determine the OLR from the SLR_{HC} and RLR_{HC} at the 0 dBr point.

Although these scenarios only show connections on the same VG, the concept can be expanded to any packet network situation by inserting the packet network at the 0 dBr point.

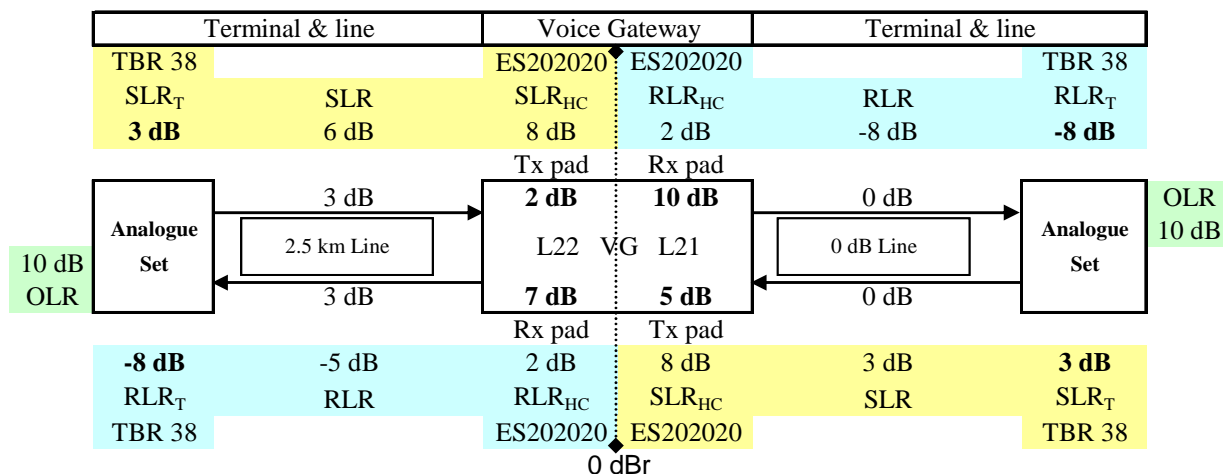

Figure 3: Scenario 3: Analogue Set-VG-Digital Set

The final scenario, shown in figure 4, is similar to Scenario 2 except both analogue sets are on 4 dB lines and instead of a Enterprise VG they are connected to a Local Exchange or to a PSTN-type VG that has the same constant-voltage with current limit line interfaces as a Local Exchange. The nominal 4 dB line loss and 7 dB Rx loss pad values in the Local Exchange are taken from a background paper on TBR 38. The SLR of 7 dB and RLR of -4 dB combined with the 7 dB Rx pad to produce SLR_{HC} and RLR_{HC} values of 7 dB and 3 dB respectively. This produces the optimum OLR of 10 dB, but it is slightly out of sync with the optimum SLR_{HC} and RLR_{HC} values of 8 dB and 2 dB, respectively. Keep in mind that these are nominal loss planning values and do not reflect the production tolerance of telephones or the range of subscriber lines. In this scenario, the terminal does not include the line because TBR 38 only specifies SLR_T and RLR_T . In the previous VG scenarios, the terminal & line demarcation aligns with the SLR and RLR boundaries, which includes both the set and the subscriber line.

The purpose of including this Local Exchange scenario is to illustrate the loss plan differences between the L22 VG interface in scenarios 2 and 3 and the L2 Local Exchange interface in scenario 4. The L22 Tx pad is 2 dB while the Local Exchange Tx pad is 0 dB for essentially the same connection, an analogue set on a 2,5 to 3 km line to a line card. In some situations, the same product may be capable of being either a VG or a Local Exchange. Loss plan designers should be aware of the subtle difference between the two loss plans.

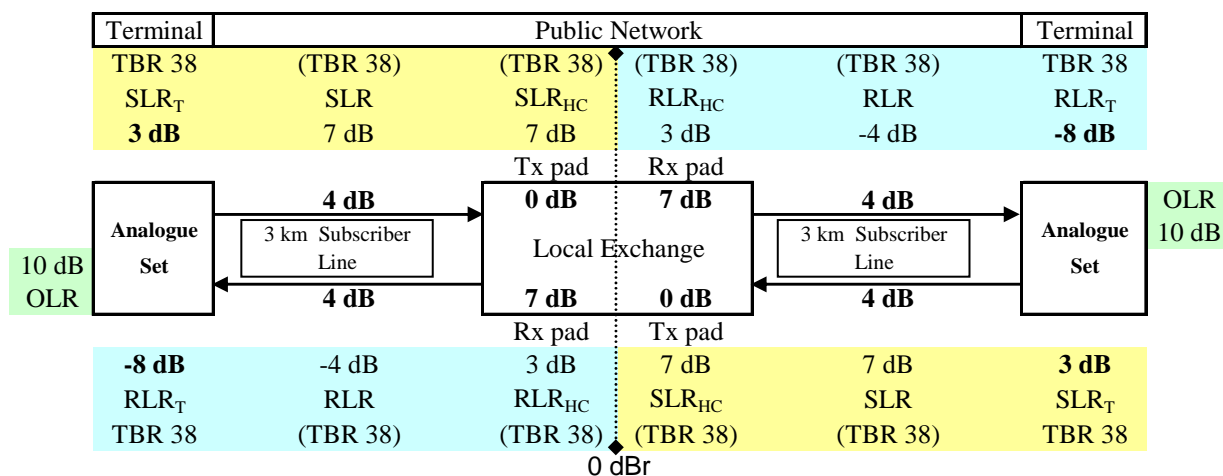

Figure 4: Scenario 4: Analogue Set-Local Exchange-Analogue Set

4.4 0 dBr Reference level point

The reference or 0 dBr point for IP telephony is defined as the point where a connection is made to a packet based network. This is equivalent to a 0 dBr point in standard TDM circuit switched telephony. This is illustrated in the "LR Derivations" spreadsheet in annex B.

4.5 Reference level

The reference level for IP telephony is an SLR_{HC} of 8 dB.

NOTE: The reference level is defined as an equivalent send loudness rating of 8 dB, not a power level at 1 020 Hz.

4.5.1 Network level changes

It is critical for the operation of a half-channel loss plan that no gain or loss is inserted during transmission through the IP network. Any level changes due to transcoding for example, should be less than 1 dB.

4.6 Harmonized half-channel loss and level plans

The present document gives the requirements for the harmonized half-channel loss and level plans for two regions, the Pan-European region and the North American region.

These harmonized half-channel plans define the following (for IP network connections):

- the LR of each interface;

NOTE: The LR of an interface with no circuit loss between the terminal and the interface is equivalent to the terminal LR.

- the transmit losses required to achieve an SLR_{HC} of 8 dB for each interface;
- the receive losses required to achieve a satisfactory OLR for each receiving end point.

4.7 Regional full-channel loss and level plans

Annexes B and C of the present document provide the full-channel loss and level plans for two regions, the Pan-European region and the North American region.

Each full-channel plan defines:

- the LR of each interface;
- the interface-to-interface loss for each interface to every other interface;
- The OLR from each interface to every other interface based on the LRs, and the corresponding interface-to-interface loss.

5 Requirements for the harmonized half-channel loss and level plan

As stated in clause 4.2, the basic concept in the half-channel loss plan is to adjust all transmit levels on an IP telephony network to the same optimum half-channel SLR_{HC} - digital telephone sets provide the reference SLR of 8 dB by definition.

The half-channel loss plan operates on the following principles:

- The originating entity will adjust the SLR of the sending end point to 8 dB at the ingress to the IP network, i.e. the 0 dBr point. The SLR at the 0 dBr point is defined as the SLR_{HC} (Half-Channel SLR).
- The terminating entity will adjust the RLR at the egress from the IP network to achieve the desired OLR at the receiving end point. The RLR at the 0 dBr point is defined as the RLR_{HC} (Half-Channel RLR).

NOTE: The internationally recognized optimum OLR is 10 dB.

The advantage of this approach is that neither entity requires knowledge of the other, and loss planning becomes a local issue.

The tables provided in the following clauses for either region are structured according to the same principles. A reference configuration is illustrated in the "LR Derivations" spreadsheet in annex B.

5.1 The Pan-European half-channel loss plan

5.1.1 Voice Gateway connections

Figure 5 illustrates the connection types for a typical Pan-European VG application. There may be other applications not covered by this diagram, but sufficient information is provided for users to determine the applicable connection types for their particular application, and the corresponding interface losses to be applied.

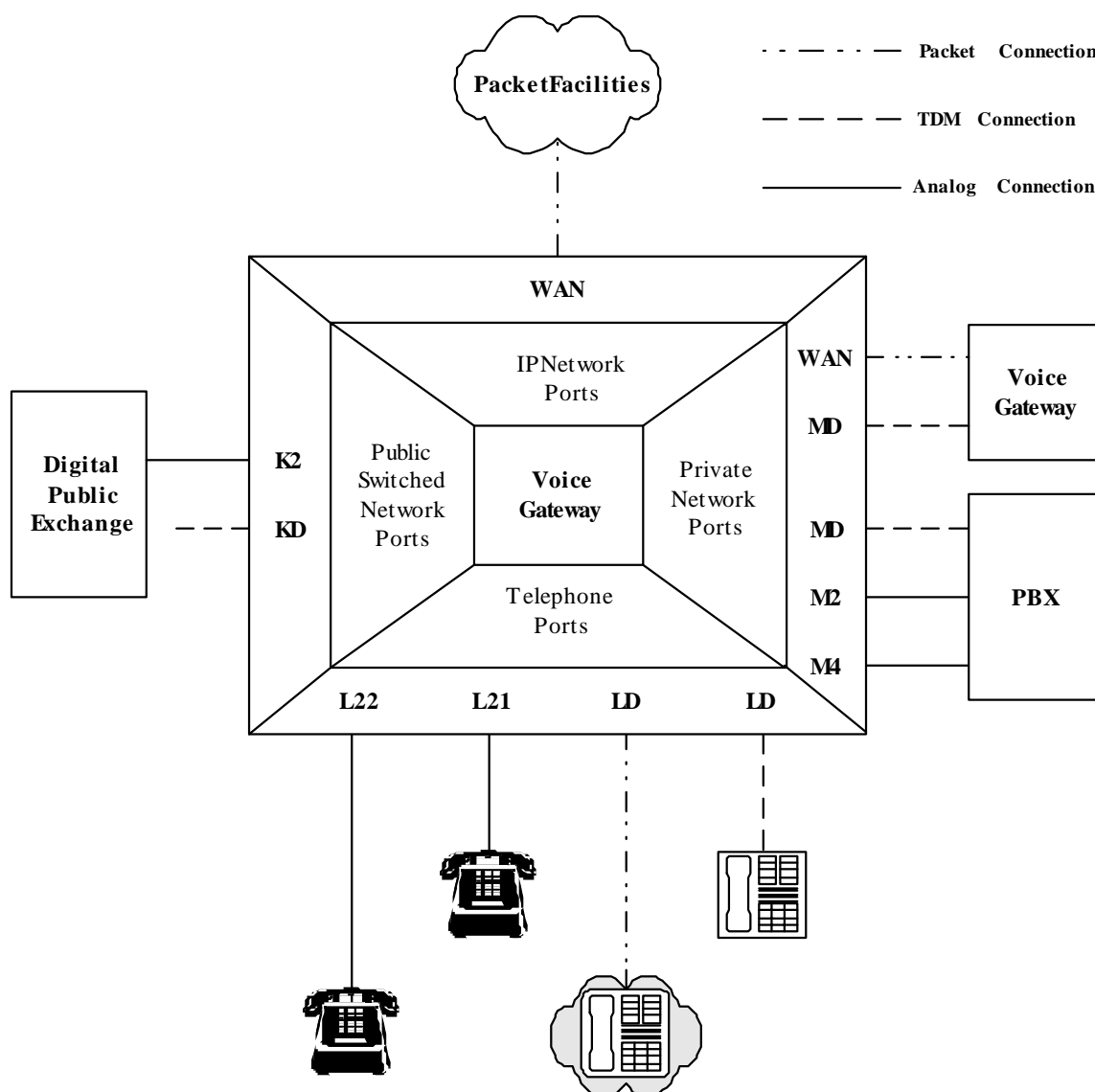

Figure 5: Pan-European Voice Gateway connections

NOTE: Figure 5 is based in part on figures 1 and 2 of ES 201 168 [2].

5.1.2 Interface descriptions

The following descriptions were adapted in part from clause 3.1.9 of ES 201 168 [2].

Telephone Interfaces:

L2 - 2-wire Analogue

The L2 interface provides for the connection of 2-wire analogue extension lines and will carry signals such as speech, voice-band analogue data and DTMF signals, etc. In addition, the interface L2 provides for ordinary functions such as direct current (DC) feeding, DC signalling, ringing, etc.

NOTE 1: The L2 interface is subdivided into short lines and long lines for transmission planning purposes. These are designated L21 and L22 respectively, and are equivalent to the North American ONS and OPS ports.

LD - Digital

The LD interface provides for the connection of digital terminals that conform to the LR requirements of ITU-T Recommendation P.310 [7].

NOTE 2: This definition differs from the one given in ES 201 168 [2], by also including system specific terminals.

Public Network Interfaces

K2 - 2-wire Analogue

The K2 interface provides for the connection of 2-wire analogue subscriber lines between a VG and a public exchange.

KD - Digital

The KD interface provides for the connection of a digital access to the public switched network.

Private Network Interfaces

M2 - 2-wire Analogue

The M2 interface provides for the connection to 2-wire analogue circuits (e.g. leased lines) between a VG and a PBX.

M4 - 4-wire Analogue

The M4 interface provides for the connection to 4-wire analogue circuits (e.g. leased lines) between a VG and a PBX.

NOTE 3: The M4 interface is used as the generic private network analogue interface for loss planning purposes. The required losses for the M4 and M2 interfaces are the same.

MD - Digital

The interface MD provides for connection to a digital inter-VG or PBX circuit.

NOTE 4: The MD interface shares the KD designation for loss planning purposes (they are both digital connection with zero loss).

Packet Network Interfaces

WAN - Wide Area Network

A WAN interface connects from VGs to packet-based wide area networks.

NOTE 5: The term WAN is used in the same context as the public switched network, in that it represents connections between geographically separated VGs. It should be noted that WAN and LAN are synonymous from a transmission perspective.

5.1.3 Voice Gateway half-channel loss plan

Table 1 shows the VG half-channel loss plan for the Pan-European region, given in loudness ratings and respective loss.

Table 1: Voice gateway half-channel loss plan

| | | WAN | | 0 dBr Point | | | | | |
|------|-----|----------------|-------------------|-------------|-------------------|---------|-----|------------------|----------------------------|
| | | | | ↓ | | | | | |
| | | a | b | c | d | e | f | g | h |
| | | | | =(a + b) | =(e + f) | | | =(c + d) | =(8 + d) |
| (dB) | SLR | Tx Loss | SLR _{HC} | | RLR _{HC} | Rx Loss | RLR | OLR ² | Desirable OLR ² |
| L21 | 3 | 5 | 8 | | 2 | 10 | -8 | 10 | 10 |
| L22 | 6 | 2 ³ | 8 | | 2 | 7 | -5 | 10 | 10 |
| LD | 8 | 0 | 8 | | 2 | 0 | 2 | 10 | 10 |
| WAN | 8 | 0 | 8 | | 2 | 0 | 2 | 10 | 10 |
| KD | 8 | 0 | 8 | | 2 | 0 | 2 | 10 | 10 |
| K2 | 16 | -6 | 10 ¹ | | 4 | -1 | 5 | 14 | 12 |
| M4 | 10 | -2 | 8 | | 2 | -2 | 4 | 10 | 10 |

| | |
|----------|---|
| Column a | shows the SLR of the telephone and trunk between the acoustic interface and the connection point to the VG. |
| Column b | shows the VG transmit loss required to achieve the required SLR_{HC} at the 0 dBr point. |
| Column c | shows the resulting Half-Channel SLR (SLR_{HC}) at the 0 dBr point (WAN). |
| Column d | shows the resulting Half-Channel RLR (RLR_{HC}) at the 0 dBr point (WAN). |
| Column e | shows the VG receive loss required to achieve the desirable OLR, based on the RLR shown in column f, and the optimum SLR of 8 dB. |
| Column f | shows the RLR of the telephone and trunk between the acoustic interface and the connection point to the VG. |
| Column g | shows the resulting OLR, based on the actual SLR. |
| Column h | shows the desirable OLR, based on the optimum SLR of 8 dB. |

NOTE 1: It is not possible to achieve the optimum SLR_{HC} of 8 dB for connections from analogue networks due to the potential for loop instability.

NOTE 2: The OLR values shown in the table are as perceived by the listener, i.e. this is shown as a one-way connection.

NOTE 3: Although the present document does not apply to Local Exchanges, in some situations, the same product may be capable of being either a VG or a Local Exchange. Loss plan designers should be aware of the subtle difference between the two loss plans: The L2 Tx loss at a Local Exchange is 0 dB, rather than the 2 dB for an L2 Tx loss at an Enterprise Voice Gateway. See figure 4.

5.2 The North American half-channel loss plan

5.2.1 Voice Gateway connections

Figure 6 illustrates the connection types for a typical North American voice gateway application. There may be other applications not covered by this diagram, but sufficient information is provided for users to determine the applicable connection types for their particular application, and the corresponding port losses to be applied.

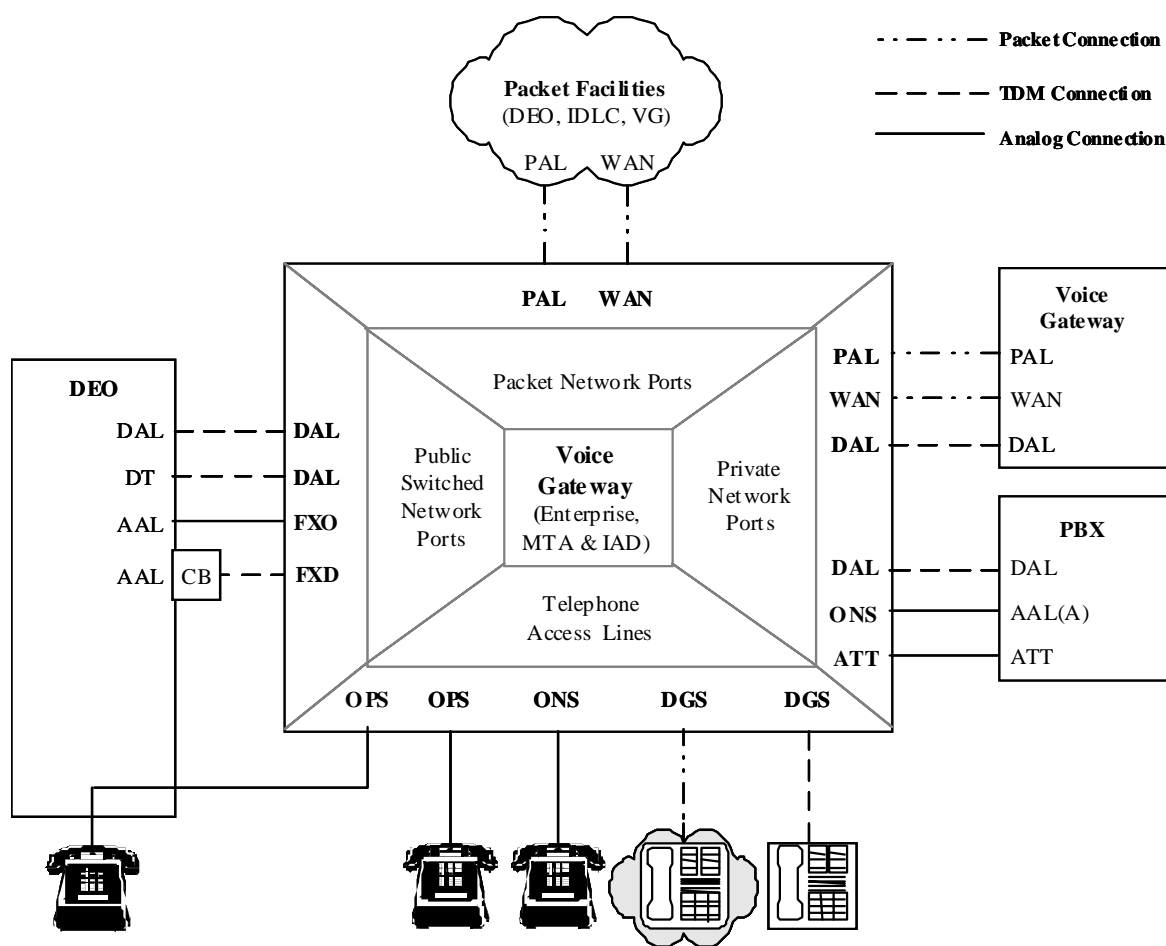

Figure 6: North American Voice Gateway connections

5.2.2 Port descriptions

ONS - On Premise Station

An ONS interface is used for standard analogue telephones, representative of 2500-type telephones, located on the same premises as the VG, and is the direct equivalent of the PBX ONS connection. The connection loss from the station to the VG is typically low. The term FXS is sometimes used in place of ONS.

OPS - Off Premise Station

An OPS interface is used for standard analogue telephones, representative of 2500-type telephones, not located on the same premises as the VG, and is the direct equivalent of the PBX OPS connection. The connection loss from the station to the VG is typically significant. This port is also used for analogue two-wire connections to remote VGs, PBXs and Key Systems, via a local DEO. The term FXS is sometimes used in place of OPS.

DGS - Digital Station

A DGS interface is used for all digital telephones conforming to ANSI/TIA/EIA-810-B (see bibliography).

NOTE 1: This includes digital telephones based on both TDM and packet transmission.

WAN - Wide Area Network

A WAN interface connects from Enterprise VGs to packet-based wide area networks. The transmission path within the WAN is entirely digital. The only distinction between a WAN port and a PAL port is that the PAL port supports less bandwidth.

NOTE 2: The term WAN is used in the same context as PSTN, in that it represents connections between geographically separated VGs. It should be noted that WAN and LAN are synonymous from a transmission perspective.

PAL - Packet Access Line

A PAL interface connects from MTA or IAD VGs to packet-based wide area networks. The transmission path within the PAL is entirely digital. The only distinction between a WAN port and a PAL port is that the PAL port supports less bandwidth.

DAL - Digital Access Line

A DAL interface connects to all TDM-based digital network connections and it is the direct equivalent of the PBX DAL interface. It should be noted that although the connection to the public switched network may be digital, there is no guarantee that the end-to-end connection will remain digital.

FXO - Foreign Exchange Office

An FXO interface is used for analogue connections to a central office. It is equivalent to the PBX term AAL(A), or analogue access line (analogue).

FXD - Foreign Exchange Digital

An FXD interface is used for digital connection, via a channel bank, to an analogue central office. It is equivalent to the PBX term AAL(D), or analogue access line (digital). A loss equivalent to the typical analogue connection loss has to be inserted at the VG, as the channel bank is located close to the central office.

ATT - Analogue Tie Trunk

An ATT interface is used for four-wire analogue private network connections, typically via the public network. This port also applies to two-wire VG interfaces that use an external four-wire termination set (4WTS) to connect to the public network. PBX documents may either use the same term, ATT, or the older term, A/TT.

5.2.3 Voice Gateway half-channel loss plan

Table 2 shows the VG half-channel loss plan for North America, given in loudness ratings and respective loss.

Table 2: Voice gateway half-channel loss plan

| | | WAN/PAL | | | | | | | | |
|------|-----|----------------------|-------------------|-------------------|----------------------|-----|---|------------------|---------------|--|
| | | 0 dBr Point | | | | | | | | |
| | | | | ↓ | | | | | | |
| | | a | b | c | d | e | f | g | h | |
| | | | | =(a + b) | =(e + f) | | | =(c + d) | =(8 + d) | |
| (dB) | SLR | Tx Loss ¹ | SLR _{HC} | RLR _{HC} | Rx Loss ¹ | RLR | | OLR ³ | Desirable OLR | |
| ONS | 4 | 3 | 7 | 2 | 9 | -7 | | 9 | 10 | |
| OPS | 8 | 0 | 8 | 3 | 6 | -3 | | 11 | 11 | |
| DGS | 8 | 0 | 8 | 2 | 0 | 2 | | 10 | 10 | |
| WAN | 8 | 0 | 8 | 2 | 0 | 2 | | 10 | 10 | |
| PAL | 8 | 0 | 8 | 2 | 0 | 2 | | 10 | 10 | |
| DAL | 8 | 0 | 8 | 2 | 0 | 2 | | 10 | 10 | |
| FXO | 17 | -6 | 11 ² | 6 | 0 | 6 | | 17 | 14 | |
| FXD | 14 | -3 | 11 ² | 6 | 3 | 3 | | 17 | 14 | |
| ATT | 15 | 0 | 15 | 4 | 3 | 1 | | 19 | 12 | |

Column **a** shows the SLR of the telephone and trunk between the acoustic interface and the connection point to the VG.

Column **b** shows the transmit loss required to achieve the required SLR_{HC} at the 0 dBr point, except for the analogue trunks which use the historical send loss.

Column **c** shows the resulting Half-Channel SLR (SLR_{HC}) at the 0 dBr point (WAN/PAL).

Column **d** shows the resulting Half-Channel RLR (RLR_{HC}) at the 0 dBr point (WAN/PAL).

- Column **e** shows the receive loss required to achieve the desirable OLR, based on the RLR shown in column **f**, and the optimum SLR of 8 dB, except for the analogue trunks which use the historical receive loss.
- Column **f** shows the RLR of the telephone and trunk between the acoustic interface and the connection point to the VG.
- Column **g** shows the resulting OLR, based on the actual SLR.
- Column **h** shows the desirable OLR, based on the optimum SLR of 8 dB.

NOTE 1: Losses have been selected as multiples of 3 dB, assuming that this simplifies the implementation. All numbers in table 2 are in dB.

NOTE 2: It is not possible to achieve the optimum SLR_{HC} of 8 dB for connections from analogue networks due to the potential for DTMF signalling overload.

NOTE 3: The OLR values shown in the table are as perceived by the listener, i.e. this is shown as a one-way connection.

Annex A (informative): Loss and level planning and loudness ratings

This tutorial is based on one in the North American Voice Gateway Transmission Requirements standard, modified for the Pan-European context.

A.1 Introduction

Telephony loss planning is concerned with the end-to-end loss between the sender and receiver over a telephony network.

It is called a loss plan, as the primary purpose is to approximate the free air loss between a talker and listener in a normal conversation. A secondary purpose is to control echo due to impedance mismatches in connections with long delays.

The loss plan is also related to the optimization of signal levels in equipment involved in the end-to-end connection.

A.2 Send and receive levels

The objective of a telephone connection is to simulate a 1 metre free air path between two talkers. This simulation involves several objective and subjective factors that are not present in the 1 metre air path. These include monaural listening, narrowband frequency response, the preferred listening level and others. For any telephone connection, the optimum OLR to achieve the preferred listening level is 10 dB. In a digital connection, the network loss is zero; therefore, the required loudness ratings are adjusted in the send and receive sections of the digital telephone set.

The send and receive levels of a telephone relate the conversion of acoustic pressure to electrical power and vice versa. The acoustic pressure units are in dBPa (Pascals), and the electrical power units are in dBm.

Pressure is measured in Newtons per square meter (Pascals), and the relationship between dB SPL and dB Pa is shown in table A.1.

Table A.1: Acoustic Levels

| dB SPL | dB Pa | Parameter |
|--------|-------|--|
| 94 | 0 | Acoustic Pressure referred to One Pascal |
| 89,3 | -4,7 | Average speech level at the MRP |
| 0 | -94 | Lower limit of human hearing |

A.3 Telephone equipment loudness ratings

The loudness ratings of a telephone are the unit-less acoustic-to-electrical-to-acoustic conversion factors as shown in figure A.1. As the acoustic and electrical units are both relative levels in dBs, the conversion factors are also in dBs.

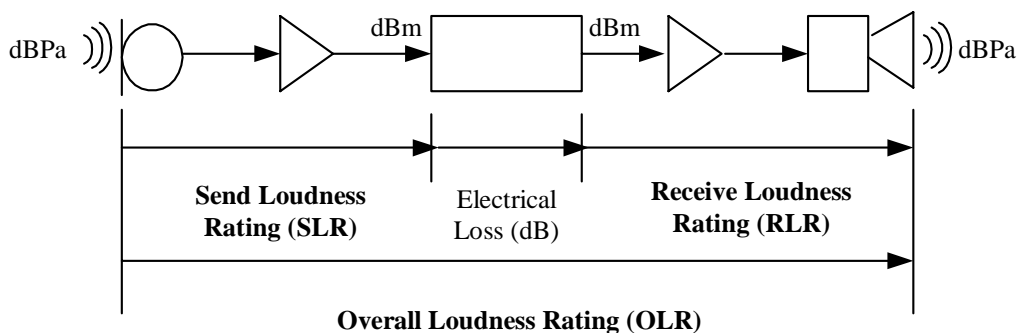

Figure A.1: Terminal Loudness Ratings

The loudness ratings of the three telephone ports defined in the present document are shown in table A.2.

Table A.2: Telephone Loudness Ratings

| Telephone Port | SLR (dB) | RLR (dB) | Notes |
|----------------|----------|----------|-------|
| L21 | 3 | -8 | 1 |
| L22 | 6 | -5 | 2 |
| LD | 8 | 2 | 3 |

NOTE 1: The L21 loudness ratings are representative of TBR 038 [3] type analogue telephones operating on short lines with the typical battery feed and $270 \Omega + (750 \Omega \parallel 150 \text{ nF})$ impedance characteristics of VG L2 ports.

NOTE 2: The L22 loudness ratings are representative of TBR 038 [3] type analogue telephones operating on nominal 2,5 km lines with 3 dB of loss and the typical battery feed and $270 \Omega + (750 \Omega \parallel 150 \text{ nF})$ impedance characteristics of VG L2 ports.

NOTE 3: The LD loudness ratings of SLR = 8 dB and RLR = 2 dB conform to the requirements specified in ITU-T Recommendation P.310 [7].

Overall Loudness Ratings

The Overall Loudness Rating (OLR) of a connection is the sum of the sending terminal SLR, any system or network loss, and the receiving terminal RLR. This is illustrated in figure A.2 for set-to-set calls within a VG.

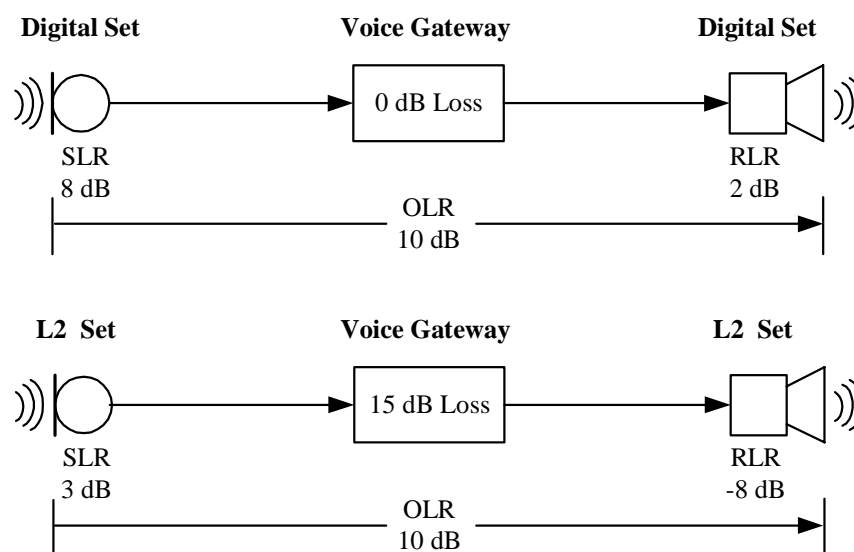

Figure A.2: Telephone-to-telephone Overall Loudness Ratings

Optimum Overall Loudness Ratings

Figure A.3 shows a plot of OLR versus R-Value using the E-Model. The majority of the OLR values in table 1 are at or above an R-Value of 90, which puts them in the "very satisfied" category.

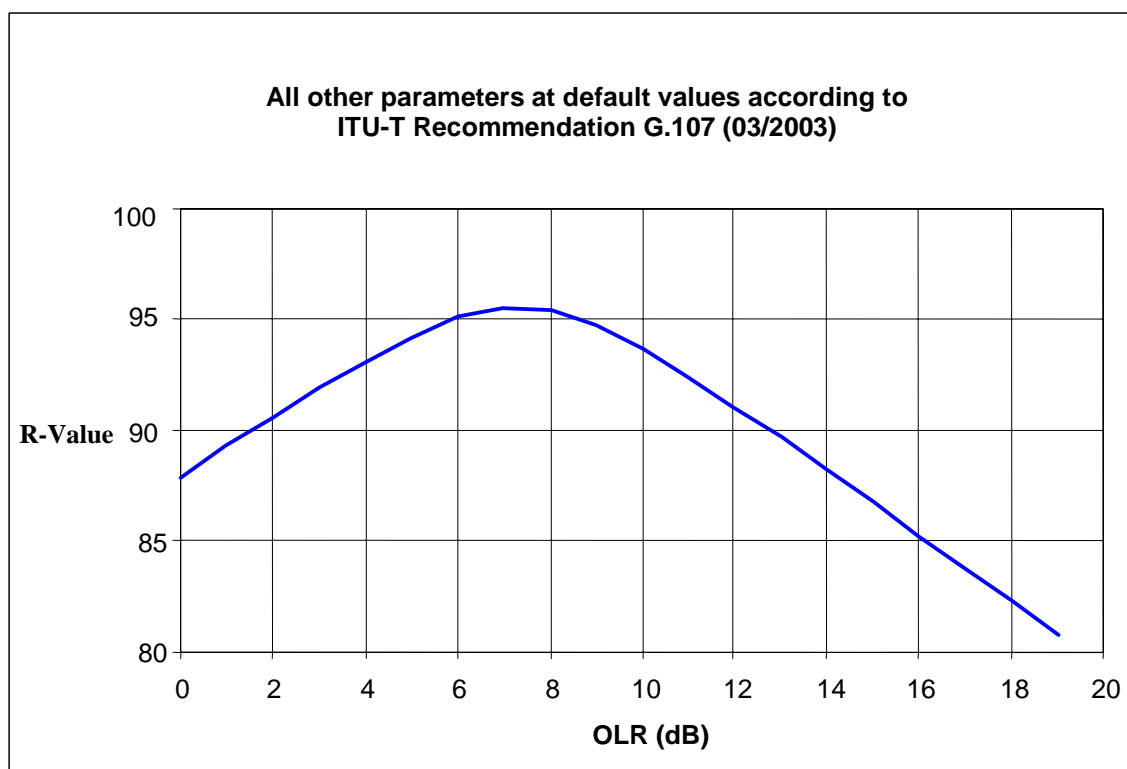

Figure A.3: E-Model Optimum Overall Loudness Rating

The recommended value for the Overall Loudness Rating (OLR) for standard applications of 3,1 kHz handset telephony is 10 dB (ITU-T Recommendation G.111 [8]).

Investigations have shown the optimum OLR to be somewhat lower than 10 dB for connections free from echo and sidetone problems. However, lower values of OLR increase the risk of perceiving echo and too low OLR values may also (if present for many years) increase the risk of hearing damage for telephone operators.

Lower speech levels corresponding to an OLR somewhat higher than 10 dB is not as critical as high speech levels as long as the deviation from 10 dB is moderate. Somewhat too low speech levels will "only" lead to small deterioration of the perceived speech quality.

The recommended value of 10 dB is therefore justified based on the above discussion, and also considering the relatively flat speech quality curve around the optimum value of 7 dB.

Deviations from recommended OLR

Connections with very low OLR values (down to OLR = -5 dB) have been in use, e.g. in Europe for internal connection between telephone sets of the same PBX.

For the development of an appropriate migration strategy from too low to recommended OLR it should be taken into consideration that, customers may react strongly on abrupt changes in OLR, see ITU-T Recommendations G.101 [5], clause 4.2 and G.111 [8], clause 3.2 for further guidance.

Connections via tandem analogue trunks may require higher insertion loss for stability and echo control reasons and are not likely to achieve an OLR close to 10 dB. Each decibel of increase in OLR (if applied to both directions of transmission) will account twice for the Talker Echo Loudness Rating (TELR), thus improving the suppression of any echo which may occur.

Derivation of Network interface loudness ratings

Network interface Loudness Ratings (LRs) are derived from the combination of terminal loudness ratings and nominal network losses. The example in figure A.4 shows the derivation of the network interface SLR = 16dB and RLR = 5dB for the K2 analogue network interface.

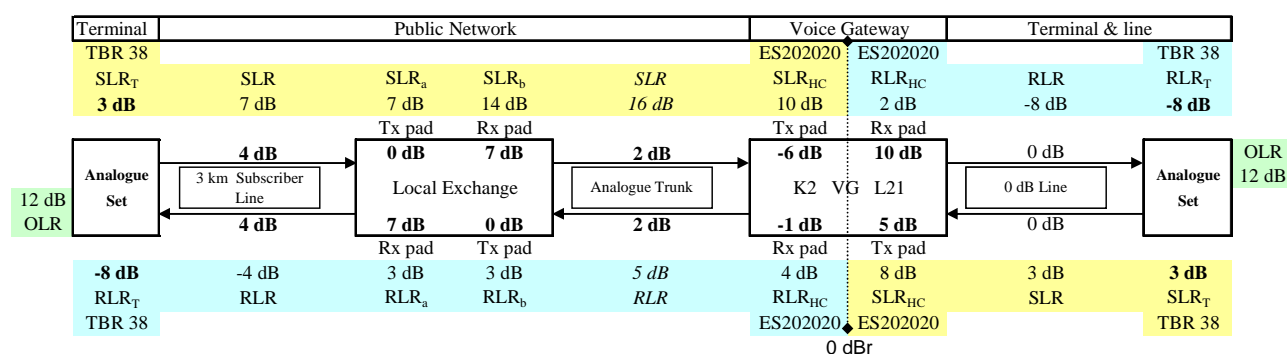

Figure A.4: Derivation of K2 network interface Loudness Ratings

A.4 Interface-to-interface loss allocation

NOTE: The following discussion is only relevant to the North American full-channel loss plan. The use of the half-channel transmit and receive losses for the Pan-European full-channel plan ensures optimum levels at the 0 dBr point.

It should be noted, that the actual allocation of the interface-to-interface loss to send and receive direction directly influences the available dynamic range of the PCM coding scheme. This may lead to substantial impacts on speech transmission quality as perceived by the user.

Care should be taken to ensure that excessive input gain or loss does not cause either overload, or a poor signal-to-noise ratio, at the zero-level point.

EXAMPLE: The ONS to OPS loss is specified as 9 dB.

This could be implemented (in an extreme case) as an ONS input loss of -9 dB (9 dB gain), and an OPS output loss of 18 dB. The overall loss would be 9 dB, but the half-channel SLR at the 0 dBr point would be -5 dB ([ONS SLR = 4] + [Tx loss = -9] = -5 dB).

SLR 8 dB = -19 dBm0 for an average talker. ONS SLR 4 dB plus 9 dB of gain means the average talker power would be -6 dBm0. A loud talker/loud set might add another 9 dB raising the power to +3 dBm0, which is the codec overload level point, where clipping occurs. Voice peaks are about 12 dB higher than the average level, so the average talker would have peaks at +6 dBm0, 3 dB above the clipping point and the loud talker would be always be clipping. Obviously, adding 9 dB of transmit gain followed by 18 dB of attenuation is the wrong strategy for this connection. The correct approach is 3 dB of transmit loss, followed by 6 dB of receive-side loss.

Annex B (informative): The Pan-European loss and level plan

B.1 Overview

Historically, separate national transmission plans have been enforced and utilized in European countries. Such national transmission plans were, in general, based on the appropriate ITU-T Recommendations. Therefore, the inter-country, intra-European telephony connections were ruled by the International transmission plan as per ITU-T Recommendations G.101 [5], G.111 [8] and G.121 [9]. Hence, there was no reason to issue a Pan-European Loss and Level Plan.

Regulatory treatment of a telephony connection in Europe consists of two parts: regulation of the public network (through the Directives on an Open Network Provision) and regulation of the terminal market (through a "terminal Directive"). Both of these regulations are undergoing changes with the effect that national regulatory authorities do not intervene where quality is ensured through effective competition.

The new directive for Radio equipment and Telecommunications Terminal Equipment (the "R&TTE" directive) includes a possibility for the Commission to issue regulation regarding voice performance. However as long as the market actors behave in a responsible manner, there will be no EU regulation of voice performance of customer premises equipment connected to a public network.

Regarding regulation of public networks, major changes will take place. Telecommunications services delivered over all types of "communications infrastructures" will be covered, including CATV and IP networks. Obligations to provide services with adequate quality will remain, however with increased choices allowed regarding quality levels. It is not foreseen that any Pan-European level plan will emerge due to regulation of "communications infrastructure".

For the telecommunications industry it is however of value to arrive at a common transmission plan for future networks, to ensure successful global communications. To this end a Pan-European full-channel loss plan has been developed using the LR values derived for the half-channel loss plan. This full-channel plan is has been developed to assist manufacturers in achieving satisfactory voice performance, and is not a regulatory requirement.

The full-channel loss plan analyses showed that, unlike the North American case, the same transmit and receive losses could be used for both the half-channel and full-channel plans, and hence these losses could be fixed.

Clause B.2 provides information how the Pan-European LRs were derived.

Clause B.3 contains the Pan-European full-channel loss plan.

Clause B.4 is the Excel spreadsheet used to derive the Pan-European LRs, and the half-channel and full-channel loss plans.

B.2 The Pan-European LR and loss plan derivations

Clause B.4 provides a spreadsheet for use with the present document as a means of calculation.

The LR values derived in this spreadsheet are nominal values based on a theoretical European model. The LR values are necessary inputs to the Pan-European half-channel loss plan in order to determine the required loss or gain required in the VG to achieve the desired SLR of 8 dB.

The nominal telephone loudness ratings of 3 and -8 are taken from TBR 038 [3].

The nominal 4 dB line loss and 7 dB local exchange Rx pad values are taken from a background paper on TBR 038 [3].

Another paper derives the nominal 4 dB line loss as 3 km of 0,5 mm cable with a typical loss of 1,25 dB per km. (see Paper 2 in the bibliography).

The L22 LR derivation assumes a 2,5 km line with a loss of 3 dB (equivalent to the North American off-premise station).

Information on European dBr levels was derived from ES 201 168 [2].

This annex also provides examples of the impact of various national set loudness ratings and PSTN losses on the LR derivations. LR derivations for the UK and the Netherlands were done as examples of two countries at the opposite ends of the European SLR range, and French LR derivation was done as an example of an RLR at the top end of the range. These examples demonstrate that the application of the Pan-European loss plan should result in satisfactory OLR performance in most regions in Europe.

B.3 The Pan-European full-channel loss plan

Full-channel loss plan interpretation

Table B.1 shows the interface-to-interface loss in the Pan-European full-channel loss plan. Arrows at the row and column designators indicate the transmission direction in which the co-ordinate loss values are to be inserted.

For example, co-ordinate 1 B indicates a nominal interface-to-interface loss of 12 dB from the L21 interface to the L22 interface, and co-ordinate 2A indicates a 12 dB loss in the other direction, from the L22 interface to the L21 interface.

NOTE 1: This is a loss plan, therefore negative values denote gain; e.g. -6 indicates 6 dB gain.

Table B.1: Voice Gateway full-channel loss plan (Pan-European)

| | | | A | B | C | D | E | F | G |
|---|-----|-----------|-----|-----|----|-----|----|----|----|
| | | | L21 | L22 | LD | WAN | KD | K2 | M4 |
| | | Loss (dB) | ↑ | ↑ | ↑ | ↑ | ↑ | ↑ | ↑ |
| 1 | L21 | → | 15 | 12 | 5 | 5 | 5 | 4 | 3 |
| 2 | L22 | → | 12 | 9 | 2 | 2 | 2 | 1 | 0 |
| 3 | LD | → | 10 | 7 | 0 | 0 | 0 | -1 | -2 |
| 4 | WAN | → | 10 | 7 | 0 | 0 | 0 | -1 | -2 |
| 5 | KD | → | 10 | 7 | 0 | 0 | 0 | -1 | -2 |
| 6 | K2 | → | 4 | 1 | -6 | -6 | -6 | -7 | -8 |
| 7 | M4 | → | 8 | 5 | -2 | -2 | -2 | -3 | -4 |

NOTE 2: The interface-to-interface losses are the sum of the transmit and receive half-channel losses defined in clause 5.1.3, table 1.

Full-channel loudness ratings table interpretation

Table B.2 is provided to show the relationship between OLR, SLR, RLR and interface-to-interface loss. For example, for an L21 to L22 connection, the L21 SLR is 3 dB, the VG loss is 12 dB (from 1B in table B.1), and the L22 RLR is -5 dB. The overall loudness ratings is therefore $3 + 12 - 5 = 10$ dB.

Table B.2: Voice gateway full-channel loudness ratings (Pan-European)

| | | | L21 | L22 | LD | WAN | KD | K2 | M4 |
|-----|-----|-----|-----|-----|----|-----|----|----|----|
| | | RLR | -8 | -5 | 2 | 2 | 2 | 5 | 4 |
| | SLR | OLR | ↑ | ↑ | ↑ | ↑ | ↑ | ↑ | ↑ |
| L21 | 3 | → | 10 | 10 | 10 | 10 | 10 | 12 | 10 |
| L22 | 6 | → | 10 | 10 | 10 | 10 | 10 | 12 | 10 |
| LD | 8 | → | 10 | 10 | 10 | 10 | 10 | 12 | 10 |
| WAN | 8 | → | 10 | 10 | 10 | 10 | 10 | 12 | 10 |
| KD | 8 | → | 10 | 10 | 10 | 10 | 10 | 12 | 10 |
| K2 | 16 | → | 12 | 12 | 12 | 12 | 12 | 14 | 12 |
| M4 | 10 | → | 10 | 10 | 10 | 10 | 10 | 12 | 10 |

B.4 Calculation spreadsheet

Clause B.4 is contained in an Excel file (ES 202 020 V1-4-2 Annex.xls contained in archive es_202020v010402p0.zip) which accompanies the present document.

Annex C (informative): The North American loss and level plan

C.1 Overview

The North American Voice Gateway loss and level plan is a section of ANSI/TIA-912-B [1] which in turn is related to, but independent from, the transmission section of ANSI/TIA/EIA-464-C (see bibliography).

C.2 The North American full-channel loss plan

Enterprise, MTA, and IAD Voice Gateways

The North American full-channel loss plan differentiates between Enterprise VGs and Integrated Access Device (IAD) and Multimedia Terminal Adaptor (MTA) VGs. An enterprise VG typically provides the same full switching capabilities that a PBX would, while an IAD or MTA would primarily provide network access only with little or no local switching. Two loss plans are therefore provided, one for enterprises VGs and one for IAD and MTA VGs.

NOTE 1: Unlike the Pan-European case, the same Enterprise VG transmit and receive losses could not be used for both the half-channel and full-channel plans, and hence the full-channel losses have to be changed on a per-connection basis.

Port-to-port loss table interpretation

In table C.1, arrows at the row and column designators indicate the transmission direction in which the co-ordinate loss values are to be inserted.

For example, co-ordinate 1 B indicates a nominal port-to-port loss of 9 dB from the ONS interface to the OPS interface, and co-ordinate 2A indicates a 9 dB loss in the other direction, from the OPS interface to the ONS interface.

NOTE 2: This is a loss plan, therefore negative values denote gain; e.g. -6 indicates 6 dB gain.

Table C.1: Enterprise voice gateway full-channel loss plan (North America)

| | | | A | B | C | D | E | F | G | H |
|---|------------------------|---|-----|-----|-----------------|-----------------|-----------------|-----|-----|-----|
| | | | ONS | OPS | DGS | WAN | DAL | FXO | FXD | ATT |
| | Loss ¹ (dB) | | ↑ | ↑ | ↑ | ↑ | ↑ | ↑ | ↑ | ↑ |
| 1 | ONS | → | 12 | 9 | 3 | 3 | 3 | 3 | 6 | 9 |
| 2 | OPS | → | 9 | 6 | 0 | 0 | 0 | 0 | 0 | 3 |
| 3 | DGS | → | 9 | 6 | 0 | 0 | 0 | 0 | 3 | 3 |
| 4 | WAN | → | 9 | 6 | 0 | 0 | 0 | 0 | 3 | 3 |
| 5 | DAL | → | 9 | 6 | 0 | 0 | 0 | 0 | 3 | 3 |
| 6 | FXO | → | 0 | 0 | -6 ² | -6 ² | -6 ² | 0 | 0 | 0 |
| 7 | FXD | → | 3 | 0 | -3 ² | -3 ² | -3 ² | 0 | 0 | 0 |
| 8 | ATT | → | 6 | 0 | 0 | 0 | 0 | 0 | 0 | 0 |

NOTE 3: Losses have been selected as multiples of 3 dB, assuming that this simplifies the implementation.

NOTE 4: There is a potential risk of DTMF overload if an FXO analogue trunk is connected to DGS, WAN or DAL and the VG is located less than 2 km from the DEO due to the gain added in the A/D direction. In these cases it is recommended that the FXD to DGS, WAN or DAL setting be used instead because the FXD setting introduces 3 dB less gain in one direction and 3 dB more loss in the other direction.

Port-to-port loudness ratings table interpretation

Table C.2 is provided to show the relationship between OLR and SLR, VG loss, and RLR.

For example, for an ONS to OPS connection, the ONS SLR is 4 dB, the VG loss is 9 dB (from 1 dB in table C.1), and the OPS RLR is -3 dB. The overall loudness ratings is therefore $4 + 9 - 3 = 10$ dB.

NOTE 5: Again, this is a loss plan, therefore negative values denote gain; e.g. -6 indicates 6 dB gain.

Table C.2: Enterprise voice gateway loudness ratings (North America)

| | | | ONS ¹ | OPS | DGS | WAN | DAL | FXO ¹ | FXD ¹ | ATT ² |
|------------------|------|-----|------------------|-----|-----|-----|-----|------------------|------------------|------------------|
| | (dB) | RLR | -7 | -3 | 2 | 2 | 2 | 6 | 3 | 1 |
| | SLR | OLR | ↑ | ↑ | ↑ | ↑ | ↑ | ↑ | ↑ | ↑ |
| ONS | 4 | → | 9 | 10 | 9 | 9 | 9 | 13 | 13 | 14 |
| OPS | 8 | → | 10 | 11 | 10 | 10 | 10 | 14 | 11 | 12 |
| DGS | 8 | → | 10 | 11 | 10 | 10 | 10 | 14 | 14 | 12 |
| WAN | 8 | → | 10 | 11 | 10 | 10 | 10 | 14 | 14 | 12 |
| DAL | 8 | → | 10 | 11 | 10 | 10 | 10 | 14 | 14 | 12 |
| FXO ¹ | 17 | → | 10 | 14 | 13 | 13 | 13 | 23 | 20 | 18 |
| FXD ¹ | 14 | → | 10 | 11 | 13 | 13 | 13 | 20 | 17 | 15 |
| ATT ² | 15 | → | 14 | 12 | 17 | 17 | 17 | 21 | 18 | 16 |

NOTE 6: The loudness ratings for the FXO and FXD ports include a nominal 6 dB DEO loss.

NOTE 7: The loudness ratings for the ATT port include a nominal 2 dB trunk loss.

Table C.3: MTA/IAD voice gateway full-channel loss plan (North America)

| | | | A | B | C | D |
|---|------------------------|---|-----|-----|-----|-----|
| | | | ONS | DGS | PAL | DAL |
| | Loss ¹ (dB) | | ↑ | ↑ | ↑ | ↑ |
| 1 | ONS | → | 12 | 3 | 3 | 3 |
| 2 | DGS | → | 9 | 0 | 0 | 0 |
| 3 | PAL | → | 9 | 0 | 0 | 0 |
| 4 | DAL | → | 9 | 0 | 0 | 0 |

NOTE 8: Losses have been selected as multiples of 3 dB, assuming that this simplifies the implementation. For the optimum OLR of 10 dB, the "to ONS" loss value is actually 13 dB.

Table C.4: MTA/IAD voice gateway loudness ratings (North America)

| | | | ONS ¹ | DGS | PAL | DAL |
|------------------|------|-----|------------------|-----|-----|-----|
| | (dB) | RLR | -7 | 2 | 2 | 2 |
| | SLR | OLR | ↑ | ↑ | ↑ | ↑ |
| ONS ¹ | 4 | → | 9 | 9 | 9 | 9 |
| DGS | 8 | → | 10 | 10 | 10 | 10 |
| PAL | 8 | → | 10 | 10 | 10 | 10 |
| DAL | 8 | → | 10 | 10 | 10 | 10 |

Annex D (informative): Relationship of channel based loss plans to Q.551

There are certain similarities in the use of the terms half-channel as used in the present document, and half-connection as used in ITU-T Recommendation Q.551 (see bibliography).

The following defines connections in the context of ITU-T Recommendation Q.551, and figure D.1 shows the relationship between the terms full and half connection, as defined in ITU-T Recommendation Q.551 (see bibliography), and full and half channel as defined in the present document.

input connection: unidirectional path from an interface of a digital exchange to an exchange test point

output connection: unidirectional path from an exchange test point to an interface of a digital exchange

half-connection: bi-directional path comprising an input connection and an output connection, both having the same exchange interface

full-connection: bi-directional path comprising two half-connection, providing a complete connection through the digital exchange

Notes on connections:

NOTE 1: These terms may be qualified by the words analogue or digital, the qualification signifying the property of the exchange interface.

NOTE 2: An analogue input (output) (half) connection may be further qualified by the words 2-wire or 4-wire.

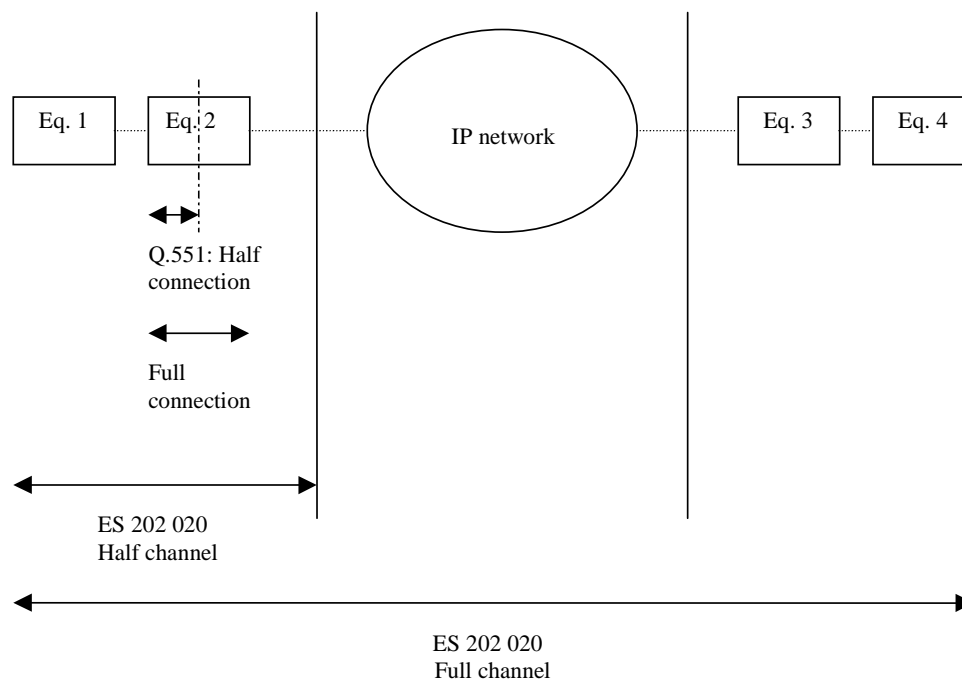

Figure D.1: Connection versus channel

Annex E (informative): Bibliography

ITU-T Recommendation P.79: "Calculation of loudness ratings for telephone sets".

ITU-T Recommendation G.711: "Pulse code modulation (PCM) of voice frequencies".

ITU-T Recommendation G.712: "Transmission performance characteristics of pulse code modulation channels".

ITU-T Recommendation G.720: "Characterization of low-rate digital voice coder performance with non-voice signals".

ITU-T Recommendation G.722: "7 kHz audio-coding within 64 kbit/s".

ITU-T Recommendation G.724: "Characteristics of a 48-channel low bit rate encoding primary multiplex operating at 1 544 kbit/s".

ITU-T Recommendation G.725: "System aspects for the use of the 7 kHz audio codec within 64 kbit/s".

ITU-T Recommendation G.726: "40, 32, 24, 16 kbit/s adaptive differential pulse code modulation (ADPCM)".

ITU-T Recommendation G.727: "5-, 4-, 3- and 2-bit/sample embedded adaptive differential pulse code modulation (ADPCM)".

ITU-T Recommendation G.728: "Coding of speech at 16 kbit/s using low-delay code excited linear prediction".

ITU-T Recommendation G.729: "Coding of speech at 8 kbit/s using conjugate-structure algebraic-code-excited linear-prediction (CS-ACELP)".

ITU-T Recommendation G.729 Annex A: "Reduced complexity 8 kbit/s CS-ACELP speech codec".

TIA-968-A-2002: "Technical Requirements for Connection of Terminal Equipment to the Telephone Network".

TIA-968-A-1-2003: "Technical Requirements for Connection of Terminal Equipment to the Telephone Network".

NOTE: TIA-968-A and Annex A-1 replaced Federal Communications Commission (FCC) 47, CFR 68.500: "Part 68 Connection of Terminal Equipment to the Telephone Network" in the year 2002.

ANSI/TIA-470.110-C-2004: "Telecommunications - Telephone Terminal Equipment - Handset Acoustic Performance Requirements".

ANSI/TIA-810-B-2006: "Telecommunications-Telephone Terminal Equipment-Transmission Requirements for Narrowband Digital Telephones".

ANSI/TIA-912-B-2006: "Telecommunications - IP Telephony Equipment - Voice Gateway Transmission Requirements".

TIA/EIA/TSB32-A-1998: "Overall Transmission Plan Aspects for Telephony in a Private Network".

ANSI/TIA-464-C-2002: "Telecommunications - Multiline Terminal Systems - Requirements for PBX Switching Equipment".

ITU-T Recommendation Q.551: "Transmission characteristics of digital exchanges".

Directive 1999/5/EC of the European Parliament and of the Council of 9 March 1999 on radio equipment and telecommunications terminal equipment and the mutual recognition of their conformity (R&TTE Directive).

Paper 1: "A strategy for the harmonization of telephone loudness requirements", Undated paper by W.J. Mellors.

Paper 2: "(GPT) - Personal communication", W. J. Mellors.

History

| Document history | | |
|-------------------------|---------------|--|
| V1.1.1 | February 2002 | Publication |
| V1.2.1 | December 2003 | Publication |
| V1.3.1 | November 2004 | Publication |
| V1.4.2 | January 2007 | Membership Approval Procedure MV 20070330: 2007-01-30 to 2007-03-30 |
| | | |