

Draft **ETSI EN 302 665** V1.0.0 (2010-03)

European Standard (Telecommunications series)

**Intelligent Transport Systems (ITS);
Communications Architecture**



Reference

DEN/ITS-0020012

Keywords

ITS, architecture, interworking, transmission

ETSI

650 Route des Lucioles
F-06921 Sophia Antipolis Cedex - FRANCE

Tel.: +33 4 92 94 42 00 Fax: +33 4 93 65 47 16

Siret N° 348 623 562 00017 - NAF 742 C
Association à but non lucratif enregistrée à la
Sous-Préfecture de Grasse (06) N° 7803/88

Important notice

Individual copies of the present document can be downloaded from:

<http://www.etsi.org>

The present document may be made available in more than one electronic version or in print. In any case of existing or perceived difference in contents between such versions, the reference version is the Portable Document Format (PDF). In case of dispute, the reference shall be the printing on ETSI printers of the PDF version kept on a specific network drive within ETSI Secretariat.

Users of the present document should be aware that the document may be subject to revision or change of status. Information on the current status of this and other ETSI documents is available at

<http://portal.etsi.org/tb/status/status.asp>

If you find errors in the present document, please send your comment to one of the following services:

http://portal.etsi.org/chaicor/ETSI_support.asp

Copyright Notification

No part may be reproduced except as authorized by written permission.
The copyright and the foregoing restriction extend to reproduction in all media.

© European Telecommunications Standards Institute 2010.
All rights reserved.

DECT[™], **PLUGTESTS**[™], **UMTS**[™], **TIPHON**[™], the TIPHON logo and the ETSI logo are Trade Marks of ETSI registered for the benefit of its Members.

3GPP[™] is a Trade Mark of ETSI registered for the benefit of its Members and of the 3GPP Organizational Partners.

LTE[™] is a Trade Mark of ETSI currently being registered

for the benefit of its Members and of the 3GPP Organizational Partners.

GSM[®] and the GSM logo are Trade Marks registered and owned by the GSM Association.

Contents

Intellectual Property Rights	5
Foreword.....	5
Introduction	5
1 Scope	7
2 References	7
2.1 Normative references	7
2.2 Informative references.....	8
3 Definitions and abbreviations.....	9
3.1 Definitions	9
3.2 Abbreviations	10
4 Basics	11
4.1 Document overview	11
4.2 Severability clause.....	12
4.3 ITSC design principles	12
4.4 ITS station reference architecture.....	14
4.5 Functional elements of ITSC.....	16
4.5.1 ITS sub-systems	16
4.5.1.1 Overview	16
4.5.1.2 Personal sub-system and station.....	17
4.5.1.3 Central ITS sub-system and station.....	18
4.5.1.4 Vehicle ITS sub-system and station	19
4.5.1.5 Roadside ITS sub-system and station.....	20
4.5.2 Functional components of an ITS station	20
4.5.2.1 Overview	20
4.5.2.2 ITS-S host	20
4.5.2.3 ITS-S gateway.....	21
4.5.2.4 ITS-S router.....	21
4.5.2.5 ITS-S border router	22
4.5.2.6 ITS-S interceptor.....	22
4.6 ITSC networking	22
4.7 ITSC implementation architecture	23
5 ITS applications.....	23
5.1 Context	23
5.2 Classes of applications	23
5.3 Prioritization and channel assignment.....	24
5.4 Secure maintenance	24
5.5 Registration authority	24
6 ITSC OSI protocol stack	24
6.1 Access layer.....	24
6.1.1 Context.....	24
6.1.2 General functionality	25
6.1.3 Communication channels.....	26
6.1.3.1 Generic logical channel types	26
6.1.3.2 Channel types and access technologies	27
6.1.4 Prioritization	27
6.1.4.1 General concept.....	27
6.1.4.2 Contention in a single station	27
6.1.4.3 Contention in the physical communication channel.....	27
6.2 Networking and transport layer	27
6.2.1 Context.....	27
6.2.2 General functionality	28
6.2.3 Networking protocols	29

6.2.4	Transport protocols	29
6.3	Facilities layer	29
6.3.1	Context.....	29
6.3.2	General functionality	30
6.3.3	Details on facilities	30
7	ITSC management entity.....	33
7.1	Context	33
7.2	Functionality.....	33
7.2.1	Overview	33
7.2.2	ITS service advertisement.....	34
7.2.2.1	General	34
7.2.2.2	FAST service advertisement	34
7.2.3	General congestion control	35
7.2.4	CI/ITS-S application mapping	35
7.2.5	Local node map.....	36
7.2.6	Inter-management communication	36
7.2.7	Regulatory information management.....	36
7.2.8	ITS application management	37
7.2.9	ITS communication service management	37
8	ITSC Security	38
8.1	Context	38
8.2	General functionality	38
Annex A (normative):	ASN.1 module.....	40
Annex B (informative):	Implementations of ITS stations.....	41
B.1	Prototypes.....	41
B.2	Examples of implementation.....	41
B.2.1	Vehicle	41
B.2.2	Roadside.....	43
Annex C (informative):	Bibliography.....	44
History		45

Intellectual Property Rights

IPRs essential or potentially essential to the present document may have been declared to ETSI. The information pertaining to these essential IPRs, if any, is publicly available for **ETSI members and non-members**, and can be found in ETSI SR 000 314: "*Intellectual Property Rights (IPRs); Essential, or potentially Essential, IPRs notified to ETSI in respect of ETSI standards*", which is available from the ETSI Secretariat. Latest updates are available on the ETSI Web server (<http://webapp.etsi.org/IPR/home.asp>).

Pursuant to the ETSI IPR Policy, no investigation, including IPR searches, has been carried out by ETSI. No guarantee can be given as to the existence of other IPRs not referenced in ETSI SR 000 314 (or the updates on the ETSI Web server) which are, or may be, or may become, essential to the present document.

Foreword

This European Standard (Telecommunications series) has been produced by ETSI Technical Committee Intelligent Transport System (ITS), and is now submitted for the Public Enquiry phase of the ETSI standards Two-step Approval Procedure.

The present document is in support of early implementations. ETSI TC ITS welcomes feedback in order to facilitate future revisions.

Proposed national transposition dates	
Date of latest announcement of this EN (doa):	3 months after ETSI publication
Date of latest publication of new National Standard or endorsement of this EN (dop/e):	6 months after doa
Date of withdrawal of any conflicting National Standard (dow):	6 months after doa

Introduction

Intelligent Transport Systems (ITS) are systems to support transportation of goods and humans with information and communication technologies in order to efficiently and safely use the transport infrastructure and transport means (cars, trains, planes, ships). Elements of ITS are standardized in various standardisation organisations, both on an international level at e.g. ISO TC204, and on regional levels, e.g. in Europe at ETSI TC ITS and at CEN TC278.

The present document specifies the architecture of communications in ITS (ITSC) supporting a variety of existing and new access technologies and ITS applications. The term ITSC denotes communications protocols, related management and additional functionality. The present document is arranged as a tool-box, i.e. conformance with the present document does not require to implement the whole functionality illustrated and partly specified in the present document.

ITSC is to a large extent independent from specific communication technologies and specific ITS applications. The ITSC architecture is intended to be an open systems architecture, i.e. an architecture that is open and not proprietary.

Activities related to the scope of the present document are e.g. the European projects:

- COMeSafety (<http://www.comesafety.org>),
- COOPERS (<http://www.coopers-ip.eu>),
- CVIS (<http://www.cvisproject.org>),
- FRAME (<http://frame-online.net>),
- GeoNet (<http://www.geonet-project.eu/>),

- KAREN (<http://www.frame-online.net/home.htm>),
- Pre-Drive C2X (<http://www.pre-drive-c2x.eu>),
- SAFESPOT (<http://www.safespot-eu.org>),
- SEVECOM (<http://www.sevecom.org>),

the industry activity:

- C2C-CC (<http://www.car-to-car.org>)

the standardisation work being conducted at:

- ISO TC204 (Intelligent Transport Systems)
 - WG16 CALM (Communications Access for Land Mobiles) (<http://www.isotc204wg16.org>),
 - WG18, jointly developing standards with CEN TC278 WG16 on cooperative systems,
- IEEE 802.11 [i.1] /p and 1609 WAVE,

other research projects.

ITS applications make use of wireless communications:

- Communications between mobile ITS stations (vehicles), and between mobile ITS stations and fixed ITS stations (roadside installations), with single-hops or multiple hops between the source and destination ITS stations.
- Access to public and private (local) networks including the global Internet.
- Infrastructure and satellite broadcast.

1 Scope

The present document specifies the global communication architecture of communications for Intelligent Transport Systems (ITSC). This version of the present document is dedicated to the road transport context.

The present document on the ITSC architecture specifies mandatory and optional elements and interfaces of ITSC.

Some elements of ITS applications, especially those directly related to ITSC, are also considered.

The present document is enabling different implementation architectures as presented in the informative annex B.

2 References

References are either specific (identified by date of publication and/or edition number or version number) or non-specific.

- For a specific reference, subsequent revisions do not apply.
- Non-specific reference may be made only to a complete document or a part thereof and only in the following cases:
 - if it is accepted that it will be possible to use all future changes of the referenced document for the purposes of the referring document;
 - for informative references.

Referenced documents which are not found to be publicly available in the expected location might be found at <http://docbox.etsi.org/Reference>.

NOTE: While any hyperlinks included in this clause were valid at the time of publication ETSI cannot guarantee their long term validity.

2.1 Normative references

The following referenced documents are indispensable for the application of the present document. For dated references, only the edition cited applies. For non-specific references, the latest edition of the referenced document (including any amendments) applies.

- [1] ETSI TS 102 636-3: "Intelligent Transport Systems (ITS); Vehicular Communications; GeoNetworking; Part 3: Network architecture".
- [2] ETSI ES 202 663: "Intelligent Transport Systems (ITS); European profile standard for the physical and medium access control layer of Intelligent Transport Systems operating in the 5 GHz frequency band".
- [3] ITU-T Recommendation X.901: "Information technology - Open distributed processing - Reference Model: Overview".
- [4] ISO/IEC 7498-1: "Information technology - Open Systems Interconnection - Basic Reference Model: The Basic Model".
- [5] ISO/IEC 8825-2: "Information technology - ASN.1 encoding rules: Specification of Packed Encoding Rules (PER)".
- [6] ISO/IEC 21210: "Intelligent Transport Systems - Communications access for land mobiles (CALM) - IPv6 networking".
- [7] ISO/IEC 21214: "Intelligent Transport Systems - Communications access for land mobiles (CALM) - IR medium".

- [8] ISO/IEC IS 21215: "Intelligent Transport Systems - Communications access for land mobiles (CALM) - M5 medium".
- [9] ISO/IEC 21217: "Intelligent Transport Systems - Communications access for land mobiles (CALM) - Architecture".
- [10] ISO/IEC 21218: "Intelligent Transport Systems - Communications access for land mobiles (CALM) - Lower layer service access points".
- [11] ISO/IEC 24102: "Intelligent Transport Systems - Communications access for land mobiles (CALM) - Management".
- [12] ISO/IEC 29281: "Intelligent Transport Systems - Communications access for land mobiles (CALM) - Non-IP networking".
- [13] IEEE Standard 802-2001: "IEEE Standard for Local and Metropolitan Area Networks: Overview and Architecture".

2.2 Informative references

The following referenced documents are not essential to the use of the present document but they assist the user with regard to a particular subject area. For non-specific references, the latest version of the referenced document (including any amendments) applies.

- [i.1] IEEE 802.11: "IEEE Standard for Information Technology-Telecommunications and information exchange between systems-Local and metropolitan area networks-Specific requirements; Part 11: Wireless LAN Medium Access Control (MAC) and Physical Layer (PHY) Specifications".
- [i.2] IEEE 1609: "Trial-Use Standard for Wireless Access in Vehicular Environments (WAVE)".
- [i.3] CEN EN 12253: "Road transport and traffic telematics - Dedicated Short Range, Communication (DSRC) - Physical layer using microwave at 5,8 GHz".
- [i.4] CEN EN 12795: "Road transport and traffic telematics - Dedicated Short Range, Communication (DSRC) - DSRC data link layer: medium access and logical link control".
- [i.5] CEN EN 12834: "Road transport and traffic telematics - Dedicated Short Range Communication (DSRC) - DSRC application layer".
- [i.6] ETSI TS 102 636 (all parts): "Intelligent Transport Systems (ITS); Vehicular Communications; GeoNetworking".
- [i.7] ETSI TS 102 636-6-1: "Intelligent Transport Systems (ITS); Vehicular Communications; GeoNetworking; Part 6: Internet Integration; Subpart 1: Transmission of IPv6 Packets".
- [i.8] ETSI TS 102 637-2: "Intelligent Transport Systems (ITS); Vehicular Communications; Basic Set of Applications; Part 2: Specification of Co-operative Awareness Basic Service".
- [i.9] ETSI TS 102 637-3: "Intelligent Transport Systems (ITS); Vehicular Communications; Basic Set of Application; Part 3: Specification of Decentralized Environmental Notification Basic Service".
- [i.10] ETSI TS 102 723-1: " Intelligent Transport Systems; OSI cross-layer topics; Part 1: Architecture and addressing schemes".
- [i.11] ETSI TS 102 723-2: " Intelligent Transport Systems; OSI cross-layer topics; Part 2: Management information base".
- [i.12] ETSI TS 102 723-3: "Intelligent Transport Systems; OSI cross-layer topics; Part 3: Interface between management entity and access layer".
- [i.13] ETSI TS 102 723-4: "Intelligent Transport Systems; OSI cross-layer topics; Part 4: Interface between management entity and network and transport layers".

- [i.14] ETSI TS 102 723-5: "Intelligent Transport Systems; OSI cross-layer topics; Part 5: Interface between management entity and facilities layer".
- [i.15] ETSI TS 102 723-6: "Intelligent Transport Systems; OSI cross-layer topics; Part 6: Interface between management entity and security entity".
- [i.16] ETSI TS 102 723-7: "Intelligent Transport Systems; OSI cross-layer topics; Part 7: Interface between security entity and access layer".
- [i.17] ETSI TS 102 723-8: "Intelligent Transport Systems; OSI cross-layer topics; Part 8: Interface between security entity and network and transport layers".
- [i.18] ETSI TS 102 723-9: "Intelligent Transport Systems; OSI cross-layer topics; Part 9: Interface between security entity and facilities layer".
- [i.19] ETSI TS 102 723-10: "Intelligent Transport Systems; OSI cross-layer topics; Part 10: Interface between access layer and network and transport layers".
- [i.20] ETSI TS 102 723-11: "Intelligent Transport Systems; OSI cross-layer topics; Part 11: Interface between network and transport layers and facilities layer".
- [i.21] ETSI EN 302 895: "Intelligent Transport Systems (ITS); Vehicular Communications; Basic Set of Applications; Local Dynamic Map (LDM) Specification".

3 Definitions and abbreviations

3.1 Definitions

For the purposes of the present document, the terms and definitions given in [3], [4], [9], [10], [11], [12], [13] and the following apply:

access layer: OSI physical and data link layers for ITSC

central ITS station: ITS station in a central ITS sub-system

central ITS sub-system: ITS sub-system in the context of an ITS centre

communication adaptation layer: optional upper part of the access layer for legacy access technologies

communication interface: instantiation of a specific access layer technology and protocol, e.g. ITS-G5, GPRS, UMTS

FA interface: interface between the facilities layer and the ITS-S applications entity

facilities layer: OSI layers five, six and seven for ITSC

generic domain: collection of legacy elements used for ITS/ITSC

IN interface: interface between the access layer and the networking & transport layer

inter-management communication: ITSC station-internal communication between management entities

in-vehicle network: implementation of the ITS station-internal network in a vehicle

ITS application: association of two or more complementary ITS-S applications

ITS domain: collection of elements used for ITS/ITSC being specified in dedicated ITS/ITSC standards

ITS service: service provided by an ITS application to the user of ITS

ITS station: functional entity specified by the ITS station (ITS-S) reference architecture

ITS sub-system: sub-system of ITS with ITSC components for a specific context

ITS-S application: fragment of an ITS application available at an ITS station that uses ITS-S services to connect to one or more other fragments of the same ITS application

ITS-S border router: routing functionality based on the ITS station reference architecture connecting to legacy networking protocols

ITS-S gateway: gateway functionality based on the ITS station reference architecture

ITS-S host: functionality of the whole ITS station reference architecture, i.e. especially also including ITS-S applications

ITS-S interceptor: generic router/gateway functionality

ITS-S router: routing functionality based on the ITS station reference architecture

ITS-S service: communication functionality offered by an ITS-S to an ITS-S application

MA interface: interface between the communication and station management entity and the ITS-S applications entity

medium: physical entity upon which for the purpose of communications a signal is impressed or from which a signal is received, e.g. wireless (radio waves with a given frequency range and bandwidth, light with a given wave length, ultrasonics) or on a wire (electrical signal, optical signal)

MF interface: interface between the communication and station management entity and the facilities layer

MI interface: interface between the communication and station management entity and the access layer

MN interface: interface between the communication and station management entity and the networking & transport layer

MS interface: interface between the communication and station management entity and the security entity

networking & transport layer: OSI layers three and four for ITSC

NF interface: interface between the networking and transport layer and the facilities layer

personal ITS station: ITS station in a personal ITS sub-system

personal ITS sub-system: ITS sub-system in the context of a portable device for ITS

roadside ITS station: ITS station in a roadside ITS sub-system

roadside ITS sub-system: ITS sub-system in the context of roadside ITS equipment

SA interface: interface between the security entity and the ITS-S applications entity

SF interface: interface between the security entity and the facilities layer

SI interface: interface between the security entity and the access layer

SN interface: interface between the security entity and the networking & transport layer

vehicle ITS station: ITS station in a vehicular ITS sub-system

vehicle ITS sub-system: ITS sub-system in the context of a ITS equipment used in a vehicle

3.2 Abbreviations

For the purposes of the present document, the abbreviations given in [4], [9], [10], [11], [12], [13] and the following apply:

AL	Access Layer
API	Application Programming Interface
CAL	Communication Adaptation Layer
CALM	Communications Access for Land Mobiles
CAM	Cooperative Awareness Message

CEN	Commission Européen de Normalisation
DENM	Decentralized Environmental Notification Messages
DSRC	Dedicated Short Range Communication
ECU	Electronic Control Unit
FA	name of interface between facilities layer and ITS-S applications
GPRS	General Packet Radio Service
HSM	Hardware Security Module
IETF	Internet Engineering Task Force
IN	name of interface between access layer and networking and transport layer
IP	Internet Protocol
IPv6	Internet Protocol version 6
IR	infra red incoherent light
ISO	International Standards Organisation
ITS	Intelligent Transport System
ITSC	ITS Communications
ITS-S	ITS-Station
IUMC	Inter-Unit Management Communication
IVN	In-Vehicle Network
LCH	Logical CHannel
LCH0	LCH for management communications between ITS stations
LCH1	LCH for organization of communication and initialisation of sessions (service advertisement)
LCH2	LCH for data exchange in sessions
LCHx	LCH with a defined meaning
LDM	Local Dynamic Map
MA	name of interface between management entity and ITS-S applications
MAE	management adaptation entity
MF	name of interface between management entity and facilities layer
MI	name of interface between management entity and access layer
MIB	Management Information Base
MN	name of interface between management entity and networking & transport layer
MS	name of interface between management entity and security entity
NF	name of interface between networking & transport layer and facilities layer
OBE	On-Board Equipment
PDA	Personal Digital Assistant
PDU	Protocol Data Unit
RSE	Road Side Equipment
RTTT	Road Transport and Traffic Telematics
SA	name of interface between security entity and ITS-S applications
SAE	Security Adaptation Entity
SF	name of interface between security entity and facilities layer
SI	name of interface between security entity and access layer
SIB	Security Information Base
SN	name of interface between security entity and networking & transport layer
UMTS	Universal MobileTelecommunications System

4 Basics

4.1 Document overview

The present document specifies the global framework of ITS communications in the road transport domain, and selected technical and procedural details of general applicability. Normative references to other ITS standards will be used if applicable.

- Clause 4 specifies basic architectural elements of ITSC.
- Clause 5 specifies the general management of ITS applications with respect of ITSC.
- Clause NOTE: Further details are outside the scope of the present document.

- 6 specifies general parts of the ITSC OSI protocol stack.
- Clause 7 specifies general parts of the ITSC management entity.
- Clause 8 specifies general parts of the ITSC security entity.
- The normative annex A specifies the ASN.1 module of the present document.
- The informative annex B describes examples of possible implementations of ITS stations.

4.2 Severability clause

The specification of ITSC is provided by:

- the set of ITSC standards prepared by ETSI TC ITS, and
- by other standards.

Elements of these standards partly may be mandatory, and partly may be optional. Thus these standards constitute a ITSC tool-box.

4.3 ITSC design principles

ITSC is a new type of communication system dedicated to transportation scenarios, e.g. as illustrated in figure 1. It is based on two domains:

- ITS domain; and
- Generic domain.

"ITS domain" refers to all elements of ITSC which are specified in ITS/ITSC standards. "Generic domain" refers to other elements used for ITS/ITSC.

NOTE 1: In ISO TC204 WG16 these two domains are distinguished by the terms "CALM-aware" (= ITS domain) and "Non-CALM-aware" (= generic domain).

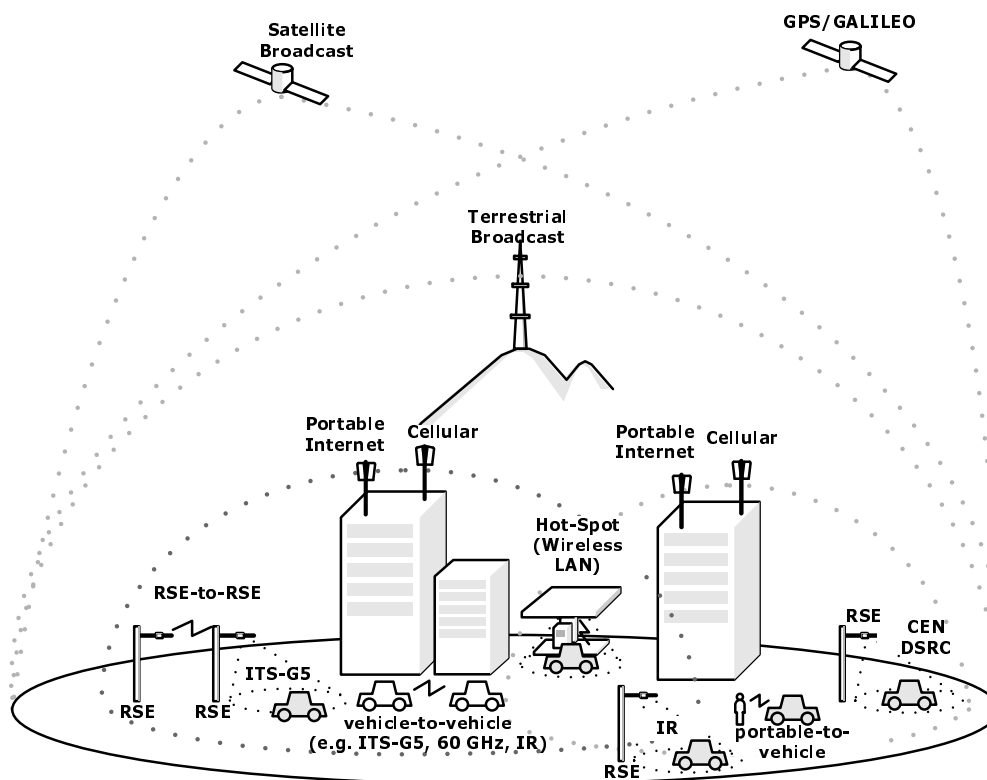

Figure 1: Scenario illustration

Essential aspects to be considered in the process of developing ITSC standards are presented in the following informative non-exhaustive list:

- mobility of ITS stations causing high dynamics of their topology;
- potential support of any kind of communication technology, including Internet, public networks and legacy systems such as Bluetooth TM, technologies for road tolling (DSRC), ..., i.e. abstraction from implementation details;
- potential support of any kind of application including those:
 - designed for ITSC;
 - using the ITS station as a transparent communication means;
 - using station-internal communications only.
- dynamic and flexible consideration of user needs, e.g. with respect to communications capacity (data rate), communications cost (in terms of money), communications reliability, communications availability, communications privacy;
- potential of efficient prioritization of application classes;
- potential of dedicated relations between applications and communication technologies dependent on regional requirements, e.g. for road safety and traffic efficiency applications, for road tolling, etc.;
- support of modular implementations with multiple physical units networked in a single ITS station;
- support of profiling;
- global applicability.

NOTE 2: Initial intensive work with the same design principles is being done at ISO TC204 WG16 under the working title CALM (Communications Access for Land Mobiles). Some CALM international standards [7], [8], [9] and [11] already were partly implemented and verified as part of the CVIS project.

4.4 ITS station reference architecture

The ITS station reference architecture explains the functionality contained in ITS stations which are part of ITS sub-systems specified in clause 4.5.

The ITS station reference architecture follows the principles of the OSI model [4] for layered communication protocols which is extended for inclusion of ITS applications.

Figure 2 presents the ITS station reference architecture. Possible details of the ITS station reference architecture are presented in the informative figure 3.

The three lower blocks in the middle of figures 2 and 3 contain functionality of the OSI communication protocol stack with:

- "Access" representing ITSC's OSI layers 1 and 2,
- "Networking & Transport" representing ITSC's OSI layers 3 and 4,
- "Facilities" representing ITSC's OSI layers 5, 6 and 7.

NOTE 1: The term "functionality" used in the present document does not at all imply specific functions to be implemented. As an example, the GeoNetworking protocol may be implemented in an implementation of an ITS-S router, but likely will not be present in an implementation of an ITS-S host.

The block "Applications" in figures 2 and 3 present the ITS-S applications making use of the ITS-S services to connect to one or more other ITS-S applications. An association of two or more complementary ITS-S applications constitutes an ITS application which provides an ITS service to a user of ITS.

NOTE 2: An example of two complementary ITS-S applications are a server application and a client application, where the server application resides in one ITS station, and the client application resides in another ITS station.

The left hand side of figures 2 and 3 present the entity "Management" which is in charge of managing communications in the ITS station. This entity grants access to the Management Information Base (MIB) [i.11].

The right hand side of figures 2 and 3 present the entity "Security" which provides security services to the OSI communication protocol stack, to the security entity and to the management entity. "Security" can also be considered as a specific part of the management entity.

The functional blocks presented in figures 2 and 3 are interconnected either via observable interfaces or via service access points (SAPs) as specified in [i.12], [i.13], [i.14], [i.15], [i.16], [i.17], [i.18], [i.19], [i.20], or via APIs. The names of these interconnections are shown in the figures 2 and 3.

In all ITSC standards, the specification of SAPs shall only be informative functional specifications. However the type of the service primitives and the type of the parameters used in the service primitives shall be specified using ASN.1 PER [5] in order to have a precise understanding of the functional meaning, and in order to be able to uniquely use the parameters of service primitives inside testable Protocol Data Units (PDUs) [i.10], if applicable.

Although the concept of the layered OSI model is based on isolated layers as presented in figure 2, where each layer contains a complete set of functionality as described above, ITSC provides further functionality related to several of these layers. Such functionality is named cross-layer functionality.

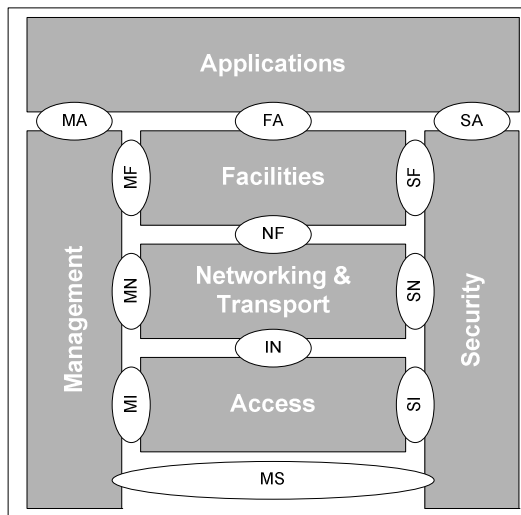

Figure 2: ITS station reference architecture/ITS-S host

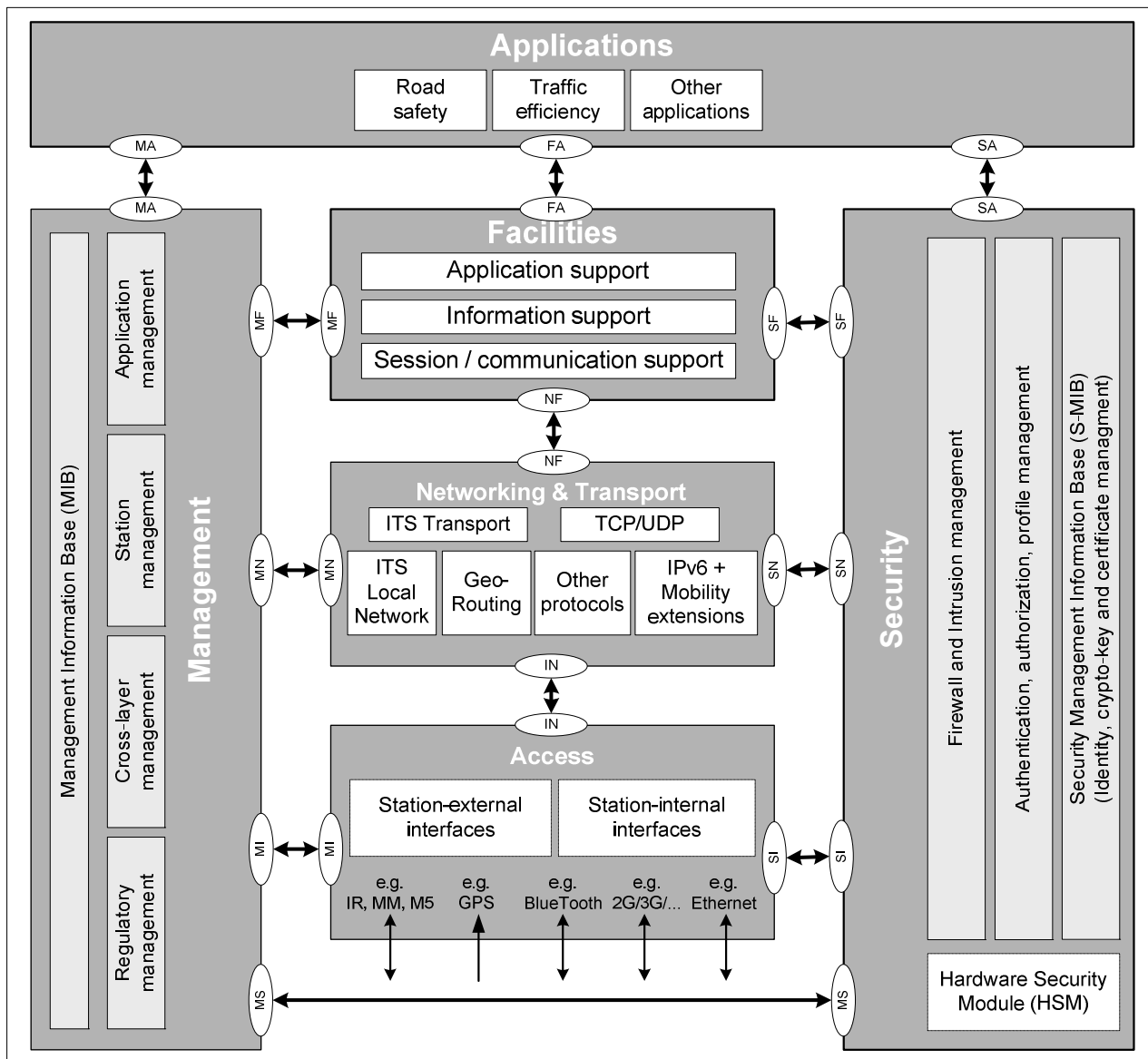

Figure 3: Examples of possible elements in the ITS station reference architecture

4.5 Functional elements of ITSC

4.5.1 ITS sub-systems

4.5.1.1 Overview

The following ITS sub-systems:

- personal ITS sub-system; in hand-held devices,
- central ITS sub-system; part of an ITS central system,
- vehicle ITS sub-system; in cars, trucks, etc., in motion or parked,
- roadside ITS sub-system; on gantries, poles, etc.,

are identified. These sub-systems are illustrated in figure 4.

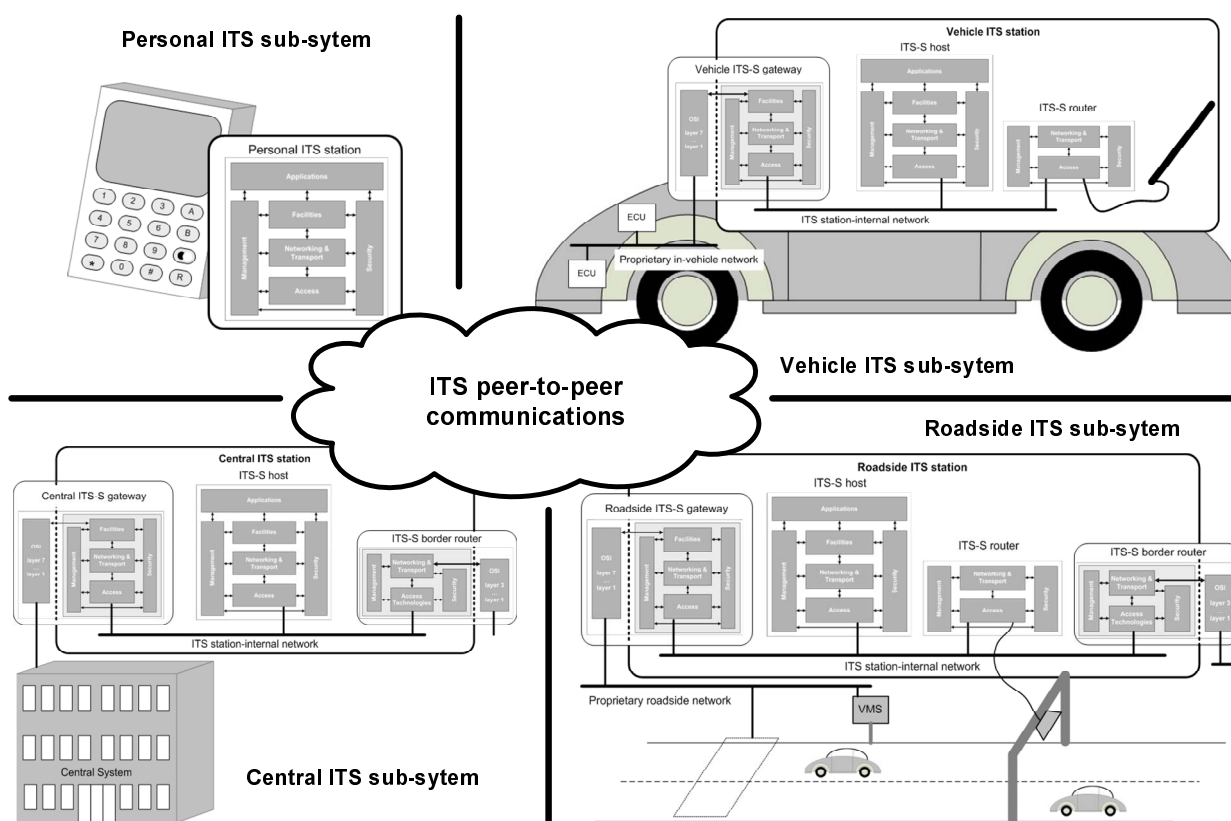

Figure 4: Illustration of ITS sub-systems

Each of these ITS sub-systems contains an ITS station, i.e. the functionality described by the ITS station reference architecture specified in clause 4.4. Dependent on the context, an ITS station typically will contain other functional components presented in clause 4.5.2.

The functionality of an ITS station may be implemented in a single physical unit or in several physical units as illustrated in annex B. Furthermore it is possible to structure the functionality, see clause 4.5.2, such that it is divided into individually addressable entities within the same physical unit. In both cases the ITS station-internal network presented in figure 12 is used to interconnect these units/entities, which may be reduced to a node in a single unit.

4.5.1.2 Personal sub-system and station

The personal ITS sub-system provides the application and communication functionality of ITSC in hand-held devices, such as PDAs, mobile phones, etc. It shall contain a personal ITS station. The device used as a personal ITS station may also perform HMI functionality as part of other ITS sub-system, connecting to this via the ITS station-internal network presented in figure 12.

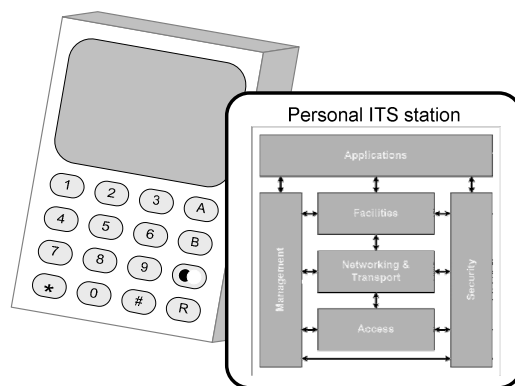

Figure 5: Personal ITS station in a personal sub-system

4.5.1.3 Central ITS sub-system and station

The central ITS sub-system shall contain a central ITS station and may contain ITS-S interceptors specified in clause 4.5.2.6

The ITS-S interceptors in the central ITS sub-system typically are a central ITS-S gateway and an ITS-S border router as presented in the informative figure 6.

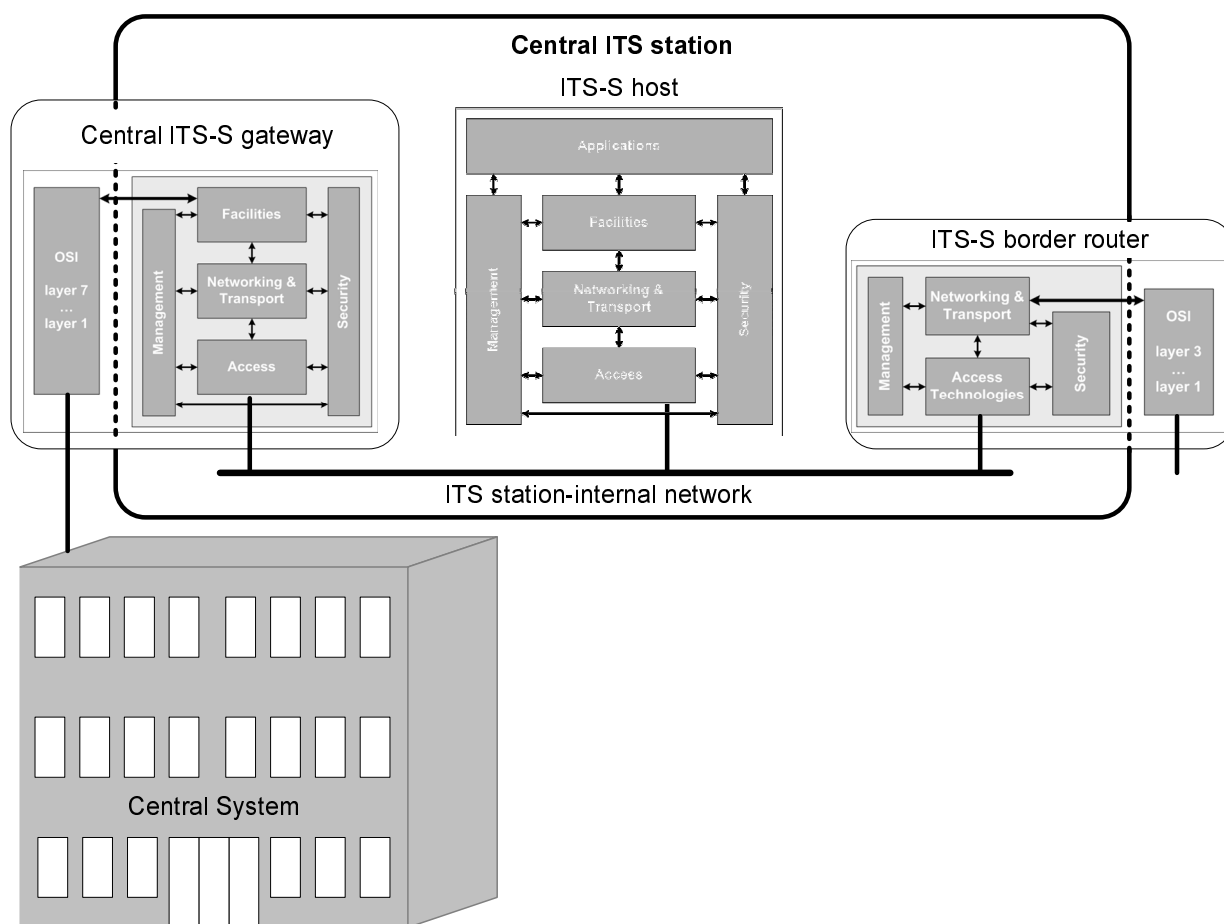

Figure 6: Central ITS station in a central sub-system

The central ITS-S gateway provides functionality to connect the components of the central system to the ITS station-internal network presented in figure 12.

NOTE: Following the principles of the ITS-S interceptor, the access of the central ITS station to the components of the central system may be implementation-specific, and not necessarily a proprietary network will be used.

4.5.1.4 Vehicle ITS sub-system and station

The vehicle ITS sub-system shall contain a vehicle ITS station and may contain ITS-S interceptors specified in clause 4.5.2.6.

The ITS-S interceptors in the vehicle ITS sub-system typically are a vehicle ITS-S gateway and an ITS-S router as presented in the informative figure 7.

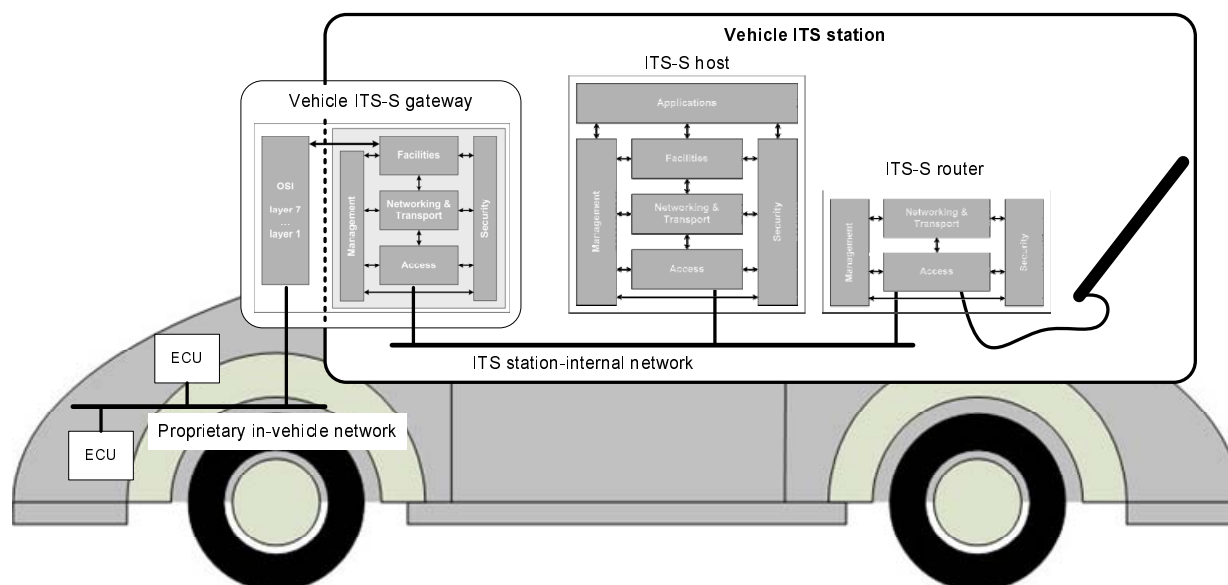

Figure 7: Vehicle ITS station in a vehicle sub-system

The vehicle ITS-S gateway provides functionality to connect the components at the proprietary network presented in figure 12, e.g. ECU, to the ITS station-internal network presented in figure 12. The interface to the in-vehicle components such as ECU is outside the scope of the present document. Access to components (ECU) may be achieved also in an implementation specific way.

NOTE: Following the principles of the ITS-S interceptor, the access of the vehicle ITS station to the components at the proprietary network may be implementation-specific, and not necessarily a proprietary network will be used.

4.5.1.5 Roadside ITS sub-system and station

The roadside ITS sub-system shall contain a roadside ITS station and may contain ITS-S interceptors specified in clause 4.5.2.6

The ITS-S interceptors in the roadside ITS sub-system typically are a roadside ITS-S gateway, an ITS-S router and an ITS-S border router as presented in the informative figure 7.

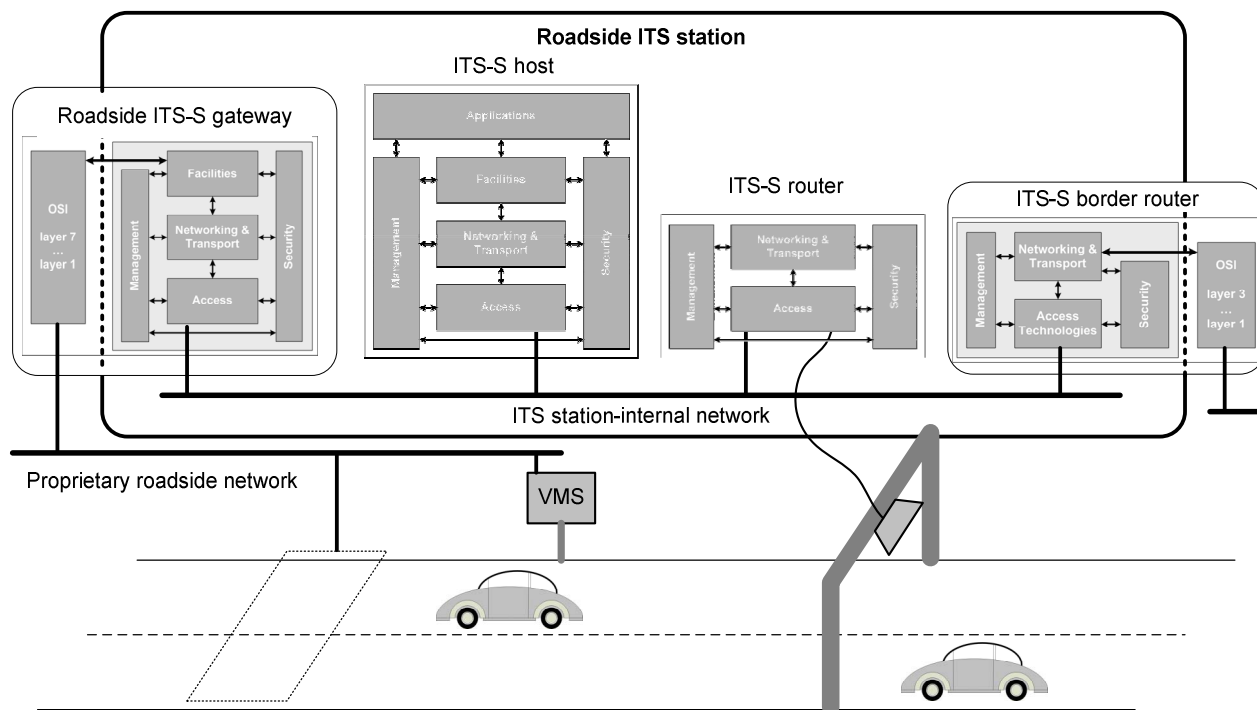

Figure 8: Roadside ITS station in a roadside sub-system

The roadside ITS-S gateway provides functionality to connect the components of the roadside system, e.g. inductive loops, variable message signs (VMS), at the proprietary network presented in figure 12 to the ITS station-internal network presented in figure 12.

NOTE: Following the principles of the ITS-S interceptor, the access of the roadside ITS station to the components of the roadside system may be implementation-specific, and not necessarily a proprietary network will be used.

4.5.2 Functional components of an ITS station

4.5.2.1 Overview

Functional components of an ITS station as presented in the following sub-clauses are:

- ITS-S host,
- ITS-S gateway,
- ITS-S router,
- ITS-S border router.

4.5.2.2 ITS-S host

With reference to figure 2 an ITS-S host contains as a minimum the ITS-S applications and the functionality of the ITS station reference architecture needed for the ITS-S applications.

4.5.2.3 ITS-S gateway

An ITS-S gateway provides the functionality as presented in figure 9. It interconnects two different OSI protocol stacks at layers 5 to 7. It shall be capable to convert protocols. The protocol stack on the right hand side in figure 9 typically is connected to the ITS station-internal network. The protocol stack on the left hand side in figure 9 typically is connected to a proprietary network.

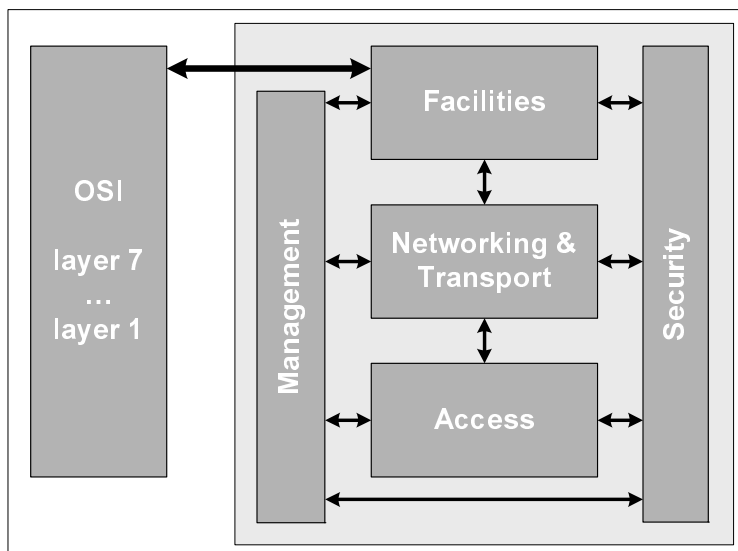

Figure 9: ITS-S gateway

4.5.2.4 ITS-S router

An ITS-S router provides the functionality as presented in figure 10, i.e. the functionality presented in figure 2 excluding "Applications" and "Facilities". It interconnects two different ITS protocol stacks at layer 3. It may be capable to convert protocols. One of these protocol stacks typically is connected to the ITS station-internal network.

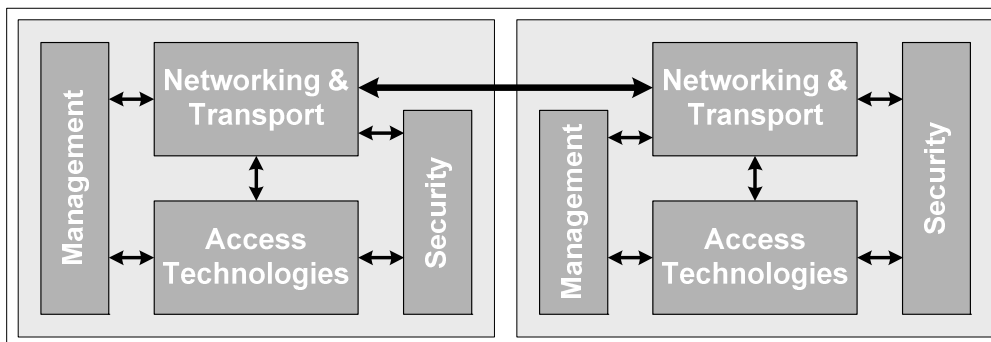

Figure 10: ITS-S router

4.5.2.5 ITS-S border router

An ITS-S border router as presented in figure 11 basically provides the same functionality as the ITS-S router presented in figure 10. The difference is, that the protocol stack related to the external network may not follow the management and security principles of ITS.

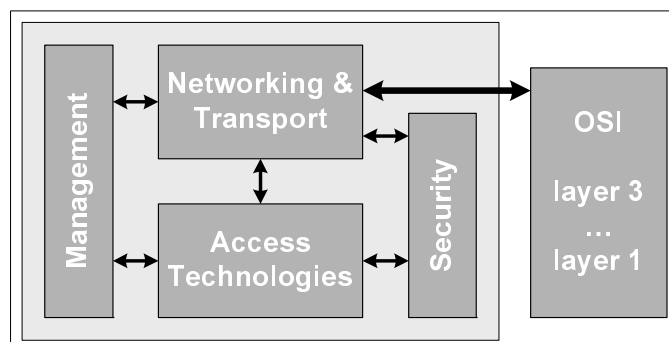

Figure 11: ITS-S border router

4.5.2.6 ITS-S interceptor

An ITS-S interceptor specified in [i.5], in the context of ITSC, is either equal to:

- an ITS-S gateway presented in figure 9, or
- an ITS-S router presented in figure 10, or
- an ITS-S border router presented in figure 11,

or may provide an implementation specific method to connect the ITS station-internal network to another network.

4.6 ITSC networking

ITSC supports networking from a top-level point of view as specified in [1]. Figure 12 identifies the ITS station boundary in this networking view.

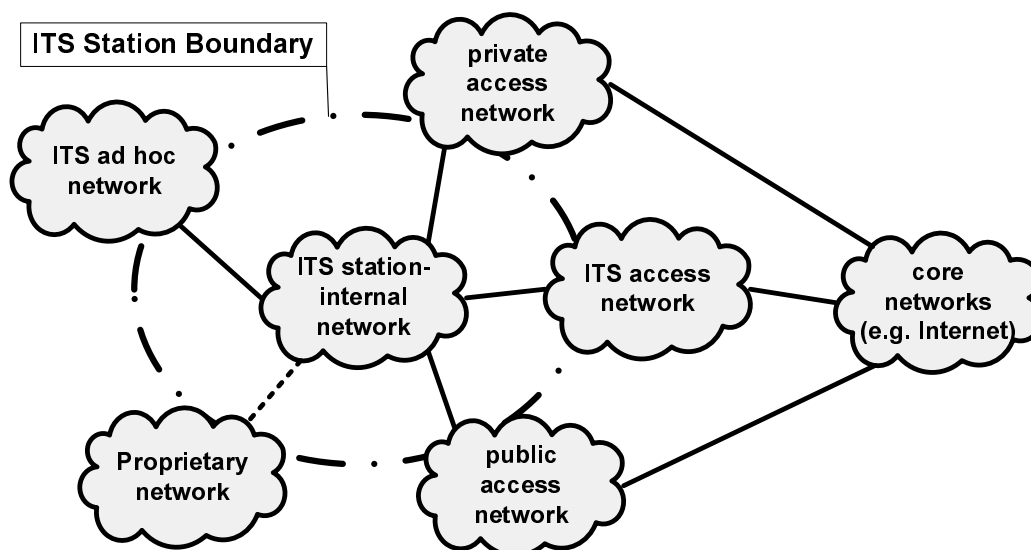

Figure 12: ITS station boundary in the context of the overall networking view

The ITS station connects to access networks via ITS-S border routers presented in figures 6 and 8.

The ITS station connects to ITS ad hoc networks via ITS-S routers presented in figures 7 and 8.

The ITS station internal network is not necessarily physically available. It may be realized simultaneously with different access technologies, both wired, e.g. Ethernet, or wireless, e.g. Bluetooth.

The ITS station typically connects to a proprietary network via an ITS-S gateway, i.e. the central ITS-S gateway in figure 6, the vehicle ITS-S gateway in figure 7 and the roadside ITS-S gateway in figure 8. The access to the proprietary network is outside the scope of the present document.

4.7 ITSC implementation architecture

The present document in no way restricts approaches to specific implementations. The present document is enabling different implementation architectures as presented in the informative annex B.

5 ITS applications

5.1 Context

This clause specifies general management of ITS applications, e.g. classification, prioritization and channel assignment, registration and secure maintenance, in the context of ITSC. An ITS application is an association of two or more complementary ITS-S applications, e.g. server part and client part. ITS-S applications reside in the block "Applications" of the ITS station reference architecture illustrated in figure 13.

ITS applications are initially grouped into "Road Safety", "Traffic Efficiency" and "Other Applications".

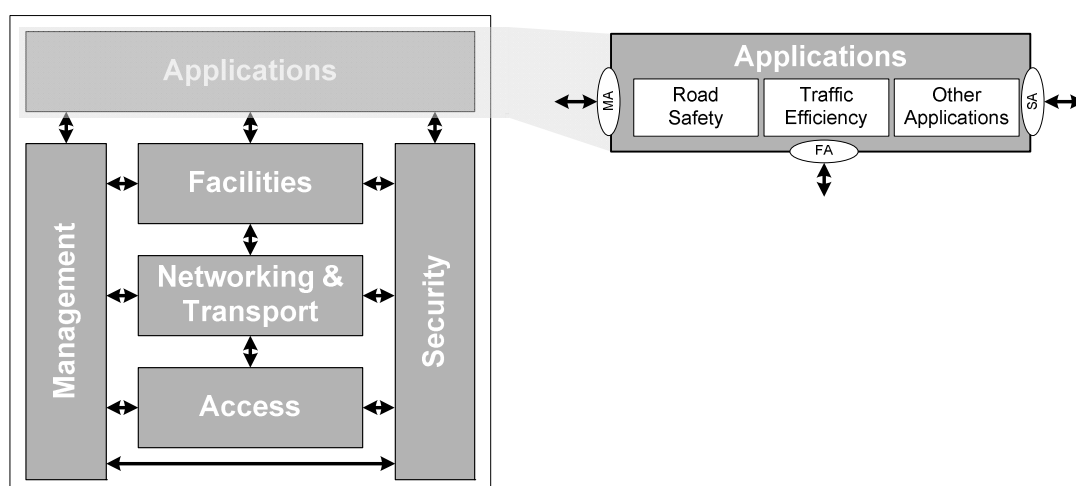

Figure 13: ITS applications as part of the ITS station reference architecture

5.2 Classes of applications

ITSC standards shall be designed to support multiple classes of ITS applications including those supporting vehicle operations. Dependent on how much these applications rely on the communication services, application classes impose more or less stringent requirements on ITSC, with respect of:

- reliability,
- security,
- latency, and
- other performance parameters.

NOTE: Whilst the reliability of communications systems can be optimised, these systems will never be 100 % reliable. Application developers should design their systems to operate safely even if a problem with the communications system occurs.

5.3 Prioritization and channel assignment

All ITS applications shall be associated with an ITS application priority according to the functional and operational requirements of the ITS application. This ITS application priority shall indicate the maximum possible value of the channel access priority; see also clause 6.1.4 on prioritization at the access layer.

All ITS applications shall be associated with a specific logical channel type for transmission of data packets. Logical channel types shall be as specified in clause 6.1.3.

5.4 Secure maintenance

Maintenance of ITS applications, i.e. installation, de-installation, updates, shall be performed in a secure way in order to support protection of ITS stations from attacks by malicious applications. The facilities layer presented in figures 2 and 20 shall provide the required functionality based on interactions with the security entity via the SF-interface and the management entity via FM-interface.

NOTE: Further details are outside the scope of the present document.

5.5 Registration authority

A basic means to enable secure maintenance is to register ITS applications and related messages at an ITS registration authority, and to restrict access to "Facilities", "Management" and "Security" dependent on the rules as defined by the ITS registration authority.

NOTE 1: There may be more than a single ITS registration authority. Details are outside the scope of the present document.

NOTE 2: This does not prohibit general access to e.g. Internet-applications, but may prohibit selected communication channels to be used for this purpose.

NOTE 3: The ITS application priority is a possible tool to control access of ITS-S applications to the communication protocol stack.

Every ITS application class/ITS application shall be uniquely identified by an application identifier in order to be handled in ITSC.

NOTE 4: Further details are outside the scope of the present document.

6 ITSC OSI protocol stack

6.1 Access layer

6.1.1 Context

This clause specifies general details of the ITSC access layer (AL). The ITSC AL is part of the ITS station reference architecture as illustrated in the informative figure 14.

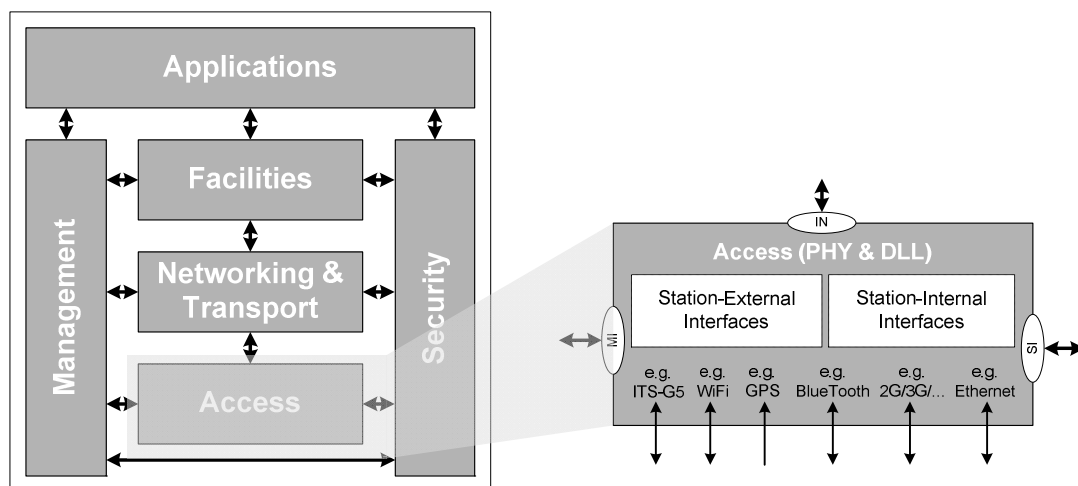

Figure 14: ITSC access layer as part of the ITS station reference architecture

Figure 14 formally distinguishes between station-internal communication interfaces (CIs) and station-external CIs. From a protocol point of view there shall be no difference in managing a CI via the IN-interface, IM-interface and SI-interface presented in figure 15. However there shall be management protocol means to clearly identify the properties and the status of every specific CI and to manipulate their parameters, see e.g. [10].

6.1.2 General functionality

Details of the ITSC AL are presented in figure 15.

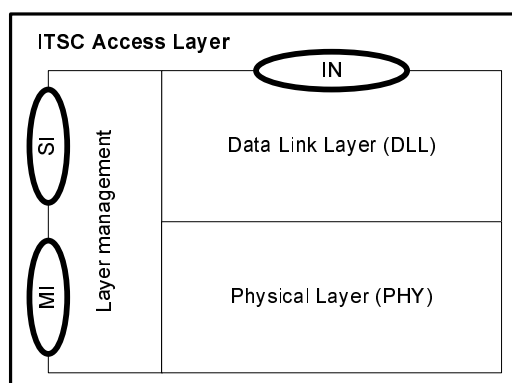

Figure 15: Access layer details

The AL consists of:

- a physical layer (PHY) connecting physically to the communication medium,
- a data link layer (DLL), which may be sub-divided into a medium access control sub-layer (MAC) managing the access to the communication medium, and a logical link control sub-layer (LLC),
- a layer management of the AL, directly managing PHY and DLL,

NOTE 1: The layer management is not part of the "Management" entity of the ITS station reference architecture presented in figure 2.

- an IN-interface specified in [i.19], connecting to the ITSC networking and transport layer by providing data link layer communication services,
- an MI-interface specified in [i.12i.12], connecting to the ITS station and communication management entity by providing management services,

- an SI-interface specified in [i.16i.16], connecting to the ITSC security entity by using security services.

As ITSC is supporting a multiplicity of different access technologies including legacy technologies, there might be the need for an adaptation of legacy technologies as presented in figure 16, i.e. a need for:

- an AL communication adaptation sub-layer (CAL),
- an AL management adaptation entity (MAE),
- an AL security adaptation entity (SAE).

CAL can be interpreted as the upper part of the DLL. If present, it shall provide the services of the IN-interface.

MAE can be interpreted as a part of the layer management. If present, it shall providing the services of the IM-interface.

SAE can be interpreted as a part of the layer management. If present, it shall use the services of the SI-interface.

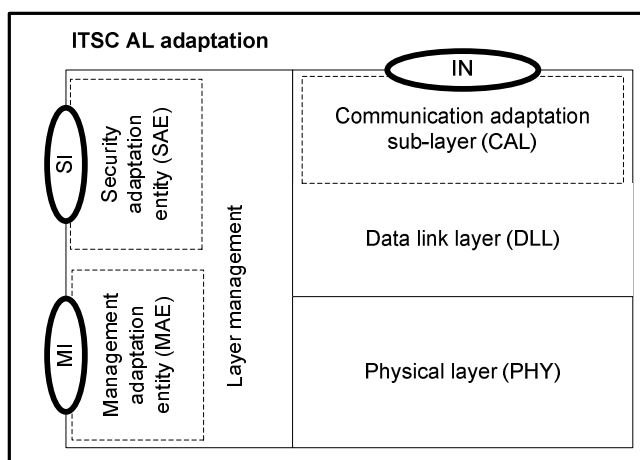

Figure 16: Access layer adaptation

NOTE 2: Further details of the AL interfaces will be specified in [i.10], [i.11], [i.12], [i.16], [i.19] and in the standards dedicated to the AL technologies.

6.1.3 Communication channels

6.1.3.1 Generic logical channel types

An ITSC CI shall provide the functionality of one or more logical channels (LCHs). Mapping of LCHs on physical channels shall be as specified in the standards on access technologies.

LCHs are numbered sequentially and shall be represented with ASN.1 type LogicalChannelType specified in annex A.

LCHs are to be identified e.g. for the following purposes:

- basic station management,
- service advertisement as presented in figures 22 and 23,
- ITS application data exchange,
- information dissemination,
- general purpose usage, e.g. Internet, video streaming.

Priority of ITS-S applications are relevant details for the definition of specific LCHs.

6.1.3.2 Channel types and access technologies

Logical channel types shall be treated as properties of a communication interface (CI) or a virtual instance (VCI) of it, if applicable. A CI is an implementation of an AL technology which is uniquely selectable by means of a CI identifier (CI-ID), e.g. as specified in [i.10],[10]. The concept of VCIs is exemplified in [10]. VCIs also are uniquely selectable by means of a CI-ID. A CI/VCI may have the property of either one or more channel types.

A mapping of logical channels onto physical channels shall be performed in compliance with the related standards dedicated to the AL technologies; see also clause 6.1.4 on prioritization.

6.1.4 Prioritization

6.1.4.1 General concept

Prioritization of transmission requests typically may be handled in the ITSC access layer at two possible different levels:

- 1) close below the IN-interface, e.g. in the DLL,
- 2) close to or inside the PHY.

Both methods are allowed. Method 1) is used to handle primarily contention of ITS applications of the same station in the CI. Method 2) is used to handle primarily contention of different ITSC stations in the physical communication channel in a medium-specific way.

6.1.4.2 Contention in a single station

The channel access priority indicated in every transmission request passed through the IN-interface shall be used to prioritize concurrent transmission requests in a CI. Prioritization at the DLL shall be based on priority queues, e.g. as specified in [10].

NOTE: Further details will be specified in [i.19].

6.1.4.3 Contention in the physical communication channel

Depending on the specific access technology, a suitable mapping of channel access priorities on channel contention classes shall be done as specified in the related standards, if applicable.

Contention handling in the physical communication channel typically is based on a very small number of different priority levels.

EXAMPLE: In case of four priority values, channel contention classes, e.g. "superior", "high", "middle", "low", may be considered.

NOTE: In [i.1] these four channel access priority classes correspond with the access categories AC_VO, AC_VI, AC_BK, AC_BE.

6.2 Networking and transport layer

6.2.1 Context

This clause specifies general details of the ITSC networking & transport layer. The ITSC networking and transport layer is part of the ITS station reference architecture as illustrated in the informative figure 17.

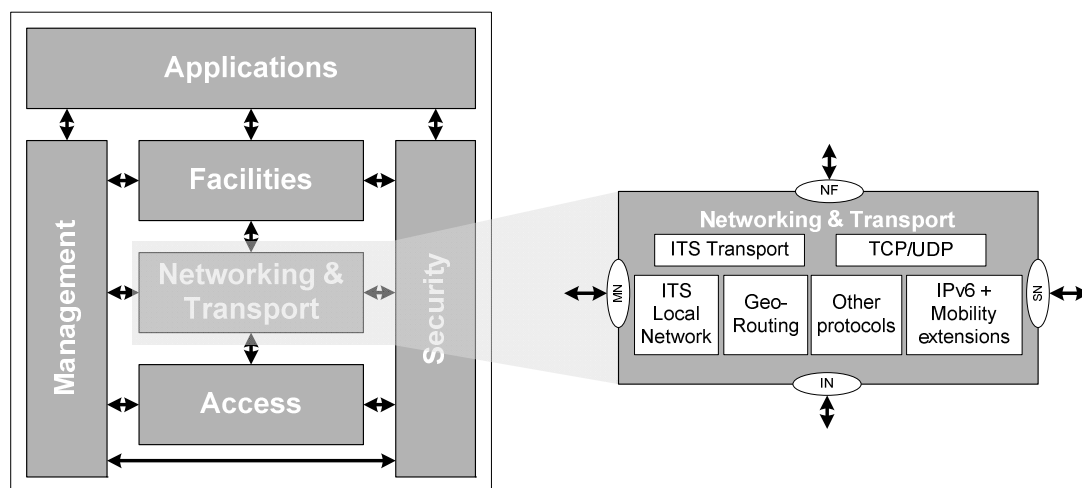

Figure 17: ITSC networking and transport layer as part of the ITS station reference architecture

6.2.2 General functionality

Details of the ITSC networking and transport layer are presented in figure 18.

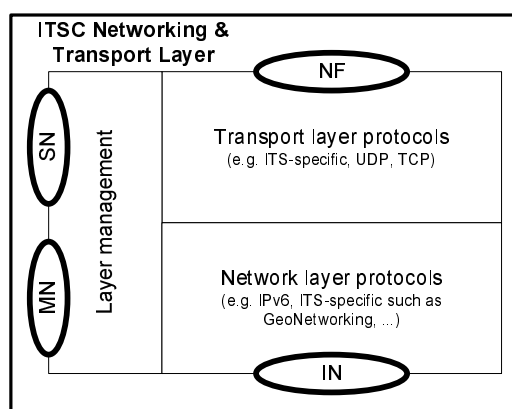

Figure 18: ITSC networking and transport layer

The ITSC networking & transport layer contains functionality from the OSI network layer and the OSI transport layer with amendments dedicated to ITSC:

- one or several networking protocols,
- one or several transport protocols,
- a network and transport layer management,

NOTE: The layer management is not part of the "Management" entity of the ITS station reference architecture presented in figure 2.

- an NF-interface specified in [i.20], connecting to the ITSC facility layer by providing communication services,
- an NM-interface specified in [i.13], connecting to the ITSC station and communication management entity by providing management services,
- an SN-interface specified in [i.17], connecting to the ITSC security entity by using security services,
- an IN-interface specified in [i.19], connecting to the ITSC AL by using communication services.

6.2.3 Networking protocols

Several different possible networking modes are identified for ITSC so far, and are indicated in figure 17:

- GeoNetworking protocol as to be specified in [i.6],
- IPv6 networking with mobility support developed at IETF and ISO specified in [6],
- IPv6 over GeoNetworking as specified in [i.7],
- CALM FAST protocol as specified in [12],
- other ways of IPv6 networking,
- other protocols.

Each networking protocol may be connected to a specific dedicated ITSC transport protocol or may connect to an already existing transport protocol, e.g. UDP, TCP. IPv6 networking comprises methods to enable interoperability with legacy IPv4 systems.

6.2.4 Transport protocols

Several different transport protocols are identified for ITSC and presented in figure 17:

- UDP/TCP,
- dedicated ITSC transport protocols,
- others.

6.3 Facilities layer

6.3.1 Context

This clause specifies general details of the ITSC facilities layer. The ITSC facilities layer is part of the ITS station reference architecture as illustrated in the informative figure 19.

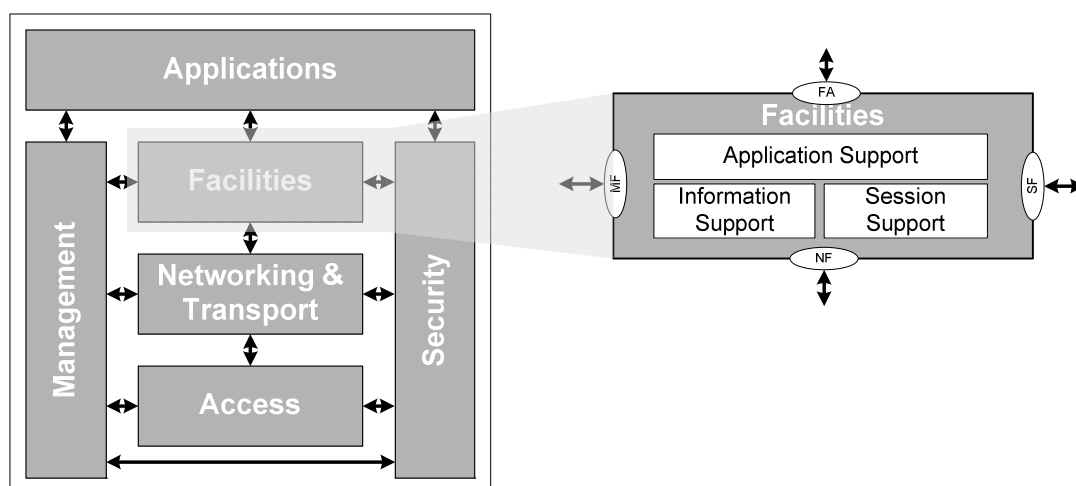

Figure 19: ITSC facilities layer as part of the ITS station reference architecture

6.3.2 General functionality

Details of the ITSC facilities layer are presented in figure 20.

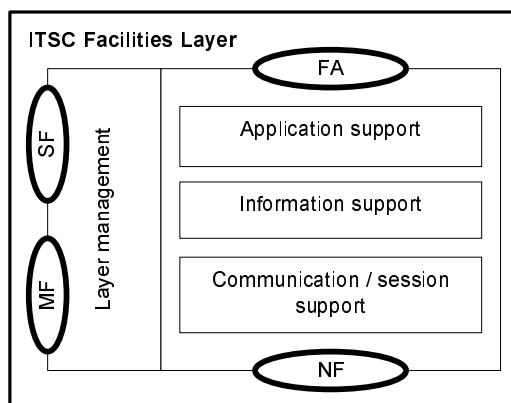

Figure 20: ITSC facilities layer

The ITSC facilities layer contains functionality from the OSI application layer, the OSI presentation layer (e.g. ASN.1 encoding and decoding, and encryption) and the OSI session layer (e.g. inter-host communication) with amendments dedicated to ITSC:

- application support,
- information support,
- communication support,
- session support,
- a facilities layer management,

NOTE: The layer management is not part of the "Management" entity of the ITS station reference architecture presented in figure 2.

- an FA-interface specified in connecting to the ITS applications,
- an MF-interface specified in [i.14], connecting to the ITSC station and communication management entity by providing management services,
- an SF-interface specified in [i.18], connecting to the ITSC security entity by using security services,
- an NF-interface specified in [i.20], connecting to the ITSC networking & transport layer by using communication services.

The ITSC facilities layer is providing support to ITS applications which can share generic functions and data according to their respective functional and operational requirements. A non exhaustive presentation of generic functions and data is listed below.

6.3.3 Details on facilities

Facilities may include:

- Generic HMI support

This facility presents information to the user of the system, e.g. to the car driver, via the HMI hardware and firmware.

- Support for data presentation

Data presentation is a basic functionality of the OSI presentation layer. Its function is to code and decode messages according to formal language being used (e.g. ASN.1).

- Addressing support

This facility supports selection of the addressing mode at lower layers.

- Position and time support

This facility provides information on the geographical position (longitude, latitude, altitude) of the ITS station, and the actual time.

- Support for location referencing and time stamping of data

- Local dynamic map (LDM) support [i.21], also being developed at CEN TC278 WG16

A cooperative system for road safety critical applications benefits from using digital maps. Such maps used in ITS may include lane-specific information including curbs, pedestrian walking, bicycle paths and road furniture such as traffic signs and traffic lights. Furthermore, all dynamic objects that are directly sensed or indicated by other road users by means of cooperative awareness messages may be referenced in such a digital map, referred to as local dynamic map (LDM). Due to the physical nature of these objects to be referenced in the LDM, spatial queries are used to determine object dependencies and relationships. In addition, all elements need to be time-stamped. An LDM containing the location of dynamic objects might also be provided for vehicles that do not have a geographic digital map available.

- Support for maintenance of ITS-S applications

This facility supports the download and activation of new application software and the update of already installed software.

- SOA application protocol support

This facility supports the operation of loosely coupled, business-aligned and networked services. An implementation example are SOA-based web services.

This facility supports applications using backend services with features such as:

- establishing a session with the backend,
- handling unexpected session losses due to the mobility of the ITS station,
- maintenance of a session during handover.

- Support for relevance checking

This facility checks whether a received message is relevant or not in the current context. This facility is closely linked to LDM and location referencing. It is also used by the generic HMI support facility to present a relevant view to the driver.

- Support for station capabilities management

This facility manages information on:

- station type, e.g. vehicle profile or roadside unit profile,
- station capabilities, e.g. the supported ITSC communication channels and other static or variable information related to the station itself.

- Support for combining and fusing data from different sources and keeping them up to date

- Support for station data provision

This facility provides static and dynamic information from the ITS station as required by ITS applications and other facilities.

- Support for common message management for data exchange between ITS-S applications

- Decentralized Environmental Notification Messages (DENM) [i.9]
- Event messages

Event messages are triggered following the detection of some events. They are repeated as long as the event is perceived by the ITS station which is detecting it. Events are signalled using broadcasting capabilities. Rules to define the signalling coverage, stop to repeat it or cancel it depend on a specific event. Typically, the DENM [i.9] and the TPEG-RTM (Transport Protocol Expert Group - Road Traffic Messages) messages are event messages.

- Periodic messages

Co-operative Awareness Messages (CAMs) [i.8] are an example of periodic messages. CAMs are periodically broadcasted by the facilities layer at a given frequency satisfying both, the road safety application requirements and the transport & network layer requirements - network heartbeat. The CAM frequency may be determined by the communication management entity taking into account the supported road safety application operating requirements, the transport & layer requirements and the current channel load.

An other example of periodic messages is the service advertisement as specified e.g. in [11].

- Service messages

Service messages are messages to manage sessions. Examples given in [11] are:

- A service context message is carried in a service context frame. It is a reply to the service advertisement message.
- Request messages, carrying request PDUs from ITS-S applications.
- Response messages, carrying response PDUs from ITS-S applications.

- Support of repetitive transmission of messages

This facility is in charge to repetitively request transmission of messages according to the requirements set up by the ITS-S application

- Support for DSRC legacy applications as specified in [12]

DSRC legacy applications, especially road tolling, may be supported via ITSC access technologies in order to enable smooth migration from the DSRC wireless link [i.3], [i.4], [i.5] to ITSC access technologies, e.g. ITS-G5 [2], CALM M5 [8].

NOTE: ISO/IEC 29281 [12] specifies a suitable procedure based on the CALM FAST networking and transport protocol for single-hop wireless communications.

- Channel selection

This facility supports selection of the proper communication interface for transmission of messages. An example is the CI selection manager specified in [11] and presented in figure 24.

- Connecting to ITS-S applications by providing services of the FA-SAP
- Connecting to the ITSC networking & transport layer by using services of the NF-SAP
- Other functionality.

7 ITSC management entity

7.1 Context

This clause specifies general details of the ITSC management entity. The ITSC management entity is part of the ITS station reference architecture as illustrated in the informative figure 21.

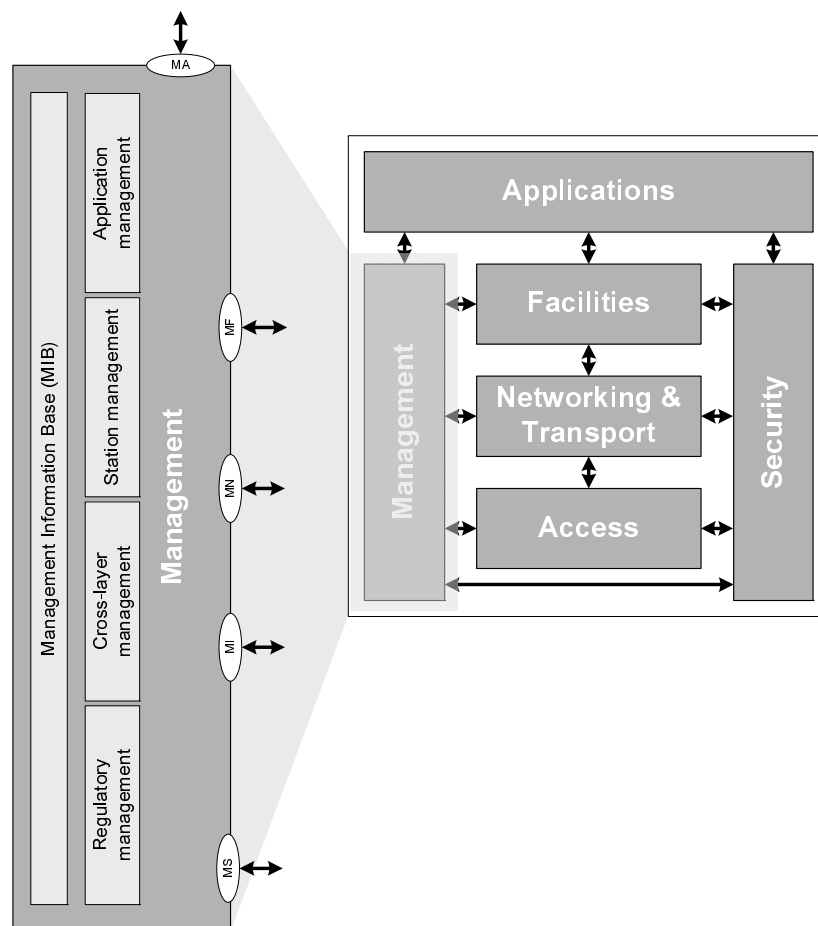

Figure 21: ITSC management entity as part of the ITS station reference architecture

7.2 Functionality

7.2.1 Overview

The ITSC management entity contains management elements which may be functionality grouped as presented in figure 21, e.g.:

- Cross-interface management
- Inter-unit management communications (IUMC) specified in [i.10]

NOTE: IUMC also is specified in [11].

- Networking management
- Communications service management
- ITS application management

- Station management
- Management of general congestion control
- Management of service advertisement
- Management of legacy system protection, e.g. protection of DSRC as specified in [10] and [11]
- A common management information base (MIB) specified in [i.11]
- An MI-interface specified in [i.12], connecting to the ITSC access layer by using access layer management services
- An MN-interface specified in [i.13], connecting to the ITSC networking and transport layer by using networking and transport layer management services
- An MF-interface specified in [i.14], connecting to the ITSC facility layer by using facility layer management services
- An AM-interface connecting to the ITS-S applications by providing management services
- An MS-interface specified in [i.15], connecting to the security entity by using security management services.

7.2.2 ITS service advertisement

7.2.2.1 General

ITS basically may support push and pull mechanisms in order to allow an ITS station to identify existence of ITS services. The push mechanism is named "ITS service advertisement". The pull mechanism is known e.g. from Internet protocols.

ITS service advertisement may be implemented optionally in different ways and for different contexts. One option on how to advertise ITS services in single-hop wireless links is specified in the draft standard [11] and named FAST service advertisement.

7.2.2.2 FAST service advertisement

For FAST service advertisement [11], providing service advertisement for single-hop wireless links, a service advertisement manager is in charge to collect requests from ITS-S applications, and to initiate periodic transmission of service advertisement messages according to the requirements set up by the "ITS application service provider" entity of the ITS applications. It receives service advertisement messages from peer stations and processes the advertisement data as required by the "ITS application service client" entity of the ITS applications.

Service advertisement and service session operation may be arranged as presented either in figure 22 or in figure 23 in [11]. Figure 22 reflects the approach of CEN DSRC [i.5] with a service advertisement frame (SAF) and a service context frame (SCF) used in the wireless link to carry the advertisement data packets. Figure 23 reflects the approach of WAVE [i.2] and does not use an SCF. The SAF is transmitted either in a LCH1 or in an application specific logical channel. All other frames are transmitted either in LCH2 or in an application specific logical channel. The ITS application decides on which option is to be used.

NOTE: The sequence of request frames and response frames in figures 22 and 23 depends on the ITS application.

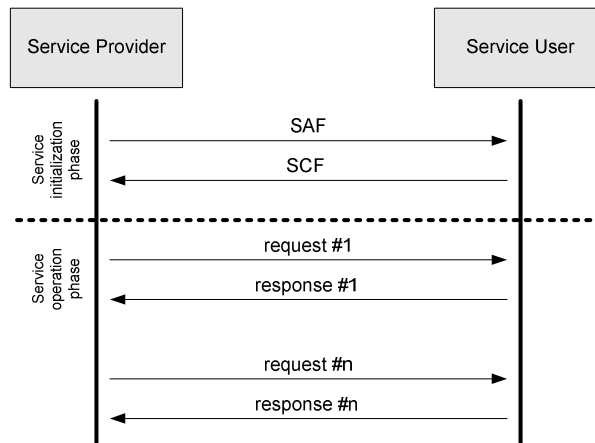

Figure 22: Example of ITSC services frame exchange (SAF and SCF) [11]

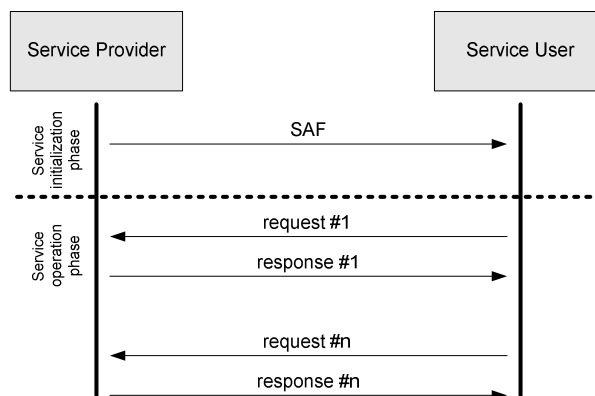

Figure 23: Example of ITSC services frame exchange [11]

7.2.3 General congestion control

Having in mind that physical communication channels have limited bandwidth, and that in a real operational environment a large number of ITS stations will try to access the physical communication channel simultaneously, special means need to be provided which allow to avoid excessive load on the physical channel.

Such means are referred to as "General Congestion Control" and will impact all communication layers and the applications as presented in figure 2. These means may include e.g.:

- dynamic modification of AL parameters, even on a packet-by-packet basis,
- dynamic modification of channel access priority of selected packets, even on a packet-by-packet basis, i.e. reduction below the maximum possible value which is equal to the ITS application priority specified in clause 5.3,
- change of CI, also referred to as vertical hand-over,
- dynamic modification of repetition rate of periodic/repetitive messages.

7.2.4 CI/ITS-S application mapping

Figure 24 shows the building blocks and data flows in the ITSC management required to dynamically select the optimum mapping of ITS-S applications on communication interfaces.

In order to decide, which is the most appropriate CI to provide a communication service for an ITS-S application, the CI/ITS application mapping manager needs to know:

- what the communication needs of the ITS-S applications are (ITS application requirement list),
- what kind of CIs are available and what the properties and statuses of these CIs are (CI status list), and
- what the applicable rules are (set of rules).

CI/ITS application mapping, if applicable, shall be distributed over the whole ITS station, i.e. being available in all ITS-S interceptors listed in clause 4.5.2.6. Mapping decisions, if applicable, shall be done in ITS-S hosts.

NOTE 1: Some applications or classes of applications, e.g. road safety, may require a specific access technology in a specific region. This will be expressed in terms of communication needs, such that the CI/ITS-S application mapping will ensure to select the proper access technology.

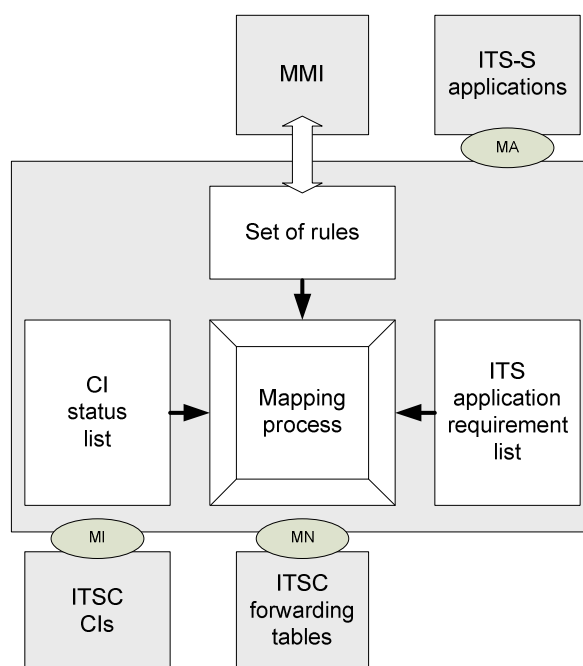

Figure 24: CI/ITS-S application mapping

NOTE 2: An example of CI/ITS application mapping is standardized in [11].

7.2.5 Local node map

The ITSC station management may maintain information on neighbouring stations, referred to as "Local Node Map" information, combining communications parameters, e.g. MAC addresses, networking addresses, ..., together with their kinematic state vector, e.g. position, speed and heading.

The local node map management shall interact with the local dynamic map (LDM) service of the station, if applicable.

7.2.6 Inter-management communication

Management communication between instances of the management entity of the same ITS station shall be done applying inter-management communication. Examples are given in [11, i.10].

7.2.7 Regulatory information management

Regulatory information (RI) shall be managed according to the needs of the access technologies. In addition, the ITSC management entity shall provide a common framework for RI management, if applicable.

NOTE: A common framework for RI management is standardized in e.g. [10], [11].

7.2.8 ITS application management

The ITS application management manages the installation and configuration of ITS-S applications that are installed at the ITS-S, and the inevitable updating. The application management supports the error handling of ITS-S applications. Safeguard mechanisms alleviating harmful application behaviours may also be provided.

The ITS application management may use the interfaces from the management entity to the application entity, the security entity and to the communication protocol layers presented in the ITS station reference architecture.

7.2.9 ITS communication service management

ITS communications service management monitors the operation of ITSC. This may include:

- Communications system configuration and update management:
 - Addition and configuration of new communications systems.
 - Updating of the core software used to implement the ITSC functions.
- Regulatory compliance, e.g. compliance with national spectrum usage rules.
- Recording and forwarding of usage billing events:
 - Particularly for third party usage of chargeable communication services accessed vehicle to vehicle communications.
 - Holding of license agreements to confirm that the ITS-S is authorised to use a communications service.
- Communications system fault monitoring, alerts, diagnosis, automatic mitigation including optional switch to an alternative communication system, and reporting.
- Maintenance utilities to allow faults to be managed, e.g. to allow a local faulty communications system to be deactivated.

Higher levels of service management will be required where the ITS-S is designed to support road safety applications. These may include:

- Monitoring service level, and
- recording the delivered performance of the communications system.

8 ITSC Security

8.1 Context

This clause specifies general details of the ITSC security entity. The ITSC security entity is part of the ITS station reference architecture as illustrated in figure 25.

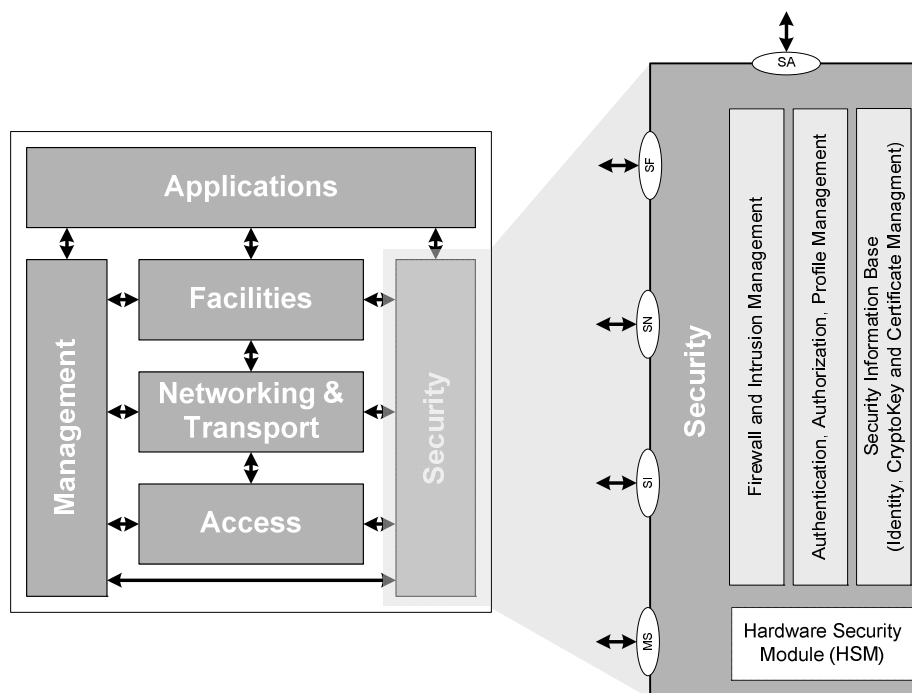

Figure 25: ITSC security entity as part of the ITS station reference architecture

8.2 General functionality

The ITSC security entity presented in figure 25 contains security functionality related to the ITSC communication protocol stack, the ITS station and ITS applications, e.g.:

- firewall and intrusion management,
- authentication, authorisation and profile management,
- identity, crypto key and certificate management,
- a common security information base (SIB),
- hardware security modules (HSM),
- an SI-interface specified in [i.16], connecting to the ITSC access layer by providing access layer security management services.

- an SN-interface specified in [i.17], connecting to the ITSC networking and transport layer by providing networking and transport layer security management services,
- an SF-interface specified in [i.18], connecting to the ITSC facility layer by providing facility layer security management services,
- an SA-interface connecting to the ITS applications by providing security management services,
- an MS-interface specified in [i.15], connecting to the ITSC management entity by providing security management services.

Annex A (normative): ASN.1 module

The ASN.1 module of the present document is **ITSCArch { itu-t(0) identified-organization(4) etsi(0) itsDomain(5) wg2 (2) ITSCArch(302665)}** as specified below.

Packed encoding rules (PER) as specified in [5] shall be applied.

```
ITSCArch { itu-t(0) identified-organization(4) etsi(0) itsDomain(5) wg2 (2) itscArch(302665) }
DEFINITIONS ::= BEGIN

-- IMPORTS

-- End of IMPORTS

-- Types

LogicalChannelTypes ::= SEQUENCE OF LogicalChannelType

LogicalChannelType ::= ENUMERATED {
-- generic logical channel types
    lch0          (0),
    lch1          (1),
    lch2          (2),
-- lch3 ... lch 15 reserved for generic channel types
-- lch16 ... lch 254 reserved for application specific channel types
    lch255       (255) -- unspecified channel type
}

-- Values

END
```

Annex B (informative): Implementations of ITS stations

B.1 Prototypes

Prototypes of implementations of selected parts of ITS done by European research projects and industry initiatives are provided in COMeSafety.

B.2 Examples of implementation

B.2.1 Vehicle

Figures B.1, B.2 and B.3 show examples of three levels of complexity of ITSC installations in a vehicle.

NOTE: The IVN is an implementation of the ITS station internal network specified in figure 12.

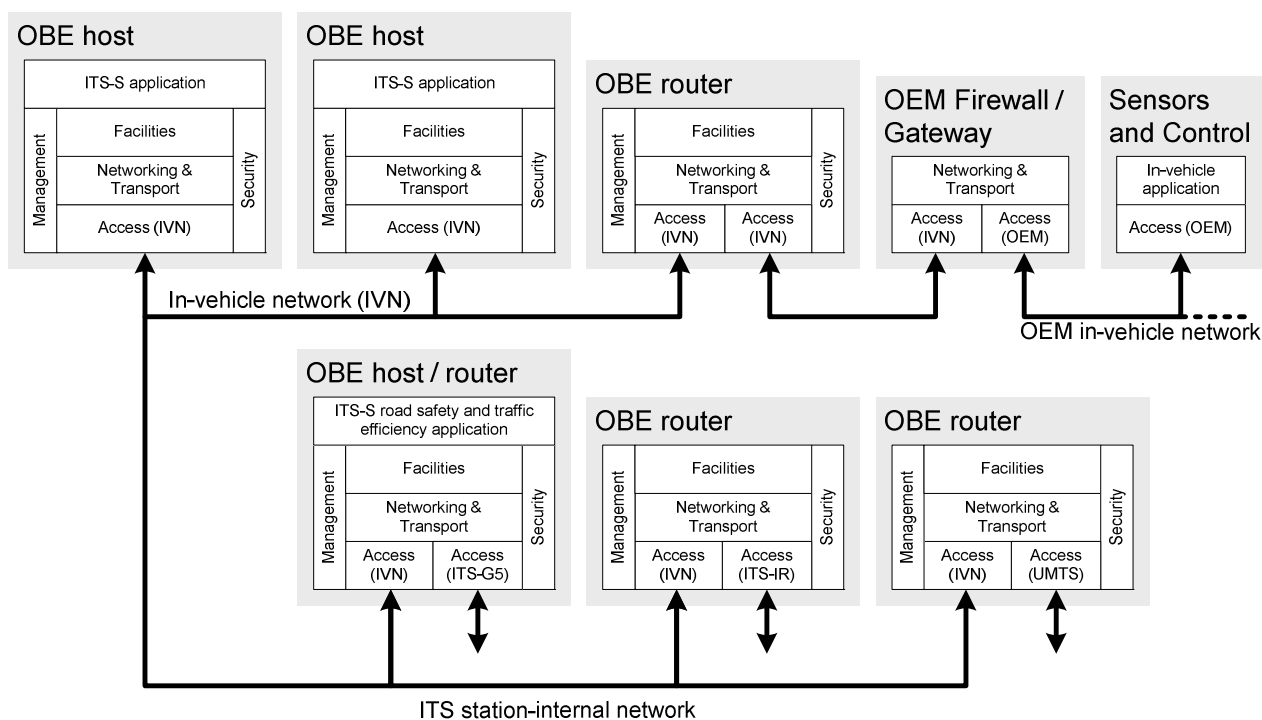

Figure B.1: Advanced vehicle implementation

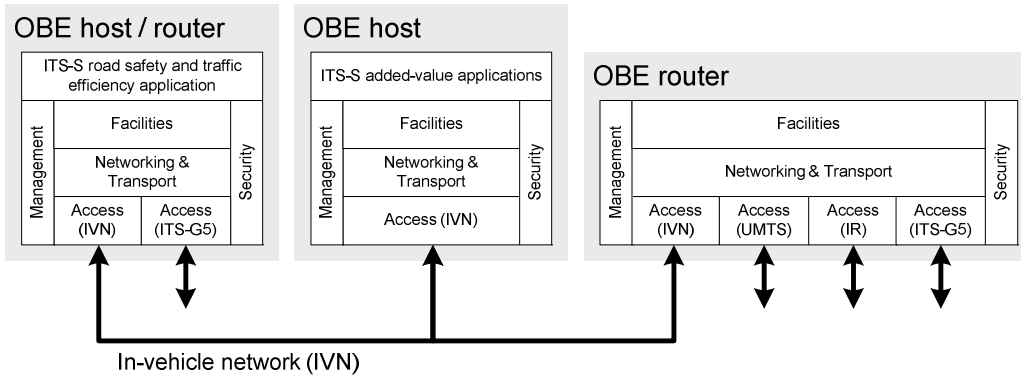

Figure B.2: Medium vehicle implementation

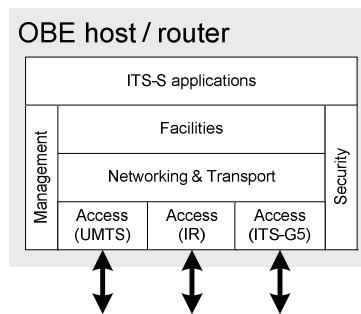

Figure B.3: Small vehicle implementation

B.2.2 Roadside

Figure B.4 shows an example of a ITSC installation at the roadside.

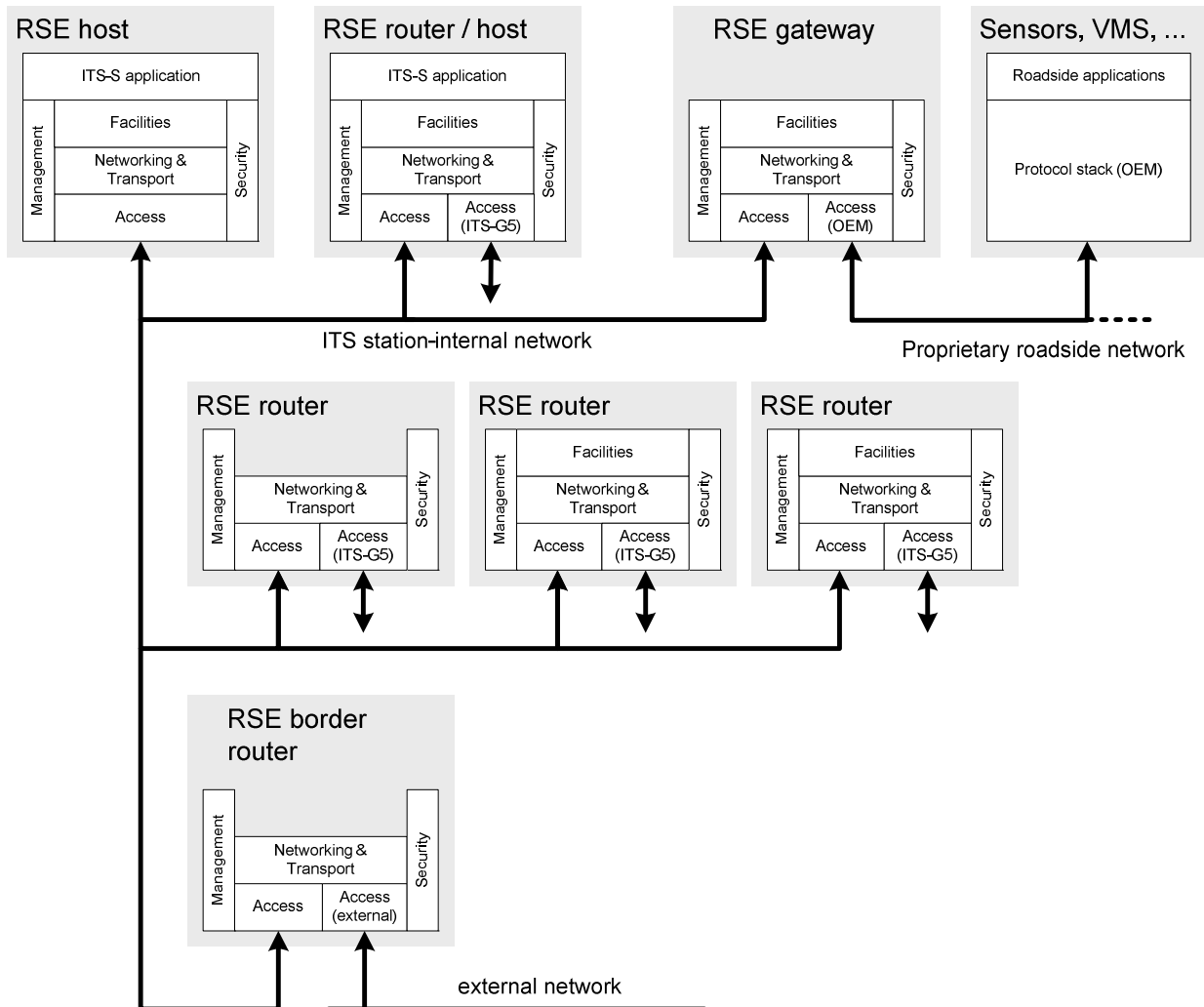

Figure B.4: Complex roadside implementation

Annex C (informative): Bibliography

COMeSafety: "European Cooperative Systems Communication Architecture; Overall Framework; Proof of Concept Implementation".

Manifesto: "Manifesto; Overview of the C2C-CC System".

History

Document history			
V1.0.0	March 2010	Public Enquiry	PE 20100715: 2010-03-17 to 2010-07-15