

Draft **EN 301 199** V1.1.1 (1998-01)

---

*European Standard (Telecommunications series)*

**Digital Video Broadcasting (DVB);  
Interaction channel for  
Local Multi-point Distribution Systems (LMDS)**

---

European Broadcasting Union



Union Européenne de Radio-Télévision

**DVB**  
Digital Video  
Broadcasting



*European Telecommunications Standards Institute*

---

---

**Reference**

DEN/JTC-DVB-64 (b3o00ico.PDF)

---

**Keywords**

DVB, broadcasting, digital, video, TV

***ETSI Secretariat***

---

**Postal address**

F-06921 Sophia Antipolis Cedex - FRANCE

---

**Office address**

650 Route des Lucioles - Sophia Antipolis  
Valbonne - FRANCE  
Tel.: +33 4 92 94 42 00 Fax: +33 4 93 65 47 16  
Siret N° 348 623 562 00017 - NAF 742 C  
Association à but non lucratif enregistrée à la  
Sous-Préfecture de Grasse (06) N° 7803/88

---

**X.400**

c= fr; a=atlas; p=etsi; s=secretariat

---

**Internet**

secretariat@etsi.fr  
<http://www.etsi.fr>

---

***Copyright Notification***

No part may be reproduced except as authorized by written permission.  
The copyright and the foregoing restriction extend to reproduction in all media.

© European Telecommunications Standards Institute 1998.  
© European Broadcasting Union 1998.  
All rights reserved.

# Contents

Intellectual Property Rights.....	<b>Error! Bookmark not defined.</b>
Foreword .....	5
1 Scope.....	6
2 References.....	6
3 Abbreviations.....	6
4 Reference model .....	7
4.1 Protocol stack model.....	7
4.2 System model.....	8
5 Interaction channel specification for LMDS networks.....	10
5.1 System concept .....	10
5.1.1 Out-of-Band (OOB) / In-Band (IB) principle .....	11
5.1.2 Intermediate Frequency (IF) spectrum allocation.....	11
5.1.3 FDM/TDMA multiple access.....	12
5.1.4 Bit rates and framing .....	13
5.2 Lower physical layer specification.....	13
5.2.1 Forward Interaction path (downstream OOB).....	16
5.2.1.1 Frequency range (downstream OOB) .....	16
5.2.1.2 Modulation and mapping (downstream OOB).....	16
5.2.1.3 Shaping filter (downstream OOB) .....	16
5.2.1.4 Randomizer (downstream OOB) .....	17
5.2.1.5 Bit rate (downstream OOB).....	18
5.2.1.6 Receiver power level (downstream OOB).....	18
5.2.1.7 Summary (downstream OOB) .....	19
5.2.1.8 Bit error rate downstream OOB (informative).....	20
5.2.2 Forward Interaction path (downstream IB) .....	20
5.2.3 Return Interaction path (upstream).....	21
5.2.3.1 IF range (upstream) .....	21
5.2.3.2 Modulation and mapping (upstream).....	21
5.2.3.3 Shaping filter (upstream) .....	21
5.2.3.4 Randomizer (upstream) .....	22
5.2.3.5 Bit rate (upstream) .....	23
5.2.3.6 Transmit power level (upstream).....	23
5.2.3.7 Carrier suppression when idle (upstream) .....	23
5.2.3.8 Summary (upstream).....	24
5.3 Framing.....	25
5.3.1 Forward Interaction path (downstream OOB).....	25
5.3.1.1 Signalling Link Extended Superframe (SL-ESF) framing format.....	25
5.3.1.2 Frame overhead .....	26
5.3.1.3 Payload structure .....	26
5.3.2 Forward interaction path (downstream IB).....	31
5.3.3 Return interaction path (upstream).....	33
5.3.3.1 Slot format .....	33
5.4 Slot timing assignment.....	34
5.4.1 Downstream slot position reference (downstream OOB).....	34
5.4.2 Downstream slot position reference (downstream IB) .....	34
5.4.3 Upstream slot positions .....	36
5.4.4 Slot position counter .....	37
5.5 MAC functionality .....	38
5.5.1 MAC reference model.....	38
5.5.2 MAC concept .....	39
5.5.2.1 Relationship between higher layers and MAC protocol .....	39
5.5.2.2 Relationship between physical layer and MAC protocol.....	40

5.5.2.3	Relationship between physical layer slot position counter and MAC slot assignment.....	40
5.5.2.4	Access modes (contention/ranging/fixed rate/reservation) .....	40
5.5.2.5	MAC error handling procedures .....	41
5.5.2.6	MAC messages .....	41
5.5.3	MAC initialization and provisioning .....	45
5.5.3.1	<MAC> Provisioning channel message (Broadcast downstream) .....	45
5.5.3.2	<MAC> Default configuration message (Broadcast downstream) .....	46
5.5.4	Sign-On and Calibration.....	47
5.5.4.1	<MAC> Sign-On Request message (Broadcast downstream) .....	50
5.5.4.2	<MAC> Sign-On Response Message (Upstream Contention Ranging) .....	51
5.5.4.3	<MAC> Range and Power Calibration Message (Singlecast downstream).....	51
5.5.4.4	<MAC> Ranging and Power Calibration Response Message (Upstream reserved or contention Ranging) .....	52
5.5.4.5	<MAC> Initialization complete message (singlecast downstream) .....	52
5.5.5	Default connection establishment.....	52
5.5.5.1	<MAC> Connect message (Singlecast downstream) .....	53
5.5.5.2	<MAC> Connect response (upstream contention, reserved or fixed rate access).....	56
5.5.5.3	<MAC> Connect confirm (singlecast downstream) .....	57
5.5.6	Data connections .....	57
5.5.6.1	Fixed rate access .....	58
5.5.6.2	Contention based access .....	58
5.5.6.3	Reservation access .....	58
5.5.7	MAC link management .....	61
5.5.7.1	Power and timing management.....	62
5.5.7.2	TDMA allocation management.....	62
5.5.7.3	Channel error management .....	64
5.5.7.4	Link management messages.....	65
<b>Annex A (informative): Bibliography.....</b>		<b>71</b>
History .....		72

---

## Intellectual Property Rights

IPRs essential or potentially essential to the present document may have been declared to ETSI. The information pertaining to these essential IPRs, if any, is publicly available for **ETSI members and non-members**, and can be found in ETR 314: "*Intellectual Property Rights (IPRs); Essential, or potentially Essential, IPRs notified to ETSI in respect of ETSI standards*", which is available **free of charge** from the ETSI Secretariat. Latest updates are available on the ETSI Web server (<http://www.etsi.fr/ipr>).

Pursuant to the ETSI Interim IPR Policy, no investigation, including IPR searches, has been carried out by ETSI. No guarantee can be given as to the existence of other IPRs not referenced in ETR 314 (or the updates on <http://www.etsi.fr/ipr>) which are, or may be, or may become, essential to the present document.

---

## Foreword

This European Standard (Telecommunications series) has been produced by the Joint Technical Committee (JTC) of the European Broadcasting Union (EBU), Comité Européen de Normalisation ELECTrotechnique (CENELEC) and the European Telecommunications Standards Institute (ETSI), and is now submitted for the Public Enquiry phase of the ETSI standards Two-step Approval Procedure (TAP).

**NOTE:** The EBU/ETSI JTC was established in 1990 to co-ordinate the drafting of standards in the specific field of broadcasting and related fields. Since 1995 the JTC became a tripartite body by including in the Memorandum of Understanding also CENELEC, which is responsible for the standardization of radio and television receivers. The EBU is a professional association of broadcasting organizations whose work includes the co-ordination of its members' activities in the technical, legal, programme-making and programme-exchange domains. The EBU has active members in about 60 countries in the European broadcasting area; its headquarters is in Geneva \*.

\* European Broadcasting Union  
CH-1218 GRAND SACONNEX (Geneva)  
Switzerland  
Tel: +41 22 717 21 11  
Fax: +41 22 717 24 81

### Digital Video Broadcasting (DVB) Project

Founded in September 1993, the DVB Project is a market-led consortium of public and private sector organizations in the television industry. Its aim is to establish the framework for the introduction of MPEG2 based digital television services. Now comprising over 200 organizations from more than 25 countries around the world, DVB fosters market-led systems, which meet the real needs, and economic circumstances, of the consumer electronics and the broadcast industry.

<b>Proposed national transposition dates</b>	
Date of latest announcement of this EN (doa):	3 months after ETSI publication
Date of latest publication of new National Standard or endorsement of this EN (dop/e):	6 months after doa
Date of withdrawal of any conflicting National Standard (dow):	6 months after doa

# 1 Scope

The present document is the baseline specification for the provision of interaction channel for Local Multi-point Distribution Systems (LMDS) networks.

It is not intended to specify a return channel solution associated to each broadcast system because the inter-operability of different delivery media to transport the return channel is desirable.

The solutions provided in the present document for interaction channel for LMDS networks are a part of a wider set of alternatives to implement interactive services for Digital Video Broadcasting (DVB) systems.

# 2 References

References may be made to:

- a) specific versions of publications (identified by date of publication, edition number, version number, etc.), in which case, subsequent revisions to the referenced document do not apply; or
- b) all versions up to and including the identified version (identified by "up to and including" before the version identity); or
- c) all versions subsequent to and including the identified version (identified by "onwards" following the version identity); or
- d) publications without mention of a specific version, in which case the latest version applies.

A non-specific reference to an ETS shall also be taken to refer to later versions published as an EN with the same number.

- |     |  |
|-----|--|
| [1] | ETS 300 800: "Digital Video Broadcasting (DVB); Interaction channel for Cable TV distribution systems (CATV)".                     |
| [2] | ISO 13818-1: "Information Technology - Generic Coding of Moving Pictures and Associated Audio Information. Part 1: Systems".       |
| [3] | ETS 300 802: "Digital Video Broadcasting (DVB); Network-independent protocols for DVB interactive services".                       |
| [4] | EN 300 421: "Digital Video Broadcasting (DVB); Framing structure, channel coding and modulation for 11/12 GHz satellite services". |
| [5] | ITU-T Recommendation I.361: "B-ISDN ATM layer specification".  |
| [6] | ITU-T Recommendation I.363: "B-ISDN ATM Adaptation Layer (AAL) specification".   |

# 3 Abbreviations

For the purposes of the present document, the following abbreviations apply:

AAL5	ATM Adaptation Layer 5
ATM	Asynchronous Transfer Mode
BC	Broadcast Channel
BIM	Broadcast Interface Module
BW	BandWidth
CRC	Cyclic Redundancy Check
DAVIC	Digital Audio - Visual Council
DL	Data Link
DVB	Digital Video Broadcasting

DVB-MS	DVB - Microwave Satellite
FAS	Frame Alignment Signal
FDM	Frequency Division Multiplex
FEC	Forward Error Correction
FIFO	First In First Out
FIP	Forward Interaction Path
IB	In-Band
ID	IDentifier
IEEE	Institute of Electrical and Electronics Engineers (USA)
IF	Intermediate Frequency
IIM	Interactive Interface Module
INA	Interactive Network Adapter
IRD	Integrated Receiver Decoder
ISDN	Integrated Services Digital Network
LFSR	Linear Feedback Shift Register
LMDS	Local Multi-point Distribution Systems
MAC	Media Access Control
MPEG	Moving Picture Export Group
MS	Microwave Satellite
MSB	Most Significant Bit
NIU	Network Interface Unit
OH	OverHead
OOB	Out-Of-Band
OSI	Open Systems Interconnection
PID	Packet IDentifier
PM	Phase Modulation
PSK	Phase Shift Keying
PSTN	Public Switched Telephone Network
QPSK	Quaternary Phase Shift Keying
RF	Radio Frequency
RIP	Return Interaction Path
RMS	Root Mean Square
RS	Reed Solomon
SL-ESF	Signalling Link Extended Superframe
STB	Set Top Box
STU	Set Top Unit
TCP	Transmission Control Protocol
TDMA	Time Division Multiple Access
TS	Transport Stream
VCI	Virtual Channel Identifier
VPI	Virtual Path Identifier

---

## 4 Reference model

This clause presents the reference model for system architecture of narrow-band interaction channels in a broadcasting scenario (asymmetric interactive services).

### 4.1 Protocol stack model

For asymmetric interactive services supporting broadcast to the home with narrowband return channel, a simple communications model consists of the following layers:

**physical layer:** Where all the physical (electrical) transmission parameters are defined.

**transport layer:** Defines all the relevant data structures and communication protocols like data containers, etc.

**application layer:** Is the interactive application software and runtime environments (e.g. home shopping application, script interpreter, etc.).

The present document addresses the lower two layers (the physical and transport) leaving the application layer open to competitive market forces.

A simplified model of the OSI layers was adopted to facilitate the production of specifications for these nodes. Figure 1 points out the lower layers of the simplified model and identifies some of the key parameters for the lower two layers. Following the user requirements for interactive services, no attempt will be made to consider higher layers in the present document.

**Layer Structure for Generic System Reference Model**

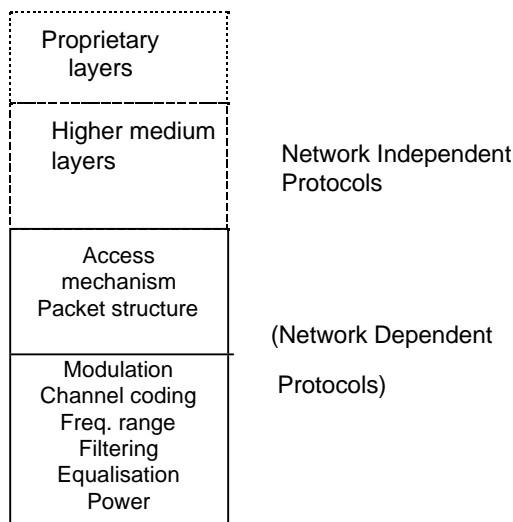

**Figure 1: Layer structure for generic system reference model**

This specification addresses the PSTN/ISDN network specific aspects only. The network independent protocols will be specified separately.

## 4.2 System model

Figure 2 shows the system model which is to be used within DVB for interactive services.

In the system model, two channels are established between the service provider and the user:

- **Broadcast Channel (BC):** A unidirectional broadband BC including video, audio and data. BC is established from the service provider to the users. It may include the Forward Interaction path.
- **Interaction channel:** A bi-directional interaction channel is established between the service provider and the user for interaction purposes. It is formed by:
  - **Return Interaction path** (return channel): From the user to the service provider. It is used to make requests to the service provider or to answer questions. It is a narrowband channel. Also commonly known as return channel.
  - **Forward Interaction path:** From the service provider to the user. It is used to provide some sort of information by the service provider to the user and any other required communication for the interactive service provision. It may be embedded into the BC. It is possible that this channel is not required in some simple implementations which make use of the BC for the carriage of data to the user.

The user terminal is formed by the Network Interface Unit (NIU) (consisting of the Broadcast Interface Module (BIM) and the Interactive Interface Module (IIM)) and the Set Top Unit (STU). The user terminal provides interface for both broadcast and interaction channels. The interface between the user terminal and the interaction network is via the IIM.



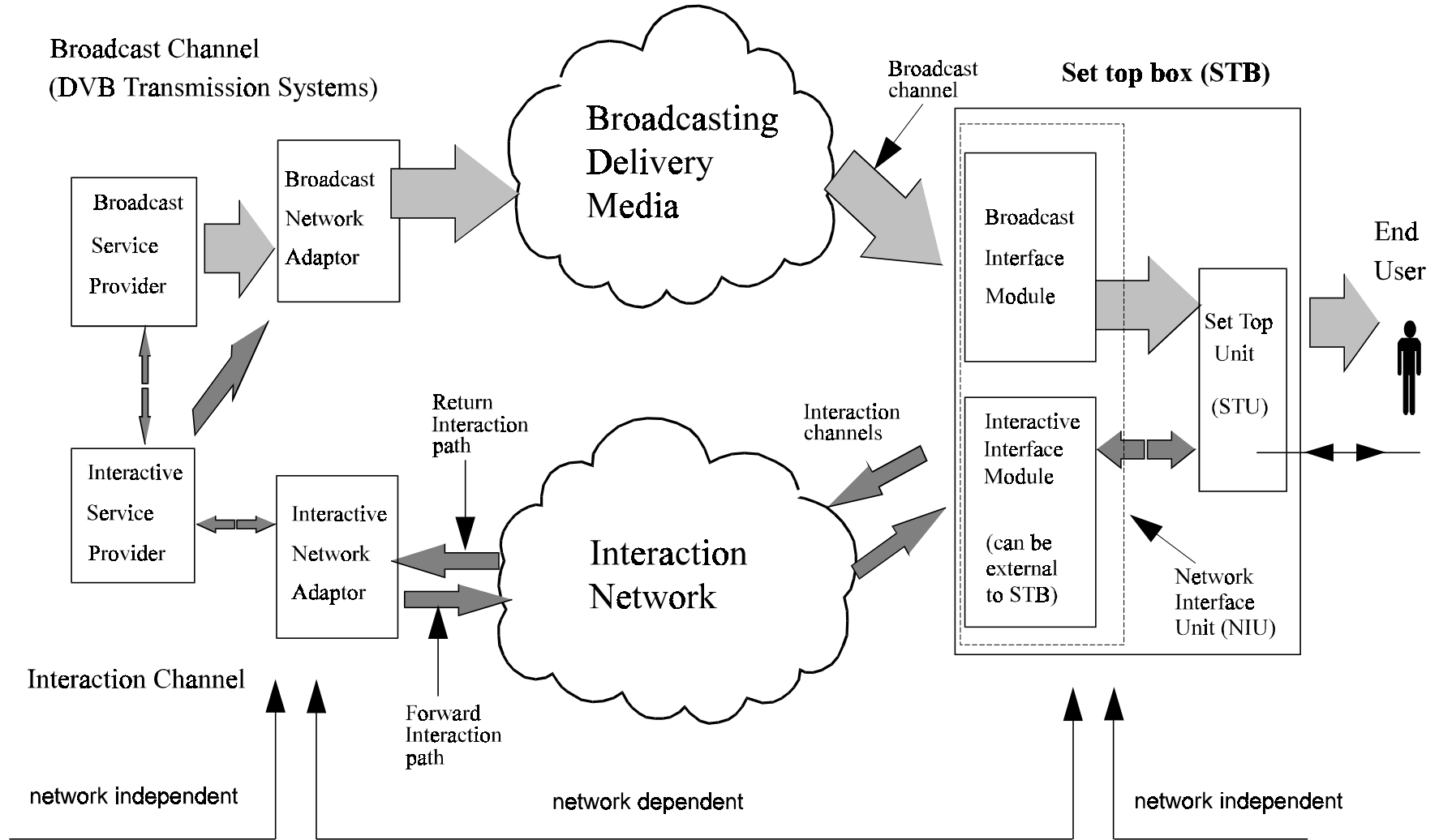
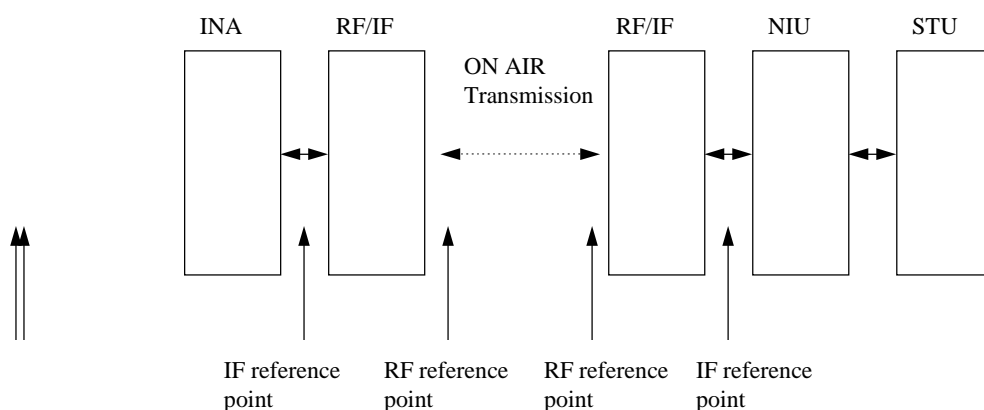

Figure 2a: Generic system reference model for interactive systems



**Figure 2b: Position of IF and RF reference points in the particular case of LMDS networks**

## 5 Interaction channel specification for LMDS networks

The LMDS infrastructures can support the implementation of the return channel for interactive services suitable for DVB broadcasting systems.

LMDS can be used to implement interactive services in the DVB environment, providing a bi-directional communication path between the user terminal and the service provider.

### 5.1 System concept

The interactive system is composed of Forward Interaction path (downstream) and Return Interaction path (upstream). The general concept is to use downstream transmission from the INA to the NIUs to provide synchronization and information to all NIUs. This allows the NIUs to adapt to the network and send synchronisation information upstream.

Upstream transmission is divided into time slots which can be used by different users, using the technique of Time Division Multiple Access (TDMA). One downstream channel is used to synchronise up to 8 upstream channels, which are all divided into time slots. A counter at the INA is sent periodically to the NIUs, so that all NIUs work with the same clock. This gives the opportunity to the INA to assign time slots to different users.

Three major access modes are provided with this system. The first one is based on contention access, which lets users send information at any time with the risk to have a collision with other user's transmissions. The second and third modes are contention-less based, where the INA either provides a finite amount of slots to a specific NIU, or a given bit rate requested by a NIU until the INA stops the connection on NIUs demand. These access modes are dynamically shared among time slots, which allows NIUs to know when contention based transmission is or is not allowed. This is to avoid a collision for the two contention-less based access modes.

Periodically, the INA will indicate to new users that they have the possibility to go through Sign-On procedure, in order to give them the opportunity to synchronise their clock to the network clock, without risking collisions with already active users. This is done by leaving a larger time interval for new users to send their information, taking into account the propagation time required from the INA to the NIUs and back.

### 5.1.1 Out-of-Band (OOB) / In-Band (IB) principle

This interactive system is based either on OOB or IB downstream signalling. However, STBs do not need to support both systems.

In the case of OOB signalling, a Forward Interaction path is added. This path is reserved for interactivity data and control information only. The presence of this added Forward Information path is in that case mandatory. However, it is also possible to send higher bit rate downstream information through a DVB-MS channel whose frequency is indicated in the forward information path.

In the case of IB signalling, the Forward Information path is embedded into the MPEG2-TS of a DVB-MS channel. It is not mandatory to include the Forward Information path in all DVB-MS channels.

Both systems can provide the same quality of service. However, the overall system architecture will differ between networks using IB and OOB STBs. Both types of systems may exist on the same networks under the condition that different frequencies are used for each system.

### 5.1.2 Intermediate Frequency (IF) spectrum allocation

The Radio Frequency (RF) spectrum allocation is still to be defined and allocated by the regulatory bodies. The following IF ranges to use are not mandatory:

For downstream, both IB and OOB channels can use the 950 MHz to 2 150 MHz band.

For upstream channels two different choices can be identified:

- 1) For the OOB signalling, in order to keep compatibility with equipment used in existing cable networks in accordance with the ETS 300 800 [1], the bands 70 MHz - 130 MHz and 5 MHz - 65 MHz can be used for downstream and upstream respectively.
- 2) For the IB signalling, taking into account the backward compatibility with the cable specifications and in order to give major capacity for the future interactive and multimedia services, the frequency allocation is 5 MHz - 305 MHz.

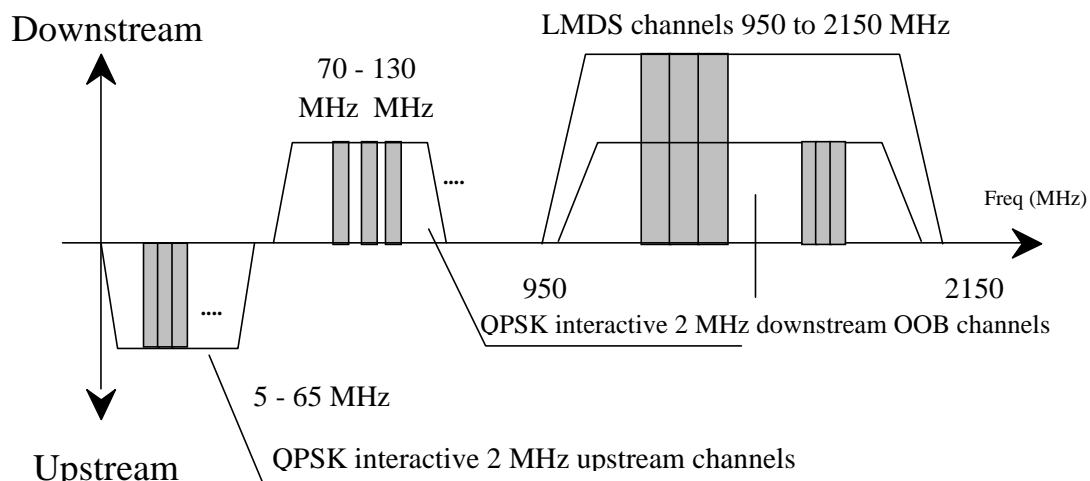

**Figure 3a: DVB preferred IF frequency ranges for LMDS interactive systems (OOB)**

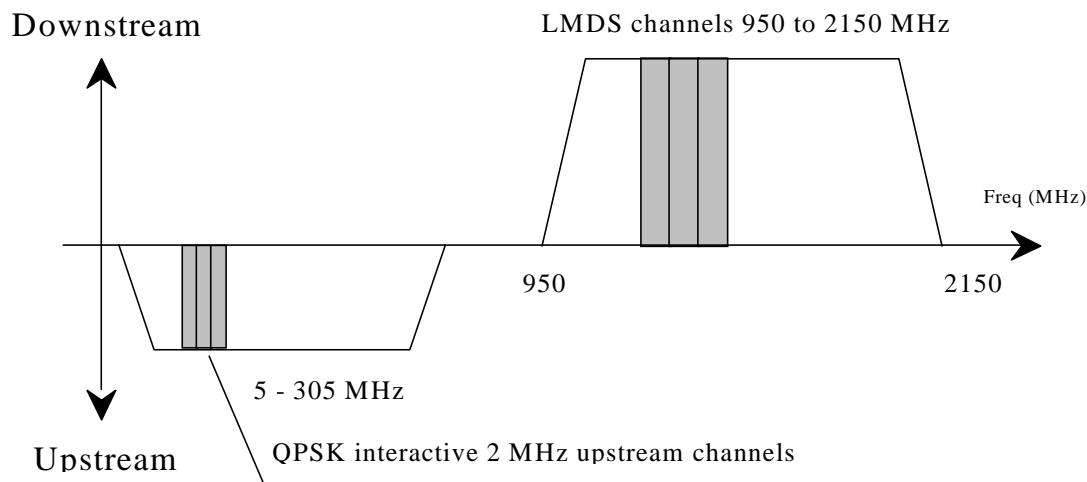

**Figure 3b: DVB preferred IF frequency ranges for LMDS interactive systems (IB)**

### 5.1.3 FDM/TDMA multiple access

A multiple access scheme is defined in order to have different users share the same transmission media. Downstream information is sent broadcast to all users of the networks. Thus, an address assignment exists for each user which allows the INA to send information singlecast to one particular user. Two addresses are stored in STBs in order to identify users on the network:

- MAC address: It is a 48-bit value representing the unique MAC address of the NIU. This MAC address may be hard coded in the NIU or be provided by external source.
- NSAP address: It is a 160-bit value representing a network address. This address is provided by higher layers during communication.

Upstream information may come from any user in the network and shall therefore also be differentiated at the INA using the set of addresses defined above.

Upstream and OOB downstream channels are divided into separate channels of 2 MHz bandwidth for downstream and upstream. Each downstream channel contains a synchronization frame used by up to 8 different upstream channels, whose frequencies are indicated by the MAC protocol.

Within upstream channels, users send packets with TDMA type access. This means that each channel is shared by many different users, who can either send packets with a possibility of collisions when this is allowed by the INA, or request transmission and use the packets assigned by the INA to each user specifically. Assuming each channel can therefore accommodate thousands of users at the same time, the upstream bandwidth can easily be used by all users present on the network at the same time.

The TDMA technique uses a slotting method which allows the transmit start times to be synchronized to a common clock source. Synchronizing the start times increases message throughput of this signalling channel since the message packets do not overlap during transmission. The period between sequential start times are identified as slots. Each slot is a point in time when a message packet can be transmitted over the signalling link.

The time reference for slot location is received via the downstream channels generated at the delivery system and received simultaneously by all STUs. This time reference is not sent in the same way for OOB and IB signalling. Since all NIUs reference the same time base, the slot times are aligned for all NIUs. However, since there is propagation delay in any transmission network, a time base ranging method accommodates deviation of transmission due to propagation delay.

Since the TDMA signalling link is used by NIUs that are engaged in interactive sessions, the number of available message slots on this channel is dependent on the number of simultaneous users. When messaging slots are not in use, an NIU may be assigned multiple message slots for increased messaging throughput. Additional slot assignments are provided to the NIU from the downstream signalling information flow.

There are different access modes for the upstream slots:

- reserved slots with fixed rate reservation (Fixed rate access: the user has a reservation of one or several time slots in each frame enabling, e.g. for voice, audio);
- reserved slots with dynamic reservation (Reservation access: the user sends control information announcing his demand for transmission capacity. He gets grants for the use of slots);
- contention based slots (These slots are accessible for every user. Collision is possible and solved by a contention resolution protocol);
- ranging slots (these slots are used upstream to measure and adjust the time delay and the power).

These slots may be mixed on a single carrier to enable different services on one carrier only. If one carrier is assigned to one specific service, only those slot types will be used which are needed for this service. Therefore a terminal can be simplified to respond to only those slot types assigned to the service.

### 5.1.4 Bit rates and framing

For the interactive downstream OOB channel, a rate of 3,088 Mbit/s may be used. For downstream IB channels, no other constraints than those specified in the DVB-MS specifications exist, but a guideline would be to use rates multiples of 8 kbit/s.

Downstream OOB channels continuously transmit a frame based on T1 type framing, in which some information is provided for synchronization of upstream slots. Downstream IB channels transmit some MPEG2-TS packets with a specific PID for synchronization of upstream slots (at least one packet containing synchronization information shall be sent in every period of 3 ms).

Upstream framing consists of packets of 512 bits (256 symbols) which are sent in a bursty mode from the different users present on the network. The upstream slot rates are 6 000 upstream slots/s.

## 5.2 Lower physical layer specification

In this subclause, detailed information is given on the lower physical layer specification. Figures 4 and 5 show the conceptual block diagrams for implementation of the present specification.

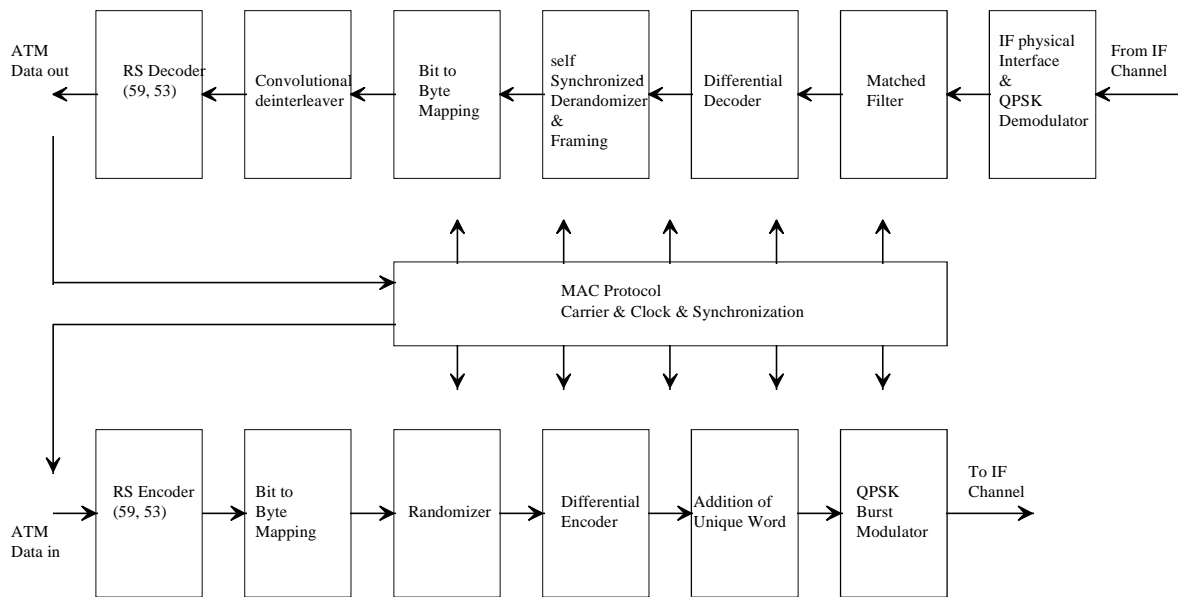

Figure 4: Conceptual block diagram for the NIU OOB transceiver

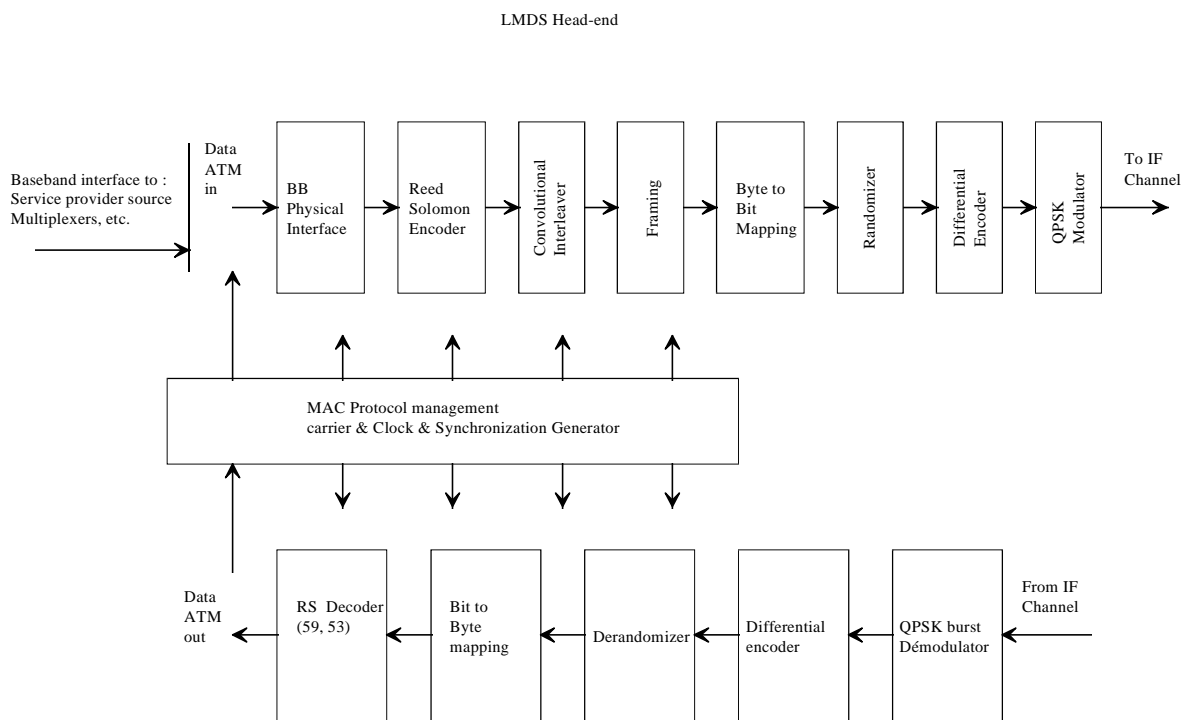

Figure 5: Conceptual block diagram for the OOB head-end transceiver

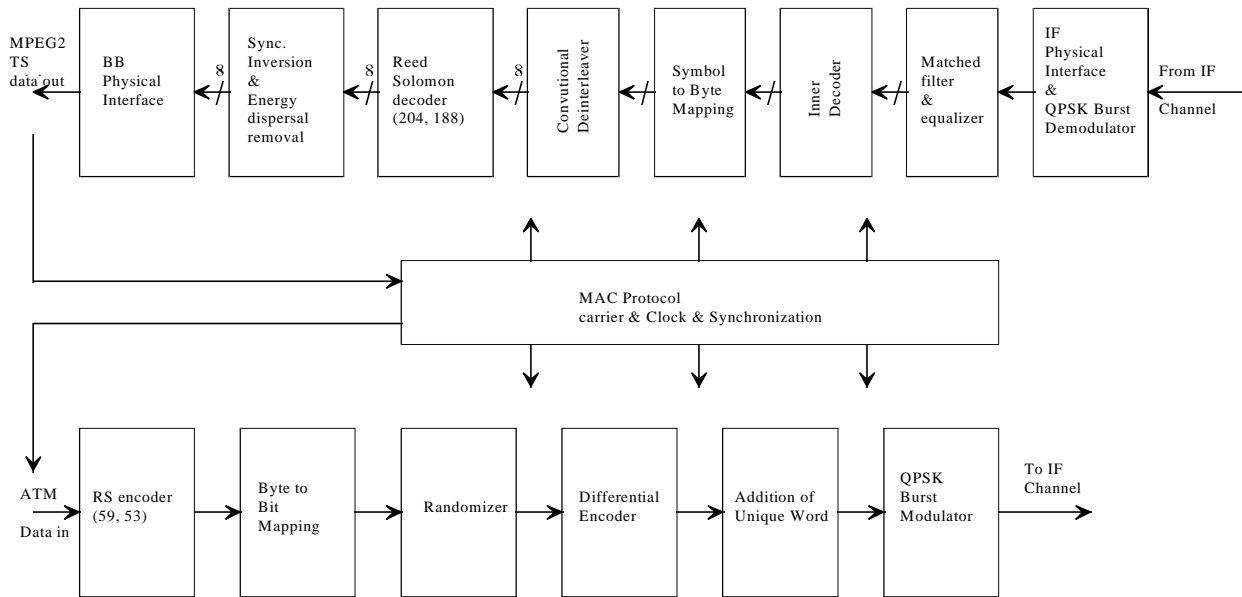

Figure 6: Conceptual block diagram for the IB NIU transceiver

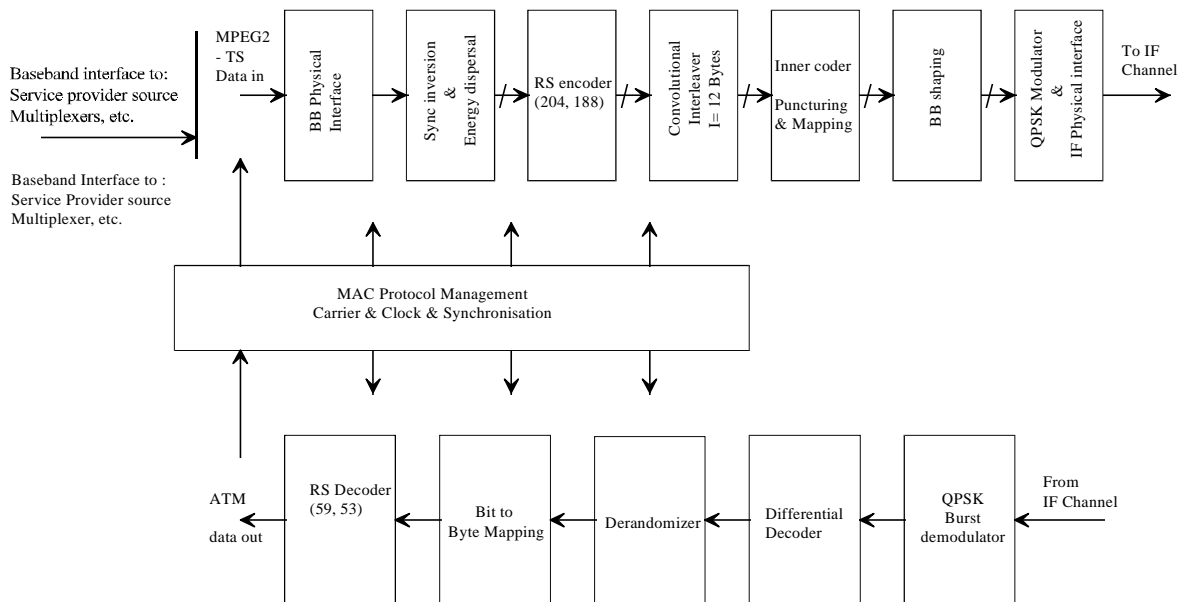

Figure 7: Conceptual block diagram for the IB head-end transceiver

## 5.2.1 Forward Interaction path (downstream OOB)

### 5.2.1.1 Frequency range (downstream OOB)

Refer to subclause 5.1.2.

### 5.2.1.2 Modulation and mapping (downstream OOB)

QPSK modulation is used as a means of encoding digital information over wireless or wireline transmission links. The method is a subset of Phase Shift Keying (PSK) which is a subset of Phase Modulation (PM). Specifically QPSK is a four level use of digital PM. Quadrature signal representations involve expressing an arbitrary phase sinusoidal waveform as a linear combination of a cosine wave and a sine wave with zero starting phases.

QPSK systems require the use of differential encoding and corresponding differential detection. This is a result of the receivers having no method of determining if a recovered reference is a sine reference or a cosine reference. In addition, the polarity of the recovered reference is uncertain.

Differential encoding transmits the information in encoded phase differences between the two successive signals. The modulator processes the digital binary symbols to achieve differential encoding and then transmits the absolute phases.

The differential encoding is implemented at the digital level.

The differential encoder shall accept bits A, B in sequence, and generate phase changes as follows:

**Table 1: Phase changes associated with bit A, B**

A	B	Phase Change
0	0	none
0	1	+90°
1	1	180°
1	0	-90°

In serial mode, A arrives first. The outputs I, Q from the differential encoder map to the phase states as in figure 8.

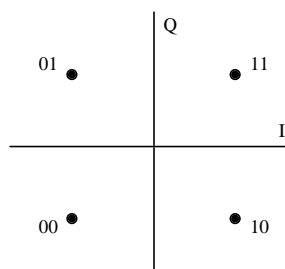

**Figure 8: Mapping for the QPSK constellation (downstream OOB)**

The phase changes can also be expressed by the following formulas (assuming the constellation is mapped from I and Q as shown in subclause 5.2.2.2):

$$\begin{cases} A_k = \overline{(I_{k-1} \oplus Q_{k-1})} \times (Q_{k-1} \oplus Q_k) + \overline{(I_k \oplus Q_{k-1})} \times (I_k \oplus I_{k-1}) \\ B_k = \overline{(I_{k-1} \oplus Q_{k-1})} \times (I_{k-1} \oplus I_k) + \overline{(I_{k-1} \oplus Q_k)} \times (Q_k \oplus Q_{k-1}) \end{cases},$$

where k is the time index.

I/Q amplitude imbalance shall be less than 1,0 dB, and phase imbalance less than 2,0°.



### 5.2.1.3 Shaping filter (downstream OOB)

The time-domain response of a square-root raised-cosine pulse with excess bandwidth parameter  $\alpha$  is given by:

$$g(t) = \frac{\sin\left[\frac{\pi t}{T}(1-\alpha)\right] + \frac{4\alpha t}{T} \cos\left[\frac{\pi t}{T}(1+\alpha)\right]}{\frac{\pi t}{T} \left[1 - \left(\frac{4\alpha t}{T}\right)^2\right]}$$

where T is the symbol period.

The output signal shall be defined as

$$S(t) = \sum_n [I_n \times g(t - nT) \times \cos(2\pi f_c t) - Q_n \times g(t - nT) \times \sin(2\pi f_c t)]$$

with  $I_n$  and  $Q_n$  equal to  $\pm 1$ , independently from each other, and  $f_c$  the QPSK modulator's carrier frequency.

The QPSK modulator divides the incoming bit stream so that bits are sent alternately to the in-phase modulator I and the out-of-phase modulator Q. These same bit streams appear at the output of the respective phase detectors in the demodulator where they are interleaved back into a serial bit stream.

The occupied bandwidth of a QPSK signal is given by the equation:

$$\text{Bandwidth} = \frac{f_b}{2} (1 + \alpha)$$

$f_b$  = bit rate

$\alpha$  = excess bandwidth = 0,30

The spectral mask is the following:

**Table 2: Spectral mask for QPSK modulated signal**

BW (MHz)	Response (dB)
1	$0 \pm 0,25$
1,544	$-3 \pm 0,25$
2,0	$-24 \pm 3$
2,16	$< -36$
3,08	$< -40$
3,6	$< -50$

Carrier suppression shall be greater than 30 dB.

### 5.2.1.4 Randomizer (downstream OOB)

After addition of the Forward Error Correction (FEC) bytes (see subclause 5.3), all of the 3,088 Mbit/s data is passed through a six register Linear Feedback Shift Register (LFSR) randomizer to ensure a random distribution of ones and zeroes.

The generating polynomial is:

$$x^6 + x^5 + 1.$$

Byte/serial conversion shall be MSB first. A complementary self-synchronizing de-randomizer is used in the receiver to recover the data.

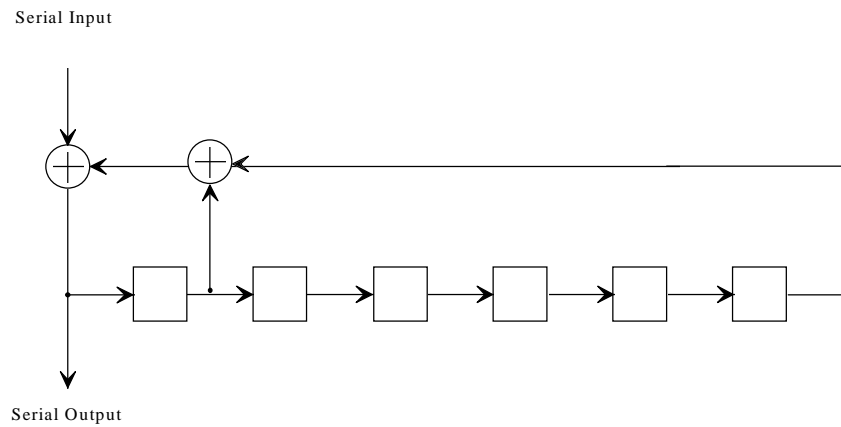

**Figure 9: Randomizer**

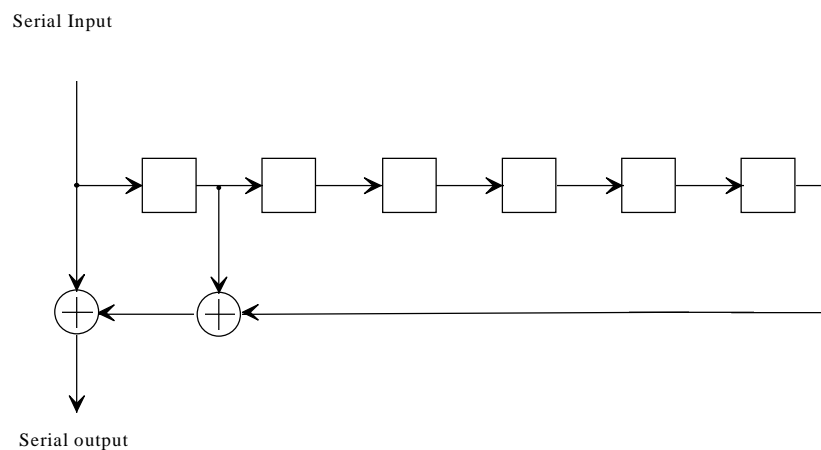

**Figure 10: De-randomizer**

#### 5.2.1.5 Bit rate (downstream OOB)

The bit rate shall be 3,088 Mbit/s. Symbol rate accuracy should be within  $\pm 50$  ppm.

#### 5.2.1.6 Receiver power level (downstream OOB)

The receiver power level shall be in the range 42 - 75 dB $\mu$ V (RMS) (75  $\Omega$ ) at the IF input point.

## 5.2.1.7 Summary (downstream OOB)

Table 3: Summary (downstream)

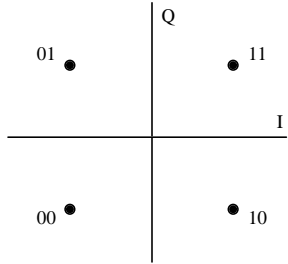
Transmission rate	3,088 Mbit/s															
Modulation	Differentially encoded QPSK.															
Transmit filtering	Filtering is $\alpha = 0,30$ square root raised cosine															
Channel spacing	2 MHz															
Frequency step size	250 kHz (centre frequency granularity)															
Randomization	After addition of the FEC bytes, all of the 3,088 Mbit/s data is passed through a six register Linear Feedback Shift Register (LFSR) randomizer to ensure a random distribution of ones and zeroes. The generating polynomial is: $x^6 + x^5 + 1$ . Byte/serial conversion shall be MSB first. A complementary self-synchronizing de-randomizer is used in the receiver to recover the data.															
Differential encoding	The differential encoder shall accept bits A, B in sequence, and generate phase changes as follows: <table border="1"> <thead> <tr> <th>A</th> <th>B</th> <th>Phase change</th> </tr> </thead> <tbody> <tr> <td>0</td> <td>0</td> <td>none</td> </tr> <tr> <td>0</td> <td>1</td> <td>+90°</td> </tr> <tr> <td>1</td> <td>1</td> <td>180°</td> </tr> <tr> <td>1</td> <td>0</td> <td>-90°</td> </tr> </tbody> </table> In serial mode, A arrives first.	A	B	Phase change	0	0	none	0	1	+90°	1	1	180°	1	0	-90°
A	B	Phase change														
0	0	none														
0	1	+90°														
1	1	180°														
1	0	-90°														
System phase noise max.: (phase noise includes both IF and RF parts).	-41 dBc/Hz at 1 kHz -71 dBc/Hz at 10 kHz -92 dBc/Hz at 100 kHz															
Signal constellation	The outputs I, Q from the differential encoder map to the phase states as in figure 11.  <p style="text-align: center;"><b>Figure 11</b></p>															
IF range (not mandatory)	950 - 2 150 MHz or 70 - 130 MHz															
Frequency stability	$\pm 50$ ppm measured at the upper limit of the IF range															
Symbol rate accuracy	$\pm 50$ ppm															
Carrier suppression	> 30 dB															
I/Q amplitude imbalance	< 1,0 dB															
I/Q phase imbalance	< 2,0°															
Receive power level at IF reference point (downstream out-of-band)	42 - 75 dB $\mu$ V (RMS) (75 $\Omega$ )															
Transmit spectral mask	Bit rate = 3,088 Mbit/s <table border="1"> <thead> <tr> <th>BW (MHz)</th> <th>Response (dB)</th> </tr> </thead> <tbody> <tr> <td>1,0</td> <td><math>0 \pm 0,25</math></td> </tr> <tr> <td>1,544</td> <td><math>-3 \pm 0,25</math></td> </tr> <tr> <td>2,0</td> <td><math>&lt; -24 \pm 3</math></td> </tr> <tr> <td>2,16</td> <td><math>&lt; -36</math></td> </tr> <tr> <td>3,088</td> <td><math>&lt; -40</math></td> </tr> </tbody> </table>	BW (MHz)	Response (dB)	1,0	$0 \pm 0,25$	1,544	$-3 \pm 0,25$	2,0	$< -24 \pm 3$	2,16	$< -36$	3,088	$< -40$			
BW (MHz)	Response (dB)															
1,0	$0 \pm 0,25$															
1,544	$-3 \pm 0,25$															
2,0	$< -24 \pm 3$															
2,16	$< -36$															
3,088	$< -40$															

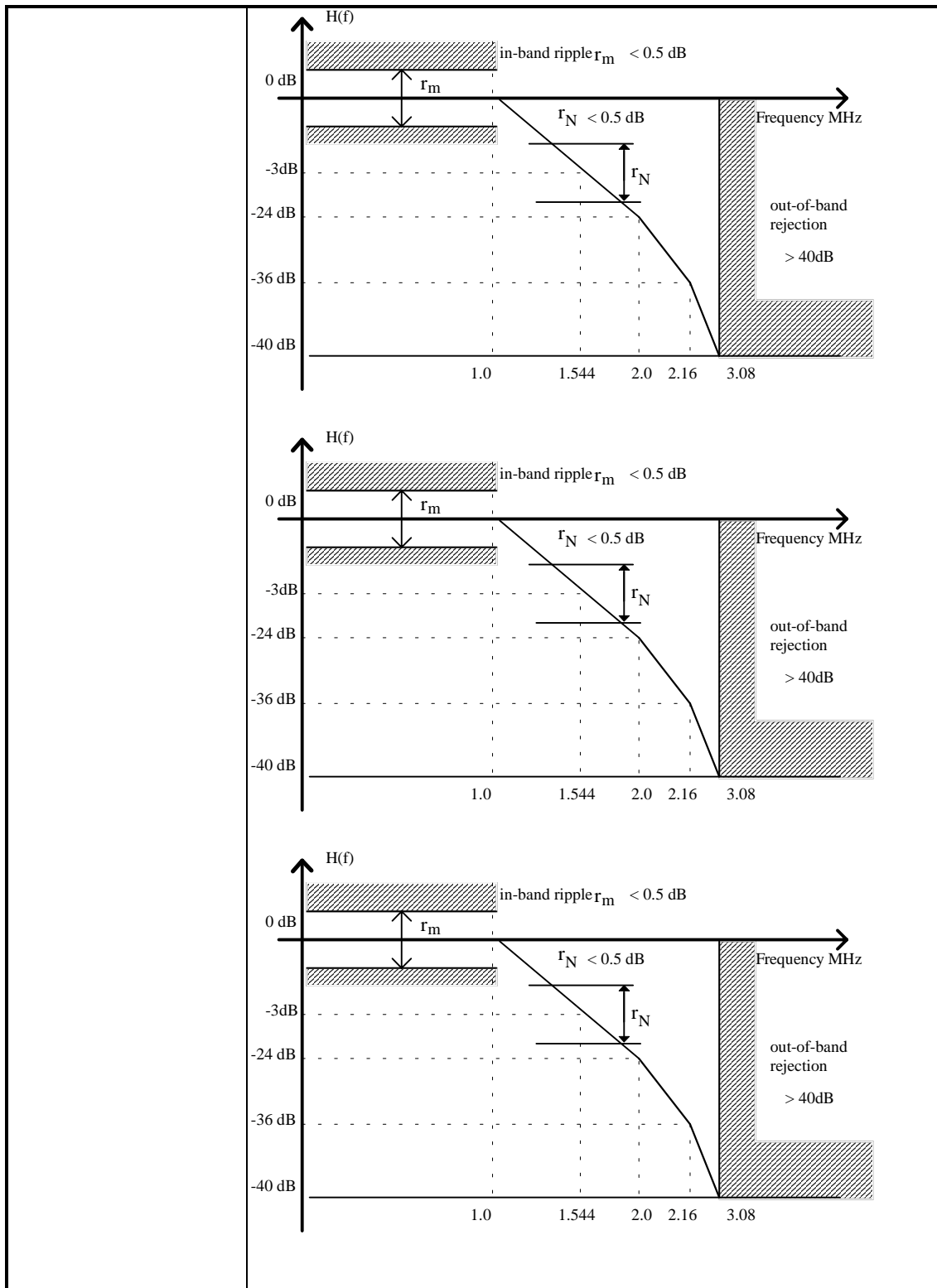

### 5.2.1.8 Bit error rate downstream OOB (informative)

To be confirmed.

### 5.2.2 Forward Interaction path (downstream IB)

The IB Forward Interaction path shall use a MPEG2-TS stream with a modulated QPSK channel as defined in EN 300 421 [4]. Frequency range, channel spacing, and other lower physical layer parameters should follow EN 300 421 [4].

## 5.2.3 Return Interaction path (upstream)

### 5.2.3.1 IF range (upstream)

The frequency range is not specified as mandatory although a guideline is provided to use the 5 - 65 MHz range. Frequency stability shall be in the range  $\pm 50$  ppm measured at the upper limit of the frequency range.

### 5.2.3.2 Modulation and mapping (upstream)

The unique word 0x 00 FC FC F3, (see subclause 5.3 for upstream framing) is not differentially encoded. The outputs I, Q map to the phase states as in figure 12.

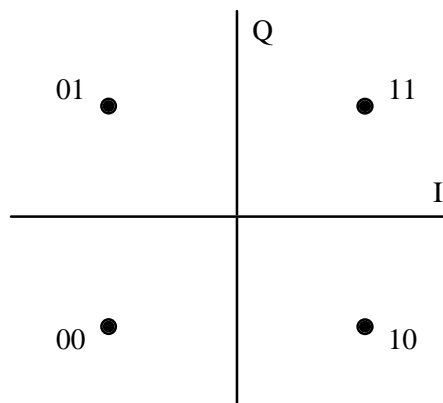

**Figure 12: Mapping for the QPSK constellation (upstream)**

For the remainder of the packet, the differential encoder shall accept bits A, B in sequence, and generate phase changes as follows. It starts with the first information digit and is initialized with the last digit of the unique word, i.e. (A, B = 1,1) since conversion is made MSB first.

**Table 4: Phase changes corresponding to bits A, B**

A	B	Phase Change
0	0	none
0	1	+90°
1	1	180°
1	0	-90°

Phase changes correspond to the following formulas (assuming I and Q are mapped to the constellation as for the unique word):

$$\begin{cases} A_k = \overline{(I_{k-1} \oplus Q_{k-1})} \times (Q_{k-1} \oplus Q_k) + \overline{(I_k \oplus Q_{k-1})} \times (I_k \oplus I_{k-1}) \\ B_k = \overline{(I_{k-1} \oplus Q_{k-1})} \times (I_{k-1} \oplus I_k) + \overline{(I_{k-1} \oplus Q_k)} \times (Q_k \oplus Q_{k-1}) \end{cases}$$

where k is the time index.

I/Q amplitude imbalance shall be less than 1,0 dB, and phase imbalance less than 2,0°.

### 5.2.3.3 Shaping filter (upstream)

The time-domain response of a square-root raised-cosine pulse with excess bandwidth parameter  $\alpha$  is given by:

$$g(t) = \frac{\sin\left[\frac{\pi t}{T}(1-\alpha)\right] + \frac{4\alpha t}{T} \cos\left[\frac{\pi t}{T}(1+\alpha)\right]}{\frac{\pi t}{T} \left[1 - \left(\frac{4\alpha t}{T}\right)^2\right]}$$

where  $T$  is the symbol period.

The output signal shall be defined as:

$$S(t) = \sum_n [I_n \times g(t - nT) \times \cos(2\pi f_c t) - Q_n \times g(t - nT) \times \sin(2\pi f_c t)]$$

with  $I_n$  and  $Q_n$  equal to  $\pm 1$ , independently from each other, and  $f_c$  the QPSK modulator's carrier frequency.

The QPSK modulator divides the incoming bit stream so that bits are sent alternately to the in-phase modulator I and the out-of-phase modulator Q. These same bit streams appear at the output of the respective phase detectors in the demodulator where they are interleaved back into a serial bit stream.

The occupied bandwidth of a QPSK signal is given by the equation:

$$\text{Bandwidth} = \frac{f_b}{2} (1 + \alpha)$$

$f_b$  = bit rate

$\alpha$  = excess bandwidth = 0,30

The spectral mask is given in table 5.

**Table 5: Spectral mask for bit rate = 3,088 Mbit/s**

BW (MHz)	Response (dB)
1,0	$0 \pm 0,25$
1,544	$-3 \pm 0,25$
2,0	$-24 \pm 3$
2,16	$< -36$
3,088	$< -40$
3,6	$< -50$

Carrier suppression shall be greater than 30 dB.

#### 5.2.3.4 Randomizer (upstream)

The unique word shall be sent in clear (see subclause 5.3). After addition of the FEC bytes, randomization shall apply only to the payload area and FEC bytes, with the randomizer performing modulo 2 addition of the data with a pseudo-random sequence. The generating polynomial is  $x^6 + x^5 + 1$  with seed all ones. It is assumed that the first value coming out of the pseudo-random generator taken into account is 0. Byte/serial conversion shall be MSB first. The binary sequence generated by the shift register starts with 00000100..... The first "0" is to be added in the first bit after the unique word.

A complementary non self-synchronizing de-randomizer is used in the receiver to recover the data. The de-randomizer shall be enabled after detection of the unique word.

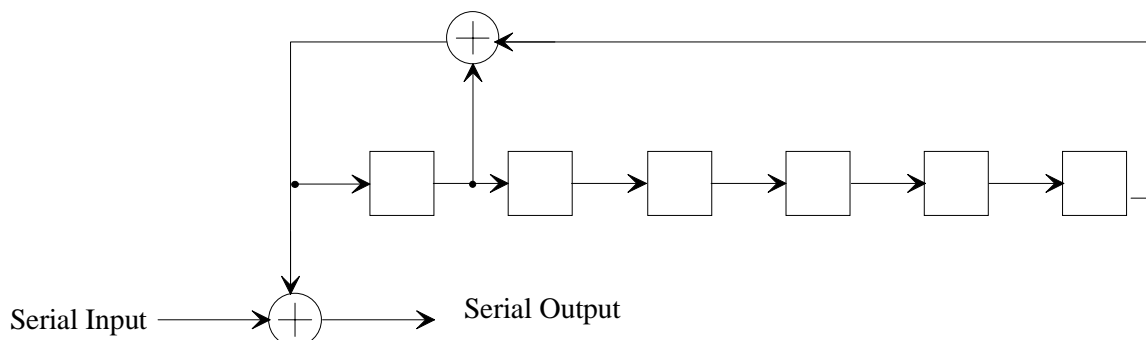

**Figure 13: Randomizer**

### 5.2.3.5 Bit rate (upstream)

The upstream bit rate is 3,088 Mb/s, which corresponds to 6 000 slots/s.

Symbol rate accuracy should be within  $\pm 50$  ppm.

### 5.2.3.6 Transmit power level (upstream)

At the IF output the transmit power level shall be in the range 85 - 113 dB $\mu$ V (RMS) (75  $\Omega$ ). This power shall be adjusted by steps of 0,5 dB by MAC messages coming from the INA.

### 5.2.3.7 Carrier suppression when idle (upstream)

The carrier suppression shall be more than 60 dB below nominal power output level, over the entire power output range. A terminal is considered to be idle if it is 3 slots before an imminent transmission or 3 slots after its most recent transmission.

## 5.2.3.8 Summary (upstream)

Table 6: Summary (upstream)

Transmission rate	3,088 Mbit/s															
System phase noise max.:	-41 dBc/Hz at 1 kHz -71 dBc/Hz at 10 kHz -92 dBc/Hz at 100 kHz															
Modulation	Differentially encoded QPSK															
Transmit filtering	$\alpha = 0,30$ square root raised cosine															
Channel spacing	2 MHz															
Frequency step size	50 kHz															
Randomization	The unique word shall be sent in the clear. After addition of the FEC bytes, randomization shall apply only to the payload area and FEC bytes, with the randomizer performing modulo 2 addition of the data with a pseudo-random sequence. The generating polynomial is $x^6 + x^5 + 1$ with seed all ones. Byte/serial conversion shall be MSB first. A complementary non self-synchronizing de-randomizer is used in the receiver to recover the data. The de-randomizer shall be enabled after detection of the unique word.															
Differential encoding	The differential encoder shall accept bits A, B in sequence, and generate phase changes as follows. In serial mode, A arrives first. <table border="1"> <thead> <tr> <th>A</th> <th>B</th> <th>Phase change</th> </tr> </thead> <tbody> <tr> <td>0</td> <td>0</td> <td>none</td> </tr> <tr> <td>0</td> <td>1</td> <td>+90°</td> </tr> <tr> <td>1</td> <td>1</td> <td>180°</td> </tr> <tr> <td>1</td> <td>0</td> <td>-90°</td> </tr> </tbody> </table>	A	B	Phase change	0	0	none	0	1	+90°	1	1	180°	1	0	-90°
A	B	Phase change														
0	0	none														
0	1	+90°														
1	1	180°														
1	0	-90°														
Signal constellation	The outputs I, Q from the differential encoder map to the phase states as in figure 14.  NOTE:  The unique word (0x 00 FC FC F3) does not go through differential encoding.															
	<p style="text-align: center;">Figure 14</p>															
Frequency range (informative)	5 - 65 MHz or 5 - 305 MHz															
Frequency stability	$\pm 50$ ppm measured at the upper limit of the IF range															
Symbol rate accuracy	$\pm 50$ ppm															
Transmit spectral mask	Bit rate = 3,088 Mbit/s <table border="1"> <thead> <tr> <th>BW (MHz)</th> <th>Response (dB)</th> </tr> </thead> <tbody> <tr> <td>1,0</td> <td><math>0 \pm 0,25</math></td> </tr> <tr> <td>1,54</td> <td><math>-3 \pm 0,25</math></td> </tr> <tr> <td>2,0</td> <td><math>-24 \pm 3</math></td> </tr> <tr> <td>2,16</td> <td><math>&lt; -36</math></td> </tr> <tr> <td>2,54</td> <td><math>&lt; -40</math></td> </tr> </tbody> </table>	BW (MHz)	Response (dB)	1,0	$0 \pm 0,25$	1,54	$-3 \pm 0,25$	2,0	$-24 \pm 3$	2,16	$< -36$	2,54	$< -40$			
BW (MHz)	Response (dB)															
1,0	$0 \pm 0,25$															
1,54	$-3 \pm 0,25$															
2,0	$-24 \pm 3$															
2,16	$< -36$															
2,54	$< -40$															
Carrier suppression when transmitter active	$> 30$ dB															
Carrier suppression when transmitter idle	The carrier suppression shall be more than 60 dB below nominal power output level over the entire power output range (see [4] for details) and 30 dB right after or before transmission. Idle transmitter definition: A terminal is considered to be idle if it is 3 slots before an imminent transmission or 3 slots after its most recent transmission.															



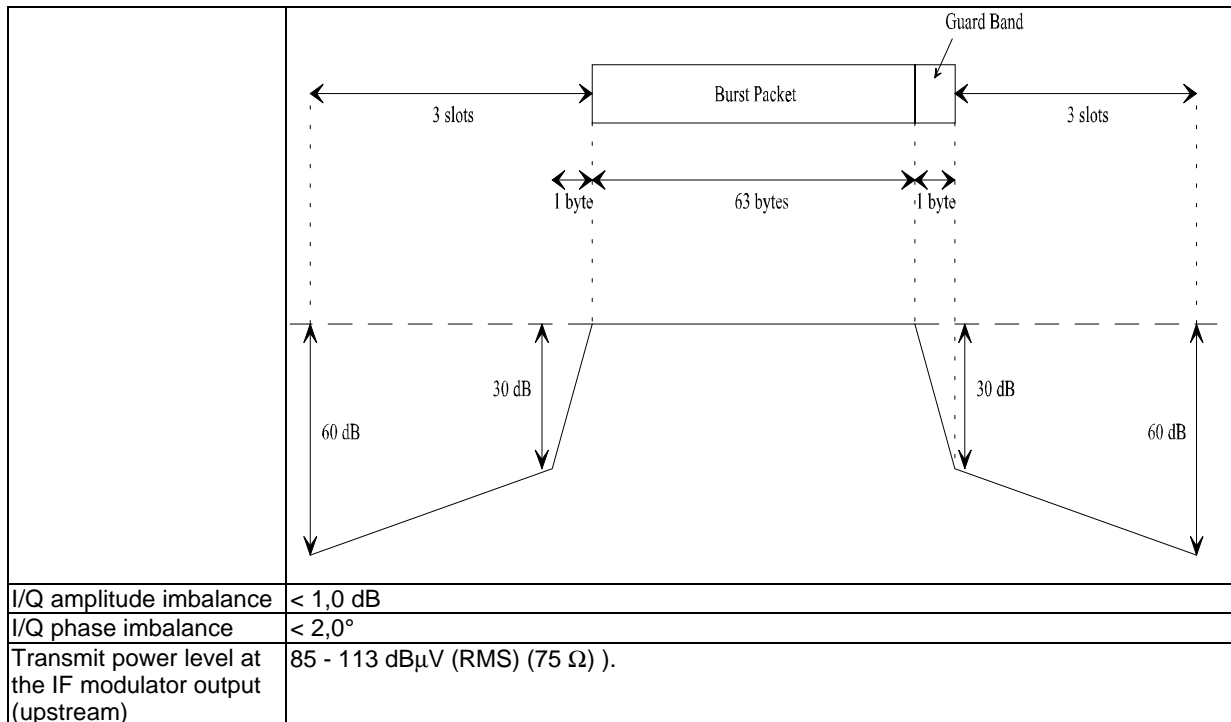

### 5.3 Framing

#### 5.3.1 Forward Interaction path (downstream OOB)

##### 5.3.1.1 Signalling Link Extended Superframe (SL-ESF) framing format

The SL-ESF frame structure is shown in figure 15. The bit stream is partitioned into 4 632-bit Extended Superframes (ESF). Each ESF consists of 24  $\times$  193-bit frames. Each frame consists of 1 Overhead (OH) bit and 24 bytes (192 bits) of payload.

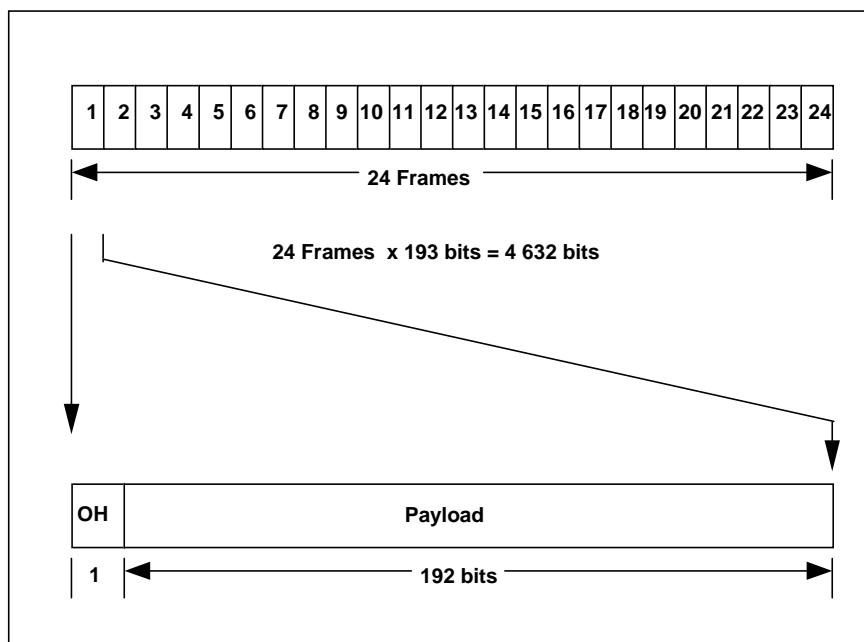

Figure 15: SL-ESF frame structure

### 5.3.1.2 Frame overhead

There are 24 frame Overhead (OH) bits in the ESF which are divided into ESF Frame Alignment Signal (FAS) (F1-F6), Cyclic Redundancy Check (CRC) (C1-C6), and M-bit Data Link (DL) (M1-M12) as shown in table 7.

**Table 7: Frame overhead**

Frame Number	Bit Number	Overhead Bit	Data (192 bits)
1	0	<b>M1</b>	
2	193	C1	
3	386	M2	
4	579	F1 = 0	
5	772	M3	
6	965	C2	
7	1 158	M4	
8	1 351	F2 = 0	
9	1 544	<b>M5</b>	
10	1 737	C3	
11	1 930	M6	
12	2 123	F3 = 1	
13	2 316	M7	
14	2 509	C4	
15	2 702	M8	
16	2 895	F4 = 0	
17	3 088	<b>M9</b>	
18	3 281	C5	
19	3 474	M10	
20	3 667	F5 = 1	
21	3 860	M11	
22	4 053	C6	
23	4 246	M12	
24	4 439	F6 = 1	
FAS: Frame Alignment Signal (F1 - F6) DL: Mbit Data Link (M1 - M12) CRC: Cyclic Redundancy Check (C1 - C6)			

#### ESF Frame Alignment Signal (FAS)

The ESF FAS is used to locate all 24 frames and overhead bit positions. The bit values of the FAS are defined as follows:

F1 = 0, F2 = 0, F3 = 1, F4 = 0, F5 = 1, F6 = 1.

#### ESF Cyclic Redundancy Check (CRC)

The CRC field contains the CRC-6 check bits calculated over the previous ESF. CRC Message Block (CMB) size = 4 632 bits. Before calculation, all 24 frame Overhead (OH) bits are equal to "1". All information in the other bit positions is unchanged. The check bit sequence C1-C6 is the remainder after multiplication by  $x^6$  and then division by the generator polynomial  $x^6+x+1$  of the CMB. C1 is the MSB of the remainder. The initial remainder value is pre-set to all zeros.

#### ESF Mbit Data Link

The M-bits in the SL-ESF serve for slot timing assignment (see subclause 5.4).

### 5.3.1.3 Payload structure

The SL-ESF frame payload structure provides a known container for defining the location of the ATM cells and the corresponding Reed Solomon (RS) parity values. The SL-ESF payload structure is shown in table 8.

**Table 8: ESF payload structure**

	2		53			2	
1	R1a	R1b	ATM Cell			RS parity	
2	R1c	R2a				R2 b	
3	R2c	R3a					
4	R3b	R3c				R4 a	
5	R4b	R4c					
6	R5a	R5b				R5 c	
7	R6a	R6b					
8	R6c	R7a				R7 b	
9	R7c	R8a					
10	R8b	R8c				T	T

The SL-ESF payload structure consists of 5 rows of 57 bytes each, 4 rows of 58 bytes each which includes 1 byte trailer, and 1 row of 59 bytes, which includes a 2 byte trailer. The first bit of the SL-ESF payload structure follows the M1-bit of the SL-ESF frame. The SL-ESF payload fields are defined as follows.

#### ATM cell structure

The format for each ATM cell structure is shown in figure 16. This structure and field coding shall be consistent with the structure and coding given in ITU-T Recommendation I.361 [5] for ATM UNI.

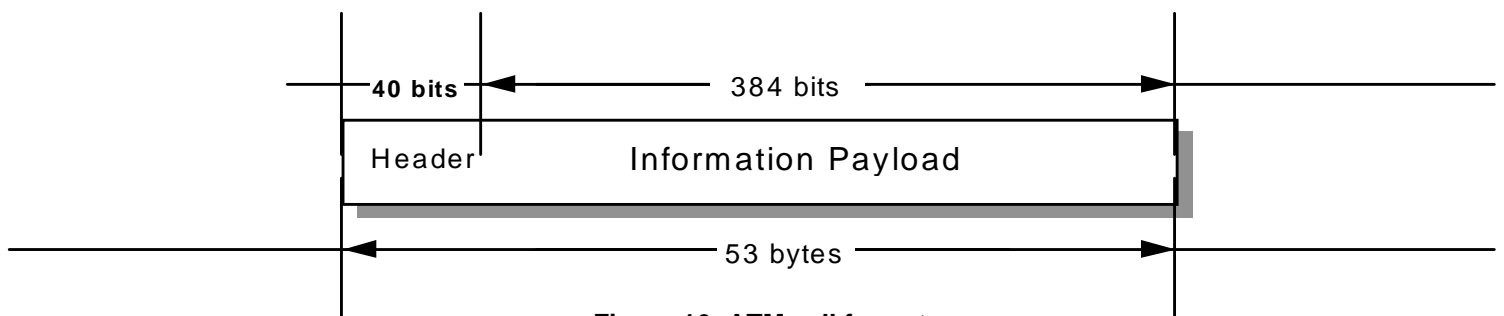
**Figure 16: ATM cell format**

#### Channel coding and interleaving

RS encoding with  $t = 1$  shall be performed on each ATM cell. This means that 1 erroneous byte per ATM cell can be corrected. This process adds 2 parity bytes to the ATM cell to give a code word of (55,53).

The RS code shall have the following generator polynomials:

**Code generator polynomial:**  $g(x) = (x + \mu^0)(x + \mu^1)$ , where  $\mu = 02$  hex

**Field generator polynomial:**  $p(x) = x^8 + x^4 + x^3 + x^2 + 1$

Convolutional interleaving shall be applied to the ATM cells contained in the SL-ESF. The Rxa - Rxc bytes and the two T bytes shall not be included in the interleaving process. Convolutional interleaving is applied by interleaving 5 lines of 55 bytes.

Following the scheme in figure 17, convolutional interleaving shall be applied to the error protected packets. The convolutional interleaving process shall be based on the Forney approach, which is compatible with the Ramsey type III approach, with  $I = 5$ . The interleaved frame shall be composed of overlapping error protected packets and a group of 10 packets shall be delimited by the start of the SL-ESF.

The interleaver is composed of  $I$  branches, cyclically connected to the input byte-stream by the input switch. Each branch shall be a First In First Out (FIFO) shift register, with depth ( $M$ ) cells (where  $M = N/I$ ,  $N = 55 =$  error protected frame length,  $I =$  interleaving depth). The input and output switches shall be synchronized.

For synchronization purposes, the first byte of each error protected packet shall be always routed into the branch "0" of the interleaver (corresponding to a null delay). The third byte of the SL-ESF payload (the byte immediately following R1b) shall be aligned to the first byte of an error protected packet.

The de-interleaver is similar, in principle, to the interleaver, but the branch indexes are reversed (i.e. branch 0 corresponds to the largest delay). The de-interleaver synchronization is achieved by routing the third data byte of the SL-ESF into the "0" branch.

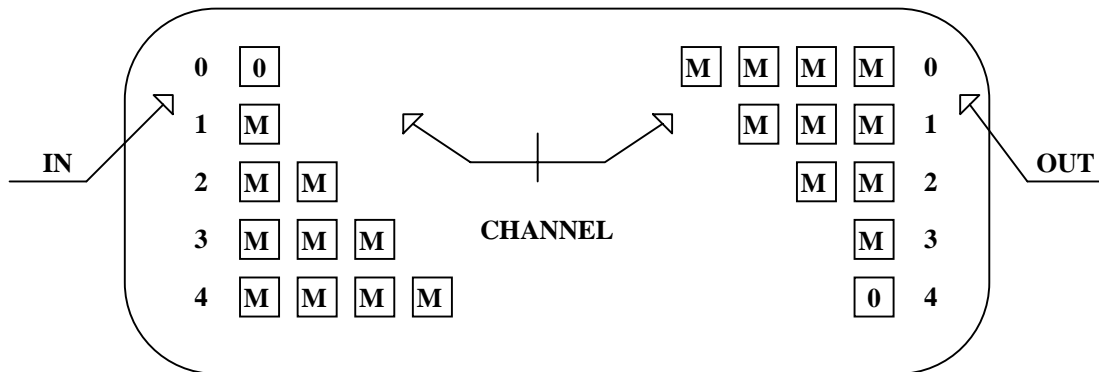

Figure 17: Interleaver and de-interleaver structures

#### Reception indicator fields and slot boundary fields

Rxa-Rxc is a 24-bit field containing slot configuration information for the upstream channel "x" and is defined as:

Rxa = (b0 .....b7)

Rxb = (b8.....b15)

Rxc = (b16... b23)

= slot configuration information for the upstream channel "x" where "x" is indicated to the NIU in the "Flag set" given in MAC messages (Default Configuration Message, Connect Message, Transmission Control message) corresponding to a particular upstream frequency. One channel requires two consecutive fields. "x" thus denotes first field used for a particular upstream frequency.

b0 = ranging control slot indicator for next superframe

b1-b6 = slot boundary definition field for next superframe

b7 = slot 1 reception indicator for second previous superframe

b8 = slot 2 reception indicator for second previous superframe

b9 = slot 3 reception indicator for second previous superframe

b10 = slot 4 reception indicator for second previous superframe

b11 = slot 5 reception indicator for second previous superframe

b12 = slot 6 reception indicator for second previous superframe

b13 = slot 7 reception indicator for second previous superframe

b14 = slot 8 reception indicator for second previous superframe

b15 = slot 9 reception indicator for second previous superframe

b16-17 = reservation control for next superframe

b18-b23 = CRC 6 parity

The 9 slots of this field and the 9 slots of the following field are valid.

**Ranging control slot indicator (b0):** When this bit is active ( $b_0 = 1$ ), the first three slots of upstream channel "x" which correspond to the occurrence of the next superframe of the related downstream channel are designated as ranging control slots. A ranging control message may be transmitted in the second ranging control slot, and the first and third ranging control slots may not be used for transmission (guard band for ranging operations).

**Slot boundary definition field (b1-b6):** Slot types are assigned to upstream slots using bits b0-b6. The slots are grouped into regions within the SL-ESF such that slots of a similar type are contained within the same region. The order of the regions is Ranging slot, Contention based slots, Reserved slots and Fixed rate based slots. If a ranging slot is available within a SL-ESF it will consist of the first three slot times in the SL-ESF. A ranging slot is indicated by  $b_0 = 1$ . The boundaries between the remaining regions of the SL-ESF are defined by b1-b6. The boundaries are defined as shown in table 9.

**Table 9: Slot boundary definition field (b1-b6)**

Boundary 0	
Boundary 1	slot 1
Boundary 2	slot 2
Boundary 3	slot 3
Boundary 4	slot 4
Boundary 5	slot 5
Boundary 6	slot 6
Boundary 7	slot 7
Boundary 8	slot 8
Boundary 9	slot 9

The boundary positions are defined by b1-b6 as shown in table 10.

**Table 10: Boundary positions (b1-b6)**

(note 1) (note 2)	0	1	2	3	4	5	6	7	8	9
<b>0(note 3)</b>	0	1	2	3	4	5	6	7	8	9
<b>1(note 3)</b>		10	11	12	13	14	15	16	17	18
<b>2(note 3)</b>			19	20	21	22	23	24	25	26
<b>3</b>				27	28	29	30	31	32	33
<b>4</b>					34	35	36	37	38	39
<b>5</b>						40	41	42	43	44
<b>6</b>							45	46	47	48
<b>7</b>								49	50	51
<b>8</b>									52	53
<b>9</b>										54

NOTE 1: row = Contention based / Reserved region boundary

NOTE 2: column = Reserved packet /Fixed rate based region boundary

NOTE 3: When the ranging control slot indicator ( $b_0$ ) is set to "1", the values in rows 0 - 2 are illegal values, and values in row 3 means that there are no aloha slots, because slots 1-3 are defined as ranging control slots.

**Example:  $b_0 = 0$ ,  $b_1-b_6 = 22$ : contention (1-2), reserved (3-5), fixed rate (6-9)**

The remaining values of the slot boundary definition field are provided in table 11.

**Table 11: Slot boundary definition field**

b1-b6 value	ranging control slots	contention slots	reservation slots	fixed rate slots
55	1-6	7-9	-	-
56	1-6	7-8	-	9
57	1-6	7	8-9	-
58	1-6	7	8	9
59	1-6	7	-	8-9
60	1-6	-	7-8	9
61	1-6	-	7	8-9
62	1-6	-	-	7-9
63	1-9	-	-	-

For b1-b6 = 55 - 63, b0 shall be set to 1.

For b1-b6 between 55 and 62, two ranging slots are provided (2 and 5).

For b1-b6 = 63, three ranging slots are provided (2, 5, and 8).

The values in tables 11 to 13 are derived from b1-b6 in the following manner:

$$b1 + (b2 \times 2) + (b3 \times 4) + (b4 \times 8) + (b5 \times 16) + (b6 \times 32)$$

**Slot reception indicators (b7-b15):** When a slot reception indicator is active ("1"), this indicates that a cell was received without collision. The relationship between a given US slot and its indicator is shown in table 12. When the indicator is inactive ("0"), this indicates that either a collision was detected or no cell was received in the corresponding upstream slot.

**Table 12: Relationship of US slot to DS indicator**

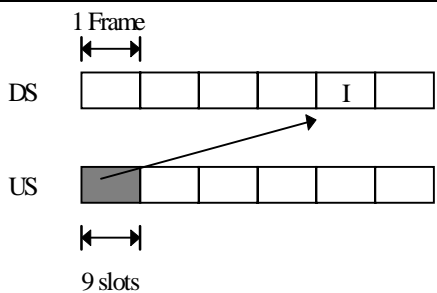
	1,544M downstream	3,088M downstream
256k	non applicable	non applicable
1,544M	non applicable	non applicable
3,088M	non applicable	 <p>1 Frame DS US 9 slots</p>
	I indicates the DS slot in which Indicators are sent. These indicators are for the US slots in the shaded area.	

**Reservation control (b16-b17):** When the reservation control field has the value of 0, no reservation attempts are allowed to be transmitted on the corresponding QPSK upstream channel during the slot positions associated with the next 3 ms period. When the reservation control field has the value of 1, reservation attempts can be made. The values 2 and 3 are reserved.

**CRC 6 parity (b18-b23):** This field contain a CRC 6 parity value calculated over the previous 18 bits. The CRC 6 parity value is described in the SL-ESF frame format.

In the case where there is more than one OOB DS QPSK channel related to an upstream QPSK channel, the SL-ESF overhead bits and the payload R-bytes shall be identical in those OOB DS channels, with the exception of the overhead

CRC (C1-C6) bits, which are specific to each of those OOB DS channels. Such related DS channels shall be synchronized.

The MAC messages that are required to perform the MAC functions for the upstream channel shall be transmitted on each of its related OOB DS channels.

### Trailer bytes

These bytes are not used. They are equal to 0.

## 5.3.2 Forward interaction path (downstream IB)

The structure that is utilized when the downstream QPSK channel is carrying MPEG2-TS packets is shown in figure 18.

<b>4</b>	<b>3</b>	<b>2</b>	<b>3</b>	<b>26</b>	<b>26</b>	<b>40</b>	<b>40</b>	<b>40</b>	<b>4</b>
MPEG Header	Upstrm Marker	Slot Number	MAC Flg Control	MAC Flags	Ext. Flags	MAC msg.	MAC msg.	MAC msg.	rsrvc

**Figure 18: Frame structure (MPEG2-TS format)**

where:

**MPEG header** is the 4 byte MPEG2-TS header as defined in ISO 13818-1 [2] with a specific PID designated for MAC messages.

**upstream marker** is a 24-bit field which provides upstream QPSK synchronization information. The definition of the field is as follows:

**bit 0: upstream marker enable (MSB)**

When this field has the value '1', the slot marker pointer is valid. When this field has the value '0', the slot marker pointer is not valid.

**bit 1-7: reserved**

**bit 8 - 23: upstream slot marker pointer**

The slot marker pointer is a 16-bit integer which indicates the number of "symbol" clocks between the first symbol of the next sync byte and the next 3 ms marker.

**slot number** is a 16-bit field which is defined as follows:

**bit 0: slot position register enable (MSB)**

When this field has the value '1', the slot position register is valid. When this field has the value '0', the slot position register is not valid.

**bit 1-3: reserved**

**bit 4** is set to the value '1'. This bit is equivalent to M12 in the case of OOB downstream.

**bit 5: odd parity**

This bit provides odd parity for upstream slot position register. This bit is equivalent to M11 in the case of OOB downstream.

**bits 6-15: upstream slot position register**

The upstream slot position register is a 10-bit counter which counts from 0 to n with bit 6 the MSB. These bits are equivalent to M10-M1 in the case of OOB downstream.

(see subclause 5.4 for more information on the functionality of the upstream slot position register)

**MAC Flag Control** is a 24-bit field (b0, b1, b2...b23) which provides control information which is used in conjunction with the MAC flags and extension flags. The definition of the MAC flag control field is as follows:

b0-b2	channel 1 flag field control
b3-b5	channel 2 flag field control
b6-b8	channel 3 flag field control
b9-b11	channel 4 flag field control
b12-b14	channel 5 flag field control
b15-b17	channel 6 flag field control
b18-b20	channel 7 flag field control
b21-b23	channel 8 flag field control

Each of the above channel "x" flag field control fields are defined as follows:

channel x flag control (a, b, c)

bit a: 0 - channel x flag field disabled

1 - channel x flag field enabled

bit b, c: 00 - all flags valid for second previous 3 ms period

(out-of-band signalling equivalent)

01 - flags valid for 1st ms of previous 3 ms period

10 - flags valid for 2nd ms of previous 3 ms period

11 - flags valid for 3rd ms of previous 3 ms period

### MAC Flags

MAC Flags is a 26-byte field containing 8 slot configuration fields (24 bits each) which contain slot configuration information for the related upstream channels followed by two reserved bytes. The definition of each slot configuration field is defined as follows:

b0 = ranging control slot indicator for next 3 ms period (MSB)

b1-b6 = slot boundary definition field for next 3 ms period

b7 = slot 1 reception indicator for [second] previous 3 ms period

b8 = slot 2 reception indicator for [second] previous 3 ms period

b9 = slot 3 reception indicator for [second] previous 3 ms period

b10 = slot 4 reception indicator for [second] previous 3 ms period

b11 = slot 5 reception indicator for [second] previous 3 ms period

b12 = slot 6 reception indicator for [second] previous 3 ms period

b13 = slot 7 reception indicator for [second] previous 3 ms period

b14 = slot 8 reception indicator for [second] previous 3 ms period

b15 = slot 9 reception indicator for [second] previous 3 ms period

b16-17 = reservation control for next 3 ms period

b18-b23 = CRC 6 parity



The slot configuration fields are used in conjunction with the MAC flag control field defined above. When the MAC flag control field designates that a 1 ms flag update is enabled; (1) the reception indicators refer to the previous 3 ms period (the bracketed term [second] is omitted from the definition), (2) only the reception indicators which relate to slots which occur during the designated 1 ms period are valid, and (3) the ranging control slot indicator, slot boundary definition field, and reservation control field are valid and consistent during each 3 ms period.

### MAC Message

The MAC Message field contains a 40-byte message, the general format defined in the subclause 5.5.

**reserve field c** is a 4-byte field reserved for future use.

## 5.3.3 Return interaction path (upstream)

### 5.3.3.1 Slot format

The format of the upstream slot is shown in figure 19. A Unique Word (UW) (4 bytes) provides a burst mode acquisition method. The payload area (53 bytes) contains a single message cell. The RS parity field (6 bytes) provides  $t = 3$  Reed Solomon protection RS(59,53) over the payload area. The guard band (1 byte) provides spacing between adjacent packets.

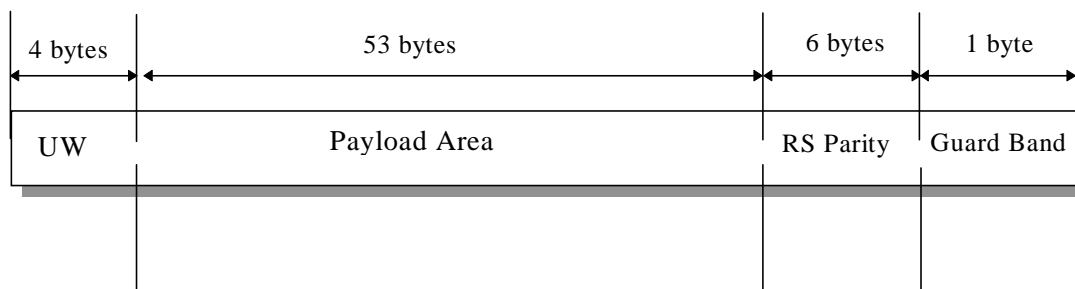

Figure 19: Slot format

The structure and field coding of the message cell shall be consistent with the structure and coding given in ITU-T Recommendation I.361 [5] for ATM UNI.

#### Unique Word (UW)

The UW is four bytes long: 0x 00 FC FC F3 hex.

#### ATM cell structure

The format for each ATM cell structure is given in figure 20. This structure and field coding shall be consistent with the structure and coding given in ITU-T Recommendation I.361 [5] for ATM UNI.

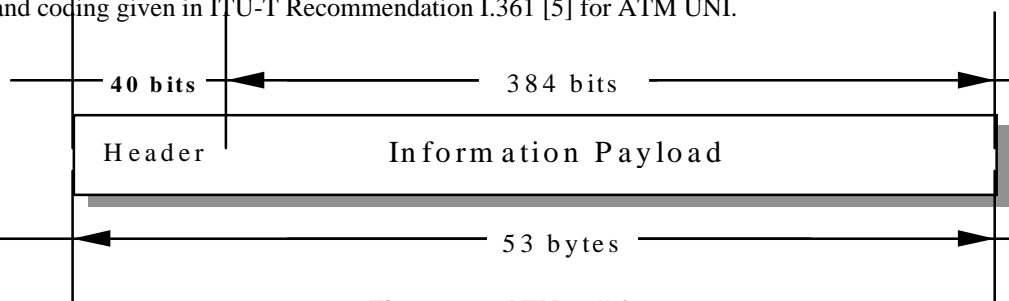

Figure 20: ATM cell format

#### Channel coding

RS encoding shall be performed on each ATM cell with  $T = 3$ . This means that 3 erroneous byte per ATM cell can be corrected. This process adds 6 parity bytes to the ATM cell to give a code word of (59,53).

The RS code shall have the following generator polynomials:

Code generator polynomial:

$$g(x) = (x + \mu^0) (x + \mu^1) (x + \mu^2) \dots (x + \mu^5),$$

where  $\mu = 02$  hex

Field generator polynomial:

$$p(x) = x^8 + x^4 + x^3 + x^2 + 1$$

### Guard band

The guard band is 1-byte long (4 QPSK symbols). It provides some extra protection against synchronization errors.

## 5.4 Slot timing assignment

### 5.4.1 Downstream slot position reference (downstream OOB)

Upstream synchronization is derived from the downstream extended superframe (OOB) by noting the slot positions as shown in table 13.

**Table 13: Downstream slot position reference**

Frame Number	Bit Number	Overhead Bit	Slot position reference
1	0	<b>M1</b>	◆ Slot Position (note)
2	193	C1	
3	386	M2	
4	579	F1 = 0	
5	772	M3	
6	965	C2	
7	1158	M4	
8	1351	F2 = 0	
9	1544	<b>M5</b>	◆ Slot Position
10	1737	C3	
11	1930	M6	
12	2123	F3 = 1	
13	2316	M7	
14	2509	C4	
15	2702	M8	
16	2895	F4 = 0	
17	3088	<b>M9</b>	◆ Slot Position
18	3281	C5	
19	3474	M10	
20	3667	F5 = 1	
21	3860	M11	
22	4053	C6	
23	4246	M12	
24	4439	F6 = 1	

NOTE: For the 3,088 Mbit/s rate downstream, the 3 ms time marker only appears once every two superframes. The M12 bit (see subclause 5.4) is used to differentiate between the two superframes.

## 5.4.2 Downstream slot position reference (downstream IB)

Upstream synchronization is derived from the downstream extended superframe (IB) by noting the 3 ms time marker downstream as shown in figure 21. From the bits of the upstream marker field contained in the MPEG2-TS packet, the 3 ms time marker is obtained by counting a number of symbol clocks equal to  $(b23-b8)$ . This marker is equivalent to the first slot position of the superframe for the OOB case.

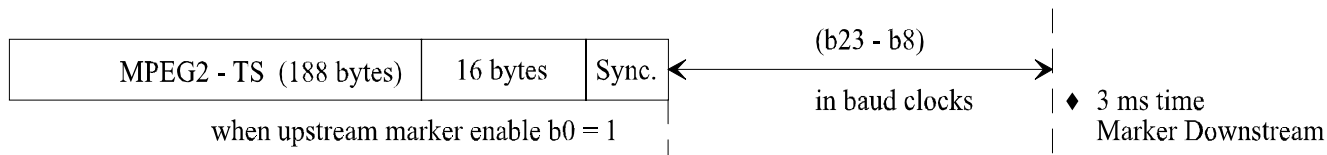

**Figure 21: Position of the 3 ms time marker for IB signalling**

In order to describe how the upstream marker is derived from the location of the 3 ms marker, consider the following system diagram.

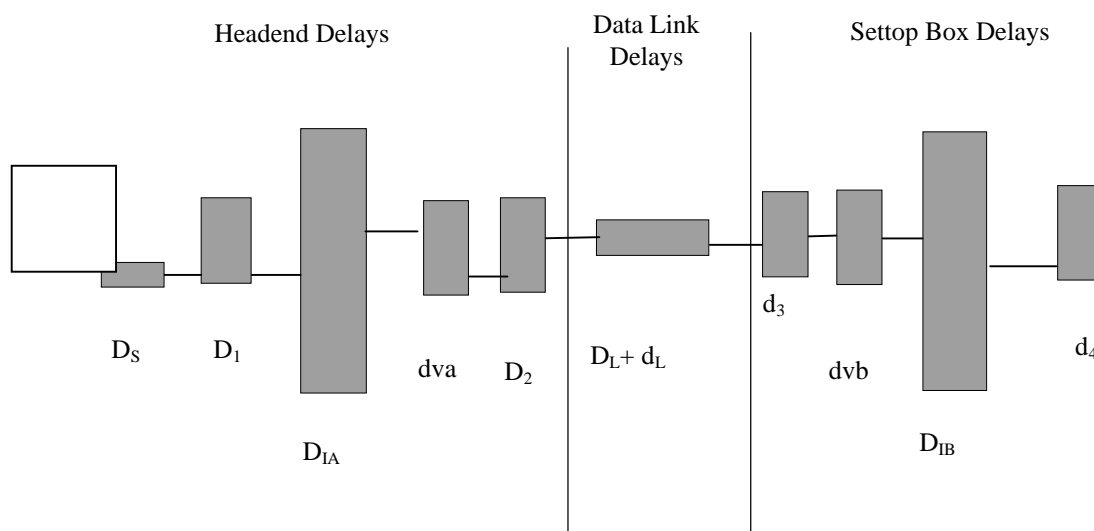

**Figure 22. System model for timing analysis**

The delay between the location of the end of the upstream marker and the beginning of the next sync byte, designated as  $D_S$ , is a constant value for each bit rate equal to the equivalent time of 194 bytes, or  $(194 \times 8/2)$  symbol clocks.

There will be some processing delay in the head-end hardware between the location where the upstream marker is inserted in the MAC packet and the arrival of the data into the interleaver. This should be a constant delay,  $D_1$ , which is the same for every incoming byte, including the sync byte following the upstream marker.

The delay due to the interleaving process in the head-end is  $D_{IA}$  and will be zero for each sync byte.

There is an additional delay,  $d_{va}$ , due to the convolutional coding process if any; this delay will be code rate dependant, according to the DVB-MS specification (It is also design dependant).

There will be some processing delay in the head-end hardware between the output of the inner coder and the output of the QPSK modulator. This should be a constant delay,  $D_2$ , for every byte in the outgoing stream.

The data link is composed of two delay values,  $D_L$ , the constant link delay that every STU experiences, and  $d_L$ , the variable link delay for each STU which is due to the fact that each STU is located at a different distance from the head-end.

This variable link delay is compensated for by the ranging operation.

There will be some processing delay in the STU hardware between the input of the QPSK demodulator and the input of the convolutional decoder. This delay is design dependent,  $d_3$ , and may be a constant delay or a variable delay for each byte in the data stream.

There is an additional delay,  $d_{vb}$ , which is due to the convolutional decoder; this delay is code rate dependant, according to the DVB-MS specification. It is also design dependant.

The delay due to the de-interleaving process in the STU is  $D_{IB}$ , and will be equal to the entire interleave delay for each sync byte.

The total interleave delay,  $D_I = D_{IA} + D_{IB}$

will be constant for each byte. The value will be given by:

$$D_I = 204 \times 8 \times \text{interleave\_depth} / \text{bit rate.}$$

There will be some processing delay in the STU hardware between the output of the de-interleaver and the circuitry that utilizes the upstream marker and following sync byte for generating the local 3 ms marker. This delay, which includes RS FEC, is design dependent,  $d_4$ , and may be a constant delay or a variable delay for each byte in the data stream.

The accumulated delay in the data link is composed of a number of constant terms and variable terms. The constant terms will be identical for every STU that is utilizing a particular QPSK channel for in-band timing and thus becomes a fixed offset between when the counter which is loading the upstream marker value and the actual location of the 3 ms marker at each STU. Each STU is responsible for compensating for the design dependent delays, before utilizing the upstream marker value for generating the 3 ms marker. The variable link delay,  $d_L$ , will be compensated for via the ranging algorithm, in the same way as performed when out-of-band signalling is employed.

### 5.4.3 Upstream slot positions

Transmission on each QPSK upstream channel is based on dividing access by multiple NIU units by utilizing a negotiated bandwidth allocation slot access method. A slotting methodology allows the transmit slot locations to be synchronies to a common slot position reference, which is provided via the related downstream MAC control channel. Synchronizing the slot locations increases message throughput of the upstream channels since the ATM cells do not overlap during transmission.

The slot position reference for upstream slot locations is received via the related downstream MAC control channel by each NIU. Since each NIU receives the downstream slot position reference at a slightly different time, due to propagation delay in the transmission network, slot position ranging is required to align the actual slot locations for each related upstream channel. The upstream slot rates are 6 000 upstream slots/s.

The number of slots available in any one second is given by:

$$\text{number of slots/s} = \text{upstream data rate} / 512 + (\text{extra guard band})$$

where extra guard band may be designated between groups of slots for alignment purposes. The M-bits in the SL-ESF serve two purposes:

- to mark the slot positions for the upstream contention based and contention-less based signalling links (see subclause 5.4.4);
- to provide slot count information for upstream message bandwidth allocation management in the NIU.

M-bits M1, M5, and M9 mark the start of an upstream slot position for upstream message transmission.

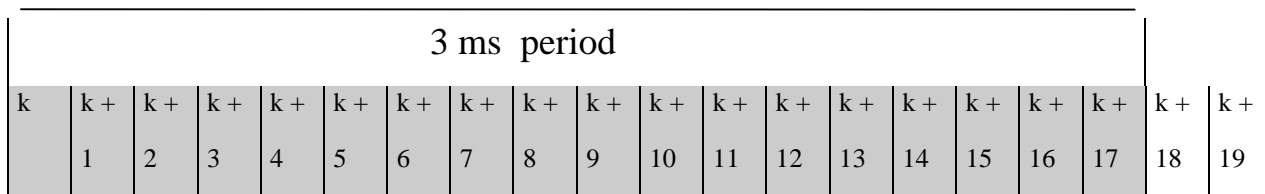

As the downstream and upstream bit rates are 3,088 Mbit/s, there are 6 slot position references downstream during the transmission of 18 upstream packets. In the case of IB downstream, packet "k" is sent when the 3 ms time marker is received.

The relationship between the received slot position reference and the actual slot transmit position is given by:

$$\text{slot\_transmit\_position} = \text{slot\_position\_reference} + \text{slot\_position\_offset}$$

where slot\_position\_offset is derived from the Time\_Offset\_Value provided via the Range\_and\_Power\_Calibration\_Message.

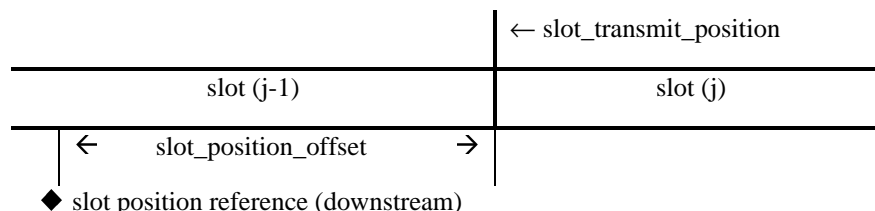

The actual slot transmission locations are given by

$$\text{slot\_transmission\_location} (m) = \text{slot\_transmission\_position} + (m \times 512);$$

where m = 0,1,2,3,4,5; is the position of the slot with respect to the slot\_transmission\_position

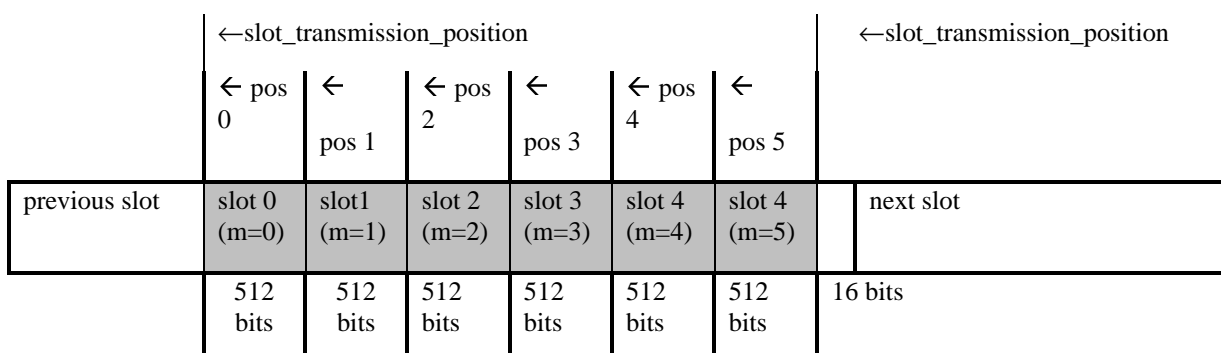

### 5.4.4 Slot position counter

Think of M-bits M10 - M1 as a register, called the upstream slot position register, which is used to generate an upstream slot position counter, which counts from 0 to n, where n is an integer which indicates slot position cycle size (the value of n is sent in the MAC default configuration message as Service\_Channel\_Last\_Slot). The upstream slot position register indicates the upstream slot positions that will correspond to the next SL-ESF frame. Upstream slot positions are counted from 0 to n. There are 6 upstream slots per millisecond. The corresponding upstream slot rates are, therefore, 6 000 upstream slots/s when the upstream data rate is 3,088 Mbit/s. The algorithm to determine the upstream slot position counter value is given below:

{n = 1;}

upstream\_slot\_position\_register = value of M-bits latched at bit\_position M11 (M10 - M1)

```
{m = 6;}
if (bit_position==M1 and previous M12 ==1)
    { upstream_slot_position_counter = upstream_slot_register * 3 * m; }
if (bit_position == M5)
    if (previous M12 == 0) )
        { upstream_slot_position_counter =
          upstream_slot_position_counter+m; }
if (bit_position == M9)
    if (previous M12 == 1) )
        { upstream_slot_position_counter = upstream_slot_position_counter + m; }
if (bit_position == M11)
    { temp_upstream_slot_position_register = (M10, M9, M8, ....., M1); }
if ( (bit_position == M12 and M12 == 1) )
    {upstream_slot_position = temp_upstream_slot_position_register;}
```

where, the M-bits will be defined as follows:

M1 - M10 =	10-bit ESF counter which counts from 0 to n with M10 the MSB;
M11 =	odd parity for the ESF counter, i.e., M11 = 1 if the ESF_value (M1-M10) has an even number of bits set to 1;
M12 =	1: ESF counter valid; 0: ESF counter not valid.

The values assigned to M12 are as follows:

The information is always transmitted in pairs of superframe, where superframe A is the first superframe in the pair, and superframe B is the second superframe in the pair. The M12 bit of superframe A is set to the value '0' and the M12 bit of superframe B is set to the value '1'.

When the downstream channel is IB, M12 = 1.

## 5.5 MAC functionality

### 5.5.1 MAC reference model

This subclause is limited to the definition and specification of the MAC layer protocol. The detailed operations within the MAC layer are hidden from the above layers.

This subclause focuses on the required message flows between the INA and the NIU for MAC. These areas are divided into three categories:

- 1) Initialization, Provisioning and Sign-On Management,
- 2) Connection Management and
- 3) Link Management.

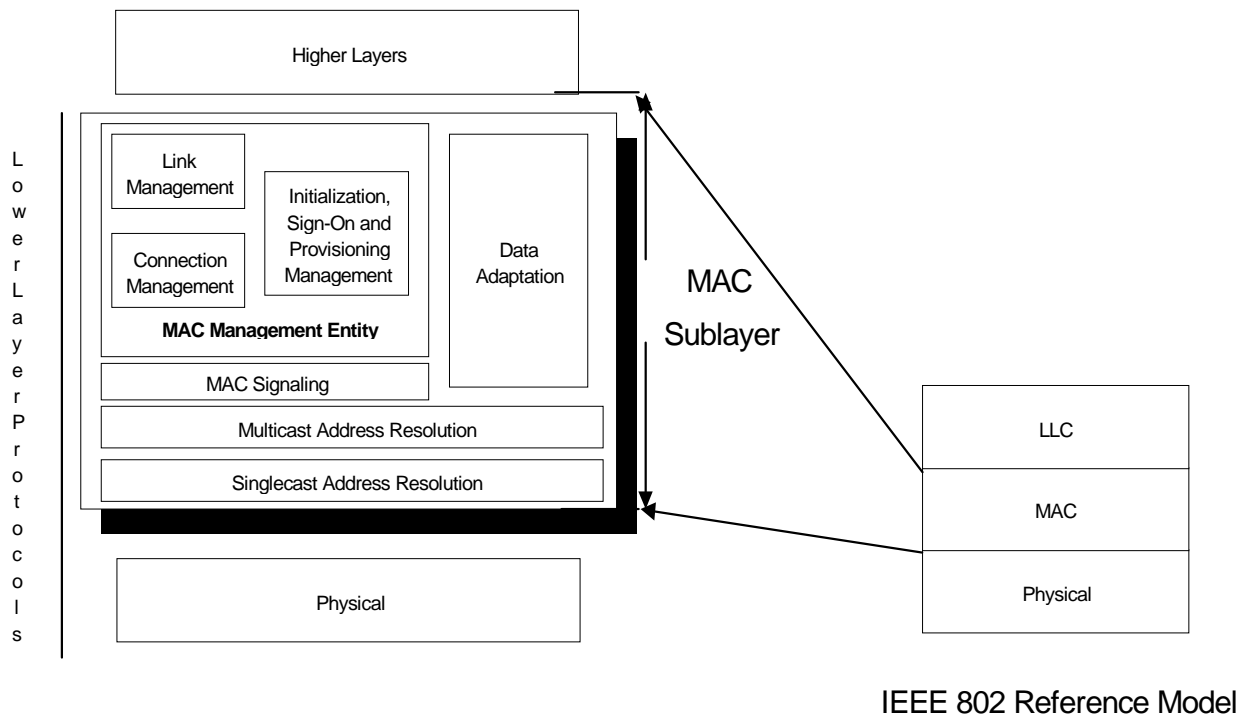

**Figure 23: MAC reference model**

## 5.5.2 MAC concept

### 5.5.2.1 Relationship between higher layers and MAC protocol

The goal of the MAC protocol is to provide tools for higher layer protocols in order to transmit and receive data transparently and independently of the physical layer. Higher layer services are provided by the INA to the STU. The INA is thus responsible of indicating the transmission mode and rate to the MAC layer for each type of service.

Specifically, for each connection provided by higher layers on the INA side (VPI/VCI), a connection ID is associated at the MAC layer. The maximum number of simultaneous connections that a NIU should support is defined as follows:

Grade A: Only one connection at a time can be handled by a NIU;

Grade B: As many connections as needed, defined dynamically by the INA, following higher layers requests.

However, bandwidth (time slots) does not need to be assigned immediately by the INA for a given connection. This means that a connection ID may exist at the NIU side without associated slot numbers.

The INA is responsible of providing transmission bandwidth to the NIUs when needed by higher layers. However, since the NIU shall transmit all data from the STU, the NIU is also responsible for requesting for more bandwidth if not already provided by the INA.

A default connection is initiated by the INA when STBs are first turned on. This connection can be used to send data from higher layers leading to further interactive connections. This connection can be associated to a zero transmission rate (no initial bandwidth allocation).

### 5.5.2.2 Relationship between physical layer and MAC protocol

Up to 8 QPSK Upstream channels can be related to each downstream channel which is designated as a MAC control channel. An example of frequency allocation is shown in the figure 24. This relationship consists of the following items:

- 1) Each of these related upstream channels share a common slot position. This reference is based on 1 ms time markers that are derived via information transmitted via the downstream MAC control channel.
- 2) Each of these related upstream channels derive slot numbers from information provided in the downstream MAC control channel.
- 3) The messaging needed to perform MAC functions for each of these related upstream channels is transmitted via the downstream MAC control channel.

The MAC protocol supports multiple downstream channels. In instances where multiple channels are used, the INA shall specify a single OOB frequency called the Provisioning Channel, where NIUs perform Initialization and Provisioning Functions. In networks where IB NIUs exist, provisioning should be included in at least one IB channel. An aperiodic message is sent on each downstream control channel which points to the downstream Provisioning Channel. In instances where only a single frequency is in use, the INA shall utilize that frequency for Initialization and Provisioning functions.

The MAC protocol supports multiple upstream channels. One of the upstream channels shall be designated the Service Channel. The Service Channel shall be used by NIUs entering the network via the Initialization and Provisioning procedure. The remaining upstream channels shall be used for upstream data transmission. In cases where only one upstream channel is utilized, the functions of the Service Channel shall reside in conjunction with regular upstream data transmission.

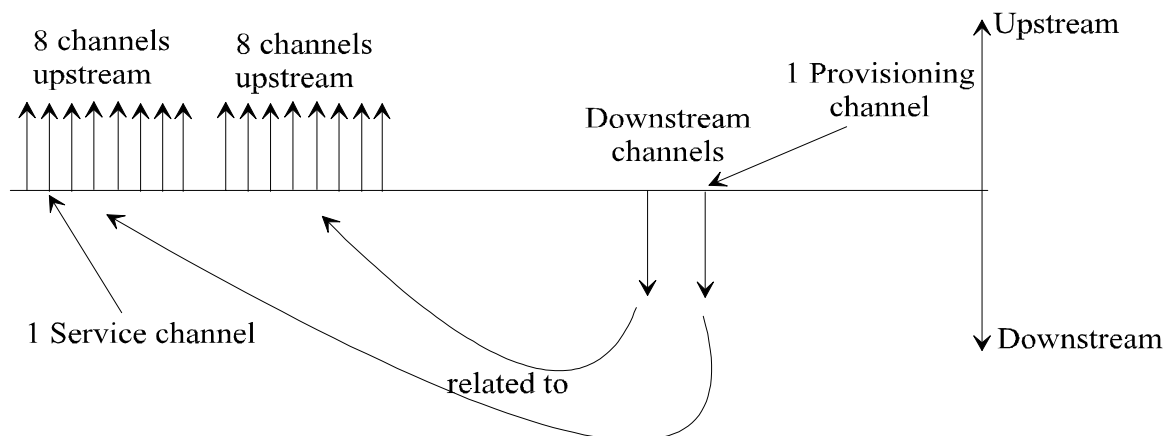

**Figure 24: Example of frequency allocation**

### 5.5.2.3 Relationship between physical layer slot position counter and MAC slot assignment

M10 - M1 is a 10-bit superframe counter at the INA side, whereas the upstream slot position counter is an upstream slot counter at the NIUs side. The NIU slot position counter ( $M10 - M1 \times 3 \times m$ , where  $m = 6$ ) may be implemented as a 16-bit counter which is compared to the 16-bit slot numbers assigned by the INA in MAC messages (list assignment). When the counter value equals any assigned value, the NIU is allowed to send a packet upstream.

In the algorithm given in subclause 5.4.3, the counter value is refreshed every time M11 is received.

### 5.5.2.4 Access modes (contention/ranging/fixed rate/reservation)

Different access modes are provided to the NIUs within access regions specified by information contained in the slot boundary fields of the downstream superframes. The limits between access regions allow users to know when to send data on contention without risks of collision with contentionless type data. The following rules define how to select access modes:



**Data connections:**

When the INA assigns a connection ID to the NIU, it either specifies a slot list to be used (Fixed rate access) or the NIU shall use contention or reservation access by following this algorithm:

When the NIU shall send more cells than what was assigned by the INA, it can use contention access only if the number of cells to transmit is less than `Maximum_contention_access_message_length` (specified in the MAC Connect Message from the INA). In that case, it shall wait for the slot reception indicator before it is allowed to send other cells with the same VPI/VCI value. The NIU can send one request for reservation access if the number of cells is less than `Maximum_reservation_access_message_length` (specified in the MAC Connect Message from the INA). If more cells shall be transmitted, the NIU shall send multiple requests for reservation access.

**MAC messages:**

MAC messages can be sent on contention access or reservation access. MAC messages sent upstream shall be less than 40 bytes long. If the MAC information exceeds 40 bytes, it shall be segmented into multiple 40 bytes independent MAC messages. Ranging access can only be used for specific MAC messages.

**a) Contention access**

Contention access indicates that data (MAC or bursty data traffic) is sent in the slots assigned to the contention access region in the upstream channel. It can be used either to send MAC messages or data. The VPI, VCI of the ATM cells are then used to determine the type and direction of the data in higher layers. Contention based access provides instant channel allocation for the NIU.

The Contention based technique is used for multiple subscribers that will have equal access to the signalling channel. It is probable that simultaneous transmissions will occur. For each ATM cell transmitted by the NIU, a positive acknowledgement is sent back by the INA, utilizing the reception indicator field, for each successfully received ATM cell. In contention based access mode, a positive acknowledgement indicates that a collision did not occur. A collision occurs if two or more NIUs attempt ATM cell transmission during the same slot. A collision will be assumed if a NIU does not receive a positive acknowledgement. If a collision occurs, then the NIU will retransmit using a procedure to be defined.

**b) Ranging access**

Ranging access indicates that the data is sent in a slot preceded and followed by slots not used by other users. These slots allow users to adjust their clock depending on their distance to the INA such that their slots fall within the correct allocated time. They are either contention based when the ranging control slot indicator `b0` received during the previous superframe was 1 (or when `b1-b6 = 55 to 63`), or reserved if the INA indicates to the NIU that a specific slot is reserved for ranging.

**c) Fixed rate access**

Fixed rate access indicates that data is sent in slots assigned to the fixed rate based access region in the upstream channel. These slots are uniquely assigned to a connection by the INA. No fixed rate access can be initiated by the NIU.

**d) Reservation access**

Reservation access implies that data is sent in the slots assigned to the reservation region in the upstream channel. These slots are uniquely assigned on a frame by frame basis to a connection by the INA. This assignment is made at the request of the NIU for a given connection.

### 5.5.2.5 MAC error handling procedures

Error handling procedures are under definition (Time out windows, retransmission, power outage, etc.).

### 5.5.2.6 MAC messages

The MAC message types are divided into the logical MAC states of Initialization, Sign-On, Connection Management and Link Management. Messages in italic represent upstream transmission from NIU to INA. MAC messages are sent using Broadcast or Singlecast Addressing. Singlecast address shall utilize the 48-bit MAC address.

Table 14: MAC messages

Message Type Value		Addressing Type
	<b>MAC Initialization, Provisioning and Sign-On Message</b>	
0x01	Provisioning Channel Message	Broadcast
0x02	Default Configuration Message	Broadcast
0x03	Sign-On Request Message	Broadcast
0x04	<i>Sign-On Response Message</i>	Singlecast
0x05	Ranging and Power Calibration Message	Singlecast
0x06	<i>Ranging and Power Calibration Response Message</i>	Singlecast
0x07	Initialization Complete Message	Singlecast
0x08-0x1F	[Reserved]	
	<b>MAC Connection Establishment and Termination Msgs</b>	
0x20-0x3F		
0x20	Connect Message	Singlecast
0x21	<i>Connect Response Message</i>	Singlecast
0x22	<i>Reservation Request Message</i>	Singlecast
0x23	Reservation Response Message	Broadcast
0x24	Connect Confirm Message	Singlecast
0x25	Release Message	Singlecast
0x26	<i>Release Response Message</i>	Singlecast
0x27	<i>Idle Message</i>	Singlecast
0x28	Reservation Grant Message	Broadcast
0x29	Reservation ID Assignment	Singlecast
0x2A	Reservation ID Assignment	Singlecast
0x2B	<i>Reservation Status Request</i>	Singlecast
0x2C-0x3F	<i>Reservation ID Response Message</i> Reserved]	Singlecast
	<b>MAC Link Management Messages</b>	
0x27	<i>Idle Message</i>	Singlecast
0x40	Transmission Control Message	Singlecast or Broadcast
0x41	Reprovision Message	Singlecast
0x42	<i>Link Management Response Message</i>	Singlecast
0x43	Status Request Message	Singlecast
0x44	<i>Status Response Message</i>	Singlecast
0x45-0x5F	[Reserved]	

To support the delivery of MAC related information to and from the NIU, a dedicated Virtual Channel shall be utilized. The VPI, VCI for this channel shall be 0x000,0x0021.

#### Upstream MAC messages:

AAL5 (as specified in ITU-T Recommendation I 363 [6]) adaptation shall be used to encapsulate each MAC PDU in an ATM cell. Upstream MAC information should be single 40 bytes cell messages.

#### Downstream OOB MAC messages:

AAL5 (as specified in ITU-T Recommendation I 363 [6]) adaptation shall be used to encapsulate each MAC PDU in an ATM cell. Downstream OOB MAC information may be longer than 40 bytes.

**Downstream IB MAC messages:**

Downstream IB MAC information is limited to 120-byte long messages (A procedure to be able to send longer messages is under definition). No AAL5 layer is defined for MPEG2-TS cells. MAC messages shall therefore be sent as explained in figure 25.

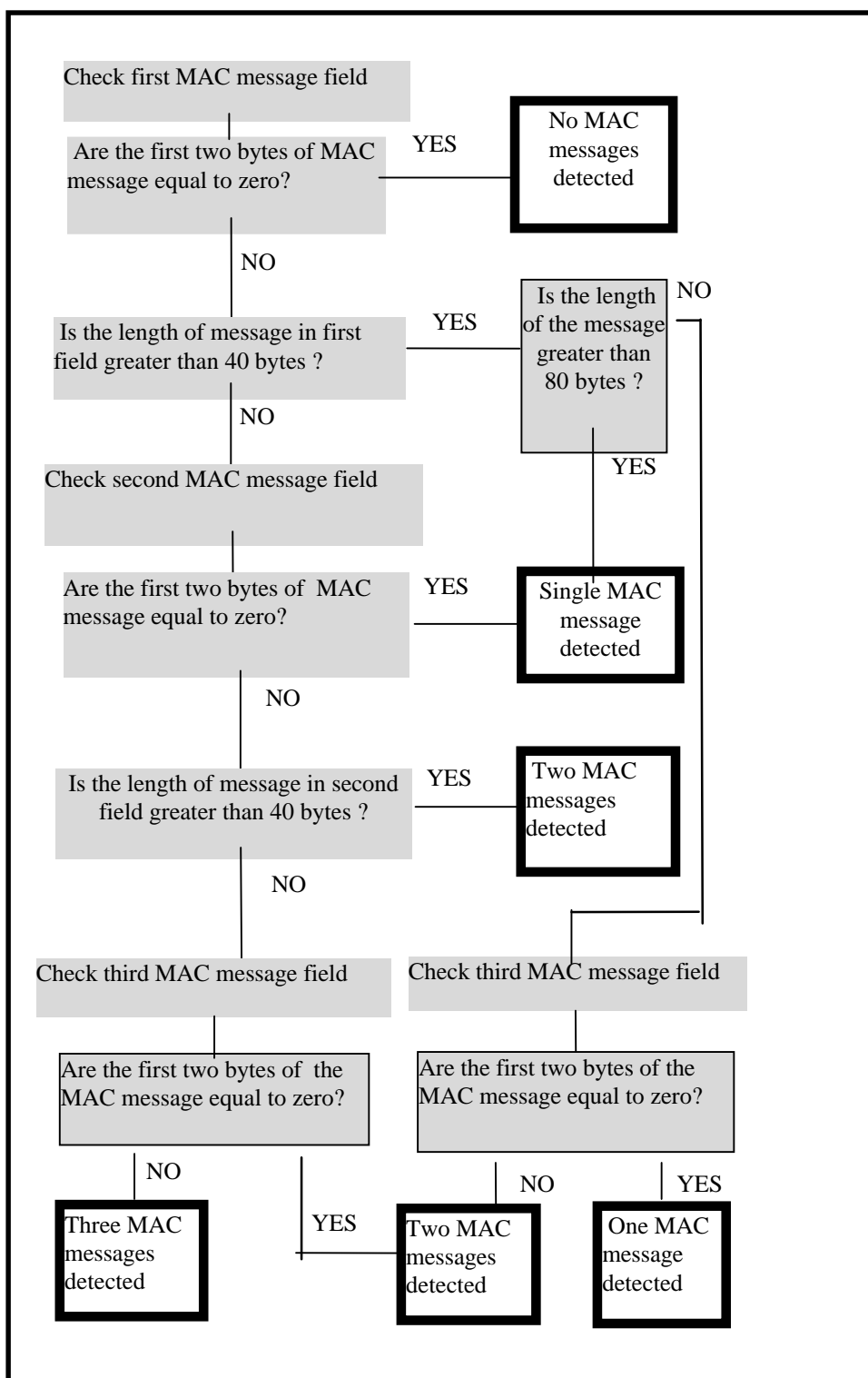

**Figure 25: Algorithm when MAC message are sent IB downstream**

Since MAC related information is terminated at the NIU and INA a privately defined message structure will be utilized. The format of this message structure is illustrated in table 15. All messages are sent most significant bit first. Message 0x23 is not used in the present release of the MAC protocol. When no MAC\_Address is specified in the message, it means that the message is sent broadcast. (Syntax\_indicator = 000).

**Table 15: MAC message structure**

<b>MAC_message(){</b>	<b>Bits</b>	<b>Bytes</b>	<b>Bit Number Description</b>
<b>Message_Configuration</b>	<b>8</b>	<b>1</b>	
Protocol_Version	5		
Syntax_Indicator	3		
<b>Message_Type</b>	<b>8</b>	<b>1</b>	
if (syntax_indicator==001) {			
<b>MAC_Address</b>	<b>(48)</b>	<b>(6)</b>	
}			
{			
<b>MAC_Information_Elements ()</b>		<b>N</b>	
}			

### Protocol Version

Protocol\_Version is a 5-bit field used to identify the current MAC version. The value for this parameter is given in table 16.

**Table 16: Protocol\_version coding**

<b>Value</b>	<b>Definition</b>
0-31	Reserved

### Syntax Indicator

Syntax\_Indicator is a 3-bit enumerated type that indicates the addressing type contained in the MAC message.

**Table 17**

<b>Enum Syntax_Indicator {No_MAC_Address ,MAC_Address_Included, reserved2..7};</b>
--

### MAC Address

MAC\_Address is a 48-bit value representing the unique MAC address of the NIU. This MAC address may be hard coded in the NIU or be provided by external source.

### 5.5.3 MAC initialization and provisioning

This subclause defines the procedure for initialization and provisioning that the MAC shall perform during power on or reset.

- 1) Upon a NIU becoming active (i.e. powered up) , it shall first find the current provisioning frequency. The NIU shall receive the **<MAC> Provisioning Channel Message**. This message shall be sent aperiodically on all downstream OOB channels when there are multiple channels. In the case of only a single channel, the message shall indicate the current channel is to be utilized for Provisioning. Upon receiving this message, the NIU shall tune to the Provisioning Channel.
- 2) After a valid lock indication on a Provisioning Channel, the NIU shall await the **<MAC> DEFAULT CONFIGURATION MESSAGE**. When received, the NIU shall configure its parameters as defined in the default configuration message. The Default Configuration Parameters shall include default timer values, default power levels, default retry counts as well as other information related to the operation of the MAC protocol.

Figure 26 shows the signalling sequence.

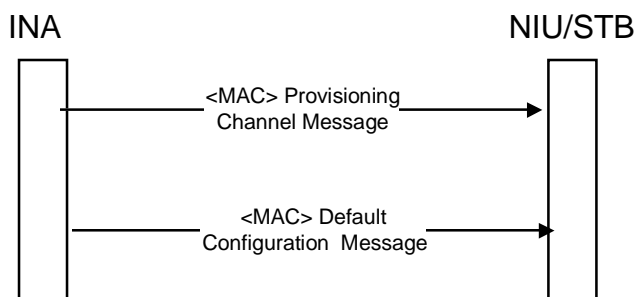

Figure 26: Initialization and provisioning signalling

#### 5.5.3.1 <MAC> Provisioning channel message (Broadcast downstream)

The **<MAC> PROVISIONING CHANNEL MESSAGE** is sent by the INA to direct the NIU to the proper OOB frequency where provisioning is performed. The format of the message is shown in table 18.

Table 18: Provisioning channel message format

Provisioning_Channel_Message(){	Bits	Bytes	Bit Number / Description
<b>Provisioning_Channel_Control_Field</b>	8	1	
<i>reserved</i>	7		7-1:
<i>provisioning_frequency_included</i>	1		0: {no=0, yes=1}
<i>if (provisioning_frequency_included) {</i>			
<b>Provisioning_Frequency</b>	(32)	(4)	
<b>DownStream_Type</b>	8	1	
}			
}			

### Provisioning Channel Control Field

Provisioning\_Channel\_Control\_Field is used to specify the downstream frequency where the NIU will be provisioned.

### Provisioning frequency included

Provisioning\_frequency\_included is a boolean when set, indicates that a downstream OOB IF frequency is specified that the NIU should tune to begin the provisioning process. When cleared, indicates that the current downstream IF frequency is the provisioning frequency.

### Provisioning frequency

Provisioning\_frequency is a 32-bit unsigned integer representing the OOB IF frequency in which NIU provisioning occurs. The unit of measure is Hz.

### Downstream Type

DownStream\_Type is an 8-bit enumerated type indicating the modulation format for the down stream connection. { reserved, reserved, QPSK\_3,088, 3..255 reserved }

### 5.5.3.2 <MAC> Default configuration message (Broadcast downstream)

The <MAC> DEFAULT CONFIGURATION MESSAGE is sent by the INA to the NIU. The message provides default parameter and configuration information to the NIU. The format of the message is shown in table 19.

**Table 19: Default configuration message structure**

Default Configuration Message(){	Bits	Bytes	Bit Number / Description
<b>Sign_On_Incr_Pwr_Retry_Count</b>	<b>8</b>	<b>1</b>	
<b>Service_Channel_Frequency</b>	<b>32</b>	<b>4</b>	
<b>Service_Channel_Control_Field</b>	<b>8</b>	<b>1</b>	
MAC_Flag_Set	5		7-3
Service_Channel	3		2-0
<b>Backup_Service_Channel_Frequency</b>	<b>32</b>	<b>4</b>	
<b>Backup_Service_Channel_Control_Field</b>	<b>8</b>	<b>1</b>	
Backup_MAC_FlagSet	5		7-3
Backup_Service_Channel	3		2-0
<b>Service_Channel_Frame_Length [reserved]</b>	<b>16</b>	<b>2</b>	unused here
<b>Service_Channel_Last_Slot</b>	<b>16</b>	<b>2</b>	
<b>Max_Power_Level</b>	<b>8</b>	<b>1</b>	
<b>Min_Power_Level</b>	<b>8</b>	<b>1</b>	
<b>Upstream_Transmission_Rate</b>	<b>3</b>	<b>1</b>	<b>unused here</b>

### Sign-On Increment Power Retry Count

Sign\_On\_Incr\_Pwr\_Retry\_Count is an 8-bit unsigned integer representing the number of attempts the NIU should try to enter the system at the same power level before incrementing its power level by steps of 0,5 dB.

### Service Channel frequency

Service\_Channel\_frequency is a 32-bit unsigned integer representing the upstream IF frequency assigned to the service channel. The unit of measure is in Hz. This channel is identified as channel #0 for collision indications.

MAC\_Flag\_Set is an 5-bit field representing the MAC Flag set assigned to the service channel. In the OOB downstream timing, the eight sets of flags are assigned the numbers 0 to 7. In the IB downstream timing, the 16 sets of flags are assigned the numbers 0 to 15. This parameter represents the first of two successively assigned flag sets. This flag set indicates the x value the channel x associated to Rxa, Rxb, Rxc in the reception indicator fields.

Service\_Channel is a 3-bit field which defines the channel assigned to the Service\_Channel\_Frequency.

### Backup Service Channel frequency

Backup\_Service\_Channel\_frequency is a 32-bit unsigned integer representing the upstream IF frequency assigned to the backup service channel. The backup service channel is used when entry on the primary service channel fails. The unit of measure is in Hz. This channel is identified as channel #1 for collision indications.

Backup\_MAC\_Flag\_Set is an 5-bit field representing the MAC Flag set assigned to the backup service channel. In the OOB downstream timing, the eight sets of flags are assigned the numbers 0 to 7. In the IB downstream timing, the 16 sets of flags are assigned the numbers 0 to 15. In the case of a 3,088 Mbit/s upstream channel, this parameter represents the first of two successively assigned flag sets.

Backup\_Service\_Channel is a 3-bit field which defines the channel assigned to the Backup\_Service\_Channel\_Frequency.

### Service\_Channel\_Frame\_Length [reserved]

Unused in this version.

### Service Channel Last Slot

Service\_Channel\_Last\_Slot is a 16-bit unsigned integer representing the last slot in the Service Channel frame that is used for contention based access. This number represents the largest slot value of the NIU slots counter ( $n \times 3 \times m$ , where  $n$  is defined in subclause 5.4.3).

### Maximum Power Level

MAX\_Power\_Level is a 8-bit unsigned integer representing the maximum power the NIU shall be allowed to use to transmit upstream. The unit of measure is in dB $\mu$ V (RMS) on 75  $\Omega$ .

### Minimum Power Level

MIN\_Power\_Level is an 8-bit unsigned integer representing the minimum power the NIU shall be allowed to use to transmit upstream. The unit of measure is in dB $\mu$ V (RMS) on 75  $\Omega$ .

### Upstream Transmission Rate

Upstream\_Transmission\_Rate is a 3-bit enumerated type that indicates the upstream transmission rate.

```
enum Upstream_Transmission_Rate { _reserved, reserved, Upstream_3-088Mb/s, reserved..7};
```

## 5.5.4 Sign-On and Calibration

The NIU shall sign on via the Sign-On Procedure. The signalling flow for Sign-On is described below.

- The NIU shall tune to the downstream Provisioning channel and the upstream service channel with the information provided in the Initialization and Provisioning sequence.
- The NIU shall await the <MAC> **Sign-On Message** from the INA Entity. The NIU shall utilize Contention based entry on the service channel to access the network.
- Upon receiving the <MAC> **Sign-On Message**, the NIU shall respond with the <MAC> **Sign-On Response Message**. The **Sign-On Response Message** shall be transmitted on a Ranging Control Slot.
- The INA, upon receiving the **Sign-On Response Message** shall validate the NIU and send the <MAC> **Ranging and Power Calibration Message**.
- The NIU shall respond to the <MAC> **Ranging and Power Calibration Message** with the <MAC> **Ranging and Power Calibration Response Message**. The <MAC> **Ranging and Power Calibration Response Message** shall be transmitted on a Ranging Control Slot.
- The INA shall send the <MAC> **Initialization Complete Message** when the NIU is calibrated. The NIU is assumed to be calibrated if the message arrives within a window of 1,5 symbols (upstream rate) and a power within a window of 1,5 dB from their optimal value.

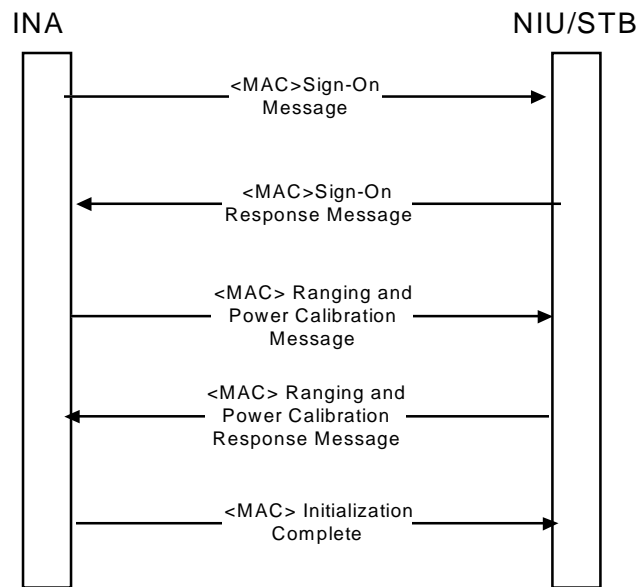

**Figure 27: Ranging and calibration signalling**

The state diagram in figure 28 details the procedure described above.



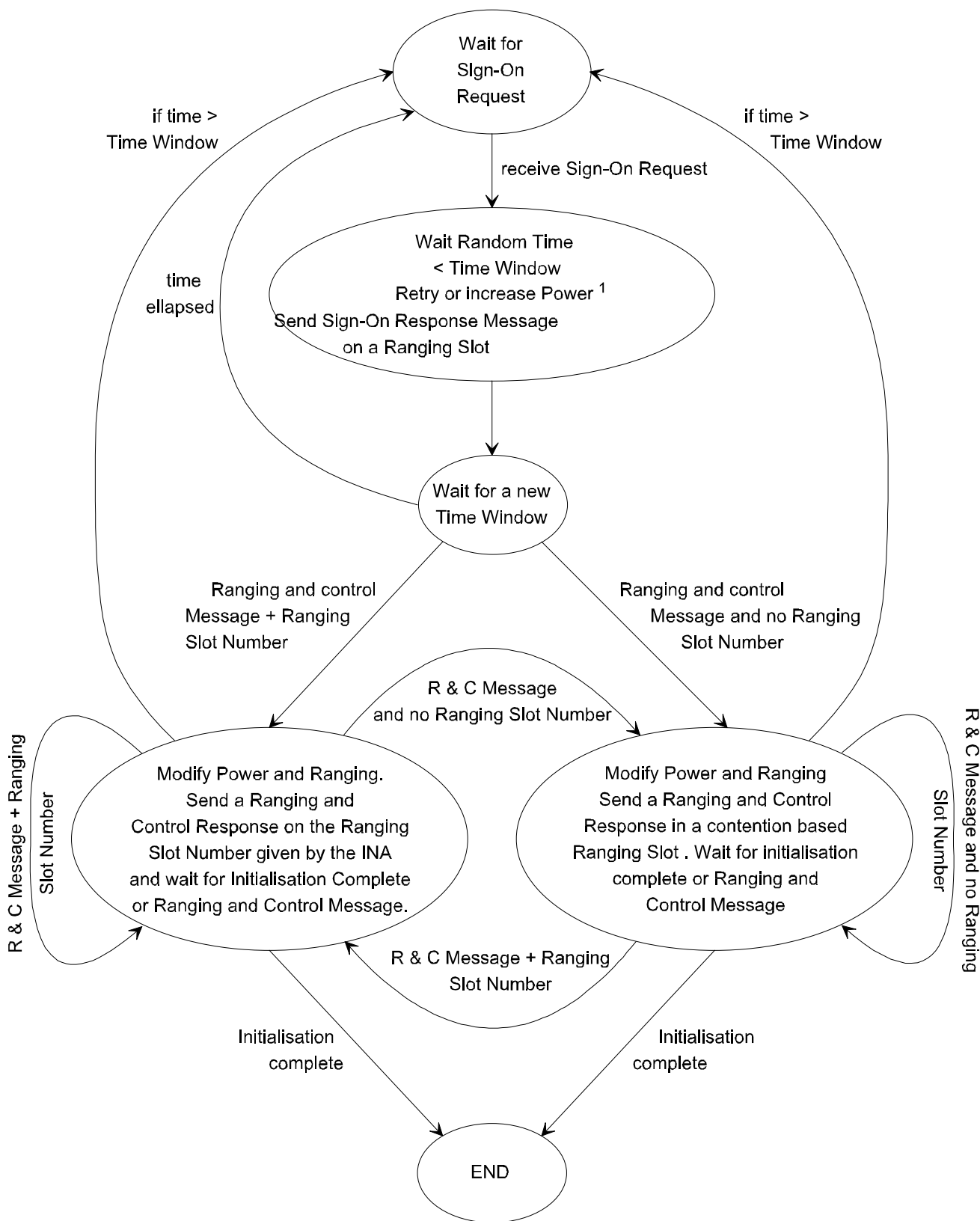

Figure 28: State diagram for ranging and calibration

### 5.5.4.1 <MAC> Sign-On Request message (Broadcast downstream)

The <MAC> SIGN-ON REQUEST message is issued periodically by the INA to allow a NIU to indicate its presence in the network. The format of this subcommand is shown in table 20.

**Table 20: Sign-On Message structure**

<b>Sign-On_Request_Message(){</b>	<b>Bits</b>	<b>Bytes</b>	<b>Bit Number / Description</b>
Sign-On_Control_Field	8	1	
<i>Reserved</i>	7		7-1
Address_Filter_Params_Included	1		0: {no,yes}
<b>Response_Collection_Time_Window</b>	16	2	
<i>if (Sign-On_Control_Field= Address_Filter_Params_Included {</i>			
<b>Address_Position_Mask</b>	(8)	(1)	
<b>Address_Comparison_Value</b>	(8)	(1)	
<i>}</i>			
<b>}</b>			

#### Sign-On Control Field

Sign-On\_Control\_Field specifies what parameters are included in the SIGN-ON REQUEST

#### Address filter parameters included

address\_filter\_params\_included is a boolean, when set, indicates that the NIU should respond to the SIGN-ON REQUEST only if its address matches the filter requirements specified in the message.

#### Response Collection Time Window

Response\_Collection\_Time\_Window is a 16-bit unsigned integer that specifies the duration of time the NIU has to respond to the SIGN-ON REQUEST. The unit of measure is the millisecond (ms).

#### Address Position Mask

Address\_Position\_Mask is an 8-bit unsigned integer that indicates the bit positions in the NIU MAC address that are used for address filtering comparison. The bit positions are comprised between bit number  $2^{\text{Mask}}$  and  $2^{\text{Mask} + 7}$ . Mask = 0 corresponds to the 8 LSBs of the address, i.e., it represents the number of bits shifted to the left. The maximum value is 40.

#### Address Comparison Value

Address\_Comparison\_Value is an 8-bit unsigned integer that specifies the value that the NIU should use for MAC address comparison.

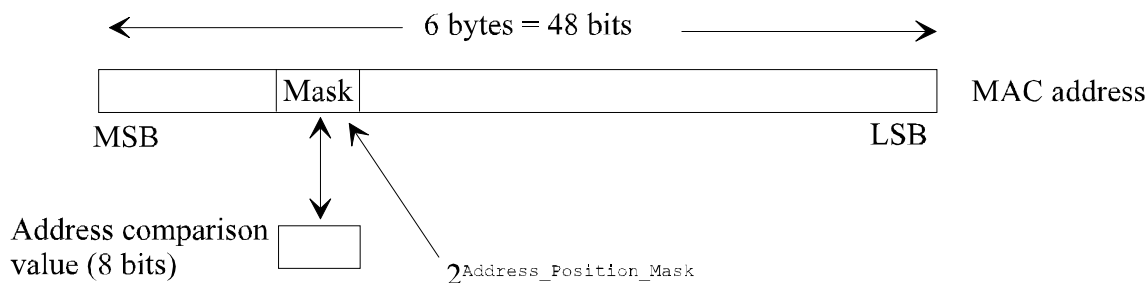

**Figure 29: Position of mask in MAC address**

### 5.5.4.2 <MAC> Sign-On Response Message (Upstream Contention Ranging)

The <MAC> Sign-On Response Message is sent by the NIU in response to the <MAC> Sign-On Request Message issued by the INA Entity. The NIU shall wait for a random time less than `Response_Collection_Time_Window` to send this message.

**Table 21: Sign-On response message structure**

<b>Sign-On_Response_Message(){</b>	<b>Bits</b>	<b>Bytes</b>	<b>Bit Number / Description</b>
[reserved]	32	4	
[reserved]	16	2	
Retry_Count	8	1	
}			

#### Retry Count

Retry\_Count is a 8-bit unsigned integer that indicates the number of transmissions of the <MAC> Sign-On Response. This field is always included in the response to the <MAC> Sign-On Request.

### 5.5.4.3 <MAC> Range and Power Calibration Message (Singlecast downstream)

The <MAC> RANGE AND POWER CALIBRATION MESSAGE is sent by the INA to the NIU to adjust the power level or time offset the NIU is using for upstream transmission. The format of this message is shown in table 22.

**Table 22: Range and Power Calibration Message structure**

<b>Range_and_Power_Calibration_Message(){</b>	<b>Bits</b>	<b>Bytes</b>	<b>Bit Number / Description</b>
<b>Range_Power_Control_Field</b>	8	1	
<i>reserved</i>	5		7-3:
ranging_slot_included	1		2: {no, yes}
time_adjustment_included	1		1: {no, yes}
power_adjustment_included	1		0: {no, yes}
<i>if (range_power_control_field == time_adjustment_included) {</i>			
<b>Time_Offset_Value</b>	(16)	(2)	
<i>}</i>			
<i>if (range_power_control_field == power_adjustment_included) {</i>			
<b>Power_Control_Setting</b>	(8)	(1)	
<i>}</i>			
<i>if (range_power_control_field == ranging_slot_included) {</i>			
<b>Ranging_Slot_Number</b>	(16)	(2)	
<i>}</i>			
<i>if (range_frequency_control-field == frequency_adjustment_included) {</i>			
<b>Frequency_Offset_Value</b>	(32)	(4)	
<i>}</i>			

#### Range and Power Control Field

Range\_Power\_Control\_Field specifies which Range and Power Control parameters are included in the message.

#### Time adjustment included

time\_adjustment\_included is a boolean when set, indicates that a relative time offset value is included that the NIU should use to adjust its upstream fixed rate based reference.

#### Power adjust included

power\_adjust\_included is a boolean when set, indicates that a relative Power Control setting is included in the message.

#### Ranging Slot Included

Ranging\_Slot\_Included is a boolean when set, indicates the calibration slot available.

#### Time Offset Value

Time\_Offset\_Value is a 16-bit short integer representing a relative offset of the upstream transmission timing. A negative value indicates an adjustment forward in time. A positive value indicates an adjustment back in time. The unit of measure is 100 ns (The NIU will adjust approximately its time offset to the closest value indicated by the Time\_Offset\_Value parameter, which implies that no extra clock is needed to adjust to the correct offset).

#### Frequency Offset Value

Frequency\_Offset\_Value is a 32 bit signed integer representing the upstream carrier offset frequency compared the centre IF frequency. The unit measure is in Hz.

#### Power Control Setting

Power\_Control\_Setting is an 8-bit signed integer to be used to set the new power level of the NIU (A positive value represents an increase of the output power level).

New output\_power\_level = current output\_power\_level + power\_control\_setting × 0,5 dB

#### Ranging Slot Number

Ranging\_Slot\_Number is a 16-bit unsigned integer that represents the reserved access Slot Number assigned for Ranging the NIU.

#### 5.5.4.4 <MAC> Ranging and Power Calibration Response Message (Upstream reserved or contention Ranging)

The <MAC> RANGING AND POWER CALIBRATION RESPONSE Message is sent by the NIU to the INA in response to the <MAC> RANGING AND POWER CALIBRATION MESSAGE. The format of the message is shown in table 23.

**Table 23: Range Response Message format**

Ranging_Power_Response_Message(){	Bits	Bytes	Bit Number / Description
Power_Control_Setting	8	1	
}			

#### Power Control Setting

Power\_Control\_Setting is an 8-bit signed integer representing the upstream power level used by the NIU. It is a copy of the power control setting parameter received from INA.

#### 5.5.4.5 <MAC> Initialization complete message (singlecast downstream)

This message has no message body. It indicates the end of the MAC Sign-On and Provisioning procedure.

### 5.5.5 Default connection establishment

Once a NIU has completed the Calibration State, it shall enter the Connection State. A low bit rate permanent connection is assigned to a NIU by the INA. After the initial calibration procedure, the INA provides a Default Connection to the NIU that the NIU shall utilize to communicate to the network. The message flow for such Connection Establishment is shown below.

- 1) After Initialization, Provisioning and Sign-On procedures are complete, the INA shall assign a default upstream and downstream connection to the NIU. This connection can be assigned on any of the upstream channels except the upstream service channel ranging area. The INA shall assign the default connection by sending the <MAC>

**Connect Message** to the NIU. This message shall contain the upstream connection parameters and downstream IF frequency on which the default connection is to reside.

- 2) The NIU, upon receiving the **<MAC> Connect Message** shall tune to the required upstream and downstream frequencies and send the **<MAC> Connect Response Message** confirming receipt of the message.
- 3) Upon receipt of the **<MAC> Connect Response Message**, the INA shall confirm the new connection to proceed by sending the **<MAC> Connect Confirm Message**.

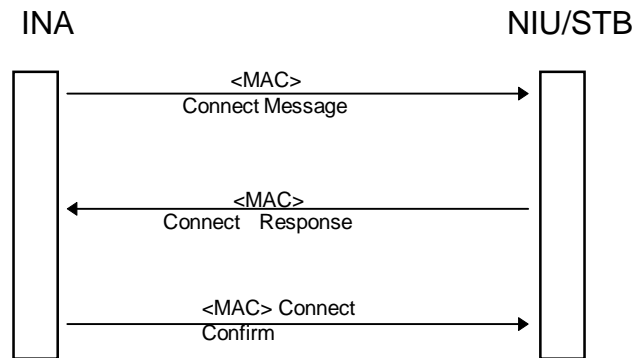

**Figure 30: Connection signalling**

#### 5.5.5.1 <MAC> Connect message (Singlecast downstream)

**Table 24: Connect message structure**

Connect_Message (){	Bits	Bytes	Bit Number/ Description
<b>Connection_ID</b>	32	4	
<b>Session_Number</b>	32	4	
<b>Resource_Number</b>	16	2	
<b>Connection_Control_Field</b>	8	1	
Descriptor_Type	3		
Upstream_Channel_Number	3		
MAC_Control_Parameters	2		
<b>Frame_Length</b>	(16)	(2)	
<b>Maximum_Contention_Access_Message_Length</b>	(8)	(1)	
<b>Maximum_Reservation_Access_Message_Length</b>	(8)	(1)	
<i>if(Descriptor_Type == DS_ATM_CBD){</i>			
<b>Downstream_ATM_CBD()</b>	(64)	(8)	
<i>}</i>			
<i>if(Descriptor_Type == DS_CBD_MPEG){</i>			
<b>Downstream_CBD_MPEG()</b>	(48)	(6)	
<i>}</i>			
<i>if(Descriptor_Type == US_ATM_Included){</i>			
<b>Upstream_ATM_CBD()</b>	(64)	(8)	
<i>}</i>			
<i>if(MAC_Control_Params == slot_list_assignment){</i>			Fixed Rate Access
<b>Number_Slots_Defined</b>	(8)	(1)	
<i>for (i=0;i&lt;Number_Slots_Assigned; i++){</i>			
<b>Slot_Number</b>	(16)	(2)	
<i>}</i>			
<i>}</i>			
<i>if (MAC_Control_Params == cyclic_Assignment){</i>			Fixed Rate Access
<b>Fixedrate_Start</b>	(16)	(2)	
<b>Fixedrate_Dist</b>	(16)	(2)	
<b>Fixedrate_End</b>	(16)	(2)	
<i>}</i>			

**Connection ID**

Connection\_ID is a 32-bit unsigned integer representing a connection Identifier for the NIU dynamic connection.

#### Session Number

Session\_Number is a 32-bit unsigned integer representing the session that the connection parameters are associated.

#### Resource Number

Resource\_Number is a 16-bit unsigned integer providing a unique number to the resource defined in the message.

#### Connection Control Field

Connection\_Control\_Field is an 8-bit unsigned integer that defines parameters and control for Descriptor\_Type, Upstream\_Channel\_Number and MAC\_Control\_Parameters. This is partitioned across the 8-bits as shown in table 25.

**Table 25: Connection control field substructure**

<b>Bit 7</b>	<b>6</b>	<b>5</b>	<b>4</b>	<b>3</b>	<b>2</b>	<b>1</b>	<b>0</b>
Descriptor_Type			Upstream_Channel_Number			MAC_Ctrl_Params	

#### Descriptor Type

Descriptor\_Type is a 3-bit unsigned integer that represents the connection descriptors present within the message. The values are defined in table 26.

**Table 26: Descriptor type substructure**

Bit Number	Definition
7	When set indicates that upstream ATM Descriptor is present in the message
6	When set indicates that downstream MPEG Descriptor is present in the message
5	When set indicates that downstream ATM Descriptor is present in the message.

#### Upstream Channel Number

Upstream\_Channel\_Number is a 3-bit unsigned integer that provides an identifier for the upstream channel.

#### MAC Control Parameters

MAC\_Control\_Parameters is a 2-bit unsigned integer that indicates the type of upstream resources assigned in the connection.

**Table 27: Control parameter substructure**

MAC_Control_Parameters	Definition
10	indicates a slot list is included
01	indicates a cyclical assignment
00	indicates contention based access only
11	[Reserved]

#### Frame length

Frame\_length - This 16-bit unsigned number represents the number of successive slots in the contentionless access region that associated with each contentionless slot assignment. In the slot\_list method of allocating slots it represents the number of successive slots associated with each element in the list. In the cyclic method of allocating slots it represents the number of successive slots associated with the Fixedrate\_Start\_slot and those which are multiples of Fixedrate\_Distance from the Fixedrate\_Start\_slot within the Fixed rate access region.

#### Maximum contention access message length

Maximum\_contention\_access\_message\_length is an 8-bit number representing the maximum length of a message in ATM sized cells that may be transmitted using contention access. Any message greater than this should use reservation access.

### Maximum reservation access message length

Maximum\_reservation\_access\_message\_length is an 8-bit number representing the maximum length of a message in ATM sized cells that may be transmitted using a single reservation access. Any message greater than this should be transmitted by making multiple reservation requests.

### Downstream ATM connection block descriptor

**Table 28: ATM connection block descriptor substructure**

Downstream_ATM_CBD(){	Bits	Bytes	Bit Number / Description
Downstream_Frequency	32	4	
Downstream_VPI	8	1	
Downstream_VCI	16	2	
Downstream_Type	8	1	
}			

#### Downstream Frequency

Downstream\_Frequency is a 32-bit unsigned integer representing the IF frequency where the connection resides. The unit of measure is in Hz.

#### Downstream Virtual Path Identifier (VPI)

Downstream\_VPI is an 8-bit unsigned integer representing the ATM VPI that is used for downstream transmission over the dynamic connection.

#### Downstream Virtual Channel Identifier (VCI)

Downstream\_VCI is an 16-bit unsigned integer representing the ATM VCI that is used for downstream transmission over the dynamic connection.

#### DownStream\_Type

DownStream\_Type is an 8-bit enumerated type indicating the modulation format for the down stream connection. { QPSK\_in\_band, reserved, QPSK\_3,088, 3..255 reserved }

### Downstream MPEG connection block descriptor

**Table 29: Downstream\_CBD\_MPEG substructure**

Downstream_CBD_MPEG(){	Bits	Bytes	Bit Number / Description
Downstream_Frequency	32	4	
Program Number	16	2	
}			

#### Downstream Frequency

Downstream\_Frequency is a 32-bit unsigned integer representing the IF frequency where the connection resides. The unit of measure is in Hz.

#### Program Number

Program\_Number is a 16-bit unsigned integer uniquely referencing the downstream virtual connection assignment.

## Upstream ATM connection block descriptor

**Table 30: Upstream\_CBD substructure**

Upstream_ATM_CBD	Bits	Bytes	Bit Number / Description
Upstream_Frequency	32	4	
Upstream_VPI	8	1	
Upstream_VCI	16	2	
MAC_Flag_Set	5	1	7 : 3
Upstream_Rate	3		2 : 0
}			

### Upstream Frequency

Upstream\_Frequency is a 32-bit unsigned integer representing the channel on assigned to the connection. The unit of measure is in Hz.

### Upstream VPI

Upstream\_VPI is an 8-bit unsigned integer representing the ATM VPI that is used for upstream transmission over the dynamic connection.

### Upstream VCI

Upstream\_VCI is an 16-bit unsigned integer representing the ATM VCI that is used for upstream transmission over the dynamic connection.

### MAC\_Flag\_Set

MAC\_Flag\_Set is an 5-bit field representing the MAC Flag set assigned to the connection. In the OOB downstream timing, the eight sets of flags are assigned the numbers 0 to 7. In the IB downstream timing, the 16 sets of flags are assigned the numbers 0 to 15. In the case of a 3,088 Mbit/s upstream channel, this parameter represents the first of two successively assigned flag sets.

### Upstream\_Rate

Upstream\_Rate is an 3-bit enumerated type indicating the data rate for the upstream connection.  
{ Reserved, reserved, Upstream\_3,088M,..7, reserved }

### Number of Slots Defined

Number\_Slots\_Defined is an 8-bit unsigned integer that represents the number of slot assignments contained in the message. The unit of measure is slots.

### Slot Number

Slot\_Number is a 16-bit unsigned integer that represents the fixed rate based slot number assigned to the NIU.

### Fixed rate Start

Fixedrate\_Start - This 16-bit unsigned number represents the starting slot within the fixed rate access region that is assigned to the NIU. The NIU may use the next Frame\_length slots of the fixed rate access regions.

### Fixed rate Distance

Fixedrate\_Distance - This 16-bit unsigned number represents the distance in slots between additional slots assigned to the NIU. The NIU is assigned all slots that are a multiple of Fixedrate\_Distance from the Fixedrate\_Start\_slot which do not exceed Fixedrate\_End\_slot The NIU may use the next Frame\_length slots of the fixed rate access regions from each of these additional slots.



### Fixed rate End

Fixedrate\_End - This 16-bit unsigned number indicates the last slot that may be used for fixed rate access. The slots assigned to the NIU, as determined by using the Fixedrate\_Start\_slot and Fixedrate\_Distance, cannot exceed this number.

#### 5.5.5.2 <MAC> Connect response (upstream contention, reserved or fixed rate access)

The <MAC> CONNECT RESPONSE MESSAGE is sent to the INA from the NIU in response to the <MAC> CONNECT MESSAGE. The message shall be transmitted on the upstream IF frequency specified in the <MAC> CONNECT MESSAGE.

**Table 31: Connect response message structure**

Connect_Response(){	Bits	Bytes	Bit Number / Description
Connection_ID	32	4	
}			

### Connection ID

Connection\_ID is a 32-bit unsigned integer representing a global connection Identifier for the NIU Dynamic Connection.

#### 5.5.5.3 <MAC> Connect confirm (singlecast downstream)

The <MAC> Connect Confirm message is sent from the INA to the NIU. Its usage is recommended when INA validation of new connection is required.

**Table 32: Connect confirm message structure**

Connect_Confirm(){	Bits	Bytes	Bit Number / Description
Connection_ID	32	4	
}			

### Connection ID

Connection\_ID is a 32-bit unsigned integer representing a global connection Identifier for the NIU Dynamic Connection.

## 5.5.6 Data connections

A connection is initiated by the INA using the <MAC> Connect Message explained in subclause 5.5.5.1. This message is either used to immediately assign time slots for a fixed rate connection or just to assign a connection ID and related parameters without time slot assignment. In particular, for reservation or contention access, no time slots are assigned in the Connect Message, but the connection ID shall be used in requests for slots by the NIU.

### Connection assignment

The INA can assign other connections by using the <MAC> **Connect message** described previously. The NIU cannot request a connection, it shall be initiated by higher layers.

### Connection release

This subclause defines the MAC signalling requirements for connection release. The figure below displays the signalling flow for releasing a connection. The NIU cannot release a connection, this shall be initiated by higher layers. This message is thus initiated by the INA only.

- 1) Upon receiving the <MAC> **Release Message** from the INA, the NIU shall teardown the upstream connection established for the particular .

- 2) Upon teardown of the upstream connection, the NIU shall send the <MAC> **Release Response Message** on the default upstream channel.

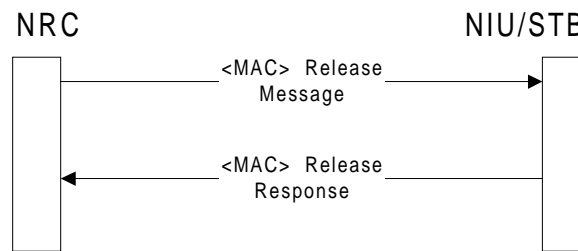

**Figure 31: Connection release signalling**

#### <MAC> Release Message (Singlecast downstream)

The <MAC> **Release Message** is sent from the INA to the NIU to terminate a previously established connection.

**Table 33: Release message structure**

<b>Release_Message(){</b>	<b>Bits</b>	<b>Bytes</b>	<b>Bit Number / Description</b>
Number_of_Connections	8	1	
<i>for(i=0;i&lt;Number_of_Connections;i++){</i>			
Connection_ID	32	4	
<i>}</i>			
<i>}</i>			

#### Connection ID

Connection\_ID is a 32-bit unsigned integer representing a global connection identifier for the NIU dynamic connection.

#### <MAC> Release Response (Upstream contention, reserved or fixed rate)

The <MAC> **RELEASE RESPONSE MESSAGE** is sent by the NIU to the INA to acknowledge the release of a connection. The format of the message is shown in table 34.

**Table 34: Release response message structure**

<b>Release_Response_Message (){</b>	<b>Bits</b>	<b>Bytes</b>	<b>Bit Number / Description</b>
Connection_ID	32	4	
<i>}</i>			

#### Connection ID

Connection\_ID is a 32-bit unsigned integer representing the global connection Identifier used by the NIU for this connection.

#### 5.5.6.1 Fixed rate access

Fixed rate access is provided by the INA using the <MAC> Connect Message.

#### 5.5.6.2 Contention based access

The NIU shall use contention based slots specified by the slot boundary definition fields (Rx) to transmit contention based messages (see subclause 5.3). The format of contention based MAC messages is described by the MAC message format (see subclause 5.5.2.3).

#### 5.5.6.3 Reservation access

This subclause defines the MAC signalling requirements for reservation access. Figure 32 shows the signalling flow for reserving an access.

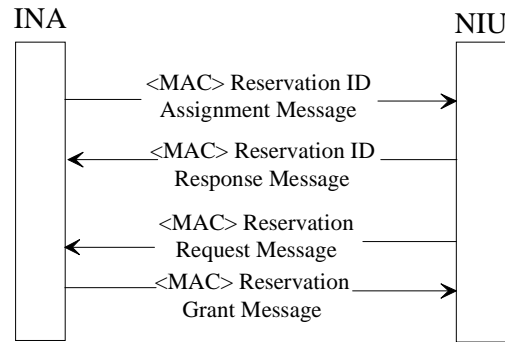

**Figure 32: Reservation access signalling**

- 1) The NIU shall wait for a <MAC> Reservation ID Assignment Message from the INA before it can request reservation access. It shall respond with a <MAC> Reservation ID response Message.
- 2) At any time when needed after receiving the reservation ID, the NIU can request a certain number of slots to the INA using the <MAC> Reservation Request Message.
- 3) The INA shall respond to that message using the <MAC> Reservation Grant Message.
- 4) If the NIU has not received the <MAC> Reservation Grant Message before the Grant\_Protocol\_Timeout, it shall send a <MAC> Reservation Status Request to the INA. This leads back to 3.

#### **<MAC> Reservation ID assignment message (singlecast downstream)**

The <MAC> Reservation ID Assignment Message is used to assign the NIU a Reservation\_ID. The NIU identifies its entry in the Reservation\_grant\_message by comparing the Reservation\_ID assigned to it by the Reservation\_ID\_assignment\_message and the entries in the Reservation\_Grant\_message.

The format of the message is given in table 35.

**Table 35: Reservation ID assignment message structure**

<b>Reservation_ID_assignment_Message ()</b>	<b>Bits</b>	<b>Bytes</b>	<b>Bit Number / Description</b>
Connection_ID	32	4	
Reservation_ID	16	2	
Grant_protocol_timeout	16	2	
}			

#### **Connection ID**

Connection\_ID is a 32-bit unsigned integer representing a global connection identifier for the NIU dynamic connection.

#### **Reservation\_ID**

Reservation\_ID is a 16-bit unsigned number representing a locally assigned identifier for the connection. This is used as a short identifier by the NIU to identify the appropriate Reservation\_Grant\_Messages.

#### **Grant\_protocol\_timeout**

Grant\_protocol\_timeout is a 16-bit unsigned number representing the time in milliseconds that the NIU should wait before verifying the status of pending grants. This parameter specifies the time that the NIU should wait after receiving the last Reservation\_grant\_message, with an entry addressed to the NIU, before initiating a reservation status request. If the NIU has pending grants and the timeout occurs, it should send the Reservation\_status\_request message to the INA. The INA will respond with the Reservation\_grant\_message (probably without granting any slots) to inform the NIU of any remaining slots left to be granted. This allows the NIU to correct any problems should they exist such as issuing an additional request for slots or waiting patiently for additional grants.

#### **<MAC> Reservation ID Response Message**

The MAC reservation ID response Message is used to acknowledge the receipt of the <MAC> Reservation\_ID\_Assignment message. The format of the message is given in table 36.

**Table 36: Reservation ID Response Message**

<b>Reservation_ID_Response_Message ()</b> {	<b>Bits</b>	<b>Bytes</b>	<b>Bit Number / Description</b>
Connection_ID	32	4	
Reservation_ID	16	2	
}			

**Connection\_ID**

Connection\_ID is a 32-bit unsigned integer representing a global connection identifier for the NIU/STB dynamic connection.

**Reservation\_ID**

Reservation\_ID is a 16-bit unsigned number representing a locally assigned identifier for the connection. This is used as a short identifier by the NIU/STB to identify the appropriate Reservation\_Grant\_Messages.

**<MAC> Reservation request message (upstream contention, fixed rate or reserved)****Table 37: Reservation request message structure**

<b>Reservation_Request_message ()</b> {	<b>Bits</b>	<b>Bytes</b>	<b>Bit Number / Description</b>
Reservation_ID	16	2	
Reservation_request_slot_count	8	1	
}			

This message is sent from the NIU to the INA.

**Reservation\_ID**

Reservation\_ID is a 16-bit unsigned number representing a locally assigned identifier for the connection. This is used as a short identifier by the NIU to identify the appropriate Reservation\_Grant\_Messages.

**Reservation Request Slot Count**

Reservation\_request\_slot\_count is an 8-bit unsigned number representing the number of slots requested by the NIU. This is the number of sequential slots that will be allocated in the reservation region of the upstream channel. The INA will respond with the Reservation\_Grant message granting the request.

**<MAC> Reservation grant message (broadcast downstream)**

The <MAC> RESERVATION GRANT MESSAGE is used to indicate to the NIU which slots have been allocated in response to the Reservation Request message. The NIU identifies its entry in the Reservation\_grant\_message by comparing the Reservation\_ID assigned to it by the Reservation\_ID\_assignment\_message and the entries in the Reservation\_Grant\_message.

The format of the message is given in table 38.

**Table 38: Reservation grant message structure**

<b>Reservation_grant_message ()</b> {	<b>Bits</b>	<b>Bit Number/ Description</b>
Reference_slot	16	
Number_grants	8	
for (l=1; l<=Number_grants; l++){		
Reservation_ID	16	
Grant_Slot_count	4	
Remaining_slot_count	5	
Grant_control	2	
Grant_slot_offset	5	
}		
}		

**Reference\_slot**

Reference\_slot is an 16-bit unsigned number indicating the reference point for the remaining parameters of this message. This represents a physical slot of the upstream channel. Since the upstream and downstream slots are not aligned, the INA shall send this message in a downstream slot such that it is received by the NIU before the Reference\_slot exists on the upstream channel.

### Number\_grants

Number\_grants is an 8-bit unsigned number representing the number of grants contained within this message.

### Reservation\_ID

Reservation\_ID is a 16-bit unsigned number representing a locally assigned identifier for the connection. This is used as a short identifier by the NIU to identify the appropriate Reservation\_Grant\_Messages.

### Grant\_slot\_count

Grant\_slot\_count is an 4-bit unsigned number representing the number of sequential slots currently granted for the upstream burst. Upon receipt of this message the NIU is assigned Grant\_slot\_count sequential slots in the reservation access region of the upstream channel starting at the position indicated by the Reference\_slot and Grant\_slot\_offset values. A value of zero indicates that no slots are being granted. This would typically be the case in a response to a Reservation\_status\_request message

### Remaining\_slot\_count

Remaining\_slot\_count is a 5-bit unsigned number representing the remaining slots to be granted by the INA with subsequent grant messages. A value of 0x1f indicates that 31 or more slots will be made available in the future. A value of 0x0 indicates that no additional slots will be granted in the future and that the slots granted in this message represent the only remaining slots available for the connection. The NIU should monitor this count to determine if sufficient slots remain to satisfy current needs. Should additional slots be required because of lost grant messages or additional demand, additional slots should be requested using the Reservation\_request\_message. Additional Reservation\_request\_messages shall be sent only when the Remaining\_slot\_count is less than 15. To minimize contention on the upstream channel, the Reservation\_request\_message may be sent in one of the slots granted by the Reservation\_Grant\_Message.

### Grant\_slot\_offset

Grant\_slot\_offset is an 5-bit unsigned number representing the starting slot to be used for the upstream burst. This number is added to the Reference slot to determine the actual physical slot. Upon receipt of this message the NIU is assigned Grant\_slot\_count sequential slots in the reservation access region of the upstream channel.

### <MAC> Reservation Status Request (Upstream contention, fixed rate or reserved)

The <MAC> RESERVATION STATUS REQUEST Message is used to determine the status of the outstanding grants to be assigned by the INA. This message is only sent after the Grant protocol time-out is exceeded. The INA will respond with the Reservation\_grant\_message (possibly without granting any slots) to inform the NIU of any remaining slots left to be granted. This allows the NIU to correct any problems should they exist such as issuing an additional request for slots or waiting patiently for additional grants.

The format of the message is given in table 39.

**Table 39: Reservation status request message structure**

<b>Reservation_Status_Request_Message ()</b>	<b>Bits</b>	<b>Bytes</b>	<b>Bit Number / Description</b>
Reservation_ID	16	2	
Remaining_request_slot_count	8	1	
}			

### Reservation\_ID

Reservation\_ID is a 16-bit unsigned number representing a locally assigned identifier for the connection. This is used as a short identifier by the NIU to identify the appropriate Reservation\_Grant\_Messages.

### **Remaining\_request\_slot\_count**

Remaining\_request\_slot\_count is an 8-bit unsigned number representing the number of slots that the NIU is expecting to be granted.

## **5.5.7 MAC link management**

The MAC link management tasks provide continuous monitoring and optimization of upstream resources. These functions include:

- power and timing management;
- fixed rate allocation management;
- channel error management.

### **5.5.7.1 Power and timing management**

Power and timing management shall provide continuous monitoring of upstream transmission from the NIU. The **<MAC> Ranging and Power Calibration Message** is used to maintain a NIU within predefined thresholds of power and time.

The upstream burst demodulator shall continuously monitor the upstream burst transmissions from an NIU. Upon detection of an NIU outside the predefined range, the INA shall send the **<MAC> Ranging and Power Calibration Message** to the NIU.

### **5.5.7.2 TDMA allocation management**

To ensure optimum assignment of TDMA resources, the INA shall ensure the upstream allocation of TDMA resources for various connections remain intact when allocating resources to a new connection. However, in the event that reconfiguration is required to minimize fragmentation of resources, then the INA shall dynamically reconfigure the upstream TDMA assignments to a NIU or group of NIUs. The **<MAC> Reprovision Message** is utilized to change previously established connection parameters.

#### **<MAC> Reprovision message (singlecast downstream)**

The **<MAC> REPROVISION MESSAGE** is sent by the INA to the NIU to reassign upstream resources (maintaining the originally requested QoS parameters at the establishment of the connection.) This message is intended for fixed rate based channel maintenance by the INA to redistribute or reassign resources allocated to a NIU.

Table 40: Reprovision message structure

Reprovision_Message (){	Bits	Bytes	Bit Number / Description
<b>Reprovision_Control_Field</b>	8	1	
<i>Reserved</i>	2		7-6
New_Downstream_IB_Frequency	1		5 : {no,yes}
New_Downstream_OOB_Frequency	1		4 : {no,yes}
New_Upstream_Frequency_Included	1		3 : {no,yes}
New_Frame_Length_Included	1		2 : {no,yes}
New_Cyclical_Assignment_Included	1		1 : {no,yes}
New_Slot_List_Included	1		0 : {no,yes}
<i>if (Reprovision_Control_Field=</i> <i>New_Downstream_OOB_Frequency)</i>			
<b>New_Downstream_IB_Frequency</b>	(32)	(4)	
<i>if (Reprovision_Control_Field=</i> <i>New_Downstream_OOB_Frequency)</i>			
<b>New_Downstream_OOB_Frequency</b>	(32)	(4)	
<b>DownStream_Type</b>	8	1	
<b>New_Downstream_OOB_Frequency</b>	(32)	(4)	
<i>if (Reprovision_Control_Field=</i> <i>New_Frequency_Included)</i>			
<b>New_Upstream_Frequency</b>	(32)	(4)	
<b>New_Upstream_Channel_Number</b>	3	1	7:5
<b>reserved</b>	2		4:3
<b>Upstream_Rate</b>	3		2:0
<b>MAC_Flag_Set</b>	5	1	7:3
<b>Reserved</b>	3		2:0
<b>New_Upstream_Frequency</b>	(32)	(4)	
<i>if (Connection_Control_Field=</i> <i>New_Frame_Size_Included)</i>			
<b>New_Frame_Length</b>	(16)	(2)	9-0 : Unsigned
<i>if (Reprovision_Control_Field=</i> <i>New_Slot_List){</i>			
<b>Number_of_Connections</b>	(8)	(1)	
<i>for(i=0;i&lt;Number_of_Connections;i++){</i>			
<b>Connection_ID</b>	(32)	(1)	
<i>if(Reprovision_Control_Field ==</i> <i>new_slot_list_included){</i>			<b>Fixed Rate Access</b>
<b>Number_Slots_Defined</b>	(8)	(1)	
<i>for(i=0;i&lt;Number_Slots_Assigned;i++){</i>			
<b>Slot_Number</b>	(16)	(2)	
<i>}</i>			
<i>if (Reprovision_Control_Field ==</i> <i>new_cyclic_Assignment_included){</i>			<b>Fixed Rate Access</b>
<b>Fixedrate_Start</b>	(16)	(2)	
<b>Fixedrate_Dist</b>	(16)	(2)	
<b>Fixedrate_End</b>	(16)	(2)	
<i>}</i>			

### Reprovision Control Field

Reprovision\_Control\_Field specifies what modifications to upstream resources are included.

### New Downstream OOB frequency

New\_Upstream\_OOB\_Frequency is a boolean that indicates that a new downstream OOB IF frequency is specified in the message

### New Downstream IB frequency

New\_Upstream\_IB\_Frequency is a boolean that indicates that a new downstream IB IF frequency is specified in the message

**New Upstream frequency Included**

New\_Upstream\_Frequency\_Include is a boolean that indicates that a new upstream IF frequency is specified in the message.

**New Frame Length Included**

New\_Frame\_Length\_Include is a boolean that indicates that a new upstream frame is specified in the message.

**New Slot List Included**

New\_Slot\_List\_Include is a boolean that indicates that a new slot list is specified in the message.

**New Cyclical Assignment Included**

New\_Cyclical\_Assignment\_Include is a boolean that indicates that a new cyclical assignment is specified in the message.

**New Downstream Frequency**

New\_Downstream\_IB\_Frequency is a 32-bit unsigned integer representing the reassigned downstream IB carrier centre frequency. The unit of measure is Hz.

**New Downstream OOB Frequency**

New\_Downstream\_OOB\_Frequency is a 32-bit unsigned integer representing the reassigned downstream OOB carrier centre frequency. The unit of measure is Hz.

DownStream\_Type is an 8-bit enumerated type indicating the modulation format for the down stream connection. { reserved, reserved, QPSK\_3,088, 3..255 reserved }

**New Upstream Frequency**

New\_Upstream\_Frequency is a 32-bit unsigned integer representing the reassigned upstream carrier centre IF frequency. The unit of measure is Hz.

UpstreamStream\_Rate is an 3-bit enumerated type indicating the data rate for the upstream connection. { Reserved, Reserved, Upstream\_3,088M, 3..7 reserved }

MAC\_Flag\_Set is an 5-bit field representing the MAC Flag set assigned to the connection. In the OOB downstream timing ,the eight sets of flags are assigned the numbers 0 to 7. In the IB downstream timing, the 16 sets of flags are assigned the numbers 0 to 15. This parameter represents the first of two successively assigned flag sets.

**New Frame Length**

New\_Frame\_Length is a 16-bit unsigned integer representing the size of the reassigned upstream Fixed rate based frame. The unit of measure is in slots.

**Number of Slots Defined**

Number\_Slots\_Defined is an 8-bit unsigned integer that represents the number of slot assignments contained in the message. The unit of measure is slots.

**Slot Number**

Slot\_Number is a 16-bit unsigned integer that represents the fixed rate based slot number assigned to the NIU.

**5.5.7.3 Channel error management**

During periods of connection inactivity, the NIU shall enter an idle mode. Idle mode is characterized by periodic transmission by the NIU of a <MAC> **Idle Message**. The idle mode transmission shall occur at a periodic rate sufficient for the INA to establish Packet Error Rate statistics.



**<MAC> Idle Message (Upstream fixed rate or reserved)**

The **<MAC> Idle Message** is sent by the NIU within the STB to the INA at predefined intervals (between 1 and 10 minutes) when upstream connection buffers are empty.

**Table 41: Idle message structure**

<b>Idle_Message(){</b>	<b>Bits</b>	<b>Bytes</b>	<b>Bit Number / Description</b>
Idle_Sequence_Count	8	1	
Power_Control_Setting	8	1	
}			

**Idle Sequence Count**

Idle\_Sequence\_Count is a 8-bit unsigned integer representing the count of **<MAC> IDLE MESSAGES** transmitted while the NIU is Idle.

**Power Control Setting**

Power\_Control\_Setting is a 8-bit unsigned integer representing the absolute power attenuation that the NIU is using for upstream transmission.

**5.5.7.4 Link management messages****<MAC> Transmission control message (singlecast or broadcast downstream)**

The **<MAC> TRANSMISSION CONTROL MESSAGE** is sent to the NIU from the INA to control several aspects of the upstream transmission. This includes stopping upstream transmission, re-enabling transmission from a NIU or group of NIUs and rapidly changing the upstream IF frequency being used by a NIU or group of NIUs. To identify a group of NIUs for switching frequencies, the **<MAC> TRANSMISSION CONTROL MESSAGE** is sent in broadcast mode with the Old\_IF frequency included in the message. When broadcast with the Old\_Frequency, the NIU shall compare its current IF frequency value to Old\_Frequency. When unequal, the NIU shall switch to the new IF frequency specified in the message. When equal, the NIU shall ignore the new IF frequency and remain on its current channel.

Table 42: Transmission control message structure

Transmission_Control_Message(){	Bits	Bytes	Bit Number / Description
<b>Transmission_Control_Field</b>	<b>8</b>		
reserved	3		7-5:
Stop_Upstream_Transmission	1		4: {no, yes}
Start_Upstream_Transmission	1		3: {no, yes}
Old_Frequency_Included	1		2: {no, yes}
Switch_Downstream_OOB_Frequency	1		1: {no, yes}
Switch_Upstream_Frequency	1		0: {no, yes}
<i>if (Transmission_Control_Field== Switch_Upstream_Frequency &amp;&amp; Old_Frequency_Included){</i>			
<b>Old_Upstream_Frequency</b>	<b>(32)</b>	<b>(4)</b>	
<i>}</i>			
<i>if (Transmission_Control_Field== Switch_Upstream_Frequency){</i>			
<b>New_Upstream_Frequency</b>	<b>(32)</b>	<b>(4)</b>	
<b>New_Upstream_Channel_Number</b>	<b>3</b>	<b>1</b>	<b>7:5</b>
reserved	<b>2</b>		<b>4:3</b>
<b>Upstream_Rate</b>	<b>3</b>		<b>2:0</b>
<b>MAC_Flag_Set</b>	<b>5</b>	<b>1</b>	<b>7:3</b>
<b>Reserved</b>	<b>3</b>		<b>2:0</b>
<b>New_Upstream_Frequency</b>	<b>(32)</b>	<b>(4)</b>	
<i>}</i>			
<i>if (Transmission_Control_Field== Switch_Downstream_OOB_Frequency &amp;&amp; Old_Frequency_Included){</i>			
<b>Old_Downstream_OOB_Frequency</b>	<b>(32)</b>	<b>(4)</b>	
<i>}</i>			
<i>if (Transmission_Control_Field== Switch_Downstream_OOB_Frequency){</i>			
<b>New_Downstream_OOB_Frequency</b>	<b>(32)</b>	<b>(4)</b>	
<b>DownStream_Type</b>	<b>8</b>	<b>1</b>	
<i>}</i>			
<i>}</i>			
<i>}</i>			

### Transmission Control Field

Transmission\_Control\_Field specifies the control being asserted on the upstream channel.

### Stop Upstream Transmission

stop\_upstream\_transmission is a boolean when set indicates that the NIU should halt its upstream transmission.

### Start Upstream Transmission

start\_upstream\_transmission is a boolean when set indicates that the Network Interface Unit should resume transmission on its upstream channel. The NIU shall respond to the ranging and power calibration message regardless of the setting of the start\_upstream\_transmission bit.

### Old Frequency Included

Old\_Frequency\_Included is a boolean when set indicates that the Old IF frequency value is included in the message and should be used to determine if a switch in IF frequency is necessary

### Switch Downstream OOB Frequency

switch\_downstream\_OOB\_frequency is a boolean when set indicates that a new downstream OOB IF frequency is included in the message.

### Switch Upstream Frequency

switch\_upstream\_frequency is a boolean when set indicates that a new upstream IF frequency is included in the message. Typically, the switch\_upstream\_frequency and the stop\_upstream\_transmission are set simultaneously to allow the NIU to stop transmission and change channel. This would be followed by the <MAC> TRANSMISSION CONTROL MESSAGE with the start\_upstream\_transmission bit set.

### Old Upstream Frequency

Old\_Upstream\_Frequency is a 32-bit unsigned integer representing the IF frequency that should be used by the NIU to compare with its current IF frequency to determine if a change in channel is required.

### New Upstream Frequency

New\_Upstream\_Frequency is a 32-bit unsigned integer representing the reassigned upstream IF carrier centre frequency. The unit of measure is Hz.

MAC\_Flag\_Set is an 5-bit field representing the MAC Flag set assigned to the connection. In the OOB downstream timing, the eight sets of flags are assigned the numbers 0 to 7. In the IB downstream timing, the 16 sets of flags are assigned the numbers 0 to 15. In the case of a 3,088 Mbit/s upstream channel, this parameter represents the first of two successively assigned flag sets.

Upstream\_Stream\_Rate is an 3-bit enumerated byte indicating the data rate for the upstream connection.  
{ reserved, reserved, Upstream\_3,088M, 3..7 reserved }

### Old downstream OOB Frequency

Old\_Downstream\_OOB\_Frequency is a 32-bit unsigned integer representing the IF frequency that should be used by the NIU to compare with its current IF frequency to determine if a change in channel is required.

### New downstream OOB Frequency

New\_Downstream\_OOB\_Frequency is a 32-bit unsigned integer representing the reassigned downstream OOB carrier centre IF frequency. The unit of measure is Hz.

DownStream\_Type is an 8-bit enumerated type indicating the modulation format for the down stream connection.  
{ reserved, reserved, QPSK\_3,088, 3..255 reserved }

### Link Management Response Message (Upstream contention, fixed rate or reserved)

The <MAC> LINK MANAGEMENT RESPONSE MESSAGE is sent by the NIU to the INA to indicate reception and processing of the previously sent Link Management Message. The format of the message is shown in table 43.

**Table 43: Link management acknowledge message format**

Link_Management_Acknowledge(){	Bits	Bytes	Bit Number / Description
Link_Management_Msg_Number	16	2	
}			

### Link Management Message Number

Link\_Management\_Msg\_Number is a 16-bit unsigned integer representing the previously received link management message. The valid values for Link\_Management\_Msg\_Number are shown in table 44.

**Table 44: Link management message number**

Message Name	Link_Management_Msg_Number
Transmission Control Message	Transmission Control Message Type Value
Reprovision Message	Reprovision Message Type Value

### <MAC> Status Request Message (downstream Singlecast)

The STATUS REQUEST message is sent by the INA to the NIU to retrieve information about the NIUs health, connection information and error states. The INA can request either the address parameters, error information,

connection parameters or physical layer parameters from the NIU. The INA can only request one parameter type at a time to a particular NIU.

**Table 45: Status request message structure**

<b>Status_Request(){</b>	<b>Bits</b>	<b>Bytes</b>	<b>Bit Number / Description</b>
Status_Control_Field	8	1	
<i>reserved</i>	5		3-7:
Status_Type	3		0-2:{enum type}
}			

#### Status Control Field

Status\_Control\_Field is a 3-bit enumerated type that indicates the status information the NIU should return

```
enum Status_Control_Field {Address_Params, Error_Params, Connection_Params, Physical_Layer_Params, reserved4..7};
```

#### <MAC> Status response message (upstream contention, fixed rate or reserved)

The <MAC> STATUS RESPONSE MESSAGE is sent by the NIU in response to the <MAC> STATUS REQUEST MESSAGE issued by the INA. The contents of the information provided in this message will vary depending on the request made by the INA and the state of the NIU. The message shall be dissociated into separate messages if the resulting length of the message exceeds 40 bytes.

**Table 46: Status response message structure**

<b>Status_Response(){</b>	<b>Bits</b>	<b>Bytes</b>	<b>Bit Number/ Description</b>
<b>NIU_Status</b>	32	4	
<b>Response_Fields_Included</b>	8	1	
<i>reserved</i>	4		4-7:
Address_Params_Included	1		3: {no, yes}
Error_Information_Included	1		2: {no, yes}
Connection_Params_Included	1		1: {no, yes}
Physical_Layer_Params_Included	1		0: {no, yes}
<i>if (Response_Fields_Included == Address_Params_Included){</i>			
<b>NSAP_Address</b>	(160)	(20)	
<b>MAC_Address</b>	(48)	(6)	
}			
<i>if (Response_Fields_Included == Error_Information_Included){</i>			
<b>Number_Error_Codes_Included</b>	(8)	(1)	
<i>for(i=0;i&lt;Number_Error_Codes_Included; i++){</i>			
<b>Error_Param_code</b>	(8)	(1)	
<b>Error_Param_Value</b>	(16)	(2)	
}			
<i>if (Response_Fields_Included == Connection_Params_Included) {</i>			
<b>Number_of_Connections</b>	(8)	(1)	
<i>for(i=0;i&lt;Number_of_Connections;i++){</i>			
<b>Connection_ID</b>	(32)	(4)	
}			
<i>if (Response_Fields_Included == Physical_Layer_Params_Included) {</i>			
<b>Power_Control_Setting</b>	(8)	(1)	
<b>Time_Offset_Value</b>	(32)	(4)	
<b>Upstream_Frequency</b>	(32)	(4)	
<b>Downstream_Frequency</b>	(32)	(4)	
}			
}			

**NIU Status**

NIU\_Status is a 32-bit unsigned integer that indicates the current state of the NIU.

<b>NIU_Status { Calibration_Operation_Complete,            Default_Connection_Established,            Network_Address_Registered,            ,reserved};</b>
--

**Response Fields Included**

Response\_Fields\_Included is an 8-bit unsigned integer that indicates what parameters are contained in the upstream status response.

**NSAP Address**

NSAP\_Address is a 20 byte address assigned to the NIU.

**MAC Address**

MAC\_Address is a 6 byte address assigned to the NIU.

**Number of Error Codes Included**

Number\_Error\_Codes\_Included is an 8-bit unsigned integer that indicates the number of error codes are contained in the response.

**Error Parameter Code**

Error\_Parameter\_Code is a 8-bit unsigned integers representing the type of error reported by the NIU.

**Table 47: Error Parameter Code**

Error Parameter Code Name	Error Parameter Code
Framing_Bit_Error_Count	0x00
Slot_Configuration_CRC_Error_Count	0x01
Reed_Solomon_Error_Count	0x02
ATM_Packet_Loss_Count	0x03

**Error Parameter Value**

Error\_Parameter\_Value is an 16-bit unsigned integers representing error counts detected by the NIU.

**Number of Connections**

Number\_of\_Connections is an 8-bit unsigned integer that indicates the number of connections that are specified in the response. Specifically, if the number of connections is too large to have a MAC message with less than 40 bytes, it is possible to send separate messages with only the number of connections indicated in each message.

**Connection ID**

Connection\_ID is a 32-bit unsigned integer representing the global connection Identifier used by the NIU for this connection.

**Power Control Setting**

Power\_Control\_Setting is a 8-bit unsigned integer representing the absolute power attenuation that the NIU is using for upstream transmission

**Time Offset Value**

Time\_Offset\_Value is a 16-bit short integer representing a relative offset of the upstream transmission timing. A negative value indicates an adjustment forward in time. A positive value indicates an adjustment back in time. The unit of measure is 100 ns.

**Upstream Frequency**

Upstream\_Frequency is a 32-bit unsigned integer representing the IF frequency assigned to the connection. The unit of measure is in Hz.

**Downstream Frequency**

Downstream\_Frequency is a 32-bit unsigned integer representing the IF frequency where the connection resides. The unit of measure is in Hz.

---

## Annex A (informative): Bibliography

For the purposes of the present document, the following informative references apply:

- DVB-A008: "Commercial requirements for asymmetric interactive services supporting broadcast to the home with narrow-band return channels".
- DAVIC 1.0 Specification: "DAVIC System Reference Model".

---

## History

<b>Document history</b>		
V1.1.1	January 1998	Public Enquiry PE 9820: 1998-01-16 to 1998-05-15