

Recommendation T/CS 34-08 (Brussels 1980, revised in Nice 1985)

AUTOMATIC SENDER FOR PUSH-BUTTON MULTIFREQUENCY SIGNALLING

Recommendation proposed by Working Group T/WG 11 "Switching and Signalling" (CS)

Revised text of the Recommendation adopted by the "Telecommunications" Commission:

"The European Conference of Postal and Telecommunications Administrations,

considering

- that telephone network terminals may be equipped with dedicated push-buttons simplifying control operations for the user;
- that the automatic sender required for the introduction of such dedicated push-buttons is also suitable for signalling between private automatic branch exchanges, and for the simple form of end-to-end data transmission envisaged in Recommendations T/CS 46-02 [1] and T/CS 46-03 [2];
- that compatibility of the equipment concerned with the multifrequency push-button signalling system specified in Recommendation T/CS 46-02 and T/CS 46-03 must be assured,

recommends

to the members, that automatic senders for push-button multifrequency signalling meet the requirements specified below."

1. AREA OF APPLICATION—GENERAL

This Recommendation deals with automatic multifrequency senders which are used in the following situations:

- (a) for signalling from subscriber's sets or from private automatic branch exchanges (PABXs) to the public exchange;
- (b) for end-to-end data transmission;
- (c) for signalling between PABXs.

It refers to the basic multifrequency push-button signalling system specified in Recommendation T/CS 46-02 [1].

The general functional diagram is given in Figure 1 (T/CS 34-08).

2. SIGNAL FREQUENCIES AND CODES

The signal frequencies and codes shall be as specified in Recommendation T/CS 46-02 [1].

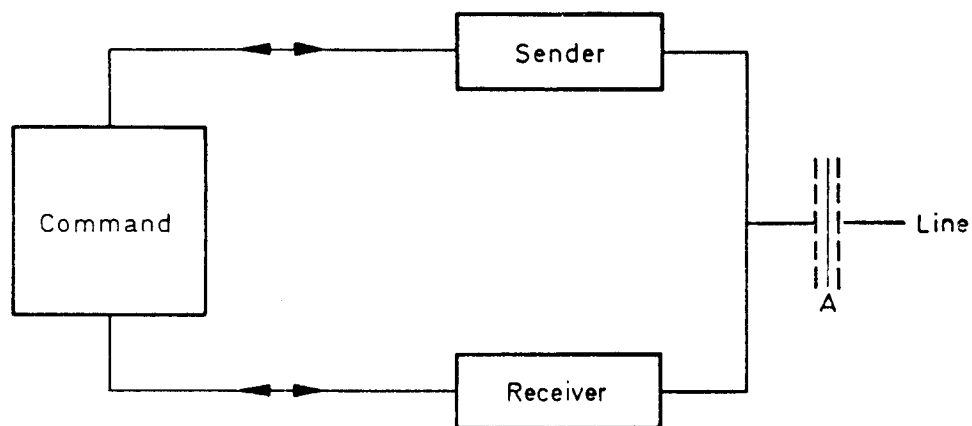

Figure 1 (T/CS 34-08).

Note: The receiver is optional and may be used for dial tone detection, etc. The requirements in this Recommendation apply mainly to interface A.

3. OPERATIONAL CONDITIONS

- 3.1. A sender at the subscriber's premises is expected to operate under varying environmental conditions.
- A general purpose sender should operate in temperature controlled locations and partly temperature controlled locations, i.e. in normal living and working areas as well as entrances, staircases of buildings, factories and industrial plants, etc. The relevant climatic conditions are described in Recommendation T/TR 02-06 [5]. The sender must meet the requirements within these conditions.
 - A wide temperature range sender should operate in open air as well as sites with heat traps, i.e. telephone booths and similar installations. The relevant climatic conditions are described in Recommendation T/TR 02-06. The wide temperature range sender must meet the requirements within these conditions.
- 3.2. The requirements specified shall be met when the sender is installed in an exchange or a private automatic branch exchange and is thus subject to the environments therein. The relevant climatic conditions are described in Recommendation T/TR 02-03 [4] and the sender must be designed to operate properly within these conditions.

4. SIGNAL OUTPUT REQUIREMENTS

4.1. Signal requirements

For the duration that the signal is output, but after the completion of the rise time, the following requirements shall be met.

4.1.1. Frequency tolerance

The output frequencies shall be maintained within $\pm 1.5\%$ of their nominal values. This tolerance shall also include the effect of different line impedances offered to the sender.

4.1.2. Sending levels

The sending levels with a load resistance of 600 ohms shall be:

for option 1: the high frequency group: $-9 \text{ dBm} \pm 2 \text{ dB}$,
the low frequency group: $-11 \text{ dBm} \pm 2 \text{ dB}$;

for option 2: the high frequency group: $-6 \text{ dBm} \pm 2 \text{ dB}$,
the low frequency group: $-8 \text{ dBm} \pm 2 \text{ dB}$;

with the restriction that the level of the higher frequency component of the compound signal shall be $2 \pm 1 \text{ dB}$ above the level of the lower frequency component.

4.1.3. Unwanted frequency components

When the signal is output:

- the total power level of all unwanted frequency components shall be at least 20 dB below the level of the low frequency group component of the signal;
- the level of any individual unwanted frequency component shall not exceed the following limits:
 - in the frequency band 300-4,300 Hz: -33 dBm ;
 - in the frequency band 4,300-28,000 Hz: -37 dBm at 4,300 Hz then falling at 12 dB/octave until 28,000 Hz;
 - in the frequency band 28,000-70,000 Hz: -70 dBm ;
 - in the frequency band 70,000-200,000 Hz: -80 dBm ;
 - in the frequency band above 200,000 Hz: -70 dBm .

4.2. Pause requirements

For the duration of the pause, but after the completion of the fall time, the following requirement regarding unwanted frequency components shall be met:

the power level of any single frequency emitted from the sender to line shall not exceed -80 dBm .

4.3. Rise time

The steady state signal requirements shall be met within 5 ms of the commencement of the signal output.

4.4. Fall time

The steady state pause requirements shall be met within 5 ms of the cessation of the signal output.

4.5. Signal timing

The timing diagram is given in Figure 2 (T/CS 34-08).

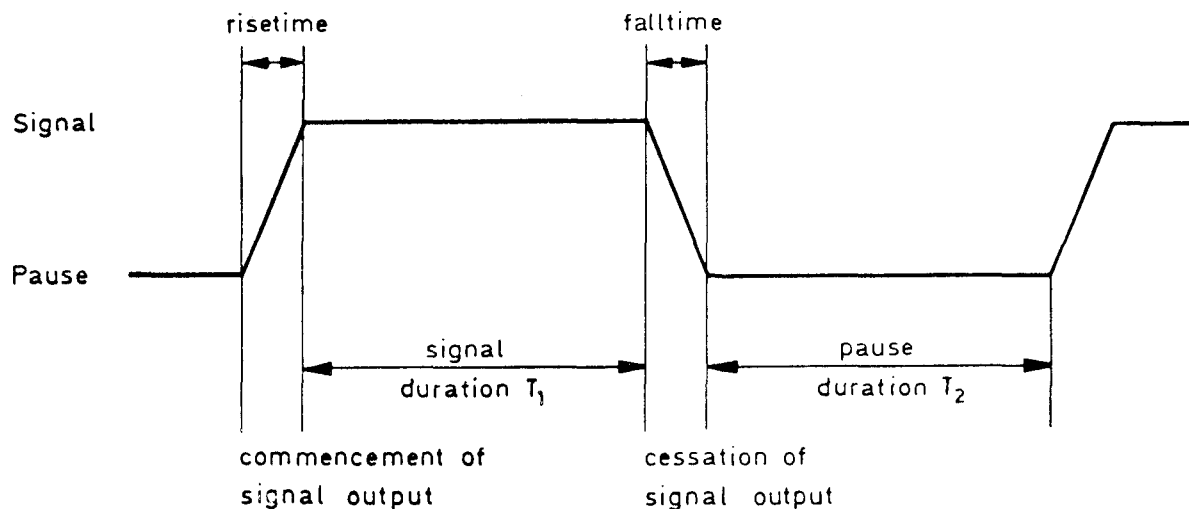

Figure 2 (T/CS 34-08). Timing diagram.

4.5.1. Signal duration

The signal duration (T_1) shall be 70 ± 5 ms (excluding risetime).

4.5.2. Pause duration

The pause duration (T_2) shall be 70 ± 5 ms (excluding falltime).

5. ELECTRICAL CHARACTERISTICS

5.1. Impedance

The return loss of the device connected to the line against a pure resistance of 600 Ohms shall be at least 14 dB in the frequency band 300-3,400 Hz.

5.2. Speech suppression

During the sending of a sequence of characters, the attenuation of the speech path to the line shall be increased by at least 60 dB.

5.3. Impedance unbalance to earth

The impedance unbalance to earth measured in accordance with the principle of measurement in CCITT Recommendation Q.45 [3] shall not be worse than or equal to:

- in the frequency band 40- 300 Hz: 40 dB;
- in the frequency band 300- 600 Hz: 50 dB;
- in the frequency band 600-3,400 Hz: 55 dB.

This requirement applies to the total device connected to the line.

5.4. Power feed

If the sender is at a subscriber's premises, the power may be derived from the line or from an independent power system. If the sender is in an exchange, all voltages used to power it must be obtained from the exchange battery.

5.5. Overvoltage protection and isolation

The sender shall be adequately protected against overvoltages, e.g. lightning, in accordance with national requirements.

When an independent power system is used, there should be adequate isolation between the power system and the line, in accordance with national requirements.

5.6. Disturbing signals

The sender shall operate correctly in the presence of dial tone and speech.

References

- [1] Recommendation T/CS 46-02. *Multifrequency signalling system to be used for push-button telephones.*
- [2] Recommendation T/CS 46-03. *Signalling system for push-button telephones combining basic multifrequency signalling with direct current signalling.*
- [3] CCITT Recommendation Q.45. *Transmission characteristics of an international exchange.*
- [4] Recommendation T/TR 02-03. *Environmental Conditions in Telecommunication Centres.*
- [5] Recommendation T/TR 02-06. *Environmental Conditions for Telecommunication Equipment, Conditions for Telecommunication Equipment at Weather-Protected Locations (excluding Telecommunication Centres with Temperature and Humidity Controls) and in the Open Air.*