

# ETSI TS 138 202 V16.2.0 (2020-11)



**5G;  
NR;  
Services provided by the physical layer  
(3GPP TS 38.202 version 16.2.0 Release 16)**



---

**Reference**

RTS/TSGR-0138202vg20

---

**Keywords**

5G

**ETSI**

650 Route des Lucioles  
F-06921 Sophia Antipolis Cedex - FRANCE

---

Tel.: +33 4 92 94 42 00 Fax: +33 4 93 65 47 16

Siret N° 348 623 562 00017 - NAF 742 C  
Association à but non lucratif enregistrée à la  
Sous-Préfecture de Grasse (06) N° 7803/88

---

**Important notice**

---

The present document can be downloaded from:

<http://www.etsi.org/standards-search>

The present document may be made available in electronic versions and/or in print. The content of any electronic and/or print versions of the present document shall not be modified without the prior written authorization of ETSI. In case of any existing or perceived difference in contents between such versions and/or in print, the prevailing version of an ETSI deliverable is the one made publicly available in PDF format at [www.etsi.org/deliver](http://www.etsi.org/deliver).

Users of the present document should be aware that the document may be subject to revision or change of status.

Information on the current status of this and other ETSI documents is available at

<https://portal.etsi.org/TB/ETSIDeliverableStatus.aspx>

If you find errors in the present document, please send your comment to one of the following services:

<https://portal.etsi.org/People/CommiteeSupportStaff.aspx>

---

**Copyright Notification**

---

No part may be reproduced or utilized in any form or by any means, electronic or mechanical, including photocopying and microfilm except as authorized by written permission of ETSI.

The content of the PDF version shall not be modified without the written authorization of ETSI.

The copyright and the foregoing restriction extend to reproduction in all media.

© ETSI 2020.

All rights reserved.

**DECT™**, **PLUGTESTS™**, **UMTS™** and the ETSI logo are trademarks of ETSI registered for the benefit of its Members.

**3GPP™** and **LTE™** are trademarks of ETSI registered for the benefit of its Members and of the 3GPP Organizational Partners.

**oneM2M™** logo is a trademark of ETSI registered for the benefit of its Members and of the oneM2M Partners.

**GSM®** and the GSM logo are trademarks registered and owned by the GSM Association.

---

## Intellectual Property Rights

### Essential patents

IPRs essential or potentially essential to normative deliverables may have been declared to ETSI. The information pertaining to these essential IPRs, if any, is publicly available for **ETSI members and non-members**, and can be found in ETSI SR 000 314: "*Intellectual Property Rights (IPRs); Essential, or potentially Essential, IPRs notified to ETSI in respect of ETSI standards*", which is available from the ETSI Secretariat. Latest updates are available on the ETSI Web server (<https://ipr.etsi.org/>).

Pursuant to the ETSI IPR Policy, no investigation, including IPR searches, has been carried out by ETSI. No guarantee can be given as to the existence of other IPRs not referenced in ETSI SR 000 314 (or the updates on the ETSI Web server) which are, or may be, or may become, essential to the present document.

### Trademarks

The present document may include trademarks and/or tradenames which are asserted and/or registered by their owners. ETSI claims no ownership of these except for any which are indicated as being the property of ETSI, and conveys no right to use or reproduce any trademark and/or tradename. Mention of those trademarks in the present document does not constitute an endorsement by ETSI of products, services or organizations associated with those trademarks.

---

## Legal Notice

This Technical Specification (TS) has been produced by ETSI 3rd Generation Partnership Project (3GPP).

The present document may refer to technical specifications or reports using their 3GPP identities. These shall be interpreted as being references to the corresponding ETSI deliverables.

The cross reference between 3GPP and ETSI identities can be found under <http://webapp.etsi.org/key/queryform.asp>.

---

## Modal verbs terminology

In the present document "**shall**", "**shall not**", "**should**", "**should not**", "**may**", "**need not**", "**will**", "**will not**", "**can**" and "**cannot**" are to be interpreted as described in clause 3.2 of the [ETSI Drafting Rules](#) (Verbal forms for the expression of provisions).

"**must**" and "**must not**" are **NOT** allowed in ETSI deliverables except when used in direct citation.

# Contents

Intellectual Property Rights .....	2
Legal Notice .....	2
Modal verbs terminology.....	2
Foreword.....	4
1 Scope .....	5
2 References .....	5
3 Definitions, symbols and abbreviations .....	5
3.1 Definitions .....	5
3.2 Symbols.....	5
3.3 Abbreviations .....	5
4 Services and functions of the physical layer .....	6
4.1 General .....	6
4.2 Overview of L1 functions.....	6
5 Model of physical layer of the UE .....	7
5.1 Uplink model.....	7
5.1.1 Uplink shared channel .....	7
5.1.2 Random access channel .....	8
5.2 Downlink model.....	8
5.2.1 Downlink shared channel.....	8
5.2.2 Broadcast channel.....	8
5.2.3 Paging channel.....	9
5.3 Sidelink model.....	10
5.3.1 Sidelink shared channel .....	10
5.3.2 Broadcast channel.....	11
6 Simultaneous transmission and reception of physical channels and physical signals.....	12
6.1 Uplink.....	12
6.2 Downlink.....	13
6.3 Sidelink .....	15
7 Measurements provided by the physical layer .....	16
7.1 UE measurements.....	16
<b>Annex A (informative): Change history .....</b>	<b>17</b>
History .....	18

---

# Foreword

This Technical Specification has been produced by the 3rd Generation Partnership Project (3GPP).

The contents of the present document are subject to continuing work within the TSG and may change following formal TSG approval. Should the TSG modify the contents of the present document, it will be re-released by the TSG with an identifying change of release date and an increase in version number as follows:

Version x.y.z

where:

- x the first digit:
  - 1 presented to TSG for information;
  - 2 presented to TSG for approval;
  - 3 or greater indicates TSG approved document under change control.
- y the second digit is incremented for all changes of substance, i.e. technical enhancements, corrections, updates, etc.
- z the third digit is incremented when editorial only changes have been incorporated in the document.

---

# 1 Scope

The present document is a technical specification of the services provided by the physical layer of 5G-NR to upper layers.

---

# 2 References

The following documents contain provisions which, through reference in this text, constitute provisions of the present document.

- [1] 3GPP TR 21.905: "Vocabulary for 3GPP Specifications"
- [2] 3GPP TS 38.201: "NR; Physical Layer – General Description"
- [3] 3GPP TS 38.211: "NR; Physical channels and modulation"
- [4] 3GPP TS 38.212: "NR; Multiplexing and channel coding"
- [5] 3GPP TS 38.213: "NR; Physical layer procedures for control"
- [6] 3GPP TS 38.214: "NR; Physical layer procedures for data"
- [7] 3GPP TS 38.215: "NR; Physical layer measurements"
- [8] 3GPP TS 38.306: "NR; User Equipment (UE) radio access capabilities"

---

# 3 Definitions, symbols and abbreviations

## 3.1 Definitions

For the purposes of the present document, the terms and definitions given in TR 21.905 [1] and the following apply. A term defined in the present document takes precedence over the definition of the same term, if any, in TR 21.905 [1].

## 3.2 Symbols

For the purposes of the present document, the following symbols apply:

## 3.3 Abbreviations

For the purposes of the present document, the abbreviations given in TR 21.905 [1] and the following apply. An abbreviation defined in the present document takes precedence over the definition of the same abbreviation, if any, in TR 21.905 [1].

For the purposes of the present document, the following abbreviations apply:

ARQ	Automatic Repeat Request
BCH	Broadcast Channel
CA	Carrier Aggregation
CRC	Cyclic Redundancy Check
DC	Dual Connectivity
DL	Downlink
FEC	Forward Error Correction
GF	Grant-Free
MAC	Medium Access Control

MIMO	Multiple Input Multiple Output
PBCH	Physical Broadcast Channel
PCH	Paging Channel
PDCCH	Physical Downlink Control Channel
PDSCH	Physical Downlink Shared Channel
PRACH	Physical Random Access Channel
PUCCH	Physical Uplink Control Channel
PUSCH	Physical Uplink Shared Channel
RACH	Random Access Channel
RF	Radio Frequency
RNTI	Radio Network Temporary Identifier
SCH	Shared Channel
SI	System Information
SPS	Semi-Persistent Scheduling
SRS	Sounding Reference Signal
TPC	Transmit Power Control
UL	Uplink

---

## 4 Services and functions of the physical layer

### 4.1 General

The physical layer offers data transport services to higher layers.

The access to these services is through the use of transport channels via the MAC sub-layer.

A transport block is defined as the data delivered by MAC layer to the physical layer and vice versa.

### 4.2 Overview of L1 functions

As mentioned in [2, TS 38.201], the physical layer is expected to perform the following functions to provide the data transport service:

- Error detection on the transport channel and indication to higher layers;
- FEC encoding/decoding of the transport channel;
- Hybrid ARQ soft-combining;
- Rate matching of the coded transport channel to physical channels;
- Mapping of the coded transport channel onto physical channels;
- Power weighting of physical channels;
- Modulation and demodulation of physical channels;
- Frequency and time synchronisation;
- Radio characteristics measurements and indication to higher layers;
- Multiple Input Multiple Output (MIMO) antenna processing;
- RF processing.

L1 functions are modelled for each transport channel in clause 5.

# 5 Model of physical layer of the UE

The 5G-NR physical-layer model captures those characteristics of the 5G-NR physical-layer that are relevant from the point-of-view of higher layers. More specifically, the physical-layer model captures:

- The structure of higher-layer data being passed down to or up from the physical layer;
- The means by which higher layers can configure the physical layer;
- The different indications (error indications, channel-quality indications, etc.) that are provided by the physical layer to higher layers.

## 5.1 Uplink model

### 5.1.1 Uplink shared channel

The physical-layer model for Uplink Shared Channel transmission is described based on the corresponding PUSCH physical-layer-processing chain, see Figure 5.1.1-1. Processing steps that are relevant for the physical-layer model, e.g. in the sense that they are configurable by higher layers, are highlighted in blue.

- Higher-layer data passed to/from the physical layer
- CRC and transport-block-error indication
- FEC and rate matching
- Data modulation
- Mapping to physical resource
- Multi-antenna processing
- Support of L1 control and Hybrid-ARQ-related signalling

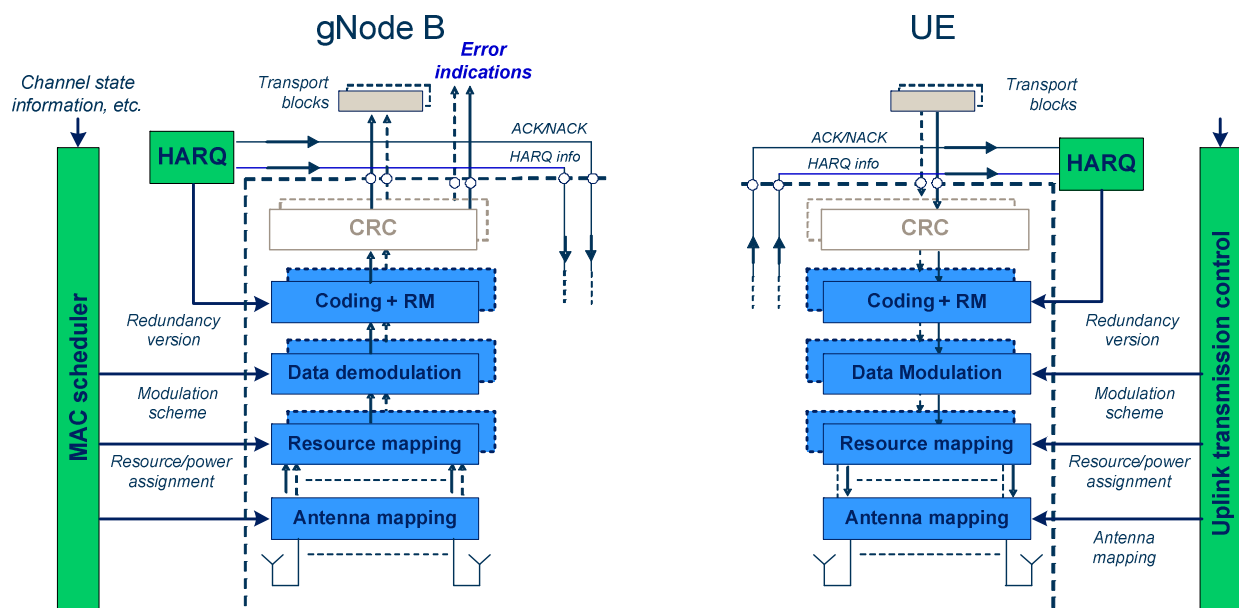

Figure 5.1.1-1: Physical-layer model for UL-SCH transmission



## 5.1.2 Random access channel

The physical-layer model for RACH transmission is characterized by a PRACH preamble format that consists of a cyclic prefix, a preamble, and a guard time during which nothing is transmitted.

## 5.2 Downlink model

### 5.2.1 Downlink shared channel

The physical-layer model for Downlink Shared Channel transmission is described based on the corresponding PDSCH physical-layer-processing chain, see Figure 5.2.1-1. Processing steps that are relevant for the physical-layer model, e.g. in the sense that they are configurable by higher layers, are highlighted in blue.

- Higher-layer data passed to/from the physical layer;
- CRC and transport-block-error indication;
- FEC and rate matching;
- Data modulation;
- Mapping to physical resource;
- Multi-antenna processing;
- Support of L1 control and Hybrid-ARQ-related signalling.

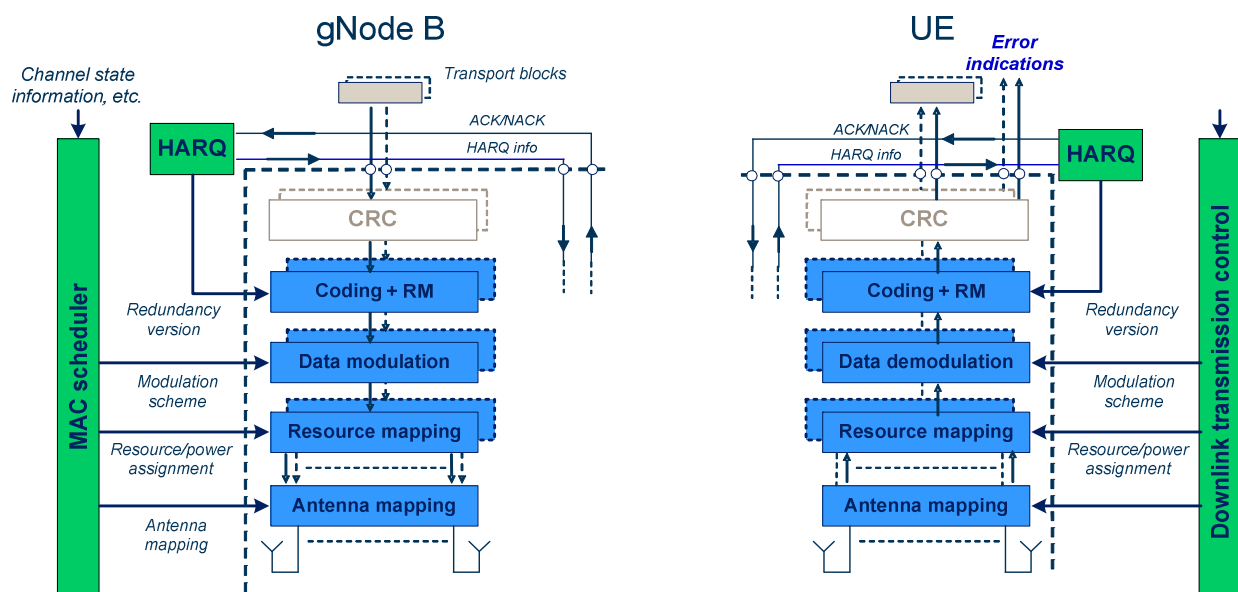
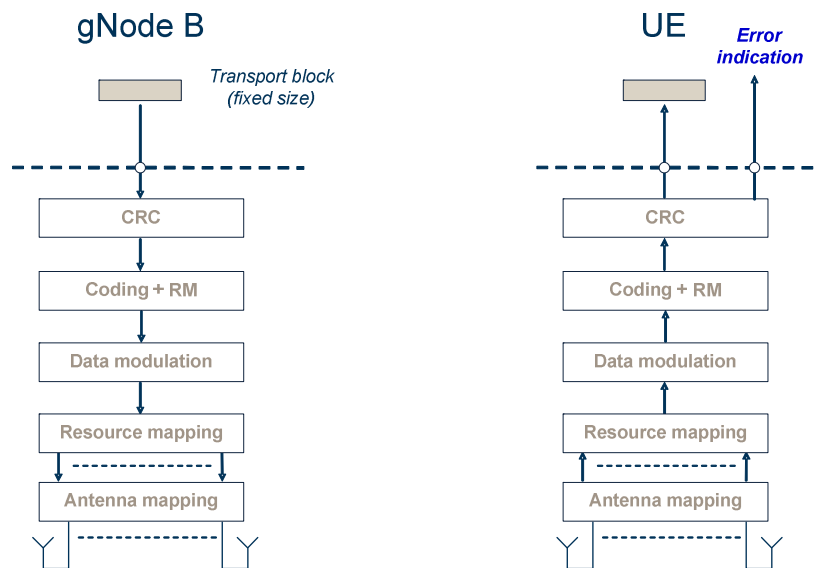

Figure 5.2.1-1: Physical-layer model for DL-SCH transmission

## 5.2.2 Broadcast channel

The physical-layer model for BCH transmission is characterized by a fixed pre-defined transport format. There is one transport block for the BCH every 80ms. The BCH physical-layer model is described based on the corresponding PBCH physical-layer-processing chain, see Figure 5.2.2-1:

- Higher-layer data passed to/from the physical layer;
- CRC and transport-block-error indication;
- FEC and rate matching;
- Data modulation;
- Mapping to physical resource;
- Multi-antenna processing.



**Figure 5.2.2-1: Physical-layer model for BCH transmission**

### 5.2.3 Paging channel

The physical-layer model for PCH transmission is described based on the corresponding physical-layer-processing chain, see Figure 5.2.3-1. The PCH is carried on PDSCH. Processing steps that are relevant for the physical-layer model, e.g. in the sense that they are configurable by higher layers, are highlighted in blue.

- Higher-layer data passed to/from the physical layer;
- CRC and transport-block-error indication;
- FEC and rate matching;
- Data modulation;
- Mapping to physical resource;
- Multi-antenna processing.

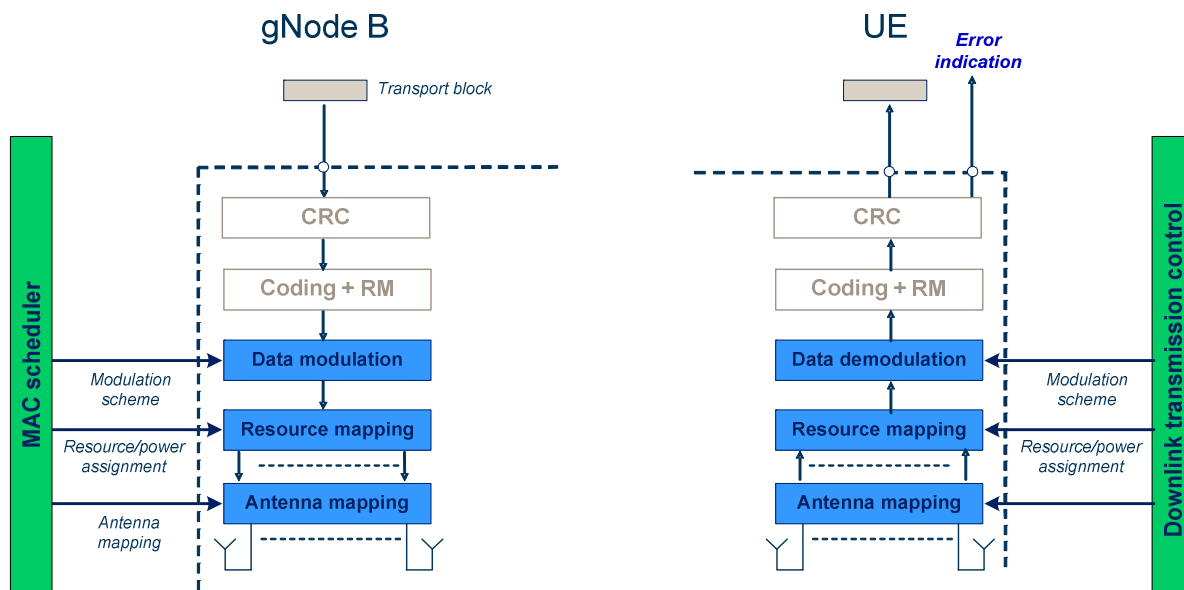

Figure 5.2.3-1: Physical-layer model for PCH transmission

## 5.3 Sidelink model

### 5.3.1 Sidelink shared channel

The physical-layer model for Sidelink Shared Channel transmission is described based on the corresponding SL-SCH physical-layer-processing chain, see Figure 5.3.1-1. Processing steps that are relevant for the physical-layer model, e.g. in the sense that they are configurable by higher layers, are highlighted in blue.

- Higher-layer data passed to/from the physical layer;
- CRC and transport-block-error indication;
- FEC and rate matching;
- Data modulation;
- Mapping to physical resource;
- Multi-antenna processing;
- Support of L1 control and Hybrid-ARQ-related signalling.

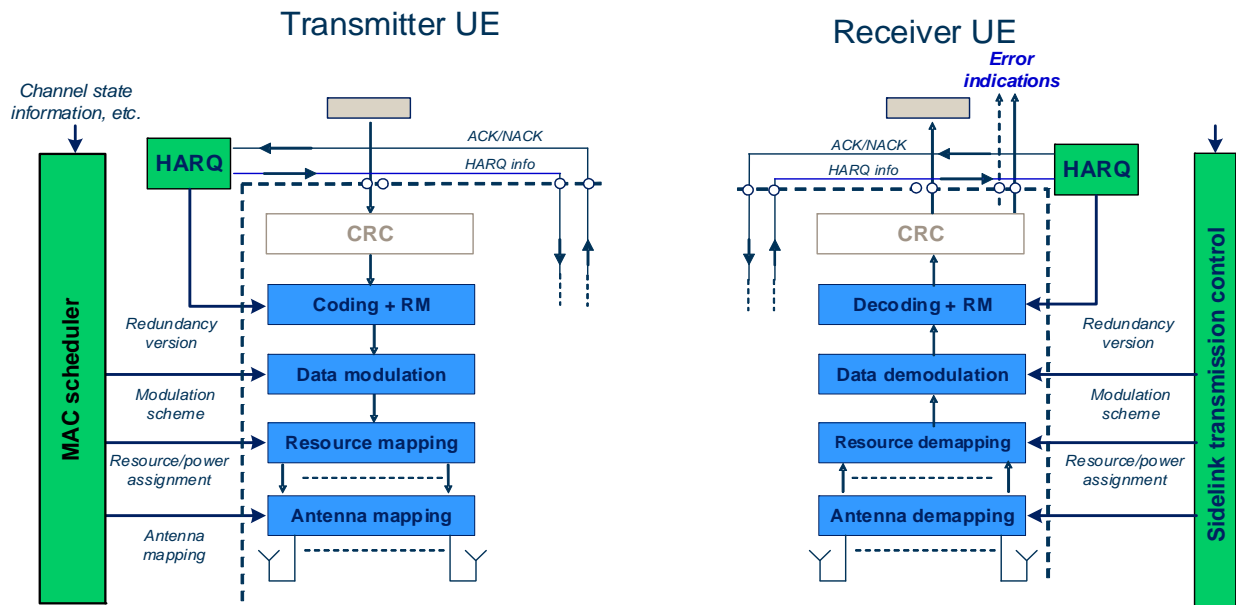

Figure 5.3.1-1: Physical-layer model for SL-SCH transmission

## 5.3.2 Broadcast channel

The physical-layer model for Sidelink Broadcast Channel transmission is characterized by a fixed pre-defined transport format. There is one transport block for every slot in which the UE transmits SL-BCH, if the UE is configured to transmit on SL-BCH. The SL-BCH physical-layer model is described based on the corresponding SL-BCH physical-layer-processing chain, see Figure 5.3.2-1:

- Higher-layer data passed to/from the physical layer;
- CRC and transport-block-error indication;
- FEC and rate matching;
- Data modulation;
- Mapping to physical resource;
- Multi-antenna processing.

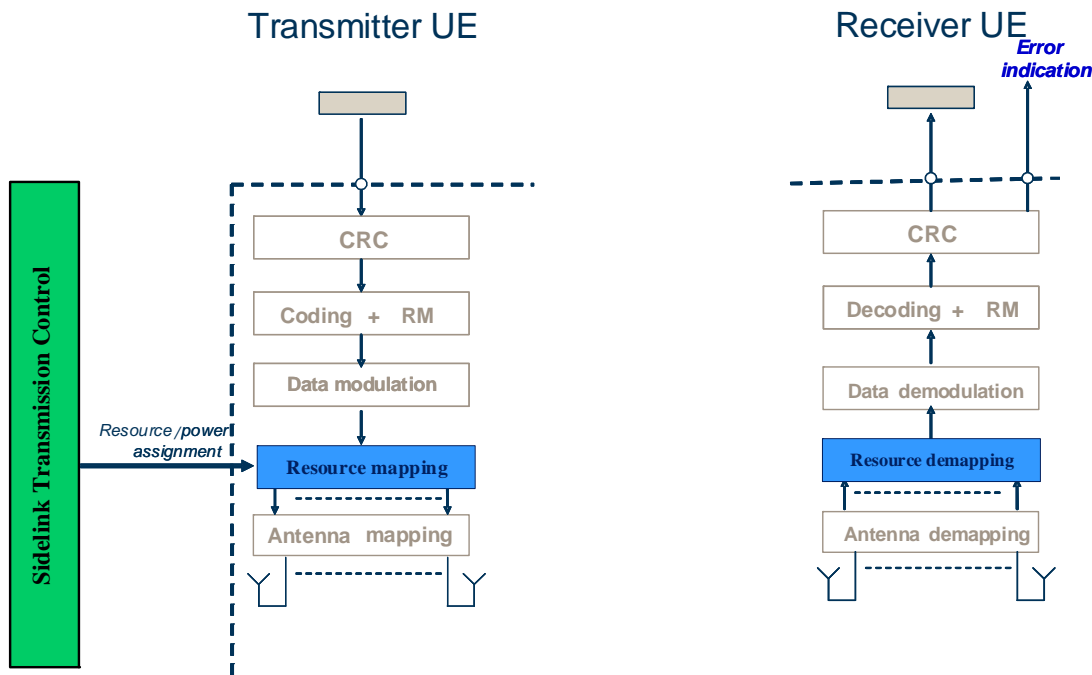

Figure 5.3.2-1: Physical-layer model for SL-BCH transmission

## 6 Simultaneous transmission and reception of physical channels and physical signals

This clause describes the requirements from the UE to send and receive multiple physical channels and physical signals simultaneously depending on the capabilities and service requirements. The following notation is used between both the uplink and downlink clauses below.

- $p$  is the number of uplink carriers configured for the UE on which physical channels can be transmitted
- $p'$  is the number of uplink carriers configured for the UE on which SRS can be transmitted
- $q$  is the number of downlink carriers configured for the UE
- $j$  is the number of cell groups configured for the UE.
- $k$  is the number of PUCCH groups configured for the UE.

### 6.1 Uplink

The tables 6.1-1 and 6.1-2 describe the possible combinations of physical channels and SRS that can be sent in simultaneously in the uplink by one UE. Table 6.1-1 introduces notation for a "Transmission Type" which represents a physical channel or sounding reference signal, and any associated transport channel. Table 6.1-2 describes the combinations of these "Transmission Types" which are supported by the UE depending on capabilities [8, TS 38.306], and enumerates how many of each can be transmitted simultaneously.

Table 6.1-1: Uplink "Transmission Types"

"Transmission Type"	Physical Channel or SRS	Associated Transport Channel	Comment
A	PRACH	RACH	Note 1, Note 3
B	PUCCH	N/A	
C	PUSCH	UL-SCH	Note 2, Note 3
D	SRS	N/A	

Note 1: RACH corresponds to contention based.  
Note 2: UCI on PUSCH without UL-SCH is possible.  
Note 3: For SCell, MsgA PRACH and MsgA PUSCH is not supported.

Table 6.1-2: Uplink "Transmission Type" combinations

Supported Combinations	Comment
$j \times A$	Note 1
$k \times B$	Note 2
$p \times C$	Note 3, Note 4
$p' \times D$	Note 3, Note 5
$\tilde{j} \times A + \tilde{k} \times B$	Note 6
$\tilde{j} \times A + \tilde{p} \times C$	Note 6
$\tilde{j} \times A + \tilde{p}' \times D$	Note 6
$\tilde{k} \times B + \tilde{p} \times C$	Note 8
$\tilde{k} \times B + \tilde{p}' \times D$	Note 7
$\tilde{p} \times C + \tilde{p}' \times D$	Note 7

Note 1: The number of cell groups  $j$  in the supported combination is subject to UE capability.  
Note 2: The number of PUCCH groups  $k$  in the supported combination is subject to UE capability.  
Note 3: The number of carriers  $p$ , and  $p'$  in the supported combinations are subject to UE capability.  
Note 4: In the case there is one SUL carrier, then  $p-1$  would be supported.  
Note 5: UE may be configured with  $p'$  but may also have capability to simultaneously sound less than this number.  
Note 6: Simultaneous PRACH with PUCCH (or PUSCH or SRS) is supported only in the case of inter-band CA, with  $\tilde{j} \leq j$ ,  $\tilde{k} \leq k$ ,  $\tilde{p} \leq p$ , and  $\tilde{p}' \leq p'$  depending on the configuration, and subject to UE capability for parallel transmission.  
Note 7: Simultaneous SRS with PUCCH (or PUSCH) is supported only in the case of inter-band CA, with  $\tilde{k} \leq k$ ,  $\tilde{p} \leq p$ , and  $\tilde{p}' \leq p'$  depending on the configuration, and subject to UE capability for parallel transmission.  
Note 8: Simultaneous PUCCH and PUSCH(s) is supported only in the case that multiple PUCCH groups are configured and the respective PUCCH and PUSCH(s) are transmitted in the different PUCCH groups, with  $\tilde{k} < k$  and  $\tilde{p} \leq p$ .  $k$  and  $p$  are subject to UE capability for supported number of PUCCH groups and UL carriers, respectively.  $\tilde{k}$  and  $\tilde{p}$  depend on configuration.

## 6.2 Downlink

The tables 6.2-1, 6.2-2 describe the possible combinations of physical channels that can be received simultaneously in the downlink by one UE. Table 6.2-1 introduces notation for a "Reception Type" which represents a physical channel and any associated transport channel. Table 6.2-2 describes the combinations of these "Reception Types" which are supported by the UE depending on capabilities [8, TS 38.306], and enumerates how many of each can be received simultaneously. The UE shall be able to receive all TBs according to the indication on PDCCH. Any subset of the combinations specified in table 6.2-2 is also supported.

**Table 6.2-1: Downlink "Reception Types"**

"Reception Type"	Physical Channel(s)	Monitored RNTI	Associated Transport Channel	Comment
A	PBCH	N/A	BCH	
B	PDCCH+PDSCH	SI-RNTI	DL-SCH	Note 1
C0	PDCCH	P-RNTI	N/A	Note 1, Note 2
C1	PDCCH+PDSCH	P-RNTI	PCH	Note 1
D0	PDCCH+PDSCH	RA-RNTI or Temporary C-RNTI or MsgB-RNTI	DL-SCH	Note 3
D1	PDCCH+PDSCH	C-RNTI, CS-RNTI, MCS-C-RNTI	DL-SCH	
D2	PDCCH	C-RNTI, CS-RNTI, MCS-C-RNTI	DL-SCH	
E	PDCCH	C-RNTI	N/A	Note 4
F0	PDCCH	Temporary C-RNTI	UL-SCH	Note 3
F1	PDCCH	C-RNTI, CS-RNTI, MCS-C-RNTI	UL-SCH	
G	PDCCH	SFI-RNTI	N/A	
H	PDCCH	INT-RNTI	N/A	
J0	PDCCH	TPC-PUSCH-RNTI	N/A	
J1	PDCCH	TPC-PUCCH-RNTI	N/A	
J2	PDCCH	TPC-SRS-RNTI	N/A	
K	PDCCH	SP-CSI-RNTI	N/A	
L0	PDCCH	SL-RNTI	SL-SCH	
L1	PDCCH	SL-CS-RNTI	SL-SCH	
M	PDCCH	SL Semi-Persistent Scheduling V-RNTI	SL-SCH	Note 5
N	PDCCH	PS-RNTI	N/A	
O	PDCCH	AI-RNTI	N/A	

Note 1: These are received from PCell only.  
 Note 2: In some cases UE is only required to monitor the short message within the DCI for P-RNTI.  
 Note 3: These are received from PCell or PSCell.  
 Note 4: This corresponds to PDCCH-ordered PRACH.  
 Note 5: This corresponds to PDCCH scheduling LTE PC5.

**Table 6.2-2: Downlink "Reception Type" combinations**

Supported Combinations			Comment
PCell	PSCell	SCell	
1. RRC_IDLE			
A + (B and/or C1 and/or D0) + F0			Note 1
2. RRC_INACTIVE			
A + (B and/or C1 and/or D0) + F0			Note 1
3. RRC_CONNECTED			
(A + C0 + (B and/or (D0 or (m1*D1+m2*D2))) + E + F0 + n*F1 + G + H + J0 + J1 + J2 + K + O + L0 + L1 + M + N)	(A + (D0 or (m1*D1+m2*D2)) + E + F0 + n*F1 + G + H + J0 + J1 + J2 + K + O + N)	m1*D1 + m2*D2 + E + n*F1 + G + H + J0 + J1 + J2 + K + O + L0 + L1 + M	Note 2, Note 3, Note 4, Note 5, Note 6, Note 7, Note 8

Note 1:	UE is not required to decode more than two PDSCH simultaneously, and decoding prioritization when more than two are received is up to UE implementation.
Note 2:	For PCell, UE is not required to decode SI-RNTI PDSCH simultaneously with C-RNTI PDSCH, unless in FR1.
Note 3:	Supported combinations are subject to UE capabilities for dual connectivity, carrier aggregation, receiving of group TPC commands, pre-emption indication and dynamic SFI monitoring.
Note 4:	The values of $m_2 \geq 0$ and $n \geq 0$ in the supported combinations are subject to the UE capability.
Note 5:	Support of monitoring PDCCH with SL-RNTI, SL-CS-RNTI, SL Semi-Persistent Scheduling V-RNTI are subject to UE capability.
Note 6:	The values of $m_1 \geq 1$ in the supported combinations are subject to the UE capability.
Note 7:	In Active time, a UE is not expected to monitor the DCI format for the PDCCH scrambled by PS-RNTI.
Note 8:	The PDCCH scrambled by PS-RNTI can only be configured on the PCell and PSCell.

## 6.3 Sidelink

The tables 6.3-1 and 6.3-2 describe the possible combinations of physical channels that can be sent simultaneously in the sidelink by a UE. Table 6.3-1 introduces notation for a sidelink "Transmission Type" which represents a physical channel, and any associated transport channel. Table 6.3-2 describes the combinations of these "Transmission Types" which are supported by the UE depending on capabilities [8, TS 38.306], and enumerates how many of each can be transmitted simultaneously.

**Table 6.3-1: Sidelink "Transmission Types"**

"Transmission Type"	Physical Channel	Associated Transport Channel	Comment
A	PSBCH	SL-BCH	
B	PSSCH	SL-SCH	
C	PSCCH	SL-SCH	
D	PSFCH	N/A	

**Table 6.3-2: Sidelink "Transmission Type" combinations**

Supported Combinations	Comment
A	
B	
C	
$N \times D$	
B+C	
Note:	Depending on the UE capability, the UE may be able to perform simultaneous Uplink and Sidelink transmissions. If the simultaneous transmission of Sidelink and Uplink is beyond the UE capability, the one not prioritized can be dropped according to [TS 38.321].

The tables 6.3-3 and 6.3-4 describe the possible combinations of physical channels that can be received simultaneously in the sidelink by a UE. Table 6.3-3 introduces notation for a sidelink "Reception Type" which represents a physical channel, and any associated transport channel. Table 6.3-4 describes the combinations of these "Transmission Types" which are supported by the UE depending on capabilities [8, TS 38.306], and enumerates how many of each can be received simultaneously.

**Table 6.3-3: Sidelink "Reception Types"**

"Transmission Type"	Physical Channel	Associated Transport Channel	Comment
A	PSBCH	SL-BCH	
B	PSSCH	SL-SCH	
C	PSCCH	SL-SCH	
D	PSFCH	N/A	



**Table 6.3-4: Sidelink "Reception Type" combinations**

Supported Combinations	Comment
A	
B	Note 1
C	Note 1
$M \times D$	
B+C	Note 1
Note 1: Corresponds to simultaneous reception within one sub-channel	

---

## 7 Measurements provided by the physical layer

### 7.1 UE measurements

The list and detailed definition of UE measurements is provided in [7, TS 38.215].

## Annex A (informative): Change history

Change history							
Date	Meeting	TDoc	CR	Rev	Cat	Subject/Comment	New version
2017-05	RAN1#89	R1-1712013				Draft skeleton	0.0.0
2017-07	AH_1706	R1-1712013				Update for agreements from meetings up to RAN1 NR AH2	0.0.1
2017-08	RAN1#90	R1-1713371				Update for agreements from meetings up to RAN1 NR AH2	0.0.2
2017-08	RAN1#90	R1-1714655				Update with change marks removed for RAN1 #90 endorsement	0.1.0
2017-09	RAN1#90	R1-1715320				Updated with minor editorial changes for review after RAN1 #90	0.1.1
2017-09	RAN#77	RP-172006				For information to plenary	1.0.0
2017-10	RAN1#90b	R1-1719229				Updated for agreements from meetings up to RAN1 #90b	1.0.1
2017-11	RAN1#91	R1-1721047				Updated after email discussion	1.1.0
2017-12	RAN1#91	R1-1721340				Updated to reflect agreements from RAN1 #91	1.2.0
2017-12	RAN#78	RP-172630				Endorsed version for approval by plenary	2.0.0
2017-12	RAN#78					Approved by plenary – Rel-15 spec under change control	15.0.0
2018-03	RAN#79	RP-180200	0001	-	F	CR capturing the Jan18 ad-hoc and RAN1#92 meeting agreements	15.1.0
2018-06	RAN#80	RP-181172	0002	1	F	CR to 38.202 capturing the RAN1#92bis and RAN1#93 meeting agreements	15.2.0
2018-06	RAN#80	RP-181257	0003	-	B	CR to 38.202 capturing the RAN1#92bis and RAN1#93 meeting agreements related to URLLC	15.2.0
2018-09	RAN#81	RP-181789	0004	-	B	CR to 38.202 capturing RAN1#94 meeting agreements	15.3.0
2018-12	RAN#82	RP-182523	0005	-	F	CR to 38.202 capturing RAN1#95 meeting agreements	15.4.0
2019-06	RAN#84	RP-191277	0006	-	F	Correction to simultaneous reception of DL Channels	15.5.0
2019-06	RAN#84	RP-191277	0007	-	F	CR on inclusion of TC-RNTI for monitored RNTI for UL-SCH and inclusion of monitoring PDCCH ordering PRACH on SCell	15.5.0
2019-12	RAN#86	RP-192623	0008	1	F	CR on simultaneous transmission of UL channels	15.6.0
2019-12	RAN#86	RP-192635	0009	-	B	Introduction of two-step RACH	16.0.0
2019-12	RAN#86	RP-192637	0010	-	B	Introduction of integrated access and backhaul for NR	16.0.0
2019-12	RAN#86	RP-192638	0011	-	B	Introduction of V2X	16.0.0
2019-12	RAN#86	RP-192639	0012	-	B	Introduction of Physical Layer Enhancements for URLLC	16.0.0
2019-12	RAN#86	RP-192641	0013	-	B	Introduction of MIMO enhancements	16.0.0
2019-12	RAN#86	RP-192642	0014	-	B	Introduction of UE Power Savings	16.0.0
2020-06	RAN#88-e	RP-200692	0015	-	F	Corrections to MIMO enhancements	16.1.0
2020-09	RAN#89-e	RP-201810	0017	-	F	DL Channel Combination associated with DCI format 2_6 monitoring	16.2.0
2020-09	RAN#89-e	RP-201807	0018	-	F	Corrections on 5G V2X sidelink features	16.2.0

---

# History

<b>Document history</b>		
V16.1.0	July 2020	Publication
V16.2.0	November 2020	Publication