

ETSI TS 137 571-1 V15.2.0 (2018-07)



**Universal Mobile Telecommunications System (UMTS);  
LTE;**

**Universal Terrestrial Radio Access (UTRA) and  
Evolved UTRA (E-UTRA) and Evolved Packet Core (EPC);  
User Equipment (UE) conformance specification  
for UE positioning;**

**Part 1: Conformance test specification  
(3GPP TS 37.571-1 version 15.2.0 Release 15)**



---

Reference

RTS/TSGR-0537571-1v120

---

Keywords

LTE,UMTS

**ETSI**

650 Route des Lucioles  
F-06921 Sophia Antipolis Cedex - FRANCE

Tel.: +33 4 92 94 42 00 Fax: +33 4 93 65 47 16

Siret N° 348 623 562 00017 - NAF 742 C  
Association à but non lucratif enregistrée à la  
Sous-Préfecture de Grasse (06) N° 7803/88

---

**Important notice**

The present document can be downloaded from:

<http://www.etsi.org/standards-search>

The present document may be made available in electronic versions and/or in print. The content of any electronic and/or print versions of the present document shall not be modified without the prior written authorization of ETSI. In case of any existing or perceived difference in contents between such versions and/or in print, the only prevailing document is the print of the Portable Document Format (PDF) version kept on a specific network drive within ETSI Secretariat.

Users of the present document should be aware that the document may be subject to revision or change of status.

Information on the current status of this and other ETSI documents is available at

<https://portal.etsi.org/TB/ETSIDeliverableStatus.aspx>

If you find errors in the present document, please send your comment to one of the following services:

<https://portal.etsi.org/People/CommiteeSupportStaff.aspx>

---

**Copyright Notification**

No part may be reproduced or utilized in any form or by any means, electronic or mechanical, including photocopying and microfilm except as authorized by written permission of ETSI.

The content of the PDF version shall not be modified without the written authorization of ETSI.

The copyright and the foregoing restriction extend to reproduction in all media.

© ETSI 2018.

All rights reserved.

**DECT™**, **PLUGTESTS™**, **UMTS™** and the ETSI logo are trademarks of ETSI registered for the benefit of its Members.  
**3GPP™** and **LTE™** are trademarks of ETSI registered for the benefit of its Members and  
of the 3GPP Organizational Partners.

**oneM2M** logo is protected for the benefit of its Members.

**GSM®** and the GSM logo are trademarks registered and owned by the GSM Association.

---

# Intellectual Property Rights

## Essential patents

IPRs essential or potentially essential to normative deliverables may have been declared to ETSI. The information pertaining to these essential IPRs, if any, is publicly available for **ETSI members and non-members**, and can be found in ETSI SR 000 314: *"Intellectual Property Rights (IPRs); Essential, or potentially Essential, IPRs notified to ETSI in respect of ETSI standards"*, which is available from the ETSI Secretariat. Latest updates are available on the ETSI Web server (<https://ipr.etsi.org/>).

Pursuant to the ETSI IPR Policy, no investigation, including IPR searches, has been carried out by ETSI. No guarantee can be given as to the existence of other IPRs not referenced in ETSI SR 000 314 (or the updates on the ETSI Web server) which are, or may be, or may become, essential to the present document.

## Trademarks

The present document may include trademarks and/or tradenames which are asserted and/or registered by their owners. ETSI claims no ownership of these except for any which are indicated as being the property of ETSI, and conveys no right to use or reproduce any trademark and/or tradename. Mention of those trademarks in the present document does not constitute an endorsement by ETSI of products, services or organizations associated with those trademarks.

---

# Foreword

This Technical Specification (TS) has been produced by ETSI 3rd Generation Partnership Project (3GPP).

The present document may refer to technical specifications or reports using their 3GPP identities, UMTS identities or GSM identities. These should be interpreted as being references to the corresponding ETSI deliverables.

The cross reference between GSM, UMTS, 3GPP and ETSI identities can be found under <http://webapp.etsi.org/key/queryform.asp>.

---

# Modal verbs terminology

In the present document "**shall**", "**shall not**", "**should**", "**should not**", "**may**", "**need not**", "**will**", "**will not**", "**can**" and "**cannot**" are to be interpreted as described in clause 3.2 of the [ETSI Drafting Rules](#) (Verbal forms for the expression of provisions).

"**must**" and "**must not**" are **NOT** allowed in ETSI deliverables except when used in direct citation.

# Contents

Intellectual Property Rights .....	2
Foreword.....	2
Modal verbs terminology.....	2
Foreword.....	27
Introduction .....	27
1 Scope .....	28
2 References .....	28
3 Definitions, symbols and abbreviations .....	30
3.1 Definitions .....	30
3.2 Symbols.....	30
3.3 Abbreviations .....	31
4 General test conditions .....	32
4.1 Introduction .....	32
4.2 GNSS test conditions.....	32
4.2.1 GNSS signals .....	32
4.2.2 GNSS frequency .....	32
4.2.3 GNSS static propagation conditions .....	33
4.2.4 GNSS multi-path conditions .....	33
4.2.5 UEs supporting multiple satellite signals.....	33
4.2.6 GNSS multi System Time Offsets .....	34
4.3 UTRA test conditions .....	34
4.3.1 UTRA frequency band and frequency range .....	34
4.3.2 UTRA frequency .....	34
4.3.3 Sensors .....	34
4.4 E-UTRA test conditions .....	34
4.4.1 E-UTRA frequency band and frequency range.....	34
4.4.2 Groups of bands .....	35
4.4.3 Sensors .....	35
4.5 A-GNSS test conditions .....	35
4.5.1 General.....	35
4.5.2 UTRAN measurement parameters .....	36
4.5.2.1 UE based A-GNSS measurement parameters .....	36
4.5.2.2 UE assisted A-GNSS measurement parameters .....	36
4.5.2.3 2D position error .....	36
4.5.2.4 Response time .....	36
4.5.3 E-UTRAN measurement parameters .....	36
4.5.3.1 UE based A-GNSS measurement parameters .....	36
4.5.3.2 UE assisted A-GNSS measurement parameters .....	36
4.5.3.3 2D Error definition.....	36
4.5.3.4 Response time .....	36
4.5.4 Converting A-GNSS UE-assisted measurement reports into position estimates .....	37
4.6 ECID test conditions .....	37
4.6.1 Simulated cells.....	37
4.6.2 Propagation conditions .....	37
4.6.2.1 Static .....	37
4.6.2.2 Multi-path fading .....	37
4.6.3 UE Rx - Tx time difference reporting range .....	37
4.7 OTDOA test conditions .....	38
4.7.1 Simulated cells.....	38
4.7.2 Propagation conditions .....	39
4.7.2.1 Static .....	39
4.7.2.2 Multi-path fading .....	39
4.7.3 Response time .....	39
4.7.4 RSTD reporting range.....	39

4.7.5	RSTD Carrier Aggregation Test Cases with Different Channel Bandwidth Combinations .....	40
4.8	MBS test conditions .....	40
4.8.1	MBS signals.....	40
4.8.2	Propagation conditions .....	40
4.8.2.1	Static .....	40
4.8.2.2	Multi-path fading .....	40
4.8.3	Response time .....	40
4.9	WLAN test conditions.....	40
4.9.1	Simulated WLAN Access Points .....	40
4.9.2	Propagation conditions .....	41
4.9.2.1	Static .....	41
4.9.3	Response time .....	41
4.9.4	Void .....	41
4.10	BLE test conditions .....	41
4.10.1	Simulated BLE.....	41
4.10.2	Propagation conditions .....	41
4.10.2.1	Static .....	41
4.10.3	Response time .....	41
4.11	NB-IOT test conditions .....	41
4.11.1	Groups of bands .....	41
4.11.2	NB-IOT inband mode .....	42
4A	Support of 4 Rx capable UEs .....	42
4A.1	RAT Independent Tests.....	42
4A.2	RAT Dependent Tests .....	42
4A.2.1	Principle of testing.....	42
4A.2.1.1	Single carrier tests .....	42
4A.2.1.2	Carrier Aggregation tests .....	42
4A.2.1.3	Antenna connection for bands where 2RX is supported .....	43
4A.2.1.4	Antenna connection for bands where 4RX is supported .....	43
5	UTRA A-GPS Minimum Performance requirements .....	44
5.1	General .....	44
5.2	Sensitivity.....	44
5.2.1	Sensitivity Coarse Time Assistance.....	44
5.2.1.1	Definition and applicability.....	44
5.2.1.2	Minimum requirements .....	44
5.2.1.3	Test purpose .....	44
5.2.1.4	Method of test .....	44
5.2.1.4.1	Initial conditions .....	44
5.2.1.4.2	Procedure.....	45
5.2.1.5	Test Requirements.....	45
5.2.2	Sensitivity Fine Time Assistance .....	46
5.2.2.1	Definition and applicability.....	46
5.2.2.2	Minimum requirements .....	46
5.2.2.3	Test purpose .....	46
5.2.2.4	Method of test .....	47
5.2.2.4.1	Initial conditions .....	47
5.2.2.4.2	Procedure.....	47
5.2.2.5	Test Requirements.....	47
5.3	Nominal Accuracy.....	48
5.3.1	Definition and applicability .....	48
5.3.2	Minimum requirements.....	48
5.3.3	Test purpose.....	48
5.3.4	Method of test .....	49
5.3.4.1	Initial conditions .....	49
5.3.4.2	Procedure .....	49
5.3.5	Test Requirements .....	50
5.4	Dynamic Range .....	50
5.4.1	Definition and applicability .....	50
5.4.2	Minimum requirements.....	50
5.4.3	Test purpose.....	51
5.4.4	Method of test .....	51

5.4.4.1	Initial conditions .....	51
5.4.4.2	Procedure .....	51
5.4.5	Test Requirements .....	52
5.5	Multi-path Performance .....	52
5.5.1	Definition and applicability .....	52
5.5.2	Minimum requirements.....	52
5.5.3	Test purpose.....	53
5.5.4	Method of test .....	53
5.5.4.1	Initial conditions .....	53
5.5.4.2	Procedure .....	53
5.5.5	Test Requirements .....	54
5.6	Moving Scenario and Periodic Update Performance.....	54
5.6.1	Definition and applicability .....	54
5.6.2	Minimum requirements.....	54
5.6.3	Test purpose.....	55
5.6.4	Method of test .....	55
5.6.4.1	Initial conditions .....	55
5.6.4.2	Procedure .....	55
5.6.5	Test Requirements .....	56
6	UTRA A-GNSS Minimum Performance requirements .....	58
6.1	General .....	58
6.2	Sensitivity.....	58
6.2.1	Sensitivity Coarse Time Assistance.....	58
6.2.1.1	Definition and applicability.....	58
6.2.1.2	Minimum requirements.....	58
6.2.1.3	Test purpose .....	59
6.2.1.4	Method of test .....	59
6.2.1.4.1	Initial conditions.....	59
6.2.1.4.2	Procedure.....	60
6.2.1.5	Test Requirements.....	60
6.2.2	Sensitivity Fine Time Assistance.....	61
6.2.2.1	Definition and applicability.....	61
6.2.2.2	Minimum requirements.....	62
6.2.2.3	Test purpose .....	62
6.2.2.4	Method of test .....	62
6.2.2.4.1	Initial conditions.....	62
6.2.2.4.2	Procedure.....	63
6.2.2.5	Test Requirements.....	63
6.3	Nominal Accuracy.....	64
6.3.1	Definition and applicability .....	64
6.3.2	Minimum requirements.....	64
6.3.3	Test purpose.....	65
6.3.4	Method of test .....	65
6.3.4.1	Initial conditions .....	65
6.3.4.2	Procedure .....	65
6.3.5	Test Requirements .....	66
6.4	Dynamic Range .....	67
6.4.1	Definition and applicability .....	67
6.4.2	Minimum requirements.....	68
6.4.3	Test purpose.....	68
6.4.4	Method of test .....	69
6.4.4.1	Initial conditions .....	69
6.4.4.2	Procedure .....	69
6.4.5	Test Requirements .....	69
6.5	Multi-path Performance .....	70
6.5.1	Definition and applicability .....	70
6.5.2	Minimum requirements.....	71
6.5.3	Test purpose.....	71
6.5.4	Method of test .....	72
6.5.4.1	Initial conditions .....	72
6.5.4.2	Procedure .....	72

6.5.5	Test Requirements .....	73
6.6	Moving Scenario and Periodic Update Performance.....	74
6.6.1	Definition and applicability .....	74
6.6.2	Minimum requirements.....	74
6.6.3	Test purpose.....	75
6.6.4	Method of test .....	75
6.6.4.1	Initial conditions .....	75
6.6.4.2	Procedure .....	76
6.6.5	Test Requirements .....	76
7	E-UTRA A-GNSS minimum performance requirements .....	78
7.0	General .....	78
7.1	Sensitivity.....	78
7.1.1	Sensitivity Coarse time assistance .....	78
7.1.1.1	Sub-tests.....	78
7.1.1.2	Test purpose .....	78
7.1.1.3	Test applicability.....	78
7.1.1.4	Minimum conformance requirements .....	78
7.1.1.5	Test description .....	79
7.1.1.5.1	Initial conditions.....	79
7.1.1.5.2	Test procedure .....	80
7.1.1.5.3	Message contents.....	81
7.1.1.6	Test requirement .....	81
7.1.2	Sensitivity Fine time assistance .....	82
7.1.2.1	Sub-tests.....	82
7.1.2.2	Test purpose .....	83
7.1.2.3	Test applicability.....	83
7.1.2.4	Minimum conformance requirements .....	83
7.1.2.5	Test description .....	84
7.1.2.5.1	Initial conditions.....	84
7.1.2.5.2	Test procedure .....	84
7.1.2.5.3	Message contents.....	85
7.1.2.6	Test requirement .....	86
7.2	Nominal Accuracy.....	87
7.2.1	Sub-tests.....	87
7.2.2	Test purpose .....	87
7.2.3	Test applicability.....	87
7.2.4	Minimum conformance requirements .....	88
7.2.5	Test description .....	89
7.2.5.1	Initial conditions.....	89
7.2.5.2	Test procedure .....	89
7.2.5.3	Message contents.....	90
7.2.6	Test requirement .....	91
7.3	Dynamic Range .....	92
7.3.1	Sub-tests.....	92
7.3.2	Test purpose .....	93
7.3.3	Test applicability.....	93
7.3.4	Minimum conformance requirements .....	93
7.3.5	Test description .....	94
7.3.5.1	Initial conditions.....	94
7.3.5.2	Test procedure .....	94
7.3.5.3	Message contents.....	95
7.3.6	Test requirement .....	96
7.4	Multi-Path scenario .....	97
7.4.1	Sub-tests.....	97
7.4.2	Test purpose .....	97
7.4.3	Test applicability.....	98
7.4.4	Minimum conformance requirements .....	98
7.4.5	Test description .....	98
7.4.5.1	Initial conditions.....	98
7.4.5.2	Test procedure .....	99
7.4.5.3	Message contents.....	100

7.4.6	Test requirement .....	100
7.5	Moving scenario and periodic update (Rel-9 to Rel-13) .....	101
7.5.1	Sub-tests .....	101
7.5.2	Test purpose .....	102
7.5.3	Test applicability .....	102
7.5.4	Minimum conformance requirements .....	102
7.5.5	Test description .....	103
7.5.5.1	Initial conditions .....	103
7.5.5.2	Test procedure .....	104
7.5.5.3	Message contents .....	105
7.5.6	Test requirement .....	106
7.5A	Moving scenario and periodic update (Rel-14 onwards) .....	107
7.5A.1	Sub-tests .....	107
7.5A.2	Test purpose .....	107
7.5A.3	Test applicability .....	107
7.5A.4	Minimum conformance requirements .....	107
7.5A.5	Test description .....	108
7.5A.6	Test requirement .....	108
8	E-UTRA ECID measurement requirements .....	108
8.1	UE Rx – Tx Time Difference .....	108
8.1.1	E-UTRAN FDD UE Rx – Tx time difference case (Rel-9 to Rel-11) .....	108
8.1.1.1	Test purpose .....	108
8.1.1.2	Test applicability .....	108
8.1.1.3	Minimum conformance requirements .....	108
8.1.1.4	Test description .....	109
8.1.1.4.1	Initial conditions .....	109
8.1.1.4.2	Test procedure .....	109
8.1.1.4.3	Message contents .....	110
8.1.1.5	Test requirement .....	114
8.1.1A	E-UTRAN FDD UE Rx – Tx time difference case (Rel-12 onwards) .....	115
8.1.1A.1	Test purpose .....	115
8.1.1A.2	Test applicability .....	115
8.1.1A.3	Minimum conformance requirements .....	115
8.1.1A.4	Test description .....	116
8.1.1A.4.1	Initial conditions .....	116
8.1.1A.4.2	Test procedure .....	116
8.1.1A.4.3	Message contents .....	116
8.1.1A.5	Test requirement .....	116
8.1.1B	E-UTRAN FDD UE Rx – Tx time difference case for UE Category 1bis .....	117
8.1.1B.1	Test purpose .....	117
8.1.1B.2	Test applicability .....	117
8.1.1B.3	Minimum conformance requirements .....	117
8.1.1B.4	Test description .....	117
8.1.1B.4.1	Initial conditions .....	117
8.1.1B.4.2	Test procedure .....	117
8.1.1B.4.3	Message contents .....	117
8.1.1B.5	Test requirement .....	117
8.1.2	E-UTRAN TDD UE Rx – Tx time difference case (Rel-9 to Rel-11) .....	117
8.1.2.1	Test purpose .....	117
8.1.2.2	Test applicability .....	117
8.1.2.3	Minimum conformance requirements .....	117
8.1.2.4	Test description .....	118
8.1.2.4.1	Initial conditions .....	118
8.1.2.4.2	Test procedure .....	118
8.1.2.4.3	Message contents .....	119
8.1.2.5	Test requirement .....	123
8.1.2A	E-UTRAN TDD UE Rx – Tx time difference case (Rel-12 onwards) .....	124
8.1.2A.1	Test purpose .....	124
8.1.2A.2	Test applicability .....	124
8.1.2A.3	Minimum conformance requirements .....	124
8.1.2A.4	Test description .....	124



8.1.2A.4.1	Initial conditions .....	124
8.1.2A.4.2	Test procedure .....	125
8.1.2A.4.3	Message contents .....	125
8.1.2A.5	Test requirement .....	125
8.1.2B	E-UTRAN TDD UE Rx – Tx time difference case for UE Category 1bis .....	125
8.1.2B.1	Test purpose .....	125
8.1.2B.2	Test applicability .....	125
8.1.2B.3	Minimum conformance requirements .....	125
8.1.2B.4	Test description .....	125
8.1.2B.4.1	Initial conditions .....	125
8.1.2B.4.2	Test procedure .....	125
8.1.2B.4.3	Message contents .....	125
8.1.2B.5	Test requirement .....	125
8.1.3	E-UTRAN FDD UE Rx–Tx Time Difference under Time-Domain Measurement Resource Restriction with Non-MBSFN ABS (eICIC) .....	126
8.1.3.1	Test purpose .....	126
8.1.3.2	Test applicability .....	126
8.1.3.3	Minimum conformance requirements .....	126
8.1.3.4	Test description .....	127
8.1.3.4.1	Initial conditions .....	127
8.1.3.4.2	Test procedure .....	128
8.1.3.4.3	Message contents .....	129
8.1.3.5	Test requirement .....	132
8.1.4	E-UTRAN TDD UE Rx–Tx Time Difference under Time-Domain Measurement Resource Restriction with Non-MBSFN ABS (eICIC) .....	134
8.1.4.1	Test purpose .....	134
8.1.4.2	Test applicability .....	134
8.1.4.3	Minimum conformance requirements .....	134
8.1.4.4	Test description .....	135
8.1.4.4.1	Initial conditions .....	136
8.1.4.4.2	Test procedure .....	136
8.1.4.4.3	Message contents .....	137
8.1.4.5	Test requirement .....	141
8.1.5	E-UTRAN FDD UE Rx–Tx time difference under Time Domain Measurement Resource Restriction with CRS Assistance Information and Non-MBSFN ABS (feICIC) .....	143
8.1.5.1	Test purpose .....	143
8.1.5.2	Test applicability .....	143
8.1.5.3	Minimum conformance requirements .....	143
8.1.5.4	Test description .....	145
8.1.5.4.1	Initial conditions .....	145
8.1.5.4.2	Test procedure .....	146
8.1.5.4.3	Message contents .....	147
8.1.5.5	Test requirement .....	151
8.1.6	E-UTRAN TDD UE Rx–Tx time difference under Time Domain Measurement Resource Restriction with CRS Assistance Information and Non-MBSFN ABS (feICIC) .....	153
8.1.6.1	Test purpose .....	153
8.1.6.2	Test applicability .....	153
8.1.6.3	Minimum conformance requirements .....	153
8.1.6.4	Test description .....	155
8.1.6.4.1	Initial conditions .....	155
8.1.6.4.2	Test procedure .....	156
8.1.6.4.3	Message contents .....	157
8.1.6.5	Test requirement .....	162
8.1.7	E-UTRAN FDD UE Rx-Tx time difference case for Cat-M1/M2 UE in CEModeA .....	164
8.1.7.1	Test purpose .....	164
8.1.7.2	Test applicability .....	164
8.1.7.3	Minimum conformance requirements .....	164
8.1.7.4	Test description .....	165
8.1.7.4.1	Initial conditions .....	165
8.1.7.4.2	Test procedure .....	166
8.1.7.4.3	Message contents .....	166
8.1.7.5	Test requirement .....	168

8.1.8	E-UTRAN HD-FDD UE Rx-Tx time difference case for Cat-M1/M2 UE in CEModeA .....	170
8.1.8.1	Test purpose .....	170
8.1.8.2	Test applicability .....	170
8.1.8.3	Minimum conformance requirements .....	170
8.1.8.4	Test description .....	170
8.1.8.4.1	Initial conditions .....	170
8.1.8.4.2	Test procedure .....	170
8.1.8.4.3	Message contents .....	170
8.1.8.5	Test requirement .....	170
8.1.9	E-UTRAN TDD UE Rx-Tx time difference case for Cat-M1/M2 UE in CEModeA .....	172
8.1.9.1	Test purpose .....	172
8.1.9.2	Test applicability .....	172
8.1.9.3	Minimum conformance requirements .....	172
8.1.9.4	Test description .....	172
8.1.9.4.1	Initial conditions .....	172
8.1.9.4.2	Test procedure .....	172
8.1.9.4.3	Message contents .....	172
8.1.9.5	Test requirement .....	173
9	E-UTRA OTDOA measurement requirements .....	175
9.1	RSTD Intra-Frequency Measurements .....	175
9.1.1	FDD RSTD Measurement Reporting Delay .....	175
9.1.1.1	Test purpose .....	175
9.1.1.2	Test applicability .....	175
9.1.1.3	Minimum conformance requirements .....	175
9.1.1.4	Test description .....	176
9.1.1.4.1	Initial conditions .....	176
9.1.1.4.2	Test procedure .....	180
9.1.1.4.3	Message contents .....	181
9.1.1.5	Test requirement .....	184
9.1.1A	FDD RSTD Measurement Reporting Delay for UE Category 1bis .....	187
9.1.1A.1	Test purpose .....	187
9.1.1A.2	Test applicability .....	187
9.1.1A.3	Minimum conformance requirements .....	187
9.1.1A.4	Test description .....	187
9.1.1A.4.1	Initial conditions .....	187
9.1.1A.4.2	Test procedure .....	190
9.1.1A.4.3	Message contents .....	190
9.1.1A.5	Test requirement .....	190
9.1.2	TDD RSTD Measurement Reporting Delay .....	191
9.1.2.1	Test purpose .....	191
9.1.2.2	Test applicability .....	191
9.1.2.3	Minimum conformance requirements .....	191
9.1.2.4	Test description .....	192
9.1.2.4.1	Initial conditions .....	192
9.1.2.4.2	Test procedure .....	195
9.1.2.4.3	Message contents .....	196
9.1.2.5	Test requirement .....	199
9.1.2A	TDD RSTD Measurement Reporting Delay for UE Category 1bis .....	202
9.1.2A.1	Test purpose .....	202
9.1.2A.2	Test applicability .....	202
9.1.2A.3	Minimum conformance requirements .....	202
9.1.2A.4	Test description .....	202
9.1.2A.4.1	Initial conditions .....	202
9.1.2A.4.2	Test procedure .....	205
9.1.2A.4.3	Message contents .....	205
9.1.2A.5	Test requirement .....	205
9.1.3	FDD RSTD Measurement Accuracy .....	206
9.1.3.1	Test purpose .....	206
9.1.3.2	Test applicability .....	206
9.1.3.3	Minimum conformance requirements .....	206
9.1.3.4	Test description .....	208

9.1.3.4.1	Initial conditions .....	208
9.1.3.4.2	Test procedure.....	211
9.1.3.4.3	Message contents .....	212
9.1.3.5	Test requirement .....	216
9.1.3A	FDD RSTD Measurement Accuracy for UE Category 1bis .....	218
9.1.3A.1	Test purpose .....	218
9.1.3A.2	Test applicability .....	218
9.1.3A.3	Minimum conformance requirements.....	218
9.1.3A.4	Test description .....	218
9.1.3A.4.1	Initial conditions .....	218
9.1.3A.4.2	Test procedure.....	221
9.1.3A.4.3	Message contents .....	221
9.1.3A.5	Test requirement .....	221
9.1.4	TDD RSTD Measurement Accuracy .....	221
9.1.4.1	Test purpose .....	221
9.1.4.2	Test applicability .....	222
9.1.4.3	Minimum conformance requirements.....	222
9.1.4.4	Test description .....	222
9.1.4.4.1	Initial conditions .....	222
9.1.4.4.2	Test procedure.....	224
9.1.4.4.3	Message contents .....	225
9.1.4.5	Test requirement .....	229
9.1.4A	TDD RSTD Measurement Accuracy for UE Category 1bis .....	230
9.1.4A.1	Test purpose .....	230
9.1.4A.2	Test applicability .....	230
9.1.4A.3	Minimum conformance requirements.....	230
9.1.4A.4	Test description .....	230
9.1.4A.4.1	Initial conditions .....	230
9.1.4A.4.2	Test procedure.....	232
9.1.4A.4.3	Message contents .....	232
9.1.4A.5	Test requirement .....	233
9.2	RSTD Inter-Frequency Measurements.....	233
9.2.1	FDD-FDD inter-frequency RSTD measurement reporting delay .....	233
9.2.1.1	Test purpose .....	233
9.2.1.2	Test applicability .....	233
9.2.1.3	Minimum conformance requirements.....	233
9.2.1.4	Test description .....	234
9.2.1.4.1	Initial conditions .....	234
9.2.1.4.2	Test procedure.....	238
9.2.1.4.3	Message contents .....	239
9.2.1.5	Test requirement .....	243
9.2.1A	FDD-FDD inter-frequency RSTD Measurement Reporting Delay for UE Category 1bis .....	246
9.2.1A.1	Test purpose .....	246
9.2.1A.2	Test applicability .....	246
9.2.1A.3	Minimum conformance requirements.....	246
9.2.1A.4	Test description .....	246
9.2.1A.4.1	Initial conditions .....	246
9.2.1A.4.2	Test procedure.....	249
9.2.1A.4.3	Message contents .....	249
9.2.1A.5	Test requirement .....	250
9.2.2	TDD-TDD inter-frequency RSTD measurement reporting delay.....	250
9.2.2.1	Test purpose .....	250
9.2.2.2	Test applicability .....	250
9.2.2.3	Minimum conformance requirements.....	250
9.2.2.4	Test description .....	252
9.2.2.4.1	Initial conditions .....	252
9.2.2.4.2	Test procedure.....	255
9.2.2.4.3	Message contents .....	256
9.2.2.5	Test requirement .....	260
9.2.2A	TDD-TDD inter-frequency RSTD Measurement Reporting Delay for UE Category 1bis .....	263
9.2.2A.1	Test purpose .....	263
9.2.2A.2	Test applicability .....	263

9.2.2A.3	Minimum conformance requirements.....	263
9.2.2A.4	Test description .....	263
9.2.2A.4.1	Initial conditions .....	263
9.2.2A.4.2	Test procedure.....	266
9.2.2A.4.3	Message contents .....	266
9.2.2A.5	Test requirement .....	267
9.2.3	Void .....	267
9.2.4	FDD-FDD inter-frequency RSTD Accuracy .....	267
9.2.4.1	Test purpose .....	267
9.2.4.2	Test applicability .....	267
9.2.4.3	Minimum conformance requirements .....	267
9.2.4.4	Test description .....	270
9.2.4.4.1	Initial conditions .....	270
9.2.4.4.2	Test procedure.....	272
9.2.4.4.3	Message contents .....	272
9.2.4.5	Test requirement .....	277
9.2.4A	FDD-FDD inter-frequency RSTD Accuracy for UE Category 1bis .....	278
9.2.4A.1	Test purpose .....	278
9.2.4A.2	Test applicability .....	278
9.2.4A.3	Minimum conformance requirements .....	278
9.2.4A.4	Test description .....	278
9.2.4A.4.1	Initial conditions .....	278
9.2.4A.4.2	Test procedure.....	280
9.2.4A.4.3	Message contents .....	280
9.2.4A.5	Test requirement .....	280
9.2.5	TDD-TDD inter-frequency RSTD Accuracy .....	280
9.2.5.1	Test purpose .....	280
9.2.5.2	Test applicability .....	280
9.2.5.3	Minimum conformance requirements .....	280
9.2.5.4	Test description .....	281
9.2.5.4.1	Initial conditions .....	281
9.2.5.4.2	Test procedure.....	283
9.2.5.4.3	Message contents .....	283
9.2.5.5	Test requirement .....	288
9.2.5A	TDD-TDD inter-frequency RSTD Accuracy for UE Category 1bis.....	290
9.2.5A.1	Test purpose .....	290
9.2.5A.2	Test applicability .....	290
9.2.5A.3	Minimum conformance requirements .....	290
9.2.5A.4	Test description .....	290
9.2.5A.4.1	Initial conditions .....	290
9.2.5A.4.2	Test procedure.....	292
9.2.5A.4.3	Message contents .....	292
9.2.5A.5	Test requirement .....	292
9.3	RSTD Intra-Frequency Measurements for UE Category M1/M2 .....	292
9.3.1	FDD intra-frequency RSTD Measurement Reporting Delay in CE Mode A .....	292
9.3.1.1	FDD intra-frequency RSTD Measurement Reporting Delay in CE Mode A for Cat M1 .....	292
9.3.1.1.1	Test purpose.....	292
9.3.1.1.2	Test applicability.....	293
9.3.1.1.3	Minimum conformance requirements .....	293
9.3.1.1.4	Test description.....	294
9.3.1.1.4.1	Initial conditions.....	294
9.3.1.1.4.2	Test procedure.....	298
9.3.1.1.4.3	Message contents.....	299
9.3.1.1.5	Test requirement .....	301
9.3.1.2	FDD intra-frequency RSTD Measurement Reporting Delay in CE Mode A for Cat M2 .....	304
9.3.1.2.1	Test purpose.....	304
9.3.1.2.2	Test applicability.....	304
9.3.1.2.3	Minimum conformance requirements .....	304
9.3.1.2.4	Test description.....	304
9.3.1.2.4.1	Initial conditions.....	304
9.3.1.2.4.2	Test procedure.....	307
9.3.1.2.4.3	Message contents.....	307

9.3.1.2.5	Test requirement .....	307
9.3.2	HD-FDD intra-frequency RSTD Measurement Reporting Delay in CE Mode A .....	307
9.3.2.1	HD-FDD intra-frequency RSTD Measurement Reporting Delay in CE Mode A for Cat M1 .....	307
9.3.2.1.1	Test purpose .....	307
9.3.2.1.2	Test applicability .....	307
9.3.2.1.3	Minimum conformance requirements .....	307
9.3.2.1.4	Test description .....	308
9.3.2.1.4.1	Initial conditions .....	308
9.3.2.1.4.2	Test procedure .....	311
9.3.2.1.4.3	Message contents .....	311
9.3.2.1.5	Test requirement .....	311
9.3.2.2	HD-FDD intra-frequency RSTD Measurement Reporting Delay in CE Mode A for Cat M2 .....	311
9.3.2.2.1	Test purpose .....	311
9.3.2.2.2	Test applicability .....	311
9.3.2.2.3	Minimum conformance requirements .....	311
9.3.2.2.4	Test description .....	311
9.3.2.2.4.1	Initial conditions .....	311
9.3.2.2.4.2	Test procedure .....	314
9.3.2.2.4.3	Message contents .....	314
9.3.2.2.5	Test requirement .....	314
9.3.3	TDD intra-frequency RSTD Measurement Reporting Delay in CE Mode A .....	314
9.3.3.1	TDD intra-frequency RSTD Measurement Reporting Delay in CE Mode A for Cat M1 .....	314
9.3.3.1.1	Test purpose .....	314
9.3.3.1.2	Test applicability .....	314
9.3.3.1.3	Minimum conformance requirements .....	314
9.3.3.1.4	Test description .....	315
9.3.3.1.4.1	Initial conditions .....	315
9.3.3.1.4.2	Test procedure .....	318
9.3.3.1.4.3	Message contents .....	318
9.3.3.1.5	Test requirement .....	318
9.3.3.2	TDD intra-frequency RSTD Measurement Reporting Delay in CE Mode A for Cat M2 .....	321
9.3.3.2.1	Test purpose .....	321
9.3.3.2.2	Test applicability .....	321
9.3.3.2.3	Minimum conformance requirements .....	321
9.3.3.2.4	Test description .....	321
9.3.3.2.4.1	Initial conditions .....	321
9.3.3.2.4.2	Test procedure .....	324
9.3.3.2.4.3	Message contents .....	324
9.3.3.2.5	Test requirement .....	324
9.3.4	FDD intra-frequency RSTD Measurement Reporting Delay in CE Mode B .....	324
9.3.4.1	FDD intra-frequency RSTD Measurement Reporting Delay in CE Mode B for Cat M1 .....	324
9.3.4.1.1	Test purpose .....	324
9.3.4.1.2	Test applicability .....	325
9.3.4.1.3	Minimum conformance requirements .....	325
9.3.4.1.4	Test description .....	325
9.3.4.1.4.1	Initial conditions .....	325
9.3.4.1.4.2	Test procedure .....	328
9.3.4.1.4.3	Message contents .....	328
9.3.4.1.5	Test requirement .....	328
9.3.4.2	FDD intra-frequency RSTD Measurement Reporting Delay in CE Mode B for Cat M2 .....	331
9.3.4.2.1	Test purpose .....	331
9.3.4.2.2	Test applicability .....	331
9.3.4.2.3	Minimum conformance requirements .....	331
9.3.4.2.4	Test description .....	331
9.3.4.2.4.1	Initial conditions .....	331
9.3.4.2.4.2	Test procedure .....	334
9.3.4.2.4.3	Message contents .....	334
9.3.4.2.5	Test requirement .....	334
9.3.5	HD-FDD intra-frequency RSTD Measurement Reporting Delay in CE Mode B .....	335
9.3.5.1	HD-FDD intra-frequency RSTD Measurement Reporting Delay in CE Mode B for Cat M1 .....	335
9.3.5.1.1	Test purpose .....	335
9.3.5.1.2	Test applicability .....	335

9.3.5.1.3	Minimum conformance requirements .....	335
9.3.5.1.4	Test description .....	335
9.3.5.1.4.1	Initial conditions .....	335
9.3.5.1.4.2	Test procedure .....	338
9.3.5.1.4.3	Message contents .....	338
9.3.5.1.5	Test requirement .....	338
9.3.5.2	HD-FDD intra-frequency RSTD Measurement Reporting Delay in CE Mode B for Cat M2 .....	338
9.3.5.2.1	Test purpose .....	338
9.3.5.2.2	Test applicability .....	338
9.3.5.2.3	Minimum conformance requirements .....	338
9.3.5.2.4	Test description .....	338
9.3.5.2.4.1	Initial conditions .....	338
9.3.5.2.4.2	Test procedure .....	341
9.3.5.2.4.3	Message contents .....	341
9.3.5.2.5	Test requirement .....	341
9.3.6	TDD intra-frequency RSTD Measurement Reporting Delay in CE Mode B .....	341
9.3.6.1	TDD intra-frequency RSTD Measurement Reporting Delay in CE Mode B for Cat M1 .....	341
9.3.6.1.1	Test purpose .....	341
9.3.6.1.2	Test applicability .....	341
9.3.6.1.3	Minimum conformance requirements .....	341
9.3.6.1.4	Test description .....	342
9.3.6.1.4.1	Initial conditions .....	342
9.3.6.1.4.2	Test procedure .....	345
9.3.6.1.4.3	Message contents .....	345
9.3.6.1.5	Test requirement .....	345
9.3.6.2	TDD intra-frequency RSTD Measurement Reporting Delay in CE Mode B for Cat M2 .....	348
9.3.6.2.1	Test purpose .....	348
9.3.6.2.2	Test applicability .....	348
9.3.6.2.3	Minimum conformance requirements .....	348
9.3.6.2.4	Test description .....	348
9.3.6.2.4.1	Initial conditions .....	348
9.3.6.2.4.2	Test procedure .....	351
9.3.6.2.4.3	Message contents .....	351
9.3.6.2.5	Test requirement .....	351
9.3.7.1	FDD intra-frequency RSTD Measurement Accuracy in CE Mode A for Cat M1 .....	351
9.3.7.1.1	Test purpose .....	352
9.3.7.1.2	Test applicability .....	352
9.3.7.1.3	Minimum conformance requirements .....	352
9.3.7.1.4	Test description .....	353
9.3.7.1.4.1	Initial conditions .....	353
9.3.7.1.4.2	Test procedure .....	357
9.3.7.1.4.3	Message contents .....	358
9.3.7.1.5	Test requirement .....	360
9.3.7.2	FDD intra-frequency RSTD Measurement Accuracy in CE Mode A for Cat M2 .....	361
9.3.7.2.1	Test purpose .....	361
9.3.7.2.2	Test applicability .....	361
9.3.7.2.3	Minimum conformance requirements .....	362
9.3.7.2.4	Test description .....	363
9.3.7.2.4.1	Initial conditions .....	363
9.3.7.2.4.2	Test procedure .....	367
9.3.7.2.4.3	Message contents .....	367
9.3.7.2.5	Test requirement .....	367
9.3.8	HD-FDD intra-frequency RSTD Measurement Accuracy in CE Mode A .....	367
9.3.8.1	HD-FDD intra-frequency RSTD Measurement Accuracy in CE Mode A for Cat M1 .....	367
9.3.8.1.1	Test purpose .....	367
9.3.8.1.2	Test applicability .....	368
9.3.8.1.3	Minimum conformance requirements .....	368
9.3.8.1.4	Test description .....	368
9.3.8.1.4.1	Initial conditions .....	368
9.3.8.1.4.2	Test procedure .....	371
9.3.8.1.4.3	Message contents .....	371
9.3.8.1.5	Test requirement .....	371

9.3.8.2	HD-FDD intra-frequency RSTD Measurement Accuracy in CE Mode A for Cat M2 .....	371
9.3.8.2.1	Test purpose .....	371
9.3.8.2.2	Test applicability .....	371
9.3.8.2.3	Minimum conformance requirements .....	371
9.3.8.2.4	Test description .....	371
9.3.8.2.4.1	Initial conditions .....	371
9.3.8.2.4.2	Test procedure .....	374
9.3.8.2.4.3	Message contents .....	374
9.3.8.2.5	Test requirement .....	374
9.3.9	TDD intra-frequency RSTD Measurement Accuracy in CE Mode A .....	374
9.3.9.1	TDD intra-frequency RSTD Measurement Accuracy in CE Mode A for Cat M1 .....	374
9.3.9.1.1	Test purpose .....	374
9.3.9.1.2	Test applicability .....	374
9.3.9.1.3	Minimum conformance requirements .....	374
9.3.9.1.4	Test description .....	375
9.3.9.1.4.1	Initial conditions .....	375
9.3.9.1.4.2	Test procedure .....	378
9.3.9.1.4.3	Message contents .....	378
9.3.9.1.5	Test requirement .....	378
9.3.9.2	TDD intra-frequency RSTD Measurement Accuracy in CE Mode A for Cat M2 .....	378
9.3.9.2.1	Test purpose .....	378
9.3.9.2.2	Test applicability .....	378
9.3.9.2.3	Minimum conformance requirements .....	378
9.3.9.2.4	Test description .....	378
9.3.9.2.4.1	Initial conditions .....	378
9.3.9.2.4.2	Test procedure .....	381
9.3.9.2.4.3	Message contents .....	381
9.3.9.2.5	Test requirement .....	381
9.3.10	FDD intra-frequency RSTD Measurement Accuracy in CE Mode B .....	381
9.3.10.1	FDD intra-frequency RSTD Measurement Accuracy in CE Mode B for Cat M1 .....	381
9.3.10.1.1	Test purpose .....	381
9.3.10.1.2	Test applicability .....	382
9.3.10.1.3	Minimum conformance requirements .....	382
9.3.10.1.4	Test description .....	383
9.3.10.1.4.1	Initial conditions .....	383
9.3.10.1.4.2	Test procedure .....	386
9.3.10.1.4.3	Message contents .....	386
9.3.10.1.5	Test requirement .....	386
9.3.10.2	FDD intra-frequency RSTD Measurement Accuracy in CE Mode B for Cat M2 .....	387
9.3.10.2.1	Test purpose .....	387
9.3.10.2.2	Test applicability .....	387
9.3.10.2.3	Minimum conformance requirements .....	388
9.3.10.2.4	Test description .....	389
9.3.10.2.4.1	Initial conditions .....	389
9.3.10.2.4.2	Test procedure .....	393
9.3.10.2.4.3	Message contents .....	393
9.3.10.2.5	Test requirement .....	394
9.3.11	HD-FDD intra-frequency RSTD Measurement Accuracy in CE Mode B .....	394
9.3.11.1	HD-FDD intra-frequency RSTD Measurement Accuracy in CE Mode B for Cat M1 .....	394
9.3.11.1.1	Test purpose .....	394
9.3.11.1.2	Test applicability .....	394
9.3.11.1.3	Minimum conformance requirements .....	394
9.3.11.1.4	Test description .....	394
9.3.11.1.4.1	Initial conditions .....	394
9.3.11.1.4.2	Test procedure .....	397
9.3.11.1.4.3	Message contents .....	397
9.3.11.1.5	Test requirement .....	397
9.3.11.2	HD-FDD intra-frequency RSTD Measurement Accuracy in CE Mode B for Cat M2 .....	397
9.3.11.2.1	Test purpose .....	397
9.3.11.2.2	Test applicability .....	397
9.3.11.2.3	Minimum conformance requirements .....	397
9.3.11.2.4	Test description .....	397

9.3.11.2.4.1	Initial conditions.....	397
9.3.11.2.4.2	Test procedure.....	400
9.3.11.2.4.3	Message contents.....	400
9.3.11.2.5	Test requirement.....	400
9.3.12	TDD intra-frequency RSTD Measurement Accuracy in CE Mode B.....	400
9.3.12.1	TDD intra-frequency RSTD Measurement Accuracy in CE Mode B for Cat M1.....	400
9.3.12.1.1	Test purpose.....	400
9.3.12.1.2	Test applicability.....	400
9.3.12.1.3	Minimum conformance requirements.....	400
9.3.12.1.4	Test description.....	401
9.3.12.1.4.1	Initial conditions.....	401
9.3.12.1.4.2	Test procedure.....	404
9.3.12.1.4.3	Message contents.....	404
9.3.12.1.5	Test requirement.....	404
9.3.12.2	TDD intra-frequency RSTD Measurement Accuracy in CE Mode B for Cat M2.....	404
9.3.12.2.1	Test purpose.....	404
9.3.12.2.2	Test applicability.....	404
9.3.12.2.3	Minimum conformance requirements.....	404
9.3.12.2.4	Test description.....	404
9.3.12.2.4.1	Initial conditions.....	404
9.3.12.2.4.2	Test procedure.....	407
9.3.12.2.4.3	Message contents.....	407
9.3.12.2.5	Test requirement.....	407
9.4	RSTD Inter-Frequency Measurements for UE Category M1/M2.....	407
9.4.1	FDD inter-frequency RSTD Measurement Reporting Delay in CE Mode A.....	407
9.4.1.1	FDD inter-frequency RSTD Measurement Reporting Delay in CE Mode A for Cat M1.....	407
9.4.1.1.1	Test purpose.....	408
9.4.1.1.2	Test applicability.....	408
9.4.1.1.3	Minimum conformance requirements.....	408
9.4.1.1.4	Test description.....	409
9.4.1.1.4.1	Initial conditions.....	409
9.4.1.1.4.2	Test procedure.....	413
9.4.1.1.4.3	Message contents.....	414
9.4.1.1.5	Test requirement.....	415
9.4.1.2	FDD inter-frequency RSTD Measurement Reporting Delay in CE Mode A for Cat M2.....	418
9.4.1.2.1	Test purpose.....	418
9.4.1.2.2	Test applicability.....	418
9.4.1.2.3	Minimum conformance requirements.....	418
9.4.1.2.4	Test description.....	418
9.4.1.2.4.1	Initial conditions.....	418
9.4.1.2.4.2	Test procedure.....	421
9.4.1.2.4.3	Message contents.....	421
9.4.1.2.5	Test requirement.....	422
9.4.2	HD-FDD inter-frequency RSTD Measurement Reporting Delay in CE Mode A.....	422
9.4.2.1	HD-FDD inter-frequency RSTD Measurement Reporting Delay in CE Mode A for Cat M1.....	422
9.4.2.1.1	Test purpose.....	423
9.4.2.1.2	Test applicability.....	423
9.4.2.1.3	Minimum conformance requirements.....	423
9.4.2.1.4	Test description.....	423
9.4.2.1.4.1	Initial conditions.....	423
9.4.2.1.4.2	Test procedure.....	426
9.4.2.1.4.3	Message contents.....	426
9.4.2.1.5	Test requirement.....	426
9.4.2.2	HD-FDD inter-frequency RSTD Measurement Reporting Delay in CE Mode A for Cat M2.....	426
9.4.2.2.1	Test purpose.....	426
9.4.2.2.2	Test applicability.....	426
9.4.2.2.3	Minimum conformance requirements.....	427
9.4.2.2.4	Test description.....	427
9.4.2.2.4.1	Initial conditions.....	427
9.4.2.2.4.2	Test procedure.....	430
9.4.2.2.4.3	Message contents.....	430
9.4.2.2.5	Test requirement.....	430



9.4.3	TDD inter-frequency RSTD Measurement Reporting Delay in CE Mode A .....	430
9.4.3.1	TDD inter-frequency RSTD Measurement Reporting Delay in CE Mode A for Cat M1 .....	430
9.4.3.1.1	Test purpose .....	431
9.4.3.1.2	Test applicability .....	431
9.4.3.1.3	Minimum conformance requirements .....	431
9.4.3.1.4	Test description .....	431
9.4.3.1.4.1	Initial conditions .....	431
9.4.3.1.4.2	Test procedure .....	434
9.4.3.1.4.3	Message contents .....	434
9.4.3.1.5	Test requirement .....	434
9.4.3.2	TDD inter-frequency RSTD Measurement Reporting Delay in CE Mode A for Cat M2 .....	437
9.4.3.2.1	Test purpose .....	437
9.4.3.2.2	Test applicability .....	437
9.4.3.2.3	Minimum conformance requirements .....	437
9.4.3.2.4	Test description .....	437
9.4.3.2.4.1	Initial conditions .....	437
9.4.3.2.4.2	Test procedure .....	440
9.4.3.2.4.3	Message contents .....	440
9.4.3.2.5	Test requirement .....	440
9.4.4	FDD inter-frequency RSTD Measurement Reporting Delay in CE Mode B .....	441
9.4.4.1	FDD inter-frequency RSTD Measurement Reporting Delay in CE Mode B for Cat M1 .....	441
9.4.4.1.1	Test purpose .....	441
9.4.4.1.2	Test applicability .....	441
9.4.4.1.3	Minimum conformance requirements .....	441
9.4.4.1.4	Test description .....	441
9.4.4.1.4.1	Initial conditions .....	441
9.4.4.1.4.2	Test procedure .....	444
9.4.4.1.4.3	Message contents .....	444
9.4.4.1.5	Test requirement .....	444
9.4.4.2	FDD inter-frequency RSTD Measurement Reporting Delay in CE Mode B for Cat M2 .....	447
9.4.4.2.1	Test purpose .....	447
9.4.4.2.2	Test applicability .....	447
9.4.4.2.3	Minimum conformance requirements .....	447
9.4.4.2.4	Test description .....	447
9.4.4.2.4.1	Initial conditions .....	447
9.4.4.2.4.2	Test procedure .....	450
9.4.4.2.4.3	Message contents .....	450
9.4.4.2.5	Test requirement .....	450
9.4.5	HD-FDD inter-frequency RSTD Measurement Reporting Delay in CE Mode B .....	451
9.4.5.1	HD-FDD inter-frequency RSTD Measurement Reporting Delay in CE Mode B for Cat M1 .....	451
9.4.5.1.1	Test purpose .....	451
9.4.5.1.2	Test applicability .....	451
9.4.5.1.3	Minimum conformance requirements .....	451
9.4.5.1.4	Test description .....	451
9.4.5.1.4.1	Initial conditions .....	451
9.4.5.1.4.2	Test procedure .....	454
9.4.5.1.4.3	Message contents .....	454
9.4.5.1.5	Test requirement .....	454
9.4.5.2	HD-FDD inter-frequency RSTD Measurement Reporting Delay in CE Mode B for Cat M2 .....	454
9.4.5.2.1	Test purpose .....	454
9.4.5.2.2	Test applicability .....	454
9.4.5.2.3	Minimum conformance requirements .....	454
9.4.5.2.4	Test description .....	454
9.4.5.2.4.1	Initial conditions .....	454
9.4.5.2.4.2	Test procedure .....	457
9.4.5.2.4.3	Message contents .....	457
9.4.5.2.5	Test requirement .....	457
9.4.6	TDD inter-frequency RSTD Measurement Reporting Delay in CE Mode B .....	457
9.4.6.1	TDD inter-frequency RSTD Measurement Reporting Delay in CE Mode B for Cat M1 .....	457
9.4.6.1.1	Test purpose .....	457
9.4.6.1.2	Test applicability .....	457
9.4.6.1.3	Minimum conformance requirements .....	457

9.4.6.1.4	Test description.....	458
9.4.6.1.4.1	Initial conditions.....	458
9.4.6.1.4.2	Test procedure.....	461
9.4.6.1.4.3	Message contents.....	461
9.4.6.1.5	Test requirement .....	461
9.4.6.2	TDD inter-frequency RSTD Measurement Reporting Delay in CE Mode B for Cat M2 .....	464
9.4.6.2.1	Test purpose.....	464
9.4.6.2.2	Test applicability.....	464
9.4.6.2.3	Minimum conformance requirements .....	464
9.4.6.2.4	Test description.....	464
9.4.6.2.4.1	Initial conditions.....	464
9.4.6.2.4.2	Test procedure.....	467
9.4.6.2.4.3	Message contents.....	467
9.4.6.2.5	Test requirement .....	467
9.4.7	FDD inter-frequency RSTD Measurement Accuracy in CE Mode A.....	467
9.4.7.1	FDD inter-frequency RSTD Measurement Accuracy in CE Mode A for Cat M1 .....	467
9.4.7.1.1	Test purpose.....	468
9.4.7.1.2	Test applicability.....	468
9.4.7.1.3	Minimum conformance requirements .....	468
9.4.7.1.4	Test description.....	469
9.4.7.1.4.1	Initial conditions.....	469
9.4.7.1.4.2	Test procedure.....	473
9.4.7.1.4.3	Message contents.....	474
9.4.7.1.5	Test requirement .....	474
9.4.7.2	FDD inter-frequency RSTD Measurement Accuracy in CE Mode A for Cat M2 .....	475
9.4.7.2.1	Test purpose.....	475
9.4.7.2.2	Test applicability.....	476
9.4.7.2.3	Minimum conformance requirements .....	476
9.4.7.2.4	Test description.....	477
9.4.7.2.4.1	Initial conditions.....	477
9.4.7.2.4.2	Test procedure.....	481
9.4.7.2.4.3	Message contents.....	481
9.4.7.2.5	Test requirement .....	481
9.4.8	HD-FDD inter-frequency RSTD Measurement Accuracy in CE Mode A.....	482
9.4.8.1	HD-FDD inter-frequency RSTD Measurement Accuracy in CE Mode A for Cat M1 .....	482
9.4.8.1.1	Test purpose.....	482
9.4.8.1.2	Test applicability.....	482
9.4.8.1.3	Minimum conformance requirements .....	482
9.4.8.1.4	Test description.....	482
9.4.8.1.4.1	Initial conditions.....	482
9.4.8.1.4.2	Test procedure.....	485
9.4.8.1.4.3	Message contents.....	485
9.4.8.1.5	Test requirement .....	485
9.4.8.2	HD-FDD inter-frequency RSTD Measurement Accuracy in CE Mode A for Cat M2 .....	485
9.4.8.2.1	Test purpose.....	485
9.4.8.2.2	Test applicability.....	485
9.4.8.2.3	Minimum conformance requirements .....	485
9.4.8.2.4	Test description.....	485
9.4.8.2.4.1	Initial conditions.....	485
9.4.8.2.4.2	Test procedure.....	488
9.4.8.2.4.3	Message contents.....	488
9.4.8.2.5	Test requirement .....	488
9.4.9	TDD inter-frequency RSTD Measurement Accuracy in CE Mode A .....	488
9.4.9.1	TDD inter-frequency RSTD Measurement Accuracy in CE Mode A for Cat M1 .....	488
9.4.9.1.1	Test purpose.....	488
9.4.9.1.2	Test applicability.....	488
9.4.9.1.3	Minimum conformance requirements .....	488
9.4.9.1.4	Test description.....	488
9.4.9.1.4.1	Initial conditions.....	488
9.4.9.1.4.2	Test procedure.....	491
9.4.9.1.4.3	Message contents.....	491
9.4.9.1.5	Test requirement .....	491

9.4.9.2	TDD inter-frequency RSTD Measurement Accuracy in CE Mode A for Cat M2 .....	492
9.4.9.2.1	Test purpose .....	492
9.4.9.2.2	Test applicability .....	493
9.4.9.2.3	Minimum conformance requirements .....	493
9.4.9.2.4	Test description .....	493
9.4.9.2.4.1	Initial conditions .....	493
9.4.9.2.4.2	Test procedure .....	496
9.4.9.2.4.3	Message contents .....	496
9.4.9.2.5	Test requirement .....	496
9.4.10	FDD inter-frequency RSTD Measurement Accuracy in CE Mode B .....	496
9.4.10.1	FDD inter-frequency RSTD Measurement Accuracy in CE Mode B for Cat M1 .....	496
9.4.10.1.1	Test purpose .....	496
9.4.10.1.2	Test applicability .....	496
9.4.10.1.3	Minimum conformance requirements .....	496
9.4.10.1.4	Test description .....	497
9.4.10.1.4.1	Initial conditions .....	497
9.4.10.1.4.2	Test procedure .....	500
9.4.10.1.4.3	Message contents .....	500
9.4.10.1.5	Test requirement .....	500
9.4.10.2	FDD inter-frequency RSTD Measurement Accuracy in CE Mode B for Cat M2 .....	501
9.4.10.2.1	Test purpose .....	501
9.4.10.2.2	Test applicability .....	502
9.4.10.2.3	Minimum conformance requirements .....	502
9.4.10.2.4	Test description .....	503
9.4.10.2.4.1	Initial conditions .....	503
9.4.10.2.4.2	Test procedure .....	507
9.4.10.2.4.3	Message contents .....	507
9.4.10.2.5	Test requirement .....	507
9.4.11	HD-FDD inter-frequency RSTD Measurement Accuracy in CE Mode B .....	508
9.4.11.1	HD-FDD inter-frequency RSTD Measurement Accuracy in CE Mode B for Cat M1 .....	508
9.4.11.1.1	Test purpose .....	508
9.4.11.1.2	Test applicability .....	508
9.4.11.1.3	Minimum conformance requirements .....	508
9.4.11.1.4	Test description .....	508
9.4.11.1.4.1	Initial conditions .....	508
9.4.11.1.4.2	Test procedure .....	511
9.4.11.1.4.3	Message contents .....	511
9.4.11.1.5	Test requirement .....	511
9.4.11.2	HD-FDD inter-frequency RSTD Measurement Accuracy in CE Mode B for Cat M2 .....	511
9.4.11.2.1	Test purpose .....	511
9.4.11.2.2	Test applicability .....	511
9.4.11.2.3	Minimum conformance requirements .....	511
9.4.11.2.4	Test description .....	511
9.4.11.2.4.1	Initial conditions .....	511
9.4.11.2.4.2	Test procedure .....	514
9.4.11.2.4.3	Message contents .....	514
9.4.11.2.5	Test requirement .....	514
9.4.12	TDD inter-frequency RSTD Measurement Accuracy in CE Mode B .....	514
9.4.12.1	TDD inter-frequency RSTD Measurement Accuracy in CE Mode B for Cat M1 .....	514
9.4.12.1.1	Test purpose .....	514
9.4.12.1.2	Test applicability .....	514
9.4.12.1.3	Minimum conformance requirements .....	514
9.4.12.1.4	Test description .....	514
9.4.12.1.4.1	Initial conditions .....	514
9.4.12.1.4.2	Test procedure .....	517
9.4.12.1.4.3	Message contents .....	517
9.4.12.1.5	Test requirement .....	517
9.4.12.2	TDD inter-frequency RSTD Measurement Accuracy in CE Mode B for Cat M2 .....	518
9.4.12.2.1	Test purpose .....	518
9.4.12.2.2	Test applicability .....	519
9.4.12.2.3	Minimum conformance requirements .....	519
9.4.12.2.4	Test description .....	519

9.4.12.2.4.1	Initial conditions.....	519
9.4.12.2.4.2	Test procedure.....	522
9.4.12.2.4.3	Message contents.....	522
9.4.12.2.5	Test requirement.....	522
9.5	HD-FDD RSTD Intra-Frequency Measurements.....	522
9.5.1	HD-FDD Intra frequency RSTD Measurement Accuracy for NB-IOT Inband Mode in normal coverage.....	522
9.5.1.1	Test purpose.....	522
9.5.1.2	Test applicability.....	522
9.5.1.3	Minimum conformance requirements.....	522
9.5.1.4	Test description.....	524
9.5.1.4.1	Initial conditions.....	524
9.5.1.4.2	Test procedure.....	526
9.5.1.4.3	Message contents.....	526
9.5.1.5	Test requirement.....	529
9.5.2	HD-FDD Intra frequency RSTD Measurement Accuracy for NB-IOT Inband Mode in enhanced coverage.....	531
9.5.2.1	Test purpose.....	531
9.5.2.2	Test applicability.....	532
9.5.2.3	Minimum conformance requirements.....	532
9.5.2.4	Test description.....	532
9.5.2.4.1	Initial conditions.....	532
9.5.2.4.2	Test procedure.....	534
9.5.2.4.3	Message contents.....	535
9.5.2.5	Test requirement.....	535
9.5.3	HD-FDD Intra frequency RSTD Measurement Reporting Delay for NB-IOT Inband Mode in enhanced coverage.....	537
9.5.3.1	Test purpose.....	538
9.5.3.2	Test applicability.....	538
9.5.3.3	Minimum conformance requirements.....	538
9.5.3.4	Test description.....	539
9.5.3.4.1	Initial conditions.....	539
9.5.3.4.2	Test procedure.....	543
9.5.3.4.3	Message contents.....	544
9.5.3.5	Test requirement.....	544
9.6	HD-FDD RSTD Inter-Frequency Measurements.....	546
9.6.1	HD-FDD Inter-Frequency RSTD Measurement Accuracy for NB-IOT Inband Mode in normal coverage.....	546
9.6.1.1	Test purpose.....	546
9.6.1.2	Test applicability.....	546
9.6.1.3	Minimum conformance requirements.....	546
9.6.1.4	Test description.....	548
9.6.1.4.1	Initial conditions.....	548
9.6.1.4.2	Test procedure.....	549
9.6.1.4.3	Message contents.....	550
9.6.1.5	Test requirement.....	551
9.6.2	HD-FDD Inter-Frequency RSTD Measurement Accuracy for NB-IOT Inband Mode in enhanced coverage.....	553
9.6.2.1	Test purpose.....	553
9.6.2.2	Test applicability.....	554
9.6.2.3	Minimum conformance requirements.....	554
9.6.2.4	Test description.....	554
9.6.2.4.1	Initial conditions.....	554
9.6.2.4.2	Test procedure.....	556
9.6.2.4.3	Message contents.....	557
9.6.2.5	Test requirement.....	557
9.6.3	HD-FDD Inter frequency RSTD Measurement Reporting Delay for NB-IOT Inband Mode in enhanced coverage.....	559
9.6.3.1	Test purpose.....	560
9.6.3.2	Test applicability.....	560
9.6.3.3	Minimum conformance requirements.....	560
9.6.3.4	Test description.....	561

9.6.3.4.1	Initial conditions .....	561
9.6.3.4.2	Test procedure.....	565
9.6.3.4.3	Message contents .....	566
9.6.3.5	Test requirement .....	566
10	E-UTRA OTDOA measurement requirements for Carrier Aggregation .....	568
10.1	FDD RSTD Measurement Reporting Delay for Carrier Aggregation .....	568
10.1.1	Test purpose.....	568
10.1.2	Test applicability .....	568
10.1.3	Minimum conformance requirements .....	568
10.1.3.1	Measurements on the secondary component carrier .....	568
10.1.3.2	Measurements on both primary component carrier and secondary component carrier .....	568
10.1.4	Test description.....	569
10.1.4.1	Initial conditions .....	569
10.1.4.2	Test procedure.....	572
10.1.4.3	Message contents .....	574
10.1.5	Test requirement .....	578
10.1A	FDD RSTD Measurement Reporting Delay for Carrier Aggregation for 20 MHz Bandwidth.....	580
10.1A.1	Test purpose.....	580
10.1A.2	Test applicability .....	580
10.1A.3	Minimum conformance requirements .....	580
10.1A.4	Test description.....	580
10.1A.4.1	Initial conditions .....	580
10.1A.4.2	Test procedure.....	581
10.1A.4.3	Message contents .....	581
10.1A.5	Test requirement .....	581
10.1B	FDD RSTD Measurement Reporting Delay Carrier Aggregation for 5 MHz + 5 MHz Bandwidth .....	581
10.1B.1	Test purpose.....	581
10.1B.2	Test applicability .....	581
10.1B.3	Minimum conformance requirements .....	582
10.1B.4	Test description.....	582
10.1B.4.1	Initial conditions .....	582
10.1B.4.2	Test procedure.....	582
10.1B.4.3	Message contents .....	582
10.1B.5	Test requirement .....	582
10.1C	FDD RSTD Measurement Reporting Delay for Carrier Aggregation for 10 MHz+5 MHz Bandwidth.....	583
10.1C.1	Test purpose.....	583
10.1C.2	Test applicability .....	583
10.1C.3	Minimum conformance requirements .....	583
10.1C.4	Test description.....	583
10.1C.4.1	Initial conditions .....	583
10.1C.4.2	Test procedure.....	584
10.1C.4.3	Message contents .....	584
10.1C.5	Test requirement .....	584
10.2	TDD RSTD Measurement Reporting Delay for Carrier Aggregation.....	585
10.2.1	Test purpose.....	585
10.2.2	Test applicability .....	585
10.2.3	Minimum conformance requirements .....	585
10.2.3.1	Measurements on the secondary component carrier .....	585
10.2.3.2	Measurements on both primary component carrier and secondary component carrier .....	585
10.2.4	Test description.....	586
10.2.4.1	Initial conditions .....	586
10.2.4.2	Test procedure.....	589
10.2.4.3	Message contents .....	591
10.2.5	Test requirement .....	595
10.2A	TDD RSTD Measurement Reporting Delay for Carrier Aggregation for 20 MHz Bandwidth.....	597
10.2A.1	Test purpose.....	597
10.2A.2	Test applicability .....	597
10.2A.3	Minimum conformance requirements .....	597
10.2A.4	Test description.....	597
10.2A.4.1	Initial conditions .....	597
10.2A.4.2	Test procedure.....	598

10.2A.4.3	Message contents .....	598
10.2A.5	Test requirement .....	598
10.2B	TDD RSTD Measurement Reporting Delay for Carrier Aggregation for 5 MHz + 5 MHz Bandwidth .....	598
10.2B.1	Test purpose.....	598
10.2B.2	Test applicability .....	598
10.2B.3	Minimum conformance requirements .....	599
10.2B.4	Test description.....	599
10.2B.4.1	Initial conditions .....	599
10.2B.4.2	Test procedure.....	599
10.2B.4.3	Message contents .....	599
10.2B.5	Test requirement .....	599
10.2C	TDD RSTD Measurement Reporting Delay for Carrier Aggregation for 10 MHz + 5 MHz Bandwidth .....	600
10.2C.1	Test purpose.....	600
10.2C.2	Test applicability .....	600
10.2C.3	Minimum conformance requirements .....	600
10.2C.4	Test description.....	600
10.2C.4.1	Initial conditions .....	600
10.2C.4.2	Test procedure.....	601
10.2C.4.3	Message contents .....	601
10.2C.5	Test requirement .....	601
10.2D	TDD RSTD Measurement Reporting Delay for Carrier Aggregation for 20 MHz +10 MHz Bandwidth .....	602
10.2D.1	Test purpose.....	602
10.2D.2	Test applicability .....	602
10.2D.3	Minimum conformance requirements .....	602
10.2D.4	Test description.....	602
10.2D.4.1	Initial conditions .....	602
10.2D.4.2	Test procedure.....	603
10.2D.4.3	Message contents .....	603
10.2D.5	Test requirement .....	603
10.3	FDD RSTD Measurement Accuracy for Carrier Aggregation .....	604
10.3.1	Test purpose.....	604
10.3.2	Test applicability .....	604
10.3.3	Minimum conformance requirements .....	604
10.3.4	Test description.....	604
10.3.4.1	Initial conditions .....	604
10.3.4.2	Test procedure.....	605
10.3.4.3	Message contents .....	606
10.3.5	Test requirement .....	609
10.3A	FDD RSTD Measurement Accuracy for Carrier Aggregation for 20 MHz Bandwidth (Rel-10 and Rel-11) .....	610
10.3A.1	Test purpose.....	610
10.3A.2	Test applicability .....	610
10.3A.3	Minimum conformance requirements .....	610
10.3A.4	Test description.....	611
10.3A.4.1	Initial conditions .....	611
10.3A.4.2	Test procedure.....	611
10.3A.4.3	Message contents .....	611
10.3A.5	Test requirement .....	611
10.3A_1	FDD RSTD Measurement Accuracy for Carrier Aggregation for 20 MHz Bandwidth (Rel-12 onwards) ....	611
10.3A_1.1	Test purpose.....	611
10.3A_1.2	Test applicability .....	612
10.3A_1.3	Minimum conformance requirements .....	612
10.3A_1.4	Test description.....	612
10.3A_1.4.1	Initial conditions .....	612
10.3A_1.4.2	Test procedure.....	612
10.3A_1.4.3	Message contents .....	612
10.3A_1.5	Test requirement .....	612
10.3B	FDD RSTD Measurement Accuracy for Carrier Aggregation for 5 MHz + 5 MHz Bandwidth.....	612
10.3B.1	Test purpose.....	612
10.3B.2	Test applicability .....	612
10.3B.3	Minimum conformance requirements .....	612
10.3B.4	Test description.....	612

10.3B.4.1	Initial conditions .....	612
10.3B.4.2	Test procedure.....	613
10.3B.4.3	Message contents .....	613
10.3B.5	Test requirement .....	613
10.3C	FDD RSTD Measurement Accuracy for Carrier Aggregation for 10 MHz + 5 MHz Bandwidth.....	613
10.3C.1	Test purpose.....	613
10.3C.2	Test applicability .....	614
10.3C.3	Minimum conformance requirements .....	614
10.3C.4	Test description.....	614
10.3C.4.1	Initial conditions .....	614
10.3C.4.2	Test procedure.....	614
10.3C.4.3	Message contents .....	614
10.3C.5	Test requirement .....	614
10.4	TDD RSTD Measurement Accuracy for Carrier Aggregation .....	615
10.4.1	Test purpose.....	615
10.4.2	Test applicability .....	615
10.4.3	Minimum conformance requirements .....	615
10.4.4	Test description.....	615
10.4.4.1	Initial conditions .....	615
10.4.4.2	Test procedure.....	618
10.4.4.3	Message contents .....	619
10.4.5	Test requirement .....	622
10.4A	TDD RSTD Measurement Accuracy for Carrier Aggregation for 20 MHz Bandwidth (Rel-10 and Rel-11) .....	623
10.4A.1	Test purpose.....	623
10.4A.2	Test applicability .....	623
10.4A.3	Minimum conformance requirements .....	623
10.4A.4	Test description.....	624
10.4A.4.1	Initial conditions .....	624
10.4A.4.2	Test procedure.....	624
10.4A.4.3	Message contents .....	624
10.4A.5	Test requirement .....	624
10.4A_1	TDD RSTD Measurement Accuracy for Carrier Aggregation for 20 MHz Bandwidth (Rel-12 onwards)....	624
10.4A_1.1	Test purpose.....	624
10.4A_1.2	Test applicability .....	625
10.4A_1.3	Minimum conformance requirements .....	625
10.4A_1.4	Test description.....	625
10.4A_1.4.1	Initial conditions .....	625
10.4A_1.4.2	Test procedure.....	625
10.4A_1.4.3	Message contents .....	625
10.4A_1.5	Test requirement .....	625
10.4B	TDD RSTD Measurement Accuracy for Carrier Aggregation for 5 MHz + 5 MHz bandwidth .....	625
10.4B.1	Test purpose.....	625
10.4B.2	Test applicability .....	625
10.4B.3	Minimum conformance requirements .....	625
10.4B.4	Test description.....	625
10.4B.4.1	Initial conditions .....	625
10.4B.4.2	Test procedure.....	626
10.4B.4.3	Message contents .....	626
10.4B.5	Test requirement .....	626
10.4C	TDD RSTD Measurement Accuracy for Carrier Aggregation for 10 MHz + 5 MHz Bandwidth .....	626
10.4C.1	Test purpose.....	626
10.4C.2	Test applicability .....	627
10.4C.3	Minimum conformance requirements .....	627
10.4C.4	Test description.....	627
10.4C.4.1	Initial conditions .....	627
10.4C.4.2	Test procedure.....	627
10.4C.4.3	Message contents .....	627
10.4C.5	Test requirement .....	627
10.4D	TDD RSTD Measurement Accuracy for Carrier Aggregation for 20 MHz+10 MHz Bandwidth .....	628
10.4D.1	Test purpose.....	628
10.4D.2	Test applicability .....	628

10.4D.3	Minimum conformance requirements .....	628
10.4D.4	Test description.....	628
10.4D.4.1	Initial conditions .....	628
10.4D.4.2	Test procedure.....	629
10.4D.4.3	Message contents .....	629
10.4D.5	Test requirement .....	629
10.5	FDD 3 DL CA RSTD Measurement Reporting Delay .....	629
10.5.1	Test Purpose.....	629
10.5.2	Test applicability .....	630
10.5.3	Minimum conformance requirements .....	630
10.5.3.1	Measurements on the secondary component carrier .....	630
10.5.3.2	Measurements on both primary component carrier and secondary component carrier .....	630
10.5.3.3	Measurements on different secondary component carriers .....	630
10.5.4	Test description.....	630
10.5.4.1	Initial conditions .....	630
10.5.4.2	Test procedure.....	634
10.5.4.3	Message contents .....	636
10.5.5	Test Requirements .....	641
10.6	TDD 3 DL CA RSTD Measurement Reporting Delay .....	643
10.6.1	Test Purpose.....	643
10.6.2	Test applicability .....	643
10.6.3	Minimum conformance requirements .....	643
10.6.3.1	Measurements on the secondary component carrier .....	643
10.6.3.2	Measurements on both primary component carrier and secondary component carrier .....	643
10.6.3.3	Measurements on different secondary component carriers .....	644
10.6.4	Test description.....	644
10.6.4.1	Initial conditions .....	644
10.6.4.2	Test procedure.....	649
10.6.4.3	Message contents .....	650
10.6.5	Test Requirements .....	655
10.7	FDD RSTD Measurement Accuracy for 3DL Carrier Aggregation .....	658
10.7.1	Test purpose.....	658
10.7.2	Test applicability .....	658
10.7.3	Minimum conformance requirements .....	658
10.7.4	Test description.....	658
10.7.4.1	Initial conditions .....	658
10.7.4.2	Test procedure.....	662
10.7.4.3	Message contents .....	663
10.7.5	Test requirement .....	668
10.8	TDD RSTD Measurement Accuracy for 3DL Carrier Aggregation .....	669
10.8.1	Test purpose.....	669
10.8.2	Test applicability .....	669
10.8.3	Minimum conformance requirements .....	669
10.8.4	Test description.....	669
10.8.4.1	Initial conditions .....	669
10.8.4.2	Test procedure.....	673
10.8.4.3	Message contents .....	674
10.8.5	Test requirement .....	679
11	E-UTRA MBS measurement requirements.....	680
11.1	MBS Measurement Reporting Delay (Release 13 only) .....	680
11.1.1	Test purpose.....	680
11.1.2	Test applicability .....	680
11.1.3	Minimum conformance requirements .....	680
11.1.4	Test description.....	680
11.1.4.1	Initial conditions .....	680
11.1.4.2	Test procedure.....	680
11.1.4.3	Message contents .....	681
11.1.5	Test requirement .....	683
11.1A	MBS Measurement Reporting Delay (Release 14 Onwards) .....	684
11.1A.1	Test purpose.....	684
11.1A.2	Test applicability .....	684



11.1A.3	Minimum conformance requirements .....	684
11.1A.4	Test description.....	684
11.1A.4.1	Initial conditions .....	684
11.1A.4.2	Test procedure.....	684
11.1A.4.3	Message contents .....	685
11.1A.5	Test requirement .....	686
11.2	MBS Sensitivity Measurement Accuracy (Release 13 only).....	686
11.2.1	Test purpose.....	686
11.2.2	Test applicability .....	686
11.2.3	Minimum conformance requirements .....	686
11.2.4	Test description.....	686
11.2.4.1	Initial conditions .....	686
11.2.4.2	Test procedure.....	686
11.2.4.3	Message contents .....	687
11.2.5	Test requirement .....	689
11.2A	MBS Sensitivity Measurement Accuracy (Release 14 Onwards) .....	690
11.2A.1	Test purpose.....	690
11.2A.2	Test applicability .....	690
11.2A.3	Minimum conformance requirements .....	691
11.2A.4	Test description.....	691
11.2A.4.1	Initial conditions .....	691
11.2A.4.2	Test procedure.....	691
11.2A.4.3	Message contents .....	691
11.2A.5	Test requirement .....	693
11.3	MBS Nominal Measurement Accuracy (Release 13 only).....	693
11.3.1	Test purpose.....	693
11.3.2	Test applicability .....	693
11.3.3	Minimum conformance requirements .....	693
11.3.4	Test description.....	693
11.3.4.1	Initial conditions .....	693
11.3.4.2	Test procedure.....	693
11.3.4.3	Message contents .....	694
11.3.5	Test requirement .....	696
11.3A	MBS Nominal Measurement Accuracy (Release 14 Onwards) .....	697
11.3A.1	Test purpose.....	697
11.3A.2	Test applicability .....	697
11.3A.3	Minimum conformance requirements .....	698
11.3A.4	Test description.....	698
11.3A.4.1	Initial conditions .....	698
11.3A.4.2	Test procedure.....	698
11.3A.4.3	Message contents .....	698
11.3A.5	Test requirement .....	700
11.4	MBS Dynamic Range Measurement Accuracy (Release 13 only).....	700
11.4.1	Test purpose.....	700
11.4.2	Test applicability .....	700
11.4.3	Minimum conformance requirements .....	700
11.4.4	Test description.....	700
11.4.4.1	Initial conditions .....	700
11.4.4.2	Test procedure.....	701
11.4.4.3	Message contents .....	701
11.4.5	Test requirement .....	705
11.4A	MBS Dynamic Range Measurement Accuracy (Release 14 Onwards).....	706
11.4A.1	Test purpose.....	706
11.4A.2	Test applicability .....	706
11.4A.3	Minimum conformance requirements .....	706
11.4A.4	Test description.....	706
11.4A.4.1	Initial conditions .....	706
11.4A.4.2	Test procedure.....	706
11.4A.4.3	Message contents .....	706
11.4A.5	Test requirement .....	709
11.5	MBS Measurement Accuracy in Multipath (Release 13 only).....	709
11.5.1	Test purpose.....	709

11.5.2	Test applicability .....	709
11.5.3	Minimum conformance requirements .....	709
11.5.4	Test description .....	710
11.5.4.1	Initial conditions .....	710
11.5.4.2	Test procedure .....	710
11.5.4.3	Message contents .....	710
11.5.5	Test requirement .....	712
11.5A	MBS Measurement Accuracy in Multipath (Release 14 Onwards) .....	713
11.5A.1	Test purpose .....	713
11.5A.2	Test applicability .....	713
11.5A.3	Minimum conformance requirements .....	713
11.5A.4	Test description .....	714
11.5A.4.1	Initial conditions .....	714
11.5A.4.2	Test procedure .....	714
11.5A.4.3	Message contents .....	714
11.5A.5	Test requirement .....	716
12	E-UTRA WLAN and BLE measurement requirements .....	716
12.1	WLAN Access Point Identification and Reporting Delay .....	716
12.1.1	WLAN AP Identification and reporting delay under nominal conditions .....	716
12.1.1.1	Test purpose .....	716
12.1.1.2	Test applicability .....	716
12.1.1.3	Minimum conformance requirements .....	716
12.1.1.4	Test description .....	717
12.1.1.4.1	Initial conditions .....	717
12.1.1.4.2	Test procedure .....	717
12.1.1.4.3	Message contents .....	718
12.1.1.5	Test requirement .....	719
12.1.2	WLAN AP Identification and reporting delay under dynamic range conditions .....	721
12.1.2.1	Test purpose .....	721
12.1.2.2	Test applicability .....	722
12.1.2.3	Minimum conformance requirements .....	722
12.1.2.4	Test description .....	722
12.1.2.4.1	Initial conditions .....	722
12.1.2.4.2	Test procedure .....	723
12.1.2.4.3	Message contents .....	723
12.1.2.5	Test requirement .....	723
12.2	BLE Identification and Reporting Delay .....	725
12.2.1	Bluetooth identification .....	725
12.2.1.1	Test purpose .....	725
12.2.1.2	Test applicability .....	725
12.2.1.3	Minimum conformance requirements .....	725
12.2.1.4	Test description .....	725
12.2.1.4.1	Initial conditions .....	725
12.2.1.4.2	Test procedure .....	726
12.2.1.4.3	Message contents .....	726
12.2.1.5	Test requirement .....	727
<b>Annex A (informative):</b>	<b>Connection Diagrams .....</b>	<b>730</b>
<b>Annex B (normative):</b>	<b>Converting A-GNSS UE-assisted measurement reports into position estimates .....</b>	<b>738</b>
B.1	Introduction .....	738
B.2	UTRAN UE measurement reports for A-GPS L1 C/A only .....	738
B.3	UTRAN UE measurement reports for A-GNSS .....	738
B.4	E-UTRAN UE measurement reports .....	740
B.5	WLS position solution .....	740
<b>Annex C (normative):</b>	<b>General test conditions and declarations .....</b>	<b>743</b>
C.1	Acceptable uncertainty of Test System .....	743
C.1.1	Measurement of test environments .....	743
C.1.2	A-GNSS Minimum Performance requirements .....	744
C.1.3	ECID and OTDOA Measurement requirements .....	745

C.1.4	MBS Minimum Performance requirements .....	754
C.1.5	WLAN and BLE measurement requirements .....	754
C.2	Test Parameter Relaxations (This clause is informative) .....	754
C.2.1	A-GNSS Minimum Performance requirements .....	755
C.2.2	ECID and OTDOA Measurement requirements .....	756
C.2.3	MBS Minimum Performance requirements .....	762
C.2.4	WLAN and BLE measurement requirements .....	762
C.3	Interpretation of measurement results .....	762
C.4	Derivation of Test Requirements (This clause is informative).....	762
<b>Annex D (normative): Rules for statistical testing .....</b>		<b>777</b>
D.1	Test Method.....	777
D.2	Error Ratio (ER).....	777
D.3	Test Design.....	777
D.3.1	Confidence level .....	777
D.3.2	Introduction: Supplier Risk versus Customer Risk.....	777
D.3.3	Supplier Risk versus Customer Risk.....	778
D.3.4	Introduction: Standard test versus early decision concept .....	778
D.3.5	Standard test versus early decision concept.....	779
D.3.6	Selectivity .....	779
D.3.7	Design of the test .....	780
D.4	Pass fail decisions.....	782
D.4.1	Numerical definition of the pass fail limits for A-GNSS test cases .....	782
D.4.2	Pass fail decision rules for A-GNSS test cases .....	782
D.4.3	Numerical definition of the pass fail limits for ECID, OTDOA, MBS, WLAN and BLE test cases.....	783
D.4.4	Pass fail decision rules for ECID, OTDOA, MBS, WLAN and BLE test cases.....	784
D.4.5	Background information to the pass fail limits .....	784
<b>Annex E (normative): Conditions for ECID and OTDOA requirements.....</b>		<b>786</b>
E.1	Conditions for E-CID UE Rx – Tx time difference Measurements.....	786
E.1.1	Conditions for E-CID UE Rx – Tx time difference by UE Category M1/M2 .....	786
E.2	Conditions for OTDOA intra-frequency RSTD Measurements .....	787
E.3	Conditions for OTDOA inter-frequency RSTD Measurements .....	787
E.3.1	Conditions for OTDOA inter-frequency RSTD Measurements by UE Category M1 and M2.....	787
E.4	Conditions for UE Rx-Tx Time Difference Measurement under Time Domain Measurement Resource Restriction with CRS Assistance Information .....	788
E.5	Conditions for NB-IOT OTDOA intra-frequency RSTD Measurements.....	788
E.6	Conditions for NB-IOT OTDOA inter-frequency RSTD Measurements.....	788
<b>Annex F (normative): UTRAN Generic procedures.....</b>		<b>789</b>
F.1	General .....	789
F.2	UTRAN connection set up .....	789
F.2.1	Initial conditions .....	789
F.2.2	Procedures.....	789
F.2.3	Specific message contents .....	790
F.3	UTRAN connection release.....	790
F.3.1	Procedure .....	790
F.3.2	Specific message contents .....	790
<b>Annex G (normative): Environmental conditions .....</b>		<b>791</b>
G.1	General .....	791
G.2	Environmental requirements .....	791
G.2.1	Temperature.....	791
G.2.2	Voltage.....	791
<b>Annex H (informative): MBS Beacon parameters.....</b>		<b>792</b>
H.1	General .....	792
H.2	Beacon parameters .....	792
<b>Annex I (informative): Change history .....</b>		<b>793</b>
History .....		801

---

# Foreword

This Technical Specification has been produced by the 3<sup>rd</sup> Generation Partnership Project (3GPP).

The contents of the present document are subject to continuing work within the TSG and may change following formal TSG approval. Should the TSG modify the contents of the present document, it will be re-released by the TSG with an identifying change of release date and an increase in version number as follows:

Version x.y.z

where:

- x the first digit:
  - 1 presented to TSG for information;
  - 2 presented to TSG for approval;
  - 3 or greater indicates TSG approved document under change control.
- y the second digit is incremented for all changes of substance, i.e. technical enhancements, corrections, updates, etc.
- z the third digit is incremented when editorial only changes have been incorporated in the document.

---

# Introduction

The present document is part 1 of a multi-parts TS:

**3GPP TS 37.571-1: Universal Terrestrial Radio Access (UTRA) and Evolved UTRA (E-UTRA) and Evolved Packet Core (EPC); User Equipment (UE) conformance specification for UE positioning; Part 1: Conformance test specification.**

3GPP TS 37.571-2: Universal Terrestrial Radio Access (UTRA) and Evolved UTRA (E-UTRA) and Evolved Packet Core (EPC); User Equipment (UE) conformance specification for UE positioning; Part 2: Protocol conformance.

3GPP TS 37.571-3: Universal Terrestrial Radio Access (UTRA) and Evolved UTRA (E-UTRA) and Evolved Packet Core (EPC); User Equipment (UE) conformance specification for UE positioning; Part 3: Implementation Conformance Statement (ICS).

3GPP TS 37.571-4: Universal Terrestrial Radio Access (UTRA) and Evolved UTRA (E-UTRA) and Evolved Packet Core (EPC); User Equipment (UE) conformance specification for UE positioning; Part 4: Test suites.

3GPP TS 37.571-5: Universal Terrestrial Radio Access (UTRA) and Evolved UTRA (E-UTRA) and Evolved Packet Core (EPC); User Equipment (UE) conformance specification for UE positioning; Part 5: Test scenarios and assistance data.

---

# 1 Scope

The present document specifies the procedures for the conformance test of the measurement requirements for FDD or TDD mode of UTRA and FDD or TDD mode of E-UTRA for the User Equipment (UE) that supports one or more of the defined positioning methods. These positioning methods are for UTRA: Assisted Global Positioning System (A-GPS), Assisted Global Navigation Satellite Systems (A-GNSS) and for E-UTRA: Assisted Global Navigation Satellite System (A-GNSS), Observed Time Difference of Arrival (OTDOA), Enhanced Cell ID (ECID), Metropolitan Beacon System (MBS).

Tests are only applicable to those mobiles that are intended to support the appropriate functionality. To indicate the circumstances in which tests apply, this is noted in the "Test applicability " part of the test.

The Implementation Conformance Statement (ICS) pro-forma could be found in the 3<sup>rd</sup> part of the present document.

---

# 2 References

The following documents contain provisions which, through reference in this text, constitute provisions of the present document.

- References are either specific (identified by date of publication, edition number, version number, etc.) or non-specific.
- For a specific reference, subsequent revisions do not apply.
- For a non-specific reference, the latest version applies. In the case of a reference to a 3GPP document (including a GSM document), a non-specific reference implicitly refers to the latest version of that document in the same Release as the present document unless the context in which the reference is made suggests a different Release is relevant (information on the applicable release in a particular context can be found in e.g. test case title, description or applicability, message description or content).

- [1] 3GPP TR 21.905: "Vocabulary for 3GPP Specifications".
- [2] 3GPP TS 36.101: "Evolved Universal Terrestrial Radio Access (E-UTRA); User Equipment (UE) radio transmission and reception".
- [3] 3GPP TS 36.171: "Evolved Universal Terrestrial Radio Access (E-UTRA); Requirements for Support of Assisted Global Navigation Satellite System (A-GNSS)".
- [4] 3GPP TS 36.355: "Evolved Universal Terrestrial Radio Access (E-UTRA); LTE Positioning Protocol (LPP)".
- [5] 3GPP TS 36.302: "Evolved Universal Terrestrial Radio Access (E-UTRA); Services provided by the physical layer".
- [6] 3GPP TS 36.214: "Evolved Universal Terrestrial Radio Access (E-UTRA); Physical layer; Measurements".
- [7] ETSI TR 102 273-1-2: "Electromagnetic compatibility and Radio spectrum Matters (ERM); Improvement on Radiated Methods of Measurement (using test site) and evaluation of the corresponding measurement uncertainties; Part 1: Uncertainties in the measurement of mobile radio equipment characteristics; Sub-part 2: Examples and annexes".
- [8] IS-GPS-200, Revision D, Navstar GPS Space Segment/Navigation User Interfaces, March 7th, 2006.
- [9] P. Axelrad, R.G. Brown, "GPS Navigation Algorithms", in Chapter 9 of "Global Positioning System: Theory and Applications", Volume 1, B.W. Parkinson, J.J. Spilker (Ed.), Am. Inst. of Aeronautics and Astronautics Inc., 1996.
- [10] S.K. Gupta, "Test and Evaluation Procedures for the GPS User Equipment", ION-GPS Red Book, Volume 1, p.119.

- [11] 3GPP TS 36.509: "Evolved Universal Terrestrial Radio Access (E-UTRA) and Evolved Packet Core (EPC); Special conformance testing functions for User Equipment (UE)".
- [12] IS-GPS-705, Navstar GPS Space Segment/User Segment L5 Interfaces, September 22, 2005.
- [13] IS-GPS-800, Navstar GPS Space Segment/User Segment L1C Interfaces, September 4, 2008.
- [14] IS-QZSS, Quasi Zenith Satellite System Navigation Service Interface Specifications for QZSS, Ver.1.1, July 31, 2009.
- [15] Galileo OS Signal in Space ICD (OS SIS ICD), Issue 1.2, February 2014, European Union.
- [16] Global Navigation Satellite System GLONASS Interface Control Document, Version 5.1, 2008.
- [17] Specification for the Wide Area Augmentation System (WAAS), US Department of Transportation, Federal Aviation Administration, DTFA01-96-C-00025, 2001.
- [18] 3GPP TS 36.508: "Evolved Universal Terrestrial Radio Access (E-UTRA) and Evolved Packet Core (EPC); Common test environments for User Equipment (UE) conformance testing".
- [19] 3GPP TS 25.172: "Requirements for support of Assisted Galileo and Additional Navigation Satellite Systems (A-GANSS); Frequency Division Duplex (FDD)".
- [20] 3GPP TS 37.571-5: "Universal Terrestrial Radio Access (UTRA) and Evolved UTRA (E-UTRA) and Evolved Packet Core (EPC); User Equipment (UE) conformance specification for UE positioning; Part 5: Test scenarios and assistance data
- [21] 3GPP TS 36.104: "Evolved Universal Terrestrial Radio Access (E-UTRA); Base Station (BS) radio transmission and reception".
- [22] 3GPP TS 36.331: "Evolved Universal Terrestrial Radio Access (E-UTRA); Radio Resource Control (RRC); Protocol specification".
- [23] 3GPP TS 36.133: "Evolved Universal Terrestrial Radio Access (E-UTRA); Requirements for support of radio resource management".
- [24] 3GPP TS 36.521-1: "Evolved Universal Terrestrial Radio Access (E-UTRA); User Equipment (UE) conformance specification Radio transmission and reception Part 1: Conformance Testing".
- [25] 3GPP TS 36.521-3: "Evolved Universal Terrestrial Radio Access (E-UTRA); User Equipment (UE) conformance specification; Radio transmission and reception; Part 3: Radio Resource Management (RRM) conformance testing".
- [26] 3GPP TS 36.211: "Evolved Universal Terrestrial Radio Access (E-UTRA); Physical Channels and Modulation".
- [27] 3GPP TR 25.990: "Vocabulary for UTRAN".
- [28] 3GPP TS 34.108: "Common test environments for User Equipment (UE) conformance testing".
- [29] 3GPP TS 34.109: "Terminal logical test interface; Special conformance testing functions".
- [30] 3GPP TS 25.331: "Radio Resource Control (RRC) protocol specification".
- [31] 3GPP TS 25.171: "Requirements for support of Assisted Global Positioning System (A-GPS); Frequency Division Duplex (FDD)".
- [32] 3GPP TS 25.302: "Services provided by the physical layer".
- [33] 3GPP TS 25.215: "Physical layer; Measurements (FDD)".
- [34] 3GPP TS 36.321: "Medium Access Control (MAC) protocol specification".
- [35] 3GPP TS 36.423: "X2 application protocol (X2AP)".
- [36] 3GPP TS 25.173: "Requirements for support of Assisted Galileo and Additional Navigation Satellite Systems (A-GANSS); Time Division Duplex (TDD)".

- [37] BDS-SIS-ICD-B1I: "BeiDou Navigation Satellite System Signal In Space Interface Control Document Open Service Signal".
- [38] ATIS-0500027: "Recommendations for Establishing Wide Scale Indoor Location Performance", May 2015.
- [39] 3GPP TS 37.171: "Universal Terrestrial Radio Access (UTRA) and Evolved Universal Terrestrial Radio Access (E-UTRA); User Equipment (UE) performance requirements for RAT-Independent Positioning Enhancements".
- [40] IEEE Standard 802.11: Wireless LAN Medium Access Control (MAC) and Physical Layer (PHY) Specifications.
- [41] 3GPP TS 36.305: "Evolved Universal Terrestrial Radio Access Network (E-UTRAN); Stage 2 functional specification of User Equipment (UE) positioning in E-UTRAN".
- [42] 3GPP TS 23.401: "General Packet Radio Service (GPRS) enhancements for Evolved Universal Terrestrial Radio Access Network (E-UTRAN) access".

## 3 Definitions, symbols and abbreviations

### 3.1 Definitions

For the purposes of the present document, the terms and definitions given in TR 21.905 [1], 3GPP TR 25.990 [27], TS 36.101 [2], 3GPP TS 36.104 [21] and the following apply. A term defined in the present document takes precedence over the definition of the same term, if any, in TR 21.905 [1].

**Horizontal Dilution Of Precision (HDOP):** measure of position determination accuracy that is a function of the geometrical layout of the satellites used for the fix, relative to the receiver antenna

### 3.2 Symbols

For the purposes of the present document, the abbreviations given in TR 21.905 [1], 3GPP TR 25.990 [27] and the following apply. An abbreviation defined in the present document takes precedence over the definition of the same abbreviation, if any, in TR 21.905 [1].

B1I	BeiDou B1I navigation signal with carrier frequency of 1561.098 MHz
E1	Galileo E1 navigation signal with carrier frequency of 1575.420 MHz.
E5	Galileo E5 navigation signal with carrier frequency of 1191.795 MHz.
E6	Galileo E6 navigation signal with carrier frequency of 1278.750 MHz.
G1	GLONASS navigation signal in the L1 sub-bands with carrier frequencies $1602 \text{ MHz} \pm k \times 562.5 \text{ kHz}$ .
G2	GLONASS navigation signal in the L2 sub-bands with carrier frequencies $1246 \text{ MHz} \pm k \times 437.5 \text{ kHz}$ .
k	GLONASS channel number, $k = -7 \dots 13$ .
L1 C/A	GPS or QZSS L1 navigation signal carrying the Coarse/Acquisition code with carrier frequency of 1575.420 MHz.
L1C	GPS or QZSS L1 Civil navigation signal with carrier frequency of 1575.420 MHz.
L2C	GPS or QZSS L2 Civil navigation signal with carrier frequency of 1227.600 MHz.
L5	GPS or QZSS L5 navigation signal with carrier frequency of 1176.450 MHz.
PRP	Received (linear) average power of the resource elements that carry E-UTRA PRS, measured at the UE antenna connector.
<b>G</b>	Geometry Matrix.
$\rho_{GNSS_m,i}$	Measured pseudo-range of satellite $i$ of GNSS <sub>m</sub> .
<b>W</b>	Weighting Matrix.
$\mathbf{1}_{GNSS_m,i}$	Line of sight unit vector from the user to the satellite $i$ of GNSS <sub>m</sub> .
<b>x</b>	State vector of user position and clock bias.
T <sub>s</sub>	Basic time unit, defined in TS 36.211 [26], clause 4.
Ê <sub>s</sub>	Received energy per RE (power normalized to the subcarrier spacing) during the useful part of the symbol, i.e. excluding the cyclic prefix, at the UE antenna connector.

$I_o$	The total received power density, including signal and interference, as measured at the UE antenna connector.
$I_{ot}$	The received power spectral density of the total noise and interference for a certain RE (power integrated over the RE and normalized to the subcarrier spacing) as measured at the UE antenna connector.
$N_{oc}$	The power spectral density of a white noise source (average power per RE normalised to the subcarrier spacing), simulating interference from cells that are not defined in a test procedure, as measured at the UE antenna connector.
$PRS \hat{E}_s / I_{ot}$	The ratio of the average received energy per PRS RE during the useful part of the symbol to the average received power spectral density of the total noise and interference for this RE, where the ratio is measured over all REs which carry PRS.

### 3.3 Abbreviations

For the purposes of the present document, the following abbreviations apply:

A-GANSS	Assisted Galileo and Additional Navigation Satellite Systems
A-Galileo	Assisted-Galileo
A-GLONASS	Assisted-- GLObal'naya NAVigatsionnaya Sputnikovaya Sistema (English: Global Navigation Satellite System)
A-GNSS	Assisted Global Navigation Satellite System
A-GPS	Assisted - Global Positioning System
AP	Access Point
AWGN	Additive White Gaussian Noise
BDS	BeiDou Navigation Satellite System
BLE	Bluetooth Low Energy
BSS	Bluetooth System Simulator
BSSID	Basic Service Set IDENTification
C/A	Coarse/Acquisition
DRX	Discontinuous Reception
DUT	Device Under Test
ECEF	Earth Centred, Earth Fixed
ECID	Enhanced Cell Identification
EPRE	Energy Per Resource Element
E-UTRA	Evolved UMTS Terrestrial Radio Access
E-UTRAN	Evolved UMTS Terrestrial Radio Access Network
FDD	Frequency Division Duplex
GANSS	Galileo and Additional Navigation Satellite Systems
GEO	Geostationary Earth Orbit
GLONASS	GLObal'naya NAVigatsionnaya Sputnikovaya Sistema (English: Global Navigation Satellite System)
GNSS	Global Navigation Satellite System
GPS	Global Positioning System
GSS	GNSS System Simulator
HD-FDD	Half Duplex - Frequency Division Duplex
HDOP	Horizontal Dilution Of Precision
ICD	Interface Control Document
ICS	Implementation Conformance Statement
IGSO	Inclined Geosynchronous Satellite Orbit
IS	Interface Specification
LOS	Line Of Sight
LPP	LTE Positioning Protocol
MBS	Metropolitan Beacon System
MSS	MBS System Simulator
MEO	Medium Earth Orbit
NB-IOT	Narrow Band - Internet Of Things
NPRS	NB-IOT Positioning Reference Signal
OCNG	OFDMA Channel Noise Generator
OCNS	Orthogonal Channel Noise Simulator
OTDOA	Observed Time Difference Of Arrival
PBCH	Physical Broadcast Channel



PCC	Primary Component Carrier
PCell	Primary Cell
PCFICH	Physical Control Format Indicator Channel
PDCCH	Physical Downlink Control Channel
PDSCH	Physical Downlink Shared Channel
PHICH	Physical Hybrid ARQ Indicator Channel
PPM	Parts per million
PRS	Positioning Reference Signal
PSS	Primary Synchronization Signal
QZSS	Quasi-Zenith Satellite System
RB	Resource Block
RE	Resource Element
RRC	Radio Resource Control
RSSI	Received Signal Strength Indicator
RSTD	Reference Signal Time Difference
SBAS	Space Based Augmentation System
SCC	Secondary Component Carrier
SCell	Secondary Cell
SFN	System Frame Number
SNR	Signal to Noise Ratio
SS	System simulator
SSS	Secondary Synchronization Signal
SV	Space Vehicle
SV ID	Space Vehicle Identity
TBS	Terrestrial Beacon System
TDD	Time Division Duplex
TOD	Time Of Day
TOW	Time Of Week
TTF	Time To First Fix
UE	User Equipment
UUID	Universal Unique Identifier
UTRA	Universal Terrestrial Radio Access
UTRAN	Universal Terrestrial Radio Access Network
WGS-84	World Geodetic System 1984
WLAN	Wireless Local Area Network
WLS	Weighted Least Square
WSS	WLAN System Simulator

---

## 4 General test conditions

### 4.1 Introduction

This clause defines the various common test conditions required for the various measurement requirements in the remainder of the document.

In this clause the terms GNSS and A-GNSS also include the cases where the only satellite system used is GPS unless otherwise stated.

### 4.2 GNSS test conditions

#### 4.2.1 GNSS signals

The GNSS signal is defined at the A-GNSS antenna connector of the UE. For UE with integral antenna only, a reference antenna with a gain of 0 dBi is assumed.

#### 4.2.2 GNSS frequency

The GNSS signals shall be transmitted with a frequency accuracy of  $\pm 0.025$  PPM.

### 4.2.3 GNSS static propagation conditions

The propagation for the static performance measurement is an Additive White Gaussian Noise (AWGN) environment. No fading and multi-paths exist for this propagation model.

### 4.2.4 GNSS multi-path conditions

Doppler frequency difference between direct and reflected signal paths is applied to the carrier and code frequencies. The Carrier and Code Doppler frequencies of LOS and multi-path for GNSS signals are defined in table 4.2.1.

**Table 4.2.1: Multi-path Conditions for GNSS Signals**

Initial relative Delay [GNSS chip]	Carrier Doppler frequency of tap [Hz]	Code Doppler frequency of tap [Hz]	Relative mean Power [dB]
0	$F_d$	$F_d / N$	0
X	$F_d - 0.1$	$(F_d - 0.1) / N$	Y

NOTE: Discrete Doppler frequency is used for each tap.

Where the X and Y depends on the GNSS signal type and is shown in Table 4.2.2, and N is the ratio between the transmitted carrier frequency of the signals and the transmitted chip rate as shown in Table 4.2.3 (where k in Table 4.2.3 is the GLONASS frequency channel number).

**Table 4.2.2**

System	Signals	X [m]	Y [dB]
Galileo	E1	125	-4.5
	E5a	15	-6
	E5b	15	-6
GPS/Modernized GPS	L1 C/A	0.5 chip / 150m	-6
	L1C	125	-4.5
	L2C	150	-6
	L5	15	-6
GLONASS	G1	275	-12.5
	G2	275	-12.5
BDS	B1I	75	-4.5

**Table 4.2.3**

System	Signals	N
Galileo	E1	1540
	E5a	115
	E5b	118
GPS/Modernized GPS	L1 C/A	1540
	L1C	1540
	L2C	1200
	L5	115
GLONASS	G1	$3135.03 + k \cdot 1.10$
	G2	$2438.36 + k \cdot 0.86$
BDS	B1I	763

The initial carrier phase difference between taps shall be randomly selected between 0 and  $2\pi$  radians. The initial value shall have uniform random distribution.

### 4.2.5 UEs supporting multiple satellite signals

For UEs supporting multiple satellite signals, different minimum performance requirements may be associated with different signals. The satellite simulator shall generate all signals supported by the UE. Signals not supported by the UE do not need to be simulated. The relative power levels of each signal type for each GNSS are defined in Table 4.2.4. The individual test scenarios in clauses 6 and 7 define the reference signal power level for each satellite. The power level of each simulated satellite signal type shall be set to the reference signal power level defined in each test scenario in clauses 6 and 7 plus the relative power level defined in Table 4.2.4.

**Table 4.2.4: Relative signal power levels for each signal type for each GNSS**

	Galileo		GPS/Modernized GPS		GLONASS		QZSS		SBAS		BDS		
	Signal power levels relative to reference power levels	E1	0 dB	L1 C/A	0 dB	G1	0 dB	L1 C/A	0 dB	L1	0 dB	B1I	D1
E6		+2 dB	L1C	+1.5 dB	G2	-6 dB	L1C	+1.5 dB				D2	+5 dB
E5		+2 dB	L2C	-1.5 dB			L2C	-1.5 dB					
			L5	+3.6 dB			L5	+3.6 dB					

NOTE 1: For test cases which involve “Modernized GPS”, the satellite simulator shall also generate the GPS L1 C/A signal if the UE supports “GPS” in addition to “Modernized GPS”.

NOTE 2: The signal power levels in the Test Parameter Tables represent the total signal power of the satellite per channel not e.g. pilot and data channels separately.

NOTE 3: For test cases which involve "BDS", D1 represents MEO/IGSO satellites B1I signal type and D2 represents GEO satellites B1I signal type.

## 4.2.6 GNSS multi System Time Offsets

If more than one GNSS is used in a test, the accuracy of the GNSS-GNSS Time Offsets used at the system simulator shall be better than 3 ns.

## 4.3 UTRA test conditions

### 4.3.1 UTRA frequency band and frequency range

The UTRA tests in clauses 5 and 6 in the present document are performed at mid range of the UTRA operating frequency band of the UE. The UARFCNs to be used for mid range are defined in 3GPP TS 34.108 [28], clause 5.1.1.

If the UE supports multiple frequency bands then the Sensitivity tests in clauses 5.2 and 6.2 shall be repeated in each supported frequency band.

### 4.3.2 UTRA frequency

For the UTRA tests in clause 5 the UTRA frequency shall be offset with respect to the nominal frequency by an amount equal to the sum of +0.025 PPM and the offset in PPM of the actual transmitted GPS carrier frequency with respect to the nominal GPS frequency.

### 4.3.3 Sensors

The UTRA tests in clause 6 shall be met without the use of any data coming from sensors that can aid the positioning. A dedicated test message 'RESET UE POSITIONING STORED INFORMATION' has been defined in TS 34.109 [29] for the purpose of disabling any such sensors.

## 4.4 E-UTRA test conditions

### 4.4.1 E-UTRA frequency band and frequency range

The E-UTRA A-GNSS tests in clause 7, MBS tests in clause 11, WLAN and BLE tests in clause 12 are performed on the mid range EARFCN of the E-UTRA operating frequency band of the UE and the channel bandwidth as defined in TS 36.508 [18] clause 4.3.1.

If the UE supports multiple frequency bands then the A-GNSS Sensitivity tests in clause 7.1 shall be repeated in each supported frequency band.

The E-UTRA ECID tests in clause 8 and the OTDOA tests in clauses 9 and 10 are performed on the EARFCN(s) of the E-UTRA operating frequency band of the UE and the channel bandwidth(s) specified in the test cases and as defined in TS 36.508 [18] clause 4.3.1 and 4.4.2.

## 4.4.2 Groups of bands

The E-UTRA tests in clauses 8, 9 and 10 use the band groupings below in order to increase the readability of the specification.

**Table 4.4.2-1: E-UTRA band groups**

Group	E-UTRA FDD		E-UTRA TDD		E-UTRA Frame Structure 3	
	Band group notation	Operating bands	Band group notation	Operating bands	Band group notation	Operating bands
A	FDD_A	1, 4, 6, 10, 11, 18, 19, 21, 23, 24, 32 <sup>Note 2</sup> , 67 <sup>Note 2</sup> , 69 <sup>Note 2</sup> , 70 <sup>Note 6</sup>	TDD_A	33, 34, 35, 36, 37, 38, 39, 40, 45	FS3_A	-
B	FDD_B1	65, 66 <sup>Note 5</sup>	TDD_B	-	FS3_B	-
	FDD_B2	74 <sup>Note 7</sup>				
C	FDD_C	9, 30	TDD_C	42, 43, 48	FS3_C	-
D	FDD_D	28, 68	TDD_D	-	FS3_D	-
E	FDD_E	2, 5, 7, 27	TDD_E	41, 44	FS3_E	-
F	FDD_F	26 <sup>Note 3</sup>	TDD_F	-	FS3_F	-
G	FDD_G	3, 8, 12, 13, 14, 17, 20, 22, 29 <sup>Note 2</sup> , 71	TDD_G	47 <sup>Note 4</sup>	FS3_G	46 <sup>Note 2</sup>
H	FDD_H	25	TDD_H	-	FS3_H	-
I	FDD_I	-	TDD_I	-	FS3_I	-
J	FDD_J	-	TDD_J	-	FS3_J	-
K	FDD_K	-	TDD_K	-	FS3_K	-
L	FDD_L	-	TDD_L	-	FS3_L	-
M	FDD_M	-	TDD_M	-	FS3_M	-
N	FDD_N	31, 72	TDD_N	-	FS3_N	-

NOTE 1: The bands within the same group have the same Io conditions in a corresponding requirement in this specification.

NOTE 2: This band is used only for E-UTRA carrier aggregation with other E-UTRA bands.

NOTE 3: The minimum Io condition for Band 26 is reduced by 0.5 dB when the carrier frequency of the assigned E-UTRA channel bandwidth is within 865-894 MHz.

NOTE 4: This band is used only for V2V operation.

NOTE 5: The range 2180-2200 MHz of the DL operating band 66 is restricted to E-UTRA operation when carrier aggregation is configured.

NOTE 6: The range 2010-2020 MHz of the DL operating band is restricted to E-UTRA operation when carrier aggregation is configured and TX-RX separation is 300 MHz. The range 2005-2020 MHz of the DL operating band is restricted to E-UTRA operation when carrier aggregation is configured and TX-RX separation is 295 MHz.

NOTE 7: The minimum Io condition for Band 74 is reduced by 0.5 dB when the carrier frequency of the assigned E-UTRA channel bandwidth is within 1475.9-1510.9 MHz.

## 4.4.3 Sensors

All the minimum performance requirements in clause 7 shall be met without the use of any data coming from sensors that can aid the positioning. A dedicated test message 'RESET UE POSITIONING STORED INFORMATION' has been defined in TS 36.509 [11] for the purpose of disabling any such sensors.

## 4.5 A-GNSS test conditions

### 4.5.1 General

Clauses 5, 6 and 7 define the minimum performance requirements for both UE based and UE assisted A-GNSS terminals. If a terminal supports both modes then it shall be tested in both modes.

## 4.5.2 UTRAN measurement parameters

### 4.5.2.1 UE based A-GNSS measurement parameters

In case of UE-based A-GNSS, the measurement parameters are contained in the RRC UE POSITIONING POSITION ESTIMATE INFO IE. The measurement parameter is the horizontal position estimate reported by the UE and expressed in latitude/longitude.

### 4.5.2.2 UE assisted A-GNSS measurement parameters

In case of UE-assisted A-GNSS, the measurement parameters are contained in the RRC UE POSITIONING GANSS MEASURED RESULTS IE and/or the RRC UE POSITIONING GPS MEASURED RESULTS IE. The measurement parameters are the UE GANSS Code Phase measurements and/or the UE GPS Code Phase measurements, as specified in 3GPP TS 25.302 [32] and 3GPP TS 25.215 [33]. The UE GANSS Code Phase measurements and/or the UE GPS Code Phase measurements are converted into a horizontal position estimate using the procedure detailed in Annex B.

### 4.5.2.3 2D position error

The 2D position error is defined by the horizontal difference in meters between the ellipsoid point reported or calculated from the UE Measurement Report and the actual simulated position of the UE in the test case considered.

### 4.5.2.4 Response time

Max Response Time is defined as the time starting from the moment that the UE has received the final RRC measurement control message containing reporting criteria different from "No Reporting" sent before the UE sends the measurement report containing the position estimate or the GANSS and/or GPS measured result, and ending when the UE starts sending the measurement report containing the position estimate or the GANSS and/or GPS measured result on the Uu interface. The response times specified for all test cases are Time-to-First-Fix (TTFF) unless otherwise stated, i.e. the UE shall not re-use any information on GNSS time, location or other aiding data that was previously acquired or calculated and stored internally in the UE. A dedicated test message 'RESET UE POSITIONING STORED INFORMATION' specified in 3GPP TS 34.109 [29], clause 5.4, has been defined for the purpose of deleting this information.

## 4.5.3 E-UTRAN measurement parameters

### 4.5.3.1 UE based A-GNSS measurement parameters

In case of UE-based A-GNSS, the measurement parameters are contained in the LPP *GNSS-LocationInformation* IE which is included in the *A-GNSS-ProvideLocationInformation* IE provided in the LPP message of type PROVIDE LOCATION INFORMATION. The measurement parameter in case of UE-based A-GNSS is the horizontal position estimate reported by the UE and expressed in latitude/longitude.

### 4.5.3.2 UE assisted A-GNSS measurement parameters

In case of UE-assisted A-GNSS, the measurement parameters are contained in the LPP *GNSS-SignalMeasurementInformation* IE which is included in the *A-GNSS-ProvideLocationInformation* IE provided in the LPP message of type PROVIDE LOCATION INFORMATION. The measurement parameters in case of UE-assisted A-GNSS are the UE GNSS code phase measurements, as specified in 3GPP TS 36.302 [5] and 3GPP TS 36.214 [6]. The UE GNSS code phase measurements are converted into a horizontal position estimate using the procedure detailed in Annex B.

### 4.5.3.3 2D Error definition

The 2D position error is defined by the horizontal difference in meters between the ellipsoid point reported or calculated from the LPP message of type PROVIDE LOCATION INFORMATION and the actual position of the UE in the test case considered.

### 4.5.3.4 Response time

Max Response Time is defined as the time starting from the moment that the UE has received the LPP message of type REQUEST LOCATION INFORMATION, and ending when the UE starts sending the LPP message of type PROVIDE LOCATION INFORMATION on the Uu interface. The response times specified for all test cases are Time-to-First-Fix (TTFF) unless otherwise stated, i.e. the UE shall not re-use any information on GNSS time, location or other aiding data

that was previously acquired or calculated and stored internally in the UE. A dedicated test message 'RESET UE POSITIONING STORED INFORMATION' has been defined in TS 36.509 [11] clause 6.9 for the purpose of deleting this information.

#### 4.5.4 Converting A-GNSS UE-assisted measurement reports into position estimates

To convert the A-GNSS UE measurement reports in case of UE-assisted mode of A-GNSS into position errors, a transformation between the "measurement domain" (code-phases, etc.) into the "state" domain (position estimate) is necessary. Such a transformation procedure is outlined in Annex B.

### 4.6 ECID test conditions

#### 4.6.1 Simulated cells

For the ECID performance test cases in clause 8.1, a cell environment as defined in 3GPP TS 36.508 [18] with Cell 1 is used. The default parameters for simulated cells are the same as specified in 3GPP TS 36.508 [18].

#### 4.6.2 Propagation conditions

##### 4.6.2.1 Static

See TS 36.521-1 [24] clause B.1.

##### 4.6.2.2 Multi-path fading

See TS 36.521-1[24] clauses B.2, B.2.1 and B.2.2.

#### 4.6.3 UE Rx - Tx time difference reporting range

The reporting range of FDD UE Rx - Tx time difference is defined from 0 to  $20472T_s$  with  $2T_s$  resolution for UE Rx - Tx time difference less than  $4096T_s$  and  $8T_s$  for UE Rx - Tx time difference equal to or greater than  $4096T_s$ .

The mapping of measured quantity for FDD is defined in Table 4.6.3-1.

**Table 4.6.3-1: FDD UE Rx - Tx time difference measurement report mapping**

Reported value	Measured quantity value	Unit
RX-TX_TIME_DIFFERENCE_FDD_0000	$T_{UE\ Rx-Tx} < 2$	$T_s$
RX-TX_TIME_DIFFERENCE_FDD_0001	$2 \leq T_{UE\ Rx-Tx} < 4$	$T_s$
RX-TX_TIME_DIFFERENCE_FDD_0002	$4 \leq T_{UE\ Rx-Tx} < 6$	$T_s$
...	...	...
RX-TX_TIME_DIFFERENCE_FDD_2046	$4092 \leq T_{UE\ Rx-Tx} < 4094$	$T_s$
RX-TX_TIME_DIFFERENCE_FDD_2047	$4094 \leq T_{UE\ Rx-Tx} < 4096$	$T_s$
RX-TX_TIME_DIFFERENCE_FDD_2048	$4096 \leq T_{UE\ Rx-Tx} < 4104$	$T_s$
RX-TX_TIME_DIFFERENCE_FDD_2049	$4104 \leq T_{UE\ Rx-Tx} < 4112$	$T_s$
...	...	...
RX-TX_TIME_DIFFERENCE_FDD_4093	$20456 \leq T_{UE\ Rx-Tx} < 20464$	$T_s$
RX-TX_TIME_DIFFERENCE_FDD_4094	$20464 \leq T_{UE\ Rx-Tx} < 20472$	$T_s$
RX-TX_TIME_DIFFERENCE_FDD_4095	$20472 \leq T_{UE\ Rx-Tx}$	$T_s$

The reporting range of TDD UE Rx - Tx time difference is defined from 624 to  $21096T_s$  with  $2T_s$  resolution for UE Rx - Tx time difference less than  $4720T_s$  and  $8T_s$  for UE Rx - Tx time difference equal to or greater than  $4720T_s$ .

The mapping of measured quantity for TDD is defined in Table 4.6.3-2.

**Table 4.6.3-2: TDD UE Rx - Tx time difference measurement report mapping**

Reported value	Measured quantity value	Unit
RX-TX_TIME_DIFFERENCE_TDD_0000	$T_{UE\ Rx-Tx} < 626$	$T_s$
RX-TX_TIME_DIFFERENCE_TDD_0001	$626 \leq T_{UE\ Rx-Tx} < 628$	$T_s$
RX-TX_TIME_DIFFERENCE_TDD_0002	$628 \leq T_{UE\ Rx-Tx} < 630$	$T_s$
...	...	...
RX-TX_TIME_DIFFERENCE_TDD_2046	$4716 \leq T_{UE\ Rx-Tx} < 4718$	$T_s$
RX-TX_TIME_DIFFERENCE_TDD_2047	$4718 \leq T_{UE\ Rx-Tx} < 4720$	$T_s$
RX-TX_TIME_DIFFERENCE_TDD_2048	$4720 \leq T_{UE\ Rx-Tx} < 4728$	$T_s$
RX-TX_TIME_DIFFERENCE_TDD_2049	$4728 \leq T_{UE\ Rx-Tx} < 4736$	$T_s$
...	...	...
RX-TX_TIME_DIFFERENCE_TDD_4093	$21080 \leq T_{UE\ Rx-Tx} < 21088$	$T_s$
RX-TX_TIME_DIFFERENCE_TDD_4094	$21088 \leq T_{UE\ Rx-Tx} < 21096$	$T_s$
RX-TX_TIME_DIFFERENCE_TDD_4095	$21096 \leq T_{UE\ Rx-Tx}$	$T_s$

## 4.7 OTDOA test conditions

### 4.7.1 Simulated cells

For the intra-frequency OTDOA measurement test cases in clause 9.1, a multi cell environment as defined in 3GPP TS 36.508 [18] with Cell 1, Cell 2, and Cell 4 (if needed in the test) is used.

For the inter-frequency OTDOA measurement test cases in clause 9.2, a multi cell environment as defined in 3GPP TS 36.508 [18] with Cell 1 (called Cell 1 in the tests), Cell 3 (called Cell 2 in the tests), and Cell 6 (called Cell 3 in the tests) (if needed in the test) is used.

For the intra-frequency OTDOA measurement test cases for UE Category M1/M2 in clause 9.3, a multi cell environment as defined in 3GPP TS 36.508 [18] with Cell 1, Cell 2, and Cell 4 (if needed in the test) is used.

For the inter-frequency OTDOA measurement test cases for UE Category M1/M2 in clause 9.4, a multi cell environment as defined in 3GPP TS 36.508 [18] with Cell 1 (called Cell 1 in the tests), Cell 3 (called Cell 2 in the tests), and Cell 6 (called Cell 3 in the tests) (if needed in the test) is used.

For the intra-frequency NB-IOT OTDOA measurement accuracy test cases in clause 9.5, a multi cell environment with LTE Cell 1 and Cell 1a (see 3GPP TS 36.508 [18] Clause 4.4.2) and NB-IOT Ncell 1 and Ncell 1a (see 3GPP TS 36.508 [18] Clause 8.1.4.2) is used.

For the intra-frequency NB-IOT OTDOA measurement reporting delay test cases in clause 9.5, a multi cell environment with NB-IOT Ncell 1, Ncell 1a and Ncell 2 (see 3GPP TS 36.508 [18] Clause 8.1.4.2) is used.

For the inter-frequency NB-IOT OTDOA measurement accuracy test cases in clause 9.6, a multi cell environment with LTE Cell 1 and Cell 1a (see 3GPP TS 36.508 [18] Clause 4.4.2) and NB-IOT Ncell 1 and Ncell 1a (see 3GPP TS 36.508 [18] Clause 8.1.4.2) is used.

For the inter-frequency NB-IOT OTDOA measurement reporting delay test cases in clause 9.9, a multi cell environment with NB-IOT Ncell 1, Ncell 1a and Ncell 2 (see 3GPP TS 36.508 [18] Clause 8.1.4.2) is used.

For the OTDOA measurement test cases for Carrier Aggregation in clause 10, a multi cell environment is used with Cell 1 as the PCell on the PCC, Cell 2 is an active SCell on the SCC, and Cell 3 is a neighbour cell on the SCC. For the OTDOA measurement test cases for 3 DL Carrier Aggregation in clause 10, a multi cell environment is used with Cell 1 as the PCell on the PCC, Cell 2 is an active SCell on SCC1, Cell 3 is an active SCell on SCC2 and Cell 4 is a neighbour cell on SCC2.

The default parameters for simulated cells are the same as specified in 3GPP TS 36.508 [18], with the following exceptions:

- All cells transmit PRS according to the PRS configuration provided in the OTDOA assistance data defined for each test. The positioning subframes are low-interference subframes, i.e. contain no PDSCH transmissions.

- The physical layer cell identities are selected such that the relative shifts of PRS patterns among cells used in the tests are as given by the test parameters of the individual test cases.
- The cells shall be synchronized and the timing offset (the RSTD) between the cells referenced to the UE's antenna input is given in the individual test cases.

## 4.7.2 Propagation conditions

### 4.7.2.1 Static

See TS 36.521-1 [24] clause B.1.

### 4.7.2.2 Multi-path fading

See TS 36.521-1[24] clauses B.2, B.2.1 and B.2.2.

## 4.7.3 Response time

The response time is defined as the time starting from the moment that the UE has received the LPP message of type REQUEST LOCATION INFORMATION, and ending when the UE starts sending the LPP message of type PROVIDE LOCATION INFORMATION on the Uu interface. The response time specified for the Measurement Reporting Delay test cases assumes that the UE shall not reuse any RSTD information or other aiding data that was previously acquired and stored internally in the UE. A dedicated test message 'RESET UE POSITIONING STORED INFORMATION' has been defined in TS 36.509 [11] clause 6.9 for the purpose of deleting this information.

## 4.7.4 RSTD reporting range

The reporting range of RSTD is defined from  $-15391T_s$  to  $15391T_s$  with  $1T_s$  resolution for absolute value of RSTD less or equal to  $4096T_s$  and  $5T_s$  for absolute value of RSTD greater than  $4096T_s$ .

The mapping of measured quantity is defined in Table 4.7.4-1.

**Table 4.7.4-1: RSTD report mapping**

Reported Value	Measured Quantity Value	Unit
RSTD_0000	$-15391 > \text{RSTD}$	$T_s$
RSTD_0001	$-15391 \leq \text{RSTD} < -15386$	$T_s$
...	...	...
RSTD_2258	$-4106 \leq \text{RSTD} < -4101$	$T_s$
RSTD_2259	$-4101 \leq \text{RSTD} < -4096$	$T_s$
RSTD_2260	$-4096 \leq \text{RSTD} < -4095$	$T_s$
RSTD_2261	$-4095 \leq \text{RSTD} < -4094$	$T_s$
...	...	...
RSTD_6353	$-3 \leq \text{RSTD} < -2$	$T_s$
RSTD_6354	$-2 \leq \text{RSTD} < -1$	$T_s$
RSTD_6355	$-1 \leq \text{RSTD} \leq 0$	$T_s$
RSTD_6356	$0 < \text{RSTD} \leq 1$	$T_s$
RSTD_6357	$1 < \text{RSTD} \leq 2$	$T_s$
RSTD_6358	$2 < \text{RSTD} \leq 3$	$T_s$
...	...	...
RSTD_10450	$4094 < \text{RSTD} \leq 4095$	$T_s$
RSTD_10451	$4095 < \text{RSTD} \leq 4096$	$T_s$
RSTD_10452	$4096 < \text{RSTD} \leq 4101$	$T_s$
RSTD_10453	$4101 < \text{RSTD} \leq 4106$	$T_s$
...	...	...
RSTD_12709	$15381 < \text{RSTD} \leq 15386$	$T_s$
RSTD_12710	$15386 < \text{RSTD} \leq 15391$	$T_s$
RSTD_12711	$15391 < \text{RSTD}$	$T_s$



## 4.7.5 RSTD Carrier Aggregation Test Cases with Different Channel Bandwidth Combinations

RSTD carrier aggregation test cases may be defined with different channel bandwidth combinations to verify the same requirement.

If multiple carrier aggregation test cases with different channel bandwidth combinations are defined to verify the same requirement that is channel bandwidth independent, then the UE needs to be tested only with one bandwidth combination out of the bandwidth combination sets supported by that UE.

## 4.8 MBS test conditions

### 4.8.1 MBS signals

A single or multi MBS beacon environment, depending on the test, is used.

The MBS signal is defined at the antenna connector of the UE. For UE with integral antenna only, a reference antenna with a gain of 0 dBi is assumed.

The beacons shall be synchronized, and the beacon code phase delays are defined in each test. The MBS signals shall be transmitted with a frequency accuracy of  $\pm 2.5$  PPM from the specified MBS carrier centre frequency.

### 4.8.2 Propagation conditions

#### 4.8.2.1 Static

See TS 36.521-1 [24] clause B.1.

#### 4.8.2.2 Multi-path fading

According to the Extended Pedestrian A model with a Maximum Doppler frequency of 5Hz (EPA 5Hz) in TS 36.521-1 [24] clauses B.2, B.2.1 and B.2.2.

### 4.8.3 Response time

The response time is defined as the time starting from the moment that the UE has received the LPP message of type REQUEST LOCATION INFORMATION, and ending when the UE starts sending the LPP message of type PROVIDE LOCATION INFORMATION on the Uu interface. The response time specified for the Measurement Reporting Delay test case assumes that the UE shall not reuse any information that was previously acquired and stored internally in the UE. A dedicated test message 'RESET UE POSITIONING STORED INFORMATION' has been defined in TS 36.509 [11] clause 6.9 for the purpose of deleting this information.

## 4.9 WLAN test conditions

### 4.9.1 Simulated WLAN Access Points

A multi-WLAN AP environment is used.

The WLAN signal is defined at the antenna connector of the UE. For UE with integral antenna only, a reference antenna with a gain of 0 dBi is assumed.

The beacon signals from multiple WLAN APs shall be available at the UE with a periodicity of at least 102.4 ms (Beacon Interval). In order to ensure that the UE is in passive scan mode, this interval can be reduced. Beacon signals from different APs shall be received at different time slots or in non-overlapping frequency channels. Non-overlapping frequency channels shall be at least 25 MHz apart in the WLAN 2.4 GHz band and at least 20 MHz apart in the WLAN 5 GHz band.

The WLAN Test Frequency IDs to be used during the tests are specified in the test cases and are as defined in TS 36.508 [18] clause 4.3.1.6.

## 4.9.2 Propagation conditions

### 4.9.2.1 Static

See TS 36.521-1 [24] clause B.1.

## 4.9.3 Response time

The response time is defined as the time starting from the moment that the UE has received the LPP message of type REQUEST LOCATION INFORMATION, and ending when the UE starts sending the LPP message of type PROVIDE LOCATION INFORMATION on the Uu interface. The response time specified for the Measurement Reporting Delay test case assumes that the UE shall not reuse any information that was previously acquired and stored internally in the UE. A dedicated test message 'RESET UE POSITIONING STORED INFORMATION' has been defined in TS 36.509 [11] clause 6.9 for the purpose of deleting this information.

### 4.9.4 Void

## 4.10 BLE test conditions

### 4.10.1 Simulated BLE

A multi-BLE device environment is used.

The BLE signal is defined at the antenna connector of the UE. For UE with integral antenna only, a reference antenna with a gain of 0 dBi is assumed.

The beacon signals from multiple BLE devices shall be available at the UE with a broadcast interval of 100 ms. Signals from different BLE devices shall be received at different time slots or in non-overlapping BLE advertising frequency channels. The BLE advertising channels are Channel 37 (2402 MHz), Channel 38 (2426 MHz) and Channel 39 (2480 MHz). The beacons shall be of type Non-Connectable Advertising beacons.

### 4.10.2 Propagation conditions

#### 4.10.2.1 Static

See TS 36.521-1 [24] clause B.1.

### 4.10.3 Response time

The response time is defined as the time starting from the moment that the UE has received the LPP message of type REQUEST LOCATION INFORMATION, and ending when the UE starts sending the LPP message of type PROVIDE LOCATION INFORMATION on the Uu interface. The response time specified for the Measurement Reporting Delay test case assumes that the UE shall not reuse any information that was previously acquired and stored internally in the UE. A dedicated test message 'RESET UE POSITIONING STORED INFORMATION' has been defined in TS 36.509 [11] clause 6.9 for the purpose of deleting this information.

## 4.11 NB-IOT test conditions

### 4.11.1 Groups of bands

The NB-IOT tests in clause 9 use the band groupings below in order to increase the readability of the specification

Table 4.11.1-2: Band groups for NB-IoT

Group	E-UTRA FDD		E-UTRA TDD	
	Band group notation	Operating bands	Band group notation	Operating bands
A	NFDD_A	-	NTDD_A	-
B	NFDD_B	-	NTDD_B	-
C	NFDD_C	-	NTDD_C	-
D	NFDD_D	-	NTDD_D	-
E	NFDD_E	-	NTDD_E	-
F	NFDD_F	-	NTDD_F	-
G	NFDD_G	1, 2, 3, 5, 8, 11, 12, 13, 17, 18, 19, 20, 21, 25, 26, 28, 31, 66, 70	NTDD_G	-
H	NFDD_H	-	NTDD_H	-
I	NFDD_I	-	NTDD_I	-
J	NFDD_J	-	NTDD_J	-
K	NFDD_K	-	NTDD_K	-
L	NFDD_L	-	NTDD_L	-
M	NFDD_M	-	NTDD_M	-
N	NFDD_N	-	NTDD_N	-

## 4.11.2 NB-IOT inband mode

The E-UTRA donor cell shall use the settings defined in Clause 4.4.1 unless otherwise stated.

---

## 4A Support of 4 Rx capable UEs

In this section, the method for applying 2RX tests to UEs supporting 4RX antenna ports is specified.

### 4A.1 RAT Independent Tests

All tests in Sections 5 to 7, 11 and 12 are applicable for all types of UEs independently of the number of RX antennae. Only one of the E-UTRAN/UTRAN RX antennae shall be connected to the SS.

### 4A.2 RAT Dependent Tests

All tests in Sections 8 to 10 are specified for UEs supporting either category 0 (1RX) or 2RX. No tests cases are currently specified in Sections 8 to 10 that are applicable only to 4RX antenna ports, so 4RX capable UEs are always tested by reusing tests that were originally specified for 2RX UEs.

#### 4A.2.1 Principle of testing

##### 4A.2.1.1 Single carrier tests

ECID (Section 8) and OTDOA Measurement Accuracy test cases shall be tested on all bands supported by the UE. For bands where 2RX is supported, the test shall be performed with the antenna connection specified in 4A.2.1.3. For bands where only 4RX is supported, the test shall be performed with the antenna connection specified in 4A.2.1.4.

OTDOA Measurement Reporting Delay test cases shall be tested on any band where 2RX is supported, using the antenna connection specified in 4A.2.1.3. If 2RX is not supported on any band, any 4RX band shall be tested, using the antenna connection specified in 4A.2.1.4.

##### 4A.2.1.2 Carrier Aggregation tests

For all carrier aggregation tests, the antenna connection for each cell needs to be considered separately. If a PCell or SCell is in a band where 2RX is supported, the test shall be performed using the antenna connection specified in 4A.2.1.3 for that cell. Otherwise, the test shall be performed using the antenna connection specified in 4A.2.1.4 for that cell.

#### 4A.2.1.3 Antenna connection for bands where 2RX is supported

For bands where 2RX is supported, it is left to the UE declaration and AP configuration to decide which 2 of the 4 Rx ports are connected with data source from system simulator. The remaining 2 Rx ports shall be connected with zero input. No test parameters or requirements are modified.

#### 4A.2.1.4 Antenna connection for bands where 4RX is supported

For bands where 4RX is supported, all 4 Rx are connected with data source from system simulator. The system simulator shall provide independent noise and fading (low correlation) for each antenna port.

## 5 UTRA A-GPS Minimum Performance requirements

### 5.1 General

This clause defines the minimum performance requirements for FDD UTRA terminals where the only Assisted Global Navigation Satellite System (A-GNSS) supported is Assisted Global Positioning System (A-GPS) L1 C/A. The procedures for UEs that support other or additional A-GNSSs are specified in clause 6. Note that for TDD UTRA terminals where the only Assisted Global Navigation Satellite System (A-GNSS) supported is Assisted Global Positioning System (A-GPS) L1 C/A there are no requirements.

This clause defines requirements for both UE based and UE assisted modes; if a terminal supports both modes then it shall be tested in both modes

The requirements in this clause are defined for CELL\_DCH and CELL\_FACH states. All tests shall be performed in CELL\_DCH state and the Nominal Accuracy Performance test case shall be also performed in CELL\_FACH state.

### 5.2 Sensitivity

#### 5.2.1 Sensitivity Coarse Time Assistance

##### 5.2.1.1 Definition and applicability

Sensitivity with coarse time assistance is the minimum level of GPS satellite signals required for the UE to make an A-GPS position estimate to a specific accuracy and within a specific response time when the network only provides coarse time assistance.

The requirements and this test apply to all types of UTRA for the FDD UE that supports only A-GPS.

##### 5.2.1.2 Minimum requirements

The first fix position estimates shall meet the accuracy and response time requirements in table 5.2.1.2 for the parameters specified in table 5.2.1.1.

**Table 5.2.1.1: Test parameters for Sensitivity Coarse Time Assistance**

Parameters	Unit	Value
Number of generated satellites	-	8
HDOP Range	-	1.1 to 1.6
Propagation conditions	-	AWGN
GPS Coarse Time assistance error range	seconds	±2
GPS Signal for one satellite	dBm	-142
GPS Signal for remaining satellites	dBm	-147

**Table 5.2.1.2: Minimum requirements for Sensitivity Coarse Time Assistance**

Success rate	2-D position error	Max response time
95 %	100 m	20 s

The reference for this requirement is 3GPP TS 25.171 [31], clause 5.1.1.1.

##### 5.2.1.3 Test purpose

To verify the UE's first position estimate meets the minimum requirements under GPS satellite signal conditions that represent weak signal conditions and with only Coarse Time Assistance provided by the SS.

##### 5.2.1.4 Method of test

###### 5.2.1.4.1 Initial conditions

Test environment: normal; see Annex G.

1. Connect SS and GSS to the UE antenna connector or antenna connectors as shown in figures A.1 or A.2.
2. Set the GPS test parameters as specified in table 5.2.1.3 for GPS scenario #1. Select the first satellite PRN defined in the table in 3GPP TS 37.571-5 [20] clause 5.2.1.2.5 for the one satellite with the higher level.
3. Switch on the UE.
4. Set up a connection using the procedure in clause F.2.

#### 5.2.1.4.2 Procedure

1. Start GPS scenario #1 as specified in 3GPP TS 37.571-5 [20] clause 5.2.1.2 with the UE location randomly selected to be within 3 km of the Reference Location and the altitude of the UE randomly selected between 0 m to 500 m above WGS-84 reference ellipsoid using the method described in 3GPP TS 37.571-5 [20] clause 5.2.1.2.4
2. Send a RESET UE POSITIONING STORED INFORMATION message followed by RRC MEASUREMENT CONTROL messages containing appropriate assistance data; as specified in 3GPP TS 37.571-5 [20], clauses 5.2.2 and 5.2.6 for UE based testing; or clauses 5.2.4 and 5.2.6 for UE assisted testing with the value of GPS TOW msec offset by a random value as specified in 3GPP TS 37.571-5 [20] clause 5.2.6.2; as required to obtain a fix using the procedure specified in 3GPP TS 34.108 [28], clauses 7.5.1 or 7.5.4.
3. If the UE returns a valid result in the MEASUREMENT REPORT message within the Max response time specified in table 5.2.1.4 then record the result and process it as specified in step 4. If the UE does not return a valid result within the Max response time specified in table 5.2.1.4 or reports a UE positioning error in the MEASUREMENT REPORT message then record one Bad Result.
4. For UE based testing compare the reported position estimate in the MEASUREMENT REPORT message against the simulated position of the UE used in step 1, and calculate the 2D position error as specified in clause 4.5.2.3. Compare the 2D position error against the value in table 5.2.1.4 and record one Good Result or Bad Result as appropriate; or

For UE assisted testing convert the GPS measured results reported in the MEASUREMENT REPORT message to a 2D position using the method described in Annex B and then compare the result against the simulated position of the UE, used in step 1, and calculate the 2D position error as specified in clause 4.5.2.3. Compare the 2D position error against the value in table 5.2.1.4 and record one Good Result or Bad Result as appropriate.

5. Repeat steps 1 to 4 using GPS scenario #2 instead of #1 so that the reference location changes sufficiently such that the UE shall have to use the new assistance data. Select the first satellite PRN defined in the table in 3GPP TS 37.571-5 [20] clause 5.2.1.2.5 for the one satellite with the higher level. Use new random values for the UE location and altitude in step 1 and for the GPS TOW msec offset in step 2.
6. Repeat steps 1 to 5 until the statistical requirements of clause 5.2.1.5 are met. Each time scenario #1 or #2 is used, the start time of the GPS scenario shall be advanced by 2 minutes from the time used previously for that scenario. Once a scenario reaches the end of its viable running time, restart it from its nominal start time again. Each time scenario #1 or #2 is used select the next satellite PRN from the one used previously, defined in the table in 3GPP TS 37.571-5 [20] clause 5.2.1.2.5, for the one satellite with the higher level.
7. Release the connection using the procedure in clause F.3.

#### 5.2.1.5 Test Requirements

For the parameters specified in table 5.2.1.3 the UE shall meet the requirements and the success rate specified in table 5.2.1.4 with a confidence level of 95% according to annex D.

**Table 5.2.1.3: Test parameters for Sensitivity Coarse Time Assistance**

Parameters	Unit	Value
Number of generated satellites	-	8
HDOP Range	-	1.1 to 1.6
Propagation conditions	-	AWGN
GPS Coarse Time assistance error range	seconds	$\pm 1.8$
GPS Signal for one satellite	dBm	-141
GPS Signal for remaining satellites	dBm	-146

**Table 5.2.1.4: Test requirements for Sensitivity Coarse Time Assistance**

Success rate	2-D position error	Max response time
95 %	101.3 m	20.3 s

NOTE: If the above Test Requirement differs from the Minimum Requirement then the Test Tolerance applied for this test is non-zero. The Test Tolerance for this test is defined in clause C.2 and the explanation of how the Minimum Requirement has been relaxed by the Test Tolerance is given in clause C.4.

## 5.2.2 Sensitivity Fine Time Assistance

### 5.2.2.1 Definition and applicability

Sensitivity with fine time assistance is the minimum level of GPS satellite signals required for the UE to make an A-GPS position estimate to a specific accuracy and within a specific response time when the network provides fine time assistance in addition to coarse time assistance.

The requirements and this test apply to all types of UTRA for the FDD UE that supports only A-GPS and that is capable of providing an enhanced performance when the network provides Fine Time Assistance.

### 5.2.2.2 Minimum requirements

The first fix position estimates shall meet the accuracy and response time requirements in table 5.2.2.2 for the parameters specified in table 5.2.2.1.

**Table 5.2.2.1: Test parameters for Sensitivity Fine Time Assistance**

Parameters	Unit	Value
Number of generated satellites	-	8
HDOP Range	-	1.1 to 1.6
Propagation conditions	-	AWGN
GPS Coarse time assistance error range	seconds	$\pm 2$
GPS Fine Time assistance error range	$\mu\text{s}$	$\pm 10$
GPS Signal for all satellites	dBm	-147

**Table 5.2.2.2: Minimum requirements for Sensitivity Fine Time Assistance**

Success rate	2-D position error	Max response time
95 %	100 m	20 s

The reference for this requirement is 3GPP TS 25.171 [31], clause 5.1.2.1.

### 5.2.2.3 Test purpose

To verify the UE's first position estimate meets the minimum requirements under GPS satellite signal conditions that represent weak signal conditions and with Fine Time Assistance provided by the SS.

## 5.2.2.4 Method of test

### 5.2.2.4.1 Initial conditions

Test environment: normal; see Annex G.

1. Connect SS and GSS to the UE antenna connector or antenna connectors as shown in figures A.1 or A.2.
2. Set the GPS test parameters as specified in table 5.2.2.3 for GPS scenario #1.
3. Switch on the UE.
4. Set up a connection using the procedure in clause F.2.

### 5.2.2.4.2 Procedure

1. Start GPS scenario #1 as specified in 3GPP TS 37.571-5 [20] clause 5.2.1.2 with the UE location randomly selected to be within 3 km of the Reference Location and the altitude of the UE randomly selected between 0 m to 500 m above WGS-84 reference ellipsoid using the method described in 3GPP TS 37.571-5 [20] clause 5.2.1.2.4
2. Send a RESET UE POSITIONING STORED INFORMATION message followed by RRC MEASUREMENT CONTROL messages containing appropriate assistance data; as specified in 3GPP TS 37.571-5 [20], clauses 5.2.2 and 5.2.6 for UE based testing; or clauses 5.2.4 and 5.2.6 for UE assisted testing with the values of GPS TOW msec and UTRAN GPS timing of cell frames offset by random values as specified in 3GPP TS 37.571-5 [20] clause 5.2.6.2; as required to obtain a fix using the procedure specified in 3GPP TS 34.108 [28], clauses 7.5.1 or 7.5.4.
3. If the UE returns a valid result in the MEASUREMENT REPORT message within the Max response time specified in table 5.2.2.4 then record the result and process it as specified in step 4. If the UE does not return a valid result within the Max response time specified in table 5.2.2.4 or reports a UE positioning error in the MEASUREMENT REPORT message then record one Bad Result.
4. For UE based testing compare the reported position estimate in the MEASUREMENT REPORT message against the simulated position of the UE used in step 1, and calculate the 2D position error as specified in clause 4.5.2.3. Compare the 2D position error against the value in table 5.2.2.4 and record one Good Result or Bad Result as appropriate; or

For UE assisted testing convert the GPS measured results reported in the MEASUREMENT REPORT message to a 2D position using the method described in Annex B and then compare the result against the simulated position of the UE used in step 1, and calculate the 2D position error as specified in clause 4.5.2.3. Compare the 2D position error against the value in table 5.2.2.4 and record one Good Result or Bad Result as appropriate.

5. Repeat steps 1 to 4 using GPS scenario #2 instead of #1 so that the reference location changes sufficiently such that the UE shall have to use the new assistance data. Use new random values for the UE location and altitude in step 1 and for the GPS TOW msec and UTRAN GPS timing of cell frames offsets in step 2.
6. Repeat steps 1 to 5 until the statistical requirements of clause 5.2.2.5 are met. Each time scenario #1 or #2 is used, the start time of the GPS scenario shall be advanced by 2 minutes from the time used previously for that scenario. Once a scenario reaches the end of its viable running time, restart it from its nominal start time again.
7. Release the connection using the procedure in clause F.3.

## 5.2.2.5 Test Requirements

For the parameters specified in table 5.2.2.3 the UE shall meet the requirements and the success rate specified in table 5.2.2.4 with a confidence level of 95% according to annex D.



**Table 5.2.2.3: Test parameters for Sensitivity Fine Time Assistance**

Parameters	Unit	Value
Number of generated satellites	-	8
HDOP Range	-	1.1 to 1.6
Propagation conditions	-	AWGN
GPS Coarse time assistance error range	seconds	$\pm 1.8$
GPS Fine Time assistance error range	$\mu\text{s}$	$\pm 9$
GPS Signal for all satellites	dBm	-146

**Table 5.2.2.4: Test requirements for Sensitivity Fine Time Assistance**

Success rate	2-D position error	Max response time
95 %	101.3 m	20.3 s

NOTE: If the above Test Requirement differs from the Minimum Requirement then the Test Tolerance applied for this test is non-zero. The Test Tolerance for this test is defined in clause C.2 and the explanation of how the Minimum Requirement has been relaxed by the Test Tolerance is given in clause C.4.

## 5.3 Nominal Accuracy

### 5.3.1 Definition and applicability

Nominal accuracy is the accuracy of the UE's A-GPS position estimate under ideal GPS signal conditions.

The requirements and this test apply to all types of UTRA for the FDD UE that supports only A-GPS.

### 5.3.2 Minimum requirements

The first fix position estimates shall meet the accuracy and response time requirements in table 5.3.2 for the parameters specified in table 5.3.1.

**Table 5.3.1: Test parameters for Nominal Accuracy**

Parameters	Unit	Value
Number of generated satellites	-	8
HDOP Range	-	1.1 to 1.6
Propagation conditions	-	AWGN
GPS Coarse Time assistance error range	seconds	$\pm 2$
GPS Signal for all satellites	dBm	-130

**Table 5.3.2: Minimum requirements for Nominal Accuracy**

Success rate	2-D position error	Max response time
95 %	30 m	20 s

The reference for this requirement is 3GPP TS 25.171 [31], clause 5.2.1.

### 5.3.3 Test purpose

To verify the UE's first position estimate meets the minimum requirements under GPS satellite signal conditions that represent ideal conditions.

## 5.3.4 Method of test

### 5.3.4.1 Initial conditions

Test environment: normal; see Annex G.

1. Connect SS and GSS to the UE antenna connector or antenna connectors as shown in figures A.1 or A.2.
2. Set the GPS test parameters as specified in table 5.3.3 for GPS scenario #1.
3. Switch on the UE.
4. Set up a connection using the procedure in clause F.2.

### 5.3.4.2 Procedure

1. Start GPS scenario #1 as specified in 3GPP TS 37.571-5 [20] clause 5.2.1.2 with the UE location randomly selected to be within 3 km of the Reference Location and the altitude of the UE randomly selected between 0 m to 500 m above WGS-84 reference ellipsoid using the method described in 3GPP TS 37.571-5 [20] clause 5.2.1.2.4
2. Send a RESET UE POSITIONING STORED INFORMATION message followed by RRC MEASUREMENT CONTROL messages containing appropriate assistance data; as specified in 3GPP TS 37.571-5 [20], clauses 5.2.2 and 5.2.6 for UE based testing; or clauses 5.2.4 and 5.2.6 for UE assisted testing with the value of GPS TOW msec offset by a random value as specified in 3GPP TS 37.571-5 [20] clause 5.2.6.2; using the exception to the RRC MEASUREMENT CONTROL message listed in table 5.3.2A; as required to obtain a fix using the procedure specified in 3GPP TS 34.108 [28], clauses 7.5.1 or 7.5.4.

**Table 5.3.2A: Contents of RRC MEASUREMENT CONTROL message**

Information Element	Value/Remark
- UE positioning reporting quantity - Horizontal accuracy	10 (15.9 m)

3. If the UE returns a valid result in the MEASUREMENT REPORT message within the Max response time specified in table 5.3.4 then record the result and process it as specified in step 4. If the UE does not return a valid result within the Max response time specified in table 5.3.4 or reports a UE positioning error in the MEASUREMENT REPORT message then record one Bad Result.
4. For UE based testing compare the reported position estimate in the MEASUREMENT REPORT message against the simulated position of the UE used in step 1, and calculate the 2D position error as specified in clause 4.5.2.3. Compare the 2D position error against the value in table 5.3.4 and record one Good Result or Bad Result as appropriate; or  
  
For UE assisted testing convert the GPS measured results reported in the MEASUREMENT REPORT message to a 2D position using the method described in Annex B and then compare the result against the simulated position of the UE used in step 1, and calculate the 2D position error as specified in clause 4.5.2.3. Compare the 2D position error against the value in table 5.3.4 and record one Good Result or Bad Result as appropriate.
5. Repeat steps 1 to 4 using GPS scenario #2 instead of #1 so that the reference location changes sufficiently such that the UE shall have to use the new assistance data. Use new random values for the UE location and altitude in step 1 and for the GPS TOW msec offset in step 2.
6. Repeat steps 1 to 5 until the statistical requirements of clause 5.3.5 are met. Each time scenario #1 or #2 is used, the start time of the GPS scenario shall be advanced by 2 minutes from the time used previously for that scenario. Once a scenario reaches the end of its viable running time, restart it from its nominal start time again.
7. Release the connection using the procedure in clause F.3.

## 5.3.5 Test Requirements

For the parameters specified in table 5.3.3 the UE shall meet the requirements and the success rate specified in table 5.3.4 with a confidence level of 95% according to annex D.

**Table 5.3.3: Test parameters for Nominal Accuracy**

Parameters	Unit	Value
Number of generated satellites	-	8
HDOP Range	-	1.1 to 1.6
Propagation conditions	-	AWGN
GPS Coarse Time assistance error range	seconds	$\pm 1.8$
GPS Signal for all satellites	dBm	-130

**Table 5.3.4: Test requirements for Nominal Accuracy**

Success rate	2-D position error	Max response time
95 %	31.3 m	20.3 s

NOTE: If the above Test Requirement differs from the Minimum Requirement then the Test Tolerance applied for this test is non-zero. The Test Tolerance for this test is defined in clause C.2 and the explanation of how the Minimum Requirement has been relaxed by the Test Tolerance is given in clause C.4.

## 5.4 Dynamic Range

### 5.4.1 Definition and applicability

Dynamic Range is the maximum difference in level of the GPS signals from a number of satellites that allows the UE to make an A-GPS position estimate with a specific accuracy and a specific response time.

The requirements and this test apply to all types of UTRA for the FDD UE that supports only A-GPS.

### 5.4.2 Minimum requirements

The first fix position estimates shall meet the accuracy and response time requirements in table 5.4.2 for the parameters specified in table 5.4.1.

**Table 5.4.1: Test parameters for Dynamic Range**

Parameters	Unit	Value
Number of generated satellites	-	6
HDOP Range	-	1.4 to 2.1
GPS Coarse Time assistance error range	seconds	$\pm 2$
Propagation conditions	-	AWGN
GPS Signal for 1 <sup>st</sup> satellite	dBm	-129
GPS Signal for 2 <sup>nd</sup> satellite	dBm	-135
GPS Signal for 3 <sup>rd</sup> satellite	dBm	-141
GPS Signal for 4 <sup>th</sup> satellite	dBm	-147
GPS Signal for 5 <sup>th</sup> satellite	dBm	-147
GPS Signal for 6 <sup>th</sup> satellite	dBm	-147

**Table 5.4.2: Minimum requirements for Dynamic Range**

Success rate	2-D position error	Max response time
95 %	100 m	20 s

The reference for this requirement is 3GPP TS 25.171 [31], clause 5.3.1.

### 5.4.3 Test purpose

To verify the UE's first position estimate meets the minimum requirements under GPS satellite signal conditions that have a wide dynamic range. Strong satellites are likely to degrade the acquisition of weaker satellites due to their cross-correlation products.

### 5.4.4 Method of test

#### 5.4.4.1 Initial conditions

Test environment: normal; see Annex G.

1. Connect SS and GSS to the UE antenna connector or antenna connectors as shown in figures A.1 or A.2.
2. Set the GPS test parameters as specified in table 5.4.3 for GPS scenario #1. Select the first three satellite PRNs defined in the table in 3GPP TS 37.571-5 [20] clause 5.2.1.2.5 for the three satellites with the higher levels.
3. Switch on the UE.
4. Set up a connection using the procedure in clause F.2.

#### 5.4.4.2 Procedure

1. Start GPS scenario #1 as specified in 3GPP TS 37.571-5 [20] clause 5.2.1.2 with the UE location randomly selected to be within 3 km of the Reference Location and the altitude of the UE randomly selected between 0 m to 500 m above WGS-84 reference ellipsoid using the method described in 3GPP TS 37.571-5 [20] clause 5.2.1.2.4
2. Send a RESET UE POSITIONING STORED INFORMATION message followed by RRC MEASUREMENT CONTROL messages containing appropriate assistance data; as specified in 3GPP TS 37.571-5 [20], clauses 5.2.2 and 5.2.6 for UE based testing; or clauses 5.2.4 and 5.2.6 for UE assisted testing with the value of GPS TOW msec offset by a random value as specified in 3GPP TS 37.571-5 [20] clause 5.2.6.2; as required to obtain a fix using the procedure specified in 3GPP TS 34.108 [28], clauses 7.5.1 or 7.5.4.
3. If the UE returns a valid result in the MEASUREMENT REPORT message within the Max response time specified in table 5.4.4 then record the result and process it as specified in step 4. If the UE does not return a valid result within the Max response time specified in table 5.4.4 or reports a UE positioning error in the MEASUREMENT REPORT message then record one Bad Result.
4. For UE based testing compare the reported position estimate in the MEASUREMENT REPORT message against the simulated position of the UE used in step 1, and calculate the 2D position error as specified in clause 4.5.2.3. Compare the 2D position error against the value in table 5.4.4 and record one Good Result or Bad Result as appropriate; or  
  
For UE assisted testing convert the GPS measured results reported in the MEASUREMENT REPORT message to a 2D position using the method described in Annex B and then compare the result against the simulated position of the UE used in step 1, and calculate the 2D position error as specified in clause 4.5.2.3. Compare the 2D position error against the value in table 5.4.4 and record one Good Result or Bad Result as appropriate.
5. Repeat steps 1 to 4 using GPS scenario #2 instead of #1 so that the reference location changes sufficiently such that the UE shall have to use the new assistance data. Select the first three satellite PRNs defined in the table in 3GPP TS 37.571-5 [20] clause 5.2.1.2.5 for the three satellites with the higher levels. Use new random values for the UE location and altitude in step 1 and for the GPS TOW msec offset in step 2.
6. Repeat steps 1 to 5 until the statistical requirements of clause 5.4.5 are met. Each time scenario #1 or #2 is used, the start time of the GPS scenario shall be advanced by 2 minutes from the time used previously for that scenario. Once a scenario reaches the end of its viable running time, restart it from its nominal start time again. Each time scenario #1 or #2 is used, increment the set of three satellite PRNs by one from the ones used previously, defined in the table in 3GPP TS 37.571-5 [20] clause 5.2.1.2.5, for the three satellites with the higher levels (i.e. if the set of satellites is a, b, c, d, e, f and the first set used was a, b, c, the second set shall be b, c, d and so on).
7. Release the connection using the procedure in clause F.3.

## 5.4.5 Test Requirements

For the parameters specified in table 5.4.3 the UE shall meet the requirements and the success rate specified in table 5.4.4 with a confidence level of 95% according to annex D.

**Table 5.4.3: Test parameters for Dynamic Range**

Parameters	Unit	Value
Number of generated satellites	-	6
HDOP Range	-	1.4 to 2.1
GPS Coarse Time assistance error range	seconds	$\pm 2+TT$
Propagation conditions	-	AWGN
GPS Signal for 1 <sup>st</sup> satellite	dBm	-128.2
GPS Signal for 2 <sup>nd</sup> satellite	dBm	-134
GPS Signal for 3 <sup>rd</sup> satellite	dBm	-140
GPS Signal for 4 <sup>th</sup> satellite	dBm	-146
GPS Signal for 5 <sup>th</sup> satellite	dBm	-146
GPS Signal for 6 <sup>th</sup> satellite	dBm	-146

**Table 5.4.4: Test requirements for Dynamic Range**

Success rate	2-D position error	Max response time
95 %	101.3 m	20.3 s

NOTE: If the above Test Requirement differs from the Minimum Requirement then the Test Tolerance applied for this test is non-zero. The Test Tolerance for this test is defined in clause C.2 and the explanation of how the Minimum Requirement has been relaxed by the Test Tolerance is given in clause C.4.

## 5.5 Multi-path Performance

### 5.5.1 Definition and applicability

Multi-path performance measures the accuracy and response time of the UE's A-GPS position estimate in a specific GPS signal multi-path environment.

The requirements and this test apply to all types of UTRA for the FDD UE that supports only A-GPS.

### 5.5.2 Minimum requirements

The first fix position estimates shall meet the accuracy and response time requirements in table 5.5.2 for the parameters specified in table 5.5.1.

**Table 5.5.1: Test parameters for Multi-path Performance**

Parameters	Unit	Value
Number of generated satellites (see note)	-	5
GPS Coarse Time assistance error range	seconds	$\pm 2$
HDOP Range	-	1.8 to 2.5
GPS signal for Satellite 1, 2 (see note)	dBm	-130
GPS signal for Satellite 3, 4, 5 (see note)	dBm	LOS signal of -130 dBm, multi-path signal of -136 dBm
NOTE: Satellites 1, 2 no multi-path. Satellites 3, 4, 5 multi-path defined in clause 4.2.4.		

**Table 5.5.2: Minimum requirements for Multi-path Performance**

Success rate	2-D position error	Max response time
95 %	100 m	20 s

The reference for this requirement is 3GPP TS 25.171 [31], clause 5.4.1.

### 5.5.3 Test purpose

To verify the UE's first position estimate meets the minimum requirements under GPS satellite signal conditions that represent simple multi-path conditions.

### 5.5.4 Method of test

#### 5.5.4.1 Initial conditions

Test environment: normal; see Annex G.

1. Connect SS and GSS to the UE antenna connector or antenna connectors as shown in figures A.1 or A.2.
2. Set the GPS test parameters as specified in table 5.5.3 for GPS scenario #1. Select the first two satellite PRNs defined in the table in 3GPP TS 37.571-5 [20] clause 5.2.1.2.5 for the two satellites with the higher levels.
3. Switch on the UE.
4. Set up a connection using the procedure in clause F.2.

#### 5.5.4.2 Procedure

1. Start GPS scenario #1 as specified in 3GPP TS 37.571-5 [20] clause 5.2.1.2 with the UE location randomly selected to be within 3 km of the Reference Location and the altitude of the UE randomly selected between 0 m to 500 m above WGS-84 reference ellipsoid using the method described in 3GPP TS 37.571-5 [20] clause 5.2.1.2.4. The initial carrier phase difference between taps of the multi-path model shall be randomly selected between 0 and  $2\pi$  radians by selecting the next random number from a standard uniform random number generator, in the range 0 to  $2\pi$ , representing radians with a resolution of 0.1, representing 0.1 radians.
2. Send a RESET UE POSITIONING STORED INFORMATION message followed by RRC MEASUREMENT CONTROL messages containing appropriate assistance data; as specified in 3GPP TS 37.571-5 [20], clauses 5.2.2 and 5.2.6 for UE based testing; or clauses 5.2.4 and 5.2.6 for UE assisted testing with the value of GPS TOW msec offset by a random value as specified in 3GPP TS 37.571-5 [20] clause 5.2.6.2; as required to obtain a fix using the procedure specified in 3GPP TS 34.108 [28], clauses 7.5.1 or 7.5.4.
3. If the UE returns a valid result in the MEASUREMENT REPORT message within the Max response time specified in table 5.5.4 then record the result and process it as specified in step 4. If the UE does not return a valid result within the Max response time specified in table 5.5.4 or reports a UE positioning error in the MEASUREMENT REPORT message then record one Bad Result.
4. For UE based testing compare the reported position estimate in the MEASUREMENT REPORT message against the simulated position of the UE used in step 1, and calculate the 2D position error as specified in clause 4.5.2.3. Compare the 2D position error against the value in table 5.5.4 and record one Good Result or Bad Result as appropriate; or

For UE assisted testing convert the GPS measured results reported in the MEASUREMENT REPORT message to a 2D position using the method described in Annex B and then compare the result against the simulated position of the UE used in step 1, and calculate the 2D position error as specified in clause 4.5.2.3. Compare the 2D position error against the value in table 5.5.4 and record one Good Result or Bad Result as appropriate.

5. Repeat steps 1 to 4 using GPS scenario #2 instead of #1 so that the reference location changes sufficiently such that the UE shall have to use the new assistance data. Select the first two satellite PRNs defined in the table in 3GPP TS 37.571-5 [20] clause 5.2.1.2.5 for the two satellites with the higher levels. Use new random values for the UE location and altitude, and the initial carrier phase difference between taps of the multi-path model in step 1 and for the GPS TOW msec offset in step 2.
6. Repeat steps 1 to 5 until the statistical requirements of clause 5.5.5 are met. Each time scenario #1 or #2 is used, the start time of the GPS scenario shall be advanced by 2 minutes from the time used previously for that scenario. Once a scenario reaches the end of its viable running time, restart it from its nominal start time again. Each time scenario #1 or #2 is used, increment the set of two satellite PRNs by one from the ones used previously, defined in the table in 3GPP TS 37.571-5 [20] clause 5.2.1.2.5, for the two satellites with the higher level (i.e. if the set of satellites is a, b, c, d, e and the first set used was a, b the second set shall be b, c and so on).
7. Release the connection using the procedure in clause F.3.

## 5.5.5 Test Requirements

For the parameters specified in table 5.5.3 the UE shall meet the requirements and the success rate specified in table 5.5.4 with a confidence level of 95% according to annex D.

**Table 5.5.3: Test parameters for Multi-path Performance**

Parameters	Unit	Value
Number of generated satellites (see note)	-	5
GPS Coarse Time assistance error range	seconds	$\pm 2+TT$
HDOP Range	-	1.8 to 2.5
GPS signal for Satellite 1, 2 (see note)	dBm	-130
GPS signal for Satellite 3, 4, 5 (see note)	dBm	LOS signal of -130 dBm, multi-path signal of -136.2 dBm
NOTE: Satellites 1, 2 no multi-path. Satellites 3, 4, 5 multi-path defined in clause 4.2.4.		

**Table 5.5.4: Test requirements for Multi-path Performance**

Success rate	2-D position error	Max response time
95 %	101.3 m	20.3 s

NOTE: If the above Test Requirement differs from the Minimum Requirement then the Test Tolerance applied for this test is non-zero. The Test Tolerance for this test is defined in clause C.2 and the explanation of how the Minimum Requirement has been relaxed by the Test Tolerance is given in clause C.4.

## 5.6 Moving Scenario and Periodic Update Performance

### 5.6.1 Definition and applicability

Moving scenario and periodic update performance measures the accuracy of the UE's A-GPS position estimates and the periodic update capability of the UE in a moving scenario.

The requirements and this test apply to all types of UTRA for the FDD UE that supports only A-GPS.

### 5.6.2 Minimum requirements

The position estimates, after the first reported position estimate, shall meet the accuracy requirement in table 5.6.2 with the periodical reporting interval of 2 seconds for the parameters specified in table 5.6.1.

NOTE: In the actual testing the UE may report error messages until it has been able to acquire GPS measured results or a position estimate. The SS shall only consider the first measurement report different from an error message as the first position estimate in the requirement in table 5.6.2.

**Table 5.6.1: Test parameters for Moving Scenario and Periodic Update Performance**

Parameters	Unit	Value
Number of generated satellites	-	5
HDOP Range	-	1.8 to 2.5
Propagation condition	-	AWGN
GPS signal for all satellites	dBm	-130

**Table 5.6.2: Minimum requirements for Moving Scenario and Periodic Update Performance**

Success Rate	2-D position error
95 %	100 m

The reference for this requirement is 3GPP TS 25.171 [31], clause 5.5.1.

### 5.6.3 Test purpose

To verify the UE's position estimates, after the first reported position estimate, meet the minimum requirements under GPS satellite signal conditions that simulate a moving scenario. A good tracking performance, with regular position estimate reporting is essential for certain location services.

### 5.6.4 Method of test

#### 5.6.4.1 Initial conditions

Test environment: normal; see Annex G.

The UE is requested to use periodical reporting with a reporting interval of 2 seconds.

The GPS signals simulate the UE moving on a rectangular trajectory of 940 m by 1 440 m with rounded corners defined in figure 5.6.1 and table 5.6.3. The initial reference is first defined followed by acceleration to final speed of 100 km/h in 250 m. The UE then maintains the speed for 400 m. This is followed by deceleration to final speed of 25 km/h in 250 m. The UE then turn 90 degrees with turning radius of 20 m at 25 km/h. This is followed by acceleration to final speed of 100 km/h in 250 m. The sequence is repeated to complete the rectangle.

**Table 5.6.3: Trajectory Parameters for Moving Scenario and Periodic Update Performance test case**

Parameter	Distance (m)	Speed (km/h)
$l_{11}, l_{15}, l_{21}, l_{25}$	20	25
$l_{12}, l_{14}, l_{22}, l_{24}$	250	25 to 100 and 100 to 25
$l_{13}$	400	100
$l_{23}$	900	100

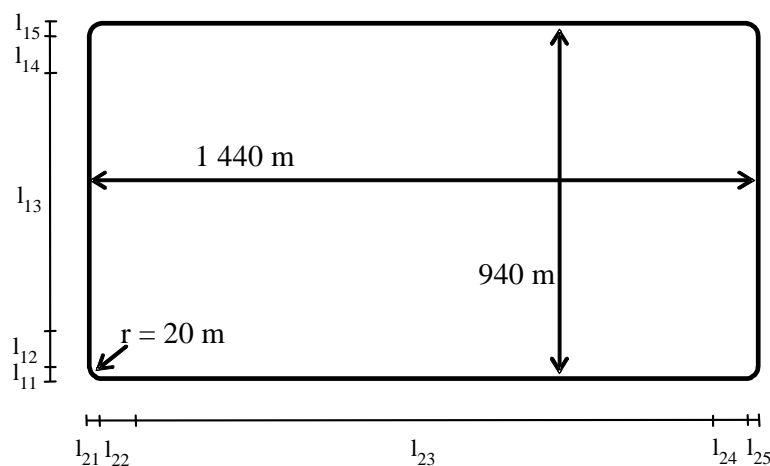

**Figure 5.6.1: Rectangular Trajectory for Moving Scenario and Periodic Update Performance test case**

1. Connect SS and GSS to the UE antenna connector or antenna connectors as shown in figures A.1 or A.2.
2. Set the GPS test parameters as specified in table 5.6.4 for GPS scenario #3.
3. Switch on the UE.
4. Set up a connection using the procedure in clause F.2.

#### 5.6.4.2 Procedure

1. Start GPS scenario #3 as specified in 3GPP TS 37.571-5 [20], clause 5.2.1.2



2. Send a RESET UE POSITIONING STORED INFORMATION message followed by RRC MEASUREMENT CONTROL messages containing appropriate assistance data; as specified in 3GPP TS 37.571-5 [20], clauses 5.2.2 and 5.2.6 for UE based testing; or clauses 5.2.4 and 5.2.6 for UE assisted testing; as required to obtain fixes using the procedure specified in 3GPP TS 34.108 [28], clauses 7.5.2 or 7.5.5.
3. Ignore any error messages that the UE may report in MEASUREMENT REPORT messages until it has been able to acquire the GPS signals and reports the first GPS measured result or position estimate.
4. Discard the first GPS measured result or position estimate.
5. Record the time of reception of the next MEASUREMENT REPORT message after reception of the first GPS measured result or position estimate.
6. After the reception of the first GPS measured result or position estimate reported in a MEASUREMENT REPORT message, every time the UE returns a GPS measured result or position estimate in the MEASUREMENT REPORT message record the time of reception and the result. If the difference between the time of reception and the time of reception of the previous result is less than 1.5 seconds or greater than 2.5 seconds, or if the UE reports a UE positioning error in any MEASUREMENT REPORT messages, then record one Bad Result. Otherwise process the result as specified in step 7.
7. For UE based testing compare the reported position estimate in the MEASUREMENT REPORT message against the simulated position of the UE at the time of applicability reported in the position estimate and calculate the 2D position error as specified in clause 4.5.2.3. Compare the 2D position error against the value in table 5.6.5 and record one Good Result or Bad Result as appropriate; or

For UE assisted testing convert the GPS measured results reported in the MEASUREMENT REPORT message to a 2D position using the method described in Annex B and then compare the result against the simulated position of the UE at the time of applicability reported in the GPS measured results and calculate the 2D position error as specified in clause 4.5.2.3. Compare the 2D position error against the value in table 5.6.5 and record one Good Result or Bad Result as appropriate.

8. If the UE sends the first MEASUREMENT REPORT that contains a measured result or position estimate later than 240s after the start of the GPS scenario, fail the UE and stop the test early. Otherwise collect MEASUREMENT REPORTs during 900s, starting from the time recorded in step 5. If at any time the difference between the times of reception of two consecutive results is greater than 240s, fail the UE and stop the test early. Use the collected Good Results and Bad Results to determine the PASS/FAIL according to clause 5.6.5.
9. Release the connection using the procedure in clause F.3.

## 5.6.5 Test Requirements

For the parameters specified in table 5.6.4, after the first reported position estimate, the UE shall meet the accuracy requirement and the success rate specified in table 5.6.5 with a periodical reporting interval of 2 seconds +/- 20% plus measurement system uncertainty of 100ms.

NOTE: Due to the statistical nature of the results it is not possible to design a test with predefined confidence level for the success rate in Table 5.6.5, therefore a simple PASS/FAIL of the results gathered against this success rate is used.

**Table 5.6.4: Test parameters for Moving Scenario and Periodic Update Performance**

Parameters	Unit	Value
Number of generated satellites	-	5
HDOP Range	-	1.8 to 2.5
Propagation condition	-	AWGN
GPS signal for all satellites	dBm	-130

**Table 5.6.5: Test requirements for Moving Scenario and Periodic Update Performance**

Success Rate	2-D position error
95 %	101.3 m

NOTE 1: If the above Test Requirement differs from the Minimum Requirement then the Test Tolerance applied for this test is non-zero. The Test Tolerance for this test is defined in clause C.2 and the explanation of how the Minimum Requirement has been relaxed by the Test Tolerance is given in clause C.4.

NOTE 2: In the actual testing the UE may report error messages until it has been able to acquire GPS measured results or a position estimate. The test equipment shall only consider the first measurement report different from an error message as the first position estimate in the requirement in table 5.6.5.

## 6 UTRA A-GNSS Minimum Performance requirements

### 6.1 General

This clause defines the minimum performance requirements for both UE based and UE assisted A-GNSS UTRA terminals. If a terminal supports both modes then it shall be tested in both modes. It excludes performance requirements for FDD UEs where the only A-GNSS supported is A-GPS L1C/A which are specified in clause 5. It excludes performance requirements for TDD UEs where the only A-GNSS supported is A-GPS L1C/A for which there is no requirement.

The requirements are defined for CELL\_DCH and CELL\_FACH states. All tests shall be performed in CELL\_DCH state and the Nominal Accuracy Performance test case shall be also performed in CELL\_FACH state.

### 6.2 Sensitivity

#### 6.2.1 Sensitivity Coarse Time Assistance

##### 6.2.1.1 Definition and applicability

Sensitivity with coarse time assistance is the minimum level of GNSS satellite signals required for the UE to make an A-GNSS position estimate to a specific accuracy and within a specific response time when the network only provides coarse time assistance.

The requirements and this test apply to all types of UTRA for the UE that supports A-GNSS.

This test case includes sub-test cases dependent on the GNSS supported by the UE. Each sub-test case is identified by a Sub-Test Case Number as defined in Table 6.2.1.1.

**Table 6.2.1.1: Sub-Test Case Number Definition**

Sub-Test Case Number	Supported GNSS
1	UE supporting A-GLONASS only
2	UE supporting A-Galileo only
3	UE supporting A-GPS and Modernized GPS only
4	UE supporting A-GPS and A-GLONASS only
8	UE supporting A-GPS and A-Galileo only
9	UE supporting A-BDS only
10	UE supporting A-GPS and A-BDS only

##### 6.2.1.2 Minimum requirements

The first fix position estimates shall meet the accuracy and response time requirements in table 6.2.1.2-3 for the parameters specified in table 6.2.1.2-1.

**Table 6.2.1.2-1: Test parameters for Sensitivity Coarse Time Assistance**

System	Parameters	Unit	Value
	Number of generated satellites per system	-	See Table 6.2.1.2-2
	Total number of generated satellites	-	6
	HDOP range		1.4 to 2.1
	Propagation conditions	-	AWGN
	GNSS coarse time assistance error range	seconds	±2
Galileo	Reference high signal power level	dBm	-142
	Reference low signal power level	dBm	-147
GPS <sup>(1)</sup>	Reference high signal power level	dBm	-142
	Reference low signal power level	dBm	-147
GLONASS	Reference high signal power level	dBm	-142
	Reference low signal power level	dBm	-147
BDS	Reference high signal power level	dBm	-136
	Reference low signal power level	dBm	-145

NOTE 1: "GPS" here means GPS L1 C/A, Modernized GPS, or both, dependent on UE capabilities.

**Table 6.2.1.2-2: Power level and satellite allocation**

		Satellite allocation for each constellation		
		GNSS-1 <sup>(1)</sup>	GNSS-2	GNSS-3
Single constellation	High signal level	1	-	-
	Low signal level	5	-	-
Dual constellation	High signal level	1	-	-
	Low signal level	2	3	-
Triple constellation	High signal level	1	-	-
	Low signal level	1	2	2

Note: For GPS capable receivers, GNSS-1, i.e. the system having the satellite with high signal level, shall be GPS.

**Table 6.2.1.2-3: Minimum requirements for Sensitivity Coarse Time Assistance**

System	Success rate	2-D position error	Max response time
All	95 %	100 m	20 s

The reference for this requirement is 3GPP TS 25.172 [19], clause 5.1.1.1, and 3GPP TS 25.173 [36], clause 5.1.1.1.

### 6.2.1.3 Test purpose

To verify the UE's first position estimate meets the minimum requirements under GNSS satellite signal conditions that represent weak signal conditions and with only Coarse Time Assistance provided by the SS.

### 6.2.1.4 Method of test

#### 6.2.1.4.1 Initial conditions

Test environment: normal; see Annex G.

1. Connect SS and GSS to the UE antenna connector or antenna connectors as shown in figures A.1 or A.2.
2. Set the GNSS test parameters as specified in table 6.2.1.5-1 for GNSS scenario #1. For GNSS-1, select the first satellite SV ID defined in the relevant table in 3GPP TS 37.571-5 [20] clause 6.2.1.2 for the one satellite with the higher level.
3. Switch on the UE.
4. Set up a connection using the procedure in clause F.2.

#### 6.2.1.4.2 Procedure

1. Start GNSS scenario #1 as specified in 3GPP TS 37.571-5 [20] clause 6.2.1.2 with the UE location randomly selected to be within 3 km of the Reference Location and the altitude of the UE randomly selected between 0 m to 500 m above WGS-84 reference ellipsoid using the method described in 3GPP TS 37.571-5 [20] clause 6.2.1.2.6.
2. Send a RESET UE POSITIONING STORED INFORMATION message followed by RRC MEASUREMENT CONTROL messages containing appropriate assistance data; as specified in 3GPP TS 37.571-5 [20], clauses 6.2.2 and 6.2.7 for UE based testing; or clauses 6.2.4 and 6.2.7 for UE assisted testing with the value of GPS TOW msec or GANSS TOD offset by a random value as specified in 3GPP TS 37.571-5 [20] clause 6.2.7.2; as required to obtain a fix using the procedure specified in 3GPP TS 34.108 [28], clauses 7.5.6 or 7.5.8.
3. If the UE returns a valid result in the MEASUREMENT REPORT message within the Max response time specified in table 6.2.1.5-3 then record the result and process it as specified in step 4. If the UE does not return a valid result within the Max response time specified in table 6.2.1.5-3 or reports a UE positioning error in the MEASUREMENT REPORT message then record one Bad Result.
4. For UE based testing compare the reported position estimate in the MEASUREMENT REPORT message against the simulated position of the UE used in step 1, and calculate the 2D position error as specified in clause 4.5.2.3. Compare the 2D position error against the value in table 6.2.1.5-3 and record one Good Result or Bad Result as appropriate; or

For UE assisted testing convert the GNSS measured results reported in the MEASUREMENT REPORT message to a 2D position using the method described in Annex B and then compare the result against the simulated position of the UE, used in step 1, and calculate the 2D position error as specified in clause 4.5.2.3. Compare the 2D position error against the value in table 6.2.1.5-3 and record one Good Result or Bad Result as appropriate.

5. Repeat steps 1 to 4 using GNSS scenario #2 instead of #1 so that the reference location changes sufficiently such that the UE shall have to use the new assistance data. For GNSS-1, select the first satellite SV ID defined in the relevant table in 3GPP TS 37.571-5 [20] clause 6.2.1.2 for the one satellite with the higher level. Use new random values for the UE location and altitude in step 1 and for the GPS TOW msec or GANSS TOD offset in step 2.
6. Repeat steps 1 to 5 until the statistical requirements of clause 6.2.1.5 are met. Each time scenario #1 or #2 is used, the start time of the GNSS scenario shall be advanced by 2 minutes from the time used previously for that scenario. Once a scenario reaches the end of its viable running time, restart it from its nominal start time again. Each time scenario #1 or #2 is used for GNSS-1, select the next satellite SV ID from the one used previously, defined in the relevant table in 3GPP TS 37.571-5 [20] clause 6.2.1.2, for the one satellite with the higher level.
7. Release the connection using the procedure in clause F.3.

#### 6.2.1.5 Test Requirements

For the parameters specified in table 6.2.1.5-1 the UE shall meet the requirements and the success rate specified in table 6.2.1.5-3 with a confidence level of 95% according to Annex D.

**Table 6.2.1.5-1: Test parameters for Sensitivity Coarse Time Assistance**

System	Parameters	Unit	Value
	Number of generated satellites per system	-	See Table 6.2.1.5-2
	Total number of generated satellites	-	6
	HDOP range		1.4 to 2.1
	Propagation conditions	-	AWGN
	GNSS coarse time assistance error range	seconds	±1.8
Galileo	Reference high signal power level	dBm	-141
	Reference low signal power level	dBm	-146
GPS <sup>(1)</sup>	Reference high signal power level	dBm	-141
	Reference low signal power level	dBm	-146
GLONASS	Reference high signal power level	dBm	-141
	Reference low signal power level	dBm	-146
BDS	Reference high signal power level	dBm	-135
	Reference low signal power level	dBm	-144
NOTE 1: "GPS" here means GPS L1 C/A, Modernized GPS, or both, dependent on UE capabilities.			

**Table 6.2.1.5-2: Power level and satellite allocation**

		Satellite allocation for each constellation		
		GNSS-1 <sup>(1)</sup>	GNSS-2	GNSS-3
Single constellation	High signal level	1	-	-
	Low signal level	5	-	-
Dual constellation	High signal level	1	-	-
	Low signal level	2	3	-
Triple constellation	High signal level	1	-	-
	Low signal level	1	2	2
Note: For GPS capable receivers, GNSS-1, i.e. the system having the satellite with high signal level, shall be GPS.				

**Table 6.2.1.5-3: Test requirements for Sensitivity Coarse Time Assistance**

System	Success rate	2-D position error	Max response time
All	95 %	101.3 m	20.3 s

NOTE: If the above Test Requirement differs from the Minimum Requirement then the Test Tolerance applied for this test is non-zero. The Test Tolerance for this test is defined in clause C.2 and the explanation of how the Minimum Requirement has been relaxed by the Test Tolerance is given in clause C.4.

## 6.2.2 Sensitivity Fine Time Assistance

### 6.2.2.1 Definition and applicability

Sensitivity with fine time assistance is the minimum level of GNSS satellite signals required for the UE to make an A-GNSS position estimate to a specific accuracy and within a specific response time when the network provides fine time assistance in addition to coarse time assistance.

The requirements and this test apply to all types of UTRA for the UE that supports A-GNSS and that is capable of providing an enhanced performance when the network provides Fine Time Assistance.

This test case includes sub-test cases dependent on the GNSS supported by the UE. Each sub-test case is identified by a Sub-Test Case Number as defined in Table 6.2.2.1.

**Table 6.2.2.1: Sub-Test Case Number Definition**

Sub-Test Case Number	Supported GNSS
1	UE supporting A-GLONASS only
2	UE supporting A-Galileo only
3	UE supporting A-GPS and Modernized GPS only
4	UE supporting A-GPS and A-GLONASS only
8	UE supporting A-GPS and A-Galileo only
9	UE supporting A-BDS only
10	UE supporting A-GPS and A-BDS only

### 6.2.2.2 Minimum requirements

The first fix position estimates shall meet the accuracy and response time requirements in table 6.2.2.2-3 for the parameters specified in table 6.2.2.2-1.

**Table 6.2.2.2-1: Test parameters for Sensitivity Fine Time Assistance**

System	Parameters	Unit	Value
	Number of generated satellites per system	-	See Table 6.2.2.2-2
	Total number of generated satellites	-	6
	HDOP range		1.4 to 2.1
	Propagation conditions	-	AWGN
	GNSS coarse time assistance error range	seconds	±2
	GNSS fine time assistance error range	µs	±10
Galileo	Reference signal power level	dBm	-147
GPS <sup>(1)</sup>	Reference signal power level	dBm	-147
GLONASS	Reference signal power level	dBm	-147
BDS	Reference signal power level	dBm	-147
Note: "GPS" here means GPS L1 C/A, Modernized GPS, or both, dependent on UE capabilities.			

**Table 6.2.2.2-2: Satellite allocation**

	Satellite allocation for each constellation		
	GNSS-1	GNSS-2	GNSS-3
Single constellation	6	-	-
Dual constellation	3	3	-
Triple constellation	2	2	2

**Table 6.2.2.2-3: Minimum requirements for Sensitivity Fine Time Assistance**

System	Success rate	2-D position error	Max response time
All	95 %	100 m	20 s

The reference for this requirement is 3GPP TS 25.172 [19], clause 5.1.2.1, and 3GPP TS 25.173 [36], clause 5.1.2.1.

### 6.2.2.3 Test purpose

To verify the UE's first position estimate meets the minimum requirements under GNSS satellite signal conditions that represent weak signal conditions and with Fine Time Assistance provided by the SS.

### 6.2.2.4 Method of test

#### 6.2.2.4.1 Initial conditions

Test environment: normal; see Annex G.

1. Connect SS and GSS to the UE antenna connector or antenna connectors as shown in figures A.1 or A.2.
2. Set the GNSS test parameters as specified in table 6.2.2.5-1 for GNSS scenario #1.
3. Switch on the UE.
4. Set up a connection using the procedure in clause F.2.

#### 6.2.2.4.2 Procedure

1. Start GNSS scenario #1 as specified in 3GPP TS 37.571-5 [20] clause 6.2.1.2 with the UE location randomly selected to be within 3 km of the Reference Location and the altitude of the UE randomly selected between 0 m to 500 m above WGS-84 reference ellipsoid using the method described in 3GPP TS 37.571-5 [20] clause 6.2.1.2.6.
2. Send a RESET UE POSITIONING STORED INFORMATION message followed by RRC MEASUREMENT CONTROL messages containing appropriate assistance data; as specified in 3GPP TS 37.571-5 [20], clauses 6.2.2 and 6.2.7 for UE based testing; or clauses 6.2.4 and 6.2.7 for UE assisted testing with the values of GPS TOW msec or GANSS TOD, and UTRAN GPS timing of cell frames or UTRAN GANSS timing of cell frames offset by random values as specified in 3GPP TS 37.571-5 [20] clause 6.2.7.2; as required to obtain a fix using the procedure specified in 3GPP TS 34.108 [28], clauses 7.5.6 or 7.5.8.
3. If the UE returns a valid result in the MEASUREMENT REPORT message within the Max response time specified in table 6.2.2.5-3 then record the result and process it as specified in step 4. If the UE does not return a valid result within the Max response time specified in table 6.2.2.5-3 or reports a UE positioning error in the MEASUREMENT REPORT message then record one Bad Result.
4. For UE based testing compare the reported position estimate in the MEASUREMENT REPORT message against the simulated position of the UE used in step 1, and calculate the 2D position error as specified in clause 6.1.1.3. Compare the 2D position error against the value in table 6.2.2.5-3 and record one Good Result or Bad Result as appropriate; or

For UE assisted testing convert the GNSS measured results reported in the MEASUREMENT REPORT message to a 2D position using the method described in Annex B and then compare the result against the simulated position of the UE used in step 1, and calculate the 2D position error as specified in clause 6.1.1.3. Compare the 2D position error against the value in table 6.2.2.5-3 and record one Good Result or Bad Result as appropriate.

5. Repeat steps 1 to 4 using GNSS scenario #2 instead of #1 so that the reference location changes sufficiently such that the UE shall have to use the new assistance data. Use new random values for the UE location and altitude in step 1 and for the GPS TOW msec or GANSS TOD, and UTRAN GPS timing of cell frames or UTRAN GANSS timing of cell frames offsets in step 2.
6. Repeat steps 1 to 5 until the statistical requirements of clause 6.2.2.5 are met. Each time scenario #1 or #2 is used, the start time of the GNSS scenario shall be advanced by 2 minutes from the time used previously for that scenario. Once a scenario reaches the end of its viable running time, restart it from its nominal start time again.
7. Release the connection using the procedure in clause F.3.

#### 6.2.2.5 Test Requirements

For the parameters specified in table 6.2.2.5-1 the UE shall meet the requirements and the success rate specified in table 6.2.2.5-3 with a confidence level of 95% according to Annex D.



**Table 6.2.2.5-1: Test parameters for Sensitivity Fine Time Assistance**

System	Parameters	Unit	Value
	Number of generated satellites per system	-	See Table 6.2.2.5-2
	Total number of generated satellites	-	6
	HDOP range		1.4 to 2.1
	Propagation conditions	-	AWGN
	GNSS coarse time assistance error range	seconds	$\pm 1.8$
	GNSS fine time assistance error range	$\mu\text{s}$	$\pm 9$
Galileo	Reference signal power level	dBm	-146
GPS <sup>(1)</sup>	Reference signal power level	dBm	-146
GLONASS	Reference signal power level	dBm	-146
BDS	Reference signal power level	dBm	-146

Note: "GPS" here means GPS L1 C/A, Modernized GPS, or both, dependent on UE capabilities.

**Table 6.2.2.5-2: Satellite allocation**

	Satellite allocation for each constellation		
	GNSS-1	GNSS-2	GNSS-3
Single constellation	6	-	-
Dual constellation	3	3	-
Triple constellation	2	2	2

**Table 6.2.2.5-3: Test requirements for Sensitivity Fine Time Assistance**

System	Success rate	2-D position error	Max response time
All	95 %	101.3 m	20.3 s

NOTE: If the above Test Requirement differs from the Minimum Requirement then the Test Tolerance applied for this test is non-zero. The Test Tolerance for this test is defined in clause C.2 and the explanation of how the Minimum Requirement has been relaxed by the Test Tolerance is given in clause C.4.

## 6.3 Nominal Accuracy

### 6.3.1 Definition and applicability

Nominal accuracy is the accuracy of the UE's A-GNSS position estimate under ideal GNSS signal conditions.

The requirements and this test apply to all types of UTRA for the UE that supports A-GNSS.

This test case includes sub-test cases dependent on the GNSS supported by the UE. Each sub-test case is identified by a Sub-Test Case Number as defined in Table 6.3.1.

**Table 6.3.1: Sub-Test Case Number Definition**

Sub-Test Case Number	Supported GNSS
1	UE supporting A-GLONASS only
2	UE supporting A-Galileo only
3	UE supporting A-GPS and Modernized GPS only
4	UE supporting A-GPS and A-GLONASS only
8	UE supporting A-GPS and A-Galileo only
9	UE supporting A-BDS only
10	UE supporting A-GPS and A-BDS only

### 6.3.2 Minimum requirements

The first fix position estimates shall meet the accuracy and response time requirements in table 6.3.2-3 for the parameters specified in table 6.3.2-1.

**Table 6.3.2-1: Test parameters for Nominal Accuracy**

System	Parameters	Unit	Value
	Number of generated satellites per system	-	See Table 6.3.2-2
	Total number of generated satellites	-	6 or 7 <sup>(2)</sup>
	HDOP Range	-	1.4 to 2.1
	Propagation conditions	-	AWGN
	GNSS coarse time assistance error range	seconds	±2
GPS <sup>(1)</sup>	Reference signal power level for all satellites	dBm	-128.5
Galileo	Reference signal power level for all satellites	dBm	-127
GLONASS	Reference signal power level for all satellites	dBm	-131
QZSS	Reference signal power level for all satellites	dBm	-128.5
SBAS	Reference signal power level for all satellites	dBm	-131
BDS	Reference signal power level for all satellites	dBm	-133
Note 1: "GPS" here means GPS L1 C/A, Modernized GPS, or both, dependent on UE capabilities.			
Note 2: 7 satellites apply only for SBAS case.			

If QZSS is supported, one of the GPS satellites will be replaced by a QZSS satellite with respective signal support.

If SBAS is supported, the SBAS satellite with the highest elevation will be added to the scenario.

**Table 6.3.2-2: Satellite allocation**

	Satellite allocation for each constellation			
	GNSS 1 <sup>(1)</sup>	GNSS 2 <sup>(1)</sup>	GNSS 3 <sup>(1)</sup>	SBAS
Single constellation	6	--	--	1
Dual constellation	3	3	--	1
Triple constellation	2	2	2	1
Note: GNSS refers to global systems i.e., GPS, Galileo, GLONASS and BDS.				

**Table 6.3.2-3: Minimum requirements for Nominal Accuracy**

System	Success rate	2-D position error	Max response time
All	95 %	15 m	20 s

The reference for this requirement is 3GPP TS 25.172 [19], clause 5.2.1, and 3GPP TS 25.173 [36], clause 5.2.1.

### 6.3.3 Test purpose

To verify the UE's first position estimate meets the minimum requirements under GNSS satellite signal conditions that represent ideal conditions.

### 6.3.4 Method of test

#### 6.3.4.1 Initial conditions

Test environment: normal; see Annex G.

1. Connect SS and GSS to the UE antenna connector or antenna connectors as shown in figures A.1 or A.2.
2. Set the GNSS test parameters as specified in table 6.3.4.2 for GNSS scenario #3.
3. Switch on the UE.
4. Set up a connection using the procedure in clause F.2.

#### 6.3.4.2 Procedure

1. Start GNSS scenario #3 as specified in 3GPP TS 37.571-5 [20] clause 6.2.1.2 with the UE location randomly selected to be within 3 km of the Reference Location and the altitude of the UE randomly selected between 0 m

to 500 m above WGS-84 reference ellipsoid using the method described in 3GPP TS 37.571-5 [20] clause 6.2.1.2.6.

2. Send a RESET UE POSITIONING STORED INFORMATION message followed by RRC MEASUREMENT CONTROL messages containing appropriate assistance data; as specified in 3GPP TS 37.571-5 [20], clauses 6.2.2 and 6.2.7 for UE based testing; or clauses 6.2.4 and 6.2.7 for UE assisted testing with the value of GPS TOW msec or GANSS TOD offset by a random value as specified in 3GPP TS 37.571-5 [20] clause 6.2.7.2; using the exception to the RRC MEASUREMENT CONTROL message listed in table 6.3.5-1; as required to obtain a fix using the procedure specified in 3GPP TS 34.108 [28], clauses 7.5.6 or 7.5.8.

**Table 6.3.4.2: Contents of RRC MEASUREMENT CONTROL message**

Information Element	Value/Remark
- UE positioning reporting quantity - Horizontal accuracy	'6' (7.7m)

3. If the UE returns a valid result in the MEASUREMENT REPORT message within the Max response time specified in table 6.3.5-3 then record the result and process it as specified in step 4. If the UE does not return a valid result within the Max response time specified in table 6.3.5-3 or reports a UE positioning error in the MEASUREMENT REPORT message then record one Bad Result.
4. For UE based testing compare the reported position estimate in the MEASUREMENT REPORT message against the simulated position of the UE used in step 1, and calculate the 2D position error as specified in clause 6.1.1.3. Compare the 2D position error against the value in table 6.3.5-3 and record one Good Result or Bad Result as appropriate; or

For UE assisted testing convert the GNSS measured results reported in the MEASUREMENT REPORT message to a 2D position using the method described in Annex B and then compare the result against the simulated position of the UE used in step 1, and calculate the 2D position error as specified in clause 6.1.1.3. Compare the 2D position error against the value in table 6.3.5-3 and record one Good Result or Bad Result as appropriate.

5. Repeat steps 1 to 4 using GNSS scenario #4 instead of #3 so that the reference location changes sufficiently such that the UE shall have to use the new assistance data. Use new random values for the UE location and altitude in step 1 and for the GPS TOW msec or GANSS TOD offset in step 2.
6. Repeat steps 1 to 5 until the statistical requirements of clause 6.3.5 are met. Each time scenario #3 or #4 is used, the start time of the GNSS scenario shall be advanced by 2 minutes from the time used previously for that scenario. Once a scenario reaches the end of its viable running time, restart it from its nominal start time again.
7. Release the connection using the procedure in clause F.3.

### 6.3.5 Test Requirements

For the parameters specified in table 6.3.5-1 the UE shall meet the requirements and the success rate specified in table 6.3.5-3 with a confidence level of 95% according to Annex D.

**Table 6.3.5-1: Test parameters for Nominal Accuracy**

System	Parameters	Unit	Value
	Number of generated satellites per system	-	See Table 6.3.5-3
	Total number of generated satellites	-	6 or 7 <sup>(2)</sup>
	HDOP Range	-	1.4 to 2.1
	Propagation conditions	-	AWGN
	GNSS coarse time assistance error range	seconds	±1.8
GPS <sup>(1)</sup>	Reference signal power level for all satellites	dBm	-128.5
Galileo	Reference signal power level for all satellites	dBm	-127
GLONASS	Reference signal power level for all satellites	dBm	-131
QZSS	Reference signal power level for all satellites	dBm	-128.5
SBAS	Reference signal power level for all satellites	dBm	-131
BDS	Reference signal power level for all satellites	dBm	-133
Note 1: "GPS" here means GPS L1 C/A, Modernized GPS, or both, dependent on UE capabilities.			
Note 2: 7 satellites apply only for SBAS case.			

If QZSS is supported, one of the GPS satellites will be replaced by a QZSS satellite with respective signal support.

If SBAS is supported, the SBAS satellite with the highest elevation will be added to the scenario.

**Table 6.3.5-2: Satellite allocation**

	Satellite allocation for each constellation			
	GNSS 1 <sup>(1)</sup>	GNSS 2 <sup>(1)</sup>	GNSS 3 <sup>(1)</sup>	SBAS
Single constellation	6	--	--	1
Dual constellation	3	3	--	1
Triple constellation	2	2	2	1
Note: GNSS refers to global systems i.e., GPS, Galileo, GLONASS and BDS.				

**Table 6.3.5-3: Test requirements for Nominal Accuracy**

System	Success rate	2-D position error	Max response time
All	95 %	16.3 m	20.3 s

NOTE: If the above Test Requirement differs from the Minimum Requirement then the Test Tolerance applied for this test is non-zero. The Test Tolerance for this test is defined in clause C.2 and the explanation of how the Minimum Requirement has been relaxed by the Test Tolerance is given in clause C.4.

## 6.4 Dynamic Range

### 6.4.1 Definition and applicability

Dynamic Range is the maximum difference in level of the GNSS signals from a number of satellites that allows the UE to make an A-GNSS position estimate with a specific accuracy and a specific response time.

The requirements and this test apply to all types of UTRA for the UE that supports A-GNSS.

This test case includes sub-test cases dependent on the GNSS supported by the UE. Each sub-test case is identified by a Sub-Test Case Number as defined in Table 6.4.1.

**Table 6.4.1: Sub-Test Case Number Definition**

Sub-Test Case Number	Supported GNSS
1	UE supporting A-GLONASS only
2	UE supporting A-Galileo only
3	UE supporting A-GPS and Modernized GPS only
4	UE supporting A-GPS and A-GLONASS only
8	UE supporting A-GPS and A-Galileo only
9	UE supporting A-BDS only
10	UE supporting A-GPS and A-BDS only

## 6.4.2 Minimum requirements

The first fix position estimates shall meet the accuracy and response time requirements in table 6.4.2-3 for the parameters specified in table 6.4.2-1.

**Table 6.4.2-1: Test parameters for Dynamic Range**

System	Parameters	Unit	Value
	Number of generated satellites per system	-	See Table 6.4.2-2
	Total number of generated satellites	-	6
	HDOP Range	-	1.4 to 2.1
	Propagation conditions	-	AWGN
	GNSS coarse time assistance error range	seconds	±2
Galileo	Reference high signal power level	dBm	-127.5
	Reference low signal power level	dBm	-147
GPS <sup>(1)</sup>	Reference high signal power level	dBm	-129
	Reference low signal power level	dBm	-147
GLONASS	Reference high signal power level	dBm	-131.5
	Reference low signal power level	dBm	-147
BDS	Reference high signal power level	dBm	-133.5
	Reference low signal power level	dBm	-145

Note: "GPS" here means GPS L1 C/A, Modernized GPS, or both, dependent on UE capabilities.

**Table 6.4.2-2: Power level and satellite allocation**

		Satellite allocation for each constellation		
		GNSS 1 <sup>(1)</sup>	GNSS 2 <sup>(1)</sup>	GNSS 3 <sup>(1)</sup>
Single constellation	High signal level	2	--	--
	Low signal level	4	--	--
Dual constellation	High signal level	1	1	--
	Low signal level	2	2	--
Triple constellation	High signal level	1	1	1
	Low signal level	1	1	1

Note: GNSS refers to global systems i.e., GPS, Galileo, GLONASS and BDS.

**Table 6.4.2-3: Minimum requirements for Dynamic Range**

System	Success rate	2-D position error	Max response time
All	95 %	100 m	20 s

The reference for this requirement is 3GPP TS 25.172 [19], clause 5.3.1, and 3GPP TS 25.173 [36], clause 5.3.1.

## 6.4.3 Test purpose

To verify the UE's first position estimate meets the minimum requirements under GNSS satellite signal conditions that have a wide dynamic range. Strong satellites are likely to degrade the acquisition of weaker satellites due to their cross-correlation products.

## 6.4.4 Method of test

### 6.4.4.1 Initial conditions

Test environment: normal; see Annex G.

1. Connect SS and GSS to the UE antenna connector or antenna connectors as shown in figures A.1 or A.2.
2. Set the GNSS test parameters as specified in table 6.4.5-1 for GNSS scenario #1. Randomly select from the satellite SV IDs defined in the table in 3GPP TS 37.571-5 [20] clause 6.2.1.2 for the satellites with the higher levels.
3. Switch on the UE.
4. Set up a connection using the procedure in clause F.2.

### 6.4.4.2 Procedure

1. Start GNSS scenario #1 as specified in 3GPP TS 37.571-5 [20] clause 6.2.1.2 with the UE location randomly selected to be within 3 km of the Reference Location and the altitude of the UE randomly selected between 0 m to 500 m above WGS-84 reference ellipsoid using the method described in 3GPP TS 37.571-5 [20] clause 6.2.1.2.6.
2. Send a RESET UE POSITIONING STORED INFORMATION message followed by RRC MEASUREMENT CONTROL messages containing appropriate assistance data; as specified in 3GPP TS 37.571-5 [20], clauses 6.2.2 and 6.2.7 for UE based testing; or clauses 6.2.4 and 6.2.7 for UE assisted testing with the value of GPS TOW msec or GANSS TOD offset by a random value as specified in 3GPP TS 37.571-5 [20] clause 6.2.7.2; as required to obtain a fix using the procedure specified in 3GPP TS 34.108 [28], clauses 7.5.6 or 7.5.8.
3. If the UE returns a valid result in the MEASUREMENT REPORT message within the Max response time specified in table 6.4.5-3 then record the result and process it as specified in step 4. If the UE does not return a valid result within the Max response time specified in table 6.4.5-3 or reports a UE positioning error in the MEASUREMENT REPORT message then record one Bad Result.
4. For UE based testing compare the reported position estimate in the MEASUREMENT REPORT message against the simulated position of the UE used in step 1, and calculate the 2D position error as specified in clause 6.1.1.3. Compare the 2D position error against the value in table 6.4.5-3 and record one Good Result or Bad Result as appropriate; or

For UE assisted testing convert the GNSS measured results reported in the MEASUREMENT REPORT message to a 2D position using the method described in Annex B and then compare the result against the simulated position of the UE used in step 1, and calculate the 2D position error as specified in clause 6.1.1.3. Compare the 2D position error against the value in table 6.4.5-3 and record one Good Result or Bad Result as appropriate.

5. Repeat steps 1 to 4 using GNSS scenario #2 instead of #1 so that the reference location changes sufficiently such that the UE shall have to use the new assistance data. Randomly select from the satellite SV IDs defined in the table in 3GPP TS 37.571-5 [20] clause 6.2.1.2 for the satellites with the higher levels. Use new random values for the UE location and altitude in step 1 and for the GPS TOW msec or GANSS TOD offset in step 2.
6. Repeat steps 1 to 5 until the statistical requirements of clause 6.4.5 are met. Each time scenario #1 or #2 is used, the start time of the GNSS scenario shall be advanced by 2 minutes from the time used previously for that scenario. Once a scenario reaches the end of its viable running time, restart it from its nominal start time again. Each time scenario #1 or #2 is used, randomly select from the set of satellite SV IDs defined in the table in 3GPP TS 37.571-5 [20] clause 6.2.1.2, for the satellites with the higher levels.
7. Release the connection using the procedure in clause F.3.

## 6.4.5 Test Requirements

For the parameters specified in table 6.4.5-1 the UE shall meet the requirements and the success rate specified in table 6.4.5-3 with a confidence level of 95% according to Annex D.

**Table 6.4.5-1: Test parameters for Dynamic Range**

System	Parameters	Unit	Value
	Number of generated satellites per system	-	See Table 6.4.5-2
	Total number of generated satellites	-	6
	HDOP Range	-	1.4 to 2.1
	Propagation conditions	-	AWGN
	GNSS coarse time assistance error range	seconds	±2
Galileo	Reference high signal power level	dBm	-126.7
	Reference low signal power level	dBm	-146
GPS <sup>(1)</sup>	Reference high signal power level	dBm	-128.2
	Reference low signal power level	dBm	-146
GLONASS	Reference high signal power level	dBm	-130.7
	Reference low signal power level	dBm	-146
BSD	Reference high signal power level	dBm	-132.7
	Reference low signal power level	dBm	-144
Note: "GPS" here means GPS L1 C/A, Modernized GPS, or both, dependent on UE capabilities.			

**Table 6.4.5-2: Power level and satellite allocation**

		Satellite allocation for each constellation		
		GNSS 1 <sup>(1)</sup>	GNSS 2 <sup>(1)</sup>	GNSS 3 <sup>(1)</sup>
Single constellation	High signal level	2	--	--
	Low signal level	4	--	--
Dual constellation	High signal level	1	1	--
	Low signal level	2	2	--
Triple constellation	High signal level	1	1	1
	Low signal level	1	1	1
Note: GNSS refers to global systems i.e., GPS, Galileo, GLONASS and BDS.				

**Table 6.4.5-3: Test requirements for Dynamic Range**

System	Success rate	2-D position error	Max response time
All	95 %	101.3 m	20.3 s

NOTE: If the above Test Requirement differs from the Minimum Requirement then the Test Tolerance applied for this test is non-zero. The Test Tolerance for this test is defined in clause C.2 and the explanation of how the Minimum Requirement has been relaxed by the Test Tolerance is given in clause C.4.

## 6.5 Multi-path Performance

### 6.5.1 Definition and applicability

Multi-path performance measures the accuracy and response time of the UE's A-GNSS position estimate in a specific GNSS signal multi-path environment.

The requirements and this test apply to all types of UTRA for the UE that supports A-GNSS.

This test case includes sub-test cases dependent on the GNSS supported by the UE. Each sub-test case is identified by a Sub-Test Case Number as defined in Table 6.5.1.

**Table 6.5.1: Sub-Test Case Number Definition**

Sub-Test Case Number	Supported GNSS
1	UE supporting A-GLONASS only
2	UE supporting A-Galileo only
3	UE supporting A-GPS and Modernized GPS only
4	UE supporting A-GPS and A-GLONASS only
8	UE supporting A-GPS and A-Galileo only
9	UE supporting A-BDS only
10	UE supporting A-GPS and A-BDS only

## 6.5.2 Minimum requirements

The first fix position estimates shall meet the accuracy and response time requirements in table 6.5.2-3 for the parameters specified in table 6.5.2-1.

**Table 6.5.2-1: Test parameters for Multi-path Performance**

System	Parameters	Unit	Value
	Number of generated satellites per system	-	See Table 6.5.2-2
	Total number of generated satellites	-	6
	HDOP range		1.4 to 2.1
	Propagation conditions	-	AWGN
	GNSS coarse time assistance error range	seconds	±2
Galileo	Reference signal power level	dBm	-127
GPS <sup>(1)</sup>	Reference signal power level	dBm	-128.5
GLONASS	Reference signal power level	dBm	-131
BDS	Reference signal power level	dBm	-133
Note: "GPS" here means GPS L1 C/A, Modernized GPS, or both, dependent on UE capabilities.			

**Table 6.5.2-2: Channel model allocation**

		Channel model allocation for each constellation		
		GNSS-1	GNSS-2	GNSS-3
Single constellation	One-tap channel	2	--	--
	Two-tap channel	4	--	--
Dual constellation	One-tap channel	1	1	--
	Two-tap channel	2	2	--
Triple constellation	One-tap channel	1	1	1
	Two-tap channel	1	1	1
Note: One-tap channel: no multi-path. Two-tap channel: multi-path defined in clause 4.2.4				

**Table 6.5.2-3: Minimum requirements for Multi-path Performance**

System	Success rate	2-D position error	Max response time
All	95 %	100 m	20 s

The reference for this requirement is 3GPP TS 25.172 [19], clause 5.4.1, and 3GPP TS 25.173 [36], clause 5.4.1.

## 6.5.3 Test purpose

To verify the UE's first position estimate meets the minimum requirements under GNSS satellite signal conditions that represent simple multi-path conditions.



## 6.5.4 Method of test

### 6.5.4.1 Initial conditions

Test environment: normal; see Annex G.

1. Connect SS and GSS to the UE antenna connector or antenna connectors as shown in figures A.1 or A.2.
2. Set the GNSS test parameters as specified in table 6.5.5-1 for GNSS scenario #1. Randomly select from the satellite SV IDs defined in the table in 3GPP TS 37.571-5 [20] clause 6.2.1.2 for the satellites with one-tap channel.
3. Switch on the UE.
4. Set up a connection using the procedure in clause F.2.

### 6.5.4.2 Procedure

1. Start GNSS scenario #1 as specified in 3GPP TS 37.571-5 [20] clause 6.2.1.2 with the UE location randomly selected to be within 3 km of the Reference Location and the altitude of the UE randomly selected between 0 m to 500 m above WGS-84 reference ellipsoid using the method described in 3GPP TS 37.571-5 [20] clause 6.2.1.2.6. The initial carrier phase difference between taps of the multi-path model shall be randomly selected between 0 and  $2\pi$  radians by selecting the next random number from a standard uniform random number generator, in the range 0 to  $2\pi$ , representing radians with a resolution of 0.1, representing 0.1 radians.
2. Send a RESET UE POSITIONING STORED INFORMATION message followed by RRC MEASUREMENT CONTROL messages containing appropriate assistance data; as specified in 3GPP TS 37.571-5 [20], clauses 6.2.2 and 6.2.7 for UE based testing; or clauses 6.2.4 and 6.2.7 for UE assisted testing with the value of GPS TOW msec or GANSS TOD offset by a random value as specified in 3GPP TS 37.571-5 [20] clause 6.2.7.2; as required to obtain a fix using the procedure specified in 3GPP TS 34.108 [28], clauses 7.5.6 or 7.5.8.
3. If the UE returns a valid result in the MEASUREMENT REPORT message within the Max response time specified in table 6.5.5-4 then record the result and process it as specified in step 4. If the UE does not return a valid result within the Max response time specified in table 6.5.5-4 or reports a UE positioning error in the MEASUREMENT REPORT message then record one Bad Result.
4. For UE based testing compare the reported position estimate in the MEASUREMENT REPORT message against the simulated position of the UE used in step 1, and calculate the 2D position error as specified in clause 6.1.1.3. Compare the 2D position error against the value in table 6.5.5-4 and record one Good Result or Bad Result as appropriate; or

For UE assisted testing convert the GNSS measured results reported in the MEASUREMENT REPORT message to a 2D position using the method described in Annex B and then compare the result against the simulated position of the UE used in step 1, and calculate the 2D position error as specified in clause 6.1.1.3. Compare the 2D position error against the value in table 6.5.5-4 and record one Good Result or Bad Result as appropriate.

5. Repeat steps 1 to 4 using GNSS scenario #2 instead of #1 so that the reference location changes sufficiently such that the UE shall have to use the new assistance data. Randomly select from the satellite SV IDs defined in the table in 3GPP TS 37.571-5 [20] clause 6.2.1.2 for the satellites with one-tap channel. Use new random values for the UE location and altitude, and the initial carrier phase difference between taps of the multi-path model in step 1 and for the GPS TOW msec or GANSS TOD offset in step 2.
6. Repeat steps 1 to 5 until the statistical requirements of clause 6.5.5 are met. Each time scenario #1 or #2 is used, the start time of the GNSS scenario shall be advanced by 2 minutes from the time used previously for that scenario. Once a scenario reaches the end of its viable running time, restart it from its nominal start time again. Each time scenario #1 or #2 is used, randomly select from the satellite SV IDs defined in the table in 3GPP TS 37.571-5 [20] clause 6.2.1.2, for the satellites with one-tap channel.
7. Release the connection using the procedure in clause F.3.

## 6.5.5 Test Requirements

For the parameters specified in table 6.5.5-1 the UE shall meet the requirements and the success rate specified in table 6.5.5-4 with a confidence level of 95% according to Annex D.

**Table 6.5.5-1: Test parameters for Multi-path Performance**

System	Parameters	Unit	Value
	Number of generated satellites per system	-	See Table 6.5.5-1
	Total number of generated satellites	-	6
	HDOP range		1.4 to 2.1
	Propagation conditions	-	AWGN
	GNSS coarse time assistance error range	seconds	$\pm 1.8$
Galileo	Reference signal power level	dBm	-127
GPS <sup>(1)</sup>	Reference signal power level	dBm	-128.5
GLONASS	Reference signal power level	dBm	-131
BDS	Reference signal power level	dBm	-133
Note: "GPS" here means GPS L1 C/A, Modernized GPS, or both, dependent on UE capabilities.			

**Table 6.5.5-2: Channel model allocation**

		Channel model allocation for each constellation		
		GNSS-1	GNSS-2	GNSS-3
Single constellation	One-tap channel	2	--	--
	Two-tap channel	4	--	--
Dual constellation	One-tap channel	1	1	--
	Two-tap channel	2	2	--
Triple constellation	One-tap channel	1	1	1
	Two-tap channel	1	1	1
Note: One-tap channel: no multi-path. Two-tap channel: multi-path defined in clause 4.2.4 with Relative mean Power (Y) defined in Table 6.5.5-3.				

**Table 6.5.5-3: Relative mean Power (Y) for use in Table 6.5.5-2**

System	Signals	Y [dB]
Galileo	E1	-4.7
	E5a	-6.2
	E5b	-6.2
GPS/Modernized GPS	L1 C/A	-6.2
	L1C	-4.7
	L2C	-6.2
GLONASS	L5	-6.2
	G1	-12.7
	G2	-12.7
BDS	B1I	-4.7

**Table 6.5.5-4: Test requirements for Multi-path Performance**

System	Success rate	2-D position error	Max response time
All	95 %	101.3 m	20.3 s

NOTE: If the above Test Requirement differs from the Minimum Requirement then the Test Tolerance applied for this test is non-zero. The Test Tolerance for this test is defined in clause C.2 and the explanation of how the Minimum Requirement has been relaxed by the Test Tolerance is given in clause C.4.

## 6.6 Moving Scenario and Periodic Update Performance

### 6.6.1 Definition and applicability

Moving scenario and periodic update performance measures the accuracy of the UE's A-GNSS position estimates and the periodic update capability of the UE in a moving scenario.

The requirements and this test apply to all types of UTRA for the UE that supports A-GNSS.

This test case includes sub-test cases dependent on the GNSS supported by the UE. Each sub-test case is identified by a Sub-Test Case Number as defined in Table 6.6.1.

**Table 6.6.1: Sub-Test Case Number Definition**

Sub-Test Case Number	Supported GNSS
1	UE supporting A-GLONASS only
2	UE supporting A-Galileo only
3	UE supporting A-GPS and Modernized GPS only
4	UE supporting A-GPS and A-GLONASS only
8	UE supporting A-GPS and A-Galileo only
9	UE supporting A-BDS only
10	UE supporting A-GPS and A-BDS only

### 6.6.2 Minimum requirements

The position estimates, after the first reported position estimate, shall meet the accuracy requirement in table 6.6.2-3 with the periodical reporting interval of 2 seconds for the parameters specified in table 6.6.2-1.

NOTE: In the actual testing the UE may report error messages until it has been able to acquire GNSS measured results or a position estimate. The SS shall only consider the first measurement report different from an error message as the first position estimate in the requirement in table 6.6.2-1.

**Table 6.6.2-1: Test parameters for Moving Scenario and Periodic Update Performance**

System	Parameters	Unit	Value
	Number of generated satellites per system	-	See Table 6.6.2-2
	Total number of generated satellites	-	6
	HDOP Range per system	-	1.4 to 2.1
	Propagation conditions	-	AWGN
	GNSS coarse time assistance error range	seconds	$\pm 2$
Galileo	Reference signal power level for all satellites	dBm	-127
GPS <sup>(1)</sup>	Reference signal power level for all satellites	dBm	-128.5
GLONASS	Reference signal power level for all satellites	dBm	-131
BDS	Reference signal power level for all satellites	dBm	-133
Note: "GPS" here means GPS L1 C/A, Modernized GPS, or both, dependent on UE capabilities.			

**Table 6.6.2-2: Satellite allocation**

	Satellite allocation for each constellation		
	GNSS 1 <sup>(1)</sup>	GNSS 2 <sup>(1)</sup>	GNSS 3 <sup>(1)</sup>
Single constellation	6	--	--
Dual constellation	3	3	--
Triple constellation	2	2	2
Note: GNSS refers to global systems i.e., GPS, Galileo, GLONASS and BDS.			

**Table 6.6.2-3: Minimum requirements for Moving Scenario and Periodic Update Performance**

System	Success rate	2-D position error	Periodical reporting interval
All	95 %	50 m	2 s

The reference for this requirement is 3GPP TS 25.172 [19], clause 5.5.1, and 3GPP TS 25.173 [36], clause 5.5.1.

### 6.6.3 Test purpose

To verify the UE's position estimates, after the first reported position estimate, meet the minimum requirements under GNSS satellite signal conditions that simulate a moving scenario. A good tracking performance, with regular position estimate reporting is essential for certain location services.

### 6.6.4 Method of test

#### 6.6.4.1 Initial conditions

Test environment: normal; see Annex G.

The UE is requested to use periodical reporting with a reporting interval of 2 seconds.

The GNSS signals simulate the UE moving on a rectangular trajectory of 940 m by 1 440 m with rounded corners defined in figure 6.6.1 and table 6.6.4.1. The initial reference is first defined followed by acceleration to final speed of 100 km/h in 250 m. The UE then maintains the speed for 400 m. This is followed by deceleration to final speed of 25 km/h in 250 m. The UE then turn 90 degrees with turning radius of 20 m at 25 km/h. This is followed by acceleration to final speed of 100 km/h in 250 m. The sequence is repeated to complete the rectangle.

**Table 6.6.4.1: Trajectory Parameters for Moving Scenario and Periodic Update Performance test case**

Parameter	Distance (m)	Speed (km/h)
$l_{11}, l_{15}, l_{21}, l_{25}$	20	25
$l_{12}, l_{14}, l_{22}, l_{24}$	250	25 to 100 and 100 to 25
$l_{13}$	400	100
$l_{23}$	900	100

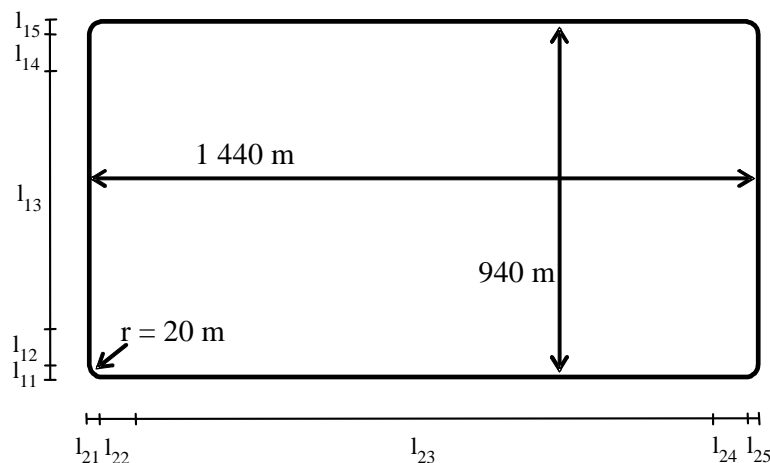

**Figure 6.6.1: Rectangular Trajectory for Moving Scenario and Periodic Update Performance test case**

1. Connect SS and GSS to the UE antenna connector or antenna connectors as shown in figures A.1 or A.2.
2. Set the GNSS test parameters as specified in table 6.6.5-1 for GNSS scenario #5.
3. Switch on the UE.

4. Set up a connection using the procedure in clause F.2.

### 6.6.4.2 Procedure

1. Start GNSS scenario #5 as specified in 3GPP TS 37.571-5 [20], clause 6.2.1.2.
2. Send a RESET UE POSITIONING STORED INFORMATION message followed by RRC MEASUREMENT CONTROL messages containing appropriate assistance data; as specified in 3GPP TS 37.571-5 [20], clauses 6.2.2 and 6.2.7 for UE based testing; or clauses 6.2.4 and 6.2.7 for UE assisted testing; using the exception to the RRC MEASUREMENT CONTROL message listed in table 6.6.4.2; as required to obtain fixes using the procedure specified in 3GPP TS 34.108 [28], clauses 7.5.7 or 7.5.9.

**Table 6.6.4.2: Contents of RRC MEASUREMENT CONTROL message**

Information Element	Value/Remark
- UE positioning reporting quantity - Horizontal accuracy	'13' (24.5m)

3. Ignore any error messages that the UE may report in MEASUREMENT REPORT messages until it has been able to acquire the GNSS signals and reports the first GNSS measured result or position estimate.
4. Discard the first GNSS measured result or position estimate.
5. Record the time of reception of the next MEASUREMENT REPORT message after reception of the first GNSS measured result or position estimate.
6. After the reception of the first GNSS measured result or position estimate reported in a MEASUREMENT REPORT message, every time the UE returns a GNSS measured result or position estimate in the MEASUREMENT REPORT message record the time of reception and the result. If the difference between the time of reception and the time of reception of the previous result is less than 1.5 seconds or greater than 2.5 seconds, or if the UE reports a UE positioning error in any MEASUREMENT REPORT messages, then record one Bad Result. Otherwise process the result as specified in step 7.
7. For UE based testing compare the reported position estimate in the MEASUREMENT REPORT message against the simulated position of the UE at the time of applicability reported in the position estimate and calculate the 2D position error as specified in clause 6.1.1.3. Compare the 2D position error against the value in table 6.6.9 and record one Good Result or Bad Result as appropriate; or  
  
For UE assisted testing convert the GNSS measured results reported in the MEASUREMENT REPORT message to a 2D position using the method described in Annex B and then compare the result against the simulated position of the UE at the time of applicability reported in the GNSS measured results and calculate the 2D position error as specified in clause 6.1.1.3. Compare the 2D position error against the value in table 6.6.9 and record one Good Result or Bad Result as appropriate.
8. If the UE sends the first MEASUREMENT REPORT that contains a measured result or position estimate later than 240s after the start of the GNSS scenario, fail the UE and stop the test early. Otherwise collect MEASUREMENT REPORTs during 900s, starting from the time recorded in step 5. If at any time the difference between the times of reception of two consecutive results is greater than 240s, fail the UE and stop the test early. Use the collected Good Results and Bad Results to determine the PASS/FAIL according to clause 6.6.5.
9. Release the connection using the procedure in clause F.3.

### 6.6.5 Test Requirements

For the parameters specified in table 6.6.5-1, after the first reported position estimate, the UE shall meet the accuracy requirement and the success rate specified in table 6.6.5-3 with a periodical reporting interval of 2 seconds +/- 20% plus measurement system uncertainty of 100ms.

**NOTE:** Due to the statistical nature of the results it is not possible to design a test with predefined confidence level for the success rate in Table 6.6.5-3; therefore a simple PASS/FAIL of the results gathered against this success rate is used.

**Table 6.6.5-1: Test parameters for Moving Scenario and Periodic Update Performance**

System	Parameters	Unit	Value
	Number of generated satellites per system	-	See Table 6.6.5-2
	Total number of generated satellites	-	6
	HDOP Range per system	-	1.4 to 2.1
	Propagation conditions	-	AWGN
	GNSS coarse time assistance error range	seconds	±1.8
Galileo	Reference signal power level for all satellites	dBm	-127
GPS <sup>(1)</sup>	Reference signal power level for all satellites	dBm	-128.5
GLONASS	Reference signal power level for all satellites	dBm	-131
BDS	Reference signal power level for all satellites	dBm	-133
Note: "GPS" here means GPS L1 C/A, Modernized GPS, or both, dependent on UE capabilities.			

**Table 6.6.5-2: Satellite allocation**

	Satellite allocation for each constellation		
	GNSS 1 <sup>(1)</sup>	GNSS 2 <sup>(1)</sup>	GNSS 3 <sup>(1)</sup>
Single constellation	6	--	--
Dual constellation	3	3	--
Triple constellation	2	2	2
Note: GNSS refers to global systems i.e., GPS, Galileo, GLONASS and BDS.			

**Table 6.6.5-3: Test requirements for Moving Scenario and Periodic Update Performance**

System	Success rate	2-D position error
All	95 %	51.3 m

NOTE 1: If the above Test Requirement differs from the Minimum Requirement then the Test Tolerance applied for this test is non-zero. The Test Tolerance for this test is defined in clause C.2 and the explanation of how the Minimum Requirement has been relaxed by the Test Tolerance is given in clause C.4.

NOTE 2: In the actual testing the UE may report error messages until it has been able to acquire GNSS measured results or a position estimate. The test equipment shall only consider the first measurement report different from an error message as the first position estimate in the requirement in table 6.6.5-3.

## 7 E-UTRA A-GNSS minimum performance requirements

### 7.0 General

This clause defines the minimum performance requirements for both UE based and UE assisted A-GNSS FDD and TDD E-UTRA terminals. If a terminal supports both modes then it shall be tested in both modes.

### 7.1 Sensitivity

#### 7.1.1 Sensitivity Coarse time assistance

##### 7.1.1.1 Sub-tests

This test includes sub-tests dependent on the GNSS supported by the UE. Each sub-test is identified by a Sub-Test Number as defined in Table 7.1.1.1

**Table 7.1.1.1: Sub-Test Number Definition**

Sub-Test Number	Supported GNSS
1	UE supporting A-GPS L1C/A only
2	UE supporting A-GLONASS only
3	UE supporting A-Galileo only
4	UE supporting A-GPS and Modernized GPS only
5	UE supporting A-GPS and A-GLONASS only
8	UE supporting A-GPS and A-Galileo only
9	UE supporting A-BDS only
10	UE supporting A-GPS and A-BDS only
11	UE supporting A-GPS and A-GLONASS and A-BDS only

##### 7.1.1.2 Test purpose

To verify the performance of the first position estimate, when the UE is provided with only coarse time assistance.

##### 7.1.1.3 Test applicability

This test applies to all types of E-UTRA UE that supports A-GNSS except Cat-M1 and Cat-M2 devices that do not support VoLTE.

##### 7.1.1.4 Minimum conformance requirements

The first fix position estimates shall meet the accuracy and response time requirements in table 7.1.1.2 for the parameters specified in table 7.1.1.3 or 7.1.1.4.

**Table 7.1.1.2: Requirements Sensitivity Coarse time assistance**

Success rate	2-D position error	Max response time
95 %	100 m	20 s

**Table 7.1.1.3: Parameters Sensitivity Coarse time assistance - Sub-Test 1**

Parameters	Unit	Value
Number of generated satellites	-	8
HDOP Range	-	1.1 to 1.6
Propagation conditions	-	AWGN
GPS Coarse time assistance error range	seconds	$\pm 2$
GPS L1 C/A Signal for one satellites	dBm	-142
GPS L1 C/A Signal for remaining satellites	dBm	-147

**Table 7.1.1.4: Parameters Sensitivity Coarse time assistance - Sub-Tests 2 to 5 and Sub-Tests 8 to 10**

System	Parameters	Unit	Value
	Number of generated satellites per system	-	See Table 7.1.1.5
	Total number of generated satellites	-	6
	HDOP range		1.4 to 2.1
	Propagation conditions	-	AWGN
	GNSS coarse time assistance error range	seconds	$\pm 2$
Galileo	Reference high signal power level	dBm	-142
	Reference low signal power level	dBm	-147
GPS <sup>(1)</sup>	Reference high signal power level	dBm	-142
	Reference low signal power level	dBm	-147
GLONASS	Reference high signal power level	dBm	-142
	Reference low signal power level	dBm	-147
BDS	Reference high signal power level	dBm	-136
	Reference low signal power level	dBm	-145
NOTE 1: "GPS" here means GPS L1 C/A, Modernized GPS, or both, dependent on UE capabilities.			

**Table 7.1.1.5: Power level and satellite allocation**

		Satellite allocation for each constellation		
		GNSS-1 <sup>(1)</sup>	GNSS-2	GNSS-3
Single constellation	High signal level	1	-	-
	Low signal level	5	-	-
Dual constellation	High signal level	1	-	-
	Low signal level	2	3	-
Triple constellation	High signal level	1	-	-
	Low signal level	1	2	2
Note 1: For GPS capable receivers, GNSS-1, i.e. the system having the satellite with high signal level, shall be GPS.				

The normative reference for this requirement is TS 36.171 [3] clause 5.1.1 and 6.1.1.

## 7.1.1.5 Test description

### 7.1.1.5.1 Initial conditions

Initial conditions are a set of test configurations the UE needs to be tested in and the steps for the SS to take with the UE to reach the correct measurement state.

Test Environment: Normal, as defined in TS 36.508 [18] clause 4.1.

Frequencies to be tested: Mid Range, as defined in TS 36.508 [18] clause 4.3.1.

Channel Bandwidth to be tested: as defined in TS 36.508 [18] clause 4.3.1.

1. Connect SS and GSS to the UE antenna connector or antenna connectors as shown in Annex A.



2. Set the GNSS test parameters as specified in table 7.1.1.6 or 7.1.1.7 for GNSS scenario #1 in TS 37.571-5 [20]. For GNSS-1, select the first satellite SV ID defined in the relevant table of Satellites to be simulated in clause 6.2.1.2 in TS 37.571-5 [20] for the one satellite with the higher level.
3. The parameter settings for the cell are set up according to TS 36.508 [18] clause 4.4.3, single cell scenario.
4. Switch on the UE.
5. Establish a signalling connection according to the generic procedure in TS 36.508 [18] clause 4.5.3 (State 3, Generic RB established) on a channel in the Mid EARFCN range.

#### 7.1.1.5.2 Test procedure

1. Start GNSS scenario #1 as specified in clause 6.2.1.2 of TS 37.571-5 [20] with the UE location randomly selected to be within 3 km of the Reference Location and the altitude of the UE randomly selected between 0 m to 500 m above WGS-84 reference ellipsoid using the method described in clause 6.2.1.2.6 of TS 37.571-5 [20]
2. Send a RESET UE POSITIONING STORED INFORMATION message.
3. Send an LPP REQUEST CAPABILITIES message.
4. The UE returns an LPP PROVIDE CAPABILITIES message indicating the assistance data supported by the UE in the Assistance Data Support List in the A GNSS Provide Capabilities IE.
5. Send an LPP PROVIDE ASSISTANCE DATA message to provide the assistance data that is supported by the UE as indicated in step 4 and in accordance with clause 6.2.6 of TS 37.571-5 [20], and with the values defined in clause 6.2.7 of TS 37.571-5 [20] with the value of GNSS Reference Time offset by a random value as specified in clause 6.2.7.2 of TS 37.571-5 [20]. If the UE message at step 4 includes the ackRequested IE set to TRUE, then the SS shall send an acknowledgment in the LPP PROVIDE ASSISTANCE DATA message.
6. Send an LPP REQUEST LOCATION INFORMATION message to obtain a fix.
7. If the UE returns a valid result in the LPP PROVIDE LOCATION INFORMATION message within the Max response time specified in table 7.1.1.9 then record the result and process it as specified in step 8. If the UE does not return a valid result within the Max response time specified in table 7.1.1.9 or reports an Error in the LPP PROVIDE LOCATION INFORMATION message then record one Bad Result.
- 7a. If the UE message at step 7 includes the ackRequested IE set to TRUE, then the SS shall send a LPP acknowledgment message.
8. For UE based testing compare the reported Location Information in the LPP PROVIDE LOCATION INFORMATION message against the simulated position of the UE used in step 1, and calculate the 2D position error as specified in clause 4.5.2.3. Compare the 2D position error against the value in table 7.1.1.9 and record one Good Result or Bad Result as appropriate; or  
  
For UE assisted testing convert the GNSS Signal Measurement Information reported in the LPP PROVIDE LOCATION INFORMATION message to a 2D position using the method described in clause 4.4.3 and then compare the result against the simulated position of the UE, used in step 1, and calculate the 2D position error as specified in clause 4.5.2.3. Compare the 2D position error against the value in table 7.1.1.9 and record one Good Result or Bad Result as appropriate.
9. Repeat steps 1 to 8 using GNSS scenario #2 instead of #1 so that the reference location changes sufficiently such that the UE shall have to use the new assistance data. For GNSS-1, select the first satellite SV ID defined in the relevant table of Satellites to be simulated in clause 6.2.1.2 in TS 37.571-5 [20] for the one satellite with the higher level. Use new random values for the UE location and altitude in step 1 and for the GNSS Reference Time offset in step 5.
10. Repeat steps 1 to 9 until the statistical requirements of clause 7.1.1.6 are met. Each time scenario #1 or #2 is used, the start time of the GNSS scenario shall be advanced by 2 minutes from the time used previously for that scenario. Once a scenario reaches the end of its viable running time, restart it from its nominal start time again. Each time scenario #1 or #2 is used, for GNSS-1 select the next satellite SV ID from the one used previously, defined in the relevant table of Satellites to be simulated in clause 6.2.1.2 in TS 37.571-5 [20], for the one satellite with the higher level.
11. Release the signalling connection.

### 7.1.1.5.3 Message contents

Message contents are according to TS 36.508 [18] clauses 4.6 and 4.7 and as follows:

#### RESET UE POSITIONING STORED INFORMATION

Information Element	Value/remark
UE POSITIONING TECHNOLOGY	AGNSS

#### LPP REQUEST CAPABILITIES

Information Element	Value/remark
<i>a-gnss-RequestCapabilities</i>	TRUE

#### LPP REQUEST LOCATION INFORMATION

Information Element	Value/remark	Comment
commonEsRequestLocationInformation		
> locationInformationType	'locationEstimateRequired' or 'locationMeasurementsRequired'	Depending on test case and UE capabilities, i.e. support for UE-based or UE-assisted
> additionalInformation	'onlyReturnInformationRequested'	
> qos		
>> horizontalAccuracy	'19' (51.2m)	
>> verticalCoordinateRequest	FALSE	
>> responseTime		
>>>time	'20'	
a-gnss-RequestLocationInformation		
> gnss-PositioningInstructions		
>> gnssMethods		
>>> gnss-ids	Sub-test 1: 'gps' Sub-test 2: 'glonass' Sub-test 3: 'galileo' Sub-test 4: 'gps' Sub-test 5: 'gps' and 'glonass' Sub-test 8: 'gps' and 'galileo' Sub-test 9: 'bds' Sub-test 10: 'gps'and'bds' Sub-test 11: 'gps' and 'glonass' and 'bds'	
>> fineTimeAssistanceMeasReq	FALSE	
>> adrMeasReq	FALSE	
>> multiFreqMeasReq	TRUE or FALSE	Depending on UE capabilities
>> assistanceAvailability	FALSE	

### 7.1.1.6 Test requirement

For the parameters specified in table 7.1.1.6 or 7.1.1.7 the UE shall meet the requirements and the success rate specified in table 7.1.1.9 with a confidence level of 95% according to Annex D.

**Table 7.1.1.6: Test parameters Sensitivity Coarse time assistance - Sub-Test 1**

Parameters	Unit	Value
Number of generated satellites	-	8
HDOP Range	-	1.1 to 1.6
Propagation conditions	-	AWGN
GPS Coarse Time assistance error range	seconds	±1.8
GPS L1 C/A Signal for one satellite	dBm	-141
GPS L1 C/A Signal for remaining satellites	dBm	-146

**Table 7.1.1.7: Test parameters Sensitivity Coarse time assistance - Sub-Tests 2 to 5 and Sub-Tests 8 to 10**

System	Parameters	Unit	Value
	Number of generated satellites per system	-	See Table 7.1.1.8
	Total number of generated satellites	-	6
	HDOP range	-	1.4 to 2.1
	Propagation conditions	-	AWGN
	GNSS coarse time assistance error range	seconds	±1.8
Galileo	Reference high signal power level	dBm	-141
	Reference low signal power level	dBm	-146
GPS <sup>(1)</sup>	Reference high signal power level	dBm	-141
	Reference low signal power level	dBm	-146
GLONASS	Reference high signal power level	dBm	-141
	Reference low signal power level	dBm	-146
BDS	Reference high signal power level	dBm	-135
	Reference low signal power level	dBm	-144
NOTE 1: "GPS" here means GPS L1 C/A, Modernized GPS, or both, dependent on UE capabilities.			

**Table 7.1.1.8: Power level and satellite allocation**

		Satellite allocation for each constellation		
		GNSS-1 <sup>(1)</sup>	GNSS-2	GNSS-3
Single constellation	High signal level	1	-	-
	Low signal level	5	-	-
Dual constellation	High signal level	1	-	-
	Low signal level	2	3	-
Triple constellation	High signal level	1	-	-
	Low signal level	1	2	2
Note 1: For GPS capable receivers, GNSS-1, i.e. the system having the satellite with high signal level, shall be GPS.				

**Table 7.1.1.9: Test requirements for Sensitivity Coarse Time Assistance**

System	Success rate	2-D position error	Max response time
All	95 %	101.3 m	20.3 s

## 7.1.2 Sensitivity Fine time assistance

### 7.1.2.1 Sub-tests

This test includes sub-tests dependent on the GNSS supported by the UE. Each sub-test is identified by a Sub-Test Number as defined in Table 7.1.2.1

**Table 7.1.2.1: Sub-Test Number Definition**

Sub-Test Number	Supported GNSS
1	UE supporting A-GPS L1C/A only
2	UE supporting A-GLONASS only
3	UE supporting A-Galileo only
4	UE supporting A-GPS and Modernized GPS only
5	UE supporting A-GPS and A-GLONASS only
8	UE supporting A-GPS and A-Galileo only
9	UE supporting A-BDS only
10	UE supporting A-GPS and A-BDS only
11	UE supporting A-GPS and A-GLONASS and A-BDS only

### 7.1.2.2 Test purpose

To verify the performance of the first position estimate, when the UE is additionally provided with fine time assistance.

### 7.1.2.3 Test applicability

This test applies to all types of E-UTRA UE that supports A-GNSS and that is capable of providing an enhanced performance when the network provides Fine Time Assistance, except Cat-M1 and Cat-M2 devices that do not support VoLTE.

### 7.1.2.4 Minimum conformance requirements

The first fix position estimates shall meet the accuracy and response time requirements in table 7.1.2.2 for the parameters specified in table 7.1.2.3 or 7.1.2.4.

**Table 7.1.2.2: Requirements Sensitivity Fine time assistance**

Success rate	2-D position error	Max response time
95 %	100 m	20 s

**Table 7.1.2.3: Parameters Sensitivity Fine time assistance - Sub-Test 1**

Parameters	Unit	Value
Number of generated satellites	-	8
HDOP Range	-	1.1 to 1.6
Propagation conditions	-	AWGN
GPS Coarse time assistance error range	seconds	±2
GPS L1 C/A Fine time assistance error range	µs	±10
GPS L1 C/A Signal for all satellites	dBm	-147

**Table 7.1.2.4: Parameters Sensitivity Fine time assistance - Sub-Tests 2 to 5 and Sub-Tests 8 to 10**

System	Parameters	Unit	Value
	Number of generated satellites per system	-	See Table 7.1.2.5
	Total number of generated satellites	-	6
	HDOP range	-	1.4 to 2.1
	Propagation conditions	-	AWGN
	GNSS coarse time assistance error range	seconds	±2
	GNSS fine time assistance error range	µs	±10
Galileo	Reference signal power level	dBm	-147
GPS <sup>(1)</sup>	Reference signal power level	dBm	-147
GLONASS	Reference signal power level	dBm	-147
BDS	Reference signal power level	dBm	-147
NOTE 1: "GPS" here means GPS L1 C/A, Modernized GPS, or both, dependent on UE capabilities.			

**Table 7.1.2.5: Satellite allocation**

	Satellite allocation for each constellation		
	GNSS-1	GNSS-2	GNSS-3
Single constellation	6	-	-
Dual constellation	3	3	-
Triple constellation	2	2	2

The normative reference for this requirement is TS 36.171 [3] clause 5.1.2 and 6.1.2.

## 7.1.2.5 Test description

### 7.1.2.5.1 Initial conditions

Initial conditions are a set of test configurations the UE needs to be tested in and the steps for the SS to take with the UE to reach the correct measurement state.

Test Environment: Normal, as defined in TS 36.508 [18] clause 4.1.

Frequencies to be tested: Mid Range, as defined in TS 36.508 [18] clause 4.3.1.

Channel Bandwidth to be tested: as defined in TS 36.508 [18] clause 4.3.1.

1. Connect SS and GSS to the UE antenna connector or antenna connectors as shown in Annex A.
2. Set the GNSS test parameters as specified in table 7.1.2.6 or 7.1.2.7 for GNSS scenario #1 in TS 37.571-5 [20].
3. The parameter settings for the cell are set up according to TS 36.508 [18] clause 4.4.3, single cell scenario.
4. Switch on the UE.
5. Establish a signalling connection according to the generic procedure in TS 36.508 [18] clause 4.5.3 (State 3, Generic RB established) on a channel in the Mid EARFCN range.

### 7.1.2.5.2 Test procedure

1. Start GNSS scenario #1 as specified in clause 6.2.1.2 of TS 37.571-5 [20] with the UE location randomly selected to be within 3 km of the Reference Location and the altitude of the UE randomly selected between 0 m to 500 m above WGS-84 reference ellipsoid using the method described in clause 6.2.1.2.6 of TS 37.571-5 [20]
2. Send a RESET UE POSITIONING STORED INFORMATION message.
3. Send an LPP REQUEST CAPABILITIES message.
4. The UE returns an LPP PROVIDE CAPABILITIES message indicating the assistance data supported by the UE in the Assistance Data Support List in the A GNSS Provide Capabilities IE.
5. Send an LPP PROVIDE ASSISTANCE DATA message to provide the assistance data that is supported by the UE as indicated in step 4 and in accordance with clause 6.2.6 of TS 37.571-5 [20], and with the values defined in clause 6.2.7 of TS 37.571-5 [20] with the value of GNSS Reference Time and GNSS Reference Time for one cell offset by a random value as specified in clause 6.2.7.2 of TS 37.571-5 [20]. If the UE message at step 4 includes the ackRequested IE set to TRUE, then the SS shall send an acknowledgment in the LPP PROVIDE ASSISTANCE DATA message.
6. Send an LPP REQUEST LOCATION INFORMATION message to obtain a fix.
7. If the UE returns a valid result in the LPP PROVIDE LOCATION INFORMATION message within the Max response time specified in table 7.1.2.9 then record the result and process it as specified in step 8. If the UE does not return a valid result within the Max response time specified in table 7.1.2.9 or reports an Error in the LPP PROVIDE LOCATION INFORMATION message then record one Bad Result.
- 7a. If the UE message at step 7 includes the ackRequested IE set to TRUE, then the SS shall send a LPP acknowledgment message.

8. For UE based testing compare the reported Location Information in the LPP PROVIDE LOCATION INFORMATION message against the simulated position of the UE used in step 1, and calculate the 2D position error as specified in clause 4.5.2.3. Compare the 2D position error against the value in table 7.1.2.9 and record one Good Result or Bad Result as appropriate; or

For UE assisted testing convert the GNSS Measurement Information reported in the LPP PROVIDE LOCATION INFORMATION message to a 2D position using the method described in clause 4.4.3 and then compare the result against the simulated position of the UE used in step 1, and calculate the 2D position error as specified in clause 4.5.2.3. Compare the 2D position error against the value in table 7.1.2.9 and record one Good Result or Bad Result as appropriate.

9. Repeat steps 1 to 8 using GNSS scenario #2 instead of #1 so that the reference location changes sufficiently such that the UE shall have to use the new assistance data. Use new random values for the UE location and altitude in step 1 and for the GNSS Reference Time GNSS Reference Time for one cell offsets in step 5.
10. Repeat steps 1 to 9 until the statistical requirements of clause 7.1.2.6 are met. Each time scenario #1 or #2 is used, the start time of the GNSS scenario shall be advanced by 2 minutes from the time used previously for that scenario. Once a scenario reaches the end of its viable running time, restart it from its nominal start time again.
11. Release the signalling connection.

### 7.1.2.5.3 Message contents

Message contents are according to TS 36.508 [18] clauses 4.6 and 4.7 and as follows:

#### RESET UE POSITIONING STORED INFORMATION

Information Element	Value/remark
UE POSITIONING TECHNOLOGY	AGNSS

#### LPP REQUEST CAPABILITIES

Information Element	Value/remark
<i>a-gnss-RequestCapabilities</i>	TRUE

## LPP REQUEST LOCATION INFORMATION

Information Element	Value/remark	Comment
commonEsRequestLocationInformation		
> locationInformationType	'locationEstimateRequired' or 'locationMeasurementsRequired'	Depending on test case and UE capabilities, i.e. support for UE-based or UE-assisted
> additionalInformation	'onlyReturnInformationRequested'	
> qos		
>> horizontalAccuracy	'19' (51.2m)	
>> verticalCoordinateRequest	FALSE	
>> responseTime		
>>>time	'20'	
a-gnss-RequestLocationInformation		
> gnss-PositioningInstructions		
>> gnssMethods		
>>> gnss-ids	Sub-test 1: 'gps' Sub-test 2: 'glonass' Sub-test 3: 'galileo' Sub-test 4: 'gps' Sub-test 5: 'gps' and 'glonass' Sub-test 8: 'gps' and 'galileo' Sub-test 9: 'bds' Sub-test 10: 'gps'and'bds' Sub-test 11: 'gps' and 'glonass' and 'bds'	
>> fineTimeAssistanceMeasReq	FALSE	
>> adrMeasReq	FALSE	
>> multiFreqMeasReq	TRUE or FALSE	Depending on UE capabilities
>> assistanceAvailability	FALSE	

## 7.1.2.6 Test requirement

For the parameters specified in table 7.1.2.6 or 7.1.2.7 the UE shall meet the requirements and the success rate specified in table 7.1.2.9 with a confidence level of 95% according to Annex D.

**Table 7.1.2.6: Test parameters Sensitivity Fine time assistance - Sub-Test 1**

Parameters	Unit	Value
Number of generated satellites	-	8
HDOP Range	-	1.1 to 1.6
Propagation conditions	-	AWGN
GPS Coarse time assistance error range	seconds	±1.8
GPS Fine Time assistance error range	µs	±9
GPS L1 C/A Signal for all satellites	dBm	-146

**Table 7.1.2.7: Test parameters Sensitivity Fine time assistance - Sub-Tests 2 to 5 and Sub-Tests 8 to 10**

System	Parameters	Unit	Value
	Number of generated satellites per system	-	See Table 7.1.2.8
	Total number of generated satellites	-	6
	HDOP range		1.4 to 2.1
	Propagation conditions	-	AWGN
	GNSS coarse time assistance error range	seconds	±1.8
	GNSS fine time assistance error range	µs	±9
Galileo	Reference signal power level	dBm	-146
GPS <sup>(1)</sup>	Reference signal power level	dBm	-146
GLONASS	Reference signal power level	dBm	-146
BDS	Reference signal power level	dBm	-146
NOTE 1: "GPS" here means GPS L1 C/A, Modernized GPS, or both, dependent on UE capabilities.			

**Table 7.1.2.8: Satellite allocation**

	Satellite allocation for each constellation		
	GNSS-1	GNSS-2	GNSS-3
Single constellation	6	-	-
Dual constellation	3	3	-
Triple constellation	2	2	2

**Table 7.1.2.9: Test requirements for Sensitivity Fine Time Assistance**

System	Success rate	2-D position error	Max response time
All	95 %	101.3 m	20.3 s

## 7.2 Nominal Accuracy

### 7.2.1 Sub-tests

This test includes sub-tests dependent on the GNSS supported by the UE. Each sub-test is identified by a Sub-Test Number as defined in Table 7.2.1

**Table 7.2.1: Sub-Test Number Definition**

Sub-Test Number	Supported GNSS
1	UE supporting A-GPS L1C/A only
2	UE supporting A-GLONASS only
3	UE supporting A-Galileo only
4	UE supporting A-GPS and Modernized GPS only
5	UE supporting A-GPS and A-GLONASS only
8	UE supporting A-GPS and A-Galileo only
9	UE supporting A-BDS only
10	UE supporting A-GPS and A-BDS only
11	UE supporting A-GPS and A-GLONASS and A-BDS only

### 7.2.2 Test purpose

To verify the performance of the first position estimate, when the UE is provided with ideal GNSS signal conditions.

### 7.2.3 Test applicability

This test applies to all types of E-UTRA UE that supports A-GNSS, except Cat-M1 and Cat-M2 devices that do not support VoLTE.



## 7.2.4 Minimum conformance requirements

The first fix position estimates shall meet the accuracy and response time requirements in table 7.2.2 or 7.2.3 for the parameters specified in table 7.2.4 or 7.2.5.

**Table 7.2.2: Requirements Nominal Accuracy - Sub-Test 1**

Success rate	2-D position error	Max response time
95 %	30 m	20 s

**Table 7.2.3: Requirements Nominal Accuracy - Sub-Tests 2 to 5 and Sub-Tests 8 to 10**

Success rate	2-D position error	Max response time
95 %	15 m	20 s

**Table 7.2.4: Parameters Nominal Accuracy - Sub-Test 1**

Parameters	Unit	Value
Number of generated satellites	-	8
HDOP Range	-	1.1 to 1.6
Propagation conditions	-	AWGN
GPS Coarse Time assistance error range	seconds	$\pm 2$
GPS L1 C/A Signal for all satellites	dBm	-130

**Table 7.2.5: Parameters Nominal Accuracy - Sub-Tests 2 to 5 and Sub-Tests 8 to 10**

System	Parameters	Unit	Value
	Number of generated satellites per system	-	See Table 7.2.6
	Total number of generated satellites	-	6 or 7 <sup>(2)</sup>
	HDOP Range	-	1.4 to 2.1
	Propagation conditions	-	AWGN
	GNSS coarse time assistance error range	seconds	$\pm 2$
GPS <sup>(1)</sup>	Reference signal power level for all satellites	dBm	-128.5
Galileo	Reference signal power level for all satellites	dBm	-127
GLONASS	Reference signal power level for all satellites	dBm	-131
QZSS	Reference signal power level for all satellites	dBm	-128.5
SBAS	Reference signal power level for all satellites	dBm	-131
BDS	Reference signal power level for all satellites	dBm	-133
NOTE 1: "GPS" here means GPS L1 C/A, Modernized GPS, or both, dependent on UE capabilities.			
NOTE 2: 7 satellites apply only for SBAS case.			

If QZSS is supported, one of the GPS satellites will be replaced by a QZSS satellite with respective signal support.

If SBAS is supported, the SBAS satellite with the highest elevation will be added to the scenario.

**Table 7.2.6: Satellite allocation**

	Satellite allocation for each constellation			
	GNSS 1 <sup>(1)</sup>	GNSS 2 <sup>(1)</sup>	GNSS 3 <sup>(1)</sup>	SBAS
Single constellation	6	--	--	1
Dual constellation	3	3	--	1
Triple constellation	2	2	2	1
NOTE 1: GNSS refers to global systems i.e., GPS, Galileo, GLONASS and BDS.				

The normative reference for this requirement is TS 36.171 [3] clause 5.2 and 6.2.

## 7.2.5 Test description

### 7.2.5.1 Initial conditions

Initial conditions are a set of test configurations the UE needs to be tested in and the steps for the SS to take with the UE to reach the correct measurement state.

Test Environment: Normal, as defined in TS 36.508 [18] clause 4.1.

Frequencies to be tested: Mid Range, as defined in TS 36.508 [18] clause 4.3.1.

Channel Bandwidth to be tested: as defined in TS 36.508 [18] clause 4.3.1.

1. Connect SS and GSS to the UE antenna connector or antenna connectors as shown in Annex A.
2. Set the GNSS test parameters as specified in table 7.2.7 or 7.2.8 for GNSS scenario #3 in TS 37.571-5 [20].
3. The parameter settings for the cell are set up according to TS 36.508 [18] clause 4.4.3, single cell scenario.
4. Switch on the UE.
5. Establish a signalling connection according to the generic procedure in TS 36.508 [18] clause 4.5.3 (State 3, Generic RB established) on a channel in the Mid EARFCN range.

### 7.2.5.2 Test procedure

1. Start GNSS scenario #3 as specified in clause 6.2.1.2 of TS 37.571-5 [20] with the UE location randomly selected to be within 3 km of the Reference Location and the altitude of the UE randomly selected between 0 m to 500 m above WGS-84 reference ellipsoid using the method described in clause 6.2.1.2.6 of TS 37.571-5 [20]
2. Send a RESET UE POSITIONING STORED INFORMATION message.
3. Send an LPP REQUEST CAPABILITIES message.
4. The UE returns an LPP PROVIDE CAPABILITIES message indicating the assistance data supported by the UE in the Assistance Data Support List in the A GNSS Provide Capabilities IE.
5. Send an LPP PROVIDE ASSISTANCE DATA message to provide the assistance data that is supported by the UE as indicated in the step 4 and in accordance with clause 6.2.6 of TS 37.571-5 [20], and with the values defined in clause 6.2.7 of TS 37.571-5 [20] with the value of GNSS Reference Time offset by a random value as specified in clause 6.2.7.2 of TS 37.571-5 [20]. If the UE message at step 4 includes the ackRequested IE set to TRUE, then the SS shall send an acknowledgment in the (first) LPP PROVIDE ASSISTANCE DATA message.
6. Send an LPP REQUEST LOCATION INFORMATION message to obtain a fix.
7. If the UE returns a valid result in the LPP PROVIDE LOCATION INFORMATION message within the Max response time specified in table 7.2.10 then record the result and process it as specified in step 8. If the UE does not return a valid result within the Max response time specified in table 7.2.10 or reports an Error in the LPP PROVIDE LOCATION INFORMATION message then record one Bad Result.
- 7a. If the UE message at step 7 includes the ackRequested IE set to TRUE, then the SS shall send a LPP acknowledgment message.
8. For UE based testing compare the reported Location Information in the LPP PROVIDE LOCATION INFORMATION message against the simulated position of the UE used in step 1, and calculate the 2D position error as specified in clause 4.5.2.3. Compare the 2D position error against the value in table 7.2.10 and record one Good Result or Bad Result as appropriate; or

For UE assisted testing convert the GNSS Measurement Information reported in the LPP PROVIDE LOCATION INFORMATION message to a 2D position using the method described in clause 4.4.3 and then compare the result against the simulated position of the UE used in step 1, and calculate the 2D position error as specified in clause 4.5.2.3. Compare the 2D position error against the value in table 7.2.10 and record one Good Result or Bad Result as appropriate.

9. Repeat steps 1 to 8 using GNSS scenario #4 instead of #3 so that the reference location changes sufficiently such that the UE shall have to use the new assistance data. Use new random values for the UE location and altitude in step 1 and for the GNSS Reference Time offset in step 5.
10. Repeat steps 1 to 9 until the statistical requirements of clause 7.2.6 are met. Each time scenario #3 or #4 is used, the start time of the GNSS scenario shall be advanced by 2 minutes from the time used previously for that scenario. Once a scenario reaches the end of its viable running time, restart it from its nominal start time again.
11. Release the signalling connection.

### 7.2.5.3 Message contents

Message contents are according to TS 36.508 [18] clauses 4.6 and 4.7 and as follows:

#### RESET UE POSITIONING STORED INFORMATION

Information Element	Value/remark
UE POSITIONING TECHNOLOGY	AGNSS

#### LPP REQUEST CAPABILITIES

Information Element	Value/remark
<i>a-gnss-RequestCapabilities</i>	TRUE

## LPP REQUEST LOCATION INFORMATION

Information Element	Value/remark	Comment
commonEsRequestLocationInformation		
> locationInformationType	'locationEstimateRequired' or 'locationMeasurementsRequired'	Depending on test case and UE capabilities, i.e. support for UE-based or UE-assisted
> additionalInformation	'onlyReturnInformationRequested'	
> qos		
>> horizontalAccuracy (Sub-Test 1)	'10' (15.9m)	
>> horizontalAccuracy (Sub-Tests 2 to 10)	'6' (7.7m)	
>> verticalCoordinateRequest	FALSE	
>> responseTime		
>>>time	'20'	
a-gnss-RequestLocationInformation		
> gnss-PositioningInstructions		
>> gnssMethods		
>>> gnss-ids	Sub-test 1: 'gps' and possibly 'sbas' and/or 'qzss' Sub-test 2: 'glonass' and possibly 'sbas' and/or 'qzss' Sub-test 3: 'galileo' and possibly 'sbas' and/or 'qzss' Sub-test 4: 'gps' and possibly 'sbas' and/or 'qzss' Sub-test 5: 'gps' and 'glonass' and possibly 'sbas' and/or 'qzss' Sub-test 8: 'gps' and 'galileo' and possibly 'sbas' and/or 'qzss' Sub-test 9: 'bds' and possibly 'sbas' and/or 'qzss' Sub-test 10: 'gps' and 'bds' and possibly 'sbas' and/or 'qzss' Sub-test 11: 'gps' and 'glonass' and 'bds' and possibly 'sbas' and/or 'qzss'	Depending on UE capabilities
>> fineTimeAssistanceMeasReq	FALSE	
>> adrMeasReq	FALSE	
>> multiFreqMeasReq	TRUE or FALSE	Depending on UE capabilities
>> assistanceAvailability	FALSE	

## 7.2.6 Test requirement

For the parameters specified in table 7.2.7 or 7.2.8 the UE shall meet the requirements and the success rate specified in table 7.2.10 or 7.2.11 with a confidence level of 95% according to Annex D.

**Table 7.2.7: Test parameters Nominal Accuracy - Sub-Test 1**

Parameters	Unit	Value
Number of generated satellites	-	8
HDOP Range	-	1.1 to 1.6
Propagation conditions	-	AWGN
GPS Coarse Time assistance error range	seconds	±1.8
GPS L1 C/A Signal for all satellites	dBm	-130

**Table 7.2.8: Test parameters Nominal Accuracy - Sub-Tests 2 to 5 and Sub-Tests 8 to 10**

System	Parameters	Unit	Value
	Number of generated satellites per system	-	See Table 7.2.9
	Total number of generated satellites	-	6 or 7 <sup>(2)</sup>
	HDOP Range	-	1.4 to 2.1
	Propagation conditions	-	AWGN
	GNSS coarse time assistance error range	seconds	±1.8
GPS <sup>(1)</sup>	Reference signal power level for all satellites	dBm	-128.5
Galileo	Reference signal power level for all satellites	dBm	-127
GLONASS	Reference signal power level for all satellites	dBm	-131
QZSS	Reference signal power level for all satellites	dBm	-128.5
SBAS	Reference signal power level for all satellites	dBm	-131
BDS	Reference signal power level for all satellites	dBm	-133
NOTE 1: "GPS" here means GPS L1 C/A, Modernized GPS, or both, dependent on UE capabilities.			
NOTE 2: 7 satellites apply only for SBAS case.			

If QZSS is supported, one of the GPS satellites will be replaced by a QZSS satellite with respective signal support.

If SBAS is supported, the SBAS satellite with the highest elevation will be added to the scenario.

**Table 7.2.9: Satellite allocation**

	Satellite allocation for each constellation			
	GNSS 1 <sup>(1)</sup>	GNSS 2 <sup>(1)</sup>	GNSS 3 <sup>(1)</sup>	SBAS
Single constellation	6	-	-	1
Dual constellation	3	3	-	1
Triple constellation	2	2	2	1
NOTE 1: GNSS refers to global systems i.e., GPS, Galileo, GLONASS and BDS.				

**Table 7.2.10: Test requirements for Nominal Accuracy – Sub-Test 1**

System	Success rate	2-D position error	Max response time
All	95 %	31.3 m	20.3 s

**Table 7.2.11: Test requirements for Nominal Accuracy – Sub-Tests 2 to 5 and Sub-Tests 8 to 10**

System	Success rate	2-D position error	Max response time
All	95 %	16.3 m	20.3 s

## 7.3 Dynamic Range

### 7.3.1 Sub-tests

This test includes sub-tests dependent on the GNSS supported by the UE. Each sub-test is identified by a Sub-Test Number as defined in Table 7.3.1

**Table 7.3.1: Sub-Test Number Definition**

Sub-Test Number	Supported GNSS
1	UE supporting A-GPS L1C/A only
2	UE supporting A-GLONASS only
3	UE supporting A-Galileo only
4	UE supporting A-GPS and Modernized GPS only
5	UE supporting A-GPS and A-GLONASS only
8	UE supporting A-GPS and A-Galileo only
9	UE supporting A-BDS only
10	UE supporting A-GPS and A-BDS only
11	UE supporting A-GPS and A-GLONASS and A-BDS only

### 7.3.2 Test purpose

To verify the performance of the first position estimate, when the UE is provided with GNSS signals with large dynamic ranges.

### 7.3.3 Test applicability

This test applies to all types of E-UTRA UE that supports A-GNSS, except Cat-M1 and Cat-M2 devices that do not support VoLTE.

### 7.3.4 Minimum conformance requirements

The first fix position estimates shall meet the accuracy and response time requirements in table 7.3.2 for the parameters specified in table 7.3.3 or 7.3.4.

**Table 7.3.2: Requirements Dynamic Range**

Success rate	2-D position error	Max response time
95 %	100 m	20 s

**Table 7.3.3: Parameters Dynamic Range - Sub-Test 1**

Parameters	Unit	Value
Number of generated satellites	-	6
HDOP Range	-	1.4 to 2.1
GPS Coarse Time assistance error range	seconds	±2
Propagation conditions	-	AWGN
GPS L1 C/A Signal for 1 <sup>st</sup> satellite	dBm	-129
GPS L1 C/A Signal for 2 <sup>nd</sup> satellite	dBm	-135
GPS L1 C/A Signal for 3 <sup>rd</sup> satellite	dBm	-141
GPS L1 C/A Signal for 4 <sup>th</sup> satellite	dBm	-147
GPS L1 C/A Signal for 5 <sup>th</sup> satellite	dBm	-147
GPS L1 C/A Signal for 6 <sup>th</sup> satellite	dBm	-147

**Table 7.3.4: Parameters Dynamic Range - Sub-Tests 2 to 5 and Sub-Tests 8 to 10**

System	Parameters	Unit	Value
	Number of generated satellites per system	-	See Table 7.3.5
	Total number of generated satellites	-	6
	HDOP Range	-	1.4 to 2.1
	Propagation conditions	-	AWGN
	GNSS coarse time assistance error range	seconds	±2
Galileo	Reference high signal power level	dBm	-127.5
	Reference low signal power level	dBm	-147
GPS <sup>(1)</sup>	Reference high signal power level	dBm	-129
	Reference low signal power level	dBm	-147
GLONASS	Reference high signal power level	dBm	-131.5
	Reference low signal power level	dBm	-147
BDS	Reference high signal power level	dBm	-133.5
	Reference low signal power level	dBm	-145
NOTE 1: "GPS" here means GPS L1 C/A, Modernized GPS, or both, dependent on UE capabilities.			

**Table 7.3.5: Power level and satellite allocation**

		Satellite allocation for each constellation		
		GNSS 1 <sup>(1)</sup>	GNSS 2 <sup>(1)</sup>	GNSS 3 <sup>(1)</sup>
Single constellation	High signal level	2	--	--
	Low signal level	4	--	--
Dual constellation	High signal level	1	1	--
	Low signal level	2	2	--
Triple constellation	High signal level	1	1	1
	Low signal level	1	1	1
NOTE 1: GNSS refers to global systems i.e., GPS, Galileo, GLONASS and BDS.				

The normative reference for this requirement is TS 36.171 [3] clause 5.3 and 6.3.

## 7.3.5 Test description

### 7.3.5.1 Initial conditions

Initial conditions are a set of test configurations the UE needs to be tested in and the steps for the SS to take with the UE to reach the correct measurement state.

Test Environment: Normal, as defined in TS 36.508 [18] clause 4.1.

Frequencies to be tested: Mid Range, as defined in TS 36.508 [18] clause 4.3.1.

Channel Bandwidth to be tested: as defined in TS 36.508 [18] clause 4.3.1.

1. Connect SS and GSS to the UE antenna connector or antenna connectors as shown in Annex A.
2. Set the GNSS test parameters as specified in table 7.3.6 or 7.3.7 for GNSS scenario #1 in TS 37.571-5 [20]. Randomly select from the satellite SV IDs defined in the relevant table of Satellites to be simulated in clause 6.2.1.2 in TS 37.571-5 [20] for the satellites with the higher levels.
3. The parameter settings for the cell are set up according to TS 36.508 [18] clause 4.4.3, single cell scenario.
4. Switch on the UE.
5. Establish a signalling connection according to the generic procedure in TS 36.508 [18] clause 4.5.3 (State 3, Generic RB established) on a channel in the Mid EARFCN range.

### 7.3.5.2 Test procedure

1. Start GNSS scenario #1 as specified in clause 6.2.1.2 of TS 37.571-5 [20] with the UE location randomly selected to be within 3 km of the Reference Location and the altitude of the UE randomly selected between 0 m to 500 m above WGS-84 reference ellipsoid using the method described in clause 6.2.1.2.6 of TS 37.571-5 [20]

2. Send a RESET UE POSITIONING STORED INFORMATION message.
3. Send an LPP REQUEST CAPABILITIES message.
4. The UE returns an LPP PROVIDE CAPABILITIES message indicating the assistance data supported by the UE in the Assistance Data Support List in the A GNSS Provide Capabilities IE.
5. Send an LPP PROVIDE ASSISTANCE DATA message to provide the assistance data that is supported by the UE as indicated in the step 4 and in accordance with clause 6.2.6 of TS 37.571-5 [20], and with the values defined in clause 6.2.7 of TS 37.571-5 [20] with the value of GNSS Reference Time offset by a random value as specified in clause 6.2.7.2 of TS 37.571-5 [20]. If the UE message at step 4 includes the ackRequested IE set to TRUE, then the SS shall send an acknowledgment in the (first) LPP PROVIDE ASSISTANCE DATA message.
6. Send an LPP REQUEST LOCATION INFORMATION message to obtain a fix.
7. If the UE returns a valid result in the LPP PROVIDE LOCATION INFORMATION message within the Max response time specified in table 7.3.9 then record the result and process it as specified in step 8. If the UE does not return a valid result within the Max response time specified in table 7.3.9 or reports an Error in the LPP PROVIDE LOCATION INFORMATION message then record one Bad Result.
  - 7a. If the UE message at step 7 includes the ackRequested IE set to TRUE, then the SS shall send a LPP acknowledgment message.
8. For UE based testing compare the reported Location Information in the LPP PROVIDE LOCATION INFORMATION message against the simulated position of the UE used in step 1, and calculate the 2D position error as specified in clause 4.5.2.3. Compare the 2D position error against the value in table 7.3.9 and record one Good Result or Bad Result as appropriate; or
 

For UE assisted testing convert the GNSS Measurement Information reported in the LPP PROVIDE LOCATION INFORMATION message to a 2D position using the method described in clause 4.4.3 and then compare the result against the simulated position of the UE used in step 1, and calculate the 2D position error as specified in clause 4.5.2.3. Compare the 2D position error against the value in table 7.3.9 and record one Good Result or Bad Result as appropriate.
9. Repeat steps 1 to 8 using GNSS scenario #2 instead of #1 so that the reference location changes sufficiently such that the UE shall have to use the new assistance data. Randomly select from the satellite SV IDs defined in the relevant table of Satellites to be simulated in clause 6.2.1.2 in TS 37.571-5 [20] for the satellites with the higher levels. Use new random values for the UE location and altitude in step 1 and for the GNSS Reference Time offset in step 5.
10. Repeat steps 1 to 9 until the statistical requirements of clause 7.3.6 are met. Each time scenario #1 or #2 is used, the start time of the GNSS scenario shall be advanced by 2 minutes from the time used previously for that scenario. Once a scenario reaches the end of its viable running time, restart it from its nominal start time again. Each time scenario #1 or #2 is used, randomly select from the satellite SV IDs defined in the relevant table of Satellites to be simulated in clause 6.2.1.2 in TS 37.571-5 [20], for the satellites with the higher levels.
11. Release the signalling connection.

### 7.3.5.3 Message contents

Message contents are according to TS 36.508 [18] clauses 4.6 and 4.7 and as follows:

#### RESET UE POSITIONING STORED INFORMATION

Information Element	Value/remark
UE POSITIONING TECHNOLOGY	AGNSS

#### LPP REQUEST CAPABILITIES

Information Element	Value/remark
<i>a-gnss-RequestCapabilities</i>	TRUE



## LPP REQUEST LOCATION INFORMATION

Information Element	Value/remark	Comment
commonEsRequestLocationInformation		
> locationInformationType	'locationEstimateRequired' or 'locationMeasurementsRequired'	Depending on test case and UE capabilities, i.e. support for UE-based or UE-assisted
> additionalInformation	'onlyReturnInformationRequested'	
> qos		
>> horizontalAccuracy	'19' (51.2m)	
>> verticalCoordinateRequest	FALSE	
>> responseTime		
>>>time	'20'	
a-gnss-RequestLocationInformation		
> gnss-PositioningInstructions		
>> gnssMethods		
>>> gnss-ids	Sub-test 1: 'gps' Sub-test 2: 'glonass' Sub-test 3: 'galileo' Sub-test 4: 'gps' Sub-test 5: 'gps' and 'glonass' Sub-test 8: 'gps' and 'galileo' Sub-test 9: 'bds' Sub-test 10: 'gps'and'bds' Sub-test 11: 'gps' and 'glonass' and 'bds'	
>> fineTimeAssistanceMeasReq	FALSE	
>> adrMeasReq	FALSE	
>> multiFreqMeasReq	TRUE or FALSE	Depending on UE capabilities
>> assistanceAvailability	FALSE	

## 7.3.6 Test requirement

For the parameters specified in table 7.3.6 or 7.3.7 the UE shall meet the requirements and the success rate specified in table 7.3.9 with a confidence level of 95% according to Annex D.

**Table 7.3.6: Test parameters Dynamic Range - Sub-Test 1**

Parameters	Unit	Value
Number of generated satellites	-	6
HDOP Range	-	1.4 to 2.1
GPS Coarse Time assistance error range	seconds	±1.8
Propagation conditions	-	AWGN
GPS L1 C/A Signal for 1 <sup>st</sup> satellite	dBm	-128.2
GPS L1 C/A Signal for 2 <sup>nd</sup> satellite	dBm	-134
GPS L1 C/A Signal for 3 <sup>rd</sup> satellite	dBm	-140
GPS L1 C/A Signal for 4 <sup>th</sup> satellite	dBm	-146
GPS L1 C/A Signal for 5 <sup>th</sup> satellite	dBm	-146
GPS L1 C/A Signal for 6 <sup>th</sup> satellite	dBm	-146

**Table 7.3.7: Test parameters Dynamic Range - Sub-Tests 2 to 5 and Sub-Tests 8 to 10**

System	Parameters	Unit	Value
	Number of generated satellites per system	-	See Table 7.3.8
	Total number of generated satellites	-	6
	HDOP Range	-	1.4 to 2.1
	Propagation conditions	-	AWGN
	GNSS coarse time assistance error range	seconds	±1.8
Galileo	Reference high signal power level	dBm	-126.7
	Reference low signal power level	dBm	-146
GPS <sup>(1)</sup>	Reference high signal power level	dBm	-128.2
	Reference low signal power level	dBm	-146
GLONASS	Reference high signal power level	dBm	-130.7
	Reference low signal power level	dBm	-146
BDS	Reference high signal power level	dBm	-132.7
	Reference low signal power level	dBm	-144
NOTE 1: "GPS" here means GPS L1 C/A, Modernized GPS, or both, dependent on UE capabilities.			

**Table 7.3.8: Power level and satellite allocation**

		Satellite allocation for each constellation		
		GNSS 1 <sup>(1)</sup>	GNSS 2 <sup>(1)</sup>	GNSS 3 <sup>(1)</sup>
Single constellation	High signal level	2	--	--
	Low signal level	4	--	--
Dual constellation	High signal level	1	1	--
	Low signal level	2	2	--
Triple constellation	High signal level	1	1	1
	Low signal level	1	1	1
NOTE 1: GNSS refers to global systems i.e., GPS, Galileo, GLONASS and BDS.				

**Table 7.3.9: Test requirements for Dynamic Range**

System	Success rate	2-D position error	Max response time
All	95 %	101.3 m	20.3 s

## 7.4 Multi-Path scenario

### 7.4.1 Sub-tests

This test includes sub-tests dependent on the GNSS supported by the UE. Each sub-test is identified by a Sub-Test Number as defined in Table 7.4.1

**Table 7.4.1: Sub-Test Number Definition**

Sub-Test Number	Supported GNSS
1	UE supporting A-GPS L1C/A only
2	UE supporting A-GLONASS only
3	UE supporting A-Galileo only
4	UE supporting A-GPS and Modernized GPS only
5	UE supporting A-GPS and A-GLONASS only
8	UE supporting A-GPS and A-Galileo only
9	UE supporting A-BDS only
10	UE supporting A-GPS and A-BDS only
11	UE supporting A-GPS and A-GLONASS and A-BDS only

### 7.4.2 Test purpose

To verify the performance of the first position estimate, when the UE is provided with GNSS signals with multi-path components.

### 7.4.3 Test applicability

This test applies to all types of E-UTRA UE that supports A-GNSS, except Cat-M1 and Cat-M2 devices that do not support VoLTE.

### 7.4.4 Minimum conformance requirements

The first fix position estimates shall meet the accuracy and response time requirements in table 7.4.2 for the parameters specified in table 7.4.3 or 7.4.4.

**Table 7.4.2: Requirements Multi-Path scenario**

Success rate	2-D position error	Max response time
95 %	100 m	20 s

**Table 7.4.3: Parameters Multi-Path scenario - Sub-Test 1**

Parameters	Unit	Value
Number of generated satellites (Satellites 1, 2 unaffected by multi-path) (Satellites 3, 4, 5 affected by multi-path)	-	5
GPS Coarse time assistance error range	seconds	±2
HDOP Range	-	1.8 to 2.5
GPS L1 C/A Signal for satellite 1, 2	dBm	-130
GPS L1 C/A Signal for satellite 3, 4, 5	dBm	LOS signal of -130 dBm, multi-path signal of -136 dBm

**Table 7.4.4: Parameters Multi-Path scenario - Sub-Tests 2 to 5 and Sub-Tests 8 to 10**

System	Parameters	Unit	Value
	Number of generated satellites per system	-	See Table 7.4.5
	Total number of generated satellites	-	6
	HDOP range		1.4 to 2.1
	Propagation conditions	-	AWGN
	GNSS coarse time assistance error range	seconds	±2
Galileo	Reference signal power level	dBm	-127
GPS <sup>(1)</sup>	Reference signal power level	dBm	-128.5
GLONASS	Reference signal power level	dBm	-131
BDS	Reference signal power level	dBm	-133
NOTE 1: "GPS" here means GPS L1 C/A, Modernized GPS, or both, dependent on UE capabilities.			

**Table 7.4.5: Channel model allocation**

		Channel model allocation for each constellation		
		GNSS-1	GNSS-2	GNSS-3
Single constellation	One-tap channel	2	--	--
	Two-tap channel	4	--	--
Dual constellation	One-tap channel	1	1	--
	Two-tap channel	2	2	--
Triple constellation	One-tap channel	1	1	1
	Two-tap channel	1	1	1

The normative reference for this requirement is TS 36.171 [3] clause 5.4 and 6.4.

### 7.4.5 Test description

#### 7.4.5.1 Initial conditions

Initial conditions are a set of test configurations the UE needs to be tested in and the steps for the SS to take with the UE to reach the correct measurement state.

Test Environment: Normal, as defined in TS 36.508 [18] clause 4.1.

Frequencies to be tested: Mid Range, as defined in TS 36.508 [18] clause 4.3.1.

Channel Bandwidth to be tested: as defined in TS 36.508 [18] clause 4.3.1.

1. Connect SS and GSS to the UE antenna connector or antenna connectors as shown in Annex A.
2. Set the GNSS test parameters as specified in table 7.4.6 or 7.4.7 for GNSS scenario #1 in TS 37.571-5 [20]. Randomly select from the satellite SV IDs defined in the relevant table of Satellites to be simulated in clause 6.2.1.2 in TS 37.571-5 [20] for the satellites with one-tap channels.
3. The parameter settings for the cell are set up according to TS 36.508 [18] clause 4.4.3, single cell scenario.
4. Switch on the UE.
5. Establish a signalling connection according to the generic procedure in TS 36.508 [18] clause 4.5.3 (State 3, Generic RB established) on a channel in the Mid EARFCN range.

#### 7.4.5.2 Test procedure

1. Start GNSS scenario #1 as specified in clause 6.2.1.2 of TS 37.571-5 [20] with the UE location randomly selected to be within 3 km of the Reference Location and the altitude of the UE randomly selected between 0 m to 500 m above WGS-84 reference ellipsoid using the method described in clause 6.2.1.2.6 of TS 37.571-5 [20]. The initial carrier phase difference between taps of the multi-path model shall be randomly selected between 0 and  $2\pi$  radians by selecting the next random number from a standard uniform random number generator, in the range 0 to  $2\pi$ , representing radians with a resolution of 0.1, representing 0.1 radians.
2. Send a RESET UE POSITIONING STORED INFORMATION message.
3. Send an LPP REQUEST CAPABILITIES message.
4. The UE returns an LPP PROVIDE CAPABILITIES message indicating the assistance data supported by the UE in the Assistance Data Support List in the A GNSS Provide Capabilities IE.
5. Send an LPP PROVIDE ASSISTANCE DATA message to provide the assistance data that is supported by the UE as indicated in the step 4 and in accordance with clause 6.2.6 of TS 37.571-5 [20], and with the values defined in clause 6.2.7 of TS 37.571-5 [20] with the value of GNSS Reference Time offset by a random value as specified in clause 6.2.7.2 of TS 37.571-5 [20]. If the UE message at step 4 includes the ackRequested IE set to TRUE, then the SS shall send an acknowledgment in the LPP PROVIDE ASSISTANCE DATA message.
6. Send an LPP REQUEST LOCATION INFORMATION message to obtain a fix.
7. If the UE returns a valid result in the LPP PROVIDE LOCATION INFORMATION message within the Max response time specified in table 7.4.10 then record the result and process it as specified in step 8. If the UE does not return a valid result within the Max response time specified in table 7.4.10 or reports an Error in the LPP PROVIDE LOCATION INFORMATION message then record one Bad Result.
- 7a. If the UE message at step 7 includes the ackRequested IE set to TRUE, then the SS shall send a LPP acknowledgment message.
8. For UE based testing compare the reported Location Information in the LPP PROVIDE LOCATION INFORMATION message against the simulated position of the UE used in step 1, and calculate the 2D position error as specified in clause 4.5.2.3. Compare the 2D position error against the value in table 7.4.10 and record one Good Result or Bad Result as appropriate; or

For UE assisted testing convert the GNSS Measurement Information reported in the LPP PROVIDE LOCATION INFORMATION message to a 2D position using the method described in clause 4.4.3 and then compare the result against the simulated position of the UE used in step 1, and calculate the 2D position error as specified in clause 4.5.2.3. Compare the 2D position error against the value in table 7.4.10 and record one Good Result or Bad Result as appropriate.

9. Repeat steps 1 to 8 using GNSS scenario #2 instead of #1 so that the reference location changes sufficiently such that the UE shall have to use the new assistance data. Randomly select from the satellite SV IDs defined in the relevant table of Satellites to be simulated in clause 6.2.1.2 in TS 37.571-5 [20] for the satellites with the one-tap

channels. Use new random values for the UE location and altitude, and the initial carrier phase difference between taps of the multi-path model in step 1 and for the GNSS Reference Time offset in step 5.

10. Repeat steps 1 to 9 until the statistical requirements of clause 7.4.6 are met. Each time scenario #1 or #2 is used, the start time of the GNSS scenario shall be advanced by 2 minutes from the time used previously for that scenario. Once a scenario reaches the end of its viable running time, restart it from its nominal start time again. Each time scenario #1 or #2 is used, randomly select from the satellite SV IDs defined in the relevant table of Satellites to be simulated in clause 6.2.1.2 in TS 37.571-5 [20], for the satellites with the one-tap channels.

11. Release the signalling connection

### 7.4.5.3 Message contents

Message contents are according to TS 36.508 [18] clauses 4.6 and 4.7 and as follows:

#### RESET UE POSITIONING STORED INFORMATION

Information Element	Value/remark
UE POSITIONING TECHNOLOGY	AGNSS

#### LPP REQUEST CAPABILITIES

Information Element	Value/remark
<i>a-gnss-RequestCapabilities</i>	TRUE

#### LPP REQUEST LOCATION INFORMATION

Information Element	Value/remark	Comment
commonIEsRequestLocationInformation		
> locationInformationType	'locationEstimateRequired' or 'locationMeasurementsRequired'	Depending on test case and UE capabilities, i.e. support for UE-based or UE-assisted
> additionalInformation	'onlyReturnInformationRequested'	
> qos		
>> horizontalAccuracy	'19' (51.2m)	
>> verticalCoordinateRequest	FALSE	
>> responseTime		
>>>time	'20'	
a-gnss-RequestLocationInformation		
> gnss-PositioningInstructions		
>> gnssMethods		
>>> gnss-ids	Sub-test 1: 'gps' Sub-test 2: 'glonass' Sub-test 3: 'galileo' Sub-test 4: 'gps' Sub-test 5: 'gps' and 'glonass' Sub-test 8: 'gps' and 'galileo' Sub-test 9: 'bds' Sub-test 10: 'gps'and'bds' Sub-test 11: 'gps' and 'glonass' and 'bds'	
>> fineTimeAssistanceMeasReq	FALSE	
>> adrMeasReq	FALSE	
>> multiFreqMeasReq	TRUE or FALSE	Depending on UE capabilities
>> assistanceAvailability	FALSE	

### 7.4.6 Test requirement

For the parameters specified in table 7.4.6 or 7.4.7 the UE shall meet the requirements and the success rate specified in table 7.4.10 with a confidence level of 95% according to Annex D.

**Table 7.4.6: Test parameters Multi-Path scenario - Sub-Test 1**

Parameters	Unit	Value
Number of generated satellites (see note)	-	5
GPS Coarse Time assistance error range	seconds	$\pm 1.8$
HDOP Range	-	1.8 to 2.5
GPS L1 C/A Signal for Satellite 1, 2 (see note)	dBm	-130
GPS L1 C/A Signal for Satellite 3, 4, 5 (see note)	dBm	LOS signal of -130 dBm, multi-path signal of -136.2 dBm
NOTE: Satellites 1, 2 no multi-path. Satellites 3, 4, 5 multi-path defined in clause 4.2.4.		

**Table 7.4.7: Test parameters Multi-Path scenario - Sub-Tests 2 to 5 and Sub-Tests 8 to 10**

System	Parameters	Unit	Value
	Number of generated satellites per system	-	See Table 6.18
	Total number of generated satellites	-	6
	HDOP Range per system	-	1.4 to 2.1
	Propagation conditions	-	AWGN
	GNSS coarse time assistance error range	seconds	$\pm 2$
Galileo	Reference signal power level for all satellites	dBm	-127
GPS <sup>(1)</sup>	Reference signal power level for all satellites	dBm	-128.5
GLONASS	Reference signal power level for all satellites	dBm	-131
BDS	Reference signal power level for all satellites	dBm	-133
NOTE 1: "GPS" here means GPS L1 C/A, Modernized GPS, or both, dependent on UE capabilities.			

**Table 6.18: Satellite allocation**

	Satellite allocation for each constellation		
	GNSS 1 <sup>(1)</sup>	GNSS 2 <sup>(1)</sup>	GNSS 3 <sup>(1)</sup>
Single constellation	6	--	--
Dual constellation	3	3	--
Triple constellation	2	2	2
NOTE 1: GNSS refers to global systems i.e., GPS, Galileo, GLONASS and BDS.			

**Table 7.4.10: Test requirements for Multi-Path scenario**

System	Success rate	2-D position error	Max response time
All	95 %	101.3 m	20.3 s

## 7.5 Moving scenario and periodic update (Rel-9 to Rel-13)

### 7.5.1 Sub-tests

This test includes sub-tests dependent on the GNSS supported by the UE. Each sub-test is identified by a Sub-Test Number as defined in Table 7.5.1

**Table 7.5.1: Sub-Test Number Definition**

Sub-Test Number	Supported GNSS
1	UE supporting A-GPS L1C/A only
2	UE supporting A-GLONASS only
3	UE supporting A-Galileo only
4	UE supporting A-GPS and Modernized GPS only
5	UE supporting A-GPS and A-GLONASS only
8	UE supporting A-GPS and A-Galileo only
9	UE supporting A-BDS only
10	UE supporting A-GPS and A-BDS only
11	UE supporting A-GPS and A-GLONASS and A-BDS only

## 7.5.2 Test purpose

To verify the performance when the UE is requested to use periodical reporting with a reporting interval of 2 seconds.

## 7.5.3 Test applicability

This test applies to all types of E-UTRA UE except Cat-M1 UE that supports A-GNSS with LPP Release 9 to 13, except Cat-M1 and Cat-M2 devices that do not support VoLTE.

## 7.5.4 Minimum conformance requirements

The position estimates, after the first reported position estimate, shall meet the accuracy requirement in table 7.5.2 or 7.5.3 with the periodical reporting interval of 2 seconds for the parameters specified in table 7.5.4 or 7.5.5.

NOTE: In the actual testing the UE may report error messages until it has been able to acquire GNSS measured results or a position estimate. The SS shall only consider the first measurement report different from an error message as the first position estimate in the requirement in table 7.5.2 or 7.5.3.

**Table 7.5.2: Requirements Moving scenario and periodic update - Sub-Test 1**

Success Rate	2-D position error	Periodical reporting interval
95 %	100 m	2 s

**Table 7.5.3: Requirements Moving scenario and periodic update - Sub-Tests 2 to 5 and Sub-Tests 8 to 10**

Success Rate	2-D position error	Periodical reporting interval
95 %	50 m	2 s

**Table 7.5.4: Parameters Moving scenario and periodic update - Sub-Test 1**

Parameters	Unit	Value
Number of generated satellites	-	5
HDOP Range	-	1.8 to 2.5
Propagation condition	-	AWGN
GPS L1 C/A signal for all satellites	dBm	-130

**Table 7.5.5: Parameters Moving scenario and periodic update - Sub-Tests 2 to 5 and Sub-Tests 8 to 10**

System	Parameters	Unit	Value
	Number of generated satellites per system	-	See Table 7.5.6
	Total number of generated satellites	-	6
	HDOP range		1.4 to 2.1
	Propagation conditions	-	AWGN
Galileo	Reference signal power level	dBm	-127
GPS <sup>(1)</sup>	Reference signal power level	dBm	-128.5
GLONASS	Reference signal power level	dBm	-131
BDS	Reference signal power level	dBm	-133
NOTE 1: "GPS" here means GPS L1 C/A, Modernized GPS, or both, dependent on UE capabilities.			

**Table 7.5.6: Satellite allocation**

	Satellite allocation for each constellation		
	GNSS 1 <sup>(1)</sup>	GNSS 2 <sup>(1)</sup>	GNSS 3 <sup>(1)</sup>
Single constellation	6	--	--
Dual constellation	3	3	--
Triple constellation	2	2	2
NOTE 1: GNSS refers to global systems i.e., GPS, Galileo, GLONASS and BDS.			

The normative reference for this requirement is TS 36.171 [3] clause 5.5 and 6.5.

### 7.5.5 Test description

#### 7.5.5.1 Initial conditions

Initial conditions are a set of test configurations the UE needs to be tested in and the steps for the SS to take with the UE to reach the correct measurement state.

Test Environment: Normal, as defined in TS 36.508 [18] clause 4.1.

Frequencies to be tested: Mid Range, as defined in TS 36.508 [18] clause 4.3.1.

Channel Bandwidth to be tested: as defined in TS 36.508 [18] clause 4.3.1

The UE moves on a rectangular trajectory of 940 m by 1 440 m with rounded corner defined in Figure 7.1. The initial reference is first defined followed by acceleration to final speed of 100 km/h in 250 m. The UE then maintains the speed for 400 m. This is followed by deceleration to final speed of 25 km/h in 250 m. The UE then turn 90 degrees with turning radius of 20 m at 25 km/h. This is followed by acceleration to final speed of 100 km/h in 250 m. The sequence is repeated to complete the rectangle.

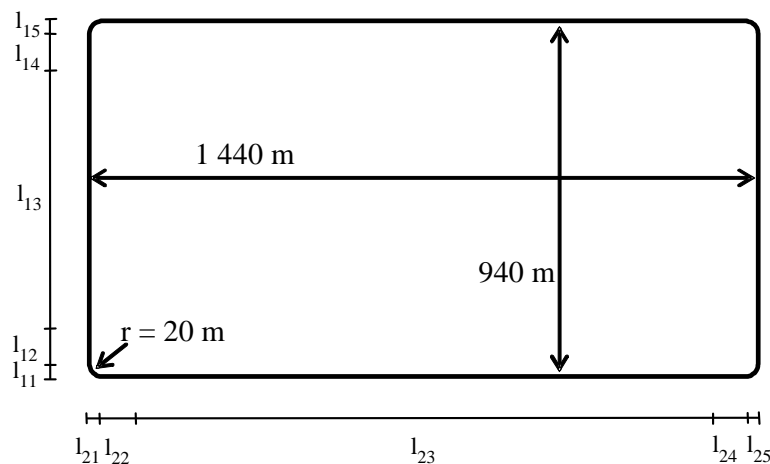

**Figure 7.1: Rectangular trajectory of the moving scenario and periodic update test case**



### Trajectory Parameters

Parameter	Distance (m)	Speed (km/h)
$l_{11}, l_{15}, l_{21}, l_{25}$	20	25
$l_{12}, l_{14}, l_{22}, l_{24}$	250	25 to 100 and 100 to 25
$l_{13}$	400	100
$l_{23}$	900	100

1. Connect SS and GSS to the UE antenna connector or antenna connectors as shown in Annex A.
2. Set the GPS test parameters as specified in table 7.5.7 or 7.5.8 for GPS scenario #5 in TS 37.571-5 [20].
3. The parameter settings for the cell are set up according to TS 36.508 [18] clause 4.4.3, single cell scenario.
4. Switch on the UE.
5. Establish a signalling connection according to the generic procedure in TS 36.508 [18] clause 4.5.3 (State 3, Generic RB established) on a channel in the Mid EARFCN range.

#### 7.5.5.2 Test procedure

1. Start GNSS scenario #5 as specified in clause 6.2.1.2 of TS 37.571-5 [20]
2. Send a RESET UE POSITIONING STORED INFORMATION message.
3. Send an LPP REQUEST CAPABILITIES message.
4. The UE returns an LPP PROVIDE CAPABILITIES message indicating the assistance data supported by the UE in the Assistance Data Support List in the A GNSS Provide Capabilities IE.
5. Send an LPP PROVIDE ASSISTANCE DATA message to provide the assistance data that is supported by the UE as indicated in the step 4 and in accordance with clause 6.2.6 of TS 37.571-5 [20], and with the values defined in clause 6.2.7 of TS 37.571-5 [20]. If the UE message at step 4 includes the ackRequested IE set to TRUE, then the SS shall send an acknowledgment in the LPP PROVIDE ASSISTANCE DATA message.
6. Send an LPP REQUEST LOCATION INFORMATION message to obtain a fix.
7. Ignore any Error messages that the UE may report in LPP PROVIDE LOCATION INFORMATION messages until it has been able to acquire the GNSS signals and reports the first GNSS Measurement Information or Location Information.
8. Discard the first GNSS Measurement Information or Location Information.
9. Record the time of reception of the next LPP PROVIDE LOCATION INFORMATION message after reception of the first GNSS Measurement Information or Location Information.
10. After the reception of the first GNSS Measurement Information or Location Information reported in a LPP PROVIDE LOCATION INFORMATION message, every time the UE returns a GNSS Measurement Information or Location Information in the LPP PROVIDE LOCATION INFORMATION message record the time of reception and the result. If the difference between the time of reception and the time of reception of the previous result is less than 1.5 seconds or greater than 2.5 seconds, or if the UE reports an Error in any LPP PROVIDE LOCATION INFORMATION messages, then record one Bad Result. Otherwise process the result as specified in step 11.
- 10a. If the UE messages at steps 7 to 10 include the ackRequested IE set to TRUE, then the SS shall send LPP acknowledgment messages as required.
11. For UE based testing compare the reported Location Information in the LPP PROVIDE LOCATION INFORMATION message against the simulated position of the UE at the time of applicability reported in the Location Information, and calculate the 2D position error as specified in clause 4.5.2.3. Compare the 2D position error against the value in table 7.5.10 or 7.5.11 and record one Good Result or Bad Result as appropriate; or

For UE assisted testing convert the GNSS Measurement Information reported in the LPP PROVIDE LOCATION INFORMATION message to a 2D position using the method described in clause 4.4.3 and then compare the result against the simulated position of the UE at the time of applicability reported in the GNSS Measurement Information, and calculate the 2D position error as specified in clause 4.5.2.3. Compare the 2D position error against the value in table 7.5.10 or 7.5.11 and record one Good Result or Bad Result as appropriate.

12. If the UE sends the first LPP PROVIDE LOCATION INFORMATION that contains GNSS Measurement Information or Location Information later than 240s after the start of the GNSS scenario, fail the UE and stop the test early. Otherwise collect LPP PROVIDE LOCATION INFORMATION results during 900s, starting from the time recorded in step 9. If at any time the difference between the times of reception of two consecutive results is greater than 240s, fail the UE and stop the test early. Use the collected Good Results and Bad Results to determine the PASS/FAIL according to clause 7.5.6.

13. Release the signalling connection.

### 7.5.5.3 Message contents

Message contents are according to TS 36.508 [18] clauses 4.6 and 4.7 and as follows:

#### RESET UE POSITIONING STORED INFORMATION

Information Element	Value/remark
UE POSITIONING TECHNOLOGY	AGNSS

#### LPP REQUEST CAPABILITIES

Information Element	Value/remark
<i>a-gnss-RequestCapabilities</i>	TRUE

## LPP REQUEST LOCATION INFORMATION

Information Element	Value/remark	Comment
commonEsRequestLocationInformation		
> locationInformationType	'locationEstimateRequired' or 'locationMeasurementsRequired'	Depending on test case and UE capabilities, i.e. support for UE-based or UE-assisted
> periodicalReporting		
>> reportingAmount	'ra-Infinity'	Infinite means during the complete test time
>> reportingInterval	'ri0-5'	2 seconds
> additionalInformation	'onlyReturnInformationRequested'	
> qos		
>> horizontalAccuracy (Sub-Test 1)	'19' (51.2m)	
>> horizontalAccuracy (Sub-Tests 2 to 10)	'13' (24.5m)	
>> verticalCoordinateRequest	FALSE	
>> responseTime	Not present	
a-gnss-RequestLocationInformation		
> gnss-PositioningInstructions		
>> gnssMethods		
>>> gnss-ids	Sub-test 1: 'gps' Sub-test 2: 'glonass' Sub-test 3: 'galileo' Sub-test 4: 'gps' Sub-test 5: 'gps' and 'glonass' Sub-test 8: 'gps' and 'galileo' Sub-test 9: 'bds' Sub-test 10: 'gps'and'bds' Sub-test 11: 'gps' and 'glonass' and 'bds'	
>> fineTimeAssistanceMeasReq	FALSE	
>> adrMeasReq	FALSE	
>> multiFreqMeasReq	TRUE or FALSE	Depending on UE capabilities
>> assistanceAvailability	FALSE	

## 7.5.6 Test requirement

For the parameters specified in table 7.5.7 or 7.5.8 the UE shall meet the requirements and the success rate specified in table 7.5.10 or 7.5.11 after the first reported position estimates.

- NOTES: 1. In the testing the UE may report error messages until it has been able to acquire GNSS measured results or a position estimate. The test equipment shall only consider the first measurement report different from an error message as the first position estimate in the requirement in table 7.5.10 or 7.5.11.
2. Due to the statistical nature of the results it is not possible to design a test with predefined confidence level for the success rate in table 7.5.10 or 7.5.11, therefore a simple PASS/FAIL of the results gathered against this success rate is used.

**Table 7.5.7: Test parameters Moving scenario and periodic update - Sub-Test 1**

Parameters	Unit	Value
Number of generated satellites	-	5
HDOP Range	-	1.8 to 2.5
Propagation condition	-	AWGN
GPS L1 C/A Signal for all satellites	dBm	-130

**Table 7.5.8: Test parameters Moving scenario and periodic update - Sub-Tests 2 to 5 and Sub-Tests 8 to 10**

System	Parameters	Unit	Value
	Number of generated satellites per system	-	See Table 7.5.9
	Total number of generated satellites	-	6
	HDOP Range per system	-	1.4 to 2.1
	Propagation conditions	-	AWGN
Galileo	Reference signal power level for all satellites	dBm	-127
GPS <sup>(1)</sup>	Reference signal power level for all satellites	dBm	-128.5
GLONASS	Reference signal power level for all satellites	dBm	-131
BDS	Reference signal power level for all satellites	dBm	-133
NOTE 1: "GPS" here means GPS L1 C/A, Modernized GPS, or both, dependent on UE capabilities.			

**Table 7.5.9: Satellite allocation**

	Satellite allocation for each constellation		
	GNSS 1 <sup>(1)</sup>	GNSS 2 <sup>(1)</sup>	GNSS 3 <sup>(1)</sup>
Single constellation	6	--	--
Dual constellation	3	3	--
Triple constellation	2	2	2
NOTE 1: GNSS refers to global systems i.e., GPS, Galileo, GLONASS and BDS.			

**Table 7.5.10: Test requirements for Moving scenario and periodic update - Sub-Test 1**

System	Success rate	2-D position error	Periodical reporting interval
All	95 %	101.3 m	Between 1.5 s and 2.5s

**Table 7.5.11: Test requirements for Moving scenario and periodic update - Sub-Tests 2 to 5 and Sub-Tests 8 to 10**

System	Success rate	2-D position error	Periodical reporting interval
All	95 %	51.3 m	Between 1.5 s and 2.5s

## 7.5A Moving scenario and periodic update (Rel-14 onwards)

### 7.5A.1 Sub-tests

Same as defined in clause 7.5.1.

### 7.5A.2 Test purpose

Same as defined in clause 7.5.2.

### 7.5A.3 Test applicability

This test applies to all types of E-UTRA UE with LPP Release 14 onwards that supports A-GNSS with periodical reporting, except Cat-M1 and Cat-M2 devices that do not support VoLTE.

NOTE: The capability to support periodical reporting is indicated in LPP [4] by either omitting the field *periodicalReportingNotSupported-r14* in the LPP PROVIDE CAPABILITIES message, or by including the field *periodicalReportingNotSupported-r14* in the LPP PROVIDE CAPABILITIES message but with bits for UE-assisted or UE-based mode set to zero.

### 7.5A.4 Minimum conformance requirements

Same as defined in clause 7.5.4.

### 7.5A.5 Test description

Same as defined in clause 7.5.5.

### 7.5A.6 Test requirement

Same as defined in clause 7.5.6.

---

## 8 E-UTRA ECID measurement requirements

### 8.1 UE Rx – Tx Time Difference

#### 8.1.1 E-UTRAN FDD UE Rx – Tx time difference case (Rel-9 to Rel-11)

##### 8.1.1.1 Test purpose

The purpose of this test is to verify that the E-UTRAN FDD UE Rx – Tx time difference measurement accuracy is within the specified limits in TS 36.133 [23] clause 9.1.9.

##### 8.1.1.2 Test applicability

This test applies to all types of E-UTRA FDD UE release 9 to release 11 that supports ECID positioning.

##### 8.1.1.3 Minimum conformance requirements

NOTE: This measurement is used for UE positioning purposes.

The UE RX-TX time difference is measured from the PCell.

The accuracy requirements in Table 8.1.1.3-1 are valid under the following conditions:

Cell specific reference signals are transmitted either from one, two or four antenna ports.

Conditions defined in TS 36.101 [2] clause 7.3 for reference sensitivity are fulfilled.

No changes to the uplink transmission timing are applied during the measurement period.

RSRP<sub>dBm</sub> according to clause E.1 for a corresponding Band.

Table 8.1.1.3-1: UE Rx – Tx time difference measurement accuracy

Accuracy	Conditions				
	$\hat{\epsilon}_s/\text{lot}$	Downlink transmission bandwidth of PCell	$I_o$ <sup>Note 1</sup> range		
E-UTRA operating band groups <sup>Note 6</sup>			Minimum $I_o$	Maximum $I_o$	
$T_s$ <sup>Note 2</sup>	dB	MHz		$\text{dBm}/15\text{kHz}$ <sup>Note 5</sup>	$\text{dBm}/\text{BW}_{\text{Channel}}$
$\pm 20$	$\geq -3$ dB	$\leq 3$ MHz	FDD_A <sup>Note 7</sup> , TDD_A	-121	-50
			FDD_B	-120.5	-50
			FDD_C, TDD_C	-120	-50
			FDD_D	-119.5	-50
			FDD_E, TDD_E	-119	-50
			FDD_F	-118.5	-50
			FDD_G <sup>Note 4</sup>	-118	-50
			FDD_H	-117.5	-50
			FDD_N	-114.5	-50
$\pm 10$	$\geq -3$ dB	$\geq 5$ MHz	Note 3	Note 3	Note 3
NOTE 1: When in dBm/15kHz, the minimum $I_o$ condition is expressed as the average $I_o$ per RE over all REs in that symbol. $I_o$ may be different in different symbols within a subframe.					
NOTE 2: $T_s$ is the basic timing unit defined in TS 36.211 [26].					
NOTE 3: The same bands and the same $I_o$ conditions for each band apply for this requirement as for the corresponding requirement with downlink bandwidth $\leq 3$ MHz.					
NOTE 4: Except Band 29.					
NOTE 5: The condition level is increased by $\Delta > 0$ , when applicable, as described in TS 36.521-3 [25] Sections I.4.2 and I.4.3.					
NOTE 6: E-UTRA operating band groups are as defined in Section 4.4.2.					
NOTE 7: Except Band 32.					

The normative reference for this requirement is TS 36.133 [23] clause 9.1.9 and A.9.7.1.

### 8.1.1.4 Test description

The test consists of two sub-tests; the difference between the sub-tests is the bandwidth, 1.4 MHz and 10 MHz. Each sub-test has two test points with time delays starting at  $32 T_s$  and  $5008 T_s$  respectively. There is only one active cell in the tests. The tested UE is connected with the serving cell, configured to transmit SRS signals periodically, and signalled to report UE Rx – Tx time difference measurement. The test equipment measures the transmit timing of the UE using the transmitted SRS. The test equipment then compares this timing to the UE Rx-Tx measurement reported by the UE.

#### 8.1.1.4.1 Initial conditions

Test Environment: Normal as defined in TS 36.508 [18] clause 4.1.

Frequencies to be tested: Mid Range, as defined in TS 36.508 [18] clause 4.3.1.1.

Channel Bandwidth to be tested: 1.4 and 10 MHz. In the case that 1.4 MHz channel bandwidth is not defined for the operating band under test, as defined in TS 36.101 [2] clause 5.6.1, then the corresponding sub-test shall be omitted.

1. Connect the SS (node B emulator) and AWGN noise source to the UE antenna connectors as shown in Annex A figure A.5a for 4RX capable UE without any 2RX bands. Otherwise use Annex A figure A.5.
2. Propagation conditions are set according to clause 4.6.2.1.
3. Message contents are defined in clause 8.1.1.4.3.
4. Cell 1 is the serving cell. Cell 1 is the cell used for connection setup with the power levels set according to TS 36.521-3 [25] clauses C.0 and C.1 for this test.

#### 8.1.1.4.2 Test procedure

1. Bring the UE to State 3A or 3A-RF according to TS 36.508 [18] clause 4.5.3A or 5.2A.2, using a value of initial timing advance command  $T_A = 2$  in the Random Access Response which indicates an initial timing advance

value  $N_{TA} = 32 T_s$ . Note that in the remainder of the test the timing advance command  $T_A = 31$  which indicates a timing advance adjustment value  $N_{TA} = 0 T_s$ .

2. Set the parameters according to Sub-test 1 in Tables 8.1.1.5-1 and 8.1.1.5-2 as appropriate. Propagation conditions are set according to clause 4.6.2.1.
3. The SS adjusts the downlink timing for Cell 1 to a delay of  $+8 T_s$ , compared to the current value.
4. Wait for 1.6 s to allow for the possibility that the UE makes autonomous timing adjustments.
- 4a. The SS shall transmit an LPP REQUEST CAPABILITIES message.
- 4b. The UE shall transmit an LPP PROVIDE CAPABILITIES message indicating the ECID capabilities supported by the UE in the *ECID-ProvideCapabilities* IE.
5. The SS shall transmit an LPP REQUEST LOCATION INFORMATION message, including the *ECID-RequestLocationInformation* IE. If the UE message at step 4b includes the *ackRequested* IE set to TRUE, then the SS shall send an acknowledgment in the LPP REQUEST LOCATION INFORMATION message.
6. The UE shall transmit an LPP PROVIDE LOCATION INFORMATION message including the *ecid-SignalMeasurementInformation* IE.
7. As soon as possible after step 6 the SS shall measure the transmit timing of the UE using the transmitted SRS, relative to the current downlink timing.
8. If the UE message at step 6 includes the *ackRequested* IE set to TRUE, then the SS shall send a LPP acknowledgment message.
9. The SS shall check the reported value of *ue-RxTxTimeDiff* in the *ecid-SignalMeasurementInformation* IE provided by the UE in step 6 and compare it with the value measured in step 7. The SS shall check that the reported value is within the limits specified in table 8.1.1.5-3 for Sub-test 1 compared to the measured value. If the reported value is within the limits the number of successful results for “Sub-test 1 – Test point 1” is increased by one. If the reported value is not within the limits, or the UE reports an error in the LPP PROVIDE LOCATION INFORMATION message in step 6, or does not respond at step 6 within the time given by the *time* IE in the *ECID-RequestLocationInformation* IE in step 5, then the number of unsuccessful results for “Sub-test 1 – Test point 1” is increased by one.
10. Repeat steps 3-9 until the confidence level according to Annex D.4.3 is achieved.  
NOTE: To avoid a large divergence between the sent TA and the set downlink timing, the SS may reset the downlink timing for Cell 1 to its initial value after a certain amount of loops. The loop during the reset does not count for the result statistics.
11. Repeat steps 1-10 for “Sub-test 1 – Test point 2”. Set a value of initial timing advance command  $T_A = 313$  in the Random Access Response which indicates an initial timing advance value  $N_{TA} = 5008 T_s$  in step 1.
12. Repeat steps 1-11 for Sub-test 2 (consisting of Test point 1 and Test point 2) in Tables 8.1.1.5-1 and 8.1.1.5-2 as appropriate. In step 3 the SS adjusts the downlink timing for Cell 1 to a delay of  $+4 T_s$  compared to the current value.

If both test points of a sub-test pass, the sub-test passes. If one test point of a sub-test fails, the sub-test fails.

If all (applicable) sub-tests pass, the whole test passes. If one (applicable) sub-test fails, the whole test fails.

#### 8.1.1.4.3 Message contents

Message contents are according to TS 36.508 [18] clause 4.6 with the following exceptions:

**Table 8.1.1.4.3-1: SoundingRS-RL-ConfigCommon-DEFAULT: UE Rx – Tx time difference for E-UTRAN FDD test requirement**

Derivation Path: TS 36.508 [18] clause 4.6.3, Table 4.6.3-21 SoundingRS-UL-ConfigCommon-DEFAULT			
Information Element	Value/remark	Comment	Condition
SoundingRS-UL-ConfigCommon-DEFAULT ::= SEQUENCE {			
setup SEQUENCE {			
srs-BandwidthConfig	bw7 for sub-test 1 bw5 for sub-test 2	Set according to specific sub-test	
srs-SubframeConfig	Sc1		FDD
ackNackSRS-SimultaneousTransmission	FALSE		
srsMaxUpPts	Not present		FDD
}			

**Table 8.1.1.4.3-2: SoundingRS-RL-ConfigDedicated-DEFAULT: UE Rx – Tx time difference for E-UTRAN FDD test requirement**

Derivation Path: TS 36.508 [18] clause 4.6.3, Table 4.6.3-22 SoundingRS-UL-ConfigDedicated-DEFAULT			
Information Element	Value/remark	Comment	Condition
SoundingRS-UL-ConfigDedicated-DEFAULT ::= CHOICE {			
setup SEQUENCE {			
srs-Bandwidth	bw0	bw0 used with no frequency hopping. bw3 used with frequency hopping	
srs-HoppingBandwidth	hbw0		
freqDomainPosition	0		
duration	TRUE	Indefinite duration	
srs-ConfigIndex	0		
transmissionComb	0		
cyclicShift	cs0	No cyclic shift	
}			

**Table 8.1.1.4.3-2a: LPP REQUEST CAPABILITIES: UE Rx – Tx time difference for E-UTRAN FDD test requirement**

Information Element	Value/remark
<i>ecid-RequestCapabilities</i>	TRUE



**Table 8.1.1.4.3-3: ECID-RequestLocationInformation: UE Rx – Tx time difference for E-UTRAN FDD test requirement**

Derivation Path: TS 36.355 clause 6.2			
Information Element	Value/remark	Comment	Condition
LPP-Message ::= SEQUENCE {			
transactionID SEQUENCE {			
Initiator	locationServer		
transactionNumber	1		
}			
endTransaction	FALSE		
sequenceNumber	Not present		
acknowledgement	Not present		
lpp-MessageBody CHOICE {			
c1 CHOICE {			
requestLocationInformation SEQUENCE {			
criticalExtensions CHOICE {			
c1 CHOICE {			
requestLocationInformation-r9 SEQUENCE {			
commonIEsRequestLocationInformation SEQUENCE {			
locationInformationType	locationMeasurementsRequired		
triggeredReporting	Not present		
periodicalReporting	Not present		
additionalInformation	onlyReturnInformationRequested		
qos SEQUENCE {			
horizontalAccuracy	Not present		
verticalCoordinateRequest	FALSE		
verticalAccuracy	Not present		
responseTime SEQUENCE {			
time	2		
responseTimeEarlyFix-r12	Not present		Rel-12 onwards
}			
velocityRequest	FALSE		
}			
environment	Not present		
locationCoordinateTypes	Not present		
velocityTypes	Not present		
}			
a-gnss-RequestLocationInformation	Not present		
otdoa-RequestLocationInformation	Not present		
ecid-RequestLocationInformation ::= SEQUENCE {			
requestedMeasurements	0 0 1	ueRxTxReq	
}			
epdu-RequestLocationInformation	Not Present		
}			
}			
}			
}			
}			

**Table 8.1.1.4.3-4: ECID-ProvideLocationInformation: UE Rx – Tx time difference for E-UTRAN FDD test requirement**

Derivation Path: 36.355 clause 6.2			
Information Element	Value/remark	Comment	Condition
LPP-Message ::= SEQUENCE {			
transactionID SEQUENCE {			
Initiator	locationServer		
transactionNumber	1		
}			
endTransaction	TRUE		
sequenceNumber	(0..255)		
acknowledgement			
lpp-MessageBody CHOICE {			
c1 CHOICE {			
provideLocationInformation SEQUENCE {			
criticalExtensions CHOICE {			
c1 CHOICE {			
provideLocationInformation-r9 SEQUENCE {			
commonIEsProvideLocationInformation	Not present.		
a-gnss-ProvideLocationInformation	Not present		
otdoa-ProvideLocationInformation	Not present		
ecid-ProvideLocationInformation ::=			
SEQUENCE {			
ecid-SignalMeasurementInformation ::=			
SEQUENCE {			
primaryCellMeasuredResults	Not Present		
MeasuredResultsList ::= SEQUENCE			
(SIZE(1..32)) OF			
MeasuredResultsElement			
MeasuredResultsElement ::= SEQUENCE {			
physCellId			
cellGlobalId			
arfcnEUTRA			
systemFrameNumber			
rsrp-Result	Not Present		
rsrq-Result	Not Present		
ue-RxTxTimeDiff		Set according to specific sub-test and test point.	
}			
}			
}			
epdu-ProvideLocationInformation	Not present		
}			
}			
}			
}			

**Table 8.1.1.4.3-5: CQI-ReportConfig-DEFAULT: UE Rx – Tx time difference for E-UTRAN FDD test requirement**

Derivation Path: TS 36.508 [18] clause 4.6.3, Table 4.6.3-2 CQI-ReportConfig-DEFAULT			
Information Element	Value/remark	Comment	Condition
CQI-ReportConfig-DEFAULT ::= SEQUENCE {			
cqi-ReportModeAperiodic	rm30	This IE should be omitted for Sub-test 1	
nomPDSCH-RS-EPRE-Offset	0		
cqi-ReportPeriodic CHOICE {			
release	NULL		
}			

### 8.1.1.5 Test requirement

Table 8.1.1.5-1 defines the primary level settings including test tolerances for all sub-tests.

**Table 8.1.1.5-1: FDD UE Rx – Tx time difference test parameters**

Parameter	Unit	Sub-test 1	Sub-test 2
E-UTRAN RF Channel Number		1	1
$BW_{\text{channel}}$	MHz	1.4	10
DRX		OFF	
PDSCH Reference measurement channel defined in TS 36.521-3 [25] clause A.1.1		R.2 FDD	R.0 FDD
PDSCH allocation	$n_{\text{PRB}}$	2–3	13–36
PDCCH/PCFICH/PHICH Reference measurement channel defined in TS 36.521-3 [25] clause A.2.1		R.8 FDD	R.6 FDD
OCNG Patterns defined in TS 36.521-3 [25] clause D.1		OP.3 FDD	OP.1 FDD
PBCH_RA	dB	0	0
PBCH_RB	dB		
PSS_RA	dB		
SSS_RA	dB		
PCFICH_RB	dB		
PHICH_RA	dB		
PHICH_RB	dB		
PDCCH_RA	dB		
PDCCH_RB	dB		
PDSCH_RA	dB		
PDSCH_RB	dB		
OCNG_RA <sup>Note 1</sup>	dB		
OCNG_RB <sup>Note 1</sup>	dB		
$N_{oc}$ <sup>Note 2</sup>	dBm/15 kHz		
RSRP <sup>Note 3</sup>	dBm/15 kHz	-101	-101
$\hat{E}_s / N_{oc}$	dB	2.7	2.7
$I_o$ <sup>Note 3</sup>	dBm/1.08 MHz	-76.55	N/A
	dBm/9 MHz	N/A	-67.35
$\hat{E}_s / I_{ot}$	dB	-2.7	-2.7
Propagation Condition		AWGN	
<p>Note 1: OCNG shall be used such that the resources in the active cell are fully allocated and a constant total transmitted power spectral density is achieved for all OFDM symbols.</p> <p>Note 2: Interference from other cells and noise sources not specified in the test is assumed to be constant over subcarriers and time and shall be modelled as AWGN of appropriate power for <math>N_{oc}</math> to be fulfilled.</p> <p>Note 3: RSRP and <math>I_o</math> levels have been derived from other parameters for information purposes. They are not settable parameters themselves.</p>			

**Table 8.1.1.5-2: Sounding Reference Symbol Configuration to be used in FDD UE Rx – Tx time difference test**

Field	Sub-test 1	Sub-test 2	Comment
	Value		
srsBandwidthConfiguration	bw7	bw5	
srsSubframeConfiguration	sc1		
ackNackSrsSimultaneousTransmission	FALSE		
srsMaxUpPTS	N/A		Not applicable for FDD
srsBandwidth	0		No hopping
srsHoppingBandwidth	hbw0		
frequencyDomainPosition	0		
Duration	TRUE		Indefinite duration
Srs-ConfigurationIndex	0		SRS periodicity of 2ms.
transmissionComb	0		
cyclicShift	cs0		No cyclic shift
SRS-AntennaPort	an1		Number of antenna ports used for SRS transmission
Note:	For further information see clause 6.3.2 in 3GPP TS 36.331 [22].		

The UE Rx – Tx time difference measurement accuracy shall fulfil the requirements in Table 8.1.1.5-3.

**Table 8.1.1.5-3: Test requirements UE Rx – Tx time difference measurement accuracy requirements**

	Sub-test 1	Sub-test 2
Lowest reported value	(Measured value from step 7 - 23) $T_s$ converted to RX-TX_TIME_DIFFERENCE according to Table 4.6.3-1	(Measured value from step 7 - 13) $T_s$ converted to RX-TX_TIME_DIFFERENCE according to Table 4.6.3-1
Highest reported value	(Measured value from step 7 + 23) $T_s$ converted to RX-TX_TIME_DIFFERENCE according to Table 4.6.3-1	(Measured value from step 7 + 13) $T_s$ converted to RX-TX_TIME_DIFFERENCE according to Table 4.6.3-1

NOTE: Each sub-test in table 8.1.1.5-3 has two test points starting at 32  $T_s$  and 5008  $T_s$ .

The test tolerances are defined in Annex C.

For the overall test to pass, the ratio of successful reported values in each test point of each sub-test shall be more than 90% with a confidence level of 95%. In the case that 1.4 MHz channel bandwidth is not defined for the operating band under test then Sub-test 1 shall be omitted.

## 8.1.1A E-UTRAN FDD UE Rx – Tx time difference case (Rel-12 onwards)

### 8.1.1A.1 Test purpose

Same as defined in clause 8.1.1.1.

### 8.1.1A.2 Test applicability

This test applies to all types of E-UTRA FDD UE release 12 onwards that supports ECID positioning.

### 8.1.1A.3 Minimum conformance requirements

Same as defined in clause 8.1.1.3 except that Table 8.1.1A.3-1 replaces Table 8.1.1.3-1.

**Table 8.1.1A.3-1: UE Rx – Tx time difference measurement accuracy from Release 12 onwards**

Accuracy	Conditions				
	Ês/lot	Downlink bandwidth	I <sub>o</sub> <sup>Note 1</sup> range		
E-UTRA operating band groups <sup>Note 6</sup>			Minimum I <sub>o</sub>	Maximum I <sub>o</sub>	
T <sub>s</sub> <sup>Note 2</sup>	dB	MHz		dBm/15kHz <sup>Note 5</sup>	dBm/BW <sub>Channel</sub>
±20	≥-3 dB	≥1.4 MHz	FDD_A <sup>Note 7</sup> , TDD_A	-121	-50
			FDD_B	-120.5	-50
			FDD_C, TDD_C	-120	-50
			FDD_D	-119.5	-50
			FDD_E, TDD_E	-119	-50
			FDD_F	-118.5	-50
			FDD_G <sup>Note 4</sup>	-118	-50
			FDD_H	-117.5	-50
			FDD_N	-114.5	-50
±14	≥-3 dB	≥ 3 MHz	Note 3	Note 3	Note 3
±10	≥-3 dB	≥ 5 MHz	Note 3	Note 3	Note 3
±7	≥-3 dB	≥10 MHz	Note 3	Note 3	Note 3

NOTE 1: When in dBm/15kHz, the minimum I<sub>o</sub> condition is expressed as the average I<sub>o</sub> per RE over all REs in that symbol. I<sub>o</sub> may be different in different symbols within a subframe.  
 NOTE 2: T<sub>s</sub> is the basic timing unit defined in TS 36.211 [26].  
 NOTE 3: The same bands and the same I<sub>o</sub> conditions for each band apply for this requirement as for the corresponding requirement with downlink bandwidth ≥1.4 MHz.  
 NOTE 4: Except Band 29.  
 NOTE 5: The condition level is increased by Δ>0, when applicable, as described in TS 36.521-3 [25] Sections I.4.2 and I.4.3.  
 NOTE 6: E-UTRA operating band groups are as defined in Section 4.4.2.  
 NOTE 7: Except Band 32.

**8.1.1A.4 Test description**

Same as defined in clause 8.1.1.4.

**8.1.1A.4.1 Initial conditions**

Same as defined in clause 8.1.1.4.1.

**8.1.1A.4.2 Test procedure**

Same as defined in clause 8.1.1.4.2.

**8.1.1A.4.3 Message contents**

Same as defined in clause 8.1.1.4.3.

**8.1.1A.5 Test requirement**

Same as defined in clause 8.1.1.5 except that Table 8.1.1A.5-3 replaces Table 8.1.1.5-3.

**Table 8.1.1A.5-3: Test requirements UE Rx – Tx time difference measurement accuracy requirements**

	Sub-test 1	Sub-test 2
Lowest reported value	(Measured value from step 7 - 23) T <sub>s</sub> converted to RX-TX_TIME_DIFFERENCE according to Table 4.6.3-1	(Measured value from step 7 - 10) T <sub>s</sub> converted to RX-TX_TIME_DIFFERENCE according to Table 4.6.3-1
Highest reported value	(Measured value from step 7 + 23) T <sub>s</sub> converted to RX-TX_TIME_DIFFERENCE according to Table 4.6.3-1	(Measured value from step 7 + 10) T <sub>s</sub> converted to RX-TX_TIME_DIFFERENCE according to Table 4.6.3-1

## 8.1.1B E-UTRAN FDD UE Rx – Tx time difference case for UE Category 1bis

### 8.1.1B.1 Test purpose

Same as defined in clause 8.1.1.1.

### 8.1.1B.2 Test applicability

This test applies to all types of E-UTRA FDD UE release 13 onwards of category 1bis that supports ECID positioning.

### 8.1.1B.3 Minimum conformance requirements

Same as defined in clause 8.1.1A.3.

### 8.1.1B.4 Test description

Same as defined in clause 8.1.1.4.

#### 8.1.1B.4.1 Initial conditions

Same as defined in clause 8.1.1.4.1.

#### 8.1.1B.4.2 Test procedure

Same as defined in clause 8.1.1.4.2.

#### 8.1.1B.4.3 Message contents

Same as defined in clause 8.1.1.4.3.

### 8.1.1B.5 Test requirement

Same as defined in clause 8.1.1A.5 except that the Cell Antenna Configuration is 1x1 instead of the default 1x2.

## 8.1.2 E-UTRAN TDD UE Rx – Tx time difference case (Rel-9 to Rel-11)

### 8.1.2.1 Test purpose

The purpose of this test is to verify that the E-UTRAN TDD UE Rx – Tx time difference measurement accuracy is within the specified limits in TS 36.133 [23] clause 9.1.9.

### 8.1.2.2 Test applicability

This test applies to all types of E-UTRA TDD UE release 9 to release 11 with LPP release 13 onwards that supports ECID positioning. Note that for LPP releases before release 13 the UE TDD Rx - Tx time difference measurement report mapping is ambiguous and therefore this test shall not be used.

### 8.1.2.3 Minimum conformance requirements

NOTE: This measurement is used for UE positioning purposes.

The UE RX-TX time difference is measured from the PCell.

The accuracy requirements in Table 8.1.1.3-1 are valid under the following conditions:

Cell specific reference signals are transmitted either from one, two or four antenna ports.

Conditions defined in TS 36.101 [2] clause 7.3 for reference sensitivity are fulfilled.

No changes to the uplink transmission timing are applied during the measurement period.

RSRP<sub>dBm</sub> according to clause E.1 for a corresponding Band.

The normative reference for this requirement is TS 36.133 [23] clause 9.1.9 and A.9.7.1.

### 8.1.2.4 Test description

The test consists of two sub-tests; the difference between the sub-tests is the bandwidth, 1.4 MHz and 10 MHz. Each sub-test has two test points with time delays starting at  $32 T_s$  and  $5008 T_s$  respectively. There is only one active cell in the tests. The tested UE is connected with the serving cell, configured to transmit SRS signals periodically, and signalled to report UE Rx – Tx time difference measurement. The test equipment measures the transmit timing of the UE using the transmitted SRS. The test equipment then compares this timing to the UE Rx-Tx measurement reported by the UE.

#### 8.1.2.4.1 Initial conditions

Test Environment: Normal as defined in TS 36.508 [18] clause 4.1.

Frequencies to be tested: Mid Range, as defined in TS 36.508 [18] clause 4.3.1.2.

Channel Bandwidth to be tested: 1.4 and 10 MHz. In the case that 1.4 MHz channel bandwidth is not defined for the operating band under test, as defined in TS 36.101 [2] clause 5.6.1, then the corresponding sub-test shall be omitted.

1. Connect the SS (node B emulator) and AWGN noise source to the UE antenna connectors as shown in Annex A figure A.5a for 4RX capable UE without any 2RX bands. Otherwise use Annex A figure A.5.
2. Propagation conditions are set according to clause 4.6.2.1.
3. Message contents are defined in clause 8.1.2.4.3.
4. Cell 1 is the serving cell. Cell 1 is the cell used for connection setup with the power levels set according to TS 36.521-3 [25] clauses C.0 and C.1 for this test.

#### 8.1.2.4.2 Test procedure

1. Bring the UE to State 3A or 3A-RF according to TS 36.508 [18] clause 4.5.3A or 5.2A.2, using a value of initial timing advance command  $T_A = 2$  in the Random Access Response which indicates an initial timing advance value  $N_{TA} = 32 T_s$ . Note that in the remainder of the test the timing advance command  $T_A = 31$  which indicates a timing advance adjustment value  $N_{TA} = 0 T_s$ .
2. Set the parameters according to Sub-test 1 in Tables 8.1.2.5-1 and 8.1.5.2-2 as appropriate. Propagation conditions are set according to clause 4.6.2.1.
3. The SS adjusts the downlink timing for Cell 1 to a delay of  $+8 T_s$ , compared to the current value.
4. Wait for 1.6 s to allow for the possibility that the UE makes autonomous timing adjustments.
- 4a. The SS shall transmit an LPP REQUEST CAPABILITIES message.
- 4b. The UE shall transmit an LPP PROVIDE CAPABILITIES message indicating the ECID capabilities supported by the UE in the *ECID-ProvideCapabilities* IE. The IE *ueRxTxSupTDD-r13* shall be present (TRUE).
5. The SS shall transmit a LPP REQUEST LOCATION INFORMATION message, including the *ECID-RequestLocationInformation* IE. If the UE message at step 4b includes the *ackRequested* IE set to TRUE, then the SS shall send an acknowledgment in the LPP REQUEST LOCATION INFORMATION message.
6. The UE shall transmit an LPP PROVIDE LOCATION INFORMATION message including the *ecid-SignalMeasurementInformation* IE.
7. As soon as possible after step 6 the SS shall measure the transmit timing of the UE using the transmitted SRS, relative to the current downlink timing.
8. If the UE message at step 6 includes the *ackRequested* IE set to TRUE, then the SS shall send a LPP acknowledgment message.
9. The SS shall check the reported value of *ue-RxTxTimeDiff* in the *ecid-SignalMeasurementInformation* IE provided by the UE in step 6 and compare it with the value measured in step 7. The SS shall check that the reported values are within the limits specified in table 8.1.2.5-3 for Sub-test 1 compared to the measured value. If the reported value is within the limits the number of successful results for “Sub-test 1 – Test point 1” is increased by one. If the reported value is not within the limits, or the UE reports an error in the LPP PROVIDE LOCATION INFORMATION message in step 6, or does not respond at step 6 within the time given by the *time*

IE in the *ECID-RequestLocationInformation* IE in step 5, then the number of unsuccessful results for “Sub-test 1 – Test point 1” is increased by one.

10. Repeat steps 3-9 until the confidence level according to Annex D.4.3 is achieved.

NOTE: To avoid a large divergence between the sent TA and the set downlink timing, the SS may reset the downlink timing for Cell 1 to its initial value after a certain amount of loops. The loop during the reset does not count for the result statistics.

11. Repeat steps 1-10 for “Sub-test 1 – Test point 2”. Set a value of initial timing advance command  $T_A = 313$  in the Random Access Response which indicates an initial timing advance value  $N_{TA} = 5008 T_s$  in step 1.

12. Repeat steps 1-11 for Sub-test 2 (consisting of Test point 1 and Test point 2) in Tables 8.1.2.5-1 and 8.1.2.5-2 as appropriate. In step 3 the SS adjusts the downlink timing for Cell 1 to a delay of  $+4 T_s$  compared to the current value.

If both test points of a sub-test pass, the sub-test passes. If one test point of a sub-test fails, the sub-test fails.

If all (applicable) sub-tests pass, the whole test passes. If one (applicable) sub-test fails, the whole test fails.

### 8.1.2.4.3 Message contents

Message contents are according to TS 36.508 [18] clause 4.6 with the following exceptions:

**Table 8.1.2.4.3-1: SoundingRS-RL-ConfigCommon-DEFAULT: UE Rx – Tx time difference for E-UTRAN TDD test requirement**

Derivation Path: TS 36.508 [18] clause 4.6.3, Table 4.6.3-21 SoundingRS-UL-ConfigCommon-DEFAULT			
Information Element	Value/remark	Comment	Condition
SoundingRS-UL-ConfigCommon-DEFAULT ::= SEQUENCE {			
setup SEQUENCE {			
srs-BandwidthConfig	bw7 for sub-test 1 bw5 for sub-test 2	Set according to specific sub-test	
srs-SubframeConfig	Sc1		TDD
ackNackSRS-SimultaneousTransmission	FALSE		
srsMaxUpPts	TRUE		TDD
}			

**Table 8.1.2.4.3-2: SoundingRS-RL-ConfigDedicated-DEFAULT: UE Rx – Tx time difference for E-UTRAN TDD test requirement**

Derivation Path: TS 36.508 [18] clause 4.6.3, Table 4.6.3-22 SoundingRS-UL-ConfigDedicated-DEFAULT			
Information Element	Value/remark	Comment	Condition
SoundingRS-UL-ConfigDedicated-DEFAULT ::= CHOICE {			
setup SEQUENCE {			
srs-Bandwidth	bw0	bw0 used with no frequency hopping. bw3 used with frequency hopping	
srs-HoppingBandwidth	hbw0		
freqDomainPosition	0		
duration	TRUE	Indefinite duration	
srs-ConfigIndex	10		
transmissionComb	0		
cyclicShift	cs0	No cyclic shift	
}			



**Table 8.1.2.4.3-2a: LPP REQUEST CAPABILITIES: UE Rx – Tx time difference for E-UTRAN TDD test requirement**

Information Element	Value/remark
<i>ecid-RequestCapabilities</i>	TRUE

**Table 8.1.2.4.3-2b: LPP PROVIDE CAPABILITIES: UE Rx – Tx time difference for E-UTRAN TDD test requirement**

Information Element	Value/remark
<i>ueRxTxSupTDD-r13</i>	TRUE

**Table 8.1.2.4.3-3: ECID-RequestLocationInformation: UE Rx – Tx time difference for E-UTRAN TDD test requirement**

Derivation Path: TS 36.355 clause 6.2			
Information Element	Value/remark	Comment	Condition
LPP-Message ::= SEQUENCE {			
transactionID SEQUENCE {			
Initiator	locationServer		
transactionNumber	1		
}			
endTransaction	FALSE		
sequenceNumber	Not present		
acknowledgement	Not present		
lpp-MessageBody CHOICE {			
c1 CHOICE {			
requestLocationInformation SEQUENCE {			
criticalExtensions CHOICE {			
c1 CHOICE {			
requestLocationInformation-r9 SEQUENCE {			
commonIEsRequestLocationInformation SEQUENCE {			
locationInformationType	locationMeasurementsRequired		
triggeredReporting	Not present		
periodicalReporting	Not present		
additionalInformation	onlyReturnInformationRequested		
qos SEQUENCE {			
horizontalAccuracy	Not present		
verticalCoordinateRequest	FALSE		
verticalAccuracy	Not present		
responseTime SEQUENCE {			
time	2		
responseTimeEarlyFix-r12	Not present		Rel-12 onwards
}			
velocityRequest	FALSE		
}			
environment	Not present		
locationCoordinateTypes	Not present		
velocityTypes	Not present		
}			
a-gnss-RequestLocationInformation	Not present		
otdoa-RequestLocationInformation	Not present		
ecid-RequestLocationInformation ::= SEQUENCE {			
requestedMeasurements	0 0 1	ueRxTxReq	
}			
epdu-RequestLocationInformation	Not Present		
}			
}			
}			
}			
}			

**Table 8.1.2.4.3-4: ECID-ProvideLocationInformation: UE Rx – Tx time difference for E-UTRAN TDD test requirement**

Derivation Path: 36.355 clause 6.2			
Information Element	Value/remark	Comment	Condition
LPP-Message ::= SEQUENCE {			
transactionID SEQUENCE {			
initiator	locationServer		
transactionNumber	1		
}			
endTransaction	TRUE		
sequenceNumber	(0..255)		
acknowledgement			
lpp-MessageBody CHOICE {			
c1 CHOICE {			
provideLocationInformation SEQUENCE {			
criticalExtensions CHOICE {			
c1 CHOICE {			
provideLocationInformation-r9 SEQUENCE {			
commonIEsProvideLocationInformation	Not present.		
a-gnss-ProvideLocationInformation	Not present		
otdoa-ProvideLocationInformation	Not present		
ecid-ProvideLocationInformation ::=			
SEQUENCE {			
ecid-SignalMeasurementInformation ::=			
SEQUENCE {			
primaryCellMeasuredResults	Not Present		
MeasuredResultsList ::= SEQUENCE			
(SIZE(1..32)) OF			
MeasuredResultsElement			
MeasuredResultsElement ::= SEQUENCE {			
physCellId			
cellGlobalId			
arfcnEUTRA			
systemFrameNumber			
rsrp-Result	Not Present		
rsrq-Result	Not Present		
ue-RxTxTimeDiff		Set according to specific sub-test and test point.	
}			
}			
}			
}			
epdu-ProvideLocationInformation	Not present		
}			
}			
}			
}			
}			
}			

**Table 8.1.2.4.3-5: CQI-ReportConfig-DEFAULT: UE Rx – Tx time difference for E-UTRAN TDD test requirement**

Derivation Path: TS 36.508 [18] clause 4.6.3, Table 4.6.3-2 CQI-ReportConfig-DEFAULT			
Information Element	Value/remark	Comment	Condition
CQI-ReportConfig-DEFAULT ::= SEQUENCE {			
cqi-ReportModeAperiodic	rm30	This IE should be omitted for Sub-test 1	
nomPDSCH-RS-EPRE-Offset	0		
cqi-ReportPeriodic CHOICE {			
release	NULL		
}			

### 8.1.2.5 Test requirement

Table 8.1.2.5-1 defines the primary level settings including test tolerances for all sub-tests.

**Table 8.1.2.5-1: Cell specific test parameters for UE Rx-Tx time difference measurement**

Parameter	Unit	Sub-test 1	Sub-test 2
E-UTRAN RF Channel Number	-	1	1
BW <sub>channel</sub>	MHz	1.4	10
Uplink-downlink configuration of cell <sup>Note 1</sup>		1	1
Special subframe configuration of cell <sup>Note 1</sup>		6	6
PDSCH Reference measurement channel defined in TS 36.521-3 [25] clause A.1.2	-	R.2 TDD	R.0 TDD
PDSCH allocation	$n_{PRB}$	2-3	13-36
PDCCH/PCFICH/PHICH Reference measurement channel defined in TS 36.521-3 [25] clause A.2.2	-	R.8 TDD	R.6 TDD
OCNG Patterns defined in TS 36.521-3 [25] clause D.2	-	OP.3 TDD	OP.1 TDD
PBCH_RA	dB	0	0
PBCH_RB	dB		
PSS_RA	dB		
SSS_RA	dB		
PCFICH_RB	dB		
PHICH_RA	dB		
PHICH_RB	dB		
PDCCH_RA	dB		
PDCCH_RB	dB		
PDSCH_RA	dB		
PDSCH_RB	dB		
OCNG_RA <sup>Note 2</sup>	dB		
OCNG_RB <sup>Note 2</sup>	dB		
$N_{oc}$ <sup>Note 3</sup>	dBm/15 kHz		
RSRP <sup>Note 4</sup>	dBm/15 kHz	-100.7	-100.7
$\hat{E}_s/N_{oc}$	dB	-2.7	-2.7
$I_o$ <sup>Note 4</sup>	dBm/1.08 MHz	-77.55	N/A
	dBm/9 MHz	N/A	-67.35
$\hat{E}_s/I_{ot}$	dB	-2.7	-2.7
Propagation Condition		AWGN	
Note 1:	For special subframe and uplink-downlink configurations see Tables 4.2-1 and 4.2-2 in 3GPP TS 36.211 [26].		
Note 2:	OCNG shall be used such that the cell is fully allocated and a constant total transmitted power spectral density is achieved for all OFDM symbols.		
Note 3:	Interference from other cells and noise sources not specified in the test is assumed to be constant over subcarriers and time and shall be modelled as AWGN of appropriate power for $N_{oc}$ to be fulfilled.		
Note 4:	RSRP and $I_o$ levels have been derived from other parameters for information purposes. They are not settable parameters themselves.		

**Table 8.1.2.5-2: Sounding Reference Symbol Configuration to be used in TDD UE Rx – Tx time difference test**

Field	Sub-test 1	Sub-test 2	Comment
	Value		
srsBandwidthConfiguration	bw7	bw5	
srsSubframeConfiguration	sc1		
ackNackSrsSimultaneousTransmission	FALSE		
srsMaxUpPTS	TRUE		
srsBandwidth	0		No hopping
srsHoppingBandwidth	hbw0		
frequencyDomainPosition	0		
Duration	TRUE		Indefinite duration
Srs-ConfigurationIndex	10		SRS periodicity of 10ms.
transmissionComb	0		
cyclicShift	cs0		No cyclic shift
SRS-AntennaPort	an1		Number of antenna ports used for SRS transmission
Note:	For further information see clause 6.3.2 in 3GPP TS 36.331 [22].		

The UE Rx – Tx time difference measurement accuracy shall fulfil the requirements in Table 8.1.2.5-3.

**Table 8.1.2.5-3: Test requirements UE Rx – Tx time difference measurement accuracy requirements**

	Sub-test 1	Sub-test 2
Lowest reported value	(Measured value from step 7 - 23) $T_s$ converted to RX-TX_TIME_DIFFERENCE according to Table 4.6.3-2	(Measured value from step 7 - 13) $T_s$ converted to RX-TX_TIME_DIFFERENCE according to Table 4.6.3-2
Highest reported value	(Measured value from step 7 + 23) $T_s$ converted to RX-TX_TIME_DIFFERENCE according to Table 4.6.3-2	(Measured value from step 7 + 13) $T_s$ converted to RX-TX_TIME_DIFFERENCE according to Table 4.6.3-2

NOTE: Each sub-test in table 8.1.2.5-3 has two test points starting at 32  $T_s$  and 5008  $T_s$ .

The test tolerances are defined in Annex C.

For the overall test to pass, the ratio of successful reported values in each test point of each sub-test shall be more than 90% with a confidence level of 95%. In the case that 1.4 MHz channel bandwidth is not defined for the operating band under test then Sub-test 1 shall be omitted.

## 8.1.2A E-UTRAN TDD UE Rx – Tx time difference case (Rel-12 onwards)

### 8.1.2A.1 Test purpose

Same as defined in clause 8.1.2.1.

### 8.1.2A.2 Test applicability

This test applies to all types of E-UTRA TDD UE release 12 onwards with LPP release 13 onwards that supports ECID positioning. Note that for LPP releases before release 13 the UE TDD Rx - Tx time difference measurement report mapping is ambiguous and therefore this test shall not be used.

### 8.1.2A.3 Minimum conformance requirements

Same as defined in clause 8.1.2.3 except that Table 8.1.1A.3-1 replaces Table 8.1.1.3-1.

### 8.1.2A.4 Test description

Same as defined in clause 8.1.2.4.

#### 8.1.2A.4.1 Initial conditions

Same as defined in clause 8.1.2.4.1.

**8.1.2A.4.2 Test procedure**

Same as defined in clause 8.1.2.4.2.

**8.1.2A.4.3 Message contents**

Same as defined in clause 8.1.2.4.3.

**8.1.2A.5 Test requirement**

Same as defined in clause 8.1.2.5 except that Table 8.1.2A.5-3 replaces Table 8.1.2.5-3.

**Table 8.1.2A.5-3: Test requirements UE Rx – Tx time difference measurement accuracy requirements**

	<b>Sub-test 1</b>	<b>Sub-test 2</b>
Lowest reported value	(Measured value from step 7 - 23) $T_s$ converted to RX-TX_TIME_DIFFERENCE according to Table 4.6.3-2	(Measured value from step 7 - 10) $T_s$ converted to RX-TX_TIME_DIFFERENCE according to Table 4.6.3-2
Highest reported value	(Measured value from step 7 + 23) $T_s$ converted to RX-TX_TIME_DIFFERENCE according to Table 4.6.3-2	(Measured value from step 7 + 10) $T_s$ converted to RX-TX_TIME_DIFFERENCE according to Table 4.6.3-2

**8.1.2B E-UTRAN TDD UE Rx – Tx time difference case for UE Category 1bis****8.1.2B.1 Test purpose**

Same as defined in clause 8.1.2.1.

**8.1.2B.2 Test applicability**

This test applies to all types of E-UTRA TDD UE release 13 onwards of category 1bis that supports ECID positioning.

**8.1.2B.3 Minimum conformance requirements**

Same as defined in clause 8.1.2A.3.

**8.1.2B.4 Test description**

Same as defined in clause 8.1.2.4.

**8.1.2B.4.1 Initial conditions**

Same as defined in clause 8.1.2.4.1.

**8.1.2B.4.2 Test procedure**

Same as defined in clause 8.1.2.4.2.

**8.1.2B.4.3 Message contents**

Same as defined in clause 8.1.2.4.3.

**8.1.2B.5 Test requirement**

Same as defined in clause 8.1.2A.5 except that the Cell Antenna Configuration is 1x1 instead of the default 1x2.

### 8.1.3 E-UTRAN FDD UE Rx–Tx Time Difference under Time-Domain Measurement Resource Restriction with Non-MBSFN ABS (eICIC)

#### 8.1.3.1 Test purpose

To verify that the E-UTRAN FDD UE Rx – Tx time difference measurement accuracy is within the specified limits under a time-domain measurement resource restriction pattern, and when non-MBSFN ABS is configured in the interfering cells.

#### 8.1.3.2 Test applicability

This test applies to all types of E-UTRA FDD UE release 10 and ECID positioning. Applicability requires support for FGI bit 115.

#### 8.1.3.3 Minimum conformance requirements

NOTE: This measurement is used for UE positioning purposes.

The requirements in this section apply for UE configured with a time-domain measurement resource restriction pattern for PCell measurements. The UE Rx-Tx time difference is measured from the Pcell.

The accuracy requirements in Table 8.1.3.3-1 are valid under the following conditions:

- Cell specific reference signals are transmitted either from one, two or four antenna ports,
- Conditions defined in 36.101[2] Clause 7.3 for reference sensitivity are fulfilled,
- No changes to the uplink transmission timing are applied during the measurement period,

RSRP<sub>dBm</sub> according to Annex E.4 for a corresponding Band,

- The time domain measurement resource restriction pattern configured for the PCell indicates at least one subframe per radio frame for performing the PCell measurements,
- Four symbols containing CRS are available in all subframes indicated by the time domain measurement resource restriction pattern.

**Table 8.1.3.3-1: UE Rx–Tx time difference measurement accuracy under time domain measurement resource restriction**

Accuracy	Conditions				
	$\hat{E}s/lot$ <sup>Note 6</sup>	Downlink transmission bandwidth of PCell	$Io$ <sup>Note 1, 5</sup> range		
E-UTRA operating band groups <sup>Note 8</sup>			Minimum $Io$	Maximum $Io$	
$T_s$ <sup>Note 2</sup>	dB	MHz		dBm/15kHz <sup>Note 7</sup>	dBm/BW <sub>Channel</sub>
±20	≥-3 dB	≤ 3 MHz	FDD_A <sup>Note 9</sup> , TDD_A	-121	-50
			FDD_B	-120.5	-50
			FDD_C, TDD_C	-120	-50
			FDD_D	-119.5	-50
			FDD_E, TDD_E	-119	-50
			FDD_F	-118.5	-50
			FDD_G <sup>Note 4</sup>	-118	-50
			FDD_H	-117.5	-50
FDD_N	-114.5	-50			
±10	≥-3 dB	≥ 5 MHz	Note 3	Note 3	Note 3

NOTE 1: When in dBm/15kHz, the minimum  $Io$  condition is expressed as the average  $Io$  per RE over all REs in that symbol.  $Io$  may be different in different symbols within a subframe.

NOTE 2:  $T_s$  is the basic timing unit defined in TS 36.211.

NOTE 3: The same bands and the same  $Io$  conditions for each band apply for this requirement as for the corresponding requirement with downlink bandwidth ≤ 3 MHz.

NOTE 4: Except Band 29.

NOTE 5:  $Io$  is defined for the subframes indicated by the time-domain measurement resource restriction pattern for serving cell measurements. The specified  $Io$  range applies to CRS and non-CRS symbols.  $Io$  may be different in different symbols within a subframe.

NOTE 6: CRS  $\hat{E}s/lot$  is in subframes indicated for PCell measurements by the time-domain measurement resource restriction pattern.

NOTE 7: The condition level is increased by  $\Delta > 0$ , when applicable, as described in TS 36.521-3 [25] Sections I.4.2 and I.4.3.

NOTE 8: E-UTRA operating band groups are as defined in Section 4.4.2.

NOTE 9: Except Band 32.

NOTE: It is up to the UE implementation whether the UE Rx-Tx time difference measurement is performed in any subframe or in subframes indicated by the time-domain measurement resource restriction pattern.

The normative reference for this requirement is TS 36.133 [23] clause 9.1.9.3 and A.9.7.3.

### 8.1.3.4 Test description

The test has two test points with time delays starting at 32  $T_s$  and 5008  $T_s$ , respectively.

In this test case, there are two synchronous cells, Cell 1 and Cell 2, on the same RF channel. Cell 1 is the PCell on which UE Rx-Tx is measured, and Cell 2 is the interfering cell. Non-MBSFN ABS pattern is configured in Cell 2 during the entire test.

The tested UE is connected to the PCell and configured to transmit SRS signals periodically. The SRS configuration is provided to the UE before the measurement starts. The UE is configured to report UE Rx–Tx time difference measurement. The test equipment measures the transmit timing of the UE using the transmitted SRS, and measures the receive timing using the downlink CRS. The test equipment then compares the difference of these two timings to the UE Rx-Tx measurement reported by the UE. The UE is configured by higher layers via Cell 1 with a time-domain measurement resource restriction pattern for performing E-UTRAN FDD intra-frequency measurements on PCell. The information for both patterns shall be provided to the UE before the measurement starts.

#### 8.1.3.4.1 Initial conditions

Test Environment: Normal as defined in TS 36.508 [18] clause 4.1.

Frequencies to be tested: According to TS 36.521-1 [24] Annex E table E-1 and TS 36.508 [18] clauses 4.4.2 and 4.3.1.

Channel Bandwidth to be tested: 10 MHz as defined in TS 36.508 [18] clause 4.3.1.



1. Connect the SS (node B emulator) and AWGN noise source to the UE antenna connectors as shown in TS 36.508 [18] Annex A figure A.54 (without faders).
2. Propagation conditions are set according to clause 4.6.2.1.
3. Message contents are defined in clause 8.1.3.4.3.
4. Cell 1 is the serving cell. Cell 1 is the cell used for connection setup with the power levels set according to TS 36.521-3 [25] clauses C.0 and C.1 for this test. Cell 2 is the neighbour cells. Both cells are on the same RF channel.

**Table 8.1.3.4.1-1: General test parameters for FDD UE Rx–Tx time difference measurement under time-domain measurement resource restriction with non-MBSFN ABS**

Parameter	Unit	Value	Comment
Serving cell (PCell)		Cell 1	The measured cell
Neighbour cell		Cell 2	The cell interfering to Cell 1
PCell ABS configuration		Non-MBSFN ABS	As defined in TS 36.521-3 [25] Table C.3.1.1.1-1
E-UTRA RF Channel Number		1	One FDD carrier frequency is used
Downlink Channel Bandwidth (BW <sub>channel</sub> )	MHz	10	For both cells in the test
CP length		Normal	For both cells in the test
DRX			OFF
Time offset between cells	μs	3	Synchronous cells
Physical cell ID PCI		$(PCI_{cell1} - PCI_{cell2}) \bmod 6 \neq 0$	Cell PCIs for Cell 1 and Cell 2 are selected randomly so that the condition is met
ABS pattern		'10000000100000001000000000001000000010000000'	Non-MBSFN ABS. FDD ABS Pattern Info IE, as defined in TS 36.423 [35], clause 9.2.54. Configured in Cell 2. The first/leftmost bit corresponds to the subframe #0 of a radio frame satisfying SFN mod 40 = 0. No MBSFN subframes are configured in Cell 1 or Cell 2 during the ABS subframes of Cell 2.
Time-domain measurement resource restriction pattern for serving cell measurements		'10000000100000001000000000001000000010000000'	Configured for measurements on Cell 1.

#### 8.1.3.4.2 Test procedure

1. Bring the UE to State 3A or 3A-RF according to TS 36.508 [18] clause 4.5.3A or 5.2A.2 with exceptions listed in 7.2A.6, using a value of initial timing advance command  $T_A = 2$  in the Random Access Response which indicates an initial timing advance value  $N_{TA} = 32 T_s$ . Note that in the remainder of the test the timing advance command  $T_A = 31$  which indicates a timing advance adjustment value  $N_{TA} = 0 T_s$ .
2. Set the parameters according to Tables 8.1.3.5-1 and 8.1.3.5-2. Propagation conditions are set according to clause 4.6.2.1.
3. The SS adjusts the downlink timing for Cell 1 to a delay of  $+4 T_s$ , compared to the current value.
4. Wait for 1.6 s to allow for the possibility that the UE makes autonomous timing adjustments.
5. The SS shall transmit an LPP REQUEST CAPABILITIES message.
6. The UE shall transmit an LPP PROVIDE CAPABILITIES message indicating the ECID capabilities supported by the UE in the *ECID-ProvideCapabilities* IE.
7. The SS shall transmit an LPP REQUEST LOCATION INFORMATION message, including the *ECID-RequestLocationInformation* IE. If the UE message at step 6 includes the *ackRequested* IE set to TRUE, then the SS shall send an acknowledgment in the LPP REQUEST LOCATION INFORMATION message.
8. The UE shall transmit an LPP PROVIDE LOCATION INFORMATION message including the *ecid-SignalMeasurementInformation* IE.

9. As soon as possible after step 8 the SS shall measure the transmit timing of the UE using the transmitted SRS, relative to the current downlink timing.
10. If the UE message at step 8 includes the `ackRequested` IE set to TRUE, then the SS shall send a LPP acknowledgment message.
11. The SS shall check the reported value of `ue-RxTxTimeDiff` in the `ecid-SignalMeasurementInformation` IE provided by the UE in step 8 and compare it with the value measured in step 9. The SS shall check that the reported value is within the limits specified in table 8.1.3.5-3 compared to the measured value. If the reported value is within the limits the number of successful results for the test point is increased by one. If the reported value is not within the limits, or the UE reports an error in the LPP PROVIDE LOCATION INFORMATION message in step 6, or does not respond at step 8 within the time given by the `responseTime` IE in the `ECID-RequestLocationInformation` IE in step 7, then the number of unsuccessful results for the test point test is increased by one.
12. Repeat steps 3-11 until the confidence level according to Annex D.4.3 is achieved.  
NOTE: To avoid a large divergence between the sent TA and the set downlink timing, the SS may reset the downlink timing for Cell 1 to its initial value after a certain amount of loops. The loop during the reset does not count for the result statistics.
13. Repeat steps 1-12 for test point 2.

8.1.3.4.3 Message contents

**Table 8.1.3.4.3-1: SoundingRS-RL-ConfigCommon-DEFAULT: FDD UE Rx–Tx time difference measurement under time-domain measurement resource restriction with non-MBSFN ABS (eICIC)**

Derivation Path: TS 36.508 [18] clause 4.6.3, Table 4.6.3-21 SoundingRS-UL-ConfigCommon-DEFAULT

Information Element	Value/remark	Comment	Condition
SoundingRS-UL-ConfigCommon-DEFAULT ::= SEQUENCE {			
setup SEQUENCE {			
srs-BandwidthConfig	bw5		
srs-SubframeConfig	sc1		FDD
ackNackSRS-SimultaneousTransmission	FALSE		
srsMaxUpPts	Not present		FDD
}			
}			

**Table 8.1.3.4.3-2: SoundingRS-RL-ConfigDedicated-DEFAULT: FDD UE Rx–Tx time difference measurement under time-domain measurement resource restriction with non-MBSFN ABS (eICIC)**

Derivation Path: TS 36.508 [18] clause 4.6.3, Table 4.6.3-22 SoundingRS-UL-ConfigDedicated-DEFAULT

Information Element	Value/remark	Comment	Condition
SoundingRS-UL-ConfigDedicated-DEFAULT ::= CHOICE {			
setup SEQUENCE {			
srs-Bandwidth	bw0		
srs-HoppingBandwidth	hbw0		
freqDomainPosition	0		
duration	TRUE	Indefinite duration	
srs-ConfigIndex	0		
transmissionComb	0		
cyclicShift	cs0	No cyclic shift	
}			
}			

**Table 8.1.3.4.3-3: LPP REQUEST CAPABILITIES: FDD UE Rx–Tx time difference measurement under time-domain measurement resource restriction with non-MBSFN ABS (eICIC)**

Information Element	Value/remark
<code>ecid-RequestCapabilities</code>	TRUE

**Table 8.1.3.4.3-4: ECID-RequestLocationInformation: FDD UE Rx–Tx time difference measurement under time-domain measurement resource restriction with non-MBSFN ABS (eICIC)**

Derivation Path: TS 36.355 [4] clause 6.2			
Information Element	Value/remark	Comment	Condition
LPP-Message ::= SEQUENCE {			
transactionID SEQUENCE {			
Initiator	locationServer		
transactionNumber	1		
}			
endTransaction	FALSE		
sequenceNumber	Not present		
acknowledgement	Not present		
lpp-MessageBody CHOICE {			
c1 CHOICE {			
requestLocationInformation SEQUENCE {			
criticalExtensions CHOICE {			
c1 CHOICE {			
requestLocationInformation-r9 SEQUENCE {			
commonIEsRequestLocationInformation SEQUENCE {			
locationInformationType	locationMeasurementsRequired		
triggeredReporting	Not present		
periodicalReporting	Not present		
additionalInformation	onlyReturnInformationRequested		
qos SEQUENCE {			
horizontalAccuracy	Not present		
verticalCoordinateRequest	FALSE		
verticalAccuracy	Not present		
responseTime SEQUENCE {			
time	2		
responseTimeEarlyFix-r12	Not present		Rel-12 onwards
}			
velocityRequest	FALSE		
}			
environment	Not present		
locationCoordinateTypes	Not present		
velocityTypes	Not present		
}			
a-gnss-RequestLocationInformation	Not present		
otdoa-RequestLocationInformation	Not present		
ecid-RequestLocationInformation ::= SEQUENCE {			
requestedMeasurements	0 0 1	ueRxTxReq	
}			
epdu-RequestLocationInformation	Not Present		
}			
}			
}			
}			
}			

**Table 8.1.3.4.3-5: ECID-ProvideLocationInformation: FDD UE Rx-Tx time difference measurement under time-domain measurement resource restriction with non-MBSFN ABS (eICIC)**

Derivation Path: TS 36.355 [4] clause 6.2			
Information Element	Value/remark	Comment	Condition
LPP-Message ::= SEQUENCE {			
transactionID SEQUENCE {			
Initiator	locationServer		
transactionNumber	1		
}			
endTransaction	TRUE		
sequenceNumber	(0..255)		
acknowledgement			
lpp-MessageBody CHOICE {			
c1 CHOICE {			
provideLocationInformation SEQUENCE {			
criticalExtensions CHOICE {			
c1 CHOICE {			
provideLocationInformation-r9 SEQUENCE {			
commonIEsProvideLocationInformation	Not present.		
a-gnss-ProvideLocationInformation	Not present		
otdoa-ProvideLocationInformation	Not present		
ecid-ProvideLocationInformation ::=			
SEQUENCE {			
ecid-SignalMeasurementInformation ::=			
SEQUENCE {			
primaryCellMeasuredResults	Not Present		
MeasuredResultsList ::= SEQUENCE			
(SIZE(1..32)) OF			
MeasuredResultsElement			
MeasuredResultsElement ::= SEQUENCE {			
physCellId			
cellGlobalId			
arfcnEUTRA			
systemFrameNumber			
rsrp-Result	Not Present		
rsrq-Result	Not Present		
ue-RxTxTimeDiff		Set according to specific sub-test and test point.	
}			
}			
}			
epdu-ProvideLocationInformation	Not present		
}			
}			
}			
}			
}			
}			
}			
}			
}			

**Table 8.1.3.4.3-6: *RadioResourceConfigDedicated-SRB2-DRB(n, m)*: Additional FDD UE Rx–Tx time difference measurement under time-domain measurement resource restriction with non-MBSFN ABS (eICIC)**

Derivation Path: TS 36.508 [18] clause 4.6.3, Table 4.6.3-16 RadioResourceConfigDedicated-SRB2-DRB(n,m)			
Information Element	Value/remark	Comment	Condition
RadioResourceConfigDedicated-SRB2-DRB(n, m) ::= SEQUENCE {			
MeasSubframePatternPCell-r10 CHOICE {			
setup SEQUENCE {			
subframePatternFDD-r10	'1000000010000001000 00001000000010000000'	BIT STRING (SIZE (40))	Cell1
}			
}			
}			

### 8.1.3.5 Test requirement

Table 8.1.3.5-1 defines the primary level settings including test tolerances for the test.

The UE Rx – Tx time difference measurement accuracy shall fulfil the requirements in Table 8.1.3.5-3.

**Table 8.1.3.5-1: Cell-specific test parameters for FDD UE Rx–Tx time difference measurement under time-domain measurement resource restriction with non-MBSFN ABS**

Parameter	Unit	Cell 1	Cell 2
E-UTRAN RF Channel Number		1	1
Channel bandwidth ( $BW_{\text{channel}}$ )	MHz	10	10
PDSCH Reference measurement channel defined in TS 36.521-3 [25] A.1.1		R.0 FDD	N/A
PDSCH allocation	$n_{PRB}$	13–36	N/A
PDCCH/PCFICH/PHICH Reference measurement channel defined in TS 36.521-3 [25] A.2.1		R.6 FDD	N/A
OCNG Patterns defined in TS 36.521-3 [25] D.1.1 (OP.1 FDD) and in D.1.6 (OP.6 FDD)		OP.5 FDD	OP.6 FDD
PBCH_RA	dB	0	Non-ABS and ABS subframe channel powers defined in Table C.3.1.1.1-1 in TS 36.521-3 [25].
PBCH_RB	dB		
PSS_RA	dB		
SSS_RA	dB		
PCFICH_RB	dB		
PHICH_RA	dB		
PHICH_RB	dB		
PDCCH_RA	dB		
PDCCH_RB	dB		
PDSCH_RA	dB		
PDSCH_RB	dB		
OCNG_RA <sup>Note1</sup>	dB		
OCNG_RB <sup>Note1</sup>	dB		
$N_{oc}$ <sup>Note 2</sup>	dBm/15 kHz		
$CRS \hat{E}_s / N_{oc}$	dB	-2.7	1
$CRS \left( \hat{E}_s / I_{ot} \right)_{meas}$ <sup>Note 3</sup>	dB	-2.7	-0.87
$CRS \left( \hat{E}_s / I_{ot} \right)_{nonABS}$ <sup>Note 3</sup>	dB	-6.24	-0.87
RSRP <sup>Note 4</sup>	dBm/15 kHz	-100.7	-97
$(Io)_{meas}$ <sup>Note 4</sup>	dBm/9 MHz	-67.8	-67.8
$(Io)_{nonABS}$ <sup>Note 4</sup>	dBm/9 MHz	-65.75	-65.75
Propagation condition		AWGN	
NOTE 1: OCNG shall be used such that the resources in the active cell are fully allocated and a constant total transmitted power spectral density is achieved for all OFDM symbols.			
NOTE 2: Interference from other cells and noise sources not specified in the test is assumed to be constant over subcarriers and time and shall be modelled as AWGN of appropriate power for $N_{oc}$ to be fulfilled. Applies to all subframes.			
Note 3: $\left( \hat{E}_s / I_{ot} \right)_{meas}$ is calculated in CRS REs in the subframes indicated for PCell measurements by measurement resource restriction pattern, whilst $\left( \hat{E}_s / I_{ot} \right)_{nonABS}$ is calculated in CRS REs in the subframes not indicated for PCell measurements by measurement resource restriction pattern.			
Note 4: RSRP and $I_o$ levels have been derived from other parameters for information purposes. They are not settable parameters themselves. $(Io)_{meas}$ is calculated in CRS symbols in the subframes indicated for PCell measurements by measurement resource restriction pattern, whilst $(Io)_{nonABS}$ is calculated in CRS symbols in the subframes not indicated for PCell measurements by measurement resource restriction pattern.			

**Table 8.1.3.5-2: Sounding Reference Symbol Configuration to be used in FDD UE Rx–Tx time difference test**

Field	Value	Comment
UL bandwidth	50 RBs	Same as the DL bandwidth
srsBandwidthConfiguration	bw5	
srsSubframeConfiguration	sc1	
ackNackSrsSimultaneousTransmission	FALSE	
srsMaxUpPTS	N/A	Not applicable for FDD
srsBandwidth	0	No hopping
srsHoppingBandwidth	hbw0	
frequencyDomainPosition	0	
Duration	TRUE	Indefinite duration
srs-ConfigIndex	0	SRS periodicity of 2ms
transmissionComb	0	
cyclicShift	cs0	No cyclic shift
srsAntennaPort	an1	Number of SRS antenna ports
Note:	For further information see clause 6.3.2 in TS 36.331 [22].	

**Table 8.1.3.5-3: Test requirements UE Rx – Tx time difference measurement accuracy requirements**

	Test requirement
Lowest reported value	(Measured value from step 7 - 13) $T_s$ converted to RX-TX_TIME_DIFFERENCE according to Table 4.6.3-1
Highest reported value	(Measured value from step 7 + 13) $T_s$ converted to RX-TX_TIME_DIFFERENCE according to Table 4.6.3-1

NOTE: The test in table 8.1.3.5-3 has two test points starting at  $32 T_s$  and  $5008 T_s$ .

The test tolerances are defined in Annex C.

For the overall test to pass, the ratio of successful reported values in each test point shall be more than 90% with a confidence level of 95%.

## 8.1.4 E-UTRAN TDD UE Rx–Tx Time Difference under Time-Domain Measurement Resource Restriction with Non-MBSFN ABS (eICIC)

### 8.1.4.1 Test purpose

To verify that the E-UTRAN TDD UE Rx – Tx time difference measurement accuracy is within the specified limits under a time-domain measurement resource restriction pattern, and when non-MBSFN ABS is configured in the interfering cells.

### 8.1.4.2 Test applicability

This test applies to all types of E-UTRA TDD UE release 10 with LPP release 13 onwards and ECID positioning. Applicability requires support for FGI bit 115. Note that for LPP releases before release 13 the UE Rx - Tx time difference measurement report mapping is ambiguous and therefore this test shall not be used.

### 8.1.4.3 Minimum conformance requirements

NOTE: This measurement is used for UE positioning purposes.

The requirements in this section apply for UE configured with a time-domain measurement resource restriction pattern for PCell measurements. The UE Rx-Tx time difference is measured from the Pcell.

The accuracy requirements in Table 8.1.4.3-1 are valid under the following conditions:

- Cell specific reference signals are transmitted either from one, two or four antenna ports,
- Conditions defined in 36.101[2] Clause 7.3 for reference sensitivity are fulfilled,

- No changes to the uplink transmission timing are applied during the measurement period,  $RSRP|_{dBm}$  according to Annex E.4 for a corresponding Band,
- The time domain measurement resource restriction pattern configured for the PCell indicates at least one subframe per radio frame for performing the PCell measurements,
- Four symbols containing CRS are available in all subframes indicated by the time domain measurement resource restriction pattern.

**Table 8.1.4.3-1: UE Rx–Tx time difference measurement accuracy under time domain measurement resource restriction**

Accuracy	Conditions				
	$\hat{E}s/Iot$ <sup>Note 6</sup>	Downlink transmission bandwidth of PCell	$I_o$ <sup>Note 1, 5</sup> range		
			E-UTRA operating band groups <sup>Note 8</sup>	Minimum $I_o$	Maximum $I_o$
$T_s$ <sup>Note 2</sup>	dB	MHz		dBm/15kHz <sup>Note 7</sup>	dBm/BW <sub>Channel</sub>
±20	≥-3 dB	≤ 3 MHz	FDD_A <sup>Note 9</sup> , TDD_A	-121	-50
			FDD_B	-120.5	-50
			FDD_C, TDD_C	-120	-50
			FDD_D	-119.5	-50
			FDD_E, TDD_E	-119	-50
			FDD_F	-118.5	-50
			FDD_G <sup>Note 4</sup>	-118	-50
			FDD_H	-117.5	-50
			FDD_N	-114.5	-50
±10	≥-3 dB	≥ 5 MHz	Note 3	Note 3	Note 3

NOTE 1: When in dBm/15kHz, the minimum  $I_o$  condition is expressed as the average  $I_o$  per RE over all REs in that symbol.  $I_o$  may be different in different symbols within a subframe.  
 NOTE 2:  $T_s$  is the basic timing unit defined in TS 36.211.  
 NOTE 3: The same bands and the same  $I_o$  conditions for each band apply for this requirement as for the corresponding requirement with downlink bandwidth ≤ 3 MHz.  
 NOTE 4: Except Band 29.  
 NOTE 5:  $I_o$  is defined for the subframes indicated by the time-domain measurement resource restriction pattern for serving cell measurements. The specified  $I_o$  range applies to CRS and non-CRS symbols.  $I_o$  may be different in different symbols within a subframe.  
 NOTE 6: CRS  $\hat{E}s/Iot$  is in subframes indicated for PCell measurements by the time-domain measurement resource restriction pattern.  
 NOTE 7: The condition level is increased by  $\Delta > 0$ , when applicable, as described in TS 36.521-3 [25] Sections I.4.2 and I.4.3.  
 NOTE 8: E-UTRA operating band groups are as defined in Section 4.4.2.  
 NOTE 9: Except Band 32.

NOTE: It is up to the UE implementation whether the UE Rx-Tx time difference measurement is performed in any subframe or in subframes indicated by the time-domain measurement resource restriction pattern.

The normative reference for this requirement is TS 36.133 [23] clause 9.1.9.3 and A.9.7.4.

### 8.1.4.4 Test description

The test has two test points with time delays starting at 32  $T_s$  and 5008  $T_s$ , respectively.

In the test, there are two synchronous cells, Cell 1 and Cell 2, on the same RF channel. Cell 1 is the PCell on which UE Rx-Tx is measured, and Cell 2 is the interfering cell. Non-MBSFN ABS pattern is configured in Cell 2 during the entire test.

The tested UE is connected to the PCell and configured to transmit SRS signals periodically. The SRS configuration is provided to the UE before the measurement starts. The UE is configured to report UE Rx–Tx time difference measurement. The test equipment measures the transmit timing of the UE using the transmitted SRS, and measures the receive timing using the downlink CRS. The test equipment then compares the difference of these two timings to the UE Rx-Tx measurement reported by the UE. The UE is configured by higher layers via Cell 1 with a time-domain measurement resource restriction pattern for performing E-UTRAN TDD UE Rx-Tx time difference measurements on PCell. The information for both patterns shall be provided to the UE before the measurement starts.



#### 8.1.4.4.1 Initial conditions

Test Environment: Normal as defined in TS 36.508 [18] clause 4.1.

Frequencies to be tested: According to TS 36.521-1 [24] Annex E table E-1 and TS 36.508 [18] clauses 4.4.2 and 4.3.1.

Channel Bandwidth to be tested: 10 MHz as defined in TS 36.508 [18] clause 4.3.1.

1. Connect the SS (node B emulator) and AWGN noise source to the UE antenna connectors as shown in TS 36.508 [18] Annex A figure A.54 (without faders).
2. Propagation conditions are set according to clause 4.6.2.1.
3. Message contents are defined in clause 8.1.4.4.3.
4. Cell 1 is the serving cell. Cell 1 is the cell used for connection setup with the power levels set according to TS 36.521-3 [25] clauses C.0 and C.1 for this test. Cell 2 is the neighbour cells. Both cells are on the same RF channel.

**Table 8.1.4.4.1-1: General test parameters for E-UTRAN TDD UE Rx-Tx time difference measurement under time-domain measurement resource restriction with non-MBSFN ABS**

Parameter	Unit	Value	Comment
Serving cell (PCell)		Cell 1	Cell to be measured
Neighbour cell		Cell 2	The cell interfering to Cell 1
PCell ABS configuration		Non-MBSFN ABS	As defined in TS 36.521-3 [25] Table C.3.1.1.1-1
E-UTRA RF Channel Number		1	One TDD carrier frequency is used
Downlink Channel Bandwidth ( $BW_{channel}$ )	MHz	10	For both cells in the test
CP length		Normal	For both cells in the test
Special subframe configuration		6	For Cell 1 and Cell 2. For special subframe configurations see Table 4.2-1 in TS 36.211 [26].
Uplink/downlink subframe configuration		1	For Cell 1 and Cell 2. For uplink-downlink subframe configurations see Table 4.2- in TS 36.211 [26].
DRX			OFF
Time offset between cells	$\mu$ s	3	Synchronous cells
Physical cell ID PCI		$(PCI_{cell1} - PCI_{cell2}) \bmod 6 \neq 0$	Cell PCIs for Cell 1 and Cell 2 are selected randomly so that the condition is met.
ABS pattern		'00000000010000000001'	Non-MBSFN ABS. TDD ABS Pattern Info IE, as defined in TS 36.423 [35], clause 9.2.54. Configured in Cell 2. The first/leftmost bit corresponds to the subframe #0 of a radio frame satisfying $SFN \bmod 20 = 0$ . No MBSFN subframes are configured in the ABS subframes in Cell 2.
Time-domain measurement resource restriction pattern for serving cell measurements		'00000000010000000001'	Configured for measurements on Cell 1.

#### 8.1.4.4.2 Test procedure

1. Bring the UE to State 3A or 3A-RF according to TS 36.508 [18] clause 4.5.3A or 5.2A.2 with exceptions listed in 7.2A.6, using a value of initial timing advance command  $T_A = 2$  in the Random Access Response which indicates an initial timing advance value  $N_{TA} = 32 T_s$ . Note that in the remainder of the test the timing advance command  $T_A = 31$  which indicates a timing advance adjustment value  $N_{TA} = 0 T_s$ .
2. Set the parameters according to Tables 8.1.4.5-1 and 8.1.4.5-2. Propagation conditions are set according to clause 4.6.2.1.
3. The SS adjusts the downlink timing for Cell 1 to a delay of  $+4 T_s$ , compared to the current value.
4. Wait for 1.6 s to allow for the possibility that the UE makes autonomous timing adjustments.

5. The SS shall transmit an LPP REQUEST CAPABILITIES message.
6. The UE shall transmit an LPP PROVIDE CAPABILITIES message indicating the ECID capabilities supported by the UE in the *ECID-ProvideCapabilities* IE. The IE *ueRxTxSupTDD-r13* shall be present (TRUE).
7. The SS shall transmit an LPP REQUEST LOCATION INFORMATION message, including the *ECID-RequestLocationInformation* IE. If the UE message at step 6 includes the *ackRequested* IE set to TRUE, then the SS shall send an acknowledgment in the LPP REQUEST LOCATION INFORMATION message.
8. The UE shall transmit an LPP PROVIDE LOCATION INFORMATION message including the *ecid-SignalMeasurementInformation* IE.
9. As soon as possible after step 8 the SS shall measure the transmit timing of the UE using the transmitted SRS, relative to the current downlink timing.
10. If the UE message at step 8 includes the *ackRequested* IE set to TRUE, then the SS shall send a LPP acknowledgment message.
11. The SS shall check the reported value of *ue-RxTxTimeDiff* in the *ecid-SignalMeasurementInformation* IE provided by the UE in step 8 and compare it with the value measured in step 9. The SS shall check that the reported value is within the limits specified in table 8.1.4.5-3 compared to the measured value. If the reported value is within the limits the number of successful results for the test point is increased by one. If the reported value is not within the limits, or the UE reports an error in the LPP PROVIDE LOCATION INFORMATION message in step 6, or does not respond at step 8 within the time given by the *responseTime* IE in the *ECID-RequestLocationInformation* IE in step 7, then the number of unsuccessful results for the test point test is increased by one.
12. Repeat steps 3-11 until the confidence level according to Annex D.4.3 is achieved.

NOTE: To avoid a large divergence between the sent TA and the set downlink timing, the SS may reset the downlink timing for Cell 1 to its initial value after a certain amount of loops. The loop during the reset does not count for the result statistics.

13. Repeat steps 1-12 for test point 2.

#### 8.1.4.4.3 Message contents

**Table 8.1.4.4.3-1: SoundingRS-RL-ConfigCommon-DEFAULT: TDD UE Rx-Tx time difference measurement under time-domain measurement resource restriction with non-MBSFN ABS (eICIC)**

Derivation Path: TS 36.508 [18] clause 4.6.3, Table 4.6.3-21 SoundingRS-UL-ConfigCommon-DEFAULT			
Information Element	Value/remark	Comment	Condition
SoundingRS-UL-ConfigCommon-DEFAULT ::= SEQUENCE {			
setup SEQUENCE {			
srs-BandwidthConfig	bw5		
srs-SubframeConfig	sc1		FDD
ackNackSRS-SimultaneousTransmission	FALSE		
srsMaxUpPts	Not present		FDD
}			
}			

**Table 8.1.4.4.3-2: SoundingRS-RL-ConfigDedicated-DEFAULT: TDD UE Rx–Tx time difference measurement under time-domain measurement resource restriction with non-MBSFN ABS (eICIC)**

Derivation Path: TS 36.508 [18] clause 4.6.3, Table 4.6.3-22 SoundingRS-UL-ConfigDedicated-DEFAULT			
Information Element	Value/remark	Comment	Condition
SoundingRS-UL-ConfigDedicated-DEFAULT ::= CHOICE {			
setup SEQUENCE {			
srs-Bandwidth	bw0		
srs-HoppingBandwidth	hbw0		
freqDomainPosition	0		
duration	TRUE	Indefinite duration	
srs-ConfigIndex	0		
transmissionComb	0		
cyclicShift	cs0	No cyclic shift	
}			
}			

**Table 8.1.4.4.3-3: LPP REQUEST CAPABILITIES: TDD UE Rx–Tx time difference measurement under time-domain measurement resource restriction with non-MBSFN ABS (eICIC)**

Information Element	Value/remark
<i>ecid-RequestCapabilities</i>	TRUE

**Table 8.1.4.4.3-3a: LPP PROVIDE CAPABILITIES: TDD UE Rx–Tx time difference measurement under time-domain measurement resource restriction with non-MBSFN ABS (eICIC)**

Information Element	Value/remark
<i>ueRxTxSupTDD-r13</i>	TRUE

**Table 8.1.4.4.3-4: ECID-RequestLocationInformation: TDD UE Rx–Tx time difference measurement under time-domain measurement resource restriction with non-MBSFN ABS (eICIC)**

Derivation Path: TS 36.355 [4] clause 6.2			
Information Element	Value/remark	Comment	Condition
LPP-Message ::= SEQUENCE {			
transactionID SEQUENCE {			
Initiator	locationServer		
transactionNumber	1		
}			
endTransaction	FALSE		
sequenceNumber	Not present		
acknowledgement	Not present		
lpp-MessageBody CHOICE {			
c1 CHOICE {			
requestLocationInformation SEQUENCE {			
criticalExtensions CHOICE {			
c1 CHOICE {			
requestLocationInformation-r9 SEQUENCE {			
commonIEsRequestLocationInformation SEQUENCE {			
locationInformationType	locationMeasurementsRequired		
triggeredReporting	Not present		
periodicalReporting	Not present		
additionalInformation	onlyReturnInformationRequested		
qos SEQUENCE {			
horizontalAccuracy	Not present		
verticalCoordinateRequest	FALSE		
verticalAccuracy	Not present		
responseTime SEQUENCE {			
time	2		
responseTimeEarlyFix-r12	Not present		Rel-12 onwards
}			
velocityRequest	FALSE		
}			
environment	Not present		
locationCoordinateTypes	Not present		
velocityTypes	Not present		
}			
a-gnss-RequestLocationInformation	Not present		
otdoa-RequestLocationInformation	Not present		
ecid-RequestLocationInformation ::= SEQUENCE {			
requestedMeasurements	0 0 1	ueRxTxReq	
}			
epdu-RequestLocationInformation	Not Present		
}			
}			
}			
}			
}			

**Table 8.1.4.4.3-5: ECID-ProvideLocationInformation: TDD UE Rx-Tx time difference measurement under time-domain measurement resource restriction with non-MBSFN ABS (eICIC)**

Derivation Path: TS 36.355 [4] clause 6.2			
Information Element	Value/remark	Comment	Condition
LPP-Message ::= SEQUENCE {			
transactionID SEQUENCE {			
Initiator	locationServer		
transactionNumber	1		
}			
endTransaction	TRUE		
sequenceNumber	(0..255)		
acknowledgement			
lpp-MessageBody CHOICE {			
c1 CHOICE {			
provideLocationInformation SEQUENCE {			
criticalExtensions CHOICE {			
c1 CHOICE {			
provideLocationInformation-r9 SEQUENCE {			
commonIEsProvideLocationInformation	Not present.		
a-gnss-ProvideLocationInformation	Not present		
otdoa-ProvideLocationInformation	Not present		
ecid-ProvideLocationInformation ::=			
SEQUENCE {			
ecid-SignalMeasurementInformation ::=			
SEQUENCE {			
primaryCellMeasuredResults	Not Present		
MeasuredResultsList ::= SEQUENCE			
(SIZE(1..32)) OF			
MeasuredResultsElement			
MeasuredResultsElement ::= SEQUENCE {			
physCellId			
cellGlobalId			
arfcnEUTRA			
systemFrameNumber			
rsrp-Result	Not Present		
rsrq-Result	Not Present		
ue-RxTxTimeDiff		Set according to specific sub-test and test point.	
}			
}			
}			
epdu-ProvideLocationInformation	Not present		
}			
}			
}			
}			
}			
}			
}			
}			
}			

**Table 8.1.4.4.3-6: *RadioResourceConfigDedicated-SRB2-DRB(n, m)*: Additional TDD UE Rx–Tx time difference measurement under time-domain measurement resource restriction with non-MBSFN ABS (eICIC)**

Derivation Path: TS 36.508 [18] clause 4.6.3, Table 4.6.3-16 RadioResourceConfigDedicated-SRB2-DRB(n,m)			
Information Element	Value/remark	Comment	Condition
RadioResourceConfigDedicated-SRB2-DRB(n, m) ::= SEQUENCE {			
MeasSubframePatternPCell-r10 CHOICE {			
setup SEQUENCE {			
subframePatternTDD-r10			
subframeConfig1-5-r10	'00000000010000000001'	BIT STRING (SIZE (20))	Cell 1
}			
}			
}			

#### 8.1.4.5 Test requirement

Table 8.1.4.5-1 defines the primary level settings including test tolerances for the test.

The UE Rx – Tx time difference measurement accuracy shall fulfil the requirements in Table 8.1.4.5-3.

**Table 8.1.4.5-1: Cell-specific test parameters for TDD UE Rx–Tx time difference measurement under time-domain measurement resource restriction with non-MBSFN ABS**

Parameter	Unit	Cell 1	Cell 2
PDSCH Reference measurement channel defined in TS 36.521-3 [25] A.1.2		R.0 TDD	N/A
PDSCH allocation	$n_{PRB}$	13–36	N/A
PDCCH/PCFICH/PHICH Reference measurement channel defined in TS 36.521-3 [25] A.2.2		R.6 TDD	R.6 TDD
OCNG Patterns defined in TS 36.521-3 [25] D.2.1 (OP.1 TDD) and D.2.2 (OP.2 TDD)		OP.1 TDD	OP.2 TDD
PBCH_RA	dB	0	Non-ABS and ABS subframe channel powers defined in Table C.3.1.1.1-1 in TS 36.521-3 [25].
PBCH_RB	dB		
PSS_RA	dB		
SSS_RA	dB		
PCFICH_RB	dB		
PHICH_RA	dB		
PHICH_RB	dB		
PDCCH_RA	dB		
PDCCH_RB	dB		
PDSCH_RA	dB		
PDSCH_RB	dB		
OCNG_RA <sup>Note1</sup>	dB		
OCNG_RB <sup>Note1</sup>	dB		
$N_{oc}$ <sup>Note2</sup>	dBm/15 kHz		
$CRS \hat{E}_s / N_{oc}$	dB	-2.7	1
$CRS \left( \hat{E}_s / I_{ot} \right)_{meas}$ <sup>Note 3</sup>	dB	-2.7	-0.87
$CRS \left( \hat{E}_s / I_{ot} \right)_{nonABS}$ <sup>Note 3</sup>	dB	-6.24	-0.87
RSRP <sup>Note 4</sup>	dBm/15 kHz	-100.7	-97
$(I_o)_{meas}$ <sup>Note 4</sup>	dBm/9 MHz	-67.8	-67.8
$(I_o)_{nonABS}$ <sup>Note 4</sup>	dBm/9 MHz	-65.75	-65.75
Propagation Condition		AWGN	
<p>Note 1: OCNG shall be used such that the resources in the active cell are fully allocated and a constant total transmitted power spectral density is achieved for all OFDM symbols.</p> <p>Note 2: Interference from other cells and noise sources not specified in the test is assumed to be constant over subcarriers and time and shall be modelled as AWGN of appropriate power for <math>N_{oc}</math> to be fulfilled.</p> <p>Note 3: <math>\left( \hat{E}_s / I_{ot} \right)_{meas}</math> is calculated in CRS REs in the subframes indicated for PCell measurements by measurement resource restriction pattern, whilst <math>\left( \hat{E}_s / I_{ot} \right)_{nonABS}</math> is calculated in CRS REs in the subframes not indicated for PCell measurements by measurement resource restriction pattern.</p> <p>Note 4: RSRP and <math>I_o</math> levels have been derived from other parameters for information purposes. They are not settable parameters themselves. <math>(I_o)_{meas}</math> is calculated in CRS symbols in the subframes indicated for PCell measurements by measurement resource restriction pattern, whilst <math>(I_o)_{nonABS}</math> is calculated in CRS symbols</p>			

**Table 8.1.4.5-2: Sounding Reference Symbol Configuration to be used in TDD UE Rx–Tx time difference test**

Field	Value	Comment
UL bandwidth	50 RBs	Same as the DL bandwidth
srsBandwidthConfiguration	bw5	
srsSubframeConfiguration	sc1	
ackNackSrsSimultaneousTransmission	FALSE	
srsMaxUpPTS	TRUE	
srsBandwidth	0	No hopping
srsHoppingBandwidth	hbw0	
frequencyDomainPosition	0	
Duration	TRUE	Indefinite duration
Srs-ConfigurationIndex	10	SRS periodicity of 10ms for all Tests.
transmissionComb	0	
cyclicShift	cs0	No cyclic shift
SRS-AntennaPort	an1	Number of antenna ports used for SRS transmission
Note: For further information see clause 6.3.2 in TS 36.331 [22].		

**Table 8.1.4.5-3: Test requirements UE Rx – Tx time difference measurement accuracy requirements**

	Test requirement
Lowest reported value	(Measured value from step 7 - 13) $T_s$ converted to RX-TX_TIME_DIFFERENCE according to Table 4.6.3-2
Highest reported value	(Measured value from step 7 + 13) $T_s$ converted to RX-TX_TIME_DIFFERENCE according to Table 4.6.3-2

NOTE: The test in table 8.1.4.5-3 has two test points starting at 32  $T_s$  and 5008  $T_s$ .

The test tolerances are defined in Annex C.

For the overall test to pass, the ratio of successful reported values in each test point shall be more than 90% with a confidence level of 95%.

## 8.1.5 E-UTRAN FDD UE Rx–Tx time difference under Time Domain Measurement Resource Restriction with CRS Assistance Information and Non-MBSFN ABS (feICIC)

### 8.1.5.1 Test purpose

The purpose of this test is to verify that the E-UTRAN FDD UE Rx – Tx time difference measurement accuracy is within the specified limits in TS 36.133 [23] clause 9.1.9.4 when the UE is provided with a time-domain measurement resource restriction pattern and CRS assistance information, and when non-MBSFN ABS is configured in the interfering cells.

### 8.1.5.2 Test applicability

This test applies to all types of E-UTRA FDD UE release 11 and forward that supports ECID positioning and CRS interference handling. Applicability requires support of FGI bit 115.

### 8.1.5.3 Minimum conformance requirements

NOTE: This measurement is used for UE positioning purposes.

The UE RX-TX time difference is measured from the PCell.

For UE configured with a time-domain measurement resource restriction pattern for PCell measurements, the accuracy requirements in Table 8.1.5.3-1 apply provided that the following conditions are met for the PCell:



PCell cell specific reference signals are transmitted from one, two or four antenna ports,

Conditions defined in TS 36.101 [2] clause 7.3 for reference sensitivity are fulfilled,

No changes to the uplink transmission timing are applied during the measurement period,

$RSRP|_{dBm}$  according to clause E.4 for a corresponding Band,

The time domain measurement resource restriction pattern configured for the measured cell indicates at least one subframe per radio frame for performing the RSRP measurement,

Four symbols containing CRS are available in all subframes indicated by the time domain measurement resource restriction pattern, and

The UE is provided via PCell with the CRS assistance information (TS 36.331 [22]) and the CRS assistance information is valid throughout the entire evaluation period.

The requirements in this section shall also be met when the number of transmit antenna ports TS 36.211 [26] of one or more cells whose CRS assistance information is provided TS 36.331 [22] is different from the number of transmit antenna ports of the measured cell.

When the CRS assistance information is provided, the transmission bandwidth in all intra-frequency cells in the CRS assistance information is the same or larger than the transmission bandwidth of the PCell for which measurement is performed.

**Table 8.1.5.3-1: UE Rx – Tx time difference measurement accuracy**

Accuracy	Conditions				
	CRS $\hat{E}_s/lot$ <sup>Note 9</sup>	Downlink transmission bandwidth of PCell	lo range <sup>Note 8</sup>		
E-UTRA operating band groups <sup>Note 6</sup>			Minimum lo <sup>Note 1</sup>	Maximum lo	
$T_s$ <sup>Note 2</sup>	dB	MHz		dBm/15kHz <sup>Note 5</sup>	dBm/BW <sub>Channel</sub>
±20	≥-7.76 dB	≤ 3 MHz	FDD_A <sup>Note 7</sup> , TDD_A	-121	-50
			FDD_B	-120.5	-50
			FDD_C, TDD_C	-120	-50
			FDD_D	-119.5	-50
			FDD_E, TDD_E	-119	-50
			FDD_F	-118.5	-50
			FDD_G <sup>Note 4</sup>	-118	-50
			FDD_H	-117.5	-50
			FDD_N	-114.5	-50
±10	≥-7.76 dB	≥ 5 MHz	Note 3	Note 3	Note 3

NOTE 1: This lo condition is expressed as the average lo per RE over all REs in an OFDM symbol.  
 NOTE 2: Ts is the basic timing unit defined in TS 36.211 [26].  
 NOTE 3: The same bands and the same lo conditions for each band apply for this requirement as for the corresponding requirement with downlink bandwidth ≤ 3 MHz.  
 NOTE 4: Except Band 29.  
 NOTE 5: The condition level is increased by Δ>0, when applicable, as described in TS 36.521-3 [25] Sections I.4.2 and I.4.3.  
 NOTE 6: E-UTRA operating band groups are as defined in Section 4.4.2.  
 NOTE 7: Except Band 32.  
 NOTE 8: lo is defined in subframes indicated for PCell measurements by the time domain measurement resource restriction pattern. The specified lo range applies to CRS and non-CRS symbols. lo may be different in different symbols within a subframe.  
 NOTE 9: CRS  $\hat{E}_s/lot$  is in subframes indicated for PCell measurements by the time-domain measurement resource restriction pattern.

NOTE: It is up to the UE implementation whether the UE Rx-Tx time difference measurement is performed in any subframe or in subframes indicated by the time-domain measurement resource restriction pattern.

The normative reference for this requirement is TS 36.133 [23] clause 9.1.9.4 and A.9.7.5.

#### 8.1.5.4 Test description

The test has two test points with time delays starting at  $32 T_s$  and  $5008 T_s$ , respectively. In this test case, there are three cells, Cell 1, Cell 2 and Cell 3, on the same RF channel. Cell 1 is the PCell on which UE Rx-Tx is measured. Cell 2 and Cell 3 are the interfering cells. A non-MBSFN ABS pattern is configured in each of the Cell 2 and Cell 3 during the entire test. The tested UE is connected to the PCell and configured to transmit SRS signals periodically. The SRS configuration is provided to the UE before the measurement starts. The UE is configured to report UE Rx-Tx time difference measurement. The test equipment measures the transmit timing of the UE using the transmitted SRS. The test equipment then compares this timing to the UE Rx-Tx measurement reported by the UE. The UE is configured by higher layers via Cell 1 with a time-domain measurement resource restriction pattern for performing E-UTRAN FDD intra-frequency measurements on PCell. The UE is also provided via higher layers with the CRS assistance information for Cell 2. The information for both measurement patterns and the CRS assistance information shall be provided via RRC to the UE before the measurement starts.

##### 8.1.5.4.1 Initial conditions

Test Environment: Normal as defined in TS 36.508 [18] clause 4.1.

Frequencies to be tested: According to TS 36.521-1 [24] Annex E table E-1 and TS 36.508 [18] clauses 4.4.2 and 4.3.1.

Channel Bandwidth to be tested: 10 MHz as defined in TS 36.508 [18] clause 4.3.1.

1. Connect the SS (node B emulator) and AWGN noise source to the UE antenna connectors as shown in TS 36.508 [18] Annex A figure A.54 (without faders).
2. Propagation conditions are set according to clause 4.6.2.1.
3. Message contents are defined in clause 8.1.5.4.3.
4. Cell 1 is the serving cell. Cell 1 is the cell used for connection setup with the power levels set according to TS 36.521-3 [25] clauses C.0 and C.1 for this test. Cell 2 and Cell 3 are the neighbour cells. All cells are on the same RF channel. Cell 3 in the test is the Cell 4 defined in clause 4.7.1

**Table 8.1.5.4.1-1: General test parameters for FDD UE Rx–Tx time difference measurement under time-domain measurement resource restriction with CRS assistance information and non-MBSFN ABS**

Parameter	Unit	Value	Comment
Serving cell (PCell)		Cell 1	The measured cell
Neighbour cell		Cell 2 and Cell 3	Cell 2 is the first interfering cell to Cell 1, whilst Cell 3 is the second interfering cell to Cell 1.
ABS transmission configuration		Non-MBSFN ABS	As defined in TS 36.521-3 [25] Table C.3.1.2-1.
E-UTRA RF Channel Number		1	One FDD carrier frequency is used
Downlink Channel Bandwidth (BW <sub>channel</sub> )	MHz	10	For all cells in the test
CP length		Normal	For all cells in the test
DRX			OFF
Time offset between cells	μs	Cell 2 offset with respect to Cell 1: 3 Cell 3 offset with respect to Cell 1: 2	Three synchronous cells
Physical cell ID PCI		$(PCI_{cell1} - PCI_{cell2}) \bmod 6 = 0$ $(PCI_{cell1} - PCI_{cell3}) \bmod 6 \neq 0$  PCI <sub>cell1</sub> not equal to PCI <sub>cell2</sub>	Cell PCIs are selected so that all conditions are met
ABS pattern		'1000000010000000100000000000100000000010000000100000000'	Non-MBSFN ABS. FDD ABS Pattern Info IE, as defined in TS 36.423 [35], clause 9.2.54. The first/leftmost bit corresponds to the PCell subframe #0 of a radio frame satisfying SFN mod x = 0, where x is the size of the bit string (40) divided by 10. No MBSFN subframes are configured in the ABS subframes. Configured in Cell 2 and Cell 3 during the testing.
Time-domain measurement resource restriction pattern for PCell measurements		'1000000010000000100000000000100000000010000000100000000'	Configured for measurements on Cell 1.
CRS assistance information	physCellId	see PCI conditions above	The CRS assistance information is provided for Cell 2 and Cell 3 in CRS-AssistanceInfo. It includes a single MBSFN-SubframeConfig element with subframe allocation one Frame='000000'.
	antennaPortsCount	1	
	mbsfn-SubframeConfigList	oneFrame = '000000'	

#### 8.1.5.4.2 Test procedure

- Bring the UE to State 3A or 3A-RF according to TS 36.508 [18] clause 4.5.3A or 5.2A.2 with exceptions listed in 7.2A.6, using a value of initial timing advance command  $T_A = 2$  in the Random Access Response which indicates an initial timing advance value  $N_{TA} = 32 T_s$ . Note that in the remainder of the test the timing advance command  $T_A = 31$  which indicates a timing advance adjustment value  $N_{TA} = 0 T_s$ .
- Set the parameters according to Tables 8.1.5.5-1 and 8.1.5.5-2. Propagation conditions are set according to clause 4.6.2.1.
- The SS adjusts the downlink timing for Cell 1 to a delay of  $+4 T_s$ , compared to the current value.
- Wait for 1.6 s to allow for the possibility that the UE makes autonomous timing adjustments.
- The SS shall transmit an LPP REQUEST CAPABILITIES message.
- The UE shall transmit an LPP PROVIDE CAPABILITIES message indicating the ECID capabilities supported by the UE in the *ECID-ProvideCapabilities* IE.
- The SS shall transmit an LPP REQUEST LOCATION INFORMATION message, including the *ECID-RequestLocationInformation* IE. If the UE message at step 6 includes the *ackRequested* IE set to TRUE, then the SS shall send an acknowledgment in the LPP REQUEST LOCATION INFORMATION message.

8. The UE shall transmit an LPP PROVIDE LOCATION INFORMATION message including the *ecid-SignalMeasurementInformation* IE.
9. As soon as possible after step 8 the SS shall measure the transmit timing of the UE using the transmitted SRS, relative to the current downlink timing.
10. If the UE message at step 8 includes the *ackRequested* IE set to TRUE, then the SS shall send a LPP acknowledgment message.
11. The SS shall check the reported value of *ue-RxTxTimeDiff* in the *ecid-SignalMeasurementInformation* IE provided by the UE in step 8 and compare it with the value measured in step 9. The SS shall check that the reported value is within the limits specified in table 8.1.5.5-3 compared to the measured value. If the reported value is within the limits the number of successful results for the test point is increased by one. If the reported value is not within the limits, or the UE reports an error in the LPP PROVIDE LOCATION INFORMATION message in step 6, or does not respond at step 8 within the time given by the *time* IE in the *ECID-RequestLocationInformation* IE in step 7, then the number of unsuccessful results for the test point test is increased by one.
12. Repeat steps 3-11 until the confidence level according to Annex D.4.3 is achieved.  
NOTE: To avoid a large divergence between the sent TA and the set downlink timing, the SS may reset the downlink timing for Cell 1 to its initial value after a certain amount of loops. The loop during the reset does not count for the result statistics.
13. Repeat steps 1-12 for test point 2.

#### 8.1.5.4.3 Message contents

Message contents are according to TS 36.508 [18] clause 5.2A.5.1 with the following exceptions:

**Table 8.1.5.4.3-1: SoundingRS-RL-ConfigCommon-DEFAULT: FDD UE Rx–Tx time difference measurement under time-domain measurement resource restriction with CRS assistance information and non-MBSFN ABS (feICIC)**

Derivation Path: TS 36.508 [18] clause 4.6.3, Table 4.6.3-21 SoundingRS-UL-ConfigCommon-DEFAULT			
Information Element	Value/remark	Comment	Condition
SoundingRS-UL-ConfigCommon-DEFAULT ::= SEQUENCE {			
setup SEQUENCE {			
srs-BandwidthConfig	bw5		
srs-SubframeConfig	sc1		FDD
ackNackSRS-SimultaneousTransmission	FALSE		
srsMaxUpPts	Not present		FDD
}			
}			

**Table 8.1.5.4.3-2: SoundingRS-RL-ConfigDedicated-DEFAULT: FDD UE Rx–Tx time difference measurement under time-domain measurement resource restriction with CRS assistance information and non-MBSFN ABS (feICIC)**

Derivation Path: TS 36.508 [18] clause 4.6.3, Table 4.6.3-22 SoundingRS-UL-ConfigDedicated-DEFAULT			
Information Element	Value/remark	Comment	Condition
SoundingRS-UL-ConfigDedicated-DEFAULT ::= CHOICE {			
setup SEQUENCE {			
srs-Bandwidth	bw0		
srs-HoppingBandwidth	hbw0		
freqDomainPosition	0		
duration	TRUE	Indefinite duration	
srs-ConfigIndex	0		
transmissionComb	0		
cyclicShift	cs0	No cyclic shift	
}			
}			

**Table 8.1.5.4.3-3: LPP REQUEST CAPABILITIES: FDD UE Rx–Tx time difference measurement under time-domain measurement resource restriction with CRS assistance information and non-MBSFN ABS (feICIC)**

Information Element	Value/remark
<i>ecid-RequestCapabilities</i>	TRUE

**Table 8.1.5.4.3-4: ECID-RequestLocationInformation: FDD UE Rx–Tx time difference measurement under time-domain measurement resource restriction with CRS assistance information and non-MBSFN ABS (feICIC)**

Derivation Path: TS 36.355 [4] clause 6.2			
Information Element	Value/remark	Comment	Condition
LPP-Message ::= SEQUENCE {			
transactionID SEQUENCE {			
Initiator	locationServer		
transactionNumber	1		
}			
endTransaction	FALSE		
sequenceNumber	Not present		
acknowledgement	Not present		
lpp-MessageBody CHOICE {			
c1 CHOICE {			
requestLocationInformation SEQUENCE {			
criticalExtensions CHOICE {			
c1 CHOICE {			
requestLocationInformation-r9 SEQUENCE {			
commonEsRequestLocationInformation SEQUENCE {			
locationInformationType	locationMeasurementsRequired		
triggeredReporting	Not present		
periodicalReporting	Not present		
additionalInformation	onlyReturnInformationRequested		
qos SEQUENCE {			
horizontalAccuracy	Not present		
verticalCoordinateRequest	FALSE		
verticalAccuracy	Not present		
responseTime SEQUENCE {			
time	2		
responseTimeEarlyFix-r12	Not present		Rel-12 onwards
}			
velocityRequest	FALSE		
}			
environment	Not present		
locationCoordinateTypes	Not present		
velocityTypes	Not present		
}			
a-gnss-RequestLocationInformation	Not present		
otdoa-RequestLocationInformation	Not present		
ecid-RequestLocationInformation ::= SEQUENCE {			
requestedMeasurements	0 0 1	ueRxTxReq	
}			
epdu-RequestLocationInformation	Not Present		
}			
}			
}			
}			
}			

**Table 8.1.5.4.3-5: ECID-ProvideLocationInformation: FDD UE Rx-Tx time difference measurement under time-domain measurement resource restriction with CRS assistance information and non-MBSFN ABS (feICIC)**

Derivation Path: TS 36.355 [4] clause 6.2			
Information Element	Value/remark	Comment	Condition
LPP-Message ::= SEQUENCE {			
transactionID SEQUENCE {			
Initiator	locationServer		
transactionNumber	1		
}			
endTransaction	TRUE		
sequenceNumber	(0..255)		
acknowledgement			
lpp-MessageBody CHOICE {			
c1 CHOICE {			
provideLocationInformation SEQUENCE {			
criticalExtensions CHOICE {			
c1 CHOICE {			
provideLocationInformation-r9 SEQUENCE {			
commonIEsProvideLocationInformation	Not present.		
a-gnss-ProvideLocationInformation	Not present		
otdoa-ProvideLocationInformation	Not present		
ecid-ProvideLocationInformation ::=			
SEQUENCE {			
ecid-SignalMeasurementInformation ::=			
SEQUENCE {			
primaryCellMeasuredResults	Not Present		
MeasuredResultsList ::= SEQUENCE			
(SIZE(1..32)) OF			
MeasuredResultsElement			
MeasuredResultsElement ::= SEQUENCE {			
physCellId			
cellGlobalId			
arfcnEUTRA			
systemFrameNumber			
rsrp-Result	Not Present		
rsrq-Result	Not Present		
ue-RxTxTimeDiff		Set according to specific sub-test and test point.	
}			
}			
}			
epdu-ProvideLocationInformation	Not present		
}			
}			
}			
}			
}			
}			
}			
}			
}			

**Table 8.1.5.4.3-6: *RadioResourceConfigDedicated-SRB2-DRB(n, m)*: FDD UE Rx–Tx time difference measurement under time-domain measurement resource restriction with CRS assistance information and non-MBSFN ABS (feICIC)**

Derivation Path: TS 36.508 [18] clause 4.6.3, Table 4.6.3-16			
Information Element	Value/remark	Comment	Condition
neighCellsCRS-Info-r11 ::= CHOICE {			
NeighCellsCRS-Info-r11 ::= CHOICE {			
Release	NULL		
Setup	CRS-AssistanceInfoList-r11		
}			
}			

**Table 8.1.5.4.3-7: *RadioResourceConfigDedicated-SRB2-DRB(n, m)*: FDD UE Rx–Tx time difference measurement under time-domain measurement resource restriction with CRS assistance information and non-MBSFN ABS (feICIC)**

Derivation Path: TS 36.508 [18] clause 4.6.3, Table 4.6.3-16			
Information Element	Value/remark	Comment	Condition
CRS-AssistanceInfoList-r11 ::= SEQUENCE (SIZE (1..maxCellReport)) OF CRS-AssistanceInfo-r11			
CRS-AssistanceInfo-r11 ::= SEQUENCE {			
physCellId-r11	( $PCI_{cell1} - PCI_{cell3} \bmod 6 = 0$ ( $PCI_{cell2} - PCI_{cell3} \bmod 6 \neq 0$ )	Cell PCIs are selected so that both conditions are met	
antennaPortsCount-r11	an1		
mbsfn-SubframeConfigList-r11	MBSFN-SubframeConfigList		
}			

**Table 8.1.5.4.3-8: *RadioResourceConfigDedicated-SRB2-DRB(n, m)*: FDD UE Rx–Tx time difference measurement under time-domain measurement resource restriction with CRS assistance information and non-MBSFN ABS (feICIC)**

Derivation Path: TS 36.508 [18] clause 4.6.3, Table 4.6.3-16			
Information Element	Value/remark	Comment	Condition
MBSFN-SubframeConfigList ::= SEQUENCE (SIZE (1..maxMBSFN-Allocations)) OF MBSFN-SubframeConfig			
MBSFN-SubframeConfig ::= SEQUENCE {			
subframeAllocation CHOICE {			
oneFrame	'000000'	Only the CRS information of Cell 2 is provided in CRS-AssistanceInfo. It includes a single MBSFN-SubframeConfig element with subframe allocation <i>oneFrame</i> = '000000' BIT STRING (SIZE(6))	
}			
}			

**Table 8.1.5.4.3-9: *RadioResourceConfigDedicated-SRB2-DRB(n, m)*: Additional FDD UE Rx–Tx time difference measurement under time-domain measurement resource restriction with CRS assistance information and non-MBSFN ABS (felCIC)**

Derivation Path: TS 36.508 [18] clause 4.6.3, Table 4.6.3-16 RadioResourceConfigDedicated-SRB2-DRB(n,m)			
Information Element	Value/remark	Comment	Condition
RadioResourceConfigDedicated-SRB2-DRB(n, m) ::= SEQUENCE {			
MeasSubframePatternPCell-r10 CHOICE {			
setup SEQUENCE {			
subframePatternFDD-r10	'10000000100000001000 00001000000010000000'	BIT STRING (SIZE (40))	Cell1
}			
}			
}			

### 8.1.5.5 Test requirement

Table 8.1.5.5-1 defines the primary level settings including test tolerances for the test.

The UE Rx – Tx time difference measurement accuracy shall fulfil the requirements in Table 8.1.5.5-3.



**Table 8.1.5.5-1: Test parameters test parameters for FDD UE Rx–Tx time difference measurement under time-domain measurement resource restriction with CRS assistance information and non-MBSFN ABS**

Parameter	Unit	Cell 1	Cell 2	Cell 3
E-UTRAN RF Channel Number		1	1	1
PDSCH Reference measurement channel defined in TS 36.521-3 [25] A.1.1		R.0 FDD	N/A	N/A
PDSCH allocation	$n_{PRB}$	13–36	N/A	N/A
PDCCH/PCFICH/PHICH Reference measurement channel defined in TS 36.521-3 [25] A.2.1		R.6 FDD	N/A	N/A
OCNG Patterns defined in TS 36.521-3 [25] D.1.5 (OP.5 FDD) and in D.1.6 (OP.6 FDD)		OP.5 FDD	OP.6 FDD	OP.6 FDD
PBCH_RA	dB	0	Non-ABS and ABS subframe channel powers defined in Table C.3.1.1.1-1-1 in TS 36.521-3 [25].	
PBCH_RB	dB			
PSS_RA	dB			
SSS_RA	dB			
PCFICH_RB	dB			
PHICH_RA	dB			
PHICH_RB	dB			
PDCCH_RA	dB			
PDCCH_RB	dB			
PDSCH_RA	dB			
PDSCH_RB	dB			
OCNG_RA <sup>Note 1</sup>	dB			
OCNG_RB <sup>Note 1</sup>	dB			
$N_{oc}$ <sup>Note 2</sup>	dBm/15 kHz			
CRS $\hat{E}_s/N_{oc}$	dB	-2.60	3	1
CRS $(\hat{E}_s/I_{ot})_{meas}$ <sup>Note 3</sup>	dB	-7.36	1.10	-0.90
CRS $(\hat{E}_s/I_{ot})_{nonABS}$ <sup>Note 3</sup>	dB	-8.89	-1.48	-4.50
RSRP <sup>Note 4</sup>	dBm/15 kHz	-100.6	-95	-97
$(I_o)_{meas}$ <sup>Note 4</sup>	dBm/9 MHz	-	-	-
$(I_o)_{nonABS}$ <sup>Note 4</sup>	dBm/9 MHz	-63.40	-63.40	-63.40
Propagation condition		AWGN		
Note 1:	OCNG shall be used such that the resources in the active cell are fully allocated and a constant total transmitted power spectral density is achieved for all OFDM symbols.			
Note 2:	Interference from other cells and noise sources not specified in the test is assumed to be constant over subcarriers and time and shall be modelled as AWGN of appropriate power for $N_{oc}$ to be fulfilled. Applies to all subframes.			
Note 3:	$(\hat{E}_s/I_{ot})_{meas}$ is calculated in CRS REs in the subframes indicated for PCell measurements by measurement resource restriction pattern, whilst $(\hat{E}_s/I_{ot})_{nonABS}$ is calculated in CRS REs in the subframes not indicated for PCell measurements by measurement resource restriction pattern.			
Note 4:	RSRP and $I_o$ levels have been derived from other parameters for information purposes. They are not settable parameters themselves. $(I_o)_{meas}$ is calculated in CRS symbols in the subframes indicated for PCell measurements by measurement resource restriction pattern, whilst $(I_o)_{nonABS}$ is calculated in CRS symbols in the subframes not indicated for PCell measurements by measurement resource restriction pattern.			

**Table 8.1.5.5-2: Sounding Reference Symbol Configuration to be used in FDD UE Rx–Tx time difference test**

Field	Value	Comment
UL bandwidth	50 RBs	Same as the DL bandwidth
srsBandwidthConfiguration	bw5	
srsSubframeConfiguration	sc1	
ackNackSrsSimultaneousTransmission	FALSE	
srsMaxUpPTS	N/A	Not applicable for FDD
srsBandwidth	0	No hopping
srsHoppingBandwidth	hbw0	
frequencyDomainPosition	0	
Duration	TRUE	Indefinite duration
srs-ConfigIndex	0	SRS periodicity of 2ms
transmissionComb	0	
cyclicShift	cs0	No cyclic shift
srsAntennaPort	an1	Number of SRS antenna ports
Note:	For further information see clause 6.3.2 in TS 36.331 [22].	

**Table 8.1.5.5-3: Test requirements UE Rx – Tx time difference measurement accuracy requirements**

	Test requirement
Lowest reported value	(Measured value from step 7 - 13) $T_s$ converted to RX-TX_TIME_DIFFERENCE according to Table 4.6.3-1
Highest reported value	(Measured value from step 7 + 13) $T_s$ converted to RX-TX_TIME_DIFFERENCE according to Table 4.6.3-1

NOTE: The test in table 8.1.5.5-3 has two test points starting at 32  $T_s$  and 5008  $T_s$ .

The test tolerances are defined in Annex C.

For the overall test to pass, the ratio of successful reported values in each test point shall be more than 90% with a confidence level of 95%.

## 8.1.6 E-UTRAN TDD UE Rx–Tx time difference under Time Domain Measurement Resource Restriction with CRS Assistance Information and Non-MBSFN ABS (feICIC)

### 8.1.6.1 Test purpose

The purpose of this test is to verify that the E-UTRAN TDD UE Rx – Tx time difference measurement accuracy is within the specified limits in TS 36.133 [23] clause 9.1.9.4 when the UE is provided with a time-domain measurement resource restriction pattern and CRS assistance information, and when non-MBSFN ABS is configured in the interfering cells.

### 8.1.6.2 Test applicability

This test applies to all types of E-UTRA TDD UE release 11 and forward with LPP release 13 onwards that supports ECID positioning and CRS interference handling. Applicability requires support of FGI bit 115. Note that for LPP releases before release 13 the UE Rx - Tx time difference measurement report mapping is ambiguous and therefore this test shall not be used.

### 8.1.6.3 Minimum conformance requirements

NOTE: This measurement is used for UE positioning purposes.

The UE RX-TX time difference is measured from the PCell.

For UE configured with a time-domain measurement resource restriction pattern for PCell measurements, the accuracy requirements in Table 8.1.5.3-1 apply provided that the following conditions are met for the PCell:

PCell cell specific reference signals are transmitted from one, two or four antenna ports,

Conditions defined in TS 36.101 [2] clause 7.3 for reference sensitivity are fulfilled,

No changes to the uplink transmission timing are applied during the measurement period,

$RSRP|_{dBm}$  according to clause E.4 for a corresponding Band,

The time domain measurement resource restriction pattern configured for the measured cell indicates at least one subframe per radio frame for performing the RSRP measurement,

Four symbols containing CRS are available in all subframes indicated by the time domain measurement resource restriction pattern, and

The UE is provided via PCell with the CRS assistance information (TS 36.331 [22]) and the CRS assistance information is valid throughout the entire evaluation period.

The requirements in this section shall also be met when the number of transmit antenna ports TS 36.211 [26] of one or more cells whose CRS assistance information is provided TS 36.331 [22] is different from the number of transmit antenna ports of the measured cell.

When the CRS assistance information is provided, the transmission bandwidth in all intra-frequency cells in the CRS assistance information is the same or larger than the transmission bandwidth of the PCell for which measurement is performed.

**Table 8.1.6.3-1: TDD UE Rx – Tx time difference measurement accuracy**

Accuracy	Conditions				
	CRS $\hat{E}_s/lot$ <sup>Note 9</sup>	Downlink transmission bandwidth of PCell	Io range <sup>Note 8</sup>		
E-UTRA operating band groups <sup>Note 6</sup>			Minimum Io	Maximum Io	
Ts <sup>Note 2</sup>	dB	MHz		dBm/15kHz <sup>Note 5</sup>	dBm/BW <sub>Channel</sub>
±20	≥-7.76 dB	≤ 3 MHz	FDD_A <sup>Note 7</sup> , TDD_A	-121	-50
			FDD_B	-120.5	-50
			FDD_C, TDD_C	-120	-50
			FDD_D	-119.5	-50
			FDD_E, TDD_E	-119	-50
			FDD_F	-118.5	-50
			FDD_G <sup>Note 4</sup>	-118	-50
			FDD_H	-117.5	-50
			FDD_N	-114.5	-50
±10	≥-7.76 dB	≥ 5 MHz	Note 3	Note 3	Note 3

NOTE 1: This Io condition is expressed as the average Io per RE over all REs in an OFDM symbol.  
 NOTE 2: Ts is the basic timing unit defined in TS 36.211 [26].  
 NOTE 3: The same bands and the same Io conditions for each band apply for this requirement as for the corresponding requirement with downlink bandwidth ≤ 3 MHz.  
 NOTE 4: Except Band 29.  
 NOTE 5: The condition level is increased by Δ>0, when applicable, as described in TS 36.521-3 [25] Sections I.4.2 and I.4.3.  
 NOTE 6: E-UTRA operating band groups are as defined in Section 4.4.2.  
 NOTE 7: Except Band 32.  
 NOTE 8: Io is defined in subframes indicated for PCell measurements by the time domain measurement resource restriction pattern. The specified Io range applies to CRS and non-CRS symbols. Io may be different in different symbols within a subframe.  
 NOTE 9: CRS  $\hat{E}_s/lot$  is in subframes indicated for PCell measurements by the time-domain measurement resource restriction pattern.

NOTE: It is up to the UE implementation whether the UE Rx-Tx time difference measurement is performed in any subframe or in subframes indicated by the time-domain measurement resource restriction pattern.

The normative reference for this requirement is TS 36.133 [23] clause 9.1.9.4 and A.9.7.6.

#### 8.1.6.4 Test description

The test has two test points with time delays starting at 32  $T_s$  and 5008  $T_s$ , respectively. In this test case, there are three cells, Cell 1, Cell 2 and Cell 3, on the same RF channel. Cell 1 is the PCell on which UE Rx-Tx is measured. Cell 2 and Cell 3 are the interfering cells. A non-MBSFN ABS pattern is configured in each of the Cell 2 and Cell 3 during the entire test. The tested UE is connected to the PCell and configured to transmit SRS signals periodically. The SRS configuration is provided to the UE before the measurement starts. The UE is configured to report UE Rx-Tx time difference measurement. The test equipment measures the transmit timing of the UE using the transmitted SRS. The test equipment then compares this timing to the UE Rx-Tx measurement reported by the UE. The UE is configured by higher layers via Cell 1 with a time-domain measurement resource restriction pattern for performing E-UTRAN FDD intra-frequency measurements on PCell. The UE is also provided via higher layers with the CRS assistance information for Cell 2. The information for both measurement patterns and the CRS assistance information shall be provided via RRC to the UE before the measurement starts.

##### 8.1.6.4.1 Initial conditions

Test Environment: Normal as defined in TS 36.508 [18] clause 4.1.

Frequencies to be tested: According to TS 36.521-1 [24] Annex E table E-1 and TS 36.508 [18] clauses 4.4.2 and 4.3.1.

Channel Bandwidth to be tested: 10 MHz as defined in TS 36.508 [18] clause 4.3.1.

1. Connect the SS (node B emulator) and AWGN noise source to the UE antenna connectors as shown in TS 36.508 [18] Annex A Figure A.54 (without faders).
2. Propagation conditions are set according to clause 4.6.2.1.
3. Message contents are defined in clause 8.1.6.4.3.
4. Cell 1 is the serving cell. Cell 1 is the cell used for connection setup with the power levels set according to TS 36.521-3 [25] clauses C.0 and C.1 for this test. Cell 2 and Cell 3 are the neighbour cells. All cells are on the same RF channel. Cell 3 in the test is the Cell 4 defined in clause 4.7.1

**Table 8.1.6.4.1-1: General test parameters for TDD UE Rx–Tx time difference measurement under time-domain measurement resource restriction with CRS assistance information and non-MBSFN ABS**

Parameter	Unit	Value	Comment
Serving cell (PCell)		Cell 1	Cell to be measured
Neighbour cell		Cell 2 and Cell 3	Cell 2 is the first interfering cell to Cell 1, whilst Cell 3 is the second interfering cell to Cell 1.
ABS transmission configuration		Non-MBSFN ABS	As defined in TS 36.521-3 [25] Table C.3.1.2.1-1
E-UTRA RF Channel Number		1	One TDD carrier frequency is used
Downlink Channel Bandwidth (BW <sub>channel</sub> )	MHz	10	For all cells in the test
CP length		Normal	For all cells in the test
Special subframe configuration		6	For all cells in the test. For special subframe configurations see Table 4.2-1 in TS 36.211 [26].
Uplink/downlink subframe configuration		1	For all cells in the test. For uplink-downlink subframe configurations see Table 4.2-2 in TS 36.211 [26].
DRX			OFF
Time offset between cells	μs	Cell 2 offset with respect to Cell 1: 3 Cell 3 offset with respect to Cell 1: 2	Three synchronous cells
Physical cell ID PCI		$(PCI_{cell1} - PCI_{cell2}) \bmod 6 = 0$ $(PCI_{cell1} - PCI_{cell3}) \bmod 6 \neq 0$  PCI <sub>cell1</sub> not equal to PCI <sub>cell2</sub>	Cell PCIs are selected so that both conditions are met
ABS pattern		'00000000010000000001'	Non-MBSFN ABS. TDD ABS Pattern Info IE, as defined in TS 36.423 [35], clause 9.2.54. The first/leftmost bit corresponds to the PCell subframe #0 of a radio frame satisfying SFN mod x = 0, where x is the size of the bit string (20) divided by 10. No MBSFN subframes are configured in the ABS subframes. Configured in Cell 2 and Cell 3 during the testing.
Time-domain measurement resource restriction pattern for serving cell measurements		'00000000010000000001'	Configured for measurements on Cell 1.
CRS assistance information	physCellId	see PCI conditions above	The CRS assistance information is provided for Cell 2 and Cell 3 in CRS-AssistanceInfo. It includes a single MBSFN-SubframeConfig element with subframe allocation one Frame='000000'.
	antennaPortsCount	1	
	mbsfn-SubframeConfigList	oneFrame = '000000'	

#### 8.1.6.4.2 Test procedure

1. Bring the UE to State 3A or 3A-RF according to TS 36.508 [18] clause 4.5.3A or 5.2A.2, with exceptions listed in 7.2A.6 using a value of initial timing advance command  $T_A = 2$  in the Random Access Response which indicates an initial timing advance value  $N_{TA} = 32 T_s$ . Note that in the remainder of the test the timing advance command  $T_A = 31$  which indicates a timing advance adjustment value  $N_{TA} = 0 T_s$ .
2. Set the parameters according to Tables 8.1.6.5-1 and 8.1.6.5-2 as appropriate. Propagation conditions are set according to clause 4.6.2.1.
3. The SS adjusts the downlink timing for Cell 1 to a delay of  $+4 T_s$ , compared to the current value.
4. Wait for 1.6s to allow for the possibility that the UE makes autonomous timing adjustments.
5. The SS shall transmit an LPP REQUEST CAPABILITIES message.

6. The UE shall transmit an LPP PROVIDE CAPABILITIES message indicating the ECID capabilities supported by the UE in the *ECID-ProvideCapabilities* IE. The IE *ueRxTxSupTDD-r13* shall be present (TRUE).
7. The SS shall transmit an LPP REQUEST LOCATION INFORMATION message, including the *ECID-RequestLocationInformation* IE. If the UE message at step 4b includes the *ackRequested* IE set to TRUE, then the SS shall send an acknowledgment in the LPP REQUEST LOCATION INFORMATION message.
8. The UE shall transmit an LPP PROVIDE LOCATION INFORMATION message including the *ecid-SignalMeasurementInformation* IE.
9. As soon as possible after step 8 the SS shall measure the transmit timing of the UE using the transmitted SRS, relative to the current downlink timing.
10. If the UE message at step 8 includes the *ackRequested* IE set to TRUE, then the SS shall send a LPP acknowledgment message.
11. The SS shall check the reported value of *ue-RxTxTimeDiff* in the *ecid-SignalMeasurementInformation* IE provided by the UE in step 8 and compare it with the value measured in step 9. The SS shall check that the reported value is within the limits specified in table 8.1.6.5-3 for test compared to the measured value. If the reported value is within the limits the number of successful results for test is increased by one. If the reported value is not within the limits, or the UE reports an error in the LPP PROVIDE LOCATION INFORMATION message in step 8, or does not respond at step 8 within the time given by the *time* IE in the *ECID-RequestLocationInformation* IE in step 7, then the number of unsuccessful results for test is increased by one.
12. Repeat steps 3-11 until the confidence level according to Annex D.4.3 is achieved.  
NOTE: To avoid a large divergence between the sent TA and the set downlink timing, the SS may reset the downlink timing for Cell 1 to its initial value after a certain amount of loops. The loop during the reset does not count for the result statistics.
13. Repeat steps 1-12 for test point 2.

#### 8.1.6.4.3 Message contents

Message contents are according to TS 36.508 [18] clause 5.2A.5.1 with the following exceptions:

**Table 8.1.6.4.3-1: SoundingRS-RL-ConfigCommon-DEFAULT: TDD UE Rx–Tx time difference measurement under time-domain measurement resource restriction with CRS assistance information and non-MBSFN ABS**

Derivation Path: TS 36.508 [18] clause 4.6.3, Table 4.6.3-21 SoundingRS-UL-ConfigCommon-DEFAULT			
Information Element	Value/remark	Comment	Condition
SoundingRS-UL-ConfigCommon-DEFAULT ::= SEQUENCE {			
setup SEQUENCE {			
srs-BandwidthConfig	bw0		
srs-SubframeConfig	sc1		FDD
ackNackSRS-SimultaneousTransmission	FALSE		
srsMaxUpPts	Not present		FDD
}			
}			

**Table 8.1.6.4.3-2: SoundingRS-RL-ConfigDedicated-DEFAULT: TDD UE Rx–Tx time difference measurement under time-domain measurement resource restriction with CRS assistance information and non-MBSFN ABS**

Derivation Path: TS 36.508 [18] clause 4.6.3, Table 4.6.3-22 SoundingRS-UL-ConfigDedicated-DEFAULT			
Information Element	Value/remark	Comment	Condition
SoundingRS-UL-ConfigDedicated-DEFAULT ::= CHOICE {			
setup SEQUENCE {			
srs-Bandwidth	bw5		
srs-HoppingBandwidth	hbw0		
freqDomainPosition	0		
duration	TRUE	Indefinite duration	
srs-ConfigIndex	0		
transmissionComb	0		
cyclicShift	cs0	No cyclic shift	
}			
}			

**Table 8.1.6.4.3-3: LPP REQUEST CAPABILITIES: TDD UE Rx–Tx time difference measurement under time-domain measurement resource restriction with CRS assistance information and non-MBSFN ABS**

Information Element	Value/remark
<i>ecid-RequestCapabilities</i>	TRUE

**Table 8.1.6.4.3-3a: LPP PROVIDE CAPABILITIES: TDD UE Rx–Tx time difference measurement under time-domain measurement resource restriction with CRS assistance information and non-MBSFN ABS**

Information Element	Value/remark
<i>ueRxTxSupTDD-r13</i>	TRUE

**Table 8.1.6.4.3-4: ECID-RequestLocationInformation: TDD UE Rx–Tx time difference measurement under time-domain measurement resource restriction with CRS assistance information and non-MBSFN ABS**

Derivation Path: TS 36.355 [4] clause 6.2			
Information Element	Value/remark	Comment	Condition
LPP-Message ::= SEQUENCE {			
transactionID SEQUENCE {			
Initiator	locationServer		
transactionNumber	1		
}			
endTransaction	FALSE		
sequenceNumber	Not present		
acknowledgement	Not present		
lpp-MessageBody CHOICE {			
c1 CHOICE {			
requestLocationInformation SEQUENCE {			
criticalExtensions CHOICE {			
c1 CHOICE {			
requestLocationInformation-r9 SEQUENCE {			
commonIEsRequestLocationInformation SEQUENCE {			
locationInformationType	locationMeasurementsRequired		
triggeredReporting	Not present		
periodicalReporting	Not present		
additionalInformation	onlyReturnInformationRequested		
qos SEQUENCE {			
horizontalAccuracy	Not present		
verticalCoordinateRequest	FALSE		
verticalAccuracy	Not present		
responseTime SEQUENCE {			
time	2		
responseTimeEarlyFix-r12	Not present		Rel-12 onwards
}			
velocityRequest	FALSE		
}			
environment	Not present		
locationCoordinateTypes	Not present		
velocityTypes	Not present		
}			
a-gnss-RequestLocationInformation	Not present		
otdoa-RequestLocationInformation	Not present		
ecid-RequestLocationInformation ::= SEQUENCE {			
requestedMeasurements	0 0 1	ueRxTxReq	
}			
epdu-RequestLocationInformation	Not Present		
}			
}			
}			
}			
}			



**Table 8.1.6.4.3-5: ECID-ProvideLocationInformation: TDD UE Rx–Tx time difference measurement under time-domain measurement resource restriction with CRS assistance information and non-MBSFN ABS**

Derivation Path: TS 36.355 [4] clause 6.2			
Information Element	Value/remark	Comment	Condition
LPP-Message ::= SEQUENCE {			
transactionID SEQUENCE {			
Initiator	locationServer		
transactionNumber	1		
}			
endTransaction	TRUE		
sequenceNumber	(0..255)		
acknowledgement			
lpp-MessageBody CHOICE {			
c1 CHOICE {			
provideLocationInformation SEQUENCE {			
criticalExtensions CHOICE {			
c1 CHOICE {			
provideLocationInformation-r9 SEQUENCE {			
commonIEsProvideLocationInformation	Not present.		
a-gnss-ProvideLocationInformation	Not present		
otdoa-ProvideLocationInformation	Not present		
ecid-ProvideLocationInformation ::= SEQUENCE {			
ecid-SignalMeasurementInformation ::= SEQUENCE {			
primaryCellMeasuredResults	Not Present		
MeasuredResultsList ::= SEQUENCE (SIZE(1..32)) OF MeasuredResultsElement			
MeasuredResultsElement ::= SEQUENCE {			
physCellId			
cellGlobalId			
arfcnEUTRA			
systemFrameNumber			
rsrp-Result	Not Present		
rsrq-Result	Not Present		
ue-RxTxTimeDiff		Set according to specific sub-test and test point.	
}			
}			
}			
epdu-ProvideLocationInformation	Not present		
}			
}			
}			
}			
}			
}			
}			
}			

**Table 8.1.6.4.3-6: *RadioResourceConfigDedicated-SRB2-DRB(n, m)*: TDD UE Rx–Tx time difference measurement under time-domain measurement resource restriction with CRS assistance information and non-MBSFN ABS**

Derivation Path: TS 36.508 [18] clause 4.6.3, Table 4.6.3-16			
Information Element	Value/remark	Comment	Condition
neighCellsCRS-Info-r11 ::= CHOICE {			
NeighCellsCRS-Info-r11 ::= CHOICE {			
Release	NULL		
Setup	CRS-AssistanceInfoList-r11		
}			
}			

**Table 8.1.6.4.3-7: *RadioResourceConfigDedicated-SRB2-DRB(n, m)*: TDD UE Rx–Tx time difference measurement under time-domain measurement resource restriction with CRS assistance information and non-MBSFN ABS**

Derivation Path: TS 36.508 [18] clause 4.6.3, Table 4.6.3-16			
Information Element	Value/remark	Comment	Condition
CRS-AssistanceInfoList-r11 ::= SEQUENCE (SIZE (1..maxCellReport)) OF CRS-AssistanceInfo-r11			
CRS-AssistanceInfo-r11 ::= SEQUENCE {			
physCellId-r11	$(PCI_{cell1} - PCI_{cell3}) \bmod 6 = 0$ $(PCI_{cell2} - PCI_{cell3}) \bmod 6 \neq 0$	Cell PCIs are selected so that both conditions are met	
antennaPortsCount-r11	an1		
mbsfn-SubframeConfigList-r11	MBSFN-SubframeConfigList		
}			

**Table 8.1.6.4.3-8: *RadioResourceConfigDedicated-SRB2-DRB(n, m)*: TDD UE Rx–Tx time difference measurement under time-domain measurement resource restriction with CRS assistance information and non-MBSFN ABS**

Derivation Path: TS 36.508 [18] clause 4.6.3, Table 4.6.3-16			
Information Element	Value/remark	Comment	Condition
MBSFN-SubframeConfigList ::= SEQUENCE (SIZE (1..maxMBSFN-Allocations)) OF MBSFN-SubframeConfig			
MBSFN-SubframeConfig ::= SEQUENCE {			
subframeAllocation CHOICE {			
oneFrame	'000000'	Only the CRS information of Cell 2 is provided in CRS-AssistanceInfo. It includes a single MBSFN-SubframeConfig element with subframe allocation <i>oneFrame</i> ='000000' BIT STRING (SIZE(6))	
}			
}			

**Table 8.1.6.4.3-9: *RadioResourceConfigDedicated-SRB2-DRB(n, m)*: Additional TDD UE Rx–Tx time difference measurement under time-domain measurement resource restriction with CRS assistance information and non-MBSFN ABS (felCIC)**

Derivation Path: TS 36.508 [18] clause 4.6.3, Table 4.6.3-16 RadioResourceConfigDedicated-SRB2-DRB(n,m)			
Information Element	Value/remark	Comment	Condition
RadioResourceConfigDedicated-SRB2-DRB(n, m) ::= SEQUENCE {			
MeasSubframePatternPCell-r10 CHOICE {			
setup SEQUENCE {			
subframePatternTDD-r10			
subframeConfig1-5-r10	'00000000010000000001'	BIT STRING (SIZE (20))	Cell 1
}			
}			
}			

### 8.1.6.5 Test requirement

Table 8.1.6.5-1 defines the primary level settings including test tolerances for the test.

The UE Rx – Tx time difference measurement accuracy shall fulfil the requirements in Table 8.1.6.5-3.

**Table 8.1.6.5-1: Test parameters test parameters for TDD UE Rx–Tx time difference measurement under time-domain measurement resource restriction with CRS assistance information and non-MBSFN ABS**

Parameter	Unit	Cell 1	Cell 2	Cell 3
E-UTRAN RF Channel Number		1	1	1
PDSCH Reference measurement channel defined in TS 36.521-3 [25] A.1.2		R.0 TDD	N/A	N/A
PDSCH allocation	$n_{PRB}$	13–36	N/A	N/A
PDCCH/PCFICH/PHICH Reference measurement channel defined in TS 36.521-3 [25] A.2.2		R.6 TDD	N/A	N/A
OCNG Patterns defined in TS 36.521-3 [25] D.2.1 (OP.1 TDD) and D.2.2 (OP.2 TDD)		OP.1 TDD	OP.2 TDD	OP.2 TDD
PBCH_RA	dB	0	Non-ABS and ABS subframe channel powers defined in TS 36.521-3 [25] Table C.3.1.2.1-1	
PBCH_RB	dB			
PSS_RA	dB			
SSS_RA	dB			
PCFICH_RB	dB			
PHICH_RA	dB			
PHICH_RB	dB			
PDCCH_RA	dB			
PDCCH_RB	dB			
PDSCH_RA	dB			
PDSCH_RB	dB			
OCNG_RA <sup>Note1</sup>	dB			
OCNG_RB <sup>Note1</sup>	dB			
$N_{oc}$ <sup>Note2</sup>	dBm/15 kHz			
CRS $\hat{E}_s/N_{oc}$	dB	-2.60	3	1
CRS $(\hat{E}_s/I_{ot})_{meas}$ <sup>Note 3</sup>	dB	-7.36	1.10	-0.90
CRS $(\hat{E}_s/I_{ot})_{nonABS}$ <sup>Note 3</sup>	dB	-8.89	-1.48	-4.50
RSRP <sup>Note 4</sup>	dBm/15 kHz	-100.6	-95	-97
$(I_o)_{meas}$ <sup>Note 4</sup>	dBm/9 MHz	-	-	-
$(I_o)_{nonABS}$ <sup>Note 4</sup>	dBm/9 MHz	-63.40	-63.40	-63.40
Propagation Condition		AWGN		
<p>Note 1: OCNG shall be used such that the resources in the active cell are fully allocated and a constant total transmitted power spectral density is achieved for all OFDM symbols.</p> <p>Note 2: Interference from other cells and noise sources not specified in the test is assumed to be constant over subcarriers and time and shall be modelled as AWGN of appropriate power for <math>N_{oc}</math> to be fulfilled.</p> <p>Note 3: <math>(\hat{E}_s/I_{ot})_{meas}</math> is calculated in CRS REs in the subframes indicated for PCell measurements by measurement resource restriction pattern, whilst <math>(\hat{E}_s/I_{ot})_{nonABS}</math> is calculated in CRS REs in the subframes not indicated for PCell measurements by measurement resource restriction pattern.</p> <p>Note 4: RSRP and <math>I_o</math> levels have been derived from other parameters for information purposes. They are not settable parameters themselves. <math>(I_o)_{meas}</math> is calculated in CRS symbols in the subframes indicated for PCell measurements by measurement resource restriction pattern, whilst <math>(I_o)_{nonABS}</math> is calculated in CRS symbols</p>				

**Table 8.1.6.5-2: Sounding Reference Symbol Configuration to be used in FDD UE Rx–Tx time difference test**

Field	Value	Comment
UL bandwidth	50 RBs	Same as the DL bandwidth
srsBandwidthConfiguration	bw5	
srsSubframeConfiguration	sc1	
ackNackSrsSimultaneousTransmission	FALSE	
srsMaxUpPTS	TRUE	
srsBandwidth	0	No hopping
srsHoppingBandwidth	hbw0	
frequencyDomainPosition	0	
Duration	TRUE	Indefinite duration
Srs-ConfigurationIndex	10	SRS periodicity of 10ms for all Tests.
transmissionComb	0	
cyclicShift	cs0	No cyclic shift
SRS-AntennaPort	an1	Number of antenna ports used for SRS transmission
Note: For further information see clause 6.3.2 in TS 36.331 [22].		

**Table 8.1.6.5-3: Test requirements UE Rx – Tx time difference measurement accuracy requirements**

	Test requirement
Lowest reported value	(Measured value from step 7 - 13) $T_s$ converted to RX-TX_TIME_DIFFERENCE according to Table 4.6.3-2
Highest reported value	(Measured value from step 7 + 13) $T_s$ converted to RX-TX_TIME_DIFFERENCE according to Table 4.6.3-2

NOTE: The test in table 8.1.6.5-3 has two test points starting at 32  $T_s$  and 5008  $T_s$ .

The test tolerances are defined in Annex C.

For the overall test to pass, the ratio of successful reported values in each test point shall be more than 90% with a confidence level of 95%.

## 8.1.7 E-UTRAN FDD UE Rx-Tx time difference case for Cat-M1/M2 UE in CEModeA

*Editor's note: This test is incomplete. The following aspects are missing:*

- *Core requirements in TS 36.133 are in square brackets*
- *Accuracy limits are TBD*

### 8.1.7.1 Test purpose

The purpose of this test is to verify that the E-UTRAN FDD UE Rx – Tx time difference measurement accuracy for Category M1/M2 UEs is within the specified limits in TS 36.133 [23] clause 9.1.21.19 and 9.1.25.3.

### 8.1.7.2 Test applicability

This test applies to E-UTRA FDD UE Category M1/M2 release 14 and forward that supports ECID positioning.

### 8.1.7.3 Minimum conformance requirements

NOTE: This measurement is used for UE positioning purposes.

The UE RX-TX time difference is measured from the PCell.

The accuracy requirements in Table 8.1.7.3-1 are valid under the following conditions:

Conditions defined in TS 36.101 [2] clause 7.3 for reference sensitivity are fulfilled.

No changes to the uplink transmission timing are applied during the measurement period.

$RSRP_{dBm}$  according to clause E.1-1 for a corresponding Band.

**Table 8.1.7.3-1: UE Rx – Tx time difference measurement accuracy for CEModeA**

Accuracy	Conditions				
	$\hat{E}s/lot$	Downlink transmission bandwidth of PCell	$I_o$ <sup>Note 1</sup> range		
			E-UTRA operating band groups <sup>Note 6</sup>	Minimum $I_o$	Maximum $I_o$
$T_s$ <sup>Note 2</sup>	dB	MHz		dBm/15kHz <sup>Note 5</sup>	dBm/BW <sub>Channel</sub>
[±20]	≥-3 dB	≥ 6	FDD-M1_A, TDD-M1_A	-121	-50
			FDD-M1_B	-120.5	-50
			FDD-M1_C, TDD-M1_C	-120	-50
			FDD-M1_D	-119.5	-50
			FDD-M1_E, TDD-M1_E	-119	-50
			FDD-M1_F	-118.5	-50
			FDD-M1_G	-118	-50
			FDD-M1_H	-117.5	-50
[±10] <sup>Note 8</sup>	≥-3 dB	≥ 24	Note 3	Note 3	Note 3

NOTE 1: When in dBm/15kHz, the minimum  $I_o$  condition is expressed as the average  $I_o$  per RE over all REs in that symbol.  $I_o$  may be different in different symbols within a subframe.  
NOTE 2:  $T_s$  is the basic timing unit defined in TS 36.211 [26].  
NOTE 3: The same bands and the same  $I_o$  conditions for each band apply for this requirement as for the corresponding requirement with downlink bandwidth ≤ 3 MHz.  
NOTE 4: Except Band 29.  
NOTE 5: The condition level is increased by  $\Delta > 0$ , when applicable, as described in TS 36.521-3 [25] Sections I.4.2 and I.4.3.  
NOTE 6: E-UTRA operating band groups are as defined in Section 4.4.2.  
NOTE 7: Except Band 32.  
NOTE 8: Only for Category M2.

The normative reference for this requirement is TS 36.133 [23] clause 9.1.21.19, 9.1.25.3 and A.9.7.7.

### 8.1.7.4 Test description

There is only one active cell in the tests. The tested UE is connected with the serving cell, configured to transmit SRS signals periodically, and signalled to report UE Rx – Tx time difference measurement. The test equipment measures the transmit timing of the UE using the transmitted SRS. The test equipment then compares this timing to the UE Rx-Tx measurement reported by the UE.

#### 8.1.7.4.1 Initial conditions

Test Environment: Normal as defined in TS 36.508 [18] clause 4.1.

Frequencies to be tested: Mid Range, as defined in TS 36.508 [18] clause 4.3.1.1.

Channel Bandwidth to be tested: 10 MHz as defined in TS 36.508 [18] clause 4.3.1.

1. Connect the SS (node B emulator) and AWGN noise source to the UE antenna connectors as shown in Annex A figure A.5.
2. Propagation conditions are set according to clause 4.6.2.1.
3. Message contents are defined in clause 8.1.7.4.3.
4. Cell 1 is the serving cell. Cell 1 is the cell used for connection setup with the power levels set according to TS 36.521-3 [25] clauses C.0 and C.1 for this test.

### 8.1.7.4.2 Test procedure

1. Bring the UE to Generic RB Established State 3A-RF-CE according to 3GPP TS 36.508 [18] clause 7.2A.3AA, using a value of initial timing advance command  $T_A = 2$  in the Random Access Response which indicates an initial timing advance value  $N_{TA} = 32 T_s$ . Note that in the remainder of the test the timing advance command  $T_A = 31$  which indicates a timing advance adjustment value  $N_{TA} = 0 T_s$ .
2. Set the parameters according to Table 8.1.7.5-1 and 8.1.7.5-2 as appropriate. Propagation conditions are set according to clause 4.6.2.1.
3. The SS adjusts the downlink timing for Cell 1 to a delay of  $+8 T_s$ , compared to the current value.
4. Wait for 1.6 s to allow for the possibility that the UE makes autonomous timing adjustments.
- 4a. The SS shall transmit an LPP REQUEST CAPABILITIES message.
- 4b. The UE shall transmit an LPP PROVIDE CAPABILITIES message indicating the ECID capabilities supported by the UE in the *ECID-ProvideCapabilities* IE.
5. The SS shall transmit an LPP REQUEST LOCATION INFORMATION message, including the *ECID-RequestLocationInformation* IE. If the UE message at step 4b includes the *ackRequested* IE set to TRUE, then the SS shall send an acknowledgment in the LPP REQUEST LOCATION INFORMATION message.
6. The UE shall transmit an LPP PROVIDE LOCATION INFORMATION message including the *ecid-SignalMeasurementInformation* IE.
7. As soon as possible after step 6 the SS shall measure the transmit timing of the UE using the transmitted SRS, relative to the current downlink timing.
8. If the UE message at step 6 includes the *ackRequested* IE set to TRUE, then the SS shall send a LPP acknowledgment message.
9. The SS shall check the reported value of *ue-RxTxTimeDiff* in the *ecid-SignalMeasurementInformation* IE provided by the UE in step 6 and compare it with the value measured in step 7. The SS shall check that the reported value is within the limits specified in table 8.1.7.5-3 compared to the measured value. If the reported value is within the limits the number of successful results is increased by one. If the reported value is not within the limits, or the UE reports an error in the LPP PROVIDE LOCATION INFORMATION message in step 6, or does not respond at step 6 within the time given by the *time* IE in the *ECID-RequestLocationInformation* IE in step 5, then the number of unsuccessful results is increased by one.
10. Repeat steps 3-9 until the confidence level according to Annex D.4.3 is achieved.  
NOTE: To avoid a large divergence between the sent TA and the set downlink timing, the SS may reset the downlink timing for Cell 1 to its initial value after a certain amount of loops. The loop during the reset does not count for the result statistics.

### 8.1.7.4.3 Message contents

Message contents are according to TS 36.508 [18] clause 4.6 with the following exceptions:

**Table 8.1.7.4.3-1: SoundingRS-RL-ConfigCommon-DEFAULT: UE Rx – Tx time difference for E-UTRAN FDD test requirement**

Derivation Path: TS 36.508 [18] clause 4.6.3, Table 4.6.3-21 SoundingRS-UL-ConfigCommon-DEFAULT			
Information Element	Value/remark	Comment	Condition
SoundingRS-UL-ConfigCommon-DEFAULT ::= SEQUENCE {			
setup SEQUENCE {			
srs-BandwidthConfig	bw5		
srs-SubframeConfig	sc1		FDD
ackNackSRS-SimultaneousTransmission	FALSE		
srsMaxUpPts	Not present		FDD
}			

**Table 8.1.7.4.3-2: SoundingRS-RL-ConfigDedicated-DEFAULT: UE Rx – Tx time difference for E-UTRAN FDD test requirement**

Derivation Path: TS 36.508 [18] clause 4.6.3, Table 4.6.3-22 SoundingRS-UL-ConfigDedicated-DEFAULT			
Information Element	Value/remark	Comment	Condition
SoundingRS-UL-ConfigDedicated-DEFAULT ::= CHOICE {			
setup SEQUENCE {			
srs-Bandwidth	bw0	bw0 used with no frequency hopping. bw3 used with frequency hopping	
srs-HoppingBandwidth	hbw0		
freqDomainPosition	0		
duration	TRUE	Indefinite duration	
srs-ConfigIndex	0		
transmissionComb	0		
cyclicShift	cs0	No cyclic shift	
}			
}			

**Table 8.1.7.4.3-2a: LPP REQUEST CAPABILITIES: UE Rx – Tx time difference for E-UTRAN FDD test requirement**

Information Element	Value/remark
<i>ecid-RequestCapabilities</i>	TRUE



**Table 8.1.7.4.3-3: ECID-RequestLocationInformation: UE Rx – Tx time difference for E-UTRAN FDD test requirement**

Derivation Path: TS 36.355 clause 6.2			
Information Element	Value/remark	Comment	Condition
LPP-Message ::= SEQUENCE {			
transactionID SEQUENCE {			
Initiator	locationServer		
transactionNumber	1		
}			
endTransaction	FALSE		
sequenceNumber	Not present		
acknowledgement	Not present		
lpp-MessageBody CHOICE {			
c1 CHOICE {			
requestLocationInformation SEQUENCE {			
criticalExtensions CHOICE {			
c1 CHOICE {			
requestLocationInformation-r9 SEQUENCE {			
commonIEsRequestLocationInformation SEQUENCE {			
locationInformationType	locationMeasurementsRequired		
triggeredReporting	Not present		
periodicalReporting	Not present		
additionalInformation	onlyReturnInformationRequested		
qos SEQUENCE {			
horizontalAccuracy	Not present		
verticalCoordinateRequest	FALSE		
verticalAccuracy	Not present		
responseTime SEQUENCE {			
time	2		
responseTimeEarlyFix-r12	Not present		Rel-12 onwards
}			
velocityRequest	FALSE		
}			
environment	Not present		
locationCoordinateTypes	Not present		
velocityTypes	Not present		
}			
a-gnss-RequestLocationInformation	Not present		
otdoa-RequestLocationInformation	Not present		
ecid-RequestLocationInformation ::= SEQUENCE {			
requestedMeasurements	0 0 1	ueRxTxReq	
}			
epdu-RequestLocationInformation	Not Present		
}			
}			
}			
}			
}			

### 8.1.7.5 Test requirement

Table 8.1.7.5-1 defines the primary level settings including test tolerances.

**Table 8.1.7.5-1: FDD UE Rx – Tx time difference test parameters**

Parameter	Unit	Test 1	
E-UTRAN RF Channel Number		1	
Channel Bandwidth ( $BW_{channel}$ )	MHz	10	
DRX		OFF	
PRACH Configuration		PRACH_4CE As specified in TS 36.133 [23] A.3.16	
MPDCCH Reference measurement channel <sup>Note1</sup>		R.16 FDD	
OCNG Pattern <sup>Note2</sup>		OP.21 FDD	
PBCH_RA	dB	0	
PBCH_RB	dB		
PSS_RA	dB		
SSS_RA	dB		
PHICH_RA	dB		
PHICH_RB	dB		
MPDCCH_RA	dB		
MPDCCH_RB	dB		
OCNG_RA <sup>Note3</sup>	dB		
OCNG_RB <sup>Note3</sup>	dB		
$N_{oc}$	dBm/15 kHz		-98
$\hat{E}_s / N_{oc}$	dB		3
$\hat{E}_s / I_{ot}$	dB		3
$I_o$ <sup>Note4</sup>	dBm/9 MHz	-65.5	
Propagation Condition		AWGN	
Note 1: For the reference measurement channels, see TS 36.521-3 [25] A.7.1			
Note 2: For the OCNG pattern, see clause A.3.2.			
Note 3: OCNG shall be used such that both cells are fully allocated and a constant total transmitted power spectral density is achieved for all OFDM symbols.			
Note 4: $I_o$ level has been derived from other parameters for information purpose. It is not a settable parameter.			

**Table 8.1.7.5-2: Sounding Reference Symbol Configuration to be used in FDD UE Rx – Tx time difference test**

Field	Test 1	Comment
srsBandwidthConfiguration	bw5	
srsSubframeConfiguration	sc1	
ackNackSrsSimultaneousTransmission	FALSE	
srsMaxUpPTS	N/A	Not applicable for FDD
srsBandwidth	0	No hopping
srsHoppingBandwidth	hbw0	
frequencyDomainPosition	0	
Duration	TRUE	Indefinite duration
Srs-ConfigurationIndex	0	SRS periodicity of 2ms for all Tests.
transmissionComb	0	
cyclicShift	cs0	No cyclic shift
SRS-AntennaPort	an1	Number of antenna ports used for SRS transmission
Note: For further information see clause 6.3.2 in TS 36.331.		

The UE Rx – Tx time difference measurement accuracy shall fulfil the requirements in Table 8.1.7.5-3.

**Table 8.1.7.5-3: Test requirements UE Rx – Tx time difference measurement accuracy requirements**

Lowest reported value	(Measured value from step 7 - TBD) $T_s$ converted to RX-TX_TIME_DIFFERENCE according to Table 4.6.3-1
Highest reported value	(Measured value from step 7 + TBD) $T_s$ converted to RX-TX_TIME_DIFFERENCE according to Table 4.6.3-1

The test tolerances are defined in Annex C.

The rate of successful tests during repeated tests shall be at least 90% with a confidence level of 95%.

## 8.1.8 E-UTRAN HD-FDD UE Rx-Tx time difference case for Cat-M1/M2 UE in CEModeA

*Editor's note: This test is incomplete. The following aspects are missing:*

*Core requirements in TS 36.133 are in square brackets*

*Accuracy limits are TBD*

### 8.1.8.1 Test purpose

The purpose of this test is to verify that the E-UTRAN HD-FDD UE Rx – Tx time difference measurement accuracy for Category M1/M2 UEs is within the specified limits in TS 36.133 [23] clause 9.1.21.19 and 9.1.25.3.

### 8.1.8.2 Test applicability

This test applies to E-UTRA HD-FDD UE Category M1/M2 release 14 and forward that supports ECID positioning.

### 8.1.8.3 Minimum conformance requirements

Same in section 8.1.7.3.

The normative reference for this requirement is TS 36.133 [23] clause 9.1.21.19, 9.1.25.3 and A.9.7.8.

### 8.1.8.4 Test description

Same as in clause 8.1.7.4.

#### 8.1.8.4.1 Initial conditions

Same as in clause 8.1.7.4.1.

#### 8.1.8.4.2 Test procedure

Same as in clause 8.1.7.4.2.

#### 8.1.8.4.3 Message contents

Same as in clause 8.1.7.4.3.

### 8.1.8.5 Test requirement

Table 8.1.8.5-1 defines the primary level settings including test tolerances.

**Table 8.1.8.5-1: HD-FDD UE Rx – Tx time difference test parameters**

Parameter	Unit	Test 1	
E-UTRAN RF Channel Number		1	
Channel Bandwidth ( $BW_{channel}$ )	MHz	10	
DRX		OFF	
PRACH Configuration		PRACH_4CE As specified in TS 36.133 [23] A.3.16	
MPDCCH Reference measurement channel <sup>Note1</sup>		R.6 HD-FDD	
OCNG Pattern <sup>Note2</sup>		OP.21 FDD	
PBCH_RA	dB	0	
PBCH_RB	dB		
PSS_RA	dB		
SSS_RA	dB		
PHICH_RA	dB		
PHICH_RB	dB		
MPDCCH_RA	dB		
MPDCCH_RB	dB		
OCNG_RA <sup>Note3</sup>	dB		
OCNG_RB <sup>Note3</sup>	dB		
$N_{oc}$	dBm/15 kHz		-98
$\hat{E}_s / N_{oc}$	dB		3
$\hat{E}_s / I_{ot}$	dB		3
$I_o$ <sup>Note4</sup>	dBm/9 MHz	-65.5	
Propagation Condition		AWGN	
Note 1: For the reference measurement channels, see TS 36.521-3 [25] A.7.2			
Note 2: For the OCNG pattern, see clause A.3.2.			
Note 3: OCNG shall be used such that both cells are fully allocated and a constant total transmitted power spectral density is achieved for all OFDM symbols.			
Note 4: $I_o$ level has been derived from other parameters for information purpose. It is not a settable parameter.			

**Table 8.1.8.5-2: Sounding Reference Symbol Configuration to be used in HD-FDD UE Rx – Tx time difference test**

Field	Test 1	Comment
srsBandwidthConfiguration	bw5	
srsSubframeConfiguration	sc1	
ackNackSrsSimultaneousTransmission	FALSE	
srsMaxUpPTS	N/A	Not applicable for FDD
srsBandwidth	0	No hopping
srsHoppingBandwidth	hbw0	
frequencyDomainPosition	0	
Duration	TRUE	Indefinite duration
Srs-ConfigurationIndex	0	SRS periodicity of 2ms for all Tests.
transmissionComb	0	
cyclicShift	cs0	No cyclic shift
SRS-AntennaPort	an1	Number of antenna ports used for SRS transmission
Note: For further information see clause 6.3.2 in TS 36.331.		

The UE Rx – Tx time difference measurement accuracy shall fulfil the requirements in Table 8.1.8.5-3.

**Table 8.1.8.5-3: Test requirements UE Rx – Tx time difference measurement accuracy requirements**

Lowest reported value	(Measured value from step 7 - TBD) $T_s$ converted to RX-TX_TIME_DIFFERENCE according to Table 4.6.3-1
Highest reported value	(Measured value from step 7 + TBD) $T_s$ converted to RX-TX_TIME_DIFFERENCE according to Table 4.6.3-1

The test tolerances are defined in Annex C.

The rate of successful tests during repeated tests shall be at least 90% with a confidence level of 95%.

## 8.1.9 E-UTRAN TDD UE Rx-Tx time difference case for Cat-M1/M2 UE in CEModeA

*Editor's note: This test is incomplete. The following aspects are missing:*

*Core requirements in TS 36.133 are in square brackets*

*Accuracy limits are TBD*

### 8.1.9.1 Test purpose

The purpose of this test is to verify that the E-UTRAN TDD UE Rx – Tx time difference measurement accuracy for Category M1/M2 UEs is within the specified limits in TS 36.133 [23] clause 9.1.21.19 and 9.1.25.3.

### 8.1.9.2 Test applicability

This test applies to E-UTRA TDD UE Category M1/M2 release 14 and forward that supports ECID positioning.

### 8.1.9.3 Minimum conformance requirements

Same in section 8.1.7.3.

The normative reference for this requirement is TS 36.133 [23] clause 9.1.21.19, 9.1.25.3 and A.9.7.9.

### 8.1.9.4 Test description

Same as in clause 8.1.7.4.

#### 8.1.9.4.1 Initial conditions

Same as in clause 8.1.7.4.1.

#### 8.1.9.4.2 Test procedure

Same as in clause 8.1.7.4.2.

#### 8.1.9.4.3 Message contents

Same as in clause 8.1.7.4.3 with the following exceptions:

**Table 8.1.9.4.3-1: SoundingRS-RL-ConfigCommon-DEFAULT: UE Rx – Tx time difference for E-UTRAN TDD test requirement**

Derivation Path: TS 36.508 [18] clause 4.6.3, Table 4.6.3-21 SoundingRS-UL-ConfigCommon-DEFAULT			
Information Element	Value/remark	Comment	Condition
SoundingRS-UL-ConfigCommon-DEFAULT ::= SEQUENCE {			
setup SEQUENCE {			
srs-BandwidthConfig	bw5		
srs-SubframeConfig	Sc3		TDD
ackNackSRS-SimultaneousTransmission	FALSE		
srsMaxUpPts	FALSE		TDD
}			

**Table 8.1.9.4.3-2: SoundingRS-RL-ConfigDedicated-DEFAULT: UE Rx – Tx time difference for E-UTRAN TDD test requirement**

Derivation Path: TS 36.508 [18] clause 4.6.3, Table 4.6.3-22 SoundingRS-UL-ConfigDedicated-DEFAULT			
Information Element	Value/remark	Comment	Condition
SoundingRS-UL-ConfigDedicated-DEFAULT ::= CHOICE {			
setup SEQUENCE {			
srs-Bandwidth	bw0	bw0 used with no frequency hopping. bw3 used with frequency hopping	
srs-HoppingBandwidth	hbw0		
freqDomainPosition	0		
duration	TRUE	Indefinite duration	
srs-ConfigIndex	15		
transmissionComb	0		
cyclicShift	cs0	No cyclic shift	
}			

### 8.1.9.5 Test requirement

Table 8.1.9.5-1 defines the primary level settings including test tolerances.

**Table 8.1.9.5-1: TDD UE Rx – Tx time difference test parameters**

Parameter	Unit	Test 1	
E-UTRAN RF Channel Number		1	
Channel Bandwidth ( $BW_{channel}$ )	MHz	10	
DRX		OFF	
PRACH Configuration		PRACH_4CE As specified in TS 36.133 [23] A.3.16	
MPDCCH Reference measurement channel <sup>Note1</sup>		R.14 TDD	
OCNG Pattern <sup>Note2</sup>		OP.11 TDD	
PBCH_RA	dB	0	
PBCH_RB	dB		
PSS_RA	dB		
SSS_RA	dB		
PHICH_RA	dB		
PHICH_RB	dB		
MPDCCH_RA	dB		
MPDCCH_RB	dB		
OCNG_RA <sup>Note3</sup>	dB		
OCNG_RB <sup>Note3</sup>	dB		
$N_{oc}$	dBm/15 kHz		-98
$\hat{E}_s / N_{oc}$	dB		3
$\hat{E}_s / I_{ot}$	dB		3
$I_o$ <sup>Note4</sup>	dBm/9 MHz	-65.5	
Propagation Condition		AWGN	
Note 1: For the reference measurement channels, see TS 36.521-3 [25] A.7.3			
Note 2: For the OCNG pattern, see clause A.3.2.			
Note 3: OCNG shall be used such that both cells are fully allocated and a constant total transmitted power spectral density is achieved for all OFDM symbols.			
Note 4: $I_o$ level has been derived from other parameters for information purpose. It is not a settable parameter.			

**Table 8.1.9.5-2: Sounding Reference Symbol Configuration to be used in TDD UE Rx – Tx time difference test**

Field	Test 1	Comment
srsBandwidthConfiguration	bw5	
srsSubframeConfiguration	sc3	
ackNackSrsSimultaneousTransmission	FALSE	
srsMaxUpPTS	FALSE	
srsBandwidth	0	No hopping
srsHoppingBandwidth	hbw0	
frequencyDomainPosition	0	
Duration	TRUE	Indefinite duration
Srs-ConfigurationIndex	15	SRS periodicity of 10ms
transmissionComb	0	
cyclicShift	cs0	No cyclic shift
SRS-AntennaPort	an1	Number of antenna ports used for SRS transmission
Note: For further information see clause 6.3.2 in TS 36.331.		

The UE Rx – Tx time difference measurement accuracy shall fulfil the requirements in Table 8.1.9.5-3.

**Table 8.1.9.5-3: Test requirements UE Rx – Tx time difference measurement accuracy requirements**

Lowest reported value	(Measured value from step 7 - TBD) $T_s$ converted to RX-TX_TIME_DIFFERENCE according to Table 4.6.3-1
Highest reported value	(Measured value from step 7 + TBD) $T_s$ converted to RX-TX_TIME_DIFFERENCE according to Table 4.6.3-1

The test tolerances are defined in Annex C.

The rate of successful tests during repeated tests shall be at least 90% with a confidence level of 95%.

## 9 E-UTRA OTDOA measurement requirements

### 9.1 RSTD Intra-Frequency Measurements

#### 9.1.1 FDD RSTD Measurement Reporting Delay

##### 9.1.1.1 Test purpose

To verify that the RSTD measurement reporting delay meets the requirements in an environment with fading propagation conditions.

##### 9.1.1.2 Test applicability

This test applies to all types of E-UTRA FDD UE release 9 and forward that supports UE-assisted OTDOA except UE Category 1bis.

##### 9.1.1.3 Minimum conformance requirements

When the physical layer cell identities of neighbour cells together with the OTDOA assistance data are provided, the UE shall be able to detect and measure intra-frequency RSTD, specified in 3GPP TS 36.214 [6], for at least  $n=16$  cells, including the reference cell, on the same carrier frequency  $f_1$  as that of the reference cell within

$T_{\text{RSTD IntraFreqFDD, E-UTRAN}}$  ms as given below (see also Figure 9.1.1.3-1):

$$T_{\text{RSTD IntraFreqFDD, E-UTRAN}} = T_{\text{PRS}} \cdot (M - 1) + \Delta \quad \text{ms},$$

where

$T_{\text{RSTD IntraFreqFDD, E-UTRAN}}$  is the total time for detecting and measuring at least  $n$  cells,

$T_{\text{PRS}}$  is the cell-specific positioning subframe configuration period as defined in 3GPP TS 36.211 [26],

$M$  is the number of PRS positioning occasions as defined in Table 9.1.1.3-1, where each PRS positioning occasion comprises of  $N_{\text{PRS}}$  ( $1 \leq N_{\text{PRS}} \leq 6$ ) consecutive downlink positioning subframes defined in 3GPP TS 36.211 [26], and

$\Delta = 160 \cdot \left\lceil \frac{n}{M} \right\rceil$  ms is the measurement time for a single PRS positioning occasion which includes the sampling time and the processing time.

**Table 9.1.1.3-1: Number of PRS positioning occasions within  $T_{\text{RSTD IntraFreqFDD, E-UTRAN}}$** 

Positioning subframe configuration period $T_{\text{PRS}}$	Number of PRS positioning occasions $M$
	$f_1$ <small>Note 1</small>
160 ms	16
>160 ms	8
Note 1: When only intra-frequency RSTD measurements are performed over cells belonging to the serving FDD carrier frequency $f_1$ .	



The UE physical layer shall be capable of reporting RSTD for the reference cell and all the neighbour cells  $i$  out of at least  $(n-1)$  neighbour cells within  $T_{\text{RSTD IntraFreqFDD, E-UTRAN}}$  provided:

$$\left( \text{PRS } \hat{E}_s / \text{Iot} \right)_{\text{ref}} \geq -6 \text{ dB for all Frequency Bands for the reference cell,}$$

$$\left( \text{PRS } \hat{E}_s / \text{Iot} \right)_i \geq -13 \text{ dB for all Frequency Bands for neighbour cell } i,$$

$$\left( \text{PRS } \hat{E}_s / \text{Iot} \right)_{\text{ref}} \text{ and } \left( \text{PRS } \hat{E}_s / \text{Iot} \right)_i \text{ conditions apply for all subframes of at least } L = \frac{M}{2} \text{ PRS positioning}$$

occasions,

PRP 1,2|dBm according to clause E.2 for a corresponding Band.

The time  $T_{\text{RSTD IntraFreqFDD, E-UTRAN}}$  starts from the first subframe of the PRS positioning occasion closest in time after both the OTDOA-RequestLocationInformation message and the OTDOA-ProvideAssistanceData message as specified in 3GPP TS 36.355 [4], are delivered to the physical layer of the UE as illustrated in Figure 9.1.1.3-1.

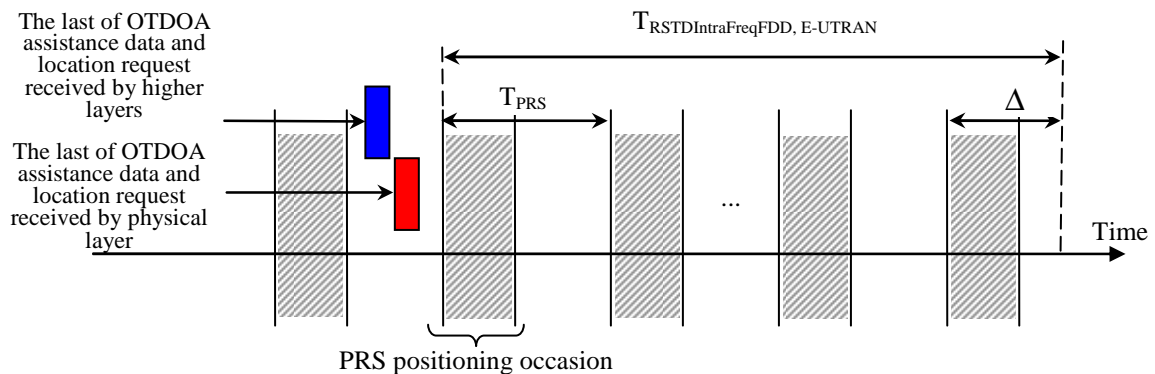

**Figure 9.1.1.3-1: Illustration of the RSTD reporting time requirement in an FDD system**

This requirement assumes that the measurement report is not delayed by other LPP signalling on the DCCH. This measurement reporting delay excludes a delay uncertainty resulted when inserting the measurement report to the TTI of the uplink DCCH. The delay uncertainty is:  $2 \times \text{TTI}_{\text{DCCH}}$ . This measurement reporting delay excludes any delay caused by no UL resources for UE to send the measurement report.

The normative reference for this requirement is TS 36.133 [23] clause 8.1.2.5.1 and A.8.12.1.

#### 9.1.1.4 Test description

##### 9.1.1.4.1 Initial conditions

Test Environment: Normal; as defined in TS 36.508 [18] clause 4.1.

Frequencies to be tested: Mid Range, as defined in TS 36.508 [18] clause 4.3.1.1.

Channel bandwidth to be tested: 10 MHz as defined in TS 36.508 [18] clause 4.3.1.

1. Connect the SS, faders and AWGN noise sources to the UE antenna connector or antenna connectors as shown in Annex A, Figure A.4.
2. The general test parameter settings are set up according to Table 9.1.1.4.1-1.
3. Propagation conditions are set according to clause 4.7.2.1.
4. Message contents are defined in clause 9.1.1.4.3.

5. In the test there are three synchronized cells: Cell 1, Cell 2 and Cell 3. Cell 1 is the OTDOA assistance data reference as well as the serving cell. Cell 2 and Cell 3 are the neighbour cells. All cells are on the same RF channel. Cell 3 in the test is the Cell 4 defined in clause 4.7.1. The assistance data neighbour cell list includes in total 15 cells, where 13 of the cells are not simulated (dummy cells; as defined in 3GPP TS 37.571-5 clause 7.2.2).
6. The true RSTD (which is the receive time difference for frame 0 between two cells as seen at the UE antenna connector) is set to 31 Ts (about 1  $\mu$ s) between neighbour Cell 2 and serving Cell 1; and set to -31 Ts (about -1  $\mu$ s) between neighbour Cell 3 and serving Cell 1.

**Table 9.1.1.4.1-1: General test parameters for E-UTRAN FDD intra-frequency RSTD measurement reporting delay under fading propagation conditions**

Parameter	Unit	Value	Comment
Reference cell		Cell 1	Reference cell is the cell in the OTDOA assistance data with respect to which the RSTD measurement is defined, as specified in 3GPP TS 36.214 [6] and 3GPP TS 36.355 [4]. The reference cell is the serving cell in this test case.
Neighbour cells		Cell 2 and Cell 3	Cell 2 and Cell 3 appear at random places in the neighbour cell list in the OTDOA assistance data, but Cell 2 always appears in the first half of the list, whilst Cell 3 appears in the second half of the list.
PCFICH/PDCCH/PHICH parameters		DL Reference Measurement Channel R.6 FDD	As specified in TS 36.521-3 [25] clause A.2.1
Channel Bandwidth ( $BW_{\text{channel}}$ )	MHz	10	
PRS Transmission Bandwidth <sup>Note 2</sup>	RB	50	PRS are transmitted over the system bandwidth
PRS configuration index $I_{\text{PRS}}$ <sup>Note 2</sup>		171	This corresponds to periodicity of 320 ms and PRS subframe offset of $I_{\text{PRS}} - 160$ DL subframes, as defined in 3GPP TS 36.211 [26], Table 6.10.4.3-1
Number of consecutive downlink positioning subframes $N_{\text{PRS}}$ <sup>Note 2</sup>		1	As defined in 3GPP TS 36.211 [26]. The number of subframes in a positioning occasion
Physical cell ID PCI <sup>Note 2</sup>		(PCI of Cell 1 – PCI of Cell 2) mod 6 = 0 and (PCI of Cell 1 – PCI of Cell 3) mod 6 = 0	The cell PCIs are selected such that the relative shifts of PRS patterns among cells are as given by the test parameters
CP length <sup>Note 2</sup>		Normal	
DRX		ON	DRX parameters are further specified in Table 9.1.1.4.1-2
Radio frame receive time offset between the cells at the UE antenna connector <sup>Note 3</sup>	$\mu\text{s}$	Cell 2 to Cell 1: 1 Cell 3 to Cell 1: -1	PRS are transmitted from synchronous cells
Expected RSTD <sup>Note 1</sup>	$\mu\text{s}$	Cell 2: 3 Cell 3: 3 Other neighbour cells: randomly between -3 and 3	The expected RSTD is what is expected at the receiver. The corresponding parameter in the OTDOA assistance data specified in TS 36.355 [4] is the expectedRSTD indicator
Expected RSTD uncertainty for all neighbour cells <sup>Note 1</sup>	$\mu\text{s}$	5	The corresponding parameter in the OTDOA assistance data specified in TS 36.355 [4] is the expectedRSTD-Uncertainty index
Number of cells provided in OTDOA assistance data		16	Including the reference cell
PRS muting info <sup>Note 2</sup>		Cell 1: '11110000' Cell 2: '00001111' Cell 3: '11110000'	Corresponds to prs-MutingInfo defined in TS 36.355 [4]
T1	s	3	The length of the time interval from the beginning of each test
T2	s	1.28	The length of the time interval that follows immediately after time interval T1
T3	s	1.28	The length of the time interval that follows immediately after time interval T2

Note 1:	Parameters “Expected RSTD” and “Expected RSTD uncertainty for all neighbour cells” are not settable parameters. These are parameters signalled in LPP only. For the values to be used in LPP see Table 9.1.1.4.3-5 and TS 37.571-5 [20], clause 7.2.2.
Note 2:	Parameters “PRS Transmission Bandwidth”, “PRS configuration index”, “Number of consecutive downlink positioning subframes”, “Physical cell ID PCI”, “CP length”, and “PRS muting info” are settable parameters and also parameters signalled in LPP. The values to be used for “Physical cell ID PCI” are as follows: Cell 1: 0, Cell 2: 6, Cell 3: 12. For all the values to be used in LPP see Table 9.1.1.4.3-5 and TS 37.571-5 [20], clause 7.2.2.
Note 3:	The parameter “Radio frame receive time offset between the cells at the UE antenna connector” is not a settable parameter but is used to set the “true RSTD” values in step 6 of clause 9.1.1.4.1.

**Table 9.1.1.4.1-2: DRX parameters for E-UTRAN FDD intra-frequency RSTD measurement reporting delay under fading propagation conditions**

Field	Value	Comment
onDurationTimer	psf1	As specified in 3GPP TS 36.331 [22], clause 6.3.2
drx-InactivityTimer	psf1	
drx-RetransmissionTimer	sf1	
longDRX-CycleStartOffset	sf320	
shortDRX	Disable	

#### 9.1.1.4.2 Test procedure

The test consists of three consecutive time intervals, with duration of T1, T2 and T3 defined in Table 9.1.1.4.1-1. Cell 1 is active in T1, T2 and T3, whilst Cell 2 and Cell 3 are activated only in the beginning of T2. Cell 2 is active until the end of T3, and Cell 3 is active until the end of T2. The beginning of the time interval T2 shall be aligned 5 ms before the first PRS positioning subframe of a positioning occasion in the reference cell, where 5 ms is the necessary test tolerance. Cell 1 transmits PRS in T2, while Cell 2 transmits PRS only in T3, and Cell 3 transmits PRS only in T2.

NOTE: The information on when PRS is muted is conveyed to the UE using PRS muting information in the OTDOA assistance data.

The OTDOA-RequestLocationInformation message and the OTDOA assistance data as defined in clause 9.1.1.4.3 shall be provided to the UE during T1. The last TTI containing the OTDOA-RequestLocationInformation message shall be provided to the UE  $\Delta T$  ms before the start of T2, where  $\Delta T = 150$  ms is the maximum processing time of the OTDOA-RequestLocationInformation message and the OTDOA assistance data.

1. Ensure that the UE is in state Generic RB Established State 3A-RF according to 3GPP TS 36.508 [18] clause 7.2A.3.
2. The SS shall send a RESET UE POSITIONING STORED INFORMATION message.
3. Set the parameters according to Table 9.1.1.5-1. Propagation conditions are set according to clause 4.7.2.2 (ETU30).
4. T1 starts.
5. The SS shall transmit an RRCConnectionReconfiguration message with the DRX configuration. PDCCHs indicating new transmissions shall be sent continuously until the start of T2 to ensure that the UE would not enter the DRX state before T2.
6. The UE shall transmit RRCConnectionReconfigurationComplete message.
- 6a. The SS shall transmit an LPP REQUEST CAPABILITIES message.
- 6b. The UE shall transmit an LPP PROVIDE CAPABILITIES message indicating the OTDOA capabilities supported by the UE in the *OTDOA-ProvideCapabilities* IE.
7. The SS shall send a LPP PROVIDE ASSISTANCE DATA message, including the *OTDOA-ProvideAssistanceData* IE. The position of neighbour Cell 2 in the *OTDOA-NeighbourCellInfoList* is randomly selected to be in the first 7 elements of the sequence, and the position of neighbour Cell 3 is randomly selected to be in the last 8 elements of the sequence, as described in 3GPP TS 37.571-5 [20], clause 7.2.3. If the UE message at step 6b includes the *ackRequested* IE set to TRUE, then the SS shall send an acknowledgment in the LPP PROVIDE ASSISTANCE DATA message.

8. The SS shall send a LPP REQUEST LOCATION INFORMATION message, including the *OTDOA-RequestLocationInformation* IE such that the UE receives the message  $\Delta T$  ms before the start of T2, where  $\Delta T = 150$  ms.
9. When T1 expires, the SS shall switch the power setting from T1 to T2 as specified in Table 9.1.1.5-2.
10. When T2 expires, the SS shall switch the power setting from T2 to T3 as specified in Table 9.1.1.5-2.
11. The UE shall transmit a LPP PROVIDE LOCATION INFORMATION message including the *OTDOA-ProvideLocationInformation* IE within the response time (see clause 4.7.3) specified in clause 9.1.1.5. The UE shall perform and report the RSTD measurements for both Cell 2 and Cell 3 with respect to the reference cell in the OTDOA assistance data, Cell 1. If the UE transmits an *OTDOA-ProvideLocationInformation* IE including the *rstd* field for both Cell 2 and Cell 3 within the response time then the number of successful tests is increased by one. If the UE fails to report the *OTDOA-ProvideLocationInformation* IE with both the *rstd* fields included within the response time then the number of failure tests is increased by one.
12. If the UE message at step 11 includes the *ackRequested* IE set to TRUE, the SS shall send a LPP acknowledgement message.
13. Repeat steps 2-12 until the confidence level according to Annex D is achieved. For each iteration, at step 7 change the random position of the Cells 2 and 3 in the *OTDOA-NeighbourCellInfoList*.

9.1.1.4.3 Message contents

**Table 9.1.1.4.3-1: RESET UE POSITIONING STORED INFORMATION**

Derivation Path: 36.509 [11] clause 6.9			
Information Element	Value/remark	Comment	Condition
UE Positioning Technology	0 0 0 0 0 0 1	OTDOA	

**Table 9.1.1.4.3-2: MAC-MainConfig-RBC: FDD RSTD Measurement Reporting Delay**

Derivation Path: TS 36.508 [18] clause 4.8.2.1.5, Table 4.8.2.1.5-1 MAC-MainConfig-RBC			
Information Element	Value/remark	Comment	Condition
MAC-MainConfig-RBC ::= SEQUENCE {			
drx-Config CHOICE {			
setup SEQUENCE {			
onDurationTimer	psf1		
drx-InactivityTimer	psf1		
drx-RetransmissionTimer	sf1		
longDRX-CycleStartOffset CHOICE {			
sf320	0		
}			
shortDRX	Not present		
}			
}			

**Table 9.1.1.4.3-2a: LPP Request Capabilities**

Information Element	Value/remark
<i>otdoa-RequestCapabilities</i>	TRUE

**Table 9.1.1.4.3-3: LPP RequestLocationInformation**

Derivation Path: 36.355 clause 6.2			
Information Element	Value/remark	Comment	Condition
LPP-Message ::= SEQUENCE {			
transactionID SEQUENCE {			
initiator	locationServer		
transactionNumber	1		
}			
endTransaction	FALSE		
sequenceNumber	Not present		
acknowledgement	Not present		
lpp-MessageBody CHOICE {			
c1 CHOICE {			
requestLocationInformation SEQUENCE {			
criticalExtensions CHOICE {			
c1 CHOICE {			
requestLocationInformation-r9 SEQUENCE {			
commonIEsRequestLocationInformation SEQUENCE {			
locationInformationType	locationMeasurementsRequired		
triggeredReporting	Not present		
periodicalReporting	Not present		
additionalInformation	onlyReturnInformationRequested		
qos SEQUENCE {			
horizontalAccuracy	Not present		
verticalCoordinateRequest	FALSE		
verticalAccuracy	Not present		
responseTime SEQUENCE {			
time	3	See clause 9.1.1.5	
responseTimeEarlyFix-r12	Not present		Rel-12 onwards
}			
velocityRequest	FALSE		
}			
environment	Not present		
locationCoordinateTypes	Not present		
velocityTypes	Not present		
}			
a-gnss-RequestLocationInformation	Not present		
otdoa-RequestLocationInformation SEQUENCE {			
assistanceAvailability	FALSE		
}			
ecid-RequestLocationInformation	Not present		
epdu-RequestLocationInformation	Not Present		
}			
}			
}			
}			
}			
}			

Table 9.1.1.4.3-4: Void

Table 9.1.1.4.3-5: LPP ProvideAssistanceData

Derivation Path: 36.355 clause 6.2			
Information Element	Value/remark	Comment	Condition
LPP-Message ::= SEQUENCE {			
transactionID SEQUENCE {			
Initiator	locationServer		
transactionNumber	(0..255)		
}			
endTransaction	TRUE		
sequenceNumber	Not present		
acknowledgement	Not present		
lpp-MessageBody CHOICE {			
c1 CHOICE {			
provideAssistanceData SEQUENCE {			
criticalExtensions CHOICE {			
c1 CHOICE {			
provideAssistanceData-r9 SEQUENCE {			
commonIEsProvideAssistanceData	Not present		
a-gnss-ProvideAssistanceData	Not present		
otdoa-ProvideAssistanceData SEQUENCE {			
otdoa-ReferenceCellInfo	As defined in TS 37.571-5 [20], clause 7.2.2.		
otdoa-NeighbourCellInfo	As defined in TS 37.571-5 [20], clause 7.2.2.		
otdoa-Error	Not present		
}			
epdu-ProvideAssistanceData	Not present		
}			
}			
}			
}			



**Table 9.1.1.4.3-6: LPP ProvideLocation Information**

Derivation Path: 36.355 clause 6.2			
Information Element	Value/remark	Comment	Condition
LPP-Message ::= SEQUENCE {			
transactionID SEQUENCE {			
initiator	locationServer		
transactionNumber	1		
}			
endTransaction	TRUE		
sequenceNumber	(0..255)		
acknowledgement			
lpp-MessageBody CHOICE {			
c1 CHOICE {			
provideLocationInformation SEQUENCE {			
criticalExtensions CHOICE {			
c1 CHOICE {			
provideLocationInformation-r9 SEQUENCE {			
commonIEsProvideLocationInformation	Not present.		
a-gnss-ProvideLocationInformation	Not present		
otdoa-ProvideLocationInformation			
SEQUENCE {			
otdoaSignalMeasurementInformation			
SEQUENCE {			
systemFrameNumber			
physCellIdRef	Cell 1		
cellGlobalIdRef			
earfcnRef			
referenceQuality			
neighbourMeasurementList			
SEQUENCE (SIZE(n)) {			
physCellIdNeighbor	Cell 2		
cellGlobalIdNeighbour			
earfcnNeighbour			
rstd	Present		
rstd-Quality			
}			
neighbourMeasurementList			
SEQUENCE (SIZE(n)) {			
physCellIdNeighbor	Cell 3		
cellGlobalIdNeighbour			
earfcnNeighbour			
rstd	Present		
rstd-Quality			
}			
}			
otdoa-Error	May be present with error reason 'undefined' or 'attemptedButUnableToMeasureSomeNeighbourCells'		
}			
ecid-ProvideLocationInformation	Not present		
epdu-ProvideLocationInformation	Not present		
}			
}			
}			
}			
}			

9.1.1.5 Test requirement

Table 9.1.1.5-1 and 9.1.1.5-2 define the primary level settings including test tolerances for the test.

**Table 9.1.1.5-1: Cell-specific test parameters for E-UTRAN FDD intra-frequency RSTD measurement reporting delay under fading propagation conditions during T1**

Parameter	Unit	Cell 1	Cell 2	Cell 3
E-UTRA RF Channel Number		1	1	1
Correlation Matrix and Antenna Configuration		1x2 Low	1x2 Low	1x2 Low
OCNG patterns defined in TS 36.521-3 [25] clause D.1		OP.5 FDD	N/A	N/A
PBCH_RA	dB	0	N/A	N/A
PBCH_RB				
PSS_RA				
SSS_RA				
PCFICH_RB				
PHICH_RA				
PHICH_RB				
PDCCH_RA				
PDCCH_RB				
OCNG_RA <sup>Note 1</sup>				
OCNG_RB <sup>Note 1</sup>				
$N_{oc}$ <sup>Note 3</sup>	dBm/15 kHz	-95		
$PRS \hat{E}_s / N_{oc}$	dB	-Infinity	-Infinity	-Infinity
$I_0$ <sup>Note 4</sup>	dBm/9 MHz	-67.22	N/A	N/A
$\hat{E}_s / N_{oc}$	dB	0	-Infinity	-Infinity
Propagation Condition		ETU30		
<p>Note 1: OCNG shall be used such that active cell (Cell 1) is fully allocated and a constant total transmitted power spectral density is achieved for all OFDM symbols.</p> <p>Note 2: The resources for uplink transmission are assigned to the UE prior to the start of time period T2.</p> <p>Note 3: Interference from other cells and noise sources not specified in the test are assumed to be constant over subcarriers and time and shall be modelled as AWGN of appropriate power for <math>N_{oc}</math> to be fulfilled.</p> <p>Note 4: <math>I_0</math> levels have been derived from other parameters and are given for information purpose. These are not settable test parameters.</p>				

**Table 9.1.1.5-2: Cell-specific test parameters for E-UTRAN FDD intra-frequency RSTD measurement reporting delay under fading propagation conditions during T2 and T3**

Parameter	Unit	Cell 1		Cell 2		Cell 3	
		T2	T3	T2	T3	T2	T3
E-UTRA RF Channel Number		1		1		1	
Correlation Matrix and Antenna Configuration		1x2 Low		1x2 Low		1x2 Low	
OCNG patterns defined in TS 36.521-3 [25] clause D.1		OP.5 FDD		OP.6 FDD		OP.6 FDD	N/A
PBCH_RA	dB	0		0		0	N/A
PBCH_RB							
PSS_RA							
SSS_RA							
PCFICH_RB							
PHICH_RA							
PHICH_RB							
PDCCH_RA							
PDCCH_RB							
OCNG_RA <sup>Note 1</sup>							
OCNG_RB <sup>Note 1</sup>							
PRS_RA	dB	-3	N/A	N/A	3	3	N/A
$N_{oc}$ <sup>Note 3</sup>	dBm/15 kHz	-98	-95	-98	-95	-98	-95
$PRS \hat{E}_s / N_{oc}$	dB	-1	-Infinity	-Infinity	-7	-7	-Infinity
$PRS \hat{E}_s / I_{ot}$ <sup>Note 4</sup>	dB	-1.79	-Infinity	-Infinity	-7	-9.54	-Infinity
$I_o$ <sup>Note 4</sup>	dBm/9 MHz	-69.55	-67.08	-69.55	-67.08	-69.55	N/A
PRP <sup>Note 4</sup>	dBm/15 kHz	-99	-Infinity	-Infinity	-102	-105	-Infinity
RSRP <sup>Note 4</sup>	dBm/15 kHz	-96	-93	-105	-105	-108	-Infinity
$\hat{E}_s / N_{oc}$ <sup>Note 4</sup>	dB	2	2	-7	-10	-10	-Infinity
Propagation Condition		ETU30					
<p>Note 1: OCNG shall be used such that active cells (all, except Cell 3 in T3) are fully allocated and a constant total transmitted power spectral density is achieved for all OFDM symbols other than those in the subframes with transmitted PRS.</p> <p>Note 2: The resources for uplink transmission are assigned to the UE prior to the start of time period T2.</p> <p>Note 3: Interference from other cells and noise sources not specified in the test are assumed to be constant over subcarriers and time and shall be modelled as AWGN of appropriate power for <math>N_{oc}</math> to be fulfilled.</p> <p>Note 4: If PRS_RA is not "N/A", <math>\hat{E}_s / N_{oc}</math>, <math>PRS \hat{E}_s / I_{ot}</math>, <math>I_o</math>, RSRP and PRP levels have been derived from other parameters and are given for information purpose. If PRS_RA is "N/A", <math>I_o</math> and RSRP levels have been derived from other parameters and are given for information purpose. These are not settable test parameters. Interference conditions shall be applied to all PRS symbols of DL positioning subframes.</p>							

The response time including test tolerance is 3.3 s. The response time is equal to the LPP time IE value plus the test tolerance. The LPP time IE value is derived from the RSTD reporting delay plus  $\Delta T$ , where  $\Delta T = 150$  ms, giving a value of 2710 ms. This is rounded up to the next allowed LPP value of 3 seconds. The RSTD measurement reporting

delay in the test is derived from the following expression,  $T_{PRS}(M-1) + 160 \left\lceil \frac{n}{M} \right\rceil$ , where  $M=8$  and  $n=16$  are the

parameters specified in clause 9.1.1.3 and Table 9.1.1.3-1. This gives the total RSTD reporting delay of 2560 ms for the 15 neighbour cells including Cell 2 and Cell 3 with respect to the reference cell, Cell 1.

The test tolerances are defined in clauses C.1.3 and C4.

The rate of successful tests during repeated tests shall be at least 90% with a confidence level of 95%.

## 9.1.1A FDD RSTD Measurement Reporting Delay for UE Category 1bis

### 9.1.1A.1 Test purpose

To verify that the RSTD measurement reporting delay meets the requirements in an environment with fading propagation conditions.

### 9.1.1A.2 Test applicability

This test applies to E-UTRA FDD UE Category 1bis release 13 and forward that supports UE-assisted OTDOA.

### 9.1.1A.3 Minimum conformance requirements

Same as 9.1.1.3 but using Table 9.1.1A.3-1 instead of Table 9.1.1.3-1.

**Table 9.1.1A.3-1: Number of PRS positioning occasions within  $T_{\text{RSTD IntraFreqFDD, E-UTRAN}}$**

Positioning subframe configuration period $T_{\text{PRS}}$	Number of PRS positioning occasions $M$
	$f_1$ <small>Note 1</small>
160 ms	32
>160 ms	16
Note 1: When only intra-frequency RSTD measurements are performed over cells belonging to the serving FDD carrier frequency $f_1$ .	

The normative reference for this requirement is TS 36.133 [23] clause 8.1.2.5.3 and A.8.12.1.

### 9.1.1A.4 Test description

#### 9.1.1A.4.1 Initial conditions

Same as 9.1.1.4.1 with the following exceptions:

1. Connect the SS, faders and AWGN noise sources to the UE antenna connector or antenna connectors as shown in Annex A, Figure A.4, using only the main Tx/Rx path.
2. The general test parameter settings are set up according to Table 9.1.1A.4.1-1.

**Table 9.1.1A.4.1-1: General test parameters for E-UTRAN FDD intra-frequency RSTD measurement reporting delay under fading propagation conditions**

Parameter	Unit	Value	Comment
Reference cell		Cell 1	Reference cell is the cell in the OTDOA assistance data with respect to which the RSTD measurement is defined, as specified in 3GPP TS 36.214 [6] and 3GPP TS 36.355 [4]. The reference cell is the serving cell in this test case.
Neighbour cells		Cell 2 and Cell 3	Cell 2 and Cell 3 appear at random places in the neighbour cell list in the OTDOA assistance data, but Cell 2 always appears in the first half of the list, whilst Cell 3 appears in the second half of the list.
PCFICH/PDCCH/PHICH parameters		DL Reference Measurement Channel R.6 FDD	As specified in TS 36.521-3 [25] clause A.2.1
Channel Bandwidth ( $BW_{\text{channel}}$ )	MHz	10	
PRS Transmission Bandwidth <sup>Note 2</sup>	RB	50	PRS are transmitted over the system bandwidth
PRS configuration index $I_{\text{PRS}}$ <sup>Note 2</sup>		171	This corresponds to periodicity of 320 ms and PRS subframe offset of $I_{\text{PRS}} - 160$ DL subframes, as defined in 3GPP TS 36.211 [26], Table 6.10.4.3-1
Number of consecutive downlink positioning subframes $N_{\text{PRS}}$ <sup>Note 2</sup>		1	As defined in 3GPP TS 36.211 [26]. The number of subframes in a positioning occasion
Physical cell ID PCI <sup>Note 2</sup>		(PCI of Cell 1 – PCI of Cell 2) mod 6 = 0 and (PCI of Cell 1 – PCI of Cell 3) mod 6 = 0	The cell PCIs are selected such that the relative shifts of PRS patterns among cells are as given by the test parameters
CP length <sup>Note 2</sup>		Normal	
DRX		ON	DRX parameters are further specified in Table 9.1.1.4.1-2
Radio frame receive time offset between the cells at the UE antenna connector <sup>Note 3</sup>	$\mu\text{s}$	Cell 2 to Cell 1: 1 Cell 3 to Cell 1: -1	PRS are transmitted from synchronous cells
Expected RSTD <sup>Note 1</sup>	$\mu\text{s}$	Cell 2: 3 Cell 3: 3 Other neighbour cells: randomly between -3 and 3	The expected RSTD is what is expected at the receiver. The corresponding parameter in the OTDOA assistance data specified in TS 36.355 [4] is the expectedRSTD indicator
Expected RSTD uncertainty for all neighbour cells <sup>Note 1</sup>	$\mu\text{s}$	5	The corresponding parameter in the OTDOA assistance data specified in TS 36.355 [4] is the expectedRSTD-Uncertainty index
Number of cells provided in OTDOA assistance data		16	Including the reference cell
PRS muting info <sup>Note 2</sup>		Cell 1: '1111111100000000' Cell 2: '0000000011111111' Cell 3: '1111111100000000'	Corresponds to prs-MutingInfo defined in TS 36.355 [4]
T1	s	3	The length of the time interval from the beginning of each test
T2	s	2.56	The length of the time interval that follows immediately after time interval T1
T3	s	2.56	The length of the time interval that follows immediately after time interval T2

Note 1: Parameters “Expected RSTD” and “Expected RSTD uncertainty for all neighbour cells” are not settable parameters. These are parameters signalled in LPP only. For the values to be used in LPP see Table 9.1.1.4.3-5 and TS 37.571-5 [20], clause 7.2.2.

Note 2: Parameters “PRS Transmission Bandwidth”, “PRS configuration index”, “Number of consecutive downlink positioning subframes”, “Physical cell ID PCI”, “CP length”, and “PRS muting info” are settable parameters and also parameters signalled in LPP. The values to be used for “Physical cell ID PCI” are as follows: Cell 1: 0, Cell 2: 6, Cell 3: 12. For all the values to be used in LPP see Table 9.1.1.4.3-5 and TS 37.571-5 [20], clause 7.2.2.

Note 3: The parameter “Radio frame receive time offset between the cells at the UE antenna connector” is not a settable parameter but is used to set the “true RSTD” values in step 6 of clause 9.1.1.4.1.

9.1.1A.4.2 Test procedure

Same as 9.1.1.4.2.

9.1.1A.4.3 Message contents

Same as 9.1.1.4.3 with the following exceptions:

**Table 9.1.1A.4.3-1: LPP RequestLocationInformation**

Derivation Path: Table 9.1.1.4.3-3			
Information Element	Value/remark	Comment	Condition
LPP-Message ::= SEQUENCE {			
lpp-MessageBody CHOICE {			
c1 CHOICE {			
requestLocationInformation SEQUENCE {			
criticalExtensions CHOICE {			
c1 CHOICE {			
requestLocationInformation-r9 SEQUENCE {			
commonIEsRequestLocationInformation SEQUENCE {			
qos SEQUENCE {			
responseTime SEQUENCE {			
time	6	See clause 9.1.1A.5	
}			
}			
}			
}			
}			
}			
}			
}			
}			
}			

9.1.1A.5 Test requirement

Table 9.1.1.5-1 and 9.1.1.5-2 define the primary level settings including test tolerances for the test.

The response time including test tolerance is 6.3 s. The response time is equal to the LPP time IE value plus the test tolerance. The LPP time IE value is derived from the RSTD reporting delay plus ΔT, where ΔT = 150 ms, giving a value of 5110 ms. This is rounded up to the next allowed LPP value of 6 seconds. The RSTD measurement reporting delay in the test is derived from the following expression,  $T_{PRS} (M - 1) + 160 \left\lceil \frac{n}{M} \right\rceil$ , where M =8 and n =16 are the parameters specified in clause 9.1.1A.3 and Table 9.1.1A.3-1. This gives the total RSTD reporting delay of 4960 ms for the 15 neighbour cells including Cell 2 and Cell 3 with respect to the reference cell, Cell 1.

The test tolerances are defined in clauses C.1.3 and C4.

The rate of successful tests during repeated tests shall be at least 90% with a confidence level of 95%.

## 9.1.2 TDD RSTD Measurement Reporting Delay

### 9.1.2.1 Test purpose

To verify that the RSTD measurement reporting delay meets the requirements in an environment with fading propagation conditions.

### 9.1.2.2 Test applicability

This test applies to all types of E-UTRA TDD UE release 9 and forward that supports UE-assisted OTDOA except UE Category 1bis.

### 9.1.2.3 Minimum conformance requirements

When the physical layer cell identities of neighbour cells together with the OTDOA assistance data are provided, the UE shall be able to detect and measure intra-frequency RSTD, specified in 3GPP TS 36.214 [6], for at least  $n=16$  cells, including the reference cell, on the same carrier frequency  $f_1$  as that of the reference cell within

$T_{\text{RSTD IntraFreqTDD, E-UTRAN}}$  ms as given below:

$$T_{\text{RSTD IntraFreqTDD, E-UTRAN}} = T_{\text{PRS}} \cdot (M - 1) + \Delta \quad \text{ms},$$

where

$T_{\text{RSTD IntraFreqTDD, E-UTRAN}}$  is the total time for detecting and measuring at least  $n$  cells,

$T_{\text{PRS}}$  is the cell-specific positioning subframe configuration period as defined in 3GPP TS 36.211 [26],

$M$  is the number of PRS positioning occasions as defined in Table 9.1.2.3-1, where each PRS positioning occasion comprises of  $N_{\text{PRS}}$  ( $1 \leq N_{\text{PRS}} \leq 6$ ) consecutive downlink positioning subframes defined in 3GPP TS 36.211 [26], and

$\Delta = 160 \cdot \left\lceil \frac{n}{M} \right\rceil$  ms is the measurement time for a single PRS positioning occasion which includes the sampling time and the processing time.

**Table 9.1.2.3-1: Number of PRS positioning occasions within  $T_{\text{RSTD IntraFreqTDD, E-UTRAN}}$**

Positioning subframe configuration period $T_{\text{PRS}}$	Number of PRS positioning occasions $M$
	$f_1$ Note 1
160 ms	16
>160 ms	8
Note 1: When only intra-frequency RSTD measurements are performed over cells belonging to the serving FDD carrier frequency $f_1$ .	

The UE physical layer shall be capable of reporting RSTD for the reference cell and all the neighbour cells  $i$  out of at least  $(n-1)$  neighbour cells within  $T_{\text{RSTD IntraFreqTDD, E-UTRAN}}$  provided:

$(\text{PRS } \hat{E}_s / \text{Iot})_{\text{ref}} \geq -6$  dB for all Frequency Bands for the reference cell,

$(\text{PRS } \hat{E}_s / \text{Iot})_i \geq -13$  dB for all Frequency Bands for neighbour cell  $i$ ,

$(\text{PRS } \hat{E}_s / \text{Iot})_{\text{ref}}$  and  $(\text{PRS } \hat{E}_s / \text{Iot})_i$  conditions apply for all subframes of at least  $L = \frac{M}{2}$  PRS positioning

occasions,

PRP 1,2]<sub>dBm</sub> according to clause E.2 for a corresponding Band.

The time  $T_{\text{RSTD IntraFreqTDD, E-UTRAN}}$  starts from the first subframe of the PRS positioning occasion closest in time after both the OTDOA-RequestLocationInformation message and the OTDOA assistance data in the OTDOA-ProvideAssistanceData message as specified in 3GPP TS 36.355 [4], are delivered to the physical layer of the UE.

The requirements shall apply for all TDD special subframe configurations specified in 3GPP TS 36.211 [26] and for the TDD uplink-downlink configurations as specified in Table 9.1.2.3-2.



**Table 9.1.2.3-2: TDD uplink-downlink subframe configurations applicable for TDD intra-frequency requirements**

PRS Transmission Bandwidth [RB]	Applicable TDD uplink-downlink configurations
6, 15	1, 2, 3, 4 and 5
25, 50, 75, 100	0, 1, 2, 3, 4, 5 and 6
Note: Uplink-downlink configurations are specified in Table 4.2-2 in 3GPP TS 36.211 [26].	

This requirement assumes that the measurement report is not delayed by other LPP signalling on the DCCH. This measurement reporting delay excludes a delay uncertainty resulted when inserting the measurement report to the TTI of the uplink DCCH. The delay uncertainty is:  $2 \times TTI_{DCCH}$ . This measurement reporting delay excludes any delay caused by no UL resources for UE to send the measurement report.

The normative reference for this requirement is TS 36.133 [23] clause 8.1.2.5.2 and A.8.12.2.

#### 9.1.2.4 Test description

##### 9.1.2.4.1 Initial conditions

Test Environment: Normal; as defined in TS 36.508 [18] clause 4.1.

Frequencies to be tested: Mid Range, as defined in TS 36.508 [18] clause 4.3.1.2.

Channel bandwidth to be tested: 10 MHz as defined in TS 36.508 [18] clause 4.3.1.

1. Connect the SS, faders and AWGN noise sources to the UE antenna connector or antenna connectors as shown in Annex A, Figure A.4.
2. The general test parameter settings are set up according to Table 9.1.2.4.1-1.
3. Propagation conditions are set according to clause 4.7.2.1.
4. Message contents are defined in clause 9.1.2.4.3.
5. In the test there are three synchronized cells: Cell 1, Cell 2 and Cell 3. Cell 1 is the OTDOA assistance data reference as well as the serving cell. Cell 2 and Cell 3 are the neighbour cells. All cells are on the same RF channel. Cell 3 in the test is the Cell 4 defined in clause 4.7.1. The assistance data neighbour cell list includes in total 15 cells, where 13 of the cells are not simulated (dummy cells; as defined in 3GPP TS 37.571-5 clause 7.2.2).
6. The true RSTD (which is the receive time difference for frame 0 between two cells as seen at the UE antenna connector) is set to 31 Ts (about 1  $\mu$ s) between neighbour Cell 2 and serving Cell 1; and set to -31 Ts (about -1  $\mu$ s) between neighbour Cell 3 and serving Cell 1.

**Table 9.1.2.4-1: General test parameters for E-UTRAN TDD intra-frequency RSTD measurement reporting delay under fading propagation conditions**

Parameter	Unit	Value	Comment
Reference cell		Cell 1	Reference is the cell in the OTDOA assistance data with respect to which the RSTD measurement is defined, as specified in 3GPP TS 36.214 [6] and 3GPP TS 36.355 [4]. The reference cell is the serving cell in this test case.
Neighbour cells		Cell 2 and Cell 3	Cell 2 and Cell 3 appear at random places in the neighbour cell list in the OTDOA assistance data, but Cell 2 always appears in the first half of the list, whilst Cell 3 appears in the second half of the list.
PCFICH/PDCCH/PHICH parameters		DL Reference Measurement Channel R.6 TDD	As specified in TS 36.521-3 [25] clause A.2.2
Channel Bandwidth (BW <sub>channel</sub> )	MHz	10	
PRS Transmission Bandwidth <sup>Note 2</sup>	RB	50	PRS are transmitted over the system bandwidth
PRS configuration index $I_{PRS}$ <sup>Note 2</sup>		174	This corresponds to periodicity of 320 ms and PRS subframe offset of $I_{PRS} - 160$ DL subframes, as defined in 3GPP TS 36.211 [26], Table 6.10.4.3-1
Number of consecutive downlink positioning subframes $N_{PRS}$ <sup>Note 2</sup>		1	As defined in 3GPP TS 36.211 [26]. The number of subframes in a positioning occasion
Physical cell ID PCI <sup>Note 2</sup>		(PCI of Cell 1 – PCI of Cell 2) mod 6 = 0 and (PCI of Cell 1 – PCI of Cell 3) mod 6 = 0	The cell PCIs are selected such that the relative shifts of PRS patterns among cells are as given by the test parameters
TDD uplink-downlink configuration		1	As specified in TS 36.211 [26], Section 4.2; corresponds to a configuration with 5 ms switch-point periodicity and two downlink consecutive subframes
TDD special subframe configuration		6	As specified in TS 36.211 [26], Section 4.2; corresponds to DwPTS of $19760 \cdot T_s$ and UpPTS of $4384 \cdot T_s$
CP length <sup>Note 2</sup>		Normal	The same CP length applies for DL and UL
DRX		ON	DRX parameters are further specified in Table 9.1.2.4-2
Radio frame receive time offset between the cells at the UE antenna connector <sup>Note 3</sup>	μs	Cell 2 to Cell 1: 1 Cell 3 to Cell 1: -1	PRS are transmitted from synchronous cells
Expected RSTD <sup>Note 1</sup>	μs	Cell 2: 3 Cell 3: 3 Other neighbour cells: randomly between -3 and 3	The expected RSTD is what is expected at the receiver. The corresponding parameter in the OTDOA assistance data specified in TS 36.355 [4] is the expectedRSTD indicator
Expected RSTD uncertainty for all neighbour cells <sup>Note 1</sup>	μs	5	The corresponding parameter in the OTDOA assistance data specified in TS 36.355 [4] is the expectedRSTD-Uncertainty index
Number of cells provided in OTDOA assistance data		16	Including the reference cell
PRS muting info <sup>Note 2</sup>		Cell 1: '11110000' Cell 2: '00001111' Cell 3: '11110000'	Corresponds to prs-MutingInfo defined in TS 36.355 [4]
T1	s	3	The length of the time interval from the beginning of each test
T2	s	1.28	The length of the time interval that follows immediately after time interval T1
T3	s	1.28	The length of the time interval that follows immediately after time interval T2

Note 1:	Parameters "Expected RSTD" and "Expected RSTD uncertainty for all neighbour cells" are not settable parameters. These are parameters signalled in LPP only. For the values to be used in LPP see Table 9.1.2.4.3-5 and TS 37.571-5 [20], clause 7.2.2.
Note 2:	Parameters "PRS Transmission Bandwidth", "PRS configuration index", "Number of consecutive downlink positioning subframes", "Physical cell ID PCI", "CP length", and "PRS muting info" are settable parameters and also parameters signalled in LPP. The values to be used for "Physical cell ID PCI" are as follows: Cell 1: 0, Cell 2: 6, Cell 3: 12. For all the values to be used in LPP see Table 9.1.2.4.3-5 and TS 37.571-5 [20], clause 7.2.2.
Note 3:	The parameter "Radio frame receive time offset between the cells at the UE antenna connector" is not a settable parameter but is used to set the "true RSTD" values in step 6 of clause 9.1.2.4.1.

**Table 9.1.2.4-2: DRX parameters for E-UTRAN TDD intra-frequency RSTD measurement reporting delay under fading propagation conditions**

Field	Value	Comment
onDurationTimer	psf1	As specified in 3GPP TS 36.331 [22], clause 6.3.2.
drx-InactivityTimer	psf1	
drx-RetransmissionTimer	sf1	
longDRX-CycleStartOffset	sf320	
shortDRX	disable	

#### 9.1.2.4.2 Test procedure

The test consists of three consecutive time intervals, with duration of T1, T2 and T3 defined in Table 9.1.2.4-1. Cell 1 is active in T1, T2 and T3, whilst Cell 2 and Cell 3 are activated only in the beginning of T2. Cell 2 is active until the end of T3, and Cell 3 is active until the end of T2. The beginning of the time interval T2 shall be aligned 5 ms before the first PRS positioning subframe of a positioning occasion in the reference cell, where 5 ms is the necessary test tolerance. Cell 1 transmits PRS in T2, while Cell 2 transmits PRS only in T3, and Cell 3 transmits PRS only in T2.

NOTE: The information on when PRS is muted is conveyed to the UE using PRS muting information in the OTDOA assistance data.

The OTDOA-RequestLocationInformation message and the OTDOA assistance data as defined in clause 9.1.2.4.3 shall be provided to the UE during T1. The last TTI containing the OTDOA-RequestLocationInformation message shall be provided to the UE  $\Delta T$  ms before the start of T2, where  $\Delta T = 150$  ms is the maximum processing time of the OTDOA-RequestLocationInformation message and the OTDOA assistance data.

1. Ensure that the UE is in state Generic RB Established State 3A-RF according to 3GPP TS 36.508 [18] clause 7.2A.3.
2. The SS shall send a RESET UE POSITIONING STORED INFORMATION message.
3. Set the parameters according to Table 9.1.2.5-1. Propagation conditions are set according to clause 4.7.2.2 (ETU30).
4. T1 starts.
5. The SS shall transmit an RRCConnectionReconfiguration message with the DRX configuration. PDCCHs indicating new transmissions shall be sent continuously until the start of T2 to ensure that the UE would not enter the DRX state before T2.
6. The UE shall transmit RRCConnectionReconfigurationComplete message.
- 6a. The SS shall transmit an LPP REQUEST CAPABILITIES message.
- 6b. The UE shall transmit an LPP PROVIDE CAPABILITIES message indicating the OTDOA capabilities supported by the UE in the *OTDOA-ProvideCapabilities* IE.
7. The SS shall send a LPP PROVIDE ASSISTANCE DATA message, including the *OTDOA-ProvideAssistanceData* IE. The position of neighbour Cell 2 in the *OTDOA-NeighbourCellInfoList* is randomly selected to be in the first 7 elements of the sequence, and the position of neighbour Cell 3 is randomly selected to be in the last 8 elements of the sequence, as described in 3GPP TS 37.571-5 [20], clause 7.2.3. If the UE message at step 6b includes the *ackRequested* IE set to TRUE, then the SS shall send an acknowledgment in the LPP PROVIDE ASSISTANCE DATA message.

8. The SS shall send a LPP REQUEST LOCATION INFORMATION message, including the *OTDOA-RequestLocationInformation* IE such that the UE receives the message  $\Delta T$  ms before the start of T2, where  $\Delta T = 150$  ms.
9. When T1 expires, the SS shall switch the power setting from T1 to T2 as specified in Table 9.1.2.5-3.
10. When T2 expires, the SS shall switch the power setting from T2 to T3 as specified in Table 9.1.2.5-3.
11. The UE shall transmit a LPP PROVIDE LOCATION INFORMATION including the *OTDOA-ProvideLocationInformation* IE within the response time (see clause 4.7.3) specified in clause 9.1.1.5. The UE shall perform and report the RSTD measurements for both Cell 2 and Cell 3 with respect to the reference cell in the OTDOA assistance data, Cell 1. If the UE transmits an *OTDOA-ProvideLocationInformation* IE including the *rstd* field for both Cell 2 and Cell 3 within the response time then the number of successful tests is increased by one. If the UE fails to report the *OTDOA-ProvideLocationInformation* IE with both the *rstd* fields included within the response time then the number of failure tests is increased by one.
12. If the UE message at step 11 includes the *ackRequested* IE set to TRUE, the SS shall send a LPP acknowledgement message.
13. Repeat steps 2-12 until the confidence level according to Annex D is achieved. For each iteration, at step 9 change the random position of the Cells 2 and 3 in the *OTDOA-NeighbourCellInfoList*.

9.1.2.4.3 Message contents

**Table 9.1.2.4.3-1: RESET UE POSITIONING STORED INFORMATION**

Derivation Path: 36.509 [11] clause 6.9			
Information Element	Value/remark	Comment	Condition
UE Positioning Technology	0 0 0 0 0 0 1	OTDOA	

**Table 9.1.2.4.3-2: MAC-MainConfig-RBC: TDD RSTD Measurement Reporting Delay**

Derivation Path: TS 36.508 [18] clause 4.8.2.1.5, Table 4.8.2.1.5-1 MAC-MainConfig-RBC			
Information Element	Value/remark	Comment	Condition
MAC-MainConfig-RBC ::= SEQUENCE {			
drx-Config CHOICE {			
setup SEQUENCE {			
onDurationTimer	psf1		
drx-InactivityTimer	psf1		
drx-RetransmissionTimer	sf1		
longDRX-CycleStartOffset CHOICE {			
sf320	0		
}			
shortDRX	Not present		
}			
}			
}			

**Table 9.1.2.4.3-2a: LPP Request Capabilities**

Information Element	Value/remark
<i>otdoa-RequestCapabilities</i>	TRUE

**Table 9.1.2.4.3-3: LPP RequestLocationInformation**

Derivation Path: 36.355 clause 6.2			
Information Element	Value/remark	Comment	Condition
LPP-Message ::= SEQUENCE {			
transactionID SEQUENCE {			
initiator	locationServer		
transactionNumber	1		
}			
endTransaction	FALSE		
sequenceNumber	Not present		
acknowledgement	Not present		
lpp-MessageBody CHOICE {			
c1 CHOICE {			
requestLocationInformation SEQUENCE {			
criticalExtensions CHOICE {			
c1 CHOICE {			
requestLocationInformation-r9 SEQUENCE {			
commonIEsRequestLocationInformation SEQUENCE {			
locationInformationType	locationMeasurementsRequired		
triggeredReporting	Not present		
periodicalReporting	Not present		
additionalInformation	onlyReturnInformationRequested		
qos SEQUENCE {			
horizontalAccuracy	Not present		
verticalCoordinateRequest	FALSE		
verticalAccuracy	Not present		
responseTime SEQUENCE {			
time	3	See clause 9.1.2.5	
responseTimeEarlyFix-r12	Not present		Rel-12 onwards
}			
velocityRequest	FALSE		
}			
environment	Not present		
locationCoordinateTypes	Not present		
velocityTypes	Not present		
}			
a-gnss-RequestLocationInformation	Not present		
otdoa-RequestLocationInformation SEQUENCE {			
assistanceAvailability	FALSE		
}			
ecid-RequestLocationInformation	Not present		
epdu-RequestLocationInformation	Not Present		
}			
}			
}			
}			
}			

Table 9.1.2.4.3-4: Void

Table 9.1.2.4.3-5: LPP ProvideAssistanceData

Derivation Path: 36.355 clause 6.2			
Information Element	Value/remark	Comment	Condition
LPP-Message ::= SEQUENCE {			
transactionID SEQUENCE {			
Initiator	locationServer		
transactionNumber	(0..255)		
}			
endTransaction	TRUE		
sequenceNumber	Not present		
acknowledgement	Not present		
lpp-MessageBody CHOICE {			
c1 CHOICE {			
provideAssistanceData SEQUENCE {			
criticalExtensions CHOICE {			
c1 CHOICE {			
provideAssistanceData-r9 SEQUENCE {			
commonIEsProvideAssistanceData	Not present		
a-gnss-ProvideAssistanceData	Not present		
otdoa-ProvideAssistanceData SEQUENCE {			
otdoa-ReferenceCellInfo	As defined in TS 37.571-5 [20], clause 7.2.2.		
otdoa-NeighbourCellInfo	As defined in TS 37.571-5 [20], clause 7.2.2.		
otdoa-Error	Not present		
}			
epdu-ProvideAssistanceData	Not present		
}			
}			
}			
}			
}			
}			

**Table 9.1.2.4.3-6: LPP ProvideLocation Information**

Derivation Path: 36.355 clause 6.2			
Information Element	Value/remark	Comment	Condition
LPP-Message ::= SEQUENCE {			
transactionID SEQUENCE {			
initiator	locationServer		
transactionNumber	1		
}			
endTransaction	TRUE		
sequenceNumber	(0..255)		
acknowledgement			
lpp-MessageBody CHOICE {			
c1 CHOICE {			
provideLocationInformation SEQUENCE {			
criticalExtensions CHOICE {			
c1 CHOICE {			
provideLocationInformation-r9 SEQUENCE {			
commonIEsProvideLocationInformation	Not present.		
a-gnss-ProvideLocationInformation	Not present		
otdoa-ProvideLocationInformation			
SEQUENCE {			
otdoaSignalMeasurementInformation			
SEQUENCE {			
systemFrameNumber			
physCellIdRef	Cell 1		
cellGlobalIdRef			
earfcnRef			
referenceQuality			
neighbourMeasurementList			
SEQUENCE (SIZE(n)) {			
physCellIdNeighbor	Cell 2		
cellGlobalIdNeighbour			
earfcnNeighbour			
rstd	Present		
rstd-Quality			
}			
neighbourMeasurementList			
SEQUENCE (SIZE(n)) {			
physCellIdNeighbor	Cell 3		
cellGlobalIdNeighbour			
earfcnNeighbour			
rstd	Present		
rstd-Quality			
}			
}			
otdoa-Error	May be present with error reason 'undefined' or 'attemptedButUnableToMeasureSomeNeighbourCells'		
}			
ecid-ProvideLocationInformation	Not present		
epdu-ProvideLocationInformation	Not present		
}			
}			

9.1.2.5 Test requirement

Table 9.1.2.5-1 and 9.1.2.5-2 define the primary level settings including test tolerances for the test.



**Table 9.1.2.5-1: Cell-specific test parameters for E-UTRAN TDD intra-frequency RSTD measurement reporting delay under fading propagation conditions during T1**

Parameter	Unit	Cell 1	Cell 2	Cell 3
E-UTRA RF Channel Number		1	1	1
Correlation Matrix and Antenna Configuration		1x2 Low	1x2 Low	1x2 Low
OCNG patterns defined in TS 36.521-3 [25] clause D.2		OP.1 TDD	N/A	N/A
PBCH_RA	dB	0	N/A	N/A
PBCH_RB				
PSS_RA				
SSS_RA				
PCFICH_RB				
PHICH_RA				
PHICH_RB				
PDCCH_RA				
PDCCH_RB				
OCNG_RA <sup>Note 1</sup>				
OCNG_RB <sup>Note 1</sup>				
$N_{oc}$ <sup>Note 3</sup>	dBm/ 15 kHz	-95		
$PRS \hat{E}_s / N_{oc}$	dB	-Infinity	-Infinity	-Infinity
$I_o$ <sup>Note 4</sup>	dBm/ 9 MHz	-67.22	N/A	N/A
$\hat{E}_s / N_{oc}$	dB	0	-Infinity	-Infinity
Propagation Condition		ETU30		
Note 1:	OCNG shall be used such that active cell (Cell 1) is fully allocated and a constant total transmitted power spectral density is achieved for all OFDM symbols.			
Note 2:	The resources for uplink transmission are assigned to the UE prior to the start of time period T2.			
Note 3:	Interference from other cells and noise sources not specified in the test are assumed to be constant over subcarriers and time and shall be modelled as AWGN of appropriate power for $N_{oc}$ to be fulfilled.			
Note 4:	$I_o$ levels have been derived from other parameters and are given for information purpose. These are not settable test parameters.			

**Table 9.1.2.5-2: Cell-specific test parameters for E-UTRAN TDD intra-frequency RSTD measurement reporting delay under fading propagation conditions**

Parameter	Unit	Cell 1		Cell 2		Cell 3	
		T2	T3	T2	T3	T2	T3
E-UTRA RF Channel Number		1		1		1	
Correlation Matrix and Antenna Configuration		1x2 Low		1x2 Low		1x2 Low	
OCNG patterns defined in TS 36.521-3 [25] clause D.2		OP.1 TDD		OP.2 TDD		OP.2 TDD	N/A
PBCH_RA	dB	0		0		0	N/A
PBCH_RB							
PSS_RA							
SSS_RA							
PCFICH_RB							
PHICH_RA							
PHICH_RB							
PDCCH_RA							
PDCCH_RB							
OCNG_RA <small>Note 1</small>							
OCNG_RB <small>Note 1</small>							
PRS_RA	dB	-3	N/A	N/A	3	3	N/A
$N_{oc}$ <small>Note 3</small>	dBm/15 kHz	-98	-95	-98	-95	-98	-95
$\hat{E}_s/N_{oc}$	dB	-1	-Infinity	-Infinity	-7	-7	-Infinity
$\hat{E}_s/I_{ot}$ <small>Note 4</small>	dB	-1.79	-Infinity	-Infinity	-7	-9.54	-Infinity
$I_o$ <small>Note 4</small>	dBm/9 MHz	-69.55	-67.08	-69.55	-67.08	-69.55	N/A
PRP <small>Note 4</small>	dBm/15 kHz	-99	-Infinity	-Infinity	-102	-105	-Infinity
RSRP <small>Note 4</small>	dBm/15 kHz	-96	-93	-105	-105	-108	-Infinity
$\hat{E}_s/N_{oc}$ <small>Note 4</small>	dB	2	2	-7	-10	-10	-Infinity
Propagation Condition		ETU30					
Note 1:	OCNG shall be used such that active cells (all, except Cell 3 in T3) are fully allocated and a constant total transmitted power spectral density is achieved for all OFDM symbols other than those in the subframes with transmitted PRS.						
Note 2:	The resources for uplink transmission are assigned to the UE prior to the start of time period T2.						
Note 3:	Interference from other cells and noise sources not specified in the test are assumed to be constant over subcarriers and time and shall be modelled as AWGN of appropriate power for $N_{oc}$ to be fulfilled.						
Note 4:	If PRS_RA is not "N/A", $\hat{E}_s/N_{oc}$ , $\hat{E}_s/I_{ot}$ , $I_o$ , RSRP and PRP levels have been derived from other parameters and are given for information purpose. If PRS_RA is "N/A", $I_o$ and RSRP levels have been derived from other parameters and are given for information purpose. These are not settable test parameters. Interference conditions shall be applied to all PRS symbols of DL positioning subframes.						

The response time including test tolerance is 3.3 s. The response time is equal to the LPP time IE value plus the test tolerance. The LPP time IE value is derived from the RSTD reporting delay plus  $\Delta T$ , where  $\Delta T = 150$  ms, giving a value of 2710 ms. This is rounded up to the next allowed LPP value of 3 seconds. The RSTD measurement reporting

delay in the test is derived from the following expression,  $T_{PRS}(M-1) + 160 \left\lceil \frac{n}{M} \right\rceil$ , where  $M=8$  and  $n=16$  are the

parameters specified in clause 9.1.2.3 and Table 9.1.2.3-1. This gives the total RSTD reporting delay of 2560 ms for the 15 neighbour cells including Cell 2 and Cell 3 with respect to the reference cell, Cell 1.

The test tolerances are defined in clauses C.1.3 and C4.

The rate of successful tests during repeated tests shall be at least 90% with a confidence level of 95%.

## 9.1.2A TDD RSTD Measurement Reporting Delay for UE Category 1bis

### 9.1.2A.1 Test purpose

To verify that the RSTD measurement reporting delay meets the requirements in an environment with fading propagation conditions.

### 9.1.2A.2 Test applicability

This test applies to E-UTRA TDD UE Category 1bis release 13 and forward that supports UE-assisted OTDOA.

### 9.1.2A.3 Minimum conformance requirements

Same as 9.1.2.3 but using Table 9.1.2A.3-1 instead of Table 9.1.2.3-1.

**Table 9.1.2A.3-1: Number of PRS positioning occasions within  $T_{\text{RSTD IntraFreqTDD, E-UTRAN}}$**

Positioning subframe configuration period $T_{\text{PRS}}$	Number of PRS positioning occasions $M$
	$f_1$ <small>Note 1</small>
160 ms	32
>160 ms	16
Note 1: When only intra-frequency RSTD measurements are performed over cells belonging to the serving TDD carrier frequency $f_1$	

The normative reference for this requirement is TS 36.133 [23] clause 8.1.2.5.4 and A.8.12.2.

### 9.1.2A.4 Test description

#### 9.1.2A.4.1 Initial conditions

Same as 9.1.2.4.1 with the following exceptions:

1. Connect the SS, faders and AWGN noise sources to the UE antenna connector or antenna connectors as shown in Annex A, Figure A.4, using only the main Tx/Rx path.
2. The general test parameter settings are set up according to Table 9.1.2A.4.1-1.

**Table 9.1.2.4A-1: General test parameters for E-UTRAN TDD intra-frequency RSTD measurement reporting delay under fading propagation conditions**

Parameter	Unit	Value	Comment
Reference cell		Cell 1	Reference is the cell in the OTDOA assistance data with respect to which the RSTD measurement is defined, as specified in 3GPP TS 36.214 [6] and 3GPP TS 36.355 [4]. The reference cell is the serving cell in this test case.
Neighbour cells		Cell 2 and Cell 3	Cell 2 and Cell 3 appear at random places in the neighbour cell list in the OTDOA assistance data, but Cell 2 always appears in the first half of the list, whilst Cell 3 appears in the second half of the list.
PCFICH/PDCCH/PHICH parameters		DL Reference Measurement Channel R.6 TDD	As specified in TS 36.521-3 [25] clause A.2.2
Channel Bandwidth (BW <sub>channel</sub> )	MHz	10	
PRS Transmission Bandwidth <sup>Note 2</sup>	RB	50	PRS are transmitted over the system bandwidth
PRS configuration index $I_{PRS}$ <sup>Note 2</sup>		174	This corresponds to periodicity of 320 ms and PRS subframe offset of $I_{PRS} - 160$ DL subframes, as defined in 3GPP TS 36.211 [26], Table 6.10.4.3-1
Number of consecutive downlink positioning subframes $N_{PRS}$ <sup>Note 2</sup>		1	As defined in 3GPP TS 36.211 [26]. The number of subframes in a positioning occasion
Physical cell ID PCI <sup>Note 2</sup>		(PCI of Cell 1 – PCI of Cell 2) mod 6 = 0 and (PCI of Cell 1 – PCI of Cell 3) mod 6 = 0	The cell PCIs are selected such that the relative shifts of PRS patterns among cells are as given by the test parameters
TDD uplink-downlink configuration		1	As specified in TS 36.211 [26], Section 4.2; corresponds to a configuration with 5 ms switch-point periodicity and two downlink consecutive subframes
TDD special subframe configuration		6	As specified in TS 36.211 [26], Section 4.2; corresponds to DwPTS of $19760 \cdot T_s$ and UpPTS of $4384 \cdot T_s$
CP length <sup>Note 2</sup>		Normal	The same CP length applies for DL and UL
DRX		ON	DRX parameters are further specified in Table 9.1.2.4-2
Radio frame receive time offset between the cells at the UE antenna connector <sup>Note 3</sup>	μs	Cell 2 to Cell 1: 1 Cell 3 to Cell 1: -1	PRS are transmitted from synchronous cells
Expected RSTD <sup>Note 1</sup>	μs	Cell 2: 3 Cell 3: 3 Other neighbour cells: randomly between -3 and 3	The expected RSTD is what is expected at the receiver. The corresponding parameter in the OTDOA assistance data specified in TS 36.355 [4] is the expectedRSTD indicator
Expected RSTD uncertainty for all neighbour cells <sup>Note 1</sup>	μs	5	The corresponding parameter in the OTDOA assistance data specified in TS 36.355 [4] is the expectedRSTD-Uncertainty index
Number of cells provided in OTDOA assistance data		16	Including the reference cell
PRS muting info <sup>Note 2</sup>		Cell 1: '1111111100000000' Cell 2: '0000000011111111' Cell 3: '1111111100000000'	Corresponds to prs-MutingInfo defined in TS 36.355 [4]
T1	s	3	The length of the time interval from the beginning of each test
T2	s	2.56	The length of the time interval that follows immediately after time interval T1
T3	s	2.56	The length of the time interval that follows immediately after time interval T2

Note 1: Parameters “Expected RSTD” and “Expected RSTD uncertainty for all neighbour cells” are not settable parameters. These are parameters signalled in LPP only. For the values to be used in LPP see Table 9.1.2.4.3-5 and TS 37.571-5 [20], clause 7.2.2.

Note 2: Parameters “PRS Transmission Bandwidth”, “PRS configuration index”, “Number of consecutive downlink positioning subframes”, “Physical cell ID PCI”, “CP length”, and “PRS muting info” are settable parameters and also parameters signalled in LPP. The values to be used for “Physical cell ID PCI” are as follows: Cell 1: 0, Cell 2: 6, Cell 3: 12. For all the values to be used in LPP see Table 9.1.2.4.3-5 and TS 37.571-5 [20], clause 7.2.2.

Note 3: The parameter “Radio frame receive time offset between the cells at the UE antenna connector” is not a settable parameter but is used to set the “true RSTD” values in step 6 of clause 9.1.2.4.1.

9.1.2A.4.2 Test procedure

Same as 9.1.2.4.2

9.1.2A.4.3 Message contents

Same as 9.1.2.4.3 with the following exceptions:

**Table 9.1.2A.4.3-1: LPP RequestLocationInformation**

Derivation Path: Table 9.1.2.4.3-3			
Information Element	Value/remark	Comment	Condition
LPP-Message ::= SEQUENCE {			
lpp-MessageBody CHOICE {			
c1 CHOICE {			
requestLocationInformation SEQUENCE {			
criticalExtensions CHOICE {			
c1 CHOICE {			
requestLocationInformation-r9 SEQUENCE {			
commonIEsRequestLocationInformation SEQUENCE {			
qos SEQUENCE {			
responseTime SEQUENCE {			
time	6	See clause 9.1.2A.5	
}			
}			
}			
}			
}			
}			
}			
}			
}			
}			

9.1.2A.5 Test requirement

Table 9.1.2.5-1 and 9.1.2.5-2 define the primary level settings including test tolerances for the test.

The response time including test tolerance is 6.3 s. The response time is equal to the LPP time IE value plus the test tolerance. The LPP time IE value is derived from the RSTD reporting delay plus ΔT, where ΔT = 150 ms, giving a value of 5110 ms. This is rounded up to the next allowed LPP value of 6 seconds. The RSTD measurement reporting delay in the test is derived from the following expression,  $T_{PRS} (M - 1) + 160 \left\lceil \frac{n}{M} \right\rceil$ , where  $M = 8$  and  $n = 16$  are the parameters specified in clause 9.1.2A.3 and Table 9.1.2A.3-1. This gives the total RSTD reporting delay of 4960 ms for the 15 neighbour cells including Cell 2 and Cell 3 with respect to the reference cell, Cell 1.

The test tolerances are defined in clauses C.1.3 and C4.

The rate of successful tests during repeated tests shall be at least 90% with a confidence level of 95%.

## 9.1.3 FDD RSTD Measurement Accuracy

### 9.1.3.1 Test purpose

To verify that the RSTD FDD intra-frequency measurement accuracy is within the specified limits.

### 9.1.3.2 Test applicability

This test applies to all types of E-UTRA FDD UE release 9 and forward that supports UE-assisted OTDOA except UE Category 1bis.

### 9.1.3.3 Minimum conformance requirements

The accuracy requirements in Table 9.1.3.3-1 are valid under the following conditions:

Conditions defined in TS 36.101 [2] clause 7.3 for reference sensitivity are fulfilled.

PRP  $1,2_{\text{dBm}}$  according to clause E.2 for a corresponding Band.

There are no measurement gaps overlapping with the PRS subframes of the measured cell.

The parameter *expectedRSTDUncertainty* signalled over LPP as defined in 3GPP TS 36.355 [4] is less than 5  $\mu\text{s}$ .

Table 9.1.3.3-1: RSTD measurement accuracy

Accuracy	Conditions					
	PRS $\hat{E}_s/lot$	Minimum PRS bandwidth, which is minimum of serving cell channel bandwidth and the PRS bandwidths of the reference cell and the measured neighbour cell $i$ <sup>Note 6</sup>	Minimum number of available measurement subframes among the reference cell and the measured neighbour cell $i$	Io <sup>Note 9</sup> range		
				E-UTRA operating band groups <sup>Note 10</sup>	Minimum Io <sup>Note 1</sup>	Maximum Io
Ts <sup>Note 2</sup>	dB	RB			dBm/15kHz <sup>Note 8</sup>	dBm/BW <sub>Chan</sub> <sub>nel</sub>
±15	(PRS $\hat{E}_s/lot$ ) <sub>ref</sub> ≥ -6dB and (PRS $\hat{E}_s/lot$ ) <sub>i</sub> ≥ -13dB	≥ 6	6	FDD_A, TDD_A	-121	-50
				FDD_B	-120.5	-50
				FDD_C, TDD_C	-120	-50
				FDD_D	-119.5	-50
				FDD_E, TDD_E	-119	-50
				FDD_F	-118.5	-50
				FDD_G	-118	-50
				FDD_H	-117.5	-50
FDD_N	-114.5	-50				
±10 <sup>Note 11</sup>	(PRS $\hat{E}_s/lot$ ) <sub>ref</sub> ≥ -6dB and (PRS $\hat{E}_s/lot$ ) <sub>i</sub> ≥ -13dB	≥ 15	6	Note 5	Note 5	Note 5
±6	(PRS $\hat{E}_s/lot$ ) <sub>ref</sub> ≥ -6dB and (PRS $\hat{E}_s/lot$ ) <sub>i</sub> ≥ -13dB	≥ 25	≥ 2	Note 5	Note 5	Note 5
±5	(PRS $\hat{E}_s/lot$ ) <sub>ref</sub> ≥ -6dB and (PRS $\hat{E}_s/lot$ ) <sub>i</sub> ≥ -13dB	≥ 50	≥ 1	Note 5	Note 5	Note 5
±4 <sup>Note 11</sup>	(PRS $\hat{E}_s/lot$ ) <sub>ref</sub> ≥ -6dB and (PRS $\hat{E}_s/lot$ ) <sub>i</sub> ≥ -13dB	≥ 75	≥ 1	Note 5	Note 5	Note 5

NOTE 1: This minimum Io condition is expressed as the average Io per RE over all REs in an OFDM symbol.  
 NOTE 2: Ts is the basic timing unit defined in TS 36.211 [26].  
 NOTE 3: PRS bandwidth is as indicated in *prs-Bandwidth* in the OTDOA assistance data defined in TS 36.355 [4].  
 NOTE 4: Void.  
 NOTE 5: The same bands and the same Io conditions for each band apply for this requirement as for the corresponding requirement with the PRS bandwidth ≥ 6 RB.  
 NOTE 6: The serving cell, the reference cell, and the measured neighbour cell  $i$  are on the same carrier frequency.  
 NOTE 7: Void.  
 NOTE 8: The condition level is increased by  $\Delta > 0$ , when applicable, as described in TS 36.133 [23] Annexes B.4.2 and B.4.3.  
 NOTE 9: The Io is defined in PRS positioning subframes. The same Io range applies to PRS and non-PRS symbols. Io levels are different in PRS and non-PRS symbols within the same subframe.  
 NOTE 10: E-UTRA operating band groups are as defined in clause 4.4.2.  
 NOTE 11: Only applicable from Rel-12 onwards

The normative reference for this requirement is TS 36.133 [23] clause 9.1.10.1 and A.9.8.1.



### 9.1.3.4 Test description

#### 9.1.3.4.1 Initial conditions

Test Environment: Normal; as defined in TS 36.508 [18] clause 4.1.

Frequencies to be tested: Mid Range, as defined in TS 36.508 [18] clause 4.3.1.1.

Channel bandwidth to be tested: 1.4 MHz (Test 1 and 2) and 10 MHz (Test 3 and 4). In the case that 1.4 MHz channel bandwidth is not defined for the operating band under test, as defined in TS 36.101 [2] clause 5.6.1, then this part of the test shall be omitted.

1. Connect the SS and AWGN noise sources to the UE antenna connector or antenna connectors as shown in Annex A, Figure A.3a for 4RX capable UE without any 2RX bands. Otherwise use Annex A figure A.3.
2. The general test parameter settings are set up according to Table 9.1.3.4.1-1.
3. Propagation conditions are set according to clause 4.7.2.1.
4. Message contents are defined in clause 9.1.3.4.3.
5. All cells are on the same carrier frequency. Cell 1 is the serving cell and OTDOA assistance data reference cell; Cell 2 is the neighbour cell. The assistance data neighbour cell list includes in total 15 cells, where 14 of the cells are not simulated (dummy cells; as defined in 3GPP TS 37.571-5 [20], clause 7.2.2).
6. The true RSTD (which is the receive time difference for frame 0 between cell 2 and cell 1 as seen at the UE antenna connector) is set to the following values:
  - Test 1: -92 Ts (about -3  $\mu$ s)
  - Test 2: 92 Ts (about 3  $\mu$ s)
  - Test 3: 92 Ts (about 3  $\mu$ s)
  - Test 4: -92 Ts (about -3  $\mu$ s)

Note that the related expectedRSTD values to be signalled over LPP are defined in Table 9.1.3.4-1 for each test.

**Table 9.1.3.4.1-1: General Test Parameters for intra frequency RSTD Tests for E-UTRAN FDD**

Parameter	Unit	Value				Comment
		Test 1	Test 2	Test 3	Test 4	
PCFICH/PDCCH/PHICH parameters		R.14 FDD		R.6 FDD		As specified in TS 36.521-3 [25] clause A.2.1.
OCNG Patterns defined in TS 36.521-3 [25] clause D.1		OP.7 FDD		OP.6 FDD		OCNG shall be used such that both cells are fully allocated and a constant total transmitted power spectral density is achieved for all OFDM symbols (other than those in the PRS subframes).
Reference cell		Cell 1				
Neighbour cell		Cell 2				
E-UTRA RF Channel Number		1				One FDD carrier frequency is used.
Channel Bandwidth (BW <sub>channel</sub> )	MHz	1.4		10		
PRS Transmission Bandwidth <sup>Note 2</sup>	RB	6		50		
PRS configuration Index I <sub>PRS</sub> <sup>Note 2</sup>		12		2		As defined in 3GPP TS 36.211 [26]
Number of consecutive positioning downlink subframes N <sub>PRS</sub> <sup>Note 2</sup>		6		1		As defined in 3GPP TS 36.211 [26]
prs-MutingInfo <sup>Note 2</sup>		Cell 1: '11110000' Cell 2: '11110000'				See section 6.5.1.2 in 3GPP TS 36.355 [4] for more information
Cell ID <sup>Note 2</sup>		(Cell ID of cell 1 – Cell ID of cell 2) mod 6 = 0	(Cell ID of cell 1 – Cell ID of cell 2) mod 6 = 1	(Cell ID of cell 1 – Cell ID of cell 2) mod 6 = 0	(Cell ID of cell 1 – Cell ID of cell 2) mod 6 = 3	
Expected RSTD <sup>Note 1</sup>	us	Cell 2: 1 Other neighbour cells: randomly between -3 and 3	Cell 2: -1 Other neighbour cells: randomly between -3 and 3	Cell 2: -1 Other neighbour cells: randomly between -3 and 3	Cell 2: 1 Other neighbour cells: randomly between -3 and 3	
Expected RSTD uncertainty for all neighbour cells <sup>Note 1</sup>	us	5	5	5	5	
CP length <sup>Note 2</sup>		Normal				
DRX		OFF				
Radio frame receive time offset between the cells at the UE antenna connector <sup>Note 3</sup>	us	Cell 2 to Cell 1: -3	Cell 2 to Cell 1: 3	Cell 2 to Cell 1: 3	Cell 2 to Cell 1: -3	PRS are transmitted from synchronous cells
Number of cells provided in OTDOA assistance data		16				The number of cells includes the reference cell
T <sub>RSTD IntraFreqFDD, E-UTRAN</sub> <sup>Note 4</sup>	ms	2560				Derived according to the RSTD measurement requirements specified in Section 9.1.1.3

<p>NOTE 1: Parameters “Expected RSTD” and “Expected RSTD uncertainty for all neighbour cells” are not settable parameters. These are parameters signalled in LPP only. For the values to be used in LPP see Table 9.1.3.4.3-4 and TS 37.571-5 [20], clause 7.2.2.</p> <p>NOTE 2: Parameters “PRS Transmission Bandwidth”, “PRS configuration index”, “Number of consecutive positioning downlink subframes”, “prs-MutingInfo”, “Cell ID” and “CP length” are settable parameters and also parameters signalled in LPP. The values to be used for “Cell ID” are as follows: Cell 1: 0, Cell 2: Test 1: 6, Test 2: 7, Test 3: 6, Test 4: 9. For all the values to be used in LPP see Table 9.1.3.4.3-4 and TS 37.571-5 [20], clause 7.2.2.</p> <p>NOTE 3: The parameter “Radio frame receive time offset between the cells at the UE antenna connector” is not a settable parameter but is used to set the “true RSTD” values in step 6 of clause 9.1.3.4.1.</p> <p>NOTE 4: The parameter “<math>T_{\text{RSTD IntraFreqFDD, E-UTRAN}}</math>” is not a settable parameter but is used to set the LPP “time” value in Table 9.1.3.4.3-2. The value of the LPP time IE is set to <math>T_{\text{RSTD IntraFreqFDD, E-UTRAN}} + \Delta T</math> ms, where <math>\Delta T = 150</math> ms, giving a value of 2710 ms. This is rounded up to the next allowed LPP value of 3 seconds.</p>
---

### 9.1.3.4.2 Test procedure

The test consists of a set-up period and a measurement period. Cell 1 and Cell 2 are both active during the complete test. The beginning of the measurement period shall be aligned with the first PRS positioning subframe of a positioning occasion in the reference cell.

NOTE: The information on when PRS is muted is conveyed to the UE using PRS muting information in the OTDOA assistance data.

The OTDOA-RequestLocationInformation message and the OTDOA assistance data as defined in clause 9.1.3.4.3 shall be provided to the UE during the set-up period. The last TTI containing the OTDOA-RequestLocationInformation message shall be provided to the UE  $\Delta T$  ms before the start of the measurement period, where  $\Delta T = 150$  ms is the maximum processing time of the OTDOA-RequestLocationInformation message and the OTDOA assistance data in the UE.

1. Ensure that the UE is in state Generic RB Established State 3A-RF according to 3GPP TS 36.508 [18] clause 7.2A.3.
2. The SS shall send a RESET UE POSITIONING STORED INFORMATION message.
3. Set the parameters according to Table 9.1.3.5-1 as appropriate. Propagation conditions are set according to clause 4.7.2.1.
- 3a. The SS shall send an LPP REQUEST CAPABILITIES message.
- 3b. The UE shall send an LPP PROVIDE CAPABILITIES message indicating the OTDOA capabilities supported by the UE in the *OTDOA-ProvideCapabilities* IE.
4. The SS shall send a LPP PROVIDE ASSISTANCE DATA message, including the *OTDOA-ProvideAssistanceData* IE. If the UE message at step 3b includes the *ackRequested* IE set to TRUE, then the SS shall send an acknowledgment in the LPP PROVIDE ASSISTANCE DATA message.
5. The SS shall send a LPP REQUEST LOCATION INFORMATION message, including the *OTDOA-RequestLocationInformation* IE such that the UE receives the message  $\Delta T$  ms before the start of measurement period, where  $\Delta T = 150$  ms.
6. The UE shall transmit a LPP PROVIDE LOCATION INFORMATION message, including the *OTDOA-ProvideLocationInformation* IE.
7. If the UE message at step 6 includes the *ackRequested* IE set to TRUE, the SS shall send a LPP acknowledgement message.
8. The SS shall check the *rstd* value for Cell 2 in the *OTDOA-SignalMeasurementInformation* IE according to Table 9.1.3.5-2.
9. Repeat step 2-8 until the confidence level according to Annex D is achieved.
10. Repeat step 1-9 for each sub-test in Table 9.1.3.5-1 as appropriate.

## 9.1.3.4.3 Message contents

**Table 9.1.3.4.3-1: RESET UE POSITIONING STORED INFORMATION**

Derivation Path: 36.509 [11] clause 6.9			
Information Element	Value/remark	Comment	Condition
UE Positioning Technology	0 0 0 0 0 0 0 1	OTDOA	

**Table 9.1.3.4.3-1a: LPP Request Capabilities**

Information Element	Value/remark
<i>otdoa-RequestCapabilities</i>	TRUE

**Table 9.1.3.4.3-2: LPP RequestLocationInformation**

Derivation Path: 36.355 clause 6.2			
Information Element	Value/remark	Comment	Condition
LPP-Message ::= SEQUENCE {			
transactionID SEQUENCE {			
initiator	locationServer		
transactionNumber	1		
}			
endTransaction	FALSE		
sequenceNumber	Not present		
acknowledgement	Not present		
lpp-MessageBody CHOICE {			
c1 CHOICE {			
requestLocationInformation SEQUENCE {			
criticalExtensions CHOICE {			
c1 CHOICE {			
requestLocationInformation-r9 SEQUENCE {			
commonIEsRequestLocationInformation SEQUENCE {			
locationInformationType	locationMeasurementsRequired		
triggeredReporting	Not present		
periodicalReporting	Not present		
additionalInformation	onlyReturnInformationRequested		
qos SEQUENCE {			
horizontalAccuracy	Not present		
verticalCoordinateRequest	FALSE		
verticalAccuracy	Not present		
responseTime SEQUENCE {			
time	3	See Note 4 of Table 9.1.3.4.1-1	
responseTimeEarlyFix-r12	Not present		Rel-12 onwards
}			
velocityRequest	FALSE		
}			
environment	Not present		
locationCoordinateTypes	Not present		
velocityTypes	Not present		
}			
a-gnss-RequestLocationInformation	Not present		
otdoa-RequestLocationInformation SEQUENCE {			
assistanceAvailability	FALSE		
}			
ecid-RequestLocationInformation	Not present		
epdu-RequestLocationInformation	Not Present		
}			
}			
}			
}			
}			

Table 9.1.3.4.3-3: Void

Table 9.1.3.4.3-4: LPP ProvideAssistanceData

Derivation Path: 36.355 clause 6.2			
Information Element	Value/remark	Comment	Condition
LPP-Message ::= SEQUENCE {			
transactionID SEQUENCE {			
Initiator	locationServer		
transactionNumber	(0..255)		
}			
endTransaction	TRUE		
sequenceNumber	Not present		
acknowledgement	Not present		
lpp-MessageBody CHOICE {			
c1 CHOICE {			
provideAssistanceData SEQUENCE {			
criticalExtensions CHOICE {			
c1 CHOICE {			
provideAssistanceData-r9 SEQUENCE {			
commonIEsProvideAssistanceData	Not present		
a-gnss-ProvideAssistanceData	Not present		
otdoa-ProvideAssistanceData SEQUENCE {			
otdoa-ReferenceCellInfo	As defined in TS 37.571-5 [20], clause 7.2.2.		
otdoa-NeighbourCellInfo	As defined in TS 37.571-5 [20], clause 7.2.2.		
otdoa-Error	Not present		
}			
epdu-ProvideAssistanceData	Not present		
}			
}			
}			
}			

**Table 9.1.3.4.3-5: LPP ProvideLocation Information**

Derivation Path: 36.355 clause 6.2			
Information Element	Value/remark	Comment	Condition
LPP-Message ::= SEQUENCE {			
transactionID SEQUENCE {			
initiator	locationServer		
transactionNumber	1		
}			
endTransaction	TRUE		
sequenceNumber	(0..255)		
acknowledgement			
lpp-MessageBody CHOICE {			
c1 CHOICE {			
provideLocationInformation SEQUENCE {			
criticalExtensions CHOICE {			
c1 CHOICE {			
provideLocationInformation-r9 SEQUENCE {			
commonIEsProvideLocationInformation	Not present.		
a-gnss-ProvideLocationInformation	Not present		
otdoa-ProvideLocationInformation			
SEQUENCE {			
otdoaSignalMeasurementInformation			
SEQUENCE {			
systemFrameNumber			
physCellIdRef	Cell 1		
cellGlobalIdRef			
earfcnRef			
referenceQuality			
neighbourMeasurementList			
SEQUENCE (SIZE(1)) {			
physCellIdNeighbor	Cell 2		
cellGlobalIdNeighbour			
earfcnNeighbour			
rstd	Set according to Table 9.1.3.5-2 for each specific test		
rstd-Quality			
}			
}			
otdoa-Error	May be present with error reason 'undefined' or 'attemptedButUnableToMeasureSomeNeighbourCells'		
}			
ecid-ProvideLocationInformation	Not present		
epdu-ProvideLocationInformation	Not present		
}			
}			
}			



**Table 9.1.3.4.3-6: CQI-ReportConfig-DEFAULT: FDD RSTD Measurement Accuracy**

Derivation Path: TS 36.508 [18] clause 4.6.3, Table 4.6.3-2 CQI-ReportConfig-DEFAULT			
Information Element	Value/remark	Comment	Condition
CQI-ReportConfig-DEFAULT ::= SEQUENCE {			
cqi-ReportModeAperiodic	rm30	This IE should be omitted for Test 1 and Test 2	
nomPDSCH-RS-EPRE-Offset	0		
cqi-ReportPeriodic CHOICE {			
release	NULL		
}			

### 9.1.3.5 Test requirement

Table 9.1.3.5-1 defines the primary level settings including test tolerances for all tests.

The RSTD FDD intra-frequency accuracy test shall meet the reported values in Table 9.1.3.5-2.

**Table 9.1.3.5-1: Cell Specific Test Parameters for intra frequency RSTD Tests for E-UTRAN FDD**

Parameter	Unit	Test 1		Test 2		Test 3		Test 4	
		Cell 1	Cell 2	Cell 1	Cell 2	Cell 1	Cell 2	Cell 1	Cell 2
E-UTRA RF Channel Number		1							
PBCH_RA	dB	0	0	0	0	0	0	0	0
PBCH_RB									
PSS_RA									
SSS_RA									
PCFICH_RB									
PHICH_RA									
PHICH_RB									
PDCCH_RA									
PDCCH_RB									
OCNG_RA <sup>Note 1</sup>									
OCNG_RB <sup>Note 1</sup>									
PRS_RA	dB	0	0	-2.7	0.3	0	0	-2.7	0.3
$N_{oc}$ <sup>Note 2</sup>	dBm/15 kHz	-98	-98	-98	-98	-98	-98	-98	-98
PRS $\hat{E}_s/N_{oc}$	dB	-2.37	-8.02	-5.7	-12.7	-2.37	-8.02	-5.7	-12.7
PRS $\hat{E}_s/I_{ot}$ <sup>Note 3</sup>	dB	-3	-10	-5.7	-12.7	-3	-10	-5.7	-12.7
$I_o$ <sup>Note 3</sup>	dBm/1.08 MHz	-78.92	-78.92	-79.2	-79.2	N/A	N/A	N/A	N/A
	dBm/9 MHz	N/A	N/A	N/A	N/A	-69.72	-69.72	-69.99	-69.99
PRP <sup>Note 3</sup>	dBm/15kHz	-100.37	-106.02	-103.7	-110.7	-100.37	-106.02	-103.7	-110.7
$\hat{E}_s/N_{oc}$ <sup>Note 3</sup>	dB	-2.37	-8.02	-3	-13	-2.37	-8.02	-3	-13
RSRP <sup>Note 3</sup>	dBm/15kHz	-100.37	-106.02	-101	-111	-100.37	-106.02	-101	-111
Propagation condition		AWGN							
<p>Note 1: OCNG shall be used such that both cells are fully allocated and a constant total transmitted power spectral density is achieved for all OFDM symbols (other than those in the PRS subframes).</p> <p>Note 2: Interference from other cells and noise sources not specified in the test is assumed to be constant over subcarriers and time and shall be modelled as AWGN of appropriate power for <math>N_{oc}</math> to be fulfilled.</p> <p>Note 3: <math>\hat{E}_s/N_{oc}</math>, PRS <math>\hat{E}_s/I_{ot}</math>, <math>I_o</math>, RSRP and PRP levels have been derived from other parameters for information purposes. They are not settable parameters themselves. <math>I_o</math> values are derived in the case that there is no PBCH, PSS or SSS in the OFDM symbols carrying PRS.</p>									

**Table 9.1.3.5-2: RSTD FDD intra-frequency accuracy requirements for the reported values**

	Test 1	Test 2	Test 3	Test 4
Lowest reported value	RSTD_6248	RSTD_6431	RSTD_6441	RSTD_6258
Highest reported value	RSTD_6280	RSTD_6463	RSTD_6453	RSTD_6270

For the overall test to pass, the ratio of successful reported values in each sub-test shall be more than 90% with a confidence level of 95%. In the case that 1.4 MHz channel bandwidth is not defined for the operating band under test then Test 1 and Test 2 shall be omitted.

## 9.1.3A FDD RSTD Measurement Accuracy for UE Category 1bis

### 9.1.3A.1 Test purpose

To verify that the RSTD FDD intra-frequency measurement accuracy is within the specified limits.

### 9.1.3A.2 Test applicability

This test applies to E-UTRA FDD UE Category 1bis release 13 and forward that supports UE-assisted OTDOA.

### 9.1.3A.3 Minimum conformance requirements

Same as 9.1.3.3

The normative reference for this requirement is TS 36.133 [23] clause 9.1.10.5 and A.9.8.1.2A.

### 9.1.3A.4 Test description

#### 9.1.3A.4.1 Initial conditions

Same as 9.1.3.4.1 with the following exceptions:

1. Connect the SS, faders and AWGN noise sources to the UE antenna connector or antenna connectors as shown in Annex A, Figure A.3, using only the main Tx/Rx path.
2. The general test parameter settings are set up according to Table 9.1.3A.4.1-1

**Table 9.1.3A.4.1-1: General Test Parameters for intra frequency RSTD Tests for E-UTRAN FDD for UE Category 1bis**

Parameter	Unit	Value				Comment
		Test 1	Test 2	Test 3	Test 4	
PCFICH/PDCCH/PHICH parameters		R.14 FDD		R.6 FDD		As specified in TS 36.521-3 [25] clause A.2.1.
OCNG Patterns defined in TS 36.521-3 [25] clause D.1		OP.7 FDD		OP.6 FDD		OCNG shall be used such that both cells are fully allocated and a constant total transmitted power spectral density is achieved for all OFDM symbols (other than those in the PRS subframes).
Reference cell		Cell 1				
Neighbour cell		Cell 2				
E-UTRA RF Channel Number		1				One FDD carrier frequency is used.
Channel Bandwidth (BW <sub>channel</sub> )	MHz	1.4		10		
PRS Transmission Bandwidth <sup>Note 2</sup>	RB	6		50		
PRS configuration Index I <sub>PRS</sub> <sup>Note 2</sup>		12		2		As defined in 3GPP TS 36.211 [26]
Number of consecutive positioning downlink subframes N <sub>PRS</sub> <sup>Note 2</sup>		6		1		As defined in 3GPP TS 36.211 [26]
prs-MutingInfo <sup>Note 2</sup>		Cell 1: '1111111100000000' Cell 2: '1111111100000000'				See section 6.5.1.2 in 3GPP TS 36.355 [4] for more information
Cell ID <sup>Note 2</sup>		(Cell ID of cell 1 – Cell ID of cell 2) mod 6 = 0	(Cell ID of cell 1 – Cell ID of cell 2) mod 6 = 1	(Cell ID of cell 1 – Cell ID of cell 2) mod 6 = 0	(Cell ID of cell 1 – Cell ID of cell 2) mod 6 = 3	
Expected RSTD <sup>Note 1</sup>	us	Cell 2: 1 Other neighbour cells: randomly between -3 and 3	Cell 2: -1 Other neighbour cells: randomly between -3 and 3	Cell 2: -1 Other neighbour cells: randomly between -3 and 3	Cell 2: 1 Other neighbour cells: randomly between -3 and 3	
Expected RSTD uncertainty for all neighbour cells <sup>Note 1</sup>	us	5	5	5	5	
CP length <sup>Note 2</sup>		Normal				
DRX		OFF				
Radio frame receive time offset between the cells at the UE antenna connector <sup>Note 3</sup>	us	Cell 2 to Cell 1: -3	Cell 2 to Cell 1: 3	Cell 2 to Cell 1: 3	Cell 2 to Cell 1: -3	PRS are transmitted from synchronous cells
Number of cells provided in OTDOA assistance data		16				The number of cells includes the reference cell
T <sub>RSTD IntraFreqFDD, E-UTRAN</sub> <sup>Note 4</sup>	ms	5120				Derived according to the RSTD measurement requirements specified in Section 9.1.1A.3

NOTE 1: Parameters “Expected RSTD” and “Expected RSTD uncertainty for all neighbour cells” are not settable parameters. These are parameters signalled in LPP only. For the values to be used in LPP see Table 9.1.3.4.3-4 and TS 37.571-5 [20], clause 7.2.2.

NOTE 2: Parameters “PRS Transmission Bandwidth”, “PRS configuration index”, “Number of consecutive positioning downlink subframes”, “prs-MutingInfo”, “Cell ID” and “CP length” are settable parameters and also parameters signalled in LPP. The values to be used for “Cell ID” are as follows: Cell 1: 0, Cell 2: Test 1: 6, Test 2: 7, Test 3: 6, Test 4: 9. For all the values to be used in LPP see Table 9.1.3.4.3-4 and TS 37.571-5 [20], clause 7.2.2.

NOTE 3: The parameter “Radio frame receive time offset between the cells at the UE antenna connector” is not a settable parameter but is used to set the “true RSTD” values in step 6 of clause 9.1.3.4.1.

NOTE 4: The parameter “ $T_{RSTD \text{ IntraFreqFDD, E-UTRAN}}$ ” is not a settable parameter but is used to set the LPP “time” value in Table 9.1.3A.4.3-2. The value of the LPP time IE is set to  $T_{RSTD \text{ IntraFreqFDD, E-UTRAN}} + \Delta T$  ms, where  $\Delta T = 150$  ms, giving a value of 5270 ms. This is rounded up to the next allowed LPP value of 6 seconds.

9.1.3A.4.2 Test procedure

Same as 9.1.3.4.2.

9.1.3A.4.3 Message contents

Same as 9.1.3.4.3 with the following exceptions

**Table 9.1.3A.4.3-1: LPP RequestLocationInformation**

Derivation Path: Table 9.1.3.4.3-2			
Information Element	Value/remark	Comment	Condition
LPP-Message ::= SEQUENCE {			
lpp-MessageBody CHOICE {			
c1 CHOICE {			
requestLocationInformation SEQUENCE {			
criticalExtensions CHOICE {			
c1 CHOICE {			
requestLocationInformation-r9 SEQUENCE {			
commonIEsRequestLocationInformation SEQUENCE {			
qos SEQUENCE {			
responseTime SEQUENCE {			
time	6	See Note 4 of Table 9.1.3A.4.1-1	
}			
}			
}			
}			
}			
}			
}			
}			

9.1.3A.5 Test requirement

Same as 9.1.3.5.

9.1.4 TDD RSTD Measurement Accuracy

9.1.4.1 Test purpose

To verify that the RSTD TDD intra-frequency measurement accuracy is within the specified limits.

### 9.1.4.2 Test applicability

This test applies to all types of E-UTRA TDD UE release 9 and forward that supports UE-assisted OTDOA except UE Category 1bis.

### 9.1.4.3 Minimum conformance requirements

The accuracy requirements in Table 9.1.3.3-1 are valid under the following conditions:

Conditions defined in TS 36.101 [2] clause 7.3 for reference sensitivity are fulfilled.

PRP  $1,2_{\text{dBm}}$  according to clause E.2 for a corresponding Band.

There are no measurement gaps overlapping with the PRS subframes of the measured cell.

The parameter *expectedRSTDUncertainty* signalled over LPP as defined in 3GPP TS 36.355 [4] is less than 5  $\mu\text{s}$ .

The normative reference for this requirement is TS 36.133 [23] clause 9.1.10.1 and A.9.8.2.

### 9.1.4.4 Test description

#### 9.1.4.4.1 Initial conditions

Test Environment: Normal; as defined in TS 36.508 [18] clause 4.1.

Frequencies to be tested: Mid Range, as defined in TS 36.508 [18] clause 4.3.1.2.

Channel bandwidth to be tested: 1.4 MHz (Test 1 and 2) and 10 MHz (Test 3 and 4). In the case that 1.4 MHz channel bandwidth is not defined for the operating band under test, as defined in TS 36.101 [2] clause 5.6.1, then this part of the test shall be omitted.

1. Connect the SS and AWGN noise sources to the UE antenna connector or antenna connectors as shown in Annex A, Figure A.3a for 4RX capable UE without any 2RX bands. Otherwise use Annex A figure A.3.
2. The general test parameter settings are set up according to Table 9.1.4.4.1-1.
3. Propagation conditions are set according to clause 4.7.2.1.
4. Message contents are defined in clause 9.1.4.4.3.
5. All cells are on the same carrier frequency. Cell 1 is the serving cell and OTDOA assistance data reference cell; Cell 2 is the neighbour cell. The assistance data neighbour cell list includes in total 15 cells, where 14 of the cells are not simulated (dummy cells; as defined in 3GPP TS 37.571-5 clause 7.2.2).
6. The true RSTD (which is the receive time difference for frame 0 between cell 2 and cell 1 as seen at the UE antenna connector) is set to the following values:
  - Test 1: -92 Ts (about -3  $\mu\text{s}$ )
  - Test 2: 92 Ts (about 3  $\mu\text{s}$ )
  - Test 3: 92 Ts (about 3  $\mu\text{s}$ )
  - Test 4: -92 Ts (about -3  $\mu\text{s}$ )

Note that the related *expectedRSTD* values to be signalled over LPP are defined in Table 9.1.4.4-1 for each test.

Table 9.1.4.4.1-1: General Test Parameters for intra frequency RSTD Tests for E-UTRAN TDD

Parameter	Unit	Value				Comment
		Test 1	Test 2	Test 3	Test 4	
PCFICH/PDCCH/PHICH parameters		R.14 TDD		R.6 TDD		As specified in TS 36.521-3 [25] clause A.2.2.
OCNG Patterns defined in TS 36.521-3 [25] clause D.2		OP.4 TDD		OP.2 TDD		OCNG shall be used such that both cells are fully allocated and a constant total transmitted power spectral density is achieved for all OFDM symbols (other than those in the PRS subframes).
Reference cell		Cell 1				
Neighbour cell		Cell 2				
E-UTRA RF Channel Number		1				One TDD carrier frequency is used.
Channel Bandwidth ( $BW_{\text{channel}}$ )	MHz	1.4		10		
Special subframe configuration		6		6		As specified in table 4.2-1 in TS 36.211 [26]. The same configuration in both cells.
Uplink-downlink configuration		3		1		As specified in table 4.2-2 in TS 36.211 [26] and table 9.1.2.3-2. The same configuration in both cells.
PRS Transmission Bandwidth <sup>Note 2</sup>	RB	6		50		
PRS configuration Index $I_{\text{PRS}}$ <sup>Note 2</sup>		9		14		As defined in 3GPP TS 36.211 [26].
Number of consecutive positioning downlink subframes $N_{\text{PRS}}$ <sup>Note 2</sup>		6		1		As defined in 3GPP TS 36.211 [26].
prs-MutingInfo <sup>Note 2</sup>		Cell 1: '11110000' Cell 2: '11110000'				See section 6.5.1.2 in 3GPP TS 36.355 [4] for more information
Cell ID <sup>Note 2</sup>		(Cell ID of cell 1 – Cell ID of cell 2) mod 6 = 0	(Cell ID of cell 1 – Cell ID of cell 2) mod 6 = 1	(Cell ID of cell 1 – Cell ID of cell 2) mod 6 = 0	(Cell ID of cell 1 – Cell ID of cell 2) mod 6 = 3	
Expected RSTD <sup>Note 1</sup>	us	Cell 2: 1 Other neighbour cells: randomly between -3 and 3	Cell 2: -1 Other neighbour cells: randomly between -3 and 3	Cell 2: -1 Other neighbour cells: randomly between -3 and 3	Cell 2: 1 Other neighbour cells: randomly between -3 and 3	
Expected RSTD uncertainty for all neighbour cells <sup>Note 1</sup>	us	5	5	5	5	
CP length <sup>Note 2</sup>		Normal				



DRX		OFF				
Radio frame receive time offset between the cells at the UE antenna connector Note 3	us	Cell 2 to Cell 1: -3	Cell 2 to Cell 1: 3	Cell 2 to Cell 1: 3	Cell 2 to Cell 1: -3	PRS are transmitted from synchronous cells
Number of cells provided in OTDOA assistance data		16				The number of cells includes the reference cell
$T_{\text{RSTD IntraFreqTDD, E-UTRAN}}$ Note 4	ms	2560				Derived according to the RSTD measurement requirements specified in Section 9.1.2.3
<p>NOTE 1: Parameters "Expected RSTD" and "Expected RSTD uncertainty for all neighbour cells" are not settable parameters. These are parameters signalled in LPP only. For the values to be used in LPP see Table 9.1.4.4.3-4 and TS 37.571-5 [20], clause 7.2.2.</p> <p>NOTE 2: Parameters "PRS Transmission Bandwidth", "PRS configuration index", "Number of consecutive positioning downlink subframes", "prs-MutingInfo", "Cell ID" and "CP length" are settable parameters and also parameters signalled in LPP. The values to be used for "Cell ID" are as follows: Cell 1: 0, Cell 2: Test 1: 6, Test 2: 7, Test 3: 6, Test 4: 9. For all the values to be used in LPP see Table 9.1.4.4.3-4 and TS 37.571-5 [20], clause 7.2.2.</p> <p>NOTE 3: The parameter "Radio frame receive time offset between the cells at the UE antenna connector" is not a settable parameter but is used to set the "true RSTD" values in step 6 of clause 9.1.4.4.1.</p> <p>NOTE 4: The parameter "<math>T_{\text{RSTD IntraFreqTDD, E-UTRAN}}</math>" is not a settable parameter but is used to set the LPP "time" value in Table 9.1.4.4.3-2. The value of the LPP time IE is set to <math>T_{\text{RSTD IntraFreqTDD, E-UTRAN}} + \Delta T</math> ms, where <math>\Delta T = 150</math> ms, giving a value of 2710 ms. This is rounded up to the next allowed LPP value of 3 seconds.</p>						

#### 9.1.4.4.2 Test procedure

The test consists of a set-up period and a measurement period. Cell 1 and Cell 2 are both active during the complete test. The beginning of the measurement period shall be aligned with the first PRS positioning subframe of a positioning occasion in the reference cell.

NOTE: The information on when PRS is muted is conveyed to the UE using PRS muting information in the OTDOA assistance data.

The OTDOA-RequestLocationInformation message and the OTDOA assistance data as defined in clause 9.1.4.4.3 shall be provided to the UE during the set-up period. The last TTI containing the OTDOA-RequestLocationInformation message shall be provided to the UE  $\Delta T$  ms before the start of the measurement period, where  $\Delta T = 150$  ms is the maximum processing time of the OTDOA-RequestLocationInformation message and the OTDOA assistance data in the UE.

1. Ensure that the UE is in state Generic RB Established State 3A-RF according to 3GPP TS 36.508 [18] clause 7.2A.3.
2. The SS shall send a RESET UE POSITIONING STORED INFORMATION message.
3. Set the parameters according to Table 9.1.4.5-1 as appropriate. Propagation conditions are set according to clause 4.7.2.1.
- 3a. The SS shall send an LPP REQUEST CAPABILITIES message.
- 3b. The UE shall send an LPP PROVIDE CAPABILITIES message indicating the OTDOA capabilities supported by the UE in the *OTDOA-ProvideCapabilities* IE.
4. The SS shall send a LPP PROVIDE ASSISTANCE DATA message, including the *OTDOA-ProvideAssistanceData* IE. If the UE message at step 3b includes the *ackRequested* IE set to TRUE, then the SS shall send an acknowledgment in the LPP PROVIDE ASSISTANCE DATA message.
5. The SS shall send a LPP REQUEST LOCATION INFORMATION message, including the *OTDOA-RequestLocationInformation* IE such that the UE receives the message  $\Delta T$  ms before the start of measurement period, where  $\Delta T = 150$  ms.

6. The UE shall transmit a LPP PROVIDE LOCATION INFORMATION message, including the *OTDOA-ProvideLocationInformation* IE.
7. If the UE message at step 6 includes the *ackRequested* IE set to TRUE, the SS shall send a LPP acknowledgement message.
8. The SS shall check the *rstl* value for Cell 2 in the *OTDOA-SignalMeasurementInformation* IE according to Table 9.1.4.5-2.
9. Repeat step 2-8 until the confidence level according to Annex D is achieved.
10. Repeat step 1-9 for each sub-test in Table 9.1.4.5-1 as appropriate.

#### 9.1.4.4.3 Message contents

**Table 9.1.4.4.3-1: RESET UE POSITIONING STORED INFORMATION**

Derivation Path: 36.509 [11] clause 6.9			
Information Element	Value/remark	Comment	Condition
UE Positioning Technology	0 0 0 0 0 0 1	OTDOA	

**Table 9.1.4.4.3-1a: LPP Request Capabilities**

Information Element	Value/remark
<i>otdoa-RequestCapabilities</i>	TRUE

**Table 9.1.4.4.3-2: LPP RequestLocationInformation**

Derivation Path: 36.355 clause 6.2			
Information Element	Value/remark	Comment	Condition
LPP-Message ::= SEQUENCE {			
transactionID SEQUENCE {			
initiator	locationServer		
transactionNumber	1		
}			
endTransaction	FALSE		
sequenceNumber	Not present		
acknowledgement	Not present		
lpp-MessageBody CHOICE {			
c1 CHOICE {			
requestLocationInformation SEQUENCE {			
criticalExtensions CHOICE {			
c1 CHOICE {			
requestLocationInformation-r9 SEQUENCE {			
commonIEsRequestLocationInformation SEQUENCE {			
locationInformationType	locationMeasurementsRequired		
triggeredReporting	Not present		
periodicalReporting	Not present		
additionalInformation	onlyReturnInformationRequested		
qos SEQUENCE {			
horizontalAccuracy	Not present		
verticalCoordinateRequest	FALSE		
verticalAccuracy	Not present		
responseTime SEQUENCE {			
time	3	See Note 4 of Table 9.1.4.4.1-1	
responseTimeEarlyFix-r12	Not present		Rel-12 onwards
}			
velocityRequest	FALSE		
}			
environment	Not present		
locationCoordinateTypes	Not present		
velocityTypes	Not present		
}			
a-gnss-RequestLocationInformation	Not present		
otdoa-RequestLocationInformation SEQUENCE {			
assistanceAvailability	FALSE		
}			
ecid-RequestLocationInformation	Not present		
epdu-RequestLocationInformation	Not Present		
}			
}			
}			
}			
}			
}			

**Table 9.1.4.4.3-3: Void**

**Table 9.1.4.4.3-4: LPP ProvideAssistanceData**

Derivation Path: 36.355 clause 6.2			
Information Element	Value/remark	Comment	Condition
LPP-Message ::= SEQUENCE {			
transactionID SEQUENCE {			

Initiator	locationServer		
transactionNumber	(0..255)		
}			
endTransaction	TRUE		
sequenceNumber	Not present		
acknowledgement	Not present		
lpp-MessageBody CHOICE {			
c1 CHOICE {			
provideAssistanceData SEQUENCE {			
criticalExtensions CHOICE {			
c1 CHOICE {			
provideAssistanceData-r9 SEQUENCE {			
commonIEsProvideAssistanceData	Not present		
a-gnss-ProvideAssistanceData	Not present		
otdoa-ProvideAssistanceData SEQUENCE {			
otdoa-ReferenceCellInfo	As defined in TS 37.571-5 [20], clause 7.2.2.		
otdoa-NeighbourCellInfo	As defined in TS 37.571-5 [20], clause 7.2.2.		
otdoa-Error	Not present		
}			
epdu-ProvideAssistanceData	Not present		
}			
}			
}			
}			
}			

**Table 9.1.4.4.3-5: LPP ProvideLocation Information**

Derivation Path: 36.355 clause 6.2			
Information Element	Value/remark	Comment	Condition
LPP-Message ::= SEQUENCE {			
transactionID SEQUENCE {			
initiator	locationServer		
transactionNumber	1		
}			
endTransaction	TRUE		
sequenceNumber	(0..255)		
acknowledgement			
lpp-MessageBody CHOICE {			
c1 CHOICE {			
provideLocationInformation SEQUENCE {			
criticalExtensions CHOICE {			
c1 CHOICE {			
provideLocationInformation-r9 SEQUENCE {			
commonIEsProvideLocationInformation	Not present.		
a-gnss-ProvideLocationInformation	Not present		
otdoa-ProvideLocationInformation			
SEQUENCE {			
otdoaSignalMeasurementInformation			
SEQUENCE {			
systemFrameNumber			
physCellIdRef	Cell 1		
cellGlobalIdRef			
earfcnRef			
referenceQuality			
neighbourMeasurementList			
SEQUENCE (SIZE(1)) {			
physCellIdNeighbor	Cell 2		
cellGlobalIdNeighbour			
earfcnNeighbour			
rstd	Set according to Table 9.1.4.5-2 for each specific test		
rstd-Quality			
}			
}			
otdoa-Error	May be present with error reason 'undefined' or 'attemptedButUnableToMeasureSomeNeighbourCells'		
}			
ecid-ProvideLocationInformation	Not present		
epdu-ProvideLocationInformation	Not present		
}			
}			
}			
}			
}			

**Table 9.1.4.4.3-6: CQI-ReportConfig-DEFAULT: TDD RSTD Measurement Accuracy**

Derivation Path: TS 36.508 [18] clause 4.6.3, Table 4.6.3-2 CQI-ReportConfig-DEFAULT			
Information Element	Value/remark	Comment	Condition
CQI-ReportConfig-DEFAULT ::= SEQUENCE {			
cqi-ReportModeAperiodic	rm30	This IE should be omitted for Test 1 and Test 2	
nomPDSCH-RS-EPRE-Offset	0		
cqi-ReportPeriodic CHOICE {			
release	NULL		
}			

9.1.4.5 Test requirement

Table 9.1.4.5-1 defines the primary level settings including test tolerances for all tests.

Each RSTD TDD intra-frequency accuracy test shall meet the reported values in Table 9.1.4.5-2.

**Table 9.1.4.5-1: Cell Specific Test Parameters for intra frequency RSTD Tests for E-UTRAN TDD**

Parameter	Unit	Test 1		Test 2		Test 3		Test 4	
		Cell 1	Cell 2	Cell 1	Cell 2	Cell 1	Cell 2	Cell 1	Cell 2
E-UTRA RF Channel Number		1							
PBCH_RA	dB								
PBCH_RB									
PSS_RA									
SSS_RA									
PCFICH_RB									
PHICH_RA		0	0	0	0	0	0	0	0
PHICH_RB									
PDCCH_RA									
PDCCH_RB									
OCNG_RA <sup>Note 1</sup>									
OCNG_RB <sup>Note 1</sup>									
PRS_RA		dB	0	0	-2.7	0.3	0	0	-2.7
$N_{oc}$ <sup>Note 2</sup>	dBm/15 kHz	-98	-98	-98	-98	-98	-98	-98	-98
$PRS \hat{E}_s / N_{oc}$	dB	-2.37	-8.02	-5.7	-12.7	-2.37	-8.02	-5.7	-12.7
$PRS \hat{E}_s / I_{ot}$ <sup>Note 3</sup>	dB	-3	-10	-5.7	-12.7	-3	-10	-5.7	-12.7
$I_o$ <sup>Note 3</sup>	dBm/1.08 MHz	-78.92	-78.92	-79.2	-79.2	N/A	N/A	N/A	N/A
	dBm/9 MHz	N/A	N/A	N/A	N/A	-69.72	-69.72	-69.99	-69.99
PRP <sup>Note 3</sup>	dBm/15kHz	-100.37	-106.02	-103.7	-110.7	-100.37	-106.02	-103.7	-110.7
$\hat{E}_s / N_{oc}$ <sup>Note 3</sup>	dB	-2.37	-8.02	-3	-13	-2.37	-8.02	-3	-13
RSRP <sup>Note 3</sup>	dBm/15kHz	-100.37	-106.02	-101	-111	-100.37	-106.02	-101	-111
Propagation condition		AWGN							
<p>Note 1: OCNG shall be used such that both cells are fully allocated and a constant total transmitted power spectral density is achieved for all OFDM symbols (other than those in the PRS subframes).</p> <p>Note 2: Interference from other cells and noise sources not specified in the test is assumed to be constant over subcarriers and time and shall be modelled as AWGN of appropriate power for <math>N_{oc}</math> to be fulfilled.</p> <p>Note 3: <math>\hat{E}_s / N_{oc}</math>, <math>PRS \hat{E}_s / I_{ot}</math>, <math>I_o</math>, RSRP and PRP levels have been derived from other parameters for information purposes. They are not settable parameters themselves. <math>I_o</math> values are derived in the case that there is no PBCH, PSS or SSS in the OFDM symbols carrying PRS.</p>									

**Table 9.1.4.5-2: RSTD TDD intra-frequency accuracy requirements for the reported values**

	<b>Test 1</b>	<b>Test 2</b>	<b>Test 3</b>	<b>Test 4</b>
Lowest reported value	RSTD_6248	RSTD_6431	RSTD_6441	RSTD_6258
Highest reported value	RSTD_6280	RSTD_6463	RSTD_6453	RSTD_6270

For the overall test to pass, the ratio of successful reported values in each sub-test shall be more than 90% with a confidence level of 95%. In the case that 1.4 MHz channel bandwidth is not defined for the operating band under test then Test 1 and Test 2 shall be omitted.

## 9.1.4A TDD RSTD Measurement Accuracy for UE Category 1bis

### 9.1.4A.1 Test purpose

To verify that the RSTD TDD intra-frequency measurement accuracy is within the specified limits.

### 9.1.4A.2 Test applicability

This test applies to E-UTRA TDD UE Category 1bis release 13 and forward that supports UE-assisted OTDOA.

### 9.1.4A.3 Minimum conformance requirements

Same as 9.1.4.3

The normative reference for this requirement is TS 36.133 [23] clause 9.1.10.6 and A.9.8.2.2A.

### 9.1.4A.4 Test description

#### 9.1.4A.4.1 Initial conditions

Same as 9.1.4.4.1 with the following exceptions:

1. Connect the SS, faders and AWGN noise sources to the UE antenna connector or antenna connectors as shown in Annex A, Figure A.3, using only the main Tx/Rx path.
2. The general test parameter settings are set up according to Table 9.1.4A.4.1-1

**Table 9.1.4A.4.1-1: General Test Parameters for intra frequency RSTD Tests for E-UTRAN TDD for UE Category 1bis**

Parameter	Unit	Value				Comment
		Test 1	Test 2	Test 3	Test 4	
PCFICH/PDCCH/PHICH parameters		R.14 TDD		R.6 TDD		As specified in TS 36.521-3 [25] clause A.2.2.
OCNG Patterns defined in TS 36.521-3 [25] clause D.2		OP.4 TDD		OP.2 TDD		OCNG shall be used such that both cells are fully allocated and a constant total transmitted power spectral density is achieved for all OFDM symbols (other than those in the PRS subframes).
Reference cell		Cell 1				
Neighbour cell		Cell 2				
E-UTRA RF Channel Number		1				One TDD carrier frequency is used.
Channel Bandwidth ( $BW_{channel}$ )	MHz	1.4		10		
Special subframe configuration		6		6		As specified in table 4.2-1 in TS 36.211 [26]. The same configuration in both cells.
Uplink-downlink configuration		3		1		As specified in table 4.2-2 in TS 36.211 [26] and table 9.1.2.3-2. The same configuration in both cells.
PRS Transmission Bandwidth <sup>Note 2</sup>	RB	6		50		
PRS configuration Index $I_{PRS}$ <sup>Note 2</sup>		9		14		As defined in 3GPP TS 36.211 [26].
Number of consecutive positioning downlink subframes $N_{PRS}$ <sup>Note 2</sup>		6		1		As defined in 3GPP TS 36.211 [26].
prs-MutingInfo <sup>Note 2</sup>		Cell 1: '1111111100000000' Cell 2: '1111111100000000'				See section 6.5.1.2 in 3GPP TS 36.355 [4] for more information
Cell ID <sup>Note 2</sup>		(Cell ID of cell 1 – Cell ID of cell 2) mod 6 = 0	(Cell ID of cell 1 – Cell ID of cell 2) mod 6 = 1	(Cell ID of cell 1 – Cell ID of cell 2) mod 6 = 0	(Cell ID of cell 1 – Cell ID of cell 2) mod 6 = 3	
Expected RSTD <sup>Note 1</sup>	us	Cell 2: 1 Other neighbour cells: randomly between -3 and 3	Cell 2: -1 Other neighbour cells: randomly between -3 and 3	Cell 2: -1 Other neighbour cells: randomly between -3 and 3	Cell 2: 1 Other neighbour cells: randomly between -3 and 3	
Expected RSTD uncertainty for all neighbour cells <sup>Note 1</sup>	us	5	5	5	5	
CP length <sup>Note 2</sup>		Normal				



DRX		OFF				
Radio frame receive time offset between the cells at the UE antenna connector Note 3	us	Cell 2 to Cell 1: -3	Cell 2 to Cell 1: 3	Cell 2 to Cell 1: 3	Cell 2 to Cell 1: -3	PRS are transmitted from synchronous cells
Number of cells provided in OTDOA assistance data		16				The number of cells includes the reference cell
$T_{RSTD \text{ IntraFreqTDD, E-UTRAN}}$ Note 4	ms	5120				Derived according to the RSTD measurement requirements specified in Section 9.1.2A.3
<p>NOTE 1: Parameters "Expected RSTD" and "Expected RSTD uncertainty for all neighbour cells" are not settable parameters. These are parameters signalled in LPP only. For the values to be used in LPP see Table 9.1.4.4.3-4 and TS 37.571-5 [20], clause 7.2.2.</p> <p>NOTE 2: Parameters "PRS Transmission Bandwidth", "PRS configuration index", "Number of consecutive positioning downlink subframes", "prs-MutingInfo", "Cell ID" and "CP length" are settable parameters and also parameters signalled in LPP. The values to be used for "Cell ID" are as follows: Cell 1: 0, Cell 2: Test 1: 6, Test 2: 7, Test 3: 6, Test 4: 9. For all the values to be used in LPP see Table 9.1.4.4.3-4 and TS 37.571-5 [20], clause 7.2.2.</p> <p>NOTE 3: The parameter "Radio frame receive time offset between the cells at the UE antenna connector" is not a settable parameter but is used to set the "true RSTD" values in step 6 of clause 9.1.4.4.1.</p> <p>NOTE 4: The parameter "<math>T_{RSTD \text{ IntraFreqTDD, E-UTRAN}}</math>" is not a settable parameter but is used to set the LPP "time" value in Table 9.1.4A.4.3-1. The value of the LPP time IE is set to <math>T_{RSTD \text{ IntraFreqTDD, E-UTRAN}} + \Delta T</math> ms, where <math>\Delta T = 150</math> ms, giving a value of 5270 ms. This is rounded up to the next allowed LPP value of 6 seconds.</p>						

9.1.4A.4.2 Test procedure

Same as 9.1.3.4.2.

9.1.4A.4.3 Message contents

Same as 9.1.4.4.3 with the following exceptions

Table 9.1.4A.4.3-1: LPP RequestLocationInformation

Derivation Path: Table 9.1.4.4.3-2			
Information Element	Value/remark	Comment	Condition
LPP-Message ::= SEQUENCE {			
lpp-MessageBody CHOICE {			
c1 CHOICE {			
requestLocationInformation SEQUENCE {			
criticalExtensions CHOICE {			
c1 CHOICE {			
requestLocationInformation-r9 SEQUENCE {			
commonIEsRequestLocationInformation SEQUENCE {			
qos SEQUENCE {			
responseTime SEQUENCE {			
time	6	See Note 4 of Table 9.1.3A.4.1-1	
}			
}			
}			
}			
}			
}			
}			
}			
}			
}			

#### 9.1.4A.5 Test requirement

Same as 9.1.4.5.

## 9.2 RSTD Inter-Frequency Measurements

### 9.2.1 FDD-FDD inter-frequency RSTD measurement reporting delay

#### 9.2.1.1 Test purpose

To verify that the FDD-FDD inter-frequency RSTD measurement reporting delay meets the requirements in an environment with fading propagation conditions.

#### 9.2.1.2 Test applicability

This test applies to all types of E-UTRA FDD UE release 10 and forward that support inter-frequency RSTD measurements except UE Category 1bis.

#### 9.2.1.3 Minimum conformance requirements

When the physical layer cell identities of neighbour cells together with the OTDOA assistance data are provided, the UE shall be able to detect and measure inter-frequency RSTD, specified in 3GPP TS 36.214 [6], for at least  $n=16$  cells, including the reference cell, within  $T_{\text{RSTD InterFreqFDD, E-UTRAN}}$  ms as given below:

$$T_{\text{RSTD InterFreqFDD, E-UTRAN}} = T_{\text{PRS}} \cdot (M - 1) + \Delta \quad \text{ms},$$

where

$T_{\text{RSTD InterFreqFDD, E-UTRAN}}$  is the total time for detecting and measuring at least  $n$  cells,

$T_{\text{PRS}}$  is the largest value of the cell-specific positioning subframe configuration period, defined in 3GPP TS 36.211 [26], among the measured  $n$  cells including the reference cell,

$M$  is the number of PRS positioning occasions as defined in Table 9.2.1.3-1, where each PRS positioning occasion comprises of  $N_{PRS}$  ( $1 \leq N_{PRS} \leq 6$ ) consecutive downlink positioning subframes defined in 3GPP TS 36.211 [26], and

$\Delta = 160 \cdot \left\lceil \frac{n}{M} \right\rceil$  ms is the measurement time for a single PRS positioning occasion which includes the sampling time and the processing time.

**Table 9.2.1.3-1: Number of PRS positioning occasions within  $T_{RSTD \text{ InterFreqFDD, E-UTRAN}}$**

Positioning subframe configuration period $T_{PRS}$	Number of PRS positioning occasions $M$	
	f2 <sup>Note 1</sup>	f1 and f2 <sup>Note 2</sup>
160 ms	16	32
>160 ms	8	16
Note 1: When inter-frequency RSTD measurements are performed over the reference cell and neighbour cells, which belong to the FDD inter-frequency carrier frequency f2. Note 2: When inter-frequency RSTD measurements are performed over the reference cell and the neighbour cells, which belong to the serving FDD carrier frequency f1 and the FDD inter-frequency carrier frequency f2 respectively.		

The UE physical layer shall be capable of reporting RSTD for the reference cell and all the neighbour cells  $i$  out of at least  $(n-1)$  neighbour cells within  $T_{RSTD \text{ InterFreqFDD, E-UTRAN}}$  provided:

$(\text{PRS } \hat{E}_s / \text{Iot})_{ref} \geq -6$  dB for all Frequency Bands for the reference cell,

$(\text{PRS } \hat{E}_s / \text{Iot})_i \geq -13$  dB for all Frequency Bands for neighbour cell  $i$ ,

$(\text{PRS } \hat{E}_s / \text{Iot})_{ref}$  and  $(\text{PRS } \hat{E}_s / \text{Iot})_i$  conditions apply for all subframes of at least  $L = \frac{M}{2}$  PRS positioning occasions,

PRP 1,2<sub>dBm</sub> according to E.3 for a corresponding Band.

$\text{PRS } \hat{E}_s / \text{Iot}$  is as defined in Section 9.1.1.3.

The time  $T_{RSTD \text{ InterFreqFDD, E-UTRAN}}$  starts from the first subframe of the PRS positioning occasion closest in time after both the OTDOA-RequestLocationInformation message and the OTDOA assistance data in the OTDOA-ProvideAssistanceData message as specified in 3GPP TS 36.355 [4], are delivered to the physical layer of the UE.

This requirement assumes that the measurement report is not delayed by other LPP signalling on the DCCH. This measurement reporting delay excludes a delay uncertainty resulted when inserting the measurement report to the TTI of the uplink DCCH. The delay uncertainty is:  $2 \times TTI_{DCCH}$ . This measurement reporting delay excludes any delay caused by no UL resources for UE to send the measurement report.

The normative reference for this requirement is TS 36.133 [23] clause 8.1.2.6.1 and A.8.13.1.

## 9.2.1.4 Test description

### 9.2.1.4.1 Initial conditions

Test Environment: Normal; as defined in TS 36.508 [18] clause 4.1.

Frequencies to be tested: Mid Range, as defined in TS 36.508 [18] clause 4.3.1.1.

Channel bandwidth to be tested: 10 MHz as defined in TS 36.508 [18] clause 4.3.1.

1. Connect the SS, faders and AWGN noise sources to the UE antenna connector or antenna connectors as shown in Annex A, Figure A.4.

2. The general test parameter settings are set up according to Table 9.2.1.4.1-1.
3. Propagation conditions are set according to clause 4.7.2.1.
4. Message contents are defined in clause 9.2.1.4.3.
5. In the test there are three synchronized cells: Cell 1, Cell 2 and Cell 3. Cell 1 is the OTDOA assistance data reference as well as the serving cell. Cell 2 and Cell 3 are the neighbour cells. Cell 1 is on FDD RF channel 1. Cell 2 and Cell 3 are on a FDD RF channel 2. The assistance data neighbour cell list includes in total 15 cells, where 13 of the cells are not simulated (dummy cells; as defined in 3GPP TS 37.571-5 clause 7.2.2).
6. The true RSTD (which is the receive time difference for frame 0 between two cells as seen at the UE antenna connector) is set to 31 Ts (about 1  $\mu$ s) between neighbour Cell 2 and serving Cell 1; and set to -31 Ts (about -1  $\mu$ s) between neighbour Cell 3 and serving Cell 1.
7. The gap pattern configuration # 0 as defined in Table 8.1.2.1-1 in 3GPP TS 36.133 [23] is configured and does not overlap with PRS subframes of Cell 1.

**Table 9.2.1.4.1-1: General test parameters for E-UTRAN FDD-FDD inter-frequency RSTD measurement reporting delay under fading propagation conditions**

Parameter	Unit	Value	Comment
Reference cell		Cell 1	Reference cell is the cell with respect to which the RSTD measurement is defined, as specified in 3GPP TS 36.214 [6] and 3GPP TS 36.355 [4]. The reference cell is the serving cell on RF channel 1 in this test case.
Neighbour cells		Cell 2 and Cell 3	Cells on RF channel 2. The cells appear at random places in the neighbour cell list in the OTDOA assistance data, but Cell 2 always appears in the first half of the list, whilst Cell 3 appears in the second half of the list.
PCFICH/PDCCH/PHICH parameters		DL Reference Measurement Channel R.6 FDD	As specified in TS 36.521-3 [25] clause A.2.1
Channel Bandwidth (BW <sub>channel</sub> )	MHz	10	
PRS Bandwidth <sup>Note 2</sup>	RB	50	PRS are transmitted over the system bandwidth
Gap pattern Id		0	As specified in Table 8.1.2.1-1 in TS 36.133[23].
Gap offset		9	As specified in 36.331 [22], Section 6.3.5
PRS configuration index $I_{PRS}$ <sup>Note 2</sup>		Cell 1: 181, Cell 2, Cell 3: 171	This corresponds to periodicity of 320 ms and PRS subframe offset of $I_{PRS} - 160$ DL subframes, as defined in 3GPP TS 36.211 [26], Table 6.10.4.3-1
Number of consecutive downlink positioning subframes $N_{PRS}$ <sup>Note 2</sup>		1	As defined in TS 36.211 [26]. The number of subframes in a positioning occasion
Physical cell ID PCI <sup>Note 2</sup>		(PCI of Cell 1 – PCI of Cell 2) mod 6 = 0 and (PCI of Cell 1 – PCI of Cell 3) mod 6 = 0	The cell PCIs are selected such that the relative shifts of PRS patterns among cells are as given by the test parameters
CP length <sup>Note 2</sup>		Normal	
DRX		ON	DRX parameters are further specified in Table 9.2.1.4.1-2
prs-SubframeOffset <sup>Note 2</sup>		310	Number of subframes rounded to the closest integer. The corresponding parameter in the OTDOA assistance data is prs-SubframeOffset specified in TS 36.355 [4]
slotNumberOffset <sup>Note 2</sup>		0	The slot number offset at the transmitter between a neighbour cell and the assistance data reference cell specified in TS 36.355 [4]
Radio frame receive time offset between the cells at the UE antenna connector <sup>Note 3</sup>	µs	Cell 2 to Cell 1: 1 Cell 3 to Cell 1: -1	PRS are transmitted from synchronous cells
Expected RSTD <sup>Note 1</sup>	µs	Cell 2: -2 Cell 3: 2 Other neighbour cells: randomly between -3 and 3	The expected RSTD is what is expected at the receiver. The corresponding parameter in the OTDOA assistance data specified in TS 36.355 [4] is the expectedRSTD indicator
Expected RSTD uncertainty for all neighbour cells <sup>Note 1</sup>	µs	5	The corresponding parameter in the OTDOA assistance data specified in TS 36.355 [4] is the expectedRSTD-Uncertainty index

Number of cells provided in OTDOA assistance data		16	The list includes the reference cell (received in <i>OTDOA-ReferenceCellInfo</i> [4]) on RF channel 1 and 15 other cells on RF channel 2, all received in <i>OTDOA-ProvideAssistanceData</i> [4].
PRS muting info <sup>Note 2</sup>		Cell 1: '1111111100000000' Cell 2: '0000000011111111' Cell 3: '1111111100000000'	Corresponds to <i>prs-MutingInfo</i> defined in TS 36.355 [4]
T1	s	3	The length of the time interval from the beginning of each test
T2	s	2.48	The length of the time interval that follows immediately after time interval T1
T3	s	2.48	The length of the time interval that follows immediately after time interval T2
<p>Note 1: Parameters "Expected RSTD" and "Expected RSTD uncertainty for all neighbour cells" are not settable parameters. These are parameters signalled in LPP only. For the values to be used in LPP see Table 9.2.1.4.3-5 and TS 37.571-5 [20], clause 7.2.2.</p> <p>Note 2: Parameters "PRS Bandwidth", "PRS configuration index", "Number of consecutive downlink positioning subframes", "Physical cell ID PCI", "CP length", "prs-SubframeOffset", "slotNumberOffset" and "PRS muting info" are settable parameters and also parameters signalled in LPP. The values to be used for "Physical cell ID PCI" are as follows: Cell 1: 0, Cell 2: 6, Cell 3: 12. For all the values to be used in LPP see Table 9.2.1.4.3-5 and TS 37.571-5 [20], clause 7.2.2.</p> <p>Note 3: The parameter "Radio frame receive time offset between the cells at the UE antenna connector" is not a settable parameter but is used to set the "true RSTD" values in step 6 of clause 9.2.1.4.1.</p>			

**Table 9.2.1.4.1-2: DRX parameters for E-UTRAN FDD-FDD inter-frequency RSTD measurement reporting delay under fading propagation conditions**

Field	Value	Comment
onDurationTimer	psf1	As specified in 3GPP TS 36.331 [22], clause 6.3.2
drx-InactivityTimer	psf1	
drx-RetransmissionTimer	sf1	
longDRX-CycleStartOffset	sf320	
shortDRX	Disable	

#### 9.2.1.4.2 Test procedure

The test consists of three consecutive time intervals, with duration of T1, T2 and T3 defined in Table 9.2.1.4.1-1. Cell 1 is active in T1, T2 and T3, whilst Cell 2 and Cell 3 are activated only in the beginning of T2. Cell 2 is active until the end of T3, and Cell 3 is active until the end of T2. The beginning of the time interval T2 shall be aligned 5 ms before the first PRS positioning subframe of a positioning occasion in the reference cell, where 5 ms is the necessary test tolerance. Cell 1 transmits PRS only in T2, Cell 2 transmits PRS only in T3, and Cell 3 transmits PRS only in T2.

NOTE: The information on when PRS is muted is conveyed to the UE using PRS muting information in the OTDOA assistance data.

The OTDOA-RequestLocationInformation message and the OTDOA assistance data as defined in clause 9.2.1.4.3 shall be provided to the UE during T1. The last TTI containing the OTDOA-RequestLocationInformation message shall be provided to the UE  $\Delta T$  ms before the start of T2, where  $\Delta T = 150$  ms is the maximum processing time of the OTDOA-RequestLocationInformation message and the OTDOA assistance data.

1. Ensure that the UE is in state Generic RB Established State 3A-RF according to 3GPP TS 36.508 [18] clause 7.2A.3.
2. The SS shall send a RESET UE POSITIONING STORED INFORMATION message.
3. Set the parameters according to Table 9.2.1.5-1. Propagation conditions are set according to clause 4.7.2.2 (ETU30).
4. T1 starts.

5. The SS shall transmit an RRCConnectionReconfiguration message with the DRX configuration and the measurement gap configuration. PDCCHs indicating new transmissions shall be sent continuously until the start of T2 to ensure that the UE would not enter the DRX state before T2.
6. The UE shall transmit RRCConnectionReconfigurationComplete message.
- 6a. The SS shall transmit an LPP REQUEST CAPABILITIES message.
- 6b. The UE shall transmit an LPP PROVIDE CAPABILITIES message indicating the OTDOA capabilities supported by the UE in the *OTDOA-ProvideCapabilities* IE.
7. The SS shall send a LPP PROVIDE ASSISTANCE DATA message, including the *OTDOA-ProvideAssistanceData* IE. The position of neighbour Cell 2 in the *OTDOA-NeighbourCellInfoList* is randomly selected to be in the first 7 elements of the sequence, and the position of neighbour Cell 3 is randomly selected to be in the last 8 elements of the sequence, as described in 3GPP TS 37.571-5 [20], clause 7.2.3. If the UE message at step 6b includes the *ackRequested* IE set to TRUE, then the SS shall send an acknowledgment in the LPP PROVIDE ASSISTANCE DATA message.
8. The SS shall send a LPP REQUEST LOCATION INFORMATION message, including the *OTDOA-RequestLocationInformation* IE such that the UE receives the message  $\Delta T$  ms before the start of T2, where  $\Delta T = 150$  ms.
9. When T1 expires, the SS shall switch the power setting from T1 to T2 as specified in Table 9.2.1.5-2.
10. When T2 expires, the SS shall switch the power setting from T2 to T3 as specified in Table 9.2.1.5-2.
11. The UE shall transmit a LPP PROVIDE LOCATION INFORMATION message including the *OTDOA-ProvideLocationInformation* IE within the response time (see clause 4.7.3) specified in clause 9.2.1.5. The UE shall perform and report the RSTD measurements for both Cell 2 and Cell 3 with respect to the reference cell in the OTDOA assistance data, Cell 1. If the UE transmits an *OTDOA-ProvideLocationInformation* IE including the *rstd* field for both Cell 2 and Cell 3 within the response time then the number of successful tests is increased by one. If the UE fails to report the *OTDOA-ProvideLocationInformation* IE with both the *rstd* fields included within the response time then the number of failure tests is increased by one.
12. If the UE message at step 11 includes the *ackRequested* IE set to TRUE, the SS shall send a LPP acknowledgement message.
13. Repeat steps 2-12 until the confidence level according to Annex D is achieved. For each iteration, at step 7 change the random position of the Cells 2 and 3 in the *OTDOA-NeighbourCellInfoList*.

#### 9.2.1.4.3 Message contents

**Table 9.2.1.4.3-1: RESET UE POSITIONING STORED INFORMATION**

Derivation Path: 36.509 [11] clause 6.9			
Information Element	Value/remark	Comment	Condition
UE Positioning Technology	0 0 0 0 0 0 1	OTDOA	



**Table 9.2.1.4.3-2: MAC-MainConfig-RBC: FDD-FDD Inter-frequency RSTD Measurement Reporting Delay**

Derivation Path: TS 36.508 [18] clause 4.8.2.1.5, Table 4.8.2.1.5-1 MAC-MainConfig-RBC			
Information Element	Value/remark	Comment	Condition
MAC-MainConfig-RBC ::= SEQUENCE {			
drx-Config CHOICE {			
setup SEQUENCE {			
onDurationTimer	psf1		
drx-InactivityTimer	psf1		
drx-RetransmissionTimer	sf1		
longDRX-CycleStartOffset CHOICE {			
sf320	0		
}			
shortDRX	Not present		
}			
}			
}			

**Table 9.2.1.4.3-3: MeasGapConfig-GP1: FDD-FDD inter-frequency RSTD Measurement Reporting Delay**

Derivation Path: TS 36.508 [18] clause 4.6.6, Table 4.6.6-1A: MeasGapConfig-GP1			
Information Element	Value/remark	Comment	Condition
MeasGapConfig-GP1 ::= CHOICE {			
setup SEQUENCE {			
gapOffset CHOICE {			
gp0	9	TGRP = 40 ms	
}			
}			
}			

**Table 9.2.1.4.3-3a: LPP Request Capabilities**

Information Element	Value/remark
<i>otdoa-RequestCapabilities</i>	TRUE

**Table 9.2.1.4.3-4: LPP RequestLocationInformation**

Derivation Path: 36.355 clause 6.2			
Information Element	Value/remark	Comment	Condition
LPP-Message ::= SEQUENCE {			
transactionID SEQUENCE {			
initiator	locationServer		
transactionNumber	1		
}			
endTransaction	FALSE		
sequenceNumber	Not present		
acknowledgement	Not present		
lpp-MessageBody CHOICE {			
c1 CHOICE {			
requestLocationInformation SEQUENCE {			
criticalExtensions CHOICE {			
c1 CHOICE {			
requestLocationInformation-r9 SEQUENCE {			
commonIEsRequestLocationInformation SEQUENCE {			
locationInformationType	locationMeasurementsRequired		
triggeredReporting	Not present		
periodicalReporting	Not present		
additionalInformation	onlyReturnInformationRequested		
qos SEQUENCE {			
horizontalAccuracy	Not present		
verticalCoordinateRequest	FALSE		
verticalAccuracy	Not present		
responseTime SEQUENCE {			
time	6	See clause 9.2.1.5	
responseTimeEarlyFix-r12	Not present		Rel-12 onwards
}			
velocityRequest	FALSE		
}			
environment	Not present		
locationCoordinateTypes	Not present		
velocityTypes	Not present		
}			
a-gnss-RequestLocationInformation	Not present		
otdoa-RequestLocationInformation SEQUENCE {			
assistanceAvailability	FALSE		
}			
ecid-RequestLocationInformation	Not present		
epdu-RequestLocationInformation	Not Present		
}			
}			
}			
}			
}			

Table 9.2.1.4.3-5: LPP ProvideAssistanceData

Derivation Path: 36.355 clause 6.2			
Information Element	Value/remark	Comment	Condition
LPP-Message ::= SEQUENCE {			
transactionID SEQUENCE {			
Initiator	locationServer		
transactionNumber	(0..255)		
}			
endTransaction	TRUE		
sequenceNumber	Not present		
acknowledgement	Not present		
lpp-MessageBody CHOICE {			
c1 CHOICE {			
provideAssistanceData SEQUENCE {			
criticalExtensions CHOICE {			
c1 CHOICE {			
provideAssistanceData-r9 SEQUENCE {			
commonIEsProvideAssistanceData	Not present		
a-gnss-ProvideAssistanceData	Not present		
otdoa-ProvideAssistanceData SEQUENCE {			
otdoa-ReferenceCellInfo	As defined in TS 37.571-5 [20], clause 7.2.2.		
otdoa-NeighbourCellInfo	As defined in TS 37.571-5 [20], clause 7.2.2.		
otdoa-Error	Not present		
}			
epdu-ProvideAssistanceData	Not present		
}			
}			
}			
}			

**Table 9.2.1.4.3-6: LPP ProvideLocation Information**

Derivation Path: 36.355 clause 6.2			
Information Element	Value/remark	Comment	Condition
LPP-Message ::= SEQUENCE {			
transactionID SEQUENCE {			
initiator	locationServer		
transactionNumber	1		
}			
endTransaction	TRUE		
sequenceNumber	(0..255)		
acknowledgement			
lpp-MessageBody CHOICE {			
c1 CHOICE {			
provideLocationInformation SEQUENCE {			
criticalExtensions CHOICE {			
c1 CHOICE {			
provideLocationInformation-r9 SEQUENCE {			
commonIEsProvideLocationInformation	Not present.		
a-gnss-ProvideLocationInformation	Not present		
otdoa-ProvideLocationInformation SEQUENCE {			
otdoaSignalMeasurementInformation SEQUENCE {			
systemFrameNumber			
physCellIdRef	Cell 1		
cellGlobalIdRef			
earfcnRef			
referenceQuality			
neighbourMeasurementList SEQUENCE (SIZE(n)) {			
physCellIdNeighbor	Cell 2		
cellGlobalIdNeighbour			
earfcnNeighbour	RF channel 2		
rstd	Present		
rstd-Quality			
}			
neighbourMeasurementList SEQUENCE (SIZE(n)) {			
physCellIdNeighbor	Cell 3		
cellGlobalIdNeighbour			
earfcnNeighbour	RF channel 2		
rstd	Present		
rstd-Quality			
}			
} otdoa-Error	May be present with error reason 'undefined' or 'attemptedButUnableToMeasureSomeNeighbourCells'		
}			
ecid-ProvideLocationInformation	Not present		
epdu-ProvideLocationInformation	Not present		
}			
}			
}			

9.2.1.5 Test requirement

Table 9.2.1.5-1 and 9.2.1.5-2 define the primary level settings including test tolerances for the test.

**Table 9.2.1.5-1: Cell-specific test parameters for E-UTRAN FDD-FDD inter-frequency RSTD measurement reporting delay under fading propagation conditions during T1**

Parameter	Unit	Cell 1	Cell 2	Cell 3
E-UTRA RF Channel Number		1	N/A	N/A
Correlation Matrix and Antenna Configuration		1x2 Low	1x2 Low	1x2 Low
OCNG patterns defined in TS 36.521-3 [25] clause D.1		OP.5 FDD	N/A	N/A
PBCH_RA	dB	0	N/A	N/A
PBCH_RB				
PSS_RA				
SSS_RA				
PCFICH_RB				
PHICH_RA				
PHICH_RB				
PDCCH_RA				
PDCCH_RB				
OCNG_RA <sup>Note 1</sup>				
OCNG_RB <sup>Note 1</sup>				
$N_{oc}$ <sup>Note 3</sup>	dBm/ 15 kHz	-95	N/A	N/A
$PRS \hat{E}_s / N_{oc}$	dB	-Infinity	-Infinity	-Infinity
$I_o$ <sup>Note 4</sup>	dBm/ 9 MHz	-67.22	N/A	N/A
$\hat{E}_s / N_{oc}$	dB	0	-Infinity	-Infinity
Propagation Condition		ETU30		
Note 1:	OCNG shall be used such that the active cell (Cell 1) is fully allocated and a constant total transmitted power spectral density is achieved for all OFDM symbols.			
Note 2:	The resources for uplink transmission are assigned to the UE prior to the start of time period T2.			
Note 3:	Interference from other cells and noise sources not specified in the test are assumed to be constant over subcarriers and time and shall be modelled as AWGN of appropriate power for $N_{oc}$ to be fulfilled.			
Note 4:	$I_o$ levels have been derived from other parameters and are given for information purpose. These are not settable test parameters.			

**Table 9.2.1.5-2: Cell-specific test parameters for E-UTRAN FDD-FDD inter-frequency RSTD measurement reporting delay under fading propagation conditions during T2 and T3**

Parameter	Unit	Cell 1		Cell 2		Cell 3	
		T2	T3	T2	T3	T2	T3
E-UTRA RF Channel Number		1		2		2	N/A
Correlation Matrix and Antenna Configuration		1x2 Low		1x2 Low		1x2 Low	
OCNG patterns defined in TS 36.521-3 [25] clause D.1		OP.5 FDD		OP.6 FDD		OP.6 FDD	N/A
PBCH_RA	dB	0		0		0	N/A
PBCH_RB							
PSS_RA							
SSS_RA							
PCFICH_RB							
PHICH_RA							
PHICH_RB							
PDCCH_RA							
PDCCH_RB							
OCNG_RA <sup>Note 1</sup>							
OCNG_RB <sup>Note 1</sup>							
PRS_RA	dB	-3	N/A	N/A	3	3	N/A
$N_{oc}$ <sup>Note 3</sup>	dBm/15 kHz	-98	-98	-98	-95	-98	N/A
$\text{PRS } \hat{E}_s/N_{oc}$	dB	-1	-	-Infinity	-7	-8	-
$\text{PRS } \hat{E}_s/I_{ot}$ <sup>Note 4</sup>	dB	-1	-	-Infinity	-7	-8	-
$I_o$ <sup>Note 4</sup>	dBm/9 MHz	-69.68	-70.22	-70.11	-67.08	-70.11	N/A
PRP <sup>Note 4</sup>	dBm/15 kHz	-99	-	-Infinity	-102	-106	-
RSRP <sup>Note 4</sup>	dBm/15 kHz	-96	-96	-105	-105	-109	-
$\hat{E}_s/N_{oc}$ <sup>Note 4</sup>	dB	2	2	-7	-10	-11	-
Propagation Condition		ETU30					
Note 1:	OCNG shall be used such that active cells (all, except Cell 3 in T3) are fully allocated and a constant total transmitted power spectral density is achieved for all OFDM symbols other than those in the subframes with transmitted PRS.						
Note 2:	The resources for uplink transmission are assigned to the UE prior to the start of time period T2.						
Note 3:	Interference from other cells and noise sources not specified in the test and assumed to be constant over subcarriers and time and shall be modelled as AWGN of appropriate power for $N_{oc}$ to be fulfilled.						
Note 4:	If PRS_RA is not "N/A", $\hat{E}_s/N_{oc}$ , $\text{PRS } \hat{E}_s/I_{ot}$ , $I_o$ , RSRP and PRP levels have been derived from other parameters and are given for information purpose. If PRS_RA is "N/A", $I_o$ and RSRP levels have been derived from other parameters and are given for information purpose. These are not settable test parameters. Interference conditions shall be applied to all PRS symbols of DL positioning subframes.						

The response time including test tolerance is 6.3 s. The response time is equal to the LPP time IE value plus the test tolerance. The LPP time IE value is derived from the RSTD reporting delay plus  $\Delta T$ , where  $\Delta T = 150$  ms, giving a value of 5110 ms. This is rounded up to the next allowed LPP value of 6 seconds. The RSTD measurement reporting

delay in the test is derived from the following expression,  $T_{PRS}(M-1) + 160 \left\lceil \frac{n}{M} \right\rceil$ , where  $M=16$  and  $n=16$  are the parameters specified in clause 9.2.1.3 and Table 9.2.1.3-1. This gives the total RSTD reporting delay of 4960 ms for the 15 neighbour cells including Cell 2 and Cell 3 with respect to the reference cell, Cell 1.

The test tolerances are defined in clauses C.1.3 and C4.

The rate of successful tests during repeated tests shall be at least 90% with a confidence level of 95%.

## 9.2.1A FDD-FDD inter-frequency RSTD Measurement Reporting Delay for UE Category 1bis

### 9.2.1A.1 Test purpose

To verify that the FDD-FDD inter-frequency RSTD measurement reporting delay meets the requirements in an environment with fading propagation conditions.

### 9.2.1A.2 Test applicability

This test applies to E-UTRA FDD UE Category 1bis release 13 and forward that support inter-frequency RSTD measurements.

### 9.2.1A.3 Minimum conformance requirements

Same as 9.2.1.3 but using Table 9.2.1A.3-1 instead of Table 9.2.1.3-1.

**Table 9.2.1A.3-1: Number of PRS positioning occasions within  $T_{RSTD \text{ InterFreqFDD, E-UTRAN}}$**

Positioning subframe configuration period $T_{PRS}$	Number of PRS positioning occasions $M$	
	f2 <sup>Note 1</sup>	f1 and f2 <sup>Note 2</sup>
160 ms	32	64
>160 ms	16	32
Note 1:	When inter-frequency RSTD measurements are performed over the reference cell and neighbour cells, which belong to the FDD inter-frequency carrier frequency f2.	
Note 2:	When inter-frequency RSTD measurements are performed over the reference cell and the neighbour cells, which belong to the serving FDD carrier frequency f1 and the FDD inter-frequency carrier frequency f2 respectively.	

The normative reference for this requirement is TS 36.133 [23] clause 8.1.2.6.5 and A.8.13.1.

### 9.2.1A.4 Test description

#### 9.2.1A.4.1 Initial conditions

Same as 9.2.1.4.1 with the following exceptions:

1. Connect the SS, faders and AWGN noise sources to the UE antenna connector or antenna connectors as shown in Annex A, Figure A.4, using only the main Tx/Rx path.
2. The general test parameter settings are set up according to Table 9.2.1A.4.1-1.

**Table 9.2.1A.4.1-1: General test parameters for E-UTRAN FDD-FDD inter-frequency RSTD measurement reporting delay under fading propagation conditions for UE Category 1bis**



Parameter	Unit	Value	Comment
Reference cell		Cell 1	Reference cell is the cell with respect to which the RSTD measurement is defined, as specified in 3GPP TS 36.214 [6] and 3GPP TS 36.355 [4]. The reference cell is the serving cell on RF channel 1 in this test case.
Neighbour cells		Cell 2 and Cell 3	Cells on RF channel 2. The cells appear at random places in the neighbour cell list in the OTDOA assistance data, but Cell 2 always appears in the first half of the list, whilst Cell 3 appears in the second half of the list.
PCFICH/PDCCH/PHICH parameters		DL Reference Measurement Channel R.6 FDD	As specified in TS 36.521-3 [25] clause A.2.1
Channel Bandwidth (BW <sub>channel</sub> )	MHz	10	
PRS Bandwidth <sup>Note 2</sup>	RB	50	PRS are transmitted over the system bandwidth
Gap pattern Id		0	As specified in Table 8.1.2.1-1 in TS 36.133[23].
Gap offset		9	As specified in 36.331 [22], Section 6.3.5
PRS configuration index $I_{PRS}$ <sup>Note 2</sup>		Cell 1: 181, Cell 2, Cell 3: 171	This corresponds to periodicity of 320 ms and PRS subframe offset of $I_{PRS} - 160$ DL subframes, as defined in 3GPP TS 36.211 [26], Table 6.10.4.3-1
Number of consecutive downlink positioning subframes $N_{PRS}$ <sup>Note 2</sup>		1	As defined in TS 36.211 [26]. The number of subframes in a positioning occasion
Physical cell ID PCI <sup>Note 2</sup>		(PCI of Cell 1 – PCI of Cell 2) mod 6 = 0 and (PCI of Cell 1 – PCI of Cell 3) mod 6 = 0	The cell PCIs are selected such that the relative shifts of PRS patterns among cells are as given by the test parameters
CP length <sup>Note 2</sup>		Normal	
DRX		ON	DRX parameters are further specified in Table 9.2.1.4.1-2
prs-SubframeOffset <sup>Note 2</sup>		310	Number of subframes rounded to the closest integer. The corresponding parameter in the OTDOA assistance data is prs-SubframeOffset specified in TS 36.355 [4]
slotNumberOffset <sup>Note 2</sup>		0	The slot number offset at the transmitter between a neighbour cell and the assistance data reference cell specified in TS 36.355 [4]
Radio frame receive time offset between the cells at the UE antenna connector <sup>Note 3</sup>	µs	Cell 2 to Cell 1: 1 Cell 3 to Cell 1: -1	PRS are transmitted from synchronous cells
Expected RSTD <sup>Note 1</sup>	µs	Cell 2: -2 Cell 3: 2 Other neighbour cells: randomly between -3 and 3	The expected RSTD is what is expected at the receiver. The corresponding parameter in the OTDOA assistance data specified in TS 36.355 [4] is the expectedRSTD indicator
Expected RSTD uncertainty for all neighbour cells <sup>Note 1</sup>	µs	5	The corresponding parameter in the OTDOA assistance data specified in TS 36.355 [4] is the expectedRSTD-Uncertainty index

Number of cells provided in OTDOA assistance data		16	The list includes the reference cell (received in <i>OTDOA-ReferenceCellInfo</i> [4]) on RF channel 1 and 15 other cells on RF channel 2, all received in <i>OTDOA-ProvideAssistanceData</i> [4].
PRS muting info <sup>Note 2</sup>		Cell 1: '1111111111111111111100000000000000' Cell 2: '00000000000000000111111111111111' Cell 3: '1111111111111111111100000000000000'	Corresponds to <i>prs-MutingInfo</i> defined in TS 36.355 [4]
T1	s	3	The length of the time interval from the beginning of each test
T2	s	4.96	The length of the time interval that follows immediately after time interval T1
T3	s	4.96	The length of the time interval that follows immediately after time interval T2
<p>Note 1: Parameters "Expected RSTD" and "Expected RSTD uncertainty for all neighbour cells" are not settable parameters. These are parameters signalled in LPP only. For the values to be used in LPP see Table 9.2.1.4.3-5 and TS 37.571-5 [20], clause 7.2.2.</p> <p>Note 2: Parameters "PRS Bandwidth", "PRS configuration index", "Number of consecutive downlink positioning subframes", "Physical cell ID PCI", "CP length", "prs-SubframeOffset", "slotNumberOffset" and "PRS muting info" are settable parameters and also parameters signalled in LPP. The values to be used for "Physical cell ID PCI" are as follows: Cell 1: 0, Cell 2: 6, Cell 3: 12. For all the values to be used in LPP see Table 9.2.1.4.3-5 and TS 37.571-5 [20], clause 7.2.2.</p> <p>Note 3: The parameter "Radio frame receive time offset between the cells at the UE antenna connector" is not a settable parameter but is used to set the "true RSTD" values in step 6 of clause 9.2.1.4.1.</p>			

9.2.1A.4.2 Test procedure

Same as 9.2.1.4.2.

9.2.1A.4.3 Message contents

Same as 9.2.1.4.3 with the following exceptions:

**Table 9.2.1A.4.3-1: LPP RequestLocationInformation**

Derivation Path: Table 9.2.1.4.3-4			
Information Element	Value/remark	Comment	Condition
LPP-Message ::= SEQUENCE {			
lpp-MessageBody CHOICE {			
c1 CHOICE {			
requestLocationInformation SEQUENCE {			
criticalExtensions CHOICE {			
c1 CHOICE {			
requestLocationInformation-r9 SEQUENCE {			
commonIEsRequestLocationInformation SEQUENCE {			
qos SEQUENCE {			
responseTime SEQUENCE {			
time	11	See clause 9.2.1A.5	
}			
}			
}			
}			
}			
}			
}			
}			
}			
}			

**9.2.1A.5 Test requirement**

Table 9.2.1.5-1 and 9.2.1.5-2 define the primary level settings including test tolerances for the test.

The response time including test tolerance is 11.3 s. The response time is equal to the LPP time IE value plus the test tolerance. The LPP time IE value is derived from the RSTD reporting delay plus ΔT, where ΔT = 150 ms, giving a value of 10230 ms. This is rounded up to the next allowed LPP value of 11 seconds. The RSTD measurement reporting delay in the test is derived from the following expression,  $T_{PRS} (M - 1) + 160 \left\lceil \frac{n}{M} \right\rceil$ , where  $M = 32$  and  $n = 16$  are the parameters specified in clause 9.2.1A.3 and Table 9.2.1A.3-1. This gives the total RSTD reporting delay of 10080 ms for the 15 neighbour cells including Cell 2 and Cell 3 with respect to the reference cell, Cell 1.

The test tolerances are defined in clauses C.1.3 and C4.

The rate of successful tests during repeated tests shall be at least 90% with a confidence level of 95%.

**9.2.2 TDD-TDD inter-frequency RSTD measurement reporting delay**

**9.2.2.1 Test purpose**

To verify that the TDD-TDD inter-frequency RSTD measurement reporting delay meets the requirements in an environment with fading propagation conditions.

**9.2.2.2 Test applicability**

This test applies to all types of E-UTRA TDD UE release 10 and forward that support inter-frequency RSTD measurements except UE Category 1bis.

**9.2.2.3 Minimum conformance requirements**

When the physical layer cell identities of neighbour cells together with the OTDOA assistance data are provided, the UE shall be able to detect and measure inter-frequency RSTD, specified in 3GPP TS 36.214 [6], for at least  $n=16$  cells, including the reference cell, within  $T_{RSTD \text{ InterFreqTDD, E-UTRAN}}$  ms as given below:

$$T_{\text{RSTD InterFreqTDD, E-UTRAN}} = T_{\text{PRS}} \cdot (M - 1) + \Delta \quad \text{ms},$$

where

$T_{\text{RSTD InterFreqTDD, E-UTRAN}}$  is the total time for detecting and measuring at least  $n$  cells,

$T_{\text{PRS}}$  is the largest value of the cell-specific positioning subframe configuration period, defined in 3GPP TS 36.211 [26], among the measured  $n$  cells including the reference cell,

$M$  is the number of PRS positioning occasions as defined in Table 9.2.2.3-1, where each PRS positioning occasion comprises of  $N_{\text{PRS}}$  ( $1 \leq N_{\text{PRS}} \leq 6$ ) consecutive downlink positioning subframes defined in 3GPP TS 36.211 [26], and

$\Delta = 160 \cdot \left\lceil \frac{n}{M} \right\rceil$  ms is the measurement time for a single PRS positioning occasion which includes the sampling time and the processing time.

**Table 9.2.2.3-1: Number of PRS positioning occasions within  $T_{\text{RSTD InterFreqTDD, E-UTRAN}}$**

Positioning subframe configuration period $T_{\text{PRS}}$	Number of PRS positioning occasions $M$	
	f2 <sup>Note 1</sup>	f1 and f2 <sup>Note 2</sup>
160 ms	16	32
>160 ms	8	16
Note 1: When inter-frequency RSTD measurements are performed over the reference cell and neighbour cells, which belong to the TDD inter-frequency carrier frequency f2. Note 2: When inter-frequency RSTD measurements are performed over the reference cell and the neighbour cells, which belong to the serving TDD carrier frequency f1 and the TDD inter-frequency carrier frequency f2 respectively.		

The UE physical layer shall be capable of reporting RSTD for the reference cell and all the neighbour cells  $i$  out of at least  $(n-1)$  neighbour cells within  $T_{\text{RSTD InterFreqTDD, E-UTRAN}}$  provided:

$$\left( \text{PRS } \hat{E}_s / \text{Iot} \right)_{\text{ref}} \geq -6 \text{ dB for all Frequency Bands for the reference cell,}$$

$$\left( \text{PRS } \hat{E}_s / \text{Iot} \right)_i \geq -13 \text{ dB for all Frequency Bands for neighbour cell } i,$$

$\left( \text{PRS } \hat{E}_s / \text{Iot} \right)_{\text{ref}}$  and  $\left( \text{PRS } \hat{E}_s / \text{Iot} \right)_i$  conditions apply for all subframes of at least  $L = \frac{M}{2}$  PRS positioning occasions,

PRP 1,2|dBm according to E.3 for a corresponding Band.

$\text{PRS } \hat{E}_s / \text{Iot}$  is as defined in Section 9.1.1.3.

The time  $T_{\text{RSTD InterFreqTDD, E-UTRAN}}$  starts from the first subframe of the PRS positioning occasion closest in time after both the OTDOA-RequestLocationInformation message and the OTDOA assistance data in the OTDOA-ProvideAssistanceData message as specified in 3GPP TS 36.355 [4], are delivered to the physical layer of the UE.

This requirement assumes that the measurement report is not delayed by other LPP signalling on the DCCH. This measurement reporting delay excludes a delay uncertainty resulted when inserting the measurement report to the TTI of the uplink DCCH. The delay uncertainty is:  $2 \times \text{TTI}_{\text{DCCH}}$ . This measurement reporting delay excludes any delay caused by no UL resources for UE to send the measurement report.

The normative reference for this requirement is TS 36.133 [23] clause 8.1.2.6.3 and A.8.13.2.

#### 9.2.2.4 Test description

##### 9.2.2.4.1 Initial conditions

Test Environment: Normal; as defined in TS 36.508 [18] clause 4.1.

Frequencies to be tested: Mid Range, as defined in TS 36.508 [18] clause 4.3.1.1.

Channel bandwidth to be tested: 10 MHz as defined in TS 36.508 [18] clause 4.3.1.

1. Connect the SS, faders and AWGN noise sources to the UE antenna connector or antenna connectors as shown in Annex A, Figure A.4.
2. The general test parameter settings are set up according to Table 9.2.2.4.1-1.
3. Propagation conditions are set according to clause 4.7.2.1.
4. Message contents are defined in clause 9.2.2.4.3.
5. In the test there are three synchronized cells: Cell 1, Cell 2 and Cell 3. Cell 1 is the OTDOA assistance data reference as well as the serving cell. Cell 2 and Cell 3 are the neighbour cells. Cell 1 is on TDD RF channel 1. Cell 2 and Cell 3 are on a TDD RF channel 2. The assistance data neighbour cell list includes in total 15 cells, where 13 of the cells are not simulated (dummy cells; as defined in 3GPP TS 37.571-5 clause 7.2.2).
6. The true RSTD (which is the receive time difference for frame 0 between two cells as seen at the UE antenna connector) is set to 31 Ts (about 1  $\mu$ s) between neighbour Cell 2 and serving Cell 1; and set to -31 Ts (about -1  $\mu$ s) between neighbour Cell 3 and serving Cell 1.
7. The gap pattern configuration # 0 as defined in Table 8.1.2.1-1 in 3GPP TS 36.133 [23] is configured and does not overlap with PRS subframes of Cell 1.

**Table 9.2.2.4.1-1: General test parameters for E-UTRAN TDD-TDD inter-frequency RSTD measurement reporting delay under fading propagation conditions**

Parameter	Unit	Value	Comment
Reference cell		Cell 1	Reference cell is the cell with respect to which the RSTD measurement is defined, as specified in 3GPP TS 36.214 [6] and 3GPP TS 36.355 [4]. The reference cell is the serving cell on RF channel 1 in this test case.
Neighbour cells		Cell 2 and Cell 3	Cells on RF channel 2. The cells appear at random places in the neighbour cell list in the OTDOA assistance data, but Cell 2 always appears in the first half of the list, whilst Cell 3 appears in the second half of the list.
PCFICH/PDCCH/PHICH parameters		DL Reference Measurement Channel R.6 TDD	As specified in TS 36.521-3 [25] clause A.2.2
Channel Bandwidth (BW <sub>channel</sub> )	MHz	10	
PRS Bandwidth <sup>Note 2</sup>	RB	50	PRS are transmitted over the system bandwidth
Gap pattern Id		0	As specified in Table 8.1.2.1-1 in TS 36.133 [23].
Gap offset		12	As specified in 36.331 [22], Section 6.3.5
PRS configuration index $I_{PRS}$ <sup>Note 2</sup>		Cell 1: 184, Cell 2, Cell 3: 174	This corresponds to periodicity of 320 ms and PRS subframe offset of $I_{PRS} - 160$ DL subframes, as defined in 3GPP TS 36.211 [26], Table 6.10.4.3-1
Number of consecutive downlink positioning subframes $N_{PRS}$ <sup>Note 2</sup>		1	As defined in TS 36.211 [26]. The number of subframes in a positioning occasion
Physical cell ID PCI <sup>Note 2</sup>		(PCI of Cell 1 – PCI of Cell 2) mod 6 = 0 and (PCI of Cell 1 – PCI of Cell 3) mod 6 = 0	The cell PCIs are selected such that the relative shifts of PRS patterns among cells are as given by the test parameters
TDD uplink-downlink configuration		1	As specified in TS 36.211 [26], Section 4.2; corresponds to a configuration with 5 ms switch-point periodicity and two downlink consecutive subframes
TDD special subframe configuration		6	As specified in TS 36.211 [26], Section 4.2; corresponds to DwPTS of $19760 \cdot T_s$ and UpPTS of $4384 \cdot T_s$
CP length <sup>Note 2</sup>		Normal	
DRX		ON	DRX parameters are further specified in Table 9.2.2.4.1-2
prs-SubframeOffset <sup>Note 2</sup>		310	Number of subframes rounded to the closest integer. The corresponding parameter in the OTDOA assistance data is prs-SubframeOffset specified in TS 36.355 [4]
slotNumberOffset <sup>Note 2</sup>		0	The slot number offset at the transmitter between a neighbour cell and the assistance data reference cell specified in TS 36.355 [4]
Radio frame receive time offset between the cells at the UE antenna connector <sup>Note 3</sup>	µs	Cell 2 to Cell 1: 1 Cell 3 to Cell 1: -1	PRS are transmitted from synchronous cells

Expected RSTD <sup>Note 1</sup>	$\mu\text{s}$	Cell 2: -2 Cell 3: 2 Other neighbour cells: randomly between -3 and 3	The expected RSTD is what is expected at the receiver. The corresponding parameter in the OTDOA assistance data specified in TS 36.355 [4] is the expectedRSTD indicator
Expected RSTD uncertainty for all neighbour cells <sup>Note 1</sup>	$\mu\text{s}$	5	The corresponding parameter in the OTDOA assistance data specified in TS 36.355 [4] is the expectedRSTD-Uncertainty index
Number of cells provided in OTDOA assistance data		16	The list includes the reference cell (received in <i>OTDOA-ReferenceCellInfo</i> [4]) on RF channel 1 and 15 other cells on RF channel 2, all received in <i>OTDOA-ProvideAssistanceData</i> [4].
PRS muting info <sup>Note 2</sup>		Cell 1: '1111111100000000' Cell 2: '0000000011111111' Cell 3: '1111111100000000'	Corresponds to prs-MutingInfo defined in TS 36.355 [4]
T1	s	3	The length of the time interval from the beginning of each test
T2	s	2.48	The length of the time interval that follows immediately after time interval T1
T3	s	2.48	The length of the time interval that follows immediately after time interval T2
Note 1:	Parameters "Expected RSTD" and "Expected RSTD uncertainty for all neighbour cells" are not settable parameters. These are parameters signalled in LPP only. For the values to be used in LPP see Table 9.2.2.4.3-5 and TS 37.571-5 [20], clause 7.2.2.		
Note 2:	Parameters "PRS Bandwidth", "PRS configuration index", "Number of consecutive downlink positioning subframes", "Physical cell ID PCI", "CP length", "prs-SubframeOffset", "slotNumberOffset" and "PRS muting info" are settable parameters and also parameters signalled in LPP. The values to be used for "Physical cell ID PCI" are as follows: Cell 1: 0, Cell 2: 6, Cell 3: 12. For all the values to be used in LPP see Table 9.2.2.4.3-5 and TS 37.571-5 [20], clause 7.2.2.		
Note 3:	The parameter "Radio frame receive time offset between the cells at the UE antenna connector" is not a settable parameter but is used to set the "true RSTD" values in step 6 of clause 9.2.2.4.1.		

**Table 9.2.2.4.1-2: DRX parameters for E-UTRAN TDD-TDD inter-frequency RSTD measurement reporting delay under fading propagation conditions**

Field	Value	Comment
onDurationTimer	psf1	As specified in 3GPP TS 36.331 [22], clause 6.3.2
drx-InactivityTimer	psf1	
drx-RetransmissionTimer	sf1	
longDRX-CycleStartOffset	sf320	
shortDRX	Disable	

#### 9.2.2.4.2 Test procedure

The test consists of three consecutive time intervals, with duration of T1, T2 and T3 defined in Table 9.2.2.4.1-1. Cell 1 is active in T1, T2 and T3, whilst Cell 2 and Cell 3 are activated only in the beginning of T2. Cell 2 is active until the end of T3, and Cell 3 is active until the end of T2. The beginning of the time interval T2 shall be aligned 5 ms before the first PRS positioning subframe of a positioning occasion in the reference cell, where 5 ms is the necessary test tolerance. Cell 1 transmits PRS only in T2, Cell 2 transmits PRS only in T3, and Cell 3 transmits PRS only in T2.

**NOTE:** The information on when PRS is muted is conveyed to the UE using PRS muting information in the OTDOA assistance data.

The OTDOA-RequestLocationInformation message and the OTDOA assistance data as defined in clause 9.2.2.4.3 shall be provided to the UE during T1. The last TTI containing the OTDOA-RequestLocationInformation message shall be provided to the UE  $\Delta T$  ms before the start of T2, where  $\Delta T = 150$  ms is the maximum processing time of the OTDOA-RequestLocationInformation message and the OTDOA assistance data.



1. Ensure that the UE is in state Generic RB Established State 3A-RF according to 3GPP TS 36.508 [18] clause 7.2A.3.
2. The SS shall send a RESET UE POSITIONING STORED INFORMATION message.
3. Set the parameters according to Table 9.2.2.5-1. Propagation conditions are set according to clause 4.7.2.2 (ETU30).
4. T1 starts.
5. The SS shall transmit an RRCConnectionReconfiguration message with the DRX configuration and the measurement gap configuration. PDCCHs indicating new transmissions shall be sent continuously until the start of T2 to ensure that the UE would not enter the DRX state before T2.
6. The UE shall transmit RRCConnectionReconfigurationComplete message.
- 6a. The SS shall transmit an LPP REQUEST CAPABILITIES message.
- 6b. The UE shall transmit an LPP PROVIDE CAPABILITIES message indicating the OTDOA capabilities supported by the UE in the *OTDOA-ProvideCapabilities* IE.
7. The SS shall send a LPP PROVIDE ASSISTANCE DATA message, including the *OTDOA-ProvideAssistanceData* IE. The position of neighbour Cell 2 in the *OTDOA-NeighbourCellInfoList* is randomly selected to be in the first 7 elements of the sequence, and the position of neighbour Cell 3 is randomly selected to be in the last 8 elements of the sequence, as described in 3GPP TS 37.571-5 [20], clause 7.2.3. If the UE message at step 6b includes the *ackRequested* IE set to TRUE, then the SS shall send an acknowledgment in the LPP PROVIDE ASSISTANCE DATA message.
8. The SS shall send a LPP REQUEST LOCATION INFORMATION message, including the *OTDOA-RequestLocationInformation* IE such that the UE receives the message  $\Delta T$  ms before the start of T2, where  $\Delta T = 150$  ms.
9. When T1 expires, the SS shall switch the power setting from T1 to T2 as specified in Table 9.2.2.5-2.
10. When T2 expires, the SS shall switch the power setting from T2 to T3 as specified in Table 9.2.2.5-2.
11. The UE shall transmit a LPP PROVIDE LOCATION INFORMATION message including the *OTDOA-ProvideLocationInformation* IE within the response time (see clause 4.7.3) specified in clause 9.2.2.5. The UE shall perform and report the RSTD measurements for both Cell 2 and Cell 3 with respect to the reference cell in the OTDOA assistance data, Cell 1. If the UE transmits an *OTDOA-ProvideLocationInformation* IE including the *rstd* field for both Cell 2 and Cell 3 within the response time then the number of successful tests is increased by one. If the UE fails to report the *OTDOA-ProvideLocationInformation* IE with both the *rstd* fields included within the response time then the number of failure tests is increased by one.
12. If the UE message at step 11 includes the *ackRequested* IE set to TRUE, the SS shall send a LPP acknowledgement message.
13. Repeat steps 2-12 until the confidence level according to Annex D is achieved. For each iteration, at step 7 change the random position of the Cells 2 and 3 in the *OTDOA-NeighbourCellInfoList*.

#### 9.2.2.4.3 Message contents

**Table 9.2.2.4.3-1: RESET UE POSITIONING STORED INFORMATION**

Derivation Path: 36.509 [11] clause 6.9			
Information Element	Value/remark	Comment	Condition
UE Positioning Technology	0 0 0 0 0 0 1	OTDOA	

**Table 9.2.2.4.3-2: MAC-MainConfig-RBC: TDD-TDD Inter-frequency RSTD Measurement Reporting Delay**

Derivation Path: TS 36.508 [18] clause 4.8.2.1.5, Table 4.8.2.1.5-1 MAC-MainConfig-RBC			
Information Element	Value/remark	Comment	Condition
MAC-MainConfig-RBC ::= SEQUENCE {			
drx-Config CHOICE {			
setup SEQUENCE {			
onDurationTimer	psf1		
drx-InactivityTimer	psf1		
drx-RetransmissionTimer	sf1		
longDRX-CycleStartOffset CHOICE {			
sf320	0		
}			
shortDRX	Not present		
}			
}			
}			

**Table 9.2.2.4.3-3: MeasGapConfig-GP1: TDD-TDD inter-frequency RSTD Measurement Reporting Delay**

Derivation Path: TS 36.508 [18] clause 4.6.6, Table 4.6.6-1A: MeasGapConfig-GP1			
Information Element	Value/remark	Comment	Condition
MeasGapConfig-GP1 ::= CHOICE {			
setup SEQUENCE {			
gapOffset CHOICE {			
gp0	12	TGRP = 40 ms	
}			
}			
}			

**Table 9.2.2.4.3-3a: LPP Request Capabilities**

Information Element	Value/remark
<i>otdoa-RequestCapabilities</i>	TRUE

**Table 9.2.2.4.3-4: LPP RequestLocationInformation**

Derivation Path: 36.355 clause 6.2			
Information Element	Value/remark	Comment	Condition
LPP-Message ::= SEQUENCE {			
transactionID SEQUENCE {			
initiator	locationServer		
transactionNumber	1		
}			
endTransaction	FALSE		
sequenceNumber	Not present		
acknowledgement	Not present		
lpp-MessageBody CHOICE {			
c1 CHOICE {			
requestLocationInformation SEQUENCE {			
criticalExtensions CHOICE {			
c1 CHOICE {			
requestLocationInformation-r9 SEQUENCE {			
commonIEsRequestLocationInformation SEQUENCE {			
locationInformationType	locationMeasurementsRequired		
triggeredReporting	Not present		
periodicalReporting	Not present		
additionalInformation	onlyReturnInformationRequested		
qos SEQUENCE {			
horizontalAccuracy	Not present		
verticalCoordinateRequest	FALSE		
verticalAccuracy	Not present		
responseTime SEQUENCE {			
time	6	See clause 9.2.2.5	
responseTimeEarlyFix-r12	Not present		Rel-12 onwards
}			
velocityRequest	FALSE		
}			
environment	Not present		
locationCoordinateTypes	Not present		
velocityTypes	Not present		
}			
a-gnss-RequestLocationInformation	Not present		
otdoa-RequestLocationInformation SEQUENCE {			
assistanceAvailability	FALSE		
}			
ecid-RequestLocationInformation	Not present		
epdu-RequestLocationInformation	Not Present		
}			
}			
}			
}			
}			

Table 9.2.2.4.3-5: LPP ProvideAssistanceData

Derivation Path: 36.355 clause 6.2			
Information Element	Value/remark	Comment	Condition
LPP-Message ::= SEQUENCE {			
transactionID SEQUENCE {			
Initiator	locationServer		
transactionNumber	(0..255)		
}			
endTransaction	TRUE		
sequenceNumber	Not present		
acknowledgement	Not present		
lpp-MessageBody CHOICE {			
c1 CHOICE {			
provideAssistanceData SEQUENCE {			
criticalExtensions CHOICE {			
c1 CHOICE {			
provideAssistanceData-r9 SEQUENCE {			
commonIEsProvideAssistanceData	Not present		
a-gnss-ProvideAssistanceData	Not present		
otdoa-ProvideAssistanceData SEQUENCE {			
otdoa-ReferenceCellInfo	As defined in TS 37.571-5 [20], clause 7.2.2.		
otdoa-NeighbourCellInfo	As defined in TS 37.571-5 [20], clause 7.2.2.		
otdoa-Error	Not present		
}			
epdu-ProvideAssistanceData	Not present		
}			
}			
}			
}			

**Table 9.2.2.4.3-6: LPP ProvideLocation Information**

Derivation Path: 36.355 clause 6.2			
Information Element	Value/remark	Comment	Condition
LPP-Message ::= SEQUENCE {			
transactionID SEQUENCE {			
initiator	locationServer		
transactionNumber	1		
}			
endTransaction	TRUE		
sequenceNumber	(0..255)		
acknowledgement			
lpp-MessageBody CHOICE {			
c1 CHOICE {			
provideLocationInformation SEQUENCE {			
criticalExtensions CHOICE {			
c1 CHOICE {			
provideLocationInformation-r9 SEQUENCE {			
commonIEsProvideLocationInformation	Not present.		
a-gnss-ProvideLocationInformation	Not present		
otdoa-ProvideLocationInformation SEQUENCE {			
otdoaSignalMeasurementInformation SEQUENCE {			
systemFrameNumber			
physCellIdRef	Cell 1		
cellGlobalIdRef			
earfcnRef			
referenceQuality			
neighbourMeasurementList SEQUENCE (SIZE(n)) {			
physCellIdNeighbor	Cell 2		
cellGlobalIdNeighbour			
earfcnNeighbour	RF channel 2		
rstd	Present		
rstd-Quality			
}			
neighbourMeasurementList SEQUENCE (SIZE(n)) {			
physCellIdNeighbor	Cell 3		
cellGlobalIdNeighbour			
earfcnNeighbour	RF channel 2		
rstd	Present		
rstd-Quality			
}			
} otdoa-Error	May be present with error reason 'undefined' or 'attemptedButUnableToMeasureSomeNeighbourCells'		
}			
ecid-ProvideLocationInformation	Not present		
epdu-ProvideLocationInformation	Not present		
}			
}			
}			

9.2.2.5 Test requirement

Table 9.2.2.5-1 and 9.2.2.5-2 define the primary level settings including test tolerances for the test.

**Table 9.2.2.5-1: Cell-specific test parameters for E-UTRAN TDD-TDD inter-frequency RSTD measurement reporting delay under fading propagation conditions during T1**

Parameter	Unit	Cell 1	Cell 2	Cell 3
E-UTRA RF Channel Number		1	N/A	N/A
Correlation Matrix and Antenna Configuration		1x2 Low	1x2 Low	1x2 Low
OCNG patterns defined in TS 36.521-3 [25] clause D.2		OP.1 TDD	N/A	N/A
PBCH_RA	dB	0	N/A	N/A
PBCH_RB				
PSS_RA				
SSS_RA				
PCFICH_RB				
PHICH_RA				
PHICH_RB				
PDCCH_RA				
PDCCH_RB				
OCNG_RA <sup>Note 1</sup>				
OCNG_RB <sup>Note 1</sup>				
$N_{oc}$ <sup>Note 3</sup>	dBm/ 15 kHz	-95	N/A	N/A
$PRS \hat{E}_s / N_{oc}$	dB	-Infinity	-Infinity	-Infinity
$I_o$ <sup>Note 4</sup>	dBm/ 9 MHz	-67.22	N/A	N/A
$\hat{E}_s / N_{oc}$	dB	0	-Infinity	-Infinity
Propagation Condition		ETU30		
Note 1:	OCNG shall be used such that the active cell (Cell 1) is fully allocated and a constant total transmitted power spectral density is achieved for all OFDM symbols.			
Note 2:	The resources for uplink transmission are assigned to the UE prior to the start of time period T2.			
Note 3:	Interference from other cells and noise sources not specified in the test are assumed to be constant over subcarriers and time and shall be modelled as AWGN of appropriate power for $N_{oc}$ to be fulfilled.			
Note 4:	$I_o$ levels have been derived from other parameters and are given for information purpose. These are not settable test parameters.			

**Table 9.2.2.5-2: Cell-specific test parameters for E-UTRAN TDD-TDD inter-frequency RSTD measurement reporting delay under fading propagation conditions during T2 and T3**

Parameter	Unit	Cell 1		Cell 2		Cell 3	
		T2	T3	T2	T3	T2	T3
E-UTRA RF Channel Number		1		2		2	N/A
Correlation Matrix and Antenna Configuration		1x2 Low		1x2 Low		1x2 Low	
OCNG patterns defined in TS 36.521-3 [25] clause D.2		OP.1 TDD		OP.2 TDD		OP.2 TDD	N/A
PBCH_RA	dB	0		0		0	N/A
PBCH_RB							
PSS_RA							
SSS_RA							
PCFICH_RB							
PHICH_RA							
PHICH_RB							
PDCCH_RA							
PDCCH_RB							
OCNG_RA <sup>Note 1</sup>							
OCNG_RB <sup>Note 1</sup>							
PRS_RA	dB	-3	N/A	N/A	3	3	N/A
$N_{oc}$ <sup>Note 3</sup>	dBm/15 kHz	-98	-98	-98	-95	-98	N/A
$\hat{E}_s/N_{oc}$	dB	-1	-Infinity	-Infinity	-7	-8	-Infinity
$\hat{E}_s/I_{ot}$ <sup>Note 4</sup>	dB	-1	-Infinity	-Infinity	-7	-8	-Infinity
$I_o$ <sup>Note 4</sup>	dBm/9 MHz	-69.68	-70.22	-70.11	-67.08	-70.11	N/A
PRP <sup>Note 4</sup>	dBm/15 kHz	-99	-Infinity	-Infinity	-102	-106	-Infinity
RSRP <sup>Note 4</sup>	dBm/15 kHz	-96	-96	-105	-105	-109	-Infinity
$\hat{E}_s/N_{oc}$ <sup>Note 4</sup>	dB	2	2	-7	-10	-11	-Infinity
Propagation Condition		ETU30					
Note 1:	OCNG shall be used such that active cells (all, except Cell 3 in T3) are fully allocated and a constant total transmitted power spectral density is achieved for all OFDM symbols other than those in the subframes with transmitted PRS.						
Note 2:	The resources for uplink transmission are assigned to the UE prior to the start of time period T2.						
Note 3:	Interference from other cells and noise sources not specified in the test are assumed to be constant over subcarriers and time and shall be modelled as AWGN of appropriate power for $N_{oc}$ to be fulfilled.						
Note 4:	If PRS_RA is not "N/A", $\hat{E}_s/N_{oc}$ , $\hat{E}_s/I_{ot}$ , $I_o$ , RSRP and PRP levels have been derived from other parameters and are given for information purpose. If PRS_RA is "N/A", $I_o$ and RSRP levels have been derived from other parameters and are given for information purpose. These are not settable test parameters. Interference conditions shall be applied to all PRS symbols of DL positioning subframes						

The response time including test tolerance is 6.3 s. The response time is equal to the LPP time IE value plus the test tolerance. The LPP time IE value is derived from the RSTD reporting delay plus  $\Delta T$ , where  $\Delta T = 150$  ms, giving a value of 5110 ms. This is rounded up to the next allowed LPP value of 6 seconds. The RSTD measurement reporting

delay in the test is derived from the following expression,  $T_{PRS}(M-1) + 160 \left\lceil \frac{n}{M} \right\rceil$ , where  $M=16$  and  $n=16$  are the parameters specified in clause 9.2.2.3 and Table 9.2.2.3-1. This gives the total RSTD reporting delay of 4960 ms for the 15 neighbour cells including Cell 2 and Cell 3 with respect to the reference cell, Cell 1.

The test tolerances are defined in clauses C.1.3 and C4.

The rate of successful tests during repeated tests shall be at least 90% with a confidence level of 95%.

## 9.2.2A TDD-TDD inter-frequency RSTD Measurement Reporting Delay for UE Category 1bis

### 9.2.2A.1 Test purpose

To verify that the TDD-TDD inter-frequency RSTD measurement reporting delay meets the requirements in an environment with fading propagation conditions.

### 9.2.2A.2 Test applicability

This test applies to E-UTRA TDD UE Category 1bis release 13 and forward that support inter-frequency RSTD measurements.

### 9.2.2A.3 Minimum conformance requirements

Same as 9.2.2.3 but using Table 9.2.2A.3-1 instead of Table 9.2.2.3-1.

**Table 9.2.2A.3-1: Number of PRS positioning occasions within  $T_{RSTD \text{ InterFreqTDD, E-UTRAN}}$**

Positioning subframe configuration period $T_{PRS}$	Number of PRS positioning occasions $M$	
	f2 <sup>Note 1</sup>	f1 and f2 <sup>Note 2</sup>
160 ms	32	64
>160 ms	16	32
Note 1:	When inter-frequency RSTD measurements are performed over the reference cell and neighbour cells, which belong to the TDD inter-frequency carrier frequency f2.	
Note 2:	When inter-frequency RSTD measurements are performed over the reference cell and the neighbour cells, which belong to the serving TDD carrier frequency f1 and the FDD inter-frequency carrier frequency f2 respectively.	

The normative reference for this requirement is TS 36.133 [23] clause 8.1.2.6.7 and A.8.13.2.

### 9.2.2A.4 Test description

#### 9.2.2A.4.1 Initial conditions

Same as 9.2.2.4.1 with the following exceptions:

1. Connect the SS, faders and AWGN noise sources to the UE antenna connector or antenna connectors as shown in Annex A, Figure A.4, using only the main Tx/Rx path.
2. The general test parameter settings are set up according to Table 9.2.2A.4.1-1.



**Table 9.2.2A.4.1-1: General test parameters for E-UTRAN TDD-TDD inter-frequency RSTD measurement reporting delay under fading propagation conditions for UE Category 1bis**

Parameter	Unit	Value	Comment
Reference cell		Cell 1	Reference cell is the cell with respect to which the RSTD measurement is defined, as specified in 3GPP TS 36.214 [6] and 3GPP TS 36.355 [4]. The reference cell is the serving cell on RF channel 1 in this test case.
Neighbour cells		Cell 2 and Cell 3	Cells on RF channel 2. The cells appear at random places in the neighbour cell list in the OTDOA assistance data, but Cell 2 always appears in the first half of the list, whilst Cell 3 appears in the second half of the list.
PCFICH/PDCCH/PHICH parameters		DL Reference Measurement Channel R.6 TDD	As specified in TS 36.521-3 [25] clause A.2.2
Channel Bandwidth (BW <sub>channel</sub> )	MHz	10	
PRS Bandwidth <sup>Note 2</sup>	RB	50	PRS are transmitted over the system bandwidth
Gap pattern Id		0	As specified in Table 8.1.2.1-1 in TS 36.133[23].
Gap offset		12	As specified in 36.331 [22], Section 6.3.5
PRS configuration index $I_{PRS}$ <sup>Note 2</sup>		Cell 1: 184, Cell 2, Cell 3: 174	This corresponds to periodicity of 320 ms and PRS subframe offset of $I_{PRS} - 160$ DL subframes, as defined in 3GPP TS 36.211 [26], Table 6.10.4.3-1
Number of consecutive downlink positioning subframes $N_{PRS}$ <sup>Note 2</sup>		1	As defined in TS 36.211 [26]. The number of subframes in a positioning occasion
Physical cell ID PCI <sup>Note 2</sup>		(PCI of Cell 1 – PCI of Cell 2)mod6=0 and (PCI of Cell 1 – PCI of Cell 3)mod6=0	The cell PCIs are selected such that the relative shifts of PRS patterns among cells are as given by the test parameters
TDD uplink-downlink configuration		1	As specified in TS 36.211 [26], Section 4.2; corresponds to a configuration with 5 ms switch-point periodicity and two downlink consecutive subframes
TDD special subframe configuration		6	As specified in TS 36.211 [26], Section 4.2; corresponds to DwPTS of $19760 \cdot T_s$ and UpPTS of $4384 \cdot T_s$
CP length <sup>Note 2</sup>		Normal	
DRX		ON	DRX parameters are further specified in Table 9.2.1.4.1-2
prs-SubframeOffset <sup>Note 2</sup>		310	Number of subframes rounded to the closest integer. The corresponding parameter in the OTDOA assistance data is prs-SubframeOffset specified in TS 36.355 [4]
slotNumberOffset <sup>Note 2</sup>		0	The slot number offset at the transmitter between a neighbour cell and the assistance data reference cell specified in TS 36.355 [4]
Radio frame receive time offset between the cells at the UE antenna connector <sup>Note 3</sup>	µs	Cell 2 to Cell 1: 1 Cell 3 to Cell 1: -1	PRS are transmitted from synchronous cells

Expected RSTD <sup>Note 1</sup>	µs	Cell 2: -2 Cell 3: 2 Other neighbour cells: randomly between -3 and 3	The expected RSTD is what is expected at the receiver. The corresponding parameter in the OTDOA assistance data specified in TS 36.355 [4] is the expectedRSTD indicator
Expected RSTD uncertainty for all neighbour cells <sup>Note 1</sup>	µs	5	The corresponding parameter in the OTDOA assistance data specified in TS 36.355 [4] is the expectedRSTD-Uncertainty index
Number of cells provided in OTDOA assistance data		16	The list includes the reference cell (received in <i>OTDOA-ReferenceCellInfo</i> [4]) on RF channel 1 and 15 other cells on RF channel 2, all received in <i>OTDOA-ProvideAssistanceData</i> [4].
PRS muting info <sup>Note 2</sup>		Cell 1: '11111111111111111000000000000000' 00' Cell 2: '000000000000000011111111111111' 11' Cell 3: '11111111111111111000000000000000' 00'	Corresponds to prs-MutingInfo defined in TS 36.355 [4]
T1	s	3	The length of the time interval from the beginning of each test
T2	s	4.96	The length of the time interval that follows immediately after time interval T1
T3	s	4.96	The length of the time interval that follows immediately after time interval T2
<p>Note 1: Parameters "Expected RSTD" and "Expected RSTD uncertainty for all neighbour cells" are not settable parameters. These are parameters signalled in LPP only. For the values to be used in LPP see Table 9.2.1.4.3-5 and TS 37.571-5 [20], clause 7.2.2.</p> <p>Note 2: Parameters "PRS Bandwidth", "PRS configuration index", "Number of consecutive downlink positioning subframes", "Physical cell ID PCI", "CP length", "prs-SubframeOffset", "slotNumberOffset" and "PRS muting info" are settable parameters and also parameters signalled in LPP. The values to be used for "Physical cell ID PCI" are as follows: Cell 1: 0, Cell 2: 6, Cell 3: 12. For all the values to be used in LPP see Table 9.2.1.4.3-5 and TS 37.571-5 [20], clause 7.2.2.</p> <p>Note 3: The parameter "Radio frame receive time offset between the cells at the UE antenna connector" is not a settable parameter but is used to set the "true RSTD" values in step 6 of clause 9.2.1.4.1.</p>			

9.2.2A.4.2 Test procedure

Same as 9.2.2.4.2.

9.2.2A.4.3 Message contents

Same as 9.2.2.4.3 with the following exceptions:

Table 9.2.2A.4.3-1: LPP RequestLocationInformation

Derivation Path: Table 9.2.2.4.3-4			
Information Element	Value/remark	Comment	Condition
LPP-Message ::= SEQUENCE {			
lpp-MessageBody CHOICE {			
c1 CHOICE {			
requestLocationInformation SEQUENCE {			
criticalExtensions CHOICE {			
c1 CHOICE {			
requestLocationInformation-r9 SEQUENCE {			
commonIEsRequestLocationInformation SEQUENCE {			
qos SEQUENCE {			
responseTime SEQUENCE {			
time	11	See clause 9.2.2A.5	
}			
}			
}			
}			
}			
}			
}			
}			
}			
}			

### 9.2.2A.5 Test requirement

Table 9.2.2.5-1 and 9.2.2.5-2 define the primary level settings including test tolerances for the test.

The response time including test tolerance is 11.3 s. The response time is equal to the LPP time IE value plus the test tolerance. The LPP time IE value is derived from the RSTD reporting delay plus  $\Delta T$ , where  $\Delta T = 150$  ms, giving a value of 10230 ms. This is rounded up to the next allowed LPP value of 11 seconds. The RSTD measurement reporting delay in the test is derived from the following expression,  $T_{PRS} (M - 1) + 160 \left\lceil \frac{n}{M} \right\rceil$ , where  $M = 32$  and  $n = 16$  are the parameters specified in clause 9.2.2A.3 and Table 9.2.2A.3-1. This gives the total RSTD reporting delay of 10080 ms for the 15 neighbour cells including Cell 2 and Cell 3 with respect to the reference cell, Cell 1.

The test tolerances are defined in clauses C.1.3 and C4.

The rate of successful tests during repeated tests shall be at least 90% with a confidence level of 95%.

### 9.2.3 Void

### 9.2.4 FDD-FDD inter-frequency RSTD Accuracy

#### 9.2.4.1 Test purpose

To verify that the Reference Signal Time Difference (RSTD) FDD-FDD inter-frequency measurement accuracy is within the specified limit for all bands in AWGN channels.

#### 9.2.4.2 Test applicability

This test applies to all types of E-UTRA FDD UE release 10 and forward that support inter-frequency RSTD measurements except UE Category 1bis.

#### 9.2.4.3 Minimum conformance requirements

The accuracy of FDD-FDD inter-frequency RSTD measurement shall meet the requirement defined in the Table 9.2.4.3-1 without DRX as well as for all the DRX cycles specified in TS 36.331 [22].

The accuracy requirements in Table 9.2.4.3-1 are valid under the following conditions:

Conditions defined in TS 36.101 [2] Section 7.3 for reference sensitivity are fulfilled.

PRP 1,2<sub>dBm</sub> according to clause E.3 for a corresponding Band.

There are no measurement gaps overlapping with the PRS subframes in cells belonging to the serving carrier frequency.

The parameter `expectedRSTDUncertainty` signalled over LPP by E-SMLC as defined in TS 36.355 [4] is less than 5  $\mu$ s.

Table 9.2.4.3-1: RSTD measurement accuracy

Accuracy	Conditions					
	PRS $\hat{E}_s/lot$	Minimum PRS bandwidth which is minimum of serving cell channel bandwidth <sup>Note 9</sup> and the PRS bandwidths of the reference cell and the measured neighbour cell $i$	Minimum number of available measurement subframes among the reference cell and the measured neighbour cell $i$	$I_o$ <sup>Note 8</sup> range		
E-UTRA operating band groups <sup>Note 10</sup>				Minimum $I_o$ <sup>Note 1</sup>	Maximum $I_o$	
$T_s$ <sup>Note 2</sup>	dB	RB			dBm/15kHz <sup>Note 7</sup>	dBm/BW <sub>channel</sub>
±21	(PRS $\hat{E}_s/lot$ ) <sub>ref</sub> ≥ -6dB and (PRS $\hat{E}_s/lot$ ) <sub>i</sub> ≥ -13dB	≥ 6	4	FDD_A, TDD_A	-121	-50
				FDD_B	-120.5	-50
				FDD_C, TDD_C	-120	-50
				FDD_D	-119.5	-50
				FDD_E, TDD_E	-119	-50
				FDD_F	-118.5	-50
				FDD_G	-118	-50
				FDD_H	-117.5	-50
FDD_N	-114.5	-50				
±16 <sup>Note 11</sup>	(PRS $\hat{E}_s/lot$ ) <sub>ref</sub> ≥ -6dB and (PRS $\hat{E}_s/lot$ ) <sub>i</sub> ≥ -13dB	≥ 15	4	Note 5	Note 5	Note 5
±10	(PRS $\hat{E}_s/lot$ ) <sub>ref</sub> ≥ -6dB and (PRS $\hat{E}_s/lot$ ) <sub>i</sub> ≥ -13dB	≥ 25	≥ 2	Note 5	Note 5	Note 5
±9	(PRS $\hat{E}_s/lot$ ) <sub>ref</sub> ≥ -6dB and (PRS $\hat{E}_s/lot$ ) <sub>i</sub> ≥ -13dB	≥ 50	≥ 1	Note 5	Note 5	Note 5
±8 <sup>Note 11</sup>	(PRS $\hat{E}_s/lot$ ) <sub>ref</sub> ≥ -6dB and (PRS $\hat{E}_s/lot$ ) <sub>i</sub> ≥ -13dB	≥ 75	≥ 1	Note 5	Note 5	Note 5

NOTE 1: This minimum  $I_o$  condition is expressed as the average  $I_o$  per RE over all REs in an OFDM symbol.  
 NOTE 2:  $T_s$  is the basic timing unit defined in TS 36.211 [26].  
 NOTE 3: PRS bandwidth is as indicated in *prs-Bandwidth* in the OTDOA assistance data defined in [24].  
 NOTE 4: Void.  
 NOTE 5: The same bands and the same  $I_o$  conditions for each band apply for this requirement as for the corresponding requirement with the PRS bandwidth ≥ 6 RB.  
 NOTE 6: Void.  
 NOTE 7: The condition level is increased by  $\Delta > 0$ , when applicable, as described in TS 36.133 [23] Annexes B.4.2 and B.4.3.  
 NOTE 8: The  $I_o$  is defined in PRS positioning subframes. The same  $I_o$  range applies to PRS and non-PRS symbols.  $I_o$  levels are different in PRS and non-PRS symbols within the same subframe.  
 NOTE 9: If a CA capable UE is configured with SCell, the serving cell channel bandwidth is the minimum of the serving cell channel bandwidths in the component carriers involved in the RSTD measurement. If one of the serving cells is not involved in this RSTD measurement for CA, the channel bandwidth of that serving cell is not included in the determination of the minimum PRS bandwidth.  
 NOTE 10: E-UTRA operating band groups are as defined in clause 4.4.2.  
 NOTE 11: Only applicable from Rel-12 onwards

The normative reference for this requirement is TS 36.133 [23] clause 9.1.10.2 and A.9.8.3.

## 9.2.4.4 Test description

### 9.2.4.4.1 Initial conditions

Test Environment: Normal; as defined in TS 36.508 [18] clause 4.1.

Frequencies to be tested: Mid Range, as defined in TS 36.508 [18] clause 4.3.1.1.

Channel bandwidth to be tested: 1.4 MHz (Test 1) and 10 MHz (Test 2). In the case that 1.4 MHz channel bandwidth is not defined for the operating band under test, as defined in TS 36.101 [2] clause 5.6.1, then this part of the test shall be omitted.

1. Connect the SS and AWGN noise sources to the UE antenna connector or antenna connectors as shown in Annex A, Figure A.3a for 4RX capable UE without any 2RX bands. Otherwise use Annex A figure A.3.
2. The general test parameter settings are set up according to Table 9.2.4.4.1-1.
3. Propagation conditions are set according to clause 4.7.2.1.
4. Message contents are defined in clause 9.2.4.4.3.
5. Two cells are on the different carrier frequencies. Cell 1 is the serving cell and OTDOA assistance data reference cell; Cell 2 is the neighbour cell. The assistance data neighbour cell list includes in total 15 cells, where 14 of the cells are not simulated (dummy cells; as defined in 3GPP TS 37.571-5 [20], clause 7.2.2).
6. The true RSTD (which is the receive time difference for frame 0 between the two cells as seen at the UE antenna connector) is set to 92 Ts (about 3  $\mu$ s) between neighbour cell 2 and serving cell 1 for Test 1 and -92 Ts (about -3  $\mu$ s) for Test 2.

Note that the related expectedRSTD values to be signalled over LPP are defined in Table 9.2.4.4-1.

7. The gap pattern configuration # 0 as defined in Table 8.1.2.1-1 in 3GPP TS 36.133 [23] is configured and does not overlap with PRS subframes of Cell 1.

Table 9.2.4.4.1-1: General Test Parameters for inter-frequency RSTD Tests for E-UTRAN FDD

Parameter	Unit	Value		Comment
		Test 1	Test 2	
PCFICH/PDCCH/PHICH parameters		R.14 FDD	R.6 FDD	As specified in TS 36.521-3 [25] clause A.2.1.
OCNG Patterns defined in TS 36.521-3 [25] clause D.1		OP.7 FDD	OP.6 FDD	OCNG shall be used such that both cells are fully allocated and a constant total transmitted power spectral density is achieved for all OFDM symbols (other than those in the PRS subframes).
Reference cell		Cell 1		Cell 1 on RF channel number 1
Neighbour cell		Cell 2		Cell 2 on RF channel number 2
E-UTRA RF Channel Number		1,2		Two FDD carrier frequencies are used.
Channel Bandwidth ( $BW_{\text{channel}}$ )	MHz	1.4	10	
GapOffset		18	11	For Cell 1
Gap Pattern ID		0	0	For Cell 1
PRS Bandwidth	RB	6	50	
PRS configuration Index $I_{\text{PRS}}$ Note 2		Cell 1: 12 Cell 2: 19	Cell 1: 2 Cell 2: 12	As defined in 3GPP TS 36.211 [26]
PRS subframe offset		7	10	For Cell 2
Number of consecutive positioning downlink subframes $N_{\text{PRS}}$ Note 2		6	1	As defined in 3GPP TS 36.211 [26]
prs-MutingInfo Note 2		Cell 1: '11110000' Cell 2: '11110000'		See section 6.5.1.2 in 3GPP TS 36.355 [4] for more information
Cell ID Note 2		Cell 1: 0 Cell 2: 1		
Expected RSTD Note 1	$\mu\text{s}$	Cell 2: 1 Other neighbour cells: randomly between -3 and 3		The expected RSTD is what is expected at the receiver. The corresponding parameter in the OTDOA assistance data specified in TS 36.355 [4] is the expectedRSTD indicator
Expected RSTD uncertainty for all neighbour cells Note 1	$\mu\text{s}$	5		The corresponding parameter in the OTDOA assistance data specified in TS 36.355 [4] is the expectedRSTD-Uncertainty index
CP length Note 2		Normal		
DRX		OFF		
Radio frame receive time offset between the cells at the UE antenna connector Note 3	$\mu\text{s}$	Cell 2 to Cell 1: 3	Cell 2 to Cell 1: -3	PRS are transmitted from synchronous cells
Number of cells provided in OTDOA assistance data		16		The list includes the reference cell (received in <i>OTDOA-ReferenceCellInfo</i> [4]) on RF channel 1 and 15 other cells on RF channel 2, all received in <i>OTDOA-ProvideAssistanceData</i> [4].
$T_{\text{RSTD InterFreqFDD, E-UTRAN}}$ Note 4	ms	5120		Derived according to the RSTD measurement requirements specified in Section 8.1.2.6.1 in TS 36.133 [23].
<p>NOTE 1: Parameters "Expected RSTD" and "Expected RSTD uncertainty for all neighbour cells" in Table 9.2.4.4.1-1 are not settable parameters. These are parameters signalled in LPP only. For the values to be used in LPP see Table 9.2.4.4.3-4 and TS 37.571-5 [20], clause 7.2.2.</p> <p>NOTE 2: Parameters "PRS Bandwidth", "PRS configuration index", "Number of consecutive positioning downlink subframes", "prs-MutingInfo", "Cell ID" and "CP length" in Table 9.2.4.4.1-1 are settable parameters and also parameters signalled in LPP. For all the values to be used in LPP see Table 9.2.4.4.3-4 and TS 37.571-5 [20], clause 7.2.2.</p> <p>NOTE 3: The parameter "Radio frame receive time offset between the cells at the UE antenna connector" is not a settable parameter but is used to set the "true RSTD" values in step 6 of clause 9.2.4.4.1.</p> <p>NOTE 4: The parameter "<math>T_{\text{RSTD InterFreqFDD, E-UTRAN}}</math>" is not a settable parameter but is used to set the LPP "time" value in Table 9.2.4.4.3-3. The value of the LPP time IE is set to <math>T_{\text{RSTD InterFreqFDD, E-UTRAN}} + \Delta T</math> ms, where <math>\Delta T = 150</math> ms, giving a value of 5270 ms. This is rounded up to the next allowed LPP value of 6 seconds.</p>				



#### 9.2.4.4.2 Test procedure

The test consists of a set-up period and a measurement period. Cell 1 and Cell 2 are both active during the complete test. The beginning of the measurement period shall be aligned with the first PRS positioning subframe of a positioning occasion in the reference cell.

NOTE: The information on when PRS is muted is conveyed to the UE using PRS muting information in the OTDOA assistance data.

The OTDOA-RequestLocationInformation message and the OTDOA assistance data as defined in clause 9.2.4.4.3 shall be provided to the UE during the set-up period. The last TTI containing the OTDOA-RequestLocationInformation message shall be provided to the UE  $\Delta T$  ms before the start of the measurement period, where  $\Delta T = 150$  ms is the maximum processing time of the OTDOA-RequestLocationInformation message and the OTDOA assistance data in the UE.

1. Ensure that the UE is in state Generic RB Established State 3A-RF according to 3GPP TS 36.508 [18] clause 7.2A.3.
2. The SS shall send a RESET UE POSITIONING STORED INFORMATION message.
3. Set the parameters according to Table 9.2.4.5-1 as appropriate. Propagation conditions are set according to clause 4.7.2.1.
4. The SS shall transmit an RRCConnectionReconfiguration message with the measurement gap configuration.
5. The UE shall transmit RRCConnectionReconfigurationComplete message.
- 5a. The SS shall transmit an LPP REQUEST CAPABILITIES message.
- 5b. The UE shall transmit an LPP PROVIDE CAPABILITIES message indicating the OTDOA capabilities supported by the UE in the *OTDOA-ProvideCapabilities* IE.
6. The SS shall send a LPP PROVIDE ASSISTANCE DATA message, including the *OTDOA-ProvideAssistanceData* IE. If the UE message at step 5b includes the *ackRequested* IE set to TRUE, then the SS shall send an acknowledgment in the LPP PROVIDE ASSISTANCE DATA message.
7. The SS shall send a LPP REQUEST LOCATION INFORMATION message, including the *OTDOA-RequestLocationInformation* IE such that the UE receives the message  $\Delta T$  ms before the start of measurement period, where  $\Delta T = 150$  ms.
8. The UE shall transmit a LPP PROVIDE LOCATION INFORMATION message, including the *OTDOA-ProvideLocationInformation* IE.
9. If the UE message at step 8 includes the *ackRequested* IE set to TRUE, the SS shall send a LPP acknowledgement message.
10. The SS shall check the *rstd* value for Cell 2 in the *OTDOA-SignalMeasurementInformation* IE according to Table 9.2.4.5-2.
11. Repeat step 2-10 until the confidence level according to Annex D is achieved.
12. Repeat step 1-11 for each sub-test in Table 9.2.4.5-1 as appropriate.

#### 9.2.4.4.3 Message contents

**Table 9.2.4.4.3-1: RESET UE POSITIONING STORED INFORMATION**

Derivation Path: 36.509 [11] clause 6.9			
Information Element	Value/remark	Comment	Condition
UE Positioning Technology	0 0 0 0 0 0 1	OTDOA	

**Table 9.2.4.4.3-2: MeasGapConfig-GP1: FDD-FDD inter-frequency RSTD Accuracy**

Derivation Path: TS 36.508 [18] clause 4.6.6, Table 4.6.6-1A: MeasGapConfig-GP1			
Information Element	Value/remark	Comment	Condition
MeasGapConfig-GP1 ::= CHOICE {			
setup SEQUENCE {			
gapOffset CHOICE {			
gp0	18 (Test 1) 11 (Test 2)	TGRP = 40 ms	
}			
}			
}			

**Table 9.2.4.4.3-2a: LPP Request Capabilities**

Information Element	Value/remark
<i>otdoa-RequestCapabilities</i>	TRUE

**Table 9.2.4.4.3-3: LPP RequestLocationInformation**

Derivation Path: 36.355 clause 6.2			
Information Element	Value/remark	Comment	Condition
LPP-Message ::= SEQUENCE {			
transactionID SEQUENCE {			
initiator	locationServer		
transactionNumber	1		
}			
endTransaction	FALSE		
sequenceNumber	Not present		
acknowledgement	Not present		
lpp-MessageBody CHOICE {			
c1 CHOICE {			
requestLocationInformation SEQUENCE {			
criticalExtensions CHOICE {			
c1 CHOICE {			
requestLocationInformation-r9 SEQUENCE {			
commonIEsRequestLocationInformation SEQUENCE {			
locationInformationType	locationMeasurementsRequired		
triggeredReporting	Not present		
periodicalReporting	Not present		
additionalInformation	onlyReturnInformationRequested		
qos SEQUENCE {			
horizontalAccuracy	Not present		
verticalCoordinateRequest	FALSE		
verticalAccuracy	Not present		
responseTime SEQUENCE {			
time	6	See Note 4 of Table 9.2.4.4.1-1	
responseTimeEarlyFix-r12	Not present		Rel-12 onwards
}			
velocityRequest	FALSE		
}			
environment	Not present		
locationCoordinateTypes	Not present		
velocityTypes	Not present		
}			
a-gnss-RequestLocationInformation	Not present		
otdoa-RequestLocationInformation SEQUENCE {			
assistanceAvailability	FALSE		
}			
ecid-RequestLocationInformation	Not present		
epdu-RequestLocationInformation	Not Present		
}			
}			
}			
}			
}			

Table 9.2.4.4.3-4: LPP ProvideAssistanceData

Derivation Path: 36.355 clause 6.2			
Information Element	Value/remark	Comment	Condition
LPP-Message ::= SEQUENCE {			
transactionID SEQUENCE {			
Initiator	locationServer		
transactionNumber	(0..255)		
}			
endTransaction	TRUE		
sequenceNumber	Not present		
acknowledgement	Not present		
lpp-MessageBody CHOICE {			
c1 CHOICE {			
provideAssistanceData SEQUENCE {			
criticalExtensions CHOICE {			
c1 CHOICE {			
provideAssistanceData-r9 SEQUENCE {			
commonIEsProvideAssistanceData	Not present		
a-gnss-ProvideAssistanceData	Not present		
otdoa-ProvideAssistanceData SEQUENCE {			
otdoa-ReferenceCellInfo	As defined in TS 37.571-5 [20], clause 7.2.2.		
otdoa-NeighbourCellInfo	As defined in TS 37.571-5 [20], clause 7.2.2.		
otdoa-Error	Not present		
}			
epdu-ProvideAssistanceData	Not present		
}			
}			
}			
}			

Table 9.2.4.4.3-5: LPP ProvideLocation Information

Derivation Path: 36.355 clause 6.2			
Information Element	Value/remark	Comment	Condition
LPP-Message ::= SEQUENCE {			
transactionID SEQUENCE {			
initiator	locationServer		
transactionNumber	1		
}			
endTransaction	TRUE		
sequenceNumber	(0..255)		
acknowledgement			
lpp-MessageBody CHOICE {			
c1 CHOICE {			
provideLocationInformation SEQUENCE {			
criticalExtensions CHOICE {			
c1 CHOICE {			
provideLocationInformation-r9 SEQUENCE {			
commonIEsProvideLocationInformation	Not present.		
a-gnss-ProvideLocationInformation	Not present		
otdoa-ProvideLocationInformation SEQUENCE {			
otdoaSignalMeasurementInformation SEQUENCE {			
systemFrameNumber			
physCellIdRef	Cell 1		
cellGlobalIdRef			
earfcnRef			
referenceQuality			
neighbourMeasurementList SEQUENCE (SIZE(1)) {			
physCellIdNeighbor	Cell 2		
cellGlobalIdNeighbour			
earfcnNeighbour	RF channel 2		
rstd	Set according to Table 9.2.4.5-2 for each specific test		
rstd-Quality			
}			
}			
otdoa-Error	May be present with error reason 'undefined' or 'attemptedButUnableToMeasureSomeNeighbourCells'		
}			
ecid-ProvideLocationInformation	Not present		
epdu-ProvideLocationInformation	Not present		
}			
}			
}			
}			
}			

**Table 9.2.4.4.3-6: CQI-ReportConfig-DEFAULT: FDD-FDD inter-frequency RSTD Accuracy**

Derivation Path: TS 36.508 [18] clause 4.6.3, Table 4.6.3-2 CQI-ReportConfig-DEFAULT			
Information Element	Value/remark	Comment	Condition
CQI-ReportConfig-DEFAULT ::= SEQUENCE {			
cqi-ReportModeAperiodic	rm30	This IE should be omitted for Test 1	
nomPDSCH-RS-EPRE-Offset	0		
cqi-ReportPeriodic CHOICE {			
release	NULL		
}			

### 9.2.4.5 Test requirement

Table 9.2.4.5-1 defines the primary level settings including test tolerances for all tests.

RSTD FDD-FDD inter-frequency accuracy test shall meet the reported values in Table 9.2.4.5-2.

**Table 9.2.4.5-1: Cell Specific Test Parameters for inter-frequency RSTD Tests for E-UTRAN FDD**

Parameter	Unit	Test 1		Test 2						
		Cell 1	Cell 2	Cell 1	Cell 2					
E-UTRA RF Channel Number		1	2	1	2					
PBCH_RA	dB	0	0	0	0					
PBCH_RB										
PSS_RA										
SSS_RA										
PCFICH_RB										
PHICH_RA										
PHICH_RB										
PDCCH_RA										
PDCCH_RB										
OCNG_RA <sup>Note 1</sup>										
OCNG_RB <sup>Note 1</sup>										
PRS_RA						dB	-2.7	0.3	-2.7	0.3
$N_{oc}$ <sup>Note 2</sup>						dBm/15 kHz	-98			
PRS $\hat{E}_s/N_{oc}$	dB	-5.7	-12.7	-5.7	-12.7					
PRS $\hat{E}_s/I_{ot}$ <sup>Note 3</sup>	dB	-5.7	-12.7	-5.7	-12.7					
$I_o$ <sup>Note 3</sup>	dBm/1.08 MHz	-79.24	-79.39	N/A	N/A					
	dBm/9 MHz	N/A	N/A	-70.03	-70.18					
PRP <sup>Note 3</sup>	dBm/15kHz	-103.7	-110.7	-103.7	-110.7					
$\hat{E}_s/N_{oc}$ <sup>Note 3</sup>	dB	-3	-13	-3	-13					
RSRP <sup>Note 3</sup>	dBm/15kHz	-101	-111	-101	-111					
Propagation condition		AWGN								
Note 1:	OCNG shall be used such that both cells are fully allocated and a constant total transmitted power spectral density is achieved for all OFDM symbols (other than those in the PRS subframes).									
Note 2:	Interference from other cells and noise sources not specified in the test is assumed to be constant over subcarriers and time and shall be modelled as AWGN of appropriate power for $N_{oc}$ to be fulfilled.									
Note 3:	$\hat{E}_s/N_{oc}$ , PRS $\hat{E}_s/I_{ot}$ , RSRP, $I_o$ and PRP levels have been derived from other parameters for information purposes. They are not settable parameters themselves. $I_o$ values are derived in the case that there is no PBCH, PSS or SSS in the OFDM symbols carrying PRS									

**Table 9.2.4.5-2: RSTD FDD inter-frequency accuracy requirements for the reported values**

	Test 1	Test 2
Lowest reported value	RSTD_6424	RSTD_6253
Highest reported value	RSTD_6470	RSTD_6275

For the overall test to pass, the ratio of successful reported values in each sub-test shall be more than 90% with a confidence level of 95%. In the case that 1.4 MHz channel bandwidth is not defined for the operating band under test then Test 1 shall be omitted.

## 9.2.4A FDD-FDD inter-frequency RSTD Accuracy for UE Category 1bis

### 9.2.4A.1 Test purpose

To verify that the Reference Signal Time Difference (RSTD) FDD-FDD inter-frequency measurement accuracy is within the specified limit for all bands in AWGN channels.

### 9.2.4A.2 Test applicability

This test applies to E-UTRA FDD UE Category 1bis release 13 and forward that support inter-frequency RSTD measurements.

### 9.2.4A.3 Minimum conformance requirements

Same as 9.2.4.3

The normative reference for this requirement is TS 36.133 [23] clause 9.1.10.6 and A.9.8.3.2A.

### 9.2.4A.4 Test description

#### 9.2.4A.4.1 Initial conditions

Same as 9.2.4.4.1 with the following exceptions:

1. Connect the SS, faders and AWGN noise sources to the UE antenna connector or antenna connectors as shown in Annex A, Figure A.3, using only the main Tx/Rx path.
2. The general test parameter settings are set up according to Table 9.2.4A.4.1-1

**Table 9.2.4A.4.1-1: General Test Parameters for inter-frequency RSTD Tests for E-UTRAN FDD for UE Category 1bis**

Parameter	Unit	Value		Comment
		Test 1	Test 2	
PCFICH/PDCCH/PHICH parameters		R.14 FDD	R.6 FDD	As specified in TS 36.521-3 [25] clause A.2.1.
OCNG Patterns defined in TS 36.521-3 [25] clause D.1		OP.7 FDD	OP.6 FDD	OCNG shall be used such that both cells are fully allocated and a constant total transmitted power spectral density is achieved for all OFDM symbols (other than those in the PRS subframes).
Reference cell		Cell 1		Cell 1 on RF channel number 1
Neighbour cell		Cell 2		Cell 2 on RF channel number 2
E-UTRA RF Channel Number		1,2		Two FDD carrier frequencies are used.
Channel Bandwidth ( $BW_{channel}$ )	MHz	1.4	10	
GapOffset		18	11	For Cell 1
Gap Pattern ID		0	0	For Cell 1
PRS Bandwidth	RB	6	50	
PRS configuration Index $I_{PRS}$ Note 2		Cell 1: 12 Cell 2: 19	Cell 1: 2 Cell 2: 12	As defined in 3GPP TS 36.211 [26]
PRS subframe offset		7	10	For Cell 2
Number of consecutive positioning downlink subframes $N_{PRS}$ Note 2		6	1	As defined in 3GPP TS 36.211 [26]
prs-MutingInfo Note 2		Cell 1: '1111111100000000' Cell 2: '1111111100000000'		See section 6.5.1.2 in 3GPP TS 36.355 [4] for more information
Cell ID Note 2		Cell 1: 0 Cell 2: 1		
Expected RSTD Note 1	$\mu$ s	Cell 2: 1 Other neighbour cells: randomly between -3 and 3		The expected RSTD is what is expected at the receiver. The corresponding parameter in the OTDOA assistance data specified in TS 36.355 [4] is the expectedRSTD indicator
Expected RSTD uncertainty for all neighbour cells Note 1	$\mu$ s	5		The corresponding parameter in the OTDOA assistance data specified in TS 36.355 [4] is the expectedRSTD-Uncertainty index
CP length Note 2		Normal		
DRX		OFF		
Radio frame receive time offset between the cells at the UE antenna connector Note 3	$\mu$ s	Cell 2 to Cell 1: 3	Cell 2 to Cell 1: -3	PRS are transmitted from synchronous cells
Number of cells provided in OTDOA assistance data		16		The list includes the reference cell (received in <i>OTDOA-ReferenceCellInfo</i> [4]) on RF channel 1 and 15 other cells on RF channel 2, all received in <i>OTDOA-ProvideAssistanceData</i> [4].
$T_{RSTD\ InterFreqFDD, E-UTRAN}$ Note 4	ms	10240		Derived according to the RSTD measurement requirements specified in Section 8.1.2.6.5 in TS 36.133 [23].

NOTE 1: Parameters "Expected RSTD" and "Expected RSTD uncertainty for all neighbour cells" in Table 9.2.4.4.1-1 are not settable parameters. These are parameters signalled in LPP only. For the values to be used in LPP see Table 9.2.4.4.3-4 and TS 37.571-5 [20], clause 7.2.2.

NOTE 2: Parameters "PRS Bandwidth", "PRS configuration index", "Number of consecutive positioning downlink subframes", "prs-MutingInfo", "Cell ID" and "CP length" in Table 9.2.4.4.1-1 are settable parameters and also parameters signalled in LPP. For all the values to be used in LPP see Table 9.2.4.4.3-4 and TS 37.571-5 [20], clause 7.2.2.

NOTE 3: The parameter "Radio frame receive time offset between the cells at the UE antenna connector" is not a settable parameter but is used to set the "true RSTD" values in step 6 of clause 9.2.4.4.1.

NOTE 4: The parameter " $T_{RSTD\ InterFreqFDD, E-UTRAN}$ " is not a settable parameter but is used to set the LPP "time" value in Table 9.2.4.4.3-3. The value of the LPP time IE is set to  $T_{RSTD\ InterFreqFDD, E-UTRAN} + \Delta T$  ms, where  $\Delta T = 150$  ms, giving a value of 10390 ms. This is rounded up to the next allowed LPP value of 11 seconds.



9.2.4A.4.2 Test procedure

Same as 9.2.4.4.2.

9.2.4A.4.3 Message contents

Same as 9.2.4.4.3 with the following exceptions

**Table 9.2.4A.4.3-1: LPP RequestLocationInformation**

Derivation Path: Table 9.2.4.4.3-2			
Information Element	Value/remark	Comment	Condition
LPP-Message ::= SEQUENCE {			
lpp-MessageBody CHOICE {			
c1 CHOICE {			
requestLocationInformation SEQUENCE {			
criticalExtensions CHOICE {			
c1 CHOICE {			
requestLocationInformation-r9 SEQUENCE {			
commonIEsRequestLocationInformation SEQUENCE {			
qos SEQUENCE {			
responseTime SEQUENCE {			
time	11	See Note 4 of Table 9.2.4A.4.1-1	
}			
}			
}			
}			
}			
}			
}			
}			
}			
}			

9.2.4A.5 Test requirement

Same as 9.2.4.5.

9.2.5 TDD-TDD inter-frequency RSTD Accuracy

9.2.5.1 Test purpose

To verify that the Reference Signal Time Difference (RSTD) of TDD-TDD inter-frequency measurement accuracy is within the specified limit for all bands in AWGN channels

9.2.5.2 Test applicability

This test applies to all types of E-UTRA TDD UE release 10 and forward that support inter-frequency RSTD measurements except UE Category 1bis.

9.2.5.3 Minimum conformance requirements

This RSTD measurement is used for UE positioning purposes.

The accuracy of TDD-TDD inter-frequency RSTD measurement shall meet the requirement defined in the Table 9.2.4.3-1 without DRX as well as for all the DRX cycles specified in TS 36.331 [22].

The accuracy requirements in Table 9.2.4.3-1 are valid under the following conditions:

Conditions defined in TS 36.101 [2] Section 7.3 for reference sensitivity are fulfilled.

PRP 1,2<sub>dBm</sub> according to clause E.3 for a corresponding Band

There are no measurement gaps overlapping with the PRS subframes in cells belonging to the serving carrier frequency.

The parameter `expectedRSTDUncertainty` signalled over LPP by E-SMLC as defined in TS 36.355 [4] is less than 5  $\mu$ s.

The normative reference for this requirement is TS 36.133 [23] clause 9.1.10.2 and A.9.8.4.

## 9.2.5.4 Test description

### 9.2.5.4.1 Initial conditions

Test Environment: Normal; as defined in TS 36.508 [18] clause 4.1.

Frequencies to be tested: Mid Range, as defined in TS 36.508 [18] clause 4.3.1.2.

Channel bandwidth to be tested: 1.4 MHz (Test 1) and 10 MHz (Test 2). In the case that 1.4 MHz channel bandwidth is not defined for the operating band under test, as defined in TS 36.101 [2] clause 5.6.1, then this part of the test shall be omitted.

1. Connect the SS and AWGN noise sources to the UE antenna connector or antenna connectors as shown in Annex A, Figure A.3a for 4RX capable UE without any 2RX bands. Otherwise use Annex A figure A.3.
2. The general test parameter settings are set up according to Table 9.2.5.4.1-1.
3. Propagation conditions are set according to clause 4.7.2.1.
4. Message contents are defined in clause 9.2.5.4.3.
5. Two cells are on the different carrier frequencies. Cell 1 is the serving cell and OTDOA assistance data reference cell; Cell 2 is the neighbour cell. The assistance data neighbour cell list includes in total 15 cells, where 14 of the cells are not simulated (dummy cells; as defined in 3GPP TS 37.571-5 [20], clause 7.2.2).
6. The true RSTD (which is the receive time difference for frame 0 between the two cells as seen at the UE antenna connector) is set to 92 Ts (about 3  $\mu$ s) between neighbour cell 2 and serving cell 1 for Test 1 and -92 Ts (about -3  $\mu$ s) for Test 2.

Note that the related `expectedRSTD` values to be signalled over LPP are defined in Table 9.2.5.4-1.

7. The gap pattern configuration # 0 as defined in Table 8.1.2.1-1 in 3GPP TS 36.133 [23] is configured and does not overlap with PRS subframes of Cell 1.

Table 9.2.5.4.1-1: General Test Parameters for inter-frequency RSTD Tests for E-UTRAN TDD-TDD

Parameter	Unit	Value		Comment
		Test 1	Test 2	
PCFICH/PDCCH/PHICH parameters		R.14 TDD	R.6 TDD	As specified in TS 36.521-3 [25] clause A.2.2.
OCNG Patterns defined in TS 36.521-3 [25] clause D.2		OP.4 TDD	OP.2 TDD	OCNG shall be used such that both cells are fully allocated and a constant total transmitted power spectral density is achieved for all OFDM symbols (other than those in the PRS subframes).
Reference cell		Cell 1		Cell 1 on RF channel number 1
Neighbour cell		Cell 2		Cell 2 on RF channel number 2
E-UTRA RF Channel Number		1,2		Two TDD carrier frequencies are used.
Channel Bandwidth ( $BW_{\text{channel}}$ )	MHz	1.4	10	
PRS Bandwidth <sup>Note 2</sup>	RB	6	50	
GapOffset		34	13	For Cell 1
Gap Pattern ID		0		For Cell 1
Special subframe configuration		6		As specified in table 4.2-1 in TS 36.211 [26]. The same configuration in both cells.
Uplink-downlink configuration		3	1	As specified in table 4.2-2 in TS 36.211 [26] and table 9.1.2.3-2. The same configuration in both cells.
PRS configuration Index $I_{\text{PRS}}$ <sup>Note 2</sup>		Cell 1: 15 Cell 2: 35	Cell 1: 4 Cell 2: 14	As defined in 3GPP TS 36.211 [26]
PRS subframe offset		20	10	For Cell 2
Number of consecutive positioning downlink subframes $N_{\text{PRS}}$ <sup>Note 2</sup>		6	1	As defined in 3GPP TS 36.211 [26]
prs-MutingInfo <sup>Note 2</sup>		Cell 1: '11110000' Cell 2: '11110000'		See section 6.5.1.2 in 3GPP TS 36.355 [4] for more information
Cell ID <sup>Note 2</sup>		Cell 1: 0 Cell 2: 1		
Expected RSTD <sup>Note 1</sup>	$\mu\text{s}$	Cell 2: 1 Other neighbour cells: randomly between -3 and 3		The expected RSTD is what is expected at the receiver. The corresponding parameter in the OTDOA assistance data specified in TS 36.355 [4] is the expectedRSTD indicator
Expected RSTD uncertainty for all neighbour cells <sup>Note 1</sup>	$\mu\text{s}$	5		The corresponding parameter in the OTDOA assistance data specified in TS 36.355 [4] is the expectedRSTD-Uncertainty index
CP length <sup>Note 2</sup>		Normal		
DRX		OFF		
Radio frame receive time offset between the cells at the UE antenna connector <sup>Note 3</sup>	$\mu\text{s}$	Cell 2 to Cell 1: 3	Cell 2 to Cell 1: -3	PRS are transmitted from synchronous cells
Number of cells provided in OTDOA assistance data		16		The list includes the reference cell (received in <i>OTDOA-ReferenceCellInfo</i> [4]) on RF channel 1 and 15 other cells on RF channel 2, all received in <i>OTDOA-ProvideAssistanceData</i> [4].
$T_{\text{RSTD InterFreqTDD, E-UTRAN}}$ <sup>Note 4</sup>	ms	5120		Derived according to the RSTD measurement requirements specified in Section 8.1.2.6.3 in TS 36.133 [23].
<p>NOTE 1: Parameters "Expected RSTD" and "Expected RSTD uncertainty for all neighbour cells" are not settable parameters. These are parameters signalled in LPP only. For the values to be used in LPP see Table 9.2.5.4.3-4 and TS 37.571-5 [20], clause 7.2.2.</p> <p>NOTE 2: Parameters "PRS Bandwidth", "PRS configuration index", "Number of consecutive positioning downlink subframes", "prs-MutingInfo", "Cell ID" and "CP length" are settable parameters and also parameters signalled in LPP. For all the values to be used in LPP see Table 9.2.5.4.3-4 and TS 37.571-5 [20], clause 7.2.2.</p> <p>NOTE 3: The parameter "Radio frame receive time offset between the cells at the UE antenna connector" is not a settable parameter but is used to set the "true RSTD" values in step 6 of clause 9.2.5.4.1.</p> <p>NOTE 4: The parameter "<math>T_{\text{RSTD InterFreqTDD, E-UTRAN}}</math>" is not a settable parameter but is used to set the LPP "time" value in Table 9.2.5.4.3-3. The value of the LPP time IE is set to <math>T_{\text{RSTD InterFreqTDD, E-UTRAN}} + \Delta T</math> ms, where <math>\Delta T = 150</math> ms, giving a value of 5270 ms. This is rounded up to the next allowed LPP value of 6 seconds.</p>				

#### 9.2.5.4.2 Test procedure

The test consists of a set-up period and a measurement period. Cell 1 and Cell 2 are both active during the complete test. The beginning of the measurement period shall be aligned with the first PRS positioning subframe of a positioning occasion in the reference cell.

NOTE: The information on when PRS is muted is conveyed to the UE using PRS muting information in the OTDOA assistance data.

The OTDOA-RequestLocationInformation message and the OTDOA assistance data as defined in clause 9.2.5.4.3 shall be provided to the UE during the set-up period. The last TTI containing the OTDOA-RequestLocationInformation message shall be provided to the UE  $\Delta T$  ms before the start of the measurement period, where  $\Delta T = 150$  ms is the maximum processing time of the OTDOA-RequestLocationInformation message and the OTDOA assistance data in the UE.

1. Ensure that the UE is in state Generic RB Established State 3A-RF according to 3GPP TS 36.508 [18] clause 7.2A.3.
2. The SS shall send a RESET UE POSITIONING STORED INFORMATION message.
3. Set the parameters according to Table 9.2.5.5-1 as appropriate. Propagation conditions are set according to clause 4.7.2.1.
4. The SS shall transmit an RRCConnectionReconfiguration message with the measurement gap configuration.
5. The UE shall transmit RRCConnectionReconfigurationComplete message.
- 5a. The SS shall transmit an LPP REQUEST CAPABILITIES message.
- 5b. The UE shall transmit an LPP PROVIDE CAPABILITIES message indicating the OTDOA capabilities supported by the UE in the *OTDOA-ProvideCapabilities* IE.
6. The SS shall send a LPP PROVIDE ASSISTANCE DATA message, including the *OTDOA-ProvideAssistanceData* IE. If the UE message at step 5b includes the *ackRequested* IE set to TRUE, then the SS shall send an acknowledgment in the LPP PROVIDE ASSISTANCE DATA message.
7. The SS shall send a LPP REQUEST LOCATION INFORMATION message, including the *OTDOA-RequestLocationInformation* IE such that the UE receives the message  $\Delta T$  ms before the start of measurement period, where  $\Delta T = 150$  ms.
8. The UE shall transmit a LPP PROVIDE LOCATION INFORMATION message, including the *OTDOA-ProvideLocationInformation* IE.
9. If the UE message at step 8 includes the *ackRequested* IE set to TRUE, the SS shall send a LPP acknowledgement message.
10. The SS shall check the *rstd* value for Cell 2 in the *OTDOA-SignalMeasurementInformation* IE according to Table 9.2.5.5-2.
11. Repeat step 2-10 until the confidence level according to Annex D is achieved.
12. Repeat step 1-11 for each sub-test in Table 9.2.5.5-1 as appropriate.

#### 9.2.5.4.3 Message contents

**Table 9.2.5.4.3-1: RESET UE POSITIONING STORED INFORMATION**

Derivation Path: 36.509 [11] clause 6.9			
Information Element	Value/remark	Comment	Condition
UE Positioning Technology	0 0 0 0 0 0 1	OTDOA	

**Table 9.2.5.4.3-2: MeasGapConfig-GP1: TDD-TDD inter-frequency RSTD Accuracy**

Derivation Path: TS 36.508 [18] clause 4.6.6, Table 4.6.6-1A: MeasGapConfig-GP1			
Information Element	Value/remark	Comment	Condition
MeasGapConfig-GP1 ::= CHOICE {			
setup SEQUENCE {			
gapOffset CHOICE {			
gp0	34 (Test 1) 13 (Test 2)	TGRP = 40 ms	
}			
}			
}			

**Table 9.2.5.4.3-2a: LPP Request Capabilities**

Information Element	Value/remark
<i>otdoa-RequestCapabilities</i>	TRUE

**Table 9.2.5.4.3-3: LPP RequestLocationInformation**

Derivation Path: 36.355 clause 6.2			
Information Element	Value/remark	Comment	Condition
LPP-Message ::= SEQUENCE {			
transactionID SEQUENCE {			
initiator	locationServer		
transactionNumber	1		
}			
endTransaction	FALSE		
sequenceNumber	Not present		
acknowledgement	Not present		
lpp-MessageBody CHOICE {			
c1 CHOICE {			
requestLocationInformation SEQUENCE {			
criticalExtensions CHOICE {			
c1 CHOICE {			
requestLocationInformation-r9 SEQUENCE {			
commonIEsRequestLocationInformation SEQUENCE {			
locationInformationType	locationMeasurementsRequired		
triggeredReporting	Not present		
periodicalReporting	Not present		
additionalInformation	onlyReturnInformationRequested		
qos SEQUENCE {			
horizontalAccuracy	Not present		
verticalCoordinateRequest	FALSE		
verticalAccuracy	Not present		
responseTime SEQUENCE {			
time	6	See Note 4 of Table 9.2.5.4.1-1	
responseTimeEarlyFix-r12	Not present		Rel-12 onwards
}			
velocityRequest	FALSE		
}			
environment	Not present		
locationCoordinateTypes	Not present		
velocityTypes	Not present		
}			
a-gnss-RequestLocationInformation	Not present		
otdoa-RequestLocationInformation SEQUENCE {			
assistanceAvailability	FALSE		
}			
ecid-RequestLocationInformation	Not present		
epdu-RequestLocationInformation	Not Present		
}			
}			
}			
}			
}			

Table 9.2.5.4.3-4: LPP ProvideAssistanceData

Derivation Path: 36.355 clause 6.2			
Information Element	Value/remark	Comment	Condition
LPP-Message ::= SEQUENCE {			
transactionID SEQUENCE {			
Initiator	locationServer		
transactionNumber	(0..255)		
}			
endTransaction	TRUE		
sequenceNumber	Not present		
acknowledgement	Not present		
lpp-MessageBody CHOICE {			
c1 CHOICE {			
provideAssistanceData SEQUENCE {			
criticalExtensions CHOICE {			
c1 CHOICE {			
provideAssistanceData-r9 SEQUENCE {			
commonIEsProvideAssistanceData	Not present		
a-gnss-ProvideAssistanceData	Not present		
otdoa-ProvideAssistanceData SEQUENCE {			
otdoa-ReferenceCellInfo	As defined in TS 37.571-5 [20], clause 7.2.2.		
otdoa-NeighbourCellInfo	As defined in TS 37.571-5 [20], clause 7.2.2.		
otdoa-Error	Not present		
}			
epdu-ProvideAssistanceData	Not present		
}			
}			
}			
}			

Table 9.2.5.4.3-5: LPP ProvideLocation Information

Derivation Path: 36.355 clause 6.2			
Information Element	Value/remark	Comment	Condition
LPP-Message ::= SEQUENCE {			
transactionID SEQUENCE {			
initiator	locationServer		
transactionNumber	1		
}			
endTransaction	TRUE		
sequenceNumber	(0..255)		
acknowledgement			
lpp-MessageBody CHOICE {			
c1 CHOICE {			
provideLocationInformation SEQUENCE {			
criticalExtensions CHOICE {			
c1 CHOICE {			
provideLocationInformation-r9 SEQUENCE {			
commonIEsProvideLocationInformation	Not present.		
a-gnss-ProvideLocationInformation	Not present		
otdoa-ProvideLocationInformation			
SEQUENCE {			
otdoaSignalMeasurementInformation			
SEQUENCE {			
systemFrameNumber			
physCellIdRef	Cell 1		
cellGlobalIdRef			
earfcnRef			
referenceQuality			
neighbourMeasurementList			
SEQUENCE (SIZE(1)) {			
physCellIdNeighbor	Cell 2		
cellGlobalIdNeighbour			
earfcnNeighbour	RF channel 2		
rstd	Set according to Table 9.2.5.5-2 for each specific test		
rstd-Quality			
}			
}			
otdoa-Error	May be present with error reason 'undefined' or 'attemptedButUnableToMeasureSomeNeighbourCells'		
}			
ecid-ProvideLocationInformation	Not present		
epdu-ProvideLocationInformation	Not present		
}			
}			
}			
}			
}			



**Table 9.2.5.4.3-6: CQI-ReportConfig-DEFAULT: TDD-TDD inter-frequency RSTD Accuracy**

Derivation Path: TS 36.508 [18] clause 4.6.3, Table 4.6.3-2 CQI-ReportConfig-DEFAULT			
Information Element	Value/remark	Comment	Condition
CQI-ReportConfig-DEFAULT ::= SEQUENCE {			
cqi-ReportModeAperiodic	rm30	This IE should be omitted for Test 1	
nomPDSCH-RS-EPRE-Offset	0		
cqi-ReportPeriodic CHOICE {			
release	NULL		
}			

**9.2.5.5 Test requirement**

Table 9.2.5.5-1 defines the primary level settings including test tolerances for all tests.

The RSTD TDD-TDD inter frequency measurement accuracy test shall meet the reported values in Table 9.2.5.5-2.

**Table 9.2.5.5-1: Cell Specific Test Parameters for inter frequency RSTD Tests for E-UTRAN TDD-TDD**

Parameter	Unit	Test 1		Test 2	
		Cell 1	Cell 2	Cell 1	Cell 2
E-UTRA RF Channel Number		1	2	1	2
PBCH_RA	dB	0			
PBCH_RB					
PSS_RA					
SSS_RA					
PCFICH_RB					
PHICH_RA					
PHICH_RB					
PDCCH_RA					
PDCCH_RB					
OCNG_RA <sup>Note 1</sup>					
OCNG_RB <sup>Note 1</sup>					
PRS_RA					
$N_{oc}$ <sup>Note 2</sup>	dBm/15 kHz	-98			
PRS $\hat{E}_s/N_{oc}$	dB	-5.7	-12.7	-5.7	-12.7
PRS $\hat{E}_s/I_{ot}$ <sup>Note 3</sup>	dB	-5.7	-12.7	-5.7	-12.7
$I_o$ <sup>Note 3</sup>	dBm/1.08 MHz	-79.24	-79.39	N/A	N/A
	dBm/9 MHz	N/A	N/A	-70.03	-70.18
PRP <sup>Note 3</sup>	dBm/15kHz	-103.7	-110.7	-103.7	-110.7
$\hat{E}_s/N_{oc}$ <sup>Note 3</sup>	dB	-3	-13	-3	-13
RSRP <sup>Note 3</sup>	dBm/15kHz	-101	-111	-101	-111
Propagation condition		AWGN			
Note 1: OCNG shall be used such that both cells are fully allocated and a constant total transmitted power spectral density is achieved for all OFDM symbols (other than those in the PRS subframes). Note 2: Interference from other cells and noise sources not specified in the test is assumed to be constant over subcarriers and time and shall be modelled as AWGN of appropriate power for $N_{oc}$ to be fulfilled. Note 3: $\hat{E}_s/N_{oc}$ , PRS $\hat{E}_s/I_{ot}$ , $I_o$ , RSRP and PRP levels have been derived from other parameters for information purposes. They are not settable parameters themselves. $I_o$ values are derived in the case that there is no PBCH, PSS or SSS in the OFDM symbols carrying PRS.					

**Table 9.2.5.5-2: RSTD TDD inter-frequency accuracy requirements for the reported values**

	Test 1	Test 2
Lowest reported value	RSTD_6424	RSTD_6253
Highest reported value	RSTD_6470	RSTD_6275

For the overall test to pass, the ratio of successful reported values in each sub-test shall be more than 90% with a confidence level of 95%. In the case that 1.4 MHz channel bandwidth is not defined for the operating band under test then Test 1 shall be omitted.

## 9.2.5A TDD-TDD inter-frequency RSTD Accuracy for UE Category 1bis

### 9.2.5A.1 Test purpose

To verify that the Reference Signal Time Difference (RSTD) TDD-TDD inter-frequency measurement accuracy is within the specified limit for all bands in AWGN channels.

### 9.2.5A.2 Test applicability

This test applies to E-UTRA TDD UE Category 1bis release 13 and forward that support inter-frequency RSTD measurements.

### 9.2.5A.3 Minimum conformance requirements

Same as 9.2.5.3

The normative reference for this requirement is TS 36.133 [23] clause 9.1.10.6 and A.9.8.4.2A.

### 9.2.5A.4 Test description

#### 9.2.5A.4.1 Initial conditions

Same as 9.2.5.4.1 with the following exceptions:

1. Connect the SS, faders and AWGN noise sources to the UE antenna connector or antenna connectors as shown in Annex A, Figure A.3, using only the main Tx/Rx path.
2. The general test parameter settings are set up according to Table 9.2.5A.4.1-1

**Table 9.2.5A.4.1-1: General Test Parameters for inter-frequency RSTD Tests for E-UTRAN TDD-TDD for UE Category 1bis**

Parameter	Unit	Value		Comment
		Test 1	Test 2	
PCFICH/PDCCH/PHICH parameters		R.14 TDD	R.6 TDD	As specified in TS 36.521-3 [25] clause A.2.2.
OCNG Patterns defined in TS 36.521-3 [25] clause D.2		OP.4 TDD	OP.2 TDD	OCNG shall be used such that both cells are fully allocated and a constant total transmitted power spectral density is achieved for all OFDM symbols (other than those in the PRS subframes).
Reference cell		Cell 1		Cell 1 on RF channel number 1
Neighbour cell		Cell 2		Cell 2 on RF channel number 2
E-UTRA RF Channel Number		1,2		Two TDD carrier frequencies are used.
Channel Bandwidth ( $BW_{\text{channel}}$ )	MHz	1.4	10	
PRS Bandwidth <sup>Note 2</sup>	RB	6	50	
GapOffset		34	13	For Cell 1
Gap Pattern ID		0		For Cell 1
Special subframe configuration		6		As specified in table 4.2-1 in TS 36.211 [26]. The same configuration in both cells.
Uplink-downlink configuration		3	1	As specified in table 4.2-2 in TS 36.211 [26] and table 9.1.2.3-2. The same configuration in both cells.
PRS configuration Index $I_{\text{PRS}}$ <sup>Note 2</sup>		Cell 1: 15 Cell 2: 35	Cell 1: 4 Cell 2: 14	As defined in 3GPP TS 36.211 [26]
PRS subframe offset		20	10	For Cell 2
Number of consecutive positioning downlink subframes $N_{\text{PRS}}$ <sup>Note 2</sup>		6	1	As defined in 3GPP TS 36.211 [26]
prs-MutingInfo <sup>Note 2</sup>		Cell 1: '1111111100000000' Cell 2: '1111111100000000'		See section 6.5.1.2 in 3GPP TS 36.355 [4] for more information
Cell ID <sup>Note 2</sup>		Cell 1: 0 Cell 2: 1		
Expected RSTD <sup>Note 1</sup>	$\mu\text{s}$	Cell 2: 1 Other neighbour cells: randomly between -3 and 3		The expected RSTD is what is expected at the receiver. The corresponding parameter in the OTDOA assistance data specified in TS 36.355 [4] is the expectedRSTD indicator
Expected RSTD uncertainty for all neighbour cells <sup>Note 1</sup>	$\mu\text{s}$	5		The corresponding parameter in the OTDOA assistance data specified in TS 36.355 [4] is the expectedRSTD-Uncertainty index
CP length <sup>Note 2</sup>		Normal		
DRX		OFF		
Radio frame receive time offset between the cells at the UE antenna connector <sup>Note 3</sup>	$\mu\text{s}$	Cell 2 to Cell 1: 3	Cell 2 to Cell 1: -3	PRS are transmitted from synchronous cells
Number of cells provided in OTDOA assistance data		16		The list includes the reference cell (received in <i>OTDOA-ReferenceCellInfo</i> [4]) on RF channel 1 and 15 other cells on RF channel 2, all received in <i>OTDOA-ProvideAssistanceData</i> [4].
$T_{\text{RSTD InterFreqTDD, E-UTRAN}}$ <sup>Note 4</sup>	ms	10240		Derived according to the RSTD measurement requirements specified in Section 8.1.2.6.7 in TS 36.133 [23].
<p>NOTE 1: Parameters "Expected RSTD" and "Expected RSTD uncertainty for all neighbour cells" are not settable parameters. These are parameters signalled in LPP only. For the values to be used in LPP see Table 9.2.5.4.3-4 and TS 37.571-5 [20], clause 7.2.2.</p> <p>NOTE 2: Parameters "PRS Bandwidth", "PRS configuration index", "Number of consecutive positioning downlink subframes", "prs-MutingInfo", "Cell ID" and "CP length" are settable parameters and also parameters signalled in LPP. For all the values to be used in LPP see Table 9.2.5.4.3-4 and TS 37.571-5 [20], clause 7.2.2.</p> <p>NOTE 3: The parameter "Radio frame receive time offset between the cells at the UE antenna connector" is not a settable parameter but is used to set the "true RSTD" values in step 6 of clause 9.2.5.4.1.</p> <p>NOTE 4: The parameter "<math>T_{\text{RSTD InterFreqTDD, E-UTRAN}}</math>" is not a settable parameter but is used to set the LPP "time" value in Table 9.2.5A.4.3-3. The value of the LPP time IE is set to <math>T_{\text{RSTD InterFreqTDD, E-UTRAN}} + \Delta T</math> ms, where <math>\Delta T = 150</math> ms, giving a value of 10390 ms. This is rounded up to the next allowed LPP value of 11 seconds.</p>				

9.2.5A.4.2 Test procedure

Same as 9.2.5.4.2.

9.2.5A.4.3 Message contents

Same as 9.2.5.4.3 with the following exceptions

**Table 9.2.5A.4.3-1: LPP RequestLocationInformation**

Derivation Path: Table 9.2.5.4.3-2			
Information Element	Value/remark	Comment	Condition
LPP-Message ::= SEQUENCE {			
lpp-MessageBody CHOICE {			
c1 CHOICE {			
requestLocationInformation SEQUENCE {			
criticalExtensions CHOICE {			
c1 CHOICE {			
requestLocationInformation-r9 SEQUENCE {			
commonIEsRequestLocationInformation SEQUENCE {			
qos SEQUENCE {			
responseTime SEQUENCE {			
time	11	See Note 4 of Table 9.2.5A.4.1-1	
}			
}			
}			
}			
}			
}			
}			
}			
}			

9.2.5A.5 Test requirement

Same as 9.2.5.5.

**9.3 RSTD Intra-Frequency Measurements for UE Category M1/M2**

**9.3.1 FDD intra-frequency RSTD Measurement Reporting Delay in CE Mode A**

**9.3.1.1 FDD intra-frequency RSTD Measurement Reporting Delay in CE Mode A for Cat M1**

*Editor’s note: This test is incomplete. The following aspects are missing:*

- TBD in TS 36.133 how to capture prsOccGroupLength in the measurement period
- Response Time to be calculated based as Nprs\_total is missing in TS 36.133
- Annex E-2 is missing as it is also missing in TS 36.133.
- Assistance Data in TS 37.571-5 is missing

9.3.1.1.1 Test purpose

To verify that the RSTD measurement reporting delay for UE Category M1 meets the performance requirements in normal coverage mode in an environment with fading propagation conditions.

9.3.1.1.2 Test applicability

This test applies to E-UTRA FDD UE Category M1 release 14 and forward that supports UE-assisted OTDOA.

9.3.1.1.3 Minimum conformance requirements

When the physical layer cell identities of neighbour cells together with the OTDOA assistance data are provided, the UE shall be able to detect and measure intra-frequency RSTD, specified in 3GPP TS 36.214 [6], for at least  $n=16$  cells, including the reference cell, on the same carrier frequency  $f_1$  as that of the reference cell within  $T_{RSTD \text{ IntraFreqFDD, Cat}_M}$  ms as given below (see also Figure 9.3.1.1.3-1):

$$T_{RSTD \text{ IntraFreqFDD, Cat}_M} = T_{PRS} \cdot (M - 1) + \Delta + T_{MIB} \text{ ms,}$$

where

$T_{RSTD \text{ IntraFreqFDD, Cat}_M}$  is the total time for detecting and measuring at least  $n$  cells,

$T_{PRS}$  is the cell-specific positioning subframe configuration period as defined in 3GPP TS 36.211 [26],

$M$  is the number of PRS positioning occasions as defined in Table 9.3.1.1.3-1, , where downlink positioning subframes defined in TS 36.211 [16],

$\Delta = T_{PRS} \cdot \left\lceil \frac{n}{M} \right\rceil$  ms is the measurement time for a single PRS positioning occasion which includes the sampling time and the processing time,

$N_{PRS}$  is the cell-specific number of PRS subframes within a PRS occasion as defined in TS36.355 [4],

$N_{PRS\_total}$  is the minimum number of PRS subframes per cell measurement as specified in TS 36.133 [23] Section 9.1.21.20.

$T_{PRS}$ ,  $N_{PRS}$ , and  $N_{PRS\_total}$  are the parameters of the same cell, for which  $T_{PRS} \cdot \left\lceil \frac{N_{PRS\_total}}{N_{PRS}} \right\rceil$  is the largest among all the measured cells.

$T_{MIB}$  is the time required for acquiring the MIB information of the target cell.  $T_{MIB} = 0$  if the SFN of at least one cell in OTDOA assistance data is known to the UE.

**Table 9.3.1.1.3-1: Number of PRS positioning occasions within  $T_{RSTD \text{ IntraFreqFDD, Cat}_M}$**

Positioning subframe configuration period $T_{PRS}$	Number of PRS positioning occasions $M$
	$f_1$ <small>Note 1</small>
160 ms	$16 \cdot \left\lceil \frac{N_{PRS\_Total}}{N_{PRS}} \right\rceil$
>160 ms	$8 \cdot \left\lceil \frac{N_{PRS\_Total}}{N_{PRS}} \right\rceil$
Note 1: When only intra-frequency RSTD measurements are performed over cells belonging to the serving FDD carrier frequency $f_1$ .	

The UE physical layer shall be capable of reporting RSTD for the reference cell and all the neighbour cells  $i$  out of at least  $(n-1)$  neighbour cells within  $T_{RSTD \text{ IntraFreqFDD, Cat}_M}$  provided:

$$\left( PRS \hat{E}_s / I_{ot} \right)_{ref} \geq -6 \text{ dB for all Frequency Bands for the reference cell,}$$

$$\left( PRS \hat{E}_s / I_{ot} \right)_i \geq -13 \text{ dB for all Frequency Bands for neighbour cell } i,$$

$(\text{PRS } \hat{E}_s / \text{Iot})_{ref}$  and  $(\text{PRS } \hat{E}_s / \text{Iot})_i$  conditions apply for all subframes of at least  $L = \frac{M}{2}$  PRS positioning occasions,

occasions,

PRP 1,2|dBm according to clause E.2 for a corresponding Band.

$\text{PRS } \hat{E}_s / \text{Iot}$  is defined as the ratio of the average received energy per PRS RE during the useful part of the symbol to the average received power spectral density of the total noise and interference for this RE, where the ratio is measured over all REs which carry PRS.

The time  $T_{\text{RSTD IntraFreqFDD, Cat}_M}$  starts from the first subframe of the PRS positioning occasion closest in time after both the OTDOA-RequestLocationInformation message and the OTDOA assistance data in the OTDOA-ProvideAssistanceData message as specified in 3GPP TS 36.355 [4], are delivered to the physical layer of the UE as illustrated in Figure 9.3.1.1.3-1.

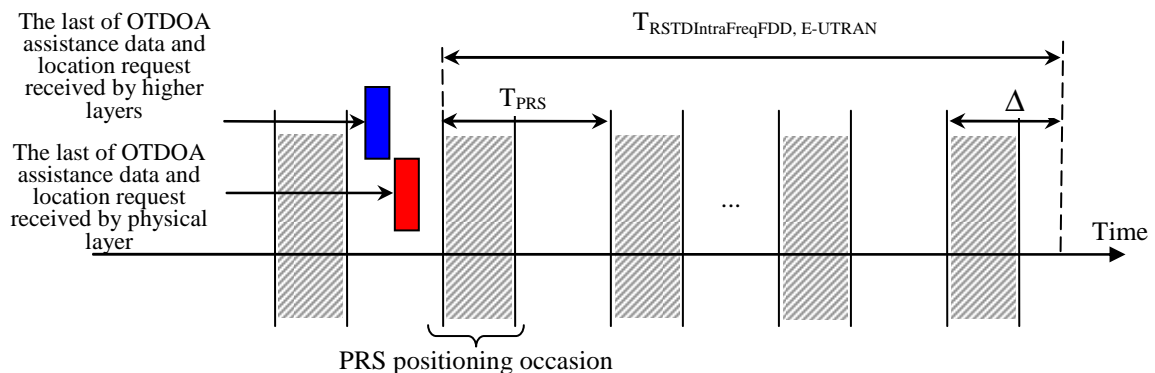

**Figure 9.3.1.1.3-1: Illustration of the RSTD reporting time requirement in an FDD system**

This requirement assumes that the measurement report is not delayed by other LPP signalling on the DCCH. This measurement reporting delay excludes a delay uncertainty resulted when inserting the measurement report to the TTI of the uplink DCCH. The delay uncertainty is  $N_{rep} \times \text{TTI}_{\text{DCCH}}$ , where  $N_{rep}$  is the maximum number of PUSCH repetitions configured for the UE, otherwise uncertainty is defined as  $2 \times \text{TTI}_{\text{DCCH}}$ . This measurement reporting delay excludes any delay caused by no UL resources for UE to send the measurement report.

The normative reference for this requirement is TS 36.133 [23] clause 8.13.2.3.1 and A.8.12.3.

#### 9.3.1.1.4 Test description

##### 9.3.1.1.4.1 Initial conditions

Test Environment: Normal; as defined in TS 36.508 [18] clause 4.1.

Frequencies to be tested: Mid Range, as defined in TS 36.508 [18] clause 4.3.1.1.

Channel bandwidth to be tested: 10 MHz as defined in TS 36.508 [18] clause 4.3.1.

1. Connect the SS, faders and AWGN noise sources to the UE antenna connector or antenna connectors as shown in Annex A, Figure A.4 using only the main Tx/Rx antenna of the UE.
2. The general test parameter settings are set up according to Table 9.3.1.1.4.1-1.
3. Propagation conditions are set according to clause 4.7.2.1.
4. Message contents are defined in clause 9.3.1.1.4.3.
5. In the test there are three synchronized cells: Cell 1, Cell 2 and Cell 3. Cell 1 is the OTDOA assistance data reference as well as the serving cell. Cell 2 and Cell 3 are the neighbour cells. All cells are on the same RF channel. Cell 3 in the test is the Cell 4 defined in clause 4.7.1. The assistance data neighbour cell list includes in

total 15 cells, where 13 of the cells are not simulated (dummy cells; as defined in 3GPP TS 37.571-5 clause 7.2.5).

6. The true RSTD (which is the receive time difference for frame 0 between two cells as seen at the UE antenna connector) is set to 31 Ts (about 1  $\mu$ s) between neighbour Cell 2 and serving Cell 1; and set to -31 Ts (about -1  $\mu$ s) between neighbour Cell 3 and serving Cell 1.



**Table 9.3.1.1.4.1-1: General test parameters for E-UTRAN FDD intra-frequency RSTD measurement reporting delay under fading propagation conditions**

Parameter	Unit	Value	Comment
Reference cell		Cell 1	Reference cell is the cell in the OTDOA assistance data with respect to which the RSTD measurement is defined, as specified in 3GPP TS 36.214 [6] and 3GPP TS 36.355 [4]. The reference cell is the serving cell in this test case.
Neighbour cells		Cell 2 and Cell 3	Cell 2 and Cell 3 appear at random places in the neighbour cell list in the OTDOA assistance data, but Cell 2 always appears in the first half of the list, whilst Cell 3 appears in the second half of the list.
MPDCCH		DL Reference Measurement Channel R.16 FDD	As specified in TS 36.521-3 [25] clause A.7.1
$mPDCCH\text{-startSF-UeSS}$		10	Parameter $G$ in $T = r_{\max} \cdot G$ which determines subframe $k0$ in which MPDCCH starts
Channel Bandwidth ( $BW_{\text{channel}}$ )	MHz	10	
PRS Transmission Bandwidth <sup>Note 2</sup>	RB	50 <sup>Note 4</sup>	PRS are transmitted over the system bandwidth
PRS configuration index $I_{\text{PRS}}$ <sup>Note 2</sup>		311	This corresponds to periodicity of 320 ms and PRS subframe offset of $I_{\text{PRS}} - 160$ DL subframes, as defined in 3GPP TS 36.211 [26], Table 6.10.4.3-1
Number of consecutive downlink positioning subframes $N_{\text{PRS}}$ <sup>Note 2</sup>		6	As defined in 3GPP TS 36.211 [26]. The number of subframes in a positioning occasion
Physical cell ID PCI <sup>Note 2</sup>		(PCI of Cell 1 – PCI of Cell 2) mod 6 = 0 and (PCI of Cell 1 – PCI of Cell 3) mod 6 = 0	The cell PCIs are selected such that the relative shifts of PRS patterns among cells are as given by the test parameters
CP length <sup>Note 2</sup>		Normal	
DRX		ON	DRX parameters are further specified in Table 9.3.1.1.4.1-2
Radio frame receive time offset between the cells at the UE antenna connector <sup>Note 3</sup>	μs	Cell 2 to Cell 1: 1 Cell 3 to Cell 1: -1	PRS are transmitted from synchronous cells
Expected RSTD <sup>Note 1</sup>	μs	Cell 2: 3 Cell 3: 3 Other neighbour cells: randomly between -3 and 3	The expected RSTD is what is expected at the receiver. The corresponding parameter in the OTDOA assistance data specified in TS 36.355 [4] is the expectedRSTD indicator
Expected RSTD uncertainty for all neighbour cells <sup>Note 1</sup>	μs	5	The corresponding parameter in the OTDOA assistance data specified in TS 36.355 [4] is the expectedRSTD-Uncertainty index
Number of cells provided in OTDOA assistance data		16	Including the reference cell
PRS muting info <sup>Note 2</sup>		Cell 1: '11110000' Cell 2: '00001111' Cell 3: '11110000'	Corresponds to prs-MutingInfo defined in TS 36.355 [4]
T1	s	3	The length of the time interval from the beginning of each test
T2	s	2.56	The length of the time interval that follows immediately after time interval T1

T3	s	2.56	The length of the time interval that follows immediately after time interval T2
Note 1:	Parameters "Expected RSTD" and "Expected RSTD uncertainty for all neighbour cells" are not settable parameters. These are parameters signalled in LPP only. For the values to be used in LPP see Table 9.3.1.1.4.3-5 and TS 37.571-5 [20], clause 7.2.5.		
Note 2:	Parameters "PRS Transmission Bandwidth", "PRS configuration index", "Number of consecutive downlink positioning subframes", "Physical cell ID PCI", "CP length", and "PRS muting info" are settable parameters and also parameters signalled in LPP. The values to be used for "Physical cell ID PCI" are as follows: Cell 1: 0, Cell 2: 6, Cell 3: 12. For all the values to be used in LPP see Table 9.3.1.1.4.3-5 and TS 37.571-5 [20], clause 7.2.5.		
Note 3:	The parameter "Radio frame receive time offset between the cells at the UE antenna connector" is not a settable parameter but is used to set the "true RSTD" values in step 6 of clause 9.3.1.1.4.1.		
Note 4:	If the PRS transmission bandwidth is larger than the UE RF bandwidth, the UE is measuring RSTD within its RF bandwidth.		

**Table 9.3.1.1.4.1-2: DRX parameters for E-UTRAN FDD intra-frequency RSTD measurement reporting delay under fading propagation conditions**

Field	Value	Comment
onDurationTimer	psf1	As specified in 3GPP TS 36.331 [22], clause 6.3.2
drx-InactivityTimer	psf1	
drx-RetransmissionTimer	sf1	
longDRX-CycleStartOffset	sf320	
shortDRX	Disable	

9.3.1.1.4.2 Test procedure

The test consists of three consecutive time intervals, with duration of T1, T2 and T3 defined in Table 9.3.1.1.4.1-1. Cell 1 is active in T1, T2 and T3, whilst Cell 2 and Cell 3 are activated only in the beginning of T2. Cell 2 is active until the end of T3, and Cell 3 is active until the end of T2. The beginning of the time interval T2 shall be aligned 5 ms before the first PRS positioning subframe of a positioning occasion in the reference cell, where 5 ms is the necessary test tolerance. Cell 1 transmits PRS in T2, while Cell 2 transmits PRS only in T3, and Cell 3 transmits PRS only in T2.

NOTE: The information on when PRS is muted is conveyed to the UE using PRS muting information in the OTDOA assistance data.

The OTDOA-RequestLocationInformation message and the OTDOA assistance data as defined in clause 9.3.1.1.4.3 shall be provided to the UE during T1. The last TTI containing the OTDOA-RequestLocationInformation message shall be provided to the UE  $\Delta T$  ms before the start of T2, where  $\Delta T = 150$  ms is the maximum processing time of the OTDOA-RequestLocationInformation message and the OTDOA assistance data.

1. Ensure that the UE is in state Generic RB Established State 3A-RF-CE according to 3GPP TS 36.508 [18] clause 7.2A.3AA.
2. The SS shall send a RESET UE POSITIONING STORED INFORMATION message.
3. Set the parameters according to Table 9.3.1.1.5-1. Propagation conditions are set according to clause 4.7.2.2 (ETU30).
4. T1 starts.
5. The SS shall transmit an RRCConnectionReconfiguration message with the DRX configuration. PDCCHs indicating new transmissions shall be sent continuously until the start of T2 to ensure that the UE would not enter the DRX state before T2.
6. The UE shall transmit RRCConnectionReconfigurationComplete message.
- 6a. The SS shall transmit an LPP REQUEST CAPABILITIES message.
- 6b. The UE shall transmit an LPP PROVIDE CAPABILITIES message indicating the OTDOA capabilities supported by the UE in the *OTDOA-ProvideCapabilities* IE.

7. The SS shall send a LPP PROVIDE ASSISTANCE DATA message, including the *OTDOA-ProvideAssistanceData* IE. The position of neighbour Cell 2 in the *OTDOA-NeighbourCellInfoList* is randomly selected to be in the first 7 elements of the sequence, and the position of neighbour Cell 3 is randomly selected to be in the last 8 elements of the sequence, as described in 3GPP TS 37.571-5 [20], clause 7.2.3. If the UE message at step 6b includes the *ackRequested* IE set to TRUE, then the SS shall send an acknowledgment in the LPP PROVIDE ASSISTANCE DATA message.
8. The SS shall send a LPP REQUEST LOCATION INFORMATION message, including the *OTDOA-RequestLocationInformation* IE such that the UE receives the message  $\Delta T$  ms before the start of T2, where  $\Delta T = 150$  ms.
9. When T1 expires, the SS shall switch the power setting from T1 to T2 as specified in Table 9.3.1.1.5-2.
10. When T2 expires, the SS shall switch the power setting from T2 to T3 as specified in Table 9.3.1.1.5-2.
11. The UE shall transmit a LPP PROVIDE LOCATION INFORMATION message including the *OTDOA-ProvideLocationInformation* IE within the response time (see clause 4.7.3) specified in clause 9.3.1.1.5. The UE shall perform and report the RSTD measurements for both Cell 2 and Cell 3 with respect to the reference cell in the OTDOA assistance data, Cell 1. If the UE transmits an *OTDOA-ProvideLocationInformation* IE including the *rstd* field for both Cell 2 and Cell 3 within the response time then the number of successful tests is increased by one. If the UE fails to report the *OTDOA-ProvideLocationInformation* IE with both the *rstd* fields included within the response time then the number of failure tests is increased by one.
12. If the UE message at step 11 includes the *ackRequested* IE set to TRUE, the SS shall send a LPP acknowledgement message.
13. Repeat steps 2-12 until the confidence level according to Annex D is achieved. For each iteration, at step 7 change the random position of the Cells 2 and 3 in the *OTDOA-NeighbourCellInfoList*.

9.3.1.1.4.3 Message contents

**Table 9.3.1.1.4.3-1: RESET UE POSITIONING STORED INFORMATION**

Derivation Path: 36.509 [11] clause 6.9			
Information Element	Value/remark	Comment	Condition
UE Positioning Technology	0 0 0 0 0 0 1	OTDOA	

**Table 9.3.1.1.4.3-2: MAC-MainConfig-RBC: FDD RSTD Measurement Reporting Delay**

Derivation Path: TS 36.508 [18] clause 4.8.2.1.5, Table 4.8.2.1.5-1 MAC-MainConfig-RBC			
Information Element	Value/remark	Comment	Condition
MAC-MainConfig-RBC ::= SEQUENCE {			
drx-Config CHOICE {			
setup SEQUENCE {			
onDurationTimer	psf1		
drx-InactivityTimer	psf1		
drx-RetransmissionTimer	sf1		
longDRX-CycleStartOffset CHOICE {			
sf320	0		
}			
shortDRX	Not present		
}			
}			
}			

**Table 9.3.1.1.4.3-3: LPP Request Capabilities**

Information Element	Value/remark
<i>otdoa-RequestCapabilities</i>	TRUE

**Table 9.3.1.1.4.3-4: LPP RequestLocationInformation**

Derivation Path: 36.355 clause 6.2			
Information Element	Value/remark	Comment	Condition
LPP-Message ::= SEQUENCE {			
transactionID SEQUENCE {			
initiator	locationServer		
transactionNumber	1		
}			
endTransaction	FALSE		
sequenceNumber	Not present		
acknowledgement	Not present		
lpp-MessageBody CHOICE {			
c1 CHOICE {			
requestLocationInformation SEQUENCE {			
criticalExtensions CHOICE {			
c1 CHOICE {			
requestLocationInformation-r9 SEQUENCE {			
commonIEsRequestLocationInformation SEQUENCE {			
locationInformationType	locationMeasurementsRequired		
triggeredReporting	Not present		
periodicalReporting	Not present		
additionalInformation	onlyReturnInformationRequested		
qos SEQUENCE {			
horizontalAccuracy	Not present		
verticalCoordinateRequest	FALSE		
verticalAccuracy	Not present		
responseTime SEQUENCE {			
time	6	See clause 9.3.1.1.5	
responseTimeEarlyFix-r12	Not present		Rel-12 onwards
}			
velocityRequest	FALSE		
}			
environment	Not present		
locationCoordinateTypes	Not present		
velocityTypes	Not present		
}			
a-gnss-RequestLocationInformation	Not present		
otdoa-RequestLocationInformation SEQUENCE {			
assistanceAvailability	FALSE		
}			
ecid-RequestLocationInformation	Not present		
epdu-RequestLocationInformation	Not Present		
}			
}			
}			
}			
}			
}			
}			
}			
}			
}			
}			

Table 9.3.1.1.4.3-5: LPP ProvideAssistanceData

Derivation Path: 36.355 clause 6.2			
Information Element	Value/remark	Comment	Condition
LPP-Message ::= SEQUENCE {			
transactionID SEQUENCE {			
Initiator	locationServer		
transactionNumber	(0..255)		
}			
endTransaction	TRUE		
sequenceNumber	Not present		
acknowledgement	Not present		
lpp-MessageBody CHOICE {			
c1 CHOICE {			
provideAssistanceData SEQUENCE {			
criticalExtensions CHOICE {			
c1 CHOICE {			
provideAssistanceData-r9 SEQUENCE {			
commonIEsProvideAssistanceData	Not present		
a-gnss-ProvideAssistanceData	Not present		
otdoa-ProvideAssistanceData SEQUENCE {			
otdoa-ReferenceCellInfo	As defined in TS 37.571-5 [20], clause 7.2.5.		
otdoa-NeighbourCellInfo	As defined in TS 37.571-5 [20], clause 7.2.5.		
otdoa-Error	Not present		
}			
epdu-ProvideAssistanceData	Not present		
}			
}			
}			
}			
}			
}			

## 9.3.1.1.5 Test requirement

Table 9.3.1.1.5-1 and 9.3.1.1.5-2 define the primary level settings including test tolerances for the test.

**Table 9.3.1.1.5-1: Cell-specific test parameters for E-UTRAN FDD intra-frequency RSTD measurement reporting delay under fading propagation conditions during T1**

Parameter	Unit	Cell 1	Cell 2	Cell 3
E-UTRA RF Channel Number		1	1	1
Correlation Matrix and Antenna Configuration		1x1	1x1	1x1
OCNG patterns defined in TS 36.521-3 [25] clause D.1		OP.21 FDD	N/A	N/A
PBCH_RA	dB	0	N/A	N/A
PBCH_RB				
PSS_RA				
SSS_RA				
PCFICH_RB				
PHICH_RA				
PHICH_RB				
PDCCH_RA				
PDCCH_RB				
OCNG_RA <sup>Note 1</sup>				
OCNG_RB <sup>Note 1</sup>				
$N_{oc}$ <sup>Note 3</sup>	dBm/ 15 kHz	-95		
$PRS \hat{E}_s / N_{oc}$	dB	-Infinity	-Infinity	-Infinity
$I_0$ <sup>Note 4</sup>	dBm/ 9 MHz	-67.22	N/A	N/A
$\hat{E}_s / N_{oc}$	dB	0	-Infinity	-Infinity
Propagation Condition		ETU30		
Note 1:	OCNG shall be used such that active cell (Cell 1) is fully allocated and a constant total transmitted power spectral density is achieved for all OFDM symbols.			
Note 2:	The resources for uplink transmission are assigned to the UE prior to the start of time period T2.			
Note 3:	Interference from other cells and noise sources not specified in the test are assumed to be constant over subcarriers and time and shall be modelled as AWGN of appropriate power for $N_{oc}$ to be fulfilled.			
Note 4:	$I_0$ levels have been derived from other parameters and are given for information purpose. These are not settable test parameters.			

**Table 9.3.1.1.5-2: Cell-specific test parameters for E-UTRAN FDD intra-frequency RSTD measurement reporting delay under fading propagation conditions during T2 and T3**

Parameter	Unit	Cell 1		Cell 2		Cell 3	
		T2	T3	T2	T3	T2	T3
E-UTRA RF Channel Number		1		1		1	
Correlation Matrix and Antenna Configuration		1x1		1x1		1x1	
OCNG patterns defined in TS 36.521-3 [25] clause D.1		OP.21 FDD		OP.6 FDD		OP.6 FDD	N/A
PBCH_RA	dB	0		0		0	N/A
PBCH_RB							
PSS_RA							
SSS_RA							
PCFICH_RB							
PHICH_RA							
PHICH_RB							
PDCCH_RA							
PDCCH_RB							
OCNG_RA <sup>Note 1</sup>							
OCNG_RB <sup>Note 1</sup>							
PRS_RA	dB	-3	N/A	N/A	3	3	N/A
$N_{oc}$ <sup>Note 3</sup>	dBm/15 kHz	-98	-95	-98	-95	-98	-95
$\text{PRS } \hat{E}_s/N_{oc}$	dB	-1	-Infinity	-Infinity	-7	-7	-Infinity
$\text{PRS } \hat{E}_s/I_{ot}$ <sup>Note 4</sup>	dB	-1.79	-Infinity	-Infinity	-7	-9.54	-Infinity
$I_o$ <sup>Note 4</sup>	dBm/9 MHz	-69.55	-67.08	-69.55	-67.08	-69.55	N/A
PRP <sup>Note 4</sup>	dBm/15 kHz	-99	-Infinity	-Infinity	-102	-105	-Infinity
RSRP <sup>Note 4</sup>	dBm/15 kHz	-96	-93	-105	-105	-108	-Infinity
$\hat{E}_s/N_{oc}$ <sup>Note 4</sup>	dB	2	2	-7	-10	-10	-Infinity
Propagation Condition		ETU30					
<p>Note 1: OCNG shall be used such that active cells (all, except Cell 3 in T3) are fully allocated and a constant total transmitted power spectral density is achieved for all OFDM symbols other than those in the subframes with transmitted PRS.</p> <p>Note 2: The resources for uplink transmission are assigned to the UE prior to the start of time period T2.</p> <p>Note 3: Interference from other cells and noise sources not specified in the test are assumed to be constant over subcarriers and time and shall be modelled as AWGN of appropriate power for <math>N_{oc}</math> to be fulfilled.</p> <p>Note 4: If PRS_RA is not "N/A", <math>\hat{E}_s/N_{oc}</math>, <math>\text{PRS } \hat{E}_s/I_{ot}</math>, <math>I_o</math>, RSRP and PRP levels have been derived from other parameters and are given for information purpose. If PRS_RA is "N/A", <math>I_o</math> and RSRP levels have been derived from other parameters and are given for information purpose. These are not settable test parameters. Interference conditions shall be applied to all PRS symbols of DL positioning subframes.</p>							

The response time including test tolerance is 6.3 s. The response time is equal to the LPP time IE value plus the test tolerance. The LPP time IE value is derived from the RSTD reporting delay plus  $\Delta T$ , where  $\Delta T = N_{rep} \times TTI_{DCCH} = N_{rep} \times 75$  ms, giving a value of [5270] ms. This is rounded up to the next allowed LPP value of 6 seconds. The RSTD

measurement reporting delay in the test is derived from the following expression  $T_{PRS} (M - 1) + 320 \cdot \left\lceil \frac{n}{M} \right\rceil$ , where



$M = 16$  and  $n = 16$  are the parameters specified in clause 9.3.1.1.3, Table 9.3.1.1.3-1 and Note 4 of Table 9.3.1.1.4.1-1. This gives the total RSTD reporting delay of [5210] ms for the 15 neighbour cells including Cell 2 and Cell 3 with respect to the reference cell, Cell 1.

The test tolerances are defined in clauses C.1.3 and C4.

The rate of successful tests during repeated tests shall be at least 90% with a confidence level of 95%.

### 9.3.1.2 FDD intra-frequency RSTD Measurement Reporting Delay in CE Mode A for Cat M2

**Editor's note: This test is incomplete. The following aspects are missing:**

- TBD in TS 36.133 how to capture `prsOccGroupLength` in the measurement period
- Assistance Data in TS 37.571-5 is missing

#### 9.3.1.2.1 Test purpose

To verify that the RSTD measurement reporting delay for UE Category M2 meets the performance requirements in normal coverage mode in an environment with fading propagation conditions.

#### 9.3.1.2.2 Test applicability

This test applies to E-UTRA FDD UE Category M2 release 14 and forward that supports UE-assisted OTDOA.

#### 9.3.1.2.3 Minimum conformance requirements

Same as in clause 9.3.1.1.3.

The normative reference for this requirement is TS 36.133 [23] clause 8.16.2.3.1 and A.8.12.3.

#### 9.3.1.2.4 Test description

##### 9.3.1.2.4.1 Initial conditions

Same as in clause 9.3.1.1.4.1 but replacing Table 9.3.1.1.4.1-1 with Table 9.3.1.2.4.1-1.

**Table 9.3.1.2.4.1-1: General test parameters for E-UTRAN FDD intra-frequency RSTD measurement reporting delay under fading propagation conditions**

Parameter	Unit	Value		Comment
		Test 1	Test 2	
Reference cell		Cell 1		Reference cell is the cell in the OTDOA assistance data with respect to which the RSTD measurement is defined, as specified in 3GPP TS 36.214 [6] and 3GPP TS 36.355 [4]. The reference cell is the serving cell in this test case.
Neighbour cells		Cell 2 and Cell 3		Cell 2 and Cell 3 appear at random places in the neighbour cell list in the OTDOA assistance data, but Cell 2 always appears in the first half of the list, whilst Cell 3 appears in the second half of the list.
MPDCCH		DL Reference Measurement Channel R.16 FDD		As specified in TS 36.521-3 [25] clause A.7.1
$mPDCCH\text{-startSF-UeSS}$		10		Parameter $G$ in $T = r_{\max} \cdot G$ which determines subframe $k0$ in which MPDCCH starts
Channel Bandwidth ( $BW_{\text{channel}}$ )	MHz	10		
PRS Transmission Bandwidth <sup>Note 2</sup>	RB	50 <sup>Note 4</sup>		PRS are transmitted over the system bandwidth
PRS configuration index $I_{\text{PRS}}$ <sup>Note 2</sup>		311		This corresponds to periodicity of 320 ms and PRS subframe offset of $I_{\text{PRS}} - 160$ DL subframes, as defined in 3GPP TS 36.211 [26], Table 6.10.4.3-1
Number of consecutive downlink positioning subframes $N_{\text{PRS}}$ <sup>Note 2</sup>		6	2	As defined in 3GPP TS 36.211 [26]. The number of subframes in a positioning occasion
Physical cell ID PCI <sup>Note 2</sup>		(PCI of Cell 1 – PCI of Cell 2) mod 6 = 0 and (PCI of Cell 1 – PCI of Cell 3) mod 6 = 0		The cell PCIs are selected such that the relative shifts of PRS patterns among cells are as given by the test parameters
CP length <sup>Note 2</sup>		Normal		
DRX		ON		DRX parameters are further specified in Table 9.3.1.1.4.1-2
Radio frame receive time offset between the cells at the UE antenna connector <sup>Note 3</sup>	μs	Cell 2 to Cell 1: 1 Cell 3 to Cell 1: -1		PRS are transmitted from synchronous cells
Expected RSTD <sup>Note 1</sup>	μs	Cell 2: 3 Cell 3: 3 Other neighbour cells: randomly between -3 and 3		The expected RSTD is what is expected at the receiver. The corresponding parameter in the OTDOA assistance data specified in TS 36.355 [4] is the expectedRSTD indicator
Expected RSTD uncertainty for all neighbour cells <sup>Note 1</sup>	μs	5		The corresponding parameter in the OTDOA assistance data specified in TS 36.355 [4] is the expectedRSTD-Uncertainty index
Number of cells provided in OTDOA assistance data		16		Including the reference cell
PRS muting info <sup>Note 2</sup>		Cell 1: '11110000' Cell 2: '00001111' Cell 3: '11110000'		Corresponds to prs-MutingInfo defined in TS 36.355 [4]
T1	s	3		The length of the time interval from the beginning of each test
T2	s	2.56		The length of the time interval that follows immediately after time interval T1

T3	s	2.56	The length of the time interval that follows immediately after time interval T2
Note 1:	Parameters "Expected RSTD" and "Expected RSTD uncertainty for all neighbour cells" are not settable parameters. These are parameters signalled in LPP only. For the values to be used in LPP see Table 9.3.1.1.4.3-5 and TS 37.571-5 [20], clause 7.2.5.		
Note 2:	Parameters "PRS Transmission Bandwidth", "PRS configuration index", "Number of consecutive downlink positioning subframes", "Physical cell ID PCI", "CP length", and "PRS muting info" are settable parameters and also parameters signalled in LPP. The values to be used for "Physical cell ID PCI" are as follows: Cell 1: 0, Cell 2: 6, Cell 3: 12. For all the values to be used in LPP see Table 9.3.1.1.4.3-5 and TS 37.571-5 [20], clause 7.2.5.		
Note 3:	The parameter "Radio frame receive time offset between the cells at the UE antenna connector" is not a settable parameter but is used to set the "true RSTD" values in step 6 of clause 9.3.1.1.4.1.		
Note 4:	If the PRS transmission bandwidth is larger than the UE RF bandwidth, the UE is measuring RSTD within its RF bandwidth.		

#### 9.3.1.2.4.2 Test procedure

Same as in clause 9.3.1.1.4.2 but with the following additional step:

14. Repeat step 1-13 for each sub-test in Table 9.3.1.2.4.1-1 as appropriate

#### 9.3.1.2.4.3 Message contents

Same as in clause 9.3.1.1.4.3.

#### 9.3.1.2.5 Test requirement

Same as in clause 9.3.1.1.5.

For the overall test to pass, the ratio of successful reported values in each sub-test shall be more than 90% with a confidence level of 95%.

## 9.3.2 HD-FDD intra-frequency RSTD Measurement Reporting Delay in CE Mode A

### 9.3.2.1 HD-FDD intra-frequency RSTD Measurement Reporting Delay in CE Mode A for Cat M1

**Editor's note: This test is incomplete. The following aspects are missing:**

- TBD in TS 36.133 how to capture prsOccGroupLength in the measurement period
- Response Time to be calculated based as Nprs\_total is missing in TS 36.133
- Assistance Data in TS 37.571-5 is missing

#### 9.3.2.1.1 Test purpose

To verify that the RSTD measurement reporting delay for UE Category M1 meets the performance requirements normal coverage mode in an environment with fading propagation conditions.

#### 9.3.2.1.2 Test applicability

This test applies to E-UTRA HD-FDD UE Category M1 release 14 and forward that supports UE-assisted OTDOA.

#### 9.3.2.1.3 Minimum conformance requirements

Same as in clause 9.3.1.1.3.

The normative reference for this requirement is TS 36.133 [23] clause 8.13.2.3.3 and A.8.12.4.

9.3.2.1.4 Test description

9.3.2.1.4.1 Initial conditions

Same as in clause 9.3.1.1.4.1 but replacing Table 9.3.1.1.4.1-1 with Table 9.3.2.1.4.1-1

**Table 9.3.2.1.4.1-1: General test parameters for E-UTRAN HD-FDD intra-frequency RSTD measurement reporting delay under fading propagation conditions**

Parameter	Unit	Value	Comment
Reference cell		Cell 1	Reference cell is the cell in the OTDOA assistance data with respect to which the RSTD measurement is defined, as specified in 3GPP TS 36.214 [6] and 3GPP TS 36.355 [4]. The reference cell is the serving cell in this test case.
Neighbour cells		Cell 2 and Cell 3	Cell 2 and Cell 3 appear at random places in the neighbour cell list in the OTDOA assistance data, but Cell 2 always appears in the first half of the list, whilst Cell 3 appears in the second half of the list.
MPDCCH		DL Reference Measurement Channel R.6 HD-FDD	As specified in TS 36.521-3 [25] clause A.7.2
<i>mPDCCH-startSF-U ESS</i>		10	Parameter $G$ in $T = r_{\max} \cdot G$ which determines subframe $k0$ in which MPDCCH starts
Channel Bandwidth ( $BW_{\text{channel}}$ )	MHz	10	
PRS Transmission Bandwidth <sup>Note 2</sup>	RB	50 <sup>Note 4</sup>	PRS are transmitted over the system bandwidth
PRS configuration index $I_{\text{PRS}}$ <sup>Note 2</sup>		311	This corresponds to periodicity of 320 ms and PRS subframe offset of $I_{\text{PRS}} - 160$ DL subframes, as defined in 3GPP TS 36.211 [26], Table 6.10.4.3-1
Number of consecutive downlink positioning subframes $N_{\text{PRS}}$ <sup>Note 2</sup>		6	As defined in 3GPP TS 36.211 [26]. The number of subframes in a positioning occasion
Physical cell ID PCI <sup>Note 2</sup>		(PCI of Cell 1 – PCI of Cell 2) mod 6 = 0 and (PCI of Cell 1 – PCI of Cell 3) mod 6 = 0	The cell PCIs are selected such that the relative shifts of PRS patterns among cells are as given by the test parameters
CP length <sup>Note 2</sup>		Normal	
DRX		ON	DRX parameters are further specified in Table 9.3.1.1.4.1-2
Radio frame receive time offset between the cells at the UE antenna connector <sup>Note 3</sup>	μs	Cell 2 to Cell 1: 1 Cell 3 to Cell 1: -1	PRS are transmitted from synchronous cells
Expected RSTD <sup>Note 1</sup>	μs	Cell 2: 3 Cell 3: 3 Other neighbour cells: randomly between -3 and 3	The expected RSTD is what is expected at the receiver. The corresponding parameter in the OTDOA assistance data specified in TS 36.355 [4] is the expectedRSTD indicator
Expected RSTD uncertainty for all neighbour cells <sup>Note 1</sup>	μs	5	The corresponding parameter in the OTDOA assistance data specified in TS 36.355 [4] is the expectedRSTD-Uncertainty index
Number of cells provided in OTDOA assistance data		16	Including the reference cell
PRS muting info <sup>Note 2</sup>		Cell 1: '11110000' Cell 2: '00001111' Cell 3: '11110000'	Corresponds to prs-MutingInfo defined in TS 36.355 [4]
T1	s	3	The length of the time interval from the beginning of each test
T2	s	2.56	The length of the time interval that follows immediately after time interval T1

T3	s	2.56	The length of the time interval that follows immediately after time interval T2
Note 1:	Parameters "Expected RSTD" and "Expected RSTD uncertainty for all neighbour cells" are not settable parameters. These are parameters signalled in LPP only. For the values to be used in LPP see Table 9.3.1.1.4.3-5 and TS 37.571-5 [20], clause 7.2.5.		
Note 2:	Parameters "PRS Transmission Bandwidth", "PRS configuration index", "Number of consecutive downlink positioning subframes", "Physical cell ID PCI", "CP length", and "PRS muting info" are settable parameters and also parameters signalled in LPP. The values to be used for "Physical cell ID PCI" are as follows: Cell 1: 0, Cell 2: 6, Cell 3: 12. For all the values to be used in LPP see Table 9.3.1.1.4.3-5 and TS 37.571-5 [20], clause 7.2.5.		
Note 3:	The parameter "Radio frame receive time offset between the cells at the UE antenna connector" is not a settable parameter but is used to set the "true RSTD" values in step 6 of clause 9.3.1.1.4.1.		
Note 4:	If the PRS transmission bandwidth is larger than the UE RF bandwidth, the UE is measuring RSTD within its RF bandwidth.		

#### 9.3.2.1.4.2 Test procedure

Same as in clause 9.3.1.1.4.2.

#### 9.3.2.1.4.3 Message contents

Same as in clause 9.3.1.1.4.3

#### 9.3.2.1.5 Test requirement

Same as in clause 9.3.1.1.5.

### 9.3.2.2 HD-FDD intra-frequency RSTD Measurement Reporting Delay in CE Mode A for Cat M2

**Editor's note: This test is incomplete. The following aspects are missing:**

- TBD in TS 36.133 how to capture prsOccGroupLength in the measurement period
- Assistance Data in TS 37.571-5 is missing

#### 9.3.2.2.1 Test purpose

To verify that the RSTD measurement reporting delay for UE Category M2 meets the performance requirements normal coverage mode in an environment with fading propagation conditions.

#### 9.3.2.2.2 Test applicability

This test applies to E-UTRA HD-FDD UE Category M2 release 14 and forward that supports UE-assisted OTDOA.

#### 9.3.2.2.3 Minimum conformance requirements

Same as in clause 9.3.1.1.3.

The normative reference for this requirement is TS 36.133 [23] clause 8.16.2.3.3 and A.8.12.4.

#### 9.3.2.2.4 Test description

##### 9.3.2.2.4.1 Initial conditions

Same as in clause 9.3.1.1.4.1 but replacing Table 9.3.1.1.4.1-1 with Table 9.3.2.2.4.1-1.



**Table 9.3.2.2.4.1-1: General test parameters for E-UTRAN HD-FDD intra-frequency RSTD measurement reporting delay under fading propagation conditions**

Parameter	Unit	Value		Comment
		Test 1	Test 2	
Reference cell		Cell 1		Reference cell is the cell in the OTDOA assistance data with respect to which the RSTD measurement is defined, as specified in 3GPP TS 36.214 [6] and 3GPP TS 36.355 [4]. The reference cell is the serving cell in this test case.
Neighbour cells		Cell 2 and Cell 3		Cell 2 and Cell 3 appear at random places in the neighbour cell list in the OTDOA assistance data, but Cell 2 always appears in the first half of the list, whilst Cell 3 appears in the second half of the list.
MPDCCH		DL Reference Measurement Channel R.6 HD-FDD		As specified in TS 36.521-3 [25] clause A.7.2
<i>mPDCCH-startSF-UeSS</i>		10		Parameter $G$ in $T = r_{\max} \cdot G$ which determines subframe $k0$ in which MPDCCH starts
Channel Bandwidth ( $BW_{\text{channel}}$ )	MHz	10		
PRS Transmission Bandwidth Note 2	RB	50 Note 4		PRS are transmitted over the system bandwidth
PRS configuration index $I_{\text{PRS}}$ Note 2		311		This corresponds to periodicity of 320 ms and PRS subframe offset of $I_{\text{PRS}} - 160$ DL subframes, as defined in 3GPP TS 36.211 [26], Table 6.10.4.3-1
Number of consecutive downlink positioning subframes $N_{\text{PRS}}$ Note 2		6	2	As defined in 3GPP TS 36.211 [26]. The number of subframes in a positioning occasion
Physical cell ID PCI Note 2		(PCI of Cell 1 – PCI of Cell 2) mod 6 = 0 and (PCI of Cell 1 – PCI of Cell 3) mod 6 = 0		The cell PCIs are selected such that the relative shifts of PRS patterns among cells are as given by the test parameters
CP length Note 2		Normal		
DRX		ON		DRX parameters are further specified in Table 9.3.1.1.4.1-2
Radio frame receive time offset between the cells at the UE antenna connector Note 3	$\mu\text{s}$	Cell 2 to Cell 1: 1 Cell 3 to Cell 1: -1		PRS are transmitted from synchronous cells
Expected RSTD Note 1	$\mu\text{s}$	Cell 2: 3 Cell 3: 3 Other neighbour cells: randomly between -3 and 3		The expected RSTD is what is expected at the receiver. The corresponding parameter in the OTDOA assistance data specified in TS 36.355 [4] is the expectedRSTD indicator
Expected RSTD uncertainty for all neighbour cells Note 1	$\mu\text{s}$	5		The corresponding parameter in the OTDOA assistance data specified in TS 36.355 [4] is the expectedRSTD-Uncertainty index
Number of cells provided in OTDOA assistance data		16		Including the reference cell
PRS muting info Note 2		Cell 1: '11110000' Cell 2: '00001111' Cell 3: '11110000'		Corresponds to prs-MutingInfo defined in TS 36.355 [4]
T1	s	3		The length of the time interval from the beginning of each test
T2	s	2.56		The length of the time interval that follows immediately after time interval T1

T3	s	2.56	The length of the time interval that follows immediately after time interval T2
Note 1:	Parameters "Expected RSTD" and "Expected RSTD uncertainty for all neighbour cells" are not settable parameters. These are parameters signalled in LPP only. For the values to be used in LPP see Table 9.3.1.1.4.3-5 and TS 37.571-5 [20], clause 7.2.5.		
Note 2:	Parameters "PRS Transmission Bandwidth", "PRS configuration index", "Number of consecutive downlink positioning subframes", "Physical cell ID PCI", "CP length", and "PRS muting info" are settable parameters and also parameters signalled in LPP. The values to be used for "Physical cell ID PCI" are as follows: Cell 1: 0, Cell 2: 6, Cell 3: 12. For all the values to be used in LPP see Table 9.3.1.1.4.3-5 and TS 37.571-5 [20], clause 7.2.5.		
Note 3:	The parameter "Radio frame receive time offset between the cells at the UE antenna connector" is not a settable parameter but is used to set the "true RSTD" values in step 6 of clause 9.3.1.1.4.1.		
Note 4:	If the PRS transmission bandwidth is larger than the UE RF bandwidth, the UE is measuring RSTD within its RF bandwidth.		

#### 9.3.2.2.4.2 Test procedure

Same as in clause 9.3.1.1.4.2 but with the following additional step:

14. Repeat step 1-13 for each sub-test in Table 9.3.2.2.4.1-1 as appropriate.

#### 9.3.2.2.4.3 Message contents

Same as in clause 9.3.1.1.4.3.

#### 9.3.2.2.5 Test requirement

Same as in clause 9.3.2.1.5.

For the overall test to pass, the ratio of successful reported values in each sub-test shall be more than 90% with a confidence level of 95%.

### 9.3.3 TDD intra-frequency RSTD Measurement Reporting Delay in CE Mode A

#### 9.3.3.1 TDD intra-frequency RSTD Measurement Reporting Delay in CE Mode A for Cat M1

**Editor's note: This test is incomplete. The following aspects are missing:**

- TBD in TS 36.133 how to capture prsOccGroupLength in the measurement period
- Response Time to be calculated based as Nprs\_total is missing in TS 36.133
- Assistance Data in TS 37.571-5 is missing

##### 9.3.3.1.1 Test purpose

To verify that the RSTD measurement reporting delay for UE Category M1 meets the performance requirements in normal coverage mode in an environment with fading propagation conditions.

##### 9.3.3.1.2 Test applicability

This test applies to E-UTRA TDD UE Category M1 release 14 and forward that supports UE-assisted OTDOA.

##### 9.3.3.1.3 Minimum conformance requirements

Same as in clause 9.3.1.1.3.

The intra-frequency requirements in this clause shall apply for all TDD special subframe configurations specified in TS 36.211 [26] and for the TDD uplink-downlink configurations as specified in Table 9.3.3.1.3-1.

**Table 9.3.3.1.3-1: TDD uplink-downlink subframe configurations applicable for TDD intra-frequency requirements**

PRS Transmission Bandwidth [RB]	Applicable TDD uplink-downlink configurations
6	1, 2, 3, 4 and 5
Note: Uplink-downlink configurations are specified in Table 4.2-2 in TS 36.211 [26].	

The normative reference for this requirement is TS 36.133 [23] clause 8.13.2.3.2 and A.8.12.5.

9.3.3.1.4 Test description

9.3.3.1.4.1 Initial conditions

Same as in clause 9.3.1.1.4.1 but replacing Table 9.3.1.1.4.1-1 with Table 9.3.3.1.4.1-1

**Table 9.3.3.1.4.1-1: General test parameters for E-UTRAN TDD intra-frequency RSTD measurement reporting delay under fading propagation conditions**

Parameter	Unit	Value	Comment
Reference cell		Cell 1	Reference cell is the cell in the OTDOA assistance data with respect to which the RSTD measurement is defined, as specified in 3GPP TS 36.214 [6] and 3GPP TS 36.355 [4]. The reference cell is the serving cell in this test case.
Neighbour cells		Cell 2 and Cell 3	Cell 2 and Cell 3 appear at random places in the neighbour cell list in the OTDOA assistance data, but Cell 2 always appears in the first half of the list, whilst Cell 3 appears in the second half of the list.
MPDCCH		DL Reference Measurement Channel R.14 TDD	As specified in TS 36.521-3 [25] clause A.7.3
<i>mPDCCH-startSF-U ESS</i>		10	Parameter $G$ in $T = r_{\max} \cdot G$ which determines subframe $k0$ in which MPDCCH starts
Channel Bandwidth ( $BW_{\text{channel}}$ )	MHz	10	
PRS Transmission Bandwidth <sup>Note 2</sup>	RB	50 <sup>Note 4</sup>	PRS are transmitted over the system bandwidth
PRS configuration index $I_{\text{PRS}}$ <sup>Note 2</sup>		304	This corresponds to periodicity of 320 ms and PRS subframe offset of $I_{\text{PRS}} - 160$ DL subframes, as defined in 3GPP TS 36.211 [26], Table 6.10.4.3-1
Number of consecutive downlink positioning subframes $N_{\text{PRS}}$ <sup>Note 2</sup>		6	As defined in 3GPP TS 36.211 [26]. The number of subframes in a positioning occasion
Physical cell ID PCI <sup>Note 2</sup>		(PCI of Cell 1 – PCI of Cell 2) mod 6 = 0 and (PCI of Cell 1 – PCI of Cell 3) mod 6 = 0	The cell PCIs are selected such that the relative shifts of PRS patterns among cells are as given by the test parameters
TDD uplink-downlink configuration		1	As specified in TS 36.211 [26], Clause 4.2; corresponds to a configuration with 5 ms switch-point periodicity and two downlink consecutive subframes
TDD special subframe configuration		6	As specified in TS 36.211 [26], Clause 4.2; corresponds to DwPTS of $19760 \cdot T_s$ and UpPTS of $4384 \cdot T_s$
CP length <sup>Note 2</sup>		Normal	
DRX		ON	DRX parameters are further specified in Table 9.3.1.1.4.1-2
Radio frame receive time offset between the cells at the UE antenna connector <sup>Note 3</sup>	$\mu\text{s}$	Cell 2 to Cell 1: 1 Cell 3 to Cell 1: -1	PRS are transmitted from synchronous cells
Expected RSTD <sup>Note 1</sup>	$\mu\text{s}$	Cell 2: 3 Cell 3: 3 Other neighbour cells: randomly between -3 and 3	The expected RSTD is what is expected at the receiver. The corresponding parameter in the OTDOA assistance data specified in TS 36.355 [4] is the expectedRSTD indicator
Expected RSTD uncertainty for all neighbour cells <sup>Note 1</sup>	$\mu\text{s}$	5	The corresponding parameter in the OTDOA assistance data specified in TS 36.355 [4] is the expectedRSTD-Uncertainty index
Number of cells provided in OTDOA assistance data		16	Including the reference cell

PRS muting info <sup>Note 2</sup>		Cell 1: '11110000' Cell 2: '00001111' Cell 3: '11110000'	Corresponds to prs-MutingInfo defined in TS 36.355 [4]
T1	s	3	The length of the time interval from the beginning of each test
T2	s	2.56	The length of the time interval that follows immediately after time interval T1
T3	s	2.56	The length of the time interval that follows immediately after time interval T2
Note 1:	Parameters "Expected RSTD" and "Expected RSTD uncertainty for all neighbour cells" are not settable parameters. These are parameters signalled in LPP only. For the values to be used in LPP see Table 9.3.1.1.4.3-5 and TS 37.571-5 [20], clause 7.2.5.		
Note 2:	Parameters "PRS Transmission Bandwidth", "PRS configuration index", "Number of consecutive downlink positioning subframes", "Physical cell ID PCI", "CP length", and "PRS muting info" are settable parameters and also parameters signalled in LPP. The values to be used for "Physical cell ID PCI" are as follows: Cell 1: 0, Cell 2: 6, Cell 3: 12. For all the values to be used in LPP see Table 9.3.1.1.4.3-5 and TS 37.571-5 [20], clause 7.2.5.		
Note 3:	The parameter "Radio frame receive time offset between the cells at the UE antenna connector" is not a settable parameter but is used to set the "true RSTD" values in step 6 of clause 9.3.1.1.4.1.		
Note 4:	If the PRS transmission bandwidth is larger than the UE RF bandwidth, the UE is measuring RSTD within its RF bandwidth.		

#### 9.3.3.1.4.2 Test procedure

Same as in clause 9.3.1.1.4.2.

#### 9.3.3.1.4.3 Message contents

Same as in clause 9.3.1.1.4.3

#### 9.3.3.1.5 Test requirement

Table 9.3.3.1.5-1 and 9.3.3.1.5-2 define the primary level settings including test tolerances for the test.

**Table 9.3.3.1.5-1: Cell-specific test parameters for E-UTRAN TDD intra-frequency RSTD measurement reporting delay under fading propagation conditions during T1**

Parameter	Unit	Cell 1	Cell 2	Cell 3
E-UTRA RF Channel Number		1	1	1
Correlation Matrix and Antenna Configuration		1x1	1x1	1x1
OCNG patterns defined in TS 36.521-3 [25] clause D.1		OP.11 TDD	N/A	N/A
PBCH_RA	dB	0	N/A	N/A
PBCH_RB				
PSS_RA				
SSS_RA				
PCFICH_RB				
PHICH_RA				
PHICH_RB				
PDCCH_RA				
PDCCH_RB				
OCNG_RA <sup>Note 1</sup>				
OCNG_RB <sup>Note 1</sup>				
$N_{oc}$ <sup>Note 3</sup>	dBm/ 15 kHz	-95		
$PRS \hat{E}_s / N_{oc}$	dB	-Infinity	-Infinity	-Infinity
$I_0$ <sup>Note 4</sup>	dBm/ 9 MHz	-67.22	N/A	N/A
$\hat{E}_s / N_{oc}$	dB	0	-Infinity	-Infinity
Propagation Condition		ETU30		
Note 1:	OCNG shall be used such that active cell (Cell 1) is fully allocated and a constant total transmitted power spectral density is achieved for all OFDM symbols.			
Note 2:	The resources for uplink transmission are assigned to the UE prior to the start of time period T2.			
Note 3:	Interference from other cells and noise sources not specified in the test are assumed to be constant over subcarriers and time and shall be modelled as AWGN of appropriate power for $N_{oc}$ to be fulfilled.			
Note 4:	$I_0$ levels have been derived from other parameters and are given for information purpose. These are not settable test parameters.			



**Table 9.3.3.1.5-2: Cell-specific test parameters for E-UTRAN TDD intra-frequency RSTD measurement reporting delay under fading propagation conditions during T2 and T3**

Parameter	Unit	Cell 1		Cell 2		Cell 3	
		T2	T3	T2	T3	T2	T3
E-UTRA RF Channel Number		1		1		1	
Correlation Matrix and Antenna Configuration		1x1		1x1		1x1	
OCNG patterns defined in TS 36.521-3 [25] clause D.1		OP.11 TDD		OP.2 TDD		OP.2 TDD	N/A
PBCH_RA	dB	0		0		0	N/A
PBCH_RB							
PSS_RA							
SSS_RA							
PCFICH_RB							
PHICH_RA							
PHICH_RB							
PDCCH_RA							
PDCCH_RB							
OCNG_RA <sup>Note 1</sup>							
OCNG_RB <sup>Note 1</sup>							
PRS_RA	dB	-3	N/A	N/A	3	3	N/A
$N_{oc}$ <sup>Note 3</sup>	dBm/15 kHz	-98	-95	-98	-95	-98	-95
$\text{PRS } \hat{E}_s/N_{oc}$	dB	-1	-Infinity	-Infinity	-7	-7	-Infinity
$\text{PRS } \hat{E}_s/I_{ot}$ <sup>Note 4</sup>	dB	-1.79	-Infinity	-Infinity	-7	-9.54	-Infinity
$I_o$ <sup>Note 4</sup>	dBm/9 MHz	-69.55	-67.08	-69.55	-67.08	-69.55	N/A
PRP <sup>Note 4</sup>	dBm/15 kHz	-99	-Infinity	-Infinity	-102	-105	-Infinity
RSRP <sup>Note 4</sup>	dBm/15 kHz	-96	-93	-105	-105	-108	-Infinity
$\hat{E}_s/N_{oc}$ <sup>Note 4</sup>	dB	2	2	-7	-10	-10	-Infinity
Propagation Condition		ETU30					
<p>Note 1: OCNG shall be used such that active cells (all, except Cell 3 in T3) are fully allocated and a constant total transmitted power spectral density is achieved for all OFDM symbols other than those in the subframes with transmitted PRS.</p> <p>Note 2: The resources for uplink transmission are assigned to the UE prior to the start of time period T2.</p> <p>Note 3: Interference from other cells and noise sources not specified in the test are assumed to be constant over subcarriers and time and shall be modelled as AWGN of appropriate power for <math>N_{oc}</math> to be fulfilled.</p> <p>Note 4: If PRS_RA is not "N/A", <math>\hat{E}_s/N_{oc}</math>, <math>\text{PRS } \hat{E}_s/I_{ot}</math>, <math>I_o</math>, RSRP and PRP levels have been derived from other parameters and are given for information purpose. If PRS_RA is "N/A", <math>I_o</math> and RSRP levels have been derived from other parameters and are given for information purpose. These are not settable test parameters. Interference conditions shall be applied to all PRS symbols of DL positioning subframes.</p>							

The response time including test tolerance is 6.3 s. The response time is equal to the LPP time IE value plus the test tolerance. The LPP time IE value is derived from the RSTD reporting delay plus  $\Delta T$ , where  $\Delta T = N_{rep} \times TTI_{DCCH} = N_{rep} \times 75$  ms, giving a value of [5270] ms. This is rounded up to the next allowed LPP value of 6 seconds. The RSTD

measurement reporting delay in the test is derived from the following expression  $T_{PRS} (M - 1) + 320 \cdot \left\lceil \frac{n}{M} \right\rceil$ , where

$M = 16$  and  $n = 16$  are the parameters specified in clause 9.3.1.1.3, Table 9.3.1.1.3-1 and Note 4 of Table 9.3.3.1.4.1-1. This gives the total RSTD reporting delay of [5210] ms for the 15 neighbour cells including Cell 2 and Cell 3 with respect to the reference cell, Cell 1.

The test tolerances are defined in clauses C.1.3 and C4.

The rate of successful tests during repeated tests shall be at least 90% with a confidence level of 95%.

### 9.3.3.2 TDD intra-frequency RSTD Measurement Reporting Delay in CE Mode A for Cat M2

**Editor's note: This test is incomplete. The following aspects are missing:**

- TBD in TS 36.133 how to capture `prsOccGroupLength` in the measurement period
- Assistance Data in TS 37.571-5 is missing

#### 9.3.3.2.1 Test purpose

To verify that the RSTD measurement reporting delay for UE Category M2 meets the performance requirements in normal coverage mode in an environment with fading propagation conditions.

#### 9.3.3.2.2 Test applicability

This test applies to E-UTRA TDD UE Category M2 release 14 and forward that supports UE-assisted OTDOA.

#### 9.3.3.2.3 Minimum conformance requirements

Same as in clause 9.3.3.1.3.

The intra-frequency requirements in this clause shall apply for all TDD special subframe configurations specified in TS 36.211 [26] and for the TDD uplink-downlink configurations as specified in Table 9.3.3.2.3-1.

**Table 9.3.3.2.3-1: TDD uplink-downlink subframe configurations applicable for TDD intra-frequency requirements**

PRS Transmission Bandwidth [RB]	Applicable TDD uplink-downlink configurations
6	1, 2, 3, 4 and 5
24	0, 1, 2, 3, 4, 5 and 6
Note:	Uplink-downlink configurations are specified in Table 4.2-2 in TS 36.211 [26].

The normative reference for this requirement is TS 36.133 [23] clause 8.16.2.3.2 and A.8.12.5.

#### 9.3.3.2.4 Test description

##### 9.3.3.2.4.1 Initial conditions

Same as in clause 9.3.1.1.4.1 but replacing Table 9.3.1.1.4.1-1 with Table 9.3.3.2.4.1-1.

**Table 9.3.3.2.4.1-1: General test parameters for E-UTRAN TDD intra-frequency RSTD measurement reporting delay under fading propagation conditions**

Parameter	Unit	Value		Comment
		Test 1	Test 2	
Reference cell		Cell 1		Reference cell is the cell in the OTDOA assistance data with respect to which the RSTD measurement is defined, as specified in 3GPP TS 36.214 [6] and 3GPP TS 36.355 [4]. The reference cell is the serving cell in this test case.
Neighbour cells		Cell 2 and Cell 3		Cell 2 and Cell 3 appear at random places in the neighbour cell list in the OTDOA assistance data, but Cell 2 always appears in the first half of the list, whilst Cell 3 appears in the second half of the list.
MPDCCH		DL Reference Measurement Channel R.14 TDD		As specified in TS 36.521-3 [25] clause A.7.3
<i>mPDCCH-startSF-UeSS</i>		10		Parameter $G$ in $T = r_{\max} \cdot G$ which determines subframe $k0$ in which MPDCCH starts
Channel Bandwidth ( $BW_{\text{channel}}$ )	MHz	10		
PRS Transmission Bandwidth <sup>Note 2</sup>	RB	50 <sup>Note 4</sup>		PRS are transmitted over the system bandwidth
PRS configuration index $I_{\text{PRS}}$ <sup>Note 2</sup>		304		This corresponds to periodicity of 320 ms and PRS subframe offset of $I_{\text{PRS}} - 160$ DL subframes, as defined in 3GPP TS 36.211 [26], Table 6.10.4.3-1
Number of consecutive downlink positioning subframes $N_{\text{PRS}}$ <sup>Note 2</sup>		6	2	As defined in 3GPP TS 36.211 [26]. The number of subframes in a positioning occasion
Physical cell ID PCI <sup>Note 2</sup>		(PCI of Cell 1 – PCI of Cell 2) mod 6 = 0 and (PCI of Cell 1 – PCI of Cell 3) mod 6 = 0		The cell PCIs are selected such that the relative shifts of PRS patterns among cells are as given by the test parameters
TDD uplink-downlink configuration		1		As specified in TS 36.211 [26], Clause 4.2; corresponds to a configuration with 5 ms switch-point periodicity and two downlink consecutive subframes
TDD special subframe configuration		6		As specified in TS 36.211 [26], Clause 4.2; corresponds to DwPTS of $19760 \cdot T_s$ and UpPTS of $4384 \cdot T_s$
CP length <sup>Note 2</sup>		Normal		
DRX		ON		DRX parameters are further specified in Table 9.3.1.1.4.1-2
Radio frame receive time offset between the cells at the UE antenna connector <sup>Note 3</sup>	$\mu\text{s}$	Cell 2 to Cell 1: 1 Cell 3 to Cell 1: -1		PRS are transmitted from synchronous cells
Expected RSTD <sup>Note 1</sup>	$\mu\text{s}$	Cell 2: 3 Cell 3: 3 Other neighbour cells: randomly between -3 and 3		The expected RSTD is what is expected at the receiver. The corresponding parameter in the OTDOA assistance data specified in TS 36.355 [4] is the expectedRSTD indicator
Expected RSTD uncertainty for all neighbour cells <sup>Note 1</sup>	$\mu\text{s}$	5		The corresponding parameter in the OTDOA assistance data specified in TS 36.355 [4] is the expectedRSTD-Uncertainty index

Number of cells provided in OTDOA assistance data		16	Including the reference cell
PRS muting info <sup>Note 2</sup>		Cell 1: '11110000' Cell 2: '00001111' Cell 3: '11110000'	Corresponds to prs-MutingInfo defined in TS 36.355 [4]
T1	s	3	The length of the time interval from the beginning of each test
T2	s	2.56	The length of the time interval that follows immediately after time interval T1
T3	s	2.56	The length of the time interval that follows immediately after time interval T2
Note 1:	Parameters "Expected RSTD" and "Expected RSTD uncertainty for all neighbour cells" are not settable parameters. These are parameters signalled in LPP only. For the values to be used in LPP see Table 9.3.1.1.4.3-5 and TS 37.571-5 [20], clause 7.2.5.		
Note 2:	Parameters "PRS Transmission Bandwidth", "PRS configuration index", "Number of consecutive downlink positioning subframes", "Physical cell ID PCI", "CP length", and "PRS muting info" are settable parameters and also parameters signalled in LPP. The values to be used for "Physical cell ID PCI" are as follows: Cell 1: 0, Cell 2: 6, Cell 3: 12. For all the values to be used in LPP see Table 9.3.1.1.4.3-5 and TS 37.571-5 [20], clause 7.2.5.		
Note 3:	The parameter "Radio frame receive time offset between the cells at the UE antenna connector" is not a settable parameter but is used to set the "true RSTD" values in step 6 of clause 9.3.1.1.4.1.		
Note 4:	If the PRS transmission bandwidth is larger than the UE RF bandwidth, the UE is measuring RSTD within its RF bandwidth.		

#### 9.3.3.2.4.2 Test procedure

Same as in clause 9.3.1.1.4.2 but with the following additional step:

14. Repeat step 1-13 for each sub-test in Table 9.3.2.2.4.1-1 as appropriate.

#### 9.3.3.2.4.3 Message contents

Same as in clause 9.3.1.1.4.3.

#### 9.3.3.2.5 Test requirement

Same as in clause 9.3.3.1.5.

For the overall test to pass, the ratio of successful reported values in each sub-test shall be more than 90% with a confidence level of 95%.

### 9.3.4 FDD intra-frequency RSTD Measurement Reporting Delay in CE Mode B

#### 9.3.4.1 FDD intra-frequency RSTD Measurement Reporting Delay in CE Mode B for Cat M1

**Editor's note: This test is incomplete. The following aspects are missing:**

- TBD in TS 36.133 how to capture prsOccGroupLength in the measurement period
- Response Time to be calculated based as Nprs\_total is missing in TS 36.133
- Annex E-2 is missing as it is also missing in TS 36.133.
- Assistance Data in TS 37.571-5 is missing

##### 9.3.4.1.1 Test purpose

To verify that the RSTD measurement reporting delay for UE Category M1 meets the performance requirements in enhanced coverage mode in an environment with fading propagation conditions.

### 9.3.4.1.2 Test applicability

This test applies to E-UTRA FDD UE Category M1 release 14 and forward that supports UE-assisted OTDOA and CE Mode B.

### 9.3.4.1.3 Minimum conformance requirements

Same as 9.3.1.1.3 with the following exceptions:

The conditions under which the UE physical layer shall be capable of reporting RSTD for the reference cell and all the neighbour cells  $i$  out of at least  $(n-1)$  neighbour cells within  $T_{\text{RSTD IntraFreqFDD, Cat}_M}$  are changed:

$(\text{PRS } \hat{E}_s / \text{Iot})_{ref} \geq -15$  dB for all Frequency Bands for the reference cell,  
 $(\text{PRS } \hat{E}_s / \text{Iot})_i \geq -15$  dB for all Frequency Bands for neighbour cell  $i$ ,  
 $(\text{PRS } \hat{E}_s / \text{Iot})_{ref}$  and  $(\text{PRS } \hat{E}_s / \text{Iot})_i$  conditions apply for all subframes of at least  $L = \frac{M}{2}$  PRS positioning occasions,  
 PRP 1,2|dBm according to clause E.2 for a corresponding Band.

The normative reference for this requirement is TS 36.133 [23] clause 8.13.3.3.1 and A.8.12.6.

### 9.3.4.1.4 Test description

#### 9.3.4.1.4.1 Initial conditions

Same as in clause 9.3.1.1.4.1 but replacing Table 9.3.1.1.4.1-1 with Table 9.3.4.1.4.1-1.

**Table 9.3.4.1.4.1-1: General test parameters for E-UTRAN FDD intra-frequency RSTD measurement reporting delay under fading propagation conditions**

Parameter	Unit	Value	Comment
Reference cell		Cell 1	Reference cell is the cell in the OTDOA assistance data with respect to which the RSTD measurement is defined, as specified in 3GPP TS 36.214 [6] and 3GPP TS 36.355 [4]. The reference cell is the serving cell in this test case.
Neighbour cells		Cell 2 and Cell 3	Cell 2 and Cell 3 appear at random places in the neighbour cell list in the OTDOA assistance data, but Cell 2 always appears in the first half of the list, whilst Cell 3 appears in the second half of the list.
MPDCCH		DL Reference Measurement Channel R.18 FDD	As specified in TS 36.521-3 [25] clause A.7.1
$mPDCCH\text{-startSF-UeSS}$		10	Parameter $G$ in $T = r_{\max} \cdot G$ which determines subframe $k0$ in which MPDCCH starts
Channel Bandwidth ( $BW_{\text{channel}}$ )	MHz	10	
PRS Transmission Bandwidth <sup>Note 2</sup>	RB	50 <sup>Note 4</sup>	PRS are transmitted over the system bandwidth
PRS configuration index $I_{\text{PRS}}$ <sup>Note 2</sup>		311	This corresponds to periodicity of 320 ms and PRS subframe offset of $I_{\text{PRS}} - 160$ DL subframes, as defined in 3GPP TS 36.211 [26], Table 6.10.4.3-1
Number of consecutive downlink positioning subframes $N_{\text{PRS}}$ <sup>Note 2</sup>		6	As defined in 3GPP TS 36.211 [26]. The number of subframes in a positioning occasion
Physical cell ID PCI <sup>Note 2</sup>		(PCI of Cell 1 – PCI of Cell 2) mod 6 = 0 and (PCI of Cell 1 – PCI of Cell 3) mod 6 = 0	The cell PCIs are selected such that the relative shifts of PRS patterns among cells are as given by the test parameters
CP length <sup>Note 2</sup>		Normal	
DRX		ON	DRX parameters are further specified in Table 9.3.1.1.4.1-2
Radio frame receive time offset between the cells at the UE antenna connector <sup>Note 3</sup>	μs	Cell 2 to Cell 1: 1 Cell 3 to Cell 1: -1	PRS are transmitted from synchronous cells
Expected RSTD <sup>Note 1</sup>	μs	Cell 2: 3 Cell 3: 3 Other neighbour cells: randomly between -3 and 3	The expected RSTD is what is expected at the receiver. The corresponding parameter in the OTDOA assistance data specified in TS 36.355 [4] is the expectedRSTD indicator
Expected RSTD uncertainty for all neighbour cells <sup>Note 1</sup>	μs	5	The corresponding parameter in the OTDOA assistance data specified in TS 36.355 [4] is the expectedRSTD-Uncertainty index
Number of cells provided in OTDOA assistance data		16	Including the reference cell
PRS muting info <sup>Note 2</sup>		Cell 1: '11110000' Cell 2: '00001111' Cell 3: '11110000'	Corresponds to prs-MutingInfo defined in TS 36.355 [4]
T1	s	3	The length of the time interval from the beginning of each test
T2	s	6.4	The length of the time interval that follows immediately after time interval T1



T3	s	6.4	The length of the time interval that follows immediately after time interval T2
Note 1:	Parameters "Expected RSTD" and "Expected RSTD uncertainty for all neighbour cells" are not settable parameters. These are parameters signalled in LPP only. For the values to be used in LPP see Table 9.3.1.1.4.3-5 and TS 37.571-5 [20], clause 7.2.5.		
Note 2:	Parameters "PRS Transmission Bandwidth", "PRS configuration index", "Number of consecutive downlink positioning subframes", "Physical cell ID PCI", "CP length", and "PRS muting info" are settable parameters and also parameters signalled in LPP. The values to be used for "Physical cell ID PCI" are as follows: Cell 1: 0, Cell 2: 6, Cell 3: 12. For all the values to be used in LPP see Table 9.3.1.1.4.3-5 and TS 37.571-5 [20], clause 7.2.5.		
Note 3:	The parameter "Radio frame receive time offset between the cells at the UE antenna connector" is not a settable parameter but is used to set the "true RSTD" values in step 6 of clause 9.3.1.1.4.1.		
Note 4:	If the PRS transmission bandwidth is larger than the UE RF bandwidth, the UE is measuring RSTD within its RF bandwidth.		

9.3.4.1.4.2 Test procedure

Same as in clause 9.3.1.1.4.2 but using condition CEModeB.

9.3.4.1.4.3 Message contents

Same as in clause 9.3.1.1.4.3 with the following exceptions:

**Table 9.3.4.1.4.3-1: LPP RequestLocationInformation**

Derivation Path: Table 9.3.1.1.4.3-4			
Information Element	Value/remark	Comment	Condition
LPP-Message ::= SEQUENCE {			
lpp-MessageBody CHOICE {			
c1 CHOICE {			
requestLocationInformation SEQUENCE {			
criticalExtensions CHOICE {			
c1 CHOICE {			
requestLocationInformation-r9 SEQUENCE {			
commonIEsRequestLocationInformation SEQUENCE {			
qos SEQUENCE {			
responseTime SEQUENCE {			
time	13	See clause 9.3.4.1.5	
}			
}			
}			
}			
}			
}			
}			
}			
}			

9.3.4.1.5 Test requirement

Table 9.3.4.1.5-1 and 9.3.4.1.5-2 define the primary level settings including test tolerances for the test.

**Table 9.3.4.1.5-1: Cell-specific test parameters for E-UTRAN FDD intra-frequency RSTD measurement reporting delay under fading propagation conditions during T1**

Parameter	Unit	Cell 1	Cell 2	Cell 3
E-UTRA RF Channel Number		1	1	1
Correlation Matrix and Antenna Configuration		1x1	1x1	1x1
OCNG patterns defined in TS 36.521-3 [25] clause D.1		OP.21 FDD	N/A	N/A
PBCH_RA	dB	0	N/A	N/A
PBCH_RB				
PSS_RA				
SSS_RA				
PCFICH_RB				
PHICH_RA				
PHICH_RB				
PDCCH_RA				
PDCCH_RB				
OCNG_RA <sup>Note 1</sup>				
OCNG_RB <sup>Note 1</sup>				
$N_{oc}$ <sup>Note 3</sup>	dBm/ 15 kHz	-95		
PRS $\hat{E}_s/N_{oc}$	dB	-Infinity	-Infinity	-Infinity
$I_0$ <sup>Note 4</sup>	dBm/ 9 MHz	-67.22	N/A	N/A
$\hat{E}_s/N_{oc}$	dB	0	-Infinity	-Infinity
Propagation Condition		ETU30		
Note 1:	OCNG shall be used such that active cell (Cell 1) is fully allocated and a constant total transmitted power spectral density is achieved for all OFDM symbols.			
Note 2:	The resources for uplink transmission are assigned to the UE prior to the start of time period T2.			
Note 3:	Interference from other cells and noise sources not specified in the test are assumed to be constant over subcarriers and time and shall be modelled as AWGN of appropriate power for $N_{oc}$ to be fulfilled.			
Note 4:	$I_0$ levels have been derived from other parameters and are given for information purpose. These are not settable test parameters.			

**Table 9.3.4.1.5-2: Cell-specific test parameters for E-UTRAN FDD intra-frequency RSTD measurement reporting delay under fading propagation conditions during T2 and T3**

Parameter	Unit	Cell 1		Cell 2		Cell 3	
		T2	T3	T2	T3	T2	T3
E-UTRA RF Channel Number		1		1		1	
Correlation Matrix and Antenna Configuration		1x1		1x1		1x1	
OCNG patterns defined in TS 36.521-3 [25] clause D.1		OP.21 FDD		OP.6 FDD		OP.6 FDD	N/A
PBCH_RA	dB	0		0		0	N/A
PBCH_RB							
PSS_RA							
SSS_RA							
PCFICH_RB							
PHICH_RA							
PHICH_RB							
PDCCH_RA							
PDCCH_RB							
OCNG_RA <sup>Note 1</sup>							
OCNG_RB <sup>Note 1</sup>							
PRS_RA	dB	-3	N/A	N/A	3	3	N/A
$N_{oc}$ <sup>Note 3</sup>	dBm/15 kHz	-98	-95	-98	-95	-98	-95
$\text{PRS } \hat{E}_s/N_{oc}$	dB	-12	-Infinity	-Infinity	-13	-13	-Infinity
$\text{PRS } \hat{E}_s/I_{ot}$ <sup>Note 4</sup>	dB	-12.21	-Infinity	-Infinity	-13	-13.27	-Infinity
$I_o$ <sup>Note 4</sup>	dBm/9 MHz	-69.92	-67.18	-69.92	-67.18	-69.92	N/A
PRP <sup>Note 4</sup>	dBm/15 kHz	-110	-Infinity	-Infinity	-108	-111	-Infinity
RSRP <sup>Note 4</sup>	dBm/15 kHz	-107	-104	-111	-111	-114	-Infinity
$\hat{E}_s/N_{oc}$ <sup>Note 4</sup>	dB	-9	-9	-13	-16	-16	-Infinity
Propagation Condition		ETU30					
Note 1:	OCNG shall be used such that active cells (all, except Cell 3 in T3) are fully allocated and a constant total transmitted power spectral density is achieved for all OFDM symbols other than those in the subframes with transmitted PRS.						
Note 2:	The resources for uplink transmission are assigned to the UE prior to the start of time period T2.						
Note 3:	Interference from other cells and noise sources not specified in the test are assumed to be constant over subcarriers and time and shall be modelled as AWGN of appropriate power for $N_{oc}$ to be fulfilled.						
Note 4:	If PRS_RA is not "N/A", $\hat{E}_s/N_{oc}$ , $\text{PRS } \hat{E}_s/I_{ot}$ , $I_o$ , RSRP and PRP levels have been derived from other parameters and are given for information purpose. If PRS_RA is "N/A", $I_o$ and RSRP levels have been derived from other parameters and are given for information purpose. These are not settable test parameters. Interference conditions shall be applied to all PRS symbols of DL positioning subframes.						

The response time including test tolerance is 13.3 s. The response time is equal to the LPP time IE value plus the test tolerance. The LPP time IE value is derived from the RSTD reporting delay plus  $\Delta T$ , where  $\Delta T = N_{rep} \times TTI_{DCCH} = N_{rep} \times 75$  ms, giving a value of [12950] ms. This is rounded up to the next allowed LPP value of 13 seconds. The RSTD

measurement reporting delay in the test is derived from the following expression  $T_{PRS} (M - 1) + 320 \cdot \left\lceil \frac{n}{M} \right\rceil$ , where

$M = 16$  and  $n = 16$  are the parameters specified in clause 9.3.1.1.3, Table 9.3.1.1.3-1 and Note 4 of Table 9.3.4.1.4.1-1. This gives the total RSTD reporting delay of [12800] ms for the 15 neighbour cells including Cell 2 and Cell 3 with respect to the reference cell, Cell 1.

The test tolerances are defined in clauses C.1.3 and C4.

The rate of successful tests during repeated tests shall be at least 90% with a confidence level of 95%.

### 9.3.4.2 FDD intra-frequency RSTD Measurement Reporting Delay in CE Mode B for Cat M2

**Editor's note: This test is incomplete. The following aspects are missing:**

- TBD in TS 36.133 how to capture `prsOccGroupLength` in the measurement period
- Assistance Data in TS 37.571-5 is missing

#### 9.3.4.2.1 Test purpose

To verify that the RSTD measurement reporting delay for UE Category M2 meets the performance requirements in enhanced coverage mode in an environment with fading propagation conditions.

#### 9.3.4.2.2 Test applicability

This test applies to E-UTRA FDD UE Category M2 release 14 and forward that supports UE-assisted OTDOA and CE Mode B.

#### 9.3.4.2.3 Minimum conformance requirements

Same as in clause 9.3.4.1.3.

The normative reference for this requirement is TS 36.133 [23] clause 8.16.3.1.1 and A.8.12.6.

#### 9.3.4.2.4 Test description

##### 9.3.4.2.4.1 Initial conditions

Same as in clause 9.3.1.1.4.1 but replacing Table 9.3.1.1.4.1-1 with Table 9.3.4.2.4.1-1.

**Table 9.3.4.2.4.1-1: General test parameters for E-UTRAN FDD intra-frequency RSTD measurement reporting delay under fading propagation conditions**

Parameter	Unit	Value		Comment
		Test 1	Test 2	
Reference cell		Cell 1		Reference cell is the cell in the OTDOA assistance data with respect to which the RSTD measurement is defined, as specified in 3GPP TS 36.214 [6] and 3GPP TS 36.355 [4]. The reference cell is the serving cell in this test case.
Neighbour cells		Cell 2 and Cell 3		Cell 2 and Cell 3 appear at random places in the neighbour cell list in the OTDOA assistance data, but Cell 2 always appears in the first half of the list, whilst Cell 3 appears in the second half of the list.
MPDCCH		DL Reference Measurement Channel R.18 FDD		As specified in TS 36.521-3 [25] clause A.7.1
<i>mPDCCH-startSF-UeSS</i>		10		Parameter $G$ in $T = r_{\max} \cdot G$ which determines subframe $k0$ in which MPDCCH starts
Channel Bandwidth ( $BW_{\text{channel}}$ )	MHz	10		
PRS Transmission Bandwidth <sup>Note 2</sup>	RB	50 <sup>Note 4</sup>		PRS are transmitted over the system bandwidth
PRS configuration index $I_{\text{PRS}}$ <sup>Note 2</sup>		311		This corresponds to periodicity of 320 ms and PRS subframe offset of $I_{\text{PRS}} - 160$ DL subframes, as defined in 3GPP TS 36.211 [26], Table 6.10.4.3-1
Number of consecutive downlink positioning subframes $N_{\text{PRS}}$ <sup>Note 2</sup>		6	4	As defined in 3GPP TS 36.211 [26]. The number of subframes in a positioning occasion
Physical cell ID PCI <sup>Note 2</sup>		(PCI of Cell 1 – PCI of Cell 2) mod 6 = 0 and (PCI of Cell 1 – PCI of Cell 3) mod 6 = 0		The cell PCIs are selected such that the relative shifts of PRS patterns among cells are as given by the test parameters
CP length <sup>Note 2</sup>		Normal		
DRX		ON		DRX parameters are further specified in Table 9.3.1.1.4.1-2
Radio frame receive time offset between the cells at the UE antenna connector <sup>Note 3</sup>	μs	Cell 2 to Cell 1: 1 Cell 3 to Cell 1: -1		PRS are transmitted from synchronous cells
Expected RSTD <sup>Note 1</sup>	μs	Cell 2: 3 Cell 3: 3 Other neighbour cells: randomly between -3 and 3		The expected RSTD is what is expected at the receiver. The corresponding parameter in the OTDOA assistance data specified in TS 36.355 [4] is the expectedRSTD indicator
Expected RSTD uncertainty for all neighbour cells <sup>Note 1</sup>	μs	5		The corresponding parameter in the OTDOA assistance data specified in TS 36.355 [4] is the expectedRSTD-Uncertainty index
Number of cells provided in OTDOA assistance data		16		Including the reference cell
PRS muting info <sup>Note 2</sup>		Cell 1: '11110000' Cell 2: '00001111' Cell 3: '11110000'		Corresponds to prs-MutingInfo defined in TS 36.355 [4]
T1	s	3		The length of the time interval from the beginning of each test
T2	s	6.4	2.56	The length of the time interval that follows immediately after time interval T1

T3	s	6.4	2.56	The length of the time interval that follows immediately after time interval T2
Note 1:	Parameters “Expected RSTD” and “Expected RSTD uncertainty for all neighbour cells” are not settable parameters. These are parameters signalled in LPP only. For the values to be used in LPP see Table 9.3.1.1.4.3-5 and TS 37.571-5 [20], clause 7.2.5.			
Note 2:	Parameters “PRS Transmission Bandwidth”, “PRS configuration index”, “Number of consecutive downlink positioning subframes”, “Physical cell ID PCI”, “CP length”, and “PRS muting info” are settable parameters and also parameters signalled in LPP. The values to be used for “Physical cell ID PCI” are as follows: Cell 1: 0, Cell 2: 6, Cell 3: 12. For all the values to be used in LPP see Table 9.3.1.1.4.3-5 and TS 37.571-5 [20], clause 7.2.5.			
Note 3:	The parameter “Radio frame receive time offset between the cells at the UE antenna connector” is not a settable parameter but is used to set the “true RSTD” values in step 6 of clause 9.3.1.1.4.1.			
Note 4:	If the PRS transmission bandwidth is larger than the UE RF bandwidth, the UE is measuring RSTD within its RF bandwidth.			

9.3.4.2.4.2 Test procedure

Same as in clause 9.3.1.1.4.2 but using condition CEModeB and with the following additional step:

14. Repeat step 1-13 for each sub-test in Table 9.3.4.2.4.1-1 as appropriate

9.3.4.2.4.3 Message contents

Same as in clause 9.3.1.1.4.3 with the following exceptions:

**Table 9.3.4.2.4.3-1: LPP RequestLocationInformation**

Derivation Path: Table 9.3.1.1.4.3-4			
Information Element	Value/remark	Comment	Condition
LPP-Message ::= SEQUENCE {			
lpp-MessageBody CHOICE {			
c1 CHOICE {			
requestLocationInformation SEQUENCE {			
criticalExtensions CHOICE {			
c1 CHOICE {			
requestLocationInformation-r9 SEQUENCE {			
commonIEsRequestLocationInformation SEQUENCE {			
qos SEQUENCE {			
responseTime SEQUENCE {			
time	13	See clause 9.3.4.1.5	Test 1
time	6	See clause 9.3.4.1.5	Test 2
}			
}			
}			
}			
}			
}			
}			
}			
}			
}			

9.3.4.2.5 Test requirement

The primary level settings including test tolerances for the test are defined in clause 9.3.4.1.5.

For Test 1, the response time is defined in clause 9.3.4.1.5.

For Test 2, the response time including test tolerance is 6.3 s. The response time is equal to the LPP time IE value plus the test tolerance. The LPP time IE value is derived from the RSTD reporting delay plus  $\Delta T$ , where  $\Delta T = N_{rep} \times TTI_{DCCCH} = N_{rep} \times 75$  ms, giving a value of [5270] ms. This is rounded up to the next allowed LPP value of 6 seconds. The RSTD

measurement reporting delay in the test is derived from the following expression  $T_{PRS}(M-1) + 320 \cdot \left\lceil \frac{n}{M} \right\rceil$ , where

$M=40$  and  $n=16$  are the parameters specified in clause 9.3.1.1.3, Table 9.3.1.1.3-1 and Note 4 of Table 9.3.4.2.4.1-1. This gives the total RSTD reporting delay of [5210] ms for the 15 neighbour cells including Cell 2 and Cell 3 with respect to the reference cell, Cell 1.

The test tolerances are defined in clauses C.1.3 and C4.

For the overall test to pass, the ratio of successful reported values in each sub-test shall be more than 90% with a confidence level of 95%.

## 9.3.5 HD-FDD intra-frequency RSTD Measurement Reporting Delay in CE Mode B

### 9.3.5.1 HD-FDD intra-frequency RSTD Measurement Reporting Delay in CE Mode B for Cat M1

*Editor's note: This test is incomplete. The following aspects are missing:*

- TBD in TS 36.133 how to capture prsOccGroupLength in the measurement period
- Response Time to be calculated based as Nprs\_total is missing in TS 36.133
- Assistance Data in TS 37.571-5 is missing

#### 9.3.5.1.1 Test purpose

To verify that the RSTD measurement reporting delay for UE Category M1 meets the performance requirements in an environment with fading propagation conditions.

#### 9.3.5.1.2 Test applicability

This test applies to E-UTRA HD-FDD UE Category M1 release 14 and forward that supports UE-assisted OTDOA and CE Mode B.

#### 9.3.5.1.3 Minimum conformance requirements

Same as in clause 9.3.4.1.3.

The normative reference for this requirement is TS 36.133 [23] clause 8.13.3.3.3 and A.8.12.7.

#### 9.3.5.1.4 Test description

##### 9.3.5.1.4.1 Initial conditions

Same as in clause 9.3.1.1.4.1 but replacing Table 9.3.1.1.4.1-1 with Table 9.3.5.1.4.1-1



**Table 9.3.5.1.4.1-1: General test parameters for E-UTRAN HD-FDD intra-frequency RSTD measurement reporting delay under fading propagation conditions**

Parameter	Unit	Value	Comment
Reference cell		Cell 1	Reference cell is the cell in the OTDOA assistance data with respect to which the RSTD measurement is defined, as specified in 3GPP TS 36.214 [6] and 3GPP TS 36.355 [4]. The reference cell is the serving cell in this test case.
Neighbour cells		Cell 2 and Cell 3	Cell 2 and Cell 3 appear at random places in the neighbour cell list in the OTDOA assistance data, but Cell 2 always appears in the first half of the list, whilst Cell 3 appears in the second half of the list.
MPDCCH		DL Reference Measurement Channel R.8 HD-FDD	As specified in TS 36.521-3 [25] clause A.7.2
<i>mPDCCH-startSF-U ESS</i>		10	Parameter $G$ in $T = r_{\max} \cdot G$ which determines subframe $k0$ in which MPDCCH starts
Channel Bandwidth ( $BW_{\text{channel}}$ )	MHz	10	
PRS Transmission Bandwidth <sup>Note 2</sup>	RB	50 <sup>Note 4</sup>	PRS are transmitted over the system bandwidth
PRS configuration index $I_{\text{PRS}}$ <sup>Note 2</sup>		311	This corresponds to periodicity of 320 ms and PRS subframe offset of $I_{\text{PRS}} - 160$ DL subframes, as defined in 3GPP TS 36.211 [26], Table 6.10.4.3-1
Number of consecutive downlink positioning subframes $N_{\text{PRS}}$ <sup>Note 2</sup>		6	As defined in 3GPP TS 36.211 [26]. The number of subframes in a positioning occasion
Physical cell ID PCI <sup>Note 2</sup>		(PCI of Cell 1 – PCI of Cell 2) mod 6 = 0 and (PCI of Cell 1 – PCI of Cell 3) mod 6 = 0	The cell PCIs are selected such that the relative shifts of PRS patterns among cells are as given by the test parameters
CP length <sup>Note 2</sup>		Normal	
DRX		ON	DRX parameters are further specified in Table 9.3.1.1.4.1-2
Radio frame receive time offset between the cells at the UE antenna connector <sup>Note 3</sup>	μs	Cell 2 to Cell 1: 1 Cell 3 to Cell 1: -1	PRS are transmitted from synchronous cells
Expected RSTD <sup>Note 1</sup>	μs	Cell 2: 3 Cell 3: 3 Other neighbour cells: randomly between -3 and 3	The expected RSTD is what is expected at the receiver. The corresponding parameter in the OTDOA assistance data specified in TS 36.355 [4] is the expectedRSTD indicator
Expected RSTD uncertainty for all neighbour cells <sup>Note 1</sup>	μs	5	The corresponding parameter in the OTDOA assistance data specified in TS 36.355 [4] is the expectedRSTD-Uncertainty index
Number of cells provided in OTDOA assistance data		16	Including the reference cell
PRS muting info <sup>Note 2</sup>		Cell 1: '11110000' Cell 2: '00001111' Cell 3: '11110000'	Corresponds to prs-MutingInfo defined in TS 36.355 [4]
T1	s	3	The length of the time interval from the beginning of each test
T2	s	6.4	The length of the time interval that follows immediately after time interval T1

T3	s	6.4	The length of the time interval that follows immediately after time interval T2
Note 1:	Parameters "Expected RSTD" and "Expected RSTD uncertainty for all neighbour cells" are not settable parameters. These are parameters signalled in LPP only. For the values to be used in LPP see Table 9.3.1.1.4.3-5 and TS 37.571-5 [20], clause 7.2.5.		
Note 2:	Parameters "PRS Transmission Bandwidth", "PRS configuration index", "Number of consecutive downlink positioning subframes", "Physical cell ID PCI", "CP length", and "PRS muting info" are settable parameters and also parameters signalled in LPP. The values to be used for "Physical cell ID PCI" are as follows: Cell 1: 0, Cell 2: 6, Cell 3: 12. For all the values to be used in LPP see Table 9.3.1.1.4.3-5 and TS 37.571-5 [20], clause 7.2.5.		
Note 3:	The parameter "Radio frame receive time offset between the cells at the UE antenna connector" is not a settable parameter but is used to set the "true RSTD" values in step 6 of clause 9.3.1.1.4.1.		
Note 4:	If the PRS transmission bandwidth is larger than the UE RF bandwidth, the UE is measuring RSTD within its RF bandwidth.		

#### 9.3.5.1.4.2 Test procedure

Same as in clause 9.3.1.1.4.2 but using condition CEModeB.

#### 9.3.5.1.4.3 Message contents

Same as in clause 9.3.4.1.4.3

#### 9.3.5.1.5 Test requirement

Same as in clause 9.3.4.1.5.

### 9.3.5.2 HD-FDD intra-frequency RSTD Measurement Reporting Delay in CE Mode B for Cat M2

**Editor's note: This test is incomplete. The following aspects are missing:**

- TBD in TS 36.133 how to capture prsOccGroupLength in the measurement period
- Assistance Data in TS 37.571-5 is missing

#### 9.3.5.2.1 Test purpose

To verify that the RSTD measurement reporting delay for UE Category M2 meets the performance requirements in an environment with fading propagation conditions.

#### 9.3.5.2.2 Test applicability

This test applies to E-UTRA HD-FDD UE Category M2 release 14 and forward that supports UE-assisted OTDOA and CE Mode B.

#### 9.3.5.2.3 Minimum conformance requirements

Same as in clause 9.3.4.1.3.

The normative reference for this requirement is TS 36.133 [23] clause 8.16.3.1.3 and A.8.12.7.

#### 9.3.5.2.4 Test description

##### 9.3.5.2.4.1 Initial conditions

Same as in clause 9.3.1.1.4.1 but replacing Table 9.3.1.1.4.1-1 with Table 9.3.5.2.4.1-1.

**Table 9.3.5.2.4.1-1: General test parameters for E-UTRAN HD-FDD intra-frequency RSTD measurement reporting delay under fading propagation conditions**

Parameter	Unit	Value		Comment
		Test 1	Test 2	
Reference cell		Cell 1		Reference cell is the cell in the OTDOA assistance data with respect to which the RSTD measurement is defined, as specified in 3GPP TS 36.214 [6] and 3GPP TS 36.355 [4]. The reference cell is the serving cell in this test case.
Neighbour cells		Cell 2 and Cell 3		Cell 2 and Cell 3 appear at random places in the neighbour cell list in the OTDOA assistance data, but Cell 2 always appears in the first half of the list, whilst Cell 3 appears in the second half of the list.
MPDCCH		DL Reference Measurement Channel R.8 HD-FDD		As specified in TS 36.521-3 [25] clause A.7.2
<i>mPDCCH-startSF-UeSS</i>		10		Parameter $G$ in $T = r_{\max} \cdot G$ which determines subframe $k0$ in which MPDCCH starts
Channel Bandwidth ( $BW_{\text{channel}}$ )	MHz	10		
PRS Transmission Bandwidth <small>Note 2</small>	RB	50 <small>Note 4</small>		PRS are transmitted over the system bandwidth
PRS configuration index $I_{\text{PRS}}$ <small>Note 2</small>		311		This corresponds to periodicity of 320 ms and PRS subframe offset of $I_{\text{PRS}} - 160$ DL subframes, as defined in 3GPP TS 36.211 [26], Table 6.10.4.3-1
Number of consecutive downlink positioning subframes $N_{\text{PRS}}$ <small>Note 2</small>		6	4	As defined in 3GPP TS 36.211 [26]. The number of subframes in a positioning occasion
Physical cell ID PCI <small>Note 2</small>		(PCI of Cell 1 – PCI of Cell 2) mod 6 = 0 and (PCI of Cell 1 – PCI of Cell 3) mod 6 = 0		The cell PCIs are selected such that the relative shifts of PRS patterns among cells are as given by the test parameters
CP length <small>Note 2</small>		Normal		
DRX		ON		DRX parameters are further specified in Table 9.3.1.1.4.1-2
Radio frame receive time offset between the cells at the UE antenna connector <small>Note 3</small>	$\mu\text{s}$	Cell 2 to Cell 1: 1 Cell 3 to Cell 1: -1		PRS are transmitted from synchronous cells
Expected RSTD <small>Note 1</small>	$\mu\text{s}$	Cell 2: 3 Cell 3: 3 Other neighbour cells: randomly between -3 and 3		The expected RSTD is what is expected at the receiver. The corresponding parameter in the OTDOA assistance data specified in TS 36.355 [4] is the expectedRSTD indicator
Expected RSTD uncertainty for all neighbour cells <small>Note 1</small>	$\mu\text{s}$	5		The corresponding parameter in the OTDOA assistance data specified in TS 36.355 [4] is the expectedRSTD-Uncertainty index
Number of cells provided in OTDOA assistance data		16		Including the reference cell
PRS muting info <small>Note 2</small>		Cell 1: '11110000' Cell 2: '00001111' Cell 3: '11110000'		Corresponds to prs-MutingInfo defined in TS 36.355 [4]
T1	s	3		The length of the time interval from the beginning of each test
T2	s	6.4	2.56	The length of the time interval that follows immediately after time interval T1

T3	s	6.4	2.56	The length of the time interval that follows immediately after time interval T2
Note 1:	Parameters "Expected RSTD" and "Expected RSTD uncertainty for all neighbour cells" are not settable parameters. These are parameters signalled in LPP only. For the values to be used in LPP see Table 9.3.1.1.4.3-5 and TS 37.571-5 [20], clause 7.2.5.			
Note 2:	Parameters "PRS Transmission Bandwidth", "PRS configuration index", "Number of consecutive downlink positioning subframes", "Physical cell ID PCI", "CP length", and "PRS muting info" are settable parameters and also parameters signalled in LPP. The values to be used for "Physical cell ID PCI" are as follows: Cell 1: 0, Cell 2: 6, Cell 3: 12. For all the values to be used in LPP see Table 9.3.1.1.4.3-5 and TS 37.571-5 [20], clause 7.2.5.			
Note 3:	The parameter "Radio frame receive time offset between the cells at the UE antenna connector" is not a settable parameter but is used to set the "true RSTD" values in step 6 of clause 9.3.1.1.4.1.			
Note 4:	If the PRS transmission bandwidth is larger than the UE RF bandwidth, the UE is measuring RSTD within its RF bandwidth.			

#### 9.3.5.2.4.2 Test procedure

Same as in clause 9.3.1.1.4.2 but using condition CEModeB and with the following additional step:

14. Repeat step 1-13 for each sub-test in Table 9.3.2.2.4.1-1 as appropriate.

#### 9.3.5.2.4.3 Message contents

Same as in clause 9.3.4.2.4.3.

#### 9.3.5.2.5 Test requirement

Same as in clause 9.3.4.2.5.

For the overall test to pass, the ratio of successful reported values in each sub-test shall be more than 90% with a confidence level of 95%.

## 9.3.6 TDD intra-frequency RSTD Measurement Reporting Delay in CE Mode B

### 9.3.6.1 TDD intra-frequency RSTD Measurement Reporting Delay in CE Mode B for Cat M1

**Editor's note: This test is incomplete. The following aspects are missing:**

- TBD in TS 36.133 how to capture prsOccGroupLength in the measurement period
- Response Time to be calculated based as Nprs\_total is missing in TS 36.133
- Assistance Data in TS 37.571-5 is missing

#### 9.3.6.1.1 Test purpose

To verify that the RSTD measurement reporting delay for UE Category M1 meets the performance requirements in an environment with fading propagation conditions.

#### 9.3.6.1.2 Test applicability

This test applies to E-UTRA TDD UE Category M1 release 14 and forward that supports UE-assisted OTDOA and CE Mode B.

#### 9.3.6.1.3 Minimum conformance requirements

Same as in clause 9.3.4.1.3.

The intra-frequency requirements in this clause shall apply for all TDD special subframe configurations specified in TS 36.211 [26] and for the TDD uplink-downlink configurations as specified in Table 9.3.6.1.3-1.

**Table 9.3.6.1.3-1: TDD uplink-downlink subframe configurations applicable for TDD intra-frequency requirements**

PRS Transmission Bandwidth [RB]	Applicable TDD uplink-downlink configurations
6	1, 2, 3, 4 and 5
Note: Uplink-downlink configurations are specified in Table 4.2-2 in TS 36.211 [26].	

The normative reference for this requirement is TS 36.133 [23] clause 8.13.3.3.2 and A.8.12.8.

9.3.6.1.4 Test description

9.3.6.1.4.1 Initial conditions

Same as in clause 9.3.1.1.4.1 but replacing Table 9.3.1.1.4.1-1 with Table 9.3.6.1.4.1-1

**Table 9.3.6.1.4.1-1: General test parameters for E-UTRAN TDD intra-frequency RSTD measurement reporting delay under fading propagation conditions**



Parameter	Unit	Value	Comment
Reference cell		Cell 1	Reference cell is the cell in the OTDOA assistance data with respect to which the RSTD measurement is defined, as specified in 3GPP TS 36.214 [6] and 3GPP TS 36.355 [4]. The reference cell is the serving cell in this test case.
Neighbour cells		Cell 2 and Cell 3	Cell 2 and Cell 3 appear at random places in the neighbour cell list in the OTDOA assistance data, but Cell 2 always appears in the first half of the list, whilst Cell 3 appears in the second half of the list.
MPDCCH		DL Reference Measurement Channel R.16 TDD	As specified in TS 36.521-3 [25] clause A.7.3
<i>mPDCCH-startSF-U ESS</i>		10	Parameter $G$ in $T = r_{\max} \cdot G$ which determines subframe $k0$ in which MPDCCH starts
Channel Bandwidth ( $BW_{\text{channel}}$ )	MHz	10	
PRS Transmission Bandwidth <sup>Note 2</sup>	RB	50 <sup>Note 4</sup>	PRS are transmitted over the system bandwidth
PRS configuration index $I_{\text{PRS}}$ <sup>Note 2</sup>		304	This corresponds to periodicity of 320 ms and PRS subframe offset of $I_{\text{PRS}} - 160$ DL subframes, as defined in 3GPP TS 36.211 [26], Table 6.10.4.3-1
Number of consecutive downlink positioning subframes $N_{\text{PRS}}$ <sup>Note 2</sup>		6	As defined in 3GPP TS 36.211 [26]. The number of subframes in a positioning occasion
Physical cell ID PCI <sup>Note 2</sup>		(PCI of Cell 1 – PCI of Cell 2) mod 6 = 0 and (PCI of Cell 1 – PCI of Cell 3) mod 6 = 0	The cell PCIs are selected such that the relative shifts of PRS patterns among cells are as given by the test parameters
TDD uplink-downlink configuration		1	As specified in TS 36.211 [26], Clause 4.2; corresponds to a configuration with 5 ms switch-point periodicity and two downlink consecutive subframes
TDD special subframe configuration		6	As specified in TS 36.211 [26], Clause 4.2; corresponds to DwPTS of $19760 \cdot T_s$ and UpPTS of $4384 \cdot T_s$
CP length <sup>Note 2</sup>		Normal	
DRX		ON	DRX parameters are further specified in Table 9.3.1.1.4.1-2
Radio frame receive time offset between the cells at the UE antenna connector <sup>Note 3</sup>	$\mu\text{s}$	Cell 2 to Cell 1: 1 Cell 3 to Cell 1: -1	PRS are transmitted from synchronous cells
Expected RSTD <sup>Note 1</sup>	$\mu\text{s}$	Cell 2: 3 Cell 3: 3 Other neighbour cells: randomly between -3 and 3	The expected RSTD is what is expected at the receiver. The corresponding parameter in the OTDOA assistance data specified in TS 36.355 [4] is the expectedRSTD indicator
Expected RSTD uncertainty for all neighbour cells <sup>Note 1</sup>	$\mu\text{s}$	5	The corresponding parameter in the OTDOA assistance data specified in TS 36.355 [4] is the expectedRSTD-Uncertainty index
Number of cells provided in OTDOA assistance data		16	Including the reference cell

PRS muting info <sup>Note 2</sup>		Cell 1: '11110000' Cell 2: '00001111' Cell 3: '11110000'	Corresponds to prs-MutingInfo defined in TS 36.355 [4]
T1	s	3	The length of the time interval from the beginning of each test
T2	s	6.4	The length of the time interval that follows immediately after time interval T1
T3	s	6.4	The length of the time interval that follows immediately after time interval T2
Note 1:	Parameters "Expected RSTD" and "Expected RSTD uncertainty for all neighbour cells" are not settable parameters. These are parameters signalled in LPP only. For the values to be used in LPP see Table 9.3.1.1.4.3-5 and TS 37.571-5 [20], clause 7.2.5.		
Note 2:	Parameters "PRS Transmission Bandwidth", "PRS configuration index", "Number of consecutive downlink positioning subframes", "Physical cell ID PCI", "CP length", and "PRS muting info" are settable parameters and also parameters signalled in LPP. The values to be used for "Physical cell ID PCI" are as follows: Cell 1: 0, Cell 2: 6, Cell 3: 12. For all the values to be used in LPP see Table 9.3.1.1.4.3-5 and TS 37.571-5 [20], clause 7.2.5.		
Note 3:	The parameter "Radio frame receive time offset between the cells at the UE antenna connector" is not a settable parameter but is used to set the "true RSTD" values in step 6 of clause 9.3.1.1.4.1.		
Note 4:	If the PRS transmission bandwidth is larger than the UE RF bandwidth, the UE is measuring RSTD within its RF bandwidth.		

#### 9.3.6.1.4.2 Test procedure

Same as in clause 9.3.1.1.4.2 but using condition CEModeB.

#### 9.3.6.1.4.3 Message contents

Same as in clause 9.3.4.1.4.3

#### 9.3.6.1.5 Test requirement

Table 9.3.6.1.5-1 and 9.3.6.1.5-2 define the primary level settings including test tolerances for the test.

**Table 9.3.6.1.5-1: Cell-specific test parameters for E-UTRAN TDD intra-frequency RSTD measurement reporting delay under fading propagation conditions during T1**

Parameter	Unit	Cell 1	Cell 2	Cell 3
E-UTRA RF Channel Number		1	1	1
Correlation Matrix and Antenna Configuration		1x1	1x1	1x1
OCNG patterns defined in TS 36.521-3 [25] clause D.1		OP.11 TDD	N/A	N/A
PBCH_RA	dB	0	N/A	N/A
PBCH_RB				
PSS_RA				
SSS_RA				
PCFICH_RB				
PHICH_RA				
PHICH_RB				
PDCCH_RA				
PDCCH_RB				
OCNG_RA <sup>Note 1</sup>				
OCNG_RB <sup>Note 1</sup>				
$N_{oc}$ <sup>Note 3</sup>	dBm/15 kHz	-95		
$PRS \hat{E}_s / N_{oc}$	dB	-Infinity	-Infinity	-Infinity
$I_0$ <sup>Note 4</sup>	dBm/9 MHz	-67.22	N/A	N/A
$\hat{E}_s / N_{oc}$	dB	0	-Infinity	-Infinity
Propagation Condition		ETU30		
<p>Note 1: OCNG shall be used such that active cell (Cell 1) is fully allocated and a constant total transmitted power spectral density is achieved for all OFDM symbols.</p> <p>Note 2: The resources for uplink transmission are assigned to the UE prior to the start of time period T2.</p> <p>Note 3: Interference from other cells and noise sources not specified in the test are assumed to be constant over subcarriers and time and shall be modelled as AWGN of appropriate power for <math>N_{oc}</math> to be fulfilled.</p> <p>Note 4: <math>I_0</math> levels have been derived from other parameters and are given for information purpose. These are not settable test parameters.</p>				

**Table 9.3.6.1.5-2: Cell-specific test parameters for E-UTRAN TDD intra-frequency RSTD measurement reporting delay under fading propagation conditions during T2 and T3**

Parameter	Unit	Cell 1		Cell 2		Cell 3	
		T2	T3	T2	T3	T2	T3
E-UTRA RF Channel Number		1		1		1	
Correlation Matrix and Antenna Configuration		1x1		1x1		1x1	
OCNG patterns defined in TS 36.521-3 [25] clause D.1		OP.11 TDD		OP.2 TDD		OP.2 TDD	N/A
PBCH_RA	dB	0		0		0	N/A
PBCH_RB							
PSS_RA							
SSS_RA							
PCFICH_RB							
PHICH_RA							
PHICH_RB							
PDCCH_RA							
PDCCH_RB							
OCNG_RA <sup>Note 1</sup>							
OCNG_RB <sup>Note 1</sup>							
PRS_RA	dB	-3	N/A	N/A	3	3	N/A
$N_{oc}$ <sup>Note 3</sup>	dBm/15 kHz	-98	-95	-98	-95	-98	-95
$PRS \hat{E}_s / N_{oc}$	dB	-12	-Infinity	-Infinity	-13	-13	-Infinity
$PRS \hat{E}_s / I_{ot}$ <sup>Note 4</sup>	dB	-12.21	-Infinity	-Infinity	-13	-13.27	-Infinity
$I_o$ <sup>Note 4</sup>	dBm/9 MHz	-69.92	-67.18	-69.92	-67.18	-69.92	-67.18
PRP <sup>Note 4</sup>	dBm/15 kHz	-110	-Infinity	-Infinity	-108	-111	-Infinity
RSRP <sup>Note 4</sup>	dBm/15 kHz	-107	-104	-111	-111	-114	-Infinity
$\hat{E}_s / N_{oc}$ <sup>Note 4</sup>	dB	-9	-9	-13	-16	-16	-Infinity
Propagation Condition		ETU30					
<p>Note 1: OCNG shall be used such that active cells (all, except Cell 3 in T3) are fully allocated and a constant total transmitted power spectral density is achieved for all OFDM symbols other than those in the subframes with transmitted PRS.</p> <p>Note 2: The resources for uplink transmission are assigned to the UE prior to the start of time period T2.</p> <p>Note 3: Interference from other cells and noise sources not specified in the test are assumed to be constant over subcarriers and time and shall be modelled as AWGN of appropriate power for <math>N_{oc}</math> to be fulfilled.</p> <p>Note 4: If PRS_RA is not "N/A", <math>\hat{E}_s / N_{oc}</math>, <math>PRS \hat{E}_s / I_{ot}</math>, <math>I_o</math>, RSRP and PRP levels have been derived from other parameters and are given for information purpose. If PRS_RA is "N/A", <math>I_o</math> and RSRP levels have been derived from other parameters and are given for information purpose. These are not settable test parameters. Interference conditions shall be applied to all PRS symbols of DL positioning subframes.</p>							

The response time is defined in clause 9.3.4.1.5.

The test tolerances are defined in clauses C.1.3 and C4.

The rate of successful tests during repeated tests shall be at least 90% with a confidence level of 95%.

### 9.3.6.2 TDD intra-frequency RSTD Measurement Reporting Delay in CE Mode B for Cat M2

Editor's note: This test is incomplete. The following aspects are missing:

- TBD in TS 36.133 how to capture prsOccGroupLength in the measurement period

- Assistance Data in TS 37.571-5 is missing

#### 9.3.6.2.1 Test purpose

To verify that the RSTD measurement reporting delay for UE Category M2 meets the performance requirements in an environment with fading propagation conditions.

#### 9.3.6.2.2 Test applicability

This test applies to E-UTRA TDD UE Category M2 release 14 and forward that supports UE-assisted OTDOA and CE Mode B.

#### 9.3.6.2.3 Minimum conformance requirements

Same as in clause 9.3.6.1.3.

The intra-frequency requirements in this clause shall apply for all TDD special subframe configurations specified in TS 36.211 [26] and for the TDD uplink-downlink configurations as specified in Table 9.3.6.2.3-1.

**Table 9.3.6.2.3-1: TDD uplink-downlink subframe configurations applicable for TDD intra-frequency requirements**

PRS Transmission Bandwidth [RB]	Applicable TDD uplink-downlink configurations
6	1, 2, 3, 4 and 5
24	0, 1, 2, 3, 4, 5 and 6
Note:	Uplink-downlink configurations are specified in Table 4.2-2 in TS 36.211 [26].

The normative reference for this requirement is TS 36.133 [23] clause 8.16.3.1.2 and A.8.12.8.

#### 9.3.6.2.4 Test description

##### 9.3.6.2.4.1 Initial conditions

Same as in clause 9.3.1.1.4.1 but replacing Table 9.3.1.1.4.1-1 with Table 9.3.6.2.4.1-1.

**Table 9.3.6.2.4.1-1: General test parameters for E-UTRAN TDD intra-frequency RSTD measurement reporting delay under fading propagation conditions**

Parameter	Unit	Value		Comment
		Test 1	Test 2	
Reference cell		Cell 1		Reference cell is the cell in the OTDOA assistance data with respect to which the RSTD measurement is defined, as specified in 3GPP TS 36.214 [6] and 3GPP TS 36.355 [4]. The reference cell is the serving cell in this test case.
Neighbour cells		Cell 2 and Cell 3		Cell 2 and Cell 3 appear at random places in the neighbour cell list in the OTDOA assistance data, but Cell 2 always appears in the first half of the list, whilst Cell 3 appears in the second half of the list.
MPDCCH		DL Reference Measurement Channel R.16 TDD		As specified in TS 36.521-3 [25] clause A.7.3
$mPDCCH\text{-startSF-UeSS}$		10		Parameter $G$ in $T = r_{\max} \cdot G$ which determines subframe $k0$ in which MPDCCH starts
Channel Bandwidth ( $BW_{\text{channel}}$ )	MHz	10		
PRS Transmission Bandwidth <sup>Note 2</sup>	RB	50 <sup>Note 4</sup>		PRS are transmitted over the system bandwidth
PRS configuration index $I_{\text{PRS}}$ <sup>Note 2</sup>		304		This corresponds to periodicity of 320 ms and PRS subframe offset of $I_{\text{PRS}} - 160$ DL subframes, as defined in 3GPP TS 36.211 [26], Table 6.10.4.3-1
Number of consecutive downlink positioning subframes $N_{\text{PRS}}$ <sup>Note 2</sup>		6	4	As defined in 3GPP TS 36.211 [26]. The number of subframes in a positioning occasion
Physical cell ID PCI <sup>Note 2</sup>		(PCI of Cell 1 – PCI of Cell 2) mod 6 = 0 and (PCI of Cell 1 – PCI of Cell 3) mod 6 = 0		The cell PCIs are selected such that the relative shifts of PRS patterns among cells are as given by the test parameters
TDD uplink-downlink configuration		1		As specified in TS 36.211 [26], Clause 4.2; corresponds to a configuration with 5 ms switch-point periodicity and two downlink consecutive subframes
TDD special subframe configuration		6		As specified in TS 36.211 [26], Clause 4.2; corresponds to DwPTS of $19760 \cdot T_s$ and UpPTS of $4384 \cdot T_s$
CP length <sup>Note 2</sup>		Normal		
DRX		ON		DRX parameters are further specified in Table 9.3.1.1.4.1-2
Radio frame receive time offset between the cells at the UE antenna connector <sup>Note 3</sup>	$\mu\text{s}$	Cell 2 to Cell 1: 1 Cell 3 to Cell 1: -1		PRS are transmitted from synchronous cells
Expected RSTD <sup>Note 1</sup>	$\mu\text{s}$	Cell 2: 3 Cell 3: 3 Other neighbour cells: randomly between -3 and 3		The expected RSTD is what is expected at the receiver. The corresponding parameter in the OTDOA assistance data specified in TS 36.355 [4] is the expectedRSTD indicator
Expected RSTD uncertainty for all neighbour cells <sup>Note 1</sup>	$\mu\text{s}$	5		The corresponding parameter in the OTDOA assistance data specified in TS 36.355 [4] is the expectedRSTD-Uncertainty index

Number of cells provided in OTDOA assistance data		16		Including the reference cell
PRS muting info <sup>Note 2</sup>		Cell 1: '11110000' Cell 2: '00001111' Cell 3: '11110000'		Corresponds to prs-MutingInfo defined in TS 36.355 [4]
T1	s	3		The length of the time interval from the beginning of each test
T2	s	6.4	2.56	The length of the time interval that follows immediately after time interval T1
T3	s	6.4	2.56	The length of the time interval that follows immediately after time interval T2
Note 1:	Parameters "Expected RSTD" and "Expected RSTD uncertainty for all neighbour cells" are not settable parameters. These are parameters signalled in LPP only. For the values to be used in LPP see Table 9.3.1.1.4.3-5 and TS 37.571-5 [20], clause 7.2.5.			
Note 2:	Parameters "PRS Transmission Bandwidth", "PRS configuration index", "Number of consecutive downlink positioning subframes", "Physical cell ID PCI", "CP length", and "PRS muting info" are settable parameters and also parameters signalled in LPP. The values to be used for "Physical cell ID PCI" are as follows: Cell 1: 0, Cell 2: 6, Cell 3: 12. For all the values to be used in LPP see Table 9.3.1.1.4.3-5 and TS 37.571-5 [20], clause 7.2.5.			
Note 3:	The parameter "Radio frame receive time offset between the cells at the UE antenna connector" is not a settable parameter but is used to set the "true RSTD" values in step 6 of clause 9.3.1.1.4.1.			
Note 4:	If the PRS transmission bandwidth is larger than the UE RF bandwidth, the UE is measuring RSTD within its RF bandwidth.			

#### 9.3.6.2.4.2 Test procedure

Same as in clause 9.3.1.1.4.2 but using condition CEModeB and with the following additional step:

14. Repeat step 1-13 for each sub-test in Table 9.3.2.2.4.1-1 as appropriate.

#### 9.3.6.2.4.3 Message contents

Same as in clause 9.3.4.2.4.3.

#### 9.3.6.2.5 Test requirement

The primary level settings including test tolerances for the test are defined in clause 9.3.6.1.5.

For Test 1, the response time is defined in clause 9.3.6.1.5.

For Test 2, the response time including test tolerance is 6.3 s. The response time is equal to the LPP time IE value plus the test tolerance. The LPP time IE value is derived from the RSTD reporting delay plus  $\Delta T$ , where  $\Delta T = N_{rep} \times TTI_{DCCH} = N_{rep} \times 75$  ms, giving a value of [5270] ms. This is rounded up to the next allowed LPP value of 6 seconds. The RSTD

measurement reporting delay in the test is derived from the following expression  $T_{PRS}(M-1) + 320 \cdot \left\lceil \frac{n}{M} \right\rceil$ , where

$M=40$  and  $n=16$  are the parameters specified in clause 9.3.1.1.3, Table 9.3.1.1.3-1 and Note 4 of Table 9.3.6.2.4.1-1. This gives the total RSTD reporting delay of [5210] ms for the 15 neighbour cells including Cell 2 and Cell 3 with respect to the reference cell, Cell 1.

The test tolerances are defined in clauses C.1.3 and C4.

For the overall test to pass, the ratio of successful reported values in each sub-test shall be more than 90% with a confidence level of 95%. 9.3.7 FDD intra-frequency RSTD Measurement Accuracy in CE Mode A

#### 9.3.7.1 FDD intra-frequency RSTD Measurement Accuracy in CE Mode A for Cat M1

**Editor's note: This test is incomplete. The following aspects are missing:**

- Requirements in TS 36.133 are partially missing
- Annex E-2 is missing as it is also missing in TS 36.133.
- Assistance Data in TS 37.571-5 is missing



#### 9.3.7.1.1 Test purpose

To verify that the RSTD measurement accuracy for UE Category M1 is within the specified limits in normal coverage mode in an environment with fading propagation conditions.

#### 9.3.7.1.2 Test applicability

This test applies to E-UTRA FDD UE Category M1 release 14 and forward that supports UE-assisted OTDOA.

#### 9.3.7.1.3 Minimum conformance requirements

The accuracy requirements in Table 9.3.7.1.3-1 are valid under the following conditions:

Conditions defined in 36.101 [2] Clause 7.3 for reference sensitivity are fulfilled.

PRP 1,2<sub>dBm</sub> according to Annex E.2 for a corresponding Band

There are no measurement gaps overlapping with the PRS subframes of the measured serving cell.

The parameter expectedRSTDUncertainty signalled over LPP by E-SMLC as defined in TS 36.355 [4] is less than 5  $\mu$ s.

Table 9.3.7.1.3-1: RSTD intra-frequency measurement accuracy for CEModeA

Accuracy	Conditions						
	PRS $\hat{E}_s/\text{lot}$	Minimum PRS bandwidth, which is minimum of serving cell channel bandwidth and the PRS bandwidths of the reference cell and the measured neighbour cell $i$ <small>Note 6</small>	Minimum number of available measurement subframes among the reference cell and the measured neighbour cell $i$	The number of consecutive downlink subframes $N_{\text{PRS}}$ among the reference cell and the measured neighbour cell $i$ as defined in [24]	$I_0$ <small>Note 4</small> range		
$T_s$ <small>Note 2</small>	dB	RB			E-UTRA operating band groups <small>Note 5</small>	Minimum $I_0$ <small>Note 1</small>	Maximum $I_0$
						dBm/15kHz	dBm/BW <sub>Channel</sub>
[±15]	(PRS $\hat{E}_s/\text{lot}$ ) <sub>ref</sub> ≥ -6dB and (PRS $\hat{E}_s/\text{lot}$ ) <sub>i</sub> ≥ -13dB	≥ 6	≥ [12]	≥ 6	FDD-M1_A, TDD-M1_A	-121	-50
					FDD-M1_B	-120.5	-50
					FDD-M1_C, TDD-M1_C	-120	-50
					FDD-M1_D	-119.5	-50
					FDD-M1_E, TDD-M1_E	-119	-50
					FDD-M1_F	-118.5	-50
					FDD-M1_G	-118	-50
					FDD-M1_H	-117.5	-50
					FDD-M1_N	-114.5	-50
<p>NOTE 1: This minimum <math>I_0</math> condition is expressed as the average <math>I_0</math> per RE over all REs in an OFDM symbol.</p> <p>NOTE 2: <math>T_s</math> is the basic timing unit defined in TS 36.211 [26].</p> <p>NOTE 3: PRS bandwidth is as indicated in <i>prs-Bandwidth</i> in the OTDOA assistance data defined in TS 36.355 [4].</p> <p>NOTE 4: The <math>I_0</math> is defined in PRS positioning subframes. The same <math>I_0</math> range applies to PRS and non-PRS symbols. <math>I_0</math> levels are different in PRS and non-PRS symbols within the same subframe.</p> <p>NOTE 5: E-UTRA operating band groups are as defined in Section 4.4.2.</p> <p>NOTE 6: The serving cell, the reference cell, and the measured neighbour cell <math>i</math> are on the same carrier frequency.</p>							

The normative reference for this requirement is TS 36.133 [23] clause 9.1.21.20 and A.9.8.20.

9.3.7.1.4 Test description

9.3.7.1.4.1 Initial conditions

Test Environment: Normal; as defined in TS 36.508 [18] clause 4.1.

Frequencies to be tested: Mid Range, as defined in TS 36.508 [18] clause 4.3.1.1.

Channel bandwidth to be tested: 10 MHz as defined in TS 36.508 [18] clause 4.3.1.

1. Connect the SS, faders and AWGN noise sources to the UE antenna connector or antenna connectors as shown in Annex A, Figure A.3 using only the main Tx/Rx antenna of the UE.
2. The general test parameter settings are set up according to Table 9.3.7.1.4.1-1.
3. Propagation conditions are set according to clause 4.7.2.1.

4. Message contents are defined in clause 9.3.7.1.4.3.
5. All cells are on the same carrier frequency. Cell 1 is the serving cell and OTDOA assistance data reference cell; Cell 2 is the neighbour cell. The assistance data neighbour cell list includes in total 15 cells, where 14 of the cells are not simulated (dummy cells; as defined in 3GPP TS 37.571-5 [20], clause 7.2.5).
6. The true RSTD (which is the receive time difference for frame 0 between cell 2 and cell 1 as seen at the UE antenna connector) is set to the following values:
  - Test 1: -92 Ts (about -3  $\mu$ s)
  - Test 2: 92 Ts (about 3  $\mu$ s)

Note that the related expectedRSTD values to be signalled over LPP are defined in Table 9.3.7.1.4-1 for each test.

**Table 9.3.7.1.4.1-1: General test parameters for E-UTRAN FDD intra-frequency RSTD measurement  
Accuracy under fading propagation conditions.**

Parameter	Unit	Value		Comment
		Test 1	Test 2	
MPDCCH		R.16 FDD		As specified in TS 36.521-3 [25] clause A.7.1
<i>mPDCCH-startSF-U ESS</i>		10		Parameter $G$ in $T = r_{\max} \cdot G$ which determines subframe $k0$ in which MPDCCH starts
OCNG Patterns defined in TS 36.521-3 [25] clause D.1		OP.21 FDD		OCNG shall be used such that both cells are fully allocated and a constant total transmitted power spectral density is achieved for all OFDM symbols (other than those in the PRS subframes).
Reference cell		Cell 1		Reference cell is the cell in the OTDOA assistance data with respect to which the RSTD measurement is defined, as specified in 3GPP TS 36.214 [6] and 3GPP TS 36.355 [4]. The reference cell is the serving cell in this test case.
Neighbour cell		Cell 2		One carrier frequency is used.
E-UTRA RF Channel Number		1		
Channel Bandwidth ( $BW_{\text{channel}}$ )	MHz	10		
PRS Transmission Bandwidth <sup>Note 2</sup>	RB	50 <sup>Note 4</sup>		PRS are transmitted over the system bandwidth
PRS configuration index $I_{\text{PRS}}$ <sup>Note 2</sup>		151		This corresponds to periodicity of 320 ms and PRS subframe offset of $I_{\text{PRS}} - 160$ DL subframes, as defined in 3GPP TS 36.211 [26], Table 6.10.4.3-1
Number of consecutive downlink positioning subframes $N_{\text{PRS}}$ <sup>Note 2</sup>		6		As defined in 3GPP TS 36.211 [26]. The number of subframes in a positioning occasion
PRS muting info <sup>Note 2</sup>		Cell 1: '11110000' Cell 2: '11110000'		Corresponds to prs-MutingInfo defined in TS 36.355 [4]
Physical cell ID PCI <sup>Note 2</sup>		(Cell ID of cell 1 – Cell ID of cell 2) mod 6 = 0	(Cell ID of cell 1 – Cell ID of cell 2) mod 6 = 1	
Expected RSTD <sup>Note 1</sup>	μs	Cell 2: 1 Other neighbour cells: randomly between -3 and 3	Cell 2: -1 Other neighbour cells: randomly between -3 and 3	The expected RSTD is what is expected at the receiver. The corresponding parameter in the OTDOA assistance data specified in TS 36.355 [4] is the expectedRSTD indicator
Expected RSTD uncertainty for all neighbour cells <sup>Note 1</sup>	μs	5	5	The corresponding parameter in the OTDOA assistance data specified in TS 36.355 [4] is the expectedRSTD-Uncertainty index
CP length <sup>Note 2</sup>		Normal		
DRX		OFF		
Radio frame receive time offset between the cells at the UE antenna connector <sup>Note 3</sup>	μs	Cell 2 to Cell 1: -3	Cell 2 to Cell 1: 3	PRS are transmitted from synchronous cells
Number of cells provided in OTDOA assistance data		16		Including the reference cell
$T_{\text{RSTD IntraFreqFDD, E-UTRAN}}$	ms	5120		Derived according to the RSTD measurement requirements specified in section 9.3.7.1.3

Note 1:	Parameters "Expected RSTD" and "Expected RSTD uncertainty for all neighbour cells" are not settable parameters. These are parameters signalled in LPP only. For the values to be used in LPP see Table 9.3.7.1.4.3-5 and TS 37.571-5 [20], clause 7.2.5.
Note 2:	Parameters "PRS Transmission Bandwidth", "PRS configuration index", "Number of consecutive positioning downlink subframes", "prs-MutingInfo", "Cell ID" and "CP length" are settable parameters and also parameters signalled in LPP. The values to be used for "Cell ID" are as follows: Cell 1: 0, Cell 2: Test 1: 6, Test 2: 7, Test 3: 6, Test 4: 9. For all the values to be used in LPP see Table 9.3.7.1.4.3-4 and TS 37.571-5 [20], clause 7.2.5.
Note 3:	The parameter "Radio frame receive time offset between the cells at the UE antenna connector" is not a settable parameter but is used to set the "true RSTD" values in step 6 of clause 9.3.7.1.4.1.
Note 4:	If the PRS transmission bandwidth is larger than the UE RF bandwidth, the UE is measuring RSTD within its RF bandwidth.
Note 5:	The parameter " $T_{\text{RSTD IntraFreqFDD, E-UTRAN}}$ " is not a settable parameter but is used to set the LPP "time" value in Table 9.3.7.1.4.3-3. The value of the LPP time IE is set to $T_{\text{RSTD IntraFreqFDD, E-UTRAN}} + \Delta T$ ms, where $\Delta T = 150$ ms, giving a value of 5270 ms. This is rounded up to the next allowed LPP value of 6 seconds.

#### 9.3.7.1.4.2 Test procedure

The test consists of a set-up period and a measurement period. Cell 1 and Cell 2 are both active during the complete test. The beginning of the measurement period shall be aligned with the first PRS positioning subframe of a positioning occasion in the reference cell.

NOTE: The information on when PRS is muted is conveyed to the UE using PRS muting information in the OTDOA assistance data.

The OTDOA-RequestLocationInformation message and the OTDOA assistance data as defined in clause 9.3.7.1.4.3 shall be provided to the UE during the set-up period. The last TTI containing the OTDOA-RequestLocationInformation message shall be provided to the UE  $\Delta T$  ms before the start of the measurement period, where  $\Delta T = 150$  ms is the maximum processing time of the OTDOA-RequestLocationInformation message and the OTDOA assistance data in the UE.

1. Ensure that the UE is in state Generic RB Established State 3A-RF-CE according to 3GPP TS 36.508 [18] clause 7.2A.3AA.
2. The SS shall send a RESET UE POSITIONING STORED INFORMATION message.
3. Set the parameters according to Table 9.3.7.1.5-1. Propagation conditions are set according to clause 4.7.2.1.
4. The SS shall transmit an LPP REQUEST CAPABILITIES message.
5. The UE shall transmit an LPP PROVIDE CAPABILITIES message indicating the OTDOA capabilities supported by the UE in the *OTDOA-ProvideCapabilities* IE.
6. The SS shall send a LPP PROVIDE ASSISTANCE DATA message, including the *OTDOA-ProvideAssistanceData* IE. If the UE message at step 5 includes the *ackRequested* IE set to TRUE, then the SS shall send an acknowledgment in the LPP PROVIDE ASSISTANCE DATA message.
7. The SS shall send a LPP REQUEST LOCATION INFORMATION message, including the *OTDOA-RequestLocationInformation* IE such that the UE receives the message  $\Delta T$  ms before the start of T2, where  $\Delta T = 150$  ms.
8. The UE shall transmit a LPP PROVIDE LOCATION INFORMATION message, including the *OTDOA-ProvideLocationInformation* IE.
9. If the UE message at step 8 includes the *ackRequested* IE set to TRUE, the SS shall send a LPP acknowledgement message.
11. The SS shall check the *rstd* value for Cell 2 in the *OTDOA-SignalMeasurementInformation* IE according to Table 9.3.7.1.5-2.
12. Repeat steps 2-10 until the confidence level according to Annex D is achieved.
13. Repeat step 1-12 for each sub-test in Table 9.3.7.1.5-1 as appropriate.

## 9.3.7.1.4.3 Message contents

**Table 9.3.7.1.4.3-1: RESET UE POSITIONING STORED INFORMATION**

Derivation Path: 36.509 [11] clause 6.9			
Information Element	Value/remark	Comment	Condition
UE Positioning Technology	0 0 0 0 0 0 0 1	OTDOA	

**Table 9.3.7.1.4.3-2: LPP Request Capabilities**

Information Element	Value/remark
<i>otdoa-RequestCapabilities</i>	TRUE

**Table 9.3.7.1.4.3-3: LPP RequestLocationInformation**

Derivation Path: 36.355 clause 6.2			
Information Element	Value/remark	Comment	Condition
LPP-Message ::= SEQUENCE {			
transactionID SEQUENCE {			
initiator	locationServer		
transactionNumber	1		
}			
endTransaction	FALSE		
sequenceNumber	Not present		
acknowledgement	Not present		
lpp-MessageBody CHOICE {			
c1 CHOICE {			
requestLocationInformation SEQUENCE {			
criticalExtensions CHOICE {			
c1 CHOICE {			
requestLocationInformation-r9 SEQUENCE {			
commonIEsRequestLocationInformation SEQUENCE {			
locationInformationType	locationMeasurementsRequired		
triggeredReporting	Not present		
periodicalReporting	Not present		
additionalInformation	onlyReturnInformationRequested		
qos SEQUENCE {			
horizontalAccuracy	Not present		
verticalCoordinateRequest	FALSE		
verticalAccuracy	Not present		
responseTime SEQUENCE {			
time	6	See Note 4 of Table 9.3.7.1.4.1-1	
responseTimeEarlyFix-r12	Not present		Rel-12 onwards
}			
velocityRequest	FALSE		
}			
environment	Not present		
locationCoordinateTypes	Not present		
velocityTypes	Not present		
}			
a-gnss-RequestLocationInformation	Not present		
otdoa-RequestLocationInformation SEQUENCE {			
assistanceAvailability	FALSE		
}			
ecid-RequestLocationInformation	Not present		
epdu-RequestLocationInformation	Not Present		
}			
}			
}			
}			
}			
}			



Table 9.3.7.1.4.3-4: LPP ProvideAssistanceData

Derivation Path: 36.355 clause 6.2			
Information Element	Value/remark	Comment	Condition
LPP-Message ::= SEQUENCE {			
transactionID SEQUENCE {			
Initiator	locationServer		
transactionNumber	(0..255)		
}			
endTransaction	TRUE		
sequenceNumber	Not present		
acknowledgement	Not present		
lpp-MessageBody CHOICE {			
c1 CHOICE {			
provideAssistanceData SEQUENCE {			
criticalExtensions CHOICE {			
c1 CHOICE {			
provideAssistanceData-r9 SEQUENCE {			
commonIEsProvideAssistanceData	Not present		
a-gnss-ProvideAssistanceData	Not present		
otdoa-ProvideAssistanceData SEQUENCE {			
otdoa-ReferenceCellInfo	As defined in TS 37.571-5 [20], clause 7.2.5.		
otdoa-NeighbourCellInfo	As defined in TS 37.571-5 [20], clause 7.2.5.		
otdoa-Error	Not present		
}			
epdu-ProvideAssistanceData	Not present		
}			
}			
}			
}			

### 9.3.7.1.5 Test requirement

Table 9.3.7.1.5-1 defines the primary level settings including test tolerances for the test.

The RSTD FDD intra-frequency accuracy test shall meet the reported values in Table 9.3.7.1.5-2

**Table 9.3.7.1.5-1: Cell Specific Test Parameters for intra frequency RSTD Tests for E-UTRAN FDD**

Parameter	Unit	Test1		Test2		Test3		Test4	
		Cell1	Cell2	Cell1	Cell2	Cell1	Cell2	Cell1	Cell2
E-UTRA RF Channel Number		1							
PBCH_RA	dB	0	0	0	0	0	0	0	0
PBCH_RB									
PSS_RA									
SSS_RA									
MPDCCH_RA									
MPDCCH_RB									
OCNG_RA <sup>Note1</sup>									
OCNG_RB <sup>Note1</sup>									
PRS_RA	dB	0	0	-2.7	0.3	0	0	-2.7	0.3
$N_{oc}$ <sup>Note2</sup>	dBm/15 kHz	-98	-98	-98	-98	-98	-98	-98	-98
$PRS \hat{E}_s / N_{oc}$	dB	-2.37	-8.02	-5.7	-12.7	-2.37	-8.02	-5.7	-12.7
$PRS \hat{E}_s / I_{ot}$ <sup>Note3</sup>	dB	-3.01	-10.01	-5.7	-12.7	-3.01	-10.01	-5.7	-12.7
$I_o$ <sup>Note3</sup>	dBm/9 MHz	-69.23	-69.23	-70	-70	-69.23	-69.23	-70	-70
PRP <sup>Note3</sup>	dBm/15kHz	-100.37	-106.02	-103.7	-110.7	-100.37	-106.02	-103.7	-110.7
$\hat{E}_s / N_{oc}$ <sup>Note 3</sup>	dB	-2.37	-8.02	-3	-13	-2.37	-8.02	-3	-13
RSRP <sup>Note 3</sup>	dBm/15kHz	-100.37	-106.02	-101	-111	-100.37	-106.02	-101	-111
Propagation condition		AWGN							
<p>Note 1: OCNG shall be used such that both cells are fully allocated and a constant total transmitted power spectral density is achieved for all OFDM symbols (other than those in the PRS subframes).</p> <p>Note 2: Interference from other cells and noise sources not specified in the test is assumed to be constant over subcarriers and time and shall be modelled as AWGN of appropriate power for <math>N_{oc}</math> to be fulfilled.</p> <p>Note 3: <math>\hat{E}_s / N_{oc}</math>, <math>PRS \hat{E}_s / I_{ot}</math>, <math>I_o</math>, RSRP and PRP levels have been derived from other parameters for information purposes. They are not settable parameters themselves. <math>I_o</math> values are derived in the case that there is no PBCH, PSS or SSS in the OFDM symbols carrying PRS</p>									

**Table 9.3.7.1.5-2: RSTD FDD intra-frequency accuracy requirements for the reported values**

	Test 1	Test 2
Lowest reported value	[RSTD_6449]	[RSTD_6432]
Highest reported value	[RSTD_6479]	[RSTD_6462]

The test tolerances are defined in clauses C.1.3 and C4.

For the overall test to pass, the ratio of successful reported values in each sub-test shall be more than 90% with a confidence level of 95%.

### 9.3.7.2 FDD intra-frequency RSTD Measurement Accuracy in CE Mode A for Cat M2

**Editor’s note: This test is incomplete. The following aspects are missing:**

- Requirements in TS 36.133 are partially missing
- Assistance Data in TS 37.571-5 is missing

#### 9.3.7.2.1 Test purpose

To verify that the RSTD measurement accuracy for UE Category M2 is within the specified limits in normal coverage mode in an environment with fading propagation conditions.

#### 9.3.7.2.2 Test applicability

This test applies to E-UTRA FDD UE Category M2 release 14 and forward that supports UE-assisted OTDOA.

### 9.3.7.2.3 Minimum conformance requirements

The accuracy requirements in Table 9.3.7.2.3-1 are valid under the following conditions:

Conditions defined in 36.101 [2] Clause 7.3 for reference sensitivity are fulfilled.

PRP 1,2<sub>dBm</sub> according to Annex E.2 for a corresponding Band

There are no measurement gaps overlapping with the PRS subframes of the measured serving cell.

The parameter expectedRSTDUncertainty signalled over LPP by E-SMLC as defined in TS 36.355 [4] is less than 5  $\mu$ s.

Table 9.3.7.2.3-1: RSTD intra-frequency measurement accuracy for CEModeA

Accuracy	Conditions						
	PRS $\hat{E}_s/I_{ot}$	Minimum PRS bandwidth, which is minimum of serving cell channel bandwidth and the PRS bandwidths of the reference cell and the measured neighbour cell $i$ <small>Note 6</small>	Minimum number of available measurement subframes among the reference cell and the measured neighbour cell $i$	The number of consecutive downlink subframes $N_{PRS}$ among the reference cell and the measured neighbour cell $i$ as defined in [24]	$I_o$ <sup>Note 4</sup> range		
$T_s$ <sup>Note 2</sup>	dB	RB			E-UTRA operating band groups <small>Note 5</small>	Minimum $I_o$ <sup>Note 1</sup>	Maximum $I_o$
						dBm/15kHz	dBm/BW <sub>Channel</sub>
[±15]	(PRS $\hat{E}_s/I_{ot})_{ref} \geq -6dB$ and (PRS $\hat{E}_s/I_{ot})_i \geq -13dB$	$\geq 6$	$\geq [12]$	$\geq 6$	FDD-M1_A, TDD-M1_A	-121	-50
					FDD-M1_B	-120.5	-50
					FDD-M1_C, TDD-M1_C	-120	-50
					FDD-M1_D	-119.5	-50
					FDD-M1_E, TDD-M1_E	-119	-50
					FDD-M1_F	-118.5	-50
					FDD-M1_G	-118	-50
					FDD-M1_H	-117.5	-50
					FDD-M1_N	-114.5	-50
[±6]	(PRS $\hat{E}_s/I_{ot})_{ref} \geq -6dB$ and (PRS $\hat{E}_s/I_{ot})_i \geq -13dB$	$\geq 24$	$\geq [4]$	$\geq 2$	Note 7	Note 7	Note 7

NOTE 1: This minimum  $I_o$  condition is expressed as the average  $I_o$  per RE over all REs in an OFDM symbol.  
 NOTE 2:  $T_s$  is the basic timing unit defined in TS 36.211 [26].  
 NOTE 3: PRS bandwidth is as indicated in *prs-Bandwidth* in the OTDOA assistance data defined in TS 36.355 [4].  
 NOTE 4: The  $I_o$  is defined in PRS positioning subframes. The same  $I_o$  range applies to PRS and non-PRS symbols.  $I_o$  levels are different in PRS and non-PRS symbols within the same subframe.  
 NOTE 5: E-UTRA operating band groups are as defined in Section 4.4.2.  
 NOTE 6: The serving cell, the reference cell, and the measured neighbour cell  $i$  are on the same carrier frequency.  
 NOTE 7: The same bands and the same  $I_o$  conditions for each band apply for this requirement as for the corresponding requirement with the PRS bandwidth  $\geq 6$  RB.

The normative reference for this requirement is TS 36.133 [23] clause 9.1.25.4 and A.9.8.20.

9.3.7.2.4 Test description

9.3.7.2.4.1 Initial conditions

Same as in clause 9.3.7.1.4.1 adding Test 3 and Test 4 and replacing Table 9.3.7.1.4.1-1 with Table 9.3.7.2.4.1-1.

The true RSTD (which is the receive time difference for frame 0 between cell 2 and cell 1 as seen at the UE antenna connector) is set to the following values:

Test 1:  $-92 T_s$  (about  $-3 \mu s$ )

Test 2:  $92 T_s$  (about  $3 \mu s$ )

Test 3:  $92 T_s$  (about  $3 \mu s$ )

Test 4:  $-92 T_s$  (about  $-3 \mu s$ )

Note that the related expectedRSTD values to be signalled over LPP are defined in Table 9.3.7.2.4-1 for each test.

**Table 9.3.7.2.4.1-1: General test parameters for E-UTRAN FDD intra-frequency RSTD measurement  
Accuracy under fading propagation conditions**

Parameter	Unit	Value				Comment
		Test1	Test2	Test3	Test4	
M-PDCCH parameters		R.16 FDD		R.16 FDD		As specified in TS 36.521-3 [25] clause A.7.1.
<i>mPDCCH-startSF-UESS</i>		10		10		Parameter G in $T = r_{\max} \cdot G$ which determines subframe $k_0$ in which MPDCCH starts
OCNG Patterns defined in TS 36.521-3 [25] clause D.1		OP.21 FDD		OP.21 FDD		OCNG shall be used such that both cells are fully allocated and a constant total transmitted power spectral density is achieved for all OFDM symbols (other than those in the PRS subframes).
Reference cell		Cell 1				
Neighbour cell		Cell 2				
E-UTRA RF Channel Number		1				One carrier frequency is used.
System channel Bandwidth ( $BW_{\text{channel}}$ )	MHz	10		10		
PRS Transmission Bandwidth <sup>Note 2</sup>	RB	50 <sup>Note 4</sup>		50 <sup>Note 4</sup>		PRS bandwidth is as indicated in <i>prs-Bandwidth</i> in the OTDOA assistance data defined in TS 36.355 [4].
PRS configuration Index $I_{\text{PRS}}$ <sup>Note 2</sup>		151		151		As defined in TS 36.211 [26]
Number of consecutive positioning downlink subframes $N_{\text{PRS}}$ <sup>Note 2</sup>		6		2		As defined in TS 36.211 [26]
prs-MutingInfo <sup>Note 2</sup>		Cell 1: '11110000' Cell 2: '11110000'				See section 6.5.1.2 in 3GPP TS 36.355 [4] for more information
Cell ID <sup>Note 2</sup>		(Cell ID of cell 1 – Cell ID of cell 2) mod 6 = 0	(Cell ID of cell 1 – Cell ID of cell 2) mod 6 = 1	(Cell ID of cell 1 – Cell ID of cell 2) mod 6 = 0	(Cell ID of cell 1 – Cell ID of cell 2) mod 6 = 3	
Expected RSTD <sup>Note 1</sup>	μs	Cell 2: 1 Other neighbour cells: randomly between -3 and 3	Cell 2: -1 Other neighbour cells: randomly between -3 and 3	Cell 2: -1 Other neighbour cells: randomly between -3 and 3	Cell 2: 1 Other neighbour cells: randomly between -3 and 3	
Expected RSTD uncertainty for all neighbour cells <sup>Note 1</sup>	μs	5	5	5	5	
CP length <sup>Note 2</sup>		Normal				
DRX		OFF				
Radio frame receive time offset between the cells at the UE antenna connector <sup>Note 3</sup>	μs	Cell 2 to Cell 1: -3	Cell 2 to Cell 1: 3	Cell 2 to Cell 1: 3	Cell 2 to Cell 1: -3	PRS are transmitted from synchronous cells
Number of cells provided in OTDOA assistance data		16				The number of cells includes the reference cell

$T_{\text{RSTD IntraFreqFDD, E-UTRAN}}$ Note 5	ms	5120	Derived according to the RSTD measurement requirements specified in section 9.3.7.2.3
<p>NOTE 1: Parameters “Expected RSTD” and “Expected RSTD uncertainty for all neighbour cells” are not settable parameters. These are parameters signalled in LPP only. For the values to be used in LPP see Table 9.3.7.1.4.3-4 and TS 37.571-5 [20], clause 7.2.5.</p> <p>NOTE 2: Parameters “PRS Transmission Bandwidth”, “PRS configuration index”, “Number of consecutive positioning downlink subframes”, “prs-MutingInfo”, “Cell ID” and “CP length” are settable parameters and also parameters signalled in LPP. The values to be used for “Cell ID” are as follows: Cell 1: 0, Cell 2: Test 1: 6, Test 2: 7, Test 3: 6, Test 4: 9. For all the values to be used in LPP see Table 9.3.7.1.4.3-4 and TS 37.571-5 [20], clause 7.2.5.</p> <p>NOTE 3: The parameter “Radio frame receive time offset between the cells at the UE antenna connector” is not a settable parameter but is used to set the “true RSTD” values in step 6 of clause 9.1.3.4.1.</p> <p>NOTE 4: If the PRS transmission bandwidth is larger than the UE RF bandwidth, the UE is measuring RSTD within its RF bandwidth.</p> <p>NOTE 5: The parameter “<math>T_{\text{RSTD IntraFreqFDD, E-UTRAN}}</math>” is not a settable parameter but is used to set the LPP “time” value in Table 9.3.7.1.4.3-3. The value of the LPP time IE is set to <math>T_{\text{RSTD IntraFreqFDD, E-UTRAN}} + \Delta T</math> ms, where <math>\Delta T = 150</math> ms, giving a value of 5270 ms. This is rounded up to the next allowed LPP value of 6 seconds.</p>			

9.3.7.2.4.2 Test procedure

Same as in clause 9.3.7.1.4.2.

9.3.7.2.4.3 Message contents

Same as in clause 9.3.7.1.4.3.

9.3.7.2.5 Test requirement

Same as in clause 9.3.7.1.5 but replacing Table 9.3.7.1.5-2 with Table 9.3.7.2.5-1:

**Table 9.3.7.2.5-1: RSTD FDD intra-frequency accuracy requirements for the reported values**

	Test 1	Test 2	Test 3	Test 4
Lowest reported value	[RSTD_6449]	[RSTD_6432]	[RSTD_6432]	[RSTD_6449]
Highest reported value	[RSTD_6479]	[RSTD_6462]	[RSTD_6462]	[RSTD_6479]

For the overall test to pass, the ratio of successful reported values in each sub-test shall be more than 90% with a confidence level of 95%.

9.3.8 HD-FDD intra-frequency RSTD Measurement Accuracy in CE Mode A

9.3.8.1 HD-FDD intra-frequency RSTD Measurement Accuracy in CE Mode A for Cat M1

**Editor’s note: This test is incomplete. The following aspects are missing:**

- Requirements in TS 36.133 are partially missing
- Assistance Data in TS 37.571-5 is missing

9.3.8.1.1 Test purpose

To verify that the RSTD measurement accuracy for UE Category M1 is within the specified limits normal coverage mode in an environment with fading propagation conditions.



#### 9.3.8.1.2 Test applicability

This test applies to E-UTRA HD-FDD UE Category M1 release 14 and forward that supports UE-assisted OTDOA.

#### 9.3.8.1.3 Minimum conformance requirements

Same as in clause 9.3.7.1.3.

The normative reference for this requirement is TS 36.133 [23] clause 9.1.21.20 and A.9.8.21.

#### 9.3.8.1.4 Test description

##### 9.3.8.1.4.1 Initial conditions

Same as in clause 9.3.7.1.4.1 but replacing Table 9.3.7.1.4.1-1 with Table 9.3.8.1.4.1-1

**Table 9.3.8.1.4.1-1: General test parameters for E-UTRAN HD-FDD intra-frequency RSTD measurement Accuracy under fading propagation conditions**

Parameter	Unit	Value		Comment
		Test 1	Test 2	
MPDCCH		R.6 HD-FDD		As specified in TS 36.521-3 [25] clause A.7.2
<i>mPDCCH-startSF-U ESS</i>		10		Parameter $G$ in $T = r_{\max} \cdot G$ which determines subframe $k0$ in which MPDCCH starts
OCNG Patterns defined in TS 36.521-3 [25] clause D.1		OP.21 FDD		OCNG shall be used such that both cells are fully allocated and a constant total transmitted power spectral density is achieved for all OFDM symbols (other than those in the PRS subframes).
Reference cell		Cell 1		Reference cell is the cell in the OTDOA assistance data with respect to which the RSTD measurement is defined, as specified in 3GPP TS 36.214 [6] and 3GPP TS 36.355 [4]. The reference cell is the serving cell in this test case.
Neighbour cell		Cell 2		One carrier frequency is used.
E-UTRA RF Channel Number		1		
Channel Bandwidth ( $BW_{\text{channel}}$ )	MHz	10		
PRS Transmission Bandwidth <sup>Note 2</sup>	RB	50 <sup>Note 4</sup>		PRS are transmitted over the system bandwidth
PRS configuration index $I_{\text{PRS}}$ <sup>Note 2</sup>		151		This corresponds to periodicity of 320 ms and PRS subframe offset of $I_{\text{PRS}} - 160$ DL subframes, as defined in 3GPP TS 36.211 [26], Table 6.10.4.3-1
Number of consecutive downlink positioning subframes $N_{\text{PRS}}$ <sup>Note 2</sup>		6		As defined in 3GPP TS 36.211 [26]. The number of subframes in a positioning occasion
PRS muting info <sup>Note 2</sup>		Cell 1: '11110000' Cell 2: '11110000'		Corresponds to prs-MutingInfo defined in TS 36.355 [4]
Physical cell ID PCI <sup>Note 2</sup>		(Cell ID of cell 1 – Cell ID of cell 2) mod 6 = 0	(Cell ID of cell 1 – Cell ID of cell 2) mod 6 = 1	
Expected RSTD <sup>Note 1</sup>	μs	Cell 2: 1 Other neighbour cells: randomly between -3 and 3	Cell 2: -1 Other neighbour cells: randomly between -3 and 3	The expected RSTD is what is expected at the receiver. The corresponding parameter in the OTDOA assistance data specified in TS 36.355 [4] is the expectedRSTD indicator
Expected RSTD uncertainty for all neighbour cells <sup>Note 1</sup>	μs	5	5	The corresponding parameter in the OTDOA assistance data specified in TS 36.355 [4] is the expectedRSTD-Uncertainty index
CP length <sup>Note 2</sup>		Normal		
DRX		OFF		
Radio frame receive time offset between the cells at the UE antenna connector <sup>Note 3</sup>	μs	Cell 2 to Cell 1: -3	Cell 2 to Cell 1: 3	PRS are transmitted from synchronous cells
Number of cells provided in OTDOA assistance data		16		Including the reference cell
$T_{\text{RSTD IntraFreqHD-FDD, E-UTRAN}}$	ms	5120		Derived according to the RSTD measurement requirements specified in section 9.3.7.1.3

Note 1:	Parameters “Expected RSTD” and “Expected RSTD uncertainty for all neighbour cells” are not settable parameters. These are parameters signalled in LPP only. For the values to be used in LPP see Table 9.3.7.1.4.3-5 and TS 37.571-5 [20], clause 7.2.5.
Note 2:	Parameters “PRS Transmission Bandwidth”, “PRS configuration index”, “Number of consecutive positioning downlink subframes”, “prs-MutingInfo”, “Cell ID” and “CP length” are settable parameters and also parameters signalled in LPP. The values to be used for “Cell ID” are as follows: Cell 1: 0, Cell 2: Test 1: 6, Test 2: 7, Test 3: 6, Test 4: 9. For all the values to be used in LPP see Table 9.3.7.1.4.3-4 and TS 37.571-5 [20], clause 7.2.5.
Note 3:	The parameter “Radio frame receive time offset between the cells at the UE antenna connector” is not a settable parameter but is used to set the “true RSTD” values in step 6 of clause 9.3.7.1.4.1.
Note 4:	If the PRS transmission bandwidth is larger than the UE RF bandwidth, the UE is measuring RSTD within its RF bandwidth.
Note 5:	The parameter “ $T_{\text{RSTD IntraFreqHD-FDD, E-UTRAN}}$ ” is not a settable parameter but is used to set the LPP “time” value in Table 9.3.7.1.4.3-3. The value of the LPP time IE is set to $T_{\text{RSTD IntraFreqHD-FDD, E-UTRAN}} + \Delta T$ ms, where $\Delta T = 150$ ms, giving a value of 5270 ms. This is rounded up to the next allowed LPP value of 6 seconds.

#### 9.3.8.1.4.2 Test procedure

Same as in clause 9.3.7.1.4.2.

#### 9.3.8.1.4.3 Message contents

Same as in clause 9.3.7.1.4.3

#### 9.3.8.1.5 Test requirement

Same as in clause 9.3.7.1.5.

### 9.3.8.2 HD-FDD intra-frequency RSTD Measurement Accuracy in CE Mode A for Cat M2

**Editor’s note: This test is incomplete. The following aspects are missing:**

- TBD in TS 36.133 how to capture prsOccGroupLength in the measurement period
- Assistance Data in TS 37.571-5 is missing

#### 9.3.8.2.1 Test purpose

To verify that the RSTD measurement accuracy for UE Category M2 is within the specified limits normal coverage mode in an environment with fading propagation conditions.

#### 9.3.8.2.2 Test applicability

This test applies to E-UTRA HD-FDD UE Category M2 release 14 and forward that supports UE-assisted OTDOA.

#### 9.3.8.2.3 Minimum conformance requirements

Same as in clause 9.3.7.2.3.

The normative reference for this requirement is TS 36.133 [23] clause 9.1.25.4 and A.9.8.21.

#### 9.3.8.2.4 Test description

##### 9.3.8.2.4.1 Initial conditions

Same as in clause 9.3.7.2.4.1 but replacing Table 9.3.7.2.4.1-1 with Table 9.3.8.2.4.1-1.

**Table 9.3.8.2.4.1-1: General test parameters for E-UTRAN HD-FDD intra-frequency RSTD measurement Accuracy under fading propagation conditions**

Parameter	Unit	Value				Comment
		Test1	Test2	Test3	Test4	
M-PDCCH parameters		R.6 HD-FDD		R.6 HD-FDD		As specified in TS 36.521-3 [25] clause A.7.2.
<i>mPDCCH-startSF-U ESS</i>		10		10		Parameter $G$ in $T = r_{\max} \cdot G$ which determines subframe $k0$ in which MPDCCH starts
OCNG Patterns defined in TS 36.521-3 [25] clause D.1		OP.21 FDD		OP.21 FDD		OCNG shall be used such that both cells are fully allocated and a constant total transmitted power spectral density is achieved for all OFDM symbols (other than those in the PRS subframes).
Reference cell		Cell 1				
Neighbour cell		Cell 2				
E-UTRA RF Channel Number		1				One carrier frequency is used.
System channel Bandwidth ( $BW_{\text{channel}}$ )	MHz	10		10		
PRS Transmission Bandwidth Note 2	RB	50 <sup>Note 4</sup>		50 <sup>Note 4</sup>		PRS bandwidth is as indicated in <i>prs-Bandwidth</i> in the OTDOA assistance data defined in TS 36.355 [4].
PRS configuration Index $I_{\text{PRS}}$ Note 2		151		151		As defined in TS 36.211 [26]
Number of consecutive positioning downlink subframes $N_{\text{PRS}}$ Note 2		6		2		As defined in TS 36.211 [26]
<i>prs-MutingInfo</i> Note 2		Cell 1: '11110000' Cell 2: '11110000'				See section 6.5.1.2 in 3GPP TS 36.355 [4] for more information
Cell ID Note 2		(Cell ID of cell 1 – Cell ID of cell 2) mod 6 = 0	(Cell ID of cell 1 – Cell ID of cell 2) mod 6 = 1	(Cell ID of cell 1 – Cell ID of cell 2) mod 6 = 0	(Cell ID of cell 1 – Cell ID of cell 2) mod 6 = 3	
Expected RSTD Note 1	μs	Cell 2: 1 Other neighbour cells: randomly between -3 and 3	Cell 2: -1 Other neighbour cells: randomly between -3 and 3	Cell 2: -1 Other neighbour cells: randomly between -3 and 3	Cell 2: 1 Other neighbour cells: randomly between -3 and 3	
Expected RSTD uncertainty for all neighbour cells Note 1	μs	5	5	5	5	
CP length Note 2		Normal				
DRX		OFF				
Radio frame receive time offset between the cells at the UE antenna connector Note 3	μs	Cell 2 to Cell 1: -3	Cell 2 to Cell 1: 3	Cell 2 to Cell 1: 3	Cell 2 to Cell 1: -3	PRS are transmitted from synchronous cells
Number of cells provided in OTDOA assistance data		16				The number of cells includes the reference cell

$T_{\text{RSTD IntraFreqHD-FDD, E-UTRAN}}$ Note 5	ms	5120	Derived according to the RSTD measurement requirements specified in section 9.3.7.2.3
<p>NOTE 1: Parameters “Expected RSTD” and “Expected RSTD uncertainty for all neighbour cells” are not settable parameters. These are parameters signalled in LPP only. For the values to be used in LPP see Table 9.3.7.1.4.3-4 and TS 37.571-5 [20], clause 7.2.5.</p> <p>NOTE 2: Parameters “PRS Transmission Bandwidth”, “PRS configuration index”, “Number of consecutive positioning downlink subframes”, “prs-MutingInfo”, “Cell ID” and “CP length” are settable parameters and also parameters signalled in LPP. The values to be used for “Cell ID” are as follows: Cell 1: 0, Cell 2: Test 1: 6, Test 2: 7, Test 3: 6, Test 4: 9. For all the values to be used in LPP see Table 9.3.7.1.4.3-4 and TS 37.571-5 [20], clause 7.2.5.</p> <p>NOTE 3: The parameter “Radio frame receive time offset between the cells at the UE antenna connector” is not a settable parameter but is used to set the “true RSTD” values in step 6 of clause 9.1.3.4.1.</p> <p>NOTE 4: If the PRS transmission bandwidth is larger than the UE RF bandwidth, the UE is measuring RSTD within its RF bandwidth.</p> <p>NOTE 5: The parameter “<math>T_{\text{RSTD IntraFreqHD-FDD, E-UTRAN}}</math>” is not a settable parameter but is used to set the LPP “time” value in Table 9.3.7.1.4.3-3. The value of the LPP time IE is set to <math>T_{\text{RSTD IntraFreqHD-FDD, E-UTRAN}} + \Delta T</math> ms, where <math>\Delta T = 150</math> ms, giving a value of 5270 ms. This is rounded up to the next allowed LPP value of 6 seconds.</p>			

#### 9.3.8.2.4.2 Test procedure

Same as in clause 9.3.7.1.4.2.

#### 9.3.8.2.4.3 Message contents

Same as in clause 9.3.7.1.4.3.

#### 9.3.8.2.5 Test requirement

Same as in clause 9.3.7.2.5.

For the overall test to pass, the ratio of successful reported values in each sub-test shall be more than 90% with a confidence level of 95%.

## 9.3.9 TDD intra-frequency RSTD Measurement Accuracy in CE Mode A

### 9.3.9.1 TDD intra-frequency RSTD Measurement Accuracy in CE Mode A for Cat M1

**Editor’s note: This test is incomplete. The following aspects are missing:**

- Requirements in TS 36.133 are partially missing

- Assistance Data in TS 37.571-5 is missing

#### 9.3.9.1.1 Test purpose

To verify that the RSTD measurement accuracy for UE Category M1 is within the specified limits in normal coverage mode in an environment with fading propagation conditions.

#### 9.3.9.1.2 Test applicability

This test applies to E-UTRA TDD UE Category M1 release 14 and forward that supports UE-assisted OTDOA.

#### 9.3.9.1.3 Minimum conformance requirements

Same as in clause 9.3.7.1.3.

The normative reference for this requirement is TS 36.133 [23] clause 9.1.21.20 and A.9.8.22.

9.3.9.1.4 Test description

9.3.9.1.4.1 Initial conditions

Same as in clause 9.3.7.1.4.1 but replacing Table 9.3.7.1.4.1-1 with Table 9.3.9.1.4.1-1



**Table 9.3.9.1.4.1-1: General test parameters for E-UTRAN TDD intra-frequency RSTD measurement  
Accuracy under fading propagation conditions**

Parameter	Unit	Value		Comment
		Test 1	Test 2	
MPDCCH		R.14 TDD		As specified in TS 36.521-3 [25] clause A.7.3
<i>mPDCCH-startSF-U ESS</i>		10		Parameter $G$ in $T = r_{\max} \cdot G$ which determines subframe $k0$ in which MPDCCH starts
OCNG Patterns defined in TS 36.521-3 [25] clause D.1		OP.11 TDD		OCNG shall be used such that both cells are fully allocated and a constant total transmitted power spectral density is achieved for all OFDM symbols (other than those in the PRS subframes).
Reference cell		Cell 1		Reference cell is the cell in the OTDOA assistance data with respect to which the RSTD measurement is defined, as specified in 3GPP TS 36.214 [6] and 3GPP TS 36.355 [4]. The reference cell is the serving cell in this test case.
Neighbour cell		Cell 2		One carrier frequency is used.
E-UTRA RF Channel Number		1		
Channel Bandwidth ( $BW_{\text{channel}}$ )	MHz	10		
Special subframe configuration		6		As specified in table 4.2-1 in TS 36.211 [26]. The same configuration in both cells.
Uplink-downlink configuration		1		As specified in table 4.2-2 in TS 36.211 [26] and table 8.1.2.5.2-2. The same configuration in both cells.
PRS Transmission Bandwidth <sup>Note 2</sup>	RB	50 <sup>Note 4</sup>		PRS are transmitted over the system bandwidth
PRS configuration index $I_{\text{PRS}}$ <sup>Note 2</sup>		154		This corresponds to periodicity of 320 ms and PRS subframe offset of $I_{\text{PRS}} - 160$ DL subframes, as defined in 3GPP TS 36.211 [26], Table 6.10.4.3-1
Number of consecutive downlink positioning subframes $N_{\text{PRS}}$ <sup>Note 2</sup>		6		As defined in 3GPP TS 36.211 [26]. The number of subframes in a positioning occasion
PRS muting info <sup>Note 2</sup>		Cell 1: '11110000' Cell 2: '11110000'		Corresponds to prs-MutingInfo defined in TS 36.355 [4]
Physical cell ID PCI <sup>Note 2</sup>		(Cell ID of cell 1 – Cell ID of cell 2) mod 6 = 0	(Cell ID of cell 1 – Cell ID of cell 2) mod 6 = 1	
Expected RSTD <sup>Note 1</sup>	μs	Cell 2: 1 Other neighbour cells: randomly between -3 and 3	Cell 2: -1 Other neighbour cells: randomly between -3 and 3	The expected RSTD is what is expected at the receiver. The corresponding parameter in the OTDOA assistance data specified in TS 36.355 [4] is the expectedRSTD indicator
Expected RSTD uncertainty for all neighbour cells <sup>Note 1</sup>	μs	5	5	The corresponding parameter in the OTDOA assistance data specified in TS 36.355 [4] is the expectedRSTD-Uncertainty index
CP length <sup>Note 2</sup>		Normal		
DRX		OFF		
Radio frame receive time offset between the cells at the UE antenna connector <sup>Note 3</sup>	μs	Cell 2 to Cell 1: -3	Cell 2 to Cell 1: 3	PRS are transmitted from synchronous cells

Number of cells provided in OTDOA assistance data		16	Including the reference cell
$T_{\text{RSTD IntraFreqTDD, E-UTRAN}}$	ms	5120	Derived according to the RSTD measurement requirements specified in section 9.3.7.1.3
Note 1:	Parameters "Expected RSTD" and "Expected RSTD uncertainty for all neighbour cells" are not settable parameters. These are parameters signalled in LPP only. For the values to be used in LPP see Table 9.3.7.1.4.3-5 and TS 37.571-5 [20], clause 7.2.5.		
Note 2:	Parameters "PRS Transmission Bandwidth", "PRS configuration index", "Number of consecutive positioning downlink subframes", "prs-MutingInfo", "Cell ID" and "CP length" are settable parameters and also parameters signalled in LPP. The values to be used for "Cell ID" are as follows: Cell 1: 0, Cell 2: Test 1: 6, Test 2: 7, Test 3: 6, Test 4: 9. For all the values to be used in LPP see Table 9.3.7.1.4.3-4 and TS 37.571-5 [20], clause 7.2.5.		
Note 3:	The parameter "Radio frame receive time offset between the cells at the UE antenna connector" is not a settable parameter but is used to set the "true RSTD" values in step 6 of clause 9.3.7.1.4.1.		
Note 4:	If the PRS transmission bandwidth is larger than the UE RF bandwidth, the UE is measuring RSTD within its RF bandwidth.		
Note 5:	The parameter " $T_{\text{RSTD IntraFreqTDD, E-UTRAN}}$ " is not a settable parameter but is used to set the LPP "time" value in Table 9.3.7.1.4.3-3. The value of the LPP time IE is set to $T_{\text{RSTD IntraFreqTDD, E-UTRAN}} + \Delta T$ ms, where $\Delta T = 150$ ms, giving a value of 5270 ms. This is rounded up to the next allowed LPP value of 6 seconds.		

#### 9.3.9.1.4.2 Test procedure

Same as in clause 9.3.7.1.4.2.

#### 9.3.9.1.4.3 Message contents

Same as in clause 9.3.7.1.4.3

#### 9.3.9.1.5 Test requirement

Same as in clause 9.3.7.1.5.

### 9.3.9.2 TDD intra-frequency RSTD Measurement Accuracy in CE Mode A for Cat M2

**Editor's note: This test is incomplete. The following aspects are missing:**

- Requirements in TS 36.133 are partially missing
- Assistance Data in TS 37.571-5 is missing

#### 9.3.9.2.1 Test purpose

To verify that the RSTD measurement accuracy for UE Category M2 is within the specified limits in normal coverage mode in an environment with fading propagation conditions.

#### 9.3.9.2.2 Test applicability

This test applies to E-UTRA TDD UE Category M2 release 14 and forward that supports UE-assisted OTDOA.

#### 9.3.9.2.3 Minimum conformance requirements

Same as in clause 9.3.7.1.3.

The normative reference for this requirement is TS 36.133 [23] clause 9.1.25.4 and A.9.8.22.

#### 9.3.9.2.4 Test description

##### 9.3.9.2.4.1 Initial conditions

Same as in clause 9.3.7.2.4.1 but replacing Table 9.3.7.2.4.1-1 with Table 9.3.9.2.4.1-1.

**Table 9.3.9.2.4.1-1: General test parameters for E-UTRAN TDD intra-frequency RSTD measurement  
Accuracy under fading propagation conditions**

Parameter	Unit	Value				Comment
		Test1	Test2	Test3	Test4	
M-PDCCH parameters		R.14 TDD		R.14 TDD		As specified in TS 36.521-3 [25] clause A.7.3.
<i>mPDCCH-startSF-UESS</i>		10		10		Parameter G in $T = r_{\max} \cdot G$ which determines subframe $k_0$ in which MPDCCH starts
OCNG Patterns defined in TS 36.521-3 [25] clause D.1		OP.11 TDD		OP.11 FTDD		OCNG shall be used such that both cells are fully allocated and a constant total transmitted power spectral density is achieved for all OFDM symbols (other than those in the PRS subframes).
Reference cell		Cell 1				
Neighbour cell		Cell 2				
E-UTRA RF Channel Number		1				One carrier frequency is used.
System channel Bandwidth ( $BW_{\text{channel}}$ )	MHz	10		10		
Special subframe configuration		6				As specified in table 4.2-1 in TS 36.211 [26]. The same configuration in both cells.
Uplink-downlink configuration		1				As specified in table 4.2-2 in TS 36.211 [26] and table 8.1.2.5.2-2. The same configuration in both cells.
PRS Transmission Bandwidth <sup>Note 2</sup>	RB	50 <sup>Note 4</sup>		50 <sup>Note 4</sup>		PRS bandwidth is as indicated in <i>prs-Bandwidth</i> in the OTDOA assistance data defined in TS 36.355 [4].
PRS configuration Index $I_{\text{PRS}}$ <sup>Note 2</sup>		154		154		As defined in TS 36.211 [26]
Number of consecutive positioning downlink subframes $N_{\text{PRS}}$ <sup>Note 2</sup>		6		2		As defined in TS 36.211 [26]
<i>prs-MutingInfo</i> <sup>Note 2</sup>		Cell 1: '11110000' Cell 2: '11110000'				See section 6.5.1.2 in 3GPP TS 36.355 [4] for more information
Cell ID <sup>Note 2</sup>		(Cell ID of cell 1 – Cell ID of cell 2) mod 6 = 0	(Cell ID of cell 1 – Cell ID of cell 2) mod 6 = 1	(Cell ID of cell 1 – Cell ID of cell 2) mod 6 = 0	(Cell ID of cell 1 – Cell ID of cell 2) mod 6 = 3	
Expected RSTD <sup>Note 1</sup>	μs	Cell 2: 1 Other neighbour cells: randomly between -3 and 3	Cell 2: -1 Other neighbour cells: randomly between -3 and 3	Cell 2: -1 Other neighbour cells: randomly between -3 and 3	Cell 2: 1 Other neighbour cells: randomly between -3 and 3	
Expected RSTD uncertainty for all neighbour cells <sup>Note 1</sup>	μs	5		5		
CP length <sup>Note 2</sup>		Normal				

DRX		OFF				
Radio frame receive time offset between the cells at the UE antenna connector Note 3	$\mu\text{s}$	Cell 2 to Cell 1: -3	Cell 2 to Cell 1: 3	Cell 2 to Cell 1: 3	Cell 2 to Cell 1: -3	PRS are transmitted from synchronous cells
Number of cells provided in OTDOA assistance data		16				The number of cells includes the reference cell
$T_{\text{RSTD IntraFreqTDD, E-UTRAN}}$ Note 5	ms	5120				Derived according to the RSTD measurement requirements specified in section 9.3.7.2.3
<p>NOTE 1: Parameters "Expected RSTD" and "Expected RSTD uncertainty for all neighbour cells" are not settable parameters. These are parameters signalled in LPP only. For the values to be used in LPP see Table 9.3.7.1.4.3-4 and TS 37.571-5 [20], clause 7.2.5.</p> <p>NOTE 2: Parameters "PRS Transmission Bandwidth", "PRS configuration index", "Number of consecutive positioning downlink subframes", "prs-MutingInfo", "Cell ID" and "CP length" are settable parameters and also parameters signalled in LPP. The values to be used for "Cell ID" are as follows: Cell 1: 0, Cell 2: Test 1: 6, Test 2: 7, Test 3: 6, Test 4: 9. For all the values to be used in LPP see Table 9.3.7.1.4.3-4 and TS 37.571-5 [20], clause 7.2.5.</p> <p>NOTE 3: The parameter "Radio frame receive time offset between the cells at the UE antenna connector" is not a settable parameter but is used to set the "true RSTD" values in step 6 of clause 9.1.3.4.1.</p> <p>NOTE 4: If the PRS transmission bandwidth is larger than the UE RF bandwidth, the UE is measuring RSTD within its RF bandwidth.</p> <p>NOTE 5: The parameter "<math>T_{\text{RSTD IntraFreqTDD, E-UTRAN}}</math>" is not a settable parameter but is used to set the LPP "time" value in Table 9.3.7.1.4.3-3. The value of the LPP time IE is set to <math>T_{\text{RSTD IntraFreqTDD, E-UTRAN}} + \Delta T</math> ms, where <math>\Delta T = 150</math> ms, giving a value of 5270 ms. This is rounded up to the next allowed LPP value of 6 seconds.</p>						

#### 9.3.9.2.4.2 Test procedure

Same as in clause 9.3.7.1.4.2.

#### 9.3.9.2.4.3 Message contents

Same as in clause 9.3.7.1.4.3.

#### 9.3.9.2.5 Test requirement

Same as in clause 9.3.7.2.5.

For the overall test to pass, the ratio of successful reported values in each sub-test shall be more than 90% with a confidence level of 95%.

## 9.3.10 FDD intra-frequency RSTD Measurement Accuracy in CE Mode B

### 9.3.10.1 FDD intra-frequency RSTD Measurement Accuracy in CE Mode B for Cat M1

**Editor's note: This test is incomplete. The following aspects are missing:**

- Requirements in TS 36.133 are partially missing
- Annex E-2 is missing as it is also missing in TS 36.133.
- Assistance Data in TS 37.571-5 is missing

#### 9.3.10.1.1 Test purpose

To verify that the RSTD measurement accuracy for UE Category M1 is within the specified limits in enhanced coverage mode in an environment with fading propagation conditions.

9.3.10.1.2 Test applicability

This test applies to E-UTRA FDD UE Category M1 release 14 and forward that supports UE-assisted OTDOA and CE Mode B.

9.3.10.1.3 Minimum conformance requirements

The accuracy requirements in Table 9.3.10.1.3-1 are valid under the following conditions:

Conditions defined in 36.101 [2] Clause 7.3 for reference sensitivity are fulfilled.

PRP  $1,2_{dBm}$  according to Annex E.2 for a corresponding Band

There are no measurement gaps overlapping with the PRS subframes of the measured serving cell.

The parameter expectedRSTDUncertainty signalled over LPP by E-SMLC as defined in TS 36.355 [4] is less than 5  $\mu s$ .

**Table 9.3.10.1.3-1: RSTD intra-frequency measurement accuracy for CEModeB**

Accuracy	Conditions				Io <sup>Note 4</sup> range		
	PRS $\hat{E}_s/I_{ot}$	Minimum PRS bandwidth, which is minimum of serving cell channel bandwidth and the PRS bandwidths of the reference cell and the measured neighbour cell <i>i</i> <small>Note 6</small>	Minimum number of available measurement subframes among the reference cell and the measured neighbour cell <i>i</i>	The number of consecutive downlink subframes $N_{PRS}$ among the reference cell and the measured neighbour cell <i>i</i> as defined in [24]	E-UTRA operating band groups <small>Note 5</small>	Minimum Io <sup>Note 1</sup>	Maximum Io
<small>Ts</small> <sup>Note 2</sup>	dB	RB				dBm/15kHz	dBm/BW <sub>Channel</sub>
[±15]	(PRS $\hat{E}_s/I_{ot}$ ) <sub>ref</sub> ≥ -15dB and (PRS $\hat{E}_s/I_{ot}$ ) <sub>i</sub> ≥ -15dB	≥ 6	≥ [12]	≥ 6	FDD-M1_A, TDD-M1_A	-121	-50
					FDD-M1_B	-120.5	-50
					FDD-M1_C, TDD-M1_C	-120	-50
					FDD-M1_D	-119.5	-50
					FDD-M1_E, TDD-M1_E	-119	-50
					FDD-M1_F	-118.5	-50
					FDD-M1_G	-118	-50
					FDD-M1_H	-117.5	-50
					FDD-M1_N	-114.5	-50

NOTE 1: This minimum Io condition is expressed as the average Io per RE over all REs in an OFDM symbol.  
 NOTE 2: Ts is the basic timing unit defined in TS 36.211 [26].  
 NOTE 3: PRS bandwidth is as indicated in *prs-Bandwidth* in the OTDOA assistance data defined in TS 36.355 [4].  
 NOTE 4: The Io is defined in PRS positioning subframes. The same Io range applies to PRS and non-PRS symbols. Io levels are different in PRS and non-PRS symbols within the same subframe.  
 NOTE 5: E-UTRA operating band groups are as defined in Section 4.4.2.  
 NOTE 6: The serving cell, the reference cell, and the measured neighbour cell *i* are on the same carrier frequency.

The normative reference for this requirement is TS 36.133 [23] clause 9.1.21.21 and A.9.8.23.

9.3.10.1.4 Test description

9.3.10.1.4.1 Initial conditions

Same as in clause 9.3.7.1.4.1 but replacing Table 9.3.7.1.4.1-1 with Table 9.3.10.1.4.1-1.



**Table 9.3.10.1.4.1-1: General test parameters for E-UTRAN FDD intra-frequency RSTD measurement  
Accuracy under fading propagation conditions.**

Parameter	Unit	Value		Comment
		Test 1	Test 2	
MPDCCH		R.18 FDD		As specified in TS 36.521-3 [25] clause A.7.1
<i>mPDCCH-startSF-UeSS</i>		10		Parameter $G$ in $T = r_{\max} \cdot G$ which determines subframe $k0$ in which MPDCCH starts
OCNG Patterns defined in TS 36.521-3 [25] clause D.1		OP.21 FDD		OCNG shall be used such that both cells are fully allocated and a constant total transmitted power spectral density is achieved for all OFDM symbols (other than those in the PRS subframes).
Reference cell		Cell 1		Reference cell is the cell in the OTDOA assistance data with respect to which the RSTD measurement is defined, as specified in 3GPP TS 36.214 [6] and 3GPP TS 36.355 [4]. The reference cell is the serving cell in this test case.
Neighbour cell		Cell 2		One carrier frequency is used.
E-UTRA RF Channel Number		1		
Channel Bandwidth ( $BW_{\text{channel}}$ )	MHz	10		
PRS Transmission Bandwidth <sup>Note 2</sup>	RB	50 <sup>Note 4</sup>		PRS are transmitted over the system bandwidth
PRS configuration index $I_{\text{PRS}}$ <sup>Note 2</sup>		151		This corresponds to periodicity of 320 ms and PRS subframe offset of $I_{\text{PRS}} - 160$ DL subframes, as defined in 3GPP TS 36.211 [26], Table 6.10.4.3-1
Number of consecutive downlink positioning subframes $N_{\text{PRS}}$ <sup>Note 2</sup>		6		As defined in 3GPP TS 36.211 [26]. The number of subframes in a positioning occasion
PRS muting info <sup>Note 2</sup>		Cell 1: '11110000' Cell 2: '11110000'		Corresponds to prs-MutingInfo defined in TS 36.355 [4]
Physical cell ID PCI <sup>Note 2</sup>		(Cell ID of cell 1 – Cell ID of cell 2) mod 6 = 0	(Cell ID of cell 1 – Cell ID of cell 2) mod 6 = 1	
Expected RSTD <sup>Note 1</sup>	μs	Cell 2: 1 Other neighbour cells: randomly between -3 and 3	Cell 2: -1 Other neighbour cells: randomly between -3 and 3	The expected RSTD is what is expected at the receiver. The corresponding parameter in the OTDOA assistance data specified in TS 36.355 [4] is the expectedRSTD indicator
Expected RSTD uncertainty for all neighbour cells <sup>Note 1</sup>	μs	5	5	The corresponding parameter in the OTDOA assistance data specified in TS 36.355 [4] is the expectedRSTD-Uncertainty index
CP length <sup>Note 2</sup>		Normal		
DRX		OFF		
Radio frame receive time offset between the cells at the UE antenna connector <sup>Note 3</sup>	μs	Cell 2 to Cell 1: -3	Cell 2 to Cell 1: 3	PRS are transmitted from synchronous cells
Number of cells provided in OTDOA assistance data		16		Including the reference cell
$T_{\text{RSTD IntraFreqFDD, E-UTRAN}}$	ms	12800		Derived according to the RSTD measurement requirements specified in section 9.3.10.1.3

- Note 1: Parameters “Expected RSTD” and “Expected RSTD uncertainty for all neighbour cells” are not settable parameters. These are parameters signalled in LPP only. For the values to be used in LPP see Table 9.3.10.1.4.3-5 and TS 37.571-5 [20], clause 7.2.5.
- Note 2: Parameters “PRS Transmission Bandwidth”, “PRS configuration index”, “Number of consecutive positioning downlink subframes”, “prs-MutingInfo”, “Cell ID” and “CP length” are settable parameters and also parameters signalled in LPP. The values to be used for “Cell ID” are as follows: Cell 1: 0, Cell 2: Test 1: 6, Test 2: 7, Test 3: 6, Test 4: 9. For all the values to be used in LPP see Table 9.3.10.1.4.3-4 and TS 37.571-5 [20], clause 7.2.5.
- Note 3: The parameter “Radio frame receive time offset between the cells at the UE antenna connector” is not a settable parameter but is used to set the “true RSTD” values in step 6 of clause 9.3.10.1.4.1.
- Note 4: If the PRS transmission bandwidth is larger than the UE RF bandwidth, the UE is measuring RSTD within its RF bandwidth.
- Note 5: The parameter “ $T_{\text{RSTD IntraFreqFDD, E-UTRAN}}$ ” is not a settable parameter but is used to set the LPP “time” value in Table 9.3.10.1.4.3-3. The value of the LPP time IE is set to  $T_{\text{RSTD IntraFreqFDD, E-UTRAN}} + \Delta T$  ms, where  $\Delta T = 150$  ms, giving a value of 12950 ms. This is rounded up to the next allowed LPP value of 13 seconds.

9.3.10.1.4.2 Test procedure

Same as in clause 9.3.7.1.4.2 but using condition CEModeB.

9.3.10.1.4.3 Message contents

Same as in clause 9.3.7.1.4.3 with the following exceptions

**Table 9.3.10.1.4.3-1: LPP RequestLocationInformation**

Derivation Path: Table 9.3.7.1.4.3-4			
Information Element	Value/remark	Comment	Condition
LPP-Message ::= SEQUENCE {			
lpp-MessageBody CHOICE {			
c1 CHOICE {			
requestLocationInformation SEQUENCE {			
criticalExtensions CHOICE {			
c1 CHOICE {			
requestLocationInformation-r9 SEQUENCE {			
commonIEsRequestLocationInformation SEQUENCE {			
qos SEQUENCE {			
responseTime SEQUENCE {			
time	13	See Note 4 in Table 9.3.10.1.4.1-1	
}			
}			
}			
}			
}			
}			
}			
}			
}			
}			

9.3.10.1.5 Test requirement

Table 9.3.10.1.5-1 defines the primary level settings including test tolerances for the test.

The RSTD FDD intra-frequency accuracy test shall meet the reported values in Table 9.3.10.1.5-2

**Table 9.3.10.1.5-1: Cell Specific Test Parameters for intra frequency RSTD Tests for E-UTRAN FDD**

Parameter	Unit	Test1		Test2		Test3		Test4	
		Cell1	Cell2	Cell1	Cell2	Cell1	Cell2	Cell1	Cell2
E-UTRA RF Channel Number		1							
PBCH_RA									
PBCH_RB									
PSS_RA									
SSS_RA									
MPDCCH_RA									
MPDCCH_RB									
OCNG_RA <sup>Note1</sup>									
OCNG_RB <sup>Note1</sup>									
PRS_RA	dB	0	0	0	0	0	0	0	0
PRS_RA	dB	0	0	-2.7	0.3	0	0	-2.7	0.3
$N_{oc}$ <sup>Note2</sup>	dBm/15 kHz	-98	-98	-98	-98	-98	-98	-98	-98
$PRS \hat{E}_s / N_{oc}$	dB	-5	-13	-14.7	-14.7	-5	-13	-14.7	-14.7
$PRS \hat{E}_s / I_{ot}$ <sup>Note3</sup>	dB	-5.21	-14.19	-14.7	-14.7	-5.21	-14.19	-14.7	-14.7
$I_o$ <sup>Note3</sup>	dBm/9 MHz	-69.79	-69.79	-70.06	-70.06	-69.79	-69.79	-70.06	-70.06
PRP <sup>Note3</sup>	dBm/15kHz	-103	-111	-112.7	-112.7	-103	-111	-112.7	-112.7
$\hat{E}_s / N_{oc}$ <sup>Note 3</sup>	dB	-5	-13	-12	-15	-5	-13	-12	-15
RSRP <sup>Note 3</sup>	dBm/15kHz	-103	-111	-110	-113	-103	-111	-110	-113
Propagation condition		AWGN							
Note 1:	OCNG shall be used such that both cells are fully allocated and a constant total transmitted power spectral density is achieved for all OFDM symbols (other than those in the PRS subframes).								
Note 2:	Interference from other cells and noise sources not specified in the test is assumed to be constant over subcarriers and time and shall be modelled as AWGN of appropriate power for $N_{oc}$ to be fulfilled.								
Note 3:	$\hat{E}_s / N_{oc}$ , $PRS \hat{E}_s / I_{ot}$ , $I_o$ , RSRP and PRP levels have been derived from other parameters for information purposes. They are not settable parameters themselves. $I_o$ values are derived in the case that there is no PBCH, PSS or SSS in the OFDM symbols carrying PRS								

**Table 9.3.10.1.5-2: RSTD FDD intra-frequency accuracy requirements for the reported values**

	Test 1	Test 2
Lowest reported value	[RSTD_6449]	[RSTD_6432]
Highest reported value	[RSTD_6479]	[RSTD_6462]

The test tolerances are defined in clauses C.1.3 and C4.

For the overall test to pass, the ratio of successful reported values in each sub-test shall be more than 90% with a confidence level of 95%.

### 9.3.10.2 FDD intra-frequency RSTD Measurement Accuracy in CE Mode B for Cat M2

**Editor's note: This test is incomplete. The following aspects are missing:**

- Requirements in TS 36.133 are partially missing
- Assistance Data in TS 37.571-5 is missing

#### 9.3.10.2.1 Test purpose

To verify that the RSTD measurement accuracy for UE Category M2 is within the specified limits in enhanced coverage mode in an environment with fading propagation conditions.

#### 9.3.10.2.2 Test applicability

This test applies to E-UTRA FDD UE Category M2 release 14 and forward that supports UE-assisted OTDOA and CE Mode B.

### 9.3.10.2.3 Minimum conformance requirements

The accuracy requirements in Table 9.3.10.2.3-1 are valid under the following conditions:

Conditions defined in 36.101 [2] Clause 7.3 for reference sensitivity are fulfilled.

PRP 1,2<sub>dBm</sub> according to Annex E.2 for a corresponding Band

There are no measurement gaps overlapping with the PRS subframes of the measured serving cell.

The parameter expectedRSTDUncertainty signalled over LPP by E-SMLC as defined in TS 36.355 [4] is less than 5  $\mu$ s.

**Table 9.3.10.2.3-1: RSTD intra-frequency measurement accuracy for CEModeB**

Accuracy	Conditions						
	PRS $\hat{E}_s/I_{ot}$	Minimum PRS bandwidth, which is minimum of serving cell channel bandwidth and the PRS bandwidths of the reference cell and the measured neighbour cell $i$ <small>Note 6</small>	Minimum number of available measurement subframes among the reference cell and the measured neighbour cell $i$	The number of consecutive downlink subframes $N_{PRS}$ among the reference cell and the measured neighbour cell $i$ as defined in [24]	$I_o$ <sup>Note 4</sup> range		
$T_s$ <sup>Note 2</sup>	dB	RB			E-UTRA operating band groups <small>Note 5</small>	Minimum $I_o$ <sup>Note 1</sup>	Maximum $I_o$
						dBm/15kHz	dBm/BW <sub>Channel</sub>
[±15]	(PRS $\hat{E}_s/I_{ot})_{ref} \geq -15$ dB and (PRS $\hat{E}_s/I_{ot})_i \geq -15$ dB	$\geq 6$	$\geq [12]$	$\geq 6$	FDD-M1_A, TDD-M1_A	-121	-50
					FDD-M1_B	-120.5	-50
					FDD-M1_C, TDD-M1_C	-120	-50
					FDD-M1_D	-119.5	-50
					FDD-M1_E, TDD-M1_E	-119	-50
					FDD-M1_F	-118.5	-50
					FDD-M1_G	-118	-50
					FDD-M1_H	-117.5	-50
					FDD-M1_N	-114.5	-50
[±6]	(PRS $\hat{E}_s/I_{ot})_{ref} \geq -15$ dB and (PRS $\hat{E}_s/I_{ot})_i \geq -15$ dB	$\geq 24$	$\geq [4]$	$\geq 4$	Note 7	Note 7	Note 7

NOTE 1: This minimum  $I_o$  condition is expressed as the average  $I_o$  per RE over all REs in an OFDM symbol.  
 NOTE 2:  $T_s$  is the basic timing unit defined in TS 36.211 [26].  
 NOTE 3: PRS bandwidth is as indicated in *prs-Bandwidth* in the OTDOA assistance data defined in TS 36.355 [4].  
 NOTE 4: The  $I_o$  is defined in PRS positioning subframes. The same  $I_o$  range applies to PRS and non-PRS symbols.  $I_o$  levels are different in PRS and non-PRS symbols within the same subframe.  
 NOTE 5: E-UTRA operating band groups are as defined in Section 4.4.2.  
 NOTE 6: The serving cell, the reference cell, and the measured neighbour cell  $i$  are on the same carrier frequency.  
 NOTE 7: The same bands and the same  $I_o$  conditions for each band apply for this requirement as for the corresponding requirement with the PRS bandwidth  $\geq 6$  RB.

The normative reference for this requirement is TS 36.133 [23] clause 9.1.25.5 and A.9.8.23.

9.3.10.2.4 Test description

9.3.10.2.4.1 Initial conditions

Same as in clause 9.3.10.1.4.1 adding Test 3 and Test 4 and replacing Table 9.3.10.1.4.1-1 with Table 9.3.10.2.4.1-1.

The true RSTD (which is the receive time difference for frame 0 between cell 2 and cell 1 as seen at the UE antenna connector) is set to the following values:

- Test 1:  $-92 T_s$  (about  $-3 \mu s$ )
- Test 2:  $92 T_s$  (about  $3 \mu s$ )
- Test 3:  $92 T_s$  (about  $3 \mu s$ )
- Test 4:  $-92 T_s$  (about  $-3 \mu s$ )

Note that the related expectedRSTD values to be signalled over LPP are defined in Table 9.3.10.2.4-1 for each test.

**Table 9.3.10.2.4.1-1: General test parameters for E-UTRAN FDD intra-frequency RSTD measurement  
Accuracy under fading propagation conditions**



Parameter	Unit	Value				Comment
		Test1	Test2	Test3	Test4	
M-PDCCH parameters		R.18 FDD		R.18 FDD		As specified in TS 36.521-3 [25] clause A.7.1.
<i>mPDCCH-startSF-UESS</i>		10		10		Parameter G in $T = r_{\max} \cdot G$ which determines subframe $k_0$ in which MPDCCH starts
OCNG Patterns defined in TS 36.521-3 [25] clause D.1		OP.21 FDD		OP.21 FDD		OCNG shall be used such that both cells are fully allocated and a constant total transmitted power spectral density is achieved for all OFDM symbols (other than those in the PRS subframes).
Reference cell		Cell 1				
Neighbour cell		Cell 2				
E-UTRA RF Channel Number		1				One carrier frequency is used.
System channel Bandwidth ( $BW_{\text{channel}}$ )	MHz	10		10		
PRS Transmission Bandwidth <sup>Note 2</sup>	RB	50 <sup>Note 4</sup>		50 <sup>Note 4</sup>		PRS bandwidth is as indicated in <i>prs-Bandwidth</i> in the OTDOA assistance data defined in TS 36.355 [4].
PRS configuration Index $I_{\text{PRS}}$ <sup>Note 2</sup>		151		151		As defined in TS 36.211 [26]
Number of consecutive positioning downlink subframes $N_{\text{PRS}}$ <sup>Note 2</sup>		6		4		As defined in TS 36.211 [26]
prs-MutingInfo <sup>Note 2</sup>		Cell 1: '11110000' Cell 2: '11110000'				See section 6.5.1.2 in 3GPP TS 36.355 [4] for more information
Cell ID <sup>Note 2</sup>		(Cell ID of cell 1 – Cell ID of cell 2) mod 6 = 0	(Cell ID of cell 1 – Cell ID of cell 2) mod 6 = 1	(Cell ID of cell 1 – Cell ID of cell 2) mod 6 = 0	(Cell ID of cell 1 – Cell ID of cell 2) mod 6 = 3	
Expected RSTD <sup>Note 1</sup>	μs	Cell 2: 1 Other neighbour cells: randomly between -3 and 3	Cell 2: -1 Other neighbour cells: randomly between -3 and 3	Cell 2: -1 Other neighbour cells: randomly between -3 and 3	Cell 2: 1 Other neighbour cells: randomly between -3 and 3	
Expected RSTD uncertainty for all neighbour cells <sup>Note 1</sup>	μs	5	5	5	5	
CP length <sup>Note 2</sup>		Normal				
DRX		OFF				
Radio frame receive time offset between the cells at the UE antenna connector <sup>Note 3</sup>	μs	Cell 2 to Cell 1: -3	Cell 2 to Cell 1: 3	Cell 2 to Cell 1: 3	Cell 2 to Cell 1: -3	PRS are transmitted from synchronous cells
Number of cells provided in OTDOA assistance data		16				The number of cells includes the reference cell

$T_{\text{RSTD IntraFreqFDD, E-UTRAN}}$ Note 5	ms	12800	5120	Derived according to the RSTD measurement requirements specified in section 9.3.10.2.3
<p>NOTE 1: Parameters "Expected RSTD" and "Expected RSTD uncertainty for all neighbour cells" are not settable parameters. These are parameters signalled in LPP only. For the values to be used in LPP see Table 9.3.10.1.4.3-4 and TS 37.571-5 [20], clause 7.2.5.</p> <p>NOTE 2: Parameters "PRS Transmission Bandwidth", "PRS configuration index", "Number of consecutive positioning downlink subframes", "prs-MutingInfo", "Cell ID" and "CP length" are settable parameters and also parameters signalled in LPP. The values to be used for "Cell ID" are as follows: Cell 1: 0, Cell 2: Test 1: 6, Test 2: 7, Test 3: 6, Test 4: 9. For all the values to be used in LPP see Table 9.3.10.1.4.3-4 and TS 37.571-5 [20], clause 7.2.5.</p> <p>NOTE 3: The parameter "Radio frame receive time offset between the cells at the UE antenna connector" is not a settable parameter but is used to set the "true RSTD" values in step 6 of clause 9.1.3.4.1.</p> <p>NOTE 4: If the PRS transmission bandwidth is larger than the UE RF bandwidth, the UE is measuring RSTD within its RF bandwidth.</p> <p>NOTE 5: The parameter "<math>T_{\text{RSTD IntraFreqFDD, E-UTRAN}}</math>" is not a settable parameter but is used to set the LPP "time" value in Table 9.3.10.2.4.3-1. The value of the LPP time IE is set to <math>T_{\text{RSTD IntraFreqFDD, E-UTRAN}} + \Delta T</math> ms, where <math>\Delta T = 150</math> ms, giving a value of 12950 ms for Test 1 and 2 and 5270 ms for Test 3 and 4. This is rounded up to the next allowed LPP value of 13 or 6 seconds, respectively.</p>				

9.3.10.2.4.2 Test procedure

Same as in clause 9.3.7.1.4.2 but using condition CEModeB.

9.3.10.2.4.3 Message contents

Same as in clause 9.3.7.1.4.3 with the following exceptions:

**Table 9.3.10.2.4.3-1: LPP RequestLocationInformation**

Derivation Path: Table 9.3.7.1.4.3-4			
Information Element	Value/remark	Comment	Condition
LPP-Message ::= SEQUENCE {			
lpp-MessageBody CHOICE {			
c1 CHOICE {			
requestLocationInformation SEQUENCE {			
criticalExtensions CHOICE {			
c1 CHOICE {			
requestLocationInformation-r9 SEQUENCE {			
commonIEsRequestLocationInformation SEQUENCE {			
qos SEQUENCE {			
responseTime SEQUENCE {			
time	13	See Note 4 in Table 9.3.10.2.4.1-1	Test 1 or Test 2
time	6	See Note 4 in Table 9.3.10.2.4.1-1	Test 3 or Test 4
}			
}			
}			
}			
}			
}			
}			
}			
}			
}			

### 9.3.10.2.5 Test requirement

Same as in clause 9.3.10.1.5 but replacing Table 9.3.10.1.5-2 with Table 9.3.10.2.5-1:

**Table 9.3.10.2.5-1: RSTD FDD intra-frequency accuracy requirements for the reported values**

	Test 1	Test 2	Test 3	Test 4
Lowest reported value	[RSTD_6449]	[RSTD_6432]	[RSTD_6432]	[RSTD_6449]
Highest reported value	[RSTD_6479]	[RSTD_6462]	[RSTD_6462]	[RSTD_6479]

For the overall test to pass, the ratio of successful reported values in each sub-test shall be more than 90% with a confidence level of 95%.

## 9.3.11 HD-FDD intra-frequency RSTD Measurement Accuracy in CE Mode B

### 9.3.11.1 HD-FDD intra-frequency RSTD Measurement Accuracy in CE Mode B for Cat M1

**Editor's note: This test is incomplete. The following aspects are missing:**

- Requirements in TS 36.133 are partially missing
- Assistance Data in TS 37.571-5 is missing

#### 9.3.11.1.1 Test purpose

To verify that the RSTD measurement accuracy for UE Category M1 is within the specified limits enhanced coverage mode in an environment with fading propagation conditions.

#### 9.3.11.1.2 Test applicability

This test applies to E-UTRA HD-FDD UE Category M1 release 14 and forward that supports UE-assisted OTDOA and CE Mode B.

#### 9.3.11.1.3 Minimum conformance requirements

Same as in clause 9.3.10.1.3.

The normative reference for this requirement is TS 36.133 [23] clause 9.1.21.21 and A.9.8.24.

#### 9.3.11.1.4 Test description

##### 9.3.11.1.4.1 Initial conditions

Same as in clause 9.3.10.1.4.1 but replacing Table 9.3.10.1.4.1-1 with Table 9.3.11.1.4.1-1

**Table 9.3.11.1.4.1-1: General test parameters for E-UTRAN HD-FDD intra-frequency RSTD measurement Accuracy under fading propagation conditions**

Parameter	Unit	Value		Comment
		Test 1	Test 2	
MPDCCH		R.8 HD-FDD		As specified in TS 36.521-3 [25] clause A.7.2
<i>mPDCCH-startSF-U ESS</i>		10		Parameter $G$ in $T = r_{\max} \cdot G$ which determines subframe $k0$ in which MPDCCH starts
OCNG Patterns defined in TS 36.521-3 [25] clause D.1		OP.21 FDD		OCNG shall be used such that both cells are fully allocated and a constant total transmitted power spectral density is achieved for all OFDM symbols (other than those in the PRS subframes).
Reference cell		Cell 1		Reference cell is the cell in the OTDOA assistance data with respect to which the RSTD measurement is defined, as specified in 3GPP TS 36.214 [6] and 3GPP TS 36.355 [4]. The reference cell is the serving cell in this test case.
Neighbour cell		Cell 2		One carrier frequency is used.
E-UTRA RF Channel Number		1		
Channel Bandwidth ( $BW_{\text{channel}}$ )	MHz	10		
PRS Transmission Bandwidth <sup>Note 2</sup>	RB	50 <sup>Note 4</sup>		PRS are transmitted over the system bandwidth
PRS configuration index $I_{\text{PRS}}$ <sup>Note 2</sup>		151		This corresponds to periodicity of 320 ms and PRS subframe offset of $I_{\text{PRS}} - 160$ DL subframes, as defined in 3GPP TS 36.211 [26], Table 6.10.4.3-1
Number of consecutive downlink positioning subframes $N_{\text{PRS}}$ <sup>Note 2</sup>		6		As defined in 3GPP TS 36.211 [26]. The number of subframes in a positioning occasion
PRS muting info <sup>Note 2</sup>		Cell 1: '11110000' Cell 2: '11110000'		Corresponds to prs-MutingInfo defined in TS 36.355 [4]
Physical cell ID PCI <sup>Note 2</sup>		(Cell ID of cell 1 – Cell ID of cell 2) mod 6 = 0	(Cell ID of cell 1 – Cell ID of cell 2) mod 6 = 1	
Expected RSTD <sup>Note 1</sup>	μs	Cell 2: 1 Other neighbour cells: randomly between -3 and 3	Cell 2: -1 Other neighbour cells: randomly between -3 and 3	The expected RSTD is what is expected at the receiver. The corresponding parameter in the OTDOA assistance data specified in TS 36.355 [4] is the expectedRSTD indicator
Expected RSTD uncertainty for all neighbour cells <sup>Note 1</sup>	μs	5	5	The corresponding parameter in the OTDOA assistance data specified in TS 36.355 [4] is the expectedRSTD-Uncertainty index
CP length <sup>Note 2</sup>		Normal		
DRX		OFF		
Radio frame receive time offset between the cells at the UE antenna connector <sup>Note 3</sup>	μs	Cell 2 to Cell 1: -3	Cell 2 to Cell 1: 3	PRS are transmitted from synchronous cells
Number of cells provided in OTDOA assistance data		16		Including the reference cell
$T_{\text{RSTD IntraFreqHD-FDD, E-UTRAN}}$	ms	12800		Derived according to the RSTD measurement requirements specified in section 9.3.10.1.3

Note 1:	Parameters “Expected RSTD” and “Expected RSTD uncertainty for all neighbour cells” are not settable parameters. These are parameters signalled in LPP only. For the values to be used in LPP see Table 9.3.10.1.4.3-5 and TS 37.571-5 [20], clause 7.2.5.
Note 2:	Parameters “PRS Transmission Bandwidth”, “PRS configuration index”, “Number of consecutive positioning downlink subframes”, “prs-MutingInfo”, “Cell ID” and “CP length” are settable parameters and also parameters signalled in LPP. The values to be used for “Cell ID” are as follows: Cell 1: 0, Cell 2: Test 1: 6, Test 2: 7, Test 3: 6, Test 4: 9. For all the values to be used in LPP see Table 9.3.10.1.4.3-4 and TS 37.571-5 [20], clause 7.2.5.
Note 3:	The parameter “Radio frame receive time offset between the cells at the UE antenna connector” is not a settable parameter but is used to set the “true RSTD” values in step 6 of clause 9.3.10.1.4.1.
Note 4:	If the PRS transmission bandwidth is larger than the UE RF bandwidth, the UE is measuring RSTD within its RF bandwidth.
Note 5:	The parameter “ $T_{\text{RSTD IntraFreqHD-FDD, E-UTRAN}}$ ” is not a settable parameter but is used to set the LPP “time” value in Table 9.3.10.1.4.3-3. The value of the LPP time IE is set to $T_{\text{RSTD IntraFreqHD-FDD, E-UTRAN}} + \Delta T$ ms, where $\Delta T = 150$ ms, giving a value of 12950 ms. This is rounded up to the next allowed LPP value of 13 seconds.

#### 9.3.11.1.4.2 Test procedure

Same as in clause 9.3.7.1.4.2 but using condition CEModeB.

#### 9.3.11.1.4.3 Message contents

Same as in clause 9.3.10.1.4.3.

#### 9.3.11.1.5 Test requirement

Same as in clause 9.3.10.1.5.

### 9.3.11.2 HD-FDD intra-frequency RSTD Measurement Accuracy in CE Mode B for Cat M2

**Editor’s note: This test is incomplete. The following aspects are missing:**

- TBD in TS 36.133 how to capture prsOccGroupLength in the measurement period
- Assistance Data in TS 37.571-5 is missing

#### 9.3.11.2.1 Test purpose

To verify that the RSTD measurement accuracy for UE Category M2 is within the specified limits enhanced coverage mode in an environment with fading propagation conditions.

#### 9.3.11.2.2 Test applicability

This test applies to E-UTRA HD-FDD UE Category M2 release 14 and forward that supports UE-assisted OTDOA and CE Mode B.

#### 9.3.11.2.3 Minimum conformance requirements

Same as in clause 9.3.10.2.3.

The normative reference for this requirement is TS 36.133 [23] clause 9.1.25.5 and A.9.8.24.

#### 9.3.11.2.4 Test description

##### 9.3.11.2.4.1 Initial conditions

Same as in clause 9.3.10.2.4.1 but replacing Table 9.3.10.2.4.1-1 with Table 9.3.11.2.4.1-1.

**Table 9.3.11.2.4.1-1: General test parameters for E-UTRAN HD-FDD intra-frequency RSTD measurement Accuracy under fading propagation conditions**

Parameter	Unit	Value				Comment
		Test1	Test2	Test3	Test4	
M-PDCCH parameters		R.8 HD-FDD		R.8 HD-FDD		As specified in TS 36.521-3 [25] clause A.7.2.
<i>mPDCCH-startSF-U ESS</i>		10		10		Parameter $G$ in $T = r_{\max} \cdot G$ which determines subframe $k0$ in which MPDCCH starts
OCNG Patterns defined in TS 36.521-3 [25] clause D.1		OP.21 FDD		OP.21 FDD		OCNG shall be used such that both cells are fully allocated and a constant total transmitted power spectral density is achieved for all OFDM symbols (other than those in the PRS subframes).
Reference cell		Cell 1				
Neighbour cell		Cell 2				
E-UTRA RF Channel Number		1				One carrier frequency is used.
System channel Bandwidth ( $BW_{\text{channel}}$ )	MHz	10		10		
PRS Transmission Bandwidth Note 2	RB	50 <sup>Note 4</sup>		50 <sup>Note 4</sup>		PRS bandwidth is as indicated in <i>prs-Bandwidth</i> in the OTDOA assistance data defined in TS 36.355 [4].
PRS configuration Index $I_{\text{PRS}}$ Note 2		151		151		As defined in TS 36.211 [26]
Number of consecutive positioning downlink subframes $N_{\text{PRS}}$ Note 2		6		4		As defined in TS 36.211 [26]
<i>prs-MutingInfo</i> Note 2		Cell 1: '11110000' Cell 2: '11110000'				See section 6.5.1.2 in 3GPP TS 36.355 [4] for more information
Cell ID Note 2		(Cell ID of cell 1 – Cell ID of cell 2) mod 6 = 0	(Cell ID of cell 1 – Cell ID of cell 2) mod 6 = 1	(Cell ID of cell 1 – Cell ID of cell 2) mod 6 = 0	(Cell ID of cell 1 – Cell ID of cell 2) mod 6 = 3	
Expected RSTD Note 1	μs	Cell 2: 1 Other neighbour cells: randomly between -3 and 3	Cell 2: -1 Other neighbour cells: randomly between -3 and 3	Cell 2: -1 Other neighbour cells: randomly between -3 and 3	Cell 2: 1 Other neighbour cells: randomly between -3 and 3	
Expected RSTD uncertainty for all neighbour cells Note 1	μs	5	5	5	5	
CP length Note 2		Normal				
DRX		OFF				
Radio frame receive time offset between the cells at the UE antenna connector Note 3	μs	Cell 2 to Cell 1: -3	Cell 2 to Cell 1: 3	Cell 2 to Cell 1: 3	Cell 2 to Cell 1: -3	PRS are transmitted from synchronous cells
Number of cells provided in OTDOA assistance data		16				The number of cells includes the reference cell



$T_{\text{RSTD IntraFreqHD-FDD, E-UTRAN}}$ Note 5	ms	12800	5120	Derived according to the RSTD measurement requirements specified in section 9.3.10.2.3
<p>NOTE 1: Parameters "Expected RSTD" and "Expected RSTD uncertainty for all neighbour cells" are not settable parameters. These are parameters signalled in LPP only. For the values to be used in LPP see Table 9.3.10.1.4.3-4 and TS 37.571-5 [20], clause 7.2.5.</p> <p>NOTE 2: Parameters "PRS Transmission Bandwidth", "PRS configuration index", "Number of consecutive positioning downlink subframes", "prs-MutingInfo", "Cell ID" and "CP length" are settable parameters and also parameters signalled in LPP. The values to be used for "Cell ID" are as follows: Cell 1: 0, Cell 2: Test 1: 6, Test 2: 7, Test 3: 6, Test 4: 9. For all the values to be used in LPP see Table 9.3.10.1.4.3-4 and TS 37.571-5 [20], clause 7.2.5.</p> <p>NOTE 3: The parameter "Radio frame receive time offset between the cells at the UE antenna connector" is not a settable parameter but is used to set the "true RSTD" values in step 6 of clause 9.1.3.4.1.</p> <p>NOTE 4: If the PRS transmission bandwidth is larger than the UE RF bandwidth, the UE is measuring RSTD within its RF bandwidth.</p> <p>NOTE 5: The parameter "<math>T_{\text{RSTD IntraFreqHD-FDD, E-UTRAN}}</math>" is not a settable parameter but is used to set the LPP "time" value in Table 9.3.10.2.4.3-1. The value of the LPP time IE is set to <math>T_{\text{RSTD IntraFreqHD-FDD, E-UTRAN}} + \Delta T</math> ms, where <math>\Delta T = 150</math> ms, giving a value of 12950 ms for Test 1 and 2 and 5270 ms for Test 3 and 4. This is rounded up to the next allowed LPP value of 13 or 6 seconds, respectively.</p>				

#### 9.3.11.2.4.2 Test procedure

Same as in clause 9.3.7.1.4.2 but using condition CEModeB.

#### 9.3.11.2.4.3 Message contents

Same as in clause 9.3.10.2.4.3.

#### 9.3.11.2.5 Test requirement

Same as in clause 9.3.10.2.5.

For the overall test to pass, the ratio of successful reported values in each sub-test shall be more than 90% with a confidence level of 95%.

## 9.3.12 TDD intra-frequency RSTD Measurement Accuracy in CE Mode B

### 9.3.12.1 TDD intra-frequency RSTD Measurement Accuracy in CE Mode B for Cat M1

**Editor's note: This test is incomplete. The following aspects are missing:**

- Requirements in TS 36.133 are partially missing

- Assistance Data in TS 37.571-5 is missing

#### 9.3.12.1.1 Test purpose

To verify that the RSTD measurement accuracy for UE Category M1 is within the specified limits in enhanced coverage mode in an environment with fading propagation conditions.

#### 9.3.12.1.2 Test applicability

This test applies to E-UTRA TDD UE Category M1 release 14 and forward that supports UE-assisted OTDOA and CE Mode B.

#### 9.3.12.1.3 Minimum conformance requirements

Same as in clause 9.3.10.1.3.

The normative reference for this requirement is TS 36.133 [23] clause 9.1.21.21 and A.9.8.25.

9.3.12.1.4 Test description

9.3.12.1.4.1 Initial conditions

Same as in clause 9.3.10.1.4.1 but replacing Table 9.3.10.1.4.1-1 with Table 9.3.12.1.4.1-1

**Table 9.3.12.1.4.1-1: General test parameters for E-UTRAN TDD intra-frequency RSTD measurement  
Accuracy under fading propagation conditions**

Parameter	Unit	Value		Comment
		Test 1	Test 2	
MPDCCH		R.16 TDD		As specified in TS 36.521-3 [25] clause A.7.3
<i>mPDCCH-startSF-U ESS</i>		10		Parameter $G$ in $T = r_{\max} \cdot G$ which determines subframe $k0$ in which MPDCCH starts
OCNG Patterns defined in TS 36.521-3 [25] clause D.1		OP.11 TDD		OCNG shall be used such that both cells are fully allocated and a constant total transmitted power spectral density is achieved for all OFDM symbols (other than those in the PRS subframes).
Reference cell		Cell 1		Reference cell is the cell in the OTDOA assistance data with respect to which the RSTD measurement is defined, as specified in 3GPP TS 36.214 [6] and 3GPP TS 36.355 [4]. The reference cell is the serving cell in this test case.
Neighbour cell		Cell 2		One carrier frequency is used.
E-UTRA RF Channel Number		1		
Channel Bandwidth ( $BW_{\text{channel}}$ )	MHz	10		
Special subframe configuration		6		As specified in table 4.2-1 in TS 36.211 [26]. The same configuration in both cells.
Uplink-downlink configuration		1		As specified in table 4.2-2 in TS 36.211 [26] and table 8.1.2.5.2-2. The same configuration in both cells.
PRS Transmission Bandwidth <sup>Note 2</sup>	RB	50 <sup>Note 4</sup>		PRS are transmitted over the system bandwidth
PRS configuration index $I_{\text{PRS}}$ <sup>Note 2</sup>		154		This corresponds to periodicity of 320 ms and PRS subframe offset of $I_{\text{PRS}} - 160$ DL subframes, as defined in 3GPP TS 36.211 [26], Table 6.10.4.3-1
Number of consecutive downlink positioning subframes $N_{\text{PRS}}$ <sup>Note 2</sup>		6		As defined in 3GPP TS 36.211 [26]. The number of subframes in a positioning occasion
PRS muting info <sup>Note 2</sup>		Cell 1: '11110000' Cell 2: '11110000'		Corresponds to prs-MutingInfo defined in TS 36.355 [4]
Physical cell ID PCI <sup>Note 2</sup>		(Cell ID of cell 1 – Cell ID of cell 2) mod 6 = 0	(Cell ID of cell 1 – Cell ID of cell 2) mod 6 = 1	
Expected RSTD <sup>Note 1</sup>	μs	Cell 2: 1 Other neighbour cells: randomly between -3 and 3	Cell 2: -1 Other neighbour cells: randomly between -3 and 3	The expected RSTD is what is expected at the receiver. The corresponding parameter in the OTDOA assistance data specified in TS 36.355 [4] is the expectedRSTD indicator
Expected RSTD uncertainty for all neighbour cells <sup>Note 1</sup>	μs	5	5	The corresponding parameter in the OTDOA assistance data specified in TS 36.355 [4] is the expectedRSTD-Uncertainty index
CP length <sup>Note 2</sup>		Normal		
DRX		OFF		
Radio frame receive time offset between the cells at the UE antenna connector <sup>Note 3</sup>	μs	Cell 2 to Cell 1: -3	Cell 2 to Cell 1: 3	PRS are transmitted from synchronous cells

Number of cells provided in OTDOA assistance data		16	Including the reference cell
$T_{\text{RSTD IntraFreqTDD, E-UTRAN}}$	ms	12800	Derived according to the RSTD measurement requirements specified in section 9.3.10.1.3
Note 1:	Parameters "Expected RSTD" and "Expected RSTD uncertainty for all neighbour cells" are not settable parameters. These are parameters signalled in LPP only. For the values to be used in LPP see Table 9.3.10.1.4.3-5 and TS 37.571-5 [20], clause 7.2.5.		
Note 2:	Parameters "PRS Transmission Bandwidth", "PRS configuration index", "Number of consecutive positioning downlink subframes", "prs-MutingInfo", "Cell ID" and "CP length" are settable parameters and also parameters signalled in LPP. The values to be used for "Cell ID" are as follows: Cell 1: 0, Cell 2: Test 1: 6, Test 2: 7, Test 3: 6, Test 4: 9. For all the values to be used in LPP see Table 9.3.10.1.4.3-4 and TS 37.571-5 [20], clause 7.2.5.		
Note 3:	The parameter "Radio frame receive time offset between the cells at the UE antenna connector" is not a settable parameter but is used to set the "true RSTD" values in step 6 of clause 9.3.10.1.4.1.		
Note 4:	If the PRS transmission bandwidth is larger than the UE RF bandwidth, the UE is measuring RSTD within its RF bandwidth.		
Note 5:	The parameter " $T_{\text{RSTD IntraFreqTDD, E-UTRAN}}$ " is not a settable parameter but is used to set the LPP "time" value in Table 9.3.10.1.4.3-3. The value of the LPP time IE is set to $T_{\text{RSTD IntraFreqTDD, E-UTRAN}} + \Delta T$ ms, where $\Delta T = 150$ ms, giving a value of 12950 ms. This is rounded up to the next allowed LPP value of 13 seconds.		

#### 9.3.12.1.4.2 Test procedure

Same as in clause 9.3.7.1.4.2 but using condition CEModeB.

#### 9.3.12.1.4.3 Message contents

Same as in clause 9.3.10.1.4.3.

#### 9.3.12.1.5 Test requirement

Same as in clause 9.3.10.1.5.

### 9.3.12.2 TDD intra-frequency RSTD Measurement Accuracy in CE Mode B for Cat M2

**Editor's note: This test is incomplete. The following aspects are missing:**

- Requirements in TS 36.133 are partially missing
- Assistance Data in TS 37.571-5 is missing

#### 9.3.12.2.1 Test purpose

To verify that the RSTD measurement accuracy for UE Category M2 is within the specified limits in enhanced coverage mode in an environment with fading propagation conditions.

#### 9.3.12.2.2 Test applicability

This test applies to E-UTRA TDD UE Category M2 release 14 and forward that supports UE-assisted OTDOA and CE Mode B.

#### 9.3.12.2.3 Minimum conformance requirements

Same as in clause 9.3.10.1.3.

The normative reference for this requirement is TS 36.133 [23] clause 9.1.25.5 and A.9.8.25.

#### 9.3.12.2.4 Test description

##### 9.3.12.2.4.1 Initial conditions

Same as in clause 9.3.10.2.4.1 but replacing Table 9.3.10.2.4.1-1 with Table 9.3.12.2.4.1-1.

**Table 9.3.12.2.4.1-1: General test parameters for E-UTRAN TDD intra-frequency RSTD measurement  
Accuracy under fading propagation conditions**

Parameter	Unit	Value				Comment
		Test1	Test2	Test3	Test4	
M-PDCCH parameters		R.16 TDD		R.16 TDD		As specified in TS 36.521-3 [25] clause A.7.3.
<i>mPDCCH-startSF-UESS</i>		10		10		Parameter G in $T = r_{\max} \cdot G$ which determines subframe $k_0$ in which MPDCCH starts
OCNG Patterns defined in TS 36.521-3 [25] clause D.1		OP.11 TDD		OP.11 TDD		OCNG shall be used such that both cells are fully allocated and a constant total transmitted power spectral density is achieved for all OFDM symbols (other than those in the PRS subframes).
Reference cell		Cell 1				
Neighbour cell		Cell 2				
E-UTRA RF Channel Number		1				One carrier frequency is used.
System channel Bandwidth ( $BW_{\text{channel}}$ )	MHz	10		10		
Special subframe configuration		6				As specified in table 4.2-1 in TS 36.211 [26]. The same configuration in both cells.
Uplink-downlink configuration		1				As specified in table 4.2-2 in TS 36.211 [26] and table 8.1.2.5.2-2. The same configuration in both cells.
PRS Transmission Bandwidth <sup>Note 2</sup>	RB	50 <sup>Note 4</sup>		50 <sup>Note 4</sup>		PRS bandwidth is as indicated in <i>prs-Bandwidth</i> in the OTDOA assistance data defined in TS 36.355 [4].
PRS configuration Index $I_{\text{PRS}}$ <sup>Note 2</sup>		154		154		As defined in TS 36.211 [26]
Number of consecutive positioning downlink subframes $N_{\text{PRS}}$ <sup>Note 2</sup>		6		4		As defined in TS 36.211 [26]
<i>prs-MutingInfo</i> <sup>Note 2</sup>		Cell 1: '11110000' Cell 2: '11110000'				See section 6.5.1.2 in 3GPP TS 36.355 [4] for more information
Cell ID <sup>Note 2</sup>		(Cell ID of cell 1 – Cell ID of cell 2) mod 6 = 0	(Cell ID of cell 1 – Cell ID of cell 2) mod 6 = 1	(Cell ID of cell 1 – Cell ID of cell 2) mod 6 = 0	(Cell ID of cell 1 – Cell ID of cell 2) mod 6 = 3	
Expected RSTD <sup>Note 1</sup>	μs	Cell 2: 1 Other neighbour cells: randomly between -3 and 3	Cell 2: -1 Other neighbour cells: randomly between -3 and 3	Cell 2: -1 Other neighbour cells: randomly between -3 and 3	Cell 2: 1 Other neighbour cells: randomly between -3 and 3	
Expected RSTD uncertainty for all neighbour cells <sup>Note 1</sup>	μs	5		5		
CP length <sup>Note 2</sup>		Normal				

DRX		OFF				
Radio frame receive time offset between the cells at the UE antenna connector Note 3	$\mu\text{s}$	Cell 2 to Cell 1: -3	Cell 2 to Cell 1: 3	Cell 2 to Cell 1: 3	Cell 2 to Cell 1: -3	PRS are transmitted from synchronous cells
Number of cells provided in OTDOA assistance data		16				The number of cells includes the reference cell
$T_{\text{RSTD IntraFreqTDD, E-UTRAN}}$ Note 5	ms	12800		5120		Derived according to the RSTD measurement requirements specified in section 9.3.10.2.3
<p>NOTE 1: Parameters "Expected RSTD" and "Expected RSTD uncertainty for all neighbour cells" are not settable parameters. These are parameters signalled in LPP only. For the values to be used in LPP see Table 9.3.10.1.4.3-4 and TS 37.571-5 [20], clause 7.2.5.</p> <p>NOTE 2: Parameters "PRS Transmission Bandwidth", "PRS configuration index", "Number of consecutive positioning downlink subframes", "prs-MutingInfo", "Cell ID" and "CP length" are settable parameters and also parameters signalled in LPP. The values to be used for "Cell ID" are as follows: Cell 1: 0, Cell 2: Test 1: 6, Test 2: 7, Test 3: 6, Test 4: 9. For all the values to be used in LPP see Table 9.3.10.1.4.3-4 and TS 37.571-5 [20], clause 7.2.5.</p> <p>NOTE 3: The parameter "Radio frame receive time offset between the cells at the UE antenna connector" is not a settable parameter but is used to set the "true RSTD" values in step 6 of clause 9.1.3.4.1.</p> <p>NOTE 4: If the PRS transmission bandwidth is larger than the UE RF bandwidth, the UE is measuring RSTD within its RF bandwidth.</p> <p>NOTE 5: The parameter "<math>T_{\text{RSTD IntraFreqTDD, E-UTRAN}}</math>" is not a settable parameter but is used to set the LPP "time" value in Table 9.3.10.2.4.3-3. The value of the LPP time IE is set to <math>T_{\text{RSTD IntraFreqTDD, E-UTRAN}} + \Delta T</math> ms, where <math>\Delta T = 150</math> ms, giving a value of 12950 ms for Test 1 and 2 and 5270 ms for Test 3 and 4. This is rounded up to the next allowed LPP value of 13 or 6 seconds, respectively.</p>						

#### 9.3.12.2.4.2 Test procedure

Same as in clause 9.3.7.1.4.2 but using condition CEModeB.

#### 9.3.12.2.4.3 Message contents

Same as in clause 9.3.10.1.4.3.

#### 9.3.12.2.5 Test requirement

Same as in clause 9.3.10.2.5.

For the overall test to pass, the ratio of successful reported values in each sub-test shall be more than 90% with a confidence level of 95%.

## 9.4 RSTD Inter-Frequency Measurements for UE Category M1/M2

### 9.4.1 FDD inter-frequency RSTD Measurement Reporting Delay in CE Mode A

#### 9.4.1.1 FDD inter-frequency RSTD Measurement Reporting Delay in CE Mode A for Cat M1

**Editor's note: This test is incomplete. The following aspects are missing:**

- TBD in TS 36.133 how to capture prsOccGroupLength in the measurement period
- Response Time to be calculated based as Nprs\_total is missing in TS 36.133
- Measurement gap configuration in TS 36.133 is not correct (gapID0 does not support 151 gap offset).



- Annex E-2 is missing as it is also missing in TS 36.133.

- Assistance Data in TS 37.571-5 is missing

#### 9.4.1.1.1 Test purpose

To verify that the RSTD measurement reporting delay for UE Category M1 meets the performance requirements in normal coverage mode in an environment with fading propagation conditions.

#### 9.4.1.1.2 Test applicability

This test applies to E-UTRA FDD UE Category M1 release 14 and forward that supports UE-assisted OTDOA and inter-frequency RSTD measurements.

#### 9.4.1.1.3 Minimum conformance requirements

When the physical layer cell identities of neighbour cells together with the OTDOA assistance data are provided, the UE shall be able to detect and measure inter-frequency RSTD, specified in 3GPP TS 36.214 [6], for at least  $n=16$  cells, including the reference cell, on the same carrier frequency  $f_1$  as that of the reference cell within  $T_{\text{RSTD InterFreqFDD, Cat}_M}$  ms as given below (see also Figure 9.4.1.1.3-1):

$$T_{\text{RSTD InterFreqFDD, Cat}_M} = T_{\text{PRS}} \cdot (M - 1) + \Delta + T_{\text{MIB}} \text{ ms,}$$

where

$T_{\text{RSTD InterFreqFDD, Cat}_M}$  is the total time for detecting and measuring at least  $n$  cells,

$T_{\text{PRS}}$  is the cell-specific positioning subframe configuration period as defined in 3GPP TS 36.211 [26]; if  $T_{\text{PRS}} < \text{MGRP}$ ,  $T_{\text{PRS}}$  equals to MGRP; MGRP is the Measurement Gap Repetition Period as defined in 3GPP TS 36.133 [23] section 8.1.2.1,

$M$  is the number of PRS positioning occasions as defined in Table 9.4.1.1.3-1, , where downlink positioning subframes defined in TS 36.211 [16],

$\Delta = T_{\text{PRS}} \cdot \left\lceil \frac{n}{M} \right\rceil$  ms is the measurement time for a single PRS positioning occasion which includes the sampling time and the processing time,

$N_{\text{PRS}}$  is the cell-specific number of PRS subframes within a PRS occasion as defined in TS36.355 [4],

$N_{\text{actual\_PRS}}$  is the cell-specific number of PRS subframes within a PRS occasion and can be measured by UE within MGL; if  $\text{MGRP} \geq N_{\text{PRS}} > (\text{MGL} - 2\text{ms})$ ,  $N_{\text{actual\_PRS}}$  equals to  $(\text{MGL} - 2\text{ms})$ ; if  $N_{\text{PRS}} > \text{MGRP}$ ,  $N_{\text{actual\_PRS}}$  equals to

$$(\text{MGL} - 2) \cdot \left\lceil \frac{N_{\text{PRS}}}{\text{MGRP}} \right\rceil;$$

$N_{\text{PRS\_total}}$  is the minimum number of PRS subframes per cell measurement as specified in TS 36.133 [23] Section 9.1.21.17.

$T_{\text{PRS}}$ ,  $N_{\text{PRS}}$ ,  $N_{\text{actual\_PRS}}$  and  $N_{\text{PRS\_total}}$  are the parameters of the same cell, for which  $T_{\text{PRS}} \cdot \left\lceil \frac{N_{\text{PRS\_total}}}{N_{\text{actual\_PRS}}} \right\rceil$  is

the largest among all the measured cells.

$T_{\text{MIB}}$  is the time required for acquiring the MIB information of the target cell.  $T_{\text{MIB}} = 0$  if the SFN of at least one cell in OTDOA assistance data is known to the UE.

**Table 9.4.1.1.3-1: Number of PRS positioning occasions within  $T_{\text{RSTD InterFreqFDD, Cat}_M}$** 

Positioning subframe configuration period $T_{\text{PRS}}$	Number of PRS positioning occasions $M$
	f1 and f2 <sup>Note 1</sup>
160 ms	$32 \cdot \left\lceil \frac{N_{\text{PRS\_Total}}}{N_{\text{actual\_PRS}}} \right\rceil$
>160 ms	$16 \cdot \left\lceil \frac{N_{\text{PRS\_Total}}}{N_{\text{actual\_PRS}}} \right\rceil$
Note 1: When intra-frequency RSTD and inter-frequency RSTD measurements are performed over cells belonging to the serving FDD carrier frequency f1 and one inter-frequency carrier frequency f2, respectively.	

The UE physical layer shall be capable of reporting RSTD for the reference cell and all the neighbour cells  $i$  out of at least  $(n-1)$  neighbour cells within  $T_{\text{RSTD InterFreqFDD, Cat}_M}$  provided:

$$\left( \text{PRS } \hat{E}_s / \text{Iot} \right)_{\text{ref}} \geq -6 \text{ dB for all Frequency Bands for the reference cell,}$$

$$\left( \text{PRS } \hat{E}_s / \text{Iot} \right)_i \geq -13 \text{ dB for all Frequency Bands for neighbour cell } i,$$

$$\left( \text{PRS } \hat{E}_s / \text{Iot} \right)_{\text{ref}} \text{ and } \left( \text{PRS } \hat{E}_s / \text{Iot} \right)_i \text{ conditions apply for all subframes of at least } L = \frac{M}{2} \text{ PRS positioning}$$

occasions,

PRP 1,2<sub>dBm</sub> according to clause E.3.1 for a corresponding Band.

$\text{PRS } \hat{E}_s / \text{Iot}$  is defined as the ratio of the average received energy per PRS RE during the useful part of the symbol to the average received power spectral density of the total noise and interference for this RE, where the ratio is measured over all REs which carry PRS.

The time  $T_{\text{RSTD InterFreqFDD, Cat}_M}$  starts from the first subframe of the PRS positioning occasion closest in time after both the OTDOA-RequestLocationInformation message and the OTDOA assistance data in the OTDOA-ProvideAssistanceData message as specified in 3GPP TS 36.355 [4], are delivered to the physical layer of the UE.

This requirement assumes that the measurement report is not delayed by other LPP signalling on the DCCH. This measurement reporting delay excludes a delay uncertainty resulted when inserting the measurement report to the TTI of the uplink DCCH. The delay uncertainty is  $N_{\text{rep}} \times \text{TTI}_{\text{DCCH}}$ , where  $N_{\text{rep}}$  is the maximum number of PUSCH repetitions configured for the UE, otherwise uncertainty is defined as  $2 \times \text{TTI}_{\text{DCCH}}$ . This measurement reporting delay excludes any delay caused by no UL resources for UE to send the measurement report.

The normative reference for this requirement is TS 36.133 [23] clause 8.13.2.4.1 and A.8.13.3.

#### 9.4.1.1.4 Test description

##### 9.4.1.1.4.1 Initial conditions

Test Environment: Normal; as defined in TS 36.508 [18] clause 4.1.

Frequencies to be tested: Mid Range, as defined in TS 36.508 [18] clause 4.3.1.1.

Channel bandwidth to be tested: 10 MHz as defined in TS 36.508 [18] clause 4.3.1.

1. Connect the SS, faders and AWGN noise sources to the UE antenna connector or antenna connectors as shown in Annex A, Figure A.4 using only the main Tx/Rx antenna of the UE.
2. The general test parameter settings are set up according to Table 9.4.1.1.4.1-1.
3. Propagation conditions are set according to clause 4.7.2.1.
4. Message contents are defined in clause 9.4.1.1.4.3.

5. In the test there are three synchronized cells: Cell 1, Cell 2 and Cell 3. Cell 1 is the OTDOA assistance data reference as well as the serving cell. Cell 2 and Cell 3 are the neighbour cells. Cell 1 is on FDD RF channel 1. Cell 2 and Cell 3 are on a FDD RF channel 2. The assistance data neighbour cell list includes in total 15 cells, where 13 of the cells are not simulated (dummy cells; as defined in 3GPP TS 37.571-5 clause 7.2.5).
6. The true RSTD (which is the receive time difference for frame 0 between two cells as seen at the UE antenna connector) is set to 31 Ts (about 1  $\mu$ s) between neighbour Cell 2 and serving Cell 1; and set to -31 Ts (about -1  $\mu$ s) between neighbour Cell 3 and serving Cell 1.

**Table 9.4.1.1.4.1-1: General test parameters for E-UTRAN FDD inter-frequency RSTD measurement reporting delay under fading propagation conditions**

Parameter	Unit	Value	Comment
Reference cell		Cell 1	Reference cell is the cell in the OTDOA assistance data with respect to which the RSTD measurement is defined, as specified in 3GPP TS 36.214 [6] and 3GPP TS 36.355 [4]. The reference cell is the serving cell in this test case.
Neighbour cells		Cell 2 and Cell 3	Cell 2 and Cell 3 appear at random places in the neighbour cell list in the OTDOA assistance data, but Cell 2 always appears in the first half of the list, whilst Cell 3 appears in the second half of the list.
MPDCCH		DL Reference Measurement Channel R.16 FDD	As specified in TS 36.521-3 [25] clause A.7.1
$mPDCCH\text{-startSF}\text{-UESS}$		10	Parameter $G$ in $T = r_{\max} \cdot G$ which determines subframe $k0$ in which MPDCCH starts
Channel Bandwidth (BW <sub>channel</sub> )	MHz	10	
Gap pattern Id		0	As specified in TS 36.133 [23] Table 8.1.2.1-1. Applies for measurements on Cell 2 and Cell 3
Gap offset		151	As specified in TS 36.331 [22], Clause 6.3.5
PRS Transmission Bandwidth <sup>Note 2</sup>	RB	50 <sup>Note 4</sup>	PRS are transmitted over the system bandwidth
PRS configuration index $I_{PRS}$ <sup>Note 2</sup>		Cell 1: 142, Cell 2, Cell 3: 152	This corresponds to periodicity of 320 ms and PRS subframe offset of $I_{PRS} - 160$ DL subframes, as defined in 3GPP TS 36.211 [26], Table 6.10.4.3-1
Number of consecutive downlink positioning subframes $N_{PRS}$ <sup>Note 2</sup>		4	As defined in 3GPP TS 36.211 [26]. The number of subframes in a positioning occasion
Physical cell ID PCI <sup>Note 2</sup>		(PCI of Cell 1 – PCI of Cell 2) mod 6 = 0 and (PCI of Cell 1 – PCI of Cell 3) mod 6 = 0	The cell PCIs are selected such that the relative shifts of PRS patterns among cells are as given by the test parameters
CP length <sup>Note 2</sup>		Normal	
DRX		ON	DRX parameters are further specified in Table 9.4.1.1.4.1-2
prs-SubframeOffset		10	Number of subframes rounded to the closest integer. The corresponding parameter in the OTDOA assistance data is prs-SubframeOffset specified in TS 36.355 [4]
slotNumberOffset		0	The slot number offset at the transmitter between a neighbour cell and the assistance data reference cell specified in TS 36.355 [4]
Radio frame receive time offset between the cells at the UE antenna connector <sup>Note 3</sup>	µs	Cell 2 to Cell 1: 1 Cell 3 to Cell 1: -1	PRS are transmitted from synchronous cells

Expected RSTD <sup>Note 1</sup>	µs	Cell 2: -2 Cell 3: 2 Other neighbour cells: randomly between -3 and 3	The expected RSTD is what is expected at the receiver. The corresponding parameter in the OTDOA assistance data specified in TS 36.355 [4] is the expectedRSTD indicator
Expected RSTD uncertainty for all neighbour cells <sup>Note 1</sup>	µs	5	The corresponding parameter in the OTDOA assistance data specified in TS 36.355 [4] is the expectedRSTD-Uncertainty index
Number of cells provided in OTDOA assistance data		16	Including the reference cell
PRS muting info <sup>Note 2</sup>		Cell 1: '1111111100000000' Cell 2: '0000000011111111' Cell 3: '1111111100000000'	Corresponds to prs-MutingInfo defined in TS 36.355 [4]
T1	s	3	The length of the time interval from the beginning of each test
T2	s	7.68	The length of the time interval that follows immediately after time interval T1
T3	s	7.68	The length of the time interval that follows immediately after time interval T2
<p>Note 1: Parameters "Expected RSTD" and "Expected RSTD uncertainty for all neighbour cells" are not settable parameters. These are parameters signalled in LPP only. For the values to be used in LPP see Table 9.4.1.1.4.3-5 and TS 37.571-5 [20], clause 7.2.5.</p> <p>Note 2: Parameters "PRS Transmission Bandwidth", "PRS configuration index", "Number of consecutive downlink positioning subframes", "Physical cell ID PCI", "CP length", and "PRS muting info" are settable parameters and also parameters signalled in LPP. The values to be used for "Physical cell ID PCI" are as follows: Cell 1: 0, Cell 2: 6, Cell 3: 12. For all the values to be used in LPP see Table 9.4.1.1.4.3-5 and TS 37.571-5 [20], clause 7.2.5.</p> <p>Note 3: The parameter "Radio frame receive time offset between the cells at the UE antenna connector" is not a settable parameter but is used to set the "true RSTD" values in step 6 of clause 9.4.1.1.4.1.</p> <p>Note 4: If the PRS transmission bandwidth is larger than the UE RF bandwidth, the UE is measuring RSTD within its RF bandwidth.</p>			

**Table 9.4.1.1.4.1-2: DRX parameters for E-UTRAN FDD inter-frequency RSTD measurement reporting delay under fading propagation conditions**

Field	Value	Comment
onDurationTimer	psf1	As specified in 3GPP TS 36.331 [22], clause 6.3.2
drx-InactivityTimer	psf1	
drx-RetransmissionTimer	sf1	
longDRX-CycleStartOffset	sf320	
shortDRX	Disable	

9.4.1.1.4.2 Test procedure

The test consists of three consecutive time intervals, with duration of T1, T2 and T3 defined in Table 9.4.1.1.4.1-1. Cell 1 is active in T1, T2 and T3, whilst Cell 2 and Cell 3 are activated only in the beginning of T2. Cell 2 is active until the end of T3, and Cell 3 is active until the end of T2. The beginning of the time interval T2 shall be aligned 5 ms before the first PRS positioning subframe of a positioning occasion in the reference cell, where 5 ms is the necessary test tolerance. Cell 1 transmits PRS in T2, while Cell 2 transmits PRS only in T3, and Cell 3 transmits PRS only in T2.

NOTE: The information on when PRS is muted is conveyed to the UE using PRS muting information in the OTDOA assistance data.

The OTDOA-RequestLocationInformation message and the OTDOA assistance data as defined in clause 9.4.1.1.4.3 shall be provided to the UE during T1. The last TTI containing the OTDOA-RequestLocationInformation message shall be provided to the UE ΔT ms before the start of T2, where ΔT = 150 ms is the maximum processing time of the OTDOA-RequestLocationInformation message and the OTDOA assistance data.

1. Ensure that the UE is in state Generic RB Established State 3A-RF-CE according to 3GPP TS 36.508 [18] clause 7.2A.3AA.

2. The SS shall send a RESET UE POSITIONING STORED INFORMATION message.
3. Set the parameters according to Table 9.4.1.1.5-1. Propagation conditions are set according to clause 4.7.2.2 (ETU30).
4. T1 starts.
5. The SS shall transmit an RRCConnectionReconfiguration message with the DRX configuration and the measurement gap configuration. PDCCHs indicating new transmissions shall be sent continuously until the start of T2 to ensure that the UE would not enter the DRX state before T2.
6. The UE shall transmit RRCConnectionReconfigurationComplete message.
- 6a. The SS shall transmit an LPP REQUEST CAPABILITIES message.
- 6b. The UE shall transmit an LPP PROVIDE CAPABILITIES message indicating the OTDOA capabilities supported by the UE in the *OTDOA-ProvideCapabilities* IE.
7. The SS shall send a LPP PROVIDE ASSISTANCE DATA message, including the *OTDOA-ProvideAssistanceData* IE. The position of neighbour Cell 2 in the *OTDOA-NeighbourCellInfoList* is randomly selected to be in the first 7 elements of the sequence, and the position of neighbour Cell 3 is randomly selected to be in the last 8 elements of the sequence, as described in 3GPP TS 37.571-5 [20], clause 7.2.5. If the UE message at step 6b includes the *ackRequested* IE set to TRUE, then the SS shall send an acknowledgment in the LPP PROVIDE ASSISTANCE DATA message.
8. The SS shall send a LPP REQUEST LOCATION INFORMATION message, including the *OTDOA-RequestLocationInformation* IE such that the UE receives the message  $\Delta T$  ms before the start of T2, where  $\Delta T = 150$  ms.
9. When T1 expires, the SS shall switch the power setting from T1 to T2 as specified in Table 9.4.1.1.5-2.
10. When T2 expires, the SS shall switch the power setting from T2 to T3 as specified in Table 9.4.1.1.5-2.
11. The UE shall transmit a LPP PROVIDE LOCATION INFORMATION message including the *OTDOA-ProvideLocationInformation* IE within the response time (see clause 4.7.3) specified in clause 9.4.1.1.5. The UE shall perform and report the RSTD measurements for both Cell 2 and Cell 3 with respect to the reference cell in the OTDOA assistance data, Cell 1. If the UE transmits an *OTDOA-ProvideLocationInformation* IE including the *rstd* field for both Cell 2 and Cell 3 within the response time then the number of successful tests is increased by one. If the UE fails to report the *OTDOA-ProvideLocationInformation* IE with both the *rstd* fields included within the response time then the number of failure tests is increased by one.
12. If the UE message at step 11 includes the *ackRequested* IE set to TRUE, the SS shall send a LPP acknowledgement message.
13. Repeat steps 2-12 until the confidence level according to Annex D is achieved. For each iteration, at step 7 change the random position of the Cells 2 and 3 in the *OTDOA-NeighbourCellInfoList*.

#### 9.4.1.1.4.3 Message contents

Same as in clause 9.3.1.1.4.3 with the following exceptions.

**Table 9.4.1.1.4.3-1: MeasGapConfig-GP1: FDD-FDD inter-frequency RSTD Measurement Reporting Delay**

Derivation Path: TS 36.508 [18] clause 4.6.6, Table 4.6.6-1A: MeasGapConfig-GP1			
Information Element	Value/remark	Comment	Condition
MeasGapConfig-GP1 ::= CHOICE {			
setup SEQUENCE {			
gapOffset CHOICE {			
gp0	TBD	TGRP = 40 ms	
}			
}			
}			

**Table 9.4.1.1.4.3-2: LPP RequestLocationInformation**

Derivation Path: Table 9.3.1.1.4.3-4			
Information Element	Value/remark	Comment	Condition
LPP-Message ::= SEQUENCE {			
lpp-MessageBody CHOICE {			
c1 CHOICE {			
requestLocationInformation SEQUENCE {			
criticalExtensions CHOICE {			
c1 CHOICE {			
requestLocationInformation-r9 SEQUENCE {			
commonIEsRequestLocationInformation SEQUENCE {			
qos SEQUENCE {			
responseTime SEQUENCE {			
time	16	See clause 9.4.1.1.5	
}			
}			
}			
}			
}			
}			
}			
}			
}			
}			

9.4.1.1.5 Test requirement

Table 9.4.1.1.5-1 and 9.4.1.1.5-2 define the primary level settings including test tolerances for the test.



**Table 9.4.1.1.5-1: Cell-specific test parameters for E-UTRAN FDD inter-frequency RSTD measurement reporting delay under fading propagation conditions during T1**

Parameter	Unit	Cell 1	Cell 2	Cell 3
E-UTRA RF Channel Number		1	2	2
Correlation Matrix and Antenna Configuration		1x1	1x1	1x1
OCNG patterns defined in TS 36.521-3 [25] clause D.1		OP.21 FDD	N/A	N/A
PBCH_RA	dB	0	N/A	N/A
PBCH_RB				
PSS_RA				
SSS_RA				
PCFICH_RB				
PHICH_RA				
PHICH_RB				
PDCCH_RA				
PDCCH_RB				
OCNG_RA <sup>Note 1</sup>				
OCNG_RB <sup>Note 1</sup>				
$N_{oc}$ <sup>Note 3</sup>	dBm/ 15 kHz	-95		
PRS $\hat{E}_s/N_{oc}$	dB	-Infinity	-Infinity	-Infinity
$I_0$ <sup>Note 4</sup>	dBm/ 9 MHz	-67.22	N/A	N/A
$\hat{E}_s/N_{oc}$	dB	0	-Infinity	-Infinity
Propagation Condition		ETU30		
Note 1:	OCNG shall be used such that active cell (Cell 1) is fully allocated and a constant total transmitted power spectral density is achieved for all OFDM symbols.			
Note 2:	The resources for uplink transmission are assigned to the UE prior to the start of time period T2.			
Note 3:	Interference from other cells and noise sources not specified in the test are assumed to be constant over subcarriers and time and shall be modelled as AWGN of appropriate power for $N_{oc}$ to be fulfilled.			
Note 4:	$I_0$ levels have been derived from other parameters and are given for information purpose. These are not settable test parameters.			

**Table 9.4.1.1.5-2: Cell-specific test parameters for E-UTRAN FDD inter-frequency RSTD measurement reporting delay under fading propagation conditions during T2 and T3**

Parameter	Unit	Cell 1		Cell 2		Cell 3	
		T2	T3	T2	T3	T2	T3
E-UTRA RF Channel Number		1		2		2	
Correlation Matrix and Antenna Configuration		1x1		1x1		1x1	
OCNG patterns defined in TS 36.521-3 [25] clause D.1		OP.21 FDD		OP.6 FDD		OP.6 FDD	N/A
PBCH_RA	dB	0		0		0	N/A
PBCH_RB							
PSS_RA							
SSS_RA							
PCFICH_RB							
PHICH_RA							
PHICH_RB							
PDCCH_RA							
PDCCH_RB							
OCNG_RA <sup>Note 1</sup>							
OCNG_RB <sup>Note 1</sup>							
PRS_RA	dB	-3	N/A	N/A	3	3	N/A
$N_{oc}$ <sup>Note 3</sup>	dBm/15 kHz	-98	-98	-98	-95	-98	-95
$PRS \hat{E}_s / N_{oc}$	dB	-1	-Infinity	-Infinity	-7	-8	-Infinity
$PRS \hat{E}_s / I_{ot}$ <sup>Note 4</sup>	dB	-1	-Infinity	-Infinity	-7	-8	-Infinity
$I_o$ <sup>Note 4</sup>	dBm/9 MHz	-69.68	-70.22	-70.11	-67.08	-70.11	-67.08
PRP <sup>Note 4</sup>	dBm/15 kHz	-99	-Infinity	-Infinity	-102	-106	-Infinity
RSRP <sup>Note 4</sup>	dBm/15 kHz	-96	-96	-105	-105	-109	-Infinity
$\hat{E}_s / N_{oc}$ <sup>Note 4</sup>	dB	2	2	-7	-10	-11	-Infinity
Propagation Condition		ETU30					
<p>Note 1: OCNG shall be used such that active cells (all, except Cell 3 in T3) are fully allocated and a constant total transmitted power spectral density is achieved for all OFDM symbols other than those in the subframes with transmitted PRS.</p> <p>Note 2: The resources for uplink transmission are assigned to the UE prior to the start of time period T2.</p> <p>Note 3: Interference from other cells and noise sources not specified in the test are assumed to be constant over subcarriers and time and shall be modelled as AWGN of appropriate power for <math>N_{oc}</math> to be fulfilled.</p> <p>Note 4: If PRS_RA is not "N/A", <math>\hat{E}_s / N_{oc}</math>, <math>PRS \hat{E}_s / I_{ot}</math>, <math>I_o</math>, RSRP and PRP levels have been derived from other parameters and are given for information purpose. If PRS_RA is "N/A", <math>I_o</math> and RSRP levels have been derived from other parameters and are given for information purpose. These are not settable test parameters. Interference conditions shall be applied to all PRS symbols of DL positioning subframes.</p>							

The response time including test tolerance is 16.3 s. The response time is equal to the LPP time IE value plus the test tolerance. The LPP time IE value is derived from the RSTD reporting delay plus  $\Delta T$ , where  $\Delta T = N_{rep} \times TTI_{DCCH} = N_{rep} \times 75$  ms, giving a value of [15510] ms. This is rounded up to the next allowed LPP value of 16 seconds. The RSTD

measurement reporting delay in the test is derived from the following expression  $T_{PRS} (M - 1) + 320 \cdot \left\lceil \frac{n}{M} \right\rceil$ , where

$M = 48$  and  $n = 16$  are the parameters specified in clause 9.4.1.1.3, Table 9.4.1.1.3-1 and Note 4 of Table 9.4.1.1.4.1-1. This gives the total RSTD reporting delay of [15360] ms for the 15 neighbour cells including Cell 2 and Cell 3 with respect to the reference cell, Cell 1.

The test tolerances are defined in clauses C.1.3 and C4.

The rate of successful tests during repeated tests shall be at least 90% with a confidence level of 95%.

#### 9.4.1.2 FDD inter-frequency RSTD Measurement Reporting Delay in CE Mode A for Cat M2

**Editor's note: This test is incomplete. The following aspects are missing:**

- TBD in TS 36.133 how to capture `prsOccGroupLength` in the measurement period
- Assistance Data in TS 37.571-5 is missing

##### 9.4.1.2.1 Test purpose

To verify that the RSTD measurement reporting delay for UE Category M2 meets the performance requirements in normal coverage mode in an environment with fading propagation conditions.

##### 9.4.1.2.2 Test applicability

This test applies to E-UTRA FDD UE Category M2 release 14 and forward that supports UE-assisted OTDOA and inter-frequency RSTD measurements.

##### 9.4.1.2.3 Minimum conformance requirements

Same as in clause 9.4.1.1.3.

The normative reference for this requirement is TS 36.133 [23] clause 8.16.2.4.1 and A.8.13.3.

##### 9.4.1.2.4 Test description

###### 9.4.1.2.4.1 Initial conditions

Same as in clause 9.4.1.1.4.1 but replacing Table 9.4.1.1.4.1-1 with Table 9.4.1.2.4.1-1.

**Table 9.4.1.2.4.1-1: General test parameters for E-UTRAN FDD inter-frequency RSTD measurement reporting delay under fading propagation conditions**

Parameter	Unit	Value		Comment
Reference cell		Cell 1		Reference cell is the cell in the OTDOA assistance data with respect to which the RSTD measurement is defined, as specified in 3GPP TS 36.214 [6] and 3GPP TS 36.355 [4]. The reference cell is the serving cell in this test case.
Neighbour cells		Cell 2 and Cell 3		Cell 2 and Cell 3 appear at random places in the neighbour cell list in the OTDOA assistance data, but Cell 2 always appears in the first half of the list, whilst Cell 3 appears in the second half of the list.
MPDCCH		DL Reference Measurement Channel R.16 FDD		As specified in TS 36.521-3 [25] clause A.7.1
<i>mPDCCH-startSF-U ESS</i>		10		Parameter $G$ in $T = r_{\max} \cdot G$ which determines subframe $k0$ in which MPDCCH starts
Channel Bandwidth (BW <sub>channel</sub> )	MHz	10		
Gap pattern Id		0		As specified in TS 36.133 [23] Table 8.1.2.1-1. Applies for measurements on Cell 2 and Cell 3
Gap offset		151		As specified in TS 36.331 [22], Clause 6.3.5
PRS Transmission Bandwidth <sup>Note 2</sup>	RB	50 <sup>Note 4</sup>		PRS are transmitted over the system bandwidth
PRS configuration index $I_{\text{PRS}}$ <sup>Note 2</sup>		Cell 1: 142, Cell 2, Cell 3: 152		This corresponds to periodicity of 320 ms and PRS subframe offset of $I_{\text{PRS}} - 160$ DL subframes, as defined in 3GPP TS 36.211 [26], Table 6.10.4.3-1
Number of consecutive downlink positioning subframes $N_{\text{PRS}}$ <sup>Note 2</sup>		4	2	As defined in 3GPP TS 36.211 [26]. The number of subframes in a positioning occasion
Physical cell ID PCI <sup>Note 2</sup>		(PCI of Cell 1 – PCI of Cell 2) mod 6 = 0 and (PCI of Cell 1 – PCI of Cell 3) mod 6 = 0		The cell PCIs are selected such that the relative shifts of PRS patterns among cells are as given by the test parameters
CP length <sup>Note 2</sup>		Normal		
DRX		ON		DRX parameters are further specified in Table 9.4.1.1.4.1-2
prs-SubframeOffset		10		Number of subframes rounded to the closest integer. The corresponding parameter in the OTDOA assistance data is prs-SubframeOffset specified in TS 36.355 [4]
slotNumberOffset		0		The slot number offset at the transmitter between a neighbour cell and the assistance data reference cell specified in TS 36.355 [4]
Radio frame receive time offset between the cells at the UE antenna connector <sup>Note 3</sup>	µs	Cell 2 to Cell 1: 1 Cell 3 to Cell 1: -1		PRS are transmitted from synchronous cells

Expected RSTD <sup>Note 1</sup>	µs	Cell 2: -2 Cell 3: 2 Other neighbour cells: randomly between -3 and 3	The expected RSTD is what is expected at the receiver. The corresponding parameter in the OTDOA assistance data specified in TS 36.355 [4] is the expectedRSTD indicator	
Expected RSTD uncertainty for all neighbour cells <sup>Note 1</sup>	µs	5	The corresponding parameter in the OTDOA assistance data specified in TS 36.355 [4] is the expectedRSTD-Uncertainty index	
Number of cells provided in OTDOA assistance data		16	Including the reference cell	
PRS muting info <sup>Note 2</sup>		Cell 1: '1111111100000000' Cell 2: '0000000011111111' Cell 3: '1111111100000000'	Corresponds to prs-MutingInfo defined in TS 36.355 [4]	
T1	s	3	The length of the time interval from the beginning of each test	
T2	s	7.68	5.12	The length of the time interval that follows immediately after time interval T1
T3	s	7.68	5.12	The length of the time interval that follows immediately after time interval T2
<p>Note 1: Parameters "Expected RSTD" and "Expected RSTD uncertainty for all neighbour cells" are not settable parameters. These are parameters signalled in LPP only. For the values to be used in LPP see Table 9.4.1.1.4.3-5 and TS 37.571-5 [20], clause 7.2.5.</p> <p>Note 2: Parameters "PRS Transmission Bandwidth", "PRS configuration index", "Number of consecutive downlink positioning subframes", "Physical cell ID PCI", "CP length", and "PRS muting info" are settable parameters and also parameters signalled in LPP. The values to be used for "Physical cell ID PCI" are as follows: Cell 1: 0, Cell 2: 6, Cell 3: 12. For all the values to be used in LPP see Table 9.4.1.1.4.3-5 and TS 37.571-5 [20], clause 7.2.5.</p> <p>Note 3: The parameter "Radio frame receive time offset between the cells at the UE antenna connector" is not a settable parameter but is used to set the "true RSTD" values in step 6 of clause 9.4.1.1.4.1.</p> <p>Note 4: If the PRS transmission bandwidth is larger than the UE RF bandwidth, the UE is measuring RSTD within its RF bandwidth.</p>				

9.4.1.2.4.2 Test procedure

Same as in clause 9.4.1.1.4.2 but with the following additional step:

14. Repeat step 1-13 for each sub-test in Table 9.4.1.2.4.1-1 as appropriate

9.4.1.2.4.3 Message contents

Same as in clause 9.4.1.1.4.3 with the following exceptions:

Table 9.4.2.1.4.3-1: LPP RequestLocationInformation

Derivation Path: Table 9.3.1.1.4.3-4			
Information Element	Value/remark	Comment	Condition
LPP-Message ::= SEQUENCE {			
lpp-MessageBody CHOICE {			
c1 CHOICE {			
requestLocationInformation SEQUENCE {			
criticalExtensions CHOICE {			
c1 CHOICE {			
requestLocationInformation-r9 SEQUENCE {			
commonIEsRequestLocationInformation SEQUENCE {			
qos SEQUENCE {			
responseTime SEQUENCE {			
time	16	See clause 9.4.1.1.5	Test 1
time	11	See clause 9.4.1.1.5	Test 2
}			
}			
}			
}			
}			
}			
}			
}			
}			
}			

#### 9.4.1.2.5 Test requirement

The primary level settings including test tolerances for the test are defined in clause 9.4.1.1.5.

For Test 1, the response time is defined in clause 9.4.1.1.5.

For Test 2, the response time including test tolerance is 11.3 s. The response time is equal to the LPP time IE value plus the test tolerance. The LPP time IE value is derived from the RSTD reporting delay plus  $\Delta T$ , where  $\Delta T = N_{rep} \times TTI_{DCCH} = N_{rep} \times 75$  ms, giving a value of [10390] ms. This is rounded up to the next allowed LPP value of 11 seconds. The

RSTD measurement reporting delay in the test is derived from the following expression  $T_{PRS} (M - 1) + 320 \cdot \left\lceil \frac{n}{M} \right\rceil$ ,

where  $M = 32$  and  $n = 16$  are the parameters specified in clause 9.4.1.1.3, Table 9.4.1.1.3-1 and Note 4 of Table 9.4.1.2.4.1-1. This gives the total RSTD reporting delay of [10240] ms for the 15 neighbour cells including Cell 2 and Cell 3 with respect to the reference cell, Cell 1.

The test tolerances are defined in clauses C.1.3 and C4.

For the overall test to pass, the ratio of successful reported values in each sub-test shall be more than 90% with a confidence level of 95%.

## 9.4.2 HD-FDD inter-frequency RSTD Measurement Reporting Delay in CE Mode A

### 9.4.2.1 HD-FDD inter-frequency RSTD Measurement Reporting Delay in CE Mode A for Cat M1

**Editor's note:** This test is incomplete. The following aspects are missing:

- TBD in TS 36.133 how to capture prsOccGroupLength in the measurement period
- Response Time to be calculated based as Nprs\_total is missing in TS 36.133
- Assistance Data in TS 37.571-5 is missing

#### 9.4.2.1.1 Test purpose

To verify that the RSTD measurement reporting delay for UE Category M1 meets the performance requirements normal coverage mode in an environment with fading propagation conditions.

#### 9.4.2.1.2 Test applicability

This test applies to E-UTRA HD-FDD UE Category M1 release 14 and forward that supports UE-assisted OTDOA and inter-frequency RSTD measurements.

#### 9.4.2.1.3 Minimum conformance requirements

Same as in clause 9.4.1.1.3.

The normative reference for this requirement is TS 36.133 [23] clause 8.13.2.4.3 and A.8.13.4.

#### 9.4.2.1.4 Test description

##### 9.4.2.1.4.1 Initial conditions

Same as in clause 9.4.1.1.4.1 but replacing Table 9.4.1.1.4.1-1 with Table 9.4.2.1.4.1-1



**Table 9.4.2.1.4.1-1: General test parameters for E-UTRAN HD-FDD inter-frequency RSTD measurement reporting delay under fading propagation conditions**

Parameter	Unit	Value	Comment
Reference cell		Cell 1	Reference cell is the cell in the OTDOA assistance data with respect to which the RSTD measurement is defined, as specified in 3GPP TS 36.214 [6] and 3GPP TS 36.355 [4]. The reference cell is the serving cell in this test case.
Neighbour cells		Cell 2 and Cell 3	Cell 2 and Cell 3 appear at random places in the neighbour cell list in the OTDOA assistance data, but Cell 2 always appears in the first half of the list, whilst Cell 3 appears in the second half of the list.
MPDCCH		DL Reference Measurement Channel R.6 HD-FDD	As specified in TS 36.521-3 [25] clause A.7.2
<i>mPDCCH-startSF-U ESS</i>		10	Parameter $G$ in $T = r_{\max} \cdot G$ which determines subframe $k0$ in which MPDCCH starts
Channel Bandwidth (BW <sub>channel</sub> )	MHz	10	
Gap pattern Id		0	As specified in TS 36.133 [23] Table 8.1.2.1-1. Applies for measurements on Cell 2 and Cell 3
Gap offset		151	As specified in TS 36.331 [22], Clause 6.3.5
PRS Transmission Bandwidth <sup>Note 2</sup>	RB	50 <sup>Note 4</sup>	PRS are transmitted over the system bandwidth
PRS configuration index $I_{\text{PRS}}$ <sup>Note 2</sup>		Cell 1: 142, Cell 2, Cell 3: 152	This corresponds to periodicity of 320 ms and PRS subframe offset of $I_{\text{PRS}} - 160$ DL subframes, as defined in 3GPP TS 36.211 [26], Table 6.10.4.3-1
Number of consecutive downlink positioning subframes $N_{\text{PRS}}$ <sup>Note 2</sup>		4	As defined in 3GPP TS 36.211 [26]. The number of subframes in a positioning occasion
Physical cell ID PCI <sup>Note 2</sup>		(PCI of Cell 1 – PCI of Cell 2) mod 6 = 0 and (PCI of Cell 1 – PCI of Cell 3) mod 6 = 0	The cell PCIs are selected such that the relative shifts of PRS patterns among cells are as given by the test parameters
CP length <sup>Note 2</sup>		Normal	
DRX		ON	DRX parameters are further specified in Table 9.4.1.1.4.1-2
prs-SubframeOffset		10	Number of subframes rounded to the closest integer. The corresponding parameter in the OTDOA assistance data is prs-SubframeOffset specified in TS 36.355 [4]
slotNumberOffset		0	The slot number offset at the transmitter between a neighbour cell and the assistance data reference cell specified in TS 36.355 [4]
Radio frame receive time offset between the cells at the UE antenna connector <sup>Note 3</sup>	µs	Cell 2 to Cell 1: 1 Cell 3 to Cell 1: -1	PRS are transmitted from synchronous cells

Expected RSTD <sup>Note 1</sup>	µs	Cell 2: -2 Cell 3: 2 Other neighbour cells: randomly between -3 and 3	The expected RSTD is what is expected at the receiver. The corresponding parameter in the OTDOA assistance data specified in TS 36.355 [4] is the expectedRSTD indicator
Expected RSTD uncertainty for all neighbour cells <sup>Note 1</sup>	µs	5	The corresponding parameter in the OTDOA assistance data specified in TS 36.355 [4] is the expectedRSTD-Uncertainty index
Number of cells provided in OTDOA assistance data		16	Including the reference cell
PRS muting info <sup>Note 2</sup>		Cell 1: '1111111100000000' Cell 2: '0000000011111111' Cell 3: '1111111100000000'	Corresponds to prs-MutingInfo defined in TS 36.355 [4]
T1	s	3	The length of the time interval from the beginning of each test
T2	s	7.68	The length of the time interval that follows immediately after time interval T1
T3	s	7.68	The length of the time interval that follows immediately after time interval T2
<p>Note 1: Parameters "Expected RSTD" and "Expected RSTD uncertainty for all neighbour cells" are not settable parameters. These are parameters signalled in LPP only. For the values to be used in LPP see Table 9.4.1.1.4.3-5 and TS 37.571-5 [20], clause 7.2.5.</p> <p>Note 2: Parameters "PRS Transmission Bandwidth", "PRS configuration index", "Number of consecutive downlink positioning subframes", "Physical cell ID PCI", "CP length", and "PRS muting info" are settable parameters and also parameters signalled in LPP. The values to be used for "Physical cell ID PCI" are as follows: Cell 1: 0, Cell 2: 6, Cell 3: 12. For all the values to be used in LPP see Table 9.4.1.1.4.3-5 and TS 37.571-5 [20], clause 7.2.5.</p> <p>Note 3: The parameter "Radio frame receive time offset between the cells at the UE antenna connector" is not a settable parameter but is used to set the "true RSTD" values in step 6 of clause 9.4.1.1.4.1.</p> <p>Note 4: If the PRS transmission bandwidth is larger than the UE RF bandwidth, the UE is measuring RSTD within its RF bandwidth.</p>			

#### 9.4.2.1.4.2 Test procedure

Same as in clause 9.4.1.1.4.2.

#### 9.4.2.1.4.3 Message contents

Same as in clause 9.4.1.1.4.3

#### 9.4.2.1.5 Test requirement

Same as in clause 9.4.1.1.5.

### 9.4.2.2 HD-FDD inter-frequency RSTD Measurement Reporting Delay in CE Mode A for Cat M2

**Editor's note: This test is incomplete. The following aspects are missing:**

- TBD in TS 36.133 how to capture prsOccGroupLength in the measurement period
- Assistance Data in TS 37.571-5 is missing

#### 9.4.2.2.1 Test purpose

To verify that the RSTD measurement reporting delay for UE Category M2 meets the performance requirements normal coverage mode in an environment with fading propagation conditions.

#### 9.4.2.2.2 Test applicability

This test applies to E-UTRA HD-FDD UE Category M2 release 14 and forward that supports UE-assisted OTDOA and inter-frequency RSTD measurements.

#### 9.4.2.2.3 Minimum conformance requirements

Same as in clause 9.4.1.1.3.

The normative reference for this requirement is TS 36.133 [23] clause 8.16.2.4.3 and A.8.13.4.

#### 9.4.2.2.4 Test description

##### 9.4.2.2.4.1 Initial conditions

Same as in clause 9.4.1.1.4.1 but replacing Table 9.4.1.1.4.1-1 with Table 9.4.2.2.4.1-1.

**Table 9.4.2.2.4.1-1: General test parameters for E-UTRAN HD-FDD inter-frequency RSTD measurement reporting delay under fading propagation conditions**

Parameter	Unit	Value		Comment
Reference cell		Cell 1		Reference cell is the cell in the OTDOA assistance data with respect to which the RSTD measurement is defined, as specified in 3GPP TS 36.214 [6] and 3GPP TS 36.355 [4]. The reference cell is the serving cell in this test case.
Neighbour cells		Cell 2 and Cell 3		Cell 2 and Cell 3 appear at random places in the neighbour cell list in the OTDOA assistance data, but Cell 2 always appears in the first half of the list, whilst Cell 3 appears in the second half of the list.
MPDCCH		DL Reference Measurement Channel R.6 HD-FDD		As specified in TS 36.521-3 [25] clause A.7.2
<i>mPDCCH-startSF-U ESS</i>		10		Parameter $G$ in $T = r_{\max} \cdot G$ which determines subframe $k0$ in which MPDCCH starts
Channel Bandwidth (BW <sub>channel</sub> )	MHz	10		
Gap pattern Id		0		As specified in TS 36.133 [23] Table 8.1.2.1-1. Applies for measurements on Cell 2 and Cell 3
Gap offset		151		As specified in TS 36.331 [22], Clause 6.3.5
PRS Transmission Bandwidth <sup>Note 2</sup>	RB	50 <sup>Note 4</sup>		PRS are transmitted over the system bandwidth
PRS configuration index $I_{\text{PRS}}$ <sup>Note 2</sup>		Cell 1: 142, Cell 2, Cell 3: 152		This corresponds to periodicity of 320 ms and PRS subframe offset of $I_{\text{PRS}} - 160$ DL subframes, as defined in 3GPP TS 36.211 [26], Table 6.10.4.3-1
Number of consecutive downlink positioning subframes $N_{\text{PRS}}$ <sup>Note 2</sup>		4	2	As defined in 3GPP TS 36.211 [26]. The number of subframes in a positioning occasion
Physical cell ID PCI <sup>Note 2</sup>		(PCI of Cell 1 – PCI of Cell 2) mod 6 = 0 and (PCI of Cell 1 – PCI of Cell 3) mod 6 = 0		The cell PCIs are selected such that the relative shifts of PRS patterns among cells are as given by the test parameters
CP length <sup>Note 2</sup>		Normal		
DRX		ON		DRX parameters are further specified in Table 9.4.1.1.4.1-2
prs-SubframeOffset		10		Number of subframes rounded to the closest integer. The corresponding parameter in the OTDOA assistance data is prs-SubframeOffset specified in TS 36.355 [4]
slotNumberOffset		0		The slot number offset at the transmitter between a neighbour cell and the assistance data reference cell specified in TS 36.355 [4]
Radio frame receive time offset between the cells at the UE antenna connector <sup>Note 3</sup>	µs	Cell 2 to Cell 1: 1 Cell 3 to Cell 1: -1		PRS are transmitted from synchronous cells

Expected RSTD <sup>Note 1</sup>	µs	Cell 2: -2 Cell 3: 2 Other neighbour cells: randomly between -3 and 3	The expected RSTD is what is expected at the receiver. The corresponding parameter in the OTDOA assistance data specified in TS 36.355 [4] is the expectedRSTD indicator	
Expected RSTD uncertainty for all neighbour cells <sup>Note 1</sup>	µs	5	The corresponding parameter in the OTDOA assistance data specified in TS 36.355 [4] is the expectedRSTD-Uncertainty index	
Number of cells provided in OTDOA assistance data		16	Including the reference cell	
PRS muting info <sup>Note 2</sup>		Cell 1: '1111111100000000' Cell 2: '0000000011111111' Cell 3: '1111111100000000'	Corresponds to prs-MutingInfo defined in TS 36.355 [4]	
T1	s	3	The length of the time interval from the beginning of each test	
T2	s	7.68	5.12	The length of the time interval that follows immediately after time interval T1
T3	s	7.68	5.12	The length of the time interval that follows immediately after time interval T2
<p>Note 1: Parameters "Expected RSTD" and "Expected RSTD uncertainty for all neighbour cells" are not settable parameters. These are parameters signalled in LPP only. For the values to be used in LPP see Table 9.4.1.1.4.3-5 and TS 37.571-5 [20], clause 7.2.5.</p> <p>Note 2: Parameters "PRS Transmission Bandwidth", "PRS configuration index", "Number of consecutive downlink positioning subframes", "Physical cell ID PCI", "CP length", and "PRS muting info" are settable parameters and also parameters signalled in LPP. The values to be used for "Physical cell ID PCI" are as follows: Cell 1: 0, Cell 2: 6, Cell 3: 12. For all the values to be used in LPP see Table 9.4.1.1.4.3-5 and TS 37.571-5 [20], clause 7.2.5.</p> <p>Note 3: The parameter "Radio frame receive time offset between the cells at the UE antenna connector" is not a settable parameter but is used to set the "true RSTD" values in step 6 of clause 9.4.1.1.4.1.</p> <p>Note 4: If the PRS transmission bandwidth is larger than the UE RF bandwidth, the UE is measuring RSTD within its RF bandwidth.</p>				

9.4.2.2.4.2 Test procedure

Same as in clause 9.4.1.1.4.2 but with the following additional step:

14. Repeat step 1-13 for each sub-test in Table 9.4.2.2.4.1-1 as appropriate.

9.4.2.2.4.3 Message contents

Same as in clause 9.4.1.2.4.3.

9.4.2.2.5 Test requirement

Same as in clause 9.4.1.2.5.

For the overall test to pass, the ratio of successful reported values in each sub-test shall be more than 90% with a confidence level of 95%.

9.4.3 TDD inter-frequency RSTD Measurement Reporting Delay in CE Mode A

9.4.3.1 TDD inter-frequency RSTD Measurement Reporting Delay in CE Mode A for Cat M1

Editor's note: This test is incomplete. The following aspects are missing:

- TBD in TS 36.133 how to capture prsOccGroupLength in the measurement period
- Response Time to be calculated based as Nprs\_total is missing in TS 36.133
- Assistance Data in TS 37.571-5 is missing

#### 9.4.3.1.1 Test purpose

To verify that the RSTD measurement reporting delay for UE Category M1 meets the performance requirements in normal coverage mode in an environment with fading propagation conditions.

#### 9.4.3.1.2 Test applicability

This test applies to E-UTRA TDD UE Category M1 release 14 and forward that supports UE-assisted OTDOA and inter-frequency RSTD measurements.

#### 9.4.3.1.3 Minimum conformance requirements

Same as in clause 9.4.1.1.3.

The inter-frequency requirements in this clause shall apply for all TDD special subframe configurations specified in TS 36.211 [26] and for the TDD uplink-downlink configurations as specified in Table 9.4.3.1.3-1.

**Table 9.4.3.1.3-1: TDD uplink-downlink subframe configurations applicable for TDD inter-frequency requirements**

PRS Transmission Bandwidth [RB]	Applicable TDD uplink-downlink configurations
6	1, 2, 3, 4 and 5
Note: Uplink-downlink configurations are specified in Table 4.2-2 in TS 36.211 [26].	

The normative reference for this requirement is TS 36.133 [23] clause 8.13.2.4.2 and A.8.13.5.

#### 9.4.3.1.4 Test description

##### 9.4.3.1.4.1 Initial conditions

Same as in clause 9.4.1.1.4.1 but replacing Table 9.4.1.1.4.1-1 with Table 9.4.3.1.4.1-1



**Table 9.4.2.1.4.1-1: General test parameters for E-UTRAN TDD inter-frequency RSTD measurement reporting delay under fading propagation conditions**

Parameter	Unit	Value	Comment
Reference cell		Cell 1	Reference cell is the cell in the OTDOA assistance data with respect to which the RSTD measurement is defined, as specified in 3GPP TS 36.214 [6] and 3GPP TS 36.355 [4]. The reference cell is the serving cell in this test case.
Neighbour cells		Cell 2 and Cell 3	Cell 2 and Cell 3 appear at random places in the neighbour cell list in the OTDOA assistance data, but Cell 2 always appears in the first half of the list, whilst Cell 3 appears in the second half of the list.
MPDCCH		DL Reference Measurement Channel R.14 TDD	As specified in TS 36.521-3 [25] clause A.7.3
<i>mPDCCH-startSF-U ESS</i>		10	Parameter $G$ in $T = r_{\max} \cdot G$ which determines subframe $k0$ in which MPDCCH starts
Channel Bandwidth (BW <sub>channel</sub> )	MHz	10	
Gap pattern Id		0	As specified in TS 36.133 [23] Table 8.1.2.1-1. Applies for measurements on Cell 2 and Cell 3
Gap offset		151	As specified in TS 36.331 [22], Clause 6.3.5
PRS Transmission Bandwidth <sup>Note 2</sup>	RB	50 <sup>Note 4</sup>	PRS are transmitted over the system bandwidth
PRS configuration index $I_{\text{PRS}}$ <sup>Note 2</sup>		Cell 1: 142, Cell 2, Cell 3: 152	This corresponds to periodicity of 320 ms and PRS subframe offset of $I_{\text{PRS}} - 160$ DL subframes, as defined in 3GPP TS 36.211 [26], Table 6.10.4.3-1
Number of consecutive downlink positioning subframes $N_{\text{PRS}}$ <sup>Note 2</sup>		4	As defined in 3GPP TS 36.211 [26]. The number of subframes in a positioning occasion
Physical cell ID PCI <sup>Note 2</sup>		(PCI of Cell 1 – PCI of Cell 2) mod 6 = 0 and (PCI of Cell 1 – PCI of Cell 3) mod 6 = 0	The cell PCIs are selected such that the relative shifts of PRS patterns among cells are as given by the test parameters
TDD uplink-downlink configuration		1	As specified in TS 36.211 [26], Clause 4.2; corresponds to a configuration with 5 ms switch-point periodicity and two downlink consecutive subframes
TDD special subframe configuration		6	As specified in TS 36.211 [26], Clause 4.2; corresponds to DwPTS of $19760 \cdot T_s$ and UpPTS of $4384 \cdot T_s$
CP length <sup>Note 2</sup>		Normal	
DRX		ON	DRX parameters are further specified in Table 9.4.1.1.4.1-2
prs-SubframeOffset		10	Number of subframes rounded to the closest integer. The corresponding parameter in the OTDOA assistance data is prs-SubframeOffset specified in TS 36.355 [4]

slotNumberOffset		0	The slot number offset at the transmitter between a neighbour cell and the assistance data reference cell specified in TS 36.355 [4]
Radio frame receive time offset between the cells at the UE antenna connector Note 3	µs	Cell 2 to Cell 1: 1 Cell 3 to Cell 1: -1	PRS are transmitted from synchronous cells
Expected RSTD Note 1	µs	Cell 2: -2 Cell 3: 2 Other neighbour cells: randomly between -3 and 3	The expected RSTD is what is expected at the receiver. The corresponding parameter in the OTDOA assistance data specified in TS 36.355 [4] is the expectedRSTD indicator
Expected RSTD uncertainty for all neighbour cells Note 1	µs	5	The corresponding parameter in the OTDOA assistance data specified in TS 36.355 [4] is the expectedRSTD-Uncertainty index
Number of cells provided in OTDOA assistance data		16	Including the reference cell
PRS muting info Note 2		Cell 1: '1111111100000000' Cell 2: '0000000011111111' Cell 3: '1111111100000000'	Corresponds to prs-MutingInfo defined in TS 36.355 [4]
T1	s	3	The length of the time interval from the beginning of each test
T2	s	7.68	The length of the time interval that follows immediately after time interval T1
T3	s	7.68	The length of the time interval that follows immediately after time interval T2
<p>Note 1: Parameters "Expected RSTD" and "Expected RSTD uncertainty for all neighbour cells" are not settable parameters. These are parameters signalled in LPP only. For the values to be used in LPP see Table 9.4.1.1.4.3-5 and TS 37.571-5 [20], clause 7.2.5.</p> <p>Note 2: Parameters "PRS Transmission Bandwidth", "PRS configuration index", "Number of consecutive downlink positioning subframes", "Physical cell ID PCI", "CP length", and "PRS muting info" are settable parameters and also parameters signalled in LPP. The values to be used for "Physical cell ID PCI" are as follows: Cell 1: 0, Cell 2: 6, Cell 3: 12. For all the values to be used in LPP see Table 9.4.1.1.4.3-5 and TS 37.571-5 [20], clause 7.2.5.</p> <p>Note 3: The parameter "Radio frame receive time offset between the cells at the UE antenna connector" is not a settable parameter but is used to set the "true RSTD" values in step 6 of clause 9.4.1.1.4.1.</p> <p>Note 4: If the PRS transmission bandwidth is larger than the UE RF bandwidth, the UE is measuring RSTD within its RF bandwidth.</p>			

#### 9.4.3.1.4.2 Test procedure

Same as in clause 9.4.1.1.4.2.

#### 9.4.3.1.4.3 Message contents

Same as in clause 9.4.1.1.4.3

#### 9.4.3.1.5 Test requirement

Table 9.4.3.1.5-1 and 9.4.3.1.5-2 define the primary level settings including test tolerances for the test.

**Table 9.4.3.1.5-1: Cell-specific test parameters for E-UTRAN TDD inter-frequency RSTD measurement reporting delay under fading propagation conditions during T1**

Parameter	Unit	Cell 1	Cell 2	Cell 3
E-UTRA RF Channel Number		1	2	2
Correlation Matrix and Antenna Configuration		1x1	1x1	1x1
OCNG patterns defined in TS 36.521-3 [25] clause D.1		OP.11 TDD	N/A	N/A
PBCH_RA	dB	0	N/A	N/A
PBCH_RB				
PSS_RA				
SSS_RA				
PCFICH_RB				
PHICH_RA				
PHICH_RB				
PDCCH_RA				
PDCCH_RB				
OCNG_RA <sup>Note 1</sup>				
OCNG_RB <sup>Note 1</sup>				
$N_{oc}$ <sup>Note 3</sup>	dBm/15 kHz	-95		
$PRS \hat{E}_s / N_{oc}$	dB	-Infinity	-Infinity	-Infinity
$I_0$ <sup>Note 4</sup>	dBm/9 MHz	-67.22	N/A	N/A
$\hat{E}_s / N_{oc}$	dB	0	-Infinity	-Infinity
Propagation Condition		ETU30		
<p>Note 1: OCNG shall be used such that active cell (Cell 1) is fully allocated and a constant total transmitted power spectral density is achieved for all OFDM symbols.</p> <p>Note 2: The resources for uplink transmission are assigned to the UE prior to the start of time period T2.</p> <p>Note 3: Interference from other cells and noise sources not specified in the test are assumed to be constant over subcarriers and time and shall be modelled as AWGN of appropriate power for <math>N_{oc}</math> to be fulfilled.</p> <p>Note 4: <math>I_0</math> levels have been derived from other parameters and are given for information purpose. These are not settable test parameters.</p>				

**Table 9.4.3.1.5-2: Cell-specific test parameters for E-UTRAN TDD inter-frequency RSTD measurement reporting delay under fading propagation conditions during T2 and T3**

Parameter	Unit	Cell 1		Cell 2		Cell 3	
		T2	T3	T2	T3	T2	T3
E-UTRA RF Channel Number		1		2		2	
Correlation Matrix and Antenna Configuration		1x1		1x1		1x1	
OCNG patterns defined in TS 36.521-3 [25] clause D.1		OP.11 TDD		OP.2 TDD		OP.2 TDD	N/A
PBCH_RA	dB	0		0		0	N/A
PBCH_RB							
PSS_RA							
SSS_RA							
PCFICH_RB							
PHICH_RA							
PHICH_RB							
PDCCH_RA							
PDCCH_RB							
OCNG_RA <sup>Note 1</sup>							
OCNG_RB <sup>Note 1</sup>							
PRS_RA	dB	-3	N/A	N/A	3	3	N/A
$N_{oc}$ <sup>Note 3</sup>	dBm/15 kHz	-98	-95	-98	-95	-98	-95
$\text{PRS } \hat{E}_s/N_{oc}$	dB	-1	-Infinity	-Infinity	-7	-7	-Infinity
$\text{PRS } \hat{E}_s/I_{ot}$ <sup>Note 4</sup>	dB	-1.79	-Infinity	-Infinity	-7	-9.54	-Infinity
$I_o$ <sup>Note 4</sup>	dBm/9 MHz	-69.55	-67.08	-69.55	-67.08	-69.55	N/A
PRP <sup>Note 4</sup>	dBm/15 kHz	-99	-Infinity	-Infinity	-102	-105	-Infinity
RSRP <sup>Note 4</sup>	dBm/15 kHz	-96	-93	-105	-105	-108	-Infinity
$\hat{E}_s/N_{oc}$ <sup>Note 4</sup>	dB	2	2	-7	-10	-10	-Infinity
Propagation Condition		ETU30					
<p>Note 1: OCNG shall be used such that active cells (all, except Cell 3 in T3) are fully allocated and a constant total transmitted power spectral density is achieved for all OFDM symbols other than those in the subframes with transmitted PRS.</p> <p>Note 2: The resources for uplink transmission are assigned to the UE prior to the start of time period T2.</p> <p>Note 3: Interference from other cells and noise sources not specified in the test are assumed to be constant over subcarriers and time and shall be modelled as AWGN of appropriate power for <math>N_{oc}</math> to be fulfilled.</p> <p>Note 4: If PRS_RA is not "N/A", <math>\hat{E}_s/N_{oc}</math>, <math>\text{PRS } \hat{E}_s/I_{ot}</math>, <math>I_o</math>, RSRP and PRP levels have been derived from other parameters and are given for information purpose. If PRS_RA is "N/A", <math>I_o</math> and RSRP levels have been derived from other parameters and are given for information purpose. These are not settable test parameters. Interference conditions shall be applied to all PRS symbols of DL positioning subframes.</p>							

The response time including test tolerance is 16.3 s. The response time is equal to the LPP time IE value plus the test tolerance. The LPP time IE value is derived from the RSTD reporting delay plus  $\Delta T$ , where  $\Delta T = N_{rep} \times TTI_{DCCH} = N_{rep} \times 75$  ms, giving a value of [15510] ms. This is rounded up to the next allowed LPP value of 16 seconds. The RSTD

measurement reporting delay in the test is derived from the following expression  $T_{PRS} (M - 1) + 320 \cdot \left\lceil \frac{n}{M} \right\rceil$ , where

$M = 48$  and  $n = 16$  are the parameters specified in clause 9.4.1.1.3, Table 9.4.1.1.3-1 and Note 4 of Table 9.4.1.1.4.1-1. This gives the total RSTD reporting delay of [15360] ms for the 15 neighbour cells including Cell 2 and Cell 3 with respect to the reference cell, Cell 1.

The test tolerances are defined in clauses C.1.3 and C4.

The rate of successful tests during repeated tests shall be at least 90% with a confidence level of 95%.

### 9.4.3.2 TDD inter-frequency RSTD Measurement Reporting Delay in CE Mode A for Cat M2

**Editor's note: This test is incomplete. The following aspects are missing:**

- TBD in TS 36.133 how to capture `prsOccGroupLength` in the measurement period
- Assistance Data in TS 37.571-5 is missing

#### 9.4.3.2.1 Test purpose

To verify that the RSTD measurement reporting delay for UE Category M2 meets the performance requirements in normal coverage mode in an environment with fading propagation conditions.

#### 9.4.3.2.2 Test applicability

This test applies to E-UTRA TDD UE Category M2 release 14 and forward that supports UE-assisted OTDOA and inter-frequency RSTD measurements.

#### 9.4.3.2.3 Minimum conformance requirements

Same as in clause 9.4.3.1.3.

The intra-frequency requirements in this clause shall apply for all TDD special subframe configurations specified in TS 36.211 [26] and for the TDD uplink-downlink configurations as specified in Table 9.4.3.2.3-1.

**Table 9.4.3.2.3-1: TDD uplink-downlink subframe configurations applicable for TDD intra-frequency requirements**

PRS Transmission Bandwidth [RB]	Applicable TDD uplink-downlink configurations
6	1, 2, 3, 4 and 5
24	0, 1, 2, 3, 4, 5 and 6
Note:	Uplink-downlink configurations are specified in Table 4.2-2 in TS 36.211 [26].

The normative reference for this requirement is TS 36.133 [23] clause 8.16.2.4.2 and A.8.13.5.

#### 9.4.3.2.4 Test description

##### 9.4.3.2.4.1 Initial conditions

Same as in clause 9.4.1.1.4.1 but replacing Table 9.4.1.1.4.1-1 with Table 9.4.3.2.4.1-1.

**Table 9.4.3.2.4.1-1: General test parameters for E-UTRAN TDD inter-frequency RSTD measurement reporting delay under fading propagation conditions**

Parameter	Unit	Value	Comment	
Reference cell		Cell 1	Reference cell is the cell in the OTDOA assistance data with respect to which the RSTD measurement is defined, as specified in 3GPP TS 36.214 [6] and 3GPP TS 36.355 [4]. The reference cell is the serving cell in this test case.	
Neighbour cells		Cell 2 and Cell 3	Cell 2 and Cell 3 appear at random places in the neighbour cell list in the OTDOA assistance data, but Cell 2 always appears in the first half of the list, whilst Cell 3 appears in the second half of the list.	
MPDCCH		DL Reference Measurement Channel R.14 TDD	As specified in TS 36.521-3 [25] clause A.7.3	
<i>mPDCCH-startSF-UeSS</i>		10	Parameter $G$ in $T = r_{\max} \cdot G$ which determines subframe $k0$ in which MPDCCH starts	
Channel Bandwidth (BW <sub>channel</sub> )	MHz	10		
Gap pattern Id		0	As specified in TS 36.133 [23] Table 8.1.2.1-1. Applies for measurements on Cell 2 and Cell 3	
Gap offset		151	As specified in TS 36.331 [22], Clause 6.3.5	
PRS Transmission Bandwidth <sup>Note 2</sup>	RB	50 <sup>Note 4</sup>	PRS are transmitted over the system bandwidth	
PRS configuration index $I_{\text{PRS}}$ <sup>Note 2</sup>		Cell 1: 142, Cell 2, Cell 3: 152	This corresponds to periodicity of 320 ms and PRS subframe offset of $I_{\text{PRS}} - 160$ DL subframes, as defined in 3GPP TS 36.211 [26], Table 6.10.4.3-1	
Number of consecutive downlink positioning subframes $N_{\text{PRS}}$ <sup>Note 2</sup>		4	2	As defined in 3GPP TS 36.211 [26]. The number of subframes in a positioning occasion
Physical cell ID PCI <sup>Note 2</sup>		(PCI of Cell 1 – PCI of Cell 2) mod 6 = 0 and (PCI of Cell 1 – PCI of Cell 3) mod 6 = 0	The cell PCIs are selected such that the relative shifts of PRS patterns among cells are as given by the test parameters	
TDD uplink-downlink configuration		1	As specified in TS 36.211 [26], Clause 4.2; corresponds to a configuration with 5 ms switch-point periodicity and two downlink consecutive subframes	
TDD special subframe configuration		6	As specified in TS 36.211 [26], Clause 4.2; corresponds to DwPTS of $19760 \cdot T_s$ and UpPTS of $4384 \cdot T_s$	
CP length <sup>Note 2</sup>		Normal		
DRX		ON	DRX parameters are further specified in Table 9.4.1.1.4.1-2	
prs-SubframeOffset		10	Number of subframes rounded to the closest integer. The corresponding parameter in the OTDOA assistance data is prs-SubframeOffset specified in TS 36.355 [4]	



slotNumberOffset		0	The slot number offset at the transmitter between a neighbour cell and the assistance data reference cell specified in TS 36.355 [4]	
Radio frame receive time offset between the cells at the UE antenna connector Note 3	µs	Cell 2 to Cell 1: 1 Cell 3 to Cell 1: -1	PRS are transmitted from synchronous cells	
Expected RSTD Note 1	µs	Cell 2: -2 Cell 3: 2 Other neighbour cells: randomly between -3 and 3	The expected RSTD is what is expected at the receiver. The corresponding parameter in the OTDOA assistance data specified in TS 36.355 [4] is the expectedRSTD indicator	
Expected RSTD uncertainty for all neighbour cells Note 1	µs	5	The corresponding parameter in the OTDOA assistance data specified in TS 36.355 [4] is the expectedRSTD-Uncertainty index	
Number of cells provided in OTDOA assistance data		16	Including the reference cell	
PRS muting info Note 2		Cell 1: '1111111100000000' Cell 2: '0000000011111111' Cell 3: '1111111100000000'	Corresponds to prs-MutingInfo defined in TS 36.355 [4]	
T1	s	3	The length of the time interval from the beginning of each test	
T2	s	7.68	5.12	The length of the time interval that follows immediately after time interval T1
T3	s	7.68	5.12	The length of the time interval that follows immediately after time interval T2
<p>Note 1: Parameters "Expected RSTD" and "Expected RSTD uncertainty for all neighbour cells" are not settable parameters. These are parameters signalled in LPP only. For the values to be used in LPP see Table 9.4.1.1.4.3-5 and TS 37.571-5 [20], clause 7.2.5.</p> <p>Note 2: Parameters "PRS Transmission Bandwidth", "PRS configuration index", "Number of consecutive downlink positioning subframes", "Physical cell ID PCI", "CP length", and "PRS muting info" are settable parameters and also parameters signalled in LPP. The values to be used for "Physical cell ID PCI" are as follows: Cell 1: 0, Cell 2: 6, Cell 3: 12. For all the values to be used in LPP see Table 9.4.1.1.4.3-5 and TS 37.571-5 [20], clause 7.2.5.</p> <p>Note 3: The parameter "Radio frame receive time offset between the cells at the UE antenna connector" is not a settable parameter but is used to set the "true RSTD" values in step 6 of clause 9.4.1.1.4.1.</p> <p>Note 4: If the PRS transmission bandwidth is larger than the UE RF bandwidth, the UE is measuring RSTD within its RF bandwidth.</p>				

#### 9.4.3.2.4.2 Test procedure

Same as in clause 9.4.1.1.4.2 but with the following additional step:

14. Repeat step 1-13 for each sub-test in Table 9.4.2.2.4.1-1 as appropriate.

#### 9.4.3.2.4.3 Message contents

Same as in clause 9.4.1.2.4.3.

#### 9.4.3.2.5 Test requirement

The primary level settings including test tolerances for the test are defined in clause 9.4.3.1.5.

For Test 1, the response time is defined in clause 9.4.3.1.5.

For Test 2, the response time including test tolerance is 11.3 s. The response time is equal to the LPP time IE value plus the test tolerance. The LPP time IE value is derived from the RSTD reporting delay plus  $\Delta T$ , where  $\Delta T = N_{rep} \times TTI_{DCC}$  =  $N_{rep} \times 75$  ms, giving a value of [10390] ms. This is rounded up to the next allowed LPP value of 11 seconds. The

RSTD measurement reporting delay in the test is derived from the following expression  $T_{PRS} (M - 1) + 320 \cdot \left\lceil \frac{n}{M} \right\rceil$ ,

where  $M = 32$  and  $n = 16$  are the parameters specified in clause 9.4.1.1.3, Table 9.4.1.1.3-1 and Note 4 of Table 9.4.3.2.4.1-1. This gives the total RSTD reporting delay of [10240] ms for the 15 neighbour cells including Cell 2 and Cell 3 with respect to the reference cell, Cell 1.

For the overall test to pass, the ratio of successful reported values in each sub-test shall be more than 90% with a confidence level of 95%.

## 9.4.4 FDD inter-frequency RSTD Measurement Reporting Delay in CE Mode B

### 9.4.4.1 FDD inter-frequency RSTD Measurement Reporting Delay in CE Mode B for Cat M1

**Editor's note: This test is incomplete. The following aspects are missing:**

- TBD in TS 36.133 how to capture prsOccGroupLength in the measurement period
- Response Time to be calculated based as Nprs\_total is missing in TS 36.133
- Measurement gap configuration in TS 36.133 is not correct (gapID0 does not support 151 gap offset).
- Assistance Data in TS 37.571-5 is missing

#### 9.4.4.1.1 Test purpose

To verify that the RSTD measurement reporting delay for UE Category M1 meets the performance requirements in enhanced coverage mode in an environment with fading propagation conditions.

#### 9.4.4.1.2 Test applicability

This test applies to E-UTRA FDD UE Category M1 release 14 and forward that supports UE-assisted OTDOA, inter-frequency RSTD measurements and CE Mode B.

#### 9.4.4.1.3 Minimum conformance requirements

Same as 9.4.1.1.3 with the following exceptions:

The conditions under which the UE physical layer shall be capable of reporting RSTD for the reference cell and all the neighbour cells  $i$  out of at least  $(n-1)$  neighbour cells within  $T_{\text{RSTD IntraFreqFDD, Cat\_M}}$  are changed:

$(\text{PRS } \hat{E}_s / \text{Iot})_{ref} \geq -15$  dB for all Frequency Bands for the reference cell,  
 $(\text{PRS } \hat{E}_s / \text{Iot})_i \geq -15$  dB for all Frequency Bands for neighbour cell  $i$ ,  
 $(\text{PRS } \hat{E}_s / \text{Iot})_{ref}$  and  $(\text{PRS } \hat{E}_s / \text{Iot})_i$  conditions apply for all subframes of at least  $L = \frac{M}{2}$  PRS positioning occasions,  
 PRP 1,2|<sub>dBm</sub> according to clause E.3.1 for a corresponding Band.

The normative reference for this requirement is TS 36.133 [23] clause 8.13.3.7.1 and A.8.13.6.

#### 9.4.4.1.4 Test description

##### 9.4.4.1.4.1 Initial conditions

Same as in clause 9.4.1.1.4.1 but replacing Table 9.4.1.1.4.1-1 with Table 9.4.4.1.4.1-1.

**Table 9.4.4.1.4.1-1: General test parameters for E-UTRAN FDD inter-frequency RSTD measurement reporting delay under fading propagation conditions**

Parameter	Unit	Value	Comment
Reference cell		Cell 1	Reference cell is the cell in the OTDOA assistance data with respect to which the RSTD measurement is defined, as specified in 3GPP TS 36.214 [6] and 3GPP TS 36.355 [4]. The reference cell is the serving cell in this test case.
Neighbour cells		Cell 2 and Cell 3	Cell 2 and Cell 3 appear at random places in the neighbour cell list in the OTDOA assistance data, but Cell 2 always appears in the first half of the list, whilst Cell 3 appears in the second half of the list.
MPDCCH		DL Reference Measurement Channel R.16 FDD	As specified in TS 36.521-3 [25] clause A.7.1
<i>mPDCCH-startSF-U ESS</i>		10	Parameter $G$ in $T = r_{\max} \cdot G$ which determines subframe $k0$ in which MPDCCH starts
Channel Bandwidth (BW <sub>channel</sub> )	MHz	10	
Gap pattern Id		0	As specified in TS 36.133 [23] Table 8.1.2.1-1. Applies for measurements on Cell 2 and Cell 3
Gap offset		151	As specified in TS 36.331 [22], Clause 6.3.5
PRS Transmission Bandwidth <sup>Note 2</sup>	RB	50 <sup>Note 4</sup>	PRS are transmitted over the system bandwidth
PRS configuration index $I_{\text{PRS}}$ <sup>Note 2</sup>		Cell 1: 142, Cell 2, Cell 3: 152	This corresponds to periodicity of 320 ms and PRS subframe offset of $I_{\text{PRS}} - 160$ DL subframes, as defined in 3GPP TS 36.211 [26], Table 6.10.4.3-1
Number of consecutive downlink positioning subframes $N_{\text{PRS}}$ <sup>Note 2</sup>		4	As defined in 3GPP TS 36.211 [26]. The number of subframes in a positioning occasion
Physical cell ID PCI <sup>Note 2</sup>		(PCI of Cell 1 – PCI of Cell 2) mod 6 = 0 and (PCI of Cell 1 – PCI of Cell 3) mod 6 = 0	The cell PCIs are selected such that the relative shifts of PRS patterns among cells are as given by the test parameters
CP length <sup>Note 2</sup>		Normal	
DRX		ON	DRX parameters are further specified in Table 9.4.1.1.4.1-2
Radio frame receive time offset between the cells at the UE antenna connector <sup>Note 3</sup>	μs	Cell 2 to Cell 1: 1 Cell 3 to Cell 1: -1	PRS are transmitted from synchronous cells
Expected RSTD <sup>Note 1</sup>	μs	Cell 2: 3 Cell 3: 3 Other neighbour cells: randomly between -3 and 3	The expected RSTD is what is expected at the receiver. The corresponding parameter in the OTDOA assistance data specified in TS 36.355 [4] is the expectedRSTD indicator
Expected RSTD uncertainty for all neighbour cells <sup>Note 1</sup>	μs	5	The corresponding parameter in the OTDOA assistance data specified in TS 36.355 [4] is the expectedRSTD-Uncertainty index
Number of cells provided in OTDOA assistance data		16	Including the reference cell
PRS muting info <sup>Note 2</sup>		Cell 1: '1111111100000000' Cell 2: '0000000011111111' Cell 3: '1111111100000000'	Corresponds to prs-MutingInfo defined in TS 36.355 [4]

T1	s	3	The length of the time interval from the beginning of each test
T2	s	20.48	The length of the time interval that follows immediately after time interval T1
T3	s	20.48	The length of the time interval that follows immediately after time interval T2
<p>Note 1: Parameters "Expected RSTD" and "Expected RSTD uncertainty for all neighbour cells" are not settable parameters. These are parameters signalled in LPP only. For the values to be used in LPP see Table 9.4.1.1.4.3-5 and TS 37.571-5 [20], clause 7.2.5.</p> <p>Note 2: Parameters "PRS Transmission Bandwidth", "PRS configuration index", "Number of consecutive downlink positioning subframes", "Physical cell ID PCI", "CP length", and "PRS muting info" are settable parameters and also parameters signalled in LPP. The values to be used for "Physical cell ID PCI" are as follows: Cell 1: 0, Cell 2: 6, Cell 3: 12. For all the values to be used in LPP see Table 9.4.1.1.4.3-5 and TS 37.571-5 [20], clause 7.2.5.</p> <p>Note 3: The parameter "Radio frame receive time offset between the cells at the UE antenna connector" is not a settable parameter but is used to set the "true RSTD" values in step 6 of clause 9.4.1.1.4.1.</p> <p>Note 4: If the PRS transmission bandwidth is larger than the UE RF bandwidth, the UE is measuring RSTD within its RF bandwidth.</p>			

9.4.4.1.4.2 Test procedure

Same as in clause 9.4.1.4.2 but using condition CEModeB.

9.4.4.1.4.3 Message contents

Same as in clause 9.4.1.1.4.3 with the following exceptions:

**Table 9.4.4.1.4.3-1: LPP RequestLocationInformation**

Derivation Path: Table 9.4.1.1.4.3-4			
Information Element	Value/remark	Comment	Condition
LPP-Message ::= SEQUENCE {			
lpp-MessageBody CHOICE {			
c1 CHOICE {			
requestLocationInformation SEQUENCE {			
criticalExtensions CHOICE {			
c1 CHOICE {			
requestLocationInformation-r9 SEQUENCE {			
commonIEsRequestLocationInformation SEQUENCE {			
qos SEQUENCE {			
responseTime SEQUENCE {			
time	42	See clause 9.4.4.1.5	
}			
}			
}			
}			
}			
}			
}			
}			
}			
}			

9.4.4.1.5 Test requirement

Table 9.4.4.1.5-1 and 9.4.4.1.5-2 define the primary level settings including test tolerances for the test.

**Table 9.4.4.1.5-1: Cell-specific test parameters for E-UTRAN FDD inter-frequency RSTD measurement reporting delay under fading propagation conditions during T1**

Parameter	Unit	Cell 1	Cell 2	Cell 3
E-UTRA RF Channel Number		1	2	2
Correlation Matrix and Antenna Configuration		1x1	1x1	1x1
OCNG patterns defined in TS 36.521-3 [25] clause D.1		OP.21 FDD	N/A	N/A
PBCH_RA	dB	0	N/A	N/A
PBCH_RB				
PSS_RA				
SSS_RA				
PCFICH_RB				
PHICH_RA				
PHICH_RB				
PDCCH_RA				
PDCCH_RB				
OCNG_RA <sup>Note 1</sup>				
OCNG_RB <sup>Note 1</sup>				
$N_{oc}$ <sup>Note 3</sup>	dBm/ 15 kHz	-95		
$PRS \hat{E}_s / N_{oc}$	dB	-Infinity	-Infinity	-Infinity
$I_0$ <sup>Note 4</sup>	dBm/ 9 MHz	-67.22	N/A	N/A
$\hat{E}_s / N_{oc}$	dB	0	-Infinity	-Infinity
Propagation Condition		ETU30		
Note 1:	OCNG shall be used such that active cell (Cell 1) is fully allocated and a constant total transmitted power spectral density is achieved for all OFDM symbols.			
Note 2:	The resources for uplink transmission are assigned to the UE prior to the start of time period T2.			
Note 3:	Interference from other cells and noise sources not specified in the test are assumed to be constant over subcarriers and time and shall be modelled as AWGN of appropriate power for $N_{oc}$ to be fulfilled.			
Note 4:	$I_0$ levels have been derived from other parameters and are given for information purpose. These are not settable test parameters.			

**Table 9.4.4.1.5-2: Cell-specific test parameters for E-UTRAN FDD inter-frequency RSTD measurement reporting delay under fading propagation conditions during T2 and T3**

Parameter	Unit	Cell 1		Cell 2		Cell 3	
		T2	T3	T2	T3	T2	T3
E-UTRA RF Channel Number		1		2		2	
Correlation Matrix and Antenna Configuration		1x1		1x1		1x1	
OCNG patterns defined in TS 36.521-3 [25] clause D.1		OP.21 FDD		OP.6 FDD		OP.6 FDD	N/A
PBCH_RA	dB	0		0		0	N/A
PBCH_RB							
PSS_RA							
SSS_RA							
PCFICH_RB							
PHICH_RA							
PHICH_RB							
PDCCH_RA							
PDCCH_RB							
OCNG_RA <sup>Note 1</sup>							
OCNG_RB <sup>Note 1</sup>							
PRS_RA	dB	0	N/A	N/A	0	0	N/A
$N_{oc}$ <sup>Note 3</sup>	dBm/15 kHz	-98	-95	-98	-95	-98	-95
$\text{PRS } \hat{E}_s/N_{oc}$	dB	-12	-Infinity	-Infinity	-13	-14	-Infinity
$\text{PRS } \hat{E}_s/I_{ot}$ <sup>Note 4</sup>	dB	-12	-Infinity	-Infinity	-13	-14	-Infinity
$I_o$ <sup>Note 4</sup>	dBm/9 MHz	-70.17	-67.13	-70.19	-70.18	-70.19	-70.18
PRP <sup>Note 4</sup>	dBm/15 kHz	-110	-Infinity	-Infinity	-108	-112	-Infinity
RSRP <sup>Note 4</sup>	dBm/15 kHz	-110	-110	-114	-108	-112	-Infinity
$\hat{E}_s/N_{oc}$ <sup>Note 4</sup>	dB	-9	-9	-14	-13	-14	-Infinity
Propagation Condition		ETU30					
<p>Note 1: OCNG shall be used such that active cells (all, except Cell 3 in T3) are fully allocated and a constant total transmitted power spectral density is achieved for all OFDM symbols other than those in the subframes with transmitted PRS.</p> <p>Note 2: The resources for uplink transmission are assigned to the UE prior to the start of time period T2.</p> <p>Note 3: Interference from other cells and noise sources not specified in the test are assumed to be constant over subcarriers and time and shall be modelled as AWGN of appropriate power for <math>N_{oc}</math> to be fulfilled.</p> <p>Note 4: If PRS_RA is not "N/A", <math>\hat{E}_s/N_{oc}</math>, <math>\text{PRS } \hat{E}_s/I_{ot}</math>, <math>I_o</math>, RSRP and PRP levels have been derived from other parameters and are given for information purpose. If PRS_RA is "N/A", <math>I_o</math> and RSRP levels have been derived from other parameters and are given for information purpose. These are not settable test parameters. Interference conditions shall be applied to all PRS symbols of DL positioning subframes.</p>							

The response time including test tolerance is 42.3 s. The response time is equal to the LPP time IE value plus the test tolerance. The LPP time IE value is derived from the RSTD reporting delay plus  $\Delta T$ , where  $\Delta T = N_{rep} \times TTI_{DCCH} = N_{rep} \times 75$  ms, giving a value of [41110] ms. This is rounded up to the next allowed LPP value of 42 seconds. The RSTD

measurement reporting delay in the test is derived from the following expression  $T_{PRS} (M - 1) + 320 \cdot \left\lceil \frac{n}{M} \right\rceil$ , where

$M = 128$  and  $n = 16$  are the parameters specified in clause 9.4.1.1.3, Table 9.4.1.1.3-1 and Note 4 of Table 9.4.4.1.4.1-1. This gives the total RSTD reporting delay of [40960] ms for the 15 neighbour cells including Cell 2 and Cell 3 with respect to the reference cell, Cell 1.

The test tolerances are defined in clauses C.1.3 and C4.

The rate of successful tests during repeated tests shall be at least 90% with a confidence level of 95%.

#### 9.4.4.2 FDD inter-frequency RSTD Measurement Reporting Delay in CE Mode B for Cat M2

*Editor's note: This test is incomplete. The following aspects are missing:*

- *TBD in TS 36.133 how to capture prsOccGroupLength in the measurement period*
- *Assistance Data in TS 37.571-5 is missing*

##### 9.4.4.2.1 Test purpose

To verify that the RSTD measurement reporting delay for UE Category M2 meets the performance requirements in enhanced coverage mode in an environment with fading propagation conditions.

##### 9.4.4.2.2 Test applicability

This test applies to E-UTRA FDD UE Category M2 release 14 and forward that supports UE-assisted OTDOA, inter-frequency RSTD measurements and CE Mode B.

##### 9.4.4.2.3 Minimum conformance requirements

Same as in clause 9.4.4.1.3.

The normative reference for this requirement is TS 36.133 [23] clause 8.16.3.2.1 and A.8.13.6.

##### 9.4.4.2.4 Test description

###### 9.4.4.2.4.1 Initial conditions

Same as in clause 9.4.1.1.4.1 but replacing Table 9.4.1.1.4.1-1 with Table 9.4.4.2.4.1-1.



**Table 9.4.4.2.4.1-1: General test parameters for E-UTRAN FDD inter-frequency RSTD measurement reporting delay under fading propagation conditions**

Parameter	Unit	Value		Comment
		Test 1	Test 2	
Reference cell		Cell 1		Reference cell is the cell in the OTDOA assistance data with respect to which the RSTD measurement is defined, as specified in 3GPP TS 36.214 [6] and 3GPP TS 36.355 [4]. The reference cell is the serving cell in this test case.
Neighbour cells		Cell 2 and Cell 3		Cell 2 and Cell 3 appear at random places in the neighbour cell list in the OTDOA assistance data, but Cell 2 always appears in the first half of the list, whilst Cell 3 appears in the second half of the list.
MPDCCH		DL Reference Measurement Channel R.16 FDD		As specified in TS 36.521-3 [25] clause A.7.1
<i>mPDCCH-startSF-UeSS</i>		10		Parameter $G$ in $T = r_{\max} \cdot G$ which determines subframe $k0$ in which MPDCCH starts
Channel Bandwidth ( $BW_{\text{channel}}$ )	MHz	10		
Gap pattern Id		0		As specified in TS 36.133 [23] Table 8.1.2.1-1. Applies for measurements on Cell 2 and Cell 3
Gap offset		151		As specified in TS 36.331 [22], Clause 6.3.5
PRS Transmission Bandwidth <sup>Note 2</sup>	RB	50 <sup>Note 4</sup>		PRS are transmitted over the system bandwidth
PRS configuration index $I_{\text{PRS}}$ <sup>Note 2</sup>		Cell 1: 142, Cell 2, Cell 3: 152		This corresponds to periodicity of 320 ms and PRS subframe offset of $I_{\text{PRS}} - 160$ DL subframes, as defined in 3GPP TS 36.211 [26], Table 6.10.4.3-1
Number of consecutive downlink positioning subframes $N_{\text{PRS}}$ <sup>Note 2</sup>		4	4	As defined in 3GPP TS 36.211 [26]. The number of subframes in a positioning occasion
Physical cell ID PCI <sup>Note 2</sup>		(PCI of Cell 1 – PCI of Cell 2) mod 6 = 0 and (PCI of Cell 1 – PCI of Cell 3) mod 6 = 0		The cell PCIs are selected such that the relative shifts of PRS patterns among cells are as given by the test parameters
CP length <sup>Note 2</sup>		Normal		
DRX		ON		DRX parameters are further specified in Table 9.4.1.1.4.1-2
Radio frame receive time offset between the cells at the UE antenna connector <sup>Note 3</sup>	µs	Cell 2 to Cell 1: 1 Cell 3 to Cell 1: -1		PRS are transmitted from synchronous cells
Expected RSTD <sup>Note 1</sup>	µs	Cell 2: 3 Cell 3: 3 Other neighbour cells: randomly between -3 and 3		The expected RSTD is what is expected at the receiver. The corresponding parameter in the OTDOA assistance data specified in TS 36.355 [4] is the expectedRSTD indicator
Expected RSTD uncertainty for all neighbour cells <sup>Note 1</sup>	µs	5		The corresponding parameter in the OTDOA assistance data specified in TS 36.355 [4] is the expectedRSTD-Uncertainty index
Number of cells provided in OTDOA assistance data		16		Including the reference cell
PRS muting info <sup>Note 2</sup>		Cell 1: '1111111100000000' Cell 2: '0000000011111111' Cell 3: '1111111100000000'		Corresponds to prs-MutingInfo defined in TS 36.355 [4]

T1	s	3		The length of the time interval from the beginning of each test
T2	s	20.48	5.12	The length of the time interval that follows immediately after time interval T1
T3	s	20.48	5.12	The length of the time interval that follows immediately after time interval T2
<p>Note 1: Parameters "Expected RSTD" and "Expected RSTD uncertainty for all neighbour cells" are not settable parameters. These are parameters signalled in LPP only. For the values to be used in LPP see Table 9.4.1.1.4.3-5 and TS 37.571-5 [20], clause 7.2.5.</p> <p>Note 2: Parameters "PRS Transmission Bandwidth", "PRS configuration index", "Number of consecutive downlink positioning subframes", "Physical cell ID PCI", "CP length", and "PRS muting info" are settable parameters and also parameters signalled in LPP. The values to be used for "Physical cell ID PCI" are as follows: Cell 1: 0, Cell 2: 6, Cell 3: 12. For all the values to be used in LPP see Table 9.4.1.1.4.3-5 and TS 37.571-5 [20], clause 7.2.5.</p> <p>Note 3: The parameter "Radio frame receive time offset between the cells at the UE antenna connector" is not a settable parameter but is used to set the "true RSTD" values in step 6 of clause 9.4.1.1.4.1.</p> <p>Note 4: If the PRS transmission bandwidth is larger than the UE RF bandwidth, the UE is measuring RSTD within its RF bandwidth.</p>				

9.4.4.2.4.2 Test procedure

Same as in clause 9.4.1.1.4.2 but using condition CEModeB and with the following additional step:

14. Repeat step 1-13 for each sub-test in Table 9.4.4.2.4.1-1 as appropriate

9.4.4.2.4.3 Message contents

Same as in clause 9.4.1.1.4.3 with the following exceptions:

**Table 9.4.4.2.4.3-1: LPP RequestLocationInformation**

Derivation Path: Table 9.4.1.1.4.3-4			
Information Element	Value/remark	Comment	Condition
LPP-Message ::= SEQUENCE {			
lpp-MessageBody CHOICE {			
c1 CHOICE {			
requestLocationInformation SEQUENCE {			
criticalExtensions CHOICE {			
c1 CHOICE {			
requestLocationInformation-r9 SEQUENCE {			
commonIEsRequestLocationInformation SEQUENCE {			
qos SEQUENCE {			
responseTime SEQUENCE {			
time	42	See clause 9.4.4.1.5	Test 1
time	11	See clause 9.4.4.1.5	Test 2
}			
}			
}			
}			
}			
}			
}			
}			
}			
}			

9.4.4.2.5 Test requirement

The primary level settings including test tolerances for the test are defined in clause 9.4.4.1.5.

For Test 1, the response time is defined in clause 9.4.4.1.5.

For Test 2, the response time including test tolerance is 11.3 s. The response time is equal to the LPP time IE value plus the test tolerance. The LPP time IE value is derived from the RSTD reporting delay plus  $\Delta T$ , where  $\Delta T = N_{rep} \times TTI_{DCCH} = N_{rep} \times 75$  ms, giving a value of [10390] ms. This is rounded up to the next allowed LPP value of 11 seconds. The

RSTD measurement reporting delay in the test is derived from the following expression  $T_{PRS} (M - 1) + 320 \cdot \left\lceil \frac{n}{M} \right\rceil$ ,

where  $M = 32$  and  $n = 16$  are the parameters specified in clause 9.4.1.1.3, Table 9.4.1.1.3-1 and Note 4 of Table 9.4.4.2.4.1-1. This gives the total RSTD reporting delay of [10240] ms for the 15 neighbour cells including Cell 2 and Cell 3 with respect to the reference cell, Cell 1.

The test tolerances are defined in clauses C.1.3 and C4.

For the overall test to pass, the ratio of successful reported values in each sub-test shall be more than 90% with a confidence level of 95%.

## 9.4.5 HD-FDD inter-frequency RSTD Measurement Reporting Delay in CE Mode B

### 9.4.5.1 HD-FDD inter-frequency RSTD Measurement Reporting Delay in CE Mode B for Cat M1

*Editor's note: This test is incomplete. The following aspects are missing:*

*TBD in TS 36.133 how to capture prsOccGroupLength in the measurement period*

*Response Time to be calculated based as Nprs\_total is missing in TS 36.133*

*Assistance Data in TS 37.571-5 is missing*

#### 9.4.5.1.1 Test purpose

To verify that the RSTD measurement reporting delay for UE Category M1 meets the performance requirements in an environment with fading propagation conditions.

#### 9.4.5.1.2 Test applicability

This test applies to E-UTRA HD-FDD UE Category M1 release 14 and forward that supports UE-assisted OTDOA, inter-frequency RSTD measurements and CE Mode B.

#### 9.4.5.1.3 Minimum conformance requirements

Same as in clause 9.4.4.1.3.

The normative reference for this requirement is TS 36.133 [23] clause 8.13.3.7.3 and A.8.13.7.

#### 9.4.5.1.4 Test description

##### 9.4.5.1.4.1 Initial conditions

Same as in clause 9.4.1.1.4.1 but replacing Table 9.4.1.1.4.1-1 with Table 9.4.5.1.4.1-1

**Table 9.4.5.1.4.1-1: General test parameters for E-UTRAN HD-FDD inter-frequency RSTD measurement reporting delay under fading propagation conditions**

Parameter	Unit	Value	Comment
Reference cell		Cell 1	Reference cell is the cell in the OTDOA assistance data with respect to which the RSTD measurement is defined, as specified in 3GPP TS 36.214 [6] and 3GPP TS 36.355 [4]. The reference cell is the serving cell in this test case.
Neighbour cells		Cell 2 and Cell 3	Cell 2 and Cell 3 appear at random places in the neighbour cell list in the OTDOA assistance data, but Cell 2 always appears in the first half of the list, whilst Cell 3 appears in the second half of the list.
MPDCCH		DL Reference Measurement Channel R.8 HD-FDD	As specified in TS 36.521-3 [25] clause A.7.2
$mPDCCH\text{-startSF-UeSS}$		10	Parameter $G$ in $T = r_{\max} \cdot G$ which determines subframe $k0$ in which MPDCCH starts
Channel Bandwidth (BW <sub>channel</sub> )	MHz	10	
Gap pattern Id		0	As specified in TS 36.133 [23] Table 8.1.2.1-1. Applies for measurements on Cell 2 and Cell 3
Gap offset		151	As specified in TS 36.331 [22], Clause 6.3.5
PRS Transmission Bandwidth <sup>Note 2</sup>	RB	50 <sup>Note 4</sup>	PRS are transmitted over the system bandwidth
PRS configuration index $I_{PRS}$ <sup>Note 2</sup>		Cell 1: 142, Cell 2, Cell 3: 152	This corresponds to periodicity of 320 ms and PRS subframe offset of $I_{PRS} - 160$ DL subframes, as defined in 3GPP TS 36.211 [26], Table 6.10.4.3-1
Number of consecutive downlink positioning subframes $N_{PRS}$ <sup>Note 2</sup>		4	As defined in 3GPP TS 36.211 [26]. The number of subframes in a positioning occasion
Physical cell ID PCI <sup>Note 2</sup>		(PCI of Cell 1 – PCI of Cell 2) mod 6 = 0 and (PCI of Cell 1 – PCI of Cell 3) mod 6 = 0	The cell PCIs are selected such that the relative shifts of PRS patterns among cells are as given by the test parameters
CP length <sup>Note 2</sup>		Normal	
DRX		ON	DRX parameters are further specified in Table 9.4.1.1.4.1-2
Radio frame receive time offset between the cells at the UE antenna connector <sup>Note 3</sup>	μs	Cell 2 to Cell 1: 1 Cell 3 to Cell 1: -1	PRS are transmitted from synchronous cells
Expected RSTD <sup>Note 1</sup>	μs	Cell 2: 3 Cell 3: 3 Other neighbour cells: randomly between -3 and 3	The expected RSTD is what is expected at the receiver. The corresponding parameter in the OTDOA assistance data specified in TS 36.355 [4] is the expectedRSTD indicator
Expected RSTD uncertainty for all neighbour cells <sup>Note 1</sup>	μs	5	The corresponding parameter in the OTDOA assistance data specified in TS 36.355 [4] is the expectedRSTD-Uncertainty index
Number of cells provided in OTDOA assistance data		16	Including the reference cell
PRS muting info <sup>Note 2</sup>		Cell 1: '1111111100000000' Cell 2: '0000000011111111' Cell 3: '1111111100000000'	Corresponds to prs-MutingInfo defined in TS 36.355 [4]

T1	s	3	The length of the time interval from the beginning of each test
T2	s	20.48	The length of the time interval that follows immediately after time interval T1
T3	s	20.48	The length of the time interval that follows immediately after time interval T2
Note 1:	Parameters "Expected RSTD" and "Expected RSTD uncertainty for all neighbour cells" are not settable parameters. These are parameters signalled in LPP only. For the values to be used in LPP see Table 9.4.1.1.4.3-5 and TS 37.571-5 [20], clause 7.2.5.		
Note 2:	Parameters "PRS Transmission Bandwidth", "PRS configuration index", "Number of consecutive downlink positioning subframes", "Physical cell ID PCI", "CP length", and "PRS muting info" are settable parameters and also parameters signalled in LPP. The values to be used for "Physical cell ID PCI" are as follows: Cell 1: 0, Cell 2: 6, Cell 3: 12. For all the values to be used in LPP see Table 9.4.1.1.4.3-5 and TS 37.571-5 [20], clause 7.2.5.		
Note 3:	The parameter "Radio frame receive time offset between the cells at the UE antenna connector" is not a settable parameter but is used to set the "true RSTD" values in step 6 of clause 9.4.1.1.4.1.		
Note 4:	If the PRS transmission bandwidth is larger than the UE RF bandwidth, the UE is measuring RSTD within its RF bandwidth.		

#### 9.4.5.1.4.2 Test procedure

Same as in clause 9.4.1.1.4.2 but using condition CEModeB.

#### 9.4.5.1.4.3 Message contents

Same as in clause 9.4.4.1.4.3

#### 9.4.5.1.5 Test requirement

Same as in clause 9.4.4.1.5.

### 9.4.5.2 HD-FDD inter-frequency RSTD Measurement Reporting Delay in CE Mode B for Cat M2

**Editor's note: This test is incomplete. The following aspects are missing:**

**TBD in TS 36.133 how to capture prsOccGroupLength in the measurement period**

**Assistance Data in TS 37.571-5 is missing**

#### 9.4.5.2.1 Test purpose

To verify that the RSTD measurement reporting delay for UE Category M2 meets the performance requirements in an environment with fading propagation conditions.

#### 9.4.5.2.2 Test applicability

This test applies to E-UTRA HD-FDD UE Category M2 release 14 and forward that supports UE-assisted OTDOA, inter-frequency RSTD measurements and CE Mode B.

#### 9.4.5.2.3 Minimum conformance requirements

Same as in clause 9.4.4.1.3.

The normative reference for this requirement is TS 36.133 [23] clause 8.16.3.2.3 and A.8.13.7.

#### 9.4.5.2.4 Test description

##### 9.4.5.2.4.1 Initial conditions

Same as in clause 9.4.1.1.4.1 but replacing Table 9.4.1.1.4.1-1 with Table 9.4.5.2.4.1-1.

**Table 9.4.5.2.4.1-1: General test parameters for E-UTRAN HD-FDD inter-frequency RSTD measurement reporting delay under fading propagation conditions**



Parameter	Unit	Value		Comment
		Test 1	Test 2	
Reference cell		Cell 1		Reference cell is the cell in the OTDOA assistance data with respect to which the RSTD measurement is defined, as specified in 3GPP TS 36.214 [6] and 3GPP TS 36.355 [4]. The reference cell is the serving cell in this test case.
Neighbour cells		Cell 2 and Cell 3		Cell 2 and Cell 3 appear at random places in the neighbour cell list in the OTDOA assistance data, but Cell 2 always appears in the first half of the list, whilst Cell 3 appears in the second half of the list.
MPDCCH		DL Reference Measurement Channel R.8 HD-FDD		As specified in TS 36.521-3 [25] clause A.7.2
$mPDCCH\text{-startSF-UeSS}$		10		Parameter $G$ in $T = r_{\max} \cdot G$ which determines subframe $k0$ in which MPDCCH starts
Channel Bandwidth ( $BW_{\text{channel}}$ )	MHz	10		
Gap pattern Id		0		As specified in TS 36.133 [23] Table 8.1.2.1-1. Applies for measurements on Cell 2 and Cell 3
Gap offset		Cell 1: 142, Cell 2, Cell 3: 152		As specified in TS 36.331 [22], Clause 6.3.5
PRS Transmission Bandwidth <small>Note 2</small>	RB	50 <small>Note 4</small>		PRS are transmitted over the system bandwidth
PRS configuration index $I_{\text{PRS}}$ <small>Note 2</small>		311		This corresponds to periodicity of 320 ms and PRS subframe offset of $I_{\text{PRS}} - 160$ DL subframes, as defined in 3GPP TS 36.211 [26], Table 6.10.4.3-1
Number of consecutive downlink positioning subframes $N_{\text{PRS}}$ <small>Note 2</small>		4	4	As defined in 3GPP TS 36.211 [26]. The number of subframes in a positioning occasion
Physical cell ID PCI <small>Note 2</small>		(PCI of Cell 1 – PCI of Cell 2) mod 6 = 0 and (PCI of Cell 1 – PCI of Cell 3) mod 6 = 0		The cell PCIs are selected such that the relative shifts of PRS patterns among cells are as given by the test parameters
CP length <small>Note 2</small>		Normal		
DRX		ON		DRX parameters are further specified in Table 9.4.1.1.4.1-2
Radio frame receive time offset between the cells at the UE antenna connector <small>Note 3</small>	$\mu\text{s}$	Cell 2 to Cell 1: 1 Cell 3 to Cell 1: -1		PRS are transmitted from synchronous cells
Expected RSTD <small>Note 1</small>	$\mu\text{s}$	Cell 2: 3 Cell 3: 3 Other neighbour cells: randomly between -3 and 3		The expected RSTD is what is expected at the receiver. The corresponding parameter in the OTDOA assistance data specified in TS 36.355 [4] is the expectedRSTD indicator
Expected RSTD uncertainty for all neighbour cells <small>Note 1</small>	$\mu\text{s}$	5		The corresponding parameter in the OTDOA assistance data specified in TS 36.355 [4] is the expectedRSTD-Uncertainty index
Number of cells provided in OTDOA assistance data		16		Including the reference cell
PRS muting info <small>Note 2</small>		Cell 1: '1111111100000000' Cell 2: '0000000011111111' Cell 3: '1111111100000000'		Corresponds to prs-MutingInfo defined in TS 36.355 [4]

T1	s	3		The length of the time interval from the beginning of each test
T2	s	20.48	5.12	The length of the time interval that follows immediately after time interval T1
T3	s	20.48	5.12	The length of the time interval that follows immediately after time interval T2
Note 1:	Parameters "Expected RSTD" and "Expected RSTD uncertainty for all neighbour cells" are not settable parameters. These are parameters signalled in LPP only. For the values to be used in LPP see Table 9.4.1.1.4.3-5 and TS 37.571-5 [20], clause 7.2.5.			
Note 2:	Parameters "PRS Transmission Bandwidth", "PRS configuration index", "Number of consecutive downlink positioning subframes", "Physical cell ID PCI", "CP length", and "PRS muting info" are settable parameters and also parameters signalled in LPP. The values to be used for "Physical cell ID PCI" are as follows: Cell 1: 0, Cell 2: 6, Cell 3: 12. For all the values to be used in LPP see Table 9.4.1.1.4.3-5 and TS 37.571-5 [20], clause 7.2.5.			
Note 3:	The parameter "Radio frame receive time offset between the cells at the UE antenna connector" is not a settable parameter but is used to set the "true RSTD" values in step 6 of clause 9.4.1.1.4.1.			
Note 4:	If the PRS transmission bandwidth is larger than the UE RF bandwidth, the UE is measuring RSTD within its RF bandwidth.			

#### 9.4.5.2.4.2 Test procedure

Same as in clause 9.4.1.1.4.2 but using condition CEModeB and with the following additional step:

14. Repeat step 1-13 for each sub-test in Table 9.4.2.2.4.1-1 as appropriate.

#### 9.4.5.2.4.3 Message contents

Same as in clause 9.4.4.2.4.3.

#### 9.4.5.2.5 Test requirement

Same as in clause 9.4.4.2.5.

For the overall test to pass, the ratio of successful reported values in each sub-test shall be more than 90% with a confidence level of 95%.

## 9.4.6 TDD inter-frequency RSTD Measurement Reporting Delay in CE Mode B

### 9.4.6.1 TDD inter-frequency RSTD Measurement Reporting Delay in CE Mode B for Cat M1

**Editor's note: This test is incomplete. The following aspects are missing:**

**TBD in TS 36.133 how to capture prsOccGroupLength in the measurement period**

**Response Time to be calculated based as Nprs\_total is missing in TS 36.133**

**Assistance Data in TS 37.571-5 is missing**

#### 9.4.6.1.1 Test purpose

To verify that the RSTD measurement reporting delay for UE Category M1 meets the performance requirements in an environment with fading propagation conditions.

#### 9.4.6.1.2 Test applicability

This test applies to E-UTRA TDD UE Category M1 release 14 and forward that supports UE-assisted OTDOA, inter-frequency RSTD measurements and CE Mode B.

#### 9.4.6.1.3 Minimum conformance requirements

Same as in clause 9.4.4.1.3.

The inter-frequency requirements in this clause shall apply for all TDD special subframe configurations specified in TS 36.211 [26] and for the TDD uplink-downlink configurations as specified in Table 9.4.6.1.3-1.

**Table 9.4.6.1.3-1: TDD uplink-downlink subframe configurations applicable for TDD inter-frequency requirements**

PRS Transmission Bandwidth [RB]	Applicable TDD uplink-downlink configurations
6	1, 2, 3, 4 and 5
Note: Uplink-downlink configurations are specified in Table 4.2-2 in TS 36.211 [26].	

The normative reference for this requirement is TS 36.133 [23] clause 8.13.3.7.2 and A.8.13.8.

9.4.6.1.4 Test description

9.4.6.1.4.1 Initial conditions

Same as in clause 9.4.1.1.4.1 but replacing Table 9.4.1.1.4.1-1 with Table 9.4.6.1.4.1-1

**Table 9.4.6.1.4.1-1: General test parameters for E-UTRAN TDD inter-frequency RSTD measurement reporting delay under fading propagation conditions**

Parameter	Unit	Value	Comment
Reference cell		Cell 1	Reference cell is the cell in the OTDOA assistance data with respect to which the RSTD measurement is defined, as specified in 3GPP TS 36.214 [6] and 3GPP TS 36.355 [4]. The reference cell is the serving cell in this test case.
Neighbour cells		Cell 2 and Cell 3	Cell 2 and Cell 3 appear at random places in the neighbour cell list in the OTDOA assistance data, but Cell 2 always appears in the first half of the list, whilst Cell 3 appears in the second half of the list.
MPDCCH		DL Reference Measurement Channel R.16 TDD	As specified in TS 36.521-3 [25] clause A.7.3
$mPDCCH\text{-startSF-U ESS}$		10	Parameter $G$ in $T = r_{\max} \cdot G$ which determines subframe $k0$ in which MPDCCH starts
Channel Bandwidth (BW <sub>channel</sub> )	MHz	10	
Gap pattern Id		0	As specified in TS 36.133 [23] Table 8.1.2.1-1. Applies for measurements on Cell 2 and Cell 3
Gap offset		151	As specified in TS 36.331 [22], Clause 6.3.5
PRS Transmission Bandwidth <sup>Note 2</sup>	RB	50 <sup>Note 4</sup>	PRS are transmitted over the system bandwidth
PRS configuration index $I_{\text{PRS}}$ <sup>Note 2</sup>		Cell 1: 142, Cell 2, Cell 3: 152	This corresponds to periodicity of 320 ms and PRS subframe offset of $I_{\text{PRS}} - 160$ DL subframes, as defined in 3GPP TS 36.211 [26], Table 6.10.4.3-1
Number of consecutive downlink positioning subframes $N_{\text{PRS}}$ <sup>Note 2</sup>		4	As defined in 3GPP TS 36.211 [26]. The number of subframes in a positioning occasion
Physical cell ID PCI <sup>Note 2</sup>		(PCI of Cell 1 – PCI of Cell 2) mod 6 = 0 and (PCI of Cell 1 – PCI of Cell 3) mod 6 = 0	The cell PCIs are selected such that the relative shifts of PRS patterns among cells are as given by the test parameters
CP length <sup>Note 2</sup>		Normal	
DRX		ON	DRX parameters are further specified in Table 9.4.1.1.4.1-2
Radio frame receive time offset between the cells at the UE antenna connector <sup>Note 3</sup>	μs	Cell 2 to Cell 1: 1 Cell 3 to Cell 1: -1	PRS are transmitted from synchronous cells
Expected RSTD <sup>Note 1</sup>	μs	Cell 2: 3 Cell 3: 3 Other neighbour cells: randomly between -3 and 3	The expected RSTD is what is expected at the receiver. The corresponding parameter in the OTDOA assistance data specified in TS 36.355 [4] is the expectedRSTD indicator
Expected RSTD uncertainty for all neighbour cells <sup>Note 1</sup>	μs	5	The corresponding parameter in the OTDOA assistance data specified in TS 36.355 [4] is the expectedRSTD-Uncertainty index
Number of cells provided in OTDOA assistance data		16	Including the reference cell
PRS muting info <sup>Note 2</sup>		Cell 1: '1111111100000000' Cell 2: '0000000011111111' Cell 3: '1111111100000000'	Corresponds to prs-MutingInfo defined in TS 36.355 [4]

T1	s	3	The length of the time interval from the beginning of each test
T2	s	20.48	The length of the time interval that follows immediately after time interval T1
T3	s	20.48	The length of the time interval that follows immediately after time interval T2
Note 1:	Parameters "Expected RSTD" and "Expected RSTD uncertainty for all neighbour cells" are not settable parameters. These are parameters signalled in LPP only. For the values to be used in LPP see Table 9.4.1.1.4.3-5 and TS 37.571-5 [20], clause 7.2.5.		
Note 2:	Parameters "PRS Transmission Bandwidth", "PRS configuration index", "Number of consecutive downlink positioning subframes", "Physical cell ID PCI", "CP length", and "PRS muting info" are settable parameters and also parameters signalled in LPP. The values to be used for "Physical cell ID PCI" are as follows: Cell 1: 0, Cell 2: 6, Cell 3: 12. For all the values to be used in LPP see Table 9.4.1.1.4.3-5 and TS 37.571-5 [20], clause 7.2.5.		
Note 3:	The parameter "Radio frame receive time offset between the cells at the UE antenna connector" is not a settable parameter but is used to set the "true RSTD" values in step 6 of clause 9.4.1.1.4.1.		
Note 4:	If the PRS transmission bandwidth is larger than the UE RF bandwidth, the UE is measuring RSTD within its RF bandwidth.		

#### 9.4.6.1.4.2 Test procedure

Same as in clause 9.4.1.1.4.2 but using condition CEModeB.

#### 9.4.6.1.4.3 Message contents

Same as in clause 9.4.4.1.4.3

#### 9.4.6.1.5 Test requirement

Table 9.4.6.1.5-1 and 9.4.6.1.5-2 define the primary level settings including test tolerances for the test.

**Table 9.4.6.1.5-1: Cell-specific test parameters for E-UTRAN TDD inter-frequency RSTD measurement reporting delay under fading propagation conditions during T1**

Parameter	Unit	Cell 1	Cell 2	Cell 3
E-UTRA RF Channel Number		1	2	2
Correlation Matrix and Antenna Configuration		1x1	1x1	1x1
OCNG patterns defined in TS 36.521-3 [25] clause D.1		OP.11 TDD	N/A	N/A
PBCH_RA	dB	0	N/A	N/A
PBCH_RB				
PSS_RA				
SSS_RA				
PCFICH_RB				
PHICH_RA				
PHICH_RB				
PDCCH_RA				
PDCCH_RB				
OCNG_RA <sup>Note 1</sup>				
OCNG_RB <sup>Note 1</sup>				
$N_{oc}$ <sup>Note 3</sup>	dBm/15 kHz	-95		
PRS $\hat{E}_s/N_{oc}$	dB	-Infinity	-Infinity	-Infinity
$I_0$ <sup>Note 4</sup>	dBm/9 MHz	-67.22	N/A	N/A
$\hat{E}_s/N_{oc}$	dB	0	-Infinity	-Infinity
Propagation Condition		ETU30		
<p>Note 1: OCNG shall be used such that active cell (Cell 1) is fully allocated and a constant total transmitted power spectral density is achieved for all OFDM symbols.</p> <p>Note 2: The resources for uplink transmission are assigned to the UE prior to the start of time period T2.</p> <p>Note 3: Interference from other cells and noise sources not specified in the test are assumed to be constant over subcarriers and time and shall be modelled as AWGN of appropriate power for <math>N_{oc}</math> to be fulfilled.</p> <p>Note 4: <math>I_0</math> levels have been derived from other parameters and are given for information purpose. These are not settable test parameters.</p>				

**Table 9.4.6.1.5-2: Cell-specific test parameters for E-UTRAN TDD inter-frequency RSTD measurement reporting delay under fading propagation conditions during T2 and T3**

Parameter	Unit	Cell 1		Cell 2		Cell 3	
		T2	T3	T2	T3	T2	T3
E-UTRA RF Channel Number		1		2		2	
Correlation Matrix and Antenna Configuration		1x1		1x1		1x1	
OCNG patterns defined in TS 36.521-3 [25] clause D.1		OP.11 TDD		OP.2 TDD		OP.2 TDD	N/A
PBCH_RA	dB	0		0		0	N/A
PBCH_RB							
PSS_RA							
SSS_RA							
PCFICH_RB							
PHICH_RA							
PHICH_RB							
PDCCH_RA							
PDCCH_RB							
OCNG_RA <sup>Note 1</sup>							
OCNG_RB <sup>Note 1</sup>							
PRS_RA	dB	-3	N/A	N/A	3	3	N/A
$N_{oc}$ <sup>Note 3</sup>	dBm/ 15 kHz	-98	-95	-98	-95	-98	-95
$PRS \hat{E}_s / N_{oc}$	dB	-12	-Infinity	-Infinity	-13	-14	-Infinity
$PRS \hat{E}_s / I_{ot}$ <sup>Note 4</sup>	dB	-12	-Infinity	-Infinity	-13	-14	-Infinity
$I_o$ <sup>Note 4</sup>	dBm/ 9 MHz	-70.17	-67.13	-70.19	-70.18	-70.19	-70.18
PRP <sup>Note 4</sup>	dBm/ 15 kHz	-110	-Infinity	-Infinity	-108	-112	-Infinity
RSRP <sup>Note 4</sup>	dBm/ 15 kHz	-110	-110	-114	-108	-112	-Infinity
$\hat{E}_s / N_{oc}$ <sup>Note 4</sup>	dB	-9	-9	-14	-13	-14	-Infinity
Propagation Condition		ETU30					
<p>Note 1: OCNG shall be used such that active cells (all, except Cell 3 in T3) are fully allocated and a constant total transmitted power spectral density is achieved for all OFDM symbols other than those in the subframes with transmitted PRS.</p> <p>Note 2: The resources for uplink transmission are assigned to the UE prior to the start of time period T2.</p> <p>Note 3: Interference from other cells and noise sources not specified in the test are assumed to be constant over subcarriers and time and shall be modelled as AWGN of appropriate power for <math>N_{oc}</math> to be fulfilled.</p> <p>Note 4: If PRS_RA is not "N/A", <math>\hat{E}_s / N_{oc}</math>, <math>PRS \hat{E}_s / I_{ot}</math>, <math>I_o</math>, RSRP and PRP levels have been derived from other parameters and are given for information purpose. If PRS_RA is "N/A", <math>I_o</math> and RSRP levels have been derived from other parameters and are given for information purpose. These are not settable test parameters. Interference conditions shall be applied to all PRS symbols of DL positioning subframes.</p>							

The response time is defined in clause 9.4.4.1.5.

The test tolerances are defined in clauses C.1.3 and C4.

The rate of successful tests during repeated tests shall be at least 90% with a confidence level of 95%.



## 9.4.6.2 TDD inter-frequency RSTD Measurement Reporting Delay in CE Mode B for Cat M2

Editor's note: This test is incomplete. The following aspects are missing:

TBD in TS 36.133 how to capture prsOccGroupLength in the measurement period

Assistance Data in TS 37.571-5 is missing

### 9.4.6.2.1 Test purpose

To verify that the RSTD measurement reporting delay for UE Category M2 meets the performance requirements in an environment with fading propagation conditions.

### 9.4.6.2.2 Test applicability

This test applies to E-UTRA TDD UE Category M2 release 14 and forward that supports UE-assisted OTDOA, inter-frequency RSTD measurements and CE Mode B.

### 9.4.6.2.3 Minimum conformance requirements

Same as in clause 9.4.6.1.3.

The inter-frequency requirements in this clause shall apply for all TDD special subframe configurations specified in TS 36.211 [26] and for the TDD uplink-downlink configurations as specified in Table 9.4.6.2.3-1.

**Table 9.4.6.2.3-1: TDD uplink-downlink subframe configurations applicable for TDD inter-frequency requirements**

PRS Transmission Bandwidth [RB]	Applicable TDD uplink-downlink configurations
6	1, 2, 3, 4 and 5
24	0, 1, 2, 3, 4, 5 and 6
Note:	Uplink-downlink configurations are specified in Table 4.2-2 in TS 36.211 [26].

The normative reference for this requirement is TS 36.133 [23] clause 8.16.3.2.2 and A.8.13.8.

### 9.4.6.2.4 Test description

#### 9.4.6.2.4.1 Initial conditions

Same as in clause 9.4.1.1.4.1 but replacing Table 9.4.1.1.4.1-1 with Table 9.4.6.2.4.1-1.

**Table 9.4.6.2.4.1-1: General test parameters for E-UTRAN TDD inter-frequency RSTD measurement reporting delay under fading propagation conditions**

Parameter	Unit	Value		Comment
		Test 1	Test 2	
Reference cell		Cell 1		Reference cell is the cell in the OTDOA assistance data with respect to which the RSTD measurement is defined, as specified in 3GPP TS 36.214 [6] and 3GPP TS 36.355 [4]. The reference cell is the serving cell in this test case.
Neighbour cells		Cell 2 and Cell 3		Cell 2 and Cell 3 appear at random places in the neighbour cell list in the OTDOA assistance data, but Cell 2 always appears in the first half of the list, whilst Cell 3 appears in the second half of the list.
MPDCCH		DL Reference Measurement Channel R.16 TDD		As specified in TS 36.521-3 [25] clause A.7.3
$mPDCCH\text{-startSF-UeSS}$		10		Parameter $G$ in $T = r_{\max} \cdot G$ which determines subframe $k0$ in which MPDCCH starts
Channel Bandwidth ( $BW_{\text{channel}}$ )	MHz	10		
Gap pattern Id		0		As specified in TS 36.133 [23] Table 8.1.2.1-1. Applies for measurements on Cell 2 and Cell 3
Gap offset		151		As specified in TS 36.331 [22], Clause 6.3.5
PRS Transmission Bandwidth <sup>Note 2</sup>	RB	50 <sup>Note 4</sup>		PRS are transmitted over the system bandwidth
PRS configuration index $I_{\text{PRS}}$ <sup>Note 2</sup>		Cell 1: 142, Cell 2, Cell 3: 152		This corresponds to periodicity of 320 ms and PRS subframe offset of $I_{\text{PRS}} - 160$ DL subframes, as defined in 3GPP TS 36.211 [26], Table 6.10.4.3-1
Number of consecutive downlink positioning subframes $N_{\text{PRS}}$ <sup>Note 2</sup>		4	4	As defined in 3GPP TS 36.211 [26]. The number of subframes in a positioning occasion
Physical cell ID PCI <sup>Note 2</sup>		(PCI of Cell 1 – PCI of Cell 2) mod 6 = 0 and (PCI of Cell 1 – PCI of Cell 3) mod 6 = 0		The cell PCIs are selected such that the relative shifts of PRS patterns among cells are as given by the test parameters
CP length <sup>Note 2</sup>		Normal		
DRX		ON		DRX parameters are further specified in Table 9.4.1.1.4.1-2
Radio frame receive time offset between the cells at the UE antenna connector <sup>Note 3</sup>	μs	Cell 2 to Cell 1: 1 Cell 3 to Cell 1: -1		PRS are transmitted from synchronous cells
Expected RSTD <sup>Note 1</sup>	μs	Cell 2: 3 Cell 3: 3 Other neighbour cells: randomly between -3 and 3		The expected RSTD is what is expected at the receiver. The corresponding parameter in the OTDOA assistance data specified in TS 36.355 [4] is the expectedRSTD indicator
Expected RSTD uncertainty for all neighbour cells <sup>Note 1</sup>	μs	5		The corresponding parameter in the OTDOA assistance data specified in TS 36.355 [4] is the expectedRSTD-Uncertainty index
Number of cells provided in OTDOA assistance data		16		Including the reference cell
PRS muting info <sup>Note 2</sup>		Cell 1: '1111111100000000' Cell 2: '0000000011111111' Cell 3: '1111111100000000'		Corresponds to prs-MutingInfo defined in TS 36.355 [4]

T1	s	3		The length of the time interval from the beginning of each test
T2	s	20.48	5.12	The length of the time interval that follows immediately after time interval T1
T3	s	20.48	5.12	The length of the time interval that follows immediately after time interval T2
Note 1:	Parameters "Expected RSTD" and "Expected RSTD uncertainty for all neighbour cells" are not settable parameters. These are parameters signalled in LPP only. For the values to be used in LPP see Table 9.4.1.1.4.3-5 and TS 37.571-5 [20], clause 7.2.5.			
Note 2:	Parameters "PRS Transmission Bandwidth", "PRS configuration index", "Number of consecutive downlink positioning subframes", "Physical cell ID PCI", "CP length", and "PRS muting info" are settable parameters and also parameters signalled in LPP. The values to be used for "Physical cell ID PCI" are as follows: Cell 1: 0, Cell 2: 6, Cell 3: 12. For all the values to be used in LPP see Table 9.4.1.1.4.3-5 and TS 37.571-5 [20], clause 7.2.5.			
Note 3:	The parameter "Radio frame receive time offset between the cells at the UE antenna connector" is not a settable parameter but is used to set the "true RSTD" values in step 6 of clause 9.4.1.1.4.1.			
Note 4:	If the PRS transmission bandwidth is larger than the UE RF bandwidth, the UE is measuring RSTD within its RF bandwidth.			

#### 9.4.6.2.4.2 Test procedure

Same as in clause 9.4.1.1.4.2 but using condition CEModeB and with the following additional step:

14. Repeat step 1-13 for each sub-test in Table 9.4.2.2.4.1-1 as appropriate.

#### 9.4.6.2.4.3 Message contents

Same as in clause 9.4.4.2.4.3.

#### 9.4.6.2.5 Test requirement

The primary level settings including test tolerances for the test are defined in clause 9.4.6.1.5.

For Test 1, the response time is defined in clause 9.4.6.1.5.

For Test 2, the response time including test tolerance is 11.3 s. The response time is equal to the LPP time IE value plus the test tolerance. The LPP time IE value is derived from the RSTD reporting delay plus  $\Delta T$ , where  $\Delta T = N_{rep} \times TTI_{DCCH} = N_{rep} \times 75$  ms, giving a value of [10390] ms. This is rounded up to the next allowed LPP value of 11 seconds. The

RSTD measurement reporting delay in the test is derived from the following expression  $T_{PRS} (M - 1) + 320 \cdot \left\lceil \frac{n}{M} \right\rceil$ ,

where  $M = 40$  and  $n = 16$  are the parameters specified in clause 9.4.1.1.3, Table 9.4.1.1.3-1 and Note 4 of Table 9.4.6.2.4.1-1. This gives the total RSTD reporting delay of [10240] ms for the 15 neighbour cells including Cell 2 and Cell 3 with respect to the reference cell, Cell 1.

The test tolerances are defined in clauses C.1.3 and C4.

For the overall test to pass, the ratio of successful reported values in each sub-test shall be more than 90% with a confidence level of 95%.

## 9.4.7 FDD inter-frequency RSTD Measurement Accuracy in CE Mode A

### 9.4.7.1 FDD inter-frequency RSTD Measurement Accuracy in CE Mode A for Cat M1

**Editor's note: This test is incomplete. The following aspects are missing:**

**Requirements in TS 36.133 are partially missing**

**Annex E-2 is missing as it is also missing in TS 36.133.**

**Assistance Data in TS 37.571-5 is missing**

#### 9.4.7.1.1 Test purpose

To verify that the RSTD measurement accuracy for UE Category M1 is within the specified limits in normal coverage mode in an environment with fading propagation conditions.

#### 9.4.7.1.2 Test applicability

This test applies to E-UTRA FDD UE Category M1 release 14 and forward that supports UE-assisted OTDOA and inter-frequency RSTD measurements.

#### 9.4.7.1.3 Minimum conformance requirements

The accuracy requirements in Table 9.4.7.1.3-1 are valid under the following conditions:

Conditions defined in 36.101 [2] Clause 7.3 for reference sensitivity are fulfilled.

PRP  $1,2_{\text{dBm}}$  according to Annex E.3.1 for a corresponding Band

There are no measurement gaps overlapping with the PRS subframes of the measured serving cell.

The parameter expectedRSTDUncertainty signalled over LPP by E-SMLC as defined in TS 36.355 [4] is less than 5  $\mu\text{s}$ .

Table 9.4.7.1.3-1: RSTD inter-frequency measurement accuracy for CEModeA

Accuracy	PRs $\hat{E}_s/\text{lot}$	Minimum PRs bandwidth, which is minimum of serving cell channel bandwidth and the PRs bandwidths of the reference cell and the measured neighbour cell $i$	Conditions						
			Minimum number of available measurement subframes among the reference cell and the measured neighbour cell $i$	The number of consecutive downlink subframes $N_{\text{PRS}}$ among the reference cell and the measured neighbour cell $i$ as defined in [24]	$l_0$ <sup>Note 4</sup> range				
$T_s$ <sup>Note 2</sup>	dB	RB					E-UTRA operating band groups <sup>Note 5</sup>	Minimum $l_0$ <sup>Note 1</sup>	Maximum $l_0$
								dBm/15kHz	dBm/BW <sub>Channel</sub>
[±21]	(PRs $\hat{E}_s/\text{lot}$ ) <sub>ref</sub> ≥ -6dB and (PRs $\hat{E}_s/\text{lot}$ ) <sub>i</sub> ≥ -13dB	≥ 6	≥ 12	≥ 4	FDD-M1_A, TDD-M1_A	-121	-50		
					FDD-M1_B	-120.5	-50		
					FDD-M1_C, TDD-M1_C	-120	-50		
					FDD-M1_D	-119.5	-50		
					FDD-M1_E, TDD-M1_E	-119	-50		
					FDD-M1_F	-118.5	-50		
					FDD-M1_G	-118	-50		
					FDD-M1_H	-117.5	-50		
					FDD-M1_N	-114.5	-50		

NOTE 1: This minimum  $l_0$  condition is expressed as the average  $l_0$  per RE over all REs in an OFDM symbol.  
 NOTE 2:  $T_s$  is the basic timing unit defined in TS 36.211 [26].  
 NOTE 3: PRs bandwidth is as indicated in *prs-Bandwidth* in the OTDOA assistance data defined in TS 36.355 [4].  
 NOTE 4: The  $l_0$  is defined in PRs positioning subframes. The same  $l_0$  range applies to PRs and non-PRs symbols.  $l_0$  levels are different in PRs and non-PRs symbols within the same subframe.  
 NOTE 5: E-UTRA operating band groups are as defined in Section 4.4.2.

The normative reference for this requirement is TS 36.133 [23] clause 9.1.21.17 and A.9.8.26.

9.4.7.1.4 Test description

9.4.7.1.4.1 Initial conditions

Test Environment: Normal; as defined in TS 36.508 [18] clause 4.1.

Frequencies to be tested: Mid Range, as defined in TS 36.508 [18] clause 4.3.1.1.

Channel bandwidth to be tested: 10 MHz as defined in TS 36.508 [18] clause 4.3.1.

1. Connect the SS, faders and AWGN noise sources to the UE antenna connector or antenna connectors as shown in Annex A, Figure A.3 using only the main Tx/Rx antenna of the UE.
2. The general test parameter settings are set up according to Table 9.4.7.1.4.1-1.
3. Propagation conditions are set according to clause 4.7.2.1.

4. Message contents are defined in clause 9.4.7.1.4.3.
5. Cell 1 is the serving cell and OTDOA assistance data reference cell; Cell 2 is the neighbour cell. Cell 1 is on RF channel 1 and Cell 2 is on RF channel 2. The assistance data neighbour cell list includes in total 15 cells, where 14 of the cells are not simulated (dummy cells; as defined in 3GPP TS 37.571-5 [20], clause 7.2.5).
6. The true RSTD (which is the receive time difference for frame 0 between cell 2 and cell 1 as seen at the UE antenna connector) is set to the following values:  
    Test 1:  $-92 T_s$  (about  $-3 \mu s$ )  
Note that the related expectedRSTD values to be signalled over LPP are defined in Table 9.4.7.1.4-1 for each test.

**Table 9.4.7.1.4.1-1: General test parameters for E-UTRAN FDD inter-frequency RSTD measurement  
Accuracy under fading propagation conditions.**



Parameter	Unit	Value	Comment
		Test 1	
MPDCCH		R.16 FDD	As specified in TS 36.521-3 [25] clause A.7.1
<i>mPDCCH-startSF-U ESS</i>		10	Parameter $G$ in $T = r_{\max} \cdot G$ which determines subframe $k0$ in which MPDCCH starts
Reference cell		Cell 1	Reference cell is the cell in the OTDOA assistance data with respect to which the RSTD measurement is defined, as specified in 3GPP TS 36.214 [6] and 3GPP TS 36.355 [4]. The reference cell is the serving cell in this test case.
Neighbour cell		Cell 2	One carrier frequency is used.
E-UTRA RF Channel Number		Cell 1: 1 Cell 2: 2	The two cells are on different frequencies.
Channel Bandwidth ( $BW_{\text{channel}}$ )	MHz	10	
PRS Transmission Bandwidth <sup>Note 2</sup>	RB	50 <sup>Note 4</sup>	PRS are transmitted over the system bandwidth
Number of consecutive downlink positioning subframes $N_{\text{PRS}}$ <sup>Note 2</sup>		4	As defined in 3GPP TS 36.211 [26]. The number of subframes in a positioning occasion
PRS muting info <sup>Note 2</sup>		Cell 1: '11110000' Cell 2: '11110000'	Corresponds to prs-MutingInfo defined in TS 36.355 [4]
Physical cell ID PCI <sup>Note 2</sup>		(Cell ID of cell 1 – Cell ID of cell 2) mod 6 = 0	
prs-SubframeOffset		10	Number of subframes rounded to the closest integer. The corresponding parameter in the OTDOA assistance data is prs-SubframeOffset specified in TS 36.355 [4]
slotNumberOffset		0	The slot number offset at the transmitter between a neighbour cell and the assistance data reference cell specified in TS 36.355 [4]
Expected RSTD <sup>Note 1</sup>	$\mu\text{s}$	Cell 2: 1 Other neighbour cells: randomly between -3 and 3	The expected RSTD is what is expected at the receiver. The corresponding parameter in the OTDOA assistance data specified in TS 36.355 [4] is the expectedRSTD indicator
Expected RSTD uncertainty for all neighbour cells <sup>Note 1</sup>	$\mu\text{s}$	5	The corresponding parameter in the OTDOA assistance data specified in TS 36.355 [4] is the expectedRSTD-Uncertainty index
CP length <sup>Note 2</sup>		Normal	
DRX		OFF	
Radio frame receive time offset between the cells at the UE antenna connector <sup>Note 3</sup>	$\mu\text{s}$	Cell 2 to Cell 1: -3	PRS are transmitted from synchronous cells
Number of cells provided in OTDOA assistance data		16	Including the reference cell
$T_{\text{RSTD InterFreq FDD-FDD, E-UTRAN}}$	ms	15360	Derived according to the RSTD measurement requirements specified in section 9.4.7.1.3

Note 1:	Parameters “Expected RSTD” and “Expected RSTD uncertainty for all neighbour cells” are not settable parameters. These are parameters signalled in LPP only. For the values to be used in LPP see Table 9.4.7.1.4.3-5 and TS 37.571-5 [20], clause 7.2.5.
Note 2:	Parameters “PRS Transmission Bandwidth”, “PRS configuration index”, “Number of consecutive positioning downlink subframes”, “prs-MutingInfo”, “Cell ID” and “CP length” are settable parameters and also parameters signalled in LPP. The values to be used for “Cell ID” are as follows: Cell 1: 0, Cell 2: 6. For all the values to be used in LPP see Table 9.4.7.1.4.3-4 and TS 37.571-5 [20], clause 7.2.5.
Note 3:	The parameter “Radio frame receive time offset between the cells at the UE antenna connector” is not a settable parameter but is used to set the “true RSTD” values in step 6 of clause 9.4.7.1.4.1.
Note 4:	If the PRS transmission bandwidth is larger than the UE RF bandwidth, the UE is measuring RSTD within its RF bandwidth.
Note 5:	The parameter “ $T_{\text{RSTD InterFreqFDD-FDD, E-UTRAN}}$ ” is not a settable parameter but is used to set the LPP “time” value in Table 9.4.7.1.4.3-3. The value of the LPP time IE is set to $T_{\text{RSTD InterFreqFDD-FDD, E-UTRAN}} + \Delta T$ ms, where $\Delta T = 150$ ms, giving a value of 15510 ms. This is rounded up to the next allowed LPP value of 16 seconds.

#### 9.4.7.1.4.2 Test procedure

The test consists of a set-up period and a measurement period. Cell 1 and Cell 2 are both active during the complete test. The beginning of the measurement period shall be aligned with the first PRS positioning subframe of a positioning occasion in the reference cell.

NOTE: The information on when PRS is muted is conveyed to the UE using PRS muting information in the OTDOA assistance data.

The OTDOA-RequestLocationInformation message and the OTDOA assistance data as defined in clause 9.4.7.1.4.3 shall be provided to the UE during the set-up period. The last TTI containing the OTDOA-RequestLocationInformation message shall be provided to the UE  $\Delta T$  ms before the start of the measurement period, where  $\Delta T = 150$  ms is the maximum processing time of the OTDOA-RequestLocationInformation message and the OTDOA assistance data in the UE.

1. Ensure that the UE is in state Generic RB Established State 3A-RF-CE according to 3GPP TS 36.508 [18] clause 7.2A.3AA.
2. The SS shall send a RESET UE POSITIONING STORED INFORMATION message.
3. Set the parameters according to Table 9.4.7.1.5-1. Propagation conditions are set according to clause 4.7.2.1.
4. The SS shall transmit an RRCConnectionReconfiguration message with the measurement gap configuration.
5. The UE shall transmit RRCConnectionReconfigurationComplete message.
6. The SS shall transmit an LPP REQUEST CAPABILITIES message.
7. The UE shall transmit an LPP PROVIDE CAPABILITIES message indicating the OTDOA capabilities supported by the UE in the *OTDOA-ProvideCapabilities* IE.
8. The SS shall send a LPP PROVIDE ASSISTANCE DATA message, including the *OTDOA-ProvideAssistanceData* IE. If the UE message at step 7 includes the *ackRequested* IE set to TRUE, then the SS shall send an acknowledgment in the LPP PROVIDE ASSISTANCE DATA message.
9. The SS shall send a LPP REQUEST LOCATION INFORMATION message, including the *OTDOA-RequestLocationInformation* IE such that the UE receives the message  $\Delta T$  ms before the start of T2, where  $\Delta T = 150$  ms.
10. The UE shall transmit a LPP PROVIDE LOCATION INFORMATION message, including the *OTDOA-ProvideLocationInformation* IE.
11. If the UE message at step 10 includes the *ackRequested* IE set to TRUE, the SS shall send a LPP acknowledgement message.
12. The SS shall check the *rstd* value for Cell 2 in the *OTDOA-SignalMeasurementInformation* IE according to Table 9.4.7.1.5-2.

13. Repeat steps 2-12 until the confidence level according to Annex D is achieved.

14. Repeat step 1-13 for each sub-test in Table 9.4.7.1.5-1 as appropriate.

9.4.7.1.4.3 Message contents

Same as in clause 9.3.7.1.4.3 with the following exceptions.

**Table 9.4.7.1.4.3-1: MeasGapConfig-GP1: FDD-FDD inter-frequency RSTD Measurement Reporting Delay**

Derivation Path: TS 36.508 [18] clause 4.6.6, Table 4.6.6-1A: MeasGapConfig-GP1			
Information Element	Value/remark	Comment	Condition
MeasGapConfig-GP1 ::= CHOICE {			
setup SEQUENCE {			
gapOffset CHOICE {			
gp0	TBD	TGRP = 40 ms	
}			
}			
}			

**Table 9.4.7.1.4.3-2: LPP RequestLocationInformation**

Derivation Path: Table 9.3.7.1.4.3-4			
Information Element	Value/remark	Comment	Condition
LPP-Message ::= SEQUENCE {			
lpp-MessageBody CHOICE {			
c1 CHOICE {			
requestLocationInformation SEQUENCE {			
criticalExtensions CHOICE {			
c1 CHOICE {			
requestLocationInformation-r9 SEQUENCE {			
commonIEsRequestLocationInformation SEQUENCE {			
qos SEQUENCE {			
responseTime SEQUENCE {			
time	16	See Note 5 in Table 9.4.7.1.4.1-1	
}			
}			
}			
}			
}			
}			
}			
}			

9.4.7.1.5 Test requirement

Table 9.4.7.1.5-1 defines the primary level settings including test tolerances for the test.

The RSTD FDD inter-frequency accuracy test shall meet the reported values in Table 9.4.7.1.5-2

**Table 9.4.7.1.5-1: Cell Specific Test Parameters for inter frequency RSTD Tests for E-UTRAN FDD**

Parameter	Unit	Test1		Test2						
		Cell1	Cell2	Cell1	Cell2					
E-UTRA RF Channel Number		1	2	1	2					
Gap offset		151	N/A	151	N/A					
Gap pattern		#0	N/A	#0	N/A					
OCNG Patterns defined in TS 36.521-3 [25] clause D.1		OP.21 FDD	OP.6 FDD	OP.21 FDD	OP.6 FDD					
PRS configuration Index $I_{PRS}$ , as defined in TS 36.211		142	152	142	152					
PBCH_RA	dB	0	0	0	0					
PBCH_RB										
PSS_RA										
SSS_RA										
MPDCCH_RA										
MPDCCH_RB										
OCNG_RA <sup>Note1</sup>										
OCNG_RB <sup>Note1</sup>										
PRS_RA						dB	0	0	0	0
$N_{oc}$ <sup>Note2</sup>						dBm/15 kHz	-98	-98	-98	-98
PRS $\hat{E}_s/N_{oc}$	dB	-1	-11	-1	-11					
PRS $\hat{E}_s/I_{ot}$ <sup>Note3</sup>	dB	-1	-11	-1	-11					
$I_o$ <sup>Note3</sup>	dBm/9 MHz	-69.68	-70.16	-69.68	-70.16					
PRP <sup>Note3</sup>	dBm/15kHz	-99	-109	-99	-109					
$\hat{E}_s/N_{oc}$ <sup>Note 3</sup>	dB	-1	-11	-1	-11					
RSRP <sup>Note 3</sup>	dBm/15kHz	-99	-109	-99	-109					
Propagation condition		AWGN								
<p>Note 1: OCNG shall be used such that both cells are fully allocated and a constant total transmitted power spectral density is achieved for all OFDM symbols (other than those in the PRS subframes).</p> <p>Note 2: Interference from other cells and noise sources not specified in the test is assumed to be constant over subcarriers and time and shall be modelled as AWGN of appropriate power for <math>N_{oc}</math> to be fulfilled.</p> <p>Note 3: <math>\hat{E}_s/N_{oc}</math>, PRS <math>\hat{E}_s/I_{ot}</math>, <math>I_o</math>, RSRP and PRP levels have been derived from other parameters for information purposes. They are not settable parameters themselves. <math>I_o</math> values are derived in the case that there is no PBCH, PSS or SSS in the OFDM symbols carrying PRS</p>										

**Table 9.4.7.1.5-2: RSTD FDD inter-frequency accuracy requirements for the reported values**

	Test 1
Lowest reported value	[RSTD_6443]
Highest reported value	[RSTD_6485]

The test tolerances are defined in clauses C.1.3 and C4.

For the overall test to pass, the ratio of successful reported values in each sub-test shall be more than 90% with a confidence level of 95%.

### 9.4.7.2 FDD inter-frequency RSTD Measurement Accuracy in CE Mode A for Cat M2

**Editor's note: This test is incomplete. The following aspects are missing:**

Requirements in TS 36.133 are partially missing

Assistance Data in TS 37.571-5 is missing

#### 9.4.7.2.1 Test purpose

To verify that the RSTD measurement accuracy for UE Category M2 is within the specified limits in normal coverage mode in an environment with fading propagation conditions.

#### 9.4.7.2.2 Test applicability

This test applies to E-UTRA FDD UE Category M2 release 14 and forward that supports UE-assisted OTDOA and inter-frequency RSTD measurements.

#### 9.4.7.2.3 Minimum conformance requirements

The accuracy requirements in Table 9.4.7.2.3-1 are valid under the following conditions:

Conditions defined in 36.101 [2] Clause 7.3 for reference sensitivity are fulfilled.

PRP 1,2<sub>dBm</sub> according to Annex E.2 for a corresponding Band

There are no measurement gaps overlapping with the PRS subframes of the measured serving cell.

The parameter expectedRSTDUncertainty signalled over LPP by E-SMLC as defined in TS 36.355 [4] is less than 5  $\mu$ s.

Table 9.4.7.2.3-1: RSTD inter-frequency measurement accuracy for CEModeA

Accuracy	PRS $\hat{\epsilon}_s/\text{lot}$	Minimum PRS bandwidth, which is minimum of serving cell channel bandwidth and the PRS bandwidths of the reference cell and the measured neighbour cell $i$	Conditions			$l_o$ <sup>Note 4</sup> range	
			Minimum number of available measurement subframes among the reference cell and the measured neighbour cell $i$	The number of consecutive downlink subframes $N_{\text{PRS}}$ among the reference cell and the measured neighbour cell $i$ as defined in [24]	E-UTRA operating band groups <sup>Note 5</sup>	Minimum $l_o$ <sup>Note 1</sup>	Maximum $l_o$
$T_s$ <sup>Note 2</sup>	dB	RB				dBm/15kHz	dBm/BW <sub>Channel</sub>
[±21]	(PRS $\hat{\epsilon}_s/\text{lot}_{\text{ref}} \geq -6\text{dB}$ and (PRS $\hat{\epsilon}_s/\text{lot}_i \geq -13\text{dB}$ )	$\geq 6$	$\geq [12]$	$\geq 4$	FDD-M1_A, TDD-M1_A	-121	-50
					FDD-M1_B	-120.5	-50
					FDD-M1_C, TDD-M1_C	-120	-50
					FDD-M1_D	-119.5	-50
					FDD-M1_E, TDD-M1_E	-119	-50
					FDD-M1_F	-118.5	-50
					FDD-M1_G	-118	-50
					FDD-M1_H	-117.5	-50
					FDD-M1_N	-114.5	-50
[±10]	(PRS $\hat{\epsilon}_s/\text{lot}_{\text{ref}} \geq -6\text{dB}$ and (PRS $\hat{\epsilon}_s/\text{lot}_i \geq -13\text{dB}$ )	$\geq 24$	$\geq [4]$	$\geq 2$	Note 6	Note 6	Note 6

NOTE 1: This minimum  $l_o$  condition is expressed as the average  $l_o$  per RE over all REs in an OFDM symbol.  
 NOTE 2:  $T_s$  is the basic timing unit defined in TS 36.211 [26].  
 NOTE 3: PRS bandwidth is as indicated in *prs-Bandwidth* in the OTDOA assistance data defined in TS 36.355 [4].  
 NOTE 4: The  $l_o$  is defined in PRS positioning subframes. The same  $l_o$  range applies to PRS and non-PRS symbols.  $l_o$  levels are different in PRS and non-PRS symbols within the same subframe.  
 NOTE 5: E-UTRA operating band groups are as defined in Section 4.4.2.  
 NOTE 6: The same bands and the same  $l_o$  conditions for each band apply for this requirement as for the corresponding requirement with the PRS bandwidth  $\geq 6$  RB.

The normative reference for this requirement is TS 36.133 [23] clause 9.1.25.4 and A.9.8.20.

9.4.7.2.4 Test description

9.4.7.2.4.1 Initial conditions

Same as in clause 9.4.7.1.4.1 adding Test 2 and replacing Table 9.4.7.1.4.1-1 with Table 9.4.7.2.4.1-1.

The true RSTD (which is the receive time difference for frame 0 between cell 2 and cell 1 as seen at the UE antenna connector) is set to the following values:

Test 1: -92  $T_s$  (about -3  $\mu\text{s}$ )

Test 2: 92 Ts (about 3  $\mu$ s)

Note that the related expectedRSTD values to be signalled over LPP are defined in Table 9.4.7.2.4-1 for each test.

**Table 9.4.7.2.4.1-1: General test parameters for E-UTRAN FDD inter-frequency RSTD measurement  
Accuracy under fading propagation conditions**



Parameter	Unit	Value		Comment
		Test1	Test3	
M-PDCCH parameters		R.16 FDD	R.16 FDD	As specified in TS 36.521-3 [25] clause A.7.1.
<i>mPDCCH-startSF-UESS</i>		10	10	Parameter $G$ in $T = r_{\max} \cdot G$ which determines subframe $k0$ in which MPDCCH starts
Reference cell		Cell 1		
Neighbour cell		Cell 2		
E-UTRA RF Channel Number		Cell 1: 1 Cell 2: 2		The two cells are on different frequencies.
System channel Bandwidth ( $BW_{\text{channel}}$ )	MHz	10	10	
PRS Transmission Bandwidth <sup>Note 2</sup>	RB	50 <sup>Note 4</sup>	50 <sup>Note 4</sup>	PRS bandwidth is as indicated in <i>prs-Bandwidth</i> in the OTDOA assistance data defined in TS 36.355 [4].
Number of consecutive positioning downlink subframes $N_{\text{PRS}}$ <sup>Note 2</sup>		4	2	As defined in TS 36.211 [26]
<i>prs-MutingInfo</i> <sup>Note 2</sup>		Cell 1: '11110000' Cell 2: '11110000'		See section 6.5.1.2 in 3GPP TS 36.355 [4] for more information
Cell ID <sup>Note 2</sup>		(Cell ID of cell 1 – Cell ID of cell 2) mod 6 = 0	(Cell ID of cell 1 – Cell ID of cell 2) mod 6 = 0	
<i>prs-SubframeOffset</i>		10	10	Number of subframes rounded to the closest integer. The corresponding parameter in the OTDOA assistance data is <i>prs-SubframeOffset</i> specified in TS 36.355 [4]
<i>slotNumberOffset</i>		0	0	The slot number offset at the transmitter between a neighbour cell and the assistance data reference cell specified in TS 36.355 [4]
Expected RSTD <sup>Note 1</sup>	$\mu\text{s}$	Cell 2: 1 Other neighbour cells: randomly between -3 and 3	Cell 2: -1 Other neighbour cells: randomly between -3 and 3	
Expected RSTD uncertainty for all neighbour cells <sup>Note 1</sup>	$\mu\text{s}$	5	5	
CP length <sup>Note 2</sup>		Normal		
DRX		OFF		
Radio frame receive time offset between the cells at the UE antenna connector <sup>Note 3</sup>	$\mu\text{s}$	Cell 2 to Cell 1: -3	Cell 2 to Cell 1: 3	PRS are transmitted from synchronous cells
Number of cells provided in OTDOA assistance data		16		The number of cells includes the reference cell
$T_{\text{RSTD InterFreqFDD-FDD, E-UTRAN}}$ <sup>Note 5</sup>	ms	15360	10240	Derived according to the RSTD measurement requirements specified in section 9.4.7.2.3

NOTE 1: Parameters “Expected RSTD” and “Expected RSTD uncertainty for all neighbour cells” are not settable parameters. These are parameters signalled in LPP only. For the values to be used in LPP see Table 9.4.7.1.4.3-4 and TS 37.571-5 [20], clause 7.2.5.

NOTE 2: Parameters “PRS Transmission Bandwidth”, “PRS configuration index”, “Number of consecutive positioning downlink subframes”, “prs-MutingInfo”, “Cell ID” and “CP length” are settable parameters and also parameters signalled in LPP. The values to be used for “Cell ID” are as follows: Cell 1: 0, Cell 2: 6. For all the values to be used in LPP see Table 9.4.7.1.4.3-4 and TS 37.571-5 [20], clause 7.2.5.

NOTE 3: The parameter “Radio frame receive time offset between the cells at the UE antenna connector” is not a settable parameter but is used to set the “true RSTD” values in step 6 of clause 9.1.3.4.1.

NOTE 4: If the PRS transmission bandwidth is larger than the UE RF bandwidth, the UE is measuring RSTD within its RF bandwidth.

NOTE 5: The parameter “ $T_{RSTD\ InterFreqFDD-FDD, E-UTRAN}$ ” is not a settable parameter but is used to set the LPP “time” value in Table 9.4.7.2.4.3-1. The value of the LPP time IE is set to  $T_{RSTD\ InterFreqFDD-FDD, E-UTRAN} + \Delta T$  ms, where  $\Delta T = 150$  ms, giving a value of 15510 ms for Test 1 and 10390 ms for Test 2. This is rounded up to the next allowed LPP value of 16 and 11 seconds, respectively.

9.4.7.2.4.2 Test procedure

Same as in clause 9.4.7.1.4.2.

9.4.7.2.4.3 Message contents

Same as in clause 9.4.7.1.4.3 with the following exceptions:

**Table 9.4.7.2.4.3-1: LPP RequestLocationInformation**

Derivation Path: Table 9.4.7.1.4.3-4			
Information Element	Value/remark	Comment	Condition
LPP-Message ::= SEQUENCE {			
lpp-MessageBody CHOICE {			
c1 CHOICE {			
requestLocationInformation SEQUENCE {			
criticalExtensions CHOICE {			
c1 CHOICE {			
requestLocationInformation-r9 SEQUENCE {			
commonIEsRequestLocationInformation SEQUENCE {			
qos SEQUENCE {			
responseTime SEQUENCE {			
time	16	See Note 5 in Table 9.4.7.2.4.1-1	Test 1
time	11	See Note 5 in Table 9.4.7.2.4.1-1	Test 2
}			
}			
}			
}			
}			
}			
}			
}			
}			
}			

9.4.7.2.5 Test requirement

Same as in clause 9.4.7.1.5 but replacing Table 9.4.7.1.5-2 with Table 9.4.7.2.5-1:

**Table 9.4.7.2.5-1: RSTD FDD inter-frequency accuracy requirements for the reported values**

	Test 1	Test 2
Lowest reported value	[RSTD_6443]	[RSTD_6428]
Highest reported value	[RSTD_6485]	[RSTD_6466]

For the overall test to pass, the ratio of successful reported values in each sub-test shall be more than 90% with a confidence level of 95%.

## 9.4.8 HD-FDD inter-frequency RSTD Measurement Accuracy in CE Mode A

### 9.4.8.1 HD-FDD inter-frequency RSTD Measurement Accuracy in CE Mode A for Cat M1

*Editor's note: This test is incomplete. The following aspects are missing:*

*Requirements in TS 36.133 are partially missing*

*Assistance Data in TS 37.571-5 is missing*

#### 9.4.8.1.1 Test purpose

To verify that the RSTD measurement accuracy for UE Category M1 is within the specified limits normal coverage mode in an environment with fading propagation conditions.

#### 9.4.8.1.2 Test applicability

This test applies to E-UTRA HD-FDD UE Category M1 release 14 and forward that supports UE-assisted OTDOA and inter-frequency RSTD measurements.

#### 9.4.8.1.3 Minimum conformance requirements

Same as in clause 9.4.7.1.3.

The normative reference for this requirement is TS 36.133 [23] clause 9.1.21.17 and A.9.8.27.

#### 9.4.8.1.4 Test description

##### 9.4.8.1.4.1 Initial conditions

Same as in clause 9.4.7.1.4.1 but replacing Table 9.4.7.1.4.1-1 with Table 9.4.8.1.4.1-1

**Table 9.4.8.1.4.1-1: General test parameters for E-UTRAN HD-FDD inter-frequency RSTD measurement Accuracy under fading propagation conditions**

Parameter	Unit	Value	Comment
		Test 1	
MPDCCH		R.6 HD-FDD	As specified in TS 36.521-3 [25] clause A.7.2
<i>mPDCCH-startSF-UeSS</i>		10	Parameter $G$ in $T = r_{\max} \cdot G$ which determines subframe $k0$ in which MPDCCH starts
Reference cell		Cell 1	Reference cell is the cell in the OTDOA assistance data with respect to which the RSTD measurement is defined, as specified in 3GPP TS 36.214 [6] and 3GPP TS 36.355 [4]. The reference cell is the serving cell in this test case.
Neighbour cell		Cell 2	One carrier frequency is used.
E-UTRA RF Channel Number		Cell 1: 1 Cell 2: 2	The two cells are on different frequencies.
Channel Bandwidth ( $BW_{\text{channel}}$ )	MHz	10	
PRS Transmission Bandwidth <sup>Note 2</sup>	RB	50 <sup>Note 4</sup>	PRS are transmitted over the system bandwidth
Number of consecutive downlink positioning subframes $N_{\text{PRS}}$ <sup>Note 2</sup>		4	As defined in 3GPP TS 36.211 [26]. The number of subframes in a positioning occasion
PRS muting info <sup>Note 2</sup>		Cell 1: '11110000' Cell 2: '11110000'	Corresponds to prs-MutingInfo defined in TS 36.355 [4]
Physical cell ID PCI <sup>Note 2</sup>		(Cell ID of cell 1 – Cell ID of cell 2) mod 6 = 0	
prs-SubframeOffset		10	Number of subframes rounded to the closest integer. The corresponding parameter in the OTDOA assistance data is prs-SubframeOffset specified in TS 36.355 [4]
slotNumberOffset		0	The slot number offset at the transmitter between a neighbour cell and the assistance data reference cell specified in TS 36.355 [4]
Expected RSTD <sup>Note 1</sup>	$\mu\text{s}$	Cell 2: 1 Other neighbour cells: randomly between -3 and 3	The expected RSTD is what is expected at the receiver. The corresponding parameter in the OTDOA assistance data specified in TS 36.355 [4] is the expectedRSTD indicator
Expected RSTD uncertainty for all neighbour cells <sup>Note 1</sup>	$\mu\text{s}$	5	The corresponding parameter in the OTDOA assistance data specified in TS 36.355 [4] is the expectedRSTD-Uncertainty index
CP length <sup>Note 2</sup>		Normal	
DRX		OFF	
Radio frame receive time offset between the cells at the UE antenna connector <sup>Note 3</sup>	$\mu\text{s}$	Cell 2 to Cell 1: -3	PRS are transmitted from synchronous cells
Number of cells provided in OTDOA assistance data		16	Including the reference cell
$T_{\text{RSTD InterFreqHD-FDD, E-UTRAN}}$	ms	15360	Derived according to the RSTD measurement requirements specified in section 9.4.7.1.3

Note 1:	Parameters “Expected RSTD” and “Expected RSTD uncertainty for all neighbour cells” are not settable parameters. These are parameters signalled in LPP only. For the values to be used in LPP see Table 9.4.7.1.4.3-5 and TS 37.571-5 [20], clause 7.2.5.
Note 2:	Parameters “PRS Transmission Bandwidth”, “PRS configuration index”, “Number of consecutive positioning downlink subframes”, “prs-MutingInfo”, “Cell ID” and “CP length” are settable parameters and also parameters signalled in LPP. The values to be used for “Cell ID” are as follows: Cell 1: 0, Cell 2: 6. For all the values to be used in LPP see Table 9.4.7.1.4.3-4 and TS 37.571-5 [20], clause 7.2.5.
Note 3:	The parameter “Radio frame receive time offset between the cells at the UE antenna connector” is not a settable parameter but is used to set the “true RSTD” values in step 6 of clause 9.4.7.1.4.1.
Note 4:	If the PRS transmission bandwidth is larger than the UE RF bandwidth, the UE is measuring RSTD within its RF bandwidth.
Note 5:	The parameter “ $T_{\text{RSTD InterFreqHD-FDD, E-UTRAN}}$ ” is not a settable parameter but is used to set the LPP “time” value in Table 9.4.7.1.4.3-3. The value of the LPP time IE is set to $T_{\text{RSTD InterFreqHD-FDD, E-UTRAN}} + \Delta T$ ms, where $\Delta T = 150$ ms, giving a value of 15510 ms. This is rounded up to the next allowed LPP value of 16 seconds.

#### 9.4.8.1.4.2 Test procedure

Same as in clause 9.4.7.1.4.2.

#### 9.4.8.1.4.3 Message contents

Same as in clause 9.4.7.1.4.3

#### 9.4.8.1.5 Test requirement

Same as in clause 9.4.7.1.5.

### 9.4.8.2 HD-FDD inter-frequency RSTD Measurement Accuracy in CE Mode A for Cat M2

**Editor’s note: This test is incomplete. The following aspects are missing:**

**TBD in TS 36.133 how to capture prsOccGroupLength in the measurement period**

**Assistance Data in TS 37.571-5 is missing**

#### 9.4.8.2.1 Test purpose

To verify that the RSTD measurement accuracy for UE Category M2 is within the specified limits normal coverage mode in an environment with fading propagation conditions.

#### 9.4.8.2.2 Test applicability

This test applies to E-UTRA HD-FDD UE Category M2 release 14 and forward that supports UE-assisted OTDOA and inter-frequency RSTD measurements.

#### 9.4.8.2.3 Minimum conformance requirements

Same as in clause 9.4.7.2.3.

The normative reference for this requirement is TS 36.133 [23] clause 9.1.25.1 and A.9.8.27.

#### 9.4.8.2.4 Test description

##### 9.4.8.2.4.1 Initial conditions

Same as in clause 9.4.7.2.4.1 but replacing Table 9.4.7.2.4.1-1 with Table 9.4.8.2.4.1-1.

**Table 9.4.8.2.4.1-1: General test parameters for E-UTRAN HD-FDD inter-frequency RSTD measurement Accuracy under fading propagation conditions**

Parameter	Unit	Value		Comment
		Test1	Test3	
M-PDCCH parameters		R.6 HD-FDD	R.6 HD-FDD	As specified in TS 36.521-3 [25] clause A.7.2.
<i>mPDCCH-startSF-UESS</i>		10	10	Parameter $G$ in $T = r_{\max} \cdot G$ which determines subframe $k0$ in which MPDCCH starts
Reference cell		Cell 1		
Neighbour cell		Cell 2		
E-UTRA RF Channel Number		Cell 1: 1 Cell 2: 2		The two cells are on different frequencies.
System channel Bandwidth ( $BW_{\text{channel}}$ )	MHz	10	10	
PRS Transmission Bandwidth <sup>Note 2</sup>	RB	50 <sup>Note 4</sup>	50 <sup>Note 4</sup>	PRS bandwidth is as indicated in <i>prs-Bandwidth</i> in the OTDOA assistance data defined in TS 36.355 [4].
Number of consecutive positioning downlink subframes $N_{\text{PRS}}$ <sup>Note 2</sup>		4	2	As defined in TS 36.211 [26]
<i>prs-MutingInfo</i> <sup>Note 2</sup>		Cell 1: '11110000' Cell 2: '11110000'		See section 6.5.1.2 in 3GPP TS 36.355 [4] for more information
Cell ID <sup>Note 2</sup>		(Cell ID of cell 1 – Cell ID of cell 2) mod 6 = 0	(Cell ID of cell 1 – Cell ID of cell 2) mod 6 = 0	
<i>prs-SubframeOffset</i>		10	10	Number of subframes rounded to the closest integer. The corresponding parameter in the OTDOA assistance data is <i>prs-SubframeOffset</i> specified in TS 36.355 [4]
<i>slotNumberOffset</i>		0	0	The slot number offset at the transmitter between a neighbour cell and the assistance data reference cell specified in TS 36.355 [4]
Expected RSTD <sup>Note 1</sup>	$\mu\text{s}$	Cell 2: 1 Other neighbour cells: randomly between -3 and 3	Cell 2: -1 Other neighbour cells: randomly between -3 and 3	
Expected RSTD uncertainty for all neighbour cells <sup>Note 1</sup>	$\mu\text{s}$	5	5	
CP length <sup>Note 2</sup>		Normal		
DRX		OFF		
Radio frame receive time offset between the cells at the UE antenna connector <sup>Note 3</sup>	$\mu\text{s}$	Cell 2 to Cell 1: -3	Cell 2 to Cell 1: 3	PRS are transmitted from synchronous cells
Number of cells provided in OTDOA assistance data		16		The number of cells includes the reference cell
$T_{\text{RSTD InterFreqFDD-FDD, E-UTRAN}}$ <sup>Note 5</sup>	ms	15360	10240	Derived according to the RSTD measurement requirements specified in section 9.4.7.2.3



NOTE 1: Parameters "Expected RSTD" and "Expected RSTD uncertainty for all neighbour cells" are not settable parameters. These are parameters signalled in LPP only. For the values to be used in LPP see Table 9.4.7.1.4.3-4 and TS 37.571-5 [20], clause 7.2.5.

NOTE 2: Parameters "PRS Transmission Bandwidth", "PRS configuration index", "Number of consecutive positioning downlink subframes", "prs-MutingInfo", "Cell ID" and "CP length" are settable parameters and also parameters signalled in LPP. The values to be used for "Cell ID" are as follows: Cell 1: 0, Cell 2: 6. For all the values to be used in LPP see Table 9.4.7.1.4.3-4 and TS 37.571-5 [20], clause 7.2.5.

NOTE 3: The parameter "Radio frame receive time offset between the cells at the UE antenna connector" is not a settable parameter but is used to set the "true RSTD" values in step 6 of clause 9.1.3.4.1.

NOTE 4: If the PRS transmission bandwidth is larger than the UE RF bandwidth, the UE is measuring RSTD within its RF bandwidth.

NOTE 5: The parameter " $T_{\text{RSTD InterFreqFDD-FDD, E-UTRAN}}$ " is not a settable parameter but is used to set the LPP "time" value in Table 9.4.7.2.4.3-1. The value of the LPP time IE is set to  $T_{\text{RSTD InterFreqFDD-FDD, E-UTRAN}} + \Delta T$  ms, where  $\Delta T = 150$  ms, giving a value of 15510 ms for Test 1 and 10390 ms for Test 2. This is rounded up to the next allowed LPP value of 16 and 11 seconds, respectively.

#### 9.4.8.2.4.2 Test procedure

Same as in clause 9.4.7.1.4.2.

#### 9.4.8.2.4.3 Message contents

Same as in clause 9.4.7.1.4.3.

#### 9.4.8.2.5 Test requirement

Same as in clause 9.4.7.2.5.

For the overall test to pass, the ratio of successful reported values in each sub-test shall be more than 90% with a confidence level of 95%.

## 9.4.9 TDD inter-frequency RSTD Measurement Accuracy in CE Mode A

### 9.4.9.1 TDD inter-frequency RSTD Measurement Accuracy in CE Mode A for Cat M1

**Editor's note: This test is incomplete. The following aspects are missing:**

**Requirements in TS 36.133 are partially missing**

**Assistance Data in TS 37.571-5 is missing**

#### 9.4.9.1.1 Test purpose

To verify that the RSTD measurement accuracy for UE Category M1 is within the specified limits in normal coverage mode in an environment with fading propagation conditions.

#### 9.4.9.1.2 Test applicability

This test applies to E-UTRA TDD UE Category M1 release 14 and forward that supports UE-assisted OTDOA and inter-frequency RSTD measurements.

#### 9.4.9.1.3 Minimum conformance requirements

Same as in clause 9.4.7.1.3.

The normative reference for this requirement is TS 36.133 [23] clause 9.1.21.17 and A.9.8.28.

#### 9.4.9.1.4 Test description

##### 9.4.9.1.4.1 Initial conditions

Same as in clause 9.4.7.1.4.1 but replacing Table 9.4.7.1.4.1-1 with Table 9.4.9.1.4.1-1

**Table 9.4.9.1.4.1-1: General test parameters for E-UTRAN TDD inter-frequency RSTD measurement  
Accuracy under fading propagation conditions**

Parameter	Unit	Value	Comment
		Test 1	
MPDCCH		R.14 TDD	As specified in TS 36.521-3 [25] clause A.7.3
<i>mPDCCH-startSF-UeSS</i>		10	Parameter $G$ in $T = r_{\max} \cdot G$ which determines subframe $k0$ in which MPDCCH starts
Reference cell		Cell 1	Reference cell is the cell in the OTDOA assistance data with respect to which the RSTD measurement is defined, as specified in 3GPP TS 36.214 [6] and 3GPP TS 36.355 [4]. The reference cell is the serving cell in this test case.
Neighbour cell		Cell 2	One carrier frequency is used.
E-UTRA RF Channel Number		Cell 1: 1 Cell 2: 2	The two cells are on different frequencies.
Channel Bandwidth ( $BW_{\text{channel}}$ )	MHz	10	
PRS Transmission Bandwidth <sup>Note 2</sup>	RB	50 <sup>Note 4</sup>	PRS are transmitted over the system bandwidth
Number of consecutive downlink positioning subframes $N_{\text{PRS}}$ <sup>Note 2</sup>		4	As defined in 3GPP TS 36.211 [26]. The number of subframes in a positioning occasion
PRS muting info <sup>Note 2</sup>		Cell 1: '11110000' Cell 2: '11110000'	Corresponds to prs-MutingInfo defined in TS 36.355 [4]
Physical cell ID PCI <sup>Note 2</sup>		(Cell ID of cell 1 – Cell ID of cell 2) mod 6 = 0	
prs-SubframeOffset		10	Number of subframes rounded to the closest integer. The corresponding parameter in the OTDOA assistance data is prs-SubframeOffset specified in TS 36.355 [4]
slotNumberOffset		0	The slot number offset at the transmitter between a neighbour cell and the assistance data reference cell specified in TS 36.355 [4]
Expected RSTD <sup>Note 1</sup>	$\mu\text{s}$	Cell 2: 1 Other neighbour cells: randomly between -3 and 3	The expected RSTD is what is expected at the receiver. The corresponding parameter in the OTDOA assistance data specified in TS 36.355 [4] is the expectedRSTD indicator
Expected RSTD uncertainty for all neighbour cells <sup>Note 1</sup>	$\mu\text{s}$	5	The corresponding parameter in the OTDOA assistance data specified in TS 36.355 [4] is the expectedRSTD-Uncertainty index
TDD uplink-downlink configuration		1	As specified in TS 36.211 [26], Clause 4.2; corresponds to a configuration with 5 ms switch-point periodicity and two downlink consecutive subframes
TDD special subframe configuration		6	As specified in TS 36.211 [26], Clause 4.2; corresponds to DwPTS of $19760 \cdot T_s$ and UpPTS of $4384 \cdot T_s$
CP length <sup>Note 2</sup>		Normal	
DRX		OFF	
Radio frame receive time offset between the cells at the UE antenna connector <sup>Note 3</sup>	$\mu\text{s}$	Cell 2 to Cell 1: -3	PRS are transmitted from synchronous cells

Number of cells provided in OTDOA assistance data		16	Including the reference cell
$T_{RSTD \text{ InterFreqTDD, E-UTRAN}}$	ms	15360	Derived according to the RSTD measurement requirements specified in section 9.4.7.1.3
<p>Note 1: Parameters "Expected RSTD" and "Expected RSTD uncertainty for all neighbour cells" are not settable parameters. These are parameters signalled in LPP only. For the values to be used in LPP see Table 9.4.7.1.4.3-5 and TS 37.571-5 [20], clause 7.2.5.</p> <p>Note 2: Parameters "PRS Transmission Bandwidth", "PRS configuration index", "Number of consecutive positioning downlink subframes", "prs-MutingInfo", "Cell ID" and "CP length" are settable parameters and also parameters signalled in LPP. The values to be used for "Cell ID" are as follows: Cell 1: 0, Cell 2: 6. For all the values to be used in LPP see Table 9.4.7.1.4.3-4 and TS 37.571-5 [20], clause 7.2.5.</p> <p>Note 3: The parameter "Radio frame receive time offset between the cells at the UE antenna connector" is not a settable parameter but is used to set the "true RSTD" values in step 6 of clause 9.4.7.1.4.1.</p> <p>Note 4: If the PRS transmission bandwidth is larger than the UE RF bandwidth, the UE is measuring RSTD within its RF bandwidth.</p> <p>Note 5: The parameter "<math>T_{RSTD \text{ InterFreqTDD, E-UTRAN}}</math>" is not a settable parameter but is used to set the LPP "time" value in Table 9.4.7.1.4.3-3. The value of the LPP time IE is set to <math>T_{RSTD \text{ InterFreqTDD, E-UTRAN}} + \Delta T</math> ms, where <math>\Delta T = 150</math> ms, giving a value of 15510 ms. This is rounded up to the next allowed LPP value of 16 seconds.</p>			

9.4.9.1.4.2 Test procedure

Same as in clause 9.4.7.1.4.2.

9.4.9.1.4.3 Message contents

Same as in clause 9.4.7.1.4.3

9.4.9.1.5 Test requirement

Table 9.4.9.1.5-1 defines the primary level settings including test tolerances for the test.

The RSTD FDD inter-frequency accuracy test shall meet the reported values in Table 9.4.9.1.5-2

Table 9.4.9.1.5-1: Cell Specific Test Parameters for inter frequency RSTD Tests for E-UTRAN TDD

Parameter	Unit	Test1		Test2						
		Cell1	Cell2	Cell1	Cell2					
E-UTRA RF Channel Number		1	2	1	2					
Gap offset		151	N/A	151	N/A					
Gap pattern		#0	N/A	#0	N/A					
OCNG Patterns defined in TS 36.521-3 [25] clause D.1		OP.11 TDD	OP.2 TDD	OP.11 TDD	OP.2 TDD					
PRS configuration Index $I_{PRS}$ , as defined in TS 36.211		142	152	142	152					
PBCH_RA	dB	0	0	0	0					
PBCH_RB										
PSS_RA										
SSS_RA										
MPDCCH_RA										
MPDCCH_RB										
OCNG_RA <sup>Note1</sup>										
OCNG_RB <sup>Note1</sup>										
PRS_RA						dB	0	0	0	0
$N_{oc}$ <sup>Note2</sup>						dBm/15 kHz	-98	-98	-98	-98
PRS $\hat{E}_s/N_{oc}$	dB	-1	-11	-1	-11					
PRS $\hat{E}_s/I_{ot}$ <sup>Note3</sup>	dB	-1	-11	-1	-11					
$I_o$ <sup>Note3</sup>	dBm/9 MHz	-69.68	-70.16	-69.68	-70.16					
PRP <sup>Note3</sup>	dBm/15kHz	-99	-109	-99	-109					
$\hat{E}_s/N_{oc}$ <sup>Note 3</sup>	dB	-1	-11	-1	-11					
RSRP <sup>Note 3</sup>	dBm/15kHz	-99	-109	-99	-109					
Propagation condition		AWGN								
<p>Note 1: OCNG shall be used such that both cells are fully allocated and a constant total transmitted power spectral density is achieved for all OFDM symbols (other than those in the PRS subframes).</p> <p>Note 2: Interference from other cells and noise sources not specified in the test is assumed to be constant over subcarriers and time and shall be modelled as AWGN of appropriate power for <math>N_{oc}</math> to be fulfilled.</p> <p>Note 3: <math>\hat{E}_s/N_{oc}</math>, PRS <math>\hat{E}_s/I_{ot}</math>, <math>I_o</math>, RSRP and PRP levels have been derived from other parameters for information purposes. They are not settable parameters themselves. <math>I_o</math> values are derived in the case that there is no PBCH, PSS or SSS in the OFDM symbols carrying PRS</p>										

Table 9.4.9.1.5-2: RSTD FDD inter-frequency accuracy requirements for the reported values

	Test 1
Lowest reported value	[RSTD_6443]
Highest reported value	[RSTD_6485]

The test tolerances are defined in clauses C.1.3 and C4.

For the overall test to pass, the ratio of successful reported values in each sub-test shall be more than 90% with a confidence level of 95%.

#### 9.4.9.2 TDD inter-frequency RSTD Measurement Accuracy in CE Mode A for Cat M2

**Editor's note: This test is incomplete. The following aspects are missing:**

Requirements in TS 36.133 are partially missing

Assistance Data in TS 37.571-5 is missing

##### 9.4.9.2.1 Test purpose

To verify that the RSTD measurement accuracy for UE Category M2 is within the specified limits in normal coverage mode in an environment with fading propagation conditions.

#### 9.4.9.2.2 Test applicability

This test applies to E-UTRA TDD UE Category M2 release 14 and forward that supports UE-assisted OTDOA and inter-frequency RSTD measurements.

#### 9.4.9.2.3 Minimum conformance requirements

Same as in clause 9.4.7.1.3.

The normative reference for this requirement is TS 36.133 [23] clause 9.1.25.1 and A.9.8.28.

#### 9.4.9.2.4 Test description

##### 9.4.9.2.4.1 Initial conditions

Same as in clause 9.4.7.2.4.1 but replacing Table 9.4.7.2.4.1-1 with Table 9.4.9.2.4.1-1.

**Table 9.4.9.2.4.1-1: General test parameters for E-UTRAN TDD inter-frequency RSTD measurement  
Accuracy under fading propagation conditions**

Parameter	Unit	Value		Comment
		Test1	Test3	
M-PDCCH parameters		R.14 TDD	R.14 TDD	As specified in TS 36.521-3 [25] clause A.7.3.
<i>mPDCCH-startSF-UESS</i>		10	10	Parameter $G$ in $T = r_{\max} \cdot G$ which determines subframe $k0$ in which MPDCCH starts
Reference cell		Cell 1		
Neighbour cell		Cell 2		
E-UTRA RF Channel Number		Cell 1: 1 Cell 2: 2		The two cells are on different frequencies.
System channel Bandwidth ( $BW_{\text{channel}}$ )	MHz	10	10	
PRS Transmission Bandwidth <sup>Note 2</sup>	RB	50 <sup>Note 4</sup>	50 <sup>Note 4</sup>	PRS bandwidth is as indicated in <i>prs-Bandwidth</i> in the OTDOA assistance data defined in TS 36.355 [4].
Number of consecutive positioning downlink subframes $N_{\text{PRS}}$ <sup>Note 2</sup>		4	2	As defined in TS 36.211 [26]
<i>prs-MutingInfo</i> <sup>Note 2</sup>		Cell 1: '11110000' Cell 2: '11110000'		See section 6.5.1.2 in 3GPP TS 36.355 [4] for more information
Cell ID <sup>Note 2</sup>		(Cell ID of cell 1 – Cell ID of cell 2) mod 6 = 0	(Cell ID of cell 1 – Cell ID of cell 2) mod 6 = 0	
<i>prs-SubframeOffset</i>		10	10	Number of subframes rounded to the closest integer. The corresponding parameter in the OTDOA assistance data is <i>prs-SubframeOffset</i> specified in TS 36.355 [4]
<i>slotNumberOffset</i>		0	0	The slot number offset at the transmitter between a neighbour cell and the assistance data reference cell specified in TS 36.355 [4]
Expected RSTD <sup>Note 1</sup>	$\mu\text{s}$	Cell 2: 1 Other neighbour cells: randomly between -3 and 3	Cell 2: -1 Other neighbour cells: randomly between -3 and 3	
Expected RSTD uncertainty for all neighbour cells <sup>Note 1</sup>	$\mu\text{s}$	5	5	
TDD uplink-downlink configuration		1		As specified in TS 36.211 [26], Clause 4.2; corresponds to a configuration with 5 ms switch-point periodicity and two downlink consecutive subframes
TDD special subframe configuration		6		As specified in TS 36.211 [26], Clause 4.2; corresponds to DwPTS of $19760 \cdot T_s$ and UpPTS of $4384 \cdot T_s$
CP length <sup>Note 2</sup>		Normal		
DRX		OFF		
Radio frame receive time offset between the cells at the UE antenna connector <sup>Note 3</sup>	$\mu\text{s}$	Cell 2 to Cell 1: -3	Cell 2 to Cell 1: 3	PRS are transmitted from synchronous cells
Number of cells provided in OTDOA assistance data		16		The number of cells includes the reference cell
$T_{\text{RSTD InterFreqFDD-FDD, E-UTRAN}}$ <sup>Note 5</sup>	ms	15360	10240	Derived according to the RSTD measurement requirements specified in section 9.4.7.2.3



NOTE 1:	Parameters “Expected RSTD” and “Expected RSTD uncertainty for all neighbour cells” are not settable parameters. These are parameters signalled in LPP only. For the values to be used in LPP see Table 9.4.7.1.4.3-4 and TS 37.571-5 [20], clause 7.2.5.
NOTE 2:	Parameters “PRS Transmission Bandwidth”, “PRS configuration index”, “Number of consecutive positioning downlink subframes”, “prs-MutingInfo”, “Cell ID” and “CP length” are settable parameters and also parameters signalled in LPP. The values to be used for “Cell ID” are as follows: Cell 1: 0, Cell 2: 6. For all the values to be used in LPP see Table 9.4.7.1.4.3-4 and TS 37.571-5 [20], clause 7.2.5.
NOTE 3:	The parameter “Radio frame receive time offset between the cells at the UE antenna connector” is not a settable parameter but is used to set the “true RSTD” values in step 6 of clause 9.1.3.4.1.
NOTE 4:	If the PRS transmission bandwidth is larger than the UE RF bandwidth, the UE is measuring RSTD within its RF bandwidth.
NOTE 5:	The parameter “ $T_{\text{RSTD InterFreqFDD-FDD, E-UTRAN}}$ ” is not a settable parameter but is used to set the LPP “time” value in Table 9.4.7.2.4.3-1. The value of the LPP time IE is set to $T_{\text{RSTD InterFreqFDD-FDD, E-UTRAN}} + \Delta T$ ms, where $\Delta T = 150$ ms, giving a value of 15510 ms for Test 1 and 10390 ms for Test 2. This is rounded up to the next allowed LPP value of 16 and 11 seconds, respectively.

#### 9.4.9.2.4.2 Test procedure

Same as in clause 9.4.7.1.4.2.

#### 9.4.9.2.4.3 Message contents

Same as in clause 9.4.7.1.4.3.

#### 9.4.9.2.5 Test requirement

Same as in clause 9.4.9.1.5 but replacing Table 9.4.9.1.5-2 with Table 9.4.9.2.5-1:

**Table 9.4.9.2.5-1: RSTD FDD inter-frequency accuracy requirements for the reported values**

	Test 1	Test 2
Lowest reported value	[RSTD_6443]	[RSTD_6428]
Highest reported value	[RSTD_6485]	[RSTD_6466]

For the overall test to pass, the ratio of successful reported values in each sub-test shall be more than 90% with a confidence level of 95%.

## 9.4.10 FDD inter-frequency RSTD Measurement Accuracy in CE Mode B

### 9.4.10.1 FDD inter-frequency RSTD Measurement Accuracy in CE Mode B for Cat M1

**Editor’s note: This test is incomplete. The following aspects are missing:**

**Requirements in TS 36.133 are partially missing**

**Assistance Data in TS 37.571-5 is missing**

#### 9.4.10.1.1 Test purpose

To verify that the RSTD measurement accuracy for UE Category M1 is within the specified limits in enhanced coverage mode in an environment with fading propagation conditions.

#### 9.4.10.1.2 Test applicability

This test applies to E-UTRA FDD UE Category M1 release 14 and forward that supports UE-assisted OTDOA, inter-frequency RSTD measurements and CE Mode B.

#### 9.4.10.1.3 Minimum conformance requirements

The accuracy requirements in Table 9.4.10.1.3-1 are valid under the following conditions:

Conditions defined in 36.101 [2] Clause 7.3 for reference sensitivity are fulfilled.

PRP 1,2<sub>dBm</sub> according to Annex E.3.1 for a corresponding Band

There are no measurement gaps overlapping with the PRS subframes of the measured serving cell.

The parameter expectedRSTDUncertainty signalled over LPP by E-SMLC as defined in TS 36.355 [4] is less than 5  $\mu$ s.

**Table 9.4.10.1.3-1: RSTD inter-frequency measurement accuracy for CEModeB**

Accuracy	Conditions						
	PRS $\hat{E}_s/\text{lot}$	Minimum PRS bandwidth, which is minimum of serving cell channel bandwidth and the PRS bandwidths of the reference cell and the measured neighbour cell $i$	Minimum number of available measurement subframes among the reference cell and the measured neighbour cell $i$	The number of consecutive downlink subframes $N_{\text{PRS}}$ among the reference cell and the measured neighbour cell $i$ as defined in [24]	$Io$ <sup>Note 4</sup> range		
					E-UTRA operating band groups <sup>Note 5</sup>	Minimum $Io$ <sup>Note 1</sup>	Maximum $Io$
$T_s$ <sup>Note 2</sup>	dB	RB				dBm/15kHz	dBm/BW <sub>Channel</sub>
[±21]	(PRS $\hat{E}_s/\text{lot}$ ) <sub>ref</sub> ≥ -15dB and (PRS $\hat{E}_s/\text{lot}$ ) <sub>i</sub> ≥ -15dB	≥ 6	≥ 30	≥ 4	FDD-M1_A, TDD-M1_A	-121	-50
					FDD-M1_B	-120.5	-50
					FDD-M1_C, TDD-M1_C	-120	-50
					FDD-M1_D	-119.5	-50
					FDD-M1_E, TDD-M1_E	-119	-50
					FDD-M1_F	-118.5	-50
					FDD-M1_G	-118	-50
					FDD-M1_H	-117.5	-50
					FDD-M1_N	-114.5	-50

NOTE 1: This minimum  $Io$  condition is expressed as the average  $Io$  per RE over all REs in an OFDM symbol.  
 NOTE 2:  $T_s$  is the basic timing unit defined in TS 36.211 [26].  
 NOTE 3: PRS bandwidth is as indicated in *prs-Bandwidth* in the OTDOA assistance data defined in TS 36.355 [4].  
 NOTE 4: The  $Io$  is defined in PRS positioning subframes. The same  $Io$  range applies to PRS and non-PRS symbols.  $Io$  levels are different in PRS and non-PRS symbols within the same subframe.  
 NOTE 5: E-UTRA operating band groups are as defined in Section 4.4.2.

The normative reference for this requirement is TS 36.133 [23] clause 9.1.21.18 and A.9.8.29.

9.4.10.1.4 Test description

9.4.10.1.4.1 Initial conditions

Same as in clause 9.4.7.1.4.1 but replacing Table 9.4.7.1.4.1-1 with Table 9.4.10.1.4.1-1.

**Table 9.4.10.1.4.1-1: General test parameters for E-UTRAN FDD inter-frequency RSTD measurement  
Accuracy under fading propagation conditions.**

Parameter	Unit	Value	Comment
		Test 1	
MPDCCH		R.18 FDD	As specified in TS 36.521-3 [25] clause A.7.1
<i>mPDCCH-startSF-UeSS</i>		10	Parameter $G$ in $T = r_{\max} \cdot G$ which determines subframe $k0$ in which MPDCCH starts
Reference cell		Cell 1	Reference cell is the cell in the OTDOA assistance data with respect to which the RSTD measurement is defined, as specified in 3GPP TS 36.214 [6] and 3GPP TS 36.355 [4]. The reference cell is the serving cell in this test case.
Neighbour cell		Cell 2	One carrier frequency is used.
E-UTRA RF Channel Number		1	
Channel Bandwidth ( $BW_{\text{channel}}$ )	MHz	10	
PRS Transmission Bandwidth <sup>Note 2</sup>	RB	50 <sup>Note 4</sup>	PRS are transmitted over the system bandwidth
Number of consecutive downlink positioning subframes $N_{\text{PRS}}$ <sup>Note 2</sup>		4	As defined in 3GPP TS 36.211 [26]. The number of subframes in a positioning occasion
PRS muting info <sup>Note 2</sup>		Cell 1: '11110000' Cell 2: '11110000'	Corresponds to prs-MutingInfo defined in TS 36.355 [4]
Physical cell ID PCI <sup>Note 2</sup>		(Cell ID of cell 1 – Cell ID of cell 2) mod 6 = 0	
prs-SubframeOffset		10	Number of subframes rounded to the closest integer. The corresponding parameter in the OTDOA assistance data is prs-SubframeOffset specified in TS 36.355 [4]
slotNumberOffset		0	The slot number offset at the transmitter between a neighbour cell and the assistance data reference cell specified in TS 36.355 [4]
Expected RSTD <sup>Note 1</sup>	$\mu\text{s}$	Cell 2: 1 Other neighbour cells: randomly between -3 and 3	The expected RSTD is what is expected at the receiver. The corresponding parameter in the OTDOA assistance data specified in TS 36.355 [4] is the expectedRSTD indicator
Expected RSTD uncertainty for all neighbour cells <sup>Note 1</sup>	$\mu\text{s}$	5	The corresponding parameter in the OTDOA assistance data specified in TS 36.355 [4] is the expectedRSTD-Uncertainty index
CP length <sup>Note 2</sup>		Normal	
DRX		OFF	
Radio frame receive time offset between the cells at the UE antenna connector <sup>Note 3</sup>	$\mu\text{s}$	Cell 2 to Cell 1: -3	PRS are transmitted from synchronous cells
Number of cells provided in OTDOA assistance data		16	Including the reference cell
$T_{\text{RSTD InterFreq FDD-FDD, E-UTRAN}}$	ms	40960	Derived according to the RSTD measurement requirements specified in section 9.4.10.1.3

- Note 1: Parameters “Expected RSTD” and “Expected RSTD uncertainty for all neighbour cells” are not settable parameters. These are parameters signalled in LPP only. For the values to be used in LPP see Table 9.4.10.1.4.3-5 and TS 37.571-5 [20], clause 7.2.5.
- Note 2: Parameters “PRS Transmission Bandwidth”, “PRS configuration index”, “Number of consecutive positioning downlink subframes”, “prs-MutingInfo”, “Cell ID” and “CP length” are settable parameters and also parameters signalled in LPP. The values to be used for “Cell ID” are as follows: Cell 1: 0, Cell 2: Test 1: 6, Test 2: 7, Test 3: 6, Test 4: 9. For all the values to be used in LPP see Table 9.4.10.1.4.3-4 and TS 37.571-5 [20], clause 7.2.5.
- Note 3: The parameter “Radio frame receive time offset between the cells at the UE antenna connector” is not a settable parameter but is used to set the “true RSTD” values in step 6 of clause 9.4.10.1.4.1.
- Note 4: If the PRS transmission bandwidth is larger than the UE RF bandwidth, the UE is measuring RSTD within its RF bandwidth.
- Note 5: The parameter “ $T_{\text{RSTD InterFreqFDD-FDD, E-UTRAN}}$ ” is not a settable parameter but is used to set the LPP “time” value in Table 9.4.10.1.4.3-3. The value of the LPP time IE is set to  $T_{\text{RSTD InterFreqFDD-FDD, E-UTRAN}} + \Delta T$  ms, where  $\Delta T = 150$  ms, giving a value of 41210 ms. This is rounded up to the next allowed LPP value of 42 seconds.

9.4.10.1.4.2 Test procedure

Same as in clause 9.4.7.1.4.2 but using condition CEModeB.

9.4.10.1.4.3 Message contents

Same as in clause 9.4.7.1.4.3 with the following exceptions

**Table 9.4.10.1.4.3-1: LPP RequestLocationInformation**

Derivation Path: Table 9.4.7.1.4.3-4			
Information Element	Value/remark	Comment	Condition
LPP-Message ::= SEQUENCE {			
lpp-MessageBody CHOICE {			
c1 CHOICE {			
requestLocationInformation SEQUENCE {			
criticalExtensions CHOICE {			
c1 CHOICE {			
requestLocationInformation-r9 SEQUENCE {			
commonIEsRequestLocationInformation SEQUENCE {			
qos SEQUENCE {			
responseTime SEQUENCE {			
time	42	See Note 5 in Table 9.4.10.1.4.1-1	
}			
}			
}			
}			
}			
}			
}			
}			
}			
}			

9.4.10.1.5 Test requirement

Table 9.4.10.1.5-1 defines the primary level settings including test tolerances for the test.

The RSTD FDD inter-frequency accuracy test shall meet the reported values in Table 9.4.10.1.5-2

**Table 9.4.10.1.5-1: Cell Specific Test Parameters for inter frequency RSTD Tests for E-UTRAN FDD**

Parameter	Unit	Test1		Test2	
		Cell1	Cell2	Cell1	Cell2
E-UTRA RF Channel Number		1	2	1	2
Gap offset		9	N/A	9	N/A
Gap pattern		#0	N/A	#0	N/A
OCNG Patterns defined in TS 36.521-3 [25] clause D.1		OP.21 FDD	OP.6 FDD	OP.21 FDD	OP.6 FDD
PRS configuration Index $I_{PRS}$ , as defined in TS 36.211 [26]		142	152	142	152
PBCH_RA	dB	0	0	0	0
PBCH_RB					
PSS_RA					
SSS_RA					
MPDCCH_RA					
MPDCCH_RB					
OCNG_RA <sup>Note1</sup>					
OCNG_RB <sup>Note1</sup>					
PRS_RA					
PRS_RA					
$N_{oc}$ <sup>Note2</sup>	dBm/15 kHz	-98	-98	-98	-98
PRS $\hat{E}_s/N_{oc}$	dB	-11	-14	-11	-14
PRS $\hat{E}_s/I_{ot}$ <sup>Note3</sup>	dB	-11	-14	-11	-14
$I_o$ <sup>Note3</sup>	dBm/9 MHz	-70.16	-70.19	-70.16	-70.19
PRP <sup>Note3</sup>	dBm/15kHz	-109	-112	-109	-112
$\hat{E}_s/N_{oc}$ <sup>Note 3</sup>	dB	-11	-14	-11	-14
RSRP <sup>Note 3</sup>	dBm/15kHz	-109	-112	-109	-112
Propagation condition		AWGN			
<p>Note 1: OCNG shall be used such that both cells are fully allocated and a constant total transmitted power spectral density is achieved for all OFDM symbols (other than those in the PRS subframes).</p> <p>Note 2: Interference from other cells and noise sources not specified in the test is assumed to be constant over subcarriers and time and shall be modelled as AWGN of appropriate power for <math>N_{oc}</math> to be fulfilled.</p> <p>Note 3: <math>\hat{E}_s/N_{oc}</math>, PRS <math>\hat{E}_s/I_{ot}</math>, <math>I_o</math>, RSRP and PRP levels have been derived from other parameters for information purposes. They are not settable parameters themselves. <math>I_o</math> values are derived in the case that there is no PBCH, PSS or SSS in the OFDM symbols carrying PRS</p>					

**Table 9.4.10.1.5-2: RSTD FDD inter-frequency accuracy requirements for the reported values**

	Test 1
Lowest reported value	[RSTD_6443]
Highest reported value	[RSTD_6485]

The test tolerances are defined in clauses C.1.3 and C4.

For the overall test to pass, the ratio of successful reported values in each sub-test shall be more than 90% with a confidence level of 95%.

#### 9.4.10.2 FDD inter-frequency RSTD Measurement Accuracy in CE Mode B for Cat M2

**Editor's note: This test is incomplete. The following aspects are missing:**

Requirements in TS 36.133 are partially missing

Assistance Data in TS 37.571-5 is missing

##### 9.4.10.2.1 Test purpose

To verify that the RSTD measurement accuracy for UE Category M2 is within the specified limits in enhanced coverage mode in an environment with fading propagation conditions.

#### 9.4.10.2.2 Test applicability

This test applies to E-UTRA FDD UE Category M2 release 14 and forward that supports UE-assisted OTDOA, inter-frequency RSTD measurements and CE Mode B.

#### 9.4.10.2.3 Minimum conformance requirements

The accuracy requirements in Table 9.4.10.2.3-1 are valid under the following conditions:

Conditions defined in 36.101 [2] Clause 7.3 for reference sensitivity are fulfilled.

PRP 1,2<sub>dBm</sub> according to Annex E.2 for a corresponding Band

There are no measurement gaps overlapping with the PRS subframes of the measured serving cell.

The parameter expectedRSTDUncertainty signalled over LPP by E-SMLC as defined in TS 36.355 [4] is less than 5  $\mu$ s.

**Table 9.4.10.2.3-1: RSTD inter-frequency measurement accuracy for CEModeB**

Accuracy	PRs $\hat{\epsilon}_s/\text{lot}$	Minimum PRS bandwidth, which is minimum of serving cell channel bandwidth and the PRS bandwidths of the reference cell and the measured neighbour cell $i$	Conditions			$\text{Io}^{\text{Note 4}}$ range	
			Minimum number of available measurement subframes among the reference cell and the measured neighbour cell $i$	The number of consecutive downlink subframes $N_{\text{PRS}}$ among the reference cell and the measured neighbour cell $i$ as defined in [24]	E-UTRA operating band groups <small>Note 5</small>	Minimum $\text{Io}^{\text{Note 1}}$	Maximum $\text{Io}$
$T_s^{\text{Note 2}}$	dB	RB				dBm/15kHz	dBm/BW <sub>Channel</sub>
[±21]	(PRs $\hat{\epsilon}_s/\text{lot})_{\text{ref}} \geq -15\text{dB}$ and (PRs $\hat{\epsilon}_s/\text{lot})_i \geq -13\text{dB}$	$\geq 6$	$\geq 30$	$\geq 4$	FDD-M1_A, TDD-M1_A	-121	-50
					FDD-M1_B	-120.5	-50
					FDD-M1_C, TDD-M1_C	-120	-50
					FDD-M1_D	-119.5	-50
					FDD-M1_E, TDD-M1_E	-119	-50
					FDD-M1_F	-118.5	-50
					FDD-M1_G	-118	-50
					FDD-M1_H	-117.5	-50
					FDD-M1_N	-114.5	-50
[±10]	(PRs $\hat{\epsilon}_s/\text{lot})_{\text{ref}} \geq -15\text{dB}$ and (PRs $\hat{\epsilon}_s/\text{lot})_i \geq -13\text{dB}$	$\geq 24$	$\geq 8$	$\geq 2$	Note 6	Note 6	Note 6

NOTE 1: This minimum  $\text{Io}$  condition is expressed as the average  $\text{Io}$  per RE over all REs in an OFDM symbol.  
 NOTE 2:  $T_s$  is the basic timing unit defined in TS 36.211 [26].  
 NOTE 3: PRS bandwidth is as indicated in *prs-Bandwidth* in the OTDOA assistance data defined in TS 36.355 [4].  
 NOTE 4: The  $\text{Io}$  is defined in PRS positioning subframes. The same  $\text{Io}$  range applies to PRS and non-PRS symbols.  $\text{Io}$  levels are different in PRS and non-PRS symbols within the same subframe.  
 NOTE 5: E-UTRA operating band groups are as defined in Section 4.4.2.  
 NOTE 7: The same bands and the same  $\text{Io}$  conditions for each band apply for this requirement as for the corresponding requirement with the PRS bandwidth  $\geq 6$  RB.

The normative reference for this requirement is TS 36.133 [23] clause 9.1.25.2 and A.9.8.29.

9.4.10.2.4 Test description

9.4.10.2.4.1 Initial conditions

Same as in clause 9.4.10.1.4.1 adding Test 2 and replacing Table 9.4.10.1.4.1-1 with Table 9.4.10.2.4.1-1.

The true RSTD (which is the receive time difference for frame 0 between cell 2 and cell 1 as seen at the UE antenna connector) is set to the following values:

Test 1:  $-92 T_s$  (about  $-3 \mu\text{s}$ )



Test 2: 92 Ts (about 3  $\mu$ s)

Note that the related expectedRSTD values to be signalled over LPP are defined in Table 9.4.10.2.4-1 for each test.

**Table 9.4.10.2.4.1-1: General test parameters for E-UTRAN FDD inter-frequency RSTD measurement  
Accuracy under fading propagation conditions**

Parameter	Unit	Value		Comment
		Test1	Test3	
M-PDCCH parameters		R.18 FDD	R.18 FDD	As specified in TS 36.521-3 [25] clause A.7.1.
<i>mPDCCH-startSF-UESS</i>		10	10	Parameter $G$ in $T = r_{\max} \cdot G$ which determines subframe $k0$ in which MPDCCH starts
Reference cell		Cell 1		
Neighbour cell		Cell 2		
E-UTRA RF Channel Number		1		One carrier frequency is used.
System channel Bandwidth ( $BW_{\text{channel}}$ )	MHz	10	10	
PRS Transmission Bandwidth <sup>Note 2</sup>	RB	50 <sup>Note 4</sup>	50 <sup>Note 4</sup>	PRS bandwidth is as indicated in <i>prs-Bandwidth</i> in the OTDOA assistance data defined in TS 36.355 [4].
Number of consecutive positioning downlink subframes $N_{\text{PRS}}$ <sup>Note 2</sup>		4	2	As defined in TS 36.211 [26]
prs-MutingInfo <sup>Note 2</sup>		Cell 1: '11110000' Cell 2: '11110000'		See section 6.5.1.2 in 3GPP TS 36.355 [4] for more information
Cell ID <sup>Note 2</sup>		(Cell ID of cell 1 – Cell ID of cell 2) mod 6 = 0	(Cell ID of cell 1 – Cell ID of cell 2) mod 6 = 0	
prs-SubframeOffset		10	10	Number of subframes rounded to the closest integer. The corresponding parameter in the OTDOA assistance data is prs-SubframeOffset specified in TS 36.355 [4]
slotNumberOffset		0	0	The slot number offset at the transmitter between a neighbour cell and the assistance data reference cell specified in TS 36.355 [4]
Expected RSTD <sup>Note 1</sup>	µs	Cell 2: 1 Other neighbour cells: randomly between -3 and 3	Cell 2: -1 Other neighbour cells: randomly between -3 and 3	
Expected RSTD uncertainty for all neighbour cells <sup>Note 1</sup>	µs	5	5	
CP length <sup>Note 2</sup>		Normal		
DRX		OFF		
Radio frame receive time offset between the cells at the UE antenna connector <sup>Note 3</sup>	µs	Cell 2 to Cell 1: -3	Cell 2 to Cell 1: 3	PRS are transmitted from synchronous cells
Number of cells provided in OTDOA assistance data		16		The number of cells includes the reference cell
$T_{\text{RSTD InterFreqFDD-FDD, E-UTRAN}}$ <sup>Note 5</sup>	ms	40960	10240	Derived according to the RSTD measurement requirements specified in section 9.4.10.2.3

NOTE 1: Parameters “Expected RSTD” and “Expected RSTD uncertainty for all neighbour cells” are not settable parameters. These are parameters signalled in LPP only. For the values to be used in LPP see Table 9.4.10.1.4.3-4 and TS 37.571-5 [20], clause 7.2.5.

NOTE 2: Parameters “PRS Transmission Bandwidth”, “PRS configuration index”, “Number of consecutive positioning downlink subframes”, “prs-MutingInfo”, “Cell ID” and “CP length” are settable parameters and also parameters signalled in LPP. The values to be used for “Cell ID” are as follows: Cell 1: 0, Cell 2: Test 1: 6, Test 2: 7, Test 3: 6, Test 4: 9. For all the values to be used in LPP see Table 9.4.10.1.4.3-4 and TS 37.571-5 [20], clause 7.2.5.

NOTE 3: The parameter “Radio frame receive time offset between the cells at the UE antenna connector” is not a settable parameter but is used to set the “true RSTD” values in step 6 of clause 9.1.3.4.1.

NOTE 4: If the PRS transmission bandwidth is larger than the UE RF bandwidth, the UE is measuring RSTD within its RF bandwidth.

NOTE 5: The parameter “ $T_{RSTD\ InterFreqFDD-FDD, E-UTRAN}$ ” is not a settable parameter but is used to set the LPP “time” value in Table 9.4.10.2.4.3-1. The value of the LPP time IE is set to  $T_{RSTD\ InterFreqFDD-FDD, E-UTRAN} + \Delta T$  ms, where  $\Delta T = 150$  ms, giving a value of 41210 ms for Test and 10390 ms for Test 2. This is rounded up to the next allowed LPP value of 42 and 11 seconds, respectively.

9.4.10.2.4.2 Test procedure

Same as in clause 9.4.7.1.4.2 but using condition CEModeB.

9.4.10.2.4.3 Message contents

Same as in clause 9.4.7.1.4.3 with the following exceptions:

**Table 9.4.10.2.4.3-1: LPP RequestLocationInformation**

Derivation Path: Table 9.4.7.1.4.3-4			
Information Element	Value/remark	Comment	Condition
LPP-Message ::= SEQUENCE {			
lpp-MessageBody CHOICE {			
c1 CHOICE {			
requestLocationInformation SEQUENCE {			
criticalExtensions CHOICE {			
c1 CHOICE {			
requestLocationInformation-r9 SEQUENCE {			
commonIEsRequestLocationInformation SEQUENCE {			
qos SEQUENCE {			
responseTime SEQUENCE {			
time	42	See Note 5 in Table 9.4.10.2.4.1-1	Test 1
time	11	See Note 5 in Table 9.4.10.2.4.1-1	Test 2
}			
}			
}			
}			
}			
}			
}			
}			

9.4.10.2.5 Test requirement

Same as in clause 9.4.10.1.5 but replacing Table 9.4.10.1.5-2 with Table 9.4.10.2.5-1:

**Table 9.4.10.2.5-1: RSTD FDD inter-frequency accuracy requirements for the reported values**

	Test 1	Test 2
Lowest reported value	[RSTD_6443]	[RSTD_6428]
Highest reported value	[RSTD_6485]	[RSTD_6466]

For the overall test to pass, the ratio of successful reported values in each sub-test shall be more than 90% with a confidence level of 95%.

## 9.4.11 HD-FDD inter-frequency RSTD Measurement Accuracy in CE Mode B

### 9.4.11.1 HD-FDD inter-frequency RSTD Measurement Accuracy in CE Mode B for Cat M1

*Editor's note: This test is incomplete. The following aspects are missing:*

*Requirements in TS 36.133 are partially missing*

*Assistance Data in TS 37.571-5 is missing*

#### 9.4.11.1.1 Test purpose

To verify that the RSTD measurement accuracy for UE Category M1 is within the specified limits enhanced coverage mode in an environment with fading propagation conditions.

#### 9.4.11.1.2 Test applicability

This test applies to E-UTRA HD-FDD UE Category M1 release 14 and forward that supports UE-assisted OTDOA, inter-frequency RSTD measurements and CE Mode B.

#### 9.4.11.1.3 Minimum conformance requirements

Same as in clause 9.4.10.1.3.

The normative reference for this requirement is TS 36.133 [23] clause 9.1.21.18 and A.9.8.30.

#### 9.4.11.1.4 Test description

##### 9.4.11.1.4.1 Initial conditions

Same as in clause 9.4.10.1.4.1 but replacing Table 9.4.10.1.4.1-1 with Table 9.4.11.1.4.1-1

**Table 9.4.11.1.4.1-1: General test parameters for E-UTRAN HD-FDD inter-frequency RSTD measurement Accuracy under fading propagation conditions**

Parameter	Unit	Value	Comment
		Test 1	
MPDCCH		R.8 HD-FDD	As specified in TS 36.521-3 [25] clause A.7.2
<i>mPDCCH-startSF-UeSS</i>		10	Parameter $G$ in $T = r_{\max} \cdot G$ which determines subframe $k0$ in which MPDCCH starts
Reference cell		Cell 1	Reference cell is the cell in the OTDOA assistance data with respect to which the RSTD measurement is defined, as specified in 3GPP TS 36.214 [6] and 3GPP TS 36.355 [4]. The reference cell is the serving cell in this test case.
Neighbour cell		Cell 2	One carrier frequency is used.
E-UTRA RF Channel Number		1	
Channel Bandwidth ( $BW_{\text{channel}}$ )	MHz	10	
PRS Transmission Bandwidth <sup>Note 2</sup>	RB	50 <sup>Note 4</sup>	PRS are transmitted over the system bandwidth
Number of consecutive downlink positioning subframes $N_{\text{PRS}}$ <sup>Note 2</sup>		4	As defined in 3GPP TS 36.211 [26]. The number of subframes in a positioning occasion
PRS muting info <sup>Note 2</sup>		Cell 1: '11110000' Cell 2: '11110000'	Corresponds to prs-MutingInfo defined in TS 36.355 [4]
Physical cell ID PCI <sup>Note 2</sup>		(Cell ID of cell 1 – Cell ID of cell 2) mod 6 = 0	
prs-SubframeOffset		10	Number of subframes rounded to the closest integer. The corresponding parameter in the OTDOA assistance data is prs-SubframeOffset specified in TS 36.355 [4]
slotNumberOffset		0	The slot number offset at the transmitter between a neighbour cell and the assistance data reference cell specified in TS 36.355 [4]
Expected RSTD <sup>Note 1</sup>	$\mu\text{s}$	Cell 2: 1 Other neighbour cells: randomly between -3 and 3	The expected RSTD is what is expected at the receiver. The corresponding parameter in the OTDOA assistance data specified in TS 36.355 [4] is the expectedRSTD indicator
Expected RSTD uncertainty for all neighbour cells <sup>Note 1</sup>	$\mu\text{s}$	5	The corresponding parameter in the OTDOA assistance data specified in TS 36.355 [4] is the expectedRSTD-Uncertainty index
CP length <sup>Note 2</sup>		Normal	
DRX		OFF	
Radio frame receive time offset between the cells at the UE antenna connector <sup>Note 3</sup>	$\mu\text{s}$	Cell 2 to Cell 1: -3	PRS are transmitted from synchronous cells
Number of cells provided in OTDOA assistance data		16	Including the reference cell
$T_{\text{RSTD InterFreqHD-FDD, E-UTRAN}}$	ms	40960	Derived according to the RSTD measurement requirements specified in section 9.4.10.1.3

Note 1:	Parameters “Expected RSTD” and “Expected RSTD uncertainty for all neighbour cells” are not settable parameters. These are parameters signalled in LPP only. For the values to be used in LPP see Table 9.4.10.1.4.3-5 and TS 37.571-5 [20], clause 7.2.5.
Note 2:	Parameters “PRS Transmission Bandwidth”, “PRS configuration index”, “Number of consecutive positioning downlink subframes”, “prs-MutingInfo”, “Cell ID” and “CP length” are settable parameters and also parameters signalled in LPP. The values to be used for “Cell ID” are as follows: Cell 1: 0, Cell 2: Test 1: 6, Test 2: 7, Test 3: 6, Test 4: 9. For all the values to be used in LPP see Table 9.4.10.1.4.3-4 and TS 37.571-5 [20], clause 7.2.5.
Note 3:	The parameter “Radio frame receive time offset between the cells at the UE antenna connector” is not a settable parameter but is used to set the “true RSTD” values in step 6 of clause 9.4.10.1.4.1.
Note 4:	If the PRS transmission bandwidth is larger than the UE RF bandwidth, the UE is measuring RSTD within its RF bandwidth.
Note 5:	The parameter “ $T_{\text{RSTD InterFreqHD-FDD, E-UTRAN}}$ ” is not a settable parameter but is used to set the LPP “time” value in Table 9.4.10.2.4.3-1. The value of the LPP time IE is set to $T_{\text{RSTD InterFreqHD-FDD, E-UTRAN}} + \Delta T$ ms, where $\Delta T = 150$ ms, giving a value of 41210 ms. This is rounded up to the next allowed LPP value of 42 seconds.

#### 9.4.11.1.4.2 Test procedure

Same as in clause 9.4.7.1.4.2 but using condition CEModeB.

#### 9.4.11.1.4.3 Message contents

Same as in clause 9.4.10.1.4.3.

#### 9.4.11.1.5 Test requirement

Same as in clause 9.4.10.1.5.

### 9.4.11.2 HD-FDD inter-frequency RSTD Measurement Accuracy in CE Mode B for Cat M2

**Editor’s note: This test is incomplete. The following aspects are missing:**

**TBD in TS 36.133 how to capture prsOccGroupLength in the measurement period**

**Assistance Data in TS 37.571-5 is missing**

#### 9.4.11.2.1 Test purpose

To verify that the RSTD measurement accuracy for UE Category M2 is within the specified limits enhanced coverage mode in an environment with fading propagation conditions.

#### 9.4.11.2.2 Test applicability

This test applies to E-UTRA HD-FDD UE Category M2 release 14 and forward that supports UE-assisted OTDOA, inter-frequency RSTD measurements and CE Mode B.

#### 9.4.11.2.3 Minimum conformance requirements

Same as in clause 9.4.10.2.3.

The normative reference for this requirement is TS 36.133 [23] clause 9.1.25.2 and A.9.8.30.

#### 9.4.11.2.4 Test description

##### 9.4.11.2.4.1 Initial conditions

Same as in clause 9.4.10.2.4.1 but replacing Table 9.4.10.2.4.1-1 with Table 9.4.11.2.4.1-1.



**Table 9.4.11.2.4.1-1: General test parameters for E-UTRAN HD-FDD inter-frequency RSTD measurement Accuracy under fading propagation conditions**

Parameter	Unit	Value		Comment
		Test1	Test3	
M-PDCCH parameters		R.8 HD-FDD	R.8 HD-FDD	As specified in TS 36.521-3 [25] clause A.7.1.
<i>mPDCCH-startSF-UESS</i>		10	10	Parameter $G$ in $T = r_{\max} \cdot G$ which determines subframe $k0$ in which MPDCCH starts
Reference cell		Cell 1		
Neighbour cell		Cell 2		
E-UTRA RF Channel Number		1		One carrier frequency is used.
System channel Bandwidth ( $BW_{\text{channel}}$ )	MHz	10	10	
PRS Transmission Bandwidth <sup>Note 2</sup>	RB	50 <sup>Note 4</sup>	50 <sup>Note 4</sup>	PRS bandwidth is as indicated in <i>prs-Bandwidth</i> in the OTDOA assistance data defined in TS 36.355 [4].
Number of consecutive positioning downlink subframes $N_{\text{PRS}}$ <sup>Note 2</sup>		4	2	As defined in TS 36.211 [26]
prs-MutingInfo <sup>Note 2</sup>		Cell 1: '11110000' Cell 2: '11110000'		See section 6.5.1.2 in 3GPP TS 36.355 [4] for more information
Cell ID <sup>Note 2</sup>		(Cell ID of cell 1 – Cell ID of cell 2) mod 6 = 0	(Cell ID of cell 1 – Cell ID of cell 2) mod 6 = 0	
prs-SubframeOffset		10	10	Number of subframes rounded to the closest integer. The corresponding parameter in the OTDOA assistance data is prs-SubframeOffset specified in TS 36.355 [4]
slotNumberOffset		0	0	The slot number offset at the transmitter between a neighbour cell and the assistance data reference cell specified in TS 36.355 [4]
Expected RSTD <sup>Note 1</sup>	$\mu\text{s}$	Cell 2: 1 Other neighbour cells: randomly between -3 and 3	Cell 2: -1 Other neighbour cells: randomly between -3 and 3	
Expected RSTD uncertainty for all neighbour cells <sup>Note 1</sup>	$\mu\text{s}$	5	5	
CP length <sup>Note 2</sup>		Normal		
DRX		OFF		
Radio frame receive time offset between the cells at the UE antenna connector <sup>Note 3</sup>	$\mu\text{s}$	Cell 2 to Cell 1: -3	Cell 2 to Cell 1: 3	PRS are transmitted from synchronous cells
Number of cells provided in OTDOA assistance data		16		The number of cells includes the reference cell
$T_{\text{RSTD InterFreqHD-FDD, E-UTRAN}}$ <sup>Note 5</sup>	ms	40960	10240	Derived according to the RSTD measurement requirements specified in section 9.4.10.2.3

NOTE 1: Parameters “Expected RSTD” and “Expected RSTD uncertainty for all neighbour cells” are not settable parameters. These are parameters signalled in LPP only. For the values to be used in LPP see Table 9.4.10.1.4.3-4 and TS 37.571-5 [20], clause 7.2.5.

NOTE 2: Parameters “PRS Transmission Bandwidth”, “PRS configuration index”, “Number of consecutive positioning downlink subframes”, “prs-MutingInfo”, “Cell ID” and “CP length” are settable parameters and also parameters signalled in LPP. The values to be used for “Cell ID” are as follows: Cell 1: 0, Cell 2: Test 1: 6, Test 2: 7, Test 3: 6, Test 4: 9. For all the values to be used in LPP see Table 9.4.10.1.4.3-4 and TS 37.571-5 [20], clause 7.2.5.

NOTE 3: The parameter “Radio frame receive time offset between the cells at the UE antenna connector” is not a settable parameter but is used to set the “true RSTD” values in step 6 of clause 9.1.3.4.1.

NOTE 4: If the PRS transmission bandwidth is larger than the UE RF bandwidth, the UE is measuring RSTD within its RF bandwidth.

NOTE 5: The parameter “ $T_{\text{RSTD InterFreqHD-FDD, E-UTRAN}}$ ” is not a settable parameter but is used to set the LPP “time” value in Table 9.4.10.1.4.3-3. The value of the LPP time IE is set to  $T_{\text{RSTD InterFreqHD-FDD, E-UTRAN}} + \Delta T$  ms, where  $\Delta T = 150$  ms, giving a value of 41210 ms for Test and 10390 ms for Test 2. This is rounded up to the next allowed LPP value of 42 and 11 seconds, respectively.

#### 9.4.11.2.4.2 Test procedure

Same as in clause 9.4.7.1.4.2 but using condition CEModeB.

#### 9.4.11.2.4.3 Message contents

Same as in clause 9.4.10.2.4.3.

#### 9.4.11.2.5 Test requirement

Same as in clause 9.4.10.2.5.

For the overall test to pass, the ratio of successful reported values in each sub-test shall be more than 90% with a confidence level of 95%.

## 9.4.12 TDD inter-frequency RSTD Measurement Accuracy in CE Mode B

### 9.4.12.1 TDD inter-frequency RSTD Measurement Accuracy in CE Mode B for Cat M1

**Editor’s note: This test is incomplete. The following aspects are missing:**

**Requirements in TS 36.133 are partially missing**

**Assistance Data in TS 37.571-5 is missing**

#### 9.4.12.1.1 Test purpose

To verify that the RSTD measurement accuracy for UE Category M1 is within the specified limits in enhanced coverage mode in an environment with fading propagation conditions.

#### 9.4.12.1.2 Test applicability

This test applies to E-UTRA TDD UE Category M1 release 14 and forward that supports UE-assisted OTDOA, inter-frequency RSTD measurements and CE Mode B.

#### 9.4.12.1.3 Minimum conformance requirements

Same as in clause 9.4.10.1.3.

The normative reference for this requirement is TS 36.133 [23] clause 9.1.21.18 and A.9.8.31.

#### 9.4.12.1.4 Test description

##### 9.4.12.1.4.1 Initial conditions

Same as in clause 9.4.10.1.4.1 but replacing Table 9.4.10.1.4.1-1 with Table 9.4.12.1.4.1-1

**Table 9.4.12.1.4.1-1: General test parameters for E-UTRAN TDD inter-frequency RSTD measurement  
Accuracy under fading propagation conditions**

Parameter	Unit	Value	Comment
		Test 1	
MPDCCH		R.16 TDD	As specified in TS 36.521-3 [25] clause A.7.3
<i>mPDCCH-startSF-U ESS</i>		10	Parameter $G$ in $T = r_{\max} \cdot G$ which determines subframe $k0$ in which MPDCCH starts
Reference cell		Cell 1	Reference cell is the cell in the OTDOA assistance data with respect to which the RSTD measurement is defined, as specified in 3GPP TS 36.214 [6] and 3GPP TS 36.355 [4]. The reference cell is the serving cell in this test case.
Neighbour cell		Cell 2	One carrier frequency is used.
E-UTRA RF Channel Number		1	
Channel Bandwidth ( $BW_{\text{channel}}$ )	MHz	10	
PRS Transmission Bandwidth <sup>Note 2</sup>	RB	50 <sup>Note 4</sup>	PRS are transmitted over the system bandwidth
Number of consecutive downlink positioning subframes $N_{\text{PRS}}$ <sup>Note 2</sup>		4	As defined in 3GPP TS 36.211 [26]. The number of subframes in a positioning occasion
PRS muting info <sup>Note 2</sup>		Cell 1: '11110000' Cell 2: '11110000'	Corresponds to prs-MutingInfo defined in TS 36.355 [4]
Physical cell ID PCI <sup>Note 2</sup>		(Cell ID of cell 1 – Cell ID of cell 2) mod 6 = 0	
prs-SubframeOffset		10	Number of subframes rounded to the closest integer. The corresponding parameter in the OTDOA assistance data is prs-SubframeOffset specified in TS 36.355 [4]
slotNumberOffset		0	The slot number offset at the transmitter between a neighbour cell and the assistance data reference cell specified in TS 36.355 [4]
Expected RSTD <sup>Note 1</sup>	$\mu\text{s}$	Cell 2: 1 Other neighbour cells: randomly between -3 and 3	The expected RSTD is what is expected at the receiver. The corresponding parameter in the OTDOA assistance data specified in TS 36.355 [4] is the expectedRSTD indicator
Expected RSTD uncertainty for all neighbour cells <sup>Note 1</sup>	$\mu\text{s}$	5	The corresponding parameter in the OTDOA assistance data specified in TS 36.355 [4] is the expectedRSTD-Uncertainty index
TDD uplink-downlink configuration		1	As specified in TS 36.211 [26], Clause 4.2; corresponds to a configuration with 5 ms switch-point periodicity and two downlink consecutive subframes
TDD special subframe configuration		6	As specified in TS 36.211 [26], Clause 4.2; corresponds to DwPTS of $19760 \cdot T_s$ and UpPTS of $4384 \cdot T_s$
CP length <sup>Note 2</sup>		Normal	
DRX		OFF	
Radio frame receive time offset between the cells at the UE antenna connector <sup>Note 3</sup>	$\mu\text{s}$	Cell 2 to Cell 1: -3	PRS are transmitted from synchronous cells

Number of cells provided in OTDOA assistance data		16	Including the reference cell
$T_{RSTD \text{ InterFreqTDD, E-UTRAN}}$	ms	40960	Derived according to the RSTD measurement requirements specified in section 9.4.10.1.3
<p>Note 1: Parameters "Expected RSTD" and "Expected RSTD uncertainty for all neighbour cells" are not settable parameters. These are parameters signalled in LPP only. For the values to be used in LPP see Table 9.4.10.1.4.3-5 and TS 37.571-5 [20], clause 7.2.5.</p> <p>Note 2: Parameters "PRS Transmission Bandwidth", "PRS configuration index", "Number of consecutive positioning downlink subframes", "prs-MutingInfo", "Cell ID" and "CP length" are settable parameters and also parameters signalled in LPP. The values to be used for "Cell ID" are as follows: Cell 1: 0, Cell 2: Test 1: 6, Test 2: 7, Test 3: 6, Test 4: 9. For all the values to be used in LPP see Table 9.4.10.1.4.3-4 and TS 37.571-5 [20], clause 7.2.5.</p> <p>Note 3: The parameter "Radio frame receive time offset between the cells at the UE antenna connector" is not a settable parameter but is used to set the "true RSTD" values in step 6 of clause 9.4.10.1.4.1.</p> <p>Note 4: If the PRS transmission bandwidth is larger than the UE RF bandwidth, the UE is measuring RSTD within its RF bandwidth.</p> <p>Note 5: The parameter "<math>T_{RSTD \text{ InterFreqTDD, E-UTRAN}}</math>" is not a settable parameter but is used to set the LPP "time" value in Table 9.4.10.1.4.3-3. The value of the LPP time IE is set to <math>T_{RSTD \text{ InterFreqTDD, E-UTRAN}} + \Delta T</math> ms, where <math>\Delta T = 150</math> ms, giving a value of 41210 ms. This is rounded up to the next allowed LPP value of 42 seconds.</p>			

9.4.12.1.4.2 Test procedure

Same as in clause 9.4.7.1.4.2 but using condition CEModeB.

9.4.12.1.4.3 Message contents

Same as in clause 9.4.10.1.4.3.

9.4.12.1.5 Test requirement

Table 9.4.12.1.5-1 defines the primary level settings including test tolerances for the test.

The RSTD TDD inter-frequency accuracy test shall meet the reported values in Table 9.4.12.1.5-2

**Table 9.4.12.1.5-1: Cell Specific Test Parameters for inter frequency RSTD Tests for E-UTRAN TDD**

Parameter	Unit	Test1		Test2	
		Cell1	Cell2	Cell1	Cell2
E-UTRA RF Channel Number		1	2	1	2
Gap offset		9	N/A	9	N/A
Gap pattern		#0	N/A	#0	N/A
OCNG Patterns defined in TS 36.521-3 [25] clause D.1		OP.11 TDD	OP.2 TDD	OP.11 TDD	OP.2 TDD
PRS configuration Index $I_{PRS}$ , as defined in TS 36.211 [26]		142	152	142	152
PBCH_RA	dB	0	0	0	0
PBCH_RB					
PSS_RA					
SSS_RA					
MPDCCH_RA					
MPDCCH_RB					
OCNG_RA <sup>Note1</sup>					
OCNG_RB <sup>Note1</sup>					
PRS_RA					
$N_{oc}$ <sup>Note2</sup>	dBm/15 kHz	-98	-98	-98	-98
PRS $\hat{E}_s/N_{oc}$	dB	-11	-14	-11	-14
PRS $\hat{E}_s/I_{ot}$ <sup>Note3</sup>	dB	-11	-14	-11	-14
$I_o$ <sup>Note3</sup>	dBm/9 MHz	-70.16	-70.19	-70.16	-70.19
PRP <sup>Note3</sup>	dBm/15kHz	-109	-112	-109	-112
$\hat{E}_s/N_{oc}$ <sup>Note 3</sup>	dB	-11	-14	-11	-14
RSRP <sup>Note 3</sup>	dBm/15kHz	-109	-112	-109	-112
Propagation condition		AWGN			
<p>Note 1: OCNG shall be used such that both cells are fully allocated and a constant total transmitted power spectral density is achieved for all OFDM symbols (other than those in the PRS subframes).</p> <p>Note 2: Interference from other cells and noise sources not specified in the test is assumed to be constant over subcarriers and time and shall be modelled as AWGN of appropriate power for <math>N_{oc}</math> to be fulfilled.</p> <p>Note 3: <math>\hat{E}_s/N_{oc}</math>, PRS <math>\hat{E}_s/I_{ot}</math>, <math>I_o</math>, RSRP and PRP levels have been derived from other parameters for information purposes. They are not settable parameters themselves. <math>I_o</math> values are derived in the case that there is no PBCH, PSS or SSS in the OFDM symbols carrying PRS</p>					

**Table 9.4.12.1.5-2: RSTD TDD inter-frequency accuracy requirements for the reported values**

	Test 1
Lowest reported value	[RSTD_6443]
Highest reported value	[RSTD_6485]

The test tolerances are defined in clauses C.1.3 and C4.

For the overall test to pass, the ratio of successful reported values in each sub-test shall be more than 90% with a confidence level of 95%.

**9.4.12.2 TDD inter-frequency RSTD Measurement Accuracy in CE Mode B for Cat M2**

**Editor’s note: This test is incomplete. The following aspects are missing:**

**Requirements in TS 36.133 are partially missing**

**Assistance Data in TS 37.571-5 is missing**

**9.4.12.2.1 Test purpose**

To verify that the RSTD measurement accuracy for UE Category M2 is within the specified limits in enhanced coverage mode in an environment with fading propagation conditions.

#### 9.4.12.2.2 Test applicability

This test applies to E-UTRA TDD UE Category M2 release 14 and forward that supports UE-assisted OTDOA, inter-frequency RSTD measurements and CE Mode B.

#### 9.4.12.2.3 Minimum conformance requirements

Same as in clause 9.4.10.1.3.

The normative reference for this requirement is TS 36.133 [23] clause 9.1.25.2 and A.9.8.31.

#### 9.4.12.2.4 Test description

##### 9.4.12.2.4.1 Initial conditions

Same as in clause 9.4.10.2.4.1 but replacing Table 9.4.10.2.4.1-1 with Table 9.4.12.2.4.1-1.



**Table 9.4.12.2.4.1-1: General test parameters for E-UTRAN TDD inter-frequency RSTD measurement  
Accuracy under fading propagation conditions**

Parameter	Unit	Value		Comment
		Test1	Test3	
M-PDCCH parameters		R.16 TDD	R.16 TDD	As specified in TS 36.521-3 [25] clause A.7.3.
<i>mPDCCH-startSF-UESS</i>		10	10	Parameter $G$ in $T = r_{\max} \cdot G$ which determines subframe $k0$ in which MPDCCH starts
Reference cell		Cell 1		
Neighbour cell		Cell 2		
E-UTRA RF Channel Number		1		One carrier frequency is used.
System channel Bandwidth ( $BW_{\text{channel}}$ )	MHz	10	10	
PRS Transmission Bandwidth <sup>Note 2</sup>	RB	50 <sup>Note 4</sup>	50 <sup>Note 4</sup>	PRS bandwidth is as indicated in <i>prs-Bandwidth</i> in the OTDOA assistance data defined in TS 36.355 [4].
Number of consecutive positioning downlink subframes $N_{\text{PRS}}$ <sup>Note 2</sup>		4	2	As defined in TS 36.211 [26]
prs-MutingInfo <sup>Note 2</sup>		Cell 1: '11110000' Cell 2: '11110000'		See section 6.5.1.2 in 3GPP TS 36.355 [4] for more information
Cell ID <sup>Note 2</sup>		(Cell ID of cell 1 – Cell ID of cell 2) mod 6 = 0	(Cell ID of cell 1 – Cell ID of cell 2) mod 6 = 0	
prs-SubframeOffset		10	10	Number of subframes rounded to the closest integer. The corresponding parameter in the OTDOA assistance data is prs-SubframeOffset specified in TS 36.355 [4]
slotNumberOffset		0	0	The slot number offset at the transmitter between a neighbour cell and the assistance data reference cell specified in TS 36.355 [4]
Expected RSTD <sup>Note 1</sup>	$\mu\text{s}$	Cell 2: 1 Other neighbour cells: randomly between -3 and 3	Cell 2: -1 Other neighbour cells: randomly between -3 and 3	
Expected RSTD uncertainty for all neighbour cells <sup>Note 1</sup>	$\mu\text{s}$	5	5	
TDD uplink-downlink configuration		1		As specified in TS 36.211 [26], Clause 4.2; corresponds to a configuration with 5 ms switch-point periodicity and two downlink consecutive subframes
TDD special subframe configuration		6		As specified in TS 36.211 [26], Clause 4.2; corresponds to DwPTS of $19760 \cdot T_s$ and UpPTS of $4384 \cdot T_s$
CP length <sup>Note 2</sup>		Normal		
DRX		OFF		
Radio frame receive time offset between the cells at the UE antenna connector <sup>Note 3</sup>	$\mu\text{s}$	Cell 2 to Cell 1: -3	Cell 2 to Cell 1: 3	PRS are transmitted from synchronous cells
Number of cells provided in OTDOA assistance data		16		The number of cells includes the reference cell
$T_{\text{RSTD InterFreqTDD, E-UTRAN}}$ <sup>Note 5</sup>	ms	40960	10240	Derived according to the RSTD measurement requirements specified in section 9.4.10.2.3

NOTE 1:	Parameters “Expected RSTD” and “Expected RSTD uncertainty for all neighbour cells” are not settable parameters. These are parameters signalled in LPP only. For the values to be used in LPP see Table 9.4.10.1.4.3-4 and TS 37.571-5 [20], clause 7.2.5.
NOTE 2:	Parameters “PRS Transmission Bandwidth”, “PRS configuration index”, “Number of consecutive positioning downlink subframes”, “prs-MutingInfo”, “Cell ID” and “CP length” are settable parameters and also parameters signalled in LPP. The values to be used for “Cell ID” are as follows: Cell 1: 0, Cell 2: Test 1: 6, Test 2: 7, Test 3: 6, Test 4: 9. For all the values to be used in LPP see Table 9.4.10.1.4.3-4 and TS 37.571-5 [20], clause 7.2.5.
NOTE 3:	The parameter “Radio frame receive time offset between the cells at the UE antenna connector” is not a settable parameter but is used to set the “true RSTD” values in step 6 of clause 9.1.3.4.1.
NOTE 4:	If the PRS transmission bandwidth is larger than the UE RF bandwidth, the UE is measuring RSTD within its RF bandwidth.
NOTE 5:	The parameter “ $T_{\text{RSTD InterFreqTDD, E-UTRAN}}$ ” is not a settable parameter but is used to set the LPP “time” value in Table 9.4.10.2.4.3-1. The value of the LPP time IE is set to $T_{\text{RSTD InterFreqTDD, E-UTRAN}} + \Delta T$ ms, where $\Delta T = 150$ ms, giving a value of 41210 ms for Test and 10390 ms for Test 2. This is rounded up to the next allowed LPP value of 42 and 11 seconds, respectively.

#### 9.4.12.2.4.2 Test procedure

Same as in clause 9.4.7.1.4.2 but using condition CEModeB.

#### 9.4.12.2.4.3 Message contents

Same as in clause 9.4.10.1.4.3.

#### 9.4.12.2.5 Test requirement

Same as in clause 9.4.12.1.5 but replacing Table 9.4.12.1.5-2 with Table 9.4.12.2.5-1:

**Table 9.4.12.2.5-1: RSTD TDD inter-frequency accuracy requirements for the reported values**

	Test 1	Test 2
Lowest reported value	[RSTD_6443]	[RSTD_6428]
Highest reported value	[RSTD_6485]	[RSTD_6466]

For the overall test to pass, the ratio of successful reported values in each sub-test shall be more than 90% with a confidence level of 95%.

## 9.5 HD-FDD RSTD Intra-Frequency Measurements

### 9.5.1 HD-FDD Intra frequency RSTD Measurement Accuracy for NB-IOT Inband Mode in normal coverage

#### 9.5.1.1 Test purpose

To verify that the RSTD HD-FDD intra-frequency measurement accuracy is within the specified limits for NB-IOT Inband Mode in normal coverage.

#### 9.5.1.2 Test applicability

This test applies to E-UTRA HD-FDD UE release 14 and forward of UE Category NB1 that supports UE-assisted OTDOA.

#### 9.5.1.3 Minimum conformance requirements

UE shall follow the procedure for idle state positioning measurement as defined in TS 36.305 [41] section 7.1.3.

When the physical layer cell identities of neighbour cells together with the OTDOA assistance data are provided and when the UE has entered the idle state, the UE shall be able to detect and measure intra-frequency RSTD, specified in TS 36.214 [6], for at least  $n = 16$  cells, including the reference cell, on the same carrier frequency  $f_1$  as that of the reference cell within  $T_{\text{RSTD IntraFreq, NB}}$  ms as given below:

$$T_{\text{RSTD IntraFreq,NB}} = T_{\text{NPRS}} \cdot (M-1) + \Delta \quad \text{ms},$$

where

$T_{\text{RSTD IntraFreq,NB}}$  is the total time for detecting and measuring at least  $n$  cells;

$T_{\text{NPRS}}$  is the cell-specific positioning subframe configuration period as defined in TS 36.355 [4] if Part B subframe configuration is provided; otherwise if only Part A subframe configuration is provided, the  $T_{\text{NPRS}}$  equals to the length of the subframe pattern,

$M$  is the number of NPRS positioning occasions as defined in Table 9.5.1.3-1,

$\Delta = T_{\text{NPRS}} \cdot \left\lceil \frac{n}{M} \right\rceil$  ms is the measurement time for a single NPRS positioning occasion which includes the sampling time and the processing time;

$N_{\text{NPRS}}$  is the cell-specific number of NPRS subframes within a NPRS occasion as defined in TS 36.355[4] if Part B subframe configuration is provided; if only Part A subframe configuration is provided, the NPRS occasion length is 10 ms,

$N_{\text{NPRS\_total}}$  is the minimum number of NPRS subframes per cell measurement as defined in Table 9.5.1.3-2.

$T_{\text{NPRS}}$ ,  $N_{\text{NPRS}}$ , and  $N_{\text{NPRS\_total}}$  are the parameters of the same cell, for which  $T_{\text{NPRS}} \cdot \left\lceil \frac{N_{\text{NPRS\_total}}}{N_{\text{NPRS}}} \right\rceil$  is the largest among all the measured cells.

**Table 9.5.1.3-1: Number of NPRS positioning occasions within  $T_{\text{RSTD IntraFreq,NB}}$**

Positioning subframe configuration period $T_{\text{NPRS}}$	Number of NPRS positioning occasions $M$	
	f1 <sup>Note1</sup>	f1 and f2 <sup>Note2</sup>
160 ms	16* $\lceil N_{\text{NPRS\_total}} / N_{\text{NPRS}} \rceil$	32* $\lceil N_{\text{NPRS\_total}} / N_{\text{NPRS}} \rceil$
>160 ms	8* $\lceil N_{\text{NPRS\_total}} / N_{\text{NPRS}} \rceil$	16* $\lceil N_{\text{NPRS\_total}} / N_{\text{NPRS}} \rceil$
Note 1: When only intra-frequency RSTD measurements are performed over cells belonging to the serving carrier frequency f1. Note 2: When intra-frequency RSTD and inter-frequency RSTD measurements are performed over cells belonging to the serving carrier frequency f1 and one inter-frequency carrier frequency f2, respectively.		

The UE physical layer shall be capable of reporting RSTD for the reference cell and all the neighbour cells  $i$  out of at least  $(n-1)$  neighbour cells within  $T_{\text{RSTD IntraFreq,NB}}$  provided:

$$\left( \text{NPRS } \hat{E}_s / \text{Iot} \right)_{\text{ref}} \geq -15 \text{ dB for all Frequency Bands for the reference cell,}$$

$$\left( \text{NPRS } \hat{E}_s / \text{Iot} \right)_i \geq -15 \text{ dB for all Frequency Bands for neighbour cell } i,$$

$$\left( \text{NPRS } \hat{E}_s / \text{Iot} \right)_{\text{ref}} \text{ and } \left( \text{NPRS } \hat{E}_s / \text{Iot} \right)_i \text{ conditions apply for all subframes of at least } L = \frac{M}{2} \text{ NPRS}$$

positioning occasions,

NPRP 1,2<sub>dBm</sub> according to Annex E.5 for a corresponding Band

$NPRS \hat{E}_s / I_{ot}$  is defined as the ratio of the average received energy per PRS RE during the useful part of the symbol to the average received power spectral density of the total noise and interference for this RE, where the ratio is measured over all REs which carry NPRS.

The time  $T_{RSTD \text{ IntraFreq, NB}}$  starts from the point when UE receive both the OTDOA-RequestLocationInformation message and the OTDOA assistance data in the OTDOA-ProvideAssistanceData message as specified in TS 36.355 [4], are delivered to the physical layer of the UE.

The accuracy requirements in Table 9.5.1.3-2 are valid under the following conditions:

Conditions defined in 36.101 [2] Clause 7.3 for reference sensitivity are fulfilled.

NPRP 1,2<sub>dBm</sub> according to Annex E.5 for a corresponding Band

There are no measurement gaps overlapping with the NPRS subframes of the measured serving cell.

The parameter expectedRSTDUncertainty signalled over LPP by E-SMLC as defined in TS 36.355 [4] is less than 5  $\mu$ s.

**Table 9.5.1.3-2: Intra RSTD measurement accuracy for normal coverage**

Accuracy	Conditions					
	NPRS $\hat{E}_s / I_{ot}$	UE NPRS measurement bandwidth on the reference cell and the measured neighbour cell $j$ <sup>Note 3</sup>	Minimum number of available measurement subframes among the reference cell and the measured neighbour cell $i$ , $N_{NPRS\_total}$ <sup>Note 6</sup>	$I_{o}$ <sup>Note 7</sup> range		
				E-UTRA operating band groups <sup>Note 7</sup>	Minimum $I_{o}$ <sup>Note 1</sup>	Maximum $I_{o}$
$T_s$ <sup>Note 2</sup>	dB	RB		dBm/15kHz	dBm/BW <sub>Channel</sub>	
$\pm 20$	$(NPRS \hat{E}_s / I_{ot})_{ref} \geq -6$ dB and $(NPRS \hat{E}_s / I_{ot})_i \geq -13$ dB	1	320	NFDD_G	-118	-70

NOTE 1: This minimum  $I_o$  condition is expressed as the average  $I_o$  per RE over all REs in an OFDM symbol.  
 NOTE 2:  $T_s$  is the basic timing unit defined in TS 36.211 [26].  
 NOTE 3: The serving cell, the reference cell, and the measured neighbour cell  $i$  are on the same carrier frequency.  
 NOTE 4: The  $I_o$  is defined in NPRS positioning subframes. The same  $I_o$  range applies to NPRS and non-NPRS symbols.  $I_o$  levels are different in NPRS and non-NPRS symbols within the same subframe.  
 NOTE 5: E-UTRA operating band groups are as defined in Section 3.5.  
 NOTE 6:  $N_{NPRS\_total}$  can be in one or more NPRS positioning occasions.

The normative reference for this requirement is TS 36.133 [23] clauses 4.8.1, 9.1.22.10 and A.9.8.16.

**9.5.1.4 Test description**

**9.5.1.4.1 Initial conditions**

Test Environment: Normal; as defined in TS 36.508 [18] clause 8.1.1.

Frequencies to be tested: Mid Range, as defined in TS 36.508 [18] clause 8.1.3.1.1.

Channel bandwidth to be tested: 10 MHz. If the band under test does not support 10 MHz bandwidth, 5 MHz shall be used.

1. Connect the SS and AWGN noise sources to the UE antenna connector or antenna connectors as shown in Annex A, Figure A.3 but using only the main TX/RX antenna.
2. The general test parameter settings are set up according to Table 9.5.1.4.1-1.
3. Propagation conditions are set according to clause 4.7.2.1.
4. Message contents are defined in clause 9.5.1.4.3.
5. All cells are on the same carrier frequency. nCell 1 is the serving cell and OTDOA assistance data reference cell; nCell 2 is the neighbour cell. eCell 1 and eCell 2 are the LTE donor cells to nCell 1 and nCell 2, respectively. The assistance data neighbour cell list includes in total 15 cells, where 14 of the cells are not simulated (dummy cells; as defined in 3GPP TS 37.571-5 [20], clause 7.2.2).
6. The true RSTD (which is the receive time difference for frame 0 between nCell 2 and nCell 1 as seen at the UE antenna connector) is set to 92 Ts (about 3  $\mu$ s). Note that the related expectedRSTD values to be signalled over LPP are defined in Table 9.5.1.4-1.

**Table 9.5.1.4-1: General test parameters**

Parameter	Unit	Value	Comment
NB-IoT operational mode		Inband	
Reference cell		nCell 1	
Neighbor cells		nCell 2, eCell 2 and eCell 1	
NPDCCH parameters		R.26 HD-FDD	As defined in TS 36.133 [23] section A.3.1.6.1
NOCNG pattern		NOP.1 FDD	As defined in TS 36.133 [23] section A.3.2.3.1
nprsID		Test1: (nprsID of Cell 1 – nprsID of Cell 2)mod6=1	As defined in TS36.355 [4]
nprs-period	ms	1280	As defined in TS36.355 [4]
nprs-startSF		sf0	Subframe offset of the NPRS positioning occasion as defined in TS36.355 [4]
Number of consecutive downlink positioning subframes nprs-NumSF		640	As defined in TS36.355 [4]
NPRS muting info		nCell 1: '11110000' nCell 2: '11110000'	Corresponds to nprs-MutingInfoB defined in TS 36.355 [4]
PartA Configuration		as in the following 2 rows	
subframePattern10		'0111001110'	Corresponds to subframePattern10-r14 defined in TS 36.355 [4]
nprsSequenceInfo		BW <sub>channel</sub> 5MHz: 54 BW <sub>channel</sub> 10MHz: 130	Corresponds to nprsSequenceInfo defined in TS 36.355 [4]
CP length		Normal	
NPRACH Configuration		NPRACH.R-1	Refer to TS 36.133 [23] section A.3.18
DRX cycle length		1.28	The value shall be used for all cells in the test.
Expected RSTD	$\mu$ s	nCell 2: 3 Other neighbour cells: randomly between -3 and 3	The expected RSTD is what is expected at the receiver. The corresponding parameter in the OTDOA assistance data specified in TS 36.355 [4] is the expectedRSTD indicator
Expected RSTD uncertainty for all neighbour cells	$\mu$ s	5	The corresponding parameter in the OTDOA assistance data specified in TS 36.355 [4] is the expectedRSTD-Uncertainty index
Number of cells provided in OTDOA assistance data		16	Including the reference cell
Measurement period	s	11.52	Derived according to the RSTD measurement period in clause 9.5.1.3

#### 9.5.1.4.2 Test procedure

The test consists of a set-up period and a measurement period. nCell 1 and nCell 2 (and their LTE donor cells eCell 1 and eCell 2) are active during the complete test. The beginning of the measurement period shall be aligned with the first PRS positioning subframe of a positioning occasion in the reference cell.

NOTE: The information on when PRS is muted is conveyed to the UE using PRS muting information in the OTDOA assistance data.

The OTDOA-RequestLocationInformation message and the OTDOA assistance data as defined in clause 9.5.1.4.3 shall be provided to the UE during the set-up period. The last TTI containing the OTDOA-RequestLocationInformation message shall be provided to the UE  $\Delta T$  ms before the start of the measurement period, where  $\Delta T = 150$  ms is the maximum processing time of the OTDOA-RequestLocationInformation message and the OTDOA assistance data in the UE.

1. Ensure that the UE is in state Generic RB Established State 3A-NB with CP ClIoT optimisation according to 3GPP TS 36.508 [18] clause 8.1.5 in nCell 1.
2. The SS shall send a RESET UE POSITIONING STORED INFORMATION message.
3. Set the parameters according to Table 9.5.1.5-1 and Table 9.5.1.5-2 as appropriate. Propagation conditions are set according to clause 4.7.2.1.
4. The SS shall send an LPP REQUEST CAPABILITIES message.
5. The UE shall send an LPP PROVIDE CAPABILITIES message indicating the OTDOA capabilities supported by the UE in the *OTDOA-ProvideCapabilities* IE.
6. The SS shall send a LPP PROVIDE ASSISTANCE DATA message, including the *OTDOA-ProvideAssistanceData* IE. If the UE message at step 5 includes the *ackRequested* IE set to TRUE, then the SS shall send an acknowledgment in the LPP PROVIDE ASSISTANCE DATA message.
7. The SS shall send a LPP REQUEST LOCATION INFORMATION message, including the *OTDOA-RequestLocationInformation* IE such that the UE receives the message  $\Delta T$  ms before the start of measurement period, where  $\Delta T = 150$  ms.
8. When the Inactivity Timer expires, the SS shall send a RRC Connection Release to send the UE to idle state.
9. The UE shall perform location measurements in idle state start a Mobile Originated Data Transport according to 3GPP TS 23.401 [42] clause 5.3.4B.2.
10. When the signalling connection between the UE and SS is re-established, the UE shall transmit a LPP PROVIDE LOCATION INFORMATION message, including the *OTDOA-ProvideLocationInformation* IE.
11. If the UE message at step 10 includes the *ackRequested* IE set to TRUE, the SS shall send a LPP acknowledgement message.
12. The SS shall check the *rstd* value for nCell 2 in the *OTDOA-SignalMeasurementInformation* IE according to Table 9.5.1.5-3.
13. Repeat step 2-12 until the confidence level according to Annex D is achieved.

#### 9.5.1.4.3 Message contents

Message contents are according to TS 36.508 [18] clause 8.1.4.3 and clause 8.1.6 using condition "Inband\_Same" with the following exceptions:

**Table 9.5.1.4.3-1: RESET UE POSITIONING STORED INFORMATION**

Derivation Path: 36.509 [11] clause 6.9			
Information Element	Value/remark	Comment	Condition
UE Positioning Technology	0 0 0 0 0 0 1	OTDOA	

**Table 9.5.1.4.3-1a: LPP Request Capabilities**

<b>Information Element</b>	<b>Value/remark</b>
<i>otdoa-RequestCapabilities</i>	TRUE



**Table 9.5.1.4.3-2: LPP RequestLocationInformation**

Derivation Path: 36.355 clause 6.2			
Information Element	Value/remark	Comment	Condition
LPP-Message ::= SEQUENCE {			
transactionID SEQUENCE {			
initiator	locationServer		
transactionNumber	1		
}			
endTransaction	FALSE		
sequenceNumber	Not present		
acknowledgement	Not present		
lpp-MessageBody CHOICE {			
c1 CHOICE {			
requestLocationInformation SEQUENCE {			
criticalExtensions CHOICE {			
c1 CHOICE {			
requestLocationInformation-r9 SEQUENCE {			
commonIEsRequestLocationInformation SEQUENCE {			
locationInformationType	locationMeasurementsRequired		
triggeredReporting	Not present		
periodicalReporting	Not present		
additionalInformation	onlyReturnInformationRequested		
qos SEQUENCE {			
horizontalAccuracy	Not present		
verticalCoordinateRequest	FALSE		
verticalAccuracy	Not present		
responseTime SEQUENCE {			
time	12	See Measurement Period of Table 9.5.1.4.1-1	
responseTimeEarlyFix-r12	Not present		
}			
velocityRequest	FALSE		
responseTimeNB-r14	Not present	Only required if response time shall be >128s	
}			
environment	Not present		
locationCoordinateTypes	Not present		
velocityTypes	Not present		
messageSizeLimitNB-r14	Not present		
}			
a-gnss-RequestLocationInformation	Not present		
otdoa-RequestLocationInformation SEQUENCE {			
assistanceAvailability	FALSE		
}			
ecid-RequestLocationInformation	Not present		
epdu-RequestLocationInformation	Not Present		
sensor-RequestLocationInformation-r13	Not Present		
tbs-RequestLocationInformation-r13	Not Present		
wlan-RequestLocationInformation-r13	Not Present		
bt-RequestLocationInformation-r13	Not Present		
}			
}			
}			

**Table 9.5.1.4.3-1: LPP ProvideAssistanceData**

Derivation Path: 36.355 clause 6.2			
Information Element	Value/remark	Comment	Condition
LPP-Message ::= SEQUENCE {			
transactionID SEQUENCE {			
Initiator	locationServer		
transactionNumber	(0..255)		
}			
endTransaction	TRUE		
sequenceNumber	Not present		
acknowledgement	Not present		
lpp-MessageBody CHOICE {			
c1 CHOICE {			
provideAssistanceData SEQUENCE {			
criticalExtensions CHOICE {			
c1 CHOICE {			
provideAssistanceData-r9 SEQUENCE {			
commonIEsProvideAssistanceData	Not present		
a-gnss-ProvideAssistanceData	Not present		
otdoa-ProvideAssistanceData SEQUENCE {			
otdoa-ReferenceCellInfo	Not present		
otdoa-NeighbourCellInfo	Not present		
otdoa-Error	Not present		
otdoa-ReferenceCellInfoNB-r14	As defined in TS 37.571-5 [20], clause 7.4.2.		
otdoa-NeighbourCellInfoNB-r14	As defined in TS 37.571-5 [20], clause 7.4.2.		
}			
}			
}			
}			
}			
}			
}			
}			

**9.5.1.5 Test requirement**

Table 9.5.1.5-1 and 9.5.1.5-2 define the primary level settings including test tolerances for all tests.

The RSTD FDD intra-frequency accuracy test shall meet the reported values in Table 9.5.1.5-3.

Table 9.5.1.5-1: Cell Specific Test Parameters for intra frequency RSTD Tests for NB-IOT Cells

Parameter	Unit	Test 1	
		nCell 1	nCell 2
$BW_{channel}$	kHz	180	180
PRB location within eCell		eCell 1 $BW_{channel}$ 5MHz: 17 eCell 1 $BW_{channel}$ 10MHz: 30	eCell 2 $BW_{channel}$ 5MHz: 17 eCell 2 $BW_{channel}$ 10MHz: 30
NPBCH_RA	dB	0	0
NPBCH_RB			
NPSS_RA			
NSSS_RA			
NPDCCH_RA			
NPDCCH_RB			
NPDSCH_RA			
NPDSCH_RB			
OCNG_RA <sup>Note 1</sup>			
OCNG_RB <sup>Note 1</sup>			
NPRS_RA			
$N_{oc}$ <sup>Note 2</sup>	dBm/ 15 kHz	-98	-98
$NPRS \hat{E}_s / N_{oc}$	dB	-5.7	-12.7
$NPRS \hat{E}_s / I_{ot}$ <sup>Note 3</sup>	dB	-5.7	-12.7
$I_o$ <sup>Note 3</sup>	dBm/ 180kHz	-86.89	-86.89
NPRP <sup>Note 3</sup>	dBm/ 15 kHz	-103.7	-110.7
NRSRP <sup>Note 3</sup>	dBm/ 15 kHz	-104	-111
$\hat{E}_s / N_{oc}$ <sup>Note 3</sup>	dB	-6	-13
Propagation Condition		AWGN	AWGN
Antenna Configuration		1x1	1x1
Timing offset to nCell 1	us	N/A	3
<p>Note 1: OCNG shall be used such that active cells are fully allocated and a constant total transmitted power spectral density is achieved for all OFDM symbols other than those in the subframes with transmitted NPRS.</p> <p>Note 2: Interference from other cells and noise sources not specified in the test are assumed to be constant over subcarriers and time and shall be modelled as AWGN of appropriate power for <math>N_{oc}</math> to be fulfilled.</p> <p>Note 3: If NPRS_RA is not "N/A", <math>\hat{E}_s / N_{oc}</math>, <math>NPRS \hat{E}_s / I_{ot}</math>, <math>I_o</math>, NRSRP and NPRP levels have been derived from other parameters and are given for information purpose. If NPRS_RA is "N/A", <math>I_o</math> and NRSRP levels have been derived from other parameters and are given for information purpose. These are not settable test parameters. Interference conditions shall be applied to all PRS symbols of DL positioning subframes.</p>			

Table 9.5.1.5-2: Cell Specific Test Parameters for intra frequency RSTD Tests for E-UTRA Cells

Parameter	Unit	eCell 1			eCell 2		
		T1	T2	T3	T1	T2	T3
$BW_{channel}$	MHz	5 or 10			5 or 10		
NOCNG Pattern defined in clause D.3	-	$BW_{channel}$ 5MHz: NOP.4 FDD $BW_{channel}$ 10MHz: NOP.1 FDD			$BW_{channel}$ 5MHz: NOP.4 FDD $BW_{channel}$ 10MHz: NOP.1 FDD		
PBCH_RA	dB	-3			-3		
PBCH_RB	dB						
PSS_RA	dB						
SSS_RA	dB						
PDCCH_RA	dB						
PDCCH_RB	dB						
PDSCH_RA	dB						
PDSCH_RB	dB						
OCNG_RA <sup>Note 1</sup>	dB						
OCNG_RB <sup>Note 1</sup>	dB						
$N_{oc}$ <sup>Note2</sup>	dBm/15 kHz	-98			-98		
$\hat{E}_s / N_{oc}$ <sup>Note2</sup>	dBm	3	3	3	3	3	3
Propagation Condition		AWGN			AWGN		
Antenna Configuration		1x1			1x1		
Timing offset to eCell 1	ms	-			3		
Note 1: OCNG shall be used such that the Cell is fully allocated and a constant total transmitted power spectral density is achieved for all OFDM symbols. Note 2: Interference from other cells and noise sources not specified in the test is assumed to be constant over subcarriers and time and shall be modelled as AWGN of appropriate power $N_{oc}$ .							

Table 9.5.1.5-3: RSTD HD-FDD intra-frequency accuracy requirements for the reported values

Lowest reported value	RSTD_6425
Highest reported value	RSTD_6469

For the overall test to pass, the ratio of successful reported values shall be more than 90% with a confidence level of 95%.

The expected response time is 12 s. The response time is equal to the LPP time IE value. The LPP time IE value is derived from the RSTD reporting delay plus  $\Delta T$ , where  $\Delta T = 150$  ms, giving a value of 11670 ms. This is rounded up to the next allowed LPP value of 12 seconds. The RSTD measurement reporting delay in the test is derived from the following expression,  $T_{RSTD \text{ IntraFreq,NB}} = T_{NPRS} \cdot (M-1) + \Delta$  ms, where  $T_{NPRS} = 1280$  ms,  $M = 8$

$\left| N_{NPRS\_total} / N_{NPRS} \right|$ ,  $\Delta = T_{NPRS} \cdot \left[ \frac{n}{M} \right]$ ,  $N_{NPRS\_total} = 320$  ms,  $N_{NPRS} = 640$  ms and  $n = 16$ . All the parameters are specified in clause 9.5.1.3 and Table 9.5.1.3-1. This gives the total RSTD reporting delay of 11520 ms for the 15 neighbour cells including nCell 2 with respect to the reference cell, nCell 1. This expected response time excludes any delay caused by RRC connection release before the idle mode measurement. This expected response time excludes any delay caused by establishing a signalling connection with the SS (including random access procedure) as defined in TS 36.305 [41] for LPP measurement reporting. The response time is not explicitly evaluated for this test; hence, no test tolerance values need to be applied.

## 9.5.2 HD-FDD Intra frequency RSTD Measurement Accuracy for NB-IOT Inband Mode in enhanced coverage

### 9.5.2.1 Test purpose

To verify that the RSTD HD-FDD intra-frequency measurement accuracy is within the specified limits for NB-IOT Inband Mode in enhanced coverage.

9.5.2.2 Test applicability

This test applies to E-UTRA HD-FDD UE release 14 and forward of UE Category NB1 that supports UE-assisted OTDOA.

9.5.2.3 Minimum conformance requirements

Same as clause 9.5.1.3, replacing Table 9.5.1.3-1 with Table 9.5.2.3-1 and Table 9.5.1.3-2 with Table 9.5.2.3-2.

**Table 9.5.2.3-1: Number of NPRS positioning occasions within  $T_{RSTD}$  IntraFreq, NB**

Positioning subframe configuration period $T_{NPRS}$	Number of NPRS positioning occasions $M$	
	f1 <sup>Note1</sup>	f1 and f2 <sup>Note2</sup>
160 ms	$16^* \lfloor N_{NPRS\_total} / N_{NPRS} \rfloor$	$32^* \lfloor N_{NPRS\_total} / N_{NPRS} \rfloor$
>160 ms	$8^* \lfloor N_{NPRS\_total} / N_{NPRS} \rfloor$	$16^* \lfloor N_{NPRS\_total} / N_{NPRS} \rfloor$
Note 1: When only intra-frequency RSTD measurements are performed over cells belonging to the serving carrier frequency f1. Note 2: When intra-frequency RSTD and inter-frequency RSTD measurements are performed over cells belonging to the serving carrier frequency f1 and one inter-frequency carrier frequency f2, respectively.		

**Table 9.5.2.3-2: Intra RSTD measurement accuracy for enhanced coverage**

Accuracy	Conditions					
	NPRS $\hat{E}s/lot$	UE NPRS measurement bandwidth on the reference cell and the measured neighbour cell $j$ <sup>Note 3</sup>	Minimum number of available measurement subframes among the reference cell and the measured neighbour cell $i$ , $N_{NPRS\_total}$ <sup>Note 6</sup>	$lo$ <sup>Note 7</sup> range		
E-UTRA operating band groups <sup>Note 7</sup>				Minimum $lo$ <sup>Note 1</sup>	Maximum $lo$	
$T_s$ <sup>Note 2</sup>	dB	RB		dBm/15kHz	dBm/BW <sub>Channel</sub>	
$\pm 32$	$(NPRS \hat{E}s/lot)_{ref} \geq -15dB$ and $(NPRS \hat{E}s/lot)_i \geq -15dB$	1	320	NFDD_G	-118	-70
NOTE 1: This minimum $lo$ condition is expressed as the average $lo$ per RE over all REs in an OFDM symbol. NOTE 2: $T_s$ is the basic timing unit defined in TS 36.211 [26]. NOTE 3: The serving cell, the reference cell, and the measured neighbour cell $i$ are on the same carrier frequency. NOTE 4: The $lo$ is defined in NPRS positioning subframes. The same $lo$ range applies to NPRS and non-NPRS symbols. $lo$ levels are different in NPRS and non-NPRS symbols within the same subframe. NOTE 5: E-UTRA operating band groups are as defined in Section 3.5. NOTE 6: $N_{NPRS\_total}$ can be in one or more NPRS positioning occasions.						

The normative reference for this requirement is TS 36.133 [23] clauses 4.8.2, 9.1.22.12 and A.9.8.18.

9.5.2.4 Test description

9.5.2.4.1 Initial conditions

Test Environment: Normal; as defined in TS 36.508 [18] clause 8.1.1.

Frequencies to be tested: Mid Range, as defined in TS 36.508 [18] clause 8.1.3.1.1.

Channel bandwidth to be tested: 10 MHz. If the band under test does not support 10 MHz bandwidth, 5 MHz shall be used.

1. Connect the SS and AWGN noise sources to the UE antenna connector or antenna connectors as shown in Annex A, Figure A.3 but using only the main TX/RX antenna.
2. The general test parameter settings are set up according to Table 9.5.2.4.1-1.
3. Propagation conditions are set according to clause 4.7.2.1.
4. Message contents are defined in clause 9.5.2.4.3.
5. All cells are on the same carrier frequency. nCell 1 is the serving cell and OTDOA assistance data reference cell; nCell 2 is the neighbour cell. eCell 1 and eCell 2 are the LTE donor cells to nCell 1 and nCell 2, respectively. The assistance data neighbour cell list includes in total 15 cells, where 14 of the cells are not simulated (dummy cells; as defined in 3GPP TS 37.571-5 [20], clause 7.2.2).
6. The true RSTD (which is the receive time difference for frame 0 between nCell 2 and nCell 1 as seen at the UE antenna connector) is set to 92 Ts (about 3  $\mu$ s). Note that the related expectedRSTD values to be signalled over LPP are defined in Table 9.5.2.4-1.

Table 9.5.2.4-1: General test parameters

Parameter	Unit	Value	Comment
NB-IoT operational mode		Inband	
Reference cell		nCell 1	
Neighbor cells		nCell 2, eCell 2 and eCell 1	
NPDCCH parameters		R.26 HD-FDD	As defined in TS 36.133 [23] section A.3.1.6.1
NOCNG pattern		NOP.1 FDD	As defined in TS 36.133 [23] section A.3.2.3.1
nprsID		Test1: (nprsID of Cell 1 – nprsID of Cell 2)mod6=1	As defined in TS36.355 [4]
nprs-period	ms	1280	As defined in TS36.355 [4]
nprs-startSF		sf0	Subframe offset of the NPRS positioning occasion as defined in TS36.355 [4]
Number of consecutive downlink positioning subframes nprs-NumSF		640	As defined in TS36.355 [4]
NPRS muting info		nCell 1: '11110000' nCell 2: '11110000'	Corresponds to nprs-MutingInfoB defined in TS 36.355 [4]
PartA Configuration		as in the following two rows	
subframePattern10		'0111001110'	Corresponds to subframePattern10-r14 defined in TS 36.355 [4]
nprsSequenceInfo		BW <sub>channel</sub> 5MHz: 54 BW <sub>channel</sub> 10MHz: 130	Corresponds to nprsSequenceInfo defined in TS 36.355 [4]
CP length		Normal	
NPRACH Configuration		NPRACH.R-1	Refer to TS 36.133 [23] section A.3.18
DRX cycle length		1.28	The value shall be used for all cells in the test.
Expected RSTD	μs	nCell 2: 3 Other neighbour cells: randomly between -3 and 3	The expected RSTD is what is expected at the receiver. The corresponding parameter in the OTDOA assistance data specified in TS 36.355 [4] is the expectedRSTD indicator
Expected RSTD uncertainty for all neighbour cells	μs	5	The corresponding parameter in the OTDOA assistance data specified in TS 36.355 [4] is the expectedRSTD-Uncertainty index
Number of cells provided in OTDOA assistance data		16	Including the reference cell
Measurement period	s	11.52	Derived according to the RSTD measurement period in clause 9.5.2.3

#### 9.5.2.4.2 Test procedure

The test consists of a set-up period and a measurement period. nCell 1 and nCell 2 (and their LTE donor cells eCell 1 and eCell 2) are active during the complete test. The beginning of the measurement period shall be aligned with the first PRS positioning subframe of a positioning occasion in the reference cell.

NOTE: The information on when PRS is muted is conveyed to the UE using PRS muting information in the OTDOA assistance data.

The OTDOA-RequestLocationInformation message and the OTDOA assistance data as defined in clause 9.5.2.4.3 shall be provided to the UE during the set-up period. The last TTI containing the OTDOA-RequestLocationInformation message of the last NPDCCH repetition shall be provided to the UE  $\Delta T$  ms before the start of the measurement period, where  $\Delta T = 150$  ms is the maximum processing time of the OTDOA-RequestLocationInformation message and the OTDOA assistance data in the UE.

1. Ensure that the UE is in state Generic RB Established State 3A-NB with CP CIoT optimisation according to 3GPP TS 36.508 [18] clause 8.1.5 in nCell 1.
2. The SS shall send a RESET UE POSITIONING STORED INFORMATION message.
3. Set the parameters according to Table 9.5.2.5-1 and Table 9.5.2.5-2 as appropriate. Propagation conditions are set according to clause 4.7.2.1.
4. The SS shall send an LPP REQUEST CAPABILITIES message.
5. The UE shall send an LPP PROVIDE CAPABILITIES message indicating the OTDOA capabilities supported by the UE in the *OTDOA-ProvideCapabilities* IE.
6. The SS shall send a LPP PROVIDE ASSISTANCE DATA message, including the *OTDOA-ProvideAssistanceData* IE. If the UE message at step 5 includes the *ackRequested* IE set to TRUE, then the SS shall send an acknowledgment in the LPP PROVIDE ASSISTANCE DATA message.
7. The SS shall send a LPP REQUEST LOCATION INFORMATION message, including the *OTDOA-RequestLocationInformation* IE such that the UE receives the message  $\Delta T$  ms before the start of measurement period, where  $\Delta T = 150$  ms.
8. When the Inactivity Timer expires, the SS shall send a RRC Connection Release to send the UE to idle state.
9. The UE shall perform location measurements in idle state start a Mobile Originated Data Transport according to 3GPP TS 23.401 [42] clause 5.3.4B.2.
10. When the signalling connection between the UE and SS is re-established, the UE shall transmit a LPP PROVIDE LOCATION INFORMATION message, including the *OTDOA-ProvideLocationInformation* IE.
11. If the UE message at step 10 includes the *ackRequested* IE set to TRUE, the SS shall send a LPP acknowledgement message.
12. The SS shall check the *rstd* value for nCell 2 in the *OTDOA-SignalMeasurementInformation* IE according to Table 9.5.1.5-3.
13. Repeat step 2-12 until the confidence level according to Annex D is achieved.

#### 9.5.2.4.3 Message contents

Same as clause 9.5.1.4.3.

#### 9.5.2.5 Test requirement

Table 9.5.2.5-1 and 9.5.2.5-2 define the primary level settings including test tolerances for all tests.

The RSTD FDD intra-frequency accuracy test shall meet the reported values in Table 9.5.2.5-3.



Table 9.5.2.5-1: Cell Specific Test Parameters for intra frequency RSTD Tests for NB-IOT Cells

Parameter	Unit	Test 1	
		nCell 1	nCell 2
$BW_{channel}$	kHz	180	180
PRB location within eCell		eCell 1 $BW_{channel}$ 5MHz: 17 eCell 1 $BW_{channel}$ 10MHz: 30	eCell 2 $BW_{channel}$ 5MHz: 17 eCell 2 $BW_{channel}$ 10MHz: 30
NPBCH_RA	dB	0	0
NPBCH_RB			
NPSS_RA			
NSSS_RA			
NPDCCH_RA			
NPDCCH_RB			
NPDSCH_RA			
NPDSCH_RB			
OCNG_RA <sup>Note 1</sup>			
OCNG_RB <sup>Note 1</sup>			
NPRS_RA			
$N_{oc}$ <sup>Note 2</sup>	dBm/ 15 kHz	-98	-98
$NPRS \hat{E}_s / N_{oc}$	dB	-14.7	-14.7
$NPRS \hat{E}_s / I_{ot}$ <sup>Note 3</sup>	dB	-14.7	-14.7
$I_o$ <sup>Note 3</sup>	dBm/ 180kHz	-87.14	-87.14
NPRP <sup>Note 3</sup>	dBm/ 15 kHz	-112.7	-112.7
NRSRP <sup>Note 3</sup>	dBm/ 15 kHz	-113	-113
$\hat{E}_s / N_{oc}$ <sup>Note 3</sup>	dB	-15	-15
Propagation Condition		AWGN	AWGN
Antenna Configuration		1x1	1x1
Timing offset to nCell 1	us	N/A	3
<p>Note 1: OCNG shall be used such that active cells are fully allocated and a constant total transmitted power spectral density is achieved for all OFDM symbols other than those in the subframes with transmitted NPRS.</p> <p>Note 2: Interference from other cells and noise sources not specified in the test are assumed to be constant over subcarriers and time and shall be modelled as AWGN of appropriate power for <math>N_{oc}</math> to be fulfilled.</p> <p>Note 3: If NPRS_RA is not "N/A", <math>\hat{E}_s / N_{oc}</math>, <math>NPRS \hat{E}_s / I_{ot}</math>, <math>I_o</math>, NRSRP and NPRP levels have been derived from other parameters and are given for information purpose. If NPRS_RA is "N/A", <math>I_o</math> and NRSRP levels have been derived from other parameters and are given for information purpose. These are not settable test parameters. Interference conditions shall be applied to all PRS symbols of DL positioning subframes.</p>			

Table 9.5.2.5-2: Cell Specific Test Parameters for intra frequency RSTD Tests for E-UTRA Cells

Parameter	Unit	eCell 1			eCell 2		
		T1	T2	T3	T1	T2	T3
$BW_{channel}$	MHz	5 or 10			5 or 10		
NOCNG Pattern defined in clause D.3	-	$BW_{channel}$ 5MHz: NOP.4 FDD $BW_{channel}$ 10MHz: NOP.1 FDD			$BW_{channel}$ 5MHz: NOP.4 FDD $BW_{channel}$ 10MHz: NOP.1 FDD		
PBCH_RA	dB	-3			-3		
PBCH_RB	dB						
PSS_RA	dB						
SSS_RA	dB						
PDCCH_RA	dB						
PDCCH_RB	dB						
PDSCH_RA	dB						
PDSCH_RB	dB						
OCNG_RA <sup>Note 1</sup>	dB						
OCNG_RB <sup>Note 1</sup>	dB						
$N_{oc}$ <sup>Note2</sup>	dBm/15 kHz	-98			-98		
$\hat{E}_s / N_{oc}$ <sup>Note2</sup>	dBm	3	3	3	3	3	3
Propagation Condition		AWGN			AWGN		
Antenna Configuration		1x1			1x1		
Timing offset to eCell 1	ms	-			3		
Note 1: OCNG shall be used such that the Cell is fully allocated and a constant total transmitted power spectral density is achieved for all OFDM symbols. Note 2: Interference from other cells and noise sources not specified in the test is assumed to be constant over subcarriers and time and shall be modelled as AWGN of appropriate power $N_{oc}$ .							

Table 9.5.2.5-3: RSTD HD-FDD intra-frequency accuracy requirements for the reported values

Lowest reported value	RSTD_6413
Highest reported value	RSTD_6481

For the overall test to pass, the ratio of successful reported values shall be more than 90% with a confidence level of 95%.

The expected response time is 12 s. The response time is equal to the LPP time IE value. The LPP time IE value is derived from the RSTD reporting delay plus  $\Delta T$ , where  $\Delta T = 150$  ms, giving a value of 11670 ms. This is rounded up to the next allowed LPP value of 12 seconds. The RSTD measurement reporting delay in the test is derived from the following expression,  $T_{RSTD \text{ IntraFreq,NB}} = T_{NPRS} \cdot (M-1) + \Delta$  ms, where  $T_{NPRS} = 1280$  ms,  $M = 8$

$\left| N_{NPRS\_total} / N_{NPRS} \right|$ ,  $\Delta = T_{NPRS} \cdot \left\lceil \frac{n}{M} \right\rceil$ ,  $N_{NPRS\_total} = 320$  ms,  $N_{NPRS} = 640$  ms and  $n = 16$ . All the parameters are specified in clause 9.5.2.3 and Table 9.5.2.3-1. This gives the total RSTD reporting delay of 11520 ms for the 15 neighbour cells including nCell 2 with respect to the reference cell, nCell 1. This expected response time excludes any delay caused by RRC connection release before the idle mode measurement. This expected response time excludes any delay caused by establishing a signalling connection with the SS (including random access procedure) as defined in TS 36.305 [41] for LPP measurement reporting. The response time is not explicitly evaluated for this test; hence, no test tolerance values need to be applied.

### 9.5.3 HD-FDD Intra frequency RSTD Measurement Reporting Delay for NB-IOT Inband Mode in enhanced coverage

**Editor's note:** This test is incomplete. The following aspects are missing:

- Core requirements in TS 36.133 are between square brackets
- PRS Part A configuration is missing TS 36.133
- Message contents are TBD

- TT are TBD
- The response time needs to be calculated
- The expected RSTD indicated in Table 9.5.3.3-1 and the timing offsets configured for the nCells in Table 9.5.5-1 do not match. This needs to be corrected in RAN4.

### 9.5.3.1 Test purpose

To verify that the RSTD HD-FDD intra-frequency measurement reporting delay is within the specified limits for NB-IOT Inband Mode in enhanced coverage.

### 9.5.3.2 Test applicability

This test applies to E-UTRA HD-FDD UE release 14 and forward of UE Category NB1 that supports UE-assisted OTDOA.

### 9.5.3.3 Minimum conformance requirements

UE shall follow the procedure for idle state positioning measurement as defined in TS 36.305 [41] section 7.1.3.

When the physical layer cell identities of neighbour cells together with the OTDOA assistance data are provided and when the UE has entered the idle state, the UE shall be able to detect and measure intra-frequency RSTD, specified in TS 36.214 [6], for at least  $n = 16$  cells, including the reference cell, on the same carrier frequency  $f_1$  as that of the reference cell within  $T_{\text{RSTD IntraFreq,NB}}$  ms as given below:

$$T_{\text{RSTD IntraFreq,NB}} = T_{\text{NPRS}} \cdot (M-1) + \Delta \quad \text{ms},$$

where

$T_{\text{RSTD IntraFreq,NB}}$  is the total time for detecting and measuring at least  $n$  cells;

$T_{\text{NPRS}}$  is the cell-specific positioning subframe configuration period as defined in TS 36.355 [4] if Part B subframe configuration is provided; otherwise if only Part A subframe configuration is provided, the  $T_{\text{NPRS}}$  equals to the length of the subframe pattern,

$M$  is the number of NPRS positioning occasions as defined in Table 9.5.3.3-1,

$\Delta = T_{\text{NPRS}} \cdot \left\lceil \frac{n}{M} \right\rceil$  ms is the measurement time for a single NPRS positioning occasion which includes the sampling time and the processing time;

$N_{\text{NPRS}}$  is the cell-specific number of NPRS subframes within a NPRS occasion as defined in TS 36.355 [4] if Part B subframe configuration is provided; if only Part A subframe configuration is provided, the NPRS occasion length is 10 ms,

$N_{\text{NPRS\_total}}$  is the minimum number of NPRS subframes per cell measurement as defined in Table 9.5.3.3-1.

$T_{\text{NPRS}}$ ,  $N_{\text{NPRS}}$ , and  $N_{\text{NPRS\_total}}$  are the parameters of the same cell, for which  $T_{\text{NPRS}} \cdot \left\lceil \frac{N_{\text{NPRS\_total}}}{N_{\text{NPRS}}} \right\rceil$  is the largest among all the measured cells.

**Table 9.5.3.3-1: Number of NPRS positioning occasions within  $T_{\text{RSTD IntraFreq, NB}}$** 

Positioning subframe configuration period $T_{\text{NPRS}}$	Number of NPRS positioning occasions $M$	
	f1 <sup>Note1</sup>	f1 and f2 <sup>Note2</sup>
160 ms	16* $\left\lfloor \frac{N_{\text{NPRS\_total}}}{N_{\text{NPRS}}} \right\rfloor$	32* $\left\lfloor \frac{N_{\text{NPRS\_total}}}{N_{\text{NPRS}}} \right\rfloor$
>160 ms	8* $\left\lfloor \frac{N_{\text{NPRS\_total}}}{N_{\text{NPRS}}} \right\rfloor$	16* $\left\lfloor \frac{N_{\text{NPRS\_total}}}{N_{\text{NPRS}}} \right\rfloor$
Note 1: When only intra-frequency RSTD measurements are performed over cells belonging to the serving carrier frequency f1. Note 2: When intra-frequency RSTD and inter-frequency RSTD measurements are performed over cells belonging to the serving carrier frequency f1 and one inter-frequency carrier frequency f2, respectively.		

The UE physical layer shall be capable of reporting RSTD for the reference cell and all the neighbour cells  $i$  out of at least  $(n-1)$  neighbour cells within  $T_{\text{RSTD IntraFreq, NB}}$  provided:

$$\left( \text{NPRS } \hat{E}_s / \text{Iot} \right)_{\text{ref}} \geq -15 \text{ dB for all Frequency Bands for the reference cell,}$$

$$\left( \text{NPRS } \hat{E}_s / \text{Iot} \right)_i \geq -15 \text{ dB for all Frequency Bands for neighbour cell } i,$$

$$\left( \text{NPRS } \hat{E}_s / \text{Iot} \right)_{\text{ref}} \text{ and } \left( \text{NPRS } \hat{E}_s / \text{Iot} \right)_i \text{ conditions apply for all subframes of at least } L = \frac{M}{2} \text{ NPRS}$$

positioning occasions,

NPRP 1,2<sub>dBm</sub> according to Annex E.5 for a corresponding Band

$\text{NPRS } \hat{E}_s / \text{Iot}$  is defined as the ratio of the average received energy per PRS RE during the useful part of the symbol to the average received power spectral density of the total noise and interference for this RE, where the ratio is measured over all REs which carry NPRS.

The time  $T_{\text{RSTD IntraFreq, NB}}$  starts from the point when UE receive both the OTDOA-RequestLocationInformation message and the OTDOA assistance data in the OTDOA-ProvideAssistanceData message as specified in TS 36.355 [4], are delivered to the physical layer of the UE.

The normative reference for this requirement is TS 36.133 [23] clauses 4.8.2 and A.4.7.1.

### 9.5.3.4 Test description

#### 9.5.3.4.1 Initial conditions

Test Environment: Normal; as defined in TS 36.508 [18] clause 8.1.1.

Frequencies to be tested: Mid Range, as defined in TS 36.508 [18] clause 8.1.3.1.1.

Channel bandwidth to be tested: 10 MHz. If the band under test does not support 10 MHz bandwidth, 5 MHz shall be used.

1. Connect the SS and AWGN noise sources to the UE antenna connector or antenna connectors as shown in Annex A, Figure A.3 but using only the main TX/RX antenna.
2. The general test parameter settings are set up according to Table 9.5.3.4.1-1.
3. Propagation conditions are set according to clause 4.7.2.1.
4. Message contents are defined in clause 9.5.3.4.3.
5. There are three synchronous cells: nCell 1, nCell 2 and nCell 3. nCell 1 is the reference as well as the serving cell. nCell 2 and nCell 3 are the neighbour cells. All cells are on the same RF channel. The assistance data

neighbour cell list includes in total 15 cells, where 13 of the cells are not simulated (dummy cells; as defined in 3GPP TS 37.571-5 [20], clause 7.2.2).

6. The true RSTD (which is the received time difference for frame 0 between two cells as seen at the UE antenna connector) is set to 92 Ts (about 3  $\mu$ s) between neighbour nCell 2 and serving nCell 1; and set to 92 Ts (about 3  $\mu$ s) between neighbour nCell 3 and serving nCell 1.

**Table 9.5.3.4-1: General test parameters**

Parameter	Unit	Value	Comment
NB-IoT operational mode		Standalone	
Reference cell		nCell 1	Reference cell is the cell in the OTDOA assistance data with respect to which the RSTD measurement is defined, as specified in TS 36.214 [6] and TS 36.355 [4]. The reference cell is the PCell in this test case.
Neighbor cells		nCell 2 and nCell 3	Cell 2 and Cell 3 appear at random places in the neighbour cell list in the OTDOA assistance data, but Cell 2 always appears in the first half of the list, whilst Cell 3 appears in the second half of the list.
nprsID		(nprsID of Cell 1 – nprsID of Cell 2) mod 6 = 1 and (nprsID of Cell 1 – nprsID of Cell 3) mod 6 = 2	As defined in TS 36.355 [4]
nprs-period	ms	1280	As defined in TS 36.355 [4]
nprs-startSF		sf0	Subframe offset of the NPRS positioning occasion as defined in TS 36.355 [4]
Number of consecutive downlink positioning subframes nprs-NumSF		320	As defined in TS 36.355 [4]
NPRS muting info		nCell 1: '11110000' nCell 2: '00001111' nCell 3: '11110000'	Corresponds to nprs-MutingInfoB defined in TS 36.355 [4]
Part A Configuration		N/A	NPRS is configured based on Part B but not Part A.
CP length		Normal	
NPRACH Configuration		NPRACH.R-1	Refer to A.3.18
DRX cycle length		1.28	The value shall be used for all cells in the test.
Radio frame receive time offset between the cells at the UE antenna connector	µs	nCell 2 to nCell 1: 1 nCell 3 to nCell 1: -1	PRS are transmitted from synchronous cells
Expected RSTD	µs	nCell 2: 3 nCell 3: 3 Other neighbour cells: randomly between -3 and 3	The expected RSTD is what is expected at the receiver. The corresponding parameter in the OTDOA assistance data specified in TS 36.355 [4] is the expectedRSTD indicator
Expected RSTD uncertainty for all neighbour cells	µs	5	The corresponding parameter in the OTDOA assistance data specified in TS 36.355 [4] is the expectedRSTD-Uncertainty index
Number of cells provided in OTDOA assistance data		16	Including the reference cell
T1	s	[2.76]	The length of the time interval from the beginning of each test
T2	s	[5.12]	The length of the time interval that follows immediately after time interval T1
T3	s	[5.12]	The length of the time interval that follows immediately after time interval T2
T4	s	[5.12]	The length of the time interval that follows immediately after time interval T3
T5	s	[5.12]	The length of the time interval that follows immediately after time interval T4

T6	s	[55]	The length of the time interval that follows immediately after time interval T5
----	---	------	---

#### 9.5.3.4.2 Test procedure

The test consists of six consecutive time intervals, with duration of T1, T2, T3, T4, T5 and T6. nCell 1 is active throughout T1, T2, T3, T4, T5 and T6, whilst nCell 2 and nCell 3 are activated only in the beginning of T2. nCell 2 is active until the end of T5 and nCell 3 is active until the end of T4. nCell 1 transmits NPRS in T2 and T4, while nCell 2 transmits NPRS in T3 and T5 and nCell 3 transmits NPRS only in T2 and T4. Note: The information on when NPRS is muted is conveyed to the UE using PRS muting information.

NOTE: The information on when PRS is muted is conveyed to the UE using PRS muting information in the OTDOA assistance data.

The OTDOA-RequestLocationInformation message and the OTDOA assistance data as defined in clause 9.5.3.4.3 shall be provided to the UE during the set-up period, T1. The last TTI containing the OTDOA-RequestLocationInformation message shall be provided to the UE  $\Delta T$  ms before the start of the measurement period, where  $\Delta T = 150$  ms is the maximum processing time of the OTDOA-RequestLocationInformation message and the OTDOA assistance data in the UE.

1. Ensure that the UE is in state Generic RB Established State 3A-NB with CP ClIoT optimisation according to 3GPP TS 36.508 [18] clause 8.1.5 in nCell 1.
2. The SS shall send a RESET UE POSITIONING STORED INFORMATION message.
3. Set the parameters according to Table 9.5.3.5-1 and Table 9.5.3.5-2 as appropriate. Propagation conditions are set according to clause 4.7.2.1.
4. The SS shall send an LPP REQUEST CAPABILITIES message.
5. The UE shall send an LPP PROVIDE CAPABILITIES message indicating the OTDOA capabilities supported by the UE in the *OTDOA-ProvideCapabilities* IE.
6. The SS shall send a LPP PROVIDE ASSISTANCE DATA message, including the *OTDOA-ProvideAssistanceData* IE. If the UE message at step 5 includes the *ackRequested* IE set to TRUE, then the SS shall send an acknowledgment in the LPP PROVIDE ASSISTANCE DATA message.
7. The SS shall send a LPP REQUEST LOCATION INFORMATION message, including the *OTDOA-RequestLocationInformation* IE such that the UE receives the message  $\Delta T$  ms before the start of measurement period, where  $\Delta T = 150$  ms.
8. When the Inactivity Timer expires, the SS shall send a RRC Connection Release to send the UE to idle state.
9. When T1 expires, the SS shall switch the power setting from T1 to T2 as specified in Table 9.5.3.5-2.
10. When T2 expires, the SS shall switch the power setting from T2 to T3 as specified in Table 9.5.3.5-2.
11. When T3 expires, the SS shall switch the power setting from T3 to T4 as specified in Table 9.5.3.5-2.
12. When T4 expires, the SS shall switch the power setting from T4 to T5 as specified in Table 9.5.3.5-2.
13. When T5 expires, the SS shall switch the power setting from T5 to T6 as specified in Table 9.5.3.5-1.
14. The UE shall perform location measurements in idle state and start a Mobile Originated Data Transport according to 3GPP TS 23.401 [42] clause 5.3.4B.2.
15. When the signalling connection between the UE and SS is re-established, the UE shall transmit a LPP PROVIDE LOCATION INFORMATION message, including the *OTDOA-ProvideLocationInformation* IE. The LPP PROVIDE LOCATION INFORMATION shall be transmitted within the response time (see clause 4.7.3) specified in clause 9.5.3.5. The UE shall perform and report the RSTD measurements for both nCell 2 and nCell 3 with respect to the reference cell in the OTDOA assistance data, nCell 1. If the UE transmits an *OTDOA-ProvideLocationInformation* IE including the *rstd* field for both nCell 2 and nCell 3 within the response time then the number of successful tests is increased by one. If the UE fails to report the



*OTDOA-ProvideLocationInformation* IE with both the *rstd* fields included within the response time then the number of failure tests is increased by one.

16. If the UE message at step 15 includes the *ackRequested* IE set to TRUE, the SS shall send a LPP acknowledgement message.

17. Repeat step 2-16 until the confidence level according to Annex D is achieved.

#### 9.5.3.4.3 Message contents

Same as in Clause 9.5.1.3.4.3 with the following exceptions: TBD.

#### 9.5.3.5 Test requirement

Table 9.5.3.5-1 and 9.5.3.5-2 define the primary level settings including test tolerances for all tests.

**Table 9.5.3.5-1: Cell Specific Test Parameters for intra frequency RSTD Tests for T1 and T6**

Parameter	Unit	nCell 1	nCell 2	nCell 3
NB-IoT RF Channel Number		1	1	1
NB-IoT Channel Bandwidth ( $BW_{channel}$ )	kHz	200	200	200
OCNG Pattern <sup>Note 1</sup>		NOP.3 FDD	N/A	N/A
NPDSCH parameters <sup>Note 2</sup>		R.18 HD-FDD	N/A	N/A
NPDCCH parameters <sup>Note 2</sup>		R.30 HD-FDD	N/A	N/A
NPBCH_RA	dB	0	N/A	N/A
NPBCH_RB				
NPSS_RA				
NSSS_RA				
NPDCCH_RA				
NPDCCH_RB				
NPDSCH_RA				
NPDSCH_RB				
OCNG_RA <sup>Note 1</sup>				
OCNG_RB <sup>Note 1</sup>				
$N_{oc}$ <sup>Note 3</sup>	dBm/ 15 kHz	-98		
$NPRS \hat{E}_s / N_{oc}$	dB	-Infinity	-Infinity	-Infinity
$\hat{E}_s / N_{oc}$	dB	-12	-Infinity	-Infinity
Propagation Condition		AWGN		
Antenna Configuration		1x1		
Timing offset to nCell 1	$\mu$ s	N/A	1	-1
Note 1:	OCNG shall be used such that the cell is fully allocated and a constant total transmitted power spectral density is achieved for all OFDM symbols. The OCNG pattern is chosen during the test according to the presence of a DL reference measurement channel.			
Note 2:	The NPDSCH and NPDCCH reference measurement channels are used in the test only when a downlink transmission dedicated to the UE under test is required.			
Note 3:	Interference from other cells and noise sources not specified in the test are assumed to be constant over subcarriers and time and shall be modelled as AWGN of appropriate power for $N_{oc}$ to be fulfilled.			

Table 9.5.3.5-2: Cell Specific Test Parameters for intra frequency RSTD Tests for T2 to T5

Parameter	Unit	Cell 1		Cell 2		Cell 3			
		T2 and T4	T3 and T5	T2 and T4	T3 and T5	T2 and T4	T3 and T5		
$BW_{channel}$	kHz	200		200		200			
NB-IoT RF Channel Number		1		1		1			
OCNG patterns		NOP.3 FDD		N/A	NOP.3 FDD	NOP.3 FDD	N/A		
NPBCH_RA	dB	0		0		0		N/A	
NPBCH_RB									
NPSS_RA									
NSSS_RA									
NPDCCH_RA									
NPDCCH_RB									
NPDSCH_RA									
NPDSCH_RB									
OCNG_RA <sup>Note 1</sup>									
OCNG_RB <sup>Note 1</sup>									
NPRS_RA	dB	-3	N/A	N/A	0	0	N/A		
$N_{oc}$ <sup>Note 3</sup>	dBm/15 kHz	-98	-95	-98	-95	-98	-95		
$NPRS \hat{E}_s / N_{oc}$	dB	-15	-Infinity	-Infinity	-15	-15	-Infinity		
$NPRS \hat{E}_s / I_{ot}$ <sup>Note 4</sup>	dB	-15	-Infinity	-Infinity	-15	-15	-Infinity		
$I_o$ <sup>Note 4</sup>	dBm/180kHz	-87.14	-87.12	-87.14	-87.12	-87.14	-87.12		
NPRP <sup>Note 4</sup>	dBm/15 kHz	-113	-Infinity	-Infinity	-110	-113	-Infinity		
NRSRP <sup>Note 4</sup>	dBm/15 kHz	-110	-107	-113	-110	-113	-Infinity		
$\hat{E}_s / N_{oc}$ <sup>Note 4</sup>	dB	-12	-12	-15	-15	-15	-Infinity		
Propagation Condition		AWGN							
Antenna Configuration		1x1							
Timing offset to nCell 1	$\mu$ s	N/A		1		-1			
Note 1:	OCNG shall be used such that active cells (all, except Cell 3 in T3) are fully allocated and a constant total transmitted power spectral density is achieved for all OFDM symbols other than those in the subframes with transmitted NPRS.								
Note 3:	Interference from other cells and noise sources not specified in the test are assumed to be constant over subcarriers and time and shall be modelled as AWGN of appropriate power for $N_{oc}$ to be fulfilled.								
Note 4:	If NPRS_RA is not "N/A", $\hat{E}_s / N_{oc}$ , $NPRS \hat{E}_s / I_{ot}$ , $I_o$ , NRSRP and NPRP levels have been derived from other parameters and are given for information purpose. If NPRS_RA is "N/A", $I_o$ and NRSRP levels have been derived from other parameters and are given for information purpose. These are not settable test parameters. Interference conditions shall be applied to all PRS symbols of DL positioning subframes.								

The response time including test tolerance is [TBD] s. The response time is equal to the LPP time IE value. The LPP time IE value is derived from the RSTD reporting delay plus  $\Delta T$ , where  $\Delta T = 150$  ms, giving a value of [TBD] ms. This is rounded up to the next allowed LPP value of [TBD] seconds. The RSTD measurement reporting delay in the test is derived from the following expression,  $T_{RSTD \text{ IntraFreq,NB}} = T_{NPRS} \cdot (M-1) + \Delta$  ms, where  $T_{NPRS} = 1280$

ms,  $M = 8 \left\lceil N_{NPRS\_total} / N_{NPRS} \right\rceil$ ,  $\Delta = T_{NPRS} \cdot \left\lceil \frac{n}{M} \right\rceil$ ,  $N_{NPRS\_total} = 320$  ms,  $N_{NPRS} = 320$  ms and  $n = 16$ . All the

parameters are specified in clause 9.5.3.3 and Table 9.5.3.3-1. This gives the total RSTD reporting delay of 11520 ms for the 15 neighbour cells including nCell 2 with respect to the reference cell, nCell 1. This expected response time excludes any delay caused by RRC connection release before the idle mode measurement. This expected response time excludes any delay caused by establishing a signalling connection with the SS (including random access procedure) as defined in TS 36.305 [41] for LPP measurement reporting. The response time is not explicitly evaluated for this test; hence, no test tolerance values need to be applied.

For the overall test to pass, the ratio of successful reported values shall be more than 90% with a confidence level of 95%.

## 9.6 HD-FDD RSTD Inter-Frequency Measurements

### 9.6.1 HD-FDD Inter-Frequency RSTD Measurement Accuracy for NB-IOT Inband Mode in normal coverage

#### 9.6.1.1 Test purpose

To verify that the RSTD HD-FDD inter-frequency measurement accuracy is within the specified limits for NB-IOT Inband Mode in normal coverage.

#### 9.6.1.2 Test applicability

This test applies to E-UTRA HD-FDD UE release 14 and forward of UE Category NB1 that supports UE-assisted OTDOA and inter-frequency RSTD measurements.

#### 9.6.1.3 Minimum conformance requirements

UE shall follow the procedure for idle state positioning measurement as defined in TS 36.305 [41] section 7.1.3.

When the physical layer cell identities of neighbour cells together with the OTDOA assistance data are provided and when the UE has entered the idle state, the UE shall be able to detect and measure intra-frequency RSTD, specified in TS 36.214 [6], for at least  $n = 16$  cells, including the reference cell, on the same carrier frequency  $f_1$  as that of the reference cell within  $T_{\text{RSTD InterFreq, NB}}$  ms as given below:

$$T_{\text{RSTD InterFreq, NB}} = T_{\text{NPRS}} \cdot (M - 1) + \Delta \quad \text{ms},$$

where

$T_{\text{RSTD InterFreq, NB}}$  is the total time for detecting and measuring at least  $n$  cells;

$T_{\text{NPRS}}$  is the cell-specific positioning subframe configuration period as defined in TS 36.355 [4] if Part B subframe configuration is provided; otherwise if only Part A subframe configuration is provided, the  $T_{\text{NPRS}}$  equals to the length of the subframe pattern,

$M$  is the number of NPRS positioning occasions as defined in Table 9.6.1.3-1,

$\Delta = T_{\text{NPRS}} \cdot \left\lceil \frac{n}{M} \right\rceil$  ms is the measurement time for a single NPRS positioning occasion which includes the sampling time and the processing time;

$N_{\text{NPRS}}$  is the cell-specific number of NPRS subframes within a NPRS occasion as defined in TS 36.355[4] if Part B subframe configuration is provided; if only Part A subframe configuration is provided, the NPRS occasion length is 10 ms,

$N_{\text{NPRS\_total}}$  is the minimum number of NPRS subframes per cell measurement as defined in Table 9.6.1.3-2.

$T_{NPRS}$ ,  $N_{NPRS}$ , and  $N_{NPRS\_total}$  are the parameters of the same cell, for which  $T_{NPRS} \cdot \left\lceil \frac{N_{NPRS\_total}}{N_{NPRS}} \right\rceil$  is the largest among all the measured cells.

**Table 9.6.1.3-1: Number of NPRS positioning occasions within  $T_{RSTD\ InterFreq, NB}$**

Positioning subframe configuration period $T_{NPRS}$	Number of NPRS positioning occasions $M$	
	f1 <sup>Note1</sup>	f1 and f2 <sup>Note2</sup>
160 ms	16* $\lceil N_{NPRS\_total} / N_{NPRS} \rceil$	32* $\lceil N_{NPRS\_total} / N_{NPRS} \rceil$
>160 ms	8* $\lceil N_{NPRS\_total} / N_{NPRS} \rceil$	16* $\lceil N_{NPRS\_total} / N_{NPRS} \rceil$
Note 1: When only intra-frequency RSTD measurements are performed over cells belonging to the serving carrier frequency f1. Note 2: When intra-frequency RSTD and inter-frequency RSTD measurements are performed over cells belonging to the serving carrier frequency f1 and one inter-frequency carrier frequency f2, respectively.		

The UE physical layer shall be capable of reporting RSTD for the reference cell and all the neighbour cells  $i$  out of at least  $(n-1)$  neighbour cells within  $T_{RSTD\ InterFreq, NB}$  provided:

$$\left( \text{NPRS } \hat{E}_s / \text{Iot} \right)_{ref} \geq -15 \text{ dB for all Frequency Bands for the reference cell,}$$

$$\left( \text{NPRS } \hat{E}_s / \text{Iot} \right)_i \geq -15 \text{ dB for all Frequency Bands for neighbour cell } i,$$

$$\left( \text{NPRS } \hat{E}_s / \text{Iot} \right)_{ref} \text{ and } \left( \text{NPRS } \hat{E}_s / \text{Iot} \right)_i \text{ conditions apply for all subframes of at least } L = \frac{M}{2} \text{ NPRS positioning occasions,}$$

NPRP 1,2<sub>dBm</sub> according to Annex E.5 for a corresponding Band

$\text{NPRS } \hat{E}_s / \text{Iot}$  is defined as the ratio of the average received energy per PRS RE during the useful part of the symbol to the average received power spectral density of the total noise and interference for this RE, where the ratio is measured over all REs which carry NPRS.

The time  $T_{RSTD\ InterFreq, NB}$  starts from the point when UE receive both the OTDOA-RequestLocationInformation message and the OTDOA assistance data in the OTDOA-ProvideAssistanceData message as specified in TS 36.355 [4], are delivered to the physical layer of the UE.

The accuracy requirements in Table 9.6.1.3-2 are valid under the following conditions:

Conditions defined in 36.101 [2] Clause 7.3 for reference sensitivity are fulfilled.

NPRP 1,2<sub>dBm</sub> according to Annex E.5 for a corresponding Band

There are no measurement gaps overlapping with the NPRS subframes of the measured serving cell.

The parameter expectedRSTDUncertainty signalled over LPP by E-SMLC as defined in TS 36.355 [4] is less than 5  $\mu$ s.

**Table 9.6.1.3-2: Inter RSTD measurement accuracy for normal coverage**

Accuracy	Conditions					
	NPRS $\hat{E}_s/lot$	UE NPRS measurement bandwidth on the reference cell and the measured neighbour cell $i$ <sup>Note 3</sup>	Minimum number of available measurement subframes among the reference cell and the measured neighbour cell $i$ , $N_{NPRS\_total}$ <sup>Note 6</sup>	$Io$ <sup>Note 7</sup> range		
				E-UTRA operating band groups <sup>Note 7</sup>	Minimum $Io$ <sup>Note 1</sup>	Maximum $Io$
$T_s$ <sup>Note 2</sup>	dB	RB			dBm/15kHz	dBm/BW <sub>Channel</sub>
$\pm 28$	(NPRS $\hat{E}_s/lot$ ) <sub>ref</sub> $\geq -6$ dB and (NPRS $\hat{E}_s/lot$ ) <sub><math>i</math></sub> $\geq -13$ dB	1	320	NFDD_G	-118	-70

NOTE 1: This minimum  $Io$  condition is expressed as the average  $Io$  per RE over all REs in an OFDM symbol.  
 NOTE 2:  $T_s$  is the basic timing unit defined in TS 36.211 [26].  
 NOTE 3: The serving cell, the reference cell, and the measured neighbour cell  $i$  are on the same carrier frequency.  
 NOTE 4: The  $Io$  is defined in NPRS positioning subframes. The same  $Io$  range applies to NPRS and non-NPRS symbols.  $Io$  levels are different in NPRS and non-NPRS symbols within the same subframe.  
 NOTE 5: E-UTRA operating band groups are as defined in Section 3.5.  
 NOTE 6:  $N_{NPRS\_total}$  can be in one or more NPRS positioning occasions.

The normative reference for this requirement is TS 36.133 [23] clauses 4.8.3, 9.1.22.11 and A.9.8.17.

**9.6.1.4 Test description**

**9.6.1.4.1 Initial conditions**

Test Environment: Normal; as defined in TS 36.508 [18] clause 8.1.1.

Frequencies to be tested: Mid Range, as defined in TS 36.508 [18] clause 8.1.3.1.1.

Channel bandwidth to be tested: 10 MHz. If the band under test does not support 10 MHz bandwidth, 5 MHz shall be used.

1. Connect the SS and AWGN noise sources to the UE antenna connector or antenna connectors as shown in Annex A, Figure A.3 but using only the main TX/RX antenna.
2. The general test parameter settings are set up according to Table 9.6.1.4.1-1.
3. Propagation conditions are set according to clause 4.7.2.1.
4. Message contents are defined in clause 9.6.1.4.3.
5. The two NB-IOT cells are on different PRBs of the same LTE carrier frequency. The two LTE Cells are on the same carrier frequency. nCell 1 is the serving cell and OTDOA assistance data reference cell; nCell 2 is the neighbour cell. eCell 1 and eCell 2 are the LTE donor cells to nCell 1 and nCell 2, respectively. The assistance data neighbour cell list includes in total 15 cells, where 14 of the cells are not simulated (dummy cells; as defined in 3GPP TS 37.571-5 [20], clause 7.2.2).
6. The true RSTD (which is the receive time difference for frame 0 between nCell 2 and nCell 1 as seen at the UE antenna connector) is set to 92  $T_s$  (about 3  $\mu s$ ). Note that the related expected RSTD values to be signalled over LPP are defined in Table 9.6.1.4-1.

Table 9.6.1.4-1: General test parameters

Parameter	Unit	Value	Comment
NB-IoT operational mode		Inband	
Reference cell		nCell 1	
Neighbor cells		nCell 2, eCell 2 and eCell 1	
NPDCCH parameters		R.26 HD-FDD	As defined in TS 36.133 [23] section A.3.1.6.1
NOCNG pattern		NOP.1 FDD	As defined in TS 36.133 [23] section A.3.2.3.1
nprsID		Test1: (nprsID of Cell 1 – nprsID of Cell 2)mod6=1	As defined in TS36.355 [4]
nprs-period	ms	1280	As defined in TS36.355 [4]
nprs-startSF		sf0	Subframe offset of the NPRS positioning occasion as defined in TS36.355 [4]
nprs-slotNumberOffset		0	As defined in TS36.355 [4]
nprs-SubframeOffset		640	As defined in TS36.355 [4]
Number of consecutive downlink positioning subframes nprs-NumSF		640	As defined in TS36.355 [4]
NPRS muting info		nCell 1: '1111111100000000' nCell 2: '1111111100000000'	Corresponds to nprs-MutingInfoB defined in TS 36.355 [4]
PartA Configuration		as in the following 3 rows	
subframePattern10		'0111001110'	Corresponds to subframePattern10-r14 defined in TS 36.355 [4]
nprsSequenceInfo nCell1		BW <sub>channel</sub> 5MHz: 54 BW <sub>channel</sub> 10MHz: 130	Corresponds to nprsSequenceInfo defined in TS 36.355 [4]
nprsSequenceInfo nCell2		BW <sub>channel</sub> 5MHz: 59 BW <sub>channel</sub> 10MHz: 135	Corresponds to nprsSequenceInfo defined in TS 36.355 [4]
CP length		Normal	
NPRACH Configuration		NPRACH.R-1	Refer to TS 36.133 [23] section A.3.18
DRX cycle length		1.28	The value shall be used for all cells in the test.
Expected RSTD	μs	nCell 2: 3 Other neighbour cells: randomly between -3 and 3	The expected RSTD is what is expected at the receiver. The corresponding parameter in the OTDOA assistance data specified in TS 36.355 [4] is the expectedRSTD indicator
Expected RSTD uncertainty for all neighbour cells	μs	5	The corresponding parameter in the OTDOA assistance data specified in TS 36.355 [4] is the expectedRSTD-Uncertainty index
Number of cells provided in OTDOA assistance data		16	Including the reference cell
Measurement period	s	20.48	Derived according to the RSTD measurement period in clause 9.6.1.3

#### 9.6.1.4.2 Test procedure

The test consists of a set-up period and a measurement period. nCell 1 and nCell 2 (and their LTE donor cells eCell 1 and eCell 2) are active during the complete test. The beginning of the measurement period shall be aligned with the first PRS positioning subframe of a positioning occasion in the reference cell.

NOTE: The information on when PRS is muted is conveyed to the UE using PRS muting information in the OTDOA assistance data.

The OTDOA-RequestLocationInformation message and the OTDOA assistance data as defined in clause 9.6.1.4.3 shall be provided to the UE during the set-up period. The last TTI containing the OTDOA-RequestLocationInformation

message shall be provided to the UE  $\Delta T$  ms before the start of the measurement period, where  $\Delta T = 150$  ms is the maximum processing time of the OTDOA-RequestLocationInformation message and the OTDOA assistance data in the UE.

1. Ensure that the UE is in state Generic RB Established State 3A-NB with CP CIoT optimisation according to 3GPP TS 36.508 [18] clause 8.1.5 in nCell 1.
2. The SS shall send a RESET UE POSITIONING STORED INFORMATION message.
3. Set the parameters according to Table 9.6.1.5-1 and Table 9.6.1.5-2 as appropriate. Propagation conditions are set according to clause 4.7.2.1.
4. The SS shall send an LPP REQUEST CAPABILITIES message.
5. The UE shall send an LPP PROVIDE CAPABILITIES message indicating the OTDOA capabilities supported by the UE in the *OTDOA-ProvideCapabilities* IE.
6. The SS shall send a LPP PROVIDE ASSISTANCE DATA message, including the *OTDOA-ProvideAssistanceData* IE. If the UE message at step 5 includes the *ackRequested* IE set to TRUE, then the SS shall send an acknowledgment in the LPP PROVIDE ASSISTANCE DATA message.
7. The SS shall send a LPP REQUEST LOCATION INFORMATION message, including the *OTDOA-RequestLocationInformation* IE such that the UE receives the message  $\Delta T$  ms before the start of measurement period, where  $\Delta T = 150$  ms.
8. When the Inactivity Timer expires, the SS shall send a RRC Connection Release to send the UE to idle state.
9. The UE shall perform location measurements in idle state start a Mobile Originated Data Transport according to 3GPP TS 23.401 [42] clause 5.3.4B.2.
10. When the signalling connection between the UE and SS is re-established, the UE shall transmit a LPP PROVIDE LOCATION INFORMATION message, including the *OTDOA-ProvideLocationInformation* IE.
11. If the UE message at step 10 includes the *ackRequested* IE set to TRUE, the SS shall send a LPP acknowledgement message.
12. The SS shall check the *rstd* value for nCell 2 in the *OTDOA-SignalMeasurementInformation* IE according to Table 9.6.1.5-3.
13. Repeat step 2-12 until the confidence level according to Annex D is achieved.

#### 9.6.1.4.3 Message contents

Same as clause 9.5.1.4.3 with the following exceptions:

**Table 9.6.1.4.3-1: LPP RequestLocationInformation**

Derivation Path: Table 9.5.1.4.3-2			
Information Element	Value/remark	Comment	Condition
LPP-Message ::= SEQUENCE {			
lpp-MessageBody CHOICE {			
c1 CHOICE {			
requestLocationInformation SEQUENCE {			
criticalExtensions CHOICE {			
c1 CHOICE {			
requestLocationInformation-r9 SEQUENCE {			
commonIEsRequestLocationInformation SEQUENCE {			
qos SEQUENCE {			
responseTime SEQUENCE {			
time	21	See Measurement Period of Table 9.6.1.4.1-1	
}			
}			
}			
}			
}			
}			
}			
}			
}			
}			

**9.6.1.5 Test requirement**

Table 9.6.1.5-1 and 9.6.1.5-2 define the primary level settings including test tolerances for all tests.

The RSTD FDD inter-frequency accuracy test shall meet the reported values in Table 9.6.1.5-3.



Table 9.6.1.5-1: Cell Specific Test Parameters for inter frequency RSTD Tests for NB-IOT Cells

Parameter	Unit	Test 1	
		nCell 1	nCell 2
$BW_{channel}$	kHz	180	180
PRB location within eCell		eCell 1 $BW_{channel}$ 5MHz: 17 eCell 1 $BW_{channel}$ 10MHz: 30	eCell 2 $BW_{channel}$ 5MHz: 22 eCell 2 $BW_{channel}$ 10MHz: 35
NPBCH_RA	dB	0	0
NPBCH_RB			
NPSS_RA			
NSSS_RA			
NPDCCH_RA			
NPDCCH_RB			
NPDSCH_RA			
NPDSCH_RB			
OCNG_RA <sup>Note 1</sup>			
OCNG_RB <sup>Note 1</sup>			
NPRS_RA			
$N_{oc}$ <sup>Note 2</sup>	dBm/ 15 kHz	-98	-98
$NPRS \hat{E}_s / N_{oc}$	dB	-5.7	-5.7
$NPRS \hat{E}_s / I_{ot}$ <sup>Note 3</sup>	dB	-5.7	-5.7
$I_o$ <sup>Note 3</sup>	dBm/ 180kHz	-86.93	-86.93
NPRP <sup>Note 3</sup>	dBm/ 15 kHz	-103.7	-110.7
NRSRP <sup>Note 3</sup>	dBm/ 15 kHz	-104	-111
$\hat{E}_s / N_{oc}$ <sup>Note 3</sup>	dB	-6	-13
Propagation Condition		AWGN	AWGN
Antenna Configuration		1x1	1x1
Timing offset to nCell 1	us	N/A	3
<p>Note 1: OCNG shall be used such that active cells are fully allocated and a constant total transmitted power spectral density is achieved for all OFDM symbols other than those in the subframes with transmitted NPRS.</p> <p>Note 2: Interference from other cells and noise sources not specified in the test are assumed to be constant over subcarriers and time and shall be modelled as AWGN of appropriate power for <math>N_{oc}</math> to be fulfilled.</p> <p>Note 3: If NPRS_RA is not "N/A", <math>\hat{E}_s / N_{oc}</math>, <math>NPRS \hat{E}_s / I_{ot}</math>, <math>I_o</math>, NRSRP and NPRP levels have been derived from other parameters and are given for information purpose. If NPRS_RA is "N/A", <math>I_o</math> and NRSRP levels have been derived from other parameters and are given for information purpose. These are not settable test parameters. Interference conditions shall be applied to all PRS symbols of DL positioning subframes.</p>			

Table 9.6.1.5-2: Cell Specific Test Parameters for inter frequency RSTD Tests for E-UTRA Cells

Parameter	Unit	eCell 1			eCell 2		
		T1	T2	T3	T1	T2	T3
$BW_{channel}$	MHz	5 or 10			5 or 10		
NOCNG Pattern defined in clause D.3	-	$BW_{channel}$ 5MHz: NOP.4 FDD $BW_{channel}$ 10MHz: NOP.1 FDD			$BW_{channel}$ 5MHz: NOP.4 FDD $BW_{channel}$ 10MHz: NOP.1 FDD		
PBCH_RA	dB	-3			-3		
PBCH_RB	dB						
PSS_RA	dB						
SSS_RA	dB						
PDCCH_RA	dB						
PDCCH_RB	dB						
PDSCH_RA	dB						
PDSCH_RB	dB						
OCNG_RA <sup>Note 1</sup>	dB						
OCNG_RB <sup>Note 1</sup>	dB						
$N_{oc}$ <sup>Note2</sup>	dBm/15 kHz	-98			-98		
$\hat{E}_s/N_{oc}$ <sup>Note2</sup>	dBm	3	3	3	3	3	3
Propagation Condition		AWGN			AWGN		
Antenna Configuration		1x1			1x1		
Timing offset to eCell 1	ms	-			3		
Note 1: OCNG shall be used such that the Cell is fully allocated and a constant total transmitted power spectral density is achieved for all OFDM symbols. Note 2: Interference from other cells and noise sources not specified in the test is assumed to be constant over subcarriers and time and shall be modelled as AWGN of appropriate power $N_{oc}$ .							

Table 9.6.1.5-3: RSTD HD-FDD inter-frequency accuracy requirements for the reported values

Lowest reported value	RSTD_6416
Highest reported value	RSTD_6478

For the overall test to pass, the ratio of successful reported values shall be more than 90% with a confidence level of 95%.

The expected response time is 21 s. The response time is equal to the LPP time IE value. The LPP time IE value is derived from the RSTD reporting delay plus  $\Delta T$ , where  $\Delta T = 150$  ms, giving a value of 20630 ms. This is rounded up to the next allowed LPP value of 21 seconds. The RSTD measurement reporting delay in the test is derived from the following expression,  $T_{RSTD \text{ IntraFreq,NB}} = T_{NPRS} \cdot (M-1) + \Delta$  ms, where  $T_{NPRS} = 1280$  ms,  $M = 16$

$\left| N_{NPRS\_total} / N_{NPRS} \right|$ ,  $\Delta = T_{NPRS} \cdot \left[ \frac{n}{M} \right]$ ,  $N_{NPRS\_total} = 320$  ms,  $N_{NPRS} = 640$  ms and  $n = 16$ . All the parameters are specified in clause 9.6.1.3 and Table 9.6.1.3-1. This gives the total RSTD reporting delay of 20480 ms for the 15 neighbour cells including nCell 2 with respect to the reference cell, nCell 1. This expected response time excludes any delay caused by RRC connection release before the idle mode measurement. This expected response time excludes any delay caused by establishing a signalling connection with the SS (including random access procedure) as defined in TS 36.305 [41] for LPP measurement reporting. The response time is not explicitly evaluated for this test; hence, no test tolerance values need to be applied.

## 9.6.2 HD-FDD Inter-Frequency RSTD Measurement Accuracy for NB-IOT Inband Mode in enhanced coverage

### 9.6.2.1 Test purpose

To verify that the RSTD HD-FDD inter-frequency measurement accuracy is within the specified limits for NB-IOT Inband Mode in enhanced coverage.

9.6.2.2 Test applicability

This test applies to E-UTRA HD-FDD UE release 14 and forward of UE Category NB1 that supports UE-assisted OTDOA and inter-frequency RSTD measurements.

9.6.2.3 Minimum conformance requirements

Same as clause 9.6.1.3, replacing Table 9.6.1.3-1 with Table 9.6.2.3-1 and Table 9.6.1.3-2 with Table 9.6.2.3-2.

**Table 9.6.2.3-1: Number of NPRS positioning occasions within  $T_{RSTD\ InterFreq, NB}$**

Positioning subframe configuration period $T_{NPRS}$	Number of NPRS positioning occasions $M$	
	f1 <sup>Note1</sup>	f1 and f2 <sup>Note2</sup>
160 ms	$16^* \lfloor N_{NPRS\_total} / N_{NPRS} \rfloor$	$32^* \lfloor N_{NPRS\_total} / N_{NPRS} \rfloor$
>160 ms	$8^* \lfloor N_{NPRS\_total} / N_{NPRS} \rfloor$	$16^* \lfloor N_{NPRS\_total} / N_{NPRS} \rfloor$
Note 1: When only intra-frequency RSTD measurements are performed over cells belonging to the serving carrier frequency f1. Note 2: When intra-frequency RSTD and inter-frequency RSTD measurements are performed over cells belonging to the serving carrier frequency f1 and one inter-frequency carrier frequency f2, respectively.		

**Table 9.6.1.3-2: Inter RSTD measurement accuracy for normal coverage**

Accuracy	Conditions					
	NPRS $\hat{E}s/lot$	UE NPRS measurement bandwidth on the reference cell and the measured neighbour cell $j$ <sup>Note 3</sup>	Minimum number of available measurement subframes among the reference cell and the measured neighbour cell $i$ , $N_{NPRS\_total}$ <sup>Note 6</sup>	$Io$ <sup>Note 7</sup> range		
E-UTRA operating band groups <sup>Note 7</sup>				Minimum $Io$ <sup>Note 1</sup>	Maximum $Io$	
$T_s$ <sup>Note 2</sup>	dB	RB		dBm/15kHz	dBm/BW <sub>Channel</sub>	
$\pm 40$	$(NPRS \hat{E}s/lot)_{ref} \geq -15dB$ and $(NPRS \hat{E}s/lot)_i \geq -15dB$	1	320	NFDD_G	-118	-70
NOTE 1: This minimum $Io$ condition is expressed as the average $Io$ per RE over all REs in an OFDM symbol. NOTE 2: $T_s$ is the basic timing unit defined in TS 36.211 [26]. NOTE 3: The serving cell, the reference cell, and the measured neighbour cell $i$ are on the same carrier frequency. NOTE 4: The $Io$ is defined in NPRS positioning subframes. The same $Io$ range applies to NPRS and non-NPRS symbols. $Io$ levels are different in NPRS and non-NPRS symbols within the same subframe. NOTE 5: E-UTRA operating band groups are as defined in Section 3.5. NOTE 6: $N_{NPRS\_total}$ can be in one or more NPRS positioning occasions.						

The normative reference for this requirement is TS 36.133 [23] clauses 4.8.4, 9.1.22.13 and A.9.8.19.

9.6.2.4 Test description

9.6.2.4.1 Initial conditions

Test Environment: Normal; as defined in TS 36.508 [18] clause 8.1.1.

Frequencies to be tested: Mid Range, as defined in TS 36.508 [18] clause 8.1.3.1.1.

Channel bandwidth to be tested: 10 MHz. If the band under test does not support 10 MHz bandwidth, 5 MHz shall be used.

1. Connect the SS and AWGN noise sources to the UE antenna connector or antenna connectors as shown in Annex A, Figure A.3 but using only the main TX/RX antenna.
2. The general test parameter settings are set up according to Table 9.6.2.4.1-1.
3. Propagation conditions are set according to clause 4.7.2.1.
4. Message contents are defined in clause 9.6.2.4.3.
5. The two NB-IOT cells are on different PRBs of the same LTE carrier frequency. The two LTE Cells are on the same carrier frequency. nCell 1 is the serving cell and OTDOA assistance data reference cell; nCell 2 is the neighbour cell. eCell 1 and eCell 2 are the LTE donor cells to nCell 1 and nCell 2, respectively. The assistance data neighbour cell list includes in total 15 cells, where 14 of the cells are not simulated (dummy cells; as defined in 3GPP TS 37.571-5 [20], clause 7.2.2).
6. The true RSTD (which is the receive time difference for frame 0 between nCell 2 and nCell 1 as seen at the UE antenna connector) is set to 92 Ts (about 3  $\mu$ s). Note that the related expectedRSTD values to be signalled over LPP are defined in Table 9.6.2.4-1.

Table 9.6.2.4-1: General test parameters

Parameter	Unit	Value	Comment
NB-IoT operational mode		Inband	
Reference cell		nCell 1	
Neighbor cells		nCell 2, eCell 2 and eCell 1	
NPDCCH parameters		R.26 HD-FDD	As defined in TS 36.133 [23] section A.3.1.6.1
NOCNG pattern		NOP.1 FDD	As defined in TS 36.133 [23] section A.3.2.3.1
nprsID		Test1: (nprsID of Cell 1 – nprsID of Cell 2)mod6=1	As defined in TS36.355 [4]
nprs-period	ms	1280	As defined in TS36.355 [4]
nprs-startSF		sf0	Subframe offset of the NPRS positioning occasion as defined in TS36.355 [4]
nprs-slotNumberOffset		0	As defined in TS36.355 [4]
nprs-SubframeOffset		640	As defined in TS36.355 [4]
Number of consecutive downlink positioning subframes nprs-NumSF		640	As defined in TS36.355 [4]
NPRS muting info		nCell 1: '1111111100000000' nCell 2: '1111111100000000'	Corresponds to nprs-MutingInfoB defined in TS 36.355 [4]
PartA Configuration		as in the following 3 rows	
subframePattern10		'0111001110'	Correponds to subframePattern10-r14 defined in TS 36.355 [4]
nprsSequenceInfo nCell1		BW <sub>channel</sub> 5MHz: 54 BW <sub>channel</sub> 10MHz: 130	Correponds to nprsSequenceInfo defined in TS 36.355 [4]
nprsSequenceInfo nCell2		BW <sub>channel</sub> 5MHz: 59 BW <sub>channel</sub> 10MHz: 135	Correponds to nprsSequenceInfo defined in TS 36.355 [4]
CP length		Normal	
NPRACH Configuration		NPRACH.R-1	Refer to TS 36.133 [23] section A.3.18
DRX cycle length		1.28	The value shall be used for all cells in the test.
Expected RSTD	μs	nCell 2: 3 Other neighbour cells: randomly between -3 and 3	The expected RSTD is what is expected at the receiver. The corresponding parameter in the OTDOA assistance data specified in TS 36.355 [4] is the expectedRSTD indicator
Expected RSTD uncertainty for all neighbour cells	μs	5	The corresponding parameter in the OTDOA assistance data specified in TS 36.355 [4] is the expectedRSTD-Uncertainty index
Number of cells provided in OTDOA assistance data		16	Including the reference cell
Measurement period	s	20.48	Derived according to the RSTD measurement period in clause 9.6.2.3

#### 9.6.2.4.2 Test procedure

The test consists of a set-up period and a measurement period. nCell 1 and nCell 2 (and their LTE donor cells eCell 1 and eCell 2) are active during the complete test. The beginning of the measurement period shall be aligned with the first PRS positioning subframe of a positioning occasion in the reference cell.

**NOTE:** The information on when PRS is muted is conveyed to the UE using PRS muting information in the OTDOA assistance data.

The OTDOA-RequestLocationInformation message and the OTDOA assistance data as defined in clause 9.6.2.4.3 shall be provided to the UE during the set-up period. The last TTI containing the OTDOA-RequestLocationInformation message of the last NPDCCH repetition shall be provided to the UE  $\Delta T$  ms before the start of the measurement period,

where  $\Delta T = 150$  ms is the maximum processing time of the OTDOA-RequestLocationInformation message and the OTDOA assistance data in the UE.

1. Ensure that the UE is in state Generic RB Established State 3A-NB with CP ClIoT optimisation according to 3GPP TS 36.508 [18] clause 8.1.5 in nCell 1.
2. The SS shall send a RESET UE POSITIONING STORED INFORMATION message.
3. Set the parameters according to Table 9.6.2.5-1 and Table 9.6.2.5-2 as appropriate. Propagation conditions are set according to clause 4.7.2.1.
4. The SS shall send an LPP REQUEST CAPABILITIES message.
5. The UE shall send an LPP PROVIDE CAPABILITIES message indicating the OTDOA capabilities supported by the UE in the *OTDOA-ProvideCapabilities* IE.
6. The SS shall send a LPP PROVIDE ASSISTANCE DATA message, including the *OTDOA-ProvideAssistanceData* IE. If the UE message at step 5 includes the *ackRequested* IE set to TRUE, then the SS shall send an acknowledgment in the LPP PROVIDE ASSISTANCE DATA message.
7. The SS shall send a LPP REQUEST LOCATION INFORMATION message, including the *OTDOA-RequestLocationInformation* IE such that the UE receives the message  $\Delta T$  ms before the start of measurement period, where  $\Delta T = 150$  ms.
8. When the Inactivity Timer expires, the SS shall send a RRC Connection Release to send the UE to idle state.
9. The UE shall perform location measurements in idle state start a Mobile Originated Data Transport according to 3GPP TS 23.401 [42] clause 5.3.4B.2.
10. When the signalling connection between the UE and SS is re-established, the UE shall transmit a LPP PROVIDE LOCATION INFORMATION message, including the *OTDOA-ProvideLocationInformation* IE.
11. If the UE message at step 10 includes the *ackRequested* IE set to TRUE, the SS shall send a LPP acknowledgement message.
12. The SS shall check the *rstd* value for nCell 2 in the *OTDOA-SignalMeasurementInformation* IE according to Table 9.6.2.5-3.
13. Repeat step 2-12 until the confidence level according to Annex D is achieved.

#### 9.6.2.4.3 Message contents

Same as clause 9.6.1.4.3.

#### 9.6.2.5 Test requirement

Table 9.6.2.5-1 and 9.6.2.5-2 define the primary level settings including test tolerances for all tests.

The RSTD FDD inter-frequency accuracy test shall meet the reported values in Table 9.6.2.5-3.

Table 9.6.2.5-1: Cell Specific Test Parameters for inter frequency RSTD Tests for NB-IOT Cells

Parameter	Unit	Test 1	
		nCell 1	nCell 2
$BW_{channel}$	kHz	180	180
PRB location within eCell		eCell 1 $BW_{channel}$ 5MHz: 17 eCell 1 $BW_{channel}$ 10MHz: 30	eCell 2 $BW_{channel}$ 5MHz: 22 eCell 2 $BW_{channel}$ 10MHz: 35
NPBCH_RA	dB	0	0
NPBCH_RB			
NPSS_RA			
NSSS_RA			
NPDCCH_RA			
NPDCCH_RB			
NPDSCH_RA			
NPDSCH_RB			
OCNG_RA <sup>Note 1</sup>			
OCNG_RB <sup>Note 1</sup>			
NPRS_RA			
$N_{oc}$ <sup>Note 2</sup>	dBm/ 15 kHz	-98	-98
$NPRS \hat{E}_s / N_{oc}$	dB	-14.7	-14.7
$NPRS \hat{E}_s / I_{ot}$ <sup>Note 3</sup>	dB	-14.7	-14.7
$I_o$ <sup>Note 3</sup>	dBm/ 180kHz	-87.14	-87.14
NPRP <sup>Note 3</sup>	dBm/ 15 kHz	-112.7	-112.7
NRSRP <sup>Note 3</sup>	dBm/ 15 kHz	-113	-113
$\hat{E}_s / N_{oc}$ <sup>Note 3</sup>	dB	-15	-15
Propagation Condition		AWGN	AWGN
Antenna Configuration		1x1	1x1
Timing offset to nCell 1	us	N/A	3
<p>Note 1: OCNG shall be used such that active cells are fully allocated and a constant total transmitted power spectral density is achieved for all OFDM symbols other than those in the subframes with transmitted NPRS.</p> <p>Note 2: Interference from other cells and noise sources not specified in the test are assumed to be constant over subcarriers and time and shall be modelled as AWGN of appropriate power for <math>N_{oc}</math> to be fulfilled.</p> <p>Note 3: If NPRS_RA is not "N/A", <math>\hat{E}_s / N_{oc}</math>, <math>NPRS \hat{E}_s / I_{ot}</math>, <math>I_o</math>, NRSRP and NPRP levels have been derived from other parameters and are given for information purpose. If NPRS_RA is "N/A", <math>I_o</math> and NRSRP levels have been derived from other parameters and are given for information purpose. These are not settable test parameters. Interference conditions shall be applied to all PRS symbols of DL positioning subframes.</p>			

**Table 9.6.2.5-2: Cell Specific Test Parameters for inter frequency RSTD Tests for E-UTRA Cells**

Parameter	Unit	eCell 1			eCell 2		
		T1	T2	T3	T1	T2	T3
BW <sub>channel</sub>	MHz	5 or 10			5 or 10		
NOCNG Pattern defined in clause D.3	-	BW <sub>channel</sub> 5MHz: NOP.4 FDD BW <sub>channel</sub> 10MHz: NOP.1 FDD			BW <sub>channel</sub> 5MHz: NOP.4 FDD BW <sub>channel</sub> 10MHz: NOP.1 FDD		
PBCH_RA	dB	-3			-3		
PBCH_RB	dB						
PSS_RA	dB						
SSS_RA	dB						
PDCCH_RA	dB						
PDCCH_RB	dB						
PDSCH_RA	dB						
PDSCH_RB	dB						
OCNG_RA <sup>Note 1</sup>	dB						
OCNG_RB <sup>Note 1</sup>	dB						
N <sub>oc</sub> <sup>Note2</sup>	dBm/15 kHz	-98			-98		
$\hat{E}_s / N_{oc}$ <sup>Note2</sup>	dBm	3	3	3	3	3	3
Propagation Condition		AWGN			AWGN		
Antenna Configuration		1x1			1x1		
Timing offset to eCell 1	ms	-			3		
Note 1: OCNG shall be used such that the Cell is fully allocated and a constant total transmitted power spectral density is achieved for all OFDM symbols. Note 2: Interference from other cells and noise sources not specified in the test is assumed to be constant over subcarriers and time and shall be modelled as AWGN of appropriate power $N_{oc}$ .							

**Table 9.6.2.5-3: RSTD HD-FDD inter-frequency accuracy requirements for the reported values**

Lowest reported value	RSTD_6404
Highest reported value	RSTD_6490

For the overall test to pass, the ratio of successful reported values shall be more than 90% with a confidence level of 95%.

The expected response time is 21 s. The response time is equal to the LPP time IE value. The LPP time IE value is derived from the RSTD reporting delay plus ΔT, where ΔT = 150 ms, giving a value of 20630 ms. This is rounded up to the next allowed LPP value of 21 seconds. The RSTD measurement reporting delay in the test is derived from the following expression,  $T_{RSTD\ IntraFreq,NB} = T_{NPRS} \cdot (M - 1) + \Delta$  ms, where  $T_{NPRS} = 1280$  ms,  $M = 16$

$\left| N_{NPRS\_total} / N_{NPRS} \right|$ ,  $\Delta = T_{NPRS} \cdot \left\lceil \frac{n}{M} \right\rceil$ ,  $N_{NPRS\_total} = 320$  ms,  $N_{NPRS} = 640$  ms and  $n = 16$ . All the parameters are specified in clause 9.6.2.3 and Table 9.6.2.3-1. This gives the total RSTD reporting delay of 20480 ms for the 15 neighbour cells including nCell 2 with respect to the reference cell, nCell 1. This expected response time excludes any delay caused by RRC connection release before the idle mode measurement. This expected response time excludes any delay caused by establishing a signalling connection with the SS (including random access procedure) as defined in TS 36.305 [41] for LPP measurement reporting. The response time is not explicitly evaluated for this test; hence, no test tolerance values need to be applied.

### 9.6.3 HD-FDD Inter frequency RSTD Measurement Reporting Delay for NB-IOT Inband Mode in enhanced coverage

**Editor’s note: This test is incomplete. The following aspects are missing:**

- Core requirements in TS 36.133 are between square brackets
- PRS Part A configuration is missing TS 36.133
- Message contents are TBD



- TT are TBD
- The response time needs to be calculated
- The expected RSTD indicated in Table 9.6.3.3-1 and the timing offsets configured for the nCells in Table 9.6.5-1 do not match. This needs to be corrected in RAN4.

### 9.6.3.1 Test purpose

To verify that the RSTD HD-FDD Inter-frequency measurement reporting delay is within the specified limits for NB-IOT Inband Mode in enhanced coverage.

### 9.6.3.2 Test applicability

This test applies to E-UTRA HD-FDD UE release 14 and forward of UE Category NB1 that supports UE-assisted OTDOA and inter-frequency RSTD measurements.

### 9.6.3.3 Minimum conformance requirements

UE shall follow the procedure for idle state positioning measurement as defined in TS 36.305 [41] section 7.1.3.

When the physical layer cell identities of neighbour cells together with the OTDOA assistance data are provided and when the UE has entered the idle state, the UE shall be able to detect and measure Inter-frequency RSTD, specified in TS 36.214 [6], for at least  $n = 16$  cells, including the reference cell, on the same carrier frequency  $f_1$  as that of the reference cell within  $T_{\text{RSTD InterFreq,NB}}$  ms as given below:

$$T_{\text{RSTD InterFreq,NB}} = T_{\text{NPRS}} \cdot (M-1) + \Delta \quad \text{ms},$$

where

$T_{\text{RSTD InterFreq,NB}}$  is the total time for detecting and measuring at least  $n$  cells;

$T_{\text{NPRS}}$  is the cell-specific positioning subframe configuration period as defined in TS 36.355 [4] if Part B subframe configuration is provided; otherwise if only Part A subframe configuration is provided, the  $T_{\text{NPRS}}$  equals to the length of the subframe pattern,

$M$  is the number of NPRS positioning occasions as defined in Table 4.8.1-1,

$\Delta = T_{\text{NPRS}} \cdot \left\lceil \frac{n}{M} \right\rceil$  ms is the measurement time for a single NPRS positioning occasion which includes the sampling time and the processing time;

$N_{\text{NPRS}}$  is the cell-specific number of NPRS subframes within a NPRS occasion as defined in TS 36.355 [4] if Part B subframe configuration is provided; if only Part A subframe configuration is provided, the NPRS occasion length is 10 ms,

$N_{\text{NPRS\_total}}$  is the minimum number of NPRS subframes per cell measurement as specified in Section 9.1.22.13.

$T_{\text{NPRS}}$ ,  $N_{\text{NPRS}}$ , and  $N_{\text{NPRS\_total}}$  are the parameters of the same cell, for which  $T_{\text{NPRS}} \cdot \left\lceil \frac{N_{\text{NPRS\_total}}}{N_{\text{NPRS}}} \right\rceil$  is the largest among all the measured cells.

**Table 9.6.3.3-1: Number of NPRS positioning occasions within  $T_{\text{RSTD InterFreq, NB}}$** 

Positioning subframe configuration period $T_{\text{NPRS}}$	Number of NPRS positioning occasions $M$	
	f1 <sup>Note1</sup>	f1 and f2 <sup>Note2</sup>
160 ms	16* $\left\lfloor \frac{N_{\text{NPRS\_total}}}{N_{\text{NPRS}}} \right\rfloor$	32* $\left\lfloor \frac{N_{\text{NPRS\_total}}}{N_{\text{NPRS}}} \right\rfloor$
>160 ms	8* $\left\lfloor \frac{N_{\text{NPRS\_total}}}{N_{\text{NPRS}}} \right\rfloor$	16* $\left\lfloor \frac{N_{\text{NPRS\_total}}}{N_{\text{NPRS}}} \right\rfloor$
Note 1: When only intra-frequency RSTD measurements are performed over cells belonging to the serving carrier frequency f1. Note 2: When intra-frequency RSTD and inter-frequency RSTD measurements are performed over cells belonging to the serving carrier frequency f1 and one inter-frequency carrier frequency f2, respectively.		

The UE physical layer shall be capable of reporting RSTD for the reference cell and all the neighbour cells  $i$  out of at least  $(n-1)$  neighbour cells within  $T_{\text{RSTD InterFreq, NB}}$  provided:

$$\left( \text{NPRS } \hat{E}_s / \text{Iot} \right)_{\text{ref}} \geq -15 \text{ dB for all Frequency Bands for the reference cell,}$$

$$\left( \text{NPRS } \hat{E}_s / \text{Iot} \right)_i \geq -15 \text{ dB for all Frequency Bands for neighbour cell } i,$$

$$\left( \text{NPRS } \hat{E}_s / \text{Iot} \right)_{\text{ref}} \text{ and } \left( \text{NPRS } \hat{E}_s / \text{Iot} \right)_i \text{ conditions apply for all subframes of at least } L = \frac{M}{2} \text{ NPRS}$$

positioning occasions,

NPRP 1,2<sub>dBm</sub> according to Annex E.5 for a corresponding Band

$\text{NPRS } \hat{E}_s / \text{Iot}$  is defined as the ratio of the average received energy per PRS RE during the useful part of the symbol to the average received power spectral density of the total noise and interference for this RE, where the ratio is measured over all REs which carry NPRS.

The time  $T_{\text{RSTD InterFreq, NB}}$  starts from the point when UE receive both the OTDOA-RequestLocationInformation message and the OTDOA assistance data in the OTDOA-ProvideAssistanceData message as specified in TS 36.355 [4], are delivered to the physical layer of the UE.

The normative reference for this requirement is TS 36.133 [23] clauses 4.8.4 and A.4.7.2.

### 9.6.3.4 Test description

#### 9.6.3.4.1 Initial conditions

Test Environment: Normal; as defined in TS 36.508 [18] clause 8.1.1.

Frequencies to be tested: Mid Range, as defined in TS 36.508 [18] clause 8.1.3.1.1.

Channel bandwidth to be tested: 10 MHz. If the band under test does not support 10 MHz bandwidth, 5 MHz shall be used.

1. Connect the SS and AWGN noise sources to the UE antenna connector or antenna connectors as shown in Annex A, Figure A.3 but using only the main TX/RX antenna.
2. The general test parameter settings are set up according to Table 9.6.3.4.1-1.
3. Propagation conditions are set according to clause 4.7.2.1.
4. Message contents are defined in clause 9.6.3.4.3.
5. There are three synchronous cells: nCell 1, nCell 2 and nCell 3. nCell 1 is the reference as well as the serving cell. nCell 2 and nCell 3 are the neighbour cells. All cells are on different RF channels. The assistance data

neighbour cell list includes in total 15 cells, where 13 of the cells are not simulated (dummy cells; as defined in 3GPP TS 37.571-5 [20], clause 7.2.2).

6. The true RSTD (which is the received time difference for frame 0 between two cells as seen at the UE antenna connector) is set to  $-62 T_s$  (about  $2 \mu s$ ) between neighbour nCell 2 and serving nCell 1; and set to  $62 T_s$  (about  $2 \mu s$ ) between neighbour nCell 3 and serving nCell 1.

**Table 9.6.3.4-1: General test parameters**

Parameter	Unit	Value	Comment
NB-IoT operational mode		Standalone	
Reference cell		nCell 1	Reference cell is the cell in the OTDOA assistance data with respect to which the RSTD measurement is defined, as specified in TS 36.214 [6] and TS 36.355 [4]. The reference cell is the PCell in this test case.
Neighbor cells		nCell 2 and nCell 3	Cell 2 and Cell 3 appear at random places in the neighbour cell list in the OTDOA assistance data, but Cell 2 always appears in the first half of the list, whilst Cell 3 appears in the second half of the list.
nprsID		(nprsID of Cell 1 – nprsID of Cell 2)mod6=1 and (nprsID of Cell 1 – nprsID of Cell 3)mod6=2	As defined in TS 36.355 [4]
nprs-period	ms	640	As defined in TS 36.355 [4]
nprs-startSF		sf0	Subframe offset of the NPRS positioning occasion as defined in TS36.355 [4]
Number of consecutive downlink positioning subframes nprs-NumSF		320	As defined in TS36.355 [4]
nprs-SubframeOffset		0	As defined in TS36.355 [4]
NPRS muting info		Cell 1: '1111111100000000' Cell 2: '0000000011111111' Cell 3: '1111111100000000'	Corresponds to nprs-MutingInfoB defined in TS 36.355 [4]
Part A Configuration		N/A	NPRS is configured based on Part B but not Part A.
CP length		Normal	
NPRACH Configuration		NPRACH.R-1	Refer to A.3.18
DRX cycle length		1.28	The value shall be used for all cells in the test.
Radio frame receive time offset between the cells at the UE antenna connector	µs	nCell 2 to nCell 1: 1 nCell 3 to nCell 1: -1	PRS are transmitted from synchronous cells
Expected RSTD	µs	Cell 2: -2 Cell 3: 2 Other neighbour cells: randomly between -3 and 3	The expected RSTD is what is expected at the receiver. The corresponding parameter in the OTDOA assistance data specified in TS 36.355 [4] is the expectedRSTD indicator
Expected RSTD uncertainty for all neighbour cells	µs	5	The corresponding parameter in the OTDOA assistance data specified in TS 36.355 [4] is the expectedRSTD-Uncertainty index
Number of cells provided in OTDOA assistance data		16	Including the reference cell
T1	s	[2.76]	The length of the time interval from the beginning of each test
T2	s	[5.12]	The length of the time interval that follows immediately after time interval T1
T3	s	[5.12]	The length of the time interval that follows immediately after time interval T2
T4	s	[5.12]	The length of the time interval that follows immediately after time interval T3

T5	s	[5..12]	The length of the time interval that follows immediately after time interval T4
T6	s	[55]	The length of the time interval that follows immediately after time interval T5

#### 9.6.3.4.2 Test procedure

The test consists of six consecutive time intervals, with duration of T1, T2, T3, T4, T5 and T6. nCell 1 is active throughout T1, T2, T3, T4, T5 and T6, whilst nCell 2 and nCell 3 are activated only in the beginning of T2. nCell 2 is active until the end of T5 and nCell 3 is active until the end of T4. nCell 1 transmits NPRS in T2 and T4, while nCell 2 transmits NPRS in T3 and T5 and nCell 3 transmits NPRS only in T2 and T4. Note: The information on when NPRS is muted is conveyed to the UE using PRS muting information.

NOTE: The information on when PRS is muted is conveyed to the UE using PRS muting information in the OTDOA assistance data.

The OTDOA-RequestLocationInformation message and the OTDOA assistance data as defined in clause 9.6.3.4.3 shall be provided to the UE during the set-up period, T1. The last TTI containing the OTDOA-RequestLocationInformation message shall be provided to the UE  $\Delta T$  ms before the start of the measurement period, where  $\Delta T = 150$  ms is the maximum processing time of the OTDOA-RequestLocationInformation message and the OTDOA assistance data in the UE.

1. Ensure that the UE is in state Generic RB Established State 3A-NB with CP ClIoT optimisation according to 3GPP TS 36.508 [18] clause 8.1.5 in nCell 1.
2. The SS shall send a RESET UE POSITIONING STORED INFORMATION message.
3. Set the parameters according to Table 9.6.3.5-1 and Table 9.6.3.5-2 as appropriate. Propagation conditions are set according to clause 4.7.2.1.
4. The SS shall send an LPP REQUEST CAPABILITIES message.
5. The UE shall send an LPP PROVIDE CAPABILITIES message indicating the OTDOA capabilities supported by the UE in the *OTDOA-ProvideCapabilities* IE.
6. The SS shall send a LPP PROVIDE ASSISTANCE DATA message, including the *OTDOA-ProvideAssistanceData* IE. If the UE message at step 5 includes the *ackRequested* IE set to TRUE, then the SS shall send an acknowledgment in the LPP PROVIDE ASSISTANCE DATA message.
7. The SS shall send a LPP REQUEST LOCATION INFORMATION message, including the *OTDOA-RequestLocationInformation* IE such that the UE receives the message  $\Delta T$  ms before the start of measurement period, where  $\Delta T = 150$  ms.
8. When the Inactivity Timer expires, the SS shall send a RRC Connection Release to send the UE to idle state.
9. When T1 expires, the SS shall switch the power setting from T1 to T2 as specified in Table 9.6.3.5-2.
10. When T2 expires, the SS shall switch the power setting from T2 to T3 as specified in Table 9.6.3.5-2.
11. When T3 expires, the SS shall switch the power setting from T3 to T4 as specified in Table 9.6.3.5-2.
12. When T4 expires, the SS shall switch the power setting from T4 to T5 as specified in Table 9.6.3.5-2.
13. When T5 expires, the SS shall switch the power setting from T5 to T6 as specified in Table 9.6.3.5-1.
14. The UE shall perform location measurements in idle state and start a Mobile Originated Data Transport according to 3GPP TS 23.401 [42] clause 5.3.4B.2.
15. When the signalling connection between the UE and SS is re-established, the UE shall transmit a LPP PROVIDE LOCATION INFORMATION message, including the *OTDOA-ProvideLocationInformation* IE. The LPP PROVIDE LOCATION INFORMATION shall be transmitted within the response time (see clause 4.7.3) specified in clause 9.6.3.5. The UE shall perform and report the RSTD measurements for both nCell 2 and nCell 3 with respect to the reference cell in the OTDOA assistance data, nCell 1. If the UE transmits an

*OTDOA-ProvideLocationInformation* IE including the *rstd* field for both nCell 2 and nCell 3 within the response time then the number of successful tests is increased by one. If the UE fails to report the *OTDOA-ProvideLocationInformation* IE with both the *rstd* fields included within the response time then the number of failure tests is increased by one.

16. If the UE message at step 15 includes the *ackRequested* IE set to TRUE, the SS shall send a LPP acknowledgement message.

17. Repeat step 2-16 until the confidence level according to Annex D is achieved.

#### 9.6.3.4.3 Message contents

Same as in Clause 9.6.1.3.4.3 with the following exceptions: TBD.

#### 9.6.3.5 Test requirement

Table 9.6.3.5-1 and 9.6.3.5-2 define the primary level settings including test tolerances for all tests.

**Table 9.6.3.5-1: Cell Specific Test Parameters for Inter frequency RSTD Tests for T1 and T6**

Parameter	Unit	nCell 1	nCell 2	nCell 3
NB-IoT RF Channel Number		1	1	1
NB-IoT Channel Bandwidth ( $BW_{channel}$ )	kHz	200	200	200
OCNG Pattern <sup>Note 1</sup>		NOP.3 FDD	N/A	N/A
NPDSCH parameters <sup>Note 2</sup>		R.18 HD-FDD	N/A	N/A
NPDCCH parameters <sup>Note 2</sup>		R.30 HD-FDD	N/A	N/A
NPBCH_RA	dB	0	N/A	N/A
NPBCH_RB				
NPSS_RA				
NSSS_RA				
NPDCCH_RA				
NPDCCH_RB				
NPDSCH_RA				
NPDSCH_RB				
OCNG_RA <sup>Note 1</sup>				
OCNG_RB <sup>Note 1</sup>				
$N_{oc}$ <sup>Note 3</sup>	dBm/ 15 kHz	-98		
$NPRS \hat{E}_s / N_{oc}$	dB	-Infinity	-Infinity	-Infinity
$\hat{E}_s / N_{oc}$	dB	-12	-Infinity	-Infinity
Propagation Condition		AWGN		
Antenna Configuration		1x1		
Timing offset to nCell 1	$\mu$ s	N/A	1	-1
Note 1:	OCNG shall be used such that the cell is fully allocated and a constant total transmitted power spectral density is achieved for all OFDM symbols. The OCNG pattern is chosen during the test according to the presence of a DL reference measurement channel.			
Note 2:	The NPDSCH and NPDCCH reference measurement channels are used in the test only when a downlink transmission dedicated to the UE under test is required.			
Note 3:	Interference from other cells and noise sources not specified in the test are assumed to be constant over subcarriers and time and shall be modelled as AWGN of appropriate power for $N_{oc}$ to be fulfilled.			

Table 9.6.3.5-2: Cell Specific Test Parameters for Inter frequency RSTD Tests for T2 to T5

Parameter	Unit	Cell 1		Cell 2		Cell 3		
		T2 and T4	T3 and T5	T2 and T4	T3 and T5	T2 and T4	T3 and T5	
BW <sub>channel</sub>	kHz	200		200		200		
NB-IoT RF Channel Number		1		1		1		
OCNG patterns		NOP.3 FDD		N/A	NOP.3 FDD	NOP.3 FDD	N/A	
NPBCH_RA	dB	0		0		0		N/A
NPBCH_RB								
NPSS_RA								
NSSS_RA								
NPDCCH_RA								
NPDCCH_RB								
NPDSCH_RA								
NPDSCH_RB								
OCNG_RA <sup>Note 1</sup>								
OCNG_RB <sup>Note 1</sup>								
NPRS_RA	dB	-3	N/A	N/A	0	0	N/A	
$N_{oc}$ <sup>Note 2</sup>	dBm/ 15 kHz	-98	-95	-98	-95	-98	-95	
$NPRS \hat{E}_s / N_{oc}$	dB	-15	-Infinity	-Infinity	-15	-15	-Infinity	
$NPRS \hat{E}_s / I_{ot}$ <sup>Note 3</sup>	dB	-15	-Infinity	-Infinity	-15	-15	-Infinity	
$I_o$ <sup>Note 3</sup>	dBm/ 180kHz	-87.17	-87.20	-87.17	-87.15	-87.17	-87.15	
NPRP <sup>Note 3</sup>	dBm/ 15 kHz	-113	-Infinity	-Infinity	-110	-113	-Infinity	
NRSRP <sup>Note 3</sup>	dBm/ 15 kHz	-110	-107	-113	-110	-113	-Infinity	
$\hat{E}_s / N_{oc}$ <sup>Note 3</sup>	dB	-12	-12	-15	-15	-15	-Infinity	
Propagation Condition		AWGN						
Antenna Configuration		1x1						
Timing offset to nCell 1	μs	N/A		1		-1		
Note 1:	OCNG shall be used such that active cells (all, except Cell 3 in T3) are fully allocated and a constant total transmitted power spectral density is achieved for all OFDM symbols other than those in the subframes with transmitted NPRS.							
Note 2:	Interference from other cells and noise sources not specified in the test are assumed to be constant over subcarriers and time and shall be modelled as AWGN of appropriate power for $N_{oc}$ to be fulfilled.							
Note 3:	If NPRS_RA is not "N/A", $\hat{E}_s / N_{oc}$ , $NPRS \hat{E}_s / I_{ot}$ , $I_o$ , NRSRP and NPRP levels have been derived from other parameters and are given for information purpose. If NPRS_RA is "N/A", $I_o$ and NRSRP levels have been derived from other parameters and are given for information purpose. These are not settable test parameters. Interference conditions shall be applied to all PRS symbols of DL positioning subframes.							

The response time including test tolerance is [TBD] s. The response time is equal to the LPP time IE value. The LPP time IE value is derived from the RSTD reporting delay plus  $\Delta T$ , where  $\Delta T = 150$  ms, giving a value of [TBD] ms. This is rounded up to the next allowed LPP value of [TBD] seconds. The RSTD measurement reporting delay in the test is derived from the following expression,  $T_{RSTD \text{ IntraFreq,NB}} = T_{NPRS} \cdot (M-1) + \Delta$  ms, where  $T_{NPRS} = 1280$

ms,  $M = 8 \left\lceil N_{NPRS\_total} / N_{NPRS} \right\rceil$ ,  $\Delta = T_{NPRS} \cdot \left\lceil \frac{n}{M} \right\rceil$ ,  $N_{NPRS\_total} = 320$  ms,  $N_{NPRS} = 320$  ms and  $n = 16$ . All the

parameters are specified in clause 9.6.3.3 and Table 9.6.3.3-1. This gives the total RSTD reporting delay of 11520 ms



for the 15 neighbour cells including nCell 2 with respect to the reference cell, nCell 1. This expected response time excludes any delay caused by RRC connection release before the idle mode measurement. This expected response time excludes any delay caused by establishing a signalling connection with the SS (including random access procedure) as defined in TS 36.305 [41] for LPP measurement reporting. The response time is not explicitly evaluated for this test; hence, no test tolerance values need to be applied.

For the overall test to pass, the ratio of successful reported values shall be more than 90% with a confidence level of 95%.

## 10 E-UTRA OTDOA measurement requirements for Carrier Aggregation

### 10.1 FDD RSTD Measurement Reporting Delay for Carrier Aggregation

#### 10.1.1 Test purpose

To verify that the RSTD measurement reporting delay meets the requirements in an environment with fading propagation conditions. This test case verifies the measurement period requirements for RSTD measurements performed on the secondary component carrier and also the measurement period requirements for RSTD measurements performed on both the primary and secondary component carriers.

#### 10.1.2 Test applicability

This test applies to all types of E-UTRA FDD UE release 10 and forward that supports UE-assisted OTDOA for Carrier Aggregation.

#### 10.1.3 Minimum conformance requirements

##### 10.1.3.1 Measurements on the secondary component carrier

The RSTD measurements when all cells are on the configured secondary component carrier shall meet all applicable requirements (FDD) specified in TS 36.133 [23] section 8.1.2.5, i.e., E-UTRAN intra-frequency RSTD measurement period applies, regardless of whether the SCell on the corresponding frequency is activated or deactivated by the MAC-CE commands as specified in 3GPP TS 36.321 [34].

##### 10.1.3.2 Measurements on both primary component carrier and secondary component carrier

The RSTD measurements of cells on both primary component carrier and configured secondary component carrier shall meet all applicable requirements (FDD) specified in TS 36.133 [23] section 8.1.2.6, i.e., E-UTRAN inter-frequency RSTD measurement period applies regardless of whether the SCell on the corresponding frequency is activated or deactivated by the MAC-CE commands as specified in 3GPP TS 36.321 [34], with the following exception

- the number of PRS positioning occasions is as specified in Table 10.1.3.2-1 shall apply.

**Table 10.1.3.2-1: Number of PRS positioning occasions within measurement period**

Positioning subframe configuration period $T_{\text{PRS}}$	Number of PRS positioning occasions $M$
160 ms	32
>160 ms	16

The normative reference for this requirement is TS 36.133 [23] clause 8.4.3, 8.4.4 and A.8.17.1.

## 10.1.4 Test description

### 10.1.4.1 Initial conditions

Test Environment: Normal; as defined in TS 36.508 [18] clause 4.1.

Frequencies to be tested: Mid Range, as defined in TS 36.508 [18] clause 4.3.1.1.

Channel bandwidth to be tested: 10 MHz as defined in TS 36.508 [18] clause 4.3.1.

1. Connect the SS, faders and AWGN noise sources to the UE antenna connector or antenna connectors as shown in TS 36.508 [18] Annex A, Figure group A.42 as appropriate.
2. The general test parameter settings are set up according to Table 10.1.4.1-1.
3. Propagation conditions are set according to clause 4.7.2.1.
4. Message contents are defined in clause 10.1.4.3.
5. In the tests, there are two configured component carriers: PCC and SCC, and three synchronized cells: Cell 1, Cell 2 and Cell 3. Cell 1 is PCell on the PCC, Cell 2 is an active SCell on the SCC, and Cell 3 is a neighbour cell on the SCC. In both tests, Cell 2 is the OTDOA assistance data reference cell. The assistance data neighbour cell list includes in total 15 cells, where 14 of the cells are not simulated (dummy cells; as defined in 3GPP TS 37.571-5 clause 7.3.2) for Test 1 and where 13 of the cells are not simulated for Test 2. PCell (Cell 1) is the cell used for connection setup with the power level and mapping set according to TS 36.521-1 [24] Annex C.0 and C.1 as appropriate for this test. Cell 2 and Cell 3 are powered OFF.
6. The true RSTD (which is the receive time difference for frame 0 between two cells as seen at the UE antenna connector) is set to 31 Ts (about 1  $\mu$ s) between Cell 1 and OTDOA assistance data reference cell, Cell 2; and set to -31 Ts (about -1  $\mu$ s) between neighbour Cell 3 and OTDOA assistance data reference cell, Cell 2.

**Table 10.1.4.1-1: General test parameters for E-UTRAN FDD RSTD measurement reporting delay under fading propagation conditions for Carrier Aggregation**

Parameter	Unit	Value		Comment
		Test 1	Test 2	
PCell		Cell 1		PCell is on RF channel 1 (PCC).
SCell		Cell 2		SCell on RF channel 2 (SCC). Cell 2 is the assistance data reference cell.
Other neighbour cell		Cell 3		Neighbour cell on RF channel 2 (SCC).
PCFICH/PDCCH/PHICH parameters		DL Reference Measurement Channel R.6 FDD		As specified in TS 36.521-3 [25] clause A.2.1
Channel Bandwidth (BW <sub>channel</sub> )	MHz	10		
PRS Transmission Bandwidth <sup>Note 2</sup>	RB	50		PRS are transmitted over the system bandwidth
PRS configuration index $I_{PRS}$ <sup>Note 2</sup>		171 for all cells on PCC 181 for all cells on SCC		This corresponds to periodicity of 320 ms and PRS subframe offset of $I_{PRS} - 160$ DL subframes, as defined in 3GPP TS 36.211 [26], Table 6.10.4.3-1
Number of consecutive downlink positioning subframes $N_{PRS}$ <sup>Note 2</sup>		1		As defined in 3GPP TS 36.211 [26]. The number of subframes in a positioning occasion
Physical cell ID PCI <sup>Note 2</sup>		(PCI of Cell 2 – PCI of Cell 3)mod6=0		The PCI of Cell 1 is selected randomly. PCIs of Cell 2 and Cell 3 are selected randomly such that the relative subcarrier shifts of PRS patterns among these cells are as given by the condition.
CP length <sup>Note 2</sup>		Normal		
DRX		ON		DRX parameters are further specified in Table 10.1.4.1-2
Radio frame receive time offset between the cells at the UE antenna connector <sup>Note 3</sup>	μs	Cell 1 to Cell 2: 1 Cell 3 to Cell 2: -1	Cell 1 to Cell 2: 1 Cell 3 to Cell 2: -1	PRS are transmitted from synchronous cells
Expected RSTD <sup>Note 1</sup>	μs	Cell 3: 2 Other neighbour cells: randomly between -3 and 3	Cell 1: -2 Cell 3: 2 Other neighbour cells: randomly between -3 and 3	The expected RSTD is what is expected at the receiver. The corresponding parameter in the OTDOA assistance data specified in TS 36.355 [4] is the expectedRSTD indicator
Expected RSTD uncertainty for all neighbour cells <sup>Note 1</sup>	μs	5		The corresponding parameter in the OTDOA assistance data specified in TS 36.355 [4] is the expectedRSTD-Uncertainty index
Number of cells provided in OTDOA assistance data		16 cells in total		The list includes the reference cell and 15 other cells. Cell 1 (when included) appears at random places in the first half of the neighbour cell list in the OTDOA assistance data. Cell 3 always appears at random places in the second half of the list
		OTDOA neighbour cells include Cell 3 and other 14 cells on SCC	OTDOA neighbour cells include Cell 1 and other 7 cells on PCC, and Cell 3 and other 6 cells on SCC	
prs-SubframeOffset <sup>Note 2</sup>		Cells on PCC: 310 Cells on SCC, except reference cell: 0		Subframe offset, counted in full subframes. The corresponding parameter in the OTDOA assistance data is prs-SubframeOffset specified in TS 36.355 [4]

slotNumberOffset <sup>Note 2</sup>		Cells on PCC: 0 Cells on SCC, except reference cell: 0		The slot number offset at the transmitter between a neighbour cell and the assistance data reference cell. The corresponding parameter in the OTDOA assistance data is slotNumberOffset specified in TS 36.355 [4].
PRS muting info <sup>Note 2</sup>		Cell 1: '11110000' Cell 2: '00001111' Cell 3: '11110000'	Cell 1: '1111111100000000' Cell 2: '0000000011111111' Cell 3: '1111111100000000'	Corresponds to prs-MutingInfo defined in TS 36.355 [4]
T1	S	3		The length of the time interval from the beginning of each test
T2	S	1.28	2.48	The length of the time interval that follows immediately after time interval T1
T3	S	1.28	2.48	The length of the time interval that follows immediately after time interval T2
Note 1:	Parameters "Expected RSTD" and "Expected RSTD uncertainty for all neighbour cells" are not settable parameters. These are parameters signalled in LPP only. For the values to be used in LPP see Table 10.1.4.3-4 and TS 37.571-5 [20], clause 7.3.2.			
Note 2:	Parameters "PRS Transmission Bandwidth", "PRS configuration index", "Number of consecutive downlink positioning subframes", "Physical cell ID PCI", "CP length", "prs-SubframeOffset", "slotNumberOffset" and "PRS muting info" are settable parameters and also parameters signalled in LPP. The values to be used for "Physical cell ID PCI" are as follows: Cell 1: 0, Cell 2: 6, Cell 3: 12. For the values to be used in LPP see Table 10.1.4.3-4 and TS 37.571-5 [20], clause 7.3.2.			
Note 3:	The parameter "Radio frame receive time offset between the cells at the UE antenna connector" is used to set the "true RSTD" values in step 6 of clause 10.1.4.1.			

**Table 10.1.4.1-2: DRX parameters for E-UTRAN FDD RSTD measurement reporting delay under fading propagation conditions for Carrier Aggregation**

Field	Value	Comment
onDurationTimer	psf1	As specified in 3GPP TS 36.331 [22], clause 6.3.2
drx-InactivityTimer	psf1	
drx-RetransmissionTimer	sf1	
longDRX-CycleStartOffset	sf320	
shortDRX	Disable	

10.1.4.2 Test procedure

The test case includes two tests. Test 1 is designed for the scenario where the UE receives OTDOA assistance data with cells on SCC, and the UE is expected to report RSTD measurements performed on SCC only. Test 2 is designed for the scenario where the UE receives OTDOA assistance data with cells on PCC and SCC, and the UE is expected to report RSTD measurements performed on PCC and on SCC.

Each test consists of three consecutive time intervals, with duration of T1, T2 and T3 defined in Table 10.1.4.1-1. Cell 1 is active in T1, T2 and T3, whilst Cell 2 is active only in T2 and T3, and Cell 3 is active only during T2. The beginning of the time interval T2 shall be aligned 5 ms before the first PRS positioning subframe of a positioning occasion in the OTDOA assistance data reference cell, where 5 ms is the necessary test tolerance. Cell 1 transmits PRS in T2, while Cell 2 transmits PRS only in T3, and Cell 3 transmits PRS only in T2.

NOTE: The information on when PRS is muted is conveyed to the UE using PRS muting information in the OTDOA assistance data.

The OTDOA-RequestLocationInformation message and the OTDOA assistance data as defined in clause 10.1.4.3 shall be provided to the UE during T1. The last TTI containing the OTDOA-RequestLocationInformation message shall be provided to the UE ΔT ms before the start of T2, where ΔT = 150 ms is the maximum processing time of the OTDOA-RequestLocationInformation message and the OTDOA assistance data.

1. Ensure that the UE is in state Generic RB Established State 3A-RF according to 3GPP TS 36.508 [18] clause 7.2A.3.
2. Configure Cell 2 and Cell 3 on the SCC according to TS 36.521-3 [25] Annex C.0 and C.1 for all downlink physical channels.
3. The SS shall configure the SCell (Cell 2) on the SCC as per TS 36.508 [18] clause 5.2A.4.
4. The SS activates the SCell (Cell 2) by sending the Activation/Deactivation MAC control element according to TS 36.321 [34] clauses 5.13 and 6.1.3.8. Wait for at least 2 seconds as per TS 36.133 [23] clause 8.3.3.2.
5. The SS shall send a RESET UE POSITIONING STORED INFORMATION message.
6. Set the parameters according to Table 10.1.5-1. Propagation conditions are set according to clause 4.7.2.2 (ETU30).
7. T1 starts.
8. The SS shall transmit an RRCConnectionReconfiguration message with the DRX configuration. PDCCHs indicating new transmissions shall be sent continuously until the start of T2 to ensure that the UE would not enter the DRX state before T2.
9. The UE shall transmit RRCConnectionReconfigurationComplete message.
- 9a. The SS shall transmit an LPP REQUEST CAPABILITIES message.
- 9b. The UE shall transmit an LPP PROVIDE CAPABILITIES message indicating the OTDOA capabilities supported by the UE in the *OTDOA-ProvideCapabilities* IE.
10. The SS shall send a LPP PROVIDE ASSISTANCE DATA message, including the *OTDOA-ProvideAssistanceData* IE. The position of neighbour Cell 3 in the *OTDOA-NeighbourCellInfoList* is randomly selected to be in the last 8 elements of the sequence for Test 1 and in the 7 elements of the relevant sequence for Test 2, and the position of neighbour Cell 1 is randomly selected to be in the first 7 elements of the relevant sequence for Test 2, as described in 3GPP TS 37.571-5 [20], clause 7.3.2. If the UE message at step 9b includes the *ackRequested* IE set to TRUE, then the SS shall send an acknowledgment in the LPP PROVIDE ASSISTANCE DATA message.
11. The SS shall send a LPP REQUEST LOCATION INFORMATION message, including the *OTDOA-RequestLocationInformation* IE such that the UE receives the message  $\Delta T$  ms before the start of T2, where  $\Delta T = 150$  ms.
12. When T1 expires, the SS shall switch the power setting from T1 to T2 as specified in Table 10.1.5-2.
13. When T2 expires, the SS shall switch the power setting from T2 to T3 as specified in Table 10.1.5-2.
14. The UE shall transmit a LPP PROVIDE LOCATION INFORMATION message including the *OTDOA-ProvideLocationInformation* IE within the response time (see clause 4.7.3) specified in clause 10.1.5.  
  
For Test 1 the UE shall perform and report the RSTD measurement for Cell 3 with respect to the reference cell in the OTDOA assistance data, Cell 2. If the UE transmits an *OTDOA-ProvideLocationInformation* IE including the *rstd* field for Cell 3 within the response time then the number of successful tests is increased by one. If the UE fails to report the *OTDOA-ProvideLocationInformation* IE with the *rstd* field included within the response time then the number of failure tests is increased by one.  
  
For Test 2 the UE shall perform and report the RSTD measurements for Cell 1 with respect to the reference cell in the OTDOA assistance data, Cell 2 and also Cell 3 with respect to the reference cell in the OTDOA assistance data, Cell 2. If the UE transmits an *OTDOA-ProvideLocationInformation* IE including the *rstd* field for Cell 1 (with respect to Cell 2) and Cell 3 (with respect to Cell 2) within the response time then the number of successful tests is increased by one. If the UE fails to report the *OTDOA-ProvideLocationInformation* IE with both the *rstd* fields included within the response time then the number of failure tests is increased by one.
15. If the UE message at step 14 includes the *ackRequested* IE set to TRUE, the SS shall send a LPP acknowledgement message.

16. Repeat steps 5-15 until the confidence level according to Annex D is achieved. For each iteration, at step 10 change the random positions of the Cell 3 and Cell 1(for Test 2 only) in the relevant sequence in the *OTDOA-NeighbourCellInfoList*.

17. Repeat from clause 10.1.4.1 for Test 2.

### 10.1.4.3 Message contents

**Table 10.1.4.3-1: RESET UE POSITIONING STORED INFORMATION**

Derivation Path: 36.509 [11] clause 6.9			
Information Element	Value/remark	Comment	Condition
UE Positioning Technology	0 0 0 0 0 0 1	OTDOA	

**Table 10.1.4.3-2: MAC-MainConfig-RBC: FDD RSTD Measurement Reporting Delay for Carrier Aggregation**

Derivation Path: TS 36.508 [18] clause 4.8.2.1.5, Table 4.8.2.1.5-1 MAC-MainConfig-RBC			
Information Element	Value/remark	Comment	Condition
MAC-MainConfig-RBC ::= SEQUENCE {			
drx-Config CHOICE {			
setup SEQUENCE {			
onDurationTimer	psf1		
drx-InactivityTimer	psf1		
drx-RetransmissionTimer	sf1		
longDRX-CycleStartOffset CHOICE {			
sf320	0		
}			
shortDRX	Not present		
}			
}			
}			

**Table 10.1.4.3-2a: LPP Request Capabilities**

Information Element	Value/remark
<i>otdoa-RequestCapabilities</i>	TRUE

Table 10.1.4.3-3: LPP RequestLocationInformation

Derivation Path: 36.355 clause 6.2			
Information Element	Value/remark	Comment	Condition
LPP-Message ::= SEQUENCE {			
transactionID SEQUENCE {			
Initiator	locationServer		
transactionNumber	1		
}			
endTransaction	FALSE		
sequenceNumber	Not present		
acknowledgement	Not present		
lpp-MessageBody CHOICE {			
c1 CHOICE {			
requestLocationInformation SEQUENCE {			
criticalExtensions CHOICE {			
c1 CHOICE {			
requestLocationInformation-r9 SEQUENCE {			
commonIEsRequestLocationInformation SEQUENCE {			
locationInformationType	locationMeasurementsRequired		
triggeredReporting	Not present		
periodicalReporting	Not present		
additionalInformation	onlyReturnInformationRequested		
qos SEQUENCE {			
horizontalAccuracy	Not present		
verticalCoordinateRequest	FALSE		
verticalAccuracy	Not present		
responseTime SEQUENCE {			
time	Test 1: 3 Test 2: 6	See clause 10.1.5	
responseTimeEarlyFix-r12	Not present		Rel-12 onwards
}			
velocityRequest	FALSE		
}			
environment	Not present		
locationCoordinateTypes	Not present		
velocityTypes	Not present		
}			
a-gnss-RequestLocationInformation	Not present		
otdoa-RequestLocationInformation SEQUENCE {			
assistanceAvailability	FALSE		
}			
ecid-RequestLocationInformation	Not present		
epdu-RequestLocationInformation	Not Present		
}			
}			
}			
}			
}			



**Table 10.1.4.3-4: LPP ProvideAssistanceData**

Derivation Path: 36.355 clause 6.2			
Information Element	Value/remark	Comment	Condition
LPP-Message ::= SEQUENCE {			
transactionID SEQUENCE {			
Initiator	locationServer		
transactionNumber	(0..255)		
}			
endTransaction	TRUE		
sequenceNumber	Not present		
acknowledgement	Not present		
lpp-MessageBody CHOICE {			
c1 CHOICE {			
provideAssistanceData SEQUENCE {			
criticalExtensions CHOICE {			
c1 CHOICE {			
provideAssistanceData-r9 SEQUENCE {			
commonIEsProvideAssistanceData	Not present		
a-gnss-ProvideAssistanceData	Not present		
otdoa-ProvideAssistanceData SEQUENCE {			
otdoa-ReferenceCellInfo	As defined in TS 37.571-5 [20], clause 7.3.2.		
otdoa-NeighbourCellInfo	As defined in TS 37.571-5 [20], clause 7.3.2.		
otdoa-Error	Not present		
}			
epdu-ProvideAssistanceData	Not present		
}			
}			
}			
}			

Table 10.1.4.3-5: LPP ProvideLocation Information

Derivation Path: 36.355 clause 6.2			
Information Element	Value/remark	Comment	Condition
LPP-Message ::= SEQUENCE {			
transactionID SEQUENCE {			
Initiator	locationServer		
transactionNumber	1		
}			
endTransaction	TRUE		
sequenceNumber	(0..255)		
acknowledgement			
lpp-MessageBody CHOICE {			
c1 CHOICE {			
provideLocationInformation SEQUENCE {			
criticalExtensions CHOICE {			
c1 CHOICE {			
provideLocationInformation-r9 SEQUENCE {			
commonIEsProvideLocationInformation	Not present.		
a-gnss-ProvideLocationInformation	Not present		
otdoa-ProvideLocationInformation			
SEQUENCE {			
otdoaSignalMeasurementInformation			
SEQUENCE {			
systemFrameNumber			
physCellIdRef	Cell 2		
cellGlobalIdRef			
earfcnRef			
referenceQuality			
neighbourMeasurementList			
SEQUENCE (SIZE(n)) {			
physCellIdNeighbour	Cell 3		
cellGlobalIdNeighbour			
earfcnNeighbour			
rstd	Present	With respect to Cell 2	
rstd-Quality			
}			
neighbourMeasurementList			
SEQUENCE (SIZE(n)) {			
physCellIdNeighbour	Cell 1	Test 2 only	
cellGlobalIdNeighbour			
earfcnNeighbour			
rstd	Present	Test 2 only With respect to Cell 2	
rstd-Quality			
}			
}			
}			
otdoa-Error	May be present with error reason 'undefined' or 'attemptedButUnableToMeasureSomeNeighbourCells'		
}			
ecid-ProvideLocationInformation	Not present		
epdu-ProvideLocationInformation	Not present		
}			
}			
}			
}			

## 10.1.5 Test requirement

Table 10.1.5-1 and 10.1.5-2 define the primary level settings including test tolerances for the tests.

**Table 10.1.5-1: Cell-specific test parameters for E-UTRAN FDD RSTD measurement reporting delay under fading propagation conditions during T1 for Carrier Aggregation**

Parameter	Unit	Cell 1	Cell 2	Cell 3
E-UTRA RF Channel Number		1	N/A	N/A
Correlation Matrix and Antenna Configuration		1x2 Low	1x2 Low	1x2 Low
OCNG patterns defined in TS 36.521-3 [25] clause D.1		OP.5 FDD	N/A	N/A
PBCH_RA	dB	0	N/A	N/A
PBCH_RB				
PSS_RA				
SSS_RA				
PCFICH_RB				
PHICH_RA				
PHICH_RB				
PDCCH_RA				
PDCCH_RB				
OCNG_RA <sup>Note 1</sup>				
OCNG_RB <sup>Note 1</sup>				
$N_{oc}$ <sup>Note 3</sup>	dBm/ 15 kHz	-95	N/A	N/A
$PRS \hat{E}_s / N_{oc}$	dB	-Infinity	-Infinity	-Infinity
$I_o$ <sup>Note 4</sup>	dBm/ 9 MHz	-67.22	N/A	N/A
$\hat{E}_s / N_{oc}$	dB	0	-Infinity	-Infinity
Propagation Condition		ETU30		
Note 1:	OCNG shall be used such that active cell (Cell 1) is fully allocated and a constant total transmitted power spectral density is achieved for all OFDM symbols.			
Note 2:	The resources for uplink transmission are assigned to the UE prior to the start of time period T2.			
Note 3:	Interference from other cells and noise sources not specified in the test are assumed to be constant over subcarriers and time and shall be modelled as AWGN of appropriate power for $N_{oc}$ to be fulfilled.			
Note 4:	$I_o$ levels have been derived from other parameters and are given for information purpose. These are not settable test parameters.			

**Table 10.1.5-2: Cell-specific test parameters for E-UTRAN FDD RSTD measurement reporting delay under fading propagation conditions during T2 and T3 for Carrier Aggregation**

Parameter	Unit	Cell 1		Cell 2		Cell 3	
		T2	T3	T2	T3	T2	T3
E-UTRA RF Channel Number		1		2		2	
Correlation Matrix and Antenna Configuration		1x2 Low		1x2 Low		1x2 Low	
OCNG patterns defined in TS 36.521-3 [25] clause D.1		OP.5 FDD		OP.6 FDD		OP.6 FDD	N/A
PBCH_RA	dB	0		0		0	N/A
PBCH_RB							
PSS_RA							
SSS_RA							
PCFICH_RB							
PHICH_RA							
PHICH_RB							
PDCCH_RA							
PDCCH_RB							
OCNG_RA <small>Note 1</small>							
OCNG_RB <small>Note 1</small>							
PRS_RA	dB	-6	N/A	N/A	3	3	N/A
$N_{oc}$ <small>Note 3</small>	dBm/15 kHz	-98	-98	-98	-95	-98	-95
$\hat{E}_s/N_{oc}$	dB	-4	-Infinity	-Infinity	-1	-8	-Infinity
$\hat{E}_s/I_{ot}$ <small>Note 4</small>	dB	-4	-Infinity	-Infinity	-1	-8	-Infinity
$I_o$ <small>Note 4</small>	dBm/9 MHz	-69.94	N/A	N/A	-66.68	-70.11	N/A
PRP <small>Note 4</small>	dBm/15 kHz	-102	-Infinity	-Infinity	-96	-106	-Infinity
RSRP <small>Note 4</small>	dBm/15 kHz	-96	-96	-105	-99	-109	-Infinity
$\hat{E}_s/N_{oc}$ <small>Note 4</small>	dB	2	2	-7	-4	-11	-Infinity
Propagation Condition		ETU30					
<p>Note 1: OCNG shall be used such that active cells (all, except Cell 3 in T3) are fully allocated and a constant total transmitted power spectral density is achieved for all OFDM symbols other than those in the subframes with transmitted PRS.</p> <p>Note 2: The resources for uplink transmission are assigned to the UE prior to the start of time period T2.</p> <p>Note 3: Interference from other cells and noise sources not specified in the test are assumed to be constant over subcarriers and time and shall be modelled as AWGN of appropriate power for <math>N_{oc}</math> to be fulfilled.</p> <p>Note 4: If PRS_RA is not "N/A", <math>\hat{E}_s/N_{oc}</math>, <math>\hat{E}_s/I_{ot}</math>, <math>I_o</math>, RSRP and PRP levels have been derived from other parameters and are given for information purpose. If PRS_RA is "N/A", <math>I_o</math> and RSRP levels have been derived from other parameters and are given for information purpose. These are not settable test parameters. Interference conditions shall be applied to all PRS symbols of DL positioning subframes.</p>							

The response time including test tolerance is 3.3s for Test 1 and 6.3s for Test 2. The response time is equal to the LPP time IE value plus the test tolerance. The LPP time IE value is derived from the RSTD reporting delay plus  $\Delta T$ , where  $\Delta T = 150$  ms, giving a value of 2710 ms for Test 1 and 5110ms for Test 2. This is rounded up to the next allowed LPP value of 3 seconds for Test 1 and 6 seconds for Test 2.

The RSTD measurement reporting delay in the tests is derived from the following expression,

$T_{PRS} (M - 1) + 160 \left\lceil \frac{n}{M} \right\rceil$ , where  $M = 8$  and  $n = 16$  for Test 1, and  $M = 16$  and  $n = 16$  for Test 2 are the parameters specified in clause 10.1.3.1 for Test 1 and clause 10.1.3.2 for Test 2.

This gives the total RSTD reporting delay of 2560 ms for Test 1 for the 15 neighbour cells including Cell 3 with respect to the reference cell, Cell 2.

This gives the total RSTD reporting delay of 4960 ms for Test 2 for the 15 neighbour cells including Cell 1 and Cell 3 with respect to the reference cell, Cell 2.

The test tolerances are defined in clauses C.1.3 and C.4.

For the overall test to pass, the rate of successful tests during repeated tests in both Test 1 and Test 2 shall be more than 90% with a confidence level of 95%.

## 10.1A FDD RSTD Measurement Reporting Delay for Carrier Aggregation for 20 MHz Bandwidth

### 10.1A.1 Test purpose

Same as defined in clause 10.1.1.

**NOTE:** This test verifies the requirement which is independent of channel bandwidth and is performed according to the principle defined in clause 4.7.5.

### 10.1A.2 Test applicability

This test applies to all types of E-UTRA FDD UE release 10 and forward that supports UE-assisted OTDOA for Carrier Aggregation.

### 10.1A.3 Minimum conformance requirements

Same as defined in clause 10.1.3.

The normative reference for this requirement is TS 36.133 [23] clause 8.4.3, 8.4.4 and A.8.17.3.

### 10.1A.4 Test description

#### 10.1A.4.1 Initial conditions

Same as defined in clause 10.1.4.1 except that the values of the parameters in Table 10.1A.4.1-1 will replace the values of the corresponding parameters in Table 10.1.4.1-1.

Channel bandwidth to be tested: 20 MHz.

**Table 10.1A.4.1-1: General test parameters for E-UTRAN FDD RSTD measurement reporting delay under fading propagation conditions for carrier aggregation for 20 MHz**

Parameter	Unit	Value		Comment
		Test 1	Test 2	
PCFICH/PDCCH/PHICH parameters		DL Reference Measurement Channel R.10 FDD		As specified in TS 36.521-3 [25] clause A.2.1
Channel Bandwidth ( $BW_{channel}$ )	MHz	20		
PRS Transmission Bandwidth	RB	100		PRS are transmitted over the system bandwidth
Note 1:	See Table 10.1.4.1-1 for the other parameters.			
Note 2:	This test verifies the requirement which is independent of channel bandwidth and is performed according to the principle defined in clause 4.7.5.			

### 10.1A.4.2 Test procedure

Same as defined in clause 10.1.4.2.

### 10.1A.4.3 Message contents

Same as defined in clause 10.1.4.3.

### 10.1A.5 Test requirement

Same as defined in clause 10.1.5 except that the values of the parameters in Table 10.1A.5-1 and Table 10.1A.5-2 will replace the values of the corresponding parameters in Table 10.1.5-1 and Table 10.1.5-2, respectively.

**Table 10.1A.5-1: Cell-specific test parameters for E-UTRAN FDD RSTD measurement reporting delay under fading propagation conditions during T1 for carrier aggregation for 20 MHz**

Parameter	Unit	Cell 1	Cell 2	Cell 3
OCNG patterns defined in TS 36.521-3 [25] clause D.1		OP.13 FDD	N/A	N/A
$I_o$ <sup>Note 1</sup>	dBm/ 18 MHz	-64.21	N/A	N/A
Note 1: $I_o$ levels have been derived from other parameters for information purposes. They are not settable parameters themselves.				
Note 2: See Table 10.1.5-1 for the other parameters.				

**Table 10.1A.5-2: Cell-specific test parameters for E-UTRAN FDD RSTD measurement reporting delay under fading propagation conditions during T2 and T3 for carrier aggregation for 20 MHz**

Parameter	Unit	Cell 1		Cell 2		Cell 3	
		T2	T3	T2	T3	T2	T3
OCNG patterns defined in TS 36.521-3 [25] clause D.1		OP.13 FDD		OP.14 FDD		OP.14 FDD	N/A
$I_o$ <sup>Note 1</sup>	dBm/ 18 MHz	-66.93	N/A	N/A	-63.67	-67.09	N/A
Note 1: $I_o$ levels have been derived from other parameters for information purposes. They are not settable parameters themselves.							
Note 2: See Table 10.1.5-2 for the other parameters.							

## 10.1B FDD RSTD Measurement Reporting Delay Carrier Aggregation for 5 MHz + 5 MHz Bandwidth

### 10.1B.1 Test purpose

Same as defined in clause 10.1.1.

NOTE: This test verifies the requirement which is independent of channel bandwidth and is performed according to the principle defined in clause 4.7.5.

### 10.1B.2 Test applicability

This test applies to all types of E-UTRA FDD UE release 12 and forward that supports UE-assisted OTDOA for Carrier Aggregation.

### 10.1B.3 Minimum conformance requirements

Same as defined in clause 10.1.3.

The normative reference for this requirement is TS 36.133 [23] clause 8.4.3, 8.4.4 and A.8.17.7.

### 10.1B.4 Test description

#### 10.1B.4.1 Initial conditions

Same as defined in clause 10.1.4.1 except that the values of the parameters in Table 10.1B.4.1-1 will replace the values of the corresponding parameters in Table 10.1.4.1-1.

Channel bandwidth to be tested: 5 MHz.

**Table 10.1B.4.1-1: General test parameters for E-UTRAN FDD RSTD measurement reporting delay under fading propagation conditions for carrier aggregation for 5 MHz + 5 MHz**

Parameter	Unit	Value		Comment
		Test 1	Test 2	
PCFICH/PDCCH/PHICH parameters		DL Reference Measurement Channel R.11 FDD		As specified in TS 36.521-3 [25] clause A.2.1
Channel Bandwidth ( $BW_{\text{channel}}$ )	MHz	5		
PRS Transmission Bandwidth	RB	25		PRS are transmitted over the system bandwidth
PRS occasion length $N_{\text{PRS}}$		2		
Note 1:	See Table 10.1.4.1-1 for the other parameters.			
Note 2:	This test verifies the requirement which is independent of channel bandwidth and is performed according to the principle defined in section 4.7.5.			

#### 10.1B.4.2 Test procedure

Same as defined in clause 10.1.4.2.

#### 10.1B.4.3 Message contents

Same as defined in clause 10.1.4.3.

### 10.1B.5 Test requirement

Same as defined in clause 10.1.5 except that the values of the parameters in Table 10.1B.5-1 and Table 10.1B.5-2 will replace the values of the corresponding parameters in Table 10.1.5-1 and Table 10.1.5-2, respectively.

**Table 10.1B.5-1: Cell-specific test parameters for E-UTRAN FDD RSTD measurement reporting delay under fading propagation conditions during T1 for carrier aggregation for 5 MHz + 5 MHz**

Parameter	Unit	Cell 1	Cell 2	Cell 3
OCNG patterns defined in TS 36.521-3 [25] clause D.1.18		OP.18 FDD	N/A	N/A
$I_0$ Note 1	dBm/ 4.5 MHz	-70.23	N/A	N/A
Note 1:	I <sub>0</sub> levels have been derived from other parameters for information purposes. They are not settable parameters themselves.			
Note 2:	See Table 10.1.5-1 for the other parameters.			

**Table 10.1B.5-2: Cell-specific test parameters for E-UTRAN FDD RSTD measurement reporting delay under fading propagation conditions during T2 and T3 for carrier aggregation for 5 MHz + 5 MHz**

Parameter	Unit	Cell 1		Cell 2		Cell 3	
		T2	T3	T2	T3	T2	T3
OCNG patterns defined in TS 36.521-3 [25] clause D.1		OP.18 FDD		OP.19 FDD		OP.19 FDD	N/A
$I_o$ <sup>Note 1</sup>	dBm/ 4.5 MHz	-72.95	N/A	N/A	-69.69	-73.12	N/A
Note 1: $I_o$ levels have been derived from other parameters for information purposes. They are not settable parameters themselves. Note 2: See Table 10.1.5-2 for the other parameters.							

## 10.1C FDD RSTD Measurement Reporting Delay for Carrier Aggregation for 10 MHz+5 MHz Bandwidth

### 10.1C.1 Test purpose

Same as defined in clause 10.1.1.

NOTE: This test verifies the requirement which is independent of channel bandwidth and is performed according to the principle defined in clause 4.7.5.

### 10.1C.2 Test applicability

This test applies to all types of E-UTRA FDD UE release 12 and forward that supports UE-assisted OTDOA for Carrier Aggregation.

### 10.1C.3 Minimum conformance requirements

Same as defined in clause 10.1.3.

The normative reference for this requirement is TS 36.133 [23] clause 8.4.3, 8.4.4 and A.8.17.5.

### 10.1C.4 Test description

#### 10.1C.4.1 Initial conditions

Same as defined in clause 10.1.4.1 except that the values of the parameters in Table 10.1C.4.1-1 will replace the values of the corresponding parameters in Table 10.1.4.1-1.

Channel bandwidth to be tested: Cell 1: 10 MHz, Cell 2 and Cell 3: 5 MHz.



**Table 10.1C.4.1-1: General test parameters for E-UTRAN FDD RSTD measurement reporting delay under fading propagation conditions for carrier aggregation for 10 MHz + 5 MHz**

Parameter	Unit	Value		Comment
		Test 1	Test 2	
PCFICH/PDCCH/PHICH parameters		Cell 1: R.6 FDD Cell 2: R.11 FDD Cell 3: R.11 FDD	Cell 1: R.6 FDD Cell 2: R.11 FDD Cell 3: R.11 FDD	As specified in TS 36.521-3 [25] clause A.2.1
Channel Bandwidth (BW <sub>channel</sub> )	MHz	Cell 1: 10 Cell 2: 5 Cell 3: 5	Cell 1: 10 Cell 2: 5 Cell 3: 5	
PRS Transmission Bandwidth	RB	Cell 1: 50 Cell 2: 25 Cell 3: 25	Cell 1: 50 Cell 2: 25 Cell 3: 25	PRS are transmitted over the system bandwidth
PRS occasion length $N_{PRS}$		Cell 1: 1 Cell 2: 2 Cell 3: 2	Cell 1: 1 Cell 2: 2 Cell 3: 2	
Note 1: See Table 10.1.4.1-1 for the other parameters.				
Note 2: This test verifies the requirement which is independent of channel bandwidth and is performed according to the principle defined in section 4.7.5.				

### 10.1C.4.2 Test procedure

Same as defined in clause 10.1.4.2.

### 10.1C.4.3 Message contents

Same as defined in clause 10.1.4.3.

### 10.1C.5 Test requirement

Same as defined in clause 10.1.5 except that the values of the parameters in Table 10.1C.5-1 and Table 10.1C.5-2 will replace the values of the corresponding parameters in Table 10.1.5-1 and Table 10.1.5-2, respectively.

**Table 10.1C.5-1: Cell-specific test parameters for E-UTRAN FDD RSTD measurement reporting delay under fading propagation conditions during T1 for carrier aggregation for 10 MHz + 5 MHz**

Parameter	Unit	Cell 1	Cell 2	Cell 3
$I_0$ <sup>Note 1</sup>	dBm/ 9 MHz	-67.22	N/A	N/A
	dBm/ 4.5 MHz	N/A	N/A	N/A
Note 1: $I_0$ levels have been derived from other parameters for information purposes. They are not settable parameters themselves.				
Note 2: See Table 10.1.5-1 for the other parameters.				

**Table 10.1C.5-2: Cell-specific test parameters for E-UTRAN FDD RSTD measurement reporting delay under fading propagation conditions during T2 and T3 for carrier aggregation for 10 MHz + 5 MHz**

Parameter	Unit	Cell 1		Cell 2		Cell 3	
		T2	T3	T2	T3	T2	T3
OCNG patterns defined in TS 36.521-3 [25] clause D.1		OP.5 FDD		OP.19 FDD		OP.19 FDD	N/A
$I_o$ <sup>Note 1</sup>	dBm/9 MHz	-69.94	N/A	N/A	N/A	N/A	N/A
	dBm/4.5 MHz	N/A	N/A	N/A	-69.69	-73.12	N/A
Note 1:	I <sub>o</sub> levels have been derived from other parameters for information purposes. They are not settable parameters themselves.						
Note 2:	See Table 10.1.5-2 for the other parameters.						

## 10.2 TDD RSTD Measurement Reporting Delay for Carrier Aggregation

### 10.2.1 Test purpose

To verify that the RSTD measurement reporting delay meets the requirements in an environment with fading propagation conditions. This test case verifies the measurement period requirements for RSTD measurements performed on the secondary component carrier and also the measurement period requirements for RSTD measurements performed on both the primary and secondary component carriers.

### 10.2.2 Test applicability

This test applies to all types of E-UTRA TDD UE release 10 and forward that supports UE-assisted OTDOA for Carrier Aggregation.

### 10.2.3 Minimum conformance requirements

#### 10.2.3.1 Measurements on the secondary component carrier

The RSTD measurements when all cells are on the configured secondary component carrier shall meet all applicable requirements (TDD) specified in TS 36.133 [23] section 8.1.2.5, i.e., E-UTRAN intra-frequency RSTD measurement period applies, regardless of whether the SCell on the corresponding frequency is activated or deactivated by the MAC-CE commands as specified in 3GPP TS 36.321 [34].

#### 10.2.3.2 Measurements on both primary component carrier and secondary component carrier

The RSTD measurements of cells on both primary component carrier and configured secondary component carrier shall meet all applicable requirements (TDD) specified in TS 36.133 [23] section 8.1.2.6, i.e., E-UTRAN inter-frequency RSTD measurement period applies regardless of whether the SCell on the corresponding frequency is activated or deactivated by the MAC-CE commands as specified in 3GPP TS 36.321 [34], with the following exceptions

- the number of PRS positioning occasions is as specified in Table 10.2.3.2-1 shall apply, and
- TDD uplink-downlink subframes configurations as specified in TS 36.133 [23] section 8.1.2.5.2, Table 8.1.2.5.2-2 shall apply.

**Table 10.2.3.2-1: Number of PRS positioning occasions within measurement period**

Positioning subframe configuration period $T_{PRS}$	Number of PRS positioning occasions $M$
160 ms	32
>160 ms	16

The normative reference for this requirement is TS 36.133 [23] clause 8.4.3, 8.4.4 and A.8.17.2.

## 10.2.4 Test description

### 10.2.4.1 Initial conditions

Test Environment: Normal; as defined in TS 36.508 [18] clause 4.1.

Frequencies to be tested: Mid Range, as defined in TS 36.508 [18] clause 4.3.1.2.

Channel bandwidth to be tested: 10 MHz as defined in TS 36.508 [18] clause 4.3.1.

1. Connect the SS, faders and AWGN noise sources to the UE antenna connector or antenna connectors as shown in TS 36.508 [18] Annex A, Figure group A.42 as appropriate.
2. The general test parameter settings are set up according to Table 10.2.4.1-1.
3. Propagation conditions are set according to clause 4.7.2.1.
4. Message contents are defined in clause 10.2.4.3.
5. In the tests, there are two configured component carriers: PCC and SCC, and three synchronized cells: Cell 1, Cell 2 and Cell 3. Cell 1 is PCell on the PCC, Cell 2 is an active SCell on the SCC, and Cell 3 is a neighbour cell on the SCC. In both tests, Cell 2 is the OTDOA assistance data reference cell. The assistance data neighbour cell list includes in total 15 cells, where 14 of the cells are not simulated (dummy cells; as defined in 3GPP TS 37.571-5 clause 7.3.2) for Test 1 and where 13 of the cells are not simulated for Test 2. PCell (Cell 1) is the cell used for connection setup with the power level and mapping set according to TS 36.521-1 [24] Annex C.0 and C.1 as appropriate for this test. Cell 2 and Cell 3 are powered OFF.
6. The true RSTD (which is the receive time difference for frame 0 between two cells as seen at the UE antenna connector) is set to 31 Ts (about 1  $\mu$ s) between Cell 1 and OTDOA assistance data reference cell, Cell 2; and set to -31 Ts (about -1  $\mu$ s) between neighbour Cell 3 and OTDOA assistance data reference cell, Cell 2.

**Table 10.2.4.1-1: General test parameters for E-UTRAN TDD RSTD measurement reporting delay under fading propagation conditions for Carrier Aggregation**

Parameter	Unit	Value		Comment
		Test 1	Test 2	
PCell		Cell 1		PCell is on RF channel 1 (PCC).
SCell		Cell 2		SCell on RF channel 2 (SCC). Cell 2 is the assistance data reference cell.
Other neighbour cell		Cell 3		Neighbour cell on RF channel 2 (SCC).
PCFICH/PDCCH/PHICH parameters		DL Reference Measurement Channel R.6 TDD		As specified in TS 36.521-3 [25] clause A.2.2
Channel Bandwidth ( $BW_{\text{channel}}$ )	MHz	10		
PRS Transmission Bandwidth <sup>Note 2</sup>	RB	50		PRS are transmitted over the system bandwidth
PRS configuration index $I_{\text{PRS}}$ <sup>Note 2</sup>		174 for all cells on PCC 184 for all cells on SCC		This corresponds to periodicity of 320 ms and PRS subframe offset of $I_{\text{PRS}} - 160$ DL subframes, as defined in 3GPP TS 36.211 [26], Table 6.10.4.3-1
Number of consecutive downlink positioning subframes $N_{\text{PRS}}$ <sup>Note 2</sup>		1		As defined in 3GPP TS 36.211 [26]. The number of subframes in a positioning occasion
Physical cell ID PCI <sup>Note 2</sup>		(PCI of Cell 2 – PCI of Cell 3) mod 6 = 0		The PCI of Cell 1 is selected randomly. PCIs of Cell 2 and Cell 3 are selected randomly such that the relative subcarrier shifts of PRS patterns among these cells are as given by the condition
TDD uplink-downlink configuration		1		As specified in TS 36.211 [26], Section 4.2; corresponds to a configuration with 5 ms switch-point periodicity and two downlink consecutive subframes
TDD special subframe configuration		6		As specified in TS 36.211 [26], Section 4.2; corresponds to DwPTS of $19760 \cdot T_s$ and UpPTS of $4384 \cdot T_s$
CP length <sup>Note 2</sup>		Normal		
DRX		ON		DRX parameters are further specified in Table 10.2.4.1-2
Radio frame receive time offset between the cells at the UE antenna connector <sup>Note 3</sup>	$\mu\text{s}$	Cell 1 to Cell 2: 1 Cell 3 to Cell 2: -1	Cell 1 to Cell 2: 1 Cell 3 to Cell 2: -1	PRS are transmitted from synchronous cells
Expected RSTD <sup>Note 1</sup>	$\mu\text{s}$	Cell 3: 2 Other neighbour cells: randomly between -3 and 3	Cell 1: -2 Cell 3: 2 Other neighbour cells: randomly between -3 and 3	The expected RSTD is what is expected at the receiver. The corresponding parameter in the OTDOA assistance data specified in TS 36.355 [4] is the expectedRSTD indicator
Expected RSTD uncertainty for all neighbour cells <sup>Note 1</sup>	$\mu\text{s}$	5		The corresponding parameter in the OTDOA assistance data specified in TS 36.355 [4] is the expectedRSTD-Uncertainty index
		16 cells in total		

Number of cells provided in OTDOA assistance data		OTDOA neighbour cells include Cell 3 and other 14 cells on SCC	OTDOA neighbour cells include Cell 1 and other 7 cells on PCC, and Cell 3 and other 6 cells on SCC	The list includes the reference cell and 15 other cells. Cell 1 (when included) appears at random places in the first half of the neighbour cell list in the OTDOA assistance data. Cell 3 always appears at random places in the second half of the list
prs-SubframeOffset <sup>Note2</sup>		Cells on PCC: 310 Cells on SCC, except reference cell: 0		Subframe offset, counted in full subframes. The corresponding parameter in the OTDOA assistance data is prs-SubframeOffset specified in TS 36.355 [4]
slotNumberOffset <sup>Note 2</sup>		Cells on PCC: 0 Cells on SCC, except reference cell: 0		The slot number offset at the transmitter between a neighbour cell and the assistance data reference cell. The corresponding parameter in the OTDOA assistance data is slotNumberOffset specified in TS 36.355 [4].
PRS muting info <sup>Note 2</sup>		Cell 1: '11110000' Cell 2: '00001111' Cell 3: '11110000'	Cell 1: '1111111100000000' Cell 2: '0000000011111111' Cell 3: '1111111100000000'	Corresponds to prs-MutingInfo defined in TS 36.355 [4]
T1	s	3		The length of the time interval from the beginning of each test
T2	s	1.28	2.48	The length of the time interval that follows immediately after time interval T1
T3	s	1.28	2.48	The length of the time interval that follows immediately after time interval T2
Note 1:	Parameters "Expected RSTD" and "Expected RSTD uncertainty for all neighbour cells" are not settable parameters. These are parameters signalled in LPP only. For the values to be used in LPP see Table 10.2.4.3-4 and TS 37.571-5 [20], clause 7.3.2.			
Note 2:	Parameters "PRS Transmission Bandwidth", "PRS configuration index", "Number of consecutive downlink positioning subframes", "Physical cell ID PCI", "CP length", "prs-SubframeOffset", "slotNumberOffset" and "PRS muting info" are settable parameters and also parameters signalled in LPP. The values to be used for "Physical cell ID PCI" are as follows: Cell 1: 0, Cell 2: 6, Cell 3: 12. For the values to be used in LPP see Table 10.2.4.3-4 and TS 37.571-5 [20], clause 7.3.2.			
Note 3:	The parameter "Radio frame receive time offset between the cells at the UE antenna connector" is used to set the "true RSTD" values in step 6 of clause 10.2.4.1.			

**Table 10.2.4.1-2: DRX parameters for E-UTRAN TDD RSTD measurement reporting delay under fading propagation conditions for Carrier Aggregation**

Field	Value	Comment
onDurationTimer	psf1	As specified in 3GPP TS 36.331 [22], clause 6.3.2.
drx-InactivityTimer	psf1	
drx-RetransmissionTimer	sf1	
longDRX-CycleStartOffset	sf320	
shortDRX	disable	

10.2.4.2 Test procedure

The test case includes two tests. Test 1 is designed for the scenario where the UE receives OTDOA assistance data with cells on SCC, and the UE is expected to report RSTD measurements performed on SCC only. Test 2 is designed for the scenario where the UE receives OTDOA assistance data with cells on PCC and SCC, and the UE is expected to report RSTD measurements performed on PCC and on SCC.

Each test consists of three consecutive time intervals, with duration of T1, T2 and T3 defined in Table 10.2.4-1. Cell 1 is active in T1, T2 and T3, whilst Cell 2 and Cell 3 are activated only in the beginning of T2. Cell 2 is active until the end of T3, and Cell 3 is active until the end of T2. The beginning of the time interval T2 shall be aligned 5 ms before the first PRS positioning subframe of a positioning occasion in the reference cell, where 5 ms is the necessary test tolerance. Cell 1 transmits PRS in T2, while Cell 2 transmits PRS only in T3, and Cell 3 transmits PRS only in T2.

NOTE: The information on when PRS is muted is conveyed to the UE using PRS muting information in the OTDOA assistance data.

The OTDOA-RequestLocationInformation message and the OTDOA assistance data as defined in clause 10.2.4.3 shall be provided to the UE during T1. The last TTI containing the OTDOA-RequestLocationInformation message shall be provided to the UE  $\Delta T$  ms before the start of T2, where  $\Delta T = 150$  ms is the maximum processing time of the OTDOA-RequestLocationInformation message and the OTDOA assistance data.

1. Ensure that the UE is in state Generic RB Established State 3A-RF according to 3GPP TS 36.508 [18] clause 7.2A.3.
2. Configure Cell 2 and Cell 3 on the SCC according to TS 36.521-3 [25] Annex C.0 and C.1 for all downlink physical channels.
3. The SS shall configure the SCell (Cell 2) on the SCC as per TS 36.508 [18] clause 5.2A.4.
4. The SS activates the SCell (Cell 2) by sending the Activation/Deactivation MAC control element according to TS 36.321 [34] clauses 5.13 and 6.1.3.8. Wait for at least 2 seconds as per TS 36.133 [23] clause 8.3.3.2.
5. The SS shall send a RESET UE POSITIONING STORED INFORMATION message.
6. Set the parameters according to Table 10.2.5-1. Propagation conditions are set according to clause 4.7.2.2 (ETU30).
7. T1 starts.
8. The SS shall transmit an RRCConnectionReconfiguration message with the DRX configuration. PDCCHs indicating new transmissions shall be sent continuously until the start of T2 to ensure that the UE would not enter the DRX state before T2.
9. The UE shall transmit RRCConnectionReconfigurationComplete message.
- 9a. The SS shall transmit an LPP REQUEST CAPABILITIES message.
- 9b. The UE shall transmit an LPP PROVIDE CAPABILITIES message indicating the OTDOA capabilities supported by the UE in the *OTDOA-ProvideCapabilities* IE.
10. The SS shall send a LPP PROVIDE ASSISTANCE DATA message, including the *OTDOA-ProvideAssistanceData* IE. The position of neighbour Cell 3 in the *OTDOA-NeighbourCellInfoList* is randomly selected to be in the last 8 elements of the sequence for Test 1 and in the 7 elements of the relevant sequence for Test 2, and the position of neighbour Cell 1 is randomly selected to be in the first 7 elements of the relevant sequence for Test 2, as described in 3GPP TS 37.571-5 [20], clause 7.3.2. If the UE message at step 9b includes the *ackRequested* IE set to TRUE, then the SS shall send an acknowledgment in the LPP PROVIDE ASSISTANCE DATA message.
11. The SS shall send a LPP REQUEST LOCATION INFORMATION message, including the *OTDOA-RequestLocationInformation* IE such that the UE receives the message  $\Delta T$  ms before the start of T2, where  $\Delta T = 150$  ms.
12. When T1 expires, the SS shall switch the power setting from T1 to T2 as specified in Table 10.2.5-3.
13. When T2 expires, the SS shall switch the power setting from T2 to T3 as specified in Table 10.2.5-3.
14. The UE shall transmit a LPP PROVIDE LOCATION INFORMATION including the *OTDOA-ProvideLocationInformation* IE within the response time (see clause 4.7.3) specified in clause 10.2.5.

For Test 1 the UE shall perform and report the RSTD measurement for Cell 3 with respect to the reference cell in the OTDOA assistance data, Cell 2. If the UE transmits an *OTDOA-ProvideLocationInformation* IE including the *rstd* field for Cell 3 within the response time then the number of successful tests is increased by one. If the

UE fails to report the *OTDOA-ProvideLocationInformation* IE with the *rstd* field included within the response time then the number of failure tests is increased by one.

For Test 2 the UE shall perform and report the RSTD measurements for Cell 1 with respect to the reference cell in the OTDOA assistance data, Cell 2 and also Cell 3 with respect to the reference cell in the OTDOA assistance data, Cell 2. If the UE transmits an *OTDOA-ProvideLocationInformation* IE including the *rstd* field for Cell 1 (with respect to Cell 2) and Cell 3 (with respect to Cell 2) within the response time then the number of successful tests is increased by one. If the UE fails to report the *OTDOA-ProvideLocationInformation* IE with both the *rstd* fields included within the response time then the number of failure tests is increased by one.

- 15. If the UE message at step 14 includes the *ackRequested* IE set to TRUE, the SS shall send a LPP acknowledgement message.
- 16. Repeat steps 5-15 until the confidence level according to Annex D is achieved. For each iteration, at step 10 change the random positions of the Cell 3 and Cell 1(for Test 2 only) in the relevant sequence in the *OTDOA-NeighbourCellInfoList*.
- 17. Repeat from clause 10.2.4.1 for Test 2.

10.2.4.3 Message contents

**Table 10.2.4.3-1: RESET UE POSITIONING STORED INFORMATION**

Derivation Path: 36.509 [11] clause 6.9			
Information Element	Value/remark	Comment	Condition
UE Positioning Technology	0 0 0 0 0 0 1	OTDOA	

**Table 10.2.4.3-2: MAC-MainConfig-RBC: TDD RSTD Measurement Reporting Delay for Carrier Aggregation**

Derivation Path: TS 36.508 [18] clause 4.8.2.1.5, Table 4.8.2.1.5-1 MAC-MainConfig-RBC			
Information Element	Value/remark	Comment	Condition
MAC-MainConfig-RBC ::= SEQUENCE {			
drx-Config CHOICE {			
setup SEQUENCE {			
onDurationTimer	psf1		
drx-InactivityTimer	psf1		
drx-RetransmissionTimer	sf1		
longDRX-CycleStartOffset CHOICE {			
sf320	0		
}			
shortDRX	Not present		
}			
}			

**Table 10.2.4.3-2a: LPP Request Capabilities**

Information Element	Value/remark
<i>otdoa-RequestCapabilities</i>	TRUE



**Table 10.2.4.3-3: LPP RequestLocationInformation**

Derivation Path: 36.355 clause 6.2			
Information Element	Value/remark	Comment	Condition
LPP-Message ::= SEQUENCE {			
transactionID SEQUENCE {			
Initiator	locationServer		
transactionNumber	1		
}			
endTransaction	FALSE		
sequenceNumber	Not present		
acknowledgement	Not present		
lpp-MessageBody CHOICE {			
c1 CHOICE {			
requestLocationInformation SEQUENCE {			
criticalExtensions CHOICE {			
c1 CHOICE {			
requestLocationInformation-r9 SEQUENCE {			
commonIEsRequestLocationInformation SEQUENCE {			
locationInformationType	locationMeasurementsRequired		
triggeredReporting	Not present		
periodicalReporting	Not present		
additionalInformation	onlyReturnInformationRequested		
qos SEQUENCE {			
horizontalAccuracy	Not present		
verticalCoordinateRequest	FALSE		
verticalAccuracy	Not present		
responseTime SEQUENCE {			
time	Test 1: 3 Test 2: 6	See clause 10.2.5	
responseTimeEarlyFix-r12	Not present		Rel-12 onwards
}			
velocityRequest	FALSE		
}			
environment	Not present		
locationCoordinateTypes	Not present		
velocityTypes	Not present		
}			
a-gnss-RequestLocationInformation	Not present		
otdoa-RequestLocationInformation SEQUENCE {			
assistanceAvailability	FALSE		
}			
ecid-RequestLocationInformation	Not present		
epdu-RequestLocationInformation	Not Present		
}			
}			
}			
}			

Table 10.2.4.3-4: LPP ProvideAssistanceData

Derivation Path: 36.355 clause 6.2			
Information Element	Value/remark	Comment	Condition
LPP-Message ::= SEQUENCE {			
transactionID SEQUENCE {			
Initiator	locationServer		
transactionNumber	(0..255)		
}			
endTransaction	TRUE		
sequenceNumber	Not present		
acknowledgement	Not present		
lpp-MessageBody CHOICE {			
c1 CHOICE {			
provideAssistanceData SEQUENCE {			
criticalExtensions CHOICE {			
c1 CHOICE {			
provideAssistanceData-r9 SEQUENCE {			
commonIEsProvideAssistanceData	Not present		
a-gnss-ProvideAssistanceData	Not present		
otdoa-ProvideAssistanceData SEQUENCE {			
otdoa-ReferenceCellInfo	As defined in TS 37.571-5 [20], clause 7.3.2.		
otdoa-NeighbourCellInfo	As defined in TS 37.571-5 [20], clause 7.3.2.		
otdoa-Error	Not present		
}			
epdu-ProvideAssistanceData	Not present		
}			
}			
}			
}			

Table 10.2.4.3-5: LPP ProvideLocation Information

Derivation Path: 36.355 clause 6.2			
Information Element	Value/remark	Comment	Condition
LPP-Message ::= SEQUENCE {			
transactionID SEQUENCE {			
Initiator	locationServer		
transactionNumber	1		
}			
endTransaction	TRUE		
sequenceNumber	(0..255)		
acknowledgement			
lpp-MessageBody CHOICE {			
c1 CHOICE {			
provideLocationInformation SEQUENCE {			
criticalExtensions CHOICE {			
c1 CHOICE {			
provideLocationInformation-r9 SEQUENCE {			
commonIEsProvideLocationInformation	Not present.		
a-gnss-ProvideLocationInformation	Not present		
otdoa-ProvideLocationInformation			
SEQUENCE {			
otdoaSignalMeasurementInformation			
SEQUENCE {			
systemFrameNumber			
physCellIdRef	Cell 2		
cellGlobalIdRef			
earfcnRef			
referenceQuality			
neighbourMeasurementList			
SEQUENCE (SIZE(n)) {			
physCellIdNeighbour	Cell 3		
cellGlobalIdNeighbour			
earfcnNeighbour			
rstd	Present	With respect to Cell 2	
rstd-Quality			
}			
neighbourMeasurementList			
SEQUENCE (SIZE(n)) {			
physCellIdNeighbour	Cell 1	Test 2 only	
cellGlobalIdNeighbour			
earfcnNeighbour			
rstd	Present	Test 2 only With respect to Cell 2	
rstd-Quality			
}			
}			
}			
otdoa-Error	May be present with error reason 'undefined' or 'attemptedButUnableToMeasureSomeNeighbourCells'		
}			
ecid-ProvideLocationInformation	Not present		
epdu-ProvideLocationInformation	Not present		
}			
}			
}			
}			

## 10.2.5 Test requirement

Table 10.2.5-1 and 10.2.5-2 define the primary level settings including test tolerances for the test.

**Table 10.2.5-1: Cell-specific test parameters for E-UTRAN TDD RSTD measurement reporting delay under fading propagation conditions during T1 for Carrier Aggregation**

Parameter	Unit	Cell 1	Cell 2	Cell 3
E-UTRA RF Channel Number		1	N/A	N/A
Correlation Matrix and Antenna Configuration		1x2 Low	1x2 Low	1x2 Low
OCNG patterns defined in TS 36.521-3 [25] clause D.2		OP.1 TDD	N/A	N/A
PBCH_RA	dB	0	N/A	N/A
PBCH_RB				
PSS_RA				
SSS_RA				
PCFICH_RB				
PHICH_RA				
PHICH_RB				
PDCCH_RA				
PDCCH_RB				
OCNG_RA <sup>Note 1</sup>				
OCNG_RB <sup>Note 1</sup>				
$N_{oc}$ <sup>Note 3</sup>	dBm/ 15 kHz	-95	N/A	N/A
$PRS \hat{E}_s / N_{oc}$	dB	-Infinity	-Infinity	-Infinity
$I_o$ <sup>Note 4</sup>	dBm/ 9 MHz	-67.22	N/A	N/A
$\hat{E}_s / N_{oc}$	dB	0	-Infinity	-Infinity
Propagation Condition		ETU30		
Note 1:	OCNG shall be used such that active cell (Cell 1) is fully allocated and a constant total transmitted power spectral density is achieved for all OFDM symbols.			
Note 2:	The resources for uplink transmission are assigned to the UE prior to the start of time period T2.			
Note 3:	Interference from other cells and noise sources not specified in the test are assumed to be constant over subcarriers and time and shall be modelled as AWGN of appropriate power for $N_{oc}$ to be fulfilled.			
Note 4:	$I_o$ levels have been derived from other parameters and are given for information purpose. These are not settable test parameters.			

**Table 10.2.5-2: Cell-specific test parameters for E-UTRAN TDD RSTD measurement reporting delay under fading propagation conditions during T2 and T3 for Carrier Aggregation**

Parameter	Unit	Cell 1		Cell 2		Cell 3	
		T2	T3	T2	T3	T2	T3
E-UTRA RF Channel Number		1		2		2	
Correlation Matrix and Antenna Configuration		1x2 Low		1x2 Low		1x2 Low	
OCNG patterns defined in TS 36.521-3 [25] clause D.2		OP.1 TDD		OP.2 TDD		OP.2 TDD	N/A
PBCH_RA	dB	0		0		0	N/A
PBCH_RB							
PSS_RA							
SSS_RA							
PCFICH_RB							
PHICH_RA							
PHICH_RB							
PDCCH_RA							
PDCCH_RB							
OCNG_RA <small>Note 1</small>							
OCNG_RB <small>Note 1</small>							
PRS_RA	dB	-6	N/A	N/A	3	3	N/A
$N_{oc}$ <small>Note 3</small>	dBm/15 kHz	-98	-98	-98	-95	-98	-95
$\hat{E}_s/N_{oc}$	dB	-4	-Infinity	-Infinity	-1	-8	-Infinity
$\hat{E}_s/I_{ot}$ <small>Note 4</small>	dB	-4	-Infinity	-Infinity	-1	-8	-Infinity
$I_o$ <small>Note 4</small>	dBm/9 MHz	-69.94	N/A	N/A	-66.68	-70.11	N/A
PRP <small>Note 4</small>	dBm/15 kHz	-102	-Infinity	-Infinity	-96	-106	-Infinity
RSRP <small>Note 4</small>	dBm/15 kHz	-96	-96	-105	-99	-109	-Infinity
$\hat{E}_s/N_{oc}$ <small>Note 4</small>	dB	2	2	-7	-4	-11	-Infinity
Propagation Condition		ETU30					
Note 1:	OCNG shall be used such that active cells (all, except Cell 3 in T3) are fully allocated and a constant total transmitted power spectral density is achieved for all OFDM symbols other than those in the subframes with transmitted PRS.						
Note 2:	The resources for uplink transmission are assigned to the UE prior to the start of time period T2.						
Note 3:	Interference from other cells and noise sources not specified in the test are assumed to be constant over subcarriers and time and shall be modelled as AWGN of appropriate power for $N_{oc}$ to be fulfilled.						
Note 4:	If PRS_RA is not "N/A", $\hat{E}_s/N_{oc}$ , $\hat{E}_s/I_{ot}$ , $I_o$ , RSRP and PRP levels have been derived from other parameters and are given for information purpose. If PRS_RA is "N/A", $I_o$ and RSRP levels have been derived from other parameters and are given for information purpose. These are not settable test parameters. Interference conditions shall be applied to all PRS symbols of DL positioning subframes.						

The response time including test tolerance is 3.3s for Test 1 and 6.3s for Test 2. The response time is equal to the LPP time IE value plus the test tolerance. The LPP time IE value is derived from the RSTD reporting delay plus  $\Delta T$ , where  $\Delta T = 150$  ms, giving a value of 2710 ms for Test 1 and 5110ms for Test 2. This is rounded up to the next allowed LPP value of 3 seconds for Test 1 and 6 seconds for Test 2.

The RSTD measurement reporting delay in the tests is derived from the following expression,

$T_{PRS} (M - 1) + 160 \left\lceil \frac{n}{M} \right\rceil$ , where  $M = 8$  and  $n = 16$  for Test 1, and  $M = 16$  and  $n = 16$  for Test 2 are the parameters specified in clause 10.2.3.1 for Test 1 and clause 10.2.3.2 for Test 2.

This gives the total RSTD reporting delay of 2560 ms for Test 1 for the 15 neighbour cells including Cell 3 with respect to the reference cell, Cell 2.

This gives the total RSTD reporting delay of 4960 ms for Test 2 for the 15 neighbour cells including Cell 1 and Cell 3 with respect to the reference cell, Cell 2.

The test tolerances are defined in clauses C.1.3 and C.4.

For the overall test to pass, the rate of successful tests during repeated tests in both Test 1 and Test 2 shall be more than 90% with a confidence level of 95%.

## 10.2A TDD RSTD Measurement Reporting Delay for Carrier Aggregation for 20 MHz Bandwidth

### 10.2A.1 Test purpose

Same as defined in clause 10.2.1.

**NOTE:** This test verifies the requirement which is independent of channel bandwidth and is performed according to the principle defined in clause 4.7.5.

### 10.2A.2 Test applicability

This test applies to all types of E-UTRA TDD UE release 10 and forward that supports UE-assisted OTDOA for Carrier Aggregation.

### 10.2A.3 Minimum conformance requirements

Same as defined in clause 10.2.3.

The normative reference for this requirement is TS 36.133 [23] clause 8.4.3, 8.4.4 and A.8.17.4.

### 10.2A.4 Test description

#### 10.2A.4.1 Initial conditions

Same as defined in clause 10.2.4.1 except that the values of the parameters in Table 10.2A.4.1-1 will replace the values of the corresponding parameters in Table 10.2.4.1-1.

Channel bandwidth to be tested: 20 MHz.

**Table 10.2A.4.1-1: General test parameters for E-UTRAN TDD RSTD measurement reporting delay under fading propagation conditions for carrier aggregation for 20 MHz**

Parameter	Unit	Value		Comment
		Test 1	Test 2	
PCFICH/PDCCH/PHICH parameters		DL Reference Measurement Channel R.10 TDD		As specified in TS 36.521-3 [25] clause A.2.2
Channel Bandwidth ( $BW_{channel}$ )	MHz	20		
PRS Transmission Bandwidth	RB	100		PRS are transmitted over the system bandwidth
Note 1:	See Table 10.2.4.1-1 for the other parameters.			
Note 2:	This test verifies the requirement which is independent of channel bandwidth and is performed according to the principle defined in clause 4.7.5.			

### 10.2A.4.2 Test procedure

Same as defined in clause 10.2.4.2.

### 10.2A.4.3 Message contents

Same as defined in clause 10.2.4.3.

### 10.2A.5 Test requirement

Same as defined in clause 10.2.5 except that the values of the parameters in Table 10.2A.5-1 and Table 10.2A.5-2 will replace the values of the corresponding parameters in Table 10.2.5-1 and Table 10.2.5-2, respectively.

**Table 10.2A.5-1: Cell-specific test parameters for E-UTRAN TDD RSTD measurement reporting delay under fading propagation conditions during T1 for carrier aggregation for 20 MHz**

Parameter	Unit	Cell 1	Cell 2	Cell 3
OCNG patterns defined in TS 36.521-3 [25] clause D.2		OP.7 TDD	N/A	N/A
$I_{o}$ <sup>Note 1</sup>	dBm/ 18 MHz	-64.21	N/A	N/A
Note 1: $I_{o}$ levels have been derived from other parameters for information purposes. They are not settable parameters themselves.				
Note 2: See Table 10.2.5-1 for the other parameters.				

**Table 10.2A.5-2: Cell-specific test parameters for E-UTRAN TDD RSTD measurement reporting delay under fading propagation conditions during T2 and T3 for carrier aggregation for 20 MHz**

Parameter	Unit	Cell 1		Cell 2		Cell 3	
		T2	T3	T2	T3	T2	T3
OCNG patterns defined in TS 36.521-3 [25] clause D.2		OP.7 TDD		OP.8 TDD		OP.8 TDD	N/A
$I_{o}$ <sup>Note 1</sup>	dBm/ 18 MHz	-66.93	N/A	N/A	-63.67	-67.09	N/A
Note 1: $I_{o}$ levels have been derived from other parameters for information purposes. They are not settable parameters themselves.							
Note 2: See Table 10.2.5-2 for the other parameters.							

## 10.2B TDD RSTD Measurement Reporting Delay for Carrier Aggregation for 5 MHz + 5 MHz Bandwidth

### 10.2B.1 Test purpose

Same as defined in clause 10.2.1.

NOTE: This test verifies the requirement which is independent of channel bandwidth and is performed according to the principle defined in clause 4.7.5.

### 10.2B.2 Test applicability

This test applies to all types of E-UTRA TDD UE release 12 and forward that supports UE-assisted OTDOA for Carrier Aggregation.

## 10.2B.3 Minimum conformance requirements

Same as defined in clause 10.2.3.

The normative reference for this requirement is TS 36.133 [23] clause 8.4.3, 8.4.4 and A.8.17.8.

## 10.2B.4 Test description

### 10.2B.4.1 Initial conditions

Same as defined in clause 10.2.4.1 except that the values of the parameters in Table 10.2B.4.1-1 will replace the values of the corresponding parameters in Table 10.2.4.1-1.

Channel bandwidth to be tested: 5 MHz.

**Table 10.2B.4.1-1: General test parameters for E-UTRAN TDD RSTD measurement reporting delay under fading propagation conditions for carrier aggregation for 5 MHz + 5 MHz**

Parameter	Unit	Value		Comment
		Test 1	Test 2	
PCFICH/PDCCH/PHICH parameters		DL Reference Measurement Channel R.11 TDD		As specified in TS 36.521-3 [25] clause A.2.2
Channel Bandwidth ( $BW_{\text{channel}}$ )	MHz	5		
PRS Transmission Bandwidth	RB	25		PRS are transmitted over the system bandwidth
PRS occasion length $N_{\text{PRS}}$		2		
Note 1: See Table 10.2.4.1-1 for the other parameters.				
Note 2: This test verifies the requirement which is independent of channel bandwidth and is performed according to the principle defined in section 4.7.5.				

### 10.2B.4.2 Test procedure

Same as defined in clause 10.2.4.2.

### 10.2B.4.3 Message contents

Same as defined in clause 10.2.4.3.

## 10.2B.5 Test requirement

Same as defined in clause 10.2.5 except that the values of the parameters in Table 10.2B.5-1 and Table 10.2B.5-2 will replace the values of the corresponding parameters in Table 10.2.5-1 and Table 10.2.5-2, respectively.

**Table 10.2B.5-1: Cell-specific test parameters for E-UTRAN TDD RSTD measurement reporting delay under fading propagation conditions during T1 for carrier aggregation for 5 MHz + 5 MHz**

Parameter	Unit	Cell 1	Cell 2	Cell 3
OCNG patterns defined in TS 36.521-3 [25] clause D.2		OP.9 TDD	N/A	N/A
$I_0$ <sup>Note 1</sup>	dBm/ 4.5 MHz	-70.23	N/A	N/A
Note 1: $I_0$ levels have been derived from other parameters for information purposes. They are not settable parameters themselves.				
Note 2: See Table 10.2.5-1 for the other parameters.				



**Table 10.2B.5-2: Cell-specific test parameters for E-UTRAN TDD RSTD measurement reporting delay under fading propagation conditions during T2 and T3 for carrier aggregation for 5 MHz + 5 MHz**

Parameter	Unit	Cell 1		Cell 2		Cell 3	
		T2	T3	T2	T3	T2	T3
OCNG patterns defined in TS 36.521-3 [25] clause D.2		OP.9 TDD		OP.10 TDD		OP.10 TDD	N/A
$I_o$ <sup>Note 1</sup>	dBm/ 4.5 MHz	-72.95	N/A	N/A	-69.69	-73.12	N/A
Note 1: $I_o$ levels have been derived from other parameters for information purposes. They are not settable parameters themselves.							
Note 2: See Table 10.2.5-2 for the other parameters.							

## 10.2C TDD RSTD Measurement Reporting Delay for Carrier Aggregation for 10 MHz + 5 MHz Bandwidth

### 10.2C.1 Test purpose

Same as defined in clause 10.2.1.

NOTE: This test verifies the requirement which is independent of channel bandwidth and is performed according to the principle defined in clause 4.7.5.

### 10.2C.2 Test applicability

This test applies to all types of E-UTRA TDD UE release 12 and forward that supports UE-assisted OTDOA for Carrier Aggregation.

### 10.2C.3 Minimum conformance requirements

Same as defined in clause 10.2.3.

The normative reference for this requirement is TS 36.133 [23] clause 8.4.3, 8.4.4 and A.8.17.6.

### 10.2C.4 Test description

#### 10.2C.4.1 Initial conditions

Same as defined in clause 10.2.4.1 except that the values of the parameters in Table 10.2C.4.1-1 will replace the values of the corresponding parameters in Table 10.2.4.1-1.

Channel bandwidth to be tested: Cell 1: 10 MHz, Cell 2 and Cell 3: 5 MHz.

**Table 10.2C.4.1-1: General test parameters for E-UTRAN TDD RSTD measurement reporting delay under fading propagation conditions for carrier aggregation for 10 MHz + 5 MHz**

Parameter	Unit	Value		Comment
		Test 1	Test 2	
PCFICH/PDCCH/PHICH parameters		Cell 1: R.6 TDD Cell 2: R.11 TDD Cell 3: R.11 TDD	Cell 1: R.6 TDD Cell 2: R.11 TDD Cell 3: R.11 TDD	As specified in TS 36.521-3 [25] clause A.2.2
Channel Bandwidth (BW <sub>channel</sub> )	MHz	Cell 1: 10 Cell 2: 5 Cell 3: 5	Cell 1: 10 Cell 2: 5 Cell 3: 5	
PRS Transmission Bandwidth	RB	Cell 1: 50 Cell 2: 25 Cell 3: 25	Cell 1: 50 Cell 2: 25 Cell 3: 25	PRS are transmitted over the system bandwidth
PRS occasion length $N_{PRS}$		Cell 1: 1 Cell 2: 2 Cell 3: 2	Cell 1: 1 Cell 2: 2 Cell 3: 2	
Note 1: See Table 10.2.4.1-1 for the other parameters.				
Note 2: This test verifies the requirement which is independent of channel bandwidth and is performed according to the principle defined in section 4.7.5.				

### 10.2C.4.2 Test procedure

Same as defined in clause 10.2.4.2.

### 10.2C.4.3 Message contents

Same as defined in clause 10.2.4.3.

### 10.2C.5 Test requirement

Same as defined in clause 10.2.5 except that the values of the parameters in Table 10.2C.5-1 and Table 10.2C.5-2 will replace the values of the corresponding parameters in Table 10.2.5-1 and Table 10.2.5-2, respectively.

**Table 10.2C.5-1: Cell-specific test parameters for E-UTRAN TDD RSTD measurement reporting delay under fading propagation conditions during T1 for carrier aggregation for 10 MHz + 5 MHz**

Parameter	Unit	Cell 1	Cell 2	Cell 3
$I_0$ <sup>Note 1</sup>	dBm/ 9 MHz	-67.22	N/A	N/A
	dBm/ 4.5 MHz	N/A	N/A	N/A
Note 1: $I_0$ levels have been derived from other parameters for information purposes. They are not settable parameters themselves.				
Note 2: See Table 10.2.5-1 for the other parameters.				

**Table 10.2C.5-2: Cell-specific test parameters for E-UTRAN TDD RSTD measurement reporting delay under fading propagation conditions during T2 and T3 for carrier aggregation for 10 MHz + 5 MHz**

Parameter	Unit	Cell 1		Cell 2		Cell 3	
		T2	T3	T2	T3	T2	T3
OCNG patterns defined in TS 36.521-3 [25] clause D.2		OP.1 TDD		OP.10 TDD		OP.10 TDD	N/A
I <sub>o</sub> <sup>Note 1</sup>	dBm/9 MHz	-69.94	N/A	N/A	N/A	N/A	N/A
	dBm/4.5 MHz	N/A	N/A	N/A	-69.69	-73.12	N/A
Note 1:	I <sub>o</sub> levels have been derived from other parameters for information purposes. They are not settable parameters themselves.						
Note 2:	See Table 10.2.5-2 for the other parameters.						

## 10.2D TDD RSTD Measurement Reporting Delay for Carrier Aggregation for 20 MHz +10 MHz Bandwidth

### 10.2D.1 Test purpose

Same as defined in clause 10.2.1

NOTE: This test verifies the requirement which is independent of channel bandwidth and is performed according to the principle defined in clause 4.7.5.

### 10.2D.2 Test applicability

This test applies to all types of E-UTRA TDD UE release 10 and forward that supports UE-assisted OTDOA for Carrier Aggregation.

### 10.2D.3 Minimum conformance requirements

Same as defined in clause 10.2.3

The normative reference for this requirement is TS 36.133 [23] clause 8.4.3, 8.4.4 and A.8.17.9.

### 10.2D.4 Test description

#### 10.2D.4.1 Initial conditions

Same as defined in clause 10.2.4.1 except that the values of the parameters in Table 10.2D.4.1-1 will replace the values of the corresponding parameters in Table 10.2.4.1-1.

Channel bandwidth to be tested: Cell 1: 20 MHz, Cell 2 and Cell 3: 10 MHz.

**Table 10.2D.4.1-1: General test parameters for E-UTRAN TDD RSTD measurement reporting delay under fading propagation conditions for carrier aggregation for 20 MHz+10 MHz**

Parameter	Unit	Value		Comment
		Test 1	Test 2	
PCFICH/PDCCH/PHICH parameters		Cell 1: R.10 TDD Cell 2: R.6 TDD Cell 3: R.6 TDD	Cell 1: R.10 TDD Cell 2: R.6 TDD Cell 3: R.6 TDD	As specified in TS 36.521-3 [25] clause A.2.2
Channel Bandwidth (BW <sub>channel</sub> )	MHz	Cell 1: 20 Cell 2: 10 Cell 3: 10	Cell 1: 20 Cell 2: 10 Cell 3: 10	
PRS Transmission Bandwidth	RB	Cell 1: 100 Cell 2: 50 Cell 3: 50	Cell 1: 100 Cell 2: 50 Cell 3: 50	PRS are transmitted over the system bandwidth
Note 1: See Table 10.2.4.1-1 for the other parameters.				
Note 2: This test verifies the requirement which is independent of channel bandwidth and is performed according to the principle defined in section 4.7.5.				

### 10.2D.4.2 Test procedure

Same as defined in clause 10.2.4.2

### 10.2D.4.3 Message contents

Same as defined in clause 10.2.4.3

### 10.2D.5 Test requirement

Same as defined in clause 10.2.5 except that the values of the parameters in Table 10.2D.5-1 and Table 10.2D.5-2 will replace the values of the corresponding parameters in Table 10.2.5-1 and Table 10.2.5-2, respectively.

**Table 10.2D.5-1: Cell-specific test parameters for E-UTRAN TDD RSTD measurement reporting delay under fading propagation conditions during T1 for carrier aggregation for 20 MHz+10 MHz**

Parameter	Unit	Cell 1	Cell 2	Cell 3
I <sub>0</sub> <sup>Note 1</sup>	dBm/ 18 MHz	-64.21	N/A	N/A
	dBm/ 9 MHz	N/A	N/A	N/A
Note 1: I <sub>0</sub> levels have been derived from other parameters for information purposes. They are not settable parameters themselves.				
Note 2: See Table 10.2.5-1 for the other parameters.				

**Table 10.2D.5-2: Cell-specific test parameters for E-UTRAN TDD RSTD measurement reporting delay under fading propagation conditions during T2 and T3 for carrier aggregation for 20 MHz+10 MHz**

Parameter	Unit	Cell 1		Cell 2		Cell 3	
		T2	T3	T2	T3	T2	T3
OCNG patterns defined in TS36.521-3 clause D.2		OP.7 TDD		OP.2 TDD		OP.2 TDD	N/A
I <sub>0</sub> <sup>Note 1</sup>	dBm/ 18 MHz	-66.93	N/A	N/A	N/A	N/A	N/A
	dBm/ 9 MHz	N/A	N/A	N/A	-66.68	-70.11	N/A
Note 1: I <sub>0</sub> levels have been derived from other parameters for information purposes. They are not settable parameters themselves.							
Note 2: See Table 10.2.5-2 for the other parameters.							

## 10.3 FDD RSTD Measurement Accuracy for Carrier Aggregation

### 10.3.1 Test purpose

To verify that the FDD RSTD measurement accuracy is within the specified limits when both the reference cell and neighbouring cell belong to the secondary component carrier.

### 10.3.2 Test applicability

This test applies to all types of E-UTRA FDD UE release 10 and forward that supports UE-assisted OTDOA for Carrier Aggregation.

### 10.3.3 Minimum conformance requirements

The UE may operate in either E-UTRA inter-band or intra-band carrier aggregation mode. The requirements in this section shall apply regardless whether the configured downlink secondary cell is activated or deactivated by the MAC-CE command (3GPP TS 36.321 [34]). The requirements apply for bandwidths defined in the bandwidth combination set for the CA configurations supported by the UE as defined in TS 36.101 [2].

The RSTD measurements, which are obtained when both the reference cell and neighbouring cell belong to the secondary component carrier, shall meet the intra-frequency RSTD accuracy requirements defined in TS 36.133 [23] section 9.1.3.

The normative reference for this requirement is TS 36.133 [23] clause 9.1.12 and A.9.8.5.

### 10.3.4 Test description

#### 10.3.4.1 Initial conditions

Test Environment: Normal; as defined in TS 36.508 [18] clause 4.1.

Frequencies to be tested: Mid Range, as defined in TS 36.508 [18] clause 4.3.1.1.

Channel bandwidth to be tested: 10 MHz.

1. Connect the SS (node B emulator) and AWGN noise sources to the UE antenna connectors as follows:
  - For UEs supporting only 2Rx in all the bands under test, use TS 36.508 [18] Annex A, Figure group A.41 as appropriate.
  - For UEs supporting 4Rx in any of the bands under test use TS 36.508 [18] Annex A, Figure A.90. Use the 2Rx module for cells on bands supporting 2Rx and the 4Rx module for cells on bands supporting 4Rx.
2. The general test parameter settings are set up according to Table 10.3.4.1-1.
3. Propagation conditions are set according to clause 4.7.2.1.
4. Message contents are defined in clause 10.3.4.3.
5. There are three synchronized cells on two different carrier frequencies. Cell 1 is the PCell on primary component carrier F1 (RF channel number 1), Cell 2 is the SCell and OTDOA assistance data reference cell on secondary component carrier F2 (RF channel number 2), and Cell 3 is the neighbour cell on F2. PCell (Cell 1) is the cell used for connection setup with the power level and mapping set according to TS 36.521-1 [24] Annex C.0 and C.1 as appropriate for this test. Cell 2 and Cell 3 are powered OFF.

Cell 3 is included in the OTDOA assistance data neighbour cell list, whilst Cell 1 is not included in the OTDOA assistance data. The assistance data neighbour cell list includes in total 15 cells, where 14 of the cells are not simulated (dummy cells; as defined in 3GPP TS 37.571-5 [20], clause 7.3.2).

Note that the measurement gap is not configured in the test because of UE carrier aggregation capability.

6. The true RSTD (which is the receive time difference for frame 0 between the two cells as seen at the UE antenna connector) is set to 31 Ts (about 1  $\mu$ s) between neighbour Cell 3 and OTDOA assistance data reference cell, Cell 2.

Note that the related expectedRSTD value to be signalled over LPP is defined in Table 10.3.4.1-1.

**Table 10.3.4.1-1: General Test Parameters for RSTD Test for E-UTRAN FDD for Carrier Aggregation**

Parameter	Unit	Value	Comment
PCFICH/PDCCH/PHICH parameters		R.6 FDD	As specified in TS 36.521-3 [25] clause A.2.1
OCNG Patterns defined in TS 36.521-3 [25] clause D.1		OP.6 FDD	OCNG shall be used such that both cells are fully allocated and a constant total transmitted power spectral density is achieved for all OFDM symbols (other than those in the PRS subframes).
Assistance data reference cell		Cell 2	Cell 2 is the SCell on RF channel number 2
PCell		Cell 1	Cell 1 on RF channel number 1
Neighbour cell		Cell 3	Cell 3 on RF channel number 2
E-UTRA RF Channel Number		1,2	Two FDD carrier frequencies are used.
Channel Bandwidth ( $BW_{\text{channel}}$ )	MHz	10	
PRS Transmission Bandwidth <sup>Note 2</sup>	RB	50	PRS Bandwidth: bandwidth is as indicated in <i>prs-Bandwidth</i> in the OTDOA assistance data defined in 3GPP TS 36.355 [4].
PRS configuration Index $I_{\text{PRS}}$ <sup>Note 2</sup>		2	As defined in 3GPP TS 36.211 [26]
Number of consecutive positioning downlink subframes $N_{\text{PRS}}$ <sup>Note 2</sup>		1	As defined in 3GPP TS 36.211 [26]
prs-MutingInfo <sup>Note 2</sup>		Cell 1: '11110000' Cell 2: '11110000' Cell 3: '11110000'	See section 6.5.1.2 in 3GPP TS 36.355 [4] for more information
Cell ID <sup>Note 2</sup>		(Cell ID of cell 2 – Cell ID of cell 3) mod 6 = 3	PCI of cell 1 is selected randomly.
Expected RSTD <sup>Note 1</sup>	$\mu\text{s}$	Cell 3: -2 Other neighbour cells: randomly between -3 and 3	The expected RSTD is what is expected at the receiver. The corresponding parameter in the OTDOA assistance data specified in TS 36.355 [4] is the expectedRSTD indicator
Expected RSTD uncertainty for all neighbour cells <sup>Note 1</sup>	$\mu\text{s}$	5	The corresponding parameter in the OTDOA assistance data specified in TS 36.355 [4] is the expectedRSTD-Uncertainty index
CP length <sup>Note 2</sup>		Normal	
DRX		OFF	
Radio frame receive time offset between the cells at the UE antenna connector <sup>Note 3</sup>	$\mu\text{s}$	Cell 1 to Cell 2: -1 Cell 3 to Cell 2: 1	PRS are transmitted from synchronous cells
Number of cells provided in OTDOA assistance data		16	The list includes the assistance-data-reference cell and 15 other cells. All cells provided in OTDOA assistance data are on RF channel 2.
$T_{\text{RSTD IntraFreqFDD, E-UTRAN}}$ <sup>Note 4</sup>	ms	2560	Derived according to the RSTD measurement requirements specified in Section 10.1.3
<p>NOTE 1: Parameters “Expected RSTD” and “Expected RSTD uncertainty for all neighbour cells” are not settable parameters. These are parameters signalled in LPP only. For the values to be used in LPP see Table 10.3.4.3-3 and TS 37.571-5 [20], clause 7.3.2.</p> <p>NOTE 2: Parameters “PRS Transmission Bandwidth”, “PRS configuration index”, “Number of consecutive positioning downlink subframes”, “prs-MutingInfo”, “Cell ID” and “CP length” are settable parameters and also parameters signalled in LPP. The values to be used for “Cell ID” are as follows: Cell 1: 0, Cell 2: 7, Cell 3: 10. For the values to be used in LPP see Table 10.3.4.3-3 and TS 37.571-5 [20], clause 7.3.2.</p> <p>NOTE 3: The parameter “Radio frame receive time offset between the cells at the UE antenna connector” is used to set the “true RSTD” value in step 6 of clause 10.3.4.1.</p> <p>NOTE 4: The parameter “<math>T_{\text{RSTD IntraFreqFDD, E-UTRAN}}</math>” is not a settable parameter but is used to set the LPP “time” value in Table 10.3.4.3-2. The value of the LPP time IE is set to <math>T_{\text{RSTD IntraFreqFDD, E-UTRAN}} + \Delta T</math> ms, where <math>\Delta T = 150</math> ms, giving a value of 2710 ms. This is rounded up to the next allowed LPP value of 3 seconds.</p>			

### 10.3.4.2 Test procedure

The RSTD measurements are performed between Cell 2 and Cell 3 to verify that when both the reference cell and neighbouring cell belong to the secondary component carrier the RSTD measurement accuracy can meet the intra-frequency RSTD accuracy requirements defined in section 10.3.3.

The test consists of a set-up period and a measurement period. All cells are active during the complete test. The beginning of the measurement period shall be aligned with the first PRS positioning subframe of a positioning occasion in the reference cell.

NOTE: The information on when PRS is muted is conveyed to the UE using PRS muting information in the OTDOA assistance data.

The OTDOA-RequestLocationInformation message and the OTDOA assistance data as defined in clause 10.3.4.3 shall be provided to the UE during the set-up period. The last TTI containing the OTDOA-RequestLocationInformation message shall be provided to the UE  $\Delta T$  ms before the start of the measurement period, where  $\Delta T = 150$  ms is the maximum processing time of the OTDOA-RequestLocationInformation message and the OTDOA assistance data in the UE.

1. Ensure that the UE is in state Generic RB Established State 3A-RF according to 3GPP TS 36.508 [18] clause 7.2A.3.
2. Configure Cell 2 and Cell 3 on the SCC according to TS 36.521-3 [25] Annex C.0 and C.1 for all downlink physical channels.
3. The SS shall configure the SCell (Cell 2) on the SCC as per TS 36.508 [18] clause 5.2A.4.
4. The SS activates the SCell (Cell 2) by sending the Activation/Deactivation MAC control element according to TS 36.321 [34] clauses 5.13 and 6.1.3.8. Wait for at least 2 seconds as per TS 36.133 [23] clause 8.3.3.2.
5. The SS shall send a RESET UE POSITIONING STORED INFORMATION message.
6. Set the parameters according to Table 10.3.5-1 as appropriate. Propagation conditions are set according to clause 4.7.2.1.
- 6a. The SS shall send an LPP REQUEST CAPABILITIES message.
- 6b. The UE shall send an LPP PROVIDE CAPABILITIES message indicating the OTDOA capabilities supported by the UE in the *OTDOA-ProvideCapabilities* IE
7. The SS shall send a LPP PROVIDE ASSISTANCE DATA message, including the *OTDOA-ProvideAssistanceData* IE. If the UE message at step 6b includes the *ackRequested* IE set to TRUE, then the SS shall send an acknowledgment in the LPP PROVIDE ASSISTANCE DATA message.
8. The SS shall send a LPP REQUEST LOCATION INFORMATION message, including the *OTDOA-RequestLocationInformation* IE such that the UE receives the message  $\Delta T$  ms before the start of measurement period, where  $\Delta T = 150$  ms.
9. The UE shall transmit a LPP PROVIDE LOCATION INFORMATION message, including the *OTDOA-ProvideLocationInformation* IE.
10. If the UE message at step 9 includes the *ackRequested* IE set to TRUE, the SS shall send a LPP acknowledgement message.
11. The SS shall check the *rstd* value for Cell 3 in the *OTDOA-SignalMeasurementInformation* IE according to Table 10.3.5-2.
12. Repeat step 5-11 until the confidence level according to Annex D is achieved.

### 10.3.4.3 Message contents

**Table 10.3.4.3-1: RESET UE POSITIONING STORED INFORMATION**

Derivation Path: 36.509 [11] clause 6.9			
Information Element	Value/remark	Comment	Condition
UE Positioning Technology	0 0 0 0 0 0 1	OTDOA	





Table 10.3.4.3-3: LPP ProvideAssistanceData

Derivation Path: 36.355 clause 6.2			
Information Element	Value/remark	Comment	Condition
LPP-Message ::= SEQUENCE {			
transactionID SEQUENCE {			
Initiator	locationServer		
transactionNumber	(0..255)		
}			
endTransaction	TRUE		
sequenceNumber	Not present		
acknowledgement	Not present		
lpp-MessageBody CHOICE {			
c1 CHOICE {			
provideAssistanceData SEQUENCE {			
criticalExtensions CHOICE {			
c1 CHOICE {			
provideAssistanceData-r9 SEQUENCE {			
commonIEsProvideAssistanceData	Not present		
a-gnss-ProvideAssistanceData	Not present		
otdoa-ProvideAssistanceData SEQUENCE {			
otdoa-ReferenceCellInfo	As defined in TS 37.571-5 [20], clause 7.3.2.		
otdoa-NeighbourCellInfo	As defined in TS 37.571-5 [20], clause 7.3.2.		
otdoa-Error	Not present		
}			
epdu-ProvideAssistanceData	Not present		
}			
}			
}			
}			

**Table 10.3.4.3-4: LPP ProvideLocation Information**

Derivation Path: 36.355 clause 6.2			
Information Element	Value/remark	Comment	Condition
LPP-Message ::= SEQUENCE {			
transactionID SEQUENCE {			
Initiator	locationServer		
transactionNumber	1		
}			
endTransaction	TRUE		
sequenceNumber	(0..255)		
acknowledgement			
lpp-MessageBody CHOICE {			
c1 CHOICE {			
provideLocationInformation SEQUENCE {			
criticalExtensions CHOICE {			
c1 CHOICE {			
provideLocationInformation-r9 SEQUENCE {			
commonIEsProvideLocationInformation	Not present.		
a-gnss-ProvideLocationInformation	Not present		
otdoa-ProvideLocationInformation SEQUENCE {			
otdoaSignalMeasurementInformation SEQUENCE {			
systemFrameNumber			
physCellIdRef	Cell 2		
cellGlobalIdRef			
earfcnRef			
referenceQuality			
neighbourMeasurementList SEQUENCE (SIZE(1)) {			
physCellIdNeighbour	Cell 3		
cellGlobalIdNeighbour			
earfcnNeighbour			
rstd	Set according to Table 10.3.5-2		
rstd-Quality			
}			
}			
otdoa-Error	May be present with error reason 'undefined' or 'attemptedButUnableToMeasureSomeNeighbourCells'		
}			
ecid-ProvideLocationInformation	Not present		
epdu-ProvideLocationInformation	Not present		
}			
}			
}			
}			
}			

### 10.3.5 Test requirement

Table 10.3.5-1 defines the primary level settings including test tolerances for the test.

The FDD RSTD accuracy test shall meet the reported values in Table 10.3.5-2.

**Table 10.3.5-1: Cell Specific Test Parameters for RSTD Test for E-UTRAN FDD for Carrier Aggregation**

Parameter	Unit	Cell 1	Cell 2	Cell 3				
E-UTRA RF Channel Number		1	2	2				
PBCH_RA								
PBCH_RB								
PSS_RA								
SSS_RA								
PCFICH_RB								
PHICH_RA	dB	0	0	0				
PHICH_RB								
PDCCH_RA								
PDCCH_RB								
OCNG_RA <sup>Note 1</sup>								
OCNG_RB <sup>Note 1</sup>								
PRS_RA					-3	0.3	0.3	
$N_{oc}$ <sup>Note 2</sup>					dBm/15 kHz			-98
$PRS \hat{E}_s / N_{oc}$					-6	-5.7	-12.7	
$PRS \hat{E}_s / I_{ot}$ <sup>Note 3</sup>					-6	-5.7	-12.7	
$I_o$ <sup>Note 3</sup>	dBm/9 MHz			-70.04				
PRP <sup>Note 3</sup>	dBm/15 kHz			-104				
$\hat{E}_s / N_{oc}$ <sup>Note 3</sup>	dB			-3				
RSRP <sup>Note 3</sup>	dBm/15 kHz			-101				
Propagation condition		AWGN						
<p>Note 1: OCNG shall be used such that both cells are fully allocated and a constant total transmitted power spectral density is achieved for all OFDM symbols (other than those in the PRS subframes).</p> <p>Note 2: Interference from other cells and noise sources not specified in the test is assumed to be constant over subcarriers and time and shall be modelled as AWGN of appropriate power for <math>N_{oc}</math> to be fulfilled.</p> <p>Note 3: <math>\hat{E}_s / N_{oc}</math>, <math>PRS \hat{E}_s / I_{ot}</math>, <math>I_o</math>, RSRP and PRP levels have been derived from other parameters for information purposes. They are not settable parameters themselves. <math>I_o</math> values are derived in the case that there is no PBCH, PSS or SSS in the OFDM symbols carrying PRS.</p>								

**Table 10.3.5-2: RSTD FDD accuracy requirements for the reported values for Carrier Aggregation**

	Value
Lowest reported value	RSTD_6380
Highest reported value	RSTD_6392

For the test to pass, the ratio of successful reported values shall be more than 90% with a confidence level of 95%.

## 10.3A FDD RSTD Measurement Accuracy for Carrier Aggregation for 20 MHz Bandwidth (Rel-10 and Rel-11)

### 10.3A.1 Test purpose

Same as defined in clause 10.3.1.

### 10.3A.2 Test applicability

This test applies to all types of E-UTRA FDD UE release 10 and 11 that supports UE-assisted OTDOA for Carrier Aggregation.

### 10.3A.3 Minimum conformance requirements

Same as defined in clause 10.3.3.

The normative reference for this requirement is TS 36.133 [23] clause 9.1.12 and A.9.8.7.

## 10.3A.4 Test description

### 10.3A.4.1 Initial conditions

Same as defined in clause 10.3.4.1 except that the values of the parameters in Table 10.3A.4.1-1 will replace the values of the corresponding parameters in Table 10.3.4.1-1.

Channel bandwidth to be tested: 20 MHz.

**Table 10.3A.4.1-1: General Test Parameters for RSTD Test for E-UTRAN FDD for Carrier Aggregation for 20 MHz**

Parameter	Unit	Value	Comment
PCFICH/PDCCH/PHICH parameters		R.10 FDD	As specified in clause TS 36.521-3 [25] clause A.2.1
OCNG Patterns defined in TS 36.521-3 [25] clause D.1		OP.14 FDD	OCNG shall be used such that both cells are fully allocated and a constant total transmitted power spectral density is achieved for all OFDM symbols (other than those in the PRS subframes).
Channel Bandwidth (BW <sub>channel</sub> )	MHz	20	
PRS Bandwidth	RB	100	PRS Bandwidth bandwidth is as indicated in <i>prs-Bandwidth</i> in the OTDOA assistance data defined in 3GPP TS 36.355 [4].
Note 1: See Table 10.3.4.1-1 for other general test parameters.			

### 10.3A.4.2 Test procedure

Same as defined in clause 10.3.4.2.

### 10.3A.4.3 Message contents

Same as defined in clause 10.3.4.3.

## 10.3A.5 Test requirement

Same as defined in clause 10.3.5 except that the value of the parameter in Table 10.3A.5-1 will replace the value of the corresponding parameter in Table 10.3.5-1.

**Table 10.3A.5-1: Cell Specific Test Parameters for RSTD Test for E-UTRAN FDD for Carrier Aggregation for 20 MHz**

Parameter	Unit	Cell1	Cell2	Cell3
Io <sup>Note1</sup>	dBm/18 MHz	-67.03	-66.98	-66.98
Note 1: Io level has been derived from other parameters for information purposes. It is not settable parameter itself. Io values are derived in the case that there is no PBCH, PSS or SSS in the OFDM symbols carrying PRS				
Note 2: See Table 10.3.5-1 for other cell specific test parameters.				

## 10.3A\_1 FDD RSTD Measurement Accuracy for Carrier Aggregation for 20 MHz Bandwidth (Rel-12 onwards)

### 10.3A\_1.1 Test purpose

Same as defined in clause 10.3A.1.

## 10.3A\_1.2 Test applicability

This test applies to all types of E-UTRA FDD UE release 12 and forward that supports UE-assisted OTDOA for Carrier Aggregation.

## 10.3A\_1.3 Minimum conformance requirements

Same as defined in clause 10.3A.3.

The normative reference for this requirement is TS 36.133 [23] clause 9.1.12 and A.9.8.7.

## 10.3A\_1.4 Test description

### 10.3A\_1.4.1 Initial conditions

Same as defined in clause 10.3A.4.1.

### 10.3A\_1.4.2 Test procedure

Same as defined in clause 10.3A.4.2.

### 10.3A\_1.4.3 Message contents

Same as defined in clause 10.3A.4.3.

## 10.3A\_1.5 Test requirement

Same as defined in clause 10.3A.5 except that in addition Table 10.3A\_1.5-1 will replace Table 10.3.5-2.

**Table 10.3A\_1.5-1: RSTD FDD accuracy requirements for the reported values for Carrier Aggregation**

	Value
Lowest reported value	RSTD_6381
Highest reported value	RSTD_6391

## 10.3B FDD RSTD Measurement Accuracy for Carrier Aggregation for 5 MHz + 5 MHz Bandwidth

### 10.3B.1 Test purpose

Same as defined in clause 10.3.1.

### 10.3B.2 Test applicability

This test applies to all types of E-UTRA FDD UE release 10 and forward that supports UE-assisted OTDOA for Carrier Aggregation.

### 10.3B.3 Minimum conformance requirements

Same as defined in clause 10.3.3.

The normative reference for this requirement is TS 36.133 [23] clause 9.1.12 and A.9.8.11.

### 10.3B.4 Test description

#### 10.3B.4.1 Initial conditions

Same as defined in clause 10.3.4.1 except that the values of the parameters in Table 10.3B.4.1-1 will replace the values of the corresponding parameters in Table 10.3.4.1-1.

Channel bandwidth to be tested: 5 MHz.

**Table 10.3B.4.1-1: General Test Parameters for RSTD Test for E-UTRAN FDD for Carrier Aggregation for 5 MHz + 5 MHz**

Parameter	Unit	Value	Comment
PCFICH/PDCCH/PHICH parameters		R.11 FDD	As specified in TS 36.521-3 [25] clause A.2.1
OCNG Patterns defined in TS 36.521-3 [25] clause D.1		OP.19 FDD	OCNG shall be used such that both cells are fully allocated and a constant total transmitted power spectral density is achieved for all OFDM symbols (other than those in the PRS subframes). There is no PDSCH allocated in the subframe transmitting PRS.
Channel Bandwidth ( $BW_{\text{channel}}$ )	MHz	5	
PRS Bandwidth	RB	25	PRS Bandwidth bandwidth is as indicated in <i>prs-Bandwidth</i> in the OTDOA assistance data defined in 3GPP TS 36.355 [4].
Number of consecutive positioning downlink subframes $N_{\text{PRS}}$		2	As defined in 3GPP TS 36.211 [26]
Note 1: See Table 10.3.4.1-1 for other general test parameters.			

### 10.3B.4.2 Test procedure

Same as defined in clause 10.3.4.2.

### 10.3B.4.3 Message contents

Same as defined in clause 10.3.4.3.

### 10.3B.5 Test requirement

Same as defined in clause 10.3.5 except that the value of the parameter in Table 10.3B.5-1 will replace the value of the corresponding parameter in Table 10.3.5-1 and the FDD RSTD accuracy shall meet the reported values in Table 10.3B.5-2.

**Table 10.3B.5-1: Cell Specific Test Parameters for RSTD Test for E-UTRAN FDD for Carrier Aggregation for 5 MHz + 5 MHz**

Parameter	Unit	Cell1	Cell2	Cell3
$I_0$ <sup>Note1</sup>	dBm/4.5 MHz	-73.05	-73.00	-73.00
Note 1: $I_0$ level has been derived from other parameters for information purposes. It is not settable parameter itself. $I_0$ values are derived in the case that there is no PBCH, PSS or SSS in the OFDM symbols carrying PRS				
Note 2: See Table 10.3.5-1 for other cell specific test parameters.				

**Table 10.3B.5-2: RSTD FDD accuracy requirements for the reported values for Carrier Aggregation for 5 MHz+5 MHz bandwidth**

	Value
Lowest reported value	RSTD_6379
Highest reported value	RSTD_6393

## 10.3C FDD RSTD Measurement Accuracy for Carrier Aggregation for 10 MHz + 5 MHz Bandwidth

### 10.3C.1 Test purpose

Same as defined in clause 10.3.1.

## 10.3C.2 Test applicability

This test applies to all types of E-UTRA FDD UE release 11 and forward that supports UE-assisted OTDOA for Carrier Aggregation.

## 10.3C.3 Minimum conformance requirements

Same as defined in clause 10.3.3.

The normative reference for this requirement is TS 36.133 [23] clause 9.1.12 and A.9.8.9.

## 10.3C.4 Test description

### 10.3C.4.1 Initial conditions

Same as defined in clause 10.3.4.1 except that the values of the parameters in Table 10.3C.4.1-1 will replace the values of the corresponding parameters in Table 10.3.4.1-1.

Channel bandwidth to be tested: Cell 1: 10 MHz, Cell 2 and Cell 3: 5 MHz.

**Table 10.3C.4.1-1: General Test Parameters for RSTD Test for E-UTRAN FDD for Carrier Aggregation for 10 MHz + 5 MHz**

Parameter	Unit	Value	Comment
PCFICH/PDCCH/PHICH parameters		Cell1: R.6 FDD Cell2: R.11 FDD Cell3: R.11 FDD	As specified in TS 36.521-3 [25] clause A.2.1
OCNG Patterns defined in TS 36.521-3 [25] clause D.1		Cell1: OP.6 FDD Cell2: OP.19 FDD Cell3: OP.19 FDD	OCNG shall be used such that both cells are fully allocated and a constant total transmitted power spectral density is achieved for all OFDM symbols (other than those in the PRS subframes). There is no PDSCH allocated in the subframe transmitting PRS.
Channel Bandwidth (BW <sub>channel</sub> )	MHz	Cell1: 10 Cell2: 5 Cell3: 5	
PRS Bandwidth	RB	Cell1: 50 Cell2: 25 Cell3: 25	PRS Bandwidth bandwidth is as indicated in <i>prs-Bandwidth</i> in the OTDOA assistance data defined in 3GPP TS 36.355 [4].
Number of consecutive positioning downlink subframes $N_{PRS}$		2	As defined in 3GPP TS 36.211 [26]
Note 1: See Table 10.3.4.1-1 for other general test parameters.			

### 10.3C.4.2 Test procedure

Same as defined in clause 10.3.4.2.

### 10.3C.4.3 Message contents

Same as defined in clause 10.3.4.3.

## 10.3C.5 Test requirement

Same as defined in clause 10.3.5 except that the value of the parameter in Table 10.3C.5-1 will replace the value of the corresponding parameter in Table 10.3.5-1 and the FDD RSTD accuracy shall meet the reported values in Table 10.3C.5-2.

**Table 10.3C.5-1: Cell Specific Test Parameters for RSTD Test for E-UTRAN FDD for Carrier Aggregation for 10 MHz +5 MHz**

Parameter	Unit	Cell1	Cell2	Cell3
I <sub>0</sub> <sup>Note1</sup>	dBm/9 MHz	-70.04	N/A	N/A
	dBm/4.5 MHz	N/A	-73.00	-73.00
Note 1:	I <sub>0</sub> level has been derived from other parameters for information purposes. It is not settable parameter itself. I <sub>0</sub> values are derived in the case that there is no PBCH, PSS or SSS in the OFDM symbols carrying PRS			
Note 2:	See Table 10.3.5-1 for other cell specific test parameters.			

**Table 10.3C.5-2: RSTD FDD accuracy requirements for the reported values for Carrier Aggregation for 10 MHz+5 MHz bandwidth**

	Value
Lowest reported value	RSTD_6379
Highest reported value	RSTD_6393

## 10.4 TDD RSTD Measurement Accuracy for Carrier Aggregation

### 10.4.1 Test purpose

To verify that the TDD RSTD measurement accuracy is within the specified limits when both the reference cell and neighbouring cell belong to the secondary component carrier.

### 10.4.2 Test applicability

This test applies to all types of E-UTRA TDD UE release 10 and forward that supports UE-assisted OTDOA for Carrier Aggregation.

### 10.4.3 Minimum conformance requirements

The UE may operate in either E-UTRA inter-band or intra-band carrier aggregation mode. The requirements in this section shall apply regardless whether the configured downlink secondary cell is activated or deactivated by the MAC-CE command (3GPP TS 36.321 [34]). The requirements apply for bandwidths defined in the bandwidth combination set for the CA configurations supported by the UE as defined in TS 36.101 [2].

The RSTD measurements, which are obtained when both the reference cell and neighbouring cell belong to the secondary component carrier, shall meet the intra-frequency RSTD accuracy requirements defined in TS 36.133 [23] section 9.1.3.

The normative reference for this requirement is TS 36.133 [23] clause 9.1.12 and A.9.8.6.

### 10.4.4 Test description

#### 10.4.4.1 Initial conditions

Test Environment: Normal; as defined in TS 36.508 [18] clause 4.1.

Frequencies to be tested: Mid Range, as defined in TS 36.508 [18] clause 4.3.1.2.

Channel bandwidth to be tested: 10 MHz.

1. Connect the SS (node B emulator) and AWGN noise sources to the UE antenna connectors as follows:
  - For UEs supporting only 2Rx in all the bands under test, use TS 36.508 [18] Annex A, Figure group A.41 as appropriate.
  - For UEs supporting 4Rx in any of the bands under test use TS 36.508 [18] Annex A, Figure A.90. Use the 2Rx module for cells on bands supporting 2Rx and the 4Rx module for cells on bands supporting 4Rx.
2. The general test parameter settings are set up according to Table 10.4.4.1-1.



3. Propagation conditions are set according to clause 4.7.2.1.
4. Message contents are defined in clause 10.4.4.3.
5. There are three synchronized cells on two different carrier frequencies. Cell 1 is the PCell on primary component carrier F1 (RF channel number 1), Cell 2 is the SCell and OTDOA assistance data reference cell on secondary component carrier F2 (RF channel number 2), and Cell 3 is the neighbour cell on F2. PCell (Cell 1) is the cell used for connection setup with the power level and mapping set according to TS 36.521-1 [24] Annex C.0 and C.1 as appropriate for this test. Cell 2 and Cell 3 are powered OFF.

Cell 3 is included in the OTDOA assistance data neighbour cell list, whilst Cell 1 is not included in the OTDOA assistance data. The assistance data neighbour cell list includes in total 15 cells, where 14 of the cells are not simulated (dummy cells; as defined in 3GPP TS 37.571-5 [20], clause 7.3.2).

Note that the measurement gap is not configured in the test because of UE carrier aggregation capability.

6. The true RSTD (which is the receive time difference for frame 0 between the two cells as seen at the UE antenna connector) is set to 31 Ts ( about 1  $\mu$ s) between neighbour Cell 3 and OTDOA assistance data reference cell, Cell 2.

Note that the related expectedRSTD value to be signalled over LPP is defined in Table 10.4.4.1-1.

**Table 10.4.4.1-1: General Test Parameters for RSTD Test for E-UTRAN TDD for Carrier Aggregation**

Parameter	Unit	Value	Comment
PCFICH/PDCCH/PHICH parameters		R.6 TDD	As specified in TS 36.521-3 [25] clause A.2.2
OCNG Patterns defined in TS 36.521-3 [25] clause D.2		OP.2 TDD	OCNG shall be used such that both cells are fully allocated and a constant total transmitted power spectral density is achieved for all OFDM symbols (other than those in the PRS subframes).
Assistance data reference cell		Cell 2	Cell 2 is the SCell on RF channel number 2
PCell		Cell 1	Cell 1 on RF channel number 1
Neighbour cell		Cell 3	Cell 3 on RF channel number 2
E-UTRA RF Channel Number		1,2	Two TDD carrier frequencies are used.
Channel Bandwidth ( $BW_{channel}$ )	MHz	10	
Special subframe configuration		6	As specified in table 4.2-1 in TS 36.211 [26]. The same configuration in both cells.
Uplink-downlink configuration		1	As specified in table 4.2-2 in TS 36.211 [26] and table 8.1.2.5.2-2 in TS 36.133 [23]. The same configuration in both cells.
PRS Transmission Bandwidth <sup>Note 2</sup>	RB	50	PRS Bandwidth: bandwidth is as indicated in <i>prs-Bandwidth</i> in the OTDOA assistance data defined in 3GPP TS 36.355 [4].
PRS configuration Index $I_{PRS}$ <sup>Note 2</sup>		Cell 1: 14 Cell 2: 14 Cell 3: 14	As defined in 3GPP TS 36.211 [26]
Number of consecutive positioning downlink subframes $N_{PRS}$ <sup>Note 2</sup>		1	As defined in 3GPP TS 36.211 [26]
prs-MutingInfo <sup>Note 2</sup>		Cell 1: '11110000' Cell 2: '11110000' Cell 3: '11110000'	See section 6.5.1.2 in 3GPP TS 36.355 [4] for more information
Cell ID <sup>Note 2</sup>		(Cell ID of cell 2 – Cell ID of cell 3) mod 6 = 3	PCI of cell 1 is selected randomly.
Expected RSTD <sup>Note 1</sup>	μs	Cell 3: -2 Other neighbour cells: randomly between -3 and 3	The expected RSTD is what is expected at the receiver. The corresponding parameter in the OTDOA assistance data specified in TS 36.355 [4] is the expectedRSTD indicator
Expected RSTD uncertainty for all neighbour cells <sup>Note 1</sup>	μs	5	The corresponding parameter in the OTDOA assistance data specified in TS 36.355 [4] is the expectedRSTD-Uncertainty index
CP length <sup>Note 2</sup>		Normal	
DRX		OFF	
Radio frame receive time offset between the cells at the UE antenna connector <sup>Note 3</sup>	μs	Cell 1 to Cell 2: -1 Cell 3 to Cell 2: 1	PRS are transmitted from synchronous cells
Number of cells provided in OTDOA assistance data		16	The list includes the assistance-data-reference cell and 15 other cells. All cells provided in OTDOA assistance data are on RF channel 2.
$T_{RSTD \text{ IntraFreqFDD, E-UTRAN}}$ <sup>Note 4</sup>	ms	2560	Derived according to the RSTD measurement requirements specified in Section 10.2.3
<p>NOTE 1: Parameters “Expected RSTD” and “Expected RSTD uncertainty for all neighbour cells” are not settable parameters. These are parameters signalled in LPP only. For the values to be used in LPP see Table 10.4.4.3-3 and TS 37.571-5 [20], clause 7.3.2.</p> <p>NOTE 2: Parameters “PRS Transmission Bandwidth”, “PRS configuration index”, “Number of consecutive positioning downlink subframes”, “prs-MutingInfo”, “Cell ID” and “CP length” are settable parameters and also parameters signalled in LPP. The values to be used for “Cell ID” are as follows: Cell 1: 0, Cell 2: 7, Cell 3: 10. For the values to be used in LPP see Table 10.4.4.3-3 and TS 37.571-5 [20], clause 7.3.2.</p> <p>NOTE 3: The parameter “Radio frame receive time offset between the cells at the UE antenna connector” is used to set the “true RSTD” value in step 6 of clause 10.4.4.1.</p> <p>NOTE 4: The parameter “<math>T_{RSTD \text{ IntraFreqFDD, E-UTRAN}}</math>” is not a settable parameter but is used to set the LPP “time” value in Table 10.4.4.3-2. The value of the LPP time IE is set to <math>T_{RSTD \text{ IntraFreqFDD, E-UTRAN}} + \Delta T</math> ms, where <math>\Delta T = 150</math> ms, giving a value of 2710 ms. This is rounded up to the next allowed LPP value of 3 seconds.</p>			

#### 10.4.4.2 Test procedure

The RSTD measurements are performed between Cell 2 and Cell 3 to verify that when both the reference cell and neighbouring cell belong to the secondary component carrier the RSTD measurement accuracy can meet the intra-frequency RSTD accuracy requirements defined in section 10.4.3.

The test consists of a set-up period and a measurement period. All Cells are active during the complete test. The beginning of the measurement period shall be aligned with the first PRS positioning subframe of a positioning occasion in the reference cell.

NOTE: The information on when PRS is muted is conveyed to the UE using PRS muting information in the OTDOA assistance data.

The OTDOA-RequestLocationInformation message and the OTDOA assistance data as defined in clause 10.4.4.3 shall be provided to the UE during the set-up period. The last TTI containing the OTDOA-RequestLocationInformation message shall be provided to the UE  $\Delta T$  ms before the start of the measurement period, where  $\Delta T = 150$  ms is the maximum processing time of the OTDOA-RequestLocationInformation message and the OTDOA assistance data in the UE.

1. Ensure that the UE is in state Generic RB Established State 3A-RF according to 3GPP TS 36.508 [18] clause 7.2A.3.
2. Configure Cell 2 and Cell 3 on the SCC according to TS 36.521-3 [25] Annex C.0 and C.1 for all downlink physical channels.
3. The SS shall configure the SCell (Cell 2) on the SCC as per TS 36.508 [18] clause 5.2A.
4. The SS activates the SCell (Cell 2) by sending the Activation/Deactivation MAC control element according to TS 36.321 [34] clauses 5.13 and 6.1.3.8. Wait for at least 2 seconds as per TS 36.133 [23] clause 8.3.3.2.
5. The SS shall send a RESET UE POSITIONING STORED INFORMATION message.
6. Set the parameters according to Table 10.4.5-1 as appropriate. Propagation conditions are set according to clause 4.7.2.1.
- 6a. The SS shall send an LPP REQUEST CAPABILITIES message.
- 6b. The UE shall send an LPP PROVIDE CAPABILITIES message indicating the OTDOA capabilities supported by the UE in the *OTDOA-ProvideCapabilities* IE.
7. The SS shall send a LPP PROVIDE ASSISTANCE DATA message, including the *OTDOA-ProvideAssistanceData* IE. If the UE message at step 6b includes the *ackRequested* IE set to TRUE, then the SS shall send an acknowledgment in the LPP PROVIDE ASSISTANCE DATA message.
8. The SS shall send a LPP REQUEST LOCATION INFORMATION message, including the *OTDOA-RequestLocationInformation* IE such that the UE receives the message  $\Delta T$  ms before the start of measurement period, where  $\Delta T = 150$  ms.
9. The UE shall transmit a LPP PROVIDE LOCATION INFORMATION message, including the *OTDOA-ProvideLocationInformation* IE.
10. If the UE message at step 9 includes the *ackRequested* IE set to TRUE, the SS shall send a LPP acknowledgement message.
11. The SS shall check the *rstd* value for Cell 3 in the *OTDOA-SignalMeasurementInformation* IE according to Table 10.4.5-2.
12. Repeat step 5-11 until the confidence level according to Annex D is achieved.

## 10.4.4.3 Message contents

**Table 10.4.4.3-1: RESET UE POSITIONING STORED INFORMATION**

Derivation Path: 36.509 [11] clause 6.9			
Information Element	Value/remark	Comment	Condition
UE Positioning Technology	0 0 0 0 0 0 0 1	OTDOA	

**Table 10.4.4.3-1a: LPP Request Capabilities**

Information Element	Value/remark
<i>otdoa-RequestCapabilities</i>	TRUE

**Table 10.4.4.3-2: LPP RequestLocationInformation**

Derivation Path: 36.355 clause 6.2			
Information Element	Value/remark	Comment	Condition
LPP-Message ::= SEQUENCE {			
transactionID SEQUENCE {			
Initiator	locationServer		
transactionNumber	1		
}			
endTransaction	FALSE		
sequenceNumber	Not present		
acknowledgement	Not present		
lpp-MessageBody CHOICE {			
c1 CHOICE {			
requestLocationInformation SEQUENCE {			
criticalExtensions CHOICE {			
c1 CHOICE {			
requestLocationInformation-r9 SEQUENCE {			
commonIEsRequestLocationInformation SEQUENCE {			
locationInformationType	locationMeasurementsRequired		
triggeredReporting	Not present		
periodicalReporting	Not present		
additionalInformation	onlyReturnInformationRequested		
qos SEQUENCE {			
horizontalAccuracy	Not present		
verticalCoordinateRequest	FALSE		
verticalAccuracy	Not present		
responseTime SEQUENCE {			
time	3	See Note 4 of Table 10.4.4.1-1	
responseTimeEarlyFix-r12	Not present		Rel-12 onwards
}			
velocityRequest	FALSE		
}			
environment	Not present		
locationCoordinateTypes	Not present		
velocityTypes	Not present		
}			
a-gnss-RequestLocationInformation	Not present		
otdoa-RequestLocationInformation SEQUENCE {			
assistanceAvailability	FALSE		
}			
ecid-RequestLocationInformation	Not present		
epdu-RequestLocationInformation	Not Present		
}			
}			
}			
}			
}			

Table 10.4.4.3-3: LPP ProvideAssistanceData

Derivation Path: 36.355 clause 6.2			
Information Element	Value/remark	Comment	Condition
LPP-Message ::= SEQUENCE {			
transactionID SEQUENCE {			
Initiator	locationServer		
transactionNumber	(0..255)		
}			
endTransaction	TRUE		
sequenceNumber	Not present		
acknowledgement	Not present		
lpp-MessageBody CHOICE {			
c1 CHOICE {			
provideAssistanceData SEQUENCE {			
criticalExtensions CHOICE {			
c1 CHOICE {			
provideAssistanceData-r9 SEQUENCE {			
commonIEsProvideAssistanceData	Not present		
a-gnss-ProvideAssistanceData	Not present		
otdoa-ProvideAssistanceData SEQUENCE {			
otdoa-ReferenceCellInfo	As defined in TS 37.571-5 [20], clause 7.3.2.		
otdoa-NeighbourCellInfo	As defined in TS 37.571-5 [20], clause 7.3.2.		
otdoa-Error	Not present		
}			
epdu-ProvideAssistanceData	Not present		
}			
}			
}			
}			

**Table 10.4.4.3-4: LPP ProvideLocation Information**

Derivation Path: 36.355 clause 6.2			
Information Element	Value/remark	Comment	Condition
LPP-Message ::= SEQUENCE {			
transactionID SEQUENCE {			
initiator	locationServer		
transactionNumber	1		
}			
endTransaction	TRUE		
sequenceNumber	(0..255)		
acknowledgement			
lpp-MessageBody CHOICE {			
c1 CHOICE {			
provideLocationInformation SEQUENCE {			
criticalExtensions CHOICE {			
c1 CHOICE {			
provideLocationInformation-r9 SEQUENCE {			
commonIEsProvideLocationInformation	Not present.		
a-gnss-ProvideLocationInformation	Not present		
otdoa-ProvideLocationInformation			
SEQUENCE {			
otdoaSignalMeasurementInformation			
SEQUENCE {			
systemFrameNumber			
physCellIdRef	Cell 2		
cellGlobalIdRef			
earfcnRef			
referenceQuality			
neighbourMeasurementList			
SEQUENCE (SIZE(1)) {			
physCellIdNeighbour	Cell 3		
cellGlobalIdNeighbour			
earfcnNeighbour			
rstd	Set according to Table 10.4.5-2		
rstd-Quality			
}			
}			
otdoa-Error	May be present with error reason 'undefined' or 'attemptedButUnableToMeasureSomeNeighbourCells'		
}			
ecid-ProvideLocationInformation	Not present		
epdu-ProvideLocationInformation	Not present		
}			
}			
}			
}			

### 10.4.5 Test requirement

Table 10.4.5-1 defines the primary level settings including test tolerances for the test.

The TDD RSTD accuracy test shall meet the reported values in Table 10.4.5-2.

**Table 10.4.5-1: Cell Specific Test Parameters for RSTD Test for E-UTRAN TDD for Carrier Aggregation**

Parameter	Unit	Cell 1	Cell 2	Cell 3				
E-UTRA RF Channel Number		1	2	2				
PBCH_RA								
PBCH_RB								
PSS_RA								
SSS_RA								
PCFICH_RB								
PHICH_RA	dB	0	0	0				
PHICH_RB								
PDCCH_RA								
PDCCH_RB								
OCNG_RA <sup>Note 1</sup>								
OCNG_RB <sup>Note 1</sup>								
PRS_RA					-3	0.3	0.3	
$N_{oc}$ <sup>Note 2</sup>					dBm/15 kHz			-98
$PRS \hat{E}_s / N_{oc}$					-6	-5.7	-12.7	
$PRS \hat{E}_s / I_{ot}$ <sup>Note 3</sup>					-6	-5.7	-12.7	
$I_o$ <sup>Note 3</sup>	dBm/9 MHz			-70.04				
PRP <sup>Note 3</sup>	dBm/15 kHz			-104				
$\hat{E}_s / N_{oc}$ <sup>Note 3</sup>	dB			-3				
RSRP <sup>Note 3</sup>	dBm/15 kHz			-101				
Propagation condition		AWGN						
<p>Note 1: OCNG shall be used such that both cells are fully allocated and a constant total transmitted power spectral density is achieved for all OFDM symbols (other than those in the PRS subframes).</p> <p>Note 2: Interference from other cells and noise sources not specified in the test is assumed to be constant over subcarriers and time and shall be modelled as AWGN of appropriate power for <math>N_{oc}</math> to be fulfilled.</p> <p>Note 3: <math>\hat{E}_s / N_{oc}</math>, <math>PRS \hat{E}_s / I_{ot}</math>, <math>I_o</math>, RSRP and PRP levels have been derived from other parameters for information purposes. They are not settable parameters themselves. <math>I_o</math> values are derived in the case that there is no PBCH, PSS or SSS in the OFDM symbols carrying PRS.</p>								

**Table 10.4.5-2: RSTD TDD accuracy requirements for the reported values for Carrier Aggregation**

	Value
Lowest reported value	RSTD_6380
Highest reported value	RSTD_6392

For the test to pass, the ratio of successful reported values shall be more than 90% with a confidence level of 95%.

## 10.4A TDD RSTD Measurement Accuracy for Carrier Aggregation for 20 MHz Bandwidth (Rel-10 and Rel-11)

### 10.4A.1 Test purpose

Same as defined in clause 10.4.1.

### 10.4A.2 Test applicability

This test applies to all types of E-UTRA TDD UE release 10 and 11 that supports UE-assisted OTDOA for Carrier Aggregation.

### 10.4A.3 Minimum conformance requirements

Same as defined in clause 10.4.3.



The normative reference for this requirement is TS 36.133 [23] clause 9.1.12 and A.9.8.8.

## 10.4A.4 Test description

### 10.4A.4.1 Initial conditions

Same as defined in clause 10.4.4.1 except that the values of the parameters in Table 10.4A.4.1-1 will replace the values of the corresponding parameters in Table 10.4.4.1-1.

Channel bandwidth to be tested: 20 MHz.

**Table 10.4A.4.1-1: General Test Parameters for RSTD Test for E-UTRAN TDD for Carrier Aggregation for 20 MHz**

Parameter	Unit	Value	Comment
PCFICH/PDCCH/PHICH parameters		R.10 TDD	As specified in clause TS 36.521-3 [25] clause A.2.2
OCNG Patterns defined in TS 36.521-3 [25] clause D.2		OP.8 TDD	OCNG shall be used such that both cells are fully allocated and a constant total transmitted power spectral density is achieved for all OFDM symbols (other than those in the PRS subframes).
Channel Bandwidth (BW <sub>channel</sub> )	MHz	20	
PRS Bandwidth	RB	100	PRS Bandwidth: bandwidth is as indicated in <i>prs-Bandwidth</i> in the OTDOA assistance data defined in 3GPP TS 36.355 [4].
Note 1: See Table 10.4.4.1-1 for other general test parameters.			

### 10.4A.4.2 Test procedure

Same as defined in clause 10.4.4.2.

### 10.4A.4.3 Message contents

Same as defined in clause 10.4.4.3.

## 10.4A.5 Test requirement

Same as defined in clause 10.4.5 except that the value of the parameter in Table 10.4A.5-1 will replace the value of the corresponding parameter in Table 10.4.5-1.

**Table 10.4A.5-1: Cell Specific Test Parameters for RSTD Test for E-UTRAN TDD for Carrier Aggregation for 20 MHz**

Parameter	Unit	Cell1	Cell2	Cell3
Io <sup>Note1</sup>	dBm/18 MHz	-67.03	-66.98	-66.98
Note 1: Io level has been derived from other parameters for information purposes. It is not settable parameter itself. Io values are derived in the case that there is no PBCH, PSS or SSS in the OFDM symbols carrying PRS				
Note 2: See Table 10.4.5-1 for other cell specific test parameters.				

## 10.4A\_1 TDD RSTD Measurement Accuracy for Carrier Aggregation for 20 MHz Bandwidth (Rel-12 onwards)

### 10.4A\_1.1 Test purpose

Same as defined in clause 10.4A.1.

## 10.4A\_1.2 Test applicability

This test applies to all types of E-UTRA TDD UE release 12 and forward that supports UE-assisted OTDOA for Carrier Aggregation.

## 10.4A\_1.3 Minimum conformance requirements

Same as defined in clause 10.4A.3.

The normative reference for this requirement is TS 36.133 [23] clause 9.1.12 and A.9.8.8.

## 10.4A\_1.4 Test description

### 10.4A\_1.4.1 Initial conditions

Same as defined in clause 10.4A.4.1.

### 10.4A\_1.4.2 Test procedure

Same as defined in clause 10.4A.4.2.

### 10.4A\_1.4.3 Message contents

Same as defined in clause 10.4A.4.3.

## 10.4A\_1.5 Test requirement

Same as defined in clause 10.4A.5 except that in addition Table 10.4A\_1.5-1 will replace Table 10.4.5-2.

**Table 10.4A\_1.5-1: RSTD FDD accuracy requirements for the reported values for Carrier Aggregation**

	Value
Lowest reported value	RSTD_6381
Highest reported value	RSTD_6391

## 10.4B TDD RSTD Measurement Accuracy for Carrier Aggregation for 5 MHz + 5 MHz bandwidth

### 10.4B.1 Test purpose

Same as defined in clause 10.4.1.

### 10.4B.2 Test applicability

This test applies to all types of E-UTRA TDD UE release 10 and forward that supports UE-assisted OTDOA for Carrier Aggregation.

### 10.4B.3 Minimum conformance requirements

Same as defined in clause 10.4.3.

The normative reference for this requirement is TS 36.133 [23] clause 9.1.12 and A.9.8.12.

### 10.4B.4 Test description

#### 10.4B.4.1 Initial conditions

Same as defined in clause 10.4.4.1 except that the values of the parameters in Table 10.4B.4.1-1 will replace the values of the corresponding parameters in Table 10.4.4.1-1.

Channel bandwidth to be tested: 5 MHz.

**Table 10.4B.4.1-1: General Test Parameters for RSTD Test for E-UTRAN TDD for Carrier Aggregation for 5 MHz + 5 MHz**

Parameter	Unit	Value	Comment
PCFICH/PDCCH/PHICH parameters		R.11 TDD	As specified in clause TS 36.521-3 [25] clause A.2.2
OCNG Patterns defined in TS 36.521-3 [25] clause D.2		OP.10 TDD	OCNG shall be used such that both cells are fully allocated and a constant total transmitted power spectral density is achieved for all OFDM symbols (other than those in the PRS subframes). There is no PDSCH allocated in the subframe transmitting PRS.
Channel Bandwidth ( $BW_{\text{channel}}$ )	MHz	5	
PRS Bandwidth	RB	25	PRS Bandwidth bandwidth is as indicated in <i>prs-Bandwidth</i> in the OTDOA assistance data defined in 3GPP TS 36.355 [4].
Number of consecutive positioning downlink subframes $N_{\text{PRS}}$		2	As defined in 3GPP TS 36.211 [26]
Note 1: See Table 10.4.4.1-1 for other general test parameters.			

#### 10.4B.4.2 Test procedure

Same as defined in clause 10.4.4.2.

#### 10.4B.4.3 Message contents

Same as defined in clause 10.4.4.3.

#### 10.4B.5 Test requirement

Same as defined in clause 10.4.5 except that the value of the parameter in Table 10.4B.5-1 will replace the value of the corresponding parameter in Table 10.4.5-1 and the TDD RSTD accuracy shall meet the reported values in Table 10.4B.5-2.

**Table 10.4B.5-1: Cell Specific Test Parameters for RSTD Test for E-UTRAN TDD for Carrier Aggregation for 5 MHz + 5 MHz bandwidth**

Parameter	Unit	Cell1	Cell2	Cell3
$I_0$ <sup>Note1</sup>	dBm/4.5 MHz	-73.05	-73.00	-73.00
Note 1: $I_0$ level has been derived from other parameters for information purposes. It is not settable parameter itself. $I_0$ values are derived in the case that there is no PBCH, PSS or SSS in the OFDM symbols carrying PRS				
Note 2: See Table 10.4.5-1 for other cell specific test parameters.				

**Table 10.4B.5-2: RSTD TDD accuracy requirements for the reported values for Carrier Aggregation for 5 MHz+5 MHz bandwidth**

	Value
Lowest reported value	RSTD_6379
Highest reported value	RSTD_6393

### 10.4C TDD RSTD Measurement Accuracy for Carrier Aggregation for 10 MHz + 5 MHz Bandwidth

#### 10.4C.1 Test purpose

Same as defined in clause 10.4.1.

## 10.4C.2 Test applicability

This test applies to all types of E-UTRA TDD UE release 11 and forward that supports UE-assisted OTDOA for Carrier Aggregation.

## 10.4C.3 Minimum conformance requirements

Same as defined in clause 10.4.3.

The normative reference for this requirement is TS 36.133 [23] clause 9.1.12 and A.9.8.10.

## 10.4C.4 Test description

### 10.4C.4.1 Initial conditions

Same as defined in clause 10.4.4.1 except that the values of the parameters in Table 10.4C.4.1-1 will replace the values of the corresponding parameters in Table 10.4.4.1-1.

Channel bandwidth to be tested: Cell 1: 10 MHz, Cell 2 and Cell 3: 5 MHz.

**Table 10.4C.4.1-1: General Test Parameters for RSTD Test for E-UTRAN TDD for Carrier Aggregation for 10 MHz + 5 MHz**

Parameter	Unit	Value	Comment
PCFICH/PDCCH/PHICH parameters		Cell1: R.6 TDD Cell2: R.11 TDD Cell3: R.11 TDD	As specified in clause TS 36.521-3 [25] clause A.2.2
OCNG Patterns defined in TS 36.521-3 [25] clause D.2		Cell1: OP.2 TDD Cell2: OP.10 TDD Cell3: OP.10 TDD	OCNG shall be used such that both cells are fully allocated and a constant total transmitted power spectral density is achieved for all OFDM symbols (other than those in the PRS subframes). There is no PDSCH allocated in the subframe transmitting PRS.
Channel Bandwidth ( $BW_{\text{channel}}$ )	MHz	Cell1: 10 Cell2: 5 Cell3: 5	
PRS Bandwidth	RB	Cell1: 50 Cell2: 25 Cell3: 25	PRS Bandwidth bandwidth is as indicated in <i>prs-Bandwidth</i> in the OTDOA assistance data defined in 3GPP TS 36.355 [4].
Number of consecutive positioning downlink subframes $N_{\text{PRS}}$		2	As defined in 3GPP TS 36.211 [26]
Note 1: See Table 10.4.4.1-1 for other general test parameters.			

### 10.4C.4.2 Test procedure

Same as defined in clause 10.4.4.2.

### 10.4C.4.3 Message contents

Same as defined in clause 10.4.4.3.

## 10.4C.5 Test requirement

Same as defined in clause 10.4.5 except that the value of the parameter in Table 10.4C.5-1 will replace the value of the corresponding parameter in Table 10.4.5-1 and the TDD RSTD accuracy shall meet the reported values in Table 10.4C.5-2.

**Table 10.4C.5-1: Cell Specific Test Parameters for RSTD Test for E-UTRAN TDD for Carrier Aggregation for 10 MHz + 5 MHz**

Parameter	Unit	Cell1	Cell2	Cell3
I <sub>o</sub> <sup>Note1</sup>	dBm/9 MHz	-70.04	N/A	N/A
	dBm/4.5 MHz	N/A	-73.00	-73.00
Note 1:	I <sub>o</sub> level has been derived from other parameters for information purposes. It is not settable parameter itself. I <sub>o</sub> values are derived in the case that there is no PBCH, PSS or SSS in the OFDM symbols carrying PRS			
Note 2:	See Table 10.4.5-1 for other cell specific test parameters.			

**Table 10.4C.5-2: RSTD TDD accuracy requirements for the reported values for Carrier Aggregation for 10 MHz+5 MHz bandwidth**

	Value
Lowest reported value	RSTD_6379
Highest reported value	RSTD_6393

## 10.4D TDD RSTD Measurement Accuracy for Carrier Aggregation for 20 MHz+10 MHz Bandwidth

### 10.4D.1 Test purpose

Same as defined in clause 10.4.1

### 10.4D.2 Test applicability

This test applies to all types of E-UTRA TDD UE release 10 and forward that supports UE-assisted OTDOA for Carrier Aggregation.

### 10.4D.3 Minimum conformance requirements

Same as defined in clause 10.4.3

The normative reference for this requirement is TS 36.133 [23] clause 9.1.12 and A.9.8.13.

### 10.4D.4 Test description

#### 10.4D.4.1 Initial conditions

Same as defined in clause 10.4.4.1 except that the values of the parameters in Table 10.4D.4.1-1 will replace the values of the corresponding parameters in Table 10.4.4.1-1.

Channel bandwidth to be tested: Cell 1: 20 MHz, Cell 2 and Cell 3: 10 MHz.

**Table 10.4D.4.1-1: General Test Parameters for RSTD Test for E-UTRAN TDD for Carrier Aggregation for 20 MHz+10 MHz**

Parameter	Unit	Value	Comment
PCFICH/PDCCH/PHICH parameters		Cell 1: R.10 TDD Cell 2: R.6 TDD Cell 3: R.6 TDD	As specified in clause TS 36.521-3 [25] clause A.2.2
OCNG Patterns defined in TS 36.521-3 [25] clause D.2		Cell 1: OP.8 TDD Cell 2: OP.2 TDD Cell 3: OP.2 TDD	OCNG shall be used such that both cells are fully allocated and a constant total transmitted power spectral density is achieved for all OFDM symbols (other than those in the PRS subframes). There is no PDSCH allocated in the subframe transmitting PRS.
Channel Bandwidth ( $BW_{\text{channel}}$ )	MHz	Cell 1: 20 Cell 2: 10 Cell 3: 10	
PRS Bandwidth	RB	Cell 1: 100 Cell 2: 50 Cell 3: 50	PRS Bandwidth bandwidth is as indicated in <i>prs-Bandwidth</i> in the OTDOA assistance data defined in 3GPP TS36.355 [4].
Note 1: See Table 10.4.4.1-1 for other general test parameters.			

### 10.4D.4.2 Test procedure

Same as defined in clause 10.4.4.2

### 10.4D.4.3 Message contents

Same as defined in clause 10.4.4.3

### 10.4D.5 Test requirement

Same as defined in clause 10.4.5 except that the value of the parameter in Table 10.4D.5-1 will replace the value of the corresponding parameter in Table 10.4.5-1.

**Table 10.4D.5-1: Cell Specific Test Parameters for RSTD Test for E-UTRAN TDD for Carrier Aggregation for 20 MHz+10 MHz**

Parameter	Unit	Cell 1	Cell 2	Cell 3
$I_o$ <sup>Note1</sup>	dBm/ 18 MHz	-67.03	N/A	N/A
	dBm/ 9 MHz	N/A	-69.99	-69.99
Note 1: $I_o$ level has been derived from other parameters for information purposes. It is not settable parameter itself. $I_o$ values are derived in the case that there is no PBCH, PSS or SSS in the OFDM symbols carrying PRS				
Note 2: See Table 10.4.5-1 for other cell specific test parameters.				

## 10.5 FDD 3 DL CA RSTD Measurement Reporting Delay

### 10.5.1 Test Purpose

The purpose of the test case is to verify that the RSTD measurement reporting delay meets the requirements in an environment with fading propagation conditions. This test case verifies the measurement period requirements for RSTD measurements performed on the same secondary component carrier, the measurement period requirements for RSTD measurements performed on both the primary and secondary component carriers, and also the measurement period requirements for RSTD measurements performed on different secondary component carriers.

## 10.5.2 Test applicability

This test applies to all types of E-UTRA FDD UE release 12 and forward that supports UE-assisted OTDOA for 3DL Carrier Aggregation.

## 10.5.3 Minimum conformance requirements

### 10.5.3.1 Measurements on the secondary component carrier

The RSTD measurements when all cells are on the configured secondary component carrier shall meet all applicable requirements (FDD) specified in TS 36.133 [23] section 8.1.2.5, i.e., E-UTRAN intra-frequency RSTD measurement period applies, regardless of whether the SCell on the corresponding frequency is activated or deactivated by the MAC-CE commands as specified in 3GPP TS 36.321 [34].

### 10.5.3.2 Measurements on both primary component carrier and secondary component carrier

The RSTD measurements of cells on both primary component carrier and configured secondary component carrier shall meet all applicable requirements (FDD) specified in TS 36.133 [23] section 8.1.2.6, i.e., E-UTRAN inter-frequency RSTD measurement period applies regardless of whether the SCell on the corresponding frequency is activated or deactivated by the MAC-CE commands as specified in 3GPP TS 36.321 [34], with the following exception

- the number of PRS positioning occasions is as specified in Table 10.5.3.2-1 shall apply.

**Table 10.5.3.2-1: Number of PRS positioning occasions within measurement period**

Positioning subframe configuration period $T_{\text{PRS}}$	Number of PRS positioning occasions $M$
160 ms	32
>160 ms	16

### 10.5.3.3 Measurements on different secondary component carriers

The RSTD measurements of cells on a configured secondary component carrier and another configured secondary component carrier shall meet all applicable requirements (FDD-FDD inter-Frequency OTDOA) specified in TS 36.133 [23] section 8.1.2.6, i.e., E-UTRAN inter-frequency RSTD measurement period applies regardless of whether the SCell on the corresponding frequency is activated or deactivated by the MAC-CE commands as specified in 3GPP TS 36.321 [34], with the following exceptions

- the number of PRS positioning occasions is as specified in Table 10.5.3.3-1 shall apply.

**Table 10.5.3.3-1: Number of PRS positioning occasions within measurement period**

Positioning subframe configuration period $T_{\text{PRS}}$	Number of PRS positioning occasions $M$
160 ms	32
>160 ms	16

The normative reference for this requirement is TS 36.133 [23] clause 8.4.3, 8.4.4, 8.4.5 and A.8.17.10.

## 10.5.4 Test description

### 10.5.4.1 Initial conditions

Test Environment: Normal; as defined in TS 36.508 [18] clause 4.1.

Frequencies to be tested: Mid Range, as defined in TS 36.508 [18] clause 4.3.1.1.

Channel bandwidth to be tested: the largest aggregated bandwidth combination supported by the UE of the Channel bandwidths defined in Table 10.5.4.1-1. The Channel bandwidths for CA Intra-Band combinations are, as defined in TS

36.508 [18] clause 4.3.1 and for CA Inter-Band combinations are defined in TS 36.521-1[24] clause 5.4.2A. In case of multiple possible Channel bandwidth combinations, the first combination listed in the above mentioned clauses shall be selected.

1. Connect the SS, faders and AWGN noise sources to the UE antenna connector or antenna connectors as shown in TS 36.508 [18] Annex A, Figure A.68 as appropriate.
2. The general test parameter settings are set up according to Table 10.5.4.1-1.
3. Propagation conditions are set according to clause 4.7.2.1.
4. Message contents are defined in clause 10.5.4.3.
5. In the tests, there are three configured component carriers: PCC, SCC1 and SCC2, and four synchronized cells: Cell 1, Cell 2, Cell 3 and Cell 4. Cell 1 is PCell on the PCC, Cell 2 is SCell on the SCC1, Cell 3 is SCell on the SCC2 and Cell 4 is a neighbour cell on the SCC2. In all tests, Cell 3 is the OTDOA assistance data reference cell. The assistance data neighbour cell list includes in total 15 cells, where 14 of the cells are not simulated (dummy cells; as defined in 3GPP TS 37.571-5 clause 7.3.2) for Test 1 and where 12 of the cells are not simulated for Test 2. PCell (Cell 1) is the cell used for connection setup with the power level and mapping set according to TS 36.521-1 [24] Annex C.0 and C.1 as appropriate for this test. Cell 2, Cell 3 and Cell 4 are powered OFF.
6. The true RSTD (which is the receive time difference for frame 0 between two cells as seen at the UE antenna connector) is set to 31 Ts (about 1  $\mu$ s) between Cell 1 and OTDOA assistance data reference cell, Cell 3, and set to -31 Ts (about -1  $\mu$ s) between Cell 2 and OTDOA assistance data reference cell, Cell 3, and set to 92 Ts (about 3  $\mu$ s) between neighbour Cell 4 and OTDOA assistance data reference cell, Cell 3.



**Table 10.5.4.1-1: General test parameters for E-UTRAN FDD RSTD measurement reporting delay under fading propagation conditions for carrier aggregation**

Parameter	Unit	Value		Comment
		Test 1	Test 2	
PCell		Cell 1		PCell is on RF channel 1 (PCC).
SCell 1		Cell 2		SCell 1 on RF channel 2 (SCC1).
SCell 2		Cell 3		SCell 2 on RF channel 3 (SCC2). Cell 3 is the assistance data reference cell.
Other neighbour cell		Cell 4		Neighbour cell on RF channel 3 (SCC2).
PCFICH/PDCCH/PHICH parameters (PCFICH/PDCCH/PHICH parameters depend on selected channel bandwidth)		5MHz: R.11 FDD 10MHz: R.6 FDD 20MHz: R.10 FDD		As specified in TS 36.521-3 [25] clause A.2.1
Channel Bandwidth ( $BW_{channel}$ )	MHz	5,10,20		
PRS Transmission Bandwidth (PRS transmission bandwidth depends on selected channel bandwidth) <sup>Note 2</sup>	RB	5MHz: 25 10MHz: 50 20MHz:100		PRS are transmitted over the system bandwidth
Number of consecutive downlink positioning subframes $N_{PRS}$ . ( $N_{PRS}$ depends on selected channel bandwidth) <sup>Note 2</sup>		5MHz: 2 10MHz: 1 20MHz:1		As defined in TS 36.211 [26]. The number of subframes in a positioning occasion
PRS configuration index $I_{PRS}$ <sup>Note 2</sup>		171 for all cells on PCC 181 for all cells on SCC1 191 for all cells on SCC2		This corresponds to periodicity of 320 ms and PRS subframe offset of $I_{PRS} - 160$ DL subframes, as defined in TS 36.211 [26], Table 6.10.4.3-1
Physical cell ID PCI <sup>Note 2</sup>		$(\text{PCI of Cell 3} - \text{PCI of Cell 4}) \bmod 6 = 0$		The PCIs of Cell 1 and Cell 2 are selected randomly. PCIs of Cell 3 and Cell 4 are selected randomly such that the relative subcarrier shifts of PRS patterns among these cells are as given by the condition
CP length <sup>Note 2</sup>		Normal		
DRX		ON		DRX parameters are further specified in Table 10.5.4.1-2
Radio frame receive time offset between the cells at the UE antenna connector <sup>Note 3</sup>	$\mu\text{s}$	Cell 1 to Cell 3: 1 Cell 2 to Cell 3: -1 Cell 4 to Cell 3: 3	Cell 1 to Cell 3: 1 Cell 2 to Cell 3: -1 Cell 4 to Cell 3:	PRS are transmitted from synchronous cells
Expected RSTD <sup>Note 1</sup>	$\mu\text{s}$	Cell 4: 2 Other neighbour cells: randomly between -3 and 3	Cell 1: -2 Cell 2: 0 Cell 4: 2 Other neighbour cells: randomly between -3 and 3	The expected RSTD is what is expected at the receiver. The corresponding parameter in the OTDOA assistance data specified in TS 36.355 [4] is the expectedRSTD indicator
Expected RSTD uncertainty for all neighbour cells <sup>Note 1</sup>	$\mu\text{s}$	5		The corresponding parameter in the OTDOA assistance data specified in TS 36.355 [4] is the expectedRSTD-Uncertainty index
		16 cells in total		

Number of cells provided in OTDOA assistance data		OTDOA neighbour cells include Cell 4 and other 14 cells on SCC2	OTDOA neighbour cells include Cell 1 and other 3 cells on PCC, Cell 2 and other 3 cells on SCC1 and Cell 4 and other 6 cells on SCC2	The list includes the reference cell and 15 other cells. Cell 1 and Cell 2 (when included) appears at random places in the first half of the neighbour cell list in the OTDOA assistance data. Cell 4 always appears at random places in the second half of the list.
prs-SubframeOffset <sup>Note 2</sup>		Cells on PCC: 300 Cells on SCC1: 310 Cells on SCC2, except reference cell: 0		Subframe offset, counted in full subframes. The corresponding parameter in the OTDOA assistance data is prs-SubframeOffset specified in TS 36.355 [4]
slotNumberOffset <sup>Note 2</sup>		Cells on PCC: 0 Cells on SCC1: 0 Cells on SCC2, except reference cell: 0		The slot number offset at the transmitter between a neighbour cell and the assistance data reference cell. The corresponding parameter in the OTDOA assistance data is slotNumberOffset specified in TS 36.355 [4].
PRS muting info <sup>Note 2</sup>		Cell 1: '11110000' Cell 2: '00001111' Cell 3: '11110000' Cell 4: '00001111'	Cell 1: '1111111100000000' Cell 2: '0000000011111111' Cell 3: '1111111100000000' Cell 4: '0000000011111111'	Corresponds to prs-MutingInfo defined in TS 36.355 [4]
T1	s	3		The length of the time interval from the beginning of each test
T2	s	1.28	2.48	The length of the time interval that follows immediately after time interval T1
T3	s	1.28	2.48	The length of the time interval that follows immediately after time interval T2
<p>Note 1: Parameters "Expected RSTD" and "Expected RSTD uncertainty for all neighbour cells" are not settable parameters. These are parameters signalled in LPP only. For the values to be used in LPP see Table 10.5.4.3-4 and TS 37.571-5 [20], clause 7.3.2.</p> <p>Note 2: Parameters "PRS Transmission Bandwidth", "PRS configuration index", "Number of consecutive downlink positioning subframes", "Physical cell ID PCI", "CP length", "prs-SubframeOffset", "slotNumberOffset" and "PRS muting info" are settable parameters and also parameters signalled in LPP. The values to be used for "Physical cell ID PCI" are as follows: Cell 1: 0, Cell 2: 3, Cell 3: 6, Cell 4: 12. For the values to be used in LPP see Table 10.5.4.3-4 and TS 37.571-5 [20], clause 7.3.2.</p> <p>Note 3: The parameter "Radio frame receive time offset between the cells at the UE antenna connector" is used to set the "true RSTD" values in step 6 of clause 10.5.4.1.</p>				

**Table 10.5.4.1-2: DRX parameters for the test of E-UTRAN FDD intra-frequency RSTD measurement reporting delay under fading propagation conditions for carrier aggregation**

Field	Value	Comment
onDurationTimer	psf1	As specified in TS 36.331 [22], Clause 6.3.2
Drx-InactivityTimer	psf1	
drx-RetransmissionTimer	sf1	
longDRX-CycleStartOffset	sf320	
shortDRX	Disable	

10.5.4.2 Test procedure

The test case includes two tests. Test 1 is designed for the scenario where the UE receives OTDOA assistance data with cells only on SCC2, and the UE is expected to report RSTD measurements performed on SCC2 only. Test 2 is designed

for the scenario where the UE receives OTDOA assistance data with cells on PCC, SCC1 and SCC2, and the UE is expected to report RSTD measurements performed on PCC, SCC1 and SCC2.

Each test consists of three consecutive time intervals, with duration of T1, T2 and T3. Cell 1 is active in T1, T2 and T3, Cell 2 is active only in T2 and T3, Cell 3 is active only during T2 and T3, and Cell 4 is active only during T2. The beginning of the time interval T2 shall be aligned 5 ms before the first PRS positioning subframe of a positioning occasion in the OTDOA assistance data reference cell, where 5 ms is the necessary test tolerance. Cell 1 transmits PRS in T2, Cell 2 transmits PRS only in T3, Cell 3 transmits PRS only in T3, and Cell 4 transmits PRS only in T2.

NOTE: The information on when PRS is muted is conveyed to the UE using PRS muting information in the OTDOA assistance data.

The OTDOA-RequestLocationInformation message and the OTDOA assistance data as defined in 10.5.4.3 shall be provided to the UE during T1. The last TTI containing the OTDOA-RequestLocationInformation message shall be provided to the UE  $\Delta T$  ms before the start of T2, where  $\Delta T = 150$  ms is the maximum processing time of the OTDOA-RequestLocationInformation message and the OTDOA assistance data.

1. Ensure that the UE is in state Generic RB Established State 3A-RF according to 3GPP TS 36.508 [18] clause 7.2A.3.
2. Configure Cell 2 on SCC1 and Cell 3 and Cell 4 on SCC2 according to TS 36.521-3 [25] Annex C.0 and C.1 for all downlink physical channels.
3. The SS shall configure the SCells (Cell 2 and Cell 3) on the SCCs as per TS 36.508 [18] clause 5.2A.4.
4. The SS activates the SCells (Cell 2 and Cell 3) by sending the Activation/Deactivation MAC control element according to TS 36.321 [34] clauses 5.13 and 6.1.3.8. Wait for at least 2 seconds as per TS 36.133 [23] clause 8.3.3.2.
5. The SS shall send a RESET UE POSITIONING STORED INFORMATION message.
6. Set the parameters according to Table 10.5.5-1. Propagation conditions are set according to clause 4.7.2.2 (ETU30).
7. T1 starts.
8. The SS shall transmit an RRCConnectionReconfiguration message with the DRX configuration. PDCCHs indicating new transmissions shall be sent continuously until the start of T2 to ensure that the UE would not enter the DRX state before T2.
9. The UE shall transmit RRCConnectionReconfigurationComplete message.
- 9a. The SS shall transmit an LPP REQUEST CAPABILITIES message.
- 9b. The UE shall transmit an LPP PROVIDE CAPABILITIES message indicating the OTDOA capabilities supported by the UE in the *OTDOA-ProvideCapabilities* IE.
10. The SS shall send a LPP PROVIDE ASSISTANCE DATA message, including the *OTDOA-ProvideAssistanceData* IE. The position of neighbour Cell 4 in the *OTDOA-NeighbourCellInfoList* is randomly selected to be in the last 8 elements of the sequence for Test 1 and in the 7 elements of the relevant sequence for Test 2, and the position of Cell 1 and the position of Cell 2 are randomly selected to be in the 4 elements of the relevant sequence for Test 2, as described in 3GPP TS 37.571-5 [20], clause 7.3.2. If the UE message at step 9b includes the *ackRequested* IE set to TRUE, then the SS shall send an acknowledgment in the LPP PROVIDE ASSISTANCE DATA message.
11. The SS shall send a LPP REQUEST LOCATION INFORMATION message, including the *OTDOA-RequestLocationInformation* IE such that the UE receives the message  $\Delta T$  ms before the start of T2, where  $\Delta T = 150$  ms.
12. When T1 expires, the SS shall switch the power setting from T1 to T2 as specified in Table 10.5.5-2.
13. When T2 expires, the SS shall switch the power setting from T2 to T3 as specified in Table 10.5.5-2.
14. The UE shall transmit a LPP PROVIDE LOCATION INFORMATION message including the *OTDOA-ProvideLocationInformation* IE within the response time (see clause 4.7.3) specified in clause 10.5.5.

For Test 1 the UE shall perform and report the RSTD measurement for Cell 4 with respect to the reference cell in the OTDOA assistance data, Cell 3. If the UE transmits an *OTDOA-ProvideLocationInformation* IE including the *rstd* field for Cell 4 within the response time then the number of successful tests is increased by one. If the UE fails to report the *OTDOA-ProvideLocationInformation* IE with the *rstd* field included within the response time then the number of failure tests is increased by one.

For Test 2 the UE shall perform and report the RSTD measurements for Cell 1 with respect to the reference cell in the OTDOA assistance data, Cell 3 and also Cell 2 with respect to the reference cell in the OTDOA assistance data, Cell 3 and also Cell 4 with respect to the reference cell in the OTDOA assistance data, Cell 3. If the UE transmits an *OTDOA-ProvideLocationInformation* IE including the *rstd* field for Cell 1 (with respect to Cell 3) and Cell 2 (with respect to Cell 3) and Cell 4 (with respect to Cell 3) within the response time then the number of successful tests is increased by one. If the UE fails to report the *OTDOA-ProvideLocationInformation* IE with the three *rstd* fields included within the response time then the number of failure tests is increased by one.

15. If the UE message at step 14 includes the *ackRequested* IE set to TRUE, the SS shall send a LPP acknowledgement message.

16. Repeat steps 5-15 until the confidence level according to Annex D is achieved. For each iteration, at step 10 change the random positions of Cell 4 and Cell 1(for Test 2 only) and Cell 2(for Test 2 only) in the relevant sequence in the *OTDOA-NeighbourCellInfoList*.

17. Repeat from clause 10.5.4.1 for Test 2.

### 10.5.4.3 Message contents

**Table 10.5.4.3-1: RESET UE POSITIONING STORED INFORMATION**

Derivation Path: 36.509 [11] clause 6.9			
Information Element	Value/remark	Comment	Condition
UE Positioning Technology	0 0 0 0 0 0 1	OTDOA	

**Table 10.5.4.3-2: MAC-MainConfig-RBC: FDD RSTD Measurement Reporting Delay for Carrier Aggregation**

Derivation Path: TS 36.508 [18] clause 4.8.2.1.5, Table 4.8.2.1.5-1 MAC-MainConfig-RBC			
Information Element	Value/remark	Comment	Condition
MAC-MainConfig-RBC ::= SEQUENCE {			
drx-Config CHOICE {			
setup SEQUENCE {			
onDurationTimer	psf1		
drx-InactivityTimer	psf1		
drx-RetransmissionTimer	sf1		
longDRX-CycleStartOffset CHOICE {			
sf320	0		
}			
shortDRX	Not present		
}			
}			

**Table 10.5.4.3-2a: LPP Request Capabilities**

Information Element	Value/remark
<i>otdoa-RequestCapabilities</i>	TRUE

Table 10.5.4.3-3: LPP RequestLocationInformation

Derivation Path: 36.355 clause 6.2			
Information Element	Value/remark	Comment	Condition
LPP-Message ::= SEQUENCE {			
transactionID SEQUENCE {			
Initiator	locationServer		
transactionNumber	1		
}			
endTransaction	FALSE		
sequenceNumber	Not present		
acknowledgement	Not present		
lpp-MessageBody CHOICE {			
c1 CHOICE {			
requestLocationInformation SEQUENCE {			
criticalExtensions CHOICE {			
c1 CHOICE {			
requestLocationInformation-r9 SEQUENCE {			
commonIEsRequestLocationInformation SEQUENCE {			
locationInformationType	locationMeasurementsRequired		
triggeredReporting	Not present		
periodicalReporting	Not present		
additionalInformation	onlyReturnInformationRequested		
qos SEQUENCE {			
horizontalAccuracy	Not present		
verticalCoordinateRequest	FALSE		
verticalAccuracy	Not present		
responseTime SEQUENCE {			
time	Test 1: 3 Test 2: 6	See clause 10.5.5	
responseTimeEarlyFix-r12	Not present		Rel-12 onwards
}			
velocityRequest	FALSE		
}			
environment	Not present		
locationCoordinateTypes	Not present		
velocityTypes	Not present		
}			
a-gnss-RequestLocationInformation	Not present		
otdoa-RequestLocationInformation SEQUENCE {			
assistanceAvailability	FALSE		
}			
ecid-RequestLocationInformation	Not present		
epdu-RequestLocationInformation	Not Present		
}			
}			
}			
}			
}			

Table 10.5.4.3-4: LPP ProvideAssistanceData

Derivation Path: 36.355 clause 6.2			
Information Element	Value/remark	Comment	Condition
LPP-Message ::= SEQUENCE {			
transactionID SEQUENCE {			
Initiator	locationServer		
transactionNumber	(0..255)		
}			
endTransaction	TRUE		
sequenceNumber	Not present		
acknowledgement	Not present		
lpp-MessageBody CHOICE {			
c1 CHOICE {			
provideAssistanceData SEQUENCE {			
criticalExtensions CHOICE {			
c1 CHOICE {			
provideAssistanceData-r9 SEQUENCE {			
commonIEsProvideAssistanceData	Not present		
a-gnss-ProvideAssistanceData	Not present		
otdoa-ProvideAssistanceData SEQUENCE {			
otdoa-ReferenceCellInfo	As defined in TS 37.571-5 [20], clause 7.3.2.		
otdoa-NeighbourCellInfo	As defined in TS 37.571-5 [20], clause 7.3.2.		
otdoa-Error	Not present		
}			
epdu-ProvideAssistanceData	Not present		
}			
}			
}			
}			

**Table 10.5.4.3-5: LPP ProvideLocation Information**



Derivation Path: 36.355 clause 6.2			
Information Element	Value/remark	Comment	Condition
LPP-Message ::= SEQUENCE {			
transactionID SEQUENCE {			
Initiator	locationServer		
transactionNumber	1		
}			
endTransaction	TRUE		
sequenceNumber	(0..255)		
acknowledgement			
lpp-MessageBody CHOICE {			
c1 CHOICE {			
provideLocationInformation SEQUENCE {			
criticalExtensions CHOICE {			
c1 CHOICE {			
provideLocationInformation-r9 SEQUENCE {			
commonIEsProvideLocationInformation	Not present.		
a-gnss-ProvideLocationInformation	Not present		
otdoa-ProvideLocationInformation			
SEQUENCE {			
otdoaSignalMeasurementInformation			
SEQUENCE {			
systemFrameNumber			
physCellIdRef	Cell 3		
cellGlobalIdRef			
earfcnRef			
referenceQuality			
neighbourMeasurementList			
SEQUENCE {			
NeighbourMeasurementElement			
SEQUENCE {			
physCellIdNeighbour	Cell 4		
cellGlobalIdNeighbour			
earfcnNeighbour			
rstd	Present	With respect to Cell 3	
rstd-Quality			
}			
NeighbourMeasurementElement		Test 2 only	
SEQUENCE {			
physCellIdNeighbour	Cell 1		
cellGlobalIdNeighbour			
earfcnNeighbour			
rstd	Present	Test 2 only With respect to Cell 3	
rstd-Quality			
}			
}			
NeighbourMeasurementElement		Test 2 only	
SEQUENCE {			
physCellIdNeighbour	Cell 2		
cellGlobalIdNeighbour			
earfcnNeighbour			
rstd	Present	Test 2 only With respect to Cell 3	
rstd-Quality			
}			
}			
}			
otdoa-Error	May be present with error reason 'undefined' or 'attemptedButUnableToMeasureSomeNeighbourCells'		
}			

ecid-ProvideLocationInformation	Not present		
epdu-ProvideLocationInformation	Not present		
}			
}			
}			
}			
}			

### 10.5.5 Test Requirements

Table 10.5.5-1 and 10.5.5-2 define the primary level settings including test tolerances for the tests.

**Table 10.5.5-1: Cell-specific test parameters for E-UTRAN FDD RSTD measurement reporting delay under fading propagation conditions during T1 for carrier aggregation**

Parameter	Unit	Cell 1	Cell 2	Cell 3	Cell 4
E-UTRA RF Channel Number		1	N/A	N/A	N/A
Correlation Matrix and Antenna Configuration		1x2 Low	1x2 Low	1x2 Low	1x2 Low
OCNG patterns defined in TS 36.521-3 [25] clause D.1. (OCNG patterns depend on selected channel bandwidth)		5MHz: OP.18 FDD 10MHz: OP.5 FDD 20MHz: OP.13 FDD	N/A	N/A	N/A
PBCH_RA	dB	0	N/A	N/A	N/A
PBCH_RB					
PSS_RA					
SSS_RA					
PCFICH_RB					
PHICH_RA					
PHICH_RB					
PDCCH_RA					
PDCCH_RB					
OCNG_RA <sup>Note 1</sup>					
OCNG_RB <sup>Note 1</sup>					
$N_{oc}$ <sup>Note 3</sup>	dBm/15 kHz	-95	N/A	N/A	N/A
$PRS \hat{E}_s / N_{oc}$	dB	-Infinity	-Infinity	-Infinity	-Infinity
$I_o$ <sup>Note 4</sup>	dBm/9 MHz	-67.22 + 10log( $N_{RB,c} / 50$ )	N/A	N/A	N/A
$\hat{E}_s / N_{oc}$	dB	0	-Infinity	-Infinity	-Infinity
Propagation Condition		ETU30			
<p>Note 1: OCNG shall be used such that active cell (Cell 1) is fully allocated and a constant total transmitted power spectral density is achieved for all OFDM symbols.</p> <p>Note 2: The resources for uplink transmission are assigned to the UE prior to the start of time period T2.</p> <p>Note 3: Interference from other cells and noise sources not specified in the test are assumed to be constant over subcarriers and time and shall be modelled as AWGN of appropriate power for <math>N_{oc}</math> to be fulfilled.</p> <p>Note 4: <math>I_o</math> levels have been derived from other parameters and are given for information purpose. These are not settable test parameters.</p>					

**Table 10.5.5-2: Cell-specific test parameters for E-UTRAN FDD RSTD measurement reporting delay under fading propagation conditions during T2 and T3 for carrier aggregation**

Parameter	Unit	Cell 1		Cell 2		Cell 3		Cell 4	
		T2	T3	T2	T3	T2	T3	T2	T3
E-UTRA RF Channel Number		1		2		3		3	
Correlation Matrix and Antenna Configuration		1x2 Low		1x2 Low		1x2 Low		1x2 Low	
OCNG patterns defined in TS 36.521-3 [25] clause D.1 (There is no PDSCH allocated in the subframe transmitting PRS) (OCNG patterns depend on selected channel bandwidth)		5MHz: OP.18 FDD 10MHz: OP.5 FDD 20MHz: OP.13 FDD		5MHz: OP.19 FDD 10MHz: OP.6 FDD 20MHz: OP.14 FDD		5MHz: OP.19 FDD 10MHz: OP.6 FDD 20MHz: OP.14 FDD		5MHz: OP.19 FDD 10MHz: OP.6 FDD 20MHz: OP.14 FDD	
PBCH_RA	dB	0		0		0		0	
PBCH_RB									
PSS_RA									
SSS_RA									
PCFICH_RB									
PHICH_RA									
PHICH_RB									
PDCCH_RA									
PDCCH_RB									
OCNG_RA <sup>Note 1</sup>									
OCNG_RB <sup>Note 1</sup>									
PRS_RA	dB	-6	N/A	N/A	3	N/A	3	3	N/A
$N_{oc}$ <sup>Note 3</sup>	dBm/15 kHz	-98	-98	-98	-95	-98	-95	-98	-95
$PRS \hat{E}_s / N_{oc}$	dB	-4	-	-	-1	-	-1	-8	-
$PRS \hat{E}_s / I_{ot}$ <sup>Note 4</sup>	dB	-4	-	-	-1	-	-1	-8	-
$I_o$ <sup>Note 4</sup>	dBm/9 MHz	-69.94 +10log(N <sub>RB,c</sub> /50)	N/A	N/A	-66.68 +10log(N <sub>RB,c</sub> /50)	N/A	-66.68 +10log(N <sub>RB,c</sub> /50)	-70.11 +10log(N <sub>RB,c</sub> /50)	N/A
PRP <sup>Note 4</sup>	dBm/15 kHz	-102	-	-	-96	-	-96	-106	-
RSRP <sup>Note 4</sup>	dBm/15 kHz	-96	-96	-105	-99	-105	-99	-109	-
$\hat{E}_s / N_{oc}$ <sup>Note 4</sup>	dB	2	2	-7	-4	-7	-4	-11	-
Propagation Condition		ETU30							
<p>Note 1: OCNG shall be used such that active cells (all, except Cell 3 in T3) are fully allocated and a constant total transmitted power spectral density is achieved for all OFDM symbols other than those in the subframes with transmitted PRS.</p> <p>Note 2: The resources for uplink transmission are assigned to the UE prior to the start of time period T2.</p> <p>Note 3: Interference from other cells and noise sources not specified in the test are assumed to be constant over subcarriers and time and shall be modelled as AWGN of appropriate power for <math>N_{oc}</math> to be fulfilled.</p> <p>Note 4: If PRS_RA is not "N/A", <math>\hat{E}_s / N_{oc}</math>, <math>PRS \hat{E}_s / I_{ot}</math>, <math>I_o</math>, RSRP and PRP levels have been derived from other parameters and are given for information purpose. If PRS_RA is "N/A", <math>I_o</math> and RSRP levels have been derived from other parameters and are given for information purpose. These are not settable test parameters. Interference conditions shall be applied to all PRS symbols of DL positioning subframes.</p>									

The response time including test tolerance is 3.3 s for Test 1 and 6.3 s for Test 2. The response time is equal to the LPP time IE value plus the test tolerance. The LPP time IE value is derived from the RSTD reporting delay plus  $\Delta T$ , where  $\Delta T = 150$  ms, giving a value of 2710 ms for Test 1 and 5110ms for Test 2. This is rounded up to the next allowed LPP value of 3 seconds for Test 1 and 6 seconds for Test 2.

The RSTD measurement reporting delay in the tests are derived from the following expression,

$T_{PRS} (M - 1) + 160 \left\lceil \frac{n}{M} \right\rceil$ , where  $M = 8$  and  $n = 16$  for Test 1, and  $M = 16$  and  $n = 16$  for Test 2 are the parameters specified in clause 10.5.3.1 for Test 1 and clause 10.5.3.2 for Test 2.

This gives the total RSTD reporting delay of 2560 ms for Test 1 for the 15 neighbour cells including Cell 4 with respect to the reference cell, Cell 3.

This gives the total RSTD reporting delay of 4960 ms for Test 2 for the 15 neighbour cells including Cell 1, Cell 2 and Cell 4 with respect to the reference cell, Cell 3.

The test tolerances are defined in clauses C.1.3 and C.4.

For the overall test to pass, the rate of successful tests during repeated tests in both Test 1 and Test 2 shall be more than 90% with a confidence level of 95%.

## 10.6 TDD 3 DL CA RSTD Measurement Reporting Delay

### 10.6.1 Test Purpose

The purpose of the test case is to verify that the RSTD measurement reporting delay meets the requirements in an environment with fading propagation conditions. This test case verifies the measurement period requirements for RSTD measurements performed on the same secondary component carrier, the measurement period requirements for RSTD measurements performed on both the primary and secondary component carriers, and also the measurement period requirements for RSTD measurements performed on different secondary component carriers.

### 10.6.2 Test applicability

This test applies to all types of E-UTRA TDD UE release 12 and forward that supports UE-assisted OTDOA for 3DL Carrier Aggregation.

### 10.6.3 Minimum conformance requirements

#### 10.6.3.1 Measurements on the secondary component carrier

The RSTD measurements when all cells are on the configured secondary component carrier shall meet all applicable requirements (TDD) specified in TS 36.133 [23] section 8.1.2.5, i.e., E-UTRAN intra-frequency RSTD measurement period applies, regardless of whether the SCell on the corresponding frequency is activated or deactivated by the MAC-CE commands as specified in 3GPP TS 36.321 [34].

#### 10.6.3.2 Measurements on both primary component carrier and secondary component carrier

The RSTD measurements of cells on both primary component carrier and configured secondary component carrier shall meet all applicable requirements (TDD) specified in TS 36.133 [23] section 8.1.2.6, i.e., E-UTRAN inter-frequency RSTD measurement period applies regardless of whether the SCell on the corresponding frequency is activated or deactivated by the MAC-CE commands as specified in 3GPP TS 36.321 [34], with the following exception

- the number of PRS positioning occasions is as specified in Table 10.6.3.2-1 shall apply.
- TDD uplink-downlink subframes configurations as specified in TS 36.133 [23] section 8.1.2.5.2, Table 8.1.2.5.2-2 shall apply.

**Table 10.6.3.2-1: Number of PRS positioning occasions within measurement period**

Positioning subframe configuration period $T_{\text{PRS}}$	Number of PRS positioning occasions $M$
160 ms	32
>160 ms	16

### 10.6.3.3 Measurements on different secondary component carriers

The RSTD measurements of cells on a configured secondary component carrier and another configured secondary component carrier shall meet all applicable requirements (TDD-TDD inter-Frequency OTDOA) specified in TS 36.133 [23] section 8.1.2.6, i.e., E-UTRAN inter-frequency RSTD measurement period applies regardless of whether the SCell on the corresponding frequency is activated or deactivated by the MAC-CE commands as specified in 3GPP TS 36.321 [34], with the following exceptions

- the number of PRS positioning occasions is as specified in Table 10.6.3.3-1 shall apply.
- TDD uplink-downlink subframes configurations as specified in TS 36.133 [23] section 8.1.2.5.2, Table 8.1.2.5.2-2 shall apply.

**Table 10.6.3.3-1: Number of PRS positioning occasions within measurement period**

Positioning subframe configuration period $T_{\text{PRS}}$	Number of PRS positioning occasions $M$
160 ms	32
>160 ms	16

The normative reference for this requirement is TS 36.133 [23] clause 8.4.3, 8.4.4, 8.4.5 and A.8.17.11.

## 10.6.4 Test description

### 10.6.4.1 Initial conditions

Test Environment: Normal; as defined in TS 36.508 [18] clause 4.1.

Frequencies to be tested: Mid Range, as defined in TS 36.508 [18] clause 4.3.1.1.

Channel bandwidth to be tested: the largest aggregated bandwidth combination (where all channels have the same bandwidth) supported by the UE of the Channel bandwidths defined in Table 10.6.4.1-1. The Channel bandwidths for CA Intra-Band combinations are defined in TS 36.508 [18] clause 4.3.1 and for CA Inter-Band combinations are defined in TS 36.521-1 [24] clause 5.4.2A. In case of multiple possible Channel bandwidth combinations, the first combination listed in the above mentioned clauses shall be selected.

1. Connect the SS, faders and AWGN noise sources to the UE antenna connector or antenna connectors as shown in TS 36.508 [18] Annex A, Figure A.68 as appropriate.
2. The general test parameter settings are set up according to Table 10.6.4.1-1.
3. Propagation conditions are set according to clause 4.7.2.1.
4. Message contents are defined in clause 10.6.4.3.
5. In the tests, there are three configured component carriers: PCC, SCC1 and SCC2, and four synchronized cells: Cell 1, Cell 2, Cell 3 and Cell 4. Cell 1 is PCell on the PCC, Cell 2 is SCell on the SCC1, Cell 3 is SCell on the SCC2 and Cell 4 is a neighbour cell on the SCC2. In all tests, Cell 3 is the OTDOA assistance data reference cell. The assistance data neighbour cell list includes in total 15 cells, where 14 of the cells are not simulated (dummy cells; as defined in 3GPP TS 37.571-5 clause 7.3.2) for Test 1 and where 12 of the cells are not simulated for Test 2. PCell (Cell 1) is the cell used for connection setup with the power level and mapping set according to TS 36.521-1 [24] Annex C.0 and C.1 as appropriate for this test. Cell 2, Cell 3 and Cell 4 are powered OFF.

6. The true RSTD (which is the receive time difference for frame 0 between two cells as seen at the UE antenna connector) is set to 31 Ts (about 1  $\mu$ s) between Cell 1 and OTDOA assistance data reference cell, Cell 3, and set to -31 Ts (about -1  $\mu$ s) between Cell 2 and OTDOA assistance data reference cell, Cell 3, and set to 92 Ts (about 3  $\mu$ s) between neighbour Cell 4 and OTDOA assistance data reference cell, Cell 3.

**Table 10.6.4.1-1: General test parameters for E-UTRAN TDD RSTD measurement reporting delay under fading propagation conditions for carrier aggregation**

Parameter	Unit	Value		Comment
		Test 1	Test 2	
PCell		Cell 1		PCell is on RF channel 1 (PCC).
SCell 1		Cell 2		SCell 1 on RF channel 2 (SCC1).
SCell 2		Cell 3		SCell 2 on RF channel 3 (SCC2). Cell 3 is the assistance data reference cell.
Other neighbour cell		Cell 4		Neighbour cell on RF channel 3 (SCC2).
PCFICH/PDCCH/PHICH parameters (PCFICH/PDCCH/PHICH parameters depend on selected channel bandwidth)		5MHz: R.11 TDD 10MHz: R.6 TDD 20MHz: R.10 TDD		As specified in TS 36.521-3 [25] clause A.2.1
Channel Bandwidth ( $BW_{channel}$ )	MHz	5MHz or 10MHz or 20MHz		All channels in a test have the same bandwidth.
PRS Transmission Bandwidth (PRS transmission bandwidth depends on selected channel bandwidth) <sup>Note 2</sup>	RB	5MHz: 25 10MHz: 50 20MHz:100		PRS are transmitted over the system bandwidth
Number of consecutive downlink positioning subframes $N_{PRS}$ . ( $N_{PRS}$ depends on selected channel bandwidth) <sup>Note 2</sup>		5MHz: 2 10MHz: 1 20MHz:1		As defined in TS 36.211 [26]. The number of subframes in a positioning occasion
PRS configuration index $I_{PRS}$ <sup>Note 2</sup>		174 for all cells on PCC 184 for all cells on SCC1 194 for all cells on SCC2		This corresponds to periodicity of 320 ms and PRS subframe offset of $I_{PRS} - 160$ DL subframes, as defined in TS 36.211 [26], Table 6.10.4.3-1
Physical cell ID PCI <sup>Note 2</sup>		(PCI of Cell 3 – PCI of Cell 4)mod6=0		The PCIs of Cell 1 and Cell 2 are selected randomly. PCIs of Cell 3 and Cell 4 are selected randomly such that the relative subcarrier shifts of PRS patterns among these cells are as given by the condition
TDD uplink-downlink configuration		1		As specified in TS 36.211 [26], Clause 4.2; corresponds to a configuration with 5 ms switch-point periodicity and two downlink consecutive subframes
TDD special subframe configuration		6		As specified in TS 36.211 [26], Clause 4.2; corresponds to DwPTS of $19760 \cdot T_s$ and UpPTS of $4384 \cdot T_s$
CP length <sup>Note 2</sup>		Normal		
DRX		ON		DRX parameters are further specified in Table 10.6.4.1-2
Radio frame receive time offset between the cells at the UE antenna connector <sup>Note 3</sup>	$\mu s$	Cell 1 to Cell 3: 1 Cell 2 to Cell 3: -1 Cell 4 to Cell 3: 3	Cell 1 to Cell 3: 1 Cell 2 to Cell 3: -1 Cell 4 to Cell 3:	PRS are transmitted from synchronous cells



Expected RSTD <sup>Note 1</sup>	µs	Cell 4: 2 Other neighbour cells: randomly between -3 and 3	Cell 1: -2 Cell 2: 0 Cell 4: 2 Other neighbour cells: randomly between -3 and 3	The expected RSTD is what is expected at the receiver. The corresponding parameter in the OTDOA assistance data specified in TS 36.355 [4] is the expectedRSTD indicator
Expected RSTD uncertainty for all neighbour cells <sup>Note 1</sup>	µs	5		The corresponding parameter in the OTDOA assistance data specified in TS 36.355 [4] is the expectedRSTD-Uncertainty index
Number of cells provided in OTDOA assistance data		16 cells in total		The list includes the reference cell and 15 other cells. Cell 1 and Cell 2 (when included) appears at random places in the first half of the neighbour cell list in the OTDOA assistance data. Cell 4 always appears at random places in the second half of the list.
		OTDOA neighbour cells include Cell 4 and other 14 cells on SCC2	OTDOA neighbour cells include Cell 1 and other 3 cells on PCC, Cell 2 and other 3 cells on SCC1 and Cell 4 and other 6 cells on SCC2	
prs-SubframeOffset <sup>Note 2</sup>		Cells on PCC: 300 Cells on SCC1: 310 Cells on SCC2, except reference cell: 0		Subframe offset, counted in full subframes. The corresponding parameter in the OTDOA assistance data is prs-SubframeOffset specified in TS 36.355 [4]
slotNumberOffset <sup>Note 2</sup>		Cells on PCC: 0 Cells on SCC1: 0 Cells on SCC2, except reference cell: 0		The slot number offset at the transmitter between a neighbour cell and the assistance data reference cell. The corresponding parameter in the OTDOA assistance data is slotNumberOffset specified in TS 36.355 [4].
PRS muting info <sup>Note 2</sup>		Cell 1: '11110000' Cell 2: '00001111' Cell 3: '11110000' Cell 4: '00001111'	Cell 1: '1111111100000000' Cell 2: '0000000011111111' Cell 3: '1111111100000000' Cell 4: '0000000011111111'	Corresponds to prs-MutingInfo defined in TS 36.355 [4]
T1	s	3		The length of the time interval from the beginning of each test
T2	s	1.28	2.48	The length of the time interval that follows immediately after time interval T1
T3	s	1.28	2.48	The length of the time interval that follows immediately after time interval T2
<p>Note 1: Parameters "Expected RSTD" and "Expected RSTD uncertainty for all neighbour cells" are not settable parameters. These are parameters signalled in LPP only. For the values to be used in LPP see Table 10.6.4.3-4 and TS 37.571-5 [20], clause 7.3.2.</p> <p>Note 2: Parameters "PRS Transmission Bandwidth", "PRS configuration index", "Number of consecutive downlink positioning subframes", "Physical cell ID PCI", "CP length", "prs-SubframeOffset", "slotNumberOffset" and "PRS muting info" are settable parameters and also parameters signalled in LPP. The values to be used for "Physical cell ID PCI" are as follows: Cell 1: 0, Cell 2: 3, Cell 3: 6, Cell 4: 12. For the values to be used in LPP see Table 10.6.4.3-4 and TS 37.571-5 [20], clause 7.3.2.</p> <p>Note 3: The parameter "Radio frame receive time offset between the cells at the UE antenna connector" is used to set the "true RSTD" values in step 6 of clause 10.6.4.1.</p>				

**Table 10.6.4.1-2: DRX parameters for the test of E-UTRAN TDD intra-frequency RSTD measurement reporting delay under fading propagation conditions for carrier aggregation**

Field	Value	Comment
onDurationTimer	psf1	As specified in TS 36.331 [22], Clause 6.3.2
Drx-InactivityTimer	psf1	
drx-RetransmissionTimer	sf1	
longDRX-CycleStartOffset	sf320	
shortDRX	Disable	

### 10.6.4.2 Test procedure

The test case includes two tests. Test 1 is designed for the scenario where the UE receives OTDOA assistance data with cells only on SCC2, and the UE is expected to report RSTD measurements performed on SCC2 only. Test 2 is designed for the scenario where the UE receives OTDOA assistance data with cells on PCC, SCC1 and SCC2, and the UE is expected to report RSTD measurements performed on PCC, SCC1 and SCC2.

Each test consists of three consecutive time intervals, with duration of T1, T2 and T3. Cell 1 is active in T1, T2 and T3, Cell 2 is active only in T2 and T3, Cell 3 is active only during T2 and T3, and Cell 4 is active only during T2. The beginning of the time interval T2 shall be aligned 5 ms before the first PRS positioning subframe of a positioning occasion in the OTDOA assistance data reference cell, where 5 ms is the necessary test tolerance. Cell 1 transmits PRS in T2, Cell 2 transmits PRS only in T3, Cell 3 transmits PRS only in T3, and Cell 4 transmits PRS only in T2.

**NOTE:** The information on when PRS is muted is conveyed to the UE using PRS muting information in the OTDOA assistance data.

The OTDOA-RequestLocationInformation message and the OTDOA assistance data as defined in 10.6.4.3 shall be provided to the UE during T1. The last TTI containing the OTDOA-RequestLocationInformation message shall be provided to the UE  $\Delta T$  ms before the start of T2, where  $\Delta T = 150$  ms is the maximum processing time of the OTDOA-RequestLocationInformation message and the OTDOA assistance data.

1. Ensure that the UE is in state Generic RB Established State 3A-RF according to 3GPP TS 36.508 [18] clause 7.2A.3.
2. Configure Cell 2 on SCC1 and Cell 3 and Cell 4 on SCC2 according to TS 36.521-3 [25] Annex C.0 and C.1 for all downlink physical channels.
3. The SS shall configure the SCells (Cell 2 and Cell 3) on the SCCs as per TS 36.508 [18] clause 5.2A.4.
4. The SS activates the SCells (Cell 2 and Cell 3) by sending the Activation/Deactivation MAC control element according to TS 36.321 [34] clauses 5.13 and 6.1.3.8. Wait for at least 2 seconds as per TS 36.133 [23] clause 8.3.3.2.
5. The SS shall send a RESET UE POSITIONING STORED INFORMATION message.
6. Set the parameters according to Table 10.6.5-1. Propagation conditions are set according to clause 4.7.2.2 (ETU30).
7. T1 starts.
8. The SS shall transmit an RRCConnectionReconfiguration message with the DRX configuration. PDCCHs indicating new transmissions shall be sent continuously until the start of T2 to ensure that the UE would not enter the DRX state before T2.
9. The UE shall transmit RRCConnectionReconfigurationComplete message.
- 9a. The SS shall transmit an LPP REQUEST CAPABILITIES message.
- 9b. The UE shall transmit an LPP PROVIDE CAPABILITIES message indicating the OTDOA capabilities supported by the UE in the *OTDOA-ProvideCapabilities* IE.
10. The SS shall send a LPP PROVIDE ASSISTANCE DATA message, including the *OTDOA-ProvideAssistanceData* IE. The position of neighbour Cell 4 in the *OTDOA-NeighbourCellInfoList* is randomly selected to be in the last 8 elements of the sequence for Test 1 and in the 7 elements of the relevant sequence for Test 2, and the position of Cell 1 and the position of Cell 2 are randomly selected to be in the 4

elements of the relevant sequence for Test 2, as described in 3GPP TS 37.571-5 [20], clause 7.3.2. If the UE message at step 9b includes the *ackRequested* IE set to TRUE, then the SS shall send an acknowledgment in the LPP PROVIDE ASSISTANCE DATA message.

11. The SS shall send a LPP REQUEST LOCATION INFORMATION message, including the *OTDOA-RequestLocationInformation* IE such that the UE receives the message  $\Delta T$  ms before the start of T2, where  $\Delta T = 150$  ms.
12. When T1 expires, the SS shall switch the power setting from T1 to T2 as specified in Table 10.6.5-2.
13. When T2 expires, the SS shall switch the power setting from T2 to T3 as specified in Table 10.6.5-2.
14. The UE shall transmit a LPP PROVIDE LOCATION INFORMATION message including the *OTDOA-ProvideLocationInformation* IE within the response time (see clause 4.7.3) specified in clause 10.6.5.

For Test 1 the UE shall perform and report the RSTD measurement for Cell 4 with respect to the reference cell in the OTDOA assistance data, Cell 3. If the UE transmits an *OTDOA-ProvideLocationInformation* IE including the *rstd* field for Cell 4 within the response time then the number of successful tests is increased by one. If the UE fails to report the *OTDOA-ProvideLocationInformation* IE with the *rstd* field included within the response time then the number of failure tests is increased by one.

For Test 2 the UE shall perform and report the RSTD measurements for Cell 1 with respect to the reference cell in the OTDOA assistance data, Cell 3 and also Cell 2 with respect to the reference cell in the OTDOA assistance data, Cell 3 and also Cell 4 with respect to the reference cell in the OTDOA assistance data, Cell 3. If the UE transmits an *OTDOA-ProvideLocationInformation* IE including the *rstd* field for Cell 1 (with respect to Cell 3) and Cell 2 (with respect to Cell 3) and Cell 4 (with respect to Cell 3) within the response time then the number of successful tests is increased by one. If the UE fails to report the *OTDOA-ProvideLocationInformation* IE with the three *rstd* fields included within the response time then the number of failure tests is increased by one.

15. If the UE message at step 14 includes the *ackRequested* IE set to TRUE, the SS shall send a LPP acknowledgement message.
16. Repeat steps 5-15 until the confidence level according to Annex D is achieved. For each iteration, at step 10 change the random positions of Cell 4 and Cell 1 (for Test 2 only) and Cell 2 (for Test 2 only) in the relevant sequence in the *OTDOA-NeighbourCellInfoList*.
17. Repeat from clause 10.6.4.1 for Test 2.

### 10.6.4.3 Message contents

**Table 10.6.4.3-1: RESET UE POSITIONING STORED INFORMATION**

Derivation Path: 36.509 [11] clause 6.9			
Information Element	Value/remark	Comment	Condition
UE Positioning Technology	0 0 0 0 0 0 1	OTDOA	

**Table 10.6.4.3-2: MAC-MainConfig-RBC: TDD RSTD Measurement Reporting Delay for Carrier Aggregation**

Derivation Path: TS 36.508 [18] clause 4.8.2.1.5, Table 4.8.2.1.5-1 MAC-MainConfig-RBC			
Information Element	Value/remark	Comment	Condition
MAC-MainConfig-RBC ::= SEQUENCE {			
drx-Config CHOICE {			
setup SEQUENCE {			
onDurationTimer	psf1		
drx-InactivityTimer	psf1		
drx-RetransmissionTimer	sf1		
longDRX-CycleStartOffset CHOICE {			
sf320	0		
}			
shortDRX	Not present		
}			
}			

**Table 10.6.4.3-2a: LPP Request Capabilities**

Information Element	Value/remark
<i>otdoa-RequestCapabilities</i>	TRUE

**Table 10.6.4.3-3: LPP RequestLocationInformation**

Derivation Path: 36.355 clause 6.2			
Information Element	Value/remark	Comment	Condition
LPP-Message ::= SEQUENCE {			
transactionID SEQUENCE {			
Initiator	locationServer		
transactionNumber	1		
}			
endTransaction	FALSE		
sequenceNumber	Not present		
acknowledgement	Not present		
lpp-MessageBody CHOICE {			
c1 CHOICE {			
requestLocationInformation SEQUENCE {			
criticalExtensions CHOICE {			
c1 CHOICE {			
requestLocationInformation-r9 SEQUENCE {			
commonEsRequestLocationInformation SEQUENCE {			
locationInformationType	locationMeasurementsRequired		
triggeredReporting	Not present		
periodicalReporting	Not present		
additionalInformation	onlyReturnInformationRequested		
qos SEQUENCE {			
horizontalAccuracy	Not present		
verticalCoordinateRequest	FALSE		
verticalAccuracy	Not present		
responseTime SEQUENCE {			
time	Test 1: 3 Test 2: 6	See clause 10.6.5	
responseTimeEarlyFix-r12	Not present		Rel-12 onwards
}			
velocityRequest	FALSE		
}			
environment	Not present		
locationCoordinateTypes	Not present		
velocityTypes	Not present		
}			
a-gnss-RequestLocationInformation	Not present		
otdoa-RequestLocationInformation SEQUENCE {			
assistanceAvailability	FALSE		
}			
ecid-RequestLocationInformation	Not present		
epdu-RequestLocationInformation	Not Present		
}			
}			
}			
}			

Table 10.6.4.3-4: LPP ProvideAssistanceData

Derivation Path: 36.355 clause 6.2			
Information Element	Value/remark	Comment	Condition
LPP-Message ::= SEQUENCE {			
transactionID SEQUENCE {			
Initiator	locationServer		
transactionNumber	(0..255)		
}			
endTransaction	TRUE		
sequenceNumber	Not present		
acknowledgement	Not present		
lpp-MessageBody CHOICE {			
c1 CHOICE {			
provideAssistanceData SEQUENCE {			
criticalExtensions CHOICE {			
c1 CHOICE {			
provideAssistanceData-r9 SEQUENCE {			
commonIEsProvideAssistanceData	Not present		
a-gnss-ProvideAssistanceData	Not present		
otdoa-ProvideAssistanceData SEQUENCE {			
otdoa-ReferenceCellInfo	As defined in TS 37.571-5 [20], clause 7.3.2.		
otdoa-NeighbourCellInfo	As defined in TS 37.571-5 [20], clause 7.3.2.		
otdoa-Error	Not present		
}			
epdu-ProvideAssistanceData	Not present		
}			
}			
}			
}			

**Table 10.6.4.3-5: LPP ProvideLocation Information**

Derivation Path: 36.355 clause 6.2			
Information Element	Value/remark	Comment	Condition
LPP-Message ::= SEQUENCE {			
transactionID SEQUENCE {			
Initiator	locationServer		
transactionNumber	1		
}			
endTransaction	TRUE		
sequenceNumber	(0..255)		
acknowledgement			
lpp-MessageBody CHOICE {			
c1 CHOICE {			
provideLocationInformation SEQUENCE {			
criticalExtensions CHOICE {			
c1 CHOICE {			
provideLocationInformation-r9 SEQUENCE {			
commonIEsProvideLocationInformation	Not present.		
a-gnss-ProvideLocationInformation	Not present		
otdoa-ProvideLocationInformation			
SEQUENCE {			
otdoaSignalMeasurementInformation			
SEQUENCE {			
systemFrameNumber			
physCellIdRef	Cell 3		
cellGlobalIdRef			
earfcnRef			
referenceQuality			
neighbourMeasurementList			
SEQUENCE {			
NeighbourMeasurementElement			
SEQUENCE {			
physCellIdNeighbour	Cell 4		
cellGlobalIdNeighbour			
earfcnNeighbour			
rstd	Present	With respect to Cell 3	
rstd-Quality			
}			
NeighbourMeasurementElement		Test 2 only	
SEQUENCE {			
physCellIdNeighbour	Cell 1		
cellGlobalIdNeighbour			
earfcnNeighbour			
rstd	Present	Test 2 only With respect to Cell 3	
rstd-Quality			
}			
}			
}			
}			
otdoa-Error	May be present with error reason 'undefined' or 'attemptedButUnableToMeasureSomeNeighbourCells'		
}			

ecid-ProvideLocationInformation	Not present		
epdu-ProvideLocationInformation	Not present		
}			
}			
}			
}			
}			
}			

### 10.6.5 Test Requirements

Table 10.6.5-1 and 10.6.5-2 define the primary level settings including test tolerances for the tests.

**Table 10.6.5-1: Cell-specific test parameters for E-UTRAN TDD RSTD measurement reporting delay under fading propagation conditions during T1 for carrier aggregation**

Parameter	Unit	Cell 1	Cell 2	Cell 3	Cell 4
E-UTRA RF Channel Number		1	N/A	N/A	N/A
Correlation Matrix and Antenna Configuration		1x2 Low	1x2 Low	1x2 Low	1x2 Low
OCNG patterns defined in TS 36.521-3 [25] clause D.1. (OCNG patterns depend on selected channel bandwidth)		5MHz: OP.10 TDD 10MHz: OP.1 TDD 20MHz: OP.7 TDD	N/A	N/A	N/A
PBCH_RA	dB	0	N/A	N/A	N/A
PBCH_RB					
PSS_RA					
SSS_RA					
PCFICH_RB					
PHICH_RA					
PHICH_RB					
PDCCH_RA					
PDCCH_RB					
OCNG_RA <sup>Note 1</sup>					
OCNG_RB <sup>Note 1</sup>					
$N_{oc}$ <sup>Note 3</sup>	dBm/15 kHz	-95	N/A	N/A	N/A
$PRS \hat{E}_s / N_{oc}$	dB	-Infinity	-Infinity	-Infinity	-Infinity
$I_o$ <sup>Note 4</sup>	dBm/9 MHz	-67.22 +10log( $N_{RB,c} / 50$ )	N/A	N/A	N/A
$\hat{E}_s / N_{oc}$	dB	0	-Infinity	-Infinity	-Infinity
Propagation Condition		ETU30			
<p>Note 1: OCNG shall be used such that active cell (Cell 1) is fully allocated and a constant total transmitted power spectral density is achieved for all OFDM symbols.</p> <p>Note 2: The resources for uplink transmission are assigned to the UE prior to the start of time period T2.</p> <p>Note 3: Interference from other cells and noise sources not specified in the test are assumed to be constant over subcarriers and time and shall be modelled as AWGN of appropriate power for <math>N_{oc}</math> to be fulfilled.</p> <p>Note 4: <math>I_o</math> levels have been derived from other parameters and are given for information purpose. These are not settable test parameters.</p>					



**Table 10.6.5-2: Cell-specific test parameters for E-UTRAN TDD RSTD measurement reporting delay under fading propagation conditions during T2 and T3 for carrier aggregation**

Parameter	Unit	Cell 1		Cell 2		Cell 3		Cell 4		
		T2	T3	T2	T3	T2	T3	T2	T3	
E-UTRA RF Channel Number		1		2		3		3		
Correlation Matrix and Antenna Configuration		1x2 Low		1x2 Low		1x2 Low		1x2 Low		
OCNG patterns defined in TS 36.521-3 [25] clause D.1 (There is no PDSCH allocated in the subframe transmitting PRS) (OCNG patterns depend on selected channel bandwidth)		5MHz: OP.10 TDD 10MHz: OP.1 TDD 20MHz: OP.7 TDD		5MHz: OP.10 TDD 10MHz: OP.1 TDD 20MHz: OP.7 TDD		5MHz: OP.10 TDD 10MHz: OP.1 TDD 20MHz: OP.7 TDD		5MHz: OP.10 TDD 10MHz: OP.1 TDD 20MHz: OP.7 TDD		
PBCH_RA	dB	0		0		0		0		N/A
PBCH_RB										
PSS_RA										
SSS_RA										
PCFICH_RB										
PHICH_RA										
PHICH_RB										
PDCCH_RA										
PDCCH_RB										
OCNG_RA <sup>Note 1</sup>										
OCNG_RB <sup>Note 1</sup>										
PRS_RA	dB	-6	N/A	N/A	3	N/A	3	3	N/A	
$N_{oc}$ <sup>Note 3</sup>	dBm/15 kHz	-98	-98	-98	-95	-98	-95	-98	-95	
$PRS \hat{E}_s / N_{oc}$	dB	-4	-	-	-1	-	-1	-8	-	
$PRS \hat{E}_s / I_{ot}$ <sup>Note 4</sup>	dB	-4	-	-	-1	-	-1	-8	-	
$I_o$ <sup>Note 4</sup>	dBm/9 MHz	-69.94 +10log( $N_{RB,c} / 50$ )	N/A	N/A	-66.68 +10log( $N_{RB,c} / 50$ )	N/A	-66.68 +10log( $N_{RB,c} / 50$ )	-70.11 +10log( $N_{RB,c} / 50$ )	N/A	
PRP <sup>Note 4</sup>	dBm/15 kHz	-102	-	-	-96	-	-96	-106	-	
RSRP <sup>Note 4</sup>	dBm/15 kHz	-96	-96	-105	-99	-105	-99	-109	-	
$\hat{E}_s / N_{oc}$ <sup>Note 4</sup>	dB	2	2	-7	-4	-7	-4	-11	-	
Propagation Condition		ETU30								
<p>Note 1: OCNG shall be used such that active cells (all, except Cell 3 in T3) are fully allocated and a constant total transmitted power spectral density is achieved for all OFDM symbols other than those in the subframes with transmitted PRS.</p> <p>Note 2: The resources for uplink transmission are assigned to the UE prior to the start of time period T2.</p> <p>Note 3: Interference from other cells and noise sources not specified in the test are assumed to be constant over subcarriers and time and shall be modelled as AWGN of appropriate power for <math>N_{oc}</math> to be fulfilled.</p> <p>Note 4: If PRS_RA is not "N/A", <math>\hat{E}_s / N_{oc}</math>, <math>PRS \hat{E}_s / I_{ot}</math>, <math>I_o</math>, RSRP and PRP levels have been derived from other parameters and are given for information purpose. If PRS_RA is "N/A", <math>I_o</math> and RSRP levels have been derived from other parameters and are given for information purpose. These are not settable test parameters. Interference conditions shall be applied to all PRS symbols of DL positioning subframes.</p>										

The response time including test tolerance is 3.3 s for Test 1 and 6.3 s for Test 2. The response time is equal to the LPP time IE value plus the test tolerance. The LPP time IE value is derived from the RSTD reporting delay plus  $\Delta T$ , where  $\Delta T = 150$  ms, giving a value of 2710 ms for Test 1 and 5110ms for Test 2. This is rounded up to the next allowed LPP value of 3 seconds for Test 1 and 6 seconds for Test 2.

The RSTD measurement reporting delay in the tests are derived from the following expression,

$T_{PRS} (M - 1) + 160 \left\lceil \frac{n}{M} \right\rceil$ , where  $M = 8$  and  $n = 16$  for Test 1, and  $M = 16$  and  $n = 16$  for Test 2 are the parameters specified in clause 10.6.3.1 for Test 1 and clause 10.6.3.2 for Test 2.

This gives the total RSTD reporting delay of 2560 ms for Test 1 for the 15 neighbour cells including Cell 4 with respect to the reference cell, Cell 3.

This gives the total RSTD reporting delay of 4960 ms for Test 2 for the 15 neighbour cells including Cell 1, Cell 2 and Cell 4 with respect to the reference cell, Cell 3.

The test tolerances are defined in clauses C.1.3 and C.4.

For the overall test to pass, the rate of successful tests during repeated tests in both Test 1 and Test 2 shall be more than 90% with a confidence level of 95%.

## 10.7 FDD RSTD Measurement Accuracy for 3DL Carrier Aggregation

### 10.7.1 Test purpose

To verify that the FDD RSTD measurement accuracy is within the specified limits.

### 10.7.2 Test applicability

This test applies to all types of E-UTRA FDD UE release 12 and forward that supports UE-assisted OTDOA for 3DL Carrier Aggregation.

### 10.7.3 Minimum conformance requirements

This section contains RSTD measurement accuracy requirements for a UE configured with one or two downlink SCeLL(s). The UE may operate in one of the E-UTRA carrier aggregations listed in TS 36.133 [23] section 8.3.1. The requirements in this section shall apply regardless of whether the configured downlink secondary cell is activated or deactivated by the MAC-CE command [34]. The requirements apply for bandwidths defined in the bandwidth combination set for the CA configurations supported by the UE defined in TS 36.101 [2].

The RSTD measurements, which are obtained when both the reference cell and neighbouring cell belong to the primary component carrier, shall meet the intra-frequency RSTD accuracy requirements defined in TS 36.133 [23] section 9.1.10.1.

The RSTD measurements, which are obtained when both the reference cell and neighbouring cell belong to the same secondary component carrier, shall meet the intra-frequency RSTD accuracy requirements defined in TS 36.133 [23] section 9.1.10.1.

The RSTD measurements, which are obtained when the reference cell and neighbouring cell do not belong to the same carrier, shall meet the inter-frequency RSTD accuracy requirements defined in TS 36.133 [23] section 9.1.10.2.

The normative reference for this requirement is TS 36.133 [23] clause 9.1.12 and A.9.8.14.

### 10.7.4 Test description

#### 10.7.4.1 Initial conditions

Test Environment: Normal; as defined in TS 36.508 [18] clause 4.1.

Frequencies to be tested: Mid Range, as defined in TS 36.508 [18] clause 4.3.1.1.

Channel bandwidths to be tested: the largest and the smallest aggregated bandwidth combinations supported by the UE of the Channel bandwidths defined in Table 10.7.4.1-1. The Channel bandwidths for CA Intra-Band combinations are as defined in TS 36.508 [18] clause 4.3.1 and for CA Inter-Band combinations are defined in TS 36.521-1 [24] clause 5.4.2A. In case of multiple possible Channel bandwidth combinations, the first combination listed in the above mentioned clauses shall be selected.

1. Connect the SS (node B emulator) and AWGN noise sources to the UE antenna connectors as follows:
  - For UEs supporting only 2Rx in all the bands under test, use TS 36.508 [18] Annex A, Figure group A.68 as appropriate.
  - For UEs supporting 4Rx in any of the bands under test use TS 36.508 [18] Annex A, Figure A.90. Use the 2Rx module for cells on bands supporting 2Rx and the 4Rx module for cells on bands supporting 4Rx.
2. The general test parameter settings are set up according to Table 10.7.4.1-1.
3. Propagation conditions are set according to clause 4.7.2.1.
4. Message contents are defined in clause 10.7.4.3.
5. There are four synchronized cells on three different carrier frequencies. Cell 1 is the PCell on primary component carrier F1 (RF channel number 1), Cell 2 is an SCell on secondary component carrier F2 (RF channel number 2), Cell 3 is an SCell and reference cell on secondary component carrier F3 (RF channel number 3), and Cell 4 is the neighbour cell on F3. PCell (Cell 1) is the cell used for connection setup with the power level and mapping set according to TS 36.521-1 [24] Annex C.0 and C.1 as appropriate for this test. Cell 2, Cell 3 and Cell 4 are powered OFF.

Cell 1, Cell 2, Cell 3, and Cell 4 are included in the OTDOA assistance data neighbour cell list.

The assistance data neighbour cell list includes in total 15 cells, where 12 of the cells are not simulated (dummy cells; as defined in 3GPP TS 37.571-5 [20], clause 7.3.2).

Note that the measurement gap is not configured in the test because of UE carrier aggregation capability.

6. The true RSTD (which is the receive time difference for frame 0 between the two cells as seen at the UE antenna connector) is set to 31 Ts (about 1  $\mu$ s) between Cell 1 and OTDOA assistance data reference cell, Cell 3, and set to -31 Ts (about -1  $\mu$ s) between Cell 2 and OTDOA assistance data reference cell, Cell 3, and set to 92 Ts (about 3  $\mu$ s) between neighbour Cell 4 and OTDOA assistance data reference cell, Cell 3.

Note that the related expectedRSTD values to be signalled over LPP are defined in Table 10.7.4.1-1.

**Table 10.7.4.1-1: General Test Parameters for RSTD Test for E-UTRAN FDD for Carrier Aggregation**

Parameter	Unit	Value	Comment
PCell		Cell 1	Cell 1 on RF channel number 1
SCell 1		Cell 2	Cell 2 is an SCell on RF channel number 2
SCell 2 (Assistance data reference cell)		Cell 3	Cell 3 is an SCell on RF channel number 3
Neighbour cell		Cell 4	Cell 4 on RF channel number 3
Channel Bandwidth ( $BW_{channel}$ )	MHz	5,10,20	
PRS Transmission Bandwidth (PRS transmission bandwidth depends on selected channel bandwidth) <sup>Note 2</sup>	RB	5MHz: 25 10MHz: 50 20MHz:100	PRS are transmitted over the system bandwidth. PRS Bandwidth: bandwidth is as indicated in <i>prs-Bandwidth</i> in the OTDOA assistance data defined in 3GPP TS 36.355 [4].
PCFICH/PDCCH/PHICH parameters (PCFICH/PDCCH/PHICH parameters depend on selected channel bandwidth)		5MHz: R.11 FDD 10MHz: R.6 FDD 20MHz: R.10 FDD	As specified in TS 36.521-3 [25] clause A.2.1
OCNG Patterns defined in TS 36.521-3 [25] clause D.1 (There is no PDSCH allocated in the subframe transmitting PRS) (OCNG Patterns depend on selected channel bandwidth)		5MHz: OP.18 FDD 10MHz: OP.5 FDD 20MHz: OP.13 FDD	OCNG shall be used such that all cells are fully allocated and a constant total transmitted power spectral density is achieved for all OFDM symbols (other than those in the PRS subframes).
PRS configuration Index $I_{PRS}$ <sup>Note 2</sup>		171 for all cells on PCC 181 for all cells on SCC1 191 for all cells on SCC2	This corresponds to periodicity of 320 ms and PRS subframe offset of $I_{PRS} - 160$ DL subframes, as defined in TS 36.211 [26], Table 6.10.4.3-1
Number of consecutive positioning downlink subframes $N_{PRS}$ ( $N_{PRS}$ depends on selected channel bandwidth) <sup>Note 2</sup>		5MHz: 2 10MHz: 1 20MHz:1	As defined in 3GPP TS 36.211 [26]
prs-SubframeOffset <sup>Note 2</sup>		Cells on PCC: 300 Cells on SCC1: 310 Cells on SCC2, except reference cell: 0	Subframe offset, counted in full subframes. The corresponding parameter in the OTDOA assistance data is prs-SubframeOffset specified in TS 36.355 [4]
slotNumberOffset <sup>Note 2</sup>		Cells on PCC: 0 Cells on SCC1: 0 Cells on SCC2, except reference cell: 0	The slot number offset at the transmitter between a neighbour cell and the assistance data reference cell. The corresponding parameter in the OTDOA assistance data is slotNumberOffset specified in TS 36.355 [4].
prs-MutingInfo <sup>Note 2</sup>		Cell 1:'11110000' Cell 2:'11110000' Cell 3:'11110000' Cell 4:'11110000'	See section 6.5.1.2 in 3GPP TS 36.355 [4] for more information
Cell ID <sup>Note 2</sup>		(Cell ID of cell 4 – Cell ID of cell 3) mod 6 = 3	PCIs of cell 1 and cell 2 are selected randomly.
Radio frame receive time offset between the cells at the UE antenna connector <sup>Note 3</sup>	µs	Cell 1 to Cell 3: 1 Cell 2 to Cell 3: -1 Cell 4 to Cell 3: 3	PRS are transmitted from synchronous cells

Expected RSTD <sup>Note 1</sup>	$\mu\text{s}$	Cell 1: -2 Cell 2: 0 Cell 4: 2 Other neighbour cells: randomly between -3 and 3	The expected RSTD is what is expected at the receiver. The corresponding parameter in the OTDOA assistance data specified in TS 36.355 [4] is the expectedRSTD indicator
Expected RSTD uncertainty for all neighbour cells <sup>Note 1</sup>	$\mu\text{s}$	5	The corresponding parameter in the OTDOA assistance data specified in TS 36.355 [4] is the expectedRSTD-Uncertainty index
CP length <sup>Note 2</sup>		Normal	
DRX		OFF	
Number of cells provided in OTDOA assistance data		16	The list includes the assistance-data-reference cell and 15 other cells. Cell 1 and Cell 2 appear at random places in the first half of the neighbour cell list in the OTDOA assistance data. Cell 4 always appears at random places in the second half of the list.
$T_{\text{RSTD InterFreqFDD, E-UTRAN}}$ <sup>Note 4</sup>	ms	4960	Derived according to the RSTD measurement requirements specified in Section 10.5.3
<p>NOTE 1: Parameters "Expected RSTD" and "Expected RSTD uncertainty for all neighbour cells" are not settable parameters. These are parameters signalled in LPP only. For the values to be used in LPP see Table 10.7.4.3-3 and TS 37.571-5 [20], clause 7.3.2.</p> <p>NOTE 2: Parameters "PRS Transmission Bandwidth", "PRS configuration index", "Number of consecutive positioning downlink subframes", "prs-SubframeOffset", "slotNumberOffset", "prs-MutingInfo", "Cell ID" and "CP length" are settable parameters and also parameters signalled in LPP. The values to be used for "Cell ID" are as follows: Cell 1: 0, Cell 2: 3, Cell 3: 7, Cell 4: 10. For the values to be used in LPP see Table 10.7.4.3-3 and TS 37.571-5 [20], clause 7.3.2.</p> <p>NOTE 3: The parameter "Radio frame receive time offset between the cells at the UE antenna connector" is used to set the "true RSTD" value in step 6 of clause 10.7.4.1.</p> <p>NOTE 4: The parameter "<math>T_{\text{RSTD InterFreqFDD, E-UTRAN}}</math>" is not a settable parameter but is used to set the LPP "time" value in Table 10.7.4.3-2. The value of the LPP time IE is set to <math>T_{\text{RSTD InterFreqFDD, E-UTRAN}} + \Delta T</math> ms, where <math>\Delta T = 150</math> ms, giving a value of 5110 ms. This is rounded up to the next allowed LPP value of 6 seconds.</p>			

### 10.7.4.2 Test procedure

The RSTD measurements are performed:

- between Cell 4 and Cell 3 to verify the accuracy of RSTD measurement when the reference cell and neighbouring cell belong to the same secondary component carrier can meet the intra-frequency RSTD accuracy requirements defined in section 10.7.3.
- between Cell 1 and Cell 3 to verify the accuracy of RSTD measurement between the PCell and an SCell can meet the inter-frequency RSTD accuracy requirements defined in section 10.7.3.
- between Cell 2 and Cell 3 to verify the accuracy of RSTD measurement between two SCells can meet the inter-frequency RSTD accuracy requirements defined in section 10.7.3.

The test consists of a set-up period and a measurement period. All cells are active during the complete test. The beginning of the measurement period shall be aligned with the first PRS positioning subframe of a positioning occasion in the reference cell.

NOTE: The information on when PRS is muted is conveyed to the UE using PRS muting information in the OTDOA assistance data.

The OTDOA-RequestLocationInformation message and the OTDOA assistance data as defined in clause 10.7.4.3 shall be provided to the UE during the set-up period. The last TTI containing the OTDOA-RequestLocationInformation message shall be provided to the UE  $\Delta T$  ms before the start of the measurement period, where  $\Delta T = 150$  ms is the maximum processing time of the OTDOA-RequestLocationInformation message and the OTDOA assistance data in the UE.

1. Ensure that the UE is in state Generic RB Established State 3A-RF according to 3GPP TS 36.508 [18] clause 7.2A.3.
2. Configure Cell 2 on SCC1 and Cell 3 and Cell 4 on SCC2 according to TS 36.521-3 [25] Annex C.0 and C.1 for all downlink physical channels.
3. The SS shall configure the SCells (Cell 2 and Cell 3) on the SCCs as per TS 36.508 [18] clause 5.2A.4.
4. The SS activates the SCells (Cell 2 and Cell 3) by sending the Activation/Deactivation MAC control element according to TS 36.321 [34] clauses 5.13 and 6.1.3.8. Wait for at least 2 seconds as per TS 36.133 [23] clause 8.3.3.2.
5. The SS shall send a RESET UE POSITIONING STORED INFORMATION message.
6. Set the parameters according to Table 10.7.5-1 as appropriate. Propagation conditions are set according to clause 4.7.2.1.
- 6a. The SS shall send an LPP REQUEST CAPABILITIES message.
- 6b. The UE shall send an LPP PROVIDE CAPABILITIES message indicating the OTDOA capabilities supported by the UE in the *OTDOA-ProvideCapabilities* IE
7. The SS shall send a LPP PROVIDE ASSISTANCE DATA message, including the *OTDOA-ProvideAssistanceData* IE. The position of Cell 1 in the *OTDOA-NeighbourCellInfoList* and the position of Cell 2 are randomly selected in the relevant sequence and the position of Cell 4 is randomly selected in the relevant sequence as described in 3GPP TS 37.571-5 [20], clause 7.3.2. If the UE message at step 6b includes the *ackRequested* IE set to TRUE, then the SS shall send an acknowledgment in the LPP PROVIDE ASSISTANCE DATA message.
8. The SS shall send a LPP REQUEST LOCATION INFORMATION message, including the *OTDOA-RequestLocationInformation* IE such that the UE receives the message  $\Delta T$  ms before the start of measurement period, where  $\Delta T = 150$  ms.
9. The UE shall transmit a LPP PROVIDE LOCATION INFORMATION message, including the *OTDOA-ProvideLocationInformation* IE.
10. If the UE message at step 9 includes the *ackRequested* IE set to TRUE, the SS shall send a LPP acknowledgement message.
11. The SS shall check the *rsd* values for Cell 1, Cell 2 and Cell 4 in the *OTDOA-SignalMeasurementInformation* IE according to Table 10.7.5-2.
12. Repeat step 5-11 until the confidence level according to Annex D is achieved. For each iteration, at step 7 change the random positions of Cell 1 and Cell 2 and Cell 4 in the relevant sequence in the *OTDOA-NeighbourCellInfoList*.
13. Repeat complete test for the other channel bandwidth(s) supported by the UE (if any).

### 10.7.4.3 Message contents

**Table 10.7.4.3-1: RESET UE POSITIONING STORED INFORMATION**

Derivation Path: 36.509 [11] clause 6.9			
Information Element	Value/remark	Comment	Condition
UE Positioning Technology	0 0 0 0 0 0 1	OTDOA	

**Table 10.7.4.3-1a: LPP Request Capabilities**

Information Element	Value/remark
<i>otdoa-RequestCapabilities</i>	TRUE



**Table 10.7.4.3-2: LPP RequestLocationInformation**

Derivation Path: 36.355 clause 6.2			
Information Element	Value/remark	Comment	Condition
LPP-Message ::= SEQUENCE {			
transactionID SEQUENCE {			
Initiator	locationServer		
transactionNumber	1		
}			
endTransaction	FALSE		
sequenceNumber	Not present		
acknowledgement	Not present		
lpp-MessageBody CHOICE {			
c1 CHOICE {			
requestLocationInformation SEQUENCE {			
criticalExtensions CHOICE {			
c1 CHOICE {			
requestLocationInformation-r9 SEQUENCE {			
commonIEsRequestLocationInformation SEQUENCE {			
locationInformationType	locationMeasurementsRequired		
triggeredReporting	Not present		
periodicalReporting	Not present		
additionalInformation	onlyReturnInformationRequested		
qos SEQUENCE {			
horizontalAccuracy	Not present		
verticalCoordinateRequest	FALSE		
verticalAccuracy	Not present		
responseTime SEQUENCE {			
time	6	See Note 4 of Table 10.7.4.1-1	
responseTimeEarlyFix-r12	Not present		Rel-12 onwards
}			
velocityRequest	FALSE		
}			
environment	Not present		
locationCoordinateTypes	Not present		
velocityTypes	Not present		
}			
a-gnss-RequestLocationInformation	Not present		
otdoa-RequestLocationInformation SEQUENCE {			
assistanceAvailability	FALSE		
}			
ecid-RequestLocationInformation	Not present		
epdu-RequestLocationInformation	Not Present		
}			
}			
}			
}			
}			

Table 10.7.4.3-3: LPP ProvideAssistanceData

Derivation Path: 36.355 clause 6.2			
Information Element	Value/remark	Comment	Condition
LPP-Message ::= SEQUENCE {			
transactionID SEQUENCE {			
Initiator	locationServer		
transactionNumber	(0..255)		
}			
endTransaction	TRUE		
sequenceNumber	Not present		
acknowledgement	Not present		
lpp-MessageBody CHOICE {			
c1 CHOICE {			
provideAssistanceData SEQUENCE {			
criticalExtensions CHOICE {			
c1 CHOICE {			
provideAssistanceData-r9 SEQUENCE {			
commonIEsProvideAssistanceData	Not present		
a-gnss-ProvideAssistanceData	Not present		
otdoa-ProvideAssistanceData SEQUENCE {			
otdoa-ReferenceCellInfo	As defined in TS 37.571-5 [20], clause 7.3.2.		
otdoa-NeighbourCellInfo	As defined in TS 37.571-5 [20], clause 7.3.2.		
otdoa-Error	Not present		
}			
epdu-ProvideAssistanceData	Not present		
}			
}			
}			
}			

**Table 10.7.4.3-4: LPP ProvideLocation Information**

Derivation Path: 36.355 clause 6.2			
Information Element	Value/remark	Comment	Condition
LPP-Message ::= SEQUENCE {			
transactionID SEQUENCE {			
Initiator	locationServer		
transactionNumber	1		
}			
endTransaction	TRUE		
sequenceNumber	(0..255)		
acknowledgement			
lpp-MessageBody CHOICE {			
c1 CHOICE {			
provideLocationInformation SEQUENCE {			
criticalExtensions CHOICE {			
c1 CHOICE {			
provideLocationInformation-r9 SEQUENCE {			
commonIEsProvideLocationInformation	Not present.		
a-gnss-ProvideLocationInformation	Not present		
otdoa-ProvideLocationInformation			
SEQUENCE {			
otdoaSignalMeasurementInformation			
SEQUENCE {			
systemFrameNumber			
physCellIdRef	Cell 3		
cellGlobalIdRef			
earfcnRef			
referenceQuality			
neighbourMeasurementList			
SEQUENCE{			
NeighbourMeasurementElement			
SEQUENCE {			
physCellIdNeighbour	Cell 1		
cellGlobalIdNeighbour			
earfcnNeighbour			
rstd	Set according to Table 10.7.5-2	With respect to Cell 3	
rstd-Quality			
}			
NeighbourMeasurementElement			
SEQUENCE {			
physCellIdNeighbour	Cell 2		
cellGlobalIdNeighbour			
earfcnNeighbour			
rstd	Set according to Table 10.7.5-2	With respect to Cell 3	
rstd-Quality			
}			
NeighbourMeasurementElement			
SEQUENCE {			
physCellIdNeighbour	Cell 4		
cellGlobalIdNeighbour			
earfcnNeighbour			
rstd	Set according to Table 10.7.5-2	With respect to Cell 3	
rstd-Quality			
}			
}			
}			
otdoa-Error	May be present with error reason 'undefined' or 'attemptedButUnableToMeasureSomeNeighbourCells'		
}			
ecid-ProvideLocationInformation	Not present		
epdu-ProvideLocationInformation	Not present		

}			
}			
}			
}			
}			
}			

### 10.7.5 Test requirement

Table 10.7.5-1 defines the primary level settings including test tolerances for the test.

The FDD RSTD accuracy test shall meet the reported values in Table 10.7.5-2.

**Table 10.7.5-1: Cell Specific Test Parameters for RSTD Test for E-UTRAN FDD for Carrier Aggregation**

Parameter	Unit	Cell 1	Cell 2	Cell 3	Cell 4
E-UTRA RF Channel Number		1	2	3	3
PBCH_RA	dB	0	0	0	0
PBCH_RB					
PSS_RA					
SSS_RA					
PCFICH_RB					
PHICH_RA					
PHICH_RB					
PDCCH_RA					
PDCCH_RB					
OCNG_RA <sup>Note1</sup>					
OCNG_RB <sup>Note1</sup>					
PRS_RA	dB	-3	0	0.3	0.3
$N_{oc}$ <sup>Note2</sup>	dBm/15 kHz	-98			
PRS $\hat{E}_s/N_{oc}$	dB	-6	-6	-5.7	-12.7
PRS $\hat{E}_s/I_{ot}$ <sup>Note3</sup>	dB	-6	-6	-5.7	-12.7
$I_o$ <sup>Note3</sup>	dBm/9 MHz	-70.04 +10log ( $N_{RB,c}/50$ )	-70.04 +10log ( $N_{RB,c}/50$ )	-69.99 +10log ( $N_{RB,c}/50$ )	-69.99 +10log ( $N_{RB,c}/50$ )
PRP <sup>Note3</sup>	dBm/15kHz	-104	-104	-103.7	-110.7
RSRP <sup>Note3</sup>	dBm/15kHz	-101	-104	-104	-111
$\hat{E}_s/N_{oc}$ <sup>Note3</sup>	dB	-3	-6	-6	-13
Propagation condition		AWGN			
<p>Note 1: OCNG shall be used such that all cells are fully allocated and a constant total transmitted power spectral density is achieved for all OFDM symbols (other than those in the PRS subframes).</p> <p>Note 2: Interference from other cells and noise sources not specified in the test is assumed to be constant over subcarriers and time and shall be modelled as AWGN of appropriate power for <math>N_{oc}</math> to be fulfilled.</p> <p>Note 3: <math>\hat{E}_s/N_{oc}</math>, PRS <math>\hat{E}_s/I_{ot}</math>, RSRP, <math>I_o</math> and PRP levels have been derived from other parameters for information purposes. They are not settable parameters themselves. <math>I_o</math> values are derived in the case that there is no PBCH, PSS or SSS in the OFDM symbols carrying PRS.</p>					

**Table 10.7.5-2: RSTD FDD accuracy requirements for the reported values for Carrier Aggregation**

	Value Cell 1	Value Cell 2	Value Cell 4
Lowest reported value (depends on selected channel bandwidth)	5MHz: RSTD_6374 10MHz: RSTD_6375 20MHz: RSTD_6376	5MHz: RSTD_6313 10MHz: RSTD_6314 20MHz: RSTD_6315	5MHz: RSTD_6440 10MHz: RSTD_6441 20MHz: RSTD_6442
Highest reported value (depends on selected channel bandwidth)	5MHz: RSTD_6398 10MHz: RSTD_6397 20MHz: RSTD_6396	5MHz: RSTD_6337 10MHz: RSTD_6336 20MHz: RSTD_6335	5MHz: RSTD_6454 10MHz: RSTD_6453 20MHz: RSTD_6452

For the test to pass, the ratio of successful reported values shall be more than 90% with a confidence level of 95% for each of Cell 1, Cell 2 and Cell 4 for each supported channel bandwidth.

## 10.8 TDD RSTD Measurement Accuracy for 3DL Carrier Aggregation

### 10.8.1 Test purpose

To verify that the TDD RSTD measurement accuracy is within the specified limits.

### 10.8.2 Test applicability

This test applies to all types of E-UTRA TDD UE release 12 and forward that supports UE-assisted OTDOA for 3DL Carrier Aggregation.

### 10.8.3 Minimum conformance requirements

This section contains RSTD measurement accuracy requirements for a UE configured with one or two downlink SCell(s). The UE may operate in one of the E-UTRA carrier aggregations listed in TS 36.133 [23] section 8.3.1. The requirements in this section shall apply regardless of whether the configured downlink secondary cell is activated or deactivated by the MAC-CE command [34]. The requirements apply for bandwidths defined in the bandwidth combination set for the CA configurations supported by the UE defined in TS 36.101 [2].

The RSTD measurements, which are obtained when both the reference cell and neighbouring cell belong to the primary component carrier, shall meet the intra-frequency RSTD accuracy requirements defined in TS 36.133 [23] section 9.1.10.1.

The RSTD measurements, which are obtained when both the reference cell and neighbouring cell belong to the same secondary component carrier, shall meet the intra-frequency RSTD accuracy requirements defined in TS 36.133 [23] section 9.1.10.1.

The RSTD measurements, which are obtained when the reference cell and neighbouring cell do not belong to the same carrier, shall meet the inter-frequency RSTD accuracy requirements defined in TS 36.133 [23] section 9.1.10.2.

The normative reference for this requirement is TS 36.133 [23] clause 9.1.12 and A.9.8.15.

### 10.8.4 Test description

#### 10.8.4.1 Initial conditions

Test Environment: Normal; as defined in TS 36.508 [18] clause 4.1.

Frequencies to be tested: Mid Range, as defined in TS 36.508 [18] clause 4.3.1.1.

Channel bandwidths to be tested: the largest and the smallest aggregated bandwidth combinations supported by the UE of the Channel bandwidths defined in Table 10.8.4.1-1. The Channel bandwidths for CA Intra-Band combinations are as defined in TS 36.508 [18] clause 4.3.1 and for CA Inter-Band combinations are defined in TS 36.521-1[24] clause 5.4.2A. In case of multiple possible Channel bandwidth combinations, the first combination listed in the above mentioned clauses shall be selected.

1. Connect the SS (node B emulator) and AWGN noise sources to the UE antenna connectors as follows:
  - For UEs supporting only 2Rx in all the bands under test, use TS 36.508 [18] Annex A, Figure group A.68 as appropriate.
  - For UEs supporting 4Rx in any of the bands under test use TS 36.508 [18] Annex A, Figure A.90. Use the 2Rx module for cells on bands supporting 2Rx and the 4Rx module for cells on bands supporting 4Rx.
2. The general test parameter settings are set up according to Table 10.8.4.1-1.
3. Propagation conditions are set according to clause 4.7.2.1.
4. Message contents are defined in clause 10.8.4.3.

5. There are four synchronized cells on three different carrier frequencies. Cell 1 is the PCell on primary component carrier F1 (RF channel number 1), Cell 2 is an SCell on secondary component carrier F2 (RF channel number 2), Cell 3 is an SCell and reference cell on secondary component carrier F3 (RF channel number 3), and Cell 4 is the neighbour cell on F3. PCell (Cell 1) is the cell used for connection setup with the power level and mapping set according to TS 36.521-1 [24] Annex C.0 and C.1 as appropriate for this test. Cell 2, Cell 3 and Cell 4 are powered OFF.

Cell 1, Cell 2, Cell 3, and Cell 4 are included in the OTDOA assistance data neighbour cell list.

The assistance data neighbour cell list includes in total 15 cells, where 12 of the cells are not simulated (dummy cells; as defined in 3GPP TS 37.571-5 [20], clause 7.3.2).

Note that the measurement gap is not configured in the test because of UE carrier aggregation capability.

6. The true RSTD (which is the receive time difference for frame 0 between the two cells as seen at the UE antenna connector) is set to 31 Ts (about 1  $\mu$ s) between Cell 1 and OTDOA assistance data reference cell, Cell 3, and set to -31 Ts (about -1  $\mu$ s) between Cell 2 and OTDOA assistance data reference cell, Cell 3, and set to 92 Ts (about 3  $\mu$ s) between neighbour Cell 4 and OTDOA assistance data reference cell, Cell 3.

Note that the related expected RSTD values to be signalled over LPP are defined in Table 10.8.4.1-1.

**Table 10.8.4.1-1: General Test Parameters for RSTD Test for E-UTRAN TDD for Carrier Aggregation**



Parameter	Unit	Value	Comment
PCell		Cell 1	Cell 1 on RF channel number 1
SCell 1		Cell 2	Cell 2 is an SCell on RF channel number 2
SCell 2 (Assistance data reference cell)		Cell 3	Cell 3 is an SCell on RF channel number 3
Neighbour cell		Cell 4	Cell 4 on RF channel number 3
Channel Bandwidth ( $BW_{channel}$ )	MHz	5,10,20	
PRS Transmission Bandwidth (PRS transmission bandwidth depends on selected channel bandwidth) <sup>Note 2</sup>	RB	5MHz: 25 10MHz: 50 20MHz:100	PRS are transmitted over the system bandwidth. PRS Bandwidth: bandwidth is as indicated in <i>prs-Bandwidth</i> in the OTDOA assistance data defined in 3GPP TS 36.355 [4].
PCFICH/PDCCH/PHICH parameters (PCFICH/PDCCH/PHICH parameters depend on selected channel bandwidth)		5MHz: R.11 TDD 10MHz: R.6 TDD 20MHz: R.10 TDD	As specified in TS 36.521-3 [25] clause A.2.1
OCNG Patterns defined in TS 36.521-3 [25] clause D.1 (There is no PDSCH allocated in the subframe transmitting PRS) (OCNG Patterns depend on selected channel bandwidth)		5MHz: OP.10 TDD 10MHz: OP.2 TDD 20MHz: OP.8 TDD	OCNG shall be used such that all cells are fully allocated and a constant total transmitted power spectral density is achieved for all OFDM symbols (other than those in the PRS subframes).
PRS configuration Index $I_{PRS}$ <sup>Note 2</sup>		171 for all cells on PCC 181 for all cells on SCC1 191 for all cells on SCC2	This corresponds to periodicity of 320 ms and PRS subframe offset of $I_{PRS} - 160$ DL subframes, as defined in TS 36.211 [26], Table 6.10.4.3-1
Number of consecutive positioning downlink subframes $N_{PRS}$ ( $N_{PRS}$ depends on selected channel bandwidth) <sup>Note 2</sup>		5MHz: 2 10MHz: 1 20MHz:1	As defined in 3GPP TS 36.211 [26]
prs-SubframeOffset <sup>Note 2</sup>		Cells on PCC: 300 Cells on SCC1: 310 Cells on SCC2, except reference cell: 0	Subframe offset, counted in full subframes. The corresponding parameter in the OTDOA assistance data is prs-SubframeOffset specified in TS 36.355 [4]
slotNumberOffset <sup>Note 2</sup>		Cells on PCC: 0 Cells on SCC1: 0 Cells on SCC2, except reference cell: 0	The slot number offset at the transmitter between a neighbour cell and the assistance data reference cell. The corresponding parameter in the OTDOA assistance data is slotNumberOffset specified in TS 36.355 [4].
prs-MutingInfo <sup>Note 2</sup>		Cell 1:'11110000' Cell 2:'11110000' Cell 3:'11110000' Cell 4:'11110000'	See section 6.5.1.2 in 3GPP TS 36.355 [4] for more information
Special subframe configuration		6	As specified in table 4.2-1 in TS 36.211 [26]. The same configuration in both cells.
Uplink-downlink configuration		1	As specified in table 4.2-2 in TS 36.211 [26] and table 8.1.2.5.2-2 in TS 36.133 [23]. The same configuration in both cells.
Cell ID <sup>Note 2</sup>		(Cell ID of cell 4 – Cell ID of cell 3) mod 6 = 3	PCIs of cell 1 and cell 2 are selected randomly.
Radio frame receive time offset between the cells at the UE antenna connector <sup>Note 3</sup>	µs	Cell 1 to Cell 3: 1 Cell 2 to Cell 3: -1 Cell 4 to Cell 3: 3	PRS are transmitted from synchronous cells

Expected RSTD <sup>Note 1</sup>	$\mu\text{s}$	Cell 1: -2 Cell 2: 0 Cell 4: 2 Other neighbour cells: randomly between -3 and 3	The expected RSTD is what is expected at the receiver. The corresponding parameter in the OTDOA assistance data specified in TS 36.355 [4] is the expectedRSTD indicator
Expected RSTD uncertainty for all neighbour cells <sup>Note 1</sup>	$\mu\text{s}$	5	The corresponding parameter in the OTDOA assistance data specified in TS 36.355 [4] is the expectedRSTD-Uncertainty index
CP length <sup>Note 2</sup>		Normal	
DRX		OFF	
Number of cells provided in OTDOA assistance data		16	The list includes the assistance-data-reference cell and 15 other cells. Cell 1 and Cell 2 appear at random places in the first half of the neighbour cell list in the OTDOA assistance data. Cell 4 always appears at random places in the second half of the list.
$T_{\text{RSTD InterFreqTDD, E-UTRAN}}$ <sup>Note 4</sup>	ms	4960	Derived according to the RSTD measurement requirements specified in Section 10.6.3
<p>NOTE 1: Parameters "Expected RSTD" and "Expected RSTD uncertainty for all neighbour cells" are not settable parameters. These are parameters signalled in LPP only. For the values to be used in LPP see Table 10.8.4.3-3 and TS 37.571-5 [20], clause 7.3.2.</p> <p>NOTE 2: Parameters "PRS Transmission Bandwidth", "PRS configuration index", "Number of consecutive positioning downlink subframes", "prs-SubframeOffset", "slotNumberOffset", "prs-MutingInfo", "Cell ID" and "CP length" are settable parameters and also parameters signalled in LPP. The values to be used for "Cell ID" are as follows: Cell 1: 0, Cell 2: 3, Cell 3: 7, Cell 4: 10. For the values to be used in LPP see Table 10.8.4.3-3 and TS 37.571-5 [20], clause 7.3.2.</p> <p>NOTE 3: The parameter "Radio frame receive time offset between the cells at the UE antenna connector" is used to set the "true RSTD" value in step 6 of clause 10.8.4.1.</p> <p>NOTE 4: The parameter "<math>T_{\text{RSTD InterFreqTDD, E-UTRAN}}</math>" is not a settable parameter but is used to set the LPP "time" value in Table 10.8.4.3-2. The value of the LPP time IE is set to <math>T_{\text{RSTD InterFreqTDD, E-UTRAN}} + \Delta T</math> ms, where <math>\Delta T = 150</math> ms, giving a value of 5110 ms. This is rounded up to the next allowed LPP value of 6 seconds.</p>			

## 10.8.4.2 Test procedure

The RSTD measurements are performed:

- between Cell 4 and Cell 3 to verify the accuracy of RSTD measurement when the reference cell and neighbouring cell belong to the same secondary component carrier can meet the intra-frequency RSTD accuracy requirements defined in section 10.8.3.
- between Cell 1 and Cell 3 to verify the accuracy of RSTD measurement between the PCell and an SCell can meet the inter-frequency RSTD accuracy requirements defined in section 10.8.3.
- between Cell 2 and Cell 3 to verify the accuracy of RSTD measurement between two SCells can meet the inter-frequency RSTD accuracy requirements defined in section 10.8.3.

The test consists of a set-up period and a measurement period. All cells are active during the complete test. The beginning of the measurement period shall be aligned with the first PRS positioning subframe of a positioning occasion in the reference cell.

NOTE: The information on when PRS is muted is conveyed to the UE using PRS muting information in the OTDOA assistance data.

The OTDOA-RequestLocationInformation message and the OTDOA assistance data as defined in clause 10.8.4.3 shall be provided to the UE during the set-up period. The last TTI containing the OTDOA-RequestLocationInformation message shall be provided to the UE  $\Delta T$  ms before the start of the measurement period, where  $\Delta T = 150$  ms is the maximum processing time of the OTDOA-RequestLocationInformation message and the OTDOA assistance data in the UE.

1. Ensure that the UE is in state Generic RB Established State 3A-RF according to 3GPP TS 36.508 [18] clause 7.2A.3.
2. Configure Cell 2 on SCC1 and Cell 3 and Cell 4 on SCC2 according to TS 36.521-3 [25] Annex C.0 and C.1 for all downlink physical channels.
3. The SS shall configure the SCells (Cell 2 and Cell 3) on the SCCs as per TS 36.508 [18] clause 5.2A.4.
4. The SS activates the SCells (Cell 2 and Cell 3) by sending the Activation/Deactivation MAC control element according to TS 36.321 [34] clauses 5.13 and 6.1.3.8. Wait for at least 2 seconds as per TS 36.133 [23] clause 8.3.3.2.
5. The SS shall send a RESET UE POSITIONING STORED INFORMATION message.
6. Set the parameters according to Table 10.8.5-1 as appropriate. Propagation conditions are set according to clause 4.7.2.1.
- 6a. The SS shall send an LPP REQUEST CAPABILITIES message.
- 6b. The UE shall send an LPP PROVIDE CAPABILITIES message indicating the OTDOA capabilities supported by the UE in the *OTDOA-ProvideCapabilities* IE
7. The SS shall send a LPP PROVIDE ASSISTANCE DATA message, including the *OTDOA-ProvideAssistanceData* IE. The position of Cell 1 in the *OTDOA-NeighbourCellInfoList* and the position of Cell 2 are randomly selected in the relevant sequence and the position of Cell 4 is randomly selected in the relevant sequence as described in 3GPP TS 37.571-5 [20], clause 7.3.2. If the UE message at step 6b includes the *ackRequested* IE set to TRUE, then the SS shall send an acknowledgment in the LPP PROVIDE ASSISTANCE DATA message.
8. The SS shall send a LPP REQUEST LOCATION INFORMATION message, including the *OTDOA-RequestLocationInformation* IE such that the UE receives the message  $\Delta T$  ms before the start of measurement period, where  $\Delta T = 150$  ms.
9. The UE shall transmit a LPP PROVIDE LOCATION INFORMATION message, including the *OTDOA-ProvideLocationInformation* IE.
10. If the UE message at step 9 includes the *ackRequested* IE set to TRUE, the SS shall send a LPP acknowledgement message.
11. The SS shall check the *rstd* values for Cell 1, Cell 2 and Cell 4 in the *OTDOA-SignalMeasurementInformation* IE according to Table 10.8.5-2.
12. Repeat step 5-11 until the confidence level according to Annex D is achieved. For each iteration, at step 7 change the random positions of Cell 1 and Cell 2 and Cell 4 in the relevant sequence in the *OTDOA-NeighbourCellInfoList*.
13. Repeat complete test for the other channel bandwidth(s) supported by the UE (if any).

#### 10.8.4.3 Message contents

**Table 10.8.4.3-1: RESET UE POSITIONING STORED INFORMATION**

Derivation Path: 36.509 [11] clause 6.9			
Information Element	Value/remark	Comment	Condition
UE Positioning Technology	0 0 0 0 0 0 1	OTDOA	

**Table 10.8.4.3-1a: LPP Request Capabilities**

Information Element	Value/remark
<i>otdoa-RequestCapabilities</i>	TRUE

**Table 10.8.4.3-2: LPP RequestLocationInformation**

Derivation Path: 36.355 clause 6.2			
Information Element	Value/remark	Comment	Condition
LPP-Message ::= SEQUENCE {			
transactionID SEQUENCE {			
Initiator	locationServer		
transactionNumber	1		
}			
endTransaction	FALSE		
sequenceNumber	Not present		
acknowledgement	Not present		
lpp-MessageBody CHOICE {			
c1 CHOICE {			
requestLocationInformation SEQUENCE {			
criticalExtensions CHOICE {			
c1 CHOICE {			
requestLocationInformation-r9 SEQUENCE {			
commonIEsRequestLocationInformation SEQUENCE {			
locationInformationType	locationMeasurementsRequired		
triggeredReporting	Not present		
periodicalReporting	Not present		
additionalInformation	onlyReturnInformationRequested		
qos SEQUENCE {			
horizontalAccuracy	Not present		
verticalCoordinateRequest	FALSE		
verticalAccuracy	Not present		
responseTime SEQUENCE {			
time	6	See Note 4 of Table 10.8.4.1-1	
responseTimeEarlyFix-r12	Not present		Rel-12 onwards
}			
velocityRequest	FALSE		
}			
environment	Not present		
locationCoordinateTypes	Not present		
velocityTypes	Not present		
}			
a-gnss-RequestLocationInformation	Not present		
otdoa-RequestLocationInformation SEQUENCE {			
assistanceAvailability	FALSE		
}			
ecid-RequestLocationInformation	Not present		
epdu-RequestLocationInformation	Not Present		
}			
}			
}			
}			
}			

Table 10.8.4.3-3: LPP ProvideAssistanceData

Derivation Path: 36.355 clause 6.2			
Information Element	Value/remark	Comment	Condition
LPP-Message ::= SEQUENCE {			
transactionID SEQUENCE {			
Initiator	locationServer		
transactionNumber	(0..255)		
}			
endTransaction	TRUE		
sequenceNumber	Not present		
acknowledgement	Not present		
lpp-MessageBody CHOICE {			
c1 CHOICE {			
provideAssistanceData SEQUENCE {			
criticalExtensions CHOICE {			
c1 CHOICE {			
provideAssistanceData-r9 SEQUENCE {			
commonIEsProvideAssistanceData	Not present		
a-gnss-ProvideAssistanceData	Not present		
otdoa-ProvideAssistanceData SEQUENCE {			
otdoa-ReferenceCellInfo	As defined in TS 37.571-5 [20], clause 7.3.2.		
otdoa-NeighbourCellInfo	As defined in TS 37.571-5 [20], clause 7.3.2.		
otdoa-Error	Not present		
}			
epdu-ProvideAssistanceData	Not present		
}			
}			
}			
}			

**Table 10.8.4.3-4: LPP ProvideLocation Information**

Derivation Path: 36.355 clause 6.2			
Information Element	Value/remark	Comment	Condition
LPP-Message ::= SEQUENCE {			
transactionID SEQUENCE {			
Initiator	locationServer		
transactionNumber	1		
}			
endTransaction	TRUE		
sequenceNumber	(0..255)		
acknowledgement			
lpp-MessageBody CHOICE {			
c1 CHOICE {			
provideLocationInformation SEQUENCE {			
criticalExtensions CHOICE {			
c1 CHOICE {			
provideLocationInformation-r9 SEQUENCE {			
commonIEsProvideLocationInformation	Not present.		
a-gnss-ProvideLocationInformation	Not present		
otdoa-ProvideLocationInformation			
SEQUENCE {			
otdoaSignalMeasurementInformation			
SEQUENCE {			
systemFrameNumber			
physCellIdRef	Cell 3		
cellGlobalIdRef			
earfcnRef			
referenceQuality			
neighbourMeasurementList			
SEQUENCE{			
NeighbourMeasurementElement			
SEQUENCE {			
physCellIdNeighbour	Cell 1		
cellGlobalIdNeighbour			
earfcnNeighbour			
rstd	Set according to Table 10.8.5-2	With respect to Cell 3	
rstd-Quality			
}			
NeighbourMeasurementElement			
SEQUENCE {			
physCellIdNeighbour	Cell 2		
cellGlobalIdNeighbour			
earfcnNeighbour			
rstd	Set according to Table 10.8.5-2	With respect to Cell 3	
rstd-Quality			
}			
NeighbourMeasurementElement			
SEQUENCE {			
physCellIdNeighbour	Cell 4		
cellGlobalIdNeighbour			
earfcnNeighbour			
rstd	Set according to Table 10.8.5-2	With respect to Cell 3	
rstd-Quality			
}			
}			
}			
otdoa-Error	May be present with error reason 'undefined' or 'attemptedButUnableToMeasureSomeNeighbourCells'		
}			
ecid-ProvideLocationInformation	Not present		
epdu-ProvideLocationInformation	Not present		

}			
}			
}			
}			
}			
}			

### 10.8.5 Test requirement

Table 10.8.5-1 defines the primary level settings including test tolerances for the test.

The TDD RSTD accuracy test shall meet the reported values in Table 10.8.5-2.

**Table 10.8.5-1: Cell Specific Test Parameters for RSTD Test for E-UTRAN TDD for Carrier Aggregation**

Parameter	Unit	Cell 1	Cell 2	Cell 3	Cell 4
E-UTRA RF Channel Number		1	2	3	3
PBCH_RA	dB	0	0	0	0
PBCH_RB					
PSS_RA					
SSS_RA					
PCFICH_RB					
PHICH_RA					
PHICH_RB					
PDCCH_RA					
PDCCH_RB					
OCNG_RA <sup>Note1</sup>					
OCNG_RB <sup>Note1</sup>					
PRS_RA					
$N_{oc}$ <sup>Note2</sup>	dBm/15 kHz	-98			
PRS $\hat{E}_s/N_{oc}$	dB	-6	-6	-5.7	-12.7
PRS $\hat{E}_s/I_{ot}$ <sup>Note3</sup>	dB	-6	-6	-5.7	-12.7
$I_o$ <sup>Note3</sup>	dBm/9 MHz	-70.04 +10log ( $N_{RB,c}/50$ )	-70.04 +10log ( $N_{RB,c}/50$ )	-69.99 +10log ( $N_{RB,c}/50$ )	-69.99 +10log ( $N_{RB,c}/50$ )
PRP <sup>Note3</sup>	dBm/15kHz	-104	-104	-103.7	-110.7
RSRP <sup>Note3</sup>	dBm/15kHz	-101	-104	-104	-111
$\hat{E}_s/N_{oc}$ <sup>Note3</sup>	dB	-3	-6	-6	-13
Propagation condition		AWGN			
<p>Note 1: OCNG shall be used such that all cells are fully allocated and a constant total transmitted power spectral density is achieved for all OFDM symbols (other than those in the PRS subframes).</p> <p>Note 2: Interference from other cells and noise sources not specified in the test is assumed to be constant over subcarriers and time and shall be modelled as AWGN of appropriate power for <math>N_{oc}</math> to be fulfilled.</p> <p>Note 3: <math>\hat{E}_s/N_{oc}</math>, PRS <math>\hat{E}_s/I_{ot}</math>, RSRP, <math>I_o</math> and PRP levels have been derived from other parameters for information purposes. They are not settable parameters themselves. <math>I_o</math> values are derived in the case that there is no PBCH, PSS or SSS in the OFDM symbols carrying PRS.</p>					

**Table 10.8.5-2: RSTD TDD accuracy requirements for the reported values for Carrier Aggregation**

	Value Cell 1	Value Cell 2	Value Cell 4
Lowest reported value (depends on selected channel bandwidth)	5MHz: RSTD_6374 10MHz: RSTD_6375 20MHz: RSTD_6376	5MHz: RSTD_6313 10MHz: RSTD_6314 20MHz: RSTD_6315	5MHz: RSTD_6440 10MHz: RSTD_6441 20MHz: RSTD_6442
Highest reported value (depends on selected channel bandwidth)	5MHz: RSTD_6398 10MHz: RSTD_6397 20MHz: RSTD_6396	5MHz: RSTD_6337 10MHz: RSTD_6336 20MHz: RSTD_6335	5MHz: RSTD_6454 10MHz: RSTD_6453 20MHz: RSTD_6452



For the test to pass, the ratio of successful reported values shall be more than 90% with a confidence level of 95% for each of Cell 1, Cell 2 and Cell 4 for each supported channel bandwidth.

---

## 11 E-UTRA MBS measurement requirements

### 11.1 MBS Measurement Reporting Delay (Release 13 only)

#### 11.1.1 Test purpose

The purpose of the test is to verify that the MBS measurements meet the measurement time requirements specified in clause 4.2.3 of TS 37.171 [39] in an environment with fading propagation conditions specified in clause 4.8.2.2 (EPA 5 Hz).

#### 11.1.2 Test applicability

This test applies to all types of E-UTRA UE that supports UE-assisted MBS with LPP Release 13 only.

#### 11.1.3 Minimum conformance requirements

The MBS measurement reporting delay (response time) shall be  $\leq 12000$  msec.

The normative reference for this requirement is TS 37.171 [39] clauses 4.2.3 and A.3.1.

#### 11.1.4 Test description

##### 11.1.4.1 Initial conditions

Test environment: normal; see Annex G.

1. Connect SS and MSS to the UE antenna connector or antenna connectors as shown in figures A.6 or A.7.
2. Switch on the UE.
3. Establish a signalling connection according to the generic procedure in TS 36.508 [18] clause 4.5.3 (State 3, Generic RB established) on a channel in the Mid EARFCN range.

##### 11.1.4.2 Test procedure

1. Set the MSS test parameters as specified in clause 11.1.5.
2. The SS shall send a RESET UE POSITIONING STORED INFORMATION message.
3. The SS shall send an LPP REQUEST CAPABILITIES message.
4. The UE shall transmit an LPP PROVIDE CAPABILITIES message indicating the TBS capabilities supported by the UE in the *TBS-ProvideCapabilities* IE.
5. The SS shall send a LPP REQUEST LOCATION INFORMATION message, including the *TBS-RequestLocationInformation* IE. If the UE message at step 4 includes the *ackRequested* IE set to TRUE, then the SS shall send an acknowledgment in the LPP REQUEST LOCATION INFORMATION message.
6. The UE shall perform and report the code phase measurement for the simulated beacon. If the UE transmits a *TBS-ProvideLocationInformation* IE including the *transmitterID* and *codePhase* fields for the simulated beacon within the required response time in 11.1.5, then the number of successful tests is increased by one. Otherwise the number of failure tests is increased by one.
7. If the UE message at step 6 includes the *ackRequested* IE set to TRUE, the SS shall send a LPP acknowledgement message.
8. Repeat steps 1-7 until the confidence level according to Annex D is achieved. For each iteration, at step 1 reselect the PN code assigned to the MBS beacon.
9. Release the signalling connection.

## 11.1.4.3 Message contents

Table 11.1.4.3-1: RESET UE POSITIONING STORED INFORMATION

Derivation Path: TS 36.509 [11] clause 6.9			
Information Element	Value/remark	Comment	Condition
UE Positioning Technology	0 0 0 0 0 1 0	MBS	

Table 11.1.4.3-2: LPP RequestCapabilities

Information Element	Value/remark
<i>tbs-RequestCapabilities-r13</i>	TRUE

**Table 11.1.4.3-3: LPP RequestLocationInformation**

Derivation Path: TS 36.355 [4] clause 6.2			
Information Element	Value/remark	Comment	Condition
LPP-Message ::= SEQUENCE {			
transactionID SEQUENCE {			
Initiator	locationServer		
transactionNumber	1		
}			
endTransaction	FALSE		
sequenceNumber	Not present		
acknowledgement	Not present		
lpp-MessageBody CHOICE {			
c1 CHOICE {			
requestLocationInformation SEQUENCE {			
criticalExtensions CHOICE {			
c1 CHOICE {			
requestLocationInformation-r9 SEQUENCE {			
commonIEsRequestLocationInformation SEQUENCE {			
locationInformationType	locationMeasurementsRequired		
triggeredReporting	Not present		
periodicalReporting	Not present		
additionalInformation	onlyReturnInformationRequested		
qos SEQUENCE {			
horizontalAccuracy	Not present		
verticalCoordinateRequest	FALSE		
verticalAccuracy	Not present		
responseTime SEQUENCE {			
Time	12		
responseTimeEarlyFix-r12	Not present		
}			
velocityRequest	FALSE		
}			
Environment	Not present		
locationCoordinateTypes	Not present		
velocityTypes	Not present		
}			
a-gnss-RequestLocationInformation	Not present		
otdoa-RequestLocationInformation	Not present		
ecid-RequestLocationInformation	Not present		
epdu-RequestLocationInformation	Not present		
sensor-RequestLocationInformation-r13	Not present		
tbs-RequestLocationInformation-r13 SEQUENCE {			
mbsSgnMeasListReq-r13	TRUE		
}			
wlan-RequestLocationInformation-r13	Not present		
bt-RequestLocationInformation-r13	Not Present		
}			
}			
}			
}			
}			

Table 11.1.4.3-4: LPP ProvideLocationInformation

Derivation Path: TS 36.355 [4] clause 6.2			
Information Element	Value/remark	Comment	Condition
LPP-Message ::= SEQUENCE {			
transactionID SEQUENCE {			
Initiator	locationServer		
transactionNumber	1		
}			
endTransaction	TRUE		
sequenceNumber	(0..255)		
Acknowledgement			
lpp-MessageBody CHOICE {			
c1 CHOICE {			
provideLocationInformation SEQUENCE {			
criticalExtensions CHOICE {			
c1 CHOICE {			
provideLocationInformation-r9 SEQUENCE {			
commonIEsProvideLocationInformation	Not present.		
a-gnss-ProvideLocationInformation	Not present		
otdoa-ProvideLocationInformation	Not present		
ecid-ProvideLocationInformation	Not present		
epdu-ProvideLocationInformation	Not present		
sensor-ProvideLocationInformation-r13	Not present		
tbs-ProvideLocationInformation-r13			
SEQUENCE {			
tbs-MeasurementInformation-r13			
SEQUENCE {			
measurementReferenceTime-r13			
mbs-SgnMeasList-r13			
SEQUENCE (SIZE(n)) {			
transmitterID-r13	Present		
codePhase-r13	Present		
codePhaseRMSError-r13			
}			
}			
tbs-Error-r13	May be present with error reason 'undefined' or 'thereWereNotEnoughMBSBeaconsReceived'		
}			
wlan-ProvideLocationInformation-r13	Not present		
bt-ProvideLocationInformation-r13	Not present		
}			
}			
}			

### 11.1.5 Test requirement

The details of the beacon parameters are in Table 11.1.5-1 and Table 11.1.5-2.

**Table 11.1.5-1: General test parameters for the beacon to be simulated for the measurement reporting delay test**

Parameter	Unit	Value	Comment
Number of beacons	Integer	1	Beacon transmitted in any beacon slot, but static for the test, in the MBS beacon transmission period. Other slots contain no simulated beacons <sup>Note 1</sup>
Centre Frequency	MHz	925.977	
RF Channel	N/A	EPA 5Hz	
MBS Beacon Configuration	N/A	TB1 (2 MHz)	For details see Annex H
MBS Packet Type	N/A	Type 2	For details see Annex H
Beacon PN Code	Integer	Chosen for the beacon from the PN code list for TB1	For details see Annex H <sup>Note 1</sup>
Transmit power	dBm	-30	
Response time	Seconds	12	Value of Time used in LPP RequestLocationInformation message in Table 11.1.4.3-3
Note 1: The slots and PN codes are chosen at random, such that the UE does not and cannot have advanced knowledge of what that slot/PN code might be.			

**Table 11.1.5-2: MBS Beacon Payload fields for the beacon to be simulated for the measurement reporting delay test**

MBS Tx ID (see Annex H)	Slot Index (see Annex H)	All Other fields (see Annex H)
Equal to Slot number	Equal to Slot number	min value (bit_value = 0) <sup>Note 1</sup>
Note 1: bit_value is the conversion of the binary number represented by the corresponding bits in the payload to decimal.		

The MBS measurement reporting delay (response time) shall be  $\leq 12300$  msec.

The test tolerances are defined in clauses C.1.4 and C.4.

The rate of successful tests during repeated tests shall be at least 90% with a confidence level of 95%.

## 11.1A MBS Measurement Reporting Delay (Release 14 Onwards)

### 11.1A.1 Test purpose

Same as defined in clause 11.1.1

### 11.1A.2 Test applicability

This test applies to all types of E-UTRA UE that supports UE-assisted MBS with LPP Release 14 onwards.

### 11.1A.3 Minimum conformance requirements

Same as defined in clause 11.1.3

### 11.1A.4 Test description

#### 11.1A.4.1 Initial conditions

Same as defined in clause 11.1.4.1

#### 11.1A.4.2 Test procedure

Same as defined in clause 11.1.4.2, except step 4a is introduced and step 5 is modified as follows:



## 11.1A.5 Test requirement

Same as defined in clause 11.1.5, with the beacon parameters set according to the assistance data in TS 37.571-5 [20] clause 8.

## 11.2 MBS Sensitivity Measurement Accuracy (Release 13 only)

### 11.2.1 Test purpose

The purpose of this test is to verify that the MBS Code Phase measurement accuracy is within the specified limits under target sensitivity conditions. This test will verify the requirements in clause 5.2 of TS 37.171 [39] for MBS measurements. The channel type for this test is AWGN, as specified in clause 4.8.2.1.

### 11.2.2 Test applicability

This test applies to all types of E-UTRA UE that supports UE-assisted MBS with LPP Release 13 only.

### 11.2.3 Minimum conformance requirements

The MBS code phase measurement accuracy shall fulfil the requirement given in Table 11.2.3-1.

**Table 11.2.3-1: Accuracy requirements for sensitivity scenario**

Signal Strength (dBm)	Code phase measurement accuracy (ms) <sup>Note 1</sup>	Accuracy requirement for the difference of code phase measurements (ms) <sup>Note 2</sup>
-130	$1.66 \times 10^{-4}$	$2.35 \times 10^{-4}$
Note 1: Provided for reference only		
Note 2: To be used for testing		

The accuracy requirement for the difference of code phase measurements is derived from the requirement for the code phase measurement accuracy, assuming a scaling factor of  $\sqrt{2}$  due to the compounding of two error distributions.

The normative reference for this requirement is TS 37.171 [39] clause 5.2 (Sensitivity) and clause A.4.2.

### 11.2.4 Test description

#### 11.2.4.1 Initial conditions

Test environment: normal; see Annex G.

1. Connect SS and MSS to the UE antenna connector or antenna connectors as shown in figures A.6 or A.7.
2. Switch on the UE.
3. Establish a signalling connection according to the generic procedure in TS 36.508 [18] clause 4.5.3 (State 3, Generic RB established) on a channel in the Mid EARFCN range.

#### 11.2.4.2 Test procedure

1. Set the MSS test parameters as specified in clause 11.2.5.
2. The SS shall send a RESET UE POSITIONING STORED INFORMATION message.
3. The SS shall send an LPP REQUEST CAPABILITIES message.
4. The UE shall transmit an LPP PROVIDE CAPABILITIES message indicating the TBS capabilities supported by the UE in the *TBS-ProvideCapabilities* IE.
5. The SS shall send a LPP REQUEST LOCATION INFORMATION message, including the *TBS-RequestLocationInformation* IE. If the UE message at step 4 includes the *ackRequested* IE set to TRUE, then the SS shall send an acknowledgment in the LPP REQUEST LOCATION INFORMATION message.

6. The UE shall perform and report the code phase measurement for each simulated beacon. If the UE transmits a *TBS-ProvideLocationInformation* IE including the *transmitterID* and *codePhase* field for the two simulated beacons and the difference between *codePhase* field values for the two beacons meet the corresponding requirements in Table 11.2.5-3, then the number of successful tests is increased by one. Otherwise the number of failure tests is increased by one.
7. If the UE message at step 6 includes the *ackRequested* IE set to TRUE, the SS shall send a LPP acknowledgement message.
8. Repeat steps 1-7 until the confidence level according to Annex D is achieved. For each iteration, at step 1 reselect the PN code assigned to each MBS beacon.
9. Release the signalling connection.

### 11.2.4.3 Message contents

**Table 11.2.4.3-1: RESET UE POSITIONING STORED INFORMATION**

Derivation Path: TS 36.509 [11] clause 6.9			
Information Element	Value/remark	Comment	Condition
UE Positioning Technology	0 0 0 0 0 0 1 0	MBS	

**Table 11.2.4.3-2: LPP RequestCapabilities**

Information Element	Value/remark
<i>tbs-RequestCapabilities-r13</i>	TRUE



**Table 11.2.4.3-3: LPP RequestLocationInformation**

Derivation Path: TS 36.355 [4] clause 6.2			
Information Element	Value/remark	Comment	Condition
LPP-Message ::= SEQUENCE {			
transactionID SEQUENCE {			
Initiator	locationServer		
transactionNumber	1		
}			
endTransaction	FALSE		
sequenceNumber	Not present		
acknowledgement	Not present		
lpp-MessageBody CHOICE {			
c1 CHOICE {			
requestLocationInformation SEQUENCE {			
criticalExtensions CHOICE {			
c1 CHOICE {			
requestLocationInformation-r9 SEQUENCE {			
commonIEsRequestLocationInformation SEQUENCE {			
locationInformationType	locationMeasurementsRequired		
triggeredReporting	Not present		
periodicalReporting	Not present		
additionalInformation	onlyReturnInformationRequested		
qos SEQUENCE {			
horizontalAccuracy	Not present		
verticalCoordinateRequest	FALSE		
verticalAccuracy	Not present		
responseTime SEQUENCE {			
Time	12		
responseTimeEarlyFix-r12	Not present		
}			
velocityRequest	FALSE		
}			
Environment	Not present		
locationCoordinateTypes	Not present		
velocityTypes	Not present		
}			
a-gnss-RequestLocationInformation	Not present		
otdoa-RequestLocationInformation	Not present		
ecid-RequestLocationInformation	Not present		
epdu-RequestLocationInformation	Not present		
sensor-RequestLocationInformation-r13	Not present		
tbs-RequestLocationInformation-r13 SEQUENCE {			
mbsSgnMeasListReq-r13	TRUE		
}			
wlan-RequestLocationInformation-r13	Not present		
bt-RequestLocationInformation-r13	Not Present		
}			
}			
}			
}			
}			

Table 11.2.4.3-4: LPP ProvideLocationInformation

Derivation Path: TS 36.355 [4] clause 6.2			
Information Element	Value/remark	Comment	Condition
LPP-Message ::= SEQUENCE {			
transactionID SEQUENCE {			
Initiator	locationServer		
transactionNumber	1		
}			
endTransaction	TRUE		
sequenceNumber	(0..255)		
Acknowledgement			
lpp-MessageBody CHOICE {			
c1 CHOICE {			
provideLocationInformation SEQUENCE {			
criticalExtensions CHOICE {			
c1 CHOICE {			
provideLocationInformation-r9 SEQUENCE {			
commonIEsProvideLocationInformation	Not present.		
a-gnss-ProvideLocationInformation	Not present		
otdoa-ProvideLocationInformation	Not present		
ecid-ProvideLocationInformation	Not present		
epdu-ProvideLocationInformation	Not present		
sensor-ProvideLocationInformation-r13	Not present		
tbs-ProvideLocationInformation-r13			
SEQUENCE {			
tbs-MeasurementInformation-r13			
SEQUENCE {			
measurementReferenceTime-r13			
mbs-SgnMeasList-r13			
SEQUENCE (SIZE(n)) {			
transmitterID-r13	Present		
codePhase-r13	Present		
codePhaseRMSError-r13			
}			
mbs-SgnMeasList-r13			
SEQUENCE (SIZE(n)) {			
transmitterID-r13	Present		
codePhase-r13	Present		
codePhaseRMSError-r13			
}			
}			
tbs-Error-r13	May be present with error reason 'undefined' or 'thereWereNotEnoughMBSBeaconsReceived'		
}			
wlan-ProvideLocationInformation-r13	Not present		
bt-ProvideLocationInformation-r13	Not present		
}			
}			
}			

### 11.2.5 Test requirement

The details of the beacon parameters are in Table 11.2.5-1 and Table 11.2.5-2.

**Table 11.2.5-1: General test parameters for the beacons to be simulated for measurement accuracy in Sensitivity test**

Parameter	Unit	Value	Comment
Number of Beacons		2	Beacons transmitted in any two beacon slots in the beacon transmission period, but static for the test. Other slots contain no simulated beacons <sup>Note 1</sup>
Centre Frequency	MHz	925.977	
RF Channel	N/A	AWGN	
MBS Beacon Configuration	N/A	TB1 (2 MHz)	For details see Annex H
MBS Packet Type	N/A	Type 2	For details see Annex H\
Beacon PN Code	Integer	Chosen for each beacon from the PN code list for TB1	Each of the 2 beacons uses a different PN code. For details see Annex H <sup>Note 1</sup>
Response time	Seconds	12	Value of Time used in LPP RequestLocationInformation message in Table 11.2.4.3-3
Note 1: The slots and PN codes are chosen at random, such that the UE does not and cannot have advanced knowledge of what that slot/PN code might be.			

**Table 11.2.5-2: MBS Beacon Payload fields, code phase delay difference and transmit powers for the beacons to be simulated for measurement accuracy in sensitivity test**

MBS Tx ID (See Annex H)	Slot Index (See Annex H)	All Other fields (See Annex H)	Code phase delay difference between beacons (ms)	Transmit Power (dBm)
Equal to Slot number	Equal to Slot number	min value (bit_value = 0) <sup>Note 1</sup>	0	-128
Note 1: bit_value is the conversion of the binary number represented by the corresponding bits in the payload to decimal.				

The MBS code phase measurement accuracy shall fulfil the requirements given in Table 11.2.5-3.

**Table 11.2.5-3: Accuracy requirements for Sensitivity scenario**

Code phase measurement accuracy (ms) <sup>Note 1</sup>	Accuracy requirement for the difference of code phase measurements (ms) <sup>Note 2</sup>
$1.66 \times 10^{-4}$	$2.40 \times 10^{-4}$
Note 1: Provided for reference only Note 2: To be used for testing	

The test tolerances are defined in clauses C.1.4 and C.4.

The rate of successful tests during repeated tests shall be at least 90% with a confidence level of 95%.

## 11.2A MBS Sensitivity Measurement Accuracy (Release 14 Onwards)

### 11.2A.1 Test purpose

Same as defined in clause 11.2.1

### 11.2A.2 Test applicability

This test applies to all types of E-UTRA UE that supports UE-assisted MBS with LPP Release 14 onwards.

## 11.2A.3 Minimum conformance requirements

Same as defined in clause 11.2.3 except that the accuracy requirements are:

**Table 11.2A.3-1: Accuracy requirements for sensitivity scenario**

MBS Configuration	Signal Strength (dBm)	Code phase measurement accuracy (ms) <sup>Note 1</sup>	Accuracy requirement for the difference of code phase measurements (ms) <sup>Note 2</sup>
TB1 (2 MHz)	-130	$1.66 \times 10^{-4}$	$2.35 \times 10^{-4}$
TB2 (5 MHz)	-130	$6.6 \times 10^{-5}$	$9.3 \times 10^{-5}$
Note 1: Provided for reference only			
Note 2: To be used for testing			

## 11.2A.4 Test description

### 11.2A.4.1 Initial conditions

Same as defined in clause 11.2.4.1

### 11.2A.4.2 Test procedure

Same as defined in clause 11.2.4.2, except step 4a is introduced and step 5 is modified as follows:

- 4a. The SS shall send an LPP PROVIDE ASSISTANCE DATA message to provide the MBS assistance data in accordance with TS 37.571-5 [20], and with the values defined therein. If the UE message at step 4 includes the *ackRequested* IE set to TRUE, then the SS shall send an acknowledgment in the LPP PROVIDE ASSISTANCE DATA message.
5. The SS shall send a LPP REQUEST LOCATION INFORMATION message, including the *TBS-RequestLocationInformation* IE.

### 11.2A.4.3 Message contents

Same as defined in clause 11.2.4.3, with the addition of the LPP Provide Assistance Data



## 11.2A.5 Test requirement

Same as defined in clause 11.2.5, with the beacon parameters set according to the assistance data in TS 37.571-5 [20] clause 8 and with the measurement accuracy requirement in Table 11.2A.5-1.

**Table 11.2A.5-1: Accuracy requirements for Sensitivity scenario**

MBS Configuration	Code phase measurement accuracy (ms) <sup>Note 1</sup>	Accuracy requirement for the difference of code phase measurements (ms) <sup>Note 2</sup>
TB1 (2 MHz)	$1.66 \times 10^{-4}$	$2.40 \times 10^{-4}$
TB2 (5 MHz)	$6.6 \times 10^{-5}$	$9.8 \times 10^{-5}$
Note 1: Provided for reference only		
Note 2: To be used for testing		

## 11.3 MBS Nominal Measurement Accuracy (Release 13 only)

### 11.3.1 Test purpose

The purpose of this test is to verify that the MBS Code Phase measurement accuracy is within the specified limits under ideal conditions. This test will verify the requirements in clauses 5.3 of 37.171 [39] for MBS measurements. The channel type for this test is AWGN, as specified in clause 4.8.2.1.

### 11.3.2 Test applicability

This test applies to all types of E-UTRA UE that supports UE-assisted MBS with LPP Release 13 only.

### 11.3.3 Minimum conformance requirements

The MBS code phase measurement accuracy shall fulfil the requirement given in Table 11.3.3-1.

**Table 11.3.3-1: Accuracy requirements for Nominal scenario**

Signal Strength (dBm)	Code phase measurement accuracy (ms) <sup>Note 1</sup>	Accuracy requirement for the difference of code phase measurements (ms) <sup>Note 2</sup>
-30	$5.0 \times 10^{-5}$	$7.1 \times 10^{-5}$
Note 1: Provided for reference only		
Note 2: To be used for testing		

The accuracy requirement for the difference of code phase measurements is derived from the requirement for the code phase measurement accuracy, assuming a scaling factor of  $\sqrt{2}$  due to the compounding of two error distributions.

The normative reference for this requirement is TS 37.171 [39] clause 5.3 (Nominal) and clause A.4.2.

### 11.3.4 Test description

#### 11.3.4.1 Initial conditions

Test environment: normal; see Annex G.

1. Connect SS and MSS to the UE antenna connector or antenna connectors as shown in figures A.6 or A.7.
2. Switch on the UE.
3. Establish a signalling connection according to the generic procedure in TS 36.508 [18] clause 4.5.3 (State 3, Generic RB established) on a channel in the Mid EARFCN range.

#### 11.3.4.2 Test procedure

1. Set the MSS test parameters as specified in clause 11.3.5.
2. The SS shall send a RESET UE POSITIONING STORED INFORMATION message.

3. The SS shall send an LPP REQUEST CAPABILITIES message.
4. The UE shall transmit an LPP PROVIDE CAPABILITIES message indicating the TBS capabilities supported by the UE in the *TBS-ProvideCapabilities* IE.
5. The SS shall send a LPP REQUEST LOCATION INFORMATION message, including the *TBS-RequestLocationInformation* IE. If the UE message at step 4 includes the *ackRequested* IE set to TRUE, then the SS shall send an acknowledgment in the LPP REQUEST LOCATION INFORMATION message.
6. The UE shall perform and report the code phase measurement for each simulated beacon. If the UE transmits a *TBS-ProvideLocationInformation* IE including the *transmitterID* and *codePhase* field for the two simulated beacons and the difference between *codePhase* field values for the two beacons meet the corresponding requirements in Table 11.3.5-3, then the number of successful tests is increased by one. Otherwise the number of failure tests is increased by one.
7. If the UE message at step 6 includes the *ackRequested* IE set to TRUE, the SS shall send a LPP acknowledgement message.
8. Repeat steps 1-7 until the confidence level according to Annex D is achieved. For each iteration, at step 1 reselect the PN code assigned to each MBS beacon.
9. Release the signalling connection.

### 11.3.4.3 Message contents

**Table 11.3.4.3-1: RESET UE POSITIONING STORED INFORMATION**

Derivation Path: TS 36.509 [11] clause 6.9			
Information Element	Value/remark	Comment	Condition
UE Positioning Technology	0 0 0 0 0 1 0	MBS	

**Table 11.3.4.3-2: LPP RequestCapabilities**

Information Element	Value/remark
<i>tbs-RequestCapabilities-r13</i>	TRUE

**Table 11.3.4.3-3: LPP RequestLocationInformation**

Derivation Path: TS 36.355 [4] clause 6.2			
Information Element	Value/remark	Comment	Condition
LPP-Message ::= SEQUENCE {			
transactionID SEQUENCE {			
Initiator	locationServer		
transactionNumber	1		
}			
endTransaction	FALSE		
sequenceNumber	Not present		
acknowledgement	Not present		
lpp-MessageBody CHOICE {			
c1 CHOICE {			
requestLocationInformation SEQUENCE {			
criticalExtensions CHOICE {			
c1 CHOICE {			
requestLocationInformation-r9 SEQUENCE {			
commonIEsRequestLocationInformation SEQUENCE {			
locationInformationType	locationMeasurementsRequired		
triggeredReporting	Not present		
periodicalReporting	Not present		
additionalInformation	onlyReturnInformationRequested		
qos SEQUENCE {			
horizontalAccuracy	Not present		
verticalCoordinateRequest	FALSE		
verticalAccuracy	Not present		
responseTime SEQUENCE {			
Time	12		
responseTimeEarlyFix-r12	Not present		
}			
velocityRequest	FALSE		
}			
Environment	Not present		
locationCoordinateTypes	Not present		
velocityTypes	Not present		
}			
a-gnss-RequestLocationInformation	Not present		
otdoa-RequestLocationInformation	Not present		
ecid-RequestLocationInformation	Not present		
epdu-RequestLocationInformation	Not present		
sensor-RequestLocationInformation-r13	Not present		
tbs-RequestLocationInformation-r13 SEQUENCE {			
mbsSgnMeasListReq-r13	TRUE		
}			
wlan-RequestLocationInformation-r13	Not present		
bt-RequestLocationInformation-r13	Not Present		
}			
}			
}			
}			
}			



Table 11.3.4.3-4: LPP ProvideLocationInformation

Derivation Path: TS 36.355 [4] clause 6.2			
Information Element	Value/remark	Comment	Condition
LPP-Message ::= SEQUENCE {			
transactionID SEQUENCE {			
Initiator	locationServer		
transactionNumber	1		
}			
endTransaction	TRUE		
sequenceNumber	(0..255)		
Acknowledgement			
lpp-MessageBody CHOICE {			
c1 CHOICE {			
provideLocationInformation SEQUENCE {			
criticalExtensions CHOICE {			
c1 CHOICE {			
provideLocationInformation-r9 SEQUENCE {			
commonIEsProvideLocationInformation	Not present.		
a-gnss-ProvideLocationInformation	Not present		
otdoa-ProvideLocationInformation	Not present		
ecid-ProvideLocationInformation	Not present		
epdu-ProvideLocationInformation	Not present		
sensor-ProvideLocationInformation-r13	Not present		
tbs-ProvideLocationInformation-r13			
SEQUENCE {			
tbs-MeasurementInformation-r13			
SEQUENCE {			
measurementReferenceTime-r13			
mbs-SgnMeasList-r13			
SEQUENCE (SIZE(n)) {			
transmitterID-r13	Present		
codePhase-r13	Present		
codePhaseRMSError-r13			
}			
mbs-SgnMeasList-r13			
SEQUENCE (SIZE(n)) {			
transmitterID-r13	Present		
codePhase-r13	Present		
codePhaseRMSError-r13			
}			
}			
tbs-Error-r13	May be present with error reason 'undefined' or 'thereWereNotEnoughMBSBeaconsReceived'		
}			
wlan-ProvideLocationInformation-r13	Not present		
bt-ProvideLocationInformation-r13	Not present		
}			
}			
}			

### 11.3.5 Test requirement

The details of the beacon parameters are in Table 11.3.5-1 and Table 11.3.5-2.

**Table 11.3.5-1: General test parameters for the beacons to be simulated for measurement accuracy in Nominal test**

Parameter	Unit	Value	Comment
Number of Beacons		2	Beacons transmitted in any two beacon slots in the beacon transmission period, but static for the test. Other slots contain no simulated beacons <sup>Note 1</sup>
Centre Frequency	MHz	925.977	
RF Channel	N/A	AWGN	
MBS Beacon Configuration	N/A	TB1 (2 MHz)	For details see Annex H
MBS Packet Type	N/A	Type 2	For details see Annex H
Beacon PN Code	Integer	Chosen for each beacon from the PN code list for TB1	Each of the 2 beacons uses a different PN code. For details see Annex H <sup>Note 1</sup>
Response time	Seconds	12	Value of Time used in LPP RequestLocationInformation message in Table 11.3.4.3-3
Note 1: The slots and PN codes are chosen at random, such that the UE does not and cannot have advanced knowledge of what that slot/PN code might be.			

**Table 11.3.5-2: MBS Beacon Payload fields, code phase delay difference and transmit powers for the beacons to be simulated for measurement accuracy in Nominal test**

MBS Tx ID (See Annex H)	Slot Index (See Annex H)	All Other fields (See Annex H)	Code phase delay difference between beacons (ms)	Transmit Power (dBm)
Equal to Slot number	Equal to Slot number	min value (bit_value = 0) <sup>Note 1</sup>	0	-30
Note: bit_value is the conversion of the binary number represented by the corresponding bits in the payload to decimal.				

The MBS code phase measurement accuracy shall fulfil the requirements given in Table 11.3.5-3.

**Table 11.3.5-3: Accuracy requirements for Nominal scenario**

Code phase measurement accuracy (ms) <sup>Note 1</sup>	Accuracy requirement for the difference of code phase measurements (ms) <sup>Note 2</sup>
$5.0 \times 10^{-5}$	$7.6 \times 10^{-5}$
Note 1: Provided for reference only Note 2: To be used for testing	

The test tolerances are defined in clauses C.1.4 and C.4.

The rate of successful tests during repeated tests shall be at least 90% with a confidence level of 95%.

## 11.3A MBS Nominal Measurement Accuracy (Release 14 Onwards)

### 11.3A.1 Test purpose

Same as defined in clause 11.3.1

### 11.3A.2 Test applicability

This test applies to all types of E-UTRA UE supports UE-assisted MBS with LPP Release 14 onwards.

### 11.3A.3 Minimum conformance requirements

Same as defined in clause 11.3.3 except that the accuracy requirements are:

**Table 11.3A.3-1: Accuracy requirements for Nominal scenario**

MBS Configuration	Signal Strength (dBm)	Code phase measurement accuracy (ms) <sup>Note 1</sup>	Accuracy requirement for the difference of code phase measurements (ms) <sup>Note 2</sup>
TB1 (2 MHz)	-30	$5.0 \times 10^{-5}$	$7.1 \times 10^{-5}$
TB2 (5 MHz)	-30	$2.0 \times 10^{-5}$	$2.8 \times 10^{-5}$
Note 1: Provided for reference only Note 2: To be used for testing			

### 11.3A.4 Test description

#### 11.3A.4.1 Initial conditions

Same as defined in clause 11.3.4.1

#### 11.3A.4.2 Test procedure

Same as defined in clause 11.3.4.2, except step 4a is introduced and step 5 is modified as follows:

- 4a. The SS shall send an LPP PROVIDE ASSISTANCE DATA message to provide the MBS assistance data in accordance with TS 37.571-5 [20], and with the values defined therein. If the UE message at step 4 includes the *ackRequested* IE set to TRUE, then the SS shall send an acknowledgment in the LPP PROVIDE ASSISTANCE DATA message.
5. The SS shall send a LPP REQUEST LOCATION INFORMATION message, including the *TBS-RequestLocationInformation* IE.

#### 11.3A.4.3 Message contents

Same as defined in clause 11.3.4.3, with the addition of the LPP Provide Assistance Data.



## 11.3A.5 Test requirement

Same as defined in clause 11.3.5, with the beacon parameters set according to the assistance data in TS 37.571-5 [20] clause 8 and with the measurement accuracy requirement in Table 11.3A.5-1.

**Table 11.3A.5-1: Accuracy requirements for Nominal scenario**

MBS Configuration	Code phase measurement accuracy (ms) <sup>Note 1</sup>	Accuracy requirement for the difference of code phase measurements (ms) <sup>Note 2</sup>
TB1 (2 MHz)	$5.0 \times 10^{-5}$	$7.6 \times 10^{-5}$
TB2 (5 MHz)	$2.0 \times 10^{-5}$	$3.3 \times 10^{-5}$
Note 1: Provided for reference only Note 2: To be used for testing		

## 11.4 MBS Dynamic Range Measurement Accuracy (Release 13 only)

### 11.4.1 Test purpose

The purpose of this test is to verify that the MBS Code Phase measurement accuracy is within the specified limits under maximum dynamic range conditions. This test will verify the requirements in clauses 5.4 of TS 37.171 [39] for MBS measurements. The channel type for this test is AWGN, as specified in clause 4.8.2.1.

### 11.4.2 Test applicability

This test applies to all types of E-UTRA UE that supports UE-assisted MBS with LPP Release 13 only.

### 11.4.3 Minimum conformance requirements

The MBS code phase measurement accuracy shall fulfil the requirements given in Table 11.4.3-1.

**Table 11.4.3-1: Accuracy requirements for Dynamic Range scenario**

Signal Strength (dBm)	Code phase measurement accuracy (ms) <sup>Note 1</sup>	Accuracy requirement for the difference of code phase measurements (ms) <sup>Note 2</sup>
-30	$5.0 \times 10^{-5}$	$7.1 \times 10^{-5}$
-130	$1.66 \times 10^{-4}$	$2.35 \times 10^{-4}$
Note 1: Provided for reference only Note 2: To be used for testing		

The accuracy requirement for the difference of code phase measurements is derived from the requirement for the code phase measurement accuracy, assuming a scaling factor of  $\sqrt{2}$  due to the compounding of two error distributions.

The normative reference for this requirement is TS 37.171 [39] clause 5.4 (Dynamic Range) and clause A.4.2.

### 11.4.4 Test description

#### 11.4.4.1 Initial conditions

Test environment: normal; see Annex G.

1. Connect SS and MSS to the UE antenna connector or antenna connectors as shown in figures A.6 or A.7.
2. Switch on the UE.
3. Establish a signalling connection according to the generic procedure in TS 36.508 [18] clause 4.5.3 (State 3, Generic RB established) on a channel in the Mid EARFCN range.

#### 11.4.4.2 Test procedure

1. Set the MSS test parameters as specified in clause 11.4.5.
2. The SS shall send a RESET UE POSITIONING STORED INFORMATION message.
3. The SS shall send an LPP REQUEST CAPABILITIES message.
4. The UE shall transmit an LPP PROVIDE CAPABILITIES message indicating the TBS capabilities supported by the UE in the *TBS-ProvideCapabilities* IE.
5. The SS shall send a LPP REQUEST LOCATION INFORMATION message, including the *TBS-RequestLocationInformation* IE. If the UE message at step 4 includes the *ackRequested* IE set to TRUE, then the SS shall send an acknowledgment in the LPP REQUEST LOCATION INFORMATION message.
6. The UE shall perform and report the code phase measurement for each simulated beacon. If the UE transmits a *TBS-ProvideLocationInformation* IE including the *transmitterID* and *codePhase* field for the four simulated beacons and the difference between *codePhase* field values for the two high power beacons and the difference in the *codePhase* field values for the two low power beacons meet the corresponding requirements in Table 11.4.5-3, then the number of successful tests is increased by one. Otherwise the number of failure tests is increased by one.
7. If the UE message at step 6 includes the *ackRequested* IE set to TRUE, the SS shall send a LPP acknowledgement message.
8. Repeat steps 1-7 until the confidence level according to Annex D is achieved. For each iteration, at step 1 reselect the PN code assigned to each MBS beacon.
9. Release the signalling connection.

#### 11.4.4.3 Message contents

**Table 11.4.4.3-1: RESET UE POSITIONING STORED INFORMATION**

Derivation Path: TS 36.509 [11] clause 6.9			
Information Element	Value/remark	Comment	Condition
UE Positioning Technology	0 0 0 0 0 1 0	MBS	

**Table 11.4.4.3-2: LPP RequestCapabilities**

Information Element	Value/remark
<i>tbs-RequestCapabilities-r13</i>	TRUE



**Table 11.4.4.3-4: LPP ProvideLocationInformation**



Derivation Path: TS 36.355 [4] clause 6.2			
Information Element	Value/remark	Comment	Condition
LPP-Message ::= SEQUENCE {			
transactionID SEQUENCE {			
Initiator	locationServer		
transactionNumber	1		
}			
endTransaction	TRUE		
sequenceNumber	(0..255)		
Acknowledgement			
lpp-MessageBody CHOICE {			
c1 CHOICE {			
provideLocationInformation SEQUENCE {			
criticalExtensions CHOICE {			
c1 CHOICE {			
provideLocationInformation-r9 SEQUENCE {			
commonIEsProvideLocationInformation	Not present.		
a-gnss-ProvideLocationInformation	Not present		
otdoa-ProvideLocationInformation	Not present		
ecid-ProvideLocationInformation	Not present		
epdu-ProvideLocationInformation	Not present		
sensor-ProvideLocationInformation-r13	Not present		
tbs-ProvideLocationInformation-r13			
SEQUENCE {			
tbs-MeasurementInformation-r13			
SEQUENCE {			
measurementReferenceTime-r13			
mbs-SgnMeasList-r13			
SEQUENCE (SIZE(n)) {			
transmitterID-r13	Present		
codePhase-r13	Present		
codePhaseRMSError-r13			
}			
mbs-SgnMeasList-r13			
SEQUENCE (SIZE(n)) {			
transmitterID-r13	Present		
codePhase-r13	Present		
codePhaseRMSError-r13			
}			
mbs-SgnMeasList-r13			
SEQUENCE (SIZE(n)) {			
transmitterID-r13	Present		
codePhase-r13	Present		
codePhaseRMSError-r13			
}			
mbs-SgnMeasList-r13			
SEQUENCE (SIZE(n)) {			
transmitterID-r13	Present		
codePhase-r13	Present		
codePhaseRMSError-r13			
}			
}			
tbs-Error-r13	May be present with error reason 'undefined' or 'thereWereNotEnoughMBSBeaconsReceived'		
}			
wlan-ProvideLocationInformation-r13	Not present		
bt-ProvideLocationInformation-r13	Not present		
}			
}			
}			

## 11.4.5 Test requirement

The details of the beacon parameters are in Table 11.4.5-1 and Table 11.4.5-2.

**Table 11.4.5-1: General test parameters for the beacons to be simulated for measurement accuracy in Dynamic Range test**

Parameter	Unit	Value	Comment
Number of Beacons		4	Beacons 1 to 4. Transmitted in any four consecutive beacon slots in the beacon transmission period, but static for the test. Other slots contain no simulated beacons <sup>Note 1</sup>
Centre Frequency	MHz	925.977	
RF Channel	N/A	AWGN	
MBS Beacon Configuration	N/A	TB1 (2 MHz)	For details see Annex H
MBS Packet Type	N/A	Type 2	For details see Annex H
Beacon PN Code	Integer	Chosen for each beacon from the PN code list for TB1	Each of the 4 beacons uses a different PN code. For details see Annex H <sup>Note 1</sup>
Response time	Seconds	12	Value of Time used in LPP RequestLocationInformation message in Table 11.4.4.3-3
Note 1: The slots and PN codes are chosen at random, such that the UE does not and cannot have advanced knowledge of what that slot/PN code might be.			

**Table 11.4.5-2: MBS Beacon Payload fields, code phase delay difference and transmit powers for the beacons to be simulated for measurement accuracy in Dynamic Range test**

Beacon	MBS Tx ID (See Annex H)	Slot Index (See Annex H)	All Other fields (See Annex H)	Code phase delay difference between beacons (ms)	Transmit Power (dBm)
1	Equal to Slot number	Equal to Slot number	min value (bit_value = 0) <sup>Note 1</sup>	Beacon 1 to beacon 3: 0 <sup>Note 2</sup>	-30 (high power)
2	Equal to Slot number	Equal to Slot number	min value (bit_value = 0) <sup>Note 1</sup>	Beacon 2 to beacon 4: 0 <sup>Note 2</sup>	-128 (low power)
3	Equal to Slot number	Equal to Slot number	min value (bit_value = 0) <sup>Note 1</sup>	Beacon 1 to beacon 3: 0 <sup>Note 2</sup>	-30 (high power)
4	Equal to Slot number	Equal to Slot number	min value (bit_value = 0) <sup>Note 1</sup>	Beacon 2 to beacon 4: 0 <sup>Note 2</sup>	-128 (low power)
Note 1: bit_value is the conversion of the binary number represented by the corresponding bits in the payload to decimal. Note 2: The code phase delay difference between beacon 1 and 3 and beacon 2 and 4 shall be set to some non-zero value.					

The MBS code phase measurement accuracy shall fulfil the requirements given in Table 11.4.5-3.

**Table 11.4.5-3: Accuracy requirements for Dynamic Range scenario**

Beacon Signal Strength	Code phase measurement accuracy (ms) <sup>Note 1</sup>	Accuracy requirement for the difference of code phase measurements (ms) <sup>Note 2</sup>
High Power (-30 dBm)	$5.0 \times 10^{-5}$	$7.6 \times 10^{-5}$
Low Power (-130 dBm)	$1.66 \times 10^{-4}$	$2.40 \times 10^{-4}$
Note 1: Provided for reference only Note 2: To be used for testing		

The test tolerances are defined in clauses C.1.4 and C.4.

The rate of successful tests during repeated tests shall be at least 90% with a confidence level of 95%.

## 11.4A MBS Dynamic Range Measurement Accuracy (Release 14 Onwards)

### 11.4A.1 Test purpose

Same as defined in clause 11.4.1

### 11.4A.2 Test applicability

This test applies to all types of E-UTRA UE that supports UE-assisted MBS with LPP Release 14 onwards.

### 11.4A.3 Minimum conformance requirements

Same as defined in clause 11.4.3 except that the accuracy requirements are:

**Table 11.4A.3-1: Accuracy requirements for Dynamic Range scenario**

MBS Configuration	Signal Strength (dBm)	Code phase measurement accuracy (ms) <sup>Note 1</sup>	Accuracy requirement for the difference of code phase measurements (ms) <sup>Note 2</sup>
TB1 (2 MHz)	-30	$5.0 \times 10^{-5}$	$7.1 \times 10^{-5}$
	-130	$1.66 \times 10^{-4}$	$2.35 \times 10^{-4}$
TB2 (5 MHz)	-30	$2.0 \times 10^{-5}$	$2.8 \times 10^{-5}$
	-130	$6.6 \times 10^{-5}$	$9.3 \times 10^{-5}$
Note 1: Provided for reference only Note 2: To be used for testing			

### 11.4A.4 Test description

#### 11.4A.4.1 Initial conditions

Same as defined in clause 11.4.4.1

#### 11.4A.4.2 Test procedure

Same as defined in clause 11.4.4.2, except step 4a is introduced and step 5 is modified as follows:

- 4a. The SS shall send an LPP PROVIDE ASSISTANCE DATA message to provide the MBS assistance data in accordance with TS 37.571-5 [20], and with the values defined therein. If the UE message at step 4 includes the *ackRequested* IE set to TRUE, then the SS shall send an acknowledgment in the LPP PROVIDE ASSISTANCE DATA message.
5. The SS shall send a LPP REQUEST LOCATION INFORMATION message, including the *TBS-RequestLocationInformation* IE.

#### 11.4A.4.3 Message contents

Same as defined in clause 11.4.4.3, with the addition of the LPP Provide Assistance Data.

**Table 11.4A.4.3-5: LPP ProvideAssistanceData**

Derivation Path: TS 36.355 [4] clause 6.2			
Information Element	Value/remark	Comment	Condition
LPP-Message ::= SEQUENCE {			
transactionID SEQUENCE {			
Initiator	locationServer		
transactionNumber	(0..255)		
}			
endTransaction	TRUE		
sequenceNumber	Not present		
acknowledgement			
lpp-MessageBody CHOICE {			
c1 CHOICE {			
provideAssistanceData SEQUENCE {			
criticalExtensions CHOICE {			
c1 CHOICE {			
provideAssistanceData-r9 SEQUENCE {			
commonEsProvideAssistanceData	Not present		
a-gnss-ProvideAssistanceData	Not present		
otdoa-ProvideAssistanceData	Not present		
epdu-ProvideAssistanceData	Not present		
sensor-ProvideAssistanceData-r14	Not present		Rel-14 onwards
tbs-ProvideAssistanceData-r14 SEQUENCE {			Rel-14 onwards
tbs-AssistanceDataList-r14 SEQUENCE {			
mbs-AssistanceDataList-r14 SEQUENCE {			
mbs-AssistanceDataElement-r14 SEQUENCE {		Beacon 1 tb1	
mbs-AlmanacAssistance-r14	Not Present		
mbs-AcquisitionAssistance-r14	As defined in TS 37.571-5 [20], clause 8		
}			
mbs-AssistanceDataElement-r14 SEQUENCE {		Beacon 2 tb1	
mbs-AlmanacAssistance-r14	Not Present		
mbs-AcquisitionAssistance-r14	As defined in TS 37.571-5 [20], clause 8		
}			
mbs-AssistanceDataElement-r14 SEQUENCE {		Beacon 3 tb1	
mbs-AlmanacAssistance-r14	Not Present		
mbs-AcquisitionAssistance-r14	As defined in TS 37.571-5 [20], clause 8		
}			
mbs-AssistanceDataElement-r14 SEQUENCE {		Beacon 4 tb1	
mbs-AlmanacAssistance-r14	Not Present		
mbs-AcquisitionAssistance-r14	As defined in TS 37.571-5 [20], clause 8		
}			
mbs-AssistanceDataElement-r14 SEQUENCE {		Beacon 1 tb2	
mbs-AlmanacAssistance-r14	Not Present		
mbs-AcquisitionAssistance-r14	As defined in TS 37.571-5 [20], clause 8		
}			
mbs-AssistanceDataElement-r14 SEQUENCE {		Beacon 2 tb2	
mbs-AlmanacAssistance-r14	Not Present		
mbs-AcquisitionAssistance-r14	As defined in TS 37.571-5 [20], clause 8		
}			
mbs-AssistanceDataElement-r14 SEQUENCE {		Beacon 3 tb2	
mbs-AlmanacAssistance-r14	Not Present		

mbs-AcquisitionAssistance-r14	As defined in TS 37.571-5 [20], clause 8		
}			
mbs-AssistanceDataElement-r14 SEQUENCE {		Beacon 4 tb2	
mbs-AlmanacAssistance-r14	Not Present		
mbs-AcquisitionAssistance-r14	As defined in TS 37.571-5 [20], clause 8		
}			
}			
}			
tbs-Error-r14	Not Present		
}			
wlan-ProvideAssistanceData-r14	Not Present		Rel-14 onwards
}			
}			
}			
}			
}			
}			

## 11.4A.5 Test requirement

Same as defined in clause 11.4.5, with the beacon parameters set according to the assistance data in TS 37.571-5 [20] clause 8 and with the measurement accuracy requirement a in Table 11.3A.5-1.

**Table 11.4A.5-1: Accuracy requirements for Dynamic Range scenario**

MBS Configuration	Beacon Signal Strength	Code phase measurement accuracy (ms) <sup>Note 1</sup>	Accuracy requirement for the difference of code phase measurements (ms) <sup>Note 2</sup>
TB1 (2 MHz)	High Power (-30 dBm)	$5.0 \times 10^{-5}$	$7.6 \times 10^{-5}$
	Low Power (-130 dBm)	$1.66 \times 10^{-4}$	$2.40 \times 10^{-4}$
TB2 (5 MHz)	High Power (-30 dBm)	$2.0 \times 10^{-5}$	$3.3 \times 10^{-5}$
	Low Power (-130 dBm)	$6.6 \times 10^{-5}$	$9.8 \times 10^{-5}$
Note 1: Provided for reference only			
Note 2: To be used for testing			

## 11.5 MBS Measurement Accuracy in Multipath (Release 13 only)

### 11.5.1 Test purpose

The purpose of this test is to verify that the MBS Code Phase measurement accuracy is within the specified limits in a multipath environment. This test will verify the requirements in clause 5.5 of TS 37.171 [39] for MBS measurements. The channel type for the test is EPA 5 Hz, as specified in clause 4.8.2.2.

### 11.5.2 Test applicability

This test applies to all types of E-UTRA UE that supports UE-assisted MBS with LPP Release 13 only.

### 11.5.3 Minimum conformance requirements

The MBS code phase measurement accuracy shall fulfil the requirements in Table 11.5.3-1.

**Table 11.5.3-1: Accuracy requirements for Multipath scenario**

Direct Path Signal Strength (dBm)	Code phase measurement accuracy (ms) <sup>Note 1</sup>	Accuracy requirement for the difference of code phase measurements (ms) <sup>Note 2</sup>
-30	$1.66 \times 10^{-4}$	$2.35 \times 10^{-4}$
Note 1: Provided for reference only		
Note 2: To be used for testing		

The accuracy requirement for the difference of code phase measurements is derived from the requirement for the code phase measurement accuracy, assuming a scaling factor of  $\sqrt{2}$  due to the compounding of two error distributions.

The normative reference for this requirement is TS 37.171 [39] clause 5.5 (Multipath) and clause A.4.3.

## 11.5.4 Test description

### 11.5.4.1 Initial conditions

Test environment: normal; see Annex G.

1. Connect SS and MSS to the UE antenna connector or antenna connectors as shown in figures A.6 or A.7.
2. Switch on the UE.
3. Establish a signalling connection according to the generic procedure in TS 36.508 [18] clause 4.5.3 (State 3, Generic RB established) on a channel in the Mid EARFCN range.

### 11.5.4.2 Test procedure

1. Set the MSS test parameters as specified in clause 11.5.5.
2. The SS shall send a RESET UE POSITIONING STORED INFORMATION message.
3. The SS shall send an LPP REQUEST CAPABILITIES message.
4. The UE shall transmit an LPP PROVID CAPABILITIES message indicating the TBS capabilities supported by the UE in the *TBS-ProvideCapabilities* IE.
5. The SS shall send a LPP REQUEST LOCATION INFORMATION message, including the *TBS-RequestLocationInformation*. If the UE message at step 4 includes the *ackRequested* IE set to TRUE, then the SS shall send an acknowledgment in the LPP REQUEST LOCATION INFORMATION message.
6. The UE shall perform and report the code phase measurement for each simulated beacon. If the UE transmits a *TBS-ProvideLocationInformation* IE including the *transmitterID* and *codePhase* field for the two simulated and the difference between *codePhase* field values for the two beacons meets the requirement in Table 11.5.5-3, then the number of successful tests is increased by one. Otherwise the number of failure tests is increased by one.
7. If the UE message at step 6 includes the *ackRequested* IE set to TRUE, the SS shall send a LPP acknowledgement message.
8. Repeat steps 1-7 until the confidence level according to Annex D is achieved. For each iteration, at step 1 reselect the PN code assigned to each MBS beacon.
9. Release the signalling connection.

### 11.5.4.3 Message contents

**Table 11.5.4.3-1: RESET UE POSITIONING STORED INFORMATION**

Derivation Path: TS 36.509 [11] clause 6.9			
Information Element	Value/remark	Comment	Condition
UE Positioning Technology	0 0 0 0 0 1 0	MBS	

**Table 11.5.4.3-2: LPP Request Capabilities**

Information Element	Value/remark
<i>tbs-RequestCapabilities-r13</i>	TRUE

**Table 11.5.4.3-3: LPP RequestLocationInformation**

Derivation Path: TS 36.355 [4] clause 6.2			
Information Element	Value/remark	Comment	Condition
LPP-Message ::= SEQUENCE {			
transactionID SEQUENCE {			
Initiator	locationServer		
transactionNumber	1		
}			
endTransaction	FALSE		
sequenceNumber	Not present		
acknowledgement	Not present		
lpp-MessageBody CHOICE {			
c1 CHOICE {			
requestLocationInformation SEQUENCE {			
criticalExtensions CHOICE {			
c1 CHOICE {			
requestLocationInformation-r9 SEQUENCE {			
commonEsRequestLocationInformation SEQUENCE {			
locationInformationType	locationMeasurementsRequired		
triggeredReporting	Not present		
periodicalReporting	Not present		
additionalInformation	onlyReturnInformationRequested		
qos SEQUENCE {			
horizontalAccuracy	Not present		
verticalCoordinateRequest	FALSE		
verticalAccuracy	Not present		
responseTime SEQUENCE {			
Time	12		
responseTimeEarlyFix-r12	Not present		
}			
velocityRequest	FALSE		
}			
Environment	Not present		
locationCoordinateTypes	Not present		
velocityTypes	Not present		
}			
a-gnss-RequestLocationInformation	Not present		
otdoa-RequestLocationInformation	Not present		
ecid-RequestLocationInformation	Not present		
epdu-RequestLocationInformation	Not present		
sensor-RequestLocationInformation-r13	Not present		
tbs-RequestLocationInformation-r13 SEQUENCE {			
mbsSgnMeasListReq-r13	TRUE		
}			
wlan-RequestLocationInformation-r13	Not present		
bt-RequestLocationInformation-r13	Not Present		
}			
}			
}			
}			
}			



Table 11.5.4.3-4: LPP ProvideLocationInformation

Derivation Path: TS 36.355 [4] clause 6.2			
Information Element	Value/remark	Comment	Condition
LPP-Message ::= SEQUENCE {			
transactionID SEQUENCE {			
Initiator	locationServer		
transactionNumber	1		
}			
endTransaction	TRUE		
sequenceNumber	(0..255)		
Acknowledgement			
lpp-MessageBody CHOICE {			
c1 CHOICE {			
provideLocationInformation SEQUENCE {			
criticalExtensions CHOICE {			
c1 CHOICE {			
provideLocationInformation-r9 SEQUENCE {			
commonIEsProvideLocationInformation	Not present.		
a-gnss-ProvideLocationInformation	Not present		
otdoa-ProvideLocationInformation	Not present		
ecid-ProvideLocationInformation	Not present		
epdu-ProvideLocationInformation	Not present		
sensor-ProvideLocationInformation-r13	Not present		
tbs-ProvideLocationInformation-r13			
SEQUENCE {			
tbs-MeasurementInformation-r13			
SEQUENCE {			
measurementReferenceTime-r13			
mbs-SgnMeasList-r13			
SEQUENCE (SIZE(n)) {			
transmitterID-r13	Present		
codePhase-r13	Present		
codePhaseRMSError-r13			
}			
mbs-SgnMeasList-r13			
SEQUENCE (SIZE(n)) {			
transmitterID-r13	Present		
codePhase-r13	Present		
codePhaseRMSError-r13			
}			
}			
}			
tbs-Error-r13	May be present with error reason 'undefined' or 'thereWereNotEnoughMBSBeaconsReceived'		
}			
wlan-ProvideLocationInformation-r13	Not present		
bt-ProvideLocationInformation-r13	Not present		
}			
}			
}			

### 11.5.5 Test requirement

The details of the beacon parameters are in Table 11.5.5-1 and Table 11.5.5-2.

**Table 11.5.5-1: General test parameters for the beacons to be simulated for measurement accuracy in Multipath test**

Parameter	Unit	Value	Comment
Number of beacons	Integer	2	Beacons transmitted in the any two beacon slots in the beacon transmission period, but static for the test. Other slots contain no simulated beacons. <sup>Note 1</sup>
Centre Frequency	MHz	925.977	
RF Channel	N/A	EPA 5 Hz	
MBS Beacon Configuration	N/A	TB1 (2 MHz)	For details see Annex H
MBS Packet Type	N/A	Type 2	For details see Annex H
Beacon PN Code	Integer	Chosen for each beacon from the PN code list for TB1	Each of the 2 beacons uses a different PN code For details see Annex H <sup>Note 1</sup>
Response time	Seconds	12	Value of Time used in LPP RequestLocationInformation message in Table 11.5.4.3-3
Note 1: The slots and PN codes are chosen at random, such that the UE does not and cannot have advanced knowledge of what that slot/PN code might be.			

**Table 11.5.5-2: MBS Beacon Payload fields, and code phase delay difference and transmit powers for the beacons to be simulated for measurement accuracy in Multipath test**

MBS Tx ID (See Annex H)	Slot Index (See Annex H)	All Other fields (See Annex H)	Code phase delay difference between beacons (ms)	Transmit Power (dBm)
Equal to Slot number	Equal to Slot number	min value (bit_value = 0) <sup>Note 1</sup>	0	-30
Note 1: bit_value is the conversion of the binary number represented by the corresponding bits in the payload to decimal.				

The MBS code phase measurement accuracy shall fulfil the requirements in Table 11.5.5-3.

**Table 11.5.5-3: Accuracy requirements for Multipath scenario**

Code phase measurement accuracy (ms) <sup>Note 1</sup>	Accuracy requirement for the difference of code phase measurements (ms) <sup>Note 2</sup>
$1.66 \times 10^{-4}$	$2.40 \times 10^{-4}$
Note 1: Provided for reference only Note 2: To be used for testing	

The test tolerances are defined in clauses C.1.4 and C.4.

The rate of successful tests during repeated tests shall be at least 90% with a confidence level of 95%.

## 11.5A MBS Measurement Accuracy in Multipath (Release 14 Onwards)

### 11.5A.1 Test purpose

Same as defined in clause 11.5.1

### 11.5A.2 Test applicability

This test applies to all types of E-UTRA UE that supports UE-assisted MBS with LPP Release 14 onwards.

### 11.5A.3 Minimum conformance requirements

Same as defined in clause 11.5.3

## 11.5A.4 Test description

### 11.5A.4.1 Initial conditions

Same as defined in clause 11.5.4.1

### 11.5A.4.2 Test procedure

Same as defined in clause 11.5.4.2, except step 4a is introduced and step 5 is modified as follows:

- 4a. The SS shall send an LPP PROVIDE ASSISTANCE DATA message to provide the MBS assistance data in accordance with TS 37.571-5 [20], and with the values defined therein. If the UE message at step 4 includes the *ackRequested* IE set to TRUE, then the SS shall send an acknowledgment in the LPP PROVIDE ASSISTANCE DATA message.
5. The SS shall send a LPP REQUEST LOCATION INFORMATION message, including the TBS *RequestLocationInformation*.

### 11.5A.4.3 Message contents

Same as defined in clause 11.5.4.3, with the addition of the LPP Provide Assistance Data.



## 11.5A.5 Test requirement

Same as defined in clause 11.5.5, with the beacon parameters set according to the assistance data in TS 37.571-5 [20] clause 8.

# 12 E-UTRA WLAN and BLE measurement requirements

## 12.1 WLAN Access Point Identification and Reporting Delay

### 12.1.1 WLAN AP Identification and reporting delay under nominal conditions

#### 12.1.1.1 Test purpose

The purpose of this test is to verify that the E-UTRAN UE WLAN AP measurements fulfil the performance requirements for WLAN AP identification under nominal conditions in TS 37.171 [39] clause 7.3 and reporting delay in TS 37.171 [39] clause 4.3.

#### 12.1.1.2 Test applicability

This test applies to all types of E-UTRA UE that support LPP release 14 and forward and WLAN positioning. Optionally, this test can be run by LPP release 13 UEs.

#### 12.1.1.3 Minimum conformance requirements

Under nominal conditions of the WLAN signal, the UE shall be able to identify 6 WLAN APs. The minimum requirements for Nominal conditions are shown in Table 12.1.1.3-1. In these requirements, AWGN channel model is used and the signal level is above the noise floor.

**Table 12.1.1.3-1: Requirements for WLAN Access Point Identification under Nominal conditions**

Number of WLAN APs	Signal Strength (dBm)	% of reported Access Points
6	-60	90

For LTE, the WLAN measurement time is defined as the time starting from the moment that the UE has received the LPP message of type REQUEST LOCATION INFORMATION, and ending when the UE starts sending the LPP message of type PROVIDE LOCATION INFORMATION on the Uu interface. The response times specified for all test cases are based on new measurements unless otherwise stated, i.e. the UE shall not re use any information on measurements or other aiding data that was previously acquired or calculated and stored internally in the UE. A dedicated test message 'RESET UE POSITIONING STORED INFORMATION' has been defined in TS 36.509 [11] clause 6.9 for the purpose of deleting this information. No WLAN assistance data is provided to the UE.

The signals from the WLAN APs shall be available at the UE for the duration of the measurement time. Each WLAN AP transmits a beacon signal with a beacon interval smaller or equal to 102.4 ms. The beacon frames from different access points shall be transmitted in different time slots or non-overlapping frequency channels. The beacon frames have variable time duration of ~1ms.

The WLAN Measurement Reporting Delay is given as:

$$T_{\text{WLAN\_meas}} = \tau + 20 \text{ sec}$$

where:

$T_{\text{WLAN\_meas}}$  is the total time for detecting and measuring the WLAN Access Points

$\tau$  is the elapsed time from the trigger of the measurement to the start of the first WLAN transmission period and is shown in Figure 12.1.1.3-1.

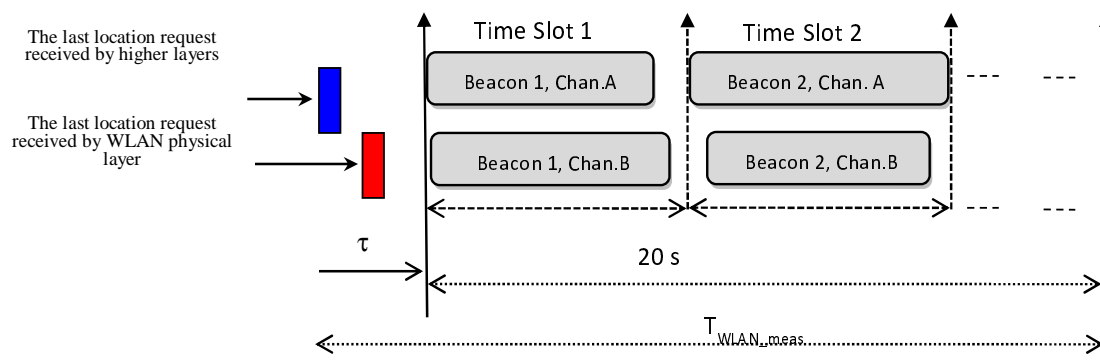

**Figure 12.1.1.3-1: Illustration of the WLAN Measurement Time**

The normative reference for the WLAN reporting delay requirement is 3GPP TS 37.171 [39] clause 4.3 and the normative reference for the WLAN AP Identification under nominal conditions requirement is 3GPP TS 37.171 [39] clause 7.3.

#### 12.1.1.4 Test description

There is one active LTE cell and 6 WLAN APs transmitting beacon signals at least every 102.4 ms. The APs are transmitting in 3 non-overlapping frequency channels in the same WLAN Frequency Band. Non-overlapping frequency channels are those whose centre frequencies are separated by at least 25 MHz in the WLAN 2.4 GHz band and by at least 20 MHz in the WLAN 5 GHz band. There are 2 APs in every channel. The tested UE is connected to the serving cell and signalled to report WLAN AP measurements. The test consists of two successive time periods, with duration of T1 and T2, respectively. WLAN-RequestLocationInformation message shall be provided to the UE during T1. WLAN Access Points only transmit signal during T2. The test equipment compares the BSSID reported by the UE in the WLAN AP measurements with the BSSID of the APs simulated in the test.

##### 12.1.1.4.1 Initial conditions

Test Environment: Normal as defined in TS 36.508 [18] clause 4.1.

E-UTRA frequencies to be tested: Mid Range, as defined in TS 36.508 [18] clause 4.3.1.

WLAN Channel Numbers to be tested: as specified in Table 12.1.1.5-2 and as defined in TS 36.508 [18] clause 4.3.1.6.

1. Connect the SS (node B emulator) and AWGN noise source to the UE antenna connectors as shown in Annex A figure A.8.
2. Propagation conditions are set according to clause 4.9.2.1.
3. Message contents are defined in clause 12.1.1.4.3.
4. Cell 1 is the serving cell. Cell 1 is the cell used for connection setup with the power levels set according to TS 36.521-3 [25] clauses C.0 and C.1 for this test. After the connection is established, the parameter settings for the cell are set according to Table 12.1.1.5-2.
5. Switch on the UE.
6. Establish a signalling connection according to the generic procedure in TS 36.508 [18] clause 4.5.3 (State 3, Generic RB established) on a channel in the Mid EARFCN range.

##### 12.1.1.4.2 Test procedure

1. Set the SS test parameters as specified in clause 12.1.1.5. The BSSID of the simulated APs shall be generated in a random manner.

2. The SS shall send a RESET UE POSITIONING STORED INFORMATION message.
3. T1 starts.
4. The SS shall send an LPP REQUEST CAPABILITIES message.
5. The UE shall transmit an LPP PROVIDE CAPABILITIES message indicating the WLAN capabilities supported by the UE in the *WLAN-ProvideCapabilities* IE.
6. The SS shall send a LPP REQUEST LOCATION INFORMATION message, including the *WLAN-RequestLocationInformation* IE such that the UE receives the message  $\Delta T$  ms before the start of T2, where  $\Delta T = 150$  ms. If the UE message at step 5 includes the *ackRequested* IE set to TRUE, then the SS shall send an acknowledgment in the LPP REQUEST LOCATION INFORMATION message.
- 6a. If the UE sends a LPP REQUEST ASSISTANCE DATA message requesting WLAN assistance data, the SS shall send a LPP PROVIDE ASSISTANCE DATA message, including *wlan-ProvideAssistanceData-r14* IE with no WLAN assistance data and the *wlan-Error-r14* IE with *WLAN-LocationServerErrorCauses-r13* with *cause-r13* set to *requestedADNotAvailable-v1420*.  
  
If the UE message includes the *ackRequested* IE set to TRUE, then the SS shall send an acknowledgment in the LPP PROVIDE ASSISTANCE DATA message.
7. When T1 expires, the SS shall switch the WLAN power setting from T1 to T2 as specified in Table 12.1.1.5-2.
8. The UE shall perform and report the WLAN AP measurements for the simulated WLAN APs. The UE shall transmit a *WLAN-ProvideLocationInformation* IE including the *wlan-MeasurementList-r13* field. If the report is sent within the maximum response time specified in Clause 12.1.1.5 and it includes WLAN Measurements for at least the percentage of the simulated APs indicated in Table 12.1.1.3-1, the number of successful tests is increased by one. Otherwise, the number of failure tests is increased by one. The verification shall be done by comparing the reported list of *ssid-r13* against the simulated BSSIDs.
9. If the UE message at step 8 includes the *ackRequested* IE set to TRUE, the SS shall send a LPP acknowledgement message.
10. Repeat steps 1-9 until the confidence level according to Annex D, clauses D.4.3 and D.4.4 is achieved. For each iteration, at step 1 reselect a new list of WLAN APs. The BSSID of the new APs shall be different from the previous set of simulated BSSIDs.
- 10a. The test is repeated for both the 2.4GHz and 5GHz WLAN bands if supported by the UE.
11. Release the signalling connection.

12.1.1.4.3 Message contents

Message contents are according to TS 36.508 [18] clause 4.6 with the following exceptions:

**Table 12.1.1.4.3-1: RESET UE POSITIONING STORED INFORMATION**

Derivation Path: 36.509 [11] clause 6.9			
Information Element	Value/remark	Comment	Condition
UE Positioning Technology	0 0 0 0 0 1 1	WLAN	

**Table 12.1.1.4.3-2: LPP-RequestCapabilities**

Derivation Path: 36.355 [4] clause 6.3	
Information Element	Value/remark
<i>wlan-RequestCapabilities-r13</i>	TRUE

**Table 12.1.1.4.3-3: LPP-RequestLocationInformation**

Derivation Path: TS 36.355 clause 6.3			
Information Element	Value/remark	Comment	Condition
LPP-Message ::= SEQUENCE {			
lpp-MessageBody CHOICE {			
c1 CHOICE {			
requestLocationInformation SEQUENCE {			
criticalExtensions CHOICE {			
c1 CHOICE {			
requestLocationInformation-r9 SEQUENCE {			
commonIEsRequestLocationInformation SEQUENCE {			
locationInformationType	locationMeasurementsRequired		
additionalInformation	onlyReturnInformationRequested		
qos SEQUENCE {			
verticalCoordinateRequest	FALSE		
responseTime SEQUENCE {			
time	21	See clause 12.1.1.5	
}			
velocityRequest	FALSE		
}			
}			
wlan-RequestLocationInformation-r13 ::= SEQUENCE {			
requestedMeasurements-r13	If reporting of RSSI is supported by the UE: 1 0 If reporting of RSSI is not supported by the UE: 0 0	RSSI Requested if reporting of RSSI is supported by the UE as indicated by IE rssi-r13 in the LPP PROVIDE CAPABILITIES message	
}			
}			
}			
}			

### 12.1.1.5 Test requirement

The UE shall send *WLAN-ProvideLocationInformation* within a maximum response time of 21.15 seconds (including test tolerance of 300ms) from the beginning of T2. The maximum response time is equal to the LPP time IE value of 21 seconds, minus ΔT, where ΔT = 150 ms, plus the test tolerance of 300ms. The LPP time IE value is derived from  $T_{WLAN\_meas}$ , where  $T_{WLAN\_meas} = \tau + 20$  seconds as described in clause 12.1.1.3, and where the value of  $\tau$  is equal to ΔT, where ΔT = 150 ms, plus one beacon interval, which is taken as 100 ms, giving a value for  $\tau$  of 250 ms. This value for  $T_{WLAN\_meas}$  of 20.25 seconds is then rounded up to the next allowed LPP value of 21 seconds.

The *wlan-MeasurementInformation* IE shall include WLAN measurements for each AP indicating at least wlan-AP-Identifier (BSSID) and RSSI (if reporting of RSSI is supported by the UE as indicated by the UE in the LPP PROVIDE CAPABILITIES message). The list of reported BSSIDs shall contain at least the BSSID of 90% of the WLAN APs simulated in the test, as defined in Table 12.1.1.3-1.

The rate of correct events observed during repeated tests shall be at least 90% with a confidence level of 95%.



**Table 12.1.1.5-1: General WLAN AP test parameters  
for WLAN AP Identification and reporting delay under nominal conditions test**

<b>Parameter</b>	<b>Unit</b>	<b>Value</b>	<b>Comment</b>
Number of Access Points	N/A	6	AP 1-AP 6
Time Slot 1	ms	1	AP 1, AP 2
Time Slot 2	ms	1	AP 3, AP 4
Time Slot 3	ms	1	AP 5
Time Slot 4	ms	1	AP 6
T1	s	5	During this time the WLAN signals are not transmitted
T2	s	25	UE should report WLAN measurement information within 21.15s (including test tolerance)

**Table 12.1.1.5-2: Cell specific and WLAN AP specific test parameters for WLAN AP Identification and reporting delay under nominal conditions test**

Parameter	Unit	Cell 1		AP.1, 4		AP.2, 5		AP.3, 6	
		T1	T2	T1	T2	T1	T2	T1	T2
WLAN Test Frequency ID		N/A		1		2		3	
PDSCH parameters: DL Reference Measurement Channel <sup>Note 6</sup>		R.0 FDD R.0 TDD		N/A		N/A		N/A	
PCFICH/PDCCH/PHICH parameters: DL Reference Measurement Channel <sup>Note 6</sup>		R.6 FDD R.6 TDD		N/A		N/A		N/A	
OCNG Patterns <sup>Note 6</sup>		OP.1 FDD OP.1 TDD		N/A		N/A		N/A	
PBCH_RA	dB	0		N/A		N/A		N/A	
PBCH_RB	dB								
PSS_RA	dB								
SSS_RA	dB								
PCFICH_RB	dB								
PHICH_RA	dB								
PHICH_RB	dB								
PDCCH_RA	dB								
PDCCH_RB	dB								
PDSCH_RA	dB								
PDSCH_RB	dB								
OCNG_RA <sup>Note 1</sup>	dB								
OCNG_RB <sup>Note 1</sup>	dB								
$N_{oc1}$ <sup>Note 2</sup>	dBm/15 KHz								
$N_{oc2}$ <sup>Note 3</sup>	dBm/20 MHz	N/A		-75		-75		-75	
$\frac{E_s}{N_{oc1}}$	dB	3	3	N/A		N/A		N/A	
$\frac{E_s}{I_{ot}}$ <sup>Note 4</sup>	dB	3	3						
RSRP <sup>Note 4</sup>	dBm/15 kHz	-95	-95						
SCH_RP <sup>Note 4</sup>	dBm/15 kHz	-95	-95						
$I_o$ <sup>Note 3</sup>	dBm/Ch BW	-65.5	-65.5						
WLAN Received Power Level	dBm	N/A	N/A	-	-60	-	-60	-	-60
WLAN SNR <sup>Note 4</sup>	dB	N/A		15		15		15	
Propagation Condition		AWGN							
Antenna Configuration		1x2		-	-	-	-	-	-
Note 1:	OCNG shall be used such that all cells are fully allocated and a constant total transmitted power spectral density is achieved for all OFDM symbols.								
Note 2:	Interference from other cells and noise sources not specified in the test is assumed to be constant over subcarriers and time and shall be modelled as AWGN of appropriate power for $N_{oc1}$ to be fulfilled.								
Note 3:	Interference from other cells and noise sources not specified in the test is assumed to be constant over the bandwidth and time and shall be modelled as AWGN of appropriate power for $N_{oc2}$ to be fulfilled.								
Note 4:	$E_s/I_{ot}$ , RSRP, SCH_RP, $I_o$ and WLAN SNR have been derived from other parameters for information purposes. They are not settable parameters themselves.								
Note 5:	The resources for uplink transmission are assigned to the UE prior to the start of time period T2.								
Note 6:	If Cell 1 is LTE FDD, the FDD OCNG and RMCs shall be used. If Cell 1 is LTE TDD, the TDD OCNG and RMCs shall be used.								

## 12.1.2 WLAN AP Identification and reporting delay under dynamic range conditions

### 12.1.2.1 Test purpose

The purpose of this test is to verify that the E-UTRAN UE WLAN AP measurements fulfil the performance requirements for WLAN AP identification under dynamic range conditions in TS 37.171 [39] clause 7.4 and reporting delay in TS 37.171 [39] clause 4.3.

### 12.1.2.2 Test applicability

This test applies to all types of E-UTRA UE that support LPP release 14 and forward and WLAN positioning. Optionally, this test can be run by LPP release 13 UEs.

### 12.1.2.3 Minimum conformance requirements

The WLAN Access Point identification under dynamic range conditions verifies the UE capability to identify and report WLAN APs when the received power difference between WLAN APs is large. The power difference between APs follows the adjacent channel rejection criteria defined by IEEE in [40].

The UE shall be able to identify at least 3 WLAN AP located in 3 adjacent channels where the separation between channels is  $\geq 20$  MHz and the middle channel is received with high power and the side channels are received with low power.

**Table 12.1.2.3-1: Requirements for WLAN Access Point Identification under Dynamic Range conditions**

Number of WLAN APs	Signal Strength (dBm)	% of reported Access Points
3	See [40]	100

For LTE, the WLAN measurement time is defined as the time starting from the moment that the UE has received the LPP message of type REQUEST LOCATION INFORMATION, and ending when the UE starts sending the LPP message of type PROVIDE LOCATION INFORMATION on the Uu interface. The response times specified for all test cases are based on new measurements unless otherwise stated, i.e. the UE shall not re use any information on measurements or other aiding data that was previously acquired or calculated and stored internally in the UE. A dedicated test message 'RESET UE POSITIONING STORED INFORMATION' has been defined in TS 36.509 [11] clause 6.9 for the purpose of deleting this information. No WLAN assistance data is provided to the UE.

The signals from the WLAN APs shall be available at the UE for the duration of the measurement time. Each WLAN AP transmits a beacon signal with a beacon interval smaller or equal to  $T_{WLAN\_TP}$  (102.4 ms). The beacon frames from different access points shall be transmitted in different time slots or non-overlapping frequency channels. The beacon frames have variable time duration of  $\sim 1$ ms.

The WLAN Measurement Reporting Delay is given as:

$$T_{WLAN\_meas} = \tau + 20 \text{ .sec}$$

where:

$T_{WLAN\_meas}$  is the total time for detecting and measuring the WLAN Access Points

$\tau$  is the elapsed time from the trigger of the measurement to the start of the first WLAN transmission period and is shown in Figure 12.1.1.3-1.

The normative reference for the WLAN reporting delay requirement is 3GPP TS 37.171 [39] clause 4.3 and the normative reference for the WLAN AP Identification under dynamic range requirement is 3GPP TS 37.171 [39] clause 7.4.

### 12.1.2.4 Test description

In this test, there are LTE cell1 and 3 WLAN APs transmitting beacon signals at least every 102.4 ms. The APs are transmitting in 3 non-overlapping frequency channels in the same WLAN Frequency Band. Non-overlapping frequency channels are those whose centre frequencies are separated by at least 25 MHz in the WLAN 2.4 GHz band and by at least 20 MHz in the WLAN 5 GHz band. There is 1 AP in every channel. The tested UE is connected to the serving cell and signalled to report WLAN AP measurements. The test consists of two successive time periods, with duration of T1 and T2, respectively. WLAN-RequestLocationInformation message shall be provided to the UE during T1. WLAN Access Points only transmit signal during T2. The test equipment compares the BSSID reported by the UE in the WLAN AP measurements with the BSSID of the APs simulated in the test.

#### 12.1.2.4.1 Initial conditions

Same as in Clause 12.1.1.4.1

#### 12.1.2.4.2 Test procedure

Same as in clause 12.1.1.4.2 with the exception that SS test parameters are specified in clause 12.1.2.5 and the percentage of reported WLAN APs to count an iteration as successful is defined in Table 12.1.2.3-1

#### 12.1.2.4.3 Message contents

Same as in clause 12.1.1.4.3.

#### 12.1.2.5 Test requirement

The UE shall send *WLAN-ProvideLocationInformation* within a maximum response time of 21.15 seconds (including test tolerance of 300ms) from the beginning of T2. See clause 12.1.1.5 for more details.

The *wlan-MeasurementInformation* IE shall include WLAN measurements for each AP indicating at least wlan-AP-Identifier (BSSID) and RSSI (if reporting of RSSI is supported by the UE as indicated by the UE in the LPP PROVIDE CAPABILITIES message). The list of reported BSSIDs shall contain the BSSID of 100% of the WLAN APs simulated in the test, as defined in Table 12.1.2.3-1.

The rate of correct events observed during repeated tests shall be at least 90% with a confidence level of 95%.

**Table 12.1.2.5-1: General test parameters for WLAN AP Identification and reporting delay under dynamic range conditions test**

Parameter	Unit	Value	Comment
Number of Access Points	N/A	3	AP 1-AP 3
Time Slot 1	ms	1	AP 1, AP 2, AP 3
T1	s	5	During this time the WLAN signals are not transmitted
T2	s	25	UE should report WLAN measurement information within 21.15s (including test tolerance)

**Table 12.1.2.5-2: Cell specific test parameters for WLAN AP Identification and reporting delay under dynamic range conditions test**

Parameter	Unit	Cell 1		AP 1		AP 2		AP 3	
		T1	T2	T1	T2	T1	T2	T1	T2
WLAN Channel Number		N/A		1		2		3	
PDSCH parameters: DL Reference Measurement Channel <sup>Note 6</sup>		R.0 FDD R.0 TDD		N/A		N/A		N/A	
PCFICH/PDCCH/PHICH parameters: DL Reference Measurement Channel <sup>Note 6</sup>		R.6 FDD R.6 TDD		N/A		N/A		N/A	
OCNG Patterns <sup>Note 6</sup>		OP.1 FDD OP.1 TDD		N/A		N/A		N/A	
PBCH_RA	dB	0		N/A		N/A		N/A	
PBCH_RB	dB								
PSS_RA	dB								
SSS_RA	dB								
PCFICH_RB	dB								
PHICH_RA	dB								
PHICH_RB	dB								
PDCCH_RA	dB								
PDCCH_RB	dB								
PDSCH_RA	dB								
PDSCH_RB	dB								
OCNG_RA <sup>Note 1</sup>	dB								
OCNG_RB <sup>Note 1</sup>	dB								
N <sub>oc1</sub> <sup>Note 2</sup>	dBm/15 KHz	-98		N/A		N/A		N/A	
N <sub>oc2</sub> <sup>Note 3</sup>	dBm/20 MHz	N/A		-85		-85		-85	
E <sub>s</sub> /N <sub>oc1</sub>	dB	3	3	N/A		N/A		N/A	
E <sub>s</sub> /I <sub>ot</sub> <sup>Note 4</sup>	dB	3	3						
RSRP <sup>Note 4</sup>	dBm/15 kHz	-95	-95						
SCH_RP <sup>Note 4</sup>	dBm/15 kHz	-95	-95						
I <sub>o</sub> <sup>Note 3</sup>	dBm/Ch BW	-	-						
WLAN Received Power Level	dBm	N/A	N/A	- inf	WLAN 2.4 GHz band: -73 WLAN 5 GHz band: -78	- inf	WLAN 2.4 GHz band: -39 WLAN 5 GHz band: -63	- inf	WLAN 2.4 GHz band: -73 WLAN 5 GHz band: -78
WLAN SNR <sup>Note 4</sup>	db	N/A		WLAN 2.4 GHz band: 12 WLAN 5 GHz band: 7		WLAN 2.4 GHz band: 46 WLAN 5 GHz band: 22		WLAN 2.4 GHz band: 12 WLAN 5 GHz band: 7	
Propagation Condition		AWGN							
Antenna Configuration		1x2		-		-		-	
Note 1:	OCNG shall be used such that all cells are fully allocated and a constant total transmitted power spectral density is achieved for all OFDM symbols.								
Note 2:	Interference from other cells and noise sources not specified in the test is assumed to be constant over subcarriers and time and shall be modelled as AWGN of appropriate power for N <sub>oc1</sub> to be fulfilled.								
Note 3:	Interference from other cells and noise sources not specified in the test is assumed to be constant over the bandwidth and time and shall be modelled as AWGN of appropriate power for N <sub>oc2</sub> to be fulfilled.								
Note 4:	Es/Iot, RSRP, SCH_RP, Io and WLAN SNR have been derived from other parameters for information purposes. They are not settable parameters themselves.								
Note 5:	The resources for uplink transmission are assigned to the UE prior to the start of time period T2.								
Note 6:	If Cell 1 is LTE FDD, the FDD OCNG and RMCs shall be used. If Cell 1 is LTE TDD, the TDD OCNG and RMCs shall be used.								

## 12.2 BLE Identification and Reporting Delay

### 12.2.1 Bluetooth identification

#### 12.2.1.1 Test purpose

The purpose of this test is to verify that the E-UTRAN UE BLE measurements fulfil the performance requirements for Bluetooth Access Point identification and reporting delay in TS 37.171 [39] clause 4.4.

#### 12.2.1.2 Test applicability

This test applies to all types of E-UTRA UE that support LPP release 14 and forward and BLE positioning. Optionally, this test can be run by LPP release 13 UEs.

#### 12.2.1.3 Minimum conformance requirements

In the RRC\_CONNECTED state the measurement period for Bluetooth Access Point identification shall be  $T_{BT\_meas}$ . The value of  $T_{BT\_meas}$  is 10.24s, and can be extended to 40.96s if extended inquiry is allowed, provided that the following conditions are met:

- At least one Bluetooth beacon signal is transmitted on one of the Bluetooth advertising channels with a broadcast interval of 100 ms.

The UE physical layer shall be capable of reporting Bluetooth Access Point(s) measurements to higher layers within the measurement period of  $T_{BT\_meas}$ . For LTE, the BLE measurement time is defined as the time starting from the moment that the UE has received the LPP message of type REQUEST LOCATION INFORMATION, and ending when the UE starts sending the LPP message of type PROVIDE LOCATION INFORMATION on the Uu interface. The response times specified for all test cases are based on new measurements unless otherwise stated, i.e. the UE shall not re use any information on measurements or other aiding data that was previously acquired or calculated and stored internally in the UE. A dedicated test message 'RESET UE POSITIONING STORED INFORMATION' has been defined in TS 36.509 [11] clause 6.9 for deleting this information. The measurements for  $n$  BLE devices shall be available at the UE for a period of 15 seconds. Each BLE device transmits a beacon signal with a broadcast interval of  $T_{BLE\_TP}$  of 100 ms. Beacon frames from different BLE devices shall be transmitted in different time slots or non-overlapping frequency channels.

The normative reference for this requirement is 3GPP TS 37.171 [39] clause 4.4.

#### 12.2.1.4 Test description

There is one active LTE cell and 6 BLE devices transmitting advertising non-connectable beacon signals at least every 100 ms. The BLE devices are transmitting in 3 non-overlapping BLE advertising frequency channels. The BLE advertising channels are Channel 37 (2402 MHz), Channel 38 (2426 MHz) and Channel 39 (2480 MHz). There are 2 BLE devices transmitting in each channel. The tested UE is connected to the serving cell and signalled to report BLE measurements. The test consists of two successive time periods, with duration of T1 and T2, respectively. BT-RequestLocationInformation message shall be provided to the UE during T1. BLE devices only transmit signal during T2. The test equipment compares the UUID reported by the UE in the BLE measurements with the UUID of the BLE devices simulated in the test.

##### 12.2.1.4.1 Initial conditions

Test Environment: Normal as defined in TS 36.508 [18] clause 4.1.

E-UTRA frequencies to be tested: Mid Range, as defined in TS 36.508 [18] clause 4.3.1.

1. Connect the SS (node B emulator) and AWGN noise source to the UE antenna connectors as shown in Annex A figure A.9.
2. Propagation conditions are set according to clause 4.10.2.1.
3. Message contents are defined in clause 12.2.1.4.3.
4. Cell 1 is the serving cell. Cell 1 is the cell used for connection setup with the power levels set according to TS 36.521-3 [25] clauses C.0 and C.1 for this test. After the connection is established, the parameter settings for the cell are set according to Table 12.2.1.5-2.

5. Switch on the UE.
6. Establish a signalling connection according to the generic procedure in TS 36.508 [18] clause 4.5.3 (State 3, Generic RB established) on a channel in the Mid EARFCN range.

#### 12.2.1.4.2 Test procedure

1. Set the SS test parameters as specified in clause 12.2.1.5. The UUID of the simulated BLE devices shall be generated in a random manner.
2. The SS shall send a RESET UE POSITIONING STORED INFORMATION message.
3. T1 starts.
4. The SS shall send an LPP REQUEST CAPABILITIES message.
5. The UE shall transmit an LPP PROVIDE CAPABILITIES message including *BT-ProvideCapabilities* IE and indicating support for BLE.
6. The SS shall send a LPP REQUEST LOCATION INFORMATION message, including the *BT-RequestLocationInformation* IE such that the UE receives the message  $\Delta T$  ms before the start of T2, where  $\Delta T = 150$  ms. If the UE message at step 5 includes the *ackRequested* IE set to TRUE, then the SS shall send an acknowledgment in the LPP REQUEST LOCATION INFORMATION message.
7. When T1 expires, the SS shall switch the BLE power setting from T1 to T2 as specified in Table 12.2.1.5-2.
8. The UE shall perform and report the BLE measurements for the simulated BLE devices. The UE shall transmit a *BT-ProvideLocationInformation* IE including the *BT-MeasurementList-r13* field. If the report is sent within the maximum response time specified in Clause 12.2.1.5 and it includes BT Measurements for all of the simulated BLE devices, the number of successful tests is increased by one. Otherwise, the number of failure tests is increased by one. The verification shall be done by comparing the reported list of *btAddr-r13* against the simulated UUIDs.
9. If the UE message at step 8 includes the *ackRequested* IE set to TRUE, the SS shall send a LPP acknowledgement message.
10. Repeat steps 1-9 until the confidence level according to Annex D, clauses D.4.3 and D.4.4 is achieved. For each iteration, at step 1 reselect a new list of BLE devices. The UUID of the new BLE devices shall be different from the previous set of simulated UUIDs.
11. Release the signalling connection.

#### 12.2.1.4.3 Message contents

Message contents are according to TS 36.508 [18] clause 4.6 with the following exceptions:

**Table 12.2.1.4.3-1: RESET UE POSITIONING STORED INFORMATION**

Derivation Path: 36.509 [11] clause 6.9			
Information Element	Value/remark	Comment	Condition
UE Positioning Technology	0 0 0 0 0 1 0 0	BLE	

**Table 12.2.1.4.3-2: LPP-RequestCapabilities**

Derivation Path: 36.355 [4] clause 6.3	
Information Element	Value/remark
<i>bt-RequestCapabilities-r13</i>	TRUE

**Table 12.2.1.4.3-3: LPP-RequestLocationInformation**

Derivation Path: TS 36.355 clause 6.3			
Information Element	Value/remark	Comment	Condition
LPP-Message ::= SEQUENCE {			
lpp-MessageBody CHOICE {			
c1 CHOICE {			
requestLocationInformation SEQUENCE {			
criticalExtensions CHOICE {			
c1 CHOICE {			
requestLocationInformation-r9 SEQUENCE {			
commonIEsRequestLocationInformation SEQUENCE {			
locationInformationType	locationMeasurementsRequired		
additionalInformation	onlyReturnInformationRequested		
qos SEQUENCE {			
verticalCoordinateRequest	FALSE		
responseTime SEQUENCE {			
time	10		
}			
velocityRequest	FALSE		
}			
}			
BT-RequestLocationInformation-r13 ::= SEQUENCE {			
requestedMeasurements-r13	If reporting of RSSI is supported by the UE: 1 If reporting of RSSI is not supported by the UE: 0	RSSI Requested if reporting of RSSI is supported by the UE as indicated by IE rssi-r13 in the LPP PROVIDE CAPABILITIES message	
}			
}			
}			
}			
}			
}			
}			

**12.2.1.5 Test requirement**

The UE shall send *BT-ProvideLocationInformation*, with a measurement reporting delay less than 10.54s (including test tolerance) from the beginning of time period T2. The measurement report shall include BT Measurements for all of the simulated BLE devices identified by the corresponding UUID.

The rate of correct events observed during repeated tests shall be at least 90% with a confidence level of 95%.



**Table 12.2.1.5-1: General test parameters for Bluetooth Identification**

Parameter	Unit	Value	Comment
Bluetooth Low Energy (BLE) Devices		BLE 1, BLE 2, BLE 3, BLE 4, BLE 5 and BLE 6	BLE 1 and BLE 2 are on Bluetooth Advertising Channel 1 (2402 MHz). BLE 3 and BLE 4 are on Bluetooth Advertising Channel 2 (2426 MHz). BLE 5 and BLE 6 are on Bluetooth Advertising Channel 3 (2480 MHz).
Bluetooth Advertising Channel Numbers and frequencies		Channel 37:2402 MHz, Channel 38:2426 MHz, Channel 39:2480 MHz	
Bluetooth beacon signal broadcast interval	ms	100 ms	
T1	s	5	During this time the BLE signals are not transmitted
T2	s	15	UE should report Bluetooth measurement information within 10.54s.

**Table 12.2.1.5-2: Cell specific test parameters for Bluetooth Identification**

Parameter	Unit	Cell 1		BLE 1, BLE 2		BLE 3, BLE 4		BLE 5, BLE 6	
		T1	T2	T1	T2	T1	T2	T1	T2

Bluetooth Advertising Channel Number		N/A	37	38	39				
PDSCH parameters: DL Reference Measurement Channel <sup>Note 6</sup>		R.0 FDD R.0 TDD	N/A	N/A	N/A				
PCFICH/PDCCH/PHICH parameters: DL Reference Measurement Channel <sup>Note 6</sup>		R.6 FDD R.6 TDD	N/A	N/A	N/A				
OCNG Patterns <sup>Note 6</sup>		OP.1 FDD OP.1 TDD	N/A	N/A	N/A				
PBCH_RA	dB	0	N/A	N/A	N/A				
PBCH_RB	dB								
PSS_RA	dB								
SSS_RA	dB								
PCFICH_RB	dB								
PHICH_RA	dB								
PHICH_RB	dB								
PDCCH_RA	dB								
PDCCH_RB	dB								
PDSCH_RA	dB								
PDSCH_RB	dB								
OCNG_RA <sup>Note 1</sup>	dB								
OCNG_RB <sup>Note 1</sup>	dB								
$N_{oc1}$ <sup>Note 2</sup>	dBm/15 kHz					-98	N/A	N/A	N/A
$N_{oc2}$ <sup>Note 3</sup>	dBm/2MHz	N/A	-84	-84	-84				
$E_s/N_{oc1}$	dB	3	3	N/A	N/A				
$E_s/I_{ot}$ <sup>Note 4</sup>	dB	3	3						
RSRP <sup>Note 4</sup>	dBm/15 kHz	-95	-95						
SCH_RP <sup>Note 4</sup>	dBm/15 kHz	-95	-95						
$I_o$ <sup>Note 3</sup>	dBm/Ch BW	- 65.5	- 65.5						
Bluetooth RSSI <sup>Note 4</sup>	dBm/2 MHz	N/A	N/A	- infinity	-60	- infinity	-60	- infinity	-60
SINR <sup>Note 4</sup>	dB	N/A	N/A	- infinity	- 63.2	- infinity	- 63.2	- infinity	- 63.2
Propagation Condition		AWGN							
Antenna Configuration		1x2	-	-	-				
<p>Note 1: OCNG shall be used such that all cells are fully allocated and a constant total transmitted power spectral density is achieved for all OFDM symbols.</p> <p>Note 2: Interference from other cells and noise sources not specified in the test is assumed to be constant over subcarriers and time and shall be modelled as AWGN of appropriate power for <math>N_{oc1}</math> to be fulfilled.</p> <p>Note 3: Interference from other cells and noise sources not specified in the test is assumed to be constant over the bandwidth and time and shall be modelled as AWGN of appropriate power for <math>N_{oc2}</math> to be fulfilled.</p> <p>Note 4: <math>E_s/I_{ot}</math>, RSRP, SCH_RP, <math>I_o</math> and Bluetooth RSSI have been derived from other parameters for information purposes. They are not settable parameters themselves.</p> <p>Note 5: The resources for uplink transmission are assigned to the UE prior to the start of time period T2.</p> <p>Note 6: If Cell 1 is LTE FDD, the FDD OCNG and RMCs shall be used. If Cell 1 is LTE TDD, the TDD OCNG and RMCs shall be used</p>									

---

# Annex A (informative): Connection Diagrams

## Definition of Terms

**GNSS:** In this clause the term GNSS also includes the case where the only satellite system used is GPS.

**System Simulator or SS:** A device or system, that is capable of generating simulated Node B and/or eNode B signalling and analysing UE signalling responses on one RF channel, in order to create the required test environment for the UE under test. It will also include the following capabilities:

1. Control of the UE Tx output power through TPC commands.
2. Measurement of signalling timing and delays.
3. Ability to simulate UTRAN and/or E-UTRAN signalling.

**GNSS System Simulator or GSS:** A device or system, that is capable of generating simulated GNSS satellite transmissions in order to create the required test environment for the UE under test. It will also include the following capabilities:

1. Control of the output power of individual satellites and the simulation of atmospheric delays and multi-path.
2. Generation of appropriate assistance data to be transmitted to the UE via the SS.
3. Ability to synchronize with UTRAN and/or E-UTRAN timing in the SS.

**MBS System Simulator or MSS:** A device or system, that is capable of generating simulated MBS transmissions in order to create the required test environment for the UE under test. It will also include the following capabilities:

1. Control of the output power of individual beacons and the simulation of delays and multi-path.
2. Generation of appropriate messaging to be transmitted to the UE via the SS.

**WLAN System Simulator or WSS:** A device or system, that is capable of generating simulated WLAN beacons in order to create the required test environment for the UE under test. It will also include the following capabilities:

1. Control of the output power of individual beacons and the simulation of delays and AWGN.

**BLE System Simulator or BSS:** A device or system, that is capable of generating simulated BLE advertising signals in order to create the required test environment for the UE under test. It will also include the following capabilities:

1. Control of the output power of individual BLE signals and the simulation of delays and AWGN.

**Test System:** A combination of devices brought together into a system for the purpose of making one or more measurements on a UE in accordance with the test case requirements. The following diagrams are all examples of Test Systems.

**NOTE:** The above terms are logical definitions to be used to describe the test methods used in the present document, in practice, real devices called "System Simulators" may also include additional measurement capabilities or may only support those features required for the test cases they are designed to perform.

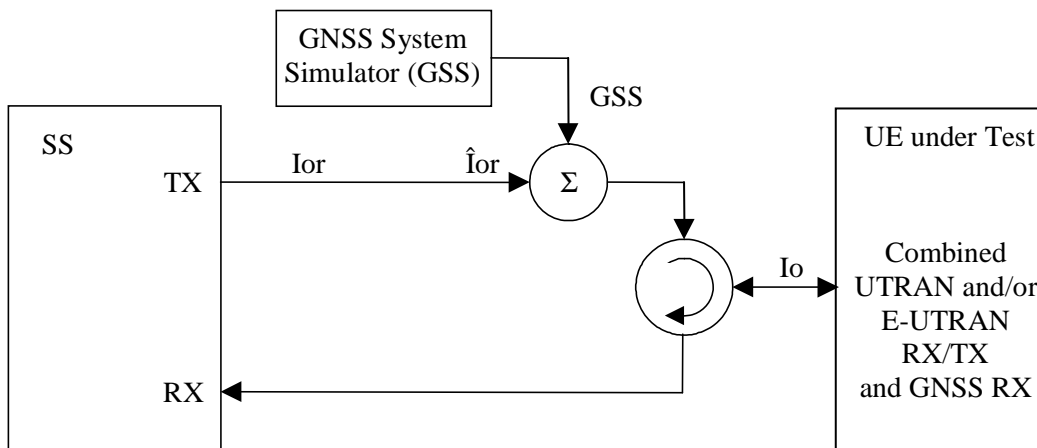

**Figure A.1: Connection for A-GNSS Minimum Performance requirements tests for UE with combined UTRAN and/or E-UTRAN / GNSS antenna**

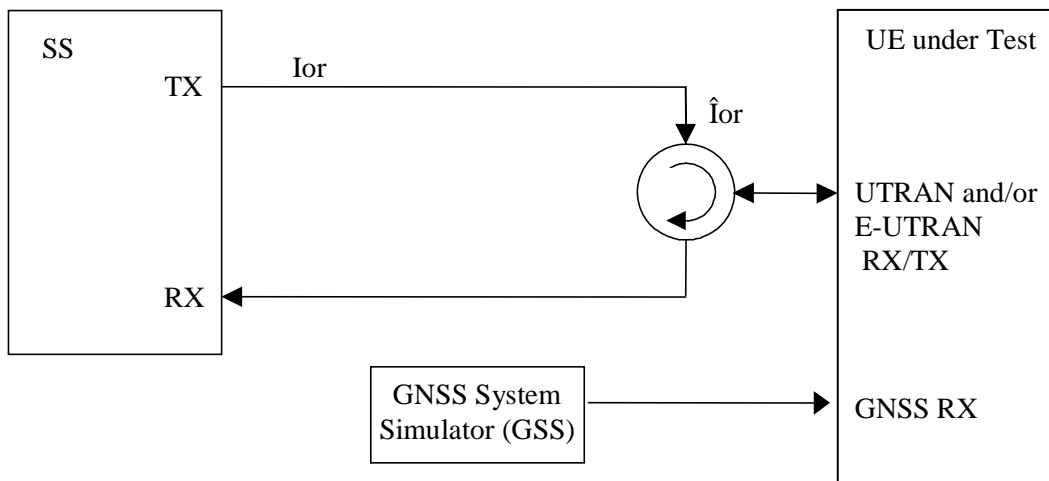

**Figure A.2: Connection for A-GNSS Minimum Performance requirements tests for UE with separate UTRAN and/or E-UTRAN and GNSS antennas**

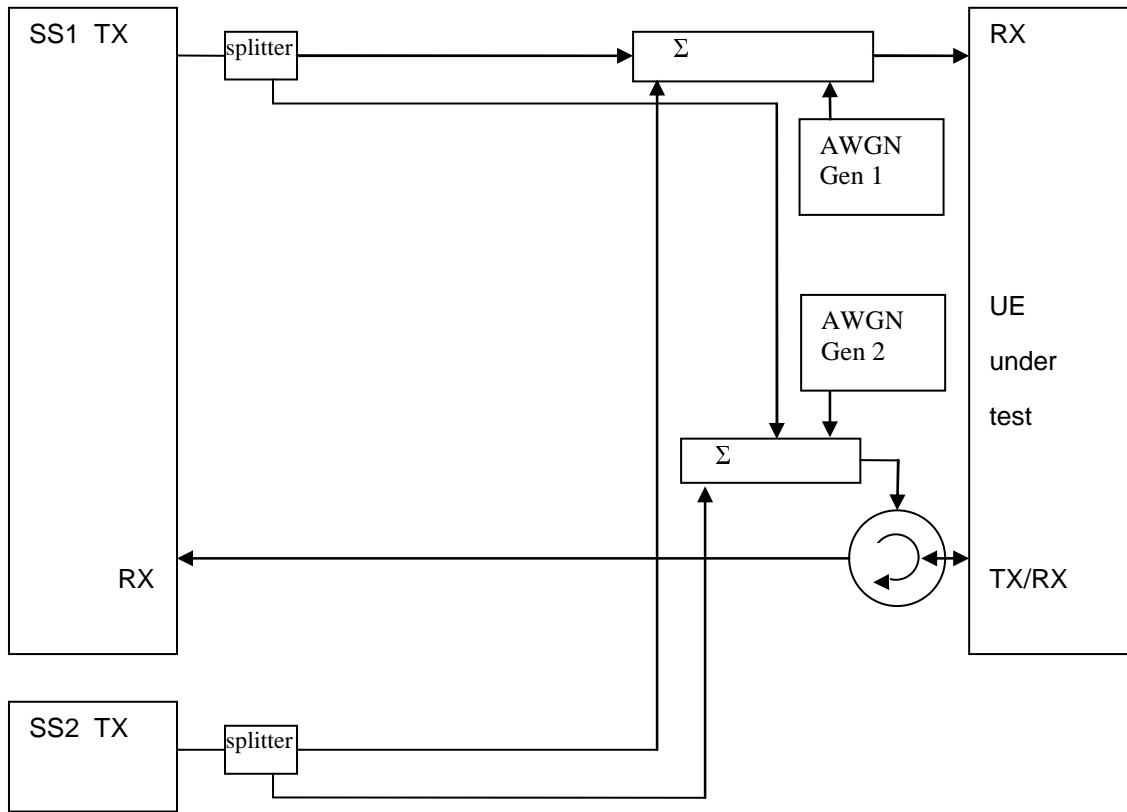

Figure A.3: Connection for 2 cells OTDOA tests with static propagation

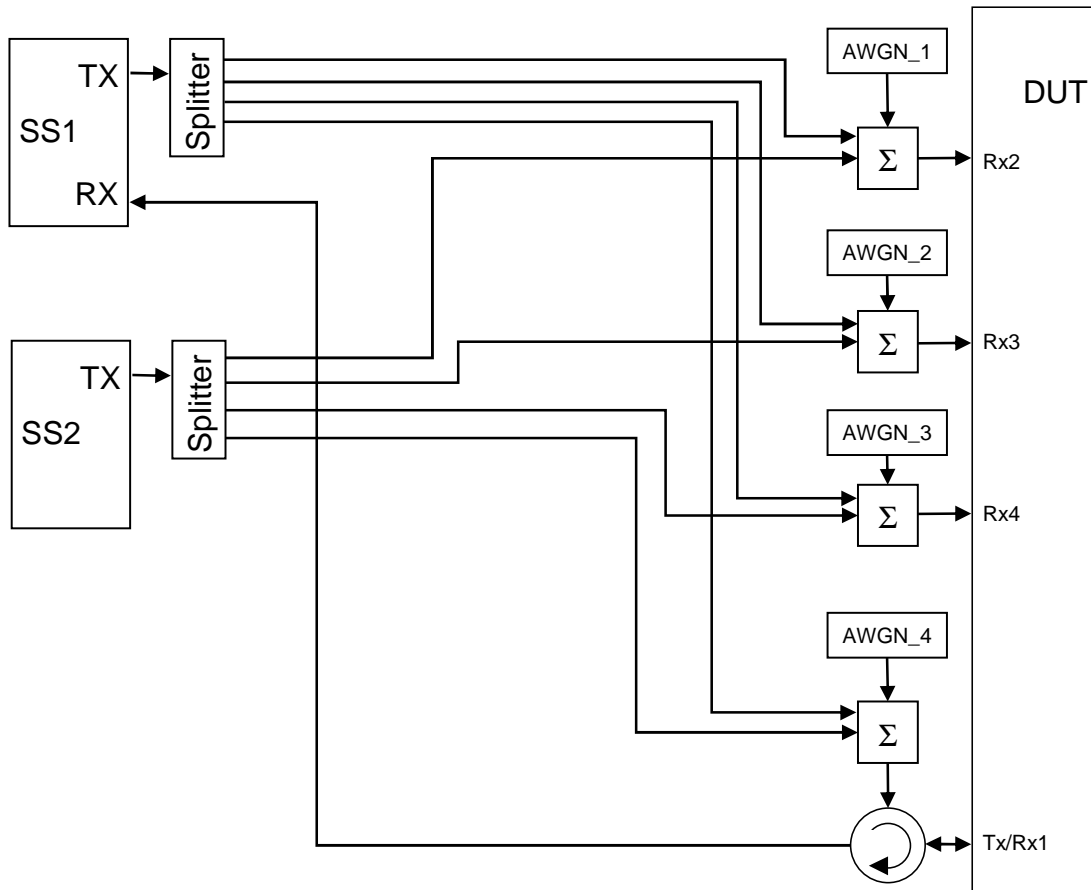

Figure A.3a: Connection for 2 cells OTDOA tests with static propagation for 4Rx capable UE

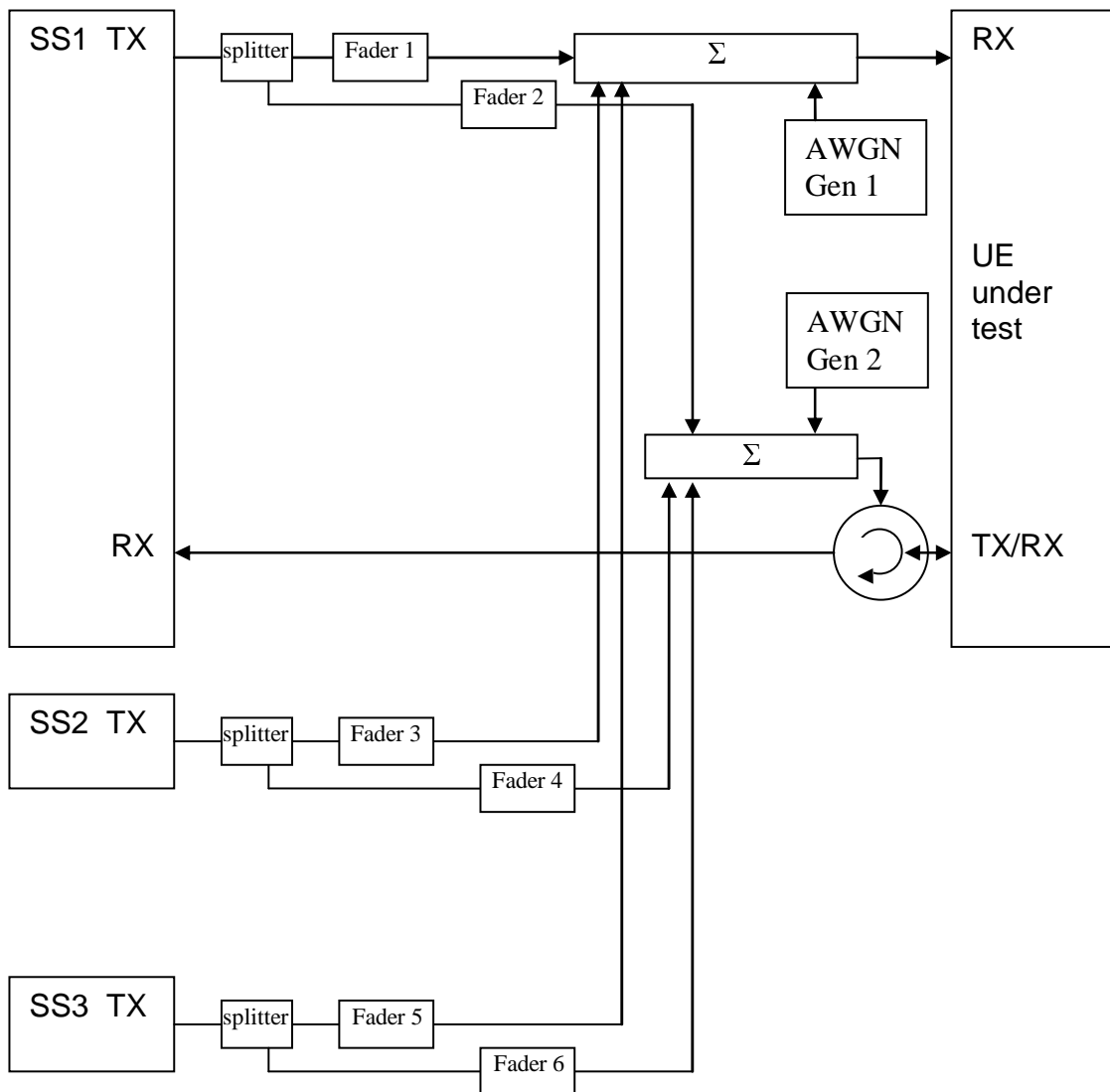

Figure A.4: Connection for 3 cells OTDOA tests with multipath fading propagation conditions

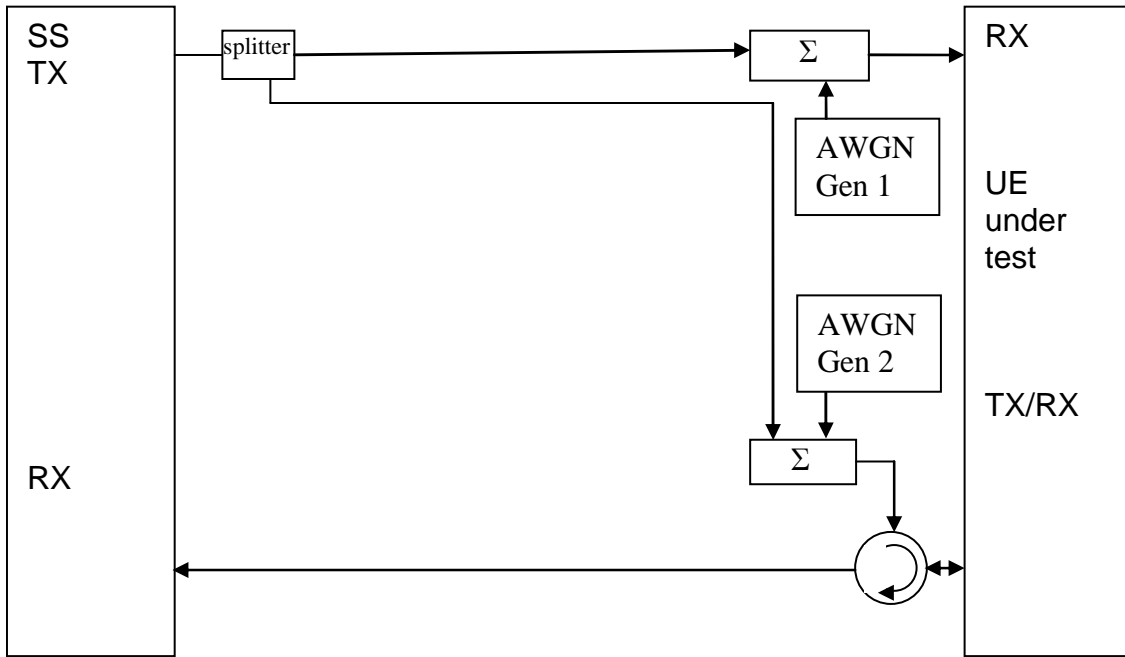

Figure A.5: Connection for 1 cell ECID tests with static propagation conditions

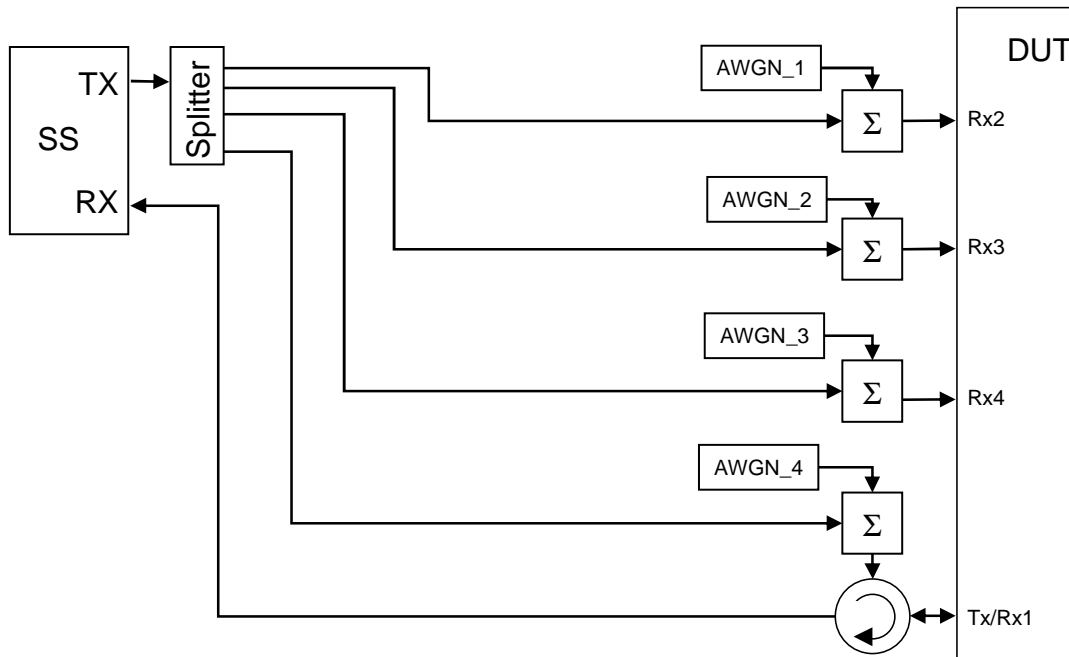
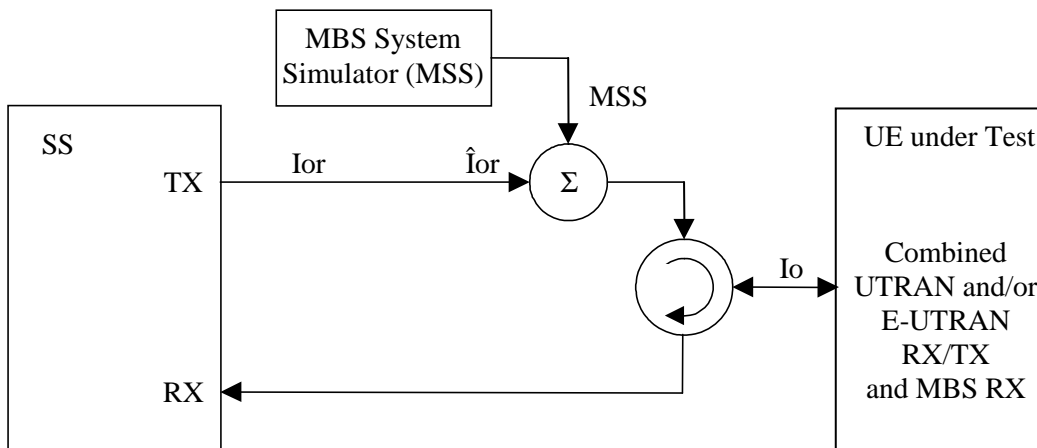
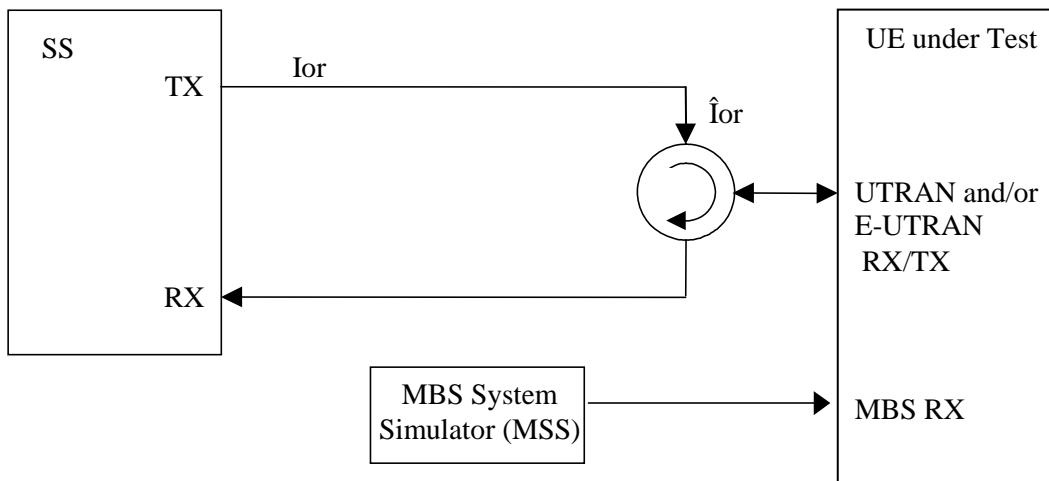

Figure A.5a: Connection 1 cell ECID tests with static propagation for 4Rx capable UE

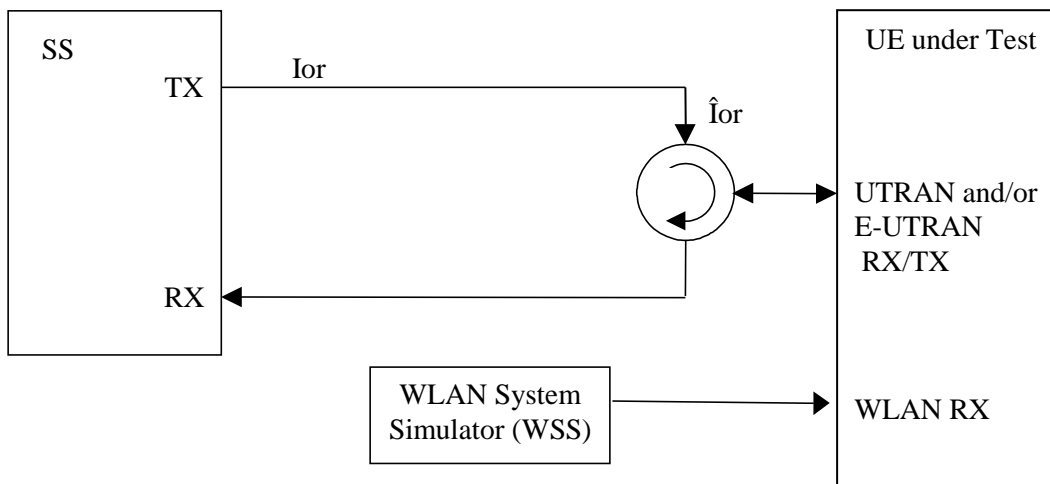



**Figure A.6: Connection for MBS Minimum Performance requirements tests for UE with combined UTRAN and/or E-UTRAN / MBS antenna**



**Figure A.7: Connection for MBS Minimum Performance requirements tests for UE with separate UTRAN and/or E-UTRAN and MBS antennas**



**Figure A.8: Connection for WLAN tests for UE with separate UTRAN and/or E-UTRAN and WLAN antennas**

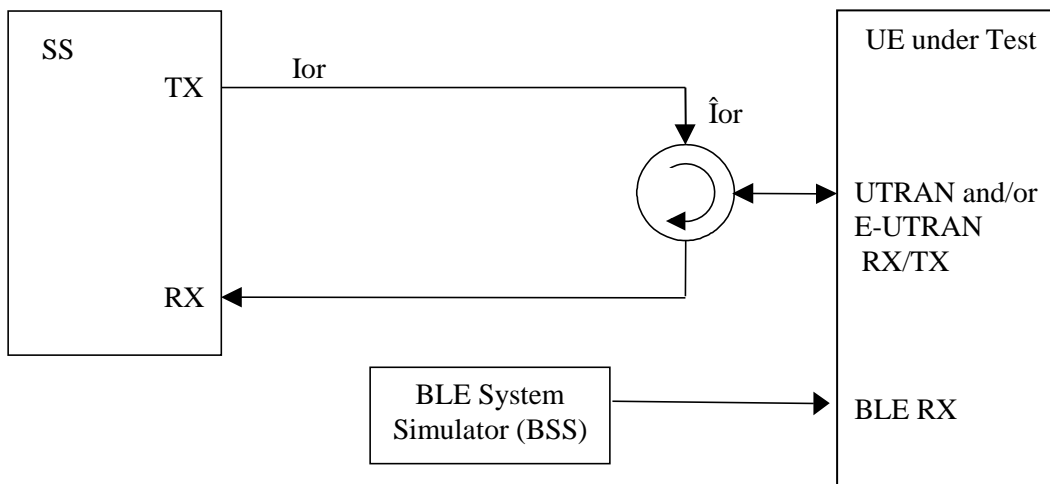

**Figure A.9: Connection for BLE tests for UE with separate UTRAN and/or E-UTRAN and BLE antennas**

---

## Annex B (normative): Converting A-GNSS UE-assisted measurement reports into position estimates

### B.1 Introduction

In this clause the terms GNSS and A-GNSS also include the cases where the only satellite system used is GPS unless otherwise stated.

To convert the A-GNSS UE measurement reports in case of UE-assisted mode of A-GNSS into position errors, a transformation between the "measurement domain" (code-phases, etc.) into the "state" domain (position estimate) is necessary. Such a transformation procedure is outlined in the following clauses. The details can be found in [8-10] and [12-17].

### B.2 UTRAN UE measurement reports for A-GPS L1 C/A only

In case of UTRAN UE-assisted A-GPS L1 C/A only, the measurement parameters are contained in the RRC UE POSITIONING GPS MEASURED RESULTS IE (clause 10.3.7.93 in 3GPP TS 25.331 [30]). The measurement parameters required for calculating the UE position are:

- 1) Reference Time: The UE has two choices for the Reference Time:
  - a) "UE GPS timing of cell frames";
  - b) "GPS TOW msec".
- 2) Measurement Parameters: 1 to <maxSat>:
  - a) "Satellite ID (SV PRN)";
  - b) "Whole GPS chips";
  - c) "Fractional GPS Chips";
  - d) "Pseudorange RMS Error".

Additional information required at the system simulator:

- 1) "UE positioning GPS reference UE position" (clause 10.3.8.4c in 3GPP TS 25.331 [30]):  
Used for initial approximate receiver coordinates.
- 2) "UE positioning GPS navigation model" (clause 10.3.7.94 in 3GPP TS 25.331 [30]):  
Contains the GPS ephemeris and clock correction parameters as specified in [8]; used for calculating the satellite positions and clock corrections.
- 3) "UE positioning GPS ionospheric model" (clause 10.3.7.92 in 3GPP TS 25.331 [30]):  
Contains the ionospheric parameters which allow the single frequency user to utilize the ionospheric model as specified in [8] for computation of the ionospheric delay.

### B.3 UTRAN UE measurement reports for A-GNSS

In case of UTRAN UE-assisted A-GNSS, the measurement parameters are contained in the RRC UE POSITIONING GANSS MEASURED RESULTS IE (clause 10.3.7.93a in 3GPP TS 25.331 [30]). In case the UE provides also measurements on the GPS L1 C/A signal, the measurement parameters are contained in the RRC UE POSITIONING GPS MEASURED RESULTS IE (clause 10.3.7.93 in 3GPP TS 25.331 [30]). The measurement parameters required for calculating the UE position are:

- 1) Reference Time: The UE has two choices for the Reference Time:
  - a) "UE GANSS Timing of Cell Frames" and/or "UE GPS Timing of Cell Frames";
  - b) "GANSS TOD msec" and/or "GPS TOW msec" if GPS L1 C/A signal measurements are also provided.

NOTE: It is not expected that an UE will ever report both a GANSS TOD and a GPS TOW. However if two time stamps are provided and they derive from different user times, be aware that no compensation is made for this difference and this could affect the location accuracy.

- 2) Measurement Parameters for each GANSS and GANSS Signal: 1 to <maxGANSSSat>:
  - a) "Satellite ID"; mapping according to table 10.3.7.88b in 3GPP TS 25.331 [30];
  - b) "GANSS Code Phase";
  - c) "GANSS Integer Code Phase";
  - d) "GANSS Integer Code Phase Extension";
  - e) "Code Phase RMS Error";
- 3) Additional Measurement Parameters in case of GPS L1 C/A signal measurements are also provided: 1 to <maxSat>:
  - a) "Satellite ID (SV PRN)";
  - b) "Whole GPS chips";
  - c) "Fractional GPS Chips";
  - d) "Pseudorange RMS Error".

Additional information required at the system simulator:

- 1) "UE Positioning GANSS Reference UE Position" or "UE Positioning GPS Reference UE Position" (clause 10.3.8.4c in 3GPP TS 25.331 [30]):  
Used for initial approximate receiver coordinates.
- 2) "UE Positioning GANSS Navigation Model" and "UE Positioning GANSS Additional Navigation Models" (clauses 10.3.7.94a and 10.3.7.94b in 3GPP TS 25.331 [30]):  
Contains the ephemeris and clock correction parameters as specified in the relevant ICD of each supported GANSS; used for calculating the satellite positions and clock corrections.
- 3) "UE Positioning GANSS Ionospheric Model" (clause 10.3.7.92a in 3GPP TS 25.331 [30]):  
Contains the ionospheric parameters which allow the single frequency user to utilize the ionospheric model as specified in [15] for computation of the ionospheric delay.
- 4) "UE Positioning GANSS Additional Ionospheric Model" (clause 10.3.7.92b in 3GPP TS 25.331 [30]):  
Contains the ionospheric parameters which allow the single frequency user to utilize the ionospheric model as specified in the relevant ICD of each supported GANSS [14], [37] for computation of the ionospheric delay.
- 5) "UE Positioning GANSS Time Model" (clause 10.3.7.97a in 3GPP TS 25.331 [30]):  
Contains the GNSS-GNSS Time Offset for each supported GANSS. Note, that "UE Positioning GANSS Time Model" IE contains only the sub-ms part of the offset. Any potential integer seconds offset may be obtained from "UE Positioning GPS UTC Model" (clause 10.3.7.97 in 3GPP TS 25.331 [30]), "UE Positioning GANSS UTC Model" (clause 10.3.7.97c in 3GPP TS 25.331 [30]), or "UE Positioning GANSS Additional UTC Models" (clause 10.3.7.97d in 3GPP TS 25.331 [30]).
- 6) "UE Positioning GPS Navigation Model" (clause 10.3.7.94 in 3GPP TS 25.331 [30]):  
Contains the GPS ephemeris and clock correction parameters as specified in [8]; used for calculating the GPS satellite positions and clock corrections in case of GPS L1 C/A signal measurements are the only GPS measurements provided in addition to GANSS measurements.
- 7) "UE Positioning GPS Ionospheric Model" (clause 10.3.7.92 in 3GPP TS 25.331 [30]):  
Contains the ionospheric parameters which allow the single frequency user to utilize the ionospheric model as specified in [8] for computation of the ionospheric delay.

## B.4 E-UTRAN UE measurement reports

In case of E-UTRAN UE-assisted A-GNSS, the measurement parameters are contained in the LPP GNSS-SignalMeasurementInformation IE (clause 6.5.2.6 in 3GPP TS 36.355 [4]). The measurement parameters required for calculating the UE position are:

- 1) Reference Time: The UE has two choices for the Reference Time:
  - a) "networkTime";
  - b) "gnss-TOD-msec".
- 2) Measurement Parameters for each GNSS and GNSS signal: 1 to 64:
  - a) "svID";
  - b) "codePhase";
  - c) "integerCodePhase";
  - d) "codePhaseRMSError".

Additional information required at the system simulator:

- 1) "GNSS-ReferenceLocation" (clause 6.5.2.2 in 3GPP TS 36.355 [4]):  
Used for initial approximate receiver coordinates.
- 2) "GNSS-NavigationModel" (clause 6.5.2.2 in 3GPP TS 36.355 [4]):  
Contains the GNSS ephemeris and clock correction parameters as specified in the relevant ICD of each supported GNSS; used for calculating the satellite positions and clock corrections.
- 3) "GNSS-IonosphericModel" (clause 6.5.2.2 in 3GPP TS 36.355 [4]):  
Contains the ionospheric parameters which allow the single frequency user to utilize the ionospheric model as specified in the relevant ICD of each supported GNSS [8], [14], [15] and [37] for computation of the ionospheric delay.

## B.5 WLS position solution

The WLS position solution problem is concerned with the task of solving for four unknowns;  $x_u$ ,  $y_u$ ,  $z_u$  the receiver coordinates in a suitable frame of reference (usually ECEF) and  $b_u$  the receiver clock bias. It typically requires the following steps:

Step 1: Formation of pseudo-ranges

The observation of code phase reported by the UE for each satellite  $SV_i$  is related to the pseudo-range/c modulo the "GNSS Code Phase Ambiguity" (UTRAN), or "gnss-CodePhaseAmbiguity" (E-UTRAN), or modulo 1 ms (the length of the C/A code period) in case of GPS L1 C/A signal measurements. For the formation of pseudo-ranges, the integer number of milliseconds to be added to each code-phase measurement has to be determined first. Since 1 ms corresponds to a travelled distance of 300 km, the number of integer ms can be found with the help of reference location and satellite ephemeris. The distance between the reference location and each satellite  $SV_i$  is calculated and the integer number of milliseconds to be added to the UE code phase measurements is obtained.

Step 2: Correction of pseudo-ranges for the GNSS-GNSS time offsets

In the case that the UE reports measurements for more than a single GNSS, the pseudo-ranges are corrected for the time offsets between the GNSSs relative to the selected reference time using the GNSS-GNSS time offsets available at the system simulator:

$$\rho_{GNSS_m,i} \equiv \rho_{GNSS_m,i} - c \cdot (t_{GNSS_k} - t_{GNSS_m}),$$

where  $\rho_{GNSS_m,i}$  is the measured pseudo-range of satellite  $i$  of GNSS<sub>m</sub>. The system time  $t_{GNSS_k}$  of GNSS<sub>k</sub> is the reference time frame, and  $(t_{GNSS_k} - t_{GNSS_m})$  is the available GNSS-GNSS time offset, and  $c$  is the speed of light.

## Step 3: Formation of weighting matrix

The UE reported "codePhaseRMSError" (E-UTRAN) or "Code Phase RMS Error" and/or "Pseudorange RMS Error" (UTRAN) values are used to calculate the weighting matrix for the WLS algorithm [9]. According to 3GPP TS 25.331 [30] and 3GPP TS 36.355 [4], the encoding for this field is a 6 bit value that consists of a 3 bit mantissa,  $X_i$  and a 3 bit exponent,  $Y_i$  for each  $SV_i$ :

$$w_i = RMSError = 0.5 \times \left( 1 + \frac{X_i}{8} \right) \times 2^{Y_i}$$

The weighting Matrix  $\mathbf{W}$  is defined as a diagonal matrix containing the estimated variances calculated from the "codePhaseRMSError" (E-UTRAN) or "Code Phase RMS Error" and/or "Pseudorange RMS Error" (UTRAN) values:

$$\mathbf{W} = \text{diag} \left\{ 1/w_{GNSS_{1,1}}^2, 1/w_{GNSS_{1,2}}^2, \dots, 1/w_{GNSS_{1,n}}^2, \dots, 1/w_{GNSS_{m,1}}^2, 1/w_{GNSS_{m,2}}^2, \dots, 1/w_{GNSS_{m,l}}^2 \right\}$$

## Step 4: WLS position solution

The WLS position solution is described in reference [9] and usually requires the following steps:

- 1) Computation of satellite locations at time of transmission using the ephemeris parameters and user algorithms defined in the relevant ICD of the particular GNSS. The satellite locations are transformed into WGS-84 reference frame, if needed.
- 2) Computation of clock correction parameters using the parameters and algorithms as defined in the relevant ICD of the particular GNSS.
- 3) Computation of atmospheric delay corrections using the parameters and algorithms defined in the relevant ICD of the particular GNSS for the ionospheric delay, and using the Gupta model in reference [10] p.121 equation (2) for the tropospheric delay. For GNSSs which do not natively provide ionospheric correction models (e.g., GLONASS), the ionospheric delay is determined using the available ionospheric model adapted to the particular GNSS frequency.
- 4) The WLS position solution starts with an initial estimate of the user state (position and clock offset). The Reference Location is used as initial position estimate. The following steps are required:
  - a) Calculate geometric range (corrected for Earth rotation) between initial location estimate and each satellite included in the UE measurement report.
  - b) Predict pseudo-ranges for each measurement including clock and atmospheric biases as calculated in 1) to 3) above and defined in the relevant ICD of the particular GNSS and [9].
  - c) Calculate difference between predicted and measured pseudo-ranges  $\Delta \mathbf{p}$
  - d) Calculate the "Geometry Matrix"  $\mathbf{G}$  as defined in [9]:

$$\mathbf{G} \equiv \begin{bmatrix} -\hat{\mathbf{1}}_{GNSS_{1,1}}^T & 1 \\ -\hat{\mathbf{1}}_{GNSS_{1,2}}^T & 1 \\ \vdots & \vdots \\ -\hat{\mathbf{1}}_{GNSS_{1,n}}^T & 1 \\ \vdots & \vdots \\ -\hat{\mathbf{1}}_{GNSS_{m,1}}^T & 1 \\ -\hat{\mathbf{1}}_{GNSS_{m,2}}^T & 1 \\ \vdots & \vdots \\ -\hat{\mathbf{1}}_{GNSS_{m,l}}^T & 1 \end{bmatrix} \quad \text{with } \hat{\mathbf{1}}_{GNSS_{m,i}} \equiv \frac{\mathbf{r}_{GNSS_{m,i}} - \hat{\mathbf{r}}_u}{\left| \mathbf{r}_{GNSS_{m,i}} - \hat{\mathbf{r}}_u \right|} \quad \text{where } \mathbf{r}_{GNSS_{m,i}} \text{ is the satellite position vector for } SV_i \text{ of } GNSS_m$$

(calculated in 1) above), and  $\hat{\mathbf{r}}_u$  is the estimate of the user location.

- e) Calculate the WLS solution according to [9]:

$$\Delta\hat{\mathbf{x}} = (\mathbf{G}^T \mathbf{W} \mathbf{G})^{-1} \mathbf{G}^T \mathbf{W} \Delta\rho$$

f) Adding the  $\Delta\hat{\mathbf{x}}$  to the initial state estimate gives an improved estimate of the state vector:

$$\hat{\mathbf{x}} \rightarrow \hat{\mathbf{x}} + \Delta\hat{\mathbf{x}}.$$

5) This new state vector  $\hat{\mathbf{x}}$  can be used as new initial estimate and the procedure is repeated until the change in  $\hat{\mathbf{x}}$  is sufficiently small.

Step 5: Transformation from Cartesian coordinate system to Geodetic coordinate system

The state vector  $\hat{\mathbf{x}}$  calculated in Step 4 contains the UE position in ECEF Cartesian coordinates together with the UE receiver clock bias relative to the selected GNSS system time. Only the user position is of further interest. It is usually desirable to convert from ECEF coordinates  $x_u, y_u, z_u$  to geodetic latitude  $\varphi$ , longitude  $\lambda$  and altitude  $h$  on the WGS84 reference ellipsoid.

Step 6: Calculation of "2-D Position Errors"

The latitude  $\varphi$  / longitude  $\lambda$  obtained after Step 5 is used to calculate the 2-D position error.

## Annex C (normative): General test conditions and declarations

The requirements of this clause apply to all applicable tests in the present document.

In all the relevant clauses in this clause all 2D position error measurements shall be carried out according to the general rules for statistical testing in Annex D.

In this clause, the terms GNSS and A-GNSS also include the cases where the only satellite system used is GPS unless otherwise stated.

The test tolerances may not be valid for operating bands above 4200 MHz since some test system uncertainties are changed for frequencies above 4200 MHz. The test tolerances for bands above 4200 MHz are For Further Study [FFS].

### C.1 Acceptable uncertainty of Test System

The maximum acceptable uncertainty of the Test System is specified below for each test, where appropriate. The Test System shall enable the stimulus signals in the test case to be adjusted to within the specified range, and the equipment under test to be measured with an uncertainty not exceeding the specified values. All ranges and uncertainties are absolute values, and are valid for a confidence level of 95 %, unless otherwise stated.

A confidence level of 95 % is the measurement uncertainty tolerance interval for a specific measurement that contains 95 % of the performance of a population of test equipment.

It should be noted that the uncertainties in clause C.1 apply to the Test System operating into a nominal 50 ohm load and do not include system effects due to mismatch between the DUT and the Test System.

#### C.1.1 Measurement of test environments

The measurement accuracy of the UE environmental test conditions, defined in Annex G or TS 36.508 [18] clause 4.1, shall be:

Pressure	$\pm 5$ kPa
Temperature	$\pm 2$ degrees
Relative Humidity	$\pm 5$ %
DC Voltage	$\pm 1.0$ %
AC Voltage	$\pm 1.5$ %
Vibration	10 %
Vibration frequency	0.1 Hz

The above values shall apply unless the test environment is otherwise controlled and the specification for the control of the test environment specifies the uncertainty for the parameter.



## C.1.2 A-GNSS Minimum Performance requirements

**Table C.1.1: Maximum Test System Uncertainty for A-GNSS Minimum Performance tests**

Clause	Maximum Test System Uncertainty		Derivation of Test System Uncertainty
5.2.1, 6.2.1, 7.1.1 Sensitivity Coarse Time Assistance	Coarse Time Assistance	±200 ms	
	Absolute GNSS signal level	±1 dB	
	Position error	±0.05 m	Position error consists of ±0.05 m system uncertainty. The effect of position reporting resolution of approximately ±1.2 m (see note) is not included in the allowable test system uncertainty but is included in the Test Parameter Relaxations since this resolution limitation limits the reporting capability of the UE. For simplicity the combined Test Parameter Relaxation is given as ±1.3 m
	Response time	± 300 ms	
5.2.2, 6.2.2, 7.1.2 Sensitivity Fine Time Assistance	Coarse Time Assistance	±200 ms	
	Fine Time Assistance	±1 us	
	Absolute GNSS signal level	±1 dB	
	Position error	±0.05 m	Position error as above
	Response time	± 300 ms	
5.3, 6.3, 7.2 Nominal Accuracy	Coarse Time Assistance	±200 ms	
	Absolute GNSS signal level	±1 dB	
	Position error	±0.05 m	Position error as above
	Response time	± 300 ms	
5.4, 6.4, 7.3 Dynamic Range	Coarse Time Assistance	±200 ms	
	Absolute GNSS signal level	±1 dB	
	Relative GNSS signal level	±0.2 dB	
	Position error	±0.05 m	Position error as above
	Response time	± 300 ms	
5.5, 6.5, 7.4 Multi-path scenario	Coarse Time Assistance	±200 ms	
	Absolute GNSS signal level	±1 dB	
	Relative GNSS signal level	±0.2 dB	
	Position error	±0.05 m	Position error as above
	Response time	± 300 ms	
5.6, 6.6, 7.5 Moving scenario and periodic update	Absolute GNSS signal level	±1 dB	
	Position error	±0.05 m	Position error as above
	Differential response time	± 100 ms	
	± 100 ms		

NOTE: For UE based mode the effect of position reporting resolution is given by:

$$\sqrt{\left(\frac{90 \times 2 \times \pi \times R}{2E23 \times 360}\right)^2 + \left(\frac{360 \times 2 \times \pi \times R \times \cos \phi}{2E24 \times 360}\right)^2}$$

meters, where R is the radius of the earth and  $\phi$  is the latitude of the location. For the GNSS scenarios defined in TS 37.571-5 [20] this equates to approximately Editor's note: this needs checking once the GNSS scenarios are agreed [TBD] m. For simplicity this is given as ±1.2 m.

For UE assisted mode it is assumed that the output from the WLS position solution calculation in Annex B is coded using the same position coding method as for UE based mode before being used to calculate position error. Therefore the effect of reporting resolution will be the same as for UE based mode.

### C.1.3 ECID and OTDOA Measurement requirements

**Table C.1.3-1: Maximum Test System Uncertainty for ECID and OTDOA Measurement Requirements**

Clause	Maximum Test System Uncertainty	Derivation of Test System Uncertainty
8.1.1 E-UTRAN FDD UE Rx – Tx time difference case (Rel-9 to Rel-11)	$N_{oc} \pm 1.0$ dB averaged over $BW_{Config}$ $\hat{E}_s / N_{oc} \pm 0.3$ dB  $\pm 3T_s$ Uplink signal transmit timing relative to downlink	Note: $\hat{E}_s / N_{oc}$ is the ratio of cell 1 signal / AWGN  $T_s = 1/(15000 \times 2048)$ seconds, the basic timing unit defined in TS 36.211 [26]
8.1.1A E-UTRAN FDD UE Rx – Tx time difference case (Rel-12 onwards)	Same as 8.1.1	Same as 8.1.1
8.1.1B E-UTRAN FDD UE Rx – Tx time difference case for UE Category 1bis	Same as 8.1.1	Same as 8.1.1
8.1.2 E-UTRAN TDD UE Rx – Tx time difference case (Rel-9 to Rel-11)	Same as 8.1.1	Same as 8.1.1
8.1.2A E-UTRAN TDD UE Rx – Tx time difference case (Rel-12 onwards)	Same as 8.1.1	Same as 8.1.1
8.1.2B E-UTRAN TDD UE Rx – Tx time difference case for UE Category 1bis	Same as 8.1.1	Same as 8.1.1
8.1.3 E-UTRAN FDD UE Rx-Tx time difference under Time Domain Measurement Resource Restriction with Non-MBSFN ABS (eICIC)	$N_{oc} \pm 1.0$ dB averaged over $BW_{Config}$ $\hat{E}_{S1} / N_{oc} \pm 0.3$ dB averaged over $BW_{Config}$ $\hat{E}_{S2} / N_{oc} \pm 0.3$ dB dB averaged over $BW_{Config}$  $\pm 3T_s$ Uplink signal transmit timing relative to downlink	Note: $\hat{E}_{S1} / N_{oc}$ is the ratio of cell 1 signal / AWGN $\hat{E}_{S2} / N_{oc}$ is the ratio of cell 2 signal / AWGN  $T_s = 1/(15000 \times 2048)$ seconds, the basic timing unit defined in TS 36.211 [26]
8.1.4 E-UTRAN TDD UE Rx-Tx time difference under Time Domain Measurement Resource Restriction with Non-MBSFN ABS (eICIC)	Same as 8.1.3	Same as 8.1.3
8.1.5 E-UTRAN FDD UE Rx–Tx time difference under Time Domain Measurement Resource Restriction with CRS Assistance Information and Non-MBSFN ABS (feICIC)	$N_{oc} \pm 1.0$ dB averaged over $BW_{Config}$ $\hat{E}_{S1} / N_{oc} \pm 0.3$ dB averaged over $BW_{Config}$ $\hat{E}_{S2} / N_{oc} \pm 0.3$ dB dB averaged over $BW_{Config}$ $\hat{E}_{S3} / N_{oc} \pm 0.3$ dB dB averaged over $BW_{Config}$  $\pm 3T_s$ Uplink signal transmit timing relative to downlink	Note: $\hat{E}_{S1} / N_{oc}$ is the ratio of cell 1 signal / AWGN $\hat{E}_{S2} / N_{oc}$ is the ratio of cell 1 signal / AWGN $\hat{E}_{S3} / N_{oc}$ is the ratio of cell 1 signal / AWGN  $T_s = 1/(15000 \times 2048)$ seconds, the basic timing unit defined in TS 36.211 [26]
8.1.6 E-UTRAN TDD UE Rx–Tx time difference under Time Domain Measurement Resource Restriction with CRS Assistance Information and Non-MBSFN ABS (feICIC)	Same as 8.1.5	Same as 8.1.5
8.1.7 E-UTRAN FDD UE Rx-Tx time difference case for Cat-M1/M2 UE in CEModeA	Same as 8.1.1	Same as 8.1.1
8.1.8 E-UTRAN HD-FDD UE Rx-Tx time difference case for Cat-M1/M2 UE in CEModeA	Same as 8.1.1	Same as 8.1.1
8.1.9 E-UTRAN TDD UE Rx-Tx time difference case for Cat-M1/M2 UE in CEModeA	Same as 8.1.1	Same as 8.1.1

9.1.1 FDD RSTD Measurement Reporting Delay	$N_{oc} \pm 1.0$ dB averaged over $BW_{Config}$ PRS $\hat{E}_{s1} / N_{oc} \pm 0.6$ dB averaged over $BW_{Config}$ $\hat{E}_{s1} / N_{oc} \pm 0.6$ dB averaged over $BW_{Config}$ PRS $\hat{E}_{s2} / N_{oc} \pm 0.6$ dB averaged over $BW_{Config}$ $\hat{E}_{s2} / N_{oc} \pm 0.6$ dB averaged over $BW_{Config}$ PRS $\hat{E}_{s3} / N_{oc} \pm 0.6$ dB averaged over $BW_{Config}$ $\hat{E}_{s3} / N_{oc} \pm 0.6$ dB averaged over $BW_{Config}$ Response Time = $\pm 300$ ms	Note: PRS $\hat{E}_{s1} / N_{oc}$ and $\hat{E}_{s1} / N_{oc}$ are the ratios of cell 1 signal / AWGN PRS $\hat{E}_{s2} / N_{oc}$ and $\hat{E}_{s2} / N_{oc}$ are the ratios of cell 2 signal / AWGN PRS $\hat{E}_{s3} / N_{oc}$ and $\hat{E}_{s3} / N_{oc}$ are the ratios of cell 3 signal / AWGN  PRS $\hat{E}_s / N_{oc}$ and $\hat{E}_s / N_{oc}$ uncertainty for fading condition comprises two quantities: 1. Signal-to-noise ratio uncertainty 2. Fading profile power uncertainty  Items 1 and 2 are assumed to be uncorrelated so can be root sum squared: PRS $\hat{E}_s / N_{oc}$ and $\hat{E}_s / N_{oc}$ uncertainty = SQRT (Signal-to-noise ratio uncertainty <sup>2</sup> + Fading profile power uncertainty <sup>2</sup> ) Signal-to-noise ratio uncertainty $\pm 0.3$ dB Fading profile power uncertainty $\pm 0.5$ dB
9.1.1A FDD RSTD Measurement Reporting Delay for UE Category 1bis	Same as 9.1.1	
9.1.2 TDD RSTD Measurement Reporting Delay	Same as 9.1.1	
9.1.2A TDD RSTD Measurement Reporting Delay for UE Category 1bis	Same as 9.1.1	
9.1.3 FDD RSTD Measurement Accuracy	$N_{oc} \pm 1.0$ dB averaged over $BW_{Config}$ PRS $\hat{E}_{s1} / N_{oc} \pm 0.3$ dB averaged over $BW_{Config}$ $\hat{E}_{s1} / N_{oc} \pm 0.3$ dB averaged over $BW_{Config}$ PRS $\hat{E}_{s2} / N_{oc} \pm 0.3$ dB averaged over $BW_{Config}$ $\hat{E}_{s2} / N_{oc} \pm 0.3$ dB averaged over $BW_{Config}$ Cell Timing Difference = $\pm 1 T_s$	Note: PRS $\hat{E}_{s1} / N_{oc}$ and $\hat{E}_{s1} / N_{oc}$ are the ratios of cell 1 signal / AWGN PRS $\hat{E}_{s2} / N_{oc}$ and $\hat{E}_{s2} / N_{oc}$ are the ratios of cell 2 signal / AWGN
9.1.3A FDD RSTD Measurement Accuracy for UE Category 1bis	Same as 9.1.3	
9.1.4 TDD RSTD Measurement Accuracy	Same as 9.1.3	
9.1.4A TDD RSTD Measurement Accuracy for UE Category 1bis	Same as 9.1.3	

9.2.1 FDD-FDD inter-frequency RSTD measurement reporting delay	$N_{oc1} \pm 1.0$ dB averaged over $BW_{Config}$ $N_{oc2} \pm 1.0$ dB averaged over $BW_{Config}$ PRRS $\hat{E}_{s1} / N_{oc1} \pm 0.6$ dB averaged over $BW_{Config}$ $\hat{E}_{s1} / N_{oc1} \pm 0.6$ dB averaged over $BW_{Config}$ PRRS $\hat{E}_{s2} / N_{oc2} \pm 0.6$ dB averaged over $BW_{Config}$ $\hat{E}_{s2} / N_{oc2} \pm 0.6$ dB averaged over $BW_{Config}$ $\hat{E}_{s2} / N_{oc2} \pm 0.6$ dB averaged over $BW_{Config}$ PRRS $\hat{E}_{s3} / N_{oc2} \pm 0.6$ dB averaged over $BW_{Config}$ $\hat{E}_{s3} / N_{oc2} \pm 0.6$ dB averaged over $BW_{Config}$ Response Time = $\pm 300$ ms	Note: PRRS $\hat{E}_{s1} / N_{oc1}$ and $\hat{E}_{s1} / N_{oc1}$ are the ratios of cell 1 signal / AWGN for frequency 1 PRRS $\hat{E}_{s2} / N_{oc2}$ and $\hat{E}_{s2} / N_{oc2}$ are the ratios of cell 2 signal / AWGN for frequency 2 PRRS $\hat{E}_{s3} / N_{oc2}$ and $\hat{E}_{s3} / N_{oc2}$ are the ratios of cell 3 signal / AWGN for frequency 2 PRRS $\hat{E}_s / N_{oc}$ and $\hat{E}_s / N_{oc}$ uncertainty for fading condition comprises two quantities: 1. Signal-to-noise ratio uncertainty 2. Fading profile power uncertainty Items 1 and 2 are assumed to be uncorrelated so can be root sum squared: PRRS $\hat{E}_s / N_{oc}$ and $\hat{E}_s / N_{oc}$ uncertainty = SQRT (Signal-to-noise ratio uncertainty <sup>2</sup> + Fading profile power uncertainty <sup>2</sup> ) Signal-to-noise ratio uncertainty $\pm 0.3$ dB Fading profile power uncertainty $\pm 0.5$ dB
9.2.1A FDD-FDD inter-frequency RSTD measurement reporting delay for UE Category 1bis	Same as 9.2.1	
9.2.2 TDD-TDD inter-frequency RSTD measurement reporting delay	Same as 9.2.1	
9.2.2A TDD-TDD inter-frequency RSTD measurement reporting delay for UE Category 1bis	Same as 9.2.1	
9.2.4 FDD-FDD inter frequency RSTD Accuracy	$N_{oc1} \pm 1.0$ dB averaged over $BW_{Config}$ $N_{oc2} \pm 1.0$ dB averaged over $BW_{Config}$ PRRS $\hat{E}_{s1} / N_{oc1} \pm 0.3$ dB averaged over $BW_{Config}$ $\hat{E}_{s1} / N_{oc1} \pm 0.3$ dB averaged over $BW_{Config}$ PRRS $\hat{E}_{s2} / N_{oc2} \pm 0.3$ dB averaged over $BW_{Config}$ $\hat{E}_{s2} / N_{oc2} \pm 0.3$ dB averaged over $BW_{Config}$ $\hat{E}_{s2} / N_{oc2} \pm 0.3$ dB averaged over $BW_{Config}$ Cell Timing Difference = $\pm 2 T_s$	Note: PRRS $\hat{E}_{s1} / N_{oc1}$ and $\hat{E}_{s1} / N_{oc1}$ are the ratios of cell 1 signal / AWGN for frequency 1 PRRS $\hat{E}_{s2} / N_{oc2}$ and $\hat{E}_{s2} / N_{oc2}$ are the ratios of cell 2 signal / AWGN for frequency 2
9.2.4A FDD-FDD inter frequency RSTD Accuracy for UE Category 1bis	Same as 9.2.4	
9.2.5 TDD-TDD inter frequency RSTD Accuracy	Same as 9.2.4	
9.2.5A TDD-TDD inter frequency RSTD Accuracy for UE Category 1bis	Same as 9.2.4	
9.3.1.1 FDD intra-frequency RSTD Measurement Reporting Delay in CE Mode A for Cat M1	Same as 9.1.1	Same as 9.1.1
9.3.1.2 FDD intra-frequency RSTD Measurement Reporting Delay in CE Mode A for Cat M2	Same as 9.1.1	Same as 9.1.1
9.3.2.1 HD-FDD intra-frequency RSTD Measurement Reporting Delay in CE Mode A for Cat M1	Same as 9.1.1	Same as 9.1.1
9.3.2.2 HD-FDD intra-frequency RSTD Measurement Reporting Delay in CE Mode A for Cat M2	Same as 9.1.1	Same as 9.1.1
9.3.3.1 TDD intra-frequency RSTD Measurement Reporting Delay in CE Mode A for Cat M1	Same as 9.1.1	Same as 9.1.1

9.3.3.2 TDD intra-frequency RSTD Measurement Reporting Delay in CE Mode A for Cat M2	Same as 9.1.1	Same as 9.1.1
9.3.4.1 FDD intra-frequency RSTD Measurement Reporting Delay in CE Mode B for Cat M1	Same as 9.1.1	Same as 9.1.1
9.3.4.2 FDD intra-frequency RSTD Measurement Reporting Delay in CE Mode B for Cat M2	Same as 9.1.1	Same as 9.1.1
9.3.5.1 HD-FDD intra-frequency RSTD Measurement Reporting Delay in CE Mode B for Cat M1	Same as 9.1.1	Same as 9.1.1
9.3.5.2 HD-FDD intra-frequency RSTD Measurement Reporting Delay in CE Mode B for Cat M2	Same as 9.1.1	Same as 9.1.1
9.3.6.1 TDD intra-frequency RSTD Measurement Reporting Delay in CE Mode B for Cat M1	Same as 9.1.1	Same as 9.1.1
9.3.6.2 TDD intra-frequency RSTD Measurement Reporting Delay in CE Mode B for Cat M2	Same as 9.1.1	Same as 9.1.1
9.3.7.1 FDD intra-frequency RSTD Measurement Accuracy in CE Mode A for Cat M1	Same as 9.1.3	Same as 9.1.3
9.3.7.2 FDD intra-frequency RSTD Measurement Accuracy in CE Mode A for Cat M2	Same as 9.1.3	Same as 9.1.3
9.3.8.1 HD-FDD intra-frequency RSTD Measurement Accuracy in CE Mode A for Cat M1	Same as 9.1.3	Same as 9.1.3
9.3.8.2 HD-FDD intra-frequency RSTD Measurement Accuracy in CE Mode A for Cat M2	Same as 9.1.3	Same as 9.1.3
9.3.9.1 TDD intra-frequency RSTD Measurement Accuracy in CE Mode A for Cat M1	Same as 9.1.3	Same as 9.1.3
9.3.9.2 TDD intra-frequency RSTD Measurement Accuracy in CE Mode A for Cat M2	Same as 9.1.3	Same as 9.1.3
9.3.10.1 FDD intra-frequency RSTD Measurement Accuracy in CE Mode B for Cat M1	Same as 9.1.3	Same as 9.1.3
9.3.10.2 FDD intra-frequency RSTD Measurement Accuracy in CE Mode B for Cat M2	Same as 9.1.3	Same as 9.1.3
9.3.11.1 HD-FDD intra-frequency RSTD Measurement Accuracy in CE Mode B for Cat M1	Same as 9.1.3	Same as 9.1.3
9.3.11.2 HD-FDD intra-frequency RSTD Measurement Accuracy in CE Mode B for Cat M2	Same as 9.1.3	Same as 9.1.3
9.3.12.1 TDD intra-frequency RSTD Measurement Accuracy in CE Mode B for Cat M1	Same as 9.1.3	Same as 9.1.3
9.3.12.2 TDD intra-frequency RSTD Measurement Accuracy in CE Mode B for Cat M2	Same as 9.1.3	Same as 9.1.3
9.4.1.1 FDD inter-frequency RSTD Measurement Reporting Delay in CE Mode A for Cat M1	Same as 9.2.1	Same as 9.2.1
9.4.1.2 FDD inter-frequency RSTD Measurement Reporting Delay in CE Mode A for Cat M2	Same as 9.2.1	Same as 9.2.1
9.4.2.1 HD-FDD inter-frequency RSTD Measurement Reporting Delay in CE Mode A for Cat M1	Same as 9.2.1	Same as 9.2.1
9.4.2.2 HD-FDD inter-frequency RSTD Measurement Reporting Delay in CE Mode A for Cat M2	Same as 9.2.1	Same as 9.2.1
9.4.3.1 TDD inter-frequency RSTD Measurement Reporting Delay in CE Mode A for Cat M1	Same as 9.2.1	Same as 9.2.1
9.4.3.2 TDD inter-frequency RSTD Measurement Reporting Delay in CE Mode A for Cat M2	Same as 9.2.1	Same as 9.2.1

9.4.4.1 FDD inter-frequency RSTD Measurement Reporting Delay in CE Mode B for Cat M1	Same as 9.2.1	Same as 9.2.1
9.4.4.2 FDD inter-frequency RSTD Measurement Reporting Delay in CE Mode B for Cat M2	Same as 9.2.1	Same as 9.2.1
9.4.5.1 HD-FDD inter-frequency RSTD Measurement Reporting Delay in CE Mode B for Cat M1	Same as 9.2.1	Same as 9.2.1
9.4.5.2 HD-FDD inter-frequency RSTD Measurement Reporting Delay in CE Mode B for Cat M2	Same as 9.2.1	Same as 9.2.1
9.4.6.1 TDD inter-frequency RSTD Measurement Reporting Delay in CE Mode B for Cat M1	Same as 9.2.1	Same as 9.2.1
9.4.6.2 TDD inter-frequency RSTD Measurement Reporting Delay in CE Mode B for Cat M2	Same as 9.2.1	Same as 9.2.1
9.4.7.1 FDD inter-frequency RSTD Measurement Accuracy in CE Mode A for Cat M1	Same as 9.2.4	Same as 9.2.4
9.4.7.2 FDD inter-frequency RSTD Measurement Accuracy in CE Mode A for Cat M2	Same as 9.2.4	Same as 9.2.4
9.4.8.1 HD-FDD inter-frequency RSTD Measurement Accuracy in CE Mode A for Cat M1	Same as 9.2.4	Same as 9.2.4
9.4.8.2 HD-FDD inter-frequency RSTD Measurement Accuracy in CE Mode A for Cat M2	Same as 9.2.4	Same as 9.2.4
9.4.9.1 TDD inter-frequency RSTD Measurement Accuracy in CE Mode A for Cat M1	Same as 9.2.4	Same as 9.2.4
9.4.9.2 TDD inter-frequency RSTD Measurement Accuracy in CE Mode A for Cat M2	Same as 9.2.4	Same as 9.2.4
9.4.10.1 FDD inter-frequency RSTD Measurement Accuracy in CE Mode B for Cat M1	Same as 9.2.4	Same as 9.2.4
9.4.10.2 FDD inter-frequency RSTD Measurement Accuracy in CE Mode B for Cat M2	Same as 9.2.4	Same as 9.2.4
9.4.11.1 HD-FDD inter-frequency RSTD Measurement Accuracy in CE Mode B for Cat M1	Same as 9.2.4	Same as 9.2.4
9.4.11.2 HD-FDD inter-frequency RSTD Measurement Accuracy in CE Mode B for Cat M2	Same as 9.2.4	Same as 9.2.4
9.4.12.1 TDD inter-frequency RSTD Measurement Accuracy in CE Mode B for Cat M1	Same as 9.2.4	Same as 9.2.4
9.4.12.2 TDD inter-frequency RSTD Measurement Accuracy in CE Mode B for Cat M2	Same as 9.2.4	Same as 9.2.4
9.5.1 HD-FDD Intra frequency RSTD Measurement Accuracy for NB-IOT Inband Mode in normal coverage	$N_{oc} \pm 1.0$ dB averaged over $BW_{Config}$ NPRS $\hat{E}_{s1} / N_{oc} \pm 0.3$ dB averaged over $BW_{Config}$ $\hat{E}_{s1} / N_{oc} \pm 0.3$ dB averaged over $BW_{Config}$ NPRS $\hat{E}_{s2} / N_{oc} \pm 0.3$ dB averaged over $BW_{Config}$ $\hat{E}_{s2} / N_{oc} \pm 0.3$ dB averaged over $BW_{Config}$ Cell Timing Difference = $\pm 1 T_s$	Note: NPRS $\hat{E}_{s1} / N_{oc}$ and $\hat{E}_{s1} / N_{oc}$ are the ratios of nCell 1 signal / AWGN NPRS $\hat{E}_{s2} / N_{oc}$ and $\hat{E}_{s2} / N_{oc}$ are the ratios of nCell 2 signal / AWGN
9.5.2 HD-FDD Intra frequency RSTD Measurement Accuracy for NB-IOT Inband Mode in enhanced coverage	Same as 9.5.1	Same as 9.5.1
9.5.3 HD-FDD Intra frequency RSTD Measurement Reporting Delay for NB-IOT Inband Mode in enhanced coverage	TBD	TBD

9.6.1 HD-FDD Inter-Frequency RSTD Measurement Accuracy for NB-IOT Inband Mode in normal coverage	$N_{oc1} \pm 1.0$ dB averaged over $BW_{Config}$ $N_{oc2} \pm 1.0$ dB averaged over $BW_{Config}$ NPRS $\hat{E}_{s1} / N_{oc1} \pm 0.3$ dB averaged over $BW_{Config}$ $\hat{E}_{s1} / N_{oc1} \pm 0.3$ dB averaged over $BW_{Config}$ NPRS $\hat{E}_{s2} / N_{oc2} \pm 0.3$ dB averaged over $BW_{Config}$ $\hat{E}_{s2} / N_{oc2} \pm 0.3$ dB averaged over $BW_{Config}$ Cell Timing Difference = $\pm 2 T_s$	Note: NPRS $\hat{E}_{s1} / N_{oc1}$ and $\hat{E}_{s1} / N_{oc1}$ are the ratios of nCell 1 signal / AWGN for frequency 1 NPRS $\hat{E}_{s2} / N_{oc2}$ and $\hat{E}_{s2} / N_{oc2}$ are the ratios of nCell 2 signal / AWGN for frequency 2
9.6.2 HD-FDD Inter-Frequency RSTD Measurement Accuracy for NB-IOT Inband Mode in enhanced coverage	Same as 9.6.1	Same as 9.6.1
9.6.3 HD-FDD Inter frequency RSTD Measurement Reporting Delay for NB-IOT Inband Mode in enhanced coverage	TBD	TBD
10.1 FDD RSTD Measurement Reporting Delay for Carrier Aggregation	$N_{oc1} \pm 1.0$ dB averaged over $BW_{Config}$ $N_{oc2} \pm 1.0$ dB averaged over $BW_{Config}$ PRS $\hat{E}_{s1} / N_{oc1} \pm 0.6$ dB averaged over $BW_{Config}$ $\hat{E}_{s1} / N_{oc1} \pm 0.6$ dB averaged over $BW_{Config}$ PRS $\hat{E}_{s2} / N_{oc2} \pm 0.6$ dB averaged over $BW_{Config}$ $\hat{E}_{s2} / N_{oc2} \pm 0.6$ dB averaged over $BW_{Config}$ PRS $\hat{E}_{s3} / N_{oc2} \pm 0.6$ dB averaged over $BW_{Config}$ $\hat{E}_{s3} / N_{oc2} \pm 0.6$ dB averaged over $BW_{Config}$ Response Time = $\pm 300$ ms	Note: PRS $\hat{E}_{s1} / N_{oc1}$ and $\hat{E}_{s1} / N_{oc1}$ are the ratios of cell 1 signal / AWGN for frequency 1 PRS $\hat{E}_{s2} / N_{oc2}$ and $\hat{E}_{s2} / N_{oc2}$ are the ratios of cell 2 signal / AWGN for frequency 2 PRS $\hat{E}_{s3} / N_{oc2}$ and $\hat{E}_{s3} / N_{oc2}$ are the ratios of cell 3 signal / AWGN for frequency 2  PRS $\hat{E}_s / N_{oc}$ and $\hat{E}_s / N_{oc}$ uncertainty for fading condition comprises two quantities: 1. Signal-to-noise ratio uncertainty 2. Fading profile power uncertainty  Items 1 and 2 are assumed to be uncorrelated so can be root sum squared: PRS $\hat{E}_s / N_{oc}$ and $\hat{E}_s / N_{oc}$ uncertainty = SQRT (Signal-to-noise ratio uncertainty <sup>2</sup> + Fading profile power uncertainty <sup>2</sup> ) Signal-to-noise ratio uncertainty $\pm 0.3$ dB Fading profile power uncertainty $\pm 0.5$ dB
10.1A FDD RSTD Measurement Reporting Delay for Carrier Aggregation for 20 MHz	Same as 10.1	Same as 10.1
10.1B FDD RSTD Measurement Reporting Delay Carrier Aggregation for 5 MHz +5 MHz Bandwidth	Same as 10.1	Same as 10.1
10.1C FDD RSTD Measurement Reporting Delay for Carrier Aggregation for 10 MHz+5 MHz Bandwidth	Same as 10.1	Same as 10.1
10.2 TDD RSTD Measurement Reporting Delay for Carrier Aggregation	Same as 10.1	Same as 10.1
10.2A TDD RSTD Measurement Reporting Delay for Carrier Aggregation for 20 MHz	Same as 10.1	Same as 10.1
10.2B TDD RSTD Measurement Reporting Delay Carrier Aggregation for 5 MHz +5 MHz Bandwidth	Same as 10.1	Same as 10.1



10.2C TDD RSTD Measurement Reporting Delay for Carrier Aggregation for 10 MHz+5 MHz Bandwidth	Same as 10.1	Same as 10.1
10.2D TDD RSTD Measurement Reporting Delay for Carrier Aggregation for 20 MHz +10 MHz Bandwidth	Same as 10.1	Same as 10.1
10.3 FDD RSTD Measurement Accuracy for Carrier Aggregation	$N_{oc1} \pm 1.0$ dB averaged over $BW_{Config}$ $N_{oc2} \pm 1.0$ dB averaged over $BW_{Config}$ PRRS $\hat{E}_{s1} / N_{oc1} \pm 0.3$ dB averaged over $BW_{Config}$ $\hat{E}_{s1} / N_{oc1} \pm 0.3$ dB averaged over $BW_{Config}$ PRRS $\hat{E}_{s2} / N_{oc2} \pm 0.3$ dB averaged over $BW_{Config}$ $\hat{E}_{s2} / N_{oc2} \pm 0.3$ dB averaged over $BW_{Config}$ PRRS $\hat{E}_{s3} / N_{oc2} \pm 0.3$ dB averaged over $BW_{Config}$ $\hat{E}_{s3} / N_{oc2} \pm 0.3$ dB averaged over $BW_{Config}$ Cell Timing Difference = $\pm 1 T_s$	Note: PRRS $\hat{E}_{s1} / N_{oc1}$ and $\hat{E}_{s1} / N_{oc1}$ are the ratios of cell 1 signal / AWGN for frequency 1 PRRS $\hat{E}_{s2} / N_{oc2}$ and $\hat{E}_{s2} / N_{oc2}$ are the ratios of cell 2 signal / AWGN for frequency 2 PRRS $\hat{E}_{s3} / N_{oc2}$ and $\hat{E}_{s3} / N_{oc2}$ are the ratios of cell 3 signal / AWGN for frequency 2
10.3A FDD RSTD Measurement Accuracy for Carrier Aggregation for 20 MHz (Rel-10 and Rel-11)	Same as 10.3	
10.3A_1 FDD RSTD Measurement Accuracy for Carrier Aggregation for 20 MHz (Rel-12 onwards)	Same as 10.3	Same as 10.3
10.3B FDD RSTD Measurement Accuracy for Carrier Aggregation for 5 MHz+5 MHz Bandwidth	Same as 10.3	Same as 10.3
10.3C FDD RSTD Measurement Accuracy for Carrier Aggregation for 10 MHz+5 MHz Bandwidth	Same as 10.3	Same as 10.3
10.4 TDD RSTD Measurement Accuracy for Carrier Aggregation	Same as 10.3	
10.4A TDD RSTD Measurement Accuracy for Carrier Aggregation for 20 MHz (Rel-10 and Rel-11)	Same as 10.3	
10.4A_1 TDD RSTD Measurement Accuracy for Carrier Aggregation for 20 MHz (Rel-12 onwards)	Same as 10.3	Same as 10.3
10.4B TDD RSTD Measurement Accuracy for Carrier Aggregation for 5 MHz+5 MHz Bandwidth	Same as 10.3	Same as 10.3
10.4C TDD RSTD Measurement Accuracy for Carrier Aggregation for 10 MHz+5 MHz Bandwidth	Same as 10.3	Same as 10.3
10.4D TDD RSTD Measurement Accuracy for Carrier Aggregation for 20 MHz+10 MHz Bandwidth	Same as 10.3	Same as 10.3

10.5 FDD 3 DL CA RSTD Measurement Reporting Delay	$N_{oc1} \pm 1.0$ dB averaged over $BW_{Config}$ $N_{oc2} \pm 1.0$ dB averaged over $BW_{Config}$ $N_{oc3} \pm 1.0$ dB averaged over $BW_{Config}$ PRRS $\hat{E}_{s1} / N_{oc1} \pm 0.6$ dB averaged over $BW_{Config}$ $\hat{E}_{s1} / N_{oc1} \pm 0.6$ dB averaged over $BW_{Config}$ PRRS $\hat{E}_{s2} / N_{oc2} \pm 0.6$ dB averaged over $BW_{Config}$ $\hat{E}_{s2} / N_{oc2} \pm 0.6$ dB averaged over $BW_{Config}$ PRRS $\hat{E}_{s3} / N_{oc3} \pm 0.6$ dB averaged over $BW_{Config}$ $\hat{E}_{s3} / N_{oc3} \pm 0.6$ dB averaged over $BW_{Config}$ PRRS $\hat{E}_{s4} / N_{oc3} \pm 0.6$ dB averaged over $BW_{Config}$ $\hat{E}_{s4} / N_{oc3} \pm 0.6$ dB averaged over $BW_{Config}$ Response Time = $\pm 300$ ms	Note: PRRS $\hat{E}_{s1} / N_{oc1}$ and $\hat{E}_{s1} / N_{oc1}$ are the ratios of cell 1 signal / AWGN for frequency 1 PRRS $\hat{E}_{s2} / N_{oc2}$ and $\hat{E}_{s2} / N_{oc2}$ are the ratios of cell 2 signal / AWGN for frequency 2 PRRS $\hat{E}_{s3} / N_{oc3}$ and $\hat{E}_{s3} / N_{oc3}$ are the ratios of cell 3 signal / AWGN for frequency 3 PRRS $\hat{E}_{s4} / N_{oc3}$ and $\hat{E}_{s4} / N_{oc3}$ are the ratios of cell 4 signal / AWGN for frequency 3  PRRS $\hat{E}_s / N_{oc}$ and $\hat{E}_s / N_{oc}$ uncertainty for fading condition comprises two quantities: 1. Signal-to-noise ratio uncertainty 2. Fading profile power uncertainty  Items 1 and 2 are assumed to be uncorrelated so can be root sum squared: PRRS $\hat{E}_s / N_{oc}$ and $\hat{E}_s / N_{oc}$ uncertainty = SQRT (Signal-to-noise ratio uncertainty <sup>2</sup> + Fading profile power uncertainty <sup>2</sup> ) Signal-to-noise ratio uncertainty $\pm 0.3$ dB Fading profile power uncertainty $\pm 0.5$ dB
10.6 TDD 3 DL CA RSTD Measurement Reporting Delay	Same as 10.5	Same as 10.5
10.7 FDD RSTD Measurement Accuracy for 3DL Carrier Aggregation	$N_{oc1} \pm 1.0$ dB averaged over $BW_{Config}$ $N_{oc2} \pm 1.0$ dB averaged over $BW_{Config}$ $N_{oc3} \pm 1.0$ dB averaged over $BW_{Config}$ PRRS $\hat{E}_{s1} / N_{oc1} \pm 0.3$ dB averaged over $BW_{Config}$ $\hat{E}_{s1} / N_{oc1} \pm 0.3$ dB averaged over $BW_{Config}$ PRRS $\hat{E}_{s2} / N_{oc2} \pm 0.3$ dB averaged over $BW_{Config}$ $\hat{E}_{s2} / N_{oc2} \pm 0.3$ dB averaged over $BW_{Config}$ PRRS $\hat{E}_{s3} / N_{oc3} \pm 0.3$ dB averaged over $BW_{Config}$ $\hat{E}_{s3} / N_{oc3} \pm 0.3$ dB averaged over $BW_{Config}$ PRRS $\hat{E}_{s4} / N_{oc3} \pm 0.3$ dB averaged over $BW_{Config}$ $\hat{E}_{s4} / N_{oc3} \pm 0.3$ dB averaged over $BW_{Config}$ Cell Timing Difference (Intra-freq) = $\pm 1 T_s$ Cell Timing Difference (Inter-freq) = $\pm 2 T_s$	Note: PRRS $\hat{E}_{s1} / N_{oc1}$ and $\hat{E}_{s1} / N_{oc1}$ are the ratios of cell 1 signal / AWGN for frequency 1 PRRS $\hat{E}_{s2} / N_{oc2}$ and $\hat{E}_{s2} / N_{oc2}$ are the ratios of cell 2 signal / AWGN for frequency 2 PRRS $\hat{E}_{s3} / N_{oc3}$ and $\hat{E}_{s3} / N_{oc3}$ are the ratios of cell 3 signal / AWGN for frequency 3 PRRS $\hat{E}_{s4} / N_{oc3}$ and $\hat{E}_{s4} / N_{oc3}$ are the ratios of cell 4 signal / AWGN for frequency 3
10.8 TDD RSTD Measurement Accuracy for 3DL Carrier Aggregation	Same as 10.7	Same as 10.7
In addition, the following Test System uncertainties and related constraints apply. Any additional constraints are defined in the specific tests.		
AWGN Bandwidth	$\geq 1.08$ MHz, 2.7 MHz, 4.5 MHz, 9 MHz, 13.5 MHz, 18 MHz; $N_{RB} \times 180$ kHz according to $BW_{Config}$	
AWGN absolute power uncertainty	Test-specific	
AWGN flatness and signal flatness, max deviation for any Resource Block, relative to average over $BW_{Config}$	$\pm 2$ dB	
AWGN peak to average ratio	$\geq 10$ dB @0.001%	

Signal-to noise ratio uncertainty	Test-specific
Fading profile power uncertainty	±0.5 dB
Fading profile delay uncertainty, relative to frame timing	±5 ns (excludes absolute errors related to baseband timing)

## C.1.4 MBS Minimum Performance requirements

**Table C.1.4-1: Maximum Test System Uncertainty for MBS Minimum Performance tests**

Clause	Maximum Test System Uncertainty		Derivation of Test System Uncertainty
11.1, 11.1A MBS Measurement Reporting Delay	Beacon power level	±2 dB	
	Response time	±300 ms	
11.2, 11.2A MBS Sensitivity Measurement Accuracy	Beacon power level	±2 dB	
	Code phase delay difference	±5 ns	Code phase delay difference error value of +/- 5ns, being derived from 10% of the most stringent code phase delay measurement accuracy requirement
11.3, 11.3A MBS Nominal Measurement Accuracy	Beacon power level	±2 dB	
	Code phase delay	±5 ns	Code phase delay error as above
11.4, 11.4A MBS Dynamic Range Measurement Accuracy	Beacon power level	±2 dB	
	Code phase delay	±5 ns	Code phase delay error as above
11.5, 11.5A MBS Measurement Accuracy in Multipath	Beacon power level	±2 dB	
	Code phase delay	±5 ns	Code phase delay error as above

Note: Code phase delay is equal to the propagation delay from the (simulated) beacon transmitter to the UE receive antenna based on the propagation distance in the test case.

## C.1.5 WLAN and BLE measurement requirements

**Table C.1.5-1: Maximum Test System Uncertainty for WLAN and BLE measurement tests**

Clause	Maximum Test System Uncertainty		Derivation of Test System Uncertainty
12.1.1 WLAN AP Identification and reporting delay under nominal conditions	Response time	±300 ms	
12.1.2 WLAN AP Identification and reporting delay under dynamic range conditions	Response time	±300 ms	
	AP Power Level Difference	±1 dB	
12.2.1 Bluetooth identification	Response time	±300 ms	

Note: AP Power Level Difference is the difference between the WLAN Received Power Level from the high power WLAN AP with respect to the low power WLAN APs.

## C.2 Test Parameter Relaxations (This clause is informative)

The Test Parameter Relaxations defined in this clause have been used to relax the Conformance requirement to derive the Test Requirements.

The Test Parameter Relaxations are derived from Test System uncertainties, regulatory requirements and criticality to system performance. As a result, the Test Parameter Relaxations may sometimes be set to zero.

The Test Parameter Relaxations should not be modified for any reason e.g. to take account of commonly known test system errors (such as mismatch, cable loss, etc.).

## C.2.1 A-GNSS Minimum Performance requirements

**Table C.2.1: Test Parameter Relaxations for A-GNSS Minimum Performance tests**

Clause	Test Parameter Relaxation	
5.2.1, 6.2.1, 7.1.1 Sensitivity Coarse Time Assistance	Coarse Time Assistance	200 ms
	Absolute GNSS signal level	1 dB
	Position error	1.3 m
	Response time	300 ms
5.2.2, 6.2.2, 7.1.2 Sensitivity Fine Time Assistance	Coarse Time Assistance	200 ms
	Fine Time Assistance	1 us
	Absolute GNSS signal level	1 dB
	Position error	1.3 m
	Response time	300 ms
5.3, 6.3, 7.2 Nominal Accuracy	Coarse Time Assistance	200 ms
	Absolute GNSS signal level	0 dB
	Position error	1.3 m
	Response time	300 ms
5.4, 6.4, 7.3 Dynamic Range	Coarse Time Assistance	200 ms
	Absolute GNSS signal level	1 dB
	Relative GNSS signal level	0.2 dB
	Position error	1.3 m
	Response time	300 ms
5.5, 6.5, 7.4 Multi-path scenario	Coarse Time Assistance	200 ms
	Absolute GNSS signal level	0 dB
	Relative GNSS signal level	0.2 dB
	Position error	1.3 m
	Response time	300 ms
5.6, 6.6, 7.5 Moving scenario and periodic update	Absolute GNSS signal level	0 dB
	Position error	1.3 m
	Differential Response Time	100 ms

## C.2.2 ECID and OTDOA Measurement requirements

**Table C.2.2: Test Parameter Relaxations for ECID and OTDOA Measurement requirements**

Clause	Test Parameter Relaxation	
8.1.1 E-UTRAN FDD UE Rx – Tx time difference case (Rel-9 to Rel-11)		
8.1.1A E-UTRAN FDD UE Rx – Tx time difference case (Rel-12 onwards)		
8.1.1B E-UTRAN FDD UE Rx – Tx time difference case for UE Category 1bis		
8.1.2 E-UTRAN TDD UE Rx – Tx time difference case (Rel-9 to Rel-11)		
8.1.2A E-UTRAN TDD UE Rx – Tx time difference case (Rel-12 onwards)		
8.1.2B E-UTRAN TDD UE Rx – Tx time difference case for UE Category 1bis		
8.1.3 E-UTRAN FDD UE Rx-Tx time difference under Time Domain Measurement Resource Restriction with Non-MBSFN ABS (eICIC)	Parameters $N_{oc}$ : -98dBm/15kHz $\hat{E}_{s1} / N_{oc}$ : -3.00dB $\hat{E}_{s2} / N_{oc}$ : +1.00dB	Test Tolerance 0dB +0.3dB 0dB
8.1.4 E-UTRAN TDD UE Rx-Tx time difference under Time Domain Measurement Resource Restriction with Non-MBSFN ABS (eICIC)	Same as 8.1.3	Same as 8.1.3
8.1.5 E-UTRAN FDD UE Rx–Tx time difference under Time Domain Measurement Resource Restriction with CRS Assistance Information and Non-MBSFN ABS (feICIC)	Parameters $N_{oc}$ : -98dBm/15kHz $\hat{E}_{s1} / N_{oc}$ : -3.00dB $\hat{E}_{s2} / N_{oc}$ : +3.00dB $\hat{E}_{s3} / N_{oc}$ : +1.00dB	Test Tolerance 0dB +0.4dB 0dB 0dB
8.1.6 E-UTRAN TDD UE Rx–Tx time difference under Time Domain Measurement Resource Restriction with CRS Assistance Information and Non-MBSFN ABS (feICIC)	Same as 8.1.5	Same as 8.1.5
8.1.7 E-UTRAN FDD UE Rx-Tx time difference case for Cat-M1/M2 UE in CEModeA	Same as 8.1.1	Same as 8.1.1
8.1.8 E-UTRAN HD-FDD UE Rx-Tx time difference case for Cat-M1/M2 UE in CEModeA	Same as 8.1.1	Same as 8.1.1
8.1.9 E-UTRAN TDD UE Rx-Tx time difference case for Cat-M1/M2 UE in CEModeA	Same as 8.1.1	Same as 8.1.1
9.1.1 FDD RSTD Measurement Reporting Delay	Response time	300 ms
9.1.1A FDD RSTD Measurement Reporting Delay for UE Category 1bis	Response time	300 ms
9.1.2 TDD RSTD Measurement Reporting Delay	Response time	300 ms
9.1.2A TDD RSTD Measurement Reporting Delay for UE Category 1bis	Response time	300 ms
9.1.3 FDD RSTD Measurement Accuracy	For Test 2 and Test 4: PRS $\hat{E}_{s1} / N_{oc}$ averaged over $BW_{Config}$ PRS $\hat{E}_{s2} / N_{oc}$ averaged over $BW_{Config}$  For all tests: Cell Timing Difference	+0.3 dB  +0.3 dB  $\pm 1 T_s$
9.1.3A FDD RSTD Measurement Accuracy for UE Category 1bis	Same as 9.1.3	Same as 9.1.3
9.1.4 TDD RSTD Measurement Accuracy	Same as 9.1.3	Same as 9.1.3

9.1.4A TDD RSTD Measurement Accuracy for UE Category 1bis	Same as 9.1.3	Same as 9.1.3
9.2.1 FDD-FDD inter-frequency RSTD measurement reporting delay	Response time	300 ms
9.2.1A FDD-FDD inter-frequency RSTD measurement reporting delay for UE Category 1bis	Response time	300 ms
9.2.2 TDD-TDD inter-frequency RSTD measurement reporting delay	Response time	300 ms
9.2.2A TDD-TDD inter-frequency RSTD measurement reporting delay for UE Category 1bis	Response time	300 ms
9.2.4 FDD-FDD inter frequency RSTD Accuracy	PRs $\hat{E}_{S1} / N_{oc1}$ averaged over $BW_{Config}$ PRs $\hat{E}_{S2} / N_{oc2}$ averaged over $BW_{Config}$	+0.3 dB +0.3 dB
	Cell Timing Difference	$\pm 2 T_s$
9.2.4A FDD-FDD inter frequency RSTD Accuracy for UE Category 1bis	Same as 9.2.4	Same as 9.2.4
9.2.5 TDD-TDD inter frequency RSTD Accuracy	Same as 9.2.4	Same as 9.2.4
9.2.5A TDD-TDD inter frequency RSTD Accuracy for UE Category 1bis	Same as 9.2.4	Same as 9.2.4
9.3.1.1 FDD intra-frequency RSTD Measurement Reporting Delay in CE Mode A for Cat M1	Same as 9.1.1	Same as 9.1.1
9.3.1.2 FDD intra-frequency RSTD Measurement Reporting Delay in CE Mode A for Cat M2	Same as 9.1.1	Same as 9.1.1
9.3.2.1 HD-FDD intra-frequency RSTD Measurement Reporting Delay in CE Mode A for Cat M1	Same as 9.1.1	Same as 9.1.1
9.3.2.2 HD-FDD intra-frequency RSTD Measurement Reporting Delay in CE Mode A for Cat M2	Same as 9.1.1	Same as 9.1.1
9.3.3.1 TDD intra-frequency RSTD Measurement Reporting Delay in CE Mode A for Cat M1	Same as 9.1.1	Same as 9.1.1
9.3.3.2 TDD intra-frequency RSTD Measurement Reporting Delay in CE Mode A for Cat M2	Same as 9.1.1	Same as 9.1.1
9.3.4.1 FDD intra-frequency RSTD Measurement Reporting Delay in CE Mode B for Cat M1	Same as 9.1.1	Same as 9.1.1
9.3.4.2 FDD intra-frequency RSTD Measurement Reporting Delay in CE Mode B for Cat M2	Same as 9.1.1	Same as 9.1.1
9.3.5.1 HD-FDD intra-frequency RSTD Measurement Reporting Delay in CE Mode B for Cat M1	Same as 9.1.1	Same as 9.1.1
9.3.5.2 HD-FDD intra-frequency RSTD Measurement Reporting Delay in CE Mode B for Cat M2	Same as 9.1.1	Same as 9.1.1
9.3.6.1 TDD intra-frequency RSTD Measurement Reporting Delay in CE Mode B for Cat M1	Same as 9.1.1	Same as 9.1.1
9.3.6.2 TDD intra-frequency RSTD Measurement Reporting Delay in CE Mode B for Cat M2	Same as 9.1.1	Same as 9.1.1
9.3.7.1 FDD intra-frequency RSTD Measurement Accuracy in CE Mode A for Cat M1	Same as 9.1.3	Same as 9.1.3
9.3.7.2 FDD intra-frequency RSTD Measurement Accuracy in CE Mode A for Cat M2	Same as 9.1.3	Same as 9.1.3
9.3.8.1 HD-FDD intra-frequency RSTD Measurement Accuracy in CE Mode A for Cat M1	Same as 9.1.3	Same as 9.1.3

9.3.8.2 HD-FDD intra-frequency RSTD Measurement Accuracy in CE Mode A for Cat M2	Same as 9.1.3	Same as 9.1.3
9.3.9.1 TDD intra-frequency RSTD Measurement Accuracy in CE Mode A for Cat M1	Same as 9.1.3	Same as 9.1.3
9.3.9.2 TDD intra-frequency RSTD Measurement Accuracy in CE Mode A for Cat M2	Same as 9.1.3	Same as 9.1.3
9.3.10.1 FDD intra-frequency RSTD Measurement Accuracy in CE Mode B for Cat M1	Same as 9.1.3	Same as 9.1.3
9.3.10.2 FDD intra-frequency RSTD Measurement Accuracy in CE Mode B for Cat M2	Same as 9.1.3	Same as 9.1.3
9.3.11.1 HD-FDD intra-frequency RSTD Measurement Accuracy in CE Mode B for Cat M1	Same as 9.1.3	Same as 9.1.3
9.3.11.2 HD-FDD intra-frequency RSTD Measurement Accuracy in CE Mode B for Cat M2	Same as 9.1.3	Same as 9.1.3
9.3.12.1 TDD intra-frequency RSTD Measurement Accuracy in CE Mode B for Cat M1	Same as 9.1.3	Same as 9.1.3
9.3.12.2 TDD intra-frequency RSTD Measurement Accuracy in CE Mode B for Cat M2	Same as 9.1.3	Same as 9.1.3
9.4.1.1 FDD inter-frequency RSTD Measurement Reporting Delay in CE Mode A for Cat M1	Same as 9.2.1	Same as 9.2.1
9.4.1.2 FDD inter-frequency RSTD Measurement Reporting Delay in CE Mode A for Cat M2	Same as 9.2.1	Same as 9.2.1
9.4.2.1 HD-FDD inter-frequency RSTD Measurement Reporting Delay in CE Mode A for Cat M1	Same as 9.2.1	Same as 9.2.1
9.4.2.2 HD-FDD inter-frequency RSTD Measurement Reporting Delay in CE Mode A for Cat M2	Same as 9.2.1	Same as 9.2.1
9.4.3.1 TDD inter-frequency RSTD Measurement Reporting Delay in CE Mode A for Cat M1	Same as 9.2.1	Same as 9.2.1
9.4.3.2 TDD inter-frequency RSTD Measurement Reporting Delay in CE Mode A for Cat M2	Same as 9.2.1	Same as 9.2.1
9.4.4.1 FDD inter-frequency RSTD Measurement Reporting Delay in CE Mode B for Cat M1	Same as 9.2.1	Same as 9.2.1
9.4.4.2 FDD inter-frequency RSTD Measurement Reporting Delay in CE Mode B for Cat M2	Same as 9.2.1	Same as 9.2.1
9.4.5.1 HD-FDD inter-frequency RSTD Measurement Reporting Delay in CE Mode B for Cat M1	Same as 9.2.1	Same as 9.2.1
9.4.5.2 HD-FDD inter-frequency RSTD Measurement Reporting Delay in CE Mode B for Cat M2	Same as 9.2.1	Same as 9.2.1
9.4.6.1 TDD inter-frequency RSTD Measurement Reporting Delay in CE Mode B for Cat M1	Same as 9.2.1	Same as 9.2.1
9.4.6.2 TDD inter-frequency RSTD Measurement Reporting Delay in CE Mode B for Cat M2	Same as 9.2.1	Same as 9.2.1
9.4.7.1 FDD inter-frequency RSTD Measurement Accuracy in CE Mode A for Cat M1	Same as 9.2.4	Same as 9.2.4
9.4.7.2 FDD inter-frequency RSTD Measurement Accuracy in CE Mode A for Cat M2	Same as 9.2.4	Same as 9.2.4
9.4.8.1 HD-FDD inter-frequency RSTD Measurement Accuracy in CE Mode A for Cat M1	Same as 9.2.4	Same as 9.2.4
9.4.8.2 HD-FDD inter-frequency RSTD Measurement Accuracy in CE Mode A for Cat M2	Same as 9.2.4	Same as 9.2.4



9.4.9.1 TDD inter-frequency RSTD Measurement Accuracy in CE Mode A for Cat M1	Same as 9.2.4	Same as 9.2.4
9.4.9.2 TDD inter-frequency RSTD Measurement Accuracy in CE Mode A for Cat M2	Same as 9.2.4	Same as 9.2.4
9.4.10.1 FDD inter-frequency RSTD Measurement Accuracy in CE Mode B for Cat M1	Same as 9.2.4	Same as 9.2.4
9.4.10.2 FDD inter-frequency RSTD Measurement Accuracy in CE Mode B for Cat M2	Same as 9.2.4	Same as 9.2.4
9.4.11.1 HD-FDD inter-frequency RSTD Measurement Accuracy in CE Mode B for Cat M1	Same as 9.2.4	Same as 9.2.4
9.4.11.2 HD-FDD inter-frequency RSTD Measurement Accuracy in CE Mode B for Cat M2	Same as 9.2.4	Same as 9.2.4
9.4.12.1 TDD inter-frequency RSTD Measurement Accuracy in CE Mode B for Cat M1	Same as 9.2.4	Same as 9.2.4
9.4.12.2 TDD inter-frequency RSTD Measurement Accuracy in CE Mode B for Cat M2	Same as 9.2.4	Same as 9.2.4
9.5.1 HD-FDD Intra frequency RSTD Measurement Accuracy for NB-IOT Inband Mode in normal coverage	For Test 2 and Test 4: PRRS $\hat{E}_{S1} / N_{oc}$ averaged over $BW_{Config}$ PRRS $\hat{E}_{S2} / N_{oc}$ averaged over $BW_{Config}$  For all tests: Cell Timing Difference	+0.3 dB +0.3 dB  $\pm 1 T_s$
9.5.2 HD-FDD Intra frequency RSTD Measurement Accuracy for NB-IOT Inband Mode in enhanced coverage	Same as 9.5.1	Same as 9.5.1
9.5.3 HD-FDD Intra frequency RSTD Measurement Reporting Delay for NB-IOT Inband Mode in enhanced coverage	TBD	TBD
9.6.1 HD-FDD Inter-Frequency RSTD Measurement Accuracy for NB-IOT Inband Mode in normal coverage	PRRS $\hat{E}_{S1} / N_{oc1}$ averaged over $BW_{Config}$ PRRS $\hat{E}_{S2} / N_{oc2}$ averaged over $BW_{Config}$  Cell Timing Difference	+0.3 dB +0.3 dB  $\pm 2 T_s$
9.6.2 HD-FDD Inter-Frequency RSTD Measurement Accuracy for NB-IOT Inband Mode in enhanced coverage	Same as 9.6.1	Same as 9.6.1
9.6.3 HD-FDD Inter frequency RSTD Measurement Reporting Delay for NB-IOT Inband Mode in enhanced coverage	TBD	TBD
10.1 FDD RSTD Measurement Reporting Delay for Carrier Aggregation	Response time	300 ms
10.1A FDD RSTD Measurement Reporting Delay for Carrier Aggregation for 20 MHz	Response time	300 ms
10.1B FDD RSTD Measurement Reporting Delay Carrier Aggregation for 5 MHz +5 MHz Bandwidth	Response time	300 ms
10.1C FDD RSTD Measurement Reporting Delay for Carrier Aggregation for 10 MHz+5 MHz Bandwidth	Response time	300 ms

10.2 TDD RSTD Measurement Reporting Delay for Carrier Aggregation	Response time	300 ms
10.2A TDD RSTD Measurement Reporting Delay for Carrier Aggregation for 20 MHz	Response time	300 ms
10.2B TDD RSTD Measurement Reporting Delay Carrier Aggregation for 5 MHz +5 MHz Bandwidth	Response time	300 ms
10.2C TDD RSTD Measurement Reporting Delay for Carrier Aggregation for 10 MHz+5 MHz Bandwidth	Response time	300 ms
10.2D TDD RSTD Measurement Reporting Delay for Carrier Aggregation for 20 MHz +10 MHz Bandwidth	Response time	300 ms
10.3 FDD RSTD Measurement Accuracy for Carrier Aggregation	PRRS $\hat{E}_{S2} / N_{oc2}$ averaged over $BW_{Config}$	+0.3 dB
	PRRS $\hat{E}_{S3} / N_{oc2}$ averaged over $BW_{Config}$	+0.3 dB
	Cell Timing Difference	$\pm 1 T_s$
10.3A FDD RSTD Measurement Accuracy for Carrier Aggregation for 20 MHz (Rel-10 and Rel-11)	Same as 10.3	Same as 10.3
10.3A_1 FDD RSTD Measurement Accuracy for Carrier Aggregation for 20 MHz (Rel-12 onwards)	Same as 10.3	Same as 10.3
10.3B FDD RSTD Measurement Accuracy for Carrier Aggregation for 5MHz+5MHz Bandwidth	Same as 10.3	Same as 10.3
10.3C FDD RSTD Measurement Accuracy for Carrier Aggregation for 10MHz+5MHz Bandwidth	Same as 10.3	Same as 10.3
10.4 TDD RSTD Measurement Accuracy for Carrier Aggregation	Same as 10.3	Same as 10.3
10.4A TDD RSTD Measurement Accuracy for Carrier Aggregation for 20 MHz (Rel-10 and Rel-11)	Same as 10.3	Same as 10.3
10.4A_1 TDD RSTD Measurement Accuracy for Carrier Aggregation for 20 MHz (Rel-12 onwards)	Same as 10.3	Same as 10.3
10.4B TDD RSTD Measurement Accuracy for Carrier Aggregation for 5MHz+5MHz Bandwidth	Same as 10.3	Same as 10.3
10.4C TDD RSTD Measurement Accuracy for Carrier Aggregation for 10MHz+5MHz Bandwidth	Same as 10.3	Same as 10.3
10.4D TDD RSTD Measurement Accuracy for Carrier Aggregation for 20 MHz+10 MHz Bandwidth	Same as 10.3	Same as 10.3
10.5 FDD 3 DL CA RSTD Measurement Reporting Delay	Response time	300 ms
10.6 TDD 3 DL CA RSTD Measurement Reporting Delay	Response time	300 ms
10.7 FDD RSTD Measurement Accuracy for 3DL Carrier Aggregation	PRRS $\hat{E}_{S3} / N_{oc3}$ averaged over $BW_{Config}$	+0.3 dB
	PRRS $\hat{E}_{S4} / N_{oc3}$ averaged over $BW_{Config}$	+0.3 dB
	Cell Timing Difference (Intra-band)	$\pm 1 T_s$
	Cell Timing Difference (Inter-band)	$\pm 2 T_s$

10.8 TDD RSTD Measurement Accuracy for 3DL Carrier Aggregation	Same as 10.7	Same as 10.7
--	--------------	--------------

### C.2.3 MBS Minimum Performance requirements

**Table C.2.3-1: Test Parameter Relaxations for MBS Minimum Performance tests**

Clause	Test Parameter Relaxation	
11.1,11.1A MBS Measurement Reporting Delay	Beacon power level	0 dB (no relaxation)
	Response time	300 ms
11.2,11.2A MBS Sensitivity Measurement Accuracy	Beacon power level	2 dB
	Code phase difference	5 ns
11.3,11.3A MBS Nominal Measurement Accuracy	Beacon power level	0 dB (no relaxation)
	Code phase difference	5 ns
11.4,11.4A MBS Dynamic Range Measurement Accuracy	Beacon power level	2 dB
	Code phase difference	5 ns
11.5,11.5A MBS Measurement Accuracy in Multipath	Beacon power level	0 dB (no relaxation)
	Code phase difference	5 ns

### C.2.4 WLAN and BLE measurement requirements

**Table C.2.4-1: Test Parameter Relaxations for WLAN and BLE measurement tests**

Clause	Test Parameter Relaxation	
12.1.1 WLAN AP Identification and reporting delay under nominal conditions	Response time	300 ms
12.1.2 WLAN AP Identification and reporting delay under dynamic range conditions	Response time	300 ms
	Low Power WLAN APs Received Power Level	1 dB
12.2.1 Bluetooth identification	Response time	300 ms

## C.3 Interpretation of measurement results

The measurement results returned by the Test System are compared - without any modification - against the Test Requirements as defined by the shared risk principle.

The Shared Risk principle is defined in TR 102 273-1-2 [7], clause 6.5.

The actual measurement uncertainty of the Test System for the measurement of each parameter shall be included in the test report.

The recorded value for the Test System uncertainty shall be, for each measurement, equal to or lower than the appropriate figure in clause C.1.

If the Test System for a test is known to have a measurement uncertainty greater than that specified in clause C.1, it is still permitted to use this apparatus provided that an adjustment is made value as follows.

Any additional uncertainty in the Test System over and above that specified in clause C.1 shall be used to tighten the Test Requirement - making the test harder to pass. (This may require modification of stimulus signals). This procedure will ensure that a Test System not compliant with clause C.1 does not increase the chance of passing a device under test where that device would otherwise have failed the test if a Test System compliant with clause C.1 had been used.

## C.4 Derivation of Test Requirements (This clause is informative)

The Test Requirements have been calculated by relaxing the Conformance requirement of the core specification using the Test Parameter Relaxations defined in clause C.2. When the Test Parameter Relaxation is zero, the Test Requirement will be the same as the Conformance requirement. When the Test Parameter Relaxation is non-zero, the Test Requirements will differ from the Conformance requirement, and the formula used for this relaxation is given in table C.4.1, C.4.2, C.4.3 and C.4.4.

**Table C.4.1: Derivation of Test Requirements for A-GNSS Minimum Performance tests**

Test	Conformance requirement in 3GPP TS 25.171 or 3GPP TS 25.172 or 3GPP TS 36.171		Test Parameter Relaxation (TPR)	Test Requirement
5.2.1, 6.2.1, 7.1.1 Sensitivity Coarse Time Assistance	Coarse Time Assistance	±2 s	200 ms	Formulas: UL-TPR, LL+TPR: ±1.8 s
	Absolute GPS L1 C/A signal level (test 5.2.1 and test 7.1.1 sub-test 1)	-142, -147 dBm	1 dB	Level + TPR: -141, -146 dBm
	Absolute GNSS signal level (Galileo)	-142, -147 dBm	1 dB	Level + TPR: -141, -146 dBm
	Absolute GNSS signal level (GPS) (test 6.2.1 and test 7.1.1 sub-tests 4, 5, 8 and 10)	-142, -147 dBm	1 dB	Level + TPR: -141, -146 dBm
	Absolute GNSS signal level (GLONASS)	-142, -147 dBm	1 dB	Level + TPR: -141, -146 dBm
	Absolute GNSS signal level (BDS)	-136, -145 dBm	1 dB	Level + TPR: -135, -144 dBm
	Position error	100 m	1.3 m	Error +TPR: 101.3 m
	Response time	20 s	300 ms	Time + TPR: 20.3 s
5.2.2, 6.2.2, 7.1.2 Sensitivity Fine Time Assistance	Coarse Time Assistance	±2 s	200 ms	Formulas: UL-TPR, LL+TPR: ±1.8 s
	Fine Time Assistance	±10 us	1 us	UL-TPR, LL+TPR: ±9 us
	Absolute GPS L1 C/A signal level (test 5.2.2 and test 7.1.2 sub-test 1)	-147 dBm	1 dB	Level + TPR: -146 dBm
	Absolute GNSS signal level (Galileo)	-147 dBm	1 dB	Level + TPR: -146 dBm
	Absolute GNSS signal level (GPS) (test 6.2.2 and test 7.1.2 sub-tests 4, 5, 8 and 10)	-147 dBm	1 dB	Level + TPR: -146 dBm
	Absolute GNSS signal level (GLONASS)	-147 dBm	1 dB	Level + TPR: -146 dBm
	Absolute GNSS signal level (BDS)	-147 dBm	1 dB	Level + TPR: -146 dBm
	Position error	100 m	1.3 m	Error +TPR: 101.3 m
Response time	20 s	300 ms	Time + TPR: 20.3 s	
5.3, 6.3, 7.2 Nominal Accuracy	Coarse Time Assistance	±2 s	200 ms	Formulas: UL-TPR, LL+TPR: ±1.8 s
	Absolute GPS L1 C/A signal level (test 5.3 and test 7.2 sub-test 1)	-130 dBm	0 dB	Formulas: Level + TPR: -130 dBm
	Absolute GNSS signal level (Galileo)	-127 dBm	0 dB	Level + TPR: -127 dBm
	Absolute GNSS signal level (GPS) (test 6.3 and test 7.2 sub-tests 4, 5, 8 and 10)	-128.5 dBm	0 dB	Level + TPR: -128.5 dBm
	Absolute GNSS signal level (GLONASS)	-131 dBm	0 dB	Level + TPR: -131 dBm
	Absolute GNSS signal level (QZSS)	-128.5 dBm	0 dB	Level + TPR: -128.5 dBm
	Absolute GNSS signal level (SBAS)	-131 dBm	0 dB	Level + TPR: -131 dBm
	Absolute GNSS signal level (BDS)	-133 dBm	0 dB	Level + TPR: -133 dBm
	Position error	30 m	1.3 m	Error +TPR: 31.3 m
	Response time	20 s	300 ms	Time + TPR: 20.3 s
5.4, 6.4, 7.3 Dynamic Range	Coarse Time Assistance	±2 s	200 ms	Formulas: UL-TPR, LL+TPR: ±1.8 s
	Absolute GPS L1 C/A signal level (test 5.4 and test 7.3 sub-test 1)	-129 to -147 dBm	1 dB	Level + TPR: each level +1 dBm
	Absolute GNSS signal level (Galileo)	-127.5 to -147 dBm	1 dB	Level + TPR: each level +1 dBm

Test	Conformance requirement in 3GPP TS 25.171 or 3GPP TS 25.172 or 3GPP TS 36.171		Test Parameter Relaxation (TPR)	Test Requirement
	Absolute GNSS signal level (GPS) (test 6.4 and test 7.3 sub-tests 4, 5, 8 and 10)	-129 to -147 dBm	1 dB	Level + TPR: each level +1 dBm
	Absolute GNSS signal level (GLONASS)	-131.5 to -147 dBm	1 dB	Level + TPR: each level +1 dBm
	Absolute GNSS signal level (BDS)	-133.5 to -145 dBm	1 dB	Level + TPR: each level +1 dBm
	Relative GPS L1 C/A signal level (test 5.4 and test 7.3 sub-test 1)	18 dB	0.2 dB	Level - TPR: highest level -0.2 dB: -128.2 dBm
	Relative GNSS signal level (Galileo)	19.5 dB	0.2 dB	Level - TPR: highest level -0.2 dB: -126.7 dBm
	Relative GNSS signal level (GPS) (test 6.4 and test 7.3 sub-tests 4, 5, 8 and 10)	18 dB	0.2 dB	Level - TPR: highest level -0.2 dB: -128.2 dBm
	Relative GNSS signal level (GLONASS)	15.5 dB	0.2 dB	Level - TPR: highest level -0.2 dB: -130.7 dBm
	Relative GNSS signal level (BDS)	11.5 dB	0.2 dB	Level - TPR: highest level -0.2 dB: -132.7 dBm
	Position error	100 m	1.3 m	Error +TPR: 101.3 m
	Response time	20 s	300 ms	Time + TPR: 20.3 s
5.5, 6.5, 7.4 Multi-path scenario	Coarse Time Assistance	±2 s	200 ms	Formulas: UL-TPR, LL+TPR: ±1.8 s
	Absolute GPS L1 C/A signal level (test 5.5 and test 7.4 sub-test 1)	-130 dBm	0 dB	Formulas: Level + TPR: -130 dBm
	Absolute GNSS signal level (Galileo)	-127 dBm	0 dB	Level + TPR: -127 dBm
	Absolute GNSS signal level (GPS) (test 6.5 and test 7.4 sub-tests 4, 5, 8 and 10)	-128.5 dBm	0 dB	Level + TPR: -128.5 dBm
	Absolute GNSS signal level (GLONASS)	-131 dBm	0 dB	Level + TPR: -131 dBm
	Absolute GNSS signal level (BDS)	-133 dBm	0 dB	Level + TPR: -133 dBm
	Relative GPS L1 C/A signal level (test 5.5 and test 7.4 sub-test 1)	6 dB	0.2 dB	Relative level + TPR: relative level + 0.2dB: 6.2 dB
	Relative GNSS signal level (all GNSSs) (test 6.5 and test 7.4 sub-tests 4, 5, 8 and 10)	Y dB where "Y" is given in Table 4.2.2	0.2 dB	Relative level + TPR: relative level + 0.2dB: Y + 0.2 dB
	Position error	100 m	1.3 m	Error +TPR: 101.3 m
	Response time	20 s	300 ms	Time + TPR: 20.3 s
5.6, 6.6, 7.5 Moving scenario and periodic update	Absolute GPS L1 C/A Signal level (test 5.6 and test 7.5 sub-test 1)	-130 dBm	0 dB	Formulas: Level + TPR: -130 dBm
	Absolute GNSS signal level (Galileo)	-127 dBm	0 dB	Level + TPR: -127 dBm
	Absolute GNSS signal level (GPS) (test 6.6 and test 7.5 sub-tests 4, 5, 8 and 10)	-128.5 dBm	0 dB	Level + TPR: -128.5 dBm
	Absolute GNSS signal level (GLONASS)	-131 dBm	0 dB	Level + TPR: -131 dBm
	Absolute GNSS signal level (BDS)	-133 dBm	0 dB	Level + TPR: -133 dBm
	Position error	100 m	1.3 m	Error +TPR: 101.3 m
	Differential response time	2s +/- 20 %	100 ms	Time +TPR: 1.5 s and 2.5 s



**Table C.4.2: Derivation of Test Requirements for ECID and OTDOA Measurement tests**



Test	Minimum Requirement in TS 36.133	Test Parameter Relaxation (TPR)	Test Requirement in TS 36.571-1
8.1.1 E-UTRAN FDD UE Rx - Tx time difference case (Rel-9 to Rel-11)	<p><u>Test 1:</u>  <math>N_{oc}</math>: -98dBm/15kHz  <math>\hat{E}_s / N_{oc}</math>: -3.0dB  <u>Reported RxTx time difference value:</u> Measured value converted to RX-TX_TIME_DIFFERENCE according to Table 4.6.3-1</p> <p><u>Test 2:</u>  <math>N_{oc}</math>: -98dBm/15kHz  <math>\hat{E}_s / N_{oc}</math>: -3.0dB  <u>Reported RxTx time difference value:</u> Measured value converted to RX-TX_TIME_DIFFERENCE according to Table 4.6.3-1</p>	<p><u>Test 1:</u>  0dB  0.3dB  Via mapping</p> <p><u>Test 2:</u>  0dB  0.3dB  Via mapping</p>	<p><u>Test 2:</u>  <math>N_{oc}</math>: -98dBm/15kHz  <math>\hat{E}_s / N_{oc}</math>: -2.7.0dB  (Measured value from step 7 - 23) <math>T_s</math> converted to RX-TX_TIME_DIFFERENCE according to Table 4.6.3-1  <u>To</u>  (Measured value from step 7 +23) <math>T_s</math> converted to RX-TX_TIME_DIFFERENCE according to Table 4.6.3-1</p> <p><u>Test 2:</u>  <math>N_{oc}</math>: -98dBm/15kHz  <math>\hat{E}_{s1} / N_{oc}</math>: +6.0dB  <math>\hat{E}_{s2} / N_{oc}</math>: +2.0dB  Measured value from step 7 -13) <math>T_s</math> converted to RX-TX_TIME_DIFFERENCE according to Table 4.6.3-1  <u>To</u>  (Measured value from step 7 +13) <math>T_s</math> converted to RX-TX_TIME_DIFFERENCE according to Table 4.6.3-1</p>
8.1.1A E-UTRAN FDD UE Rx – Tx time difference case (Rel-12 onwards)	Same as 8.1.1	Same as 8.1.1	<p><u>Test 1:</u>  <math>N_{oc}</math>: -98dBm/15kHz  <math>\hat{E}_s / N_{oc}</math>: -2.7.0dB  (Measured value from step 7 - 23) <math>T_s</math> converted to RX-TX_TIME_DIFFERENCE according to Table 4.6.3-1  <u>To</u>  (Measured value from step 7 +23) <math>T_s</math> converted to RX-TX_TIME_DIFFERENCE according to Table 4.6.3-1</p> <p><u>Test 2:</u>  <math>N_{oc}</math>: -98dBm/15kHz  <math>\hat{E}_{s1} / N_{oc}</math>: +6.0dB  <math>\hat{E}_{s2} / N_{oc}</math>: +2.0dB  Measured value from step 7 -10) <math>T_s</math> converted to RX-TX_TIME_DIFFERENCE according to Table 4.6.3-1  <u>To</u>  (Measured value from step 7 +10) <math>T_s</math> converted to RX-TX_TIME_DIFFERENCE according to Table 4.6.3-1</p>
8.1.1B E-UTRAN FDD UE Rx – Tx time difference case for UE Category 1bis	Same as 8.1.1	Same as 8.1.1	Same as 8.1.1A
8.1.2 E-UTRAN TDD UE Rx - Tx time difference case (Rel-9 to Rel-11)	Same as 8.1.1 except use Table 4.6.3-2	Same as 8.1.1	Same as 8.1.1 except use Table 4.6.3-2
8.1.2A E-UTRAN TDD UE Rx – Tx time difference case (Rel-12 onwards)	Same as 8.1.1 except use Table 4.6.3-2	Same as 8.1.1	Same as 8.1.1A except use Table 4.6.3-2
8.1.2B E-UTRAN TDD UE Rx – Tx time difference case for UE Category 1bis	Same as 8.1.1 except use Table 4.6.3-2	Same as 8.1.1	Same as 8.1.1A except use Table 4.6.3-2

<p>8.1.3 E-UTRAN FDD UE Rx-Tx time difference under Time Domain Measurement Resource Restriction with Non-MBSFN ABS (eICIC)</p>	<p><u>Test 1:</u>  <math>N_{oc}</math>: -98dBm/15kHz  <math>\hat{E}_{S1} / N_{oc}</math>: -3.00dB  <math>\hat{E}_{S2} / N_{oc}</math>: +1.00dB  <u>Reported RxTx time difference value:</u> Measured value converted to RX-TX_TIME_DIFFERENCE according to Table 4.6.3-1</p> <p><u>Test 2:</u>  <math>N_{oc}</math>: -98dBm/15kHz  <math>\hat{E}_{S1} / N_{oc}</math>: -3.00dB  <math>\hat{E}_{S2} / N_{oc}</math>: +1.00dB  <u>Reported RxTx time difference value:</u> Measured value converted to RX-TX_TIME_DIFFERENCE according to Table 4.6.3-1</p>	<p><u>Test 1:</u>  0dB  0.3dB  0dB  Via mapping</p> <p><u>Test 2:</u>  0dB  0.3dB  0dB  Via mapping</p>	<p><u>Test 2:</u>  <math>N_{oc}</math>: -98dBm/15kHz  <math>\hat{E}_{S1} / N_{oc}</math>: -2.70dB  <math>\hat{E}_{S2} / N_{oc}</math>: +1.00dB  Measured value from step 7 -13) <math>T_s</math> converted to RX-TX_TIME_DIFFERENCE according to Table 4.6.3-1  <u>To</u>  (Measured value from step 7 +13) <math>T_s</math> converted to RX-TX_TIME_DIFFERENCE according to Table 4.6.3-1</p> <p><u>Test 2:</u>  <math>N_{oc}</math>: -98dBm/15kHz  <math>\hat{E}_{S1} / N_{oc}</math>: -2.70dB  <math>\hat{E}_{S2} / N_{oc}</math>: +1.00dB  Measured value from step 7 -13) <math>T_s</math> converted to RX-TX_TIME_DIFFERENCE according to Table 4.6.3-1  <u>To</u>  (Measured value from step 7 +13) <math>T_s</math> converted to RX-TX_TIME_DIFFERENCE according to Table 4.6.3-1</p>
<p>8.1.4 E-UTRAN TDD UE Rx-Tx time difference under Time Domain Measurement Resource Restriction with Non-MBSFN ABS (eICIC)</p>	<p>Same as 8.1.3 except use Table 4.6.3-2</p>	<p>Same as 8.1.3</p>	<p>Same as 8.1.3 except use Table 4.6.3-2</p>
<p>8.1.5 E-UTRAN FDD UE Rx-Tx time difference under Time Domain Measurement Resource Restriction with CRS Assistance Information and Non-MBSFN ABS (feICIC)</p>	<p><u>Test 1:</u>  <math>N_{oc}</math>: -98dBm/15kHz  <math>\hat{E}_{S1} / N_{oc}</math>: -3.00dB  <math>\hat{E}_{S2} / N_{oc}</math>: +3.00dB  <math>\hat{E}_{S3} / N_{oc}</math>: +1.00dB  <u>Reported RxTx time difference value:</u> Measured value converted to RX-TX_TIME_DIFFERENCE according to Table 4.6.3-1</p> <p><u>Test 2:</u>  <math>N_{oc}</math>: -98dBm/15kHz  <math>\hat{E}_{S1} / N_{oc}</math>: -3.00dB  <math>\hat{E}_{S2} / N_{oc}</math>: +3.00dB  <math>\hat{E}_{S3} / N_{oc}</math>: +1.00dB  <u>Reported RxTx time difference value:</u> Measured value converted to RX-TX_TIME_DIFFERENCE according to Table 4.6.3-1</p>	<p><u>Test 1:</u>  0dB  0.4dB  0dB  0dB  Via mapping</p> <p><u>Test 2:</u>  0dB  0.4dB  0dB  0dB  Via mapping</p>	<p><u>Test 1:</u>  <math>N_{oc}</math>: -98dBm/15kHz  <math>\hat{E}_{S1} / N_{oc}</math>: -2.60dB  <math>\hat{E}_{S2} / N_{oc}</math>: +3.00dB  <math>\hat{E}_{S3} / N_{oc}</math>: +1.00dB  Measured value from step 7 -13) <math>T_s</math> converted to RX-TX_TIME_DIFFERENCE according to Table 4.6.3-1  <u>To</u>  (Measured value from step 7 +13) <math>T_s</math> converted to RX-TX_TIME_DIFFERENCE according to Table 4.6.3-1</p> <p><u>Test 2:</u>  <math>N_{oc}</math>: -98dBm/15kHz  <math>\hat{E}_{S1} / N_{oc}</math>: -2.60dB  <math>\hat{E}_{S2} / N_{oc}</math>: +3.00dB  <math>\hat{E}_{S3} / N_{oc}</math>: +1.00dB  Measured value from step 7 -13) <math>T_s</math> converted to RX-TX_TIME_DIFFERENCE according to Table 4.6.3-1  <u>To</u>  (Measured value from step 7 +13) <math>T_s</math> converted to RX-TX_TIME_DIFFERENCE according to Table 4.6.3-1</p>
<p>8.1.6 E-UTRAN TDD UE Rx-Tx time difference under Time Domain Measurement Resource Restriction with CRS Assistance Information and Non-MBSFN ABS (feICIC)</p>	<p>Same as 8.1.5 except use Table 4.6.3-2</p>	<p>Same as 8.1.5</p>	<p>Same as 8.1.5 except use Table 4.6.3-2</p>

8.1.7 E-UTRAN FDD UE Rx-Tx time difference case for Cat-M1/M2 UE in CEModeA	Same as 8.1.1	Same as 8.1.1	Same as 8.1.1
8.1.8 E-UTRAN HD-FDD UE Rx-Tx time difference case for Cat-M1/M2 UE in CEModeA	Same as 8.1.1	Same as 8.1.1	Same as 8.1.1
8.1.9 E-UTRAN TDD UE Rx-Tx time difference case for Cat-M1/M2 UE in CEModeA	Same as 8.1.1 except use Table 4.6.3-2	Same as 8.1.1	Same as 8.1.1 except use Table 4.6.3-2
9.1.1 FDD RSTD Measurement Reporting Delay	Response Time = 3 s	300 ms	Time + TPR: 3.3 s
9.1.1A FDD RSTD Measurement Reporting Delay for UE Category 1bis	Response Time = 6 s	300 ms	Time + TPR: 6.3 s
9.1.2 TDD RSTD Measurement Reporting Delay	Response Time = 3 s	300 ms	Time + TPR: 3.3 s
9.1.2A TDD RSTD Measurement Reporting Delay for UE Category 1bis	Response Time = 6 s	300 ms	Time + TPR: 6.3 s
9.1.3 FDD RSTD Measurement Accuracy	For Test 2 and Test 4: PRS $\hat{E}_{s1} / N_{oc} = -6\text{dB}$ PRS $\hat{E}_{s2} / N_{oc} = -13\text{dB}$  For All Tests: See Table 9.1.3.3-1 for measurement accuracy.	+0.3 dB +0.3 dB  $\pm 1 T_s$	Level + TPR, -5.7 dB Level + TPR, -12.7 dB  See Table 9.1.3.5-2.
9.1.3A FDD RSTD Measurement Accuracy for UE Category 1bis	Same as 9.1.3		
9.1.4 TDD RSTD Measurement Accuracy	Same as 9.1.3		
9.1.4A TDD RSTD Measurement Accuracy for UE Category 1bis	Same as 9.1.3		
9.2.1 FDD-FDD inter-frequency RSTD measurement reporting delay	Response Time = 6 s	300 ms	Time + TPR: 6.3 s
9.2.1A FDD-FDD inter-frequency RSTD measurement reporting delay for UE Category 1bis	Response Time = 11 s	300 ms	Time + TPR: 11.3 s
9.2.2 TDD-TDD inter-frequency RSTD measurement reporting delay	Response Time = 6 s	300 ms	Time + TPR: 6.3 s
9.2.2A TDD-TDD inter-frequency RSTD measurement reporting delay for UE Category 1bis	Response Time = 11 s	300 ms	Time + TPR: 11.3 s
9.2.4 FDD-FDD inter frequency RSTD Accuracy	PRS $\hat{E}_{s1} / N_{oc1} = -6\text{dB}$ PRS $\hat{E}_{s2} / N_{oc2} = -13\text{dB}$  See TS 36.133 [23] Table 9.1.10.3-1 for measurement accuracy.	+0.3 dB +0.3 dB  $\pm 2 T_s$	Level + TPR, -5.7 dB Level + TPR, -12.7 dB  See Table 9.2.4.5-2.
9.2.4A FDD-FDD inter frequency RSTD Accuracy for UE Category 1bis	Same as 9.2.4		
9.2.5 TDD-TDD inter frequency RSTD Accuracy	Same as 9.2.4		
9.2.5A TDD-TDD inter frequency RSTD Accuracy for UE Category 1bis	Same as 9.2.4		

9.3.1.1 FDD intra-frequency RSTD Measurement Reporting Delay in CE Mode A for Cat M1	Response Time = 6 s	300 ms	Time + TPR: 6.3 s
9.3.1.2 FDD intra-frequency RSTD Measurement Reporting Delay in CE Mode A for Cat M2	Response Time = 6 s	300 ms	Time + TPR: 6.3 s
9.3.2.1 HD-FDD intra-frequency RSTD Measurement Reporting Delay in CE Mode A for Cat M1	Response Time = 6 s	300 ms	Time + TPR: 6.3 s
9.3.2.2 HD-FDD intra-frequency RSTD Measurement Reporting Delay in CE Mode A for Cat M2	Response Time = 6 s	300 ms	Time + TPR: 6.3 s
9.3.3.1 TDD intra-frequency RSTD Measurement Reporting Delay in CE Mode A for Cat M1	Response Time = 6 s	300 ms	Time + TPR: 6.3 s
9.3.3.2 TDD intra-frequency RSTD Measurement Reporting Delay in CE Mode A for Cat M2	Response Time = 6 s	300 ms	Time + TPR: 6.3 s
9.3.4.1 FDD intra-frequency RSTD Measurement Reporting Delay in CE Mode B for Cat M1	Response Time = 13 s	300 ms	Time + TPR: 13.3 s
9.3.4.2 FDD intra-frequency RSTD Measurement Reporting Delay in CE Mode B for Cat M2	Test 1: Response Time 13 s Test 2: Response Time 6 s	300 ms	Test 1: Time + TPR: 13.3 s Test 2: Time + TPR: 6.3 s
9.3.5.1 HD-FDD intra-frequency RSTD Measurement Reporting Delay in CE Mode B for Cat M1	Response Time = 13 s	300 ms	Time + TPR: 13.3 s
9.3.5.2 HD-FDD intra-frequency RSTD Measurement Reporting Delay in CE Mode B for Cat M2	Test 1: Response Time 13 s Test 2: Response Time 6 s	300 ms	Test 1: Time + TPR: 13.3 s Test 2: Time + TPR: 6.3 s
9.3.6.1 TDD intra-frequency RSTD Measurement Reporting Delay in CE Mode B for Cat M1	Response Time = 13 s	300 ms	Time + TPR: 13.3 s
9.3.6.2 TDD intra-frequency RSTD Measurement Reporting Delay in CE Mode B for Cat M2	Test 1: Response Time 13 s Test 2: Response Time 6 s	300 ms	Test 1: Time + TPR: 13.3 s Test 2: Time + TPR: 6.3 s
9.3.7.1 FDD intra-frequency RSTD Measurement Accuracy in CE Mode A for Cat M1	Same as 9.1.3	Same as 9.1.3	Same as 9.1.3
9.3.7.2 FDD intra-frequency RSTD Measurement Accuracy in CE Mode A for Cat M2	Same as 9.1.3	Same as 9.1.3	Same as 9.1.3
9.3.8.1 HD-FDD intra-frequency RSTD Measurement Accuracy in CE Mode A for Cat M1	Same as 9.1.3	Same as 9.1.3	Same as 9.1.3
9.3.8.2 HD-FDD intra-frequency RSTD Measurement Accuracy in CE Mode A for Cat M2	Same as 9.1.3	Same as 9.1.3	Same as 9.1.3
9.3.9.1 TDD intra-frequency RSTD Measurement Accuracy in CE Mode A for Cat M1	Same as 9.1.3	Same as 9.1.3	Same as 9.1.3
9.3.9.2 TDD intra-frequency RSTD Measurement Accuracy in CE Mode A for Cat M2	Same as 9.1.3	Same as 9.1.3	Same as 9.1.3
9.3.10.1 FDD intra-frequency RSTD Measurement Accuracy in CE Mode B for Cat M1	PRS $\hat{E}_{S1} / N_{oc1} = -15\text{dB}$ PRS $\hat{E}_{S2} / N_{oc2} = -15\text{dB}$  See TS 36.133 [23] Table 9.1.10.3-1 for measurement accuracy.	+0.3 dB +0.3 dB  $\pm 2 T_s$	Level + TPR, -14.7 dB Level + TPR, -14.7 dB  See Table 9.3.10.1.5-2.
9.3.10.2 FDD intra-frequency RSTD Measurement Accuracy in CE Mode B for Cat M2	Same as 9.3.10.1	Same as 9.3.10.1	Same as 9.3.10.1
9.3.11.1 HD-FDD intra-frequency RSTD Measurement Accuracy in CE Mode B for Cat M1	Same as 9.3.10.1	Same as 9.3.10.1	Same as 9.3.10.1
9.3.11.2 HD-FDD intra-frequency RSTD Measurement Accuracy in CE Mode B for Cat M2	Same as 9.3.10.1	Same as 9.3.10.1	Same as 9.3.10.1
9.3.12.1 TDD intra-frequency RSTD Measurement Accuracy in CE Mode B for Cat M1	Same as 9.3.10.1	Same as 9.3.10.1	Same as 9.3.10.1

9.3.12.2 TDD intra-frequency RSTD Measurement Accuracy in CE Mode B for Cat M2	Same as 9.3.10.1	Same as 9.3.10.1	Same as 9.3.10.1
9.4.1.1 FDD inter-frequency RSTD Measurement Reporting Delay in CE Mode A for Cat M1	Response Time = 16 s	300 ms	Time + TPR: 16.3 s
9.4.1.2 FDD inter-frequency RSTD Measurement Reporting Delay in CE Mode A for Cat M2	Test 1: Response Time 16 s Test 2: Response Time 11 s	300 ms	Test 1: Time + TPR: 16.3 s Test 2: Time + TPR: 11.3 s
9.4.2.1 HD-FDD inter-frequency RSTD Measurement Reporting Delay in CE Mode A for Cat M1	Response Time = 16 s	300 ms	Time + TPR: 16.3 s
9.4.2.2 HD-FDD inter-frequency RSTD Measurement Reporting Delay in CE Mode A for Cat M2	Test 1: Response Time 16 s Test 2: Response Time 11 s	300 ms	Test 1: Time + TPR: 16.3 s Test 2: Time + TPR: 11.3 s
9.4.3.1 TDD inter-frequency RSTD Measurement Reporting Delay in CE Mode A for Cat M1	Response Time = 16 s	300 ms	Time + TPR: 16.3 s
9.4.3.2 TDD inter-frequency RSTD Measurement Reporting Delay in CE Mode A for Cat M2	Test 1: Response Time 16 s Test 2: Response Time 11 s	300 ms	Test 1: Time + TPR: 16.3 s Test 2: Time + TPR: 11.3 s
9.4.4.1 FDD inter-frequency RSTD Measurement Reporting Delay in CE Mode B for Cat M1	Response Time = 42 s	300 ms	Time + TPR: 42.3 s
9.4.4.2 FDD inter-frequency RSTD Measurement Reporting Delay in CE Mode B for Cat M2	Test 1: Response Time 42 s Test 2: Response Time 11 s	300 ms	Test 1: Time + TPR: 42.3 s Test 2: Time + TPR: 11.3 s
9.4.5.1 HD-FDD inter-frequency RSTD Measurement Reporting Delay in CE Mode B for Cat M1	Response Time = 42 s	300 ms	Time + TPR: 42.3 s
9.4.5.2 HD-FDD inter-frequency RSTD Measurement Reporting Delay in CE Mode B for Cat M2	Test 1: Response Time 42 s Test 2: Response Time 11 s	300 ms	Test 1: Time + TPR: 42.3 s Test 2: Time + TPR: 11.3 s
9.4.6.1 TDD inter-frequency RSTD Measurement Reporting Delay in CE Mode B for Cat M1	Response Time = 42 s	300 ms	Time + TPR: 42.3 s
9.4.6.2 TDD inter-frequency RSTD Measurement Reporting Delay in CE Mode B for Cat M2	Test 1: Response Time 42 s Test 2: Response Time 11 s	300 ms	Test 1: Time + TPR: 42.3 s Test 2: Time + TPR: 11.3 s
9.4.7.1 FDD inter-frequency RSTD Measurement Accuracy in CE Mode A for Cat M1	See TS 36.133 [23] Table 9.1.10.3-1 for measurement accuracy.	$\pm 2 T_s$	See Table 9.4.7.1.5-2.
9.4.7.2 FDD inter-frequency RSTD Measurement Accuracy in CE Mode A for Cat M2	Same as 9.4.7.1	Same as 9.4.7.1	Same as 9.4.7.1
9.4.8.1 HD-FDD inter-frequency RSTD Measurement Accuracy in CE Mode A for Cat M1	Same as 9.4.7.1	Same as 9.4.7.1	Same as 9.4.7.1
9.4.8.2 HD-FDD inter-frequency RSTD Measurement Accuracy in CE Mode A for Cat M2	Same as 9.4.7.1	Same as 9.4.7.1	Same as 9.4.7.1
9.4.9.1 TDD inter-frequency RSTD Measurement Accuracy in CE Mode A for Cat M1	Same as 9.4.7.1	Same as 9.4.7.1	Same as 9.4.7.1
9.4.9.2 TDD inter-frequency RSTD Measurement Accuracy in CE Mode A for Cat M2	Same as 9.4.7.1	Same as 9.4.7.1	Same as 9.4.7.1
9.4.10.1 FDD inter-frequency RSTD Measurement Accuracy in CE Mode B for Cat M1	Same as 9.4.7.1	Same as 9.4.7.1	Same as 9.4.7.1
9.4.10.2 FDD inter-frequency RSTD Measurement Accuracy in CE Mode B for Cat M2	Same as 9.4.7.1	Same as 9.4.7.1	Same as 9.4.7.1
9.4.11.1 HD-FDD inter-frequency RSTD Measurement Accuracy in CE Mode B for Cat M1	Same as 9.4.7.1	Same as 9.4.7.1	Same as 9.4.7.1
9.4.11.2 HD-FDD inter-frequency RSTD Measurement Accuracy in CE Mode B for Cat M2	Same as 9.4.7.1	Same as 9.4.7.1	Same as 9.4.7.1
9.4.12.1 TDD inter-frequency RSTD Measurement Accuracy in CE Mode B for Cat M1	Same as 9.4.7.1	Same as 9.4.7.1	Same as 9.4.7.1

9.4.12.2 TDD inter-frequency RSTD Measurement Accuracy in CE Mode B for Cat M2	Same as 9.4.7.1	Same as 9.4.7.1	Same as 9.4.7.1
9.5.1 HD-FDD Intra frequency RSTD Measurement Accuracy for NB-IOT Inband Mode in normal coverage	NPRS $\hat{E}_{S1} / N_{oc} = -6\text{dB}$ NPRS $\hat{E}_{S2} / N_{oc} = -13\text{dB}$  For All Tests: See Table 9.5.1.3-2 for measurement accuracy.	+0.3 dB +0.3 dB  $\pm 1 T_s$	Level + TPR, -5.7 dB Level + TPR, -12.7 dB  See Table 9.5.1.5-3.
9.5.2 HD-FDD Intra frequency RSTD Measurement Accuracy for NB-IOT Inband Mode in enhanced coverage	NPRS $\hat{E}_{S1} / N_{oc} = -15\text{dB}$ NPRS $\hat{E}_{S2} / N_{oc} = -15\text{dB}$  For All Tests: See Table 9.5.2.3-2 for measurement accuracy.	+0.3 dB +0.3 dB  $\pm 1 T_s$	Level + TPR, -14.7 dB Level + TPR, -14.7 dB  See Table 9.5.2.5-3.
9.5.3 HD-FDD Intra frequency RSTD Measurement Reporting Delay for NB-IOT Inband Mode in enhanced coverage	TBD	TBD	TBD
9.6.1 HD-FDD Inter-Frequency RSTD Measurement Accuracy for NB-IOT Inband Mode in normal coverage	NPRS $\hat{E}_{S1} / N_{oc1} = -6\text{dB}$ NPRS $\hat{E}_{S2} / N_{oc2} = -13\text{dB}$  For All Tests: See Table 9.6.1.3-2 for measurement accuracy.	+0.3 dB +0.3 dB  $\pm 2 T_s$	Level + TPR, -5.7 dB Level + TPR, -12.7 dB  See Table 9.6.1.5-3.
9.6.2 HD-FDD Inter-Frequency RSTD Measurement Accuracy for NB-IOT Inband Mode in enhanced coverage	NPRS $\hat{E}_{S1} / N_{oc1} = -15\text{dB}$ NPRS $\hat{E}_{S2} / N_{oc2} = -15\text{dB}$  For All Tests: See Table 9.6.2.3-2 for measurement accuracy.	+0.3 dB +0.3 dB  $\pm 2 T_s$	Level + TPR, -14.7 dB Level + TPR, -14.7 dB  See Table 9.6.2.5-3.
9.6.3 HD-FDD Inter frequency RSTD Measurement Reporting Delay for NB-IOT Inband Mode in enhanced coverage	TBD	TBD	TBD
10.1 FDD RSTD Measurement Reporting Delay for Carrier Aggregation	Test 1: Response Time = 3 s  Test 2: Response Time = 6 s	300 ms  300 ms	Time + TPR: 3.3 s  Time + TPR: 6.3 s
10.1A FDD RSTD Measurement Reporting Delay for Carrier Aggregation for 20 MHz	Same as 10.1		
10.1B FDD RSTD Measurement Reporting Delay Carrier Aggregation for 5 MHz +5 MHz Bandwidth	Same as 10.1		
10.1C FDD RSTD Measurement Reporting Delay for Carrier Aggregation for 10 MHz+5 MHz Bandwidth	Same as 10.1		
10.2 TDD RSTD Measurement Reporting Delay for Carrier Aggregation	Same as 10.1		
10.2A TDD RSTD Measurement Reporting Delay for Carrier Aggregation for 20 MHz	Same as 10.1		

10.2B TDD RSTD Measurement Reporting Delay Carrier Aggregation for 5 MHz +5 MHz Bandwidth	Same as 10.1		
10.2C TDD RSTD Measurement Reporting Delay for Carrier Aggregation for 10 MHz+5 MHz Bandwidth	Same as 10.1		
10.2D TDD RSTD Measurement Reporting Delay for Carrier Aggregation for 20 MHz +10 MHz Bandwidth	Same as 10.1		
10.3 FDD RSTD Measurement Accuracy for Carrier Aggregation	$\text{PRS } \hat{E}_{S2} / N_{oc2} = -6\text{dB}$ $\text{PRS } \hat{E}_{S3} / N_{oc2} = -13\text{dB}$  See TS 36.133 [23] Table 9.1.10.1-1 for measurement accuracy.	+0.3 dB +0.3 dB  $\pm 1 T_s$	Level + TPR, -5.7 dB Level + TPR, -12.7 dB  See Table 10.3.5-2.
10.3A FDD RSTD Measurement Accuracy for Carrier Aggregation for 20 MHz (Rel-10 and Rel-11)	Same as 10.3	Same as 10.3	Same as 10.3
10.3A_1 FDD RSTD Measurement Accuracy for Carrier Aggregation for 20 MHz (Rel-12 onwards)	$\text{PRS } \hat{E}_{S2} / N_{oc2} = -6\text{dB}$ $\text{PRS } \hat{E}_{S3} / N_{oc2} = -13\text{dB}$  See TS 36.133 [23] Table 9.1.10.1-1 for measurement accuracy.	+0.3 dB +0.3 dB  $\pm 1 T_s$	Level + TPR, -5.7 dB Level + TPR, -12.7 dB  See Table 10.3A_1.5-1.
10.3B FDD RSTD Measurement Accuracy for Carrier Aggregation for 5 MHz+5 MHz Bandwidth	$\text{PRS } \hat{E}_{S2} / N_{oc2} = -6\text{dB}$ $\text{PRS } \hat{E}_{S3} / N_{oc2} = -13\text{dB}$  See TS 36.133 [23] Table 9.1.10.1-1 for measurement accuracy.	+0.3 dB +0.3 dB  $\pm 1 T_s$	Level + TPR, -5.7 dB Level + TPR, -12.7 dB  See Table 10.3B.5-2.
10.3C FDD RSTD Measurement Accuracy for Carrier Aggregation for 10 MHz+5 MHz Bandwidth	Same as 10.3B	Same as 10.3B	Same as 10.3B
10.4 TDD RSTD Measurement Accuracy for Carrier Aggregation	Same as 10.3	Same as 10.3	Level + TPR, -5.7 dB Level + TPR, -12.7 dB  See Table 10.4.5-2.
10.4A TDD RSTD Measurement Accuracy for Carrier Aggregation for 20 MHz (Rel-10 and Rel-11)	Same as 10.3	Same as 10.3	Same as 10.4
10.4A_1 TDD RSTD Measurement Accuracy for Carrier Aggregation for 20 MHz (Rel-12 onwards)	$\text{PRS } \hat{E}_{S2} / N_{oc2} = -6\text{dB}$ $\text{PRS } \hat{E}_{S3} / N_{oc2} = -13\text{dB}$  See TS 36.133 [23] Table 9.1.10.1-1 for measurement accuracy.	+0.3 dB +0.3 dB  $\pm 1 T_s$	Level + TPR, -5.7 dB Level + TPR, -12.7 dB  See Table 10.4A_1.5-1.
10.4B TDD RSTD Measurement Accuracy for Carrier Aggregation for 5 MHz+5 MHz Bandwidth	Same as 10.3B	Same as 10.3B	Level + TPR, -5.7 dB Level + TPR, -12.7 dB  See Table 10.4B.5-2.

10.4C TDD RSTD Measurement Accuracy for Carrier Aggregation for 10 MHz+5 MHz Bandwidth	Same as 10.3B	Same as 10.3B	Same as 10.4B
10.4D TDD RSTD Measurement Accuracy for Carrier Aggregation for 20 MHz+10 MHz Bandwidth	Same as 10.3	Same as 10.3	Same as 10.4
10.5 FDD 3 DL CA RSTD Measurement Reporting Delay	Same as 10.1	Same as 10.1	Same as 10.1
10.6 TDD 3 DL CA RSTD Measurement Reporting Delay	Same as 10.1	Same as 10.1	Same as 10.1
10.7 FDD RSTD Measurement Accuracy for 3DL Carrier Aggregation	$\text{PRS } \hat{E}_{S3} / N_{oc3} = -6\text{dB}$ $\text{PRS } \hat{E}_{S4} / N_{oc3} = -13\text{dB}$  See TS 36.133 [23] Table 9.1.10.1-1 for measurement accuracy or intra-band.  See TS 36.133 [23] Table 9.1.10.2-1 for measurement accuracy or inter-band	+0.3 dB +0.3 dB  $\pm 1 T_s$  $\pm 2 T_s$	Level + TPR, -5.7 dB Level + TPR, -12.7 dB  See Table 10.7.5-2  See Table 10.7.5-2
10.8 TDD RSTD Measurement Accuracy for 3DL Carrier Aggregation	Same as 10.7	Same as 10.7	Level + TPR, -5.7 dB Level + TPR, -12.7 dB  See Table 10.8.5-2  See Table 10.8.5-2



**Table C.4.3: Derivation of Test Requirements for MBS Minimum Performance tests**

Test	Conformance requirements in 11.1.3, 11.2.3, 11.3.3, 11.4.3 and 11.5.3		Test Parameter Relaxation (TPR)	Test Requirement
11.1, 11.1A MBS Measurement Reporting Delay	Beacon power level	-30 dBm	0 dB	Level+TPR: -30 dBm
	Response time	12 seconds	300 ms	Time+TPR: 12.3 s
11.2 MBS Sensitivity Measurement Accuracy	Beacon power level	-130 dBm	2 dB	Level+TPR: -128 dBm
	Code phase difference	$2.35 \times 10^{-4}$ ms	5 ns	Error+TPR: $2.40 \times 10^{-4}$ ms
11.2A MBS Sensitivity Measurement Accuracy	Beacon power level	-130 dBm	2 dB	Level+TPR: -128 dBm
	Code phase difference	$2.35 \times 10^{-4}$ ms	5 ns	Error+TPR: $2.40 \times 10^{-4}$ ms
	Code phase difference	$9.3 \times 10^{-5}$ ms	5 ns	Error+TPR: $9.8 \times 10^{-5}$ ms
11.3 MBS Nominal Measurement Accuracy	Beacon power level	-30 dBm	0 dB	Level+TPR: -30 dBm
	Code phase difference	$7.1 \times 10^{-5}$ ms	5 ns	Error+TPR: $7.6 \times 10^{-5}$ ms
11.3A MBS Nominal Measurement Accuracy	Beacon power level	-30 dBm	0 dB	Level+TPR: -30 dBm
	TB1 Code phase difference	$7.1 \times 10^{-5}$ ms	5 ns	Error+TPR: $7.6 \times 10^{-5}$ ms
	TB2 Code phase difference	$2.8 \times 10^{-5}$ ms	5 ns	Error+TPR: $3.3 \times 10^{-5}$ ms
11.4 MBS Dynamic Range Measurement Accuracy	High Power Beacon power level	-30 dBm	0 dB	Level+TPR: -30 dBm
	Code phase difference	$7.1 \times 10^{-5}$ ms	5 ns	Error+TPR: $7.6 \times 10^{-5}$ ms
	Low Power Beacon power level	-130 dBm	2 dB	Level+TPR: -128 dBm
	Code phase difference	$2.35 \times 10^{-4}$ ms	5 ns	Error+TPR: $2.40 \times 10^{-4}$ ms
11.4A MBS Dynamic Range Measurement Accuracy	High Power Beacon power level	-30 dBm	0 dB	Level+TPR: -30 dBm
	TB1 High Power code phase difference	$7.1 \times 10^{-5}$ ms	5 ns	Error+TPR: $7.6 \times 10^{-5}$ ms
	TB2 High Power code phase difference	$2.8 \times 10^{-5}$ ms	5 ns	Error+TPR: $3.3 \times 10^{-5}$ ms
	Low Power Beacon power level	-130 dBm	2 dB	Level+TPR: -128 dBm
	TB1 Low Power code phase difference	$2.35 \times 10^{-4}$ ms	5 ns	Error+TPR: $2.40 \times 10^{-4}$ ms
	TB2 Low Power code phase difference	$9.3 \times 10^{-5}$ ms	5 ns	Error+TPR: $9.8 \times 10^{-5}$ ms
11.5, 11.5A MBS Measurement Accuracy in Multipath	Beacon power level	-30 dBm	0 dB	Level+TPR: -30 dBm
	Code phase difference	$2.35 \times 10^{-4}$ ms	5 ns	Error+TPR: $2.40 \times 10^{-4}$ ms

**Table C.4.4: Derivation of Test Requirements for WLAN and BLE measurement tests**

Test	Conformance requirements in 12.1.1, 12.1.2 and 12.2.1		Test Parameter Relaxation (TPR)	Test Requirement
12.1.1 WLAN AP Identification and reporting delay under nominal conditions	Response time	20.85 seconds	300 ms	Time+TPR: 21.15 s
12.1.2 WLAN AP Identification and reporting delay under dynamic range conditions	Response time	20.85 seconds	300 ms	Time+TPR: 21.15 s
	Low Power WLAN APs Received Power Level	WLAN 2.4 GHz band: -74 dBm WLAN 5 GHz band: -79 dBm	1 dB	Power+TPR: WLAN 2.4 GHz band: -73 dBm WLAN 5 GHz band: -78 dBm
12.2.1 Bluetooth identification	Response time	10.24 seconds	300 ms	Time+TPR: 10.54 s

---

## Annex D (normative): Rules for statistical testing

### D.1 Test Method

In this clause the terms GNSS and A-GNSS also include the cases where the only satellite system used is GPS unless otherwise stated.

Each test is performed in the following manner:

- a) Setup the required test conditions.
- b) Start each repetition after having applied the message 'RESET UE POSITIONING STORED INFORMATION'. This ensures that each result is independent from the previous one.
- c) Make the required measurement a repeated number of times. The results, measured, are simplified to:  
good result, if the measured result is  $\leq$  limit.  
bad result, if the measured result is  $>$  limit

For the relevant A-GNSS test cases measure the 2D position and Time to First Fix (TTFF) a repeated number of times. Measure the 2D position and Time to First Fix (if applicable) repeated times. Start each repetition after having applied the message 'RESET UE POSITIONING STORED INFORMATION'. This ensures that each result is independent from the previous one. The results, measured, are simplified to:

- good result, if the 2D position and TTFF are  $\leq$  limit.  
bad result, if the 2D position or TTFF or both are  $>$  limit
- d) Record the number of results (ns) and the number of bad results (ne)
  - e) Stop the test at a pass or a fail event.
  - f) Once the test is stopped, decide according to the pass fail decision rules (D.4.2)

### D.2 Error Ratio (ER)

The Error Ratio (ER) is defined as the ratio of bad results (ne) to all results (ns).  
(1-ER is the success ratio)

### D.3 Test Design

A statistical test is characterised by:

Test-time, Selectivity and Confidence level

#### D.3.1 Confidence level

The outcome of a statistical test is a decision. This decision may be correct or in-correct. The Confidence Level CL describes the probability that the decision is a correct one. The complement is the wrong decision probability (risk)  $D = 1-CL$

#### D.3.2 Introduction: Supplier Risk versus Customer Risk

There are two targets of decision:

- a) A measurement on the pass-limit shows, that the DUT has the specified quality or is better with probability CL (CL e.g.95%) This shall lead to a "pass decision"

The pass-limit is on the good side of the specified DUT-quality. A more stringent CL (CL e.g.99%) shifts the pass-limit further into the good direction. Given that the quality of the DUTs is distributed, a greater CL passes less and better DUTs.

A measurement on the bad side of the pass-limit is simply “not pass” (undecided)

aa) Complementary:

A measurement on the fail-limit shows, that the DUT is worse than the specified quality with probability CL.

The fail-limit is on the bad side of the specified DUT-quality. A more stringent CL shifts the fail-limit further into the bad direction. Given that the quality of the DUTs is distributed, a greater CL fails less and worse DUTs.

A measurement on the good side of the fail-limit is simply “not fail”.

b) A DUT, known to have the specified quality, shall be measured and decided pass with probability CL. This leads to the pass limit.

For CL e.g. 95%, the pass limit is on the bad side of the specified DUT-quality. CL e.g.99% shifts the pass-limit further into the bad direction. Given that the DUT-quality is distributed, a greater CL passes more and worse DUTs.

bb) A DUT, known to be an ( $\epsilon \rightarrow 0$ ) beyond the specified quality, shall be measured and decided fail with probability CL.

For CL e.g.95%, the fail limit is on the good side of the specified DUT-quality.

Note the different sense for CL in (a), (aa) versus (b), (bb).

NOTE: For constant CL in all 4 bullets, (a) is equivalent to (bb) and (aa) is equivalent to (b).

### D.3.3 Supplier Risk versus Customer Risk

The table below summarizes the different targets of decision.

**Table D.3.3: Equivalent statements**

	Equivalent statements, using different cause-to-effect-directions, and assuming CL = constant >0.5	
cause-to-effect-directions	Known measurement result $\rightarrow$ estimation of the DUT's quality	Known DUT's quality $\rightarrow$ estimation of the measurement's outcome
Supplier Risk	<b>A measurement on the pass-limit shows, that the DUT has the specified quality or is better (a)</b>	A DUT, known to have an ( $\epsilon \rightarrow 0$ ) beyond the specified DUT-quality, shall be measured and decided fail (bb)
Customer Risk	A measurement on the fail-limit shall shows, that the DUT is worse than the specified quality (aa)	<b>A DUT, known to have the specified quality, shall be measured and decided pass (b)</b>

NOTE: The bold text shows the obvious interpretation of Supplier Risk and Customer Risk. The same statements can be based on other DUT-quality-definitions.

### D.3.4 Introduction: Standard test versus early decision concept

In standard statistical tests, a certain number of results (ns) is predefined in advance of the test. After ns results the number of bad results (ne) is counted and the error ratio (ER) is calculated as ne/ns.

Applying statistical theory, a decision limit can be designed, against which the calculated ER is compared to derive the decision. Such a limit is one decision point and is characterised by:

- D: the wrong decision probability (a predefined parameter)
- ns: the number of results (a fixed predefined parameter)

- ne: the number of bad results (the limit based on just ns)

In the formula for the limit, D and ns are parameters and ne is the variable. In the standard test ns and D are constant. The property of such a test is: It discriminates between two states only, depending on the test design:

- pass (with CL) / undecided (undecided in the sense: finally undecided)
- fail (with CL) / undecided (undecided in the sense: finally undecided)
- pass (with CL) / fail (with CL) (however against two limits).

In contrast to the standard statistical tests, the early decision concept predefines a set of (ne, ns) co-ordinates, representing the limit-curve for decision. After each result a preliminary ER is calculated and compared against the limit-curve. After each result one may make the decision or not (undecided for later decision). The parameters and variables in the limit-curve for the early decision concept have a similar but not equal meaning:

- D: the wrong decision probability (a predefined parameter)
- ns: the number of results (a variable parameter)
- ne: the number of bad results (the limit. It varies together with ns)

To avoid a “final undecided” in the standard test, a second limit must be introduced and the single decision co-ordinate (ne, ns) needs a high ne, leading to a fixed (high) test time. In the early decision concept, having the same selectivity and the same confidence level an “undecided” does not need to be avoided, as it can be decided later. A perfect DUT will hit the decision coordinate (ne, ns) with ne=0. This test time is short.

### D.3.5 Standard test versus early decision concept

For Supplier Risk:

The wrong decision probability D in the standard test is the probability, to decide a DUT in-correctly in the single decision point. In the early decision concept there is a probability of in-correct decisions d at each point of the limit-curve. The sum of all those wrong decision probabilities accumulate to D. Hence  $d < D$

For Customer Risk:

The correct decision probability CL in the standard test is the probability, to decide a DUT correctly in the single decision point. In the early decision concept there is a probability of correct decisions cl at each point of the limit-curve. The sum of all those correct decision probabilities accumulate to CL. Hence  $cl < CL$  or  $d > D$

### D.3.6 Selectivity

There is no statistical test which can discriminate between a limit-DUT-quality and a DUT-quality which is an ( $\epsilon \rightarrow 0$ ) apart from the limit in finite time and confidence level  $CL > 1/2$ . Either the test discriminates against one limit with the results pass (with CL)/undecided or fail (with CL)/undecided, or the test ends in a result pass (with CL)/fail (with CL) but this requires a second limit.

For  $CL > 0.5$ , a (measurement-result = specified-DUT-quality), generates undecided in test “supplier risk against pass limit” (a in clause D.3.2) and also in the equivalent test against the fail limit (aa in clause D.3.2)

For  $CL > 0.5$ , a DUT, known to be on the limit, will be decided pass for the test “customer risk against pass limit” (b in clause D.3.2) and also in the equivalent test against fail limit (bb in clause D.3.2).

This overlap or undecided area is not a fault or a contradiction, however it can be avoided by introducing a Bad or a Good DUT quality according to:

- Bad DUT quality: specified DUT-quality \* M ( $M > 1$ )
- Good DUT quality: specified DUT-quality \* m ( $m < 1$ )

Using e.g.  $M > 1$  and  $CL = 95\%$  the test for different DUT qualities yield different pass probabilities:

Figure D.3.6: Pass probability versus DUT quality

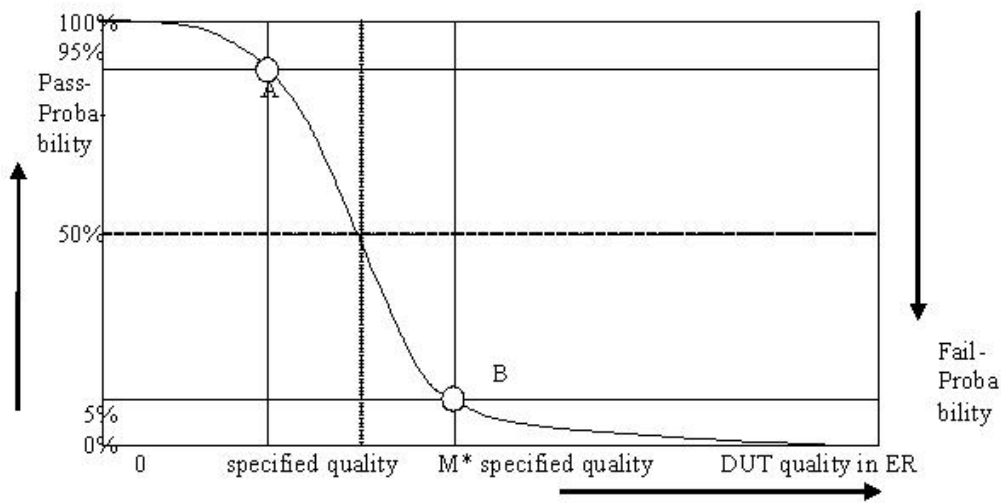

### D.3.7 Design of the test

The test is defined according to the following design principles:

1. The early decision concept is applied.
2. A second limit is introduced: Bad DUT factor  $M > 1$
3. To decide the test pass:

Supplier risk is applied based on the Bad DUT quality

To decide the test fail

Customer Risk is applied based on the specified DUT quality

The A-GNSS test cases are defined using the following parameters:

1. Specified DUT quality: ER = 0.05
2. Bad DUT quality:  $M = 1.5$  (selectivity)
3. Confidence level CL = 95% (for specified DUT and Bad DUT-quality)

The ECID and OTDOA test cases are defined using the following parameters:

1. Specified DUT quality: ER = 0.1
2. Bad DUT quality:  $M = 1.5$  (selectivity)
3. Confidence level CL = 95% (for specified DUT and Bad DUT-quality)

This has the following consequences:

- a) A measurement on the fail limit is connected with 2 equivalent statements:

A measurement on the fail-limit shows, that the DUT is worse than the specified DUT-quality	A DUT, known to have the specified quality, shall be measured and decided pass
---	--

A measurement on the pass limit is connected with the complementary statements:

A measurement on the pass limit shows, that the DUT is better than the Bad DUT-quality.	A DUT, known to have the Bad DUT quality, shall be measured and decided fail
---	--

The left column is used to decide the measurement.

The right column is used to verify the design of the test by simulation.

The simulation is based on the two fulcrums A and B only in Figure D.3.6. There is freedom to shape the remainder of the function.

b) Test time

1. The minimum and maximum test time is fixed.
  2. The average test time is a function of the DUT's quality.
  3. The individual test time is not predictable (except ideal DUT).
- c) The number of decision co-ordinates ( $n_e$ ,  $n_s$ ) in the early decision concept is responsible for the selectivity of the test and the maximum test time. Having fixed the number of decision co-ordinates there is still freedom to select the individual decision co-ordinates in many combinations, all leading to the same confidence level.

## D.4 Pass fail decisions

### D.4.1 Numerical definition of the pass fail limits for A-GNSS test cases

ne	ns <sub>p</sub>	ns <sub>f</sub>	ne	ns <sub>p</sub>	ns <sub>f</sub>	ne	ns <sub>p</sub>	ns <sub>f</sub>	ne	ns <sub>p</sub>	ns <sub>f</sub>
0	77	NA	43	855	576	86	1525	1297	129	2173	2050
1	106	NA	44	871	592	87	1540	1314	130	2188	2067
2	131	NA	45	887	608	88	1556	1331	131	2203	2085
3	154	NA	46	903	625	89	1571	1349	132	2218	2103
4	176	NA	47	919	641	90	1586	1366	133	2233	2121
5	197	NA	48	935	657	91	1601	1383	134	2248	2139
6	218	42	49	951	674	92	1617	1401	135	2263	2156
7	238	52	50	967	690	93	1632	1418	136	2277	2174
8	257	64	51	982	706	94	1647	1435	137	2292	2192
9	277	75	52	998	723	95	1662	1453	138	2307	2210
10	295	87	53	1014	739	96	1677	1470	139	2322	2227
11	314	100	54	1030	756	97	1692	1487	140	2337	2245
12	333	112	55	1046	772	98	1708	1505	141	2352	2263
13	351	125	56	1061	789	99	1723	1522	142	2367	2281
14	369	139	57	1077	805	100	1738	1540	143	2381	2299
15	387	152	58	1093	822	101	1753	1557	144	2396	2317
16	405	166	59	1108	839	102	1768	1574	145	2411	2335
17	422	180	60	1124	855	103	1783	1592	146	2426	2352
18	440	194	61	1140	872	104	1798	1609	147	2441	2370
19	457	208	62	1155	889	105	1813	1627	148	2456	2388
20	474	222	63	1171	906	106	1828	1644	149	2470	2406
21	492	237	64	1186	922	107	1844	1662	150	2485	2424
22	509	251	65	1202	939	108	1859	1679	151	2500	2442
23	526	266	66	1217	956	109	1874	1697	152	2515	2460
24	543	281	67	1233	973	110	1889	1714	153	2530	2478
25	560	295	68	1248	990	111	1904	1732	154	2544	2496
26	577	310	69	1264	1007	112	1919	1750	155	2559	2513
27	593	325	70	1279	1024	113	1934	1767	156	2574	2531
28	610	341	71	1295	1040	114	1949	1785	157	2589	2549
29	627	356	72	1310	1057	115	1964	1802	158	2603	2567
30	643	371	73	1326	1074	116	1979	1820	159	2618	2585
31	660	387	74	1341	1091	117	1994	1838	160	2633	2603
32	676	402	75	1357	1108	118	2009	1855	161	2648	2621
33	693	418	76	1372	1126	119	2024	1873	162	2662	2639
34	709	433	77	1387	1143	120	2039	1890	163	2677	2657
35	725	449	78	1403	1160	121	2054	1908	164	2692	2675
36	742	465	79	1418	1177	122	2069	1926	165	2707	2693
37	758	480	80	1433	1194	123	2084	1943	166	2721	2711
38	774	496	81	1449	1211	124	2099	1961	167	2736	2729
39	790	512	82	1464	1228	125	2114	1979	168	2751	2747
40	807	528	83	1479	1245	126	2128	1997	169	2765	NA
41	823	544	84	1495	1263	127	2143	2014			
42	839	560	85	1510	1280	128	2158	2032			

NOTE: The first column is the number of bad results (ne)  
The second column is the number of results for the pass limit (ns<sub>p</sub>)  
The third column is the number of results for the fail limit (ns<sub>f</sub>)

### D.4.2 Pass fail decision rules for A-GNSS test cases

Having observed 0 bad results, pass the test at  $\geq 77$  results, otherwise continue

Having observed 1 bad result, pass the test at  $\geq 106$  results, otherwise continue

Having observed 2 bad results, pass the test at  $\geq 131$  results, otherwise continue

etc. until

Having observed 6 bad results, pass the test at  $\geq 218$  results, fail the test at  $\leq 42$  results, otherwise continue

Having observed 7 bad results, pass the test at  $\geq 238$  results, fail the test at  $\leq 52$  results, otherwise continue

etc. until

Having observed 168 bad results, pass the test at  $\geq 2751$  results, fail the test at  $\leq 2747$  results, otherwise continue

Having observed 169 bad results, pass the test at  $\geq 2765$  results, otherwise fail

NOTE: an ideal DUT passes after 77 results. The maximum test time is 2765 results.

### D.4.3 Numerical definition of the pass fail limits for ECID, OTDOA, MBS, WLAN and BLE test cases

ne	ns <sub>p</sub>	ns <sub>f</sub>	ne	ns <sub>p</sub>	ns <sub>f</sub>	ne	ns <sub>p</sub>	ns <sub>f</sub>	ne	ns <sub>p</sub>	ns <sub>f</sub>
0	33	NA	43	408	283	86	737	644	129	1056	1021
1	46	NA	44	416	291	87	745	653	130	1064	1030
2	58	2	45	424	299	88	752	661	131	1071	1039
3	69	5	46	432	307	89	760	670	132	1078	1048
4	79	8	47	440	315	90	767	679	133	1086	1057
5	89	12	48	447	324	91	775	687	134	1093	1066
6	99	17	49	455	332	92	782	696	135	1100	1074
7	109	22	50	463	340	93	790	705	136	1108	1083
8	118	27	51	471	348	94	797	713	137	1115	1092
9	127	33	52	478	356	95	804	722	138	1122	1101
10	136	39	53	486	365	96	812	731	139	1130	1110
11	145	45	54	494	373	97	819	739	140	1137	1119
12	154	51	55	502	381	98	827	748	141	1144	1128
13	163	58	56	509	389	99	834	757	142	1152	1137
14	172	64	57	517	398	100	842	766	143	1159	1147
15	180	71	58	525	406	101	849	774	144	1166	1155
16	189	78	59	532	414	102	857	783	145	1174	1164
17	197	85	60	540	423	103	864	792	146	1181	1173
18	206	92	61	548	431	104	871	801	147	NA	1182
19	214	99	62	555	440	105	879	809	148		
20	223	106	63	563	448	106	886	818	149		
21	231	113	64	571	456	107	894	827	150		
22	239	120	65	578	465	108	901	836	151		
23	248	128	66	586	473	109	909	844	152		
24	256	135	67	594	482	110	916	853	153		
25	264	142	68	601	490	111	923	862	154		
26	272	150	69	609	499	112	931	871	155		
27	281	157	70	616	507	113	938	880	156		
28	289	165	71	624	516	114	946	888	157		
29	297	173	72	632	524	115	953	897	158		
30	305	180	73	639	533	116	960	906	159		
31	313	188	74	647	541	117	968	915	160		
32	321	196	75	654	550	118	975	924	161		
33	329	204	76	662	558	119	983	933	162		
34	337	211	77	669	567	120	990	941	163		
35	345	219	78	677	575	121	997	950	164		
36	353	227	79	684	584	122	1005	959	165		
37	361	235	80	692	592	123	1012	968	166		
38	369	243	81	700	601	124	1019	977	167		
39	377	251	82	707	610	125	1027	986	168		
40	385	259	83	715	618	126	1034	994	169		
41	393	267	84	722	627	127	1042	1003			
42	400	275	85	730	635	128	1049	1012			

The first column is the number of errors (ne = number of exceeded delays or number of wrong reports)

The second column is the number of samples for the pass limit (ns<sub>p</sub>, ns=Number of samples= number of successes + number of exceedings or number of reports)

The third column is the number of samples for the fail limit (ns<sub>f</sub>)



#### D.4.4 Pass fail decision rules for ECID, OTDOA, MBS, WLAN and BLE test cases

Having observed 0 errors, pass the test at 33+ samples, otherwise continue

Having observed 1 error, pass the test at 46+ samples, otherwise continue

Having observed 2 errors, pass the test at 58+ samples, fail the test at 2 samples, otherwise continue

Having observed 146 errors, pass the test at 1181+ samples, fail the test at 1173- samples, otherwise continue

Having observed 147 errors, fail the test at 1182- samples,

Where x+ means: x or more, x- means x or less

NOTE: an ideal DUT passes after 33 samples. The maximum test time is 1181 samples.

#### D.4.5 Background information to the pass fail limits

There is freedom to design the decision co-ordinates (ne, ns).

The binomial distribution and its inverse is used to design the pass and fail limits. Note that this method is not unique and that other methods exist.

$$\text{fail}(ne, d_f) := \frac{ne}{(ne + \text{qnbinom}(d_f, ne, ER))}$$

$$\text{pass}(ne, cl_p, M) := \frac{ne}{(ne + \text{qnbinom}(cl_p, ne, ER \cdot M))}$$

Where

fail(..) is the error ratio for the fail limit

pass(..) is the error ratio for the pass limit

ER is the specified error ratio e.g. 0.05

ne is the number of bad results. This is the variable in both equations

M is the Bad DUT factor M=1.5

$d_f$  is the wrong decision probability of a single (ne, ns) co-ordinate for the fail limit. It is found by simulation to be  $d_f = 0.004$

$cl_p$  is the confidence level of a single (ne, ns) co-ordinate for the pass limit. It is found by simulation to be  $cl_p = 0.9975$

qnbinom(..): The inverse cumulative function of the negative binomial distribution

The simulation works as follows:

A large population of limit DUTs with true ER = 0.05 is decided against the pass and fail limits.

$cl_p$  and  $d_f$  are tuned such that CL (95%) of the population passes and D (5%) of the population fails.

A population of Bad DUTs with true ER = M\*0.05 is decided against the same pass and fail limits.

$cl_p$  and  $d_f$  are tuned such that CL (95%) of the population fails and D (5%) of the population passes.

This procedure and the relationship to the measurement is justified in clause D.3.7. The number of DUTs decreases during the simulation, as the decided DUTs leave the population. That number decreases with an approximately exponential characteristics. After 169 bad results all DUTs of the population are decided.

NOTE: The exponential decrease of the population is an optimal design goal for the decision co-ordinates (ne, ns), which can be achieved with other formulas or methods as well.

## Annex E (normative): Conditions for ECID and OTDOA requirements

### E.1 Conditions for E-CID UE Rx – Tx time difference Measurements

This clause defines the E-UTRAN RSRP applicable for ECID UE Rx-Tx time difference Measurements for a corresponding operating band

The conditions for E-UTRAN ECID UE Rx-Tx time difference measurements are as defined in Table E.1-1.

**Table E.1-1: Conditions for ECID UE Rx-Tx time difference measurements**

Parameter	E-UTRA operating band groups <sup>Note 3</sup>	Minimum RSRP <sup>Note 1</sup>
		dBm/15kHz
Conditions	FDD_A, TDD_A	-127
	FDD_B	-126.5
	FDD_C, TDD_C	-126
	FDD_D	-125.5
	FDD_E, TDD_E	-125
	FDD_F	-124.5 <sup>Note 2</sup>
	FDD_G	-124
	FDD_H	-123.5
	FDD_N	-120.5
NOTE 1: This condition level is increased by $\Delta > 0$ , when applicable, as described in Sections B.4.2 and B.4.3 of TS 36.133 [23].		
NOTE 2: The condition is -125 dBm/15kHz when the carrier frequency of the assigned E-UTRA channel bandwidth is within 865-894 MHz.		
NOTE 3: E-UTRA operating band groups are as defined in clause 4.4.2.		

#### E.1.1 Conditions for E-CID UE Rx – Tx time difference by UE Category M1/M2

This clause defines the E-UTRAN RSRP applicable for ECID UE Rx-Tx time difference Measurements for a corresponding operating band for UE Category M1 and M2.

The conditions for CE mode A intra-frequency E-UTRAN FDD, HD-FDD and TDD measurements are defined in Table E.1.1-1.

**Table B.2.14-1: E-UTRAN ECID UE Rx-Tx time difference measurements for FDD, HD-FDD and TDD for CE mode A**

Parameter	E-UTRA operating band groups <sup>Note 3</sup>	Minimum RSRP <sup>Note 1</sup>
		dBm/15kHz
Conditions	FDD-M1_A, TDD-M1_A	-127
	FDD-M1_D	-125.5
	FDD-M1_E, TDD-M1_E	-125
	FDD-M1_F	-124.5 <sup>Note 2</sup>
	FDD-M1_G	-124
	FDD-M1_N	-120.5
NOTE 1: This condition level is increased by $\Delta > 0$ , when applicable, as described in Sections B.4.2 and B.4.3 of TS 36.133 [23].		
NOTE 2: The condition is -125 dBm/15kHz when the carrier frequency of the assigned E-UTRA channel bandwidth is within 865-894 MHz.		
NOTE 3: E-UTRA operating band groups are as defined in clause 4.4.2.		

## E.2 Conditions for OTDOA intra-frequency RSTD Measurements

This clause defines the E-UTRAN intra-frequency PRP<sub>1,2</sub> applicable for OTDOA intra-frequency RSTD measurements for a corresponding operating band.

The conditions for E-UTRAN OTDOA intra-frequency RSTD measurements are as defined in Table E.2-1

**Table E.2-1: Conditions for OTDOA intra-frequency RSTD measurements**

Parameter	E-UTRA operating band group s <sup>Note 3</sup>	Minimum PRP <sub>1,2</sub> Note 1
		dBm/15kHz
Conditions	FDD_A, TDD_A	-127
	FDD_B	-126.5
	FDD_C, TDD_C	-126
	FDD_D	-125.5
	FDD_E, TDD_E	-125
	FDD_F	-124.5 <sup>Note 2</sup>
	FDD_G	-124
	FDD_H	-123.5
	FDD_N	-120.5

NOTE 1: This condition level is increased by  $\Delta > 0$ , when applicable, as described in Sections B.4.2 and B.4.3 of TS 36.133[23].

NOTE 2: The condition is -125 dBm/15kHz when the carrier frequency of the assigned E-UTRA channel bandwidth is within 865-894 MHz.

NOTE 3: E-UTRA operating band groups are as defined in clause 4.4.2.

## E.3 Conditions for OTDOA inter-frequency RSTD Measurements

This clause defines the E-UTRAN inter-frequency PRP<sub>1,2</sub> applicable for OTDOA Inter-frequency RSTD measurements for a corresponding operating band.

The conditions for E-UTRAN OTDOA inter-frequency RSTD measurements are as defined in Table E.2-1.

### E.3.1 Conditions for OTDOA inter-frequency RSTD Measurements by UE Category M1 and M2

This clause defines the E-UTRAN inter-frequency PRP<sub>1,2</sub> applicable for a corresponding operating band.

The conditions for CE mode A inter-frequency E-UTRAN HD-FDD, FDD and TDD measurements are defined in Table E.3.1-1.

The conditions for CE mode B for inter-frequency E-UTRAN HD-FDD, FDD and TDD measurements are defined in Table E.3.1-2.

**Table E.3.1-1: E-UTRAN inter-frequency measurements for HD-FDD, FDD and TDD for CE mode A**

Parameter	E-UTRA operating band groups <sup>Note 2</sup>	Minimum PRP <sub>1,2</sub>
		dBm/15kHz
Conditions	FDD_A, TDD_A	-127
	FDD_D	-125.5
	FDD_E, TDD_E	-125
	FDD_F	-124.5 <sup>Note 1</sup>
	FDD_G	-124
	FDD_N	-120.5

NOTE 1: The condition is -125 dBm/15kHz when the carrier frequency of the assigned E-UTRA channel bandwidth is within 865-894 MHz.

NOTE 2: E-UTRA operating band groups are as defined in Section 4.4.2.

**Table E.3.1-2: E-UTRAN inter-frequency measurements for HD-FDD, FDD and TDD for CE mode B**

Parameter	E-UTRA operating band groups <sup>Note 2</sup>	Minimum PRP1,2
		dBm/15kHz
Conditions	FDD_A, TDD_A	-136
	FDD_D	-134.5
	FDD_E, TDD_E	-134
	FDD_F	-133.5 <sup>Note 1</sup>
	FDD_G	-133
	FDD_N	-129.5
NOTE 1: The condition is -125 dBm/15kHz when the carrier frequency of the assigned E-UTRA channel bandwidth is within 865-894 MHz.		
NOTE 2: E-UTRA operating band groups are as defined in Section 4.4.2.		

## E.4 Conditions for UE Rx-Tx Time Difference Measurement under Time Domain Measurement Resource Restriction with CRS Assistance Information

This clause defines the E-UTRAN RSRP applicable for UE Rx-Tx Time Difference Measurement under Time Domain Measurement Resource Restriction with CRS Assistance Information for a corresponding operating band.

The conditions for UE Rx-Tx time difference measurements, when time domain measurement resource restriction pattern and CRS assistance information are provided, are as defined in Table E.1-1.

## E.5 Conditions for NB-IOT OTDOA intra-frequency RSTD Measurements

This clause defines the NB-IoT intra-frequency PRP1,2 applicable for a corresponding operating band.

The conditions for intra-frequency RSTD measurements in normal coverage are defined in Table E.5-1.

The conditions for intra-frequency RSTD measurements in enhanced coverage are defined in Table E.5-2.

**Table E.5-1: NB-IoT intra-frequency RSTD measurements for HD-FDD in normal coverage**

Parameter	E-UTRA operating band groups <sup>Note 1</sup>	Minimum PRP1,2
		dBm/15kHz
Conditions	NFDD_G	-129
NOTE 1: E-UTRA operating band groups are as defined in Section 4.11.1		

**Table E.5-2: NB-IoT intra-frequency RSTD measurements for HD-FDD in enhanced coverage**

Parameter	E-UTRA operating band groups <sup>Note 1</sup>	Minimum PRP1,2
		dBm/15kHz
Conditions	NFDD_G	-135
NOTE 1: E-UTRA operating band groups are as defined in Section 4.11.1		

## E.6 Conditions for NB-IOT OTDOA inter-frequency RSTD Measurements

This clause defines the NB-IoT intra-frequency PRP1,2 applicable for a corresponding operating band.

The conditions for inter-frequency RSTD measurements in normal coverage are defined in Table E.5-1.

The conditions for inter-frequency RSTD measurements in enhanced coverage are defined in Table E.5-2.

# Annex F (normative): UTRAN Generic procedures

## F.1 General

This normative annex specifies the set up and release procedure that shall be used for each UTRAN test case.

In this clause the terms GNSS and A-GNSS also include the cases where the only satellite system used is GPS unless otherwise stated.

## F.2 UTRAN connection set up

### F.2.1 Initial conditions

System Simulator:

- 1 cell, default parameters. The default system information, as specified in clause 6.1 of TS 34.108 [28], is broadcast with the exceptions of SIB15, SIB15.1, SIB15.2 and SIB15.3 which are not broadcast.

User Equipment:

- The UE shall be operated in Normal Propagation Conditions as specified in clause 5.2.1 of TS 34.108 [28].
- The UE is in state "MM idle" state with valid TMSI and CKSN.
- The UE is in state "PMM idle" with valid P-TMSI.

### F.2.2 Procedures

CS Domain

Step	Direction		Message	Comments
	UE	SS		
1	<--		SYSTEM INFORMATION (BCCH)	Broadcast
2	<--		PAGING TYPE1 (PCCH)	Paging (CS domain, TMSI)
3	-->		RRC CONNECTION REQUEST (CCCH)	RRC
4	<--		RRC CONNECTION SETUP (CCCH)	RRC
5	-->		RRC CONNECTION SETUP COMPLETE (DCCH)	RRC
6	-->		PAGING RESPONSE	RR
7	<--		AUTHENTICATION REQUEST	MM
8	-->		AUTHENTICATION RESPONSE	MM
9	<--		SECURITY MODE COMMAND	RRC
10	-->		SECURITY MODE COMPLETE	RRC

PS Domain

Step	Direction		Message	Comments
	UE	SS		
1	<--		PAGING TYPE1 (PCCH)	Paging (PS domain, PMSI or IMSI)
2	-->		RRC CONNECTION REQUEST (CCCH)	RRC
3	<--		RRC CONNECTION SETUP (CCCH)	RRC
4	-->		RRC CONNECTION SETUP COMPLETE (DCCH)	RRC (Transport Channel: DCH or FACH)
5	-->		SERVICE REQUEST	GMM
6	<--		AUTHENTICATION REQUEST	GMM
7	-->		AUTHENTICATION RESPONSE	GMM
8	<--		SECURITY MODE COMMAND	RRC
9	-->		SECURITY MODE COMPLETE	RRC

## F.2.3 Specific message contents

The default message contents specified in clause 9.1 of TS 34.108 [28] will be used for the Moving Scenario and Periodic Update test. For all Minimum Performance TTFF Tests the default message contents specified in clause 9.1 of TS 34.108 [28] will be used with the following exception.

Contents of PAGING TYPE1:

Information Element	Value/remark
Paging Cause	Terminating High Priority Signalling

Contents of RRC CONNECTION SETUP:

For A-GNSS performance testing in CELL\_DCH state: The RRC Connection Setup is defined in clause 9.1.1 of TS 34.108 [28] "Contents of RRC CONNECTION SETUP message: UM (Transition to CELL\_DCH)".

For A-GNSS performance testing in CELL\_FACH state: The RRC Connection Setup is defined in clause 9.1.1 of TS 34.108 [28] "Contents of RRC CONNECTION SETUP message: UM (Transition to CELL\_FACH)".

Contents of RRC CONNECTION SETUP COMPLETE:

Information Element	Value/remark
UE radio access capability - UE positioning capability	Defines the A-GNSS mode the UE supports (UE-based, UE-assisted, or both). UE shall be tested for all modes it supports.

## F.3 UTRAN connection release

### F.3.1 Procedure

Step	Direction		Message	Comments
	UE	SS		
1	<--		RRC CONNECTION RELEASE	RRC
2		-->	RRC CONNECTION RELEASE COMPLETE	RRC

### F.3.2 Specific message contents

The default message contents specified in clause 9.1 of TS 34.108 [28] are used.

## Annex G (normative): Environmental conditions

### G.1 General

This normative annex specifies the environmental requirements of the UE. Within these limits the requirements of the present documents shall be fulfilled.

### G.2 Environmental requirements

The requirements in this clause apply to all types of UE(s).

#### G.2.1 Temperature

The UE shall fulfil all the requirements in the full temperature range of:

**Table G.2.1.1**

+15°C to +35°C	for normal conditions (with relative humidity up to 75 %)
----------------	---

#### G.2.2 Voltage

The UE shall fulfil all the requirements in the full voltage range, i.e. the voltage range between the extreme voltages.

The manufacturer shall declare the lower and higher extreme voltages and the approximate shutdown voltage. For the equipment that can be operated from one or more of the power sources listed below, the lower extreme voltage shall not be higher, and the higher extreme voltage shall not be lower than that specified below.

**Table G.2.2.1**

Power source	Normal conditions voltage
AC mains	nominal
Regulated lead acid battery	1.1 × nominal
Non regulated batteries:	
- Leclanché / lithium	Nominal
- Mercury/nickel and cadmium	Nominal



---

# Annex H (informative): MBS Beacon parameters

## H.1 General

This informative annex consolidates a description of the MBS beacon parameters that are specified in the MBS ICD [38]. They are provided here for reference.

## H.2 Beacon parameters

This is a summary of the MBS beacon parameters to be used for MBS testing:

**Beacon PN Code:** 1023 chip length for TB1. Actual PN codes are listed in the MBS ICD [38]

**MBS Beacon Configuration:** TB1 (2.046 MHz, contains data) [38]

**MBS Packet Type:** Type 2 [38]

**MBS Transmitter ID (TxID):** Field used to signal a unique ID that identifies each transmitter within one major deployment area, such as within North America. Range:  $[0, 2^{15}-1]$  [38]

**Slot Index:** This is the physical time slot within a MBS transmission period, in which a transmitter is transmitting. Each slot is 100 ms in duration and a MBS transmission period is 1 sec long. [38]

**All other fields:** Set to the min value (bit value equal to 0) for testing [38]

## Annex I (informative): Change history

Change history							
Date	TSG #	TSG Doc.	CR	Rev	Subject/Comment TS 36.571-1	Old	New
2010-08	RAN#48	R5-104316			Initial draft TS 36.571-1 created		0.0.0
2010-11	RAN#49	R5-106613			V1.0.0 created for presentation to RAN Plenary	0.0.0	1.0.0
2011-02	RAN#50	R5-110124			Various values and corrections added	1.0.0	1.1.0
2011-08	RAN#52	R5-113133			Text changes from R5-112139, R5-112386, R5-112837, R5-112838, R5-112839 added	1.1.0	1.2.0
2011-08	RAN#53				Text changes from R5-113135, R5-113150, R5-114066, R5-113587 added	1.2.0	-
2011-11	RAN#53	R5-115206			Initial draft TS 37.571-1 created from TS 36.571-1, TS 34.171 and TS 34.172	-	1.0.0
2011-11	RAN#53	R5-115207			V2.0.0 created for presentation to RAN Plenary with additions from R5-115246, R5-115247, R5-115248, R5-115809	1.0.0	2.0.0
2011-12	RAN#54	-	-	-	Moved to Rel-9 with editorial changes only	2.0.0	9.0.0
2012-03	RAN#55	R5-120087	0001	-	Modify OTDOA connection diagrams	9.0.0	9.1.0
2012-03	RAN#55	R5-120089	0002	-	OTDOA parameter corrections	9.0.0	9.1.0
2012-03	RAN#55	R5-120414	0003	-	Adding ECID test cases to Annexes in TS 37.571-1	9.0.0	9.1.0
2012-03	RAN#55	R5-120822	0004	-	Correct A-GNSS signalling	9.0.0	9.1.0
2012-03	RAN#55	R5-120823	0005	-	ECID procedure modifications	9.0.0	9.1.0
2012-03	RAN#55	R5-120893	0006	-	OTDOA procedure updates	9.0.0	9.1.0
2012-06	RAN#56	R5-121126	0007	-	Update to Figure 9.1.1.3-1	9.1.0	9.2.0
2012-06	RAN#56	R5-121127	0008	-	Clarification to notes in tests 9.1.3 & 9.1.4	9.1.0	9.2.0
2012-06	RAN#56	R5-121128	0009	-	Clarifications to frequencies and bandwidths to be used	9.1.0	9.2.0
2012-06	RAN#56	R5-121129	0010	-	Setting responseTime in ECID test cases	9.1.0	9.2.0
2012-06	RAN#56	R5-121130	0011	-	Modifications to signalling used in OTDOA test cases	9.1.0	9.2.0
2012-06	RAN#56	R5-121908	0012	-	Adding operating band 26 to TS 37.571-1	9.1.0	9.2.0
2012-06	RAN#56	-	-	-	Added missing contents from R5-121126, R5-121127, R5-121128	9.2.0	9.2.1
2012-06	RAN#56	-	-	-	Upgraded to v10.0.0 with no change.	9.2.1	10.0.0
2012-09	RAN#57	R5-123066	0013	-	Correction to RSTD Measurement Accuracy Tests 9.1.3 and 9.1.4	10.0.0	10.1.0
2012-09	RAN#57	R5-123913	0014	-	Addition of RRM Test Case 9.8.4 TDD inter-frequency RSTD Accuracy	10.0.0	10.1.0
2012-12	RAN#58	R5-125136	0015	-	Corrections to references	10.1.0	10.2.0
2012-12	RAN#58	R5-125188	0016	-	Correction to LPP Message Content for GNSS Moving Scenario Test	10.1.0	10.2.0
2012-12	RAN#58	R5-125806	0018	-	New test case 10.1 FDD RSTD Measurement Reporting Delay for Carrier Aggregation	10.1.0	10.2.0
2012-12	RAN#58	R5-125807	0019	-	New test case 10.2 TDD RSTD Measurement Reporting Delay for Carrier Aggregation	10.1.0	10.2.0
2012-12	RAN#58	R5-125808	0020	-	New test case 10.3 FDD RSTD Measurement Accuracy for Carrier Aggregation	10.1.0	10.2.0
2012-12	RAN#58	R5-125809	0021	-	New test case 10.4 TDD RSTD Measurement Accuracy for Carrier Aggregation	10.1.0	10.2.0
2012-12	RAN#58	R5-125831	0022	-	Adding bands 28 and 44 to TS 37.571-1	10.1.0	10.2.0
2012-12	RAN#58	R5-125847	0023	-	Corrections to procedures for RSTD tests	10.1.0	10.2.0
2012-12	RAN#58	R5-125848	0024	-	Correction of OCNG Patterns for UE Rx - Tx Time Difference Test Cases	10.1.0	10.2.0
2012-12	RAN#58	R5-125916	0025	-	Add editor's note for value of lprs for test case 9.1.4	10.1.0	10.2.0
2012-12	RAN#58	R5-124120	0026	-	New common text for test cases 10.1 - 10.4 for RSTD for Carrier Aggregation	10.1.0	10.2.0
2013-03	RAN#59	R5-130959	0027	-	LBS Perf: Corrections to TCs 8.1.1 and 8.1.2	10.2.0	10.3.0
2013-06	RAN#60	R5-131097	0028	-	Removal of Note 1 from OTDOA parameter tables	10.3.0	10.4.0
2013-06	RAN#60	R5-131176	0029	-	Clarification to RSTD Delay Test procedures	10.3.0	10.4.0
2013-06	RAN#60	R5-131943	0030	-	New Test Case for FDD-FDD inter-frequency RSTD Accuracy	10.3.0	10.4.0
2013-06	RAN#60	R5-131944	0031	-	New Test Case for FDD-FDD inter-frequency RSTD measurement reporting delay	10.3.0	10.4.0
2013-06	RAN#60	R5-131945	0032	-	OTDOA test case alignment with RAN 4	10.3.0	10.4.0
2013-06	RAN#60	R5-131946	0033	-	Corrections to ECID and OTDOA tests Note: same contents as R5-131945 was submitted by accident.	10.3.0	10.4.0
2013-06	RAN#60	R5-131947	0034	-	RSTD test parameter updates	10.3.0	10.4.0
2013-06	RAN#60	R5-131993	0035	-	Test Description for TDD inter-frequency accuracy test case	10.3.0	10.4.0
2013-06	RAN#60	R5-131994	0036	-	New test case for TDD inter-frequency RSTD reporting delay 9.2.2	10.3.0	10.4.0
2013-09	RAN#61	R5-133173	0037	-	Tidy up of Table 9.2.1.4.1-1	10.4.0	10.5.0
2013-09	RAN#61	R5-133174	0038	-	Corrections to ECID and OTDOA tests	10.4.0	10.5.0

Change history							
Date	TSG #	TSG Doc.	CR	Rev	Subject/Comment TS 36.571-1	Old	New
2013-09	RAN#61	R5-133375	0039	-	Uncertainties and Test Tolerances for RSTD test cases 9.1.1 and 9.1.2	10.4.0	10.5.0
2013-09	RAN#61	R5-133378	0040	-	Uncertainties and Test Tolerances for RSTD test cases 9.1.3 and 9.1.4	10.4.0	10.5.0
2013-09	RAN#61	R5-133848	0041	-	LBS Perf: Uncertainties and test tolerances for TCs 8.1.1 and 8.1.2	10.4.0	10.5.0
2013-09	RAN#61	R5-133885	0042	-	LBS Perf: Revision of test procedure for TC-s 8.1.1-2	10.4.0	10.5.0
2013-12	RAN#62	R5-134200	0043	-	Updates to ECID and RSTD tests following RAN 4 updates	10.5.0	10.6.0
2013-12	RAN#62	R5-134202	0044	-	Addition of Capability exchange in ECID and RSTD tests	10.5.0	10.6.0
2013-12	RAN#62	R5-134205	0045	-	Addition of Applicabilities for 9.2.1 - 9.2.5	10.5.0	10.6.0
2013-12	RAN#62	R5-134849	0046	-	Addition of missing acknowledgements in ECID tests	10.5.0	10.6.0
2013-12	RAN#62	R5-134850	0047	-	Corrections to references for OCNG and RMC	10.5.0	10.6.0
2013-12	RAN#62	R5-134899	0048	-	Introduction 8.1.3 E-UTRAN FDD UE Rx-Tx time difference (felCIC)	10.5.0	10.6.0
2013-12	RAN#62	R5-134970	0049	-	Introduction 8.1.4 E-UTRAN TDD UE Rx-Tx time difference (felCIC)	10.5.0	10.6.0
2013-12	RAN#62	R5-134979	0050	-	Addition of new tests 10.1a, 10.2a, 10.3a and 10.4a for 20MHz CA	10.5.0	10.6.0
2013-12	RAN#62	R5-134980	0051	-	LBS Perf: Corrections to RSTD reporting tests	10.5.0	10.6.0
2013-12	RAN#62	R5-135016	0052	-	Uncertainties and Test Tolerances for RSTD test cases 9.2.1 and 9.2.2	10.5.0	10.6.0
2013-12	RAN#62	R5-135018	0053	-	Uncertainties and Test Tolerances for RSTD test cases 9.2.4 and 9.2.5	10.5.0	10.6.0
2014-03	RAN#63	R5-140107	0054	-	Corrections to PRS_RA in RSTD tests	10.6.0	10.7.0
2014-03	RAN#63	R5-140278	0055	-	Addition of E-UTRA band groups	10.6.0	10.7.0
2014-03	RAN#63	R5-140308	0056	-	LBS RF: Aperiodic CQI configuration for 1.4 MHz bandwidth subtests	10.6.0	10.7.0
2014-03	RAN#63	R5-141033	0057	-	RSTD test case updates	10.6.0	10.7.0
2014-03	RAN#63	R5-140875	0058	-	Additions to TC 8.1.6 E-UTRAN TDD UE Rx-Tx time difference (felCIC)	10.7.0	11.0.0
2014-03	RAN#63	R5-141010	0059	-	Additions to TC 8.1.5 E-UTRAN FDD UE Rx-Tx time difference (felCIC)	10.7.0	11.0.0
2014-06	RAN#64	R5-142098	0060	-	Corrections for OCNG patterns defined in RSTD Tables	11.0.0	11.1.0
2014-06	RAN#64	R5-142211	0061	-	Additions to felCIC UE Rx-Tx test cases in Annex C	11.0.0	11.1.0
2014-06	RAN#64	R5-142302	0062	-	LBS RF: Aperiodic CQI configuration for 1.4 MHz bandwidth tests	11.0.0	11.1.0
2014-06	RAN#64	R5-143109	0063	-	Additions to TC 8.1.6 E-UTRAN TDD UE Rx-Tx time difference (felCIC)	11.0.0	11.1.0
2014-06	RAN#64	R5-143111	0064	-	Additions to FDD interruption requirements for SCell	11.0.0	11.1.0
2014-06	RAN#64	R5-143180	0065	-	Additions to TC 8.1.5 E-UTRAN FDD UE Rx-Tx time difference (felCIC)	11.0.0	11.1.0
2014-06	RAN#64	R5-143211	0066	-	LBS RF: Update of RSTD tests	11.0.0	11.1.0
2014-09	RAN#65	R5-144080	0068	-	Corrections to RSTD Measurement Reporting Delay for Carrier Aggregation tests	11.1.0	11.2.0
2014-09	RAN#65	R5-144125	0069	-	Corrections to Physical Cell Id (PCI) Configuration Conditions in UE Rx-Tx time difference felCIC	11.1.0	11.2.0
2014-09	RAN#65	R5-144193	0072	-	Cell-specific test parameters for E-UTRAN	11.1.0	11.2.0
2014-09	RAN#65	R5-144215	0081	-	Clarification to RSTD Reporting Delay tests	11.1.0	11.2.0
2014-09	RAN#65	R5-144409	0083	-	Update to initial conditions and measurement procedure in for UTRA A-GPS and A-GNSS tests	11.1.0	11.2.0
2014-09	RAN#65	R5-144553	0084	-	Removal of editors note in TC 9.1.4	11.1.0	11.2.0
2014-09	RAN#65	R5-144620	0085	-	Updates OTDOA Neighbour Cell Info List	11.1.0	11.2.0
2014-09	RAN#65	R5-144763	0086	-	Correction for RSTD Measurement Accuracy in CA requirements in RRM	11.1.0	11.2.0
2014-09	RAN#65	R5-144789	0070	-	Uncertainties and Test Tolerances for RSTD test cases 10.1, 10.1A, 10.2 and 10.2A	11.1.0	11.2.0
2014-09	RAN#65	R5-144790	0071	-	Uncertainties and Test Tolerances for RSTD test cases 10.3, 10.3A, 10.4 and 10.4A	11.1.0	11.2.0
2014-09	RAN#65	R5-144791	0082	-	Updates to Annex E of TS 37.571-1	11.1.0	11.2.0
2014-09	RAN#65	R5-144792	0087	-	RSTD tests RAN 4 alignment	11.1.0	11.2.0
2014-09	RAN#65	R5-144865	0088	-	Editor's note to PRS levels with fading	11.1.0	11.2.0
2014-09	RAN#65	R5-144870	0089	-	Corrections to Note 3 for RSTD CA tests	11.1.0	11.2.0
2014-09	RAN#65	R5-144914	0090	-	Corrections to TDD RSTD Measurement Reporting Delay for Carrier Aggregation	11.1.0	11.2.0
2014-09	RAN#65	R5-144915	0091	-	RSTD CA Measurement Accuracy connection diagrams	11.1.0	11.2.0
2014-09	RAN#65	R5-144203	0073	-	Addition of new TC 10.1B FDD RSTD Measurement Reporting Delay CA for 5+5MHz	11.2.0	12.0.0
2014-09	RAN#65	R5-144204	0074	-	Addition of new TC 10.1C FDD RSTD Measurement Reporting Delay CA for 10+5MHz	11.2.0	12.0.0

Change history							
Date	TSG #	TSG Doc.	CR	Rev	Subject/Comment TS 36.571-1	Old	New
2014-09	RAN#65	R5-144205	0075	-	Addition of new TC 10.2B TDD RSTD Measurement Reporting Delay CA for 5+5MHz	11.2.0	12.0.0
2014-09	RAN#65	R5-144206	0076	-	Addition of new TC 10.2C TDD RSTD Measurement Reporting Delay CA for 10+5MHz	11.2.0	12.0.0
2014-09	RAN#65	R5-144207	0077	-	Addition of new TC 10.3B FDD RSTD Measurement Accuracy CA for 5+5MHz	11.2.0	12.0.0
2014-09	RAN#65	R5-144208	0078	-	Addition of new TC 10.3C FDD RSTD Measurement Accuracy CA for 10+5MHz	11.2.0	12.0.0
2014-09	RAN#65	R5-144209	0079	-	Addition of new TC 10.4B TDD RSTD Measurement Accuracy CA for 5+5MHz	11.2.0	12.0.0
2014-09	RAN#65	R5-144210	0080	-	Addition of new TC 10.4C TDD RSTD Measurement Accuracy CA for 10+5MHz	11.2.0	12.0.0
2014-12	RAN#66	R5-145133	0092	-	Update Galileo ICD reference	12.0.0	12.1.0
2014-12	RAN#66	R5-145211	0093	-	lo value incorrectly calculated	12.0.0	12.1.0
2014-12	RAN#66	R5-145212	0094	-	Editorial Note clarification	12.0.0	12.1.0
2014-12	RAN#66	R5-145213	0095	-	Alignment of Es/Nos value	12.0.0	12.1.0
2014-12	RAN#66	R5-145214	0096	-	Duplicated lo values listed in RSTD tables	12.0.0	12.1.0
2014-12	RAN#66	R5-145215	0097	-	Correction to References in Specification	12.0.0	12.1.0
2014-12	RAN#66	R5-145254	0098	-	LBS Perf: Corrections to measurement gap configuration	12.0.0	12.1.0
2014-12	RAN#66	R5-145490	0099	-	Test Tolerances for TC 8.1.5 E-UTRAN FDD UE Rx-Tx time difference (feICIC)	12.0.0	12.1.0
2014-12	RAN#66	R5-145491	0100	-	Test Tolerances for TC 8.1.6 E-UTRAN TDD UE Rx-Tx time difference (feICIC)	12.0.0	12.1.0
2014-12	RAN#66	R5-145492	0101	-	Uncertainties and Test Tolerances to Annex C for feICIC UE Rx-Tx test cases	12.0.0	12.1.0
2014-12	RAN#66	R5-145502	0102	-	Correction to periodicity of ABS pattern in UE RX-TX time difference for feICIC	12.0.0	12.1.0
2014-12	RAN#66	R5-145503	0103	-	Introduction of BDS testing in Annex C of 37.571	12.0.0	12.1.0
2014-12	RAN#66	R5-145510	0104	-	Correction to Annex E notes and tables	12.0.0	12.1.0
2014-12	RAN#66	R5-145836	0105	-	Changes to RSTD tests to align with RAN 4	12.0.0	12.1.0
2014-12	RAN#66	R5-145843	0106	-	Introduction of feICIC applicability statement for UE Rx-TX Time Difference test cases	12.0.0	12.1.0
2014-12	RAN#66	R5-145864	0107	-	Introduction of content for BDS and UTRA TDD UE in section 1-3 of TS 37.571-1	12.0.0	12.1.0
2014-12	RAN#66	R5-145865	0108	-	Introduction of content for BDS in section 4 in TS 37.571-1	12.0.0	12.1.0
2014-12	RAN#66	R5-145870	0109	-	Corrections to measurement procedures for UTRA A-GPS and A-GNSS tests	12.0.0	12.1.0
2014-12	RAN#66	R5-145871	0110	-	Correction to UE Rx-Tx Time difference tests	12.0.0	12.1.0
2014-12	RAN#66	R5-145920	0111	-	Introduction of test cases for BDS and UTRA TDD UE in section 6 of TS 37.571-1	12.0.0	12.1.0
2014-12	RAN#66	R5-145930	0112	-	Introduction of test cases for BDS in section 7 of TS 37.571-1	12.0.0	12.1.0
2015-03	RAN#67	R5-150051	0113	-	Updates to RSTD values and terminology following changes in RAN 4	12.1.0	12.2.0
2015-03	RAN#67	R5-150074	0114	-	Remove incorrect note from CA RSTD accuracy tests	12.1.0	12.2.0
2015-03	RAN#67	R5-150082	0115	-	Uncertainties and Test Tolerances for RSTD test cases 10.1, 10.1A, 10.1B, 10.1C, 10.2, 10.2A, 10.2B, and 10.2C	12.1.0	12.2.0
2015-03	RAN#67	R5-150085	0116	-	Uncertainties and Test Tolerances for RSTD test cases 10.3B, 10.3C, 10.4B, and 10.4C	12.1.0	12.2.0
2015-03	RAN#67	R5-150107	0117	-	Corrections to table headings in CA RSTD tests	12.1.0	12.2.0
2015-03	RAN#67	R5-150378	0118	-	Very minor corrections to references for feICIC test cases, 8.1.5 and 8.1.6	12.1.0	12.2.0
2015-03	RAN#67	R5-150609	0119	-	Abbreviation Corrections for BDS in 37.571-1	12.1.0	12.2.0
2015-03	RAN#67	R5-150833	0120	-	Addition of BDS ICD reference	12.1.0	12.2.0
2015-03	RAN#67	R5-150834	0121	-	Corrections to BDS Test Requirements for Minimum Performance tests	12.1.0	12.2.0
2015-03	RAN#67	R5-150835	0122	-	The lo Unit Parameter is Incorrect	12.1.0	12.2.0
2015-03	RAN#67	R5-150836	0123	-	Inconsistent Text Referenced	12.1.0	12.2.0
2015-03	RAN#67	R5-150837	0124	-	Missing Abbreviations in Specification	12.1.0	12.2.0
2015-03	RAN#67	R5-150888	0125	-	New TC: TDD RSTD Measurement Accuracy for Carrier Aggregation for 20MHz+10MHz bandwidth	12.1.0	12.2.0
2015-03	RAN#67	R5-150911	0126	-	New TC: TDD RSTD Measurement Reporting Delay for Carrier Aggregation for 20MHz +10MHz Bandwidth	12.1.0	12.2.0
2015-06	RAN#68	R5-151070	0128	-	Delete "FFS" from ECID test conditions	12.2.0	12.3.0
2015-06	RAN#68	R5-151083	0129	-	Uncertainties and Test Tolerances for RSTD test case 10.2D	12.2.0	12.3.0
2015-06	RAN#68	R5-151085	0130	-	Uncertainties and Test Tolerances for RSTD test case 10.4D	12.2.0	12.3.0
2015-06	RAN#68	R5-151086	0131	-	RSTD accuracy changes for Rel-12	12.2.0	12.3.0
2015-06	RAN#68	R5-151088	0132	-	Formatting error in Parameter Sensitivity Coarse Tables	12.2.0	12.3.0
2015-06	RAN#68	R5-151089	0133	-	Incorrect Expected RSTD value in Table 9.2.5.4.1-1	12.2.0	12.3.0
2015-06	RAN#68	R5-151162	0135	-	Correction of the TPR of Absolute GNSS signal level for Dynamic Range	12.2.0	12.3.0

Change history							
Date	TSG #	TSG Doc.	CR	Re v	Subject/Comment TS 36.571-1	Old	New
2015-06	RAN#68	R5-151331	0136	-	Addition of band 32 to 37.571-1	12.2.0	12.3.0
2015-06	RAN#68	R5-151335	0137	-	Corrections to message contents for felCIC TCs in 37.571-1	12.2.0	12.3.0
2015-06	RAN#68	R5-151912	0134	1	LPP responseTime update and correction	12.2.0	12.3.0
2015-06	RAN#68	R5-151913	0138	1	Introduction of new test case 8.1.3 to 37.571-1	12.2.0	12.3.0
2015-06	RAN#68	R5-151914	0139	1	Introduction of new test case 8.1.4 to 37.571-1	12.2.0	12.3.0
2015-06	RAN#68	R5-152014	0127	1	Add TDD to A-GNSS testing	12.2.0	12.3.0
2015-09	RAN#69	R5-153253	0140	-	CA LBS: Clarification of PHICH configuration	12.3.0	12.4.0
2015-09	RAN#69	R5-153661	0144	-	Update of Galileo OS SIS ICD reference	12.3.0	12.4.0
2015-09	RAN#69	R5-153863	0143	1	Update of felCIC Test cases 8.1.5 and 8.1.6	12.3.0	12.4.0
2015-09	RAN#69	R5-153864	0141	1	Update of elCIC Test case 8.1.3	12.3.0	12.4.0
2015-09	RAN#69	R5-153865	0142	1	Update of elCIC Test case 8.1.4	12.3.0	12.4.0

Change history							
Date	TSG #	TSG Doc.	CR	Rev	Subject/Comment TS 36.571-1	Old	New
2015-09	RAN#69	-	-	-	update of the "non-specific references" in section 2 according to the approved R5-153582 and an action point on ETSI MCC	12.3.0	12.4.0
2015-12	RAN#70	R5-155018	0145	-	Uncertainties and Test Tolerances for RSTD Test Cases 10.3A_1 and 10.4A_1	12.4.0	12.5.0
2015-12	RAN#70	R5-155035	0146	-	Incorrect Table Note referenced in LPP Request Table	12.4.0	12.5.0
2015-12	RAN#70	R5-155063	0149	-	Incorrect references in TDD test cases	12.4.0	12.5.0
2015-12	RAN#70	R5-155064	0150	-	Reference [2] has no explanation	12.4.0	12.5.0
2015-12	RAN#70	R5-155065	0151	-	Remove square brackets from RSTD tests	12.4.0	12.5.0
2015-12	RAN#70	R5-155066	0152	-	Incorrect Section number referenced	12.4.0	12.5.0
2015-12	RAN#70	R5-155081	0153	-	Editorial changes to correct Section and Table references	12.4.0	12.5.0
2015-12	RAN#70	R5-155875	0154	1	Two new 3 DL CA RSTD Measurement Reporting Delay test cases	12.4.0	12.5.0
2015-12	RAN#70	R5-156111	0155	1	Two new 3 DL CA RSTD Measurement Accuracy test cases	12.4.0	12.5.0
2016-03	RAN#71	R5-160041	0156	-	Correction to Cells in OTDOA 3DL RSTD Measurement	12.5.0	12.6.0
2016-03	RAN#71	R5-160900	0164	-	Add Cell values in RSTD Table for 3DL RSTD	12.5.0	12.6.0
2016-03	RAN#71	R5-160909	0157	1	Correction of Cell Time offset in RSTD CA	12.5.0	12.6.0
2016-03	RAN#71	R5-161016	0161	1	Add Cell values in OTDOA table for 3DL RSTD Measurement Reporting Delay	12.5.0	12.6.0
2016-03	RAN#71	R5-161053	0158	1	Correction to Trstd values in 3DL RSTD Measurement Accuracy test cases	12.5.0	12.6.0
2016-03	RAN#71	R5-161054	0160	1	Addition of antenna diagram Figure for 3DL CA test cases	12.5.0	12.6.0
2016-06	RAN#72	R5-162114	0165	-	Uncertainties and Test Tolerances for RSTD Test Cases 10.5 and 10.6	12.6.0	12.7.0
2016-06	RAN#72	R5-162116	0166	-	Uncertainties and Test Tolerances for RSTD Test Cases 10.7 and 10.8	12.6.0	12.7.0
2016-06	RAN#72	R5-163116	0167	1	Uncertainties and Test tolerances for TS 37.571-1 Test cases 8.1.3 and 8.1.4	12.6.0	12.7.0
2016-06	RAN#72	R5-162970	0168	1	Add missing LTE FDD TDD bands to E-UTRA Band Groups	12.7.0	13.0.0
2016-06	RAN#72	R5-162971	0169	1	Add missing LTE FDD band to Annex E	12.7.0	13.0.0
2016-09	RAN#73	R5-165350	0179	-	Incorrect FDD Band reference noted for Band 32	13.0.0	13.1.0
2016-09	RAN#73	R5-165360	0181	-	Correct editorial changes in Annex C of 37.571-1	13.0.0	13.1.0
2016-09	RAN#73	R5-166125	0173	1	Updates to the UE Rx – Tx Time Difference tests for Rel-12 onwards	13.0.0	13.1.0
2016-09	RAN#73	R5-166126	0178	1	Add missing references to GPS and Galileo and A-GPS and A-Galileo	13.0.0	13.1.0
2016-09	RAN#73	R5-166127	0180	1	Add Derivation of Test Requirements for test cases 8.1.5 and 8.1.6	13.0.0	13.1.0
2016-09	RAN#73	R5-166168	0182	1	Addition of performance test specification for Indoor Positioning Enhancements (MBS)	13.0.0	13.1.0
2016-09	RAN#73	R5-166179	0171	1	Addition of editor's notes for TDD UE Rx-TX tests	13.0.0	13.1.0
2016-09	RAN#73	R5-166181	0174	1	Unification of Channel BW testing requirements for OTDOA 3 DL CA test cases	13.0.0	13.1.0

Change history							
Date	TSG #	TSG Doc.	CR	Rev	Subject/Comment TS 36.571-1	Old	New
2016-09	RAN#73	R5-166283	0183	-	Change of Reference Channel for 1.4 MHz RSTD tests	13.0.0	13.1.0
2016-12	RAN#74	R5-168060	0185	-	Change references to Reference Channel for RSTD tests	13.1.0	13.2.0
2016-12	RAN#74	R5-168063	0186	-	Change of applicability of UE Rx-Tx tests for TDD	13.1.0	13.2.0
2016-12	RAN#74	R5-168147	0187	-	Corrections for errors in 37.571-1	13.1.0	13.2.0
2016-12	RAN#74	R5-169602	0184	1	Addition of test tolerances to the performance test specification for Indoor Positioning Enhancements (MBS)	13.1.0	13.2.0
2016-12	RAN#74	R5-169611	0190	1	Clarification of MBS beacon code phase delay	13.1.0	13.2.0
2016-12	RAN#74	R5-169663	0188	1	Editorial correction on OTDOA TC10.6	13.1.0	13.2.0
2016-12	RAN#74	R5-168396	0189	-	Band 70 addition to band groups in 37.571-1	13.2.0	14.0.0
2017-01	RAN#74	-	-	-	correction of floating point of R5-169602 in Table 11.4.5-3	14.0.0	14.0.1
2017-03	RAN#75	R5-171304	0195	-	Removal of square brackets in the performance test specification for Indoor Positioning Enhancements (MBS)	14.0.1	14.1.0
2017-03	RAN#75	R5-171902	0191	1	Update TS 37.571-1 with Addition of LTE Band 48	14.0.1	14.1.0
2017-03	RAN#75	R5-171904	0192	1	Clarification on DRX for Single Mode OTDOA Measurement Reporting Delay Test Cases	14.0.1	14.1.0
2017-03	RAN#75	R5-171905	0193	1	Clarification on DRX for 2CC OTDOA Measurement Reporting Delay Test Cases	14.0.1	14.1.0
2017-03	RAN#75	R5-171906	0194	1	Clarification on DRX for 3CC OTDOA Measurement Reporting Delay Test Cases	14.0.1	14.1.0
2017-06	RAN#76	R5-172179	0197	-	Add Minimum Performance Sub-tests for 3 GNSS	14.1.0	14.2.0
2017-06	RAN#76	R5-172623	0198	-	Introduction of periodical reporting capability for GNSS	14.1.0	14.2.0
2017-06	RAN#76	R5-173364	0200	1	Introduction of MBS Assistance Data Measurement Test Cases	14.1.0	14.2.0
2017-06	RAN#76	R5-173414	0201	1	Addition of ACKs in step 5 of test procedures	14.1.0	14.2.0
2017-09	RAN#77	R5-173569	0202	-	Correction of PRS Subframe Offset for TC 10.5 and 10.6	14.2.0	14.3.0
2017-09	RAN#77	R5-173570	0203	-	Correction of SRS-Bandwidth for ECID TC 8.1.3 and 8.1.4	14.2.0	14.3.0
2017-09	RAN#77	R5-173571	0204	-	Correction of SRS-Bandwidth for ECID TC 8.1.5 and 8.1.6	14.2.0	14.3.0
2017-09	RAN#77	R5-173572	0205	-	Correction of message contents for ECID (Editorial Change)	14.2.0	14.3.0
2017-09	RAN#77	R5-173576	0209	-	WLAN and BLE Annex D updates (Editorial Change)	14.2.0	14.3.0
2017-09	RAN#77	R5-173863	0214	-	Editorial change to clarify the MBS test cases applicability	14.2.0	14.3.0
2017-09	RAN#77	R5-174053	0215	-	Update Statement Concerning Test System Uncertainties for Operating Bands Above 3 GHz	14.2.0	14.3.0
2017-09	RAN#77	R5-175116	0206	1	New Abbreviations and References for WLAN and BLE (Editorial Change)	14.2.0	14.3.0
2017-09	RAN#77	R5-175117	0207	1	WLAN test conditions	14.2.0	14.3.0
2017-09	RAN#77	R5-175118	0208	1	WLAN and BLE Connection Diagrams	14.2.0	14.3.0
2017-09	RAN#77	R5-175119	0212	1	BLE test conditions	14.2.0	14.3.0
2017-09	RAN#77	R5-175186	0210	1	New WLAN AP Identification in Nominal Accuracy Test	14.2.0	14.3.0
2017-09	RAN#77	R5-175187	0211	1	New WLAN AP Identification in Dynamic Range Test	14.2.0	14.3.0
2017-09	RAN#77	R5-175188	0213	1	New BLE Reporting Test	14.2.0	14.3.0

Change history							
Date	TSG #	TSG Doc.	CR	Rev	Subject/Comment TS 36.571-1	Old	New
2017-12	RAN#78	R5-176110	0219	-	Add 4Rx support for OTDOA/ECID tests – Tests	14.3.0	14.4.0
2017-12	RAN#78	R5-176111	0220	-	Add 4Rx support for OTDOA/ECID tests – Connection Diagrams	14.3.0	14.4.0
2017-12	RAN#78	R5-177118	0222	1	Adapt LTE A-GNSS test cases for BL/CE devices	14.3.0	14.4.0
2017-12	RAN#78	R5-177411	0216	1	Complete WLAN and BLE test cases	14.3.0	14.4.0
2017-12	RAN#78	R5-177413	0217	1	Editorial - Alignment of 2CC 5MHz OTDOA Nprs with core spec	14.3.0	14.4.0
2017-12	RAN#78	R5-177414	0218	1	Add 4Rx support for OTDOA/ECID tests – Common Sections	14.3.0	14.4.0
2017-12	RAN#78	R5-177415	0221	1	Add release information for sub-tests of test case 7.5.	14.3.0	14.4.0
2017-12	RAN#78	R5-176791	0223	-	Band 72 addition to band groups in 37.571-1	14.4.0	15.0.0
2017-12	RAN#78	R5-176816	0224	-	Band 71 addition to band groups in 37.571-1	14.4.0	15.0.0
2018-03	RAN#79	R5-180295	0228	-	New OTDOA Cat1bis TC 9.1.3A and 9.1.4A	15.0.0	15.1.0
2018-03	RAN#79	R5-180296	0229	-	New OTDOA Cat1bis TC 9.2.4A and 9.2.5A	15.0.0	15.1.0
2018-03	RAN#79	R5-180297	0230	-	Annex C OTDOA Cat1bis tests	15.0.0	15.1.0
2018-03	RAN#79	R5-180298	0231	-	UE Category M1/M2 General Sections for OTDOA	15.0.0	15.1.0
2018-03	RAN#79	R5-180299	0232	-	New OTDOA Cat M1/M2 reporting delay normal mode tests	15.0.0	15.1.0
2018-03	RAN#79	R5-180300	0233	-	New OTDOA Cat M1/M2 reporting delay enhanced mode tests	15.0.0	15.1.0
2018-03	RAN#79	R5-180301	0234	-	New OTDOA Cat M1/M2 reporting accuracy normal mode tests	15.0.0	15.1.0
2018-03	RAN#79	R5-180303	0236	-	New OTDOA Cat M1/M2 inter-freq reporting delay normal mode tests	15.0.0	15.1.0
2018-03	RAN#79	R5-180304	0237	-	New OTDOA Cat M1/M2 inter-freq reporting delay enhanced mode tests	15.0.0	15.1.0
2018-03	RAN#79	R5-180307	0240	-	New ECID Cat M1/M2 tests	15.0.0	15.1.0
2018-03	RAN#79	R5-180308	0241	-	Annex C OTDOA and ECID Cat M1/M2	15.0.0	15.1.0
2018-03	RAN#79	R5-180311	0244	-	NB-IOT Annex E	15.0.0	15.1.0
2018-03	RAN#79	R5-180325	0245	-	Band 68 addition to band groups in 37.571-1	15.0.0	15.1.0
2018-03	RAN#79	R5-180352	0246	-	[Editorial] Correct normative reference for minimum conformance requirements	15.0.0	15.1.0
2018-03	RAN#79	R5-180583	0247	-	feMTC Annex E	15.0.0	15.1.0
2018-03	RAN#79	R5-180584	0248	-	4Rx support for OTDOA 2CC	15.0.0	15.1.0
2018-03	RAN#79	R5-180585	0249	-	4Rx support for OTDOA 3CC	15.0.0	15.1.0
2018-03	RAN#79	R5-181360	0250	2	WLAN core specification updates	15.0.0	15.1.0
2018-03	RAN#79	R5-181584	0235	1	New OTDOA Cat M1/M2 reporting accuracy enhanced mode tests	15.0.0	15.1.0
2018-03	RAN#79	R5-181585	0238	1	New OTDOA Cat M1/M2 inter-freq reporting accuracy normal mode tests	15.0.0	15.1.0
2018-03	RAN#79	R5-181586	0239	1	New OTDOA Cat M1/M2 inter-freq reporting accuracy enhanced mode tests	15.0.0	15.1.0
2018-03	RAN#79	R5-181599	0226	1	New OTDOA Cat1bis TC 9.1.1A and 9.1.2A	15.0.0	15.1.0
2018-03	RAN#79	R5-181600	0227	1	New OTDOA Cat1bis TC 9.2.1A and 9.2.2A	15.0.0	15.1.0
2018-03	RAN#79	R5-181605	0242	1	NB-IOT General Sections	15.0.0	15.1.0



Change history							
Date	TSG #	TSG Doc.	CR	Re v	Subject/Comment TS 36.571-1	Old	New
2018-03	RAN#79	R5-181606	0243	1	NB-IOT OTDOA Test Cases	15.0.0	15.1.0
2018-03	RAN#79	R5-181613	0251	1	Addition of the Band 74 information into TS 37.571-1	15.0.0	15.1.0
2018-06	RAN#80	R5-182218	0256	-	Common clauses updates for new NB-IOT OTDOA tests	15.1.0	15.2.0
2018-06	RAN#80	R5-182219	0257	-	Annex C updates for NB-IOT OTDOA	15.1.0	15.2.0
2018-06	RAN#80	R5-182279	0258	-	New ECID Cat1bis tests	15.1.0	15.2.0
2018-06	RAN#80	R5-182280	0259	-	New ECID Cat1bis tests - Annexes	15.1.0	15.2.0
2018-06	RAN#80	R5-182382	0261	-	Corrections to WLAN dynamic range test case	15.1.0	15.2.0
2018-06	RAN#80	R5-182384	0263	-	Corrections to maximum response time for WLAN test cases	15.1.0	15.2.0
2018-06	RAN#80	R5-183252	0252	1	Completion of OTDOA NB-IOT TC 9.5.1 and 9.5.2	15.1.0	15.2.0
2018-06	RAN#80	R5-183253	0253	1	Completion of OTDOA NB-IOT TC 9.6.1 and 9.6.2	15.1.0	15.2.0
2018-06	RAN#80	R5-183261	0264	1	Clarifications for RSSI reporting in WLAN and BLE test cases	15.1.0	15.2.0
2018-06	RAN#80	R5-183844	0254	1	New OTDOA NB-IOT TC 9.5.3	15.1.0	15.2.0
2018-06	RAN#80	R5-183845	0255	1	New OTDOA NB-IOT TC 9.6.3	15.1.0	15.2.0
2018-06	RAN#80	R5-183847	0260	1	Removing editor note from A-GNSS min perf test cases for Cat M1	15.1.0	15.2.0
2018-06	RAN#80	R5-183848	0262	1	Clarifications and additions to EUTRAN, WLAN and BLE test frequencies and bandwidths	15.1.0	15.2.0
2018-06	RAN#80	R5-183849	0265	1	Corrections to WLAN and BLE applicabilities	15.1.0	15.2.0

---

# History

<b>Document history</b>		
V15.2.0	July 2018	Publication