

ETSI TS 137 145-1 V15.2.0 (2019-04)



**Universal Mobile Telecommunications System (UMTS);
LTE;
Active Antenna System (AAS) Base Station (BS)
conformance testing;
Part 1: conducted conformance testing
(3GPP TS 37.145-1 version 15.2.0 Release 15)**



ReferenceRTS/TSGR-0437145-1v120

KeywordsLTE,UMTS

ETSI

650 Route des Lucioles
F-06921 Sophia Antipolis Cedex - FRANCE

Tel.: +33 4 92 94 42 00 Fax: +33 4 93 65 47 16

Siret N° 348 623 562 00017 - NAF 742 C
Association à but non lucratif enregistrée à la
Sous-Préfecture de Grasse (06) N° 7803/88

Important notice

The present document can be downloaded from:

<http://www.etsi.org/standards-search>

The present document may be made available in electronic versions and/or in print. The content of any electronic and/or print versions of the present document shall not be modified without the prior written authorization of ETSI. In case of any existing or perceived difference in contents between such versions and/or in print, the prevailing version of an ETSI deliverable is the one made publicly available in PDF format at www.etsi.org/deliver.

Users of the present document should be aware that the document may be subject to revision or change of status.

Information on the current status of this and other ETSI documents is available at

<https://portal.etsi.org/TB/ETSIDeliverableStatus.aspx>

If you find errors in the present document, please send your comment to one of the following services:

<https://portal.etsi.org/People/CommiteeSupportStaff.aspx>

Copyright Notification

No part may be reproduced or utilized in any form or by any means, electronic or mechanical, including photocopying and microfilm except as authorized by written permission of ETSI.

The content of the PDF version shall not be modified without the written authorization of ETSI.

The copyright and the foregoing restriction extend to reproduction in all media.

© ETSI 2019.

All rights reserved.

DECT™, **PLUGTESTS™**, **UMTS™** and the ETSI logo are trademarks of ETSI registered for the benefit of its Members.

3GPP™ and **LTE™** are trademarks of ETSI registered for the benefit of its Members and of the 3GPP Organizational Partners.

oneM2M™ logo is a trademark of ETSI registered for the benefit of its Members and of the oneM2M Partners.

GSM® and the GSM logo are trademarks registered and owned by the GSM Association.

Intellectual Property Rights

Essential patents

IPRs essential or potentially essential to normative deliverables may have been declared to ETSI. The information pertaining to these essential IPRs, if any, is publicly available for **ETSI members and non-members**, and can be found in ETSI SR 000 314: *"Intellectual Property Rights (IPRs); Essential, or potentially Essential, IPRs notified to ETSI in respect of ETSI standards"*, which is available from the ETSI Secretariat. Latest updates are available on the ETSI Web server (<https://ipr.etsi.org/>).

Pursuant to the ETSI IPR Policy, no investigation, including IPR searches, has been carried out by ETSI. No guarantee can be given as to the existence of other IPRs not referenced in ETSI SR 000 314 (or the updates on the ETSI Web server) which are, or may be, or may become, essential to the present document.

Trademarks

The present document may include trademarks and/or tradenames which are asserted and/or registered by their owners. ETSI claims no ownership of these except for any which are indicated as being the property of ETSI, and conveys no right to use or reproduce any trademark and/or tradename. Mention of those trademarks in the present document does not constitute an endorsement by ETSI of products, services or organizations associated with those trademarks.

Foreword

This Technical Specification (TS) has been produced by ETSI 3rd Generation Partnership Project (3GPP).

The present document may refer to technical specifications or reports using their 3GPP identities, UMTS identities or GSM identities. These should be interpreted as being references to the corresponding ETSI deliverables.

The cross reference between GSM, UMTS, 3GPP and ETSI identities can be found under <http://webapp.etsi.org/key/queryform.asp>.

Modal verbs terminology

In the present document "**shall**", "**shall not**", "**should**", "**should not**", "**may**", "**need not**", "**will**", "**will not**", "**can**" and "**cannot**" are to be interpreted as described in clause 3.2 of the [ETSI Drafting Rules](#) (Verbal forms for the expression of provisions).

"**must**" and "**must not**" are **NOT** allowed in ETSI deliverables except when used in direct citation.

Contents

Intellectual Property Rights	2
Foreword.....	2
Modal verbs terminology.....	2
Foreword.....	12
1 Scope	13
2 References	13
3 Definitions, symbols and abbreviations	15
3.1 Definitions	15
3.2 Symbols.....	18
3.3 Abbreviations	21
4 General test conditions and declarations	22
4.1 Measurement uncertainties and test requirements	22
4.1.1 General.....	22
4.1.2 Acceptable uncertainty of Test System.....	23
4.1.2.1 General	23
4.1.2.2 Measurement of transmitter	24
4.1.2.3 Measurement of receiver	25
4.1.3 Interpretation of measurement results	27
4.2 Conducted and radiated requirement reference points	28
4.3 Base station classes for AAS BS	28
4.4 Regional requirements.....	29
4.5 Operating bands and band categories	29
4.6 Channel arrangements	30
4.7 Requirements for AAS BS capable of multi-band operation	30
4.8 AAS BS configurations	31
4.8.1 Transmit configurations	31
4.8.2 Receive configurations	31
4.8.3 Power supply options.....	32
4.8.4 BS with integrated Iuant BS modem	32
4.9 Capability sets	32
4.10 Manufacturer declarations for AAS BS testing.....	32
4.11 Test signal configurations for AAS BS	37
4.11.1 General.....	37
4.11.1a NR Test signal used to build Test Configurations	37
4.11.2 Test signal configurations.....	37
4.11.2.1 ATC1: UTRA multicarrier operation	37
4.11.2.1.1 General	37
4.11.2.1.2 ATC1a generation	37
4.11.2.1.3 ATC1b generation	38
4.11.2.1.4 ATC1 power allocation	38
4.11.2.2 ANTC1: UTRA FDD multicarrier non-contiguous operation	38
4.11.2.2.1 General	38
4.11.2.2.2 ANTC1 generation	38
4.11.2.2.3 ANTC1 power allocation.....	38
4.11.2.3 ATC2: E-UTRA multicarrier operation	39
4.11.2.3.1 General	39
4.11.2.3.2 ATC2a generation	39
4.11.2.3.3 ATC2b generation	39
4.11.2.3.4 ATC2 power allocation	40
4.11.2.4 ANTC2: E-UTRA multicarrier non-contiguous operation.....	40
4.11.2.4.1 General	40
4.11.2.4.2 ANTC2 generation	40
4.11.2.4.3 ANTC2 power allocation.....	40
4.11.2.5 ATC3: UTRA and E-UTRA multi RAT operation	40

4.11.2.5.1	General	40
4.11.2.5.2	ATC3a generation	41
4.11.2.5.3	ATC3b generation	41
4.11.2.5.4	ATC3 power allocation	41
4.11.2.6	ANTC3: UTRA and E-UTRA multi RAT non-contiguous operation.....	41
4.11.2.6.1	General	41
4.11.2.6.2	ANTC3a generation.....	41
4.11.2.6.3	ANTC3 power allocation.....	42
4.11.2.7	ATC4: Single carrier for receiver tests.....	42
4.11.2.7.1	ATC4a generation	42
4.11.2.7.2	ATC4b generation	42
4.11.2.7.3	ATC4c generation	42
4.11.2.7.4	ATC4d generation	42
4.11.2.8	Generation of MB-MSR test configurations	43
4.11.2.8.1	ATC5a: MB-MSR test configuration for full carrier allocation	43
4.11.2.8.2	ATC5b: MB-MSR test configuration with high PSD per carrier	44
4.11.2.9	ATC6: E-UTRA and NR multi RAT operation	44
4.11.2.9.1	General	44
4.11.2.9.2	ATC6 generation	45
4.11.2.9.3	ATC6 power allocation	45
4.11.2.10	ANTC6: E-UTRA and NR multi RAT non-contiguous operation.....	45
4.11.2.10.1	General	45
4.11.2.10.2	ANTC6 generation	45
4.11.2.10.3	ANTC6 power allocation.....	46
4.11.2.11	ATC7: NR multicarrier operation	46
4.11.2.11.1	General	46
4.11.2.11.2	ATC7 generation	46
4.11.2.11.3	ATC7 power allocation	46
4.11.2.12	ANTC7: NR multicarrier non-contiguous operation.....	46
4.11.2.12.1	General	46
4.11.2.12.2	ANTC7 generation	46
4.11.2.12.3	ANTC7 power allocation.....	47
4.12	RF channels and test models	47
4.12.1	RF channels	47
4.12.2	Test models.....	48
4.13	Format and interpretation of tests.....	49
5	Applicability of Requirements	50
5.1	General	50
5.2	Test configurations for TAB connectors for operating bands where MSR is supported	51
5.3	Test configurations for multi-carrier capable TAB connector(s) in operating bands where one RAT capability sets are supported.....	55
5.3.1	General.....	55
5.3.2	TAB connector supporting one RAT only MSR in the operating band.....	55
5.3.3	TAB connector supporting Single-RAT UTRA in the operating band.....	59
5.3.4	TAB connector supporting Single-RAT E-UTRA in the operating band	60
5.4	Test configurations for <i>Multi-band TAB connectors</i>	62
5.4.1	Multi-band TAB connector supporting MSR operation	62
5.4.2	Multi-band TAB connector supporting Single-RAT only	63
6	Conducted transmitter characteristics	64
6.1	General	64
6.2	Base station output power	65
6.2.1	General.....	65
6.2.2	Maximum output power.....	65
6.2.2.1	Definition and applicability.....	65
6.2.2.2	Minimum Requirement	65
6.2.2.3	Test Purpose	66
6.2.2.4	Method of test	66
6.2.2.4.1	Initial conditions	66
6.2.2.4.2	Procedure.....	66
6.2.2.5	Test Requirements.....	66

6.2.3	UTRA FDD primary CPICH power	67
6.2.3.1	Definition and applicability.....	67
6.2.3.2	Minimum requirement	67
6.2.3.3	Test purpose	67
6.2.3.4	Method of test	67
6.2.3.4.1	Initial conditions.....	67
6.2.3.4.2	Procedure.....	67
6.2.3.5	Test requirements.....	68
6.2.4	UTRA TDD primary CCPCH power.....	68
6.2.4.1	Definition and applicability.....	68
6.2.4.2	Minimum requirement	68
6.2.4.3	Test purpose	68
6.2.4.4	Method of test	68
6.2.4.4.1	Initial conditions.....	68
6.2.4.4.2	Procedure.....	69
6.2.4.5	Test requirements.....	69
6.2.5	UTRA FDD additional CPICH power for MIMO mode	70
6.2.5.1	Definition and applicability.....	70
6.2.5.2	Minimum requirement	70
6.2.5.3	Test purpose	71
6.2.5.4	Method of test	71
6.2.5.4.1	Initial conditions.....	71
6.2.5.4.2	Procedure.....	71
6.2.5.5	Test requirements.....	71
6.2.6	E-UTRA DL RS power.....	72
6.2.6.1	Definition and applicability.....	72
6.2.6.2	Minimum requirement	72
6.2.6.3	Test purpose	72
6.2.6.4	Method of test	72
6.2.6.4.1	Initial conditions.....	72
6.2.6.4.2	Procedure.....	73
6.2.6.5	Test requirements.....	73
6.3	Output power dynamics.....	73
6.3.1	General.....	73
6.3.2	UTRA Inner loop power control in the downlink.....	73
6.3.2.1	Definition and applicability.....	73
6.3.2.2	Minimum requirement	73
6.3.2.3	Test purpose	73
6.3.2.4	Method of test	74
6.3.2.4.1	Initial conditions.....	74
6.3.2.4.2	Procedure.....	74
6.3.2.5	Test requirements.....	75
6.3.2.5.1	UTRA FDD	75
6.3.2.5.2	UTRA TDD	76
6.3.3	Power control dynamic range	76
6.3.3.1	Definition and applicability.....	76
6.3.3.2	Minimum requirement	76
6.3.3.3	Test purpose	76
6.3.3.4	Method of test	77
6.3.3.4.1	Initial conditions.....	77
6.3.3.4.2	Procedure.....	77
6.3.3.5	Test requirements.....	78
6.3.3.5.1	UTRA FDD	78
6.3.3.5.2	UTRA TDD	78
6.3.4	Total power dynamic range	79
6.3.4.1	Definition and applicability.....	79
6.3.4.2	Minimum requirement	79
6.3.4.3	Test purpose	79
6.3.4.4	Method of test	79
6.3.4.4.1	Initial conditions.....	79
6.3.4.4.2	Procedure.....	80
6.3.4.5	Test requirements.....	81

6.3.4.5.1	UTRA FDD	81
6.3.4.5.2	E-UTRA	81
6.3.4.5.3	NR	81
6.3.5	IPDL time mask	82
6.3.5.1	Definition and applicability.....	82
6.3.5.2	Minimum requirement	82
6.3.5.3	Test purpose	82
6.3.5.4	Method of test	82
6.3.5.4.1	Initial conditions	82
6.3.5.4.2	Procedure.....	82
6.3.5.5	Test requirements	83
6.3.6	RE Power control dynamic range	83
6.3.6.1	Definition and applicability.....	83
6.3.6.2	Minimum requirement	83
6.3.6.3	Method of test	83
6.4	Transmit ON/OFF power	83
6.4.1	General.....	83
6.4.2	Transmitter OFF power	84
6.4.2.1	Definition and applicability.....	84
6.4.2.2	Minimum requirement	84
6.4.2.3	Test purpose	84
6.4.2.4	Method of test	84
6.4.2.4.1	Initial conditions	84
6.4.2.4.2	Procedure.....	84
6.4.2.5	Test requirements	85
6.4.3	Transmitter transient period.....	85
6.4.3.1	Definition and applicability.....	85
6.4.3.2	Minimum requirement	85
6.4.3.3	Test purpose	86
6.4.3.4	Method of test	86
6.4.3.4.1	Initial conditions	86
6.4.3.4.2	Procedure.....	86
6.4.3.5	Test requirements	87
6.4.3.5.1	MSR operation	87
6.4.3.5.1	UTRA TDD operation.....	88
6.4.3.5.1	E-UTRA operation	88
6.5	Transmitted signal quality	88
6.5.1	General.....	88
6.5.2	Frequency Error	88
6.5.2.1	Definition and applicability.....	88
6.5.2.2	Minimum Requirement	88
6.5.2.3	Test purpose	88
6.5.2.4	Method of test	88
6.5.2.5	Test Requirements.....	89
6.5.2.5.1	UTRA FDD test requirement	89
6.5.2.5.2	UTRA TDD test requirement	89
6.5.2.5.3	E-UTRA and NR test requirement	89
6.5.3	Time alignment error	89
6.5.3.1	Definition and applicability.....	89
6.5.3.2	Minimum requirement	90
6.5.3.3	Test purpose	90
6.5.3.4	Method of test	90
6.5.3.4.1	Initial conditions	90
6.5.3.4.2	Procedure.....	90
6.5.3.5	Test requirement	92
6.5.3.5.1	UTRA FDD test requirement	92
6.5.3.5.2	UTRA TDD test requirement	92
6.5.3.5.3	E-UTRA test requirement.....	92
6.5.3.5.4	NR test requirement.....	92
6.5.4	Modulation quality.....	92
6.5.4.1	Definition and applicability.....	92
6.5.4.2	Minimum Requirement	93

6.5.4.3	Test purpose	93
6.5.4.4	UTRA FDD Method of test.....	93
6.5.4.4.1	Initial conditions	93
6.5.4.4.2	Procedure.....	93
6.5.4.5	UTRA TDD Method of test	94
6.5.4.5.1	Initial conditions.....	94
6.5.4.5.2	Procedure.....	95
6.5.4.6	E-UTRA and NR Method of test.....	97
6.5.4.6.1	Initial conditions	97
6.5.4.6.2	Procedure.....	97
6.5.4.7	Test Requirements.....	97
6.5.4.7.1	UTRA FDD test requirement	97
6.5.4.7.2	UTRA TDD test requirement	98
6.5.4.7.3	E-UTRA and NR test requirement	98
6.6	Unwanted Emissions	99
6.6.1	General.....	99
6.6.2	Occupied bandwidth	99
6.6.2.1	Definition and applicability.....	99
6.6.2.2	Minimum requirement	99
6.6.2.3	Test purpose	100
6.6.2.4	Method of test	100
6.6.2.4.1	Initial conditions	100
6.6.2.4.2	Procedure.....	100
6.6.2.5	Test requirements	102
6.6.2.5.1	MSR	102
6.6.2.5.2	UTRA FDD	103
6.6.2.5.3	UTRA TDD.....	103
6.6.2.5.4	E-UTRA	103
6.6.3	Adjacent Channel Leakage power Ratio.....	103
6.6.3.1	Definition and applicability.....	103
6.6.3.2	Minimum requirement	103
6.6.3.3	Test purpose	104
6.6.3.4	Method of test	104
6.6.3.4.1	Initial conditions	104
6.6.3.4.2	Procedure.....	105
6.6.3.5	Test requirements	107
6.6.3.5.1	General Requirements	107
6.6.3.5.2	Absolute Limits	107
6.6.3.5.3	MSR	108
6.6.3.5.4	UTRA FDD	113
6.6.3.5.5	UTRA TDD, 1,28Mcps option	114
6.6.3.5.6	E-UTRA	114
6.6.4	Spectrum emission mask	117
6.6.4.1	Definition and applicability.....	117
6.6.4.2	Minimum requirement	117
6.6.4.3	Test purpose	117
6.6.4.4	Method of test	117
6.6.4.4.1	Initial conditions	117
6.6.4.4.2	Procedure.....	118
6.6.4.5	Test requirements	119
6.6.4.5.1	General	119
6.6.4.5.2	Basic Limits.....	120
6.6.5	Operating band unwanted emission	131
6.6.5.1	Definition and applicability.....	131
6.6.5.2	Minimum requirement	131
6.6.5.3	Test purpose	131
6.6.5.4	Method of test	131
6.6.5.4.1	Initial conditions	131
6.6.5.4.2	Procedure.....	132
6.6.5.5	Test requirements	132
6.6.5.5.1	General	132
6.6.5.5.2	Basic Limits for MSR Band Categories 1 and 3.....	133

6.6.5.5.3	Basic Limits for MSR Band Category 2.....	141
6.6.5.5.4	Basic Limits for MSR Additional requirements.....	148
6.6.5.5.5	Basic Limits for E-UTRA.....	150
6.6.6	Spurious emission.....	172
6.6.6.1	Definition and applicability.....	172
6.6.6.2	Minimum requirement.....	173
6.6.6.3	Test purpose.....	173
6.6.6.4	Method of test.....	173
6.6.6.4.1	Initial conditions.....	173
6.6.6.4.2	Procedure.....	174
6.6.6.5	Test requirements.....	174
6.6.6.5.1	General.....	174
6.6.6.5.2	Basic limits.....	175
6.7	Transmitter intermodulation.....	195
6.7.1	Definition and applicability.....	195
6.7.1.1	General.....	195
6.7.2	Minimum requirement.....	196
6.7.3	Test purpose.....	196
6.7.4	Method of test.....	196
6.7.4.1	Initial conditions.....	196
6.7.4.2	Procedure.....	196
6.7.5	Test requirements.....	199
6.7.5.1	MSR test requirements.....	199
6.7.5.1.1	General test requirement.....	199
6.7.5.1.2	Additional test requirement (BC1 and BC2).....	199
6.7.5.1.3	Additional test requirement (BC3).....	200
6.7.5.1.4	Intra-system test requirement.....	200
6.7.5.2	Single RAT UTRA operation.....	200
6.7.5.2.1	General test requirement for UTRA FDD.....	200
6.7.5.2.2	General test requirement for UTRA TDD.....	200
6.7.5.2.3	Intra-system test requirement.....	201
6.7.5.4	Single RAT E-UTRA operation.....	201
6.7.5.4.1	General test requirement.....	201
6.7.5.4.2	Additional test requirement for Band 41.....	201
6.7.5.4.3	Intra-system test requirement.....	201
7	Conducted receiver characteristics.....	201
7.1	General.....	201
7.2	Reference sensitivity level.....	202
7.2.1	Definition and applicability.....	202
7.2.2	Minimum Requirement.....	202
7.2.3	Test Purpose.....	203
7.2.4	Method of test.....	203
7.2.4.1	Initial conditions.....	203
7.2.4.2	Procedure.....	203
7.2.5	Test Requirements.....	204
7.2.5.1	UTRA FDD operation.....	204
7.2.5.2	UTRA TDD 1,28 Mcps option operation.....	204
7.2.5.3	E-UTRA operation.....	204
7.2.5.4	NR operation.....	205
7.3	Dynamic range.....	207
7.3.1	Definition and applicability.....	207
7.3.2	Minimum requirement.....	207
7.3.3	Test purpose.....	208
7.3.4	Method of test.....	208
7.3.4.1	Initial conditions.....	208
7.3.4.2	Procedure.....	208
7.3.5	Test requirements.....	209
7.3.5.1	UTRA FDD operation.....	209
7.3.5.2	UTRA TDD 1,28 Mcps option operation.....	209
7.3.5.3	E-UTRA operation.....	209
7.3.5.4	NR operation.....	211

7.4	Adjacent channel selectivity and narrowband blocking	213
7.4.1	Definition and applicability	213
7.4.2	Minimum requirement	214
7.4.4	Method of test	214
7.4.4.1	Initial conditions	214
7.4.4.2	Procedure	214
7.4.4.2.1	General procedure	214
7.4.4.2.2	MSR operation	215
7.4.4.2.3	Single RAT UTRA FDD operation	215
7.4.4.2.4	Single RAT UTRA TDD 1,28Mcps option operation	216
7.4.4.2.5	Single RAT E-UTRA operation	216
7.4.5	Test requirements	217
7.4.5.1	MSR operation	217
7.4.5.1.1	General blocking test requirement	217
7.4.5.1.2	General narrowband blocking test requirement	218
7.4.5.1.3	Additional BC3 blocking test requirement	219
7.4.5.2	Single RAT UTRA FDD operation	219
7.4.5.3	Single RAT UTRA TDD 1,28 Mcps option operation	220
7.4.5.4	Single RAT E-UTRA operation	220
7.5	Blocking	223
7.5.1	Definition and applicability	223
7.5.2	Minimum requirement	223
7.5.3	Test purpose	223
7.5.4	Method of test	223
7.5.4.1	Initial conditions	223
7.5.4.2	Procedure	224
7.5.4.2.1	General Procedure	224
7.5.4.2.2	MSR operation	224
7.5.4.2.3	Single RAT UTRA FDD operation	224
7.5.4.2.4	Single RAT UTRA TDD 1,28 Mcps option operation	225
7.5.4.2.5	Single RAT E-UTRA operation	225
7.5.5	Test requirements	226
7.5.5.1	MSR operation	226
7.5.5.1.1	General out-of-band blocking test requirements	226
7.5.5.1.2	Co-location test requirements	226
7.5.5.2	Single RAT UTRA FDD operation	231
7.5.5.3	Single RAT UTRA TDD 1,28 Mcps option operation	246
7.5.5.3.1	General requirements	246
7.5.5.3.2	Co-location with GSM, DCS, UTRA FDD and/or E-UTRA FDD, UTRA TDD and/or E-UTRA TDD	250
7.5.5.4	Single RAT E-UTRA operation	254
7.5.5.4.1	General test requirement	254
7.5.5.4.2	Co-location with other base stations	258
7.6	Receiver spurious emissions	262
7.6.1	Definition and applicability	262
7.6.2	Minimum Requirement	263
7.6.3	Test Purpose	263
7.6.4	Method of test	263
7.6.4.1	Initial conditions	263
7.6.4.2	Procedure	263
7.6.4.2.1	General procedure	263
7.6.4.2.2	MSR operation	263
7.6.4.2.3	Single RAT UTRA FDD operation	264
7.6.4.2.4	Single RAT UTRA TDD 1,28Mcps option operation	264
7.6.4.2.5	Single RAT E-UTRA operation	265
7.6.5	Test Requirements	265
7.6.5.1	General	265
7.6.5.2	Basic limits	266
7.6.5.2.1	MSR operation	266
7.6.5.2.2	Single RAT UTRA FDD operation	266
7.6.5.2.3	Single RAT UTRA TDD 1,28Mcps option operation	267
7.6.5.2.4	Single RAT E-UTRA operation	267

7.7	Receiver intermodulation	268
7.7.1	Definition and applicability	268
7.7.2	Minimum requirement	268
7.7.3	Test purpose.....	268
7.7.4	Method of test	268
7.7.4.1	Initial conditions	268
7.7.4.2	Procedure	269
7.7.4.2.1	General procedure	269
7.7.4.2.2	MSR operation	269
7.7.4.2.3	Single RAT UTRA FDD operation.....	269
7.7.4.2.4	Single RAT UTRA TDD 1,28Mcps option operation.....	270
7.7.4.2.5	Single RAT E-UTRA operation	270
7.7.5	Test requirements.....	270
7.7.5.1	MSR operation	270
7.7.5.1.1	General intermodulation test requirement	270
7.7.5.1.2	General narrowband intermodulation test requirement	272
7.7.5.2	Single RAT UTRA FDD operation.....	274
7.7.5.3	Single RAT UTRA TDD 1,28Mcps option operation.....	274
7.7.5.4	Single RAT E-UTRA operation.....	275
7.8	In-channel selectivity	278
7.8.1	Definition and applicability	278
7.8.2	Minimum requirement	278
7.8.3	Test purpose.....	278
7.8.4	Method of test	278
7.8.4.1	Initial conditions	278
7.8.4.2	Procedure	279
7.8.5	Test requirements.....	279
8	Performance requirements.....	282
8.1	General	282
8.2	Performance requirements MSR	282
8.3	Performance requirements UTRA FDD	283
8.3.1	Definition and applicability	283
8.3.2	Minimum Requirement.....	284
8.3.3	Test purpose.....	284
8.3.4	Method of test	284
8.3.4.1	Initial Conditions.....	284
8.3.4.2	Procedure	284
8.3.5	Test Requirement.....	284
8.4	Performance requirements UTRA TDD.....	285
8.4.1	Definition and applicability	285
8.4.2	Minimum Requirement.....	285
8.4.3	Test purpose.....	285
8.4.4	Method of test	285
8.4.4.1	Initial Conditions.....	285
8.4.4.2	Procedure	286
8.4.5	Test Requirement.....	286
8.5	Performance requirements E-UTRA	286
8.5.1	Definition and applicability	286
8.5.2	Minimum Requirement.....	287
8.5.3	Test purpose.....	287
8.5.4	Method of test	287
8.5.4.1	Initial Conditions.....	287
8.5.4.2	Procedure	287
8.5.5	Test Requirement.....	287
8.6	Performance requirements NR	287
Annex A (normative):	Characteristics of interfering signals	288
Annex B (normative):	Environmental requirements for the BS equipment	289
B.1	General	289

B.2	Normal test environment	289
B.3	Extreme test environment.....	289
B.3.1	General	289
B.3.2	Extreme temperature	289
B.4	Vibration.....	290
B.5	Power supply	290
B.6	Measurement of test environments.....	290
Annex C (informative): Test tolerances and derivation of test requirements.....		291
Annex D (informative): Measurement system set-up		292
D.1	Transmitter	292
D.1.1	AAS BS output power, transmitter ON/OFF power, modulation quality, frequency error and operating band unwanted emissions	292
D.1.2	Transmitter intermodulation.....	293
D.1.3	Transmitter spurious emissions	293
D.2	Receiver.....	295
D.2.1	Reference sensitivity level.....	295
D.2.2	Receiver Dynamic Range.....	295
D.2.3	Receiver Adjacent channel selectivity and narrowband blocking	296
D.2.4	Receiver spurious emissions.....	296
D.2.5	Receiver In-channel selectivity	297
D.2.6	Receiver Intermodulation	298
Annex E (informative): Change history		299
History		302

Foreword

This Technical Specification has been produced by the 3rd Generation Partnership Project (3GPP).

The contents of the present document are subject to continuing work within the TSG and may change following formal TSG approval. Should the TSG modify the contents of the present document, it will be re-released by the TSG with an identifying change of release date and an increase in version number as follows:

Version x.y.z

where:

- x the first digit:
 - 1 presented to TSG for information;
 - 2 presented to TSG for approval;
 - 3 or greater indicates TSG approved document under change control.
- y the second digit is incremented for all changes of substance, i.e. technical enhancements, corrections, updates, etc.
- z the third digit is incremented when editorial only changes have been incorporated in the document.

1 Scope

The present document specifies the conducted test methods and conformance requirements for *single RAT E-UTRA operation*, *single RAT UTRA operation* (FDD and TDD) and Multi-Standard Radio (MSR) UTRA, E-UTRA and NR Active Antenna System (AAS) Base Station (BS). These have been derived from, and are consistent with the non-AAS BS specifications in 3GPP TS 25.104 [2], 3GPP TS 25.105 [3], 3GPP TS 36.104 [4], 3GPP TS 38.104 [36] or 3GPP TS 37.104 [5]. The technical specification 3GPP TS 37.145 is in 2 parts, part 3GPP TS 37.145-1 (the present document) covers conducted requirements and part 3GPP TS 37.145-2 covers radiated requirements.

The present document does not establish conducted test methods and conformance requirements for Band 46 operation as it is not supported by AAS BS, but Band 46 test requirements are still applicable for AAS BS for protection of and against Band 46 operation.

The present document does not establish conducted test methods and conformance requirements for Narrow-Band Internet of Things (NB-IoT) in band, NB-IoT guard band, or standalone NB-IoT operation, for AAS BS in *single RAT E-UTRA operation* as defined in 3GPP TS 36.141 [14], or for AAS BS in *MSR operation* using E-UTRA as defined in 3GPP TS 37.141 [13].

2 References

The following documents contain provisions which, through reference in this text, constitute provisions of the present document.

- References are either specific (identified by date of publication, edition number, version number, etc.) or non-specific.
- For a specific reference, subsequent revisions do not apply.
- For a non-specific reference, the latest version applies. In the case of a reference to a 3GPP document (including a GSM document), a non-specific reference implicitly refers to the latest version of that document *in the same Release as the present document*.

- [1] 3GPP TR 21.905: "Vocabulary for 3GPP Specifications"
- [2] 3GPP TS 25.104: "Base Station (BS) radio transmission and reception (FDD)"
- [3] 3GPP TS 25.105: "Base Station (BS) radio transmission and reception (TDD)"
- [4] 3GPP TS 36.104: "Evolved Universal Terrestrial Radio Access (E-UTRA); Base Station (BS) radio transmission and reception"
- [5] 3GPP TS 37.104: "E-UTRA, UTRA and GSM/EDGE; Multi-Standard Radio (MSR) Base Station (BS) radio transmission and reception"
- [6] 3GPP TS 37.105: "Active Antenna System (AAS) Base Station (BS) transmission and reception"
- [7] Recommendation ITU-R M.1545: "Measurement uncertainty as it applies to test limits for the terrestrial component of International Mobile Telecommunications-2000"
- [8] 3GPP TS 37.105 (V14.1.0): "Active Antenna System (AAS) Base Station (BS) radio transmission and reception (Release 14)"
- [9] 3GPP TS 25.104 (V14.2.0): "Base Station (BS) radio transmission and reception (FDD) (Release 14)"
- [10] 3GPP TS 25.105 (V14.0.0): "Base Station (BS) radio transmission and reception (TDD) (Release 14)"
- [11] 3GPP TS 36.104 (V14.4.0): "Evolved Universal Terrestrial Radio Access (E-UTRA); Base Station (BS) radio transmission and reception (Release 14)"
- [12] 3GPP TS 37.104 (V14.4.0): "E-UTRA, UTRA and GSM/EDGE Multi-Standard Radio (MSR) Base Station (BS) radio transmission and reception (Release 14)"

- [13] 3GPP TS 37.141:"E-UTRA, UTRA and GSM/EDGE; Multi-Standard Radio (MSR) Base Station (BS) conformance testing"
- [14] 3GPP TS 36.141: "Evolved Universal Terrestrial Radio Access (E-UTRA); Base Station (BS) conformance testing"
- [15] 3GPP TS 25.141: "Base Station (BS) conformance testing (FDD)"
- [16] 3GPP TS 37.141 (V14.4.0): "E-UTRA, UTRA and GSM/EDGE; Multi-Standard Radio (MSR) Base Station (BS) conformance testing (Release 14)"
- [17] 3GPP TS 36.141 (V14.4.0): "Evolved Universal Terrestrial Radio Access (E-UTRA); Base Station (BS) conformance testing (Release 14)"
- [18] 3GPP TS 25.141 (V14.2.0): "Base Station (BS) conformance testing (FDD) (Release 14)"
- [19] 3GPP TS 25.142: "Base Station (BS) conformance testing (TDD)"
- [20] 3GPP TS 25.142 (V14.0.0): "Base Station (BS) conformance testing (TDD) (Release 14)"
- [21] 3GPP TR 25.942: "Radio Frequency (RF) system scenarios"
- [22] 3GPP TS 45.004: "Digital cellular telecommunications system (Phase 2+); Modulation"
- [23] 3GPP TS 25.214: "Physical layer procedures (FDD)"
- [24] "Title 47 of the Code of Federal Regulations (CFR)", Federal Communications Commission
- [25] CEPT ECC Decision (13)03: "The harmonised use of the frequency band 1452-1492 MHz for Mobile/Fixed Communications Networks Supplemental Downlink (MFCN SDL)"
- [26] IEC 60721: "Classification of environmental conditions"
- [27] IEC 60721-3-3: "Classification of environmental conditions - Part 3-3: Classification of groups of environmental parameters and their severities - Stationary use at weather protected locations"
- [28] IEC 60721-3-4: "Classification of environmental conditions - Part 3: Classification of groups of environmental parameters and their severities - Section 4: Stationary use at non-weather protected locations"
- [29] ETSI EN 300 019-1-3: "Environmental Engineering (EE); Environmental conditions and environmental tests for telecommunications equipment; Part 1-3: Classification of environmental conditions; Stationary use at weatherprotected locations"
- [30] ETSI EN 300 019-1-4: "Environmental Engineering (EE); Environmental conditions and environmental tests for telecommunications equipment; Part 1-4: Classification of environmental conditions; Stationary use at non-weatherprotected locations"
- [31] IEC 60068-2-1 (2007): "Environmental testing - Part 2: Tests. Tests A: Cold"
- [32] IEC 60068-2-2 (2007): "Environmental testing - Part 2: Tests. Tests B: Dry heat"
- [33] IEC 60068-2-6 (2007): "Environmental testing - Part 2: Tests - Test Fc: Vibration (sinusoidal)"
- [34] Recommendation ITU-T O.153: "Basic parameters for the measurement of error performance at bit rates below the primary rate"
- [35] Recommendation ITU-R SM.329: "Unwanted emissions in the spurious domain"
- [36] 3GPP TS 38.104: "NR; Base Station (BS) radio transmission and reception"
- [37] 3GPP TS 38.141-1: "NR;Base Station (BS) conformance testing; Part 1: Conducted conformance testing"

3 Definitions, symbols and abbreviations

3.1 Definitions

For the purposes of the present document, the terms and definitions given in 3GPP TR 21.905 [1] and the following apply. A term defined in the present document takes precedence over the definition of the same term, if any, in 3GPP TR 21.905 [1].

active antenna system base station: base station system which combines an Antenna Array with an Active transceiver unit array and a *Radio Distribution Network*

active receiver unit: number of active receivers is the same as the [number of receiver diversity branches] to which compliance is declared for clause 8 performance requirements

active transmitter unit: transmitter unit which is ON, and has the ability to send modulated data streams that are parallel and distinct to those sent from other transmitter units to one or more *TAB connectors* at the *transceiver array boundary*

band category: group of operating bands for which the same MSR scenarios apply

Base Station RF Bandwidth: bandwidth in which a base station transmits and/or receives single or multiple carrier(s) and/or RATs simultaneously within a supported operating band

NOTE: In single carrier operation, the *Base Station RF Bandwidth* is equal to the channel bandwidth.

Base Station RF Bandwidth edge: frequency of one of the edges of the *Base Station RF Bandwidth*

basic limit: emissions limit taken from the non AAS specifications that is converted into a per *TAB connector TX cell group* AAS emissions limit by scaling

beam: main lobe of a radiation pattern from an AAS BS

NOTE: For certain AAS antenna array, there may be more than one beam.

beam centre direction: direction equal to the geometric centre of the -3 dB EIRP contour of the beam

beam direction pair: data set consisting of the *beam centre direction* and the related *beam peak direction*

beam peak direction: direction where the maximum EIRP is supposed to be found

beamwidth: angles describing the major and minor axes of an ellipsoid closest fit to an essentially elliptic half-power contour of a beam

carrier: modulated waveform conveying the physical channels

carrier aggregation: aggregation of two or more E-UTRA component carriers in order to support wider *transmission bandwidths*

channel bandwidth: RF bandwidth supporting a single RF carrier with the *transmission bandwidth* configured in the uplink or downlink of a cell

NOTE 1: The *channel bandwidth* is measured in MHz and is used as a reference for transmitter and receiver RF requirements.

NOTE 2: For UTRA FDD, the *channel bandwidth* is the nominal channel spacing specified in 3GPP TS 25.104 [2], For UTRA TDD 1,28 Mcps option, the *channel bandwidth* is the nominal channel spacing specified in 3GPP TS 25.105 [3].

NOTE 3: For E-UTRA, the *channel bandwidths* are specified in 3GPP TS 36.104 [4]. Standalone NB-IoT channel bandwidths specified in 3GPP TS 36.104 [4] are not applicable to AAS BS.

NOTE 4: In TS 38.104 [33] for NR, *channel bandwidths* are referred to as BS channel bandwidths, since for NR BS and UE channel bandwidths may differ.

channel edge: lowest or highest frequency of an NR carrier, separated by the *BS channel bandwidth*

code domain power: part of the mean power which correlates with a particular (OVSF) code channel in a UTRA signal

NOTE: The sum of all powers in the code domain equals the mean power in a bandwidth of $(1 + \alpha)$ times the chip rate of the radio access mode.

contiguous spectrum: spectrum consisting of a contiguous block of spectrum with no *sub-block gap(s)*

downlink operating band: part of the (FDD) operating band designated for downlink

EIRP accuracy directions set: *beam peak directions* for which the EIRP accuracy requirement is intended to be met.

NOTE: The *beam peak directions* are related to a corresponding contiguous range or discrete list of *beam centre directions* by the *beam direction pairs* included in the set.

equivalent isotropic radiated power: equivalent power radiated from an isotropic directivity device producing the same field intensity at a point of observation as the field intensity radiated in the direction of the same point of observation by the discussed device

NOTE: Isotropic directivity is equal in all directions (0 dBi).

equivalent isotropic sensitivity: sensitivity for an isotropic directivity device equivalent to the sensitivity of the discussed device exposed to an incoming wave from a defined AoA

NOTE 1: The sensitivity is the minimum received power level at which a RAT specific requirement is met.

NOTE 2: Isotropic directivity is equal in all directions (0 dBi).

highest carrier: The carrier with the highest carrier frequency transmitted/received in a specified operating band

hybrid AAS BS: AAS BS which has both a conducted RF interface and a radiated RF interface in the far field and conforms to a *hybrid requirements set*

NOTE: For NR operation, a *hybrid AAS BS* corresponds to NR *type I-H* in [37].

hybrid requirements set: complete set of requirements applied to a *hybrid AAS BS* with both conducted and radiated requirements.

inter-band gap: frequency gap between two supported consecutive operating bands

inter-band carrier aggregation: carrier aggregation of component carriers in different operating bands

NOTE: Carriers aggregated in each band can be contiguous or non-contiguous.

intra-band contiguous carrier aggregation: *contiguous carriers* aggregated in the same operating band

intra-band non-contiguous carrier aggregation: non-contiguous carriers aggregated in the same operating band

Inter RF Bandwidth gap: frequency gap between two consecutive *Base Station RF Bandwidths* that are placed within two supported operating bands

lowest carrier: the carrier with the lowest carrier frequency transmitted/received in a specified operating band

maximum carrier output power per TAB connector: *mean power level measured on a particular carrier at the array boundary antenna connectors, during the transmitter ON period in a specified reference condition*

maximum throughput: maximum achievable throughput for a reference measurement channel

MSR operation: operation of AAS BS declared to be MSR in particular *operating band(s)*

multi-band requirements: requirements applying per one single operating band with exclusion bands or other multi-band provisions as defined for each requirement

multi-band TAB connector: *TAB connector* supporting operation in multiple *operating bands* through common active electronic component(s)

NOTE: For common TX and RX *TAB connectors*, the definition applies where common active electronic components are in the transmit path and/or in the receive path.

NB-IoT in-band operation: NB-IoT is operating in-band when it utilizes the resource block(s) within a normal E-UTRA carrier

NB-IoT guard band operation: NB-IoT is operating in guard band when it utilizes the unused resource block(s) within a E-UTRA carrier's guard-band

NB-IoT standalone operation: NB-IoT is operating standalone when it utilizes its own spectrum, for example the spectrum currently being used by GERAN systems as a replacement of one or more GSM carriers, as well as scattered spectrum for potential IoT deployment

non-AAS BS: BS conforming to one of the RF requirement specifications 3GPP TS 25.104 [2], 3GPP TS 25.105 [3], 3GPP TS 36.104 [4] or 3GPP TS37.104 [5]

NOTE: For AAS BS in *single RAT E-UTRA operation* or in *MSR operation* using E-UTRA, the NB-IoT operation (including in-band, guard band and standalone operation) is excluded from the consideration in the performance comparison among AAS BS and *non-AAS BS* in this specification.

non-contiguous spectrum: spectrum consisting of two or more sub-blocks separated by sub-block gap(s)

operating band: frequency range in which the AAS BS operates (paired or unpaired), that is defined with a specific set of technical requirements

OTA sensitivity directions declaration: set of manufacturer declarations comprising one or more EIS values (with related RAT and *channel bandwidth*), and the directions where it (they) applies

NOTE: All the directions apply to all the EIS values in an OSDD.

Radio Bandwidth: frequency difference between the upper edge of the highest used carrier and the lower edge of the lowest used carrier

radio distribution network: passive network which distributes radio signals generated by the transceiver unit array to the antenna array, and/or distributes the radio signals collected by the antenna array to the transceiver unit array

NOTE: In the case when the active transceiver units are physically integrated with the array elements of the antenna array, the radio distribution network is a one-to-one mapping

rated carrier output power per TAB connector: mean power level associated with a particular carrier the manufacturer has declared to be available at the *TAB connector*, during the *transmitter ON period* in a specified reference condition

rated total output power per TAB connector: mean power level associated with a particular operating band the manufacturer has declared to be available at the *TAB connector*, during the *transmitter ON period* in a specified reference condition

receiver target: angles of arrival in which reception is performed

receiver target redirection range: union of all the *sensitivity RoAoA* achievable through redirecting the *receiver target* related to the OSDD

receiver target reference direction: direction inside the *receiver target redirection range* declared by the manufacturer for conformance testing. For an OSDD without *receiver target redirection range*, this is a direction inside the *sensitivity RoAoA*

reference beam direction: declared *beam direction pair*, including reference *beam centre direction* and reference *beam peak direction* where the reference *beam peak direction* is the direction for the intended maximum EIRP within the EIRP accuracy compliance directions set

sensitivity RoAoA: RoAoA within which the declared EIS(s) of an OSDD is intended to be achieved at any instance of time for a specific AAS BS direction setting

single band requirements: requirements applying per one single operating band without exclusion bands or other multi-band provisions

single band TAB connector: *TAB connector* supporting operation either in a single operating band only, or in multiple operating bands but without any common active electronic component(s)

single RAT E-UTRA operation: operation of AAS BS declared to be single RAT E-UTRA in the operating band

NOTE: *Single RAT E-UTRA operation* does not cover in-band NB-IoT, nor guardband NB-IoT operation.

single RAT UTRA operation: operation of AAS BS declared to be single RAT UTRA in the operating band

sub-block: one contiguous allocated block of spectrum for use by the same Base Station

NOTE: There may be multiple instances of *sub-blocks* within an *Base Station RF Bandwidth*.

sub-block gap: frequency gap between two consecutive *sub-blocks* within an *Base Station RF Bandwidth*, where the RF requirements in the gap are based on co-existence for un-coordinated operation

TAB connector: transceiver array boundary connector

TAB connectors beam forming group: Group of *TAB connectors* associated with an EIRP beam declaration, comprising of the complete set of *TAB connectors* from which a declared beam is transmitted

TAB connector RX min cell group: operating band specific declared group of *TAB connectors* to which requirements are applied

NOTE: The group corresponds to the group of *TAB connectors* which are responsible for receiving a cell when the AAS BS setting corresponding to the declared minimum number of cells with transmission on all *TAB connectors* supporting an operating band, but its existence is not limited to that condition.

TAB connector TX min cell group: operating band specific declared group of *TAB connectors* to which requirements are applied.

NOTE: The group corresponds to the group of *TAB connectors* which are responsible for transmitting a cell when the AAS BS setting corresponding to the declared minimum number of cells with transmission on all *TAB connectors* supporting an operating band, but its existence is not limited to that condition.

throughput: number of payload bits successfully received per second for a reference measurement channel in a specified reference condition

transceiver array boundary: conducted interface between the transceiver unit array and the composite antenna

transmission bandwidth: bandwidth of an instantaneous E-UTRA transmission from a UE or BS, measured in resource block units

transmitter OFF period: time period during which the transmitter is scheduled not to transmit

NOTE: For AAS BS, this definition applies per *TAB connector* and operating band.

transmitter ON period: time period during which the transmitter is transmitting data and/or reference symbols

NOTE: For AAS BS, this definition applies per *TAB connector* and operating band.

transmitter transient period: time period during which the transmitter is changing from the OFF period to the ON period or vice versa

NOTE: For AAS BS, this definition applies per *TAB connector* and operating band.

uplink operating band: part of the (FDD) operating band designated for uplink

3.2 Symbols

For the purposes of the present document, the following symbols apply:

α	Roll-off factor
β	Percentage of the mean transmitted power emitted outside the occupied bandwidth on the assigned channel
BW_{Channel}	Channel bandwidth (for E-UTRA)
$BW_{\text{Channel_CA}}$	Aggregated channel bandwidth, expressed in MHz. $BW_{\text{Channel_CA}} = F_{\text{edge_high}} - F_{\text{edge_low}}$
BW_{Config}	Transmission bandwidth configuration (for E-UTRA), expressed in MHz, where $BW_{\text{Config}} = N_{\text{RB}} \times 180$ kHz in the uplink and $BW_{\text{Config}} = 15$ kHz + $N_{\text{RB}} \times 180$ kHz in the downlink

DwPTS	Downlink part of the special subframe (for E-UTRA TDD operation)
f	Frequency
Δf	Separation between the Base Station RF bandwidth edge frequency and the nominal -3dB point of the measuring filter closest to the carrier frequency
Δf_{\max}	The largest value of Δf used for defining the requirement
Δf_{OBUE}	Maximum offset of the <i>operating band</i> unwanted emissions mask from the downlink <i>operating band edge</i>
Δf_{OOb}	Maximum offset of the out-of-band boundary from the uplink <i>operating band edge</i>
F_c	Carrier centre frequency
F_{filter}	Filter centre frequency
f_{offset}	Separation between the Base Station RF bandwidth edge frequency and the centre of the measuring filter
$f_{\text{offset}_{\max}}$	The maximum value of f_{offset} used for defining the requirement
$F_{\text{BW RF,high}}$	Upper RF bandwidth edge, where $F_{\text{BW RF,high}} = F_{c,\text{high}} + F_{\text{offset, RAT}}$
$F_{\text{BW RF,low}}$	Lower RF bandwidth edge, where $F_{\text{BW RF,low}} = F_{c,\text{low}} - F_{\text{offset, RAT}}$
$F_{c,\text{high}}$	Centre frequency of the highest transmitted/received carrier
$F_{c,\text{low}}$	Centre frequency of the lowest transmitted/received carrier
$F_{\text{edge}_{\text{low}}}$	The lower edge of aggregated channel bandwidth, expressed in MHz. $F_{\text{edge}_{\text{low}}} = F_{c,\text{low}} - F_{\text{offset}}$
$F_{\text{edge}_{\text{high}}}$	The upper edge of aggregated channel bandwidth, expressed in MHz. $F_{\text{edge}_{\text{high}}} = F_{c,\text{high}} + F_{\text{offset}}$
	$F_{\text{offset, RAT}}$ Frequency offset from the centre frequency of the <i>highest</i> transmitted/received carrier to the <i>upper</i> RF bandwidth edge, sub-block edge or inter-RF bandwidth edge, or from the centre frequency of the <i>lowest</i> transmitted/received carrier to the <i>lower</i> RF bandwidth edge, sub-block edge or inter-RF bandwidth edge for a specific RAT
$F_{\text{UL}_{\text{low}}}$	The lowest frequency of the <i>uplink operating band</i>
$F_{\text{UL}_{\text{high}}}$	The highest frequency of the <i>uplink operating band</i>
F_{uw}	Frequency offset of unwanted signal
N_{cells}	A declared number corresponding to the minimum number of cells that can be transmitted by an AAS BS in a particular band with transmission on all TAB connectors supporting the operating band
N_{RB}	Transmission bandwidth configuration, expressed in units of resource blocks (for E-UTRA)
$N_{\text{RXU,active}}$	The number of active receiver units. The same as the [number of receiver diversity branches] to which compliance is declared for chapter 8 performance requirements.
$N_{\text{RXU,counted}}$	The number of active receiver units that are taken into account for unwanted emission scaling.
$N_{\text{RXU,countedpercell}}$	The number of active receiver units that are taken into account for unwanted emissions scaling per cell
$N_{\text{TXU, active}}$	The number of <i>active transmitter units</i>
$N_{\text{TXU,counted}}$	The number of <i>active transmitter units</i> , as calculated in subclause 6.1, that are taken into account for conducted TX power limit
$N_{\text{TXU,countedpercell}}$	The number of <i>active transmitter units</i> that are taken into account for emissions scaling per cell
$P_{\text{EM,B32,ind}}$	Declared emission level in Band 32, ind=a, b, c, d, e (see table 4.10, D6.8)
$P_{\text{max,c,cell}}$	The <i>maximum carrier output power per TAB connector TX min cell group</i>
$P_{\text{max,c,TABC}}$	The <i>maximum carrier output power per TAB connector</i>
$P_{\text{Rated,c,TABC}}$	The <i>rated carrier output power per TAB connector</i>
$P_{\text{Rated,c,sys}}$	The sum of $P_{\text{Rated,c,TABC}}$ for all <i>TAB connectors</i> for a single carrier
$P_{\text{Rated,t,group}}$	The sum of $P_{\text{Rated,t,TABC}}$ for all <i>TAB connectors</i> belonging to a specified group
$P_{\text{Rated,t,TABC}}$	The <i>rated total output power per TAB connector</i>
P_{REFSENS}	Reference Sensitivity power level
W_{gap}	Sub-block gap size or Inter RF Bandwidth gap size

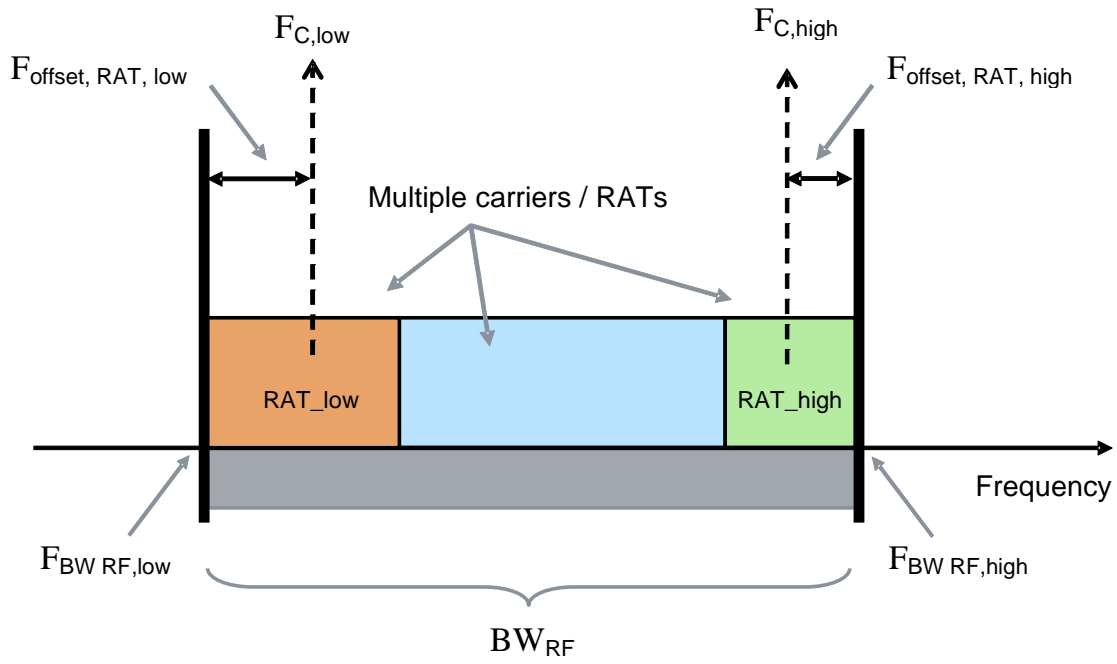

Figure 3.2-1: Illustration of RF bandwidth related symbols and definitions for Multi-standard Radio

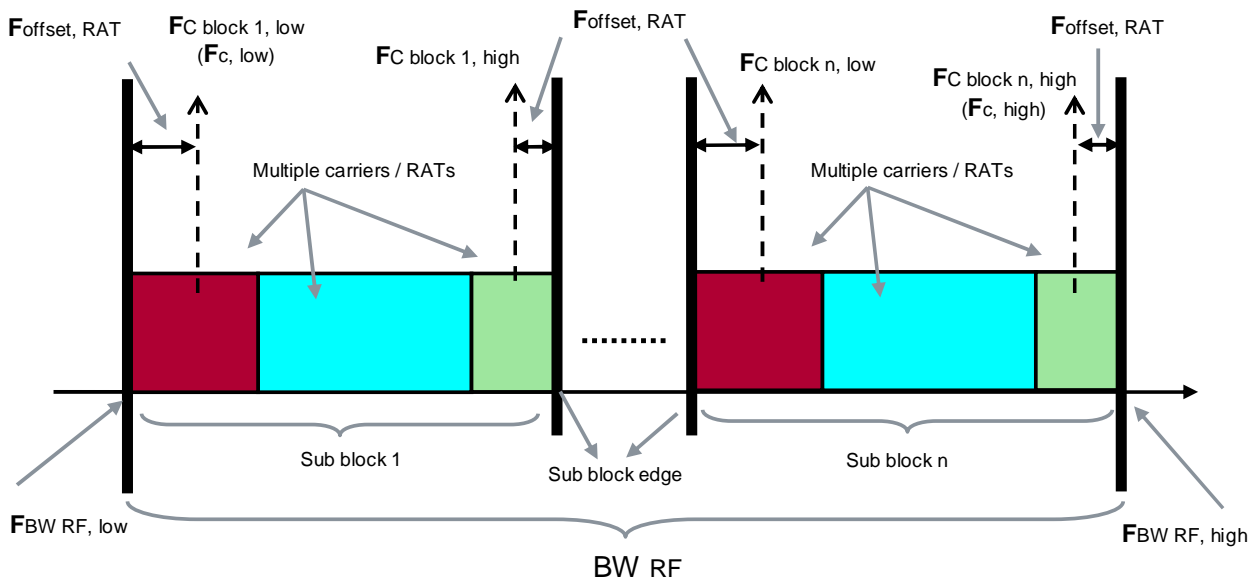

Figure 3.2-2: Illustration of RF bandwidth related symbols and definitions for non-contiguous Multi-standard Radio

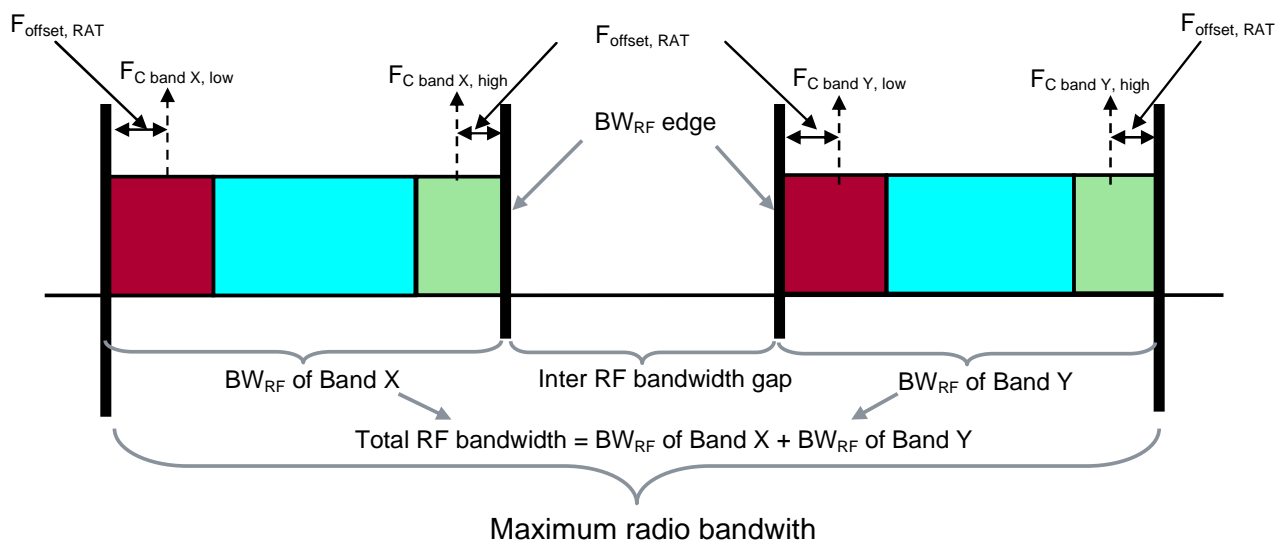

Figure 3.2-3: Illustration of maximum *Radio Bandwidth* and *Total RF bandwidth* for Multi-band Multi-standard Radio

3.3 Abbreviations

For the purposes of the present document, the abbreviations given in 3GPP TR 21.905 [1] and the following apply. An abbreviation defined in the present document takes precedence over the definition of the same abbreviation, if any, in 3GPP TR 21.905 [1].

AAS BS	Active Antenna System Base Station
ACLR	Adjacent Channel Leakage power Ratio
ACS	Adjacent Channel Selectivity
AoA	Angle of Arrival
ARFCN	Absolute Radio Frequency Channel Number
B	Bottom RF channel (for testing purposes)
BC	Band Category
BER	Bit Error Rate
BLER	Block Error Rate
CA	Carrier Aggregation
CACLR	Cumulative ACLR
CP	Cyclic prefix
CRC	Cyclic Redundancy Check
CW	Continuous Wave (unmodulated signal)
DC-HSDPA	Dual Cell HSDPA
D-CPICH	Demodulation Common Pilot Channel
DIP	Dominant Interferer Proportion
EARFCN	E-UTRA Absolute Radio Frequency Channel Number
EIRP	Equivalent Isotropic Radiated Power
EIS	Equivalent Isotropic Sensitivity
EVM	Error Vector Magnitude
FCC	Federal Communications Commission
FDD	Frequency Division Duplex
FRC	Fixed Reference Channel
GSCN	Global Synchronization Channel Number
GSM	Global System for Mobile communication
HS-DSCH	High Speed Downlink Shared Channel
ICS	In-Channel Selectivity
Iuant	E-Node B internal logical interface between the implementation specific O&M function and the RET antennas and TMAs control unit function of the E-Node B
ITU	International Telecommunication Union

ITU-R	Radio communication Sector of the ITU
LA	Local Area
M	Middle RF channel (for testing purposes)
MB-MSR	Multi-Band Multi-Standard Radio
MBT	Multi-Band Testing
MIMO	Multiple Inputs Multiple Outputs
MR	Medium Range
MSR	Multi-Standard Radio
NB-IoT	Narrowband – Internet of Things
NR	New Radio
OBUE	Operating Band Unwanted Emissions
OBW	Occupied Band Width
OFDM	Orthogonal Frequency Division Multiplex
OSDD	OTA Sensitivity Directions Declaration
OTA	Over The Air
PCCPCH	Primary Common Control Physical CHannel
QAM	Quadrature Amplitude Modulation
QPSK	Quadrature Phase-Shift Keying
RAT	Radio Access Technology
RB	Resource Block (for E-UTRA)
RDN	Radio Distribution Network
RE	Resource Element
REFSENS	Reference Sensitivity
RF	Radio Frequency
RMS	Root Mean Square (value)
RoAoA	Range of Angles of Arrival
RRC	Root Raised Cosine
RS	Reference Symbol
RX	Receiver
SBT	Single Band Testing
SC	Single Carrier
SCS	Sub-Carrier Spacing
SNR	Signal-to-Noise Ratio
T	Top RF channel (for testing purposes)
TAB	Tranceiver Array Boundary
TAE	Time Alignment Error
TDD	Time Division Duplex
TT	Test Tolerance
TX	Transmitter
UARFCN	UTRA Absolute Radio Frequency Channel Number
UE	User Equipment
WA	Wide Area

4 General test conditions and declarations

4.1 Measurement uncertainties and test requirements

4.1.1 General

The requirements of this clause apply to all applicable tests in part 1 of this specification,, i.e. to all conducted test

The minimum requirements are given in 3GPP TS 37.105 [6] and the references therein. Test requirements are given in this specification or are included by reference to 3GPP TS 25.141 [15], 3GPP TS 25.142 [19], 3GPP TS 36.141 [14], 3GPP TS 38.141 [37] or 3GPP TS 37.141 [13]. Test Tolerances for the conducted test requirements explicitly stated in the present document are given in annex C of the present document. Test Tolerances for test requirements included by reference to 3GPP TS 25.141 [15], 3GPP TS 25.142 [19], 3GPP TS 36.141 [14], 3GPP TS 38.141 [37] or 3GPP TS 37.141 [13] are defined in the respective referred test specification.

Test requirements and Test Tolerances for NB-IoT in-band, NB-IoT guard band, or standalone NB-IoT operation are not supported by AAS BS and not covered by this specification. When referring to standalone E-UTRA test

requirements for *single RAT operation* in 3GPP TS 36.141 [14] or to E-UTRA test requirements for *MSR operation* in 3GPP TS 37.141 [13], any test requirements specified in those specifications for E-UTRA with NB-IoT (in-band or guard band) or for standalone NB-IoT, shall not be considered for the AAS BS. Unless otherwise stated, the exclusion of the NB-IoT test requirements in this specification applies to all operation modes (i.e. *in-band NB-IoT operation*, *guard band NB-IoT operation* and *standalone NB-IoT operation*).

Test Tolerances are individually calculated for each test. The Test Tolerances are used to relax the minimum requirements to create test requirements.

When a test requirement differs from the corresponding minimum requirement, then the Test Tolerance applied for the test is non-zero. The Test Tolerance for the test and the explanation of how the minimum requirement has been relaxed by the Test Tolerance are given in annex C.

4.1.2 Acceptable uncertainty of Test System

4.1.2.1 General

The maximum acceptable uncertainty of the Test System is specified below for each test defined explicitly in the present specification, where appropriate. The maximum acceptable uncertainty of the Test System for test requirements included by reference is defined in the respective referred test specification.

When a requirement is applied per *TAB connector* then the test uncertainty is applied to the measured value. When a requirement is applied for a group of *TAB connectors* then the test uncertainty is applied to sum of the measured power on each *TAB connector* in the group.

The Test System shall enable the stimulus signals in the test case to be adjusted to within the specified tolerance and the equipment under test to be measured with an uncertainty not exceeding the specified values. All tolerances and uncertainties are absolute values, and are valid for a confidence level of 95 %, unless otherwise stated.

A confidence level of 95 % is the measurement uncertainty tolerance interval for a specific measurement that contains 95 % of the performance of a population of test equipment.

For RF tests, it should be noted that the uncertainties in subclause 4.1.2 apply to the Test System operating into a nominal 50 ohm load and do not include system effects due to mismatch between the DUT and the Test System.

4.1.2.2 Measurement of transmitter

Table 4.1.2.2-1: Maximum Test System uncertainty for transmitter tests

Subclause	Maximum Test System Uncertainty	Derivation of Test System Uncertainty
6.2 Base Station output power	± 0.7 dB for UTRA and E-UTRA and NR, $f \leq 3.0$ GHz ± 1.0 dB, 3.0 GHz $< f \leq 4.2$ GHz for UTRA and E-UTRA and NR	
6.4 Transmit ON/OFF power	± 2.0 dB, $f \leq 3.0$ GHz ± 2.5 dB, 3.0 GHz $< f \leq 4.2$ GHz	
6.6.6 Transmitter spurious emissions, Mandatory Requirements	9 kHz $< f \leq 4$ GHz: ± 2.0 dB 4 GHz $< f \leq 19$ GHz: ± 4.0 dB	
6.6.6 Transmitter spurious emissions, Additional BC2 Requirement	9 kHz $< f \leq 4$ GHz: ± 2.0 dB 4 GHz $< f \leq 12.75$ GHz: ± 4.0 dB	
6.6.6 Transmitter spurious emissions, Protection of BS receiver	± 3.0 dB	
6.6.6 Transmitter spurious emissions, Additional spurious emission requirements	± 2.0 dB for > -60 dBm, $f \leq 3.0$ GHz ± 2.5 dB, 3.0 GHz $< f \leq 4.2$ GHz ± 3.0 dB for ≤ -60 dBm, $f \leq 3.0$ GHz ± 3.5 dB, 3.0 GHz $< f \leq 4.2$ GHz	
6.6.6 Transmitter spurious emissions, Co-location	± 3.0 dB	
6.6.5 Operating band unwanted emissions	± 1.5 dB, $f \leq 3.0$ GHz ± 1.8 dB, 3.0 GHz $< f \leq 4.2$ GHz	
6.6.2 Occupied bandwidth	For E-UTRA: 1.4 MHz, 3 MHz Channel BW: ± 30 kHz 5 MHz, 10 MHz Channel BW: ± 100 kHz 15 MHz, 20 MHz: Channel BW: ± 300 kHz For UTRA: ± 100 kHz For NR: 5 MHz, 10 MHz BS Channel BW: ± 100 kHz 15 MHz, 20 MHz, 25 MHz, 30 MHz, 40 MHz, 50 MHz BS Channel BW: ± 300 kHz 60 MHz, 70 MHz, 80 MHz, 90 MHz, 100 MHz BS Channel BW: ± 600 kHz	
6.6.3 Adjacent Channel Leakage power Ratio (ACLR)	Relative ACLR: $BW \leq 20$ MHz: ± 0.8 dB $BW > 20$ MHz: ± 1.2 dB ACLR Absolute power ± 2.0 dB, $f \leq 3.0$ GHz ACLR Absolute power ± 2.5 dB, 3.0 GHz $< f \leq 4.2$ GHz Relative CACLR $BW \leq 20$ MHz: ± 0.8 dB $BW > 20$ MHz: ± 1.2 dB CACLR absolute power ± 2.0 dB, $f \leq 3.0$ GHz CACLR absolute power ± 2.5 dB, 3.0 GHz $< f \leq 4.2$ GHz	
6.7 Transmitter intermodulation (interferer requirements) This tolerance applies to the stimulus and not the measurements defined in 6.6.6, 6.6.5 and 6.6.3	The value below applies only to the interfering signal and is unrelated to the measurement uncertainty of the tests (6.6.1, 6.6.2 and 6.6.4) which have to be carried out in the presence of the interferer. ± 1.0 dB	The uncertainty of interferer has double the effect on the result due to the frequency offset

4.1.2.3 Measurement of receiver

Table 4.1.2.3-1: Maximum Test System Uncertainty for receiver tests

Subclause	Maximum Test System Uncertainty	Derivation of Test System Uncertainty
7.4 Adjacent channel selectivity, general blocking and narrowband blocking	± 1.4 dB, $f \leq 3.0$ GHz ± 1.8 dB, 3.0 GHz $< f \leq 4.2$ GHz	<p>Overall system uncertainty comprises three quantities:</p> <ol style="list-style-type: none"> 1. Wanted signal level error 2. Interferer signal level error 3. Additional impact of interferer leakage <p>Items 1 and 2 are assumed to be uncorrelated so can be root sum squared to provide the ratio error of the two signals. The interferer leakage effect is systematic, and is added arithmetically.</p> <p>Test System uncertainty = [SQRT (wanted_level_error² + interferer_level_error²)] + leakage effect.</p> <p>$f \leq 3.0$ GHz Wanted signal level ± 0.7 dB Interferer signal level ± 0.7 dB 3.0 GHz $< f \leq 4.2$ GHz Wanted signal level ± 1.0 dB Interferer signal level ± 1.0 dB</p> <p>$f \leq 4.2$ GHz Impact of interferer leakage 0.4 dB</p>
7.5 Blocking	1 MHz $\leq f_{\text{interferer}} \leq 3$ GHz: ± 1.3 dB 3 GHz $< f_{\text{interferer}} \leq 12.75$ GHz: ± 3.2 dB	<p>Overall system uncertainty comprises three quantities:</p> <ol style="list-style-type: none"> 1. Wanted signal level error 2. Interferer signal level error 3. Interferer broadband noise <p>Items 1 and 2 are assumed to be uncorrelated so can be root sum squared to provide the ratio error of the two signals. The Interferer Broadband noise effect is systematic, and is added arithmetically.</p> <p>Test System uncertainty = [SQRT (wanted_level_error² + interferer_level_error²)] + Broadband noise effect.</p> <p>Out of band blocking, using CW interferer: Wanted signal level: ± 0.7 dB up to 3 GHz ± 1.0 dB up to 4.2 GHz Interferer signal level: ± 1.0 dB up to 3 GHz ± 3.0 dB up to 12.75 GHz Impact of interferer Broadband noise 0.1 dB</p>
7.6 Receiver spurious emissions	30 MHz $\leq f \leq 4$ GHz: ± 2.0 dB 4 GHz $< f \leq 19$ GHz: ± 4.0 dB	

Subclause	Maximum Test System Uncertainty	Derivation of Test System Uncertainty
7.7 Receiver intermodulation (General requirements)	± 1.8 dB, $f \leq 3.0$ GHz ± 2.4 dB, 3.0 GHz $< f \leq 4.2$ GHz	<p>Overall system uncertainty comprises four quantities:</p> <ol style="list-style-type: none"> 1. Wanted signal level error 2. CW Interferer level error 3. Modulated Interferer level error 4. Impact of interferer ACLR <p>The effect of the closer CW signal has twice the effect.</p> <p>Items 1, 2 and 3 are assumed to be uncorrelated so can be root sum squared to provide the combined effect of the three signals. The interferer ACLR effect is systematic, and is added arithmetically.</p> <p>Test System uncertainty = $\text{SQRT} [(2 \times \text{CW_level_error})^2 + (\text{mod interferer_level_error})^2 + (\text{wanted signal_level_error})^2] + \text{ACLR effect.}$</p> <p>$f \leq 3.0$ GHz Wanted signal level ± 0.7 dB CW interferer level ± 0.5 dB Mod interferer level ± 0.7 dB 3.0 GHz $< f \leq 4.2$ GHz Wanted signal level ± 1.0 dB CW Interferer level ± 0.7 dB Mod Interferer level ± 1.0 dB</p> <p>$f \leq 4.2$ GHz Impact of interferer ACLR 0.4 dB</p>
7.7 Receiver intermodulation (Narrowband requirements)	± 1.8 dB, $f \leq 3.0$ GHz ± 2.4 dB, 3.0 GHz $< f \leq 4.2$ GHz	Same as Receiver intermodulation (General requirements).
NOTE: Unless otherwise noted, only the Test System stimulus error is considered here. The effect of errors in the throughput measurements or the BER/FER due to finite test duration is not considered.		

4.1.3 Interpretation of measurement results

The measurement results returned by the Test System are compared - without any modification - against the test requirements as defined by the Shared Risk principle.

The Shared Risk principle is defined in Recommendation ITU-R M.1545 [7].

The actual measurement uncertainty of the Test System for the measurement of each parameter shall be included in the test report.

The recorded value for the Test System uncertainty shall be, for each measurement, equal to or lower than the appropriate figure in subclause 4.1.2 of the present document.

If the Test System for a test is known to have a measurement uncertainty greater than that specified in subclause 4.1.2, it is still permitted to use this apparatus provided that an adjustment is made as follows.

Any additional uncertainty in the Test System over and above that specified in subclause 4.1.2 shall be used to tighten the test requirement, making the test harder to pass. For some tests e.g. receiver tests, this may require modification of stimulus signals. This procedure will ensure that a Test System not compliant with subclause 4.1.2 does not increase the chance of passing a device under test where that device would otherwise have failed the test if a Test System compliant with subclause 4.1.2 had been used.

4.2 Conducted and radiated requirement reference points

AAS BS requirements are defined for two points of reference, signified by radiated requirements and conducted requirements.

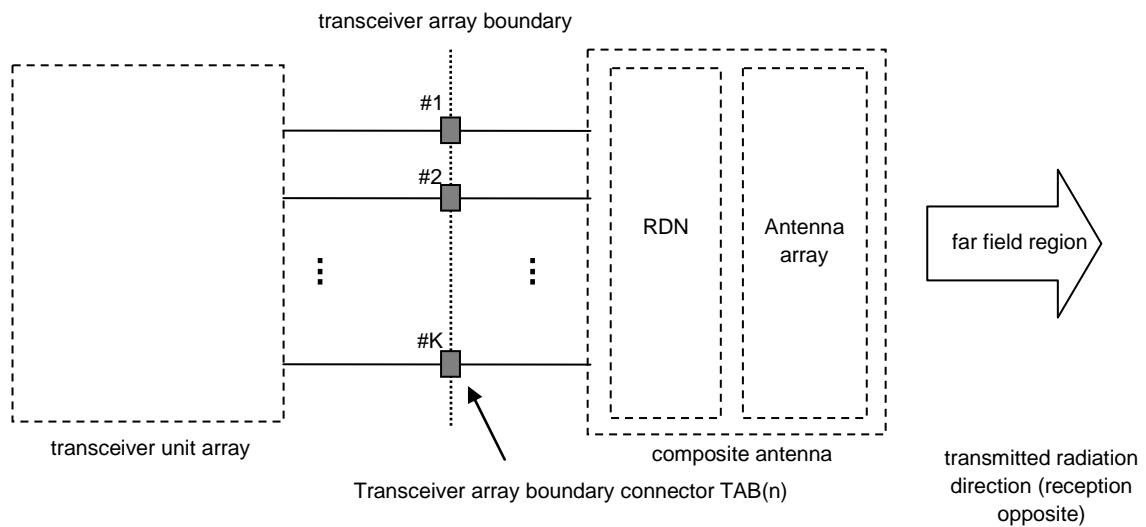

Figure 4.2-1: Radiated and conducted points of reference of AAS BS

Radiated characteristics are defined over the air (OTA) with a point of reference in the far field (Fraunhofer) region. Radiated requirements are also referred to as OTA requirements.

Conducted characteristics are defined at individual or groups of *TAB connectors* at the *transceiver array boundary*, which is the conducted interface between the transceiver unit array and the composite antenna.

The transceiver unit array is part of the composite transceiver functionality generating modulated transmit signal structures and performing receiver combining and demodulation.

The transceiver unit array contains an implementation specific number of transmitter units and an implementation specific number of receiver units. Transmitter units and receiver units may be combined into transceiver units. The transmitter/receiver units have the ability to receive/send parallel independent modulated symbol streams.

The composite antenna contains a *radio distribution network* (RDN) and an antenna array. The RDN is a linear passive network that distributes the RF power between the *transceiver array boundary* and the antenna array, in an implementation specific way.

How a conducted requirement is applied to the *transceiver array boundary* is detailed in the respective requirement subclause.

Part 1 of this specification details the test requirements of the conducted requirements only and hence only requires the conducted reference points.

4.3 Base station classes for AAS BS

The requirements in this specification apply to AAS BS of Wide Area BS, Medium Range BS and Local Area BS classes unless otherwise stated.

Wide Area BS are characterised by requirements derived from Macro Cell scenarios. For a hybrid AAS BS of Wide Area BS class, the minimum coupling loss between any *TAB connector* and the UE is 70 dB.

NOTE: Whenever WA BS is referred in this specification, the NB-IoT Wide Area BS and related requirements as defined in 3GPP TS 36.104 [4], are not applicable for AAS BS.

Medium Range BS are characterised by requirements derived from Micro Cell scenarios. For a hybrid AAS BS of Medium Range BS class, the minimum coupling loss between any *TAB connector* and the UE is 53 dB.

Local Area BS are characterised by requirements derived from Pico Cell scenarios. For a hybrid AAS BS of Local Area BS class, the minimum coupling loss between any *TAB connector* and the UE is 45 dB.

4.4 Regional requirements

Some requirements in the present document may only apply in certain regions either as optional requirements, or set by local and regional regulation as mandatory requirements. It is normally not stated in the 3GPP specifications under what exact circumstances that the requirements apply, since this is defined by local or regional regulation.

Table 4.4-1 lists all requirements in the present specification that may be applied differently in different regions. Non-AAS requirements are applicable as defined in the present document. In many cases, such requirements include regional requirements that are implicitly referenced from the present specification, and listed in the specification for the specifications concerned [2] [5].

Table 4.4-1: List of regional requirements

Subclause number	Requirement	Comments
4.5	Operating bands and Band Categories	Some bands may be applied regionally.
6.2.2.2.1	Base station output power	These requirements apply in Japan for an E-UTRA BS operating in Band 34 and Band 41.
6.6.2	Occupied bandwidth	The requirement may be applied regionally. There may also be regional requirements to declare the Occupied bandwidth according to the definition.
6.6.4	Spectrum emission mask	The mask specified may be mandatory in certain regions. In other regions this mask may not be applied. Additional spectrum protection requirements may apply regionally.
6.6.5	Operating band unwanted emissions	The BS may have to comply with the applicable emission limits established by FCC Title 47 [15], when deployed in regions where those limits are applied and under the conditions declared by the manufacturer.
6.6.5	Operating band unwanted emissions	The requirements for protection of DTT may apply regionally.
6.6.5	Operating band unwanted emissions	Regional requirement as defined in TS 37.104, subclause 6.6.2.4.4 [12] may be applied for the protection of systems operating in frequency bands adjacent to Band 1 as defined in TS 37.104, subclause 4.5, [12] in geographic areas in which both an adjacent band service and UTRA and/or E-UTRA are deployed.
6.6.5	Operating band unwanted emissions	Additional requirements for Band 41 may apply in certain regions as additional Operating band unwanted emission limits.
6.6.5	Operating band unwanted emissions	Additional Band 32 unwanted emissions requirements may apply in certain regions.
6.6.6	Spurious emissions	Category A limits are mandatory for regions where Category A limits for spurious emissions, as defined in Recommendation ITU-R SM.329 [35] apply. Category B limits are mandatory for regions where Category B limits for spurious emissions, as defined in Recommendation ITU-R SM.329 [35] apply.
6.6.6	Spurious emissions	Additional spurious emissions requirements may be applied for the protection of system operating in frequency ranges other than the AAS BS operating band as described in TS 37.104 [12] subclause 6.6.1.3.
6.6.6	Spurious emissions	In addition to 3GPP requirements, the BS may have to comply with the applicable emission limits established by FCC Title 47 [15], when deployed in regions where those limits are applied, and under the conditions declared by the manufacturer.
6.7	Transmitter intermodulation	Additional requirements may apply in certain regions.

4.5 Operating bands and band categories

The operating bands and band categories for AAS BS are the same as for *non-AAS BS*, as described in 3GPP TS 37.104 [5].

NOTE 1: AAS BS does not support GSM, but BC2 is still applicable for protection of/against GSM operation in BC2 operating bands.

NOTE 2: AAS BS does not support Band 46 (and all its sub-bands defined in 3GPP TS 36.104 [12], subclause 5.5) operation, but Band 46 test requirements are still applicable for AAS BS for protection of and against Band 46 operation.

NOTE 3: Bands in BC1 and BC2 categories are also used for NB-IoT operation. NB-IoT is not applicable for AAS BS.

4.6 Channel arrangements

The channel arrangements for AAS BS are the same as those for UTRA *non-AAS BS* and/or E-UTRA *non-AAS BS* and/or NR *non-AAS BS* as described in 3GPP TS 37.104 [5].

NOTE: Test requirements for nominal carrier spacing of 19.8 MHz and 20.1 MHz for carriers in Band 46 as specified in 36.104 [12] subclause 5.7.1, are not applicable for AAS BS.

4.7 Requirements for AAS BS capable of multi-band operation

For AAS BS capable of operation in multiple operating bands, the RF requirements in clause 6 and 7 apply separately to each supported operating band unless otherwise stated.

An AAS BS may be capable of supporting operation in multiple operating bands with one of the following implementations of *TAB connectors* in the *transceiver array boundary*:

- All *TAB connectors* are single band *TAB connectors*:
 - Different sets of *single band TAB connectors* support different operating bands, but each *TAB connector* supports only operation in one single operating band.
 - Sets of *single band TAB connectors* support operation in multiple operating bands with some *single band TAB connectors* supporting more than one operating band.
- All *TAB connectors* are multiband *TAB connectors*.
- A combination of single band sets and multi-band sets of *TAB connectors* provides support of the AAS BS capability of operation in multiple operating bands.

Unless otherwise stated all requirements specified for an operating band apply only to the set of *TAB connectors* supporting that operating band.

In certain requirements it is explicitly stated that specific additions or exclusions to the requirement apply at *multi-band TAB connectors* as detailed in the requirement subclause.

In the case of an operating band being supported only by *single band TAB connectors* in a *TAB connector TX min cell group* or a *TAB connector RX min cell group*, *single band requirements* apply to that set of *TAB connectors*.

NOTE: Each supported operating band needs to be operated separately during conformance testing on *single band TAB connectors*.

In the case of an operating band being supported only by *multi-band TAB connectors* supporting the same operating band combination in a *TAB connector TX min cell group* or a *TAB connector RX min cell group*, *multi-band requirements* apply to that set of *TAB connectors*.

The case of an operating band being supported by both *multi-band TAB connectors* and *single band TAB connectors* in a *TAB connector TX min cell group* or a *TAB connector RX min cell group* is not covered by the present release of this specification.

The case of an operating band being supported by *multi-band TAB connectors* which are not all supporting the same operating band combination in a *TAB connector TX min cell group* or a *TAB connector RX min cell group* is not covered by the present release of this specification.

For *multi-band TAB connectors* supporting the bands for TDD, the RF requirements in the present specification assume no simultaneous uplink and downlink occur between the bands.

The RF requirements for *multi-band TAB connectors* supporting bands for both FDD and TDD are not covered by the present release of this specification.

4.8 AAS BS configurations

4.8.1 Transmit configurations

Unless otherwise stated, the conducted transmitter characteristics in clause 6 are specified at the AAS BS *transceiver array boundary* at the *TAB connector(s)* antenna connector with a full complement of transceiver units for the configuration in normal operating conditions.

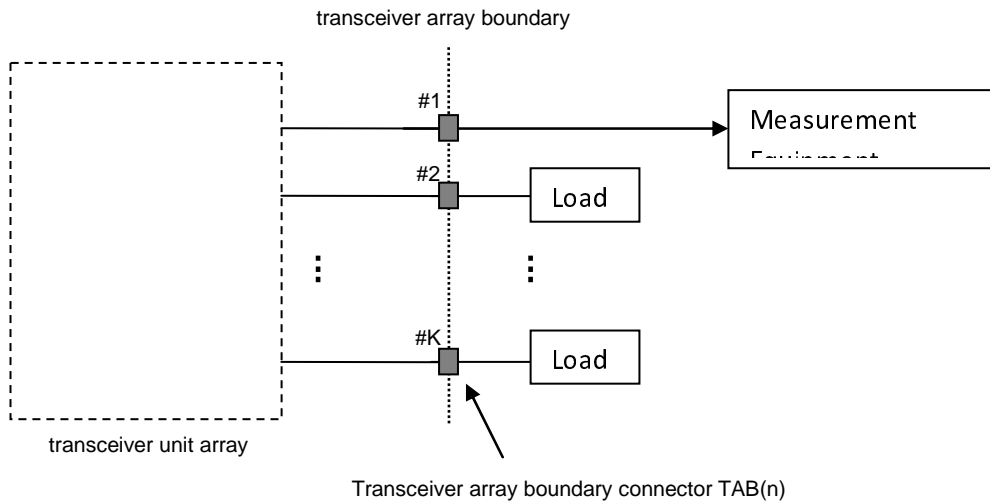

Figure 4.8.1-1: Transmitter test ports

Unless otherwise stated, for the tests in clause 6 of the present document, the requirement applies for each transmit *TAB connector*.

4.8.2 Receive configurations

Unless otherwise stated, the conducted receiver characteristics in clause 7 are specified at the *TAB connector* with a full complement of transceiver units for the configuration in normal operating conditions.

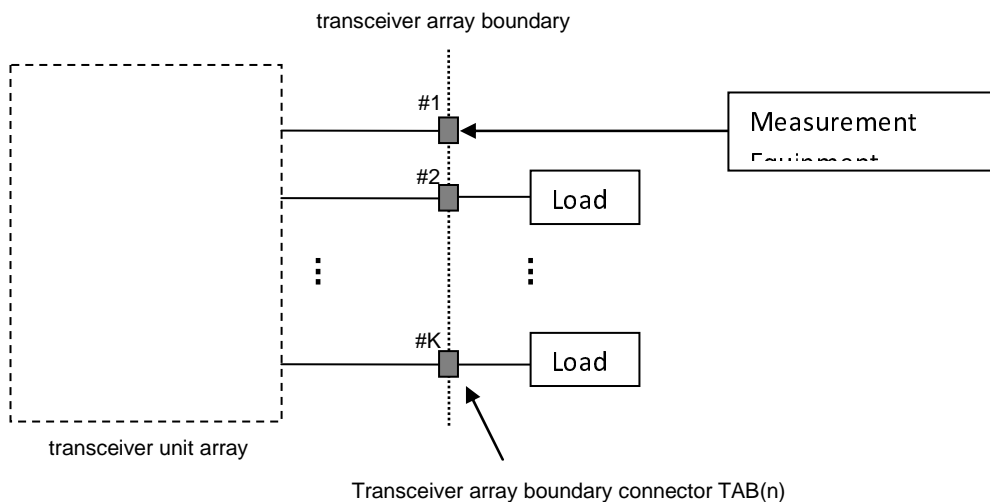

Figure 4.8.2-1: Receiver test ports

For the tests in clause 7 of the present document, the requirement applies at each receive *TAB connector*.

Conducted receive requirements are tested at the *TAB connector*, with the remaining receiver units(s) disabled or their *TAB connector(s)* being terminated.

4.8.3 Power supply options

If the AAS BS is supplied with a number of different power supply configurations, it may not be necessary to test RF parameters for each of the power supply options, provided that it can be demonstrated that the range of conditions over which the equipment is tested is at least as great as the range of conditions due to any of the power supply configurations.

4.8.4 BS with integrated Iuant BS modem

Unless otherwise stated, for the tests in the present document, the integrated Iuant BS modem shall be switched off. Spurious emissions according to subclauses 6.6.4 and 7.6 shall be measured only for frequencies above 20 MHz with the integrated Iuant BS modem switched on.

4.9 Capability sets

Capability set is defined as the *TAB connectors* capability to support certain RAT combinations in an operating band.

The manufacturer shall declare the supported capability set(s) according to table 4.9-1 for each supported *TAB connector* and supported operating band.

Table 4.9-1 Capability sets

Capability Set supported by the BS	CSA1	CSA2	CSA3	CSA3A	CSA4	CSA5
Supported RATs	TAB connector supports MSR operation of UTRA only in the band	TAB connector supports MSR operation of E-UTRA only in the band	TAB connector supports UTRA and E-UTRA MSR in the band	TAB connector supports NR and E-UTRA MSR in the band	TAB connector supports single-RAT UTRA in the band	TAB connector supports single-RAT E-UTRA in the band
Supported configurations	SR UTRA (SC, MC)	SR E-UTRA (SC, MC, CA)	MR UTRA + E-UTRA SR UTRA (SC, MC) SR E-UTRA (SC, MC, CA)	MR E-UTRA + NR SR NR (SC, MC, CA) SR E-UTRA (SC, MC, CA)	SR UTRA (SC, MC)	SR E-UTRA (SC, MC, CA)
Applicable BC	BC1, BC2 or BC3	BC1, BC2 or BC3	BC1, BC2 or BC3	BC1, BC2 or BC3	BC1, BC2 or BC3	BC1, BC2 or BC3

The applicable test configurations for each RF requirement are defined in subclauses 5.1, 5.2 and 5.3 for the declared capability set(s). For a *multi-band TAB connector* the applicable test configurations for each RF requirement are defined in subclause 5.4 for the declared capability set(s).

NOTE: Not every supported configuration within a capability set is tested, but the tables in subclauses 5.2, 5.3 and 5.4 provide a judicious choice among the supported configurations and test configurations to ensure proper test coverage.

4.10 Manufacturer declarations for AAS BS testing

The following declarations are required.

Table 4.10-1 Manufacturers declarations

Declaration identifier	Declaration	Description
D6.1	Operating bands	Operating bands supported by each <i>TAB connector</i> .
D6.3	Spurious emission category	Declare the AAS BS spurious emission category as either category A or B with respect to the limits for spurious emissions, as defined in Recommendation ITU-R SM.329 [35].
D6.4	Geographic area support	The manufacturer shall declare the regions the AAS BS may operate in. e.g. CEPT.
D6.5	Band 20 or Band XX support, operating in geographical areas allocated to broadcasting (DTT)	If the AAS BS has <i>TAB connectors</i> declared to support Band 20 the manufacturer shall declare if the AAS BS may operate in geographical areas allocated to broadcasting (DTT).
D6.6	Band 20 or Band XX support, emission level for channel N ($P_{EM,N}$)	If the AAS BS has <i>TAB connectors</i> declared to support Band 20 or Band XX and has been declared to operate in geographical areas allocated to broadcasting (DTT), the emission level for channel N (Annex G of 3GPP TS 36.104 [11]) shall be declared.
D6.7	Band 20 or Band XX support, Maximum output Power in 10 MHz (P_{10MHz})	If the AAS BS has <i>TAB connectors</i> declared to support Band 20 or Band XX and has been declared to operate in geographical areas allocated to broadcasting (DTT), the maximum output power in 10 MHz (Annex G of 3GPP TS 36.104 [11]) shall be declared.
D6.8	Band 32 or Band XXXII support, Declared emission level in Band 32/XXXII ($P_{EM,B32,ind}$)	If the AAS BS has <i>TAB connectors</i> declared to support Band 32 or Band XXXII the manufacturer shall declare if the AAS BS may operate in geographical areas allocated to broadcasting (DTT), the emission level in Band 32/XXXII ($P_{EM,B32,ind}$, ind=a, b, c, d, e) shall be declared.
D6.10	Co-existence with other systems	The manufacturer shall declare whether the AAS BS under test is intended to operate in geographic areas where one or more of the systems GSM850, GSM900, DCS1800, PCS1900, UTRA FDD, UTRA TDD, E-UTRA and/or PHS operating in another band are deployed.
D6.11	Co-location with other base stations	The manufacturer shall declare whether the AAS BS under test is intended to operate co-located with Base Stations of one or more of the systems GSM850, GSM900, DCS1800, PCS1900, UTRA FDD, UTRA TDD and/or E-UTRA operating in another band.
D6.12	TAB connector capability set (CSA)	The manufacturer shall declare the supported capability set(s) according to table 4.9-1 for all <i>TAB connector(s)</i> and supported operating band.
D6.13	Single or Multi-band TAB connector	<i>Multi-band TAB connector</i> or <i>single band TAB connector</i> . Declared for every <i>TAB connector</i>
D6.14	Contiguous or non-contiguous spectrum	Ability to support contiguous or non-contiguous (or both) frequency distribution of carriers when operating multi-carrier, per TAB connector, per band, per RAT.
D6.15	Contiguous and non-contiguous parameters identical	If contiguous and non-contiguous operation is possible then parameters are the same.
D6.16	Maximum Radio Bandwidth of the multi-band TAB connector.	Largest <i>radio bandwidth</i> that can be supported by the <i>multi-band TAB connector</i> . May be different for transmit and receive. Declared for each supported operating band and operating band combination (D6.41) supported for every <i>multi-band TAB connector</i> .
D6.17	Maximum Base Station RF Bandwidth	Largest <i>Base Station RF Bandwidth</i> in the operating band, declared for each supported operating band for every <i>TAB connector</i> .
D6.18	Maximum Base Station RF Bandwidth for contiguous operation.	Largest <i>Base Station RF Bandwidth</i> for contiguous spectrum operation, declared for each supported operating band and CS for every <i>TAB connector</i> .
D6.19	Maximum Base Station RF Bandwidth for non-contiguous operation.	Largest <i>Base Station RF Bandwidth</i> for non-contiguous spectrum operation, declared for each supported operating band and CS for every <i>TAB connector</i> .
D6.20	E-UTRA supported channel bandwidths	E-UTRA <i>channel bandwidth</i> supported for each supported operating band for every <i>TAB connector</i> .
D6.21	TAB connector operating band support	List of operational bands and band combinations supported by the <i>TAB connector</i> , declared for every <i>TAB connector</i> .
D6.22	CA only operation	Capable of operating with CA only but not multiple carriers. Declared per operating band per <i>TAB connector</i> .
D6.23	Single or multiple carrier	Capable of operating with a single carrier (only) or multiple carriers per operating band, per RAT for all <i>TAB connectors</i> .
D6.24	maximum number of supported carriers per band	Maximum number of supported carriers per supported band, made per band, per RAT for all <i>TAB connectors</i> .
D6.25	Total maximum number of supported carriers	Maximum number of supported carriers for all supported bands, declared for every <i>TAB connector</i> .

Declaration identifier	Declaration	Description
D6.26	Reduced number of supported carriers at the rated total output power in Multi-RAT operations	Declared for each supported operating band for all <i>TAB connectors</i> .
D6.27	Reduced total output power at the total number of supported carriers in Multi-RAT operations	Declared for each supported operating band for all <i>TAB connectors</i> .
D6.28	Other band combination multi-band restrictions	Declare any other limitations under simultaneous operation in the declared band combinations (D6.41) for each <i>multi-band TAB connector</i> which have any impact on the test configuration generation. For every <i>multi-band TAB connector</i> .
D6.30	The rated carrier output power for each <i>TAB connector</i> $P_{\text{Rated,c,TABC}}$	$P_{\text{Rated,c,TABC}}$, is declared per supported operating band, per supported RAT for all <i>TAB connector(s)</i> .
D6.31	The rated carrier output power per <i>TAB connector</i> , for contiguous spectrum operation	The rated carrier output power per <i>TAB connector</i> , for contiguous spectrum operation. Declared for each supported operational band and CS, for all <i>TAB connectors</i>
D6.32	The rated carrier output power per <i>TAB connector</i> , for non-contiguous spectrum operation	The rated carrier output power per <i>TAB connector</i> , for non-contiguous spectrum operation. Declared for each supported operational band and CS, for all <i>TAB connectors</i>
D6.33	The rated output power per RAT for each <i>TAB connector</i> , $P_{\text{Rated,RAT,TABC}}$	$P_{\text{Rated,RAT,TABC}}$ is declared per supported operating band, per supported RAT for all <i>TAB connector(s)</i> .
D6.34	The <i>rated total output power per TAB connector</i> , $P_{\text{Rated,t,TABC}}$	The rated total output power $P_{\text{Rated,t,TABC}}$ is declared for supported operating band, for all <i>TAB connector(s)</i> . For <i>multi-band TAB connectors</i> $P_{\text{Rated,t,TABC}}$ is declared for each supported band in each supported band combination.
D6.35	The <i>rated total output power per TAB connector</i> , for contiguous spectrum operation	The <i>rated total output power per TAB connector</i> , for contiguous spectrum operation. Declared for each supported operational band and CS, for all <i>TAB connectors</i> .
D6.36	The <i>rated total output power per TAB connector</i> , for non-contiguous spectrum operation	The <i>rated total output power per TAB connector</i> , for non-contiguous spectrum operation. Declared for each supported operational band and CS, for all <i>TAB connectors</i> .
D6.37	The rated multi-band total output power per <i>TAB connector</i> , $P_{\text{Rated,MB,TABC}}$	The rated multi-band total output power ($P_{\text{Rated,MB,TABC}}$), declared for all declared operating band combinations for every <i>multi-band TAB connector</i> .
D6.38	N_{cells}	Number corresponding to the minimum number of cells that can be transmitted by an AAS BS in a particular band with transmission on all <i>TAB connectors</i> supporting the operating band.
D6.39	Maximum supported power difference between carriers	Maximum supported power difference between carriers in each supported operating band, for all <i>TAB connector(s)</i> .
D6.40	Maximum supported power difference between carriers in different operating bands	Supported power difference between any two carriers in any two different supported operating bands, for all declared operating band combination for every <i>multi-band TAB connector(s)</i> .
D6.41	AAS BS operating band combination support	List of operational bands combinations supported by the AAS BS.
D6.42	Total number of supported carriers for the declared band combinations of the AAS BS	Total number of supported carriers for the declared band combinations (D6.41) of the AAS BS.
D6.43	Intra-system interfering signal <i>TAB connector</i> declaration list	List of <i>TAB connectors</i> for which an intra-system interfering signal level is required to be declared. Declaration is required if the intra-system interfering signal level is larger than the co-location interfering signal level.
D6.44	Intra-system interfering signal level	The interfering signal level in dBm per <i>TAB connector</i> declared for each supported operational band, for all <i>TAB connectors</i> covered by D6.43.
D6.45	P-CPICH transmission group(s)	Groups of <i>TAB connectors</i> which are declared to transmit the P-CPICH. Declared per operating band, UTRA FDD only.
D6.48	CCPCH transmission group(s)	Groups of <i>TAB connectors</i> which are declared to transmit the CCPCH. Declared per operating band, UTRA TDD only

Declaration identifier	Declaration	Description
D6.51	UTRA FDD MIMO support.	Number of 'antennas' supported by the UTRA FDD MIMO mode (i.e. 2 or 4). The concept of "antenna 2", "antenna 3" and "antenna 4" is described in 3GPP TS 25.104 [2]. Declared per operating band, UTRA FDD only.
D6.52	S-CPICH transmission group(s)	Groups of <i>TAB connectors</i> which are declared to transmit the S-CPICH for each of the 'antennas' declared in D6.49 For UTRA FDD AAS BS operating only "antenna 1" and "antenna 2", mapping for 'antenna 2' is declared. For UTRA FDD AAS BS operating "antenna 1", "antenna 2", "antenna 3" and "antenna 4", mapping for "antenna 2", "antenna 3", and "antenna 4", is declared. Declared per operating band, UTRA FDD only. NOTE: Mapping for "antenna 1" is the same as D6.45.
D6.54	DL RS transmission groups	Groups of <i>TAB connectors</i> which are declared to transmit the DL RS. Declared per operating band, E-UTRA only.
D6.57	UTRA Inner loop power control dynamic range	Power control dynamic range for UTRA inner loop power control. Declared for each supported operating band, for all <i>TAB connector(s)</i> . UTRA only.
D6.58	TAE groups	Set of declared <i>TAB connector beam forming groups</i> on which the TAE requirements apply. <i>All TAB connectors</i> belong to at least 1 <i>TAB connector beam forming group</i> (even if it's a <i>TAB connector beam forming group</i> consisting of 1 connector). The smallest possible number of <i>TAB connector beam forming groups</i> need to be declared such that there is no <i>TAB connector</i> not contained in at least one of the declared <i>TAB connector beam forming groups</i> . Declared for each supported RAT and operating band.
D6.59	Inter-band CA or HSDPA	Band combinations declared to support inter-band CA or multi-band HSDPA. Declared for every <i>multi-band TAB connector</i> which support CA or multi-band HSDPA. NOTE: Inter-band HSDPA is called multi-band HSDPA in UTRA specifications. Examples of the multi-band HSDPA are DB-DC-HSDPA or Dual band 4C-HSDPA.
D6.60	Intra-band contiguous CA or HSDPA	Bands declared to support intra-band contiguous CA (per CA capable <i>TAB connector</i> , as in D6.22) or contiguous multi-carrier HSDPA. Declared for every <i>TAB connector</i> which support CA or multi-band HSDPA. NOTE: Intra-band HSDPA is called multi-carrier HSDPA in UTRA specifications. Examples of the contiguous multi-carrier HSDPA are DC-HSDPA, 4C-HSDPA, or 8C-HSDPA.
D6.61	Intra-band non-contiguous CA or HSDPA	Bands declared to support intra-band non-contiguous CA (per CA capable <i>TAB connector</i> , as in D6.22) or non-contiguous multi-carrier HSDPA. Declared for every <i>TAB connector</i> which support CA or multi-band HSDPA. NOTE: Intra-band HSDPA is called multi-carrier HSDPA in UTRA specifications. Example of the non-contiguous multi-carrier HSDPA is NC-4C-HSDPA.
D6.70	Equivalent TAB connectors	List of <i>TAB connectors</i> which have been declared equivalent. Equivalent TAB connectors imply that the <i>TAB connectors</i> are expected to behave in the same way when presented with identical signals under the same operating conditions. All declarations made for the <i>TAB connectors</i> are identical and the transmitter unit and/or receiver unit driving the <i>TAB connector</i> are of identical design.
D6.71	BS class	BS Class of the AAS BS, declared as Wide Area BS, Medium Range BS, or Local Area BS.
D6.72	TAB connector RX min cell group	Declared as a group of TAB connectors to which RX requirements are applied. This declaration corresponds to group of TAB connectors which are responsible for receiving a cell when the hybrid AAS BS setting corresponding to the declared minimum number of cells (Ncells) with transmission on all TAB connectors supporting an operating band.

Declaration identifier	Declaration	Description
D6.73	TAB connector TX min cell group	Declared group of TAB connectors to which TX requirements are applied. This declaration corresponds to group of TAB connectors which are responsible for transmitting a cell when the hybrid AAS BS setting corresponding to the declared minimum number of cells (Ncells) with transmission on all TAB connectors supporting an operating band.
D6.74	TAB connectors used for performance requirement testing	To reduce test complexity, declaration of a representative (sub)set of TAB connectors to be used for performance requirement test purposes. At least one TAB connector mapped to each demodulation branch is declared.
D6.75	NR supported channel bandwidths and SCS	NR channel bandwidth and SCS supported. Declared per supported operating band and TAB connector.

4.11 Test signal configurations for AAS BS

4.11.1 General

The test configurations shall be constructed using the methods defined below subject to the parameters declared by the manufacturer as listed in subclause 4.10.

For test contiguous spectrum operation configurations used in receiver tests only the carriers in the outermost frequency positions in the *TAB connector Base Station RF Bandwidth* need to be generated by the test equipment. For non-contiguous spectrum operation test configurations used in receiver tests, outermost carriers for each sub-block need to be generated by the test equipment.

The applicable test models for generation of the carrier transmit test signal are defined in subclause 4.12.2.

NOTE: In case carriers are shifted to align with the channel raster F_{Offset} .

4.11.1a NR Test signal used to build Test Configurations

The signal's Channel Bandwidth and Subcarrier spacing used to build NR Test Configurations shall be selected according to table 4.11.1a-1.

Table 4.11.1a-1: Signal to be used to build NR TCs

Operating Band characteristics		$F_{\text{DL_high}} - F_{\text{DL_low}} < 100 \text{ MHz}$	$F_{\text{DL_high}} - F_{\text{DL_low}} \geq 100 \text{ MHz}$
TC signal characteristics	BW_{channel}	5 MHz (Note 1)	20 MHz (Note 1)
	Subcarrier spacing	Smallest supported subcarrier spacing	
Note 1: If this channel bandwidth is not supported, the narrowest supported channel bandwidth shall be used.			

4.11.2 Test signal configurations

4.11.2.1 ATC1: UTRA multicarrier operation

4.11.2.1.1 General

The purpose of ATC1 is to test UTRA multi-carrier aspects.

4.11.2.1.2 ATC1a generation

ATC1 should be constructed using the following method:

- The *Base Station RF Bandwidth* shall be the declared maximum *Base Station RF Bandwidth* for contiguous operation (see table 4.10-1, D6.18).
- Place one UTRA FDD carrier adjacent to the upper *Base Station RF Bandwidth edge* and one UTRA FDD carrier adjacent to the lower *Base Station RF Bandwidth edge*. The specified F_{Offset} shall apply.

- For transmitter tests, alternately place a UTRA FDD carrier adjacent to the already placed carriers at the low and high *Base Station RF Bandwidth edges* until there is no more space to fit a carrier or the *TAB connector* does not support more carriers. The nominal carrier spacing defined in subclause 4.6 shall apply.
- The carrier(s) may be shifted maximum 100 kHz towards lower frequencies for B_{RFBW} and M_{RFBW} and towards higher frequencies for T_{RFBW} to align with the channel raster.

4.11.2.1.3 ATC1b generation

ATC1b is constructed using the following method:

- The *Base Station RF Bandwidth* shall be the declared maximum *Base Station RF Bandwidth* for contiguous operation (see table 4.10-1, D6.18).
- Place one UTRA TDD carrier adjacent to the upper *Base Station RF Bandwidth edge* and one UTRA TDD carrier adjacent to the lower *Base Station RF Bandwidth edge*. The specified F_{Offset} shall apply.
- For transmitter tests, alternately place a UTRA TDD carrier adjacent to the already placed carriers at the low and high *Base Station RF Bandwidth edges* until there is no more space to fit a carrier or the *TAB connector* does not support more carriers. The nominal carrier spacing defined in subclause 4.6 shall apply.

4.11.2.1.4 ATC1 power allocation

Set the power of each carrier to the same power so that the sum of the carrier powers equals $P_{\text{rated,RAT,TABC}}$ for UTRA according to the manufacturer's declaration in subclause 4.10.

4.11.2.2 ANTC1: UTRA FDD multicarrier non-contiguous operation

4.11.2.2.1 General

The purpose of ANTC1 is to test UTRA FDD multicarrier non-contiguous aspects.

4.11.2.2.2 ANTC1 generation

The purpose of NTC1a is to test UTRA multicarrier non-contiguous aspects. NTC1a is constructed using the following method:

- The *Base Station RF Bandwidth* of each supported operating band shall be the declared maximum *Base Station RF Bandwidth* for non-contiguous operation (see table 4.10-1, D6.19) of the *TAB connector*. The *station RF bandwidth* consists of one *sub-block gap* and two sub-blocks located at the edges of the declared maximum *Base Station RF Bandwidth* for non-contiguous operation.
- For transmitter tests, place one UTRA carrier adjacent to the upper *Base Station RF Bandwidth edge* and one UTRA carrier adjacent to the lower *Base Station RF Bandwidth edge*. The specified $F_{\text{Offset-RAT}}$ shall apply.
- For receiver tests, place one UTRA carrier adjacent to the upper *Base Station RF Bandwidth edge* and one UTRA carrier adjacent to the lower *Base Station RF Bandwidth edge*. For single-band operation, if the maximum *Base Station RF Bandwidth* for non-contiguous operation is at least 35 MHz and the *TAB connector* supports at least 4 UTRA FDD carriers, place a UTRA FDD carrier adjacent to each already placed carrier for each sub-block. The nominal carrier spacing defined in subclause 4.6 shall apply.
- The sub-block edges adjacent to the *sub-block gap* shall be determined using the specified $F_{\text{Offset-RAT}}$ for the carrier adjacent to the *sub-block gap*.
- The UTRA FDD carrier in the lower sub-block may be shifted maximum 100 kHz towards lower frequencies and the UTRA FDD carrier in the upper sub-block may be shifted maximum 100 kHz towards higher frequencies to align with the channel raster.

4.11.2.2.3 ANTC1 power allocation

Set the power of each carrier to the same power so that the sum of the carrier powers equals $P_{\text{Rated,RAT,TABC}}$ according to the manufacturer's declaration in subclause 4.10.

4.11.2.3 ATC2: E-UTRA multicarrier operation

4.11.2.3.1 General

The purpose of ATC2a is to test E-UTRA multi-carrier aspects excluding CA occupied bandwidth.

The purpose of ATC2b is to test E-UTRA Contiguous CA occupied bandwidth.

4.11.2.3.2 ATC2a generation

ATC2a is constructed using the following method:

- The *Base Station RF Bandwidth* of each supported operating band shall be the declared maximum *Base Station RF Bandwidth* for contiguous operation (see table 4.10-1, D6.18) of the *TAB connector*.
- Select the narrowest supported E-UTRA carrier and place it adjacent to the low *Base Station RF Bandwidth edge*. Place a 5 MHz E-UTRA carrier adjacent to the high *Base Station RF Bandwidth edge*. The specified $F_{\text{Offset-RAT}}$ shall apply.
- For transmitter tests, select as many 5 MHz E-UTRA carriers that the *TAB connector* supports and that fit in the rest of the *Base Station RF Bandwidth*. Place the carriers adjacent to each other starting from the high *Base Station RF Bandwidth edge*. The nominal carrier spacing defined in subclause 4.6 shall apply. The specified $F_{\text{Offset-RAT}}$ shall apply.
- If 5 MHz E-UTRA carriers are not supported by the *TAB connector* the narrowest supported *channel bandwidth* shall be selected instead.

The test configuration should be constructed on a per band basis for all component carriers of the inter-band CA bands declared to be supported by the *TAB connector* (see table 4.10-1, D6.29). All configured component carriers are transmitted simultaneously in the tests where the transmitter should be on.

4.11.2.3.3 ATC2b generation

ATC2b is constructed on a per band basis using the following method:

- All component carrier combinations supported by the *TAB connector*, which have different sum of *channel bandwidth* of component carrier, shall be tested. For all component carrier combinations which have the same sum of *channel bandwidth* of component carriers, only one of the component carrier combinations shall be tested.
- Of all component carrier combinations which have same sum of *channel bandwidth* of component carrier, select those with the narrowest carrier at the lower *Base Station RF Bandwidth edge*.
- Of the combinations selected in the previous step, select one with the narrowest carrier at the upper *Base Station RF Bandwidth edge*.
- If there are multiple combinations fulfilling previous steps, select the one with the smallest number of component carrier.
- If there are multiple combinations fulfilling previous steps, select the one with the widest carrier being adjacent to the lowest carrier.
- If there are multiple combinations fulfilling previous steps, select the one with the widest carrier being adjacent to the highest carrier.
- If there are multiple combinations fulfilling previous steps, select the one with the widest carrier being adjacent to the carrier which has been selected in the previous step.
- If there are multiple combinations fulfilling previous steps, repeat the previous step until there is only one combination left.
- The nominal carrier spacing defined in subclause 4.6 shall apply.

4.11.2.3.4 ATC2 power allocation

Set the power of each carrier to the same power so that the sum of the carrier powers equals $P_{\text{rated,RAT,TABC}}$ for E-UTRA according to the manufacturer's declaration in subclause 4.10.

For a *TAB connector* declared to support only CA operation (see table 4.10-1, D6.22), set the power spectral density of each carrier to the same level so that the sum of the carrier powers equals the rated total output power ($P_{\text{Rated,t,TABC}}$) according to the manufacturer's declaration in subclause 4.10.

4.11.2.4 ANTC2: E-UTRA multicarrier non-contiguous operation

4.11.2.4.1 General

The purpose of ANTC2 is to test E-UTRA multicarrier non-contiguous aspects.

4.11.2.4.2 ANTC2 generation

ANTC2 is constructed as NTC2 in 3GPP TS 37.141[16] subclause 4.8.2a.1.

The purpose of NTC2 is to test E-UTRA multicarrier non-contiguous aspects. NTC2 is constructed using the following method:

- The *Base Station RF Bandwidth* of each supported operating band shall be the declared maximum *Base Station RF Bandwidth* for non-contiguous operation (D6.19) of the *TAB connector*. The *Base Station RF Bandwidth* consists of one *sub-block gap* and two sub-blocks located at the edges of the declared maximum *Base Station RF Bandwidth* (D.17).
- For transmitter tests, place a 5 MHz E-UTRA carrier adjacent to the upper *Base Station RF Bandwidth edge* and a 5 MHz E-UTRA carrier adjacent to the lower *Base Station RF Bandwidth edge*. The specified $F_{\text{Offset-RAT}}$ shall apply. If 5 MHz E-UTRA carriers are not supported by the *TAB connector*, the narrowest supported *channel bandwidth* shall be selected instead.
- For receiver tests, place a 5 MHz E-UTRA carrier adjacent to the upper *Base Station RF Bandwidth edge* and a 5 MHz E-UTRA carrier adjacent to the lower *Base Station RF Bandwidth edge*. If 5 MHz E-UTRA carriers are not supported by the *TAB connector*, the narrowest supported *channel bandwidth* shall be selected instead.
- For single-band operation receiver tests, if the remaining gap is at least 15 MHz plus two times the *channel bandwidth* used in the previous step and the *TAB connector* supports at least 4 E-UTRA carriers, place a E-UTRA carrier of this *channel bandwidth* adjacent to each already placed carrier for each sub-block. The nominal carrier spacing defined in subclause 4.6 shall apply.
- The sub-block edges adjacent to the *sub-block gap* shall be determined using the specified $F_{\text{Offset-RAT}}$ for the carrier adjacent to the *sub-block gap*.

4.11.2.4.3 ANTC2 power allocation

Set the power of each carrier to the same power so that the sum of the carrier powers equals $P_{\text{rated,RAT,TABC}}$ according to the manufacturer's declaration in subclause 4.10.

4.11.2.5 ATC3: UTRA and E-UTRA multi RAT operation

4.11.2.5.1 General

The purpose of ATC3 is to test UTRA and E-UTRA multi-RAT aspects.

If the rated total output power and total number of supported carriers are not simultaneously supported in Multi-RAT operations, two instances of ATC3 shall be generated using the following values for rated total output power and the total number of supported carriers:

- 1) The rated total output power and the reduced number of supported carriers at the rated total output power in Multi-RAT operations.
- 2) The reduced total output power at the total number of supported carriers in Multi-RAT operations and the total number of supported carriers.

Tests that use ATC3 shall be performed using both instances 1) and 2) of ATC3.

4.11.2.5.2 ATC3a generation

ATC3a is constructed using the following method:

- The *Base Station RF Bandwidth* of each supported operating band shall be the declared maximum *Base Station RF Bandwidth* (D6.17) of the *TAB connector*.
- Select an FDD UTRA carrier to be placed at the lower *Base Station RF Bandwidth edge*. The specified $F_{\text{Offset-RAT}}$ shall apply. The UTRA FDD may be shifted maximum 100 kHz towards lower frequencies to align with the channel raster.
- Place a 5 MHz E-UTRA carrier at the upper *Base Station RF Bandwidth edge*. If that is not possible use the narrowest E-UTRA carrier supported by the *TAB connector*. The specified $F_{\text{Offset-RAT}}$ shall apply.
- For transmitter tests, alternately add FDD UTRA carriers at the low end and 5 MHz E-UTRA carriers at the high end adjacent to the already placed carriers until the *Base Station RF Bandwidth* is filled or the total number of supported carriers (D6.25) is reached. The nominal carrier spacing defined in subclause 4.6 shall apply.

4.11.2.5.3 ATC3b generation

ATC3b is constructed using the following method:

- The *Base Station RF Bandwidth* of each supported operating band shall be the declared maximum *Base Station RF Bandwidth* (D6.17) of the *TAB connector*.
- Select a UTRA TDD carrier to be placed at the lower *Base Station RF Bandwidth edge*. The specified $F_{\text{Offset-RAT}}$ shall apply.
- Place a 5 MHz E-UTRA carrier at the upper *Base Station RF Bandwidth edge*. If that is not possible use the narrowest E-UTRA carrier supported by the *TAB connector*. The specified $F_{\text{Offset-RAT}}$ shall apply.
- For transmitter tests, alternately add UTRA TDD carriers at the low end and 5 MHz E-UTRA carriers at the high end adjacent to the already placed carriers until the *Base Station RF Bandwidth* is filled or the total number of supported carriers is reached. The nominal carrier spacing defined in clause 4.6 shall apply.

4.11.2.5.4 ATC3 power allocation

Set the power of each carrier to the same power so that the sum of the carrier powers equals $P_{\text{Rated,RAT,TABC}}$ according to the manufacturer's declaration in subclause 4.10.

4.11.2.6 ANTC3: UTRA and E-UTRA multi RAT non-contiguous operation

4.11.2.6.1 General

The purpose of ANTC3 is to test UTRA and E-UTRA multi RAT non-contiguous aspects.

If $P_{\text{Rated,t,TABC}}$ and total number of supported carriers are not simultaneously supported in Multi-RAT operations, two instances of ANTC3 shall be generated using the following values for $P_{\text{Rated,t,TABC}}$ and the total number of supported carriers:

- 1) $P_{\text{Rated,t,TAB}}$ and the reduced number of supported carriers (DUID26) at the rated total output power in Multi-RAT operations.
- 2) The reduced total output power at the total number of supported carriers in Multi-RAT operations (DUID27) at the total number of supported carriers (DUID25).

If the reduced number of supported carriers is 4 or more, only instance 1) of ANTC3 shall be used in the tests, otherwise both instances 1) and 2) of ANTC3 shall be used in the tests.

4.11.2.6.2 ANTC3a generation

ANTC3a is constructed using the following method:

- The *Base Station RF Bandwidth* of each supported operating band shall be the declared maximum *Base Station RF Bandwidth* for non-contiguous operation (D6.19) of the *TAB connector*. The *Base Station RF Bandwidth*

consists of one *sub-block gap* and two sub-blocks located at the edges of the declared maximum *Base Station RF Bandwidth* for non-contiguous operation (D6.19).

- For transmitter tests, place an UTRA carrier at the lower *Base Station RF Bandwidth edge* and a 5 MHz E-UTRA carrier at the upper *Base Station RF Bandwidth edge*. The specified $F_{\text{Offset-RAT}}$ shall apply. If 5 MHz E-UTRA carriers are not supported by the *TAB connector*, the narrowest supported *channel bandwidth* shall be selected instead. The UTRA FDD may be shifted maximum 100 kHz towards lower frequencies to align with the channel raster.
- For receiver tests, place an UTRA carrier at the lower *Base Station RF Bandwidth edge* and a 5 MHz E-UTRA carrier at the upper *Base Station RF Bandwidth edge*. The specified $F_{\text{Offset-RAT}}$ shall apply. If 5 MHz E-UTRA carriers are not supported by the *TAB connector*, the narrowest supported *channel bandwidth* shall be selected instead. The UTRA FDD may be shifted maximum 100 kHz towards lower frequencies to align with the channel raster.
- For single-band operation receiver tests, if the remaining gap is at least 20 MHz plus the *channel bandwidth* of the E-UTRA carrier used in the previous step and the *TAB connector* supports at least 2 UTRA and 2 E-UTRA carriers, place a E-UTRA carrier of this *channel bandwidth* adjacent to the carrier at the lower *Base Station RF Bandwidth edge* and UTRA carrier adjacent to the carrier at the upper *Base Station RF Bandwidth edge*. The nominal carrier spacing defined in subclause 4.6 shall apply. The UTRA FDD may be shifted maximum 100 kHz towards higher frequencies to align with the channel raster.
- The sub-block edges adjacent to the *sub-block gap* shall be determined using the specified $F_{\text{Offset-RAT}}$ for the carrier adjacent to the *sub-block gap*.

4.11.2.6.3 ANTC3 power allocation

Set the power of each carrier to the same power so that the sum of the carrier powers equals the $P_{\text{Rated,t,TABC}}$ according to the cases in subclause 4.11.2.6.1.

4.11.2.7 ATC4: Single carrier for receiver tests

4.11.2.7.1 ATC4a generation

ATC4a is constructed using the following method:

- Place a single UTRA carrier in the middle of the maximum supported *Base Station RF Bandwidth*. The carrier may be shifted maximum 100 kHz towards lower frequencies for B_{RFBW} and M_{RFBW} and towards higher frequencies for T_{RFBW} to align with the channel raster.

4.11.2.7.2 ATC4b generation

ATC4b is constructed using the following method:

- Place the narrowest supported E-UTRA carrier in the middle of the maximum supported *Base Station RF Bandwidth*.

4.11.2.7.3 ATC4c generation

ATC4c is constructed using the following method:

- Place a single UTRA TDD carrier in the middle of the maximum supported *Base Station RF Bandwidth*.

4.11.2.7.4 ATC4d generation

ATC4d is constructed using the following method:

- Place a single NR carrier as specified in subclause 4.11.1a in the middle of the maximum radiated *Base Station RF Bandwidth*.

4.11.2.8 Generation of MB-MSR test configurations

4.11.2.8.1 ATC5a: MB-MSR test configuration for full carrier allocation

4.11.2.8.1.1 General

The purpose of ATC5a is to test *multi-band TAB connectors*, considering maximum supported number of carriers.

4.11.2.8.1.2 ATC5a generation

ATC5a is based on re-using the existing test configurations applicable per band on *multi-band TAB connectors*. ATC5a is constructed using the following method:

- The *Base Station RF Bandwidth* of each supported operating band shall be the declared maximum *Base Station RF Bandwidth* (see table 4.10-1, D6.17) of the *multi-band TAB connector*.
- The number of carriers of each supported operating band shall be the declared maximum number of supported carriers by the *multi-band TAB connector* in each band (see table 4.10-1, D6.25). Carriers shall first be placed at the outermost edges of the declared maximum *Radio Bandwidth* (see table 4.10-1, D6.16) Additional carriers shall next be placed at the edges of the *Base Station RF Bandwidths*, if possible.
- The allocated *Base Station RF Bandwidth* of the outermost bands shall be located at the outermost edges of the declared maximum *Radio Bandwidth* (see table 4.10-1, D6.16).
- Each concerned band shall be considered as an independent band and the carrier placement in each band shall be according to the test configuration referenced in Table 4.11.2.8.1.2-1, where the declared parameters for multi-band operation shall apply. The mirror image of the single band test configuration shall be used in the highest band being tested for the *TAB connector*.
- If a *multi-band TAB connector* supports three carriers only, two carriers shall be placed in one band according to the relevant test configuration while the remaining carrier shall be placed at the edge of the maximum *Radio Bandwidth* (DUID9) in the other band.
- If the sum of the *base Station RF bandwidths* of each of the supported operating bands is greater than the declared *Radio Bandwidth* (see table 4.10-1, D6.16) for the declared band combinations (see table 4.10-1, D6.41) of the *TAB connector* then repeat the steps above for test configurations where the *Base Station RF Bandwidth* of one of the operating band shall be reduced so that the declared *Radio Bandwidth* (see table 4.10-1, D6.16) of the *TAB connector* is not exceeded and vice versa.
- If the sum of the maximum number of supported carrier of each supported operating bands for the *multi-band TAB connector* is larger than the declared total number of supported carriers for the declared band combinations (see table 4.10-1, D6.42) of the AAS BS, repeat the steps above for test configurations where in each test configuration the number of carriers of one of the operating band shall be reduced so that the total number of supported carriers is not be exceeded and vice versa.

Table 4.11.2.8.1.2-1: The applicability of test configuration for carrier placement in each band

BC	CSA 1	CSA 2	CSA 3	CSA 3A	CSA 4	CSA 5
BC1	ATC1a	ATC2a	ATC3a	ATC6	ATC1a	ATC2a
BC2	ATC1a	ATC2a	ATC3a	ATC6	ATC1a	ATC2a
BC3	ATC1b	ATC2a	ATC3b	ATC6	ATC1b	ATC2a

4.11.2.8.1.3 ATC5a power allocation

Unless otherwise stated, set the power of each carrier ($P_{\text{Rated,c,TABC}}$) in all supported operating bands to the same power so that the sum of the carrier powers equals the rated total output power ($P_{\text{Rated,MB,TABC}}$) according to the manufacturer's declaration.

If the allocated power of a supported operating band(s) exceeds the declared rated total output power of the operating band(s) ($P_{\text{Rated,MB,TABC}}$) in multi-band operation, the exceeded part shall, if possible, be reallocated into the other band(s). If the power allocated for a carrier exceeds the rated carrier output power declared for that carrier ($P_{\text{Rated,c,TABC}}$), the exceeded power shall, if possible, be reallocated into the other carriers.

4.11.2.8.2 ATC5b: MB-MSR test configuration with high PSD per carrier

4.11.2.8.2.1 General

The purpose of ATC5b is to test multi-band operation aspects considering higher PSD cases with reduced number of carriers and non-contiguous operation (if supported) in multi-band mode.

4.11.2.8.2.2 ATC5b generation

ATC5b is based on re-using the existing test configurations applicable per band on *multi-band TAB connectors*. ATC5b is constructed using the following method:

- The *Base Station RF Bandwidth* of each supported operating band shall be the declared maximum *Base Station RF Bandwidth* (see table 4.10-1, D6.16) of the *multi-band TAB connector*.
- The allocated *Radio Bandwidth* of the outermost bands shall be located at the outermost edges of the declared maximum *Radio Bandwidth* (see table 4.10-1, D6.16).
- The maximum number of carriers is limited to two per band. Carriers shall be placed at the outermost edges of the declared maximum *Radio Bandwidth* (see table 4.10-1, D6.16).
- Each concerned band shall be considered as an independent band and the carrier placement in each band shall be according to the test configuration referenced in Table 4.11.2.8.2.2-1, where the declared parameters for multi-band operation shall apply. Narrowest supported E-UTRA *channel bandwidth* shall be used in the test configuration. The mirror image of the single band test configuration shall be used in the highest band being tested for the *TAB connector*.
- For AAS BS supporting CSA4 in the band, if a multi-band TAB connector supports three carriers only, two carriers shall be placed in one band according to AUTC2 while the remaining carrier shall be placed at the edge of the Maximum *Base Station RF Bandwidth* in the other band.
- If the sum of the *base Station RF bandwidths* of each of the supported operating bands is greater than the declared *Radio Bandwidth* (see table 4.10-1, D6.16) for the declared band combinations (see table 4.10-1, D6.41) of the *TAB connector* then repeat the steps above for test configurations where the *Base Station RF Bandwidth* of one of the operating band shall be reduced so that the declared *Radio Bandwidth* (see table 4.10-1, D6.16) of the *TAB connector* is not exceeded and vice versa.

Table 4.11.2.8.2.2-1: The applicability of test configuration for carrier placement in each band

BC	CSA 1	CSA 2	CSA 3	CSA 3A	CSA 4	CSA 5
BC1	ANTC1a	ANTC2	ANTC3a	ANTC6	ANTC1	ANTC2
BC2	ANTC1a	ANTC2	ANTC3a	ANTC6	ANTC1	ANTC2
BC3	ATC1b	ANTC2	ANTC3a	ANTC6	N/A	ANTC2

4.11.2.8.2.3 ATC5b power allocation

Unless otherwise stated, set the power of each carrier ($P_{\text{Rated},c,\text{TABC}}$) in all supported operating bands to the same power so that the sum of the carrier powers equals the rated total output power ($P_{\text{Rated},\text{MB},\text{TABC}}$) according to the manufacturer's declaration.

If the allocated power of a supported operating band(s) exceeds the declared rated total output power of the operating band(s) ($P_{\text{Rated},t,\text{TABC}}$) in multi-band operation, the exceeded part shall, if possible, be reallocated into the other band(s). If the power allocated for a carrier exceeds the rated carrier output power declared for that carrier ($P_{\text{Rated},c,\text{TABC}}$), the exceeded power shall, if possible, be reallocated into the other carriers.

4.11.2.9 ATC6: E-UTRA and NR multi RAT operation

4.11.2.9.1 General

The purpose of ATC6 is to test E-UTRA and NR multi-RAT aspects.

If the rated total output power and total number of supported carriers are not simultaneously supported in Multi-RAT operations, two instances of ATC6 shall be generated using the following values for rated total output power and the total number of supported carriers:

- 1) The rated total output power and the reduced number of supported carriers at the rated total output power in Multi-RAT operations.
- 2) The reduced total output power at the total number of supported carriers in Multi-RAT operations and the total number of supported carriers.

Tests that use ATC6 shall be performed using both instances 1) and 2) of ATC6.

4.11.2.9.2 ATC6 generation

ATC6 is constructed using the following method:

- The *Base Station RF Bandwidth* of each supported operating band shall be the declared maximum *Base Station RF Bandwidth* (D6.17) of the *TAB connector*.
- Select a NR carrier as specified in subclause 4.11.1a to be placed at the lower *Base Station RF Bandwidth edge*. The specified $F_{\text{Offset-RAT}}$ shall apply.
- Place a 5 MHz E-UTRA carrier at the upper *Base Station RF Bandwidth edge*. If that is not possible use the narrowest E-UTRA carrier supported by the beam. The specified $F_{\text{Offset-RAT}}$ shall apply.
- For transmitter tests, alternately add NR carriers as specified in subclause 4.11.1a at the low end and 5 MHz E-UTRA carriers at the high end adjacent to the already placed carriers until the *Base Station RF Bandwidth* is filled or the total number of supported carriers (see table 4.10-1, D9.14) is reached. The nominal carrier spacing defined in subclause 4.6 shall apply.

4.11.2.9.3 ATC6 power allocation

Set the power of each carrier to the same power so that the sum of the carrier powers equals $P_{\text{Rated,RAT,TABC}}$ according to the manufacturer's declaration in subclause 4.10.

4.11.2.10 ANTC6: E-UTRA and NR multi RAT non-contiguous operation

4.11.2.10.1 General

The purpose of ANTC6 is to test E-UTRA and NR multi RAT non-contiguous aspects.

If $P_{\text{Rated,t,TABC}}$ and total number of supported carriers are not simultaneously supported in Multi-RAT operations, two instances of ANTC6 shall be generated using the following values for $P_{\text{Rated,t,TABC}}$ and the total number of supported carriers:

- 1) $P_{\text{Rated,t,TAB}}$ and the reduced number of supported carriers (DUID26) at the rated total output power in Multi-RAT operations.
- 2) The reduced total output power at the total number of supported carriers in Multi-RAT operations (DUID27) at the total number of supported carriers (DUID25).

If the reduced number of supported carriers is 4 or more, only instance 1) of ANTC6 shall be used in the tests, otherwise both instances 1) and 2) of ANTC6 shall be used in the tests.

4.11.2.10.2 ANTC6 generation

ANTC6 is constructed using the following method:

- The *Base Station RF Bandwidth* of each supported operating band shall be the declared maximum *Base Station RF Bandwidth* for non-contiguous operation (D6.19) of the *TAB connector*. The *Base Station RF Bandwidth* consists of one *sub-block gap* and two sub-blocks located at the edges of the declared maximum *Base Station RF Bandwidth* for non-contiguous operation (D6.19).
- For transmitter tests, place an NR carrier as specified in subclause 4.11.1a at the lower *Base Station RF Bandwidth edge* and a 5 MHz E-UTRA carrier at the upper *Base Station RF Bandwidth edge*. The specified $F_{\text{Offset-RAT}}$ shall apply. If 5 MHz E-UTRA carriers are not supported by the beam, the narrowest supported *channel bandwidth* shall be selected instead.
- For receiver tests, place a NR carrier as specified in subclause 4.11.1a at the lower *Base Station RF Bandwidth edge* and a 5 MHz E-UTRA carrier at the upper *Base Station RF Bandwidth edge*. The specified $F_{\text{Offset-RAT}}$ shall

apply. If 5 MHz E-UTRA carriers are not supported by the beam, the narrowest supported *channel bandwidth* shall be selected instead.

- The sub-block edges adjacent to the sub-block gap shall be determined using the specified $F_{\text{Offset-RAT}}$ for the carrier adjacent to the sub-block gap.

4.11.2.10.3 ANTC6 power allocation

Set the power of each carrier to the same power so that the sum of the carrier powers equals the $P_{\text{Rated,t,TABC}}$ according to the cases in subclause 4.11.2.6.1.

4.11.2.11 ATC7: NR multicarrier operation

4.11.2.11.1 General

The purpose of ATC7 is to test NR multi-carrier aspects excluding CA occupied bandwidth.

4.11.2.11.2 ATC7 generation

ATC7 is constructed using the following method:

- The *Base Station RF Bandwidth* of each supported operating band shall be the declared maximum *Base Station RF Bandwidth* for contiguous operation (see table 4.10-1, D6.18) of the *TAB connector*.
- Select the NR carrier as specified in subclause 4.11.1a and place it adjacent to the low *Base Station RF Bandwidth edge*. Place a similar NR carrier adjacent to the high *Base Station RF Bandwidth edge*. The specified $F_{\text{Offset-RAT}}$ shall apply.
- For transmitter tests, select as many similar NR carriers that the *TAB connector* supports and that fit in the rest of the *Base Station RF Bandwidth*. Place the carriers adjacent to each other starting from the high *Base Station RF Bandwidth edge*. The nominal carrier spacing defined in subclause 4.6 shall apply. The specified $F_{\text{Offset-RAT}}$ shall apply.

The test configuration should be constructed on a per band basis for all component carriers of the inter-band CA bands declared to be supported by the *TAB connector* (see table 4.10-1, D6.29). All configured component carriers are transmitted simultaneously in the tests where the transmitter should be on.

4.11.2.11.3 ATC7 power allocation

Set the power of each carrier to the same power so that the sum of the carrier powers equals $P_{\text{rated,RAT,TABC}}$ for NR according to the manufacturer's declaration in subclause 4.10.

For a *TAB connector* declared to support only CA operation (see table 4.10-1, D6.22), set the power spectral density of each carrier to the same level so that the sum of the carrier powers equals the rated total output power ($P_{\text{Rated,t,TABC}}$) according to the manufacturer's declaration in subclause 4.10.

4.11.2.12 ANTC7: NR multicarrier non-contiguous operation

4.11.2.12.1 General

The purpose of ANTC7 is to test NR multicarrier non-contiguous aspects.

4.11.2.12.2 ANTC7 generation

ANTC7 is constructed using the following method:

- The *Base Station RF Bandwidth* of each supported operating band shall be the declared maximum *Base Station RF Bandwidth* for non-contiguous operation (D6.19) of the *TAB connector*. The *Base Station RF Bandwidth* consists of one *sub-block gap* and two sub-blocks located at the edges of the declared maximum *Base Station RF Bandwidth* (D.17).
- For transmitter tests, place a NR carrier as specified in subclause 4.11.1a adjacent to the upper *Base Station RF Bandwidth edge* and a similar NR carrier adjacent to the lower *Base Station RF Bandwidth edge*. The specified $F_{\text{Offset-RAT}}$ shall apply.

- For receiver tests, place a similar NR carrier adjacent to the upper *Base Station RF Bandwidth edge* and a similar NR carrier adjacent to the lower *Base Station RF Bandwidth edge*.
- The sub-block edges adjacent to the *sub-block gap* shall be determined using the specified $F_{\text{Offset-RAT}}$ for the carrier adjacent to the *sub-block gap*.

4.11.2.12.3 ANTC7 power allocation

Set the power of each carrier to the same power so that the sum of the carrier powers equals $P_{\text{rated,RAT,TABC}}$ according to the manufacturer's declaration in subclause 4.10.

4.12 RF channels and test models

4.12.1 RF channels

For single carrier tests unless otherwise stated the tests shall be performed with a single carrier at each of the RF channels B, M and T.

Many tests in this TS are performed with the maximum *Base Station RF Bandwidth* located at the bottom, middle and top of the supported frequency range in the operating band. These are denoted as B_{RFBW} (bottom), M_{RFBW} (middle) and T_{RFBW} (top).

Unless otherwise stated, the test shall be performed at B_{RFBW} , M_{RFBW} and T_{RFBW} defined as following:

- B_{RFBW} : maximum *Base Station RF Bandwidth* located at the bottom of the supported frequency range in the operating band.
- M_{RFBW} : maximum *Base Station RF Bandwidth* located in the middle of the supported frequency range in the operating band. M_{RFBW} may be shifted maximum 100 kHz towards lower frequencies to align carriers with the channel raster.
- T_{RFBW} : maximum *Base Station RF Bandwidth* located at the top of the supported frequency range in the operating band.

For the test of certain conducted RF requirements the present specification refers to test procedures defined in the single-RAT specifications [15], [14], [19]. In this case, the interpretation of the RF channels to be tested shall be according to the definitions in the corresponding single-RAT specifications [15], [14], [19].

Occupied bandwidth test in this TS is performed with the Aggregated Channel Bandwidth and sub-block bandwidths located at the bottom, middle and top of the supported frequency range in the operating band. These are denoted as $B_{\text{BW Channel CA}}$ (bottom), $M_{\text{BW Channel CA}}$ (middle) and $T_{\text{BW Channel CA}}$ (top) for contiguous spectrum operation.

Unless otherwise stated, the test for contiguous spectrum operation shall be performed at $B_{\text{BW Channel CA}}$, $M_{\text{BW Channel CA}}$ and $T_{\text{BW Channel CA}}$ defined as following:

- $B_{\text{BW Channel CA}}$: Aggregated Channel Bandwidth located at the bottom of the supported frequency range in each operating band;
- $M_{\text{BW Channel CA}}$: Aggregated Channel Bandwidth located close in the middle of the supported frequency range in each operating band, with the center frequency of each component carrier aligned to the channel raster;
- $T_{\text{BW Channel CA}}$: Aggregated Channel Bandwidth located at the top of the supported frequency range in each operating band.

For a *multi-band TAB connector* capable of dual-band operation, unless otherwise stated, the test shall be performed at $B_{\text{RFBW_T_RFBW}}$ and $B'_{\text{RFBW_T_RFBW}}$ defined as following:

- $B_{\text{RFBW_T_RFBW}}$: the *Base Station RF Bandwidths* located at the bottom of the supported frequency range in the lower operating band and at the highest possible simultaneous frequency position, within the maximum *Radio Bandwidth*, in the upper operating band.
- $B'_{\text{RFBW_T_RFBW}}$: the *Base Station RF Bandwidths* located at the top of the supported frequency range in the upper operating band and at the lowest possible simultaneous frequency position, within the maximum *Radio Bandwidth*, in the lower operating band.

NOTE: $B_{\text{RFBW}}T_{\text{RFBW}} = B'_{\text{RFBW}}T_{\text{RFBW}} = B_{\text{RFBW}}T_{\text{RFBW}}$ when the declared maximum *Radio Bandwidth* (see table 4.10-1, D6.16) spans both operating bands. $B_{\text{RFBW}}T_{\text{RFBW}}$ means the *Base Station RF Bandwidths* are located at the bottom of the supported frequency range in the lower operating band and at the top of the supported frequency range in the upper operating band.

When a test is performed by a test laboratory, the position of B, M and T for single carrier, B_{RFBW} , M_{RFBW} and T_{RFBW} for single band operation, $B_{\text{BW Channel CA}}$, $M_{\text{BW Channel CA}}$ and $T_{\text{BW Channel CA}}$ for contiguous spectrum operation in each supported operating band, the position of $B_{\text{RFBW}}T_{\text{RFBW}}$ and $B'_{\text{RFBW}}T_{\text{RFBW}}$ in the supported operating band combinations shall be specified by the laboratory. The laboratory may consult with operators, the manufacturer or other bodies.

4.12.2 Test models

a) Unless otherwise stated, carriers used for transmitter tests shall be configured as follows:

- UTRA FDD carriers shall be configured according to TM1 as defined in 3GPP TS 25.141 [18], subclause 6.1.1.1.
- UTRA TDD carriers shall be configured according to table 6.1A as defined in 3GPP TS 25.142 [20], subclause 6.2.4.1.2.
- E-UTRA carriers shall be configured according to E-TM1 as defined in 3GPP TS 36.141 [17], subclause 6.1.1.1. For BC3 CS3 BS testing, E-UTRA carriers shall be configured according to E-TM1_BC3CS3 defined in annex E of 3GPP TS 37.141 [16].
- NR carriers shall be configured according to NR-FR1-TM1 as defined in 3GPP TS 38.141-1 [37], subclause 4.9.2.2. For BC3 BS testing, NR carriers shall be configured according to NR-FR1-TM1_CS3 defined in annex E of 3GPP TS 37.141 [13].

b) The configuration of the carriers in test configurations used for testing modulation quality and frequency error shall be as follows:

- For the case that modulation accuracy is measured for UTRA FDD, the UTRA FDD carriers shall be configured according to the supported TM1, TM4 and if HS-PDSCH transmission using 16QAM is supported also TM5 as defined in 3GPP TS 25.141 [18], subclauses 6.1.1.1, 6.1.1.4 and 6.1.1.4A whilst any remaining carriers from other RAT(s) shall be configured according to a).
- For the case that modulation accuracy is measured for UTRA TDD, the UTRA TDD carriers shall be configured according to the supported modulation in table 6.2A, table 6.39A, table 6.39B, table 6.39C, table 6.39D, table 6.40A, table 6.40B, table 6.41A, table 6.41B as defined in 3GPP TS 25.142 [20], subclauses 6.3.4, 6.8.1, 6.8.2 and 6.8.3 whilst any remaining carriers from other RAT(s) shall be configured according to a).
- For the case that modulation accuracy is measured for E-UTRA, the E-UTRA carriers shall be configured according to the supported E-TM3.1, E-TM3.2, E-TM3.3 and E-TM2 as defined in 3GPP TS 36.141 [17] subclauses 6.1.1.4, 6.1.1.5, 6.1.1.6 and 6.1.1.3 whilst any remaining carriers from other RAT(s) shall be configured according to a). For BC3 CS3 BS testing, E-UTRA carriers shall be configured according to E-TM3.1_BC3CS3, E-TM3.2_BC3CS3, E-TM3.3_BC3CS3 and E-TM2_BC3CS3 defined in annex E of 3GPP TS 37.141 [16].
- For the case that modulation accuracy is measured for NR, the NR carriers shall be configured according to the supported NR-FR1-TM3.1, NR-FR1-TM3.1a, NR-FR1-TM3.2, NR-FR1-TM3.3, NR-FR1-TM2 and NR-FR1-TM2a as defined in 3GPP TS 38.141-1 [37] subclause 4.9.2.2 whilst any remaining carriers from other RAT(s) shall be configured according to a). For BC3 BS testing, NR carriers shall be configured according to NR-FR1-TM3.1_BC3, NR-FR1-TM3.1a_BC3, NR-FR1-TM3.2_BC3, NR-FR1-TM3.3_BC3, NR-FR1-TM2_BC3 and NR-FR1-TM2a_BC3 defined in annex E of 3GPP TS 37.141 [13].

c) Unless otherwise stated, transmitter carriers used for receiver tests shall be configured as follows:

- UTRA FDD carriers shall be configured according to TM1 as defined in 3GPP TS 25.141 [18], subclause 6.1.1.1.
- UTRA TDD carriers shall be configured according to table 6.1A as defined in 3GPP TS 25.142 [20], subclause 6.2.4.1.2.
- E-UTRA carriers shall be configured according to E-TM1 as defined in 3GPP TS 36.141 [17], subclause 6.1.1.1. For BC3 CS3 BS testing, E-UTRA carriers shall be configured according to E-TM1_BC3CS3 defined in annex E of 3GPP TS 37.141 [16].

- NR carriers shall be configured according to NR-FR1-TM1 as defined in 3GPP TS 38.141-1 [37], subclause 4.9.2.2. For BC3 BS testing, NR carriers shall be configured according to NR-FR1-TM1_CS3 defined in annex E of 3GPP TS 37.141 [16]. 3GPP TS 37.141 [13].

For the test of certain RF requirements clause 5 refers to the test configurations as defined in the single-RAT specifications. In this case, the transmitter test signals and test models as defined within the referred test specification for the RF requirement shall be used.

4.13 Format and interpretation of tests

Each test in the following clauses has a standard format:

X Title

All tests are applicable to all equipment within the scope of the present document, unless otherwise stated.

X.1 Definition and applicability

This subclause gives the general definition of the parameter under consideration and specifies whether the test is applicable to all equipment or only to a certain subset. Required manufacturer declarations may be included here.

X.2 Minimum requirement

This subclause contains the reference to the subclause to the 3GPP reference (or core) specification which defines the minimum requirement. For each requirement, there are separate references for MSR and single RAT, where applicable in the core requirement. If the requirement does not apply to a particular RAT, this is explicitly stated here (rather than through a reference).

X.3 Test purpose

This subclause defines the purpose of the test.

X.4 Method of test

X.4.1 General

In some cases there are alternative test procedures or initial conditions. In such cases, guidance for which initial conditions and test procedures can be applied are stated here. In the case only one test procedure is applicable, that is stated here. Guidance to which TAB connectors are subject to the test is also given here.

X.4.2y First test method

X.4.2y.1 Initial conditions

This subclause defines the initial conditions for each test, including the test environment, the RF channels to be tested and the basic measurement set-up. The test system is assumed to be correctly calibrated as part of the initial conditions. Calibration is not explicitly mentioned.

X.4.2y.2 Procedure

This subclause describes the steps necessary to perform the test and provides further details of the test definition like point of access (e.g. test port), domain (e.g. frequency-span), range, weighting (e.g. bandwidth), and algorithms (e.g. averaging). The procedure may comprise data processing of the measurement result before comparison with the test requirement (e.g. average result from several measurement positions).

X.4.3y Alternative test method (if any)

If there are alternative test methods, each is described with its initial conditions and procedures.

X.5 Test requirement

This subclause defines the pass/fail criteria for the equipment under test, see subclause 4.1.3 Interpretation of measurement results. Test requirements for every minimum requirement referred in subclause X.2 are listed here. Cases where minimum requirements do not apply need not be mentioned.

The test requirements may be different depending on the test method applied. A test requirement for each test method applicable to the respective MSR/Single RAT requirement is given in separate subclauses where applicable.

5 Applicability of Requirements

5.1 General

The present clause defines for each conducted test requirement the set of mandatory test configurations which shall be used for demonstrating conformance for each *TAB connector*.

Test configurations for *TAB connectors* supporting multiple RAT in the tested operating band are specified in subclause 5.2.

Test configurations for *TAB connectors* declared to support single RAT requirements (see table 4.10-1, D6.13) by either MSR requirements for UTRA only or E-UTRA only or with a single-RAT UTRA requirements or single RAT E-UTRA requirements are specified in subclause 5.3.

Test configurations for *Multi-band TAB connectors* are specified in subclause 5.4.

Requirements apply to *TAB connectors* according to the declared RAT Capability Set (see table 4.10-1, D6.12) within each supported operating band and capability set of the *TAB connector* and the Band Category of the declared operating band (see table 4.10-1, D6.1), as listed in the heading of each table. Some RF requirements listed in the tables may not be mandatory or they may apply only regionally. This is further specified for each requirement in subclauses 6 and 7, and in table 4.4-1.

For a declared RAT Capability Set (see table 4.10-1, D6.12) in tables 5.2-1, 5.3.2-1, 5.3.3-1, 5.3.4-1, 5.4.1-1 or 5.4.2.1 only the requirements listed in the column for that Capability Set apply. Requirements listed under CSA other than the declared CSA(s) need not be tested.

For a *TAB connector* declared to support MSR and to be capable of contiguous spectrum operation only, the test configuration(s) in tables 5.2-1 and 5.3.2-1 denoted by a "C" and entries that refer to single-RAT specifications shall be used for testing.

For a *TAB connector* that is declared: to support MSR and to be capable of contiguous and non-contiguous spectrum operation (see table 4.10-1, D6.14), where the parameters according to subclause 4.10 are identical for contiguous and non-contiguous operation (see table 4.10-1, D6.15), shall use for each declared operating band the test configuration(s) in tables 5.2-1 and 5.3.2-1 denoted by "CNC" and entries that refer to single-RAT specifications shall be used.

For a *TAB connector* that is declared: to support MSR and to be capable of contiguous and non-contiguous spectrum operation (see table 4.10-1, D6.14), where the parameters according to subclause 4.10 are not identical for contiguous and non-contiguous operation (see table 4.10-1, D6.15), shall use for each declared operating band the test configuration(s) in tables 5.2-1 and 5.3.2-1 denoted by "C/NC" and entries that refer to single-RAT specifications shall be used.

For a MSR capable *multi-band TAB connector* the applicability of the requirement for each operating band is determined by the RAT configuration within that operating band as identified in tables 5.2-1 and 5.3.2-1, unless otherwise stated. The testing of MSR capable *multi-band TAB connectors* shall be according to table 5.4.1-1 as follows:

- For requirements test denoted by SBT (Single Band Test), the test configuration(s) in tables 5.2-1 and 5.3.2-1 shall be used for each operating band depending on the RAT configuration within that band.
- For requirements test denoted by MBT (Multi-Band Test), the test configuration(s) in table 5.4.1-1 shall be used depending on the Band Category of the declared operating band combination.

For a single-RAT UTRA only *TAB connector* for each declared operating band subclause 5.3.3 defines for each conducted test requirement the set of mandatory test configurations which shall be used for demonstrating conformance. The applicable test configurations are specified in table 5.3.3-1 for each supported RF configuration, which shall be declared according to subclause 4.10. The generation and power allocation for each test configuration is defined in subclause 4.11.2.

For a single-RAT E-UTRA only *TAB connector* for each declared operating band subclause 5.3.4 defines for each conducted test requirement the set of mandatory test configurations which shall be used for demonstrating conformance. The applicable test configurations are specified in table 5.3.4-1 for each supported RF configuration, which shall be

declared according to subclause 4.10. The generation and power allocation for each test configuration is defined in subclause 4.11.2.

For a *TAB connector* declared to be capable of single carrier operation only in an operating band (see table 4.10-1, D6.23), a single carrier (SC) shall be used for testing.

5.2 Test configurations for TAB connectors for operating bands where MSR is supported

Table 5.2-1: Test configuration applicability to requirements and capability sets for TAB connectors supporting MSR operation

TAB connector test case		UTRA + E-UTRA (CSA3)			E-UTRA + NR (CSA3A)		
		BC1	BC2	BC3	BC1	BC2	BC3
6.2	Base Station output power	-	-	-			
6.2.2	Base Station maximum output power	C: ATC3a CNC: ATC3a C/NC: ATC3a, ANTC3a	C: ATC3a CNC: ATC3a C/NC: ATC3a, ANTC3a	C: ATC3b	C: ATC6 CNC: ATC6 C/NC: ATC6, ANTC6	C: ATC6 CNC: ATC6 C/NC: ATC6, ANTC6	C: ATC6 CNC: ATC6 C/NC: ATC6, ANTC6
	Additional regional requirement (only for band 34)	N/A	N/A	(note)	N/A	N/A	(note)
6.2.3	UTRA FDD primary CPICH power	Subclause 5.3.3	Subclause 5.3.3	N/A	N/A	N/A	N/A
6.2.3A	UTRA FDD secondary CPICH power	Subclause 5.3.3	Subclause 5.3.3	N/A	N/A	N/A	N/A
6.2.4	UTRA TDD primary CCPCH power	N/A	N/A	Subclause 5.3.3	N/A	N/A	N/A
6.2.6	E-UTRA DL RS power	Subclause 5.3.4	Subclause 5.3.4	Subclause 5.3.4	Subclause 5.3.4	Subclause 5.3.4	Subclause 5.3.4
6.3	Output power dynamics	-	-	-	-	-	-
	E-UTRA	Subclause 5.3.4	Subclause 5.3.4	Subclause 5.3.4	Subclause 5.3.4	Subclause 5.3.4	Subclause 5.3.4
	UTRA FDD	Subclause 5.3.3	Subclause 5.3.3	N/A	N/A	N/A	N/A
	UTRA TDD	N/A	N/A	Subclause 5.3.3	N/A	N/A	N/A
	NR	N/A	N/A	N/A	SC	SC	SC
6.4	Transmit ON/OFF power	-	-	-	-	-	-
6.4.1	Transmitter OFF power	N/A	N/A	C: ATC3b	N/A	N/A	C: ATC6 CNC: ATC6 C/NC: ATC6, ANTC6
6.4.2	Transmitter transient period	N/A	N/A	C: ATC3b	N/A	N/A	C: ATC6 CNC: ATC6 C/NC: ATC6, ANTC6
6.5	Transmitted signal quality	-	-	-	-	-	-
6.5.2	Frequency error	-	-	-	-	-	-
	E-UTRA	Same TC as used in subclause 6.5.4	Same TC as used in subclause 6.5.4	Same TC as used in subclause 6.5.4	Same TC as used in subclause 6.5.4	Same TC as used in subclause 6.5.4	Same TC as used in subclause 6.5.4
	UTRA FDD	Same TC as used in subclause 6.5.4	Same TC as used in subclause 6.5.4	N/A	N/A	N/A	N/A
	UTRA TDD	N/A	N/A	Same TC as used in	N/A	N/A	N/A

TAB connector test case	UTRA + E-UTRA (CSA3)			E-UTRA + NR (CSA3A)		
	BC1	BC2	BC3	BC1	BC2	BC3
			subclause 6.5.4			
NR	N/A	N/A	N/A	Same TC as used in subclause 6.5.4	Same TC as used in subclause 6.5.4	Same TC as used in subclause 6.5.4
6.5.3 Time alignment error	-	-	-	-	-	-
E-UTRA	Subclause 5.3.4	Subclause 5.3.4	Subclause 5.3.4	Subclause 5.3.4	Subclause 5.3.4	Subclause 5.3.4
UTRA FDD	Subclause 5.3.3	Subclause 5.3.3	N/A	N/A	N/A	N/A
UTRA TDD	N/A	N/A	Subclause 5.3.3	N/A	N/A	N/A
NR	N/A	N/A	N/A	ATC7	ATC7	ATC7, ANTC7
6.5.4 Modulation quality - EVM	-	-	-	-	-	-
E-UTRA	C: ATC3a CNC: ATC3a C/NC: ATC3a, ANTC3a	C: ATC3a CNC: ATC3a C/NC: ATC3a, ANTC3a	C: ATC3b	C: ATC6 CNC: ATC6 C/NC: ATC6, ANTC6	C: ATC6 CNC: ATC6 C/NC: ATC6, ANTC6	C: ATC6 CNC: ATC6 C/NC: ATC6, ANTC6
UTRA FDD	C: ATC3a CNC: ATC3a C/NC: ATC3a, ANTC3a	C: ATC3a CNC: ATC3a C/NC: ATC3a, ANTC3a	N/A	N/A	N/A	N/A
UTRA TDD	N/A	N/A	C: ATC3b	N/A	N/A	N/A
NR	N/A	N/A	N/A	C: ATC6 CNC: ATC6 C/NC: ATC6, ANTC6	C: ATC6 CNC: ATC6 C/NC: ATC6, ANTC6	C: ATC6 CNC: ATC6 C/NC: ATC6, ANTC6
6.5.5 Transmit pulse shape filter	Not tested	Not tested	Not tested	Not tested	Not tested	Not tested
6.6 Unwanted Emissions	-	-	-	-	-	-
6.6.2 Occupied bandwidth	-	-	-	-	-	-
Minimum requirement	Subclause 5.3.3 Subclause 5.3.4	Subclause 5.3.3 Subclause 5.3.4	Subclause 5.3.3 Subclause 5.3.4	Subclause 5.3.3 Subclause 5.3.4	Subclause 5.3.3 Subclause 5.3.4	Subclause 5.3.3 Subclause 5.3.4
6.6.3 Adjacent Channel Leakage power Ratio	-	-	-	-	-	-
E-UTRA	C: ATC2a CNC: ANTC2 C/NC:ATC2a, ANTC2	C: ATC2a CNC: ANTC2 C/NC:ATC2a, ANTC2	C: ATC2a CNC: ANTC2 C/NC:A TC2a, ANTC2	C: ATC2a CNC: ANTC2 C/NC:ATC2a, ANTC2	C: ATC2a CNC: ANTC2 C/NC:ATC2a, ANTC2	C: ATC2a CNC: ANTC2 C/NC:A TC2a, ANTC2
UTRA FDD	Subclause 5.3.3	Subclause 5.3.3	N/A	N/A	N/A	N/A
UTRA TDD	N/A	N/A	Subclause 5.3.3	N/A	N/A	N/A
NR	N/A	N/A	N/A	C: ATC7 CNC: ANTC7 C/NC: ATC7, ANTC7	C: ATC7 CNC: ANTC7 C/NC: ATC7, ANTC7	C: ATC7 CNC: ANTC7 C/NC: ATC7, ANTC7

TAB connector test case	UTRA + E-UTRA (CSA3)			E-UTRA + NR (CSA3A)		
	BC1	BC2	BC3	BC1	BC2	BC3
Cumulative ACLR	CNC: ANTC3a C/NC:AN TC3a	CNC: ANTC3a C/NC:ANTC3 a		CNC: ANTC6 C/NC:AN TC6	CNC: ANTC6 C/NC:ANTC6	CNC: ANTC6 C/NC:A NTC6
6.6.5 Operating band unwanted emission	-	-	-	-	-	-
General requirement for Band Categories 1 and 3	Subclause 5.3.3 Subclause 5.3.4 C: ATC3a CNC: ATC3a, ANTC3a C/NC: ATC3a, ANTC3a	N/A	Subclaus e 5.3.3 Subclaus e 5.3.4 C: ATC3b	Subclaus e 5.3.3 Subclaus e 5.3.4 C: ATC6 CNC: ATC6, ANTC6 C/NC: ATC6, ANTC6	N/A	Subclaus e 5.3.3 Subclaus e 5.3.4 C: ATC6 CNC: ATC6, ANTC6 C/NC: ATC6, ANTC6
General requirement for Band Category 2	N/A	Subclause 5.3.3 Subclause 5.3.4 C: ATC3a CNC: ATC3a, ANTC3a C/NC: ATC3a, ANTC3a	N/A	N/A	Subclause 5.3.3 Subclause 5.3.4 C: ATC6 CNC: ATC6, ANTC6 C/NC: ATC6, ANTC6	N/A
Additional requirements	(note)	(note)	(note)	(note)	(note)	(note)
6.6.6 Spurious emission	-	-	-	-	-	-
(Category A)	C: ATC3a CNC: ANTC3a C/NC: ATC3a, ANTC3a	C: ATC3a CNC: ANTC3a C/NC: ATC3a, ANTC3a	C: ATC3b	C: ATC6 CNC: ANTC6 C/NC: ATC6, ANTC6	C: ATC6 CNC: ANTC6 C/NC: ATC6, ANTC6	C: ATC6 CNC: ANTC6 C/NC: ATC6, ANTC6
(Category B)	C: ATC3a CNC: ANTC3a C/NC: ATC3a, ANTC3a	C: ATC3a CNC: ANTC3a C/NC: ATC3a, ANTC3a	C: ATC3b	C: ATC6 CNC: ANTC6 C/NC: ATC6, ANTC6	C: ATC6 CNC: ANTC6 C/NC: ATC6, ANTC6	C: ATC6 CNC: ANTC6 C/NC: ATC6, ANTC6
Additional requirement for BC2 (Category B)	N/A	N/A	N/A	N/A	N/A	N/A
Protection of the BS receiver of own or different BS	C: ATC3a CNC: ANTC3a C/NC: ATC3a, ANTC3a	C: ATC3a CNC: ANTC3a C/NC: ATC3a, ANTC3a	C: ATC3b	C: ATC6 CNC: ANTC6 C/NC: ATC6, ANTC6	C: ATC6 CNC: ANTC6 C/NC: ATC6, ANTC6	C: ATC6 CNC: ANTC6 C/NC: ATC6, ANTC6
Additional spurious emissions requirements	C: ATC3a, CNC: ANTC3a, C/NC: ATC3a, ATC3a	C: ATC3a CNC: ANTC3a C/NC: ATC3a, ANTC3a	C: ATC3b	C: ATC6, CNC: ANTC6, C/NC: ATC6, ATC6	C: ATC6 CNC: ANTC6 C/NC: ATC6, ANTC6	C: ATC6 CNC: ANTC6 C/NC: ATC6, ANTC6
Co-location with other Base Stations	C: ATC3a CNC: ANTC3a C/NC: ATC3a, ANTC3a	C: ATC3a CNC: ANTC3a C/NC: ATC3a, ANTC3a	C: ATC3b	C: ATC6 CNC: ANTC6 C/NC: ATC6, ANTC6	C: ATC6 CNC: ANTC6 C/NC: ATC6, ANTC6	C: ATC6 CNC: ANTC6 C/NC: ATC6, ANTC6
6.7 Transmitter intermodulation	-	-	-	-	-	-
General requirement	Same TC as used in subclause 6.6	Same TC as used in subclause 6.6	Same TC as used in	Same TC as used in	Same TC as used in subclause 6.6	Same TC as used in

TAB connector test case	UTRA + E-UTRA (CSA3)			E-UTRA + NR (CSA3A)		
	BC1	BC2	BC3	BC1	BC2	BC3
			subclause 6.6	subclause 6.6		subclause 6.6
Additional requirement (BC1 and BC2)	CNC: ANTC3a C/NC: ANTC3a	Same TC as used in subclause 6.6	N/A	CNC: ANTC6 C/NC: ANTC6	Same TC as used in subclause 6.6	N/A
Additional requirement (BC3)	N/A	N/A	Same TC as used in subclause 6.6	N/A	N/A	Same TC as used in subclause 6.6
7.2 Reference sensitivity level	-	-	-	-	-	-
E-UTRA requirement	Subclause 5.3.4	Subclause 5.3.4	Subclause 5.3.4	Subclause 5.3.4	Subclause 5.3.4	Subclause 5.3.4
UTRA FDD requirement	Subclause 5.3.3	Subclause 5.3.3	N/A	N/A	N/A	N/A
UTRA TDD requirement	N/A	N/A	Subclause 5.3.3	N/A	N/A	N/A
NR	N/A	N/A	N/A	SC	SC	SC
7.3 Dynamic range	-	-	-	-	-	-
E-UTRA	Subclause 5.3.4	Subclause 5.3.4	Subclause 5.3.4	Subclause 5.3.4	Subclause 5.3.4	Subclause 5.3.4
UTRA FDD	Subclause 5.3.3	Subclause 5.3.3	N/A	N/A	N/A	N/A
UTRA TDD	N/A	N/A	Subclause 5.3.3	N/A	N/A	N/A
NR	N/A	N/A	N/A	SC	SC	SC
7.4 Adjacent channel selectivity and narrowband blocking	-	-	-	-	-	-
General blocking requirement	C: ATC3a CNC: ANTC3a C/NC: ATC3a, ANTC3a	C: ATC3a CNC: ANTC3a C/NC: ATC3a, ANTC3a	C: ATC3b	C: ATC6 CNC: ANTC6 C/NC: ATC6, ANTC6	C: ATC6 CNC: ANTC6 C/NC: ATC6, ANTC6	C: ATC6 CNC: ANTC6 C/NC: ATC6, ANTC6
General narrowband blocking requirement	C: ATC3a, ATC4b CNC: ANTC3a, ATC4b C/NC: ATC3a, ANTC3a, ATC4b	C: ATC3a, ATC4b CNC: ANTC3a, ATC4b C/NC: ATC3a, ANTC3a, ATC4b	C: ATC3b, ATC4b	C: ATC6, ATC4b, ATC4d CNC: ANTC6, ATC4b, ATC4d C/NC: ATC6, ANTC6, ATC4b, ATC4d	C: ATC6, ATC4b, ATC4d CNC: ANTC6, ATC4b, ATC4d C/NC: ATC6, ANTC6, ATC4b, ATC4d	C: ATC6, ATC4b, ATC4d CNC: ANTC6, ATC4b, ATC4d C/NC: ATC6, ANTC6, ATC4b, ATC4d
Additional BC3 blocking minimum requirement	N/A	N/A	C: ATC3b	N/A	N/A	C: ATC6 CNC: ANTC6 C/NC: ATC6, ANTC6
7.5 Blocking	-	-	-	-	-	-
General requirement	C: ATC3a CNC: ANTC3a C/NC: ATC3a, ANTC3a	C: ATC3a CNC: ANTC3a C/NC: ATC3a, ANTC3a	C: ATC3b	C: ATC6 CNC: ANTC6 C/NC: ATC6, ANTC6	C: ATC6 CNC: ANTC6 C/NC: ATC6, ANTC6	C: ATC6 CNC: ANTC6 C/NC: ATC6, ANTC6
Co-location requirement	C: ATC3a CNC: ANTC3a C/NC:	C: ATC3a CNC: ANTC3a C/NC:	C: ATC3b	C: ATC6 CNC: ANTC6 C/NC:	C: ATC6 CNC: ANTC6 C/NC: ATC6, ANTC6	C: ATC6 CNC: ANTC6 C/NC:

TAB connector test case	UTRA + E-UTRA (CSA3)			E-UTRA + NR (CSA3A)		
	BC1	BC2	BC3	BC1	BC2	BC3
	ATC3a, ANTC3a	ATC3a, ANTC3a		ATC6, ANTC6		ATC6, ANTC6
7.6 Receiver spurious emissions	-	-	-	-	-	-
General requirement	C: ATC3a CNC: ANTC3a C/NC: ATC3a, ANTC3a	C: ATC3a CNC: ANTC3a C/NC: ATC3a, ANTC3a	C: ATC3b	C: ATC6 CNC: ANTC6 C/NC: ATC6, ANTC6	C: ATC6 CNC: ANTC6 C/NC: ATC6, ANTC6	C: ATC6 CNC: ANTC6 C/NC: ATC6, ANTC6
Additional requirement for BC2 (Category B)	N/A	N/A	N/A	N/A	N/A	N/A
7.7 Receiver intermodulation	-	-	-	-	-	-
General intermodulation requirement	C: ATC3a CNC: ANTC3a C/NC: ATC3a, ANTC3a	C: ATC3a CNC ANTC3a C/NC: ATC3a, ANTC3a	C: ATC3b	C: ATC6 CNC: ANTC6 C/NC: ATC6, ANTC6	C: ATC6 CNC ANTC6 C/NC: ATC6, ANTC6	C: ATC6 CNC: ANTC6 C/NC: ATC6, ANTC6
General narrowband intermodulation requirement	C: ATC3a, ATC4b CNC:ANT C3a, ATC4b C/NC: ATC3a, ANTC3a, ATC4b	C: ATC3a ATC4b CNC:ANTC3a ,ATC4b C/NC: ATC3a, ANTC3a; ATC4b	C: ATC3b, ATC4b	C: ATC6, ATC4b, ATC4d CNC:ANT C6, ATC4b, ATC4d C/NC: ATC6, ANTC6, ATC4b, ATC4d	C: ATC6 ATC4b, ATC4d CNC:ANTC6, ATC4b, ATC4d C/NC: ATC6, ANTC6; ATC4b, ATC4d	C: ATC6, ATC4b, ATC4d CNC: ANTC6 , ATC4b, ATC4d C/NC: ATC6, ANTC6, ATC4b, ATC4d
7.8 In-channel selectivity	Subclause 5.3.4	Subclause 5.3.4	Subclau se 5.3.4	-	-	-
E-UTRA requirement	Subclause 5.3.4	Subclause 5.3.4	Subclau se 5.3.4	Subclaus e 5.3.4	Subclause 5.3.4	Subclau se 5.3.4
NR requirement	N/A	N/A	N/A	SC	SC	SC
NOTE: Compliance stated by manufacturer declaration.						

5.3 Test configurations for multi-carrier capable TAB connector(s) in operating bands where one RAT capability sets are supported

5.3.1 General

A TAB connector may support only one RAT operation in an operating band by fulfilling different sets of requirements. Both UTRA and E-UTRA have two complete sets of requirements that may be fulfilled depending on whether the TAB connector is declared to be MSR or single RAT in the operating band. MSR and single RAT requirements are addressed separately by separate test requirements (and corresponding core requirements). They are also identified by different capability sets as described in subclauses 4.11 and 5.2.

5.3.2 TAB connector supporting one RAT only MSR in the operating band

This subclause contains test configuration applicability to requirements and capability sets for TAB connectors supporting one RAT only MSR operation operating with multiple carriers (MC).

Table 5.3.2-1: Test configuration applicability to requirements and capability sets for TAB connectors supporting one RAT only MSR operation

Capability Set	UTRA (MC) capable BS (CSA1)			E-UTRA (MC) capable BS (CSA2)		
	BC1	BC2	BC3	BC1	BC2	BC3
6.2 Base Station output power	-	-	-	-	-	-

Capability Set		UTRA (MC) capable BS (CSA1)			E-UTRA (MC) capable BS (CSA2)		
TAB connector test case		BC1	BC2	BC3	BC1	BC2	BC3
6.2.2	Base Station maximum output power	C: ATC1a CNC: ATC1a C/NC: ATC1a, ANTC1a	C: ATC1a CNC: ATC1a C/NC: ATC1a, ANTC1a	C: ATC1b	C: ATC2a CNC: ATC2a C/NC: ATC2a, ANTC2	C: ATC2a CNC: ATC2a C/NC: ATC2a, ANTC2	C: ATC2a CNC: ATC2a C/NC: ATC2a, ANTC2
	Additional regional requirement (only for band 34)	N/A	N/A	N/A	N/A	N/A	NOTE1
6.2.3	UTRA FDD primary CPICH power	Subclause 5.3.3	Subclause 5.3.3	N/A	N/A	N/A	N/A
6.2.3A	UTRA FDD secondary CPICH power	Subclause 5.3.3	Subclause 5.3.3	N/A	N/A	N/A	N/A
6.2.4	UTRA TDD primary CCPCH power	N/A	N/A	Subclause 5.3.3	N/A	N/A	N/A
6.2.5	UTRA FDD additional CPICH power for MIMO mode	Subclause 5.3.3	Subclause 5.3.3	N/A	N/A	N/A	N/A
6.2.6	E-UTRA DL RS power	N/A	N/A	N/A	Subclause 5.3.4	Subclause 5.3.4	Subclause 5.3.4
6.3	Output power dynamics	-	-	-	-	-	-
6.3.2	UTRA Inner loop power control in the downlink	N/A	N/A	N/A	Subclause 5.3.4	Subclause 5.3.4	Subclause 5.3.4
6.3.3	Power control dynamic range	Subclause 5.3.3	Subclause 5.3.3	N/A	N/A	N/A	N/A
6.3.4	Total power dynamic range	N/A	N/A	Subclause 5.3.3	N/A	N/A	N/A
6.3.5	IPDL time mask	Subclause 5.3.3	Subclause 5.3.3	N/A			
6.3.6	RE Power control dynamic range	N/A	N/A	N/A	Subclause 5.3.4	Subclause 5.3.4	Subclause 5.3.4
6.4	Transmit ON/OFF power	-	-	-	-	-	-
6.4.1	Transmitter OFF power	N/A	N/A	C: ATC1b	N/A	N/A	C: ATC2a CNC: ATC2a C/NC: ATC2a, ANTC2
6.4.2	Transmitter transient period	N/A	N/A	C: ATC1b	N/A	N/A	C: ATC2a CNC: ATC2a C/NC: ATC2a, ANTC2
6.5	Transmitted signal quality	-	-	-	-	-	-
6.5.2	Frequency error	-	-	-	-	-	-
	E-UTRA	N/A	N/A	N/A	Same TC as used in subclause 6.5.4	Same TC as used in subclause 6.5.4	Same TC as used in subclause 6.5.4
	UTRA FDD	Same TC as used in subclause 6.5.4	Same TC as used in subclause 6.5.4	N/A	N/A	N/A	N/A
	UTRA TDD	N/A	N/A	Same TC as used in subclause 6.5.1	N/A	N/A	N/A
6.5.3	Time alignment error	-	-	-	-	-	-
	E-UTRA	N/A	N/A	N/A	Subclause 5.3.4	Subclause 5.3.4	Subclause 5.3.4
	UTRA FDD	Subclause 5.3.3	Subclause 5.3.3	N/A	N/A	N/A	N/A
	UTRA TDD	N/A	N/A	Subclause 5.3.3	N/A	N/A	N/A
6.5.4	Modulation quality - EVM	-	-	-	-	-	-

Capability Set	UTRA (MC) capable BS (CSA1)			E-UTRA (MC) capable BS (CSA2)		
TAB connector test case	BC1	BC2	BC3	BC1	BC2	BC3
E-UTRA	N/A	N/A	N/A	C: ATC2a CNC: ATC2a C/NC: ATC2a, ANTC2	C: ATC2a CNC: ATC2a C/NC: ATC2a, ANTC2	C: ATC2a CNC: ATC2aC/N C: ATC2a, ANTC2
UTRA FDD	C: ATC1a CNC: ATC1a C/NC: ATC1a, ANTC1a	C: ATC1a CNC: ATC1a C/NC: ATC1a, ANTC1a	N/A	N/A	N/A	N/A
UTRA TDD	N/A	N/A	C: ATC1b	N/A	N/A	N/A
6.5.5 Transmit pulse shape filter	Not tested	Not tested	Not tested	Not tested	Not tested	Not tested
6.6 Unwanted Emissions	-	-	-	-	-	-
6.6.2 Occupied bandwidth	-	-	-	-	-	-
Minimum requirement	Subclause 5.3.3	Subclause 5.3.3	Subclause 5.3.3	Subclause 5.3.4	Subclause 5.3.4	Subclause 5.3.4
6.6.3 Adjacent Channel Leakage power Ratio		-	-	-	-	-
E-UTRA	N/A	N/A	N/A	C: ATC2a CNC: ANTC2 C/NC: ATC2a, ANTC2	C: ATC2a CNC: ANTC2 C/NC: ATC2a, ANTC2	C: ATC2a CNC: ANTC2 C/NC: ATC2a, ANTC2
UTRA FDD	Subclause 5.3.3	Subclause 5.3.3	N/A	N/A	N/A	N/A
UTRA TDD	N/A	N/A	Subclause 5.3.3	N/A	N/A	N/A
Cumulative ACLR	CNC: ANTC1a C/NC: ANTC1a	CNC: ANTC1a C/NC: ANTC1a	-	CNC: ANTC2 C/NC: ANTC2	CNC: ANTC2 C/NC: ANTC2	CNC: ANTC2 C/NC: ANTC2
6.6.4 Spectrum emission mask						
6.6.5 Operating band unwanted emission	-	-	-	-	-	-
General requirement for Band Categories 1 and 3	Subclause 5.3.3 C: ATC1a CNC: ATC1a, ANTC1a C/NC: ATC1a, ANTC1a	N/A	Subclause 5.3.3 C: ATC1b	Subclause 5.3.4 C: ATC2a CNC: ATC2a, ANTC2 C/NC: ATC2a, ANTC2	N/A	Subclause 5.3.4 C: ATC2a CNC: ATC2a, ANTC2 C/NC: ATC2a, ANTC2
General requirement for Band Category 2	N/A	Subclause 5.3.3 C: ATC1a CNC: ATC1a, ANTC1a C/NC: ATC1a, ANTC1a	N/A	N/A	Subclause 5.3.4 C: ATC2a CNC: ATC2a, ANTC2 C/NC: ATC2a, ANTC2	N/A
Additional requirements	(note)	(note)	(note)	(note)	(note)	(note)
6.6.6 Spurious emission	-	-	-	-	-	-
(Category A)	C: ATC1a CNC: ANTC1a C/NC: ATC1a, ANTC1a	C: ATC1a CNC: ANTC1a C/NC: ATC1a, ANTC1a	C: ATC1b	C: ATC2a CNC: ANTC2 C/NC: ATC2a, ANTC2	C: ATC2a CNC: ANTC2 C/NC: ATC2a, ANTC2	C: ATC2a CNC: ANTC2 C/NC: ATC2a, ANTC2
(Category B)	C: ATC1a CNC: ANTC1a	C: ATC1a CNC: ANTC1a	C: ATC1b	C: ATC2a CNC: ANTC2	C: ATC2a CNC: ANTC2	C: ATC2a CNC: ANTC2

Capability Set		UTRA (MC) capable BS (CSA1)			E-UTRA (MC) capable BS (CSA2)		
TAB connector test case		BC1	BC2	BC3	BC1	BC2	BC3
		C/NC: ATC1a, ANTC1a	C/NC: ATC1a, ANTC1a		C/NC: ATC2a, ANTC2	C/NC: ATC2a, ANTC2	C/NC: ATC2a, ANTC2
	Additional requirement for BC2 (Category B)	N/A	N/A	N/A	N/A	N/A	N/A
	Protection of the BS receiver of own or different BS	C: ATC1a CNC: ANTC1a C/NC: ATC1a, ANTC1a	C: ATC1a CNC: ANTC1a C/NC: ATC1a, ANTC1a	C: ATC1b	C: ATC2a CNC: ANTC2 C/NC: ATC2a, ANTC2	C: ATC2a CNC: ANTC2 C/NC: ATC2a, ANTC2	C: ATC2a CNC: ANTC2 C/NC: ATC2a, ANTC2
	Additional spurious emissions requirements	C: ATC1a CNC: ANTC1a C/NC: ATC1a, ANTC1a	C: ATC1a CNC: ANTC1a C/NC: ATC1a, ANTC1a	C: ATC1b	C: ATC2a CNC: ANTC2 C/NC: ATC2a, ANTC2	C: ATC2a CNC: ANTC2 C/NC: ATC2a, ANTC2	C: ATC2a CNC: ANTC2 C/NC: ATC2a, ANTC2
	Co-location with other Base Stations	C: ATC1a CNC: ANTC1a C/NC: ATC1a, ANTC1a	C: ATC1a CNC: ANTC1a C/NC: ATC1a, ANTC1a	C: ATC1b	C: ATC2a CNC: ANTC2 C/NC: ATC2a, ANTC2	C: ATC2a CNC: ANTC2 C/NC: ATC2a, ANTC2	C: ATC2a CNC: ANTC2C/N C: ATC2a, ANTC2
6.7	Transmitter intermodulation	-	-	-	-	-	-
	General requirement	Same TC as used in subclause 6.6	Same TC as used in subclause 6.6	Same TC as used in subclause 6.6	Same TC as used in subclause 6.6	Same TC as used in subclause 6.6	Same TC as used in subclause 6.6
	Additional requirement (BC1 and BC2)	CNC: ANTC1a C/NC:ANTC1a	Same TC as used in 6.6	N/A	CNC: ANTC2 C/NC: ANTC2	Same TC as used in 6.6	N/A
	Additional requirement (BC3)	N/A	N/A	Same TC as used in subclause 6.6	N/A	N/A	Same TC as used in 6.6
7.2	Reference sensitivity level	-	-	-	-	-	-
	E-UTRA requirement	N/A	N/A	N/A	Subclause 5.3.4	Subclause 5.3.4	Subclause 5.3.4
	UTRA FDD requirement	Subclause 5.3.3	Subclause 5.3.3	N/A	N/A	N/A	N/A
	UTRA TDD requirement	N/A	N/A	Subclause 5.3.3	N/A	N/A	N/A
7.3	Dynamic range	-	-	-	-	-	-
	E-UTRA	N/A	N/A	N/A	Subclause 5.3.4	Subclause 5.3.4	Subclause 5.3.4
	UTRA FDD	Subclause 5.3.3	Subclause 5.3.3	N/A	N/A	N/A	N/A
	UTRA TDD	N/A	N/A	Subclause 5.3.3	N/A	N/A	N/A
7.4	Adjacent channel selectivity and narrowband blocking	-	-	-	-	-	-
	General blocking requirement	C: ATC1a CNC: ANTC1a C/NC: ATC1a , ANTC1a	C: ATC1a, ATC4aCN C: ANTC1a C/NC: ATC1a , ANTC1a	C: ATC1b ATC4c	C: ATC2a CNC: ANTC2 C/NC: ATC2a, ANTC2	C: ATC2a CNC: ANTC2 C/NC: ATC2a, ANTC2	C: ATC2a CNC: ANTC2 C/NC: ATC2a, ANTC2
	General narrowband blocking requirement	C: ATC1a, ATC4a CNC: ANTC1a, ATC4a C/NC: ATC1a,	C: ATC1a, ATC4a CNC:ANTC1a, ATC4a C/NC: ATC1a,	C: ATC1b ATC4c	C: ATC2a, ATC4b CNC:ANTC2, ATC4b C/NC: ATC2a, ANTC2	C: ATC2a, ATC4b CNC: ANTC2, ATC4b C/NC: ATC2a, ANTC2	C: ATC2a, ATC4b CNC: ANTC2, ATC4b C/NC: ATC2a,

Capability Set		UTRA (MC) capable BS (CSA1)			E-UTRA (MC) capable BS (CSA2)		
TAB connector test case		BC1	BC2	BC3	BC1	BC2	BC3
		ANTC1a, ATC4a	ANTC1a, ATC4a			ANTC2, ATC4b	ANTC2, ATC4b
	Additional BC3 blocking minimum requirement	N/A	N/A	C: ATC1b	N/A	N/A	C: ATC2a CNC: ANTC2 C/NC: ATC2a, ANTC2
7.5	Blocking	-	-	-	-	-	-
	General requirement	C: ATC1a CNC: ANTC1a C/NC: ATC1a, ANTC1a	C: ATC1a CNC: ANTC1a C/NC: ATC1a, ANTC1a	C: ATC1b	C: ATC2a CNC: ANTC2 C/NC: ATC2a, ANTC2	C: ATC2a CNC: ANTC2 C/NC: ATC2a, ANTC2	C: ATC2a CNC: ANTC2 C/NC: ATC2a, ANTC2
	Co-location requirement	C: ATC1a CNC: ANTC1a C/NC: ATC1a, ANTC1a	C: ATC1a CNC: ANTC1a C/NC: ATC1a, ANTC1a	C: ATC1b	C: ATC2a CNC: ANTC2 C/NC: ATC2a, ANTC2	C: ATC2a CNC: ANTC2 C/NC: ATC2a, ANTC2	C: ATC2a CNC: ANTC2 C/NC: ATC2a, ANTC2
7.6	Receiver spurious emissions	-	-	-	-	-	-
	General requirement	C: ATC1a CNC: ANTC1a C/NC: ATC1a, ANTC1a	C: ATC1a CNC: ANTC1a C/NC: ATC1a, ANTC1a	C: ATC1b	C: ATC2a CNC: ANTC2 C/NC: ATC2a, ANTC2	C: ATC2a CNC: ANTC2 C/NC: ATC2a, ANTC2	C: ATC2a CNC: ANTC2 C/NC: ATC2a, ANTC2
	Additional requirement for BC2 (Category B)	N/A	N/A	N/A	N/A	N/A	N/A
7.7	Receiver intermodulation	-	-	-	-	-	-
	General intermodulation requirement	C: ATC1a CNC: ANTC1a C/NC: ATC1a , ANTC1a	C: ATC1a CNC: ANTC1a C/NC: ATC1a , ANTC1a	C: ATC1b	C: ATC2a CNC: ANTC2 C/NC: ATC2a, ANTC2	C: ATC2a CNC: ANTC2 C/NC: ATC2a, ANTC2	C: ATC2a CNC: ANTC2 C/NC: ATC2a, ANTC2
	General narrowband intermodulation requirement	C: ATC1a, ATC4a CNC:ANTC 1a, ATC4a C/NC: ATC1a, ANTC1a, ATC4a	C: ATC1a, ATC4a CNC:ANTC 1a, ATC4a C/NC: ATC1a, ANTC1a, ATC4a	C: ATC1b, ATC4c	C: ATC2a, ATC4b CNC: ANTC2, ATC4b C/NC: ATC2a, ANTC2, ATC4b	C: ATC2a, ATC4b CNC: ANTC2, ATC4b C/NC: ATC2a, ANTC2, ATC4b	C: ATC2a, ATC4b CNC: ANTC2, ATC4b C/NC: ATC2a, ANTC2, ATC4b
7.8	In-channel selectivity	-	-	-	-	-	-
	E-UTRA requirement	N/A	N/A	N/A	Subclause 5.3.4	Subclause 5.3.4	Subclause 5.3.4
NOTE: Compliance stated by manufacturer.							

5.3.3 TAB connector supporting Single-RAT UTRA in the operating band

This subclause contains the test configurations for TAB connectors supporting single-RAT UTRA in the operating band. The test configurations apply to *TAB connectors* operating with multiple carriers (MC).

For a *TAB connector* declared to support multi-carrier operation in contiguous spectrum operation in single band only, the test configurations in the second column of table 5.3.3-1 for FDD, and in the fifth column of table 5.3.3-1 for TDD, shall be used for testing.

NOTE: The applicability of test configurations for TDD in this subclause is only applicable to UTRA TDD 1,28 Mcps option.

For FDD a *TAB connector* declared to support multi-carrier operation in contiguous and non-contiguous spectrum in single band and where the parameters in the manufacture's declaration according to subclause 4.10 are identical for contiguous (C) and non-contiguous (NC) spectrum operation, the test configurations in the third column of table 5.3.3-1 shall be used for testing.

For FDD a *TAB connector* declared to support multi-carrier operation in contiguous and non-contiguous spectrum in single band and where the parameters in the manufacture's declaration according to subclause 4.10 are not identical for contiguous and non-contiguous spectrum operation, the test configurations in the fourth column of table 5.3.3-1 shall be used for testing.

Table 5.3.3-1: Test configurations for a *TAB connector* supporting single-RAT UTRA operation

TAB connector test case		Single-RAT UTRA FDD MC capable TAB connector (CSA4) C capable only	Single-RAT UTRA FDD MC capable TAB connector (CSA4) C and NC capable with identical parameters	Single-RAT UTRA FDD MC capable TAB connector (CSA4) C and NC capable with different parameters	Single-RAT UTRA TDD MC capable TAB connector (CSA4) C capable only
6.2	Base Station output power	-	-	-	-
6.2.2	Base Station maximum output power	ATC1a	ATC1a	ATC1a, ANTC1	ATC1b
6.2.3	UTRA FDD primary CPICH power	SC	SC	SC	N/A
6.2.3A	UTRA FDD secondary CPICH power	SC	SC	SC	N/A
6.2.4	UTRA TDD primary CCPCH power	N/A	N/A	N/A	SC
6.3	Output power dynamics	-	-	-	-
6.3.2	UTRA Inner loop power control in the downlink	SC	SC	SC	SC
6.3.3	Power control dynamic range	SC	SC	SC	SC
6.3.4	Total power dynamic range	SC or ATC1a	SC or ATC1a	SC or ATC1a	N/A
6.3.5	IPDL time mask	SC	SC	SC	N/A
6.4	Transmit ON/OFF power	N/A	N/A	N/A	ATC1b
6.5	Transmitted signal quality	-	-	-	-
6.5.2	Frequency error	ATC1a	ATC1a	ATC1a, ANTC1	ATC1b
6.5.3	Time alignment error	ATC1a	ATC1a	ATC1a, ANTC1	ATC1b
6.5.4	Modulation quality - EVM	ATC1a	ATC1a	ATC1a, ANTC1	ATC1b
6.5.4	Modulation quality - PCDE	ATC1a	ATC1a	ATC1a, ANTC1	ATC1b
6.5.4	Modulation quality - RCDE	ATC1a	ATC1a	ATC1a	ATC1b
6.5.5	Transmit pulse shape filter	Not tested	Not tested	Not tested	Not tested
6.6	Unwanted Emissions	-	-	-	-
6.6.2	Occupied bandwidth	SC	SC	SC	SC
6.6.3	Adjacent Channel Leakage power Ratio	ATC1a	ANTC1	ATC1a, ANTC1	ATC1b
	Cumulative ACLR	-	ANTC1	ANTC1	N/A
6.6.4	Spectrum emission mask	ATC1a	ATC1a, ANTC1	ATC1a, ANTC1	ATC1b
6.6.6	Spurious emission	ATC1a	ANTC1	ATC1a, ANTC1	ATC1b
6.7	Transmitter intermodulation	ATC1a	ATC1a, ANTC1	ATC1a, ANTC1	ATC1b
7.2	Reference sensitivity level	SC	SC	SC	SC
7.3	Dynamic range	SC	SC	SC	SC
7.4	Adjacent channel selectivity and narrowband blocking	ATC1a	ANTC1	ATC1a, ANTC1	ATC1b
7.5	Blocking	ATC1a	ANTC1	ATC1a, ANTC1	ATC1b
7.6	Receiver spurious emissions	ATC1a	ANTC1	ATC1a, ANTC1	ATC1b
7.7	Receiver intermodulation	ATC1a	ANTC1	ATC1a, ANTC1	ATC1b

5.3.4 TAB connector supporting Single-RAT E-UTRA in the operating band

This subclause contains the test configurations for TAB connectors supporting single-RAT E-UTRA in the operating band. The test configurations apply to *TAB connectors* operating with multiple carriers (MC).

For a *TAB connector* declared to support multi-carrier and/or CA operation in contiguous spectrum operation in single band only, the test configurations in the second column of table 5.3.4-1 shall be used for testing.

For a *TAB connector* declared to support multi-carrier and/or CA operation in contiguous and non-contiguous spectrum in single band and where the parameters in the manufacturer's declaration according to subclause 4.10 are identical for contiguous (C) and non-contiguous (NC) spectrum operation, the test configurations in the third column of table 5.3.4-1 shall be used for testing.

For a *TAB connector* declared to support multi-carrier and/or CA in contiguous and non-contiguous spectrum in single band and where the parameters in the manufacturer's declaration according to subclause 4.10 are not identical for contiguous and non-contiguous spectrum operation, the test configurations in the fourth column of table 5.3.4-1 shall be used for testing.

Table 5.3.4-1: Test configurations for a *TAB connector* supporting single-RAT E-UTRA operation capable of both contiguous and non-contiguous spectrum in multi-carrier and/or CA operation in single band

TAB connector test case		Single-RAT E-UTRA MC capable TAB connector (CSA5) C capable only	Single-RAT E-UTRA MC capable TAB connector (CSA5) C and NC capable BS with identical parameters (CNC)	Single-RAT E-UTRA MC capable TAB connector (CSA5) C and NC capable BS with different parameters (CNC)
6.2	Base Station output power	-	-	-
6.2.2	Base Station maximum output power	ATC2a	ATC2a	ATC2a, ANTC2
6.2.6	E-UTRA DL RS power	SC	SC	SC
6.3	Output power dynamics	-	-	-
6.3.4	Total power dynamic range	SC	SC	SC
6.3.6	RE Power control dynamic range	Tested with Error Vector Magnitude	Tested with Error Vector Magnitude	Tested with Error Vector Magnitude
6.4	Transmit ON/OFF power	ATC2a	ATC2a	ATC2a, ANTC2
6.5	Transmitted signal quality	-	-	-
6.5.2	Frequency error	Tested with Error Vector Magnitude	Tested with Error Vector Magnitude	Tested with Error Vector Magnitude
6.5.3	Time alignment error	ATC2a	ATC2a	ATC2a, ANTC2
6.5.4	Modulation quality - EVM	ATC2a	ATC2a	ATC2a, ANTC2
6.5.5	Transmit pulse shape filter	Not Tested	Not Tested	Not Tested
6.6	Unwanted Emissions	-	-	-
6.6.2	Occupied bandwidth	SC, ATC2b (Note)	SC, ATC2b (Note)	SC, ATC2b (Note)
6.6.3	Adjacent Channel Leakage power Ratio	ATC2a	ANTC2	ATC2a, ANTC2
6.6.3	Cumulative ACLR	-	ANTC2	ANTC2
6.6.5	Operating band unwanted emission	ATC2a	ATC2a, ANTC2	ATC2a, ANTC2
6.6.6	Spurious emission	ATC2a	ANTC2	ATC2a, ANTC2
6.7	Transmitter intermodulation	ATC2a	Same TC as used in 6.6	Same TC as used in 6.6
7.2	Reference sensitivity level	SC	SC	SC
7.3	Dynamic range	SC	SC	SC
7.4	Adjacent channel selectivity and narrowband blocking	ATC2a	ANTC2	ATC2a, ANTC2
7.5	Blocking	ATC2a	ANTC2	ATC2a, ANTC2
7.6	Receiver spurious emissions	ATC2a	ANTC2	ATC2a, ANTC2
7.7	Receiver intermodulation	ATC2a	ANTC2	ATC2a, ANTC2
7.8	In-channel selectivity	SC	SC	SC
NOTE: ATC2b is only applicable when contiguous CA is supported.				

5.4 Test configurations for *Multi-band TAB connectors*

5.4.1 Multi-band TAB connector supporting MSR operation

Table 5.4.1-1: Test configuration for *multi-band TAB connectors* supporting MSR operation

TAB connector test case		Test for <i>Multi-Band TAB connector</i> CSA1, CSA2, CSA3, CSA3A	Test configuration for MBT	
			BC1/BC2	BC3
6.2	Base Station output power	-	-	-
6.2.2	Base Station maximum output power	SBT, MBT	ATC5a	ATC5a
	Additional regional requirement (only for band 34)	Compliance by declaration	N/A	-
6.2.3	UTRA FDD primary CPICH power	SBT	-	-
6.2.3A	UTRA FDD secondary CPICH power			
6.2.4	UTRA TDD primary CPICH power	SBT	-	-
6.2.5	UTRA FDD additional CPICH power for MIMO mode			
6.2.6	E-UTRA DL RS power	E-UTRA for DL RS power	SBT	-
6.3	Output power dynamics	-	-	-
6.3.2	UTRA Inner loop power control in the downlink	SBT	-	-
6.3.3	Power control dynamic range	SBT	-	-
6.3.4	Total power dynamic range	SBT	-	N/A
6.3.5	IPDL time mask	SBT	-	N/A
6.3.6	RE Power control dynamic range	SBT	-	N/A
6.4	Transmit ON/OFF power	-	-	-
6.4.1	Transmitter OFF power	MBT, SBT (note 3)	N/A	ATC5a
6.4.2	Transmitter transient period	MBT, SBT (note 3)	N/A	ATC5a
6.5	Transmitted signal quality	-	-	-
6.5.2	Frequency error	-	-	-
	E-UTRA	SBT, MBT	ATC5a	ATC5a
	UTRA FDD	SBT, MBT	ATC5a	N/A
	UTRA TDD	SBT, MBT	N/A	ATC5a
	NR	SBT, MBT	ATC5a	ATC5a
6.5.3	Time alignment error	-	-	-
	E-UTRA	SBT, MBT (note 1)	ATC5b	ATC5b
	UTRA FDD	SBT, MBT (note 1)	ATC5b	N/A
	UTRA TDD	SBT	N/A	-
	NR	SBT, MBT (note 1)	ATC5b	ATC5b
6.5.4	Modulation quality - EVM	-	-	-
	E-UTRA	SBT, MBT	ATC5a	ATC5a
	UTRA FDD	SBT, MBT	ATC5a	N/A
	UTRA TDD	SBT, MBT	N/A	ATC5a
	NR	SBT, MBT	ATC5a	ATC5a
6.5.5	Transmit pulse shape filter	Not tested	-	-
6.6	Unwanted Emissions	-	-	-
6.6.2	Occupied bandwidth	-	-	-
	Minimum requirement	SBT	-	-
6.6.3	Adjacent Channel Leakage power Ratio	-	-	-
	E-UTRA	SBT, MBT (note 2)	ATC5b	ATC5b
	UTRA FDD	SBT, MBT (note 2)	ATC5b	N/A
	UTRA TDD	SBT, MBT (note 2)	N/A	ATC5b
	Cumulative ACLR	SBT, MBT (note 2)	ATC5b	ATC5b
	NR	SBT, MBT (note 2)	ATC5b	ATC5b
6.6.4	Spectrum emission mask	-	-	-
6.6.5	Operating band unwanted emission	-	-	-
	General requirement for Band Categories 1 and 3	SBT, MBT	ATC5b	ATC5b
	General requirement for Band Category 2	SBT, MBT	ATC5b	N/A
	Additional requirements	SBT, MBT	-	-
6.6.6	Spurious emission	-	-	-
	(Category A)	SBT, MBT	ATC5b	ATC5b
	(Category B)	SBT, MBT	ATC5b	ATC5b
	Additional requirement for BC2 (Category B)	SBT, MBT	ATC5b	ATC5b
	Protection of the BS receiver of own or different BS	SBT, MBT	ATC5b	ATC5b
	Additional spurious emissions requirements	SBT, MBT	ATC5b	ATC5b
	Co-location with other Base Stations	-	-	-

TAB connector test case		Test for <i>Multi-Band TAB connector</i> CSA1, CSA2, CSA3, CSA3A	Test configuration for MBT	
			BC1/BC2	BC3
6.7	Transmitter intermodulation	-	-	-
	General requirement	SBT	-	-
	Additional requirement (BC1 and BC2)	SBT	-	N/A
	Additional requirement (BC3)	SBT	N/A	-
7.2	Reference sensitivity level	-	-	-
	E-UTRA requirement	SBT	-	-
	UTRA FDD requirement	SBT	-	-
	UTRA TDD requirement	SBT	-	-
	NR	SBT	-	-
7.3	Dynamic range	-	-	-
	E-UTRA	SBT	-	-
	UTRA FDD	SBT	-	-
	UTRA TDD	SBT	-	-
	NR	SBT	-	-
7.4	Adjacent channel selectivity and narrowband blocking	-	-	-
	General blocking requirement	MBT, SBT (note 3)	ATC5b	ATC5b
	General narrowband blocking requirement	MBT, SBT (note 3)	ATC5b	ATC5b
	Additional BC3 blocking minimum requirement	MBT, SBT (note 3)	N/A	ATC5b
7.5	Blocking	-	-	-
	General requirement	MBT, SBT(note 3)	ATC5b	ATC5b
	Co-location requirement	MBT, SBT(note 3)	ATC5b	ATC5b
7.6	Receiver spurious emissions	-	-	-
	General requirement	SBT, MBT	ATC5b	ATC5b
	Additional requirement for BC2 (Category B)	-	-	-
7.7	Receiver intermodulation	-	-	-
	General intermodulation requirement	MBT, SBT(note 3)	ATC5b	ATC5b
	General narrowband intermodulation requirement	MBT, SBT(note 3)	ATC5b	ATC5b
7.8	In-channel selectivity	-	-	-
	E-UTRA requirement	SBT	-	-
	NR requirement	SBT	-	-

NOTE 1: MBT is only applicable when DB-DC-HSDPA/inter-band CA is supported.
NOTE 2: For ACLR, MBT shall be applied for the Inter RF bandwidth gap only.
NOTE 3: SBT is only applicable if different Capability Sets are declared for single-band and multi-band operation.

5.4.2 Multi-band TAB connector supporting Single-RAT only

For a *multi-band TAB connector* supporting single-RAT only in the operational band, the test configurations in table 5.4.2-1, shall be used for testing.

Table 5.4.2-1: Test configuration for *multi-band TAB connectors* supporting Single-RAT only

TAB connector test case		UTRA FDD CSA4	UTRA TDD CSA4	E-UTRA Test CSA5
6.2	Base Station output power	-	-	-
6.2.2	Base Station maximum output power	ATC1a/ANTC1 (note 1) ATC5a	ATC1b (note 3), ATC5a	ATC2a/ANTC2 (note 5), ATC5a
6.2.3	UTRA FDD primary CPICH power	SC	N/A	N/A
6.2.3A	UTRA FDD secondary CPICH power	SC	N/A	N/A
6.2.4	UTRA TDD primary CCPCH power	N/A	SC	N/A
6.2.5	UTRA FDD additional CPICH power for MIMO mode	SC	N/A	N/A
6.2.6	E-UTRA DL RS power	N/A	N/A	SC
6.3	Output power dynamics	-	-	-
6.3.2	UTRA Inner loop power control in the downlink	SC	SC	N/A
6.3.3	Power control dynamic range	SC	SC	SC
6.3.4	Total power dynamic range	SC or ATC1a	N/A	SC
6.3.5	IPDL time mask	SC	N/A	N/A
6.3.6	RE Power control dynamic range	N/A	N/A	Tested with Error Vector Magnitude
6.4	Transmit ON/OFF power	-	-	-

TAB connector test case	UTRA FDD CSA4	UTRA TDD CSA4	E-UTRA Test CSA5
6.4.1 Transmitter OFF power	N/A	ATC5a	ATC5a (only applied for E-UTRA TDD BS)
6.4.2 Transmitter transient period	N/A	SC	SC
6.5 Transmitted signal quality	-	-	-
6.5.2 Frequency error	Tested with EVM	ATC1b (note 3), ATC5a	Tested with Error Vector Magnitude
6.5.3 Time alignment error	ATC1a/ANTC1 (note 1) ATC5b	ATC1b (note 3)	ATC2a/ANTC2 (note 5), ATC5b (note 6)
6.5.4 Modulation quality - EVM	ATC1a/ANTC1 (note 1), ATC5a	ATC1b (note 3), ATC5a	ATC2a/ANTC2 (note 5), ATC5a
6.5.4 Modulation quality - PCDE	ATC1a/ANTC1 (note 1)	ATC1b (note 3), ATC5a	N/A
6.5.4 Modulation quality - RCDE	AUTC1	ATC1b (note 3), ATC5a	N/A
6.5.5 Transmit pulse shape filter	not tested	not tested	not tested
6.6 Unwanted Emissions	-	-	-
6.6.2 Occupied bandwidth	SC	SC	SC, ATC2b (note 7)
6.6.3 Adjacent Channel Leakage power Ratio	ATC1a/ANTC1 (note 1) ATC5b (note 2)	ATC1b (note 3), ATC5a (note 4)	ATC2a/ANTC2 (note 5), ATC5b (note 8)
6.6.4 Spectrum emission mask	ATC1a/ANTC1 (note 1) ATC5b	ATC1b (note 3), ATC5a	N/A
6.6.5 Operating band unwanted emission	N/A	N/A	ATC2a/ANTC2 (note 5), ATC5b
6.6.6 Spurious emission	ATC1a/ANTC1 (note 1) ATC5b	ATC1b (note 3), ATC5a	ATC2a/ANTC2 (note 5), ATC5b
6.7 Transmitter intermodulation	ATC1a/ANTC1 (note 1)	ATC1b (note 3)	ATC2a/ANTC2 (note 5)
7.2 Reference sensitivity level	SC	SC	SC
7.3 Dynamic range	SC	SC	SC
7.4 Adjacent channel selectivity and narrowband blocking	ATC5b	ATC5a	ATC5b
7.5 Blocking	ATC5b	ATC5a	ATC5b
7.6 Receiver spurious emissions	ATC1a/ANTC1 (note 1) ATC5b	ATC1b (note 3), ATC5a	ATC2a/ANTC2 (note 5), ATC5b
7.7 Receiver intermodulation	ATC5b	ATC5a	ATC5b
7.8 In-channel selectivity	N/A	N/A	SC
NOTE 1: ATC1a and/or ANTC1 shall be applied in each supported operating band according to table 5.3.3-1. NOTE 2: ATC5b may be applied for <i>Inter RF Bandwidth gap</i> only. NOTE 3: ATC1b shall be applied in each supported operating band according to table 5.3.3-1. NOTE 4: ATC5a may be applied for <i>Inter RF bandwidth gap</i> only. NOTE 5: ATC2 and/or ANTC2 shall be applied in each supported operating band according to table 5.3.4-1. NOTE 6: ATC5b is only applicable when inter-band CA is supported. NOTE 7: ATC2b is only applicable when contiguous CA is supported. NOTE 8: ATC5b may be applied for <i>Inter RF bandwidth gap</i> only.			

6 Conducted transmitter characteristics

6.1 General

General test conditions for transmitter tests are given in clause 4, including interpretation of measurement results and configurations for testing. BS configurations for the tests are defined in subclause 4.8.

If a number of *TAB connectors* have been declared equivalent (see table 4.10-1, D6.70), only a representative one is necessary to demonstrate conformance.

In subclause 6.6, if representative *TAB connectors* are used then per connector criteria (option 2) shall be applied.

The manufacturer shall declare the minimum number of supported geographical cells (i.e. geographical areas). The minimum number of supported geographical cells (N_{cells}) relates to the AAS BS setting with the minimum amount of cell splitting supported with transmission on all *TAB connectors* supporting the operating band. The manufacturer shall also declare *TAB connector TX min cell groups* (as defined in clause 3) Every *TAB connector* supporting transmission in an operating band shall map to one *TAB connector TX min cell group* supporting the same. The mapping of *TAB connectors* to cells is implementation dependent.

The number of *active transmitter units* that are considered when calculating the emissions limit ($N_{\text{TXU, counted}}$) for an AAS BS is calculated as follows:

$N_{\text{TXU, counted}} = \min(N_{\text{TXU, active}}, 8 \cdot N_{\text{cells}})$ for E-UTRA single RAT AAS BS and MSR AAS BS (except UTRA only MSR AAS BS); and

$N_{\text{TXU, counted}} = \min(N_{\text{TXU, active}}, 4 \cdot N_{\text{cells}})$ for UTRA single RAT AAS BS and UTRA only MSR AAS BS

Further:

$N_{\text{TXU, counted per cell}} = N_{\text{TXU, counted}} / N_{\text{cells}}$

$N_{\text{TXU, counted per cell}}$ is used for scaling the *basic limits* as described in subclause 6.6.

NOTE: $N_{\text{TXU, active}}$ depends on the actual number of *active transmitter units* and is independent to the declaration of N_{cells} .

Any transmitter test requirement specified for Band 46 operation in 3GPP TS 36.104 [4] for E-UTRA, or in 3GPP TS 37.104 [5] for E-UTRA in MSR operation, and referred in clause 6, is not applicable for AAS BS.

Any transmitter test requirement specified for NB-IoT in-band, NB-IoT guard band, or standalone NB-IoT operation in 3GPP TS 36.141 [14] for E-UTRA with NB-IoT (in-band or guard band) or for standalone NB-IoT, or in 3GPP TS 37.141 [13] for E-UTRA with NB-IoT or standalone NB-IoT in *MSR operation*, and referred in clause 6, is not applicable for AAS BS.

6.2 Base station output power

6.2.1 General

The configured carrier power is the target maximum power for a specific carrier for the operating mode set in the BS within the limits given by the manufacturer's declaration.

6.2.2 Maximum output power

6.2.2.1 Definition and applicability

The rated carrier output power of the *AAS BS* shall be as specified in table 6.2.2.1-1.

Table 6.2.2.1-1: AAS Base Station rated output power limits for BS classes

AAS BS class	$P_{\text{Rated, c, sys}}$	$P_{\text{Rated, c, TABC}}$
Wide Area BS	(note)	(note)
Medium Range BS	$\leq 38 \text{ dBm} + 10 \log(N_{\text{TXU, counted}})$	$\leq 38 \text{ dBm}$
Local Area BS	$\leq 24 \text{ dBm} + 10 \log(N_{\text{TXU, counted}})$	$\leq 24 \text{ dBm}$
NOTE: There is no upper limit for the $P_{\text{Rated, c, sys}}$ or $P_{\text{Rated, c, TABC}}$ of the Wide Area Base Station.		

The output power limit for the respective BS classes in table 6.2.2.1-1 shall be compared to the rated output power and the declared BS class. It is not subject to testing.

The requirement in subclause 6.2.2.2 applies per *TAB connector*.

6.2.2.2 Minimum Requirement

The minimum requirement is in 3GPP TS 37.105 [8], subclause 6.2.2.2.

6.2.2.3 Test Purpose

The test purpose is to verify the accuracy of the *maximum carrier output power per TAB connector* ($P_{\max,c,TABC}$) across the frequency range and under normal and extreme conditions for all *TAB connectors* in the AAS BS.

6.2.2.4 Method of test

6.2.2.4.1 Initial conditions

Test environment:

- normal; see clause B.2.

RF channels to be tested:

- B, M and T; see subclause 4.12.1

Base Station RF Bandwidth positions to be tested:

- B_{RFBW} , M_{RFBW} and T_{RFBW} for *single band TAB connector(s)*, see subclause 4.12.1; B'_{RFBW} , T'_{RFBW} and B'_{RFBW} , T'_{RFBW} for *multi-band TAB connector(s)*, see subclause 4.12.1.

In addition, a single test case shall be performed under extreme test environment as defined in annex clause B.3 In this case, it is sufficient to test on a single combination of one ARFCN, UARFCN, EARFCN or NR-ARFCN, one RF bandwidth position and with only one applicable test configuration defined in clause 5.

NOTE: Tests under extreme power supply also test extreme temperature.

6.2.2.4.2 Procedure

The minimum requirement is applied to all *TAB connectors*, they may be tested one at a time or multiple *TAB connectors* may be tested in parallel as shown in annex subclause D.1.1. Whichever method is used the procedure is repeated until all *TAB connectors* necessary to demonstrate conformance have been tested.

- 1) Connect the power measuring equipment to the *TAB connector(s)* as shown in annex subclause D.1.1. All *TAB connectors* not under test shall be terminated.
- 2) Set each *TAB connector* to output according to the applicable test configuration in clause 5 using the corresponding test models or set of physical channels in subclause 4.12.2. For single carrier set the *TAB connector* to transmit at manufacturers declared *rated carrier output power per TAB connector* ($P_{\text{Rated},c,TABC}$).
- 3) Measure the mean power for each carrier at each *TAB connector*.

In addition, for *multi-band TAB connector(s)*, the following steps shall apply:

- 4) For *multi-band TAB connectors* and single band tests, repeat the steps above per involved band where single band test configurations and test models shall apply with no carrier activated in the other band.

6.2.2.5 Test Requirements

In normal conditions, the measurement result in step 3 of subclause 6.2.2.4.3 shall be:

- within +2.7 dB and -2.7 dB of the manufacturer's *rated carrier output power per TAB connector* ($P_{\text{Rated},c,TABC}$) for carrier frequency $f \leq 3.0$ GHz.
- within +3.0 dB and -3.0 dB of the manufacturer's *rated carrier output power per TAB connector* ($P_{\text{Rated},c,TABC}$) for carrier frequency $3.0 \text{ GHz} < f \leq 4.2 \text{ GHz}$.

In extreme conditions, measurement result in step 3 of subclause 6.2.2.4.3 shall be:

- within +3.2 dB and -3.2 dB of the manufacturer's *rated carrier output power per TAB connector* ($P_{\text{Rated},c,TABC}$) for carrier frequency $f \leq 3.0$ GHz.
- within +3.5 dB and -3.5 dB of the manufacturer's *rated carrier output power per TAB connector* ($P_{\text{Rated},c,TABC}$) for carrier frequency $3.0 \text{ GHz} < f \leq 4.2 \text{ GHz}$.

6.2.3 UTRA FDD primary CPICH power

6.2.3.1 Definition and applicability

This requirement applies to the *TAB connector* group(s) transmitting primary CPICH.

Primary CPICH (P-CPICH) power is the code domain power of the Primary Common Pilot Channel summed over the *TAB connectors* transmitting the P-CPICH for a cell. P-CPICH power is indicated on the BCH.

NOTE 1: A *TAB connector* group may comprise all *TAB connectors*.

NOTE 2: A *TAB connector* may be mapped to several groups.

NOTE 3: The manufacturer declares the *TAB connector* mapping to the P-CPICH transmission group(s) as specified in subclause 4.10.

6.2.3.2 Minimum requirement

The minimum requirement for UTRA FDD operation is in 3GPP TS 37.105 [8], subclause 6.2.3.

There is no P-CPICH power requirement for UTRA TDD 1,28 Mcps option operation.

There is no P-CPICH power requirement for E-UTRA operation.

There is no P-CPICH power requirement for NR operation.

6.2.3.3 Test purpose

The test purpose is to verify that the UTRA FDD primary CPICH power is within the limits specified by the minimum requirement.

6.2.3.4 Method of test

6.2.3.4.1 Initial conditions

Test environment:

- normal; see annex B.

RF channels to be tested:

- B, M and T; see subclause 4.12.1.

Disable inner loop power control.

Set the *TAB connectors* in the P-CPICH transmission group (see table 4.10-1, D6.45) to output a signal in accordance to TM2, in 3GPP TS 25.141 [18], subclause 6.1.1.2.

6.2.3.4.2 Procedure

The minimum requirement is applied to all *TAB connectors* in the *TAB connector* group(s) transmitting primary CPICH. *TAB connectors* may be tested one at a time or multiple *TAB connectors* may be tested in parallel as shown in annex subclause D.1.1. Whichever method is used the procedure is repeated until all *TAB connectors* necessary to demonstrate conformance have been tested.

- 1) Connect *TAB connector* to code domain analyser as shown in annex subclause D.1.1. All *TAB connectors* not under test shall be terminated.
- 2) Set the *TAB connector* to transmit at manufacturers declared *rated carrier output power per TAB connector* ($P_{\text{Rated,c,TABC}}$). Measure the P-CPICH power in one timeslot on each of the *TAB connector(s)* transmitting the P-CPICH according to annex E in 3GPP TS 25.141 [18].

In addition, for *multi-band TAB connector(s)*, the following steps shall apply:

- 3) For *multi-band TAB connectors* and single band tests, repeat the steps above per involved band where single band test configurations and test models shall apply with no carrier activated in the other band.

6.2.3.5 Test requirements

For UTRA FDD the test requirement for CPICH power is:

Either:

The sum of the measured P-CPICH code domain power on each of the *TAB connectors* transmitting the P-CPICH shall be:

Within ± 2.9 dB of the configured absolute value for carrier frequency $f \leq 3.0$ GHz.

Within ± 3.2 dB of the configured absolute value for carrier frequency $3.0 \text{ GHz} < f \leq 4.2 \text{ GHz}$.

Or

The measured P-CPICH code domain power on each of the *TAB connectors* transmitting the P-CPICH shall be:

Within ± 2.9 dB of the configured absolute value for carrier frequency $f \leq 3.0$ GHz.

Within ± 3.2 dB of the configured absolute value for carrier frequency $3.0 \text{ GHz} < f \leq 4.2 \text{ GHz}$.

NOTE: If the above Test Requirement differs from the Minimum Requirement then the Test Tolerance applied for this test is non-zero. The Test Tolerance for this test is defined in subclause 4.1.2 and the explanation of how the Minimum Requirement has been relaxed by the Test Tolerance is given in annex C.

6.2.4 UTRA TDD primary CCPCH power

6.2.4.1 Definition and applicability

This requirement applies to the *TAB connector* group(s) transmitting primary CCPCH. It comprises primary CCPCH (PCCPCH) absolute power accuracy, and differential accuracy.

Primary CCPCH power is the *code domain power* of the primary common control physical channel averaged over the transmit timeslot and summed over the *TAB connectors* transmitting the PCCPCH for a cell. Primary CCPCH power is signalled over the BCH.

The differential accuracy of the Primary CCPCH power is the relative transmitted power accuracy of PCCPCH in consecutive frames when the nominal PCCPCH power is not changed.

NOTE 1: A *TAB connector* group may comprise all *TAB connectors*.

NOTE 2: A *TAB connector* may be mapped to several groups.

NOTE 3: The manufacturer declares the *TAB connector* mapping to the PCCPCH transmission group(s). See subclause 4.10.

6.2.4.2 Minimum requirement

The minimum requirement for UTRA TDD 1,28 Mcps option operation is in 3GPP TS 37.105 [8], subclause 6.2.4.

There is no PCCPCH power requirement for UTRA FDD operation.

There is no PCCPCH power requirement for E-UTRA operation.

There is no PCCPCH power requirement for NR operation.

6.2.4.3 Test purpose

The test purpose is to verify that the UTRA TDD primary CCPCH power is within the limits specified by the minimum requirement.

6.2.4.4 Method of test

6.2.4.4.1 Initial conditions

Test environment:

- normal; see annex B.

RF channels to be tested:

- B, M and T; see subclause 4.12.1

Set the *TAB connectors* in the PCCPCH transmission group (see table 4.10-1, D6.47) to output a signal in accordance to table 6.2.4.4.1-1.

Table 6.2.4.4.1-1: Parameters of the BS transmitted signal for Primary CCPCH power testing for 1,28 Mcps TDD

Parameter	Value/description
TDD Duty Cycle	TS i ; $i = 0, 1, 2, \dots, 6$: transmit, if i is 0,4,5,6; receive, if i is 1,2,3.
Time slots carrying PCCPCH	TS 0
Relative power of PCCPCH	1/2 of BS output power
Data content of DPCH	real life (sufficient irregular)

6.2.4.4.2 Procedure

The minimum requirement is applied to all *TAB connectors* in the *TAB connector* group(s) transmitting primary CCPCH. *TAB connectors* may be tested one at a time or multiple *TAB connectors* may be tested in parallel as shown in annex subclause D.1.1. Whichever method is used the procedure is repeated until all *TAB connectors* necessary to demonstrate conformance have been tested.

The requirement has both an absolute accuracy requirement and a differential accuracy requirement which are measured at the same time.

- 1) Connect TAB connector to code domain analyser as shown in subclause D.1.1. All TAB connectors not under test shall be terminated.
- 2) Set the TAB connector to transmit at manufacturers declared rated carrier output power per TAB connector ($P_{Rated,c,TABC}$).
- 3) Measure the CCPCH power in one timeslot on each of the TAB connector(s) transmitting the PCCPCH according to annex E in 3GPP TS 25.142 [20].
- 4) Measure the PCCPCH code domain power in TS 0 of consecutive frames by applying the global in-channel Tx test method described in annex E in 3GPP TS 25.142 [20].
- 5) Calculate the differential accuracy of the Primary CCPCH power by taking the difference between the PCCPCH power measurement results of consecutive frames.

In addition, for *multi-band TAB connector(s)*, the following steps shall apply:

- 6) For multi-band TAB connectors and single band tests, repeat the steps above per involved band where single band test configurations and test models shall apply with no carrier activated in the other band.

6.2.4.5 Test requirements

For UTRA TDD 1,28 Mcps option the test requirement for PCCPCH power is:

Either:

The sum of the measured PCCPCH code domain power on each of the *TAB connectors* transmitting the PCCPCH shall be within the limits defined in table 6.2.4.5-1.

Or

The measured PCCPCH code domain power on each of the *TAB connectors* transmitting the PCCPCH shall be within the tolerance indicated in table 6.2.4.5-1.

Table 6.2.4.5-1: Test Requirements for errors between Primary CCPCH power and the broadcast value

Output power in slot, dB	PCCPCH power tolerance
$P_{\text{Rated,t,group}} - 3 < P_{\text{out}} \leq P_{\text{Rated,t,group}} + 2$	± 3.3 dB
$P_{\text{Rated,t,group}} - 6 < P_{\text{out}} \leq P_{\text{Rated,t,group}} - 3$	± 4.3 dB
$P_{\text{Rated,t,group}} - 13 < P_{\text{out}} \leq P_{\text{Rated,t,group}} - 6$	± 5.8 dB
NOTE: $P_{\text{Rated,t,group}}$ is the power sum of $P_{\text{Rated,t,TABC}}$ of all the <i>TAB connectors</i> in the group transmitting PCCPCH.	

The differential accuracy of the Primary CCPCH power, shall be within ± 0.6 dB.

NOTE: If the above Test Requirement differs from the Minimum Requirement then the Test Tolerance applied for this test is non-zero. The Test Tolerance for this test is defined in subclause 4.1.2 and the explanation of how the Minimum Requirement has been relaxed by the Test Tolerance is given in annex C.

6.2.5 UTRA FDD additional CPICH power for MIMO mode

6.2.5.1 Definition and applicability

This subclause includes requirements on secondary CPICH power level, for two and four *TAB connector* groups, as well as Demodulation CPICH requirements. The requirements apply to all *TAB connector* groups associated with UTRA FDD MIMO transmission as "antenna 2", "antenna 3" or "antenna 4" in the AAS BS.

The concept of "antenna 2", "antenna 3" and "antenna 4" is described in 3GPP TS 25.104 [2]. The group(s) of *TAB connectors* mapped to P-CPICH transmission (see table 4.10-1 D6.45) represents "antenna 1".

NOTE 1: The manufacturer declares the mapping of *TAB connectors* to "antenna 1", "antenna 2", "antenna 3" and "antenna 4" (as defined in 3GPP TS 25.331 [16]) where applicable for AAS BS capable of UTRA FDD operation. The required declarations are specified subclause 4.10.

For UTRA FDD AAS BS operating only "antenna 1" and "antenna 2", the secondary CPICH (S-CPICH) power is the *code domain power* of the Secondary Common Pilot Channel. S-CPICH power is equal to the (dB) sum of the P-CPICH power and the power offset, which are signalled to the UE. The power offset is signalled in the IE "Power Offset for S-CPICH for MIMO", for MIMO mode as defined in subclause 10.3.6.41b in 3GPP TS 25.331 [16].

When the UE supports MIMO mode with four BS transmit antennas, the power offset of S-CPICH on antenna 2 is signalled in the IE "Power Offset for S-CPICH for MIMO mode with four transmit antennas on Antenna2" as defined in subclause 10.3.6.143 in 3GPP TS 25.331 [16]. The power offset of S-CPICH on antenna 3 and 4 is signalled in the IE "Common Power Offset for S-CPICH for MIMO mode with four transmit antennas on antenna 3 and 4", as defined in subclause 10.3.6.143 in 3GPP TS 25.331 [16].

Demodulation CPICH (D-CPICH) power is the *code domain power* of the Demodulation Common Pilot Channel. D-CPICH power is equal to the (dB) sum of the P-CPICH power and the power offset, which are signalled to the UE. The power offset of D-CPICH on antenna 3 and 4 is signalled in the IE "Common Power Offset for D-CPICH for MIMO mode with four transmit antennas on antenna 3 and 4", as defined in subclause 10.3.6.143 in 3GPP TS 25.331 [16].

NOTE 2: The accuracy level of the power offset for S-CPICH may affect both MIMO HS-DSCH demodulation and CQI reporting performance.

NOTE 3: The accuracy level of the power offset for D-CPICH transmitted on antennas 3 and 4 may affect both MIMO HS-DSCH demodulation and CQI reporting performance.

NOTE 4: At high geometry level PDSCH performance may be affected if D-CPICH is not scheduled.

NOTE 5: A *TAB connector* group may comprise all *TAB connectors*.

NOTE 6: A *TAB connector* may be mapped to several groups.

6.2.5.2 Minimum requirement

The minimum requirement for UTRA FDD operation is in 3GPP TS 37.105 [8], subclause 6.2.5.3.

There is no CPICH power requirement for UTRA TDD 1,28 Mcps option operation.

There is no CPICH power requirement for E-UTRA operation.

There is no CPICH power requirement for NR operation.

6.2.5.3 Test purpose

The test purpose is to verify that the UTRA FDD CPICH power for MIMO mode is within the limits specified by the minimum requirement.

6.2.5.4 Method of test

6.2.5.4.1 Initial conditions

Test environment:

- normal; see annex B.

RF channels to be tested:

- B, M and T; see subclause 4.12.1.

Disable inner loop power control.

Set the *TAB connectors* in the P-CPICH transmission group (see table 4.10-1, D6.45) and the *TAB connectors* in the S-CPICH transmission groups (see table 4.10-1, D6.49), to output a signal in accordance to TM2, in 3GPP TS 25.141 [18], subclause 6.1.1.2.

NOTE: Although the S-CPICH transmission groups are referred to as S-CPICH as the same TM2 is used for the test, the signal being measured on the S-CPICH transmission groups is actually a P-CPICH signal.

6.2.5.4.2 Procedure

The minimum requirement is applied to all *TAB connectors* in the P-CPICH transmission group transmitting primary CPICH and the *TAB connectors* in the S-CPICH transmission groups. *TAB connectors* may be tested one at a time or multiple *TAB connectors* may be tested in parallel as shown in subclause D.1.1. Whichever method is used the procedure is repeated until all *TAB connectors* necessary to demonstrate conformance have been tested.

- 1) Connect *TAB connector* to code domain analyser as shown in subclause D.1.1. All *TAB connectors* not under test shall be terminated.
- 2) Set the *TAB connector* to transmit at manufacturers declared *rated carrier output power per TAB connector* ($P_{\text{Rated,c,TABC}}$).
- 3) Measure the P-CPICH power in one timeslot on each of the *TAB connector(s)* in the P-CPICH transmission groups according to annex E in 3GPP TS 25.141 [18].
- 4) Measure the P-CPICH power in the same timeslot as step 2 on each of the *TAB connector(s)* in each of the S-CPICH transmission groups according to annex E in 3GPP TS 25.141 [18]. Depending on the MIMO support (see table 4.10-1, D6.49), for MIMO mode there is a single S-CPICH transmission group representing "antenna 2" and for MIMO with 4 transmit antennas there are three S-CPICH transmission groups representing "antenna 2", "antenna 3" and "antenna 4".

In addition, for *multi-band TAB connector(s)*, the following steps shall apply:

- 5) For *multi-band TAB connectors* and single band tests, repeat the steps above per involved band where single band test configurations and test models shall apply with no carrier activated in the other band.

6.2.5.5 Test requirements

For UTRA FDD the test requirement for CPICH power for MIMO mode is:

Either:

The difference between the sums of the measured P-CPICH code domain power on each of the *TAB connectors* in the P-CPICH transmission group or the S-CPICH transmission groups shall be:

Within ± 2.7 dB for carrier frequency $f \leq 3.0$ GHz.

Within ± 3.0 dB for carrier frequency $3.0 \text{ GHz} < f \leq 4.2$ GHz.

Or

The difference between the measured P-CPICH code domain power on any 2 *TAB connectors* in either the P-CPICH transmission group or the S-CPICH transmission group(s) with corresponding beamforming weights shall be:

Within ± 2.7 dB for carrier frequency $f \leq 3.0$ GHz.

Within ± 3.0 dB for carrier frequency $3.0 \text{ GHz} < f \leq 4.2$ GHz.

NOTE: If the above Test Requirement differs from the Minimum Requirement then the Test Tolerance applied for this test is non-zero. The Test Tolerance for this test is defined in subclause 4.1.2 and the explanation of how the Minimum Requirement has been relaxed by the Test Tolerance is given in annex C.

6.2.6 E-UTRA DL RS power

6.2.6.1 Definition and applicability

This requirement applies to the *TAB connector* group(s) transmitting primary DL RS.

The DL RS power is the resource element power of the Downlink Reference Symbol summed over the group of *TAB connectors* transmitting the DL RS for a cell.

The absolute DL RS power is indicated on the DL-SCH. The absolute accuracy is defined as the maximum deviation between the DL RS power indicated on the DL-SCH and the DL RS power of each E-UTRA carrier.

NOTE 1: A *TAB connector* group may comprise all *TAB connectors*.

NOTE 2: A *TAB connector* may be mapped to several groups.

NOTE 3: The manufacturer declares the *TAB connector* mapping to the DL RS transmission group(s).

6.2.6.2 Minimum requirement

The minimum requirement for E-UTRA operation is in 3GPP TS 37.105 [8], subclause 6.2.6.

There is no DL RS power requirement for UTRA FDD operation.

There is no DL RS power requirement for UTRA TDD 1,28 Mcps option operation.

There is no DL RS power requirement for NR operation.

6.2.6.3 Test purpose

The test purpose is to verify that the E-UTRA FDD DL RS power is within the limits specified by the minimum requirement.

6.2.6.4 Method of test

6.2.6.4.1 Initial conditions

Test environment:

- normal; see annex B.

RF channels to be tested:

- B, M and T; see subclause 4.12.1.

Set the *TAB connectors* in the DL RS transmission group (see table 4.10-1, D6.54) to output a signal in accordance to E-TM 1.1, in 3GPP TS 36.141 [17] subclause 6.1.1.1.

6.2.6.4.2 Procedure

The minimum requirement is applied to all *TAB connectors* in the *TAB connector* group(s) transmitting primary CPICH. *TAB connectors* may be tested one at a time or multiple *TAB connectors* may be tested in parallel as shown in subclause D.1.1. Whichever method is used the procedure is repeated until all *TAB connectors* necessary to demonstrate conformance have been tested.

- 1) Connect *TAB connector* to code domain analyser as shown in subclause D.1.1. All *TAB connectors* not under test shall be terminated.
- 2) Set the *TAB connector* to transmit at manufacturers declared *rated carrier output power per TAB connector* ($P_{\text{Rated,c,TABC}}$).
- 3) Measure the DL RS power on each of the *TAB connector(s)* transmitting the DL RS according to annex F in 3GPP TS 36.141 [17].

In addition, for *multi-band TAB connector(s)*, the following steps shall apply:

- 4) For *multi-band TAB connectors* and single band tests, repeat the steps above per involved band where single band test configurations and test models shall apply with no carrier activated in the other band.

6.2.6.5 Test requirements

The DL RS power of each E-UTRA carrier shall be:

within ± 2.9 dB of the DL RS power indicated on the DL-SCH for carrier frequency $f \leq 3.0$ GHz.

within ± 3.2 dB of the DL RS power indicated on the DL-SCH for carrier frequency $3.0 \text{ GHz} < f \leq 4.2 \text{ GHz}$.

Alternatively, the DL RS power measured at each *TAB connector* shall be within ± 2.9 dB for $f \leq 3.0$ GHz and within ± 3.2 dB for $3.0 \text{ GHz} < f \leq 4.2 \text{ GHz}$ of the DL RS power level indicated on the DL-SCH multiplied by a *TAB connector* specific beamforming weight. Beamforming weights on P-CPICH are set by the AAS BS to achieve an intended radiated pattern.

6.3 Output power dynamics

6.3.1 General

The requirements in subclause 6.3 apply during the *transmitter ON period*. Transmit signal quality (as specified in subclause 6.5) shall be maintained for the output power dynamics requirements.

6.3.2 UTRA Inner loop power control in the downlink

6.3.2.1 Definition and applicability

Inner loop power control in the downlink is the ability of the AAS BS to adjust the transmitted output power of a code channel in accordance with the corresponding TPC commands received in the uplink.

This requirement applies at each *TAB connector* supporting transmission in the operating band.

6.3.2.2 Minimum requirement

The minimum requirement for UTRA FDD operation is in 3GPP TS 37.105 [8], subclause 6.3.2.

The minimum requirement for UTRA TDD 1,28 Mcps option operation is in 3GPP TS 25.105 [10], subclause 6.4.2.1.

There is no Inner loop power control requirement for E-UTRA or NR operation.

6.3.2.3 Test purpose

The test purpose is to verify that the Inner loop power control in the downlink is within the limits specified by the minimum requirement.

6.3.2.4 Method of test

6.3.2.4.1 Initial conditions

6.3.2.4.1.1 General test conditions

Test environment:

- normal; see annex B.

RF channels to be tested:

- B, M and T; see subclause 4.12.1.

Disable closed loop power control.

6.3.2.4.1.2 UTRA FDD

Set each *TAB connector* to output a signal in accordance to TM2, in 3GPP TS 25.141 [18], subclause 6.1.1.2.

The DPCH intended for power control is on channel 120 starting at -3 dB.

Establish downlink power control with parameters as specified in table 6.3.2.4.1.2-1.

Table 6.3.2.4.1.2-1: DL power control parameters

Parameter	Level/status	Unit
UL signal mean power	$P_{\text{REFSENS}} + 10 \text{ dB}$	dBm
Data sequence	PN9	

6.3.2.4.1.3 UTRA TDD

Set the initial parameters of the *TAB connector* transmitted signal according to table 6.3.2.4.1.3-1.

Operate the *TAB connector* in such a mode that it is able to interpret received TPC commands.

NOTE: The BS tester used for this test must have the ability:

- to analyze the output signal of the *TAB connector* under test with respect to code domain power, by applying the global in-channel Tx test method described in annex E of 3GPP TS 25.142 [20];
- to simulate an UE with respect to the generation of TPC commands embedded in a valid UE signal.

Table 6.3.2.4.1.3-1: Initial parameters of the *TAB connector* signal for power control steps test for 1,28 Mcps TDD

Parameter	Value/description
TDD Duty Cycle	TS i ; $i = 0, 1, 2, \dots, 6$: transmit, if i is 0, 4,5,6; receive, if i is 1,2,3.
Time slots under test	TS4, TS5 and TS6
Number of DPCH in each time slot under test	1
Data content of DPCH	real life (sufficient irregular)

6.3.2.4.2 Procedure

6.3.2.4.2.1 General procedure

The minimum requirement is applied to all *TAB connectors*, they may be tested one at a time or multiple *TAB connectors* may be tested in parallel as shown in subclause D.1.1. Whichever method is used the procedure is repeated until all *TAB connectors* necessary to demonstrate conformance have been tested.

- 1) Connect *TAB connector* to measurement equipment as shown in subclause D.1.1. All *TAB connectors* not under test shall be terminated.

- 2) Set the *TAB connector* to transmit at manufacturers *rated carrier output power per TAB connector* ($P_{\text{Rated,c,TABC}}$).

6.3.2.4.2.2 UTRA FDD

- 1) Set and send alternating TPC bits from the UE simulator or UL signal generator.
- 2) Measure mean power level of the code under the test each time TPC command is transmitted. All steps within power control dynamic range declared by manufacturer (see table 4.10-1, D6.57) shall be measured. Use the code domain power measurement method defined in annex E in 3GPP TS 25.141 [18].
- 3) Measure the 10 highest and the 10 lowest power step levels within the power control dynamic range declared by manufacturer by sending 10 consecutive equal commands as described in 3GPP TS 37.105 [8], subclause 6.3.2. Table 6.3.2.3-2

In addition, for *multi-band TAB connector(s)*, the following steps shall apply:

- 1) For *multi-band TAB connectors* and single band tests, repeat the steps above per involved band where single band test configurations and test models shall apply with no carrier activated in the other band.

6.3.2.4.2.3 UTRA TDD

- 1) Configure the *TAB connector* to enable power control steps of size 1 dB.
- 2) Set the BS tester to produce a sequence of TPC commands related to the active DPCH. This sequence shall be transmitted to the AAS BS within receive time slots TS *i* of the AAS BS and shall consist of a series of TPC commands with content "Decrease Tx power", followed by a series of TPC commands with content "Increase Tx power". Each of these series should be sufficiently long so that the code domain power of the active DPCH is controlled to reach its minimum and its maximum, respectively.
- 3) Measure the code domain power of the active DPCH over the 848 active chips of each transmit time slot AAS TS *i* of the AAS BS (this excludes the guard period) by applying the global in-channel Tx test method described in annex E in 3GPP TS 25.142 [20].
- 4) Based on the measurement made in step (5), calculate the power control step sizes and the average rate of change per 10 steps.
- 5) Configure the BS transmitter to enable power control steps of 2 dB and of 3 dB, respectively, and repeat steps (4) to (6).

In addition, for *multi-band TAB connector(s)*, the following steps shall apply:

- 6) For *multi-band TAB connectors* and single band tests, repeat the steps above per involved band where single band test configurations and test models shall apply with no carrier activated in the other band.

6.3.2.5 Test requirements

6.3.2.5.1 UTRA FDD

For UTRA FDD the test requirement Inner loop power control is:

- a) *TAB connector* shall fulfil step size requirement shown in table 6.3.2.5.1-1 for all power control steps declared by manufacture in subclause 4.10.
- b) For all measured Up/Down cycles, the difference of code domain power between before and after 10 equal commands (Up and Down), derived in step (3), shall not exceed the prescribed tolerance in table 6.3.2.5.1-2.

Table 6.3.2.5.1-1: UTRA FDD TAB connector power control step tolerance

Power control commands in the downlink	Transmitter power control step tolerance							
	2 dB step size		1.5 dB step size		1 dB step size		0.5 dB step size	
	Lower	Upper	Lower	Upper	Lower	Upper	Lower	Upper
Up(TPC command "1")	+0.9 dB	+3.1 dB	+0.65 dB	+2.35 dB	+0.4 dB	+1.6 dB	+0.15 dB	+0.85 dB
Down(TPC command "0")	-0.9 dB	-3.1 dB	-0.65 dB	-2.35 dB	-0.4 dB	-1.6 dB	-0.15 dB	-0.85 dB

Table 6.3.2.5.1-2: UTRA FDD TAB connector aggregated power control step range

Power control commands in the downlink	Transmitter aggregated power control step range after 10 consecutive equal commands (up or down)							
	2 dB step size		1.5 dB step size		1 dB step size		0.5 dB step size	
	Lower	Upper	Lower	Upper	Lower	Upper	Lower	Upper
Up(TPC command "1")	+15.9 dB	+24.1 dB	+11.9 dB	+18.1 dB	+7.9 dB	+12.1 dB	+3.9 dB	+6.1 dB
Down(TPC command "0")	-15.9 dB	-24.1 dB	-11.9 dB	-18.1 dB	-7.9 dB	-12.1 dB	-3.9 dB	-6.1 dB

NOTE: If the above Test Requirement differs from the Minimum Requirement then the Test Tolerance applied for this test is non-zero. The Test Tolerance for this test is defined in subclause 4.1.2 and the explanation of how the Minimum Requirement has been relaxed by the Test Tolerance is given in annex C.

6.3.2.5.2 UTRA TDD

For UTRA TDD 1,28 Mcps option the test requirement Inner loop power control is:

For all measurements, the tolerance of the power control step sizes and the average rate of change per 10 steps shall be within the limits given in table 6.3.2.5.2-1.

Table 6.3.2.5.2-1: Test Requirements for power control step size tolerance

Step size	Single step tolerance	Range of average rate of change in code domain power per 10 steps	
		Minimum	maximum
1 dB	±0,6 dB	±7,7 dB	±12,3 dB
2 dB	±0,85 dB	±15,7 dB	±24,3 dB
3 dB	±1,1 dB	±23,7 dB	±36,3 dB

In case, the power control step size is set to 3 dB, the number of power control steps feasible within the power control dynamic range of the TAB connector under test may be less than 10. In this case, the evaluation of the average rate of change in code domain power shall be based on the number of power control steps actually feasible, and the permitted range of average rate of change shall be reduced compared to the values given in table 6.3.2.5.2-1 in proportion to the ratio (number of power control steps actually feasible /10).

EXAMPLE: If the number of power control steps actually feasible is 9, the minimum and maximum value of the range of average rate of change in code domain power are given by 21,6 dB and 32,4 dB, respectively.

NOTE: If the above Test Requirement differs from the Minimum Requirement then the Test Tolerance applied for this test is non-zero. The Test Tolerance for this test is defined in subclause 4.1.2 and the explanation of how the Minimum Requirement has been relaxed by the Test Tolerance is given in annex C.

6.3.3 Power control dynamic range

6.3.3.1 Definition and applicability

The power control dynamic range is the difference between the maximum and the minimum *code domain power* of a code channel for a specified reference condition.

This requirement applies at each *TAB connector* supporting transmission in the operating band.

6.3.3.2 Minimum requirement

The minimum requirement for UTRA FDD operation are defined in 3GPP TS 25.104 [9], subclause 6.4.2.1.

The minimum requirement for UTRA TDD 1,28 Mcps option operation is in 3GPP TS 25.105 [10], subclause 6.4.3.1

There is no power control dynamic range requirement for E-UTRA or NR operation.

6.3.3.3 Test purpose

The test purpose is to verify that the power control dynamic range is within the limits specified by the minimum requirement.

6.3.3.4 Method of test

6.3.3.4.1 Initial conditions

6.3.3.4.1.1 General test conditions

Test environment:

- normal; see annex B.

RF channels to be tested:

- B, M and T; see subclause 4.12.1.

6.3.3.4.1.2 UTRA FDD

Set each *TAB connector* to output a signal in accordance to TM2, in 3GPP TS 25.141 [18], subclause 6.1.1.2.

6.3.3.4.1.3 UTRA TDD

Set the initial parameters of the *TAB connector* transmitted signal according to table 6.3.3.4.1.3-1.

Operate the *TAB connector* in such a mode that it is able to interpret received TPC commands.

NOTE: The BS tester used for this test must have the ability:

- to analyze the output signal of the *TAB connector* under test with respect to code domain power, by applying the global in-channel Tx test method described in annex E of 3GPP TS 25.142 [20];
- to simulate an UE with respect to the generation of TPC commands embedded in a valid UE signal.

Table 6.3.3.4.1.3-1: Parameters of the BS transmitted signal for power control dynamic range test for 1,28 Mcps TDD

Parameter	Value/description
TDD Duty Cycle	TS i ; $i = 0, 1, 2, \dots, 6$: transmit, if i is 0, 4,5,6; receive, if i is 1,2,3.
Time slots under test	TS4, TS5 and TS6
Number of DPCH in each time slot under test	1
Data content of DPCH	real life (sufficient irregular)

6.3.3.4.2 Procedure

6.3.3.4.2.1 General procedure

The minimum requirement is applied to all *TAB connectors*, they may be tested one at a time or multiple *TAB connectors* may be tested in parallel as shown in subclause D.1.1. Whichever method is used the procedure is repeated until all *TAB connectors* necessary to demonstrate conformance have been tested.

- 1) Connect *TAB connector* to measurement equipment as shown in subclause D.1.1. All *TAB connectors* not under test shall be terminated.
- 2) Set the *TAB connector* to transmit at manufacturers declared *rated carrier output power per TAB connector* ($P_{\text{Rated,c,TABC}}$)

6.3.3.4.2.1 UTRA FDD

- 1) Using TM2, set the code domain power of the DPCH under test to $P_{\text{max,c,TABC}} - 3$ dB. Power levels for other code channels may be adjusted if necessary.
- 2) Measure the code domain power of the code channel under test. Use the code domain power measurement method defined in annex E in 3GPP TS 25.141 [18].

- 3) Set the code domain power of the DPCH under test to $P_{\max,c,TABC} - 28$ dB by means determined by the manufacturer. The power levels for the other code channels used in step 2 shall remain unchanged (the overall output power will drop by approximately 3 dB).
- 4) Measure the code domain power of the code channel under test.

In addition, for *multi-band TAB connector(s)*, the following steps shall apply:

- 5) For *multi-band TAB connectors* and single band tests, repeat the steps above per involved band where single band test configurations and test models shall apply with no carrier activated in the other band.

6.3.3.4.2.2 UTRA TDD

- 1) Configure the *TAB connector* transmitter unit to enable power control steps of size 1 dB.
- 2) Set the BS tester to produce a sequence of TPC commands related to the active DPCH, with content "Decrease Tx power". This sequence shall be sufficiently long so that the code domain power of the active DPCH is controlled to reach its minimum, and shall be transmitted to the AAS BS within the receive time slots TS *i* of the BS.
- 3) Measure the code domain power of the active DPCH over the 848 active chips of a transmit time slot TS *i* of the AAS BS (this excludes the guard period) by applying the global in-channel Tx test method described in annex E of 3GPP TS 25.142 [20].
- 4) Set the BS tester to produce a sequence of TPC commands related to the active DPCH, with content "Increase Tx power". This sequence shall be sufficiently long so that the code domain power of the active DPCH is controlled to reach its maximum, and shall be transmitted to the AAS BS within the receive time slots TS *i* of the AAS BS.
- 5) Measure the code domain power of the active DPCH over the 848 active chips of a transmit time slot TS *i* of the AAS BS (this excludes the guard period) by applying the global in-channel Tx test method described in annex E in 3GPP TS 25.142 [20].
- 6) Determine the power control dynamic range by calculating the difference between the maximum code domain power measured in step (5) and the minimum code domain power measured in step (7).
- 7) Configure the *TAB connector* transmitter to enable power control steps of 2 dB and of 3 dB, respectively, and repeat steps (4) to (8).

In addition, for *multi-band TAB connector(s)*, the following steps shall apply:

- 8) For *multi-band TAB connectors* and single band tests, repeat the steps above per involved band where single band test configurations and test models shall apply with no carrier activated in the other band.

6.3.3.5 Test requirements

6.3.3.5.1 UTRA FDD

For UTRA FDD the test requirement Inner loop power control is:

Downlink (DL) power control dynamic range:

- maximum code domain power: *TAB connector* maximum output power ($P_{\max,c,TABC}$) -4.1 dB or greater;
- minimum code domain power: *TAB connector* maximum output power ($P_{\max,c,TABC}$) -26.9 dB or less.

NOTE: If the above Test Requirement differs from the Minimum Requirement then the Test Tolerance applied for this test is non-zero. The Test Tolerance for this test is defined in subclause 4.1.2 and the explanation of how the Minimum Requirement has been relaxed by the Test Tolerance is given in annex C.

6.3.3.5.2 UTRA TDD

For UTRA TDD 1,28 Mcps option the power control dynamic range derived according to subclause 6.3.2.4 shall be greater than or equal to 29,7dB.

NOTE: If the above Test Requirement differs from the Minimum Requirement then the Test Tolerance applied for this test is non-zero. The Test Tolerance for this test is defined in subclause 4.1.2 and the explanation of how the Minimum Requirement has been relaxed by the Test Tolerance is given in annex C.

6.3.4 Total power dynamic range

6.3.4.1 Definition and applicability

The total power dynamic range is the difference between the maximum and the minimum output power for a specified reference condition.

This requirement applies at each *TAB connector* supporting transmission in the operating band.

NOTE 1: The upper limit of the dynamic range is the *TAB connector* maximum output power ($P_{\text{Rated,c,TABC}}$). The lower limit of the dynamic range is the lowest minimum power from the *TAB connector* when no traffic channels are activated.

Particularly for E-UTRA, the total power dynamic range is the difference between the maximum and the minimum transmit power of an OFDM symbol for a specified reference condition.

NOTE 2: The upper limit of the dynamic range at a *TAB connector* is the OFDM symbol power at maximum output power ($P_{\text{Rated,c,TABC}}$) when transmitting on all RBs. The lower limit of the dynamic range at a *TAB connector* is the OFDM symbol power when one resource block is transmitted. The OFDM symbol carries PDSCH and not contain RS, PBCH or synchronization signals.

6.3.4.2 Minimum requirement

The minimum requirement for UTRA FDD operation are defined in 3GPP TS 25.104 [9], subclause 6.4.3.1.

There is no total power dynamic range requirement for UTRA TDD 1,28 Mcps option operation.

The minimum requirement for E-UTRA operation is in 3GPP TS 36.104 [11], subclause 6.3.2.1.

The minimum requirement for NR operation is in 3GPP TS 38.104 [36], subclause 6.3.3.2.

6.3.4.3 Test purpose

The test purpose is to verify that the total power dynamic range is within the limits specified by the minimum requirement.

6.3.4.4 Method of test

6.3.4.4.1 Initial conditions

6.3.4.4.1.1 General test conditions

Test environment:

- normal; see annex B.

RF channels to be tested:

- M; see subclause 4.12.1.

6.3.4.4.1.2 UTRA FDD

Base Station RF Bandwidth positions to be tested for multi-carrier: B_{RFBW} , M_{RFBW} and T_{RFBW} in single band operation; see subclause 4.12.1.

Set each *TAB connector* to output a signal in accordance to TM2, in 3GPP TS 25.141 [18], subclause 6.1.1.2.

6.3.4.4.1.3 E-UTRA

Set the Channel set-up of the *TAB connector* transmitted signal according to E-TM 3.1.

6.3.4.4.1.4 NR

Set the Channel set-up of the *TAB connector* transmitted signal according to

- NR-FR1-TM3.1a if 256QAM is supported by BS without power back off;
- or NR-FR1-TM3.1 if 256QAM is not supported by BS;
- or NR-FR1-TM3.1 if 256QAM is supported by BS with power back off;

6.3.4.4.2 Procedure

6.3.4.4.2.1 General procedure

The minimum requirement is applied to all *TAB connectors*, they may be tested one at a time or multiple *TAB connectors* may be tested in parallel as shown in subclause D.1.1. Whichever method is used the procedure is repeated until all *TAB connectors* necessary to demonstrate conformance have been tested.

- 1) Connect *TAB connector* to measurement equipment as shown in subclause D.1.1. All *TAB connectors* not under test shall be terminated.
- 2) Set the *TAB connector* to transmit at manufacturers declared *rated carrier output power per TAB connector* ($P_{\text{Rated,c,TABC}}$)

6.3.4.4.2.2 UTRA FDD

The downlink total dynamic range is computed as the difference of the maximum carrier output power, measured as defined in step 3 in subclause 6.2.2.4.3 and the carrier power measured at step 3 of the Error Vector Magnitude test, as described in subclause 6.5.4.4.2.1.

In addition, for *multi-band TAB connector(s)*, the following steps shall apply:

- 1) For *multi-band TAB connectors* and single band tests, repeat the steps above per involved band where single band test configurations and test models shall apply with no carrier activated in the other band.

6.3.4.4.2.3 E-UTRA

- 1) Measure the average OFDM symbol power as defined in annex F in 3GPP TS 36.141 [17].
- 2) Set the *TAB connector* to transmit a signal according to E-TM 2.
- 3) Measure the average OFDM symbol power as defined in annex F 3GPP TS 36.141 [17]. The measured OFDM symbols shall not contain RS, PBCH or synchronisation signals.
- 4) If BS supports 256QAM, set the channel set-up of the *TAB connector* transmitted signal according to E-TM 3.1a. and repeat step 1. Set the *TAB connector* to transmit a signal according to E-TM 2a and repeat step 3.

In addition, for *multi-band TAB connector(s)*, the following steps shall apply:

- 5) For *multi-band TAB connectors* and single band tests, repeat the steps above per involved band where single band test configurations and test models shall apply with no carrier activated in the other band.

6.3.4.4.2.4 NR

- 1) Measure the average OFDM symbol power as defined in annex D in 3GPP TS 38.141-1 [37].
- 2) Set the BS to transmit a signal according to:
 - NR-FR1-TM2a if 256QAM is supported by BS;
 - or NR-FR1-TM2 if 256QAM is not supported by BS;
- 3) Measure the average OFDM symbol power as defined in annex D in 3GPP TS 38.141-1 [37].

The measured OFDM symbols shall not contain RS or SSB.

In addition, for *multi-band connectors*, the following steps shall apply:

- 4) For a multi-band connectors and single band tests, repeat the steps above per involved operating band where single band test configurations and test models shall apply with no carrier activated in the other operating band.

6.3.4.5 Test requirements

6.3.4.5.1 UTRA FDD

For UTRA FDD the downlink total power dynamic range shall be 17.7 dB or greater.

NOTE: If the above Test Requirement differs from the Minimum Requirement then the Test Tolerance applied for this test is non-zero. The Test Tolerance for this test is defined in subclause 4.1.2 and the explanation of how the Minimum Requirement has been relaxed by the Test Tolerance is given in annex C.

6.3.4.5.2 E-UTRA

The downlink (DL) total power dynamic range for each E-UTRA carrier shall be larger than or equal to the level in table 6.3.4.5.1-1.

Table 6.3.4.5.2-1 E-UTRA TAB connector total power dynamic range, paired spectrum

E-UTRA channel bandwidth (MHz)	Total power dynamic range (dB)
1.4	7.3
3	11.3
5	13.5
10	16.5
15	18.3
20	19.6

NOTE 1: If the above Test Requirement differs from the Minimum Requirement then the Test Tolerance applied for this test is non-zero. The Test Tolerance for this test is defined in subclause 4.1.2 and the explanation of how the Minimum Requirement has been relaxed by the Test Tolerance is given in annex C.

NOTE 2: Additional test requirements for the Error Vector Magnitude (EVM) at the lower limit of the dynamic range are defined in subclause 6.5.4.

6.3.4.5.3 NR

The downlink (DL) total power dynamic range for each NR carrier shall be larger than or equal to the level in table 6.3.4.5.3-1.

Table 6.3.4.5.3-1: NR TAB connector total power dynamic range

NR channel bandwidth [MHz]	Total power dynamic range [dB]		
	15 kHz SCS	30 kHz SCS	60 kHz SCS
5	13.5	10	N/A
10	16.7	13.4	10
15	18.5	15.3	12.1
20	19.8	16.6	13.4
25	20.8	17.7	14.5
30	21.6	18.5	15.3
40	22.9	19.8	16.6
50	23.9	20.8	17.7
60	N/A	21.6	18.5
70	N/A	22.3	19.2
80	N/A	22.9	19.8
90	N/A	23.4	20.4
100	N/A	23.9	20.9

NOTE 1: If the above Test Requirement differs from the Minimum Requirement then the Test Tolerance applied for this test is non-zero. The Test Tolerance for this test is defined in subclause 4.1.2 and the explanation of how the Minimum Requirement has been relaxed by the Test Tolerance is given in annex C.

NOTE 2: Additional test requirements for the Error Vector Magnitude (EVM) at the lower limit of the dynamic range are defined in subclause 6.5.4.

6.3.5 IPDL time mask

6.3.5.1 Definition and applicability

To support IPDL location method in UTRA FDD operation, the AAS BS shall interrupt all transmitted signals in the downlink (i.e. common and dedicated channels). The IPDL time mask specifies the limits of the *TAB connector* output power during these idle periods.

This requirement applies only to AAS BS supporting IPDL. The requirement applies at each *TAB connector* supporting transmission in the operating band.

6.3.5.2 Minimum requirement

The minimum requirement for UTRA FDD operation are defined in 3GPP TS 25.104 [9], subclause 6.4.5.1.

There is no IPDL requirement for UTRA TDD 1,28 Mcps option operation.

There is no IPDL requirement for E-UTRA or NR operation.

6.3.5.3 Test purpose

The test purpose is to verify the ability of the AAS BS to temporarily reduce its output power on each *TAB connector* below a specified value to improve time difference measurements made by UE for location services.

6.3.5.4 Method of test

6.3.5.4.1 Initial conditions

Test environment:

- normal; see annex B.

RF channels to be tested:

- B, M and T; see subclause 4.12.1.

Set each *TAB connector* to output a signal in accordance to TM1, in subclause 4.12.2.

Configure the *TAB connector* to produce idle periods in continuous mode. The IPDL parameters as defined in 3GPP TS 25.214 [23] shall have the following values:

- IP_Spacing = 5
- IP_Length = 10 CPICH symbols
- Seed = 0

6.3.5.4.2 Procedure

The minimum requirement is applied to all *TAB connectors*, they may be tested one at a time or multiple *TAB connectors* may be tested in parallel as shown in subclause D.1.1. Whichever method is used the procedure is repeated until all *TAB connectors* necessary to demonstrate conformance have been tested.

- 1) Connect *TAB connector* to measurement equipment as shown in subclause D.1.1. All *TAB connectors* not under test shall be terminated.
- 2) Set the *TAB connector* to transmit at manufacturers declared *rated carrier output power per TAB connector* ($P_{\text{Rated,c,TABC}}$).
- 3) Measure the mean power at the *TAB connector* over a period starting 27 chips after the beginning of the IPDL period and ending 27 chips before the expiration of the IPDL period.

In addition, for *multi-band TAB connector(s)*, the following steps shall apply:

- 4) For *multi-band TAB connectors* and single band tests, repeat the steps above per involved band where single band test configurations and test models shall apply with no carrier activated in the other band.

6.3.5.5 Test requirements

The mean power measured according to step (3) in clause 6.3.5.4.2 shall be equal to or less than

$$\text{TAB connector maximum output power } (P_{\max,c,\text{TABC}}) - 34.3 \text{ dB.}$$

See also figure 6.3.5.5-1.

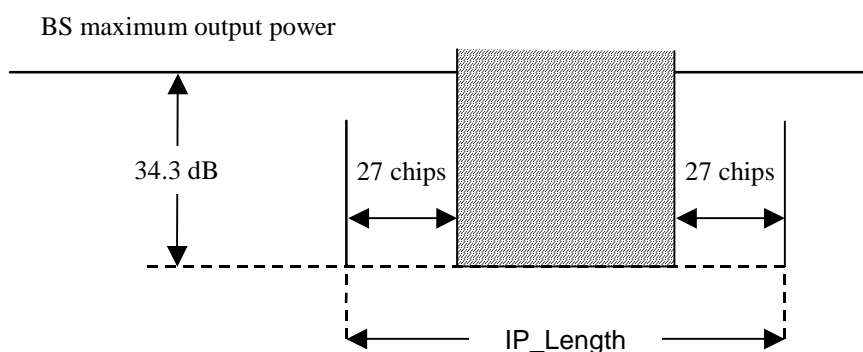

Figure 6.3.5.5-1: IPDL Time Mask

NOTE: If the above Test Requirement differs from the Minimum Requirement then the Test Tolerance applied for this test is non-zero. The Test Tolerance for this test is defined in subclause 4.1.2 and the explanation of how the Minimum Requirement has been relaxed by the Test Tolerance is given in annex C.

6.3.6 RE Power control dynamic range

6.3.6.1 Definition and applicability

The RE power control dynamic range is the difference between the power of an RE and the average RE power for a *TAB connector* at maximum output power ($P_{\text{Rated},c,\text{TABC}}$) for a specified reference condition.

This requirement applies at each *TAB connector* supporting transmission in the operating band.

6.3.6.2 Minimum requirement

There is no RE Power control dynamic range requirement for UTRA FDD operation.

There is no RE Power control dynamic range requirement for UTRA TDD 1,28 Mcps option operation.

The minimum requirement for E-UTRA operation are defined in 3GPP TS 36.104 [11], subclause 6.3.1.1.

The minimum requirement for NR operation are defined in 3GPP TS 38.104 [36], subclause 6.3.2.2.

6.3.6.3 Method of test

No specific test or test requirements are defined for RE Power control dynamic range. The Error Vector Magnitude test, as described in subclause 6.5.4 provides sufficient test coverage for this requirement.

6.4 Transmit ON/OFF power

6.4.1 General

Transmitter ON/OFF power requirements apply only to TDD operation of UTRA and E-UTRA.

6.4.2 Transmitter OFF power

6.4.2.1 Definition and applicability

Transmitter OFF power is defined as the mean power measured over $70/N$ μ s filtered with a square filter of bandwidth equal to the RF bandwidth(s) of the BS centred on the central frequency of the RF bandwidth(s) during the *transmitter OFF period*. N is equal to 1 for UTRA and E_UTRA SCS/15 for NR, where SCS is Sub Carrier Spacing in kHz.

The requirement applies at each *TAB connector* supporting transmission in the operating band.

For *multi-band TAB connectors* and for *single band TAB connectors* supporting transmission in multiple operating bands, the requirement is only applicable during the *transmitter OFF period* in all supported operating bands.

6.4.2.2 Minimum requirement

There is no transmitter off power requirement for UTRA FDD operation.

The minimum requirement for UTRA TDD 1,28 Mcps option operation are defined in 3GPP TS 37.105 [8], subclause 6.4.2.3.

The minimum requirement for E-UTRA operation are defined in 3GPP TS 37.105 [8], subclause 6.4.2.4.

The minimum requirement for MSR and NR operation are defined in 3GPP TS 37.105 [8], subclause 6.4.2.2.

6.4.2.3 Test purpose

The purpose of this test is to verify the *TAB connector* transmitter OFF power is within the limits of the minimum requirements.

6.4.2.4 Method of test

6.4.2.4.1 Initial conditions

Test environment:

- normal; see annex B.

RF channels to be tested:

- B, M and T; see subclause 4.12.1.

Base Station RF Bandwidth positions to be tested:

- M_{RFBW} in single band operation, see subclause 4.12.1; B_{RFBW_T} and B'_{RFBW_T} in multi-band operation; see subclause 4.12.1.

6.4.2.4.2 Procedure

The minimum requirement is applied to all *TAB connectors*, they may be tested one at a time or multiple *TAB connectors* may be tested in parallel as shown in subclause D.1.1. Whichever method is used the procedure is repeated until all *TAB connectors* necessary to demonstrate conformance have been tested.

- 1) Connect *TAB connector* to measurement equipment as shown in subclause D.1.1. All *TAB connectors* not under test shall be terminated.
- 2) Set each *TAB connector* to output according to the applicable test configuration in clause 5 using the corresponding test models or set of physical channels in subclause 4.12.2. For single carrier set the *TAB connector* to transmit at manufacturers declared *rated carrier output power per TAB connector* ($P_{\text{Rated,c,TABC}}$).
- 3) For UTRA and E-UTRA, measure the mean power spectral density measured over 70μ s filtered with a square filter of bandwidth equal to the RF bandwidth of the *TAB connector* centred on the central frequency of the RF bandwidth. 70μ s average window centre is set from 35μ s after end of one transmitter ON period + 17μ s to 35μ s before start of next transmitter ON period - 6.25μ s.

For NR, measure the mean power spectral density over $70/N$ μ s filtered with a square filter of bandwidth equal to the RF bandwidth of the *TAB connector* centred on the central frequency of the RF bandwidth. $70/N$ μ s

average window centre is set from $35/N$ μ s after end of one transmitter ON period + 10 μ s to $35/N$ μ s before start of next transmitter ON period – 10 μ s. $N = \text{SCS}/15$, where SCS is Sub Carrier Spacing in kHz.

In addition, for *multi-band TAB connector(s)*, the following steps shall apply:

- 4) For *multi-band TAB connectors* and single band tests, repeat the steps above per involved band where single band test configurations and test models shall apply with no carrier activated in the other band.

6.4.2.5 Test requirements

The measured mean power spectral density according to subclause 6.4.2.4.2 shall be less than -83 dBm/MHz for carrier frequency $f \leq 3.0$ GHz.

The measured mean power spectral density according to subclause 6.4.2.4.2 shall be less than -82.5 dBm/MHz for carrier frequency $3.0 \text{ GHz} < f \leq 4.2 \text{ GHz}$.

For *multi-band TAB connector*, the requirement is only applicable during the transmitter OFF period in all supported operating bands.

NOTE: If the above Test Requirement differs from the Minimum Requirement then the Test Tolerance applied for this test is non-zero. The Test Tolerance for this test is defined in subclause 4.1.2 and the explanation of how the Minimum Requirement has been relaxed by the Test Tolerance is given in annex C.

6.4.3 Transmitter transient period

6.4.3.1 Definition and applicability

The *transmitter transient period* is the time period during which the transmitter unit is changing from the OFF period to the ON period or vice versa. The *transmitter transient period* is illustrated in figure 6.4.3.1-1.

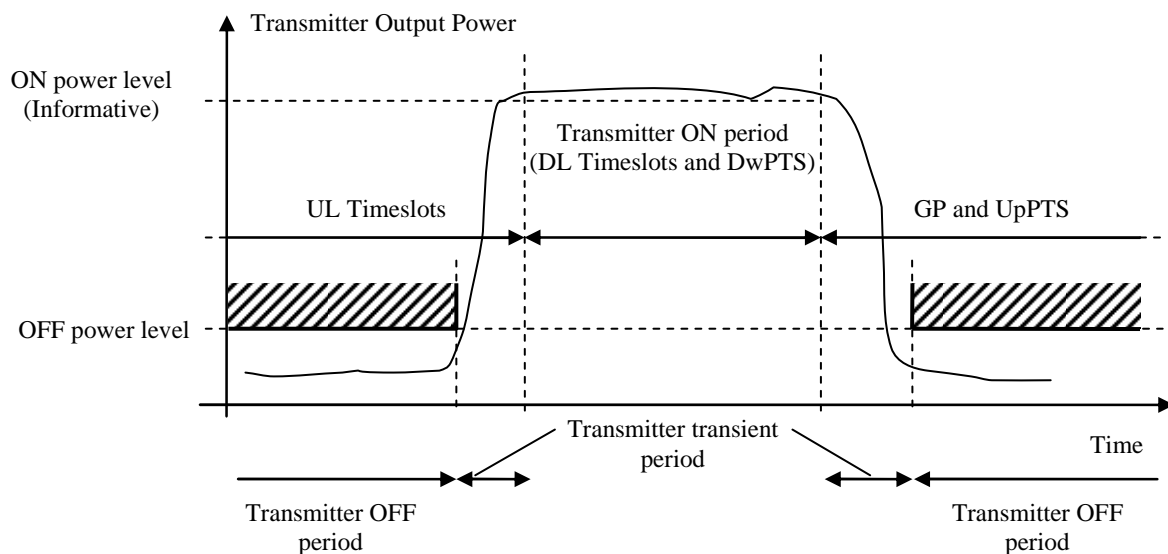

Figure 6.4.3.1-1: Illustration of the relations of transmitter ON period, transmitter OFF period and transmitter transient period

This requirement applies at each *TAB connector* supporting transmission in the operating band.

6.4.3.2 Minimum requirement

The minimum requirement for MSR operation is in 3GPP TS 37.104 [12], subclause 6.4.2.1.

There is no Transmitter transient period requirement for UTRA FDD operation.

The minimum requirement for single RAT UTRA TDD 1,28 Mcps option operation are defined in 3GPP TS 25.105 [10], subclause 6.5.2.1.2.

The minimum requirement for single RAT E-UTRA operation are defined in 3GPP TS 36.104 [11], subclause 6.4.2.1.

6.4.3.3 Test purpose

The purpose of this test is to verify the *TAB connector* transmitter transient periods are within the limits of the minimum requirements.

6.4.3.4 Method of test

6.4.3.4.1 Initial conditions

6.4.3.4.1.1 MSR operation

For MSR operation the test for transmitter off power in subclause 6.4.2 demonstrates compliance.

6.4.3.4.1.2 UTRA TDD operation

Test environment:

- normal; see clause B.2.

RF channels to be tested for single carrier (SC):

- M; see subclause 4.12.1.

RF bandwidth positions to be tested:

- M_{RFBW} in single band operation; see subclause 4.12.1; B_{RFBW_T} and B'_{RFBW_T} in multi-band operation, see subclause 4.12.1.

Table 6.4.3.4.1.2-1: Parameters of the transmitted signal for transmit ON/OFF time mask test for 1,28 Mcps TDD

Parameter	Value/description
TDD Duty Cycle	TS i ; $i = 0, 1, 2, 3, 4, 5, 6$: transmit, if i is 0,4,5,6; receive, if i is UpPCH,1,2,3.
Time slots under test	TS4, TS5 and TS6
Number of DPCH in each time slot under test	8
Data content of DPCH	real life (sufficient irregular)

6.4.3.4.1.3 E-UTRA operation

Test environment:

- normal; see clause B.2.

RF channels to be tested for single carrier:

- M; see subclause 4.12.1.

RF bandwidth positions to be tested for multi-carrier and/or CA:

- M_{RFBW} in single-band operation, see subclause 4.12.1; B_{RFBW_T} and B'_{RFBW_T} in multi-band operation, see subclause 4.12.1.

6.4.3.4.2 Procedure

6.4.3.4.2.1 MSR operation

For MSR operation the test for transmitter off power in subclause 6.4.2 demonstrates compliance.

6.4.3.4.2.2 UTRA TDD operation

The minimum requirement is applied to all *TAB connectors*, they may be tested one at a time or multiple *TAB connectors* may be tested in parallel as shown in subclause D.1.1. Whichever method is used the procedure is repeated until all *TAB connectors* necessary to demonstrate conformance have been tested.

- 1) Connect *TAB connector* to measurement equipment as shown in subclause D.1.1. All *TAB connectors* not under test shall be terminated.
- 2) Set each *TAB connector* to output according to the applicable test configuration in clause 5 using the corresponding test models or set of physical channels in subclause 4.12.2. For single carrier set the *TAB connector* to transmit at manufacturers declared *rated carrier output power per TAB connector* ($P_{\text{Rated,c,TABC}}$).
- 3) Measure the RRC filtered mean power of the *TAB connector* output signal chipwise (i.e. averaged over time intervals of one chip duration) over the transmit off power period starting 11 chips before the start of the receive time slot TS $i = \text{UpPCH}$, and ending 8 chips before the next transmit time slot TS $i+4$ starts.

6.4.3.4.2.3 E-UTRA operation

The minimum requirement is applied to all *TAB connectors*, they may be tested one at a time or multiple *TAB connectors* may be tested in parallel as shown in subclause D.1.1. Whichever method is used the procedure is repeated until all *TAB connectors* necessary to demonstrate conformance have been tested.

- 1) Connect *TAB connector* to measurement equipment as shown in subclause D.1.1. All *TAB connectors* not under test shall be terminated.

As a general rule, the resolution bandwidth of the measuring equipment should be equal to the measurement bandwidth. However, to improve measurement accuracy, sensitivity, efficiency and avoiding e.g. carrier leakage, the resolution bandwidth may be smaller than the measurement bandwidth. When the resolution bandwidth is smaller than the measurement bandwidth, the result should be integrated over the measurement bandwidth in order to obtain the equivalent noise bandwidth of the measurement bandwidth.

- 2) For a Set each *TAB connector* to output according to the applicable test configuration in clause 5 using the corresponding test models or set of physical channels in subclause 4.12.2. For single carrier set the *TAB connector* to transmit at manufacturers declared *rated carrier output power per TAB connector* ($P_{\text{Rated,c,TABC}}$).
- 3) Measure the mean power spectral density over $70\mu\text{s}$ filtered with a square filter of bandwidth equal to the RF bandwidth of the *TAB connector* centred on the central frequency of the RF bandwidth. $70\mu\text{s}$ average window centre is set from $35\mu\text{s}$ after end of one transmitter ON period + $17\mu\text{s}$ to $35\mu\text{s}$ before start of next transmitter ON period - $17\mu\text{s}$.
- 4) For a *TAB connector* supporting contiguous CA, measure the mean power spectral density over $70\mu\text{s}$ filtered with a square filter of bandwidth equal to the Aggregated Channel Bandwidth $BW_{\text{Channel_CA}}$ centred on $(F_{\text{edge_high}}+F_{\text{edge_low}})/2$. $70\mu\text{s}$ average window centre is set from $35\mu\text{s}$ after end of one transmitter ON period + $17\mu\text{s}$ to $35\mu\text{s}$ before start of next transmitter ON period - $17\mu\text{s}$.

In addition, for *multi-band TAB connector(s)*, the following steps shall apply:

- 5) For *multi-band TAB connectors* and single band tests, repeat the steps above per involved band where single band test configurations and test models shall apply with no carrier activated in the other band.

6.4.3.5 Test requirements

6.4.3.5.1 MSR operation

For MSR operation the test for transmitter off power in subclause 6.4.2 demonstrates compliance.

6.4.3.5.1 UTRA TDD operation

Each value of the power measured according to subclause 6.4.3.4.2.2 shall be below -41,3 dBm in the period from 85 chips to 88 chips after the burst and below -80 dBm in the period where the Tx OFF power specification is applicable.

For *multi-band TAB connector*, the requirement is only applicable during the transmitter OFF period in all supported operating bands.

6.4.3.5.1 E-UTRA operation

The measured mean power spectral density according to subclause 6.3.5.4.3 shall be less than -83 dBm/MHz for carrier frequency $f \leq 3.0$ GHz.

The measured mean power spectral density according to subclause 6.3.5.4.3 shall be less than -82.5 dBm/MHz for carrier frequency $3.0 \text{ GHz} < f \leq 4.2 \text{ GHz}$.

For *multi-band TAB connector*, the requirement is only applicable during the transmitter OFF period in all supported operating bands.

NOTE: If the above Test Requirement differs from the Minimum Requirement then the Test Tolerance applied for this test is non-zero. The Test Tolerance for this test is defined in subclause 4.1.2 and the explanation of how the Minimum Requirement has been relaxed by the Test Tolerance is given in annex C.

6.5 Transmitted signal quality

6.5.1 General

The requirements apply per TAB connector unless otherwise stated differently.

The requirement applies during the transmitter ON period.

6.5.2 Frequency Error

6.5.2.1 Definition and applicability

Frequency error is the measure of the difference between the actual AAS BS transmit frequency and the assigned frequency. The same source shall be used for RF frequency and data clock generation.

It is not possible to verify by testing that the data clock is derived from the same frequency source as used for RF generation. This may be confirmed by the manufacturer's declaration.

6.5.2.2 Minimum Requirement

The minimum requirement is in 3GPP TS 37.105 [8], subclause 6.5.2.

6.5.2.3 Test purpose

The test purpose is to verify that frequency error is within the limit specified by the minimum requirement.

6.5.2.4 Method of test

Requirement is tested together with modulation quality test, as described in subclause 6.5.4.

6.5.2.5 Test Requirements

6.5.2.5.1 UTRA FDD test requirement

The Frequency Error for every measured slot shall be between the minimum and maximum value specified in table 6.5.2.5.1-1.

Table 6.5.2.5.1-1: Frequency error test requirement

BS class	Accuracy
Wide Area BS	$\pm(0.05 \text{ ppm} + 12 \text{ Hz})$
Medium Range BS	$\pm(0.1 \text{ ppm} + 12 \text{ Hz})$
Local Area BS	$\pm(0.1 \text{ ppm} + 12 \text{ Hz})$

NOTE: If the above Test Requirement differs from the Minimum Requirement then the Test Tolerance applied for this test is non-zero. The Test Tolerance for this test is defined in subclause 4.1.2 and the explanation of how the Minimum Requirement has been relaxed by the Test Tolerance is given in annex C.

6.5.2.5.2 UTRA TDD test requirement

The Frequency Error for every measured slot shall be between the minimum and maximum value specified in table 6.5.2.5.2-1.

Table 6.5.2.5.2-1: Frequency error test requirement

BS class	Accuracy
Wide Area BS	$\pm(0.05 \text{ ppm} + 12 \text{ Hz})$
Medium Range BS	$\pm(0.1 \text{ ppm} + 12 \text{ Hz})$

6.5.2.5.3 E-UTRA and NR test requirement

The modulated carrier frequency of each E-UTRA or NR carrier configured by the AAS BS shall be accurate to within the accuracy range given in table 6.5.2.5.3-1 observed over a period of one subframe (1 ms).

Table 6.5.2.5.3-1: Frequency error test requirement

BS class	Accuracy
Wide Area BS	$\pm(0.05 \text{ ppm} + 12 \text{ Hz})$
Medium Range BS	$\pm(0.1 \text{ ppm} + 12 \text{ Hz})$
Local Area BS	$\pm(0.1 \text{ ppm} + 12 \text{ Hz})$

NOTE: If the above Test Requirement differs from the Minimum Requirement then the Test Tolerance applied for this test is non-zero. The Test Tolerance for this test is defined in subclause 4.1.2 and the explanation of how the Minimum Requirement has been relaxed by the Test Tolerance is given in annex C.

6.5.3 Time alignment error

6.5.3.1 Definition and applicability

This requirement applies to frame timing in:

- UTRA single/multi-carrier transmissions and their combinations with MIMO or TX diversity.
- E-UTRA single/multi-carrier transmissions and their combinations with MIMO or TX diversity.
- E-UTRA *carrier aggregation*, with or without MIMO or TX diversity.
- NR single/multi-carrier transmissions, and their combinations with MIMO.
- NR *carrier aggregation*, with or without MIMO.

Frames of the UTRA/E-UTRA/NR signals present at the *TAB connectors* are not perfectly aligned in time. In relation to each other, the RF signals present at the *transceiver array boundary* may experience certain timing differences.

For a specific set of signals/transmitter configuration/transmission mode, the Time Alignment Error (TAE) is defined as the largest timing difference between any two different E-UTRA signals or any two different UTRA signals or any two different NR signals belonging to different *TAB Connectors* belonging to different transmitter groups at the *transceiver array boundary*, where transmitter groups are associated with the *TAB connectors* in the transceiver unit array corresponding to TX diversity, MIMO transmission, *carrier aggregation*, etc.

6.5.3.2 Minimum requirement

The minimum requirement is in 3GPP TS 37.105 [8], subclause 6.5.3.

6.5.3.3 Test purpose

To verify that the time alignment error is within the limit specified by the minimum requirement.

6.5.3.4 Method of test

6.5.3.4.1 Initial conditions

6.5.3.4.1.1 General test conditions

Test environment:

- normal; see clause B.2.

RF channels to be tested for single carrier:

- M; see subclause 4.12.1.

6.5.3.4.1.2 UTRA FDD

Base Station RF Bandwidth positions to be tested for multi-carrier:

- B_{RFBW} , M_{RFBW} and T_{RFBW} ; $B_{RFBW_T_{RFBW}}$ and $B'_{RFBW_T_{RFBW}}$ in multi-band operation; see subclause 4.12.1.

Refer to subclause D.1.3 for a functional block diagram of the test set-up.

6.5.3.4.1.3 UTRA TDD

RF bandwidth positions to be tested for multi-carrier: M_{RFBW} in single band operation, see subclause 4.12.1.

- For a *TAB connectors* declared to be capable of single carrier operation only, set the base station to transmit according to table 6.5.3.4.1.3-1 on one cell using MIMO.
- For a *multi-carrier TAB connectors*, set to transmit according to table 6.5.3.4.1.3-1 on all carriers configured using the applicable test configuration and corresponding power setting specified in subclause 5.3.

Table 6.5.3.4.1.3-1: Parameters of the BS transmitted signal for 1,28 Mcps TDD

Parameter	Value/description
TDD Duty Cycle	TS i ; $i = 0, 1, 2, \dots, 6$: transmit, if i is 0,4,5,6; receive, if i is 1,2,3.
Time slots under test	TS0 and DwPTS
Spreading factor	16

6.5.3.4.1.4 E-UTRA and NR

RF bandwidth positions to be tested for multi-carrier and/or CA: M_{RFBW} in single-band operation, see subclause 4.12.1; $B_{RFBW_T_{RFBW}}$ and $B'_{RFBW_T_{RFBW}}$ in multi-band operation, see subclause 4.7.

6.5.3.4.2 Procedure

6.5.3.4.2.1 General Procedure

TAB connectors to be tested are identified from the declared sets of *TAB connector beam forming groups* (see subclause 4.10 D.6.58).

Connect two representative *TAB connectors* one from each of the declared groups to the measurement equipment according to subclause D.1.3. Terminate any unused *TAB connector(s)*.

Compliance is to be demonstrated between all pairs of *TAB connectors beam forming groups*, however it is not required to exhaustively measure the time alignment error between every combination of pairs of representative *TAB connectors*. Compliance can be demonstrated by comparison of a reduced set of representative measurement results.

6.5.3.4.2.2 UTRA FDD Procedure

- 1) If the AAS BS supports TX diversity or MIMO, set the *TAB connectors* to transmit TM1, subclause 4.12.2, at manufacturer's declared rated output power, $P_{\text{Rated,c,TABC}}$ on one cell using TX diversity or MIMO.
- 2) Measure the time alignment error between the signals using the P-CPICH on one of the representative *TAB connector* from the main signal conveyed via a *TAB connectors beam forming group* and the CPICH on the *TAB connector* from the diversity signal conveyed via another *TAB connectors beam forming group*.
- 3) If the AAS BS supports DC-HSDPA, 4C-HSDPA, NC-4C-HSDPA or 8C-HSDPA set the *TAB connectors* to transmit according to TM1, without using TX diversity or MIMO, on all carriers configured using the applicable test configuration and corresponding power setting specified in subclause 4.11.
- 4) Measure the time alignment error between the signals using the P-CPICH on one of the representative *TAB connector* and CPICH signals on representative *TAB connector* from another group.
- 5) If the AAS BS supports DB-DC-HSDPA or any of the multi-band 4C-HSDPA or 8C-HSDPA configurations set the *TAB connectors* to transmit TM1 on two carriers belonging to different frequency bands, without using TX diversity or MIMO on any of the carriers.
- 6) Measure the time alignment error between the signals using the P-CPICH and CPICH signals on the *TAB connectors*.

In addition, for *multi-band TAB connector(s)*, the following steps shall apply:

- 7) For *multi-band TAB connectors* and single band tests, repeat the steps above per involved band where single band test configurations and test models shall apply with no carrier activated in the other band.

6.5.3.4.2.3 UTRA TDD Procedure

- 1) Start the *TAB connector beam forming groups* transmission at the manufacturer's specified rated output power, $P_{\text{Rated,c,TABC}}$ at the *TAB connector*.
- 2) Measure the time alignment error between the P-CCPCH and DwPTS on the representative *TAB connectors* under test.

In addition, for *multi-band TAB connector(s)*, the following steps shall apply:

- 3) For *multi-band TAB connectors* and single band tests, repeat the steps above per involved band where single band test configurations and test models shall apply with no carrier activated in the other band.

6.5.3.4.2.4 E-UTRA and NR Procedure

- 1) Set the AAS BS to transmit E-TM1.1 or [NR-FR1-TM 1.1] or any DL signal using TX diversity, MIMO transmission or carrier aggregation.

NOTE: For TX diversity and MIMO transmission, different ports may be configured in E-TM or NR-FR1-TM (using $p = 0$ and 1).

For an AAS BS declared to be capable of single carrier operation only, set the representative *TAB connectors* to transmit according to manufacturer's declared rated output power, $P_{\text{Rated,c,TABC}}$.

If the AAS BS supports intra band contiguous or non-contiguous Carrier Aggregation set the representative *TAB connectors* to transmit using the applicable test configuration and corresponding power setting specified in subclauses 4.10 and 4.11.

If the AAS BS supports inter band carrier aggregation set the representative *TAB connectors* to transmit, for each band, a single carrier or all carriers, using the applicable test configuration and corresponding power setting specified in subclauses 4.10 and 4.11.

- 2) Measure the time alignment error between the reference symbols on the carrier(s) from the representative *TAB connector(s)*.

In addition, for *multi-band TAB connector(s)*, the following steps shall apply:

- 3) For *multi-band TAB connectors* and single band tests, repeat the steps above per involved band where single band test configurations and test models shall apply with no carrier activated in the other band.

6.5.3.5 Test requirement

6.5.3.5.1 UTRA FDD test requirement

For Tx diversity and MIMO transmission, in the tested cell, TAE shall not exceed $0.35 T_c$.

For transmission of multiple cells within a frequency band TAE shall not exceed $0.6 T_c$.

For transmission of multiple cells in different frequency bands TAE shall not exceed $5.1 T_c$.

NOTE: If the above Test Requirement differs from the Minimum Requirement then the Test Tolerance applied for this test is non-zero. The Test Tolerance for this test is defined in subclause 4.1.2 and the explanation of how the Minimum Requirement has been relaxed by the Test Tolerance is given in annex C.

6.5.3.5.2 UTRA TDD test requirement

The time alignment error shall be less than $65 + 78$ ns.

NOTE: If the above Test Requirement differs from the Minimum Requirement then the Test Tolerance applied for this test is non-zero. The Test Tolerance for this test is defined in subclause 4.1.2 and the explanation of how the Minimum Requirement has been relaxed by the Test Tolerance is given in annex C.

6.5.3.5.3 E-UTRA test requirement

For MIMO or TX diversity transmissions, at each carrier frequency, TAE shall not exceed 90 ns.

For intra-band carrier aggregation, with or without MIMO or TX diversity, TAE shall not exceed 155 ns.

For intra-band non-contiguous carrier aggregation, with or without MIMO or TX diversity, TAE shall not exceed 285 ns.

For inter-band carrier aggregation, with or without MIMO or TX diversity, TAE shall not exceed 285 ns.

NOTE: If the above Test Requirement differs from the Minimum Requirement then the Test Tolerance applied for this test is non-zero. The Test Tolerance for this test is defined in subclause 4.1.2 and the explanation of how the Minimum Requirement has been relaxed by the Test Tolerance is given in annex C.

6.5.3.5.4 NR test requirement

For MIMO or TX diversity transmissions, at each carrier frequency, TAE shall not exceed 90 ns.

For intra-band contiguous CA, with or without MIMO or TX diversity, TAE shall not exceed 285 ns.

For intra-band non-contiguous CA, with or without MIMO or TX diversity, TAE shall not exceed $3.025\mu\text{s}$.

For inter-band CA, with or without MIMO or TX diversity, TAE shall not exceed $3.025\mu\text{s}$.

NOTE: If the above Test Requirement differs from the Minimum Requirement then the Test Tolerance applied for this test is non-zero. The Test Tolerance for this test is defined in subclause 4.1.2 and the explanation of how the Minimum Requirement has been relaxed by the Test Tolerance is given in annex C.

6.5.4 Modulation quality

6.5.4.1 Definition and applicability

Modulation quality is defined by the difference between the measured carrier signal and a reference signal. Modulation quality can be expressed e.g. as Peak Code domain Error (PCDE) or Relative Code domain Error (RCDE) or Error Vector Magnitude (EVM) for UTRA and Error Vector Magnitude (EVM) for E-UTRA and NR.

6.5.4.2 Minimum Requirement

The minimum requirement for UTRA operation are defined in 3GPP TS 37.105 [8], subclause 6.5.4.3.

The minimum requirement for E-UTRA operation are defined in 3GPP TS 37.105 [8], subclause 6.5.4.4.

The minimum requirement for NR operation are defined in 3GPP TS 37.105 [8], subclause 6.5.4.2.

6.5.4.3 Test purpose

The test purpose is to verify that modulation quality is within the limit specified by the minimum requirement.

6.5.4.4 UTRA FDD Method of test

6.5.4.4.1 Initial conditions

Test environment:

- normal; see clause B.2.

RF channels to be tested for single carrier:

- B, M and T; see subclause 4.12.1.

Base Station RF Bandwidth position to be tested:

- B_{RFBW} , M_{RFBW} and T_{RFBW} single-band operation, see subclause 4.12.1 single-band operation.

6.5.4.4.2 Procedure

6.5.4.4.2.1 EVM procedure

The minimum requirement is applied to all *TAB connectors*, they may be tested one at a time or multiple *TAB connectors* may be tested in parallel as shown in subclause D.1.1. Whichever method is used the procedure is repeated until all *TAB connectors* necessary to demonstrate conformance have been tested.

- 1) For a *TAB connector* declared to be capable of single carrier operation only, set the *TAB connector* to transmit a signal according to TM1 according to subclause 4.12.2 at manufacturer's declared rated output power, $P_{\text{Rated,c,TABC}}$.

For a *TAB connector* declared to be capable of multi-carrier operation, set the *TAB connector* to transmit according to subclause 4.12.2 on all carriers configured using the applicable test configuration and corresponding power setting specified in subclause 4.11.

- 2) For each carrier, measure the Error Vector Magnitude and frequency error as defined in annex D.1.1 and the mean power of the signal. The measurement shall be performed on all 15 slots of the frame defined by the Test Model.
- 3) Using the same setting as in step 1), set the *TAB connector* to transmit a signal according to TM4, subclause 4.12.2, with X value equal to 18, and repeat step 2). If the requirement in subclause 6.5.4.5 is not fulfilled, decrease the total output power by setting the base station to transmit a signal according to TM4 with X greater than 18, and repeat step 2).

The following test shall be additionally performed if the base station supports HS-PDSCH transmission using 16QAM:

- 4) Using the same setting as in step 1), set the base station to transmit according to TM5, subclause 4.12.2.
- 5) Repeat step 2).

In addition, for *multi-band TAB connector(s)*, the following steps shall apply:

- 6) For *multi-band TAB connectors* and single band tests, repeat the steps above per involved band where single band test configurations and test models shall apply with no carrier activated in the other band.

6.5.4.4.2.2 PCDE procedure

The minimum requirement is applied to all *TAB connectors*, they may be tested one at a time or multiple *TAB connectors* may be tested in parallel as shown in subclause D.1.1. Whichever method is used the procedure is repeated until all *TAB connectors* necessary to demonstrate conformance have been tested.

- 1) For a *TAB connector* declared to be capable of single carrier operation only, set the *TAB connector* to transmit a signal according to TM3, subclause 4.12.2, at manufacturer's declared rated output power, $P_{\text{Rated,c,TABC}}$

For a *TAB connector* declared to be capable of multi-carrier operation, set the *TAB connector* to transmit according to TM3 on all carriers configured using the applicable test configuration and corresponding power setting specified in subclause 4.11.

- 2) Measure Peak code domain error according to annex D.1.1. The measurement shall be performed on all 15 slots of the frame defined by TM3. For a *TAB connector* declared to be capable of multi-carrier operation the measurement is performed on one of the carriers under test.

In addition, for *multi-band TAB connector(s)*, the following steps shall apply:

- 3) For *multi-band TAB connectors* and single band tests, repeat the steps above per involved band where single band test configurations and test models shall apply with no carrier activated in the other band.

6.5.4.4.2.3 RCDE procedure

The minimum requirement is applied to all *TAB connectors*, they may be tested one at a time or multiple *TAB connectors* may be tested in parallel as shown in subclause D.1.1. Whichever method is used the procedure is repeated until all *TAB connectors* necessary to demonstrate conformance have been tested.

- 1) For a *TAB connector* declared to be capable of single carrier operation only, set the *TAB connector* to transmit a signal according to TM6, subclause 4.12.2, at manufacturer's declared rated output power, $P_{\text{Rated,c,TABC}}$

For a *TAB connector* declared to be capable of multi-carrier operation, set the *TAB connector* to transmit according to TM6, subclause 4.12.2, on all carriers configured using the applicable test configuration and corresponding power setting specified in subclause 4.11.

- 2) Measure average Relative code domain error according to annex E. The measurement shall be performed over one frame defined by TM6 and averaged as specified in subclause 4.12.2. For a *TAB connector* declared to be capable of multi-carrier operation the measurement is performed on one of the carriers under test.

In addition, for *multi-band TAB connector(s)*, the following steps shall apply:

- 3) For *multi-band TAB connectors* and single band tests, repeat the steps above per involved band where single band test configurations and test models shall apply with no carrier activated in the other band.

6.5.4.5 UTRA TDD Method of test

6.5.4.5.1 Initial conditions

Test environment:

- normal; see clause B.2.

RF channels to be tested for single carrier:

- B, M and T; see subclause 4.12.1.

Base Station RF Bandwidth position to be tested:

- B_{RFBW} , M_{RFBW} and T_{RFBW} single-band operation, see subclause 4.12.1 single-band operation.

Table 6.5.4.5.1-1: Parameters of the *TAB connector* transmitted signal for modulation accuracy testing at maximum *TAB connector* output power for 1,28 Mcps TDD

Parameter	Value/description
TDD Duty Cycle	TS i ; $i = 0, 1, 2, \dots, 6$: Transmit, if i is 0,4,5,6; receive, if i is 1,2,3.
Time slots under test	TS4, TS5 and TS6
Number of DPCH in each time slot under test	10
Power of each DPCH	1/10 of Base Station output power
Data content of DPCH	real life (sufficient irregular)
Spreading factor	16

In addition the following test set up only applies for 16QAM capable BS.

Table 6.5.4.5.1-2: Parameters of the *TAB connector* transmitted signal for modulation accuracy testing at maximum *TAB connector* output power setting for 1,28 Mcps TDD - 16QAM capable BS

Parameter	Value/description
TDD Duty Cycle	TS i ; $i = 0, 1, 2, 3, 4, 5, 6$: transmit, if i is 0,4,5,6; receive, if i is 1,2,3.
Time slots under test	TS4, TS5 and TS6
HS-PDSCH modulation	16QAM
Number of HS-PDSCH in each time slot under test	10
Power of each HS-PDSCH	1/10 of Base Station output power
Data content of HS-PDSCH	Real life (sufficient irregular)
Spreading factor	16

6.5.4.5.2 Procedure

6.5.4.5.2.1 EVM Procedure

The minimum requirement is applied to all *TAB connectors*, they may be tested one at a time or multiple *TAB connectors* may be tested in parallel as shown in subclause D.1.1. Whichever method is used the procedure is repeated until all *TAB connectors* necessary to demonstrate conformance have been tested.

- 1) For a *TAB connector* declared to be capable of single carrier operation only, set the parameters of the *TAB connector* transmitted signal according to table 6.5.4.5.1-1 at manufacturer's declared output power, $P_{\text{Rated,c,TABC}}$.

For a *TAB connector* declared to be capable of multi-carrier operation, set the *TAB connector* to transmit according to table 6.5.4.5.1-1 on all carriers configured using the applicable test configuration and corresponding power setting specified in subclauses 5.3.

- 2) Measure the error vector magnitude (EVM) for each carrier by applying the global in-channel Tx test method described in annex E with the *TAB connector* transmitted signal set as described in table 6.5.4.5.1-1.
- 3) Measure the error vector magnitude (EVM) for each carrier by applying the global in-channel Tx test method described in annex C with the *TAB connector* transmitted signal on each carrier set as described in table 6.5.4.5.2.1-1.
- 4) For *TAB connector* declared to be capable of 16QAM repeat steps 2 and 3 using transmitted signal set as described in tables 6.5.4.5.1-2 and 6.5.4.5.2.1-2.

In addition, for *multi-band TAB connector(s)*, the following steps shall apply:

- 5) For *multi-band TAB connectors* and single band tests, repeat the steps above per involved band where single band test configurations and test models shall apply with no carrier activated in the other band.

Table 6.5.4.5.2.1-1: Parameters of the *TAB connector* transmitted signal for modulation accuracy testing at minimum *TAB connector* output power for 1,28 Mcps TDD

Parameter	Value/description
TDD Duty Cycle	TS i ; $i = 0, 1, 2, \dots, 6$: Transmit, if i is 0,4,5,6; receive, if i is 1,2,3.
Time slot under test	TS4, TS5 and TS6
Number of DPCH in each time slot under test	1
BS output power setting on each carrier	Maximum output power - 30 dB
Data content of DPCH	Real life (sufficient irregular)

Table 6.5.4.5.2.1-2: Parameters of the *TAB connector* transmitted signal for modulation accuracy testing at minimum *TAB connector* output power setting for 1,28 Mcps TDD - 16QAM capable BS

Parameter	Value/description
TDD Duty Cycle	TS i ; $i = 0, 1, 2, 3, 4, 5, 6$: transmit, if i is 0,4,5,6; receive, if i is 1,2,3.
HS-PDSCH modulation	16QAM
Time slots under test	TS4, TS5 and TS6
Number of HS-PDSCH in each time slot under test	1
BS output power setting on each carrier	Maximum output power - 30 dB
Data content of HS-PDSCH	Real life (sufficient irregular)
Spreading factor	16

6.5.4.5.2.2 PCDE Procedure

The minimum requirement is applied to all *TAB connectors*, they may be tested one at a time or multiple *TAB connectors* may be tested in parallel as shown in subclause D.1.1. Whichever method is used the procedure is repeated until all *TAB connectors* necessary to demonstrate conformance have been tested.

- 1) For a *TAB connector* declared to be capable of single carrier operation only, set the parameters of the *TAB connector* transmitted signal according to table 6.5.4.5.2.1-1 at manufacturer's declared output power, $P_{\text{Rated,c,TABC}}$.

For a *TAB connector* declared to be capable of multi-carrier operation, set the *TAB connector* to transmit according to table 6.5.4.5.2.1-1 on all carriers configured using the applicable test configuration and corresponding power setting specified in subclause 5.3.

- 2) Measure the Peak code domain error by applying the global in-channel Tx test method described in annex E.

In addition, for *multi-band TAB connector(s)*, the following steps shall apply:

- 3) For *multi-band TAB connectors* and single band tests, repeat the steps above per involved band where single band test configurations and test models shall apply with no carrier activated in the other band.

6.5.4.5.2.3 RCDE Procedure

The minimum requirement is applied to all *TAB connectors*, they may be tested one at a time or multiple *TAB connectors* may be tested in parallel as shown in subclause D.1.1. Whichever method is used the procedure is repeated until all *TAB connectors* necessary to demonstrate conformance have been tested.

- 1) For a *TAB connector* declared to be capable of single carrier operation only, set the parameters of the *TAB connector* transmitted signal according to table 6.5.4.5.2.1-1 at manufacturer's declared output power, $P_{\text{Rated,c,TABC}}$.

For a *TAB connector* declared to be capable of multi-carrier operation, set the *TAB connector* to transmit according to table 6.5.4.5.2.1-1 on all carriers configured using the applicable test configuration and corresponding power setting specified in subclauses 5.3.

- 2) Measure the Relative code domain error by applying the global in-channel Tx test method described in annex E.

In addition, for *multi-band TAB connector(s)*, the following steps shall apply:

- 3) For *multi-band TAB connectors* and single band tests, repeat the steps above per involved band where single band test configurations and test models shall apply with no carrier activated in the other band.

6.5.4.6 E-UTRA and NR Method of test

6.5.4.6.1 Initial conditions

Test environment:

- normal; see clause B.2.

RF channels to be tested for single carrier:

- B, M and T; see subclause 4.12.1.

RF bandwidth positions to be tested for multi-carrier and/or CA:

- B_{RFBW} , M_{RFBW} and T_{RFBW} in single-band operation, see subclause 4.12.1; $B_{\text{RFBW}}T_{\text{RFBW}}$ and $B'_{\text{RFBW}}T_{\text{RFBW}}$ in multi-band operation, see subclause 4.12.1.

6.5.4.6.2 Procedure

The minimum requirement is applied to all *TAB connectors*, they may be tested one at a time or multiple *TAB connectors* may be tested in parallel as shown in subclause D.1.1. Whichever method is used the procedure is repeated until all *TAB connectors* necessary to demonstrate conformance have been tested.

- 1) For a *TAB connector* declared to be capable of single carrier operation only, set the *TAB connector* to transmit a signal according to E-TM 3.1 or [NR-FR1-TM 3.1] at manufacturer's declared rated output power.

For a *TAB connector* declared to be capable of multi-carrier and/or CA operation, set the *TAB connector* to transmit according to E-TM3.1 or [NR-FR1-TM 3.1] on all carriers configured using the applicable test configuration and corresponding power setting specified in subclause 4.10 and 4.11.

- 2) Measure the EVM and frequency error as defined in annex F.
- 3) Repeat steps 1 and 2 for E-TM 3.2, E-TM 3.3 and E-TM 2 for E-UTRA or [NR-FR1-TM 3.2], [NR-FR1-TM 3.3] and [NR-FR1-TM 2] for NR. Repeat steps 1 and 2 for E-TM3.1a and E-TM 2a for E-UTRA or [NR-FR1-TM 3.1a], [NR-FR1-TM 2a] for NR for 256QAM, if supported by the BS. For E-TM2 and E-TM2a or [NR-FR1-TM 2] and [NR-FR1-TM 2a] the OFDM symbol power shall be at the lower limit of the dynamic range according to the test procedure in subclause 6.3.4.4.2.3 and test requirements in subclause 6.3.4.5.2.

In addition, for *multi-band TAB connector(s)*, the following steps shall apply:

- 4) For *multi-band TAB connectors* and single band tests, repeat the steps above per involved band where single band test configurations and test models shall apply with no carrier activated in the other band.

6.5.4.7 Test Requirements

6.5.4.7.1 UTRA FDD test requirement

The Error Vector Magnitude for each UTRA carrier and every measured slot shall be less than 17.5% when the *TAB connector* is transmitting a composite signal using only QPSK modulation and shall be less than 12.5 % when the *TAB connector* is transmitting a composite signal that includes 16QAM modulation.

The peak code domain error for every measured slot shall not exceed -32 dB at spreading factor 256.

The average Relative Code Domain Error for 64QAM modulated codes shall not exceed -20 dB at spreading factor 16.

NOTE: If the above Test Requirement differs from the Minimum Requirement then the Test Tolerance applied for this test is non-zero. The Test Tolerance for this test is defined in subclause 4.1.2 and the explanation of how the Minimum Requirement has been relaxed by the Test Tolerance is given in annex C.

6.5.4.7.2 UTRA TDD test requirement

The error vector magnitude (EVM) for each carrier measured according to subclause 6.5.4.5.2.1 shall not exceed 12,5 %.

The peak code domain error measured according to subclause 6.5.4.5.2.2 shall not exceed -27 dB.

The Relative code domain error measured according to subclause 6.5.4.5.2.3 shall not exceed -20.9 dB.

NOTE: If the above Test Requirement differs from the Minimum Requirement then the Test Tolerance applied for this test is non-zero. The Test Tolerance for this test is defined in subclause 4.1.2 and the explanation of how the Minimum Requirement has been relaxed by the Test Tolerance is given in annex C.

6.5.4.7.3 E-UTRA and NR test requirement

The EVM of each E-UTRA or NR carrier for different modulation schemes on PDSCH shall be less than the limits in table 6.5.4.7.3-1.

Table 6.5.4.7.3-1 EVM requirements

Modulation scheme for PDSCH	Required EVM (%)
QPSK	18.5 %
16QAM	13.5 %
64QAM	9 %
256QAM	4.5 %

The EVM requirement shall be applicable within a time period around the centre of the CP therefore the EVM requirement is tested against the maximum of the RMS average of 10 subframes at the two window W extremities.

Table 6.5.4.7.3-2 specifies EVM window length (W) for normal CP, the cyclic prefix length N_{cp} is 160 for symbols 0 and 144 for symbols 1-6.

Table 6.5.4.7.3-2 EVM window length for normal CP

Channel Bandwidth MHz	FFT size	Cyclic prefix length for symbols 0 in FFT samples	Cyclic prefix length for symbols 1-6 in FFT samples	EVM window length W	Ratio of W to total CP for symbols 1-6 (%) (Note)
1.4	128	10	9	5	55.6
3	256	20	18	12	66.7
5	512	40	36	32	88.9
10	1024	80	72	66	91.7
15	1536	120	108	102	94.4
20	2048	160	144	136	94.4

NOTE: These percentages are informative and apply to symbols 1 through 6. Symbol 0 has a longer CP and therefore a lower percentage.

NOTE: If the above Test Requirement differs from the Minimum Requirement then the Test Tolerance applied for this test is non-zero. The Test Tolerance for this test is defined in subclause 4.1.2 and the explanation of how the Minimum Requirement has been relaxed by the Test Tolerance is given in annex C.

6.6 Unwanted Emissions

6.6.1 General

Unwanted emissions consist of so-called out-of-band emissions and spurious emissions according to ITU definitions [14]. In ITU terminology, out of band emissions are unwanted emissions immediately outside the *channel bandwidth* resulting from the modulation process and non-linearity in the transmitter but excluding spurious emissions. Spurious emissions are emissions which are caused by unwanted transmitter effects such as harmonics emission, parasitic emission, intermodulation products and frequency conversion products, but exclude out of band emissions.

For AAS BS in *single RAT E-UTRA operation* and *MSR operation*, the out-of-band emissions requirement for the AAS BS transmitter is specified in terms of an operating band unwanted emissions requirement that defines limits for emissions in each supported *downlink operating band* plus the frequency ranges Δf_{OBUE} above and Δf_{OBUE} below each band, where Δf_{OBUE} is the maximum offset of the operating band unwanted emission mask from the operating band edge. Emissions outside of this frequency range are limited by a spurious emissions requirement. For UTRA FDD single RAT AAS BS, the out of band emission requirement for AAS BS transmitter is specified in terms of spectrum emission mask requirement.

The values of Δf_{OBUE} are defined for *hybrid AAS BS* for E-UTRA and UTRA operating bands in Table 6.6.1-1.

Table 6.6.1-1: Maximum offset of OBUE outside the downlink operating band

BS type	Operating band characteristics	Δf_{OBUE} [MHz]
Hybrid AAS BS	$F_{\text{DL_high}} - F_{\text{DL_low}} < 100 \text{ MHz}$	10
	$100 \text{ MHz} \leq F_{\text{DL_high}} - F_{\text{DL_low}} \leq 900 \text{ MHz}$	40

The unwanted emission level limit of a *TAB connector TX min cell group* is in general defined by the unwanted emission *basic limit* which is the same as the corresponding applicable *Non-AAS BS* per transmitter requirement specified in [2], [3], [4] or [5], and its scaling by $N_{\text{TXU, counted per cell}}$. The unwanted emission requirements are applied per the *TAB connector TX min cell groups* for all the configurations supported by the AAS BS. The *basic limits* and corresponding scaling are defined in each relevant subclause.

There are in addition a requirement for occupied bandwidth and an ACLR requirement.

6.6.2 Occupied bandwidth

6.6.2.1 Definition and applicability

The occupied bandwidth is the width of a frequency band such that, below the lower and above the upper frequency limits, the mean powers emitted are each equal to a specified percentage $\beta/2$ of the total mean transmitted power. See also Recommendation ITU-R SM.328 [17].

The value of $\beta/2$ shall be taken as 0.5%.

The occupied bandwidth requirement applies during the *transmitter ON period* for a single transmitted carrier. The minimum requirement below may be applied regionally. There may also be regional requirements to declare the occupied bandwidth according to the definition in the present clause.

6.6.2.2 Minimum requirement

For MSR AAS BS, the minimum requirement for occupied bandwidth is the same as that stated in 3GPP TS 37.104 [12], subclause 6.6.3.

For single RAT UTRA FDD AAS BS, the minimum requirement for occupied bandwidth is the same as that stated in 3GPP TS 25.104 [9], subclause 6.6.1.

For single RAT UTRA TDD, 1,28Mcps option AAS BS, the minimum requirement for occupied bandwidth is the same as that stated in 3GPP TS 25.105 [10], subclause 6.6.1.

For single RAT E-UTRA AAS BS, the minimum requirement for occupied bandwidth is the same as that stated in 3GPP TS 36.104 [11], subclause 6.6.1.

6.6.2.3 Test purpose

The test purpose is to verify that the emission of the *TAB connector* does not occupy an excessive bandwidth for the service to be provided and is, therefore, not likely to create interference to other users of the spectrum beyond undue limits.

6.6.2.4 Method of test

6.6.2.4.1 Initial conditions

6.6.2.4.1.1 General test conditions

Test environment:

- normal; see clause B.2.

RF channels to be tested:

- M; see subclause 4.12.1.

6.6.2.4.1.2 UTRA FDD

Set the *TAB connector* to transmit a signal in accordance to TM1, subclause 4.12.2.

6.6.2.4.1.3 UTRA TDD

Set the parameters of the BS transmitted signal according to table 6.6.2.4.1.3-1.

Table 6.6.2.4.1.3-1: Parameters of the *TAB connector* transmitted signal for occupied bandwidth testing for 1,28 Mcps TDD

Parameter	Value/description
TDD Duty Cycle	TS i ; $i = 0, 1, 2, 3, 4, 5, 6$: transmit, if i is 0,4,5,6; receive, if i is 1,2,3.
Time slots under test	TS4, TS5 and TS6
Number of DPCH in each time slot under test	8
Power of each DPCH	1/8 of Base Station output power
Data content of DPCH	real life (sufficient irregular)

6.6.2.4.1.4 E-UTRA and NR

Aggregated Channel Bandwidth positions to be tested for contiguous carrier aggregation:

- $B_{\text{BW Channel CA}}$, $M_{\text{BW Channel CA}}$ and $T_{\text{BW Channel CA}}$; see subclause 4.12.1.

For a AAS BS declared to be capable of single carrier operation, start transmission according to E- TM1.1 for E-UTRA or [NR-FR1-TM 1.1] for NR, subclause 4.12.2.

6.6.2.4.2 Procedure

6.6.2.4.2.1 General Procedure

The minimum requirement is applied to all *TAB connectors*, they may be tested one at a time or multiple *TAB connectors* may be tested in parallel as shown in subclause D.1.1. Whichever method is used the procedure is repeated until all *TAB connectors* necessary to demonstrate conformance have been tested.

- 1) Connect *TAB connector* to measurement equipment as shown in subclause D.1.1. All *TAB connectors* not under test shall be terminated.
- 2) For UTRA and E-UTRA and NR declared capable of single carrier operation set the *TAB connector* to transmit at manufacturers declared rated carrier output power per *TAB connector* ($P_{\text{Rated,c,TABC}}$).

For E-UTRA and NR declared capable of contiguous carrier aggregation operation set the *TAB connector* to transmit on all carriers configured using the applicable test configuration and corresponding power setting specified in clause 5.

6.6.2.4.2.2 UTRA FDD

- 1) Measure the spectrum of the transmitted signal across a span of 10 MHz, based on an occupied bandwidth requirement of 5 MHz. The selected resolution bandwidth (RBW) filter of the analyser shall be 30 kHz or less. The spectrum shall be measured at 400 or more points across the measurement span.

NOTE: The detection mode of the spectrum analyzer will not have any effect on the result if the statistical properties of the out-of-OBW power are the same as those of the inside-OBW power. Both are expected to have the Rayleigh distribution of the amplitude of Gaussian noise. In any case where the statistics are not the same, though, the detection mode is power responding. There are at least two ways to be power responding. The spectrum analyser can be set to "sample" detection, with its video bandwidth setting at least three times its RBW setting. Or the analyser may be set to respond to the average of the power (root-mean-square of the voltage) across the measurement cell.

- 2) Compute the total of the power, P0, (in power units, not decibel units) of all the measurement cells in the measurement span. Compute P1, the power outside the occupied bandwidth on each side. P1 is half of the total power outside the bandwidth. P1 is half of (100 % - (occupied percentage)) of P0. For the occupied percentage of 99 %, P1 is 0.005 times P0.
- 3) Determine the lowest frequency, f1, for which the sum of all power in the measurement cells from the beginning of the span to f1 exceeds P1.
- 4) Determine the highest frequency, f2, for which the sum of all power in the measurement cells from the end of the span to f2 exceeds P1.
- 5) Compute the occupied bandwidth as f2 - f1.

In addition, for *multi-band TAB connector(s)*, the following steps shall apply:

- 6) For *multi-band TAB connectors* and single band tests, repeat the steps above per involved band where single band test configurations and test models shall apply with no carrier activated in the other band.

6.6.2.4.2.3 UTRA TDD

- 1) Measure the power of the transmitted signal with a measurement filter of bandwidth 30 kHz. The characteristic of the filter shall be approximately Gaussian (typical spectrum analyser filter). The centre frequency of the filter shall be stepped in contiguous 30 kHz steps from a minimum frequency, which shall be (2,4 - 0,015) MHz below the assigned channel frequency of the transmitted signal, up to a maximum frequency, which shall be (2,4 - 0,015) MHz above the assigned channel frequency of the transmitted signal. The time duration of each step shall be sufficiently long to capture one active time slot. The measured power shall be recorded for each step.
- 2) Determine the total output power by accumulating the recorded power measurement results of all steps.
- 3) Sum up the recorded power measurement results, starting from the step at the minimum frequency defined in (3) up to the step at a lower limit frequency by which this sum is equal to or greater than 0,5 % of the total output power determined in (4). This limit frequency is recorded as "Lower Frequency".
- 4) Sum up the recorded power measurement results, starting from the step at the maximum frequency defined in (3) down to the step at an upper limit frequency by which this sum is equal to or greater than 0,5 % of the total output power determined in (4). This limit frequency is recorded as "Upper Frequency".
- 5) Calculate the occupied bandwidth as the difference between the "Upper Frequency" obtained in (5) and the "Lower Frequency" obtained in (6).

In addition, for *multi-band TAB connector(s)*, the following steps shall apply:

- 6) For *multi-band TAB connectors* and single band tests, repeat the steps above per involved band where single band test configurations and test models shall apply with no carrier activated in the other band.

6.6.2.4.2.4 E-UTRA and NR

- 1) Measure the spectrum emission of the transmitted signal using at least the number of measurement points, and across a span, as listed in table 6.6.2.4.2.4-1 for E-UTRA and 6.6.2.4.2.4-2 for NR. The selected resolution bandwidth (RBW) filter of the analyser shall be 30 kHz or less.

Table 6.6.2.4.2.4-1: Span and number of measurement points for OBW measurements

Bandwidth	E-UTRA channel bandwidth BW_{Channel} (MHz)						Aggregated channel bandwidth $BW_{\text{Channel_CA}}$ (MHz)
	1.4	3	5	10	15	20	> 20
Span (MHz)	10	10	10	20	30	40	$2 \times BW_{\text{Channel_CA}}$
Minimum number of measurement points	1429	667	400	400	400	400	$\left\lceil \frac{2 \times BW_{\text{Channel_CA}}}{100\text{kHz}} \right\rceil$

Table 6.6.2.4.2.4-2: Span and number of measurement points for OBW measurements for NR

Bandwidth	BS channel bandwidth BW_{Channel} (MHz)					Aggregated BS channel bandwidth $BW_{\text{Channel_CA}}$ (MHz)
	5	10	15	20	> 20	> 20
Span (MHz)	10	20	30	40	$2 \times BW_{\text{Channel}}$	$2 \times BW_{\text{Channel_CA}}$
Minimum number of measurement points	400	400	400	400	$\left\lceil \frac{2 \times BW_{\text{Channel}}}{T} \right\rceil$	$\left\lceil \frac{2 \times BW_{\text{Channel}}}{T} \right\rceil$
[NOTE 1: T = 200 kHz, when the BS channel bandwidth of outermost carriers are both larger than 50 MHz; Otherwise, T = 100 kHz.]						

NOTE: The detection mode of the spectrum analyzer will not have any effect on the result if the statistical properties of the out-of-OBW power are the same as those of the inside-OBW power. Both are expected to have the Rayleigh distribution of the amplitude of Gaussian noise. In any case where the statistics are not the same, though, the detection mode is power responding. The analyser may be set to respond to the average of the power (root-mean-square of the voltage) across the measurement cell.

- 2) Compute the total of the power, P0, (in power units, not decibel units) of all the measurement cells in the measurement span. Compute P1, the power outside the occupied bandwidth on each side. P1 is half of the total power outside the bandwidth. P1 is half of (100 % - (occupied percentage)) of P0. For the occupied percentage of 99 %, P1 is 0.005 times P0.
- 3) Determine the lowest frequency, f1, for which the sum of all power in the measurement cells from the beginning of the span to f1 exceeds P1.
- 4) Determine the highest frequency, f2, for which the sum of all power in the measurement cells from f2 to the end of the span exceeds P1.
- 5) Compute the occupied bandwidth as f2 - f1.

In addition, for *multi-band TAB connector(s)*, the following steps shall apply:

- 6) For *multi-band TAB connectors* and single band tests, repeat the steps above per involved band where single band test configurations and test models shall apply with no carrier activated in the other band.

6.6.2.5 Test requirements

6.6.2.5.1 MSR

The occupied bandwidth of a single carrier shall be less than the values listed in table 6.6.2.5.1-1. In addition, for E-UTRA and NR intra-band contiguous carrier aggregation, test requirement in clause 6.6.1.5 of 3GPP TS 36.141 [17] or subclause 6.6.2.5 of 3GPP TS 38.141 [37] applies for the E-UTRA or NR component carriers that are aggregated.

Table 6.6.2.5.1-1: Occupied bandwidth

RAT	Occupied bandwidth limit
E-UTRA and NR	BW_{Channel}
UTRA FDD	5 MHz
1.28 Mcps UTRA TDD	1.6 MHz

6.6.2.5.2 UTRA FDD

The occupied bandwidth shall be less than 5 MHz based on a chip rate of 3,84 Mcps.

NOTE: If the above Test Requirement differs from the Minimum Requirement then the Test Tolerance applied for this test is non-zero. The Test Tolerance for this test is defined in subclause 4.1.2 and the explanation of how the Minimum Requirement has been relaxed by the Test Tolerance is given in annex C.

6.6.2.5.3 UTRA TDD

The occupied bandwidth shall be less than 1,6 MHz.

NOTE: If the above Test Requirement differs from the Minimum Requirement then the Test Tolerance applied for this test is non-zero. The Test Tolerance for this test is defined in subclause 4.1.2 and the explanation of how the Minimum Requirement has been relaxed by the Test Tolerance is given in annex C.

6.6.2.5.4 E-UTRA

The occupied bandwidth for each E-UTRA carrier shall be less than the channel bandwidth. For contiguous CA, the occupied bandwidth shall be less than or equal to the Aggregated Channel Bandwidth as defined in 3GPP TS 36.141 [17] subclause 5.6.

NOTE: If the above Test Requirement differs from the Minimum Requirement then the Test Tolerance applied for this test is non-zero. The Test Tolerance for this test is defined in subclause 4.1.2 and the explanation of how the Minimum Requirement has been relaxed by the Test Tolerance is given in annex C.

6.6.3 Adjacent Channel Leakage power Ratio

6.6.3.1 Definition and applicability

Adjacent Channel Leakage power Ratio (ACLR) is the ratio of the filtered mean power centred on the assigned channel frequency to the filtered mean power centred on an adjacent channel frequency.

NOTE: Conformance to the AAS ACLR requirement can be demonstrated by meeting at least one of the following criteria as determined by the manufacturer:

- 1) The ratio of the sum of the filtered mean power measured on each *TAB connector* in the *TAB connector TX min cell group* at the assigned channel frequency to the sum of the filtered mean power measured on each *TAB connector* in the *TAB connector TX min cell group* at the adjacent channel frequency shall be greater than or equal to the AAS ACLR limit. This applies for each *TAB connector TX min cell group*.

Or

- 2) The ratio of the filtered mean power at the *TAB connector* centred on the assigned channel frequency to the filtered mean power at each *TAB connector* centred on the adjacent channel frequency shall be greater than or equal to the AAS limit for every *TAB connector* in the *TAB connector TX min cell group*, for each *TAB connector TX min cell group*.

6.6.3.2 Minimum requirement

For MSR operation the AAS BS minimum requirements are the same as those specified in 3GPP TS 37.105 [8], subclause 6.6.3.2.

For single RAT UTRA FDD operation, the AAS BS minimum requirements are the same as those specified in 3GPP TS 25.104 [9], subclauses 6.6.2.2.1 and 6.6.2.2.2.

For single RAT UTRA TDD 1,28 Mcps option operation, the AAS BS minimum requirements are the same as those specified in 3GPP TS 25.105 [10], subclause 6.6.2.2.

For *single RAT E-UTRA operation*, the AAS BS minimum requirements are the same as those specified in 3GPP TS 36.104 [11], subclauses 6.6.2.1 and 6.6.2.2.

6.6.3.3 Test purpose

To verify that the adjacent channel leakage power ratio requirement shall be met as specified by the minimum requirement.

6.6.3.4 Method of test

6.6.3.4.1 Initial conditions

6.6.3.4.1.1 General test conditions

Test environment:

- normal; see clause B.2.

RF channels to be tested for single carrier:

- B, M and T; see subclause 4.12.1.

Base Station RF Bandwidth positions to be tested for multi-carrier:

- B_{RFBW} , M_{RFBW} and T_{RFBW} in single-band operation; see subclause 4.12.1; B'_{RFBW} , T'_{RFBW} and B'_{RFBW} , T'_{RFBW} in multi-band operation, see subclause 4.12.1.

6.6.3.4.1.2 MSR

For E-UTRA and NR ACLR requirement outside the *Base Station RF Bandwidth edges* and the ACLR requirement applied inside sub-block gap, in addition, for non-contiguous spectrum operation or *Inter RF Bandwidth gap* for multi-band operation using, the test configurations defined in subclause 4.8, the method of test described in subclauses 6.6.4.4.1 and 6.6.4.4.2 applies.

6.6.3.4.1.3 UTRA FDD

Set the base station to transmit a signal modulated in accordance to TM1, in subclause 4.12.2.

For a *TAB connector* declared to be capable of multi-carrier operation, set the base station to transmit according to TM1 on all carriers configured

6.6.3.4.1.4 UTRA TDD

For a *TAB connector* declared to be capable of single carrier operation only, set the parameters of the transmitted signal according to table 6.6.3.4.1.4-1.

For a *TAB connector* declared to be capable of multi-carrier operation set the parameters of the transmitted signal according to table 6.6.3.4.1.4-1 on all carriers.

Table 6.6.3.4.1.4-1: Parameters of the transmitted signal for ACLR testing for 1,28 Mcps TDD

Parameter	Value/description
TDD Duty Cycle	TS i ; $i = 0, 1, 2, 3, 4, 5, 6$: transmit, if i is 0,4,5,6; receive, if i is 1,2,3.
Time slots under test	TS4, TS5 and TS6
Number of DPCH in each time slot under test	8
Power of each DPCH	1/8 of Base Station output power
Data content of DPCH	real life (sufficient irregular)

For a *TAB connector* declared capable of supporting 16QAM capable.

For a *TAB connector* declared to be capable of single carrier operation only, set the parameters of the transmitted signal according to table 6.6.3.4.1.4-2.

For a *TAB connector* declared to be capable of multi-carrier operation, set the parameters of the transmitted signal according to table 6.6.3.4.1.4-2 on all carriers.

Table 6.6.3.4.1.4-2: Parameters of the transmitted signal for ACLR testing for 1,28 Mcps TDD- 16QAM capable BS

Parameter	Value/description
TDD Duty Cycle	TS i ; $i = 0, 1, 2, 3, 4, 5, 6$: transmit, if i is 0,4,5,6; receive, if i is 1,2,3.
Time slots under test	TS4, TS5 and TS6
HS-PDSCH modulation	16QAM
Number of HS-PDSCH in each time slot under test	8
Power of each HS-PDSCH	1/8 of Base Station output power
Data content of HS-PDSCH	real life (sufficient irregular)
Spreading factor	16

6.6.3.4.1.3 E-UTRA

For a *TAB connector* declared to be capable of single carrier operation only set to transmit a signal according to E-TM1.1. in subclause 4.12.2.

For a *TAB connector* declared to be capable of multi-carrier and/or CA operation, set to transmit according to E-TM1.1 on all carriers configured.

6.6.3.4.2 Procedure

6.6.3.4.2.1 General procedure

The minimum requirement is applied to all *TAB connectors*, they may be tested one at a time or multiple *TAB connectors* may be tested in parallel as shown in subclause D.1.1. Whichever method is used the procedure is repeated until all *TAB connectors* necessary to demonstrate conformance have been tested.

- 1) Connect *TAB connector* to measurement equipment as shown in subclause D.1.1. All *TAB connectors* not under test shall be terminated.

The measurement device characteristics shall be:

- measurement filter bandwidth: defined in subclause 6.6.3.5;
- detection mode: true RMS voltage or true average power.

- 2) For single carrier operation set the *TAB connector* to transmit at manufacturers declared rated carrier output power per *TAB connector* ($P_{\text{Rated,c,TABC}}$).

For a *TAB connector* declared to be capable of multi-carrier and/or CA operation set the *TAB connector* to transmit on all carriers configured using the applicable test configuration and corresponding power setting specified in clause 5 using the corresponding test models or set of physical channels in subclause 4.12.

6.6.3.4.2.2 MSR

- 1) For E-UTRA and NR, measure ACLR:
 - outside the Base Station RF Bandwidth edges;
 - inside sub-block gap for non-contiguous spectrum operation as specified in subclause 6.6.4.5.1;
 - inside Inter RF Bandwidth gap for multi-band operation.
- 2) For UTRA FDD, measure ACLR inside sub-block gap or Inter RF Bandwidth gap as specified in subclause 6.6.4.5.2.

- 3) Measure Cumulative Adjacent Channel Leakage power Ratio (CACLR) inside sub-block gap or the *Inter RF Bandwidth gap* as specified in subclause 6.6.4.5.4.

In addition, for *multi-band TAB connector(s)*, the following steps shall apply:

- 4) For *multi-band TAB connectors* and single band tests, repeat the steps above per involved band where single band test configurations and test models shall apply with no carrier activated in the other band.

6.6.3.4.2.3 UTRA FDD

- 1) Measure Adjacent channel leakage power ratio for 5 MHz and 10 MHz offsets both side of channel frequency. In multiple carrier case only offset frequencies below the lowest and above the highest carrier frequency used shall be measured.
- 2) For the ACLR requirement applied inside sub-block gap for non-contiguous spectrum operation or inside *Inter RF Bandwidth gap* for multi-band operation:
 - a) Measure ACLR inside sub-block gap or *Inter RF Bandwidth gap* as specified in clause 6.6.3.5.4.1, if applicable.
 - b) Measure Cumulative Adjacent Channel Leakage power Ratio (CACLR) inside sub-block gap or *Inter RF Bandwidth gap* as specified in clause 6.6.3.5.4.2, if applicable.

In addition, for *multi-band TAB connector(s)*, the following steps shall apply:

- 3) For *multi-band TAB connectors* and single band tests, repeat the steps above per involved band where single band test configurations and test models shall apply with no carrier activated in the other band.

6.6.3.4.2.4 UTRA TDD 1,28Mcps option

- 1) Measure the RRC filtered mean power centred on the lowest assigned channel frequency of a operating band over the 848 active chips of the transmit time slots TS *i* (this excludes the guard period).
- 2) Average over at least one time slot.
- 3) Measure the RRC filtered mean power at the first lower adjacent RF channel (centre frequency 1,6 MHz below the lowest assigned channel frequency of the transmitted signal) over the useful part of the burst within the transmit time slots TS *i* (this excludes the guard period).
- 4) Average over at least one time slot.
- 5) Calculate the ACLR by the ratio:

$$\text{ACLR} = \text{average power acc. to (4)} / \text{average interference power acc. to (6)}.$$
- 6) Repeat steps (5), (6) and (7) for the second lower adjacent RF channel (centre frequency 3,2 MHz below the lowest assigned channel frequency of the transmitted signal) and also for the first and second upper adjacent RF channel (centre frequency 1,6 MHz and 3,2 MHz above the assigned channel frequency of the transmitted signal, respectively).
- 7) In case of a *multi-carrier TAB connector*, repeat steps (3) and (4) for the highest assigned channel frequency. Otherwise, use the result obtained in step (4) above for further calculation in step (12).
- 8) Measure the RRC filtered mean power at the first higher adjacent RF channel (centre frequency 1,6 MHz above the highest assigned channel frequency of the transmitted signal) over the useful part of the burst within the transmit time slots TS *i* (this excludes the guard period).
- 9) Average over at least one time slot.
- 10) Calculate the ACLR by the ratio

$$\text{ACLR} = \text{average power acc. to (9)} / \text{average interference power acc. to (11)}.$$

- 11) Repeat steps (10) to (12) for the second upper adjacent RF channel (centre frequency 3,2 MHz above the highest assigned channel frequency of the transmitted signal).

In addition, for *multi-band TAB connector(s)*, the following steps shall apply:

- 12) For *multi-band TAB connectors* and single band tests, repeat the steps above per involved band where single band test configurations and test models shall apply with no carrier activated in the other band.

In addition for a 16QAM capable TAB connector

The same procedure applies to 1,28 Mcps TDD option supporting 16QAM.

6.6.3.4.2.5 E-UTRA

- 1) Measure Adjacent channel leakage power ratio for the frequency offsets both side of channel frequency as specified in table 6.6.3.5.6.1-1 (Paired spectrum case) or Table 6.6.3.5.6.1-2 (Unpaired spectrum case) respectively. In multiple carrier case only offset frequencies below the lowest and above the highest carrier frequency used shall be measured.
- 2) For the ACLR requirement applied inside sub-block gap for non-contiguous spectrum operation: or inside *Inter RF Bandwidth gap* for multi-band operation:
 - a) Measure ACLR inside sub-block gap or *Inter RF Bandwidth gap* as specified in subclause 6.6.3.5.6.1, if applicable.
 - b) Measure CACLR inside sub-block gap or *Inter RF Bandwidth gap* as specified in subclause 6.6.3.5.6.2, if applicable.
- 3) Repeat the test with the channel set-up according to E- TM1.2 in subclause 4.12.2.

In addition, for *multi-band TAB connector(s)*, the following steps shall apply:

- 4) For *multi-band TAB connectors* and single band tests, repeat the steps above per involved band where single band test configurations and test models shall apply with no carrier activated in the other band.

6.6.3.5 Test requirements

6.6.3.5.1 General Requirements

For the ACLR requirement either the ACLR/CACLR limits in subclauses 6.6.3.5.3, 6.6.3.5.4, 6.6.3.5.5 and 6.6.3.5.6, or the absolute limit in subclause 6.6.3.5.2 shall apply, whichever is less stringent.

Conformance to the relative ACLR/CACLR requirement may be shown to either the measure and sum test requirement or the per *TAB connector* test requirement.

- 1) The relative ACLR/CACLR test requirements for an AAS BS when using the measure and sum alternative are that for each *TAB connector TX cell group* and each applicable limit, the ratio of the power summation of wanted at the *TAB connectors* of the *TAB connector TX cell group* to the power sum of the emissions at the *TAB connectors* of the *TAB connector TX cell group* shall not exceed the limit.
- 2) The relative ACL/CACLR R test requirements for an AAS BS when using the per *TAB connector* alternative are that for each *TAB connector TX cell group* and each applicable limit, ratio of the wanted signal to the emissions at each of the *TAB connectors* of the *TAB connector TX cell group* shall not exceed the limit.

6.6.3.5.2 Absolute Limits

The absolute limits apply for ACLR and CACLR.

Conformance may be shown to either the measure and sum test requirement or the per *TAB connector* test requirement.

- 1) The ACLR/CACLR test requirements for an AAS BS when using the measure and sum alternative are that for each *TAB connector TX cell group* and each applicable *basic limit* as specified in this subclause, the power summation of emissions at the *TAB connectors* of the *TAB connector TX cell group* shall not exceed the specified *basic limit* + $10\log_{10}(N_{\text{TXU, counted per cell}})$.
- 2) The ACLR/CACLR test requirements for an AAS BS when using the per *TAB connector* alternative are that for each *TAB connector TX cell group* and each applicable *basic limit* as specified in this subclause, the emissions at each of the *TAB connectors* of the *TAB connector TX cell group* shall not exceed the specified *basic limit* +

$10\log_{10}(N_{\text{TXU, counted per cell}}) - 10\log_{10}(n)$ where n is the number of *TAB connectors* in the *TAB connector TX cell group*.

The basic limit for the ACLR/CACLR absolute value is specified in table 6.6.3.5.2-1.

Table 6.6.3.5.2-1: Base station ACLR/CACLR absolute *basic limit*

BS category / BS class	ACLR/CACLR absolute <i>basic limit</i>
Category A Wide Area BS	-13 dBm/MHz
Category B Wide Area BS	-15 dBm/MHz
Medium Range BS	-25 dBm/MHz
Local Area BS	-32 dBm/MHz

6.6.3.5.3 MSR

6.6.3.5.3.1 MSR E-UTRA test requirement

For E-UTRA, the test requirement is specified in tables 6.6.3.5.3.1-1 and 6.6.3.5.3.1-2, and applies outside the *Base Station RF Bandwidth* or *Maximum Radio Bandwidth*.

For a *TAB connector* operating in non-contiguous spectrum, the ACLR also applies for the first adjacent channel inside any sub-blockgap with a gap size $W_{\text{gap}} \geq 15$ MHz. The ACLR requirement for the second adjacent channel applies inside any sub-block gap with a gap size $W_{\text{gap}} \geq 20$ MHz. The CACLR test requirement in subclause 6.6.3.5.6.2 applies in sub block gaps for the frequency ranges defined in table 6.6.3.5.6.2-1.

For a *multi-band TAB connector*, the ACLR also applies for the first adjacent channel inside any *Inter RF Bandwidth gap* with a gap size $W_{\text{gap}} \geq 15$ MHz. The ACLR requirement for the second adjacent channel applies inside any *Inter RF Bandwidth gap* with a gap size $W_{\text{gap}} \geq 20$ MHz. The CACLR requirement in subclause 6.6.3.5.6.2 applies in *Inter RF Bandwidth gaps* for the frequency ranges defined in table 6.6.3.5.6.2-1.

The requirement applies during the transmitter on period.

The ACLR is defined with a square filter of bandwidth equal to the transmission bandwidth configuration of the transmitted signal (BW_{Config}) centred on the assigned channel frequency and a filter centred on the adjacent channel frequency according to the tables below.

For operation in paired spectrum, the ACLR shall be higher than the value specified in table 6.6.3.5.3.1-1.

Table 6.6.3.5.3.1-1: Base Station ACLR in paired spectrum

Channel bandwidth of E-UTRA Lowest/Highest Carrier transmitted BW_{Channel} (MHz)	adjacent channel centre frequency offset below the lower or above the upper <i>Base Station RF Bandwidth edge</i>	Assumed adjacent channel carrier	Filter on the adjacent channel frequency and corresponding filter bandwidth	ACLR limit
1.4, 3.0, 5, 10, 15, 20	$0.5 \times BW_{\text{Channel}}$	E-UTRA of same BW	Square (BW_{Config})	44.2 dB
	$1.5 \times BW_{\text{Channel}}$	E-UTRA of same BW	Square (BW_{Config})	44.2 dB
	2.5 MHz	3.84 Mcps UTRA	RRC (3.84 Mcps)	44.2 dB
	7.5 MHz	3.84 Mcps UTRA	RRC (3.84 Mcps)	44.2 dB
NOTE 1: BW_{Channel} and BW_{Config} are the channel bandwidth and transmission bandwidth configuration of the E-UTRA Lowest/Highest Carrier transmitted on the assigned channel frequency.				
NOTE 2: The RRC filter shall be equivalent to the transmit pulse shape filter defined in 3GPP TS 25.104 [2], with a chip rate as defined in this table.				

For operation in unpaired spectrum, the ACLR shall be higher than the value specified in table 6.6.3.5.3.1-2.

Table 6.6.3.5.3.1-2: Base Station ACLR in unpaired spectrum with synchronized operation

Channel bandwidth of E-UTRA Lowest/Highest Carrier transmitted BW_{Channel} (MHz)	adjacent channel centre frequency offset below the lower or above the upper Base Station RF Bandwidth edge	Assumed adjacent channel carrier	Filter on the adjacent channel frequency and corresponding filter bandwidth	ACLR limit
1.4, 3	$0.5 \times BW_{\text{Channel}}$	E-UTRA of same BW	Square (BW_{Config})	44.2 dB
	$1.5 \times BW_{\text{Channel}}$	E-UTRA of same BW	Square (BW_{Config})	44.2 dB
	0.8 MHz	1.28 Mcps UTRA	RRC (1.28 Mcps)	44.2 dB
	2.4 MHz	1.28 Mcps UTRA	RRC (1.28 Mcps)	44.2 dB
5, 10, 15, 20	$0.5 \times BW_{\text{Channel}}$	E-UTRA of same BW	Square (BW_{Config})	44.2 dB
	$1.5 \times BW_{\text{Channel}}$	E-UTRA of same BW	Square (BW_{Config})	44.2 dB
	0.8 MHz	1.28 Mcps UTRA	RRC (1.28 Mcps)	44.2 dB
	2.4 MHz	1.28 Mcps UTRA	RRC (1.28 Mcps)	44.2 dB
	2.5 MHz	3.84 Mcps UTRA	RRC (3.84 Mcps)	44.2 dB
	7.5 MHz	3.84 Mcps UTRA	RRC (3.84 Mcps)	44.2 dB
	5 MHz	7.68 Mcps UTRA	RRC (7.68 Mcps)	44.2 dB
	15 MHz	7.68 Mcps UTRA	RRC (7.68 Mcps)	44.2 dB

NOTE 1: BW_{Channel} and BW_{Config} are the channel bandwidth and transmission bandwidth configuration of the E-UTRA Lowest/Highest Carrier transmitted on the assigned channel frequency.
NOTE 2: The RRC filter shall be equivalent to the transmit pulse shape filter defined in 3GPP TS 25.105 [3], with a chip rate as defined in this table.

For operation in non-contiguous paired spectrum, the ACLR shall be higher than the value specified in table 6.6.3.5.3.1-3.

Table 6.6.3.5.3.1-3: Base Station ACLR in non-contiguous paired spectrum

Sub-block gap size (W_{gap}) where the limit applies	adjacent channel centre frequency offset below or above the sub-block edge (inside the gap)	Assumed adjacent channel carrier	Filter on the adjacent channel frequency and corresponding filter bandwidth	ACLR limit
$W_{\text{gap}} \geq 15$ MHz	2.5 MHz	3.84 Mcps UTRA	RRC (3.84 Mcps)	44.2 dB
$W_{\text{gap}} \geq 20$ MHz	7.5 MHz	3.84 Mcps UTRA	RRC (3.84 Mcps)	44.2 dB

NOTE: The RRC filter shall be equivalent to the transmit pulse shape filter defined in 3GPP TS 25.104 [2], with a chip rate as defined in this table.

For operation in non-contiguous unpaired spectrum, the ACLR shall be higher than the value specified in table 6.6.3.5.3.1-4.

Table 6.6.3.5.3.1-4: Base Station ACLR in non-contiguous unpaired spectrum

Sub-block gap size (W_{gap}) where the limit applies	BS adjacent channel centre frequency offset below or above the sub-block edge (inside the gap)	Assumed adjacent channel carrier	Filter on the adjacent channel frequency and corresponding filter bandwidth	ACLR limit
$W_{\text{gap}} \geq 15$ MHz	2.5 MHz	5 MHz E-UTRA	Square (BW_{Config})	44.2 dB
$W_{\text{gap}} \geq 20$ MHz	7.5 MHz	5 MHz E-UTRA	Square (BW_{Config})	44.2 dB

6.6.3.5.3.1A NR test requirement

For NR, the test requirement is specified in tables 6.6.3.5.3.1A-1 and applies outside the *Base Station RF Bandwidth or Maximum Radio Bandwidth*.

For a *TAB connector* operating in non-contiguous spectrum, the ACLR also applies for the first adjacent channel inside any sub-block gap with a gap size as indicated in table 6.6.3.5.3.1A-2. The ACLR requirement for the second adjacent channel applies inside any sub-block gap with a gap size as indicated in table 6.6.3.5.3.1A-2. The CACLR test requirement in subclause 6.6.3.5.3.4 applies in sub block gaps for the frequency ranges defined in table 6.6.3.5.3.4-2.

For a *multi-band TAB connector*, the ACLR also applies for the first adjacent channel inside any *Inter RF Bandwidth gap* with a gap size as indicated in table 6.6.3.5.3.1A-2. The ACLR requirement for the second adjacent channel applies inside any *Inter RF Bandwidth gap* with a gap size as indicated in table 6.6.3.5.3.1A-2. The CACLR test requirement in subclause 6.6.3.5.3.4 applies in sub block gaps for the frequency ranges defined in table 6.6.3.5.3.4-2.

The requirement applies during the transmitter on period.

The ACLR is defined with a square filter of bandwidth equal to the transmission bandwidth configuration of the transmitted signal (BW_{Config}) centred on the assigned channel frequency and a filter centred on the adjacent channel frequency according to the tables below.

For operation in paired or unpaired spectrum, the ACLR shall be higher than the value specified in table 6.6.3.5.3.1A-1.

Table 6.6.3.5.3.1A-1: Base Station ACLR limit

BS channel bandwidth of lowest/highest NR carrier transmitted BW_{Channel} [MHz]	BS adjacent channel centre frequency offset below the lowest or above the highest carrier centre frequency transmitted	Assumed adjacent channel carrier (informative)	Filter on the adjacent channel frequency and corresponding filter bandwidth	ACLR limit
5, 10, 15, 20	BW_{Channel}	NR of same BW (Note 2)	Square (BW_{Config})	44.2 dB
	$2 \times BW_{\text{Channel}}$	NR of same BW (Note 2)	Square (BW_{Config})	44.2 dB
	$BW_{\text{Channel}}/2 + 2.5$ MHz	5 MHz E-UTRA	Square (4.5 MHz)	44.2 dB (NOTE 3)
	$BW_{\text{Channel}}/2 + 7.5$ MHz	5 MHz E-UTRA	Square (4.5 MHz)	44.2 dB (NOTE 3)
25, 30, 40, 50, 60, 70, 80,90, 100	BW_{Channel}	NR of same BW (Note 2)	Square (BW_{Config})	43.8 dB
	$2 \times BW_{\text{Channel}}$	NR of same BW (Note 2)	Square (BW_{Config})	43.8 dB
	$BW_{\text{Channel}}/2 + 2.5$ MHz	5 MHz E-UTRA	Square (4.5 MHz)	43.8 dB (NOTE 3)
	$BW_{\text{Channel}}/2 + 7.5$ MHz	5 MHz E-UTRA	Square (4.5 MHz)	43.8 dB (NOTE 3)
NOTE 1: BW_{Channel} and BW_{Config} are the <i>BS channel bandwidth</i> and transmission bandwidth configuration of the lowest/highest NR carrier transmitted on the assigned channel frequency.				
NOTE 2: With SCS that provides largest transmission bandwidth configuration (BW_{Config}).				
NOTE 3: The requirements are applicable when the band is also defined for E-UTRA or UTRA.				

For operation in non-contiguous paired or unpaired spectrum, the ACLR shall be higher than the value specified in table 6.6.3.5.3.1A-2.

Table 6.6.3.5.3.1A-2: Base Station ACLR limit in non-contiguous spectrum or multiple bands

BS channel bandwidth of lowest/highest NR carrier transmitted BW_{Channel} [MHz]	Sub-block or Inter RF Bandwidth gap size (W_{gap}) where the limit applies [MHz]	BS adjacent channel centre frequency offset below or above the sub-block or Base Station RF Bandwidth edge (inside the gap)	Assumed adjacent channel carrier	Filter on the adjacent channel frequency and corresponding filter bandwidth	ACLR limit
5, 10, 15, 20	$W_{\text{gap}} \geq 15$ (Note 3) $W_{\text{gap}} \geq 45$ (Note 4)	2.5 MHz	5 MHz NR (Note 2)	Square (BW_{Config})	44.2 dB
	$W_{\text{gap}} \geq 20$ (Note 3) $W_{\text{gap}} \geq 50$ (Note 4)	7.5 MHz	5 MHz NR (Note 2)		
25, 30, 40, 50, 60, 70, 80, 90, 100	$W_{\text{gap}} \geq 60$ (Note 4) $W_{\text{gap}} \geq 30$ (Note 3)	10 MHz	20 MHz NR (Note 2)	Square (BW_{Config})	43.8 dB
	$W_{\text{gap}} \geq 80$ (Note 4) $W_{\text{gap}} \geq 50$ (Note 3)	30 MHz	20 MHz NR (Note 2)		

<p>NOTE 1: BW_{Config} is the transmission bandwidth configuration of the assumed adjacent channel carrier.</p> <p>NOTE 2: With SCS that provides largest transmission bandwidth configuration (BW_{Config}).</p> <p>NOTE 3: Applicable in case the <i>BS channel bandwidth</i> of the NR carrier transmitted at the other edge of the gap is 5, 10, 15, 20 MHz.</p> <p>NOTE 4: Applicable in case the <i>BS channel bandwidth</i> of the NR carrier transmitted at the other edge of the gap is 25, 30, 40, 50, 60, 70, 80, 90, 100 MHz.</p>

6.6.3.5.3.2 MSR UTRA FDD test requirement

For UTRA FDD, the test requirement is specified in 3GPP TS 25.141 [18], subclause 6.5.2.2.5, and applies outside the *Base Station RF Bandwidth* or Maximum Radio Bandwidth.

For a *TAB connector* operating in non-contiguous spectrum, ACLR requirement also applies for the first adjacent channel, inside any sub-block gap with a gap size $W_{\text{gap}} \geq 15$ MHz. The ACLR requirement for the second adjacent channel applies inside any sub-block gap with a gap size $W_{\text{gap}} \geq 20$ MHz. The CACLR test requirement in subclause 6.6.3.5.6.2 applies in sub block gaps for the frequency ranges defined in table 6.6.3.5.6.2-1.

For a *multi-band TAB connector* ACLR requirement also applies for the first adjacent channel, inside any *Inter RF Bandwidth gap* with a gap size $W_{\text{gap}} \geq 15$ MHz. The ACLR requirement for the second adjacent channel applies inside any *Inter RF Bandwidth gap* with a gap size $W_{\text{gap}} \geq 20$ MHz. The CACLR requirement in subclause 6.6.3.5.6.2 applies in *Inter RF Bandwidth gaps* for the frequency ranges defined in table 6.6.3.5.6.2-1.

6.6.3.5.3.3 MSR UTRA TDD test requirement

For UTRA TDD, the test requirement is specified in subclause 6.6.3.5.5, and applies outside the *Base Station RF Bandwidth* or Maximum Radio Bandwidth.

6.6.3.5.3.4 Cumulative ACLR requirement in non-contiguous spectrum

The following test requirement applies for sub-block or *Inter RF Bandwidth gap* sizes listed in table 6.6.3.5.3.4-1 for UTRA FDD, UTRA TDD or E-UTRA operation or table 6.6.3.5.3.4-1A for NR operation:

- Inside a sub-block gap within an operating band for a BS operating in non-contiguous spectrum.
- Inside an *Inter RF Bandwidth gap* for a BS operating in multiple bands, where multiple bands are mapped on the same antenna connector.

The Cumulative Adjacent Channel Leakage power Ratio (CACLR) in a sub-block gap or the *Inter RF Bandwidth gap* is the ratio of:

- a) the sum of the filtered mean power centred on the assigned channel frequencies for the two carriers adjacent to each side of the sub-block gap or the *Inter RF Bandwidth gap*; and
- b) the filtered mean power centred on a frequency channel adjacent to one of the respective sub-block edges or *Base Station RF Bandwidth edges*.

The requirement applies to adjacent channels of E-UTRA or UTRA or NR carriers allocated adjacent to each side of the sub-block gap or the *Inter RF Bandwidth gap*. In case of mixed UTRA and E-UTRA (but not NR) carriers on either side of the gap, table 6.6.3.5.3.4-1 is applicable. In case of mixed NR and E-UTRA or UTRA or NR only carriers on either side of the gap, table 6.6.3.5.3.4-1A is applicable. The assumed filter for the adjacent channel frequency is defined in tables 6.6.3.5.3.4-1 and 6.6.3.5.3.4-1A and the filters on the assigned channels are defined in table 6.6.3.5.3.4-2.

NOTE: If the RAT on the assigned channel frequencies is different, the filters used are also different.

The CACLR for E-UTRA and UTRA carriers located on either side of the sub-block gap or the *Inter RF Bandwidth gap* shall be higher than the value specified in table 6.6.3.5.3.4-1.

Table 6.6.3.5.3.4-1: CA CLR in non-contiguous spectrum or multiple bands for UTRA and E-UTRA only

Band Category	Sub-block or Inter RF Bandwidth gap size (W_{gap}) where the limit applies	adjacent channel centre frequency offset below or above the sub-block edge or the Base Station RF Bandwidth edge (inside the gap)	Assumed adjacent channel carrier (informative)	Filter on the adjacent channel frequency and corresponding filter bandwidth	CA CLR limit
BC1, BC2	$5 \text{ MHz} \leq W_{gap} < 15 \text{ MHz}$	2.5 MHz	3.84 Mcps UTRA	RRC (3.84 Mcps)	44.2 dB
BC1, BC2	$10 \text{ MHz} \leq W_{gap} < 20 \text{ MHz}$	7.5 MHz	3.84 Mcps UTRA	RRC (3.84 Mcps)	44.2 dB
BC3	$5 \text{ MHz} \leq W_{gap} < 15 \text{ MHz}$	2.5 MHz	5 MHz E-UTRA	Square (BW_{Config})	44.2 dB
BC3	$10 \text{ MHz} < W_{gap} < 20 \text{ MHz}$	7.5 MHz	5 MHz E-UTRA	Square (BW_{Config})	44.2 dB

NOTE: For BC1 and BC2 the RRC filter shall be equivalent to the transmit pulse shape filter defined in 3GPP TS 25.104 [2], with a chip rate as defined in this table.

Table 6.6.3.5.3.4-1A: CA CLR in non-contiguous spectrum or multiple bands for E-UTRA and NR combinations

BS channel bandwidth of lowest/highest NR carrier transmitted $BW_{Channel}$ [MHz]	Sub-block or Inter RF Bandwidth gap size (W_{gap}) where the limit applies [MHz]	BS adjacent channel centre frequency offset below or above the sub-block or Base Station RF Bandwidth edge (inside the gap)	Assumed adjacent channel carrier	Filter on the adjacent channel frequency and corresponding filter bandwidth	CA CLR limit
5, 10, 15, 20	$5 \leq W_{gap} < 15$ (Note 3) $5 \leq W_{gap} < 45$ (Note 4)	2.5 MHz	5 MHz NR (Note 2)	Square (BW_{Config})	44.2 dB
	$10 < W_{gap} < 20$ (Note 3) $10 \leq W_{gap} < 50$ (Note 4)	7.5 MHz	5 MHz NR (Note 2)		
25, 30, 40, 50, 60, 70, 80, 90, 100	$20 \leq W_{gap} < 60$ (Note 4) $20 \leq W_{gap} < 30$ (Note 3)	10 MHz	20 MHz NR (Note 2)	Square (BW_{Config})	43.8 dB
	$40 < W_{gap} < 80$ (Note 4) $40 \leq W_{gap} < 50$ (Note 3)	30 MHz	20 MHz NR (Note 2)		

NOTE 1: BW_{Config} is the transmission bandwidth configuration of the assumed adjacent channel carrier.
 NOTE 2: With SCS that provides largest transmission bandwidth configuration (BW_{Config}).
 NOTE 3: Applicable in case the BS channel bandwidth of the UTRA, E-UTRA or NR carrier transmitted at the other edge of the gap is 5, 10, 15, 20 MHz.
 NOTE 4: Applicable in case the BS channel bandwidth of the NR carrier transmitted at the other edge of the gap is 25, 30, 40, 50, 60, 70, 80, 90, 100 MHz.

Table 6.6.3.5.3.4-2: Filter parameters for the assigned channel for UTRA, E-UTRA only combinations

RAT of the carrier adjacent to the sub-block or Inter RF Bandwidth gap	Filter on the assigned channel frequency and corresponding filter bandwidth
E-UTRA	E-UTRA of same BW
UTRA FDD	RRC (3.84 Mcps)

NOTE: The RRC filter shall be equivalent to the transmit pulse shape filter defined in 3GPP TS 25.104 [2], with a chip rate as defined in this table.

6.6.3.5.4 UTRA FDD

6.6.3.5.4.1 ACLR

The measurement result shall not be less than the ACLR limit specified in tables 6.6.3.5.4.1-1.

Table 6.6.3.5.4.1-1: BS ACLR

BS channel offset below the first or above the last carrier frequency used	ACLR limit
5 MHz	44.2 dB
10 MHz	49.2 dB
NOTE 1: In certain regions, the adjacent channel power (the RRC filtered mean power centred on an adjacent channel frequency) shall be less than or equal to -7.2 dBm/3.84 MHz (for Band I, III, IX, XI and XXI) or +2.8 dBm/3.84 MHz (for Band VI, VIII and XIX) or as specified by the ACLR limit, whichever is the higher. This note is not applicable for Home BS.	
NOTE 2: For Home BS, the adjacent channel power (the RRC filtered mean power centred on an adjacent channel frequency) shall be less than or equal to -42.7 dBm/3.84 MHz $f \leq 3.0$ GHz and -42.4 dBm/3.84 MHz for 3.0 GHz $< f \leq 4.2$ GHz or as specified by the ACLR limit, whichever is the higher.	

NOTE: If the above Test Requirement differs from the Minimum Requirement then the Test Tolerance applied for this test is non-zero. The Test Tolerance for this test is defined in subclause 4.1.2 and the explanation of how the Minimum Requirement has been relaxed by the Test Tolerance is given in annex C.

The measurement result in shall not be less than the ACLR limit specified in table 6.6.3.5.4.1-2.

Table 6.6.3.5.4.1-2: ACLR in non-contiguous spectrum or multiple bands

Sub-block or <i>Inter RF Bandwidth gap</i> size (W_{gap}) where the limit applies	adjacent channel centre frequency offset below or above the sub-block edge or the <i>Base Station RF Bandwidth edge</i> (inside the gap)	Assumed adjacent channel carrier (informative)	Filter on the adjacent channel frequency and corresponding filter bandwidth	ACLR limit
$W_{\text{gap}} \geq 15$ MHz	2.5 MHz	3.84 Mcps UTRA	RRC (3.84 Mcps)	44.2 dB
$W_{\text{gap}} \geq 20$ MHz	7.5 MHz	3.84 Mcps UTRA	RRC (3.84 Mcps)	44.2 dB
NOTE: The RRC filter shall be equivalent to the transmit pulse shape filter defined in 3GPP TS 25.104 [2], with a chip rate as defined in this table.				

6.6.3.5.4.2 Cumulative ACLR test requirement in non-contiguous spectrum or multiple-bands

The following test requirement applies for a *TAB connector* operating in non-contiguous spectrum or multiple bands.

The following requirement applies for the gap sizes listed in table 6.6.3.5.4.2-1:

- inside a sub-block gap within an operating band for a *TAB connector* operating in non-contiguous spectrum;
- inside an *Inter RF Bandwidth gap* for a *multi-band TAB connector*.

The Cumulative Adjacent Channel Leakage power Ratio (CACLR) in a sub-block gap or *Inter RF Bandwidth gap* is the ratio of:

- a) the sum of the filtered mean power centred on the assigned channel frequencies for the two carriers adjacent to each side of the sub-block gap or *Inter RF Bandwidth gap*; and
- b) the filtered mean power centred on a frequency channel adjacent to one of the respective sub-block edges or *Base Station RF Bandwidth edges*.

The assumed filter for the adjacent channel frequency is defined in table 6.6.3.5.4.2-1 and the filters on the assigned channels are defined in table 6.6.3.5.4.2-2.

The CACLR for UTRA carriers located on either side of the sub-block gap or *Inter RF Bandwidth gap* shall be higher than the value specified in table 6.6.3.5.4.2-1.

Table 6.6.3.5.4.2-1: Base Station CACLR in non-contiguous spectrum or multiple bands

Sub-block or <i>Inter RF Bandwidth gap</i> size (W_{gap}) where the limit applies	BS adjacent channel centre frequency offset below or above the sub-block edge or the <i>Base Station RF Bandwidth edge</i> (inside the gap)	Assumed adjacent channel carrier (informative)	Filter on the adjacent channel frequency and corresponding filter bandwidth	CACLR limit
$5 \text{ MHz} \leq W_{\text{gap}} < 15 \text{ MHz}$	2.5 MHz	3.84 Mcps UTRA	RRC (3.84 Mcps)	44.2 dB
$10 \text{ MHz} < W_{\text{gap}} < 20 \text{ MHz}$	7.5 MHz	3.84 Mcps UTRA	RRC (3.84 Mcps)	44.2 dB
NOTE: The RRC filter shall be equivalent to the transmit pulse shape filter defined in 3GPP TS 25.104 [2], with a chip rate as defined in this table.				

Table 6.6.3.5.4.2-2: Filter parameters for the assigned channel

RAT of the carrier adjacent to the sub-block or <i>Inter RF Bandwidth gap</i>	Filter on the assigned channel frequency and corresponding filter bandwidth
UTRA FDD	RRC (3.84 Mcps)
NOTE: The RRC filter shall be equivalent to the transmit pulse shape filter defined in 3GPP TS 25.104 [2], with a chip rate as defined in this table.	

6.6.3.5.5 UTRA TDD, 1,28Mcps option

The ACLR shall be equal or greater than the limits given in table 6.6.3.5.5-1. In case the equipment is tested against the requirements defined for operation in the same geographic area or co-sited with unsynchronised TDD or FDD on adjacent channels, the adjacent channel leakage power measured shall not exceed the maximum levels specified in tables 6.27B, 6.27C, 6.27D, 6.28B, 6.28C or 6.28D, respectively.

Table 6.6.3.5.5-1: BS ACLR Test Requirements (1,28 Mcps option)

BS adjacent channel offset below the first or above the last carrier frequency used	ACLR limit
1,6 MHz	39.2 dB
3,2 MHz	44.2 dB

The requirements shall apply outside the *Base Station RF bandwidth* or *maximum radio bandwidth* edges whatever the type of transmitter considered (single carrier, multi-carrier). It applies for all transmission modes foreseen by the manufacturer's specification.

For a *multi-band TAB connector* the ACLR requirement also applies for the first adjacent channel inside any *Inter RF Bandwidth gap* with a gap size $W_{\text{gap}} \geq 4.8 \text{ MHz}$. The ACLR requirement for the second adjacent channel applies inside any *Inter RF Bandwidth gap* with a gap size $W_{\text{gap}} \geq 6.4 \text{ MHz}$.

The same test requirements apply to 1,28 Mcps TDD option BS supporting 16QAM.

6.6.3.5.6 E-UTRA

6.6.3.5.6.1 ACLR

The ACLR is defined with a square filter of bandwidth equal to the transmission bandwidth configuration of the transmitted signal (BW_{Config}) centred on the assigned channel frequency and a filter centred on the adjacent channel frequency according to the tables below.

For operation in paired spectrum, the ACLR shall be higher than the value specified in table 6.6.3.5.6.1-1.

Table 6.6.3.5.6.1-1: ACLR in paired spectrum

Channel bandwidth of E-UTRA lowest/highest carrier transmitted BW_{Channel} (MHz)	adjacent channel centre frequency offset below the lowest or above the highest carrier centre frequency transmitted	Assumed adjacent channel carrier (informative)	Filter on the adjacent channel frequency and corresponding filter bandwidth	ACLR limit
1.4, 3.0, 5, 10, 15, 20	BW_{Channel}	E-UTRA of same BW	Square (BW_{Config})	44.2 dB
	$2 \times BW_{\text{Channel}}$	E-UTRA of same BW	Square (BW_{Config})	44.2 dB
	$BW_{\text{Channel}}/2 + 2.5$ MHz	3.84 Mcps UTRA	RRC (3.84 Mcps)	44.2 dB
	$BW_{\text{Channel}}/2 + 7.5$ MHz	3.84 Mcps UTRA	RRC (3.84 Mcps)	44.2 dB
NOTE 1: BW_{Channel} and BW_{Config} are the channel bandwidth and transmission bandwidth configuration of the E-UTRA lowest/highest/ carrier transmitted on the assigned channel frequency.				
NOTE 2: The RRC filter shall be equivalent to the transmit pulse shape filter defined in 3GPP TS 25.014 [3] with a chip rate as defined in this table.				

For operation in unpaired spectrum, the ACLR shall be higher than the value specified in table 6.6.3.5.6.1-2.

Table 6.6.3.5.6.1-2: ACLR in unpaired spectrum with synchronized operation

Channel bandwidth of E-UTRA lowest/highest carrier transmitted BW_{Channel} (MHz)	adjacent channel centre frequency offset below the lowest or above the highest carrier centre frequency transmitted	Assumed adjacent channel carrier (informative)	Filter on the adjacent channel frequency and corresponding filter bandwidth	ACLR limit
1.4, 3.0	BW_{Channel}	E-UTRA of same BW	Square (BW_{Config})	44.2 dB
	$2 \times BW_{\text{Channel}}$	E-UTRA of same BW	Square (BW_{Config})	44.2 dB
	$BW_{\text{Channel}}/2 + 0.8$ MHz	1.28 Mcps UTRA	RRC (1.28 Mcps)	44.2 dB
	$BW_{\text{Channel}}/2 + 2.4$ MHz	1.28 Mcps UTRA	RRC (1.28 Mcps)	44.2 dB
5, 10, 15, 20	BW_{Channel}	E-UTRA of same BW	Square (BW_{Config})	44.2 dB
	$2 \times BW_{\text{Channel}}$	E-UTRA of same BW	Square (BW_{Config})	44.2 dB
	$BW_{\text{Channel}}/2 + 0.8$ MHz	1.28 Mcps UTRA	RRC (1.28 Mcps)	44.2 dB
	$BW_{\text{Channel}}/2 + 2.4$ MHz	1.28 Mcps UTRA	RRC (1.28 Mcps)	44.2 dB
	$BW_{\text{Channel}}/2 + 2.5$ MHz	3.84 Mcps UTRA	RRC (3.84 Mcps)	44.2 dB
	$BW_{\text{Channel}}/2 + 7.5$ MHz	3.84 Mcps UTRA	RRC (3.84 Mcps)	44.2 dB
	$BW_{\text{Channel}}/2 + 5$ MHz	7.68 Mcps UTRA	RRC (7.68 Mcps)	44.2 dB
	$BW_{\text{Channel}}/2 + 15$ MHz	7.68 Mcps UTRA	RRC (7.68 Mcps)	44.2 dB
NOTE 1: BW_{Channel} and BW_{Config} are the channel bandwidth and transmission bandwidth configuration of the E-UTRA lowest/highest carrier transmitted on the assigned channel frequency.				
NOTE 2: The RRC filter shall be equivalent to the transmit pulse shape filter defined in 3GPP TS 25.014 [3] with a chip rate as defined in this table.				

For operation in non-contiguous paired spectrum or multiple bands, the ACLR shall be higher than the value specified in table 6.6.3.5.6.1-3.

Table 6.6.3.5.6.1-3: Base Station ACLR in non-contiguous paired spectrum or multiple bands

Sub-block or Inter RF Bandwidth gap size (W_{gap}) where the limit applies	BS adjacent channel centre frequency offset below or above the sub-block edge or the Base Station RF Bandwidth edge (inside the gap)	Assumed adjacent channel carrier (informative)	Filter on the adjacent channel frequency and corresponding filter bandwidth	ACLR limit
$W_{\text{gap}} \geq 15$ MHz	2.5 MHz	3.84 Mcps UTRA	RRC (3.84 Mcps)	44.2 dB
$W_{\text{gap}} \geq 20$ MHz	7.5 MHz	3.84 Mcps UTRA	RRC (3.84 Mcps)	44.2 dB
NOTE: The RRC filter shall be equivalent to the transmit pulse shape filter defined in 3GPP TS 25.104 [2], with a chip rate as defined in this table.				

For operation in non-contiguous unpaired spectrum or multiple bands, the ACLR shall be higher than the value specified in table 6.6.3.5.6.1-4.

Table 6.6.3.5.6.1-4: ACLR in non-contiguous unpaired spectrum or multiple bands

Sub-block or <i>Inter RF Bandwidth gap</i> size (W_{gap}) where the limit applies	adjacent channel centre frequency offset below or above the sub-block edge or the <i>Base Station RF Bandwidth edge</i> (inside the gap)	Assumed adjacent channel carrier (informative)	Filter on the adjacent channel frequency and corresponding filter bandwidth	ACLR limit
$W_{\text{gap}} \geq 15$ MHz	2.5 MHz	5 MHz E-UTRA	Square (BW_{Config})	44.2 dB
$W_{\text{gap}} \geq 20$ MHz	7.5 MHz	5 MHz E-UTRA	Square (BW_{Config})	44.2 dB

6.6.3.5.6.2 Cumulative ACLR test requirement in non-contiguous spectrum

The following test requirement applies for the sub-block or *Inter RF Bandwidth gap* sizes listed in table 6.6.3.5.6.2-1,

- Inside a sub-block gap within an operating band for a BS operating in non-contiguous spectrum.
- Inside an *Inter RF Bandwidth gap* for a *multi-band TAB connector*.

The Cumulative Adjacent Channel Leakage power Ratio (CACLR) in a sub-block gap or *Inter RF Bandwidth gap* is the ratio of:

- a) the sum of the filtered mean power centred on the assigned channel frequencies for the two carriers adjacent to each side of the sub-block gap or *Inter RF Bandwidth gap*; and
- b) the filtered mean power centred on a frequency channel adjacent to one of the respective sub-block edges or *Base Station RF Bandwidth edges*.

The assumed filter for the adjacent channel frequency is defined in tables 6.6.3.5.6.2-1 and 6.6.3.5.6.2-2. Filters on the assigned channels are defined in table 6.6.3.5.6.2-3.

For operation in non-contiguous spectrum or multiple bands, the CACLR for E-UTRA carriers located on either side of the sub-block gap or *Inter RF Bandwidth gap* shall be higher than the value specified in tables 6.6.3.5.6.2-1 and 6.6.3.5.6.2-2.

Table 6.6.3.5.6.2-1: Base Station CACLR in non-contiguous paired spectrum or multiple bands

Sub-block or <i>Inter RF Bandwidth gap</i> size (W_{gap}) where the limit applies	BS adjacent channel centre frequency offset below or above the sub-block edge or the <i>Base Station RF Bandwidth edge</i> (inside the gap)	Assumed adjacent channel carrier (informative)	Filter on the adjacent channel frequency and corresponding filter bandwidth	CACLR limit
$5 \text{ MHz} \leq W_{\text{gap}} < 15 \text{ MHz}$	2.5 MHz	3.84 Mcps UTRA	RRC (3.84 Mcps)	44.2 dB
$10 \text{ MHz} < W_{\text{gap}} < 20 \text{ MHz}$	7.5 MHz	3.84 Mcps UTRA	RRC (3.84 Mcps)	44.2 dB
NOTE: The RRC filter shall be equivalent to the transmit pulse shape filter defined in 3GPP TS 25.104 [2], with a chip rate as defined in this table.				

Table 6.6.3.5.6.2-2: Base Station CA CLR in non-contiguous unpaired spectrum or multiple bands

Sub-block or <i>Inter RF Bandwidth gap</i> size (W_{gap}) where the limit applies	BS adjacent channel centre frequency offset below or above the sub-block edge or the <i>Base Station RF Bandwidth edge</i> (inside the gap)	Assumed adjacent channel carrier (informative)	Filter on the adjacent channel frequency and corresponding filter bandwidth	CA CLR limit
$5 \text{ MHz} \leq W_{\text{gap}} < 15 \text{ MHz}$	2.5 MHz	5 MHz E-UTRA carrier	Square (BW_{Config})	44.2 dB
$10 \text{ MHz} < W_{\text{gap}} < 20 \text{ MHz}$	7.5 MHz	5 MHz E-UTRA carrier	Square (BW_{Config})	44.2 dB

Table 6.6.3.5.6.2-3: Filter parameters for the assigned channel

RAT of the carrier adjacent to the sub-block or <i>Inter RF Bandwidth gap</i>	Filter on the assigned channel frequency and corresponding filter bandwidth
E-UTRA	E-UTRA of same BW

NOTE: If the above Test Requirement differs from the Minimum Requirement then the Test Tolerance applied for this test is non-zero. The Test Tolerance for this test is defined in subclause 4.1.2 and the explanation of how the Minimum Requirement has been relaxed by the Test Tolerance is given in annex C.

6.6.4 Spectrum emission mask

6.6.4.1 Definition and applicability

This requirement is applicable for single RAT UTRA AAS BS operation only.

6.6.4.2 Minimum requirement

The minimum requirement for UTRA operation are defined in 3GPP TS 37.105 [8], subclause 6.6.4.3.

6.6.4.3 Test purpose

This test measures the emissions of the *TAB connector*, close to the assigned channel bandwidth of the wanted signal, while the transmitter unit associated with the *TAB connector* under test is in operation.

6.6.4.4 Method of test

6.6.4.4.1 Initial conditions

6.6.4.4.1.1 General test conditions

Test environment:

- normal; see clause B.2.

RF channels to be tested for single carrier:

- B, M and T; see subclause 4.12.1.

Base Station RF Bandwidth positions to be tested for multi-carrier:

- B_{RFBW} , M_{RFBW} and T_{RFBW} in single-band operation; see subclause 4.12.1; $B_{\text{RFBW}}T_{\text{RFBW}}$ and $B'_{\text{RFBW}}T_{\text{RFBW}}$ in multi-band operation, see subclause 4.12.1.

6.6.4.4.1.2 UTRA FDD

For a *TAB connector* declared to be capable of single carrier operation only, set to transmit a signal according to TM1, in subclause 4.12.2.

For a *multi-carrier TAB connector*, set to transmit according to TM1 on all carriers configured using the applicable test configuration.

6.6.4.4.1.3 UTRA TDD

For a *TAB connector* declared to be capable of single carrier operation only, set the parameters of the transmitted signal according to table 6.6.4.4.1.3-1.

For a *multi-carrier TAB connector* set to transmit according to table 6.6.4.4.1.3-1 on all carriers configured using the applicable test configuration.

Table 6.6.4.4.1.3-1: Parameters of the transmitted signal for spectrum emission mask testing for 1,28 Mcps TDD

Parameter	Value/description
TDD Duty Cycle	TS i ; $i = 0, 1, 2, 3, 4, 5, 6$: transmit, if i is 0,4,5,6; receive, if i is 1,2,3.
Time slots under test	TS4, TS5 and TS6
Number of DPCH in each time slot under test	8
Power of each DPCH	1/8 of Base Station output power
Data content of DPCH	real life (sufficient irregular)

In addition for a *TAB connector* declared capable of 16QAM.

For a *TAB connector* declared to be capable of single carrier operation only, set the parameters of the transmitted signal according to table 6.6.4.4.1.3-2.

For a *multi-carrier TAB connector* set to transmit according to table 6.6.4.4.1.3-2 on all carriers configured using the applicable test configuration.

Table 6.6.4.4.1.3-2: Parameters of the transmitted signal for spectrum emission mask testing for 1,28 Mcps TDD - 16QAM capable TAB connector

Parameter	Value/description
TDD Duty Cycle	TS i ; $i = 0, 1, 2, 3, 4, 5, 6$: transmit, if i is 0,4,5,6; receive, if i is 1,2,3.
Time slots under test	TS4, TS5 and TS6
HS-PDSCH modulation	16QAM
Number of HS-PDSCH in each time slot under test	8
Power of each HS-PDSCH	1/8 of Base Station output power
Data content of HS-PDSCH	real life (sufficient irregular)
Spreading factor	16

6.6.4.4.2 Procedure

6.6.4.4.2.1 General procedure

The minimum requirement is applied to all *TAB connectors*, they may be tested one at a time or multiple *TAB connectors* may be tested in parallel as shown in subclause D.1.1. Whichever method is used the procedure is repeated until all *TAB connectors* necessary to demonstrate conformance have been tested.

a) Connect *TAB connector* to measurement equipment as shown in subclause D.1.1. All *TAB connectors* not under test shall be terminated.

As a general rule, the resolution bandwidth of the measuring equipment should be equal to the measurement bandwidth. However, to improve measurement accuracy, sensitivity, efficiency and avoiding e.g. carrier leakage, the resolution bandwidth may be smaller than the measurement bandwidth. When the resolution bandwidth is smaller than the measurement bandwidth, the result should be integrated over the measurement bandwidth in order to obtain the equivalent noise bandwidth of the measurement bandwidth.

The measurement device characteristics shall be:

- Measurements with an offset from the carrier centre frequency between 2,515 MHz and 4.0 MHz shall use a 30 kHz measurement bandwidth.
- Measurements with an offset from the carrier centre frequency between 4.0 MHz and ($f_{\text{offsetmax}} - 500$ kHz), shall use a 1 MHz measurement bandwidth.
- Detection mode: True RMS.

b) For single carrier operation set the *TAB connector* to transmit at manufacturers declared rated carrier output power per *TAB connector* ($P_{\text{Rated,c,TABC}}$)

For a *TAB connector* declared to be capable of multi-carrier and/or CA operation set the *TAB connector* to transmit on all carriers configured using the applicable test configuration and corresponding power setting specified in clause 5 using the corresponding test models or set of physical channels in subclause 4.12.

6.6.4.4.2.1 UTRA FDD

- 1) Step the centre frequency of the measurement filter in contiguous steps and measure the emission within the specified frequency ranges with the specified measurement bandwidth. For *multi-band TAB connector* or *TAB connector* operating in non-contiguous spectrum, the emission within the Inter RF Bandwidth or sub-block gap shall be measured using the specified measurement bandwidth from the closest *Base Station RF Bandwidth* or sub block edge.

In addition, for *multi-band TAB connector(s)*, the following steps shall apply:

- 2) For *multi-band TAB connectors* and single band tests, repeat the steps above per involved band where single band test configurations and test models shall apply with no carrier activated in the other band.

6.6.4.4.2.2 UTRA TDD

- 1) Measure the power of the *TAB connector* spectrum emissions by applying measurement filters with bandwidths as specified in the relevant table in subclause 6.6.4.5.2.2. The characteristic of the filters shall be approximately Gaussian (typical spectrum analyzer filters). The centre frequency of the filter shall be stepped in contiguous steps over the ranges of frequency offsets f_{offset} as given in the tables. The step width shall be equal to the respective measurement bandwidth. The time duration of each step shall be sufficiently long to capture one active time slot.
- 2) The measurement shall be performed by applying filters with measurement bandwidth of 50 kHz or less and integrating the measured results over the nominal measurement bandwidth 1 MHz specified in the tables in subclause 6.6.4.5.2.2 when the measurement bandwidth is 1 MHz.

In addition, for *multi-band TAB connector(s)*, the following steps shall apply:

- 3) For *multi-band TAB connectors* and single band tests, repeat the steps above per involved band where single band test configurations and test models shall apply with no carrier activated in the other band.

The same procedure applies to *TAB connectors* declared to support 16QAM.

6.6.4.5 Test requirements

6.6.4.5.1 General

Conformance may be shown to either the measure and sum test requirement or the per *TAB connector* test requirement.

- 1) The spurious emission test requirements for an AAS BS when using the measure and sum alternative are that for each *TAB connector TX cell group* and each applicable *basic limit* as specified in this subclause, the power summation of emissions at the *TAB connectors* of the *TAB connector TX cell group* shall not exceed a limit specified as the *basic limit* + $10\log_{10}(N_{\text{TXU,countedpercell}})$.
- 2) The spurious emission test requirements for an AAS BS when using the per *TAB connector* alternative are that for each *TAB connector TX cell group* and each applicable *basic limit* as specified in this subclause, the emissions at each of the *TAB connectors* of the *TAB connector TX cell group* shall not exceed a limit specified as the *basic limit* + $10\log_{10}(N_{\text{TXU,countedpercell}}) - 10\log(n)$ where n is the number of *TAB connectors* in the *TAB connector TX cell group*.

The appropriate table for the basic limit is based on the same power level ($P_{\text{Rated,c,sys}}$) as used for the AAS BS rated power limits for BS classes in table 6.2.2.1-1 the same method of scaling the power level using $N_{\text{TXU,counted}}$ is used.

6.6.4.5.2 Basic Limits

6.6.4.5.2.1 UTRA FDD

The *basic limit* is specified in tables 6.6.4.5.2.1-1 to 6.6.4.5.2.1-11 for the appropriate $P_{\text{Rated,c,sys}}$, where:

- Δf is the separation between the carrier frequency and the nominal -3 dB point of the measuring filter closest to the carrier frequency.
- f_{offset} is the separation between the carrier frequency and the centre of the measurement filter;
- $f_{\text{offset,max}}$ is either 12.5 MHz or the offset to the UMTS Tx band edge as defined in clause 3.4.1, whichever is the greater.
- Δf_{max} is equal to $f_{\text{offset,max}}$ minus half of the bandwidth of the measuring filter.

Inside any *Inter RF Bandwidth gaps* with $W_{\text{gap}} < 20$ MHz for BS operating in multiple bands, emissions shall not exceed the cumulative sum of the test requirements specified at the *Base Station RF Bandwidth edges* on each side of the *Inter RF Bandwidth gap*. The *basic limit* for *Base Station RF Bandwidth edge* is specified in tables 6.6.4.5.2.1-1 to 6.6.4.5.2.1-11 below, where in this case:

- Δf is equal to 2.5 MHz plus the separation between the *Base Station RF Bandwidth edge* frequency and the nominal -3dB point of the measuring filter closest to the *Base Station RF Bandwidth edge*.
- f_{offset} is equal to 2.5 MHz plus the separation between the *Base Station RF Bandwidth edge* frequency and the centre of the measuring filter.
- $f_{\text{offset,max}}$ is either 12.5 MHz or the offset to the UMTS Tx band edge as defined in section 5.2, whichever is the greater.
- Δf_{max} is equal to $f_{\text{offset,max}}$ minus half of the bandwidth of the measuring filter.

For a *multi-band TAB connector*, the operating band unwanted emission limits apply also in a supported operating band without any carrier transmitted, in the case where there are carrier(s) transmitted in another supported operating band. In this case, no cumulative limit is applied in the *inter-band gap* between a supported downlink operating band with carrier(s) transmitted and a supported downlink operating band without any carrier transmitted and

- In case the *inter-band gap* between a downlink band with carrier(s) transmitted and a downlink band without any carrier transmitted is less than 20 MHz, $f_{\text{offset,max}}$ shall be the offset to the frequency 10 MHz outside the outermost edges of the two downlink operating bands and the operating band unwanted emission limit of the band where there are carriers transmitted, as defined in the tables of the present subclause, shall apply across both downlink bands.
- In other cases, the operating band unwanted emission limit of the band where there are carriers transmitted, as defined in the tables of the present subclause for the largest frequency offset (Δf_{max}), shall apply from 10 MHz below the lowest frequency, up to 10 MHz above the highest frequency of the downlink operating band without any carrier transmitted.

Inside any sub-block gap for a *TAB connector* operating in non-contiguous spectrum, the measurement results shall not exceed the cumulative sum of the test requirements specified for the adjacent sub blocks on each side of the sub block gap. The *basic limit* for each sub block is specified in tables 6.6.4.5.2.1-1 to 6.6.4.5.2.1-11 below, where in this case:

- Δf is equal to 2.5 MHz plus the separation between the sub block edge frequency and the nominal -3 dB point of the measuring filter closest to the sub block edge.
- f_{offset} is equal to 2.5 MHz plus the separation between the sub block edge frequency and the centre of the measuring filter.
- $f_{\text{offset,max}}$ is equal to the sub block gap bandwidth minus half of the bandwidth of the measuring filter plus 2.5 MHz.
- Δf_{max} is equal to $f_{\text{offset,max}}$ minus half of the bandwidth of the measuring filter.

Table 6.6.4.5.2.1-1: Spectrum emission mask values, $P_{\max,c,cell} - 10 \cdot \log_{10}(N_{\text{TXU,countedpercell}}) \geq 43$ dBm for UTRA FDD bands ≤ 3 GHz

Frequency offset of measurement filter - 3 dB point, Δf	Frequency offset of measurement filter centre frequency, f_{offset}	<i>basic limit</i> (notes 1 and 2)	Measurement bandwidth (Note 5)
$2.5 \text{ MHz} \leq \Delta f < 2.7 \text{ MHz}$	$2.515 \text{ MHz} \leq f_{\text{offset}} < 2.715 \text{ MHz}$	-12.5 dBm	30 kHz
$2.7 \text{ MHz} \leq \Delta f < 3.5 \text{ MHz}$	$2.715 \text{ MHz} \leq f_{\text{offset}} < 3.515 \text{ MHz}$	$-12.5 \text{ dBm} - 15 \cdot \left(\frac{f_{\text{offset}}}{\text{MHz}} - 2.715 \right) \text{ dB}$	30 kHz
(Note 4)	$3.515 \text{ MHz} \leq f_{\text{offset}} < 4.0 \text{ MHz}$	-24.5 dBm	30 kHz
$3.5 \text{ MHz} \leq \Delta f < 7.5 \text{ MHz}$	$4.0 \text{ MHz} \leq f_{\text{offset}} < 8.0 \text{ MHz}$	-11.5 dBm	1 MHz
$7.5 \text{ MHz} \leq \Delta f \leq \Delta f_{\max}$	$8.0 \text{ MHz} \leq f_{\text{offset}} < f_{\text{offset}_{\max}}$	-11.5 dBm	1 MHz
<p>NOTE 1: For a <i>TAB connector</i> supporting non-contiguous spectrum operation the <i>basic limit</i> within sub-block gaps within any operating band is calculated as a cumulative sum of contributions from adjacent sub blocks on each side of the sub block gap, where the contribution from the far-end sub-block shall be scaled according to the measurement bandwidth of the near-end sub-block. Exception is $\Delta f \geq 12.5$ MHz from both adjacent sub blocks on each side of the sub-block gap, where the spurious emission <i>basic limits</i> in subclauses 6.6.6.5.2.2 and 6.6.6.5.5.3 shall be met.</p> <p>NOTE 2: For a <i>multi-band TAB connector</i> with <i>Inter RF Bandwidth gap</i> < 20 MHz the minimum requirement within the <i>Inter RF Bandwidth gaps</i> is calculated as a cumulative sum of contributions from adjacent sub-blocks or RF Bandwidth on each side of the <i>Inter RF Bandwidth gap</i>, where the contribution from the far-end sub-block or <i>Base Station RF Bandwidth</i> shall be scaled according to the measurement bandwidth of the near-end sub-block or <i>Base Station RF Bandwidth</i>.</p> <p>NOTE 4: This frequency range ensures that the range of values of f_{offset} is continuous.</p> <p>NOTE 5: As a general rule, the resolution bandwidth of the measuring equipment should be equal to the measurement bandwidth. However, to improve measurement accuracy, sensitivity and efficiency, the resolution bandwidth can be smaller than the measurement bandwidth. When the resolution bandwidth is smaller than the measurement bandwidth, the result should be integrated over the measurement bandwidth in order to obtain the equivalent noise bandwidth of the measurement bandwidth.</p>			

**Table 6.6.4.5.2.1-2: Spectrum emission mask values, $P_{\max,c,cell} - 10 \cdot \log_{10}(N_{TXU, counted\ per\ cell}) \geq 43$ dBm
UTRA FDD bands > 3 GHz**

Frequency offset of measurement filter -3 dB point, Δf	Frequency offset of measurement filter centre frequency, f_{offset}	<i>basic limit</i> (notes 1 and 2)	Measurement bandwidth (Note 5)
$2.5 \text{ MHz} \leq \Delta f < 2.7 \text{ MHz}$	$2.515 \text{ MHz} \leq f_{\text{offset}} < 2.715 \text{ MHz}$	-12.2 dBm	30 kHz
$2.7 \text{ MHz} \leq \Delta f < 3.5 \text{ MHz}$	$2.715 \text{ MHz} \leq f_{\text{offset}} < 3.515 \text{ MHz}$	$-12.2 \text{ dBm} - 15 \cdot \left(\frac{f_{\text{offset}}}{\text{MHz}} - 2.715 \right) \text{ dB}$	30 kHz
(Note 4)	$3.515 \text{ MHz} \leq f_{\text{offset}} < 4.0 \text{ MHz}$	-24.2 dBm	30 kHz
$3.5 \text{ MHz} \leq \Delta f < 7.5 \text{ MHz}$	$4.0 \text{ MHz} \leq f_{\text{offset}} < 8.0 \text{ MHz}$	-11.2 dBm	1 MHz
$7.5 \text{ MHz} \leq \Delta f \leq \Delta f_{\max}$	$8.0 \text{ MHz} \leq f_{\text{offset}} < f_{\text{offset}_{\max}}$	-11.2 dBm	1 MHz
<p>NOTE 1: For a <i>TAB connector</i> supporting non-contiguous spectrum operation the <i>basic limit</i> within sub-block gaps within any operating band is calculated as a cumulative sum of contributions from adjacent sub blocks on each side of the sub block gap, where the contribution from the far-end sub-block shall be scaled according to the measurement bandwidth of the near-end sub-block. Exception is $\Delta f \geq 12.5$ MHz from both adjacent sub blocks on each side of the sub-block gap, where the spurious emission <i>basic limits</i> in clause 6.6.6.5.2.2 and 6.6.6.5.5.3 shall be met.</p> <p>NOTE 2: For a <i>multi-band TAB connector</i> with <i>Inter RF Bandwidth gap</i> < 20 MHz the minimum requirement within the <i>Inter RF Bandwidth gaps</i> is calculated as a cumulative sum of contributions from adjacent sub-blocks or <i>Base Station RF Bandwidth</i> on each side of the <i>Inter RF Bandwidth gap</i>, where the contribution from the far-end sub-block or <i>Base Station RF Bandwidth</i> shall be scaled according to the measurement bandwidth of the near-end sub-block or <i>Base Station RF Bandwidth</i>.</p> <p>NOTE 4: This frequency range ensures that the range of values of f_{offset} is continuous.</p> <p>NOTE 5: As a general rule, the resolution bandwidth of the measuring equipment should be equal to the measurement bandwidth. However, to improve measurement accuracy, sensitivity and efficiency, the resolution bandwidth can be smaller than the measurement bandwidth. When the resolution bandwidth is smaller than the measurement bandwidth, the result should be integrated over the measurement bandwidth in order to obtain the equivalent noise bandwidth of the measurement bandwidth.</p>			

**Table 6.6.4.5.2.1-3: Spectrum emission mask values,
 $39 \text{ dBm} \leq P_{\text{max,c,cell}} - 10 \cdot \log_{10}(N_{\text{TXU,countedpercell}}) < 43 \text{ dBm}$ for UTRA FDD bands $\leq 3 \text{ GHz}$**

Frequency offset of measurement filter -3 dB point, Δf	Frequency offset of measurement filter centre frequency, f_{offset}	<i>basic limit</i> (notes 1 and 2)	Measurement bandwidth (Note 5)
$2.5 \text{ MHz} \leq \Delta f < 2.7 \text{ MHz}$	$2.515 \text{ MHz} \leq f_{\text{offset}} < 2.715 \text{ MHz}$	-12.5 dBm	30 kHz
$2.7 \text{ MHz} \leq \Delta f < 3.5 \text{ MHz}$	$2.715 \text{ MHz} \leq f_{\text{offset}} < 3.515 \text{ MHz}$	$-12.5 \text{ dBm} - 15 \cdot \left(\frac{f_{\text{offset}}}{\text{MHz}} - 2.715 \right) \text{ dB}$	30 kHz
(Note 4)	$3.515 \text{ MHz} \leq f_{\text{offset}} < 4.0 \text{ MHz}$	-24.5 dBm	30 kHz
$3.5 \text{ MHz} \leq \Delta f < 7.5 \text{ MHz}$	$4.0 \text{ MHz} \leq f_{\text{offset}} < 8.0 \text{ MHz}$	-11.5 dBm	1 MHz
$7.5 \text{ MHz} \leq \Delta f \leq \Delta f_{\text{max}}$	$8.0 \text{ MHz} \leq f_{\text{offset}} < f_{\text{offset}_{\text{max}}}$	$P_{\text{max,c,cell}} - 10 \cdot \log_{10}(N_{\text{TXU,countedpercell}}) - 54.5 \text{ dB}$	1 MHz
<p>NOTE 1: For a <i>TAB connector</i> supporting non-contiguous spectrum operation the <i>basic limit</i> within sub-block gaps within any operating band is calculated as a cumulative sum of contributions from adjacent sub blocks on each side of the sub block gap, where the contribution from the far-end sub-block shall be scaled according to the measurement bandwidth of the near-end sub-block. Exception is $\Delta f \geq 12.5 \text{ MHz}$ from both adjacent sub blocks on each side of the sub-block gap, where the spurious emission <i>basic limits</i> in subclauses 6.6.6.5.2.2 and 6.6.6.5.5.3 shall be met.</p> <p>NOTE 2: For a <i>multi-band TAB connector</i> with <i>Inter RF Bandwidth gap</i> $< 20 \text{ MHz}$ the minimum requirement within the <i>Inter RF Bandwidth gaps</i> is calculated as a cumulative sum of contributions from adjacent sub-blocks or <i>Base Station RF Bandwidth</i> on each side of the <i>Inter RF Bandwidth gap</i>, where the contribution from the far-end sub-block or <i>Base Station RF Bandwidth</i> shall be scaled according to the measurement bandwidth of the near-end sub-block or <i>Base Station RF Bandwidth</i>.</p> <p>NOTE 4: This frequency range ensures that the range of values of f_{offset} is continuous.</p> <p>NOTE 5: As a general rule, the resolution bandwidth of the measuring equipment should be equal to the measurement bandwidth. However, to improve measurement accuracy, sensitivity and efficiency, the resolution bandwidth can be smaller than the measurement bandwidth. When the resolution bandwidth is smaller than the measurement bandwidth, the result should be integrated over the measurement bandwidth in order to obtain the equivalent noise bandwidth of the measurement bandwidth.</p>			

**Table 6.6.4.5.2.1-4: Spectrum emission mask values,
 $39 \text{ dBm} \leq P_{\text{max,c,cell}} - 10 \cdot \log_{10}(N_{\text{TXU,countedpercell}}) < 43 \text{ dBm}$ for UTRA FDD bands > 3 GHz**

Frequency offset of measurement filter -3 dB point, Δf	Frequency offset of measurement filter centre frequency, f_{offset}	<i>basic limit</i> (notes 1 and 2)	Measurement bandwidth (Note 5)
$2.5 \text{ MHz} \leq \Delta f < 2.7 \text{ MHz}$	$2.515 \text{ MHz} \leq f_{\text{offset}} < 2.715 \text{ MHz}$	-12.2 dBm	30 kHz
$2.7 \text{ MHz} \leq \Delta f < 3.5 \text{ MHz}$	$2.715 \text{ MHz} \leq f_{\text{offset}} < 3.515 \text{ MHz}$	$-12.2 \text{ dBm} - 15 \cdot \left(\frac{f_{\text{offset}} - 2.715}{\text{MHz}} \right) \text{ dB}$	30 kHz
(Note 4)	$3.515 \text{ MHz} \leq f_{\text{offset}} < 4.0 \text{ MHz}$	-24.2 dBm	30 kHz
$3.5 \text{ MHz} \leq \Delta f < 7.5 \text{ MHz}$	$4.0 \text{ MHz} \leq f_{\text{offset}} < 8.0 \text{ MHz}$	-11.2 dBm	1 MHz
$7.5 \text{ MHz} \leq \Delta f \leq \Delta f_{\text{max}}$	$8.0 \text{ MHz} \leq f_{\text{offset}} < f_{\text{offset}_{\text{max}}}$	$P_{\text{max,c,cell}} - 10 \cdot \log_{10}(N_{\text{TXU,countedpercell}}) - 54.2 \text{ dB}$	1 MHz
<p>NOTE 1: For a <i>TAB connector</i> supporting non-contiguous spectrum operation the <i>basic limit</i> within sub-block gaps within any operating band is calculated as a cumulative sum of contributions from adjacent sub blocks on each side of the sub block gap, where the contribution from the far-end sub-block shall be scaled according to the measurement bandwidth of the near-end sub-block. Exception is $\Delta f \geq 12.5 \text{ MHz}$ from both adjacent sub blocks on each side of the sub-block gap, where the spurious emission <i>basic limits</i> in clause 6.6.6.5.2.2 and 6.6.6.5.5.3 shall be met.</p> <p>NOTE 2: For a <i>multi-band TAB connector</i> with <i>Inter RF Bandwidth gap</i> < 20 MHz the minimum requirement within the <i>Inter RF Bandwidth gaps</i> is calculated as a cumulative sum of contributions from adjacent sub-blocks or <i>Base Station RF Bandwidth</i> on each side of the <i>Inter RF Bandwidth gap</i>, where the contribution from the far-end sub-block or <i>Base Station RF Bandwidth</i> shall be scaled according to the measurement bandwidth of the near-end sub-block or <i>Base Station RF Bandwidth</i>.</p> <p>NOTE 4: This frequency range ensures that the range of values of f_{offset} is continuous.</p> <p>NOTE 5: As a general rule, the resolution bandwidth of the measuring equipment should be equal to the measurement bandwidth. However, to improve measurement accuracy, sensitivity and efficiency, the resolution bandwidth can be smaller than the measurement bandwidth. When the resolution bandwidth is smaller than the measurement bandwidth, the result should be integrated over the measurement bandwidth in order to obtain the equivalent noise bandwidth of the measurement bandwidth.</p>			

Table 6.6.4.5.2.1-5: Spectrum emission mask values, $31 \text{ dBm} \leq P_{\text{max,c,cell}} - 10 \cdot \log_{10}(N_{\text{TXU,countedpercell}}) < 39 \text{ dBm}$ for UTRA FDD bands $\leq 3 \text{ GHz}$

Frequency offset of measurement filter - 3 dB point, Δf	Frequency offset of measurement filter centre frequency, f_{offset}	<i>basic limit</i> (notes 1 and 2)	Measurement bandwidth (Note 5)
$2.5 \text{ MHz} \leq \Delta f < 2.7 \text{ MHz}$	$2.515 \text{ MHz} \leq f_{\text{offset}} < 2.715 \text{ MHz}$	$P_{\text{max,c,cell}} - 10 \cdot \log_{10}(N_{\text{TXU,countedpercell}}) - 51.5 \text{ dB}$	30 kHz
$2.7 \text{ MHz} \leq \Delta f < 3.5 \text{ MHz}$	$2.715 \text{ MHz} \leq f_{\text{offset}} < 3.515 \text{ MHz}$	$P_{\text{max,c,cell}} - 10 \cdot \log_{10}(N_{\text{TXU,countedpercell}}) - 51.5 \text{ dB} - 15 \cdot \left(\frac{f_{\text{offset}} - 2.715}{\text{MHz}} \right) \text{ dB}$	30 kHz
(Note 4)	$3.515 \text{ MHz} \leq f_{\text{offset}} < 4.0 \text{ MHz}$	$P_{\text{max,c,cell}} - 10 \cdot \log_{10}(N_{\text{TXU,countedpercell}}) - 63.5 \text{ dB}$	30 kHz
$3.5 \text{ MHz} \leq \Delta f < 7.5 \text{ MHz}$	$4.0 \text{ MHz} \leq f_{\text{offset}} < 8.0 \text{ MHz}$	$P_{\text{max,c,cell}} - 10 \cdot \log_{10}(N_{\text{TXU,countedpercell}}) - 50.5 \text{ dB}$	1 MHz
$7.5 \text{ MHz} \leq \Delta f \leq \Delta f_{\text{max}}$	$8.0 \text{ MHz} \leq f_{\text{offset}} < f_{\text{offset}_{\text{max}}}$	$P_{\text{max,c,cell}} - 10 \cdot \log_{10}(N_{\text{TXU,countedpercell}}) - 54.5 \text{ dB}$	1 MHz
<p>NOTE 1: For a <i>TAB connector</i> supporting non-contiguous spectrum operation the <i>basic limit</i> within sub-block gaps within any operating band is calculated as a cumulative sum of contributions from adjacent sub blocks on each side of the sub block gap, where the contribution from the far-end sub-block shall be scaled according to the measurement bandwidth of the near-end sub-block. Exception is $\Delta f \geq 12.5 \text{ MHz}$ from both adjacent sub blocks on each side of the sub-block gap, where the spurious emission <i>basic limits</i> in subclauses 6.6.6.5.2.2 and 6.6.6.5.5.3 shall be met.</p> <p>NOTE 2: For a <i>multi-band TAB connector</i> with <i>Inter RF Bandwidth gap</i> $< 20 \text{ MHz}$ the minimum requirement within the <i>Inter RF Bandwidth gaps</i> is calculated as a cumulative sum of contributions from adjacent sub-blocks or <i>Base Station RF Bandwidth</i> on each side of the <i>Inter RF Bandwidth gap</i>, where the contribution from the far-end sub-block or <i>Base Station RF Bandwidth</i> shall be scaled according to the measurement bandwidth of the near-end sub-block or <i>Base Station RF Bandwidth</i>.</p> <p>NOTE 4: This frequency range ensures that the range of values of f_{offset} is continuous.</p> <p>NOTE 5: As a general rule, the resolution bandwidth of the measuring equipment should be equal to the measurement bandwidth. However, to improve measurement accuracy, sensitivity and efficiency, the resolution bandwidth can be smaller than the measurement bandwidth. When the resolution bandwidth is smaller than the measurement bandwidth, the result should be integrated over the measurement bandwidth in order to obtain the equivalent noise bandwidth of the measurement bandwidth.</p>			

**Table 6.6.4.5.2.1-6: Spectrum emission mask values,
 $31 \text{ dBm} \leq P_{\text{max,c,cell}} - 10 \cdot \log_{10}(N_{\text{TXU,countedpercell}}) < 39 \text{ dBm}$ for UTRA FDD bands > 3 GHz**

Frequency offset of measurement filter - 3 dB point, Δf	Frequency offset of measurement filter centre frequency, f_{offset}	<i>basic limit</i> (notes 1 and 2)	Measurement bandwidth (Note 5)
$2.5 \text{ MHz} \leq \Delta f < 2.7 \text{ MHz}$	$2.515 \text{ MHz} \leq f_{\text{offset}} < 2.715 \text{ MHz}$	$P_{\text{max,c,cell}} - 10 \cdot \log_{10}(N_{\text{TXU,countedpercell}}) - 51.2 \text{ dB}$	30 kHz
$2.7 \text{ MHz} \leq \Delta f < 3.5 \text{ MHz}$	$2.715 \text{ MHz} \leq f_{\text{offset}} < 3.515 \text{ MHz}$	$P_{\text{max,c,cell}} - 10 \cdot \log_{10}(N_{\text{TXU,countedpercell}}) - 51.2 \text{ dB} - 15 \cdot \left(\frac{f_{\text{offset}} - 2.715}{\text{MHz}} \right) \text{ dB}$	30 kHz
(Note 4)	$3.515 \text{ MHz} \leq f_{\text{offset}} < 4.0 \text{ MHz}$	$P_{\text{max,c,cell}} - 10 \cdot \log_{10}(N_{\text{TXU,countedpercell}}) - 63.2 \text{ dB}$	30 kHz
$3.5 \text{ MHz} \leq \Delta f < 7.5 \text{ MHz}$	$4.0 \text{ MHz} \leq f_{\text{offset}} < 8.0 \text{ MHz}$	$P_{\text{max,c,cell}} - 10 \cdot \log_{10}(N_{\text{TXU,countedpercell}}) - 50.2 \text{ dB}$	1 MHz
$7.5 \text{ MHz} \leq \Delta f \leq \Delta f_{\text{max}}$	$8.0 \text{ MHz} \leq f_{\text{offset}} < f_{\text{offset}_{\text{max}}}$	$P_{\text{max,c,cell}} - 10 \cdot \log_{10}(N_{\text{TXU,countedpercell}}) - 54.2 \text{ dB}$	1 MHz
<p>NOTE 1: For a <i>TAB connector</i> supporting non-contiguous spectrum operation the <i>basic limit</i> within sub-block gaps within any operating band is calculated as a cumulative sum of contributions from adjacent sub blocks on each side of the sub block gap, where the contribution from the far-end sub-block shall be scaled according to the measurement bandwidth of the near-end sub-block. Exception is $\Delta f \geq 12.5 \text{ MHz}$ from both adjacent sub blocks on each side of the sub-block gap, where the spurious emission <i>basic limits</i> in subclauses 6.6.6.5.2.2 and 6.6.6.5.5.3 shall be met.</p> <p>NOTE 2: For a <i>multi-band TAB connector</i> with <i>Inter RF Bandwidth gap</i> < 20 MHz the minimum requirement within the <i>Inter RF Bandwidth gaps</i> is calculated as a cumulative sum of contributions from adjacent sub-blocks or <i>Base Station RF Bandwidth</i> on each side of the <i>Inter RF Bandwidth gap</i>, where the contribution from the far-end sub-block or <i>Base Station RF Bandwidth</i> shall be scaled according to the measurement bandwidth of the near-end sub-block or <i>Base Station RF Bandwidth</i>.</p> <p>NOTE 4: This frequency range ensures that the range of values of f_{offset} is continuous.</p> <p>NOTE 5: As a general rule, the resolution bandwidth of the measuring equipment should be equal to the measurement bandwidth. However, to improve measurement accuracy, sensitivity and efficiency, the resolution bandwidth can be smaller than the measurement bandwidth. When the resolution bandwidth is smaller than the measurement bandwidth, the result should be integrated over the measurement bandwidth in order to obtain the equivalent noise bandwidth of the measurement bandwidth.</p>			

Table 6.6.4.5.2.1-7: Spectrum emission mask values, $P_{\max,c,cell} - 10 \cdot \log_{10}(N_{\text{TXU,countedpercell}}) < 31$ dBm for UTRA FDD bands ≤ 3 GHz

Frequency offset of measurement filter - 3 dB point, Δf	Frequency offset of measurement filter centre frequency, f_{offset}	<i>basic limit</i> (Notes 1 and 2)	Measurement bandwidth (Note 5)
$2.5 \text{ MHz} \leq \Delta f < 2.7 \text{ MHz}$	$2.515 \text{ MHz} \leq f_{\text{offset}} < 2.715 \text{ MHz}$	-20.5 dBm	30 kHz
$2.7 \leq \Delta f < 3.5 \text{ MHz}$	$2.715 \text{ MHz} \leq f_{\text{offset}} < 3.515 \text{ MHz}$	$-20.5 \text{ dBm} - 15 \cdot \left(\frac{f_{\text{offset}}}{\text{MHz}} - 2.715 \right) \text{ dB}$	30 kHz
(Note 4)	$3.515 \text{ MHz} \leq f_{\text{offset}} < 4.0 \text{ MHz}$	-32.5 dBm	30 kHz
$3.5 \text{ MHz} \leq \Delta f < 7.5 \text{ MHz}$	$4.0 \text{ MHz} \leq f_{\text{offset}} < 8.0 \text{ MHz}$	-19.5 dBm	1 MHz
$7.5 \text{ MHz} \leq \Delta f \leq \Delta f_{\max}$	$8.0 \text{ MHz} \leq f_{\text{offset}} < f_{\text{offset}_{\max}}$	-23.5 dBm	1 MHz

NOTE 1: For a *TAB connector* supporting non-contiguous spectrum operation the *basic limit* within sub-block gaps within any operating band is calculated as a cumulative sum of contributions from adjacent sub blocks on each side of the sub block gap, where the contribution from the far-end sub-block shall be scaled according to the measurement bandwidth of the near-end sub-block. Exception is $\Delta f \geq 12.5$ MHz from both adjacent sub blocks on each side of the sub-block gap, where the spurious emission *basic limits* in subclauses 6.6.6.5.2.2 and 6.6.6.5.5.3 shall be met.

NOTE 2: For a *multi-band TAB connector* with *Inter RF Bandwidth gap* < 20 MHz the minimum requirement within the *Inter RF Bandwidth gaps* is calculated as a cumulative sum of contributions from adjacent sub-blocks or *Base Station RF Bandwidth* on each side of the *Inter RF Bandwidth gap*, where the contribution from the far-end sub-block or *Base Station RF Bandwidth* shall be scaled according to the measurement bandwidth of the near-end sub-block or *Base Station RF Bandwidth*.

NOTE 4: This frequency range ensures that the range of values of f_{offset} is continuous.

NOTE 5: As a general rule, the resolution bandwidth of the measuring equipment should be equal to the measurement bandwidth. However, to improve measurement accuracy, sensitivity and efficiency, the resolution bandwidth can be smaller than the measurement bandwidth. When the resolution bandwidth is smaller than the measurement bandwidth, the result should be integrated over the measurement bandwidth in order to obtain the equivalent noise bandwidth of the measurement bandwidth.

Table 6.6.4.5.2.1-8: Spectrum emission mask values, $P_{\max,c,cell} - 10 \cdot \log_{10}(N_{\text{TXU,countedpercell}}) < 31$ dBm for UTRA FDD bands > 3 GHz

Frequency offset of measurement filter - 3 dB point, Δf	Frequency offset of measurement filter centre frequency, f_{offset}	<i>basic limit</i> (notes 1 and 2)	Measurement bandwidth (Note 5)
$2.5 \text{ MHz} \leq \Delta f < 2.7 \text{ MHz}$	$2.515 \text{ MHz} \leq f_{\text{offset}} < 2.715 \text{ MHz}$	-20.2 dBm	30 kHz
$2.7 \leq \Delta f < 3.5 \text{ MHz}$	$2.715 \text{ MHz} \leq f_{\text{offset}} < 3.515 \text{ MHz}$	$-20.2 \text{ dBm} - 15 \cdot \left(\frac{f_{\text{offset}}}{\text{MHz}} - 2.715 \right) \text{ dB}$	30 kHz
(Note 4)	$3.515 \text{ MHz} \leq f_{\text{offset}} < 4.0 \text{ MHz}$	-32.2 dBm	30 kHz
$3.5 \text{ MHz} \leq \Delta f < 7.5 \text{ MHz}$	$4.0 \text{ MHz} \leq f_{\text{offset}} < 8.0 \text{ MHz}$	-19.2 dBm	1 MHz
$7.5 \text{ MHz} \leq \Delta f \leq \Delta f_{\max}$	$8.0 \text{ MHz} \leq f_{\text{offset}} < f_{\text{offset}_{\max}}$	-23.2 dBm	1 MHz

NOTE 1: For a *TAB connector* supporting non-contiguous spectrum operation the *basic limit* within sub-block gaps within any operating band is calculated as a cumulative sum of contributions from adjacent sub blocks on each side of the sub block gap, where the contribution from the far-end sub-block shall be scaled according to the measurement bandwidth of the near-end sub-block. Exception is $\Delta f \geq 12.5$ MHz from both adjacent sub blocks on each side of the sub-block gap, where the spurious emission *basic limits* in subclauses 6.6.6.5.2.2 and 6.6.6.5.5.3 shall be met.

NOTE 2: For a *multi-band TAB connector* with *Inter RF Bandwidth gap* < 20 MHz the minimum requirement within the *Inter RF Bandwidth gaps* is calculated as a cumulative sum of contributions from adjacent sub-blocks or *Base Station RF Bandwidth* on each side of the *Inter RF Bandwidth gap*, where the contribution from the far-end sub-block or *Base Station RF Bandwidth* shall be scaled according to the measurement bandwidth of the near-end sub-block or *Base Station RF Bandwidth*.

NOTE 4: This frequency range ensures that the range of values of f_{offset} is continuous.

NOTE 5: As a general rule, the resolution bandwidth of the measuring equipment should be equal to the measurement bandwidth. However, to improve measurement accuracy, sensitivity and efficiency, the resolution bandwidth can be smaller than the measurement bandwidth. When the resolution bandwidth is smaller than the measurement bandwidth, the result should be integrated over the measurement bandwidth in order to obtain the equivalent noise bandwidth of the measurement bandwidth.

For operation in band II, IV, V, X, XII, XIII, XIV, XXV and XXVI, the applicable additional requirement in tables 6.6.4.5.2.1-9 to 6.6.4.5.2.1-11 apply in addition to the minimum requirements in tables 6.6.4.5.2.1-1 to 6.6.4.5.2.1-8.

Table 6.6.4.5.2.1-9: Additional spectrum emission limits for Bands II, IV, X, XXV

Frequency offset of measurement filter -3dB point, Δf	Frequency offset of measurement filter centre frequency, f_{offset}	Additional requirement	Measurement bandwidth (Note 5)
$2.5 \text{ MHz} \leq \Delta f < 3.5 \text{ MHz}$	$2.515 \text{ MHz} \leq f_{\text{offset}} < 3.515 \text{ MHz}$	-15 dBm	30 kHz
$3.5 \text{ MHz} \leq \Delta f \leq \Delta f_{\max}$	$4.0 \text{ MHz} \leq f_{\text{offset}} < f_{\text{offset}_{\max}}$	-13 dBm	1 MHz

NOTE 5: As a general rule, the resolution bandwidth of the measuring equipment should be equal to the measurement bandwidth. However, to improve measurement accuracy, sensitivity and efficiency, the resolution bandwidth can be smaller than the measurement bandwidth. When the resolution bandwidth is smaller than the measurement bandwidth, the result should be integrated over the measurement bandwidth in order to obtain the equivalent noise bandwidth of the measurement bandwidth.

Table 6.6.4.5.2.1-10: Additional spectrum emission limits for Bands V, XXVI

Frequency offset of measurement filter -3dB point, Δf	Frequency offset of measurement filter centre frequency, f_{offset}	Additional requirement	Measurement bandwidth (Note 5)
$2.5 \text{ MHz} \leq \Delta f < 3.5 \text{ MHz}$	$2.515 \text{ MHz} \leq f_{\text{offset}} < 3.515 \text{ MHz}$	-15 dBm	30 kHz
$3.5 \text{ MHz} \leq \Delta f \leq \Delta f_{\max}$	$3.55 \text{ MHz} \leq f_{\text{offset}} < f_{\text{offset}_{\max}}$	-13 dBm	100 kHz

NOTE 5: As a general rule, the resolution bandwidth of the measuring equipment should be equal to the measurement bandwidth. However, to improve measurement accuracy, sensitivity and efficiency, the resolution bandwidth can be smaller than the measurement bandwidth. When the resolution bandwidth is smaller than the measurement bandwidth, the result should be integrated over the measurement bandwidth in order to obtain the equivalent noise bandwidth of the measurement bandwidth.

Table 6.6.4.5.2.1-11: Additional spectrum emission limits for Bands XII, XIII, XIV

Frequency offset of measurement filter -3dB point, Δf	Frequency offset of measurement filter centre frequency, f_{offset}	Additional requirement	Measurement bandwidth (Note 5)
$2.5 \text{ MHz} \leq \Delta f < 2.6 \text{ MHz}$	$2.515 \text{ MHz} \leq f_{\text{offset}} < 2.615 \text{ MHz}$	-13 dBm	30 kHz
$2.6 \text{ MHz} \leq \Delta f \leq \Delta f_{\text{max}}$	$2.65 \text{ MHz} \leq f_{\text{offset}} < f_{\text{offset}_{\text{max}}}$	-13 dBm	100 kHz

NOTE 5: As a general rule, the resolution bandwidth of the measuring equipment should be equal to the measurement bandwidth. However, to improve measurement accuracy, sensitivity and efficiency, the resolution bandwidth can be smaller than the measurement bandwidth. When the resolution bandwidth is smaller than the measurement bandwidth, the result should be integrated over the measurement bandwidth in order to obtain the equivalent noise bandwidth of the measurement bandwidth.

In certain regions the following requirement may apply for protection of DTT. For a *TAB connector* operating in Band XX, the level of emissions in the band 470-790 MHz, measured in an 8MHz filter bandwidth on centre frequencies F_{filter} according to table 6.21F, shall not exceed the maximum emission level $P_{\text{EM},N}$ declared by the manufacturer.

Table 6.6.4.5.2.1-12: Declared emissions levels for protection of DTT

Filter centre frequency, F_{filter}	Measurement bandwidth	Declared emission level (dBm)
$F_{\text{filter}} = 8 \cdot N + 306 \text{ (MHz)}$; $21 \leq N \leq 60$	8 MHz	$P_{\text{EM},N}$

NOTE 1: The regional requirement is defined in terms of EIRP (effective isotropic radiated power), which is dependent on both the BS emissions at the antenna connector and the deployment (including antenna gain and feeder loss). The requirement defined above provides the characteristics of the basestation needed to verify compliance with the regional requirement. Compliance with the regional requirement can be determined using the method outlined in annex D of [1].

In certain regions, the following requirements may apply to a *TAB connector* operating in Band XXXII within 1452-1492 MHz. The level of unwanted emissions, measured on centre frequencies f_{offset} with filter bandwidth, according to table 6.6.4.5.2.1-13, shall neither exceed the maximum emission level $P_{\text{EM},B32,a}$, $P_{\text{EM},B32,b}$ nor $P_{\text{EM},B32,c}$ declared by the manufacturer.

Table 6.6.4.5.2.1-13: Declared frequency band XXXII unwanted emission within 1452-1492 MHz

Frequency offset of measurement filter centre frequency, f_{offset}	Declared emission level (dBm)	Measurement bandwidth
5 MHz	$P_{\text{EM},B32,a}$	5 MHz
10 MHz	$P_{\text{EM},B32,b}$	5 MHz
$15 \text{ MHz} \leq f_{\text{offset}} \leq f_{\text{offset}_{\text{max}, B32}}$	$P_{\text{EM},B32,c}$	5 MHz

NOTE: $f_{\text{offset}_{\text{max}, B32}}$ denotes the frequency difference between the lower channel carrier frequency and 1454.5 MHz, and the frequency difference between the upper channel carrier frequency and 1489.5 MHz for the set channel position.

NOTE 2: The regional requirement, included in [17], is defined in terms of EIRP per antenna, which is dependent on both the BS emissions at the antenna connector and the deployment (including antenna gain and feeder loss). The requirement defined above provides the characteristics of the base station needed to verify compliance with the regional requirement. The assessment of the EIRP level is described in annex H of 3GPP TS 36.104 [11].

In certain regions, the following requirement may apply to *TAB connector* operating in Band XXXII within 1452-1492MHz for the protection of services in spectrum adjacent to the frequency range 1452-1492 MHz. The level of emissions, measured on centre frequencies F_{filter} with filter bandwidth according to table 6.6.4.5.2.1-14, shall neither exceed the maximum emission level $P_{\text{EM},B32,d}$ nor $P_{\text{EM},B32,e}$ declared by the manufacturer. This requirement applies in the frequency range 1429-1518MHz even though part of the range falls in the spurious domain.

Table 6.6.4.5.2.1-14: Frequency band XXXII declared emission outside 1452-1492 MHz

Filter centre frequency, F_{filter}	Declared emission level (dBm)	Measurement bandwidth
$1429.5 \text{ MHz} \leq F_{\text{filter}} \leq 1448.5 \text{ MHz}$	$P_{\text{EM,B32,d}}$	1 MHz
$F_{\text{filter}} = 1450.5 \text{ MHz}$	$P_{\text{EM,B32,e}}$	3 MHz
$F_{\text{filter}} = 1493.5 \text{ MHz}$	$P_{\text{EM,B32,e}}$	3 MHz
$1495.5 \text{ MHz} \leq F_{\text{filter}} \leq 1517.5 \text{ MHz}$	$P_{\text{EM,B32,d}}$	1 MHz

NOTE 3: The regional requirement, included in [17], is defined in terms of EIRP, which is dependent on both the BS emissions at the antenna connector and the deployment (including antenna gain and feeder loss). The requirement defined above provides the characteristics of the base station needed to verify compliance with the regional requirement. The assessment of the EIRP level is described in annex H of 3GPP TS 36.104 [11].

6.6.4.5.2.2 UTRA TDD

The *basic limit* is specified in tables 6.6.4.5.2.2-1 to 6.6.4.5.2.2-3 for the appropriate $P_{\text{Rated,c,sys}}$, where:

**Table 6.6.4.5.2.2-1: *basic limits* for spectrum emission mask values,
 $P_{\text{max,c,cell}} - 10 \cdot \log_{10}(N_{\text{TXU,countedpercell}}) \geq 34 \text{ dBm}$ for 1,28 Mcps TDD**

Frequency offset of measurement filter centre frequency, f_{offset}	<i>basic limit</i>	Measurement bandwidth
$0.815 \text{ MHz} \leq f_{\text{offset}} < 1.015 \text{ MHz}$	-18.5 dBm	30 kHz
$1.015 \text{ MHz} \leq f_{\text{offset}} < 1.815 \text{ MHz}$	$-18.5 \text{ dBm} - 10 \cdot \left(\frac{f_{\text{offset}}}{\text{MHz}} - 1.015 \right) \text{ dB}$	30 kHz
$1.815 \text{ MHz} \leq f_{\text{offset}} < 2.3 \text{ MHz}$	-26.5 dBm	30 kHz
$2.3 \text{ MHz} \leq f_{\text{offset}} < f_{\text{offset,max}}$	-11.5 dBm	1 MHz

NOTE: For a *multi-band TAB connector* with *Inter RF Bandwidth gap* less than 8MHz, the *basic limit* within the *Inter RF Bandwidth gap* is calculated as a cumulative sum of emissions from the two adjacent carriers on each side of the *Inter RF Bandwidth gap*.

**Table 6.6.4.5.2.2-2: *basic limits* for spectrum emission mask values,
 $26 \text{ dBm} \leq P_{\text{max,c,cell}} - 10 \cdot \log_{10}(N_{\text{TXU,countedpercell}}) < 34 \text{ dBm}$ for 1,28 Mcps TDD**

Frequency offset of measurement filter centre frequency, f_{offset}	<i>basic limit</i>	Measurement bandwidth
$0.815 \text{ MHz} \leq f_{\text{offset}} < 1.015 \text{ MHz}$	$P_{\text{max,c,cell}} - 10 \cdot \log_{10}(N_{\text{TXU,countedpercell}}) - 52.5 \text{ dB}$	30 kHz
$1.015 \text{ MHz} \leq f_{\text{offset}} < 1.815 \text{ MHz}$	$P_{\text{max,c,cell}} - 10 \cdot \log_{10}(N_{\text{TXU,countedpercell}}) - 52.5 \text{ dB} - 10 \cdot \left(\frac{f_{\text{offset}}}{\text{MHz}} - 1.015 \right) \text{ dB}$	30 kHz
$1.815 \text{ MHz} \leq f_{\text{offset}} < 2.3 \text{ MHz}$	$P_{\text{max,c,cell}} - 10 \cdot \log_{10}(N_{\text{TXU,countedpercell}}) - 60.5 \text{ dB}$	30 kHz
$2.3 \text{ MHz} \leq f_{\text{offset}} < f_{\text{offset,max}}$	$P_{\text{max,c,cell}} - 10 \cdot \log_{10}(N_{\text{TXU,countedpercell}}) - 45.5 \text{ dB}$	1 MHz

NOTE: For a *multi-band TAB connector* with *Inter RF Bandwidth gap* less than 8MHz, the *basic limit* within the *Inter RF Bandwidth gap* is calculated as a cumulative sum of emissions from the two adjacent carriers on each side of the *Inter RF Bandwidth gap*.

**Table 6.6.4.5.2.2-3: basic limits for spectrum emission mask values,
 $P_{\max,c,cell} - 10 \cdot \log_{10}(N_{TXU, \text{counted per cell}}) < 26 \text{ dBm}$ for 1,28 Mcps TDD**

Frequency offset of measurement filter centre frequency, f_{offset}	Maximum level	Measurement bandwidth
$0.815 \text{ MHz} \leq f_{\text{offset}} < 1.015 \text{ MHz}$	-26.5 dBm	30 kHz
$1.015 \text{ MHz} \leq f_{\text{offset}} < 1.815 \text{ MHz}$	$-26.5 \text{ dBm} - 10 \cdot \left(\frac{f_{\text{offset}}}{\text{MHz}} - 1,015 \right) \text{ dB}$	30 kHz
$1.815 \text{ MHz} \leq f_{\text{offset}} < 2.3 \text{ MHz}$	-34.5 dBm	30 kHz
$2.3 \text{ MHz} \leq f_{\text{offset}} < f_{\text{offset,max}}$	-19.5 dBm	1 MHz
NOTE: For a multi-band TAB connector with Inter RF Bandwidth gap less than 8MHz, the basic limit within the Inter RF Bandwidth gap is calculated as a cumulative sum of emissions from the two adjacent carriers on each side of the Inter RF Bandwidth gap.		

The basic limits for a TAB connector declared capable of 16QAM are the same as those defined in the subclause.

6.6.5 Operating band unwanted emission

6.6.5.1 Definition and applicability

Unless otherwise stated, for E-UTRA single band and MSR the operating band unwanted emission limits are defined from Δf_{OBUE} below the lowest frequency of each supported *downlink operating band* to the lower *Base Station RF Bandwidth edge* located at $F_{\text{BW RF,low}}$ and from the upper *Base Station RF Bandwidth edge* located at $F_{\text{BW RF,high}}$ up to Δf_{OBUE} above the highest frequency of each supported *downlink operating band*. The values of Δf_{OBUE} are defined in table 6.6.1-1.

For AAS BS capable of operation in multiple operating bands, using *single band TAB connectors*, the single-band requirements apply to those connectors and the cumulative evaluation of the emission limit in the *inter RF bandwidth gap* is not applicable.

The requirements shall apply whatever the type of transmitter considered and for all transmission modes foreseen by the manufacturer's specification.

6.6.5.2 Minimum requirement

The minimum requirement for MSR operation are defined in 3GPP TS 37.105 [8], subclause 6.6.5.2.

There is no Operating band unwanted emission requirement for UTRA operation.

The minimum requirement for E-UTRA operation is in 3GPP TS 37.105 [8], subclause 6.6.5.4.

6.6.5.3 Test purpose

This test measures the emissions of the *TAB connector*, close to the assigned channel bandwidth of the wanted signal, while the transmitter is in operation.

6.6.5.4 Method of test

6.6.5.4.1 Initial conditions

6.6.5.4.1.1 General test conditions

Test environment:

- normal; see clause B.2.

RF channels to be tested for single carrier:

- B, M and T; see subclause 4.12.1.

Base Station RF Bandwidth positions to be tested for multi-carrier:

- B_{RFBW} , M_{RFBW} and T_{RFBW} in single-band operation; see subclause 4.12.1; $B_{\text{RFBW}}'T_{\text{RFBW}}$ and $B_{\text{RFBW}}'M_{\text{RFBW}}$ in multi-band operation, see subclause 4.12.1.

6.6.5.4.1.2 UTRA FDD

6.6.5.4.1.3 E-UTRA and NR

6.6.5.4.2 Procedure

The minimum requirement is applied to all *TAB connectors*, they may be tested one at a time or multiple *TAB connectors* may be tested in parallel as shown in subclause D.1.1. Whichever method is used the procedure is repeated until all *TAB connectors* necessary to demonstrate conformance have been tested.

- 1) Connect *TAB connector* to measurement equipment as shown in subclause D.1.1. All *TAB connectors* not under test shall be terminated.

As a general rule, the resolution bandwidth of the measuring equipment should be equal to the measurement bandwidth. However, to improve measurement accuracy, sensitivity, efficiency and avoiding e.g. carrier leakage, the resolution bandwidth may be smaller than the measurement bandwidth. When the resolution bandwidth is smaller than the measurement bandwidth, the result should be integrated over the measurement bandwidth in order to obtain the equivalent noise bandwidth of the measurement bandwidth.

The measurement device characteristics shall be:

- Detection mode: True RMS.

- 2) Set the set the *TAB connector* to transmit:

- a) For MSR:

- Set the *TAB connector* to transmit maximum power according to the applicable test configuration in clause 5 using the corresponding test models or set of physical channels in subclause 4.12.

- b) For E-UTRA:

- *TAB connector* declared to be capable of single carrier operation only, set the *TAB connector* to transmit a signal according to E-TM1.1 (subclause 4.12.2) at manufacturer's declared rated output power $P_{\text{rated,c,TAB}}$.
- For a *TAB connector* declared to be capable of multi-carrier and/or CA operation, set the set the *TAB connector* to transmit according to E-TM1.1 on all carriers configured using the applicable test configuration and corresponding power setting specified in subclause 4.11.

- 3) Step the centre frequency of the measurement filter in contiguous steps and measure the emission within the specified frequency ranges with the specified measurement bandwidth.

- 4) Repeat the test for the remaining test cases:

- a) For MSR with channel set-up according to clause 5 and subclause 4.12.2.

- b) For E-UTRA with the channel set-up according to E-TM 1.2

In addition, for *multi-band TAB connector(s)*, the following steps shall apply:

- 5) For *multi-band TAB connectors* and single band tests, repeat the steps above per involved band where single band test configurations and test models shall apply with no carrier activated in the other band.

6.6.5.5 Test requirements

6.6.5.5.1 General

Conformance may be shown to either the measure and sum test requirement or the per *TAB connector* test requirement.

- 1) The spurious emission test requirements for an AAS BS when using the measure and sum alternative are that for each *TAB connector TX cell group* and each applicable *basic limit* as specified in this subclause, the power summation of emissions at the *TAB connectors* of the *TAB connector TX cell group* shall not exceed a limit specified as the *basic limit* + $10\log_{10}(N_{\text{TXU,countedpercell}})$.

- 2) The spurious emission test requirements for an AAS BS when using the per *TAB connector* alternative are that for each *TAB connector TX cell group* and each applicable *basic limit* as specified in this subclause, the emissions at each of the *TAB connectors* of the *TAB connector TX cell group* shall not exceed a limit specified as the *basic limit* + $10\log_{10}(N_{\text{TXU,countedpercell}}) - 10\log(n)$ where n is the number of *TAB connectors* in the *TAB connector TX cell group*.

The appropriate table for the basic limit is based on the same power level ($P_{\text{Rated,c,sys}}$) as used for the AAS BS rated power limits for BS classes in table 6.2.2.1-1 the same method of scaling the power level using $N_{\text{TXU,counted}}$ is used.

As a general rule, the resolution bandwidth of the measuring equipment should be equal to the measurement bandwidth. However, to improve measurement accuracy, sensitivity and efficiency, the resolution bandwidth can be smaller than the measurement bandwidth. When the resolution bandwidth is smaller than the measurement bandwidth, the result should be integrated over the measurement bandwidth in order to obtain the equivalent noise bandwidth of the measurement bandwidth.

6.6.5.5.2 Basic Limits for MSR Band Categories 1 and 3

For an AAS BS of Wide Area BS class operating in Band Category 1 or Band Category 3, the requirement applies outside the *Base Station RF Bandwidth edges*. In addition, for a Wide Area BS operating in non-contiguous spectrum, it applies inside any sub-block gap. In addition, for an AAS BS of Wide Area BS class operating in multiple bands, it applies inside any *Inter RF Bandwidth gap*.

For an AAS BS of Medium Range BS class operating in Band Category 1 the requirement applies outside the *Base Station RF Bandwidth edges*. In addition, for a Medium Range BS operating in non-contiguous spectrum, it applies inside any sub-block gap. In addition, for an AAS BS of Medium Range BS class operating in multiple bands, it applies inside any *Inter RF Bandwidth gap*.

For an AAS BS of Local Area BS class operating in Band Category 1 the requirement applies outside the *Base Station RF Bandwidth edges*. In addition, for a Local Area BS operating in non-contiguous spectrum, it applies inside any sub-block gap. In addition, for an AAS BS of Local Area BS class operating in multiple bands, it applies inside any *Inter RF Bandwidth gap*.

Outside the *Base Station RF Bandwidth edges*, emissions *basic limits* are specified in tables 6.6.2.5.1-1 to 6.6.2.5.1-4 below, where:

- Δf is the separation between the *Base Station RF Bandwidth edge* frequency and the nominal -3 dB point of the measuring filter closest to the carrier frequency.
- f_{offset} is the separation between the *Base Station RF Bandwidth edge* frequency and the centre of the measuring filter.
- $f_{\text{offset,max}}$ is the offset to the frequency Δf_{OBUE} outside the downlink operating band.
- Δf_{max} is equal to $f_{\text{offset,max}}$ minus half of the bandwidth of the measuring filter.

For a *multi-band TAB connector*, inside any *Inter RF Bandwidth gaps* with $W_{\text{gap}} < 2 * \Delta f_{\text{OBUE}}$, a combined *basic limit* shall be applied which is the cumulative sum of the test requirements specified at the *Base Station RF Bandwidth edges* on each side of the *Inter RF Bandwidth gap*. The *basic limit* for *Base Station RF Bandwidth edge* is specified in tables 6.6.5.5.2-1 to 6.6.5.5.2-8, where in this case:

- Δf is the separation between the *Base Station RF Bandwidth edge* frequency and the nominal -3 dB point of the measuring filter closest to the carrier frequency.
- f_{offset} is the separation between the *Base Station RF Bandwidth edge* frequency and the centre of the measuring filter.
- $f_{\text{offset,max}}$ is equal to the *Inter RF Bandwidth gap* divided by two.
- Δf_{max} is equal to $f_{\text{offset,max}}$ minus half of the bandwidth of the measuring filter.

For a *multi-band TAB connector*, the operating band unwanted emission limits apply also in a supported operating band without any carriers transmitted, in the case where there are carriers transmitted in another operating band. In this case where there is no carrier transmitted in an operating band, no cumulative *basic limits* are applied in the *inter-band gap* between a supported downlink band with carrier(s) transmitted and a supported downlink band without any carrier transmitted and

- In case the *Inter RF Bandwidth gap* between a supported downlink band with carrier(s) transmitted and a supported downlink band without any carrier transmitted is less than $2 \cdot \Delta f_{\text{OBUE}}$ MHz, $f_{\text{offset}_{\text{max}}}$ shall be the offset to the frequency Δf_{OBUE} outside the outermost edges of the two supported downlink operating bands and the operating band unwanted emission limit of the band where there are carriers transmitted, as defined in the tables of the present subclause, shall apply across both supported downlink bands.
- In other cases, the operating band unwanted emission limit of the band where there are carriers transmitted, as defined in the tables of the present subclause for the largest frequency offset (Δf_{max}), shall apply from Δf_{OBUE} below the lowest frequency, up to Δf_{OBUE} above the highest frequency of the supported downlink operating band without any carrier transmitted.

Inside any sub-block gap for a *TAB connector* operating in non-contiguous spectrum, a combined *basic limit* shall be applied which is the cumulative sum of the test requirements specified for the adjacent sub blocks on each side of the sub block gap. The *basic limit* for each sub block is specified in tables 6.6.5.5.2-1 to 6.6.5.5.2-8, where in this case:

- Δf is the separation between the sub block edge frequency and the nominal -3 dB point of the measuring filter closest to the sub block edge frequency.
- f_{offset} is the separation between the sub block edge frequency and the centre of the measuring filter.
- $f_{\text{offset}_{\text{max}}}$ is equal to the sub block gap bandwidth divided by two.
- Δf_{max} is equal to $f_{\text{offset}_{\text{max}}}$ minus half of the bandwidth of the measuring filter.

Table 6.6.5.5.2-1: Wide Area operating band unwanted emission mask (UEM) for BC1 and BC3 bands ≤ 3 GHz for BS not supporting NR or BS supporting NR in Band n1

Frequency offset of measurement filter -3dB point, Δf	Frequency offset of measurement filter centre frequency, f_{offset}	<i>basic limit</i> (Notes 1 and 2)	Measurement bandwidth
$0 \text{ MHz} \leq \Delta f < 0.2 \text{ MHz}$	$0.015 \text{ MHz} \leq f_{\text{offset}} < 0.215 \text{ MHz}$	-12.5 dBm	30 kHz
$0.2 \text{ MHz} \leq \Delta f < 1 \text{ MHz}$	$0.215 \text{ MHz} \leq f_{\text{offset}} < 1.015 \text{ MHz}$	$-12.5 \text{ dBm} - 15 \cdot \left(\frac{f_{\text{offset}}}{\text{MHz}} - 0.215 \right) \text{ dB}$	30 kHz
(Note 3)	$1.015 \text{ MHz} \leq f_{\text{offset}} < 1.5 \text{ MHz}$	-24.5 dBm	30 kHz
$1 \text{ MHz} \leq \Delta f \leq \min(\Delta f_{\text{max}}, 10 \text{ MHz})$	$1.5 \text{ MHz} \leq f_{\text{offset}} < \min(f_{\text{offset}_{\text{max}}}, 10.5 \text{ MHz})$	-11.5 dBm	1 MHz
$10 \text{ MHz} \leq \Delta f \leq \Delta f_{\text{max}}$	$10.5 \text{ MHz} \leq f_{\text{offset}} < f_{\text{offset}_{\text{max}}}$	-15 dBm (Note 5)	1 MHz

NOTE 1: For MSR *TAB connector* supporting non-contiguous spectrum operation within any operating band the *basic limit* within sub-block gaps is calculated as a cumulative sum of contributions from adjacent sub blocks on each side of the sub block gap. Exception is $\Delta f \geq 10$ MHz from both adjacent sub blocks on each side of the sub-block gap, where the *basic limit* within sub-block gaps shall be -15 dBm/MHz.

NOTE 2: For MSR *multi-band TAB connector* with *Inter RF Bandwidth gap* < 20 MHz the *basic limit* within the *Inter RF Bandwidth gaps* is calculated as a cumulative sum of contributions from adjacent sub-blocks on each side of the *Inter RF Bandwidth gap*.

NOTE 3: This frequency range ensures that the range of values of f_{offset} is continuous.

NOTE 5: The requirement is not applicable when $\Delta f_{\text{max}} < 10$ MHz.

Table 6.6.5.5.2-2: : Wide Area operating band unwanted emission mask (UEM) for BC1 and BC3 bands > 3 GHz for BS not supporting NR or BS supporting NR in Band n1

Frequency offset of measurement filter -3dB point, Δf	Frequency offset of measurement filter centre frequency, f_{offset}	<i>basic limit</i> (Notes 1 and 2)	Measurement bandwidth
$0 \text{ MHz} \leq \Delta f < 0.2 \text{ MHz}$	$0.015 \text{ MHz} \leq f_{\text{offset}} < 0.215 \text{ MHz}$	-12.2 dBm	30 kHz
$0.2 \text{ MHz} \leq \Delta f < 1 \text{ MHz}$	$0.215 \text{ MHz} \leq f_{\text{offset}} < 1.015 \text{ MHz}$	$-12.2 \text{ dBm} - 15 \cdot \left(\frac{f_{\text{offset}}}{\text{MHz}} - 0.215 \right) \text{ dB}$	30 kHz
(Note 3)	$1.015 \text{ MHz} \leq f_{\text{offset}} < 1.5 \text{ MHz}$	-24.2 dBm	30 kHz
$1 \text{ MHz} \leq \Delta f \leq \min(\Delta f_{\text{max}}, 10 \text{ MHz})$	$1.5 \text{ MHz} \leq f_{\text{offset}} < \min(f_{\text{offset}_{\text{max}}}, 10.5 \text{ MHz})$	-11.2 dBm	1 MHz
$10 \text{ MHz} \leq \Delta f \leq \Delta f_{\text{max}}$	$10.5 \text{ MHz} \leq f_{\text{offset}} < f_{\text{offset}_{\text{max}}}$	-15 dBm (Note 5)	1 MHz
NOTE 1: For MSR <i>TAB connector</i> supporting non-contiguous spectrum operation within any operating band the <i>basic limit</i> within sub-block gaps is calculated as a cumulative sum of contributions from adjacent sub blocks on each side of the sub block gap. Exception is $\Delta f \geq 10 \text{ MHz}$ from both adjacent sub blocks on each side of the sub-block gap, where the <i>basic limit</i> within sub-block gaps shall be -15 dBm/MHz.			
NOTE 2: For MSR <i>multi-band TAB connector</i> with <i>Inter RF Bandwidth gap</i> < 2* Δf_{OBUe} MHz the <i>basic limit</i> within the <i>Inter RF Bandwidth gaps</i> is calculated as a cumulative sum of contributions from adjacent sub-blocks on each side of the <i>Inter RF Bandwidth gap</i> .			
NOTE 3: This frequency range ensures that the range of values of f_{offset} is continuous.			
NOTE 5: The requirement is not applicable when $\Delta f_{\text{max}} < 10 \text{ MHz}$.			

Table 6.6.5.5.2-2a: Wide Area operating band unwanted emission mask (UEM) for BS supporting NR and not supporting UTRA in BC1 and BC3 bands below 1GHz

Frequency offset of measurement filter -3dB point, Δf	Frequency offset of measurement filter centre frequency, f_{offset}	<i>Basic limit</i> (Note 1, 2)	Measurement bandwidth
$0 \text{ MHz} \leq \Delta f < 5 \text{ MHz}$	$0.05 \text{ MHz} \leq f_{\text{offset}} < 5.05 \text{ MHz}$	$-5.5 \text{ dBm} - \frac{7}{5} \cdot \left(\frac{f_{\text{offset}}}{\text{MHz}} - 0.05 \right) \text{ dB}$	100 kHz
$5 \text{ MHz} \leq \Delta f < \min(10 \text{ MHz}, \Delta f_{\text{max}})$	$5.05 \text{ MHz} \leq f_{\text{offset}} < \min(10.05 \text{ MHz}, f_{\text{offset}_{\text{max}}})$	-12.5 dBm	
$10 \text{ MHz} \leq \Delta f \leq \Delta f_{\text{max}}$	$10.05 \text{ MHz} \leq f_{\text{offset}} < f_{\text{offset}_{\text{max}}}$	-16 dBm (Note 3)	
NOTE 1: For a BS supporting non-contiguous spectrum operation within any <i>operating band</i> , the emission limits within sub-block gaps is calculated as a cumulative sum of contributions from adjacent sub blocks on each side of the sub block gap, where the contribution from the far-end sub-block shall be scaled according to the measurement bandwidth of the near-end sub-block. Exception is $\Delta f \geq 10 \text{ MHz}$ from both adjacent sub blocks on each side of the sub-block gap, where the emission limits within sub-block gaps shall be -16 dBm/100 kHz.			
NOTE 2: For a <i>multi-band connector</i> with <i>Inter RF Bandwidth gap</i> < 2* Δf_{OBUe} the emission limits within the <i>Inter RF Bandwidth gaps</i> is calculated as a cumulative sum of contributions from adjacent sub-blocks or RF Bandwidth on each side of the <i>Inter RF Bandwidth gap</i> , where the contribution from the far-end sub-block or RF Bandwidth shall be scaled according to the measurement bandwidth of the near-end sub-block or RF Bandwidth.			
NOTE 3: The requirement is not applicable when $\Delta f_{\text{max}} < 10 \text{ MHz}$.			

Table 6.6.5.2-2b: Wide Area operating band unwanted emission mask (UEM) for BS supporting NR (except operation in band n1) and not supporting UTRA in BC1 and BC3 bands > 1GHz.

Frequency offset of measurement filter -3dB point, Δf	Frequency offset of measurement filter centre frequency, f_{offset}	Basic limit (Note 1, 2)	Measurement bandwidth
$0 \text{ MHz} \leq \Delta f < 5 \text{ MHz}$	$0.05 \text{ MHz} \leq f_{\text{offset}} < 5.05 \text{ MHz}$	$-5.5 \text{ dBm} - \frac{7}{5} \left(\frac{f_{\text{offset}}}{\text{MHz}} - 0.05 \right) \text{ dB}$	100 kHz
$5 \text{ MHz} \leq \Delta f < \min(10 \text{ MHz}, \Delta f_{\text{max}})$	$5.05 \text{ MHz} \leq f_{\text{offset}} < \min(10.05 \text{ MHz}, f_{\text{offset}_{\text{max}}})$	-12.5 dBm	100 kHz
$10 \text{ MHz} \leq \Delta f \leq \Delta f_{\text{max}}$	$10.5 \text{ MHz} \leq f_{\text{offset}} < f_{\text{offset}_{\text{max}}}$	-15 dBm (Note 3)	1 MHz
<p>NOTE 1: For a BS supporting non-contiguous spectrum operation within any <i>operating band</i>, the emission limits within sub-block gaps is calculated as a cumulative sum of contributions from adjacent sub blocks on each side of the sub block gap, where the contribution from the far-end sub-block shall be scaled according to the measurement bandwidth of the near-end sub-block. Exception is $\Delta f \geq 10 \text{ MHz}$ from both adjacent sub blocks on each side of the sub-block gap, where the emission limits within sub-block gaps shall be -15 dBm/1 MHz.</p> <p>NOTE 2: For a <i>multi-band connector</i> with Inter RF Bandwidth gap < $2 \cdot \Delta f_{\text{OBUe}}$ the emission limits within the Inter RF Bandwidth gaps is calculated as a cumulative sum of contributions from adjacent sub-blocks or RF Bandwidth on each side of the Inter RF Bandwidth gap, where the contribution from the far-end sub-block or RF Bandwidth shall be scaled according to the measurement bandwidth of the near-end sub-block or RF Bandwidth.</p> <p>NOTE 3: The requirement is not applicable when $\Delta f_{\text{max}} < 10 \text{ MHz}$.</p>			

Table 6.6.5.2-3: Medium Range BS operating band unwanted emission mask (UEM) for BC1 for bands $\leq 3 \text{ GHz}$, $31 < P_{\text{max,c,cell}} - 10 \cdot \log_{10}(N_{\text{TXU,countedpercell}}) \leq 38 \text{ dBm}$ for BS not supporting NR

Frequency offset of measurement filter -3dB point, Δf	Frequency offset of measurement filter centre frequency, f_{offset}	basic limit (Notes 1 and 2)	Measurement bandwidth
$0 \text{ MHz} \leq \Delta f < 0.6 \text{ MHz}$	$0.015 \text{ MHz} \leq f_{\text{offset}} < 0.615 \text{ MHz}$	$P_{\text{max,c,cell}} - 10 \cdot \log_{10}(N_{\text{TXU,countedpercell}}) - 56.5 \text{ dB} - \frac{7}{5} \left(\frac{f_{\text{offset}}}{\text{MHz}} - 0.015 \right) \text{ dB}$	30 kHz
$0.6 \text{ MHz} \leq \Delta f < 1 \text{ MHz}$	$0.615 \text{ MHz} \leq f_{\text{offset}} < 1.015 \text{ MHz}$	$P_{\text{max,c,cell}} - 10 \cdot \log_{10}(N_{\text{TXU,countedpercell}}) - 51.5 \text{ dB} - 15 \left(\frac{f_{\text{offset}}}{\text{MHz}} - 0.215 \right) \text{ dB}$	30 kHz
(Note 3)	$1.015 \text{ MHz} \leq f_{\text{offset}} < 1.5 \text{ MHz}$	$P_{\text{max,c,cell}} - 10 \cdot \log_{10}(N_{\text{TXU,countedpercell}}) - 63.5 \text{ dB}$	30 kHz
$1 \text{ MHz} \leq \Delta f \leq 2.6 \text{ MHz}$	$1.5 \text{ MHz} \leq f_{\text{offset}} < 3.1 \text{ MHz}$	$P_{\text{max,c,cell}} - 10 \cdot \log_{10}(N_{\text{TXU,countedpercell}}) - 50.5 \text{ dB}$	1 MHz
$2.6 \text{ MHz} \leq \Delta f \leq 5 \text{ MHz}$	$3.1 \text{ MHz} \leq f_{\text{offset}} < 5.5 \text{ MHz}$	$\min(P_{\text{max,c,cell}} - 10 \cdot \log_{10}(N_{\text{TXU,countedpercell}}) - 50.5 \text{ dB}, -13.5 \text{ dBm})$	1 MHz
$5 \text{ MHz} \leq \Delta f \leq \min(\Delta f_{\text{max}}, 10 \text{ MHz})$	$5.5 \text{ MHz} \leq f_{\text{offset}} < \min(f_{\text{offset}_{\text{max}}}, 10.5 \text{ MHz})$	$P_{\text{max,c,cell}} - 10 \cdot \log_{10}(N_{\text{TXU,countedpercell}}) - 54.5 \text{ dB}$	1 MHz
$10 \text{ MHz} \leq \Delta f \leq \Delta f_{\text{max}}$	$10.5 \text{ MHz} \leq f_{\text{offset}} < f_{\text{offset}_{\text{max}}}$	$P_{\text{max,c,cell}} - 10 \cdot \log_{10}(N_{\text{TXU,countedpercell}}) - 56 \text{ dB}$ (Note 5)	1 MHz
<p>NOTE 1: For MSR <i>TAB connector</i> supporting non-contiguous spectrum operation within any operating band the <i>basic limit</i> within sub-block gaps is calculated as a cumulative sum of contributions from adjacent sub blocks on each side of the sub block gap. Exception is $\Delta f \geq 10 \text{ MHz}$ from both adjacent sub blocks on each side of the sub-block gap, where the <i>basic limit</i> within sub-block gaps shall be $(P_{\text{max,c,cell}} - 10 \cdot \log_{10}(N_{\text{TXU,countedpercell}}) - 56 \text{ dB})/\text{MHz}$.</p> <p>NOTE 2: For MSR <i>multi-band TAB connector</i> with Inter RF Bandwidth gap < $2 \cdot \Delta f_{\text{OBUe}}$ MHz the <i>basic limit</i> within the Inter RF Bandwidth gaps is calculated as a cumulative sum of contributions from adjacent sub-blocks on each side of the Inter RF Bandwidth gap.</p> <p>NOTE 3: This frequency range ensures that the range of values of f_{offset} is continuous.</p> <p>NOTE 5: The requirement is not applicable when $\Delta f_{\text{max}} < 10 \text{ MHz}$.</p>			

Table 6.6.5.5.2-3a: Medium Range BS operating band unwanted emission mask (UEM) for BS supporting NR and not supporting UTRA in BC1 bands ≤ 3 GHz, BS maximum output power $31 < P_{\text{rated,c,cell}} - 10 \cdot \log_{10}(N_{\text{TXU,countedpercell}}) \leq 38$ dBm

Frequency offset of measurement filter -3dB point, Δf	Frequency offset of measurement filter centre frequency, f_{offset}	Basic limit (Note 1, 2)	Measurement bandwidth
$0 \text{ MHz} \leq \Delta f < 5 \text{ MHz}$	$0.05 \text{ MHz} \leq f_{\text{offset}} < 5.05 \text{ MHz}$	$P_{\text{rated,c,cell}} - 51.5 \text{ dB} - \frac{7}{5}(f_{\text{offset}} - 0.05) \text{ dB}$ $P_{\text{rated,c,cell}} - 51.5 \text{ dB} - \frac{7}{5} \left(\frac{f_{\text{offset}}}{\text{MHz}} - 0.05 \right) \text{ dB}$	100 kHz
$5 \text{ MHz} \leq \Delta f < \min(10 \text{ MHz}, \Delta f_{\text{max}})$	$5.05 \text{ MHz} \leq f_{\text{offset}} < \min(10.05 \text{ MHz}, f_{\text{offset}_{\text{max}}})$	$P_{\text{rated,c,cell}} - 58.5 \text{ dB}$	100 kHz
$10 \text{ MHz} \leq \Delta f \leq \Delta f_{\text{max}}$	$10.05 \text{ MHz} \leq f_{\text{offset}} < f_{\text{offset}_{\text{max}}}$	$\text{Min}(P_{\text{rated,c,cell}} - 60 \text{ dB}, -25 \text{ dBm})$ (Note 3)	100 kHz
<p>NOTE 1: For a BS supporting non-contiguous spectrum operation within any <i>operating band</i> the emission limits within sub-block gaps is calculated as a cumulative sum of contributions from adjacent sub blocks on each side of the sub block gap. Exception is $\Delta f \geq 10 \text{ MHz}$ from both adjacent sub blocks on each side of the sub-block gap, where the emission limits within sub-block gaps shall be $\text{Min}(P_{\text{rated,c,cell}} - 60 \text{ dB}, -25 \text{ dBm})/100 \text{ kHz}$.</p> <p>NOTE 2: For a <i>multi-band connector</i> with Inter RF Bandwidth gap $< 2 \cdot \Delta f_{\text{OBUe}}$ the emission limits within the Inter RF Bandwidth gaps is calculated as a cumulative sum of contributions from adjacent sub-blocks or RF Bandwidth on each side of the Inter RF Bandwidth gap.</p> <p>NOTE 3: The requirement is not applicable when $\Delta f_{\text{max}} < 10 \text{ MHz}$.</p>			

Table 6.6.5.5.2-4: Medium Range BS operating band unwanted emission mask (UEM) for BC1 for bands > 3 GHz, $31 < P_{\text{max,c,cell}} - 10 \cdot \log_{10}(N_{\text{TXU,countedpercell}}) \leq 38$ dBm for BS not supporting NR

Frequency offset of measurement filter -3dB point, Δf	Frequency offset of measurement filter centre frequency, f_{offset}	basic limit (Notes 1 and 2)	Measurement bandwidth
$0 \text{ MHz} \leq \Delta f < 0.6 \text{ MHz}$	$0.015 \text{ MHz} \leq f_{\text{offset}} < 0.615 \text{ MHz}$	$P_{\text{max,c,cell}} - 10 \cdot \log_{10}(N_{\text{TXU,countedpercell}}) - 56.2 \text{ dB} - \frac{7}{5} \left(\frac{f_{\text{offset}}}{\text{MHz}} - 0.015 \right) \text{ dB}$	30 kHz
$0.6 \text{ MHz} \leq \Delta f < 1 \text{ MHz}$	$0.615 \text{ MHz} \leq f_{\text{offset}} < 1.015 \text{ MHz}$	$P_{\text{max,c,cell}} - 10 \cdot \log_{10}(N_{\text{TXU,countedpercell}}) - 51.2 \text{ dB} - 15 \left(\frac{f_{\text{offset}}}{\text{MHz}} - 0.215 \right) \text{ dB}$	30 kHz
(Note 3)	$1.015 \text{ MHz} \leq f_{\text{offset}} < 1.5 \text{ MHz}$	$P_{\text{max,c,cell}} - 10 \cdot \log_{10}(N_{\text{TXU,countedpercell}}) - 63.2 \text{ dB}$	30 kHz
$1 \text{ MHz} \leq \Delta f \leq 2.6 \text{ MHz}$	$1.5 \text{ MHz} \leq f_{\text{offset}} < 3.1 \text{ MHz}$	$P_{\text{max,c,cell}} - 10 \cdot \log_{10}(N_{\text{TXU,countedpercell}}) - 50.2 \text{ dB}$	1 MHz
$2.6 \text{ MHz} \leq \Delta f \leq 5 \text{ MHz}$	$3.1 \text{ MHz} \leq f_{\text{offset}} < 5.5 \text{ MHz}$	$\text{min}(P_{\text{max,c,cell}} - 10 \cdot \log_{10}(N_{\text{TXU,countedpercell}}) - 50.2 \text{ dB}, -13.2 \text{ dBm})$	1 MHz
$5 \text{ MHz} \leq \Delta f \leq \min(\Delta f_{\text{max}}, 10 \text{ MHz})$	$5.5 \text{ MHz} \leq f_{\text{offset}} < \min(f_{\text{offset}_{\text{max}}}, 10.5 \text{ MHz})$	$P_{\text{max,c,cell}} - 10 \cdot \log_{10}(N_{\text{TXU,countedpercell}}) - 54.2 \text{ dB}$	1 MHz
$10 \text{ MHz} \leq \Delta f \leq \Delta f_{\text{max}}$	$10.5 \text{ MHz} \leq f_{\text{offset}} < f_{\text{offset}_{\text{max}}}$	$P_{\text{max,c,cell}} - 10 \cdot \log_{10}(N_{\text{TXU,countedpercell}}) - 56 \text{ dB}$ (Note 5)	1 MHz
<p>NOTE 1: For MSR <i>TAB connector</i> supporting non-contiguous spectrum operation within any operating band the <i>basic limit</i> within sub-block gaps is calculated as a cumulative sum of contributions from adjacent sub blocks on each side of the sub block gap. Exception is $\Delta f \geq 10 \text{ MHz}$ from both adjacent sub blocks on each side of the sub-block gap, where the <i>basic limit</i> within sub-block gaps shall be $(P_{\text{max,c,cell}} - 10 \cdot \log_{10}(N_{\text{TXU,countedpercell}}) - 56 \text{ dB})/\text{MHz}$.</p> <p>NOTE 2: For MSR multi-band <i>TAB connector</i> with Inter RF Bandwidth gap $< 2 \cdot \Delta f_{\text{OBUe}}$ MHz the <i>basic limit</i> within the Inter RF Bandwidth gaps is calculated as a cumulative sum of contributions from adjacent sub-blocks on each side of the Inter RF Bandwidth gap.</p> <p>NOTE 3: This frequency range ensures that the range of values of f_{offset} is continuous.</p> <p>NOTE 5: The requirement is not applicable when $\Delta f_{\text{max}} < 10 \text{ MHz}$.</p>			

Table 6.6.5.2-4a: Medium Range BS operating band unwanted emission mask (UEM) for BS supporting NR and not supporting UTRA in BC1 bands > 3 GHz, BS maximum output power $31 < P_{\text{rated,c,cell}} \cdot 10 \cdot \log_{10}(N_{\text{TXU,countedpercell}}) \leq 38$ dBm

Frequency offset of measurement filter -3dB point, Δf	Frequency offset of measurement filter centre frequency, f_{offset}	Basic limit (Note 1, 2)	Measurement bandwidth
$0 \text{ MHz} \leq \Delta f < 5 \text{ MHz}$	$0.05 \text{ MHz} \leq f_{\text{offset}} < 5.05 \text{ MHz}$	$P_{\text{rated,c,cell}} - 51.2 \text{ dB} - \frac{7}{5}(f_{\text{offset}} - 0.05) \text{ dB}$ $\text{dB} P_{\text{rated,c,cell}} - 51.2 \text{ dB} - \frac{7}{5} \left(\frac{f_{\text{offset}}}{\text{MHz}} - 0.05 \right) \text{ dB}$	100 kHz
$5 \text{ MHz} \leq \Delta f < \min(10 \text{ MHz}, \Delta f_{\text{max}})$	$5.05 \text{ MHz} \leq f_{\text{offset}} < \min(10.05 \text{ MHz}, f_{\text{offset,max}})$	$P_{\text{rated,c,cell}} - 58.2 \text{ dB}$	100 kHz
$10 \text{ MHz} \leq \Delta f \leq \Delta f_{\text{max}}$	$10.05 \text{ MHz} \leq f_{\text{offset}} < f_{\text{offset,max}}$	$\text{Min}(P_{\text{rated,c,cell}} - 60 \text{ dB}, -25 \text{ dBm})$ (Note 3)	100 kHz
<p>NOTE 1: For a BS supporting non-contiguous spectrum operation within any <i>operating band</i> the emission limits within sub-block gaps is calculated as a cumulative sum of contributions from adjacent sub blocks on each side of the sub block gap. Exception is $\Delta f \geq 10 \text{ MHz}$ from both adjacent sub blocks on each side of the sub-block gap, where the emission limits within sub-block gaps shall be $\text{Min}(P_{\text{rated,c,cell}} - 60 \text{ dB}, -25 \text{ dBm})/100 \text{ kHz}$.</p> <p>NOTE 2: For a <i>multi-band connector</i> with Inter RF Bandwidth gap $< 2 \cdot \Delta f_{\text{OBUE}}$ the emission limits within the Inter RF Bandwidth gaps is calculated as a cumulative sum of contributions from adjacent sub-blocks or RF Bandwidth on each side of the Inter RF Bandwidth gap.</p> <p>NOTE 3: The requirement is not applicable when $\Delta f_{\text{max}} < 10 \text{ MHz}$.</p>			

Table 6.6.5.2-5: Medium Range BS operating band unwanted emission mask (UEM) for BC1 for bands $\leq 3 \text{ GHz}$, $P_{\text{max,c,cell}} \cdot 10 \cdot \log_{10}(N_{\text{TXU,countedpercell}}) \leq 31$ dBm for BS not supporting NR

Frequency offset of measurement filter -3dB point, Δf	Frequency offset of measurement filter centre frequency, f_{offset}	basic limit (Notes 1 and 2)	Measurement bandwidth
$0 \text{ MHz} \leq \Delta f < 0.6 \text{ MHz}$	$0.015 \text{ MHz} \leq f_{\text{offset}} < 0.615 \text{ MHz}$	$-25.5 \text{ dBm} - \frac{7}{5} \left(\frac{f_{\text{offset}}}{\text{MHz}} - 0.015 \right) \text{ dB}$	30 kHz
$0.6 \text{ MHz} \leq \Delta f < 1 \text{ MHz}$	$0.615 \text{ MHz} \leq f_{\text{offset}} < 1.015 \text{ MHz}$	$-20.5 \text{ dBm} - 15 \cdot \left(\frac{f_{\text{offset}}}{\text{MHz}} - 0.215 \right) \text{ dB}$	30 kHz
(Note 3)	$1.015 \text{ MHz} \leq f_{\text{offset}} < 1.5 \text{ MHz}$	-32.5 dBm	30 kHz
$1 \text{ MHz} \leq \Delta f \leq 5 \text{ MHz}$	$1.5 \text{ MHz} \leq f_{\text{offset}} < 5.5 \text{ MHz}$	-19.5 dBm	1 MHz
$5 \text{ MHz} \leq \Delta f \leq \min(\Delta f_{\text{max}}, 10 \text{ MHz})$	$5.5 \text{ MHz} \leq f_{\text{offset}} < \min(f_{\text{offset,max}}, 10.5 \text{ MHz})$	-23.5 dBm	1 MHz
$10 \text{ MHz} \leq \Delta f \leq \Delta f_{\text{max}}$	$10.5 \text{ MHz} \leq f_{\text{offset}} < f_{\text{offset,max}}$	-25 dBm (Note 5)	1 MHz
<p>NOTE 1: For MSR <i>TAB connector</i> supporting non-contiguous spectrum operation within any operating band the <i>basic limit</i> within sub-block gaps is calculated as a cumulative sum of contributions from adjacent sub blocks on each side of the sub block gap. Exception is $\Delta f \geq 10 \text{ MHz}$ from both adjacent sub blocks on each side of the sub-block gap, where the <i>basic limit</i> within sub-block gaps shall be -25 dBm/MHz.</p> <p>NOTE 2: For MSR <i>multi-band TAB connector</i> with Inter RF Bandwidth gap $< 2 \cdot \Delta f_{\text{OBUE}}$ MHz the <i>basic limit</i> within the Inter RF Bandwidth gaps is calculated as a cumulative sum of contributions from adjacent sub-blocks on each side of the Inter RF Bandwidth gap.</p> <p>NOTE 3: This frequency range ensures that the range of values of f_{offset} is continuous.</p> <p>NOTE 5: The requirement is not applicable when $\Delta f_{\text{max}} < 10 \text{ MHz}$.</p>			

Table 6.6.5.2-5a: Medium Range BS operating band unwanted emission mask (UEM) for BS supporting NR and not supporting UTRA in BC1 bands ≤ 3 GHz, BS maximum output power $P_{\text{rated,c,cell}} - 10 \cdot \log_{10}(N_{\text{TXU,countedpercell}}) \leq 31$ dBm

Frequency offset of measurement filter -3dB point, Δf	Frequency offset of measurement filter centre frequency, f_{offset}	Basic limit (Note 1, 2)	Measurement bandwidth
$0 \text{ MHz} \leq \Delta f < 5 \text{ MHz}$	$0.05 \text{ MHz} \leq f_{\text{offset}} < 5.05 \text{ MHz}$	$-20.5 \text{ dBm} - \frac{7}{5} \left(\frac{f_{\text{offset}}}{\text{MHz}} - 0.05 \right) \text{ dB}$	100 kHz
$5 \text{ MHz} \leq \Delta f < \min(10 \text{ MHz}, \Delta f_{\text{max}})$	$5.05 \text{ MHz} \leq f_{\text{offset}} < \min(10.05 \text{ MHz}, f_{\text{offset,max}})$	-27.5 dBm	100 kHz
$10 \text{ MHz} \leq \Delta f \leq \Delta f_{\text{max}}$	$10.05 \text{ MHz} \leq f_{\text{offset}} < f_{\text{offset,max}}$	-29 dBm (Note 3)	100 kHz

NOTE 1: For a BS supporting non-contiguous spectrum operation within any *operating band* the emission limits within sub-block gaps is calculated as a cumulative sum of contributions from adjacent sub blocks on each side of the sub block gap. Exception is $\Delta f \geq 10$ MHz from both adjacent sub blocks on each side of the sub-block gap, where the emission limits within sub-block gaps shall be -29dBm/100kHz.

NOTE 2: For a *multi-band connector* with Inter RF Bandwidth gap $< 2 \cdot \Delta f_{\text{OBUe}}$ the emission limits within the Inter RF Bandwidth gaps is calculated as a cumulative sum of contributions from adjacent sub-blocks or RF Bandwidth on each side of the Inter RF Bandwidth gap.

NOTE 3: The requirement is not applicable when $\Delta f_{\text{max}} < 10$ MHz.

Table 6.6.5.2-6: Medium Range BS operating band unwanted emission mask (UEM) for BC1 for bands > 3 GHz, $P_{\text{max,c,cell}} - 10 \cdot \log_{10}(N_{\text{TXU,countedpercell}}) \leq 31$ dBm

Frequency offset of measurement filter -3dB point, Δf	Frequency offset of measurement filter centre frequency, f_{offset}	basic limit (Notes 1 and 2)	Measurement bandwidth
$0 \text{ MHz} \leq \Delta f < 0.6 \text{ MHz}$	$0.015 \text{ MHz} \leq f_{\text{offset}} < 0.615 \text{ MHz}$	$-25.2 \text{ dBm} - \frac{7}{5} \left(\frac{f_{\text{offset}}}{\text{MHz}} - 0.015 \right) \text{ dB}$	30 kHz
$0.6 \text{ MHz} \leq \Delta f < 1 \text{ MHz}$	$0.615 \text{ MHz} \leq f_{\text{offset}} < 1.015 \text{ MHz}$	$-20.2 \text{ dBm} - 15 \cdot \left(\frac{f_{\text{offset}}}{\text{MHz}} - 0.215 \right) \text{ dB}$	30 kHz
(Note 3)	$1.015 \text{ MHz} \leq f_{\text{offset}} < 1.5 \text{ MHz}$	-32.2 dBm	30 kHz
$1 \text{ MHz} \leq \Delta f \leq 5 \text{ MHz}$	$1.5 \text{ MHz} \leq f_{\text{offset}} < 5.5 \text{ MHz}$	-19.2 dBm	1 MHz
$5 \text{ MHz} \leq \Delta f \leq \min(\Delta f_{\text{max}}, 10 \text{ MHz})$	$5.5 \text{ MHz} \leq f_{\text{offset}} < \min(f_{\text{offset,max}}, 10.5 \text{ MHz})$	-23.2 dBm	1 MHz
$10 \text{ MHz} \leq \Delta f \leq \Delta f_{\text{max}}$	$10.5 \text{ MHz} \leq f_{\text{offset}} < f_{\text{offset,max}}$	-25 dBm (Note 5)	1 MHz

NOTE 1: For MSR *TAB connector* supporting non-contiguous spectrum operation within any operating band the *basic limit* within sub-block gaps is calculated as a cumulative sum of contributions from adjacent sub blocks on each side of the sub block gap. Exception is $\Delta f \geq 10$ MHz from both adjacent sub blocks on each side of the sub-block gap, where the *basic limit* within sub-block gaps shall be -25 dBm/MHz.

NOTE 2: For MSR *multi-band TAB connector* with Inter RF Bandwidth gap < 20 MHz the *basic limit* within the Inter RF Bandwidth gaps is calculated as a cumulative sum of contributions from adjacent sub-blocks on each side of the Inter RF Bandwidth gap.

NOTE 3: This frequency range ensures that the range of values of f_{offset} is continuous.

NOTE 5: The requirement is not applicable when $\Delta f_{\text{max}} < 10$ MHz.

Table 6.6.5.5.2-6a: Medium Range BS operating band unwanted emission mask (UEM) for BS supporting NR and not supporting UTRA in BC1 bands > 3 GHz, BS maximum output power $P_{\text{rated,c,cell}} = 10 \cdot \log_{10}(N_{\text{TXU,countedpercell}}) \leq 31$ dBm

Frequency offset of measurement filter -3dB point, Δf	Frequency offset of measurement filter centre frequency, f_{offset}	Basic limit (Note 1, 2)	Measurement bandwidth
$0 \text{ MHz} \leq \Delta f < 5 \text{ MHz}$	$0.05 \text{ MHz} \leq f_{\text{offset}} < 5.05 \text{ MHz}$	$-20.2 \text{ dBm} - \frac{7}{5} \left(\frac{f_{\text{offset}}}{\text{MHz}} - 0.05 \right) \text{ dB}$	100 kHz
$5 \text{ MHz} \leq \Delta f < \min(10 \text{ MHz}, \Delta f_{\text{max}})$	$5.05 \text{ MHz} \leq f_{\text{offset}} < \min(10.05 \text{ MHz}, f_{\text{offset,max}})$	-27.2 dBm	100 kHz
$10 \text{ MHz} \leq \Delta f \leq \Delta f_{\text{max}}$	$10.05 \text{ MHz} \leq f_{\text{offset}} < f_{\text{offset,max}}$	-29 dBm (Note 3)	100 kHz

NOTE 1: For a BS supporting non-contiguous spectrum operation within any *operating band* the emission limits within sub-block gaps is calculated as a cumulative sum of contributions from adjacent sub blocks on each side of the sub block gap. Exception is $\Delta f \geq 10$ MHz from both adjacent sub blocks on each side of the sub-block gap, where the emission limits within sub-block gaps shall be -29dBm/100kHz.

NOTE 2: For a *multi-band connector* with Inter RF Bandwidth gap $< 2 \cdot \Delta f_{\text{OBUe}}$ the emission limits within the Inter RF Bandwidth gaps is calculated as a cumulative sum of contributions from adjacent sub-blocks or RF Bandwidth on each side of the Inter RF Bandwidth gap.

NOTE 3: The requirement is not applicable when $\Delta f_{\text{max}} < 10$ MHz.

Table 6.6.5.5.2-7: Local Area operating band unwanted emission mask (UEM) for BC1 for bands ≤ 3 GHz

Frequency offset of measurement filter -3dB point, Δf	Frequency offset of measurement filter centre frequency, f_{offset}	basic limit (Notes 1 and 2)	Measurement bandwidth
$0 \text{ MHz} \leq \Delta f < 5 \text{ MHz}$	$0.05 \text{ MHz} \leq f_{\text{offset}} < 5.05 \text{ MHz}$	$-28.5 \text{ dBm} - \frac{7}{5} \left(\frac{f_{\text{offset}}}{\text{MHz}} - 0.05 \right) \text{ dB}$	100 kHz
$5 \text{ MHz} \leq \Delta f < \min(10 \text{ MHz}, \Delta f_{\text{max}})$	$5.05 \text{ MHz} \leq f_{\text{offset}} < \min(10.05 \text{ MHz}, f_{\text{offset,max}})$	-35.5 dBm	100 kHz
$10 \text{ MHz} \leq \Delta f \leq \Delta f_{\text{max}}$	$10.05 \text{ MHz} \leq f_{\text{offset}} < f_{\text{offset,max}}$	-37 dBm (Note 5)	100 kHz

NOTE 1: For MSR *TAB connector* supporting non-contiguous spectrum operation within any operating band the *basic limit* within sub-block gaps is calculated as a cumulative sum of contributions from adjacent sub blocks on each side of the sub block gap. Exception is $\Delta f \geq 10$ MHz from both adjacent sub blocks on each side of the sub-block gap, where the *basic limit* within sub-block gaps shall be -37 dBm/100 kHz.

NOTE 2: For MSR *multi-band TAB connector* with Inter RF Bandwidth gap $< 2 \cdot \Delta f_{\text{OBUe}}$ MHz the *basic limit* within the Inter RF Bandwidth gaps is calculated as a cumulative sum of contributions from adjacent sub-blocks on each side of the Inter RF Bandwidth gap.

NOTE 3: This frequency range ensures that the range of values of f_{offset} is continuous.

NOTE 5: The requirement is not applicable when $\Delta f_{\text{max}} < 10$ MHz.

**Table 6.6.5.5.2-8: Local Area operating band unwanted emission mask (UEM)
for BC1 for bands > 3 GHz**

Frequency offset of measurement filter -3dB point, Δf	Frequency offset of measurement filter centre frequency, f_{offset}	<i>basic limit</i> (Note 1, 2)	Measurement bandwidth
$0 \text{ MHz} \leq \Delta f < 5 \text{ MHz}$	$0.05 \text{ MHz} \leq f_{\text{offset}} < 5.05 \text{ MHz}$	$-28.2 \text{ dBm} - \frac{7}{5} \left(\frac{f_{\text{offset}}}{\text{MHz}} - 0.05 \right) \text{ dB}$	100 kHz
$5 \text{ MHz} \leq \Delta f < \min(10 \text{ MHz}, \Delta f_{\text{max}})$	$5.05 \text{ MHz} \leq f_{\text{offset}} < \min(10.05 \text{ MHz}, f_{\text{offset}_{\text{max}}})$	-35.2 dBm	100 kHz
$10 \text{ MHz} \leq \Delta f \leq \Delta f_{\text{max}}$	$10.05 \text{ MHz} \leq f_{\text{offset}} < f_{\text{offset}_{\text{max}}}$	-37 dBm (Note 5)	100 kHz

NOTE 1: For MSR *TAB connector* supporting non-contiguous spectrum operation within any operating band the *basic limit* within sub-block gaps is calculated as a cumulative sum of contributions from adjacent sub blocks on each side of the sub block gap. Exception is $\Delta f \geq 10 \text{ MHz}$ from both adjacent sub blocks on each side of the sub-block gap, where the *basic limit* within sub-block gaps shall be -37 dBm/100 kHz.

NOTE 2: For MSR *multi-band TAB connector* with *Inter RF Bandwidth gap* $< 2 * \Delta f_{\text{OBUE}}$ MHz the *basic limit* within the *Inter RF Bandwidth gaps* is calculated as a cumulative sum of contributions from adjacent sub-blocks on each side of the *Inter RF Bandwidth gap*.

NOTE 3: This frequency range ensures that the range of values of f_{offset} is continuous.

NOTE 5: The requirement is not applicable when $\Delta f_{\text{max}} < 10 \text{ MHz}$.

6.6.5.5.3 Basic Limits for MSR Band Category 2

For a *TAB connector* operating in Band Category 2 the requirement applies outside the *Base Station RF Bandwidth edges*. In addition, for a *TAB connector* operating in non-contiguous spectrum, it applies inside any sub-block gap.

Outside the *Base Station RF Bandwidth edges*, *basic limits* are specified in tables 6.6.5.5.3-1 to 6.6.5.5.3-8, where:

- Δf is the separation between the *Base Station RF Bandwidth edge* frequency and the nominal -3dB point of the measuring filter closest to the carrier frequency.
- f_{offset} is the separation between the *Base Station RF Bandwidth edge* frequency and the centre of the measuring filter.
- $f_{\text{offset}_{\text{max}}}$ is the offset to the frequency 10 MHz outside the downlink operating band.
- Δf_{max} is equal to $f_{\text{offset}_{\text{max}}}$ minus half of the bandwidth of the measuring filter.

For a *multi-band TAB connector*, inside any *Inter RF Bandwidth gaps* with $W_{\text{gap}} < 20 \text{ MHz}$, a combined *basic limit* shall be applied which is the cumulative sum of the test requirements specified at the *Base Station RF Bandwidth edges* on each side of the *Inter RF Bandwidth gap*. The *basic limit* for *Base Station RF Bandwidth edge* is specified in tables 6.6.5.5.3-1 to 6.6.5.5.3-8, where in this case:

- Δf is the separation between the *Base Station RF Bandwidth edge* frequency and the nominal -3 dB point of the measuring filter closest to the carrier frequency.
- f_{offset} is the separation between the *Base Station RF Bandwidth edge* frequency and the centre of the measuring filter.
- $f_{\text{offset}_{\text{max}}}$ is equal to the *Inter RF Bandwidth gap* divided by two.
- Δf_{max} is equal to $f_{\text{offset}_{\text{max}}}$ minus half of the bandwidth of the measuring filter.

For a *multi-band TAB connector* and where there is no carrier transmitted in an operating band, no cumulative *basic limits* are applied in the *inter-band gap* between a supported downlink band with carrier(s) transmitted and a supported downlink band without any carrier transmitted and

- In case the *inter-band gap* between a supported downlink band with carrier(s) transmitted and a supported downlink band without any carrier transmitted less than is 20MHz, $f_{\text{offset}_{\text{max}}}$ shall be the offset to the frequency 10 MHz outside the outermost edges of the two supported downlink operating bands and the operating band unwanted emission limit of the band where there are carriers transmitted, as defined in the tables of the present subclause, shall apply across both supported downlink bands.

- In other cases, the operating band unwanted emission limit of the band where there are carriers transmitted, as defined in the tables of the present subclause for the largest frequency offset (Δf_{\max}), shall apply from 10 MHz below the lowest frequency, up to 10 MHz above the highest frequency of the supported downlink operating band without any carrier transmitted.

Inside any sub-block gap for a *TAB connector* operating in non-contiguous spectrum, a combined *basic* limit shall be applied which is the cumulative sum of the test requirement specified for the adjacent sub blocks on each side of the sub block gap. The *basic limit* for each sub block is specified in tables 6.6.5.5.3-1 to 6.6.5.5.3-8, where in this case:

- Δf is the separation between the sub block edge frequency and the nominal -3 dB point of the measuring filter closest to the sub block edge.
- f_{offset} is the separation between the sub block edge frequency and the centre of the measuring filter.
- $f_{\text{offset}_{\max}}$ is equal to the sub block gap bandwidth divided by two.
- Δf_{\max} is equal to $f_{\text{offset}_{\max}}$ minus half of the bandwidth of the measuring filter.

Table 6.6.5.5.3-1: Wide Area BS operating band unwanted emission mask (UEM) for BC2 for BS not supporting NR or BS supporting NR in Band n3 or n8

Frequency offset of measurement filter -3dB point, Δf	Frequency offset of measurement filter centre frequency, f_{offset}	<i>basic limit</i> (Notes 2 and 3)	Measurement bandwidth
$0 \text{ MHz} \leq \Delta f < 0.2 \text{ MHz}$ (Note 1)	$0.015 \text{ MHz} \leq f_{\text{offset}} < 0.215 \text{ MHz}$	-12.5 dBm	30 kHz
$0.2 \text{ MHz} \leq \Delta f < 1 \text{ MHz}$	$0.215 \text{ MHz} \leq f_{\text{offset}} < 1.015 \text{ MHz}$	$-12.5 \text{ dBm} - 15 \cdot \left(\frac{f_{\text{offset}}}{\text{MHz}} - 0.215 \right) \text{ dB}$	30 kHz
(Note 8)	$1.015 \text{ MHz} \leq f_{\text{offset}} < 1.5 \text{ MHz}$	-24.5 dBm	30 kHz
$1 \text{ MHz} \leq \Delta f \leq \min(\Delta f_{\max}, 10 \text{ MHz})$	$1.5 \text{ MHz} \leq f_{\text{offset}} < \min(f_{\text{offset}_{\max}}, 10.5 \text{ MHz})$	-11.5 dBm	1 MHz
$10 \text{ MHz} \leq \Delta f \leq \Delta f_{\max}$	$10.5 \text{ MHz} \leq f_{\text{offset}} < f_{\text{offset}_{\max}}$	-15 dBm (Note 10)	1 MHz
NOTE 1: For operation with a GSM/EDGE or an E-UTRA 1.4 or 3 MHz carrier adjacent to the <i>Base Station RF Bandwidth edge</i> , the limits in table 6.6.5.5.3-2 apply for $0 \text{ MHz} \leq \Delta f < 0.15 \text{ MHz}$.			
NOTE 2: For MSR <i>TAB connector</i> supporting non-contiguous spectrum operation within any operating band the <i>basic limit</i> within sub-block gaps is calculated as a cumulative sum of contributions from adjacent sub blocks on each side of the sub block gap. Exception is $\Delta f \geq 10 \text{ MHz}$ from both adjacent sub blocks on each side of the sub-block gap, where the <i>basic limit</i> within sub-block gaps shall be -15 dBm/MHz.			
NOTE 3: For MSR <i>multi-band TAB connector</i> with <i>Inter RF Bandwidth gap</i> < 20 MHz operation the <i>basic limit</i> within the <i>Inter RF Bandwidth gaps</i> is calculated as a cumulative sum of contributions from adjacent sub-blocks on each side of the <i>Inter RF Bandwidth gap</i> .			
NOTE 8: This frequency range ensures that the range of values of f_{offset} is continuous.			
NOTE 10: The requirement is not applicable when $\Delta f_{\max} < 10 \text{ MHz}$			

Table 6.6.5.3-1a: Wide Area operating band unwanted emission mask (UEM) for BS supporting NR (except operation in band n8) but not supporting UTRA in BC2 bands below 1GHz.

Frequency offset of measurement filter -3dB point, Δf	Frequency offset of measurement filter centre frequency, f_{offset}	Basic limit (Note 1, 2)	Measurement bandwidth (Note 10)
$0 \text{ MHz} \leq \Delta f < 5 \text{ MHz}$	$0.05 \text{ MHz} \leq f_{\text{offset}} < 5.05 \text{ MHz}$	$-5.5 - 7/5(f_{\text{offset}}/\text{MHz} - 0.05) \text{ dB}$	100 kHz
$5 \text{ MHz} \leq \Delta f < \min(10 \text{ MHz}, \Delta f_{\text{max}})$	$5.05 \text{ MHz} \leq f_{\text{offset}} < \min(10.05 \text{ MHz}, f_{\text{offset}_{\text{max}}})$	-12.5 dBm	100 kHz
$10 \text{ MHz} \leq \Delta f \leq \Delta f_{\text{max}}$	$10.05 \text{ MHz} \leq f_{\text{offset}} < f_{\text{offset}_{\text{max}}}$	-16 dBm (Note 11)	100 kHz
<p>NOTE 1: For MSR <i>TAB connector</i> supporting non-contiguous spectrum operation within any operating band, the <i>basic limit</i> within <i>sub-block gaps</i> is calculated as a cumulative sum of contributions from adjacent sub blocks on each side of the sub block gap, where the contribution from the far-end sub-block or <i>RF Bandwidth</i> shall be scaled according to the measurement bandwidth of the near-end sub-block or <i>RF Bandwidth</i>. Exception is $\Delta f \geq 10\text{MHz}$ from both adjacent sub blocks on each side of the <i>sub-block gap</i>, where the <i>basic limit</i> within sub-block gaps shall be -16dBm/100kHz.</p> <p>NOTE 2: For MSR <i>multi band TAB connector</i> with <i>Inter RF Bandwidth gap</i> $< 2 \times \Delta f_{\text{OBU}}$ the <i>basic limit</i> within the <i>Inter RF Bandwidth gaps</i> is calculated as a cumulative sum of contributions from adjacent sub-blocks or <i>RF Bandwidth</i> on each side of the <i>Inter RF Bandwidth gap</i>, where the contribution from the far-end sub-block or <i>RF Bandwidth</i> shall be scaled according to the measurement bandwidth of the near-end sub-block or <i>RF Bandwidth</i>.</p> <p>NOTE 3: For operation with an E-UTRA 1.4 or 3 MHz carrier adjacent to the <i>Base Station RF Bandwidth edge</i>, the limits in table 6.6.5.2.3-2 apply for $0 \text{ MHz} \leq \Delta f < 0.15 \text{ MHz}$.</p>			

Table 6.6.5.3-1b: Wide Area operating band unwanted emission mask (UEM) for BS supporting NR (except operation in band n3) but not supporting UTRA in BC2 bands above 1GHz.

Frequency offset of measurement filter -3dB point, Δf	Frequency offset of measurement filter centre frequency, f_{offset}	Basic limit (Note 1, 2)	Measurement bandwidth (Note 10)
$0 \text{ MHz} \leq \Delta f < 5 \text{ MHz}$	$0.05 \text{ MHz} \leq f_{\text{offset}} < 5.05 \text{ MHz}$	$-5.5 - 7/5(f_{\text{offset}}/\text{MHz} - 0.05) \text{ dB}$	100 kHz
$5 \text{ MHz} \leq \Delta f < \min(10 \text{ MHz}, \Delta f_{\text{max}})$	$5.05 \text{ MHz} \leq f_{\text{offset}} < \min(10.05 \text{ MHz}, f_{\text{offset}_{\text{max}}})$	-12.5 dBm	100 kHz
$10 \text{ MHz} \leq \Delta f \leq \Delta f_{\text{max}}$	$10.5 \text{ MHz} \leq f_{\text{offset}} < f_{\text{offset}_{\text{max}}}$	-15 dBm (Note 11)	1MHz
<p>NOTE 1: For MSR <i>TAB connectors</i> supporting non-contiguous spectrum operation within any operating band, the <i>basic limit</i> within <i>sub-block gaps</i> is calculated as a cumulative sum of contributions from adjacent sub blocks on each side of the <i>sub block gap</i>, where the contribution from the far-end sub-block shall be scaled according to the measurement bandwidth of the near-end sub-block. Exception is $\Delta f \geq 10\text{MHz}$ from both adjacent sub blocks on each side of the <i>sub-block gap</i>, where the <i>basic limit</i> within sub-block gaps shall be -15dBm/1MHz.</p> <p>NOTE 2: For MSR <i>multi band TAB connector</i> with <i>Inter RF Bandwidth gap</i> $< 2 \times \Delta f_{\text{OBU}}$ the <i>basic limit</i> within the <i>Inter RF Bandwidth gaps</i> is calculated as a cumulative sum of contributions from adjacent sub-blocks or <i>RF Bandwidth</i> on each side of the <i>Inter RF Bandwidth gap</i>, where the contribution from the far-end sub-block or <i>RF Bandwidth</i> shall be scaled according to the measurement bandwidth of the near-end sub-block or <i>RF Bandwidth</i>.</p> <p>NOTE 3: For operation with an E-UTRA 1.4 or 3 MHz carrier adjacent to the <i>Base Station RF Bandwidth edge</i>, the limits in table 6.6.5.3-2 apply for $0 \text{ MHz} \leq \Delta f < 0.15 \text{ MHz}$.</p>			

Table 6.6.5.3-2: Wide Area BS operating band unwanted emission limits for operation in BC2 with GSM/EDGE or E-UTRA 1.4 or 3 MHz carriers adjacent to the Base Station RF Bandwidth edge

Frequency offset of measurement filter -3dB point, Δf	Frequency offset of measurement filter centre frequency, f_{offset}	basic limit (Note 2, 3 and 4)	Measurement bandwidth
$0 \text{ MHz} \leq \Delta f < 0.05 \text{ MHz}$	$0.015 \text{ MHz} \leq f_{\text{offset}} < 0.065 \text{ MHz}$	$\text{Max}(6.5 \text{ dBm} - 60 \cdot \left(\frac{f_{\text{offset}}}{\text{MHz}} - 0.015\right) \text{ dB} + X - 12.5 \text{ dBm})$	30 kHz
$0.05 \text{ MHz} \leq \Delta f < 0.15 \text{ MHz}$	$0.065 \text{ MHz} \leq f_{\text{offset}} < 0.165 \text{ MHz}$	$\text{Max}(3.5 \text{ dBm} - 160 \cdot \left(\frac{f_{\text{offset}}}{\text{MHz}} - 0.065\right) \text{ dB} + X - 12.5 \text{ dBm})$	30 kHz

NOTE 1: The limits in this table only apply for operation with a GSM/EDGE or an E-UTRA 1.4 or 3 MHz carrier adjacent to the *Base Station RF Bandwidth edge*.

NOTE 2: For MSR *TAB connector* supporting non-contiguous spectrum operation within any operating band the *basic limit* within sub-block gaps is calculated as a cumulative sum of contributions from adjacent sub blocks on each side of the sub block gap.

NOTE 3: For MSR *multi-band TAB connector* with *Inter RF Bandwidth gap* < 20 MHz the *basic limit* within the *Inter RF Bandwidth gaps* is calculated as a cumulative sum of contributions from adjacent sub-blocks on each side of the *Inter RF Bandwidth gap*.

NOTE 4: In case the carrier adjacent to the *Base Station RF Bandwidth edge* is a GSM/EDGE carrier, the value of $X = P_{\text{GSMcarrier}} - 43$, where $P_{\text{GSMcarrier}}$ is the power level of the GSM/EDGE carrier adjacent to the *Base Station RF Bandwidth edge*. In other cases, $X = 0$.

NOTE 8: This frequency range ensures that the range of values of f_{offset} is continuous.

NOTE 10: The requirement is not applicable when $\Delta f_{\text{max}} < 10 \text{ MHz}$

Table 6.6.5.3-3: Medium Range BS operating band unwanted emission mask (UEM) for BC2, $31 < P_{\text{max,c,cell}} - 10 \cdot \log_{10}(N_{\text{TXU,countedpercell}}) \leq 38 \text{ dBm}$ for a BS not supporting NR

Frequency offset of measurement filter -3dB point, Δf	Frequency offset of measurement filter centre frequency, f_{offset}	basic limit (Notes 2 and 3)	Measurement bandwidth
$0 \text{ MHz} \leq \Delta f < 0.6 \text{ MHz}$ (Note 1)	$0.015 \text{ MHz} \leq f_{\text{offset}} < 0.615 \text{ MHz}$	$P_{\text{max,c,cell}} - 10 \cdot \log_{10}(N_{\text{TXU,countedpercell}}) - 56.5 \text{ dB} - \frac{7}{5} \left(\frac{f_{\text{offset}}}{\text{MHz}} - 0.015\right) \text{ dB}$	30 kHz
$0.6 \text{ MHz} \leq \Delta f < 1 \text{ MHz}$	$0.615 \text{ MHz} \leq f_{\text{offset}} < 1.015 \text{ MHz}$	$P_{\text{max,c,cell}} - 10 \cdot \log_{10}(N_{\text{TXU,countedpercell}}) - 51.5 \text{ dB} - 15 \left(\frac{f_{\text{offset}}}{\text{MHz}} - 0.215\right) \text{ dB}$	30 kHz
(Note 8)	$1.015 \text{ MHz} \leq f_{\text{offset}} < 1.5 \text{ MHz}$	$P_{\text{max,c,cell}} - 10 \cdot \log_{10}(N_{\text{TXU,countedpercell}}) - 63.5 \text{ dB}$	30 kHz
$1 \text{ MHz} \leq \Delta f \leq 2.8 \text{ MHz}$	$1.5 \text{ MHz} \leq f_{\text{offset}} < 3.3 \text{ MHz}$	$P_{\text{max,c,cell}} - 10 \cdot \log_{10}(N_{\text{TXU,countedpercell}}) - 50.5 \text{ dB}$	1 MHz
$2.8 \text{ MHz} \leq \Delta f \leq 5 \text{ MHz}$	$3.3 \text{ MHz} \leq f_{\text{offset}} < 5.5 \text{ MHz}$	$\min(P_{\text{max,c,cell}} - 10 \cdot \log_{10}(N_{\text{TXU,countedpercell}}) - 50.5 \text{ dB}, -13.5 \text{ dBm})$	1 MHz
$5 \text{ MHz} \leq \Delta f \leq \min(\Delta f_{\text{max}}, 10 \text{ MHz})$	$5.5 \text{ MHz} \leq f_{\text{offset}} < \min(f_{\text{offset,max}}, 10.5 \text{ MHz})$	$P_{\text{max,c,cell}} - 10 \cdot \log_{10}(N_{\text{TXU,countedpercell}}) - 54.5 \text{ dB}$	1 MHz
$10 \text{ MHz} \leq \Delta f \leq \Delta f_{\text{max}}$	$10.5 \text{ MHz} \leq f_{\text{offset}} < f_{\text{offset,max}}$	$P_{\text{max,c,cell}} - 10 \cdot \log_{10}(N_{\text{TXU,countedpercell}}) - 56 \text{ dB}$ (Note 10)	1 MHz

NOTE 1: For operation with a GSM/EDGE or an E-UTRA 1.4 or 3 MHz carrier adjacent to the *Base Station RF Bandwidth edge*, the limits in table 6.6.5.3-5 apply for $0 \text{ MHz} \leq \Delta f < 0.15 \text{ MHz}$.

NOTE 2: For MSR *TAB connector* supporting non-contiguous spectrum operation within any operating band the *basic limit* within sub-block gaps is calculated as a cumulative sum of contributions from adjacent sub blocks on each side of the sub block gap. Exception is $\Delta f \geq 10 \text{ MHz}$ from both adjacent sub blocks on each side of the sub-block gap, where the *basic limit* within sub-block gaps shall be $(P_{\text{max,c,cell}} - 10 \cdot \log_{10}(N_{\text{TXU,countedpercell}}) - 56 \text{ dB})/\text{MHz}$.

NOTE 3: For MSR *multi-band TAB connector* with *Inter RF Bandwidth gap* < 20 MHz the *basic limit* within the *Inter RF Bandwidth gaps* is calculated as a cumulative sum of contributions from adjacent sub-blocks on each side of the *Inter RF Bandwidth gap*.

NOTE 8: This frequency range ensures that the range of values of f_{offset} is continuous.

NOTE 10: The requirement is not applicable when $\Delta f_{\text{max}} < 10 \text{ MHz}$

Table 6.6.5.5.3-3a: Medium Range BS operating band unwanted emission mask (UEM) for BS supporting NR and not supporting UTRA in BC2 bands, BS maximum output power $31 < P_{\text{rated,c,cell}}$ $10 \cdot \log_{10}(N_{\text{TXU,countedpercell}}) \leq 38$ dBm

Frequency offset of measurement filter -3dB point, Δf	Frequency offset of measurement filter centre frequency, f_{offset}	Basic limit (Note 1, 2)	Measurement bandwidth (Note 10)
$0 \text{ MHz} \leq \Delta f < 5 \text{ MHz}$	$0.05 \text{ MHz} \leq f_{\text{offset}} < 5.05 \text{ MHz}$	$P_{\text{rated,c,cell}} - 51.5 \text{ dB} - (7/5) \cdot (f_{\text{offset}} / \text{MHz} - 0.05) \text{ dB}$	100 kHz
$5 \text{ MHz} \leq \Delta f < \min(10 \text{ MHz}, \Delta f_{\text{max}})$	$5.05 \text{ MHz} \leq f_{\text{offset}} < \min(10.05 \text{ MHz}, f_{\text{offset,max}})$	$P_{\text{rated,c,cell}} - 61.5 \text{ dB}$	100 kHz
$10 \text{ MHz} \leq \Delta f \leq \Delta f_{\text{max}}$	$10.05 \text{ MHz} \leq f_{\text{offset}} < f_{\text{offset,max}}$	$\text{Min}(P_{\text{rated,c,cell}} - 60 \text{ dB}, -25 \text{ dBm})$ (Note 11)	100 kHz
<p>NOTE 1: For MSR <i>TAB connectors</i> supporting non-contiguous spectrum operation within any operating band the <i>basic limit</i> within <i>sub-block gaps</i> is calculated as a cumulative sum of contributions from adjacent sub blocks on each side of the <i>sub block gap</i>, where the contribution from the far-end sub-block shall be scaled according to the measurement bandwidth of the near-end sub-block. Exception is $\Delta f \geq 10 \text{ MHz}$ from both adjacent sub blocks on each side of the <i>sub-block gap</i>, where the <i>basic limit</i> within sub-block gaps shall be $\text{Min}(P_{\text{rated,c}} - 60 \text{ dB}, -25 \text{ dBm}) / 100 \text{ kHz}$.</p> <p>NOTE 2: For MSR <i>multi band TAB connector</i> with <i>Inter RF Bandwidth gap</i> $< 2 \cdot \Delta f_{\text{OBUE}}$ the <i>basic limit</i> within the <i>Inter RF Bandwidth gaps</i> is calculated as a cumulative sum of contributions from adjacent sub-blocks or <i>RF Bandwidth</i> on each side of the <i>Inter RF Bandwidth gap</i>, where the contribution from the far-end sub-block shall be scaled according to the measurement bandwidth of the near-end sub-block.</p> <p>NOTE 3: For operation with an E-UTRA 1.4 or 3 MHz carrier adjacent to the <i>Base Station RF Bandwidth edge</i>, the limits in table 6.6.5.5.3-5 apply for $0 \text{ MHz} \leq \Delta f < 0.15 \text{ MHz}$.</p>			

Table 6.6.5.5.3-4: Medium Range BS operating band unwanted emission mask (UEM) for BC2, $P_{\text{max,c,cell}} - 10 \cdot \log_{10}(N_{\text{TXU,countedpercell}}) \leq 31$ dBm for a BS not supporting NR.

Frequency offset of measurement filter -3dB point, Δf	Frequency offset of measurement filter centre frequency, f_{offset}	basic limit (Notes 2 and 3)	Measurement bandwidth
$0 \text{ MHz} \leq \Delta f < 0.6 \text{ MHz}$ (Note 1)	$0.015 \text{ MHz} \leq f_{\text{offset}} < 0.615 \text{ MHz}$	$-25.5 \text{ dBm} - \frac{7}{5} \left(\frac{f_{\text{offset}}}{\text{MHz}} - 0.015 \right) \text{ dB}$	30 kHz
$0.6 \text{ MHz} \leq \Delta f < 1 \text{ MHz}$	$0.615 \text{ MHz} \leq f_{\text{offset}} < 1.015 \text{ MHz}$	$-20.5 \text{ dBm} - 15 \cdot \left(\frac{f_{\text{offset}}}{\text{MHz}} - 0.215 \right) \text{ dB}$	30 kHz
(Note 8)	$1.015 \text{ MHz} \leq f_{\text{offset}} < 1.5 \text{ MHz}$	-32.5 dBm	30 kHz
$1 \text{ MHz} \leq \Delta f \leq 5 \text{ MHz}$	$1.5 \text{ MHz} \leq f_{\text{offset}} < 5.5 \text{ MHz}$	-19.5 dBm	1 MHz
$5 \text{ MHz} \leq \Delta f \leq \min(\Delta f_{\text{max}}, 10 \text{ MHz})$	$5.5 \text{ MHz} \leq f_{\text{offset}} < \min(f_{\text{offset,max}}, 10.5 \text{ MHz})$	-23.5 dBm	1 MHz
$10 \text{ MHz} \leq \Delta f \leq \Delta f_{\text{max}}$	$10.5 \text{ MHz} \leq f_{\text{offset}} < f_{\text{offset,max}}$	-25 dBm (Note 10)	1 MHz
<p>NOTE 1: For operation with a GSM/EDGE or an E-UTRA 1.4 or 3 MHz carrier adjacent to the <i>Base Station RF Bandwidth edge</i>, the limits in table 6.6.5.5.3-6 apply for $0 \text{ MHz} \leq \Delta f < 0.15 \text{ MHz}$.</p> <p>NOTE 2: For MSR <i>TAB connector</i> supporting non-contiguous spectrum operation within any operating band the <i>basic limit</i> within sub-block gaps is calculated as a cumulative sum of contributions from adjacent sub blocks on each side of the sub block gap. Exception is $\Delta f \geq 10 \text{ MHz}$ from both adjacent sub blocks on each side of the sub-block gap, where the <i>basic limit</i> within sub-block gaps shall be -25 dBm/MHz.</p> <p>NOTE 3: For MSR <i>multi-band TAB connector</i> with <i>Inter RF Bandwidth gap</i> $< 20 \text{ MHz}$ the <i>basic limit</i> within the <i>Inter RF Bandwidth gaps</i> is calculated as a cumulative sum of contributions from adjacent sub-blocks on each side of the <i>Inter RF Bandwidth gap</i>.</p> <p>NOTE 8: This frequency range ensures that the range of values of f_{offset} is continuous.</p> <p>NOTE 10: The requirement is not applicable when $\Delta f_{\text{max}} < 10 \text{ MHz}$</p>			

Table 6.6.5.3-4a: Medium Range BS operating band unwanted emission mask (UEM) for BS supporting NR but not supporting UTRA in BC2 bands, BS maximum output power $P_{\text{rated,c,cell}}$
 $10 \cdot \log_{10}(N_{\text{TXU,countedpercell}}) \leq 31 \text{ dBm}$

Frequency offset of measurement filter -3dB point, Δf	Frequency offset of measurement filter centre frequency, f_{offset}	Basic limit (Note 1, 2)	Measurement bandwidth (Note 10)
$0 \text{ MHz} \leq \Delta f < 5 \text{ MHz}$	$0.05 \text{ MHz} \leq f_{\text{offset}} < 5.05 \text{ MHz}$	$-20.5 \text{ dBm} - 7/5(f_{\text{offset}}/\text{MHz} - 0.05) \text{ dB}$	100 kHz
$5 \text{ MHz} \leq \Delta f < \min(10 \text{ MHz}, \Delta f_{\text{max}})$	$5.05 \text{ MHz} \leq f_{\text{offset}} < \min(10.05 \text{ MHz}, f_{\text{offset,max}})$	-27.5 dBm	100 kHz
$10 \text{ MHz} \leq \Delta f \leq \Delta f_{\text{max}}$	$10.05 \text{ MHz} \leq f_{\text{offset}} < f_{\text{offset,max}}$	-29 dBm (Note 11)	100 kHz

NOTE 1: For MSR *TAB connectors* supporting non-contiguous spectrum operation within any operating band the *basic limit* within *sub-block gaps* is calculated as a cumulative sum of contributions from adjacent sub blocks on each side of the *sub block gap*, where the contribution from the far-end sub-block shall be scaled according to the measurement bandwidth of the near-end sub-block. Exception is $\Delta f \geq 10\text{MHz}$ from both adjacent sub blocks on each side of the *sub-block gap*, where the *basic limit* within sub-block gaps shall be -29dBm/100kHz.

NOTE 2: For MSR *multi band TAB connector* with *Inter RF Bandwidth gap* $< 2 \times \Delta f_{\text{OBU}}$ the *basic limit* within the *Inter RF Bandwidth gaps* is calculated as a cumulative sum of contributions from adjacent sub-blocks or *RF Bandwidth* on each side of the *Inter RF Bandwidth gap*, where the contribution from the far-end sub-block shall be scaled according to the measurement bandwidth of the near-end sub-block.

NOTE 3: For operation with an E-UTRA 1.4 or 3 MHz carrier adjacent to the *Base Station RF Bandwidth edge*, the limits in table 6.6.5.3-5 apply for $0 \text{ MHz} \leq \Delta f < 0.15 \text{ MHz}$.

Table 6.6.5.3-5: Medium Range operating band unwanted emission limits for operation in BC2 with GSM/EDGE or E-UTRA 1.4 or 3 MHz carriers adjacent to the Base Station RF Bandwidth edge,
 $31 < P_{\text{max,c,cell}} - 10 \cdot \log_{10}(N_{\text{TXU,countedpercell}}) \leq 38 \text{ dBm}$

Frequency offset of measurement filter -3dB point, Δf	Frequency offset of measurement filter centre frequency, f_{offset}	basic limit (Notes 2 and 3)	Measurement bandwidth
$0 \text{ MHz} \leq \Delta f < 0.05 \text{ MHz}$	$0.015 \text{ MHz} \leq f_{\text{offset}} < 0.065 \text{ MHz}$	$P_{\text{max,c,cell}} - 10 \cdot \log_{10}(N_{\text{TXU,countedpercell}}) - 36.5 \text{ dB} - 60 \left(\frac{f_{\text{offset}}}{\text{MHz}} - 0.015 \right) \text{ dB}$	30 kHz
$0.05 \text{ MHz} \leq \Delta f < 0.15 \text{ MHz}$	$0.065 \text{ MHz} \leq f_{\text{offset}} < 0.165 \text{ MHz}$	$P_{\text{max,c,cell}} - 10 \cdot \log_{10}(N_{\text{TXU,countedpercell}}) - 39.5 \text{ dB} - 160 \left(\frac{f_{\text{offset}}}{\text{MHz}} - 0.065 \right) \text{ dB}$	30 kHz

NOTE 1: The limits in this table only apply for operation with a GSM/EDGE or an E-UTRA 1.4 or 3 MHz carrier adjacent to the *Base Station RF Bandwidth edge*.

NOTE 2: For MSR *TAB connector* supporting non-contiguous spectrum operation within any operating band the *basic limit* within sub-block gaps is calculated as a cumulative sum of contributions from adjacent sub blocks on each side of the sub block gap.

NOTE 3: For MSR *multi-band TAB connector* with *Inter RF Bandwidth gap* $< 20 \text{ MHz}$ the *basic limit* within the *Inter RF Bandwidth gaps* is calculated as a cumulative sum of contributions from adjacent sub-blocks on each side of the *Inter RF Bandwidth gap*.

NOTE 8: This frequency range ensures that the range of values of f_{offset} is continuous.

NOTE 10: The requirement is not applicable when $\Delta f_{\text{max}} < 10 \text{ MHz}$

Table 6.6.5.3-6: Medium Range operating band unwanted emission limits for operation in BC2 with GSM/EDGE or E-UTRA 1.4 or 3 MHz carriers adjacent to the *Base Station RF Bandwidth edge*, $P_{\max,c,cell} \cdot 10 \cdot \log_{10}(N_{TXU, \text{counted per cell}}) \leq 31$ dBm

Frequency offset of measurement filter -3dB point, Δf	Frequency offset of measurement filter centre frequency, f_{offset}	<i>basic limit</i> (Notes 2, 3 and 4)	Measurement bandwidth
$0 \text{ MHz} \leq \Delta f < 0.05 \text{ MHz}$	$0.015 \text{ MHz} \leq f_{\text{offset}} < 0.065 \text{ MHz}$	$\text{Max}(-5.5 \text{ dBm} - 60 \cdot \left(\frac{f_{\text{offset}}}{\text{MHz}} - 0.015 \right) \text{ dB} + X \text{ dB}, -25.5 \text{ dBm})$	30 kHz
$0.05 \text{ MHz} \leq \Delta f < 0.15 \text{ MHz}$	$0.065 \text{ MHz} \leq f_{\text{offset}} < 0.165 \text{ MHz}$	$\text{Max}(-8.5 \text{ dBm} - 160 \cdot \left(\frac{f_{\text{offset}}}{\text{MHz}} - 0.065 \right) \text{ dB} + X \text{ dB}, -25.5 \text{ dBm})$	30 kHz

NOTE 1: The limits in this table only apply for operation with a GSM/EDGE or an E-UTRA 1.4 or 3 MHz carrier adjacent to the *Base Station RF Bandwidth edge*.

NOTE 2: For MSR *TAB connector* supporting non-contiguous spectrum operation within any operating band the *basic limit* within sub-block gaps is calculated as a cumulative sum of contributions from adjacent sub blocks on each side of the sub block gap.

NOTE 3: For *multi-band TAB connector* with *Inter RF Bandwidth gap* < 20 MHz the *basic limit* within the *Inter RF Bandwidth gaps* is calculated as a cumulative sum of contributions from adjacent sub-blocks on each side of the *Inter RF Bandwidth gap*.

NOTE 4: In case the carrier adjacent to the *Base Station RF Bandwidth edge* is a GSM/EDGE carrier, the value of $X = P_{\text{GSMcarrier}} - 31$, where $P_{\text{GSMcarrier}}$ is the power level of the GSM/EDGE carrier adjacent to the *Base Station RF Bandwidth edge*. In other cases, $X = 0$.

NOTE 8: This frequency range ensures that the range of values of f_{offset} is continuous.

NOTE 10: The requirement is not applicable when $\Delta f_{\max} < 10$ MHz

Table 6.6.5.3-7: Local Area operating band unwanted emission mask (UEM) for BC2

Frequency offset of measurement filter -3dB point, Δf	Frequency offset of measurement filter centre frequency, f_{offset}	<i>basic limit</i> (Notes 2 and 3)	Measurement bandwidth
$0 \text{ MHz} \leq \Delta f < 5 \text{ MHz}$ (Note 1)	$0.05 \text{ MHz} \leq f_{\text{offset}} < 5.05 \text{ MHz}$	$-28.5 \text{ dBm} - \frac{7}{5} \left(\frac{f_{\text{offset}}}{\text{MHz}} - 0.05 \right) \text{ dB}$	100 kHz
$5 \text{ MHz} \leq \Delta f < \min(10 \text{ MHz}, \Delta f_{\max})$	$5.05 \text{ MHz} \leq f_{\text{offset}} < \min(10.05 \text{ MHz}, f_{\text{offset}_{\max}})$	-35.5 dBm	100 kHz
$10 \text{ MHz} \leq \Delta f \leq \Delta f_{\max}$	$10.05 \text{ MHz} \leq f_{\text{offset}} < f_{\text{offset}_{\max}}$	-37 dBm (Note 7)	100 kHz

NOTE 1: For operation with a GSM/EDGE or an E-UTRA 1.4 or 3 MHz carrier adjacent to the *Base Station RF Bandwidth edge*, the limits in table 6.6.5.3-8 apply for $0 \text{ MHz} \leq \Delta f < 0.16 \text{ MHz}$.

NOTE 2: For MSR *TAB connector* supporting non-contiguous spectrum operation within any operating band the *basic limit* within sub-block gaps is calculated as a cumulative sum of contributions from adjacent sub blocks on each side of the sub block gap. Exception is $\Delta f \geq 10$ MHz from both adjacent sub blocks on each side of the sub-block gap, where the *basic limit* within sub-block gaps shall be -37 dBm/100 kHz.

NOTE 3: For MSR *multi-band TAB connector* with *Inter RF Bandwidth gap* < 20 MHz the *basic limit* within the *Inter RF Bandwidth gaps* is calculated as a cumulative sum of contributions from adjacent sub-blocks on each side of the *Inter RF Bandwidth gap*.

NOTE 8: This frequency range ensures that the range of values of f_{offset} is continuous.

NOTE 10: The requirement is not applicable when $\Delta f_{\max} < 10$ MHz

Table 6.6.5.5.3-8: Local Area operating band unwanted emission limits for operation in BC2 with GSM/EDGE or E-UTRA 1.4 or 3 MHz carriers adjacent to the *Base Station RF Bandwidth edge*

Frequency offset of measurement filter -3dB point, Δf	Frequency offset of measurement filter centre frequency, f_{offset}	<i>basic limit</i> (Notes 2, 3 and 4)	Measurement bandwidth
$0 \text{ MHz} \leq \Delta f < 0.05 \text{ MHz}$	$0.015 \text{ MHz} \leq f_{\text{offset}} < 0.065 \text{ MHz}$	$\text{Max}(-12.5\text{dBm} - 60 \cdot \left(\frac{f_{\text{offset}}}{\text{MHz}} - 0.015\right) \text{dB} + X\text{dB}, -33.5\text{dBm})$	30 kHz
$0.05 \text{ MHz} \leq \Delta f < 0.16 \text{ MHz}$	$0.065 \text{ MHz} \leq f_{\text{offset}} < 0.175 \text{ MHz}$	$\text{Max}(-15.5\text{dBm} - 160 \cdot \left(\frac{f_{\text{offset}}}{\text{MHz}} - 0.065\right) \text{dB} + X\text{dB}, -33.5\text{dBm})$	30 kHz

NOTE 1: The limits in this table only apply for operation with a GSM/EDGE or an E-UTRA 1.4 or 3 MHz carrier adjacent to the *Base Station RF Bandwidth edge*.

NOTE 2: For MSR *TAB connector* supporting non-contiguous spectrum operation within any operating band the *basic limit* within sub-block gaps is calculated as a cumulative sum of contributions from adjacent sub blocks on each side of the sub block gap.

NOTE 3: For MSR *multi-band TAB connector* with *Inter RF Bandwidth gap* < 20 MHz the *basic limit* within the *Inter RF Bandwidth gaps* is calculated as a cumulative sum of contributions from adjacent sub-blocks on each side of the *Inter RF Bandwidth gap*.

NOTE 4: In case the carrier adjacent to the *Base Station RF Bandwidth edge* is a GSM/EDGE carrier, the value of $X = P_{\text{GSMcarrier}} - 24$, where $P_{\text{GSMcarrier}}$ is the power level of the GSM/EDGE carrier adjacent to the *Base Station RF Bandwidth edge*. In other cases, $X = 0$.

NOTE 8: This frequency range ensures that the range of values of f_{offset} is continuous.

NOTE 10: The requirement is not applicable when $\Delta f_{\text{max}} < 10 \text{ MHz}$

6.6.5.5.4 Basic Limits for MSR Additional requirements

6.6.5.5.4.1 Limits in FCC Title 47

In addition to the requirements in subclauses 6.6.5.5.2 and 6.6.5.5.3, the *TAB connector* may have to comply with the applicable *basic limits* established by FCC Title 47 [24], when deployed in regions where those limits are applied, and under the conditions declared by the manufacturer.

6.6.5.5.4.2 Unsynchronized operation for BC3

In certain regions, the following requirements may apply to a TDD *TAB connector* operating in BC3 in the same geographic area and in the same operating band as another TDD system without synchronisation. For this case the emissions *basic limit* is -52 dBm/MHz in each supported downlink operating band except in:

- The frequency range from 10 MHz below the lower *Base Station RF Bandwidth edge* to the frequency 10 MHz above the upper *Base Station RF Bandwidth edge* of each supported band.

NOTE 1: Local or regional regulations may specify another excluded frequency range, which may include frequencies where synchronised TDD systems operate.

NOTE 2: TDD Base Stations that are synchronized and operating in BC3 can transmit without these additional co-existence requirements.

6.6.5.5.4.3 Protection of DTT

In certain regions the following requirement may apply for protection of DTT. For a *TAB connector* operating in Band 20/n20, the level of emissions in the band 470-790 MHz, measured in an 8 MHz filter bandwidth on centre frequencies F_{filter} according to table 6.6.5.5.4.3-1, a *basic limit* $P_{\text{EM,N}}$ is declared by the manufacturer. This requirement applies in the frequency range 470-790 MHz even though part of the range falls in the spurious domain.

Table 6.6.5.5.4.3-1: Declared emissions *basic limit* for protection of DTT

Filter centre frequency, F_{filter}	Measurement bandwidth	Declared emission <i>basic limit</i> (dBm)
$F_{\text{filter}} = 8 \cdot N + 306 \text{ (MHz)}$; $21 \leq N \leq 60$	8 MHz	$P_{\text{EM,N}}$

NOTE: The regional requirement is defined in terms of EIRP (effective isotropic radiated power), which is dependent on both the BS emissions at the *TAB connector* and radiated in the far field. The requirement defined above provides the characteristics of the AAS BS needed to verify compliance with the regional requirement. Compliance with the regional requirement can be determined using the method outlined in annex G of 3GPP TS 36.104 [11].

6.6.5.5.4.4 Co-existence with services in adjacent frequency bands

This requirement may be applied for the protection of systems operating in frequency bands adjacent to Band 1 as defined in subclause 4.5, in geographic areas in which both an adjacent band service and UTRA and/or E-UTRA are deployed.

The *basic limit* shall be.

Table 6.6.5.5.4.4-1: Emissions *basic limits* for protection of adjacent band services

Operating Band	Frequency range	<i>Basic limit</i>	Measurement Bandwidth
1	2100-2105 MHz	$-30 + 3.4 \times (f - 2100 \text{ MHz}) \text{ dBm}$	1 MHz
	2175-2180 MHz	$-30 + 3.4 \times (2180 \text{ MHz} - f) \text{ dBm}$	1 MHz

6.6.5.5.4.5 Additional requirements for band 41

The following requirement may apply to a *TAB connector* operating in Band 41 in certain regions. *Basic limits* are specified in table 6.6.5.5.4.5-1, where:

- Δf is the separation between the *Base Station RF Bandwidth edge* frequency and the nominal -3dB point of the measuring filter closest to the carrier frequency.
- f_{offset} is the separation between the *Base Station RF Bandwidth edge* frequency and the centre of the measuring filter.

Table 6.6.5.5.4.5-1: Additional operating band unwanted emission *basic limits* Band 41

Channel bandwidth	Frequency offset of measurement filter -3dB point, Δf	Frequency offset of measurement filter centre frequency, f_{offset}	<i>basic limit</i>	Measurement bandwidth
10 MHz	$10 \text{ MHz} \leq \Delta f < 20 \text{ MHz}$	$10.5 \text{ MHz} \leq f_{\text{offset}} < 19.5 \text{ MHz}$	-22 dBm	1 MHz
20 MHz	$20 \text{ MHz} \leq \Delta f < 40 \text{ MHz}$	$20.5 \text{ MHz} \leq f_{\text{offset}} < 39.5 \text{ MHz}$	-22 dBm	1 MHz

NOTE: This requirement applies for E-UTRA carriers allocated within 2545-2575 MHz or 2595-2645 MHz.

6.6.5.5.4.6 Additional band 32 unwanted emissions

In certain regions, the following requirements may apply to a *TAB connector* operating in Band 32 within 1452-1492 MHz. The maximum level of operating band unwanted emissions, measured on centre frequencies f_{offset} with filter bandwidth, according to table 6.6.5.5.4.6-1, shall be defined according to the *basic limits* $P_{EM,B32,a}$, $P_{EM,B32,b}$ and $P_{EM,B32,c}$ declared by the manufacturer.

Table 6.6.5.5.4.6-1: Declared operating band 32 unwanted emission within 1452-1492 MHz

Frequency offset of measurement filter centre frequency, f_{offset}	Declared emission <i>basic limit</i> (dBm)	Measurement bandwidth
2.5 MHz	$P_{EM,B32,a}$	5 MHz
7.5 MHz	$P_{EM,B32,b}$	5 MHz
$12.5 \text{ MHz} \leq f_{\text{offset}} \leq f_{\text{offset,max}, B32}$	$P_{EM,B32,c}$	5 MHz

NOTE: $f_{\text{offset,max}, B32}$ denotes the frequency difference between the lower *Base Station RF Bandwidth edge* and 1454.5 MHz, and the frequency difference between the upper *Base Station RF Bandwidth edge* and 1489.5 MHz for the set channel position.

NOTE: The regional requirement, included in [25], is defined in terms of EIRP per antenna, which is dependent on both the BS emissions at the *TAB connector* and radiated in the far field. The requirement defined above provides the characteristics of the AAS BS needed to verify compliance with the regional requirement. The assessment of the EIRP level is described in annex H of 3GPP TS 36.104 [11].

In certain regions, the following requirement may apply to a *TAB connector* operating in Band 32 within 1452-1492MHz for the protection of services in spectrum adjacent to the frequency range 1452-1492 MHz. The maximum level of emissions, measured on centre frequencies F_{filter} with filter bandwidth according to table 6.6.5.5.4.6-2, shall be defined according to the *basic limits* $P_{\text{EM,B32,d}}$ and $P_{\text{EM,B32,e}}$ declared by the manufacturer. This requirement applies in the frequency range 1429-1518MHz even though part of the range falls in the spurious domain.

Table 6.6.5.5.4.6-2: Operating band 32 declared emission outside 1452-1492 MHz

Filter centre frequency, F_{filter}	Declared emission <i>basic limit</i> (dBm)	Measurement bandwidth
$1429.5 \text{ MHz} \leq F_{\text{filter}} \leq 1448.5 \text{ MHz}$	$P_{\text{EM,B32,d}}$	1 MHz
$F_{\text{filter}} = 1450.5 \text{ MHz}$	$P_{\text{EM,B32,e}}$	3 MHz
$F_{\text{filter}} = 1493.5 \text{ MHz}$	$P_{\text{EM,B32,e}}$	3 MHz
$1495.5 \text{ MHz} \leq F_{\text{filter}} \leq 1517.5 \text{ MHz}$	$P_{\text{EM,B32,d}}$	1 MHz

NOTE: The regional requirement, included in [23], is defined in terms of EIRP, which is dependent on both the BS emissions at the antenna connector and radiated in the far field. The requirement defined above provides the characteristics of the AAS BS needed to verify compliance with the regional requirement. The assessment of the EIRP level is described in annex H of 3GPP TS 36.104 [11].

6.6.5.5.4.7 Additional requirements for Band 48

The following requirement may apply to AAS BS operating in Band 48 in certain regions. Emissions shall not exceed the maximum levels specified in Table 6.6.2.5.4.7-1.

Table 6.6.2.5.4.7-1: Additional operating band unwanted emission limits for Band 48

Channel bandwidth	Frequency offset of measurement filter -3dB point, Δf	Frequency offset of measurement filter centre frequency, f_{offset}	Minimum requirement	Measurement bandwidth
All	$0 \text{ MHz} \leq \Delta f < 10 \text{ MHz}$	$0.5 \text{ MHz} \leq f_{\text{offset}} < 9.5 \text{ MHz}$	-13 dBm	1 MHz

6.6.5.5.5 Basic Limits for E-UTRA

6.6.5.5.5.1 General

The measurement results in subclause 6.6.5.4 shall not exceed the maximum levels based on the *basic limits* in the tables below, where:

- Δf is the separation between the channel edge frequency and the nominal -3dB point of the measuring filter closest to the carrier frequency.
- f_{offset} is the separation between the channel edge frequency and the centre of the measuring filter.
- $f_{\text{offset}_{\text{max}}}$ is the offset to the frequency 10 MHz outside the downlink operating band.
- Δf_{max} is equal to $f_{\text{offset}_{\text{max}}}$ minus half of the bandwidth of the measuring filter.

For a *multi-band TAB connector*, inside any *Inter RF Bandwidth gaps* with $W_{\text{gap}} < 20 \text{ MHz}$, a combined *basic limit* shall be applied which is the cumulative sum of the test requirements specified at the *Base Station RF Bandwidth edges* on each side of the *Inter RF Bandwidth gap*. The *basic limit* for *Base Station RF Bandwidth edge* is specified in tables 6.6.5.5.5.2-1 to 6.6.5.5.5.2-9, where in this case:

- Δf is the separation between the *Base Station RF Bandwidth edge* frequency and the nominal -3 dB point of the measuring filter closest to the *Base Station RF Bandwidth edge*.
- f_{offset} is the separation between the *Base Station RF Bandwidth edge* frequency and the centre of the measuring filter.

- $f_{\text{offset}_{\text{max}}}$ is equal to the *Inter RF Bandwidth gap* minus half of the bandwidth of the measuring filter.
- Δf_{max} is equal to $f_{\text{offset}_{\text{max}}}$ minus half of the bandwidth of the measuring filter.

For *multi-band TAB connector*, the operating band unwanted emission limits apply also in a supported operating band without any carrier transmitted, in the case where there are carrier(s) transmitted in another supported operating band. In this case, no cumulative *basic limit* is applied in the *inter-band gap* between a supported downlink operating band with carrier(s) transmitted and a supported downlink operating band without any carrier transmitted and:

- In case the *inter-band gap* between a supported downlink operating band with carrier(s) transmitted and a supported downlink operating band without any carrier transmitted is less than 20 MHz, $f_{\text{offset}_{\text{max}}}$ shall be the offset to the frequency 10 MHz outside the outermost edges of the two supported downlink operating bands and the operating band unwanted emission limit of the band where there are carriers transmitted, as defined in the tables of the present subclause, shall apply across both downlink bands.
- In other cases, the operating band unwanted emission limit of the band where there are carriers transmitted, as defined in the tables of the present subclause for the largest frequency offset (Δf_{max}), shall apply from 10 MHz below the lowest frequency, up to 10 MHz above the highest frequency of the supported downlink operating band without any carrier transmitted.

For a multicarrier E-UTRA TAB connector or a *TAB connector* configured for intra-band contiguous or non-contiguous carrier aggregation the definitions above apply to the lower edge of the carrier transmitted at the lowest carrier frequency and the upper edge of the carrier transmitted at the highest carrier frequency within a specified frequency band.

In addition inside any sub-block gap for a *TAB connector* operating in non-contiguous spectrum, measurement results shall not exceed a level based on a combined *basic limit* shall be applied which is the cumulative sum specified for the adjacent sub blocks on each side of the sub block gap. The *basic limit* for each sub block is specified in tables 6.6.5.5.5.2-1 to 6.6.5.5.5.2-9, where in this case:

- Δf is the separation between the sub block edge frequency and the nominal -3 dB point of the measuring filter closest to the sub block edge.
- f_{offset} is the separation between the sub block edge frequency and the centre of the measuring filter.
- $f_{\text{offset}_{\text{max}}}$ is equal to the sub block gap bandwidth minus half of the bandwidth of the measuring filter.
- Δf_{max} is equal to $f_{\text{offset}_{\text{max}}}$ minus half of the bandwidth of the measuring filter.

6.6.5.5.5.2 Basic Limits for Wide Area BS (Category A)

For E-UTRA *TAB connector* operating in Bands 5, 6, 8, 12, 13, 14, 17, 18, 19, 26, 27, 28, 29, 31, 44, 68 *basic limits* are specified in tables 6.6.5.5.5.2-1 to 6.6.5.5.5.2-3.

Table 6.6.5.5.2-1: Wide Area BS operating band unwanted emission limits for 1.4 MHz channel bandwidth (E-UTRA bands < 1 GHz) for Category A

Frequency offset of measurement filter -3dB point, Δf	Frequency offset of measurement filter centre frequency, f_{offset}	<i>basic limit</i> (Notes 1 and 2)	Measurement bandwidth
$0 \text{ MHz} \leq \Delta f < 1.4 \text{ MHz}$	$0.05 \text{ MHz} \leq f_{\text{offset}} < 1.45 \text{ MHz}$	$+0.5 \text{ dBm} - \frac{10}{1.4} \cdot \left(\frac{f_{\text{offset}}}{\text{MHz}} - 0.05 \right) \text{ dB}$	100 kHz
$1.4 \text{ MHz} \leq \Delta f < 2.8 \text{ MHz}$	$1.45 \text{ MHz} \leq f_{\text{offset}} < 2.85 \text{ MHz}$	-9.5 dBm	100 kHz
$2.8 \text{ MHz} \leq \Delta f \leq \Delta f_{\text{max}}$	$2.85 \text{ MHz} \leq f_{\text{offset}} < f_{\text{offset}_{\text{max}}}$	-13 dBm (Note 8)	100 kHz
NOTE 1: For a <i>TAB connector</i> supporting non-contiguous spectrum operation within any operating band the <i>basic limit</i> within sub-block gaps is calculated as a cumulative sum of contributions from adjacent sub blocks on each side of the sub block gap. Exception is $\Delta f \geq 10 \text{ MHz}$ from both adjacent sub blocks on each side of the sub-block gap, where the <i>basic limit</i> within sub-block gaps shall be -13 dBm/100 kHz.			
NOTE 2: For a <i>multi-band TAB connector</i> with <i>Inter RF Bandwidth gap</i> < 20 MHz the <i>basic limit</i> within the <i>Inter RF Bandwidth gaps</i> is calculated as a cumulative sum of contributions from adjacent sub-blocks or <i>Base Station RF Bandwidth</i> on each side of the <i>Inter RF Bandwidth gap</i> .			
NOTE 8: The requirement is not applicable when $\Delta f_{\text{max}} < 10 \text{ MHz}$.			

Table 6.6.5.5.2-2: Wide Area BS operating band unwanted emission limits for 3 MHz channel bandwidth (E-UTRA bands < 1 GHz) for Category A

Frequency offset of measurement filter -3dB point, Δf	Frequency offset of measurement filter centre frequency, f_{offset}	<i>basic limit</i> (Notes 1 and 2)	Measurement bandwidth
$0 \text{ MHz} \leq \Delta f < 3 \text{ MHz}$	$0.05 \text{ MHz} \leq f_{\text{offset}} < 3.05 \text{ MHz}$	$-3.5 \text{ dBm} - \frac{10}{3} \cdot \left(\frac{f_{\text{offset}}}{\text{MHz}} - 0.05 \right) \text{ dB}$	100 kHz
$3 \text{ MHz} \leq \Delta f < 6 \text{ MHz}$	$3.05 \text{ MHz} \leq f_{\text{offset}} < 6.05 \text{ MHz}$	-13.5 dBm	100 kHz
$6 \text{ MHz} \leq \Delta f \leq \Delta f_{\text{max}}$	$6.05 \text{ MHz} \leq f_{\text{offset}} < f_{\text{offsetmax}}$	-13 dBm (Note 8)	100 kHz
<p>NOTE 1: For a <i>TAB connector</i> supporting non-contiguous spectrum operation within any operating band the <i>basic limit</i> within sub-block gaps is calculated as a cumulative sum of contributions from adjacent sub blocks on each side of the sub block gap. Exception is $\Delta f \geq 10 \text{ MHz}$ from both adjacent sub blocks on each side of the sub-block gap, where the <i>basic limit</i> within sub-block gaps shall be -13 dBm/100 kHz.</p> <p>NOTE 2: For a <i>multi-band TAB connector</i> with <i>Inter RF Bandwidth gap</i> < 20 MHz the <i>basic limit</i> within the <i>Inter RF Bandwidth gaps</i> is calculated as a cumulative sum of contributions from adjacent sub-blocks or <i>Base Station RF Bandwidth</i> on each side of the <i>Inter RF Bandwidth gap</i>.</p> <p>NOTE 8: The requirement is not applicable when $\Delta f_{\text{max}} < 10 \text{ MHz}$.</p>			

Table 6.6.5.5.2-3: Wide Area BS operating band unwanted emission limits for 5, 10, 15 and 20 MHz channel bandwidth (E-UTRA bands < 1 GHz) for Category A

Frequency offset of measurement filter -3dB point, Δf	Frequency offset of measurement filter centre frequency, f_{offset}	Test requirement (Notes 1 and 2)	Measurement bandwidth
$0 \text{ MHz} \leq \Delta f < 5 \text{ MHz}$	$0.05 \text{ MHz} \leq f_{\text{offset}} < 5.05 \text{ MHz}$	$-5.5 \text{ dBm} - \frac{7}{5} \cdot \left(\frac{f_{\text{offset}}}{\text{MHz}} - 0.05 \right) \text{ dB}$	100 kHz
$5 \text{ MHz} \leq \Delta f < \min(10 \text{ MHz}, \Delta f_{\text{max}})$	$5.05 \text{ MHz} \leq f_{\text{offset}} < \min(10.05 \text{ MHz}, f_{\text{offsetmax}})$	-12.5 dBm	100 kHz
$10 \text{ MHz} \leq \Delta f \leq \Delta f_{\text{max}}$	$10.05 \text{ MHz} \leq f_{\text{offset}} < f_{\text{offsetmax}}$	-13 dBm (Note 8)	100 kHz
<p>NOTE 1: For a <i>TAB connector</i> supporting non-contiguous spectrum operation within any operating band the <i>basic limit</i> within sub-block gaps is calculated as a cumulative sum of contributions from adjacent sub blocks on each side of the sub block gap. Exception is $\Delta f \geq 10 \text{ MHz}$ from both adjacent sub blocks on each side of the sub-block gap, where the <i>basic limit</i> within sub-block gaps shall be -13 dBm/100 kHz.</p> <p>NOTE 2: For a <i>multi-band TAB connector</i> with <i>Inter RF Bandwidth gap</i> < 20 MHz the <i>basic limit</i> within the <i>Inter RF Bandwidth gaps</i> is calculated as a cumulative sum of contributions from adjacent sub-blocks or <i>Base Station RF Bandwidth</i> on each side of the <i>Inter RF Bandwidth gap</i>.</p> <p>NOTE 8: The requirement is not applicable when $\Delta f_{\text{max}} < 10 \text{ MHz}$.</p>			

For E-UTRA *TAB connector* operating in Bands 1, 2, 3, 4, 7, 9, 10, 11, 21, 23, 24, 25, 30, 32, 33, 34, 35, 36, 37, 38, 39, 40, 41, 45, 48, 65, 66, 69, 70, *basic limits* are specified in tables 6.6.5.5.2-4, 6.6.5.5.2-6 and 6.6.5.5.2-8.

For E-UTRA *TAB connector* operating in Bands 22, 42, 43, *basic limits* are specified in tables 6.6.5.5.2-5, 6.6.5.5.2-7 and 6.6.5.5.2-9.

Table 6.6.5.5.2-4: Wide Area BS operating band unwanted emission limits for 1.4 MHz channel bandwidth (1GHz < E-UTRA bands ≤ 3 GHz) for Category A

Frequency offset of measurement filter -3dB point, Δf	Frequency offset of measurement filter centre frequency, f_{offset}	<i>basic limit</i> (Notes 1 and 2)	Measurement bandwidth
$0 \text{ MHz} \leq \Delta f < 1.4 \text{ MHz}$	$0.05 \text{ MHz} \leq f_{\text{offset}} < 1.45 \text{ MHz}$	$+0.5\text{dBm} - \frac{10}{1.4} \cdot \left(\frac{f_{\text{offset}}}{\text{MHz}} - 0.05 \right) \text{dB}$	100 kHz
$1.4 \text{ MHz} \leq \Delta f < 2.8 \text{ MHz}$	$1.45 \text{ MHz} \leq f_{\text{offset}} < 2.85 \text{ MHz}$	-9.5 dBm	100 kHz
$2.8 \text{ MHz} \leq \Delta f \leq \Delta f_{\text{max}}$	$3.3 \text{ MHz} \leq f_{\text{offset}} < f_{\text{offset}_{\text{max}}}$	-13 dBm (Note 8)	1 MHz
NOTE 1: For a <i>TAB connector</i> supporting non-contiguous spectrum operation within any operating band the <i>basic limit</i> within sub-block gaps is calculated as a cumulative sum of contributions from adjacent sub blocks on each side of the sub block gap, where the contribution from the far-end sub-block shall be scaled according to the measurement bandwidth of the near-end sub-block. Exception is $\Delta f \geq 10 \text{ MHz}$ from both adjacent sub blocks on each side of the sub-block gap, where the <i>basic limit</i> within sub-block gaps shall be -13 dBm/1 MHz.			
NOTE 2: For a <i>multi-band TAB connector</i> with <i>Inter RF Bandwidth gap</i> < 20 MHz the <i>basic limit</i> within the <i>Inter RF Bandwidth gaps</i> is calculated as a cumulative sum of contributions from adjacent sub-blocks or <i>Base Station RF Bandwidth</i> on each side of the <i>Inter RF Bandwidth gap</i> , where the contribution from the far-end sub-block or <i>Base Station RF Bandwidth</i> shall be scaled according to the measurement bandwidth of the near-end sub-block or <i>Base Station RF Bandwidth</i> .			
NOTE 8: The requirement is not applicable when $\Delta f_{\text{max}} < 10 \text{ MHz}$.			

Table 6.6.5.5.2-5: Wide Area BS operating band unwanted emission limits for 1.4 MHz channel bandwidth (E-UTRA bands > 3 GHz) for Category A

Frequency offset of measurement filter -3dB point, Δf	Frequency offset of measurement filter centre frequency, f_{offset}	<i>basic limit</i> (Notes 1 and 2)	Measurement bandwidth
$0 \text{ MHz} \leq \Delta f < 1.4 \text{ MHz}$	$0.05 \text{ MHz} \leq f_{\text{offset}} < 1.45 \text{ MHz}$	$+0.8\text{dBm} - \frac{10}{1.4} \cdot \left(\frac{f_{\text{offset}}}{\text{MHz}} - 0.05 \right) \text{dB}$	100 kHz
$1.4 \text{ MHz} \leq \Delta f < 2.8 \text{ MHz}$	$1.45 \text{ MHz} \leq f_{\text{offset}} < 2.85 \text{ MHz}$	-9.2 dBm	100 kHz
$2.8 \text{ MHz} \leq \Delta f \leq \Delta f_{\text{max}}$	$3.3 \text{ MHz} \leq f_{\text{offset}} < f_{\text{offset}_{\text{max}}}$	-13 dBm (Note 8)	1 MHz
NOTE 1: For a <i>TAB connector</i> supporting non-contiguous spectrum operation within any operating band the <i>basic limit</i> within sub-block gaps is calculated as a cumulative sum of contributions from adjacent sub blocks on each side of the sub block gap, where the contribution from the far-end sub-block shall be scaled according to the measurement bandwidth of the near-end sub-block. Exception is $\Delta f \geq 10 \text{ MHz}$ from both adjacent sub blocks on each side of the sub-block gap, where the <i>basic limit</i> within sub-block gaps shall be -13 dBm/1 MHz.			
NOTE 2: For a <i>multi-band TAB connector</i> with <i>Inter RF Bandwidth gap</i> < 20 MHz the <i>basic limit</i> within the <i>Inter RF Bandwidth gaps</i> is calculated as a cumulative sum of contributions from adjacent sub-blocks or <i>Base Station RF Bandwidth</i> on each side of the <i>Inter RF Bandwidth gap</i> , where the contribution from the far-end sub-block or <i>Base Station RF Bandwidth</i> shall be scaled according to the measurement bandwidth of the near-end sub-block or <i>Base Station RF Bandwidth</i> .			
NOTE 8: The requirement is not applicable when $\Delta f_{\text{max}} < 10 \text{ MHz}$.			

Table 6.6.5.5.2-6: Wide Area BS operating band unwanted emission limits for 3 MHz channel bandwidth (1GHz < E-UTRA bands ≤ 3 GHz) for Category A

Frequency offset of measurement filter -3dB point, Δf	Frequency offset of measurement filter centre frequency, f_{offset}	<i>basic limit</i> (Notes 1 and 2)	Measurement bandwidth
$0 \text{ MHz} \leq \Delta f < 3 \text{ MHz}$	$0.05 \text{ MHz} \leq f_{\text{offset}} < 3.05 \text{ MHz}$	$-3.5 \text{ dBm} - \frac{10}{3} \cdot \left(\frac{f_{\text{offset}}}{\text{MHz}} - 0.05 \right) \text{ dB}$	100 kHz
$3 \text{ MHz} \leq \Delta f < 6 \text{ MHz}$	$3.05 \text{ MHz} \leq f_{\text{offset}} < 6.05 \text{ MHz}$	-13.5 dBm	100 kHz
$6 \text{ MHz} \leq \Delta f \leq \Delta f_{\text{max}}$	$6.5 \text{ MHz} \leq f_{\text{offset}} < f_{\text{offset}_{\text{max}}}$	-13 dBm (Note 8)	1 MHz
<p>NOTE 1: For a <i>TAB connector</i> supporting non-contiguous spectrum operation within any operating band the <i>basic limit</i> within sub-block gaps is calculated as a cumulative sum of contributions from adjacent sub blocks on each side of the sub block gap, where the contribution from the far-end sub-block shall be scaled according to the measurement bandwidth of the near-end sub-block. Exception is $\Delta f \geq 10 \text{ MHz}$ from both adjacent sub blocks on each side of the sub-block gap, where the <i>basic limit</i> within sub-block gaps shall be -13 dBm/1 MHz.</p> <p>NOTE 2: For a <i>multi-band TAB connector</i> with <i>Inter RF Bandwidth gap</i> < 20 MHz the <i>basic limit</i> within the <i>Inter RF Bandwidth gaps</i> is calculated as a cumulative sum of contributions from adjacent sub-blocks or <i>Base Station RF Bandwidth</i> on each side of the <i>Inter RF Bandwidth gap</i>, where the contribution from the far-end sub-block or <i>Base Station RF Bandwidth</i> shall be scaled according to the measurement bandwidth of the near-end sub-block or <i>Base Station RF Bandwidth</i>.</p> <p>NOTE 8: The requirement is not applicable when $\Delta f_{\text{max}} < 10 \text{ MHz}$.</p>			

Table 6.6.5.5.2-7: Wide Area BS operating band unwanted emission limits for 3 MHz channel bandwidth (E-UTRA bands > 3 GHz) for Category A

Frequency offset of measurement filter -3dB point, Δf	Frequency offset of measurement filter centre frequency, f_{offset}	<i>basic limit</i> (Notes 1 and 2)	Measurement bandwidth
$0 \text{ MHz} \leq \Delta f < 3 \text{ MHz}$	$0.05 \text{ MHz} \leq f_{\text{offset}} < 3.05 \text{ MHz}$	$-3.2 \text{ dBm} - \frac{10}{3} \cdot \left(\frac{f_{\text{offset}}}{\text{MHz}} - 0.05 \right) \text{ dB}$	100 kHz
$3 \text{ MHz} \leq \Delta f < 6 \text{ MHz}$	$3.05 \text{ MHz} \leq f_{\text{offset}} < 6.05 \text{ MHz}$	-13.2 dBm	100 kHz
$6 \text{ MHz} \leq \Delta f \leq \Delta f_{\text{max}}$	$6.5 \text{ MHz} \leq f_{\text{offset}} < f_{\text{offset}_{\text{max}}}$	-13 dBm (Note 8)	1 MHz
<p>NOTE 1: For a <i>TAB connector</i> supporting non-contiguous spectrum operation within any operating band the <i>basic limit</i> within sub-block gaps is calculated as a cumulative sum of contributions from adjacent sub blocks on each side of the sub block gap, where the contribution from the far-end sub-block shall be scaled according to the measurement bandwidth of the near-end sub-block. Exception is $\Delta f \geq 10 \text{ MHz}$ from both adjacent sub blocks on each side of the sub-block gap, where the <i>basic limit</i> within sub-block gaps shall be -13 dBm/1 MHz.</p> <p>NOTE 2: For a <i>multi-band TAB connector</i> with <i>Inter RF Bandwidth gap</i> < 20 MHz the <i>basic limit</i> within the <i>Inter RF Bandwidth gaps</i> is calculated as a cumulative sum of contributions from adjacent sub-blocks or <i>Base Station RF Bandwidth</i> on each side of the <i>Inter RF Bandwidth gap</i>, where the contribution from the far-end sub-block or <i>Base Station RF Bandwidth</i> shall be scaled according to the measurement bandwidth of the near-end sub-block or <i>Base Station RF Bandwidth</i>.</p> <p>NOTE 8: The requirement is not applicable when $\Delta f_{\text{max}} < 10 \text{ MHz}$.</p>			

Table 6.6.5.5.2-8: Wide Area BS operating band unwanted emission limits for 5, 10, 15 and 20 MHz channel bandwidth (1GHz < E-UTRA bands ≤ 3 GHz) for Category A

Frequency offset of measurement filter -3dB point, Δf	Frequency offset of measurement filter centre frequency, f_{offset}	<i>basic limit</i> (Notes 1 and 2)	Measurement bandwidth
$0 \text{ MHz} \leq \Delta f < 5 \text{ MHz}$	$0.05 \text{ MHz} \leq f_{\text{offset}} < 5.05 \text{ MHz}$	$-5.5 \text{ dBm} - \frac{7}{5} \cdot \left(\frac{f_{\text{offset}}}{\text{MHz}} - 0.05 \right) \text{ dB}$	100 kHz
$5 \text{ MHz} \leq \Delta f < \min(10 \text{ MHz}, \Delta f_{\text{max}})$	$5.05 \text{ MHz} \leq f_{\text{offset}} < \min(10.05 \text{ MHz}, f_{\text{offset}_{\text{max}}})$	-12.5 dBm	100 kHz
$10 \text{ MHz} \leq \Delta f \leq \Delta f_{\text{max}}$	$10.5 \text{ MHz} \leq f_{\text{offset}} < f_{\text{offset}_{\text{max}}}$	-13 dBm (Note 8)	1 MHz
<p>NOTE 1: For a <i>TAB connector</i> supporting non-contiguous spectrum operation within any operating band the <i>basic limit</i> within sub-block gaps is calculated as a cumulative sum of contributions from adjacent sub blocks on each side of the sub block gap, where the contribution from the far-end sub-block shall be scaled according to the measurement bandwidth of the near-end sub-block. Exception is $\Delta f \geq 10 \text{ MHz}$ from both adjacent sub blocks on each side of the sub-block gap, where the <i>basic limit</i> within sub-block gaps shall be -13 dBm/1 MHz.</p> <p>NOTE 2: For a <i>multi-band TAB connector</i> with <i>Inter RF Bandwidth gap</i> < 20 MHz the <i>basic limit</i> within the <i>Inter RF Bandwidth gaps</i> is calculated as a cumulative sum of contributions from adjacent sub-blocks or <i>Base Station RF Bandwidth</i> on each side of the <i>Inter RF Bandwidth gap</i>, where the contribution from the far-end sub-block or <i>Base Station RF Bandwidth</i> shall be scaled according to the measurement bandwidth of the near-end sub-block or <i>Base Station RF Bandwidth</i>.</p> <p>NOTE 8: The requirement is not applicable when $\Delta f_{\text{max}} < 10 \text{ MHz}$.</p>			

Table 6.6.5.5.2-9: Wide Area BS operating band unwanted emission limits for 5, 10, 15 and 20 MHz channel bandwidth (E-UTRA bands > 3 GHz) for Category A

Frequency offset of measurement filter -3dB point, Δf	Frequency offset of measurement filter centre frequency, f_{offset}	<i>basic limit</i> (Notes 1 and 2)	Measurement bandwidth
$0 \text{ MHz} \leq \Delta f < 5 \text{ MHz}$	$0.05 \text{ MHz} \leq f_{\text{offset}} < 5.05 \text{ MHz}$	$-5.2 \text{ dBm} - \frac{7}{5} \cdot \left(\frac{f_{\text{offset}}}{\text{MHz}} - 0.05 \right) \text{ dB}$	100 kHz
$5 \text{ MHz} \leq \Delta f < \min(10 \text{ MHz}, \Delta f_{\text{max}})$	$5.05 \text{ MHz} \leq f_{\text{offset}} < \min(10.05 \text{ MHz}, f_{\text{offset}_{\text{max}}})$	-12.2 dBm	100 kHz
$10 \text{ MHz} \leq \Delta f \leq \Delta f_{\text{max}}$	$10.5 \text{ MHz} \leq f_{\text{offset}} < f_{\text{offset}_{\text{max}}}$	-13 dBm (Note 8)	1 MHz
<p>NOTE 1: For a <i>TAB connector</i> supporting non-contiguous spectrum operation within any operating band the <i>basic limit</i> within sub-block gaps is calculated as a cumulative sum of contributions from adjacent sub blocks on each side of the sub block gap, where the contribution from the far-end sub-block shall be scaled according to the measurement bandwidth of the near-end sub-block. Exception is $\Delta f \geq 10 \text{ MHz}$ from both adjacent sub blocks on each side of the sub-block gap, where the <i>basic limit</i> within sub-block gaps shall be -13 dBm/1 MHz.</p> <p>NOTE 2: For a <i>multi-band TAB connector</i> with <i>Inter RF Bandwidth gap</i> < 20 MHz the <i>basic limit</i> within the <i>Inter RF Bandwidth gaps</i> is calculated as a cumulative sum of contributions from adjacent sub-blocks or <i>Base Station RF Bandwidth</i> on each side of the <i>Inter RF Bandwidth gap</i>, where the contribution from the far-end sub-block or <i>Base Station RF Bandwidth</i> shall be scaled according to the measurement bandwidth of the near-end sub-block or <i>Base Station RF Bandwidth</i>.</p> <p>NOTE 8: The requirement is not applicable when $\Delta f_{\text{max}} < 10 \text{ MHz}$.</p>			

6.6.5.5.3 Basic limits for Wide Area BS Category B (Option1)

For Category B Operating band unwanted emissions, there are two options for the limits that may be applied regionally, option 1 is as follows. For E-UTRA *TAB connector* operating in Bands 5, 8, 12, 13, 14, 17, 20, 26, 27, 28, 29, 31, 44, 67, 68 *basic limits* are specified in tables 6.6.5.5.3-1 to 6.6.5.5.3-3.

Table 6.6.5.5.3-1: Wide Area BS operating band unwanted emission limits for 1.4 MHz channel bandwidth (E-UTRA bands < 1 GHz) for Category B

Frequency offset of measurement filter -3dB point, Δf	Frequency offset of measurement filter centre frequency, f_{offset}	<i>basic limit</i> (Notes 1 and 2)	Measurement bandwidth
$0 \text{ MHz} \leq \Delta f < 1.4 \text{ MHz}$	$0.05 \text{ MHz} \leq f_{\text{offset}} < 1.45 \text{ MHz}$	$+0.5\text{dBm} - \frac{10}{1.4} \cdot \left(\frac{f_{\text{offset}}}{\text{MHz}} - 0.05 \right) \text{dB}$	100 kHz
$1.4 \text{ MHz} \leq \Delta f < 2.8 \text{ MHz}$	$1.45 \text{ MHz} \leq f_{\text{offset}} < 2.85 \text{ MHz}$	-9.5 dBm	100 kHz
$2.8 \text{ MHz} \leq \Delta f \leq \Delta f_{\text{max}}$	$2.85 \text{ MHz} \leq f_{\text{offset}} < f_{\text{offset}_{\text{max}}}$	-16 dBm (Note 8)	100 kHz

NOTE 1: For a *TAB connector* supporting non-contiguous spectrum operation within any operating band the *basic limit* within sub-block gaps is calculated as a cumulative sum of contributions from adjacent sub blocks on each side of the sub block gap. Exception is $\Delta f \geq 10 \text{ MHz}$ from both adjacent sub blocks on each side of the sub-block gap, where the *basic limit* within sub-block gaps shall be -16 dBm/100 kHz.

NOTE 2: For a *multi-band TAB connector* with *Inter RF Bandwidth gap* < 20 MHz the *basic limit* within the *Inter RF Bandwidth gaps* is calculated as a cumulative sum of contributions from adjacent sub-blocks or *Base Station RF Bandwidth* on each side of the *Inter RF Bandwidth gap*.

NOTE 8: The requirement is not applicable when $\Delta f_{\text{max}} < 10 \text{ MHz}$.

Table 6.6.5.5.3-2: Wide Area BS operating band unwanted emission limits for 3 MHz channel bandwidth (E-UTRA bands < 1 GHz) for Category B

Frequency offset of measurement filter -3dB point, Δf	Frequency offset of measurement filter centre frequency, f_{offset}	<i>basic limit</i> (Notes 1 and 2)	Measurement bandwidth
$0 \text{ MHz} \leq \Delta f < 3 \text{ MHz}$	$0.05 \text{ MHz} \leq f_{\text{offset}} < 3.05 \text{ MHz}$	$-3.5\text{dBm} - \frac{10}{3} \cdot \left(\frac{f_{\text{offset}}}{\text{MHz}} - 0.05 \right) \text{dB}$	100 kHz
$3 \text{ MHz} \leq \Delta f < 6 \text{ MHz}$	$3.05 \text{ MHz} \leq f_{\text{offset}} < 6.05 \text{ MHz}$	-13.5 dBm	100 kHz
$6 \text{ MHz} \leq \Delta f \leq \Delta f_{\text{max}}$	$6.05 \text{ MHz} \leq f_{\text{offset}} < f_{\text{offset}_{\text{max}}}$	-16 dBm (Note 8)	100 kHz

NOTE 1: For a *TAB connector* supporting non-contiguous spectrum operation within any operating band the *basic limit* within sub-block gaps is calculated as a cumulative sum of contributions from adjacent sub blocks on each side of the sub block gap. Exception is $\Delta f \geq 10 \text{ MHz}$ from both adjacent sub blocks on each side of the sub-block gap, where the *basic limit* within sub-block gaps shall be -16 dBm/100 kHz.

NOTE 2: For a *multi-band TAB connector* with *Inter RF Bandwidth gap* < 20 MHz the *basic limit* within the *Inter RF Bandwidth gaps* is calculated as a cumulative sum of contributions from adjacent sub-blocks or *Base Station RF Bandwidth* on each side of the *Inter RF Bandwidth gap*.

Table 6.6.5.5.3-3: Wide Area BS operating band unwanted emission limits for 5, 10, 15 and 20 MHz channel bandwidth (E-UTRA bands < 1 GHz) for Category B

Frequency offset of measurement filter -3dB point, Δf	Frequency offset of measurement filter centre frequency, f_{offset}	<i>basic limit</i> (Notes 1 and 2)	Measurement bandwidth
$0 \text{ MHz} \leq \Delta f < 5 \text{ MHz}$	$0.05 \text{ MHz} \leq f_{\text{offset}} < 5.05 \text{ MHz}$	$-5.5 \text{ dBm} - \frac{7}{5} \cdot \left(\frac{f_{\text{offset}}}{\text{MHz}} - 0.05 \right) \text{ dB}$	100 kHz
$5 \text{ MHz} \leq \Delta f < \min(10 \text{ MHz}, \Delta f_{\text{max}})$	$5.05 \text{ MHz} \leq f_{\text{offset}} < \min(10.05 \text{ MHz}, f_{\text{offset}_{\text{max}}})$	-12.5 dBm	100 kHz
$10 \text{ MHz} \leq \Delta f \leq \Delta f_{\text{max}}$	$10.05 \text{ MHz} \leq f_{\text{offset}} < f_{\text{offset}_{\text{max}}}$	-16 dBm (Note 8)	100 kHz
NOTE 1: For a <i>TAB connector</i> supporting non-contiguous spectrum operation within any operating band the <i>basic limit</i> within sub-block gaps is calculated as a cumulative sum of contributions from adjacent sub blocks on each side of the sub block gap. Exception is $\Delta f \geq 10 \text{ MHz}$ from both adjacent sub blocks on each side of the sub-block gap, where the <i>basic limit</i> within sub-block gaps shall be -16 dBm/100 kHz.			
NOTE 2: For a <i>multi-band TAB connector</i> with <i>Inter RF Bandwidth gap</i> < 20 MHz the <i>basic limit</i> within the <i>Inter RF Bandwidth gaps</i> is calculated as a cumulative sum of contributions from adjacent sub-blocks or <i>Base Station RF Bandwidth</i> on each side of the <i>Inter RF Bandwidth gap</i> .			
NOTE 8: The requirement is not applicable when $\Delta f_{\text{max}} < 10 \text{ MHz}$.			

For E-UTRA *TAB connector* operating in Bands 1, 2, 3, 4, 7, 10, 25, 30, 33, 34, 35, 36, 37, 38, 39, 40, 41, 45, 48, 65, 66, 69, 70, *basic limits* are specified in tables 6.6.5.5.3-4, 6.6.5.5.3-6 and 6.6.5.5.3-8.

For E-UTRA *TAB connector* operating in Bands 22, 42, 43, *basic limits* are specified in tables 6.6.5.5.3-5, 6.6.5.5.3-7 and 6.6.5.5.3-9.

Table 6.6.5.5.3-4: Wide Area BS operating band unwanted emission limits for 1.4 MHz channel bandwidth (1GHz < E-UTRA bands ≤ 3 GHz) for Category B

Frequency offset of measurement filter -3dB point, Δf	Frequency offset of measurement filter centre frequency, f_{offset}	<i>basic limit</i> (Notes 1 and 2)	Measurement bandwidth
$0 \text{ MHz} \leq \Delta f < 1.4 \text{ MHz}$	$0.05 \text{ MHz} \leq f_{\text{offset}} < 1.45 \text{ MHz}$	$+0.5 \text{ dBm} - \frac{10}{1.4} \cdot \left(\frac{f_{\text{offset}}}{\text{MHz}} - 0.05 \right) \text{ dB}$	100 kHz
$1.4 \text{ MHz} \leq \Delta f < 2.8 \text{ MHz}$	$1.45 \text{ MHz} \leq f_{\text{offset}} < 2.85 \text{ MHz}$	-9.5 dBm	100 kHz
$2.8 \text{ MHz} \leq \Delta f \leq \Delta f_{\text{max}}$	$3.3 \text{ MHz} \leq f_{\text{offset}} < f_{\text{offset}_{\text{max}}}$	-15 dBm (Note 8)	1 MHz
NOTE 1: For a <i>TAB connector</i> supporting non-contiguous spectrum operation within any operating band the <i>basic limit</i> within sub-block gaps is calculated as a cumulative sum of contributions from adjacent sub blocks on each side of the sub block gap, where the contribution from the far-end sub-block shall be scaled according to the measurement bandwidth of the near-end sub-block. Exception is $\Delta f \geq 10 \text{ MHz}$ from both adjacent sub blocks on each side of the sub-block gap, where the <i>basic limit</i> within sub-block gaps shall be -15 dBm/1 MHz.			
NOTE 2: For a <i>multi-band TAB connector</i> with <i>Inter RF Bandwidth gap</i> < 20 MHz the <i>basic limit</i> within the <i>Inter RF Bandwidth gaps</i> is calculated as a cumulative sum of contributions from adjacent sub-blocks or <i>Base Station RF Bandwidth</i> on each side of the <i>Inter RF Bandwidth gap</i> , where the contribution from the far-end sub-block or <i>Base Station RF Bandwidth</i> shall be scaled according to the measurement bandwidth of the near-end sub-block or <i>Base Station RF Bandwidth</i> .			
NOTE 8: The requirement is not applicable when $\Delta f_{\text{max}} < 10 \text{ MHz}$.			

Table 6.6.5.5.3-5: Wide Area BS operating band unwanted emission limits for 1.4 MHz channel bandwidth (E-UTRA bands > 3 GHz) for Category B

Frequency offset of measurement filter -3dB point, Δf	Frequency offset of measurement filter centre frequency, f_{offset}	<i>basic limit</i> (Notes 1 and 2)	Measurement bandwidth
$0 \text{ MHz} \leq \Delta f < 1.4 \text{ MHz}$	$0.05 \text{ MHz} \leq f_{\text{offset}} < 1.45 \text{ MHz}$	$+0.8\text{dBm} - \frac{10}{1.4} \cdot \left(\frac{f_{\text{offset}}}{\text{MHz}} - 0.05 \right) \text{dB}$	100 kHz
$1.4 \text{ MHz} \leq \Delta f < 2.8 \text{ MHz}$	$1.45 \text{ MHz} \leq f_{\text{offset}} < 2.85 \text{ MHz}$	-9.2 dBm	100 kHz
$2.8 \text{ MHz} \leq \Delta f \leq \Delta f_{\text{max}}$	$3.3 \text{ MHz} \leq f_{\text{offset}} < f_{\text{offset}_{\text{max}}}$	-15 dBm (Note 8)	1 MHz
<p>NOTE 1: For a <i>TAB connector</i> supporting non-contiguous spectrum operation within any operating band the <i>basic limit</i> within sub-block gaps is calculated as a cumulative sum of contributions from adjacent sub blocks on each side of the sub block gap, where the contribution from the far-end sub-block shall be scaled according to the measurement bandwidth of the near-end sub-block. Exception is $\Delta f \geq 10 \text{ MHz}$ from both adjacent sub blocks on each side of the sub-block gap, where the <i>basic limit</i> within sub-block gaps shall be -15 dBm/1 MHz.</p> <p>NOTE 2: For a <i>multi-band TAB connector</i> with <i>Inter RF Bandwidth gap</i> < 20 MHz the <i>basic limit</i> within the <i>Inter RF Bandwidth gaps</i> is calculated as a cumulative sum of contributions from adjacent sub-blocks or <i>Base Station RF Bandwidth</i> on each side of the <i>Inter RF Bandwidth gap</i>, where the contribution from the far-end sub-block or <i>Base Station RF Bandwidth</i> shall be scaled according to the measurement bandwidth of the near-end sub-block or <i>Base Station RF Bandwidth</i>.</p> <p>NOTE 8: The requirement is not applicable when $\Delta f_{\text{max}} < 10 \text{ MHz}$.</p>			

Table 6.6.5.5.3-6: Wide Area BS operating band unwanted emission limits for 3 MHz channel bandwidth (1GHz < E-UTRA bands \leq 3 GHz) for Category B

Frequency offset of measurement filter -3dB point, Δf	Frequency offset of measurement filter centre frequency, f_{offset}	<i>basic limit</i> (Notes 1 and 2)	Measurement bandwidth
$0 \text{ MHz} \leq \Delta f < 3 \text{ MHz}$	$0.05 \text{ MHz} \leq f_{\text{offset}} < 3.05 \text{ MHz}$	$-3.5\text{dBm} - \frac{10}{3} \cdot \left(\frac{f_{\text{offset}}}{\text{MHz}} - 0.05 \right) \text{dB}$	100 kHz
$3 \text{ MHz} \leq \Delta f < 6 \text{ MHz}$	$3.05 \text{ MHz} \leq f_{\text{offset}} < 6.05 \text{ MHz}$	-13.5 dBm	100 kHz
$6 \text{ MHz} \leq \Delta f \leq \Delta f_{\text{max}}$	$6.5 \text{ MHz} \leq f_{\text{offset}} < f_{\text{offset}_{\text{max}}}$	-15 dBm (Note 8)	1 MHz
<p>NOTE 1: For a <i>TAB connector</i> supporting non-contiguous spectrum operation within any operating band the <i>basic limit</i> within sub-block gaps is calculated as a cumulative sum of contributions from adjacent sub blocks on each side of the sub block gap, where the contribution from the far-end sub-block shall be scaled according to the measurement bandwidth of the near-end sub-block. Exception is $\Delta f \geq 10 \text{ MHz}$ from both adjacent sub blocks on each side of the sub-block gap, where the <i>basic limit</i> within sub-block gaps shall be -15 dBm/1 MHz.</p> <p>NOTE 2: For a <i>multi-band TAB connector</i> with <i>Inter RF Bandwidth gap</i> < 20 MHz the <i>basic limit</i> within the <i>Inter RF Bandwidth gaps</i> is calculated as a cumulative sum of contributions from adjacent sub-blocks or <i>Base Station RF Bandwidth</i> on each side of the <i>Inter RF Bandwidth gap</i>, where the contribution from the far-end sub-block or <i>Base Station RF Bandwidth</i> shall be scaled according to the measurement bandwidth of the near-end sub-block or <i>Base Station RF Bandwidth</i>.</p> <p>NOTE 8: The requirement is not applicable when $\Delta f_{\text{max}} < 10 \text{ MHz}$.</p>			

Table 6.6.5.5.3-7: Wide Area BS operating band unwanted emission limits for 3 MHz channel bandwidth (E-UTRA bands > 3 GHz) for Category B

Frequency offset of measurement filter -3dB point, Δf	Frequency offset of measurement filter centre frequency, f_{offset}	<i>basic limit</i> (Notes 1 and 2)	Measurement bandwidth
$0 \text{ MHz} \leq \Delta f < 3 \text{ MHz}$	$0.05 \text{ MHz} \leq f_{\text{offset}} < 3.05 \text{ MHz}$	$-3.2 \text{ dBm} - \frac{10}{3} \cdot \left(\frac{f_{\text{offset}}}{\text{MHz}} - 0.05 \right) \text{ dB}$	100 kHz
$3 \text{ MHz} \leq \Delta f < 6 \text{ MHz}$	$3.05 \text{ MHz} \leq f_{\text{offset}} < 6.05 \text{ MHz}$	-13.2 dBm	100 kHz
$6 \text{ MHz} \leq \Delta f \leq \Delta f_{\text{max}}$	$6.5 \text{ MHz} \leq f_{\text{offset}} < f_{\text{offset}_{\text{max}}}$	-15 dBm (Note 8)	1 MHz
<p>NOTE 1: For a <i>TAB connector</i> supporting non-contiguous spectrum operation within any operating band the <i>basic limit</i> within sub-block gaps is calculated as a cumulative sum of contributions from adjacent sub blocks on each side of the sub block gap, where the contribution from the far-end sub-block shall be scaled according to the measurement bandwidth of the near-end sub-block. Exception is $\Delta f \geq 10 \text{ MHz}$ from both adjacent sub blocks on each side of the sub-block gap, where the <i>basic limit</i> within sub-block gaps shall be -15 dBm/1 MHz.</p> <p>NOTE 2: For a <i>multi-band TAB connector</i> with <i>Inter RF Bandwidth gap</i> < 20 MHz the <i>basic limit</i> within the <i>Inter RF Bandwidth gaps</i> is calculated as a cumulative sum of contributions from adjacent sub-blocks or <i>Base Station RF Bandwidth</i> on each side of the <i>Inter RF Bandwidth gap</i>, where the contribution from the far-end sub-block or <i>Base Station RF Bandwidth</i> shall be scaled according to the measurement bandwidth of the near-end sub-block or <i>Base Station RF Bandwidth</i>.</p> <p>NOTE 8: The requirement is not applicable when $\Delta f_{\text{max}} < 10 \text{ MHz}$.</p>			

Table 6.6.5.5.3-8: Wide Area BS operating band unwanted emission limits for 5, 10, 15 and 20 MHz channel bandwidth (1GHz < E-UTRA bands \leq 3 GHz) for Category B

Frequency offset of measurement filter -3dB point, Δf	Frequency offset of measurement filter centre frequency, f_{offset}	<i>basic limit</i> (Notes 1 and 2)	Measurement bandwidth
$0 \text{ MHz} \leq \Delta f < 5 \text{ MHz}$	$0.05 \text{ MHz} \leq f_{\text{offset}} < 5.05 \text{ MHz}$	$-5.5 \text{ dBm} - \frac{7}{5} \cdot \left(\frac{f_{\text{offset}}}{\text{MHz}} - 0.05 \right) \text{ dB}$	100 kHz
$5 \text{ MHz} \leq \Delta f < \min(10 \text{ MHz}, \Delta f_{\text{max}})$	$5.05 \text{ MHz} \leq f_{\text{offset}} < \min(10.05 \text{ MHz}, f_{\text{offset}_{\text{max}}})$	-12.5 dBm	100 kHz
$10 \text{ MHz} \leq \Delta f \leq \Delta f_{\text{max}}$	$10.5 \text{ MHz} \leq f_{\text{offset}} < f_{\text{offset}_{\text{max}}}$	-15 dBm (Note 8)	1 MHz
<p>NOTE 1: For a <i>TAB connector</i> supporting non-contiguous spectrum operation within any operating band the <i>basic limit</i> within sub-block gaps is calculated as a cumulative sum of contributions from adjacent sub blocks on each side of the sub block gap, where the contribution from the far-end sub-block shall be scaled according to the measurement bandwidth of the near-end sub-block. Exception is $\Delta f \geq 10 \text{ MHz}$ from both adjacent sub blocks on each side of the sub-block gap, where the <i>basic limit</i> within sub-block gaps shall be -15 dBm/1 MHz.</p> <p>NOTE 2: For a <i>multi-band TAB connector</i> with <i>Inter RF Bandwidth gap</i> < 20 MHz the <i>basic limit</i> within the <i>Inter RF Bandwidth gaps</i> is calculated as a cumulative sum of contributions from adjacent sub-blocks or <i>Base Station RF Bandwidth</i> on each side of the <i>Inter RF Bandwidth gap</i>, where the contribution from the far-end sub-block or <i>Base Station RF Bandwidth</i> shall be scaled according to the measurement bandwidth of the near-end sub-block or <i>Base Station RF Bandwidth</i>.</p> <p>NOTE 8: The requirement is not applicable when $\Delta f_{\text{max}} < 10 \text{ MHz}$.</p>			

Table 6.6.5.5.3-9: Wide Area BS operating band unwanted emission limits for 5, 10, 15 and 20 MHz channel bandwidth (E-UTRA bands > 3 GHz) for Category B

Frequency offset of measurement filter -3dB point, Δf	Frequency offset of measurement filter centre frequency, f_{offset}	<i>basic limit</i> (Notes 1 and 2)	Measurement bandwidth
$0 \text{ MHz} \leq \Delta f < 5 \text{ MHz}$	$0.05 \text{ MHz} \leq f_{\text{offset}} < 5.05 \text{ MHz}$	$-5.2 \text{ dBm} - \frac{7}{5} \cdot \left(\frac{f_{\text{offset}}}{\text{MHz}} - 0.05 \right) \text{ dB}$	100 kHz
$5 \text{ MHz} \leq \Delta f < \min(10 \text{ MHz}, \Delta f_{\text{max}})$	$5.05 \text{ MHz} \leq f_{\text{offset}} < \min(10.05 \text{ MHz}, f_{\text{offsetmax}})$	-12.2 dBm	100 kHz
$10 \text{ MHz} \leq \Delta f \leq \Delta f_{\text{max}}$	$10.5 \text{ MHz} \leq f_{\text{offset}} < f_{\text{offsetmax}}$	-15 dBm (Note 8)	1 MHz
<p>NOTE 1: For a <i>TAB connector</i> supporting non-contiguous spectrum operation within any operating band the <i>basic limit</i> within sub-block gaps is calculated as a cumulative sum of contributions from adjacent sub blocks on each side of the sub block gap, where the contribution from the far-end sub-block shall be scaled according to the measurement bandwidth of the near-end sub-block. Exception is $\Delta f \geq 10 \text{ MHz}$ from both adjacent sub blocks on each side of the sub-block gap, where the <i>basic limit</i> within sub-block gaps shall be -15 dBm/1 MHz.</p> <p>NOTE 2: For a <i>multi-band TAB connector</i> with <i>Inter RF Bandwidth gap</i> < 20 MHz the <i>basic limit</i> within the <i>Inter RF Bandwidth gaps</i> is calculated as a cumulative sum of contributions from adjacent sub-blocks or <i>Base Station RF Bandwidth</i> on each side of the <i>Inter RF Bandwidth gap</i>, where the contribution from the far-end sub-block or <i>Base Station RF Bandwidth</i> shall be scaled according to the measurement bandwidth of the near-end sub-block or <i>Base Station RF Bandwidth</i>.</p> <p>NOTE 8: The requirement is not applicable when $\Delta f_{\text{max}} < 10 \text{ MHz}$.</p>			

6.6.5.5.4 Basic limits for Wide Area BS Category B (Option 2)

For Category B Operating band unwanted emissions, there are two options for the limits that may be applied regionally, option 1 is as follows.

The limits in this subclause are intended for Europe and may be applied regionally for a *TAB connector* operating in band 1, 3, 8, 32, 33, 34 or 65.

For a *TAB connector* operating in band 1, 3, 8, 32, 33, 34 or 65, *basic limits* are specified in table 6.6.5.5.4-1 below for 5, 10, 15 and 20 MHz channel bandwidth.

Table 6.6.5.5.4-1: Regional Wide Area BS operating band unwanted emission limits in band 1, 3, 8, 32, 33, 34 or 65 for 5, 10, 15 and 20 MHz channel bandwidth for Category B

Frequency offset of measurement filter -3dB point, Δf	Frequency offset of measurement filter centre frequency, f_{offset}	<i>basic limit</i> (Notes 1 and 2)	Measurement bandwidth
$0 \text{ MHz} \leq \Delta f < 0.2 \text{ MHz}$	$0.015 \text{ MHz} \leq f_{\text{offset}} < 0.215 \text{ MHz}$	-12.5 dBm	30 kHz
$0.2 \text{ MHz} \leq \Delta f < 1 \text{ MHz}$	$0.215 \text{ MHz} \leq f_{\text{offset}} < 1.015 \text{ MHz}$	$-12.5 \text{ dBm} - 15 \cdot \left(\frac{f_{\text{offset}}}{\text{MHz}} - 0.215 \right) \text{ dB}$	30 kHz
(Note 7)	$1.015 \text{ MHz} \leq f_{\text{offset}} < 1.5 \text{ MHz}$	-24.5 dBm	30 kHz
$1 \text{ MHz} \leq \Delta f \leq \min(10 \text{ MHz}, \Delta f_{\text{max}})$	$1.5 \text{ MHz} \leq f_{\text{offset}} < \min(10.5 \text{ MHz}, f_{\text{offset}_{\text{max}}})$	-11.5 dBm	1 MHz
$10 \text{ MHz} \leq \Delta f \leq \Delta f_{\text{max}}$	$10.5 \text{ MHz} \leq f_{\text{offset}} < f_{\text{offset}_{\text{max}}}$	-15 dBm (Note 8)	1 MHz
<p>NOTE 1: For a <i>TAB connector</i> supporting non-contiguous spectrum operation within any operating band the <i>basic limit</i> within sub-block gaps is calculated as a cumulative sum of contributions from adjacent sub blocks on each side of the sub block gap, where the contribution from the far-end sub-block shall be scaled according to the measurement bandwidth of the near-end sub-block. Exception is $\Delta f \geq 10 \text{ MHz}$ from both adjacent sub blocks on each side of the sub-block gap, where the <i>basic limit</i> within sub-block gaps shall be -15 dBm/1 MHz.</p> <p>NOTE 2: For a <i>multi-band TAB connector</i> with <i>Inter RF Bandwidth gap</i> < 20 MHz the <i>basic limit</i> within the <i>Inter RF Bandwidth gaps</i> is calculated as a cumulative sum of contributions from adjacent sub-blocks or <i>Base Station RF Bandwidth</i> on each side of the <i>Inter RF Bandwidth gap</i>, where the contribution from the far-end sub-block or <i>Base Station RF Bandwidth</i> shall be scaled according to the measurement bandwidth of the near-end sub-block or <i>Base Station RF Bandwidth</i>.</p> <p>NOTE 7: This frequency range ensures that the range of values of f_{offset} is continuous.</p> <p>NOTE 8: The requirement is not applicable when $\Delta f_{\text{max}} < 10 \text{ MHz}$.</p>			

For a *TAB connector* operating in band 3, 8 or 65, *basic limits* are specified in table 6.6.5.5.4-2 for 3 MHz channel bandwidth.

Table 6.6.5.5.4-2: Regional Wide Area BS operating band unwanted emission limits in band 3, 8 or 65 for 3 MHz channel bandwidth for Category B

Frequency offset of measurement filter -3dB point, Δf	Frequency offset of measurement filter centre frequency, f_{offset}	<i>basic limit</i> (Notes 1 and 2)	Measurement bandwidth
$0 \text{ MHz} \leq \Delta f < 0.05 \text{ MHz}$	$0.015 \text{ MHz} \leq f_{\text{offset}} < 0.065 \text{ MHz}$	$6.5 \text{ dBm} - 60 \cdot \left(\frac{f_{\text{offset}}}{\text{MHz}} - 0.015 \right) \text{ dB}$	30 kHz
$0.05 \text{ MHz} \leq \Delta f < 0.15 \text{ MHz}$	$0.065 \text{ MHz} \leq f_{\text{offset}} < 0.165 \text{ MHz}$	$3.5 \text{ dBm} - 160 \cdot \left(\frac{f_{\text{offset}}}{\text{MHz}} - 0.065 \right) \text{ dB}$	30 kHz
$0.15 \text{ MHz} \leq \Delta f < 0.2 \text{ MHz}$	$0.165 \text{ MHz} \leq f_{\text{offset}} < 0.215 \text{ MHz}$	-12.5 dBm	30 kHz
$0.2 \text{ MHz} \leq \Delta f < 1 \text{ MHz}$	$0.215 \text{ MHz} \leq f_{\text{offset}} < 1.015 \text{ MHz}$	$-12.5 \text{ dBm} - 15 \cdot \left(\frac{f_{\text{offset}}}{\text{MHz}} - 0.215 \right) \text{ dB}$	30 kHz
(Note 7)	$1.015 \text{ MHz} \leq f_{\text{offset}} < 1.5 \text{ MHz}$	-24.5 dBm	30 kHz
$1 \text{ MHz} \leq \Delta f \leq 6 \text{ MHz}$	$1.5 \text{ MHz} \leq f_{\text{offset}} < 6.5 \text{ MHz}$,	-11.5 dBm	1 MHz
$6 \text{ MHz} \leq \Delta f \leq \Delta f_{\text{max}}$	$6.5 \text{ MHz} \leq f_{\text{offset}} < f_{\text{offset}_{\text{max}}}$	-15 dBm (Note 8)	1 MHz
<p>NOTE 1: For a <i>TAB connector</i> supporting non-contiguous spectrum operation within any operating band the <i>basic limit</i> within sub-block gaps is calculated as a cumulative sum of contributions from adjacent sub blocks on each side of the sub block gap, where the contribution from the far-end sub-block shall be scaled according to the measurement bandwidth of the near-end sub-block. Exception is $\Delta f \geq 10 \text{ MHz}$ from both adjacent sub blocks on each side of the sub-block gap, where the <i>basic limit</i> within sub-block gaps shall be -15 dBm/1 MHz.</p> <p>NOTE 2: For a <i>multi-band TAB connector</i> with <i>Inter RF Bandwidth gap</i> < 20 MHz the <i>basic limit</i> within the <i>Inter RF Bandwidth gaps</i> is calculated as a cumulative sum of contributions from adjacent sub-blocks or <i>Base Station RF Bandwidth</i> on each side of the <i>Inter RF Bandwidth gap</i>, where the contribution from the far-end sub-block or <i>Base Station RF Bandwidth</i> shall be scaled according to the measurement bandwidth of the near-end sub-block or <i>Base Station RF Bandwidth</i>.</p> <p>NOTE 7: This frequency range ensures that the range of values of f_{offset} is continuous.</p> <p>NOTE 8: The requirement is not applicable when $\Delta f_{\text{max}} < 10 \text{ MHz}$.</p>			

For a BS operating in band 3, 8 or 65, *basic limits* are specified in table 6.6.5.5.4-3 for 1.4 MHz channel bandwidth.

Table 6.6.5.5.4-3: Regional Wide Area BS operating band unwanted emission limits in band 3, 8 or 65 for 1.4 MHz channel bandwidth for Category B

Frequency offset of measurement filter -3dB point, Δf	Frequency offset of measurement filter centre frequency, f_{offset}	<i>basic limit</i> (Notes 1 and 2)	Measurement bandwidth
$0 \text{ MHz} \leq \Delta f < 0.05 \text{ MHz}$	$0.015 \text{ MHz} \leq f_{\text{offset}} < 0.065 \text{ MHz}$	$6.5 \text{ dBm} - 60 \cdot \left(\frac{f_{\text{offset}}}{\text{MHz}} - 0.015 \right) \text{ dB}$	30 kHz
$0.05 \text{ MHz} \leq \Delta f < 0.15 \text{ MHz}$	$0.065 \text{ MHz} \leq f_{\text{offset}} < 0.165 \text{ MHz}$	$3.5 \text{ dBm} - 160 \cdot \left(\frac{f_{\text{offset}}}{\text{MHz}} - 0.065 \right) \text{ dB}$	30 kHz
$0.15 \text{ MHz} \leq \Delta f < 0.2 \text{ MHz}$	$0.165 \text{ MHz} \leq f_{\text{offset}} < 0.215 \text{ MHz}$	-12.5 dBm	30 kHz
$0.2 \text{ MHz} \leq \Delta f < 1 \text{ MHz}$	$0.215 \text{ MHz} \leq f_{\text{offset}} < 1.015 \text{ MHz}$	$-12.5 \text{ dBm} - 15 \cdot \left(\frac{f_{\text{offset}}}{\text{MHz}} - 0.215 \right) \text{ dB}$	30 kHz
(Note 7)	$1.015 \text{ MHz} \leq f_{\text{offset}} < 1.5 \text{ MHz}$	-24.5 dBm	30 kHz
$1 \text{ MHz} \leq \Delta f \leq 2.8 \text{ MHz}$	$1.5 \text{ MHz} \leq f_{\text{offset}} < 3.3 \text{ MHz}$	-11.5 dBm	1 MHz
$2.8 \text{ MHz} \leq \Delta f \leq \Delta f_{\text{max}}$	$3.3 \text{ MHz} \leq f_{\text{offset}} < f_{\text{offset}_{\text{max}}}$	-15 dBm (Note 8)	1 MHz
NOTE 1: For a <i>TAB connector</i> supporting non-contiguous spectrum operation within any operating band the <i>basic limit</i> within sub-block gaps is calculated as a cumulative sum of contributions from adjacent sub blocks on each side of the sub block gap, where the contribution from the far-end sub-block shall be scaled according to the measurement bandwidth of the near-end sub-block. Exception is $\Delta f \geq 10 \text{ MHz}$ from both adjacent sub blocks on each side of the sub-block gap, where the <i>basic limit</i> within sub-block gaps shall be -15 dBm/1 MHz.			
NOTE 2: For a <i>multi-band TAB connector</i> with <i>Inter RF Bandwidth gap</i> < 20 MHz the <i>basic limit</i> within the <i>Inter RF Bandwidth gaps</i> is calculated as a cumulative sum of contributions from adjacent sub-blocks or <i>Base Station RF Bandwidth</i> on each side of the <i>Inter RF Bandwidth gap</i> , where the contribution from the far-end sub-block or <i>Base Station RF Bandwidth</i> shall be scaled according to the measurement bandwidth of the near-end sub-block or <i>Base Station RF Bandwidth</i> .			
NOTE 7: This frequency range ensures that the range of values of f_{offset} is continuous.			
NOTE 8: The requirement is not applicable when $\Delta f_{\text{max}} < 10 \text{ MHz}$.			

6.6.5.5.5 Basic limits for Local Area BS (Category A and B)

For an AAS BS of Local Area BS class in E-UTRA bands $\leq 3 \text{ GHz}$, *basic limits* are specified in tables 6.6.5.5.5-1, 6.6.5.5.5-3 and 6.6.5.5.5-5.

For an AAS BS of Local Area BS class in E-UTRA bands $> 3 \text{ GHz}$, *basic limits* are specified in tables 6.6.5.5.5-2, 6.6.5.5.5-4 and 6.6.5.5.5-6.

Table 6.6.5.5.5-1: Local Area BS operating band unwanted emission limits for 1.4 MHz channel bandwidth (E-UTRA bands $\leq 3 \text{ GHz}$)

Frequency offset of measurement filter -3dB point, Δf	Frequency offset of measurement filter centre frequency, f_{offset}	<i>basic limit</i> (Notes 1 and 2)	Measurement bandwidth
$0 \text{ MHz} \leq \Delta f < 1.4 \text{ MHz}$	$0.05 \text{ MHz} \leq f_{\text{offset}} < 1.45 \text{ MHz}$	$-19.5 \text{ dBm} - \frac{10}{1.4} \left(\frac{f_{\text{offset}}}{\text{MHz}} - 0.05 \right) \text{ dB}$	100 kHz
$1.4 \text{ MHz} \leq \Delta f < 2.8 \text{ MHz}$	$1.45 \text{ MHz} \leq f_{\text{offset}} < 2.85 \text{ MHz}$	-29.5 dBm	100 kHz
$2.8 \text{ MHz} \leq \Delta f \leq \Delta f_{\text{max}}$	$2.85 \text{ MHz} \leq f_{\text{offset}} < f_{\text{offset}_{\text{max}}}$	-31 dBm (Note 8)	100 kHz
NOTE 1: For a <i>TAB connector</i> supporting non-contiguous spectrum operation within any operating band the <i>basic limit</i> within sub-block gaps is calculated as a cumulative sum of contributions from adjacent sub blocks on each side of the sub block gap. Exception is $\Delta f \geq 10 \text{ MHz}$ from both adjacent sub blocks on each side of the sub-block gap, where the <i>basic limit</i> within sub-block gaps shall be -31 dBm/100 kHz.			
NOTE 2: For a <i>multi-band TAB connector</i> with <i>Inter RF Bandwidth gap</i> < 20 MHz the <i>basic limit</i> within the <i>Inter RF Bandwidth gaps</i> is calculated as a cumulative sum of contributions from adjacent sub-blocks or <i>Base Station RF Bandwidth</i> on each side of the <i>Inter RF Bandwidth gap</i> .			
NOTE 8: The requirement is not applicable when $\Delta f_{\text{max}} < 10 \text{ MHz}$.			

Table 6.6.5.5.5-2: Local Area BS operating band unwanted emission limits for 1.4 MHz channel bandwidth (E-UTRA bands > 3 GHz)

Frequency offset of measurement filter -3dB point, Δf	Frequency offset of measurement filter centre frequency, f_{offset}	<i>basic limit</i> (Notes 1 and 2)	Measurement bandwidth
$0 \text{ MHz} \leq \Delta f < 1.4 \text{ MHz}$	$0.05 \text{ MHz} \leq f_{\text{offset}} < 1.45 \text{ MHz}$	$-19.2 \text{ dBm} - \frac{10}{1.4} \cdot \left(\frac{f_{\text{offset}}}{\text{MHz}} - 0.05 \right) \text{ dB}$	100 kHz
$1.4 \text{ MHz} \leq \Delta f < 2.8 \text{ MHz}$	$1.45 \text{ MHz} \leq f_{\text{offset}} < 2.85 \text{ MHz}$	-29.2 dBm	100 kHz
$2.8 \text{ MHz} \leq \Delta f \leq \Delta f_{\text{max}}$	$2.85 \text{ MHz} \leq f_{\text{offset}} < f_{\text{offset}_{\text{max}}}$	-31 dBm (Note 8)	100 kHz
NOTE 1: For a <i>TAB connector</i> supporting non-contiguous spectrum operation within any operating band the <i>basic limit</i> within sub-block gaps is calculated as a cumulative sum of contributions from adjacent sub blocks on each side of the sub block gap. Exception is $\Delta f \geq 10 \text{ MHz}$ from both adjacent sub blocks on each side of the sub-block gap, where the <i>basic limit</i> within sub-block gaps shall be -31 dBm/100 kHz.			
NOTE 2: For a <i>multi-band TAB connector</i> with <i>Inter RF Bandwidth gap</i> < 20 MHz the <i>basic limit</i> within the <i>Inter RF Bandwidth gaps</i> is calculated as a cumulative sum of contributions from adjacent sub-blocks or <i>Base Station RF Bandwidth</i> on each side of the <i>Inter RF Bandwidth gap</i> .			
NOTE 8: The requirement is not applicable when $\Delta f_{\text{max}} < 10 \text{ MHz}$.			

Table 6.6.5.5.5-3: Local Area BS operating band unwanted emission limits for 3 MHz channel bandwidth (E-UTRA bands $\leq 3 \text{ GHz}$)

Frequency offset of measurement filter -3dB point, Δf	Frequency offset of measurement filter centre frequency, f_{offset}	<i>basic limit</i> (Notes 1 and 2)	Measurement bandwidth
$0 \text{ MHz} \leq \Delta f < 3 \text{ MHz}$	$0.05 \text{ MHz} \leq f_{\text{offset}} < 3.05 \text{ MHz}$	$-23.5 \text{ dBm} - \frac{10}{3} \cdot \left(\frac{f_{\text{offset}}}{\text{MHz}} - 0.05 \right) \text{ dB}$	100 kHz
$3 \text{ MHz} \leq \Delta f < 6 \text{ MHz}$	$3.05 \text{ MHz} \leq f_{\text{offset}} < 6.05 \text{ MHz}$	-33.5 dBm	100 kHz
$6 \text{ MHz} \leq \Delta f \leq \Delta f_{\text{max}}$	$6.05 \text{ MHz} \leq f_{\text{offset}} < f_{\text{offset}_{\text{max}}}$	-35 dBm (Note 8)	100 kHz
NOTE 1: For a <i>TAB connector</i> supporting non-contiguous spectrum operation within any operating band the <i>basic limit</i> within sub-block gaps is calculated as a cumulative sum of contributions from adjacent sub blocks on each side of the sub block gap. Exception is $\Delta f \geq 10 \text{ MHz}$ from both adjacent sub blocks on each side of the sub-block gap, where the <i>basic limit</i> within sub-block gaps shall be -35 dBm/100 kHz.			
NOTE 2: For a <i>multi-band TAB connector</i> with <i>Inter RF Bandwidth gap</i> < 20 MHz the <i>basic limit</i> within the <i>Inter RF Bandwidth gaps</i> is calculated as a cumulative sum of contributions from adjacent sub-blocks or <i>Base Station RF Bandwidth</i> on each side of the <i>Inter RF Bandwidth gap</i> .			
NOTE 8: The requirement is not applicable when $\Delta f_{\text{max}} < 10 \text{ MHz}$.			

Table 6.6.5.5.5-4: Local Area BS operating band unwanted emission limits for 3 MHz channel bandwidth (E-UTRA bands > 3 GHz)

Frequency offset of measurement filter -3dB point, Δf	Frequency offset of measurement filter centre frequency, f_{offset}	<i>basic limit</i> (Notes 1 and 2)	Measurement bandwidth
$0 \text{ MHz} \leq \Delta f < 3 \text{ MHz}$	$0.05 \text{ MHz} \leq f_{\text{offset}} < 3.05 \text{ MHz}$	$-23.2 \text{ dBm} - \frac{10}{3} \cdot \left(\frac{f_{\text{offset}}}{\text{MHz}} - 0.05 \right) \text{ dB}$	100 kHz
$3 \text{ MHz} \leq \Delta f < 6 \text{ MHz}$	$3.05 \text{ MHz} \leq f_{\text{offset}} < 6.05 \text{ MHz}$	-33.2 dBm	100 kHz
$6 \text{ MHz} \leq \Delta f \leq \Delta f_{\text{max}}$	$6.05 \text{ MHz} \leq f_{\text{offset}} < f_{\text{offset}_{\text{max}}}$	-35 dBm (Note 8)	100 kHz
NOTE 1: For a <i>TAB connector</i> supporting non-contiguous spectrum operation within any operating band the <i>basic limit</i> within sub-block gaps is calculated as a cumulative sum of contributions from adjacent sub blocks on each side of the sub block gap. Exception is $\Delta f \geq 10 \text{ MHz}$ from both adjacent sub blocks on each side of the sub-block gap, where the <i>basic limit</i> within sub-block gaps shall be -35 dBm/100 kHz.			
NOTE 2: For a <i>multi-band TAB connector</i> with <i>Inter RF Bandwidth gap</i> < 20 MHz the <i>basic limit</i> within the <i>Inter RF Bandwidth gaps</i> is calculated as a cumulative sum of contributions from adjacent sub-blocks or <i>Base Station RF Bandwidth</i> on each side of the <i>Inter RF Bandwidth gap</i> .			
NOTE 8: The requirement is not applicable when $\Delta f_{\text{max}} < 10 \text{ MHz}$.			

Table 6.6.5.5.5-5: Local Area BS operating band unwanted emission limits for 5, 10, 15 and 20 MHz channel bandwidth (E-UTRA bands ≤ 3 GHz)

Frequency offset of measurement filter -3dB point, Δf	Frequency offset of measurement filter centre frequency, f_{offset}	<i>basic limit</i> (Notes 1 and 2)	Measurement bandwidth
$0 \text{ MHz} \leq \Delta f < 5 \text{ MHz}$	$0.05 \text{ MHz} \leq f_{\text{offset}} < 5.05 \text{ MHz}$	$-28.5 \text{ dBm} - \frac{7}{5} \left(\frac{f_{\text{offset}}}{\text{MHz}} - 0.05 \right) \text{ dB}$	100 kHz
$5 \text{ MHz} \leq \Delta f < \min(10 \text{ MHz}, \Delta f_{\text{max}})$	$5.05 \text{ MHz} \leq f_{\text{offset}} < \min(10.05 \text{ MHz}, f_{\text{offset}_{\text{max}}})$	-35.5 dBm	100 kHz
$10 \text{ MHz} \leq \Delta f \leq \Delta f_{\text{max}}$	$10.05 \text{ MHz} \leq f_{\text{offset}} < f_{\text{offset}_{\text{max}}}$	-37 dBm (Note 8)	100 kHz
NOTE 1: For a <i>TAB connector</i> supporting non-contiguous spectrum operation within any operating band the <i>basic limit</i> within sub-block gaps is calculated as a cumulative sum of contributions from adjacent sub blocks on each side of the sub block gap. Exception is $\Delta f \geq 10 \text{ MHz}$ from both adjacent sub blocks on each side of the sub-block gap, where the <i>basic limit</i> within sub-block gaps shall be -37 dBm/100 kHz.			
NOTE 2: For a <i>multi-band TAB connector</i> with <i>Inter RF Bandwidth gap</i> < 20 MHz the <i>basic limit</i> within the <i>Inter RF Bandwidth gaps</i> is calculated as a cumulative sum of contributions from adjacent sub-blocks or <i>Base Station RF Bandwidth</i> on each side of the <i>Inter RF Bandwidth gap</i> .			
NOTE 8: The requirement is not applicable when $\Delta f_{\text{max}} < 10 \text{ MHz}$.			

Table 6.6.5.5.5-6: Local Area BS operating band unwanted emission limits for 5, 10, 15 and 20 MHz channel bandwidth (E-UTRA bands > 3 GHz)

Frequency offset of measurement filter -3dB point, Δf	Frequency offset of measurement filter centre frequency, f_{offset}	<i>basic limit</i> (Notes 1 and 2)	Measurement bandwidth
$0 \text{ MHz} \leq \Delta f < 5 \text{ MHz}$	$0.05 \text{ MHz} \leq f_{\text{offset}} < 5.05 \text{ MHz}$	$-28.2 \text{ dBm} - \frac{7}{5} \left(\frac{f_{\text{offset}}}{\text{MHz}} - 0.05 \right) \text{ dB}$	100 kHz
$5 \text{ MHz} \leq \Delta f < \min(10 \text{ MHz}, \Delta f_{\text{max}})$	$5.05 \text{ MHz} \leq f_{\text{offset}} < \min(10.05 \text{ MHz}, f_{\text{offset}_{\text{max}}})$	-35.2 dBm	100 kHz
$10 \text{ MHz} \leq \Delta f \leq \Delta f_{\text{max}}$	$10.05 \text{ MHz} \leq f_{\text{offset}} < f_{\text{offset}_{\text{max}}}$	-37 dBm (Note 8)	100 kHz
NOTE 1: For a <i>TAB connector</i> supporting non-contiguous spectrum operation within any operating band the <i>basic limit</i> within sub-block gaps is calculated as a cumulative sum of contributions from adjacent sub blocks on each side of the sub block gap. Exception is $\Delta f \geq 10 \text{ MHz}$ from both adjacent sub blocks on each side of the sub-block gap, where the <i>basic limit</i> within sub-block gaps shall be -37 dBm/100 kHz.			
NOTE 2: For BS a <i>multi-band TAB connector</i> with <i>Inter RF Bandwidth gap</i> < 20 MHz the <i>basic limit</i> within the <i>Inter RF Bandwidth gaps</i> is calculated as a cumulative sum of contributions from adjacent sub-blocks or <i>Base Station RF Bandwidth</i> on each side of the <i>Inter RF Bandwidth gap</i> .			
NOTE 8: The requirement is not applicable when $\Delta f_{\text{max}} < 10 \text{ MHz}$.			

6.6.5.5.5.6 Basic limits for Medium Range BS (Category A and B)

For an AAS BS of Medium Range BS class in E-UTRA bands ≤ 3 GHz, *basic limits* are specified in tables 6.6.5.5.5.6-1, 6.6.5.5.5.6-3, 6.6.5.5.5.6-5, 6.6.5.5.5.6-7, 6.6.5.5.5.6-9 and 6.6.5.5.5.6-11.

For an AAS BS of Medium Range BS class in E-UTRA bands > 3 GHz, *basic limits* are specified in tables 6.6.5.5.5.6-2, 6.6.5.5.5.6-4, 6.6.5.5.5.6-6, 6.6.5.5.5.6-8, 6.6.5.5.5.6-10 and 6.6.5.5.5.6-12.

Table 6.6.5.5.6-1: Medium Range BS operating band unwanted emission limits for 1.4 MHz channel bandwidth, $31 < P_{\max,c,cell} - 10 \cdot \log_{10}(N_{\text{TXU,countedpercell}}) \leq 38$ dBm (E-UTRA bands ≤ 3 GHz)

Frequency offset of measurement filter -3dB point, Δf	Frequency offset of measurement filter centre frequency, f_{offset}	<i>basic limit</i> (Notes 1 and 2)	Measurement bandwidth
$0 \text{ MHz} \leq \Delta f < 1.4 \text{ MHz}$	$0.05 \text{ MHz} \leq f_{\text{offset}} < 1.45 \text{ MHz}$	$P_{\max,c,cell} - 10 \cdot \log_{10}(N_{\text{TXU,countedpercell}}) - 43.5 \text{ dB} - \frac{10}{1.4} \left(\frac{f_{\text{offset}}}{\text{MHz}} - 0.05 \right) \text{ dB}$	100 kHz
$1.4 \text{ MHz} \leq \Delta f < 2.8 \text{ MHz}$	$1.45 \text{ MHz} \leq f_{\text{offset}} < 2.85 \text{ MHz}$	$P_{\max,c,cell} - 10 \cdot \log_{10}(N_{\text{TXU,countedpercell}}) - 53.5 \text{ dB}$	100 kHz
$2.8 \text{ MHz} \leq \Delta f \leq \Delta f_{\max}$	$2.85 \text{ MHz} \leq f_{\text{offset}} < f_{\text{offset,max}}$	-25 dBm (Note 8)	100 kHz
NOTE 1: For a <i>TAB connector</i> supporting non-contiguous spectrum operation within any operating band the <i>basic limit</i> within sub-block gaps is calculated as a cumulative sum of contributions from adjacent sub blocks on each side of the sub block gap. Exception is $\Delta f \geq 10$ MHz from both adjacent sub blocks on each side of the sub-block gap, where the <i>basic limit</i> within sub-block gaps shall be -25 dBm/100 kHz.			
NOTE 2: For a <i>multi-band TAB connector</i> with <i>Inter RF Bandwidth gap</i> < 20 MHz the <i>basic limit</i> within the <i>Inter RF Bandwidth gaps</i> is calculated as a cumulative sum of contributions from adjacent sub-blocks or <i>Base Station RF Bandwidth</i> on each side of the <i>Inter RF Bandwidth gap</i> .			
NOTE 8: The requirement is not applicable when $\Delta f_{\max} < 10$ MHz.			

Table 6.6.5.5.6-2: Medium Range BS operating band unwanted emission limits for 1.4 MHz channel bandwidth, $31 < P_{\max,c,cell} - 10 \cdot \log_{10}(N_{\text{TXU,countedpercell}}) \leq 38$ dBm (E-UTRA bands > 3 GHz)

Frequency offset of measurement filter -3dB point, Δf	Frequency offset of measurement filter centre frequency, f_{offset}	<i>basic limit</i> (Notes 1 and 2)	Measurement bandwidth
$0 \text{ MHz} \leq \Delta f < 1.4 \text{ MHz}$	$0.05 \text{ MHz} \leq f_{\text{offset}} < 1.45 \text{ MHz}$	$P_{\max,c,cell} - 10 \cdot \log_{10}(N_{\text{TXU,countedpercell}}) - 43.2 \text{ dB} - \frac{10}{1.4} \left(\frac{f_{\text{offset}}}{\text{MHz}} - 0.05 \right) \text{ dB}$	100 kHz
$1.4 \text{ MHz} \leq \Delta f < 2.8 \text{ MHz}$	$1.45 \text{ MHz} \leq f_{\text{offset}} < 2.85 \text{ MHz}$	$P_{\max,c,cell} - 10 \cdot \log_{10}(N_{\text{TXU,countedpercell}}) - 53.2 \text{ dB}$	100 kHz
$2.8 \text{ MHz} \leq \Delta f \leq \Delta f_{\max}$	$2.85 \text{ MHz} \leq f_{\text{offset}} < f_{\text{offset,max}}$	-25 dBm (Note 8)	100 kHz
NOTE 1: For a <i>TAB connector</i> supporting non-contiguous spectrum operation within any operating band the test requirement within sub-block gaps is calculated as a cumulative sum of contributions from adjacent sub blocks on each side of the sub block gap. Exception is $\Delta f \geq 10$ MHz from both adjacent sub blocks on each side of the sub-block gap, where the test requirement within sub-block gaps shall be -25 dBm/100 kHz.			
NOTE 2: For a <i>multi-band TAB connector</i> with <i>Inter RF Bandwidth gap</i> <i>basic limit</i> < 20 MHz the <i>basic limit</i> within the <i>Inter RF Bandwidth gaps</i> is calculated as a cumulative sum of contributions from adjacent sub-blocks or <i>Base Station RF Bandwidth</i> on each side of the <i>Inter RF Bandwidth gap</i> .			
NOTE 8: The requirement is not applicable when $\Delta f_{\max} < 10$ MHz.			

Table 6.6.5.5.6-3: Medium Range BS operating band unwanted emission limits for 1.4 MHz channel bandwidth, $P_{\max,c,cell} - 10 \cdot \log_{10}(N_{TXU, \text{countedpercell}}) \leq 31$ dBm (E-UTRA bands ≤ 3 GHz)

Frequency offset of measurement filter -3dB point, Δf	Frequency offset of measurement filter centre frequency, f_{offset}	<i>basic limit</i> (Notes 1 and 2)	Measurement bandwidth
$0 \text{ MHz} \leq \Delta f < 1.4 \text{ MHz}$	$0.05 \text{ MHz} \leq f_{\text{offset}} < 1.45 \text{ MHz}$	$-12.5 \text{ dBm} - \frac{10}{1.4} \left(\frac{f_{\text{offset}}}{\text{MHz}} - 0.05 \right) \text{ dB}$	100 kHz
$1.4 \text{ MHz} \leq \Delta f < 2.8 \text{ MHz}$	$1.45 \text{ MHz} \leq f_{\text{offset}} < 2.85 \text{ MHz}$	-22.5 dBm	100 kHz
$2.8 \text{ MHz} \leq \Delta f \leq \Delta f_{\max}$	$2.85 \text{ MHz} \leq f_{\text{offset}} < f_{\text{offset}_{\max}}$	-25 dBm (Note 8)	100 kHz

NOTE 1: For a *TAB connector* supporting non-contiguous spectrum operation within any operating band the *basic limit* within sub-block gaps is calculated as a cumulative sum of contributions from adjacent sub blocks on each side of the sub block gap. Exception is $\Delta f \geq 10$ MHz from both adjacent sub blocks on each side of the sub-block gap, where the *basic limit* within sub-block gaps shall be -25 dBm/100 kHz.

NOTE 2: For BS a *multi-band TAB connector* with *Inter RF Bandwidth gap* < 20 MHz the *basic limit* within the *Inter RF Bandwidth gaps* is calculated as a cumulative sum of contributions from adjacent sub-blocks or *Base Station RF Bandwidth* on each side of the *Inter RF Bandwidth gap*.

NOTE 8: The requirement is not applicable when $\Delta f_{\max} < 10$ MHz.

Table 6.6.5.5.6-4: Medium Range BS operating band unwanted emission limits for 1.4 MHz channel bandwidth, $P_{\max,c,cell} - 10 \cdot \log_{10}(N_{TXU, \text{countedpercell}}) \leq 31$ dBm (E-UTRA bands > 3 GHz)

Frequency offset of measurement filter -3dB point, Δf	Frequency offset of measurement filter centre frequency, f_{offset}	<i>basic limit</i> (Notes 1 and 2)	Measurement bandwidth
$0 \text{ MHz} \leq \Delta f < 1.4 \text{ MHz}$	$0.05 \text{ MHz} \leq f_{\text{offset}} < 1.45 \text{ MHz}$	$-12.2 \text{ dBm} - \frac{10}{1.4} \left(\frac{f_{\text{offset}}}{\text{MHz}} - 0.05 \right) \text{ dB}$	100 kHz
$1.4 \text{ MHz} \leq \Delta f < 2.8 \text{ MHz}$	$1.45 \text{ MHz} \leq f_{\text{offset}} < 2.85 \text{ MHz}$	-22.2 dBm	100 kHz
$2.8 \text{ MHz} \leq \Delta f \leq \Delta f_{\max}$	$2.85 \text{ MHz} \leq f_{\text{offset}} < f_{\text{offset}_{\max}}$	-25 dBm (Note 8)	100 kHz

NOTE 1: For a *TAB connector* supporting non-contiguous spectrum operation within any operating band the *basic limit* within sub-block gaps is calculated as a cumulative sum of contributions from adjacent sub blocks on each side of the sub block gap. Exception is $\Delta f \geq 10$ MHz from both adjacent sub blocks on each side of the sub-block gap, where the *basic limit* within sub-block gaps shall be -25 dBm/100 kHz.

NOTE 2: For a *multi-band TAB connector* with *Inter RF Bandwidth gap* < 20 MHz the *basic limit* within the *Inter RF Bandwidth gaps* is calculated as a cumulative sum of contributions from adjacent sub-blocks or *Base Station RF Bandwidth* on each side of the *Inter RF Bandwidth gap*.

NOTE 8: The requirement is not applicable when $\Delta f_{\max} < 10$ MHz.

Table 6.6.5.5.6-5: Medium Range BS operating band unwanted emission limits for 3 MHz channel bandwidth, $31 < P_{\max,c,cell} - 10 \cdot \log_{10}(N_{TXU, \text{countedpercell}}) \leq 38$ dBm (E-UTRA bands ≤ 3 GHz)

Frequency offset of measurement filter -3dB point, Δf	Frequency offset of measurement filter centre frequency, f_{offset}	<i>basic limit</i> (Notes 1 and 2)	Measurement bandwidth
$0 \text{ MHz} \leq \Delta f < 3 \text{ MHz}$	$0.05 \text{ MHz} \leq f_{\text{offset}} < 3.05 \text{ MHz}$	$P_{\max,c,cell} - 10 \cdot \log_{10}(N_{TXU, \text{countedpercell}}) - 47.5 \text{ dB} - \frac{10}{3} \left(\frac{f_{\text{offset}}}{\text{MHz}} - 0.05 \right) \text{ dB}$	100 kHz
$3 \text{ MHz} \leq \Delta f < 6 \text{ MHz}$	$3.05 \text{ MHz} \leq f_{\text{offset}} < 6.05 \text{ MHz}$	$P_{\max,c,cell} - 10 \cdot \log_{10}(N_{TXU, \text{countedpercell}}) - 57.5 \text{ dB}$	100 kHz
$6 \text{ MHz} \leq \Delta f \leq \Delta f_{\max}$	$6.05 \text{ MHz} \leq f_{\text{offset}} < f_{\text{offset}_{\max}}$	$\text{Min}(P_{\max,c,cell} - 10 \cdot \log_{10}(N_{TXU, \text{countedpercell}}) - 59 \text{ dB}, -25 \text{ dBm})$ (Note 8)	100 kHz

NOTE 1: For a *TAB connector* supporting non-contiguous spectrum operation within any operating band the *basic limit* within sub-block gaps is calculated as a cumulative sum of contributions from adjacent sub blocks on each side of the sub block gap. Exception is $\Delta f \geq 10$ MHz from both adjacent sub blocks on each side of the sub-block gap, where the *basic limit* within sub-block gaps shall be $\text{Min}(P_{\max,c,cell} - 10 \cdot \log_{10}(N_{TXU, \text{countedpercell}}) - 59 \text{ dB}, -25 \text{ dBm})/100$ kHz.

NOTE 2: For a *multi-band TAB connector* with *Inter RF Bandwidth gap* < 20 MHz the *basic limit* within the *Inter RF Bandwidth gaps* is calculated as a cumulative sum of contributions from adjacent sub-blocks or *Base Station RF Bandwidth* on each side of the *Inter RF Bandwidth gap*.

NOTE 8: The requirement is not applicable when $\Delta f_{\max} < 10$ MHz.

Table 6.6.5.5.6-6: Medium Range BS operating band unwanted emission limits for 3 MHz channel bandwidth, $31 < P_{\max,c,cell} - 10 \cdot \log_{10}(N_{\text{TXU,countedpercell}}) \leq 38$ dBm (E-UTRA bands > 3 GHz)

Frequency offset of measurement filter -3dB point, Δf	Frequency offset of measurement filter centre frequency, f_{offset}	<i>basic limit</i> (Notes 1 and 2)	Measurement bandwidth
$0 \text{ MHz} \leq \Delta f < 3 \text{ MHz}$	$0.05 \text{ MHz} \leq f_{\text{offset}} < 3.05 \text{ MHz}$	$P_{\max,c,cell} - 10 \cdot \log_{10}(N_{\text{TXU,countedpercell}}) - 47.2 \text{ dB} - \frac{10}{3} \left(\frac{f_{\text{offset}}}{\text{MHz}} - 0.05 \right) \text{ dB}$	100 kHz
$3 \text{ MHz} \leq \Delta f < 6 \text{ MHz}$	$3.05 \text{ MHz} \leq f_{\text{offset}} < 6.05 \text{ MHz}$	$P_{\max,c,cell} - 10 \cdot \log_{10}(N_{\text{TXU,countedpercell}}) - 57.2 \text{ dB}$	100 kHz
$6 \text{ MHz} \leq \Delta f \leq \Delta f_{\max}$	$6.05 \text{ MHz} \leq f_{\text{offset}} < f_{\text{offset}_{\max}}$	$\text{Min}(P_{\max,c,cell} - 10 \cdot \log_{10}(N_{\text{TXU,countedpercell}}) - 59 \text{ dB}, -25 \text{ dBm})$ (Note 8)	100 kHz

NOTE 1: For a *TAB connector* supporting non-contiguous spectrum operation within any operating band the *basic limit* within sub-block gaps is calculated as a cumulative sum of contributions from adjacent sub blocks on each side of the sub block gap. Exception is $\Delta f \geq 10$ MHz from both adjacent sub blocks on each side of the sub-block gap, where the *basic limit* within sub-block gaps shall be $\text{Min}(P_{\max,c,cell} - 10 \cdot \log_{10}(N_{\text{TXU,countedpercell}}) - 59 \text{ dB}, -25 \text{ dBm})/100$ kHz.

NOTE 2: For a *multi-band TAB connector* with *Inter RF Bandwidth gap* < 20 MHz the *basic limit* within the *Inter RF Bandwidth gaps* is calculated as a cumulative sum of contributions from adjacent sub-blocks or *Base Station RF Bandwidth* on each side of the *Inter RF Bandwidth gap*.

NOTE 8: The requirement is not applicable when $\Delta f_{\max} < 10$ MHz.

Table 6.6.5.5.6-7: Medium Range BS operating band unwanted emission limits for 3 MHz channel bandwidth, $P_{\max,c,cell} - 10 \cdot \log_{10}(N_{\text{TXU,countedpercell}}) \leq 31$ dBm (E-UTRA bands ≤ 3 GHz)

Frequency offset of measurement filter -3dB point, Δf	Frequency offset of measurement filter centre frequency, f_{offset}	<i>basic limit</i> (Notes 1 and 2)	Measurement bandwidth
$0 \text{ MHz} \leq \Delta f < 3 \text{ MHz}$	$0.05 \text{ MHz} \leq f_{\text{offset}} < 3.05 \text{ MHz}$	$-16.5 \text{ dBm} - \frac{10}{3} \left(\frac{f_{\text{offset}}}{\text{MHz}} - 0.05 \right) \text{ dB}$	100 kHz
$3 \text{ MHz} \leq \Delta f < 6 \text{ MHz}$	$3.05 \text{ MHz} \leq f_{\text{offset}} < 6.05 \text{ MHz}$	-26.5 dBm	100 kHz
$6 \text{ MHz} \leq \Delta f \leq \Delta f_{\max}$	$6.05 \text{ MHz} \leq f_{\text{offset}} < f_{\text{offset}_{\max}}$	-28 dBm (Note 8)	100 kHz

NOTE 1: For a *TAB connector* supporting non-contiguous spectrum operation within any operating band the *basic limit* within sub-block gaps is calculated as a cumulative sum of contributions from adjacent sub blocks on each side of the sub block gap. Exception is $\Delta f \geq 10$ MHz from both adjacent sub blocks on each side of the sub-block gap, where the *basic limit* within sub-block gaps shall be -28 dBm/100 kHz.

NOTE 2: For a *multi-band TAB connector* with *Inter RF Bandwidth gap* < 20 MHz the *basic limit* within the *Inter RF Bandwidth gaps* is calculated as a cumulative sum of contributions from adjacent sub-blocks or *Base Station RF Bandwidth* on each side of the *Inter RF Bandwidth gap*.

NOTE 8: The requirement is not applicable when $\Delta f_{\max} < 10$ MHz.

Table 6.6.5.5.6-8: Medium Range BS operating band unwanted emission limits for 3 MHz channel bandwidth, $P_{\max,c,cell} - 10 \cdot \log_{10}(N_{\text{TXU,countedpercell}}) \leq 31$ dBm (E-UTRA bands > 3 GHz)

Frequency offset of measurement filter -3dB point, Δf	Frequency offset of measurement filter centre frequency, f_{offset}	<i>basic limit</i> (Notes 1 and 2)	Measurement bandwidth
$0 \text{ MHz} \leq \Delta f < 3 \text{ MHz}$	$0.05 \text{ MHz} \leq f_{\text{offset}} < 3.05 \text{ MHz}$	$-16.2 \text{ dBm} - \frac{10}{3} \left(\frac{f_{\text{offset}}}{\text{MHz}} - 0.05 \right) \text{ dB}$	100 kHz
$3 \text{ MHz} \leq \Delta f < 6 \text{ MHz}$	$3.05 \text{ MHz} \leq f_{\text{offset}} < 6.05 \text{ MHz}$	-26.2 dBm	100 kHz
$6 \text{ MHz} \leq \Delta f \leq \Delta f_{\max}$	$6.05 \text{ MHz} \leq f_{\text{offset}} < f_{\text{offset}_{\max}}$	-28 dBm (Note 8)	100 kHz

NOTE 1: For a *TAB connector* supporting non-contiguous spectrum operation within any operating band the *basic limit* within sub-block gaps is calculated as a cumulative sum of contributions from adjacent sub blocks on each side of the sub block gap. Exception is $\Delta f \geq 10$ MHz from both adjacent sub blocks on each side of the sub-block gap, where the *basic limit* within sub-block gaps shall be -28 dBm/100 kHz.

NOTE 2: For a *multi-band TAB connector* with *Inter RF Bandwidth gap* < 20 MHz the *basic limit* within the *Inter RF Bandwidth gaps* is calculated as a cumulative sum of contributions from adjacent sub-blocks or *Base Station RF Bandwidth* on each side of the *Inter RF Bandwidth gap*.

NOTE 8: The requirement is not applicable when $\Delta f_{\max} < 10$ MHz.

Table 6.6.5.5.6-9: Medium Range BS operating band unwanted emission limits for 5, 10, 15 and 20 MHz channel bandwidth, $31 < P_{\max,c,cell} - 10 \cdot \log_{10}(N_{\text{TXU,countedpercell}}) \leq 38$ dBm (E-UTRA bands ≤ 3 GHz)

Frequency offset of measurement filter -3dB point, Δf	Frequency offset of measurement filter centre frequency, f_{offset}	<i>basic limit</i> (Notes 1 and 2)	Measurement bandwidth
$0 \text{ MHz} \leq \Delta f < 5 \text{ MHz}$	$0.05 \text{ MHz} \leq f_{\text{offset}} < 5.05 \text{ MHz}$	$P_{\max,c,cell} - 10 \cdot \log_{10}(N_{\text{TXU,countedpercell}}) - 51.5 \text{ dB} - \frac{7}{5} \left(\frac{f_{\text{offset}}}{\text{MHz}} - 0.05 \right) \text{ dB}$	100 kHz
$5 \text{ MHz} \leq \Delta f < \min(10 \text{ MHz}, \Delta f_{\max})$	$5.05 \text{ MHz} \leq f_{\text{offset}} < \min(10.05 \text{ MHz}, f_{\text{offsetmax}})$	$P_{\max,c,cell} - 10 \cdot \log_{10}(N_{\text{TXU,countedpercell}}) - 58.5 \text{ dB}$	100 kHz
$10 \text{ MHz} \leq \Delta f \leq \Delta f_{\max}$	$10.05 \text{ MHz} \leq f_{\text{offset}} < f_{\text{offsetmax}}$	$\text{Min}(P_{\max,c,cell} - 10 \cdot \log_{10}(N_{\text{TXU,countedpercell}}) - 60 \text{ dB}, -25 \text{ dBm})$ (Note 8)	100 kHz

NOTE 1: For a *TAB connector* supporting non-contiguous spectrum operation within any operating band the *basic limit* within sub-block gaps is calculated as a cumulative sum of contributions from adjacent sub blocks on each side of the sub block gap. Exception is $\Delta f \geq 10$ MHz from both adjacent sub blocks on each side of the sub-block gap, where the *basic limit* within sub-block gaps shall be $\text{Min}(P_{\max,c,cell} - 10 \cdot \log_{10}(N_{\text{TXU,countedpercell}}) - 60 \text{ dB}, -25 \text{ dBm})/100 \text{ kHz}$.

NOTE 2: For a *multi-band TAB connector* with *Inter RF Bandwidth gap* < 20 MHz the *basic limit* within the *Inter RF Bandwidth gaps* is calculated as a cumulative sum of contributions from adjacent sub-blocks or *Base Station RF Bandwidth* on each side of the *Inter RF Bandwidth gap*.

NOTE 8: The requirement is not applicable when $\Delta f_{\max} < 10$ MHz.

Table 6.6.5.5.6-10: Medium Range BS operating band unwanted emission limits for 5, 10, 15 and 20 MHz channel bandwidth, $31 < P_{\max,c,cell} - 10 \cdot \log_{10}(N_{\text{TXU,countedpercell}}) \leq 38$ dBm (E-UTRA bands > 3 GHz)

Frequency offset of measurement filter -3dB point, Δf	Frequency offset of measurement filter centre frequency, f_{offset}	<i>basic limit</i> (Notes 1 and 2)	Measurement bandwidth
$0 \text{ MHz} \leq \Delta f < 5 \text{ MHz}$	$0.05 \text{ MHz} \leq f_{\text{offset}} < 5.05 \text{ MHz}$	$P_{\max,c,cell} - 10 \cdot \log_{10}(N_{\text{TXU,countedpercell}}) - 51.2 \text{ dB} - \frac{7}{5} \left(\frac{f_{\text{offset}}}{\text{MHz}} - 0.05 \right) \text{ dB}$	100 kHz
$5 \text{ MHz} \leq \Delta f < \min(10 \text{ MHz}, \Delta f_{\max})$	$5.05 \text{ MHz} \leq f_{\text{offset}} < \min(10.05 \text{ MHz}, f_{\text{offsetmax}})$	$P_{\max,c,cell} - 10 \cdot \log_{10}(N_{\text{TXU,countedpercell}}) - 58.2 \text{ dB}$	100 kHz
$10 \text{ MHz} \leq \Delta f \leq \Delta f_{\max}$	$10.05 \text{ MHz} \leq f_{\text{offset}} < f_{\text{offsetmax}}$	$\text{Min}(P_{\max,c,cell} - 10 \cdot \log_{10}(N_{\text{TXU,countedpercell}}) - 60 \text{ dB}, -25 \text{ dBm})$ (Note 8)	100 kHz

NOTE 1: For a *TAB connector* supporting non-contiguous spectrum operation within any operating band the *basic limit* within sub-block gaps is calculated as a cumulative sum of contributions from adjacent sub blocks on each side of the sub block gap. Exception is $\Delta f \geq 10$ MHz from both adjacent sub blocks on each side of the sub-block gap, where the *basic limit* within sub-block gaps shall be $\text{Min}(P_{\max,c,cell} - 10 \cdot \log_{10}(N_{\text{TXU,countedpercell}}) - 60 \text{ dB}, -25 \text{ dBm})/100 \text{ kHz}$.

NOTE 2: For a *multi-band TAB connector* with *Inter RF Bandwidth gap* < 20 MHz the *basic limit* within the *Inter RF Bandwidth gaps* is calculated as a cumulative sum of contributions from adjacent sub-blocks or *Base Station RF Bandwidth* on each side of the *Inter RF Bandwidth gap*.

NOTE 8: The requirement is not applicable when $\Delta f_{\max} < 10$ MHz.

Table 6.6.5.5.6-11: Medium Range BS operating band unwanted emission limits for 5, 10, 15 and 20 MHz channel bandwidth, $P_{\max,c,cell} \cdot 10 \cdot \log_{10}(N_{TXU, \text{counted per cell}}) \leq 31$ dBm (E-UTRA bands ≤ 3 GHz)

Frequency offset of measurement filter -3dB point, Δf	Frequency offset of measurement filter centre frequency, f_{offset}	<i>basic limit</i> (Notes 1 and 2)	Measurement bandwidth
$0 \text{ MHz} \leq \Delta f < 5 \text{ MHz}$	$0.05 \text{ MHz} \leq f_{\text{offset}} < 5.05 \text{ MHz}$	$-20.5 \text{ dBm} - \frac{7}{5} \left(\frac{f_{\text{offset}}}{\text{MHz}} - 0.05 \right) \text{ dB}$	100 kHz
$5 \text{ MHz} \leq \Delta f < \min(10 \text{ MHz}, \Delta f_{\max})$	$5.05 \text{ MHz} \leq f_{\text{offset}} < \min(10.05 \text{ MHz}, f_{\text{offset}_{\max}})$	-27.5 dBm	100 kHz
$10 \text{ MHz} \leq \Delta f \leq \Delta f_{\max}$	$10.05 \text{ MHz} \leq f_{\text{offset}} < f_{\text{offset}_{\max}}$	-29 dBm (Note 8)	100 kHz
NOTE 1: For a <i>TAB connector</i> supporting non-contiguous spectrum operation within any operating band the <i>basic limit</i> within sub-block gaps is calculated as a cumulative sum of contributions from adjacent sub blocks on each side of the sub block gap. Exception is $\Delta f \geq 10$ MHz from both adjacent sub blocks on each side of the sub-block gap, where the <i>basic limit</i> within sub-block gaps shall be -29dBm/100 kHz.			
NOTE 2: For a <i>multi-band TAB connector</i> with <i>Inter RF Bandwidth gap</i> < 20 MHz the <i>basic limit</i> within the <i>Inter RF Bandwidth gaps</i> is calculated as a cumulative sum of contributions from adjacent sub-blocks or <i>Base Station RF Bandwidth</i> on each side of the <i>Inter RF Bandwidth gap</i> .			
NOTE 8: The requirement is not applicable when $\Delta f_{\max} < 10$ MHz.			

Table 6.6.5.5.6-12: Medium Range BS operating band unwanted emission limits for 5, 10, 15 and 20 MHz channel bandwidth, $P_{\max,c,cell} \cdot 10 \cdot \log_{10}(N_{TXU, \text{counted per cell}}) \leq 31$ dBm (E-UTRA bands > 3 GHz)

Frequency offset of measurement filter -3dB point, Δf	Frequency offset of measurement filter centre frequency, f_{offset}	<i>basic limit</i> (Notes 1 and 2)	Measurement bandwidth
$0 \text{ MHz} \leq \Delta f < 5 \text{ MHz}$	$0.05 \text{ MHz} \leq f_{\text{offset}} < 5.05 \text{ MHz}$	$-20.2 \text{ dBm} - \frac{7}{5} \left(\frac{f_{\text{offset}}}{\text{MHz}} - 0.05 \right) \text{ dB}$	100 kHz
$5 \text{ MHz} \leq \Delta f < \min(10 \text{ MHz}, \Delta f_{\max})$	$5.05 \text{ MHz} \leq f_{\text{offset}} < \min(10.05 \text{ MHz}, f_{\text{offset}_{\max}})$	-27.2 dBm	100 kHz
$10 \text{ MHz} \leq \Delta f \leq \Delta f_{\max}$	$10.05 \text{ MHz} \leq f_{\text{offset}} < f_{\text{offset}_{\max}}$	-29 dBm (Note 8)	100 kHz
NOTE 1: For a <i>TAB connector</i> supporting non-contiguous spectrum operation within any operating band the <i>basic limit</i> within sub-block gaps is calculated as a cumulative sum of contributions from adjacent sub blocks on each side of the sub block gap. Exception is $\Delta f \geq 10$ MHz from both adjacent sub blocks on each side of the sub-block gap, where the <i>basic limit</i> within sub-block gaps shall be -29dBm/100 kHz.			
NOTE 2: For a <i>multi-band TAB connector</i> with <i>Inter RF Bandwidth gap</i> < 20 MHz the <i>basic limit</i> within the <i>Inter RF Bandwidth gaps</i> is calculated as a cumulative sum of contributions from adjacent sub-blocks or <i>Base Station RF Bandwidth</i> on each side of the <i>Inter RF Bandwidth gap</i> .			
NOTE 8: The requirement is not applicable when $\Delta f_{\max} < 10$ MHz.			

6.6.5.5.7 Basic limits for Additional requirements

In certain regions the following requirement may apply. For E-UTRA *TAB connector* operating in Bands 5, 26, 27 or 28, *basic limits* are specified in table 6.6.5.5.7-1.

Table 6.6.5.5.7-1: Additional operating band unwanted emission limits for E-UTRA bands < 1 GHz

Channel bandwidth	Frequency offset of measurement filter -3dB point, Δf	Frequency offset of measurement filter centre frequency, f_{offset}	<i>basic limit</i>	Measurement bandwidth
1.4 MHz	$0 \text{ MHz} \leq \Delta f < 1 \text{ MHz}$	$0.005 \text{ MHz} \leq f_{\text{offset}} < 0.995 \text{ MHz}$	-14 dBm	10 kHz
3 MHz	$0 \text{ MHz} \leq \Delta f < 1 \text{ MHz}$	$0.015 \text{ MHz} \leq f_{\text{offset}} < 0.985 \text{ MHz}$	-13 dBm	30 kHz
5 MHz	$0 \text{ MHz} \leq \Delta f < 1 \text{ MHz}$	$0.015 \text{ MHz} \leq f_{\text{offset}} < 0.985 \text{ MHz}$	-15 dBm	30 kHz
10 MHz	$0 \text{ MHz} \leq \Delta f < 1 \text{ MHz}$	$0.05 \text{ MHz} \leq f_{\text{offset}} < 0.95 \text{ MHz}$	-13 dBm	100 kHz
15 MHz	$0 \text{ MHz} \leq \Delta f < 1 \text{ MHz}$	$0.05 \text{ MHz} \leq f_{\text{offset}} < 0.95 \text{ MHz}$	-13 dBm	100 kHz
20 MHz	$0 \text{ MHz} \leq \Delta f < 1 \text{ MHz}$	$0.05 \text{ MHz} \leq f_{\text{offset}} < 0.95 \text{ MHz}$	-13 dBm	100 kHz
All	$1 \text{ MHz} \leq \Delta f < \Delta f_{\max}$	$1.05 \text{ MHz} \leq f_{\text{offset}} < f_{\text{offset}_{\max}}$	-13 dBm (Note 8)	100 kHz
NOTE 8: The requirement is not applicable when $\Delta f_{\max} < 10$ MHz.				

In certain regions the following requirement may apply. For E-UTRA a *TAB connector* operating in Bands 2, 4, 10, 23, 25, 30, 35, 36, 41, 66, *basic limits* are specified in table 6.6.5.5.5.7-2.

Table 6.6.5.5.7-2: Additional operating band unwanted emission limits for E-UTRA bands > 1GHz

Channel bandwidth	Frequency offset of measurement filter -3dB point, Δf	Frequency offset of measurement filter centre frequency, f_{offset}	<i>basic limit</i>	Measurement bandwidth
1.4 MHz	$0 \text{ MHz} \leq \Delta f < 1 \text{ MHz}$	$0.005 \text{ MHz} \leq f_{\text{offset}} < 0.995 \text{ MHz}$	-14 dBm	10 kHz
3 MHz	$0 \text{ MHz} \leq \Delta f < 1 \text{ MHz}$	$0.015 \text{ MHz} \leq f_{\text{offset}} < 0.985 \text{ MHz}$	-13 dBm	30 kHz
5 MHz	$0 \text{ MHz} \leq \Delta f < 1 \text{ MHz}$	$0.015 \text{ MHz} \leq f_{\text{offset}} < 0.985 \text{ MHz}$	-15 dBm	30 kHz
10 MHz	$0 \text{ MHz} \leq \Delta f < 1 \text{ MHz}$	$0.05 \text{ MHz} \leq f_{\text{offset}} < 0.95 \text{ MHz}$	-13 dBm	100 kHz
15 MHz	$0 \text{ MHz} \leq \Delta f < 1 \text{ MHz}$	$0.05 \text{ MHz} \leq f_{\text{offset}} < 0.95 \text{ MHz}$	-15 dBm	100 kHz
20 MHz	$0 \text{ MHz} \leq \Delta f < 1 \text{ MHz}$	$0.05 \text{ MHz} \leq f_{\text{offset}} < 0.95 \text{ MHz}$	-16 dBm	100 kHz
All	$1 \text{ MHz} \leq \Delta f < \Delta f_{\text{max}}$	$1.5 \text{ MHz} \leq f_{\text{offset}} < f_{\text{offset}_{\text{max}}}$	-13 dBm (Note 8)	1 MHz

NOTE 8: The requirement is not applicable when $\Delta f_{\text{max}} < 10 \text{ MHz}$.

In certain regions the following requirement may apply. For E-UTRA a *TAB connector* operating in Bands 12, 13, 14, 17, 29 *basic limits* are specified in table 6.6.5.5.5.7-3.

Table 6.6.5.5.7-3: Additional operating band unwanted emission limits for E-UTRA (bands 12, 13, 14, 17 and 29)

Channel bandwidth	Frequency offset of measurement filter -3dB point, Δf	Frequency offset of measurement filter centre frequency, f_{offset}	<i>basic limit</i>	Measurement bandwidth
All	$0 \text{ MHz} \leq \Delta f < 100 \text{ kHz}$	$0.015 \text{ MHz} \leq f_{\text{offset}} < 0.085 \text{ MHz}$	-13 dBm	30 kHz
All	$100 \text{ kHz} \leq \Delta f < \Delta f_{\text{max}}$	$150 \text{ kHz} \leq f_{\text{offset}} < f_{\text{offset}_{\text{max}}}$	-13 dBm (Note 8)	100 kHz

NOTE 8: The requirement is not applicable when $\Delta f_{\text{max}} < 10 \text{ MHz}$.

In certain regions, the following requirements may apply to an E-UTRA TDD *TAB connector* operating in the same geographic area and in the same operating band as another E-UTRA TDD system without synchronisation. For this case the basic limit shall be -52 dBm/MHz in each supported downlink operating band, except in:

- The frequency range from 10 MHz below the lower channel edge to the frequency 10 MHz above the upper channel edge of each supported band.

In certain regions the following requirement may apply for protection of DTT. For E-UTRA a *TAB connector* operating in Band 20, the maximum level of emissions in the band 470-790 MHz, measured in an 8MHz filter bandwidth on centre frequencies F_{filter} according to table 6.6.5.5.5.7-4, be based upon a declared *basic limit* P_{EM} $P_{\text{EM},N}$ declared by the manufacturer. This requirement applies in the frequency range 470-790 MHz even though part of the range falls in the spurious domain.

Table 6.6.5.5.7-4: Declared emissions *basic limit* for protection of DTT

Filter centre frequency, F_{filter}	Measurement bandwidth	Declared emission <i>basic limit</i> (dBm)
$F_{\text{filter}} = 8 \cdot N + 306 \text{ (MHz)}$; $21 \leq N \leq 60$	8 MHz	$P_{\text{EM},N}$

NOTE 1: The regional requirement is defined in terms of EIRP, which is dependent on both the BS emissions at the *TAB connector* and the RND and antenna array. The EIRP level is calculated using: $P_{\text{EIRP}} = P_{\text{E}} + G_{\text{ant}}$ where P_{E} denotes the *TAB connector* unwanted emission level at the *TAB connector*, G_{ant} equals the RND and antenna array gain. The requirement defined above provides the characteristics of the base station needed to verify compliance with the regional requirement. Compliance with the regional requirement can be determined using the method outlined in annex G of 3GPP TS 36.104 [11].

In certain regions the following requirement may apply for the protection of systems operating in frequency bands adjacent to band 1 as defined in clause 5.5, in geographic areas in which both an adjacent band service E-UTRA are deployed.

The *basic limits* shall be:

Table 6.6.5.5.7-5: Emissions limits for protection of adjacent band services

Operating Band	Frequency range	Maximum Level	Measurement Bandwidth
1	2100-2105 MHz	$-30 + 3.4 \times (f - 2100 \text{ MHz}) \text{ dBm}$	1 MHz
	2175-2180 MHz	$-30 + 3.4 \times (2180 \text{ MHz} - f) \text{ dBm}$	1 MHz

In regions where FCC regulation applies, requirements for protection of GPS according to FCC Order DA 10-534 applies for operation in Band 24. The following normative requirement covers the base station, to be used together with other information about the site installation to verify compliance with the requirement in FCC Order DA 10-534. The requirement applies to a *TAB connector* operating in Band 24 to ensure that appropriate interference protection is provided to the 1559 - 1610 MHz band. This requirement applies to the frequency range 1559-1610 MHz, even though part of this range falls within the spurious domain.

The maximum level of emissions in the 1559 - 1610 MHz band, measured in measurement bandwidth according to table 6.6.5.5.7-6 shall be based upon declared *basic limits* $P_{E,1 \text{ MHz}}$ and $P_{E,1 \text{ kHz}}$ declared by the manufacturer.

Table 6.6.5.5.7-6: Declared emissions *basic limits* for protection of the 1559-1610 MHz band

Operating Band	Frequency range	Declared emission level [dBW] (Measurement bandwidth = 1 MHz)	Declared emission <i>basic limit</i> [dBW] of discrete emissions of less than 700 Hz bandwidth (Measurement bandwidth = 1 kHz)
24	1559 - 1610 MHz	$P_{E,1 \text{ MHz}}$	$P_{E,1 \text{ kHz}}$

NOTE 2: The regional requirement in FCC Order DA 10-534 is defined in terms of EIRP, which is dependent on both the BS emissions at the *TAB connector* and the RND and antenna array. The EIRP level is calculated using: $P_{\text{EIRP}} = P_E + G_{\text{ant}}$ where P_E denotes the *TAB connector* unwanted emission level at the *TAB connector*, G_{ant} equals the RDN and antenna array gain. The requirement defined above provides the characteristics of the base station needed to verify compliance with the regional requirement. Compliance with the regional requirement can be determined using the method outlined in annex G of 3GPP TS 36.104 [11].

The following requirement may apply to an E-UTRA *TAB connector* operating in Band 41 in certain regions. *Basic limits* are specified in table 6.6.5.5.7-7.

Table 6.6.5.5.7-7: Additional operating band unwanted emission *basic limits* for Band 41

Channel bandwidth	Frequency offset of measurement filter -3dB point, Δf	Frequency offset of measurement filter centre frequency, f_{offset}	<i>basic limit</i>	Measurement bandwidth
10 MHz	$10 \text{ MHz} \leq \Delta f < 20 \text{ MHz}$	$10.5 \text{ MHz} \leq f_{\text{offset}} < 19.5 \text{ MHz}$	-22 dBm	1 MHz
20 MHz	$20 \text{ MHz} \leq \Delta f < 40 \text{ MHz}$	$20.5 \text{ MHz} \leq f_{\text{offset}} < 39.5 \text{ MHz}$	-22 dBm	1 MHz

NOTE: This requirement applies for E-UTRA carriers allocated within 2545-2575 MHz or 2595-2645 MHz.

In certain regions, the following requirements may apply to E-UTRA *TAB connector* operating in Band 32 within 1452-1492 MHz. The maximum level of operating band unwanted emissions, measured on centre frequencies f_{offset} with filter bandwidth, according to table 6.6.5.5.7-8, shall be defined based on the declared *basic limits* $P_{EM,B32,a}$, $P_{EM,B32,b}$ and $P_{EM,B32,c}$ declared by the manufacturer.

Table 6.6.5.5.7-8: Declared operating band 32 unwanted emission *basic limits* within 1452-1492 MHz

Frequency offset of measurement filter centre frequency, f_{offset}	Declared emission <i>basic limits</i> (dBm)	Measurement bandwidth
2.5 MHz	$P_{EM,B32,a}$	5 MHz
7.5 MHz	$P_{EM,B32,b}$	5 MHz
$12.5 \text{ MHz} \leq f_{\text{offset}} \leq f_{\text{offset}_{\text{max},B32}}$	$P_{EM,B32,c}$	5 MHz

NOTE: $f_{\text{offset}_{\text{max},B32}}$ denotes the frequency difference between the lower channel edge and 1454.5 MHz, and the frequency difference between the upper channel edge and 1489.5 MHz for the set channel position.

NOTE 3: The regional requirement, included in [25], is defined in terms of EIRP which is dependent on both the BS emissions at the *TAB connector* and the RND and antenna array. The EIRP level is calculated using: $P_{EIRP} = P_E + G_{ant}$ where P_E denotes the *TAB connector* unwanted emission level at the *TAB connector*, G_{ant} equals the RND and antenna array gain. The requirement defined above provides the characteristics of the base station needed to verify compliance with the regional requirement. Compliance with the regional requirement can be determined using the method outlined in annex G of 3GPP TS 36.104 [11].

In certain regions, the following requirement may apply to an E-UTRA *TAB connector* operating in Band 32 within 1452-1492 MHz for the protection of services in spectrum adjacent to the frequency range 1452-1492 MHz. The maximum level of emissions, measured on centre frequencies F_{filter} with filter bandwidth according to table 6.6.5.5.7-9, shall be based upon the declared *basic limits* $P_{EM,B32,d}$ and $P_{EM,B32,e}$ declared by the manufacturer. This requirement applies in the frequency range 1429-1518MHz even though part of the range falls in the spurious domain.

Table 6.6.5.5.7-9: Operating band 32 declared emission outside 1452-1492 MHz

Filter centre frequency, F_{filter}	Declared emission <i>basic limit</i> (dBm)	Measurement bandwidth
$1429.5 \text{ MHz} \leq F_{filter} \leq 1448.5 \text{ MHz}$	$P_{EM,B32,d}$	1 MHz
$F_{filter} = 1450.5 \text{ MHz}$	$P_{EM,B32,e}$	3 MHz
$F_{filter} = 1493.5 \text{ MHz}$	$P_{EM,B32,e}$	3 MHz
$1495.5 \text{ MHz} \leq F_{filter} \leq 1517.5 \text{ MHz}$	$P_{EM,B32,d}$	1 MHz

NOTE 4: The regional requirement, included in [25], is defined in terms of EIRP, which is dependent on both the BS emissions at the *TAB connector* and the RND and antenna array. The EIRP level is calculated using: $P_{EIRP} = P_E + G_{ant}$ where P_E denotes the *TAB connector* unwanted emission level at the *TAB connector*, G_{ant} equals the RND and antenna array gain. The requirement defined above provides the characteristics of the base station needed to verify compliance with the regional requirement. Compliance with the regional requirement can be determined using the method outlined in annex G of 3GPP TS 36.104 [11].

In certain regions the following requirement may apply to an E-UTRA *TAB connector* operating in Band 45. *Basic limits* are specified in table 6.6.5.5.7-10.

Table 6.6.5.5.7-10: Emissions *basic limits* for protection of adjacent band services

Operating Band	Filter centre frequency, F_{filter}	<i>Basic limit</i> (dBm)	Measurement Bandwidth
45	$F_{filter} = 1467.5$	-20	1 MHz
	$F_{filter} = 1468.5$	-23	1 MHz
	$F_{filter} = 1469.5$	-26	1 MHz
	$F_{filter} = 1470.5$	-33	1 MHz
	$F_{filter} = 1471.5$	-40	1 MHz
	$1472.5 \text{ MHz} \leq F_{filter} \leq 1491.5 \text{ MHz}$	-47	1 MHz

The following requirement may apply to E-UTRA BS operating in Band 48 in certain regions. Emissions shall not exceed the maximum levels specified in Table 6.6.5.5.7-11.

Table 6.6.5.5.7-11: Additional operating band unwanted emission limits for Band 48

Channel bandwidth	Frequency offset of measurement filter -3dB point, Δf	Frequency offset of measurement filter centre frequency, f_{offset}	Minimum requirement	Measurement bandwidth (Note 3)
All	$0 \text{ MHz} \leq \Delta f < 10 \text{ MHz}$	$0.5 \text{ MHz} \leq f_{offset} < 9.5 \text{ MHz}$	-13 dBm	1 MHz

6.6.6 Spurious emission

6.6.6.1 Definition and applicability

The conducted transmitter spurious emission limits apply from 9 kHz to 12.75 GHz, excluding the following RAT-specific frequency ranges:

- UTRA TDD BS, 1.28 Mcps option as specified in TS 25.105 [3]: from 4 MHz below the lowest frequency of each operating band to 4 MHz above the highest frequency of each operating band.

- UTRA FDD BS as specified in TS 25.104 [2]: from 12.5MHz below the lowest carrier frequency used up to 12.5MHz above the highest carrier frequency used.
- E-UTRA BS as specified in TS 36.104 [4]: from Δf_{OBUE} below the lowest frequency of the *downlink operating band* up to Δf_{OBUE} above the highest frequency of the *downlink operating band*, where Δf_{OBUE} is defined subclause 6.6.1.
- MSR BS as specified in TS 37.104 [5]: from Δf_{OBUE} below the lowest frequency of the *downlink operating band* up to Δf_{OBUE} above the highest frequency of the *downlink operating band*, where Δf_{OBUE} is defined subclause 6.6.1.

For some operating bands the upper frequency limit is higher than 12.75 GHz in order to comply with the 5th harmonic limit of the *downlink operating band*, as specified in ITU-R recommendation SM.329 [14]. In some exceptional cases, requirements apply also closer than Δf_{OBUE} MHz from the *downlink operating band*; these cases are highlighted in the requirement tables in respective referenced UTRA, E-UTRA or MSR specifications. For operating bands supported by *multi-band TAB connectors* exclusion bands apply to each supported band.

The requirements applies for both single band and multiband *TAB connectors* (except for frequencies at which exclusion bands or other multi-band provisions apply) and for all transmission modes foreseen by the manufacturer's specification. Unless otherwise stated, all requirements are measured as mean power.

For operation in region 2, where the FCC guidance for MIMO systems in [18] is applicable, $N_{\text{TXU, countedpercell}}$ shall be equal to 1 for the purposes of calculating the spurious emissions limits in subclauses 6.6.6. For all other unwanted emissions requirements, $N_{\text{TXU, countedpercell}}$ shall be the value calculated according to subclause 6.1.

The AAS BS test requirements for co-location spurious emissions limits which are specified for Band 46 in 3GPP TS 37.104 [5], are applicable for AAS BS.

6.6.6.2 Minimum requirement

The minimum requirement for MSR operation are defined in 3GPP TS 37.105 [8], subclause 6.6.6.2.

The minimum requirement for UTRA operation are defined in 3GPP TS 37.105 [8], subclause 6.6.6.3.

The minimum requirement for E-UTRA operation are defined in 3GPP TS 37.105 [8], subclause 6.6.6.4.

6.6.2.3 Test purpose

This test measures conducted spurious emission from the AAS BS transmit *TAB connector(s)*, while the transmitter unit associated with the *TAB connector* under test is in operation.

6.6.6.4 Method of test

6.6.6.4.1 Initial conditions

Test environment:

- normal; see clause B.2.

RF channels to be tested for single carrier:

- B when testing the spurious frequencies below $F_{\text{DL_low}} - \Delta f_{\text{OBUE}}$,
- T when testing the spurious frequencies above $F_{\text{DL_high}} + \Delta f_{\text{OBUE}}$; see subclause 4.12.1.

Base Station RF Bandwidth positions to be tested for multi-carrier:

- B_{RFBW} when testing the spurious frequencies below $F_{\text{DL_low}} - \Delta f_{\text{OBUE}}$;
- T_{RFBW} when testing the spurious frequencies above $F_{\text{DL_high}} + \Delta f_{\text{OBUE}}$ in single-band operation; see subclause 4.12.1;
- $B_{\text{RFBW}}T_{\text{RFBW}}$ when testing the spurious frequencies below $F_{\text{DL_low}} - \Delta f_{\text{OBUE}}$ of the lowest operating band; $B_{\text{RFBW}}T_{\text{RFBW}}$ when testing the spurious frequencies below $F_{\text{DL_low}} - \Delta f_{\text{OBUE}}$ of the lowest operating band in multi-band operation, see subclause 4.12.1.

6.6.6.4.2 Procedure

The minimum requirement is applied to all *TAB connectors*, they may be tested one at a time or multiple *TAB connectors* may be tested in parallel as shown in subclause D.1.3. Whichever method is used the procedure is repeated until all *TAB connectors* necessary to demonstrate conformance have been tested.

- 1) Connect *TAB connector* to measurement equipment as shown in subclause D.1.3. All *TAB connectors* not under test shall be terminated.
- 2) Measurements shall use a measurement bandwidth in accordance to the conditions in 3GPP TS 37.104 [12] subclause 6.6.1.
- 3) The measurement device characteristics shall be:
 - Detection mode: True RMS.
- 4) Set the *TAB connector* to transmit:
 - a) For MSR:
 - Set the *TAB connector* to transmit maximum power according to the applicable test configuration in clause 5 using the corresponding test models or set of physical channels in subclause 4.11.
 - b) For UTRA:
 - For a *TAB connector* declared to be capable of single carrier operation only, set the *TAB connector* to transmit a signal according to TM1, subclause 4.12.2, at the manufacturer's declared rated output power, $P_{\text{rated,c,TABC}}$.
 - For a *TAB connector* declared to be capable of multi-carrier operation, set the set the *TAB connector* to transmit according to TM1 on all carriers configured using the applicable test configuration and corresponding power setting specified in subclause 4.11.
 - c) For E-UTRA:
 - *TAB connector* declared to be capable of single carrier operation only, set the *TAB connector* to transmit a signal according to E-TM1.1 in subclause 4.12.2, at manufacturer's declared rated output power $P_{\text{rated,c,TABC}}$.
 - For a *TAB connector* declared to be capable of multi-carrier and/or CA operation, set the set the *TAB connector* to transmit according to E-TM1.1 on all carriers configured using the applicable test configuration and corresponding power setting specified in subclause 4.11.
- 5) Measure the emission at the specified frequencies with specified measurement bandwidth and note that the measured value does not exceed the test requirement in subclause 6.6.6.5.

In addition, for *multi-band TAB connector(s)*, the following steps shall apply:

- 6) For *multi-band TAB connectors* and single band tests, repeat the steps above per involved band where single band test configurations and test models shall apply with no carrier activated in the other band.

6.6.6.5 Test requirements

6.6.6.5.1 General

Conformance may be shown to either the measure and sum test requirement or the per *TAB connector* test requirement:

- 1) The spurious emission test requirements for an AAS BS when using the measure and sum alternative are that for each *TAB connector TX cell group* and each applicable *basic limit* as specified in this subclause, the power summation of emissions at the *TAB connectors* of the *TAB connector TX cell group* shall not exceed a limit specified as the *basic limit* + $10\log_{10}(N_{\text{TXU,countedpercell}})$.
- 2) The spurious emission test requirements for an AAS BS when using the per *TAB connector* alternative are that for each *TAB connector TX cell group* and each applicable *basic limit* as specified in this subclause, the emissions at each of the *TAB connectors* of the *TAB connector TX cell group* shall not exceed a limit specified as

the *basic limit* + $10\log_{10}(N_{\text{TXU,countedpercell}}) - 10\log(n)$ where n is the number of *TAB connectors* in the *TAB connector TX cell group*.

The appropriate table for the basic limit is based on the same power level ($P_{\text{Rated,c,sys}}$) as used for the AAS BS rated power limits for BS classes in table 6.2.2.1-1 the same method of scaling the power level using $N_{\text{TXU,counted}}$ is used.

6.6.6.5.2 Basic limits

6.6.6.5.2.1 General

The basic limits specified in tables 6.6.6.5.2.2-1 to table 6.6.6.5.2.6-3 are applicable for the *TAB connector* under test.

The test requirements of either subclause 6.6.6.5.2.2 (Category A limits) or subclause 6.6.6.5.2.3 (Category B limits) shall apply. In addition for a *TAB connector* operating in Band Category 2, the test requirements of 6.6.6.5.2.4 shall apply in case of Category B limits.

6.6.6.5.2.2 Spurious emissions (Category A)

The basic limit of any spurious emission shall not exceed the limits in table 6.6.6.5.2.2 -1

Table 6.6.6.5.2.2 -1: Spurious emission limits, Category A

Frequency range	Maximum level	Measurement Bandwidth	Notes
9kHz - 150 kHz	-13 dBm	1 kHz	Note 1
150 kHz - 30 MHz		10 kHz	Note 1
30 MHz - 1GHz		100 kHz	Note 1
1GHz - 12.75 GHz		1 MHz	Note 2
12.75 GHz - 5 th harmonic of the upper frequency edge of the DL operating band in GHz		1 MHz	Note 2, Note 3
NOTE 1: Bandwidth as in Recommendation ITU-R SM.329 [13], s4.1			
NOTE 2: Bandwidth as in Recommendation ITU-R SM.329 [13], s4.1. Upper frequency as in Recommendation ITU-R SM.329 [13], s2.5 table 1			
NOTE 3: For E-UTRA applies only for Bands 22, 42, 43 and 48.			
NOTE 4: For UTRA applies only for Band XXII.			

6.6.6.5.2.3 Spurious emissions (Category B)

For MSR and E-UTRA the basic limits of is in table 6.6.6.5.2.3-1.

For UTRA FDD the basic limits of is in tables 6.6.6.5.2.3-2 and 6.6.6.5.2.3-3.

For UTRA FDD the basic limits of is in table 6.6.6.5.2.3-2.

Table 6.6.6.5.2.3-1: Spurious emissions limits, Category B

Frequency range	Maximum Level	Measurement Bandwidth	Notes
9 kHz ↔ 150 kHz	-36 dBm	1 kHz	Note 1
150 kHz ↔ 30 MHz	-36 dBm	10 kHz	Note 1
30 MHz ↔ 1 GHz	-36 dBm	100 kHz	Note 1
1 GHz ↔ 12.75 GHz	-30 dBm	1 MHz	Note 2
12.75 GHz ↔ 5 th harmonic of the upper frequency edge of the DL operating band in GHz	-30 dBm	1 MHz	Note 2, Note 3
NOTE 1: Bandwidth as in Recommendation ITU-R SM.329 [13], s4.1.			
NOTE 2: Bandwidth as in Recommendation ITU-R SM.329 [13], s4.1. Upper frequency as in Recommendation ITU-R SM.329 [13], s2.5 table 1.			
NOTE 3: Applies only for Bands 22, 42, 43 and 48.			

Table 6.6.5.2.3-2: Mandatory spurious emissions basic limits, UTRA FDD in operating band I, II, III, IV, VII, X, XXV, XXXII (Category B) and UTRA TDD

Band	Maximum Level	Measurement Bandwidth	Notes
9 kHz ↔ 150 kHz	-36 dBm	1 kHz	Note 1
150 kHz ↔ 30 MHz	-36 dBm	10 kHz	Note 1
30 MHz ↔ 1 GHz	-36 dBm	100 kHz	Note 1
1 GHz ↔ $F_{low} - 10$ MHz	-30 dBm	1 MHz	Note 1
$F_{low} - 10$ MHz ↔ $F_{high} + 10$ MHz	-15 dBm	1 MHz	Note 2
$F_{high} + 10$ MHz ↔ 12.75 GHz	-30 dBm	1 MHz	Note 3
12.75 GHz - 5 th harmonic of the upper frequency edge of the DL operating band in GHz	-30 dBm	1 MHz	Note 3, Note 4
NOTE 1: Bandwidth as in Recommendation ITU-R SM.329 [35], s4.1.			
NOTE 2: Limit based on Recommendation ITU-R SM.329 [35], s4.3 and Annex 7.			
NOTE 3: Bandwidth as in Recommendation ITU-R SM.329 [35], s4.1. Upper frequency as in ITU-R SM.329 [35], s2.5 table 1.			
NOTE 4: UTRA FDD applies only for Band XXII.			
Key:			
F_{low} : The lowest downlink frequency of the operating band as defined in subclause 4.5.			
F_{high} : The highest downlink frequency of the operating band as defined in subclause 4.5.			

Table 6.6.5.2.3-3: Mandatory spurious emissions basic limits, UTRA in operating band V, VIII, XII, XIII, XIV, XX, XXVI (Category B)

Band	Maximum Level	Measurement Bandwidth	Notes
9 kHz ↔ 150 kHz	-36 dBm	1 kHz	Note 1
150 kHz ↔ 30 MHz	-36 dBm	10 kHz	Note 1
30 MHz ↔ $F_{low} - 10$ MHz	-36 dBm	100 kHz	Note 1
$F_{low} - 10$ MHz ↔ $F_{high} + 10$ MHz	-16 dBm	100 kHz	Note 2
$F_{high} + 10$ MHz ↔ 1 GHz	-36 dBm	100 kHz	Note 1
1GHz ↔ 12.75GHz	-30 dBm	1 MHz	Note 3
NOTE 1: Bandwidth as in Recommendation ITU-R SM.329 [35], s4.1.			
NOTE 2: Limit based on Recommendation ITU-R SM.329 [35], s4.3 and Annex 7.			
NOTE 3: Bandwidth as in Recommendation ITU-R SM.329 [35], s4.1. Upper frequency as in ITU-R SM.329 [35], s2.5 table 1.			
Key:			
F_{low} : The lowest downlink frequency of the operating band as defined in subclause 4.5.			
F_{high} : The highest downlink frequency of the operating band as defined in subclause 4.5.			

6.6.6.5.2.4 Protection of the BS receiver of own or different BS

This requirement shall be applied for FDD operation in order to prevent the receivers of Base Stations being desensitised by emissions from the transmitter *TAB connector*. It is measured at the transmit *TAB connector* for any type of *TAB connector* which has common or separate Tx/Rx antenna ports.

The basic limit of any spurious emission shall not exceed the limits in table 6.6.6.5.2.4 -1, depending on the declared Base Station class and Band Category.

Table 6.6.6.5.2.4-1: Spurious emissions *basic limits* for protection of the BS receiver

	Frequency range	UTRA <i>basic limit</i>	E-UTRA <i>basic limit</i>	Measurement Bandwidth	
Wide Area BS	$F_{UL_low} - F_{UL_high}$	-96 dBm	-96 dBm	100 kHz	
Medium Range BS	$F_{UL_low} - F_{UL_high}$	-86 dBm	-91 dBm	100 kHz	
Local Area BS	$F_{UL_low} - F_{UL_high}$	-82 dBm	-88 dBm	100 kHz	

6.6.6.5.2.5 Co-existence with other systems in the same geographical area

These requirements may be applied for the protection of system operating in frequency ranges other than the *TAB connector* downlink operating band. The limits may apply as an optional protection of such systems that are deployed in the same geographical area as the AAS BS, or they may be set by local or regional regulation as a mandatory requirement for an operating band. It is in some cases not stated in the present document whether a requirement is mandatory or under what exact circumstances that a limit applies, since this is set by local or regional regulation. An overview of regional requirements in the present document is given in subclause 4.4.

Some requirements may apply for the protection of specific equipment (UE, MS and/or BS) or equipment operating in specific systems (GSM/EDGE, CDMA, UTRA, E-UTRA, NR, etc.) as listed below. The basic limit any spurious emission are in table 6.6.1.5.5-1 for *TAB connector(s)* where requirements for co-existence with the system listed in the first column apply. For *multi-band TAB connector(s)*, the exclusions and conditions in the Note column of table 6.6.6.5.2.5-1 apply for each supported operating band.

Table 6.6.6.5.2.5-1: Spurious emissions *basic limits* for co-existence with systems operating in other frequency bands

System type operating in the same geographical area	Band for co-existence requirement	Basic limit	Measurement Bandwidth	Notes
GSM900	921 - 960 MHz	-57 dBm	100 kHz	This requirement does not apply to UTRA FDD operating in band VIII. This requirement does not apply to E-UTRA BS operating in band 8 or NR BS operating in band n8
	876 - 915 MHz	-61 dBm	100 kHz	For the frequency range 880-915 MHz, this requirement does not apply to UTRA FDD operating in band VIII, since it is already covered by the requirement in subclause 6.6.6.5.2.4. For the frequency range 880-915 MHz, this requirement does not apply to E-UTRA BS operating in band 8 or NR BS operating in band n8, since it is already covered by the requirement in subclause 6.6.6.5.2.4.
DCS1800	1805 - 1880 MHz	-47 dBm	100 kHz	This requirement does not apply to UTRA FDD operating in band III. This requirement does not apply to UTRA TDD operating in Band b and c. For UTRA TDD BS operating in Band f, it applies for 1805 - 1850 MHz This requirement does not apply to E-UTRA BS operating in band 3 or NR BS operating in band n3.
	1710 - 1785 MHz	-61 dBm	100 kHz	This requirement does not apply to UTRA FDD operating in band III, since it is already covered by the requirement in subclause 6.6.6.5.2.4. This requirement does not apply to UTRA TDD operating in Band b and c. For UTRA TDD BS operating in Band f, it applies for 1710 - 1755 MHz This requirement does not apply to E-UTRA BS operating in band 3 or NR BS operating in band n3, since it is already covered by the requirement in subclause 6.6.6.5.2.4.
PCS1900	1930 - 1990 MHz	-47 dBm	100 kHz	This requirement does not apply to UTRA FDD BS operating in frequency band II or band XXV. This requirement does not apply to UTRA TDD This requirement does not apply to E-UTRA BS operating in frequency band 2, band 25 or band 36 or NR BS operating in band n2 or n25.

System type operating in the same geographical area	Band for co-existence requirement	Basic limit	Measurement Bandwidth	Notes
	1850 - 1910 MHz	-61 dBm	100 kHz	This requirement does not apply to UTRA FDD BS operating in frequency band II or band XXV, since it is already covered by the requirement in subclause 6.6.6.5.2.4. This requirement does not apply to UTRA TDD This requirement does not apply to E-UTRA BS operating in frequency band 2 or 25 or NR BS operating in band n2 or n25, since it is already covered by the requirement in subclause 6.6.6.5.2.4. This requirement does not apply to E-UTRA BS operating in frequency band 35.
GSM850 or CDMA850	869 - 894 MHz	-57 dBm	100 kHz	This requirement does not apply to UTRA FDD BS operating in frequency band V or XXVI. This requirement does not apply to E-UTRA BS operating in frequency band 5 or 26 or NR BS operating in band n5. This requirement applies to E-UTRA BS operating in Band 27 for the frequency range 879-894 MHz.
	824 - 849 MHz	-61 dBm	100 kHz	This requirement does not apply to UTRA FDD BS operating in frequency band V or XXVI, since it is already covered by the requirement in subclause 6.6.6.5.2.4. This requirement does not apply to E-UTRA BS operating in frequency band 5 or 26 or NR BS operating in band n5, since it is already covered by the requirement in subclause 6.6.6.5.2.4. For E-UTRA BS operating in Band 27, it applies 3 MHz below the Band 27 downlink operating band.
UTRA FDD Band I or E-UTRA Band 1 or NR band n1	2110 - 2170 MHz	-52 dBm	1 MHz	This requirement does not apply to UTRA FDD BS operating in band I, This requirement does not apply to E-UTRA BS operating in band 1 or 65 or NR BS operating in band n1.
	1920 - 1980 MHz	-49 dBm (UTRA TDD -43 dBm for WA BS -40 dBm for LA BS)	1 MHz (UTRA TDD 3.84 MHz)	This requirement does not apply to UTRA FDD BS operating in band I, since it is already covered by the requirement in subclause 6.6.6.5.2.4. This requirement does not apply to E-UTRA BS operating in band 1 or 65 or NR BS operating in band n1, since it is already covered by the requirement in subclause 6.6.6.5.2.4.
UTRA FDD Band II or E-UTRA Band 2 or NR band n2	1930 - 1990 MHz	-52 dBm	1 MHz	This requirement does not apply to UTRA FDD BS operating in band II or band XXV4. This requirement does not apply to UTRA TDD This requirement does not apply to E-UTRA BS operating in band 2 or 25 or NR BS operating in band n2 or n25.
	1850 - 1910 MHz	-49 dBm	1 MHz	This requirement does not apply to UTRA FDD BS operating in band II or band XXV, since it is already covered by the requirement in subclause 6.6.6.5.2.4. This requirement does not apply to UTRA TDD This requirement does not apply to E-UTRA BS operating in band 2 or 25 or NR BS operating in band n2, since it is already covered by the requirement in subclause 6.6.6.5.2.4
UTRA FDD Band III or E-UTRA Band 3 or NR band n3	1805 - 1880 MHz	-52 dBm	1 MHz	This requirement does not apply to UTRA FDD BS operating in band III or band IX For UTRA TDD BS operating in Band f, it applies for 1805- 1850 MHz This requirement does not apply to E-UTRA BS operating in band 3 or NR BS operating in band n3.

System type operating in the same geographical area	Band for co-existence requirement	Basic limit	Measurement Bandwidth	Notes
	1710 - 1785 MHz	-49 dBm (UTRA TDD -43 dBm for WA BS -40 dBm for LA BS)	1 MHz (UTRA TDD 3.84 MHz)	This requirement does not apply to UTRA FDD BS operating in band III, since it is already covered by the requirement in subclause 6.6.6.5.2.4. For UTRA BS operating in band IX, it applies for 1710 MHz to 1749.9 MHz and 1784.9 MHz to 1785 MHz, while the rest is covered in subclause 6.6.6.5.2.4. This requirement does not apply to E-UTRA BS operating in band 3 or 9 or NR BS operating in band n3, since it is already covered by the requirement in subclause 6.6.6.5.2.4. For UTRA TDD BS operating in Band f, it applies for 1710- 1755 MHz For E-UTRA BS operating in band 9, it applies for 1710 MHz to 1749.9 MHz and 1784.9 MHz to 1785 MHz, while the rest is covered in subclause 6.6.6.5.2.4.
UTRA FDD Band IV or E-UTRA Band 4	2110 - 2155 MHz	-52 dBm	1 MHz	This requirement does not apply to UTRA FDD BS operating in band IV or band X This requirement does not apply to UTRA TDD This requirement does not apply to E-UTRA BS operating in band 4, 10 or 66
	1710 - 1755 MHz	-49 dBm	1 MHz	This requirement does not apply to UTRA FDD BS operating in band IV or band X, since it is already covered by the requirement in subclause 6.6.6.5.2.4. This requirement does not apply to UTRA TDD This requirement does not apply to E-UTRA BS operating in band 4, 10 or 66, since it is already covered by the requirement in subclause 6.6.6.5.2.4.
UTRA FDD Band V or E-UTRA Band 5 or NR band n5	869 - 894 MHz	-52 dBm	1 MHz	This requirement does not apply to UTRA FDD BS operating in band V or XXVI This requirement does not apply to E-UTRA BS operating in band 5 or 26 or NR BS operating in band n5. This requirement applies to E-UTRA BS operating in Band 27 for the frequency range 879-894 MHz.
	824 - 849 MHz	-49 dBm (UTRA TDD -43 dBm for WA BS -40 dBm for LA BS)	1 MHz (UTRA TDD 3.84 MHz)	This requirement does not apply to UTRA FDD BS operating in band V or XXVI, since it is already covered by the requirement in subclause 6.6.6.5.2.4. This requirement does not apply to E-UTRA BS operating in band 5 or 26 or NR BS operating in band n5, since it is already covered by the requirement in subclause 6.6.6.5.2.4. For E-UTRA BS operating in Band 27, it applies 3 MHz below the Band 27 downlink operating band.
UTRA FDD Band VI or XIX, or E-UTRA Band 6, 18 or 19	860 - 890 MHz	-52 dBm	1 MHz	This requirement does not apply to UTRA FDD BS operating in band VI or XIX For UTRA TDD applicable in Japan This requirement does not apply to E-UTRA BS operating in band 6, 18, 19.
	815 - 845 MHz	-49 dBm (UTRA TDD -43 dBm)	1 MHz (UTRA TDD 3.84 MHz)	This requirement does not apply to UTRA FDD BS operating in band VI or XIX, since it is already covered by the requirement in subclause 6.6.6.5.2.4. For UTRA TDD applicable in Japan This requirement does not apply to E-UTRA BS operating in band 18 between 815-830 MHz, since it is already covered by the requirement in subclause 6.6.6.5.2.4. This requirement does not apply to E-UTRA BS operating in band 6, 19 between 830-845 MHz, since it is already covered by the requirement in subclause 6.6.6.5.2.4.

System type operating in the same geographical area	Band for co-existence requirement	Basic limit	Measurement Bandwidth	Notes
UTRA FDD Band VII or E-UTRA Band 7 or NR band n7	2620 - 2690 MHz	-52 dBm	1 MHz	This requirement does not apply to UTRA FDD BS operating in band VII, This requirement does not apply to E-UTRA BS operating in band 7 or NR BS operating in band n7. This requirement does not apply to E-UTRA BS operating in band 7 or NR BS operating in band n7, since it is already covered by the requirement in subclause 6.6.6.5.2.4.
	2500 - 2570 MHz	-49 dBm (UTRA TDD -43 dBm for WA BS -40 dBm for LA BS)	1 MHz (UTRA TDD 3.84 MHz)	This requirement does not apply to UTRA FDD BS operating in band VII or E-UTRA BS operation in band 7 or NR BS operating in band n7, since it is already covered by the requirement in subclause 6.6.6.5.2.4.
UTRA FDD Band VIII or E-UTRA Band 8 or NR band n8	925 - 960 MHz	-52 dBm	1 MHz	This requirement does not apply to UTRA FDD BS operating in band VIII. This requirement does not apply to UTRA TDD This requirement does not apply to E-UTRA BS operating in band 8 or NR BS operating in band n8.
	880 - 915 MHz	-49 dBm	1 MHz	This requirement does not apply to UTRA FDD BS operating in band VIII, since it is already covered by the requirement in subclause 6.6.6.5.2.4. This requirement does not apply to UTRA TDD This requirement does not apply to E-UTRA BS operating in band 8 or NR BS operating in band n8, since it is already covered by the requirement in subclause 6.6.6.5.2.4.
UTRA FDD Band IX or E-UTRA Band 9	1844.9 - 1879.9 MHz	-52 dBm (UTRA TDD -43 dBm)	1 MHz (UTRA TDD 3.84 MHz)	This requirement does not apply to UTRA FDD BS operating in band III or band IX For UTRA TDD applicable in Japan This requirement does not apply to E-UTRA BS operating in band 3 or 9 or NR BS operating in band n3.
	1749.9 - 1784.9 MHz	-49 dBm	1 MHz	This requirement does not apply to UTRA FDD BS operating in band III or band IX, since it is already covered by the requirement in subclause 6.6.6.5.2.4. This requirement does not apply to E-UTRA BS operating in band 3 or 9 or NR BS operating in band n3, since it is already covered by the requirement in subclause 6.6.6.5.2.4.
UTRA FDD Band X or E-UTRA Band 10	2110 - 2170 MHz	-52 dBm	1 MHz	This requirement does not apply to UTRA FDD BS operating in band IV or band X This requirement does not apply to UTRA TDD This requirement does not apply to E-UTRA BS operating in band 4, 10 or 66
	1710 - 1770 MHz	-49 dBm	1 MHz	This requirement does not apply to UTRA FDD BS operating in band X, since it is already covered by the requirement in subclause 6.6.6.5.2.4. For UTRA FDD BS operating in Band IV, it applies for 1755 MHz to 1770 MHz, while the rest is covered in subclause 6.6.6.5.2.4. This requirement does not apply to UTRA TDD This requirement does not apply to E-UTRA BS operating in band 10 or 66 or NR BS operating in band n66, since it is already covered by the requirement in subclause 6.6.6.5.2.4. For E-UTRA BS operating in Band 4, it applies for 1755 MHz to 1770 MHz, while the rest is covered in subclause 6.6.6.5.2.4.
UTRA FDD Band XI or XXI or	1475.9 - 1510.9 MHz	-52 dBm	1 MHz	This requirement does not apply to UTRA FDD BS operating in band XI, XXI, or XXXII. For UTRA TDD applicable in Japan This requirement does not apply to E-UTRA BS operating in band 11, 21 or 32.

System type operating in the same geographical area	Band for co-existence requirement	Basic limit	Measurement Bandwidth	Notes
E-UTRA Band 11 or 21	1427.9 - 1447.9 MHz	-49 dBm (UTRA TDD -43 dBm)	1 MHz (UTRA TDD 3.84 MHz)	This requirement does not apply to UTRA FDD BS operating in band XI, since it is already covered by the requirement in subclause 6.6.6.5.2.4. For UTRA BS operating in band XXXII, this requirement applies for carriers allocated within 1475.9MHz and 1495.9MHz. For UTRA TDD applicable in Japan This requirement does not apply to E-UTRA BS operating in band 11, since it is already covered by the requirement in subclause 6.6.6.5.2.4. For E-UTRA BS operating in band 32, this requirement applies for carriers allocated within 1475.9MHz and 1495.9MHz.
	1447.9 - 1462.9 MHz	-49 dBm (UTRA TDD -43 dBm)	1 MHz (UTRA TDD 3.84 MHz)	This requirement does not apply to UTRA FDD BS operating in band XXI, since it is already covered by the requirement in subclause 6.6.6.5.2.4. For UTRA BS operating in band XXXII, this requirement applies for carriers allocated within 1475.9MHz and 1495.9MHz. For UTRA TDD applicable in Japan up to 1462.9MHz. This requirement does not apply to E-UTRA BS operating in band 21, since it is already covered by the requirement in subclause 6.6.6.5.2.4. For E-UTRA BS operating in band 32, this requirement applies for carriers allocated within 1475.9MHz and 1495.9MHz.
UTRA FDD Band XII or E-UTRA Band 12 or NR band n12	729 - 746 MHz	-52 dBm	1 MHz	This requirement does not apply to UTRA FDD BS operating in band XII This requirement does not apply to UTRA TDD This requirement does not apply to E-UTRA BS operating in band 12 or NR BS operating in band n12.
	699 - 716 MHz	-49 dBm	1 MHz	This requirement does not apply to UTRA FDD BS operating in band XII, since it is already covered by the requirement in subclause 6.6.6.5.2.4. This requirement does not apply to UTRA TDD This requirement does not apply to E-UTRA BS operating in band 12 or NR BS operating in band n12, since it is already covered by the requirement in subclause 6.6.6.5.2.4. For E-UTRA BS operating in Band 29, it applies 1 MHz below the Band 29 downlink operating band (Note 6)
UTRA FDD Band XIII or E-UTRA Band 13	746 - 756 MHz	-52 dBm	1 MHz	This requirement does not apply to UTRA FDD BS operating in band XIII This requirement does not apply to UTRA TDD This requirement does not apply to E-UTRA BS operating in band 13.
	777 - 787 MHz	-49 dBm	1 MHz	This requirement does not apply to UTRA FDD BS operating in band XIII, since it is already covered by the requirement in subclause 6.6.6.5.2.4. This requirement does not apply to UTRA TDD This requirement does not apply to E-UTRA BS operating in band 13, since it is already covered by the requirement in subclause 6.6.6.5.2.4.
UTRA FDD Band XIV or E-UTRA Band 14	758 - 768 MHz	-52 dBm	1 MHz	This requirement does not apply to UTRA FDD BS operating in band XIV This requirement does not apply to UTRA TDD This requirement does not apply to E-UTRA BS operating in band 14.
	788 - 798 MHz	-49 dBm	1 MHz	This requirement does not apply to UTRA FDD BS operating in band XIV, since it is already covered by the requirement in subclause 6.6.6.5.2.4. This requirement does not apply to UTRA TDD This requirement does not apply to E-UTRA BS operating in band 14, since it is already covered by the requirement in subclause 6.6.6.5.2.4.

System type operating in the same geographical area	Band for co-existence requirement	Basic limit	Measurement Bandwidth	Notes
E-UTRA Band 17	734 - 746 MHz	-52 dBm	1 MHz	This requirement does not apply to UTRA FDD BS operating in band XII This requirement does not apply to UTRA TDD This requirement does not apply to E-UTRA BS operating in band 17.
	704 - 716 MHz	-49 dBm	1 MHz	This requirement does not apply to UTRA FDD BS operating in band XII, since it is already covered by the requirement in subclause 6.6.6.5.2.4. This requirement does not apply to UTRA TDD This requirement does not apply to E-UTRA BS operating in band 17, since it is already covered by the requirement in subclause 6.6.4.5.3. For E-UTRA BS operating in Band 29, it applies 1 MHz below the Band 29 downlink operating band (Note 6)
UTRA FDD Band XX or E-UTRA Band 20 or NR band n20	791 - 821 MHz	-52 dBm	1 MHz	This requirement does not apply to UTRA FDD BS operating in band XX This requirement does not apply to UTRA TDD This requirement does not apply to E-UTRA BS operating in band 20 or 28 or NR BS operating in band n20.
	832 - 862 MHz	-49 dBm	1 MHz	This requirement does not apply to UTRA FDD BS operating in band XX, since it is already covered by the requirement in subclause 6.6.6.5.2.4. This requirement does not apply to UTRA TDD This requirement does not apply to E-UTRA BS operating in band 20 or NR BS operating in band n20, since it is already covered by the requirement in subclause 6.6.6.5.2.4.
UTRA FDD Band XXII or E-UTRA Band 22	3510 -3590 MHz	-52 dBm	1 MHz	This requirement does not apply to UTRA FDD BS operating in band XXII This requirement does not apply to UTRA TDD This requirement does not apply to E-UTRA BS operating in band 22, 42 or 48.
	3410 -3490 MHz	-49 dBm	1 MHz	This requirement does not apply to UTRA FDD BS operating in band XXII, since it is already covered by the requirement in subclause 6.6.6.5.2.4. This requirement does not apply to UTRA TDD This requirement does not apply to E-UTRA BS operating in band 22, since it is already covered by the requirement in subclause 6.6.4.5.3. This requirement does not apply to E-UTRA BS operating in Band 42
E-UTRA Band 23	2180 - 2200 MHz	-52 dBm	1 MHz	This requirement does not apply to E-UTRA BS operating in band 23 or 66 or NR BS operating in band n66. This requirement does not apply to UTRA TDD
	2000 - 2020 MHz	-49 dBm	1 MHz	This requirement does not apply to UTRA FDD BS operating in Band II or XXV, where the limits are defined separately. This requirement does not apply to UTRA TDD This requirement does not apply to E-UTRA BS operating in band 23, since it is already covered by the requirement in subclause 6.6.6.5.2.4. This requirement does not apply to BS operating in Bands 2 or 25 or n2 or n25, where the limits are defined separately.
	2000 - 2010 MHz	-30 dBm	1 MHz	This requirement only applies to UTRA FDD BS operating in Band II or Band XXV. This requirement applies starting 5 MHz above the Band XXV downlink operating band. (Note 3)
	2010 - 2020 MHz	-49 dBm	1 MHz	This requirement does not apply to UTRA TDD This requirement only applies to E-UTRA BS operating in Band 2 or Band 25 or NR BS operating in band n2 and n25. This requirement applies starting 5 MHz above the Band 25/n25 downlink operating band. (Note 4)

System type operating in the same geographical area	Band for co-existence requirement	Basic limit	Measurement Bandwidth	Notes
E-UTRA Band 24	1525 - 1559 MHz	-52 dBm	1 MHz	This requirement does not apply to E-UTRA BS operating in band 24. This requirement does not apply to UTRA TDD
	1626.5 - 1660.5 MHz	-49 dBm	1 MHz	This requirement does not apply to E-UTRA BS operating in band 24, since it is already covered by the requirement in subclause 6.6.6.5.2.4. This requirement does not apply to UTRA TDD
UTRA FDD Band XXV or E-UTRA Band 25 or NR band n25	1930 - 1995 MHz	-52 dBm	1 MHz	This requirement does not apply to UTRA FDD BS operating in band II or band XXV This requirement does not apply to UTRA TDD This requirement does not apply to E-UTRA BS operating in band 2 or 25 or NR BS operating in band n2 or n25.
	1850 - 1915 MHz	-49 dBm	1 MHz	This requirement does not apply to UTRA FDD BS operating in band XXV, since it is already covered by the requirement in subclause 6.6.6.5.2.4. For UTRA FDD BS operating in Band II, it applies for 1910 MHz to 1915 MHz, while the rest is covered in subclause 6.6.6.5.2.4. This requirement does not apply to UTRA TDD This requirement does not apply to E-UTRA BS operating in band 25, since it is already covered by the requirement in subclause 6.6.6.5.2.4. For E-UTRA BS operating in Band 2 or NR BS operating in band n2, it applies for 1910 MHz to 1915 MHz, while the rest is covered in subclause 6.6.6.5.2.4.
UTRA FDD Band XXVI or E-UTRA Band 26	859-894 MHz	-52 dBm	1 MHz	This requirement does not apply to UTRA FDD BS operating in band V or band XXVI This requirement does not apply to UTRA TDD This requirement does not apply to E-UTRA BS operating in band 5 or 26 or NR BS operating in band n5. This requirement applies to E-UTRA BS operating in Band 27 for the frequency range 879-894 MHz.
	814-849 MHz	-49 MHz	1 MHz	This requirement does not apply to UTRA FDD BS operating in band XXVI, since it is already covered by the requirements in subclause 6.6.6.5.2.4. For UTRA FDD BS operating in band V, it applies for 814 MHz to 824 MHz, while the rest is covered in subclause 6.6.3.2 This requirement does not apply to UTRA TDD This requirement does not apply to E-UTRA BS operating in band 26, since it is already covered by the requirement in subclause 6.6.6.5.2.4. For E-UTRA BS operating in Band 5 or NR BS operating in band n5, it applies for 814 MHz to 824 MHz, while the rest is covered in subclause 6.6.6.5.2.4. For E-UTRA BS operating in Band 27, it applies 3 MHz below the Band 27 downlink operating band.
E-UTRA Band 27	852 - 869 MHz	-52 dBm	1 MHz	This requirement does not apply to UTRA BS operating in Band V or XXVI. This requirement does not apply to UTRA TDD This requirement does not apply to E-UTRA BS operating in Band 5, 26 or 27 or NR BS operating in band n5.

System type operating in the same geographical area	Band for co-existence requirement	Basic limit	Measurement Bandwidth	Notes
	807 - 824 MHz	-49 dBm	1 MHz	For UTRA BS operating in Band XXVI, it applies for 807 MHz to 814 MHz, while the rest is covered in subclause 6.6.6.5.2.4. This requirement does not apply to UTRA TDD This requirement does not apply to E-UTRA BS operating in Band 27, since it is already covered by the requirement in subclause 6.6.6.5.2.4. For E-UTRA BS operating in Band 26, it applies for 807 MHz to 814 MHz, while the rest is covered in subclause 6.6.6.5.2.4. This requirement also applies to E-UTRA BS operating in Band 28, starting 4 MHz above the Band 28 downlink operating band (Note 5).
E-UTRA Band 28 or NR band n28	758 - 803 MHz	-52 dBm	1 MHz	This requirement does not apply to E-UTRA BS operating in band 20, 28, 44, 67 or 68. This requirement does not apply to UTRA TDD
	703 - 748 MHz	-49 MHz	1 MHz	This requirement does not apply to E-UTRA BS operating in band 28, since it is already covered by the requirement in subclause 6.6.6.5.2.4. This requirement does not apply to E-UTRA BS operating in Band 44. This requirement does not apply to UTRA TDD For E-UTRA BS operating in Band 67, it applies for 703 MHz to 736 MHz. For E-UTRA BS operating in Band 68, it applies for 728MHz to 733 MHz.
E-UTRA Band 29	717 - 728 MHz	-52 dBm	1 MHz	This requirement does not apply to UTRA TDD. This requirement does not apply to E-UTRA BS operating in Band 29
E-UTRA Band 30	2350 - 2360 MHz	-52 dBm	1 MHz	This requirement does not apply to UTRA TDD. This requirement does not apply to E-UTRA BS operating in band 30 or 40 or NR BS operating in band n40.
	2305 - 2315 MHz	-49 dBm	1 MHz	This requirement does not apply to UTRA TDD. This requirement does not apply to E-UTRA BS operating in band 30, since it is already covered by the requirement in subclause 6.6.6.5.2.4. This requirement does not apply to E-UTRA BS operating in Band 40 or NR BS operating in band n40.
E-UTRA Band 31	462.5 - 467.5 MHz	-52 dBm	1 MHz	This requirement does not apply to UTRA TDD. This requirement does not apply to E-UTRA BS operating in band 31.
	452.5 - 457.5 MHz	-49 dBm	1 MHz	This requirement does not apply to UTRA TDD. This requirement does not apply to E-UTRA BS operating in band 31, since it is already covered by the requirement in subclause 6.6.6.5.2.4.
UTRA FDD Band XXXII or E-UTRA Band 32	1452 - 1496 MHz	-52 dBm	1 MHz	This requirement does not apply to UTRA BS operating in Band XI, XXI, or XXXII This requirement does not apply to UTRA TDD This requirement does not apply to E-UTRA BS operating in band 11, 21 or 32.
UTRA TDD in Band a) or E-UTRA Band 33	1900 - 1920 MHz	-52 dBm	1 MHz	This requirement does not apply to E-UTRA BS operating in Band 33.
UTRA TDD in Band a) or E-UTRA Band 34 or NR band n34	2010 - 2025 MHz	-52 dBm	1 MHz	This requirement does not apply to E-UTRA BS operating in Band 34 or NR BS operating in band n34.
UTRA TDD Band b) or E-UTRA Band 35	1850 - 1910 MHz	-52 dBm	1 MHz	This requirement does not apply to UTRA BS. This requirement does not apply to E-UTRA BS operating in Band 35.

System type operating in the same geographical area	Band for co-existence requirement	Basic limit	Measurement Bandwidth	Notes
UTRA TDD Band b) or E-UTRA Band 36	1930 - 1990 MHz	-52 dBm	1 MHz	This requirement does not apply to UTRA BS. This requirement does not apply to E-UTRA BS operating in Band 2 and 36 or NR BS operating in band n2.
UTRA TDD Band c) or E-UTRA Band 37	1910 - 1930 MHz	-52 dBm	1 MHz	This requirement does not apply to UTRA BS. This is not applicable to E-UTRA BS operating in Band 37. This unpaired band is defined in ITU-R M.1036, but is pending any future deployment.
UTRA TDD in Band d) or E-UTRA Band 38 or NR band n38	2570 - 2620 MHz	-52 dBm	1 MHz	This requirement does not apply to E-UTRA BS operating in Band 38 or 69 or NR BS operating in band n38.
UTRA TDD in Band f) or E-UTRA Band 39 or NR band n39	1880 - 1920 MHz	-52 dBm	1 MHz	Applicable in China for UTRA FDD. This is not applicable to E-UTRA BS operating in Band 39.
UTRA TDD in Band e) or E-UTRA Band 40 or NR band n40	2300 - 2400 MHz	-52 dBm	1 MHz	This is not applicable to E-UTRA BS operating in Band 30 or 40 or NR BS operating in band n40.
E-UTRA Band 41 or NR band n41	2496 - 2690 MHz	-52 dBm	1 MHz	This is not applicable to E-UTRA BS operating in Band 41 or NR BS operating in band n41.
E-UTRA Band 42	3400 - 3600 MHz	-52 dBm	1 MHz	This is not applicable to E-UTRA BS operating in Band 22, 42, 43 or 48.
E-UTRA Band 43	3600 - 3800 MHz	-52 dBm	1 MHz	This requirement does not apply to UTRA TDD. This is not applicable to E-UTRA BS operating in Band 42, 43 or 48.
E-UTRA Band 44	703 - 803 MHz	-52 dBm	1 MHz	This is not applicable to E-UTRA BS operating in Band 28 or 44
E-UTRA Band 45	1447 - 1467 MHz	-52 dBm	1 MHz	This requirement does not apply to UTRA BS. This is not applicable to E-UTRA BS operating in Band 45
E-UTRA Band 46	5150 - 5925 MHz	-52 dBm	1 MHz	This requirement does not apply to UTRA BS. This is not applicable to E-UTRA BS operating in Band 46.
E-UTRA Band 48	3550 – 3700 MHz	-52 dBm	1 MHz	This is not applicable to E-UTRA BS operating in Band 22, 42, 43 or 48.
E-UTRA Band 50 or NR band n50	1432 – 1517 MHz	-52 dBm	1 MHz	This requirement does not apply to BS operating in Band n50, n51, n74, n75 or n76.
E-UTRA Band 51 or NR Band n51	1427 – 1432 MHz	-52 dBm	1 MHz	This requirement does not apply to BS operating in Band n50, n51, n75 or n76.
E-UTRA Band 65	2110 - 2200 MHz	-52 dBm	1 MHz	This requirement does not apply to UTRA BS. This requirement does not apply to E-UTRA BS operating in band 1 or 65 or NR BS operating in band n1.
	1920 - 2010 MHz	-49 dBm	1 MHz	This requirement does not apply to UTRA BS. This requirement does not apply to E-UTRA BS operating in band 65, since it is already covered by the requirement in subclause 6.6.6.5.2.4. For E-UTRA BS operating in Band 1 or NR BS operating in band n1, it applies for 1980 MHz to 2010 MHz, while the rest is covered in subclause 6.6.6.5.2.4.
E-UTRA Band 66 or NR band n66	2110 - 2200 MHz	-52 dBm	1 MHz	This requirement does not apply to UTRA BS. This requirement does not apply to E-UTRA BS operating in band 4, 10, 23 or 66.

System type operating in the same geographical area	Band for co-existence requirement	Basic limit	Measurement Bandwidth	Notes
	1710 - 1780 MHz	-49 dBm	1 MHz	This requirement does not apply to UTRA BS. This requirement does not apply to E-UTRA BS operating in band 66, since it is already covered by the requirement in subclause 6.6.4.5.3. For E-UTRA BS operating in Band 4, it applies for 1755 MHz to 1780 MHz, while the rest is covered in subclause 6.6.6.5.2.4. For E-UTRA BS operating in Band 10, it applies for 1770 MHz to 1780 MHz, while the rest is covered in subclause 6.6.6.5.2.4.
E-UTRA Band 67	738 - 758 MHz	-52 dBm	1 MHz	This requirement does not apply to UTRA BS. This requirement does not apply to E-UTRA BS operating in Band 28 or 67.
E-UTRA Band 68	753 - 783 MHz	-52 dBm	1 MHz	This requirement does not apply to UTRA BS. This requirement does not apply to E-UTRA BS operating in band 28, or 68.
	698-728 MHz	-49 dBm	1 MHz	This requirement does not apply to UTRA BS. This requirement does not apply to E-UTRA BS operating in band 68, since it is already covered by the requirement in subclause 6.6.6.5.2.4. For E-UTRA BS operating in Band 28, it applies between 698 MHz and 703 MHz, while the rest is covered in subclause 6.6.6.5.2.4.
E-UTRA Band 69	2570 - 2620 MHz	-52 dBm	1 MHz	This requirement does not apply to E-UTRA BS operating in Band 38 or 69.
E-UTRA Band 70 or NR band n70	<u>1995 - 2020 MHz</u>	-52 dBm	1 MHz	This requirement does not apply to E-UTRA BS operating in band 2, 25 or 70 or NR BS operating in band n2 or n25.
	<u>1695 – 1710 MHz</u>	-49 dBm	1 MHz	This requirement does not apply to E-UTRA BS operating in Band 70, since it is already covered by the requirement in subclause 6.6.6.5.2.4.
E-UTRA Band 71 or NR Band n71	617 – 652 MHz	-52 dBm	1 MHz	This requirement does not apply to BS operating in band n71
	663 – 698 MHz	-49 dBm	1 MHz	This requirement does not apply to BS operating in band n71, since it is already covered by the requirement in subclause 6.6.6.5.2.4.
E-UTRA Band 72	461 – 466 MHz	-52 dBm	1 MHz	
	451 – 456 MHz	-49 dBm	1 MHz	
E-UTRA Band 74 or NR Band n74	1475 – 1518 MHz	-52 dBm	1 MHz	This requirement does not apply to BS operating in band n50, n74 or n75.
	1427 – 1470 MHz	-49 dBm	1MHz	This requirement does not apply to BS operating in band n50, n51, n74, n75 or n76.
E-UTRA Band 75 or NR Band n75	1432 – 1517 MHz	-52 dBm	1 MHz	This requirement does not apply to BS operating in Band n50, n51, n74, n75 or n76.
E-UTRA Band 76 or NR Band n76	1427 – 1432 MHz	-52 dBm	1 MHz	This requirement does not apply to BS operating in Band n50, n51, n75 or n76.
NR Band n77	3.3 – 4.2 GHz	-52 dBm	1 MHz	This requirement does not apply to BS operating in Band n77 and n 78
NR Band n78	3.3 – 3.8 GHz	-52 dBm	1 MHz	This requirement does not apply to BS operating in Band n77 and n78
NR Band n79	4.4 – 5.0 GHz	-52 dBm	1 MHz	This requirement does not apply to BS operating in Band n79
NR Band n80	1710 – 1785 MHz	-49 dBm	1 MHz	This requirement does not apply to BS operating in band n3, since it is already covered by the requirement in subclause 6.6.5.2.4.
NR Band n81	880 – 915 MHz	-49 dBm	1 MHz	This requirement does not apply to BS operating in band n8, since it is already covered by the requirement in subclause 6.6.5.2.4.

System type operating in the same geographical area	Band for co-existence requirement	Basic limit	Measurement Bandwidth	Notes
NR Band n82	832 – 862 MHz	-49 dBm	1 MHz	This requirement does not apply to BS operating in band n20, since it is already covered by the requirement in subclause 6.6.5.2.4.
NR Band n83	703 – 748 MHz	-49 dBm	1 MHz	This requirement does not apply to BS operating in band n28, since it is already covered by the requirement in subclause 6.6.5.2.4.
NR Band n84	1920 – 1980 MHz	-49 dBm	1 MHz	This requirement does not apply to BS operating in band n1, since it is already covered by the requirement in subclause 6.6.5.2.4.
E-UTRA Band 85	728 - 746 MHz	-52 dBm	1 MHz	This requirement does not apply to BS operating in band n12.
	698 - 716 MHz	-49 dBm	1 MHz	This requirement does not apply to BS operating in band n12, since it is already covered by the requirement in subclause 6.6.5.2.4.
NR Band n86	1710 – 1780 MHz	-49 dBm	1 MHz	This requirement does not apply to BS operating in band n66, since it is already covered by the requirement in subclause 6.6.5.2.4.
<p>NOTE 1: The co-existence requirements do not apply for the 10 MHz frequency range immediately outside the downlink operating band (see subclause 4.5.). Emission limits for this excluded frequency range may be covered by local or regional requirements.</p> <p>NOTE 2: The table above assumes that two operating bands, where the frequency ranges would be overlapping, are not deployed in the same geographical area. For such a case of operation with overlapping frequency arrangements in the same geographical area, special co-existence requirements may apply that are not covered by the 3GPP specifications.</p>				

NOTE 1: As defined in the scope for spurious emissions in this subclause, except for the cases where the noted requirements apply to a BS operating in Band 25/n25, Band 27, Band 28/n28 or Band 29, the co-existence requirements in Table 6.6.1.3.1-1 do not apply for the 10 MHz frequency range immediately outside the downlink operating band (see Tables 4.5-1 and 4.5-2). Emission limits for this excluded frequency range may be covered by local or regional requirements.

NOTE 2: Table 6.6.1.5.5-1 assumes that two operating bands, where the frequency ranges in table 4.4-1 or table 4.4-2 would be overlapping, are not deployed in the same geographical area. For such a case of operation with overlapping frequency arrangements in the same geographical area, special co-existence requirements may apply that are not covered by the 3GPP specifications.

NOTE 3: For the protection of DCS1800, UTRA Band III, E-UTRA Band 3 or NR Band n3 in China, the frequency ranges of the downlink and uplink protection requirements are 1805 – 1850 MHz and 1710 – 1755 MHz respectively.

NOTE 4: TDD base stations deployed in the same geographical area, that are synchronized and use the same or adjacent operating bands can transmit without additional co-existence requirements. For unsynchronized base stations, special co-existence requirements may apply that are not covered by the 3GPP specifications.

NOTE 5: For Band 28/n28 BS, specific solutions may be required to fulfil the spurious emissions limits for BS for co-existence with Band 27 UL operating band.

NOTE 6: For Band 29 BS, specific solutions may be required to fulfil the spurious emissions limits for BS for co-existence with UTRA Band XII or E-UTRA Band 12 UL operating band or E-UTRA Band 17 UL operating band.

The following requirement may be applied for the protection of PHS. This requirement is also applicable at specified frequencies falling between Δf_{OBUE} below the lowest BS transmitter frequency of the downlink operating band and Δf_{OBUE} above the highest BS transmitter frequency of the downlink operating band.

The basic limit for any spurious emission is:

Table 6.6.6.5.2.5-2: Spurious emissions *basic limits* for co-existence with PHS

Frequency range	Basic limit	Measurement Bandwidth	Notes
1884.5 - 1915.7 MHz	-41 dBm	300 kHz	Applicable for co-existence with PHS system operating in 1884.5-1915.7MHz
NOTE: The requirement is not applicable in China.			

The following requirement shall be applied to UTRA BS for co-existence with services in adjacent frequency bands. This requirement may be applied for the protection in bands adjacent to bands I or VII, as defined in clause 3.4.1, in geographic areas in which both an adjacent band service and UTRA FDD are deployed.

Table 6.6.6.5.2.5-3: spurious emissions basic limits for UTRA FDD protection of adjacent band services

Operating Band	Band	Basic limit	Measurement Bandwidth
I	2100 - 2105 MHz	$-30 + 3.4 \cdot (f - 2100 \text{ MHz}) \text{ dBm}$	1 MHz
	2175 - 2180 MHz	$-30 + 3.4 \cdot (2180 \text{ MHz} - f) \text{ dBm}$	1 MHz
VII	2610 - 2615 MHz	$-30 + 3.4 \cdot (f - 2610 \text{ MHz}) \text{ dBm}$	1 MHz
	2695 - 2700 MHz	$-30 + 3.4 \cdot (2700 \text{ MHz} - f) \text{ dBm}$	1 MHz

The following requirement shall be applied to *TAB connectors* operating in Bands 13 and 14 to ensure that appropriate interference protection is provided to 700 MHz public safety operations. This requirement is also applicable at the frequency range from 10 MHz below the lowest frequency of the BS transmitter operating band up to 10 MHz above the highest frequency of the BS transmitter operating band. The basic limit for any spurious emission is:

Table 6.6.6.5.2.5-4: Spurious emissions *basic limits* for protection of 700 MHz public safety operations

Operating Band	Band	Basic limit	Measurement Bandwidth
13	763 - 775 MHz	-46 dBm	6.25 kHz
13	793 - 805 MHz	-46 dBm	6.25 kHz
14	769 - 775 MHz	-46 dBm	6.25 kHz
14	799 - 805 MHz	-46 dBm	6.25 kHz

The following requirement shall be applied to *TAB connectors* operating in Band 26 to ensure that appropriate interference protection is provided to 800 MHz public safety operations. This requirement is also applicable at the frequency range from 10 MHz below the lowest frequency of the BS downlink operating band up to 10 MHz above the highest frequency of the BS downlink operating band.

The basic limit for any spurious emission is:

Table 6.6.6.5.2.5-5: BS Spurious emissions *basic limits* for protection of 800 MHz public safety operations

Operating Band	Frequency range	Basic limit	Measurement Bandwidth	Notes
26	851 - 859 MHz	-13 dBm	100 kHz	Applicable for offsets > 37.5 kHz from the channel edge

The following requirement may apply to E-UTRA *TAB connectors* operating in Band 41 in certain regions. This requirement is also applicable at the frequency range from 10 MHz below the lowest frequency of the BS downlink operating band up to 10 MHz above the highest frequency of the BS downlink operating band.

The basic limit for any spurious emission is:

Table 6.6.6.5.2.5-6: Additional Spurious emissions *basic limits* for Band 41

Frequency range	Basic limit	Measurement Bandwidth	Note
2505 MHz - 2535 MHz	-42dBm	1 MHz	
2535 MHz - 2655 MHz	-22dBm	1 MHz	Applicable at offsets ≥ 250 % of channel bandwidth from carrier frequency
NOTE: This requirement applies for 10 or 20 MHz E-UTRA carriers allocated within 2545 - 2575 MHz or 2595 - 2645 MHz.			

In addition to the requirements in subclauses 6.6.6.5.2.1 to 6.6.6.5.2.5 and above in the present subclause, the *TAB connector* may have to comply with the applicable emission limits established by FCC Title 47 [24], when deployed in regions where those limits are applied, and under the conditions declared by the manufacturer.

The following requirement may apply to a *TAB connector* operating in Band 30 in certain regions. This requirement is also applicable at the frequency range from 10 MHz below the lowest frequency of the BS downlink operating band up to 10 MHz above the highest frequency of the BS downlink operating band.

The basic limit for any spurious emission is:

Table 6.6.6.5.2.5-7: Additional Spurious emissions *basic limits* for Band 30

Frequency range	Basic limit	Measurement Bandwidth	
2200 MHz - 2345 MHz	-45 dBm	1 MHz	
2362.5 MHz - 2365 MHz	-25 dBm	1 MHz	
2365 MHz - 2367.5 MHz	-40 dBm	1 MHz	
2367.5 MHz - 2370 MHz	-42dBm	1 MHz	
2370 MHz - 2395 MHz	-45 dBm	1 MHz	

The following requirement may apply to E-UTRA BS operating in Band 48 in certain regions. The power of any spurious emission shall not exceed:

Table 6.6.6.5.2.5-8: Additional E-UTRA BS Spurious emissions limits for Band 48

Frequency range	Maximum Level	Measurement Bandwidth	Note
3530MHz – 3720MHz	-25dBm	1 MHz	Applicable 10MHz from the assigned channel edge
3100MHz – 3530MHz 3720MHz – 4200MHz	-40dBm	1 MHz	

6.6.6.5.2.6 Co-location with other Base Stations

These requirements may be applied for the protection of other BS receiver units when GSM900, DCS1800, PCS1900, GSM850, CDMA850, UTRA FDD, UTRA TDD and/or E-UTRA BS are co-located with a BS.

The requirements assume a 30 dB coupling loss between transmitter and receiver and are based on co-location with base stations of the same class.

The basic limit for any spurious emission are in table 6.6.6.5.2.6-1 for a MSR, E-UTRA or UTRA FDD *TAB connector* or tables 6.6.6.5.2.6-2 and 6.6.6.5.2.6-3 for UTRA TDD, where requirements for co-location with a BS type listed in the first column apply, depending on the declared Base Station class. For a *multi-band TAB connector*, the exclusions and conditions in the Notes column of table 6.6.6.5.2.6-1 apply for each supported operating band.

Table 6.6.6.5.2.6-1: Spurious emissions *basic limits* for MSR, E-UTRA or UTRA (FDD) or NR BS co-located with another BS

Type of co-located BS	Frequency range for co-location requirement	Basic limit (WA BS)	Basic limit (MR BS)	Basic limit (LA BS)	Measurement Bandwidth	Notes
GSM900	876 - 915 MHz	-98 dBm	-91 dBm	MSR -88 dBm, UTRA, E-UTRA -70 dBm	100 kHz	
DCS1800	1710 - 1785 MHz	-98 dBm	-91 dBm (UTRA -96 dBm)	MSR -88 dBm, UTRA, E-UTRA -80 dBm	100 kHz	
PCS1900	1850 - 1910 MHz	-98 dBm	-91 dBm (UTRA -96 dBm)	MSR -88 dBm, UTRA, E-UTRA -80 dBm	100 kHz	
GSM850 or CDMA850	824 - 849 MHz	-98 dBm	-91 dBm	MSR -88 dBm, UTRA, E-UTRA -70 dBm	100 kHz	
UTRA FDD Band I or E-UTRA Band 1 or NR band n1	1920 - 1980 MHz	-96 dBm	-91 dBm	-88 dBm	100 kHz	
UTRA FDD Band II or E-UTRA Band 2 or NR band n2	1850 - 1910 MHz	-96 dBm	-91 dBm	-88 dBm	100 kHz	
UTRA FDD Band III or E-UTRA Band 3 or NR band n3	1710 - 1785 MHz	-96 dBm	-91 dBm	-88 dBm	100 kHz	
UTRA FDD Band IV or E-UTRA Band 4	1710 - 1755 MHz	-96 dBm	-91 dBm	-88 dBm	100 kHz	
UTRA FDD Band V or E-UTRA Band 5 or NR band n5	824 - 849 MHz	-96 dBm	-91 dBm	-88 dBm	100 kHz	
UTRA FDD Band VI, XIX or E-UTRA Band 6, 19	830 - 845 MHz	-96 dBm	-91 dBm	-88 dBm	100 kHz	
UTRA FDD Band VII or E-UTRA Band 7 or NR band n7	2500 - 2570 MHz	-96 dBm	-91 dBm	-88 dBm	100 kHz	
UTRA FDD Band VIII or E-UTRA Band 8 or NR band n8	880 - 915 MHz	-96 dBm	-91 dBm	-88 dBm	100 kHz	
UTRA FDD Band IX or E-UTRA Band 9	1749.9 - 1784.9 MHz	-96 dBm	-91 dBm	-88 dBm	100 kHz	
UTRA FDD Band X or E-UTRA Band 10	1710 - 1770 MHz	-96 dBm	-91 dBm	-88 dBm	100 kHz	
UTRA FDD Band XI or E-UTRA Band 11	1427.9 - 1447.9 MHz	-96 dBm	-91 dBm	-88 dBm	100 kHz	
UTRA FDD Band XII or E-UTRA Band 12 or NR band n12	699 - 716 MHz	-96 dBm	-91 dBm	-88 dBm	100 kHz	
UTRA FDD Band XIII or E-UTRA Band 13	777 - 787 MHz	-96 dBm	-91 dBm	-88 dBm	100 kHz	
UTRA FDD Band XIV or E-UTRA Band 14	788 - 798 MHz	-96 dBm	-91 dBm	-88 dBm	100 kHz	
E-UTRA Band 17	704 - 716 MHz	-96 dBm	-91 dBm	-88 dBm	100 kHz	
E-UTRA Band 18	815 - 830 MHz	-96 dBm	-91 dBm	-88 dBm	100 kHz	

Type of co-located BS	Frequency range for co-location requirement	Basic limit (WA BS)	Basic limit (MR BS)	Basic limit (LA BS)	Measurement Bandwidth	Notes
UTRA FDD Band XX or E-UTRA Band 20 or NR band n20	832 - 862 MHz	-96 dBm	-91 dBm	-88 dBm	100 kHz	
UTRA FDD Band XXI or E-UTRA Band 21	1447.9 - 1462.9 MHz	-96 dBm	-91 dBm	-88 dBm	100 kHz	
UTRA FDD Band XXII or E-UTRA Band 22	3410 - 3490 MHz	-96 dBm	-91 dBm	-88 dBm	100 kHz	This is not applicable to BS operating in Band 42
E-UTRA Band 23	2000 - 2020 MHz	-96 dBm	-91 dBm	-88 dBm	100 kHz	
E-UTRA Band 24	1626.5 - 1660.5 MHz	-96 dBm	-91 dBm	-88 dBm	100 kHz	
UTRA FDD Band XXV or E-UTRA Band 25 or NR band n25	1850 - 1915 MHz	-96 dBm	-91 dBm	-88 dBm	100 kHz	
UTRA FDD Band XXVI or E-UTRA Band 26	814 - 849 MHz	-96 dBm	-91 dBm	-88 dBm	100 kHz	
E-UTRA Band 27	807 - 824 MHz	-96 dBm	-91 dBm	-88 dBm	100 kHz	
E-UTRA Band 28 or NR band n28	703 - 748 MHz	-96 dBm	-91 dBm	-88 dBm	100 kHz	This is not applicable to BS operating in Band 44
E-UTRA Band 30	2305 - 2315 MHz	-96 dBm	-91 dBm	-88 dBm	100 kHz	This is not applicable to BS operating in Band 40 or n40
E-UTRA Band 31	452.5 - 457.5 MHz	-96 dBm	-91 dBm	-88 dBm	100 kHz	
UTRA TDD Band a) or E-UTRA Band 33	1900 - 1920 MHz	-96 dBm (UTRA -86 dBm)	Note 4	-88 dBm (UTRA -78 dBm)	100 kHz (UTRA 1 MHz)	This is not applicable to BS operating in Band 33
UTRA TDD Band a) or E-UTRA Band 34 or NR band n34	2010 - 2025 MHz	-96 dBm (UTRA -86 dBm)	Note 4	-88 dBm (UTRA -78 dBm)	100 kHz (UTRA 1 MHz)	This is not applicable to BS operating in Band 34 or n34
UTRA TDD Band b) or E-UTRA Band 35	1850 - 1910 MHz	-96 dBm (UTRA -86 dBm)	Note 4	-88 dBm (UTRA -78 dBm)	100 kHz (UTRA 1 MHz)	This is not applicable to BS operating in Band 35
UTRA TDD Band b) or E-UTRA Band 36	1930 - 1990 MHz	-96 dBm (UTRA -86 dBm)	Note 4	-88 dBm (UTRA -78 dBm)	100 kHz (UTRA 1 MHz)	This is not applicable to BS operating in Band 2, n2 and 36
UTRA TDD Band c) or E-UTRA Band 37	1910 - 1930 MHz	-96 dBm (UTRA -86 dBm)	Note 4	-88 dBm (UTRA -78 dBm)	100 kHz (UTRA 1 MHz)	This is not applicable to BS operating in Band 37. This unpaired band is defined in ITU-R M.1036, but is pending any future deployment.
UTRA TDD Band d) or E-UTRA Band 38 or NR band n38	2570 - 2620 MHz	-96 dBm (UTRA -86 dBm)	Note 4	-88 dBm (UTRA -78 dBm)	100 kHz (UTRA 1 MHz)	This is not applicable to BS operating in Band 38 or n38.
UTRA TDD Band f) or E-UTRA Band 39 or NR band n39	1880 - 1920 MHz	-96 dBm (UTRA -86 dBm)	Note 4	-88 dBm (UTRA -78 dBm)	100 kHz (UTRA 1 MHz)	This is not applicable to BS operating in Band 33 and 39

Type of co-located BS	Frequency range for co-location requirement	Basic limit (WA BS)	Basic limit (MR BS)	Basic limit (LA BS)	Measurement Bandwidth	Notes
UTRA TDD Band e) or E-UTRA Band 40 or NR band n40	2300 - 2400 MHz	-96 dBm (UTRA -86 dBm)	-91 dBm Note 4	-88 dBm (UTRA -78 dBm)	100 kHz (UTRA 1 MHz)	This is not applicable to BS operating in Band 30 or 40 or n40
E-UTRA Band 41 or NR band n41	2496 - 2690 MHz	-96 dBm (UTRA -86 dBm)	-91 dBm Note 4	-88 dBm (UTRA -78 dBm)	100 kHz (UTRA 1 MHz)	This is not applicable to BS operating in Band 41 or n41
E-UTRA Band 42	3400 - 3600 MHz	-96 dBm (UTRA -86 dBm)	-91 dBm Note 4	-88 dBm (UTRA -78 dBm)	100 kHz (UTRA 1 MHz)	This is not applicable to BS operating in Band 22, 42 or 43, or 48
E-UTRA Band 43	3600 - 3800 MHz	-96 dBm (UTRA -86 dBm)	-91 dBm Note 4	-88 dBm (UTRA -78 dBm)	100 kHz (UTRA 1 MHz)	This is not applicable to BS operating in Band 42 or 43, or 48
E-UTRA Band 44	703 - 803 MHz	-96 dBm (UTRA -86 dBm)	-91 dBm Note 4	-88 dBm (UTRA -78 dBm)	100 kHz (UTRA 1 MHz)	This is not applicable to BS operating in Band 28 or 44
E-UTRA Band 45	1447 – 1467 MHz	-96 dBm (UTRA -86 dBm)	-91 dBm Note 4	-88 dBm (UTRA -78 dBm)	100 kHz (UTRA 1 MHz)	This is not applicable to BS operating in Band 45
E-UTRA Band 48	3550 – 3700 MHz	-96 dBm (UTRA -86 dBm)	-91 dBm Note 4	-88 dBm (UTRA -78 dBm)	100 kHz (UTRA 1 MHz)	This is not applicable to E-UTRA BS operating in Band 42 or 43
E-UTRA Band 50 or NR Band n50	1432 – 1517 MHz	-96 dBm	-91 dBm	-88 dBm	100 kHz	This is not applicable to BS operating in Band n51, n74 or n75
E-UTRA Band 51 or NR Band n51	1427 – 1432 MHz	N/A	N/A	-88 dBm	100 kHz	This is not applicable to BS operating in Band n50, n74, n75 or n76
E-UTRA Band 65	1920 - 2010 MHz	-96 dBm	-91 dBm	-88 dBm	100 kHz	This is not applicable to AAS BS operating in Band 65
E-UTRA Band 66 or NR band n66	1710 - 1780 MHz	-96 dBm	-91 dBm	-88 dBm	100 kHz	This is not applicable to BS operating in Band 66 or n66
E-UTRA Band 68	698 - 728 MHz	-96 dBm	-91 dBm	-88 dBm	100 kHz	This is not applicable to BS operating in Band 68
E-UTRA Band 70 or NR band n70	1695 – 1710 MHz	-96 dBm	-91 dBm	-88 dBm	100 kHz	
E-UTRA Band 71 or NR Band n71	663 – 698 MHz	-96 dBm	-91 dBm	-88 dBm	100 kHz	
E-UTRA Band 72	451 – 456 MHz	-96 dBm	-91 dBm	-88 dBm	100 kHz	
E-UTRA Band 74 or NR Band n74	1427 – 1470 MHz	-96 dBm	-91 dBm	-88 dBm	100 kHz	This is not applicable to BS operating in Band n50 or n51

Type of co-located BS	Frequency range for co-location requirement	Basic limit (WA BS)	Basic limit (MR BS)	Basic limit (LA BS)	Measurement Bandwidth	Notes
NR Band n77	3.3 – 4.2 GHz	-96 dBm	-91 dBm	-88 dBm	100 kHz	
NR Band n78	3.3 – 3.8 GHz	-96 dBm	-91 dBm	-88 dBm	100 kHz	
NR Band n79	4.4 – 5.0 GHz	-96 dBm	-91 dBm	-88 dBm	100 kHz	
NR Band n80	1710 – 1785 MHz	-96 dBm	-91 dBm	-88 dBm	100 kHz	
NR Band n81	880 – 915 MHz	-96 dBm	-91 dBm	-88 dBm	100 kHz	
NR Band n82	832 – 862 MHz	-96 dBm	-91 dBm	-88 dBm	100 kHz	
NR Band n83	703 – 748 MHz	-96 dBm	-91 dBm	-88 dBm	100 kHz	
NR Band n84	1920 – 1980 MHz	-96 dBm	-91 dBm	-88 dBm	100 kHz	
E-UTRA Band 85	698 - 716 MHz	-96 dBm	-91 dBm	-88 dBm	100 kHz	
NR Band n86	1710 – 1780 MHz	-96 dBm	-91 dBm	-88 dBm	100 kHz	

NOTE 1: As defined in the scope for spurious emissions in this subclause, the co-location requirements in table 6.6.6.5.2.6-1 do not apply for the Δf_{OBUE} frequency range immediately outside the *TAB connector* transmit frequency range of a downlink operating band (subclause 4.5). The current state-of-the-art technology does not allow a single generic solution for co-location with other system on adjacent frequencies for 30 dB BS-BS minimum coupling loss. However, there are certain site-engineering solutions that can be used. These techniques are addressed in 3GPP TR 25.942 [21].

NOTE 2: Table 6.6.6.5.2.6-1 assumes that two operating bands, where the corresponding *TAB connector* transmit and receive frequency ranges in subclause 4.5 would be overlapping, are not deployed in the same geographical area. For such a case of operation with overlapping frequency arrangements in the same geographical area, special co-location requirements may apply that are not covered by the 3GPP specifications.

NOTE 3: Co-located TDD Base Stations that are synchronized and using the same or adjacent operating band can transmit without special co-locations requirements. For unsynchronized Base Stations, special co-location requirements may apply that are not covered by the 3GPP specifications.

NOTE 4: For UTRA MR BS the measurement bandwidth is the same as for E-UTRA (100 kHz).

**Table 6.6.5.2.6-2: Spurious emissions basic limits
for UTRA TDD Wide Area BS co-located with another BS**

System type operating in the same geographical area	Band	Basic limit	Measurement bandwidth	Notes
Macro GSM900	876 - 915 MHz	-98 dBm	100 kHz	
Macro DCS1800	1710 - 1785 MHz	-98 dBm	100 kHz	This requirement does not apply to UTRA TDD operating in Band b and c. For UTRA TDD BS operating in Band f, it applies for 1710 - 1755 MHz
GSM850 or CDMA850	824 - 849 MHz	-98 dBm	100 kHz	
WA BS UTRA FDD Band I or E-UTRA Band 1	1920 - 1980 MHz	-80 dBm (Note 1)	3.84 MHz	
WA BS UTRA FDD Band III or E-UTRA Band 3	1710 - 1785 MHz	-80 dBm	3.84 MHz	For UTRA TDD BS operating in Band f, it applies for 1710 - 1755 MHz.
WA BS UTRA FDD Band V or E-UTRA Band 5	824 - 849 MHz	-80 dBm (Note 1)	3.84 MHz	
WA BS UTRA FDD Band VII or E-UTRA Band 7	2500 - 2570 MHz	- 80 dBm(Note 2)	3.84 MHz	
<p>NOTE 1: The co-location requirements do not apply for the 10 MHz frequency range immediately outside the BS transmit frequency range of the operating band (see subclause 4.5). The current state-of-the-art technology does not allow a single generic solution for co-location with other system on adjacent frequencies for 30 dB BS-BS minimum coupling loss. However, there are certain site-engineering solutions that can be used. These techniques are addressed in 3GPP TR 25.942 [21].</p> <p>NOTE 2: The requirements in table 6.17 are based on a minimum coupling loss of 30 dB between base stations. The co-location of different base station classes is not considered.</p> <p>NOTE 3: The table above assumes that two operating bands, where the frequency ranges would be overlapping, are not deployed in the same geographical area. For such a case of operation with overlapping frequency arrangements in the same geographical area, special co-existence requirements may apply that are not covered by the 3GPP specifications.</p>				

For UTRA TDD in geographic areas where 1,28 Mcps TDD is deployed, the RRC filtered mean power of any spurious emission in case of co-location shall not exceed the maximum level given in table 6.6.6.5.2.6-3.

For *multi-band TAB connector*, the exclusions and conditions in the Notes of table 6.6.6.5.2.6-3 for each supported operating band.

Table 6.6.5.2.6-3: Spurious emissions basic limits for co-location with unsynchronised 1,28 Mcps UTRA TDD and/or E-UTRA TDD

System type operating in the same geographic area	Frequency range	Basic limit	Measurement Bandwidth
WA UTRA TDD Band a) or E-UTRA Band 33	1900 - 1920 MHz	-96 dBm	100 kHz
WA UTRA TDD Band a) or E-UTRA Band 34	2010 - 2025 MHz	-96 dBm	100 kHz
WA UTRA TDD Band d) or E-UTRA Band 38	2570 - 2620 MHz	-96 dBm	100 kHz
WA UTRA TDD Band e) or E-UTRA Band 40	2300 - 2400 MHz	-96 dBm	100 kHz
WA UTRA TDD Band f) or E-UTRA Band 39	1880 - 1920 MHz	-96 dBm	100 kHz
WA E-UTRA Band 41	2496 - 2690 MHz	-96 dBm	100 kHz
WA E-UTRA Band 42	3400 - 3600 MHz	-96 dBm	100 kHz
WA E-UTRA Band 44	703 - 803 MHz	-96 dBm	100 kHz
LA UTRA TDD Band a) or E-UTRA Band 33	1900 - 1920 MHz	-88 dBm	100 kHz
LA UTRA TDD Band a) or E-UTRA Band 34	2010 - 2025 MHz	-88 dBm	100 kHz
LA UTRA TDD Band d) or E-UTRA Band 38	2570 - 2620 MHz	-88 dBm	100 kHz
LA UTRA TDD Band e) or E-UTRA Band 40	2300 - 2400 MHz	-88 dBm	100 kHz
LA UTRA TDD Band f) or E-UTRA Band 39	1880 - 1920 MHz	-88 dBm	100 kHz
LA E-UTRA Band 41	2496 - 2690 MHz	-88 dBm	100 kHz
LA E-UTRA Band 42	3400 - 3600 MHz	-88 dBm	100 kHz
LA E-UTRA Band 44	703 - 803 MHz	-88 dBm	100 kHz
<p>NOTE 1: The requirement applies for frequencies more than 10 MHz below or above the supported frequency range declared by the vendor. The current state-of-the-art technology does not allow a single generic solution for co-location with other system on adjacent frequencies for 30 dB BS-BS minimum coupling loss. However, there are certain site-engineering solutions that can be used. These techniques are addressed in 3GPP TR 25.942 [21].</p> <p>NOTE 2: The requirements in this table are based on a minimum coupling loss of 30 dB between unsynchronised TDD base stations. The scenarios leading to these requirements are addressed in 3GPP TR 25.942 [21].</p> <p>NOTE 3: The table above assumes that two operating bands, where the frequency ranges would be overlapping, are not deployed in the same geographical area. For such a case of operation with overlapping frequency arrangements in the same geographical area, special co-existence requirements may apply that are not covered by the 3GPP specifications.</p>			

6.7 Transmitter intermodulation

6.7.1 Definition and applicability

6.7.1.1 General

The transmitter intermodulation requirement is a measure of the capability of the transmitter unit to inhibit the generation of signals in its non-linear elements caused by presence of the wanted signal and an interfering signal reaching the transmitter unit via the RDN and antenna array. The requirement applies during the *transmitter ON period* and the *transmitter transient period*.

The requirement applies at each *TAB connector* supporting transmission in the operating band.

The transmitter intermodulation level is the power of the intermodulation products when an interfering signal is injected into the *TAB connector*.

For AAS BS there are two types of transmitter intermodulation cases captured by the transmitter intermodulation requirement:

- 1) Co-location transmitter intermodulation in which the interfering signal is from a co-located base station.
- 2) Intra-system transmitter intermodulation in which the interfering signal is from other transmitter units within the AAS BS.

For AAS BS, the co-location transmitter intermodulation requirement is considered sufficient if the interfering signal for the co-location requirement is higher than the declared interfering signal for intra-system transmitter intermodulation requirement.

For *TAB connectors* capable of multi-band operation where multiple bands are mapped on separate antenna connectors, the single-band requirements apply regardless of the interfering signals position relative to the *Inter RF Bandwidth gap*.

6.7.2 Minimum requirement

The minimum requirement for MSR operation are defined in 3GPP TS 37.105 [8], subclause 6.7.2.

The minimum requirement for UTRA operation are defined in 3GPP TS 37.105 [8], subclause 6.7.3.

The minimum requirement for UTRA operation are defined in 3GPP TS 37.105 [8], subclause 6.7.4.

6.7.3 Test purpose

The test purpose is to verify the ability of the transmitter units associated with the *TAB connector* under test to restrict the generation of intermodulation products in its nonlinear elements caused by presence of the wanted signal and an interfering signal reaching the transmitter via the antenna to below specified levels.

6.7.4 Method of test

6.7.4.1 Initial conditions

Test environment:

- normal; see clause B.2.

RF channels to be tested for single carrier:

- M; see subclause 4.12.1.

Base Station RF Bandwidth positions to be tested for multi-carrier:

- M_{RFBW} in single-band operation; see subclause 4.12.1; $B'_{\text{RFBW}}T'_{\text{RFBW}}$ and $B'_{\text{RFBW}}T_{\text{RFBW}}$ in multi-band operation, see subclause 4.12.1.

6.7.4.2 Procedure

The minimum requirement is applied to all *TAB connectors*, they may be tested one at a time or multiple *TAB connectors* may be tested in parallel as shown in subclause D.1.1. Whichever method is used the procedure is repeated until all *TAB connectors* necessary to demonstrate conformance have been tested.

- 1) Connect *TAB connector* to measurement equipment as shown in annex D.1.2. All *TAB connectors* not under test shall be terminated.
- 2) The measurement device characteristics shall be:
 - Detection mode: True RMS.
- 3) Set the set the *TAB connector* to transmit:
 - a) For MSR:
 - Set the *TAB connector* to transmit maximum power according to the applicable test configuration in clause 5 using the corresponding test models or set of physical channels in subclause 4.11.
 - b) For UTRA FDD:

- For a *TAB connector* declared to be capable of single carrier operation only, set the *TAB connector* to transmit a signal according to TM1, subclause 4.12.2, at the manufacturer's declared rated output power, $P_{\text{rated,c,TABC}}$.
 - For a *TAB connector* declared to be capable of multi-carrier operation, set the set the *TAB connector* to transmit according to TM1 on all carriers configured using the applicable test configuration and corresponding power setting specified in subclause 4.11.
- c) For UTRA TDD:
- For a *TAB connector* declared to be capable of single carrier operation only, set the parameters of the transmitted signal according to table 6.7.4.2-1.
 - For a *TAB connector* declared to be capable of multi-carrier operation, set to transmit according to table 6.7.4.2-1 on all carriers.

Table 6.7.4.2-1: Parameters of the transmitted signal for transmit intermodulation testing for 1,28 Mcps TDD

Parameter	Value/description
TDD Duty Cycle	TS i ; $i = 0, 1, 2, 3, 4, 5, 6$: transmit, if i is 0,4,5,6; receive, if i is 1,2,3.
Time slots under test	TS4, TS5 and TS6
Number of DPCH in each time slot under test	8
Power of each DPCH	1/8 of Base Station output power
Data content of DPCH	real life (sufficient irregular)

- d) For E-UTRA:
- *TAB connector* declared to be capable of single carrier operation only, set the *TAB connector* to transmit a signal according to E-TM1.1 in subclause 4.12.2, at manufacturer's declared rated output power $P_{\text{rated,c,TABC}}$.
 - For a *TAB connector* declared to be capable of multi-carrier and/or CA operation, set the set the *TAB connector* to transmit according to E-TM1.1 on all carriers configured using the applicable test configuration and corresponding power setting specified in subclause 4.11.
- 4) Generate the interfering signal:
- a) For MSR:
- using E-TM1.1 as defined in subclause 4.12.2, with 5 MHz channel bandwidth, at a centre frequency offset according to the conditions in table 6.7.2.1-1 in 3GPP TS 37.105 [8], but exclude interfering frequencies that are outside of the allocated downlink operating band or interfering frequencies that are not completely within the sub-block gap or within the *Inter RF Bandwidth gap*.
- b) For UTRA FDD:
- in accordance to TM1, subclause 4.12.2 with a frequency offset of according to the conditions of table 6.7.3.1-1 in 3GPP TS 37.105 [8], but exclude interfering signal frequencies that are outside of the allocated downlink operating band or interfering signal frequencies that are not completely within the sub-block gap or within the *Inter RF Bandwidth gap*.
- c) For UTRA TDD:
- The signal shall be like-modulated as the transmit signal and the active time slots of both signals shall be synchronized, with a frequency offset of according to the conditions of table 6.7.3.2-1 in 3GPP TS 37.105 [8], but exclude interfering signal frequencies that are outside of the allocated downlink operating band or interfering signal frequencies that are not completely within the sub-block gap or within the *Inter RF Bandwidth gap*.
- d) For E-UTRA:

- according to E-TM1.1, as defined in subclause 4.12.2, with 5 MHz channel bandwidth and a centre frequency offset according to the conditions of table 6.7.4.1-1 in 3GPP TS 37.105 [8], but exclude interfering frequencies that are outside of the allocated downlink operating band or interfering frequencies that are not completely within the sub-block gap or within the *Inter RF Bandwidth gap*.
- 5) Adjust ATT1 so that level of the interfering signal is as defined in:
- a) For MSR:
 - i. General co-location table 6.7.2.1-1 in 3GPP TS 37.105 [8].
 - ii. Additional co-location (BC1 and BC2) table 6.7.2.2-1 in 3GPP TS 37.105 [8].
 - iii. Additional co-location (BC3) table 6.7.2.3-1 in 3GPP TS 37.105 [8].
 - iv. Intra-system table 6.7.2.5-1 in 3GPP TS 37.105 [8].
 - b) For UTRA FDD:
 - i. General co-location table 6.7.3.1-1 in 3GPP TS 37.105 [8].
 - ii. Intra-system table 6.7.3.3-1 in 3GPP TS 37.105 [8].
 - c) For UTRA TDD:
 - i. General co-location for 1,28 Mcps TDD UTRA table 6.7.3.2-1 in 3GPP TS 37.105 [8].
 - ii. Intra-system table 6.7.3.3-1 in 3GPP TS 37.105 [8].
 - d) For E-UTRA:
 - i. General co-location table 6.7.4.1-1 in 3GPP TS 37.105 [8].
 - ii. Additional requirement for Band 41 table 6.7.4.2-1 in 3GPP TS 37.105 [8].
 - iii. Intra-system table 6.7.4.131 in 3GPP TS 37.105 [8].
- 6) If the test signal is applicable according to clause 5, perform the unwanted emission tests specified in subclauses 6.6.3, 6.6.4 and 6.6.5, for all third and fifth order intermodulation products which appear in the frequency ranges defined in subclauses 6.6.3, 6.6.4 and 6.6.5. The width of the intermodulation products shall be taken into account.
- 7) If the test signal is applicable according to clause 5, perform the Transmitter spurious emissions test as specified in subclause 6.6.6, for all third and fifth order intermodulation products which appear in the frequency ranges defined in subclause 6.6.6. The width of the intermodulation products shall be taken into account.
- 8) Verify that the emission level does not exceed the required level in subclause 6.7.5 with the exception of interfering signal frequencies.
- 9) Repeat the test for the remaining interfering signal centre frequency offsets according to the conditions of:
- a) For MSR:
 - i. General co-location table 6.7.2.1-1 in 3GPP TS 37.105 [8].
 - ii. Additional co-location (BC1 and BC2) table 6.7.2.2-1 in 3GPP TS 37.105 [8].
 - iii. Additional co-location (BC3) table 6.7.2.3-1 in 3GPP TS 37.105 [8].
 - iv. Intra-system table 6.7.2.5-1 in 3GPP TS 37.105 [8].
 - b) For UTRA FDD:
 - i. General co-location table 6.7.3.1-1 in 3GPP TS 37.105 [8].
 - ii. Intra-system table 6.7.3.3-1 in 3GPP TS 37.105 [8].
 - c) For UTRA TDD:

- i. General co-location for 1,28 Mcps TDD UTRA table 6.7.3.2-1 in 3GPP TS 37.105 [8].
 - ii. Intra-system table 6.7.3.3-1 in 3GPP TS 37.105 [8].
- d) For E-UTRA:
- i. General co-location table 6.7.4.1-1 in 3GPP TS 37.105 [8].
 - ii. Additional requirement for Band 41 table 6.7.4.2-1 in 3GPP TS 37.105 [8].
 - iii. Intra-system table 6.7.4.131 in 3GPP TS 37.105 [8].

10) Repeat the test for the remaining test signals defined in clause 5 for requirements 6.6.1, 6.6.2 and 6.6.4.

In addition, for *multi-band TAB connector(s)*, the following steps shall apply:

11) For *multi-band TAB connectors* and single band tests, repeat the steps above per involved band where single band test configurations and test models shall apply with no carrier activated in the other band.

NOTE: The third order intermodulation products are centred at $2F1 \pm F2$ and $2F2 \pm F1$. The fifth order intermodulation products are centred at $3F1 \pm 2F2$, $3F2 \pm 2F1$, $4F1 \pm F2$, and $4F2 \pm F1$ where $F1$ represents the test signal centre frequency or centre frequency of each sub-block and $F2$ represents the interfering signal centre frequency. The widths of intermodulation products are:

- $(n \cdot BW_{F1} + m \cdot 1.6\text{MHz})$ for the $nF1 \pm mF2$ products;
- $(n \cdot 1.6\text{MHz} + m \cdot BW_{F1})$ for the $nF2 \pm mF1$ products;

where BW_{F1} represents the test signal RF bandwidth or channel bandwidth in case of single carrier, or sub-block bandwidth.

6.7.5 Test requirements

6.7.5.1 MSR test requirements

6.7.5.1.1 General test requirement

In the frequency range relevant for this test the transmitter intermodulation level shall not exceed the unwanted emission limits specified for transmitter spurious emission in subclause 6.6.6, operating band unwanted emission in subclause 6.6.5 and ACLR in subclause 6.6.3 in the presence of a wanted signal and an interfering signal according subclause 6.7.4. for a *TAB connector* operating in BC1, BC2 and BC3.

The requirement is applicable outside the edges of the *Base Station RF Bandwidth*. The interfering signal offset is defined relative to the *Base Station RF Bandwidth edges* or *radio bandwidth edges*. For *TAB connectors* supporting operation in *non-contiguous spectrum*, the requirement is also applicable inside a *sub-block gap* for interfering signal offsets where the interfering signal falls completely within the *sub-block gap*. The interfering signal offset is defined relative to the *sub-block edges*.

For *TAB connectors* supporting operation in multiple operating bands, the requirement applies relative to the *Base Station RF Bandwidth edges* of each operating band. In case the inter *Base Station RF Bandwidth gap* is less than 15 MHz, the requirement in the gap applies only for interfering signal offsets where the interfering signal falls completely within the inter *Base Station RF Bandwidth gap*.

6.7.5.1.2 Additional test requirement (BC1 and BC2)

In the frequency range relevant for this test the transmitter intermodulation level shall not exceed the unwanted emission limits specified for transmitter spurious emission in subclause 6.6.6, operating band unwanted emission in subclause 6.6.5 and ACLR in subclause 6.6.3 in the presence of a wanted signal and an interfering signal according subclause 6.7.4. for a *TAB connector* operating in BC2.

The requirement is applicable outside the edges of the *Base Station RF Bandwidth* for BC2. The interfering signal offset is defined relative to the *Base Station RF Bandwidth edges*.

For *TAB connectors* supporting operation in *non-contiguous spectrum* in BC1 or BC2, the requirement is also applicable inside a *sub-block gap* with a gap size larger than or equal to two times the interfering signal centre

frequency offset. For TAB connectors supporting operation in *non-contiguous spectrum* in BC1, the requirement is not applicable inside a *sub-block gap* with a gap size equal to or larger than 5 MHz. The interfering signal offset is defined relative to the *sub-block* edges.

For *TAB connectors* supporting operation in multiple operating bands, the requirement applies relative to the *Base Station RF Bandwidth edges* of a BC2 operating band. The requirement is also applicable for BC1 and BC2 inside an inter *Base Station RF Bandwidth gap* equal to or larger than two times the interfering signal centre frequency offset. For *TAB connectors* supporting operation in multiple operating bands, the requirement is not applicable for BC1 band inside an inter *Base Station RF Bandwidth gap* with a gap size equal to or larger than 5 MHz.

6.7.5.1.3 Additional test requirement (BC3)

In the frequency range relevant for this test, the transmitter intermodulation level shall not exceed the unwanted emission limits specified for transmitter spurious emission in subclause 6.6.6, operating band unwanted emission in subclause 6.6.5 and ACLR in subclause 6.6.3 in the presence of a wanted signal and an interfering signal according subclause 6.7.4.

For *TAB connectors* supporting operation in multiple operating bands, the requirement applies relative to the *Base Station RF Bandwidth edges* of each operating band. In case the *Inter RF Bandwidth gap* is less than 3.2 MHz, the requirement in the gap applies only for interfering signal offsets where the interfering signal falls completely within the inter *Base Station RF Bandwidth gap*.

6.7.5.1.4 Intra-system test requirement

In the frequency range relevant for this test, the transmitter intermodulation level shall not exceed the unwanted emission limits specified for operating band unwanted emission in subclause 6.6.5 and ACLR in subclause 6.6.3 in the presence of a wanted signal and an interfering signal according subclause 6.7.4 for a *TAB connector* operating in BC1, BC2 and BC3.

6.7.5.2 Single RAT UTRA operation

6.7.5.2.1 General test requirement for UTRA FDD

In the frequency range relevant for this test, the transmitter intermodulation level shall not exceed the out of band emission or the spurious emission requirements of subclause 6.6.5 and subclause 6.6.6 in the presence of interfering signal according to according subclause 6.7.4.

For *TAB connectors* supporting operation in *non-contiguous spectrum*, the requirement is also applicable inside a *sub-block gap* for interfering signal offsets where the interfering signal falls completely within the *sub-block gap*. The interfering signal offset is defined relative to the *sub-block* edges.

For *TAB connectors* supporting operation in multiple operating bands, the requirement is also applicable inside an *Inter RF Bandwidth gap* for interfering signal offsets where the interfering signal falls completely within the *Base Station RF Bandwidth gap*.

NOTE: If the above Test Requirement differs from the Minimum Requirement then the Test Tolerance applied for this test is non-zero. The Test Tolerance for this test is defined in subclause 4.1.2 and the explanation of how the Minimum Requirement has been relaxed by the Test Tolerance is given in annex C.

6.7.5.2.2 General test requirement for UTRA TDD

In the frequency range relevant for this test, the transmitter intermodulation level shall not exceed the out of band emission or the spurious emission requirements of subclause 6.6.5 and subclause 6.6.6 in the presence of interfering signal according to according subclause 6.7.4.

For *TAB connectors* supporting operation in *non-contiguous spectrum*, the requirement is also applicable inside a *sub-block gap* for interfering signal offsets where the interfering signal falls completely within the *sub-block gap*. The interfering signal offset is defined relative to the *sub-block* edges.

For *TAB connectors* supporting operation in multiple operating bands, the requirement is also applicable inside an *Inter RF Bandwidth gap* for interfering signal offsets where the interfering signal falls completely within the *Inter RF Bandwidth gap*.

6.7.5.2.3 Intra-system test requirement

In the frequency range relevant for this test, the transmitter intermodulation level shall not exceed the unwanted emission limits specified for operating band unwanted emission in subclause 6.6.5 and ACLR in subclause 6.6.3 in the presence of a wanted signal and an interfering signal according to according subclause 6.7.4.

6.7.5.4 Single RAT E-UTRA operation

6.7.5.4.1 General test requirement

In the frequency range relevant for this test, the transmitter intermodulation level shall not exceed the unwanted emission limits in subclauses 6.6.6, 6.6.5 and 6.6.3 in the presence of an E-UTRA interfering signal according to according subclause 6.7.4.

The requirement is applicable outside the *Base Station RF Bandwidth* or *radio bandwidth*. The interfering signal offset is defined relative to the *Base Station RF Bandwidth edges* or *radio bandwidth edges*.

For *TAB connectors* supporting operation in *non-contiguous spectrum*, the requirement is also applicable inside a *sub-block gap* for interfering signal offsets where the interfering signal falls completely within the *sub-block gap*. The interfering signal offset is defined relative to the *sub-block edges*.

For *TAB connectors* supporting operation in multiple operating bands, the requirement applies relative to the *Base Station RF Bandwidth edges* of each supported operating band. In case the *Inter RF Bandwidth gap* is less than 15 MHz, the requirement in the gap applies only for interfering signal offsets where the interfering signal falls completely within the inter *Base Station RF Bandwidth gap*.

6.7.5.4.2 Additional test requirement for Band 41

In certain regions the following requirement may apply: For E-UTRA single RAT AAS BS operating in operating band 41 in the presence of an interfering signal according subclause 6.7.4. In the frequency range relevant for this test, the transmitter intermodulation level shall not exceed the maximum levels for spurious emission, and operating band unwanted emission specified additionally for operating band 41 *single RAT E-UTRA operation*. Also the ACLR requirements for same carrier type assumed in adjacent channels shall be fulfilled in the presence of the interfering signal.

6.7.5.4.3 Intra-system test requirement

In the frequency range relevant for this test, the transmitter intermodulation level shall not exceed the unwanted emission limits specified for operating band unwanted emission in subclause 6.6.5 and ACLR in subclause 6.6.3 in the presence of a wanted signal and an interfering signal according to according subclause 6.7.4.

7 Conducted receiver characteristics

7.1 General

Unless otherwise stated, the receiver characteristics are specified at the AAS BS *TAB connector* with full complement of transceivers for the configuration in normal operating condition.

The manufacturer shall declare the minimum number of supported geographical cells (i.e. geographical areas) in subclause 4.10. The minimum number of supported geographical cells (N_{cells}) relates to the AAS BS setting with minimum amount of cell splitting. The manufacturer shall also declare *TAB connector RX min cell groups* for this minimum number of cells configuration. Every *TAB connector* supporting reception in an operating band shall map to one *TAB connector RX min cell group* supporting the same. The mapping of *TAB connectors* to cells is implementation dependent.

The number of active receiver units that are considered when calculating the emission limit ($N_{\text{RXU, counted}}$) for an AAS base station is calculated as follows:

- $N_{\text{RXU, counted}} = \min(N_{\text{RXU, active}}, 8 \cdot N_{\text{cells}})$ for E-UTRA single RAT AAS BS and MSR AAS BS (excluding UTRA only MSR AAS BS).

And

- $N_{RXU, \text{counted}} = \min(N_{RXU, \text{active}}, 4 \cdot N_{\text{cells}})$ for UTRA single RAT AAS BS and UTRA only MSR AAS BS.

Further:

- $N_{RXU, \text{countedpercell}} = N_{RXU, \text{counted}} / N_{\text{cells}}$

$N_{RXU, \text{countedpercell}}$ is used for scaling the *basic limits* as described in subclause 7.6.

NOTE: $N_{RXU, \text{active}}$ is the number of actually active receiver units and is independent to the declaration of N_{cells} .

If a number of *TAB connectors* have been declared equivalent (see table 4.10-1, D6.70), only a representative one is necessary to demonstrate conformance.

In subclause 7.6.5.1, if representative *TAB connectors* are used then per connector criteria (option 2) shall be applied.

Any receiver test requirement specified for Band 46 operation in 3GPP TS 36.104 [4] for E-UTRA, or in 3GPP TS 37.104 [5] for E-UTRA in *MSR operation*, and referred in clause 6, is not applicable for AAS BS. The requirements for co-location blocking for Band 46 are applicable for AAS BS.

Any receiver requirement specified for NB-IoT in-band, NB-IoT guard band, or standalone NB-IoT operation in 3GPP TS 36.104 [4] for E-UTRA with NB-IoT (in-band or guard band) or for standalone NB-IoT, or in 3GPP TS 37.104 [5] for E-UTRA with NB-IoT or standalone NB-IoT in *MSR operation*, and referred in clause 7, is not applicable for AAS BS.

7.2 Reference sensitivity level

7.2.1 Definition and applicability

The reference sensitivity power level P_{REFSENS} is the minimum mean power received at the *TAB connector* at which a reference performance requirement shall be met for a specified reference measurement channel.

7.2.2 Minimum Requirement

The single RAT UTRA FDD AAS BS of Wide Area BS class shall fulfil minimum requirements for reference sensitivity specified in 3GPP TS 25.104 [9], subclause 7.2.1.

The single RAT UTRA FDD AAS BS of Medium Range BS class shall fulfil minimum requirements for reference sensitivity specified in 3GPP TS 25.104 [9], subclause 7.2.1.

The single RAT UTRA FDD AAS BS of Local Area BS class shall fulfil minimum requirements for reference sensitivity specified in 3GPP TS 25.104 [9], subclause 7.2.1.

The single RAT UTRA TDD AAS BS of Wide Area BS class shall fulfil minimum requirements for reference sensitivity specified in 3GPP TS 25.105 [10], subclause 7.2.1.1.

The single RAT UTRA TDD AAS BS of Local Area BS class shall fulfil minimum requirements for reference sensitivity specified in 3GPP TS 25.105 [10], subclause 7.2.1.1.

The single RAT E-UTRA AAS BS of Wide Area BS class shall fulfil minimum requirements for reference sensitivity specified in 3GPP TS 36.104 [11], subclause 7.2.1.

The single RAT E-UTRA AAS BS of Medium Range BS class shall fulfil minimum requirements for reference sensitivity specified in 3GPP TS 36.104 [11], subclause 7.2.1.

The single RAT E-UTRA AAS BS of Local Area BS class shall fulfil minimum requirements for reference sensitivity specified in 3GPP TS 36.104 [11], subclause 7.2.1.

The MSR NR AAS BS of Wide Area BS class shall fulfil minimum requirements for reference sensitivity specified in 3GPP TS 38.104 [36], subclause 7.2.1.

The MSR NR AAS BS of Medium Range BS class shall fulfil minimum requirements for reference sensitivity specified in 3GPP TS 38.104 [36], subclause 7.2.1.

The MSR NR AAS BS of Local Area BS class shall fulfil minimum requirements for reference sensitivity specified in 3GPP TS 38.104 [36], subclause 7.2.1.

7.2.3 Test Purpose

To verify that at each *TAB connector* the reference sensitivity level the performance requirements shall be met for a specified reference measurement channel.

7.2.4 Method of test

7.2.4.1 Initial conditions

Test environment:

- normal; see clause B.2.

RF channels to be tested for single carrier:

- B, M and T; see subclause 4.12.1.

On each of B, M and T, the test shall be performed under extreme power supply as defined in annex B.5.

NOTE: Tests under extreme power supply also test extreme temperature.

7.2.4.2 Procedure

The minimum requirement is applied to all *TAB connectors*, the procedure is repeated until all *TAB connectors* necessary to demonstrate conformance have been tested; see subclause 7.1.

- 1) Connect *TAB connector* to measurement equipment as shown in subclause D.2.1. All *TAB connectors* not under test shall be terminated.
- 2) Set all *TAB connectors* declared in the same RAT and operating band to transmit a signal according to subclause 4.12.2 at manufacturers declared rated output power $P_{\text{Rated,c,TABC}}$.
- 3) Start the signal generator for the wanted signal to transmit:
 - 12,2kbps DPCH with reference measurement channel defined in annex A in 3GPP TS 25.141 [18] (PN-9 data sequence or longer) for UTRA FDD,
 - UL reference measurement channel (12.2 kbps) defined in subclause A.2.1 in 3GPP TS 25.142 [20] for UTRA TDD 1,28Mcps operation
 - The test signal mean power as specified in subclause 7.2.5.3 for E-UTRA to the *TAB connector*.
 - The test signal mean power as specified in subclause 7.2.5.4 for NR to the *TAB connector*.
- 4) For UTRA FDD disable the TPC function.
- 5) Set the signal generator for the wanted signal power as specified in subclause 7.2.5.
- 6) Measure:
 - BER according to annex C in 3GPP TS 25.141 [18] for FDD UTRA.
 - BER according to annex F in 3GPP TS 25.142 [20] for TDD UTRA.
 - Throughput according to annex E in 3GPP TS 36.141 [17] for E-UTRA and NR.

In addition, for *multi-band TAB connector(s)*, the following steps shall apply:

- 7) For *multi-band TAB connectors* and single band tests, repeat the steps above per involved band where single band test configurations and test models shall apply with no carrier activated in the other band.

7.2.5 Test Requirements

7.2.5.1 UTRA FDD operation

The BER measurement result in step 6 of 7.2.4.2 shall not be greater than the limit specified in table 7.2.5.1-1.

Table 7.2.5.1-1: Reference sensitivity levels

BS class	Reference measurement channel data rate	reference sensitivity level (dBm)		BER
		$f \leq 3.0$ GHz	3.0 GHz $< f \leq 4.2$ GHz	
Wide Area BS	12.2 kbps	-120.3	-120.0	BER shall not exceed 0.001
Medium Range BS	12.2 kbps	-110.3	-110.0	BER shall not exceed 0.001
Local Area BS	12.2 kbps	-106.3	-106.0	BER shall not exceed 0.001

NOTE: If the above Test Requirement differs from the Minimum Requirement then the Test Tolerance applied for this test is non-zero. The Test Tolerance for this test is defined in subclause 4.1.2 and the explanation of how the Minimum Requirement has been relaxed by the Test Tolerance is given in annex C.

7.2.5.2 UTRA TDD 1,28 Mcps option operation

The BER measurement result in step 4 of 7.2.4.2.2 shall not be greater than the limit specified in table 7.2.5.1-1.

Table 7.2.5.2-1: Test Requirement for BS reference sensitivity level for 1,28 Mcps option

BS class	Reference measurement channel data rate	reference sensitivity level	BER
Wide Area BS	12.2 kbps	-109.3 dBm	BER shall not exceed 0.001
Local Area BS	12.2 kbps	-95.3 dBm	BER shall not exceed 0.001

NOTE: If the above Test Requirement differs from the Minimum Requirement then the Test Tolerance applied for this test is non-zero. The Test Tolerance for this test is defined in subclause 4.1.2 and the explanation of how the Minimum Requirement has been relaxed by the Test Tolerance is given in annex C.

7.2.5.3 E-UTRA operation

For each measured E-UTRA carrier, the throughput shall be $\geq 95\%$ of the *maximum throughput* of the reference measurement channel as specified in clause A.1 in 3GPP TS 36.141 [17] with parameters specified in table 7.2.5.3-1 for Wide Area BS, in table 7.2.5.3-2 for Local Area BS, in table 7.2-3 and in table 7.2.5.3-3 for Medium Range BS.

Table 7.2.5.3-1: Wide Area BS class reference sensitivity levels

E-UTRA channel bandwidth (MHz)	Reference measurement channel (Note 2)	Reference sensitivity power level, P_{REFSENS} (dBm)	
		$f \leq 3.0$ GHz	3.0 GHz $< f \leq 4.2$ GHz
1.4	FRC A1-1	-106.1	-105.8
3	FRC A1-2	-102.3	-102.0
5	FRC A1-3	-100.8	-100.5
10	FRC A1-3 (Note 1)	-100.8	-100.5
15	FRC A1-3 (Note 1)	-100.8	-100.5
20	FRC A1-3 (Note 1)	-100.8	-100.5

NOTE 1: P_{REFSENS} is the power level of a single instance of the reference measurement channel. This requirement shall be met for each consecutive application of a single instance of FRC A1-3 in 3GPP TS 36.141 [17] mapped to disjoint frequency ranges with a width of 25 resource blocks each.

NOTE 2: FRC reference measurement channels as defined in annex A.1 in 3GPP TS 36.141 [17].

Table 7.2.5.3-2: Local Area BS class, reference sensitivity levels

E-UTRA channel bandwidth (MHz)	Reference measurement channel (Note 2)	Reference sensitivity power level, P_{REFSENS} (dBm)	
		$f \leq 3.0$ GHz	3.0 GHz $< f \leq 4.2$ GHz
1.4	FRC A1-1	-98.1	-97.8
3	FRC A1-2	-94.3	-94.0
5	FRC A1-3	-92.8	-92.5
10	FRC A1-3 (Note 1)	-92.8	-92.5
15	FRC A1-3 (Note 1)	-92.8	-92.5
20	FRC A1-3 (Note 1)	-92.8	-92.5

NOTE 1: P_{REFSENS} is the power level of a single instance of the reference measurement channel. This requirement shall be met for each consecutive application of a single instance of FRC A1-3 in 3GPP TS 36.141 [17] mapped to disjoint frequency ranges with a width of 25 resource blocks each.

NOTE 2: FRC reference measurement channels as defined in annex A.1 in 3GPP TS 36.141 [17].

Table 7.2.5.3-3: Medium Range BS class, reference sensitivity levels

E-UTRA channel bandwidth (MHz)	Reference measurement channel (Note 2)	Reference sensitivity power level, P_{REFSENS} (dBm)	
		$f \leq 3.0$ GHz	3.0 GHz $< f \leq 4.2$ GHz
1.4	FRC A1-1	-101.1	-100.8
3	FRC A1-2	-97.3	-97.0
5	FRC A1-3	-95.8	-95.5
10	FRC A1-3 (Note 1)	-95.8	-95.5
15	FRC A1-3 (Note 1)	-95.8	-95.5
20	FRC A1-3 (Note 1)	-95.8	-95.5

NOTE 1: P_{REFSENS} is the power level of a single instance of the reference measurement channel. This requirement shall be met for each consecutive application of a single instance of FRC A1-3 in 3GPP TS 36.141 [17] mapped to disjoint frequency ranges with a width of 25 resource blocks each.

NOTE 2: FRC reference measurement channels as defined in annex A.1 in 3GPP TS 36.141 [17].

NOTE: If the above Test Requirement differs from the Minimum Requirement then the Test Tolerance applied for this test is non-zero. The Test Tolerance for this test is defined in subclause 4.1.2 and the explanation of how the Minimum Requirement has been relaxed by the Test Tolerance is given in annex C.

7.2.5.4 NR operation

For NR, the throughput shall be $\geq 95\%$ of the maximum throughput of the reference measurement channel as specified in Annex A in TS 38.104 [36] with parameters specified in table 7.2.5.4-1 for Wide Area BS, in table 7.2.5.4-2 for Medium Range BS and in table 7.2.5.4-3 for Local Area BS.

Table 7.2.5.4-1: NR Wide Area BS reference sensitivity levels

BS channel bandwidth [MHz]	Sub-carrier spacing [kHz]	Reference measurement channel	Reference sensitivity power level, P_{REFSENS} [dBm]		
			$f \leq 3.0$ GHz	3.0 GHz $< f \leq$ 4.2GHz	4.2 GHz $< f \leq$ 6.0GHz

5, 10, 15	15	G-FR1-A1-1	-101	-100.7	-100.2
10, 15	30	G- FR1-A1-2	-101.1	-100.8	-100.3
10, 15	60	G- FR1-A1-3	-98.2	-97.9	-97.4
20, 25, 30, 40, 50	15	G- FR1-A1-4	-94.6	-94.3	-93.8
20, 25, 30, 40, 50, 60, 70, 80, 90, 100	30	G- FR1-A1-5	-94.9	-94.6	-94.1
20, 25, 30, 40, 50, 60, 70, 80, 90, 100	60	G- FR1-A1-6	-95	-94.7	-94.2
NOTE: P_{REFSENS} is the power level of a single instance of the reference measurement channel. This requirement shall be met for each consecutive application of a single instance of the reference measurement channel mapped to disjoint frequency ranges with a width corresponding to the number of resource blocks of the reference measurement channel each, except for one instance that might overlap one other instance to cover the full <i>BS channel bandwidth</i> .					

Table 7.2.5.4-2: NR Medium Area BS reference sensitivity levels

BS channel bandwidth [MHz]	Sub-carrier spacing [kHz]	Reference measurement channel	Reference sensitivity power level, P_{REFSENS} [dBm]		
			$f \leq 3.0\text{GHz}$	$3.0\text{GHz} < f \leq 4.2\text{GHz}$	$4.2\text{GHz} < f \leq 6.0\text{GHz}$
5, 10, 15	15	G-FR1-A1-1	-96	-95.7	-95.2
10, 15	30	G- FR1-A1-2	-96.1	-95.8	-95.3
10, 15	60	G- FR1-A1-3	-93.2	-92.9	-92.4
20, 25, 30, 40, 50	15	G- FR1-A1-4	-89.6	-89.3	-88.8
20, 25, 30, 40, 50, 60, 70, 80, 90, 100	30	G- FR1-A1-5	-89.9	-89.6	-89.1
20, 25, 30, 40, 50, 60, 70, 80, 90, 100	60	G- FR1-A1-6	-90	-89.7	-89.2
NOTE: P_{REFSENS} is the power level of a single instance of the reference measurement channel. This requirement shall be met for each consecutive application of a single instance of the reference measurement channel mapped to disjoint frequency ranges with a width corresponding to the number of resource blocks of the reference measurement channel each, except for one instance that might overlap one other instance to cover the full <i>BS channel bandwidth</i> .					

Table 7.2.5.4-3: NR Local Area BS reference sensitivity levels

BS channel bandwidth [MHz]	Sub-carrier spacing [kHz]	Reference measurement channel	Reference sensitivity power level, P_{REFSENS} [dBm]		
			$f \leq 3.0\text{GHz}$	$3.0\text{GHz} < f \leq 4.2\text{GHz}$	$4.2\text{GHz} < f \leq 6.0\text{GHz}$

5, 10, 15	15	G-FR1-A1-1	-93	-92.7	-92.2
10, 15	30	G- FR1-A1-2	-93.1	-92.8	-92.3
10, 15	60	G- FR1-A1-3	-90.2	-89.9	-89.4
20, 25, 30, 40, 50	15	G- FR1-A1-4	-86.6	-86.3	-85.8
20, 25, 30, 40, 50, 60, 70, 80, 90, 100	30	G- FR1-A1-5	-86.9	-86.6	-86.1
20, 25, 30, 40, 50, 60, 70, 80, 90, 100	60	G- FR1-A1-6	-87	-86.7	-86.2
NOTE: P_{REFSENS} is the power level of a single instance of the reference measurement channel. This requirement shall be met for each consecutive application of a single instance of the reference measurement channel mapped to disjoint frequency ranges with a width corresponding to the number of resource blocks of the reference measurement channel each, except for one instance that might overlap one other instance to cover the full <i>BS channel bandwidth</i> .					

NOTE: If the above Test Requirement differs from the Minimum Requirement then the Test Tolerance applied for this test is non-zero. The relationship between Minimum Requirements and Test Requirements is defined in subclause 4.1 and the explanation of how the Minimum Requirement has been adjusted by the Test Tolerance is given in Annex C.

7.3 Dynamic range

7.3.1 Definition and applicability

The dynamic range is a measure of the capability of the receiver unit to receive a wanted signal in the presence of an interfering signal at the *TAB connector* inside the received *channel bandwidth* or the capability of receiving high level of wanted signal.

7.3.2 Minimum requirement

The single RAT UTRA FDD AAS BS of Wide Area BS class shall fulfil minimum requirements for dynamic range specified in 3GPP TS 25.104 [9], subclause 7.3.1.

The single RAT UTRA FDD AAS BS of Medium Range BS class shall fulfil minimum requirements for dynamic range specified in 3GPP TS 25.104 [9], subclause 7.3.1.

The single RAT UTRA FDD AAS BS of Local Area BS class shall fulfil minimum requirements for dynamic range specified in 3GPP TS 25.104 [9], subclause 7.3.1.

The single RAT UTRA TDD AAS BS of Wide Area BS class shall fulfil minimum requirements for dynamic range specified in 3GPP TS 25.105 [10], subclause 7.3.1.1.

The single RAT UTRA TDD AAS BS of Local Area BS class shall fulfil minimum requirements for dynamic range specified in 3GPP TS 25.105 [10], subclause 7.3.1.1.

The single RAT E-UTRA AAS BS of A Wide Area BS class shall fulfil minimum requirements for dynamic range specified in 3GPP TS 36.104 [11], subclause 7.3.1.

The single RAT E-UTRA AAS BS of Medium Range BS class shall fulfil minimum requirements for dynamic range specified in 3GPP TS 36.104 [11], subclause 7.3.1.

The single RAT E-UTRA AAS BS of Local Area BS class shall fulfil minimum requirements for dynamic range specified in 3GPP TS 36.104 [11], subclause 7.3.1.

The MSR NR AAS BS of A Wide Area BS class shall fulfil minimum requirements for dynamic range specified in 3GPP TS 38.104 [36], subclause 7.3.1.

The single RAT E-UTRA AAS BS of Medium Range BS class shall fulfil minimum requirements for dynamic range specified in 3GPP TS 38.104 [36], subclause 7.3.1.

The single RAT E-UTRA AAS BS of Local Area BS class shall fulfil minimum requirements for dynamic range specified in 3GPP TS 38.104 [36], subclause 7.3.1.

7.3.3 Test purpose

To verify that at the dynamic range of the receiver unit associated with each *TAB connector* shall fulfil the specified limit.

7.3.4 Method of test

7.3.4.1 Initial conditions

Test environment:

- normal; see clause B.2.

RF channels to be tested for single carrier:

- M; see subclause 4.12.1.

7.3.4.2 Procedure

The minimum requirement is applied to all *TAB connectors*, the procedure is repeated until all *TAB connectors* necessary to demonstrate conformance have been tested; see subclause 7.1.

- 1) Connect *TAB connector* to measurement equipment as shown in annex D.2.1. All *TAB connectors* not under test shall be terminated.
- 2) Set the signal generator for the wanted signal to transmit:
 - as specified in table 7.3.5.1-1 for UTRA.
 - as specified in table 7.3.5.2-1 for UTRA TDD 1,28Mcps operation.
 - as specified in table 7.3.5.3-1 to table 7.3.5.3-3 for E-UTRA.
 - as specified in table 7.3.5.4-1 to table 7.3.5.4-3 for NR.
- 3) Set the Signal generator for the AWGN interfering signal at the same frequency as the wanted signal to transmit:
 - as specified in table 7.3.5.1-1 for UTRA.
 - as specified in table 7.3.5.2-1 for UTRA TDD 1,28Mcps operation.
 - as specified in table 7.3.5.3-1 to table 7.3.5.3-3 for E-UTRA.
 - as specified in table 7.3.5.1-1 to table 7.3.5.1-3 for NR.
- 4) Measure:
 - BER according to annex C in 3GPP TS 25.141 [18] for FDD UTRA.
 - BER according to annex F in 3GPP TS 25.142 [20] for TDD UTRA.
 - Throughput according to annex E in 3GPP TS 36.141 [17] for E-UTRA.
 - Throughput according 3GPP TS 38.141 [37] for NR.

In addition, for *multi-band TAB connector(s)*, the following steps shall apply:

- 5) For *multi-band TAB connectors* and single band tests, repeat the steps above per involved band where single band test configurations and test models shall apply with no carrier activated in the other band.

7.3.5 Test requirements

7.3.5.1 UTRA FDD operation

The BER shall not exceed 0,001 for the parameters specified in table 7.3.5.1-1.

Table 7.3.5.1-1: Dynamic range

Parameter	Level Wide Area BS	Level Medium Range BS	Level Local Area BS	Unit
Reference measurement channel data rate	12,2	12.2	12.2	Kbps
Wanted signal mean power	-89.8	-79.8	-75.8	dBm
Interfering AWGN signal	-73	-63	-59	dBm/3.84 MHz

NOTE: If the above Test Requirement differs from the Minimum Requirement then the Test Tolerance applied for this test is non-zero. The Test Tolerance for this test is defined in subclause 4.1.2 and the explanation of how the Minimum Requirement has been relaxed by the Test Tolerance is given in annex C.

7.3.5.2 UTRA TDD 1,28 Mcps option operation

The BER shall not exceed 0,001 for the parameters specified in table 7.3.5.2-1.

Table 7.3.5.2-1: Test Requirements for Dynamic Range for 1,28 Mcps TDD option

Parameter	Level	Unit
Reference measurement channel data rate	12,2	kbit/s
Wanted signal mean power	Wide Area BS	-78,8
	Local Area BS	-64,8
Interfering AWGN signal	Wide Area BS	-76
	Local Area BS	-62

NOTE: If the above Test Requirement differs from the Minimum Requirement then the Test Tolerance applied for this test is non-zero. The Test Tolerance for this test is defined in subclause 4.1.2 and the explanation of how the Minimum Requirement has been relaxed by the Test Tolerance is given in annex C.

7.3.5.3 E-UTRA operation

For each measured E-UTRA carrier, the throughput shall be $\geq 95\%$ of the *maximum throughput* of the reference measurement channel as specified in annex A in 3GPP TS 36.141 [17] with parameters specified in table 7.3.5.3-1 for an AAS BS of Wide Area BS class, in Table 7.3.5.3-2 for an AAS BS of Local Area BS class and in table 7.3.5.3-3 for AAS BS of Medium Range BS class.

Table 7.3.5.3-1: AAS BS of Wide Area BS class dynamic range

E-UTRA channel bandwidth (MHz)	Reference measurement channel	Wanted signal mean power (dBm)	Interfering signal mean power (dBm) / BW_{Config}	Type of interfering signal
1.4	FRC A2-1 in annex A.2	-76.0	-88.7	AWGN
3	FRC A2-2 in annex A.2	-72.1	-84.7	AWGN
5	FRC A2-3 in annex A.2	-69.9	-82.5	AWGN
10	FRC A2-3 in annex A.2 (Note)	-69.9	-79.5	AWGN
15	FRC A2-3 in annex A.2 (Note)	-69.9	-77.7	AWGN
20	FRC A2-3 in annex A.2 (Note)	-69.9	-76.4	AWGN

NOTE: The wanted signal mean power is the power level of a single instance of the reference measurement channel. This requirement shall be met for each consecutive application of a single instance of FRC A2-3 mapped to disjoint frequency ranges with a width of 25 resource blocks each.

Table 7.3.5.3-2: AAS BS of Local Area BS class dynamic range

E-UTRA channel bandwidth (MHz)	Reference measurement channel	Wanted signal mean power (dBm)	Interfering signal mean power (dBm) / BW_{Config}	Type of interfering signal
1.4	FRC A2-1 in annex A.2	-68.0	-80.7	AWGN
3	FRC A2-2 in annex A.2	-64.1	-76.7	AWGN
5	FRC A2-3 in annex A.2	-61.9	-74.5	AWGN
10	FRC A2-3 in annex A.2 (Note)	-61.9	-71.5	AWGN
15	FRC A2-3 in annex A.2 (Note)	-61.9	-69.7	AWGN
20	FRC A2-3 in annex A.2 (Note)	-61.9	-68.4	AWGN

NOTE: The wanted signal mean power is the power level of a single instance of the reference measurement channel. This requirement shall be met for each consecutive application of a single instance of FRC A2-3 mapped to disjoint frequency ranges with a width of 25 resource blocks each.

Table 7.3.5.3-3: AAS BS of Medium Range BS class dynamic range

E-UTRA channel bandwidth (MHz)	Reference measurement channel	Wanted signal mean power (dBm)	Interfering signal mean power (dBm) / BW_{Config}	Type of interfering signal
1.4	FRC A2-1 in annex A.2	-71.0	-83.7	AWGN
3	FRC A2-2 in annex A.2	-67.1	-79.7	AWGN
5	FRC A2-3 in annex A.2	-64.9	-77.5	AWGN
10	FRC A2-3 in annex A.2 (Note)	-64.9	-74.5	AWGN
15	FRC A2-3 in annex A.2 (Note)	-64.9	-72.7	AWGN
20	FRC A2-3 in annex A.2 (Note)	-64.9	-71.4	AWGN

NOTE: The wanted signal mean power is the power level of a single instance of the reference measurement channel. This requirement shall be met for each consecutive application of a single instance of FRC A2-3 mapped to disjoint frequency ranges with a width of 25 resource blocks each.

NOTE: If the above Test Requirement differs from the Minimum Requirement then the Test Tolerance applied for this test is non-zero. The Test Tolerance for this test is defined in subclause 4.1.2 and the explanation of how the Minimum Requirement has been relaxed by the Test Tolerance is given in annex C.

7.3.5.4 NR operation

For NR, the throughput shall be $\geq 95\%$ of the maximum throughput of the reference measurement channel as specified in Annex A in TS 38.104 [36] with parameters specified in table 7.3.5.4-1 for Wide Area BS, in table 7.3.5.4-2 for Medium Range BS and in table 7.3.5.4-3 for Local Area BS.

Table 7.3.5.4-1: Wide Area BS dynamic range

BS channel bandwidth [MHz]	Subcarrier spacing [kHz]	Reference measurement channel	Wanted signal mean power [dBm]	Interfering signal mean power [dBm] / BW_{Config}	Type of interfering signal
5	15	G-FR1-A2-1	-70.4	-82.5	AWGN
	30	G- FR1-A2-2	-71.1		
10	15	G-FR1-A2-1	-70.4	-79.3	AWGN
	30	G- FR1-A2-2	-71.1		
	60	G- FR1-A2-3	-68.1		
15	15	G-FR1-A2-1	-70.4	-77.5	AWGN
	30	G- FR1-A2-2	-71.1		
	60	G- FR1-A2-3	-68.1		
20	15	G- FR1-A2-4	-64.2	-76.2	AWGN
	30	G- FR1-A2-5	-64.2		
	60	G- FR1-A2-6	-64.5		
25	15	G- FR1-A2-4	-64.2	-75.2	AWGN
	30	G- FR1-A2-5	-64.2		
	60	G- FR1-A2-6	-64.5		
30	15	G- FR1-A2-4	-64.2	-74.4	AWGN
	30	G- FR1-A2-5	-64.2		
	60	G- FR1-A2-6	-64.5		
40	15	G- FR1-A2-4	-64.2	-73.1	AWGN
	30	G- FR1-A2-5	-64.2		
	60	G- FR1-A2-6	-64.5		
50	15	G- FR1-A2-4	-64.2	-72.2	AWGN
	30	G- FR1-A2-5	-64.2		
	60	G- FR1-A2-6	-64.5		

60	30	G- FR1-A2-5	-64.2	-71.4	AWGN
	60	G- FR1-A2-6	-64.5		
70	30	G- FR1-A2-5	-64.2	-70.8	AWGN
	60	G- FR1-A2-6	-64.5		
80	30	G- FR1-A2-5	-64.2	-70.1	AWGN
	60	G- FR1-A2-6	-64.5		
90	30	G- FR1-A2-5	-64.2	-69.6	AWGN
	60	G- FR1-A2-6	-64.5		
100	30	G- FR1-A2-5	-64.2	-69.1	AWGN
	60	G- FR1-A2-6	-64.5		

NOTE: The wanted signal mean power is the power level of a single instance of the corresponding reference measurement channel. This requirement shall be met for each consecutive application of a single instance of the reference measurement channel mapped to disjoint frequency ranges with a width corresponding to the number of resource blocks of the reference measurement channel each, except for one instance that might overlap one other instance to cover the full *BS channel bandwidth*.

Table 7.3.5.4-2: Medium Range BS dynamic range

<i>BS channel bandwidth</i> [MHz]	Subcarrier spacing [kHz]	Reference measurement channel	Wanted signal mean power [dBm]	Interfering signal mean power [dBm] / BW_{Config}	Type of interfering signal
5	15	G-FR1-A2-1	-65.4	-77.5	AWGN
	30	G- FR1-A2-2	-66.1		
10	15	G-FR1-A2-1	-65.4	-74.3	AWGN
	30	G- FR1-A2-2	-66.1		
	60	G- FR1-A2-3	-63.1		
15	15	G-FR1-A2-1	-65.4	-72.5	AWGN
	30	G- FR1-A2-2	-66.1		
	60	G- FR1-A2-3	-63.1		
20	15	G- FR1-A2-4	-59.2	-71.2	AWGN
	30	G- FR1-A2-5	-59.2		
	60	G- FR1-A2-6	-59.5		
25	15	G- FR1-A2-4	-59.2	-70.2	AWGN
	30	G- FR1-A2-5	-59.2		
	60	G- FR1-A2-6	-59.5		
30	15	G- FR1-A2-4	-59.2	-69.4	AWGN
	30	G- FR1-A2-5	-59.2		
	60	G- FR1-A2-6	-59.5		
40	15	G- FR1-A2-4	-59.2	-68.1	AWGN
	30	G- FR1-A2-5	-59.2		
	60	G- FR1-A2-6	-59.5		
50	15	G- FR1-A2-4	-59.2	-67.2	AWGN
	30	G- FR1-A2-5	-59.8		
	60	G- FR1-A2-6	-59.5		
60	30	G- FR1-A2-5	-59.2	-66.4	AWGN
	60	G- FR1-A2-6	-59.5		
70	30	G- FR1-A2-5	-59.2	-65.8	AWGN
	60	G- FR1-A2-6	-59.5		
80	30	G- FR1-A2-5	-59.2	-65.1	AWGN
	60	G- FR1-A2-6	-59.5		
90	30	G- FR1-A2-5	-59.2	-64.6	AWGN
	60	G- FR1-A2-6	-59.5		
100	30	G- FR1-A2-5	-59.2	-64.1	AWGN
	60	G- FR1-A2-6	-59.5		

NOTE: The wanted signal mean power is the power level of a single instance of the corresponding reference measurement channel. This requirement shall be met for each consecutive application of a single instance of the reference measurement channel mapped to disjoint frequency ranges with a width corresponding to the number of resource blocks of the reference measurement channel each, except for one instance that might overlap one other instance to cover the full *BS channel bandwidth*.

Table 7.3.5.4-3: Local Area BS dynamic range

<i>BS channel bandwidth [MHz]</i>	<i>Subcarrier spacing [kHz]</i>	<i>Reference measurement channel</i>	<i>Wanted signal mean power [dBm]</i>	<i>Interfering signal mean power [dBm] / BW_{Config}</i>	<i>Type of interfering signal</i>
5	15	G-FR1-A2-1	-62.4	-74.5	AWGN
	30	G- FR1-A2-2	-63.1		
10	15	G-FR1-A2-1	-62.4	-71.3	AWGN
	30	G- FR1-A2-2	-63.1		
	60	G- FR1-A2-3	-60.1		
15	15	G-FR1-A2-1	-62.4	-69.5	AWGN
	30	G- FR1-A2-2	-63.1		
	60	G- FR1-A2-3	-60.1		
20	15	G- FR1-A2-4	-56.2	-68.2	AWGN
	30	G- FR1-A2-5	-56.2		
	60	G- FR1-A2-6	-56.5		
25	15	G- FR1-A2-4	-56.2	-67.2	AWGN
	30	G- FR1-A2-5	-56.2		
	60	G- FR1-A2-6	-56.5		
30	15	G- FR1-A2-4	-56.2	-66.4	AWGN
	30	G- FR1-A2-5	-56.2		
	60	G- FR1-A2-6	-56.5		
40	15	G- FR1-A2-4	-56.2	-65.1	AWGN
	30	G- FR1-A2-5	-56.2		
	60	G- FR1-A2-6	-56.5		
50	15	G- FR1-A2-4	-56.2	-64.2	AWGN
	30	G- FR1-A2-5	-56.2		
	60	G- FR1-A2-6	-56.5		
60	30	G- FR1-A2-5	-56.2	-63.4	AWGN
	60	G- FR1-A2-6	-56.5		
70	30	G- FR1-A2-5	-56.2	-62.8	AWGN
	60	G- FR1-A2-6	-56.5		
80	30	G- FR1-A2-5	-56.2	-62.1	AWGN
	60	G- FR1-A2-6	-56.5		
90	30	G- FR1-A2-5	-56.2	-61.6	AWGN
	60	G- FR1-A2-6	-56.5		
100	30	G- FR1-A2-5	-56.2	-61.1	AWGN
	60	G- FR1-A2-6	-56.5		

NOTE: The wanted signal mean power is the power level of a single instance of the corresponding reference measurement channel. This requirement shall be met for each consecutive application of a single instance of the reference measurement channel mapped to disjoint frequency ranges with a width corresponding to the number of resource blocks of the reference measurement channel each, except for one instance that might overlap one other instance to cover the full *BS channel bandwidth*.

NOTE: If the above Test Requirement differs from the Minimum Requirement then the Test Tolerance applied for this test is non-zero. The relationship between Minimum Requirements and Test Requirements is defined in subclause 4.1 and the explanation of how the Minimum Requirement has been adjusted by the Test Tolerance is given in Annex C.

7.4 Adjacent channel selectivity and narrowband blocking

7.4.1 Definition and applicability

The adjacent channel selectivity, general blocking and narrowband blocking characteristics are measures of the receiver unit ability to receive a wanted signal at its assigned channel at the *TAB connector* in the presence of an unwanted interferer inside the operating band.

NOTE For Single RAT requirements, the in-band selectivity characteristics is referred to as "adjacent channel selectivity", whereas for the MSR requirements, the corresponding property is referred to as "general blocking" since the adjacent frequency range may not carry a channel addressable from the interfered carrier.

The in-band blocking requirement applies from $F_{UL_low} - \Delta f_{OOB}$ to $F_{UL_high} + \Delta f_{OOB}$, excluding the downlink frequency range of the *operating band*. The values of Δf_{OOB} are defined in table 7.4.1-1.

Table 7.4.1-1: Maximum Δf_{OOB} offset outside the uplink operating band

Operating band characteristics	Δf_{OOB} [MHz]
$200 \text{ MHz} \geq F_{UL_high} - F_{UL_low}$	20
$200 \text{ MHz} < F_{UL_high} - F_{UL_low} \leq 900 \text{ MHz}$	60

7.4.2 Minimum requirement

The minimum requirement for MSR operation is in 3GPP TS 37.105 [8], subclause 7.4.2.

The single RAT UTRA FDD AAS BS of Wide Area BS class shall fulfil minimum requirements for adjacent channel selectivity and narrow-band blocking specified in 3GPP TS 25.104 [9], subclause 7.4.

The single RAT UTRA FDD AAS BS of Medium Range BS class shall fulfil minimum requirements for adjacent channel selectivity and narrow-band blocking specified in 3GPP TS 25.104 [9], subclause 7.4.

The single RAT UTRA FDD Local Area BS class shall fulfil minimum requirements for adjacent channel selectivity and narrow-band blocking specified in 3GPP TS 25.104 [9], subclause 7.4.

The single RAT UTRA TDD AAS BS of Wide Area BS class shall fulfil minimum requirements for adjacent channel selectivity and narrow-band blocking specified in 3GPP TS 25.105 [10], subclause 7.4.

The single RAT UTRA TDD AAS BS of Local Area BS class shall fulfil minimum requirements for adjacent channel selectivity and narrow-band blocking specified in 3GPP TS 25.105 [10], subclause 7.4.

The single RAT E-UTRA AAS BS of Wide Area BS class shall fulfil minimum requirements for adjacent channel selectivity and narrow-band blocking specified in 3GPP TS 36.104 [11], subclause 7.5.

The single RAT E-UTRA AAS BS of Medium Range BS class shall fulfil minimum requirements for adjacent channel selectivity and narrow-band blocking specified in 3GPP TS 36.104 [11], subclause 7.5.

The single RAT E-UTRA AAS BS of Local Area BS class shall fulfil minimum requirements for adjacent channel selectivity and narrow-band blocking specified in 3GPP TS 36.104 [11], subclause 7.5.

7.4.3 Test purpose

The test stresses the receiver unit ability to withstand high-level interference from unwanted signals at specified frequency offsets at the *TAB connector* without undue degradation of its sensitivity.

7.4.4 Method of test

7.4.4.1 Initial conditions

Test environment:

- Normal; see clause B.2.

RF channels to be tested for single carrier (SC):

- M; see subclause 4.12.1

Base Station RF Bandwidth positions to be tested for multi-carrier (MC):

- M_{RFBW} for *single-band TAB connector(s)*, see subclause 4.12.1, $B_{RFBW_T'RFBW}$ and $B'_{RFBW_T'RFBW}$ for *multi-band TAB connector(s)*, see subclause 4.12.1.

7.4.4.2 Procedure

7.4.4.2.1 General procedure

The general procedure steps apply to the procedures for all the RATs.

The minimum requirement is applied to all *TAB connectors*, the procedure is repeated until all *TAB connectors* necessary to demonstrate conformance have been tested; see subclause 7.1.

- 1) Connect *TAB connector* to measurement equipment as shown in annex D.2.3. All *TAB connectors* not under test shall be terminated.
- 2) Generate the wanted signal according to the applicable test configuration (see clause 5) using applicable reference measurement channel to the *TAB connector* under test as follows:
 - For E-UTRA see clause A.1 in 3GPP TS 36.141 [17].
 - For UTRA FDD see clause A.2 in 3GPP TS 25.141 [18].
 - For UTRA TDD see subclause A.2.1 in 3GPP TS 25.142 [20].
 - For NR, see subclause [4.11].
- 3) Set the transmitter unit associated with the *TAB connector* under test to transmit with the carrier set-up and power allocation according to the applicable test configuration(s) (see clause 5).

7.4.4.2.2 MSR operation

7.4.4.2.2.1 Procedure for general blocking

- 1) Adjust the signal generators to the type of interfering signal, levels and the frequency offsets as specified in table 7.4.5.1.1-1.
- 2) The interfering signal shall be swept with a step size of 1 MHz starting from the minimum offset to the channel edges of the wanted signals as specified in table 7.4.5.1.1-1.
- 3) Measure the performance of the wanted signal at the receiver unit associated with the *TAB connector* under test, as defined in subclause 7.4.5.1, for the relevant carriers specified by the test configuration in subclause 4.11.

In addition, for *multi-band TAB connector(s)*, the following steps shall apply:

- 4) For *multi-band TAB connectors* and single band tests, repeat the steps above per involved band where single band test configurations and test models shall apply with no carrier activated in the other band.

7.4.4.2.2.2 Procedure for narrowband blocking

- 1) Adjust the signal generators to the type of interfering signal, levels and the frequency offsets as specified in table 7.4.5.1.2-1.
- 2) Set-up and sweep the interfering RB centre frequency offset to the channel edge of the wanted signal according to table 7.4.5.1.2-1.
- 3) Measure the performance of the wanted signal at the receiver unit associated with the *TAB connector* under test, as defined in subclause 7.4.5.1, for the relevant carriers specified by the test configuration in subclause 4.11.

In addition, for *multi-band TAB connector(s)*, the following steps shall apply:

- 4) For *multi-band TAB connectors* and single band tests, repeat the steps above per involved band where single band test configurations and test models shall apply with no carrier activated in the other band.

7.4.4.2.2.3 Procedure for additional BC3 blocking requirement

- 1) Adjust the signal generators to the type of interfering signal, levels and the frequency offsets as specified in table 7.4.5.5-1.
- 2) Measure the performance of the wanted signal at the receiver unit associated with the *TAB connector* under test, as defined in subclause 7.4.5, for the relevant carriers specified by the test configuration in subclause 4.8.

7.4.4.2.3 Single RAT UTRA FDD operation

- 1) Generate the wanted signal and adjust the ATT1 to set the input level to the base station under test to the level specified in table 7.4.5.2-1 For a *TAB connector* supporting multi-carrier operation, generate the wanted signal

according to the applicable test configuration (see clause 4.11) using applicable reference measurement channel to the *TAB connector* under test. Power settings are specified in table 7.4.5.2-1.

- 2) Set-up the interfering signal at the adjacent channel frequency and adjust the ATT2 to obtain the specified level of interfering signal at the base station input defined in table 7.4.5.2-1. Note that the interfering signal shall have an ACLR of at least 63 dB in order to eliminate the impact of interfering signal adjacent channel leakage power on the ACS measurement.
- 3) Measure the BER of the wanted signal at the receiver unit associated with the *TAB connector* under test.

In addition, for *multi-band TAB connector(s)*, the following steps shall apply:

- 4) For *multi-band TAB connectors* and single band tests, repeat the steps above per involved band where single band test configurations and test models shall apply with no carrier activated in the other band.

7.4.4.2.4 Single RAT UTRA TDD 1,28Mcps option operation

- 1) Generate the wanted signal according to the test configurations in subclause 4.11 and adjust the input level to the *TAB connector* under test according to table 7.4.5.3-1. The UL reference measurement channel (12,2 kbps) defined in subclause A.2.1 in 3GPP TS 25.142 [20] shall be used for each wanted carrier.
- 2) Set-up the interfering signal at the adjacent channel frequency and adjust the interfering signal level at the *TAB connector* according to table 7.4.5.3-1. The interfering signal is equivalent to a continuous CDMA signal with one code of chip frequency 1,28 Mchip/s, filtered by an RRC transmit pulse-shaping filter with roll-off $\alpha = 0,22$.
- 3) Measure the BER of the wanted signal at the receiver unit associated with the *TAB connector* under test.

In addition, for *multi-band TAB connector(s)*, the following steps shall apply:

- 4) For *multi-band TAB connectors* and single band tests, repeat the steps above per involved band where single band test configurations and test models shall apply with no carrier activated in the other band.

7.4.4.2.5 Single RAT E-UTRA operation

7.4.4.2.5.1 Procedure for adjacent channel selectivity

- 1) Generate the wanted signal using the applicable test configuration specified in subclause 5.3.4 and adjust the input level to the *TAB connector* under test to the level specified in table 7.4.5.4-1 for the appropriate BS class.
- 2) Set-up the interfering signal at the adjacent channel frequency and adjust the interfering signal level at the *TAB connector* under test to the level defined in table 7.4.5.4-1 for the appropriate BS class.
- 3) Measure the throughput according to annex E in 3GPP TS 36.141 [17], for multi-carrier and/or CA operation the throughput shall be measured for relevant carriers specified by the test configuration specified in subclause 5.3.4.

In addition, for *multi-band TAB connector(s)*, the following steps shall apply:

- 4) For *multi-band TAB connectors* and single band tests, repeat the steps above per involved band where single band test configurations and test models shall apply with no carrier activated in the other band.

7.4.4.2.5.2 Procedure for narrow-band blocking

- 1) For *TAB connector* operating E-UTRA FDD declared to be capable of single carrier operation only in the operating band, set the transmitter unit associated with the *TAB connector* under test to transmit according to subclause 4.12.2 at manufacturers declared rated output power $P_{\text{Rated,c,TABC}}$.

For a *TAB connector* operating E-UTRA FDD declared to be capable of multi-carrier and/or CA operation in the operating band, set the transmitter unit associated with the *TAB connector* under test to transmit according to subclause 4.12.2 on all carriers configured using the applicable test configuration and corresponding power setting specified in subclause 5.3.4.

- 2) Generate the wanted signal using the applicable test configuration specified in subclause 5.3.4 and adjust the input level to the *TAB connector* under test to the level specified in table 7.4.5.4-1.

- 3) Adjust the interfering signal level at the *TAB connector* input to the level defined in table 7.4.5.4-1. Set-up and sweep the interfering RB centre frequency offset to the channel edge of the wanted signal according to table 7.4.5.4-2.
- 4) Measure the throughput according to annex E in 3GPP TS 36.141 [17], for multi-carrier and/or CA operation the throughput shall be measured for relevant carriers specified by the test configuration specified in subclause 5.3.4.

In addition, for *multi-band TAB connector(s)*, the following steps shall apply:

- 5) For *multi-band TAB connectors* and single band tests, repeat the steps above per involved band where single band test configurations and test models shall apply with no carrier activated in the other band.

7.4.5 Test requirements

7.4.5.1 MSR operation

7.4.5.1.1 General blocking test requirement

For the general blocking requirement, the interfering signal shall be a UTRA FDD signal as specified in clause A.1 in 3GPP TS 25.141 [18] for a UTRA, E-UTRA or NR (≤ 20 MHz) wanted signal. The interfering signal shall be a 20 MHz E-UTRA signal for NR wanted signal channel bandwidth greater than 20 MHz.

For *TAB connector* operating in non-contiguous spectrum, the requirement applies in addition inside any *sub-block gap*, in case the *sub-block gap* size is at least 15 MHz. The interfering signal offset is defined relative to the sub-block edges inside the *sub-block gap*.

For *multi-band TAB connector* the requirement applies in addition inside any *Inter RF Bandwidth gap*, in case the gap size is at least 15 MHz. The interfering signal offset is defined relative to the *Base Station RF Bandwidth edges* inside the *Inter RF Bandwidth gap*.

For the wanted and interfering signal coupled to the *TAB connector*, using the parameters in tables 7.4.5.1.1-1 and 7.4.5.1.1-2, the following requirements shall be met:

- For any measured E-UTRA carrier, the throughput shall be $\geq 95\%$ of the *maximum throughput* of the reference measurement channel defined in subclause 7.2.5.3.
- For any measured UTRA FDD carrier, the BER shall not exceed 0.001 for the reference measurement channel defined in subclause 7.2.5.1.
- For any measured UTRA TDD carrier, the BER shall not exceed 0.001 for the reference measurement channel defined in subclause 7.2.5.2.
- For any NR carrier, the throughput shall be $\geq 95\%$ of the maximum throughput of the reference measurement channel defined in TS 38.104 [17], subclause 7.2.

For a *multi-band TAB connector*, the requirement applies according to table 7.4.5.1-1 for the in-band blocking frequency ranges of each supported operating band.

Table 7.4.5.1.1-1: General blocking requirement

Base Station class	Mean power of interfering signal (dBm)	Wanted Signal mean power (dBm) (Note 1)	Centre Frequency of Interfering Signal	Interfering signal centre frequency minimum frequency offset from the Base Station RF Bandwidth edge or sub-block edge inside a gap (MHz)
Wide Area BS	-40 +y (Note 7)	$P_{\text{REFSENS}} + x$ dB (Note 2, 5)	$F_{\text{UL_low}} - \Delta f_{\text{OOB}}$ to $F_{\text{UL_high}} + \Delta f_{\text{OOB}}$ (Note 8)	±7.5
Medium Range BS	-35 +y (Note 7)	$P_{\text{REFSENS}} + x$ dB (Note 3, 5)		
Local Area BS	-30 +y (Note 7)	$P_{\text{REFSENS}} + x$ dB (Note 4, 5)		
<p>NOTE 1: P_{REFSENS} depends on the RAT, the BS class and on the channel bandwidth, see subclause 7.2.</p> <p>NOTE 2: For WA BS not supporting NR, "x" is equal to 6 in case of E-UTRA or UTRA wanted signals.</p> <p>NOTE 3: For MR BS not supporting NR, "x" is equal to 6 in case of UTRA wanted signals, 9 in case of E-UTRA wanted signal.</p> <p>NOTE 4: For LA BS not supporting NR, "x" is equal to 11 in case of E-UTRA wanted signal, 6 in case of UTRA wanted signal.</p> <p>NOTE 5: For a BS supporting NR and not supporting UTRA, x is equal to 6.</p> <p>NOTE 6: For a BS capable of multi-band operation, "x" in Note 2, 3, 4, 5 applies in case of interfering signals that are in the in-band blocking frequency range of the operating band where the wanted signal is present or in an adjacent or overlapping band. For other in-band blocking frequency ranges of the interfering signal for the supported operating bands, "x" is equal to 1.4 dB.</p> <p>NOTE 7: For a BS not supporting NR, "y" is equal to zero for all BS classes. For a BS supporting NR and not supporting UTRA, "y" is equal to -3 for the WA and MR BS class and -5 for the LA BS class.</p> <p>NOTE 8: The downlink frequency range of an FDD operating band is excluded from the general blocking requirement.</p>				

Table 7.4.5.1.1-2: Void

NOTE: The requirement in tables 7.4.5.1.1-1 assumes that two operating bands, where the *downlink operating band* (see table 4.4-1 and table 4.4-2 in 3GPP TS 37.141 [16].) of one band would be within the in-band blocking region of the other band, are not deployed in the same geographical area.

7.4.5.1.2 General narrowband blocking test requirement

For the narrowband blocking requirement, the interfering signal shall be an E-UTRA 1RB signal as specified in clause A.3 in 3GPP TS 37.141 [16].

The requirement is applicable outside the *Base Station RF Bandwidth* or *Maximum Radio Bandwidth*. The interfering signal offset is defined relative to the *Base Station RF Bandwidth edges* or *Maximum Radio Bandwidth edges*.

For a *TAB connector* operating in non-contiguous spectrum, the requirement applies in addition inside any *sub-block gap*, in case the *sub-block gap* size is at least 3 MHz. The interfering signal offset is defined relative to the sub-block edges inside the *sub-block gap*.

For a *multi-band TAB connector*, the requirement applies in addition inside any *Inter RF Bandwidth gap* in case the gap size is at least 3 MHz. The interfering signal offset is defined relative to the *Base Station RF Bandwidth edges* inside the *Inter RF Bandwidth gap*.

For the wanted and interfering signal coupled to the *TAB connector*, using the parameters in table 7.4.5.1.2-1 the following requirements shall be met:

- For any measured E-UTRA carrier, the throughput shall be $\geq 95\%$ of the *maximum throughput* of the reference measurement channel defined in subclause 7.2.5.3.
- For any measured UTRA FDD carrier, the BER shall not exceed 0.001 for the reference measurement channel defined in subclause 7.2.5.1.
- For any measured UTRA TDD carrier, the BER shall not exceed 0.001 for the reference measurement channel defined in subclause 7.2.5.2.

- For any NR carrier, the throughput shall be $\geq 95\%$ of the maximum throughput of the reference measurement channel defined in TS 38.104 [17], subclause 7.2.5.3.

Table 7.4.5.1.2-1: Narrowband blocking requirement

Base Station Class	RAT of the carrier	Wanted signal mean power (dBm) (Note 1)	Interfering signal mean power (dBm)	Interfering RB (Note 3) centre frequency offset from the Base Station RF Bandwidth edge or sub-block edge inside a gap (kHz)
Wide Area BS	NR, E-UTRA and UTRA	$P_{\text{REFSENS}} + x$ dB (Note 2)	-49	$\pm(240 + m \cdot 180)$, m=0, 1, 2, 3, 4, 9, 14 (Note 4)
Medium Range BS			-44	
Local Area BS			-41	$\pm(550 + m \cdot 180)$, m=0, 1, 2, 3, 4, 29, 54, 79, 100 (Note 5)
NOTE 1: P_{REFSENS} depends on the RAT, the BS class and on the channel bandwidth, see subclause 7.2 in 3GPP TS 37.104 [12].				
NOTE 2: "x" is equal to 6 in case of E-UTRA, NR or UTRA wanted signals.				
NOTE 3: Interfering signal (E-UTRA 3 MHz) consisting of one resource block positioned at the stated offset, the channel bandwidth of the interfering signal is located adjacently to the Base Station RF Bandwidth edge.				
NOTE 4: Applicable for channel bandwidths equal to or below 20 MHz.				
NOTE 5: Applicable for channel bandwidths above 20MHz.				

7.4.5.1.3 Additional BC3 blocking test requirement

The interfering signal is a 1,28Mcps UTRA TDD modulated signal as specified in clause A.2 in 3GPP TS 37.141 [16].

The requirement is applicable outside the Base Station RF Bandwidth or Maximum Radio Bandwidth. The interfering signal offset is defined relative to the Base Station RF Bandwidth edges or Maximum Radio Bandwidth edges.

For a multi-band TAB connector, the requirement applies in addition inside any Inter RF Bandwidth gap, in case the gap size is at least 4.8MHz. The interfering signal offset is defined relative to the Base Station RF Bandwidth edges inside the Inter RF Bandwidth gap.

For the wanted and interfering signal coupled to the TAB connector, using the parameters in table 7.4.5.1.3-1, the following requirements shall be met:

- For any measured E-UTRA carrier, the throughput shall be $\geq 95\%$ of the maximum throughput of the reference measurement channel defined in subclause 7.2.5.3.
- For any measured UTRA TDD carrier, the BER shall not exceed 0.001 for the reference measurement channel defined in subclause 7.2.5.2.

Table 7.4.5.1.3-1: Additional blocking requirement for Band Category 3

Operating Band	Centre Frequency of Interfering Signal (MHz)	Interfering Signal mean power (dBm)	Wanted Signal mean power (dBm)	Interfering signal centre frequency minimum frequency offset from the Base Station RF Bandwidth edge (MHz)
33 - 40	($F_{\text{UL_low}} - 20$) to ($F_{\text{UL_high}} + 20$)	-40,	$P_{\text{REFSENS}} + 6$ dB (Note)	± 2.4
NOTE: P_{REFSENS} depends on the RAT and on the channel bandwidth, see subclause 7.2.				

7.4.5.2 Single RAT UTRA FDD operation

For each measured carrier, the BER shall not exceed 0,001 for the parameters specified in table 7.4.5.2-1.

For *multi-carrier TAB connector* the ACS requirement is applicable outside the *Base Station RF Bandwidth* or *Maximum Radio Bandwidth*. The interfering signal offset is defined relative to the lower/upper *Base Station RF Bandwidth edges* or *Maximum Radio Bandwidth edges*.

For a *TAB connector* operating in non-contiguous spectrum within any operating band, the requirement applies in addition inside any *sub-block gap*, in case the *sub-block gap* size is at least 5 MHz. The interfering signal offset is defined relative to the lower/upper sub-block edge inside the *sub-block gap* and is equal to -2.5 MHz/+2.5 MHz, respectively.

For a *multi-band TAB connector*, the requirement applies in addition inside any *Inter RF Bandwidth gap*, in case the *Inter RF Bandwidth gap* size is at least 5 MHz. The interfering signal offset is defined relative to lower/upper *Base Station RF Bandwidth edges* inside the *Inter RF Bandwidth gap* and is equal to -2.5 MHz/+2.5 MHz, respectively.

Table 7.4.5.2-1: Adjacent channel selectivity

Parameter	Level Wide Area BS	Level Medium Range BS	Level Local Area BS	Unit
Reference measurement channel data rate	12.2	12.2	12.2	kbps
Wanted signal mean power	-115	-105	-101	dBm
Interfering signal mean power	-52	-42	-38	dBm
F_{uw} (Modulated)	± 5	± 5	± 5	MHz

NOTE: If the above Test Requirement differs from the Minimum Requirement then the Test Tolerance applied for this test is non-zero. The Test Tolerance for this test is defined in subclause 4.1.2 and the explanation of how the Minimum Requirement has been relaxed by the Test Tolerance is given in annex C.

7.4.5.3 Single RAT UTRA TDD 1,28 Mcps option operation

The BER, measured on the wanted signal in the presence of an interfering signal, shall not exceed 0,001 for the parameters specified in table 7.4.5.3-1.

The ACS requirement is always applicable outside the *Base Station RF Bandwidth* or *Maximum Radio Bandwidth edges*. The interfering signal offset is defined relative to the lower / upper *Base Station RF Bandwidth edges* or *Maximum Radio Bandwidth edges*.

For *multi-band TAB connector*, the requirement applies in addition inside any *Inter RF Bandwidth gap* as long as the *Inter RF Bandwidth gap* size is at least 1.6MHz. The interfering signal offset is defined relative to the lower / upper *Base Station RF Bandwidth edges* inside the *Inter RF Bandwidth gap* and is equal to -0.8MHz/+0.8MHz, respectively.

Table 7.4.5.3-1: Parameters of the wanted signal and the interfering signal for ACS testing for 1,28 Mcps TDD

Parameter	Level	Unit
Reference measurement channel data rate	12,2	kbit/s
Wanted signal mean power	Wide Area BS	-104
	Local Area BS	-90
Interfering signal mean power	Wide Area BS	-55
	Local Area BS	-41
F_{uw} (modulated)	$\pm 1,6$	MHz
NOTE: F_{uw} is the frequency offset of the unwanted interfering signal from the assigned channel frequency of the wanted signal.		

7.4.5.4 Single RAT E-UTRA operation

For each measured E-UTRA carrier, the throughput shall be $\geq 95\%$ of the *maximum throughput* of the reference measurement channel.

For AAS BS of wide area BS class the wanted and the interfering signal coupled to the *TAB connector* are specified in table 7.4.5.4-1 and 7.4.5.4-2 for narrowband blocking and 7.4.5.4-3 for ACS. The reference measurement channel for

the wanted signal is specified in table 7.2.5.3-1 for each channel bandwidth and further specified in annex A in 3GPP TS 36.141 [17].

For AAS BS of Medium Range BS class, the wanted and the interfering signal coupled to the *TAB connector* are specified in tables 7.4.5.4-1 and 7.4.5.4-2 for narrowband blocking and in table 7.4.5.4-5 for ACS. The reference measurement channel for the wanted signal is specified in table 7.2.5.3-3 for each channel bandwidth and further specified in annex A in 3GPP TS 36.141 [17].

For AAS BS of Local Area BS class, the wanted and the interfering signal coupled to the *TAB connector* are specified in tables 7.4.5.4-1 and 7.4.5.4-2 for narrowband blocking and 7.4.5.4-4 for ACS. The reference measurement channel for the wanted signal is specified in table 7.2.5.3-2 for each channel bandwidth and further specified in annex A in 3GPP TS 36.141 [17].

The ACS and narrowband blocking requirement is always applicable outside the *Base Station RF Bandwidth* or *Maximum Radio Bandwidth*. The interfering signal offset is defined relative to the *Base station RF Bandwidth edges* or *Maximum Radio Bandwidth edges*.

For a *TAB connector* operating in non-contiguous spectrum within any operating band, the ACS requirement applies in addition inside any *sub-block gap*, in case the *sub-block gap* size is at least as wide as the E-UTRA interfering signal in tables 7.4.5.4-3, 7.4.5.4-4 and 7.4.5.4-5. The interfering signal offset is defined relative to the sub-block edges inside the *sub-block gap*.

For a *multi-band TAB connector*, the ACS requirement applies in addition inside any *Inter RF Bandwidth gap*, in case the *Inter RF Bandwidth gap* size is at least as wide as the E-UTRA interfering signal in tables 7.4.5.4-3, 7.4.5.4-4 and 7.4.5.4-5. The interfering signal offset is defined relative to the *Base Station RF Bandwidth edges* inside the *Inter RF Bandwidth gap*.

For a *TAB connector* operating in non-contiguous spectrum within any operating band, the narrowband blocking requirement applies in addition inside any *sub-block gap*, in case the *sub-block gap* size is at least as wide as the channel bandwidth of the E-UTRA interfering signal in table 7.4.5.4-2. The interfering signal offset is defined relative to the sub-block edges inside the *sub-block gap*.

For a *multi-band TAB connector*, the narrowband blocking requirement applies in addition inside any *Inter RF Bandwidth gap*, in case the *Inter RF Bandwidth gap* size is at least as wide as the E-UTRA interfering signal in table 7.4.5.4-2. The interfering signal offset is defined relative to the *Base Station RF Bandwidth edges* inside the *Inter RF Bandwidth gap*.

Table 7.4.5.4-1: Narrowband blocking requirement

	Wanted signal mean power (dBm) (Note)	Interfering signal mean power (dBm)	Type of interfering signal
Wide Area BS	$P_{\text{REFSENS}} + 6$ dB	-49	See table 7.4.5.4-2
Medium Range BS	$P_{\text{REFSENS}} + 6$ dB	-44	See table 7.4.5.4-2
Local Area BS	$P_{\text{REFSENS}} + 6$ dB	-41	See table 7.4.5.4-2
NOTE:	P_{REFSENS} depends on the channel bandwidth as specified in 3GPP TS 36.104 [11], subclause 7.2.1.		

Table 7.4.5.4-2: Interfering signal for Narrowband blocking requirement

E-UTRA channel BW of the lowest/highest carrier received (MHz)	Interfering RB centre frequency offset to the lower/upper <i>Base Station RF Bandwidth edge</i> or sub-block edge inside a <i>sub-block gap</i> (kHz)	Type of interfering signal (Note)
1.4	$\pm(252.5+m*180)$, m=0, 1, 2, 3, 4, 5	1.4 MHz E-UTRA signal, 1 RB
3	$\pm(247.5+m*180)$, m=0, 1, 2, 3, 4, 7, 10, 13	3 MHz E-UTRA signal, 1 RB
5	$\pm(342.5+m*180)$, m=0, 1, 2, 3, 4, 9, 14, 19, 24	5 MHz E-UTRA signal, 1 RB
10	$\pm(347.5+m*180)$, m=0, 1, 2, 3, 4, 9, 14, 19, 24	5 MHz E-UTRA signal, 1 RB
15	$\pm(352.5+m*180)$, m=0, 1, 2, 3, 4, 9, 14, 19, 24	5 MHz E-UTRA signal, 1 RB
20	$\pm(342.5+m*180)$, m=0, 1, 2, 3, 4, 9, 14, 19, 24	5 MHz E-UTRA signal, 1 RB

NOTE: Interfering signal consisting of one resource block is positioned at the stated offset, the *channel bandwidth* of the interfering signal is located adjacently to the lower/upper *Base Station RF Bandwidth edge*.

Table 7.4.5.4-3: Adjacent channel selectivity for Wide Area BS

E-UTRA channel bandwidth of the lowest/highest carrier received (MHz)	Wanted signal mean power (dBm) (Note)	Interfering signal mean power (dBm)	Interfering signal centre frequency offset from the lower/upper <i>Base Station RF Bandwidth edge</i> or sub-block edge inside a <i>sub-block gap</i> (MHz)	Type of interfering signal
1.4	$P_{\text{REFSENS}} + 11$ dB	-52	± 0.7025	1.4 MHz E-UTRA signal
3	$P_{\text{REFSENS}} + 8$ dB	-52	± 1.5075	3 MHz E-UTRA signal
5	$P_{\text{REFSENS}} + 6$ dB	-52	± 2.5025	5 MHz E-UTRA signal
10	$P_{\text{REFSENS}} + 6$ dB	-52	± 2.5075	5 MHz E-UTRA signal
15	$P_{\text{REFSENS}} + 6$ dB	-52	± 2.5125	5 MHz E-UTRA signal
20	$P_{\text{REFSENS}} + 6$ dB	-52	± 2.5025	5 MHz E-UTRA signal

NOTE: P_{REFSENS} depends on the channel bandwidth as specified in 3GPP TS 36.104 [11], subclause 7.2.1.

Table 7.4.5.4-4: Adjacent channel selectivity for Local Area BS

E-UTRA channel bandwidth of the lowest/highest carrier received (MHz)	Wanted signal mean power (dBm) (Note)	Interfering signal mean power (dBm)	Interfering signal centre frequency offset from the lower/upper <i>Base Station RF Bandwidth edge</i> or sub-block edge inside a <i>sub-block gap</i> (MHz)	Type of interfering signal
1.4	$P_{\text{REFSENS}} + 11$ dB	-44	± 0.7025	1.4 MHz E-UTRA signal
3	$P_{\text{REFSENS}} + 8$ dB	-44	± 1.5075	3 MHz E-UTRA signal
5	$P_{\text{REFSENS}} + 6$ dB	-44	± 2.5025	5 MHz E-UTRA signal
10	$P_{\text{REFSENS}} + 6$ dB	-44	± 2.5075	5 MHz E-UTRA signal
15	$P_{\text{REFSENS}} + 6$ dB	-44	± 2.5125	5 MHz E-UTRA signal
20	$P_{\text{REFSENS}} + 6$ dB	-44	± 2.5025	5 MHz E-UTRA signal

NOTE: P_{REFSENS} depends on the channel bandwidth as specified in 3GPP TS 36.104 [11], subclause 7.2.1.

Table 7.4.5.4-5: Adjacent channel selectivity for Medium Range BS

E-UTRA channel bandwidth of the lowest/highest carrier received (MHz)	Wanted signal mean power (dBm)	Interfering signal mean power (dBm)	Interfering signal centre frequency offset from the lower/upper Base Station RF Bandwidth edge or sub-block edge inside a sub-block gap (MHz)	Type of interfering signal
1.4	$P_{\text{REFSENS}} + 11$ dB	-47	± 0.7025	1.4 MHz E-UTRA signal
3	$P_{\text{REFSENS}} + 8$ dB	-47	± 1.5075	3 MHz E-UTRA signal
5	$P_{\text{REFSENS}} + 6$ dB	-47	± 2.5025	5 MHz E-UTRA signal
10	$P_{\text{REFSENS}} + 6$ dB	-47	± 2.5075	5 MHz E-UTRA signal
15	$P_{\text{REFSENS}} + 6$ dB	-47	± 2.5125	5 MHz E-UTRA signal
20	$P_{\text{REFSENS}} + 6$ dB	-47	± 2.5025	5 MHz E-UTRA signal

NOTE: P_{REFSENS} depends on the channel bandwidth as specified in 3GPP TS 36.104 [11], subclause 7.2.1.

NOTE: If the above Test Requirement differs from the Minimum Requirement then the Test Tolerance applied for this test is non-zero. The Test Tolerance for this test is defined in subclause 4.1.2 and the explanation of how the Minimum Requirement has been relaxed by the Test Tolerance is given in annex C.

7.5 Blocking

7.5.1 Definition and applicability

The out-of-band blocking characteristic is a measure of the receiver ability to receive a wanted signal at its assigned channel in the presence of an unwanted interferer outside the *uplink operating band*.

7.5.2 Minimum requirement

The minimum requirement for MSR operation is in 3GPP TS 37.105 [8], subclause 7.5.2.

The minimum requirement for single RAT UTRA operation is in 3GPP TS 37.105 [8], subclause 7.5.3.

The minimum requirement for single RAT E-UTRA operation is in 3GPP TS 37.105 [8], subclause 7.5.4.

The minimum requirement for NR operation is in 3GPP TS 38.104 [36], subclause 7.5.2.

7.5.3 Test purpose

The test stresses the ability of the receiver unit associated with the *TAB connector* under test to withstand high-level interference from unwanted signals at specified frequency bands, without undue degradation of its sensitivity.

7.5.4 Method of test

7.5.4.1 Initial conditions

Test environment:

- Normal; see clause B.2.

RF channels to be tested for single carrier (SC):

- M; see subclause 4.12.1

Base Station RF Bandwidth positions to be tested for multi-carrier (MC):

- M_{RFBW} for *single-band TAB connector(s)*, see subclause 4.12.1, $B_{\text{RFBW}}T_{\text{RFBW}}$ and $B'_{\text{RFBW}}T_{\text{RFBW}}$ for *multi-band TAB connector(s)*, see subclause 4.12.1.

In addition, for *multi-band TAB connectors*:

- For $B_{\text{RFBW}}'T_{\text{RFBW}}$, out-of-band blocking testing above the highest operating band may be omitted.
- For $B_{\text{RFBW}}T_{\text{RFBW}}'$, out-of-band blocking testing below the lowest operating band may be omitted.

7.5.4.2 Procedure

7.5.4.2.1 General Procedure

The general procedure steps apply to the procedures for all the RATs.

The minimum requirement is applied to all *TAB connectors*, the procedure is repeated until all *TAB connectors* necessary to demonstrate conformance have been tested; see subclause 7.1:

- 1) Connect *TAB connector* to measurement equipment as shown in annex D.2.3. All *TAB connectors* not under test shall be terminated.

7.5.4.2.2 MSR operation

- 1) Generate the wanted signal according to the applicable test configuration (see clause 5) using applicable reference measurement channel to the *TAB connector* under test as follows:

- For E-UTRA see clause A.1 in 3GPP TS 36.141 [17].
- For UTRA FDD see clause A.2 in 3GPP TS 25.141 [18].
- For UTRA TDD see subclause A.2.1 in 3GPP TS 25.142 [20].
- For NR, see subclause [4.11]

- 2) Set the transmitter unit associated with the *TAB connector* under test to transmit with the carrier set-up and power allocation according to the applicable test configuration(s) (see clause 5).

The transmitter unit associated with the *TAB connector* under test may be turned off for the out-of-band blocker tests when the frequency of the blocker is such that no IM2 or IM3 products fall inside the bandwidth of the wanted signal.

- 3) Adjust the signal generators to the type of interfering signals, levels and the frequency offsets as specified for general test requirements in table 7.5.5.1.1-1 and, when applicable, for co-location test requirements in table 7.5.5.1.2-1.
- 4) The CW interfering signal shall be swept with a step size of 1 MHz within the specified range.
- 5) Measure the performance of the wanted signal at the receiver unit associated with the *TAB connector*, as defined in the subclause 7.5.5, for the relevant carriers specified by the test configuration in subclause 4.11.

In addition, for *multi-band TAB connector(s)*, the following steps shall apply:

- 6) For *multi-band TAB connectors* and single band tests, repeat the steps above per involved band where single band test configurations and test models shall apply with no carrier activated in the other band.

7.5.4.2.3 Single RAT UTRA FDD operation

- 1) Generate the wanted signal according to the applicable test configuration (see clause 5) using applicable reference measurement channel to the *TAB connector* under test as shown in subclause A.2.1 in 3GPP TS 25.141 [18].

- 2) Set the transmitter unit associated with the *TAB connector* under test to transmit with the carrier set-up and power allocation according to the applicable test configuration(s) (see clause 5).

The transmitter unit associated with the *TAB connector* under test may be turned off for the out-of-band blocker tests when the frequency of the blocker is such that no IM2 or IM3 products fall inside the bandwidth of the wanted signal.

- 3) Adjust the signal generators to the type of interfering signals and the frequency offsets as specified in tables 7.5.5.2-1 to 7.5.5.2-1 . Note that the GMSK modulated interfering signal shall have an ACLR of at least 72 dB in order to eliminate the impact of interfering signal adjacent channel leakage power on the blocking

characteristics measurement. For the tests defined in tables 7.5.5.2-1 to 7.5.5.2-3, the interfering signal shall be at a frequency offset F_{uw} from the assigned channel frequency of the wanted signal which is given by:

$$F_{uw} = \pm (n \times 1 \text{ MHz}),$$

where n shall be increased in integer steps from $n = 10$ up to such a value that the centre frequency of the interfering signal covers the range from 1 MHz to 12,75 GHz.

- 4) Measure the BER of the wanted signal at the receiver unit associated with the *TAB connector* under test.

In addition, for *multi-band TAB connector(s)*, the following steps shall apply:

- 5) For *multi-band TAB connectors* and single band tests, repeat the steps above per involved band where single band test configurations and test models shall apply with no carrier activated in the other band.

7.5.4.2.4 Single RAT UTRA TDD 1,28 Mcps option operation

- 1) Generate the wanted signal according to the applicable test configuration (see clause 5) using applicable reference measurement channel to the *TAB connector* under test as shown in subclause A.2.1 in 3GPP TS 25.142 [20].
- 2) Set the transmitter unit associated with the *TAB connector* under test to transmit with the carrier set-up and power allocation according to the applicable test configuration(s) (see clause 5).

The transmitter unit associated with the *TAB connector* under test may be turned off for the out-of-band blocker tests when the frequency of the blocker is such that no IM2 or IM3 products fall inside the bandwidth of the wanted signal.

- 3) Set the signal generator to produce an interfering signal at a frequency offset F_{uw} from the assigned channel frequency of the wanted signal which is given by

$$F_{uw} = \pm 3,2 \pm n \times 1 \text{ MHz}$$

where n shall be increased in integer steps from $n = 0$ up to such a value that the centre frequency of the interfering signal covers the range from 1 MHz to 12,75 GHz. The interfering signal level measured at the *TAB connector* shall be set in dependency of its centre frequency, as specified in tables 7.5.5.3.1-1 to 7.5.5.3.1-2 and 7.5.5.3.2-1. The type of the interfering signal is either equivalent to a continuous wideband CDMA signal with one code of chip frequency 1,28 Mcps, filtered by an RRC transmit pulse-shaping filter with roll-off $\alpha = 0,22$, or a CW signal; see tables 7.5.5.3.1-1 to 7.5.5.3.1-2 and 7.5.5.3.2-1.

- 4) Measure the BER of the wanted signal at the receiver unit associated with the *TAB connector* under test.

In addition, for *multi-band TAB connector(s)*, the following steps shall apply:

- 5) For *multi-band TAB connectors* and single band tests, repeat the steps above per involved band where single band test configurations and test models shall apply with no carrier activated in the other band.

7.5.4.2.5 Single RAT E-UTRA operation

- 1) Generate the wanted signal according to the applicable test configuration (see clause 5) using applicable reference measurement channel to the *TAB connector* under test as shown in clause A.1 in 3GPP TS 36.141 [17].
- 2) Set the transmitter unit associated with the *TAB connector* under test to transmit with the carrier set-up and power allocation according to the applicable test configuration(s) (see clause 5).

The transmitter unit associated with the *TAB connector* under test may be turned off for the out-of-band blocker tests when the frequency of the blocker is such that no IM2 or IM3 products fall inside the bandwidth of the wanted signal.

- 3) Adjust the signal generators to the type of interfering signals, levels and the frequency offsets as specified for general test requirements in table 7.5.5.4.1-1 and Table 7.5.5.4.2-1 for AAS BS of wide area BS class, tables 7.5.5.4.1-2 and 7.5.5.4.2-2 for AAS BS of local area BS class and tables 7.5.5.4.1-3 and 7.5.5.4.2-3 for AAS BS of medium range BS class.
- 4) The CW interfering signal shall be swept with a step size of 1 MHz within the specified range.

- 5) Measure the performance of the wanted signal at the receiver unit associated with the *TAB connector*, as defined in the subclause 7.5.5, for the relevant carriers specified by the test configuration in subclause 4.11.

In addition, for *multi-band TAB connector(s)*, the following steps shall apply:

- 6) For *multi-band TAB connectors* and single band tests, repeat the steps above per involved band where single band test configurations and test models shall apply with no carrier activated in the other band.

7.5.5 Test requirements

7.5.5.1 MSR operation

7.5.5.1.1 General out-of-band blocking test requirements

For a wanted and an interfering signal coupled to a *TAB connector* using the parameters in table 7.5.5.1.1-1, the following requirements shall be met:

- For any measured E-UTRA carrier, the throughput shall be $\geq 95\%$ of the *maximum throughput* of the reference measurement channel defined in subclause 7.2.5.3.
- For any measured NR carrier, the throughput shall be $\geq 95\%$ of the *maximum throughput* of the reference measurement channel defined in subclause 7.2.5.4.
- For any measured UTRA FDD carrier, the BER shall not exceed 0.001 for the reference measurement channel defined in subclause 7.2.5.1.
- For any measured UTRA TDD carrier, the BER shall not exceed 0.001 for the reference measurement channel defined in subclause 7.2.5.2.

The out-of-band blocking requirement applies from 1 MHz to $F_{UL_low} - \Delta f_{OOB}$ and from $F_{UL_high} + \Delta f_{OOB}$ up to 12750 MHz, including the downlink frequency range of the *operating band*. The Δf_{OOB} is defined in table 7.4.1-1.

The in-band blocking frequency ranges of all supported operating bands shall be excluded from the requirement.

Table 7.5.5.1.1-1: Blocking performance requirement

Wanted Signal mean power [dBm]	Interfering Signal mean power [dBm]	Type of Interfering Signal
$P_{REFSENS} + 6$ dB (Note)	-15	CW carrier
NOTE: $P_{REFSENS}$ depends on the RAT, the BS class and the <i>channel bandwidth</i> ; see subclause 7.2.		

7.5.5.1.2 Co-location test requirements

This additional blocking requirement may be applied for the protection of receiver units associated with *TAB connectors* when a E-UTRA, UTRA, CDMA or GSM/EDGE BS operating in a different frequency band are co-located with the AAS BS.

The requirements in this subclause assume a 30 dB coupling loss between the interfering transmitter and the *TAB connector* and are based on co-location with base stations of the same class.

For a wanted and an interfering signal coupled to *TAB connector* using the parameters in table 7.5.5.1.2-1, the following requirements shall be met:

- For any measured E-UTRA carrier, the throughput shall be $\geq 95\%$ of the *maximum throughput* of the reference measurement channel defined in subclause 7.2.5.3.
- For any measured NR carrier, the throughput shall be $\geq 95\%$ of the *maximum throughput* of the reference measurement channel defined in subclause 7.2.5.4.
- For any measured UTRA FDD carrier, the BER shall not exceed 0.001 for the reference measurement channel defined in subclause 7.2.5.1.

- For any measured UTRA TDD carrier, the BER shall not exceed 0.001 for the reference measurement channel defined in subclause 7.2.5.2.

Table 7.5.5.1.2-1: Blocking requirement for co-location with BS in other frequency bands

Type of co-located BS	Centre Frequency of Interfering Signal (MHz)	Interfering Signal mean power for WA BS (dBm)	Interfering Signal mean power for MR BS (dBm)	Interfering Signal mean power for LA BS (dBm)	Wanted Signal mean power (dBm) (Note 1)	Type of Interfering Signal
GSM850 or CDMA850	869 - 894	+16	+8	-6	$P_{\text{REFSENS}} + x \text{ dB}$	CW carrier
GSM900	921 - 960	+16	+8	-6	$P_{\text{REFSENS}} + x \text{ dB}$	CW carrier
DCS1800	1805 - 1880 (Note 4)	+16	+8	-6	$P_{\text{REFSENS}} + x \text{ dB}$	CW carrier
PCS1900	1930 - 1990	+16	+8	-6	$P_{\text{REFSENS}} + x \text{ dB}$	CW carrier
UTRA FDD Band I or E-UTRA Band 1 or NR band n1	2110 - 2170	+16	+8	-6	$P_{\text{REFSENS}} + x \text{ dB}$	CW carrier
UTRA FDD Band II or E-UTRA Band 2 or NR band n2	1930 - 1990	+16	+8	-6	$P_{\text{REFSENS}} + x \text{ dB}$	CW carrier
UTRA FDD Band III or E-UTRA Band 3 or NR band n3	1805 - 1880 (Note 4)	+16	+8	-6	$P_{\text{REFSENS}} + x \text{ dB}$	CW carrier
UTRA FDD Band IV or E-UTRA Band 4	2110 - 2155	+16	+8	-6	$P_{\text{REFSENS}} + x \text{ dB}$	CW carrier
UTRA FDD Band V or E-UTRA Band 5 or NR band n5	869 - 894	+16	+8	-6	$P_{\text{REFSENS}} + x \text{ dB}$	CW carrier
UTRA FDD Band VI or E-UTRA Band 6	875 - 885	+16	+8	-6	$P_{\text{REFSENS}} + x \text{ dB}$	CW carrier
UTRA FDD Band VII or E-UTRA Band 7	2620 - 2690	+16	+8	-6	$P_{\text{REFSENS}} + x \text{ dB}$	CW carrier
UTRA FDD Band VIII or E-UTRA Band 8 or NR band n8	925 - 960	+16	+8	-6	$P_{\text{REFSENS}} + x \text{ dB}$	CW carrier
UTRA FDD Band IX or E-UTRA Band 9	1844.9 - 1879.9	+16	+8	-6	$P_{\text{REFSENS}} + x \text{ dB}$	CW carrier
UTRA FDD Band X or E-UTRA Band 10	2110 - 2170	+16	+8	-6	$P_{\text{REFSENS}} + x \text{ dB}$	CW carrier
UTRA FDD Band XI or E-UTRA Band 11	1475.9 - 1495.9	+16	+8	-6	$P_{\text{REFSENS}} + x \text{ dB}$	CW carrier
UTRA FDD Band XII or E-UTRA Band 12 or NR band n12	729 - 746	+16	+8	-6	$P_{\text{REFSENS}} + x \text{ dB}$	CW carrier
UTRA FDD Band XIII or E-UTRA Band 13	746 - 756	+16	+8	-6	$P_{\text{REFSENS}} + x \text{ dB}$	CW carrier
UTRA FDD Band XIV or E-UTRA Band 14	758 - 768	+16	+8	-6	$P_{\text{REFSENS}} + x \text{ dB}$	CW carrier
E-UTRA Band 17	734 - 746	+16	+8	-6	$P_{\text{REFSENS}} + x \text{ dB}$	CW carrier
E-UTRA Band 18	860 - 875	+16	+8	-6	$P_{\text{REFSENS}} + x \text{ dB}$	CW carrier
UTRA FDD Band XIX or E-UTRA Band 19	875 - 890	+16	+8	-6	$P_{\text{REFSENS}} + x \text{ dB}$	CW carrier
UTRA FDD Band XX or E-UTRA Band 20 or NR band n20	791 - 821	+16	+8	-6	$P_{\text{REFSENS}} + x \text{ dB}$	CW carrier

Type of co-located BS	Centre Frequency of Interfering Signal (MHz)	Interfering Signal mean power for WA BS (dBm)	Interfering Signal mean power for MR BS (dBm)	Interfering Signal mean power for LA BS (dBm)	Wanted Signal mean power (dBm) (Note 1)	Type of Interfering Signal
UTRA FDD Band XXI or E-UTRA Band 21	1495.9 - 1510.9	+16	+8	-6	$P_{\text{REFSENS}} + x$ dB	CW carrier
UTRA FDD Band XXII or E-UTRA Band 22	3510 - 3590	+16	+8	-6	$P_{\text{REFSENS}} + x$ dB	CW carrier
E-UTRA Band 23	2180 - 2200	+16	+8	-6	$P_{\text{REFSENS}} + x$ dB	CW carrier
E-UTRA Band 24	1525 - 1559	+16	+8	-6	$P_{\text{REFSENS}} + x$ dB	CW carrier
UTRA FDD Band XXV or E-UTRA Band 25 or NR band n25	1930 - 1995	+16	+8	-6	$P_{\text{REFSENS}} + x$ dB	CW carrier
UTRA FDD Band XXVI or E-UTRA Band 26	859 - 894	+16	+8	-6	$P_{\text{REFSENS}} + x$ dB	CW carrier
E-UTRA Band 27	852 - 869	+16	+8	-6	$P_{\text{REFSENS}} + x$ dB	CW carrier
E-UTRA Band 28 or NR band n28	758 - 803	+16	+8	-6	$P_{\text{REFSENS}} + x$ dB	CW carrier
E-UTRA Band 29	717 - 728	+16	+8	-6	$P_{\text{REFSENS}} + 6$ dB	CW carrier
E-UTRA Band 30	2350 - 2360	+16	+8	-6	$P_{\text{REFSENS}} + x$ dB	CW carrier
E-UTRA Band 31	462.5 - 467.5	+16	+8	-6	$P_{\text{REFSENS}} + 6$ dB	CW carrier
UTRA FDD Band XXXII or E-UTRA Band 32	1452 - 1496 (Note 5)	+16	+8	-6	$P_{\text{REFSENS}} + 6$ dB	CW carrier
UTRA TDD Band a) or E-UTRA Band 33	1900-1920	+16	+8	-6	$P_{\text{REFSENS}} + x$ dB	CW carrier
UTRA TDD Band a) or E-UTRA Band 34 or NR band n34	2010-2025	+16	+8	-6	$P_{\text{REFSENS}} + x$ dB	CW carrier
UTRA TDD Band b) or E-UTRA Band 35	1850-1910	+16	+8	-6	$P_{\text{REFSENS}} + x$ dB	CW carrier
UTRA TDD Band b) or E-UTRA Band 36	1930-1990	+16	+8	-6	$P_{\text{REFSENS}} + x$ dB	CW carrier
UTRA TDD Band c) or E-UTRA Band 37	1910-1930	+16	+8	-6	$P_{\text{REFSENS}} + x$ dB	CW carrier
UTRA TDD Band d) or E-UTRA Band 38 or NR band n38	2570-2620	+16	+8	-6	$P_{\text{REFSENS}} + x$ dB	CW carrier
UTRA TDD Band f) or E-UTRA Band 39 or NR band n39	1880-1920	+16	+8	-6	$P_{\text{REFSENS}} + x$ dB	CW carrier
UTRA TDD Band e) or E-UTRA Band 40 or NR band n40	2300-2400	+16	+8	-6	$P_{\text{REFSENS}} + x$ dB	CW carrier
E-UTRA Band 41 or NR band n41	2496 - 2690	+16	+8	-6	$P_{\text{REFSENS}} + x$ dB	CW carrier
E-UTRA Band 42	3400 - 3600	+16	+8	-6	$P_{\text{REFSENS}} + x$ dB	CW carrier
E-UTRA Band 43	3600 - 3800	+16	+8	-6	$P_{\text{REFSENS}} + x$ dB	CW carrier
E-UTRA Band 44	703 - 803	+16	+8	-6	$P_{\text{REFSENS}} + x$ dB	CW carrier
E-UTRA Band 45	1447 - 1467	+16	+8	-6	$P_{\text{REFSENS}} + x$ dB	CW carrier
E-UTRA Band 46	5150 - 5925	N/A	+8	-6	$P_{\text{REFSENS}} + x$ dB	CW carrier
E-UTRA Band 48	3550 - 3700	+16	+8	-6	$P_{\text{REFSENS}} + x$ dB	CW carrier
E-UTRA Band 50 or NR band n50	1432 – 1517	+16	+8	-6	$P_{\text{REFSENS}} + x$ dB	CW carrier
E-UTRA Band 51 or NR band n51	1427– 1432	N/A	N/A	-6	$P_{\text{REFSENS}} + x$ dB	CW carrier
E-UTRA Band 65	2110 - 2200	+16	+8	-6	$P_{\text{REFSENS}} + x$ dB	CW carrier

Type of co-located BS	Centre Frequency of Interfering Signal (MHz)	Interfering Signal mean power for WA BS (dBm)	Interfering Signal mean power for MR BS (dBm)	Interfering Signal mean power for LA BS (dBm)	Wanted Signal mean power (dBm) (Note 1)	Type of Interfering Signal
E-UTRA Band 66 or NR band n66	2110 - 2200	+16	+8	-6	$P_{\text{REFSENS}} + x$ dB	CW carrier
E-UTRA Band 67	738 - 758	+16	+8	-6	$P_{\text{REFSENS}} + x$ dB	CW carrier
E-UTRA Band 68	753 - 783	+16	+8	-6	$P_{\text{REFSENS}} + x$ dB*	CW carrier
E-UTRA Band 69	2570 - 2620	+16	+8	-6	$P_{\text{REFSENS}} + x$ dB	CW carrier
E-UTRA Band 70 or NR band n70	1995 - 2020	+16	+8	-6	$P_{\text{REFSENS}} + x$ dB	CW carrier
E-UTRA Band 71 or or NR band n71	617 - 652	+16	+8	-6	$P_{\text{REFSENS}} + x$ dB	CW carrier
E-UTRA Band 72	461 - 466	+16	+8	-6	$P_{\text{REFSENS}} + x$ dB	CW carrier
E-UTRA Band 73	460 - 465	+16	+8	-6	$P_{\text{REFSENS}} + x$ dB	CW carrier
E-UTRA Band 74 or NR band n74	1475 - 1518	+16	+8	-6	$P_{\text{REFSENS}} + x$ dB	CW carrier
E-UTRA Band 75 or or NR band n75	1432 - 1517	+16	+8	-6	$P_{\text{REFSENS}} + x$ dB	CW carrier
E-UTRA Band 76 or or NR band n76	1427 - 1432	N/A	N/A	-6	$P_{\text{REFSENS}} + x$ dB	CW carrier
NR band n77	3300 - 4200	+16	+8	-6	$P_{\text{REFSENS}} + x$ dB	CW carrier
NR band n78	3300 - 3800	+16	+8	-6	$P_{\text{REFSENS}} + x$ dB	CW carrier
NR band n79	4400 - 5000	+16	+8	-6	$P_{\text{REFSENS}} + x$ dB	CW carrier
<p>NOTE 1: P_{REFSENS} depends on the RAT, the BS class and the channel bandwidth, see subclause 7.2. "x" is equal to 6 in case of UTRA or E-UTRA or NR wanted signals.</p> <p>NOTE 2: Except for a <i>TAB connector</i> operating in Band 13, these requirements do not apply when the interfering signal falls within any of the supported <i>uplink operating band</i> or in the Δf_{OOB} immediately outside any of the supported <i>uplink operating band</i>. For a <i>TAB connector</i> operating in band 13 the requirements do not apply when the interfering signal falls within the frequency range 768-797MHz.</p> <p>NOTE 3: Some combinations of bands may not be possible to co-site based on the requirements above. The current state-of-the-art technology does not allow a single generic solution for co-location of UTRA TDD or E-UTRA TDD or NR TDD with E-UTRA FDD on adjacent frequencies for 30 dB BS-BS minimum coupling loss. However, there are certain site-engineering solutions that can be used. These techniques are addressed in 3GPP TR 25.942 [21].</p> <p>NOTE 4: In China, the blocking requirement for co-location with DCS1800 and Band III BS is only applicable in the frequency range 1805-1850 MHz.</p> <p>NOTE 5: For a <i>TAB connector</i> operating in band 11 or 21, this requirement applies for interfering signal within the frequency range 1475.9-1495.9 MHz.</p> <p>NOTE 6: Co-located TDD base stations that are synchronized and using the same or adjacent operating band can receive without special co-location requirements. For unsynchronized base stations, special co-location requirements may apply that are not covered by the 3GPP specifications.</p>						

7.5.5.2 Single RAT UTRA FDD operation

For each measured carrier, the BER shall not exceed 0.001 for the parameters specified in tables 7.5.5.2-1 to 7.5.5.2-9 if applicable for the *TAB connector* under test.

The requirement is applicable outside the *Base Station RF Bandwidth* or *Maximum Radio Bandwidth*. The interfering signal offset is defined relative to the lower/upper *Base Station RF Bandwidth edges* or *Maximum Radio Bandwidth edges*.

For a *TAB connector* operating in non-contiguous spectrum within any operating band, the blocking requirement applies in addition inside any *sub-block gap*, in case the *sub-block gap* size is at least 15 MHz. The interfering signal offset is defined relative to the lower/upper sub-block edge inside the *sub-block gap* and is equal to -7.5 MHz/+7.5 MHz, respectively.

For a *TAB connector* operating in non-contiguous spectrum within any operating band, the narrowband blocking requirements in tables 7.4R-7.4T apply in addition inside any *sub-block gap*, in case the *sub-block gap* size is at least 400 kHz or 600 kHz, depending on the operating band. The interfering signal offset is defined relative to the lower/upper sub-block edge inside the *sub-block gap* and is equal to -200 kHz/+200 kHz or -300 kHz/+300 kHz, respectively.

For a *multi-band TAB connector*, the requirement in the in-band blocking frequency range applies for each supported operating band. The requirement applies in addition inside any *Inter RF Bandwidth gap*, in case the *Inter RF Bandwidth gap* size is at least 15 MHz. The interfering signal offset is defined relative to lower/upper *Base Station RF bandwidth edges* inside the *Inter RF Bandwidth gap* and is equal to -7.5 MHz/+7.5 MHz, respectively.

For a *multi-band TAB connector*, the requirement in the out-of-band blocking frequency ranges apply for each operating band, with the exception that the in-band blocking frequency ranges of all supported operating bands according to tables 7.4K - 7.4M shall be excluded from the out-of-band blocking requirement.

For a *multi-band TAB connector*, the narrowband blocking requirement applies in addition inside any *Inter RF Bandwidth gap*, in case the *Inter RF Bandwidth gap* size is at least 400 kHz or 600 kHz, depending on the operating band. The interfering signal offset is defined relative to lower/upper *Base Station RF Bandwidth edges* inside the *Inter RF Bandwidth gap* and is equal to -200 kHz/+200 kHz or -300 kHz/+300 kHz, respectively.

Table 7.5.5.2-1: Blocking characteristics for Wide Area BS

Operating Band	Centre Frequency of Interfering Signal	Interfering Signal mean power	Wanted Signal mean power	Minimum Offset of Interfering Signal	Type of Interfering Signal
I	1920 - 1980 MHz	-40 dBm	-115 dBm	± 10 MHz	WCDMA signal (Note)
	1900 - 1920 MHz 1980 - 2000 MHz	-40 dBm	-115 dBm	± 10 MHz	WCDMA signal (Note)
	1 MHz - 1900 MHz 2000 MHz - 12750 MHz	-15 dBm	-115 dBm	—	CW carrier
II	1850 - 1910 MHz	-40 dBm	-115 dBm	± 10 MHz	WCDMA signal (Note)
	1830 - 1850 MHz 1910 - 1930 MHz	-40 dBm	-115 dBm	± 10 MHz	WCDMA signal (Note)
	1 MHz - 1830 MHz 1930 MHz - 12750 MHz	-15 dBm	-115 dBm	—	CW carrier
III	1710 - 1785 MHz	-40 dBm	-115 dBm	± 10 MHz	WCDMA signal (Note)
	1690 - 1710 MHz 1785 - 1805 MHz	-40 dBm	-115 dBm	± 10 MHz	WCDMA signal (Note)
	1 MHz - 1690 MHz 1805 MHz - 12750 MHz	-15 dBm	-115 dBm	—	CW carrier
IV	1710 - 1755 MHz	-40 dBm	-115 dBm	± 10 MHz	WCDMA signal (Note)
	1690 - 1710 MHz 1755 - 1775 MHz	-40 dBm	-115 dBm	± 10 MHz	WCDMA signal (Note)
	1 MHz - 1690 MHz 1775 MHz - 12750 MHz	-15 dBm	-115 dBm	—	CW carrier
V	824-849 MHz	-40 dBm	-115 dBm	± 10 MHz	WCDMA signal (Note)
	804-824 MHz 849-869 MHz	-40 dBm	-115 dBm	± 10 MHz	WCDMA signal (Note)
	1 MHz - 804 MHz 869 MHz - 12750 MHz	-15 dBm	-115 dBm	—	CW carrier
VI	810 - 830 MHz 840 - 860 MHz	-40 dBm	-115 dBm	± 10 MHz	WCDMA signal (Note)
	1 MHz - 810 MHz 860 MHz - 12750 MHz	-15 dBm	-115 dBm	—	CW carrier
VII	2500 - 2570 MHz	-40 dBm	-115 dBm	± 10 MHz	WCDMA signal (Note)
	2480 - 2500 MHz 2570 - 2590 MHz	-40 dBm	-115 dBm	± 10 MHz	WCDMA signal (Note)
	1 MHz - 2480 MHz 2590 MHz - 12750 MHz	-15 dBm	-115 dBm	—	CW carrier
VIII	880 - 915 MHz	-40 dBm	-115 dBm	± 10 MHz	WCDMA signal (Note)
	860 - 880 MHz 915 - 925 MHz	-40 dBm	-115 dBm	± 10 MHz	WCDMA signal (Note)
	1 MHz - 860 MHz 925 MHz - 12750 MHz	-15 dBm	-115 dBm	—	CW carrier
IX	1749.9 - 1784.9 MHz	-40 dBm	-115 dBm	± 10 MHz	WCDMA signal (Note)
	1729.9 - 1749.9 MHz 1784.9 - 1804.9 MHz	-40 dBm	-115 dBm	± 10 MHz	WCDMA signal (Note)
	1 MHz - 1729.9 MHz 1804.9 MHz - 12750 MHz	-15 dBm	-115 dBm	—	CW carrier
X	1710 - 1770 MHz	-40 dBm	-115 dBm	± 10 MHz	WCDMA signal (Note)
	1690 - 1710 MHz 1770 - 1790 MHz	-40 dBm	-115 dBm	± 10 MHz	WCDMA signal (Note)
	1 MHz - 1690 MHz 1790 MHz - 12750 MHz	-15 dBm	-115 dBm	—	CW carrier
XI	1427.9 - 1447.9 MHz	-40 dBm	-115 dBm	± 10 MHz	WCDMA signal (Note)
	1407.9 - 1427.9 MHz 1447.9 - 1467.9 MHz	-40 dBm	-115 dBm	± 10 MHz	WCDMA signal (Note)
	1 MHz - 1407.9 MHz 1467.9 MHz - 12750 MHz	-15 dBm	-115 dBm	—	CW carrier

Operating Band	Centre Frequency of Interfering Signal	Interfering Signal mean power	Wanted Signal mean power	Minimum Offset of Interfering Signal	Type of Interfering Signal
XII	699 - 716 MHz	-40 dBm	-115 dBm	± 10 MHz	WCDMA signal (Note)
	679 - 699 MHz 716 - 729 MHz	-40 dBm	-115 dBm	± 10 MHz	WCDMA signal (Note)
	1 MHz - 679 MHz 729 MHz - 12750 MHz	-15 dBm	-115 dBm	—	CW carrier
XIII	777 - 787 MHz	-40 dBm	-115 dBm	± 10 MHz	WCDMA signal (Note)
	757 - 777 MHz 787 - 807 MHz	-40 dBm	-115 dBm	± 10 MHz	WCDMA signal (Note)
	1 - 757 MHz 807 MHz - 12750 MHz	-15 dBm	-115 dBm	—	CW carrier
XIV	788 - 798 MHz	-40 dBm	-115 dBm	± 10 MHz	WCDMA signal (Note)
	768 - 788 MHz 798 - 818 MHz	-40 dBm	-115 dBm	± 10 MHz	WCDMA signal (Note)
	1 - 768 MHz 818 MHz - 12750 MHz	-15 dBm	-115 dBm	—	CW carrier
XIX	830 - 845 MHz	-40 dBm	-115 dBm	± 10 MHz	WCDMA signal (Note)
	810 - 830 MHz 845 - 865 MHz	-40 dBm	-115 dBm	± 10 MHz	WCDMA signal (Note)
	1 MHz - 810 MHz 865 MHz - 12750 MHz	-15 dBm	-115 dBm	—	CW carrier
XX	832 - 862 MHz	-40 dBm	-115 dBm	± 10 MHz	WCDMA signal (Note)
	821 - 832 MHz 862 - 882 MHz	-40 dBm	-115 dBm	± 10 MHz	WCDMA signal (Note)
	1 MHz - 821 MHz 882 MHz - 12750 MHz	-15 dBm	-115 dBm	—	CW carrier
XXI	1447.9 - 1462.9 MHz	-40 dBm	-115 dBm	± 10 MHz	WCDMA signal (Note)
	1427.9 - 1447.9 MHz 1462.9 - 1482.9 MHz	-40 dBm	-115 dBm	± 10 MHz	WCDMA signal (Note)
	1 MHz - 1427.9 MHz 1482.9 MHz - 12750 MHz	-15 dBm	-115 dBm	—	CW carrier
XXII	3410 - 3490 MHz	-40 dBm	-115 dBm	± 10 MHz	WCDMA signal (Note)
	3390 - 3410 MHz 3490 - 3510 MHz	-40 dBm	-115 dBm	± 10 MHz	WCDMA signal (Note)
	1 MHz - 3390 MHz 3510 MHz - 12750 MHz	-15 dBm	-115 dBm	—	CW carrier
XXV	1850 - 1915 MHz	-40 dBm	-115 dBm	± 10 MHz	WCDMA signal (Note)
	1830 - 1850 MHz 1915 - 1930 MHz	-40 dBm	-115 dBm	± 10 MHz	WCDMA signal (Note)
	1 MHz - 1830 MHz 1930 MHz - 12750 MHz	-15 dBm	-115 dBm	—	CW carrier
XXVI	814-849 MHz	-40 dBm	-115 dBm	± 10 MHz	WCDMA signal (Note)
	794-814 MHz 849-859 MHz	-40 dBm	-115 dBm	± 10 MHz	WCDMA signal (Note)
	1 MHz - 794 MHz 859 MHz - 12750 MHz	-15 dBm	-115 dBm	—	CW carrier

NOTE 1: The characteristics of the W-CDMA interfering signal are specified in annex I of 3GPP TS 25.141 [18].

NOTE 2: For a *multi-band TAB connector*, in case of interfering signal that is not in the in-band blocking frequency range of the operating band where the wanted signal is present, or in an adjacent or overlapping band, the wanted signal mean power is equal to -119.6 dBm.

NOTE: Table 7.5.5.2-1 assumes that two operating bands, where the downlink frequencies (see table 3.0) of one band would be within the in-band blocking region of the other band, are not deployed in the same geographical area.

Table 7.5.5.2-2: Blocking characteristics for Medium Range BS

Operating Band	Centre Frequency of Interfering Signal	Interfering Signal Level	Wanted Signal mean power	Minimum Offset of Interfering Signal	Type of Interfering Signal
I	1920 - 1980 MHz	-35 dBm	-105 dBm	± 10 MHz	WCDMA signal (Note)
	1900 - 1920 MHz 1980 - 2000 MHz	-35 dBm	-105 dBm	± 10 MHz	WCDMA signal (Note)
	1 MHz - 1900 MHz 2000 MHz - 12750 MHz	-15 dBm	-105 dBm	—	CW carrier
II	1850 - 1910 MHz	-35 dBm	-105 dBm	± 10 MHz	WCDMA signal (Note)
	1830 - 1850 MHz 1910 - 1930 MHz	-35 dBm	-105 dBm	± 10 MHz	WCDMA signal (Note)
	1 MHz - 1830 MHz 1930 MHz - 12750 MHz	-15 dBm	-105 dBm	—	CW carrier
III	1710 - 1785 MHz	-35 dBm	-105 dBm	± 10 MHz	WCDMA signal (Note)
	1690 - 1710 MHz 1785 - 1805 MHz	-35 dBm	-105 dBm	± 10 MHz	WCDMA signal (Note)
	1 MHz - 1690 MHz 1805 MHz - 12750 MHz	-15 dBm	-105 dBm	—	CW carrier
IV	1710 - 1755 MHz	-35 dBm	-105 dBm	± 10 MHz	WCDMA signal (Note)
	1690 - 1710 MHz 1755 - 1775 MHz	-35 dBm	-105 dBm	± 10 MHz	WCDMA signal (Note)
	1 MHz - 1690 MHz 1775 MHz - 12750 MHz	-15 dBm	-105 dBm	—	CW carrier
V	824-849 MHz	-35 dBm	-105 dBm	± 10 MHz	WCDMA signal (Note)
	804-824 MHz 849-869 MHz	-35 dBm	-105 dBm	± 10 MHz	WCDMA signal (Note)
	1 MHz - 804 MHz 869 MHz - 12750 MHz	-15 dBm	-105 dBm	—	CW carrier
VI	810 - 830 MHz 840 - 860 MHz	-35 dBm	-105 dBm	± 10 MHz	WCDMA signal (Note)
	1 MHz - 810 MHz 860 MHz - 12750 MHz	-15 dBm	-105 dBm	—	CW carrier
VII	2500 - 2570 MHz	-35 dBm	-105 dBm	± 10 MHz	WCDMA signal (Note)
	2480 - 2500 MHz 2570 - 2590 MHz	-35 dBm	-105 dBm	± 10 MHz	WCDMA signal (Note)
	1 MHz - 2480 MHz 2590 MHz - 12750 MHz	-15 dBm	-105 dBm	—	CW carrier
VIII	880 - 915 MHz	-35 dBm	-105 dBm	± 10 MHz	WCDMA signal (Note)
	860 - 880 MHz 915 - 925 MHz	-35 dBm	-105 dBm	± 10 MHz	WCDMA signal (Note)
	1 MHz - 860 MHz 925 MHz - 12750 MHz	-15 dBm	-105 dBm	—	CW carrier
IX	1749.9 - 1784.9 MHz	-35 dBm	-105 dBm	± 10 MHz	WCDMA signal (Note)
	1729.9 - 1749.9 MHz 1784.9 - 1804.9 MHz	-35 dBm	-105 dBm	± 10 MHz	WCDMA signal (Note)
	1 MHz - 1729.9 MHz 1804.9 MHz - 12750 MHz	-15 dBm	-105 dBm	—	CW carrier
X	1710 - 1770 MHz	-35 dBm	-105 dBm	± 10 MHz	WCDMA signal (Note)
	1690 - 1710 MHz 1770 - 1790 MHz	-35 dBm	-105 dBm	± 10 MHz	WCDMA signal (Note)
	1 MHz - 1690 MHz 1790 MHz - 12750 MHz	-15 dBm	-105 dBm	—	CW carrier
XI	1427.9 - 1447.9 MHz	-35 dBm	-105 dBm	± 10 MHz	WCDMA signal (Note)
	1407.9 - 1427.9 MHz 1447.9 - 1467.9 MHz	-35 dBm	-105 dBm	± 10 MHz	WCDMA signal (Note)
	1 MHz - 1407.9 MHz 1467.9 MHz - 12750 MHz	-15 dBm	-105 dBm	—	CW carrier
XII	699 - 716 MHz	-35 dBm	-105 dBm	± 10 MHz	WCDMA signal (Note)
	679 - 699 MHz 716 - 729 MHz	-35 dBm	-105 dBm	± 10 MHz	WCDMA signal (Note)
	1 MHz - 679 MHz 729 MHz - 12750 MHz	-15 dBm	-105 dBm	—	CW carrier
XIII	777 - 787 MHz	-35 dBm	-105 dBm	± 10 MHz	WCDMA signal (Note)

Operating Band	Centre Frequency of Interfering Signal	Interfering Signal Level	Wanted Signal mean power	Minimum Offset of Interfering Signal	Type of Interfering Signal
	757 - 777 MHz 787 - 807 MHz	-35 dBm	-105 dBm	± 10 MHz	WCDMA signal (Note)
	1 - 757 MHz 807 MHz - 12750 MHz	-15 dBm	-105 dBm	—	CW carrier
XIV	788 - 798 MHz	-35 dBm	-105 dBm	± 10 MHz	WCDMA signal (Note)
	768 - 788 MHz 798 - 818 MHz	-35 dBm	-105 dBm	± 10 MHz	WCDMA signal (Note)
	1 - 768 MHz 818 MHz - 12750 MHz	-15 dBm	-105 dBm	—	CW carrier
XIX	830 - 845 MHz	-35 dBm	-105 dBm	± 10 MHz	WCDMA signal (Note)
	810 - 830 MHz 845 - 865 MHz	-35 dBm	-105 dBm	± 10 MHz	WCDMA signal (Note)
	1 MHz - 810 MHz 865 MHz - 12750 MHz	-15 dBm	-105 dBm	—	CW carrier
XX	832 - 862 MHz	-35 dBm	-105 dBm	± 10 MHz	WCDMA signal (Note)
	821 - 832 MHz 862 - 882 MHz	-35 dBm	-105 dBm	± 10 MHz	WCDMA signal (Note)
	1 MHz - 821 MHz 882 MHz - 12750 MHz	-15 dBm	-105 dBm	—	CW carrier
XXI	1447.9 - 1462.9 MHz	-35 dBm	-105 dBm	± 10 MHz	WCDMA signal (Note)
	1427.9 - 1447.9 MHz 1462.9 - 1482.9 MHz	-35 dBm	-105 dBm	± 10 MHz	WCDMA signal (Note)
	1 MHz - 1427.9 MHz 1482.9 MHz - 12750 MHz	-15 dBm	-105 dBm	—	CW carrier
XXII	3410 - 3490 MHz	-35 dBm	-105 dBm	± 10 MHz	WCDMA signal (Note)
	3390 - 3410 MHz 3490 - 3510 MHz	-35 dBm	-105 dBm	± 10 MHz	WCDMA signal (Note)
	1 MHz - 3390 MHz 3510 MHz - 12750 MHz	-15 dBm	-105 dBm	—	CW carrier
XXV	1850 - 1915 MHz	-35 dBm	-105 dBm	± 10 MHz	WCDMA signal (Note)
	1830 - 1850 MHz 1915 - 1930 MHz	-35 dBm	-105 dBm	± 10 MHz	WCDMA signal (Note)
	1 MHz - 1830 MHz 1930 MHz - 12750 MHz	-15 dBm	-105 dBm	—	CW carrier
XXVI	814-849 MHz	-35 dBm	-105 dBm	± 10 MHz	WCDMA signal (Note)
	794-814 MHz 849-859 MHz	-35 dBm	-105 dBm	± 10 MHz	WCDMA signal (Note)
	1 MHz - 794 MHz 859 MHz - 12750 MHz	-15 dBm	-105 dBm	—	CW carrier
NOTE 1: The characteristics of the WCDMA interfering signal are specified in annex I of 3GPP TS 25.141 [18].					
NOTE 2: For a <i>multi-band TAB connector</i> , in case of interfering signal that is not in the in-band blocking frequency range of the operating band where the wanted signal is present, or in an adjacent or overlapping band, the wanted signal mean power is equal to -109.6 dBm.					

NOTE: Table 7.5.5.2-2 assumes that two operating bands, where the downlink frequencies (see Table 3.0) of one band would be within the in-band blocking region of the other band, are not deployed in the same geographical area.

Table 7.5.5.2-3: Blocking characteristics for Local Area

Operating Band	Centre Frequency of Interfering Signal	Interfering Signal Level	Wanted Signal mean power	Minimum Offset of Interfering Signal	Type of Interfering Signal
I	1920 - 1980 MHz	-30 dBm	-101 dBm	± 10 MHz	WCDMA signal (Note 1)
	1900 - 1920 MHz 1980 - 2000 MHz	-30 dBm	-101 dBm	± 10 MHz	WCDMA signal (Note 1)
	1 MHz -1900 MHz 2000 MHz - 12750 MHz	-15 dBm	-101 dBm	—	CW carrier
II	1850 - 1910 MHz	-30 dBm	-101 dBm	± 10 MHz	WCDMA signal (Note 1)
	1830 - 1850 MHz 1910 - 1930 MHz	-30 dBm	-101 dBm	± 10 MHz	WCDMA signal (Note 1)
	1 MHz - 1830 MHz 1930 MHz - 12750 MHz	-15 dBm	-101 dBm	—	CW carrier
III	1710 - 1785 MHz	-30 dBm	-101 dBm	± 10 MHz	WCDMA signal (Note 1)
	1690 - 1710 MHz 1785 - 1805 MHz	-30 dBm	-101 dBm	± 10 MHz	WCDMA signal (Note 1)
	1 MHz - 1690 MHz 1805 MHz - 12750 MHz	-15 dBm	-101 dBm	—	CW carrier
IV	1710 - 1755 MHz	-30 dBm	-101 dBm	± 10 MHz	WCDMA signal (Note 1)
	1690 - 1710 MHz 1755 - 1775 MHz	-30 dBm	-101 dBm	± 10 MHz	WCDMA signal (Note 1)
	1 MHz - 1690 MHz 1775 MHz - 12750 MHz	-15 dBm	-101 dBm	—	CW carrier
V	824-849 MHz	-30 dBm	-101 dBm	± 10 MHz	WCDMA signal (Note 1)
	804-824 MHz 849-869 MHz	-30 dBm	-101 dBm	± 10 MHz	WCDMA signal (Note 1)
	1 MHz - 804 MHz 869 MHz - 12750 MHz	-15 dBm	-101 dBm	—	CW carrier
VI	810 - 830 MHz 840 - 860 MHz	-30 dBm	-101 dBm	± 10 MHz	WCDMA signal (Note 1)
	1 MHz - 810 MHz 860 MHz - 12750 MHz	-15 dBm	-101 dBm	—	CW carrier
VII	2500 - 2570 MHz	-30 dBm	-101 dBm	± 10 MHz	WCDMA signal (Note 1)
	2480 - 2500 MHz 2570 - 2590 MHz	-30 dBm	-101 dBm	± 10 MHz	WCDMA signal (Note 1)
	1 MHz -2480 MHz 2590 MHz - 12750 MHz	-15 dBm	-101 dBm	—	CW carrier
VIII	880 - 915 MHz	-30 dBm	-101 dBm	± 10 MHz	WCDMA signal (Note 1)
	860 - 880 MHz 915 - 925 MHz	-30 dBm	-101 dBm	± 10 MHz	WCDMA signal (Note 1)
	1 MHz -860 MHz 925 MHz - 12750 MHz	-15 dBm	-101 dBm	—	CW carrier
IX	1749.9 - 1784.9 MHz	-30 dBm	-101 dBm	± 10 MHz	WCDMA signal (Note 1)
	1729.9 - 1749.9 MHz 1784.9 - 1804.9 MHz	-30 dBm	-101 dBm	± 10 MHz	WCDMA signal (Note 1)
	1 MHz - 1729.9 MHz 1804.9 MHz - 12750 MHz	-15 dBm	-101 dBm	—	CW carrier
X	1710 - 1770 MHz	-30 dBm	-101 dBm	± 10 MHz	WCDMA signal (Note 1)
	1690 - 1710 MHz 1770 - 1790 MHz	-30 dBm	-101 dBm	± 10 MHz	WCDMA signal (Note 1)
	1 MHz - 1690 MHz 1790 MHz - 12750 MHz	-15 dBm	-101 dBm	—	CW carrier
XI	1427.9 - 1447.9 MHz	-30 dBm	-101 dBm	± 10 MHz	WCDMA signal (Note 1)
	1407.9 - 1427.9 MHz 1447.9 - 1467.9 MHz	-30 dBm	-101 dBm	± 10 MHz	WCDMA signal (Note 1)

Operating Band	Centre Frequency of Interfering Signal	Interfering Signal Level	Wanted Signal mean power	Minimum Offset of Interfering Signal	Type of Interfering Signal
	1 MHz - 1407.9 MHz 1467.9 MHz - 12750 MHz	-15 dBm	-101 dBm	—	CW carrier
XII	699 - 716 MHz	-30 dBm	-101 dBm	±10 MHz	WCDMA signal (Note 1)
	679 - 699 MHz 716 - 729 MHz	-30 dBm	-101 dBm	±10 MHz	WCDMA signal (Note 1)
	1 MHz - 679 MHz 729 MHz - 12750 MHz	-15 dBm	-101 dBm	—	CW carrier
XIII	777 - 787 MHz	-30 dBm	-101 dBm	±10 MHz	WCDMA signal (Note 1)
	757 - 777 MHz 787 - 807 MHz	-30 dBm	-101 dBm	±10 MHz	WCDMA signal (Note 1)
	1 - 757 MHz 807 MHz - 12750 MHz	-15 dBm	-101 dBm	—	CW carrier
XIV	788 - 798 MHz	-30 dBm	-101 dBm	±10 MHz	WCDMA signal (Note 1)
	768 - 788 MHz 798 - 818 MHz	-30 dBm	-101 dBm	±10 MHz	WCDMA signal (Note 1)
	1 - 768 MHz 818 MHz - 12750 MHz	-15 dBm	-101 dBm	—	CW carrier
XIX	830 - 845 MHz	-30 dBm	-101 dBm	±10 MHz	WCDMA signal (Note 1)
	810 - 830 MHz 845 - 865 MHz	-30 dBm	-101 dBm	±10 MHz	WCDMA signal (Note 1)
	1 MHz - 810 MHz 865 MHz - 12750 MHz	-15 dBm	-101 dBm	—	CW carrier
XX	832 - 862 MHz	-30 dBm	-101 dBm	±10 MHz	WCDMA signal (Note 1)
	821 - 832 MHz 862 - 882 MHz	-30 dBm	-101 dBm	±10 MHz	WCDMA signal (Note 1)
	1 MHz - 821 MHz 882 MHz - 12750 MHz	-15 dBm	-101 dBm	—	CW carrier
XXI	1447.9 - 1462.9 MHz	-30 dBm	-101 dBm	±10 MHz	WCDMA signal (Note 1)
	1427.9 - 1447.9 MHz 1462.9 - 1482.9 MHz	-30 dBm	-101 dBm	±10 MHz	WCDMA signal (Note 1)
	1 MHz - 1427.9 MHz 1482.9 MHz - 12750 MHz	-15 dBm	-101 dBm	—	CW carrier
XXII	3410 - 3490 MHz	-30 dBm	-101 dBm	±10 MHz	WCDMA signal (Note 1)
	3390 - 3410 MHz 3490 - 3510 MHz	-30 dBm	-101 dBm	±10 MHz	WCDMA signal (Note 1)
	1 MHz - 3390 MHz 3510 MHz - 12750 MHz	-15 dBm	-101 dBm	—	CW carrier
XXV	1850 - 1915 MHz	-30 dBm	-101 dBm	±10 MHz	WCDMA signal (Note 1)
	1830 - 1850 MHz 1915 - 1930 MHz	-30 dBm	-101 dBm	±10 MHz	WCDMA signal (Note 1)
	1 MHz - 1830 MHz 1930 MHz - 12750 MHz	-15 dBm	-101 dBm	—	CW carrier
XXVI	814-849 MHz	-30 dBm	-101 dBm	±10 MHz	WCDMA signal (Note 1)
	794-814 MHz 849-859 MHz	-30 dBm	-101 dBm	±10 MHz	WCDMA signal (Note 1)
	1 MHz - 794 MHz 859 MHz - 12750 MHz	-15 dBm	-101 dBm	—	CW carrier

NOTE 1: The characteristics of the WCDMA interfering signal are specified in annex I of 3GPP TS 25.141 [18].

NOTE 2: For a *multi-band TAB connector*, in case of interfering signal that is not in the in-band blocking frequency range of the operating band where the wanted signal is present, or in an adjacent or overlapping band, the wanted signal mean power is equal to -105.6 dBm.

NOTE: Table 7.5.5.2-3 assumes that two operating bands, where the downlink frequencies (see table 3.0) of one band would be within the in-band blocking region of the other band, are not deployed in the same geographical area.

Table 7.5.5.2-4: Blocking performance requirement when co-located with BS in other bands

Type of co-located BS	Centre Frequency of Interfering Signal (MHz)	Interfering Signal mean power for WA BS (dBm)	Interfering Signal mean power for MR BS (dBm)	Interfering Signal mean power for LA BS (dBm)	Wanted Signal mean power (dBm) (Note 1)	Type of Interfering Signal
GSM850 or CDMA850	869 - 894	+16	+8	-6	$P_{\text{REFSENS}} + x \text{ dB}$	CW carrier
GSM900	921 - 960	+16	+8	-6	$P_{\text{REFSENS}} + x \text{ dB}$	CW carrier
DCS1800	1805 - 1880 (Note 4)	+16	+8	-6	$P_{\text{REFSENS}} + x \text{ dB}$	CW carrier
PCS1900	1930 - 1990	+16	+8	-6	$P_{\text{REFSENS}} + x \text{ dB}$	CW carrier
UTRA FDD Band I or E-UTRA Band 1 or NR band n1	2110 - 2170	+16	+8	-6	$P_{\text{REFSENS}} + x \text{ dB}$	CW carrier
UTRA FDD Band II or E-UTRA Band 2 or NR band n2	1930 - 1990	+16	+8	-6	$P_{\text{REFSENS}} + x \text{ dB}$	CW carrier
UTRA FDD Band III or E-UTRA Band 3 or NR band n3	1805 - 1880 (Note 4)	+16	+8	-6	$P_{\text{REFSENS}} + x \text{ dB}$	CW carrier
UTRA FDD Band IV or E-UTRA Band 4	2110 - 2155	+16	+8	-6	$P_{\text{REFSENS}} + x \text{ dB}$	CW carrier
UTRA FDD Band V or E-UTRA Band 5 or NR band n5	869 - 894	+16	+8	-6	$P_{\text{REFSENS}} + x \text{ dB}$	CW carrier
UTRA FDD Band VI or E-UTRA Band 6	875 - 885	+16	+8	-6	$P_{\text{REFSENS}} + x \text{ dB}$	CW carrier
UTRA FDD Band VII or E-UTRA Band 7	2620 - 2690	+16	+8	-6	$P_{\text{REFSENS}} + x \text{ dB}$	CW carrier
UTRA FDD Band VIII or E-UTRA Band 8 or NR band n8	925 - 960	+16	+8	-6	$P_{\text{REFSENS}} + x \text{ dB}$	CW carrier
UTRA FDD Band IX or E-UTRA Band 9	1844.9 - 1879.9	+16	+8	-6	$P_{\text{REFSENS}} + x \text{ dB}$	CW carrier
UTRA FDD Band X or E-UTRA Band 10	2110 - 2170	+16	+8	-6	$P_{\text{REFSENS}} + x \text{ dB}$	CW carrier
UTRA FDD Band XI or E-UTRA Band 11	1475.9 - 1495.9	+16	+8	-6	$P_{\text{REFSENS}} + x \text{ dB}$	CW carrier
UTRA FDD Band XII or E-UTRA Band 12 or NR band n12	729 - 746	+16	+8	-6	$P_{\text{REFSENS}} + x \text{ dB}$	CW carrier
UTRA FDD Band XIII or E-UTRA Band 13	746 - 756	+16	+8	-6	$P_{\text{REFSENS}} + x \text{ dB}$	CW carrier
UTRA FDD Band XIV or E-UTRA Band 14	758 - 768	+16	+8	-6	$P_{\text{REFSENS}} + x \text{ dB}$	CW carrier
E-UTRA Band 17	734 - 746	+16	+8	-6	$P_{\text{REFSENS}} + x \text{ dB}$	CW carrier
E-UTRA Band 18	860 - 875	+16	+8	-6	$P_{\text{REFSENS}} + x \text{ dB}$	CW carrier
UTRA FDD Band XIX or E-UTRA Band 19	875 - 890	+16	+8	-6	$P_{\text{REFSENS}} + x \text{ dB}$	CW carrier
UTRA FDD Band XX or E-UTRA Band 20 or NR band n20	791 - 821	+16	+8	-6	$P_{\text{REFSENS}} + x \text{ dB}$	CW carrier

Type of co-located BS	Centre Frequency of Interfering Signal (MHz)	Interfering Signal mean power for WA BS (dBm)	Interfering Signal mean power for MR BS (dBm)	Interfering Signal mean power for LA BS (dBm)	Wanted Signal mean power (dBm) (Note 1)	Type of Interfering Signal
UTRA FDD Band XXI or E-UTRA Band 21	1495.9 - 1510.9	+16	+8	-6	$P_{\text{REFSENS}} + x \text{ dB}$	CW carrier
UTRA FDD Band XXII or E-UTRA Band 22	3510 - 3590	+16	+8	-6	$P_{\text{REFSENS}} + x \text{ dB}$	CW carrier
E-UTRA Band 23	2180 - 2200	+16	+8	-6	$P_{\text{REFSENS}} + x \text{ dB}$	CW carrier
E-UTRA Band 24	1525 - 1559	+16	+8	-6	$P_{\text{REFSENS}} + x \text{ dB}$	CW carrier
UTRA FDD Band XXV or E-UTRA Band 25 or NR band n25	1930 - 1995	+16	+8	-6	$P_{\text{REFSENS}} + x \text{ dB}$	CW carrier
UTRA FDD Band XXVI or E-UTRA Band 26	859 - 894	+16	+8	-6	$P_{\text{REFSENS}} + x \text{ dB}$	CW carrier
E-UTRA Band 27	852 - 869	+16	+8	-6	$P_{\text{REFSENS}} + x \text{ dB}$	CW carrier
E-UTRA Band 28 or NR band n28	758 - 803	+16	+8	-6	$P_{\text{REFSENS}} + x \text{ dB}$	CW carrier
E-UTRA Band 29	717 - 728	+16	+8	-6	$P_{\text{REFSENS}} + 6 \text{ dB}$	CW carrier
E-UTRA Band 30	2350 - 2360	+16	+8	-6	$P_{\text{REFSENS}} + x \text{ dB}$	CW carrier
E-UTRA Band 31	462.5 - 467.5	+16	+8	-6	$P_{\text{REFSENS}} + 6 \text{ dB}$	CW carrier
UTRA FDD Band XXXII or E-UTRA Band 32	1452 - 1496 (Note 5)	+16	+8	-6	$P_{\text{REFSENS}} + 6 \text{ dB}$	CW carrier
UTRA TDD Band a) or E-UTRA Band 33	1900-1920	+16	+8	-6	$P_{\text{REFSENS}} + x \text{ dB}$	CW carrier
UTRA TDD Band a) or E-UTRA Band 34 or NR band n34	2010-2025	+16	+8	-6	$P_{\text{REFSENS}} + x \text{ dB}$	CW carrier
UTRA TDD Band b) or E-UTRA Band 35	1850-1910	+16	+8	-6	$P_{\text{REFSENS}} + x \text{ dB}$	CW carrier
UTRA TDD Band b) or E-UTRA Band 36	1930-1990	+16	+8	-6	$P_{\text{REFSENS}} + x \text{ dB}$	CW carrier
UTRA TDD Band c) or E-UTRA Band 37	1910-1930	+16	+8	-6	$P_{\text{REFSENS}} + x \text{ dB}$	CW carrier
UTRA TDD Band d) or E-UTRA Band 38 or NR band n38	2570-2620	+16	+8	-6	$P_{\text{REFSENS}} + x \text{ dB}$	CW carrier
UTRA TDD Band f) or E-UTRA Band 39 or NR band n39	1880-1920	+16	+8	-6	$P_{\text{REFSENS}} + x \text{ dB}$	CW carrier
UTRA TDD Band e) or E-UTRA Band 40 or NR band n40	2300-2400	+16	+8	-6	$P_{\text{REFSENS}} + x \text{ dB}$	CW carrier
E-UTRA Band 41 or NR band n41	2496 - 2690	+16	+8	-6	$P_{\text{REFSENS}} + x \text{ dB}$	CW carrier
E-UTRA Band 42	3400 - 3600	+16	+8	-6	$P_{\text{REFSENS}} + x \text{ dB}$	CW carrier
E-UTRA Band 43	3600 - 3800	+16	+8	-6	$P_{\text{REFSENS}} + x \text{ dB}$	CW carrier
E-UTRA Band 44	703 - 803	+16	+8	-6	$P_{\text{REFSENS}} + x \text{ dB}$	CW carrier
E-UTRA Band 45	1447 - 1467	+16	+8	-6	$P_{\text{REFSENS}} + x \text{ dB}$	CW carrier
E-UTRA Band 46	5150 - 5925	N/A	+8	-6	$P_{\text{REFSENS}} + x \text{ dB}$	CW carrier
E-UTRA Band 48	3550 - 3700	+16	+8	-6	$P_{\text{REFSENS}} + x \text{ dB}$	CW carrier
E-UTRA Band 50 or NR band n50	1432 – 1517	+16	+8	-6	$P_{\text{REFSENS}} + x \text{ dB}$	CW carrier
E-UTRA Band 51 or NR band n51	1427– 1432	N/A	N/A	-6	$P_{\text{REFSENS}} + x \text{ dB}$	CW carrier
E-UTRA Band 65	2110 - 2200	+16	+8	-6	$P_{\text{REFSENS}} + x \text{ dB}$	CW carrier

Type of co-located BS	Centre Frequency of Interfering Signal (MHz)	Interfering Signal mean power for WA BS (dBm)	Interfering Signal mean power for MR BS (dBm)	Interfering Signal mean power for LA BS (dBm)	Wanted Signal mean power (dBm) (Note 1)	Type of Interfering Signal
E-UTRA Band 66 or NR band n66	2110 - 2200	+16	+8	-6	$P_{\text{REFSENS}} + x$ dB	CW carrier
E-UTRA Band 67	738 - 758	+16	+8	-6	$P_{\text{REFSENS}} + x$ dB	CW carrier
E-UTRA Band 68	753 - 783	+16	+8	-6	$P_{\text{REFSENS}} + x$ dB*	CW carrier
E-UTRA Band 69	2570 - 2620	+16	+8	-6	$P_{\text{REFSENS}} + x$ dB	CW carrier
E-UTRA Band 70 or NR band n70	1995 - 2020	+16	+8	-6	$P_{\text{REFSENS}} + x$ dB	CW carrier
E-UTRA Band 71 or or NR band n71	617 - 652	+16	+8	-6	$P_{\text{REFSENS}} + x$ dB	CW carrier
E-UTRA Band 72	461 - 466	+16	+8	-6	$P_{\text{REFSENS}} + x$ dB	CW carrier
E-UTRA Band 73	460 - 465	+16	+8	-6	$P_{\text{REFSENS}} + x$ dB	CW carrier
E-UTRA Band 74 or NR band n74	1475 - 1518	+16	+8	-6	$P_{\text{REFSENS}} + x$ dB	CW carrier
E-UTRA Band 75 or or NR band n75	1432 - 1517	+16	+8	-6	$P_{\text{REFSENS}} + x$ dB	CW carrier
E-UTRA Band 76 or or NR band n76	1427 - 1432	N/A	N/A	-6	$P_{\text{REFSENS}} + x$ dB	CW carrier
NR band n77	3300 - 4200	+16	+8	-6	$P_{\text{REFSENS}} + x$ dB	CW carrier
NR band n78	3300 - 3800	+16	+8	-6	$P_{\text{REFSENS}} + x$ dB	CW carrier
NR band n79	4400 - 5000	+16	+8	-6	$P_{\text{REFSENS}} + x$ dB	CW carrier

NOTE 1: P_{REFSENS} depends on, the BS class and the channel bandwidth, see subclause 7.2. "x" is equal to 6 in case of UTRA wanted signals.

NOTE 2: Some combinations of bands may not be possible to co-site based on the requirements above. The current state-of-the-art technology does not allow a single generic solution for co-location of UTRA TDD or E-UTRA TDD with E-UTRA FDD on adjacent frequencies for 30 dB BS-BS minimum coupling loss. However, there are certain site-engineering solutions that can be used. These techniques are addressed in 3GPP TR 25.942 [21].

NOTE 3: In China, the blocking requirement for co-location with DCS1800 and Band III BS is only applicable in the frequency range 1805-1850 MHz.

NOTE 4: For a *TAB connector* operating in band XI or XXI, this requirement applies for interfering signal within the frequency range 1475.9-1495.9 MHz.

Table 7.5.5.2-5: Void

Table 7.5.5.2-6: Void

Table 7.5.5.2-7: Blocking performance requirement (narrowband) for Wide Area BS

Operating Band	Centre Frequency of Interfering Signal	Interfering Signal mean power	Wanted Signal mean power	Minimum Offset of Interfering Signal	Type of Interfering Signal (Note)
II	1850 - 1910 MHz	- 47 dBm	-115 dBm	± 2.7 MHz	GMSK modulated
III	1710 - 1785 MHz	- 47 dBm	-115 dBm	± 2.8 MHz	GMSK modulated
IV	1710 - 1755 MHz	- 47 dBm	-115 dBm	± 2.7 MHz	GMSK modulated
V	824 - 849 MHz	- 47 dBm	-115 dBm	± 2.7 MHz	GMSK modulated
VIII	880 - 915 MHz	- 47 dBm	-115 dBm	± 2.8 MHz	GMSK modulated
X	1710 - 1770 MHz	- 47 dBm	-115 dBm	± 2.7 MHz	GMSK modulated
XII	699 - 716 MHz	- 47 dBm	-115 dBm	± 2.7 MHz	GMSK modulated
XIII	777 - 787 MHz	- 47 dBm	-115 dBm	± 2.7 MHz	GMSK modulated
XIV	788 - 798 MHz	- 47 dBm	-115 dBm	± 2.7 MHz	GMSK modulated
XXV	1850 - 1915 MHz	- 47 dBm	-115 dBm	± 2.7 MHz	GMSK modulated
XXVI	814-849 MHz	-47 dBm	-115 dBm	± 2.7 MHz	GMSK modulated

NOTE: GMSK modulation as defined in 3GPP TS 45.004 [22].

Table 7.5.5.2-8: Blocking performance requirement (narrowband) for Medium range BS

Operating Band	Centre Frequency of Interfering Signal	Interfering Signal mean power	Wanted Signal mean power	Minimum Offset of Interfering Signal	Type of Interfering Signal
II	1850 - 1910 MHz	- 42 dBm	-105 dBm	±2.7 MHz	GMSK modulated
III	1710 - 1785 MHz	- 42 dBm	-105 dBm	±2.8 MHz	GMSK modulated
IV	1710 - 1755 MHz	- 42 dBm	-105 dBm	±2.7 MHz	GMSK modulated
V	824 - 849 MHz	- 42 dBm	-105 dBm	±2.7 MHz	GMSK modulated
VIII	880 - 915 MHz	- 42 dBm	-105 dBm	±2.8 MHz	GMSK modulated
X	1710 - 1770 MHz	- 42 dBm	-105 dBm	±2.7 MHz	GMSK modulated
XII	699 - 716 MHz	- 42 dBm	-105 dBm	±2.7 MHz	GMSK modulated
XIII	777 - 787 MHz	- 42 dBm	-105 dBm	±2.7 MHz	GMSK modulated
XIV	788 - 798 MHz	- 42 dBm	-105 dBm	±2.7 MHz	GMSK modulated
XXV	1850 - 1915 MHz	- 42 dBm	-105 dBm	±2.7 MHz	GMSK modulated
XXVI	814-849 MHz	- 42 dBm	-105 dBm	±2.7 MHz	GMSK modulated

NOTE: GMSK modulation as defined in 3GPP TS 45.004 [22].

Table 7.5.5.2-9: Blocking performance requirement (narrowband) for Local Area

Operating Band	Centre Frequency of Interfering Signal	Interfering Signal mean power	Wanted Signal mean power	Minimum Offset of Interfering Signal	Type of Interfering Signal
II	1850 - 1910 MHz	- 37 dBm	-101 dBm	±2.7 MHz	GMSK modulated
III	1710 - 1785 MHz	- 37 dBm	-101 dBm	±2.8 MHz	GMSK modulated
IV	1710 - 1755 MHz	- 37 dBm	-101 dBm	±2.7 MHz	GMSK modulated
V	824 - 849 MHz	- 37 dBm	-101 dBm	±2.7 MHz	GMSK modulated
VIII	880 - 915 MHz	- 37 dBm	-101 dBm	±2.8 MHz	GMSK modulated
X	1710 - 1770 MHz	- 37 dBm	-101 dBm	±2.7 MHz	GMSK modulated
XII	699 - 716 MHz	- 37 dBm	-101 dBm	±2.7 MHz	GMSK modulated
XIII	777 - 787 MHz	- 37 dBm	-101 dBm	±2.7 MHz	GMSK modulated
XIV	788 - 798 MHz	- 37 dBm	-101 dBm	±2.7 MHz	GMSK modulated
XXV	1850 - 1915 MHz	- 37 dBm	-101 dBm	±2.7 MHz	GMSK modulated
XXVI	814-849 MHz	- 37 dBm	-101 dBm	±2.7 MHz	GMSK modulated

NOTE: GMSK modulation as defined in 3GPP TS 45.004 [22].

NOTE 1: If the above Test Requirement differs from the Minimum Requirement then the Test Tolerance applied for this test is non-zero. The Test Tolerance for this test is defined in subclause 4.1.2 and the explanation of how the Minimum Requirement has been relaxed by the Test Tolerance is given in annex C.

NOTE 2: Annex C of 3GPP TS 25.141 [18] describes the procedure for BER tests taking into account the statistical consequence of frequent repetition of BER measurements within the blocking test. The consequence is: a DUT exactly on the limit may fail due to the statistical nature 2.55 times (mean value) in 12750 BER measurements using the predefined wrong decision probability of 0.02%. If the fail cases are ≤ 12 , it is allowed to repeat the fail cases 1 time before the final verdict.

7.5.5.3 Single RAT UTRA TDD 1,28 Mcps option operation

7.5.5.3.1 General requirements

The static reference performance as specified in clause 7.2 shall be met with a wanted and an interfering signal coupled to the *TAB connector* using the parameters specified in table 7.5.5.3.1-1 to table 7.5.5.3.1-12, respectively.

The blocking requirement is always applicable outside the *Base Station RF Bandwidth* or *Maximum Radio Bandwidth* edges. The interfering signal offset is defined relative to the lower / upper *Base Station RF Bandwidth* edges or *Maximum Radio Bandwidth* edges.

For *multi-band TAB connector*, the requirement in the in-band blocking frequency range applies for each supported operating band. The requirements applies in addition inside any *Inter RF Bandwidth gap* as long as the Inter RF

Bandwidth gap size is at least 4.8MHz. The interfering signal offset is defined relative to the lower / upper *Base Station RF Bandwidth edges* inside the Inter RF Bandwidth gap and is equal to -2.4 MHz/+2.4 MHz, respectively.

For *multi-band TAB connector*, the requirement in the out-of-band blocking frequency ranges apply for each supported operating band, with the exception that the in-band blocking frequency ranges of all supported operating bands shall be excluded from the out-of-band blocking requirement.

Table 7.5.5.3.1-1: Blocking requirements for Wide Area BS in operating bands defined in subclause 4.5 a) for 1,28 Mcps TDD

Centre frequency of interfering signal	Interfering signal mean power	Wanted signal mean power	Minimum offset of interfering signal	Type of interfering signal
1900 - 1920 MHz, 2010 - 2025 MHz	-40 dBm	-104 dBm	±3.2 MHz	1,28 Mcps TDD signal with one code
1880 - 1900 MHz, 1990 - 2010 MHz, 2025 - 2045 MHz	-40 dBm	-104 dBm	±3.2 MHz	1,28 Mcps TDD signal with one code
1920 - 1980 MHz	-40 dBm	-104 dBm	±3.2 MHz	1,28 Mcps TDD signal with one code
1 - 1880 MHz, 1980 - 1990 MHz, 2045 - 12750 MHz	-15 dBm	-104 dBm	—	CW carrier

NOTE: For *multi-band TAB connector*, in case the interfering signal for in-band blocking is not in the in-band blocking frequency range of the operating band where the wanted signal is present, the wanted signal mean power shall not exceed -108.6 dBm.

Table 7.5.5.3.1-2: Blocking requirements for Wide Area BS in operating bands defined in subclause 4.5 b) for 1,28 Mcps TDD

Centre frequency of interfering signal	Interfering signal mean power	Wanted signal mean power	Minimum offset of interfering signal	Type of interfering signal
1850 - 1990 MHz	-40 dBm	-104 dBm	±3.2 MHz	1,28 Mcps TDD signal with one code
1830 - 1850 MHz, 1990 - 2010 MHz	-40 dBm	-104 dBm	±3.2 MHz	1,28 Mcps TDD signal with one code
1 - 1830 MHz, 2010 - 12750 MHz	-15 dBm	-104 dBm	—	CW carrier

NOTE: For *multi-band TAB connector*, in case the interfering signal for in-band blocking is not in the in-band blocking frequency range of the operating band where the wanted signal is present, the wanted signal mean power shall not exceed -108.6 dBm.

Table 7.5.5.3.1-3: Blocking requirements for Wide Area BS in operating bands defined in subclause 4.5 c) for 1,28 Mcps TDD

Centre frequency of interfering signal	Interfering signal mean power	Wanted signal mean power	Minimum offset of interfering signal	Type of interfering signal
1910 - 1930 MHz	-40 dBm	-104 dBm	±3.2 MHz	1,28 Mcps TDD signal with one code
1890 - 1910 MHz, 1930 - 1950 MHz	-40 dBm	-104 dBm	±3.2 MHz	1,28 Mcps TDD signal with one code
1 - 1890 MHz, 1950 - 12750 MHz	-15 dBm	-104 dBm	—	CW carrier

NOTE: For *multi-band TAB connector*, in case the interfering signal for in-band blocking is not in the in-band blocking frequency range of the operating band where the wanted signal is present, the wanted signal mean power shall not exceed -108.6 dBm.

**Table 7.5.5.3.1-4: Blocking requirements for Wide Area BS
in operating bands defined in subclause 4.5 d) for 1,28 Mcps TDD**

Centre Frequency of Interfering Signal	Interfering Signal Mean Power	Wanted Signal Mean Power	Minimum Offset of Interfering Signal	Type of Interfering Signal
2570 - 2620 MHz	-40 dBm	-104 dBm	±3.2MHz	1,28 Mcps TDD signal with one code
2500 - 2570 MHz, 2620 - 2690 MHz	-40 dBm	-104 dBm	±3.2 MHz	1,28 Mcps TDD signal with one code
1 - 2500 MHz, 2690 - 12750 MHz	-15 dBm	-104 dBm	—	CW carrier
NOTE: For <i>multi-band TAB connector</i> , in case the interfering signal for in-band blocking is not in the in-band blocking frequency range of the operating band where the wanted signal is present, the wanted signal mean power shall not exceed -108.6 dBm.				

**Table 7.5.5.3.1-5: Blocking requirements for Wide Area BS
in operating bands defined in subclause 4.5 e) for 1,28 Mcps TDD**

Centre Frequency of Interfering Signal	Interfering Signal Mean Power	Wanted Signal Mean Power	Minimum Offset of Interfering Signal	Type of Interfering Signal
2300 - 2400 MHz	-40 dBm	-104 dBm	±3.2MHz	1,28 Mcps TDD signal with one code
2280 - 2300 MHz, 2400 - 2420 MHz	-40 dBm	-104 dBm	±3.2 MHz	1,28 Mcps TDD signal with one code
1 - 2280 MHz, 2420 - 12750 MHz	-15 dBm	-104 dBm	—	CW carrier
NOTE: For <i>multi-band TAB connector</i> , in case the interfering signal for in-band blocking is not in the in-band blocking frequency range of the operating band where the wanted signal is present, the wanted signal mean power shall not exceed -108.6 dBm.				

**Table 7.5.5.3.1-6: Blocking requirements for Wide Area BS
in operating bands defined in subclause 4.5 f) for 1,28Mcps TDD**

Centre Frequency of Interfering Signal	Interfering Signal Mean Power	Wanted Signal Mean Power	Minimum Offset of Interfering Signal	Type of Interfering Signal
1880 - 1920 MHz	-40 dBm	-104 dBm	±3.2 MHz	Narrow band CDMA signal with one code
1860 - 1880 MHz, 1920 - 1940 MHz	-40 dBm	-104 dBm	±3.2 MHz	Narrow band CDMA signal with one code
1 - 1860 MHz, 1940 - 12750 MHz	-15 dBm	-104 dBm	—	CW carrier
NOTE: For <i>multi-band TAB connector</i> , in case the interfering signal for in-band blocking is not in the in-band blocking frequency range of the operating band where the wanted signal is present, the wanted signal mean power shall not exceed -108.6 dBm.				

**Table 7.5.5.3.1-7: Blocking requirements for Local Area BS
in operating bands defined in subclause 4.5 a) for 1,28 Mcps TDD**

Centre frequency of interfering signal	Interfering signal level	Wanted signal level	Minimum offset of interfering signal	Type of interfering signal
1900 - 1920 MHz, 2010 - 2025 MHz	-30 dBm	$P_{\text{REFSENS}} + 6 \text{ dB}$	$\pm 3,2 \text{ MHz}$	1,28 Mcps TDD signal with one code
1880 - 1900 MHz, 1990 - 2010 MHz, 2025 - 2045 MHz	-30 dBm	$P_{\text{REFSENS}} + 6 \text{ dB}$	$\pm 3,2 \text{ MHz}$	1,28 Mcps TDD signal with one code
1920 - 1980 MHz	-30 dBm	$P_{\text{REFSENS}} + 6 \text{ dB}$	$\pm 3,2 \text{ MHz}$	1,28 Mcps TDD signal with one code
1 - 1880 MHz, 1980 - 1990 MHz, 2045 - 12750 MHz	-15 dBm	$P_{\text{REFSENS}} + 6 \text{ dB}$	—	CW carrier

NOTE: For *multi-band TAB connector*, in case the interfering signal for in-band blocking is not in the in-band blocking frequency range of the operating band where the wanted signal is present, the wanted signal mean power shall not exceed -94.6 dBm for Local Area BS.

**Table 7.5.5.3.1-8: Blocking requirements for Local Area BS
in operating bands defined in subclause 4.5 b) for 1,28 Mcps TDD**

Centre frequency of interfering signal	Interfering signal level	Wanted signal level	Minimum offset of interfering signal	Type of interfering signal
1850 - 1990 MHz	-30 dBm	$P_{\text{REFSENS}} + 6 \text{ dB}$	$\pm 3,2 \text{ MHz}$	1,28 Mcps TDD signal with one code
1830 - 1850 MHz, 1990 - 2010 MHz	-30 dBm	$P_{\text{REFSENS}} + 6 \text{ dB}$	$\pm 3,2 \text{ MHz}$	1,28 Mcps TDD signal with one code
1 - 1830 MHz, 2010 - 12750 MHz	-15 dBm	$P_{\text{REFSENS}} + 6 \text{ dB}$	—	CW carrier

NOTE: For *multi-band TAB connector*, in case the interfering signal for in-band blocking is not in the in-band blocking frequency range of the operating band where the wanted signal is present, the wanted signal mean power shall not exceed -94.6 dBm for Local Area BS.

**Table 7.5.5.3.1-9: Blocking requirements for Local Area BS
in operating bands defined in subclause 4.5 c) for 1,28 Mcps TDD**

Centre frequency of interfering signal	Interfering signal level	Wanted signal level	Minimum offset of interfering signal	Type of interfering signal
1910 - 1930 MHz	-30 dBm	$P_{\text{REFSENS}} + 6 \text{ dB}$	$\pm 3,2 \text{ MHz}$	1,28 Mcps TDD signal with one code
1890 - 1910 MHz, 1930 - 1950 MHz	-30 dBm	$P_{\text{REFSENS}} + 6 \text{ dB}$	$\pm 3,2 \text{ MHz}$	1,28 Mcps TDD signal with one code
1 - 1890 MHz, 1950 - 12750 MHz	-15 dBm	$P_{\text{REFSENS}} + 6 \text{ dB}$	—	CW carrier

NOTE: For *multi-band TAB connector*, in case the interfering signal for in-band blocking is not in the in-band blocking frequency range of the operating band where the wanted signal is present, the wanted signal mean power shall not exceed -94.6 dBm for Local Area BS.

**Table 7.5.5.3.1-10: Blocking requirements for Local Area BS
in operating bands defined in subclause 4.5 d) for 1,28 Mcps TDD**

Centre Frequency of Interfering Signal	Interfering Signal mean power	Wanted Signal mean power	Minimum Offset of Interfering Signal	Type of Interfering Signal
2570 - 2620 MHz	-30 dBm	$P_{\text{REFSENS}} + 6 \text{ dB}$	$\pm 3.2 \text{ MHz}$	1,28 Mcps TDD signal with one code
2500 - 2570 MHz, 2620 - 2690 MHz	-30 dBm	$P_{\text{REFSENS}} + 6 \text{ dB}$	$\pm 3.2 \text{ MHz}$	1,28 Mcps TDD signal with one code
1 - 2500 MHz, 2690 - 12750 MHz	-15 dBm	$P_{\text{REFSENS}} + 6 \text{ dB}$	—	CW carrier
NOTE: For <i>multi-band TAB connector</i> , in case the interfering signal for in-band blocking is not in the in-band blocking frequency range of the operating band where the wanted signal is present, the wanted signal mean power shall not exceed -94.6 dBm for Local Area BS.				

**Table 7.5.5.3.1-11: Blocking requirements for Local Area BS
in operating bands defined in subclause 4.5 e) for 1,28 Mcps TDD**

Centre Frequency of Interfering Signal	Interfering Signal mean power	Wanted Signal mean power	Minimum Offset of Interfering Signal	Type of Interfering Signal
2300 - 2400 MHz	-30 dBm	$P_{\text{REFSENS}} + 6 \text{ dB}$	$\pm 3.2 \text{ MHz}$	1,28 Mcps TDD signal with one code
2280 - 2300 MHz, 2400 - 2420 MHz	-30 dBm	$P_{\text{REFSENS}} + 6 \text{ dB}$	$\pm 3.2 \text{ MHz}$	1,28 Mcps TDD signal with one code
1 - 2280 MHz, 2420 - 12750 MHz	-15 dBm	$P_{\text{REFSENS}} + 6 \text{ dB}$	—	CW carrier
NOTE: For <i>multi-band TAB connector</i> , in case the interfering signal for in-band blocking is not in the in-band blocking frequency range of the operating band where the wanted signal is present, the wanted signal mean power shall not exceed -94.6 dBm for Local Area BS.				

**Table 7.5.5.3.1-12: Blocking requirements for Local Area BS
in operating bands defined in subclause 4.5 f) for 1,28 Mcps TDD**

Centre Frequency of Interfering Signal	Interfering Signal mean power	Wanted Signal mean power	Minimum Offset of Interfering Signal	Type of Interfering Signal
1880-1920 MHz	-30 dBm	-90 dBm	$\pm 3.2 \text{ MHz}$	Narrow band CDMA signal with one code
1860 - 1880 MHz, 1920 - 1940 MHz	-30 dBm	-90 dBm	$\pm 3.2 \text{ MHz}$	Narrow band CDMA signal with one code
1 - 1860 MHz, 1940 - 12750 MHz	-15 dBm	-90 dBm	—	CW carrier
NOTE: For <i>multi-band TAB connector</i> , in case the interfering signal for in-band blocking is not in the in-band blocking frequency range of the operating band where the wanted signal is present, the wanted signal mean power shall not exceed -94.6 dBm for Local Area BS.				

7.5.5.3.2 Co-location with GSM, DCS, UTRA FDD and/or E-UTRA FDD, UTRA TDD and/or E-UTRA TDD

This additional blocking requirement may be applied for the protection of receiver units associated with *TAB connectors* with TDD operation when GSM, DCS, UTRA FDD, E-UTRA FDD, FDD unsynchronized UTRA TDD and/or unsynchronized E-UTRA TDD BTS operating in a different frequency band are co-located with UTRA TDD Wide Area BS.

The blocking performance requirement applies to interfering signals with centre frequency within the ranges specified in the tables below, using a 1 MHz step size.

In case this additional blocking requirement is applied, the static reference performance as specified in subclause 7.2.1 shall be met with a wanted and an interfering signal coupled to BS antenna input using the following parameters.

Table 7.5.5.3.2-1: Additional blocking requirements for Wide Area BS

System type operating in the same geographic area	Centre Frequency of Interfering Signal	Interfering Signal mean power	Wanted Signal mean power	Minimum Offset of Interfering Signal	Type of Interfering Signal	Notes
Macro GSM900	921 - 960 MHz	+16 dBm	-104 dBm	—	CW carrier	
Macro DCS1800	1805 - 1880 MHz	+16 dBm	-104 dBm	—	CW carrier	For <i>TAB connector operating UTRA TDD</i> in Band 5.2(f), it applies for 1805 - 1850 MHz
GSM850 or CDMA850	869 - 894 MHz	+16 dBm	-104 dBm	—	CW carrier	
WA BS UTRA FDD Band I or E-UTRA Band 1	2110 - 2170 MHz	+16 dBm	-104 dBm	—	CW carrier	
WA BS UTRA FDD Band iii or E-UTRA Band 3	1805 - 1880 MHz	+16 dBm	-104 dBm	—	CW carrier	(NOTE 3)
WA BS UTRA FDD Band V or E-UTRA Band 5	869 - 894 MHz	+16 dBm	-104 dBm	—	CW carrier	
WA BS UTRA FDD Band VII or E-UTRA Band 7	2620 - 2690 MHz	+16 dBm	-104 dBm	—	CW carrier	
WA UTRA TDD Band a) or E-UTRA Band 33	1900 - 1920 MHz	+16 dBm	-104 dBm	—	CW carrier	
WA UTRA TDD Band a) or E-UTRA Band 34	2010 - 2025 MHz	+16 dBm	-104 dBm	—	CW carrier	
WA UTRA TDD Band d) or E-UTRA Band 38	2570 - 2620 MHz	+16 dBm	-104 dBm	—	CW carrier	
WA UTRA TDD Band f) or E-UTRA Band 39	1880 - 1920 MHz	+16 dBm	-104 dBm	—	CW carrier	
WA UTRA TDD Band e) or E-UTRA Band 40	2300 - 2400 MHz	+16 dBm	-104 dBm	—	CW carrier	
WA E-UTRA Band 41	2496 - 2690 MHz	+16 dBm	-104 dBm	—	CW carrier	
WA E-UTRA Band 42	3400 - 3600 MHz	+16 dBm	-104 dBm	—	CW carrier	
WA E-UTRA Band 44	703 - 803 MHz	+16 dBm	-104 dBm	—	CW carrier	
Pico GSM850	869 - 894	-7 dBm	-104 dBm	—	CW carrier	
Pico GSM900	921 - 960	-7 dBm	-104 dBm	—	CW carrier	
Pico DCS1800	1805 - 1880	-7 dBm	-104 dBm	—	CW carrier	

System type operating in the same geographic area	Centre Frequency of Interfering Signal	Interfering Signal mean power	Wanted Signal mean power	Minimum Offset of Interfering Signal	Type of Interfering Signal	Notes
LA BS UTRA FDD Band I or E-UTRA Band 1	2110 - 2170	-6 dBm	-104 dBm	—	CW carrier	
LA BS UTRA FDD Band III or E-UTRA Band 3	1805 - 1880 MHz	-6 dBm	-104 dBm	—	CW carrier	(NOTE 3)
LA BS UTRA FDD Band V or E-UTRA Band 5	869 - 894 MHz	-6 dBm	-104 dBm	—	CW carrier	
LA BS UTRA FDD Band VII or E-UTRA Band 7	2620 - 2690 MHz	-6 dBm	-104 dBm	—	CW carrier	
LA UTRA TDD Band a) or E-UTRA Band 33	1900 - 1920 MHz	-6 dBm	-104 dBm	—	CW carrier	
LA UTRA TDD Band a) or E-UTRA Band 34	2010 - 2025 MHz	-6 dBm	-104 dBm	—	CW carrier	
LA UTRA TDD Band d) or E-UTRA Band 38	2570 - 2620 MHz	-6 dBm	-104 dBm	—	CW carrier	
LA UTRA TDD Band f) or E-UTRA Band 39	1880 - 1920 MHz	-6 dBm	-104 dBm	—	CW carrier	
LA UTRA TDD Band e) or E-UTRA Band 40	2300 - 2400 MHz	-6 dBm	-104 dBm	—	CW carrier	
LA E-UTRA Band 41	2496 - 2690 MHz	-6 dBm	-104 dBm	—	CW carrier	
LA E-UTRA Band 42	3400 - 3600 MHz	-6 dBm	-104 dBm	—	CW carrier	
WA E-UTRA Band 44	703 - 803 MHz	-6 dBm	-104 dBm	—	CW carrier	
<p>NOTE 1: These requirements do not apply when the interfering signal falls within any of the supported <i>uplink operating band</i> or in the 10 MHz frequency range immediately outside the any of the supported <i>uplink operating band</i>.</p> <p>NOTE 2: Some combinations of bands may not be possible to co-site based on the requirements above. The current state-of-the-art technology does not allow a single generic solution for co-location of UTRA TDD with UTRA FDD or E-UTRA FDD on adjacent frequencies for 30 dB BS-BS minimum coupling loss. However, there are certain site-engineering solutions that can be used. These techniques are addressed in 3GPP TR 25.942 [21].</p> <p>NOTE 3: For <i>TAB connector operating</i> UTRA TDD in Band 5.2(f), the requirement is not covered by the present release of this specification. For the source of this requirement, refer to co-location requirements in TS 25.142 [19].</p>						

7.5.5.4 Single RAT E-UTRA operation

7.5.5.4.1 General test requirement

For each measured E-UTRA carrier, the throughput shall be $\geq 95\%$ of the *maximum throughput* of the reference measurement channel, with a wanted and an interfering signal coupled to BS antenna input using the parameters in tables 7.5.5.4.1-1, 7.5.5.4.1-2, 7.5.5.4.1-3 and 7.5.5.4.1-4. The reference measurement channel for the wanted signal is specified in tables 7.2-1, 7.2-2, 7.2-3 and 7.2-4 for each channel bandwidth and further specified in annex A.

The blocking requirement is always applicable outside the *Base Station RF Bandwidth* or *Maximum Radio Bandwidth*. The interfering signal offset is defined relative to the *Base Station RF Bandwidth edges* or *Maximum Radio Bandwidth edges*.

For a *TAB connector* operating in non-contiguous spectrum within any operating band, the blocking requirement applies in addition inside any *sub-block gap*, in case the *sub-block gap* size is at least as wide as twice the interfering signal minimum offset in table 7.6-2. The interfering signal offset is defined relative to the sub-block edges inside the *sub-block gap*.

For a *multi-band TAB connector*, the requirement in the in-band blocking frequency ranges applies for each supported operating band. The requirement applies in addition inside any *Inter RF Bandwidth gap*, in case the *Inter RF Bandwidth gap* size is at least as wide as twice the interfering signal minimum offset in table 7.6-2.

For a *multi-band TAB connector*, the requirement in the out-of-band blocking frequency ranges apply for each operating band, with the exception that the in-band blocking frequency ranges of all supported operating bands according to tables 7.5.5.4.1-1, 7.5.5.4.1-2 and 7.5.5.4.1-3 shall be excluded from the out-of-band blocking requirement.

Table 7.5.5.4.1-1: Blocking performance requirement for Wide Area BS

Operating Band	Centre Frequency of Interfering Signal (MHz)	Interfering Signal mean power (dBm)	Wanted Signal mean power (dBm) (Note 1)	Interfering signal centre frequency minimum frequency offset from the lower/upper Base Station RF Bandwidth edge or sub-block edge inside a sub-block gap (MHz)	Type of Interfering Signal
1-7, 9-11, 13, 14, 18, 19, 21-23, 24, 27, 30, 33-45, 48, 65, 66, 68, 70	(F _{UL_low} -20) to (F _{UL_high} +20)	-43	P _{PREFSENS} +6 dB (Note 2)	See table 7.5.5.4.1-4	See table 7.5.5.4.1-4
	1 (F _{UL_high} +20) to (F _{UL_low} -20) to 12750	-15	P _{PREFSENS} +6 dB	—	CW carrier
8, 26, 28	(F _{UL_low} -20) to (F _{UL_high} +10)	-43	P _{PREFSENS} +6 dB (Note 2)	See table 7.5.5.4.1-4	See table 7.5.5.4.1-4
	1 (F _{UL_high} +10) to (F _{UL_low} -20) to 12750	-15	P _{PREFSENS} +6 dB	—	CW carrier
12	(F _{UL_low} -20) to (F _{UL_high} +13)	-43	P _{PREFSENS} +6 dB (Note 2)	See table 7.5.5.4.1-4	See table 7.5.5.4.1-4
	1 (F _{UL_high} +13) to (F _{UL_low} -20) to 12750	-15	P _{PREFSENS} +6 dB	—	CW carrier
17	(F _{UL_low} -20) to (F _{UL_high} +18)	-43	P _{PREFSENS} +6 dB (Note 2)	See table 7.5.5.4.1-4	See table 7.5.5.4.1-4
	1 (F _{UL_high} +18) to (F _{UL_low} -20) to 12750	-15	P _{PREFSENS} +6 dB	—	CW carrier
20	(F _{UL_low} -11) to (F _{UL_high} +20)	-43	P _{PREFSENS} +6 dB (Note 2)	See table 7.5.5.4.1-4	See table 7.5.5.4.1-4
	1 (F _{UL_high} +20) to (F _{UL_low} -11) to 12750	-15	P _{PREFSENS} +6 dB	—	CW carrier
25	(F _{UL_low} -20) to (F _{UL_high} +15)	-43	P _{PREFSENS} +6 dB (Note 2)	See table 7.5.5.4.1-4	See table 7.5.5.4.1-4
	1 (F _{UL_high} +15) to (F _{UL_low} -20) to 12750	-15	P _{PREFSENS} +6 dB	—	CW carrier
31	(F _{UL_low} -20) to (F _{UL_high} +5)	-43	P _{PREFSENS} +6 dB (Note 2)	See table 7.5.5.4.1-4	See table 7.5.5.4.1-4
	1 (F _{UL_high} +5) to (F _{UL_low} -20) to 12750	-15	P _{PREFSENS} +6 dB	—	CW carrier
NOTE 1: P _{PREFSENS} depends on the channel bandwidth as specified in 3GPP TS 36.104 [11], subclause 7.2.1.					
NOTE 2: For a <i>multi-band TAB connector</i> , in case of interfering signal that is not in the in-band blocking frequency range of the operating band where the wanted signal is present, or in an adjacent or overlapping band, the wanted signal mean power is equal to P _{PREFSENS} + 1.4 dB.					

NOTE 1: Table 7.5.5.4.1-1 assumes that two operating bands, where the *downlink operating band* see subclause 4.5 of one band would be within the in-band blocking region of the other band, are not deployed in the same geographical area.

Table 7.5.5.4.1-2: Blocking performance requirement for Local Area BS

Operating Band	Centre Frequency of Interfering Signal (MHz)	Interfering Signal mean power (dBm)	Wanted Signal mean power (dBm) (Note 1)	Interfering signal centre frequency minimum frequency offset from the lower/upper Base Station RF Bandwidth edge or sub-block edge inside a sub-block gap (MHz)	Type of Interfering Signal
1-7, 9-11, 13-14, 18,19,21-23, 24, 27, 30, 33-45, 48, 65, 66, 68, 70	(F _{UL_low} -20) to (F _{UL_high} +20)	-35	P _{PREFSENS} +6 dB (Note 2)	See table 7.5.5.4.1-4	See table 7.5.5.4.1-4
	1 (F _{UL_high} +20) to (F _{UL_low} -20) to 12750	-15	P _{PREFSENS} +6 dB	—	CW carrier
8, 26, 28	(F _{UL_low} -20) to (F _{UL_high} +10)	-35	P _{PREFSENS} +6 dB (Note 2)	See table 7.5.5.4.1-4	See table 7.5.5.4.1-4
	1 (F _{UL_high} +10) to (F _{UL_low} -20) to 12750	-15	P _{PREFSENS} +6 dB	—	CW carrier
12	(F _{UL_low} -20) to (F _{UL_high} +13)	-35	P _{PREFSENS} +6 dB (Note 2)	See table 7.5.5.4.1-4	See table 7.5.5.4.1-4
	1 (F _{UL_high} +13) to (F _{UL_low} -20) to 12750	-15	P _{PREFSENS} +6 dB	—	CW carrier
17	(F _{UL_low} -20) to (F _{UL_high} +18)	-35	P _{PREFSENS} +6 dB (Note 2)	See table 7.5.5.4.1-4	See table 7.5.5.4.1-4
	1 (F _{UL_high} +18) to (F _{UL_low} -20) to 12750	-15	P _{PREFSENS} +6 dB	—	CW carrier
20	(F _{UL_low} -11) to (F _{UL_high} +20)	-35	P _{PREFSENS} +6 dB (Note 2)	See table 7.5.5.4.1-4	See table 7.5.5.4.1-4
	1 (F _{UL_high} +20) to (F _{UL_low} -11) to 12750	-15	P _{PREFSENS} +6 dB	—	CW carrier
25	(F _{UL_low} -20) to (F _{UL_high} +15)	-35	P _{PREFSENS} +6 dB (Note 2)	See table 7.5.5.4.1-4	See table 7.5.5.4.1-4
	1 (F _{UL_high} +15) to (F _{UL_low} -20) to 12750	-15	P _{PREFSENS} +6 dB	—	CW carrier
31	(F _{UL_low} -20) to (F _{UL_high} +5)	-35	P _{PREFSENS} +6 dB (Note 2)	See table 7.5.5.4.1-4	See table 7.5.5.4.1-4
	1 (F _{UL_high} +5) to (F _{UL_low} -20) to 12750	-15	P _{PREFSENS} +6 dB	—	CW carrier
NOTE 1: P _{PREFSENS} depends on the channel bandwidth as specified in 3GPP TS 36.104 [11], subclause 7.2.1.					
NOTE 2: For a <i>multi-band TAB connector</i> , in case of interfering signal that is not in the in-band blocking frequency range of the operating band where the wanted signal is present, or in an adjacent or overlapping band, the wanted signal mean power is equal to P _{PREFSENS} + 1.4 dB.					

NOTE 2: Table 7.5.5.4.1-2 assumes that two operating bands, where the *downlink operating band* see subclause 4.5 of one band would be within the in-band blocking region of the other band, are not deployed in the same geographical area.

Table 7.5.5.4.1-3: Blocking performance requirement for Medium Range BS

Operating Band	Centre Frequency of Interfering Signal (MHz)	Interfering Signal mean power (dBm)	Wanted Signal mean power (dBm) (Note 1)	Interfering signal centre frequency minimum frequency offset to the lower/upper Base Station RF Bandwidth edge or sub-block edge inside a sub-block gap (MHz)	Type of Interfering Signal
1-7, 9-11, 13, 14, 18,19, 21-23, 24, 27, 30, 33-45, 48, 65, 66, 68, 70	(F _{UL_low} -20) to (F _{UL_high} +20)	-38	P _{PREFSENS} +6 dB (Note 2)	See table 7.5.5.4.1-4	See table 7.5.5.4.1-4
	1 (F _{UL_high} +20) to (F _{UL_low} -20) to 12750	-15	P _{PREFSENS} +6 dB	—	CW carrier
8, 26, 28	(F _{UL_low} -20) to (F _{UL_high} +10)	-38	P _{PREFSENS} +6 dB (Note 2)	See table 7.5.5.4.1-4	See table 7.5.5.4.1-4
	1 (F _{UL_high} +10) to (F _{UL_low} -20) to 12750	-15	P _{PREFSENS} +6 dB	—	CW carrier
12	(F _{UL_low} -20) to (F _{UL_high} +13)	-38	P _{PREFSENS} +6 dB (Note 2)	See table 7.5.5.4.1-4	See table 7.5.5.4.1-4
	1 (F _{UL_high} +13) to (F _{UL_low} -20) to 12750	-15	P _{PREFSENS} +6 dB	—	CW carrier
17	(F _{UL_low} -20) to (F _{UL_high} +18)	-38	P _{PREFSENS} +6 dB (Note 2)	See table 7.5.5.4.1-4	See table 7.5.5.4.1-4
	1 (F _{UL_high} +18) to (F _{UL_low} -20) to 12750	-15	P _{PREFSENS} +6 dB	—	CW carrier
20	(F _{UL_low} -11) to (F _{UL_high} +20)	-38	P _{PREFSENS} +6 dB (Note 2)	See table 7.5.5.4.1-4	See table 7.5.5.4.1-4
	1 (F _{UL_high} +20) to (F _{UL_low} -11) to 12750	-15	P _{PREFSENS} +6 dB	—	CW carrier
25	(F _{UL_low} -20) to (F _{UL_high} +15)	-38	P _{PREFSENS} +6 dB (Note 2)	See table 7.5.5.4.1-4	See table 7.5.5.4.1-4
	1 (F _{UL_high} +15) to (F _{UL_low} -20) to 12750	-15	P _{PREFSENS} +6 dB	—	CW carrier
31	(F _{UL_low} -20) to (F _{UL_high} +5)	-38	P _{PREFSENS} +6 dB (Note 2)	See table 7.5.5.4.1-4	See table 7.5.5.4.1-4
	1 (F _{UL_high} +5) to (F _{UL_low} -20) to 12750	-15	P _{PREFSENS} +6 dB	—	CW carrier

NOTE 1: P_{PREFSENS} depends on the channel bandwidth as specified in 3GPP TS 36.104 [11], subclause 7.2.1.
NOTE 2: For a *multi-band TAB connector*, in case of interfering signal that is not in the in-band blocking frequency range of the operating band where the wanted signal is present, or in an adjacent or overlapping band, the wanted signal mean power is equal to P_{PREFSENS} + 1.4 dB.

NOTE 3: Table 7.5.5.4.1-3 assumes that two operating bands, where the *downlink operating band* see subclause 4.5 of one band would be within the in-band blocking region of the other band, are not deployed in the same geographical area.

Table 7.5.5.4.1-4: Interfering signals for blocking performance requirement

E-UTRA channel BW of the lowest/highest carrier received (MHz)	Interfering signal centre frequency minimum offset to the lower/upper <i>Base Station RF Bandwidth edge</i> or sub-block edge inside a <i>sub-block gap</i> (MHz)	Type of interfering signal
1.4	±2.1	1.4 MHz E-UTRA signal
3	±4.5	3 MHz E-UTRA signal
5	±7.5	5 MHz E-UTRA signal
10	±7.5	5 MHz E-UTRA signal
15	±7.5	5 MHz E-UTRA signal
20	±7.5	5 MHz E-UTRA signal

NOTE 4: If the above Test Requirement differs from the Minimum Requirement then the Test Tolerance applied for this test is non-zero. The Test Tolerance for this test is defined in subclause 4.1.2 and the explanation of how the Minimum Requirement has been relaxed by the Test Tolerance is given in annex C.

7.5.5.4.2 Co-location with other base stations

This additional blocking requirement may be applied for the protection of E-UTRA receiver units associated with the *TAB connectors* under test when GSM, CMDA, UTRA or E-UTRA BS operating in a different frequency band are co-located with an E-UTRA BS. The requirement is applicable to all channel bandwidths supported by the E-UTRA BS.

The requirements in this clause assume a 30 dB coupling loss between interfering transmitter and E-UTRA BS receiver and are based on co-location with base stations of the same class.

For each measured E-UTRA carrier, the throughput shall be $\geq 95\%$ of the *maximum throughput* of the reference measurement channel, with a wanted and an interfering signal coupled to the *TAB connector* using the parameters in table 7.5.5.4.2-1 for AAS BS of Wide Area BS class, in table 7.5.5.4.2-2 for AAS BS of Local Area BS class and in table 7.5.5.4.2-3 for AAS BS of Medium Range BS class. The reference measurement channel for the wanted signal is specified in tables 7.2.5.3-1, 7.2.5.3-2 and 7.2.5.3-4 for each channel bandwidth and further specified in annex A of 3GPP TS 36.141 [17].

Table 7.5.5.4.2-1: Blocking performance requirement for E-UTRA when co-located with BS in other frequency bands

Type of co-located BS	Centre Frequency of Interfering Signal (MHz)	Interfering Signal mean power for WA BS (dBm)	Interfering Signal mean power for MR BS (dBm)	Interfering Signal mean power for LA BS (dBm)	Wanted Signal mean power (dBm) (Note 1)	Type of Interfering Signal
GSM850 or CDMA850	869 - 894	+16	+8	-6	$P_{\text{REFSENS}} + x \text{ dB}$	CW carrier
GSM900	921 - 960	+16	+8	-6	$P_{\text{REFSENS}} + x \text{ dB}$	CW carrier
DCS1800	1805 - 1880 (Note 4)	+16	+8	-6	$P_{\text{REFSENS}} + x \text{ dB}$	CW carrier
PCS1900	1930 - 1990	+16	+8	-6	$P_{\text{REFSENS}} + x \text{ dB}$	CW carrier
UTRA FDD Band I or E-UTRA Band 1 or NR band n1	2110 - 2170	+16	+8	-6	$P_{\text{REFSENS}} + x \text{ dB}$	CW carrier
UTRA FDD Band II or E-UTRA Band 2 or NR band n2	1930 - 1990	+16	+8	-6	$P_{\text{REFSENS}} + x \text{ dB}$	CW carrier
UTRA FDD Band III or E-UTRA Band 3 or NR band n3	1805 - 1880 (Note 4)	+16	+8	-6	$P_{\text{REFSENS}} + x \text{ dB}$	CW carrier
UTRA FDD Band IV or E-UTRA Band 4	2110 - 2155	+16	+8	-6	$P_{\text{REFSENS}} + x \text{ dB}$	CW carrier
UTRA FDD Band V or E-UTRA Band 5 or NR band n5	869 - 894	+16	+8	-6	$P_{\text{REFSENS}} + x \text{ dB}$	CW carrier
UTRA FDD Band VI or E-UTRA Band 6	875 - 885	+16	+8	-6	$P_{\text{REFSENS}} + x \text{ dB}$	CW carrier
UTRA FDD Band VII or E-UTRA Band 7	2620 - 2690	+16	+8	-6	$P_{\text{REFSENS}} + x \text{ dB}$	CW carrier
UTRA FDD Band VIII or E-UTRA Band 8 or NR band n8	925 - 960	+16	+8	-6	$P_{\text{REFSENS}} + x \text{ dB}$	CW carrier
UTRA FDD Band IX or E-UTRA Band 9	1844.9 - 1879.9	+16	+8	-6	$P_{\text{REFSENS}} + x \text{ dB}$	CW carrier
UTRA FDD Band X or E-UTRA Band 10	2110 - 2170	+16	+8	-6	$P_{\text{REFSENS}} + x \text{ dB}$	CW carrier
UTRA FDD Band XI or E-UTRA Band 11	1475.9 - 1495.9	+16	+8	-6	$P_{\text{REFSENS}} + x \text{ dB}$	CW carrier
UTRA FDD Band XII or E-UTRA Band 12 or NR band n12	729 - 746	+16	+8	-6	$P_{\text{REFSENS}} + x \text{ dB}$	CW carrier
UTRA FDD Band XIII or E-UTRA Band 13	746 - 756	+16	+8	-6	$P_{\text{REFSENS}} + x \text{ dB}$	CW carrier
UTRA FDD Band XIV or E-UTRA Band 14	758 - 768	+16	+8	-6	$P_{\text{REFSENS}} + x \text{ dB}$	CW carrier
E-UTRA Band 17	734 - 746	+16	+8	-6	$P_{\text{REFSENS}} + x \text{ dB}$	CW carrier
E-UTRA Band 18	860 - 875	+16	+8	-6	$P_{\text{REFSENS}} + x \text{ dB}$	CW carrier
UTRA FDD Band XIX or E-UTRA Band 19	875 - 890	+16	+8	-6	$P_{\text{REFSENS}} + x \text{ dB}$	CW carrier
UTRA FDD Band XX or E-UTRA Band 20 or NR band n20	791 - 821	+16	+8	-6	$P_{\text{REFSENS}} + x \text{ dB}$	CW carrier

Type of co-located BS	Centre Frequency of Interfering Signal (MHz)	Interfering Signal mean power for WA BS (dBm)	Interfering Signal mean power for MR BS (dBm)	Interfering Signal mean power for LA BS (dBm)	Wanted Signal mean power (dBm) (Note 1)	Type of Interfering Signal
UTRA FDD Band XXI or E-UTRA Band 21	1495.9 - 1510.9	+16	+8	-6	$P_{\text{REFSENS}} + x$ dB	CW carrier
UTRA FDD Band XXII or E-UTRA Band 22	3510 - 3590	+16	+8	-6	$P_{\text{REFSENS}} + x$ dB	CW carrier
E-UTRA Band 23	2180 - 2200	+16	+8	-6	$P_{\text{REFSENS}} + x$ dB	CW carrier
E-UTRA Band 24	1525 - 1559	+16	+8	-6	$P_{\text{REFSENS}} + x$ dB	CW carrier
UTRA FDD Band XXV or E-UTRA Band 25 or NR band n25	1930 - 1995	+16	+8	-6	$P_{\text{REFSENS}} + x$ dB	CW carrier
UTRA FDD Band XXVI or E-UTRA Band 26	859 - 894	+16	+8	-6	$P_{\text{REFSENS}} + x$ dB	CW carrier
E-UTRA Band 27	852 - 869	+16	+8	-6	$P_{\text{REFSENS}} + x$ dB	CW carrier
E-UTRA Band 28 or NR band n28	758 - 803	+16	+8	-6	$P_{\text{REFSENS}} + x$ dB	CW carrier
E-UTRA Band 29	717 - 728	+16	+8	-6	$P_{\text{REFSENS}} + 6$ dB	CW carrier
E-UTRA Band 30	2350 - 2360	+16	+8	-6	$P_{\text{REFSENS}} + x$ dB	CW carrier
E-UTRA Band 31	462.5 - 467.5	+16	+8	-6	$P_{\text{REFSENS}} + 6$ dB	CW carrier
UTRA FDD Band XXXII or E-UTRA Band 32	1452 - 1496 (Note 5)	+16	+8	-6	$P_{\text{REFSENS}} + 6$ dB	CW carrier
UTRA TDD Band a) or E-UTRA Band 33	1900-1920	+16	+8	-6	$P_{\text{REFSENS}} + x$ dB	CW carrier
UTRA TDD Band a) or E-UTRA Band 34 or NR band n34	2010-2025	+16	+8	-6	$P_{\text{REFSENS}} + x$ dB	CW carrier
UTRA TDD Band b) or E-UTRA Band 35	1850-1910	+16	+8	-6	$P_{\text{REFSENS}} + x$ dB	CW carrier
UTRA TDD Band b) or E-UTRA Band 36	1930-1990	+16	+8	-6	$P_{\text{REFSENS}} + x$ dB	CW carrier
UTRA TDD Band c) or E-UTRA Band 37	1910-1930	+16	+8	-6	$P_{\text{REFSENS}} + x$ dB	CW carrier
UTRA TDD Band d) or E-UTRA Band 38 or NR band n38	2570-2620	+16	+8	-6	$P_{\text{REFSENS}} + x$ dB	CW carrier
UTRA TDD Band f) or E-UTRA Band 39 or NR band n39	1880-1920	+16	+8	-6	$P_{\text{REFSENS}} + x$ dB	CW carrier
UTRA TDD Band e) or E-UTRA Band 40 or NR band n40	2300-2400	+16	+8	-6	$P_{\text{REFSENS}} + x$ dB	CW carrier
E-UTRA Band 41 or NR band n41	2496 - 2690	+16	+8	-6	$P_{\text{REFSENS}} + x$ dB	CW carrier
E-UTRA Band 42	3400 - 3600	+16	+8	-6	$P_{\text{REFSENS}} + x$ dB	CW carrier
E-UTRA Band 43	3600 - 3800	+16	+8	-6	$P_{\text{REFSENS}} + x$ dB	CW carrier
E-UTRA Band 44	703 - 803	+16	+8	-6	$P_{\text{REFSENS}} + x$ dB	CW carrier
E-UTRA Band 45	1447 - 1467	+16	+8	-6	$P_{\text{REFSENS}} + x$ dB	CW carrier
E-UTRA Band 46	5150 - 5925	N/A	+8	-6	$P_{\text{REFSENS}} + x$ dB	CW carrier
E-UTRA Band 48	3550 - 3700	+16	+8	-6	$P_{\text{REFSENS}} + x$ dB	CW carrier
E-UTRA Band 50 or NR band n50	1432 – 1517	+16	+8	-6	$P_{\text{REFSENS}} + x$ dB	CW carrier
E-UTRA Band 51 or NR band n51	1427– 1432	N/A	N/A	-6	$P_{\text{REFSENS}} + x$ dB	CW carrier
E-UTRA Band 65	2110 - 2200	+16	+8	-6	$P_{\text{REFSENS}} + x$ dB	CW carrier

Type of co-located BS	Centre Frequency of Interfering Signal (MHz)	Interfering Signal mean power for WA BS (dBm)	Interfering Signal mean power for MR BS (dBm)	Interfering Signal mean power for LA BS (dBm)	Wanted Signal mean power (dBm) (Note 1)	Type of Interfering Signal
E-UTRA Band 66 or NR band n66	2110 - 2200	+16	+8	-6	$P_{\text{REFSENS}} + x$ dB	CW carrier
E-UTRA Band 67	738 - 758	+16	+8	-6	$P_{\text{REFSENS}} + x$ dB	CW carrier
E-UTRA Band 68	753 - 783	+16	+8	-6	$P_{\text{REFSENS}} + x$ dB*	CW carrier
E-UTRA Band 69	2570 - 2620	+16	+8	-6	$P_{\text{REFSENS}} + x$ dB	CW carrier
E-UTRA Band 70 or NR band n70	1995 - 2020	+16	+8	-6	$P_{\text{REFSENS}} + x$ dB	CW carrier
E-UTRA Band 71 or or NR band n71	617 - 652	+16	+8	-6	$P_{\text{REFSENS}} + x$ dB	CW carrier
E-UTRA Band 72	461 - 466	+16	+8	-6	$P_{\text{REFSENS}} + x$ dB	CW carrier
E-UTRA Band 73	460 - 465	+16	+8	-6	$P_{\text{REFSENS}} + x$ dB	CW carrier
E-UTRA Band 74 or NR band n74	1475 - 1518	+16	+8	-6	$P_{\text{REFSENS}} + x$ dB	CW carrier
E-UTRA Band 75 or or NR band n75	1432 - 1517	+16	+8	-6	$P_{\text{REFSENS}} + x$ dB	CW carrier
E-UTRA Band 76 or or NR band n76	1427 - 1432	N/A	N/A	-6	$P_{\text{REFSENS}} + x$ dB	CW carrier
NR band n77	3300 - 4200	+16	+8	-6	$P_{\text{REFSENS}} + x$ dB	CW carrier
NR band n78	3300 - 3800	+16	+8	-6	$P_{\text{REFSENS}} + x$ dB	CW carrier
NR band n79	4400 - 5000	+16	+8	-6	$P_{\text{REFSENS}} + x$ dB	CW carrier

NOTE 1: P_{REFSENS} depends on the BS class and the channel bandwidth, see subclause 7.2. "x" is equal to 6 in case of E-UTRA wanted signals.

NOTE 2: Except for a *TAB connector* operating in Band 13, these requirements do not apply when the interfering signal falls within any of the supported *uplink operating band* or in the 10 MHz immediately outside any of the supported *uplink operating band*.
For a *TAB connector* operating in band 13 the requirements do not apply when the interfering signal falls within the frequency range 768-797MHz.

NOTE 3: Some combinations of bands may not be possible to co-site based on the requirements above. The current state-of-the-art technology does not allow a single generic solution for co-location of UTRA TDD or E-UTRA TDD with E-UTRA FDD on adjacent frequencies for 30 dB BS-BS minimum coupling loss. However, there are certain site-engineering solutions that can be used. These techniques are addressed in 3GPP TR 25.942 [21].

NOTE 4: In China, the blocking requirement for co-location with DCS1800 and Band III BS is only applicable in the frequency range 1805-1850 MHz.

NOTE 5: For a *TAB connector* operating in band 11 or 21, this requirement applies for interfering signal within the frequency range 1475.9-1495.9 MHz.

NOTE 6: Co-located TDD base stations that are synchronized and using the same or adjacent operating band can receive without special co-location requirements. For unsynchronized base stations, special co-location requirements may apply that are not covered by the 3GPP specifications.

Table 7.5.5.4.2-2: Void

Table 7.5.5.4.2-3: Void

7.6 Receiver spurious emissions

7.6.1 Definition and applicability

The receiver spurious emissions power is the power of emissions generated or amplified in a receiver unit that appear at the *TAB connector*. The requirements apply to all AAS BS with separate RX and TX *TAB connectors*.

NOTE: In this case for FDD AAS BS the test is performed when both TX and RX are on, with the TX *TAB connector* terminated.

For a *TAB connector* supporting both RX and TX in TDD, the requirements apply during the *transmitter OFF period*. For a *TAB connector* supporting both RX and TX in FDD, the receiver spurious requirements are superseded by the TX spurious requirements in 3GPP TS 37.105 [8], subclause 6.6.6.

For RX only *multi-band TAB connector(s)*, the RX spurious emissions requirements are subject to exclusion zones in each supported operating band. For *multi-band TAB connector(s)* that both transmit and receive in operating bands supporting TDD, RX spurious emissions requirements are applicable during the TX OFF period, and are subject to exclusion zones in each supported operating band. The unwanted emission level limit of a *TAB connector RX min cell group* is in general defined by the unwanted emission *basic limit* which is the same as the corresponding applicable *Non-AAS BS* per transmitter requirement specified in [3], [4], or [5], and its scaling by $N_{\text{RXU, counted per cell}}$. The *basic limits* and corresponding scaling are defined in each relevant subclause. The receiver spurious emission requirements are applied per the *TAB connector RX min cell groups* for all the configurations supported by the AAS BS.

7.6.2 Minimum Requirement

The minimum requirement for MSR operation is in 3GPP TS 37.105 [8], subclause 7.6.2.

The minimum requirement for single RAT UTRA operation is defined in 3GPP TS 37.105 [8], subclause 7.6.3.

The minimum requirement for single RAT E-UTRA operation is defined in 3GPP TS 37.105 [8], subclause 7.6.4.

7.6.3 Test Purpose

The test purpose is to verify the ability of the AAS BS to limit the interference caused by receiver spurious emissions to other systems.

7.6.4 Method of test

7.6.4.1 Initial conditions

Test environment:

- normal; see clause B.2

RF channels to be tested for single carrier:

- M; see subclause 4.12.1.

Base Station RF Bandwidth positions to be tested for multi-carrier:

- M_{RFBW} in single-band operation, see subclause 4.12.1, $B_{\text{RFBW}} \cdot T_{\text{RFBW}}$ and $B'_{\text{RFBW}} \cdot T_{\text{RFBW}}$ in multi-band operation, see subclause 4.12.1.

7.6.4.2 Procedure

7.6.4.2.1 General procedure

The general procedure steps apply to the procedures for all the RATs.

The minimum requirement is applied to all *TAB connectors* described in subclause 7.6.1, they may be tested one at a time or multiple *TAB connectors* may be tested in parallel as shown in annex D.2.4. Whichever method is used the procedure is repeated until all *TAB connectors* necessary to demonstrate conformance have been tested; see subclause 7.1.

- 1) Connect *TAB connector* to measurement equipment as shown in annex D.2.4. All *TAB connectors* not under test shall be terminated.

7.6.4.2.2 MSR operation

- 1) Set the measurement equipment parameters as specified in table 7.6.5.2.1-1.
- 2) Set the transmitter unit associated with the *TAB connector* under test to transmit with the carrier set-up and power allocation according to the applicable test configuration(s), see clause 5.
- 3) Measure the spurious emissions over each frequency range described in subclause 7.6.5.2.1.

In addition, for *multi-band TAB connector(s)*, the following steps shall apply:

- 4) For *multi-band TAB connectors* and single band tests, repeat the steps above per involved band where single band test configurations and test models shall apply with no carrier activated in the other band.

7.6.4.2.3 Single RAT UTRA FDD operation

- 1) For *TAB connector(s)* capable of single carrier operation only, set each *TAB connector* declared in the same RAT and operating band to transmit a signal according to TM1, (subclause 4.12.2), at the manufacturer's declared rated output power, $P_{\text{Rated,c,TABC}}$.

For *TAB connector(s)* declared to be capable of multi-carrier operation, set each *TAB connector* declared in the same RAT and operating band to transmit a signal according to TM1 on all carriers configured, using the applicable test configuration and corresponding power setting for receiver tests, as specified in subclause 4.11.

- 2) Set measurement equipment parameters as specified in table 7.6.4.2.3-1.
- 3) Measure the spurious emissions over each frequency range described in clause 7.6.5.2.2

Table 7.6.4.2.3-1: Measurement equipment parameters

Measurement Band width	3.84 MHz (Root raised cosine,0.22) / 100 kHz/ 1 MHz (note)
Sweep frequency range	30 MHz to 12.75GHz
Detection	True RMS
NOTE:	As defined in subclause 7.6.2.

In addition, for *multi-band TAB connector(s)*, the following steps shall apply:

- 4) For *multi-band TAB connectors* and single band tests, repeat the steps above per involved band where single band test configurations and test models shall apply with no carrier activated in the other band.

7.6.4.2.4 Single RAT UTRA TDD 1,28Mcps option operation

- 1) For *TAB connector(s)* capable of single carrier operation only, set each *TAB connector* declared in the same RAT and operating band to transmit a signal according to table 7.6.4.2.4-1, at the manufacturer's declared rated output power, $P_{\text{Rated,c,TABC}}$.

For *TAB connector(s)* declared to be capable of multi-carrier operation, set each *TAB connector* declared in the same RAT and operating band to transmit a signal according to table 7.6.4.2.4-1 on all carriers configured, using the applicable test configuration and corresponding power setting for receiver tests, as specified in subclause 4.11.

Table 7.6.4.2.4-1: Parameters of the transmitted signal for Rx spurious emissions test for 1,28 Mcps TDD

Parameter	Value/description
TDD Duty Cycle	TS i ; $i = 0, 1, 2, \dots, 6$: transmit, if i is 0,4,5,6; receive, if i is 1,2,3.
Time slots under test	TS1, TS2 and TS3
Number of DPCH in each time slot under test	8
Power of each DPCH	1/8 of Base Station output power
Data content of DPCH	real life (sufficient irregular)

- 2) Measure the power of the spurious emissions by applying the measuring equipment with the settings as specified in table 7.6.4.2.4-2. The characteristics of the measurement filter with the bandwidth 1,28 MHz shall be RRC with roll-off $\alpha = 0,22$. The characteristics of the measurement filters with bandwidths 100 kHz and 1 MHz shall be approximately Gaussian (typical spectrum analyzer filter). The centre frequency of the filters shall be stepped in contiguous steps over the frequency bands as specified in table 7.6.4.2.4-2. The time duration of each step shall be sufficiently long to capture one even (transmit) time slot.

In addition, for *multi-band TAB connector(s)*, the following steps shall apply:

- 3) For *multi-band TAB connectors* and single band tests, repeat the steps above per involved band where single band test configurations and test models shall apply with no carrier activated in the other band.

Table 7.6.4.2.4-2: Measurement equipment settings

Stepped frequency range	Measurement bandwidth	Step width	Note	Detection mode
30 MHz - 1 GHz	100 kHz	100 kHz	With the exception of frequencies between 4 MHz below the first carrier frequency and 4 MHz above the last carrier frequency used by the BS	true RMS
1 GHz - 1,880 GHz	1 MHz	1 MHz		
1,880 GHz - 1,980 GHz	1,28 MHz	200 kHz		
1,980 GHz - 2,010 GHz	1 MHz	1 MHz		
2,010 GHz - 2,025 GHz	1,28 MHz	200 kHz		
2,025 - 2,300 GHz	1 MHz	1 MHz		
2,300 GHz - 2,400 GHz	1,28 MHz	200 kHz		
2,400 GHz - 2,500 GHz	1 MHz	1 MHz		
2,500 GHz - 2,620 GHz	1,28 MHz	200 kHz		
2,620 GHz - 12,75 GHz	1 MHz	1 MHz		

7.6.4.2.5 Single RAT E-UTRA operation

- 1) Set the measurement equipment parameters as specified in table 7.6.5.2.5-1.
- 2) Set the *TAB connector(s)* to transmit with the carrier set-up and power allocation according to the applicable test configuration(s), see clause 5.
- 3) Measure the spurious emissions over each frequency range described in subclause 7.6.5.2.4.

In addition, for *multi-band TAB connector(s)*, the following steps shall apply:

- 4) For *multi-band TAB connectors* and single band tests, repeat the steps above per involved band where single band test configurations and test models shall apply with no carrier activated in the other band.

7.6.5 Test Requirements

7.6.5.1 General

Conformance may be shown to either the measure and sum test requirement or the per *TAB connector* test requirement.

- 1) The spurious emission test requirements for an AAS BS when using the measure and sum alternative are that for each *TAB connector RX cell group* and each applicable *basic limit* as specified in subclause 7.6.5.2, the power summation of emissions at the *TAB connectors* of the *TAB connector RX cell group* shall not exceed a limit specified as the *basic limit* + $10\log_{10}(N_{\text{RXU, countedpercell}})$.
- 2) The spurious emission test requirements for an AAS BS when using the per *TAB connector* alternative are that for each *TAB connector RX cell group* and each applicable *basic limit* as specified in subclause 7.6.5.2, the emissions at each of the *TAB connectors* of the *TAB connector RX cell group* shall not exceed a limit specified as the *basic limit* + $10\log_{10}(N_{\text{RXU, countedpercell}}) - 10\log(n)$ where n is the number of *TAB connectors* in the *TAB connector RX cell group*.

7.6.5.2 Basic limits

7.6.5.2.1 MSR operation

The basic limit for MSR operation is given below:

Table 7.6.5.2.1-1: General spurious emission test requirement

Frequency range	Maximum level	Measurement Bandwidth	Notes
30 MHz - 1 GHz	-57 dBm	100 kHz	
1 GHz - 12.75 GHz	-47 dBm	1 MHz	
12.75 GHz - 5 th harmonic of the upper frequency edge of the UL operating band in GHz	-47 dBm	1 MHz	Applies only for Bands 22, 42, 43 and 48.
NOTE: The frequency range from $F_{BW\,RF,DL,low} - 10\text{ MHz}$ to $F_{BW\,RF,DL,high} + 10\text{ MHz}$ may be excluded from the requirement. For BS capable of multi-band operation, the exclusion applies for all supported operating bands. For BS capable of multi-band operation where multiple bands are mapped on separate antenna connectors, the single-band requirements apply and the excluded frequency range is only applicable for the operating band supported on each antenna connector.			

In addition to the *basic limits* in table 7.6.5.2.1-1, Additional spurious emissions requirements in subclause 6.6.6.5.2.5 form *basic limits* for additional receiver spurious emission requirements.

In case of FDD BS (for BC1 and BC2), the levels specified for Protection of the BS receivers of own or different BS in subclause 6.6.6.5.2.4, form basic levels for additional receiver spurious emission requirements.

In addition, the requirements for co-location with other base stations specified in subclause 6.6.6.5.2.6, may also form basic levels for co-location spurious emission requirements.

7.6.5.2.2 Single RAT UTRA FDD operation

The basic limit for UTRA FDD operation is given below:

For *multi-band TAB connectors*, the exclusions and conditions in the Notes column of table 7.6.5.2.1-1 apply for each supported operating band. For BS capable of multi-band operation where multiple bands are mapped on separate antenna connectors, the single-band requirements apply and the excluded frequency range is only applicable for the operating band supported on each antenna connector.

Table 7.6.5.2.2-1: Spurious emission minimum requirement

Band	Maximum level	Measurement Bandwidth	Notes
30 MHz - 1 GHz	-57 dBm	100 kHz	With the exception of frequencies between 12.5 MHz below the first carrier frequency and 12.5 MHz above the last carrier frequency transmitted used by the BS.
1 GHz - 12.75 GHz	-47 dBm	1 MHz	With the exception of frequencies between 12.5 MHz below the first carrier frequency and 12.5 MHz above the last carrier frequency transmitted used by the BS.
12.75 GHz - 5 th harmonic of the upper frequency edge of the UL operating band in GHz	-47 dBm	1 MHz	NOTE: Applies only for Band XXII

In addition to the requirements in table 7.6.5.2.2-1, the power of any spurious emission shall not exceed the levels specified for Protection of the BS receiver of own or different BS in clause 6.6.6.5.2.4 and for Co-existence with other systems in the same geographical area in clause 6.6.6.5.2.5 and 6.6.6.5.2.6. In addition, the co-existence requirements for co-located base stations specified in clause 6.5.3.7.5 and 6.5.3.7.8.2 may also be applied.

NOTE: If the above Test Requirement differs from the Minimum Requirement then the Test Tolerance applied for this test is non-zero. The Test Tolerance for this test is defined in subclause 4.1.2 and the explanation of how the Minimum Requirement has been relaxed by the Test Tolerance is given in annex C.

7.6.5.2.3 Single RAT UTRA TDD 1,28Mcps option operation

The basic limits for UTRA TDD operation are given below:

Table 7.6.5.2.3-1: General receiver spurious emission minimum requirements

Band	Maximum level	Measurement Bandwidth	Note
30 MHz - 1 GHz	-57 dBm	100 kHz	
1 GHz - 12.75 GHz	-47 dBm	1 MHz	With the exception of frequencies between 4 MHz below the first carrier frequency and 4 MHz above the last carrier frequency used by the BS.

In addition to the requirements in table 7.6.5.2.3-1, the power of any spurious emission shall not exceed the levels specified for Co-existence with other systems in the same geographical area in subclause 6.6.6.5.2.4. In addition, the co-existence requirements for co-located base stations specified in subclause 6.6.6.5.2.5 and 6.6.6.5.2.6 may also be applied.

NOTE: If the above Test Requirement differs from the Minimum Requirement then the Test Tolerance applied for this test is non-zero. The Test Tolerance for this test is defined in subclause 4.1.2 and the explanation of how the Minimum Requirement has been relaxed by the Test Tolerance is given in annex C.

7.6.5.2.4 Single RAT E-UTRA operation

The basic limit for E-UTRA operation is given below:

Table 7.6.5.2.4-1: General spurious emission test requirement

Frequency range	Maximum level	Measurement Bandwidth	Note
30 MHz - 1 GHz	-57 dBm	100 kHz	
1 GHz - 12.75 GHz	-47 dBm	1 MHz	
12.75 GHz - 5 th harmonic of the upper frequency edge of the UL operating band in GHz	-47 dBm	1 MHz	Applies only for Bands 22, 42, 43 and 48.
NOTE: The frequency range from $F_{BW\ RF,DL,low} - 10\text{ MHz}$ to $F_{BW\ RF,DL,high} + 10\text{ MHz}$ may be excluded from the requirement. For a <i>multi-band TAB connector</i> , the exclusion applies for all supported operating bands.			

In addition to the requirements in table 7.6.5.2.4-1, the power of any spurious emission shall not exceed the additional spurious emissions requirements in subclause 6.6.6.5.2.5 and in case of a *TAB connector* operating FDD (for BC1 and BC2) emission shall not exceed the levels specified for protection of the BS receivers of own or different BS in subclause 6.6.6.5.2.4. In addition, the requirements for co-location with other Base Stations specified in subclause 6.6.6.5.2.6 may also be applied.

NOTE: If the above Test Requirement differs from the Minimum Requirement then the Test Tolerance applied for this test is non-zero. The Test Tolerance for this test is defined in subclause 4.1.2 and the explanation of how the Minimum Requirement has been relaxed by the Test Tolerance is given in annex C.

7.7 Receiver intermodulation

7.7.1 Definition and applicability

Third and higher order mixing of the two interfering RF signals can produce an interfering signal in the band of the desired channel. Intermodulation response rejection is a measure of the capability of the receiver unit to receive a wanted signal on its assigned channel frequency in the presence of two interfering signals which have a specific frequency relationship to the wanted signal. The requirement applies per *TAB connector*.

7.7.2 Minimum requirement

The minimum requirement for MSR operation is defined in 3GPP TS 37.105 [8], subclause 7.7.2.

The single RAT UTRA FDD AAS BS of Wide Area BS class shall fulfil minimum requirements for receiver intermodulation specified in 3GPP TS 25.104 [9], subclause 7.6.1.

The single RAT UTRA FDD AAS BS of Medium Range BS class shall fulfil minimum requirements for receiver intermodulation specified in 3GPP TS 25.104 [9], subclause 7.6.1.

The single RAT UTRA FDD AAS BS of Local Area BS class shall fulfil minimum requirements for receiver intermodulation specified in 3GPP TS 25.104 [9], subclause 7.6.1.

The single RAT UTRA TDD AAS BS of Wide Area BS class shall fulfil minimum requirements for receiver intermodulation specified in 3GPP TS 25.105 [10], subclause 7.6.1.2.

The single RAT UTRA TDD AAS BS of Local Area BS class shall fulfil minimum requirements for receiver intermodulation specified in 3GPP TS 25.105 [10], subclause 7.6.1.2.

The single RAT E-UTRA AAS BS of Wide Area BS class shall fulfil minimum requirements for receiver intermodulation specified in 3GPP TS 36.104 [11], subclause 7.8.

The single RAT E-UTRA AAS BS of Medium Range BS class shall fulfil minimum requirements for receiver intermodulation specified in 3GPP TS 36.104 [11], subclause 7.8.

The single RAT E-UTRA AAS BS of Local Area BS class shall fulfil minimum requirements for receiver intermodulation specified in 3GPP TS 36.104 [11], subclause 7.8.

7.7.3 Test purpose

The test purpose is to verify the ability of the receiver unit associated with the *TAB connector* under test to inhibit the generation of intermodulation products in its non-linear elements caused by the presence of two high-level interfering signals at frequencies with a specific relationship to the frequency of the wanted signal.

7.7.4 Method of test

7.7.4.1 Initial conditions

Test environment:

- Normal; see clause B.2.

RF channels to be tested for single carrier (SC):

- M; see subclause 4.12.1

Base Station RF Bandwidth positions to be tested:

- For *single-band TAB connector(s)*: M_{RFBW} if ATC4 is applicable; B_{RFBW} and T_{RFBW} for other ATC, see subclause 4.12.1. For *multi-band TAB connector(s)*: $B_{\text{RFBW}}T_{\text{RFBW}}$ and $B'_{\text{RFBW}}T_{\text{RFBW}}$, see subclause 4.12.1.

7.7.4.2 Procedure

7.7.4.2.1 General procedure

The general procedure steps apply to the procedures for all the RATs.

The minimum requirement is applied to all *TAB connectors*, the procedure is repeated until all *TAB connectors* necessary to demonstrate conformance have been tested; see subclause 7.1.

- 1) Connect *TAB connector* to measurement equipment as shown in annex D.2.6. All *TAB connectors* not under test shall be terminated.
- 2) Generate the wanted signal according to the applicable test configuration (see clause 5) using applicable reference measurement channel to the *TAB connector* under test as follows:
 - For E-UTRA see clause A.1 in 3GPP TS 36.141 [17].
 - For UTRA FDD see clause A.2 in 3GPP TS 25.141 [18].
 - For UTRA TDD see subclause A.2.1 in 3GPP TS 25.142 [20].
 - For NR, see subclause [4.11]
- 3) Set the transmitter unit associated with the *TAB connector* under test to transmit with the carrier set-up and power allocation according to the applicable test configuration(s) (see clause 5).

7.7.4.2.2 MSR operation

7.7.4.2.2.1 Procedure for general and narrowband intermodulation

- 1) Adjust the signal generators to the type of interfering signals, levels and the frequency offsets as specified in table 7.7.5.1.1-1 and Table 7.7.5.1.1-2 for general intermodulation requirement, and Table 7.7.5.2.1-1 and Table 7.7.5.2.1-2 for narrowband intermodulation requirement.
- 2) Measure the performance of the wanted signal at the receiver unit associated with the *TAB connector* under test, as defined in subclause 7.7.5.1.1 and 7.7.5.1.2, for the relevant carriers specified by the test configuration in clause 5.

In addition, for *multi-band TAB connector(s)*, the following steps shall apply:

- 3) For *multi-band TAB connectors* and single band tests, repeat the steps above per involved band where single band test configurations and test models shall apply with no carrier activated in the other band.

7.7.4.2.3 Single RAT UTRA FDD operation

- 1) Generate the wanted signal (reference signal) and adjust ATT1 to set the signal level to the *TAB connector* under test to the level specified in table 7.7.5.2-1. For a *TAB connector* supporting multi-carrier operation, generate the wanted signal according to the applicable test configuration (see clause 4.11) using applicable reference measurement channel to the *TAB connector* under test. Power settings are specified in table 7.7.5.2-1.
- 2) Adjust the signal generators to the type of interfering signals and the frequency offsets as specified in tables 7.7.5.2-1 and 7.7.5.2-2. Note that the GMSK modulated interfering signal shall have an ACLR of at least 72 dB in order to eliminate the impact of interfering signal adjacent channel leakage power on the intermodulation characteristics measurement.
- 3) Adjust the ATT2 and ATT3 to obtain the specified level of interfering signal at the *TAB connector*.
- 4) Measure the BER of the wanted signal. For a *TAB connector* supporting multi-carrier operation the BER shall be measured for all relevant carriers specified by the test configuration.

In addition, for *multi-band TAB connector(s)*, the following steps shall apply:

- 5) For *multi-band TAB connectors* and single band tests, repeat the steps above per involved band where single band test configurations and test models shall apply with no carrier activated in the other band.

7.7.4.2.4 Single RAT UTRA TDD 1,28Mcps option operation

- 1) Start transmission from the BS tester to the *TAB connector* using the UL reference measurement channel (12,2 kbps) defined in subclause A.2.1 of 3GPP TS 25.142 [20]. For a *TAB connector* supporting multi-carrier operation, generate the wanted signal using the applicable test configuration specified in subclause 4.11, and the UL reference measurement channel in subclause A.2.1 of 3GPP TS 25.142 [20] shall be used on all carriers for the *TAB connector* under test. The level of the UE simulator signal measured at the *TAB connector* shall be set to 6 dB above the reference sensitivity level specified in subclause 7.2.2.
- 2) Set the first signal generator to produce a CW signal with a level measured at the *TAB connector* as specified in table 7.7.5.3-1.
- 3) Set the second signal generator to produce an interfering signal equivalent to a wideband CDMA signal with one code of chip frequency 1,28 MHz, filtered by an RRC transmit pulse-shaping filter with roll-off $\alpha = 0,22$. The level of the signal measured at the *TAB connector* shall be set as specified in table 7.7.5.3-1.
- 4) Measure the BER of the wanted signal.

In addition, for *multi-band TAB connector(s)*, the following steps shall apply:

- 5) For *multi-band TAB connectors* and single band tests, repeat the steps above per involved band where single band test configurations and test models shall apply with no carrier activated in the other band.

7.7.4.2.5 Single RAT E-UTRA operation

- 1) Generate the wanted signal using the applicable test configuration specified in clause 5 and adjust the signal level to the *TAB connector* under test to the level specified in table 7.7.5.4-1.
- 2) Adjust the signal generators to the type of interfering signals, levels and the frequency offsets as specified in table 7.7.5.4-2 for intermodulation requirement and Table 7.7.5.4-3, Table 7.7.5.4-4 and Table 7.7.5.4-5 for narrowband intermodulation requirement.
- 3) Adjust the signal generators to obtain the specified level of interfering signal at the *TAB connector*.
- 4) Measure the throughput according to annex E of 3GPP TS 36.141 [17], for multi-carrier and/or CA operation the throughput shall be measured for relevant carriers specified by the test configuration specified in clause 5.

In addition, for *multi-band TAB connector(s)*, the following steps shall apply:

- 5) For *multi-band TAB connectors* and single band tests, repeat the steps above per involved band where single band test configurations and test models shall apply with no carrier activated in the other band.

7.7.5 Test requirements

7.7.5.1 MSR operation

7.7.5.1.1 General intermodulation test requirement

Interfering signals shall be a CW signal and an E-UTRA or UTRA signal, as specified in annex A of 3GPP TS 37.141 [16].

The requirement is applicable outside the *Base Station RF Bandwidth* or *Maximum Radio Bandwidth*. The interfering signal offset is defined relative to the *Base Station RF Bandwidth edges* or *Maximum Radio Bandwidth edges*.

For *multi-band TAB connector*, the requirement applies in addition inside any *Inter RF Bandwidth gap*, in case the gap size is at least twice as wide as the UTRA/E-UTRA interfering signal centre frequency offset from the RF bandwidth edge. The interfering signal offset is defined relative to the *Base Station RF Bandwidth edges* inside the *Inter RF Bandwidth gap*.

For the wanted signal at the assigned channel frequency and two interfering signals coupled to the *TAB connector*, using the parameters in table 7.7.5.1.1-1 and 7.7.5.1.1-2, the following requirements shall be met:

- For any measured E-UTRA carrier, the throughput shall be ≥ 95 % of the *maximum throughput* of the reference measurement channel defined in subclause 7.2.5.3.

- For any measured UTRA FDD carrier, the BER shall not exceed 0.001 for the reference measurement channel defined in subclause 7.2.5.1.
- For any measured UTRA TDD carrier, the BER shall not exceed 0.001 for the reference measurement channel defined in subclause 7.2.5.2.
- For any NR carrier, the throughput shall be $\geq 95\%$ of the maximum throughput of the reference measurement channel defined in TS 38.104 [36], subclause 7.2.

Table 7.7.5.1.1-1: General intermodulation requirement

Base Station Type	Mean power of interfering signals (dBm)	Wanted Signal mean power (dBm)	Type of interfering signal
Wide Area BS	-48 +y (Note 6)	$P_{\text{PREFSENS}} +x$ dB (Note 2, 5)	See Table 7.7.5.1.1-2
Medium Range BS	-44 +y (Note 6)	$P_{\text{PREFSENS}} +x$ dB (Note 3, 5)	
Local Area BS	-38 +y (Note 6)	$P_{\text{PREFSENS}} +x$ dB (Note 4, 5)	
NOTE 1: P_{PREFSENS} depends on the RAT, the BS class and on the channel bandwidth, see subclause 7.2.			
NOTE 2: For WA BS not supporting NR, "x" is equal to 6			
NOTE 3: For MR BS not supporting NR, "x" is equal to 6 in case of UTRA wanted signals, 9 in case of E-UTRA wanted signals.			
NOTE 4: For LA BS not supporting NR, "x" is equal to 12 in case of E-UTRA wanted signals, 6 in case of UTRA wanted signals.			
NOTE 5: For a BS that transmits NR in some configurations and does not transmit UTRA in any configuration, x is equal to 6.			
NOTE 6: For a BS not supporting NR, "y" is equal to zero for all BS classes. For a BS supporting NR and not supporting UTRA; "y" is equal to -4 for the WA BS class, -3 for the MR BS class and -6 for the LA BS class.			

Table 7.7.5.1.1-2: Interfering signals for intermodulation requirement

RAT of the carrier adjacent to the upper/lower Base Station RF Bandwidth edge	Interfering signal centre frequency offset from the Base Station RF Bandwidth edge [MHz]	Type of interfering signal
E-UTRA 1.4 MHz	± 2.0 (BC1 and BC3) / ± 2.1 (BC2)	CW
	± 4.9	1.4MHz E-UTRA signal
E-UTRA 3 MHz	± 4.4 (BC1 and BC3) / ± 4.5 (BC2)	CW
	± 10.5	3MHz E-UTRA signal
UTRA FDD and E-UTRA 5 MHz	± 7.5	CW
	± 17.5	5MHz E-UTRA signal
E-UTRA 10 MHz	± 7.375	CW
	± 17.5	5MHz E-UTRA signal
E-UTRA 15 MHz	± 7.25	CW
	± 17.5	5MHz E-UTRA signal
E-UTRA 20 MHz	± 7.125	CW
	± 17.5	5MHz E-UTRA signal
1.28 Mcps UTRA TDD	± 2.3 (BC3)	CW
	± 5.6 (BC3)	1.28Mcps UTRA TDD signal
NR 5 MHz	$[\pm 7.5]$	CW
	$[\pm 17.5]$	5MHz E-UTRA signal
NR 10 MHz	$[\pm 7.45]$	CW
	$[\pm 17.5]$	5MHz E-UTRA signal
NR 15 MHz	$[\pm 7.43]$	CW
	$[\pm 17.5]$	5MHz E-UTRA signal
NR 20 MHz	$[\pm 7.38]$	CW
	$[\pm 17.5]$	5MHz E-UTRA signal
NR 25 MHz	$[\pm 7.45]$	CW
	$[\pm 25]$	20MHz E-UTRA signal

NR 30 MHz	[±7.43]	CW
	[±25]	20MHz E-UTRA signal
NR 40 MHz	[±7.45]	CW
	[±25]	20MHz E-UTRA signal
NR 50 MHz	[±7.35]	CW
	[±25]	20MHz E-UTRA signal
NR 60 MHz	[±7.49]	CW
	[±25]	20MHz E-UTRA signal
NR 70 MHz	[±7.42]	CW
	[±25]	20MHz E-UTRA signal
NR 80 MHz	[±7.44]	CW
	[±25]	20MHz E-UTRA signal
NR 90 MHz	[±25]	CW
	[±7.43]	20MHz E-UTRA signal
NR 100 MHz	[±7.45]	CW
	[±25]	20MHz E-UTRA signal

7.7.5.1.2 General narrowband intermodulation test requirement

Interfering signals shall be a CW signal and an E-UTRA 1RB signal, as specified in annex A of 3GPP TS 37.141 [16].

The requirement is applicable outside the *Base Station RF Bandwidth* or maximum *Radio Bandwidth*. The interfering signal offset is defined relative to the *Base Station RF bandwidth edges* or maximum *Radio Bandwidth edges*.

For a *TAB connector* operating in non-contiguous spectrum within each supported operating band, the requirement applies in addition inside any *sub-block gap* in case the *sub-block gap* is at least as wide as the channel bandwidth of the E-UTRA interfering signal in table 7.7.5.1.2-2. The interfering signal offset is defined relative to the sub-block edges inside the gap.

For a *multi-band TAB connector*, the requirement applies in addition inside any *Inter RF Bandwidth gap* in case the gap size is at least as wide as the E-UTRA interfering signal in table 7.7.5.1.2-2. The interfering signal offset is defined relative to the RF bandwidth edges inside the *Inter RF Bandwidth gap*.

For the wanted signal at the assigned channel frequency and two interfering signals coupled to the Base Station antenna input, using the parameters in table 7.7.5.2-1 and 7.7.5.2-2, the following requirements shall be met:

- For any measured E-UTRA carrier, the throughput shall be $\geq 95\%$ of the *maximum throughput* of the reference measurement channel defined in subclause 7.2.5.3.
- For any NR carrier, the throughput shall be $\geq 95\%$ of the maximum throughput of the reference measurement channel defined in TS 38.104 [36], subclause 7.2.5.4.
- For any measured UTRA FDD carrier, the BER shall not exceed 0.001 for the reference measurement channel defined in subclause 7.2.5.1.
- For any measured UTRA TDD carrier, the BER shall not exceed 0.001 for the reference measurement channel defined in subclause 7.2.5.2.

Table 7.7.5.1.2-1: General narrowband intermodulation requirement

Base Station Type	Mean power of interfering signals (dBm)	Wanted Signal mean power (dBm)	Type of interfering signal
Wide Area BS	-52	P _{REFSENS} +x dB (Note)	See Table 7.7.5.1.2-2
Medium Range BS	-47		
Local Area BS	-44		
NOTE: P _{REFSENS} depends on the RAT, the BS class and on the channel bandwidth, see subclause 7.2 in 3GPP TS 37.104 [12]. "x" is equal to 6 in case of NR, E-UTRA or UTRA wanted signals.			

Table 7.7.5.1.2-2: Interfering signals for narrowband intermodulation requirement

RAT of the carrier adjacent to the upper/lower Base Station RF Bandwidth edge or sub-block edge	CW or 1RB interfering signal centre frequency offset from the Base Station RF Bandwidth edge or sub-block edge inside a gap [kHz]	Type of interfering signal
E-UTRA 1.4 MHz	± 260 (BC1 and BC3) / ± 270 (BC2)	CW
	± 970 (BC1 and BC3) / ± 790 (BC2)	1.4 MHz E-UTRA signal, 1 RB (NOTE 1)
E-UTRA or E-UTRA 3 MHz	± 260 (BC1 and BC3) / ± 270 (BC2)	CW
	± 960 (BC1 and BC3) / ± 780 (BC2)	3.0 MHz E-UTRA signal, 1 RB (NOTE 1)
E-UTRA 5 MHz	± 360	CW
	± 1060	5 MHz E-UTRA signal, 1 RB (NOTE 1)
E-UTRA 10 MHz (NOTE 2)	± 325	CW
	± 1240	5 MHz E-UTRA signal, 1 RB (NOTE 1)
E-UTRA 15 MHz (NOTE 2)	± 380	CW
	± 1600	5MHz E-UTRA signal, 1 RB (NOTE 1)
E-UTRA 20 MHz (NOTE 2)	± 345	CW
	± 1780	5MHz E-UTRA signal, 1 RB (NOTE 1)
UTRA FDD	± 345 (BC1 and BC2)	CW
	± 1780 (BC1 and BC2)	5MHz E-UTRA signal, 1 RB (NOTE 1)
1.28Mcps UTRA TDD	± 190 (BC3)	CW
	± 970 (BC3)	1.4 MHz E-UTRA signal, 1 RB (NOTE 1)
NR 5 MHz	$[\pm 360]$	CW
	$[\pm 1420]$	E-UTRA signal, 1 RB (NOTE 1)
NR 10 MHz	$[\pm 325]$	CW
	$[\pm 1780]$	E-UTRA signal, 1 RB (NOTE 1)
NR 15 MHz (Note 2)	$[\pm 380]$	CW
	$[\pm 1600]$	E-UTRA signal, 1 RB (NOTE 1)
NR 20 MHz (Note 2)	$[\pm 345]$	CW
	$[\pm 1780]$	E-UTRA signal, 1 RB (NOTE 1)
NR 25 MHz (Note 2)	$[\pm 325]$	CW
	$[\pm 1990]$	E-UTRA signal, 1 RB (NOTE 1)
NR 30 MHz (Note 2)	$[\pm 320]$	CW
	$[\pm 1990]$	E-UTRA signal, 1 RB (NOTE 1)
NR 40 MHz (Note 2)	$[\pm 310]$	CW
	$[\pm 2710]$	E-UTRA signal, 1 RB (NOTE 1)
NR 50 MHz (Note 2)	$[\pm 330]$	CW
	$[\pm 3250]$	E-UTRA signal, 1 RB (NOTE 1)
NR 60 MHz (Note 2)	$[\pm 350]$	CW
	$[\pm 3790]$	E-UTRA signal, 1 RB (NOTE 1)
NR 70 MHz (Note 2)	$[\pm 400]$	CW
	$[\pm 4870]$	E-UTRA signal, 1 RB (NOTE 1)
NR 80 MHz (Note 2)	$[\pm 390]$	CW
	$[\pm 4870]$	E-UTRA signal, 1 RB (NOTE 1)
NR 90 MHz (Note 2)	$[\pm 340]$	CW
	$[\pm 5770]$	E-UTRA signal, 1 RB (NOTE 1)
NR 100 MHz (Note 2)	$[\pm 340]$	CW
	$[\pm 5770]$	E-UTRA signal, 1 RB (NOTE 1)
NOTE 1: Interfering signal consisting of one resource block positioned at the stated offset, the channel bandwidth of the interfering signal is located adjacently to the Base Station RF Bandwidth edge.		
NOTE 2: This requirement shall apply only for an E-UTRA FRC A1-3 or NR G-FRC mapped to the frequency range at the channel edge adjacent to the interfering signals.		

7.7.5.2 Single RAT UTRA FDD operation

For each measured carrier, the BER shall not exceed 0,001 for the parameters specified in tables 7.7.5.2-1 and 7.7.5.2-2.

The intermodulation performance shall be met when the following signals are applied to the receiver.

For a *TAB connector* operating in non-contiguous spectrum within any operating band, the narrowband intermodulation requirement applies in addition inside any *sub-block gap*, in case the *sub-block gap* size is at least 6.8MHz. The CW interfering signal offset is defined relative to the lower/upper sub-block edge inside the *sub-block gap* and is equal to -1 MHz/+1 MHz, respectively. The GMSK modulated interfering signal offset is defined relative to the lower/upper sub-block edge inside the *sub-block gap* and is equal to -3.4 MHz/+3.4 MHz, respectively. The requirement applies separately for both sub-blocks.

For a *multi-band TAB connector*, the narrowband intermodulation requirement applies in addition inside any *Inter RF Bandwidth gap*, in case the *Inter RF Bandwidth gap* size is at least 6.8MHz. The CW interfering signal offset is defined relative to lower/upper *Base Station RF Bandwidth edges* inside the *Inter RF Bandwidth gap* and is equal to -1 MHz/+1 MHz, respectively. The GMSK modulated interfering signal offset is defined relative to lower/upper *Base Station RF Bandwidth edges* inside the *Inter RF Bandwidth gap* and is equal to -3.4 MHz/+3.4 MHz, respectively.

Table 7.7.5.2-1: Intermodulation performance requirement

Operating Band	Type of Signal	Offset	Signal mean power		
			Wide Area BS	Medium Range BS	Local Area
All bands	Wanted signal	-	-115 dBm	-105 dBm	-101 dBm
	CW signal	±10 MHz	-48 dBm	-44 dBm	-38 dBm
	WCDMA signal (Note)	±20 MHz	-48 dBm	-44 dBm	-38 dBm

NOTE: The characteristics of the W-CDMA interfering signal are specified in annex I of 3GPP TS 25.141 [18]

Table 7.7.5.2-2: Narrowband intermodulation performance requirement

Operating band	Type of Signal	Offset	Signal mean power		
			Wide Area BS	Medium Range BS	Local Area
II, III, IV, V, VIII, X, XII, XIII, XIV, XXV, XXVI	Wanted signal	-	-115 dBm	-105 dBm	-101 dBm
	CW signal	±3.5 MHz	- 47 dBm	- 43 dBm	-37 dBm
	GMSK modulated (Note)	±5.9 MHz	- 47 dBm	- 43 dBm	-37 dBm

NOTE: GMSK as defined in 3GPP TS 45.004 [22].

NOTE: If the above Test Requirement differs from the Minimum Requirement then the Test Tolerance applied for this test is non-zero. The Test Tolerance for this test is defined in subclause 4.1.2 and the explanation of how the Minimum Requirement has been relaxed by the Test Tolerance is given in annex C.

7.7.5.3 Single RAT UTRA TDD 1,28Mcps option operation

The BER measured shall not exceed 0,001.

The static reference performance as specified in clause 7.2.5.2 should be met when the following signals are coupled to the *TAB connector*.

- A wanted signal at the assigned channel frequency, with mean power 6 dB above the static reference level.
- Two interfering signals with the parameters specified in table 7.7.5.3-1.

The blocking requirement is always applicable outside the *Base Station RF bandwidth* or maximum *Radio Bandwidth edges*. The interfering signal offset is defined relative to the lower (upper) or maximum *Radio Bandwidth edges*.

For a *multi-band TAB connector*, the requirement applies in addition inside any *Inter RF Bandwidth gap*, in case the gap size is at least 11.2MHz. The CW interfering signal offset is defined relative to lower/upper *Base Station RF bandwidth edges* inside the *Inter RF Bandwidth gap* and is equal to -2.4 MHz/+2.4 MHz, respectively. The modulated interfering signal offset is defined relative to lower/upper *Base Station RF bandwidth edges* inside the *Inter RF Bandwidth gap* and is equal to -5.6MHz/+5.6MHz, respectively.

Table 7.7.5.3-1: Parameters of the interfering signals for intermodulation characteristics testing for 1,28 Mcps TDD

Interfering Signal mean power		Offset	Type of Interfering Signal
Wide Area BS	Local Area BS		
- 48 dBm	- 38 dBm	$\pm 3,2$ MHz	CW signal
- 48 dBm	- 38 dBm	$\pm 6,4$ MHz	1,28 Mcps TDD signal with one code

NOTE: If the above Test Requirement differs from the Minimum Requirement then the Test Tolerance applied for this test is non-zero. The Test Tolerance for this test is defined in subclause 4.1.2 and the explanation of how the Minimum Requirement has been relaxed by the Test Tolerance is given in annex C.

7.7.5.4 Single RAT E-UTRA operation

For each measured E-UTRA carrier, the throughput shall be $\geq 95\%$ of the *maximum throughput* of the reference measurement channel, with a wanted signal at the assigned channel frequency and two interfering signals with the conditions specified in tables 7.7.5.4-1 and 7.7.5.4-2 for intermodulation performance and in tables 7.7.5.4-3, 7.7.5.4-4 and 7.7.5.4-5 for narrowband intermodulation performance. The reference measurement channel for the wanted signal is specified in tables 7.2.5.3-1, 7.2.5.3-2 and 7.2.5.3-3 for each channel bandwidth and further specified in annex A of 3GPP TS 36.141 [17].

The receiver intermodulation requirement is always applicable outside the *Base Station RF bandwidth* or maximum *Radio Bandwidth* edges. The interfering signal offset is defined relative to the lower (upper) or maximum *Radio Bandwidth* edges.

For a *TAB connector* operating in non-contiguous spectrum within any operating band, the narrowband intermodulation requirement applies in addition inside any *sub-block gap* in case the *sub-block gap* is at least as wide as the channel bandwidth of the E-UTRA interfering signal in table 7.7.5.4-3. The interfering signal offset is defined relative to the sub-block edges inside the *sub-block gap*. The requirement applies separately for both sub-blocks.

For a *multi-band TAB connector*, the intermodulation requirement applies in addition inside any *Inter RF Bandwidth gap*, in case the gap size is at least twice as wide as the E-UTRA interfering signal centre frequency offset from the *Base Station RF bandwidth edge*.

For a *multi-band TAB connector*, the narrowband intermodulation requirement applies in addition inside any *Inter RF Bandwidth gap* in case the gap size is at least as wide as the E-UTRA interfering signal in tables 7.7.5.4-3, 7.7.5.4-4 and 7.7.5.4-5. The interfering signal offset is defined relative to the *Base Station RF bandwidth edges* inside the *Inter RF Bandwidth gap*.

Table 7.7.5.4-1: Intermodulation performance requirement

BS type	Wanted signal mean power (dBm) (Note)	Interfering signal mean power (dBm)	Type of interfering signal
Wide Area BS	$P_{\text{REFSENS}} + 6$ dB	-52	See Table 7.7.5.4-2
Medium Range BS	$P_{\text{REFSENS}} + 6$ dB	-47	
Local Area BS	$P_{\text{REFSENS}} + 6$ dB	-44	
NOTE: P_{REFSENS} depends on the channel bandwidth as specified in 3GPP TS 36.104 [11], subclause 7.2.1. For E-UTRA channel bandwidths 10, 15 and 20 MHz this requirement shall apply only for a FRC A1-3 mapped to the frequency range at the channel edge adjacent to the interfering signals.			

Table 7.7.5.4-2: Interfering signal for Intermodulation performance requirement

E-UTRA channel bandwidth of the lowest (highest) carrier received (MHz)	Interfering signal centre frequency offset from the lower (upper) edge (MHz)	Type of interfering signal
1.4	±2.1	CW
	±4.9	1.4 MHz E-UTRA signal
3	±4.5	CW
	±10.5	3 MHz E-UTRA signal
5	±7.5	CW
	±17.5	5 MHz E-UTRA signal
10	±7.375	CW
	±17.5	5 MHz E-UTRA signal
15	±7.25	CW
	±17.5	5 MHz E-UTRA signal
20	±7.125	CW
	±17.5	5 MHz E-UTRA signal

Table 7.7.5.4-3: Narrowband intermodulation performance requirement for Wide Area BS

E-UTRA channel bandwidth of the lowest (highest) carrier received (MHz)	Wanted signal mean power (dBm) (Note 1)	Interfering signal mean power (dBm)	Interfering RB centre frequency offset from the lower (upper) edge or sub-block edge inside a <i>sub-block gap</i> (kHz)	Type of interfering signal
1.4	P _{REFSENS} + 6 dB	-52	±270	CW
		-52	±790	1.4 MHz E-UTRA signal, 1 RB (Note 2)
3	P _{REFSENS} + 6	-52	±270	CW
		-52	±780	3.0 MHz E-UTRA signal, 1 RB (Note 2)
5	P _{REFSENS} + 6 dB	-52	±360	CW
		-52	±1060	5 MHz E-UTRA signal, 1 RB (Note 2)
10	P _{REFSENS} + 6 dB (Note 3)	-52	±325	CW
		-52	±1240	5 MHz E-UTRA signal, 1 RB (Note 2)
15	P _{REFSENS} + 6 dB (Note 3)	-52	±380	CW
		-52	±1600	5 MHz E-UTRA signal, 1 RB (Note 2)
20	P _{REFSENS} + 6 dB (Note 3)	-52	±345	CW
		-52	±1780	5 MHz E-UTRA signal, 1 RB (Note 2)
<p>NOTE 1: P_{REFSENS} is related to the channel bandwidth as specified in 3GPP TS 36.104 [11], subclause 7.2.1.</p> <p>NOTE 2: Interfering signal consisting of one resource block positioned at the stated offset, the channel bandwidth of the interfering signal is located adjacently to the lower (upper) edge.</p> <p>NOTE 3: This requirement shall apply only for a FRC A1-3 mapped to the frequency range at the channel edge adjacent to the interfering signals</p>				

Table 7.7.5.4-4: Narrowband intermodulation performance requirement for Local Area BS

E-UTRA channel bandwidth of the lowest (highest) carrier received (MHz)	Wanted signal mean power (dBm) (Note 1)	Interfering signal mean power (dBm)	Interfering RB centre frequency offset from the lower (upper) edge or sub-block edge inside a sub-block (kHz)	Type of interfering signal
1.4	$P_{\text{REFSENS}} + 6$ dB	-44	± 270	CW
		-44	± 790	1.4 MHz E-UTRA signal, 1 RB (Note 2)
3	$P_{\text{REFSENS}} + 6$	-44	± 275	CW
		-44	± 790	3.0 MHz E-UTRA signal, 1 RB (Note 2)
5	$P_{\text{REFSENS}} + 6$ dB	-44	± 360	CW
		-44	± 1060	5 MHz E-UTRA signal, 1 RB (Note 2)
10	$P_{\text{REFSENS}} + 6$ dB (Note 3)	-44	± 415	CW
		-44	± 1420	5 MHz E-UTRA signal, 1 RB (Note 2)
15	$P_{\text{REFSENS}} + 6$ dB (Note 3)	-44	± 380	CW
		-44	± 1600	5 MHz E-UTRA signal, 1 RB (Note 2)
20	$P_{\text{REFSENS}} + 6$ dB (Note 3)	-44	± 345	CW
		-44	± 1780	5 MHz E-UTRA signal, 1 RB (Note 2)
NOTE 1: P_{REFSENS} is related to the channel bandwidth as specified in 3GPP TS 36.104 [11], subclause 7.2.1.				
NOTE 2: Interfering signal consisting of one resource block positioned at the stated offset, the channel bandwidth of the interfering signal is located adjacently to the lower (upper) edge.				
NOTE 3: This requirement shall apply only for a FRC A1-3 mapped to the frequency range at the channel edge adjacent to the interfering signals.				

Table 7.7.5.4-5: Narrowband intermodulation performance requirement for Medium Range BS

E-UTRA channel bandwidth of the lowest (highest) carrier received (MHz)	Wanted signal mean power (dBm) (Note 1)	Interfering signal mean power (dBm)	Interfering RB centre frequency offset to the lower (higher) edge or sub-block edge inside a <i>sub-block gap</i> (kHz)	Type of interfering signal
1.4	$P_{\text{REFSENS}} + 6$ dB	-47	± 270	CW
		-47	± 790	1.4 MHz E-UTRA signal, 1 RB (Note 2)
3	$P_{\text{REFSENS}} + 6$	-47	± 270	CW
		-47	± 780	3.0 MHz E-UTRA signal, 1 RB (Note 2)
5	$P_{\text{REFSENS}} + 6$ dB	-47	± 360	CW
		-47	± 1060	5 MHz E-UTRA signal, 1 RB (Note 2)
10	$P_{\text{REFSENS}} + 6$ dB (Note 3)	-47	± 325	CW
		-47	± 1240	5 MHz E-UTRA signal, 1 RB (Note 2)
15	$P_{\text{REFSENS}} + 6$ dB (Note 3)	-47	± 380	CW
		-47	± 1600	5 MHz E-UTRA signal, 1 RB (Note 2)
20	$P_{\text{REFSENS}} + 6$ dB (Note 3)	-47	± 345	CW
		-47	± 1780	5 MHz E-UTRA signal, 1 RB (Note 2)
NOTE 1: P_{REFSENS} is related to the channel bandwidth as specified in 3GPP TS 36.104 [11], subclause 7.2.1.				
NOTE 2: Interfering signal consisting of one resource block positioned at the stated offset, the channel bandwidth of the interfering signal is located adjacently to the lower (higher) edge.				
NOTE 3: This requirement shall apply only for a FRC A1-3 mapped to the frequency range at the channel edge adjacent to the interfering signals				

NOTE: If the above Test Requirement differs from the Minimum Requirement then the Test Tolerance applied for this test is non-zero. The Test Tolerance for this test is defined in subclause 4.1.2 and the explanation of how the Minimum Requirement has been relaxed by the Test Tolerance is given in annex C.

7.8 In-channel selectivity

7.8.1 Definition and applicability

In-channel selectivity (ICS) is a measure of the receiver unit ability to receive a wanted signal at its assigned resource block locations in the presence of an interfering signal received at a larger power spectral density. In this condition a throughput requirement shall be met for a specified reference measurement channel. The requirement applies per *TAB connector*.

7.8.2 Minimum requirement

The minimum requirement for E-UTRA operation is defined in 3GPP TS 37.105 [8], subclause 7.8.4.

The minimum requirement for MSR operation is defined in 3GPP TS 37.105 [8], subclause 7.8.2.

7.8.3 Test purpose

The purpose of this test is to verify the ability of the receiver unit associated with the *TAB connector* under test to suppress the IQ leakage.

7.8.4 Method of test

7.8.4.1 Initial conditions

Test environment:

- normal; see subclause B.2

RF channels to be tested for single carrier:

- M; see subclause 4.12.1.

7.8.4.2 Procedure

The minimum requirement is applied to all *TAB connectors*, the procedure is repeated until all *TAB connectors* necessary to demonstrate conformance have been tested; see subclause 7.1.

- 1) Connect *TAB connector* to measurement equipment as shown in annex D.2.5. All *TAB connectors* not under test shall be terminated.

For each supported E-UTRA channel BW:

- 2) Adjust the signal generator for the wanted signal as specified in table 7.8.5-1 for AAS BS of Wide Area BS class, in table 7.8.5-2 for AAS BS of Local Area BS class and in table 7.8.5-3 for AAS BS of Medium Range BS class on one side of the F_C .
- 3) Adjust the signal generator for the interfering signal as specified in table 7.8.5-1 for AAS BS of Wide Area BS class, in table 7.8.5-2 for AAS BS of Local Area BS class and in table 7.8.5-3 for AAS BS of Medium Range BS class at opposite side of the F_C and adjacent to the wanted signal.
- 4) Measure throughput according to annex E in 3GPP TS 36.141 [17].
- 5) Repeat the measurement with the wanted signal on the other side of the F_C , and the interfering signal at opposite side of the F_C and adjacent to the wanted signal.

In addition, for *multi-band TAB connector(s)*, the following steps shall apply:

- 6) For *multi-band TAB connectors* and single band tests, repeat the steps above per involved band where single band test configurations and test models shall apply with no carrier activated in the other band.

7.8.5 Test requirements

For each measured E-UTRA carrier, the throughput shall be $\geq 95\%$ of the *maximum throughput* of the reference measurement channel as specified in [Annex A] with parameters specified in table 7.8.5-1 for AAS BS of Wide Area BS, class in Table 7.8.5-2 for AAS BS of Local Area BS class and in table 7.8.5-3 for AAS BS of Medium Range BS class.

Table 7.8.5-1: Wide Area BS in-channel selectivity for E-UTRA channels

E-UTRA channel bandwidth (MHz)	Reference measurement channel	Wanted signal mean power (dBm)		Interfering signal mean power (dBm)	Type of interfering signal
		$f \leq 3.0$ GHz	3.0 GHz $< f \leq 4.2$ GHz		
1.4	A1-4 in clause A.1	-105.5	-105.1	-87	1.4 MHz E-UTRA signal, 3 RBs
3	A1-5 in clause A.1	-100.7	-100.3	-84	3 MHz E-UTRA signal, 6 RBs
5	A1-2 in clause A.1	-98.6	-98.2	-81	5 MHz E-UTRA signal, 10 RBs
10	A1-3 in clause A.1	-97.1	-96.7	-77	10 MHz E-UTRA signal, 25 RBs
15	A1-3 in clause A.1 (Note)	-97.1	-96.7	-77	15 MHz E-UTRA signal, 25 RBs (Note)
20	A1-3 in clause A.1 (Note)	-97.1	-96.7	-77	20 MHz E-UTRA signal, 25 RBs (Note)

NOTE: Wanted and interfering signal are placed adjacently around F_C .

Table 7.8.5-2: Local Area BS in-channel selectivity for E-UTRA channels

E-UTRA channel bandwidth (MHz)	Reference measurement channel	Wanted signal mean power (dBm)		Interfering signal mean power (dBm)	Type of interfering signal
		$f \leq 3.0$ GHz	$3.0 \text{ GHz} < f \leq 4.2$ GHz		
1.4	A1-4 in clause A.1	-97.5	-97.1	-79	1.4 MHz E-UTRA signal, 3 RBs
3	A1-5 in clause A.1	-92.7	-92.3	-76	3 MHz E-UTRA signal, 6 RBs
5	A1-2 in clause A.1	-90.6	-90.2	-73	5 MHz E-UTRA signal, 10 RBs
10	A1-3 in clause A.1	-89.1	-88.7	-69	10 MHz E-UTRA signal, 25 RBs
15	A1-3 in clause A.1 (Note)	-89.1	-88.7	-69	15 MHz E-UTRA signal, 25 RBs (Note)
20	A1-3 in clause A.1 (Note)	-89.1	-88.7	-69	20 MHz E-UTRA signal, 25 RBs (Note)

NOTE: Wanted and interfering signal are placed adjacently around F_c .

Table 7.8.5-3: Medium Range BS in-channel selectivity for E-UTRA channels

E-UTRA channel bandwidth (MHz)	Reference measurement channel	Wanted signal mean power (dBm)		Interfering signal mean power (dBm)	Type of interfering signal
		$f \leq 3.0$ GHz	$3.0 \text{ GHz} < f \leq 4.2$ GHz		
1.4	A1-4 in clause A.1	-100.5	-100.1	-82	1.4 MHz E-UTRA signal, 3 RBs
3	A1-5 in clause A.1	-95.7	-95.3	-79	3 MHz E-UTRA signal, 6 RBs
5	A1-2 in clause A.1	-93.6	-93.2	-76	5 MHz E-UTRA signal, 10 RBs
10	A1-3 in clause A.1	-92.1	-91.7	-72	10 MHz E-UTRA signal, 25 RBs
15	A1-3 in clause A.1 (Note)	-92.1	-91.7	-72	15 MHz E-UTRA signal, 25 RBs (Note)
20	A1-3 in clause A.1 (Note)	-92.1	-91.7	-72	20 MHz E-UTRA signal, 25 RBs (Note)

NOTE: Wanted and interfering signal are placed adjacently around F_c .

For NR channels, the throughput shall be $\geq 95\%$ of the maximum throughput of the reference measurement channel as specified in annex A of 3GPP TS 38.104 [36] with parameters specified in Table 7.8.5-4 for Wide Area BS, in Table 7.8.5-5 for Medium Range BS and in Table 7.8.5-6 for Local Area BS. The characteristics of the interfering signal is further specified in annex A of 3GPP TS 38.104 [36].

Table 7.8.5-4: Wide Area BS in-channel selectivity for NR channels

NR channel bandwidth [MHz]	Subcarrier spacing [KHz]	Reference measurement channel	Wanted signal mean power [dBm]			Interfering signal mean power [dBm]	Type of interfering signal
			$f \leq 3.0\text{GHz}$	$3.0\text{GHz} < f \leq 4.2\text{GHz}$	$4.2\text{GHz} < f \leq 6.0\text{GHz}$		
5	15	G-FR1-A1-7	-99.2	-98.8	-98.1	-81.4	DFT-s-OFDM NR signal, SCS 15 kHz, 10 PRB
10,15,20,25,30	15	G-FR1-A1-1	-97.3	-96.9	-96.2	-77.4	DFT-s-OFDM NR signal, SCS 15 kHz, 25 PRB
40,50	15	G-FR1-A1-4	-90.9	-90.5	-89.8	-71.4	NR signal, SCS 15 kHz, 100 PRB
5	30	G-FR1-A1-8	-99.9	-99.5	-98.8	-81.4	DFT-s-OFDM NR signal, SCS 30 kHz, 5 PRB
10,15,20,25,30	30	G-FR1-A1-2	-97.4	-97	-96.3	-78.4	DFT-s-OFDM NR signal, SCS 30 kHz, 10 PRB
40,50,60,70,80,90,100	30	G-FR1-A1-5	-91.2	-90.8	-90.1	-71.4	DFT-s-OFDM NR signal, SCS 30 kHz, 50 PRB
10,15,20,25,30	60	G-FR1-A1-9	-96.8	-96.4	-95.7	-78.4	DFT-s-OFDM NR signal, SCS 60 kHz, 5 PRB
40,50,60,70,80,90,100	60	G-FR1-A1-6	-91.3	-90.9	-90.2	-71.6	DFT-s-OFDM NR signal, SCS 60 kHz, 24 PRB

NOTE: Wanted and interfering signal are placed adjacently around F_c .

Table 7.8.5-5: Medium Range BS in-channel selectivity for NR channels

NR channel bandwidth [MHz]	Subcarrier spacing [KHz]	Reference measurement channel	Wanted signal mean power [dBm]			Interfering signal mean power [dBm]	Type of interfering signal
			$f \leq 3.0\text{GHz}$	$3.0\text{GHz} < f \leq 4.2\text{GHz}$	$4.2\text{GHz} < f \leq 6.0\text{GHz}$		
5	15	G-FR1-A1-7	-94.2	-93.8	-93.1	-76.4	DFT-s-OFDM NR signal, SCS 15 kHz, 10 PRB
10,15,20,25,30	15	G-FR1-A1-1	-92.3	-91.9	-91.2	-72.4	DFT-s-OFDM NR signal, SCS 15 kHz, 25 PRB
40,50	15	G-FR1-A1-4	-85.9	-85.5	-84.8	-66.4	DFT-s-OFDM NR signal, SCS 15 kHz, 100 PRB
5	30	G-FR1-A1-8	-94.9	-94.5	-93.8	-76.4	DFT-s-OFDM NR signal, SCS 30 kHz, 5 PRB
10,15,20,25,30	30	G-FR1-A1-2	-92.4	-92	-91.3	-73.4	DFT-s-OFDM NR signal, SCS 30 kHz, 10 PRB
40,50,60,70,80,90,100	30	G-FR1-A1-5	-86.2	-85.8	-85.1	-66.4	DFT-s-OFDM NR signal, SCS 30 kHz, 50 PRB
10,15,20,25,30	60	G-FR1-A1-9	-91.8	-91.4	-90.7	-73.4	DFT-s-OFDM NR signal, SCS 60 kHz, 5 PRB
40,50,60,70,80,90,100	60	G-FR1-A1-6	-86.3	-85.9	-85.2	-66.6	DFT-s-OFDM NR signal, SCS 60 kHz, 24 PRB

NOTE: Wanted and interfering signal are placed adjacently around F_c .

Table 7.8.5-6: Local area BS in-channel selectivity for NR channels

NR channel bandwidth [MHz]	Subcarrier spacing [KHz]	Reference measurement channel	Wanted signal mean power [dBm]			Interfering signal mean power [dBm]	Type of interfering signal
			$f \leq 3.0\text{GHz}$	$3.0\text{GHz} < f \leq 4.2\text{GHz}$	$4.2\text{GHz} < f \leq 6.0\text{GHz}$		
5	15	G-FR1-A1-7	-91.2	-90.8	-90.1	-73.4	DFT-s-OFDM NR signal, SCS 15 kHz, 10 PRB
10,15,20,25,30	15	G-FR1-A1-1	-89.3	-88.9	-88.2	-69.4	DFT-s-OFDM NR signal, SCS 15 kHz, 25 PRB
40,50	15	G-FR1-A1-4	-82.9	-82.5	-81.8	-63.4	DFT-s-OFDM NR signal, SCS 15 kHz, 100 PRB
5	30	G-FR1-A1-8	-91.9	-91.5	-90.8	-73.4	DFT-s-OFDM NR signal, SCS 30 kHz, 5 PRB
10,15,20,25,30	30	G-FR1-A1-2	-89.4	-89	-88.3	-70.4	DFT-s-OFDM NR signal, SCS 30 kHz, 10 PRB
40,50,60,70,80,90,100	30	G-FR1-A1-5	-83.2	-82.8	-82.1	-63.4	DFT-s-OFDM NR signal, SCS 30 kHz, 50 PRB
10,15,20,25,30	60	G-FR1-A1-9	-88.8	-88.4	-87.7	-70.4	DFT-s-OFDM NR signal, SCS 60 kHz, 5 PRB
40,50,60,70,80,90,100	60	G-FR1-A1-6	-83.3	-82.9	-82.2	-63.6	DFT-s-OFDM NR signal, SCS 60 kHz, 24 PRB

NOTE: Wanted and interfering signal are placed adjacently around F_c

NOTE: If the above Test Requirement differs from the Minimum Requirement then the Test Tolerance applied for this test is non-zero. The Test Tolerance for this test is defined in subclause 4.1.2 and the explanation of how the Minimum Requirement has been relaxed by the Test Tolerance is given in annex C.

8 Performance requirements

8.1 General

Performance requirements specify the ability of the AAS BS to correctly demodulate signals in various conditions and configurations.

The demodulation requirements for an AAS BS are the same as non-AAS BS demodulation requirements specified for:

- *Single RAT UTRA operation* in 3GPP TS 25.104 [9] clause 8 for FDD operation, and in 3GPP TS 25.105 [10] clause 8 for TDD operation,
- *Single RAT E-UTRA operation* in 3GPP TS 36.104 [11], subclauses 8.2 – 8.4.
- NR operation in 3GPP TS 38.104 [36], subclauses 8.2-8.5.

The test requirements for the AAS BS performance requirements have hence been referenced from 3GPP TS 25.141 [18] clause 8 for UTRA FDD, 3GPP TS 25.142 [20] clause 8 for UTRA TDD, 3GPP TS 36.141 [17] subclauses 8.2 – 8.4 for E-UTRA and 3GPP TS 38.104 [36] subclauses 8.2 - 8.5 respectively. Necessary amendments for the AAS BS architecture are made in this subclause.

8.2 Performance requirements MSR

For *Single RAT UTRA operation* in FDD, the minimum performance requirements are specified in subclause 8.3.

For *Single RAT UTRA operation* in TDD 1,28Mcps option, the minimum performance requirements are specified in subclause 8.4.

For *Single RAT E-UTRA operation*, the minimum performance requirements are specified in subclause 8.5.

For *NR operation*, the minimum performance requirements are specified in subclause 8.6.

8.3 Performance requirements UTRA FDD

8.3.1 Definition and applicability

Performance requirements for *single RAT UTRA operation* in FDD are specified for the measurement channels defined in 3GPP TS 25.104 [2]. The requirements only apply to those measurement channels that are supported by AAS BS. For FRC8 in 3GPP TS 25.104 [2] the non E-DPCCH boosting and E-DPCCH boosting requirement only apply for the option supported by the AAS BS. The performance requirements for the high speed train scenarios defined in 3GPP TS 25.104 [2] and 3GPP TS 25.105 [3] are optional.

Unless stated otherwise, performance requirements apply for a single cell only. Performance requirements for an AAS BS supporting DC-HSUPA or DB-DC-HSUPA are defined in terms of single carrier requirements. The requirements in clause 8 shall be met with the transmitter unit(s) associated with the *TAB connectors(s)* in the operating band ON.

NOTE: In normal operating conditions the *TAB connector(s)* are configured to transmit and receive at the same time. The transmitter unit(s) associated with the *TAB connectors* may be OFF for some of the tests.

In the referred UTRA specifications and in this section, the term BS with RX diversity refers to performance requirements for two *demodulation branches*, and BS without RX diversity refers to performance requirements for one *demodulation branch*.

For AAS BS with RX diversity, only the BS performance requirements with RX diversity apply, the required E_b/N_0 shall be applied separately for each *demodulation branch*.

For AAS BS without RX diversity, only the BS performance requirements without RX diversity apply. The required E_b/N_0 shall be applied for each AAS BS *demodulation branch*.

The E_b/N_0 used is defined as:

$$E_b / N_o = \frac{E_c}{N_o} \cdot \frac{L_{chip}}{L_{inf}}$$

Where:

E_c is the received total energy of DPDCH, DPCCH, S-DPCCH, HS-DPCCH, E-DPDCH, S-E-DPDCH, E-DPCCH and S-E-DPCCH per PN chip per *demodulation branch* from all branches

N_o is the total one-sided noise power spectral density due to all noise sources

L_{chip} is the number of chips per frame

L_{inf} is the number of information bits in DTCH excluding CRC bits per frame

Table 8.3.1-1: Summary of AAS BS performance targets for *single RAT UTRA operation* in FDD

Physical channel	Measurement channel	Static	Multi-path Case 1	Multi-path Case 2	Multi-path Case 3	Moving	Birth / Death	High Speed Train (Note)
		Performance metric						
DCH	12.2 kbps	BLER<10 ⁻²	BLER<10 ⁻²	BLER<10 ⁻²	BLER<10 ⁻²	BLER <10 ⁻²	BLER <10 ⁻²	BLER <10 ⁻²
	64 kbps	BLER<10 ⁻¹ ,10 ⁻²	BLER<10 ⁻¹ ,10 ⁻²	BLER<10 ⁻¹ ,10 ⁻²	BLER <10 ⁻¹ ,10 ⁻² ,10 ⁻³	BLER <10 ⁻¹ ,10 ⁻²	BLER <10 ⁻¹ ,10 ⁻²	-
	144 kbps	BLER<10 ⁻¹ ,10 ⁻²	BLER<10 ⁻¹ ,10 ⁻²	BLER<10 ⁻¹ ,10 ⁻²	BLER <10 ⁻¹ ,10 ⁻² ,10 ⁻³	-	-	-
	384 kbps	BLER<10 ⁻¹ ,10 ⁻²	BLER<10 ⁻¹ ,10 ⁻²	BLER<10 ⁻¹ ,10 ⁻²	BLER <10 ⁻¹ ,10 ⁻² ,10 ⁻³	-	-	-

NOTE: Optional condition, not applicable for all BSs.

In the referenced test requirements from 3GPP TS 25.141 [15] the method to test describes connection to one or a number of BS antenna connectors. When applying these methods to the AAS BS connection shall be made to the declared *TAB connectors* (see table 4.10-1, D8.1) which represent the *demodulation branches*.

8.3.2 Minimum Requirement

The minimum requirements for the *single RAT UTRA operation* in FDD for each of the tests specified in subclauses 8.2 to 8.13 of 3GPP TS 25.141 [18] are the demodulation performance requirements specified in subclauses 8.2 to 8.12 of 3GPP TS 25.104 [9].

8.3.3 Test purpose

The test shall verify the receiver's ability to achieve the specified performance metrics under the measurement channels and conditions for a given E_c/N_0 or E_b/N_0 for each of the demodulation performance requirements specified in subclauses 8.2 to 8.12 of 3GPP TS 25.104 [9].

8.3.4 Method of test

8.3.4.1 Initial Conditions

The initial conditions for each of the tests as specified in subclauses 8.2 to 8.13 of 3GPP TS 25.141 [18], shall be the same as those specified in subclauses 8.2 to 8.13 of 3GPP TS 25.141 [18].

With the exception that instead of connecting to BS antenna connectors as stated in 3GPP TS 25.141 [18], clause 8 connection shall be made to the declared *TAB connectors* which represent the *demodulation branches* (see table 4.10-1, D6.74).

All unused *TAB connectors* shall be terminated. Receiver units associated with unused *TAB connectors* may be turned OFF.

8.3.4.2 Procedure

The initial conditions shall be the same as those specified in subclauses 8.2 to 8.13 of 3GPP TS 25.141 [18].

8.3.5 Test Requirement

The test requirements for each of the tests, as specified in subclauses 8.2 to 8.13 of 3GPP TS 25.141 [18], shall be the same as those in subclauses 8.2 to 8.13 of 3GPP TS 25.141 [18].

In the referenced test requirements in this section, the term "BS with RX diversity" should be replaced with performance requirements for two *demodulation branches*, and the term "BS without RX diversity" should be replaced with performance requirements for one *demodulation branch*.

8.4 Performance requirements UTRA TDD

8.4.1 Definition and applicability

Performance requirements for *single RAT UTRA operation* in TDD are specified for the measurement channels defined in 3GPP TS 25.105 [3]. The requirements only apply to those measurement channels that are supported by AAS BS. The performance requirements for the high speed train conditions defined in 3GPP TS 25.105 [3] are optional. All Bit Error Ratio (BER) and Block Error Rate (BLER) measurements shall be carried out according to the general rules for statistical testing defined in recommendation ITU-T O.153 [34] and annex F of 3GPP TS 25.142 [20].

Unless stated otherwise, performance requirements apply for a single carrier only. Performance requirements for a AAS BS supporting MC-HSUPA are defined in terms of single carrier requirements.

The characteristics of the white noise source, simulating interference from other cells (I_{oc}), shall comply with the AWGN interferer definition in 3GPP TS 25.105 [10], subclause 5.18.

In the referred UTRA specifications and in this section, the term BS with dual RX diversity refers to performance requirements for two *demodulation branches*, and BS without RX diversity refers to performance requirements for one *demodulation branch*.

For AAS BS with RX diversity, only the BS performance requirements with dual RX diversity apply, the required \hat{I}_{or}/I_{oc} shall be applied separately for each *demodulation branch*.

For AAS BS without RX diversity, only the BS performance requirements without dual RX diversity apply. The required \hat{I}_{or}/I_{oc} shall be applied for each AAS BS *demodulation branch*.

Table 8.4.1-1: Summary of AAS BS performance targets for *single RAT UTRA operation* in TDD

Physical channel	Measurement channel	Static	Multi-path Case 1	Multi-path Case 2 (Note)	Multi-path Case 3 (Note)	High speed train (Note)
		Performance metric				
DCH	12,2 kbps	BLER < 10 ⁻²	BLER < 10 ⁻²	BLER < 10 ⁻²	BLER < 10 ⁻²	BLER < 10 ⁻²
	64 kbps	BLER < 10 ⁻¹ , 10 ⁻²	BLER < 10 ⁻¹ , 10 ⁻²	BLER < 10 ⁻¹ , 10 ⁻²	BLER < 10 ⁻¹ , 10 ⁻² , 10 ⁻³	BLER < 10 ⁻¹ , 10 ⁻²
	144 kbps	BLER < 10 ⁻¹ , 10 ⁻²	BLER < 10 ⁻¹ , 10 ⁻²	BLER < 10 ⁻¹ , 10 ⁻²	BLER < 10 ⁻¹ , 10 ⁻² , 10 ⁻³	-
	384 kbps	BLER < 10 ⁻¹ , 10 ⁻²	BLER < 10 ⁻¹ , 10 ⁻²	BLER < 10 ⁻¹ , 10 ⁻²	BLER < 10 ⁻¹ , 10 ⁻² , 10 ⁻³	-

NOTE: Optional condition, not applicable for all BSs.

In the referenced test requirements from 3GPP TS 25.142 [19] the method to test describes connection to one or a number of BS antenna connectors. When applying these methods to the AAS BS connection shall be made to the declared *TAB connectors* (see table 4.10-1, D8.1) which represent the *demodulation branches*.

8.4.2 Minimum Requirement

The minimum requirements for the *single RAT UTRA operation* in TDD for each of the tests specified in subclauses 8.2 to 8.5 of 3GPP TS 25.142 [20] are the demodulation performance requirements specified in subclauses 8.2 to 8.5 of 3GPP TS 25.105 [10].

8.4.3 Test purpose

The test shall verify the receiver's ability to achieve the specified performance metrics under the measurement channels and conditions for a given \hat{I}_{or}/I_{oc} for each of the demodulation performance requirements specified in subclauses 8.2 to 8.5 of 3GPP TS 25.105 [10].

8.4.4 Method of test

8.4.4.1 Initial Conditions

The initial conditions for each of the tests as specified in subclauses 8.2 to 8.5 of 3GPP TS 25.142 [20], shall be the same as those specified in subclauses 8.2 to 8.5 of 3GPP TS 25.142 [20].

With the exception that instead of connecting to BS antenna connectors as stated in subclauses 8.2 to 8.5 of 3GPP TS 25.142 [20] connection shall be made to the declared *TAB connectors* which represent the *demodulation branches* (see table 4.10-1, D6.74).

All unused *TAB connectors* shall be terminated. Receiver units associated with unused *TAB connectors* may be turned OFF.

8.4.4.2 Procedure

The initial conditions shall be the same as those specified in subclauses 8.2 to 8.5 of 3GPP TS 25.142 [20].

8.4.5 Test Requirement

The test requirements for each of the tests, as specified in subclauses 8.2 to 8.5 of 3GPP TS 25.142 [20], shall be the same as those in subclauses 8.2 to 8.5 of 3GPP TS 25.142 [20].

In the referenced test requirements in this section, the term "BS with RX diversity" should be replaced with performance requirements for two *demodulation branches*, and the term "BS without RX diversity" should be replaced with performance requirements for one *demodulation branch*.

8.5 Performance requirements E-UTRA

8.5.1 Definition and applicability

Performance requirements for *single RAT E-UTRA operation* are specified for the fixed reference channels (FRC) and propagation conditions defined in 3GPP TS 36.104 [8] annex A and annex B, respectively. The requirements only apply to those FRCs that are supported by the AAS BS.

Unless stated otherwise, performance requirements apply for a single carrier only. Performance requirements for a *single RAT E-UTRA operation* supporting carrier aggregation are defined in terms of single carrier requirements. For FDD operation the requirements shall be met with the transmitter unit(s) associated with the *TAB connectors(s)* in the operating band ON.

NOTE: In normal operating conditions the *TAB connector(s)* in FDD operation are configured to transmit and receive at the same time. The transmitter unit(s) associated with the *TAB connectors* may be OFF for some of the tests.

In the referred E-UTRA specification, the term "RX antennas" refers to *demodulation branches* (i.e. not physical antennas).

The SNR used in this clause is specified based on a single carrier and defined as:

$$\text{SNR} = S / N$$

Where:

S is the total signal energy in the subframe on a single *TAB connector*.

N is the noise energy in a bandwidth corresponding to the transmission bandwidth over the duration of a subframe.

For enhanced performance requirements type A in 3GPP TS 36.104 [4], the SINR used in this clause is specified based on a single carrier and defined as:

$$\text{SINR} = S / N'$$

Where:

S is the total signal energy in the subframe on a single *TAB connector*.

N' is the summation of the received energy of the strongest interferers explicitly defined in a test procedure plus the white noise energy N , in a bandwidth corresponding to the transmission bandwidth over the duration of a subframe on a single *TAB connector*. The respective energy of each interferer relative to N' is defined by its associated DIP value.

In the referenced test requirements from 3GPP TS 36.141 [14] the method to test describes connection to one or a number of BS antenna connectors. When applying these methods to the AAS BS connection shall be made to the declared *TAB connectors* (see table 4.10-1, D8.1) which represent the *demodulation branches*.

8.5.2 Minimum Requirement

The minimum requirements for *single RAT E-UTRA operation* for each of the tests specified in subclauses 8.2 to 8.4 of 3GPP TS 36.141 [17] are the demodulation performance requirements specified in subclauses 8.2 to 8.4 of 3GPP TS 36.104 [11].

8.5.3 Test purpose

The test shall verify the receiver's ability to achieve the specified performance metrics under the measurement channels and conditions for a given SNR or SINR for each of the demodulation performance requirements specified in subclauses 8.2 to 8.4 of 3GPP TS 36.104 [11].

8.5.4 Method of test

8.5.4.1 Initial Conditions

The initial conditions for each of the tests as specified in subclauses 8.2 to 8.4 of 3GPP TS 36.141 [17], shall be the same as those specified in subclauses 8.2 to 8.4 of 3GPP TS 36.141 [17].

With the exception that instead of connecting to BS antenna connectors as stated in 3GPP TS 36.141 [17] clause 8 connection shall be made to the declared *TAB connectors* which represent the *demodulation branches* (see table 4.10-1, D6.74).

All unused *TAB connectors* shall be terminated. Receiver units associated with unused *TAB connectors* may be turned OFF.

8.5.4.2 Procedure

The procedure shall be the same as those specified in subclauses 8.2 to 8.4 of 3GPP TS 36.141 [17].

8.5.5 Test Requirement

The test requirements for each of the tests, as specified in subclauses 8.2 to 8.4 of 3GPP TS 36.141 [17], shall be the same as those in subclauses 8.2 to 8.4 of 3GPP TS 36.141 [17].

In the referenced test requirements in this section, the term "number of RX antennas" should be replaced by the number of *demodulation branches*.

8.6 Performance requirements NR

TBD

Annex A (normative): Characteristics of interfering signals

Annex B (normative): Environmental requirements for the BS equipment

B.1 General

For each test in the present document, the environmental conditions under which the AAS BS is to be tested are defined. The environmental conditions and class shall be from the relevant IEC specifications or the corresponding ETSI specifications.

B.2 Normal test environment

When a normal test environment is specified for a test, the test should be performed within the minimum and maximum limits of the conditions stated in table B.2-1.

Table B.2-1: Limits of conditions for Normal Test Environment

Condition	Minimum	Maximum
Barometric pressure	86 kPa	106 kPa
Temperature	15°C	30°C
Relative Humidity	20 %	85 %
Power supply	Nominal, as declared by the manufacturer	
Vibration	Negligible	

The ranges of barometric pressure, temperature and humidity represent the maximum variation expected in the uncontrolled environment of a test laboratory. If it is not possible to maintain these parameters within the specified limits, the actual values shall be recorded in the test report.

B.3 Extreme test environment

B.3.1 General

The manufacturer shall declare one of the following:

- 1) the equipment class for the equipment under test, as defined in the IEC 60721-3-3 [27] or ETSI EN 300 019-1-3 [29] ("Stationary use at weather protected locations");
- 2) the equipment class for the equipment under test, as defined in the IEC 60721-3-4 [28] or ETSI EN 300 019-1-4 [30] ("Stationary use at non weather protected locations");
- 3) the equipment that does not comply to the mentioned classes, the relevant classes from IEC 60721 [26] documentation for Temperature, Humidity and Vibration shall be declared.

NOTE: Reduced functionality for conditions that fall outside of the standard operational conditions are not tested in the present document. These may be stated and tested separately.

B.3.2 Extreme temperature

When an extreme temperature test environment is specified for a test, the test shall be performed at the standard minimum and maximum operating temperatures defined by the manufacturer's declaration for the equipment under test.

Minimum temperature:

The test shall be performed with the environment test equipment and methods including the required environmental phenomena into the equipment, conforming to the test procedure of IEC 60068-2-1 [31].

Maximum temperature:

The test shall be performed with the environmental test equipment and methods including the required environmental phenomena into the equipment, conforming to the test procedure of IEC 60068-2-2 [32].

NOTE: It is recommended that the equipment is made fully operational prior to the equipment being taken to its lower operating temperature.

B.4 Vibration

When vibration conditions are specified for a test, the test shall be performed while the equipment is subjected to a vibration sequence as defined by the manufacturer's declaration for the equipment under test. This shall use the environmental test equipment and methods of inducing the required environmental phenomena in to the equipment, conforming to the test procedure of IEC 60068-2-6 [33]. Other environmental conditions shall be within the ranges specified in annex B.2.

NOTE: The higher levels of vibration may induce undue physical stress in to equipment after a prolonged series of tests. The testing body should only vibrate the equipment during the RF measurement process.

B.5 Power supply

When extreme power supply conditions are specified for a test, the test shall be performed at the standard upper and lower limits of operating voltage defined by manufacturer's declaration for the equipment under test.

Upper voltage limit:

The equipment shall be supplied with a voltage equal to the upper limit declared by the manufacturer (as measured at the input terminals to the equipment). The tests shall be carried out at the steady state minimum and maximum temperature limits declared by the manufacturer for the equipment, to the methods described in IEC 60068-2-1 [31] Test Ab/Ad and IEC 60068-2-2 [32] Test Bb/Bd: Dry Heat.

Lower voltage limit:

The equipment shall be supplied with a voltage equal to the lower limit declared by the manufacturer (as measured at the input terminals to the equipment). The tests shall be carried out at the steady state minimum and maximum temperature limits declared by the manufacturer for the equipment, to the methods described in IEC 60068-2-1 [31] Test Ab/Ad and IEC 60068-2-2 [32] Test Bb/Bd: Dry Heat.

B.6 Measurement of test environments

The measurement accuracy of the BS test environments shall be:

Pressure:	±5 kPa.
Temperature:	±2 degrees.
Relative Humidity:	±5 %.
DC Voltage:	±1,0 %.
AC Voltage:	±1,5 %.
Vibration:	10 %.
Vibration frequency:	0,1 Hz.

The above values shall apply unless the test environment is otherwise controlled and the specification for the control of the test environment specifies the uncertainty for the parameter.

Annex C (informative): Test tolerances and derivation of test requirements

Test requirements which are included by reference to 3GPP TS 25.141 [15], 3GPP TS 25.142 [19], 3GPP TS 36.141 [14] or 3GPP TS 37.141 [13] have been calculated within the referred test specification using the Test Tolerances defined therein.

Annex D (informative): Measurement system set-up

D.1 Transmitter

D.1.1 AAS BS output power, transmitter ON/OFF power, modulation quality, frequency error and operating band unwanted emissions

TAB connectors may be connected to the measurement equipment singularly and tested one at a time (figure D.1.1-1), or may be tested simultaneously in groups (figure D.1.1-2) where the group size may range from two to all the *TAB connectors* which are subject to particular transmitter test in this test setup.

In all cases the measurement is per *TAB connector* but the measurement may be done in parallel.

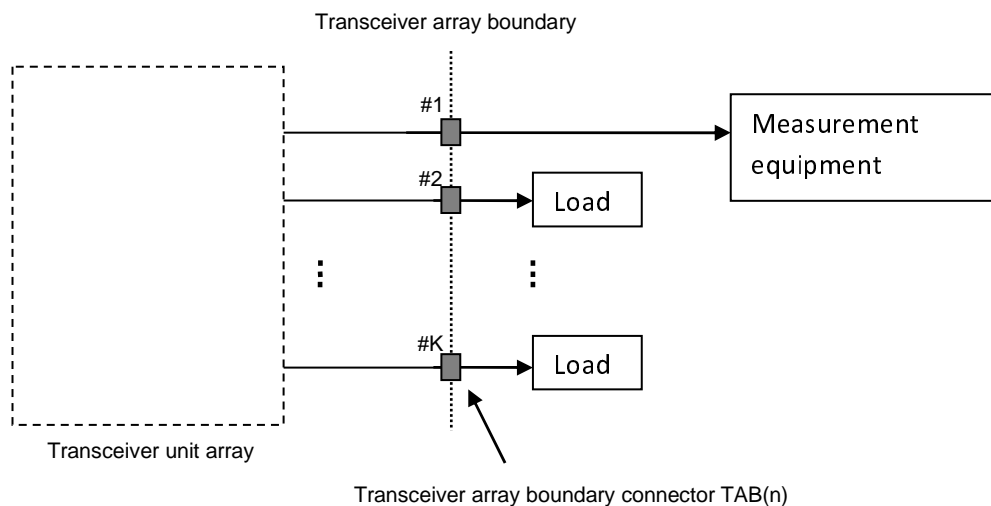

Figure D.1.1-1: Measuring system set-up for AAS BS output power, transmitter ON/OFF power, modulation quality, frequency error and operating band unwanted emissions for a single TAB connector

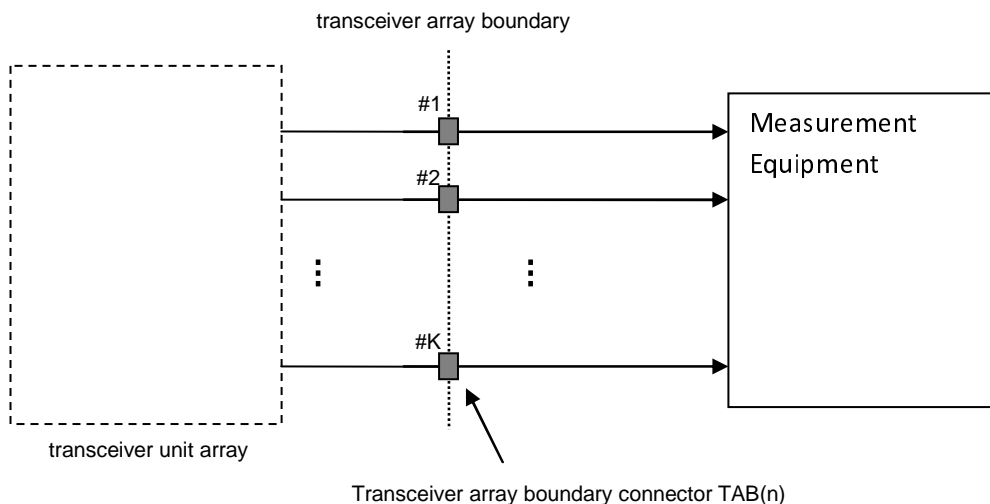

Figure D.1.1-2: Measuring system set-up for AAS BS output power, transmitter ON/OFF power, modulation quality, frequency error and operating band unwanted emissions for multiple TAB connectors

D.1.2 Transmitter intermodulation

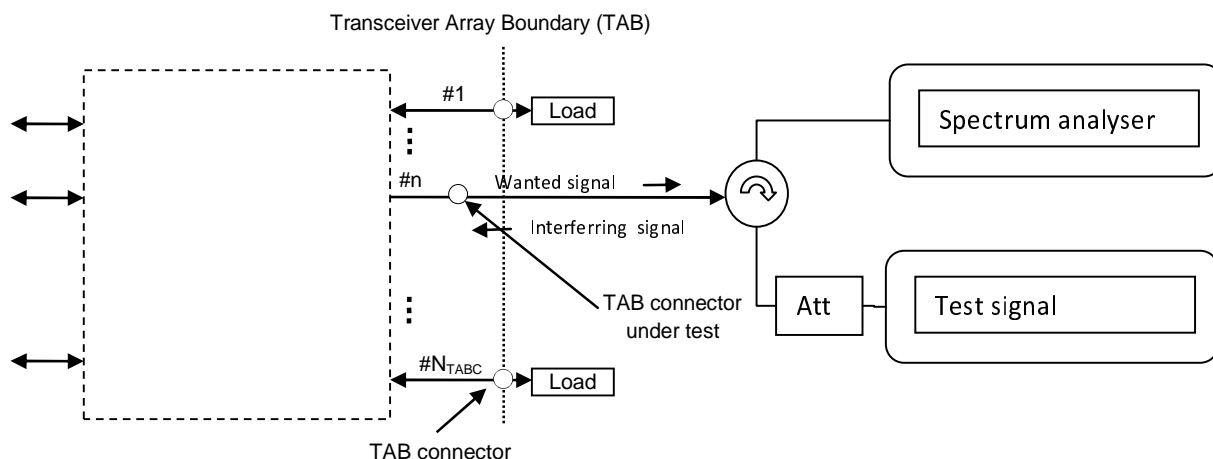

Figure D.1.2-1: Measuring system set-up for transmitter intermodulation

D.1.3 Transmitter spurious emissions

TAB connectors may be connected to the measurement equipment singularly and tested one at a time (figure D.1.3-1), or may be tested simultaneously in groups (figure D.1.3-2) where the group size may range from two to all the TAB connectors which are subject to transmitter spurious emissions test.

In all cases the measurement is per TAB connector but the measurement may be done in parallel.

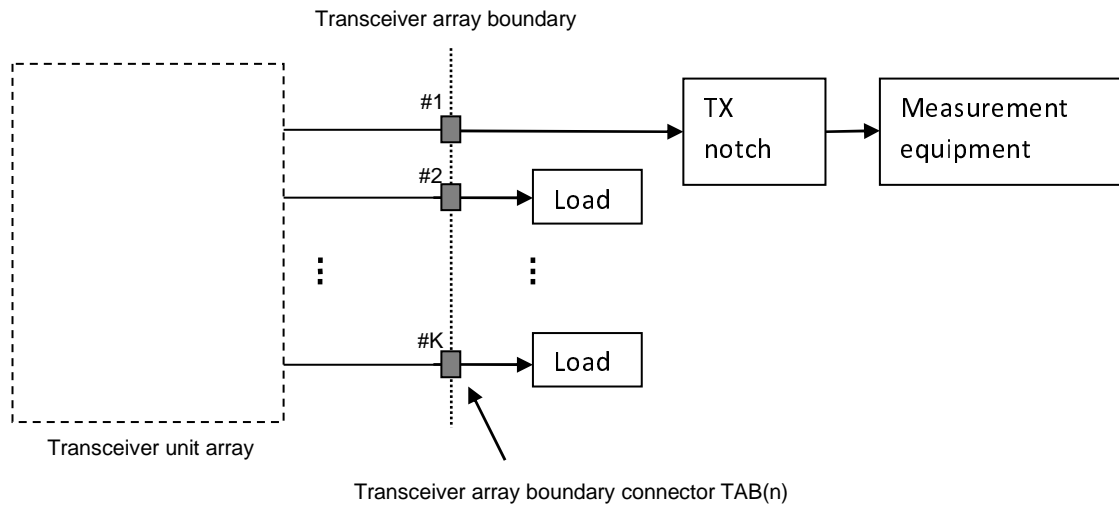

Figure D.1.3-1: Measuring system set-up for transmitter spurious emissions for a single *TAB* connector

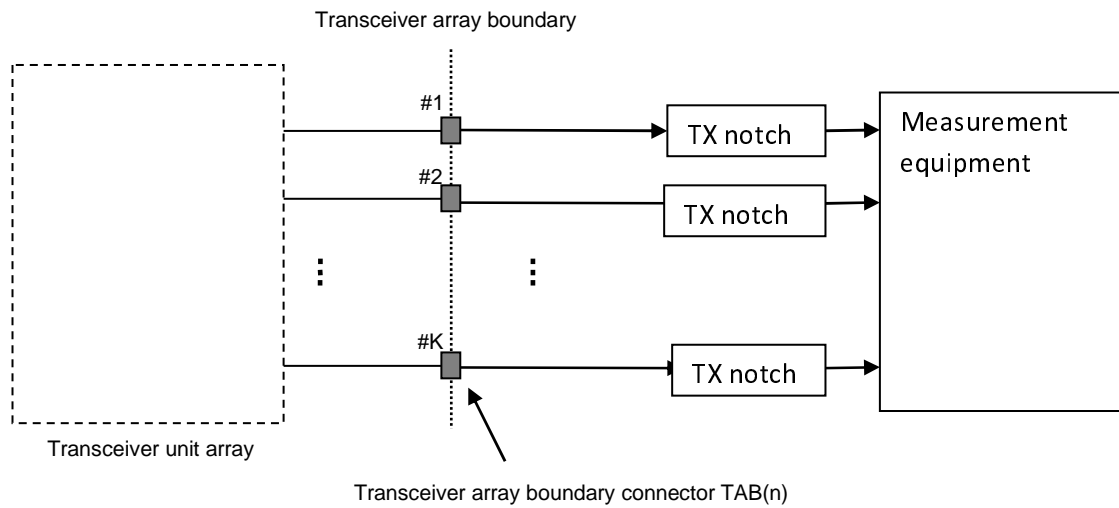

Figure D.1.3-2: Measuring system set-up for transmitter spurious emissions for multiple *TAB* connectors in parallel test

D.2 Receiver

D.2.1 Reference sensitivity level

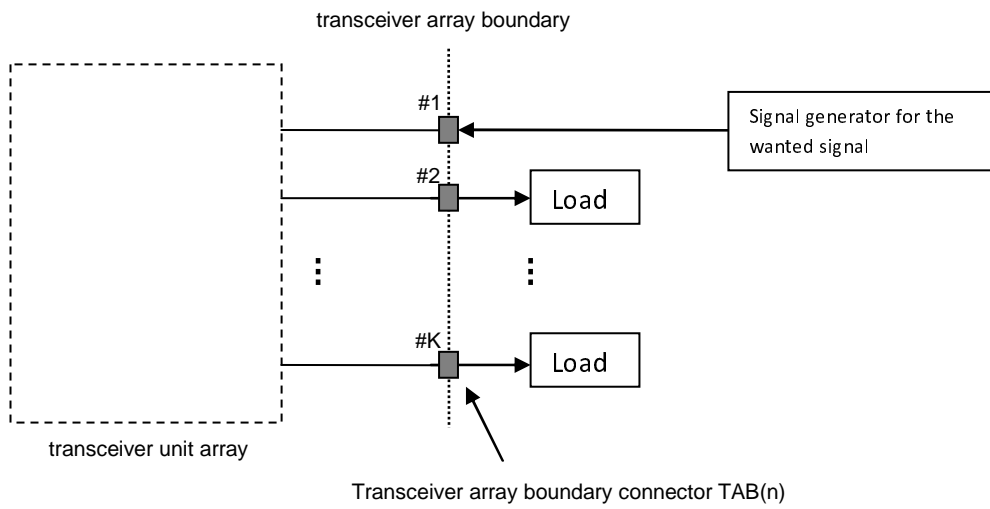

Figure D.2.1-1: Measuring system Set-up for Reference sensitivity level Test

D.2.2 Receiver Dynamic Range

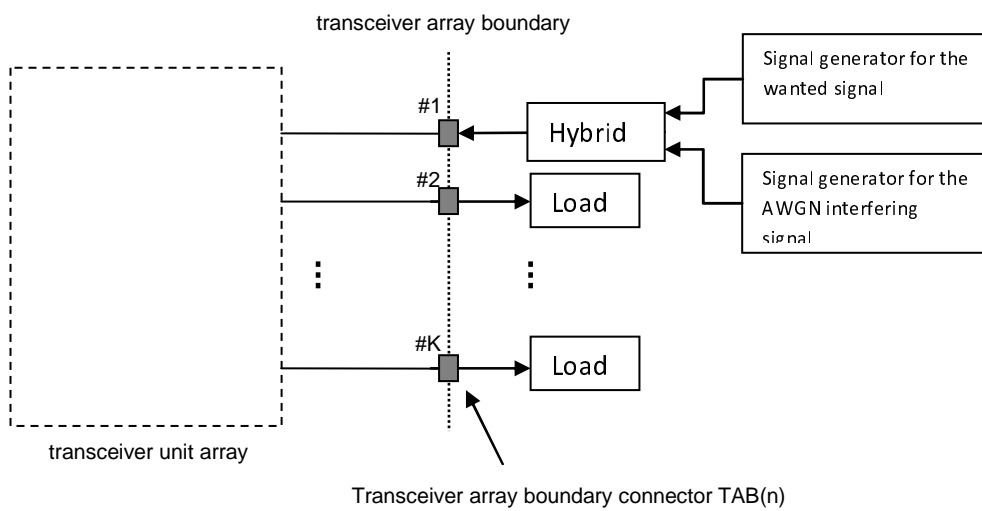

Figure D.2.2-1: Measuring system Set-up for Dynamic Range Test

D.2.3 Receiver Adjacent channel selectivity and narrowband blocking

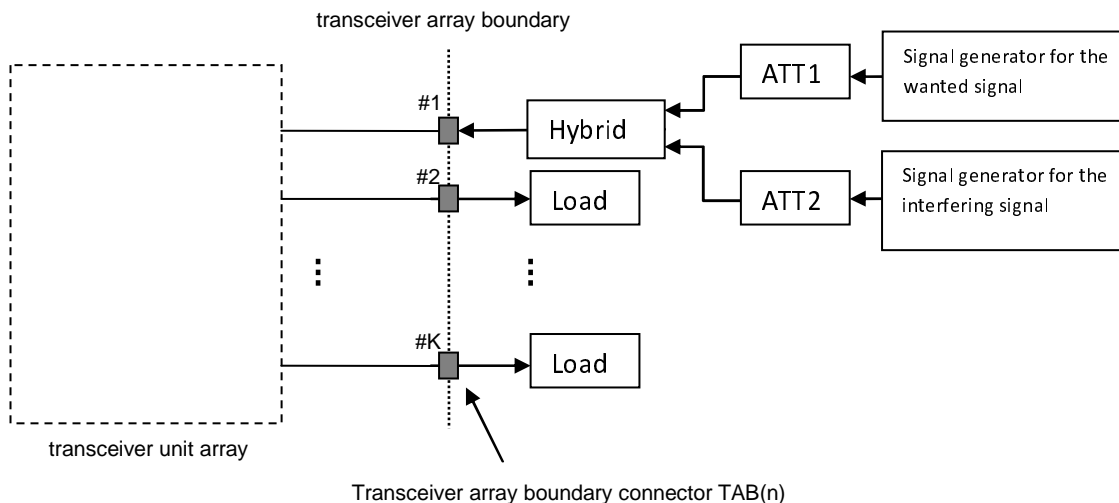

Figure D.2.3-1: Measuring system Set-up for Adjacent channel selectivity and narrowband blocking Test

D.2.4 Receiver spurious emissions

TAB connector(s) may be connected to the measurement equipment singularly and tested one at a time (figure D.2.2-1), or may be tested simultaneously in groups (figure D.2.2-2) where the group size may range from 2 to all the *TAB connectors*.

In all cases the measurement is per *TAB connector* but the measurement may be done in parallel.

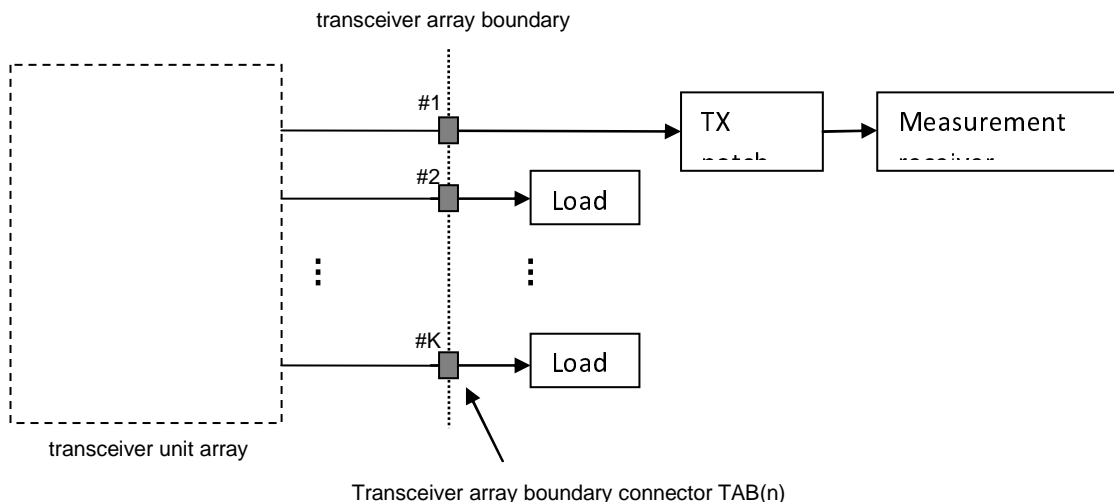

Figure D.2.4-1: Measuring system set-up for receiver spurious emissions for a single *TAB connector*

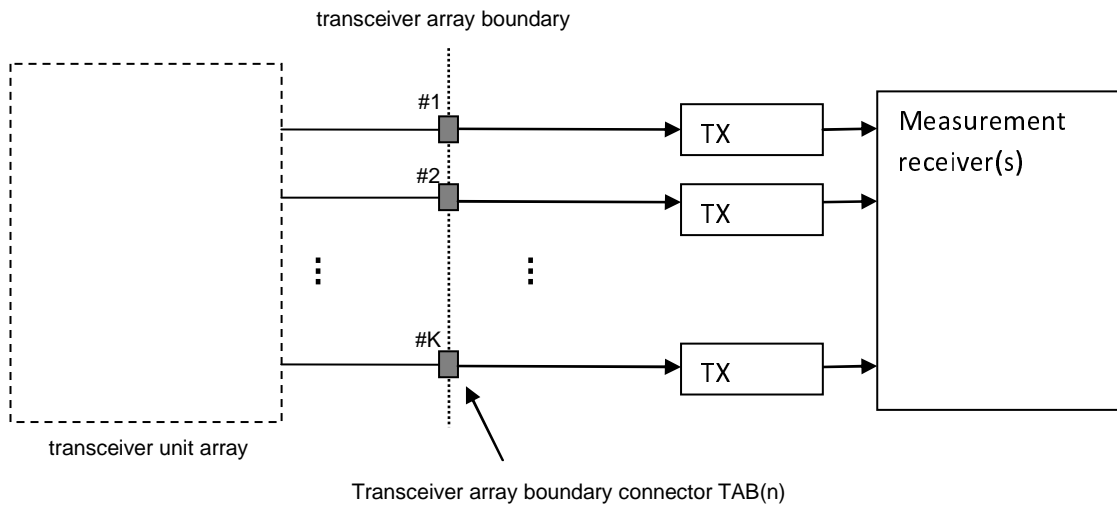

Figure D.2.4-2: Measuring system set-up for receiver spurious emissions for multiple *TAB connectors*

D.2.5 Receiver In-channel selectivity

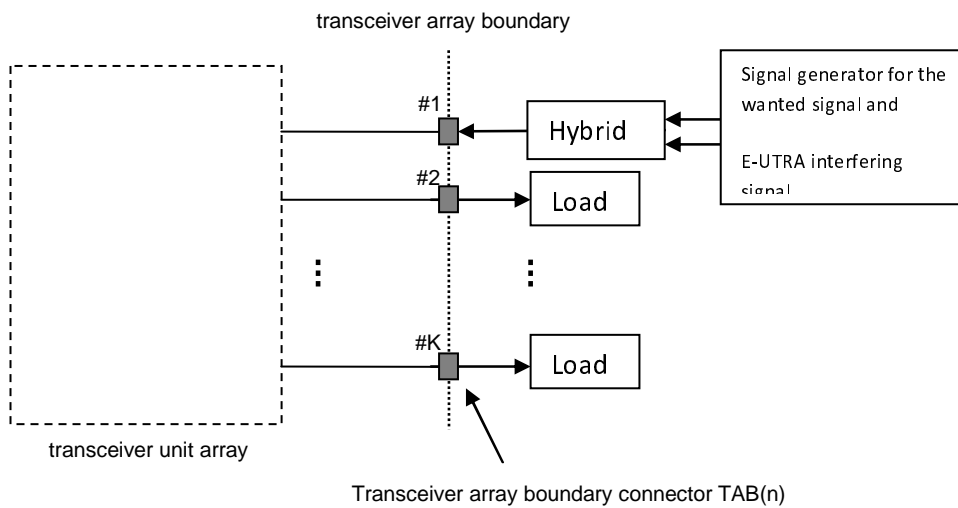

Figure D.2.5-1: Measuring system Set-up for In-channel selectivity Test

D.2.6 Receiver Intermodulation

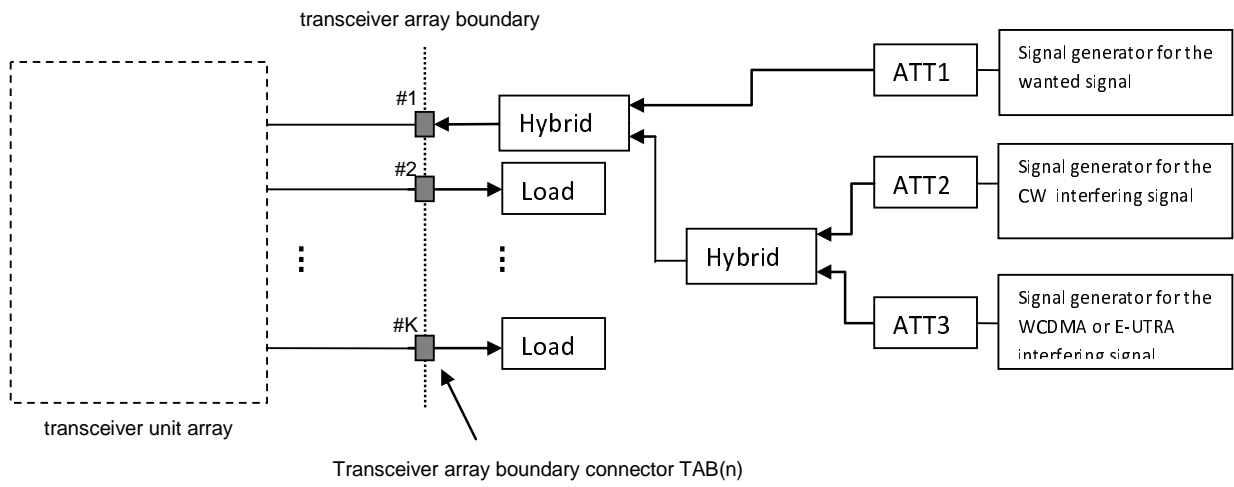

Figure D.2.6-1: Measuring system Set-up for receiver intermodulation Test

Annex E (informative): Change history

Change history							
Date	Meeting	TDoc	CR	Rev	Cat	Subject/Comment	New version
2016-02	RAN4#78	R4-161117				Specification structure	0.1.0
2016-04	RAN4#79	R4-164273				Approved text proposals in the following documents were implemented: R4-162956 - TP to TS 37.145 (part 1) - Sections 1-5 R4-162957 - TP to TS 37.145 (part 1) - Sections 6.1, 6.2, 6.3, 6.4 R4-162958 - TP to TS 37.145 (part 1) - Section 6.5 R4-162961 - TP to TS 37.145 (part 1) - Section 7 R4-162962 - TP to TS 37.145 (part 1) - Section 8 R4-162532 - TP to TS 37.145 (part 1) - Annex B	0.2.0
2016-05	RAN4#79	R4-164926				R4-164711 - TP to TS 37.145 (part 1) R4-164715 - TP to TS 37.145 (part 1) - Sections 6.5.3 (TAE) R4-164712 - TP to TS 37.145 (part 1) 6.6 and 6.7	0.3.0
2016-08	RAN4#80	R4-167178				R4-166423 - TP to TS37.145-1 - reference corrections R4-166217 - TP for TS 37.145-1: Editorial correction on table numbers R4-166935 TP for TS 37.145-1: AAS BS Performance Target R4-166936 TP to TS 37.145-1: Annex C (Test tolerances and derivation of test requirements) R4-166937 TP to TS 37.145-1 - clean-up	0.4.0
2016-09	RANP#73	RP-161449				Editorial corrections after review by ETSI editHelp	1.0.0
2016-09	RP#73					TS Approved by RAN plenary	13.0.0
2016-12	RP-74	RP-162422	0001	-	D	TS 37.145 part 1: Editorial corrections	13.1.0
2016-12	RP-74	RP-162422	0002	-	F	TS 37.145 part 1: Corrections related to band 65	13.1.0
2016-12	RP-74	RP-162422	0003	1	F	MB MSR related corrections on receiver blocking	13.1.0
2016-12	RP-74	RP-162422	0005	-	F	Correction of Manufacturer declaration description list in TS 37.145-1	13.1.0
2016-12	RP-74	RP-162422	0006	1	F	TS 37.145 part 1: Corrections	13.1.0
2016-12	RP-74	RP-162422	0007	1	D	CR to TS 37.145-1: Frequency error corrections	13.1.0
2017-03	RP-75	RP-170586	0008	-	F	RF channels for blocking test	13.2.0
2017-03	RP-75	RP-170586	0009	-	F	Corrections of the power range for SEM and OBUE requirement.	13.2.0
2017-03	RP-75	RP-170586	0010	1	F	TS 37.145-1: Corrections on test procedure related to support for 256QAM	13.2.0
2017-03	RP-75	RP-170586	0011	-	F	CR to TS 37.145-1: Removal of FFS and TBD's	13.2.0
2017-03	RP-75	RP-170586	0012	1	D	CR to TS 37.145-1: Implementation comments from MCC and drafting rules implementation	13.2.0
2017-03	RP-75	-	-	-	-	Update to Rel-14 version (MCC)	14.0.0
2017-06	RP-76	RP-171306	0058		A	CR to TS 37.145-1: Isolation of Band 46 from the AAS BS specification	14.1.0
2017-06	RP-76	RP-171306	0059		A	CR to TS 37.145-1: Isolation of the NB-IoT from the AAS BS specification	14.1.0
2017-06	RP-76	RP-171306	0060		A	CR to TS 37.145-1: BS demodulation requirements update	14.1.0
2017-06	RP-76	RP-171306	0061		A	CR to TS 37.145-1: Correction of the 256QAM test requirement for EVM	14.1.0
2017-06	RP-76	RP-171306	0062		A	CR to TS 37.145-1: Update of Rel-13 references to the UTRA, EUTRA and MSR specifications	14.1.0
2017-06	RP-76	RP-171306	0063		A	CR to TS 37.145-1: Introduction of Rel-13 bands: 45, 65, 66 and 68	14.1.0
2017-06	RP-76	RP-171306	0064		A	CR to TS 37.145-1: Correction of the test setup for the Tx spurious emissions requirement	14.1.0
2017-06	RP-76	RP-171306	0065		A	CR to TS 37.145-1: MB-MSR update	14.1.0
2017-09	RP-77	RP-171968	0067		A	CR to TS 37.145-1: Editorial corrections, Rel-14	14.2.0
2017-09	RP-77	RP-171968	0068	1	B	CR to TS 37.145-1: introduction of bands 47, 48, 69, 70	14.2.0
2017-09	RP-77	RP-171968	0069		F	CR to TS 37.145-1: versioned references updates to Rel-14 non-AAS specifications	14.2.0
2018-06	RAN#80	RP-181109	0071		A	CR to TS 37.145-1: corrections to the existing manufacturers declarations (4.10), Rel-14	14.3.0
2018-06	RAN#80	RP-181109	0073		A	CR to TS 37.145-1: correction of the performance metrics for BS demod, Rel-14	14.3.0
2018-06	RAN#80	RP-181109	0075		F	CR to TS 37.145-1: Correction of regional requirements - removal of co-location and co-existence (4.4), Rel-14	14.3.0
2018-06	RAN#80	RP-181109	0077			Correction of test scope for ACLR tests	14.3.0
2018-06	SA#80					Update to Rel-15 version (MCC)	15.0.0
2018-09	RAN#81	RP-181910	0088		A	CR to TS 37.145-1: Clarification on manufacturers declarations	15.1.0
2018-09	RAN#81	RP-181910	0096	1	A	CR to TS 37.145-1: Correction of Occupied BS test applicability for CA, Rel-15	15.1.0
2018-09	RAN#81	RP-181910	0099	1	A	CR to TS 37.145-1: E-UTRA DL RS power test requirement correction, Rel-15	15.1.0
2018-12	RAN#82	RP-182380	0102		A	CR to TS37.145-1_Adding RF channel for CA OBW (section 4.12.1) Rel.15	15.2.0
2018-12	RAN#82	RP-182380	0119	1	A	Cleanup to conducted requirements text	15.2.0
2018-12	RAN#82	RP-182380	0122		A	Clarification to ACLR test requirements	15.2.0

2018-12	RAN#82	RP-182362	0123	1	B	Introduction of NR to 37.145-1	15.2.0
2018-12	RAN#82	RP-182380	0124		A	Correction of hybrid BS demodulation declarations	15.2.0

History

Document history		
V15.1.0	October 2018	Publication
V15.2.0	April 2019	Publication