

ETSI TS 136 141 V16.18.0 (2024-01)



**LTE;
Evolved Universal Terrestrial Radio Access (E-UTRA);
Base Station (BS) conformance testing
(3GPP TS 36.141 version 16.18.0 Release 16)**



Reference

RTS/TSGR-0436141vgi0

Keywords

LTE

ETSI

650 Route des Lucioles
F-06921 Sophia Antipolis Cedex - FRANCE

Tel.: +33 4 92 94 42 00 Fax: +33 4 93 65 47 16

Siret N° 348 623 562 00017 - APE 7112B
Association à but non lucratif enregistrée à la
Sous-Préfecture de Grasse (06) N° w061004871

Important notice

The present document can be downloaded from:

<https://www.etsi.org/standards-search>

The present document may be made available in electronic versions and/or in print. The content of any electronic and/or print versions of the present document shall not be modified without the prior written authorization of ETSI. In case of any existing or perceived difference in contents between such versions and/or in print, the prevailing version of an ETSI deliverable is the one made publicly available in PDF format at www.etsi.org/deliver.

Users of the present document should be aware that the document may be subject to revision or change of status.

Information on the current status of this and other ETSI documents is available at

<https://portal.etsi.org/TB/ETSIDeliverableStatus.aspx>

If you find errors in the present document, please send your comment to one of the following services:

<https://portal.etsi.org/People/CommitteeSupportStaff.aspx>

If you find a security vulnerability in the present document, please report it through our
Coordinated Vulnerability Disclosure Program:

<https://www.etsi.org/standards/coordinated-vulnerability-disclosure>

Notice of disclaimer & limitation of liability

The information provided in the present deliverable is directed solely to professionals who have the appropriate degree of experience to understand and interpret its content in accordance with generally accepted engineering or other professional standard and applicable regulations.

No recommendation as to products and services or vendors is made or should be implied.

No representation or warranty is made that this deliverable is technically accurate or sufficient or conforms to any law and/or governmental rule and/or regulation and further, no representation or warranty is made of merchantability or fitness for any particular purpose or against infringement of intellectual property rights.

In no event shall ETSI be held liable for loss of profits or any other incidental or consequential damages.

Any software contained in this deliverable is provided "AS IS" with no warranties, express or implied, including but not limited to, the warranties of merchantability, fitness for a particular purpose and non-infringement of intellectual property rights and ETSI shall not be held liable in any event for any damages whatsoever (including, without limitation, damages for loss of profits, business interruption, loss of information, or any other pecuniary loss) arising out of or related to the use of or inability to use the software.

Copyright Notification

No part may be reproduced or utilized in any form or by any means, electronic or mechanical, including photocopying and microfilm except as authorized by written permission of ETSI.

The content of the PDF version shall not be modified without the written authorization of ETSI.

The copyright and the foregoing restriction extend to reproduction in all media.

© ETSI 2024.
All rights reserved.

Intellectual Property Rights

Essential patents

IPRs essential or potentially essential to normative deliverables may have been declared to ETSI. The declarations pertaining to these essential IPRs, if any, are publicly available for **ETSI members and non-members**, and can be found in ETSI SR 000 314: "*Intellectual Property Rights (IPRs); Essential, or potentially Essential, IPRs notified to ETSI in respect of ETSI standards*", which is available from the ETSI Secretariat. Latest updates are available on the ETSI Web server (<https://ipr.etsi.org/>).

Pursuant to the ETSI Directives including the ETSI IPR Policy, no investigation regarding the essentiality of IPRs, including IPR searches, has been carried out by ETSI. No guarantee can be given as to the existence of other IPRs not referenced in ETSI SR 000 314 (or the updates on the ETSI Web server) which are, or may be, or may become, essential to the present document.

Trademarks

The present document may include trademarks and/or tradenames which are asserted and/or registered by their owners. ETSI claims no ownership of these except for any which are indicated as being the property of ETSI, and conveys no right to use or reproduce any trademark and/or tradename. Mention of those trademarks in the present document does not constitute an endorsement by ETSI of products, services or organizations associated with those trademarks.

DECT™, **PLUGTESTS™**, **UMTS™** and the ETSI logo are trademarks of ETSI registered for the benefit of its Members. **3GPP™** and **LTE™** are trademarks of ETSI registered for the benefit of its Members and of the 3GPP Organizational Partners. **oneM2M™** logo is a trademark of ETSI registered for the benefit of its Members and of the oneM2M Partners. **GSM®** and the GSM logo are trademarks registered and owned by the GSM Association.

Legal Notice

This Technical Specification (TS) has been produced by ETSI 3rd Generation Partnership Project (3GPP).

The present document may refer to technical specifications or reports using their 3GPP identities. These shall be interpreted as being references to the corresponding ETSI deliverables.

The cross reference between 3GPP and ETSI identities can be found under <https://webapp.etsi.org/key/queryform.asp>.

Modal verbs terminology

In the present document "**shall**", "**shall not**", "**should**", "**should not**", "**may**", "**need not**", "**will**", "**will not**", "**can**" and "**cannot**" are to be interpreted as described in clause 3.2 of the [ETSI Drafting Rules](#) (Verbal forms for the expression of provisions).

"**must**" and "**must not**" are **NOT** allowed in ETSI deliverables except when used in direct citation.

Contents

Intellectual Property Rights	2
Legal Notice	2
Modal verbs terminology.....	2
Foreword.....	16
1 Scope	18
2 References	18
3 Definitions, symbols and abbreviations	19
3.1 Definitions	19
3.2 Symbols.....	22
3.3 Abbreviations	24
4 General test conditions and declarations	25
4.1 Measurement uncertainties and Test Requirements	25
4.1.1 General.....	25
4.1.2 Acceptable uncertainty of Test System.....	26
4.1.2.1 Measurement of transmitter	27
4.1.2.2 Measurement of receiver	28
4.1.2.3 Measurement of performance requirement	35
4.1.3 Interpretation of measurement results.....	41
4.2 Base station classes	41
4.3 Regional requirements.....	41
4.4 Selection of configurations for testing.....	44
4.5 BS Configurations	44
4.5.1 Transmit configurations	44
4.5.1.1 Transmission with multiple transmitter antenna connectors	45
4.5.2 Receive configurations	45
4.5.2.1 Reception with multiple receiver antenna connectors, receiver diversity	45
4.5.3 Duplexers.....	46
4.5.4 Power supply options.....	46
4.5.5 Ancillary RF amplifiers	46
4.5.6 BS with integrated Iuant BS modem	47
4.5.7 BS using antenna arrays.....	47
4.5.7.1 Receiver tests	47
4.5.7.2 Transmitter tests.....	48
4.6 Manufacturer's declarations of regional and optional requirements	48
4.6.1 Operating band and frequency range	48
4.6.2 Channel bandwidth	49
4.6.3 Base station output power.....	49
4.6.4 Spurious emissions Category.....	49
4.6.5 Additional operating band unwanted emissions	49
4.6.6 Co-existence with other systems.....	50
4.6.7 Co-location with other base stations	50
4.6.8 Manufacturer's declarations of supported RF configurations	50
4.6.9 NB-IoT sub-carrier spacing	52
4.6.10 NB-IoT power dynamic range	52
4.6.11 Sub-PRB allocation.....	52
4.7 Specified frequency range and supported channel bandwidth.....	52
4.7.1 Base Station RF Bandwidth position for multi-carrier and/or CA testing	53
4.7.2 Aggregated Channel Bandwidth position for Contiguous CA occupied bandwidth testing	53
4.7.3 NB-IoT testing.....	54
4.8 Format and interpretation of tests.....	54
4.9 Applicability of requirements.....	55
4.10 Test configurations for multi-carrier and/or CA operation.....	55
4.10.1 ETC1: Contiguous spectrum operation.....	55
4.10.1.1 ETC1 generation	55

4.10.1.2	ETC1 power allocation	56
4.10.2	ETC2: Contiguous CA occupied bandwidth.....	56
4.10.2.1	ETC2 generation	56
4.10.2.2	ETC2 power allocation	57
4.10.3	ETC3: Non-contiguous spectrum operation	57
4.10.3.1	ETC3 generation	57
4.10.3.2	ETC3 power allocation	57
4.10.3.24	VOID.....	57
4.10.4	ETC4: Multi-band test configuration for full carrier allocation.....	57
4.10.4.1	ETC4 generation	57
4.10.4.2	ETC4 power allocation	58
4.10.5	ETC5: Multi-band test configuration with high PSD per carrier	58
4.10.5.1	ETC5 generation	58
4.10.5.2	ETC5 power allocation	59
4.10.6	ETC6: NB-IoT standalone multi-carrier operation	59
4.10.6.1	ETC6 generation	59
4.10.6.2	ETC6 power allocation	59
4.10.7	ETC7: E-UTRA and NB-IoT standalone multi-carrier operation.....	59
4.10.7.1	ETC7 generation	59
4.10.7.2	ETC7 power allocation	60
4.10.8	ETC8: E-UTRA and NB-IoT in-band multi-carrier operation.....	60
4.10.8.1	ETC8 generation	60
4.10.8.2	ETC8 power allocation	60
4.10.9	ETC9: E-UTRA and NB-IoT guard-band multi-carrier operation.....	60
4.10.9.1	ETC9 generation	60
4.10.9.2	ETC9 power allocation	61
4.11	Applicability of test configurations	61
4.12	Requirements for BS capable of multi-band operation	66
4.13	Tests for BS capable of multi-band operation with three or more bands	67
5	Operating bands and channel arrangement.....	67
5.1	General	67
5.2	Void.....	67
5.3	Void.....	67
5.4	Void.....	67
5.5	Operating bands.....	67
5.6	Channel bandwidth.....	71
5.7	Channel arrangement.....	75
5.7.1	Channel spacing.....	75
5.7.1A	CA Channel spacing	75
5.7.2	Channel raster	76
5.7.3	Carrier frequency and EARFCN.....	76
5.8	Requirements for contiguous and non-contiguous spectrum.....	79
6	Transmitter characteristics	80
6.1	General	80
6.1.1	E-UTRA Test Models.....	80
6.1.1.1	E-UTRA Test Model 1.1 (E-TM1.1).....	80
6.1.1.2	E-UTRA Test Model 1.2 (E-TM1.2).....	82
6.1.1.3	E-UTRA Test Model 2 (E-TM2)	84
6.1.1.3a	E-UTRA Test Model 2a (E-TM2a).....	87
6.1.1.3b	E-UTRA Test Model 2b (E-TM2b)	87
6.1.1.3c	E-UTRA subslot TTI Test Model 2-1 (sE-TM2-1).....	87
6.1.1.3d	E-UTRA subslot TTI Test Model 2a (sE-TM2a-1).....	89
6.1.1.3e	E-UTRA slot TTI Test Model 2-2 (sE-TM2-2)	89
6.1.1.3f	E-UTRA slot TTI Test Model 2a (sE-TM2a-2).....	91
6.1.1.4	E-UTRA Test Model 3.1 (E-TM3.1).....	91
6.1.1.4a	E-UTRA Test Model 3.1a (E-TM3.1a).....	92
6.1.1.4b	E-UTRA Test Model 3.1b (E-TM3.1b).....	92
6.1.1.4c	E-UTRA subslot TTI Test Model 3.1 (sE-TM3.1-1)	93
6.1.1.4d	E-UTRA subslot TTI Test Model 3.1a (sE-TM3.1a-1).....	94
6.1.1.4e	E-UTRA slot TTI Test Model 3.1 (sE-TM3.1-2).....	95

6.1.1.4f	E-UTRA slot TTI Test Model 3.1a (sE-TM3.1a-2)	95
6.1.1.5	E-UTRA Test Model 3.2 (E-TM3.2).....	96
6.1.1.5a	E-UTRA subslot TTI Test Model 3.2 (sE-TM3.2-1)	100
6.1.1.5b	E-UTRA slot TTI Test Model 3.2 (sE-TM3.2-2).....	112
6.1.1.6	E-UTRA Test Model 3.3 (E-TM3.3).....	124
6.1.1.6a	E-UTRA subslot TTI Test Model 3.3 (sE-TM3.3-1)	129
6.1.1.6b	E-UTRA slot TTI Test Model 3.3 (sE-TM3.3-2).....	135
6.1.2	Data content of Physical channels and Signals for E-TM.....	142
6.1.2.1	Reference signals	143
6.1.2.2	Primary Synchronization signal	143
6.1.2.3	Secondary Synchronization signal	143
6.1.2.4	PBCH	143
6.1.2.5	PCFICH.....	143
6.1.2.6	PHICH.....	143
6.1.2.7	PDCCH	144
6.1.2.8	PDSCH or sPDSCH	144
6.1.2.9	sPDCCH.....	144
6.1.3	NB-IoT Test Model	145
6.1.4	Data content of Physical channels and Signals for N-TM	145
6.1.4.1	Reference signals	146
6.1.4.2	Synchronization signals	146
6.1.4.3	NPBCH	146
6.1.4.4	NPDCCH	146
6.1.4.5	NPDSCH.....	146
6.1.5	Test Model for NB-IoT guard band operation.....	147
6.1.6	Test Model for NB-IoT in-band operation.....	147
6.2	Base station output power	147
6.2.1	Definition and applicability	147
6.2.2	Minimum Requirement	148
6.2.3	Test purpose.....	148
6.2.4	Method of test	148
6.2.4.1	Initial conditions	148
6.2.4.2	Procedure	149
6.2.5	Test Requirements	149
6.2.6	Home BS output power for adjacent UTRA channel protection.....	150
6.2.6.1	Definition and applicability.....	150
6.2.6.2	Minimum Requirement	151
6.2.6.3	Test purpose	151
6.2.6.4	Method of test	151
6.2.6.4.1	Initial conditions.....	151
6.2.6.4.2	Procedure.....	151
6.2.6.5	Test Requirements.....	152
6.2.7	Home BS output power for adjacent E-UTRA channel protection.....	152
6.2.7.1	Definition and applicability.....	152
6.2.7.2	Minimum Requirement	153
6.2.7.3	Test purpose	153
6.2.7.4	Method of test	153
6.2.7.4.1	Initial conditions	153
6.2.7.4.2	Procedure.....	154
6.2.7.5	Test Requirements.....	154
6.2.8	Home BS output power for co-channel E-UTRA protection.....	155
6.2.8.1	Definition and applicability.....	155
6.2.8.2	Minimum Requirement	156
6.2.8.3	Test purpose	156
6.2.8.4	Method of test	156
6.2.8.4.1	Initial conditions	156
6.2.8.4.2	Procedure.....	156
6.2.8.5	Test Requirements.....	157
6.3	Output power dynamics.....	157
6.3.1	RE Power control dynamic range	157
6.3.1.1	Definition and applicability.....	157
6.3.1.2	Minimum Requirement	157

6.3.1.3	Method of test	158
6.3.2	Total power dynamic range	158
6.3.2.1	Definition and applicability	158
6.3.2.2	Minimum Requirement	158
6.3.2.3	Test purpose	158
6.3.2.4	Method of test	158
6.3.2.4.1	Initial conditions	158
6.3.2.4.2	Procedure	158
6.3.2.5	Test Requirement	159
6.3.3	NB-IoT RB power dynamic range for in-band or guard band operation	159
6.3.3.1	Definition and applicability	159
6.3.3.2	Minimum Requirement	159
6.3.3.3	Test purpose	159
6.3.3.4	Method of test	159
6.3.3.5	Test Requirement	159
6.4	Transmit ON/OFF power	160
6.4.1	Transmitter OFF power	160
6.4.1.1	Definition and applicability	160
6.4.1.2	Minimum Requirement	160
6.4.1.3	Test purpose	160
6.4.1.4	Method of test	160
6.4.1.4.1	Void	160
6.4.1.4.2	Void	160
6.4.1.5	Test requirement	160
6.4.2	Transmitter transient period	160
6.4.2.1	Definition and applicability	160
6.4.2.2	Minimum Requirement	161
6.4.2.3	Test purpose	161
6.4.2.4	Method of test	161
6.4.2.4.1	Initial conditions	161
6.4.2.4.2	Procedure	161
6.4.2.5	Test requirement	162
6.5	Transmitted signal quality	162
6.5.1	Frequency error	162
6.5.1.1	Definition and applicability	162
6.5.1.2	Minimum Requirement	162
6.5.1.3	Test purpose	162
6.5.1.4	Method of test	162
6.5.1.5	Test requirement	162
6.5.2	Error Vector Magnitude	163
6.5.2.1	Definition and applicability	163
6.5.2.2	Minimum Requirement	163
6.5.2.3	Test purpose	163
6.5.2.4	Method of test	163
6.5.2.4.1	Initial conditions	163
6.5.2.4.2	Procedure	163
6.5.2.5	Test requirement	164
6.5.3	Time alignment error	165
6.5.3.1	Definition and applicability	165
6.5.3.2	Minimum Requirement	165
6.5.3.3	Test Purpose	165
6.5.3.4	Method of Test	165
6.5.3.4.1	Initial Conditions	165
6.5.3.4.2	Procedure	166
6.5.3.5	Test Requirement	166
6.5.4	DL RS power	167
6.5.4.1	Definition and applicability	167
6.5.4.2	Minimum Requirement	167
6.5.4.3	Test purpose	167
6.5.4.4	Method of test	167
6.5.4.4.1	Initial conditions	167
6.5.4.4.2	Procedure	167

6.5.4.5	Test requirement	167
6.6	Unwanted emissions.....	168
6.6.1	Occupied bandwidth	168
6.6.1.1	Definition and applicability.....	168
6.6.1.2	Minimum Requirements.....	168
6.6.1.3	Test purpose	168
6.6.1.4	Method of test	168
6.6.1.4.1	Initial conditions	168
6.6.1.4.2	Procedure.....	169
6.6.1.5	Test requirements.....	170
6.6.2	Adjacent Channel Leakage power Ratio (ACLR)	170
6.6.2.1	Definition and applicability.....	170
6.6.2.2	Minimum Requirement	170
6.6.2.3	Test purpose	171
6.6.2.4	Method of test	171
6.6.2.4.1	Initial conditions.....	171
6.6.2.4.2	Procedure.....	171
6.6.2.5	Test Requirement	172
6.6.2.6	Cumulative ACLR test requirement in non-contiguous spectrum	174
6.6.3	Operating band unwanted emissions	176
6.6.3.1	Definition and applicability.....	176
6.6.3.2	Minimum Requirement	177
6.6.3.3	Test purpose	177
6.6.3.4	Method of test	177
6.6.3.4.1	Initial conditions.....	177
6.6.3.4.2	Procedure.....	178
6.6.3.5	Test requirement	178
6.6.3.5.1	Test requirements for Wide Area BS (Category A).....	179
6.6.3.5.2	Test requirements for Wide Area BS (Category B).....	184
6.6.3.5.2.1	Category B test requirements (Option 1).....	184
6.6.3.5.2.2	Category B (Option 2).....	188
6.6.3.5.2A	Test requirements for Local Area BS (Category A and B).....	190
6.6.3.5.2B	Test requirements for Home BS (Category A and B).....	193
6.6.3.5.2C	Test requirements for Medium Range BS (Category A and B).....	194
6.6.3.5.2D	Minimum requirements for Local Area and Medium Range BS in Band 46 (Category A and B).....	199
6.6.3.5.2E	Minimum requirements for stand-alone NB-IoT Wide Area BS.....	200
6.6.3.5.2F	Minimum requirements for stand-alone NB-IoT Local Area BS	201
6.6.3.5.2G	Minimum requirements for stand-alone NB-IoT Home BS	202
6.6.3.5.2H	Minimum requirements for stand-alone NB-IoT Medium Range BS	203
6.6.3.5.3	Additional requirements	204
6.6.4	Transmitter spurious emissions.....	209
6.6.4.1	Definition and applicability.....	209
6.6.4.2	Minimum Requirements.....	209
6.6.4.3	Test Purpose	209
6.6.4.4	Method of Test	209
6.6.4.4.1	Initial conditions	209
6.6.4.4.2	Procedure.....	210
6.6.4.5	Test requirements.....	210
6.6.4.5.1	Spurious emissions (Category A)	211
6.6.4.5.2	Spurious emissions (Category B)	211
6.6.4.5.3	Protection of the BS receiver of own or different BS	211
6.6.4.5.4	Co-existence with other systems in the same geographical area	212
6.6.4.5.5	Co-location with other base stations.....	227
6.7	Transmitter intermodulation.....	242
6.7.1	Definition and applicability	242
6.7.2	Minimum Requirement	243
6.7.2A	Additional requirement for Band 41	243
6.7.3	Test purpose.....	243
6.7.4	Method of test	243
6.7.4.1	Initial conditions	243
6.7.4.2	Procedures.....	243

6.7.5	Test Requirements	244
6.7.6	Additional test requirements for Band 41	245
7	Receiver characteristics	245
7.1	General	245
7.2	Reference sensitivity level.....	245
7.2.1	Definition and applicability	245
7.2.2	Minimum Requirement.....	245
7.2.3	Test purpose.....	245
7.2.4	Method of testing	246
7.2.4.1	Initial conditions	246
7.2.4.2	Procedure	246
7.2.5	Test requirement	246
7.3	Dynamic range	252
7.3.1	Definition and applicability	252
7.3.2	Minimum Requirement.....	252
7.3.3	Test purpose.....	252
7.3.4	Method of testing	252
7.3.4.1	Initial conditions	252
7.3.4.2	Procedure	252
7.3.5	Test Requirements	253
7.4	In-channel selectivity	259
7.4.1	Definition and applicability	259
7.4.2	Minimum Requirement.....	259
7.4.3	Test purpose.....	259
7.4.4	Method of testing.....	259
7.4.4.1	Initial conditions	259
7.4.4.2	Procedure	260
7.4.5	Test Requirements	261
7.5	Adjacent Channel Selectivity (ACS) and narrow-band blocking	267
7.5.1	Definition and applicability	267
7.5.2	Minimum Requirement.....	267
7.5.3	Test purpose.....	267
7.5.4	Method of test	267
7.5.4.1	Initial conditions	267
7.5.4.2	Procedure for Adjacent Channel Selectivity	267
7.5.4.3	Procedure for narrow-band blocking.....	268
7.5.5	Test Requirements	270
7.6	Blocking	279
7.6.1	Definition and applicability	279
7.6.2	Minimum Requirements	280
7.6.3	Test purpose.....	280
7.6.4	Method of test	280
7.6.4.1	Initial conditions	280
7.6.4.2	Procedure	280
7.6.5	Test Requirements	282
7.6.5.1	General requirement.....	282
7.6.5.2	Co-location with other base stations	296
7.7	Receiver spurious emissions.....	309
7.7.1	Definition and applicability	309
7.7.2	Minimum Requirements	309
7.7.3	Test purpose.....	309
7.7.4	Method of test	309
7.7.4.1	Initial conditions	309
7.7.4.2	Procedure	310
7.7.5	Test requirements.....	310
7.8	Receiver intermodulation	311
7.8.1	Definition and applicability	311
7.8.2	Minimum Requirement.....	311
7.8.3	Test purpose.....	311
7.8.4	Method of test	312
7.8.4.1	Initial conditions	312

7.8.4.2	Procedures	312
7.8.5	Test requirements	313
8	Performance requirement	328
8.1	General	328
8.2	Performance requirements for PUSCH	328
8.2.1	Performance requirements of PUSCH in multipath fading propagation conditions transmission on single antenna port	328
8.2.1.1	Definition and applicability	328
8.2.1.2	Minimum Requirement	329
8.2.1.3	Test Purpose	329
8.2.1.4	Method of test	329
8.2.1.4.1	Initial Conditions	329
8.2.1.4.2	Procedure	329
8.2.1.5	Test Requirement	329
8.2.1A	Performance requirements of PUSCH in multipath fading propagation conditions transmission on two antenna ports	347
8.2.1A.1	Definition and applicability	347
8.2.1A.2	Minimum Requirement	347
8.2.1A.3	Test Purpose	347
8.2.1A.4	Method of test	347
8.2.1A.4.1	Initial Conditions	347
8.2.1A.4.2	Procedure	347
8.2.1A.5	Test Requirement	348
8.2.2	Performance requirements for UL timing adjustment	350
8.2.2.1	Definition and applicability	350
8.2.2.2	Minimum Requirement	350
8.2.2.3	Test Purpose	350
8.2.2.4	Method of test	350
8.2.2.4.1	Initial Conditions	350
8.2.2.4.2	Procedure	350
8.2.2.5	Test Requirement	351
8.2.3	Performance requirements for HARQ-ACK multiplexed on PUSCH	352
8.2.3.1	Definition and applicability	352
8.2.3.2	Minimum Requirement	352
8.2.3.3	Test Purpose	353
8.2.3.4	Method of test	353
8.2.3.4.1	Initial Conditions	353
8.2.3.4.2	Procedure	353
8.2.3.5	Test Requirement	353
8.2.4	Performance requirements for High Speed Train conditions	354
8.2.4.1	Definition and applicability	354
8.2.4.2	Minimum Requirement	354
8.2.4.3	Test Purpose	354
8.2.4.4	Method of test	355
8.2.4.4.1	Initial Conditions	355
8.2.4.4.2	Procedure	355
8.2.4.5	Test Requirement	356
8.2.5	Performance requirements for PUSCH with TTI bundling and enhanced HARQ pattern	359
8.2.5.1	Definition and applicability	359
8.2.5.2	Minimum Requirement	359
8.2.5.3	Test Purpose	360
8.2.5.4	Method of test	360
8.2.5.4.1	Initial Conditions	360
8.2.5.4.2	Procedure	360
8.2.5.5	Test Requirement	361
8.2.6	Enhanced performance requirements type A of PUSCH in multipath fading propagation conditions with synchronous interference	361
8.2.6.1	Definition and applicability	361
8.2.6.2	Minimum Requirement	362
8.2.6.3	Test Purpose	362
8.2.6.4	Method of test	362

8.2.6.4.1	Initial Conditions	362
8.2.6.4.2	Procedure	362
8.2.6.5	Test Requirement	363
8.2.6A	Enhanced performance requirements type A of PUSCH in multipath fading propagation conditions with asynchronous interference	365
8.2.6A.1	Definition and applicability	365
8.2.6A.2	Minimum Requirement	366
8.2.6A.3	Test Purpose	366
8.2.6A.4	Method of test	366
8.2.6A.4.1	Initial Conditions	366
8.2.6A.4.2	Procedure	366
8.2.6A.5	Test Requirement	367
8.2.7	Performance requirements of PUSCH in multipath fading propagation conditions transmission on single antenna port for coverage enhancement	369
8.2.7.1	Definition and applicability	369
8.2.7.2	Minimum Requirement	369
8.2.7.3	Test Purpose	369
8.2.7.4	Method of test	369
8.2.7.4.1	Initial Conditions	369
8.2.7.4.2	Procedure	369
8.2.7.5	Test Requirement	370
8.2.8	Performance requirements of PUSCH with Frame structure type 3	371
8.2.8.1	Definition and applicability	371
8.2.8.2	Minimum Requirement	371
8.2.8.3	Test Purpose	371
8.2.8.4	Method of test	371
8.2.8.4.1	Initial Conditions	371
8.2.8.4.2	Procedure	372
8.2.8.5	Test Requirement	372
8.2.9	Enhanced performance requirements type B of PUSCH in multipath fading propagation conditions	373
8.2.9.1	Definition and applicability	373
8.2.9.2	Minimum Requirement	373
8.2.9.3	Test Purpose	373
8.2.9.4	Method of test	373
8.2.9.4.1	Initial Conditions	373
8.2.9.4.2	Procedure	373
8.2.9.5	Test Requirement	375
8.2.10	Performance requirements of PUSCH in multipath fading propagation conditions transmission on single antenna port for subPRB transmission	377
8.2.10.1	Definition and applicability	377
8.2.10.2	Minimum Requirement	377
8.2.10.3	Test Purpose	378
8.2.10.4	Method of test	378
8.2.10.4.1	Initial Conditions	378
8.2.10.4.2	Procedure	378
8.2.10.5	Test Requirement	379
8.3	Performance requirements for PUCCH	379
8.3.1	ACK missed detection for single user PUCCH format 1a transmission on single antenna port	379
8.3.1.1	Definition and applicability	379
8.3.1.2	Minimum Requirement	380
8.3.1.3	Test purpose	380
8.3.1.4	Method of test	380
8.3.1.4.1	Initial Conditions	380
8.3.1.4.2	Procedure	380
8.3.1.5	Test Requirement	380
8.3.2	CQI performance requirements for PUCCH format 2 transmission on single antenna port	381
8.3.2.1	Definition and applicability	381
8.3.2.2	Minimum Requirement	381
8.3.2.3	Test purpose	381
8.3.2.4	Method of test	381
8.3.2.4.1	Initial Conditions	381
8.3.2.4.2	Procedure	382

8.3.2.5	Test Requirement	382
8.3.3	ACK missed detection for multi user PUCCH format 1a	383
8.3.3.1	Definition and applicability	383
8.3.3.2	Minimum Requirement	383
8.3.3.3	Test purpose	383
8.3.3.4	Method of test	383
8.3.3.4.1	Initial Conditions	383
8.3.3.4.2	Procedure	383
8.3.3.5	Test Requirement	384
8.3.4	ACK missed detection for PUCCH format 1b with Channel Selection	384
8.3.4.1	Definition and applicability	384
8.3.4.2	Minimum Requirement	385
8.3.4.3	Test purpose	385
8.3.4.4	Method of test	385
8.3.4.4.1	Initial Conditions	385
8.3.4.4.2	Procedure	385
8.3.4.5	Test Requirement	386
8.3.5	ACK missed detection for PUCCH format 3	386
8.3.5.1	Definition and applicability	386
8.3.5.2	Minimum Requirement	386
8.3.5.3	Test purpose	386
8.3.5.4	Method of test	387
8.3.5.4.1	Initial Conditions	387
8.3.5.4.2	Procedure	387
8.3.5.5	Test Requirement	387
8.3.6	NACK to ACK detection for PUCCH format 3	388
8.3.6.1	Definition and applicability	388
8.3.6.2	Minimum Requirement	388
8.3.6.3	Test purpose	388
8.3.6.4	Method of test	388
8.3.6.4.1	Initial Conditions	388
8.3.6.4.2	Procedure	389
8.3.6.5	Test Requirement	389
8.3.7	ACK missed detection for PUCCH format 1a transmission on two antenna ports	389
8.3.7.1	Definition and applicability	389
8.3.7.2	Minimum Requirement	390
8.3.7.3	Test purpose	390
8.3.7.4	Method of test	390
8.3.7.4.1	Initial Conditions	390
8.3.7.4.2	Procedure	390
8.3.7.5	Test Requirement	391
8.3.8	CQI performance requirements for PUCCH format 2 transmission on two antenna ports	391
8.3.8.1	Definition and applicability	391
8.3.8.2	Minimum Requirement	391
8.3.8.3	Test purpose	391
8.3.8.4	Method of test	391
8.3.8.4.1	Initial Conditions	391
8.3.8.4.2	Procedure	392
8.3.8.5	Test Requirement	392
8.3.9	CQI performance requirements for PUCCH format 2 with DTX detection	393
8.3.9.1	Definition and applicability	393
8.3.9.2	Minimum Requirement	393
8.3.9.3	Test purpose	393
8.3.9.4	Method of test	393
8.3.9.4.1	Initial Conditions	393
8.3.9.4.2	Procedure	393
8.3.9.5	Test Requirement	394
8.3.10	ACK missed detection for PUCCH format 1a transmission on single antenna port for coverage enhancement	394
8.3.10.1	Definition and applicability	394
8.3.10.2	Minimum Requirement	395
8.3.10.3	Test purpose	395

8.3.10.4	Method of test	395
8.3.10.4.1	Initial Conditions	395
8.3.10.4.2	Procedure.....	395
8.3.10.5	Test Requirement	396
8.3.11	CQI performance requirements for PUCCH format 2 transmission on single antenna port for coverage enhancement.....	396
8.3.11.1	Definition and applicability.....	396
8.3.11.2	Minimum Requirement	396
8.3.11.3	Test purpose	396
8.3.11.4	Method of test	396
8.3.11.4.1	Initial Conditions	396
8.3.11.4.2	Procedure.....	396
8.3.11.5	Test Requirement	397
8.3.12	ACK missed detection for PUCCH format 4	397
8.3.12.1	Definition and applicability.....	397
8.3.12.2	Minimum Requirement	398
8.3.12.3	Test purpose	398
8.3.12.4	Method of test	398
8.3.12.4.1	Initial Conditions	398
8.3.12.4.2	Procedure.....	398
8.3.12.5	Test Requirement	399
8.3.13	ACK missed detection for PUCCH format 5	399
8.3.13.1	Definition and applicability.....	399
8.3.13.2	Minimum Requirement	400
8.3.13.3	Test purpose	400
8.3.13.4	Method of test	400
8.3.13.4.1	Initial Conditions	400
8.3.13.4.2	Procedure.....	400
8.3.13.5	Test Requirement	401
8.4	Performance requirements for PRACH.....	401
8.4.1	PRACH false alarm probability and missed detection.....	401
8.4.1.1	Definition and applicability.....	401
8.4.1.2	Minimum Requirement	401
8.4.1.3	Test purpose	402
8.4.1.4	Method of test	402
8.4.1.4.1	Initial Conditions	402
8.4.1.4.2	Procedure.....	402
8.4.1.5	Test Requirement	403
8.5	Performance requirements for Narrowband IoT.....	405
8.5.1	Performance requirements for NPUSCH format 1	405
8.5.1.1	Definition and applicability.....	405
8.5.1.2	Minimum Requirement	405
8.5.1.3	Test Purpose	405
8.5.1.4	Method of test	405
8.5.1.4.1	Initial Conditions	405
8.5.1.4.2	Procedure.....	406
8.5.1.5	Test Requirement	406
8.5.2	ACK missed detection for NPUSCH format 2	407
8.5.2.1	Definition and applicability.....	407
8.5.2.2	Minimum Requirement	408
8.5.2.3	Test purpose	408
8.5.2.4	Method of test	408
8.5.2.4.1	Initial Conditions	408
8.5.2.4.2	Procedure.....	408
8.5.2.5	Test Requirement	409
8.5.3	Performance requirements for NPRACH	409
8.5.3.1	Definition and applicability.....	409
8.5.3.2	Minimum Requirement	410
8.5.3.3	Test purpose	410
8.5.3.4	Method of test	410
8.5.3.4.1	Initial Conditions	410
8.5.3.4.2	Procedure.....	410

8.5.3.5	Test Requirement	411
8.6	Performance requirements for subslot-PUSCH.....	411
8.6.1	Definition and applicability	411
8.6.2	Minimum Requirement.....	411
8.6.3	Test Purpose.....	412
8.6.4	Method of test	412
8.6.4.1	Initial Conditions.....	412
8.6.4.2	Procedure	412
8.6.5	Test Requirement.....	412
8.7	Performance requirements for SPUCCH.....	413
8.7.1	ACK missed detection for single user SPUCCH format 1a.....	413
8.7.1.1	Definition and applicability.....	413
8.7.1.2	Minimum Requirement	414
8.7.1.3	Test Purpose	414
8.7.1.4	Method of test	414
8.7.1.4.1	Initial Conditions	414
8.7.1.4.2	Procedure.....	414
8.7.1.5	Test Requirement	415
8.7.2	ACK missed detection requirements for SPUCCH format 4.....	415
8.7.2.1	Definition and applicability.....	415
8.7.2.2	Minimum Requirement	415
8.7.2.3	Test Purpose	415
8.7.2.4	Method of test	415
8.7.2.4.1	Initial Conditions	415
8.7.2.4.2	Procedure.....	416
8.7.2.5	Test Requirement	416
9	(Void).....	416
Annex A (normative): Reference Measurement channels.....		417
A.0	General	417
A.1	Fixed Reference Channels for reference sensitivity and in-channel selectivity (QPSK, R=1/3).....	419
A.2	Fixed Reference Channels for dynamic range (16QAM, R=2/3).....	419
A.3	Fixed Reference Channels for performance requirements (QPSK 1/3)	420
A.4	Fixed Reference Channels for performance requirements (16QAM 3/4)	420
A.5	Fixed Reference Channels for performance requirements (64QAM 5/6)	421
A.6	PRACH Test preambles	421
A.7	Fixed Reference Channels for UL timing adjustment (Scenario 1)	422
A.8	Fixed Reference Channels for UL timing adjustment (Scenario 2)	422
A.9	Multi user PUCCH test.....	423
A.10	PUCCH transmission on two antenna ports test.....	423
A.11	Fixed Reference Channel for PUSCH with TTI bundling and enhanced HARQ pattern	423
A.14	Fixed Reference Channels for NB-IOT reference sensitivity ($\pi/2$ BPSK, R=1/3).....	424
A.14.1	Void.....	425
A.15	Fixed Reference Channels for NB-IoT dynamic range ($\pi/4$ QPSK, R=2/3).....	425
A.16	Fixed Reference Channels for NB-IoT NPUSCH format 1	426
A.16.1	One PRB.....	426
A.17	Fixed Reference Channels for performance requirements (256QAM 5/6)	426
A.18	Fixed Reference Channels for PUSCH transmission in UpPTS (16QAM 0.65)	427
A.19	Fixed Reference Channels for PUSCH transmission in UpPTS (256QAM 0.69)	427

A.20	Fixed Reference Channels for PUSCH with Frame structure type 3	428
A.21	Fixed Reference Channels for performance requirements (QPSK 3/5)	428
A.22	Fixed Reference Channels for performance requirements (64QAM 1/2)	429
A.23	Fixed Reference Channel for subslot-PUSCH	429
A.24	Fixed Reference Channels for PUSCH with SubPRB transmission	430
Annex B (normative): Propagation conditions.....		431
B.1	Static propagation condition.....	431
B.2	Multi-path fading propagation conditions.....	431
B.3	High speed train condition	432
B.4	Moving propagation conditions.....	436
B.5	Multi-Antenna channel models	437
B.5.1	Definition of MIMO Correlation Matrices.....	437
B.5.2	MIMO Correlation Matrices at High, Medium and Low Level	438
B.5A	Multi-Antenna channel models using cross polarized antennas.....	440
B.5A.1	Definition of MIMO Correlation Matrices using cross polarized antennas.....	441
B.5A.2	Spatial Correlation Matrices at UE and eNB sides.....	441
B.5A.2.1	Spatial Correlation Matrices at UE side.....	441
B.5A.2.2	Spatial Correlation Matrices at eNB side.....	442
B.5A.3	MIMO Correlation Matrices using cross polarized antennas	442
B.6	Interference model for enhanced performance requirements type A and type B	443
B.6.1	Dominant interferer proportion	443
B.6.2	Interference model for synchronous scenario.....	443
B.6.3	Interference model for asynchronous scenario	443
Annex C (normative): Characteristics of the interfering signals.....		445
Annex D (normative): Environmental requirements for the BS equipment		446
D.1	General	446
D.2	Normal test environment.....	446
D.3	Extreme test environment.....	446
D.3.1	Extreme temperature	446
D.4	Vibration.....	447
D.5	Power supply	447
D.6	Measurement of test environments.....	447
Annex E (normative): General rules for statistical testing.....		448
Annex F (normative): Global In-Channel TX-Test		449
F.1	General	449
F.2.1	Basic principle.....	449
F.2.2	Output signal of the TX under test	449
F.2.3	Reference signal	449
F.2.4	Measurement results.....	449
F.2.5	Measurement points	450
F.3.1	Pre FFT minimization process.....	450
F.3.2	Timing of the FFT window	451
F.3.3	Resource Element TX power.....	451
F.3.4	Post FFT equalisation.....	452
F.4.1	EVM.....	453
F.4.2	Averaged EVM	454

F.4.2.1	Averaged EVM (TDD)	455
Annex G (informative): Test Tolerances and Derivation of Test Requirements		457
G.1	Measurement of transmitter.....	458
G.2	Measurement of receiver	465
G.3	Measurement of Performance Requirements	471
Annex H (Informative): E-UTRAN Measurement Test Cases.....		474
Annex I (Informative): Measurement system set-up		475
I.1	Transmitter	475
I.1.1	Base station output power, output power dynamics, transmitted signal quality, Frequency error, EVM, DL RS power, Unwanted emissions.....	475
I.1.2	Transmitter intermodulation.....	475
I.1.3	Time alignment error.....	476
I.1.4	Home BS output power for adjacent channel protection.....	476
I.1.5	Home BS output power for co-channel E-UTRA protection	476
I.2	Receiver.....	477
I.2.1	Reference sensitivity level.....	477
I.2.2	Dynamic range	478
I.2.3	In-channel selectivity	478
I.2.4	Adjacent Channel Selectivity (ACS) and narrowband blocking	479
I.2.5	Blocking characteristics	479
I.2.6	Receiver spurious emission	480
I.2.7	Intermodulation characteristics	480
I.3	Performance requirement	481
I.3.1	Performance requirements for PRACH in static conditions	481
I.3.2	Performance requirements for PUSCH, PRACH, single user PUCCH in multipath fading conditions and for High Speed Train conditions	481
I.3.3	Performance requirements for multi user PUCCH in multipath fading conditions	482
I.3.4	Performance requirement for UL timing adjustment.....	482
I.3.5	Performance requirements for PUCCH transmission on two antenna ports in multipath fading conditions	483
I.3.6	Performance requirements for PUSCH transmission on two antenna ports in multipath fading conditions ..	484
I.3.7	Enhanced performance requirements type A of PUSCH in multipath fading propagation conditions with synchronous or asynchronous interference.....	485
I.3.8	Enhanced performance requirement type B of PUSCH in multipath fading propagation conditions	489
I.4	Channel access procedures.....	489
Annex J (Informative): Unwanted emission requirements for multi-carrier BS		490
J.1	General	490
J.2	Multi-carrier BS of different E-UTRA channel bandwidths	490
J.3	Multi-carrier BS of E-UTRA and UTRA.....	490
Annex K (informative): Change history		491
History		507

Foreword

This Technical Specification has been produced by the 3rd Generation Partnership Project (3GPP).

The contents of the present document are subject to continuing work within the TSG and may change following formal TSG approval. Should the TSG modify the contents of the present document, it will be re-released by the TSG with an identifying change of release date and an increase in version number as follows:

Version x.y.z

where:

- x the first digit:
 - 1 presented to TSG for information;
 - 2 presented to TSG for approval;
 - 3 or greater indicates TSG approved document under change control.
- y the second digit is incremented for all changes of substance, i.e. technical enhancements, corrections, updates, etc.
- z the third digit is incremented when editorial only changes have been incorporated in the document.

In the present document, modal verbs have the following meanings:

- shall** indicates a mandatory requirement to do something
- shall not** indicates an interdiction (prohibition) to do something

The constructions "shall" and "shall not" are confined to the context of normative provisions, and do not appear in Technical Reports.

The constructions "must" and "must not" are not used as substitutes for "shall" and "shall not". Their use is avoided insofar as possible, and they are not used in a normative context except in a direct citation from an external, referenced, non-3GPP document, or so as to maintain continuity of style when extending or modifying the provisions of such a referenced document.

- should** indicates a recommendation to do something
- should not** indicates a recommendation not to do something
- may** indicates permission to do something
- need not** indicates permission not to do something

The construction "may not" is ambiguous and is not used in normative elements. The unambiguous constructions "might not" or "shall not" are used instead, depending upon the meaning intended.

- can** indicates that something is possible
- cannot** indicates that something is impossible

The constructions "can" and "cannot" are not substitutes for "may" and "need not".

- will** indicates that something is certain or expected to happen as a result of action taken by an agency the behaviour of which is outside the scope of the present document
- will not** indicates that something is certain or expected not to happen as a result of action taken by an agency the behaviour of which is outside the scope of the present document
- might** indicates a likelihood that something will happen as a result of action taken by some agency the behaviour of which is outside the scope of the present document

might not indicates a likelihood that something will not happen as a result of action taken by some agency the behaviour of which is outside the scope of the present document

In addition:

is (or any other verb in the indicative mood) indicates a statement of fact

is not (or any other negative verb in the indicative mood) indicates a statement of fact

The constructions "is" and "is not" do not indicate requirements.

1 Scope

The present document specifies the Radio Frequency (RF) test methods and conformance requirements for E-UTRA, E-UTRA with NB-IoT or NB-IoT Base Stations (BS) operating either in the FDD mode (used in paired bands) or the TDD mode (used in unpaired bands). These have been derived from, and are consistent with the E-UTRA, E-UTRA with NB-IoT or NB-IoT Base Station (BS) specifications defined in [2].

2 References

The following documents contain provisions which, through reference in this text, constitute provisions of the present document.

- References are either specific (identified by date of publication, edition number, version number, etc.) or non-specific.
- For a specific reference, subsequent revisions do not apply.
- For a non-specific reference, the latest version applies. In the case of a reference to a 3GPP document (including a GSM document), a non-specific reference implicitly refers to the latest version of that document *in the same Release as the present document*.

- [1] 3GPP TR 21.905: "Vocabulary for 3GPP Specifications.
- [2] 3GPP TS 36 104: "E-UTRA Base Station (BS) radio transmission and reception".
- [3] ITU-R Recommendation M.1545, "Measurement uncertainty as it applies to test limits for the terrestrial component of International Mobile Telecommunications-2000".
- [4] ITU-R recommendation SM.328: "Spectra and bandwidth of emissions".
- [5] ITU-R recommendation SM.329: "Unwanted emissions in the spurious domain".
- [6] IEC 60721-3-3 (2002): "Classification of environmental conditions - Part 3: Classification of groups of environmental parameters and their severities - Section 3: Stationary use at weather protected locations".
- [7] IEC 60721-3-4 (1995): "Classification of environmental conditions - Part 3: Classification of groups of environmental parameters and their severities - Section 4: Stationary use at non-weather protected locations".
- [8] IEC 60068-2-1 (2007): "Environmental testing - Part 2: Tests. Tests A: Cold".
- [9] IEC 60068-2-2 (2007): "Environmental testing - Part 2: Tests. Tests B: Dry heat".
- [10] IEC 60068-2-6 (2007): "Environmental testing - Part 2: Tests - Test Fc: Vibration (sinusoidal)".
- [11] 3GPP TR 25.942: "RF system scenarios".
- [12] 3GPP TS 36.211: "Evolved Universal Terrestrial Radio Access (E-UTRA); Physical Channels and Modulation".
- [13] 3GPP TS 36.212: "Evolved Universal Terrestrial Radio Access (E-UTRA); Multiplexing and channel coding".
- [14] 3GPP TR 36.942: "E-UTRA RF system scenarios".
- [15] 3GPP TS 25.104: "Base Station (BS) radio transmission and Reception (FDD)".
- [16] 3GPP TS 36.213: "Evolved Universal Terrestrial Radio Access (E-UTRA); Physical layer procedures".
- [17] 3GPP TS 25.141: "Base Station (BS) conformance testing (FDD)".

- [18] 3GPP TS 37.141: " E-UTRA, UTRA and GSM/EDGE; Multi-Standard Radio (MSR) Base Station (BS) conformance testing".
- [19] CEPT ECC Decision (13)03, "The harmonised use of the frequency band 1452-1492 MHz for Mobile/Fixed Communications Networks Supplemental Downlink (MFCN SDL)".
- [20] CEPT ECC Decision (17)06, "The harmonised use of the frequency bands 1427-1452 MHz and 1492-1518 MHz for Mobile/Fixed Communications Networks Supplemental Downlink (MFCN SDL)".

3 Definitions, symbols and abbreviations

3.1 Definitions

For the purposes of the present document, the terms and definitions given in TR 21.905 [1] and the following apply. A term defined in the present document takes precedence over the definition of the same term, if any, in TR 21.905 [1].

Aggregated Channel Bandwidth: RF bandwidth in which a base station transmits and/or receives multiple contiguously aggregated carriers.

NOTE: The Aggregated Channel Bandwidth is measured in MHz.

Base station receive period: time during which the base station is receiving data subframes or UpPTS.

Base Station RF Bandwidth: RF bandwidth in which a base station transmits and/or receives single or multiple carrier(s) within a supported operating band.

NOTE: In single E-UTRA carrier operation, the Base Station RF Bandwidth is equal to the channel bandwidth.

Base Station RF Bandwidth edge: frequency of one of the edges of the Base Station RF Bandwidth.

Carrier: modulated waveform conveying the E-UTRA or UTRA (WCDMA) physical channels

Carrier aggregation: aggregation of two or more component carriers in order to support wider transmission bandwidths

Carrier aggregation band: set of one or more operating bands across which multiple carriers are aggregated with a specific set of technical requirements

NOTE: Carrier aggregation band(s) for an E-UTRA BS is declared by the manufacturer according to the designations in Tables 5.5-2 to 5.5-4

Channel bandwidth: RF bandwidth supporting a single E-UTRA RF carrier with the transmission bandwidth configured in the uplink or downlink of a cell.

NOTE The channel bandwidth is measured in MHz and is used as a reference for transmitter and receiver RF requirements.

Channel edge: lowest or highest frequency of the E-UTRA carrier.

NOTE: Channel edges are separated by the channel bandwidth.

Contiguous carriers: set of two or more carriers configured in a spectrum block where there are no RF requirements based on co-existence for un-coordinated operation within the spectrum block.

Contiguous spectrum: spectrum consisting of a contiguous block of spectrum with no sub-block gap(s).

DL RS power: resource element power of Downlink Reference Symbol.

DL NRS power: resource element power of Downlink Narrowband Reference Signal.

Downlink operating band: part of the operating band designated for downlink.

Enhanced performance requirements type A: This defines performance requirements assuming baseline receiver as demodulation reference signal based linear minimum mean square error interference rejection combining.

Enhanced performance requirements type B: This defines performance requirements assuming baseline receiver as code word level interference cancellation for intra-cell inter-user interference plus demodulation reference signal based linear minimum mean square error interference rejection combining for inter-cell interference.

Highest Carrier: carrier with the highest carrier centre frequency transmitted/received in a specified operating band.

Inter RF Bandwidth gap: frequency gap between two consecutive Base Station RF Bandwidths that are placed within two supported operating bands.

Inter-band carrier aggregation: carrier aggregation of component carriers in different operating bands.

NOTE: Carriers aggregated in each band can be contiguous or non-contiguous.

Inter-band gap: The frequency gap between two supported consecutive operating bands.

Intra-band contiguous carrier aggregation: contiguous carriers aggregated in the same operating band.

Intra-band non-contiguous carrier aggregation: non-contiguous carriers aggregated in the same operating band.

Lower sub-block edge: frequency at the lower edge of one sub-block.

NOTE: It is used as a frequency reference point for both transmitter and receiver requirements.

Lowest Carrier: carrier with the lowest carrier centre frequency transmitted/received in a specified operating band.

Maximum Base Station RF Bandwidth: maximum Base Station RF Bandwidth supported by a BS within each supported operating band.

Maximum output power: mean power level per carrier of the base station measured at the antenna connector in a specified reference condition.

Maximum Radio Bandwidth: maximum frequency difference between the upper edge of the highest used carrier and the lower edge of the lowest used carrier.

Maximum throughput: maximum achievable throughput for a reference measurement channel.

Mean power: power measured in the channel bandwidth of the carrier.

NOTE: The period of measurement shall be at least one subframe (1ms), unless otherwise stated.

Multi-band Base Station: base station characterized by the ability of its transmitter and/or receiver to process two or more carriers in common active RF components simultaneously, where at least one carrier is configured at a different operating band (which is not a sub-band or superseding-band of another supported operating band) than the other carrier(s).

Multi-carrier transmission configuration: set of one or more contiguous or non-contiguous carriers that a BS is able to transmit simultaneously according to the manufacturer's specification.

Multi-band transmitter: transmitter characterized by the ability to process two or more carriers in common active RF components simultaneously, where at least one carrier is configured at a different operating band (which is not a sub-band or superseding-band of another supported operating band) than the other carrier(s).

Multi-band receiver: receiver characterized by the ability to process two or more carriers in common active RF components simultaneously, where at least one carrier is configured at a different operating band (which is not a sub-band or superseding-band of another supported operating band) than the other carrier(s).

Non-contiguous spectrum: spectrum consisting of two or more sub-blocks separated by sub-block gap(s).

NB-IoT In-band operation: NB-IoT is operating in-band when it utilizes the resource block(s) within a normal E-UTRA carrier

NB-IoT guard band operation: NB-IoT is operating in guard band when it utilizes the unused resource block(s) within a E-UTRA carrier's guard-band.

NB-IoT standalone operation: NB-IoT is operating standalone when it utilizes its own spectrum, for example the spectrum currently being used by GERAN systems as a replacement of one or more GSM carriers, as well as scattered spectrum for potential IoT deployment.

Occupied bandwidth: width of a frequency band such that, below the lower and above the upper frequency limits, the mean powers emitted are each equal to a specified percentage $\beta/2$ of the total mean power of a given emission.

Operating band: frequency range (paired or unpaired) that is defined with a specific set of technical requirements, in which E-UTRA operates.

NOTE: The operating band(s) for an E-UTRA BS is declared by the manufacturer according to the designations in Table 5.5-1.

Output power: mean power of one carrier of the base station, delivered to a load with resistance equal to the nominal load impedance of the transmitter.

Rated output power: mean power level per carrier that the manufacturer has declared to be available at the antenna connector.

RE power control dynamic range: difference between the power of a RE and the average RE power for a BS at maximum output power for a specified reference condition.

Reference bandwidth: RF bandwidth in which an emission level is specified.

RRC filtered mean power: mean power as measured through a root raised cosine filter with roll-off factor α and a bandwidth equal to the chip rate of the radio access mode.

NOTE 1: The RRC filtered mean power of a perfectly modulated W-CDMA signal is 0.246 dB lower than the mean power of the same signal.

sTTI: A transmission time interval (TTI) of either one slot or one subslot as defined in TS 36.211 [12] on either uplink or downlink.

Sub-band: A sub-band of an operating band contains a part of the uplink and downlink frequency range of the operating band.

Sub-block: one contiguous allocated block of spectrum for transmission and reception by the same Base Station.

NOTE: There may be multiple instances of sub-blocks within a Base Station RF Bandwidth.

Sub-block bandwidth: RF bandwidth of one sub-block.

Sub-block gap: frequency gap between two consecutive sub-blocks within a Base Station RF Bandwidth, where the RF requirements in the gap are based on co-existence for un-coordinated operation.

Superseding-band: A superseding-band of an operating band includes the whole of the uplink and downlink frequency range of the operating band.

Synchronized operation: operation of TDD in two different systems, where no simultaneous uplink and downlink occur.

Throughput: the number of payload bits successfully received per second for a reference measurement channel in a specified reference condition.

Total power dynamic range: difference between the maximum and the minimum transmit power of an OFDM symbol for a specified reference condition.

Total RF Bandwidth: maximum sum of Base Station RF Bandwidths in all supported operating bands.

Transmission bandwidth: bandwidth of an instantaneous transmission from a UE or BS, measured in resource block units.

Transmission bandwidth configuration: highest transmission bandwidth allowed for uplink or downlink in a given channel bandwidth, measured in resource block units.

Transmitter OFF period: time period during which the BS transmitter is not allowed to transmit.

Transmitter ON period: time period during which the BS transmitter is transmitting data and/or reference symbols, i.e. data subframes or DwPTS.

Transmitter transient period: time period during which the transmitter is changing from the OFF period to the ON period or vice versa.

Unsynchronized operation: operation of TDD in two different systems, where the conditions for synchronized operation are not met.

Uplink operating band: part of the operating band designated for uplink.

Upper sub-block edge: frequency at the upper edge of one sub-block.

NOTE: It is used as a frequency reference point for both transmitter and receiver requirements.

3.2 Symbols

For the purposes of the present document, the following symbols apply:

α	Roll-off factor
β	Percentage of the mean transmitted power emitted outside the occupied bandwidth on the assigned channel
BW_{Channel}	Channel bandwidth
$BW_{\text{Channel,CA}}$	Aggregated Channel Bandwidth, expressed in MHz. $BW_{\text{Channel,CA}} = F_{\text{edge,high}} - F_{\text{edge,low}}$.
$BW_{\text{Channel,block}}$	Sub-block bandwidth, expressed in MHz. $BW_{\text{Channel,block}} = F_{\text{edge,block,high}} - F_{\text{edge,block,low}}$.
BW_{Config}	Transmission bandwidth configuration, expressed in MHz, where $BW_{\text{Config}} = N_{\text{RB}} \times 180$ kHz in the uplink and $BW_{\text{Config}} = 15$ kHz + $N_{\text{RB}} \times 180$ kHz in the downlink.
BW_{max}	Maximum Radio Bandwidth
BW_{tot}	Total RF Bandwidth
CA_X	Intra-band contiguous CA of component carriers in one sub-block within band X where X is the applicable E-UTRA operating band
CA_{X-X}	Intra-band non-contiguous CA of component carriers in two sub-blocks within band X where X is the applicable E-UTRA operating band
CA_{X-Y}	Inter-band CA of component carrier(s) in one sub-blocks within band X and component carrier(s) in one sub-block within Band Y where X and Y are the applicable E-UTRA operating bands
CA_{X-X-Y}	CA of component carriers in two sub-blocks within Band X and component carrier(s) in one sub-block within Band Y where X and Y are the applicable E-UTRA operating bands
f	Frequency
Δf	Separation between the channel edge frequency and the nominal -3dB point of the measuring filter closest to the carrier frequency
Δf_{max}	The largest value of Δf used for defining the requirement
F_{C}	Carrier centre frequency
$F_{\text{C,block,high}}$	Centre frequency of the highest transmitted/received carrier in a sub-block.
$F_{\text{C,block,low}}$	Centre frequency of the lowest transmitted/received carrier in a sub-block.
$F_{\text{C,high}}$	The carrier centre frequency of the highest carrier, expressed in MHz.
$F_{\text{C,low}}$	The carrier centre frequency of the lowest carrier, expressed in MHz.
$F_{\text{edge,low}}$	The lower edge of Aggregated Channel Bandwidth, expressed in MHz. $F_{\text{edge,low}} = F_{\text{C,low}} - F_{\text{offset}}$.
$F_{\text{edge,high}}$	The upper edge of Aggregated Channel Bandwidth, expressed in MHz. $F_{\text{edge,high}} = F_{\text{C,high}} + F_{\text{offset}}$.
$F_{\text{edge,block,low}}$	The lower sub-block edge, where $F_{\text{edge,block,low}} = F_{\text{C,block,low}} - F_{\text{offset}}$.
$F_{\text{edge,block,high}}$	The upper sub-block edge, where $F_{\text{edge,block,high}} = F_{\text{C,block,high}} + F_{\text{offset}}$.
F_{offset}	Frequency offset from $F_{\text{C,high}}$ to the upper Base Station RF Bandwidth edge or from $F_{\text{C,block,high}}$ to the upper sub-block edge, $F_{\text{C,low}}$ to the lower Base Station RF Bandwidth edge or from $F_{\text{C,block,low}}$ to the lower sub-block edge.
F_{filter}	Filter centre frequency
f_{offset}	Separation between the channel edge frequency and the centre of the measuring filter
$f_{\text{offset,max}}$	The maximum value of f_{offset} used for defining the requirement
E_A :	EPRE (energy per resource element) of PDSCH REs (resource elements) type A, i.e. REs in OFDM symbols that do not include reference symbols
E_B :	EPRE of PDSCH REs type B, i.e. REs in OFDM symbols that include reference symbols
E_{RS} :	EPRE of reference symbols REs
$F_{\text{DL,low}}$	The lowest frequency of the downlink operating band
$F_{\text{DL,high}}$	The highest frequency of the downlink operating band

F_{UL_low}	The lowest frequency of the uplink operating band
F_{UL_high}	The highest frequency of the uplink operating band
M_{DL}	Offset of NB-IoT Downlink channel number to Downlink EARFCN
M_{UL}	Offset of NB-IoT Uplink channel number to Uplink EARFCN
N_{DL}	Downlink EARFCN
$N_{Offs-DL}$	Offset used for calculating downlink EARFCN
$N_{Offs-UL}$	Offset used for calculating uplink EARFCN
N_{ID}^{cell}	Physical layer cell identity
N_{CS}	Number of Cyclic shifts for preamble generation in PRACH
N_{RB}	Transmission bandwidth configuration, expressed in units of resource blocks
N_{RB}^{DL}	Downlink bandwidth configuration, expressed in multiples of N_{sc}^{RB}
N_{UL}	Uplink EARFCN
N_{sc}^{RB}	Resource block size in the frequency domain, expressed as a number of subcarriers
n_f	System frame number
n_{PRB}	Physical resource block number
n_{RNTI}	Radio network temporary identifier
n_s	Slot number within a radio frame
p	Antenna port number
P_d	Probability of PRACH preamble detection
P_{fa}	Total probability of false detection of the PRACH preamble
P_{out}	Output power
$P_{EM,N}$	Declared emission level for channel N
$P_{EM,B32,B75,B76,ind}$	Declared emission level in Band 32, Band 75 and Band 76, ind=a, b, c
$P_{EM,B32,ind}$	Declared emission level in Band 32, ind= d, e
$P_{EM,B50,B74,B75,ind}$	Declared emission level for Band 50, Band 74 and Band 75, ind=a,b
$P_{rated,c}$	Rated output power (per carrier)
$P_{rated,t}$	Rated Total Output Power $P_{max,c}$ Maximum carrier output power
$P_{REFSENS}$	Reference sensitivity power level
q	Code word number
T_A	Timing advance command, as defined in [16]
T_s	Basic time unit, as defined in [12]
W_{gap}	Sub-block gap or Inter RF Bandwidth gap size

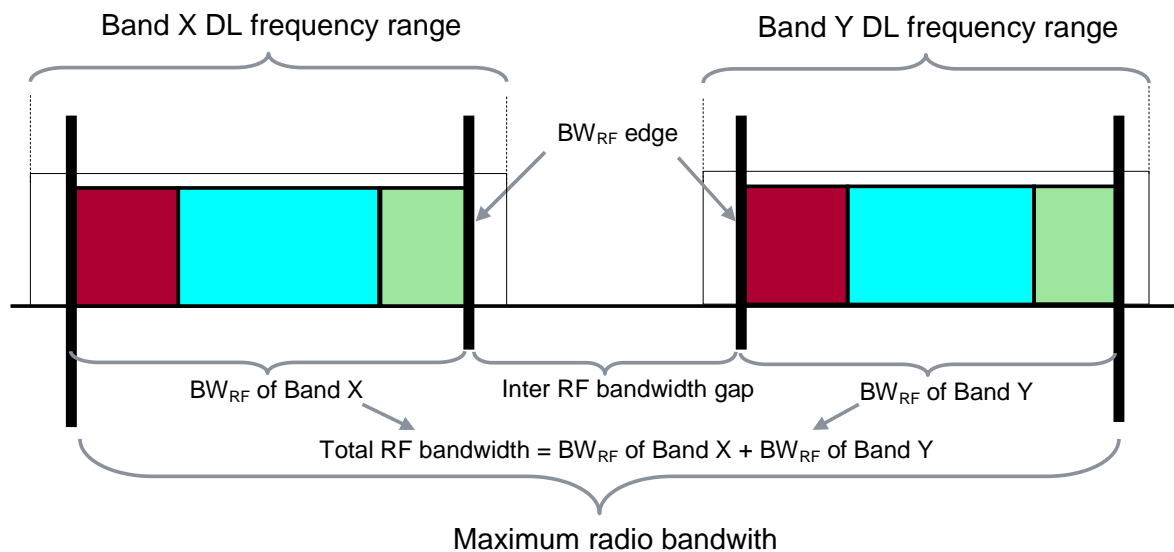

Figure 3.2-1: Illustration of Maximum Radio Bandwidth BW_{max} and Total RF Bandwidth BW_{tot} for multi-band base station

3.3 Abbreviations

For the purposes of the present document, the abbreviations given in TR 21.905 [1] and the following apply. An abbreviation defined in the present document takes precedence over the definition of the same abbreviation, if any, in TR 21.905 [1].

AC	Alternating Current
ACLR	Adjacent Channel Leakage Ratio
CACLR	Cumulative ACLR
ACK	Acknowledgement (in HARQ protocols)
ACS	Adjacent Channel Selectivity
ATT	Attenuator
AWGN	Additive White Gaussian Noise
B	Bottom RF channel (for testing purposes)
BL/CE	Bandwidth-reduced Low-complexity or Coverage Enhanced
BS	Base Station
C	Contiguous
CA	Carrier Aggregation
BW	Bandwidth
CCE	Control Channel Element
CP	Cyclic prefix
CW	Continuous Wave
DC	Direct Current
DFT	Discrete Fourier Transformation
DIP	Dominant Interferer Proportion
DTT	Digital Terrestrial Television
DUT	Device Under Test
EPRE	Energy per resource element
E-TM	E-UTRA Test Model
E-UTRA	Evolved UTRA
EARFCN	E-UTRA Absolute Radio Frequency Channel Number
EIRP	Effective Isotropic Radiated Power
EPA	Extended Pedestrian A model
ETC	E-UTRA Test Configuration
ETU	Extended Typical Urban model
EVA	Extended Vehicular A model
EVM	Error Vector Magnitude
FDD	Frequency Division Duplex
FFT	Fast Fourier Transformation
FRC	Fixed Reference Channel
GSM	Global System for Mobile communications
HARQ	Hybrid Automatic Repeat Request
ICS	In-Channel Selectivity
IQ	In-phase - <i>Quadrature</i> phase
ITU-R	Radiocommunication Sector of the ITU
Iuant	E-Node B internal logical interface between the implementation specific O&M function and the RET antennas and TMAs control unit function of the E-Node B
LA	Local Area
M	Middle RF channel (for testing purposes)
MC	Multi-carrier
MFCN	Mobile/Fixed Communications Network
MIMO	Multiple Input Multiple Output
MCS	Modulation and Coding Scheme
MR	Medium Range
NB-IoT	Narrowband – Internet of Things
NC	Non-Contiguous
NPDSCH	Narrowband Physical Downlink Shared Channel
NPUSCH	Narrowband Physical Uplink Shared Channel
NRS	Narrowband Reference Signal
OBW	Occupied Band Width
OFDM	Orthogonal Frequency Division Multiplex

OOB	Out-Of-Band
PBCH	Physical Broadcast Channel
PCFICH	Physical control format indicator channel
PDCCH	Physical downlink control channel
PDSCH	Physical downlink shared channel
PHICH	Physical hybrid-ARQ indicator channel
PUCCH	Physical Uplink Control CHannel
PRACH	Physical Random Access Channel
PRB	Physical Resource Block
PSD	Power Spectral Density
QAM	Quadrature Amplitude Modulation
QPSK	Quadrature Phase-Shift Keying
RAT	Radio Access Technology
RB	Resource Block
RE	Resource Element
REG	Resource Element Group
RF	Radio Frequency
RS	Reference Symbol
RX	Receive
RRC	Root Raised Cosine
sCCE	short Control Channel Element
SINR	Signal-to-Interference-and-Noise Ratio
SNR	Signal-to-Noise Ratio
sPDCCH	shortened Physical Downlink Control Channel
sPDSCH	shortened Physical Downlink Shared Channel
SQRT	SQuare RooT
sREG	short Resource-Element Group
SC	Single Carrier
SRS	Sounding Reference Signal
T	Top RF channel (for testing purposes)
TA	Timing Advance
TC	Test Configuration
TDD	Time Division Duplex
TT	Test Tolerance
TX	Transmit
UE	User Equipment
UMTS	Universal Mobile Telecommunications System
UTRA	UMTS Terrestrial Radio Access
WA	Wide Area

4 General test conditions and declarations

Many of the tests in this specification measure a parameter relative to a value that is not fully specified in the E-UTRA specifications. For these tests, the Minimum Requirement is determined relative to a nominal value specified by the manufacturer.

Certain functions of a BS are optional in the E-UTRA specifications. Some requirements for the BS may be regional as listed in subclause 4.3.

When specified in a test, the manufacturer shall declare the nominal value of a parameter, or whether an option is supported.

4.1 Measurement uncertainties and Test Requirements

4.1.1 General

The requirements of this clause apply to all applicable tests in this specification.

The Minimum Requirements are given in 36.104 [2] and test requirements are given in this specification. Test Tolerances are defined in Annex G of this specification. Test Tolerances are individually calculated for each test. The Test Tolerances are used to relax the Minimum Requirements in 36.104 [2] to create Test Requirements.

4.1.2 Acceptable uncertainty of Test System

The maximum acceptable uncertainty of the Test System is specified below for each test, where appropriate. The Test System shall enable the stimulus signals in the test case to be adjusted to within the specified tolerance and the equipment under test to be measured with an uncertainty not exceeding the specified values. All tolerances and uncertainties are absolute values, and are valid for a confidence level of 95 %, unless otherwise stated.

A confidence level of 95% is the measurement uncertainty tolerance interval for a specific measurement that contains 95% of the performance of a population of test equipment.

For RF tests, it should be noted that the uncertainties in subclause 4.1.2 apply to the Test System operating into a nominal 50 ohm load and do not include system effects due to mismatch between the DUT and the Test System.

Unless otherwise stated, the uncertainties in subclause 4.1.2 apply to the Test System for testing BS that supports E-UTRA or E-UTRA with NB-IoT in-band/guard band operation or NB-IoT standalone operation.

4.1.2.1 Measurement of transmitter

Table 4.1.2-1: Maximum Test System Uncertainty for transmitter tests

Subclause	Maximum Test System Uncertainty	Derivation of Test System Uncertainty
6.2. Base station output power	±0.7 dB, $f \leq 3.0\text{GHz}$ ±1.0 dB, $3.0\text{GHz} < f \leq 4.2\text{GHz}$ ±1.5 dB, $4.2\text{GHz} < f \leq 6.0\text{GHz}$ ±1.0 dB for standalone NB-IoT	
6.3.2 Total power dynamic range	± 0.4 dB	Relative error of two OFDM Symbol TX power (OSTP) measurements
6.3.3 NB-IoT RB power dynamic range for in-band or guard band operation	± 0.4 dB	
6.4.1 Transmitter OFF power	±2.0 dB, $f \leq 3.0\text{GHz}$ ±2.5 dB, $3.0\text{GHz} < f \leq 4.2\text{GHz}$ ±3 dB, $4.2\text{GHz} < f \leq 6.0\text{GHz}$	
6.4.2 Transmitter transient period	N/A	
6.5.1 Frequency error	± 12 Hz	
6.5.2 EVM	± 1 %	
6.5.3 Time alignment error	± 25 ns	
6.5.4 DL RS power	±0.8 dB, $f \leq 3.0\text{GHz}$ ±1.1 dB, $3.0\text{GHz} < f \leq 4.2\text{GHz}$ ±1.6 dB, $4.2\text{GHz} < f \leq 6.0\text{GHz}$	
6.6.1 Occupied bandwidth	1.4MHz, 3MHz Channel BW: 30kHz 5MHz, 10MHz Channel BW: 100kHz 15MHz, ≥20MHz: Channel BW: 300kHz	
6.6.2 Adjacent Channel Leakage power Ratio (ACLR)	ACLR ±0.8 dB Absolute power ±2.0 dB, $f \leq 3.0\text{GHz}$ Absolute power ±2.5 dB, $3.0\text{GHz} < f \leq 4.2\text{GHz}$ Absolute power ±3.0 dB, $4.2\text{GHz} < f \leq 6.0\text{GHz}$ CACLR±0.8 dB Absolute power ±2.0 dB, $f \leq 3.0\text{GHz}$ Absolute power ±2.5 dB, $3.0\text{GHz} < f \leq 4.2\text{GHz}$ Absolute power ±3.0 dB, $4.2\text{GHz} < f \leq 6.0\text{GHz}$	
6.6.3 Operating band unwanted emissions	±1.5 dB, $f \leq 3.0\text{GHz}$ ±1.8 dB, $3.0\text{GHz} < f \leq 4.2\text{GHz}$ ±2.2 dB, $4.2\text{GHz} < f \leq 6.0\text{GHz}$	
6.6.4.5.1 Transmitter spurious emissions, Mandatory Requirements	9 kHz < $f \leq 4$ GHz: ±2.0 dB 4 GHz < $f \leq 19$ GHz: ±4.0 dB	
6.6.4.5.2 Transmitter spurious emissions, Mandatory Requirements	9 kHz < $f \leq 4$ GHz: ±2.0 dB 4 GHz < $f \leq 19$ GHz: ±4.0 dB	
6.6.4.5.3 Transmitter spurious emissions, Protection of BS receiver	±3.0 dB	
6.6.4.5.4 Transmitter spurious emissions, Additional spurious emissions requirements	±2.0 dB for > -60dBm, $f \leq 3.0\text{GHz}$ ±2.5 dB, $3.0\text{GHz} < f \leq 4.2\text{GHz}$ ±3.0 dB, $4.2\text{GHz} < f \leq 6.0\text{GHz}$ ±3.0 dB for ≤ -60dBm, $f \leq 3.0\text{GHz}$ ±3.5 dB, $3.0\text{GHz} < f \leq 4.2\text{GHz}$ ±4.0 dB, $4.2\text{GHz} < f \leq 6.0\text{GHz}$	
6.6.4.5.5 Transmitter spurious emissions, Co-location	± 3.0 dB	
6.7 Transmitter intermodulation (interferer requirements)	The value below applies only to the interference signal and is unrelated to the measurement uncertainty of the tests (6.6.2, 6.6.3 and 6.6.4) which shall be carried out in the presence of the interferer. . ±1,0 dB	The uncertainty of interferer has double the effect on the result due to the frequency offset.

4.1.2.2 Measurement of receiver

Table 4.1.2-2: Maximum Test System Uncertainty for receiver tests

Subclause	Maximum Test System Uncertainty ¹	Derivation of Test System Uncertainty
7.2 Reference sensitivity level	±0.7 dB, $f \leq 3.0\text{GHz}$ ±1.0 dB, $3.0\text{GHz} < f \leq 4.2\text{GHz}$ ±1.5 dB, $4.2\text{GHz} < f \leq 6.0\text{GHz}$	
7.3 Dynamic range	±0.3 dB	Overall system uncertainty for static conditions is equal to signal-to-noise ratio uncertainty. Signal-to-noise ratio uncertainty ±0.3 dB Definitions of signal-to-noise ratio, AWGN and related constraints are given in Table 4.1.2-3.
7.4 In-channel selectivity	±1.4 dB, $f \leq 3.0\text{GHz}$ ±1.8 dB, $3.0\text{GHz} < f \leq 4.2\text{GHz}$ ±2.5 dB, $4.2\text{GHz} < f \leq 6.0\text{GHz}$	Overall system uncertainty comprises three quantities: 1. Wanted signal level error 2. Interferer signal level error 3. Additional impact of interferer leakage Items 1 and 2 are assumed to be uncorrelated so can be root sum squared to provide the ratio error of the two signals. The interferer leakage effect is systematic, and is added arithmetically. Test System uncertainty = $[\text{SQRT}(\text{wanted_level_error}^2 + \text{interferer_level_error}^2)] + \text{leakage effect}$. $f \leq 3.0\text{GHz}$ Wanted signal level ± 0.7dB Interferer signal level ± 0.7dB $3.0\text{GHz} < f \leq 4.2\text{GHz}$ Wanted signal level ± 1.0dB Interferer signal level ± 1.0dB $4.2\text{GHz} < f \leq 6.0\text{GHz}$ Wanted signal level ± 1.5dB Interferer signal level ± 1.5dB $f \leq 6.0\text{GHz}$ Impact of interferer leakage 0.4dB.

<p>7.5 Adjacent Channel Selectivity (ACS) and narrow-band blocking</p>	<p>±1.4 dB, $f \leq 3.0\text{GHz}$ ±1.8 dB, $3.0\text{GHz} < f \leq 4.2\text{GHz}$ ±2.5 dB, $4.2\text{GHz} < f \leq 6.0\text{GHz}$</p>	<p>Overall system uncertainty comprises three quantities:</p> <ol style="list-style-type: none"> 1. Wanted signal level error 2. Interferer signal level error 3. Additional impact of interferer ACLR <p>Items 1 and 2 are assumed to be uncorrelated so can be root sum squared to provide the ratio error of the two signals. The interferer ACLR effect is systematic, and is added arithmetically.</p> <p>Test System uncertainty = [SQRT (wanted_level_error² + interferer_level_error²)] + ACLR effect.</p> <p>$f \leq 3.0\text{GHz}$</p> <p>Wanted signal level ± 0.7dB Interferer signal level ± 0.7dB</p> <p>$3.0\text{GHz} < f \leq 4.2\text{GHz}$</p> <p>Wanted signal level ± 1.0dB Interferer signal level ± 1.0dB</p> <p>$4.2\text{GHz} < f \leq 6.0\text{GHz}$</p> <p>Wanted signal level ± 1.5dB Interferer signal level ± 1.5dB</p> <p>$f \leq 6.0\text{GHz}$</p> <p>Impact of interferer ACLR 0.4dB. See Note 2.</p>
--	---	---

<p>7.6.5.1 Blocking (General requirements)</p>	<p><u>In-band blocking, using modulated interferer:</u> ± 1.6 dB, $f \leq 3.0$GHz ± 2.0 dB, 3.0GHz $< f \leq 4.2$GHz ± 2.7 dB, 4.2GHz $< f \leq 6.0$GHz</p> <p><u>Out of band blocking, using CW interferer:</u> $f_{\text{wanted}} \leq 3$GHz 1MHz $< f_{\text{interferer}} \leq 3$ GHz: ± 1.3 dB 3.0GHz $< f_{\text{interferer}} \leq 4.2$ GHz: ± 1.5 dB 4.2GHz $< f_{\text{interferer}} \leq 12.75$ GHz: ± 3.2 dB</p> <p>3GHz $< f_{\text{wanted}} \leq 4.2$GHz: 1MHz $< f_{\text{interferer}} \leq 3$ GHz: ± 1.5 dB 3.0GHz $< f_{\text{interferer}} \leq 4.2$ GHz: ± 1.7 dB 4.2GHz $< f_{\text{interferer}} \leq 12.75$ GHz: ± 3.3 dB</p> <p>4.2GHz $< f_{\text{wanted}} \leq 6.0$GHz: 1MHz $< f_{\text{interferer}} \leq 3$ GHz: ± 1.9 dB 3.0GHz $< f_{\text{interferer}} \leq 4.2$ GHz: ± 2.0 dB 4.2GHz $< f_{\text{interferer}} \leq 12.75$ GHz: ± 3.5 dB</p>	<p>Overall system uncertainty can have these contributions:</p> <ol style="list-style-type: none"> 1. Wanted signal level error 2. Interferer signal level error 3. Interferer ACLR 4. Interferer broadband noise <p>Items 1 and 2 are assumed to be uncorrelated so can be root sum squared to provide the ratio error of the two signals. The Interferer ACLR or Broadband noise effect is systematic, and is added arithmetically.</p> <p>Test System uncertainty = $[\text{SQRT}(\text{wanted_level_error}^2 + \text{interferer_level_error}^2)] + \text{ACLR effect} + \text{Broadband noise effect}$.</p> <p><u>In-band blocking, using modulated interferer:</u> $f \leq 3.0$GHz</p> <p>Wanted signal level ± 0.7dB Interferer signal level ± 1.0dB 3.0GHz $< f \leq 4.2$GHz Wanted signal level ± 1.0dB Interferer signal level ± 1.2dB 4.2GHz $< f \leq 6.0$GHz Wanted signal level ± 1.5dB Interferer signal level ± 1.8dB</p> <p>$f \leq 6.0$GHz Interferer ACLR 0.4dB Broadband noise not applicable</p> <p><u>Out of band blocking, using CW interferer:</u> Wanted signal level: ± 0.7dB $f \leq 3.0$GHz ± 1.0dB 3.0GHz $< f \leq 4.2$GHz ± 1.5dB 4.2GHz $< f \leq 6.0$GHz</p> <p>Interferer signal level: ± 1.0dB up to 3GHz ± 1.2dB 3.0GHz $< f \leq 4.2$GHz</p>
--	--	--

		<p>± 3.0dB up to 12.75GHz Interferer ACLR not applicable Impact of interferer Broadband noise 0.1dB</p>
--	--	---

<p>7.6.5.2 Blocking (Co-location with other base stations)</p>	<p><u>Co-location blocking, using CW interferer:</u> ± 2.5 dB, $f \leq 3.0$GHz ± 2.6 dB, 3.0GHz $< f \leq 4.2$GHz ± 2.9 dB, 4.2GHz $< f \leq 6.0$GHz</p>	<p><u>Co-location blocking, using CW interferer:</u> $f \leq 3.0$GHz Wanted signal level ± 0.7dB 3.0GHz $< f \leq 4.2$GHz Wanted signal level ± 1.0dB 4.2GHz $< f \leq 6.0$GHz Wanted signal level ± 1.5dB $f \leq 6.0$GHz Interferer signal level: ± 2.0dB Interferer ACLR not applicable Impact of interferer Broadband noise 0.4dB</p>
<p>7.7 Receiver spurious emissions</p>	<p>30 MHz $\leq f \leq 4$ GHz: ± 2.0 dB 4 GHz $< f \leq 19$ GHz: ± 4.0 dB</p>	

<p>7.8 Receiver intermodulation</p>	<p>±1.8 dB, $f \leq 3.0\text{GHz}$ ±2.4 dB, $3.0\text{GHz} < f \leq 4.2\text{GHz}$ ±3.3 dB, $4.2\text{GHz} < f \leq 6.0\text{GHz}$</p>	<p>Overall system uncertainty comprises four quantities:</p> <ol style="list-style-type: none"> 1. Wanted signal level error 2. CW Interferer level error 3. Modulated Interferer level error 4. Impact of interferer ACLR <p>The effect of the closer CW signal has twice the effect.</p> <p>Items 1, 2 and 3 are assumed to be uncorrelated so can be root sum squared to provide the combined effect of the three signals. The interferer ACLR effect is systematic, and is added arithmetically.</p> <p>Test System uncertainty = $\text{SQRT} [(2 \times \text{CW_level_error})^2 + (\text{mod interferer_level_error})^2 + (\text{wanted signal_level_error})^2]$ + ACLR effect.</p> <p>$f \leq 3.0\text{GHz}$</p> <p>Wanted signal level ± 0.7dB CW Interferer level ± 0.5dB Mod Interferer level ± 0.7dB $3.0\text{GHz} < f \leq 4.2\text{GHz}$</p> <p>Wanted signal level ± 1.0dB CW Interferer level ± 0.7dB Mod Interferer level ± 1.0dB $4.2\text{GHz} < f \leq 6.0\text{GHz}$ Wanted signal level ± 1.5dB CW Interferer level ± 1.0dB Mod Interferer level ± 1.5dB</p> <p>$f \leq 6.0\text{GHz}$ Impact of interferer ACLR 0.4dB</p>
<p>Note 1: Unless otherwise noted, only the Test System stimulus error is considered here. The effect of errors in the throughput measurements due to finite test duration is not considered.</p>		

- Note 2: The Test equipment ACLR requirement for a specified uncertainty contribution is calculated as below:
- The wanted signal to noise ratio for Reference sensitivity is calculated based on a 5dB noise figure
 - The same wanted signal to (noise + interference) ratio is then assumed at the desensitisation level according to the ACS test conditions
 - The noise is subtracted from the total (noise + interference) to compute the allowable BS adjacent channel interference. From this an equivalent BS ACS figure can be obtained
 - The contribution from the Test equipment ACLR is calculated to give a 0.4dB additional rise in interference. This corresponds to a Test equipment ACLR which is 10.2 dB better than the BS ACS
 - This leads to the following Test equipment ACLR requirements for the interfering signal:

Adjacent channel Selectivity

E-UTRA 1.4MHz channel bandwidth: 56dB
E-UTRA 3MHz channel bandwidth: 56dB
E-UTRA 5MHz channel bandwidth and above: 56dB
Stand-alone NB-IoT 200kHz channel bandwidth: 56dB

Narrow band blocking

E-UTRA 1.4MHz channel bandwidth: 65dB
E-UTRA 3MHz channel bandwidth: 61dB
E-UTRA 5MHz channel bandwidth and above: 59dB
Stand-alone NB-IoT 200kHz channel bandwidth: 66dB

4.1.2.3 Measurement of performance requirement

Table 4.1.2-3: Maximum Test System Uncertainty for Performance Requirements

Subclause	Maximum Test System Uncertainty ¹	Derivation of Test System Uncertainty
8.2.1 Performance requirements of PUSCH in multipath fading propagation conditions transmission on single antenna port	± 0.6 dB	<p>Overall system uncertainty for fading conditions comprises two quantities:</p> <ol style="list-style-type: none"> 1. Signal-to-noise ratio uncertainty 2. Fading profile power uncertainty <p>Items 1 and 2 are assumed to be uncorrelated so can be root sum squared:</p> <p>Test System uncertainty = [SQRT (Signal-to-noise ratio uncertainty² + Fading profile power uncertainty²)]</p> <p>Signal-to-noise ratio uncertainty ±0.3 dB</p> <p>Fading profile power uncertainty ±0.5 dB</p>
8.2.1A Performance requirements of PUSCH in multipath fading propagation conditions transmission on two antenna ports	± 0.8 dB	<p>Overall system uncertainty for fading conditions comprises two quantities:</p> <ol style="list-style-type: none"> 1. Signal-to-noise ratio uncertainty 2. Fading profile power uncertainty <p>Items 1 and 2 are assumed to be uncorrelated so can be root sum squared:</p> <p>Test System uncertainty = [SQRT (Signal-to-noise ratio uncertainty² + Fading profile power uncertainty²)]</p> <p>Signal-to-noise ratio uncertainty ±0.3 dB</p> <p>Fading profile power uncertainty ±0.7 dB for MIMO</p>
8.2.2 Performance requirements for UL timing adjustment	± 0.6 dB	<p>Overall system uncertainty for fading conditions comprises two quantities:</p> <ol style="list-style-type: none"> 1. Signal-to-noise ratio uncertainty 2. Fading profile power uncertainty <p>Items 1 and 2 are assumed to be uncorrelated so can be root sum squared:</p> <p>Test System uncertainty = [SQRT (Signal-to-noise ratio uncertainty² + Fading profile power uncertainty²)]</p> <p>Signal-to-noise ratio uncertainty ±0.3 dB</p> <p>Fading profile power uncertainty ±0.5 dB</p>
	± 0.3 dB	<p>Overall system uncertainty for static conditions is equal to signal-to-noise ratio uncertainty.</p> <p>Signal-to-noise ratio uncertainty ±0.3 dB</p>

<p>8.2.3 Performance requirements for HARQ-ACK multiplexed on PUSCH</p>	<p>± 0.6 dB</p>	<p>Overall system uncertainty for fading conditions comprises two quantities:</p> <ol style="list-style-type: none"> 1. Signal-to-noise ratio uncertainty 2. Fading profile power uncertainty <p>Items 1 and 2 are assumed to be uncorrelated so can be root sum squared:</p> <p>Test System uncertainty = [SQRT (Signal-to-noise ratio uncertainty² + Fading profile power uncertainty²)]</p> <p>Signal-to-noise ratio uncertainty ±0.3 dB</p> <p>Fading profile power uncertainty ±0.5 dB</p>
<p>8.2.4 Performance requirements for High Speed Train conditions</p>	<p>± 0.3 dB</p>	<p>Overall system uncertainty for static conditions is equal to signal-to-noise ratio uncertainty.</p> <p>Signal-to-noise ratio uncertainty ±0.3 dB</p>
<p>8.3.1 ACK missed detection for single user PUCCH format 1a transmission on single antenna port</p>	<p>± 0.6 dB</p>	<p>Overall system uncertainty for fading conditions comprises two quantities:</p> <ol style="list-style-type: none"> 1. Signal-to-noise ratio uncertainty 2. Fading profile power uncertainty <p>Items 1 and 2 are assumed to be uncorrelated so can be root sum squared:</p> <p>Test System uncertainty = [SQRT (Signal-to-noise ratio uncertainty² + Fading profile power uncertainty²)]</p> <p>Signal-to-noise ratio uncertainty ±0.3 dB</p> <p>Fading profile power uncertainty ±0.5 dB</p>
<p>8.3.2 CQI missed detection for PUCCH format 2 transmission on single antenna port</p>	<p>± 0.6 dB</p>	<p>Overall system uncertainty for fading conditions comprises two quantities:</p> <ol style="list-style-type: none"> 1. Signal-to-noise ratio uncertainty 2. Fading profile power uncertainty <p>Items 1 and 2 are assumed to be uncorrelated so can be root sum squared:</p> <p>Test System uncertainty = [SQRT (Signal-to-noise ratio uncertainty² + Fading profile power uncertainty²)]</p> <p>Signal-to-noise ratio uncertainty ±0.3 dB</p> <p>Fading profile power uncertainty ±0.5 dB</p>

<p>8.3.3 ACK missed detection for multi user PUCCH format 1a</p>	<p>± 0.6 dB</p>	<p>Overall system uncertainty for fading conditions comprises two quantities:</p> <ol style="list-style-type: none"> 1. Signal-to-noise ratio uncertainty 2. Fading profile power uncertainty <p>Items 1 and 2 are assumed to be uncorrelated so can be root sum squared:</p> <p>Test System uncertainty = [SQRT (Signal-to-noise ratio uncertainty² + Fading profile power uncertainty²)]</p> <p>Signal-to-noise ratio uncertainty ±0.3 dB</p> <p>Fading profile power uncertainty ±0.5 dB</p>
<p>8.3.4 ACK missed detection for PUCCH format 1b with Channel Selection</p>	<p>± 0.6 dB</p>	<p>Overall system uncertainty for fading conditions comprises two quantities:</p> <ol style="list-style-type: none"> 1. Signal-to-noise ratio uncertainty 2. Fading profile power uncertainty <p>Items 1 and 2 are assumed to be uncorrelated so can be root sum squared:</p> <p>Test System uncertainty = [SQRT (Signal-to-noise ratio uncertainty² + Fading profile power uncertainty²)]</p> <p>Signal-to-noise ratio uncertainty ±0.3 dB</p> <p>Fading profile power uncertainty ±0.5 dB</p>
<p>8.3.5 ACK missed detection for PUCCH format 3</p>	<p>± 0.6 dB</p>	<p>Overall system uncertainty for fading conditions comprises two quantities:</p> <ol style="list-style-type: none"> 1. Signal-to-noise ratio uncertainty 2. Fading profile power uncertainty <p>Items 1 and 2 are assumed to be uncorrelated so can be root sum squared:</p> <p>Test System uncertainty = [SQRT (Signal-to-noise ratio uncertainty² + Fading profile power uncertainty²)]</p> <p>Signal-to-noise ratio uncertainty ±0.3 dB</p> <p>Fading profile power uncertainty ±0.5 dB</p>

<p>8.3.6 NACK to ACK detection for PUCCH format 3</p>	<p>± 0.6 dB</p>	<p>Overall system uncertainty for fading conditions comprises two quantities:</p> <ol style="list-style-type: none"> 1. Signal-to-noise ratio uncertainty 2. Fading profile power uncertainty <p>Items 1 and 2 are assumed to be uncorrelated so can be root sum squared:</p> <p>Test System uncertainty = [SQRT (Signal-to-noise ratio uncertainty² + Fading profile power uncertainty²)]</p> <p>Signal-to-noise ratio uncertainty ±0.3 dB</p> <p>Fading profile power uncertainty ±0.5 dB</p>
<p>8.3.7 ACK missed detection for PUCCH format 1a transmission on two antenna ports</p>	<p>± 0.8 dB</p>	<p>Overall system uncertainty for fading conditions comprises two quantities:</p> <ol style="list-style-type: none"> 1. Signal-to-noise ratio uncertainty 2. Fading profile power uncertainty <p>Items 1 and 2 are assumed to be uncorrelated so can be root sum squared:</p> <p>Test System uncertainty = [SQRT (Signal-to-noise ratio uncertainty² + Fading profile power uncertainty²)]</p> <p>Signal-to-noise ratio uncertainty ±0.3 dB</p> <p>Fading profile power uncertainty ±0.7 dB for Tx diversity</p>
<p>8.3.8 CQI performance requirements for PUCCH format 2 transmission on two antenna ports</p>	<p>± 0.8 dB</p>	<p>Overall system uncertainty for fading conditions comprises two quantities:</p> <ol style="list-style-type: none"> 1. Signal-to-noise ratio uncertainty 2. Fading profile power uncertainty <p>Items 1 and 2 are assumed to be uncorrelated so can be root sum squared:</p> <p>Test System uncertainty = [SQRT (Signal-to-noise ratio uncertainty² + Fading profile power uncertainty²)]</p> <p>Signal-to-noise ratio uncertainty ±0.3 dB</p> <p>Fading profile power uncertainty ±0.7 dB for Tx diversity</p>

<p>8.3.9 CQI performance requirements for PUCCH format 2 with DTX detection</p>	<p>± 0.6 dB for one antenna port ± 0.8 dB for two antenna ports</p>	<p>Overall system uncertainty for fading conditions comprises two quantities:</p> <ol style="list-style-type: none"> 1. Signal-to-noise ratio uncertainty 2. Fading profile power uncertainty <p>Items 1 and 2 are assumed to be uncorrelated so can be root sum squared:</p> <p>Test System uncertainty = [SQRT (Signal-to-noise ratio uncertainty² + Fading profile power uncertainty²)]</p> <p>Signal-to-noise ratio uncertainty ±0.3 dB</p> <p>Fading profile power uncertainty ±0.5 dB for transmission on one antenna port and ±0.7 dB for transmission on two antenna ports</p>
<p>8.4.1 PRACH false alarm probability and missed detection</p>	<p>± 0.6 dB</p>	<p>Overall system uncertainty for fading conditions comprises two quantities:</p> <ol style="list-style-type: none"> 1. Signal-to-noise ratio uncertainty 2. Fading profile power uncertainty <p>Items 1 and 2 are assumed to be uncorrelated so can be root sum squared:</p> <p>Test System uncertainty = [SQRT (Signal-to-noise ratio uncertainty² + Fading profile power uncertainty²)]</p> <p>Signal-to-noise ratio uncertainty ±0.3 dB</p> <p>Fading profile power uncertainty ±0.5 dB</p>
	<p>± 0.3 dB</p>	<p>Overall system uncertainty for static conditions is equal to signal-to-noise ratio uncertainty.</p> <p>Signal-to-noise ratio uncertainty ±0.3 dB</p>

In addition, the following Test System uncertainties and related constraints apply:

<p>AWGN Bandwidth</p>	<p>≥ 1.08MHz, 2.7MHz, 4.5MHz, 9MHz, 13.5MHz, 18MHz; N_{RB} × 180kHz according to BW_{Config}</p>
<p>AWGN absolute power uncertainty, averaged over BW_{Config}</p>	<p>±1.5 dB</p>
<p>AWGN flatness and signal flatness, max deviation for any resource block, relative to average over BW_{Config}</p>	<p>±2 dB</p>
<p>AWGN flatness over BW_{Channel}, max deviation for any resource block, relative to average over BW_{Config}</p>	<p>+2 dB</p>
<p>AWGN flatness and signal flatness, max difference between adjacent resource blocks</p>	<p>±0.5 dB</p>
<p>AWGN peak to average ratio</p>	<p>≥10 dB @0.001%</p>
<p>Signal-to noise ratio uncertainty, averaged over uplink transmission Bandwidth</p>	<p>±0.3 dB</p>
<p>Fading profile power uncertainty</p>	<p>Test-specific</p>
<p>Fading profile delay uncertainty, relative to frame timing</p>	<p>±5 ns (excludes absolute errors related to baseband timing)</p>

Note 1: Only the overall stimulus error is considered here. The effect of errors in the throughput measurements due to finite test duration is not considered.

4.1.3 Interpretation of measurement results

The measurement results returned by the Test System are compared - without any modification - against the Test Requirements as defined by the Shared Risk principle.

The Shared Risk principle is defined in ITU-R M.1545 [3].

The actual measurement uncertainty of the Test System for the measurement of each parameter shall be included in the test report.

The recorded value for the Test System uncertainty shall be, for each measurement, equal to or lower than the appropriate figure in subclause 4.1.2 of this specification.

If the Test System for a test is known to have a measurement uncertainty greater than that specified in subclause 4.1.2, it is still permitted to use this apparatus provided that an adjustment is made as follows.

Any additional uncertainty in the Test System over and above that specified in subclause 4.1.2 shall be used to tighten the Test Requirement, making the test harder to pass. (For some tests e.g. receiver tests, this may require modification of stimulus signals). This procedure (defined in Annex G) will ensure that a Test System not compliant with subclause 4.1.2 does not increase the chance of passing a device under test where that device would otherwise have failed the test if a Test System compliant with subclause 4.1.2 had been used.

4.2 Base station classes

The requirements in this specification apply to Wide Area Base Station, Medium Range Base Station, Local Area Base Station and Home Base Station unless other wise stated.

Wide Area Base Stations are characterised by requirements derived from Macro Cell scenarios with a BS to UE minimum coupling loss equals to 70 dB. The Wide Area Base Station class has the same requirements as the base station for General Purpose application in Release 8.

Medium Range Base Stations are characterised by requirements derived from Micro Cell scenarios with a BS to UE minimum coupling loss equals to 53 dB.

Local Area Base Stations are characterised by requirements derived from Pico Cell scenarios with a BS to UE minimum coupling loss equal to 45 dB.

Home Base Stations are characterised by requirements derived from Femto Cell scenarios.

The manufacturer shall declare the intended class of the BS under test.

4.3 Regional requirements

Some requirements in the present document may only apply in certain regions either as optional requirements or set by local and regional regulation as mandatory requirements. It is normally not stated in the 3GPP specifications under what exact circumstances that the requirements apply, since this is defined by local or regional regulation.

Table 4.3-1 lists all requirements that may be applied differently in different regions.

Table 4.3-1: List of regional requirements

Clause number	Requirement	Comments
5.5	Operating bands	Some bands may be applied regionally.
5.6	Channel bandwidth	Some channel bandwidths may be applied regionally.
5.7	Channel arrangement	The requirement is applied according to what operating bands in Clause 5.5 that are supported by the BS.
6.2.	Base station maximum output power	In certain regions, the minimum requirement for normal conditions may apply also for some conditions outside the range of conditions defined as normal.
		In certain regions, additional regional requirement specified in subclause 6.2.2 in [1] is applied for rated output power declared by the manufacturer. In addition for Band 46 operation, the BS may have to comply with the applicable BS power limits established regionally, when deployed in regions where those limits apply and under the conditions declared by the manufacturer.
6.6.1	Occupied bandwidth	For Band 46 operation in certain regions, the occupied bandwidth for each 20MHz channel bandwidth E-UTRA carrier shall be less than or equal to 19MHz or 19.7MHz.
6.6.3.5.1	Operating band unwanted emissions (Category A)	This requirement is mandatory for regions where Category A limits for spurious emissions, as defined in ITU-R Recommendation SM.329 [5] apply.
6.6.3.5.2	Operating band unwanted emissions (Category B)	This requirement is mandatory for regions where Category B limits for spurious emissions, as defined in ITU-R Recommendation SM.329 [5], apply.
6.6.3.5.3	Additional requirements	These requirements may apply in certain regions as additional Operating band unwanted emission limits.
6.6.4.5.1	Spurious emissions (Category A)	This requirement is mandatory for regions where Category A limits for spurious emissions, as defined in ITU-R Recommendation SM.329 [5] apply.
6.6.4.5.2	Spurious emissions (Category B)	This requirement is mandatory for regions where Category B limits for spurious emissions, as defined in ITU-R Recommendation SM.329 [5], apply.

6.6.4.5.4	Additional spurious emission requirements	These requirements may be applied for the protection of system operating in frequency ranges other than the E-UTRA BS operating band. In addition for Band 46 operation, the BS may have to comply with the applicable operating band unwanted emission limits established regionally, when deployed in regions where those limits apply and under the conditions declared by the manufacturer.
6.6.4.5.5	Co-location with other base stations	These requirements may be applied for the protection of other BS receivers when a BS operating in another frequency band is co-located with an E-UTRA BS.
6.7.2A	Additional requirements for Band 41	These requirements may apply in certain regions for Band 41.
6.7.6	Additional test requirements for Band 41	These requirements may apply in certain regions for Band 41.
7.6.5.2	Co-location with other base stations	These requirements may be applied for the protection of the BS receivers when a BS operating in another frequency band is co-located with an E-UTRA BS.

4.4 Selection of configurations for testing

Most tests in the present document are only performed for a subset of the possible combinations of test conditions. For instance:

- Not all transceivers in the configuration may be specified to be tested;
- Only one RF channel may be specified to be tested;
- Not all channel bandwidths may be specified to be tested.

4.5 BS Configurations

4.5.1 Transmit configurations

Unless otherwise stated, the transmitter characteristics in clause 6 are specified at the BS antenna connector (test port A) with a full complement of transceivers for the configuration in normal operating conditions. If any external apparatus such as a TX amplifier, a filter or the combination of such devices is used, requirements apply at the far end antenna connector (test port B).

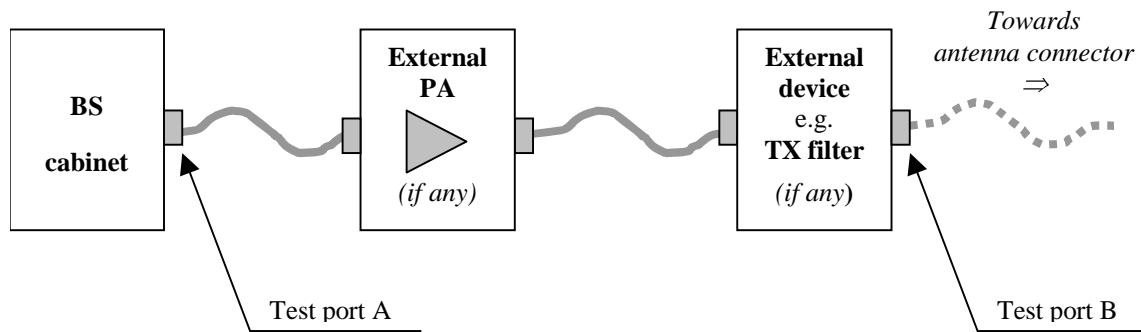

Figure 4.5-1: Transmitter test ports

4.5.1.1 Transmission with multiple transmitter antenna connectors

Unless otherwise stated, for the tests in clause 6 of the present document, the requirement applies for each transmitter antenna connector in the case of transmission with multiple transmitter antenna connectors.

Transmitter requirements are tested at the antenna connector, with the remaining antenna connector(s) being terminated. If the manufacturer has declared the transmitter paths to be equivalent, it is sufficient to measure the signal at any one of the transmitter antenna connectors,.

4.5.2 Receive configurations

Unless otherwise stated, the receiver characteristics in clause 7 are specified at the BS antenna connector (test port A) with a full complement of transceivers for the configuration in normal operating conditions. If any external apparatus such as a RX amplifier, a filter or the combination of such devices is used, requirements apply at the far end antenna connector (test port B).

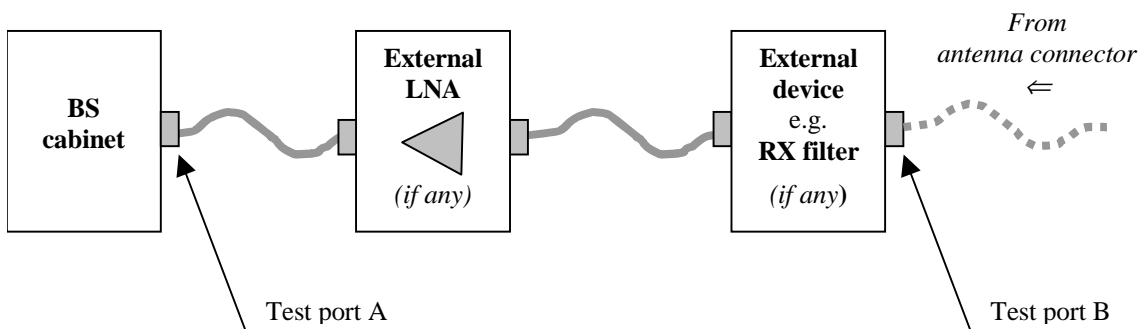

Figure 4.5-2: Receiver test ports

4.5.2.1 Reception with multiple receiver antenna connectors, receiver diversity

For the tests in clause 7 of the present document, the requirement applies at each receiver antenna connector for receivers with antenna diversity or in the case of multi-carrier reception with multiple receiver antenna connectors.

Receiver requirements are tested at the antenna connector, with the remaining receiver(s) disabled or their antenna connector(s) being terminated. If the manufacturer has declared the receiver paths to be equivalent, it is sufficient to apply the specified test signal at any one of the receiver antenna connectors.

For a multi-band BS, multi-band tests for ACS, blocking and intermodulation are performed with the interferer(s) applied to each antenna connector mapped to the receiver for the wanted signal(s), however only to one antenna at a time. Antenna connectors to which no signals are applied are terminated.

4.5.3 Duplexers

The requirements of the present document shall be met with a duplexer fitted, if a duplexer is supplied as part of the BS. If the duplexer is supplied as an option by the manufacturer, sufficient tests should be repeated with and without the duplexer fitted to verify that the BS meets the requirements of the present document in both cases.

The following tests shall be performed with the duplexer fitted, and without it fitted if this is an option:

- 1) subclause 6.2, base station output power, for the highest static power step only, if this is measured at the antenna connector;
- 2) subclause 6.6, unwanted emissions; outside the BS transmit band;
- 3) subclause 6.6.4.5.3, protection of the BS receiver;
- 4) subclause 6.7, transmit intermodulation; for the testing of conformance, the carrier frequencies should be selected to minimize intermodulation products from the transmitters falling in receive channels.

The remaining tests may be performed with or without the duplexer fitted.

NOTE 1: When performing receiver tests with a duplexer fitted, it is important to ensure that the output from the transmitters does not affect the test apparatus. This can be achieved using a combination of attenuators, isolators and filters.

NOTE 2: When duplexers are used, intermodulation products will be generated, not only in the duplexer but also in the antenna system. The intermodulation products generated in the antenna system are not controlled by 3GPP specifications, and may degrade during operation (e.g. due to moisture ingress). Therefore, to ensure continued satisfactory operation of a BS, an operator will normally select EARFCNs to minimize intermodulation products falling on receive channels. For testing of complete conformance, an operator may specify the EARFCNs to be used.

4.5.4 Power supply options

If the BS is supplied with a number of different power supply configurations, it may not be necessary to test RF parameters for each of the power supply options, provided that it can be demonstrated that the range of conditions over which the equipment is tested is at least as great as the range of conditions due to any of the power supply configurations.

This applies particularly if a BS contains a DC rail which can be supplied either externally or from an internal mains power supply. In this case, the conditions of extreme power supply for the mains power supply options can be tested by testing only the external DC supply option. The range of DC input voltages for the test should be sufficient to verify the performance with any of the power supplies, over its range of operating conditions within the BS, including variation of mains input voltage, temperature and output current.

4.5.5 Ancillary RF amplifiers

The requirements of the present document shall be met with the ancillary RF amplifier fitted. At tests according to clauses 6 and 7 for TX and RX respectively, the ancillary amplifier is connected to the BS by a connecting network (including any cable(s), attenuator(s), etc.) with applicable loss to make sure the appropriate operating conditions of the ancillary amplifier and the BS. The applicable connecting network loss range is declared by the manufacturer. Other characteristics and the temperature dependence of the attenuation of the connecting network are neglected. The actual attenuation value of the connecting network is chosen for each test as one of the applicable extreme values. The lowest value is used unless otherwise stated.

Sufficient tests should be repeated with the ancillary amplifier fitted and, if it is optional, without the ancillary RF amplifier to verify that the BS meets the requirements of the present document in both cases.

When testing, the following tests shall be repeated with the optional ancillary amplifier fitted according to the table below, where x denotes that the test is applicable:

Table 4.5-1: Tests applicable to Ancillary RF Amplifiers

Receiver Tests	Subclause	TX amplifier only	RX amplifier only	TX/RX amplifiers combined (Note)
	7.2		X	X
	7.5 (Narrowband blocking)		X	X
	7.6		X	X
	7.7		X	X
	7.8		X	
Transmitter Tests	6.2	X		X
	6.6.1	X		X
	6.6.2	X		X
	6.6.3	X		x
	6.6.4	X		X
	6.7	X		X

NOTE: Combining can be by duplex filters or any other network. The amplifiers can either be in RX or TX branch or in both. Either one of these amplifiers could be a passive network.

In test according to subclauses 6.2 and 7.2 highest applicable attenuation value is applied.

4.5.6 BS with integrated Iuant BS modem

Unless otherwise stated, for the tests in the present document, the integrated Iuant BS modem shall be switched off. Spurious emissions according to clauses 6.6.4 and 7.7 shall be measured only for frequencies above 20MHz with the integrated Iuant BS modem switched on.

4.5.7 BS using antenna arrays

A BS may be configured with a multiple antenna port connection for some or all of its transceivers or with an antenna array related to one cell (not one array per transceiver). This subclause applies to a BS which meets at least one of the following conditions:

- the transmitter output signals from one or more transceiver appear at more than one antenna port; or
- there is more than one receiver antenna port for a transceiver or per cell and an input signal is required at more than one port for the correct operation of the receiver thus the outputs from the transmitters as well as the inputs to the receivers are directly connected to several antennas (known as "aircombining"); or
- transmitters and receivers are connected via duplexers to more than one antenna.

In case of diversity or spatial multiplexing, multiple antennas are not considered as an antenna array.

If a BS is used, in normal operation, in conjunction with an antenna system which contains filters or active elements which are necessary to meet the E-UTRA requirements, the conformance tests may be performed on a system comprising the BS together with these elements, supplied separately for the purposes of testing. In this case, it must be demonstrated that the performance of the configuration under test is representative of the system in normal operation, and the conformance assessment is only applicable when the BS is used with the antenna system.

For conformance testing of such a BS, the following procedure may be used.

4.5.7.1 Receiver tests

For each test, the test signals applied to the receiver antenna connectors shall be such that the sum of the powers of the signals applied equals the power of the test signal(s) specified in the test.

An example of a suitable test configuration is shown in figure 4.5.7.1-1.

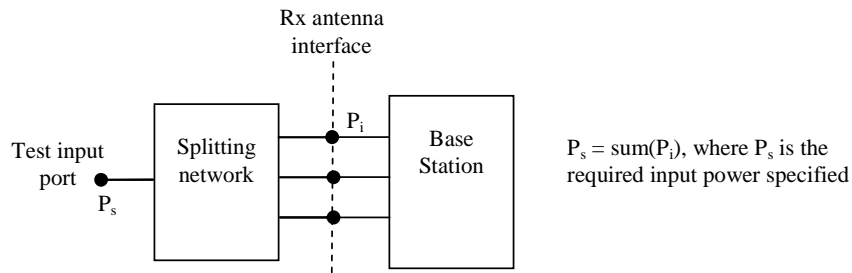

Figure 4.5.7.1-1: Receiver test set-up

For spurious emissions from the receiver antenna connector, the test may be performed separately for each receiver antenna connector.

4.5.7.2 Transmitter tests

For each test, the test signals applied to the transmitter antenna connectors (P_i) shall be such that the sum of the powers of the signals applied equals the power of the test signal(s) (P_s) specified in the test. This may be assessed by separately measuring the signals emitted by each antenna connector and summing the results, or by combining the signals and performing a single measurement. The characteristics (e.g. amplitude and phase) of the combining network should be such that the power of the combined signal is maximised.

An example of a suitable test configuration is shown in figure 4.5.7.2-1.

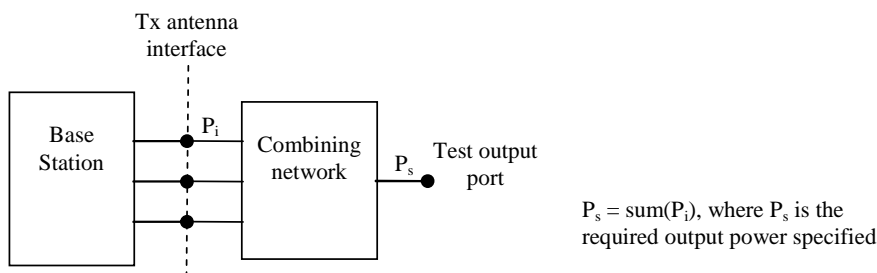

Figure 4.5.7.2-1: Transmitter test set-up

For Intermodulation attenuation, the test may be performed separately for each transmitter antenna connector.

4.6 Manufacturer's declarations of regional and optional requirements

4.6.1 Operating band and frequency range

The manufacturer shall declare which operating band(s) specified in clause 5.5 that is supported by the BS under test and if applicable, which frequency ranges within the operating band(s) that the base station can operate in. Requirements for other operating bands and frequency ranges need not be tested.

The manufacturer shall declare which operating band(s) specified in clause 5.5 are supported by the BS under test for carrier aggregation.

The manufacturer shall declare which NB-IoT operating mode (standalone, in-band and/or guard band) the BS supports for the declared supported band.

For standalone NB-IoT operating mode, the manufacturer shall declare the number of supported NB-IoT carriers.

4.6.2 Channel bandwidth

The manufacturer shall declare which of the channel bandwidths specified in TS36.104 [2] subclause 5.6 that are supported by the BS under test. Requirements for other channel bandwidths need not be tested.

For each supported channel bandwidth, the manufacturer shall declare if BS supports NB-IoT in-band and/or guard band operation and the number of supported NB-IoT PRBs.

4.6.3 Base station output power

The manufacturer shall declare for the BS under test the rated output power for each supported transmit channel bandwidth.

4.6.4 Spurious emissions Category

The manufacturer shall declare one of the following:

- a) The BS is tested against Category A limits for spurious emissions, as defined in ITU-R Recommendation SM.329 [5]. In this case
 - conformance with the operating band unwanted emissions requirements in clause 6.6.3.5.1 is mandatory, and the requirements specified in clause 6.6.3.5.2 need not be tested..
 - conformance with the spurious emissions requirements in clause 6.6.4.5.1 is mandatory, and the requirements specified in clause 6.6.4.5.2 need not be tested.
- b) The BS is tested against Category B limits for spurious emissions, as defined in ITU-R Recommendation SM.329 [5]. In this case,
 - conformance with the operating band unwanted emissions requirements in clause 6.6.3.5.2 is mandatory, and the requirements specified in clause 6.6.3.5.1 need not be tested.
 - conformance with the spurious emissions requirements in clause 6.6.4.5.2 is mandatory, and the requirements specified in clause 6.6.4.5.1 need not be tested.

4.6.5 Additional operating band unwanted emissions

The manufacturer shall declare whether the BS under test is intended to operate in geographic areas where the additional operating band unwanted emission limits defined in clause 6.6.3.5.3 apply. If this is the case, compliance with the test requirement specified in Tables 6.6.3.5.3-1, 6.6.3.5.3-2 or 6.6.3.5.3-3 are mandatory; otherwise these requirements need not be tested.

For a BS declared to support Band 20 and to operate in geographic areas within the CEPT in which frequencies are allocated to broadcasting (DTT) service, the manufacturer shall additionally declare the following quantities associated with the applicable test conditions of Table 6.6.3.5.3-4 and information in annex G of [2] :

$P_{EM,N}$ Declared emission level for channel N

P_{10MHz} Maximum output Power in 10 MHz

For a BS declared to support Band 24 and intended to operate in geographic areas in which the conditions for emissions falling into the 1559-1610 MHz band according to FCC Order DA 10-534 apply, the manufacturer shall additionally declare the following quantities associated with the applicable test conditions of Table 6.6.4.5.4-4:

$P_{E,1kHz}$ Declared emission level (measurement bandwidth = 1kHz)

$P_{E,1MHz}$ Declared emission level (measurement bandwidth = 1MHz)

For a BS declared to support Band 32, 75 or 76 and to intended operate in geographic areas within the CEPT, the manufacturer shall additionally declare the following quantities associated with the applicable test conditions of Table 6.6.3.5.3-8 and Table 6.6.3.5.3-9:

$P_{EM,B32,B75,B76,ind}$ Declared emission level in Band 32, Band 75 and Band 76, ind=a, b, c

$P_{EM,B32,ind}$ Declared emission level in Band 32, ind= d, e

For a BS declared to support Band 50, 74 or 75 and to operate in geographic areas where the additional unwanted emission limit defined in Table 6.6.3.5.3-10 applies, the manufacturer shall additionally declare the following quantity associated with the applicable test conditions of Table 6.6.3.5.3-10:

$P_{EM,B50,B74,B75,ind}$ Declared emission level for Band 50, Band 74 and Band 75, ind=a,b

4.6.6 Co-existence with other systems

The manufacturer shall declare whether the BS under test is intended to operate in geographic areas where one or more of the systems GSM850, GSM900, DCS1800, PCS1900, UTRA FDD, UTRA TDD, E-UTRA and/or PHS operating in another band are deployed. If this is the case, compliance with the applicable test requirement for spurious emissions specified in clause 6.6.4.5.4 shall be tested.

4.6.7 Co-location with other base stations

The manufacturer shall declare whether the BS under test is intended to operate co-located with base stations of one or more of the systems GSM850, GSM900, DCS1800, PCS1900, UTRA FDD, UTRA TDD and/or E-UTRA operating in another band. If this is the case,

- compliance with the applicable test requirement for spurious emissions specified in clause 6.6.4.5.5 shall be tested.
- compliance with the applicable test requirement for receiver blocking specified in clause 7.6 shall be tested.

4.6.8 Manufacturer's declarations of supported RF configurations

The manufacturer shall declare which operational configurations the BS supports by declaring the following parameters:

- Support of the BS in non-contiguous spectrum operation. If the BS does not support non-contiguous spectrum operation the parameters for non-contiguous spectrum operation below shall not be declared.
- The supported operating bands defined in subclause 5.5 for E-UTRA;
- The frequency range within the above operating band(s) supported by the BS for E-UTRA;
- The supported operating band defined in subclause 5.5 for NB-IoT and the operating mode(s);
- The frequency range within the above operating band supported by the BS for NB-IoT;
- The maximum Base Station RF Bandwidth supported by a BS within each operating band;
 - for contiguous spectrum operation
 - for non-contiguous spectrum operation
- The supported operating configurations (multi-carrier, carrier aggregation, and/or single carrier) within each operating band.
- The supported component carrier combinations at nominal channel spacing within each operating band and sub-block.
- The rated output power per carrier;
 - for contiguous spectrum operation
 - for non-contiguous spectrum operation

NOTE 1: Different rated output powers may be declared for different operating configurations.

NOTE 2: If a BS is capable of 256QAM DL operation then two rated output power declarations may be made. One declaration is applicable when configured for 256QAM transmissions and the other declaration is applicable when not configured for 256QAM transmissions.

NOTE 3: If a BS is capable of 1024QAM DL operation then up to three rated output power declarations may be made. One declaration is applicable when configured for 1024QAM transmissions, a different declaration is applicable when configured for 256QAM transmissions and the other declaration is applicable when configured neither for 256 nor 1024QAM transmissions.

- The rated total output power $P_{\text{rated,t}}$ as a sum of all carriers;
 - for contiguous spectrum operation
 - for non-contiguous spectrum operation

NOTE 1: If a BS is capable of 256QAM DL operation then two rated output power declarations may be made. One declaration is applicable when configured for 256QAM transmissions and the other declaration is applicable when not configured for 256QAM transmissions.

NOTE 2: If a BS is capable of 1024QAM DL operation then up to three rated output power declarations may be made. One declaration is applicable when configured for 1024QAM transmissions, a different declaration is applicable when configured for 256QAM transmissions and the other declaration is applicable when configured neither for 256 nor 1024QAM transmissions.

- Maximum number of supported carriers within each band;
 - for contiguous spectrum operation
 - for non-contiguous spectrum operation

If the rated total output power $P_{\text{rated,t}}$ and total number of supported carriers are not simultaneously supported, the manufacturer shall declare the following additional parameters:

- The reduced number of supported carriers at the rated total output power $P_{\text{rated,t}}$;
- The reduced total output power at the maximum number of supported carriers.

For BS capable of multi-band operation, the parameters above shall be declared for each supported operating band, in which declarations of the maximum Base Station RF Bandwidth, the rated output power per carrier, the rated total output power $P_{\text{rated,t}}$ and maximum number of supported carriers are applied for single-band operation only. In addition the manufacturer shall declare the following additional parameters for BS capable of multi-band operation:

- Supported operating band combinations of the BS
- Supported operating band(s) of each antenna connector
- Support of multi-band transmitter and/or multi-band receiver, including mapping to antenna connector(s)
- Total number of supported carriers for the declared band combinations of the BS
- Maximum number of supported carriers per band in multi-band operation
- Total RF Bandwidth BW_{tot} of transmitter and receiver for the declared band combinations of the BS
- Maximum Base Station RF Bandwidth of each supported operating band in multi-band operation
- Maximum Radio Bandwidth BW_{max} in transmit and receive direction for the declared band combinations of the BS
- Any other limitations under simultaneous operation in the declared band combinations of the BS which have any impact on the test configuration generation
- Total output power as a sum over all supported operating bands in the declared band combinations of the BS
- Maximum supported power difference between any two carriers in any two different supported operating bands
- The rated output power per carrier in multi-band operation

- Rated total output power $P_{\text{rated,t}}$ of each supported operating band in multi-band operation

4.6.9 NB-IoT sub-carrier spacing

If the BS supports NB-IoT, manufacturer shall declare if it supports 15 kHz sub-carrier spacing, 3.75 kHz sub-carrier spacing, or both for NPUSCH.

4.6.10 NB-IoT power dynamic range

If the BS supports E-UTRA with NB-IoT operating in-band and/or in guard band, manufacturer shall declare the maximum power dynamic range it could support with a minimum of +6dB as mentioned in TS 36.104 [2] clause 6.3.3.

If the BS supports 5 MHz E-UTRA with NB-IoT operating in guard band, manufacturer shall declare the maximum power that could be allocated to this NB-IoT carrier.

4.6.11 Sub-PRB allocation

Manufacturer shall declare subPRB allocation support for BL/CE UE and comply with the REFSSENS for sub-PRB allocation as mentioned in TS 36.104 [2] clause 7.1.

4.7 Specified frequency range and supported channel bandwidth

Unless otherwise stated, the test shall be performed with a lowest and the highest bandwidth supported by the BS. The manufacturer shall declare that the requirements are fulfilled for all other bandwidths supported by the BS which are not tested.

The manufacturer shall declare:

- Which of the E-UTRA operating bands defined in subclause 5.5 are supported by the BS.
- The E-UTRA frequency range within the above frequency band(s) supported by the BS.
- Which NB-IoT operating band defined in subclause 5.5 is supported by the BS.
- The NB-IoT frequency range within the above frequency band supported by the BS.
- The E-UTRA channel bandwidths supported by the BS.
- For each E-UTRA channel bandwidth, the NB-IoT operating mode(s) supported by the BS.

For CA specific testing in clause 4.7.2, the manufacturer's declaration in clause 4.6.8 will be applied.

For the single carrier testing many tests in this TS are performed with appropriate frequencies in the bottom, middle and top channels of the supported frequency range of the BS. These are denoted as RF channels B (bottom), M (middle) and T (top).

Unless otherwise stated, the test shall be performed with a single carrier at each of the RF channels B, M and T.

Unless otherwise stated, the NB-IoT standalone test shall be performed with a single carrier at each of the RF channels B (bottom), M (middle) and T (top).

When a test is performed by a test laboratory, the EARFCNs to be used for RF channels B, M and T shall be specified by the laboratory. The laboratory may consult with operators, the manufacturer or other bodies.

When a test is performed by a manufacturer, the EARFCNs to be used for RF channels B, M and T may be specified by an operator.

4.7.1 Base Station RF Bandwidth position for multi-carrier and/or CA testing

Many tests in this TS are performed with the maximum Base Station RF Bandwidth located at the bottom, middle and top of the supported frequency range in each operating band. These are denoted as B_{RFBW} (bottom), M_{RFBW} (middle) and T_{RFBW} (top).

Unless otherwise stated, the test shall be performed at B_{RFBW} , M_{RFBW} and T_{RFBW} defined as following:

- B_{RFBW} : maximum Base Station RF Bandwidth located at the bottom of the supported frequency range in each operating band;
- M_{RFBW} : maximum Base Station RF Bandwidth located in the middle of the supported frequency range in each operating band;
- T_{RFBW} : maximum Base Station RF Bandwidth located at the top of the supported frequency range in each operating band.

For BS capable of multi-band operation, unless otherwise stated, the test shall be performed at $B_{\text{RFBW_T'RFBW}}$ and $B'_{\text{RFBW_T'RFBW}}$ defined as following:

- $B_{\text{RFBW_T'RFBW}}$: the Base Station RF Bandwidths located at the bottom of the supported frequency range in the lowest operating band and at the highest possible simultaneous frequency position, within the Maximum Radio Bandwidth, BW_{max} , in the highest operating band. The Base Station RF Bandwidth(s) are located at the bottom of the supported frequency range(s) in the middle band(s).
- $B'_{\text{RFBW_T'RFBW}}$: the Base Station RF Bandwidths located at the top of the supported frequency range in the highest operating band and at the lowest possible simultaneous frequency position, within the Maximum Radio Bandwidth, BW_{max} , in the lowest operating band. The Base Station RF Bandwidth(s) are located at the top of the supported frequency range(s) in the middle band(s).

NOTE: $B_{\text{RFBW_T'RFBW}} = B'_{\text{RFBW_T'RFBW}} = B_{\text{RFBW_T'RFBW}}$ when the declared Maximum Radio Bandwidth BW_{max} , spans all operating bands. $B_{\text{RFBW_T'RFBW}}$ means the Base Station RF Bandwidths are located at the bottom of the supported frequency range in the lowest operating band and at the top of the supported frequency range in the highest operating band, and the Base Station RF Bandwidth(s) are located at the bottom of the supported frequency range(s) in the middle band(s) in the first test and then at the top of the supported frequency range(s) in the middle band(s) in the second test.

When a test is performed by a test laboratory, the position of B_{RFBW} , M_{RFBW} and T_{RFBW} in each supported operating band, as well as the position of $B_{\text{RFBW_T'RFBW}}$ and $B'_{\text{RFBW_T'RFBW}}$ in the supported operating band combinations, shall be specified by the laboratory. The laboratory may consult with operators, the manufacturer or other bodies.

4.7.2 Aggregated Channel Bandwidth position for Contiguous CA occupied bandwidth testing

Occupied bandwidth test in this TS is performed with the Aggregated Channel Bandwidth and sub-block bandwidths located at the bottom, middle and top of the supported frequency range in the operating band. These are denoted as $B_{\text{BW Channel CA}}$ (bottom), $M_{\text{BW Channel CA}}$ (middle) and $T_{\text{BW Channel CA}}$ (top) for contiguous spectrum operation.

Unless otherwise stated, the test for contiguous spectrum operation shall be performed at $B_{\text{BW Channel CA}}$, $M_{\text{BW Channel CA}}$ and $T_{\text{BW Channel CA}}$ defined as following:

- $B_{\text{BW Channel CA}}$: Aggregated Channel Bandwidth located at the bottom of the supported frequency range in each operating band;
- $M_{\text{BW Channel CA}}$: Aggregated Channel Bandwidth located close in the middle of the supported frequency range in each operating band, with the center frequency of each component carrier aligned to the channel raster;
- $T_{\text{BW Channel CA}}$: Aggregated Channel Bandwidth located at the top of the supported frequency range in each operating band.

When a test is performed by a test laboratory, the position of $B_{\text{BW Channel CA}}$, $M_{\text{BW Channel CA}}$ and $T_{\text{BW Channel CA}}$ for contiguous spectrum operation in the operating band shall be specified by the laboratory. The laboratory may consult with operators, the manufacturer or other bodies.

4.7.3 NB-IoT testing

Unless otherwise stated, the NB-IoT standalone Rx test shall be performed by using one tone at one or both NB-IoT PRB's edge positions; those are denoted $B_{\text{NB-IoT}}$ and $T_{\text{NB-IoT}}$.

Unless otherwise stated, the NB-IoT in-band test shall be performed by puncturing one E-UTRA PRB at the eligible (as specified in clause 5.7.3) in-band position closest to E-UTRA guard band; those are denoted $L_{\text{NB-IoT}}$ (Left) and $R_{\text{NB-IoT}}$ (Right).

Unless otherwise stated, the NB-IoT in-band Rx test shall be performed by using the tone located on the NB-IoT PRB's edge, which is closest to E-UTRA guard band; those are denoted $B_{\text{NB-IoT}}$ for $L_{\text{NB-IoT}}$ and $T_{\text{NB-IoT}}$ for $R_{\text{NB-IoT}}$.

Unless otherwise stated, the NB-IoT guard band test shall be performed by selecting the eligible (as specified in clause 5.7.3) guard band position closest to E-UTRA PRBs; those are denoted $L_{\text{NB-IoT}}$ (Left) and $R_{\text{NB-IoT}}$ (Right),

Unless otherwise stated, the NB-IoT guard band Rx test shall be performed by using the tone located on the NB-IoT PRB's edge, which is closest to E-UTRA channel edge; those are denoted $B_{\text{NB-IoT}}$ for $L_{\text{NB-IoT}}$ and $T_{\text{NB-IoT}}$ for $R_{\text{NB-IoT}}$.

4.8 Format and interpretation of tests

Each test in the following clauses has a standard format:

X Title

All tests are applicable to all equipment within the scope of the present document, unless otherwise stated.

X.1 Definition and applicability

This subclause gives the general definition of the parameter under consideration and specifies whether the test is applicable to all equipment or only to a certain subset. Required manufacturer declarations may be included here.

X.2 Minimum Requirement

This subclause contains the reference to the subclause to the 3GPP reference (or core) specification which defines the Minimum Requirement.

X.3 Test Purpose

This subclause defines the purpose of the test.

X.4 Method of test

X.4.1 Initial conditions

This subclause defines the initial conditions for each test, including the test environment, the RF channels to be tested and the basic measurement set-up.

X.4.2 Procedure

This subclause describes the steps necessary to perform the test and provides further details of the test definition like point of access (e.g. test port), domain (e.g. frequency-span), range, weighting (e.g. bandwidth), and algorithms (e.g. averaging).

X.5 Test Requirement

This subclause defines the pass/fail criteria for the equipment under test. See subclause 4.1.2.5 Interpretation of measurement results.

4.9 Applicability of requirements

For BS that is E-UTRA (single-RAT) capable only, the requirements in the present document are applicable and additional conformance to TS 37.141 [18] is optional. For a BS additionally conforming to TS 37.141 [18], conformance to some of the RF requirements in the present document can be demonstrated through the corresponding requirements in TS 37.141 [18] as listed in Table 4.9-1

Table 4.9-1: Alternative RF test requirements for a BS additionally conforming to TS 37.141 [18]

RF requirement	Clause in the present document	Alternative clause in TS 37.141 [18]
Base station output power	6.2.5	6.2.1.5
Transmit ON/OFF power	6.4	6.4
Unwanted emissions		
Transmitter spurious emissions	6.6.4.5	6.6.1.5 (except for 6.6.1.5.3)
Operating band unwanted emissions	6.6.3.5.1, 6.6.3.5.2 (NOTE 1)	6.6.2.5 (except for 6.6.2.5.3 and 6.6.2.5.4)
Transmitter intermodulation	6.7.5	6.7.5.1
Narrowband blocking	7.5.5	7.4.5.2
Blocking	7.6.5.1	7.4.5.1
Out-of-band blocking	7.6.5.1	7.5.5.1
Co-location with other base stations	7.6.5.2	7.5.5.2
Receiver spurious emissions	7.7.5	7.6.5.1
Intermodulation	7.8.5	7.7.5.1
Narrowband intermodulation	7.8.5	7.7.5.2
NOTE 1: This does not apply when the lowest or highest carrier frequency is configured as 1.4 or 3 MHz carrier in bands of Band Category 1 or 3 according to clause 4.4 in TS 37.141 [18].		

4.10 Test configurations for multi-carrier and/or CA operation

The test configurations shall be constructed using the methods defined below, subject to the parameters declared by the manufacturer for the supported RF configurations as listed in subclause 4.6.8. The test configurations to use for conformance testing are defined for each supported RF configuration in subclause 4.11.

The applicable test models for generation of the carrier transmit test signal are defined in subclause 6.1.1.

4.10.1 ETC1: Contiguous spectrum operation

The purpose of test configuration ETC1 is to test all BS requirements excluding CA occupied bandwidth.

For ETC1 used in receiver tests only the two outermost carriers within each supported operating band need to be generated by the test equipment.

4.10.1.1 ETC1 generation

ETC1 shall be constructed on a per band basis using the following method:

- Declared maximum Base Station RF Bandwidth supported for contiguous spectrum operation shall be used;
- Select the narrowest supported carrier and place it adjacent to the lower Base Station RF Bandwidth edge. Place a 5 MHz carrier adjacent to the upper Base Station RF Bandwidth edge.
- For transmitter tests, select as many 5 MHz carriers that the BS supports within a band and fit in the rest of the declared maximum Base Station RF Bandwidth. Place the carriers adjacent to each other starting from the upper Base Station RF Bandwidth edge. The nominal carrier spacing defined in subclause 5.7 shall apply;
- If 5 MHz carriers are not supported by the BS the narrowest supported channel BW shall be selected instead.

The test configuration should be constructed on a per band basis for all component carriers of the inter-band CA bands declared to be supported by the BS and are transmitted using the same antenna port. All configured component carriers are transmitted simultaneously in the tests where the transmitter should be on.

4.10.1.2 ETC1 power allocation

For a BS declared to support MC operation,

Set the power of each carrier to the same level so that the sum of the carrier powers equals the rated total output power $P_{\text{rated,t}}$ according to the manufacturer's declaration in subclause 4.6.8.

For a BS declared to support only CA operation,

Set the power spectral density of each carrier to the same level so that the sum of the carrier powers equals the rated total output power $P_{\text{rated,t}}$ according to the manufacturer's declaration in subclause 4.6.8.

4.10.2 ETC2: Contiguous CA occupied bandwidth

ETC2 in this subclause is used to test CA occupied bandwidth.

4.10.2.1 ETC2 generation

The CA specific test configuration should be constructed on a per band basis using the following method:

- Of all component carrier combinations supported by the BS, those which have smallest or largest sum of channel bandwidth of component carriers, shall be tested. Of all component carrier combinations which have smallest or largest sum of channel bandwidth of component carriers supported by the BS, only one combination having largest sum and one combination having smallest sum shall be tested **irrespective of the number of component carriers**.
- Of all component carrier combinations which have same sum of channel bandwidth of component carrier, select those with the narrowest carrier at the lower Base Station RF Bandwidth edge.
- Of the combinations selected in the previous step, select one with the narrowest carrier at the upper Base Station RF Bandwidth edge.
- If there are multiple combinations fulfilling previous steps, select the one with the smallest number of component carrier.
- If there are multiple combinations fulfilling previous steps, select the one with the widest carrier being adjacent to the lowest carrier.
- If there are multiple combinations fulfilling previous steps, select the one with the widest carrier being adjacent to the highest carrier
- If there are multiple combinations fulfilling previous steps, select the one with the widest carrier being adjacent to the carrier which has been selected in the previous step.
- If there are multiple combinations fulfilling previous steps, repeat the previous step until there is only one combination left.
- The nominal carrier spacing defined in subclause 5.7.1A shall apply.

4.10.2.2 ETC2 power allocation

Set the power spectral density of each carrier to be the same level so that the sum of the carrier powers equals the rated total output power $P_{\text{rated,t}}$ for E-UTRA according to the manufacturer's declaration in subclause 4.6.8.

4.10.3 ETC3: Non-contiguous spectrum operation

The purpose of ETC3 is to test all BS requirements excluding CA occupied bandwidth.

For ETC3 used in receiver tests, outermost carriers for each sub-block need to be generated by the test equipment.

4.10.3.1 ETC3 generation

ETC3 is constructed on a per band basis using the following method:

- The Base Station RF Bandwidth shall be the maximum Base Station RF Bandwidth supported for non-contiguous spectrum operation. The Base Station RF Bandwidth consists of one sub-block gap and two sub-blocks located at the edges of the declared maximum supported Base Station RF Bandwidth.
- For transmitter tests, place a 5MHz carrier adjacent to the upper Base Station RF Bandwidth edge and a 5MHz carrier adjacent to the lower Base Station RF Bandwidth edge. If 5 MHz carriers are not supported by the BS, the narrowest supported channel BW shall be selected instead.
- For receiver tests, place a 5MHz carrier adjacent to the upper Base Station RF Bandwidth edge and a 5MHz carrier adjacent to the lower Base Station RF Bandwidth edge. If 5 MHz E-UTRA carriers are not supported by the BS, the narrowest supported channel BW shall be selected instead.
- For single-band operation receiver tests, if the remaining gap is at least 15 MHz plus two times the channel BW used in the previous step and the BS supports at least 4 carriers, place a carrier of this BW adjacent to each already placed carrier for each sub-block. The nominal carrier spacing defined in subclause 5.7 shall apply.
- The sub-block edges adjacent to the sub-block gap shall be determined using the specified F_{Offset} for the carrier adjacent to the sub-block gap.

4.10.3.2 ETC3 power allocation

Set the power of each carrier to the same level so that the sum of the carrier powers equals the rated total output power $P_{\text{rated,t}}$ according to the manufacturer's declaration in subclause 4.6.8.

4.10.3.24 VOID

4.10.4 ETC4: Multi-band test configuration for full carrier allocation

The purpose of ETC4 is to test multi-band operation aspects considering maximum supported number of carriers.

4.10.4.1 ETC4 generation

ETC4 is based on re-using the existing test configuration applicable per band involved in multi-band operation. It is constructed using the following method:

- The Base Station RF Bandwidth of each supported operating band shall be the declared maximum Base Station RF Bandwidth in multi-band operation.
- The number of carriers of each supported operating band shall be the declared maximum number of supported carriers in multi-band operation. Carriers shall first be placed at the outermost edges of the declared Maximum Radio Bandwidth for outermost bands and at the Base Station RF Bandwidths edges for middle band(s) if any. Additional carriers shall next be placed at the Base Station RF Bandwidths edges, if possible.
- The allocated Base Station RF Bandwidth of the outermost bands shall be located at the outermost edges of the declared Maximum Radio Bandwidth.

- Each concerned band shall be considered as an independent band and the carrier placement in each band shall be according to ETC1, where the declared parameters for multi-band operation shall apply. The mirror image of the single-band test configuration shall be used in each alternate band(s) and in the highest band being tested for the BS to ensure a narrowband carrier being placed at both edges of the Maximum Radio Bandwidth.
- If only one carrier can be placed for the concerned band(s), the carrier(s) shall be placed at the outermost edges of the declared maximum radio bandwidth for outermost band(s) and at one of the outermost edges of the supported frequency range within the Base Station RF Bandwidths for middle band(s) if any.
- If the sum of the maximum Base Station RF Bandwidths of each supported operating bands is larger than the declared Total RF Bandwidth of transmitter and receiver for the declared band combinations of the BS, repeat the steps above for test configurations where the Base Station RF Bandwidth of one of the operating band shall be reduced so that the Total RF Bandwidth BW_{tot} of transmitter and receiver is not exceeded and vice versa.
- If the sum of the maximum number of supported carrier of each supported operating bands in multi-band operation is larger than the declared total number of supported carriers for the declared band combinations of the BS, repeat the steps above for test configurations where in each test configuration the number of carriers of one of the operating band shall be reduced so that the total number of supported carriers is not exceeded and vice versa.

4.10.4.2 ETC4 power allocation

Unless otherwise stated, set the power of each carrier in all supported operating bands to the same power so that the sum of the carrier powers equals the total output power according to the manufacturer's declaration.

If the allocated power of a supported operating band(s) exceeds the declared rated total output power $P_{rated,t}$ of the operating band(s) in multi-band operation, the exceeded part shall, if possible, be reallocated into the other band(s). If the power allocated for a carrier exceeds the rated output power declared for that carrier, the exceeded power shall, if possible, be reallocated into the other carriers.

4.10.5 ETC5: Multi-band test configuration with high PSD per carrier

The purpose of ETC5 is to test multi-band operation aspects considering higher PSD cases with reduced number of carriers and non-contiguous operation (if supported) in multi-band mode.

4.10.5.1 ETC5 generation

ETC5 is based on re-using the existing test configuration applicable per band involved in multi-band operation. It is constructed using the following method:

- The Base Station RF Bandwidth of each supported operating band shall be the declared maximum Base Station RF Bandwidth in multi-band operation.
- The allocated Base Station RF Bandwidth of the outermost bands shall be located at the outermost edges of the declared Maximum Radio Bandwidth.
- The maximum number of carriers is limited to two per band. Carriers shall first be placed at the outermost edges of the declared Maximum Radio Bandwidth for outermost bands and at the Base Station RF Bandwidths edges for middle band(s) if any. Additional carriers shall next be placed at the Base Station RF Bandwidths edges, if possible.
- Each concerned band shall be considered as an independent band and the carrier placement in each band shall be according to ETC3, where the declared parameters for multi-band operation shall apply. Narrowest supported E-UTRA channel bandwidth shall be used in the test configuration.
- If only one carrier can be placed for the concerned band(s), the carrier(s) shall be placed at the outermost edges of the declared maximum radio bandwidth for outermost band(s) and at one of the outermost edges of the supported frequency range within the Base Station RF Bandwidths for middle band(s) if any.
- If the sum of the maximum Base Station RF Bandwidth of each supported operating bands is larger than the declared Total RF Bandwidth BW_{tot} of transmitter and receiver for the declared band combinations of the BS, repeat the steps above for test configurations where the Base Station RF Bandwidth of one of the operating band shall be reduced so that the Total RF Bandwidth BW_{tot} of transmitter and receiver is not exceeded and vice versa.

4.10.5.2 ETC5 power allocation

Unless otherwise stated, set the power of each carrier in all supported operating bands to the same power so that the sum of the carrier powers equals the total output power according to the manufacturer's declaration.

If the allocated power of a supported operating band(s) exceeds the declared rated total output power $P_{\text{rated,t}}$ of the operating band(s) in multi-band operation, the exceeded part shall, if possible, be reallocated into the other band(s). If the power allocated for a carrier exceeds the rated output power declared for that carrier, the exceeded power shall, if possible, be reallocated into the other carriers.

4.10.6 ETC6: NB-IoT standalone multi-carrier operation

The purpose of the ETC6 is to test NB-IoT standalone multi-carrier aspects.

4.10.6.1 ETC6 generation

ETC6 is constructed using the following method:

- The Base Station RF Bandwidth shall be the declared maximum Base Station RF Bandwidth.
- Place a NB-IoT carrier at the upper edge and a NB-IoT carrier at the lower Base Station RF Bandwidth edge.
- For transmitter tests, add NB-IoT carriers at the edges using 600 kHz spacing until no more NB-IoT carriers are supported or no more NB-IoT carriers fit.

4.10.6.2 ETC6 power allocation

Set the power of each carrier to the same level so that the sum of the carrier powers equals the rated total output power $P_{\text{rated,t}}$ according to the manufacturer's declaration in subclause 4.6.8.

4.10.7 ETC7: E-UTRA and NB-IoT standalone multi-carrier operation

The purpose of the ETC7 is to test E-UTRA and NB-IoT standalone multi-carrier aspects.

4.10.7.1 ETC7 generation

ETC7 is constructed using the following method:

- The Base Station RF Bandwidth shall be the declared maximum Base Station RF Bandwidth.
- For receiver tests, place a NB-IoT carrier at the lower edge and a 5MHz E-UTRA carrier at the upper Base Station RF Bandwidth edge. If the BS does not support 5 MHz channel BW use the narrowest supported BW.
- For transmitter tests and in the case of a BS supporting only one NB-IoT carrier, place a NB-IoT carrier at the lower edge and a 5MHz E-UTRA carrier at the upper Base Station RF Bandwidth edge. If the BS does not support 5 MHz channel BW use the narrowest supported BW. Add additional E-UTRA carriers of the same bandwidth as the already allocated E-UTRA carriers in the middle if possible.
- For transmitter tests and in the case of a BS supporting more than one NB-IoT carrier, carry out the following steps.
 - Place a NB-IoT carrier at the upper edge and a NB-IoT carrier at the lower Base Station RF Bandwidth edge.
 - Place two 5 MHz E-UTRA carriers in the middle of the Base Station RF Bandwidth. If the BS does not support 5 MHz channel BW use the narrowest supported BW, if only one carrier is supported or two carriers do not fit place only one carrier.
 - Add NB-IoT carriers at the edges using 600 kHz spacing until no more NB-IoT carriers are supported or no more NB-IoT carriers fit.
 - Add additional E-UTRA carriers of the same bandwidth as the already allocated E-UTRA carriers in the middle if possible.

4.10.7.2 ETC7 power allocation

Set the power of each carrier to the same level so that the sum of the carrier powers equals the rated total output power $P_{\text{rated,t}}$ according to the manufacturer's declaration in subclause 4.6.8.

4.10.8 ETC8: E-UTRA and NB-IoT in-band multi-carrier operation

The purpose of the ETC8 is to test E-UTRA and NB-IoT in-band multi-carrier aspects.

4.10.8.1 ETC8 generation

ETC8 is constructed using the following method:

- The Base Station RF Bandwidth shall be the declared maximum Base Station RF Bandwidth.
- Place a 5 MHz E-UTRA carrier adjacent to the lower Base Station RF Bandwidth edge. Place the power boosted NB-IoT PRB at the outermost in-band position eligible for NB-IoT PRB at the lower Base Station RF Bandwidth edge. Place a 5 MHz E-UTRA carrier adjacent to the upper Base Station RF Bandwidth edge. In the case of a BS supporting more than one NB-IoT in-band carrier, place the power boosted NB-IoT PRB at the outermost in-band position eligible for NB-IoT PRB at the upper Base Station RF Bandwidth edge.
- For transmitter tests, select as many 5 MHz E-UTRA carriers that the BS supports and that fit in the rest of the Base Station RF Bandwidth. Place the carriers adjacent to each other starting from the high Base Station RF Bandwidth edge. The nominal carrier spacing defined in subclause 5.7 shall apply.
- If 5 MHz E-UTRA carriers are not supported by the BS the narrowest supported channel BW shall be selected instead.

4.10.8.2 ETC8 power allocation

Set the power of each carrier to the same level so that the sum of the carrier powers equals the rated total output power $P_{\text{rated,t}}$ according to the manufacturer's declaration in subclause 4.6.8.

4.10.9 ETC9: E-UTRA and NB-IoT guard-band multi-carrier operation

The purpose of the ETC9 is to test E-UTRA and NB-IoT guard-band multi-carrier aspects.

4.10.9.1 ETC9 generation

ETC9 is constructed using the following method:

- The Base Station RF Bandwidth shall be the declared maximum Base Station RF Bandwidth.
- Place a 10 MHz E-UTRA carrier adjacent to the lower Base Station RF Bandwidth edge. Place the power boosted NB-IoT PRB at the outermost guard-band position eligible for NB-IoT PRB at the lower Base Station RF Bandwidth edge and adjacent to the E-UTRA PRB edge as close as possible (i.e., away from the lower Base Station RF Bandwidth edge). Place a 10 MHz E-UTRA carrier adjacent to the upper Base Station RF Bandwidth edge. In the case of a BS supporting more than one NB-IoT guard-band carrier, place the power boosted NB-IoT PRB at the outermost guard-band position eligible for NB-IoT PRB at the upper Base Station RF Bandwidth edge and adjacent to the E-UTRA PRB edge as close as possible (i.e., away from the upper Base Station RF Bandwidth edge).
- For transmitter tests, select as many 10 MHz E-UTRA carriers that the BS supports and that fit in the rest of the Base Station RF Bandwidth. Place the carriers adjacent to each other starting from the high Base Station RF Bandwidth edge. The nominal carrier spacing defined in subclause 5.7 shall apply.
- If 10 MHz E-UTRA carriers are not supported by the BS the narrowest supported channel BW shall be selected instead.

4.10.9.2 ETC9 power allocation

Set the power of each carrier to the same level so that the sum of the carrier powers equals the rated total output power $P_{\text{rated,t}}$ according to the manufacturer's declaration in subclause 4.6.8.

4.11 Applicability of test configurations

The present subclause defines for each RF test requirement the set of mandatory test configurations which shall be used for demonstrating conformance. The applicable test configurations are specified in the tables below for each the supported RF configuration, which shall be declared according to subclause 4.6.8. The generation and power allocation for each test configuration is defined in subclause 4.10.

For a E-UTRA BS declared to be capable of single carrier operation only, a single carrier (SC) shall be used for testing.

For a E-UTRA BS declared to be capable of multi-carrier and/or CA operation in contiguous spectrum operation in single band only, the test configurations in Table 4.11-1 shall be used for testing.

Table 4.11-1: Test configurations for a E-UTRA BS capable of multi-carrier and/or CA operation in contiguous spectrum in single band only

BS test case	Contiguous spectrum capable BS
6.2 Base station output power	ETC1
6.3 Output power dynamics	
6.3.1 RE Power control dynamic range	Tested with Error Vector Magnitude
6.3.2 Total power dynamic range	SC
6.4 Transmit ON/OFF power (only applied for E-UTRA TDD BS)	ETC1
6.5 Transmitted signal quality	-
6.5.1 Frequency error	Tested with Error Vector Magnitude
6.5.2 Error Vector Magnitude	ETC1
6.5.3 Time alignment error	ETC1
6.5.4 DL RS power	SC
6.6 Unwanted emissions	-
6.6.1 Occupied bandwidth	SC, ETC2 (Note)
6.6.2 Adjacent Channel Leakage power Ratio (ACLR)	ETC1
6.6.3 Operating band unwanted emissions	ETC1
6.6.4 Transmitter spurious emissions	ETC1
6.7 Transmitter intermodulation	ETC1
7.2 Reference sensitivity level	SC
7.3 Dynamic range	SC
7.4 In-channel selectivity	SC
7.5 Adjacent Channel Selectivity(ACS) and narrow-band blocking	ETC1
7.6 Blocking	ETC1
7.7 Receiver spurious emissions	ETC1
7.8 Receiver intermodulation	ETC1
Note:	ETC2 is only applicable when contiguous CA is supported.

For a E-UTRA BS declared to be capable of multi-carrier and/or CA operation in contiguous and non-contiguous spectrum in single band and where the parameters in the manufacture's declaration according to subclause 4.6.8 are identical for contiguous (C) and non-contiguous (NC) spectrum operation, the test configurations in the second column of Table 4.11-2 shall be used for testing.

For a E-UTRA BS declared to be capable of multi-carrier and/or CA operation in contiguous and non-contiguous spectrum and in single band where the parameters in the manufacture's declaration according to subclause 4.6.8 are not identical for contiguous and non-contiguous spectrum operation, the test configurations in the third column of Table 4.11-2 shall be used for testing.

Table 4.11-2: Test configuration for a E-UTRA BS capable of multi-carrier and/or CA operation in both contiguous and non-contiguous spectrum in single band

BS test case	C and NC capable BS with identical parameters	C and NC capable BS with different parameters
6.2 Base station output power	ETC1	ETC1, ETC3
6.3 Output power dynamics		
6.3.1 RE Power control dynamic range	Tested with Error Vector Magnitude	Tested with Error Vector Magnitude
6.3.2 Total power dynamic range	SC	SC
6.4 Transmit ON/OFF power (only applied for E-UTRA TDD BS)	ETC1	ETC1, ETC3
6.5 Transmitted signal quality	-	-
6.5.1 Frequency error	Tested with Error Vector Magnitude	Tested with Error Vector Magnitude
6.5.2 Error Vector Magnitude	ETC1	ETC1, ETC3
6.5.3 Time alignment error	ETC1	ETC1, ETC3
6.5.4 DL RS power	SC	SC
6.6 Unwanted emissions	-	-
6.6.1 Occupied bandwidth	SC, ETC2 (Note)	SC, ETC2 (Note)
6.6.2 Adjacent Channel Leakage power Ratio (ACLR)	ETC3	ETC1, ETC3
6.6.2.2 Cumulative ACLR requirement in non-contiguous spectrum	ETC3	ETC3
6.6.3 Operating band unwanted emissions	ETC1, ETC3	ETC1, ETC3
6.6.4 Transmitter spurious emissions	ETC3	ETC1, ETC3
6.7 Transmitter intermodulation	Same TC as used in 6.6	Same TC as used in 6.6
7.2 Reference sensitivity level	SC	SC
7.3 Dynamic range	SC	SC
7.4 In-channel selectivity	SC	SC
7.5 Adjacent Channel Selectivity(ACS) and narrow-band blocking	ETC3	ETC1, ETC3
7.6 Blocking	ETC3	ETC1, ETC3
7.7 Receiver spurious emissions	ETC3	ETC1, ETC3
7.8 Receiver intermodulation	ETC3	ETC1, ETC3
Note:	ETC2 is only applicable when contiguous CA is supported.	

For a E-UTRA BS declared to be capable of multi-band operation, the test configuration in Table 4.11-3 shall be used for testing. In the case where multiple bands are mapped on common antenna connector, the test configuration in the second column of Table 4.11-3 shall be used. In the case where multiple bands are mapped on separate antenna connectors, the test configuration in the third column of Table 4.11-3 shall be used.

Table 4.11-3: Test configuration for a E-UTRA BS capable of multi-band operation

BS test case	Test configuration	
	Common antenna connector	Separate antenna connector
6.2 Base station output power	ETC1/3 (Note 1), ETC4	ETC1/3 (Note 1), ETC4
6.3 Output power dynamics		
6.3.1 RE Power control dynamic range	Tested with Error Vector Magnitude	Tested with Error Vector Magnitude
6.3.2 Total power dynamic range	SC	SC
6.4 Transmit ON/OFF power (only applied for E-UTRA TDD BS)	ETC4	ETC4
6.5 Transmitted signal quality		
6.5.1 Frequency error	Tested with Error Vector Magnitude	Tested with Error Vector Magnitude
6.5.2 Error Vector Magnitude	ETC1/3 (Note 1), ETC4	ETC1/3 (Note 1), ETC4
6.5.3 Time alignment error	ETC1/3 (Note 1), ETC5 (Note 2)	ETC1/3 (Note 1), ETC5 (Note 2)
6.5.4 DL RS power	SC	SC
6.6 Unwanted emissions		
6.6.1 Occupied bandwidth	SC, ETC2 (Note 3)	SC, ETC2 (Note 3)
6.6.2 Adjacent Channel Leakage power Ratio (ACLR)	ETC1/3 (Note 1), ETC5 (Note 4)	ETC1/3 (Note 1, 5), ETC5 (Note 4, 5)
6.6.2.6 Cumulative ACLR requirement in non-contiguous spectrum	ETC3 (Note 1), ETC5 (Note 4)	ETC3 (Note 1, 5)
6.6.3 Operating band unwanted emissions	ETC1/3 (Note 1), ETC5	ETC1/3 (Note 1, 5), ETC5 (Note 5)
6.6.4 Transmitter spurious emissions	ETC1/3 (Note 1), ETC5	ETC1/3 (Note 1, 5), ETC5 (Note 5)
6.7 Transmitter intermodulation	ETC1/3 (Note 1)	ETC1/3 (Note 1, 5)
7.2 Reference sensitivity level	SC	SC
7.3 Dynamic range	SC	SC
7.4 In-channel selectivity	SC	SC
7.5 Adjacent Channel Selectivity(ACS) and narrow-band blocking	ETC5	ETC1/3 (Note 1), ETC5 (Note 6)
7.6 Blocking	ETC5	ETC1/3 (Note 1), ETC5 (Note 6)
7.7 Receiver spurious emissions	ETC1/3 (Note 1), ETC5	ETC1/3 (Note 1, 5), ETC5 (Note 5)
7.8 Receiver intermodulation	ETC5	ETC1/3 (Note 1), ETC5 (Note 6)
<p>Note 1: ETC1 and/or ETC3 shall be applied in each supported operating band according to Tables 4.11-1 and 4.11-2.</p> <p>Note 2: ETC5 is only applicable when inter-band CA is supported.</p> <p>Note 3: ETC2 is only applicable when contiguous CA is supported.</p> <p>Note 4: ETC5 may be applied for Inter RF Bandwidth gap only.</p> <p>Note 5: Single-band requirement apply to each antenna connector for both multi-band operation test and single-band operation test. For single-band operation test, other antenna connector(s) is (are) terminated.</p> <p>Note 6: ETC5 is only applicable for multi-band receiver.</p>		

For a NB-IoT standalone BS declared to be capable of single carrier operation only, a single carrier (SCNS) shall be used for testing.

For a NB-IoT standalone BS declared to be capable of multi-carrier in contiguous spectrum operation in single band only, the test configurations in Table 4.11-4 shall be used for testing.

Table 4.11-4: Test configurations for a NB-IoT standalone BS capable of multi-carrier in contiguous spectrum in single band only

BS test case	Contiguous spectrum capable BS
6.2 Base station output power	ETC6
6.3 Output power dynamics	
6.3.1 RE Power control dynamic range	Not applicable
6.3.2 Total power dynamic range	Not applicable
6.3.3 NB-IoT RB power dynamic range for in-band or guard band operation	Not applicable
6.4 Transmit ON/OFF power (only applied for NB-IoT TDD BS)	SCNS
6.5 Transmitted signal quality	-
6.5.1 Frequency error	Tested with Error Vector Magnitude
6.5.2 Error Vector Magnitude	ETC6
6.5.3 Time alignment error	ETC6
6.5.4 DL RS power	SCNS
6.6 Unwanted emissions	-
6.6.1 Occupied bandwidth	SCNS
6.6.2 Adjacent Channel Leakage power Ratio (ACLR)	ETC6
6.6.3 Operating band unwanted emissions	ETC6
6.6.4 Transmitter spurious emissions	ETC6
6.7 Transmitter intermodulation	ETC6
7.2 Reference sensitivity level	SCNS
7.3 Dynamic range	SCNS
7.4 In-channel selectivity	Not applicable
7.5 Adjacent Channel Selectivity(ACS) and narrow-band blocking	ETC6
7.6 Blocking	ETC6
7.7 Receiver spurious emissions	ETC6
7.8 Receiver intermodulation	ETC6

For a BS supporting NB-IoT in-band and declared to be capable of single NB-IoT carrier operation only, a single carrier (SCNI) shall be used for testing. For a BS supporting NB-IoT in guard band and declared to be capable of single NB-IoT carrier operation only, a single carrier (SCNG) shall be used for testing.

For a E-UTRA with NB-IoT operating in-band and/or guard band BS declared to be capable of multi-carrier in contiguous spectrum operation in single band only, the test configurations in Table 4.11-5 shall be used for testing.

Table 4.11-5: Test configurations for a E-UTRA with NB-IoT operating in-band and/or guard band BS capable of multi-carrier in contiguous spectrum in single band only

BS test case	NB-IoT operating in-band	NB-IoT operating in guard band or NB-IoT operating in-band and in guard band
6.2 Base station output power	ETC8	ETC9
6.3 Output power dynamics		
6.3.1 RE Power control dynamic range	Tested with Error Vector Magnitude	Tested with Error Vector Magnitude
6.3.2 Total power dynamic range	SC (Note 1)	SC (Note 1)
6.3.3 NB-IoT RB power dynamic range for in-band or guard band operation	Tested with Unwanted Emission	Tested with Unwanted Emission
6.4 Transmit ON/OFF power (only applied for E-UTRA and E-UTRA with NB-IoT TDD BS)	ETC8	ETC9
6.5 Transmitted signal quality	-	
6.5.1 Frequency error	Tested with Error Vector Magnitude	Tested with Error Vector Magnitude
6.5.2 Error Vector Magnitude	ETC1 (Note 1)	ETC1 (Note 1)
6.5.3 Time alignment error	ETC1 (Note 1)	ETC1 (Note 1)
6.5.4 DL RS power	SC and SCNI	SC and SCNG
6.6 Unwanted emissions	-	
6.6.1 Occupied bandwidth	SC and SCNI	SC and SCNG
6.6.2 Adjacent Channel Leakage power Ratio (ACLR)	ETC8, ETC1	ETC9, ETC1
6.6.3 Operating band unwanted emissions	ETC8, ETC1	ETC9, ETC1
6.6.4 Transmitter spurious emissions	ETC8	ETC9
6.7 Transmitter intermodulation	ETC8	ETC9
7.2 Reference sensitivity level	SC and SCNI	SC and SCNG
7.3 Dynamic range	SC and SCNI	SC and SCNG
7.4 In-channel selectivity	SC and SCNI	SC and SCNI (Note 2)
7.5 Adjacent Channel Selectivity(ACS) and narrow-band blocking	ETC8	ETC9
7.6 Blocking	ETC8	ETC9
7.7 Receiver spurious emissions	ETC8	ETC9
7.8 Receiver intermodulation	ETC8	ETC9
Note 1: There is no specific test with NB-IoT for those requirements, tests could be performed using E-UTRA signal only, without NB-IoT.		
Note 2: Applicable only if BS supports NB-IoT operating in-band and guard band		

For a E-UTRA and NB-IoT standalone BS declared to be capable of multi-carrier in contiguous spectrum operation in single band only, the test configurations in Table 4.11-6 shall be used for testing.

Table 4.11-6: Test configurations for a E-UTRA and NB-IoT standalone BS capable of multi-carrier in contiguous spectrum in single band only

BS test case	Contiguous spectrum capable BS
6.2 Base station output power	ETC7
6.3 Output power dynamics	
6.3. RE Power control dynamic range	Tested with Error Vector Magnitude
6.3.2 Total power dynamic range	SC
6.3.3 NB-IoT RB power dynamic range for in-band or guard band operation	Not applicable
6.4 Transmit ON/OFF power (only applied for E-UTRA and NB-IoT TDD BS)	ETC7
6.5 Transmitted signal quality	-
6.5.1 Frequency error	Tested with Error Vector Magnitude
6.5.2 Error Vector Magnitude	ETC7
6.5.3 Time alignment error	ETC7
6.5.4 DL RS power	SC and SCNS
6.6 Unwanted emissions	-
6.6.1 Occupied bandwidth	SC and SCNS
6.6.2 Adjacent Channel Leakage power Ratio (ACLR)	ETC7
6.6.3 Operating band unwanted emissions	ETC7
6.6.4 Transmitter spurious emissions	ETC7
6.7 Transmitter intermodulation	ETC7
7.2 Reference sensitivity level	SC and SCNS
7.3 Dynamic range	SC and SCNS
7.4 In-channel selectivity	SC
7.5 Adjacent Channel Selectivity(ACS) and narrow-band blocking	ETC7
7.6 Blocking	ETC7
7.7 Receiver spurious emissions	ETC7
7.8 Receiver intermodulation	ETC7

4.12 Requirements for BS capable of multi-band operation

For BS capable of multi-band operation, the RF requirements in clause 6 and 7 apply for each supported operating band unless otherwise stated. For some requirements it is explicitly stated that specific additions or exclusions to the requirement apply for BS capable of multi-band operation.

For BS capable of multi-band operation, various structures in terms of combinations of different transmitter and receiver implementations (multi-band or single band) with mapping of transceivers to one or more antenna port(s) in different ways are possible. In the case where multiple bands are mapped on an antenna connector, the exclusions or provisions for multi-band capable BS are applicable to this antenna connector. In the case where a single band is mapped on an antenna connector, the following applies:

- Single-band ACLR, operating band unwanted emissions, transmitter spurious emissions, transmitter intermodulation and receiver spurious emissions requirements apply to this antenna connector that is mapped to single-band.
- If the BS is configured for single-band operation, single-band requirements shall apply to this antenna connector configured for single-band operation and no exclusions or provisions for multi-band capable BS are applicable. Single-band requirements are tested separately at the antenna connector configured for single-band operation, with all other antenna connectors terminated.

For a band supported by a Base Station where the transmitted carriers are not processed in active RF components together with carriers in any other band, single-band transmitter requirements shall apply. For a band supported by a Base Station where the received carriers are not processed in active RF components together with carriers in any other band, single-band receiver requirements shall apply.

For a BS capable of multi-band operation supporting bands for TDD, the RF requirements in the present specification assume synchronized operation, where no simultaneous uplink and downlink occur between the supported operating bands.

The RF requirements for multi-band operation supporting bands for both FDD and TDD are not covered by the present release of this specification.

4.13 Tests for BS capable of multi-band operation with three or more bands

For BS supports multiple multi-band combinations, the test(s) shall be applied using the following principles:

- 1) The supported multi-band combination covering the widest radio bandwidth should be tested.
- 2) Among the remaining supported multi-band combinations, the following ones should also be tested:
 - Those with a larger rated total output power (per band or per band combination).
 - Those with a larger total number of supported carriers (per band or per band combination).
 - Those with a larger Maximum Base Station RF Bandwidth (per band).

5 Operating bands and channel arrangement

5.1 General

The channel arrangements presented in this clause are based on the operating bands and channel bandwidths defined in the present release of specifications.

NOTE: Other operating bands and channel bandwidths may be considered in future releases.

5.2 Void

5.3 Void

5.4 Void

5.5 Operating bands

E-UTRA is designed to operate in the operating bands defined in Table 5.5-1. Unless stated otherwise, requirements specified for the TDD duplex mode apply for downlink and uplink operations in Frame Structure Type 2.

NB-IoT is designed to operate in the E-UTRA operating bands 1, 2, 3, 4, 5, 7, 8, 11, 12, 13, 14, 17, 18, 19, 20, 21, 25, 26, 28, 31, 41 (in certain regions), 42, 43, 65, 66, 70, 71, 72, 73, 74, 85, 87, 88 which are defined in Table 5.5-1.

Table 5.5-1: E-UTRA operating bands

E-UTRA Operating Band	Uplink (UL) operating band BS receive UE transmit		Downlink (DL) operating band BS transmit UE receive		Duplex Mode
	F _{UL_low}	F _{UL_high}	F _{DL_low}	F _{DL_high}	
1	1920 MHz	– 1980 MHz	2110 MHz	– 2170 MHz	FDD
2	1850 MHz	– 1910 MHz	1930 MHz	– 1990 MHz	FDD
3	1710 MHz	– 1785 MHz	1805 MHz	– 1880 MHz	FDD
4	1710 MHz	– 1755 MHz	2110 MHz	– 2155 MHz	FDD
5	824 MHz	– 849 MHz	869 MHz	– 894 MHz	FDD
6 (NOTE 1)	830 MHz	– 840 MHz	875 MHz	– 885 MHz	FDD
7	2500 MHz	– 2570 MHz	2620 MHz	– 2690 MHz	FDD
8	880 MHz	– 915 MHz	925 MHz	– 960 MHz	FDD
9	1749.9 MHz	– 1784.9 MHz	1844.9 MHz	– 1879.9 MHz	FDD
10	1710 MHz	– 1770 MHz	2110 MHz	– 2170 MHz	FDD
11	1427.9 MHz	– 1447.9 MHz	1475.9 MHz	– 1495.9 MHz	FDD
12	699 MHz	– 716 MHz	729 MHz	– 746 MHz	FDD
13	777 MHz	– 787 MHz	746 MHz	– 756 MHz	FDD
14	788 MHz	– 798 MHz	758 MHz	– 768 MHz	FDD
15	Reserved		Reserved		FDD
16	Reserved		Reserved		FDD
17	704 MHz	716 MHz	734 MHz	746 MHz	FDD
18	815 MHz	– 830 MHz	860 MHz	– 875 MHz	FDD
19	830 MHz	– 845 MHz	875 MHz	– 890 MHz	FDD
20	832 MHz	– 862 MHz	791 MHz	– 821 MHz	FDD
21	1447.9 MHz	– 1462.9 MHz	1495.9 MHz	– 1510.9 MHz	FDD
22	3410 MHz	– 3490 MHz	3510 MHz	– 3590 MHz	FDD
23 ¹	2000 MHz	– 2020 MHz	2180 MHz	– 2200 MHz	FDD
24 (NOTE 9)	1626.5 MHz	– 1660.5 MHz	1525 MHz	– 1559 MHz	FDD
25	1850 MHz	– 1915 MHz	1930 MHz	– 1995 MHz	FDD
26	814 MHz	– 849 MHz	859 MHz	– 894 MHz	FDD
27	807 MHz	– 824 MHz	852 MHz	– 869 MHz	FDD
28	703 MHz	– 748 MHz	758 MHz	– 803 MHz	FDD
29	N/A		717 MHz	– 728 MHz	FDD
30	2305 MHz	– 2315 MHz	2350 MHz	– 2360 MHz	FDD (NOTE 2)
31	452.5 MHz	– 457.5 MHz	462.5 MHz	– 467.5 MHz	FDD
32	N/A		1452 MHz	– 1496 MHz	FDD (NOTE 2)
33	1900 MHz	– 1920 MHz	1900 MHz	– 1920 MHz	TDD
34	2010 MHz	– 2025 MHz	2010 MHz	– 2025 MHz	TDD
35	1850 MHz	– 1910 MHz	1850 MHz	– 1910 MHz	TDD
36	1930 MHz	– 1990 MHz	1930 MHz	– 1990 MHz	TDD
37	1910 MHz	– 1930 MHz	1910 MHz	– 1930 MHz	TDD
38	2570 MHz	– 2620 MHz	2570 MHz	– 2620 MHz	TDD
39	1880 MHz	– 1920 MHz	1880 MHz	– 1920 MHz	TDD
40	2300 MHz	– 2400 MHz	2300 MHz	– 2400 MHz	TDD
41	2496 MHz	– 2690 MHz	2496 MHz	– 2690 MHz	TDD
42	3400 MHz	– 3600 MHz	3400 MHz	– 3600 MHz	TDD
43	3600 MHz	– 3800 MHz	3600 MHz	– 3800 MHz	TDD
44	703 MHz	– 803 MHz	703 MHz	– 803 MHz	TDD
45	1447 MHz	– 1467 MHz	1447 MHz	– 1467 MHz	TDD
46	5150 MHz	– 5925 MHz	5150 MHz	– 5925 MHz	TDD (NOTE 3, NOTE 4)
47	5855 MHz	– 5925 MHz	5855 MHz	– 5925 MHz	TDD
48	3550 MHz	– 3700 MHz	3550 MHz	– 3700 MHz	TDD
49	3550 MHz	– 3700 MHz	3550 MHz	– 3700 MHz	TDD (NOTE 8)
50	1432 MHz	– 1517 MHz	1432 MHz	– 1517 MHz	TDD
51	1427 MHz	– 1432 MHz	1427 MHz	– 1432 MHz	TDD
52	3300 MHz	– 3400 MHz	3300 MHz	– 3400 MHz	TDD
53	2483.5 MHz	– 2495 MHz	2483.5 MHz	– 2495 MHz	TDD

65	1920 MHz – 2010 MHz	2110 MHz – 2200 MHz	FDD
66	1710 MHz – 1780 MHz	2110 MHz – 2200 MHz	FDD (NOTE 5)
67	N/A	738 MHz – 758 MHz	FDD (NOTE 2)
68	698 MHz – 728 MHz	753 MHz – 783 MHz	FDD
69	N/A	2570 MHz – 2620 MHz	FDD (NOTE 2)
70	1695 MHz – 1710 MHz	1995 MHz – 2020 MHz	FDD (NOTE 6)
71	663 MHz – 698 MHz	617 MHz – 652 MHz	FDD
72	451 MHz – 456 MHz	461 MHz – 466 MHz	FDD
73	450 MHz – 455 MHz	460 MHz – 465 MHz	FDD
74	1427 MHz – 1470 MHz	1475 MHz – 1518 MHz	FDD
75	N/A	1432 MHz – 1517 MHz	FDD (NOTE 2)
76	N/A	1427 MHz – 1432 MHz	FDD (NOTE 2)
85	698 MHz – 716 MHz	728 MHz – 746 MHz	FDD
87	410 MHz – 415 MHz	420 MHz – 425 MHz	FDD
88	412 MHz – 417 MHz	422 MHz – 427 MHz	FDD
<p>NOTE 1: Band 6, 23 are not applicable.</p> <p>NOTE 2: Restricted to E-UTRA operation when carrier aggregation is configured. The downlink operating band is paired with the uplink operating band (external) of the carrier aggregation configuration that is supporting the configured Pcell.</p> <p>NOTE 3: This band is an unlicensed band restricted to licensed-assisted operation using Frame Structure Type 3.</p> <p>NOTE 4: Band 46 is divided into four sub-bands as in Table 5.5-1A.</p> <p>NOTE 5: The range 2180 – 2200 MHz of the DL operating band is restricted to E-UTRA operation when carrier aggregation is configured.</p> <p>NOTE 6: The range 2010-2020 MHz of the DL operating band is restricted to E-UTRA operation when carrier aggregation is configured and TX-RX separation is 300 MHz. The range 2005-2020 MHz of the DL operating band is restricted to E-UTRA operation when carrier aggregation is configured and TX-RX separation is 295 MHz.</p> <p>NOTE 7: Void</p> <p>NOTE 8: This band is restricted to licensed-assisted operation using Frame Structure Type 3.</p> <p>NOTE 9: DL operation is restricted to 1526-1536 MHz frequency range. UL operation is restricted to 1627.5 – 1637.5 MHz and 1646.5 – 1656.5 MHz per FCC Order DA 20-48.</p>			

Table 5.5-1A Sub-bands for Band 46

E-UTRA Operating Band	Uplink (UL) operating band BS receive UE transmit	Downlink (DL) operating band BS transmit UE receive
	F _{UL_low} – F _{UL_high}	F _{DL_low} – F _{DL_high}
46a	5150 MHz – 5250 MHz	5150 MHz – 5250 MHz
46b	5250 MHz – 5350 MHz	5250 MHz – 5350 MHz
46c	5470 MHz – 5725 MHz	5470 MHz – 5725 MHz
46d	5725 MHz – 5925 MHz	5725 MHz – 5925 MHz

Table 5.5-2: Void

Table 5.5-3: Void

Table 5.5-3A: Void

Table 5.5-3B: Void

Table 5.5-3C: Void

Table 5.5-4: Void

Table 5.5-5: Void

Table 5.5-6: Void

5.6 Channel bandwidth

For E-UTRA, requirements in present document are specified for the channel bandwidths listed in Table 5.6-1.

Table 5.6-1: Transmission bandwidth configuration N_{RB} in E-UTRA channel bandwidths

Channel bandwidth $BW_{Channel}$ [MHz]	1.4	3	5	10	15	20
Transmission bandwidth configuration N_{RB}	6	15	25	50	75	100

For E-UTRA, figure 5.6-1 shows the relation between the Channel bandwidth ($BW_{Channel}$) and the Transmission bandwidth configuration (N_{RB}). The channel edges are defined as the lowest and highest frequencies of the carrier separated by the channel bandwidth, i.e. at $F_C \pm BW_{Channel} / 2$.

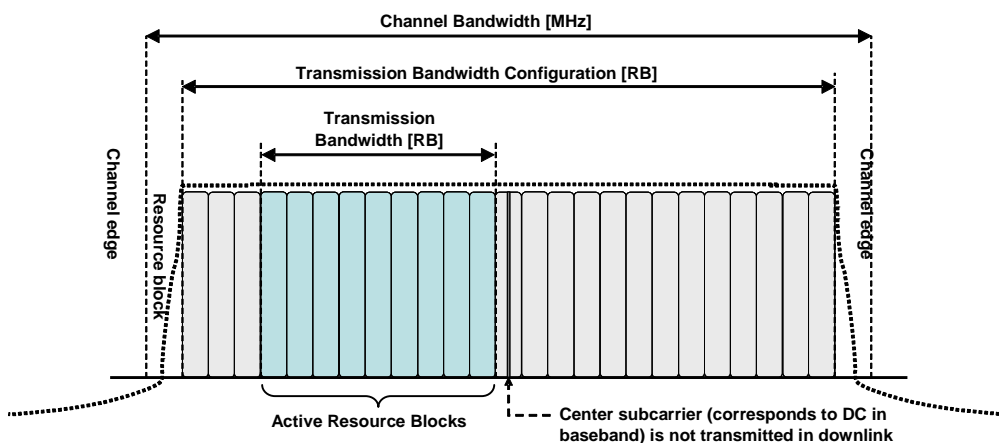

Figure 5.6-1: Definition of Channel Bandwidth and Transmission Bandwidth Configuration for one E-UTRA carrier.

Figure 5.6-2 illustrates the Aggregated Channel Bandwidth for intra-band carrier aggregation.

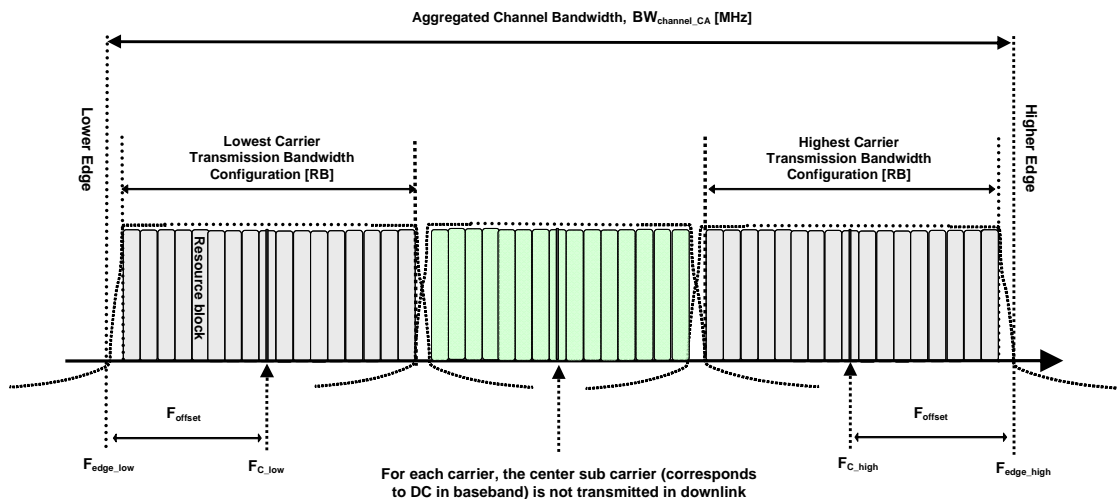

Figure 5.6-2: Definition of Aggregated Channel Bandwidth for intra-band carrier aggregation

The lower edge of the Aggregated Channel Bandwidth ($BW_{Channel_CA}$) is defined as $F_{edge_low} = F_{C_low} - F_{offset}$. The upper edge of the Aggregated Channel Bandwidth is defined as $F_{edge_high} = F_{C_high} + F_{offset}$. The Aggregated Channel Bandwidth, $BW_{Channel_CA}$, is defined as follows:

$$BW_{Channel_CA} = F_{edge_high} - F_{edge_low} \text{ [MHz]}$$

Figure 5.6-3: illustrates the sub-block bandwidth for a BS operating in non-contiguous spectrum.

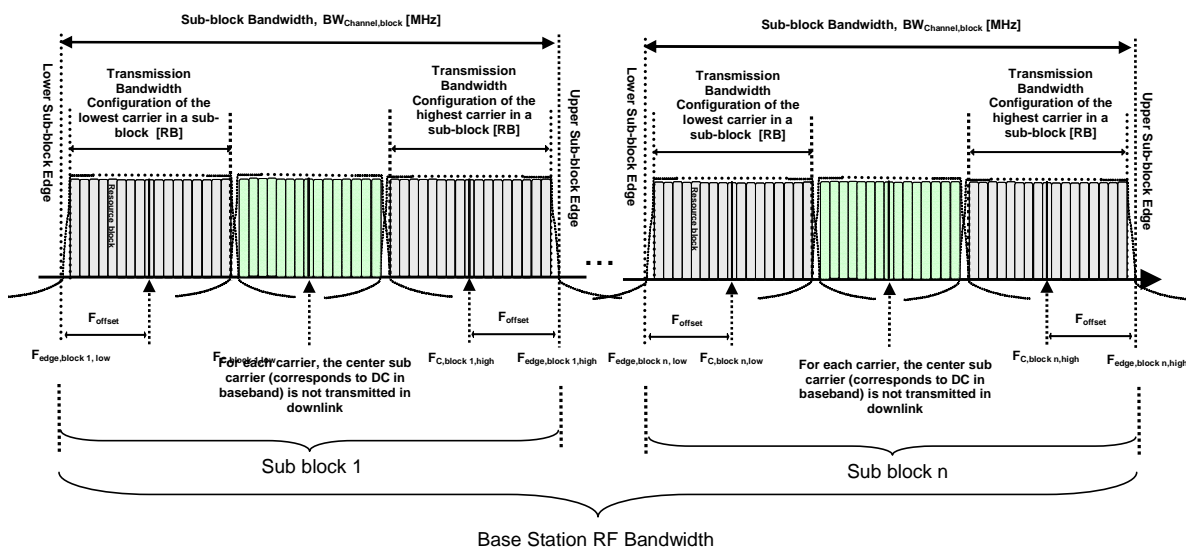

Figure 5.6-3: Definition of Sub-block Bandwidth for intra-band non-contiguous spectrum

The lower sub-block edge of the sub-block bandwidth ($BW_{Channel_block}$) is defined as $F_{edge_block, low} = F_{C_block, low} - F_{offset}$. The upper sub-block edge of the sub-block bandwidth is defined as $F_{edge_block, high} = F_{C_block, high} + F_{offset}$. The sub-block bandwidth, $BW_{Channel_block}$, is defined as follows:

$$BW_{Channel_block} = F_{edge_block, high} - F_{edge_block, low} \text{ [MHz]}$$

F_{offset} is defined in Table 5.6-2 below where $BW_{Channel}$ is defined in Table 5.6-1.

Table 5.6-2: Definition of F_{offset}

Channel Bandwidth of the Lowest or Highest Carrier: BW_{Channel} [MHz]	F_{offset} [MHz]
5, 10, 15, 20	$BW_{\text{Channel}}/2$

NOTE 1: F_{offset} is calculated separately for each Base Station RF Bandwidth edge / sub-block edge.

NOTE 2: The values of $BW_{\text{Channel_CA}}$ /sub-block bandwidth for UE and BS are the same if the channel bandwidths of lowest and the highest component carriers are identical.

For NB-IoT, requirements in present document are specified for the channel bandwidths listed in Table 5.6-3.

Table 5.6-3: Transmission bandwidth configuration N_{RB} , $N_{\text{tone 15kHz}}$ and $N_{\text{tone 3.75kHz}}$ in NB-IoT channel bandwidth

NB-IoT	Standalone	In-band	Guard Band
Channel bandwidth BW_{Channel} [kHz]	200	E-UTRA channel bandwidth in Table 5.6-1 for $BW_{\text{Channel}} > 1.4\text{MHz}$	E-UTRA channel bandwidth in Table 5.6-1 for $BW_{\text{Channel}} > 3\text{MHz}$
Transmission bandwidth configuration N_{RB}	1	1	1
Transmission bandwidth configuration $N_{\text{tone 15kHz}}$	12	12	12
Transmission bandwidth configuration $N_{\text{tone 3.75kHz}}$	48	48	48

For NB-IoT standalone operation, figure 5.6-4 shows the relation between the channel bandwidth (BW_{Channel}) and the transmission bandwidth configuration (N_{RB} , $N_{\text{tone 15kHz}}$ and $N_{\text{tone 3.75kHz}}$) for NB-IoT standalone operation. The channel edges are defined as the lowest and highest frequencies of the carrier separated by the channel bandwidth, i.e. at $F_c \pm BW_{\text{Channel}}/2$.

For NB-IoT standalone operation, NB-IoT requirements for receiver and transmitter shall apply with a frequency offset F_{offset} as defined in Table 5.6-3A.

Table 5.6-3A: F_{offset} for NB-IoT standalone operation

Lowest or Highest Carrier	F_{offset}
Standalone NB-IoT	200 kHz

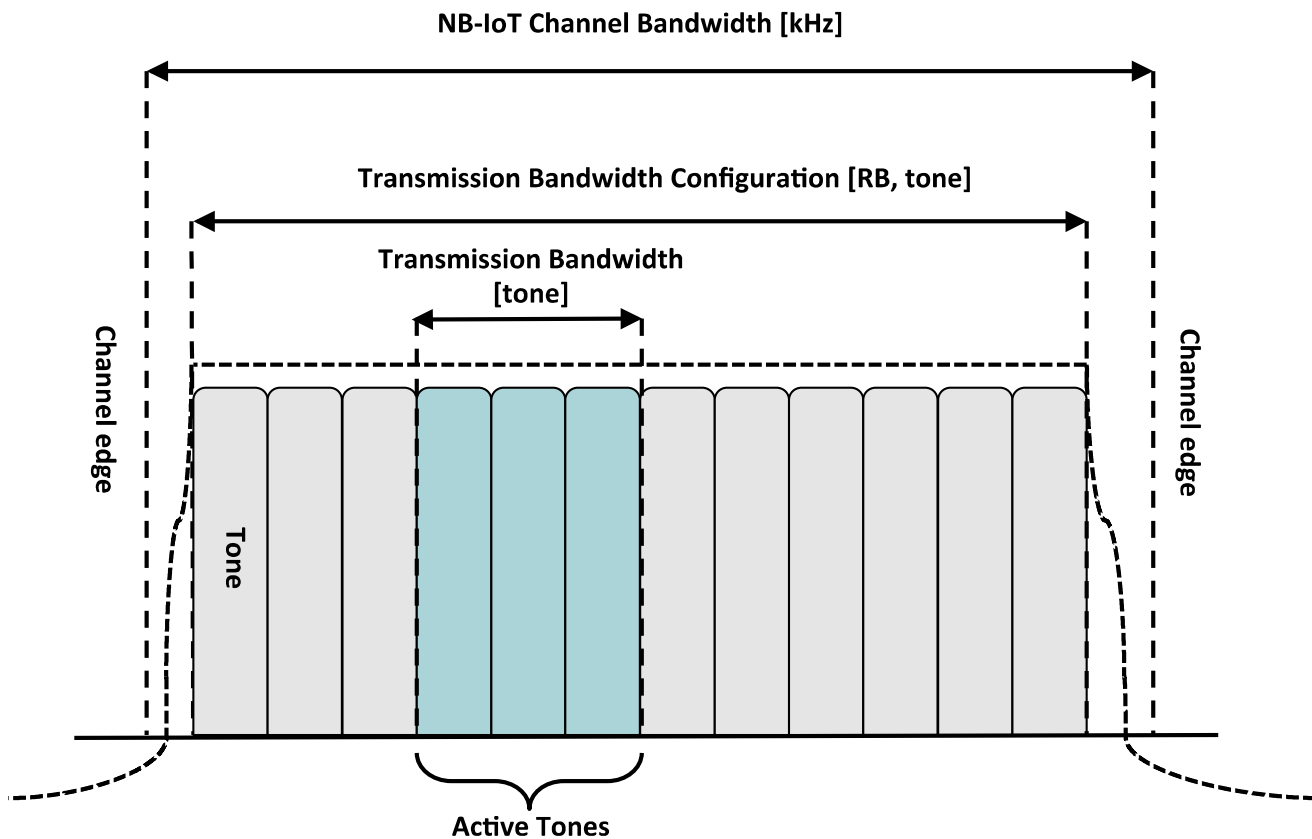

Figure 5.6-4 Definition of Channel Bandwidth and Transmission Bandwidth Configuration for NB-IoT standalone operation

For NB-IoT in-band operation, figure 5.6-5 shows the relation between the channel bandwidth (BW_{Channel}) and the transmission bandwidth configuration (N_{RB} , $N_{\text{tone 15kHz}}$ and $N_{\text{tone 3.75kHz}}$). The channel edges are defined as the lowest and highest frequencies of the carrier separated by the channel bandwidth, i.e. at $F_C \pm BW_{\text{Channel}}/2$.

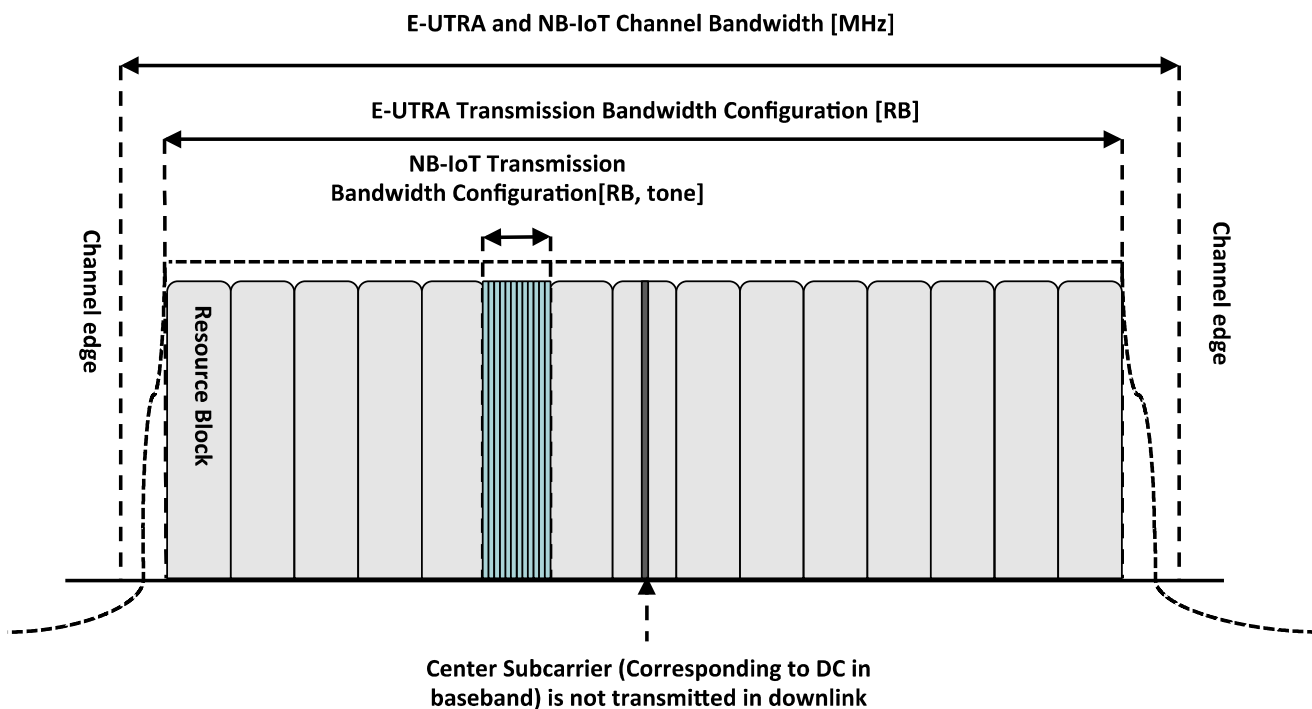

Figure 5.6-5 Definition of Channel Bandwidth and Transmission Bandwidth Configuration for NB-IoT in-band operation

For NB-IoT guard band operation, figure 5.6-6 shows the relation between the channel bandwidth (BW_{Channel}) and the transmission bandwidth configuration (N_{RB} , $N_{\text{tone 15kHz}}$ and $N_{\text{tone 3.75kHz}}$). The channel edges are defined as the lowest and highest frequencies of the carrier separated by the channel bandwidth, i.e. at $F_C \pm BW_{\text{Channel}}/2$.

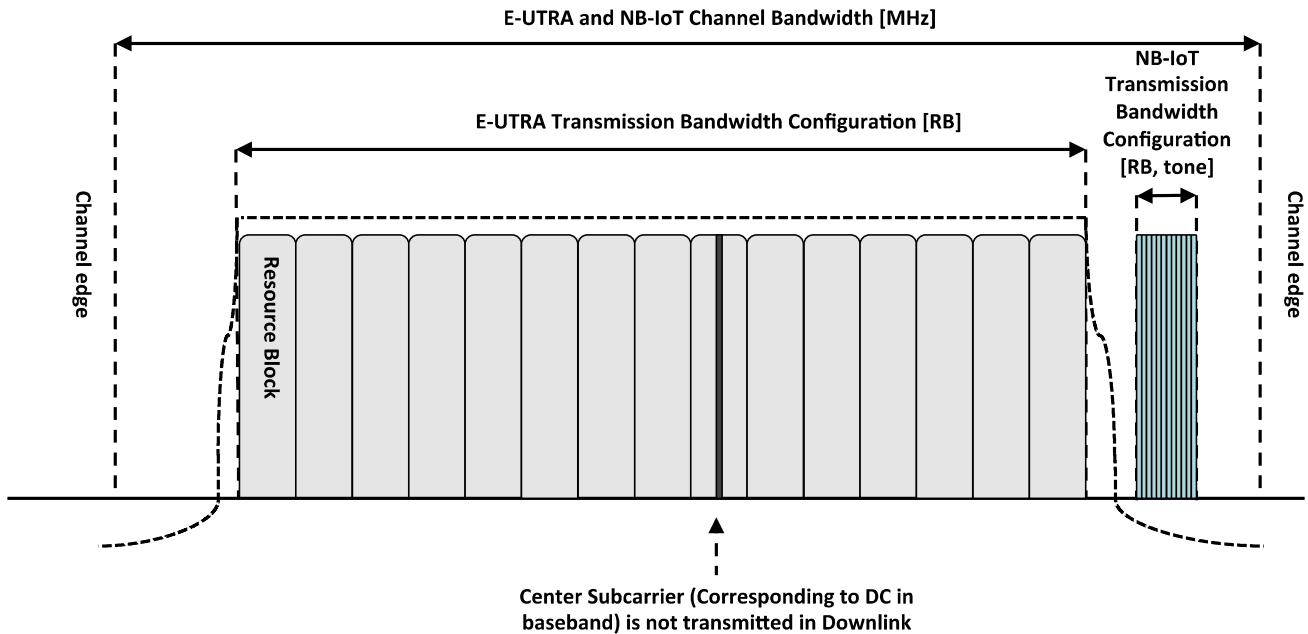

Figure 5.6-6 Definition of Channel Bandwidth and Transmission Bandwidth Configuration for NB-IoT guard band operation

5.7 Channel arrangement

5.7.1 Channel spacing

The spacing between carriers will depend on the deployment scenario, the size of the frequency block available and the channel bandwidths. The nominal channel spacing between two adjacent E-UTRA carriers is defined as following:

$$\text{Nominal Channel spacing} = (BW_{\text{Channel}(1)} + BW_{\text{Channel}(2)})/2$$

where $BW_{\text{Channel}(1)}$ and $BW_{\text{Channel}(2)}$ are the channel bandwidths of the two respective E-UTRA carriers. The channel spacing can be adjusted to optimize performance in a particular deployment scenario.

For 20MHz carriers in Band 46, the requirements apply for both 19.8 MHz and 20.1 MHz nominal carrier spacing.

5.7.1A CA Channel spacing

For intra-band contiguously aggregated carriers the channel spacing between adjacent component carriers shall be multiple of 300 kHz.

The nominal channel spacing between two adjacent aggregated E-UTRA carriers is defined as follows:

$$\text{Nominal channel spacing} = \left\lfloor \frac{BW_{\text{Channel}(1)} + BW_{\text{Channel}(2)} - 0.1|BW_{\text{Channel}(1)} - BW_{\text{Channel}(2)}|}{0.6} \right\rfloor 0.3$$

where $BW_{\text{Channel}(1)}$ and $BW_{\text{Channel}(2)}$ are the channel bandwidths of the two respective E-UTRA component carriers according to Table 5.6-1 with values in MHz. The channel spacing for intra-band contiguous carrier aggregation can be adjusted to any multiple of 300 kHz less than the nominal channel spacing to optimize performance in a particular deployment scenario.

For intra-band contiguous carrier aggregation with two or more 20MHz component carriers in Band 46, the requirements apply for both 19.8 MHz and 20.1 MHz nominal carrier spacing.

5.7.2 Channel raster

The channel raster is 100 kHz for all bands, which means that the carrier centre frequency must be an integer multiple of 100 kHz.

5.7.3 Carrier frequency and EARFCN

The carrier frequency in the uplink and downlink is designated by the E-UTRA Absolute Radio Frequency Channel Number (EARFCN) in the range 0 - 262143. The relation between EARFCN and the carrier frequency in MHz for the downlink is given by the following equation, where F_{DL_low} and $N_{Offs-DL}$ are given in table 5.7.3-1 and N_{DL} is the downlink EARFCN.

$$F_{DL} = F_{DL_low} + 0.1(N_{DL} - N_{Offs-DL})$$

The relation between EARFCN and the carrier frequency in MHz for the uplink is given by the following equation where F_{UL_low} and $N_{Offs-UL}$ are given in table 5.7.3-1 and N_{UL} is the uplink EARFCN.

$$F_{UL} = F_{UL_low} + 0.1(N_{UL} - N_{Offs-UL})$$

The carrier frequency of NB-IoT in the downlink is designated by the E-UTRA Absolute Radio Frequency Channel Number (EARFCN) in the range 0 – 262143 and the Offset of NB-IoT Channel Number to EARFCN in the range $\{-10,-9,-8,-7,-6,-5,-4,-3,-2,-1,-0.5,0,1,2,3,4,5,6,7,8,9\}$ for FDD and in the range $\{-10,-9,-8.5,-8,-7,-6,-5,-4.5,-4,-3,-2,-1,-0.5,0,1,2,3,3.5,4,5,6,7,7.5,8,9\}$ for TDD. The relation between EARFCN, Offset of NB-IoT Channel Number to EARFCN and the carrier frequency in MHz for the downlink is given by the following equation, where F_{DL} is the downlink carrier frequency of NB-IoT, F_{DL_low} and $N_{Offs-DL}$ are given in table 5.7.3-1, N_{DL} is the downlink EARFCN, M_{DL} is the Offset of NB-IoT Channel Number to downlink EARFCN.

$$F_{DL} = F_{DL_low} + 0.1(N_{DL} - N_{Offs-DL}) + 0.0025*(2M_{DL}+1)$$

The carrier frequency of NB-IoT in the uplink is designated by the E-UTRA Absolute Radio Frequency Channel Number (EARFCN) in the range 0 – 262143, and the Offset of NB-IoT Channel Number to EARFCN in the range $\{-10,-9,-8,-7,-6,-5,-4,-3,-2,-1,0,1,2,3,4,5,6,7,8,9\}$ for FDD and in the range $\{-11,-10,-9.5,-9,-8.5,-8,-7.5,-7,-6.5,-6,-5.5,-5,-4.5,-4,-3.5,-3,-2.5,-2,-1.5,-1,-0.5,0,0.5,1,1.5,2,2.5,3,3.5,4,4.5,5,5.5,6,6.5,7,7.5,8,8.5,9,9.5,10,11\}$ for TDD. The relation between EARFCN, Offset of NB-IoT Channel Number to EARFCN and the carrier frequency in MHz for the uplink is given by the following equation, where F_{UL} is the uplink carrier frequency of NB-IoT, F_{UL_low} and $N_{Offs-UL}$ are given in table 5.7.3-1, N_{UL} is the uplink EARFCN, M_{UL} is the Offset of NB-IoT Channel Number to uplink EARFCN.

$$F_{UL} = F_{UL_low} + 0.1(N_{UL} - N_{Offs-UL}) + 0.0025*(2M_{UL})$$

NOTE 1 For NB-IoT, N_{DL} or N_{UL} is different than the value of EARFCN that corresponds to E-UTRA downlink or uplink carrier frequency for in-band and guard band operation.

NOTE 2 For FDD $M_{DL} = -0.5$ is not applicable for in-band and guard band operation. For TDD $M_{DL} \{-0.5,+3.5,-4.5,+7.5,-8.5\}$ is not applicable for in-band and guard band operation.

NOTE 3: For the carrier including NPSS/NSSS for in-band and guard band operation, M_{DL} is selected from $\{-2,-1,0,1\}$.

NOTE 4: For the carrier including NPSS/NSSS for stand-alone operation, $M_{DL} = -0.5$.

Table 5.7.3-1: E-UTRA channel numbers

E-UTRA Operating Band	Downlink			Uplink		
	F _{DL_low} [MHz]	N _{Offs-DL}	Range of N _{DL}	F _{UL_low} [MHz]	N _{Offs-UL}	Range of N _{UL}
1	2110	0	0 – 599	1920	18000	18000 – 18599
2	1930	600	600 – 1199	1850	18600	18600 – 19199
3	1805	1200	1200 – 1949	1710	19200	19200 – 19949
4	2110	1950	1950 – 2399	1710	19950	19950 – 20399
5	869	2400	2400 – 2649	824	20400	20400 – 20649
6	875	2650	2650 – 2749	830	20650	20650 – 20749
7	2620	2750	2750 – 3449	2500	20750	20750 – 21449
8	925	3450	3450 – 3799	880	21450	21450 – 21799
9	1844.9	3800	3800 – 4149	1749.9	21800	21800 – 22149
10	2110	4150	4150 – 4749	1710	22150	22150 – 22749
11	1475.9	4750	4750 – 4949	1427.9	22750	22750 – 22949
12	729	5010	5010 – 5179	699	23010	23010 – 23179
13	746	5180	5180 – 5279	777	23180	23180 – 23279
14	758	5280	5280 – 5379	788	23280	23280 – 23379
...						
17	734	5730	5730 – 5849	704	23730	23730 – 23849
18	860	5850	5850 – 5999	815	23850	23850 – 23999
19	875	6000	6000 – 6149	830	24000	24000 – 24149
20	791	6150	6150 - 6449	832	24150	24150 - 24449
21	1495.9	6450	6450 – 6599	1447.9	24450	24450 – 24599
22	3510	6600	6600-7399	3410	24600	24600-25399
23	2180	7500	7500 – 7699	2000	25500	25500 – 25699
24	1525	7700	7700 – 8039	1626.5	25700	25700 – 26039
25	1930	8040	8040 – 8689	1850	26040	26040 – 26689
26	859	8690	8690 – 9039	814	26690	26690 - 27039
27	852	9040	9040 – 9209	807	27040	27040 – 27209
28	758	9210	9210 – 9659	703	27210	27210 – 27659
29 (NOTE 2)	717	9660	9660 – 9769	N/A		
30	2350	9770	9770 – 9869	2305	27660	27660 – 27759
31	462.5	9870	9870 – 9919	452.5	27760	27760 – 27809
32 (NOTE 2)	1452	9920	9920 – 10359	N/A		
33	1900	36000	36000 – 36199	1900	36000	36000 – 36199
34	2010	36200	36200 – 36349	2010	36200	36200 – 36349
35	1850	36350	36350 – 36949	1850	36350	36350 – 36949
36	1930	36950	36950 – 37549	1930	36950	36950 – 37549
37	1910	37550	37550 – 37749	1910	37550	37550 – 37749
38	2570	37750	37750 – 38249	2570	37750	37750 – 38249
39	1880	38250	38250 – 38649	1880	38250	38250 – 38649
40	2300	38650	38650 – 39649	2300	38650	38650 – 39649
41	2496	39650	39650 – 41589	2496	39650	39650 – 41589
42	3400	41590	41590 – 43589	3400	41590	41590 – 43589
43	3600	43590	43590 – 45589	3600	43590	43590 – 45589
44	703	45590	45590 – 46589	703	45590	45590 – 46589
45	1447	46590	46590 – 46789	1447	46590	46590 – 46789
46 (NOTE 3)	5150	46790	46790 – 54539	5150	46790	46790 – 54539
47	5855	54540	54540 – 55239	5855	54540	54540 – 55239
48	3550	55240	55240 – 56739	3550	55240	55240 – 56739
49	3550	56740	56740 – 58239	3550	56740	56740 – 58239
50	1432	58240	58240 - 59089	1432	58240	58240 - 59089
51	1427	59090	59090 - 59139	1427	59090	59090 - 59139
52	3300	59140	59140 – 60139	3300	59140	59140 – 60139
53	2483.5	60140	60140 - 60254	2483.5	60140	60140 - 60254
65	2110	65536	65536 – 66435	1920	131072	131072 – 131971
66 (NOTE 4)	2110	66436	66436 – 67335	1710	131972	131972 – 132671
67 (NOTE 2)	738	67336	67336 – 67535	N/A		
68	753	67536	67536 - 67835	698	132672	132672 - 132971

69 (NOTE 2)	2570	67836	67836 - 68335	N/A		
70 (NOTE 5)	1995	68336	68336 - 68585	1695	132972	132972 - 133121
71	617	68586	68586-68935	663	133122	133122-133471
72	461	68936	68936-68985	451	133472	133472-133521
73	460	68986	68986-69035	450	133522	133522-133571
74	1475	69036	69036 - 69465	1427	133572	133572 - 134001
75 (NOTE 2)	1432	69466	69466 - 70315	N/A		
76 (NOTE 2)	1427	70316	70316 - 70365	N/A		
85	728	70366	70366 - 70545	698	134002	134002 - 134181
87	420	70546	70546 - 70595	410	134182	134182 - 134231
88	422	70596	70596 - 70645	412	134232	134232 - 134281

- NOTE 1: The channel numbers that designate carrier frequencies so close to the operating band edges that the carrier extends beyond the operating band edge shall not be used. This implies that the first 7, 15, 25, 50, 75 and 100 channel numbers at the lower operating band edge and the last 6, 14, 24, 49, 74 and 99 channel numbers at the upper operating band edge shall not be used for channel bandwidths of 1.4, 3, 5, 10, 15 and 20 MHz respectively.
- NOTE 2: Restricted to E-UTRA operation when carrier aggregation is configured.
- NOTE 3: The following NDL and NUL are allowed for operation in Band 46 assuming 20MHz channel bandwidth: NDL =NUL = {n-2, n-1, n, n+1, n+2 | n = 46890 (5160 MHz), 47090 (5180 MHz), 47290 (5200 MHz), 47490 (5220 MHz), 47690 (5240 MHz), 47890 (5260 MHz), 48090 (5280 MHz), 48290 (5300 MHz), 48490 (5320 MHz), 48690 (5340 MHz), 50090 (5480 MHz), 50290 (5500 MHz), 50490 (5520 MHz), 50690 (5540 MHz), 50890 (5560 MHz), 51090 (5580 MHz), 51290 (5600 MHz), 51490 (5620 MHz), 51690 (5640 MHz), 51890 (5660 MHz), 52090 (5680 MHz), 52290 (5700 MHz), 52490 (5720 MHz), 52740 (5745 MHz), 52940 (5765 MHz), 53140 (5785 MHz), 53340 (5805 MHz), 53540 (5825 MHz), 53740 (5845 MHz), 53940 (5865 MHz), 54140 (5885 MHz), 54340 (5905 MHz)}. And the following NDL and NUL are allowed for operation in Band 46 assuming 10MHz channel bandwidth: NDL =NUL = {n-2, n-1, n, n+1, n+2 | n = 52590 (5730 MHz), 53590 (5830 MHz)}. 10 MHz channel bandwidth shall only apply in certain regions where the absence of non 3GPP technologies can be guaranteed on a long term basis in this version of specification.
- NOTE 4: Downlink frequency range 2180 – 2200 MHz is restricted to E-UTRA operation when carrier aggregation is configured.
- NOTE 5: The range 2010-2020 MHz of the DL operating band is restricted to E-UTRA operation when carrier aggregation is configured and TX-RX separation is 300 MHz. The range 2005-2020 MHz of the DL operating band is restricted to E-UTRA operation when carrier aggregation is configured and TX-RX separation is 295 MHz.

5.8 Requirements for contiguous and non-contiguous spectrum

A spectrum allocation where the BS operates can either be contiguous or non-contiguous. Unless otherwise stated, the requirements in the present specification apply for BS configured for both contiguous spectrum operation and non-contiguous spectrum operation.

For BS operation in non-contiguous spectrum, some requirements apply also inside the sub-block gaps. For each such requirement, it is stated how the limits apply relative to the sub-block edges.

6 Transmitter characteristics

6.1 General

General test conditions for transmitter tests are given in Clause 4, including interpretation of measurement results and configurations for testing. BS configurations for the tests are defined in Clause 4.5, while Annex H provides an informative description of E-UTRAN test cases.

Unless otherwise stated, a BS declared to be capable of E-UTRA with NB-IoT in-band or guard band operations is only required to pass the transmitter tests for E-UTRA with NB-IoT in-band or guard band; it is not required to perform the transmitter tests again for E-UTRA only.

Unless otherwise stated, a BS declared to be capable of E-UTRA with NB-IoT in-band and guard band operations needs only to pass the transmitter tests for E-UTRA with guard band operation.

6.1.1 E-UTRA Test Models

The set-up of physical channels for transmitter tests shall be according to one of the E-UTRA test models (E-TM) below. A reference to the applicable test model is made within each test.

The following general parameters are used by all E-UTRA test models:

- The test models are defined for a single antenna port (using $p = 0$); 1 code word ($q = 0$), 1 layer, precoding is not used; unless specified otherwise
- Duration is 10 subframes (10 ms)
- Normal CP
- Virtual resource blocks of localized type, no intra-subframe hopping for PDSCH
- UE-specific reference signals are not used

Power settings of physical channels are defined by physical channel EPRE relative to the EPRE of the RS. The relative accuracy of the physical channel EPRE as referred to the EPRE of the RS shall have a tolerance of ± 0.5 dB.

For E-UTRA TDD, test models are derived based on the uplink/downlink configuration 3 and special subframe configuration 8 defined in TS36.211, i.e. as showing in the table 6.1.1-1 (excluding Channel access procedure test for downlink operation in Band 46 where Frame structure Type 3 is defined in TS 36.211 clause 4.3 is used). Number of frames for the test models is 2.

For E-UTRA TDD with NB-IoT operating in-band and/or guard band, test models are derived based on the uplink/downlink configuration 1 and special subframe configuration 8 defined in TS 36.211 [12], i.e. as showing in the table 6.1.1-1. Number of frames for the test models is 3.

Table 6.1.1-1: Configurations of TDD eNB test models

TDD Configuration	Downlink-to-Uplink Switch-point periodicity	Number of UL/DL sub-frames per radio frame (10 ms)		DwPTS	GP	UpPTS
		DL	UL			
1	5 ms	4	4	$24144T_s$	$2192 \cdot T_s$	$4384 \cdot T_s$
3	10ms	6	3	$24144T_s$	$2192 \cdot T_s$	$4384 \cdot T_s$

6.1.1.1 E-UTRA Test Model 1.1 (E-TM1.1)

This model shall be used for tests on:

- BS output power

- Unwanted emissions
- Occupied bandwidth
- ACLR
- Operating band unwanted emissions
- Transmitter spurious emissions
- Transmitter intermodulation
- RS absolute accuracy

Table 6.1.1.1-1: Physical channel parameters of E-TM1.1

Parameter	1.4 MHz	3 MHz	5 MHz	10 MHz	15 MHz	20 MHz
Reference, Synchronisation Signals						
RS boosting, $P_B = E_B/E_A$	1	1	1	1	1	1
Synchronisation signal EPRE / E_{RS} [dB]	0.000	0.000	0.000	0.000	0.000	0.000
Reserved EPRE / E_{RS} [dB]	-inf	-inf	-inf	-inf	-inf	-inf
PBCH						
PBCH EPRE / E_{RS} [dB]	0.000	0.000	0.000	0.000	0.000	0.000
Reserved EPRE / E_{RS} [dB]	-inf	-inf	-inf	-inf	-inf	-inf
PCFICH						
# of symbols used for control channels	2	1	1	1	1	1
PCFICH EPRE / E_{RS} [dB]	3.222	0	0	0	0	0
PHICH						
# of PHICH groups	1	1	1	2	2	3
# of PHICH per group	2	2	2	2	2	2
PHICH BPSK symbol power / E_{RS} [dB]	-3.010	-3.010	-3.010	-3.010	-3.010	-3.010
PHICH group EPRE / E_{RS} [dB]	0	0	0	0	0	0
PDCCH						
# of available REGs	23	23	43	90	140	187
# of PDCCH	2	2	2	5	7	10
# of CCEs per PDCCH	1	1	2	2	2	2
# of REGs per CCE	9	9	9	9	9	9
# of REGs allocated to PDCCH	18	18	36	90	126	180
# of <NIL> REGs added for padding	5	5	7	0	14	7
PDCCH REG EPRE / E_{RS} [dB]	0.792	2.290	1.880	1.065	1.488	1.195
<NIL> REG EPRE / E_{RS} [dB]	-inf	-inf	-inf	-inf	-inf	-inf
PDSCH						
# of QPSK PDSCH PRBs which are boosted	6	15	25	50	75	100
PRB $P_A = E_A/E_{RS}$ [dB]	0	0	0	0	0	0

# of QPSK PDSCH PRBs which are de-boosted	0	0	0	0	0	0
PRB $P_A = E_A/E_{RS}$ [dB]	n.a.	n.a.	n.a.	n.a.	n.a.	n.a.

6.1.1.2 E-UTRA Test Model 1.2 (E-TM1.2)

This model shall be used for tests on:

- Unwanted emissions
- ACLR
- Operating band unwanted emissions

Table 6.1.1.2-1: Physical channel parameters of E-TM1.2

Parameter	1.4 MHz	3 MHz	5 MHz	10 MHz	15 MHz	20 MHz
Reference, Synchronisation Signals						
RS boosting, $P_B = E_B/E_A$	1	1	1	1	1	1
Synchronisation signal EPRE / E_{RS} [dB]	0.000	-4.730	-4.730	-4.730	-4.730	-4.730
Reserved EPRE / E_{RS} [dB]	-inf	-inf	-inf	-inf	-inf	-inf
PBCH						
PBCH EPRE / E_{RS} [dB]	0.000	-4.730	-4.730	-4.730	-4.730	-4.730
Reserved EPRE / E_{RS} [dB]	-inf	-inf	-inf	-inf	-inf	-inf
PCFICH						
# of symbols used for control channels	2	1	1	1	1	1
PCFICH EPRE / E_{RS} [dB]	3.222	0	0	0	0	0
PHICH						
# of PHICH groups	1	1	1	2	2	3
# of PHICH per group	2	2	2	2	2	2
PHICH BPSK symbol power / E_{RS} [dB]	-3.010	-3.010	-3.010	-3.010	-3.010	-3.010
PHICH group EPRE / E_{RS} [dB]	0	0	0	0	0	0
PDCCH						
# of available REGs	23	23	43	90	140	187
# of PDCCH	2	2	2	5	7	10
# of CCEs per PDCCH	1	1	2	2	2	2
# of REGs per CCE	9	9	9	9	9	9
# of REGs allocated to PDCCH	18	18	36	90	126	180
# of dummy REGs added for padding	5	5	7	0	14	7
PDCCH REG EPRE / E_{RS} [dB]	0.792	2.290	1.880	1.065	1.488	1.195
<NIL> REG EPRE / E_{RS} [dB]	-inf	-inf	-inf	-inf	-inf	-inf
PDSCH						
# of QPSK PDSCH PRBs which are boosted	2	6	10	20	30	40

PRB $P_A = E_A/E_{RS}$ [dB]	3 (Note 1)	3	3	3	3	3
# of QPSK PDSCH PRBs which are de-boosted	4	9	15	30	45	60
PRB $P_A = E_A/E_{RS}$ [dB]	-2.990 (Note 1)	-4.730	-4.730	-4.730	-4.730	-4.730
Note 1: In subframes containing PBCH or synchronisation signal REs, no PRB boosting/deboosting shall be applied, i.e. PRB $P_A = E_A/E_{RS} = 0$ [dB].						

Table 6.1.1.2-2: Numbers (n_{PRB}) of the boosted PRBs (FDD)

	Subfram e 0	Subfram e 1	Subfram e 2	Subfram e 3	Subfram e 4	Subfram e 5	Subfram e 6	Subfram e 7	Subfram e 8	Subfram e 9
1.4 MHz	N.A.	1 3	1 3	2 3	2 5	N.A.	0 2	0 5	2 5	1 5
3 MHz	0 1 2 11 12 13	0 4 10 11 12 13	0 3 5 6 11 13	0 1 4 5 7 12	0 2 3 4 9 10	1 2 3 11 12 14	4 6 8 11 13 14	2 5 6 12 13 14	0 3 4 7 8 11	1 3 4 5 11 12
5 MHz	0 1 3 6 7 8 16 18 20 21	0 1 4 5 9 10 12 17 18 24	0 1 2 12 13 14 19 20 23 24	0 5 8 12 13 15 17 20 21 24	0 4 6 7 12 13 15 16 22 23	0 1 2 3 8 16 18 21 22 24	1 3 5 7 9 10 12 15 21 22	0 1 2 3 7 10 14 18 20 21	1 4 8 9 10 12 15 16 18 20	1 2 3 5 6 9 10 13 16 17
10 MHz	1 2 7 8 9 10 11 16 20 31 32 33 35 36 39 40 42 46 47 48	5 6 7 9 11 15 20 21 22 24 25 27 34 35 36 37 40 44 46 49	3 5 11 12 14 17 18 19 20 22 26 27 28 29 31 34 38 41 42 49	1 2 3 5 8 14 16 22 23 26 28 30 32 34 38 41 42 45 46 47	0 3 6 7 8 9 10 12 13 16 18 21 23 31 33 41 42 45 46 47	0 2 3 4 5 7 9 10 11 12 15 19 20 28 29 30 31 34 36 48	0 1 4 6 8 9 10 16 17 19 20 21 24 29 30 31 35 37 38 47	2 3 4 5 6 9 10 12 16 17 19 22 24 25 26 30 34 37 42 48	7 9 14 15 16 21 22 28 30 31 32 34 35 41 42 43 44 46 48 49	11 13 16 17 18 21 24 27 28 29 30 32 37 38 40 42 45 47 48 49
15 MHz	0 1 2 3 5 7 8 9 12 18 19 20 21 23 24 25 29 30 31 32 33 42 47 48 49 63 65 68 71 73	0 1 3 4 5 6 7 11 18 20 21 24 26 30 31 38 46 47 49 50 51 53 54 57 60 67 68 70 73 74	2 11 12 15 18 21 22 24 25 26 29 32 33 34 42 45 46 47 50 51 52 54 58 59 60 64 68 70 72 74	2 3 4 7 9 11 12 15 17 20 24 27 33 34 35 39 42 43 45 46 48 56 59 60 62 67 70 71 73 74	4 5 6 8 13 17 22 25 27 29 31 32 33 34 35 41 44 46 48 50 52 56 59 60 64 67 69 70 71 74	0 2 3 4 7 8 18 20 23 24 25 27 29 42 43 45 47 49 50 54 56 60 62 65 66 67 70 71 72 73	2 11 14 15 18 25 26 28 30 31 32 33 36 37 38 39 41 43 45 50 53 62 65 67 68 70 71	3 4 7 12 19 23 24 26 27 28 30 33 34 35 41 42 49 53 54 58 59 60 61 62 65 67 69 70 71 73	0 3 8 9 10 13 14 15 17 18 19 22 23 24 25 26 27 32 37 39 47 50 53 56 61 63 69 71 73 74	0 3 7 8 11 13 14 16 18 23 25 30 32 35 44 46 47 48 53 55 57 59 61 62 64 67 68 69 70 71
20 MHz	0 6 10 13 15 16 20 23 25 28 29 30 31 32 33 39 41 42 44 45 54 56 57 63 66 67 68 76 77 79 82 84 85 88 92 94 95 97 98 99	1 3 7 9 10 13 19 20 21 22 23 25 26 27 30 33 34 35 36 47 49 50 51 53 55 57 60 61 64 68 76 76 79 81 77 80 83 84 86 87 89 90 93 89 95 99	1 2 3 6 8 10 11 15 16 17 19 21 25 26 28 29 32 35 39 41 42 43 44 51 52 54 60 64 69 76 79 81 84 86 88 89 90 93 94 99	5 7 9 10 12 15 16 21 23 24 27 28 29 30 33 34 35 36 39 47 49 54 55 56 57 64 66 70 72 76 77 80 81 86 87 90 91 92 98 99	2 3 4 5 6 7 14 17 19 21 22 24 26 37 42 44 47 49 51 56 57 62 63 65 67 70 71 73 76 77 81 83 85 86 87 89 94 95 97 99	1 2 5 6 8 9 12 13 21 22 25 26 28 32 35 39 40 43 45 46 57 59 61 62 64 66 68 71 73 77 78 84 85 86 93 94 95 96 97 99	0 1 2 3 5 8 9 10 12 22 25 26 27 29 31 32 33 36 38 39 43 45 49 53 55 59 62 63 64 71 72 73 75 77 78 81 84 89 97 98	0 1 3 4 5 7 11 18 19 20 21 26 27 29 30 31 33 35 39 40 41 43 44 46 47 50 53 55 56 62 64 66 67 69 70 72 74 92 93 98	2 3 4 7 11 13 15 16 24 25 27 29 35 36 40 43 44 45 46 51 52 55 56 57 63 64 65 68 71 77 78 81 82 83 84 85 86 90 94 98	0 4 7 8 10 11 16 18 22 26 29 32 35 37 43 44 46 47 48 49 53 54 57 59 60 61 64 66 67 69 70 76 78 81 84 87 89 91 95 96

Table 6.1.1.2-3: Numbers (n_{PRB}) of the boosted PRBs (TDD)

Frame1	Subframe 0	Subframe 1	Subframe 5	Subframe 6	Subframe 7	Subframe 8	Subframe 9
1.4 MHz	N.A.	N.A.	N.A.	N.A.	4 5	2 5	0 3
3 MHz	0 1 3 11 12 14	1 2 3 11 12 14	0 1 2 3 11 13	1 3 11 12 13 14	1 4 8 10 11 12	1 6 8 9 11 12	0 2 3 4 5 6
5 MHz	1 2 5 8 17 18 19 21 23 24	1 3 5 6 7 17 19 20 23 24	0 3 4 5 8 17 18 19 21 22	2 3 6 7 8 17 18 19 20 24	1 2 11 13 15 17 18 19 20 21	1 2 4 5 6 7 8 9 10 12	1 3 4 8 10 12 16 19 20 22
10 MHz	2 4 6 7 10 11 13 17 18 19 34 35 37 38 41 42 46 47 48 49	1 3 6 7 9 11 14 15 17 18 19 28 29 30 35 37 38 39 43 44	3 4 5 6 10 11 12 14 16 18 30 34 35 36 37 39 40 41 43 48	2 4 6 7 8 9 10 13 14 16 19 20 21 29 32 34 39 41 44 45	2 4 7 12 14 16 20 21 24 26 28 29 34 41 43 44 45 46 47 48	2 5 8 9 11 12 13 16 18 21 22 23 27 29 30 31 32 33 46 47	1 4 7 11 12 13 14 15 20 21 27 31 34 37 38 41 42 46 48 49
15 MHz	3 5 6 9 10 13 15 17 20 23 25 26 27 28 29 33 44 45 51 53 56 57 58 61 63 66 70 71 73 74	1 5 7 8 9 10 11 13 15 19 21 24 26 42 45 46 51 52 53 55 56 57 58 59 60 61 62 64 65 72	3 4 6 7 9 10 11 13 14 15 16 20 22 24 25 28 31 32 33 43 49 52 55 58 61 62 66 67 70 73	3 4 7 8 12 13 14 16 18 19 20 22 24 27 28 30 32 41 42 43 44 46 49 50 51 65 67 68 69 71	2 6 8 9 10 11 13 16 18 19 21 22 26 30 31 41 45 46 47 48 51 55 57 58 62 63 64 69 73 74	0 2 7 11 13 17 19 20 23 27 28 31 39 40 41 43 45 46 47 48 51 55 57 58 63 65 66 70 71 73	1 2 3 7 8 9 10 12 13 17 19 21 22 23 24 28 30 32 37 40 41 46 48 53 56 58 61 65 69 73
20 MHz	2 4 7 8 12 13 14 18 20 21 23 27 28 31 34 35 37 38 39 44 46 53 56 58 60 68 70 71 74 75 76 78 82 85 87 88 93 95 97 99	4 5 6 7 8 9 10 11 12 14 17 19 20 22 25 27 28 29 32 33 37 38 41 43 53 58 61 65 69 70 73 74 78 79 80 82 83 86 90 97	4 5 9 11 13 14 16 19 22 24 25 27 29 32 33 37 40 42 43 45 46 53 54 57 58 62 66 67 68 69 83 86 88 89 90 91 92 93 95 97	2 3 8 9 10 11 12 14 15 17 18 22 24 26 28 30 35 36 40 41 42 53 55 60 61 62 63 64 65 68 74 77 82 84 85 87 93 97 98 99	0 3 10 13 14 17 23 25 27 28 30 31 36 37 38 40 41 43 49 50 54 55 57 58 60 61 63 64 70 74 76 77 81 84 85 87 88 94 95 98	2 3 4 10 11 12 15 18 21 22 23 26 30 31 32 36 37 39 40 41 42 43 48 50 53 54 56 58 61 64 66 71 72 77 81 82 89 92 98 99	4 9 12 13 17 19 20 21 22 29 31 36 37 39 40 41 42 46 48 49 54 56 57 60 64 66 73 74 75 80 83 86 87 89 90 92 94 96 98 99

Frame2	Subframe 0	Subframe 1	Subframe 5	Subframe 6	Subframe 7	Subframe 8	Subframe 9
1.4 MHz	N.A.	N.A.	N.A.	N.A.	4 5	1 2	1 3
3 MHz	0 1 2 11 12 13	0 1 2 3 13 14	0 1 2 3 12 14	0 1 2 3 11 13	0 3 4 6 10 12	2 6 9 11 13 14	1 5 7 9 13 14
5 MHz	1 2 3 8 17 20 21 22 23 24	1 2 4 5 6 7 16 17 22 23	1 2 4 6 8 16 18 21 23 24	0 3 5 6 7 17 19 20 21 24	2 3 8 10 13 15 16 21 23 24	0 4 6 7 13 14 15 16 19 24	0 2 5 9 14 18 19 21 22 23
10 MHz	1 4 5 6 8 11 12 13 15 17 20 28 30 31 32 42 43 46 48 49	0 1 7 15 18 19 20 21 29 30 32 34 35 37 38 40 42 43 44 47	1 2 5 6 8 9 11 13 14 15 16 18 20 30 32 33 40 41 46 49	6 7 10 11 15 18 19 20 21 28 29 33 35 36 38 40 41 43 44 49	2 4 10 11 18 20 23 24 28 30 32 37 40 41 43 44 45 46 47 48	6 8 9 10 11 14 15 16 18 19 20 21 23 24 27 28 36 37 47 49	2 5 7 8 9 14 16 18 23 30 32 33 34 37 41 42 44 45 46 49
15 MHz	3 7 10 11 15 16 17 23 27 29 30 31 32 42 43 48 49 50 53 54 57 60 62 64 65 66 67 69 72 74	8 9 11 12 14 15 17 22 23 24 27 28 29 31 41 42 45 48 51 54 55 56 62 63 67 68 70 71 73 74	1 3 9 11 13 17 21 22 23 24 25 28 29 46 48 49 51 52 53 54 55 57 61 64 65 67 68 72 73 74	0 2 4 6 10 11 13 14 15 16 17 20 22 23 28 29 43 44 46 47 51 53 54 56 59 61 63 69 71 72	0 1 3 5 9 11 14 15 16 19 24 25 26 27 28 31 33 34 38 40 42 43 46 48 50 52 59 61 67 74	0 4 5 8 9 10 12 13 15 20 22 30 32 33 35 37 38 42 44 45 46 47 48 51 52 55 59 60 66 69	1 5 8 9 10 13 14 15 20 21 23 26 27 28 29 32 33 34 39 43 44 57 60 62 64 65 69 71 72 73
20 MHz	1 4 10 14 15 17 18 19 23 29 30 31 32 33 37 38 39 42 46 55 61 64 65 66 68 69 70 72 73 76 82 83 84 86 89 90 93 95 97 99	0 1 3 5 8 12 14 15 17 19 20 22 23 25 26 28 29 30 37 38 39 45 58 59 62 63 68 71 72 75 78 82 84 85 91 92 93 94 96 98	0 2 4 5 6 7 11 12 13 14 16 19 20 21 27 30 32 33 35 37 41 44 46 53 56 58 60 61 62 64 65 67 68 70 73 79 82 90 92 98	0 2 4 6 7 11 12 13 17 18 19 20 27 28 31 35 37 38 40 43 45 56 57 59 63 68 70 71 77 79 80 82 85 87 89 92 95 96 97 98	3 5 6 7 9 16 20 21 23 24 25 26 31 32 35 37 41 42 43 44 46 48 51 54 59 60 61 62 64 67 76 77 78 79 82 84 86 87 88 95	1 4 7 10 13 18 19 25 26 27 28 30 32 35 37 38 41 46 47 50 51 52 53 54 57 60 62 70 71 73 78 79 81 83 84 87 91 95 98 99	0 1 2 3 5 7 8 10 11 15 19 20 21 24 26 28 31 32 33 34 44 45 54 58 59 61 63 65 67 69 70 77 85 88 89 90 92 94 98 99

6.1.1.3 E-UTRA Test Model 2 (E-TM2)

This model shall be used for tests on:

- Total power dynamic range (lower OFDM symbol power limit at min power),
- EVM of single 64QAM PRB allocation (at min power)
- Frequency error (at min power)

Table 6.1.1.3-1: Physical channel parameters of E-TM2

Parameter	1.4 MHz	3 MHz	5 MHz	10 MHz	15 MHz	20 MHz
Reference, Synchronisation Signals						
RS boosting, $P_B = E_B/E_A$	1	1	1	1	1	1
Synchronisation signal EPRE / E_{RS} [dB]	0.000	0.000	0.000	0.000	0.000	0.000
Reserved EPRE / E_{RS} [dB]	-inf	-inf	-inf	-inf	-inf	-inf
PBCH						
PBCH EPRE / E_{RS} [dB]	0.000	0.000	0.000	0.000	0.000	0.000
Reserved EPRE / E_{RS} [dB]	-inf	-inf	-inf	-inf	-inf	-inf
PCFICH						
# of symbols used for control channels	2	1	1	1	1	1
PCFICH EPRE / E_{RS} [dB]	0	0	0	0	0	0
PHICH						
# of PHICH groups	1	1	1	2	2	3
# of PHICH per group	2	2	2	2	2	2
PHICH BPSK symbol power / E_{RS} [dB]	-3.010	-3.010	-3.010	-3.010	-3.010	-3.010
PHICH group EPRE / E_{RS} [dB]	0	0	0	0	0	0
PDCCH						
# of available REGs	23	23	43	90	140	187
# of PDCCH	1	1	1	1	1	1
# of CCEs per PDCCH	1	1	2	2	2	2
# of REGs per CCE	9	9	9	9	9	9
# of REGs allocated to PDCCH	9	9	18	18	18	18
# of <NIL> REGs added for padding	14	14	25	72	122	169
PDCCH REG EPRE / E_{RS} [dB]	0	0	0	0	0	0
<NIL> REG EPRE / E_{RS} [dB]	-inf	-inf	-inf	-inf	-inf	-inf
PDSCH						
# of 64QAM PDSCH PRBs within a slot for which EVM is measured	1	1	1	1	1	1
PRB $P_A = E_A/E_{RS}$ [dB]	0	0	0	0	0	0
# of PDSCH PRBs which are not allocated	5	14	24	49	74	99
PRB $P_A = E_A/E_{RS}$ [dB]	-inf	-inf	-inf	-inf	-inf	-inf

Table 6.1.1.3-2: Numbers (n_{PRB}) of the allocated PRB (64QAM) (FDD)

	Subframe e 0	Subframe e 1	Subframe e 2	Subframe e 3	Subframe e 4	Subframe e 5	Subframe e 6	Subframe e 7	Subframe e 8	Subframe e 9
1.4 MHz	4	1	1	2	5	3	0	0	5	4
3 MHz	13	11	13	5	9	14	6	13	0	1
5 MHz	8	17	21	8	22	2	9	14	0	13
10 MHz	16	36	19	26	42	30	17	48	9	0
15 MHz	32	46	18	72	22	4	31	58	27	3
20 MHz	63	34	44	7	94	2	97	19	56	32

Table 6.1.1.3-3: Numbers (n_{PRB}) of the allocated PRB (64QAM) (TDD)

Frame1	Subframe 0	Subframe 1	Subframe 5	Subframe 6	Subframe 7	Subframe 8	Subframe 9
1.4 MHz	4	5	5	2	0	0	3
3 MHz	10	14	12	5	0	1	7
5 MHz	17	24	21	8	1	2	12
10 MHz	35	49	42	17	2	4	25
15 MHz	53	74	63	26	3	6	38
20 MHz	71	99	85	35	4	8	51

Frame2	Subframe 0	Subframe 1	Subframe 5	Subframe 6	Subframe 7	Subframe 8	Subframe 9
1.4 MHz	4	5	2	1	3	1	4
3 MHz	11	14	5	3	8	3	11
5 MHz	18	23	8	5	13	5	19
10 MHz	37	46	17	10	26	11	38
15 MHz	56	70	25	15	40	17	57
20 MHz	75	93	34	20	53	23	76

Table 6.1.1.3-4: Numbers (n_{PRB}) of the allocated PRB (64QAM) (TDD with NB-IoT inband/guard band)

Frame 1	Subframe 0	Subframe 1	Subframe 4	Subframe 5	Subframe 6	Subframe 9
3 MHz	10	14	0	12	14	7
5 MHz	17	24	1	21	24	12
10 MHz	35	49	2	42	49	25
15 MHz	53	74	3	63	74	38
20 MHz	71	99	4	85	99	51

Frame 2	Subframe 0	Subframe 1	Subframe 4	Subframe 5	Subframe 6	Subframe 9
3 MHz	11	14	1	5	14	11
5 MHz	18	23	2	8	24	19
10 MHz	37	46	4	17	49	38
15 MHz	56	70	6	25	74	57
20 MHz	75	93	8	34	99	76

Frame 3	Subframe 0	Subframe 1	Subframe 4	Subframe 5	Subframe 6	Subframe 9
3 MHz	8	14	3	5	14	3
5 MHz	13	24	5	8	24	5
10 MHz	26	49	11	17	49	10
15 MHz	40	74	17	26	74	15
20 MHz	53	99	23	35	99	20

6.1.1.3a E-UTRA Test Model 2a (E-TM2a)

This model shall be used for tests on:

- Total power dynamic range (lower OFDM symbol power limit at min power),
- EVM of single 256QAM PRB allocation (at min power)
- Frequency error (at min power)

Physical channel parameters and numbers of the allocated PRB are defined in Tables 6.1.1.3-1, 6.1.1.3-2, 6.1.1.3-3, 6.1.1.3-4, with all 64QAM PDSCH PRBs replaced by 256QAM PDSCH PRBs.

6.1.1.3b E-UTRA Test Model 2b (E-TM2b)

This model shall be used for tests on:

- Total power dynamic range (lower OFDM symbol power limit at min power),
- EVM of single 1024QAM PRB allocation (at min power)
- Frequency error (at min power)

Physical channel parameters and numbers of the allocated PRB are defined in Tables 6.1.1.3-1, 6.1.1.3-2, 6.1.1.3-3, 6.1.1.3-4, with all 64QAM PDSCH PRBs replaced by 1024QAM PDSCH PRBs.

6.1.1.3c E-UTRA subslot TTI Test Model 2-1 (sE-TM2-1)

This model shall be used for subslot TTI tests on:

- Total power dynamic range (lower OFDM symbol power limit at min power),
- EVM of single 64QAM PRB allocation (at min power)
- Frequency error (at min power)

Table 6.1.1.3c-1: Physical channel parameters of sE-TM2-1

Parameter	3 MHz	5 MHz	10 MHz	15 MHz	20 MHz
Reference, Synchronisation Signals					
RS boosting, $P_B = E_B/E_A$	1	1	1	1	1
Synchronisation signal EPRE / E_{RS} [dB]	0.000	0.000	0.000	0.000	0.000
Reserved EPRE / E_{RS} [dB]	-inf	-inf	-inf	-inf	-inf
PBCH					
PBCH EPRE / E_{RS} [dB]	0.000	0.000	0.000	0.000	0.000
Reserved EPRE / E_{RS} [dB]	-inf	-inf	-inf	-inf	-inf
PCFICH					
# of symbols used for control channels	1	1	1	1	1
PCFICH EPRE / E_{RS} [dB]	0	0	0	0	0
PHICH					
# of PHICH groups	1	1	2	2	3
# of PHICH per group	2	2	2	2	2
PHICH BPSK symbol power / E_{RS} [dB]	-3.010	-3.010	-3.010	-3.010	-3.010
PHICH group EPRE / E_{RS} [dB]	0	0	0	0	0
sPDCCH					
# of available sREGs	30 (2OS) 45 (3OS)	50 (2OS) 75 (3OS)	100 (2OS) 150 (3OS)	150 (2OS) 225 (3OS)	200 (2OS) 300 (3OS)
# of sPDCCH	1	1	1	1	1
# of sCCEs per sPDCCH	1	2	2	2	2
# of sREGs per sCCE	4 (2OS) 6 (3OS)	4 (2OS) 6 (3OS)	4 (2OS) 6 (3OS)	4 (2OS) 6 (3OS)	4 (2OS) 6 (3OS)
# of sREGs allocated to sPDCCH	4 (2OS) 6 (3OS)	8 (2OS) 12 (3OS)	8 (2OS) 12 (3OS)	8 (2OS) 12 (3OS)	8 (2OS) 12 (3OS)
# of <NIL> sREGs added for padding	26 (2OS) 39 (3OS)	42 (2OS) 63 (3OS)	92 (2OS) 138 (3OS)	142 (2OS) 213 (3OS)	192 (2OS) 288 (3OS)
sPDCCH sREG EPRE / E_{RS} [dB]	0	0	0	0	0
<NIL> sREG EPRE / E_{RS} [dB]	-inf	-inf	-inf	-inf	-inf
sPDSCH					
# of 64QAM sPDSCH PRBs within a subslot for which EVM is measured	1	1	1	1	1
PRB $P_A = E_A/E_{RS}$ [dB]	0	0	0	0	0
# of sPDSCH PRBs which are not allocated	14	24	49	74	99
PRB $P_A = E_A/E_{RS}$ [dB]	-inf	-inf	-inf	-inf	-inf

Table 6.1.1.3c-2: Numbers (n_{PRB}) of the allocated PRB (64QAM) (FDD)

Subslot	Subframe 0						Subframe 1						Subframe 2					
	0	1	2	3	4	5	0	1	2	3	4	5	0	1	2	3	4	5
3 MHz	13	11	13	5	9	14	6	13	0	1	13	11	13	5	9	14	6	13
5 MHz	8	17	21	8	22	2	9	14	0	13	8	17	21	8	22	2	9	14
10 MHz	16	36	19	26	42	30	17	48	9	0	16	36	19	26	42	30	17	48
15 MHz	32	46	18	72	22	4	31	58	27	3	32	46	18	72	22	4	31	58
20 MHz	63	34	44	7	94	2	97	19	56	32	63	34	44	7	94	2	97	19

SubSlot	Subframe 3						Subframe 4						Subframe 5					
	0	1	2	3	4	5	0	1	2	3	4	5	0	1	2	3	4	5
3 MHz	0	1	13	11	13	5	9	14	6	13	0	1	13	11	13	5	9	14
5 MHz	0	13	8	17	21	8	22	2	9	14	0	13	8	17	21	8	22	2
10 MHz	9	0	16	36	19	26	42	30	17	48	9	0	16	36	19	26	42	30
15 MHz	27	3	32	46	18	72	22	4	31	58	27	3	32	46	18	72	22	4
20 MHz	56	32	63	34	44	7	94	2	97	19	56	32	63	34	44	7	94	2

SubSlot	Subframe 6						Subframe 7						Subframe 8					
	0	1	2	3	4	5	0	1	2	3	4	5	0	1	2	3	4	5
3 MHz	6	13	0	1	13	11	13	5	9	14	6	13	0	1	13	11	13	5
5 MHz	9	14	0	13	8	17	21	8	22	2	9	14	0	13	8	17	21	8
10 MHz	17	48	9	0	16	36	19	26	42	30	17	48	9	0	16	36	19	26
15 MHz	31	58	27	3	32	46	18	72	22	4	31	58	27	3	32	46	18	72
20 MHz	97	19	56	32	63	34	44	7	94	2	97	19	56	32	63	34	44	7

SubSlot	Subframe 9					
	0	1	2	3	4	5
3 MHz	9	14	6	13	0	1
5 MHz	22	2	9	14	0	13
10 MHz	42	30	17	48	9	0
15 MHz	22	4	31	58	27	3
20 MHz	94	2	97	19	56	32

6.1.1.3d E-UTRA subslot TTI Test Model 2a (sE-TM2a-1)

This model shall be used for subslot TTI tests on:

- Total power dynamic range (lower OFDM symbol power limit at min power),
- EVM of single 256QAM PRB allocation (at min power)
- Frequency error (at min power)

Physical channel parameters and numbers of the allocated PRB are defined in Tables 6.1.1.3c-1, 6.1.1.3c-2 with all 64QAM sPDSCH PRBs replaced by 256QAM sPDSCH PRBs.ee

6.1.1.3e E-UTRA slot TTI Test Model 2-2 (sE-TM2-2)

This model shall be used for slot TTI tests on:

- Total power dynamic range (lower OFDM symbol power limit at min power),
- EVM of single 64QAM PRB allocation (at min power)
- Frequency error (at min power)

Table 6.1.1.3e-1: Physical channel parameters of sE-TM2-2

Parameter	3 MHz	5 MHz	10 MHz	15 MHz	20 MHz
Reference, Synchronisation Signals					
RS boosting, $P_B = E_B/E_A$	1	1	1	1	1
Synchronisation signal EPRE / E_{RS} [dB]	0.000	0.000	0.000	0.000	0.000
Reserved EPRE / E_{RS} [dB]	-inf	-inf	-inf	-inf	-inf
PBCH					
PBCH EPRE / E_{RS} [dB]	0.000	0.000	0.000	0.000	0.000
Reserved EPRE / E_{RS} [dB]	-inf	-inf	-inf	-inf	-inf
PCFICH					
# of symbols used for control channels	1	1	1	1	1
PCFICH EPRE / E_{RS} [dB]	0	0	0	0	0
PHICH					
# of PHICH groups	1	1	2	2	3
# of PHICH per group	2	2	2	2	2
PHICH BPSK symbol power / E_{RS} [dB]	-3.010	-3.010	-3.010	-3.010	-3.010
PHICH group EPRE / E_{RS} [dB]	0	0	0	0	0
sPDCCH					
# of available sREGs	105	155	350	525	700
# of sPDCCH	1	1	1	1	1
# of sCCEs per sPDCCH	1	2	2	2	2
# of sREGs per CCE	4	4	4	4	4
# of sREGs allocated to sPDCCH	4	8	8	8	8
# of <NIL> sREGs added for padding	101	147	342	517	692
sPDCCH sREG EPRE / E_{RS} [dB]	0	0	0	0	0
<NIL> sREG EPRE / E_{RS} [dB]	-inf	-inf	-inf	-inf	-inf
sPDSCH					
# of 64QAM sPDSCH PRBs within a slot for which EVM is measured	1	1	1	1	1
PRB $P_A = E_A/E_{RS}$ [dB]	0	0	0	0	0
# of sPDSCH PRBs which are not allocated	14	24	49	74	99
PRB $P_A = E_A/E_{RS}$ [dB]	-inf	-inf	-inf	-inf	-inf

Table 6.1.1.3e-2: Numbers (n_{PRB}) of the allocated PRB (64QAM) (FDD)

Slot	Subframe 0		Subframe 1		Subframe 2		Subframe 3		Subframe 4		Subframe 5		Subframe 6		Subframe 7		Subframe 8		Subframe 9	
	0	1	0	1	0	1	0	1	0	1	0	1	0	1	0	1	0	1	0	1
3 MHz	13	11	13	5	9	14	6	13	0	1	13	11	13	5	9	14	6	13	0	1
5 MHz	8	17	21	8	22	2	9	14	0	13	8	17	21	8	22	2	9	14	0	13
10 MHz	16	36	19	26	42	30	17	48	9	0	16	36	19	26	42	30	17	48	9	0
15 MHz	32	46	18	72	22	4	31	58	27	3	32	46	18	72	22	4	31	58	27	3
20 MHz	63	34	44	7	94	2	97	19	56	32	63	34	44	7	94	2	97	19	56	32

Table 6.1.1.3e-3: Numbers (n_{PRB}) of the allocated PRB (64QAM) (TDD)

Frame1	Subframe 0		Subframe 1		Subframe 5		Subframe 6		Subframe 7		Subframe e 8		Subframe 9	
	0	1	0	1	0	1	0	1	0	1	0	1	0	1
Slot	0	1	0	1	0	1	0	1	0	1	0	1	0	1
3 MHz	10	14	12	5	0	1	7	10	14	12	5	0	1	7
5 MHz	17	24	21	8	1	2	12	17	24	21	8	1	2	12
10 MHz	35	49	42	17	2	4	25	35	49	42	17	2	4	25
15 MHz	53	74	63	26	3	6	38	53	74	63	26	3	6	38
20 MHz	71	99	85	35	4	8	51	71	99	85	35	4	8	51

Frame2	Subframe 0		Subframe 1		Subframe 5		Subframe 6		Subframe 7		Subframe e 8		Subframe 9	
	0	1	0	1	0	1	0	1	0	1	0	1	0	1
Slot	0	1	0	1	0	1	0	1	0	1	0	1	0	1
3 MHz	11	14	5	3	8	3	11	11	14	5	3	8	3	11
5 MHz	18	23	8	5	13	5	19	18	23	8	5	13	5	19
10 MHz	37	46	17	10	26	11	38	37	46	17	10	26	11	38
15 MHz	56	70	25	15	40	17	57	56	70	25	15	40	17	57
20 MHz	75	93	34	20	53	23	76	75	93	34	20	53	23	76

6.1.1.3f E-UTRA slot TTI Test Model 2a (sE-TM2a-2)

This model shall be used for slot TTI tests on:

- Total power dynamic range (lower OFDM symbol power limit at min power),
- EVM of single 256QAM PRB allocation (at min power)
- Frequency error (at min power)

Physical channel parameters and numbers of the allocated PRB are defined in Tables 6.1.1.3e-1, 6.1.1.3e-2, 6.1.1.3e-3, with all 64QAM sPDSCH PRBs replaced by 256QAM sPDSCH PRBs.

6.1.1.4 E-UTRA Test Model 3.1 (E-TM3.1)

This model shall be used for tests on:

- Output power dynamics
- Total power dynamic range (upper OFDM symbol power limit at max power with all 64QAM PRBs allocated)
- Transmitted signal quality
- Frequency error
- EVM for 64QAM modulation (at max power)

Table 6.1.1.4-1: Physical channel parameters of E-TM3.1

Parameter	1.4 MHz	3 MHz	5 MHz	10 MHz	15 MHz	20 MHz
Reference, Synchronisation Signals						
RS boosting, $P_B = E_B/E_A$	1	1	1	1	1	1
Synchronisation signal EPRE / E_{RS} [dB]	0.000	0.000	0.000	0.000	0.000	0.000
Reserved EPRE / E_{RS} [dB]	-inf	-inf	-inf	-inf	-inf	-inf
PBCH						
PBCH EPRE / E_{RS} [dB]	0.000	0.000	0.000	0.000	0.000	0.000
Reserved EPRE / E_{RS} [dB]	-inf	-inf	-inf	-inf	-inf	-inf
PCFICH						
# of symbols used for control channels	2	1	1	1	1	1
PCFICH EPRE / E_{RS} [dB]	3.222	0	0	0	0	0
PHICH						
# of PHICH groups	1	1	1	2	2	3
# of PHICH per group	2	2	2	2	2	2
PHICH BPSK symbol power / E_{RS} [dB]	-3.010	-3.010	-3.010	-3.010	-3.010	-3.010
PHICH group EPRE / E_{RS} [dB]	0	0	0	0	0	0
PDCCH						
# of available REGs	23	23	43	90	140	187
# of PDCCH	2	2	2	5	7	10
# of CCEs per PDCCH	1	1	2	2	2	2
# of REGs per CCE	9	9	9	9	9	9
# of REGs allocated to PDCCH	18	18	36	90	126	180
# of <NIL> REGs added for padding	5	5	7	0	14	7
PDCCH REG EPRE / E_{RS} [dB]	0.792	2.290	1.880	1.065	1.488	1.195
<NIL> REG EPRE / E_{RS} [dB]	-inf	-inf	-inf	-inf	-inf	-inf
PDSCH						
# of 64QAM PDSCH PRBs within a slot for which EVM is measured	6	15	25	50	75	100
PRB $P_A = E_A/E_{RS}$ [dB]	0	0	0	0	0	0
# of PDSCH PRBs within a slot for which EVM is not measured (used for power balancing only)	0	0	0	0	0	0
PRB $P_A = E_A/E_{RS}$ [dB]	n.a.	n.a.	n.a.	n.a.	n.a.	n.a.

6.1.1.4a E-UTRA Test Model 3.1a (E-TM3.1a)

This model shall be used for tests on:

- Output power dynamics
 - Total power dynamic range (upper OFDM symbol power limit at max power with all 256QAM PRBs allocated)
- Transmitted signal quality
 - Frequency error
 - EVM for 256QAM modulation (at max power)

Physical channel parameters are defined in Table 6.1.1.4-1, with all 64QAM PDSCH PRBs replaced by 256QAM PDSCH PRBs.

6.1.1.4b E-UTRA Test Model 3.1b (E-TM3.1b)

This model shall be used for tests on:

- Output power dynamics

- Total power dynamic range (upper OFDM symbol power limit at max power with all 1024QAM PRBs allocated)
- Transmitted signal quality
 - Frequency error
 - EVM for 1024QAM modulation (at max power)

Physical channel parameters are defined in Table 6.1.1.4-1, with all 64QAM PDSCH PRBs replaced by 1024QAM PDSCH PRBs.

6.1.1.4c E-UTRA subslot TTI Test Model 3.1 (sE-TM3.1-1)

This model shall be used for subslot TTI tests on:

- Output power dynamics
 - Total power dynamic range (upper OFDM symbol power limit at max power with all 64QAM PRBs allocated)
- Transmitted signal quality
 - Frequency error
 - EVM for 64QAM modulation (at max power)

Table 6.1.1.4c-1: Physical channel parameters of sE-TM3.1-1

Parameter	3 MHz	5 MHz	10 MHz	15 MHz	20 MHz
Reference, Synchronisation Signals					
RS boosting, $P_B = E_B/E_A$	1	1	1	1	1
Synchronisation signal EPRE / E_{RS} [dB]	0.000	0.000	0.000	0.000	0.000
Reserved EPRE / E_{RS} [dB]	-inf	-inf	-inf	-inf	-inf
PBCH					
PBCH EPRE / E_{RS} [dB]	0.000	0.000	0.000	0.000	0.000
Reserved EPRE / E_{RS} [dB]	-inf	-inf	-inf	-inf	-inf
PCFICH					
# of symbols used for control channels	1	1	1	1	1
PCFICH EPRE / E_{RS} [dB]	0	0	0	0	0
PHICH					
# of PHICH groups	1	1	2	2	3
# of PHICH per group	2	2	2	2	2
PHICH BPSK symbol power / E_{RS} [dB]	-3.010	-3.010	-3.010	-3.010	-3.010
PHICH group EPRE / E_{RS} [dB]	0	0	0	0	0
sPDCCH					
# of available sREGs	30 (2OS) 45 (3OS)	50 (2OS) 75 (3OS)	100 (2OS) 150 (3OS)	150 (2OS) 225 (3OS)	200 (2OS) 300 (3OS)
# of sPDCCH	2	2	5	7	10
# of sCCEs per sPDCCH	1	2	2	2	2
# of sREGs per CCE	4 (2OS) 6 (3OS)	4 (2OS) 6 (3OS)	4 (2OS) 6 (3OS)	4 (2OS) 6 (3OS)	4 (2OS) 6 (3OS)
# of sREGs allocated to sPDCCH	8 (2OS) 12 (3OS)	16 (2OS) 24 (3OS)	40 (2OS) 60 (3OS)	56 (2OS) 84 (3OS)	80 (2OS) 120 (3OS)
# of <NIL> sREGs added for padding	22 (2OS) 33 (3OS)	34 (2OS) 51 (3OS)	60 (2OS) 90 (3OS)	94 (2OS) 161 (3OS)	120 (2OS) 180 (3OS)
sPDCCH sREG EPRE / E_{RS} [dB]	2.290	1.880	1.065	1.488	1.195
<NIL> sREG EPRE / E_{RS} [dB]	-inf	-inf	-inf	-inf	-inf
sPDSCH					
# of 64QAM sPDSCH PRBs within a subslot for which EVM is measured	15	25	50	75	100
PRB $P_A = E_A/E_{RS}$ [dB]	0	0	0	0	0
# of sPDSCH PRBs within a subslot for which EVM is not measured (used for power balancing only)	0	0	0	0	0
PRB $P_A = E_A/E_{RS}$ [dB]	n.a.	n.a.	n.a.	n.a.	n.a.

6.1.1.4d E-UTRA subslot TTI Test Model 3.1a (sE-TM3.1a-1)

This model shall be used for subslot TTI tests on:

- Output power dynamics
 - Total power dynamic range (upper OFDM symbol power limit at max power with all 256QAM PRBs allocated)
- Transmitted signal quality
 - Frequency error
 - EVM for 256QAM modulation (at max power)

Physical channel parameters are defined in Table 6.1.1.4c-1, with all 64QAM PDSCH PRBs replaced by 256QAM PDSCH PRBs.

6.1.1.4e E-UTRA slot TTI Test Model 3.1 (sE-TM3.1-2)

This model shall be used for slot TTI tests on:

- Output power dynamics
 - Total power dynamic range (upper OFDM symbol power limit at max power with all 64QAM PRBs allocated)
- Transmitted signal quality
 - Frequency error
 - EVM for 64QAM modulation (at max power)

Table 6.1.1.4e-1: Physical channel parameters of sE-TM3.1-2

Parameter	3 MHz	5 MHz	10 MHz	15 MHz	20 MHz
Reference, Synchronisation Signals					
RS boosting, $P_B = E_B/E_A$	1	1	1	1	1
Synchronisation signal EPRE / E_{RS} [dB]	0.000	0.000	0.000	0.000	0.000
Reserved EPRE / E_{RS} [dB]	-inf	-inf	-inf	-inf	-inf
PBCH					
PBCH EPRE / E_{RS} [dB]	0.000	0.000	0.000	0.000	0.000
Reserved EPRE / E_{RS} [dB]	-inf	-inf	-inf	-inf	-inf
PCFICH					
# of symbols used for control channels	1	1	1	1	1
PCFICH EPRE / E_{RS} [dB]	0	0	0	0	0
PHICH					
# of PHICH groups	1	1	2	2	3
# of PHICH per group	2	2	2	2	2
PHICH BPSK symbol power / E_{RS} [dB]	-3.010	-3.010	-3.010	-3.010	-3.010
PHICH group EPRE / E_{RS} [dB]	0	0	0	0	0
sPDCCH					
# of available sREGs	105	155	350	525	700
# of sPDCCH	2	2	5	7	10
# of sCCEs per sPDCCH	1	2	2	2	2
# of sREGs per sCCE	4	4	4	4	4
# of sREGs allocated to sPDCCH	8	16	40	56	80
# of <NIL> sREGs added for padding	97	139	310	469	620
sPDCCH sREG EPRE / E_{RS} [dB]	2.290	1.880	1.065	1.488	1.195
<NIL> sREG EPRE / E_{RS} [dB]	-inf	-inf	-inf	-inf	-inf
sPDSCH					
# of 64QAM PDSCH sPRBs within a subslot for which EVM is measured	15	25	50	75	100
PRB $P_A = E_A/E_{RS}$ [dB]	0	0	0	0	0
# of sPDSCH PRBs within a subslot for which EVM is not measured (used for power balancing only)	0	0	0	0	0
PRB $P_A = E_A/E_{RS}$ [dB]	n.a.	n.a.	n.a.	n.a.	n.a.

6.1.1.4f E-UTRA slot TTI Test Model 3.1a (sE-TM3.1a-2)

This model shall be used for slot TTI tests on:

- Output power dynamics
 - Total power dynamic range (upper OFDM symbol power limit at max power with all 256QAM PRBs allocated)

- Transmitted signal quality
- Frequency error
- EVM for 256QAM modulation (at max power)

Physical channel parameters are defined in Table 6.1.1.4e-1, with all 64QAM PDSCH PRBs replaced by 256QAM PDSCH PRBs.

6.1.1.5 E-UTRA Test Model 3.2 (E-TM3.2)

This model shall be used for tests on:

- Transmitted signal quality
- Frequency error
- EVM for 16QAM modulation

Table 6.1.1.5-1: Physical channel parameters of E-TM3.2

Parameter	1.4 MHz	3 MHz	5 MHz	10 MHz	15 MHz	20 MHz
Reference, Synchronisation Signals						
RS boosting, $P_B = E_B/E_A$	1	1	1	1	1	1
Synchronisation signal EPRE / E_{RS} [dB]	0.000	1.573	2.426	2.426	3.005	2.426
Reserved EPRE / E_{RS} [dB]	-inf	-inf	-inf	-inf	-inf	-inf
PBCH						
PBCH EPRE / E_{RS} [dB]	0.000	1.573	2.426	2.426	3.005	2.426
Reserved EPRE / E_{RS} [dB]	-inf	-inf	-inf	-inf	-inf	-inf
PCFICH						
# of symbols used for control channels	2	1	1	1	1	1
PCFICH EPRE / E_{RS} [dB]	3.222	0	0	0	0	0
PHICH						
# of PHICH groups	1	1	1	2	2	3
# of PHICH per group	2	2	2	2	2	2
PHICH BPSK symbol power / E_{RS} [dB]	-3.010	-3.010	-3.010	-3.010	-3.010	-3.010
PHICH group EPRE / E_{RS} [dB]	0	0	0	0	0	0
PDCCH						
# of available REGs	23	23	43	90	140	187
# of PDCCH	2	2	2	5	7	10
# of CCEs per PDCCH	1	1	2	2	2	2
# of REGs per CCE	9	9	9	9	9	9
# of REGs allocated to PDCCH	18	18	36	90	126	180
# of <NIL> REGs added for padding	5	5	7	0	14	7
PDCCH REG EPRE / E_{RS} [dB]	0.792	2.290	1.880	1.065	1.488	1.195
<NIL> REG EPRE / E_{RS} [dB]	-inf	-inf	-inf	-inf	-inf	-inf
PDSCH						
# of 16QAM PDSCH PRBs within a slot for which EVM is measured	4	7	15	30	50	60
PRB $P_A = E_A/E_{RS}$ [dB]	-3 (Note 1)	-3	-3	-3	-3	-3
# of QPSK PDSCH PRBs within a slot for which EVM is not measured (used for power balancing only)	2	8	10	20	25	40
PRB $P_A = E_A/E_{RS}$ [dB]	3.005 (Note 1)	1.573	2.426	2.426	3.005	2.426
Note 1: In subframes containing PBCH or synchronisation signal REs, no PRB boosting/deboosting shall be applied, i.e. $PRB P_A = E_A/E_{RS} = 0$ [dB].						

Table 6.1.1.5-2: Numbers (n_{PRB}) of the 16QAM PRBs (FDD)

	Subframe e 0	Subframe e 1	Subframe e 2	Subframe e 3	Subframe e 4	Subframe e 5	Subframe e 6	Subframe e 7	Subframe e 8	Subframe e 9
1.4 MHz	1 3 4 5	1 2 3 5	0 1 3 4	1 2 3 5	0 2 3 5	0 1 2 4	0 1 2 5	0 2 4 5	1 2 3 5	0 1 3 5
3 MHz	0 1 2 3 11 12 13	0 3 4 10 11 12 13	0 2 3 5 6 11 13	0 1 4 5 7 10 12	0 2 3 4 9 10 13	0 1 2 3 11 12 14	4 5 6 8 11 13 14	2 5 6 9 12 13 14	0 3 4 7 8 9 11	1 2 3 4 5 11 12
5 MHz	0 1 3 4 6 7 8 16 17 18 19 20 21 23 24	0 1 2 3 4 5 6 9 10 12 13 17 18 20 24	0 1 2 3 7 8 9 10 12 13 14 19 20 23 24	0 5 6 8 10 11 12 13 15 17 18 20 21 22 24	0 1 2 4 6 7 12 13 14 15 16 17 22 23 24	0 1 2 3 4 6 7 8 16 17 18 21 22 23 24	1 3 4 5 7 9 10 11 12 13 14 15 21 22 24	0 1 2 3 4 7 8 10 13 14 18 19 20 21 24	1 4 8 9 10 11 12 13 15 16 18 20 22 23 24	1 2 3 4 5 6 9 10 11 12 13 16 17 21 23
10 MHz	1 2 3 4 5 6 7 8 9 10 11 15 16 17 20 21 28 30 31 32 33 35 36 39 40 42 44 46 47 48	0 1 2 4 5 6 7 9 10 11 13 15 18 20 21 22 24 25 27 28 29 34 35 36 37 40 43 44 46 49	0 1 3 4 5 6 7 11 12 14 17 18 19 20 21 22 24 25 26 27 28 29 31 32 34 38 41 42 45 49	0 1 2 3 5 6 8 12 14 15 16 17 18 22 23 26 28 29 30 32 34 35 38 39 40 41 42 45 46 47	0 3 6 7 8 9 10 12 13 15 16 17 18 21 23 25 28 31 33 37 38 39 41 42 44 45 46 47 48 49	0 2 3 4 5 7 9 10 11 12 13 14 15 19 20 28 29 30 31 34 36 37 38 39 40 42 44 45 48 49	0 1 3 4 5 6 8 9 10 12 13 14 13 14 16 17 18 19 20 21 23 24 29 30 31 32 35 37 38 39 40 47 48	0 1 2 3 4 5 6 7 9 10 12 14 16 17 18 19 22 24 25 26 27 28 30 31 32 34 37 42 45 48	2 5 7 8 9 10 11 14 15 16 17 21 22 27 28 29 30 31 32 34 35 37 38 41 42 43 44 46 48 49	1 3 6 9 11 13 15 16 17 18 21 24 25 26 27 28 29 30 32 34 37 38 39 40 41 42 45 47 48 49
15 MHz	0 1 2 3 5 6 7 8 9 12 14 16 17 18 19 20 21 23 24 25 26 28 29 30 31 32 33 41 42 45 47 48 49 50 52 53 56 57 60 62 63 64 65 67 68 69 70 71 72 73	0 1 2 3 4 5 6 7 8 11 18 20 21 24 25 26 27 29 30 31 33 36 37 38 39 40 43 45 46 47 48 49 50 51 53 54 55 57 58 59 60 61 65 67 68 69 70 71 73 74	1 2 3 4 9 11 12 13 14 15 17 18 20 21 22 24 25 26 28 29 31 32 33 34 40 42 43 44 45 46 47 48 48 49 55 54 56 58 59 60 61 62 63 64 68 70 71 72 73 74	2 3 4 6 7 9 11 12 14 15 17 18 20 22 24 25 27 28 29 30 31 33 34 35 38 39 40 42 43 45 46 47 48 49 55 56 59 60 61 62 63 65 66 67 68 69 70 71 73 74	2 4 5 6 8 10 13 15 16 17 18 20 22 24 25 26 27 28 29 30 31 32 33 34 35 38 40 41 44 45 46 47 48 50 51 52 53 54 56 59 60 63 64 67 69 70 71 72 73 74	0 2 3 4 5 7 8 11 12 14 16 18 20 22 23 24 25 27 28 29 30 31 33 42 43 45 46 50 51 53 54 56 58 60 61 62 66 67 68 69 70 71 72 73	0 1 2 3 9 11 12 14 15 17 18 20 23 25 26 28 29 30 31 32 33 36 37 38 39 41 42 43 45 46 50 52 53 54 57 58 59 60 64 65 67 68 70 71 72 73 74	0 1 3 4 5 6 7 8 11 12 14 19 20 21 23 24 26 27 28 30 31 33 34 35 38 40 41 42 44 45 46 49 51 52 53 54 55 58 59 60 61 62 63 65 67 69 70 71 72 73	0 1 2 3 7 8 9 10 12 13 14 15 17 18 19 21 22 23 24 25 26 27 28 29 32 33 34 36 37 39 40 43 46 47 48 49 50 53 54 56 61 62 63 66 68 69 71 72 73 74	0 1 3 7 8 11 13 14 16 18 19 20 21 22 23 25 27 28 29 30 32 34 35 36 40 41 42 43 44 45 46 47 48 50 51 53 54 55 57 59 61 62 63 64 66 67 68 69 70 71
20 MHz	0 1 4 6 7 8 9 10 11 13 14 15 16 20 21 22 23 25 26 28 29 30 31 32 33 34 36 39 41 42 44 45 54 56 57 58 60 61 63 66 67 68 72 75 76 77 79 81 82 84 85 87 88 91 92 94 95 97 98 99	1 3 5 6 7 9 10 13 17 19 20 21 22 23 24 25 26 27 28 30 32 33 34 35 36 39 41 47 48 49 50 51 53 54 55 57 58 59 60 61 64 65 67 68 75 76 77 79 80 81 83 84 86 87 89 90 91 93 95 99	0 1 2 3 6 8 10 11 15 16 17 19 21 22 23 25 26 28 29 30 32 33 35 38 39 40 41 42 43 44 46 49 51 52 53 54 57 59 60 62 63 64 65 67 69 71 72 73 76 79 81 84 86 88 89 90 92 93 94 99	5 6 7 9 10 12 14 15 16 17 24 27 28 29 30 31 33 34 35 36 37 39 41 44 45 47 49 50 53 54 55 56 57 59 64 65 66 68 70 72 75 76 77 80 81 84 85 86 87 90 91 92 94 95 97 98 99	0 2 3 4 5 6 7 11 12 14 15 17 19 21 22 24 26 32 36 37 40 42 43 44 47 48 49 50 51 54 56 57 60 62 63 65 66 67 70 71 73 76 77 78 79 81 82 83 84 85 86 87 89 91 94 95 96 97 98 99	1 2 5 6 8 9 11 12 13 15 21 22 25 26 27 28 29 30 31 32 34 35 38 39 40 41 43 44 45 46 53 57 58 59 61 62 63 64 65 66 68 69 71 72 73 75 77 78 80 82 83 84 85 86 93 94 95 96 97 99	0 1 2 3 5 8 9 10 12 13 14 16 22 25 26 27 28 29 31 32 33 34 36 37 38 39 43 44 45 46 48 49 52 53 55 59 61 62 63 64 70 71 72 73 74 75 77 78 80 81 82 84 86 89 86 92 93 97 98 99	0 1 3 4 5 7 8 10 11 15 18 19 20 21 26 27 29 30 31 33 35 37 38 39 40 41 43 44 45 46 47 48 49 50 52 53 55 56 58 60 62 64 65 66 67 69 70 71 72 73 74 81 83 84 86 92 93 94 96 98 99	2 3 4 5 7 9 11 13 15 16 17 21 23 24 25 27 28 29 31 33 35 36 40 42 43 44 45 46 48 49 51 52 53 54 55 56 57 59 61 63 64 65 68 71 76 77 78 81 82 83 84 85 86 87 90 91 93 94 98 99	0 3 4 6 7 8 10 11 13 16 18 21 22 23 25 26 28 29 32 35 36 37 38 43 44 46 47 48 49 53 54 57 58 59 60 61 64 66 67 68 69 70 72 76 77 78 80 81 82 83 84 86 87 88 89 91 92 94 95 96

	21 23 24 25 26 27 28 31 32 33 41 43 44 45 46 47 48 50 52 53 55 57 58 59 61 63 65 66 67 68 69 71 74	21 22 23 27 28 29 30 33 42 43 45 46 47 49 50 51 54 55 56 58 59 60 61 64 65 66 68 69 70 71 72 73 74	20 22 24 25 26 27 28 31 32 33 34 35 36 37 38 40 42 43 44 45 46 47 48 50 51 52 55 56 59 60 61 66 67 69 74	20 22 24 25 26 29 32 33 44 45 46 49 50 51 52 55 56 57 58 59 60 61 63 64 65 66 68 69 70 71 72 73 74	19 20 22 24 25 27 28 30 31 32 41 42 43 44 45 46 48 49 50 51 52 55 58 61 62 63 65 66 67 68 69 70 71 73 74	25 27 28 29 30 31 33 34 35 36 37 39 40 43 45 46 47 48 49 50 52 54 55 56 58 61 62 63 64 66 67 68 69 71 73
20 MHz	0 1 2 3 4 5 7 8 9 10 11 15 17 19 20 21 24 26 27 28 29 31 32 33 34 36 37 44 45 44 53 56 57 59 60 61 63 65 67 68 69 70 73 77 79 83 85 86 87 88 89 90 91 92 93 94 95 96 98 99	0 2 3 4 7 8 10 11 12 13 14 15 16 17 18 19 20 22 24 25 27 30 35 37 39 41 42 44 53 56 57 59 61 62 63 66 67 69 70 73 74 75 76 77 78 79 80 81 82 84 85 86 88 89 90 91 92 94 96 98	0 2 4 5 6 7 11 12 13 14 16 17 18 19 20 21 23 27 28 30 31 32 35 37 38 40 43 44 45 46 47 50 51 53 56 57 58 59 60 61 62 63 64 65 68 70 71 73 77 79 80 82 85 87 89 92 95 96 97 98	0 1 2 4 5 6 7 10 11 12 13 14 15 16 18 19 20 21 23 24 25 29 32 33 34 40 42 43 44 45 46 53 54 55 57 59 60 61 62 63 67 68 71 72 73 75 77 81 82 84 85 87 91 92 93 95 96 97 98 99	2 4 5 8 9 10 11 12 13 14 16 17 18 19 22 24 25 26 27 29 30 32 33 36 37 38 40 41 42 43 45 46 53 54 55 57 58 60 62 64 65 66 67 68 69 74 78 82 83 84 86 88 89 90 91 92 93 95 97 99	3 4 6 7 9 10 11 12 13 14 15 17 19 22 23 25 26 27 33 34 37 39 40 41 43 45 46 47 48 49 50 53 55 56 58 60 61 62 63 65 69 71 72 73 74 76 77 78 79 80 82 83 85 87 91 92 94 95 96 99

Frame 3	Subframe 0	Subframe 1	Subframe 4	Subframe 5	Subframe 6	Subframe 9
3 MHz	2 4 7 8 9 10 11	0 1 2 3 11 12 13	0 1 3 4 5 13 14	0 1 2 3 11 12 13	0 1 2 3 11 12 13	0 1 2 11 12 13 14
5 MHz	0 1 3 6 7 9 12 14 17 18 20 21 22 23 24	0 2 3 4 5 6 7 8 17 18 19 20 21 22 24	2 3 4 5 6 7 9 11 12 14 15 17 18 21 24	1 2 3 4 5 6 7 8 16 17 20 21 22 23 24	0 2 3 4 5 6 7 8 17 18 19 20 21 22 24	0 1 3 4 5 7 8 16 17 18 19 20 21 22 24
10 MHz	1 2 3 5 6 13 14 15 16 17 19 20 23 25 26 27 29 30 31 32 33 35 38 39 40 41 43 44 47 49	2 3 4 5 6 7 8 9 10 11 12 13 14 16 17 18 19 21 30 32 34 35 36 37 39 40 41 43 45 48	0 1 2 5 9 12 13 14 16 17 18 22 25 26 27 28 29 30 31 33 35 36 38 39 41 42 44 45 47 49	1 4 5 6 7 8 11 12 13 14 15 17 19 20 21 28 29 30 31 32 34 37 38 41 42 44 46 47 48 49	2 3 4 5 6 7 8 9 10 11 12 13 14 16 17 18 19 21 30 32 34 35 36 37 39 40 41 43 45 48	1 2 3 4 5 6 8 9 10 11 12 13 15 16 17 18 19 21 30 35 38 39 40 41 42 43 46 47 48 49
15 MHz	1 3 4 5 6 7 9 10 11 12 14 15 16 17 18 19 20 21 22 24 26 29 30 32 33 34 35 36 38 39 41 42 44 45 47 48 49 50 52 55 56 57 61 62 63 69 70 71 73 74	2 3 4 6 7 8 9 10 11 12 13 14 15 16 18 19 20 22 24 25 27 28 30 31 32 41 42 43 44 45 46 48 49 50 51 52 55 58 61 62 63 65 66 67 68 69 70 71 73 74	1 3 4 6 7 8 10 11 13 14 15 21 22 23 24 26 27 28 29 30 31 32 35 39 40 43 44 45 46 47 48 49 50 51 52 53 54 55 56 57 58 59 60 63 64 65 66 68 71 74	3 7 8 9 10 11 12 13 14 15 16 17 22 23 24 27 28 29 30 31 32 41 42 43 45 46 48 49 50 53 54 55 56 57 58 60 61 62 63 64 65 66 67 68 69 70 71 72 73 74	2 3 4 6 7 8 9 10 11 12 13 14 15 16 18 19 20 22 24 25 27 28 30 31 32 41 42 43 44 45 46 48 49 50 51 52 55 58 61 62 63 65 66 67 68 69 70 71 73 74	0 1 2 3 4 5 6 7 8 9 10 11 13 14 15 16 17 18 19 21 23 24 26 29 30 33 41 42 45 46 47 49 50 51 53 54 55 56 57 58 60 62 63 66 67 69 71 72 73 74
20 MHz	0 1 2 4 6 8 9 10 11 14 15 18 19 20 21 25 29 31 32 34 36 37 38 40 41 42 47 52 53 54 57 58 59 60 62 63 64 65 67 68 69 70 71 73 74 75 76 77 78 79 80 84 85 86 87 88 90 92 95 99	2 4 5 8 9 10 11 12 13 14 16 17 18 19 22 24 25 26 27 29 30 32 33 36 37 38 40 41 42 43 45 46 53 54 55 57 58 60 62 64 65 66 67 68 69 74 78 82 83 84 86 88 89 90 91 92 93 95 97 99	0 1 2 3 7 8 9 13 15 16 21 23 24 25 29 30 31 33 34 36 37 38 39 40 41 42 44 45 46 47 48 49 52 53 57 60 62 63 64 65 66 69 72 73 74 75 77 81 82 83 84 86 88 89 90 91 92 93 95 97	1 4 9 10 12 13 14 15 17 18 19 20 21 22 23 29 30 31 32 33 36 37 39 40 41 42 43 46 53 54 55 56 57 58 60 61 64 66 68 69 71 72 73 74 75 80 82 83 84 86 87 89 90 92 93 94 95 96 98 99	2 4 5 8 9 10 11 12 13 14 16 17 18 19 22 24 25 26 27 29 30 32 33 36 37 38 40 41 42 43 45 46 53 54 55 57 58 60 62 64 65 66 67 68 69 74 78 82 83 84 86 88 89 90 91 92 93 95 97 99	0 1 2 3 4 6 7 8 9 12 13 15 16 18 19 20 22 24 25 27 28 29 30 32 35 39 40 42 43 44 57 59 60 61 63 64 65 66 67 68 69 70 72 73 74 75 76 81 82 83 84 88 89 90 92 94 95 97 98 99

6.1.1.5a E-UTRA subslot TTI Test Model 3.2 (sE-TM3.2-1)

This model shall be used for subslot TTI tests on:

- Transmitted signal quality

- Frequency error
- EVM for 16QAM modulation

Table 6.1.1.5a-1: Physical channel parameters of sE-TM3.2-1

Parameter	3 MHz	5 MHz	10 MHz	15 MHz	20 MHz
Reference, Synchronisation Signals					
RS boosting, $P_B = E_B/E_A$	1	1	1	1	1
Synchronisation signal EPRE / E_{RS} [dB]	1.573	2.426	2.426	3.005	2.426
Reserved EPRE / E_{RS} [dB]	-inf	-inf	-inf	-inf	-inf
PBCH					
PBCH EPRE / E_{RS} [dB]	1.573	2.426	2.426	3.005	2.426
Reserved EPRE / E_{RS} [dB]	-inf	-inf	-inf	-inf	-inf
PCFICH					
# of symbols used for control channels	1	1	1	1	1
PCFICH EPRE / E_{RS} [dB]	0	0	0	0	0
PHICH					
# of PHICH groups	1	1	2	2	3
# of PHICH per group	2	2	2	2	2
PHICH BPSK symbol power / E_{RS} [dB]	-3.010	-3.010	-3.010	-3.010	-3.010
PHICH group EPRE / E_{RS} [dB]	0	0	0	0	0
sPDCCH					
# of available sREGs	30 (2OS) 45 (3OS)	50 (2OS) 75 (3OS)	100 (2OS) 150 (3OS)	150 (2OS) 225 (3OS)	200 (2OS) 300 (3OS)
# of sPDCCH	2	2	5	7	10
# of sCCEs per sPDCCH	1	2	2	2	2
# of sREGs per sCCE	4 (2OS) 6 (3OS)	4 (2OS) 6 (3OS)	4 (2OS) 6 (3OS)	4 (2OS) 6 (3OS)	4 (2OS) 6 (3OS)
# of sREGs allocated to sPDCCH	8 (2OS) 12 (3OS)	16 (2OS) 24 (3OS)	40 (2OS) 60 (3OS)	56 (2OS) 84 (3OS)	80 (2OS) 120 (3OS)
# of <NIL> sREGs added for padding	22 (2OS) 33 (3OS)	34 (2OS) 51 (3OS)	60 (2OS) 90 (3OS)	94 (2OS) 161 (3OS)	120 (2OS) 180 (3OS)
sPDCCH sREG EPRE / E_{RS} [dB]	2.290	1.880	1.065	1.488	1.195
<NIL> sREG EPRE / E_{RS} [dB]	-inf	-inf	-inf	-inf	-inf
sPDSCH					
# of 16QAM sPDSCH PRBs within a subslot for which EVM is measured	7	15	30	50	60
PRB $P_A = E_A/E_{RS}$ [dB]	-3	-3	-3	-3	-3
# of QPSK sPDSCH PRBs within a subslot for which EVM is not measured (used for power balancing only)	8	10	20	25	40
PRB $P_A = E_A/E_{RS}$ [dB]	1.573	2.426	2.426	3.005	2.426
NOTE 1: In subframes containing PBCH or synchronisation signal REs, no PRB boosting/deboosting shall be applied, i.e. PRB $P_A = E_A/E_{RS} = 0$ [dB].					

Table 6.1.1.5a-2: Numbers (n_{PRB}) of the 16QAM PRBs (FDD)

	Subframe 0						Subframe 1					
Subslot	0	1	2	3	4	5	0	1	2	3	4	5
3 MH z	0 1 2 3 11 12 13	0 3 4 10 11 12 13	0 2 3 5 6 11 13	0 1 4 5 7 10 12	0 2 3 4 9 10 13	0 1 2 3 11 12 14	4 5 6 8 11 13 14	2 5 6 9 12 13 14	0 3 4 7 8 9 11	1 2 3 4 5 11 12	0 1 2 3 11 12 13	0 3 4 10 11 12 13
5 MH z	0 1 3 4 6 7 8 16 17 18 19 20 21 23 24	0 1 2 3 4 5 6 9 10 12 13 17 18 20 24	0 1 2 3 7 8 9 10 12 13 14 19 20 23 24	0 5 6 8 10 11 12 13 15 17 18 20 21 22 24	0 1 2 4 6 7 12 13 14 15 16 17 22 23 24	0 1 2 3 4 6 7 8 16 17 18 21 22 23 24	1 3 4 5 7 9 10 11 12 13 14 15 21 22 24	0 1 2 3 4 7 8 10 13 14 18 19 20 21 24	1 4 8 9 10 11 12 13 15 16 18 20 22 23 24	1 2 3 4 5 6 9 10 11 12 13 16 17 21 23	0 1 3 4 6 7 8 16 17 18 19 20 21 23 24	0 1 2 3 4 5 6 9 10 12 13 17 18 20 24
10 MH z	1 2 3 4 5 6 7 8 9 10 11 15 16 17 20 21 28 30 31 32 33 35 36 39 40 42 44 46 47 48	0 1 2 4 5 6 7 9 10 11 13 15 18 20 21 22 24 25 27 28 29 34 35 36 37 40 43 44 46 49	0 1 3 4 5 6 7 11 12 14 17 18 19 20 21 22 24 25 26 27 28 29 31 32 34 35 38 39 41 42 44 43 45 49	0 1 2 3 5 6 8 12 14 15 16 17 18 22 23 26 28 29 30 32 34 35 38 39 40 41 42 45 46 47	0 3 6 7 8 9 10 12 13 15 16 17 18 21 23 25 28 31 33 37 38 39 41 42 44 45 46 47 48 49	0 2 3 4 5 7 9 10 11 12 13 14 15 19 20 28 29 30 31 34 36 37 38 39 40 42 44 45 48 49	0 1 3 4 5 6 8 9 10 13 14 16 17 18 19 20 21 23 24 29 30 31 32 35 37 38 39 40 42 44 47 48	0 1 2 3 4 5 6 7 9 10 12 14 16 17 18 19 22 24 25 26 27 28 30 31 32 34 37 41 42 42 45 48	2 5 7 8 9 10 11 14 15 16 17 21 22 27 28 29 30 31 32 34 35 37 38 41 42 43 44 46 48 49	1 3 6 9 11 13 15 16 17 18 21 24 25 26 27 28 29 30 32 34 37 38 39 40 41 42 45 47 48 49	1 2 3 4 5 6 7 8 9 10 11 15 16 17 20 21 28 30 31 32 33 35 36 39 40 42 44 46 47 48	0 1 2 4 5 6 7 9 10 11 13 15 18 20 21 22 24 25 27 28 29 30 32 33 35 36 39 40 42 44 43 44 46 49
15 MH z	0 1 2 3 5 6 7 8 9 12 14 16 17 18 19 20 21 23 24 25 26 28 29 30 31 32 33 41 42 45 47 48 49 50 52 53 56 57 60 62 63 64 65 67 68 69 70 71 72 73	0 1 2 3 4 5 6 7 8 11 18 20 21 24 25 26 27 29 30 31 33 36 37 38 39 40 43 45 46 47 48 49 50 51 53 54 55 57 58 59 60 61 65 67 68 69 70 71 73 74	1 2 3 4 9 11 12 13 14 15 17 18 20 21 22 24 25 26 28 29 31 32 33 34 40 42 43 44 45 46 47 48 50 51 52 54 56 58 59 60 61 62 63 64 68 70 71 72 73 74	2 3 4 6 7 9 11 12 14 15 17 18 20 22 24 25 27 28 29 30 31 33 34 35 38 39 40 42 43 45 46 47 48 49 50 51 53 54 55 56 59 60 61 62 63 65 66 67 68 69 70 71 73 74	2 4 5 6 8 10 13 15 16 17 18 20 22 24 25 26 27 28 29 30 31 32 33 34 35 38 40 41 44 45 46 47 48 49 50 51 53 50 51 52 53 54 56 58 60 54 56 63 64 65 66 67 69 70 71 72 73 74	0 2 3 4 5 7 8 11 12 14 16 17 18 18 20 22 23 24 25 27 28 29 30 31 33 42 43 45 46 47 48 49 50 51 53 54 56 58 60 61 62 63 64 65 66 67 68 69 70 71 72 73	0 1 2 3 9 11 12 14 15 17 18 20 23 25 26 28 29 30 31 32 33 36 37 38 39 42 43 43 45 46 50 52 53 54 57 58 59 60 61 62 63 63 65 67 68 70 71 72 73 74	0 1 3 4 5 6 7 8 11 12 14 19 20 21 23 24 26 27 28 30 31 33 34 35 38 40 41 42 44 45 46 49 51 52 53 54 55 58 59 60 61 62 63 65 66 69 70 71 72 73	0 1 2 3 7 8 9 10 12 13 14 15 17 18 19 21 22 23 24 28 30 31 33 35 36 39 40 43 46 47 48 49 50 53 54 55 57 56 61 62 63 66 68 69 70 72 73 74	0 1 3 7 8 11 13 14 16 18 19 20 21 22 23 25 27 28 29 30 32 34 35 36 40 33 34 43 44 45 46 47 48 50 51 53 54 55 57 59 61 62 63 64 66 67 68 71	0 1 2 3 5 6 7 8 9 12 14 16 17 18 19 20 21 23 24 25 26 28 29 30 31 32 33 41 42 45 47 48 49 50 52 53 56 57 60 62 63 64 65 67 68 69 70 71 72 73	0 1 2 3 4 5 6 7 8 11 18 16 17 18 19 20 21 23 24 25 26 28 29 30 31 32 33 41 42 45 47 48 49 50 52 53 56 57 58 62 63 64 65 67 68 69 70 71 73 74

20	0 1 4 6	1 3 5 6	0 1 2 3	5 6 7 9	0 2 3 4	1 2 5 6	0 1 2 3	0 1 3 4	2 3 4 5	0 3 4 6	0 1 4 6	1 3 5 6
MH	7 8 9	7 9 10	6 8 10	10 12	5 6 7	8 9 11	5 8 9	5 7 8	7 9 11	7 8 10	7 8 9	7 9 10
z	10 11	13 17	11 15	14 15	11 12	12 13	10 12	10 11	13 15	11 13	10 11	13 17
	13 14	19 20	16 17	16 17	14 15	15 21	13 14	15 18	16 17	16 18	13 14	19 20
	15 16	21 22	19 21	21 22	17 19	22 25	16 22	19 20	21 23	21 22	15 16	21 22
	20 21	23 24	22 23	23 24	21 22	26 27	25 26	21 26	24 25	23 25	20 21	23 24
	22 23	25 26	25 26	27 28	24 26	28 29	27 28	27 29	27 28	26 28	22 23	25 26
	25 26	27 28	28 29	29 30	32 36	30 31	29 31	30 31	29 31	29 32	25 26	27 28
	28 29	30 32	30 32	31 33	37 40	32 34	32 33	33 35	33 35	35 36	28 29	30 32
	30 31	33 34	33 35	34 35	42 43	35 38	34 36	37 38	36 40	37 38	30 31	33 34
	32 33	35 36	38 39	36 37	44 47	39 40	37 38	39 40	42 43	43 44	32 33	35 36
	34 36	39 41	40 41	39 41	48 49	41 43	39 43	41 43	44 45	46 47	34 36	39 41
	39 41	47 48	42 43	44 45	50 51	44 45	44 45	44 45	46 48	48 49	39 41	47 48
	42 44	49 50	44 46	47 49	54 56	46 53	46 48	46 47	49 51	53 54	42 44	49 50
	45 54	51 53	49 51	50 53	57 60	57 58	49 52	48 49	52 53	57 58	45 54	51 53
	56 57	54 55	52 53	54 55	62 63	59 61	53 55	50 52	54 55	59 60	56 57	54 55
	58 60	57 58	54 57	56 57	65 66	62 63	59 61	53 55	56 57	61 64	58 60	57 58
	61 63	59 60	59 60	59 64	67 70	64 65	62 63	56 58	59 61	66 67	61 63	59 60
	66 67	61 64	62 63	65 66	71 73	66 68	64 70	60 62	63 64	68 69	66 67	61 64
	68 72	65 67	64 65	68 70	76 77	69 71	71 72	64 65	65 68	70 72	68 72	65 67
	75 76	68 75	67 69	72 75	78 79	72 73	73 74	66 67	71 76	76 77	75 76	68 75
	77 79	76 77	71 72	76 77	81 82	75 77	75 77	69 70	77 78	78 80	77 79	76 77
	81 82	79 80	73 76	80 81	83 84	78 80	78 80	71 72	81 82	81 82	81 82	79 80
	84 85	81 83	79 81	84 85	85 86	82 83	81 82	73 74	83 84	83 84	84 85	81 83
	87 88	84 86	84 86	86 87	87 89	84 85	84 86	81 83	85 86	86 87	87 88	84 86
	91 92	87 89	88 89	90 91	91 94	86 93	89 90	84 86	87 90	88 89	91 92	87 89
	94 95	90 91	90 92	92 94	95 96	94 95	91 93	92 93	91 93	91 92	94 95	90 91
	97 98	93 95	93 94	95 97	97 98	96 97	97 98	94 96	94 98	94 95	97 98	93 95
	99	99	99	98 99	99	99	99	98	99	96	99	99

Sublot	Subframe 2						Subframe 3					
	0	1	2	3	4	5	0	1	2	3	4	5
3 MH z	0 2 3 5 6 11 13	0 1 4 5 7 10 12	0 2 3 4 9 10 13	0 1 2 3 11 12 14	4 5 6 8 11 13 14	2 5 6 9 12 13 14	0 3 4 7 8 9 11	1 2 3 4 5 11 12	0 1 2 3 11 12 13	0 3 4 10 11 12 13	0 2 3 5 6 11 13	0 1 4 5 7 10 12
5 MH z	0 1 2 3 7 8 9 10 12 13 14 19 20 23 24	0 5 6 8 10 11 12 13 15 17 18 20 21 22 24	0 1 2 4 6 7 12 13 14 15 16 17 22 23 24	0 1 2 3 4 6 7 8 16 17 18 21 22 23 24	1 3 4 5 7 9 10 11 12 13 14 15 21 22 24	0 1 2 3 4 7 8 10 13 14 18 19 20 21 24	1 4 8 9 10 11 12 13 15 16 18 20 22 23 24	1 2 3 4 5 6 9 10 11 12 13 16 17 21 23	0 1 3 4 6 7 8 16 17 18 19 20 21 23 24	0 1 2 3 4 5 6 9 10 12 13 17 18 20 24	0 1 2 3 7 8 9 10 12 13 14 19 20 23 24	0 5 6 8 10 11 12 13 15 17 18 20 21 22 24
10 MH z	0 1 3 4 5 6 7 11 12 14 17 18 19 20 21 22 24 25 26 27 28 29 31 32 34 38 41 42 45 49	0 1 2 3 5 6 8 12 14 15 16 17 18 22 23 26 28 29 30 32 34 35 38 39 40 41 42 45 46 47	0 3 6 7 8 9 10 12 13 15 16 17 18 21 23 25 28 31 33 37 38 42 44 45 46 47 48 49	0 2 3 4 5 7 9 10 11 12 13 14 15 17 18 19 20 28 29 30 31 34 36 37 38 39 40 42 44 45 48 49	0 1 3 4 5 6 8 9 10 13 14 16 17 18 19 20 21 23 24 29 30 31 32 35 37 38 39 40 42 45 47 48 49	0 1 2 3 4 5 6 7 9 10 12 14 16 17 18 19 22 24 25 26 27 28 30 31 32 32 30 34 37 42 45 48 49	2 5 7 8 9 10 11 14 15 16 17 21 22 27 28 29 30 31 32 34 35 37 38 41 42 43 44 46 48 49	1 3 6 9 11 13 15 16 17 18 21 24 25 26 27 28 29 30 32 34 37 38 39 40 41 42 45 47 48 49	1 2 3 4 5 6 7 8 9 10 11 15 16 17 20 21 28 30 31 32 33 35 36 39 40 42 44 46 47 48	0 1 2 4 5 6 7 9 10 11 13 15 18 20 21 22 24 25 27 28 29 34 35 36 37 40 43 44 46 49 49	0 1 3 4 5 6 7 11 12 14 17 18 19 20 21 22 24 25 26 27 28 29 31 32 34 38 41 42 45 49	0 1 2 3 5 6 8 11 12 12 14 13 15 14 17 18 19 22 23 26 28 31 33 37 38 39 40 42 44 45 46 47 48 49
15 MH z	1 2 3 4 9 11 12 13 14 15 17 18 20 21 22 24 25 26 28 29 31 32 33 34 40 42 43 44 45 46 47 48 50 51 52 54 56 58 59 60 61 62 63 64 68 70 71 72 73 74	2 3 4 6 7 9 11 12 14 15 17 18 20 22 24 25 27 28 29 30 31 33 34 35 38 39 40 42 43 45 46 47 48 50 51 52 53 54 56 60 61 62 63 67 68 69 70 71 73 74	2 4 5 6 8 10 13 15 16 17 18 20 22 24 25 26 27 28 29 30 31 32 33 34 35 38 40 41 44 44 44 45 46 47 48 51 51 52 53 58 60 54 56 61 62 63 64 65 66 67 69 70 71 72 73 74	0 2 3 4 5 7 8 11 12 14 16 17 18 20 23 22 23 24 25 28 29 29 30 31 33 36 37 38 39 41 42 43 45 46 50 51 53 54 56 58 59 60 61 63 64 65 66 67 68 69 70 71 72 72 73 73	0 1 2 3 9 11 12 14 15 17 18 20 23 25 26 28 29 30 31 32 33 36 37 38 39 41 42 43 45 46 50 52 53 54 57 58 59 60 61 62 63 64 65 67 68 70 71 72 73 74	0 1 3 4 5 6 7 8 11 12 14 19 20 21 23 24 26 27 28 30 31 33 34 35 38 40 41 42 44 45 46 49 51 52 53 54 55 58 59 60 61 62 63 65 67 69 70 71 72 73 74	0 1 2 3 7 8 9 10 12 13 14 15 17 18 19 22 23 21 22 25 27 28 29 25 26 30 32 27 28 29 32 36 40 33 34 36 37 39 40 47 48 49 50 50 51 49 50 53 54 55 57 56 61 62 63 66 68 69 71 72 73 74	0 1 3 7 8 11 13 14 16 18 19 20 21 22 23 25 27 28 29 30 32 34 35 36 40 41 42 43 44 45 46 48 49 47 48 50 51 53 54 55 57 59 61 62 63 64 66 67 68 71 72 69 70 73	0 1 2 3 4 5 6 7 8 11 18 20 21 24 25 26 27 29 30 25 26 31 33 28 29 36 37 38 39 40 43 45 46 47 48 49 50 51 53 54 55 57 60 59 60 64 65 67 68 69 70 71 73 74	1 2 3 4 9 11 12 13 14 15 17 18 20 21 22 24 25 26 28 29 31 32 33 34 40 42 43 44 45 46 47 48 50 51 52 54 56 58 59 60 61 62 63 64 68 70 71 72 73 74	2 3 4 6 7 9 11 12 14 13 15 14 17 18 20 21 22 24 25 25 27 26 28 31 33 32 33 34 40 42 43 44 45 46 47 48 50 51 52 54 56 58 59 60 61 62 63 64 68 69 70 71 73 74	

20	0 1 2 3	5 6 7 9	0 2 3 4	1 2 5 6	0 1 2 3	0 1 3 4	2 3 4 5	0 3 4 6	0 1 4 6	1 3 5 6	0 1 2 3	5 6 7 9
MH	6 8 10	10 12	5 6 7	8 9 11	5 8 9	5 7 8	7 9 11	7 8 10	7 8 9	7 9 10	6 8 10	10 12
z	11 15	14 15	11 12	12 13	10 12	10 11	13 15	11 13	10 11	13 17	11 15	14 15
	16 17	16 17	14 15	15 21	13 14	15 18	16 17	16 18	13 14	19 20	16 17	16 17
	19 21	21 22	17 19	22 25	16 22	19 20	21 23	21 22	15 16	21 22	19 21	21 22
	22 23	23 24	21 22	26 27	25 26	21 26	24 25	23 25	20 21	23 24	22 23	23 24
	25 26	27 28	24 26	28 29	27 28	27 29	27 28	26 28	22 23	25 26	25 26	27 28
	28 29	29 30	32 36	30 31	29 31	30 31	29 31	29 32	25 26	27 28	28 29	29 30
	30 32	31 33	37 40	32 34	32 33	33 35	33 35	35 36	28 29	30 32	30 32	31 33
	33 35	34 35	42 43	35 38	34 36	37 38	36 40	37 38	30 31	33 34	33 35	34 35
	38 39	36 37	44 47	39 40	37 38	39 40	42 43	43 44	32 33	35 36	38 39	36 37
	40 41	39 41	48 49	41 43	39 43	41 43	44 45	46 47	34 36	39 41	40 41	39 41
	42 43	44 45	50 51	44 45	44 45	44 45	46 48	48 49	39 41	47 48	42 43	44 45
	44 46	47 49	54 56	46 53	46 48	46 47	49 51	53 54	42 44	49 50	44 46	47 49
	49 51	50 53	57 60	57 58	49 52	48 49	52 53	57 58	45 54	51 53	49 51	50 53
	52 53	54 55	62 63	59 61	53 55	50 52	54 55	59 60	56 57	54 55	52 53	54 55
	54 57	56 57	65 66	62 63	59 61	53 55	56 57	61 64	58 60	57 58	54 57	56 57
	59 60	59 64	67 70	64 65	62 63	56 58	59 61	66 67	61 63	59 60	59 60	59 64
	62 63	65 66	71 73	66 68	64 70	60 62	63 64	68 69	66 67	61 64	62 63	65 66
	64 65	68 70	76 77	69 71	71 72	64 65	65 68	70 72	68 72	65 67	64 65	68 70
	67 69	72 75	78 79	72 73	73 74	66 67	71 76	76 77	75 76	68 75	67 69	72 75
	71 72	76 77	81 82	75 77	75 77	69 70	77 78	78 80	77 79	76 77	71 72	76 77
	73 76	80 81	83 84	78 80	78 80	71 72	81 82	81 82	81 82	79 80	73 76	80 81
	79 81	84 85	85 86	82 83	81 82	73 74	83 84	83 84	84 85	81 83	79 81	84 85
	84 86	86 87	87 89	84 85	84 86	81 83	85 86	86 87	87 88	84 86	84 86	86 87
	88 89	90 91	91 94	86 93	89 90	84 86	87 90	88 89	91 92	87 89	88 89	90 91
	90 92	92 94	95 96	94 95	91 93	92 93	91 93	91 92	94 95	90 91	90 92	92 94
	93 94	95 97	97 98	96 97	97 98	94 96	94 98	94 95	97 98	93 95	93 94	95 97
	99	98 99	99	99	99	98	99	96	99	99	99	98 99

Subslot	Subframe 4						Subframe 5					
	0	1	2	3	4	5	0	1	2	3	4	5
3 MH z	0 2 3 4 9 10 13	0 1 2 3 11 12 14	4 5 6 8 11 13 14	2 5 6 9 12 13 14	0 3 4 7 8 9 11	1 2 3 4 5 11 12	0 1 2 3 11 12 13	0 3 4 10 11 12 13	0 2 3 5 6 11 13	0 1 4 5 7 10 12	0 2 3 4 9 10 13	0 1 2 3 11 12 14
5 MH z	0 1 2 4 6 7 12 13 14 15 16 17 22 23 24	0 1 2 3 4 6 7 8 16 17 18 21 22 23 24	1 3 4 5 7 9 10 11 12 13 14 15 21 22 24	0 1 2 3 4 7 8 10 13 14 18 19 20 21 24	1 4 8 9 10 11 12 13 15 16 18 20 22 23 24	1 2 3 4 5 6 9 10 11 12 13 16 17 21 23	0 1 3 4 6 7 8 16 17 18 19 20 21 23 24	0 1 2 3 4 5 6 9 7 8 9 10 12 13 17 18 20 24	0 1 2 3 7 8 9 10 12 13 14 15 17 19 20 23 24	0 5 6 8 10 11 12 13 15 17 18 20 21 22 24	0 1 2 4 6 7 12 13 14 15 16 17 22 23 24	0 1 2 3 4 6 7 8 11 12 13 14 15 16 17 22 22 23 24
10 MH z	0 3 6 7 8 9 10 12 13 15 16 17 18 21 23 25 28 31 33 37 38 39 41 42 44 45 46 47 48 49	0 2 3 4 5 7 9 10 11 12 13 14 15 19 20 28 29 30 31 34 36 37 38 39 40 42 44 45 48 49	0 1 3 4 5 6 8 9 10 13 14 16 17 18 19 20 21 23 24 29 26 27 30 31 32 35 37 38 39 40 42 45 47 48 49	0 1 2 3 4 5 6 7 9 10 12 14 16 17 18 19 22 24 25 26 27 28 30 31 32 34 35 37 38 39 40 42 45 48 49	2 5 7 8 9 10 11 14 15 16 17 21 22 27 28 29 30 31 32 34 35 37 38 41 42 43 44 46 48 49	1 3 6 9 11 13 15 16 17 18 21 24 25 26 27 28 29 30 32 34 37 38 39 40 41 42 45 47 48 49	1 2 3 4 5 6 7 8 9 10 11 15 16 17 18 21 28 30 31 32 33 35 36 39 40 42 44 46 47 48 49	0 1 2 4 5 6 7 9 10 11 13 15 18 20 21 22 24 25 27 28 29 34 35 36 37 40 43 44 46 49	0 1 3 4 5 6 7 11 12 14 17 18 19 20 21 22 24 25 26 27 28 29 31 32 34 35 38 39 40 42 45 49	0 1 2 3 5 6 8 12 14 15 16 17 18 22 23 26 28 29 30 32 34 35 38 39 40 41 42 45 46 47	0 3 6 7 8 9 10 12 13 15 16 17 18 21 23 25 28 31 33 37 38 39 41 42 44 45 46 47 48 49	0 2 3 4 5 7 9 10 11 12 13 15 16 17 18 19 20 22 23 25 28 28 29 30 31 31 33 37 38 39 40 42 44 45 48 49
15 MH z	2 4 5 6 8 10 13 15 16 17 18 20 22 24 25 26 27 28 29 30 31 32 33 34 35 38 40 41 44 45 46 47 48 50 51 52 53 54 56 59 60 63 64 67 69 70 71 72 73 74	0 2 3 4 5 7 8 11 12 14 16 18 20 22 23 24 25 27 28 29 30 31 33 36 37 42 43 45 46 47 48 49 50 51 53 54 56 58 60 61 62 63 64 65 66 67 68 69 70 71 72 73	0 1 2 3 9 11 12 14 15 17 18 20 23 25 26 28 29 30 31 32 33 38 39 41 42 43 45 46 50 52 53 54 57 58 59 60 61 62 63 64 65 67 68 70 71 72 73 74	0 1 3 4 5 6 7 8 11 12 14 19 20 21 23 24 26 27 28 30 31 33 34 35 38 40 41 42 44 45 46 49 51 52 53 54 59 60 61 62 63 65 66 68 70 71 72 73	0 1 2 3 7 8 9 10 12 13 14 15 17 18 19 21 22 23 24 25 26 27 28 29 32 33 34 36 37 39 40 43 46 47 48 49 50 53 54 55 57 56 61 62 63 64 66 69 71 72 73 74	0 1 3 7 8 11 13 14 16 16 19 20 21 22 23 25 27 28 29 30 32 34 35 36 40 41 42 43 44 45 46 48 49 50 51 53 54 55 57 59 61 62 63 64 66 67 68 69 70 71 72 73	0 1 2 3 5 6 7 8 9 12 14 16 17 18 19 20 21 22 23 23 24 25 26 28 29 30 31 34 35 36 40 41 42 45 47 48 49 50 52 53 56 57 60 62 63 64 65 67 68 71 72 73	0 1 2 3 4 5 6 7 8 11 18 20 21 24 25 26 27 29 30 31 33 36 37 38 39 40 43 45 46 47 48 49 50 51 53 54 55 57 58 59 60 61 65 67 68 71 73 74	1 2 3 4 9 11 12 13 14 15 17 18 20 21 22 24 25 25 27 26 28 29 31 32 33 34 40 42 43 44 45 46 47 48 50 51 52 54 56 58 59 60 61 62 63 64 68 70 71 72 73 74	2 3 4 6 7 9 11 12 14 15 17 18 20 21 22 24 25 25 27 26 28 28 29 30 31 33 34 35 38 39 40 42 43 45 46 47 48 49 55 56 59 60 61 62 63 65 66 67 68 69 70 71 73 74	2 4 5 6 8 10 13 15 16 17 18 20 22 24 25 26 27 28 29 30 31 32 33 34 35 38 40 41 44 45 46 47 48 50 51 52 53 54 56 59 60 63 64 67 69 70 71 72 73 74	0 2 3 4 5 7 8 11 12 14 16 18 20 22 23 24 25 26 27 28 29 30 31 32 33 34 35 38 40 41 44 45 46 47 48 50 51 52 53 54 56 59 60 63 64 67 69 70 71 72 73 74

20	0 2 3 4	1 2 5 6	0 1 2 3	0 1 3 4	2 3 4 5	0 3 4 6	0 1 4 6	1 3 5 6	0 1 2 3	5 6 7 9	0 2 3 4	1 2 5 6
MH	5 6 7	8 9 11	5 8 9	5 7 8	7 9 11	7 8 10	7 8 9	7 9 10	6 8 10	10 12	5 6 7	8 9 11
z	11 12	12 13	10 12	10 11	13 15	11 13	10 11	13 17	11 15	14 15	11 12	12 13
	14 15	15 21	13 14	15 18	16 17	16 18	13 14	19 20	16 17	16 17	14 15	15 21
	17 19	22 25	16 22	19 20	21 23	21 22	15 16	21 22	19 21	21 22	17 19	22 25
	21 22	26 27	25 26	21 26	24 25	23 25	20 21	23 24	22 23	23 24	21 22	26 27
	24 26	28 29	27 28	27 29	27 28	26 28	22 23	25 26	25 26	27 28	24 26	28 29
	32 36	30 31	29 31	30 31	29 31	29 32	25 26	27 28	28 29	29 30	32 36	30 31
	37 40	32 34	32 33	33 35	33 35	35 36	28 29	30 32	30 32	31 33	37 40	32 34
	42 43	35 38	34 36	37 38	36 40	37 38	30 31	33 34	33 35	34 35	42 43	35 38
	44 47	39 40	37 38	39 40	42 43	43 44	32 33	35 36	38 39	36 37	44 47	39 40
	48 49	41 43	39 43	41 43	44 45	46 47	34 36	39 41	40 41	39 41	48 49	41 43
	50 51	44 45	44 45	44 45	46 48	48 49	39 41	47 48	42 43	44 45	50 51	44 45
	54 56	46 53	46 48	46 47	49 51	53 54	42 44	49 50	44 46	47 49	54 56	46 53
	57 60	57 58	49 52	48 49	52 53	57 58	45 54	51 53	49 51	50 53	57 60	57 58
	62 63	59 61	53 55	50 52	54 55	59 60	56 57	54 55	52 53	54 55	62 63	59 61
	65 66	62 63	59 61	53 55	56 57	61 64	58 60	57 58	54 57	56 57	65 66	62 63
	67 70	64 65	62 63	56 58	59 61	66 67	61 63	59 60	59 60	59 64	67 70	64 65
	71 73	66 68	64 70	60 62	63 64	68 69	66 67	61 64	62 63	65 66	71 73	66 68
	76 77	69 71	71 72	64 65	65 68	70 72	68 72	65 67	64 65	68 70	76 77	69 71
	78 79	72 73	73 74	66 67	71 76	76 77	75 76	68 75	67 69	72 75	78 79	72 73
	81 82	75 77	75 77	69 70	77 78	78 80	77 79	76 77	71 72	76 77	81 82	75 77
	83 84	78 80	78 80	71 72	81 82	81 82	81 82	79 80	73 76	80 81	83 84	78 80
	85 86	82 83	81 82	73 74	83 84	83 84	84 85	81 83	79 81	84 85	85 86	82 83
	87 89	84 85	84 86	81 83	85 86	86 87	87 88	84 86	84 86	86 87	87 89	84 85
	91 94	86 93	89 90	84 86	87 90	88 89	91 92	87 89	88 89	90 91	91 94	86 93
	95 96	94 95	91 93	92 93	91 93	91 92	94 95	90 91	90 92	92 94	95 96	94 95
	97 98	96 97	97 98	94 96	94 98	94 95	97 98	93 95	93 94	95 97	97 98	96 97
	99	99	99	98	99	96	99	99	99	98 99	99	99

Sublot	Subframe 6						Subframe 7					
	0	1	2	3	4	5	0	1	2	3	4	5
3 MH z	4 5 6 8 11 13 14	2 5 6 9 12 13 14	0 3 4 7 8 9 11	1 2 3 4 5 11 12	0 1 2 3 11 12 13	0 3 4 10 11 12 13	0 2 3 5 6 11 13	0 1 4 5 7 10 12	0 2 3 4 9 10 13	0 1 2 3 11 12 14	4 5 6 8 11 13 14	2 5 6 9 12 13 14
5 MH z	1 3 4 5 7 9 10 11 12 13 14 15 21 22 24	0 1 2 3 4 7 8 10 13 14 18 19 20 21 24	1 4 8 9 10 11 12 13 15 16 18 20 22 23 24	1 2 3 4 5 6 9 10 11 12 13 16 17 20 21 21 23	0 1 3 4 6 7 8 16 17 18 19 20 21 23 24	0 1 2 3 4 5 6 9 10 12 13 17 18 20 24	0 1 2 3 7 8 9 10 12 13 14 18 20 23 24	0 5 6 8 10 11 12 13 15 17 18 20 21 22 24	0 1 2 4 6 7 12 13 14 15 16 17 22 23 24	0 1 2 3 4 6 7 8 16 17 18 21 22 23 24	1 3 4 5 7 9 10 11 12 13 14 15 21 22 24	0 1 2 3 4 7 8 10 13 14 18 19 20 21 24
10 MH z	0 1 3 4 5 6 8 9 10 13 14 16 17 18 19 20 21 23 24 29 30 31 32 35 37 38 39 40 47 48	0 1 2 3 4 5 6 7 9 10 12 14 16 17 18 19 22 24 25 26 27 28 30 31 32 34 37 42 45 48	2 5 7 8 9 10 11 14 15 16 17 21 22 27 28 29 30 31 32 34 35 37 38 41 42 43 44 46 48 49	1 3 6 9 11 13 15 16 17 18 21 24 25 26 27 28 29 30 32 34 37 38 39 40 41 42 45 47 48 49	1 2 3 4 5 6 7 8 9 10 11 15 16 17 20 21 28 30 31 32 33 35 36 39 40 42 44 46 47 48	0 1 2 4 5 6 7 9 10 11 13 15 18 20 21 22 24 25 27 28 29 34 35 36 37 40 43 44 46 49	0 1 3 4 5 6 7 11 12 14 17 18 19 20 21 22 24 25 26 27 28 29 34 35 38 39 41 42 44 45 46 47 48 49	0 1 2 3 5 6 8 12 14 15 16 17 18 22 23 26 28 25 28 29 30 32 34 35 38 39 40 41 42 45 46 47 48 49	0 3 6 7 8 9 10 12 13 15 16 17 18 21 23 25 28 31 33 37 38 39 41 42 44 45 46 47 48 49	0 2 3 4 5 7 9 10 11 12 13 14 15 19 20 28 29 30 31 34 36 37 38 39 40 42 44 45 48 49	0 1 3 4 5 6 8 9 10 13 14 16 17 18 19 20 21 23 24 29 30 31 32 35 37 38 39 40 47 48	0 1 2 3 4 5 6 7 9 10 12 14 16 17 18 19 22 24 25 26 27 28 30 31 32 34 37 42 45 48
15 MH z	0 1 2 3 9 11 12 14 15 17 18 20 23 25 26 28 29 30 31 32 33 36 37 38 39 41 42 43 45 46 50 52 53 54 57 58 59 60 61 62 63 64 65 67 68 70 71 72 73 74	0 1 3 4 5 6 7 8 11 12 14 19 20 21 23 24 26 27 28 30 31 33 34 35 38 40 41 42 44 45 46 49 51 52 53 54 55 58 59 60 61 62 63 65 67 69 70 71 72 73 74	0 1 2 3 7 8 9 10 12 13 14 15 17 18 19 21 22 23 24 25 26 27 28 29 32 33 34 36 37 39 40 43 46 47 48 49 50 53 56 54 58 55 57 56 61 62 63 66 68 69 71 72 73 74	0 1 3 7 8 11 13 14 16 18 19 20 21 22 23 25 27 28 29 30 32 34 35 36 40 41 42 43 44 45 46 48 49 50 51 53 54 55 57 59 61 64 66 67 68 69 70 71 72 69 70	0 1 2 3 5 6 7 8 9 12 14 16 17 18 19 20 21 23 24 25 26 28 29 30 31 32 33 40 43 41 42 45 47 48 49 50 52 51 56 57 60 62 63 67 68 69 70 71 72 73	0 1 2 3 4 5 6 7 8 11 18 20 21 24 25 26 27 29 30 31 33 36 37 38 39 40 43 45 46 47 48 49 50 51 53 54 55 57 58 59 60 61 65 67 68 69 70 71 73 74	1 2 3 4 9 11 12 13 14 15 17 18 20 21 22 24 25 25 27 26 28 28 29 29 31 32 33 34 40 42 43 44 45 46 47 48 50 49 52 51 52 54 56 56 59 60 61 62 63 64 68 70 71 72 73 74	2 3 4 6 7 9 11 12 14 15 17 18 20 22 24 25 27 28 29 30 31 33 34 35 38 39 40 42 43 45 46 47 48 49 50 50 51 56 59 60 61 62 63 65 66 67 68 69 70 71 73 74	2 4 5 6 8 10 13 15 16 17 18 20 22 24 25 26 27 28 29 30 31 32 33 34 35 38 40 41 44 45 46 47 48 51 53 54 56 52 53 61 62 59 60 63 64 65 66 67 69 70 71 72 73 74	0 2 3 4 5 7 8 11 12 14 16 18 20 22 23 24 25 26 27 27 28 29 30 31 33 32 33 34 35 42 43 38 40 45 46 47 48 49 50 51 53 58 60 61 62 63 64 65 66 67 68 69 70 71 72 73	0 1 2 3 9 11 12 14 15 17 18 20 23 25 26 28 29 30 31 32 33 36 37 38 39 41 42 43 45 46 50 52 53 54 57 58 59 60 61 62 63 64 65 67 68 70 71 72 73 74	0 1 3 4 5 6 7 8 11 12 14 19 20 21 23 24 26 27 28 29 30 31 32 33 36 37 38 40 41 42 43 45 46 49 51 52 53 54 55 58 59 60 61 62 63 64 65 66 67 68 70 71 72 73 74

20	0 1 2 3	0 1 3 4	2 3 4 5	0 3 4 6	0 1 4 6	1 3 5 6	0 1 2 3	5 6 7 9	0 2 3 4	1 2 5 6	0 1 2 3	0 1 3 4
MH	5 8 9	5 7 8	7 9 11	7 8 10	7 8 9	7 9 10	6 8 10	10 12	5 6 7	8 9 11	5 8 9	5 7 8
z	10 12	10 11	13 15	11 13	10 11	13 17	11 15	14 15	11 12	12 13	10 12	10 11
	13 14	15 18	16 17	16 18	13 14	19 20	16 17	16 17	14 15	15 21	13 14	15 18
	16 22	19 20	21 23	21 22	15 16	21 22	19 21	21 22	17 19	22 25	16 22	19 20
	25 26	21 26	24 25	23 25	20 21	23 24	22 23	23 24	21 22	26 27	25 26	21 26
	27 28	27 29	27 28	26 28	22 23	25 26	25 26	27 28	24 26	28 29	27 28	27 29
	29 31	30 31	29 31	29 32	25 26	27 28	28 29	29 30	32 36	30 31	29 31	30 31
	32 33	33 35	33 35	35 36	28 29	30 32	30 32	31 33	37 40	32 34	32 33	33 35
	34 36	37 38	36 40	37 38	30 31	33 34	33 35	34 35	42 43	35 38	34 36	37 38
	37 38	39 40	42 43	43 44	32 33	35 36	38 39	36 37	44 47	39 40	37 38	39 40
	39 43	41 43	44 45	46 47	34 36	39 41	40 41	39 41	48 49	41 43	39 43	41 43
	44 45	44 45	46 48	48 49	39 41	47 48	42 43	44 45	50 51	44 45	44 45	44 45
	46 48	46 47	49 51	53 54	42 44	49 50	44 46	47 49	54 56	46 53	46 48	46 47
	49 52	48 49	52 53	57 58	45 54	51 53	49 51	50 53	57 60	57 58	49 52	48 49
	53 55	50 52	54 55	59 60	56 57	54 55	52 53	54 55	62 63	59 61	53 55	50 52
	59 61	53 55	56 57	61 64	58 60	57 58	54 57	56 57	65 66	62 63	59 61	53 55
	62 63	56 58	59 61	66 67	61 63	59 60	59 60	59 64	67 70	64 65	62 63	56 58
	64 70	60 62	63 64	68 69	66 67	61 64	62 63	65 66	71 73	66 68	64 70	60 62
	71 72	64 65	65 68	70 72	68 72	65 67	64 65	68 70	76 77	69 71	71 72	64 65
	73 74	66 67	71 76	76 77	75 76	68 75	67 69	72 75	78 79	72 73	73 74	66 67
	75 77	69 70	77 78	78 80	77 79	76 77	71 72	76 77	81 82	75 77	75 77	69 70
	78 80	71 72	81 82	81 82	81 82	79 80	73 76	80 81	83 84	78 80	78 80	71 72
	81 82	73 74	83 84	83 84	84 85	81 83	79 81	84 85	85 86	82 83	81 82	73 74
	84 86	81 83	85 86	86 87	87 88	84 86	84 86	86 87	87 89	84 85	84 86	81 83
	89 90	84 86	87 90	88 89	91 92	87 89	88 89	90 91	91 94	86 93	89 90	84 86
	91 93	92 93	91 93	91 92	94 95	90 91	90 92	92 94	95 96	94 95	91 93	92 93
	97 98	94 96	94 98	94 95	97 98	93 95	93 94	95 97	97 98	96 97	97 98	94 96
	99	98	99	96	99	99	99	98 99	99	99	99	98

Sublot	Subframe 8						Subframe 9					
	0	1	2	3	4	5	0	1	2	3	4	5
3 MH z	0 3 4 7 8 9 11	1 2 3 4 5 11 12	0 1 2 3 11 12 13	0 3 4 10 11 12 13	0 2 3 5 6 11 13	0 1 4 5 7 10 12	0 2 3 4 9 10 13	0 1 2 3 11 12 14	4 5 6 8 11 13 14	2 5 6 9 12 13 14	0 3 4 7 8 9 11	1 2 3 4 5 11 12
5 MH z	1 4 8 9 10 11 12 13 15 16 18 20 22 23 24	1 2 3 4 5 6 9 10 11 12 13 16 17 20 21 21 23	0 1 3 4 6 7 8 16 17 18 19 20 21 23 24	0 1 2 3 4 5 6 9 10 12 13 17 18 20 24	0 1 2 3 7 8 9 10 12 13 14 19 20 23 24	0 5 6 8 10 11 12 13 15 17 18 20 21 22 24	0 1 2 4 6 7 12 13 14 15 16 17 22 23 24	0 1 2 3 4 6 7 8 16 17 18 21 22 23 24	1 3 4 5 7 9 10 11 12 13 14 15 21 22 24	0 1 2 3 4 7 8 10 13 14 18 19 20 21 24	1 4 8 9 10 11 12 13 15 16 18 20 22 23 24	1 2 3 4 5 6 9 10 11 12 13 15 16 16 17 21 23
10 MH z	2 5 7 8 9 10 11 14 15 16 17 21 22 27 28 29 30 31 32 34 35 37 38 41 42 43 44 46 48 49	1 3 6 9 11 13 15 16 17 18 21 24 25 26 27 28 29 30 32 34 37 38 39 40 41 42 45 47 48 49	1 2 3 4 5 6 7 8 9 10 11 15 16 17 20 21 28 30 31 32 33 35 36 39 40 42 44 46 47 48	0 1 2 4 5 6 7 9 10 11 13 15 18 20 21 22 24 25 27 28 29 34 35 36 37 40 43 44 46 49	0 1 3 4 5 6 7 11 12 14 17 18 19 20 21 22 24 25 26 27 28 29 31 32 34 39 40 38 41 42 45 49	0 1 2 3 5 6 8 12 14 15 16 17 18 22 23 26 28 29 30 32 34 35 38 39 40 41 42 45 46 47	0 3 6 7 8 9 10 12 13 15 16 17 18 21 23 25 28 31 33 37 38 39 41 42 44 45 46 47 48 49	0 2 3 4 5 7 9 10 11 12 13 14 15 19 20 28 29 30 31 37 38 39 40 42 44 45 48 49	0 1 3 4 5 6 8 9 10 13 14 16 17 18 19 20 21 23 24 29 30 31 32 35 37 38 39 40 39 40 47 48	0 1 2 3 4 5 6 7 9 10 12 14 16 17 18 19 22 24 25 26 27 28 30 31 32 34 37 42 45 48	2 5 7 8 9 10 11 14 15 16 17 21 22 27 28 29 30 31 32 34 35 37 38 41 42 43 44 46 48 49	1 3 6 9 11 13 15 16 17 18 21 22 25 26 27 28 29 30 32 34 37 38 39 40 43 44 45 47 48 49
15 MH z	0 1 2 3 7 8 9 10 12 13 14 15 17 18 19 21 22 23 24 25 26 27 28 29 32 33 34 36 37 39 40 43 46 47 48 49 50 53 54 56 61 62 63 66 68 69 71 72 73 74	0 1 3 7 8 11 13 14 16 18 19 20 21 22 23 25 27 28 29 30 32 34 35 36 40 41 42 43 44 45 46 47 48 50 51 53 54 55 57 59 61 62 63 64 66 67 68 69 70 71	0 1 2 3 5 6 7 8 9 12 14 16 17 18 19 20 21 23 24 25 26 28 29 30 31 32 33 40 43 41 42 45 47 48 49 50 52 53 56 57 60 62 63 64 65 67 68 69 70 71 72 73	0 1 2 3 4 5 6 7 8 11 18 20 21 24 25 26 27 29 30 31 33 36 37 38 39 40 43 45 46 47 48 49 50 51 53 54 55 57 58 59 60 61 65 62 63 67 68 71 73 74	1 2 3 4 9 11 12 13 14 15 17 18 20 21 22 24 25 26 28 30 31 32 33 33 34 35 38 42 43 46 47 48 50 47 48 49 55 56 59 60 61 62 63 64 68 70 71 72 73 74	2 3 4 6 7 9 11 12 14 15 17 18 20 22 24 25 27 28 29 30 31 33 34 35 38 39 40 42 43 45 46 47 48 50 51 52 53 54 56 60 61 62 63 65 66 67 68 69 70 71 73 74	2 4 5 6 8 10 13 15 16 17 18 20 22 24 25 26 27 28 29 30 31 32 33 34 35 42 43 45 46 47 48 49 50 51 53 54 56 58 60 61 62 63 64 65 66 67 69 70 71 72 73 74	0 2 3 4 5 7 8 11 12 14 16 18 20 22 23 24 25 27 28 29 30 31 33 36 37 42 43 45 46 47 48 49 50 51 53 54 56 58 60 61 62 63 64 65 66 67 68 69 70 71 72 73	0 1 2 3 5 6 7 8 14 15 17 18 20 23 25 26 28 29 30 31 32 33 36 37 38 39 45 46 47 48 46 50 52 53 54 57 58 59 60 61 62 63 64 65 67 68 70 71 72 73 74	0 1 3 4 5 6 7 8 14 19 20 21 23 24 26 27 28 30 31 33 34 35 38 40 41 42 44 45 46 49 51 52 53 54 55 58 59 60 61 62 63 65 67 69 70 71 72 73 74	0 1 2 3 7 8 9 10 12 13 14 15 17 18 19 21 22 25 27 28 29 31 33 34 35 38 40 41 42 43 34 47 48 49 50 53 54 55 57 56 61 62 63 66 68 69 71 72 73 74	0 1 3 7 8 11 13 14 16 18 19 20 21 22 23 25 27 28 29 30 32 34 35 36 40 41 42 43 44 45 46 47 48 50 51 53 54 55 57 59 61 62 63 64 66 67 68 71 72 73

20	2 3 4 5	0 3 4 6	0 1 4 6	1 3 5 6	0 1 2 3	5 6 7 9	0 2 3 4	1 2 5 6	0 1 2 3	0 1 3 4	2 3 4 5	0 3 4 6
MH	7 9 11	7 8 10	7 8 9	7 9 10	6 8 10	10 12	5 6 7	8 9 11	5 8 9	5 7 8	7 9 11	7 8 10
z	13 15	11 13	10 11	13 17	11 15	14 15	11 12	12 13	10 12	10 11	13 15	11 13
	16 17	16 18	13 14	19 20	16 17	16 17	14 15	15 21	13 14	15 18	16 17	16 18
	21 23	21 22	15 16	21 22	19 21	21 22	17 19	22 25	16 22	19 20	21 23	21 22
	24 25	23 25	20 21	23 24	22 23	23 24	21 22	26 27	25 26	21 26	24 25	23 25
	27 28	26 28	22 23	25 26	25 26	27 28	24 26	28 29	27 28	27 29	27 28	26 28
	29 31	29 32	25 26	27 28	28 29	29 30	32 36	30 31	29 31	30 31	29 31	29 32
	33 35	35 36	28 29	30 32	30 32	31 33	37 40	32 34	32 33	33 35	33 35	35 36
	36 40	37 38	30 31	33 34	33 35	34 35	42 43	35 38	34 36	37 38	36 40	37 38
	42 43	43 44	32 33	35 36	38 39	36 37	44 47	39 40	37 38	39 40	42 43	43 44
	44 45	46 47	34 36	39 41	40 41	39 41	48 49	41 43	39 43	41 43	44 45	46 47
	46 48	48 49	39 41	47 48	42 43	44 45	50 51	44 45	44 45	44 45	46 48	48 49
	49 51	53 54	42 44	49 50	44 46	47 49	54 56	46 53	46 48	46 47	49 51	53 54
	52 53	57 58	45 54	51 53	49 51	50 53	57 60	57 58	49 52	48 49	52 53	57 58
	54 55	59 60	56 57	54 55	52 53	54 55	62 63	59 61	53 55	50 52	54 55	59 60
	56 57	61 64	58 60	57 58	54 57	56 57	65 66	62 63	59 61	53 55	56 57	61 64
	59 61	66 67	61 63	59 60	59 60	59 64	67 70	64 65	62 63	56 58	59 61	66 67
	63 64	68 69	66 67	61 64	62 63	65 66	71 73	66 68	64 70	60 62	63 64	68 69
	65 68	70 72	68 72	65 67	64 65	68 70	76 77	69 71	71 72	64 65	65 68	70 72
	71 76	76 77	75 76	68 75	67 69	72 75	78 79	72 73	73 74	66 67	71 76	76 77
	77 78	78 80	77 79	76 77	71 72	76 77	81 82	75 77	75 77	69 70	77 78	78 80
	81 82	81 82	81 82	79 80	73 76	80 81	83 84	78 80	78 80	71 72	81 82	81 82
	83 84	83 84	84 85	81 83	79 81	84 85	85 86	82 83	81 82	73 74	83 84	83 84
	85 86	86 87	87 88	84 86	84 86	86 87	87 89	84 85	84 86	81 83	85 86	86 87
	87 90	88 89	91 92	87 89	88 89	90 91	91 94	86 93	89 90	84 86	87 90	88 89
	91 93	91 92	94 95	90 91	90 92	92 94	95 96	94 95	91 93	92 93	91 93	91 92
	94 98	94 95	97 98	93 95	93 94	95 97	97 98	96 97	97 98	94 96	94 98	94 95
	99	96	99	99	99	98 99	99	99	99	98	99	96

6.1.1.5b E-UTRA slot TTI Test Model 3.2 (sE-TM3.2-2)

This model shall be used for slot TTI tests on:

- Transmitted signal quality
- Frequency error
- EVM for 16QAM modulation

Table 6.1.1.5b-1: Physical channel parameters of sE-TM3.2-2

Parameter	3 MHz	5 MHz	10 MHz	15 MHz	20 MHz
-----------	-------	-------	--------	--------	--------

Reference, Synchronisation Signals					
RS boosting, $P_B = E_B/E_A$	1	1	1	1	1
Synchronisation signal EPRE / E_{RS} [dB]	1.573	2.426	2.426	3.005	2.426
Reserved EPRE / E_{RS} [dB]	-inf	-inf	-inf	-inf	-inf
PBCH					
PBCH EPRE / E_{RS} [dB]	1.573	2.426	2.426	3.005	2.426
Reserved EPRE / E_{RS} [dB]	-inf	-inf	-inf	-inf	-inf
PCFICH					
# of symbols used for control channels	1	1	1	1	1
PCFICH EPRE / E_{RS} [dB]	0	0	0	0	0
PHICH					
# of PHICH groups	1	1	2	2	3
# of PHICH per group	2	2	2	2	2
PHICH BPSK symbol power / E_{RS} [dB]	-3.010	-3.010	-3.010	-3.010	-3.010
PHICH group EPRE / E_{RS} [dB]	0	0	0	0	0
sPDCCH					
# of available sREGs	105	155	350	525	700
# of sPDCCH	2	2	5	7	10
# of sCCEs per sPDCCH	1	2	2	2	2
# of sREGs per sCCE	4	4	4	4	4
# of sREGs allocated to sPDCCH	8	16	40	56	80
# of <NIL> sREGs added for padding	97	139	310	469	620
sPDCCH sREG EPRE / E_{RS} [dB]	2.290	1.880	1.065	1.488	1.195
<NIL> sREG EPRE / E_{RS} [dB]	-inf	-inf	-inf	-inf	-inf
sPDSCH					
# of 16QAM sPDSCH PRBs within a slot for which EVM is measured	7	15	30	50	60
PRB $P_A = E_A/E_{RS}$ [dB]	-3	-3	-3	-3	-3
# of QPSK sPDSCH PRBs within a slot for which EVM is not measured (used for power balancing only)	8	10	20	25	40
PRB $P_A = E_A/E_{RS}$ [dB]	1.573	2.426	2.426	3.005	2.426
NOTE 1: In subframes containing PBCH or synchronisation signal REs, no PRB boosting/deboosting shall be applied, i.e. PRB $P_A = E_A/E_{RS} = 0$ [dB].					

Table 6.1.1.5b-2: Numbers (n_{PRB}) of the 16QAM PRBs (FDD)

Slot	Subframe 0		Subframe 1		Subframe 2		Subframe 3		Subframe 4		Subframe 5	
	0	1	0	1	0	1	0	1	0	1	0	1
3 MHz	0 1 2 3 11 12 13	0 3 4 10 11 12 13	0 2 3 5 6 11 13	0 1 4 5 7 10 12	0 2 3 4 9 10 13	0 1 2 3 11 12 14	4 5 6 8 11 13 14	2 5 6 9 12 13 14	0 3 4 7 8 9 11	1 2 3 4 5 11 12	0 1 2 3 11 12 13	0 3 4 10 11 12 13
5 MHz	0 1 3 4 6 7 8 16 17 18 19 20 21 23 24	0 1 2 3 4 5 6 9 10 12 13 17 18 20 24	0 1 2 3 7 8 9 10 12 13 14 19 20 23 24	0 5 6 8 10 11 12 13 15 17 18 20 21 22	0 1 2 4 6 7 12 13 14 15 16 17 22 23 24	0 1 2 3 4 6 7 8 16 17 18 21 22 23 24	1 3 4 5 7 9 10 11 12 13 14 15 21 22 24	0 1 2 3 4 7 8 10 13 11 12 14 18 19 20 21 24	1 4 8 9 10 11 12 13 15 16 18 20 22 23 24	1 2 3 4 5 6 9 10 11 12 13 16 17 21 23	0 1 3 4 6 7 8 16 17 18 19 20 21 23 24	0 1 2 3 4 5 6 9 10 12 13 17 18 20 24
10 MHz	1 2 3 4 5 6 7 8 9 10 11 15 16 17 20 21 28 30 31 32 33 35 36 39 40 42 44 46 47 48	0 1 2 4 5 6 7 9 10 11 13 15 18 20 21 22 24 25 27 28 29 34 35 36 37 40 43 44 46 49	0 1 3 4 5 6 7 11 12 14 17 18 19 20 21 22 24 25 26 27 28 29 31 32 34 38 41 42 45 49	0 1 2 3 5 6 8 12 14 15 16 17 18 22 23 26 28 32 34 35 38 39 40 41 42 45 46 47	0 3 6 7 8 9 10 12 13 15 16 17 18 21 23 25 28 31 33 37 38 39 41 42 44 47 48 49	0 2 3 4 5 7 9 10 11 12 13 14 15 19 20 28 29 30 31 34 36 37 38 39 40 42 44 45 48 49	0 1 3 4 5 6 8 9 10 13 14 16 17 18 19 20 21 23 24 29 30 31 34 36 37 38 39 40 42 45 47 48	0 1 2 3 4 5 6 7 9 10 12 14 16 17 18 19 22 24 25 26 27 30 31 28 30 31 32 34 37 41 42 42 45 48	2 5 7 8 9 10 11 14 15 16 17 21 22 27 28 29 30 31 32 34 35 37 38 41 42 46 48 49	1 3 6 9 11 13 15 16 21 24 25 26 27 28 29 30 32 34 37 38 39 40 41 42 45 47 48 49	1 2 3 4 5 6 7 8 9 10 11 15 16 17 20 21 28 24 25 27 28 30 31 32 33 35 36 39 40 42 44 46 47 48	0 1 2 4 5 6 7 9 10 11 13 15 18 20 21 22 24 25 27 28 29 34 35 36 37 40 43 44 46 49
15 MHz	0 1 2 3 5 6 7 8 9 12 14 16 17 18 19 20 21 23 24 25 26 28 29 30 31 32 33 41 42 45 47 48 49 50 52 53 56 57 60 62 63 64 65 67 68 69 70 71 72 73	0 1 2 3 4 5 6 7 8 11 18 20 21 24 25 26 27 29 30 31 33 36 37 38 39 40 43 45 46 47 48 49 50 51 53 54 55 57 58 59 60 61 65 67 68 69 70 71 73 74	1 2 3 4 9 11 12 13 14 15 17 18 20 21 22 24 25 26 28 29 31 32 33 34 40 42 43 44 45 46 47 48 50 51 52 54 56 58 59 60 61 62 63 64 68 70 71 72 73 74	2 3 4 6 7 9 11 12 14 15 17 18 20 22 24 25 27 28 29 30 31 33 34 35 38 39 40 42 43 45 46 47 48 49 51 52 53 60 61 62 63 65 66 67 68 69 70 71 73 74	2 4 5 6 8 10 13 15 16 17 18 20 22 24 25 26 27 28 29 30 31 32 33 34 35 38 40 45 46 47 48 49 50 51 53 54 56 58 60 63 64 65 66 67 69 70 71 72 73 74	0 2 3 4 5 7 8 11 12 14 16 17 18 18 20 22 23 24 25 27 28 30 31 32 33 36 37 38 39 42 43 45 46 47 48 49 50 51 53 54 56 58 59 61 62 63 64 65 66 67 68 69 70 71 72 72 73 73	0 1 2 3 9 11 12 14 15 17 18 20 23 25 26 28 29 30 31 32 33 36 37 38 40 41 42 43 45 46 50 51 52 54 57 58 59 60 61 62 63 64 65 66 68 70 71 72 73 74	0 1 3 4 5 6 7 8 11 12 14 19 20 21 23 24 26 27 28 30 31 33 34 35 38 40 41 42 44 45 46 49 51 52 53 54 55 58 59 60 61 62 63 65 66 69 70 71 72 73 74	0 1 2 3 7 8 9 10 12 13 14 15 17 18 19 21 22 23 24 28 29 30 32 27 28 29 32 33 34 36 37 39 40 43 46 47 48 49 50 53 54 55 57 56 61 62 63 66 68 69 71 72 73 74	0 1 3 7 8 11 13 14 16 18 19 20 21 22 23 25 27 28 29 30 32 34 35 36 40 41 42 43 44 45 46 47 48 50 51 53 54 55 57 59 61 62 63 64 66 67 68 69 70 71	0 1 2 3 5 6 7 8 9 12 14 16 17 18 19 20 21 23 24 25 26 28 29 30 31 32 33 41 42 45 47 48 49 50 52 53 56 57 60 62 63 64 65 67 68 69 70 71 72 73 74	0 1 2 3 4 5 6 7 8 11 18 20 21 24 25 26 27 29 30 31 33 36 37 38 39 40 43 45 46 47 48 49 50 51 53 54 55 57 58 59 60 61 65 67 68 69 70 71 73 74

20	0 1 4 6	1 3 5 6	0 1 2 3	5 6 7 9	0 2 3 4	1 2 5 6	0 1 2 3	0 1 3 4	2 3 4 5	0 3 4 6	0 1 4 6	1 3 5 6
MH	7 8 9	7 9 10	6 8 10	10 12	5 6 7	8 9 11	5 8 9	5 7 8	7 9 11	7 8 10	7 8 9	7 9 10
z	10 11	13 17	11 15	14 15	11 12	12 13	10 12	10 11	13 15	11 13	10 11	13 17
	13 14	19 20	16 17	16 17	14 15	15 21	13 14	15 18	16 17	16 18	13 14	19 20
	15 16	21 22	19 21	21 22	17 19	22 25	16 22	19 20	21 23	21 22	15 16	21 22
	20 21	23 24	22 23	23 24	21 22	26 27	25 26	21 26	24 25	23 25	20 21	23 24
	22 23	25 26	25 26	27 28	24 26	28 29	27 28	27 29	27 28	26 28	22 23	25 26
	25 26	27 28	28 29	29 30	32 36	30 31	29 31	30 31	29 31	29 32	25 26	27 28
	28 29	30 32	30 32	31 33	37 40	32 34	32 33	33 35	33 35	35 36	28 29	30 32
	30 31	33 34	33 35	34 35	42 43	35 38	34 36	37 38	36 40	37 38	30 31	33 34
	32 33	35 36	38 39	36 37	44 47	39 40	37 38	39 40	42 43	43 44	32 33	35 36
	34 36	39 41	40 41	39 41	48 49	41 43	39 43	41 43	44 45	46 47	34 36	39 41
	39 41	47 48	42 43	44 45	50 51	44 45	44 45	44 45	46 48	48 49	39 41	47 48
	42 44	49 50	44 46	47 49	54 56	46 53	46 48	46 47	49 51	53 54	42 44	49 50
	45 54	51 53	49 51	50 53	57 60	57 58	49 52	48 49	52 53	57 58	45 54	51 53
	56 57	54 55	52 53	54 55	62 63	59 61	53 55	50 52	54 55	59 60	56 57	54 55
	58 60	57 58	54 57	56 57	65 66	62 63	59 61	53 55	56 57	61 64	58 60	57 58
	61 63	59 60	59 60	59 64	67 70	64 65	62 63	56 58	59 61	66 67	61 63	59 60
	66 67	61 64	62 63	65 66	71 73	66 68	64 70	60 62	63 64	68 69	66 67	61 64
	68 72	65 67	64 65	68 70	76 77	69 71	71 72	64 65	65 68	70 72	68 72	65 67
	75 76	68 75	67 69	72 75	78 79	72 73	73 74	66 67	71 76	76 77	75 76	68 75
	77 79	76 77	71 72	76 77	81 82	75 77	75 77	69 70	77 78	78 80	77 79	76 77
	81 82	79 80	73 76	80 81	83 84	78 80	78 80	71 72	81 82	81 82	81 82	79 80
	84 85	81 83	79 81	84 85	85 86	82 83	81 82	73 74	83 84	83 84	84 85	81 83
	87 88	84 86	84 86	86 87	87 89	84 85	84 86	81 83	85 86	86 87	87 88	84 86
	91 92	87 89	88 89	90 91	91 94	86 93	89 90	84 86	87 90	88 89	91 92	87 89
	94 95	90 91	90 92	92 94	95 96	94 95	91 93	92 93	91 93	91 92	94 95	90 91
	97 98	93 95	93 94	95 97	97 98	96 97	97 98	94 96	94 98	94 95	97 98	93 95
	99	99	99	98 99	99	99	99	98	99	96	99	99

Sub slot	Subframe 6		Subframe 7		Subframe 8		Subframe 9	
	0	1	0	1	0	1	0	1
3 MHz	0 2 3 5 6 11 13	0 1 4 5 7 10 12	0 2 3 4 9 10 13	0 1 2 3 11 12 14	4 5 6 8 11 13 14	2 5 6 9 12 13 14	0 3 4 7 8 9 11	1 2 3 4 5 11 12
5 MHz	0 1 2 3 7 8 9 10 12 13 14 19 20 23 24	0 5 6 8 10 11 12 13 15 17 18 20 21 22 24	0 1 2 4 6 7 12 13 14 15 16 17 22 23 24	0 1 2 3 4 6 7 8 16 17 18 21 22 23 24	1 3 4 5 7 9 10 11 12 13 14 15 21 22 24	0 1 2 3 4 7 8 10 13 14 18 19 20 21 24	1 4 8 9 10 11 12 13 15 16 18 20 22 23 24	1 2 3 4 5 6 9 10 11 12 13 16 17 21 23
10 MHz	0 1 3 4 5 6 7 11 12 14 17 18 19 20 21 22 24 25 26 27 28 29 31 32 34 38 41 42 45 49	0 1 2 3 5 6 8 12 14 15 16 17 18 22 23 26 28 29 30 32 34 35 38 39 40 41 42 45 46 47	0 3 6 7 8 9 10 12 13 15 16 17 18 21 23 25 28 31 33 37 38 39 41 42 44 45 46 47 48 49	0 2 3 4 5 7 9 10 11 12 13 14 15 19 20 28 29 30 31 34 36 37 38 39 40 42 44 45 48 49	0 1 3 4 5 6 8 9 10 13 14 16 17 18 19 20 21 23 24 29 30 31 32 35 37 38 39 40 47 48	0 1 2 3 4 5 6 7 9 10 12 14 16 17 18 19 22 24 25 26 27 28 30 31 32 34 37 42 45 48	2 5 7 8 9 10 11 14 15 16 17 21 22 27 28 29 30 31 32 34 35 37 38 41 42 43 44 46 48 49	1 3 6 9 11 13 15 16 17 18 21 24 25 26 27 28 29 30 32 34 37 38 39 40 41 42 45 47 48 49
15 MHz	1 2 3 4 9 11 12 13 14 15 17 18 20 21 22 24 25 26 28 29 31 32 33 34 40 42 43 44 45 46 47 48 50 51 52 54 56 58 59 60 61 62 63 64 68 70 71 72 73 74	2 3 4 6 7 9 11 12 14 15 17 18 20 22 24 25 27 28 29 30 31 33 34 35 38 39 40 42 43 45 46 47 48 49 55 56 59 60 61 62 63 65 66 67 68 69 70 71 73 74	2 4 5 6 8 10 13 15 16 17 18 20 22 24 25 26 27 28 29 30 31 32 33 34 35 38 40 41 44 45 46 47 48 50 51 52 53 54 56 59 60 63 64 67 69 70 71 72 73 74	0 2 3 4 5 7 8 11 12 14 16 18 20 22 23 24 25 27 28 29 30 31 33 42 43 45 46 47 48 49 50 51 53 54 56 58 60 61 62 63 64 65 66 67 68 69 70 71 72 73	0 1 2 3 9 11 12 14 15 17 18 20 23 25 26 28 29 30 31 32 33 36 37 38 39 41 42 43 45 46 50 52 53 54 57 58 59 60 61 62 63 64 65 67 68 70 71 72 73 74	0 1 3 4 5 6 7 8 11 12 14 19 20 21 23 24 26 27 28 30 31 33 34 35 38 40 41 42 44 45 46 49 51 52 53 54 55 58 59 60 61 62 63 65 67 69 71 72 72 73	0 1 2 3 7 8 9 10 12 13 14 15 17 18 19 21 22 23 24 25 26 27 28 29 32 33 34 36 37 39 40 43 46 47 48 49 50 53 54 56 61 62 63 66 68 69 71 72 73 74	0 1 3 7 8 11 13 14 16 18 19 20 21 22 23 25 27 28 29 30 32 34 35 36 40 41 42 43 44 45 46 47 48 50 51 53 54 55 57 59 61 62 63 64 66 67 68 69 70 71
20 MHz	0 1 2 3 6 8 10 11 15 16 17 19 21 22 23 25 26 28 29 30 32 33 35 38 39 40 41 42 43 44 46 49 51 52 53 54 57 59 60 62 63 64 65 67 69 71 72 73 76 79 81 84 86 88 89 90 92 93 94 99	5 6 7 9 10 12 14 15 16 17 21 22 23 24 27 28 29 30 31 33 34 35 36 37 39 41 44 45 47 49 50 53 54 55 56 57 59 64 65 66 68 70 72 75 76 77 80 81 84 85 86 87 90 91 92 94 95 97 98 99	0 2 3 4 5 6 7 11 12 14 15 17 19 21 22 24 26 32 36 37 40 42 43 44 47 48 49 50 51 54 56 57 60 62 63 65 71 73 76 77 78 79 81 82 83 84 85 86 87 89 91 94 95 96 97 98 99	1 2 5 6 8 9 11 12 13 15 21 22 25 26 27 28 29 30 31 32 34 35 38 39 40 41 43 44 45 46 53 57 58 59 61 62 63 64 65 66 68 69 71 72 73 75 77 78 80 82 83 84 85 86 93 94 95 96 97 99	0 1 2 3 5 8 9 10 12 13 14 16 22 25 26 27 28 29 31 32 33 34 36 37 38 39 43 44 45 46 48 49 52 53 55 59 61 62 63 64 70 71 72 73 74 75 77 78 80 81 82 84 86 89 90 91 93 97 98 99	0 1 3 4 5 7 8 10 11 15 18 19 20 21 26 27 29 30 31 33 35 37 38 39 40 41 43 44 45 46 47 48 49 50 52 53 55 56 58 60 62 64 65 66 67 69 70 71 72 73 74 81 83 84 86 92 93 94 96 98	2 3 4 5 7 9 11 13 15 16 17 21 23 24 25 27 28 29 31 33 35 36 40 42 43 44 45 46 48 49 51 52 53 54 55 56 57 59 61 63 64 65 68 71 76 77 78 81 82 83 84 85 86 87 90 91 93 94 98 99	0 3 4 6 7 8 10 11 13 16 18 21 22 23 25 26 28 29 32 35 36 37 38 43 44 46 47 48 49 53 54 57 58 59 60 61 64 66 67 68 69 70 72 76 77 78 80 81 82 83 84 86 87 88 89 91 92 94 95 96

Table 6.1.1.5b-3: Numbers (n_{PRB}) of the 16QAM PRBs (TDD)

Frame 1	Subframe 0		Subframe 1		Subframe 5		Subframe 6		Subframe 7		Subframe 8	
	0	1	0	1	0	1	0	1	0	1	0	1
3 MHz	0 1 2 3 11 12 14	0 1 2 3 11 12 13	0 1 2 3 11 12 14	0 1 2 3 11 12 13	1 2 7 8 10 13 14	2 3 4 6 8 13 14	0 3 6 8 9 10 14	0 1 2 3 11 12 14	0 1 2 3 11 12 13	0 1 2 3 11 12 14	0 1 2 3 11 12 13	1 2 7 8 10 13 14
5 MHz	1 2 3 4 5 6 7 8 17 18 19 20 21 23 24	0 2 3 4 5 6 7 8 17 18 19 20 21 22 24	1 2 3 4 5 6 7 8 16 17 18 19 20 21 22 23 24	1 2 3 4 5 6 7 8 16 17 20 21 22 23 24	1 2 4 6 7 8 9 11 14 15 16 18 21 23 24	0 2 3 5 6 7 10 13 15 16 17 19 20 21 24	0 2 3 4 6 7 8 13 14 15 16 19 21 23 24	1 2 3 4 5 6 7 8 17 18 19 20 21 23 24	0 2 3 4 5 6 7 8 17 18 19 20 21 22 24	1 2 3 4 5 6 7 8 16 17 18 19 20 21 22 23 24	1 2 3 4 5 6 7 8 16 17 20 21 22 23 24	1 2 4 6 7 8 9 11 14 15 16 18 21 23 24
10 MHz	1 2 3 4 6 7 9 10 11 13 14 15 17 18 19 28 29 30 34 35 37 38 39 41 42 44 46 47 48 49	2 3 4 5 6 7 8 9 10 11 12 13 14 16 17 18 19 21 30 32 34 35 36 37 39 40 41 43 45 48	2 4 5 6 7 8 9 11 12 13 14 16 18 20 21 28 29 30 31 32 33 34 41 43 44 45 46 47 48 49	1 4 5 6 7 8 11 12 13 14 15 17 19 20 21 28 29 30 31 32 34 37 38 41 42 44 46 47 48 49	0 1 2 5 6 7 8 11 13 14 15 16 18 20 21 24 25 26 28 27 30 32 34 35 37 38 40 41 43 46 47 49	2 4 5 6 7 9 10 11 15 18 19 20 21 24 25 26 28 29 30 32 33 35 36 38 40 41 43 44 48 49	2 5 6 7 8 9 10 11 14 15 16 18 19 20 21 23 27 28 30 32 33 34 37 41 42 44 45 46 47 49	1 2 3 4 6 7 9 10 11 13 14 15 17 18 19 28 29 30 34 35 37 38 39 41 42 44 46 47 48 49	2 3 4 5 6 7 8 9 10 11 12 13 14 16 17 18 19 21 30 32 34 35 36 37 39 40 41 43 45 48	2 4 5 6 7 8 9 10 11 12 13 13 14 16 18 20 21 28 29 30 31 32 33 34 35 36 37 39 40 43 44 45 46 47 48 49	1 4 5 6 7 8 11 11 12 13 14 14 15 16 18 20 21 28 29 30 31 32 33 34 41 43 44 45 46 47 48 49	0 1 2 5 6 7 8 11 13 14 15 16 18 20 21 24 25 26 28 29 30 32 33 35 37 38 39 41 42 44 46 47 48 49
15 MHz	1 3 4 5 6 7 8 9 10 11 13 15 16 17 19 20 21 22 23 24 25 26 27 28 29 33 42 44 45 46 51 52 53 55 56 57 58 59 60 61 62 63 64 65 66 70 71 72 73 74	2 3 4 6 7 8 9 10 11 12 13 14 15 16 18 19 20 22 24 25 27 28 30 31 32 41 42 43 44 45 46 48 49 50 51 52 55 56 57 58 61 62 63 65 66 67 68 69 70 71 73 74	0 1 2 3 6 7 8 9 10 11 12 13 16 17 18 19 20 21 22 23 24 26 27 28 30 31 32 41 33 41 43 45 46 47 48 51 53 55 56 57 58 60 58 61 62 63 64 65 66 69 70 71 73 74	3 7 8 9 10 11 12 13 14 15 16 17 22 23 24 27 28 29 30 31 42 43 45 46 48 49 50 53 54 55 56 57 58 60 61 62 63 64 65 66 67 68 69 70 71 72 73 74	0 1 2 3 4 6 9 10 11 13 14 15 16 17 20 21 22 23 24 25 28 29 34 37 43 44 46 47 48 49 51 52 53 54 55 57 59 61 62 63 64 65 67 68 69 70 71 72 73 74	0 1 3 4 5 8 9 10 11 12 13 14 15 16 19 20 22 24 25 26 27 28 31 32 33 34 35 36 37 38 40 42 43 44 45 46 47 48 50 51 52 55 56 59 60 61 66 67 69 74	1 3 4 5 7 8 9 10 12 13 14 15 16 17 19 20 21 23 26 27 28 29 30 31 32 33 34 36 37 38 39 42 43 44 45 46 52 53 57 58 59 60 62 63 64 65 69 71 72 73 74	1 3 4 5 6 7 8 9 10 11 13 15 16 17 19 20 21 22 23 24 25 26 27 28 29 33 42 44 45 46 51 52 53 55 56 57 58 59 60 61 62 63 64 65 66 70 71 72 73 74	2 3 4 6 7 8 9 10 11 12 13 14 15 16 18 19 20 22 24 25 27 28 30 31 32 41 42 43 44 45 46 48 49 50 51 52 55 58 59 58 61 62 63 65 66 67 68 69 70 71 73 74	0 1 2 3 6 7 8 9 10 11 12 13 16 17 18 19 20 21 22 23 24 26 27 28 30 31 32 41 33 41 43 45 46 47 48 49 50 51 53 55 56 57 58 60 58 61 62 63 64 65 66 69 70 71 73 74	3 7 8 9 10 11 12 13 14 15 16 17 22 23 24 27 28 29 30 31 42 43 45 46 48 49 50 53 54 55 56 57 58 60 61 62 63 64 65 66 67 68 69 70 71 72 73 74	0 1 2 3 4 6 9 10 11 13 14 15 16 17 20 20 22 24 25 26 27 28 31 32 33 34 35 36 37 38 39 42 43 44 45 46 52 53 57 58 59 60 62 63 64 65 69 71 72 73 74

20	2 4 5 6	2 4 5 8	0 2 3 4	1 4 9	0 1 3 4	0 2 4 5	1 3 4 5	2 4 5 6	2 4 5 8	0 2 3 4	1 4 9	0 1 3 4
MH	7 8 9	9 10 11	9 10 11	10 12	5 7 8	6 7 11	6 7 9	7 8 9	9 10 11	9 10 11	10 12	5 7 8
z	10 11	12 13	12 13	13 14	12 13	12 13	10 13	10 11	12 13	12 13	13 14	12 13
	12 13	14 16	14 15	15 17	14 15	14 16	16 18	12 13	14 16	14 15	15 17	14 15
	14 17	17 18	17 18	18 19	17 19	17 18	20 21	14 17	17 18	17 18	18 19	17 19
	18 19	19 22	21 22	20 21	20 22	19 20	24 25	18 19	19 22	21 22	20 21	20 22
	20 21	24 25	23 24	22 23	23 25	21 23	26 27	20 21	24 25	23 24	22 23	23 25
	22 23	26 27	25 26	29 30	26 28	27 28	28 30	22 23	26 27	25 26	29 30	26 28
	25 27	29 30	27 28	31 32	30 31	30 31	31 32	25 27	29 30	27 28	31 32	30 31
	28 29	32 33	30 31	33 36	33 35	32 35	35 37	28 29	32 33	30 31	33 36	33 35
	31 32	36 37	32 35	37 39	37 38	37 38	38 41	31 32	36 37	32 35	37 39	37 38
	33 34	38 40	36 37	40 41	39 41	40 43	42 43	33 34	38 40	36 37	40 41	39 41
	35 37	41 42	38 40	42 43	45 48	44 45	44 46	35 37	41 42	38 40	42 43	45 48
	38 39	43 45	41 42	46 53	49 50	46 47	47 48	38 39	43 45	41 42	46 53	49 50
	43 44	46 53	43 53	54 55	51 58	50 51	50 51	43 44	46 53	43 53	54 55	51 58
	46 53	54 55	54 55	56 57	59 62	53 56	52 53	46 53	54 55	54 55	56 57	59 62
	56 58	57 58	57 60	58 60	63 65	57 58	54 57	56 58	57 58	57 60	58 60	63 65
	60 61	60 62	61 63	61 64	67 68	59 60	59 60	60 61	60 62	61 63	61 64	67 68
	68 69	64 65	64 65	66 68	69 70	61 62	61 62	68 69	64 65	64 65	66 68	69 70
	70 71	66 67	66 68	69 71	71 72	63 64	64 67	70 71	66 67	66 68	69 71	71 72
	73 74	68 69	70 74	72 73	73 75	65 68	70 71	73 74	68 69	70 74	72 73	73 75
	75 76	74 78	76 77	74 75	76 78	70 71	73 76	75 76	74 78	76 77	74 75	76 78
	78 79	82 83	81 82	80 82	82 84	73 77	77 78	78 79	82 83	81 82	80 82	82 84
	80 82	84 86	84 85	83 84	85 86	79 80	79 81	80 82	84 86	84 85	83 84	85 86
	83 85	88 89	87 88	86 87	89 90	82 85	82 84	83 85	88 89	87 88	86 87	89 90
	86 87	90 91	89 93	89 90	91 92	87 89	86 87	86 87	90 91	89 93	89 90	91 92
	88 93	92 93	94 95	92 93	93 94	92 95	88 91	88 93	92 93	94 95	92 93	93 94
	95 97	95 97	97 98	94 95	96 97	96 97	95 98	95 97	95 97	97 98	94 95	96 97
	99	99	99	96 98	98	98	99	99	99	99	96 98	98
				99							99	

Frame 1	Subframe 9	
Subslot	0	1
3 MHz	2 3 4 6 8 13 14	0 3 6 8 9 10 14
5 MHz	0 2 3 5 6 7 10 13 15 16 17 19 20 21 24	0 2 3 4 6 7 8 13 14 15 16 19 21 23 24
10 MHz	2 4 5 6 7 9 10 11 15 18 19 20 21 24 25 26 28 29 30 32 33 35 36 38 40 41 43 44 48 49	2 5 6 7 8 9 10 11 14 15 16 18 19 20 21 23 27 28 30 32 33 34 37 41 42 44 45 46 47 49
15 MHz	0 1 3 4 5 8 9 10 11 12 13 14 15 16 19 20 22 24 25 26 27 28 31 32 33 34 35 36 37 38 40 42 43 44 45 46 47 48 50 51 52 55 56 59 60 61 66 67 69 74	1 3 4 5 7 8 9 10 12 13 14 15 16 17 19 20 21 23 26 27 28 29 30 31 32 33 34 36 37 38 39 42 43 44 45 46 52 53 57 58 59 60 62 63 64 65 69 71 72 73
20 MHz	0 2 4 5 6 7 11 12 13 14 16 17 18 19 20 21 23 27 28 30 31 32 35 37 38 40 43 44 45 46 47 50 51 53 56 57 58 59 60 61 62 63 64 65 68 70 71 73 77 79 80 82 85 87 89 92 95 96 97 98	1 3 4 5 6 7 9 10 13 16 18 20 21 24 25 26 27 28 30 31 32 35 37 38 41 42 43 44 46 47 48 50 51 52 53 54 57 59 60 61 62 64 67 70 71 73 76 77 78 79 81 82 84 86 87 88 91 95 98 99

Frame 2	Subframe 0		Subframe 1		Subframe 5		Subframe 6		Subframe 7		Subframe 8	
	0	1	0	1	0	1	0	1	0	1	0	1
3 MHz	0 1 2 3 12 13 14	0 1 2 3 11 12 13	1 2 3 11 12 13 14	0 1 2 11 12 13 14	2 4 7 8 9 10 11	0 1 3 4 5 13 14	0 4 6 8 9 11 12	0 1 2 3 12 13 14	0 1 2 3 11 12 13	1 2 3 11 12 13 14	0 1 2 11 12 13 14	2 4 7 8 9 10 11
5 MHz	0 2 3 4 5 6 7 16 17 18 19 20 21 22 23	0 1 2 3 4 5 7 8 16 17 18 19 20 23 24	1 2 3 4 5 7 8 16 17 18 20 21 22 23 24	0 1 3 4 5 7 8 16 17 18 19 20 21 22 24	0 1 3 6 7 9 12 14 17 18 20 21 22 23 24	2 3 4 5 6 7 9 11 12 14 15 17 18 21 24	0 1 3 4 5 8 10 11 12 14 16 17 20 22 24	0 2 3 4 5 6 7 16 17 18 19 20 21 22 23	0 1 2 3 4 5 7 8 16 17 18 19 20 23 24	1 2 3 4 5 7 8 16 17 18 20 21 22 23 24	0 1 3 4 5 7 8 16 17 18 19 20 21 22 24	0 1 3 6 7 9 12 14 17 18 20 21 22 23 24
10 MHz	0 1 2 6 7 8 9 11 13 14 15 16 19 29 30 32 34 35 36 37 38 39 41 42 43 44 45 47 48 49	0 2 3 4 6 7 8 9 10 11 12 15 16 17 18 19 20 29 31 33 34 35 36 37 42 45 46 47 48 49	0 1 2 3 5 6 7 8 9 10 13 14 15 16 18 20 21 28 29 30 31 32 34 35 39 40 41 42 44 46	1 2 3 4 5 6 8 9 10 11 12 13 15 16 17 18 19 21 30 35 38 39 40 41 42 43 46 47 48 49	1 2 3 5 6 13 14 15 16 17 19 20 23 27 29 30 31 32 33 35 38 39 40 41 43 44 47 49	0 1 2 5 9 12 13 14 16 17 18 22 25 28 29 30 31 33 35 36 38 39 41 42 44 45 47 49	0 1 2 3 4 5 7 8 9 10 12 13 14 15 16 18 22 27 28 29 30 31 32 33 34 42 43 45 46 49	0 1 2 6 7 8 9 11 13 14 15 16 19 29 30 32 34 35 36 37 38 39 41 42 43 44 45 47 48 49	0 2 3 4 6 7 8 9 10 11 12 15 16 17 18 19 20 29 31 33 34 35 36 37 42 45 46 47 48 49	0 1 2 3 5 6 7 8 9 10 13 14 15 16 18 20 21 28 29 30 31 32 34 35 39 40 41 42 44 46	1 2 3 4 5 6 8 9 10 11 12 13 15 16 17 18 20 21 28 29 30 31 32 34 38 39 40 41 42 43 46 47 48 49	1 2 3 5 6 13 14 15 16 17 19 22 25 27 29 30 35 33 39 40 41 42 43 44 47 49
15 MHz	0 1 2 3 4 5 6 7 8 10 11 14 15 16 18 19 20 21 23 24 25 26 27 28 31 32 33 41 43 44 45 46 47 48 50 52 53 55 57 58 59 61 63 65 66 67 68 69 71 74	1 2 3 4 5 6 7 8 9 10 11 13 14 15 16 18 20 21 22 23 27 28 29 30 33 42 43 45 46 50 51 52 55 54 55 56 58 61 64 65 66 68 69 70 71 72 73 74	0 1 2 4 5 6 7 8 9 10 11 12 13 14 15 16 18 20 22 24 25 26 29 32 33 44 45 46 49 50 51 52 55 58 59 60 61 63 64 65 66 68 69 70 71 72 73 74	0 1 2 3 4 5 6 7 8 9 10 11 13 14 15 16 17 18 19 21 23 22 23 24 26 29 30 32 33 42 45 46 47 49 50 51 53 54 55 56 57 58 60 62 63 66 67 69 71 72 73 74	1 3 4 5 6 7 9 10 11 12 14 15 16 17 18 19 20 21 22 24 26 29 30 32 33 39 40 34 35 36 38 39 41 42 44 45 47 48 49 53 54 50 52 55 56 57 58 59 60 62 63 65 66 68 71 71 73 74	1 3 4 6 7 8 10 11 13 14 15 21 22 23 24 26 27 28 29 30 31 32 35 39 40 43 44 45 46 47 48 49 50 51 52 53 54 55 56 57 58 62 63 64 66 65 66 68 71 68 71 74	0 1 2 5 6 7 10 11 12 16 17 18 19 22 23 25 27 28 29 30 31 33 34 35 36 37 39 40 43 45 46 46 47 47 48 48 50 52 53 55 57 58 59 61 63 65 66 62 63 64 66 67 68 69 71 73	0 1 2 3 4 5 6 7 8 10 11 14 15 16 18 19 20 21 23 24 25 26 27 28 31 32 33 41 43 44 45 46 47 48 50 52 53 55 57 58 59 61 63 65 66 68 69 70 71 72 73 74	1 2 3 4 5 6 7 8 9 10 11 13 14 15 16 18 20 21 22 23 27 28 29 30 33 42 43 45 46 47 49 50 51 52 53 54 55 56 58 61 64 65 66 68 69 70 71 72 73 74	0 1 2 4 5 6 7 8 9 10 11 12 13 14 15 16 18 20 22 24 25 26 29 32 33 44 45 46 49 50 51 52 55 58 59 60 61 63 64 65 66 68 69 70 71 72 73 74	0 1 2 3 4 5 6 7 8 9 10 11 13 14 15 16 17 18 19 21 23 22 23 24 26 29 30 32 33 44 45 46 49 50 51 52 55 54 55 56 57 58 60 62 63 65 66 68 69 70 71 72 73 74	1 3 4 5 6 7 9 10 11 12 14 15 16 17 18 19 20 26 27 28 29 30 31 32 35 39 40 43 44 45 46 46 47 47 48 48 50 52 53 55 57 58 59 61 63 65 66 68 69 70 71 72 73 74

20 MH z	0 1 2 3	0 2 3 4	0 1 2 4	0 1 2 3	0 1 2 4	0 1 2 3	3 4 6 7	0 1 2 3	0 2 3 4	0 1 2 4	0 1 2 3	0 1 2 4
	4 5 7 8	7 8 10	5 6 7	4 6 7 8	6 8 9	7 8 9	9 10 11	4 5 7 8	7 8 10	5 6 7	4 6 7 8	6 8 9
	9 10 11	11 12	10 11	9 12 13	10 11	13 15	12 13	9 10 11	11 12	10 11	9 12 13	10 11
	15 17	13 14	12 13	15 16	14 15	16 21	14 15	15 17	13 14	12 13	15 16	14 15
	19 20	15 16	14 15	18 19	18 19	23 24	17 19	19 20	15 16	14 15	18 19	18 19
	21 24	17 18	16 18	20 22	20 21	25 29	22 23	21 24	17 18	16 18	20 22	20 21
	26 27	19 20	19 20	24 25	25 29	30 31	25 26	26 27	19 20	19 20	24 25	25 29
	28 29	22 24	21 23	27 28	31 32	33 34	27 33	28 29	22 24	21 23	27 28	31 32
	31 32	25 27	24 25	29 30	34 36	36 37	34 37	31 32	25 27	24 25	29 30	34 36
	33 34	30 35	29 32	32 35	37 38	38 39	39 40	33 34	30 35	29 32	32 35	37 38
	36 37	37 39	33 34	39 40	40 41	40 41	41 43	36 37	37 39	33 34	39 40	40 41
	44 45	41 42	40 42	42 43	42 47	42 44	45 46	44 45	41 42	40 42	42 43	42 47
	54 56	44 53	43 44	44 57	52 53	45 46	47 48	54 56	44 53	43 44	44 57	52 53
	57 58	56 57	45 46	59 60	54 57	47 48	49 50	57 58	56 57	45 46	59 60	54 57
	59 60	59 61	53 54	61 63	58 59	49 52	53 55	59 60	59 61	53 54	61 63	58 59
	61 63	62 63	55 57	64 65	60 62	53 57	56 58	61 63	62 63	55 57	64 65	60 62
	65 67	66 67	59 60	66 67	63 64	60 62	60 61	65 67	66 67	59 60	66 67	63 64
	68 69	69 70	61 62	68 69	65 67	63 64	62 63	68 69	69 70	61 62	68 69	65 67
	70 73	73 74	63 67	70 72	68 69	65 66	65 69	70 73	73 74	63 67	70 72	68 69
	77 79	75 76	68 71	73 74	70 71	69 72	71 72	77 79	75 76	68 71	73 74	70 71
83 85	77 78	72 73	75 76	73 74	73 74	73 74	83 85	77 78	72 73	75 76	73 74	
86 87	79 80	75 77	81 82	75 76	75 77	76 77	86 87	79 80	75 77	81 82	75 76	
88 89	81 82	81 82	83 84	77 78	81 82	78 79	88 89	81 82	81 82	83 84	77 78	
90 91	84 85	84 85	88 89	79 80	83 84	80 82	90 91	84 85	84 85	88 89	79 80	
92 93	86 88	87 91	90 92	84 85	86 88	83 85	92 93	86 88	87 91	90 92	84 85	
94 95	89 90	92 93	94 95	86 87	89 90	87 91	94 95	89 90	92 93	94 95	86 87	
96 98	91 92	95 96	97 98	88 90	91 92	92 94	96 98	91 92	95 96	97 98	88 90	
99	94 96	97 98	99	92 95	93 95	95 96	99	94 96	97 98	99	92 95	
	98	99		99	97	99		98	99		99	

e	Subframe 9	
	0	1
3 MHz	0 1 3 4 5 13 14	0 4 6 8 9 11 12
5 MHz	2 3 4 5 6 7 9 11 12 14 15 17 18 21 24	0 1 3 4 5 8 10 11 12 14 16 17 20 22 24
10 MHz	0 1 2 5 9 12 13 14 16 17 18 22 25 26 27 28 29 30 31 33 35 36 38 39 41 42 44 45 47 49	0 1 2 3 4 5 7 8 9 10 12 13 14 15 16 18 22 27 28 29 30 31 32 33 34 42 43 45 46 49
15 MHz	1 3 4 6 7 8 10 11 13 14 15 21 22 23 24 26 27 28 29 30 31 32 35 39 40 43 44 45 46 47 48 49 50 51 52 53 54 55 56 57 58 59 60 63 64 65 66 68 71 74	0 1 2 5 6 7 10 11 12 16 17 18 19 22 23 25 27 28 29 30 31 33 34 35 36 37 39 40 43 45 46 47 48 49 50 52 54 55 56 58 61 62 63 64 66 67 68 69 71 73
20 MHz	0 1 2 3 7 8 9 13 15 16 21 23 24 25 29 30 31 33 34 36 37 38 39 40 41 42 44 45 46 47 48 49 52 53 57 60 62 63 64 65 66 69 72 73 74 75 77 81 82 83 84 86 88 89 90 91 92 93 95 97	3 4 6 7 9 10 11 12 13 14 15 17 19 22 23 25 26 27 33 34 37 39 40 41 43 45 46 47 48 49 50 53 55 56 58 60 61 62 63 65 69 71 72 73 74 76 77 78 79 80 82 83 85 87 91 92 94 95 96 99

6.1.1.6 E-UTRA Test Model 3.3 (E-TM3.3)

This model shall be used for tests on:

- Transmitted signal quality
- Frequency error
- EVM for QPSK modulation

Table 6.1.1.6-1: Physical channel parameters of E-TM3.3

Parameter	1.4 MHz	3 MHz	5 MHz	10 MHz	15 MHz	20 MHz
Reference, Synchronisation Signals						
RS boosting, $P_B = E_B/E_A$	1	1	1	1	1	1
Synchronisation signal EPRE / E_{RS} [dB]	0.000	2.189	2.580	2.427	2.477	2.427
Reserved EPRE / E_{RS} [dB]	-inf	-inf	-inf	-inf	-inf	-inf
PBCH						
PBCH EPRE / E_{RS} [dB]	0.000	2.189	2.580	2.427	2.477	2.427
Reserved EPRE / E_{RS} [dB]	-inf	-inf	-inf	-inf	-inf	-inf
PCFICH						
# of symbols used for control channels	2	1	1	1	1	1
PCFICH EPRE / E_{RS} [dB]	3.222	0	0	0	0	0
PHICH						
# of PHICH groups	1	1	1	2	2	3
# of PHICH per group	2	2	2	2	2	2
PHICH BPSK symbol power / E_{RS} [dB]	-3.010	-3.010	-3.010	-3.010	-3.010	-3.010
PHICH group EPRE / E_{RS} [dB]	0	0	0	0	0	0
PDCCH						
# of available REGs	23	23	43	90	140	187
# of PDCCH	2	2	2	5	7	10
# of CCEs per PDCCH	1	1	2	2	2	2
# of REGs per CCE	9	9	9	9	9	9
# of REGs allocated to PDCCH	18	18	36	90	126	180
# of <NIL> REGs added for padding	5	5	7	0	14	7
PDCCH REG EPRE / E_{RS} [dB]	0.792	2.290	1.880	1.065	1.488	1.195
<NIL> REG EPRE / E_{RS} [dB]	-inf	-inf	-inf	-inf	-inf	-inf
PDSCH						
# of QPSK PDSCH PRBs within a slot for which EVM is measured	3	7	13	25	38	50
PRB $P_A = E_A/E_{RS}$ [dB]	-6 (Note 1)	-6	-6	-6	-6	-6
# of 16QAM PDSCH PRBs within a slot for which EVM is not measured (used for power balancing only)	3	8	12	25	37	50

PRB $P_A = E_A/E_{RS}$ [dB]	2.427 (Note 1)	2.189	2.580	2.427	2.477	2.427
Note 1: In subframes containing PBCH or synchronisation signal REs, no PRB boosting/deboosting shall be applied, i.e. PRB $P_A = E_A/E_{RS} = 0$ [dB].						

Table 6.1.1.6-2: Numbers (n_{PRB}) of the QPSK PRBs (FDD)

	Subframe e 0	Subframe e 1	Subframe e 2	Subframe e 3	Subframe e 4	Subframe e 5	Subframe e 6	Subframe e 7	Subframe e 8	Subframe e 9
1.4 MHz	2 3 5	1 2 3	0 1 3	1 2 3	2 3 5	1 2 5	0 2 5	0 2 5	1 2 5	1 3 5
3 MHz	0 1 2 3 8 16 17 11 12 13	0 3 4 10 11 12 13	0 2 3 5 6 11 13	0 1 4 5 7 10 12	0 2 3 4 9 10 13	0 1 2 3 11 12 14	4 5 6 8 11 13 14	2 5 6 9 12 13 14	0 3 4 7 8 9 11	1 2 3 4 5 11 12
5 MHz	0 1 3 6 7 8 16 17 18 20 21 23 24	0 1 2 4 5 6 9 10 12 17 18 20 24	0 1 2 3 9 10 12 13 14 19 20 23 24	0 5 6 8 10 12 13 15 17 18 20 21 24	0 2 4 6 7 12 13 15 16 17 22 23 24	0 1 2 3 4 6 7 8 16 18 21 22 24	1 3 4 5 7 9 10 11 12 15 21 22 24	0 1 2 3 4 7 10 14 18 19 20 21 24	1 4 8 9 10 11 12 13 15 16 18 20 23	1 2 3 4 5 6 9 10 11 13 16 17 23
10 MHz	1 2 3 5 6 7 8 9 10 11 15 16 20 28 31 32 33 35 36 39 40 42 46 47 48	1 2 4 5 6 7 9 11 15 18 20 21 22 24 25 27 29 34 35 36 37 40 44 46 49	0 3 5 6 11 12 14 17 18 19 20 21 22 24 25 26 27 28 29 31 34 38 41 42 49	0 1 2 3 5 6 8 14 16 18 22 23 26 28 30 32 34 38 39 40 41 42 45 46 47	0 3 6 7 8 9 10 12 13 16 17 18 21 23 25 31 33 37 41 42 45 46 47 48 49	0 2 3 4 5 7 9 10 11 12 13 15 18 21 23 29 30 31 34 36 37 42 44 48 49	0 1 4 5 6 8 9 10 13 16 17 18 19 20 21 24 29 30 31 32 35 37 38 39 47	0 2 3 4 5 6 7 9 10 12 16 17 18 19 22 24 25 26 30 31 34 37 42 45 48	5 7 8 9 14 15 16 21 22 27 28 30 31 32 34 35 37 38 41 42 43 44 46 48 49	3 9 11 13 16 17 18 21 24 27 28 29 30 32 34 37 38 39 40 41 42 45 47 48 49
15 MHz	0 1 2 3 5 6 7 8 9 12 16 17 18 19 20 21 23 24 25 28 29 30 31 32 33 42 47 48 49 53 60 63 65 67 68 70 71 73	0 1 3 4 5 6 7 8 11 18 20 21 24 25 26 27 29 30 31 38 46 47 49 50 51 53 54 55 57 59 60 61 67 68 69 70 73 74	2 11 12 13 15 17 18 21 22 24 25 26 29 31 32 33 34 40 33 34 40 42 45 46 47 50 51 52 54 58 59 60 61 62 63 64 68 70 71 72 74	2 3 4 6 7 9 11 12 15 17 20 24 27 30 27 28 29 30 31 32 33 34 35 38 39 42 43 45 46 48 49 55 56 59 60 61 62 65 67 69 70 71 73 74 74	4 5 6 8 10 13 17 22 25 26 27 28 29 30 31 32 33 34 35 38 41 44 46 48 50 52 53 54 60 62 63 65 66 67 68 69 70 70 71 73 74	0 2 3 4 7 8 11 14 18 20 23 24 25 27 29 42 43 45 46 47 48 49 50 51 54 56 60 62 63 65 66 67 68 69 70 71 72 73 73	1 2 9 11 14 15 18 25 26 28 29 30 31 32 33 36 37 38 39 41 43 45 46 50 53 54 58 59 60 62 63 65 67 68 70 71 72 73	3 4 6 7 8 11 12 19 20 23 24 26 27 28 30 33 34 35 40 41 42 46 49 51 53 54 58 59 60 61 62 65 67 69 70 71 72 73 73 74	0 1 2 3 7 8 9 10 13 14 15 17 18 19 22 23 24 25 26 27 28 32 36 37 39 46 47 50 53 56 61 62 63 68 69 71 73 74 71	0 3 7 8 11 13 14 16 18 19 23 25 27 28 29 30 32 35 41 42 44 46 47 48 50 53 55 57 59 61 62 64 66 67 68 69 70 71
20 MHz	0 1 4 6 10 13 14 15 16 20 22 23 25 26 28 29 30 31 32 33 36 39 41 42 44 45 54 56 57 60 63 66 67 68 72 76 77 79 82 84 85 87 88 91 92 94 95 97 98 99	1 3 7 9 10 13 19 20 21 22 23 24 25 26 27 30 33 34 35 36 47 48 49 50 51 53 54 55 57 59 60 61 64 65 67 68 75 76 77 80 81 83 84 86 87 89 90 93 95 99	1 2 3 6 8 10 11 15 16 17 19 21 25 26 28 29 30 32 33 35 38 39 40 41 42 43 44 46 49 51 52 54 60 62 63 64 65 69 70 72 76 77 80 81 81 84 86 88 89 90 93 94 99	5 7 9 10 12 14 15 16 21 22 23 24 27 28 29 30 33 34 35 36 37 39 41 44 45 47 49 54 55 56 57 64 66 68 70 72 76 77 80 81 85 86 87 90 91 92 94 95 98 99	2 3 4 5 6 7 14 15 17 19 21 22 24 26 37 40 42 43 44 47 49 51 54 56 57 60 62 63 65 66 67 70 71 73 76 77 78 81 82 83 84 85 86 87 89 94 95 96 97 99	1 2 5 6 8 9 12 13 21 22 25 26 27 28 29 31 32 34 35 39 40 43 45 46 53 57 59 61 62 63 64 66 68 69 71 73 75 77 78 82 83 84 85 86 93 94 95 96 97 99	0 1 2 3 5 8 9 10 12 13 22 25 26 27 29 31 32 33 36 37 38 39 43 45 48 49 52 53 55 59 62 63 64 71 72 73 74 75 77 78 81 82 84 86 89 91 93 97 98 99	0 1 3 4 5 7 10 11 15 18 19 20 21 26 27 29 30 31 33 35 39 40 41 43 44 46 47 49 50 53 55 56 62 64 65 66 67 69 70 71 72 74 83 84 86 92 93 94 96 98	2 3 4 7 9 11 13 15 16 24 25 27 29 31 33 35 36 40 43 44 45 46 49 51 52 53 54 55 56 57 59 63 64 65 68 71 77 78 81 82 83 84 85 86 90 91 93 94 98 99	0 4 6 7 8 10 11 13 16 18 21 22 23 26 29 32 35 36 37 43 44 46 47 48 49 53 54 57 59 60 61 64 66 67 68 69 70 72 76 78 80 81 82 84 87 89 91 92 95 96

Table 6.1.1.6-3: Numbers (n_{PRB}) of the QPSK PRBs (TDD)

Frame1	Subframe 0	Subframe 1	Subframe 5	Subframe 6	Subframe 7	Subframe 8	Subframe 9
1.4 MHz	1 3 4	1 4 5	0 1 2	0 2 4	2 4 5	0 3 4	1 2 5
3 MHz	0 1 2 3 11 12 14	0 1 2 3 11 12 13	0 1 2 3 11 12 14	0 1 2 3 11 12 13	1 2 7 8 10 13 14	2 3 4 6 8 13 14	0 3 6 8 9 10 14
5 MHz	1 2 3 5 6 8 17 18 19 20 21 23 24	0 1 2 3 4 5 7 8 17 18 19 20 22	1 2 3 5 6 7 8 17 18 19 20 21 24	1 2 3 4 5 6 8 16 17 19 20 22 23	1 2 3 8 12 13 14 17 20 21 22 23 24	1 4 5 6 7 10 11 13 14 15 16 22 23	1 2 4 6 7 8 9 14 16 18 21 23 24
10 MHz	2 3 4 6 7 10 11 13 15 17 18 19 29 30 34 35 37 38 39 41 42 46 47 48 49	1 3 4 5 6 7 9 10 12 14 16 17 28 30 34 35 36 37 38 39 40 41 43 44 48	2 3 4 6 7 8 9 10 11 13 14 16 18 19 20 21 29 32 34 39 41 43 44 45 46	2 5 8 9 11 12 13 14 16 18 20 21 28 29 30 31 32 33 34 42 44 45 46 47 49	1 4 5 6 7 11 12 13 14 15 17 20 21 26 27 31 32 34 37 38 41 42 46 48 49	0 1 5 6 7 8 11 12 13 15 19 20 26 28 29 30 31 32 37 38 42 43 44 47 49	1 2 5 6 8 11 13 14 15 16 18 20 21 24 25 27 30 32 34 35 37 40 43 46 47
15 MHz	1 3 5 6 9 10 11 13 15 17 20 21 23 24 25 26 27 28 29 33 42 44 45 51 52 53 56 57 58 61 62 63 65 66 70 71 73 74	3 4 5 6 7 8 9 10 13 14 15 16 19 20 21 22 24 25 28 31 32 33 43 45 46 49 51 52 55 58 59 60 61 62 64 66 67 72	3 4 7 8 10 11 12 13 14 16 18 19 20 22 24 25 27 28 30 32 41 42 43 44 45 46 48 50 51 62 65 67 68 69 70 71 73 74	2 6 7 8 9 10 11 13 16 17 18 19 20 21 22 23 26 30 31 41 43 45 46 47 48 51 55 57 58 62 63 64 65 69 70 71 73 74	0 1 2 3 7 8 9 10 11 12 17 19 21 22 23 24 27 28 30 31 32 37 40 41 45 48 51 53 55 56 57 58 61 63 65 66 70 73	3 7 10 11 13 15 16 17 23 27 29 30 31 32 35 36 37 40 42 43 45 46 48 49 50 53 54 57 60 62 64 65 66 67 68 69 72 74	1 3 8 9 11 12 13 14 15 17 22 23 24 25 28 29 30 31 34 37 40 41 42 46 48 49 51 54 55 56 61 62 63 67 70 71 73 74
20 MHz	2 4 7 8 9 10 11 12 13 14 18 20 21 23 25 27 28 31 32 34 35 37 38 39 44 46 53 56 58 60 61 68 69 70 71 74 75 76 78 79 80 82 83 85 87 88 93 95 97 99	4 5 6 7 8 9 11 12 13 14 16 17 19 20 22 25 27 29 33 37 38 40 41 42 43 44 45 53 54 57 58 61 62 65 67 68 70 73 78 80 82 83 86 88 89 90 91 93 95 97	2 3 4 5 8 9 10 11 12 14 15 17 18 19 22 24 26 27 28 30 32 35 36 37 40 41 42 46 53 55 58 60 61 62 63 64 65 66 68 74 77 82 84 85 87 92 93 97 98 99	0 2 3 4 10 11 12 13 14 17 18 22 23 25 26 27 28 30 31 32 36 37 38 40 41 43 54 55 57 58 60 61 63 64 66 68 70 74 76 77 81 82 84 85 87 88 92 94 95 98	4 9 12 13 15 17 19 20 21 22 29 30 31 36 37 39 40 41 42 43 46 48 49 50 53 54 56 57 58 60 64 66 71 72 73 74 75 80 82 83 86 87 89 90 92 94 95 96 98 99	0 1 4 10 12 14 15 17 18 19 23 28 29 30 31 32 33 37 38 39 42 46 55 61 64 65 66 68 69 70 71 72 73 74 76 78 82 83 84 85 86 89 90 91 93 94 96 97 98 99	0 1 3 4 5 7 8 12 13 14 15 17 19 20 22 23 25 26 30 32 33 35 37 38 39 41 44 45 48 49 50 51 58 59 62 63 67 68 70 72 75 82 84 85 90 92 93 94 96 98

Frame2	Subframe 0	Subframe 1	Subframe 5	Subframe 6	Subframe 7	Subframe 8	Subframe 9
1.4 MHz	1 2 3	1 3 5	0 1 4	0 3 4	1 3 4	2 4 5	0 1 2
3 MHz	0 1 2 3 12 13 14	0 1 2 3 11 12 13	1 2 3 11 12 13 14	0 1 2 11 12 13 14	2 4 7 8 9 10 11	0 1 3 4 5 13 14	0 4 6 8 9 11 12
5 MHz	0 2 3 5 6 7 8 16 17 19 20 21 24	0 2 3 4 5 6 7 16 18 19 22 23 24	0 1 2 3 4 5 6 7 17 18 20 21 23	1 2 3 4 5 7 8 16 17 19 20 22 24	1 2 3 5 7 10 12 14 16 18 20 21 24	1 4 5 9 11 13 15 18 20 21 22 23 24	3 4 5 7 8 9 10 11 12 13 14 18 24
10 MHz	2 5 6 7 9 10 11 15 19 20 21 28 29 30 32 33 35 36 38 40 41 43 44 48 49	2 4 6 8 9 10 11 14 15 16 18 19 20 21 28 30 32 37 40 43 44 45 46 47 49	0 2 5 7 8 9 11 14 15 16 18 19 32 33 34 36 38 41 42 43 44 45 46 48 49	0 1 2 4 6 7 8 9 11 13 14 18 19 29 34 35 36 39 41 42 44 45 47 48 49	0 2 3 6 7 8 10 11 12 15 16 19 20 22 24 25 29 31 33 35 37 42 46 47 49	0 1 2 5 6 7 8 9 10 15 16 17 18 22 23 25 26 28 29 30 31 32 39 41 46	0 1 3 6 9 10 13 14 20 21 22 23 25 28 29 30 31 34 35 36 39 40 42 44 47
15 MHz	0 2 3 4 6 9 10 11 13 14 15 16 17 20 21 22 23 28 29 43 44 48 51 52 53 54 55 57 59 61 63 64 65 67 68 70 72 73	0 1 3 4 5 8 9 10 12 14 15 16 19 20 22 24 25 26 27 28 29 31 33 42 43 46 47 48 50 51 52 56 59 61 67 69 71 74	0 1 5 8 9 10 13 14 15 20 21 23 26 27 28 29 30 32 33 42 43 44 45 47 51 52 55 57 59 60 62 64 65 66 69 71 72 73	2 3 4 5 7 8 10 12 15 16 17 18 19 23 24 26 28 30 31 32 33 41 44 45 46 47 48 50 52 53 57 58 59 61 63 65 66 71	1 2 3 4 5 7 8 14 18 19 20 21 24 25 27 28 33 35 38 40 43 45 46 47 50 52 53 55 58 61 62 63 65 66 67 68 71 74	0 1 2 3 4 5 6 7 8 11 13 14 15 16 20 21 23 24 27 33 35 41 43 44 45 47 48 50 51 52 64 65 68 69 70 71 73 74	1 3 5 6 8 9 10 11 13 14 16 18 20 22 28 29 30 35 36 37 38 42 43 46 47 49 50 51 55 56 59 60 61 68 69 72 73 74
20 MHz	0 2 5 6 7 11 12 13 14 16 17 18 19 20 21 27 28 30 31 35 37 38 40 43 44 45 46 53 56 57 59 60 61 62 63 64 65 68 70 73 77 79 80 82 85 87 89 92 95 97	3 4 5 6 7 9 10 13 16 20 21 23 24 25 26 28 30 31 32 35 37 38 41 42 43 44 46 53 54 59 60 61 62 64 67 70 71 76 77 78 79 81 82 84 86 87 88 95 98 99	0 1 2 3 4 5 10 11 15 18 19 20 21 24 25 26 27 28 32 33 34 37 44 54 57 58 59 60 61 62 63 65 67 70 71 73 77 78 83 84 85 88 89 90 91 92 94 95 98 99	1 2 3 4 5 7 8 9 11 15 17 19 20 21 22 24 27 28 29 30 31 32 33 36 41 44 45 56 57 61 62 63 66 67 68 69 73 79 80 82 85 86 87 91 92 93 95 96 98 99	0 2 3 7 11 12 13 14 15 16 17 18 19 20 22 25 27 30 35 37 39 42 44 48 49 52 53 59 62 63 67 69 73 74 75 76 77 78 79 80 81 84 85 86 88 91 92 94 96 98	0 1 2 5 6 8 10 11 12 13 14 15 16 20 21 24 27 29 33 34 39 40 42 43 46 48 50 54 59 60 61 66 70 71 75 76 78 79 82 84 85 87 89 90 91 95 96 97 98 99	1 2 3 4 6 7 8 9 15 18 19 20 21 23 24 25 28 29 30 32 35 39 44 45 47 48 51 53 55 57 60 61 62 63 67 68 72 73 74 75 76 77 81 90 92 93 95 96 97 99

Table 6.1.1.6-4: Numbers (n_{PRB}) of the QPSK PRBs (TDD with NB-IoT inband/guard band)

Frame 1	Subframe 0	Subframe 1	Subframe 4	Subframe 5	Subframe 6	Subframe 9
3 MHz	0 1 2 3 11 12 14	0 1 2 3 11 12 13	1 2 7 8 10 13 14	0 1 2 3 11 12 14	0 1 2 3 11 12 13	0 3 6 8 9 10 14
5 MHz	1 2 3 5 6 8 17 18 19 20 21 23 24	0 1 2 3 4 5 7 8 17 18 19 20 22	1 2 3 8 12 13 14 17 20 21 22 23 24	1 2 3 5 6 7 8 17 18 19 20 21 24	0 1 2 3 4 5 7 8 17 18 19 20 22	1 2 4 6 7 8 9 14 16 18 21 23 24
10 MHz	2 3 4 6 7 10 11 13 15 17 18 19 29 30 34 35 37 38 39 41 42 46 47 48 49	1 3 4 5 6 7 9 10 12 14 16 17 28 30 34 35 36 37 38 39 40 41 43 44 48	1 4 5 6 7 11 12 13 14 15 17 20 21 26 27 31 32 34 37 38 41 42 46 48 49	2 3 4 6 7 8 9 10 11 13 14 16 18 19 20 21 29 32 34 39 41 43 44 45 46	1 3 4 5 6 7 9 10 12 14 16 17 28 30 34 35 36 37 38 39 40 41 43 44 48	1 2 5 6 8 11 13 14 15 16 18 20 21 24 25 27 30 32 34 35 37 40 43 46 47
15 MHz	1 3 5 6 9 10 11 13 15 17 20 21 23 24 25 26 27 28 29 33 42 44 45 51 52 53 56 57 58 61 62 63 65 66 70 71 73 74	3 4 5 6 7 8 9 10 13 14 15 16 19 20 21 22 24 25 28 31 32 33 43 45 46 49 51 52 55 58 59 60 61 62 64 66 67 72	0 1 2 3 7 8 9 10 11 12 17 19 21 22 23 24 27 28 30 31 32 37 40 41 45 48 51 53 55 56 57 58 61 63 65 66 70 73	3 4 7 8 10 11 12 13 14 16 18 19 20 22 24 25 27 28 30 32 41 42 43 44 45 46 48 50 51 62 65 67 68 69 70 71 73 74	3 4 5 6 7 8 9 10 13 14 15 16 19 20 21 22 24 25 28 31 32 33 43 45 46 49 51 52 55 58 59 60 61 62 64 66 67 72	1 3 8 9 11 12 13 14 15 17 22 23 24 25 28 29 30 31 34 37 40 41 42 46 48 49 51 54 55 56 61 62 63 67 70 71 73 74
20 MHz	2 4 7 8 9 10 11 12 13 14 18 20 21 23 25 27 28 31 32 34 35 37 38 39 44 46 53 56 58 60 61 68 69 70 71 74 75 76 78 79 80 82 83 85 87 88 93 95 97 99	4 5 6 7 8 9 11 12 13 14 16 17 19 20 22 25 27 29 33 37 38 40 41 42 43 44 45 53 54 57 58 61 62 65 67 68 70 73 78 80 82 83 86 88 89 90 91 93 95 97	4 9 12 13 15 17 19 20 21 22 29 30 31 36 37 39 40 41 42 43 46 48 49 50 53 54 56 57 58 60 64 66 71 72 73 74 75 80 82 83 86 87 89 90 92 94 95 96 98 99	2 3 4 5 8 9 10 11 12 14 15 17 18 19 22 24 26 27 28 30 32 35 36 37 40 41 42 46 53 55 58 60 61 62 63 64 65 66 68 74 77 82 84 85 87 92 93 97 98 99	4 5 6 7 8 9 11 12 13 14 16 17 19 20 22 25 27 29 33 37 38 40 41 42 43 44 45 53 54 57 58 61 62 65 67 68 70 73 78 80 82 83 86 88 89 90 91 93 95 97	0 1 3 4 5 7 8 12 13 14 15 17 19 20 22 23 25 26 30 32 33 35 37 38 39 41 44 45 48 49 50 51 58 59 62 63 67 68 70 72 75 82 84 85 90 92 93 94 96 98

Frame 2	Subframe 0	Subframe 1	Subframe 4	Subframe 5	Subframe 6	Subframe 9
3 MHz	0 1 2 3 12 13 14	0 1 2 3 11 12 13	2 3 4 6 8 13 14	1 2 3 11 12 13 14	0 1 2 3 11 12 13	0 4 6 8 9 11 12
5 MHz	0 2 3 5 6 7 8 16 17 19 20 21 24	0 2 3 4 5 6 7 16 18 19 22 23 24	1 4 5 6 7 10 11 13 14 15 16 22 23	0 1 2 3 4 5 6 7 17 18 20 21 23	0 1 2 3 4 5 7 8 17 18 19 20 22	3 4 5 7 8 9 10 11 12 13 14 18 24
10 MHz	2 5 6 7 9 10 11 15 19 20 21 28 29 30 32 33 35 36 38 40 41 43 44 48 49	2 4 6 8 9 10 11 14 15 16 18 19 20 21 28 30 32 37 40 43 44 45 46 47 49	0 1 5 6 7 8 11 12 13 15 19 20 26 28 29 30 31 32 37 38 42 43 44 47 49	0 2 5 7 8 9 11 14 15 16 18 19 32 33 34 36 38 41 42 43 44 45 46 48 49	1 3 4 5 6 7 9 10 12 14 16 17 28 30 34 35 36 37 38 39 40 41 43 44 48	0 1 3 6 9 10 13 14 20 21 22 23 25 28 29 30 31 34 35 36 39 40 42 44 47
15 MHz	0 2 3 4 6 9 10 11 13 14 15 16 17 20 21 22 23 28 29 43 44 48 51 52 53 54 55 57 59 61 63 64 65 67 68 70 72 73	0 1 3 4 5 8 9 10 12 14 15 16 19 20 22 24 25 26 27 28 29 31 33 42 43 46 47 48 50 51 52 56 59 61 67 69 71 74	3 7 10 11 13 15 16 17 23 27 29 30 31 32 35 36 37 40 42 43 45 46 48 49 50 53 54 57 60 62 64 65 66 67 68 69 72 74	0 1 5 8 9 10 13 14 15 20 21 23 26 27 28 29 30 32 33 42 43 44 45 47 51 52 55 57 59 60 62 64 65 66 69 71 72 73	3 4 5 6 7 8 9 10 13 14 15 16 19 20 21 22 24 25 28 31 32 33 43 45 46 49 51 52 55 58 59 60 61 62 64 66 67 72	1 3 5 6 8 9 10 11 13 14 16 18 20 22 28 29 30 35 36 37 38 42 43 46 47 49 50 51 55 56 59 60 61 68 69 72 73 74
20 MHz	0 2 5 6 7 11 12 13 14 16 17 18 19 20 21 27 28 30 31 35 37 38 40 43 44 45 46 53 56 57 59 60 61 62 63 64 65 68 70 73 77 79 80 82 85 87 89 92 95 97	3 4 5 6 7 9 10 13 16 20 21 23 24 25 26 28 30 31 32 35 37 38 41 42 43 44 46 53 54 59 60 61 62 64 67 70 71 76 77 78 79 81 82 84 86 87 88 95 98 99	0 1 4 10 12 14 15 17 18 19 23 28 29 30 31 32 33 37 38 39 42 46 55 61 64 65 66 68 69 70 71 72 73 74 76 78 82 83 84 85 86 89 90 91 93 94 96 97 98 99	0 1 2 3 4 5 10 11 15 18 19 20 21 24 25 26 27 28 32 33 34 37 44 54 57 58 59 60 61 62 63 65 67 70 71 73 77 78 83 84 85 88 89 90 91 92 94 95 98 99	4 5 6 7 8 9 11 12 13 14 16 17 19 20 22 25 27 29 33 37 38 40 41 42 43 44 45 53 54 57 58 61 62 65 67 68 70 73 78 80 82 83 86 88 89 90 91 93 95 97	1 2 3 4 6 7 8 9 15 18 19 20 21 23 24 25 28 29 30 32 35 39 44 45 47 48 51 53 55 57 60 61 62 63 67 68 72 73 74 75 76 77 81 90 92 93 95 96 97 99

Frame 3	Subframe 0	Subframe 1	Subframe 4	Subframe 5	Subframe 6	Subframe 9
3 MHz	2 4 7 8 9 10 11	0 1 2 3 11 12 13	0 1 3 4 5 13 14	0 1 2 3 11 12 13	0 1 2 3 11 12 13	0 1 2 11 12 13 14
5 MHz	1 2 3 5 7 10 12 14 16 18 20 21 24	0 1 2 3 4 5 7 8 17 18 19 20 22	1 4 5 9 11 13 15 18 20 21 22 23 24	1 2 3 4 5 6 8 16 17 19 20 22 23	0 1 2 3 4 5 7 8 17 18 19 20 22	1 2 3 4 5 7 8 16 17 19 20 22 24
10 MHz	0 2 3 6 7 8 10 11 12 15 16 19 20 22 24 25 29 31 33 35 37 42 46 47 49	1 3 4 5 6 7 9 10 12 14 16 17 28 30 34 35 36 37 38 39 40 41 43 44 48	0 1 2 5 6 7 8 9 10 15 16 17 18 22 23 25 26 28 29 30 31 32 39 41 46	2 5 8 9 11 12 13 14 16 18 20 21 28 29 30 31 32 33 34 42 44 45 46 47 49	1 3 4 5 6 7 9 10 12 14 16 17 28 30 34 35 36 37 38 39 40 41 43 44 48	0 1 2 4 6 7 8 9 11 13 14 18 19 29 34 35 36 39 41 42 44 45 47 48 49
15 MHz	1 2 3 4 5 7 8 14 18 19 20 21 24 25 27 28 33 35 38 40 43 45 46 47 50 52 53 55 58 61 62 63 65 66 67 68 71 74	3 4 5 6 7 8 9 10 13 14 15 16 19 20 21 22 24 25 28 31 32 33 43 45 46 49 51 52 55 58 59 60 61 62 64 66 67 72	0 1 2 3 4 5 6 7 8 11 13 14 15 16 20 21 23 24 27 33 35 41 43 44 45 47 48 50 51 52 64 65 68 69 70 71 73 74	2 6 7 8 9 10 11 13 16 17 18 19 20 21 22 23 26 30 31 41 43 45 46 47 48 51 55 57 58 62 63 64 65 69 70 71 73 74	3 4 5 6 7 8 9 10 13 14 15 16 19 20 21 22 24 25 28 31 32 33 43 45 46 49 51 52 55 58 59 60 61 62 64 66 67 72	2 3 4 5 7 8 10 12 15 16 17 18 19 23 24 26 28 30 31 32 33 41 44 45 46 47 48 50 52 53 57 58 59 61 63 65 66 71
20 MHz	0 2 3 7 11 12 13 14 15 16 17 18 19 20 22 25 27 30 35 37 39 42 44 48 49 52 53 59 62 63 67 69 73 74 75 76 77 78 79 80 81 84 85 86 88 91 92 94 96 98	4 5 6 7 8 9 11 12 13 14 16 17 19 20 22 25 27 29 33 37 38 40 41 42 43 44 45 53 54 57 58 61 62 65 67 68 70 73 78 80 82 83 86 88 89 90 91 93 95 97	0 1 2 5 6 8 10 11 12 13 14 15 16 20 21 24 27 29 33 34 39 40 42 43 46 48 50 54 59 60 61 66 70 71 75 76 78 79 82 84 85 87 89 90 91 95 96 97 98 99	0 2 3 4 10 11 12 13 14 17 18 22 23 25 26 27 28 30 31 32 36 37 38 40 41 43 54 55 57 58 60 61 63 64 66 68 70 74 76 77 81 82 84 85 87 88 92 94 95 98	4 5 6 7 8 9 11 12 13 14 16 17 19 20 22 25 27 29 33 37 38 40 41 42 43 44 45 53 54 57 58 61 62 65 67 68 70 73 78 80 82 83 86 88 89 90 91 93 95 97	1 2 3 4 5 7 8 9 11 15 17 19 20 21 22 24 27 28 29 30 31 32 33 36 41 44 45 56 57 61 62 63 66 67 68 69 73 79 80 82 85 86 87 91 92 93 95 96 98 99

6.1.1.6a E-UTRA subslot TTI Test Model 3.3 (sE-TM3.3-1)

This model shall be used for subslot TTI tests on:

- Transmitted signal quality
- Frequency error
- EVM for QPSK modulation

Table 6.1.1.6a-1: Physical channel parameters of sE-TM3.3-1

Parameter	3 MHz	5 MHz	10 MHz	15 MHz	20 MHz
Reference, Synchronisation Signals					
RS boosting, $P_B = E_B/E_A$	1	1	1	1	1
Synchronisation signal EPRE / E_{RS} [dB]	2.189	2.580	2.427	2.477	2.427
Reserved EPRE / E_{RS} [dB]	-inf	-inf	-inf	-inf	-inf
PBCH					
PBCH EPRE / E_{RS} [dB]	2.189	2.580	2.427	2.477	2.427
Reserved EPRE / E_{RS} [dB]	-inf	-inf	-inf	-inf	-inf
PCFICH					
# of symbols used for control channels	1	1	1	1	1
PCFICH EPRE / E_{RS} [dB]	0	0	0	0	0
PHICH					
# of PHICH groups	1	1	2	2	3
# of PHICH per group	2	2	2	2	2
PHICH BPSK symbol power / E_{RS} [dB]	-3.010	-3.010	-3.010	-3.010	-3.010
PHICH group EPRE / E_{RS} [dB]	0	0	0	0	0
sPDCCH					
# of available sREGs	30 (2OS) 45 (3OS)	50 (2OS) 75 (3OS)	100 (2OS) 150 (3OS)	150 (2OS) 225 (3OS)	200 (2OS) 300 (3OS)
# of sPDCCH	2	2	5	7	10
# of sCCEs per sPDCCH	1	2	2	2	2
# of sREGs per sCCE	4 (2OS) 6 (3OS)	4 (2OS) 6 (3OS)	4 (2OS) 6 (3OS)	4 (2OS) 6 (3OS)	4 (2OS) 6 (3OS)
# of sREGs allocated to sPDCCH	8 (2OS) 12 (3OS)	16 (2OS) 24 (3OS)	40 (2OS) 60 (3OS)	56 (2OS) 84 (3OS)	80 (2OS) 120 (3OS)
# of <NIL> sREGs added for padding	22 (2OS) 33 (3OS)	34 (2OS) 51 (3OS)	60 (2OS) 90 (3OS)	94 (2OS) 161 (3OS)	120 (2OS) 180 (3OS)
sPDCCH sREG EPRE / E_{RS} [dB]	2.290	1.880	1.065	1.488	1.195
<NIL> sREG EPRE / E_{RS} [dB]	-inf	-inf	-inf	-inf	-inf
sPDSCH					
# of QPSK sPDSCH PRBs within a subslot for which EVM is measured	7	13	25	38	50
PRB $P_A = E_A/E_{RS}$ [dB]	-6	-6	-6	-6	-6
# of 16QAM sPDSCH PRBs within a subslot for which EVM is not measured (used for power balancing only)	8	12	25	37	50
PRB $P_A = E_A/E_{RS}$ [dB]	2.189	2.580	2.427	2.477	2.427
NOTE 1: Void.					

Table 6.1.1.6a-2: Numbers (n_{PRB}) of the QPSK PRBs (FDD)

Sublot	Subframe 0						Subframe 1					
	0	1	2	3	4	5	0	1	2	3	4	5
3 M Hz	0 1 2 3 11 12 13	0 3 4 10 11 12 13	0 2 3 5 6 11 13	0 1 4 5 7 10 12	0 2 3 4 9 10 13	0 1 2 3 11 12 14	4 5 6 8 11 13 14	2 5 6 9 12 13 14	0 3 4 7 8 9 11	1 2 3 4 5 11 12	0 1 2 3 11 12 13	0 3 4 10 11 12 13
5 M Hz	0 1 3 6 7 8 16 17 18 20 21 23 24	0 1 2 4 5 6 9 10 12 17 18 20 24	0 1 2 3 9 10 12 13 14 19 20 23 24	0 5 6 8 10 12 13 15 17 18 20 21 24	0 2 4 6 7 12 13 15 16 17 22 23 24	0 1 2 3 4 6 7 8 16 18 21 22 24	1 3 4 5 7 9 10 11 12 15 21 22 24	0 1 2 3 4 7 10 14 18 19 20 21 24	1 4 8 9 10 11 12 13 15 16 18 20 23	1 2 3 4 5 6 9 10 11 13 16 17 23	0 1 3 6 7 8 16 17 18 20 21 23 24	0 1 2 4 5 6 9 10 12 17 18 20 21 24
10 M Hz	1 2 3 5 6 7 8 9 10 11 15 16 20 28 31 32 33 35 36 39 40 42 46 47 48	1 2 4 5 6 7 9 11 15 18 20 21 22 24 25 27 29 34 35 36 37 40 44 46 49	0 3 5 6 11 12 14 17 18 19 20 21 22 24 25 26 27 28 29 31 34 38 41 42 49	0 1 2 3 5 6 8 8 9 10 14 16 18 22 23 26 28 30 31 33 38 39 40 41 42 45 46 47 48 49	0 3 6 7 8 9 10 12 13 16 17 18 21 23 25 31 33 37 41 42 45 46 47 48 49	0 2 3 4 5 7 9 10 11 12 13 15 19 20 28 29 30 31 34 36 37 42 44 48 49	0 1 4 5 6 8 9 10 13 16 17 18 19 20 21 24 29 30 31 32 35 37 38 39 47	0 2 3 4 5 6 7 9 10 12 16 17 18 19 22 24 25 26 30 31 34 37 42 45 48	5 7 8 9 14 15 16 21 22 27 28 30 31 32 34 35 37 38 39 40 41 42 43 44 46 48 49	3 9 11 13 16 17 18 21 24 27 28 29 30 32 34 37 38 39 40 41 42 44 49	1 2 3 5 6 7 8 9 10 11 15 16 20 28 31 32 33 35 36 39 40 42 46 47 48	1 2 4 5 6 7 9 11 15 18 20 21 22 24 25 27 29 34 35 36 37 40 44 46 49
15 M Hz	0 1 2 3 5 6 7 8 9 12 16 17 18 19 20 21 23 24 25 28 29 30 31 32 33 42 47 48 49 53 60 63 65 67 68 70 71 73	0 1 3 4 5 6 7 8 11 18 20 21 24 25 26 27 29 30 31 38 46 47 49 50 51 53 54 55 57 59 60 61 67 68 69 70 73 74	2 1 1 12 13 15 17 18 21 22 24 25 26 29 31 32 33 34 40 42 45 46 47 50 51 52 54 58 59 60 61 62 63 64 68 70 71 72 74	2 3 4 6 7 9 11 12 15 17 20 24 27 30 33 34 35 38 39 42 43 45 46 48 49 50 52 53 54 56 59 61 62 65 67 69 70 71 73 74	4 5 6 8 10 13 17 22 25 26 27 28 29 30 31 32 33 34 35 38 41 44 46 48 50 52 53 54 56 59 60 64 67 69 70 71 73 74	0 2 3 4 7 8 11 14 18 20 23 24 25 27 29 32 33 42 43 45 46 47 48 49 50 51 54 56 60 62 63 65 66 67 68 69 70 71 72 73	1 2 9 11 14 15 18 25 26 28 29 30 31 32 33 36 37 38 39 41 43 45 46 50 53 54 58 59 60 61 62 65 67 69 70 71 72 73	3 4 6 7 8 11 12 19 20 23 24 26 27 28 30 33 34 35 40 41 42 46 49 47 48 51 53 54 58 59 60 61 62 65 67 69 70 71 72 73	0 1 2 3 7 8 9 10 13 14 15 17 18 19 22 23 24 25 26 27 28 32 36 37 39 46 47 50 53 55 57 56 61 62 63 68 69 71 73 74	0 3 7 8 11 13 14 16 18 19 23 25 27 28 29 30 32 35 41 42 44 46 47 48 50 53 55 57 62 64 66 67 68 69 70 71	0 1 2 3 5 6 7 8 9 12 16 17 18 19 20 21 23 24 25 28 29 30 31 32 33 42 47 48 49 53 60 63 65 67 68 70 71 73	0 1 3 4 5 6 7 8 11 18 20 21 24 25 26 27 29 30 31 38 46 47 49 50 51 53 54 55 57 59 60 61 67 68 69 70 73 74
20 M Hz	0 1 4 6 10 13 14 15 16 20 22 23 25 26 28 29 30 31 32 33 36 39 41 42 44 45 54 56 57 60 63 66 67 68 72 76 77 79 82 84 85 87 88 91 92 94 95 97 98 99	1 3 7 9 10 13 19 20 21 22 23 24 25 26 27 30 33 34 35 36 47 48 49 50 51 53 54 55 57 59 60 61 64 65 67 68 75 76 77 80 81 83 84 86 87 89 90 93 95 99	1 2 3 6 8 10 11 15 16 17 19 21 25 26 28 29 30 32 33 35 38 39 40 41 42 43 44 46 49 51 52 54 60 62 63 64 65 69 72 76 79 81 84 86 88 89 90 93 94 99	5 7 9 10 12 14 15 16 21 22 23 24 27 28 29 30 33 34 35 36 37 39 41 44 45 47 49 54 55 56 57 64 66 67 78 77 80 81 85 86 87 90 91 95 98 99	2 3 4 5 6 7 14 15 17 19 21 22 24 26 37 40 42 43 44 47 49 51 54 60 62 63 65 66 67 70 71 73 76 77 78 83 84 85 86 87 89 94 95 96 97 99	1 2 5 6 8 9 12 13 21 22 25 26 27 28 29 31 32 34 35 39 40 43 45 46 53 57 59 61 62 66 68 69 71 73 75 77 78 82 83 84 85 86 93 94 95 96 97 99	0 1 2 3 5 8 9 10 12 13 22 25 26 27 29 31 32 33 36 37 38 39 43 45 48 49 52 53 55 59 62 63 64 71 72 73 74 75 77 78 81 82 84 86 89 91 93 97 98 99	0 1 3 4 5 7 10 11 15 18 19 20 21 26 27 29 30 31 33 35 39 40 41 43 44 46 47 49 50 53 55 56 62 64 65 66 67 69 70 71 72 74 83 84 86 92 93 94 96 98	2 3 4 7 9 11 13 15 16 24 25 27 29 31 33 35 36 40 43 44 45 46 49 51 52 53 54 55 56 57 59 63 64 65 68 71 77 78 81 84 85 86 90 91 93 94 98 99	0 4 6 7 8 10 11 13 16 18 21 22 23 26 29 32 35 36 37 43 44 46 47 48 49 53 54 57 59 64 66 67 68 69 70 72 76 78 80 81 82 84 87 89 91 92 95 96	0 1 4 6 10 13 14 15 16 20 22 23 25 26 28 29 30 31 32 33 36 39 41 42 44 45 54 56 57 60 63 66 67 68 72 76 77 79 82 84 85 87 88 91 92 94 95 97 98 99	1 3 7 9 10 13 19 20 21 22 23 24 25 26 27 30 33 34 35 36 47 48 49 50 51 53 54 55 57 59 60 61 64 65 67 68 75 76 77 80 81 83 84 86 87 89 90 93 95 99

Sublot	Subframe 2						Subframe 3					
	0	1	2	3	4	5	0	1	2	3	4	5
3 M Hz	0 2 3 5 6 11 13	0 1 4 5 7 10 12	0 2 3 4 9 10 13	0 1 2 3 11 12 14	4 5 6 8 11 13 14	2 5 6 9 12 13 14	0 3 4 7 8 9 11	1 2 3 4 5 11 12	0 1 2 3 11 12 13	0 3 4 10 11 12 13	0 2 3 5 6 11 13	0 1 4 5 7 10 12
5 M Hz	0 1 2 3 9 10 12 13 14 19 20 23 24	0 5 6 8 10 12 13 15 17 18 20 21 24	0 2 4 6 7 12 13 15 16 17 22 23 24	0 1 2 3 4 6 7 8 16 18 21 22 24	1 3 4 5 7 9 10 11 12 15 21 22 24	0 1 2 3 4 7 10 14 18 19 20 21 24	1 4 8 9 10 11 12 13 15 16 18 20 23	1 2 3 4 5 6 9 10 11 13 16 17 23	0 1 3 6 7 8 16 17 18 20 21 23 24	0 1 2 4 5 6 9 10 12 17 18 20 24	0 1 2 3 9 10 12 13 14 19 20 23 24	0 5 6 8 10 12 13 15 17 18 20 21 24
10 M Hz	0 3 5 6 11 12 14 17 18 19 20 21 22 24 25 26 27 28 29 31 34 38 41 42 49	0 1 2 3 5 6 8 8 9 10 14 16 18 22 23 26 28 30 32 34 38 39 40 41 42 45 46 47	0 3 6 7 8 9 10 12 13 16 17 18 21 23 25 31 33 37 41 42 45 46 47 48 49	0 2 3 4 5 7 9 6 8 9 10 11 12 13 16 17 18 19 20 21 22 24 25 26 30 31 31 34 32 35 37 38 39 47	0 1 4 5 6 8 9 10 13 16 17 18 19 20 21 24 29 30 31 32 35 37 38 41 42 48	0 2 3 4 5 6 7 9 10 12 16 17 18 19 22 24 25 26 30 31 34 37 41 42 48	5 7 8 9 14 15 16 21 22 27 28 30 31 32 34 35 37 38 41 42 43 44 46 48 49	3 9 11 13 16 17 18 21 24 27 28 29 30 32 34 37 38 39 40 41 42 45 47 48 49	1 2 3 5 6 7 8 9 10 11 15 16 20 28 31 32 33 35 36 39 40 42 46 47 48	1 2 4 5 6 7 9 11 15 18 20 21 22 24 25 27 29 34 35 36 37 40 44 46 49	0 3 5 6 11 12 14 17 18 19 20 21 22 24 25 26 27 28 29 31 34 38 41 42 49	0 1 2 3 5 6 8 8 9 10 14 16 18 22 23 26 28 30 32 34 38 39 40 41 42 45 46 47
15 M Hz	2 11 12 13 15 17 18 21 22 24 25 26 29 31 32 33 34 40 42 45 46 47 50 51 52 54 58 59 60 61 62 63 64 68 70 71 72 74	2 3 4 6 7 9 11 12 15 17 20 24 27 30 33 34 35 38 39 42 43 45 46 48 49 55 56 59 60 61 62 65 67 69 70 71 73 74	4 5 6 8 10 13 17 22 25 26 27 28 29 30 31 32 33 34 35 38 41 44 46 48 50 52 53 54 56 59 60 64 67 69 70 71 73 74	0 2 3 4 7 8 11 14 18 20 23 24 25 27 29 32 33 45 46 47 48 49 50 51 54 56 60 62 63 65 66 67 68 69 70 71 72 73	1 2 9 11 14 15 18 25 26 28 29 30 31 32 33 36 37 38 39 41 43 45 46 50 53 54 58 59 60 61 62 65 67 69 70 71 72 73	3 4 6 7 8 11 12 19 20 23 24 26 27 28 30 33 34 35 40 41 42 46 49 51 53 54 58 59 60 61 62 65 67 69 70 71 72 73	0 1 2 3 7 8 9 10 13 14 15 18 19 22 27 17 18 19 22 23 24 25 26 27 28 32 36 37 39 46 47 50 53 55 57 56 61 62 63 68 69 71 73 74	0 3 7 8 11 13 14 16 18 19 23 25 27 28 29 30 32 35 41 42 44 46 47 48 50 53 55 57 62 64 66 67 70 71	0 1 2 3 5 6 7 8 9 12 16 17 18 19 20 21 23 24 25 28 29 30 31 32 33 46 47 48 49 53 60 57 59 63 65 67 68 70 71 73	0 1 3 4 5 6 7 8 11 18 20 21 24 25 26 27 29 30 31 38 46 47 49 50 57 59 60 61 67 68 69 70 73 74	2 11 12 13 15 17 18 21 22 24 25 26 29 31 32 33 34 40 42 45 46 47 50 51 52 54 58 59 60 61 62 63 64 68 70 71 72 74	2 3 4 6 7 9 11 12 15 17 20 24 27 30 33 34 35 38 39 42 43 45 46 48 49 55 56 59 60 61 62 65 67 69 70 71 73 74
20 M Hz	1 2 3 6 8 10 11 15 16 17 19 21 25 26 28 29 30 32 33 35 38 39 40 41 42 43 44 46 49 51 52 54 60 62 63 64 65 69 72 76 79 81 84 86 88 89 90 93 94 99	5 7 9 10 12 14 15 16 21 22 23 24 27 28 29 30 33 34 35 36 37 39 41 44 45 47 49 54 55 56 57 64 66 68 70 72 76 77 80 81 85 86 87 90 91 92 94 95 98 99	2 3 4 5 6 7 14 15 17 19 21 22 24 26 37 40 42 43 44 47 49 51 54 60 62 63 65 66 67 70 71 73 76 77 78 81 82 83 84 85 86 87 89 94 95 96 97 99	1 2 5 6 8 9 12 13 21 22 25 26 27 28 29 31 32 34 35 39 40 43 45 46 53 57 59 59 62 63 64 69 71 73 75 77 78 78 81 82 83 84 85 86 89 94 95 97 98 99	0 1 2 3 5 8 9 10 12 13 22 25 26 27 29 31 32 33 36 37 38 39 43 45 48 49 52 53 55 59 62 64 65 66 67 69 70 71 72 74 83 86 89 91 93 97 98 98	0 1 3 4 5 7 10 11 15 18 19 20 21 26 27 29 30 31 33 35 39 40 41 43 44 46 47 51 52 53 54 55 56 57 59 63 64 65 68 71 77 78 81 82 83 84 85 86 90 92 93 94 96 98	2 3 4 7 9 11 13 15 16 24 25 27 29 31 33 35 36 40 43 44 45 46 49 51 52 53 54 55 56 57 59 63 64 65 68 71 77 78 81 82 83 84 85 86 90 91 93 94 98 99	0 4 6 7 8 10 11 13 16 18 21 22 23 26 29 32 35 36 37 43 44 46 47 48 49 53 54 55 56 60 61 64 66 67 68 69 70 72 76 78 80 81 82 84 87 88 91 92 95 96	0 1 4 6 10 13 14 15 16 20 22 23 25 26 28 29 30 31 32 33 36 39 41 42 44 45 54 56 57 60 63 66 67 68 72 78 77 79 82 84 85 87 88 91 95 97 98 99	1 3 7 9 10 13 19 20 21 22 23 24 25 26 27 30 33 34 35 36 47 48 49 50 51 53 54 55 60 61 64 65 67 68 75 76 77 80 81 83 84 86 87 89 90 93 95 99	1 2 3 6 8 10 11 15 16 17 19 21 25 26 28 29 30 32 33 35 38 39 40 41 42 43 44 46 49 51 52 54 60 62 63 64 65 69 72 76 79 81 84 86 88 89 90 93 94 99	5 7 9 10 12 14 15 16 21 22 23 24 27 28 29 30 33 34 35 36 37 39 41 44 45 47 49 54 55 56 57 64 66 68 70 72 76 77 80 81 85 86 87 90 91 92 94 95 98 99

Sublot	Subframe 4						Subframe 5					
	0	1	2	3	4	5	0	1	2	3	4	5
3 M Hz	0 2 3 4 9 10 13	0 1 2 3 11 12 14	4 5 6 8 11 13 14	2 5 6 9 12 13 14	0 3 4 7 8 9 11	1 2 3 4 5 11 12	0 1 2 3 11 12 13	0 3 4 10 11 12 13	0 2 3 5 6 11 13	0 1 4 5 7 10 12	0 2 3 4 9 10 13	0 1 2 3 11 12 14
5 M Hz	0 2 4 6 7 12 13 15 16 17 22 23 24	0 1 2 3 4 6 7 8 16 18 21 22 24	1 3 4 5 7 9 10 11 12 15 21 22 24	0 1 2 3 4 7 10 14 18 19 20 21 24	1 4 8 9 10 11 12 13 15 16 18 20 23	1 2 3 4 5 6 9 10 11 13 16 17 23	0 1 3 6 7 8 16 17 18 20 21 23 24	0 1 2 4 5 6 9 10 12 17 18 20 24	0 1 2 3 9 10 12 13 14 19 20 23 24	0 5 6 8 10 12 13 15 17 18 20 21 24	0 2 4 6 7 12 13 15 16 17 22 23 24	0 1 2 3 4 6 7 8 15 16 21 22 24
10 M Hz	0 3 6 7 8 9 10 12 13 16 17 18 21 23 25 31 33 37 41 42 45 46 47 48 49	0 2 3 4 5 7 9 10 11 12 13 15 19 20 28 29 30 31 34 36 37 42 44 48 49	0 1 4 5 6 8 9 10 13 16 17 18 19 20 21 24 29 30 31 32 35 37 38 42 44 39 47	0 2 3 4 5 6 7 9 10 12 16 17 18 19 22 24 25 26 30 31 34 37 42 45 48	5 7 8 9 14 15 16 21 22 27 28 30 31 32 34 35 37 38 41 42 43 44 46 48 49	3 9 11 13 16 17 18 21 24 27 28 29 30 32 34 37 38 39 40 41 42 45 47 48 49	1 2 3 5 6 7 8 9 10 11 15 16 20 28 31 32 33 35 36 39 40 42 46 47 48	1 2 4 5 6 7 9 11 15 18 20 21 22 24 25 27 29 34 35 36 37 40 44 46 49	0 3 5 6 11 12 14 17 18 19 20 21 22 24 25 26 27 28 29 31 34 38 41 42 49	0 1 2 3 5 6 8 14 16 18 22 23 26 28 30 32 34 38 39 40 41 42 45 46 47	0 3 6 7 8 9 10 12 13 16 17 18 21 23 25 31 33 37 41 42 45 46 47 48 49	0 2 3 4 5 7 9 10 11 12 13 15 19 20 28 29 30 31 34 36 37 42 44 48 49
15 M Hz	4 5 6 8 10 13 17 22 25 26 27 28 29 30 31 32 33 34 35 38 41 44 46 48 50 52 53 54 56 59 60 64 67 69 70 71 73 74	0 2 3 4 7 8 11 14 18 20 23 24 25 27 29 42 43 45 46 47 48 49 50 51 54 56 60 62 63 65 66 67 68 69 70 71 72 73	1 2 9 11 14 15 18 25 26 28 29 30 31 32 33 36 37 38 39 41 43 45 46 50 53 54 58 59 60 61 62 62 63 65 67 68 70 71 72 73	3 4 6 7 8 11 12 19 20 23 24 26 27 28 30 33 34 35 40 41 42 46 49 51 53 54 58 59 60 61 62 65 67 68 69 71 72 73	0 1 2 3 7 8 9 10 13 14 15 17 18 19 22 23 24 25 26 32 36 37 39 46 47 50 53 55 57 56 61 62 63 68 69 71 73 74	0 3 7 8 11 13 14 16 18 19 23 25 27 28 29 30 32 35 44 46 47 48 50 53 55 57 59 61 62 64 66 67 68 69 70 71	0 1 2 3 5 6 7 8 9 12 16 17 18 19 20 21 23 24 25 28 29 30 31 32 33 46 47 48 49 53 60 63 65 67 68 70 71 73	0 1 3 4 5 6 7 8 11 18 20 21 24 25 26 27 29 30 31 38 46 47 49 50 51 53 58 59 60 61 67 68 69 70 73 74	2 1 1 12 13 15 17 18 21 22 24 25 26 29 31 32 33 34 40 42 45 46 47 50 51 52 54 58 59 60 61 62 63 70 71 72 74	2 3 4 6 7 9 11 12 15 17 20 24 27 30 33 34 35 38 39 42 43 45 46 48 49 55 56 59 60 61 62 65 67 71 73 74	4 5 6 8 10 13 17 22 25 26 27 28 29 30 31 32 33 34 35 38 41 44 46 48 50 52 53 54 56 59 60 64 67 69 70 71 73 74	0 2 3 4 7 8 11 14 18 20 23 24 25 27 28 29 30 31 32 33 34 35 38 41 44 46 48 50 52 53 54 56 59 60 64 67 69 70 71 73
20 M Hz	2 3 4 5 6 7 14 15 17 19 21 22 24 26 37 40 42 43 44 47 49 51 54 56 57 60 62 63 65 66 67 70 71 73 76 77 78 81 82 83 84 85 86 87 89 94 95 96 97 99	1 2 5 6 8 9 12 13 21 22 25 26 27 28 29 31 32 34 35 39 40 43 45 46 53 57 59 61 62 63 64 66 68 69 71 73 75 77 78 82 83 84 85 86 93 94 95 96 97 99	0 1 2 3 5 8 9 10 12 13 22 25 26 27 29 31 32 33 36 37 38 39 43 45 48 49 52 53 55 63 64 71 72 73 74 75 77 78 81 82 84 86 89 91 93 97 98 99	0 1 3 4 5 7 10 11 15 18 19 20 21 29 30 31 33 35 39 40 41 43 44 49 50 53 55 56 62 64 65 66 67 69 70 71 72 78 81 82 83 84 85 86 90 92 93 94 96 98	2 3 4 7 9 11 13 15 16 24 25 27 29 31 33 35 36 40 43 44 45 46 49 51 52 55 56 60 61 63 64 65 68 69 70 72 76 78 80 81 82 86 90 91 93 94 98 99	0 4 6 7 8 10 11 13 16 18 21 22 23 26 29 32 35 36 37 43 44 46 47 48 49 53 54 54 56 60 61 64 66 67 68 69 70 72 76 78 80 81 82 84 87 89 91 92 95 96	0 1 4 6 10 13 14 15 16 20 22 23 25 26 28 29 30 31 32 33 36 39 41 42 44 45 54 56 57 60 63 66 67 68 72 76 77 79 82 84 85 87 88 91 92 94 95 97 98 99	1 3 7 9 10 13 19 20 21 22 23 24 25 26 27 30 33 34 35 36 36 39 49 50 51 53 54 55 60 61 64 65 67 68 75 76 77 80 81 83 84 86 87 89 90 93 95 99	1 2 3 6 8 10 11 15 16 17 19 21 25 26 28 29 30 32 33 35 38 39 40 41 42 43 44 46 49 51 52 54 60 62 63 64 65 68 70 69 72 76 79 81 84 86 88 89 90 93 94 99	5 7 9 10 12 14 15 16 21 22 23 24 27 28 29 30 33 34 35 36 37 39 41 44 45 47 49 54 55 57 59 64 66 66 67 70 71 73 75 77 80 81 85 86 87 90 91 92 94 95 98 99	2 3 4 5 6 7 14 15 17 19 21 22 24 26 37 40 42 43 44 47 49 51 54 56 57 60 62 63 65 66 67 70 71 73 76 77 78 81 82 83 84 85 86 87 89 94 95 96 97 99	1 2 5 6 8 9 12 13 21 22 25 26 27 28 29 31 32 34 35 39 40 43 45 46 53 57 59 61 62 63 64 66 68 69 71 73 75 77 78 82 83 84 85 86 93 94 95 96 97 99

Subslot	Subframe 6						Subframe 7					
	0	1	2	3	4	5	0	1	2	3	4	5
3 M Hz	4 5 6 8 11 13 14	2 5 6 9 12 13 14	0 3 4 7 8 9 11	1 2 3 4 5 11 12	0 1 2 3 11 12 13	0 3 4 10 11 12 13	0 2 3 5 6 11 13	0 1 4 5 7 10 12	0 2 3 4 9 10 13	0 1 2 3 11 12 14	4 5 6 8 11 13 14	2 5 6 9 12 13 14
5 M Hz	1 3 4 5 7 9 10 11 12 15 21 22 24	0 1 2 3 4 7 10 12 13 19 20 21 24	1 4 8 9 10 11 12 13 15 16 18 20 23	1 2 3 4 5 6 9 10 11 13 16 17 23	0 1 3 6 7 8 16 17 18 20 21 23 24	0 1 2 4 5 6 9 10 12 17 18 20 24	0 1 2 3 9 10 12 13 14 17 18 19 20 23 24	0 5 6 8 10 12 13 15 17 18 20 21 24	0 2 4 6 7 12 13 15 16 17 22 23 24	0 1 2 3 4 6 7 8 16 18 21 22 24	1 3 4 5 7 9 10 11 12 14 18 15 21 22 24	0 1 2 3 4 7 10 14 18 19 20 21 24
10 M Hz	0 1 4 5 6 8 9 10 13 16 17 18 19 20 21 24 29 30 31 32 35 37 38 39 47	0 2 3 4 5 6 7 9 10 12 16 17 18 19 22 24 25 26 30 31 34 37 42 45 48	5 7 8 9 14 15 16 21 22 27 28 30 31 32 34 35 37 38 41 42 43 44 46 48 49	3 9 11 13 16 17 18 21 24 27 28 29 30 32 34 37 38 39 40 41 42 45 47 48 49	1 2 3 5 6 7 8 9 10 11 15 16 20 28 31 32 33 35 36 39 40 42 46 47 48	1 2 4 5 6 7 9 11 15 18 20 21 22 24 25 27 29 34 35 36 37 40 44 46 49	0 3 5 6 11 12 14 17 18 19 20 21 22 24 25 26 27 28 29 31 34 38 41 42 49	0 1 2 3 5 6 8 14 16 18 22 23 26 28 30 32 34 38 39 40 41 42 45 46 47 48 49	0 3 6 7 8 9 10 12 13 16 17 18 21 23 25 29 30 31 33 37 41 42 45 48 49	0 2 3 4 5 7 9 10 11 12 13 15 19 20 28 29 30 31 34 36 37 42 44 48 49	0 1 4 5 6 8 9 10 13 16 17 18 19 20 21 24 29 30 31 32 35 37 38 39 47	0 2 3 4 5 6 7 9 10 12 16 17 18 19 22 24 25 26 30 31 34 37 42 45 48
15 M Hz	1 2 9 11 14 15 18 25 26 28 29 30 31 32 33 36 37 38 39 41 43 45 46 50 53 54 58 59 60 62 63 65 67 68 70 71 72 73	3 4 6 7 8 11 12 19 20 23 24 26 27 28 30 33 34 35 40 41 42 46 49 51 53 54 58 59 60 61 62 65 67 69 70 71 72 73	0 1 2 3 7 8 9 10 13 14 15 17 18 19 22 23 24 25 26 27 28 32 36 37 39 46 47 50 53 55 57 56 61 62 63 68 69 71 73 74	0 3 7 8 11 13 14 16 18 19 23 25 27 28 29 30 32 35 44 46 47 48 50 53 55 57 63 65 67 68 70 71 73	0 1 2 3 5 6 7 8 9 12 16 17 18 19 20 21 23 24 25 28 29 30 31 32 33 42 47 48 49 53 60 63 65 67 68 70 71	0 1 3 4 5 6 7 8 11 18 20 21 26 27 29 30 31 38 46 47 49 50 51 53 54 55 57 59 60 61 67 68 69 70 73 74	2 11 12 13 15 17 18 21 22 24 25 26 29 31 32 33 34 40 42 45 46 47 50 51 52 54 58 59 60 61 62 63 70 71 72 74	2 3 4 6 7 9 11 12 15 17 20 24 27 30 33 34 35 38 39 42 43 45 46 48 49 55 56 59 60 61 62 65 67 69 70 74	4 5 6 8 10 13 17 22 25 26 27 28 29 30 31 32 33 34 35 38 41 44 46 48 50 52 53 54 56 59 60 64 67 69 70 71 73 74	0 2 3 4 7 8 11 14 18 20 23 24 25 27 29 32 33 42 43 47 48 49 50 51 54 56 60 62 63 65 66 67 68 69 70 71 72 73	1 2 9 11 14 15 18 25 26 28 29 30 31 32 33 36 37 38 39 41 43 45 46 50 53 54 58 59 60 62 63 65 67 68 70 71 72 73	3 4 6 7 8 11 12 19 20 23 24 26 27 28 30 33 34 35 40 41 42 46 49 51 53 54 58 59 60 61 62 65 67 69 70 71 72 73
20 M Hz	0 1 2 3 5 8 9 10 12 13 22 25 26 27 29 31 32 33 36 37 38 39 43 45 48 49 52 53 55 59 62 63 64 71 72 73 74 75 77 78 81 82 84 86 89 91 93 97 98 99	0 1 3 4 5 7 10 11 15 18 19 20 21 26 27 29 30 31 33 35 39 40 41 43 44 46 47 49 50 53 55 56 62 64 65 66 67 69 70 71 72 78 81 74 83 84 86 92 93 94 96 98	2 3 4 7 9 11 13 15 16 24 25 27 29 31 33 35 36 40 43 44 45 46 49 51 52 53 54 55 56 63 64 65 68 71 77 78 81 84 85 86 90 91 93 94 98 99	0 4 6 7 8 10 11 13 16 18 21 22 23 26 29 32 35 36 37 43 44 46 47 48 49 54 56 64 66 67 68 69 70 72 76 78 80 81 82 84 87 89 91 92 95 96	0 1 4 6 10 13 14 15 16 20 22 23 25 26 28 29 30 31 32 33 36 39 41 42 44 45 51 53 54 56 63 66 67 68 72 76 77 79 82 84 85 87 88 91 92 94 95 97 98 99	1 3 7 9 10 13 19 20 21 22 23 24 25 26 27 30 33 34 35 36 47 48 49 50 54 55 60 61 64 65 67 68 75 76 77 80 81 83 84 86 87 89 90 93 95 99	1 2 3 6 8 10 11 15 16 17 19 21 25 26 28 29 30 32 33 35 38 39 40 41 42 43 44 46 49 51 52 54 55 56 57 62 63 64 66 65 67 69 72 76 79 81 84 86 88 89 90 93 94 99	5 7 9 10 12 14 15 16 21 22 23 24 27 28 29 30 33 34 35 36 37 39 41 44 45 47 49 51 54 56 57 60 62 63 65 66 67 70 71 72 76 77 80 81 85 86 87 90 91 92 94 95 98 99	2 3 4 5 6 7 14 15 17 19 21 22 24 26 37 40 42 43 44 47 49 51 54 56 57 60 62 63 65 70 71 73 76 77 78 81 82 83 84 85 86 87 89 94 95 96 97 99	1 2 5 6 8 9 12 13 21 22 25 26 27 28 29 31 32 34 35 39 40 43 45 46 53 57 59 61 62 63 64 69 71 73 75 77 78 82 83 84 85 86 93 94 95 96 97 99	0 1 2 3 5 8 9 10 12 13 22 25 26 27 29 31 32 33 36 37 38 39 43 45 48 49 52 53 55 59 62 63 64 71 72 73 74 75 77 78 81 82 84 86 89 91 93 97 98 99	5 7 10 11 15 18 19 20 21 26 27 29 30 31 33 35 39 40 41 43 44 46 47 49 50 53 55 56 62 64 65 66 67 69 70 71 72 74 83 84 86 92 93 94 96 98

Subslot	Subframe 8						Subframe 9					
	0	1	2	3	4	5	0	1	2	3	4	5
3 M Hz	0 3 4 7 8 9 11	1 2 3 4 5 11 12	0 1 2 3 11 12 13	0 3 4 10 11 12 13	0 2 3 5 6 11 13	0 1 4 5 7 10 12	0 2 3 4 9 10 13	0 1 2 3 11 12 14	4 5 6 8 11 13 14	2 5 6 9 12 13 14	0 3 4 7 8 9 11	1 2 3 4 5 11 12
5 M Hz	1 4 8 9 10 11 12 13 15 16 18 20 23	1 2 3 4 5 6 9 10 11 13 16 17 23	0 1 3 6 7 8 16 17 18 20 21 23 24	0 1 2 4 5 6 9 10 12 13 14 17 18 20 24	0 1 2 3 9 10 12 13 14 19 20 23 24	0 5 6 8 10 12 13 15 17 18 20 21 24	0 2 4 6 7 12 13 15 16 17 22 23 24	0 1 2 3 4 6 7 8 16 18 21 22 24	1 3 4 5 7 9 10 11 12 15 21 22 24	0 1 2 3 4 7 10 14 18 19 20 21 24	1 4 8 9 10 11 12 13 15 16 18 20 23	1 2 3 4 5 6 9 10 11 13 16 17 23
10 M Hz	5 7 8 9 14 15 16 21 22 27 28 30 31 32 34 35 37 38 41 42 43 44 46 48 49	3 9 11 13 16 17 18 21 24 27 28 29 30 32 34 37 38 39 40 41 42 45 47 48 49	1 2 3 5 6 7 8 9 10 11 15 16 20 28 31 32 33 35 36 39 40 42 46 47 48	1 2 4 5 6 7 9 11 15 18 20 21 22 24 25 27 29 34 35 36 37 40 44 46 49 49	0 3 5 6 11 12 14 17 18 19 20 21 22 24 25 26 27 28 29 31 34 38 41 42 49	0 1 2 3 5 6 8 14 16 18 22 23 26 28 30 32 34 38 39 40 41 42 45 46 47 48 49	0 3 6 7 8 9 10 12 13 16 17 18 21 23 25 31 33 37 41 42 45 46 47 48 49	0 2 3 4 5 7 9 10 11 12 13 15 19 20 28 29 30 31 34 33 34 36 37 42 44 48 49	0 1 4 5 6 8 9 10 13 16 17 18 19 20 21 24 29 30 31 32 35 37 38 39 47	0 2 3 4 5 6 7 9 10 12 16 17 18 19 22 24 25 26 30 31 34 37 42 45 48	5 7 8 9 14 15 16 21 22 27 28 30 31 32 34 35 37 38 41 42 43 44 46 48 49	3 9 11 13 16 17 18 21 24 27 28 29 30 32 34 37 38 39 40 41 42 45 47 48 49
15 M Hz	0 1 2 3 7 8 9 10 13 14 15 17 18 19 22 23 24 25 26 27 28 32 36 37 39 46 47 50 53 56 61 62 63 68 69 71 73 74	0 3 7 8 11 13 14 16 18 19 23 25 27 28 29 30 32 35 44 46 47 48 50 53 55 57 59 61 62 64 66 67 68 69 70 71	0 1 2 3 5 6 7 8 9 12 16 17 18 19 20 21 23 24 25 28 29 30 31 32 33 42 47 48 49 53 60 63 65 67 68 70 71 73	0 1 3 4 5 6 7 8 11 18 20 21 24 25 26 27 29 30 31 38 46 47 49 50 51 53 54 55 57 59 60 61 67 68 69 70 73 74 72 74	2 11 12 13 15 17 18 21 22 24 25 26 32 33 34 40 42 45 46 47 50 51 52 54 58 59 60 61 62 63 64 68 70 71 72 74	2 3 4 6 7 9 11 12 15 17 20 24 27 30 33 34 35 38 39 42 43 45 46 48 49 55 56 59 60 61 62 65 67 69 70 71 73 74	4 5 6 8 10 13 17 22 25 26 27 28 30 33 31 32 33 34 35 38 41 44 46 48 50 52 53 54 56 59 60 64 67 69 70 71 73 74	0 2 3 4 7 8 11 14 18 20 23 24 25 27 29 31 32 42 43 45 46 47 48 49 50 51 54 56 60 62 63 65 66 67 68 69 70 71 72 73	1 2 9 11 14 15 18 25 26 28 29 30 31 32 33 35 40 41 42 46 49 54 58 59 60 61 62 62 63 65 67 68 70 71 72 73	3 4 6 7 8 11 12 19 20 23 24 26 27 28 30 33 34 35 40 41 42 46 49 51 53 54 58 59 60 61 62 65 67 69 70 71 72 73	0 1 2 3 7 8 9 10 13 14 15 17 18 19 22 23 24 25 26 27 28 32 36 37 39 46 47 50 53 56 61 62 63 68 69 71 73 74	0 3 7 8 11 13 14 16 18 19 23 25 27 28 29 30 32 35 44 46 47 48 50 53 55 57 59 61 62 64 66 67 68 69 70 71
20 M Hz	2 3 4 7 9 11 13 15 16 24 25 27 29 31 33 35 36 40 43 44 45 46 49 51 52 53 54 55 56 57 59 63 64 65 68 71 77 78 81 82 83 84 85 86 90 91 93 94 98 99	0 4 6 7 8 10 11 13 16 18 21 22 23 26 29 32 35 36 37 43 44 46 47 48 49 53 54 57 59 60 61 64 66 67 68 69 70 72 76 78 80 81 82 84 87 89 91 92 95 96	0 1 4 6 10 13 14 15 16 20 22 23 25 26 28 29 30 31 32 33 36 39 41 42 44 45 54 56 57 60 63 66 67 68 72 76 77 79 82 84 85 87 88 91 92 94 98 99	1 3 7 9 10 13 19 20 21 22 23 24 25 26 27 30 33 34 35 36 47 48 49 50 51 53 64 65 67 68 75 76 77 80 81 83 84 86 87 89 89 90 90 93 95 99	1 2 3 6 8 10 11 15 16 17 19 21 25 26 28 29 30 32 33 35 38 39 40 41 42 46 49 51 52 54 60 62 63 64 65 69 72 76 79 81 84 86 88 89 90 93 94 99	5 7 9 10 12 14 15 16 21 22 23 24 27 28 29 30 33 34 35 36 37 39 41 44 45 47 49 56 57 60 62 63 65 66 67 70 71 73 76 77 78 81 82 83 84 85 86 86 87 90 91 92 94 95 98 99	2 3 4 5 6 7 14 15 17 19 21 22 24 26 37 28 29 40 42 43 44 47 49 51 54 56 57 60 62 63 65 66 67 70 71 73 76 77 78 81 82 83 84 85 86 87 89 94 95 96 97 99	1 2 5 6 8 9 12 13 21 22 25 26 27 28 29 31 32 34 35 39 40 43 45 46 53 57 59 61 62 63 64 66 68 69 71 73 75 77 78 82 83 84 85 86 93 94 95 96 97 99	0 1 2 3 5 8 9 10 12 13 22 25 26 27 29 31 32 33 36 37 38 39 43 45 48 49 52 53 55 59 62 63 64 71 72 73 74 75 77 78 81 82 84 86 89 91 93 97 98 99	0 1 3 4 5 7 10 11 15 18 19 20 21 26 27 29 30 31 33 35 39 40 41 43 44 46 47 49 50 53 55 56 62 64 65 66 67 69 70 71 72 74 83 84 86 92 93 94 96 98	2 3 4 7 9 11 13 15 16 24 25 27 29 31 33 35 36 40 43 44 45 46 49 51 52 53 54 55 56 57 59 63 64 65 68 71 77 78 81 82 83 84 85 86 90 91 93 94 98 99	0 4 6 7 8 10 11 13 16 18 21 22 23 26 29 32 35 36 37 43 44 46 47 48 49 53 54 57 59 60 61 64 66 67 68 69 70 72 76 78 80 81 82 84 87 89 91 92 95 96

6.1.1.6b E-UTRA slot TTI Test Model 3.3 (sE-TM3.3-2)

This model shall be used for slot TTI tests on:

- Transmitted signal quality
- Frequency error
- EVM for QPSK modulation

Table 6.1.1.6b-1: Physical channel parameters of sE-TM3.3-2

Parameter	3 MHz	5 MHz	10 MHz	15 MHz	20 MHz
Reference, Synchronisation Signals					
RS boosting, $P_B = E_B/E_A$	1	1	1	1	1
Synchronisation signal EPRE / E_{RS} [dB]	2.189	2.580	2.427	2.477	2.427
Reserved EPRE / E_{RS} [dB]	-inf	-inf	-inf	-inf	-inf
PBCH					
PBCH EPRE / E_{RS} [dB]	2.189	2.580	2.427	2.477	2.427
Reserved EPRE / E_{RS} [dB]	-inf	-inf	-inf	-inf	-inf
PCFICH					
# of symbols used for control channels	1	1	1	1	1
PCFICH EPRE / E_{RS} [dB]	0	0	0	0	0
PHICH					
# of PHICH groups	1	1	2	2	3
# of PHICH per group	2	2	2	2	2
PHICH BPSK symbol power / E_{RS} [dB]	-3.010	-3.010	-3.010	-3.010	-3.010
PHICH group EPRE / E_{RS} [dB]	0	0	0	0	0
sPDCCH					
# of available sREGs	105	155	350	525	700
# of sPDCCH	2	2	5	7	10
# of sCCEs per sPDCCH	1	2	2	2	2
# of sREGs per sCCE	4	4	4	4	4
# of sREGs allocated to sPDCCH	8	16	40	56	80
# of <NIL> sREGs added for padding	97	139	310	469	620
sPDCCH sREG EPRE / E_{RS} [dB]	2.290	1.880	1.065	1.488	1.195
<NIL> sREG EPRE / E_{RS} [dB]	-inf	-inf	-inf	-inf	-inf
sPDSCH					
# of QPSK sPDSCH sPRBs within a slot for which EVM is measured	7	13	25	38	50
sPRB $P_A = E_A/E_{RS}$ [dB]	-6	-6	-6	-6	-6
# of 16QAM sPDSCH sPRBs within a slot for which EVM is not measured (used for power balancing only)	8	12	25	37	50
sPRB $P_A = E_A/E_{RS}$ [dB]	2.189	2.580	2.427	2.477	2.427
NOTE 1: Void.					

Table 6.1.1.6b-2: Numbers (n_{PRB}) of the QPSK PRBs (FDD)

Slot	Subframe 0		Subframe 1		Subframe 2		Subframe 3		Subframe 4		Subframe 5	
	0	1	2	3	4	5	0	1	2	3	4	5
3 M Hz	0 1 2 3 11 12 13	0 3 4 10 11 12 13	0 2 3 5 6 11 13	0 1 4 5 7 10 12	0 2 3 4 9 10 13	0 1 2 3 11 12 14	4 5 6 8 11 13 14	2 5 6 9 12 13 14	0 3 4 7 8 9 11	1 2 3 4 5 11 12	0 1 2 3 11 12 13	0 3 4 10 11 12 13
5 M Hz	0 1 3 6 7 8 16 17 18 20 21 23 24	0 1 2 4 5 6 9 10 12 17 18 20 24	0 1 2 3 9 10 12 13 14 19 20 23 24	0 5 6 8 10 12 13 15 17 18 20 21 24	0 2 4 6 7 12 13 15 16 17 22 23 24	0 1 2 3 4 6 7 8 16 18 21 22 24	1 3 4 5 7 9 10 11 12 15 21 22 24	0 1 2 3 4 7 10 14 18 19 20 21 24	1 4 8 9 10 11 12 13 15 16 18 20 23	1 2 3 4 5 6 9 10 11 13 16 17 23	0 1 3 6 7 8 16 17 18 20 21 23 24	0 1 2 4 5 6 9 10 12 17 18 20 24
10 M Hz	1 2 3 5 6 7 8 9 10 11 15 16 20 28 31 32 33 35 36 39 40 42 46 47 48	1 2 4 5 6 7 9 11 15 18 20 21 22 24 25 27 29 34 35 36 37 40 44 46 49	0 3 5 6 11 12 14 17 18 19 20 21 22 24 25 26 27 28 29 31 34 38 41 42 49	0 1 2 3 5 6 8 14 16 18 22 23 26 28 30 32 34 38 39 40 41 42 45 46 47 48 49	0 3 6 7 8 9 10 12 13 16 17 18 21 23 25 31 33 37 41 42 45 46 47 48 49	0 2 3 4 5 7 9 10 11 12 13 15 19 20 28 29 30 31 34 36 37 42 44 48 49	0 1 4 5 6 8 9 10 13 16 17 18 19 20 21 24 29 30 31 32 35 37 38 39 47	0 2 3 4 5 6 7 9 10 12 16 17 18 19 22 24 25 26 30 31 34 37 42 45 48	5 7 8 9 14 15 16 21 22 27 28 30 31 32 34 35 37 38 41 42 43 44 46 48 49	3 9 11 13 16 17 18 21 24 27 28 29 30 32 34 37 38 39 40 41 42 48 49	1 2 3 5 6 7 8 9 10 11 15 16 20 28 31 32 33 35 36 39 40 42 46 47 48	1 2 4 5 6 7 9 11 15 18 20 21 22 24 25 27 29 34 35 36 37 40 44 46 49
15 M Hz	0 1 2 3 5 6 7 8 9 12 16 17 18 19 20 21 23 24 25 28 29 30 31 32 33 42 47 48 49 53 60 63 65 67 68 70 71 73	0 1 3 4 5 6 7 8 11 18 20 21 24 25 26 27 29 30 31 38 46 47 49 50 51 53 54 55 57 59 60 61 67 68 69 70 73 74	2 1 1 12 13 15 17 18 21 22 24 25 26 29 31 32 33 34 40 42 45 46 47 50 51 52 54 58 59 60 61 62 63 64 68 70 71 72 74	2 3 4 6 7 9 11 12 15 17 20 24 27 30 33 34 35 38 39 42 43 45 46 48 49 55 56 59 60 61 62 65 67 69 70 71 73 74	4 5 6 8 10 13 17 22 25 26 27 28 29 30 31 32 33 34 35 38 41 44 46 48 50 52 53 54 56 59 60 64 66 69 70 71 73 74	0 2 3 4 7 8 11 14 18 20 23 24 25 27 29 42 43 47 48 49 50 51 54 56 60 62 63 65 66 67 68 69 70 71 72 73	1 2 9 11 14 15 18 25 26 28 29 30 31 32 33 36 37 38 39 41 43 45 46 50 53 54 58 59 60 61 62 62 63 65 67 68 70 71 72 73	3 4 6 7 8 11 12 19 20 23 24 26 27 28 30 33 34 35 40 41 42 46 49 51 53 54 58 59 60 61 62 65 67 69 70 71 72 73	0 1 2 3 7 8 9 10 13 14 15 17 18 19 22 27 28 29 30 32 34 35 40 41 42 46 49 50 53 55 57 56 61 62 63 66 67 71 73 74	0 3 7 8 11 13 14 16 18 19 23 25 27 28 29 30 32 35 41 42 47 48 50 53 55 57 59 61 62 64 66 67 68 69 70 71	0 1 2 3 5 6 7 8 9 12 16 17 18 19 20 21 23 24 25 28 29 30 31 32 33 42 47 48 49 53 60 63 65 67 68 70 71 73	0 1 3 4 5 6 7 8 11 18 20 21 24 25 26 27 29 30 31 38 46 47 49 50 51 53 54 55 57 59 60 61 67 68 69 70 73 74
20 M Hz	0 1 4 6 10 13 14 15 16 20 22 23 25 26 28 29 30 31 32 33 36 39 41 42 44 45 54 56 57 60 63 66 67 68 72 76 77 79 82 84 85 87 88 91 92 94 95 97 98 99	1 3 7 9 10 13 19 20 21 22 23 24 25 26 27 30 33 34 35 36 47 48 49 50 51 53 54 55 60 61 64 65 67 68 75 76 77 80 81 83 84 86 87 89 90 93 95 99	1 2 3 6 8 10 11 15 16 17 19 21 25 26 28 29 30 32 33 35 38 39 40 41 42 43 44 46 49 51 52 54 60 62 63 64 65 69 72 76 79 81 84 86 88 89 90 93 94 99	5 7 9 10 12 14 15 16 21 22 23 24 27 28 29 30 33 34 35 47 49 51 54 56 57 63 65 66 67 70 71 72 76 81 82 83 84 85 86 87 89 94 95 96 97 99	2 3 4 5 6 7 14 15 17 19 21 22 24 26 37 43 44 47 49 51 54 56 57 60 62 63 65 66 67 70 71 73 76 77 78 83 84 85 86 87 89 94 95 96 97 99	1 2 5 6 8 9 12 13 21 22 25 26 27 28 29 31 32 34 35 39 40 43 45 46 53 57 59 61 62 63 64 66 68 69 71 73 75 77 78 82 83 84 85 86 93 94 95 96 97 99	0 1 2 3 5 8 9 10 12 13 22 25 26 27 29 31 32 33 36 37 38 39 43 45 48 49 52 53 55 59 62 63 64 64 65 73 74 75 77 78 81 82 84 86 89 91 93 92 93 97 98 99	0 1 3 4 5 7 10 11 15 18 19 20 21 26 27 29 30 31 33 35 39 39 41 43 44 46 47 49 50 53 55 59 60 64 65 66 67 69 70 71 72 74 83 84 86 92 93 94 96 98	2 3 4 7 9 11 13 15 16 24 25 27 29 31 33 35 36 40 43 44 45 46 49 51 52 53 54 55 56 57 59 63 64 65 68 69 70 78 81 84 85 86 90 91 93 94 98 99	0 4 6 7 8 10 11 13 16 18 21 22 23 26 29 32 35 36 37 43 44 46 47 48 49 53 54 55 59 60 61 64 66 67 68 72 76 77 79 78 80 81 82 84 87 89 91 92 95 96	0 1 4 6 10 13 14 15 16 20 22 23 25 26 28 29 30 31 32 33 36 39 41 42 44 45 54 56 57 60 63 66 67 68 72 76 77 79 82 84 85 87 88 91 92 94 95 97 98 99	1 3 7 9 10 13 19 20 21 22 23 24 25 26 27 30 33 34 35 36 47 48 49 50 51 53 54 55 60 61 64 65 67 68 75 76 77 80 81 83 84 86 87 89 90 93 95 97 98 99

slot	Subframe 6		Subframe 7		Subframe 8		Subframe 9	
	0	1	2	3	4	5	0	1
3 MHz	0 2 3 5 6 11 13	0 1 4 5 7	0 2 3 4 9 10 13	0 1 2 3 11 12 14	4 5 6 8 11 13 14	2 5 6 9 12 13 14	0 3 4 7 8 9 11	1 2 3 4 5 11 12
5 MHz	0 1 2 3 9 10 12 13 14 19 20 23 24	0 5 6 8 10 12 13 15 17 18 20 21 24	0 2 4 6 7 12 13 15 16 17 22 23 24	0 1 2 3 4 6 7 8 16 18 21 22 24	1 3 4 5 7 9 10 11 12 15 21 22 24	0 1 2 3 4 7 10 14 18 19 20 21 24	1 4 8 9 10 11 12 13 15 16 18 20 23	1 2 3 4 5 6 9 10 11 13 16 17 23
10 MHz	0 3 5 6 11 12 14 17 18 19 20 21 22 24 25 26 27 28 29 31 34 38 41 42 49	0 1 2 3 5 6 8 14 16 18 22 23 26 28 30 32 34 38 39 40 41 42 45 46 47	0 3 6 7 8 9 10 12 13 16 17 18 21 23 25 31 33 37 41 42 45 46 47 48 49	0 2 3 4 5 7 9 10 11 12 13 15 19 20 28 29 30 31 34 36 37 42 44 48 49	0 1 4 5 6 8 9 10 13 16 17 18 19 20 21 24 29 30 31 32 35 37 38 39 47	0 2 3 4 5 6 7 9 10 12 16 17 18 19 22 24 25 26 30 31 34 37 42 45 48	5 7 8 9 14 15 16 21 22 27 28 30 31 32 34 35 37 38 41 42 43 44 46 48 49	3 9 11 13 16 17 18 21 24 27 28 29 30 32 34 37 38 39 40 41 42 45 47 48 49
15 MHz	2 11 12 13 15 17 18 21 22 24 25 26 29 31 32 33 34 40 42 45 46 47 50 51 52 54 58 59 60 61 62 63 64 68 70 71 72 74	2 3 4 6 7 9 11 12 15 17 20 24 27 30 33 34 35 38 39 42 43 45 46 48 49 55 56 59 60 61 62 65 64 67 70 71 73 74	4 5 6 8 10 13 17 22 25 26 27 28 29 33 34 35 38 41 44 46 48 50 52 53 54 56 59 60 64 67 69 70 71 73 74	0 2 3 4 7 8 11 14 18 20 23 24 25 27 29 42 43 45 46 47 48 49 50 51 54 56 60 62 63 65 66 67 68 69 70 71 72 73	1 2 9 11 14 15 18 25 26 28 29 30 31 32 33 36 37 38 39 41 43 45 46 50 53 54 58 59 60 62 63 65 67 68 70 71 72 73	3 4 6 7 8 11 12 19 20 23 24 26 27 28 30 33 34 35 40 41 42 46 49 51 53 54 58 59 60 61 62 65 67 69 70 71 72 73	0 1 2 3 7 8 9 10 13 14 15 17 18 19 22 23 24 25 26 27 28 32 36 37 39 46 47 50 53 56 61 62 63 68 69 71 73 74	0 3 7 8 11 13 14 16 18 19 23 25 27 28 29 30 32 35 41 42 44 46 47 48 50 53 55 57 59 61 62 64 66 67 68 69 70 71
20 MHz	1 2 3 6 8 10 11 15 16 17 19 21 25 26 28 29 30 32 33 35 38 39 40 41 42 43 44 46 49 51 52 54 60 62 63 64 65 69 72 76 79 81 84 86 88 89 90 93 94 99	5 7 9 10 12 14 15 16 21 22 23 24 27 28 29 30 33 34 35 36 37 39 41 44 45 47 49 54 55 56 57 64 66 68 70 72 76 77 80 81 85 86 87 90 91 92 94 95 98 99	2 3 4 5 6 7 14 15 17 19 21 22 24 26 37 40 42 43 44 47 49 51 54 56 57 60 62 63 65 71 73 76 77 78 81 82 83 84 85 86 87 89 94 95 96 97 99	1 2 5 6 8 9 12 13 21 22 25 26 27 28 29 31 32 34 35 39 40 43 45 46 53 57 59 61 62 63 64 66 68 69 71 73 75 77 78 82 83 84 85 86 93 94 95 96 97 99	0 1 2 3 5 8 9 10 12 13 22 25 26 27 29 31 32 33 36 37 38 39 43 45 48 49 52 53 55 59 62 63 64 71 72 73 74 75 77 78 81 82 84 86 89 91 93 97 98 99	0 1 3 4 5 7 10 11 15 18 19 20 21 26 27 29 30 31 33 35 39 40 41 43 44 46 47 49 50 53 55 56 62 64 65 66 67 69 70 71 72 74 83 84 86 92 93 94 96 98	2 3 4 7 9 11 13 15 16 24 25 27 29 31 33 35 36 40 43 44 45 46 49 51 52 53 54 55 56 57 59 63 64 65 68 71 77 78 81 82 83 84 85 86 90 91 93 94 98 99	0 4 6 7 8 10 11 13 16 18 21 22 23 26 29 32 35 36 37 43 44 46 47 48 49 53 54 57 59 60 61 64 66 67 68 69 70 72 76 78 80 81 82 84 87 89 91 92 95 96

Table 6.1.1.6b-3: Numbers (n_{PRB}) of the QPSK PRBs (TDD)

slot	Subframe 0		Subframe 1		Subframe 5		Subframe 6		Subframe 7		Subframe 8	
	0	1	2	3	4	5	0	1	2	3	4	5
3 M Hz	0 1 2 3 11 12 14	0 1 2 3 11 12 13	0 1 2 3 11 12 14	0 1 2 3 11 12 13	1 2 7 8 10 13 14	2 3 4 6 8 13 14	0 3 6 8 9 10 14	0 1 2 3 11 12 14	0 1 2 3 11 12 13	0 1 2 3 11 12 14	0 1 2 3 11 12 13	1 2 7 8 10 13 14
5 M Hz	1 2 3 5 6 8 17 18 19 20 21 23 24	0 1 2 3 4 5 7 8 17 18 19 20 22	1 2 3 5 6 7 8 17 18 19 20 21 24	1 2 3 4 5 6 8 16 17 19 20 22 23	1 2 3 8 12 13 14 17 20 21 22 23 24	1 4 5 6 7 10 11 13 14 15 16 22 23	1 2 4 6 7 8 9 14 16 18 21 23 24	1 2 3 5 6 8 17 18 19 20 21 23 24	0 1 2 3 4 5 7 8 17 18 19 20 22	1 2 3 5 6 7 8 17 18 19 20 21 24	1 2 3 4 5 6 8 16 17 19 20 22 23	1 2 3 8 12 13 14 17 20 21 22 23 24
10 M Hz	2 3 4 6 7 10 11 13 15 17 18 19 29 30 34 35 37 38 39 41 42 46 47 48 49	1 3 4 5 6 7 9 10 12 14 16 17 28 30 34 35 36 37 38 39 40 41 43 44 48	2 3 4 6 7 8 9 10 11 13 14 16 18 19 20 21 29 32 34 39 41 43 44 45 46	2 5 8 9 11 12 13 14 16 18 20 21 28 29 30 31 32 33 34 42 44 45 46 47 49	1 4 5 6 7 11 12 13 14 15 17 20 21 26 27 31 32 34 37 38 41 42 46 48 49	0 1 5 6 7 8 11 12 13 15 19 20 26 28 29 30 31 32 37 38 42 43 44 47 49	1 2 5 6 8 11 13 14 15 16 18 20 21 24 25 27 30 32 34 35 37 40 43 46 47	2 3 4 6 7 10 11 13 15 17 18 19 29 30 34 35 37 38 39 41 42 46 47 48 49	1 3 4 5 6 7 9 10 12 14 16 17 28 30 34 35 36 37 38 39 40 41 43 44 48	2 3 4 6 7 8 9 10 11 13 14 16 18 19 20 34 35 36 37 38 39 39 41 43 44 45 46	2 5 8 9 11 12 13 14 16 18 20 21 28 29 30 31 32 33 34 42 44 45 46 47 49	1 4 5 6 7 11 12 13 14 15 17 20 21 26 27 31 32 34 37 38 41 42 44 48 49
15 M Hz	1 3 5 6 9 10 11 13 15 17 20 21 23 24 25 26 27 28 29 33 42 44 45 51 52 53 56 57 58 61 62 63 65 66 70 71 73 74	3 4 5 6 7 8 9 10 13 14 15 16 19 20 21 22 24 25 28 31 32 33 43 45 46 49 51 52 55 58 59 60 61 62 64 66 67 72	3 4 7 8 10 11 12 13 14 16 18 19 20 22 24 25 27 28 30 32 41 42 43 44 45 46 47 48 48 51 57 58 62 63 65 67 68 69 70 71 73 74	2 6 7 8 9 10 11 13 16 17 18 19 20 21 22 23 26 30 31 41 43 45 46 47 48 51 55 57 58 62 63 64 65 69 70 71 73 74	0 1 2 3 7 8 9 10 11 12 17 19 21 22 23 24 27 28 30 31 32 37 40 41 45 48 51 53 55 56 57 58 61 63 65 66 70 73	3 7 10 11 13 15 16 17 23 27 29 30 31 40 42 43 45 46 48 49 50 53 54 62 64 65 66 67 68 69 72 74	1 3 8 9 11 12 13 14 15 17 22 23 24 25 28 29 30 31 34 37 40 41 42 46 48 49 51 54 61 62 63 67 70 71 73 74	1 3 5 6 9 10 11 13 15 17 20 21 23 24 25 26 27 28 29 33 42 44 45 51 52 53 56 57 58 61 62 63 65 66 70 71 73 74	3 4 5 6 7 8 9 10 13 14 15 16 19 20 21 22 24 25 28 31 32 33 44 45 46 49 51 52 59 60 61 62 64 66 67 72 74	3 4 7 8 10 11 12 13 14 16 18 19 20 22 24 25 27 28 30 32 41 42 43 44 45 46 47 48 51 55 57 58 61 62 65 67 70 71 73 74	2 6 7 8 9 10 11 13 16 17 18 19 20 21 22 23 26 30 31 41 43 45 46 47 48 51 55 57 58 62 63 64 65 68 69 71 73 74	0 1 2 3 7 8 9 10 11 12 13 16 17 18 19 20 21 22 23 26 27 28 30 31 41 43 45 46 47 48 51 55 57 58 62 63 64 65 69 70 71 73 74
20 M Hz	2 4 7 8 9 10 11 12 13 14 18 20 21 23 25 27 28 31 32 34 35 37 38 39 44 46 53 56 58 60 61 68 69 70 71 74 75 76 78 79 80 82 83 85 87 88 93 95 97 99	4 5 6 7 8 9 11 12 13 14 16 17 19 20 22 25 27 29 33 37 38 40 41 42 43 44 45 53 54 57 58 61 62 65 67 68 70 73 78 80 82 83 86 88 89 90 91 93 95 97	2 3 4 5 8 9 10 11 12 14 15 17 18 19 22 24 26 27 28 30 32 35 36 37 40 41 42 46 53 54 55 60 61 62 63 64 65 70 74 74 77 82 84 85 87 92 93 97 98 99	0 2 3 4 10 11 12 13 14 17 18 22 23 25 26 27 28 30 31 32 38 40 41 43 54 55 60 61 63 64 70 74 76 77 81 82 84 85 87 88 92 94 95 98	4 9 12 13 15 17 19 20 21 30 31 36 37 39 40 41 42 43 46 48 49 50 53 54 56 57 58 66 71 72 73 74 75 80 82 83 84 85 86 87 89 90 92 94 95 96 98 99	0 1 4 10 12 14 15 17 18 19 23 28 29 30 31 32 33 37 38 39 42 46 55 61 64 65 66 68 69 70 71 72 73 74 76 78 82 83 84 85 86 89 90 91 93 94 96 97 98 99	0 1 3 4 5 7 8 12 13 14 15 17 19 20 22 23 25 26 30 31 32 32 33 34 35 35 37 38 39 41 44 45 48 49 50 51 58 59 62 63 67 68 70 72 75 79 80 82 84 85 87 88 93 92 93 94 96 98	2 4 7 8 9 10 11 12 13 14 18 20 21 23 25 27 28 31 32 34 35 37 38 39 44 46 53 56 58 60 61 68 69 70 71 74 75 76 78 79 80 82 83 85 87 88 93 92 93 94 96 99	4 5 6 7 8 9 11 12 13 14 16 17 19 20 22 25 27 29 33 37 38 40 41 42 43 44 45 53 54 57 58 61 62 65 67 68 70 73 78 80 82 83 86 88 89 90 91 93 95 97	2 3 4 5 8 9 10 11 12 14 15 17 18 19 22 24 26 27 28 30 32 35 36 37 40 41 42 46 53 54 55 60 61 62 63 64 65 70 74 74 77 82 84 85 87 92 93 97 98 99	0 2 3 4 10 11 12 13 14 17 18 22 23 25 26 27 28 30 31 32 38 40 41 43 54 55 60 61 63 64 70 74 76 77 81 82 84 85 87 88 92 94 95 98	4 9 12 13 15 17 19 20 21 30 31 36 37 39 40 41 42 43 46 48 49 50 53 54 56 57 58 66 71 72 73 74 75 80 82 83 84 85 86 87 89 90 92 94 96 97 98 99

Frame 1 subslot	Subframe 9	
	0	1
3 MHz	2 3 4 6 8 13 14	0 3 6 8 9 10 14
5 MHz	1 4 5 6 7 10 11 13 14 15 16 22 23	1 2 4 6 7 8 9 14 16 18 21 23 24
10 MHz	0 1 5 6 7 8 11 12 13 15 19 20 26 28 29 30 31 32 37 38 42 43 44 47 49	1 2 5 6 8 11 13 14 15 16 18 20 21 24 25 27 30 32 34 35 37 40 43 46 47
15 MHz	3 7 10 11 13 15 16 17 23 27 29 30 31 32 35 36 37 40 42 43 45 46 48 49 50 53 54 57 60 62 64 65 66 67 68 69 72 74	1 3 8 9 11 12 13 14 15 17 22 23 24 25 28 29 30 31 34 37 40 41 42 46 48 49 51 54 55 56 61 62 63 67 70 71 73 74
20 MHz	0 1 4 10 12 14 15 17 18 19 23 28 29 30 31 32 33 37 38 39 42 46 55 61 64 65 66 68 69 70 71 72 73 74 76 78 82 83 84 85 86 89 90 91 93 94 96 97 98 99	0 1 3 4 5 7 8 12 13 14 15 17 19 20 22 23 25 26 30 32 33 35 37 38 39 41 44 45 48 49 50 51 58 59 62 63 67 68 70 72 75 82 84 85 90 92 93 94 96 98

Frame 2	Subframe 0		Subframe 1		Subframe 5		Subframe 6		Subframe 7		Subframe 8	
	0	1	2	3	4	5	0	1	2	3	4	5
3 M Hz	0 1 2 3 12 13 14	0 1 2 3 11 12 13	1 2 3 11 12 13 14	0 1 2 11 12 13 14	2 4 7 8 9 10 11	0 1 3 4 5 13 14	0 4 6 8 9 11 12	0 1 2 3 12 13 14	0 1 2 3 11 12 13	1 2 3 11 12 13 14	0 1 2 11 12 13 14	2 4 7 8 9 10 11
5 M Hz	0 2 3 5 6 7 8 16 17 19 20 21 24	0 2 3 4 5 6 7 16 18 19 22 23 24	0 1 2 3 4 5 6 7 17 18 20 21 23	1 2 3 4 5 7 8 16 17 19 20 22 24	1 2 3 5 7 10 12 14 16 18 20 21 22 23 24	1 4 5 9 11 13 15 18 20 21 22 23 24	3 4 5 7 8 9 10 11 12 13 14 18 24	0 2 3 5 6 7 8 16 17 19 20 21 24	0 2 3 4 5 6 7 16 18 19 22 23 24	0 1 2 3 4 5 6 7 17 18 20 21 23	1 2 3 4 5 7 8 16 17 19 20 22 24	1 2 3 5 7 10 12 14 16 18 20 21 24
10 M Hz	2 5 6 7 9 10 11 15 19 20 21 28 29 30 32 33 35 36 38 40 41 43 44 48 49	2 4 6 8 9 10 11 14 15 16 18 19 20 21 28 30 32 37 40 43 44 45 46 47 49	0 2 5 7 8 9 11 14 15 16 18 19 32 33 34 36 38 41 42 43 44 45 46 48 49	0 1 2 4 6 7 8 9 11 13 14 18 19 29 34 35 36 39 41 42 44 45 47 48 49	0 2 3 6 7 8 10 11 12 15 16 19 20 22 24 25 29 26 28 31 33 35 37 42 46 47 49	0 1 2 5 6 7 8 9 10 15 16 17 18 22 23 25 26 28 29 30 31 34 31 32 39 41 46	0 1 3 6 9 10 13 14 20 21 22 23 25 28 29 30 31 34 35 36 39 40 42 44 49	2 5 6 7 9 10 9 10 11 15 19 20 21 28 29 30 32 33 35 36 41 43 44 48 49	2 4 6 8 9 10 11 14 15 16 18 19 20 21 28 33 34 36 38 43 44 45 46 47 49	0 2 5 7 8 9 11 14 15 16 18 19 32 33 34 36 38 41 42 43 44 45 46 48 49	0 1 2 4 6 7 8 9 11 13 14 18 19 29 34 35 36 39 41 42 44 45 47 48 49	0 2 3 6 7 8 10 11 12 15 16 19 20 22 24 25 29 26 28 31 33 35 37 42 46 47 49
15 M Hz	0 2 3 4 6 9 10 11 13 14 15 16 17 20 21 22 23 28 29 43 44 48 51 52 53 54 55 57 59 61 63 64 65 67 68 70 72 73	0 1 3 4 5 8 9 10 12 14 15 16 19 20 22 24 25 26 27 28 29 31 33 42 43 46 47 48 50 51 52 56 59 61 67 69 71 74	0 1 5 8 9 10 13 14 15 20 21 23 26 27 28 29 30 32 33 42 43 44 45 47 51 52 55 57 59 60 62 64 65 66 69 71 72 73	2 3 4 5 7 8 10 12 15 16 17 18 19 23 24 26 28 30 31 32 33 41 44 45 46 47 48 50 52 53 57 58 59 61 63 65 66 71	1 2 3 4 5 7 8 14 18 19 20 21 24 25 27 28 33 35 38 40 43 45 46 47 50 48 50 55 58 61 62 63 65 66 67 68 71 74	0 1 2 3 4 5 6 7 8 11 13 14 15 16 20 21 23 24 27 33 35 41 43 44 45 47 48 50 51 52 64 65 68 69 70 71 73 74	1 3 5 6 8 9 10 11 13 14 16 18 20 22 28 29 30 35 36 37 38 42 43 46 47 49 50 51 55 56 59 60 61 68 69 72 73 74	0 2 3 4 6 9 10 11 13 14 15 16 17 20 21 22 23 28 29 43 44 48 51 52 53 54 55 57 59 61 63 64 65 67 68 70 72 73	0 1 3 4 5 8 9 10 12 14 15 16 19 20 22 24 25 26 27 28 29 31 33 44 45 46 47 54 55 58 50 61 63 64 65 66 69 69 71 73	0 1 5 8 9 10 13 14 15 20 21 23 26 27 28 29 30 32 33 42 43 44 45 47 51 52 55 57 59 60 62 64 65 66 69 71 72 73	2 3 4 5 7 8 10 12 15 16 17 18 19 23 24 26 28 30 31 32 33 41 44 45 46 50 52 53 57 58 59 61 63 65 66 71	1 2 3 4 5 7 8 14 18 19 20 21 24 25 27 28 33 30 31 32 33 41 44 45 46 47 48 50 52 53 57 58 59 61 63 65 66 74
20 M Hz	0 2 5 6 7 11 12 13 14 16 17 18 19 20 21 27 28 30 31 35 37 38 40 43 44 45 46 53 56 57 59 60 61 62 63 64 65 68 70 73 77 79 80 82 85 87 89 92 95 97	3 4 5 6 7 9 10 13 16 20 21 23 24 25 26 28 30 31 32 35 37 38 41 42 43 44 46 53 54 59 60 61 62 64 67 70 71 76 77 78 79 81 82 84 86 87 88 95 98 99	0 1 2 3 4 5 10 11 15 18 19 20 21 24 25 26 27 28 32 33 34 37 44 54 57 58 59 60 61 65 67 70 71 73 77 78 83 84 85 88 89 90 91 95 98 99	1 2 3 4 5 7 8 9 11 15 17 19 20 21 22 24 27 28 29 30 31 32 33 36 41 44 45 56 57 61 62 63 68 69 73 79 75 76 77 78 85 86 87 91 92 93 98 99	0 2 3 7 6 8 10 11 12 15 16 17 18 19 20 22 25 27 30 35 37 39 42 44 48 49 52 53 59 62 63 67 69 73 74 75 76 79 82 84 85 87 89 90 91 95 96 97 98 96 98	0 1 2 5 6 8 10 11 12 13 14 15 16 20 21 24 27 29 33 34 39 40 42 43 46 48 50 54 59 60 61 66 70 71 75 76 78 79 82 84 85 87 89 90 91 95 96 97 98 99	1 2 3 4 6 7 8 9 15 18 19 20 21 23 24 25 28 29 30 32 35 39 44 45 47 48 51 53 55 57 60 61 62 63 67 68 72 73 74 75 76 77 81 90 82 82 92 93 95 96 97 99	0 2 5 6 7 11 12 13 14 16 17 18 19 20 21 27 28 30 31 32 35 37 37 38 40 43 44 45 46 53 56 57 59 60 61 62 63 64 65 68 70 73 78 79 81 82 84 86 85 87 89 92 95 97	3 4 5 6 7 9 10 13 16 20 21 23 24 25 26 28 30 31 32 35 37 38 41 42 43 44 46 53 54 59 60 61 62 64 67 70 71 76 77 78 79 81 82 84 86 85 88 92 94 95 98 99	0 1 2 3 4 5 10 11 15 18 19 20 21 24 25 26 27 28 32 33 34 37 44 54 57 58 59 60 61 65 67 70 71 73 77 78 83 84 85 88 89 90 91 95 98 99	1 2 3 4 5 7 8 9 11 15 17 19 20 21 22 24 27 28 29 30 31 32 33 36 41 44 45 56 60 61 65 67 70 71 73 77 78 83 84 85 88 89 90 91 95 96 98 99	0 2 3 7 11 12 13 14 15 16 17 18 19 20 22 25 27 30 35 37 39 42 44 48 49 52 53 59 62 63 66 67 73 79 75 76 77 78 85 86 87 91 92 93 98 99

Frame 2 slot	Subframe 9	
	0	1
3 MHz	0 1 3 4 5 13 14	0 4 6 8 9 11 12
5 MHz	1 4 5 9 11 13 15 18 20 21 22 23 24	3 4 5 7 8 9 10 11 12 13 14 18 24
10 MHz	0 1 2 5 6 7 8 9 10 15 16 17 18 22 23 25 26 28 29 30 31 32 39 41 46	0 1 3 6 9 10 13 14 20 21 22 23 25 28 29 30 31 34 35 36 39 40 42 44 47
15 MHz	0 1 2 3 4 5 6 7 8 11 13 14 15 16 20 21 23 24 27 33 35 41 43 44 45 47 48 50 51 52 64 65 68 69 70 71 73 74	1 3 5 6 8 9 10 11 13 14 16 18 20 22 28 29 30 35 36 37 38 42 43 46 47 49 50 51 55 56 59 60 61 68 69 72 73 74
20 MHz	0 1 2 5 6 8 10 11 12 13 14 15 16 20 21 24 27 29 33 34 39 40 42 43 46 48 50 54 59 60 61 66 70 71 75 76 78 79 82 84 85 87 89 90 91 95 96 97 98 99	1 2 3 4 6 7 8 9 15 18 19 20 21 23 24 25 28 29 30 32 35 39 44 45 47 48 51 53 55 57 60 61 62 63 67 68 72 73 74 75 76 77 81 90 92 93 95 96 97 99

6.1.2 Data content of Physical channels and Signals for E-TM

Randomisation of the data content is obtained by utilizing the length-31 Gold sequence scrambling of TS36.211, Clause 7.2 [12] which is invoked by all physical channels prior to modulation and mapping to the RE grid. An appropriate number of '0' bits shall be generated prior to the scrambling.

In case multiple carriers are configured with E-TMs, the N_{ID}^{cell} shall be incremented by 1 for each additional configured carrier.

Initialization of the scrambler and RE-mappers as defined in TS36.211 [12] use the following additional parameters:

- $n_f = 0$ (used for PBCH)
- The E-TM shall start when $n_s = 0$
- $N_{ID}^{cell} = 1$ for the lowest configured carrier, $N_{ID}^{cell} = 2$ for the 2nd lowest configured carrier, ..., $N_{ID}^{cell} = n$ for the nth configured carrier
- $p = 0$ (data generated according to definitions in TS36.211 for antenna port 0). $p = 0$ shall be used for the generation of the E-TM data, even if the signal is transmitted on a physical port other than port 0.
- $q = 0$ (single code word)

6.1.2.1 Reference signals

Sequence generation, modulation and mapping to REs according to TS36.211, clause 6.10.1

6.1.2.2 Primary Synchronization signal

Sequence generation, modulation and mapping to REs according to TS36.211, clause 6.11.1

6.1.2.3 Secondary Synchronization signal

Sequence generation, modulation and mapping to REs according to TS36.211, clause 6.11.2

6.1.2.4 PBCH

- 240 REs (480 bits) are available for PBCH for the duration of the E-UTRA test models (1 frame, 10 ms)
- Generate 480 bits of 'all 0' data
- Initialize scrambling generator for each invocation of the E-TM, i.e. set always $n_f = 0$
- Perform scrambling according to TS36.211, clause 6.6.1 of the 480 bits
- Perform modulation according to TS36.211, clause 6.6.2
- Perform mapping to REs according to TS36.211, clause 6.6.4

6.1.2.5 PCFICH

- Generate 32 bit CFI codeword according to TS36.212, clause 5.3.4.
- Perform scrambling according to TS36.211, clause 6.7.1
- Perform modulation according to TS36.211, clause 6.7.2
- Perform mapping to REs according to TS36.211, clause 6.7.4

6.1.2.6 PHICH

- PHICH duration is assumed as 'Normal' according to TS36.211, clause 6.9.3
- Set $N_g = 1/6$ to obtain $N_{\text{PHICH}}^{\text{group}}$, see TS36.211, clause 6.9
- Use 2 PHICH per group, $n_{\text{PHICH}}^{\text{seq}} = 0, 4$
- For frame structure type 2 the factor m_i shall not be set as per TS36.211, Table 6.9-1, but instead shall be set to $m_i = 1$ for all transmitted subframes (Note).
- For each subframe the required amount of HARQ Indicators (HI) is as follows: $N_{\text{PHICH}}^{\text{group}} * (2 \text{ PHICH per group})$.
- Generate this amount of HIs using '0' data for each HI.
- Generate 3 bit HI codeword according to TS36.212, clause 5.3.5
- Perform scrambling and modulation according to TS36.211, clause 6.9.1
- Perform mapping to REs according to TS36.211, clause 6.9.3

NOTE: This is in order to preserve commonality between FDD and TDD E-TM.

6.1.2.7 PDCCH

- For each subframe the required amount of bits for all PDCCHs is as follows: (# of PDCCH)*(# of CCE per PDCCH)*(9 REG per CCE)*(4 RE per REG)*(2 bits per RE) with these parameters according to the E-TM definitions in subclause 6.1.1
- Generate this amount of bits according to ‘all 0’ data
- Numbering of CCEs shall be according to TS36.211, clause 6.8.1. Mapping of PDCCHs to the available CCEs is performed as follows: First PDCCH is mapped to CCE(0), second PDCCH to CCE(0+ ‘# of CCEs per PDCCH’), ... etc. The remaining resources not used for PDCCH are treated as <NIL> REGs according to TS36.211, clause 6.8.2
- Perform PDCCH multiplexing and scrambling according to TS36.211, clause 6.8.2
- Perform modulation according to TS36.211, clause 6.8.3
- Perform mapping to REs according to TS36.211, clause 6.8.5

6.1.2.8 PDSCH or sPDSCH

- For each subframe generate the required amount of bits for all PRBs according to ‘all 0’ data
- PRB numbering is according to TS36.211, clause 6.2.3
- E-TMs utilize 1 user or 2 user PDSCH transmissions distinguished by n_{RNTI} . For each E-TM, PRBs are mapped to users (n_{RNTI}) according to their respective PRB attribute as follows:

Table 6.1.2.8-1: Mapping of PRBs to n_{RNTI} for each E-TM

	n_{RNTI}
E-TM1.1	0 for all PRBs
E-TM1.2	0 for boosted PRBs or those with $P_A = 0\text{dB}$ 1 for de-boosted PRBs
E-TM2	0 for all PRBs
E-TM3.1	0 for all PRBs
E-TM3.2	0 for QPSKPRBs 1 for 16QAM PRBs
E-TM3.3	0 for 16QAM PRBs 1 for QPSK PRBs

- The required amount of PDSCH (sPDSCH for sTTI) ‘0’ bits within a subframes and allocated PRBs shall be generated for each user
- Perform user specific scrambling according to TS36.211, clause 6.3.1. This makes use of n_{RNTI} .
- Perform modulation of the scrambled bits with the modulation scheme defined for each user according to TS36.211, clause 6.3.2
- Perform mapping of the complex-valued symbols to PRBs according to TS36.211, clause 6.3.5.

6.1.2.9 sPDCCH

- For each subslot (subslot TTI) the required amount of bits for all sPDCCHs is as follows: (# of sPDCCH)*(# of sCCE per sPDCCH)*(N_{sREG} sREG per sCCE)*(12 RE per sREG)*(2 bits per RE) with these parameters according to the E-TM definitions in subclause 6.1.1, with $N_{\text{sREG}} = 4$ (for 2 symbols) or 6 (for 3 symbols)
- For each slot (slot TTI) the required amount of bits for all sPDCCHs is as follows: (# of sPDCCH)*(# of sCCE per sPDCCH)*(4 sREG per sCCE)*(12 RE per sREG)*(2 bits per RE) with these parameters according to the E-TM definitions in subclause 6.1.1

- Generate this amount of bits according to ‘all 0’ data
- Numbering of sCCEs shall be according to TS36.211, clause 6.8C.1. Mapping of sPDCCHs to the available sCCEs is performed as follows: First sPDCCH is mapped to sCCE(0), second sPDCCH to sCCE(0+ ‘# of sCCEs per sPDCCH’), ... etc. The remaining resources not used for sPDCCH are treated as <NIL> sREGs according to TS36.211, clause 6.8C.2
- Perform sPDCCH multiplexing and scrambling according to TS36.211, clause 6.8C.2
- Perform modulation according to TS36.211, clause 6.8C.3
- Perform mapping to REs according to TS36.211, clause 6.8C.5

6.1.3 NB-IoT Test Model

The set-up of physical channels for transmitter tests shall be according to the NB-IoT Test Model (N-TM) below.

The following general parameters are used:

- The test models are defined for a single antenna port (using $p = 1000$);
- Duration is 10 subframes (10 ms)
- Normal CP

The following physical channel parameters are used:

- The ratio of synchronisation signal EPRE and NRS EPRE is 0 dB
- NPDCCH format 1

For NB-IoT TDD, test models are derived based on the uplink/downlink configuration 1 and special subframe configuration 7 defined in TS 36.211 [12], i.e. as showing in the table 6.1.3-1. Number of frames for the test models is 2.

Table 6.1.3-1: Configurations of TDD eNB test models

Downlink-to-Uplink Switch-point periodicity	Number of UL/DL sub-frames per radio frame (10 ms)		DwPTS	GP	UpPTS
	DL	UL			
5ms	4	4	$24144T_s$	$2192 \cdot T_s$	$4384 \cdot T_s$

6.1.4 Data content of Physical channels and Signals for N-TM

Data content of physical channels and signals for NB-IoT should be fully aligned the specification statement in TS36.211. Detail configuration for the transmitter characteristic tests are used as follows,

In case multiple NB-IoT carriers are configured with N-TMs, the N_{ID}^{cell} for the n^{th} configured NB-IoT carrier shall be equal to $97+6*n+\max(0,m-1)$, where m is equal to 0 for stand-alone NB-IoT carrier or equal to the Cell ID of the E-UTRA carrier containing the in-band/guard-band NB-IoT carrier.

Initialization of the scrambler and RE-mappers as defined in TS36.211 use the following additional parameters:

- $n_f = 0$
- The N-TM shall start when $n_s = 0$
- $p = 1000$ shall be used for the generation of the N-TM data

- $N_{ID}^{cell} = 103$ for the lowest configured stand-alone NB-IoT carrier or in-band/guard-band NB-IoT carrier(s) within the lowest E-UTRA carrier, $N_{ID}^{cell} = 109$ for the 2nd lowest configured NB-IoT stand-alone carrier or 110 for the in-band/guard-band NB-IoT carrier(s) within the 2nd lowest E-UTRA carrier, ..., $N_{ID}^{cell} = 97+6*n+\max(0,m-1)$ for the nth configured NB-IoT stand-alone carrier or in-band/guard-band NB-IoT carrier(s) within the mth E-UTRA carrier

6.1.4.1 Reference signals

Sequence generation, modulation and mapping to REs according to TS36.211, clause 10.2.6.

6.1.4.2 Synchronization signals

Sequence generation, modulation and mapping to REs according to TS36.211, clause 10.2.7.

6.1.4.3 NPBCH

- 100 REs (200 bits) are available for NPBCH for the duration of the NB-IoT test model (1 frame, 10 ms)
- Generate 200 bits of ‘all 0’ data
- Initialize scrambling generator for each invocation of the N-TM, i.e. set always $n_f = 0$
- Perform scrambling according to TS36.211, clause 10.2.4.1
- Perform modulation according to TS36.211, clause 10.2.4.2
- Perform mapping to REs according to TS36.211, clause 10.2.4.4

6.1.4.4 NPDCCH

- NPDCCH is on the first of all available subframes which not transmit synchronization signals and NPBCH in the duration of the NB-IoT test model. The number of available bits (304 bits for stand-alone and guard band operation, or 200 bits for in-band operation) for NPDCCH is depended on the higher layer parameter *operationModeInfo* according to TS36.213, clause 16.6.1.
- Generate the amount of NPDCCH bits according to ‘all 0’ data
- Perform NPDCCH scrambling according to TS36.211, clause 10.2.5.2
- Perform modulation according to TS36.211, clause 10.2.5.3
- Perform mapping to REs according to TS36.211, clause 10.2.5.5

6.1.4.5 NPDSCH

- NPDSCH is on the rest of subframes in the duration of NB-IoT test model. The number of available bits (304 bits for stand-alone and guard band operation, or 200 bits for in-band operation) in each subframe for NPDSCH is depended on the higher layer parameter *operationModeInfo* according to TS36.213, clause 16.6.1.
- Generate the required amount of bits according to ‘all 0’ data
- N-TM utilize 1 user NPDSCH transmissions indicated by $n_{RNTI}=1000$
- Perform user specific scrambling according to TS36.211, clause 10.2.3.1. This makes use of n_{RNTI} .
- Perform modulation of the scrambled bits with the modulation scheme defined for each user according to TS36.211, clause 10.2.3.2
- Perform mapping of the complex-valued symbols to PRBs according to TS36.211, clause 10.2.3.4

6.1.5 Test Model for NB-IoT guard band operation

The physical channels for transmitter tests shall be configured according to E-TM1.1 on all E-UTRA carriers and N-TM on all NB-IoT carriers.

For guard band transmitter tests, NB-IoT PRB is placed closest to E-UTRA PRBs in the E-UTRA carrier containing the NB-IoT PRB.

The power for E-UTRA PRB and NB-IoT PRB is set by following procedures:

- The average power per PRB over all PRBs (from both NB-IoT and the E-UTRA carrier containing the NB-IoT PRB) is calculated according to manufacturer's declared rated output power ($P_{\text{rated,c}}$);

$$\text{Average power per PRB } (P_{\text{avg}}) = P_{\text{rated,c}} / (N_{\text{RB}} + 1) \text{ [W]}$$

- The power of boosted NB-IoT PRB ($P_{\text{NB-IoT}}$) is calculated according to manufacturer's declared rated NB-IoT maximum power dynamic range ($X \text{ dB} \geq 6 \text{ dB}$)

$$\text{Power per boosted NB-IoT PRB } (P_{\text{NB-IoT}}) = P_{\text{avg}} * 10^{(X/10)} \text{ [W]}$$

- The remaining power is allocated to E-UTRA PRBs.

$$\text{Power per E-UTRA PRB} = (P_{\text{rated,c}} - P_{\text{NB-IoT}}) / N_{\text{RB}} \text{ [W]}$$

6.1.6 Test Model for NB-IoT in-band operation

The physical channels for transmitter tests shall be configured according to E-TM1.1 on all E-UTRA carriers and N-TM on all NB-IoT carriers.

For in-band transmitter tests, one E-UTRA PRB is punctured and replaced by NB-IoT PRB which also contains certain REs for the hosting E-UTRA carrier.

The power for E-UTRA RE and NB-IoT RE are set by following procedures:

- The average power per RE over all PRBs (from both NB-IoT and the E-UTRA carrier containing the NB-IoT PRB) is calculated according to manufacturer's declared rated output power ($P_{\text{rated,c}}$);

$$\text{Average power per RE } (P_{\text{avg}}) = P_{\text{rated,c}} / (N_{\text{RB}} * N_{\text{SC}}^{\text{RB}}) \text{ [W]}$$

- The power per boosted NB-IoT RE ($P_{\text{NB-IoT}}$) is calculated according to manufacturer's declared rated NB-IoT maximum power dynamic range ($X \text{ dB} \geq 6 \text{ dB}$), with the power boosting only applies on the $N_{\text{NB-IoT}}$ REs containing NB-IoT signal.

$$\text{Power per boosted NB-IoT RE } (P_{\text{NB-IoT}}) = P_{\text{avg}} * 10^{(X/10)} \text{ [W]}$$

- The remaining power is allocated to $N_{\text{E-UTRA}}$ E-UTRA REs.

$$\text{Power per E-UTRA RE} = (P_{\text{rated,c}} - P_{\text{NB-IoT}} * N_{\text{NB-IoT}}) / N_{\text{E-UTRA}} \text{ [W]}$$

6.2 Base station output power

6.2.1 Definition and applicability

Output power, P_{out} , of the base station is the mean power of one carrier delivered to a load with resistance equal to the nominal load impedance of the transmitter.

Rated total output power ($P_{\text{rated,t}}$) of the base station is the mean power for BS operating in single carrier, multi-carrier, or carrier aggregation configurations that the manufacturer has declared to be available at the antenna connector during the transmitter ON period.

Base station maximum output power ($P_{\text{max,c}}$), of the base station is the mean power level per carrier measured at the antenna connector during the transmitter ON period in a specified reference condition.

Rated output power ($P_{\text{rated,c}}$), of the base station is the mean power level per carrier for BS operating in single carrier, multi-carrier, or carrier aggregation configurations that the manufacturer has declared to be available at the antenna connector during the transmitter ON period.

NOTE: Different $P_{\text{rated,c}}$ may be declared for different configurations.

NOTE: For NB-IoT in-band and guard band operation, the LTE carrier and NB-IoT carrier shall be seen as a single carrier occupied LTE channel bandwidth, the output power over this carrier is shared between LTE and NB-IoT. This note is applied for P_{out} , Rated total output power, $P_{\text{max,c}}$ and $P_{\text{rated,c}}$.

In certain regions, the minimum requirement for normal conditions may apply also for some conditions outside the ranges defined for the Normal test environment in Annex D.

The rated output power, $P_{\text{rated,c}}$, of the BS shall be as specified in Table 6.2.1-1

Table 6.2.1-1: Base Station rated output power

BS class	$P_{\text{rated,c}}$
Wide Area BS	(note)
Medium Range BS	$\leq + 38$ dBm
Local Area BS	$\leq + 24$ dBm
Home BS	$\leq + 20$ dBm (for one transmit antenna port) $\leq + 17$ dBm (for two transmit antenna ports) $\leq + 14$ dBm (for four transmit antenna ports) $< + 11$ dBm (for eight transmit antenna ports)
NOTE:	There is no upper limit required for the rated output power of the Wide Area Base Station.

In addition for Band 46 operation, the BS may have to comply with the applicable BS power limits established regionally, when deployed in regions where those limits apply and under the conditions declared by the manufacturer. The regional requirements may be in the form of conducted power, power spectral density, EIRP and other types of limits. In case of regulatory limits based on EIRP, assessment of the EIRP level is described in Annex H of TS 36.104 [2].

In addition for Band 49 operation in US, the BS EIRP power limit established by FCC for Category A CBSDs (Citizens Broadband Radio Service Devices) applies. Assessment of the EIRP level is described in Annex H of TS 36.104 [2].

In addition for Band 85 NB-IoT standalone operation, the BS rated output power limit of 43 dBm applies over the NB-IoT carriers in the range 728-729 MHz of the DL operating band. The BS output power limit of 43 dBm shall be considered as shared among all NB-IoT carriers in the 728-729 MHz frequency range or as the maximum value per NB-IoT carrier in the case where only one NB-IoT carrier is deployed in 728-729 MHz frequency range.

6.2.2 Minimum Requirement

The minimum requirement is in TS 36.104 [2] subclause 6.2.

6.2.3 Test purpose

The test purpose is to verify the accuracy of the maximum output power across the frequency range and under normal and extreme conditions for all transmitters in the BS.

6.2.4 Method of test

6.2.4.1 Initial conditions

Test environment: normal; see Annex D2.

RF channels to be tested for single carrier: B, M and T; see subclause 4.7

Base Station RF Bandwidth positions to be tested for multi-carrier and/or CA: B_{RFBW} , M_{RFBW} and T_{RFBW} in single-band operation, see subclause 4.7.1; B_{RFBW_T} and B'_{RFBW_T} in multi-band operation, see subclause 4.7.1.

In addition, on one RF channel or Base Station RF Bandwidth position in case of multi-carrier and/or CA only, the test shall be performed under extreme power supply as defined in Annex D.5.

NOTE: Tests under extreme power supply also test extreme temperature.

- 1) Connect the power measuring equipment to the base station antenna connector as shown in Annex I.1.1.

6.2.4.2 Procedure

- 1) For an E-UTRA BS declared to be capable of single carrier operation only, set the base station to transmit a signal according to E-TM1.1.

For an E-UTRA BS declared to be capable of multi-carrier and/or CA operation, set the base station to transmit according to E-TM1.1 on all carriers configured using in the applicable test configuration and corresponding power setting specified in clause 4.10 and 4.11.

- For an E-UTRA BS declared to be capable of NB-IoT in-band operation, start transmission according to E-TM1.1 with the NB-IoT PRB constructed according to N-TM at manufacturer's declared rated output power using the applicable test configuration and corresponding power setting specified in clause 4.10 and 4.11.
- For an E-UTRA BS declared to be capable of NB-IoT guard-band operation, start transmission according to E-TM1.1 with the NB-IoT PRB constructed according to N-TM at manufacturer's declared rated output power using the applicable test configuration and corresponding power setting specified in clause 4.10 and 4.11.
- For a NB-IoT BS declared to be capable of single carrier operation, start transmission according to N-TM at manufacturer's declared rated output power.
- For a NB-IoT BS declared to be capable of multi-carrier operation, set the base station to transmit according to N-TM on all carriers configured using in the applicable test configuration and corresponding power setting specified in clause 4.10 and 4.11.
- For an E-UTRA and NB-IoT standalone BS declared to be capable of multi-carrier operation, start transmission according to E-TM1.1 on all E-UTRA carriers and N-TM on all NB-IoT carriers configured using in the applicable test configuration and corresponding power setting specified in clause 4.10 and 4.11.

- 2) Measure the mean power for each carrier at the antenna connector.

In addition, for a multi-band capable BS, the following step shall apply:

- 3) For multi-band capable BS and single band tests, repeat the steps above per involved band where single band test configurations and test models shall apply with no carrier activated in the other band. For multi-band capable BS with separate antenna connector, the antenna connector not being under test in case of single-band or multi-band test shall be terminated.

6.2.5 Test Requirements

In normal conditions, for E-UTRA the measurement result in step 2 of 6.2.4.2 shall remain:

within +2.7 dB and -2.7 dB of the manufacturer's rated output power, $P_{\text{rated,c}}$, for carrier frequency $f \leq 3.0\text{GHz}$.

within +3.0 dB and -3.0 dB of the manufacturer's rated output power, $P_{\text{rated,c}}$, for carrier frequency $3.0\text{GHz} < f \leq 4.2\text{GHz}$.

In extreme conditions, for E-UTRA measurement result in step 2 of 6.2.4.2 shall remain:

within +3.2 dB and -3.2 dB of the manufacturer's rated output power, $P_{\text{rated,c}}$, for carrier frequency $f \leq 3.0\text{GHz}$.

within +3.5 dB and -3.5 dB of the manufacturer's rated output power, $P_{\text{rated,c}}$, for carrier frequency $3.0\text{GHz} < f \leq 4.2\text{GHz}$.

In normal conditions, for standalone NB-IoT the measurement result in step 2 of 6.2.4.2 shall remain:

within +3.0 dB and –3.0 dB of the manufacturer's rated output power, $P_{\text{rated,c}}$

In extreme conditions, for standalone NB-IoT measurement result in step 2 of 6.2.4.2 shall remain:

within +3.5 dB and –3.5 dB of the manufacturer's rated output power, $P_{\text{rated,c}}$

NOTE: If the above Test Requirement differs from the Minimum Requirement then the Test Tolerance applied for this test is non-zero. The Test Tolerance for this test and the explanation of how the Minimum Requirement has been relaxed by the Test Tolerance are given in Annex G.

6.2.6 Home BS output power for adjacent UTRA channel protection

6.2.6.1 Definition and applicability

The E-UTRA or NB-IoT Home BS shall be capable of adjusting the transmitter output power to minimize the interference level on the adjacent channels licensed to other operators in the same geographical area while optimize the Home BS coverage. These requirements are only applicable to Home BS. The requirements in this clause are applicable for AWGN radio propagation conditions.

The output power, P_{out} , of the Home BS shall be as specified in Table 6.2.6-1 under the following input conditions:

- $\text{CPICH } \hat{E}_c$, measured in dBm, is the code power of the Primary CPICH on one of the adjacent channels present at the Home BS antenna connector for the CPICH received on the adjacent channels. If Tx diversity is applied on the Primary CPICH, $\text{CPICH } \hat{E}_c$ shall be the sum in [W] of the code powers of the Primary CPICH transmitted from each antenna.
- I_{oh} , measured in dBm, is the total received power density, including signals and interference but excluding the own Home BS signal, present at the Home BS antenna connector on the Home BS operating channel.

In case that both adjacent channels are licensed to other operators, the most stringent requirement shall apply for P_{out} . In the case when one of the adjacent channels is licensed to an E-UTRA operator while the other adjacent channel is licensed to a UTRA operator, the more stringent requirement of this subclause and subclause 6.2.7 shall apply for P_{out} . In case the Home BS's operating channel and both adjacent channels are licensed to the same operator, the requirements of this clause do not apply.

The input conditions defined for the requirements in this clause are specified at the antenna connector of the Home BS. For Home BS receivers with diversity, the requirements apply to each antenna connector separately, with the other one(s) terminated or disabled. The requirements are otherwise unchanged. For Home BS(s) without measurement capability, a reference antenna with a gain of 0 dBi is assumed for converting these power levels into field strength requirements.

Table 6.2.6-1: Home BS output power for adjacent operator UTRA channel protection

Input Conditions	Output power, P_{out}
$I_{\text{oh}} > \text{CPICH } \hat{E}_c + 43 \text{ dB}$ And $\text{CPICH } \hat{E}_c \geq -105 \text{ dBm}$	$\leq 10 \text{ dBm}$
$I_{\text{oh}} \leq \text{CPICH } \hat{E}_c + 43 \text{ dB}$ and $\text{CPICH } \hat{E}_c \geq -105 \text{ dBm}$	$\leq \max(8 \text{ dBm}, \min(20 \text{ dBm}, \text{CPICH } \hat{E}_c + 100 \text{ dB}))$

NOTE 1: The Home BS transmitter output power specified in Table 6.2.6-1 assumes a Home BS reference antenna gain of 0 dBi, an target outage zone of 47dB around the Home BS for an UE on the adjacent channel, with an allowance of 2 dB for measurement errors, an ACIR of 33 dB, an adjacent channel UE $\text{CPICH } \hat{E}_c/I_0$ target of -18 dB and the same $\text{CPICH } \hat{E}_c$ value at the adjacent channel UE as for the Home BS.

NOTE 2: For $\text{CPICH } \hat{E}_c < -105 \text{ dBm}$, the requirements in subclause 6.2 apply.

NOTE 3: The output power P_{out} is the sum transmit power across all the antenna connectors of the Home BS, with each transmit power measured at the respective antenna connectors.

6.2.6.2 Minimum Requirement

The minimum requirement is in TS 36.104 [2] subclause 6.2.3.

6.2.6.3 Test purpose

The test purpose is to verify the capability of the Home BS to adjust the transmitter output power according to the input conditions, as specified in Table 6.2.6-1, across the frequency range and under normal and extreme conditions for all transmitters in the BS.

6.2.6.4 Method of test

6.2.6.4.1 Initial conditions

Test environment: normal; see Annex D2.

RF channels to be tested for single carrier: M ; see subclause 4.7.

In addition, on one UARFCN only, the test shall be performed under extreme power supply as defined in Annex D.5.

NOTE: Tests under extreme power supply also test extreme temperature.

Signal generators delivering co-channel and adjacent channel interferers are switched off.

- 1) Set-up the equipment as shown as shown in Annex I.1.4.
- 2) The Home BS is configured such that the adjacent channel is known to belong to another operator.

6.2.6.4.2 Procedure

- 1) Connect the combined downlink interfering signals (referred to as point D in Figure I.1-4) to the dedicated measurement port (referred to as point 1 in Figure I.1-4) if available, otherwise connect to point 2.
- 2) Configure the signal generator for co-channel interference to transmit AWGN over a bandwidth according to BW_{Config} centred on RF channel M .
- 3) Configure the signal generator for adjacent channel DL signal to transmit test model 1 in subclause 6.1.1.1 in [17] at the centre frequency equal to RF channel $M + BW_{\text{Channel}}/2 + 2.5$ MHz.
- 4) Switch on signal generators delivering co-channel and adjacent channel interferers, and adjust the ATT1 and ATT2 such that CPICH $\hat{E}_c = -80$ dBm and $I_{oh} = -50$ dBm.
- 5) Trigger the Home BS power adjustment mechanism.
- 6) Configure the E-UTRA Home BS to transmit a signal according to E-TM1.1. Configure the E-UTRA Home BS declared to be capable of NB-IoT in-band operation to transmit a signal according to E-TM1.1 with the NB-IoT PRB constructed according to N-TM at manufacturer's declared rated output power. Configure the E-UTRA Home BS declared to be capable of NB-IoT guard-band operation to transmit a signal according to E-TM1.1 with the NB-IoT PRB constructed according to N-TM at manufacturer's declared rated output power. Configure the NB-IoT Home BS to transmit a signal according to N-TM at manufacturer's declared rated output power.

NOTE: The signal shall be transmitted with the maximum allowed output power.

- 7) Measure Home BS output power, P_{out} , and check it is below the required value according to the CPICH \hat{E}_c and I_{oh} values determined in step 4.
- 8) Repeat steps 3) to 7) with the frequency in step 3 set to RF channel $M - BW_{\text{Channel}}/2 - 2.5$ MHz.
- 9) Repeat steps 3) to 8) with different settings for ATT1 and ATT2 to arrive the CPICH \hat{E}_c and I_{oh} pairs as specified in Table 6.2.6-2.

Table 6.2.6-2: CPICH \hat{E}_c and I_{oh} pairs

Test Case	CPICH \hat{E}_c (dBm)	I_{oh} (dBm)
2	-90	-60
3	-100	-70
4	-100	-50

6.2.6.5 Test Requirements

In normal operating conditions, the output power, P_{out} , of the Home BS shall be equal to or less than:

the value specified in Table 6.2.6-1 plus 2.7 dB for carrier frequency $f \leq 3.0\text{GHz}$.

the value specified in Table 6.2.6-1 plus 3.0 dB for carrier frequency $3.0\text{GHz} < f \leq 4.2\text{GHz}$.

In extreme operating conditions, the output power, P_{out} , of the Home BS shall be equal to or less than:

the value specified in Table 6.2.6-1 plus 3.2 dB for carrier frequency $f \leq 3.0\text{GHz}$.

the value specified in Table 6.2.6-1 plus 3.5 dB for carrier frequency $3.0\text{GHz} < f \leq 4.2\text{GHz}$.

NOTE: If the above Test Requirement differs from the Minimum Requirement then the Test Tolerance applied for this test is non-zero. The Test Tolerance for this test and the explanation of how the Minimum Requirement has been relaxed by the Test Tolerance are given in Annex G.

6.2.7 Home BS output power for adjacent E-UTRA channel protection

6.2.7.1 Definition and applicability

The E-UTRA or NB-IoT Home BS shall be capable of adjusting the transmitter output power to minimize the interference level on the adjacent channels licensed to other operators in the same geographical area while optimize the Home BS coverage. These requirements are only applicable to Home BS. The requirements in this clause are applicable for AWGN radio propagation conditions.

The output power, P_{out} , of the Home BS shall be as specified in Table 6.2.7-1 under the following input conditions:

- $CRS \hat{E}_s$, measured in dBm, is the Reference Signal Received Power per resource element on one of the adjacent channels present at the Home BS antenna connector for the Reference Signal received on the adjacent channels. For $CRS \hat{E}_s$ determination, the cell-specific reference signal R0 according TS 36.211 [12] shall be used. If the Home BS can reliably detect that multiple TX antennas are used for transmission on the adjacent channel, it may use the average in [W] of the $CRS \hat{E}_c$ on all detected antennas.
- I_{oh} , measured in dBm, is the total received power density, including signals and interference but excluding the own Home BS signal, present at the Home BS antenna connector on the Home BS operating channel.

In case that both adjacent channels are licensed to other operators, the most stringent requirement shall apply for P_{out} . In the case when one of the adjacent channels is licensed to an E-UTRA operator while the other adjacent channel is licensed to a UTRA operator, the more stringent requirement of this subclause and subclause 6.2.6 shall apply for P_{out} . In case the Home BS's operating channel and both adjacent channels are licensed to the same operator, the requirements of this clause do not apply.

The input conditions defined for the requirements in this clause are specified at the antenna connector of the Home BS. For Home BS receivers with diversity, the requirements apply to each antenna connector separately, with the other one(s) terminated or disabled. The requirements are otherwise unchanged. For Home BS(s) without measurement capability, a reference antenna with a gain of 0 dBi is assumed for converting these power levels into field strength requirements.

Table 6.2.7-1: Home BS output power for adjacent operator E-UTRA channel protection

Input Conditions	Output power, P _{out}
$l_{oh} > \text{CRS } \hat{E}_s +$ $10 \cdot \log_{10} \left(N_{RB}^{DL} \cdot N_{sc}^{RB} \right)$ $+ 30 \text{ dB}$ and $\text{CRS } \hat{E}_s \geq -127 \text{ dBm}$	$\leq 10 \text{ dBm}$
$l_{oh} \leq \text{CRS } \hat{E}_s +$ $10 \cdot \log_{10} \left(N_{RB}^{DL} \cdot N_{sc}^{RB} \right)$ $+ 30 \text{ dB}$ and $\text{CRS } \hat{E}_s \geq -127 \text{ dBm}$	$\leq \max(8 \text{ dBm}, \min(20 \text{ dBm}, \text{CRS } \hat{E}_s +$ $10 \cdot \log_{10} \left(N_{RB}^{DL} \cdot N_{sc}^{RB} \right)$ $+ 85 \text{ dB}))$

NOTE 1: The Home BS transmitter output power specified in Table 6.2.7-1 assumes a Home BS reference antenna gain of 0 dBi, an target outage zone of 47dB around the Home BS for an UE on the adjacent channel, with an allowance of 2 dB for measurement errors, an ACIR of 30 dB, an adjacent channel UE \hat{E}_s/I_{ot} target of -6 dB and the same CRS \hat{E}_s value at the adjacent channel UE as for the Home BS.

NOTE 2: For $\text{CRS } \hat{E}_s < -127 \text{ dBm}$, the requirements in subclause 6.2 apply.

NOTE 3: The output power P_{out} is the sum transmit power across all the antenna connectors of the Home BS, with each transmit power measured at the respective antenna connectors.

NOTE 4: N_{RB}^{DL} is the number of downlink resource blocks in the own Home BS channel.

NOTE 5: N_{sc}^{RB} is the number of subcarriers in a resource block, $N_{sc}^{RB} = 12$.

6.2.7.2 Minimum Requirement

The minimum requirement is in TS 36.104 [2] subclause 6.2.4.

6.2.7.3 Test purpose

The test purpose is to verify the capability of the Home BS to adjust the transmitter output power according to the input conditions, as specified in Table 6.2.7-1, across the frequency range and under normal and extreme conditions for all transmitters in the BS.

6.2.7.4 Method of test

6.2.7.4.1 Initial conditions

Test environment: normal; see Annex D2.

RF channels to be tested for single carrier: M; see subclause 4.7.

In addition, on one EARFCN only, the test shall be performed under extreme power supply as defined in Annex D.5.

NOTE: Tests under extreme power supply also test extreme temperature.

Signal generators delivering co-channel and adjacent channel interferers are switched off.

- 1) Set-up the equipment as shown as shown in Annex I.1.4.
- 2) The Home BS is configured such that the adjacent channel is known to belong to another operator.

6.2.7.4.2 Procedure

- 1) Connect the combined downlink interfering signals (referred to as point D in Figure I.1-4) to the dedicated measurement port (referred to as point 1 in Figure I.1-4) if available, otherwise connect to point 2.
- 2) Configure the signal generator for co-channel interference to transmit AWGN over a bandwidth according to BW_{Config} centred on RF channel M.
- 3) Configure the signal generator for adjacent channel DL signal to transmit a signal according to E-TM1.1 at the centre frequency equal to RF channel M + BW_{Channel} MHz.
- 4) Switch on signal generators delivering co-channel and adjacent channel interferers, and adjust the ATT1 and ATT2 such that $\text{CRS } \hat{E}_s = -65 - 10 \cdot \log_{10}(N_{RB}^{DL} \cdot N_{sc}^{RB})$ dBm and $I_{oh} = -50$ dBm.
- 5) Trigger the Home BS power adjustment mechanism.
- 6) Configure the E-UTRA Home BS to transmit a signal according to E-TM1.1. Configure the E-UTRA Home BS declared to be capable of NB-IoT in-band operation to transmit a signal according to E-TM1.1 with the NB-IoT PRB constructed according to N-TM at manufacturer's declared rated output power. Configure the E-UTRA Home BS declared to be capable of NB-IoT guard-band operation to transmit a signal according to E-TM1.1 with the NB-IoT PRB constructed according to N-TM at manufacturer's declared rated output power. Configure the NB-IoT Home BS to transmit a signal according to N-TM at manufacturer's declared rated output power.

NOTE: The signal is transmitted with the maximum allowed output power.

- 7) Measure Home BS output power, P_{out} , and check it is below the required value according to the $\text{CRS } \hat{E}_s$ and I_{oh} values determined in step 4.
- 8) Repeat steps 3) to 7) with the frequency in step 3 set to RF channel M - BW_{Channel} MHz.
- 9) Repeat steps 3) to 8) with different settings for ATT1 and ATT2 to arrive the $\text{CRS } \hat{E}_s$ and I_{oh} pairs as specified in Table 6.2.7-2.

Table 6.2.7-2: CRS \hat{E}_s and I_{oh} pairs

Test Case	CRS \hat{E}_s (dBm)	I_{oh} (dBm)
2	$-75 - 10 \cdot \log_{10}(N_{RB}^{DL} \cdot N_{sc}^{RB})$	-60
3	$-90 - 10 \cdot \log_{10}(N_{RB}^{DL} \cdot N_{sc}^{RB})$	-70
4	$-90 - 10 \cdot \log_{10}(N_{RB}^{DL} \cdot N_{sc}^{RB})$	-50

6.2.7.5 Test Requirements

In normal operating conditions, the output power, P_{out} , of the Home BS shall be equal to or less than:

- the value specified in Table 6.2.7-1 plus 2.7 dB for carrier frequency $f \leq 3.0$ GHz.
- the value specified in Table 6.2.6-1 plus 3.0 dB for carrier frequency $3.0\text{GHz} < f \leq 4.2\text{GHz}$.

In extreme operating conditions, the output power, P_{out} , of the Home BS shall be equal to or less than:

- the value specified in Table 6.2.7-1 plus 3.2 dB for carrier frequency $f \leq 3.0$ GHz.
- the value specified in Table 6.2.6-1 plus 3.5 dB for carrier frequency $3.0\text{GHz} < f \leq 4.2\text{GHz}$.

NOTE: If the above Test Requirement differs from the Minimum Requirement then the Test Tolerance applied for this test is non-zero. The Test Tolerance for this test and the explanation of how the Minimum Requirement has been relaxed by the Test Tolerance are given in Annex G.

6.2.8 Home BS output power for co-channel E-UTRA protection

6.2.8.1 Definition and applicability

To minimize the co-channel DL interference to non-CSG macro UEs operating in close proximity while optimizing the CSG Home BS coverage, Home BS may adjust its output power according to the requirements set out in this clause. These requirements are only applicable to Home BS. The requirements in this clause are applicable for AWGN radio propagation conditions.

For E-UTRA or NB-IoT Home BS that supports the requirements in this clause, the output power, P_{out} , of the Home BS shall be as specified in Table 6.2.8-1 under the following input conditions:

- CRS \hat{E}_s , measured in dBm, is the Reference Signal Received Power per resource element present at the Home BS antenna connector received from the co-channel Wide Area BS. For CRS \hat{E}_s determination, the cell-specific reference signal R0 according TS 36.211 [12] shall be used. If the Home BS can reliably detect that multiple TX antenna ports are used for transmission by the co-channel Wide Area Base Station, it may use the average in [W] of the CRS \hat{E}_s on all detected TX antenna ports, including R0.
- I_{oh} , measured in dBm, is the total received DL power, including all interference but excluding the own Home BS signal, present at the Home BS antenna connector on the Home BS operating channel.
- I_{ob} , measured in dBm, is the uplink received interference power, including thermal noise, within one physical resource block's bandwidth of N_{sc}^{RB} resource elements as defined in TS 36.214, present at the Home BS antenna connector on the Home BS operating channel.

The input conditions defined for the requirements in this clause are specified at the antenna connector of the Home BS. For Home BS receivers with diversity, the requirements apply to each antenna connector separately, with the other one(s) terminated or disabled. The requirements are otherwise unchanged. For Home BS(s) without measurement capability, a reference antenna with a gain of 0 dBi is assumed for converting these power levels into field strength requirements.

Table 6.2.8-1: Home BS output power for co-channel E-UTRA channel protection

Input Conditions	Output power, P_{out}
$I_{oh} (DL) > CRS \hat{E}_s + 10\log_{10}(N_{RB}^{DL} N_{sc}^{RB}) + 30 \text{ dB}$ and Option 1: $CRS \hat{E}_s \geq -127 \text{ dBm}$ or Option 2: $CRS \hat{E}_s \geq -127 \text{ dBm}$ and $I_{ob} > -103 \text{ dBm}$	$\leq 10 \text{ dBm}$
$I_{oh} (DL) \leq CRS \hat{E}_s + 10\log_{10}(N_{RB}^{DL} N_{sc}^{RB}) + 30 \text{ dB}$ and Option 1: $CRS \hat{E}_s \geq -127 \text{ dBm}$ or Option 2: $CRS \hat{E}_s \geq -127 \text{ dBm}$ and $I_{ob} > -103 \text{ dBm}$	$\leq \max(P_{min}, \min(P_{max,c}, CRS \hat{E}_s + 10\log_{10}(N_{RB}^{DL} N_{sc}^{RB}) + X))$ $30 \text{ dB} \leq X \leq 70 \text{ dB}$ $P_{min} = -10 \text{ dBm}$

Note 1: Only the option supported by the Home BS shall be tested.

Note 2: For $CRS \hat{E}_s < -127 \text{ dBm}$, or $I_{ob} \leq -103 \text{ dBm}$ when Option 2 is supported, the requirements in clauses 6.2.1 and 6.2.2 apply.

Note 3: The output power P_{out} is the sum of transmits power across all the antennas of the Home BS, with each transmit power measured at the respective antenna connectors.

Note 4: N_{RB}^{DL} is the number of downlink resource blocks in the own Home BS channel.

Note 5: N_{sc}^{RB} is the number of subcarriers in a resource block, $N_{sc}^{RB} = 12$.

Note 6: X is a network configurable parameter.

Note 7: Pmin can be lower dependent on the Home BS total dynamic range.

Note 8: Other input conditions and output power to be applied for network scenarios other than co-channel E-UTRA macro channel protection shall not be precluded.

6.2.8.2 Minimum Requirement

The minimum requirement is in TS 36.104 [2] subclause 6.2.5.

6.2.8.3 Test purpose

The test purpose is to verify the capability of the Home BS to adjust the transmitter output power according to the input conditions, as specified in Table 6.2.8-1, across the frequency range and under normal and extreme conditions for all transmitters in the BS. For Home BS that supports the requirements in this clause, only the option in Table 6.2.8-1 supported by the Home BS shall be tested.

6.2.8.4 Method of test

6.2.8.4.1 Initial conditions

Test environment: normal; see Annex D2.

RF channels to be tested for single carrier: M; see subclause 4.7.

In addition, on one EARFCN only, the test shall be performed under extreme power supply as defined in Annex D.5.

NOTE: Tests under extreme power supply also test extreme temperature.

Signal generator delivering co-channel interferers is switched off.

- 1) Set-up the equipment as shown in Annex I.1.5, base on the option supported by Home BS.
- 2) The co-channel interference should be configured containing at least signals from a neighbouring Marco BS. For option 2 of Table 6.2.8-1, additional signal generator needed to deliver the MUE UL signal.

6.2.8.4.2 Procedure

- 1) Connect the downlink co-channel interfering signals (referred to as point D in Figure I.1-5) to the dedicated measurement port (referred to as point 1 in Figure I.1-5) if available, otherwise connect to point 2. Specifically for option 2 of Table 6.2.8-1, connect the UL interference to point 2 for UL receiving on the figure of I.1.5-b.
- 2) Configure the signal generator for co-channel interference to transmit AWGN over a bandwidth according to BW_{Config} centred on RF channel M.
- 3) Configure the X as 30 dB. Switch on signal generators delivering interferers, and adjust the ATT such that $\text{CRS } \hat{E}_s = -10 - 10 \log_{10}(N_{RB}^{\text{DL}} N_{sc}^{\text{RB}})$ dBm and $I_{oh} = -50$ dBm.
- 4) Trigger the Home BS power adjustment mechanism.
- 5) Configure the E-UTRA Home BS to transmit a signal according to E-TM1.1. Configure the E-UTRA Home BS declared to be capable of NB-IoT in-band operation to transmit a signal according to E-TM1.1 with the NB-IoT PRB constructed according to N-TM at manufacturer's declared rated output power. Configure the E-UTRA Home BS declared to be capable of NB-IoT guard-band operation to transmit a signal according to E-TM1.1 with the NB-IoT PRB constructed according to N-TM at manufacturer's declared rated output power. Configure the NB-IoT Home BS to transmit a signal according to N-TM at manufacturer's declared rated output power.

NOTE: The signal is transmitted with the maximum allowed output power.

- 6) Measure Home BS output power, P_{out} , and check it is below the required value according to the CRS \hat{E}_s and I_{oh} values determined in step 4. The value of P_{min} for testing is -10dBm.
- 7) Repeat steps 4) to 6) with different settings for ATT to arrive the input parameter pairs as specified in Table 6.2.8-2 or 6.2.8-3, basing the option of Table 6.2.8-1 supported by the Home BS.

Table 6.2.8-2: CRS \hat{E}_s and I_{oh} pairs for option 1

Test Case	CRS \hat{E}_s (dBm)	I_{oh} (dBm)
1	$-20 - 10\log_{10}(N_{RB}^{DL} N_{sc}^{RB})$	-60
2	$P_{min}-30 - 10\log_{10}(N_{RB}^{DL} N_{sc}^{RB})$	-70
3	$-90 - 10\log_{10}(N_{RB}^{DL} N_{sc}^{RB})$	-50

Table 6.2.8-3: CRS \hat{E}_s , I_{oh} and I_{ob} pairs for option 2

Test Case	CRS \hat{E}_s (dBm)	I_{oh} (dBm)	I_{ob} (dBm)
1	$-20 - 10\log_{10}(N_{RB}^{DL} N_{sc}^{RB})$	-60	-98
2	$P_{min}-30 - 10\log_{10}(N_{RB}^{DL} N_{sc}^{RB})$	-70	-98
3	$-90 - 10\log_{10}(N_{RB}^{DL} N_{sc}^{RB})$	-50	-98

6.2.8.5 Test Requirements

In normal operating conditions, the output power, P_{out} , of the Home BS shall be equal to or less than the value specified in Table 6.2.8-1 plus 2.7 dB.

In extreme operating conditions, the output power, P_{out} , of the Home BS shall be equal to or less than the value specified in Table 6.2.8-1 plus 3.2 dB.

NOTE: If the above Test Requirement differs from the Minimum Requirement then the Test Tolerance applied for this test is non-zero. The Test Tolerance for this test and the explanation of how the Minimum Requirement has been relaxed by the Test Tolerance are given in Annex G.

6.3 Output power dynamics

The requirements in subclause 6.3 apply during the transmitter ON period.

6.3.1 RE Power control dynamic range

6.3.1.1 Definition and applicability

The RE power control dynamic range is the difference between the power of an RE and the average RE power for a BS at maximum output power for a specified reference condition. Unwanted emissions (as specified in subclause 6.6) and Transmit modulation quality (as specified in subclause 6.5) shall be maintained within the whole power control dynamic range.

6.3.1.2 Minimum Requirement

The minimum requirement is in TS 36.104 [2] subclause 6.3.1.1.

6.3.1.3 Method of test

No specific test or test requirements are defined for RE Power control dynamic range. The Error Vector Magnitude test, as described in subclause 6.5.2 provides sufficient test coverage for this requirement.

6.3.2 Total power dynamic range

6.3.2.1 Definition and applicability

The total power dynamic range is the difference between the maximum and the minimum transmit power of an OFDM symbol for a specified reference condition.

NOTE: The upper limit of the dynamic range is the OFDM symbol power for a BS at maximum output power. The lower limit of the dynamic range is the OFDM symbol power for a BS when one resource block is transmitted. The OFDM symbol shall carry PDSCH or sPDSCH and not contain RS, PBCH or synchronisation signals.

6.3.2.2 Minimum Requirement

The minimum requirement is in TS 36.104 [2] subclause 6.3.2.1.

6.3.2.3 Test purpose

The test purpose is to verify that the total power dynamic range is met as specified by the minimum requirement.

6.3.2.4 Method of test

6.3.2.4.1 Initial conditions

Test environment: normal; see Annex D.2.

RF channels to be tested for single carrier: B, M and T; see subclause 4.7.

Connect the signal analyzer to the base station antenna connector as shown in Annex I.1.1.

6.3.2.4.2 Procedure

- 1) Set-up BS transmission at maximum total power as specified by the supplier. Channel set-up shall be according to E-TM 3.1 (or sE-TM3.1-1 for subslot TTI, or sE-TM3.1-2 for slot TTI).
- 2) Measure the average OFDM symbol power as defined in Annex F.
- 3) Set the BS to transmit a signal according to E-TM 2 (or sE-TM2-1 for subslot TTI, or sE-TM2-2 for slot TTI).
- 4) Measure the average OFDM symbol power as defined in Annex F. The measured OFDM symbols shall not contain RS, PBCH or synchronisation signals.
- 5) Repeat step 1 and 2 for E-TM3.1a (or sE-TM3.1a-1 for subslot TTI, or sE-TM3.1a-2 for slot TTI) and step 3 and 4 for E-TM2a (or sE-TM2a-1 for subslot TTI, or sE-TM2a-2 for slot TTI) for 256QAM, if supported by the BS.
- 6) Repeat step 1 and 2 for E-TM3.1b and step 3 and 4 for E-TM2b for 1024QAM, if supported by the BS.

In addition, for a multi-band capable BS, the following step shall apply:

- 7) For multi-band capable BS and single band tests, repeat the steps above per involved band where single carrier test models shall apply with no carrier activated in the other band. For multi-band capable BS with separate antenna connector, the antenna connector not being under test shall be terminated.

6.3.2.5 Test Requirement

The downlink (DL) total power dynamic range for each E-UTRA carrier shall be larger than or equal to the level in Table 6.3.2-1.

Table 6.3.2-1 E-UTRA BS total power dynamic range, paired spectrum

E-UTRA channel bandwidth (MHz)	Total power dynamic range (dB)
1.4	7.3
3	11.3
5	13.5
10	16.5
15	18.3
20	19.6

NOTE 1: If the above Test Requirement differs from the Minimum Requirement then the Test Tolerance applied for this test is non-zero. The Test Tolerance for this test is defined in Annex G. The explanation of how the Minimum Requirement has been relaxed by the Test Tolerance is given in Annex G.

NOTE2: Additional test requirements for the Error Vector Magnitude (EVM) at the lower limit of the dynamic range are defined in subclause 6.5.2.

6.3.3 NB-IoT RB power dynamic range for in-band or guard band operation

6.3.3.1 Definition and applicability

The NB-IoT RB power dynamic range (or NB-IoT power boosting) for guard band operation is the difference between the power of NB-IoT RB (which occupies 180kHz in guard band of an E-UTRA carrier) and the average power over all RBs (from both NB-IoT and the E-UTRA carrier containing the NB-IoT RB).

The NB-IoT RB power dynamic range (or NB-IoT power boosting) for in-band operation is the difference between the average power of NB-IoT REs (which occupy certain REs in a RB of an E-UTRA carrier) and the average power over all REs (from both NB-IoT and the E-UTRA carrier containing the NB-IoT REs).

6.3.3.2 Minimum Requirement

The minimum requirement is in TS 36.104 [2] subclause 6.3.3.1.

6.3.3.3 Test purpose

The test purpose is to verify that the NB-IoT RB power dynamic range for in-band or guard band operation is met as specified by the minimum requirement.

6.3.3.4 Method of test

Requirement is tested together with unwanted emissions test, as described in subclause 6.6.3.

6.3.3.5 Test Requirement

NB-IoT power dynamic range shall be larger than or equal to +5.6 dB, except for guard band operation with E-UTRA 5 MHz channel bandwidth signal where BS manufacturer shall declare the NB-IoT dynamic range power it could support (in this version of the specification).

The +5.6 dB power dynamic range is only required for one NB-IoT RB for both in-band and guard band operation modes.

For guard band operation, this NB-IoT RB should be placed adjacent to the E-UTRA RB edge as close as possible (i.e., away from edge of channel bandwidth).

6.4 Transmit ON/OFF power

The requirements in clause 6.4 are only applied for E-UTRA TDD BS.

6.4.1 Transmitter OFF power

6.4.1.1 Definition and applicability

Transmitter OFF power is defined as the mean power measured over 70 us filtered with a square filter of bandwidth equal to the transmission bandwidth configuration of the BS (BW_{Config}) centred on the assigned channel frequency during the transmitter OFF period.

For BS supporting intra-band contiguous CA, the transmitter OFF power is defined as the mean power measured over 70 us filtered with a square filter of bandwidth equal to the Aggregated Channel Bandwidth $BW_{\text{Channel_CA}}$ centred on $(F_{\text{edge_high}}+F_{\text{edge_low}})/2$ during the transmitter OFF period.

6.4.1.2 Minimum Requirement

The minimum requirement is in TS 36.104 [2] subclause 6.4.1.1.

6.4.1.3 Test purpose

The purpose of this test is to verify the E-UTRA, E-UTRA with NB-IoT or NB-IoT BS transmitter OFF power is within the limit of the minimum requirement.

6.4.1.4 Method of test

Requirement is tested together with transmitter transient period, as described in subclause 6.4.2.4.

6.4.1.4.1 Void

6.4.1.4.2 Void

6.4.1.5 Test requirement

The conformance testing of transmit OFF power is included in the conformance testing of transmitter transient period; therefore, see subclause 6.4.2.5 for test requirements.

6.4.2 Transmitter transient period

6.4.2.1 Definition and applicability

The transmitter transient period is the time period during which the transmitter is changing from the OFF period to the ON period or vice versa. The transmitter transient period is illustrated in Figure 6.4.2.1-1.

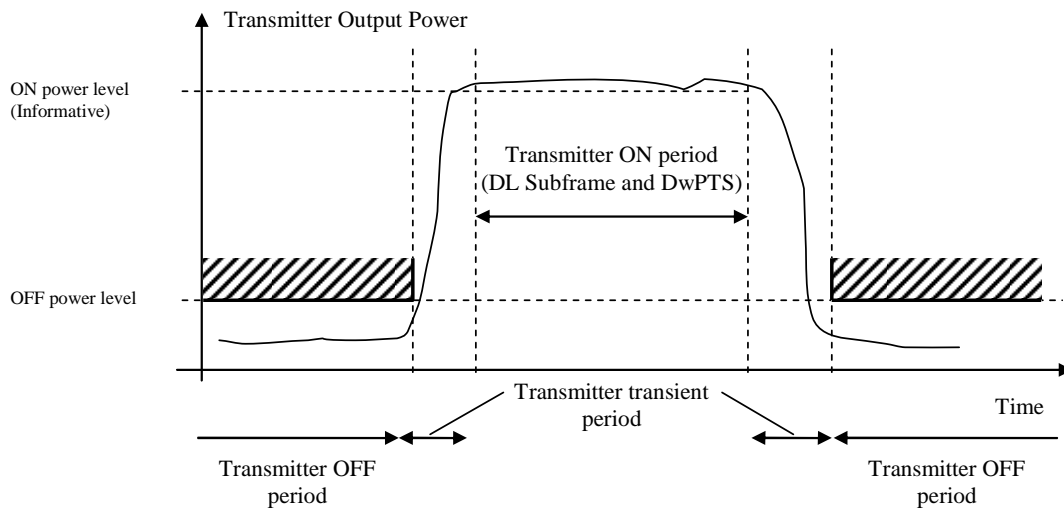

Figure 6.4.2.1-1 Illustration of the relations of transmitter ON period, transmitter OFF period and transmitter transient period.

6.4.2.2 Minimum Requirement

The minimum requirement is in TS 36.104 [2] subclause 6.4.2.1.

6.4.2.3 Test purpose

The purpose of this test is to verify the E-UTRA BS transmitter transient periods are within the limit of the minimum requirement.

6.4.2.4 Method of test

6.4.2.4.1 Initial conditions

Test environment: normal; see Annex D.2.

RF channels to be tested for single carrier: M; see subclause 4.7.

Base Station RF Bandwidth positions to be tested for multi-carrier and/or CA: M_{RFBW} in single-band operation, see subclause 4.7.1; B_{RFBW_T} and B_{RFBW_T} in multi-band operation, see subclause 4.7.1.

Connect the signal analyzer to the BS antenna connector as shown in Annex I.1.1.

As a general rule, the resolution bandwidth of the measuring equipment should be equal to the measurement bandwidth. However, to improve measurement accuracy, sensitivity, efficiency and avoiding e.g. carrier leakage, the resolution bandwidth may be smaller than the measurement bandwidth. When the resolution bandwidth is smaller than the measurement bandwidth, the result should be integrated over the measurement bandwidth in order to obtain the equivalent noise bandwidth of the measurement bandwidth.

6.4.2.4.2 Procedure

- 1) For a BS declared to be capable of single carrier operation only, set the BS to transmit a signal according to E-TM1.1 at manufacturer's declared rated output power.

For a BS declared to be capable of multi-carrier and/or CA operation, set the BS to transmit according to E-TM1.1 on all carriers configured using the applicable test configuration and corresponding power setting specified in clause 4.10 and 4.11.

- 2) Measure the mean power spectral density over $70\mu\text{s}$ filtered with a square filter of bandwidth equal to the Transmission bandwidth configuration BW_{config} centred on the assigned channel frequency. $70\mu\text{s}$ average

window centre is set from $35\mu\text{s}$ after end of one transmitter ON period + $17\mu\text{s}$ to $35\mu\text{s}$ before start of next transmitter ON period – $17\mu\text{s}$.

- 3) For BS supporting contiguous CA, measure the mean power spectral density over $70\mu\text{s}$ filtered with a square filter of bandwidth equal to the Aggregated Channel Bandwidth $BW_{\text{Channel_CA}}$ centred on $(F_{\text{edge_high}}+F_{\text{edge_low}})/2$. $70\mu\text{s}$ average window centre is set from $35\mu\text{s}$ after end of one transmitter ON period + $17\mu\text{s}$ to $35\mu\text{s}$ before start of next transmitter ON period – $17\mu\text{s}$.

For a multi-band capable BS,

with separate antenna connector, the antenna connector not being under test shall be terminated.

6.4.2.5 Test requirement

The measured mean power spectral density shall be less than -83dBm/MHz for carrier frequency $f \leq 3.0\text{GHz}$.

The measured mean power spectral density shall be less than -82.5dBm/MHz for carrier frequency $3.0\text{GHz} < f \leq 4.2\text{GHz}$.

The measured mean power spectral density shall be less than -82dBm/MHz for carrier frequency $4.2\text{GHz} < f \leq 6.0\text{GHz}$.

For BS capable of multi-band operation, the requirement is only applicable during the transmitter OFF period in all supported operating bands.

NOTE: If the above Test Requirement differs from the Minimum Requirement then the Test Tolerance applied for this test is non-zero. The Test Tolerance for this test and the explanation of how the Minimum Requirement has been relaxed by the Test Tolerance are given in Annex G.

6.5 Transmitted signal quality

The requirements in subclause 6.5 apply to the transmitter ON period.

6.5.1 Frequency error

6.5.1.1 Definition and applicability

Frequency error is the measure of the difference between the actual BS transmit frequency and the assigned frequency. The same source shall be used for RF frequency and data clock generation.

It is not possible to verify by testing that the data clock is derived from the same frequency source as used for RF generation. This may be confirmed by the manufacturer's declaration.

6.5.1.2 Minimum Requirement

The minimum requirement is in TS 36.104 [2] subclause 6.5.1.

6.5.1.3 Test purpose

To verify that the Frequency Error is within the limit of the minimum requirement.

6.5.1.4 Method of test

Requirement is tested together with Error Vector Magnitude test, as described in subclause 6.5.2.

6.5.1.5 Test requirement

For E-UTRA, the modulated carrier frequency of each E-UTRA carrier configured by the BS shall be accurate to within the accuracy range given in Table 6.5.1-1 observed over a period of one subframe (1 ms).

For NB-IoT, the modulated carrier frequency of each NB-IoT carrier configured by the BS shall be accurate to within the accuracy range given in Table 6.5.1-1 observed over a period of one subframe (1 ms).

Table 6.5.1-1: Frequency error test requirement

BS class	Accuracy
Wide Area BS	$\pm (0.05 \text{ ppm} + 12 \text{ Hz})$
Medium Range BS	$\pm (0.1 \text{ ppm} + 12 \text{ Hz})$
Local Area BS	$\pm (0.1 \text{ ppm} + 12 \text{ Hz})$
Home BS	$\pm (0.25 \text{ ppm} + 12 \text{ Hz})$

NOTE: If the above Test Requirement differs from the Minimum Requirement then the Test Tolerance applied for this test is non-zero. The Test Tolerance for this test and the explanation of how the Minimum Requirement has been relaxed by the Test Tolerance are given in Annex G.

6.5.2 Error Vector Magnitude

6.5.2.1 Definition and applicability

The Error Vector Magnitude is a measure of the difference between the ideal symbols and the measured symbols after the equalization. This difference is called the error vector. The equaliser parameters are estimated as defined in Annex F. The EVM result is defined as the square root of the ratio of the mean error vector power to the mean reference power expressed in percent.

6.5.2.2 Minimum Requirement

The minimum requirement is in TS 36.104 [2] subclause 6.5.2.

6.5.2.3 Test purpose

The test purpose is to verify that the Error Vector Magnitude is within the limit specified by the minimum requirement.

6.5.2.4 Method of test

6.5.2.4.1 Initial conditions

Test environment: normal; see Annex D.2.

RF channels to be tested for single carrier: B, M and T; see subclause 4.7.

Base Station RF Bandwidth positions to be tested for multi-carrier and/or CA: B_{RFBW} , M_{RFBW} and T_{RFBW} in single-band operation, see subclause 4.7.1; $B'_{\text{RFBW}}T'_{\text{RFBW}}$ and $B'_{\text{RFBW}}T_{\text{RFBW}}$ in multi-band operation, see subclause 4.7.1.

Connect the signal analyzer to the base station antenna connector as shown in Annex I.1.1.

6.5.2.4.2 Procedure

- 1) For a BS declared to be capable of single carrier operation only, set the BS to transmit a signal according to E-TM 3.1 (or sE-TM3.1-1 for subslot TTI, or sE-TM3.1-2 for slot TTI) at manufacturer's declared rated output power.

For a BS declared to be capable of multi-carrier and/or CA operation, set the BS to transmit according to E-TM 3.1 (or sE-TM3.1-1 for subslot TTI, or sE-TM3.1-2 for slot TTI) on all carriers configured using the applicable test configuration and corresponding power setting specified in clause 4.10 and 4.11.

For a NB-IoT BS declared to be capable of single carrier operation, start transmission according to N-TM at manufacturer's declared rated output power.

For a NB-IoT BS declared to be capable of multi-carrier operation, set the base station to transmit according to N-TM on all carriers configured using in the applicable test configuration and corresponding power setting specified in clause 4.10 and 4.11.

For an E-UTRA and NB-IoT standalone BS declared to be capable of multi-carrier operation, start transmission according to E-TM 3.1 on all E-UTRA carriers and N-TM on all NB-IoT carriers configured using in the applicable test configuration and corresponding power setting specified in clause 4.10 and 4.11.

- 2) Measure the EVM and frequency error as defined in Annex F.
- 3) For E-UTRA repeat steps 1 and 2 for E-TM 3.2 (or sE-TM3.2-1 for subslot TTI, or sE-TM3.2-2 for slot TTI), E-TM 3.3 (or sE-TM3.3-1 for subslot TTI, or sE-TM3.3-2 for slot TTI) and E-TM 2 (or sE-TM2-1 for subslot TTI, or sE-TM2-2 for slot TTI). Repeat steps 1 and 2 for E-TM3.1a (or sE-TM3.1a-1 for subslot TTI, or sE-TM3.1a-2 for slot TTI) and E-TM 2a (or sE-TM2a-1 for subslot TTI, or sE-TM2a-2 for slot TTI) for 256QAM, if supported by the BS. For E-TM2 (or sE-TM2-1 for subslot TTI, or sE-TM2-2 for slot TTI) and E-TM2a (or sE-TM2a-1 for subslot TTI, or sE-TM2a-2 for slot TTI) the OFDM symbol power shall be at the lower limit of the dynamic range according to the test procedure in subclause 6.3.2.4.2 and test requirements in subclause 6.3.2.5. Repeat steps 1 and 2 for E-TM3.1b and E-TM 2b for 1024QAM, if supported by the BS. For E-TM2b the OFDM symbol power shall be at the lower limit of the dynamic range according to the test procedure in subclause 6.3.2.4.2 and test requirements in subclause 6.3.2.5.

In addition, for a multi-band capable BS, the following step shall apply:

- 4) For multi-band capable BS and single band tests, repeat the steps above per involved band where single band test configurations and test models shall apply with no carrier activated in the other band. For multi-band capable BS with separate antenna connector, the antenna connector not being under test in case of single-band or multi-band test shall be terminated.

6.5.2.5 Test requirement

The EVM of each E-UTRA carrier for different modulation schemes on PDSCH shall be less than the limits in table 6.5.2.5-1:

Table 6.5.2.5-1 EVM requirements for E-UTRA carrier

Modulation scheme for PDSCH or sPDSCH	Required EVM [%]
QPSK	18.5 %
16QAM	13.5 %
64QAM	9 %
256QAM	4.5%
1024QAM	3.5%

The EVM of each NB-IoT carrier on NB-PDSCH shall be less than the limits in table 6.5.2.5-1a:

Table 6.5.2.5-1a EVM requirements for NB-IoT carrier

Modulation scheme for NB-PDSCH	Required EVM [%]
QPSK	18.5 %

The EVM requirement shall be applicable within a time period around the centre of the CP therefore the EVM requirement is tested against the maximum of the RMS average of 10 subframes at the two window W extremities.

Table 6.5.2.5-2 and Table 6.5.2.5-2a specify EVM window length (W) for normal CP, the cyclic prefix length N_{cp} is 160 for symbols 0 and 144 for symbols 1-6.

Table 6.5.2.5-2 EVM window length for normal CP for E-UTRA

Channel Bandwidth MHz	FFT size	Cyclic prefix length for symbols 0 in FFT samples	Cyclic prefix length for symbols 1-6 in FFT samples	EVM window length W	Ratio of W to total CP for symbols 1-6* [%]
1.4	128	10	9	5	55.6
3	256	20	18	12	66.7
5	512	40	36	32	88.9
10	1024	80	72	66	91.7
15	1536	120	108	102	94.4
20	2048	160	144	136	94.4

* Note: These percentages are informative and apply to symbols 1 through 6. Symbol 0 has a longer CP and therefore a lower percentage.

Table 6.5.2.5-2a EVM window length for normal CP for NB-IoT

FFT size	Cyclic prefix length for symbols 0 in FFT samples	Cyclic prefix length for symbols 1-6 in FFT samples	EVM window length W	Ratio of W to total CP for symbols 1-6 ¹ [%]
128	10	9	3	33.3

Note 1: These percentages are informative and apply to symbols 1 through 6. Symbol 0 has a longer CP and therefore a lower percentage.

NOTE: If the above Test Requirement differs from the Minimum Requirement then the Test Tolerance applied for this test is non-zero. The Test Tolerance for this test is defined in Annex G. The explanation of how the Minimum Requirement has been relaxed by the Test Tolerance is given in Annex G.

6.5.3 Time alignment error

6.5.3.1 Definition and applicability

Frames of the LTE signals present at the BS transmitter antenna port(s) are not perfectly aligned in time. In relation to each other, the RF signals present at the BS transmitter antenna port(s) experience certain timing differences.

For a specific set of signals/transmitter configuration/transmission mode, time alignment error (TAE) is defined as the largest timing difference between any two signals. This test is only applicable for eNode B supporting TX diversity MIMO transmission, carrier aggregation and their combinations.

6.5.3.2 Minimum Requirement

The minimum requirement is in TS 36.104 [2] subclause 6.5.3.

6.5.3.3 Test Purpose

To verify that the timing alignment error in TX diversity, MIMO transmission, carrier aggregation and their combinations is within the limit specified by the minimum requirement.

6.5.3.4 Method of Test

6.5.3.4.1 Initial Conditions

Test environment: normal; see Annex D.2.

RF channels to be tested for single carrier: M; see subclause 4.7.

Base Station RF Bandwidth positions to be tested for multi-carrier and/or CA: M_{RFBW} in single-band operation, see subclause 4.7.1; B_{RFBW_T} and B'_{RFBW_T} in multi-band operation, see subclause 4.7.1.

- 1) Connect two base station RF antenna ports to the measurement equipment according to Annex I.1.3. If available terminate the other unused antenna ports.

6.5.3.4.2 Procedure

- 1) Set the base station to transmit E-TM1.1 or any DL signal using TX diversity, MIMO transmission or carrier aggregation.

NOTE: For TX diversity and MIMO transmission, different ports may be configured in E-TM (using $p = 0$ and 1).

For a BS declared to be capable of single carrier operation only, set the BS to transmit according to manufacturer's declared rated output power.

If the BS supports intra band contiguous or non-contiguous Carrier Aggregation set the base station to transmit using the applicable test configuration and corresponding power setting specified in clause 4.10 and 4.11.

If the BS supports inter band carrier aggregation set the base station to transmit, for each band, a single carrier or all carriers, using the applicable test configuration and corresponding power setting specified in sub clause 4.10 and 4.11.

For a NB-IoT BS declared to be capable of single carrier operation, start transmission according to N-TM at manufacturer's declared rated output power.

For a NB-IoT BS declared to be capable of multi-carrier operation, set the base station to transmit according to N-TM on all carriers configured using in the applicable test configuration and corresponding power setting specified in clause 4.10 and 4.11.

For an E-UTRA and NB-IoT standalone BS declared to be capable of multi-carrier operation, start transmission according to E-TM1.1 on all E-UTRA carriers and N-TM on all NB-IoT carriers configured using in the applicable test configuration and corresponding power setting specified in clause 4.10 and 4.11.

- 2) Measure the time alignment error between the reference symbols on the carrier(s) from active antenna port(s).
- 3) Repeat the step 1 and 2 for any other possible configuration of transmit antennas.

In addition, for a multi-band capable BS, the following step shall apply:

- 4) For multi-band capable BS and single band tests, repeat the steps above per involved band where single band test configurations and test models shall apply with no carrier activated in the other band. For multi-band capable BS with separate antenna connector, the antenna connector not being under test in case of single-band or multi-band test shall be terminated.

6.5.3.5 Test Requirement

For E-UTRA:

- For MIMO or TX diversity transmissions, at each carrier frequency, TAE shall not exceed 90 ns.
- For intra-band carrier aggregation, with or without MIMO or TX diversity, TAE shall not exceed 155 ns.
- For intra-band non-contiguous carrier aggregation, with or without MIMO or TX diversity, TAE shall not exceed 285 ns.
- For inter-band carrier aggregation, with or without MIMO or TX diversity, TAE shall not exceed 285 ns.

For NB-IoT:

- For TX diversity transmissions, at each carrier frequency, TAE shall not exceed 90 ns.

NOTE: If the above Test Requirement differs from the Minimum Requirement then the Test Tolerance applied for this test is non-zero. The Test Tolerance for this test and the explanation of how the Minimum Requirement has been relaxed by the Test Tolerance are given in Annex G.

6.5.4 DL RS power

6.5.4.1 Definition and applicability

For E-UTRA, DL RS power is the resource element power of Downlink Reference Symbol.

The absolute DL RS power is indicated on the DL-SCH. The absolute accuracy is defined as the maximum deviation between the DL RS power indicated on the DL-SCH and the DL RS power of each E-UTRA carrier at the BS antenna connector.

For NB-IoT, DL NRS power is the resource element power of the Downlink Narrow-band Reference Signal.

The absolute DL NRS power is indicated on the DL-SCH. The absolute accuracy is defined as the maximum deviation between the DL NRS power indicated on the DL-SCH and the DL NRS power of each NB-IoT carrier at the BS antenna connector.

6.5.4.2 Minimum Requirement

The minimum requirement is in TS 36.104 [2] subclause 6.5.4.

6.5.4.3 Test purpose

The test purpose is to verify that the DL RS/NRS power is within the limit specified by the minimum requirement.

6.5.4.4 Method of test

6.5.4.4.1 Initial conditions

Test environment: normal; see Annex D.2.

RF channels to be tested for single carrier: B, M and T; see subclause 4.7.

Connect the signal analyzer to the base station antenna connector as shown in Annex I.1.1.

6.5.4.4.2 Procedure

For E-UTRA, set-up BS transmission at manufacturer's declared rated output power. Channel set-up shall be according to E-TM 1.1.

For NB-IoT, Set-up BS transmission at manufacturer's declared rated output power. Channel set-up shall be according to N-TM.

Measure the RS transmitted power according to annex F.

In addition, for a multi-band capable BS, the following step shall apply:

- For multi-band capable BS and single band tests, repeat the steps above per involved band where single carrier test models shall apply with no carrier activated in the other band. For multi-band capable BS with separate antenna connector, the antenna connector not being under test shall be terminated.

6.5.4.5 Test requirement

For E-UTRA, DL RS power of each E-UTRA carrier shall be:

within ± 2.9 dB of the DL RS power indicated on the DL-SCH for carrier frequency $f \leq 3.0$ GHz.

within ± 3.2 dB of the DL RS power indicated on the DL-SCH for carrier frequency 3.0 GHz $< f \leq 4.2$ GHz.

For NB-IoT, DL NRS power of each NB-IoT carrier shall be:

within ± 2.9 dB of the DL NRS power indicated on the DL-SCH for carrier frequency $f \leq 3.0$ GHz.

NOTE 1: If the above Test Requirement differs from the Minimum Requirement then the Test Tolerance applied for this test is non-zero. The Test Tolerance for this test is defined in Annex G. The explanation of how the Minimum Requirement has been relaxed by the Test Tolerance is given in Annex G.

NOTE 2: PDSCH in E-TM1.1 is configured as "all 0" and DL RS power is not indicated on PDSCH during the measurement. The absolute DL RS power indicated on the DL-SCH can be calculated as $P_{\max,c} - 10\log_{10}(12 * N_{RB})$ dBm, where N_{RB} is the transmission bandwidth configuration of E-TM1.1.

6.6 Unwanted emissions

Unwanted emissions consist of out-of-band emissions and spurious emissions [5]. Out of band emissions are unwanted emissions immediately outside the channel bandwidth resulting from the modulation process and non-linearity in the transmitter but excluding spurious emissions. Spurious emissions are emissions which are caused by unwanted transmitter effects such as harmonics emission, parasitic emission, intermodulation products and frequency conversion products, but exclude out of band emissions.

The out-of-band emissions requirement for the BS transmitter is specified both in terms of Adjacent Channel Leakage power Ratio (ACLR) and Operating band unwanted emissions. The Operating band unwanted emissions define all unwanted emissions in each supported downlink operating band plus the frequency ranges 10 MHz above and 10 MHz below each band. Unwanted emissions outside of this frequency range are limited by a spurious emissions requirement.

For a BS supporting multi-carrier and/or CA, the unwanted emissions requirements apply to channel bandwidths of the outermost carrier larger than or equal to 5 MHz.

There is in addition a requirement for occupied bandwidth.

6.6.1 Occupied bandwidth

6.6.1.1 Definition and applicability

The occupied bandwidth is the width of a frequency band such that, below the lower and above the upper frequency limits, the mean powers emitted are each equal to a specified percentage $\beta/2$ of the total mean transmitted power.

The value of $\beta/2$ shall be taken as 0.5%.

6.6.1.2 Minimum Requirements

The minimum requirement is in TS 36.104 [2] subclause 6.6.1.

6.6.1.3 Test purpose

The occupied bandwidth, defined in the Radio Regulations of the International Telecommunication Union ITU, is a useful concept for specifying the spectral properties of a given emission in the simplest possible manner; see also ITU-R Recommendation SM.328 [4]. The test purpose is to verify that the emission of the BS does not occupy an excessive bandwidth for the service to be provided and is, therefore, not likely to create interference to other users of the spectrum beyond undue limits.

6.6.1.4 Method of test

6.6.1.4.1 Initial conditions

Test environment: normal; see Annex D.2.

RF channels to be tested for single carrier: B, M and T; see subclause 4.7.

Aggregated Channel Bandwidth positions to be tested for contiguous carrier aggregation: $B_{BW \text{ Channel CA}}$, $M_{BW \text{ Channel CA}}$ and $T_{BW \text{ Channel CA}}$; see subclause 4.7.2.

- 1) Connect the Measurement device to the BS antenna connector as shown in Annex I.1.1.
- 2) For a E-UTRA BS declared to be capable of single carrier operation, start transmission according to E-TM1.1 at manufacturer’s declared rated output power.

For a E-UTRA BS declared to be capable of contiguous carrier aggregation operation, set the base station to transmit according to E-TM1.1 on all carriers configured using the applicable test configuration and corresponding power setting specified in clause 4.10 and 4.11.

For a E-UTRA BS declared to be capable of NB-IoT in-band operation, start transmission according to [E-TM1.1] with the NB-IoT PRB constructed according to N-TM at manufacturer’s declared rated output power.

For a E-UTRA BS declared to be capable of NB-IoT guard-band operation, start transmission according to E-TM1.1 with the NB-IoT PRB constructed according to N-TM at manufacturer’s declared rated output power.

For a NB-IoT BS declared to be capable of single carrier operation, start transmission according to N-TM at manufacturer’s declared rated output power.

For a NB-IoT BS declared to be capable of multi-carrier in contiguous spectrum operation in single band only, start transmission according to N-TM on all carriers configured using in the applicable test configuration and corresponding power setting specified in clause 4.10 and 4.11.

For a E-UTRA and NB-IoT standalone BS declared to be capable of multi-carrier in contiguous spectrum operation in single band only, start transmission according to E-TM1.1 on all E-UTRA carriers and N-TM on all NB-IoT carriers configured using in the applicable test configuration and corresponding power setting specified in clause 4.10 and 4.11.

6.6.1.4.2 Procedure

- 1) Measure the spectrum emission of the transmitted signal using at least the number of measurement points, and across a span, as listed in Table 6.6.1.4.2-1. The selected resolution bandwidth (RBW) filter of the analyser shall be 30 kHz or less for E-UTRA and 10 kHz or less for NB-IoT.

Table 6.6.1.4.2-1: Span and number of measurement points for OBW measurements

Channel bandwidth BW_{Channel} [MHz]	0.2	1.4	3	5	10	15	20	>20
Span [MHz]	0.4	10	10	10	20	30	40	$2 \times BW_{\text{Channel_CA}}$
Minimum number of measurement points	400	1429	667	400	400	400	400	$\left\lceil \frac{2 \times BW_{\text{Channel_CA}}}{100\text{kHz}} \right\rceil$

NOTE: The detection mode of the spectrum analyzer will not have any effect on the result if the statistical properties of the out-of-OBW power are the same as those of the inside-OBW power. Both are expected to have the Rayleigh distribution of the amplitude of Gaussian noise. In any case where the statistics are not the same, though, the detection mode must be power responding. The analyser may be set to respond to the average of the power (root-mean-square of the voltage) across the measurement cell.

- 2) Compute the total of the power, P0, (in power units, not decibel units) of all the measurement cells in the measurement span. Compute P1, the power outside the occupied bandwidth on each side. P1 is half of the total power outside the bandwidth. P1 is half of (100 % - (occupied percentage)) of P0. For the occupied percentage of 99 %, P1 is 0.005 times P0.
- 3) Determine the lowest frequency, f1, for which the sum of all power in the measurement cells from the beginning of the span to f1 exceeds P1.
- 4) Determine the highest frequency, f2, for which the sum of all power in the measurement cells from f2 to the end of the span exceeds P1.

- 5) Compute the occupied bandwidth as $f_2 - f_1$.

In addition, for a multi-band capable BS, the following step shall apply:

- 6) For multi-band capable BS and single band tests, repeat the steps above per involved band where single carrier test models shall apply, with no carrier activated in the other band. In addition, when contiguous CA is supported, single band test configurations and test models shall apply with no carrier activated in the other band. For multi-band capable BS with separate antenna connector, the antenna connector not being under test shall be terminated.

6.6.1.5 Test requirements

For E-UTRA, the occupied bandwidth for each E-UTRA carrier shall be less than the channel bandwidth as defined in Table 5.6-1. For contiguous CA, the occupied bandwidth shall be less than or equal to the Aggregated Channel Bandwidth as defined in subclause 5.6. For Band 46 operation in Japan, the occupied bandwidth for each 20MHz channel bandwidth E-UTRA carrier assigned within 5150-5350 MHz and 5470-5725 MHz shall be less than or equal to 19 MHz and 19.7MHz respectively.

For NB-IoT in-band operation, the occupied bandwidth for each E-UTRA carrier with NB-IoT shall be less than the channel bandwidth as defined in Table 5.6-1.

For NB-IoT guard-band operation, the occupied bandwidth for each E-UTRA carrier with NB-IoT shall be less than the channel bandwidth as defined in Table 5.6-1 for channel bandwidth larger than or equal to 5 MHz.

For NB-IoT stand-alone operation, the occupied bandwidth for each NB-IoT carrier shall be less than the channel bandwidth as defined in Table 5.6-3.

NOTE: If the above Test Requirement differs from the Minimum Requirement then the Test Tolerance applied for this test is non-zero. The Test Tolerance for this test and the explanation of how the Minimum Requirement has been relaxed by the Test Tolerance are given in Annex G.

6.6.2 Adjacent Channel Leakage power Ratio (ACLR)

6.6.2.1 Definition and applicability

Adjacent Channel Leakage power Ratio (ACLR) is the ratio of the filtered mean power centred on the assigned channel frequency to the filtered mean power centred on an adjacent channel frequency.

The requirements shall apply outside the Base Station RF Bandwidth or Maximum Radio Bandwidth whatever the type of transmitter considered (single carrier, multi-carrier and/or CA) and for all transmission modes foreseen by the manufacturer's specification.

For a BS operating in non-contiguous spectrum, the ACLR also applies for the first adjacent channel inside any sub-block gap with a gap size $W_{\text{gap}} \geq 15\text{MHz}$ or $W_{\text{gap}} \geq 60\text{MHz}$ for Band 46. The ACLR requirement for the second adjacent channel applies inside any sub-block gap with a gap size $W_{\text{gap}} \geq 20\text{MHz}$ or $W_{\text{gap}} \geq 80\text{MHz}$ for Band 46. The ACLR requirement in subclause 6.6.2.6 applies in sub block gaps for the frequency ranges defined in Table 6.6.2-5/6.

For a BS operating in multiple bands, where multiple bands are mapped onto the same antenna connector, the ACLR also applies for the first adjacent channel inside any Inter RF Bandwidth gap with a gap size $W_{\text{gap}} \geq 15\text{MHz}$. The ACLR requirement for the second adjacent channel applies inside any Inter RF Bandwidth gap with a gap size $W_{\text{gap}} \geq 20\text{MHz}$. The ACLR requirement in subclause 6.6.2.6 applies in Inter RF Bandwidth gaps for the frequency ranges defined in Table 6.6.2-5/6.

The requirement applies during the transmitter ON period.

6.6.2.2 Minimum Requirement

The minimum requirement is in TS 36.104 [2] subclause 6.6.2.1.

6.6.2.3 Test purpose

To verify that the adjacent channel leakage power ratio requirement shall be met as specified by the minimum requirement.

6.6.2.4 Method of test

6.6.2.4.1 Initial conditions

Test environment: normal; see Annex D.2.

RF channels to be tested for single-carrier: B, M and T; see subclause 4.7.

Base Station RF Bandwidth positions to be tested for multi-carrier and/or CA: B_{RFBW} , M_{RFBW} and T_{RFBW} in single-band operation, see subclause 4.7.1; B'_{RFBW} , T'_{RFBW} and B'_{RFBW} , T'_{RFBW} in multi-band operation, see subclause 4.7.1.

1) Connect measurement device to the base station antenna connector as shown in Annex I.1.1.

2) The measurement device characteristics shall be:

- measurement filter bandwidth: defined in subclause 6.6.2.5;
- detection mode: true RMS voltage or true average power.

The emission power should be averaged over an appropriate time duration to ensure the measurement is within the measurement uncertainty in Table 4.1.2-1.

3) For a E-UTRA BS declared to be capable of single carrier operation only, set the base station to transmit a signal according to E-TM1.1 at manufacturer's declared rated output power.

For a E-UTRA BS declared to be capable of multi-carrier and/or CA operation, set the base station to transmit according to E-TM1.1 on all carriers configured using the applicable test configuration and corresponding power setting specified in clause 4.10 and 4.11.

For a E-UTRA BS declared to be capable of NB-IoT in-band operation, start transmission according to [E-TM1.1] with the NB-IoT PRB constructed according to N-TM at manufacturer's declared rated output power.

For a E-UTRA BS declared to be capable of NB-IoT guard-band operation, start transmission according to E-TM1.1 with the NB-IoT PRB constructed according to N-TM at manufacturer's declared rated output power.

For a NB-IoT BS declared to be capable of single carrier operation, start transmission according to N-TM at manufacturer's declared rated output power.

For a NB-IoT BS declared to be capable of multi-carrier in contiguous spectrum operation in single band only, start transmission according to N-TM on all carriers configured using in the applicable test configuration and corresponding power setting specified in clause 4.10 and 4.11.

For a E-UTRA and NB-IoT standalone BS declared to be capable of multi-carrier in contiguous spectrum operation in single band only, start transmission according to E-TM1.1 on all E-UTRA carriers and N-TM on all NB-IoT carriers configured using in the applicable test configuration and corresponding power setting specified in clause 4.10 and 4.11.

4) Set carrier frequency within the frequency band supported by BS.

6.6.2.4.2 Procedure

- 1) Measure Adjacent channel leakage power ratio for the frequency offsets both side of channel frequency as specified in Table 6.6.2-1 (Paired spectrum case) or Table 6.6.2-2 (Unpaired spectrum case) respectively. In multiple carrier case only offset frequencies below the lowest and above the highest carrier frequency used shall be measured.
- 2) For the ACLR requirement applied inside sub-block gap for non-contiguous spectrum operation: or inside Inter RF Bandwidth gap for multi-band operation

- a) Measure ACLR inside sub-block gap or Inter RF Bandwidth gap as specified in subclause 6.6.2.5, if applicable.
 - b) For E-UTRA, measure CACLR inside sub-block gap or Inter RF Bandwidth gap as specified in subclause 6.6.2.6, if applicable.
- 3) For E-UTRA, repeat the test with the channel set-up according to E-TM1.2.

In addition, for a multi-band capable BS, the following step shall apply:

- 4) For multi-band capable BS and single band tests, repeat the steps above per involved band where single band test configurations and test models shall apply with no carrier activated in the other band. For multi-band capable BS with separate antenna connector, the antenna connector not being under test in case of single-band or multi-band test shall be terminated.

6.6.2.5 Test Requirement

The ACLR is defined with a square filter of bandwidth equal to the transmission bandwidth configuration of the transmitted signal (BW_{Config}) centred on the assigned channel frequency and a filter centered on the adjacent channel frequency according to the tables below.

For Category A Wide Area BS, either the ACLR limits in the tables below or the absolute limit of -13 dBm/MHz shall apply, whichever is less stringent.

For Category B Wide Area BS, either the ACLR limits in the tables below or the absolute limit of -15 dBm/MHz shall apply, whichever is less stringent.

For Medium Range BS, either the ACLR limits in the tables below or the absolute limit of -25 dBm/MHz shall apply, whichever is less stringent.

For Local Area BS, either the ACLR limits in the tables below or the absolute limit of -32dBm/MHz shall apply, whichever is less stringent.

For Home BS, either the ACLR limits in the tables below or the absolute limit of -50dBm/MHz shall apply, whichever is less stringent.

The ACLR requirements in Tables 6.6.2-1 to 6.6.2-4 (except Table 6.6.2-2b) apply to BS that supports E-UTRA or E-UTRA with NB-IoT (in band and/or guard band), in any operating band, except for Band 46. The ACLR requirements for Band 46 are in Table 6.6.2-2a and 6.6.2-4a. The ACLR requirements in Table 6.6.2-2b apply to BS that supports standalone NB-IoT.

For operation in paired spectrum, the ACLR shall be higher than the value specified in Table 6.6.2-1.

Table 6.6.2-1: Base Station ACLR in paired spectrum

Channel bandwidth of E-UTRA lowest/highest carrier transmitted BW_{Channel} [MHz]	BS adjacent channel centre frequency offset below the lowest or above the highest carrier centre frequency transmitted	Assumed adjacent channel carrier (informative)	Filter on the adjacent channel frequency and corresponding filter bandwidth	ACLR limit
1.4, 3.0, 5, 10, 15, 20	BW_{Channel}	E-UTRA of same BW	Square (BW_{Config})	44.2 dB
	$2 \times BW_{\text{Channel}}$	E-UTRA of same BW	Square (BW_{Config})	44.2 dB
	$BW_{\text{Channel}}/2 + 2.5$ MHz	3.84 Mcps UTRA	RRC (3.84 Mcps)	44.2 dB
	$BW_{\text{Channel}}/2 + 7.5$ MHz	3.84 Mcps UTRA	RRC (3.84 Mcps)	44.2 dB
NOTE 1: BW_{Channel} and BW_{Config} are the channel bandwidth and transmission bandwidth configuration of the E-UTRA lowest/highest carrier transmitted on the assigned channel frequency.				
NOTE 2: The RRC filter shall be equivalent to the transmit pulse shape filter defined in [15], with a chip rate as defined in this table.				

For operation in unpaired spectrum, the ACLR shall be higher than the value specified in Table 6.6.2-2.

Table 6.6.2-2: Base Station ACLR in unpaired spectrum with synchronized operation

Channel bandwidth of E-UTRA lowest/highest carrier transmitted BW_{Channel} [MHz]	BS adjacent channel centre frequency offset below the lowest or above the highest carrier centre frequency transmitted	Assumed adjacent channel carrier (informative)	Filter on the adjacent channel frequency and corresponding filter bandwidth	ACLR limit
1.4, 3.0	BW_{Channel}	E-UTRA of same BW	Square (BW_{Config})	44.2 dB
	$2 \times BW_{\text{Channel}}$	E-UTRA of same BW	Square (BW_{Config})	44.2 dB
	$BW_{\text{Channel}}/2 + 0.8$ MHz	1.28 Mcps UTRA	RRC (1.28 Mcps)	44.2 dB
	$BW_{\text{Channel}}/2 + 2.4$ MHz	1.28 Mcps UTRA	RRC (1.28 Mcps)	44.2 dB
5, 10, 15, 20	BW_{Channel}	E-UTRA of same BW	Square (BW_{Config})	44.2 dB
	$2 \times BW_{\text{Channel}}$	E-UTRA of same BW	Square (BW_{Config})	44.2 dB
	$BW_{\text{Channel}}/2 + 0.8$ MHz	1.28 Mcps UTRA	RRC (1.28 Mcps)	44.2 dB
	$BW_{\text{Channel}}/2 + 2.4$ MHz	1.28 Mcps UTRA	RRC (1.28 Mcps)	44.2 dB
	$BW_{\text{Channel}}/2 + 2.5$ MHz	3.84 Mcps UTRA	RRC (3.84 Mcps)	44.2 dB
	$BW_{\text{Channel}}/2 + 7.5$ MHz	3.84 Mcps UTRA	RRC (3.84 Mcps)	44.2 dB
	$BW_{\text{Channel}}/2 + 5$ MHz	7.68 Mcps UTRA	RRC (7.68 Mcps)	44.2 dB
	$BW_{\text{Channel}}/2 + 15$ MHz	7.68 Mcps UTRA	RRC (7.68 Mcps)	44.2 dB
NOTE 1: BW_{Channel} and BW_{Config} are the channel bandwidth and transmission bandwidth configuration of the E-UTRA lowest/highest carrier transmitted on the assigned channel frequency.				
NOTE 2: The RRC filter shall be equivalent to the transmit pulse shape filter defined in [15], with a chip rate as defined in this table.				

For operation in Band 46, the ACLR shall be higher than the value specified in Table 6.6.2-2a.

Table 6.6.2-2a: Base Station ACLR in Band 46

Channel bandwidth of E-UTRA lowest/highest carrier transmitted BW_{Channel} [MHz]	BS adjacent channel centre frequency offset below the lowest or above the highest carrier centre frequency transmitted	Assumed adjacent channel carrier (informative)	Filter on the adjacent channel frequency and corresponding filter bandwidth	ACLR limit
10	BW_{Channel}	E-UTRA of same BW	Square (BW_{Config})	34.2 dB
	$2 \times BW_{\text{Channel}}$	E-UTRA of same BW	Square (BW_{Config})	39.2 dB
20	BW_{Channel}	E-UTRA of same BW	Square (BW_{Config})	35 dB
	$2 \times BW_{\text{Channel}}$	E-UTRA of same BW	Square (BW_{Config})	40 dB
NOTE 1: BW_{Channel} and BW_{Config} are the channel bandwidth and transmission bandwidth configuration of the E-UTRA lowest/highest carrier transmitted on the assigned channel frequency.				

For stand-alone NB-IoT operation in paired spectrum, the ACLR shall be higher than the value specified in Table 6.6.2-2b.

Table 6.6.2-2b: Base Station ACLR for stand-alone NB-IoT operation in paired spectrum

Channel bandwidth of NB-IoT lowest/highest carrier transmitted BW_{Channel} [kHz]	BS adjacent channel centre frequency offset below the lowest or above the highest carrier centre frequency transmitted	Assumed adjacent channel carrier (informative)	Filter on the adjacent channel frequency and corresponding filter bandwidth	ACLR limit
200	300 kHz	Stand-alone NB-IoT	Square (180 kHz)	39.2 dB
	500 kHz	Stand-alone NB-IoT	Square (180 kHz)	49.2 dB

For operation in non-contiguous paired spectrum or multiple bands, the ACLR shall be higher than the value specified in Table 6.6.2-3.

Table 6.6.2-3: Base Station ACLR in non-contiguous paired spectrum or multiple bands

Sub-block or Inter RF Bandwidth gap size (W_{gap}) where the limit applies	BS adjacent channel centre frequency offset below or above the sub-block edge or the Base Station RF Bandwidth edge (inside the gap)	Assumed adjacent channel carrier (informative)	Filter on the adjacent channel frequency and corresponding filter bandwidth	ACLR limit
$W_{\text{gap}} \geq 15$ MHz	2.5 MHz	3.84 Mcps UTRA	RRC (3.84 Mcps)	44.2 dB
$W_{\text{gap}} \geq 20$ MHz	7.5 MHz	3.84 Mcps UTRA	RRC (3.84 Mcps)	44.2 dB
NOTE: The RRC filter shall be equivalent to the transmit pulse shape filter defined in TS 25.104 [15], with a chip rate as defined in this table.				

For operation in non-contiguous unpaired spectrum or multiple bands, the ACLR shall be higher than the value specified in Table 6.6.2-4.

Table 6.6.2-4: Base Station ACLR in non-contiguous unpaired spectrum or multiple bands

Sub-block or Inter RF Bandwidth gap size (W_{gap}) where the limit applies	BS adjacent channel centre frequency offset below or above the sub-block edge or the Base Station RF Bandwidth edge (inside the gap)	Assumed adjacent channel carrier (informative)	Filter on the adjacent channel frequency and corresponding filter bandwidth	ACLR limit
$W_{\text{gap}} \geq 15$ MHz	2.5 MHz	5MHz E-UTRA	Square (BW_{Config})	44.2 dB
$W_{\text{gap}} \geq 20$ MHz	7.5 MHz	5MHz E-UTRA	Square (BW_{Config})	44.2 dB

For operation in non-contiguous spectrum in Band 46, the ACLR shall be higher than the value specified in Table 6.6.2-4a.

Table 6.6.2-4a: Base Station ACLR in non-contiguous spectrum in Band 46

Sub-block gap size (W_{gap}) where the limit applies	BS adjacent channel centre frequency offset below or above the sub-block edge (inside the gap)	Assumed adjacent channel carrier (informative)	Filter on the adjacent channel frequency and corresponding filter bandwidth	ACLR limit
$W_{\text{gap}} \geq 60$ MHz	10 MHz	20MHz E-UTRA carrier	Square (BW_{Config})	35 dB
$W_{\text{gap}} \geq 80$ MHz	30 MHz	20MHz E-UTRA carrier	Square (BW_{Config})	40 dB

6.6.2.6 Cumulative ACLR test requirement in non-contiguous spectrum

The following test requirement applies for the sub-block or Inter RF Bandwidth gap sizes listed in Table 6.6.2-5/6/6a,

- Inside a sub-block gap within an operating band for a BS operating in non-contiguous spectrum.
- Inside an Inter RF Bandwidth gap for a BS operating in multiple bands, where multiple bands are mapped on the same antenna connector.

The Cumulative Adjacent Channel Leakage power Ratio (CACLR) in a sub-block gap or Inter RF Bandwidth gap is the ratio of:

- a) the sum of the filtered mean power centred on the assigned channel frequencies for the two carriers adjacent to each side of the sub-block gap or Inter RF Bandwidth gap, and
- b) the filtered mean power centred on a frequency channel adjacent to one of the respective sub-block edges or Base Station RF Bandwidth edges.

The assumed filter for the adjacent channel frequency is defined in Table 6.6.2-5/6. Filters on the assigned channels are defined in Table 6.6.2-7.

For Wide Area Category A BS, either the CACLR limits in Table 6.6.2-5/6 or the absolute limit of -13dBm/MHz shall apply, whichever is less stringent.

For Wide Area Category B BS, either the CACLR limits in Table 6.6.2-5/6 or the absolute limit of -15dBm/MHz shall apply, whichever is less stringent.

For Medium Range BS, either the CACLR limits in Table 6.6.2-5/6 or the absolute limit of -25 dBm/MHz shall apply, whichever is less stringent.

For Local Area BS, either the CACLR limits in Table 6.6.2-5/6 or the absolute limit of -32 dBm/MHz shall apply, whichever is less stringent.

The ACLR requirements in Tables 6.6.2-5 and 6.6.2-6 apply to BS that supports E-UTRA, in any operating band, except for Band 46. The ACLR requirements for Band 46 are in Table 6.6.2-6a.

For operation in non-contiguous spectrum or multiple bands, the CACLR for E-UTRA carriers located on either side of the sub-block gap or Inter RF Bandwidth gap shall be higher than the value specified in Table 6.6.2-5/6.

Table 6.6.2-5: Base Station CACLR in non-contiguous paired spectrum or multiple bands

Sub-block or Inter RF Bandwidth gap size (W_{gap}) where the limit applies	BS adjacent channel centre frequency offset below or above the sub-block edge or the Base Station RF Bandwidth edge (inside the gap)	Assumed adjacent channel carrier (informative)	Filter on the adjacent channel frequency and corresponding filter bandwidth	CACLR limit
$5 \text{ MHz} \leq W_{\text{gap}} < 15 \text{ MHz}$	2.5 MHz	3.84 Mcps UTRA	RRC (3.84 Mcps)	44.2 dB
$10 \text{ MHz} < W_{\text{gap}} < 20 \text{ MHz}$	7.5 MHz	3.84 Mcps UTRA	RRC (3.84 Mcps)	44.2 dB
NOTE: The RRC filter shall be equivalent to the transmit pulse shape filter defined in TS 25.104 [15], with a chip rate as defined in this table.				

Table 6.6.2-6: Base Station CACLR in non-contiguous unpaired spectrum or multiple bands

Sub-block or Inter RF Bandwidth gap size (W_{gap}) where the limit applies	BS adjacent channel centre frequency offset below or above the sub-block edge or the Base Station RF Bandwidth edge (inside the gap)	Assumed adjacent channel carrier (informative)	Filter on the adjacent channel frequency and corresponding filter bandwidth	CACLR limit
$5 \text{ MHz} \leq W_{\text{gap}} < 15 \text{ MHz}$	2.5 MHz	5MHz E-UTRA carrier	Square (BW_{Config})	44.2 dB
$10 \text{ MHz} < W_{\text{gap}} < 20 \text{ MHz}$	7.5 MHz	5MHz E-UTRA carrier	Square (BW_{Config})	44.2 dB

For operation in non-contiguous spectrum in Band 46, the CA CLR for E-UTRA carriers located on either side of the sub-block gap shall be higher than the value specified in Table 6.6.2-6a.

Table 6.6.2-6a: Base Station CA CLR in non-contiguous spectrum in Band 46

Sub-block gap size (W_{gap}) where the limit applies	BS adjacent channel centre frequency offset below or above the sub-block edge (inside the gap)	Assumed adjacent channel carrier (informative)	Filter on the adjacent channel frequency and corresponding filter bandwidth	CA CLR limit
$20 \text{ MHz} \leq W_{\text{gap}} < 60 \text{ MHz}$	10 MHz	20MHz E-UTRA carrier	Square (BW_{Config})	34.2 dB
$40 \text{ MHz} < W_{\text{gap}} < 80 \text{ MHz}$	30 MHz	20MHz E-UTRA carrier	Square (BW_{Config})	34.2 dB

Table 6.6.2-7: Filter parameters for the assigned channel

RAT of the carrier adjacent to the sub-block or Inter RF Bandwidth gap	Filter on the assigned channel frequency and corresponding filter bandwidth
E-UTRA	E-UTRA of same BW

NOTE: If the above Test Requirements differ from the Minimum Requirement then the Test Tolerance applied for this test is non-zero. The Test Tolerance for this test and the explanation of how the Minimum Requirement has been relaxed by the Test Tolerance are given in Annex G.

6.6.3 Operating band unwanted emissions

6.6.3.1 Definition and applicability

Unless otherwise stated, the Operating band unwanted emission limits are defined from 10 MHz below the lowest frequency of each supported downlink operating band up to 10 MHz above the highest frequency of each supported downlink operating band (see Table 5.5-1).

The requirements shall apply whatever the type of transmitter considered (single carrier, multi-carrier and/or CA) and for all transmission modes foreseen by the manufacturer's specification. In addition, for a BS operating in non-contiguous spectrum, the requirements apply inside any sub-block gap. In addition, for a BS operating in multiple bands, the requirements apply inside any Inter RF Bandwidth gap.

For BS capable of multi-band operation where multiple bands are mapped on separate antenna connectors, the single-band requirements apply and the cumulative evaluation of the emission limit in the Inter RF Bandwidth gap are not applicable.

For a BS supporting E-UTRA with guard band NB-IoT operation, the Operating band unwanted emissions requirements apply to E-UTRA carrier with channel bandwidth larger than or equal to 5 MHz.

The unwanted emission limits in the part of the downlink operating band that falls in the spurious domain are consistent with ITU-R Recommendation SM.329 [5].

For a multicarrier E-UTRA BS or BS configured for intra-band contiguous or non-contiguous carrier aggregation the definitions above apply to the lower edge of the carrier transmitted at the lowest carrier frequency and the upper edge of the carrier transmitted at the highest carrier frequency within a specified operating band.

For Wide Area BS, the requirements of either subclause 6.6.3.5.1 (Category A limits) or subclause 6.6.3.5.2 (Category B limits) shall apply.

For Local Area BS, the requirements of subclause 6.6.3.5.2A shall apply (Category A and B).

For Home BS, the requirements of subclause 6.6.3.5.2B shall apply (Category A and B).

For Medium Range BS, the requirements in subclause 6.6.3.5.2C shall apply (Category A and B).

The application of either Category A or Category B limits shall be the same as for Transmitter spurious emissions (Mandatory Requirements) in subclause 6.6.4.5.

For Category B Operating band unwanted emissions, there are two options for the limits that may be applied regionally. Either the limits in subclause 6.6.3.5.2.1 or subclause 6.6.3.5.2.2 shall be applied.

The requirements of subclauses 6.6.3.5.1 and 6.6.3.5.2 apply to Wide Area BS that supports E-UTRA with NB-IoT (in band and/or guard band). The requirements for Wide Area BS that supports standalone NB-IoT are in subclause 6.6.3.5.2E.

The requirements of subclause 6.6.3.5.2A apply to Local Area BS that supports E-UTRA with NB-IoT (in band and/or guard band). The requirements for Local Area BS that supports standalone NB-IoT are in subclause 6.6.3.5.2F.

The requirements of subclause 6.6.3.5.2B apply to Home BS that supports E-UTRA with NB-IoT (in band and/or guard band). The requirements for Home BS that supports standalone NB-IoT are in subclause 6.6.3.5.2G.

The requirements of subclauses 6.6.3.5.2C apply to Medium Range BS that supports E-UTRA with NB-IoT (in band and/or guard band). The requirements for Medium Range BS that supports standalone NB-IoT are in subclause 6.6.3.5.2H.

6.6.3.2 Minimum Requirement

The minimum requirement is in TS 36.104 [2] subclause 6.6.3.

6.6.3.3 Test purpose

This test measures the emissions of the BS, close to the assigned channel bandwidth of the wanted signal, while the transmitter is in operation.

6.6.3.4 Method of test

6.6.3.4.1 Initial conditions

Test environment: normal; see Annex D.2.

RF channels to be tested for single carrier: B, M and T; see subclause 4.7.

Base Station RF Bandwidth position to be tested for multi-carrier and/or CA: B_{RFBW} , M_{RFBW} and T_{RFBW} in single-band operation, see subclause 4.7.1; $B'_{RFBW_T'_{RFBW}}$ and $B'_{RFBW_T'_{RFBW}}$ in multi-band operation, see subclause 4.7.1.

- 1) Connect the signal analyzer to the base station antenna connector as shown in Annex I.1.1.

As a general rule, the resolution bandwidth of the measuring equipment should be equal to the measurement bandwidth. However, to improve measurement accuracy, sensitivity, efficiency and avoiding e.g. carrier leakage, the resolution bandwidth may be smaller than the measurement bandwidth. When the resolution bandwidth is smaller than the measurement bandwidth, the result should be integrated over the measurement bandwidth in order to obtain the equivalent noise bandwidth of the measurement bandwidth.

- 2) Detection mode: True RMS.

The emission power should be averaged over an appropriate time duration to ensure the measurement is within the measurement uncertainty in Table 4.1.2-1.

6.6.3.4.2 Procedure

- 1) For a E-UTRA BS declared to be capable of single carrier operation only, set the BS transmission at manufacturer's declared rated output power. Channel set-up shall be according to E-TM 1.1.

For a E-UTRA BS declared to be capable of multi-carrier and/or CA operation, set the base station to transmit according to E-TM1.1 on all carriers configured using the applicable test configuration and corresponding power setting specified in clause 4.10 and 4.11.

For a E-UTRA BS declared to be capable of NB-IoT in-band operation, start transmission according to [E-TM1.1] with the NB-IoT PRB constructed according to N-TM at manufacturer's declared rated output power.

For a E-UTRA BS declared to be capable of NB-IoT guard-band operation, start transmission according to E-TM1.1 with the NB-IoT PRB constructed according to N-TM at manufacturer's declared rated output power.

For a NB-IoT BS declared to be capable of single carrier operation, start transmission according to N-TM at manufacturer's declared rated output power.

For a NB-IoT BS declared to be capable of multi-carrier in contiguous spectrum operation in single band only, start transmission according to N-TM on all carriers configured using in the applicable test configuration and corresponding power setting specified in clause 4.10 and 4.11.

For a E-UTRA and NB-IoT standalone BS declared to be capable of multi-carrier in contiguous spectrum operation in single band only, start transmission according to E-TM1.1 on all E-UTRA carriers and N-TM on all NB-IoT carriers configured using in the applicable test configuration and corresponding power setting specified in clause 4.10 and 4.11.

- 2) Step the centre frequency of the measurement filter in contiguous steps and measure the emission within the specified frequency ranges with the specified measurement bandwidth. For BS operating in multiple bands or non-contiguous spectrum, the emission within the Inter RF Bandwidth or sub-block gap shall be measured using the specified measurement bandwidth from the closest RF Bandwidth or sub block edge.
- 3) For E-UTRA, repeat the test with the channel set-up according to E-TM 1.2

In addition, for a multi-band capable BS, the following step shall apply:

- 4) For multi-band capable BS and single band tests, repeat the steps above per involved band where single band test configurations and test models shall apply with no carrier activated in the other band. For multi-band capable BS with separate antenna connector, the antenna connector not being under test in case of single-band or multi-band test shall be terminated.

6.6.3.5 Test requirement

The measurement results in step 2 of 6.6.3.4.2 shall not exceed the maximum levels specified in the tables below, where:

- Δf is the separation between the Base Station RF Bandwidth edge frequency and the nominal -3dB point of the measuring filter closest to the carrier frequency.
- f_{offset} is the separation between the Base Station RF Bandwidth edge frequency and the centre of the measuring filter.
- $f_{\text{offset}_{\text{max}}}$ is the offset to the frequency 10 MHz outside the downlink operating band.
- Δf_{max} is equal to $f_{\text{offset}_{\text{max}}}$ minus half of the bandwidth of the measuring filter.

For BS operating in multiple bands, inside any Inter RF Bandwidth gaps with $W_{\text{gap}} < 20$ MHz, emissions shall not exceed the cumulative sum of the test requirements specified at the Base Station RF Bandwidth edges on each side of the Inter RF Bandwidth gap. The test requirement for Base Station RF Bandwidth edge is specified in Tables 6.6.3.5.1-1 to 6.6.3.5.3-3 below, where in this case:

- Δf is the separation between the Base Station RF Bandwidth edge frequency and the nominal -3 dB point of the measuring filter closest to the Base Station RF Bandwidth edge.
- f_{offset} is the separation between the Base Station RF Bandwidth edge frequency and the centre of the measuring filter.
- $f_{\text{offset}_{\text{max}}}$ is equal to the Inter RF Bandwidth gap minus half of the bandwidth of the measuring filter.
- Δf_{max} is equal to $f_{\text{offset}_{\text{max}}}$ minus half of the bandwidth of the measuring filter.

For BS capable of multi-band operation where multiple bands are mapped on the same antenna connector, the operating band unwanted emission limits apply also in a supported operating band without any carrier transmitted, in the case where there are carrier(s) transmitted in other supported operating band(s). In this case where there is no carrier transmitted in an operating band, the operating band unwanted emission limit, as defined in the tables of the present subclause for the largest frequency offset (Δf_{max}), of a band where there is no carrier transmitted shall apply from 10 MHz below the lowest frequency, up to 10 MHz above the highest frequency of the supported downlink operating band without any carrier transmitted. And, no cumulative limit is applied in the inter-band gap between a supported downlink operating band with carrier(s) transmitted and a supported downlink operating band without any carrier transmitted.

In addition inside any sub-block gap for a BS operating in non-contiguous spectrum, measurement results shall not exceed the cumulative sum of the test requirements specified for the adjacent sub blocks on each side of the sub block gap. The test requirement for each sub block is specified in Tables 6.6.3.5.1-1 to 6.6.3.5.3-3 below, where in this case:

- Δf is the separation between the sub block edge frequency and the nominal -3 dB point of the measuring filter closest to the sub block edge.
- f_{offset} is the separation between the sub block edge frequency and the centre of the measuring filter.
- $f_{\text{offset}_{\text{max}}}$ is equal to the sub block gap bandwidth minus half of the bandwidth of the measuring filter.
- Δf_{max} is equal to $f_{\text{offset}_{\text{max}}}$ minus half of the bandwidth of the measuring filter.

6.6.3.5.1 Test requirements for Wide Area BS (Category A)

For E-UTRA BS operating in Bands 5, 6, 8, 12, 13, 14, 17, 18, 19, 26, 27, 28, 29, 31, 44, 71, 72, 73, 85, 87, 88 emissions shall not exceed the maximum levels specified in Tables 6.6.3.5.1-1 to 6.6.3.5.1-3.

Table 6.6.3.5.1-1: Wide Area BS operating band unwanted emission limits for 1.4 MHz channel bandwidth (E-UTRA bands <1GHz) for Category A

Frequency offset of measurement filter -3dB point, Δf	Frequency offset of measurement filter centre frequency, f_{offset}	Test requirement (Note 1, 2)	Measurement bandwidth (Note 6)
$0 \text{ MHz} \leq \Delta f < 1.4 \text{ MHz}$	$0.05 \text{ MHz} \leq f_{\text{offset}} < 1.45 \text{ MHz}$	$+0.5 \text{ dBm} - \frac{10}{1.4} \cdot \left(\frac{f_{\text{offset}}}{\text{MHz}} - 0.05 \right) \text{ dB}$	100 kHz
$1.4 \text{ MHz} \leq \Delta f < 2.8 \text{ MHz}$	$1.45 \text{ MHz} \leq f_{\text{offset}} < 2.85 \text{ MHz}$	-9.5 dBm	100 kHz
$2.8 \text{ MHz} \leq \Delta f \leq \Delta f_{\text{max}}$	$2.85 \text{ MHz} \leq f_{\text{offset}} < f_{\text{offset}_{\text{max}}}$	-13 dBm	100 kHz
NOTE 1: For a BS supporting non-contiguous spectrum operation within any operating band the test requirement within sub-block gaps is calculated as a cumulative sum of contributions from adjacent sub blocks on each side of the sub block gap. Exception is $\Delta f \geq 10 \text{ MHz}$ from both adjacent sub blocks on each side of the sub-block gap, where the test requirement within sub-block gaps shall be -13dBm/100kHz. NOTE 2: For BS supporting multi-band operation with Inter RF Bandwidth gap < 20MHz the test requirement within the Inter RF Bandwidth gaps is calculated as a cumulative sum of contributions from adjacent sub-blocks or RF Bandwidth on each side of the Inter RF Bandwidth gap.			

Table 6.6.3.5.1-2: Wide Area BS operating band unwanted emission limits for 3 MHz channel bandwidth (E-UTRA bands <1GHz) for Category A

Frequency offset of measurement filter -3dB point, Δf	Frequency offset of measurement filter centre frequency, f_{offset}	Test requirement (Note 1, 2)	Measurement bandwidth (Note 6)
$0 \text{ MHz} \leq \Delta f < 3 \text{ MHz}$	$0.05 \text{ MHz} \leq f_{\text{offset}} < 3.05 \text{ MHz}$	$-3.5 \text{ dBm} - \frac{10}{3} \cdot \left(\frac{f_{\text{offset}}}{\text{MHz}} - 0.05 \right) \text{ dB}$	100 kHz
$3 \text{ MHz} \leq \Delta f < 6 \text{ MHz}$	$3.05 \text{ MHz} \leq f_{\text{offset}} < 6.05 \text{ MHz}$	-13.5 dBm	100 kHz
$6 \text{ MHz} \leq \Delta f \leq \Delta f_{\text{max}}$	$6.05 \text{ MHz} \leq f_{\text{offset}} < f_{\text{offsetmax}}$	-13 dBm	100 kHz
<p>NOTE 1: For a BS supporting non-contiguous spectrum operation within any operating band the test requirement within sub-block gaps is calculated as a cumulative sum of contributions from adjacent sub blocks on each side of the sub block gap. Exception is $\Delta f \geq 10 \text{ MHz}$ from both adjacent sub blocks on each side of the sub-block gap, where the test requirement within sub-block gaps shall be -13dBm/100kHz.</p> <p>NOTE 2: For BS supporting multi-band operation with Inter RF Bandwidth gap < 20MHz the test requirement within the Inter RF Bandwidth gaps is calculated as a cumulative sum of contributions from adjacent sub-blocks or RF Bandwidth on each side of the Inter RF Bandwidth gap.</p>			

Table 6.6.3.5.1-3: Wide Area BS operating band unwanted emission limits for 5, 10, 15 and 20 MHz channel bandwidth (E-UTRA bands <1GHz) for Category A

Frequency offset of measurement filter -3dB point, Δf	Frequency offset of measurement filter centre frequency, f_{offset}	Test requirement (Note 1, 2)	Measurement bandwidth (Note 6)
$0 \text{ MHz} \leq \Delta f < 5 \text{ MHz}$	$0.05 \text{ MHz} \leq f_{\text{offset}} < 5.05 \text{ MHz}$	$-5.5 \text{ dBm} - \frac{7}{5} \cdot \left(\frac{f_{\text{offset}}}{\text{MHz}} - 0.05 \right) \text{ dB}$	100 kHz
$5 \text{ MHz} \leq \Delta f < \min(10 \text{ MHz}, \Delta f_{\text{max}})$	$5.05 \text{ MHz} \leq f_{\text{offset}} < \min(10.05 \text{ MHz}, f_{\text{offsetmax}})$	-12.5 dBm	100 kHz
$10 \text{ MHz} \leq \Delta f \leq \Delta f_{\text{max}}$	$10.05 \text{ MHz} \leq f_{\text{offset}} < f_{\text{offsetmax}}$	-13 dBm (Note 5)	100 kHz
<p>NOTE 1: For a BS supporting non-contiguous spectrum operation within any operating band the test requirement within sub-block gaps is calculated as a cumulative sum of contributions from adjacent sub blocks on each side of the sub block gap. Exception is $\Delta f \geq 10 \text{ MHz}$ from both adjacent sub blocks on each side of the sub-block gap, where the test requirement within sub-block gaps shall be -13dBm/100kHz.</p> <p>NOTE 2: For BS supporting multi-band operation with Inter RF Bandwidth gap < 20MHz the test requirement within the Inter RF Bandwidth gaps is calculated as a cumulative sum of contributions from adjacent sub-blocks or RF Bandwidth on each side of the Inter RF Bandwidth gap.</p>			

For E-UTRA BS operating in Bands 1, 2, 3, 4, 7, 9, 10, 11, 21, 23, 24, 25, 30, 32, 33, 34, 35, 36, 37, 38, 39, 40, 41, 45, 48, 50, 65, 66, 69, 70, 74, 75 emissions shall not exceed the maximum levels specified in Tables 6.6.3.5.1-4, 6.6.3.5.1-5 and 6.6.3.5.1-6:

For E-UTRA BS operating in Bands 22, 42, 43, 52, emissions shall not exceed the maximum levels specified in Tables 6.6.3.5.1-4a, 6.6.3.5.1-5a and 6.6.3.5.1-6a:

Table 6.6.3.5.1-4: Wide Area BS operating band unwanted emission limits for 1.4 MHz channel bandwidth (1GHz < E-UTRA bands ≤ 3GHz) for Category A

Frequency offset of measurement filter -3dB point, Δf	Frequency offset of measurement filter centre frequency, f_{offset}	Test requirement (Note 1, 2)	Measurement bandwidth (Note 6)
$0 \text{ MHz} \leq \Delta f < 1.4 \text{ MHz}$	$0.05 \text{ MHz} \leq f_{\text{offset}} < 1.45 \text{ MHz}$	$+0.5 \text{ dBm} - \frac{10}{1.4} \cdot \left(\frac{f_{\text{offset}}}{\text{MHz}} - 0.05 \right) \text{ dB}$	100 kHz
$1.4 \text{ MHz} \leq \Delta f < 2.8 \text{ MHz}$	$1.45 \text{ MHz} \leq f_{\text{offset}} < 2.85 \text{ MHz}$	-9.5 dBm	100 kHz
$2.8 \text{ MHz} \leq \Delta f \leq \Delta f_{\text{max}}$	$3.3 \text{ MHz} \leq f_{\text{offset}} < f_{\text{offset}_{\text{max}}}$	-13 dBm	1MHz
<p>NOTE 1: For a BS supporting non-contiguous spectrum operation within any operating band the test requirement within sub-block gaps is calculated as a cumulative sum of contributions from adjacent sub blocks on each side of the sub block gap, where the contribution from the far-end sub-block shall be scaled according to the measurement bandwidth of the near-end sub-block. Exception is $\Delta f \geq 10\text{MHz}$ from both adjacent sub blocks on each side of the sub-block gap, where the test requirement within sub-block gaps shall be -13dBm/1MHz.</p> <p>NOTE 2: For BS supporting multi-band operation with Inter RF Bandwidth gap < 20MHz the test requirement within the Inter RF Bandwidth gaps is calculated as a cumulative sum of contributions from adjacent sub-blocks or RF Bandwidth on each side of the Inter RF Bandwidth gap, where the contribution from the far-end sub-block or RF Bandwidth shall be scaled according to the measurement bandwidth of the near-end sub-block or RF Bandwidth.</p>			

Table 6.6.3.5.1-4a: Wide Area BS operating band unwanted emission limits for 1.4 MHz channel bandwidth (E-UTRA bands >3GHz) for Category A

Frequency offset of measurement filter -3dB point, Δf	Frequency offset of measurement filter centre frequency, f_{offset}	Test requirement (Note 1, 2)	Measurement bandwidth (Note 6)
$0 \text{ MHz} \leq \Delta f < 1.4 \text{ MHz}$	$0.05 \text{ MHz} \leq f_{\text{offset}} < 1.45 \text{ MHz}$	$+0.8 \text{ dBm} - \frac{10}{1.4} \cdot \left(\frac{f_{\text{offset}}}{\text{MHz}} - 0.05 \right) \text{ dB}$	100 kHz
$1.4 \text{ MHz} \leq \Delta f < 2.8 \text{ MHz}$	$1.45 \text{ MHz} \leq f_{\text{offset}} < 2.85 \text{ MHz}$	-9.2 dBm	100 kHz
$2.8 \text{ MHz} \leq \Delta f \leq \Delta f_{\text{max}}$	$3.3 \text{ MHz} \leq f_{\text{offset}} < f_{\text{offset}_{\text{max}}}$	-13 dBm	1MHz
<p>NOTE 1: For a BS supporting non-contiguous spectrum operation within any operating band the test requirement within sub-block gaps is calculated as a cumulative sum of contributions from adjacent sub blocks on each side of the sub block gap, where the contribution from the far-end sub-block shall be scaled according to the measurement bandwidth of the near-end sub-block. Exception is $\Delta f \geq 10\text{MHz}$ from both adjacent sub blocks on each side of the sub-block gap, where the test requirement within sub-block gaps shall be -13dBm/1MHz.</p> <p>NOTE 2: For BS supporting multi-band operation with Inter RF Bandwidth gap < 20MHz the test requirement within the Inter RF Bandwidth gaps is calculated as a cumulative sum of contributions from adjacent sub-blocks or RF Bandwidth on each side of the Inter RF Bandwidth gap, where the contribution from the far-end sub-block or RF Bandwidth shall be scaled according to the measurement bandwidth of the near-end sub-block or RF Bandwidth.</p>			

Table 6.6.3.5.1-5: Wide Area BS operating band unwanted emission limits for 3 MHz channel bandwidth (1GHz < E-UTRA bands ≤ 3GHz) for Category A

Frequency offset of measurement filter -3dB point, Δf	Frequency offset of measurement filter centre frequency, f_{offset}	Test requirement (Note 1, 2)	Measurement bandwidth (Note 6)
$0 \text{ MHz} \leq \Delta f < 3 \text{ MHz}$	$0.05 \text{ MHz} \leq f_{\text{offset}} < 3.05 \text{ MHz}$	$-3.5 \text{ dBm} - \frac{10}{3} \cdot \left(\frac{f_{\text{offset}}}{\text{MHz}} - 0.05 \right) \text{ dB}$	100 kHz
$3 \text{ MHz} \leq \Delta f < 6 \text{ MHz}$	$3.05 \text{ MHz} \leq f_{\text{offset}} < 6.05 \text{ MHz}$	-13.5 dBm	100 kHz
$6 \text{ MHz} \leq \Delta f \leq \Delta f_{\text{max}}$	$6.5 \text{ MHz} \leq f_{\text{offset}} < f_{\text{offset}_{\text{max}}}$	-13 dBm	1MHz
<p>NOTE 1: For a BS supporting non-contiguous spectrum operation within any operating band the test requirement within sub-block gaps is calculated as a cumulative sum of contributions from adjacent sub blocks on each side of the sub block gap, where the contribution from the far-end sub-block shall be scaled according to the measurement bandwidth of the near-end sub-block. Exception is $\Delta f \geq 10\text{MHz}$ from both adjacent sub blocks on each side of the sub-block gap, where the test requirement within sub-block gaps shall be -13dBm/1MHz.</p> <p>NOTE 2: For BS supporting multi-band operation with Inter RF Bandwidth gap < 20MHz the test requirement within the Inter RF Bandwidth gaps is calculated as a cumulative sum of contributions from adjacent sub-blocks or RF Bandwidth on each side of the Inter RF Bandwidth gap, where the contribution from the far-end sub-block or RF Bandwidth shall be scaled according to the measurement bandwidth of the near-end sub-block or RF Bandwidth.</p>			

Table 6.6.3.5.1-5a: Wide Area BS operating band unwanted emission limits for 3 MHz channel bandwidth (E-UTRA bands >3GHz) for Category A

Frequency offset of measurement filter -3dB point, Δf	Frequency offset of measurement filter centre frequency, f_{offset}	Test requirement (Note 1, 2)	Measurement bandwidth (Note 6)
$0 \text{ MHz} \leq \Delta f < 3 \text{ MHz}$	$0.05 \text{ MHz} \leq f_{\text{offset}} < 3.05 \text{ MHz}$	$-3.2 \text{ dBm} - \frac{10}{3} \cdot \left(\frac{f_{\text{offset}}}{\text{MHz}} - 0.05 \right) \text{ dB}$	100 kHz
$3 \text{ MHz} \leq \Delta f < 6 \text{ MHz}$	$3.05 \text{ MHz} \leq f_{\text{offset}} < 6.05 \text{ MHz}$	-13.2 dBm	100 kHz
$6 \text{ MHz} \leq \Delta f \leq \Delta f_{\text{max}}$	$6.5 \text{ MHz} \leq f_{\text{offset}} < f_{\text{offset}_{\text{max}}}$	-13 dBm	1MHz
<p>NOTE 1: For a BS supporting non-contiguous spectrum operation within any operating band the test requirement within sub-block gaps is calculated as a cumulative sum of contributions from adjacent sub blocks on each side of the sub block gap, where the contribution from the far-end sub-block shall be scaled according to the measurement bandwidth of the near-end sub-block. Exception is $\Delta f \geq 10\text{MHz}$ from both adjacent sub blocks on each side of the sub-block gap, where the test requirement within sub-block gaps shall be -13dBm/1MHz.</p> <p>NOTE 2: For BS supporting multi-band operation with Inter RF Bandwidth gap < 20MHz the test requirement within the Inter RF Bandwidth gaps is calculated as a cumulative sum of contributions from adjacent sub-blocks or RF Bandwidth on each side of the Inter RF Bandwidth gap, where the contribution from the far-end sub-block or RF Bandwidth shall be scaled according to the measurement bandwidth of the near-end sub-block or RF Bandwidth.</p>			

Table 6.6.3.5.1-6: Wide Area BS operating band unwanted emission limits for 5, 10, 15 and 20 MHz channel bandwidth (1GHz < E-UTRA bands ≤ 3GHz) for Category A

Frequency offset of measurement filter -3dB point, Δf	Frequency offset of measurement filter centre frequency, f_{offset}	Test requirement (Note 1, 2)	Measurement bandwidth (Note 6)
$0 \text{ MHz} \leq \Delta f < 5 \text{ MHz}$	$0.05 \text{ MHz} \leq f_{\text{offset}} < 5.05 \text{ MHz}$	$-5.5 \text{ dBm} - \frac{7}{5} \left(\frac{f_{\text{offset}}}{\text{MHz}} - 0.05 \right) \text{ dB}$	100 kHz
$5 \text{ MHz} \leq \Delta f < \min(10 \text{ MHz}, \Delta f_{\text{max}})$	$5.05 \text{ MHz} \leq f_{\text{offset}} < \min(10.05 \text{ MHz}, f_{\text{offset}_{\text{max}}})$	-12.5 dBm	100 kHz
$10 \text{ MHz} \leq \Delta f \leq \Delta f_{\text{max}}$	$10.5 \text{ MHz} \leq f_{\text{offset}} < f_{\text{offset}_{\text{max}}}$	-13 dBm (Note 9)	1MHz
<p>NOTE 1: For a BS supporting non-contiguous spectrum operation within any operating band the test requirement within sub-block gaps is calculated as a cumulative sum of contributions from adjacent sub blocks on each side of the sub block gap, where the contribution from the far-end sub-block shall be scaled according to the measurement bandwidth of the near-end sub-block. Exception is $\Delta f \geq 10\text{MHz}$ from both adjacent sub blocks on each side of the sub-block gap, where the test requirement within sub-block gaps shall be -13dBm/1MHz.</p> <p>NOTE 2: For BS supporting multi-band operation with Inter RF Bandwidth gap < 20MHz the test requirement within the Inter RF Bandwidth gaps is calculated as a cumulative sum of contributions from adjacent sub-blocks or RF Bandwidth on each side of the Inter RF Bandwidth gap, where the contribution from the far-end sub-block or RF Bandwidth shall be scaled according to the measurement bandwidth of the near-end sub-block or RF Bandwidth.</p>			

Table 6.6.3.5.1-6a: Wide Area BS operating band unwanted emission limits for 5, 10, 15 and 20 MHz channel bandwidth (E-UTRA bands >3GHz) for Category A

Frequency offset of measurement filter -3dB point, Δf	Frequency offset of measurement filter centre frequency, f_{offset}	Test requirement (Note 1, 2)	Measurement bandwidth (Note 6)
$0 \text{ MHz} \leq \Delta f < 5 \text{ MHz}$	$0.05 \text{ MHz} \leq f_{\text{offset}} < 5.05 \text{ MHz}$	$-5.2 \text{ dBm} - \frac{7}{5} \left(\frac{f_{\text{offset}}}{\text{MHz}} - 0.05 \right) \text{ dB}$	100 kHz
$5 \text{ MHz} \leq \Delta f < \min(10 \text{ MHz}, \Delta f_{\text{max}})$	$5.05 \text{ MHz} \leq f_{\text{offset}} < \min(10.05 \text{ MHz}, f_{\text{offset}_{\text{max}}})$	-12.2 dBm	100 kHz
$10 \text{ MHz} \leq \Delta f \leq \Delta f_{\text{max}}$	$10.5 \text{ MHz} \leq f_{\text{offset}} < f_{\text{offset}_{\text{max}}}$	-13 dBm (Note 9)	1MHz
<p>NOTE 1: For a BS supporting non-contiguous spectrum operation within any operating band the test requirement within sub-block gaps is calculated as a cumulative sum of contributions from adjacent sub blocks on each side of the sub block gap, where the contribution from the far-end sub-block shall be scaled according to the measurement bandwidth of the near-end sub-block. Exception is $\Delta f \geq 10\text{MHz}$ from both adjacent sub blocks on each side of the sub-block gap, where the test requirement within sub-block gaps shall be -13dBm/1MHz.</p> <p>NOTE 2: For BS supporting multi-band operation with Inter RF Bandwidth gap < 20MHz the test requirement within the Inter RF Bandwidth gaps is calculated as a cumulative sum of contributions from adjacent sub-blocks or RF Bandwidth on each side of the Inter RF Bandwidth gap, where the contribution from the far-end sub-block or RF Bandwidth shall be scaled according to the measurement bandwidth of the near-end sub-block or RF Bandwidth.</p>			

6.6.3.5.2 Test requirements for Wide Area BS (Category B)

For Category B Operating band unwanted emissions, there are two options for the limits that may be applied regionally. Either the limits in subclause 6.6.3.5.2.1 or subclause 6.6.3.5.2.2 shall be applied.

6.6.3.5.2.1 Category B test requirements (Option 1)

For E-UTRA BS operating in Bands 5, 8, 12, 13, 14, 17, 20, 26, 27, 28, 29, 31, 44, 67, 68, 71, 72, 73, 85, 87, 88 emissions shall not exceed the maximum levels specified in Tables 6.6.3.5.2.1-1 to 6.6.3.5.2.1-3:

Table 6.6.3.5.2.1-1: Wide Area BS operating band unwanted emission limits for 1.4 MHz channel bandwidth (E-UTRA bands <1GHz) for Category B

Frequency offset of measurement filter -3dB point, Δf	Frequency offset of measurement filter centre frequency, f_{offset}	Test requirement (Note 1, 2)	Measurement bandwidth (Note 6)
$0 \text{ MHz} \leq \Delta f < 1.4 \text{ MHz}$	$0.05 \text{ MHz} \leq f_{\text{offset}} < 1.45 \text{ MHz}$	$+0.5 \text{ dBm} - \frac{10}{1.4} \cdot \left(\frac{f_{\text{offset}}}{\text{MHz}} - 0.05 \right) \text{ dB}$	100 kHz
$1.4 \text{ MHz} \leq \Delta f < 2.8 \text{ MHz}$	$1.45 \text{ MHz} \leq f_{\text{offset}} < 2.85 \text{ MHz}$	-9.5 dBm	100 kHz
$2.8 \text{ MHz} \leq \Delta f \leq \Delta f_{\text{max}}$	$2.85 \text{ MHz} \leq f_{\text{offset}} < f_{\text{offset}_{\text{max}}}$	-16 dBm	100 kHz
NOTE 1: For a BS supporting non-contiguous spectrum operation within any operating band the test requirement within sub-block gaps is calculated as a cumulative sum of contributions from adjacent sub blocks on each side of the sub block gap. Exception is $\Delta f \geq 10\text{MHz}$ from both adjacent sub blocks on each side of the sub-block gap, where the test requirement within sub-block gaps shall be -16dBm/100kHz.			
NOTE 2: For BS supporting multi-band operation with Inter RF Bandwidth gap < 20MHz the test requirement within the Inter RF Bandwidth gaps is calculated as a cumulative sum of contributions from adjacent sub-blocks or RF Bandwidth on each side of the Inter RF Bandwidth gap.			

Table 6.6.3.5.2.1-2: Wide Area BS operating band unwanted emission limits for 3 MHz channel bandwidth (E-UTRA bands <1GHz) for Category B

Frequency offset of measurement filter -3dB point, Δf	Frequency offset of measurement filter centre frequency, f_{offset}	Test requirement (Note 1, 2)	Measurement bandwidth (Note 6)
$0 \text{ MHz} \leq \Delta f < 3 \text{ MHz}$	$0.05 \text{ MHz} \leq f_{\text{offset}} < 3.05 \text{ MHz}$	$-3.5 \text{ dBm} - \frac{10}{3} \cdot \left(\frac{f_{\text{offset}}}{\text{MHz}} - 0.05 \right) \text{ dB}$	100 kHz
$3 \text{ MHz} \leq \Delta f < 6 \text{ MHz}$	$3.05 \text{ MHz} \leq f_{\text{offset}} < 6.05 \text{ MHz}$	-13.5 dBm	100 kHz
$6 \text{ MHz} \leq \Delta f \leq \Delta f_{\text{max}}$	$6.05 \text{ MHz} \leq f_{\text{offset}} < f_{\text{offset}_{\text{max}}}$	-16 dBm	100 kHz
NOTE 1: For a BS supporting non-contiguous spectrum operation within any operating band the test requirement within sub-block gaps is calculated as a cumulative sum of contributions from adjacent sub blocks on each side of the sub block gap. Exception is $\Delta f \geq 10\text{MHz}$ from both adjacent sub blocks on each side of the sub-block gap, where the test requirement within sub-block gaps shall be -16dBm/100kHz.			
NOTE 2: For BS supporting multi-band operation with Inter RF Bandwidth gap < 20MHz the test requirement within the Inter RF Bandwidth gaps is calculated as a cumulative sum of contributions from adjacent sub-blocks or RF Bandwidth on each side of the Inter RF Bandwidth gap.			

Table 6.6.3.5.2.1-3: Wide Area BS operating band unwanted emission limits for 5, 10, 15 and 20 MHz channel bandwidth (E-UTRA bands <1GHz) for Category B

Frequency offset of measurement filter -3dB point, Δf	Frequency offset of measurement filter centre frequency, f_{offset}	Test requirement (Note 1, 2)	Measurement bandwidth (Note 6)
$0 \text{ MHz} \leq \Delta f < 5 \text{ MHz}$	$0.05 \text{ MHz} \leq f_{\text{offset}} < 5.05 \text{ MHz}$	$-5.5 \text{ dBm} - \frac{7}{5} \cdot \left(\frac{f_{\text{offset}}}{\text{MHz}} - 0.05 \right) \text{ dB}$	100 kHz
$5 \text{ MHz} \leq \Delta f < \min(10 \text{ MHz}, \Delta f_{\text{max}})$	$5.05 \text{ MHz} \leq f_{\text{offset}} < \min(10.05 \text{ MHz}, f_{\text{offset}_{\text{max}}})$	-12.5 dBm	100 kHz
$10 \text{ MHz} \leq \Delta f \leq \Delta f_{\text{max}}$	$10.05 \text{ MHz} \leq f_{\text{offset}} < f_{\text{offset}_{\text{max}}}$	-16 dBm (Note 9)	100 kHz
NOTE 1: For a BS supporting non-contiguous spectrum operation within any operating band the test requirement within sub-block gaps is calculated as a cumulative sum of contributions from adjacent sub blocks on each side of the sub block gap. Exception is $\Delta f \geq 10\text{MHz}$ from both adjacent sub blocks on each side of the sub-block gap, where the test requirement within sub-block gaps shall be -16dBm/100kHz.			
NOTE 2: For BS supporting multi-band operation with Inter RF Bandwidth gap < 20MHz the test requirement within the Inter RF Bandwidth gaps is calculated as a cumulative sum of contributions from adjacent sub-blocks or RF Bandwidth on each side of the Inter RF Bandwidth gap.			

For E-UTRA BS operating in Bands 1, 2, 3, 4, 7, 10, 25, 30, 33, 34, 35, 36, 37, 38, 39, 40, 41, 45, 48, 50, 65, 66, 69, 70, 75 emissions shall not exceed the maximum levels specified in Tables 6.6.3.5.2.1-4, 6.6.3.5.2.1-5 and 6.6.3.5.2.1-6:

For E-UTRA BS operating in Bands 22, 42, 43, 52, emissions shall not exceed the maximum levels specified in Tables 6.6.3.5.2.1-4a, 6.6.3.5.2.1-5a and 6.6.3.5.2.1-6a:

Table 6.6.3.5.2.1-4: Wide Area BS operating band unwanted emission limits for 1.4 MHz channel bandwidth (1GHz < E-UTRA bands ≤ 3GHz) for Category B

Frequency offset of measurement filter -3dB point, Δf	Frequency offset of measurement filter centre frequency, f_{offset}	Test requirement (Note 1, 2)	Measurement bandwidth (Note 6)
$0 \text{ MHz} \leq \Delta f < 1.4 \text{ MHz}$	$0.05 \text{ MHz} \leq f_{\text{offset}} < 1.45 \text{ MHz}$	$+0.5 \text{ dBm} - \frac{10}{1.4} \cdot \left(\frac{f_{\text{offset}}}{\text{MHz}} - 0.05 \right) \text{ dB}$	100 kHz
$1.4 \text{ MHz} \leq \Delta f < 2.8 \text{ MHz}$	$1.45 \text{ MHz} \leq f_{\text{offset}} < 2.85 \text{ MHz}$	-9.5 dBm	100 kHz
$2.8 \text{ MHz} \leq \Delta f \leq \Delta f_{\text{max}}$	$3.3 \text{ MHz} \leq f_{\text{offset}} < f_{\text{offset}_{\text{max}}}$	-15 dBm	1MHz
NOTE 1: For a BS supporting non-contiguous spectrum operation within any operating band the test requirement within sub-block gaps is calculated as a cumulative sum of contributions from adjacent sub blocks on each side of the sub block gap, where the contribution from the far-end sub-block shall be scaled according to the measurement bandwidth of the near-end sub-block. Exception is $\Delta f \geq 10\text{MHz}$ from both adjacent sub blocks on each side of the sub-block gap, where the test requirement within sub-block gaps shall be -15dBm/1MHz.			
NOTE 2: For BS supporting multi-band operation with Inter RF Bandwidth gap < 20MHz the test requirement within the Inter RF Bandwidth gaps is calculated as a cumulative sum of contributions from adjacent sub-blocks or RF Bandwidth on each side of the Inter RF Bandwidth gap, where the contribution from the far-end sub-block or RF Bandwidth shall be scaled according to the measurement bandwidth of the near-end sub-block or RF Bandwidth.			

Table 6.6.3.5.2.1-4a: Wide Area BS operating band unwanted emission limits for 1.4 MHz channel bandwidth (E-UTRA bands >3GHz) for Category B

Frequency offset of measurement filter -3dB point, Δf	Frequency offset of measurement filter centre frequency, f_{offset}	Test requirement (Note 1, 2)	Measurement bandwidth (Note 6)
$0 \text{ MHz} \leq \Delta f < 1.4 \text{ MHz}$	$0.05 \text{ MHz} \leq f_{\text{offset}} < 1.45 \text{ MHz}$	$+0.8 \text{ dBm} - \frac{10}{1.4} \cdot \left(\frac{f_{\text{offset}}}{\text{MHz}} - 0.05 \right) \text{ dB}$	100 kHz
$1.4 \text{ MHz} \leq \Delta f < 2.8 \text{ MHz}$	$1.45 \text{ MHz} \leq f_{\text{offset}} < 2.85 \text{ MHz}$	-9.2 dBm	100 kHz
$2.8 \text{ MHz} \leq \Delta f \leq \Delta f_{\text{max}}$	$3.3 \text{ MHz} \leq f_{\text{offset}} < f_{\text{offset}_{\text{max}}}$	-15 dBm	1MHz
<p>NOTE 1: For a BS supporting non-contiguous spectrum operation within any operating band the test requirement within sub-block gaps is calculated as a cumulative sum of contributions from adjacent sub blocks on each side of the sub block gap, where the contribution from the far-end sub-block shall be scaled according to the measurement bandwidth of the near-end sub-block. Exception is $\Delta f \geq 10\text{MHz}$ from both adjacent sub blocks on each side of the sub-block gap, where the test requirement within sub-block gaps shall be -15dBm/1MHz.</p> <p>NOTE 2: For BS supporting multi-band operation with Inter RF Bandwidth gap < 20MHz the test requirement within the Inter RF Bandwidth gaps is calculated as a cumulative sum of contributions from adjacent sub-blocks or RF Bandwidth on each side of the Inter RF Bandwidth gap, where the contribution from the far-end sub-block or RF Bandwidth shall be scaled according to the measurement bandwidth of the near-end sub-block or RF Bandwidth.</p>			

Table 6.6.3.5.2.1-5: Wide Area BS operating band unwanted emission limits for 3 MHz channel bandwidth (1GHz < E-UTRA bands \leq 3GHz) for Category B

Frequency offset of measurement filter -3dB point, Δf	Frequency offset of measurement filter centre frequency, f_{offset}	Test requirement (Note 1, 2)	Measurement bandwidth (Note 6)
$0 \text{ MHz} \leq \Delta f < 3 \text{ MHz}$	$0.05 \text{ MHz} \leq f_{\text{offset}} < 3.05 \text{ MHz}$	$-3.5 \text{ dBm} - \frac{10}{3} \cdot \left(\frac{f_{\text{offset}}}{\text{MHz}} - 0.05 \right) \text{ dB}$	100 kHz
$3 \text{ MHz} \leq \Delta f < 6 \text{ MHz}$	$3.05 \text{ MHz} \leq f_{\text{offset}} < 6.05 \text{ MHz}$	-13.5 dBm	100 kHz
$6 \text{ MHz} \leq \Delta f \leq \Delta f_{\text{max}}$	$6.5 \text{ MHz} \leq f_{\text{offset}} < f_{\text{offset}_{\text{max}}}$	-15 dBm	1MHz
<p>NOTE 1: For a BS supporting non-contiguous spectrum operation within any operating band the test requirement within sub-block gaps is calculated as a cumulative sum of contributions from adjacent sub blocks on each side of the sub block gap, where the contribution from the far-end sub-block shall be scaled according to the measurement bandwidth of the near-end sub-block. Exception is $\Delta f \geq 10\text{MHz}$ from both adjacent sub blocks on each side of the sub-block gap, where the test requirement within sub-block gaps shall be -15dBm/1MHz.</p> <p>NOTE 2: For BS supporting multi-band operation with Inter RF Bandwidth gap < 20MHz the test requirement within the Inter RF Bandwidth gaps is calculated as a cumulative sum of contributions from adjacent sub-blocks or RF Bandwidth on each side of the Inter RF Bandwidth gap, where the contribution from the far-end sub-block or RF Bandwidth shall be scaled according to the measurement bandwidth of the near-end sub-block or RF Bandwidth.</p>			

Table 6.6.3.5.2.1-5a: Wide Area BS operating band unwanted emission limits for 3 MHz channel bandwidth (E-UTRA bands >3GHz) for Category B

Frequency offset of measurement filter -3dB point, Δf	Frequency offset of measurement filter centre frequency, f_{offset}	Test requirement (Note 1, 2)	Measurement bandwidth (Note 6)
$0 \text{ MHz} \leq \Delta f < 3 \text{ MHz}$	$0.05 \text{ MHz} \leq f_{\text{offset}} < 3.05 \text{ MHz}$	$-3.2 \text{ dBm} - \frac{10}{3} \cdot \left(\frac{f_{\text{offset}}}{\text{MHz}} - 0.05 \right) \text{ dB}$	100 kHz
$3 \text{ MHz} \leq \Delta f < 6 \text{ MHz}$	$3.05 \text{ MHz} \leq f_{\text{offset}} < 6.05 \text{ MHz}$	-13.2 dBm	100 kHz
$6 \text{ MHz} \leq \Delta f \leq \Delta f_{\text{max}}$	$6.5 \text{ MHz} \leq f_{\text{offset}} < f_{\text{offset}_{\text{max}}}$	-15 dBm	1MHz
<p>NOTE 1: For a BS supporting non-contiguous spectrum operation within any operating band the test requirement within sub-block gaps is calculated as a cumulative sum of contributions from adjacent sub blocks on each side of the sub block gap, where the contribution from the far-end sub-block shall be scaled according to the measurement bandwidth of the near-end sub-block. Exception is $\Delta f \geq 10\text{MHz}$ from both adjacent sub blocks on each side of the sub-block gap, where the test requirement within sub-block gaps shall be -15dBm/1MHz.</p> <p>NOTE 2: For BS supporting multi-band operation with Inter RF Bandwidth gap < 20MHz the test requirement within the Inter RF Bandwidth gaps is calculated as a cumulative sum of contributions from adjacent sub-blocks or RF Bandwidth on each side of the Inter RF Bandwidth gap, where the contribution from the far-end sub-block or RF Bandwidth shall be scaled according to the measurement bandwidth of the near-end sub-block or RF Bandwidth.</p>			

Table 6.6.3.5.2.1-6: Wide Area BS operating band unwanted emission limits for 5, 10, 15 and 20 MHz channel bandwidth (1GHz < E-UTRA bands \leq 3GHz) for Category B

Frequency offset of measurement filter -3dB point, Δf	Frequency offset of measurement filter centre frequency, f_{offset}	Test requirement (Note 1, 2)	Measurement bandwidth (Note 6)
$0 \text{ MHz} \leq \Delta f < 5 \text{ MHz}$	$0.05 \text{ MHz} \leq f_{\text{offset}} < 5.05 \text{ MHz}$	$-5.5 \text{ dBm} - \frac{7}{5} \cdot \left(\frac{f_{\text{offset}}}{\text{MHz}} - 0.05 \right) \text{ dB}$	100 kHz
$5 \text{ MHz} \leq \Delta f < \min(10 \text{ MHz}, \Delta f_{\text{max}})$	$5.05 \text{ MHz} \leq f_{\text{offset}} < \min(10.05 \text{ MHz}, f_{\text{offset}_{\text{max}}})$	-12.5 dBm	100 kHz
$10 \text{ MHz} \leq \Delta f \leq \Delta f_{\text{max}}$	$10.5 \text{ MHz} \leq f_{\text{offset}} < f_{\text{offset}_{\text{max}}}$	-15 dBm (Note 9)	1MHz
<p>NOTE 1: For a BS supporting non-contiguous spectrum operation within any operating band the test requirement within sub-block gaps is calculated as a cumulative sum of contributions from adjacent sub blocks on each side of the sub block gap, where the contribution from the far-end sub-block shall be scaled according to the measurement bandwidth of the near-end sub-block. Exception is $\Delta f \geq 10\text{MHz}$ from both adjacent sub blocks on each side of the sub-block gap, where the test requirement within sub-block gaps shall be -15dBm/1MHz.</p> <p>NOTE 2: For BS supporting multi-band operation with Inter RF Bandwidth gap < 20MHz the test requirement within the Inter RF Bandwidth gaps is calculated as a cumulative sum of contributions from adjacent sub-blocks or RF Bandwidth on each side of the Inter RF Bandwidth gap, where the contribution from the far-end sub-block or RF Bandwidth shall be scaled according to the measurement bandwidth of the near-end sub-block or RF Bandwidth.</p>			

Table 6.6.3.5.2.1-6a: Wide Area BS operating band unwanted emission limits for 5, 10, 15 and 20 MHz channel bandwidth (E-UTRA bands >3GHz) for Category B

Frequency offset of measurement filter -3dB point, Δf	Frequency offset of measurement filter centre frequency, f_{offset}	Test requirement (Note 1, 2)	Measurement bandwidth (Note 6)
$0 \text{ MHz} \leq \Delta f < 5 \text{ MHz}$	$0.05 \text{ MHz} \leq f_{\text{offset}} < 5.05 \text{ MHz}$	$-5.2 \text{ dBm} - \frac{7}{5} \left(\frac{f_{\text{offset}}}{\text{MHz}} - 0.05 \right) \text{ dB}$	100 kHz
$5 \text{ MHz} \leq \Delta f < \min(10 \text{ MHz}, \Delta f_{\text{max}})$	$5.05 \text{ MHz} \leq f_{\text{offset}} < \min(10.05 \text{ MHz}, f_{\text{offset,max}})$	-12.2 dBm	100 kHz
$10 \text{ MHz} \leq \Delta f \leq \Delta f_{\text{max}}$	$10.5 \text{ MHz} \leq f_{\text{offset}} < f_{\text{offset,max}}$	-15 dBm (Note 9)	1MHz
<p>NOTE 1: For a BS supporting non-contiguous spectrum operation within any operating band the test requirement within sub-block gaps is calculated as a cumulative sum of contributions from adjacent sub blocks on each side of the sub block gap, where the contribution from the far-end sub-block shall be scaled according to the measurement bandwidth of the near-end sub-block. Exception is $\Delta f \geq 10\text{MHz}$ from both adjacent sub blocks on each side of the sub-block gap, where the test requirement within sub-block gaps shall be -15dBm/1MHz.</p> <p>NOTE 2: For BS supporting multi-band operation with Inter RF Bandwidth gap < 20MHz the test requirement within the Inter RF Bandwidth gaps is calculated as a cumulative sum of contributions from adjacent sub-blocks or RF Bandwidth on each side of the Inter RF Bandwidth gap, where the contribution from the far-end sub-block or RF Bandwidth shall be scaled according to the measurement bandwidth of the near-end sub-block or RF Bandwidth.</p>			

6.6.3.5.2.2 Category B (Option 2)

The limits in this subclause are intended for Europe and may be applied regionally for BS operating in band 1, 3, 7, 8, 32, 33, 34, 38, 65 or 69.

For a BS operating in band 1, 3, 7, 8, 32, 33, 34, 38, 65 or 69, emissions shall not exceed the maximum levels specified in Table 6.6.3.5.2.2-1 below for 5, 10, 15 and 20 MHz channel bandwidth:

Table 6.6.3.5.2.2-1: Regional Wide Area BS operating band unwanted emission limits in band 1, 3, 7, 8, 32, 33, 34, 38, 65 or 69 for 5, 10, 15 and 20 MHz channel bandwidth for Category B

Frequency offset of measurement filter -3dB point, Δf	Frequency offset of measurement filter centre frequency, f_{offset}	Test requirement (Note 1, 2)	Measurement bandwidth (Note 6)
$0 \text{ MHz} \leq \Delta f < 0.2 \text{ MHz}$	$0.015 \text{ MHz} \leq f_{\text{offset}} < 0.215 \text{ MHz}$	-12.5dBm	30 kHz
$0.2 \text{ MHz} \leq \Delta f < 1 \text{ MHz}$	$0.215 \text{ MHz} \leq f_{\text{offset}} < 1.015 \text{ MHz}$	$-12.5 \text{ dBm} - 15 \cdot \left(\frac{f_{\text{offset}}}{\text{MHz}} - 0.215 \right) \text{ dB}$ (Note 3)	30 kHz
(Note 8)	$1.015 \text{ MHz} \leq f_{\text{offset}} < 1.5 \text{ MHz}$	-24.5dBm (Note 3)	30 kHz
$1 \text{ MHz} \leq \Delta f \leq \min(10 \text{ MHz}, \Delta f_{\text{max}})$	$1.5 \text{ MHz} \leq f_{\text{offset}} < \min(10.5 \text{ MHz}, f_{\text{offset}_{\text{max}}})$	-11.5dBm (Note 3)	1 MHz
$10 \text{ MHz} \leq \Delta f \leq \Delta f_{\text{max}}$	$10.5 \text{ MHz} \leq f_{\text{offset}} < f_{\text{offset}_{\text{max}}}$	-15 dBm (Note 3) (Note 9)	1 MHz
<p>NOTE 1: For a BS supporting non-contiguous spectrum operation within any operating band the test requirement within sub-block gaps is calculated as a cumulative sum of contributions from adjacent sub blocks on each side of the sub block gap, where the contribution from the far-end sub-block shall be scaled according to the measurement bandwidth of the near-end sub-block. Exception is $\Delta f \geq 10 \text{ MHz}$ from both adjacent sub blocks on each side of the sub-block gap, where the test requirement within sub-block gaps shall be -15dBm/1MHz. For BS supporting multi-band operation, either this limit or -16dBm/100kHz (f_{offset} adjusted according to the measurement bandwidth), whichever is less stringent, shall apply at $\Delta f \geq 10 \text{ MHz}$ for operating bands <1GHz.</p> <p>NOTE 2: For BS supporting multi-band operation with Inter RF Bandwidth gap < 20MHz the test requirement within the Inter RF Bandwidth gaps is calculated as a cumulative sum of contributions from adjacent sub-blocks or RF Bandwidth on each side of the Inter RF Bandwidth gap, where the contribution from the far-end sub-block or RF Bandwidth shall be scaled according to the measurement bandwidth of the near-end sub-block or RF Bandwidth.</p> <p>NOTE 3: For BS supporting multi-band operation, either this limit or -16dBm/100kHz (f_{offset} adjusted according to the measurement bandwidth), whichever is less stringent, shall apply for operating bands <1GHz.</p>			

For a BS operating in band 3, 8 or 65, emissions shall not exceed the maximum levels specified in Table 6.6.3.5.2.2-2 below for 3 MHz channel bandwidth:

Table 6.6.3.5.2.2-2: Regional Wide Area BS operating band unwanted emission limits in band 3, 8 or 65 for 3 MHz channel bandwidth for Category B

Frequency offset of measurement filter -3dB point, Δf	Frequency offset of measurement filter centre frequency, f_{offset}	Test requirement (Note 1, 2)	Measurement bandwidth (Note 6)
$0 \text{ MHz} \leq \Delta f < 0.05 \text{ MHz}$	$0.015 \text{ MHz} \leq f_{\text{offset}} < 0.065 \text{ MHz}$	$6.5 \text{ dBm} - 60 \cdot \left(\frac{f_{\text{offset}}}{\text{MHz}} - 0.015 \right) \text{ dB}$	30 kHz
$0.05 \text{ MHz} \leq \Delta f < 0.15 \text{ MHz}$	$0.065 \text{ MHz} \leq f_{\text{offset}} < 0.165 \text{ MHz}$	$3.5 \text{ dBm} - 160 \cdot \left(\frac{f_{\text{offset}}}{\text{MHz}} - 0.065 \right) \text{ dB}$	30 kHz
$0.15 \text{ MHz} \leq \Delta f < 0.2 \text{ MHz}$	$0.165 \text{ MHz} \leq f_{\text{offset}} < 0.215 \text{ MHz}$	-12.5dBm	30 kHz
$0.2 \text{ MHz} \leq \Delta f < 1 \text{ MHz}$	$0.215 \text{ MHz} \leq f_{\text{offset}} < 1.015 \text{ MHz}$	$-12.5 \text{ dBm} - 15 \cdot \left(\frac{f_{\text{offset}}}{\text{MHz}} - 0.215 \right) \text{ dB}$	30 kHz
(Note 8)	$1.015 \text{ MHz} \leq f_{\text{offset}} < 1.5 \text{ MHz}$	-24.5dBm	30 kHz
$1 \text{ MHz} \leq \Delta f \leq 6 \text{ MHz}$	$1.5 \text{ MHz} \leq f_{\text{offset}} < 6.5 \text{ MHz}$,	-11.5dBm	1 MHz
$6 \text{ MHz} \leq \Delta f \leq \Delta f_{\text{max}}$	$6.5 \text{ MHz} \leq f_{\text{offset}} < f_{\text{offset}_{\text{max}}}$	-15 dBm	1 MHz
<p>NOTE 1: For a BS supporting non-contiguous spectrum operation within any operating band the test requirement within sub-block gaps is calculated as a cumulative sum of contributions from adjacent sub blocks on each side of the sub block gap, where the contribution from the far-end sub-block shall be scaled according to the measurement bandwidth of the near-end sub-block. Exception is $\Delta f \geq 10 \text{ MHz}$ from both adjacent sub blocks on each side of the sub-block gap, where the test requirement within sub-block gaps shall be -15dBm/1MHz.</p> <p>NOTE 2: For BS supporting multi-band operation with Inter RF Bandwidth gap < 20MHz the test requirement within the Inter RF Bandwidth gaps is calculated as a cumulative sum of contributions from adjacent sub-blocks or RF Bandwidth on each side of the Inter RF Bandwidth gap, where the contribution from the far-end sub-block or RF Bandwidth shall be scaled according to the measurement bandwidth of the near-end sub-block or RF Bandwidth.</p>			

For a BS operating in band 3, 8 or 65, emissions shall not exceed the maximum levels specified in Table 6.6.3.5.2.2-3 below for 1.4 MHz channel bandwidth:

Table 6.6.3.5.2.2-3: Regional Wide Area BS operating band unwanted emission limits in band 3, 8 or 65 for 1.4 MHz channel bandwidth for Category B

Frequency offset of measurement filter -3dB point, Δf	Frequency offset of measurement filter centre frequency, f_{offset}	Test requirement (Note 1, 2)	Measurement bandwidth (Note 6)
$0 \text{ MHz} \leq \Delta f < 0.05 \text{ MHz}$	$0.015 \text{ MHz} \leq f_{\text{offset}} < 0.065 \text{ MHz}$	$6.5 \text{ dBm} - 60 \cdot \left(\frac{f_{\text{offset}}}{\text{MHz}} - 0.015 \right) \text{ dB}$	30 kHz
$0.05 \text{ MHz} \leq \Delta f < 0.15 \text{ MHz}$	$0.065 \text{ MHz} \leq f_{\text{offset}} < 0.165 \text{ MHz}$	$3.5 \text{ dBm} - 160 \cdot \left(\frac{f_{\text{offset}}}{\text{MHz}} - 0.065 \right) \text{ dB}$	30 kHz
$0.15 \text{ MHz} \leq \Delta f < 0.2 \text{ MHz}$	$0.165 \text{ MHz} \leq f_{\text{offset}} < 0.215 \text{ MHz}$	-12.5 dBm	30 kHz
$0.2 \text{ MHz} \leq \Delta f < 1 \text{ MHz}$	$0.215 \text{ MHz} \leq f_{\text{offset}} < 1.015 \text{ MHz}$	$-12.5 \text{ dBm} - 15 \cdot \left(\frac{f_{\text{offset}}}{\text{MHz}} - 0.215 \right)$ (Note 3)	30 kHz
(Note 8)	$1.015 \text{ MHz} \leq f_{\text{offset}} < 1.5 \text{ MHz}$	-24.5 dBm (Note 3)	30 kHz
$1 \text{ MHz} \leq \Delta f \leq 2.8 \text{ MHz}$	$1.5 \text{ MHz} \leq f_{\text{offset}} < 3.3 \text{ MHz}$	-11.5 dBm (Note 3)	1 MHz
$2.8 \text{ MHz} \leq \Delta f \leq \Delta f_{\text{max}}$	$3.3 \text{ MHz} \leq f_{\text{offset}} < f_{\text{offset}_{\text{max}}}$	-15 dBm (Note 3)	1 MHz
<p>NOTE 1: For a BS supporting non-contiguous spectrum operation within any operating band the test requirement within sub-block gaps is calculated as a cumulative sum of contributions from adjacent sub blocks on each side of the sub block gap, where the contribution from the far-end sub-block shall be scaled according to the measurement bandwidth of the near-end sub-block. Exception is $\Delta f \geq 10 \text{ MHz}$ from both adjacent sub blocks on each side of the sub-block gap, where the test requirement within sub-block gaps shall be -15dBm/1MHz. For BS supporting multi-band operation, either this limit or -16dBm/100kHz (f_{offset} adjusted according to the measurement bandwidth), whichever is less stringent, shall apply at $\Delta f \geq 10 \text{ MHz}$ for operating bands <1GHz.</p> <p>NOTE 2: For BS supporting multi-band operation with Inter RF Bandwidth gap < 20MHz the test requirement within the Inter RF Bandwidth gaps is calculated as a cumulative sum of contributions from adjacent sub-blocks or RF Bandwidth on each side of the Inter RF Bandwidth gap, where the contribution from the far-end sub-block or RF Bandwidth shall be scaled according to the measurement bandwidth of the near-end sub-block or RF Bandwidth.</p> <p>NOTE 3: For BS supporting multi-band operation, either this limit or -16dBm/100kHz (f_{offset} adjusted according to the measurement bandwidth), whichever is less stringent, shall apply for operating bands <1GHz.</p>			

6.6.3.5.2A Test requirements for Local Area BS (Category A and B)

For Local Area BS in E-UTRA bands $\leq 3 \text{ GHz}$, emissions shall not exceed the maximum levels specified in Tables 6.6.3.5.2A-1, 6.6.3.5.2A-2 and 6.6.3.5.2A-3.

For Local Area BS in E-UTRA bands $> 3 \text{ GHz}$, emissions shall not exceed the maximum levels specified in Tables 6.6.3.5.2A-1a, 6.6.3.5.2A-2a and 6.6.3.5.2A-3a.

Table 6.6.3.5.2A-1: Local Area BS operating band unwanted emission limits for 1.4 MHz channel bandwidth (E-UTRA bands ≤3GHz)

Frequency offset of measurement filter -3dB point, Δf	Frequency offset of measurement filter centre frequency, f_{offset}	Test requirement (Note 1, 2)	Measurement bandwidth (Note 6)
$0 \text{ MHz} \leq \Delta f < 1.4 \text{ MHz}$	$0.05 \text{ MHz} \leq f_{\text{offset}} < 1.45 \text{ MHz}$	$-19.5 \text{ dBm} - \frac{10}{1.4} \left(\frac{f_{\text{offset}}}{\text{MHz}} - 0.05 \right) \text{ dB}$	100 kHz
$1.4 \text{ MHz} \leq \Delta f < 2.8 \text{ MHz}$	$1.45 \text{ MHz} \leq f_{\text{offset}} < 2.85 \text{ MHz}$	-29.5 dBm	100 kHz
$2.8 \text{ MHz} \leq \Delta f \leq \Delta f_{\text{max}}$	$2.85 \text{ MHz} \leq f_{\text{offset}} < f_{\text{offset}_{\text{max}}}$	-31 dBm	100 kHz
NOTE 1: For a BS supporting non-contiguous spectrum operation within any operating band the test requirement within sub-block gaps is calculated as a cumulative sum of contributions from adjacent sub blocks on each side of the sub block gap. Exception is $\Delta f \geq 10\text{MHz}$ from both adjacent sub blocks on each side of the sub-block gap, where the test requirement within sub-block gaps shall be -31 dBm/100 kHz.			
NOTE 2: For BS supporting multi-band operation with Inter RF Bandwidth gap < 20MHz the test requirement within the Inter RF Bandwidth gaps is calculated as a cumulative sum of contributions from adjacent sub-blocks or RF Bandwidth on each side of the Inter RF Bandwidth gap.			

Table 6.6.3.5.2A-1a: Local Area BS operating band unwanted emission limits for 1.4 MHz channel bandwidth (E-UTRA bands >3GHz)

Frequency offset of measurement filter -3dB point, Δf	Frequency offset of measurement filter centre frequency, f_{offset}	Test requirement (Note 1, 2)	Measurement bandwidth (Note 6)
$0 \text{ MHz} \leq \Delta f < 1.4 \text{ MHz}$	$0.05 \text{ MHz} \leq f_{\text{offset}} < 1.45 \text{ MHz}$	$-19.2 \text{ dBm} - \frac{10}{1.4} \left(\frac{f_{\text{offset}}}{\text{MHz}} - 0.05 \right) \text{ dB}$	100 kHz
$1.4 \text{ MHz} \leq \Delta f < 2.8 \text{ MHz}$	$1.45 \text{ MHz} \leq f_{\text{offset}} < 2.85 \text{ MHz}$	-29.2 dBm	100 kHz
$2.8 \text{ MHz} \leq \Delta f \leq \Delta f_{\text{max}}$	$2.85 \text{ MHz} \leq f_{\text{offset}} < f_{\text{offset}_{\text{max}}}$	-31 dBm	100 kHz
NOTE 1: For a BS supporting non-contiguous spectrum operation within any operating band the test requirement within sub-block gaps is calculated as a cumulative sum of contributions from adjacent sub blocks on each side of the sub block gap. Exception is $\Delta f \geq 10\text{MHz}$ from both adjacent sub blocks on each side of the sub-block gap, where the test requirement within sub-block gaps shall be -31 dBm/100 kHz.			
NOTE 2: For BS supporting multi-band operation with Inter RF Bandwidth gap < 20MHz the test requirement within the Inter RF Bandwidth gaps is calculated as a cumulative sum of contributions from adjacent sub-blocks or RF Bandwidth on each side of the Inter RF Bandwidth gap.			

Table 6.6.3.5.2A-2: Local Area BS operating band unwanted emission limits for 3 MHz channel bandwidth (E-UTRA bands ≤3GHz)

Frequency offset of measurement filter -3dB point, Δf	Frequency offset of measurement filter centre frequency, f_{offset}	Test requirement (Note 1, 2)	Measurement bandwidth (Note 6)
$0 \text{ MHz} \leq \Delta f < 3 \text{ MHz}$	$0.05 \text{ MHz} \leq f_{\text{offset}} < 3.05 \text{ MHz}$	$-23.5 \text{ dBm} - \frac{10}{3} \left(\frac{f_{\text{offset}}}{\text{MHz}} - 0.05 \right) \text{ dB}$	100 kHz
$3 \text{ MHz} \leq \Delta f < 6 \text{ MHz}$	$3.05 \text{ MHz} \leq f_{\text{offset}} < 6.05 \text{ MHz}$	-33.5 dBm	100 kHz
$6 \text{ MHz} \leq \Delta f \leq \Delta f_{\text{max}}$	$6.05 \text{ MHz} \leq f_{\text{offset}} < f_{\text{offset}_{\text{max}}}$	-35 dBm	100 kHz
NOTE 1: For a BS supporting non-contiguous spectrum operation within any operating band the test requirement within sub-block gaps is calculated as a cumulative sum of contributions from adjacent sub blocks on each side of the sub block gap. Exception is $\Delta f \geq 10\text{MHz}$ from both adjacent sub blocks on each side of the sub-block gap, where the test requirement within sub-block gaps shall be -35 dBm/100 kHz.			
NOTE 2: For BS supporting multi-band operation with Inter RF Bandwidth gap < 20MHz the test requirement within the Inter RF Bandwidth gaps is calculated as a cumulative sum of contributions from adjacent sub-blocks or RF Bandwidth on each side of the Inter RF Bandwidth gap.			

Table 6.6.3.5.2A-2a: Local Area BS operating band unwanted emission limits for 3 MHz channel bandwidth (E-UTRA bands >3GHz)

Frequency offset of measurement filter -3dB point, Δf	Frequency offset of measurement filter centre frequency, f_{offset}	Test requirement (Note 1, 2)	Measurement bandwidth (Note 6)
$0 \text{ MHz} \leq \Delta f < 3 \text{ MHz}$	$0.05 \text{ MHz} \leq f_{\text{offset}} < 3.05 \text{ MHz}$	$-23.2 \text{ dBm} - \frac{10}{3} \left(\frac{f_{\text{offset}}}{\text{MHz}} - 0.05 \right) \text{ dB}$	100 kHz
$3 \text{ MHz} \leq \Delta f < 6 \text{ MHz}$	$3.05 \text{ MHz} \leq f_{\text{offset}} < 6.05 \text{ MHz}$	-33.2 dBm	100 kHz
$6 \text{ MHz} \leq \Delta f \leq \Delta f_{\text{max}}$	$6.05 \text{ MHz} \leq f_{\text{offset}} < f_{\text{offset}_{\text{max}}}$	-35 dBm	100 kHz
NOTE 1: For a BS supporting non-contiguous spectrum operation within any operating band the test requirement within sub-block gaps is calculated as a cumulative sum of contributions from adjacent sub blocks on each side of the sub block gap. Exception is $\Delta f \geq 10 \text{ MHz}$ from both adjacent sub blocks on each side of the sub-block gap, where the test requirement within sub-block gaps shall be -35 dBm/100 kHz.			
NOTE 2: For BS supporting multi-band operation with Inter RF Bandwidth gap < 20MHz the test requirement within the Inter RF Bandwidth gaps is calculated as a cumulative sum of contributions from adjacent sub-blocks or RF Bandwidth on each side of the Inter RF Bandwidth gap.			

Table 6.6.3.5.2A-3: Local Area BS operating band unwanted emission limits for 5, 10, 15 and 20 MHz channel bandwidth (E-UTRA bands $\leq 3 \text{ GHz}$)

Frequency offset of measurement filter -3dB point, Δf	Frequency offset of measurement filter centre frequency, f_{offset}	Test requirement (Note 1, 2)	Measurement bandwidth (Note 6)
$0 \text{ MHz} \leq \Delta f < 5 \text{ MHz}$	$0.05 \text{ MHz} \leq f_{\text{offset}} < 5.05 \text{ MHz}$	$-28.5 \text{ dBm} - \frac{7}{5} \left(\frac{f_{\text{offset}}}{\text{MHz}} - 0.05 \right) \text{ dB}$	100 kHz
$5 \text{ MHz} \leq \Delta f < \min(10 \text{ MHz}, \Delta f_{\text{max}})$	$5.05 \text{ MHz} \leq f_{\text{offset}} < \min(10.05 \text{ MHz}, f_{\text{offset}_{\text{max}}})$	-35.5 dBm	100 kHz
$10 \text{ MHz} \leq \Delta f \leq \Delta f_{\text{max}}$	$10.05 \text{ MHz} \leq f_{\text{offset}} < f_{\text{offset}_{\text{max}}}$	-37 dBm (Note 9)	100 kHz
NOTE 1: For a BS supporting non-contiguous spectrum operation within any operating band the test requirement within sub-block gaps is calculated as a cumulative sum of contributions from adjacent sub blocks on each side of the sub block gap. Exception is $\Delta f \geq 10 \text{ MHz}$ from both adjacent sub blocks on each side of the sub-block gap, where the test requirement within sub-block gaps shall be -37 dBm/100 kHz.			
NOTE 2: For BS supporting multi-band operation with Inter RF Bandwidth gap < 20MHz the test requirement within the Inter RF Bandwidth gaps is calculated as a cumulative sum of contributions from adjacent sub-blocks or RF Bandwidth on each side of the Inter RF Bandwidth gap.			

Table 6.6.3.5.2A-3a: Local Area BS operating band unwanted emission limits for 5, 10, 15 and 20 MHz channel bandwidth (E-UTRA bands >3GHz)

Frequency offset of measurement filter -3dB point, Δf	Frequency offset of measurement filter centre frequency, f_{offset}	Test requirement (Note 1, 2)	Measurement bandwidth (Note 6)
$0 \text{ MHz} \leq \Delta f < 5 \text{ MHz}$	$0.05 \text{ MHz} \leq f_{\text{offset}} < 5.05 \text{ MHz}$	$-28.2 \text{ dBm} - \frac{7}{5} \left(\frac{f_{\text{offset}}}{\text{MHz}} - 0.05 \right) \text{ dB}$	100 kHz
$5 \text{ MHz} \leq \Delta f < \min(10 \text{ MHz}, \Delta f_{\text{max}})$	$5.05 \text{ MHz} \leq f_{\text{offset}} < \min(10.05 \text{ MHz}, f_{\text{offset}_{\text{max}}})$	-35.2 dBm	100 kHz
$10 \text{ MHz} \leq \Delta f \leq \Delta f_{\text{max}}$	$10.05 \text{ MHz} \leq f_{\text{offset}} < f_{\text{offset}_{\text{max}}}$	-37 dBm (Note 9)	100 kHz
NOTE 1: For a BS supporting non-contiguous spectrum operation within any operating band the test requirement within sub-block gaps is calculated as a cumulative sum of contributions from adjacent sub blocks on each side of the sub block gap. Exception is $\Delta f \geq 10 \text{ MHz}$ from both adjacent sub blocks on each side of the sub-block gap, where the test requirement within sub-block gaps shall be -37 dBm/100 kHz.			
NOTE 2: For BS supporting multi-band operation with Inter RF Bandwidth gap < 20MHz the test requirement within the Inter RF Bandwidth gaps is calculated as a cumulative sum of contributions from adjacent sub-blocks or RF Bandwidth on each side of the Inter RF Bandwidth gap.			

6.6.3.5.2B Test requirements for Home BS (Category A and B)

For Home BS in E-UTRA bands ≤ 3 GHz, emissions shall not exceed the maximum levels specified in Tables 6.6.3.5.2B-1, 6.6.3.5.2B-2 and 6.6.3.5.2B-3.

For Home BS in E-UTRA bands > 3 GHz, emissions shall not exceed the maximum levels specified in Tables 6.6.3.5.2B-1a, 6.6.3.5.2B-2a and 6.6.3.5.2B-3a.

Table 6.6.3.5.2B-1: Home BS operating band unwanted emission limits for 1.4 MHz channel bandwidth (E-UTRA bands ≤ 3 GHz)

Frequency offset of measurement filter -3dB point, Δf	Frequency offset of measurement filter centre frequency, f_{offset}	Test requirement	Measurement bandwidth (Note 6)
$0 \text{ MHz} \leq \Delta f < 1.4 \text{ MHz}$	$0.05 \text{ MHz} \leq f_{\text{offset}} < 1.45 \text{ MHz}$	$-28.5 \text{ dBm} + \frac{6}{1.4} \left(\frac{f_{\text{offset}}}{\text{MHz}} - 0.05 \right) \text{ dB}$	100 kHz
$1.4 \text{ MHz} \leq \Delta f < 2.8 \text{ MHz}$	$1.45 \text{ MHz} \leq f_{\text{offset}} < 2.85 \text{ MHz}$	-34.5 dBm	100 kHz
$2.8 \text{ MHz} \leq \Delta f \leq \Delta f_{\text{max}}$	$3.3 \text{ MHz} \leq f_{\text{offset}} < f_{\text{offset}_{\text{max}}}$	$\begin{cases} P - 52 \text{ dB}, 2 \text{ dBm} \leq P \leq 20 \text{ dBm} \\ -50 \text{ dBm}, P < 2 \text{ dBm} \end{cases}$	1 MHz

Table 6.6.3.5.2B-1a: Home BS operating band unwanted emission limits for 1.4 MHz channel bandwidth (E-UTRA bands > 3 GHz)

Frequency offset of measurement filter -3dB point, Δf	Frequency offset of measurement filter centre frequency, f_{offset}	Test requirement	Measurement bandwidth (Note 6)
$0 \text{ MHz} \leq \Delta f < 1.4 \text{ MHz}$	$0.05 \text{ MHz} \leq f_{\text{offset}} < 1.45 \text{ MHz}$	$-28.2 \text{ dBm} - \frac{6}{1.4} \left(\frac{f_{\text{offset}}}{\text{MHz}} - 0.05 \right) \text{ dB}$	100 kHz
$1.4 \text{ MHz} \leq \Delta f < 2.8 \text{ MHz}$	$1.45 \text{ MHz} \leq f_{\text{offset}} < 2.85 \text{ MHz}$	-34.2 dBm	100 kHz
$2.8 \text{ MHz} \leq \Delta f \leq \Delta f_{\text{max}}$	$3.3 \text{ MHz} \leq f_{\text{offset}} < f_{\text{offset}_{\text{max}}}$	$\begin{cases} P - 52 \text{ dB}, 2 \text{ dBm} \leq P \leq 20 \text{ dBm} \\ -50 \text{ dBm}, P < 2 \text{ dBm} \end{cases}$	1 MHz

Table 6.6.3.5.2B-2: Home BS operating band unwanted emission limits for 3 MHz channel bandwidth (E-UTRA bands ≤ 3 GHz)

Frequency offset of measurement filter -3dB point, Δf	Frequency offset of measurement filter centre frequency, f_{offset}	Test requirement	Measurement bandwidth (Note 6)
$0 \text{ MHz} \leq \Delta f < 3 \text{ MHz}$	$0.05 \text{ MHz} \leq f_{\text{offset}} < 3.05 \text{ MHz}$	$-32.5 \text{ dBm} - 2 \left(\frac{f_{\text{offset}}}{\text{MHz}} - 0.05 \right) \text{ dB}$	100 kHz
$3 \text{ MHz} \leq \Delta f < 6 \text{ MHz}$	$3.05 \text{ MHz} \leq f_{\text{offset}} < 6.05 \text{ MHz}$	-38.5 dBm	100 kHz
$6 \text{ MHz} \leq \Delta f \leq \Delta f_{\text{max}}$	$6.5 \text{ MHz} \leq f_{\text{offset}} < f_{\text{offset}_{\text{max}}}$	$\begin{cases} P - 52 \text{ dB}, 2 \text{ dBm} \leq P \leq 20 \text{ dBm} \\ -50 \text{ dBm}, P < 2 \text{ dBm} \end{cases}$	1 MHz

Table 6.6.3.5.2B-2a: Home BS operating band unwanted emission limits for 3 MHz channel bandwidth (E-UTRA bands >3GHz)

Frequency offset of measurement filter -3dB point, Δf	Frequency offset of measurement filter centre frequency, f_{offset}	Test requirement	Measurement bandwidth (Note 6)
$0 \text{ MHz} \leq \Delta f < 3 \text{ MHz}$	$0.05 \text{ MHz} \leq f_{\text{offset}} < 3.05 \text{ MHz}$	$-32.2 \text{ dBm} - 2 \cdot \left(\frac{f_{\text{offset}}}{\text{MHz}} - 0.05 \right) \text{ dB}$	100 kHz
$3 \text{ MHz} \leq \Delta f < 6 \text{ MHz}$	$3.05 \text{ MHz} \leq f_{\text{offset}} < 6.05 \text{ MHz}$	-38.2 dBm	100 kHz
$6 \text{ MHz} \leq \Delta f \leq \Delta f_{\text{max}}$	$6.5 \text{ MHz} \leq f_{\text{offset}} < f_{\text{offset}_{\text{max}}}$	$\begin{cases} P - 52 \text{ dB}, 2 \text{ dBm} \leq P \leq 20 \text{ dBm} \\ -50 \text{ dBm}, P < 2 \text{ dBm} \end{cases}$	1 MHz

Table 6.6.3.5.2B-3: Home BS operating band unwanted emission limits for 5, 10, 15 and 20 MHz channel bandwidth (E-UTRA bands ≤ 3 GHz)

Frequency offset of measurement filter -3dB point, Δf	Frequency offset of measurement filter centre frequency, f_{offset}	Test requirement	Measurement bandwidth (Note 6)
$0 \text{ MHz} \leq \Delta f < 5 \text{ MHz}$	$0.05 \text{ MHz} \leq f_{\text{offset}} < 5.05 \text{ MHz}$	$-34.5 \text{ dBm} - \frac{6}{5} \left(\frac{f_{\text{offset}}}{\text{MHz}} - 0.05 \right) \text{ dB}$	100 kHz
$5 \text{ MHz} \leq \Delta f < \min(10 \text{ MHz}, \Delta f_{\text{max}})$	$5.05 \text{ MHz} \leq f_{\text{offset}} < \min(10.05 \text{ MHz}, f_{\text{offset}_{\text{max}}})$	-40.5 dBm	100 kHz
$10 \text{ MHz} \leq \Delta f \leq \Delta f_{\text{max}}$	$10.5 \text{ MHz} \leq f_{\text{offset}} < f_{\text{offset}_{\text{max}}}$	$\begin{cases} P - 52 \text{ dB}, 2 \text{ dBm} \leq P \leq 20 \text{ dBm} \\ -50 \text{ dBm}, P < 2 \text{ dBm} \end{cases}$ (Note 9)	1 MHz

Table 6.6.3.5.2B-3a: Home BS operating band unwanted emission limits for 5, 10, 15 and 20 MHz channel bandwidth (E-UTRA bands >3GHz)

Frequency offset of measurement filter -3dB point, Δf	Frequency offset of measurement filter centre frequency, f_{offset}	Test requirement	Measurement bandwidth (Note 6)
$0 \text{ MHz} \leq \Delta f < 5 \text{ MHz}$	$0.05 \text{ MHz} \leq f_{\text{offset}} < 5.05 \text{ MHz}$	$-34.2 \text{ dBm} - \frac{6}{5} \left(\frac{f_{\text{offset}}}{\text{MHz}} - 0.05 \right) \text{ dB}$	100 kHz
$5 \text{ MHz} \leq \Delta f < \min(10 \text{ MHz}, \Delta f_{\text{max}})$	$5.05 \text{ MHz} \leq f_{\text{offset}} < \min(10.05 \text{ MHz}, f_{\text{offset}_{\text{max}}})$	-40.2 dBm	100 kHz
$10 \text{ MHz} \leq \Delta f \leq \Delta f_{\text{max}}$	$10.5 \text{ MHz} \leq f_{\text{offset}} < f_{\text{offset}_{\text{max}}}$	$\begin{cases} P - 52 \text{ dB}, 2 \text{ dBm} \leq P \leq 20 \text{ dBm} \\ -50 \text{ dBm}, P < 2 \text{ dBm} \end{cases}$ (Note 9)	1 MHz

6.6.3.5.2C Test requirements for Medium Range BS (Category A and B)

For Medium Range BS in E-UTRA bands ≤ 3 GHz, emissions shall not exceed the maximum levels specified in Tables 6.6.3.5.2C-1, 6.6.3.5.2C-2, 6.6.3.5.2C-3, 6.6.3.5.2C-4, 6.6.3.5.2C-5 and 6.6.3.5.2C-6.

For Medium Range BS in E-UTRA bands >3GHz, emissions shall not exceed the maximum levels specified in Tables 6.6.3.5.2C-1a, 6.6.3.5.2C-2a, 6.6.3.5.2C-3a, 6.6.3.5.2C-4a, 6.6.3.5.2C-5a and 6.6.3.5.2C-6a.

Table 6.6.3.5.2C-1: Medium Range BS operating band unwanted emission limits for 1.4 MHz channel bandwidth, $31 < P_{\text{rated,c}} \leq 38$ dBm (E-UTRA bands ≤ 3 GHz)

Frequency offset of measurement filter -3dB point, Δf	Frequency offset of measurement filter centre frequency, f_{offset}	Test requirement (Note 1, 2)	Measurement bandwidth (Note 6)
$0 \text{ MHz} \leq \Delta f < 1.4 \text{ MHz}$	$0.05 \text{ MHz} \leq f_{\text{offset}} < 1.45 \text{ MHz}$	$P_{\text{rated,c}} - 43.5 \text{ dB} - \frac{10}{1.4} \left(\frac{f_{\text{offset}}}{\text{MHz}} - 0.05 \right) \text{ dB}$	100 kHz
$1.4 \text{ MHz} \leq \Delta f < 2.8 \text{ MHz}$	$1.45 \text{ MHz} \leq f_{\text{offset}} < 2.85 \text{ MHz}$	$P_{\text{rated,c}} - 53.5 \text{ dB}$	100 kHz
$2.8 \text{ MHz} \leq \Delta f \leq \Delta f_{\text{max}}$	$2.85 \text{ MHz} \leq f_{\text{offset}} < f_{\text{offset}_{\text{max}}}$	-25dBm	100 kHz
NOTE 1: For a BS supporting non-contiguous spectrum operation within any operating band the test requirement within sub-block gaps is calculated as a cumulative sum of contributions from adjacent sub blocks on each side of the sub block gap. Exception is $\Delta f \geq 10$ MHz from both adjacent sub blocks on each side of the sub-block gap, where the test requirement within sub-block gaps shall be -25dBm/100kHz.			
NOTE 2: For BS supporting multi-band operation with Inter RF Bandwidth gap < 20MHz the test requirement within the Inter RF Bandwidth gaps is calculated as a cumulative sum of contributions from adjacent sub-blocks or RF Bandwidth on each side of the Inter RF Bandwidth gap.			

Table 6.6.3.5.2C-1a: Medium Range BS operating band unwanted emission limits for 1.4 MHz channel bandwidth, $31 < P_{\text{rated,c}} \leq 38$ dBm (E-UTRA bands >3GHz)

Frequency offset of measurement filter -3dB point, Δf	Frequency offset of measurement filter centre frequency, f_{offset}	Test requirement (Note 1, 2)	Measurement bandwidth (Note 6)
$0 \text{ MHz} \leq \Delta f < 1.4 \text{ MHz}$	$0.05 \text{ MHz} \leq f_{\text{offset}} < 1.45 \text{ MHz}$	$P_{\text{rated,c}} - 43.2 \text{ dB} - \frac{10}{1.4} \left(\frac{f_{\text{offset}}}{\text{MHz}} - 0.05 \right) \text{ dB}$	100 kHz
$1.4 \text{ MHz} \leq \Delta f < 2.8 \text{ MHz}$	$1.45 \text{ MHz} \leq f_{\text{offset}} < 2.85 \text{ MHz}$	$P_{\text{rated,c}} - 53.2 \text{ dB}$	100 kHz
$2.8 \text{ MHz} \leq \Delta f \leq \Delta f_{\text{max}}$	$2.85 \text{ MHz} \leq f_{\text{offset}} < f_{\text{offset}_{\text{max}}}$	-25dBm	100 kHz
NOTE 1: For a BS supporting non-contiguous spectrum operation within any operating band the test requirement within sub-block gaps is calculated as a cumulative sum of contributions from adjacent sub blocks on each side of the sub block gap. Exception is $\Delta f \geq 10$ MHz from both adjacent sub blocks on each side of the sub-block gap, where the test requirement within sub-block gaps shall be -25dBm/100kHz.			
NOTE 2: For BS supporting multi-band operation with Inter RF Bandwidth gap < 20MHz the test requirement within the Inter RF Bandwidth gaps is calculated as a cumulative sum of contributions from adjacent sub-blocks or RF Bandwidth on each side of the Inter RF Bandwidth gap.			

Table 6.6.3.5.2C-2: Medium Range BS operating band unwanted emission limits for 1.4 MHz channel bandwidth, $P_{\text{rated,c}} \leq 31$ dBm (E-UTRA bands ≤ 3 GHz)

Frequency offset of measurement filter -3dB point, Δf	Frequency offset of measurement filter centre frequency, f_{offset}	Test requirement (Note 1, 2)	Measurement bandwidth (Note 6)
$0 \text{ MHz} \leq \Delta f < 1.4 \text{ MHz}$	$0.05 \text{ MHz} \leq f_{\text{offset}} < 1.45 \text{ MHz}$	$-12.5 \text{ dBm} - \frac{10}{1.4} \left(\frac{f_{\text{offset}}}{\text{MHz}} - 0.05 \right) \text{ dB}$	100 kHz
$1.4 \text{ MHz} \leq \Delta f < 2.8 \text{ MHz}$	$1.45 \text{ MHz} \leq f_{\text{offset}} < 2.85 \text{ MHz}$	-22.5 dBm	100 kHz
$2.8 \text{ MHz} \leq \Delta f \leq \Delta f_{\text{max}}$	$2.85 \text{ MHz} \leq f_{\text{offset}} < f_{\text{offset}_{\text{max}}}$	-25dBm	100 kHz
NOTE 1: For a BS supporting non-contiguous spectrum operation within any operating band the test requirement within sub-block gaps is calculated as a cumulative sum of contributions from adjacent sub blocks on each side of the sub block gap. Exception is $\Delta f \geq 10$ MHz from both adjacent sub blocks on each side of the sub-block gap, where the test requirement within sub-block gaps shall be -25dBm/100kHz.			
NOTE 2: For BS supporting multi-band operation with Inter RF Bandwidth gap < 20MHz the test requirement within the Inter RF Bandwidth gaps is calculated as a cumulative sum of contributions from adjacent sub-blocks or RF Bandwidth on each side of the Inter RF Bandwidth gap.			

Table 6.6.3.5.2C-2a: Medium Range BS operating band unwanted emission limits for 1.4 MHz channel bandwidth, $P_{\text{rated,c}} \leq 31$ dBm (E-UTRA bands >3GHz)

Frequency offset of measurement filter -3dB point, Δf	Frequency offset of measurement filter centre frequency, f_{offset}	Test requirement (Note 1, 2)	Measurement bandwidth (Note 6)
$0 \text{ MHz} \leq \Delta f < 1.4 \text{ MHz}$	$0.05 \text{ MHz} \leq f_{\text{offset}} < 1.45 \text{ MHz}$	$-12.2 \text{ dBm} - \frac{10}{1.4} \left(\frac{f_{\text{offset}}}{\text{MHz}} - 0.05 \right) \text{ dB}$	100 kHz
$1.4 \text{ MHz} \leq \Delta f < 2.8 \text{ MHz}$	$1.45 \text{ MHz} \leq f_{\text{offset}} < 2.85 \text{ MHz}$	-22.2 dBm	100 kHz
$2.8 \text{ MHz} \leq \Delta f \leq \Delta f_{\text{max}}$	$2.85 \text{ MHz} \leq f_{\text{offset}} < f_{\text{offset}_{\text{max}}}$	-25dBm	100 kHz
NOTE 1: For a BS supporting non-contiguous spectrum operation within any operating band the test requirement within sub-block gaps is calculated as a cumulative sum of contributions from adjacent sub blocks on each side of the sub block gap. Exception is $\Delta f \geq 10\text{MHz}$ from both adjacent sub blocks on each side of the sub-block gap, where the test requirement within sub-block gaps shall be -25dBm/100kHz.			
NOTE 2: For BS supporting multi-band operation with Inter RF Bandwidth gap < 20MHz the test requirement within the Inter RF Bandwidth gaps is calculated as a cumulative sum of contributions from adjacent sub-blocks or RF Bandwidth on each side of the Inter RF Bandwidth gap.			

Table 6.6.3.5.2C-3: Medium Range BS operating band unwanted emission limits for 3 MHz channel bandwidth, $31 < P_{\text{rated,c}} \leq 38$ dBm (E-UTRA bands $\leq 3\text{GHz}$)

Frequency offset of measurement filter -3dB point, Δf	Frequency offset of measurement filter centre frequency, f_{offset}	Test requirement (Note 1, 2)	Measurement bandwidth (Note 6)
$0 \text{ MHz} \leq \Delta f < 3 \text{ MHz}$	$0.05 \text{ MHz} \leq f_{\text{offset}} < 3.05 \text{ MHz}$	$P_{\text{rated,c}} - 47.5 \text{ dB} - \frac{10}{3} \left(\frac{f_{\text{offset}}}{\text{MHz}} - 0.05 \right) \text{ dB}$	100 kHz
$3 \text{ MHz} \leq \Delta f < 6 \text{ MHz}$	$3.05 \text{ MHz} \leq f_{\text{offset}} < 6.05 \text{ MHz}$	$P_{\text{rated,c}} - 57.5 \text{ dB}$	100 kHz
$6 \text{ MHz} \leq \Delta f \leq \Delta f_{\text{max}}$	$6.05 \text{ MHz} \leq f_{\text{offset}} < f_{\text{offset}_{\text{max}}}$	$\text{Min}(P_{\text{rated,c}} - 59 \text{ dB}, -25 \text{ dBm})$	100 kHz
NOTE 1: For a BS supporting non-contiguous spectrum operation within any operating band the test requirement within sub-block gaps is calculated as a cumulative sum of contributions from adjacent sub blocks on each side of the sub block gap. Exception is $\Delta f \geq 10\text{MHz}$ from both adjacent sub blocks on each side of the sub-block gap, where the test requirement within sub-block gaps shall be $\text{Min}(P_{\text{rated,c}} - 59 \text{ dB}, -25 \text{ dBm})/100\text{kHz}$.			
NOTE 2: For BS supporting multi-band operation with Inter RF Bandwidth gap < 20MHz the test requirement within the Inter RF Bandwidth gaps is calculated as a cumulative sum of contributions from adjacent sub-blocks or RF Bandwidth on each side of the Inter RF Bandwidth gap.			

Table 6.6.3.5.2C-3a: Medium Range BS operating band unwanted emission limits for 3 MHz channel bandwidth, $31 < P_{\text{rated,c}} \leq 38$ dBm (E-UTRA bands >3GHz)

Frequency offset of measurement filter -3dB point, Δf	Frequency offset of measurement filter centre frequency, f_{offset}	Test requirement (Note 1, 2)	Measurement bandwidth (Note 6)
$0 \text{ MHz} \leq \Delta f < 3 \text{ MHz}$	$0.05 \text{ MHz} \leq f_{\text{offset}} < 3.05 \text{ MHz}$	$P_{\text{rated,c}} - 47.2 \text{ dB} - \frac{10}{3} \left(\frac{f_{\text{offset}}}{\text{MHz}} - 0.05 \right) \text{ dB}$	100 kHz
$3 \text{ MHz} \leq \Delta f < 6 \text{ MHz}$	$3.05 \text{ MHz} \leq f_{\text{offset}} < 6.05 \text{ MHz}$	$P_{\text{rated,c}} - 57.2 \text{ dB}$	100 kHz
$6 \text{ MHz} \leq \Delta f \leq \Delta f_{\text{max}}$	$6.05 \text{ MHz} \leq f_{\text{offset}} < f_{\text{offset}_{\text{max}}}$	$\text{Min}(P_{\text{rated,c}} - 59 \text{ dB}, -25 \text{ dBm})$	100 kHz
NOTE 1: For a BS supporting non-contiguous spectrum operation within any operating band the test requirement within sub-block gaps is calculated as a cumulative sum of contributions from adjacent sub blocks on each side of the sub block gap. Exception is $\Delta f \geq 10\text{MHz}$ from both adjacent sub blocks on each side of the sub-block gap, where the test requirement within sub-block gaps shall be $\text{Min}(P_{\text{rated,c}} - 59 \text{ dB}, -25 \text{ dBm})/100\text{kHz}$.			
NOTE 2: For BS supporting multi-band operation with Inter RF Bandwidth gap < 20MHz the test requirement within the Inter RF Bandwidth gaps is calculated as a cumulative sum of contributions from adjacent sub-blocks or RF Bandwidth on each side of the Inter RF Bandwidth gap.			

Table 6.6.3.5.2C-4: Medium Range BS operating band unwanted emission limits for 3 MHz channel bandwidth, $P_{\text{rated,c}} \leq 31$ dBm (E-UTRA bands ≤ 3 GHz)

Frequency offset of measurement filter -3dB point, Δf	Frequency offset of measurement filter centre frequency, f_{offset}	Test requirement (Note 1, 2)	Measurement bandwidth (Note 6)
$0 \text{ MHz} \leq \Delta f < 3 \text{ MHz}$	$0.05 \text{ MHz} \leq f_{\text{offset}} < 3.05 \text{ MHz}$	$-16.5 \text{ dBm} - \frac{10}{3} \left(\frac{f_{\text{offset}}}{\text{MHz}} - 0.05 \right) \text{ dB}$	100 kHz
$3 \text{ MHz} \leq \Delta f < 6 \text{ MHz}$	$3.05 \text{ MHz} \leq f_{\text{offset}} < 6.05 \text{ MHz}$	-26.5 dBm	100 kHz
$6 \text{ MHz} \leq \Delta f \leq \Delta f_{\text{max}}$	$6.05 \text{ MHz} \leq f_{\text{offset}} < f_{\text{offset}_{\text{max}}}$	-28 dBm	100 kHz
<p>NOTE 1: For a BS supporting non-contiguous spectrum operation within any operating band the test requirement within sub-block gaps is calculated as a cumulative sum of contributions from adjacent sub blocks on each side of the sub block gap. Exception is $\Delta f \geq 10$ MHz from both adjacent sub blocks on each side of the sub-block gap, where the test requirement within sub-block gaps shall be -28dBm/100kHz.</p> <p>NOTE 2: For BS supporting multi-band operation with Inter RF Bandwidth gap < 20MHz the test requirement within the Inter RF Bandwidth gaps is calculated as a cumulative sum of contributions from adjacent sub-blocks or RF Bandwidth on each side of the Inter RF Bandwidth gap.</p>			

Table 6.6.3.5.2C-4a: Medium Range BS operating band unwanted emission limits for 3 MHz channel bandwidth, $P_{\text{rated,c}} \leq 31$ dBm (E-UTRA bands >3GHz)

Frequency offset of measurement filter -3dB point, Δf	Frequency offset of measurement filter centre frequency, f_{offset}	Test requirement (Note 1, 2)	Measurement bandwidth (Note 6)
$0 \text{ MHz} \leq \Delta f < 3 \text{ MHz}$	$0.05 \text{ MHz} \leq f_{\text{offset}} < 3.05 \text{ MHz}$	$-16.2 \text{ dBm} - \frac{10}{3} \left(\frac{f_{\text{offset}}}{\text{MHz}} - 0.05 \right) \text{ dB}$	100 kHz
$3 \text{ MHz} \leq \Delta f < 6 \text{ MHz}$	$3.05 \text{ MHz} \leq f_{\text{offset}} < 6.05 \text{ MHz}$	-26.2 dBm	100 kHz
$6 \text{ MHz} \leq \Delta f \leq \Delta f_{\text{max}}$	$6.05 \text{ MHz} \leq f_{\text{offset}} < f_{\text{offset}_{\text{max}}}$	-28 dBm	100 kHz
<p>NOTE 1: For a BS supporting non-contiguous spectrum operation within any operating band the test requirement within sub-block gaps is calculated as a cumulative sum of contributions from adjacent sub blocks on each side of the sub block gap. Exception is $\Delta f \geq 10$ MHz from both adjacent sub blocks on each side of the sub-block gap, where the test requirement within sub-block gaps shall be -28dBm/100kHz.</p> <p>NOTE 2: For BS supporting multi-band operation with Inter RF Bandwidth gap < 20MHz the test requirement within the Inter RF Bandwidth gaps is calculated as a cumulative sum of contributions from adjacent sub-blocks or RF Bandwidth on each side of the Inter RF Bandwidth gap.</p>			

Table 6.6.3.5.2C-5: Medium Range BS operating band unwanted emission limits for 5, 10, 15 and 20 MHz channel bandwidth, $31 < P_{\text{rated,c}} \leq 38$ dBm (E-UTRA bands ≤ 3 GHz)

Frequency offset of measurement filter -3dB point, Δf	Frequency offset of measurement filter centre frequency, f_{offset}	Test requirement (Note 1, 2)	Measurement bandwidth (Note 6)
$0 \text{ MHz} \leq \Delta f < 5 \text{ MHz}$	$0.05 \text{ MHz} \leq f_{\text{offset}} < 5.05 \text{ MHz}$	$P_{\text{rated,c}} - 51.5 \text{ dB} - \frac{7}{5} \left(\frac{f_{\text{offset}}}{\text{MHz}} - 0.05 \right) \text{ dB}$	100 kHz
$5 \text{ MHz} \leq \Delta f < \min(10 \text{ MHz}, \Delta f_{\text{max}})$	$5.05 \text{ MHz} \leq f_{\text{offset}} < \min(10.05 \text{ MHz}, f_{\text{offset}_{\text{max}}})$	$P_{\text{rated,c}} - 58.5 \text{ dB}$	100 kHz
$10 \text{ MHz} \leq \Delta f \leq \Delta f_{\text{max}}$	$10.05 \text{ MHz} \leq f_{\text{offset}} < f_{\text{offset}_{\text{max}}}$	$\text{Min}(P_{\text{rated,c}} - 60 \text{ dB}, -25 \text{ dBm})$ (Note 9)	100 kHz
<p>NOTE 1: For a BS supporting non-contiguous spectrum operation within any operating band the test requirement within sub-block gaps is calculated as a cumulative sum of contributions from adjacent sub blocks on each side of the sub block gap. Exception is $\Delta f \geq 10$ MHz from both adjacent sub blocks on each side of the sub-block gap, where the test requirement within sub-block gaps shall be $\text{Min}(P_{\text{rated,c}} - 60 \text{ dB}, -25 \text{ dBm})/100$ kHz.</p> <p>NOTE 2: For BS supporting multi-band operation with Inter RF Bandwidth gap < 20MHz the test requirement within the Inter RF Bandwidth gaps is calculated as a cumulative sum of contributions from adjacent sub-blocks or RF Bandwidth on each side of the Inter RF Bandwidth gap.</p>			

Table 6.6.3.5.2C-5a: Medium Range BS operating band unwanted emission limits for 5, 10, 15 and 20 MHz channel bandwidth, $31 < P_{\text{rated,c}} \leq 38$ dBm (E-UTRA bands >3 GHz)

Frequency offset of measurement filter -3dB point, Δf	Frequency offset of measurement filter centre frequency, f_{offset}	Test requirement (Note 1, 2)	Measurement bandwidth (Note 6)
$0 \text{ MHz} \leq \Delta f < 5 \text{ MHz}$	$0.05 \text{ MHz} \leq f_{\text{offset}} < 5.05 \text{ MHz}$	$P_{\text{rated,c}} - 51.2 \text{ dB} - \frac{7}{5} \left(\frac{f_{\text{offset}}}{\text{MHz}} - 0.05 \right) \text{ dB}$	100 kHz
$5 \text{ MHz} \leq \Delta f < \min(10 \text{ MHz}, \Delta f_{\text{max}})$	$5.05 \text{ MHz} \leq f_{\text{offset}} < \min(10.05 \text{ MHz}, f_{\text{offset}_{\text{max}}})$	$P_{\text{rated,c}} - 58.2 \text{ dB}$	100 kHz
$10 \text{ MHz} \leq \Delta f \leq \Delta f_{\text{max}}$	$10.05 \text{ MHz} \leq f_{\text{offset}} < f_{\text{offset}_{\text{max}}}$	$\text{Min}(P_{\text{rated,c}} - 60 \text{ dB}, -25 \text{ dBm})$ (Note 9)	100 kHz
NOTE 1: For a BS supporting non-contiguous spectrum operation within any operating band the test requirement within sub-block gaps is calculated as a cumulative sum of contributions from adjacent sub blocks on each side of the sub block gap. Exception is $\Delta f \geq 10$ MHz from both adjacent sub blocks on each side of the sub-block gap, where the test requirement within sub-block gaps shall be $\text{Min}(P_{\text{rated,c}} - 60 \text{ dB}, -25 \text{ dBm})/100 \text{ kHz}$.			
NOTE 2: For BS supporting multi-band operation with Inter RF Bandwidth gap < 20 MHz the test requirement within the Inter RF Bandwidth gaps is calculated as a cumulative sum of contributions from adjacent sub-blocks or RF Bandwidth on each side of the Inter RF Bandwidth gap.			

Table 6.6.3.5.2C-6: Medium Range BS operating band unwanted emission limits for 5, 10, 15 and 20 MHz channel bandwidth, $P_{\text{rated,c}} \leq 31$ dBm (E-UTRA bands ≤ 3 GHz)

Frequency offset of measurement filter -3dB point, Δf	Frequency offset of measurement filter centre frequency, f_{offset}	Test requirement (Note 1, 2)	Measurement bandwidth (Note 6)
$0 \text{ MHz} \leq \Delta f < 5 \text{ MHz}$	$0.05 \text{ MHz} \leq f_{\text{offset}} < 5.05 \text{ MHz}$	$-20.5 \text{ dBm} - \frac{7}{5} \left(\frac{f_{\text{offset}}}{\text{MHz}} - 0.05 \right) \text{ dB}$	100 kHz
$5 \text{ MHz} \leq \Delta f < \min(10 \text{ MHz}, \Delta f_{\text{max}})$	$5.05 \text{ MHz} \leq f_{\text{offset}} < \min(10.05 \text{ MHz}, f_{\text{offset}_{\text{max}}})$	-27.5 dBm	100 kHz
$10 \text{ MHz} \leq \Delta f \leq \Delta f_{\text{max}}$	$10.05 \text{ MHz} \leq f_{\text{offset}} < f_{\text{offset}_{\text{max}}}$	-29 dBm (Note 9)	100 kHz
NOTE 1: For a BS supporting non-contiguous spectrum operation within any operating band the test requirement within sub-block gaps is calculated as a cumulative sum of contributions from adjacent sub blocks on each side of the sub block gap. Exception is $\Delta f \geq 10$ MHz from both adjacent sub blocks on each side of the sub-block gap, where the test requirement within sub-block gaps shall be $-29 \text{ dBm}/100 \text{ kHz}$.			
NOTE 2: For BS supporting multi-band operation with Inter RF Bandwidth gap < 20 MHz the test requirement within the Inter RF Bandwidth gaps is calculated as a cumulative sum of contributions from adjacent sub-blocks or RF Bandwidth on each side of the Inter RF Bandwidth gap.			

Table 6.6.3.5.2C-6a: Medium Range BS operating band unwanted emission limits for 5, 10, 15 and 20 MHz channel bandwidth, $P_{\text{rated,c}} \leq 31$ dBm (E-UTRA bands >3 GHz)

Frequency offset of measurement filter -3dB point, Δf	Frequency offset of measurement filter centre frequency, f_{offset}	Test requirement (Note 1, 2)	Measurement bandwidth (Note 6)
$0 \text{ MHz} \leq \Delta f < 5 \text{ MHz}$	$0.05 \text{ MHz} \leq f_{\text{offset}} < 5.05 \text{ MHz}$	$-20.2 \text{ dBm} - \frac{7}{5} \left(\frac{f_{\text{offset}}}{\text{MHz}} - 0.05 \right) \text{ dB}$	100 kHz
$5 \text{ MHz} \leq \Delta f < \min(10 \text{ MHz}, \Delta f_{\text{max}})$	$5.05 \text{ MHz} \leq f_{\text{offset}} < \min(10.05 \text{ MHz}, f_{\text{offset}_{\text{max}}})$	-27.2 dBm	100 kHz
$10 \text{ MHz} \leq \Delta f \leq \Delta f_{\text{max}}$	$10.05 \text{ MHz} \leq f_{\text{offset}} < f_{\text{offset}_{\text{max}}}$	-29 dBm (Note 9)	100 kHz
NOTE 1: For a BS supporting non-contiguous spectrum operation within any operating band the test requirement within sub-block gaps is calculated as a cumulative sum of contributions from adjacent sub blocks on each side of the sub block gap. Exception is $\Delta f \geq 10$ MHz from both adjacent sub blocks on each side of the sub-block gap, where the test requirement within sub-block gaps shall be $-29 \text{ dBm}/100 \text{ kHz}$.			
NOTE 2: For BS supporting multi-band operation with Inter RF Bandwidth gap < 20 MHz the test requirement within the Inter RF Bandwidth gaps is calculated as a cumulative sum of contributions from adjacent sub-blocks or RF Bandwidth on each side of the Inter RF Bandwidth gap.			

6.6.3.5.2D Minimum requirements for Local Area and Medium Range BS in Band 46 (Category A and B)

For Local Area and Medium Range BS operating in Band 46, emissions shall not exceed the maximum levels specified in Tables 6.6.3.5.2D-1 and 6.6.3.5.2D-2.

Table 6.6.3.5.2D-1: Local Area and Medium Range BS operating band unwanted emission limits in Band 46 for 20MHz channel bandwidth

Frequency offset of measurement filter -3dB point, Δf	Frequency offset of measurement filter centre frequency, f_{offset}	Test requirement (Note 1)	Measurement bandwidth (Note 6)
$0 \text{ MHz} \leq \Delta f < 1 \text{ MHz}$	$0.05 \text{ MHz} \leq f_{\text{offset}} < 1.05 \text{ MHz}$	$P_{\text{rated,c}} - 32.6\text{dB} - 10 \left(\frac{f_{\text{offset}}}{\text{MHz}} - 0.05 \right) \text{dB}$	100 kHz
$1 \text{ MHz} \leq \Delta f < \min(10 \text{ MHz}, \Delta f_{\text{max}})$	$1.05 \text{ MHz} \leq f_{\text{offset}} < \min(10.05 \text{ MHz}, f_{\text{offset}_{\text{max}}})$	$P_{\text{rated,c}} - 42.6\text{dB} - \frac{8}{9} \left(\frac{f_{\text{offset}}}{\text{MHz}} - 1.05 \right) \text{dB}$	100 kHz
$10 \text{ MHz} \leq \Delta f < \min(20 \text{ MHz}, \Delta f_{\text{max}})$	$10.05 \text{ MHz} \leq f_{\text{offset}} < \min(20.05 \text{ MHz}, f_{\text{offset}_{\text{max}}})$	$P_{\text{rated,c}} - 50.6\text{dB} - \frac{12}{10} \left(\frac{f_{\text{offset}}}{\text{MHz}} - 10.05 \right) \text{dB}$	100 kHz
$20 \text{ MHz} \leq \Delta f < \min(170 \text{ MHz}, \Delta f_{\text{max}})$	$20.05 \text{ MHz} \leq f_{\text{offset}} < \min(170.05 \text{ MHz}, f_{\text{offset}_{\text{max}}})$	$\text{Max}(P_{\text{rated,c}} - 62.6\text{dB}, -40\text{dBm})$	100 kHz
$170 \text{ MHz} \leq \Delta f < \min(206 \text{ MHz}, \Delta f_{\text{max}})$	$170.05 \text{ MHz} \leq f_{\text{offset}} < \min(206.05 \text{ MHz}, f_{\text{offset}_{\text{max}}})$	$\text{Max}(P_{\text{rated,c}} - 64.6\text{dB}, -40\text{dBm})$	100 kHz
$206 \text{ MHz} \leq \Delta f \leq \Delta f_{\text{max}}$	$206.05 \text{ MHz} \leq f_{\text{offset}} < f_{\text{offset}_{\text{max}}}$	$\text{Max}(P_{\text{rated,c}} - 69.6\text{dB}, -40\text{dBm})$	100 kHz

NOTE 1: For a BS supporting non-contiguous spectrum operation within any operating band, the minimum requirement within sub-block gaps is calculated as a cumulative sum of contributions from adjacent sub blocks on each side of the sub block gap. Exception is $\Delta f \geq 20 \text{ MHz}$ from both adjacent sub blocks on each side of the sub-block gap, where the minimum requirement within sub-block gaps shall be $\text{Max}(P_{\text{rated,c}} - 62.6\text{dB}, -40 \text{ dBm})/100\text{kHz}$.

Table 6.6.3.5.2D-2: Local Area and Medium Range BS operating band unwanted emission limits in Band 46 for 10 MHz channel bandwidth

Frequency offset of measurement filter -3dB point, Δf	Frequency offset of measurement filter centre frequency, f_{offset}	Test requirement (Note 1)	Measurement bandwidth (Note 8)
$0 \text{ MHz} \leq \Delta f < 0.5 \text{ MHz}$	$0.05 \text{ MHz} \leq f_{\text{offset}} < 0.55 \text{ MHz}$	$P_{\text{rated,c}} - 27.3\text{dB} - 20 \left(\frac{f_{\text{offset}}}{\text{MHz}} - 0.05 \right) \text{dB}$	100 kHz
$0.5 \text{ MHz} \leq \Delta f < 5 \text{ MHz}$	$0.55 \text{ MHz} \leq f_{\text{offset}} < \min(5.05 \text{ MHz}, f_{\text{offset}_{\text{max}}})$	$P_{\text{rated,c}} - 37.3\text{dB} - \frac{16}{9} \left(\frac{f_{\text{offset}}}{\text{MHz}} - 0.55 \right) \text{dB}$	100 kHz
$5 \text{ MHz} \leq \Delta f < \min(10 \text{ MHz}, \Delta f_{\text{max}})$	$5.05 \text{ MHz} \leq f_{\text{offset}} < \min(10.05 \text{ MHz}, f_{\text{offset}_{\text{max}}})$	$P_{\text{rated,c}} - 45.3\text{dB} - \frac{12}{5} \left(\frac{f_{\text{offset}}}{\text{MHz}} - 5.05 \right) \text{dB}$	100 kHz
$10 \text{ MHz} \leq \Delta f < \min(85 \text{ MHz}, \Delta f_{\text{max}})$	$10.05 \text{ MHz} \leq f_{\text{offset}} < \min(85.05 \text{ MHz}, f_{\text{offset}_{\text{max}}})$	$\text{Max}(P_{\text{rated,c}} - 57.3\text{dB}, -40\text{dBm})$	100 kHz
$85 \text{ MHz} \leq \Delta f < \min(103 \text{ MHz}, \Delta f_{\text{max}})$	$85.05 \text{ MHz} \leq f_{\text{offset}} < \min(103.05 \text{ MHz}, f_{\text{offset}_{\text{max}}})$	$\text{Max}(P_{\text{rated,c}} - 59.3\text{dB}, -40\text{dBm})$	100 kHz
$103 \text{ MHz} \leq \Delta f \leq \Delta f_{\text{max}}$	$103.05 \text{ MHz} \leq f_{\text{offset}} < f_{\text{offset}_{\text{max}}}$	$\text{Max}(P_{\text{rated,c}} - 64.3\text{dB}, -40\text{dBm})$	100 kHz

NOTE 1: For a BS supporting non-contiguous spectrum operation within any operating band, the minimum requirement within sub-block gaps is calculated as a cumulative sum of contributions from adjacent sub blocks on each side of the sub block gap. Exception is $\Delta f \geq 10 \text{ MHz}$ from both adjacent sub blocks on each side of the sub-block gap, where the minimum requirement within sub-block gaps shall be $\text{Max}(P_{\text{rated,c}} - 57.3\text{dB}, -40 \text{ dBm})/100\text{kHz}$.

6.6.3.5.2E Minimum requirements for stand-alone NB-IoT Wide Area BS

For stand-alone NB-IoT BS in E-UTRA bands ≤ 3 GHz, emissions shall not exceed the maximum levels specified in Tables 6.6.3.5.2E-1.

Table 6.6.3.5.2E-1: Stand-alone NB-IoT BS operating band unwanted emission limits (E-UTRA bands ≤ 3 GHz)

Frequency offset of measurement filter -3dB point, Δf	Frequency offset of measurement filter centre frequency, f_{offset}	Minimum requirement (Note 1, 2, 3, 4)	Measurement bandwidth (Note 6)
$0 \text{ MHz} \leq \Delta f < 0.05 \text{ MHz}$	$0.015 \text{ MHz} \leq f_{\text{offset}} < 0.065 \text{ MHz}$	$Max(6.5 \text{ dBm} - 60 \cdot \left(\frac{f_{\text{offset}}}{\text{MHz}} - 0.015 \right) \text{ dB} + X \text{ dB}, -12.5 \text{ dBm})$	30 kHz
$0.05 \text{ MHz} \leq \Delta f < 0.15 \text{ MHz}$	$0.065 \text{ MHz} \leq f_{\text{offset}} < 0.165 \text{ MHz}$	$Max(3.5 \text{ dBm} - 160 \cdot \left(\frac{f_{\text{offset}}}{\text{MHz}} - 0.065 \right) \text{ dB} + X \text{ dB}, -12.5 \text{ dBm})$	30 kHz
$0.15 \text{ MHz} \leq \Delta f < 0.2 \text{ MHz}$	$0.165 \text{ MHz} \leq f_{\text{offset}} < 0.215 \text{ MHz}$	-12.5 dBm	30 kHz
$0.2 \text{ MHz} \leq \Delta f < 1 \text{ MHz}$	$0.215 \text{ MHz} \leq f_{\text{offset}} < 1.015 \text{ MHz}$	$-12.5 \text{ dBm} - 15 \cdot \left(\frac{f_{\text{offset}}}{\text{MHz}} - 0.215 \right) \text{ dB}$	30 kHz
(Note 8)	$1.015 \text{ MHz} \leq f_{\text{offset}} < 1.5 \text{ MHz}$	-24.5 dBm	30 kHz
$1 \text{ MHz} \leq \Delta f \leq \min(\Delta f_{\text{max}}, 10 \text{ MHz})$	$1.5 \text{ MHz} \leq f_{\text{offset}} < \min(f_{\text{offset}_{\text{max}}}, 10.5 \text{ MHz})$	-11.5 dBm	1 MHz
$10 \text{ MHz} \leq \Delta f \leq \Delta f_{\text{max}}$	$10.5 \text{ MHz} \leq f_{\text{offset}} < f_{\text{offset}_{\text{max}}}$	-15 dBm (Note 9)	1 MHz
<p>NOTE 1: The limits in this table only apply for operation with a standalone NB-IoT carrier adjacent to the Base Station RF Bandwidth edge.</p> <p>NOTE 2: For a BS supporting non-contiguous spectrum operation within any operating band the minimum requirement within sub-block gaps is calculated as a cumulative sum of contributions from adjacent sub blocks on each side of the sub block gap, where the contribution from the far-end sub-block shall be scaled according to the measurement bandwidth of the near-end sub-block.</p> <p>NOTE 3: For a BS supporting multi-band operation with Inter RF Bandwidth gap < 20MHz the minimum requirement within the Inter RF Bandwidth gaps is calculated as a cumulative sum of contributions from adjacent sub-blocks or RF Bandwidth on each side of the Inter RF Bandwidth gap, where the contribution from the far-end sub-block or RF Bandwidth shall be scaled according to the measurement bandwidth of the near-end sub-block or RF Bandwidth.</p> <p>NOTE 4: In case the carrier adjacent to the RF bandwidth edge is a standalone NB-IoT carrier, the value of $X = \text{PNB-IoTcarrier} - 43$, where PNB-IoTcarrier is the power level of the standalone NB-IoT carrier adjacent to the RF bandwidth edge. In other cases, $X = 0$.</p> <p>NOTE 5: For BS that only support E-UTRA and NB-IoT multi-carrier operation, the requirements in this table do not apply to an E-UTRA BS from Release 8, which is upgraded to support E-UTRA and NB-IoT multi-carrier operation, where the upgrade does not affect existing RF parts of the radio unit related to the requirements in this table. In this case, the requirements in subclauses 6.6.3.5.1 and 6.6.3.5.2 shall apply.</p>			

6.6.3.5.2F Minimum requirements for stand-alone NB-IoT Local Area BS

For stand-alone NB-IoT BS in E-UTRA bands ≤ 3 GHz, emissions shall not exceed the maximum levels specified in Table 6.6.3.5.2F-1.

Table 6.6.3.5.2F-1: Stand-alone NB-IoT BS operating band unwanted emission limits (E-UTRA bands ≤ 3 GHz)

Frequency offset of measurement filter -3dB point, Δf	Frequency offset of measurement filter centre frequency, f_{offset}	Minimum requirement (Note 1, 2, 3, 4)	Measurement bandwidth (Note 6)
$0 \text{ MHz} \leq \Delta f < 0.05 \text{ MHz}$	$0.015 \text{ MHz} \leq f_{\text{offset}} < 0.065 \text{ MHz}$	$Max(-12.5 \text{ dBm} - 60 \cdot \left(\frac{f_{\text{offset}}}{\text{MHz}} - 0.015 \right) \text{ dB} + X \text{ dB}, -33.5 \text{ dBm})$	30 kHz
$0.05 \text{ MHz} \leq \Delta f < 0.16 \text{ MHz}$	$0.065 \text{ MHz} \leq f_{\text{offset}} < 0.175 \text{ MHz}$	$Max(-15.5 \text{ dBm} - 160 \cdot \left(\frac{f_{\text{offset}}}{\text{MHz}} - 0.065 \right) \text{ dB} + X \text{ dB}, -33.5 \text{ dBm})$	30 kHz
$0.16 \text{ MHz} \leq \Delta f < 5 \text{ MHz}$ (Note 8)	$0.175 \text{ MHz} \leq f_{\text{offset}} < 5.05 \text{ MHz}$	$-28.5 \text{ dBm} - \frac{7}{5} \left(\frac{f_{\text{offset}}}{\text{MHz}} - 0.05 \right) \text{ dB}$	100 kHz
$5 \text{ MHz} \leq \Delta f < \min(10 \text{ MHz}, \Delta f_{\text{max}})$	$5.05 \text{ MHz} \leq f_{\text{offset}} < \min(10.05 \text{ MHz}, f_{\text{offset}_{\text{max}}})$	-35.5 dBm	100 kHz
$10 \text{ MHz} \leq \Delta f \leq \Delta f_{\text{max}}$	$10.05 \text{ MHz} \leq f_{\text{offset}} < f_{\text{offset}_{\text{max}}}$	-37 dBm (Note 9)	100 kHz
<p>NOTE 1: The limits in this table only apply for operation with a standalone NB-IoT carrier adjacent to the Base Station RF Bandwidth edge.</p> <p>NOTE 2: For a BS supporting non-contiguous spectrum operation within any operating band the minimum requirement within sub-block gaps is calculated as a cumulative sum of contributions from adjacent sub blocks on each side of the sub block gap, where the contribution from the far-end sub-block shall be scaled according to the measurement bandwidth of the near-end sub-block.</p> <p>NOTE 3: For a BS supporting multi-band operation with Inter RF Bandwidth gap < 20MHz the minimum requirement within the Inter RF Bandwidth gaps is calculated as a cumulative sum of contributions from adjacent sub-blocks or RF Bandwidth on each side of the Inter RF Bandwidth gap, where the contribution from the far-end sub-block or RF Bandwidth shall be scaled according to the measurement bandwidth of the near-end sub-block or RF Bandwidth.</p> <p>NOTE 4: In case the carrier adjacent to the RF bandwidth edge is a standalone NB-IoT carrier, the value of $X = \text{PNB-IoTcarrier} - 24$, where PNB-IoTcarrier is the power level of the standalone NB-IoT carrier adjacent to the RF bandwidth edge. In other cases, $X = 0$.</p>			

6.6.3.5.2G Minimum requirements for stand-alone NB-IoT Home BS

For stand-alone NB-IoT BS in E-UTRA bands ≤ 3 GHz, emissions shall not exceed the maximum levels specified in Table 6.6.3.5.2G-1.

Table 6.6.3.5.2G-1: Stand-alone NB-IoT BS operating band unwanted emission limits (E-UTRA bands ≤ 3 GHz)

Frequency offset of measurement filter -3dB point, Δf	Frequency offset of measurement filter centre frequency, f_{offset}	Minimum requirement (Note 1, 2)	Measurement bandwidth (Note 6)
$0 \text{ MHz} \leq \Delta f < 0.05 \text{ MHz}$	$0.015 \text{ MHz} \leq f_{\text{offset}} < 0.065 \text{ MHz}$	$Max(-16.5 \text{ dBm} - 60 \cdot \left(\frac{f_{\text{offset}}}{\text{MHz}} - 0.015 \right) \text{ dB} + X \text{ dB}, -37.5 \text{ dBm})$	30 kHz
$0.05 \text{ MHz} \leq \Delta f < 0.16 \text{ MHz}$	$0.065 \text{ MHz} \leq f_{\text{offset}} < 0.175 \text{ MHz}$	$Max(-19.5 \text{ dBm} - 160 \cdot \left(\frac{f_{\text{offset}}}{\text{MHz}} - 0.065 \right) \text{ dB} + X \text{ dB}, -37.5 \text{ dBm})$	30 kHz
$0.16 \text{ MHz} \leq \Delta f < 5 \text{ MHz}$ (Note 8)	$0.175 \text{ MHz} \leq f_{\text{offset}} < 5.05 \text{ MHz}$	$-32.5 \text{ dBm} - \frac{7}{5} \left(\frac{f_{\text{offset}}}{\text{MHz}} - 0.05 \right) \text{ dB}$	100 kHz
$5 \text{ MHz} \leq \Delta f < \min(10 \text{ MHz}, \Delta f_{\text{max}})$	$5.05 \text{ MHz} \leq f_{\text{offset}} < \min(10.05 \text{ MHz}, f_{\text{offset}_{\text{max}}})$	-39.5 dBm	100 kHz
$10 \text{ MHz} \leq \Delta f \leq \Delta f_{\text{max}}$	$10.05 \text{ MHz} \leq f_{\text{offset}} < f_{\text{offset}_{\text{max}}}$	-41 dBm (Note 9)	100 kHz
NOTE 1: The limits in this table only apply for operation with a standalone NB-IoT carrier adjacent to the Base Station RF Bandwidth edge.			
NOTE 2: In case the carrier adjacent to the RF bandwidth edge is a standalone NB-IoT carrier, the value of $X = \text{PNB-IoTcarrier} - 20$, where PNB-IoTcarrier is the power level of the standalone NB-IoT carrier adjacent to the RF bandwidth edge. In other cases, $X = 0$.			

6.6.3.5.2H Minimum requirements for stand-alone NB-IoT Medium Range BS

For stand-alone NB-IoT BS in E-UTRA bands ≤ 3 GHz, emissions shall not exceed the maximum levels specified in Tables 6.6.3.5.2H-1 and 6.6.3.5.2H-2.

Table 6.6.3.5.2H-1: Stand-alone NB-IoT BS operating band unwanted emission limits (E-UTRA bands ≤ 3 GHz), BS maximum output power $31 < P_{\text{rated,c}} \leq 38$ dBm

Frequency offset of measurement filter -3dB point, Δf	Frequency offset of measurement filter centre frequency, f_{offset}	Minimum requirement (Note 1, 2, 3, 4)	Measurement bandwidth (Note 6)
$0 \text{ MHz} \leq \Delta f < 0.05 \text{ MHz}$	$0.015 \text{ MHz} \leq f_{\text{offset}} < 0.065 \text{ MHz}$	$P_{\text{rated,c}} - 36.5 \text{ dB} - 60 \left(\frac{f_{\text{offset}}}{\text{MHz}} - 0.015 \right) \text{ dB}$	30 kHz
$0.05 \text{ MHz} \leq \Delta f < 0.15 \text{ MHz}$	$0.065 \text{ MHz} \leq f_{\text{offset}} < 0.165 \text{ MHz}$	$P_{\text{rated,c}} - 39.5 \text{ dB} - 160 \left(\frac{f_{\text{offset}}}{\text{MHz}} - 0.065 \right) \text{ dB}$	30 kHz
$0.15 \text{ MHz} \leq \Delta f < 0.6 \text{ MHz}$ (Note 1)	$0.165 \text{ MHz} \leq f_{\text{offset}} < 0.615 \text{ MHz}$	$P_{\text{rated,c}} - 56.5 \text{ dB} - \frac{7}{5} \left(\frac{f_{\text{offset}}}{\text{MHz}} - 0.015 \right) \text{ dB}$	30 kHz
$0.6 \text{ MHz} \leq \Delta f < 1 \text{ MHz}$	$0.615 \text{ MHz} \leq f_{\text{offset}} < 1.015 \text{ MHz}$	$P_{\text{rated,c}} - 51.5 \text{ dB} - 15 \left(\frac{f_{\text{offset}}}{\text{MHz}} - 0.215 \right) \text{ dB}$	30 kHz
(Note 8)	$1.015 \text{ MHz} \leq f_{\text{offset}} < 1.5 \text{ MHz}$	$P_{\text{rated,c}} - 63.5 \text{ dB}$	30 kHz
$1 \text{ MHz} \leq \Delta f \leq 2.8 \text{ MHz}$	$1.5 \text{ MHz} \leq f_{\text{offset}} < 3.3 \text{ MHz}$	$P_{\text{rated,c}} - 50.5 \text{ dB}$	1 MHz
$2.8 \text{ MHz} \leq \Delta f \leq 5 \text{ MHz}$	$3.3 \text{ MHz} \leq f_{\text{offset}} < 5.5 \text{ MHz}$	$\min(P_{\text{rated,c}} - 50.5 \text{ dB}, -13.5 \text{ dBm})$	1 MHz
$5 \text{ MHz} \leq \Delta f < \min(10 \text{ MHz}, \Delta f_{\text{max}})$	$5.5 \text{ MHz} \leq f_{\text{offset}} < \min(10.5 \text{ MHz}, f_{\text{offset}_{\text{max}}})$	$P_{\text{rated,c}} - 54.5 \text{ dB}$	1 MHz
$10 \text{ MHz} \leq \Delta f \leq \Delta f_{\text{max}}$	$10.5 \text{ MHz} \leq f_{\text{offset}} < f_{\text{offset}_{\text{max}}}$	$P_{\text{rated,c}} - 56 \text{ dB}$ (Note 9)	1 MHz
<p>NOTE 1: The limits in this table only apply for operation with a standalone NB-IoT carrier adjacent to the Base Station RF Bandwidth edge.</p> <p>NOTE 2: For a BS supporting non-contiguous spectrum operation within any operating band the minimum requirement within sub-block gaps is calculated as a cumulative sum of contributions from adjacent sub blocks on each side of the sub block gap, where the contribution from the far-end sub-block shall be scaled according to the measurement bandwidth of the near-end sub-block.</p> <p>NOTE 3: For a BS supporting multi-band operation with Inter RF Bandwidth gap < 20 MHz the minimum requirement within the Inter RF Bandwidth gaps is calculated as a cumulative sum of contributions from adjacent sub-blocks or RF Bandwidth on each side of the Inter RF Bandwidth gap, where the contribution from the far-end sub-block or RF Bandwidth shall be scaled according to the measurement bandwidth of the near-end sub-block or RF Bandwidth.</p>			

Table 6.6.3.5.2H-2: Stand-alone NB-IoT BS operating band unwanted emission limits (E-UTRA bands $\leq 3\text{GHz}$), BS maximum output power $P_{\text{rated,c}} \leq 31\text{ dBm}$

Frequency offset of measurement filter -3dB point, Δf	Frequency offset of measurement filter centre frequency, f_{offset}	Minimum requirement (Note 1, 2, 3, 4)	Measurement bandwidth (Note 6)
$0\text{ MHz} \leq \Delta f < 0.05\text{ MHz}$	$0.015\text{ MHz} \leq f_{\text{offset}} < 0.065\text{ MHz}$	$Max(-5.5\text{dBm} - 60 \cdot \left(\frac{f_{\text{offset}}}{\text{MHz}} - 0.015\right)\text{dB} + X\text{dB}, -25.5\text{dBm})$	30 kHz
$0.05\text{ MHz} \leq \Delta f < 0.15\text{ MHz}$	$0.065\text{ MHz} \leq f_{\text{offset}} < 0.165\text{ MHz}$	$Max(-8.5\text{dBm} - 160 \cdot \left(\frac{f_{\text{offset}}}{\text{MHz}} - 0.065\right)\text{dB} + X\text{dB}, -25.5\text{dBm})$	30 kHz
$0.15\text{ MHz} \leq \Delta f < 0.6\text{ MHz}$ (Note 1)	$0.165\text{ MHz} \leq f_{\text{offset}} < 0.615\text{ MHz}$	$-25.5\text{dBm} - \frac{7}{5} \cdot \left(\frac{f_{\text{offset}}}{\text{MHz}} - 0.015\right)\text{dB}$	30 kHz
$0.6\text{ MHz} \leq \Delta f < 1\text{ MHz}$	$0.615\text{ MHz} \leq f_{\text{offset}} < 1.015\text{ MHz}$	$-20.5\text{dBm} - 15 \cdot \left(\frac{f_{\text{offset}}}{\text{MHz}} - 0.215\right)\text{dB}$	30 kHz
(Note 8)	$1.015\text{ MHz} \leq f_{\text{offset}} < 1.5\text{ MHz}$	-32.5 dBm	30 kHz
$1\text{ MHz} \leq \Delta f \leq 5\text{ MHz}$	$1.5\text{ MHz} \leq f_{\text{offset}} < 5.5\text{ MHz}$	-19.5 dBm	1 MHz
$5\text{ MHz} \leq \Delta f < \min(10\text{ MHz}, \Delta f_{\text{max}})$	$5.5\text{ MHz} \leq f_{\text{offset}} < \min(10.5\text{ MHz}, f_{\text{offset}_{\text{max}}})$	-23.5 dBm	1 MHz
$10\text{ MHz} \leq \Delta f \leq \Delta f_{\text{max}}$	$10.5\text{ MHz} \leq f_{\text{offset}} < f_{\text{offset}_{\text{max}}}$	-25 dBm (Note 9)	1 MHz
<p>NOTE 1: The limits in this table only apply for operation with a standalone NB-IoT carrier adjacent to the Base Station RF Bandwidth edge.</p> <p>NOTE 2: For a BS supporting non-contiguous spectrum operation within any operating band the minimum requirement within sub-block gaps is calculated as a cumulative sum of contributions from adjacent sub blocks on each side of the sub block gap, where the contribution from the far-end sub-block shall be scaled according to the measurement bandwidth of the near-end sub-block.</p> <p>NOTE 3: For a BS supporting multi-band operation with Inter RF Bandwidth gap <math>< 20\text{MHz}</math> the minimum requirement within the Inter RF Bandwidth gaps is calculated as a cumulative sum of contributions from adjacent sub-blocks or RF Bandwidth on each side of the Inter RF Bandwidth gap, where the contribution from the far-end sub-block or RF Bandwidth shall be scaled according to the measurement bandwidth of the near-end sub-block or RF Bandwidth.</p> <p>NOTE 4: In case the carrier adjacent to the RF bandwidth edge is a standalone NB-IoT carrier, the value of $X = P_{\text{NB-IoT carrier}} - 31$, where $P_{\text{NB-IoT carrier}}$ is the power level of the standalone NB-IoT carrier adjacent to the RF bandwidth edge. In other cases, $X = 0$</p>			

6.6.3.5.3 Additional requirements

In certain regions the following requirement may apply. For E-UTRA, E-UTRA with NB-IoT and NB-IoT BS operating in Bands 5, 26, 27 or 28, emissions shall not exceed the maximum levels specified in Tables 6.6.3.5.3-1.

Table 6.6.3.5.3-1: Additional operating band unwanted emission limits for E-UTRA bands <math>< 1\text{GHz}</math>

Channel bandwidth	Frequency offset of measurement filter -3dB point, Δf	Frequency offset of measurement filter centre frequency, f_{offset}	Test requirement	Measurement bandwidth (Note 6)
200 kHz	$0\text{ MHz} \leq \Delta f < 1\text{ MHz}$	$0.005\text{ MHz} \leq f_{\text{offset}} < 0.995\text{ MHz}$	-6 dBm	10 kHz
1.4 MHz	$0\text{ MHz} \leq \Delta f < 1\text{ MHz}$	$0.005\text{ MHz} \leq f_{\text{offset}} < 0.995\text{ MHz}$	-14 dBm	10 kHz
3 MHz	$0\text{ MHz} \leq \Delta f < 1\text{ MHz}$	$0.015\text{ MHz} \leq f_{\text{offset}} < 0.985\text{ MHz}$	-13 dBm	30 kHz
5 MHz	$0\text{ MHz} \leq \Delta f < 1\text{ MHz}$	$0.015\text{ MHz} \leq f_{\text{offset}} < 0.985\text{ MHz}$	-15 dBm	30 kHz
10 MHz	$0\text{ MHz} \leq \Delta f < 1\text{ MHz}$	$0.05\text{ MHz} \leq f_{\text{offset}} < 0.95\text{ MHz}$	-13 dBm	100 kHz
15 MHz	$0\text{ MHz} \leq \Delta f < 1\text{ MHz}$	$0.05\text{ MHz} \leq f_{\text{offset}} < 0.95\text{ MHz}$	-13 dBm	100 kHz
20 MHz	$0\text{ MHz} \leq \Delta f < 1\text{ MHz}$	$0.05\text{ MHz} \leq f_{\text{offset}} < 0.95\text{ MHz}$	-13 dBm	100 kHz
All	$1\text{ MHz} \leq \Delta f < \Delta f_{\text{max}}$	$1.05\text{ MHz} \leq f_{\text{offset}} < f_{\text{offset}_{\text{max}}}$	-13 dBm	100 kHz

In certain regions the following requirement may apply. For E-UTRA, E-UTRA with NB-IoT and NB-IoT BS operating in Bands 2, 4, 10, 23, 25, 30, 35, 36, 41, 66, 70, emissions shall not exceed the maximum levels specified in Table 6.6.3.5.3-2.

Table 6.6.3.5.3-2: Additional operating band unwanted emission limits for E-UTRA bands >1GHz

Channel bandwidth	Frequency offset of measurement filter -3dB point, Δf	Frequency offset of measurement filter centre frequency, f_{offset}	Test requirement	Measurement bandwidth (Note 6)
200 kHz	$0 \text{ MHz} \leq \Delta f < 1 \text{ MHz}$	$0.005 \text{ MHz} \leq f_{\text{offset}} < 0.995 \text{ MHz}$	-6 dBm	10 kHz
1.4 MHz	$0 \text{ MHz} \leq \Delta f < 1 \text{ MHz}$	$0.005 \text{ MHz} \leq f_{\text{offset}} < 0.995 \text{ MHz}$	-14 dBm	10 kHz
3 MHz	$0 \text{ MHz} \leq \Delta f < 1 \text{ MHz}$	$0.015 \text{ MHz} \leq f_{\text{offset}} < 0.985 \text{ MHz}$	-13 dBm	30 kHz
5 MHz	$0 \text{ MHz} \leq \Delta f < 1 \text{ MHz}$	$0.015 \text{ MHz} \leq f_{\text{offset}} < 0.985 \text{ MHz}$	-15 dBm	30 kHz
10 MHz	$0 \text{ MHz} \leq \Delta f < 1 \text{ MHz}$	$0.05 \text{ MHz} \leq f_{\text{offset}} < 0.95 \text{ MHz}$	-13 dBm	100 kHz
15 MHz	$0 \text{ MHz} \leq \Delta f < 1 \text{ MHz}$	$0.05 \text{ MHz} \leq f_{\text{offset}} < 0.95 \text{ MHz}$	-15 dBm	100 kHz
20 MHz	$0 \text{ MHz} \leq \Delta f < 1 \text{ MHz}$	$0.05 \text{ MHz} \leq f_{\text{offset}} < 0.95 \text{ MHz}$	-16 dBm	100 kHz
All	$1 \text{ MHz} \leq \Delta f < \Delta f_{\text{max}}$	$1.5 \text{ MHz} \leq f_{\text{offset}} < f_{\text{offset}_{\text{max}}}$	-13 dBm	1 MHz

In certain regions the following requirement may apply. For E-UTRA, E-UTRA with NB-IoT and NB-IoT BS operating in Bands 12, 13, 14, 17, 29, 71, 85 emissions shall not exceed the maximum levels specified in Table 6.6.3.5.3-3.

Table 6.6.3.5.3-3: Additional operating band unwanted emission limits for E-UTRA (bands 12, 13, 14, 17, 29, 71 and 85)

Channel bandwidth	Frequency offset of measurement filter -3dB point, Δf	Frequency offset of measurement filter centre frequency, f_{offset}	Test requirement	Measurement bandwidth (Note 6)
All	$0 \text{ MHz} \leq \Delta f < 100 \text{ kHz}$	$0.015 \text{ MHz} \leq f_{\text{offset}} < 0.085 \text{ MHz}$	-13 dBm	30 kHz
All	$100 \text{ kHz} \leq \Delta f < \Delta f_{\text{max}}$	$150 \text{ kHz} \leq f_{\text{offset}} < f_{\text{offset}_{\text{max}}}$	-13 dBm	100 kHz

In certain regions, the following requirements may apply to an E-UTRA TDD BS operating in the same geographic area and in the same operating band as another E-UTRA TDD system without synchronisation. For this case the emissions shall not exceed -52 dBm/MHz in each supported downlink operating band, except in:

- The frequency range from 10 MHz below the lower channel edge to the frequency 10 MHz above the upper channel edge of each supported band.

In certain regions the following requirement may apply for protection of DTT. For E-UTRA BS operating in Band 20, the level of emissions in the band 470-790 MHz, measured in an 8MHz filter bandwidth on centre frequencies F_{filter} according to Table 6.6.3.3-4, shall not exceed the maximum emission level $P_{\text{EM},N}$ declared by the manufacturer. This requirement applies in the frequency range 470-790 MHz even though part of the range falls in the spurious domain.

Table 6.6.3.5.3-4: Declared emissions levels for protection of DTT

Filter centre frequency, F_{filter}	Measurement bandwidth	Declared emission level [dBm]
$F_{\text{filter}} = 8 \cdot N + 306 \text{ (MHz)}$; $21 \leq N \leq 60$	8 MHz	$P_{\text{EM},N}$

Note: The regional requirement is defined in terms of EIRP (effective isotropic radiated power), which is dependent on both the BS emissions at the antenna connector and the deployment (including antenna gain and feeder loss). The requirement defined above provides the characteristics of the base station needed to verify compliance with the regional requirement. Compliance with the regional requirement can be determined using the method outlined in Annex G of [2].

Table 6.6.3.5.3-5: Void

In regions where FCC regulation applies, requirements for protection of GPS according to FCC Order DA 20-48 applies for operation in Band 24. The following normative requirement covers the base station, to be used together with other information about the site installation to verify compliance with the requirement in FCC Order DA 20-48. The requirement applies to BS operating in Band 24 to ensure that appropriate interference protection is provided to the

1541 – 1650 MHz band. This requirement applies to the frequency range 1541-1650 MHz, even though part of this range falls within the spurious domain.

The level of emissions in the 1541 – 1650 MHz band, measured in measurement bandwidth according to Table 6.6.3.5.3-6 shall not exceed the maximum emission levels $P_{EM,B24,a}$, $P_{EM,B24,b}$, $P_{EM,B24,c}$, $P_{EM,B24,d}$, $P_{EM,B24,e}$ and $P_{EM,B24,f}$ declared by the manufacturer.

Table 6.6.3.5.3-6: Declared emissions levels for protection of the 1541-1650 MHz band

Operating Band	Frequency range	Declared emission level (dBW) (Measurement bandwidth = 1 MHz)	Declared emission level (dBW) of discrete emissions of less than 700 Hz bandwidth (Measurement bandwidth = 1 kHz)	Declared emission level (dBW) of discrete emissions of less than 2 kHz bandwidth (Measurement bandwidth = 1 kHz)
24	1541 - 1559 MHz	$P_{EM,B24,a}$		$P_{EM,B24,f}$
	1559 - 1610 MHz	$P_{EM,B24,b}$	$P_{EM,B24,d}$	
	1610 - 1650 MHz	$P_{EM,B24,c}$	$P_{EM,B24,e}$	

Note: The regional requirements in FCC Order DA 20-48 are defined in terms of EIRP (effective isotropic radiated power), which is dependent on both the BS emissions at the antenna connector and the deployment (including antenna gain and feeder loss). The EIRP level is calculated using: $P_{EIRP} = P_E + G_{ant}$ where P_E denotes the BS unwanted emission level at the antenna connector, G_{ant} equals the BS antenna gain minus feeder loss. The requirement defined above provides the characteristics of the base station needed to verify compliance with the regional requirement.

Table 6.6.3.5.3-7: Void

In certain regions, the following requirements may apply to E-UTRA BS operating in Band 32 within 1452-1492 MHz, in Band 75 within 1432-1517 MHz and in Band 76 within 1427-1432 MHz. The level of operating band unwanted emissions, measured on centre frequencies f_{offset} with filter bandwidth, according to Table 6.6.3.5.3-8, shall neither exceed the maximum emission level $P_{EM,B32,B75,B76,a}$, $P_{EM,B32,B75,B76,b}$ nor $P_{EM,B32,B75,B76,c}$ declared by the manufacturer.

For Band 32, this requirement applies in the frequency range 1452-1492 MHz when non-Mobile/Fixed Communications Network (MFCN) services are deployed in adjacent frequency ranges, while it applies also within 1427-1452 MHz and/or 1492-1517 MHz when MFCN services are deployed in such frequency ranges, even though part of the ranges falls in the spurious domain. For Band 75, this requirement applies in the frequency range 1427-1517 MHz. For Band 76, this requirement applies in the frequency range 1432-1517 MHz even though part of the range falls in the spurious domain.

Table 6.6.3.5.3-8: Declared operating band 32, 75 and 76 unwanted emission within 1427-1517 MHz

Frequency offset of measurement filter centre frequency, f_{offset}	Declared emission level [dBm]	Measurement bandwidth
2.5 MHz	$P_{EM,B32,a, B75, B76}$	5 MHz
7.5 MHz	$P_{EM,B32,b, B75, B76}$	5 MHz
$12.5 \text{ MHz} \leq f_{offset} \leq f_{offset_{max,B32}}$	$P_{EM,B32,c, B75, B76}$	5 MHz
NOTE: For Band 32, when non-MFCN services are deployed in the adjacent bands, $f_{offset_{max}}$ denotes the frequency difference between the lower channel edge and 1454.5 MHz, and the frequency difference between the upper channel edge and 1489.5 MHz for the set channel position. For Band 32, when MFCN services are deployed in the adjacent frequencies, Band 75 and Band 76, $f_{offset_{max}}$ denotes the frequency difference between the lower channel edge and 1429.5 MHz, and the frequency difference between the upper channel edge and 1514.5 MHz for the set channel position.		

NOTE: The regional requirement, included in [19] and [20], is defined in terms of EIRP per antenna, which is dependent on both the BS emissions at the antenna connector and the deployment (including antenna gain and feeder loss). The requirement defined above provides the characteristics of the base station needed to verify compliance with the regional requirement. The assessment of the EIRP level is described in Annex H of TS 36.104 [2].

In certain regions, the following requirement may apply to E-UTRA BS operating in Band 32 within 1452-1492 MHz for the protection of non-MFCN services in spectrum adjacent to the frequency range 1452-1492 MHz. The level of emissions, measured on centre frequencies F_{filter} with filter bandwidth according to Table 6.6.3.5.3-9, shall neither exceed the maximum emission level $P_{\text{EM},\text{B}32,\text{d}}$ nor $P_{\text{EM},\text{B}32,\text{e}}$ declared by the manufacturer. This requirement applies in the frequency range 1429-1518MHz even though part of the range falls in the spurious domain.

Table 6.6.3.5.3-9: Operating band 32 declared emission outside 1452-1492 MHz

Filter centre frequency, F_{filter}	Declared emission level [dBm]	Measurement bandwidth
$1429.5 \text{ MHz} \leq F_{\text{filter}} \leq 1448.5 \text{ MHz}$	$P_{\text{EM},\text{B}32,\text{d}}$	1 MHz
$F_{\text{filter}} = 1450.5 \text{ MHz}$	$P_{\text{EM},\text{B}32,\text{e}}$	3 MHz
$F_{\text{filter}} = 1493.5 \text{ MHz}$	$P_{\text{EM},\text{B}32,\text{e}}$	3 MHz
$1495.5 \text{ MHz} \leq F_{\text{filter}} \leq 1517.5 \text{ MHz}$	$P_{\text{EM},\text{B}32,\text{d}}$	1 MHz

NOTE: The regional requirement, included in [19], is defined in terms of EIRP, which is dependent on both the BS emissions at the antenna connector and the deployment (including antenna gain and feeder loss). The requirement defined above provides the characteristics of the base station needed to verify compliance with the regional requirement. The assessment of the EIRP level is described in Annex H of TS 36.104 [2].

In certain regions, the following requirement may apply to BS operating in Band 50 and Band 75 within 1492-1517 MHz and in Band 74 within 1492-1518 MHz. The level of emissions, measured on centre frequencies F_{filter} with filter bandwidth according to Table 6.6.3.5.3-9A, shall neither exceed the maximum emission level $P_{\text{EM},\text{B}50,\text{B}74,\text{B}75,\text{a}}$ nor $P_{\text{EM},\text{B}50,\text{B}74,\text{B}75,\text{b}}$ declared by the manufacturer.

Table 6.6.3.5.3-9A: Operating band 50, 74 and 75 declared emission above 1518 MHz

Filter centre frequency, F_{filter}	Declared emission level [dBm]	Measurement bandwidth
$1518.5 \text{ MHz} \leq F_{\text{filter}} \leq 1519.5 \text{ MHz}$	$P_{\text{EM},\text{B}50,\text{B}74,\text{B}75,\text{a}}$	1 MHz
$1520.5 \text{ MHz} \leq F_{\text{filter}} \leq 1558.5 \text{ MHz}$	$P_{\text{EM},\text{B}50,\text{B}74,\text{B}75,\text{b}}$	1 MHz

NOTE: The regional requirement, included in [20], is defined in terms of EIRP, which is dependent on both the BS emissions at the antenna connector and the deployment (including antenna gain and feeder loss). The requirement defined above provides the characteristics of the base station needed to verify compliance with the regional requirement. The assessment of the EIRP level is described in Annex H.

In certain regions, the following requirement may apply to E-UTRA BS operating in Band 50 and Band 75 within 1432-1452 MHz, and in Band 51 and Band 76. Emissions shall not exceed the maximum levels specified in Table 6.6.3.5.3-9B.

Table 6.6.3.5.3-9B: Additional operating band unwanted emission limits for BS operating in Band 50 and 75 within 1432-1452 MHz, and in Band 51 and 76

Filter centre frequency, F_{filter}	Maximum Level [dBm]	Measurement Bandwidth
$F_{\text{filter}} = 1413.5 \text{ MHz}$	-42	27 MHz

In certain regions the following requirement may apply to E-UTRA BS operating in Band 45. Emissions shall not exceed the maximum levels specified in Table 6.6.3.5.3-10.

Table 6.6.3.5.3-10: Emissions limits for protection of adjacent band services

Operating Band	Filter centre frequency, F_{filter}	Maximum Level [dBm]	Measurement Bandwidth
45	$F_{\text{filter}} = 1467.5$	-20	1 MHz
	$F_{\text{filter}} = 1468.5$	-23	1 MHz
	$F_{\text{filter}} = 1469.5$	-26	1 MHz
	$F_{\text{filter}} = 1470.5$	-33	1 MHz
	$F_{\text{filter}} = 1471.5$	-40	1 MHz
	$1472.5 \text{ MHz} \leq F_{\text{filter}} \leq 1491.5 \text{ MHz}$	-47	1 MHz

In addition for Band 46 operation, the BS may have to comply with the applicable operating band unwanted emission limits established regionally, when deployed in regions where those limits apply and under the conditions declared by the manufacturer. The regional requirements may be in the form of conducted power, power spectral density, EIRP and other types of limits. In case of regulatory limits based on EIRP, assessment of the EIRP level is described in Annex H of TS 36.104 [2].

The following requirement may apply to E-UTRA BS operating in Band 48 and Band 49 in certain regions. Emissions shall not exceed the maximum levels specified in Table 6.6.3.5.3-11.

Table 6.6.3.5.3-11: Additional operating band unwanted emission limits for Band 48 and Band 49

Channel bandwidth	Frequency offset of measurement filter -3dB point, Δf	Frequency offset of measurement filter centre frequency, f_{offset}	Minimum requirement	Measurement bandwidth (Note 6)
All	$0 \text{ MHz} \leq \Delta f < 10 \text{ MHz}$	$0.5 \text{ MHz} \leq f_{\text{offset}} < 9.5 \text{ MHz}$	-13 dBm	1 MHz

The following requirement may apply to E-UTRA BS operating in Band 53 in certain regions. Emissions shall not exceed the maximum levels specified in Table 6.6.3.5.3-12.

Table 6.6.3.5.3-12: Additional operating band unwanted emission limits for Band 53

Channel bandwidth [MHz]	Frequency range [MHz]	Frequency offset of measurement filter -3dB point, Δf	Frequency offset of measurement filter centre frequency, f_{offset}	Minimum requirement	Measurement bandwidth (Note 6)
1.4, 3, 5	2400 - 2477.5	$6 \text{ MHz} \leq \Delta f < 83.5 \text{ MHz}$	$6.5 \text{ MHz} \leq f_{\text{offset}} < 83 \text{ MHz}$	-25 dBm	1 MHz
10	2400 - 2473.5	$10 \text{ MHz} \leq \Delta f < 83.5 \text{ MHz}$	$10.5 \text{ MHz} \leq f_{\text{offset}} < 83 \text{ MHz}$	-25 dBm	1 MHz
1.4, 3, 5	2477.5 - 2478.5	$5 \text{ MHz} \leq \Delta f < 6 \text{ MHz}$	5.5 MHz	-13 dBm	1 MHz
10	2473.5 - 2478.5	$5 \text{ MHz} \leq \Delta f < 10 \text{ MHz}$	$5.5 \text{ MHz} \leq f_{\text{offset}} < 9.5 \text{ MHz}$	-13 dBm	1 MHz
All	2478.5 - 2483.5	$0 \text{ MHz} \leq \Delta f < 5 \text{ MHz}$	$0.5 \text{ MHz} \leq f_{\text{offset}} < 4.5 \text{ MHz}$	-10 dBm	1 MHz
1.4, 3, 5	2495 - 2501	$0 \text{ MHz} \leq \Delta f < 6 \text{ MHz}$	$0.5 \text{ MHz} \leq f_{\text{offset}} < 5.5 \text{ MHz}$	-13 dBm	1 MHz
10	2495 - 2505	$0 \text{ MHz} \leq \Delta f < 10 \text{ MHz}$	$0.5 \text{ MHz} \leq f_{\text{offset}} < 9.5 \text{ MHz}$	-13 dBm	1 MHz
1.4, 3, 5	2501 - 2690	$6 \text{ MHz} \leq \Delta f < 195 \text{ MHz}$	$6.5 \text{ MHz} \leq f_{\text{offset}} < 194.5 \text{ MHz}$	-25 dBm	1 MHz
10	2505 - 2690	$10 \text{ MHz} \leq \Delta f < 195 \text{ MHz}$	$10.5 \text{ MHz} \leq f_{\text{offset}} < 194.5 \text{ MHz}$	-25 dBm	1 MHz

The following notes are common to all subclauses in 6.6.3.5:

NOTE 6: As a general rule, the resolution bandwidth of the measuring equipment should be equal to the measurement bandwidth. However, to improve measurement accuracy, sensitivity and efficiency, the resolution bandwidth can be smaller than the measurement bandwidth. When the resolution bandwidth is smaller than the measurement bandwidth, the result should be integrated over the measurement bandwidth in order to obtain the equivalent noise bandwidth of the measurement bandwidth.

NOTE 7: If the above Test Requirement differs from the Minimum Requirement then the Test Tolerance applied for this test is non-zero. The Test Tolerance for this test is defined in Annex G. The explanation of how the Minimum Requirement has been relaxed by the Test Tolerance is given in Annex G.

NOTE 8: This frequency range ensures that the range of values of f_{offset} is continuous.

NOTE 9: The requirement is not applicable when $\Delta f_{\text{max}} < 10$ MHz.

NOTE 10: For Home BS, the parameter P is defined as the aggregated maximum output power of all transmit antenna connectors of Home BS.

6.6.4 Transmitter spurious emissions

6.6.4.1 Definition and applicability

Spurious emissions are emissions which are caused by unwanted transmitter effects such as harmonics emission, parasitic emission, intermodulation products and frequency conversion products, but exclude out of band emissions. This is measured at the base station antenna connector.

The transmitter spurious emission limits apply from 9 kHz to 12.75 GHz, excluding the frequency range from 10 MHz below the lowest frequency of the downlink operating band up to 10 MHz above the highest frequency of the downlink operating band (see Table 5.5-1). For BS capable of multi-band operation where multiple bands are mapped on the same antenna connector, this exclusion applies for each supported operating band. For BS capable of multi-band operation where multiple bands are mapped on separate antenna connectors, the single-band requirements apply and the multi-band exclusions and provisions are not applicable.

Exceptions are the requirements in Table 6.6.4.5.4-2, Table 6.6.4.5.4-3, Table 6.6.4.5.4-4, and specifically stated exceptions in Table 6.6.4.5.4-1 and Table 6.6.4.5.4-1a that apply also closer than 10 MHz from the downlink operating band. For some operating bands the upper frequency limit is higher than 12.75 GHz.

The requirements shall apply to BS that supports E-UTRA or E-UTRA with NB-IoT in-band/guard band operation or NB-IoT standalone operation.

The requirements shall apply whatever the type of transmitter considered (single carrier, multi-carrier and/or CA) and for all transmission modes foreseen by the manufacturer's specification.

Unless otherwise stated, all requirements are measured as mean power (RMS).

6.6.4.2 Minimum Requirements

The minimum requirement is in TS 36.104 [2] subclause 6.6.4.

6.6.4.3 Test Purpose

This test measures conducted spurious emission from the E-UTRA or NB-IoT BS transmitter antenna connector, while the transmitter is in operation.

6.6.4.4 Method of Test

6.6.4.4.1 Initial conditions

Test environment: normal; see Annex D.2.

RF channels to be tested for single carrier: B, M and T; see subclause 4.7.

Base Station RF Bandwidth positions to be tested for multi-carrier and/or CA: B_{RFBW} , M_{RFBW} and T_{RFBW} in single-band operation, see subclause 4.7.1; $B'_{\text{RFBW}}T'_{\text{RFBW}}$ and $B'_{\text{RFBW}}T_{\text{RFBW}}$ in multi-band operation, see subclause 4.7.1.

- 1) Connect the BS antenna connector to a measurement receiver according to Annex I.1.1 using an attenuator or a directional coupler if necessary
- 2) Measurements shall use a measurement bandwidth in accordance to the conditions in TS 36.104 [2] subclause 6.6.4.
- 3) Detection mode: True RMS.

The emission power should be averaged over an appropriate time duration to ensure the measurement is within the measurement uncertainty in Table 4.1.2-1.

- 4) Configure the BS with transmitter(s) active.

6.6.4.4.2 Procedure

- 1) For a E-UTRA BS declared to be capable of single carrier operation only, set the BS to transmit a signal according to E-TM1.1 at manufacturer's declared rated output power.

For a E-UTRA BS declared to be capable of multi-carrier and/or CA operation, set the base station to transmit according to E-TM1.1 on all carriers configured using the applicable test configuration and corresponding power setting specified in clause 4.10 and 4.11.

For a E-UTRA BS declared to be capable of NB-IoT in-band operation, start transmission according to [E-TM1.1] with the NB-IoT PRB constructed according to N-TM at manufacturer's declared rated output power.

For a E-UTRA BS declared to be capable of NB-IoT guard-band operation, start transmission according to E-TM1.1 with the NB-IoT PRB constructed according to N-TM at manufacturer's declared rated output power.

For a NB-IoT BS declared to be capable of single carrier operation, start transmission according to N-TM at manufacturer's declared rated output power.

For a NB-IoT BS declared to be capable of multi-carrier in contiguous spectrum operation in single band only, start transmission according to N-TM on all carriers configured using in the applicable test configuration and corresponding power setting specified in clause 4.10 and 4.11.

For a E-UTRA and NB-IoT standalone BS declared to be capable of multi-carrier in contiguous spectrum operation in single band only, start transmission according to E-TM1.1 on all E-UTRA carriers and N-TM on all NB-IoT carriers configured using in the applicable test configuration and corresponding power setting specified in clause 4.10 and 4.11.

- 2) Measure the emission at the specified frequencies with specified measurement bandwidth and note that the measured value does not exceed the specified value.

In addition, for a multi-band capable BS, the following step shall apply:

- 3) For multi-band capable BS and single band tests, repeat the steps above per involved band where single band test configurations and test models shall apply with no carrier activated in the other band. For multi-band capable BS with separate antenna connector, the antenna connector not being under test in case of single-band or multi-band test shall be terminated.

6.6.4.5 Test requirements

The measurement result in step 2 of 6.6.4.4.2 shall not exceed the maximum level specified in Table 6.6.4.5.1-1 to Table 6.6.4.5.6-1 if applicable for the BS under test.

NOTE: If a Test Requirement in this clause differs from the corresponding Minimum Requirement then the Test Tolerance applied for this test is non-zero. The Test Tolerance for this test and the explanation of how the Minimum Requirement has been relaxed by the Test Tolerance are given in Annex G.

As mandatory requirement, either subclause 6.6.4.5.1 (Category A limits) or subclause 6.6.4.5.2 (Category B limits) shall apply. The application of either Category A or Category B limits shall be the same as for Operating band unwanted emissions in subclause 6.6.3.

6.6.4.5.1 Spurious emissions (Category A)

The power of any spurious emission shall not exceed the limits in Table 6.6.4.5.1-1.

Table 6.6.4.5.1-1: BS Spurious emission limits, Category A

Frequency range	Maximum level	Measurement Bandwidth	Note
9kHz - 150kHz	-13 dBm	1 kHz	Note 1
150kHz - 30MHz		10 kHz	Note 1
30MHz - 1GHz		100 kHz	Note 1
1GHz – 12.75 GHz		1 MHz	Note 2
12.75 GHz – 5 th harmonic of the upper frequency edge of the DL operating band in GHz		1 MHz	Note 2, Note 3
12.75 GHz - 26 GHz		1 MHz	Note 2, Note 4
NOTE 1: Bandwidth as in ITU-R SM.329 [5] , s4.1			
NOTE 2: Bandwidth as in ITU-R SM.329 [5] , s4.1. Upper frequency as in ITU-R SM.329 [5] , s2.5 table 1			
NOTE 3: Applies only for Bands 22, 42, 43, 48 and 49.			
NOTE 4: Applies only for Band 46.			

6.6.4.5.2 Spurious emissions (Category B)

The power of any spurious emission shall not exceed the limits in Table 6.6.4.5.2-1.

Table 6.6.4.5.2-1: BS Spurious emissions limits, Category B

Frequency range	Maximum Level	Measurement Bandwidth	Note
9 kHz ↔ 150 kHz	-36 dBm	1 kHz	Note 1
150 kHz ↔ 30 MHz	-36 dBm	10 kHz	Note 1
30 MHz ↔ 1 GHz	-36 dBm	100 kHz	Note 1
1 GHz ↔ 12.75 GHz	-30 dBm	1 MHz	Note 2
12.75 GHz ↔ 5 th harmonic of the upper frequency edge of the DL operating band in GHz	-30 dBm	1 MHz	Note 2, Note 3
12.75 GHz ↔ 26 GHz	-30 dBm	1 MHz	Note 2, Note 4
NOTE 1: Bandwidth as in ITU-R SM.329 [5] , s4.1			
NOTE 2: Bandwidth as in ITU-R SM.329 [5], s4.1. Upper frequency as in ITU-R SM.329 [5] , s2.5 table 1			
NOTE 3: Applies only for Bands 22, 42, 43, 48 and 49.			
NOTE 4: Applies only for Band 46.			

6.6.4.5.3 Protection of the BS receiver of own or different BS

This requirement shall be applied for E-UTRA FDD operation in paired operating bands in order to prevent the receivers of the BSs being desensitised by emissions from a BS transmitter. It is measured at the transmit antenna port for any type of BS which has common or separate Tx/Rx antenna ports.

The power of any spurious emission shall not exceed the limits in Table 6.6.4.5.3-1.

Table 6.6.4.5.3-1: BS Spurious emissions limits for protection of the BS receiver

	Frequency range	Maximum Level	Measurement Bandwidth	Note
Wide Area BS	$F_{UL_low} - F_{UL_high}$	-96 dBm	100 kHz	
Medium Range BS	$F_{UL_low} - F_{UL_high}$	-91 dBm	100 kHz	
Local Area BS	$F_{UL_low} - F_{UL_high}$	-88 dBm	100 kHz	
Home BS	$F_{UL_low} - F_{UL_high}$	-88 dBm	100 kHz	
Note 1: For E-UTRA Band 28 BS operating in regions where Band 28 is only partially allocated for E-UTRA operations, this requirement only applies in the UL frequency range of the partial allocation.				

6.6.4.5.4 Co-existence with other systems in the same geographical area

6.6.4.5.4.1 Void

These requirements may be applied for the protection of system operating in frequency ranges other than the E-UTRA or NB-IoT BS operating band. The limits may apply as an optional protection of such systems that are deployed in the same geographical area as the E-UTRA BS, or they may be set by local or regional regulation as a mandatory requirement for an E-UTRA operating band. It is in some cases not stated in the present document whether a requirement is mandatory or under what exact circumstances that a limit applies, since this is set by local or regional regulation. An overview of regional requirements in the present document is given in Clause 4.3.

Some requirements may apply for the protection of specific equipment (UE, MS and/or BS) or equipment operating in specific systems (GSM, CDMA, UTRA, E-UTRA, NR, etc.) as listed below. The power of any spurious emission shall not exceed the limits of Table 6.6.4.5.4-1 for a BS where requirements for co-existence with the system listed in the first column apply. For BS capable of multi-band operation the exclusions and conditions in the Note column of Table 6.6.4.5.4-1 apply for each supported operating band. For BS capable of multi-band operation where multiple bands are mapped on separate antenna connectors, the exclusions and conditions in the Note column of Table 6.6.4.5.4-1 apply for the operating band supported at that antenna connector.

Table 6.6.4.5.4-1: BS Spurious emissions limits for E-UTRA BS for co-existence with systems operating in other frequency bands

System type for E-UTRA to co-exist with	Frequency range for co-existence requirement	Maximum Level	Measurement Bandwidth	Note
GSM900	921 - 960 MHz	-57 dBm	100 kHz	This requirement does not apply to E-UTRA BS operating in band 8
	876 - 915 MHz	-61 dBm	100 kHz	For the frequency range 880-915 MHz, this requirement does not apply to E-UTRA BS operating in band 8, since it is already covered by the requirement in subclause 6.6.4.5.3.
DCS1800	1805 - 1880 MHz	-47 dBm	100 kHz	This requirement does not apply to E-UTRA BS operating in band 3.
	1710 - 1785 MHz	-61 dBm	100 kHz	This requirement does not apply to E-UTRA BS operating in band 3, since it is already covered by the requirement in subclause 6.6.4.5.3.
PCS1900	1930 - 1990 MHz	-47 dBm	100 kHz	This requirement does not apply to E-UTRA BS operating in frequency band 2, band 25, band 36 or band 70.
	1850 - 1910 MHz	-61 dBm	100 kHz	This requirement does not apply to E-UTRA BS operating in frequency band 2 or 25, since it is already covered by the requirement in subclause 6.6.4.5.3. This requirement does not apply to E-UTRA BS operating in frequency band 35.
GSM850 or CDMA850	869 - 894 MHz	-57 dBm	100 kHz	This requirement does not apply to E-UTRA BS operating in frequency band 5 or 26. This requirement applies to E-UTRA BS operating in Band 27 for the frequency range 879-894 MHz.
	824 - 849 MHz	-61 dBm	100 kHz	This requirement does not apply to E-UTRA BS operating in frequency band 5 or 26, since it is already covered by the requirement in subclause 6.6.4.5.3. For E-UTRA BS operating in Band 27, it applies 3 MHz below the Band 27 downlink operating band.
UTRA FDD Band I or E-UTRA Band 1 or NR band n1	2110 - 2170 MHz	-52 dBm	1 MHz	This requirement does not apply to E-UTRA BS operating in band 1 or 65.
	1920 - 1980 MHz	-49 dBm	1 MHz	This requirement does not apply to E-UTRA BS operating in band 1 or 65, since it is already covered by the requirement in subclause 6.6.4.5.3.
UTRA FDD Band II or E-UTRA Band 2 or NR band n2	1930 - 1990 MHz	-52 dBm	1 MHz	This requirement does not apply to E-UTRA BS operating in band 2, 25 or band 70.
	1850 - 1910 MHz	-49 dBm	1 MHz	This requirement does not apply to E-UTRA BS operating in band 2 or 25, since it is already covered by the requirement in subclause 6.6.4.5.3
UTRA FDD Band III or E-UTRA Band 3 or NR band n3	1805 - 1880 MHz	-52 dBm	1 MHz	This requirement does not apply to E-UTRA BS operating in band 3.
	1710 - 1785 MHz	-49 dBm	1 MHz	This requirement does not apply to E-UTRA BS operating in band 3 or 9, since it is already covered by the requirement in subclause 6.6.4.5.3. For E-UTRA BS operating in band 9, it applies for 1710 MHz to 1749.9 MHz and 1784.9 MHz to 1785 MHz, while the rest is covered in clause 6.6.4.5.3.
UTRA FDD Band IV or E-UTRA Band 4	2110 - 2155 MHz	-52 dBm	1 MHz	This requirement does not apply to E-UTRA BS operating in band 4, 10 or 66
	1710 - 1755 MHz	-49 dBm	1 MHz	This requirement does not apply to E-UTRA BS operating in band 4, 10 or 66, since it is already covered by the requirement in subclause 6.6.4.5.3.
UTRA FDD Band V or E-UTRA Band 5 or NR band n5	869 - 894 MHz	-52 dBm	1 MHz	This requirement does not apply to E-UTRA BS operating in band 5 or 26. This requirement applies to E-UTRA BS operating in Band 27 for the frequency range 879-894 MHz.
	824 - 849 MHz	-49 dBm	1 MHz	This requirement does not apply to E-UTRA BS operating in band 5 or 26, since it is already covered by the requirement in subclause 6.6.4.5.3. For E-UTRA BS operating in Band 27, it applies 3 MHz below the Band 27 downlink operating band.
	860 - 890 MHz	-52 dBm	1 MHz	This requirement does not apply to E-UTRA BS operating in band 6, 18, 19.

UTRA FDD Band VI, XIX or E-UTRA Band 6, 18, 19 or NR Band n18	815 - 830 MHz	-49 dBm	1 MHz	This requirement does not apply to E-UTRA BS operating in band 18, since it is already covered by the requirement in subclause 6.6.4.5.3.
	830 - 845 MHz	-49 dBm	1 MHz	This requirement does not apply to E-UTRA BS operating in band 6, 19, since it is already covered by the requirement in subclause 6.6.4.5.3.
UTRA FDD Band VII or E-UTRA Band 7 or NR band n7	2620 - 2690 MHz	-52 dBm	1 MHz	This requirement does not apply to E-UTRA BS operating in band 7.
	2500 - 2570 MHz	-49 dBm	1 MHz	This requirement does not apply to E-UTRA BS operating in band 7, since it is already covered by the requirement in subclause 6.6.4.5.3.
UTRA FDD Band VIII or E-UTRA Band 8 or NR band n8	925 - 960 MHz	-52 dBm	1 MHz	This requirement does not apply to E-UTRA BS operating in band 8.
	880 - 915 MHz	-49 dBm	1 MHz	This requirement does not apply to E-UTRA BS operating in band 8, since it is already covered by the requirement in subclause 6.6.4.5.3.
UTRA FDD Band IX or E-UTRA Band 9	1844.9 - 1879.9 MHz	-52 dBm	1 MHz	This requirement does not apply to E-UTRA BS operating in band 3 or 9.
	1749.9 - 1784.9 MHz	-49 dBm	1 MHz	This requirement does not apply to E-UTRA BS operating in band 3 or 9, since it is already covered by the requirement in subclause 6.6.4.5.3.
UTRA FDD Band X or E-UTRA Band 10	2110 - 2170 MHz	-52 dBm	1 MHz	This requirement does not apply to E-UTRA BS operating in band 4, 10 or 66
	1710 - 1770 MHz	-49 dBm	1 MHz	This requirement does not apply to E-UTRA BS operating in band 10 or 66, since it is already covered by the requirement in subclause 6.6.4.5.3. For E-UTRA BS operating in Band 4, it applies for 1755 MHz to 1770 MHz, while the rest is covered in clause 6.6.4.5.3.
UTRA FDD Band XI or XXI E-UTRA Band 11 or 21	1475.9 - 1510.9 MHz	-52 dBm	1 MHz	This requirement does not apply to E-UTRA BS operating in band 11, 21, 32, 50, 74 or 75.
	1427.9 - 1447.9 MHz	-49 dBm	1 MHz	This requirement does not apply to E-UTRA BS operating in band 11 or 74, since it is already covered by the requirement in subclause 6.6.4.5.3. This requirement does not apply to BS operating in band 32, 50, 51, 75 or 76.
	1447.9 - 1462.9 MHz	-49 dBm	1 MHz	This requirement does not apply to E-UTRA BS operating in band 21 or 74, since it is already covered by the requirement in subclause 6.6.4.5.3. This requirement does not apply to BS operating in band 32, 50 or 75.
UTRA FDD Band XII or E-UTRA Band 12 or NR band n12	729 - 746 MHz	-52 dBm	1 MHz	This requirement does not apply to E-UTRA BS operating in band 12 or 85.
	699 - 716 MHz	-49 dBm	1 MHz	This requirement does not apply to E-UTRA BS operating in band 12 or 85, since it is already covered by the requirement in subclause 6.6.4.5.3. For E-UTRA BS operating in Band 29, it applies 1 MHz below the Band 29 downlink operating band (Note 6)
UTRA FDD Band XIII or E-UTRA Band 13	746 - 756 MHz	-52 dBm	1 MHz	This requirement does not apply to E-UTRA BS operating in band 13.
	777 - 787 MHz	-49 dBm	1 MHz	This requirement does not apply to E-UTRA BS operating in band 13, since it is already covered by the requirement in subclause 6.6.4.5.3.
UTRA FDD Band XIV or E-UTRA Band 14 or NR Band n14	758 - 768 MHz	-52 dBm	1 MHz	This requirement does not apply to E-UTRA BS operating in band 14.
	788 - 798 MHz	-49 dBm	1 MHz	This requirement does not apply to E-UTRA BS operating in band 14, since it is already covered by the requirement in subclause 6.6.4.5.3.
E-UTRA Band 17	734 - 746 MHz	-52 dBm	1 MHz	This requirement does not apply to E-UTRA BS operating in band 17.
	704 - 716 MHz	-49 dBm	1 MHz	This requirement does not apply to E-UTRA BS operating in band 17, since it is already covered by the requirement in subclause 6.6.4.5.3. For E-UTRA BS operating in Band 29, it applies 1 MHz below the Band 29 downlink operating band (Note 6)
	791 - 821 MHz	-52 dBm	1 MHz	This requirement does not apply to E-UTRA BS operating in band 20 or 28.

UTRA FDD Band XX or E-UTRA Band 20 or NR band n20	832 - 862 MHz	-49 dBm	1 MHz	This requirement does not apply to E-UTRA BS operating in band 20, since it is already covered by the requirement in subclause 6.6.4.5.3.
UTRA FDD Band XXII or E-UTRA Band 22	3510 – 3590 MHz	-52 dBm	1 MHz	This requirement does not apply to E-UTRA BS operating in band 22, 42, 48 or 49.
	3410 – 3490 MHz	-49 dBm	1 MHz	This requirement does not apply to E-UTRA BS operating in band 22, since it is already covered by the requirement in subclause 6.6.4.5.3. This requirement does not apply to E-UTRA BS operating in Band 42
E-UTRA Band 24	1525 – 1559 MHz	-52 dBm	1 MHz	This requirement does not apply to E-UTRA BS operating in band 24.
	1626.5 – 1660.5 MHz	-49 dBm	1 MHz	This requirement does not apply to E-UTRA BS operating in band 24, since it is already covered by the requirement in subclause 6.6.4.5.3.
UTRA FDD Band XXV or E-UTRA Band 25 or NR band n25	1930 - 1995 MHz	-52 dBm	1 MHz	This requirement does not apply to E-UTRA BS operating in band 2, 25 or 70
	1850 - 1915 MHz	-49 dBm	1 MHz	This requirement does not apply to E-UTRA BS operating in band 25, since it is already covered by the requirement in subclause 6.6.4.5.3. For E-UTRA BS operating in Band 2, it applies for 1910 MHz to 1915 MHz, while the rest is covered in clause 6.6.4.5.3.
UTRA FDD Band XXVI or E-UTRA Band 26 or NR Band n26	859 – 894 MHz	-52 dBm	1 MHz	This requirement does not apply to E-UTRA BS operating in band 5 or 26. This requirement applies to E-UTRA BS operating in Band 27 for the frequency range 879-894 MHz.
	814 – 849 MHz	-49 dBm	1 MHz	This requirement does not apply to E-UTRA BS operating in band 26, since it is already covered by the requirement in subclause 6.6.4.5.3. For E-UTRA BS operating in Band 5, it applies for 814 MHz to 824 MHz, while the rest is covered in clause 6.6.4. 5.3. For E-UTRA BS operating in Band 27, it applies 3 MHz below the Band 27 downlink operating band.
E-UTRA Band 27	852 – 869 MHz	-52 dBm	1 MHz	This requirement does not apply to E-UTRA BS operating in Band 5, 26 or 27.
	807 – 824 MHz	-49 dBm	1 MHz	This requirement does not apply to E-UTRA BS operating in Band 27, since it is already covered by the requirement in subclause 6.6.4.5.3. For E-UTRA BS operating in Band 26, it applies for 807 MHz to 814 MHz, while the rest is covered in clause 6.6.4.5.3. This requirement also applies to E-UTRA BS operating in Band 28, starting 4 MHz above the Band 28 downlink operating band (Note 5).
E-UTRA Band 28 or NR band n28	758 - 803 MHz	-52 dBm	1 MHz	This requirement does not apply to E-UTRA BS operating in band 20, 28, 44, 67 or 68.
	703 - 748 MHz	-49 dBm	1 MHz	This requirement does not apply to E-UTRA BS operating in band 28, since it is already covered by the requirement in subclause 6.6.4.5.3. This requirement does not apply to E-UTRA BS operating in Band 44. For E-UTRA BS operating in Band 67, it applies for 703 MHz to 736 MHz. For E-UTRA BS operating in Band 68, it applies for 728MHz to 733MHz.
E-UTRA Band 29 or NR Band n29	717 – 728 MHz	-52 dBm	1 MHz	This requirement does not apply to E-UTRA BS operating in Band 29 or 85.
E-UTRA Band 30 or NR Band n30	2350 – 2360 MHz	-52 dBm	1 MHz	This requirement does not apply to E-UTRA BS operating in band 30 or 40.
	2305 – 2315 MHz	-49 dBm	1 MHz	This requirement does not apply to E-UTRA BS operating in band 30, since it is already covered by the requirement in subclause 6.6.4.5.3. This requirement does not apply to E-UTRA BS operating in Band 40.
E-UTRA Band 31	462.5 -467.5 MHz	-52 dBm	1 MHz	This requirement does not apply to E-UTRA BS operating in band 31, 72 or 73.

	452.5 -457.5 MHz	-49 dBm	1 MHz	This requirement does not apply to E-UTRA BS operating in band 31, since it is already covered by the requirement in subclause 6.6.4.5.3. This requirement does not apply to E-UTRA BS operating in band 72 or 73.
UTRA FDD band XXXII or E-UTRA band 32	1452 – 1496 MHz	-52 dBm	1 MHz	This requirement does not apply to E-UTRA BS operating in band 11, 21, 32, 50, 74 or 75.
UTRA TDD Band a) or E-UTRA Band 33	1900 – 1920 MHz	-52 dBm	1 MHz	This requirement does not apply to E-UTRA BS operating in Band 33.
UTRA TDD Band a) or E-UTRA Band 34 or NR band n34	2010 – 2025 MHz	-52 dBm	1 MHz	This requirement does not apply to E-UTRA BS operating in Band 34.
UTRA TDD Band b) or E-UTRA Band 35	1850 – 1910 MHz	-52 dBm	1 MHz	This requirement does not apply to E-UTRA BS operating in Band 35.
UTRA TDD Band b) or E-UTRA Band 36	1930 – 1990 MHz	-52 dBm	1 MHz	This requirement does not apply to E-UTRA BS operating in Band 2 and 36.
UTRA TDD Band c) or E-UTRA Band 37	1910 – 1930 MHz	-52 dBm	1 MHz	This is not applicable to E-UTRA BS operating in Band 37. This unpaired band is defined in ITU-R M.1036, but is pending any future deployment.
UTRA TDD Band d) or E-UTRA Band 38 or NR band n38	2570 – 2620 MHz	-52 dBm	1 MHz	This requirement does not apply to E-UTRA BS operating in Band 38 or 69.
UTRA TDD Band f) or E-UTRA Band 39 or NR band n39	1880 – 1920MHz	-52 dBm	1 MHz	This is not applicable to E-UTRA BS operating in Band 39.
UTRA TDD Band e) or E-UTRA Band 40 or NR band n40	2300 – 2400MHz	-52 dBm	1 MHz	This is not applicable to E-UTRA BS operating in Band 30 or 40.
E-UTRA Band 41 or NR band n41	2496 – 2690 MHz	-52 dBm	1 MHz	This is not applicable to E-UTRA BS operating in Band 41 or 53.
E-UTRA Band 42	3400 – 3600 MHz	-52 dBm	1 MHz	This is not applicable to E-UTRA BS operating in Band 22, 42, 43, 48, 49 or 52.
E-UTRA Band 43	3600 – 3800 MHz	-52 dBm	1 MHz	This is not applicable to E-UTRA BS operating in Band 42, 43, 48 or 49.
E-UTRA Band 44	703 - 803 MHz	-52 dBm	1 MHz	This is not applicable to E-UTRA BS operating in Band 28 or 44
E-UTRA Band 45	1447 – 1467 MHz	-52 dBm	1 MHz	This is not applicable to E-UTRA BS operating in Band 45
E-UTRA Band 46 or NR Band n46	5150 - 5925 MHz	-52 dBm	1 MHz	This is not applicable to E-UTRA BS operating in Band 46.
E-UTRA Band 47	5855 - 5925 MHz	-52 dBm	1 MHz	
E-UTRA Band 48 or NR band n48	3550 - 3700 MHz	-52 dBm	1 MHz	This is not applicable to E-UTRA BS operating in Band 22, 42, 43, 48 or 49.
E-UTRA Band 49	3550 - 3700 MHz	-52 dBm	1 MHz	This is not applicable to E-UTRA BS operating in Band 22, 42, 43, 48 or 49.
E-UTRA Band 50 or NR band n50	1432 - 1517 MHz	-52 dBm	1 MHz	This requirement does not apply to E-UTRA BS operating in Band 11, 21, 32, 45, 50, 51, 74, 75 or 76.

E-UTRA Band 51 or NR band n51	1427 - 1432 MHz	-52 dBm	1 MHz	This requirement does not apply to E-UTRA BS operating in Band 50, 51, 75 or 76.
E-UTRA Band 52	3300 – 3400 MHz	-52 dBm	1 MHz	This is not applicable to E-UTRA BS operating in Band 42 or 52.
E-UTRA Band 53 or NR Band n53	2483.5 - 2495 MHz	-52 dBm	1 MHz	This is not applicable to E-UTRA BS operating in Band 41 or 53.
E-UTRA Band 65 or NR band n65	2110 - 2200 MHz	-52 dBm	1 MHz	This requirement does not apply to E-UTRA BS operating in band 1 or 65,
	1920 - 2010 MHz	-49 dBm	1 MHz	This requirement does not apply to E-UTRA BS operating in band 65, since it is already covered by the requirement in clause 6.6.4.5.3. For E-UTRA BS operating in Band 1, it applies for 1980 MHz to 2010 MHz, while the rest is covered in clause 6.6.4.5.3.
E-UTRA Band 66 or NR band n66	2110 - 2200 MHz	-52 dBm	1 MHz	This requirement does not apply to E-UTRA BS operating in band 4, 10, 23 or 66.
	1710 - 1780 MHz	-49 dBm	1 MHz	This requirement does not apply to E-UTRA BS operating in band 66, since it is already covered by the requirement in clause 6.6.4.5.3. For E-UTRA BS operating in Band 4, it applies for 1755 MHz to 1780 MHz, while the rest is covered in clause 6.6.4.5.3. For E-UTRA BS operating in Band 10, it applies for 1770 MHz to 1780 MHz, while the rest is covered in clause 6.6.4.5.3.
E-UTRA Band 67	738 - 758 MHz	-52 dBm	1 MHz	This requirement does not apply to E-UTRA BS operating in Band 28 or 67.
E-UTRA Band 68	753 -783 MHz	-52 dBm	1 MHz	This requirement does not apply to E-UTRA BS operating in band 28, or 68.
	698-728 MHz	-49 dBm	1 MHz	This requirement does not apply to E-UTRA BS operating in band 68, since it is already covered by the requirement in clause 6.6.4.5.3. For E-UTRA BS operating in Band 28, it applies between 698 MHz and 703 MHz, while the rest is covered in clause 6.6.4.5.3.
E-UTRA Band 69	2570 - 2620 MHz	-52 dBm	1 MHz	This requirement does not apply to E-UTRA BS operating in Band 38 or 69.
E-UTRA Band 70 or NR band n70	1995 - 2020 MHz	-52 dBm	1 MHz	This requirement does not apply to E-UTRA BS operating in band 2, 25 or 70
	1695 – 1710 MHz	-49 dBm	1 MHz	This requirement does not apply to E-UTRA BS operating in band 70, since it is already covered by the requirement in clause 6.6.4.5.3.
E-UTRA Band 71 or NR band n71	617 - 652 MHz	-52 dBm	1 MHz	This requirement does not apply to E-UTRA BS operating in band 71
	663 – 698 MHz	-49 dBm	1 MHz	This requirement does not apply to E-UTRA BS operating in band 71, since it is already covered by the requirement in clause 6.6.4.5.3
E-UTRA Band 72	461 - 466 MHz	-52 dBm	1 MHz	This requirement does not apply to E-UTRA BS operating in band 31, 72 or 73.
	451 - 456 MHz	-49 dBm	1 MHz	This requirement does not apply to E-UTRA BS operating in band 72, since it is already covered by the requirement in clause 6.6.4.5.3. This requirement does not apply to E-UTRA BS operating in band 73.
E-UTRA Band 73	460 - 465 MHz	-52 dBm	1 MHz	This requirement does not apply to E-UTRA BS operating in band 31, 72 or 73.
	450 - 455 MHz	-49 dBm	1 MHz	This requirement does not apply to E-UTRA BS operating in band 73, since it is already covered by the requirement in clause 6.6.4.5.3.
E-UTRA Band 74 or NR band n74	1475 – 1518 MHz	-52 dBm	1 MHz	This requirement does not apply to E-UTRA BS operating in band 11, 21, 32, 50, 74 or 75.
	1427 – 1470 MHz	-49 dBm	1MHz	This requirement does not apply to E-UTRA BS operating in Band 74, since it is already covered by the requirement in clause 6.6.4.5.3 This requirement does not apply to BS operating in band 32, 45, 50, 51, 75 or 76.
E-UTRA Band 75 or NR band n75	1432 – 1517 MHz	-52 dBm	1 MHz	This requirement does not apply to E-UTRA BS operating in band 11, 21, 32, 45, 50, 51, 74, 75 or 76.

E-UTRA Band 76 or NR band n76	1427 – 1432 MHz	-52 dBm	1 MHz	This requirement does not apply to E-UTRA BS operating in band 50, 51, 75 or 76.
NR band n77	3300 – 4200 MHz	-52 dBm	1 MHz	This is not applicable to E-UTRA BS operating in Band 22, 42, 43, 48, 49 or 52.
NRband n78	3300 – 3800 MHz	-52 dBm	1 MHz	This is not applicable to E-UTRA BS operating in Band 22, 42, 43, 48, 49 or 52.
NR Band n79	4.4 – 5.0 GHz	-52 dBm	1 MHz	
NR Band n80	1710 – 1785 MHz	-49 dBm	1 MHz	This requirement does not apply to E-UTRA BS operating in band 3, since it is already covered by the requirement in clause 6.6.4.2. For E-UTRA BS operating in band 9, it applies for 1710 MHz to 1749.9 MHz and 1784.9 MHz to 1785 MHz, while the rest is covered in clause 6.6.4.2.
NR Band n81	880 – 915 MHz	-49 dBm	1 MHz	This requirement does not apply to E-UTRA BS operating in band 8, since it is already covered by the requirement in clause 6.6.4.2.
NR Band n82	832 – 862 MHz	-49 dBm	1 MHz	This requirement does not apply to E-UTRA BS operating in band 20, since it is already covered by the requirement in subclause 6.6.4.2.
NR Band n83	703 – 748 MHz	-49 dBm	1 MHz	This requirement does not apply to E-UTRA BS operating in band 28, since it is already covered by the requirement in subclause 6.6.4.2. This requirement does not apply to E-UTRA BS operating in Band 44. For E-UTRA BS operating in Band 67, it applies for 703 MHz to 736 MHz. For E-UTRA BS operating in Band 68, it applies for 728MHz to 733MHz.
NR Band n84	1920 – 1980 MHz	-49 dBm	1 MHz	This requirement does not apply to E-UTRA BS operating in band 1 or 65, since it is already covered by the requirement in clause 6.6.4.2.
E-UTRA Band 85	728 - 746 MHz	-52 dBm	1 MHz	This requirement does not apply to E-UTRA BS operating in band 12, 29 or 85.
	698 - 716 MHz	-49 dBm	1 MHz	This requirement does not apply to E-UTRA BS operating in band 85, since it is already covered by the requirement in clause 6.6.4.5.3. For E-UTRA BS operating in Band 29, it applies 1 MHz below the Band 29 downlink operating band (Note 6).
NR Band n86	1710 - 1780 MHz	-49 dBm	1 MHz	This requirement does not apply to E-UTRA BS operating in band 66, since it is already covered by the requirement in clause 6.6.4.2. For E-UTRA BS operating in Band 4, it applies for 1755 MHz to 1780 MHz, while the rest is covered in clause 6.6.4.2. For E-UTRA BS operating in Band 10, it applies for 1770 MHz to 1780 MHz, while the rest is covered in clause 6.6.4.2.
E-UTRA Band 87	420 - 425 MHz	-52 dBm	1 MHz	This requirement does not apply to E-UTRA BS operating in band 87 or 88.
	410 – 415 MHz	-49 dBm	1 MHz	This requirement does not apply to E-UTRA BS operating in band 87, since it is already covered by the requirement in clause 6.6.4.5.3
E-UTRA Band 88	422 - 427 MHz	-52 dBm	1 MHz	This requirement does not apply to E-UTRA BS operating in band 87 or 88.
	412 - 417 MHz	-49 dBm	1 MHz	This requirement does not apply to E-UTRA BS operating in band 88, since it is already covered by the requirement in clause 6.6.4.5.3. This requirement does not apply to E-UTRA BS operating in band 87.
NR Band n89	824 - 849 MHz	-49 dBm	1 MHz	This requirement does not apply to E-UTRA BS operating in band 5 or 26, since it is already covered by the requirement in subclause 6.6.4.5.3. For E-UTRA BS operating in Band 27, it applies 3 MHz below the Band 27 downlink operating band.
NR Band n91	1427 – 1432 MHz	-52 dBm	1 MHz	This requirement does not apply to E-UTRA BS operating in Band 50, 51, 75 or 76.
	832 – 862 MHz	-49 dBm	1 MHz	This requirement does not apply to E-UTRA BS operating in band 20, since it is already covered by the requirement in subclause 6.6.4.5.3.
NR Band n92	1432 – 1517 MHz	-52 dBm	1 MHz	This requirement does not apply to E-UTRA BS operating in Band 11, 21, 32, 45, 50, 51, 74, 75 or 76.

	832 – 862 MHz	-49 dBm	1 MHz	This requirement does not apply to E-UTRA BS operating in band 20, since it is already covered by the requirement in subclause 6.6.4.5.3.
NR Band n93	1427 – 1432 MHz	-52 dBm	1 MHz	This requirement does not apply to E-UTRA BS operating in Band 50, 51, 75 or 76.
	880 – 915 MHz	-49 dBm	1 MHz	This requirement does not apply to E-UTRA BS operating in band 8, since it is already covered by the requirement in subclause 6.6.4.5.3.
NR Band n94	1432 – 1517 MHz	-52 dBm	1 MHz	This requirement does not apply to E-UTRA BS operating in Band 11, 21, 32, 45, 50, 51, 74, 75 or 76.
	880 – 915 MHz	-49 dBm	1 MHz	This requirement does not apply to E-UTRA BS operating in band 8, since it is already covered by the requirement in subclause 6.6.4.5.3.
NR Band n95	2010 – 2025 MHz	-52 dBm	1 MHz	
NR Band n96	5925 – 7125 MHz	-52 dBm	1 MHz	This is not applicable to E-UTRA BS operating in Band 46

Additional co-existence requirements in Table 6.6.4.5.4-1a may apply for some regions.

Table 6.6.4.5.4-1a: BS Spurious emissions limits for E-UTRA BS for co-existence with systems operating in Band 46

System type for E-UTRA to co-exist with	Frequency range for co-existence requirement	Maximum Level	Measurement Bandwidth	Note
E-UTRA Band 46a	5150 - 5250 MHz	-40 dBm	1 MHz	This is only applicable to E-UTRA BS operating in Band 46c or 46d.
E-UTRA Band 46b	5250 - 5350 MHz	-40 dBm	1 MHz	This is only applicable to E-UTRA BS operating in Band 46c or 46d.
E-UTRA Band 46c	5470 - 5725 MHz	-40 dBm	1 MHz	This is only applicable to E-UTRA BS operating in Band 46a or 46b.
E-UTRA Band 46d	5725 - 5925 MHz	-40 dBm	1 MHz	This is only applicable to E-UTRA BS operating in Band 46a or 46b.

NOTE 1: This requirement may apply to E-UTRA BS operating in certain regions.

NOTE 1: As defined in the scope for spurious emissions in this clause, except for the cases where the noted requirements apply to a BS operating in Band 25, Band 27, Band 28 or Band 29, the co-existence requirements in Table 6.6.4.5.4-1 do not apply for the 10 MHz frequency range immediately outside the downlink operating band (see Table 5.5-1). Emission limits for this excluded frequency range may be covered by local or regional requirements.

NOTE 2: Table 6.6.4.5.4-1 assumes that two operating bands, where the frequency ranges in Table 5.5-1 would be overlapping, are not deployed in the same geographical area. For such a case of operation with overlapping frequency arrangements in the same geographical area, special co-existence requirements may apply that are not covered by the 3GPP specifications.

NOTE 3: TDD base stations deployed in the same geographical area, that are synchronized and use the same or adjacent operating bands can transmit without additional co-existence requirements. For unsynchronized base stations (except in Band 46), special co-existence requirements may apply that are not covered by the 3GPP specifications.

NOTE 5: For E-UTRA Band 28 BS, specific solutions may be required to fulfil the spurious emissions limits for E-UTRA BS for co-existence with E-UTRA Band 27 UL operating band.

NOTE 6: For E-UTRA Band 29 BS, specific solutions may be required to fulfil the spurious emissions limits for E-UTRA BS for co-existence with UTRA Band XII or E-UTRA Band 12 UL operating band, E-UTRA Band 17 UL operating band or E-UTRA Band 85 UL operating band.

The power of any spurious emission shall not exceed the limits of Table 6.6.4.5.4-1a for a Home BS where requirements for co-existence with a Home BS type listed in the first column apply.

Table 6.6.4.5.4-1a: Home BS Spurious emissions limits for co-existence with Home BS operating in other frequency bands

Type of coexistence BS	Frequency range for co-location requirement	Maximum Level	Measurement Bandwidth	Note
UTRA FDD Band I or E-UTRA Band 1	1920 - 1980 MHz	-71 dBm	100 kHz	This requirement does not apply to Home BS operating in band 1 or 65, since it is already covered by the requirement in subclause 6.6.4.5.3.
UTRA FDD Band II or E-UTRA Band 2	1850 - 1910 MHz	-71 dBm	100 kHz	This requirement does not apply to Home BS operating in band 2 or 25, since it is already covered by the requirement in subclause 6.6.4.5.3.
UTRA FDD Band III or E-UTRA Band 3	1710 - 1785 MHz	-71 dBm	100 kHz	This requirement does not apply to Home BS operating in band 3, since it is already covered by the requirement in subclause 6.6.4.5.3. For Home BS operating in band 9, it applies for 1710 MHz to 1749.9 MHz and 1784.9 MHz to 1785 MHz, while the rest is covered in clause 6.6.4.5.3.
UTRA FDD Band IV or E-UTRA Band 4	1710 - 1755 MHz	-71 dBm	100 kHz	This requirement does not apply to Home BS operating in band 4, 10 or 66, since it is already covered by the requirement in subclause 6.6.4.5.3.
UTRA FDD Band V or E-UTRA Band 5	824 - 849 MHz	-71 dBm	100 kHz	This requirement does not apply to Home BS operating in band 5 or 26, since it is already covered by the requirement in subclause 6.6.4.5.3.
UTRA FDD Band VI, XIX or E-UTRA Band 6, 18, 19	815 - 830 MHz	-71 dBm	100 kHz	This requirement does not apply to Home BS operating in band 18, since it is already covered by the requirement in subclause 6.6.4.5.3.
	830 - 845 MHz	-71 dBm	100 kHz	This requirement does not apply to Home BS operating in band 6, 19, since it is already covered by the requirement in subclause 6.6.4.5.3.
UTRA FDD Band VII or E-UTRA Band 7	2500 - 2570 MHz	-71 dBm	100 kHz	This requirement does not apply to Home BS operating in band 7, since it is already covered by the requirement in subclause 6.6.4.5.3.
UTRA FDD Band VIII or E-UTRA Band 8	880 - 915 MHz	-71 dBm	100 kHz	This requirement does not apply to Home BS operating in band 8, since it is already covered by the requirement in subclause 6.6.4.5.3.
UTRA FDD Band IX or E-UTRA Band 9	1749.9 - 1784.9 MHz	-71 dBm	100 kHz	This requirement does not apply to Home BS operating in band 3 or 9, since it is already covered by the requirement in subclause 6.6.4.5.3.
UTRA FDD Band X or E-UTRA Band 10	1710 - 1770 MHz	-71 dBm	100 kHz	This requirement does not apply to Home BS operating in band 10 or 66, since it is already covered by the requirement in subclause 6.6.4.5.3. For Home BS operating in Band 4, it applies for 1755 MHz to 1770 MHz, while the rest is covered in clause 6.6.4.5.3.
UTRA FDD Band XI, XXI or E-UTRA Band 11, 21	1427.9 - 1447.9 MHz	-71 dBm	100 kHz	This requirement does not apply to Home BS operating in band 11 or 74, since it is already covered by the requirement in subclause 6.6.4.5.3. This requirement does not apply to BS operating in band 32, 50, 51, 75 or 76.
	1447.9 - 1462.9 MHz	-71 dBm	100 kHz	This requirement does not apply to Home BS operating in band 21 or 74, since it is already covered by the requirement in subclause 6.6.4.5.3. This requirement does not apply to BS operating in band 32, 50 or 75.

UTRA FDD Band XII or E-UTRA Band 12	699 - 716 MHz	-71 dBm	100 kHz	This requirement does not apply to Home BS operating in band 12 or 85, since it is already covered by the requirement in subclause 6.6.4.5.3. For Home BS operating in Band 29, it applies 1 MHz below the Band 29 downlink operating band (Note 5)
UTRA FDD Band XIII or E-UTRA Band 13	777 - 787 MHz	-71 dBm	100 kHz	This requirement does not apply to Home BS operating in band 13, since it is already covered by the requirement in subclause 6.6.4.5.3.
UTRA FDD Band XIV or E-UTRA Band 14	788 - 798 MHz	-71 dBm	100 kHz	This requirement does not apply to Home BS operating in band 14, since it is already covered by the requirement in subclause 6.6.4.5.3.
E-UTRA Band 17	704 - 716 MHz	-71 dBm	100 kHz	This requirement does not apply to Home BS operating in band 17, since it is already covered by the requirement in subclause 6.6.4.5.3. For Home BS operating in Band 29, it applies 1 MHz below the Band 29 downlink operating band (Note 5)
UTRA FDD Band XX or E-UTRA Band 20	832 - 862 MHz	-71 dBm	100 kHz	This requirement does not apply to Home BS operating in band 20, since it is already covered by the requirement in subclause 6.6.4.5.3.
UTRA FDD Band XXII or E-UTRA Band 22	3410 - 3490 MHz	-71 dBm	100 kHz	This requirement does not apply to Home BS operating in band 22, since it is already covered by the requirement in clause 6.6.5.3. This requirement does not apply to Home BS operating in Band 42
E-UTRA Band 24	1626.5 – 1660.5 MHz	-71 dBm	100 kHz	This requirement does not apply to Home BS operating in band 24, since it is already covered by the requirement in clause 6.6.4.5.3.
UTRA FDD Band XXV or E-UTRA Band 25	1850 - 1915 MHz	-71 dBm	100 kHz	This requirement does not apply to Home BS operating in band 25, since it is already covered by the requirement in clause 6.6.4.5.3.
UTRA FDD Band XXVI or E-UTRA Band 26	814 - 849 MHz	-71 dBm	100 kHz	This requirement does not apply to Home BS operating in band 26, since it is already covered by the requirement in clause 6.6.4.5.3. For Home BS operating in Band 5, it applies for 814 MHz to 824 MHz, while the rest is covered in clause 6.6.4.5.3.
E-UTRA Band 27	807 - 824 MHz	-71 dBm	100 kHz	This requirement does not apply to Home BS operating in band 27, since it is already covered by the requirement in clause 6.6.4.5.3. For Home BS operating in Band 26, it applies for 807 MHz to 814 MHz, while the rest is covered in clause 6.6.4.5.3. This requirement also applies to E-UTRA BS operating in Band 28, starting 4 MHz above the Band 28 downlink operating band (Note 4).
E-UTRA Band 28	703 – 748 MHz	-71 dBm	100 kHz	This requirement does not apply to Home BS operating in band 28, since it is already covered by the requirement in clause 6.6.4.5.3. This requirement does not apply to Home BS operating in Band 44. For E-UTRA BS operating in Band 67, it applies for 703 MHz to 736 MHz. For E-UTRA BS operating in Band 68, it applies for 728MHz to 733MHz.

E-UTRA Band 30	2305 – 2315 MHz	-71 dBm	100 kHz	This requirement does not apply to Home BS operating in band 30, since it is already covered by the requirement in clause 6.6.4.5.3. This requirement does not apply to Home BS operating in Band 40.
UTRA TDD Band a) or E-UTRA Band 33	1900 - 1920 MHz	-71 dBm	100 kHz	This requirement does not apply to Home BS operating in Band 33.
UTRA TDD Band a) or E-UTRA Band 34	2010 - 2025 MHz	-71 dBm	100 kHz	This requirement does not apply to Home BS operating in Band 34.
UTRA TDD Band b) or E-UTRA Band 35	1850 - 1910 MHz	-71 dBm	100 kHz	This requirement does not apply to Home BS operating in Band 35.
UTRA TDD Band b) or E-UTRA Band 36	1930 - 1990 MHz	-71 dBm	100 kHz	This requirement does not apply to Home BS operating in Band 2 and 36.
UTRA TDD Band c) or E-UTRA Band 37	1910 - 1930 MHz	-71 dBm	100 kHz	This requirement does not apply to Home BS operating in Band 37. This unpaired band is defined in ITU-R M.1036, but is pending any future deployment.
UTRA TDD Band d) or E-UTRA Band 38	2570 - 2620 MHz	-71 dBm	100 kHz	This requirement does not apply to Home BS operating in Band 38.
UTRA TDD Band f) or E-UTRA Band 39	1880 - 1920MHz	-71 dBm	100 kHz	This is not applicable to Home BS operating in Band 39.
UTRA TDD Band e) or E-UTRA Band 40	2300 - 2400MHz	-71 dBm	100 kHz	This is not applicable to Home BS operating in Band 30 or 40.
E-UTRA Band 41	2496 – 2690 MHz	-71 dBm	100 kHz	This is not applicable to Home BS operating in Band 41.
E-UTRA Band 42	3400 - 3600 MHz	-71 dBm	100 kHz	This is not applicable to Home BS operating in Band 22, 42, 43, 48 or 52
E-UTRA Band 43	3600 - 3800 MHz	-71 dBm	100 kHz	This is not applicable to Home BS operating in Band 42, 43 or 48
E-UTRA Band 44	703 - 803 MHz	-71 dBm	100 kHz	This is not applicable to Home BS operating in Band 28 or 44
E-UTRA Band 48	3550 - 3700 MHz	-71 dBm	100 kHz	This is not applicable to Home BS operating in Band 22, 42, 43 or 48.
E-UTRA Band 50	1432 - 1517 MHz	-71 dBm	100 kHz	This requirement does not apply to Home BS operating in Band 11, 21, 32, 50, 51, 74, 75 or 76.
E-UTRA Band 51	1427 - 1432 MHz	-71 dBm	100 kHz	This requirement does not apply to Home BS operating in Band 50, 51, 75 or 76.
E-UTRA Band 52	3300 - 3400 MHz	-71 dBm	100 kHz	This is not applicable to Home BS operating in Band 42 or 52
E-UTRA Band 65	1920 - 2010 MHz	-71 dBm	100 kHz	This requirement does not apply to Home BS operating in band 65, since it is already covered by the requirement in clause 6.6.4.5.3. For Home BS operating in Band 1, it applies for 1980 MHz to 2010 MHz, while the rest is covered in clause 6.6.4.5.3.
E-UTRA Band 66	1710 - 1780 MHz	-71 dBm	100 kHz	This requirement does not apply to Home BS operating in band 66, since it is already covered by the requirement in clause 6.6.4.5.3. For Home BS operating in Band 4, it applies for 1755 MHz to 1780 MHz, while the rest is covered in clause 6.6.4.5.3. For Home BS operating in Band 10, it applies for 1770 MHz to 1780 MHz, while the rest is covered in clause 6.6.4.5.3.

E-UTRA Band 68	698-728 MHz	-71 dBm	100 kHz	This requirement does not apply to Home BS operating in band 68, since it is already covered by the requirement in clause 6.6.4.5.3. For Home BS operating in Band 28, it applies between 698 MHz and 703 MHz, while the rest is covered in clause 6.6.4.5.3.
E-UTRA Band 70	1695-1710 MHz	-71 dBm	100 kHz	This requirement does not apply to Home BS operating in band 70, since it is already covered by the requirement in clause 6.6.4.5.3.
E-UTRA Band 71	663 – 698 MHz	-71 dBm	100 kHz	This requirement does not apply to Home BS operating in band 71, since it is already covered by the requirement in clause 6.6.4.5.3.
E-UTRA Band 74	1427 – 1470 MHz	-71 dBm	100 kHz	This requirement does not apply to Home BS operating in Band 74, since it is already covered by the requirement in clause 6.6.4.5.3 This requirement does not apply to BS operating in band 32, 50, 51, 75 or 76.
E-UTRA Band 85	698 - 716 MHz	-71 dBm	100 kHz	This requirement does not apply to Home BS operating in band 85, since it is already covered by the requirement in clause 6.6.4.5.3. For Home BS operating in Band 29, it applies 1 MHz below the Band 29 downlink operating band (Note 5).

NOTE 1: As defined in the scope for spurious emissions in this clause, except for the cases where the noted requirements apply to a BS operating in Band 27, Band 28 or Band 29, the coexistence requirements in Table 6.6.4.5.4-1a do not apply for the 10 MHz frequency range immediately outside the Home BS transmit frequency range of a downlink operating band (see Table 5.5-1). Emission limits for this excluded frequency range may be covered by local or regional requirements.

NOTE 2: Table 6.6.4.5.4-1a assumes that two operating bands, where the frequency ranges in Table 5.5-1 would be overlapping, are not deployed in the same geographical area. For such a case of operation with overlapping frequency arrangements in the same geographical area, special co-existence requirements may apply that are not covered by the 3GPP specifications.

NOTE 3: TDD base stations deployed in the same geographical area, that are synchronized and use the same or adjacent operating bands can transmit without additional co-existence requirements. For unsynchronized base stations, special co-existence requirements may apply that are not covered by the 3GPP specifications.

NOTE 4: For E-UTRA Band 28 BS, specific solutions may be required to fulfil the spurious emissions limits for E-UTRA BS for co-existence with E-UTRA Band 27 UL operating band.

NOTE 5: For E-UTRA Band 29 BS, specific solutions may be required to fulfil the spurious emissions limits for E-UTRA BS for co-existence with UTRA Band XII or E-UTRA Band 12 UL operating band, E-UTRA Band 17 UL operating band or E-UTRA Band 85 UL operating band.

The following requirement may be applied for the protection of PHS. This requirement is also applicable at specified frequencies falling between 10 MHz below the lowest BS transmitter frequency of the downlink operating band and 10 MHz above the highest BS transmitter frequency of the downlink operating band (see Table 5.5-1).

The power of any spurious emission shall not exceed:

Table 6.6.4.5.4-2: E-UTRA BS Spurious emissions limits for BS for co-existence with PHS

Frequency range	Maximum Level	Measurement Bandwidth	Note
1884.5 - 1915.7 MHz	-41 dBm	300 kHz	Applicable when co-existence with PHS system operating in 1884.5 -1915.7MHz

The following requirement shall be applied to BS operating in Bands 13 and 14 to ensure that appropriate interference protection is provided to 700 MHz public safety operations. This requirement is also applicable at the frequency range from 10 MHz below the lowest frequency of the BS transmitter operating band up to 10 MHz above the highest frequency of the BS transmitter operating band. The power of any spurious emission shall not exceed:

Table 6.6.4.5.4-3: BS Spurious emissions limits for protection of 700 MHz public safety operations

Operating Band	Band	Maximum Level	Measurement Bandwidth	Note
13	763 - 775 MHz	-46 dBm	6.25 kHz	
13	793 - 805 MHz	-46 dBm	6.25 kHz	
14	769 - 775 MHz	-46 dBm	6.25 kHz	
14	799 - 805 MHz	-46 dBm	6.25 kHz	

Table 6.6.4.5.4-4: Void

The following requirement shall be applied to BS operating in Band 26 to ensure that appropriate interference protection is provided to 800 MHz public safety operations. This requirement is also applicable at the frequency range from 10 MHz below the lowest frequency of the BS downlink operating band up to 10 MHz above the highest frequency of the BS downlink operating band.

The power of any spurious emission shall not exceed:

Table 6.6.4.5.4-5: BS Spurious emissions limits for protection of 800 MHz public safety operations

Operating Band	Frequency range	Maximum Level	Measurement Bandwidth	Note
26	851 - 859 MHz	-13 dBm	100 kHz	Applicable for offsets > 37.5kHz from the channel edge

The following requirement may apply to E-UTRA BS operating in Band 41 in certain regions. This requirement is also applicable at the frequency range from 10 MHz below the lowest frequency of the BS downlink operating band up to 10 MHz above the highest frequency of the BS downlink operating band.

The power of any spurious emission shall not exceed:

Table 6.6.4.5.4-6: Additional E-UTRA BS Spurious emissions limits for Band 41

Frequency range	Maximum Level	Measurement Bandwidth	Note
2505 MHz – 2535 MHz	-42 dBm	1 MHz	
NOTE: This requirement applies for 10 or 20 MHz E-UTRA carriers allocated within 2545-2645 MHz.			

The following requirement may apply to E-UTRA BS operating in Band 30 in certain regions. This requirement is also applicable at the frequency range from 10 MHz below the lowest frequency of the BS downlink operating band up to 10 MHz above the highest frequency of the BS downlink operating band.

The power of any spurious emission shall not exceed:

Table 6.6.4.5.4-7: Additional E-UTRA BS Spurious emissions limits for Band 30

Frequency range	Maximum Level	Measurement Bandwidth	Note
2200MHz – 2345MHz	-45dBm	1 MHz	
2362.5MHz – 2365MHz	-25dBm	1 MHz	
2365MHz – 2367.5MHz	-40dBm	1 MHz	
2367.5MHz – 2370MHz	-42dBm	1 MHz	
2370MHz – 2395MHz	-45dBm	1 MHz	

In addition for Band 46 operation, the BS may have to comply with the applicable spurious emission limits established regionally, when deployed in regions where those limits apply and under the conditions declared by the manufacturer. The regional requirements may be in the form of conducted power, power spectral density, EIRP and other types of limits. In case of regulatory limits based on EIRP, assessment of the EIRP level is described in Annex H of TS 36.104 [2].

The following requirement may apply to E-UTRA BS operating in Band 48 and Band 49 in certain regions. The power of any spurious emission shall not exceed:

Table 6.6.4.5.4-8: Additional E-UTRA BS Spurious emissions limits for Band 48 and Band 49

Frequency range	Maximum Level	Measurement Bandwidth	Note
3530MHz – 3720MHz	-25dBm	1 MHz	Applicable 10MHz from the assigned channel edge
3100MHz – 3530MHz 3720MHz – 4200MHz	-40dBm	1 MHz	

6.6.4.5.5 Co-location with other base stations

These requirements may be applied for the protection of other BS receivers when GSM900, DCS1800, PCS1900, GSM850, CDMA850, UTRA FDD, UTRA TDD E-UTRA and/or NR BS are co-located with an E-UTRA or NB-IoT BS.

The requirements assume a 30 dB coupling loss between transmitter and receiver and are based on co-location with base stations of the same class.

The power of any spurious emission shall not exceed the limits of Table 6.6.4.5.5-1 for a Wide Area BS where requirements for co-location with a BS type listed in the first column apply. For BS capable of multi-band operation, the exclusions and conditions in the Note column of Table 6.6.4.5.5-1 apply for each supported operating band. For BS

capable of multi-band operation where multiple bands are mapped on separate antenna connectors, the exclusions and conditions in the Note column of Table 6.6.4.5.5-1 apply for the operating band supported at that antenna connector.

Table 6.6.4.5.5-1: BS Spurious emissions limits for Wide Area BS co-located with another BS

Type of co-located BS	Frequency range for co-location requirement	Maximum Level	Measurement Bandwidth	Note
Macro GSM900	876-915 MHz	-98 dBm	100 kHz	
Macro DCS1800	1710 - 1785 MHz	-98 dBm	100 kHz	
Macro PCS1900	1850 - 1910 MHz	-98 dBm	100 kHz	
Macro GSM850 or CDMA850	824 - 849 MHz	-98 dBm	100 kHz	
WA UTRA FDD Band I or E-UTRA Band 1 or NR band n1	1920 - 1980 MHz	-96 dBm	100 kHz	
WA UTRA FDD Band II or E-UTRA Band 2 or NR band n2	1850 - 1910 MHz	-96 dBm	100 kHz	
WA UTRA FDD Band III or E-UTRA Band 3 or NR band n3	1710 - 1785 MHz	-96 dBm	100 kHz	
WA UTRA FDD Band IV or E-UTRA Band 4	1710 - 1755 MHz	-96 dBm	100 kHz	
WA UTRA FDD Band V or E-UTRA Band 5 or NR band n5	824 - 849 MHz	-96 dBm	100 kHz	
WA UTRA FDD Band VI, XIX or E-UTRA Band 6, 19	830 - 845 MHz	-96 dBm	100 kHz	
WA UTRA FDD Band VII or E-UTRA Band 7 or Nrband n7	2500 - 2570 MHz	-96 dBm	100 kHz	
WA UTRA FDD Band VIII or E-UTRA Band 8 or NR band n8	880 - 915 MHz	-96 dBm	100 kHz	
WA UTRA FDD Band IX or E-UTRA Band 9	1749.9 - 1784.9 MHz	-96 dBm	100 kHz	
WA UTRA FDD Band X or E-UTRA Band 10	1710 - 1770 MHz	-96 dBm	100 kHz	
WA UTRA FDD Band XI or E-UTRA Band 11	1427.9 – 1447.9 MHz	-96 dBm	100 kHz	This is not applicable to E-UTRA BS operating in Band 50 or 75
WA UTRA FDD Band XII or E-UTRA Band 12 or NR band n12	699 - 716 MHz	-96 dBm	100 kHz	
WA UTRA FDD Band XIII or E-UTRA Band 13	777 - 787 MHz	-96 dBm	100 kHz	
WA UTRA FDD Band XIV or E-UTRA Band 14 or NR Band n14	788 - 798 MHz	-96 dBm	100 kHz	
WA E-UTRA Band 17	704 - 716 MHz	-96 dBm	100 kHz	
WA E-UTRA Band 18 or NR Band n18	815 - 830 MHz	-96 dBm	100 kHz	
WA UTRA FDD Band XX E-UTRA Band 20 or NR band n20	832 - 862 MHz	-96 dBm	100 kHz	
WA UTRA FDD Band XXI or E-UTRA Band 21	1447.9 – 1462.9 MHz	-96 dBm	100 kHz	This is not applicable to E-UTRA BS operating in Band 32, 50 or 75
WA UTRA FDD Band XXII or E-UTRA Band 22	3410 – 3490 MHz	-96 dBm	100 kHz	This is not applicable to E-UTRA BS operating in Band 42
WA E-UTRA Band 24	1626.5 – 1660.5 MHz	-96 dBm	100 kHz	

WA UTRA FDD Band XXV or E-UTRA Band 25 or NR Band n25	1850 – 1915 MHz	-96 dBm	100 kHz	
WA UTRA FDD Band XXVI or E-UTRA Band 26 or NR Band n26	814 – 849 MHz	-96 dBm	100 kHz	
WA E-UTRA Band 27	807 - 824 MHz	-96 dBm	100 kHz	
WA E-UTRA Band 28 or NR band n28	703 – 748 MHz	-96 dBm	100 kHz	This is not applicable to E-UTRA BS operating in Band 44
WA E-UTRA Band 30 or NR Band n30	2305 – 2315 MHz	-96 dBm	100 kHz	This is not applicable to E-UTRA BS operating in Band 40
WA E-UTRA Band 31	452.5 – 457.5 MHz	-96 dBm	100 kHz	
WA UTRA TDD Band a) or E-UTRA Band 33	1900 - 1920 MHz	-96 dBm	100 kHz	This is not applicable to E-UTRA BS operating in Band 33
WA UTRA TDD Band a) or E-UTRA Band 34 or NR band n34	2010 - 2025 MHz	-96 dBm	100 kHz	This is not applicable to E-UTRA BS operating in Band 34
WA UTRA TDD Band b) or E-UTRA Band 35	1850 – 1910 MHz	-96 dBm	100 kHz	This is not applicable to E-UTRA BS operating in Band 35
WA UTRA TDD Band b) or E-UTRA Band 36	1930 - 1990 MHz	-96 dBm	100 kHz	This is not applicable to E-UTRA BS operating in Band 2 and 36
WA UTRA TDD Band c) or E-UTRA Band 37	1910 - 1930 MHz	-96 dBm	100 kHz	This is not applicable to E-UTRA BS operating in Band 37. This unpaired band is defined in ITU-R M.1036, but is pending any future deployment.
WA UTRA TDD Band d) or E-UTRA Band 38 or NR band n38	2570 – 2620 MHz	-96 dBm	100 kHz	This is not applicable to E-UTRA BS operating in Band 38.
WA UTRA TDD Band f) or E-UTRA Band 39 or NR band n39	1880 – 1920MHz	-96 dBm	100 kHz	This is not applicable to E-UTRA BS operating in Band 33 and 39
WA UTRA TDD Band e) or E-UTRA Band 40 or NR band n40	2300 – 2400MHz	-96 dBm	100 kHz	This is not applicable to E-UTRA BS operating in Band 30 or 40
WA E-UTRA Band 41 or NR band n41	2496 – 2690 MHz	-96 dBm	100 kHz	This is not applicable to E-UTRA BS operating in Band 41
WA E-UTRA Band 42	3400 – 3600 MHz	-96 dBm	100 kHz	This is not applicable to E-UTRA BS operating in Band 22, 42, 43, 48 or 52

WA E-UTRA Band 43	3600 – 3800 MHz	-96 dBm	100 kHz	This is not applicable to E-UTRA BS operating in Band 42, 43 or 48
WA E-UTRA Band 44	703 – 803 MHz	-96 dBm	100 kHz	This is not applicable to E-UTRA BS operating in Band 28 or 44
WA E-UTRA Band 45	1447 – 1467 MHz	-96 dBm	100 kHz	This is not applicable to E-UTRA BS operating in Band 45
WA E-UTRA Band 48 or NR band n48	3550 – 3700 MHz	-96 dBm	100 kHz	This is not applicable to E-UTRA BS operating in Band 42, 43 or 48
WA E-UTRA Band 50 or NR band n50	1432 – 1517 MHz	-96 dBm	100 kHz	This is not applicable to E-UTRA BS operating in Band 11, 21, 32, 74 or 75
WA E-UTRA Band 52	3300 – 3400 MHz	-96 dBm	100 kHz	This is not applicable to E-UTRA BS operating in Band 42 or 52
WA E-UTRA Band 65 or NR band n65	1920 - 2010 MHz	-96 dBm	100 kHz	
WA E-UTRA Band 66 or NR band n66	1710 - 1780 MHz	-96 dBm	100 kHz	
WA E-UTRA Band 68	698 - 728 MHz	-96 dBm	100 kHz	
WA E-UTRA Band 70 or NR band n70	1695 - 1710 MHz	-96 dBm	100 kHz	
WA E-UTRA Band 71 or NR band n71	663 - 698 MHz	-96 dBm	100 kHz	
WA E-UTRA Band 72	451 - 456 MHz	-96 dBm	100 kHz	
WA E-UTRA Band 73	450 - 455 MHz	-96 dBm	100 kHz	
WA E-UTRA Band 74 or NR band n74	1427 – 1470 MHz	-96 dBm	100 kHz	This is not applicable to E-UTRA BS operating in Band 50
WA NR band n77	3300 – 4200 MHz	-96 dBm	100 kHz	This is not applicable to E-UTRA BS operating in Band 22, 42, 43, 48 or 52
WA NR band n78	3300 – 3800 Mz	-96 dBm	100 kHz	This is not applicable to E-UTRA BS operating in Band 22, 42, 43, 48 or 52
WA NR Band n79	4.4 – 5.0 GHz	-96 dBm	100 kHz	
WA NR Band n80	1710 – 1785 MHz	-96 dBm	100 kHz	
WA NR Band n81	880 – 915 MHz	-96 dBm	100 kHz	
WA NR Band n82	832 – 862 MHz	-96 dBm	100 kHz	
WA NR Band n83	703 – 748 MHz	-96 dBm	100 kHz	
WA NR Band n84	1920 – 1980 MHz	-96 dBm	100 kHz	
WA E-UTRA Band 85	698 - 716 MHz	-96 dBm	100 kHz	
WA NR Band n86	1710 – 1780 MHz	-96 dBm	100 kHz	
WA E-UTRA Band 87	410 - 415 MHz	-96 dBm	100 kHz	
WA E-UTRA Band 88	412 - 417 MHz	-96 dBm	100 kHz	
WA NR Band n89	824 – 849 MHz	-96 dBm	100 kHz	
WA NR Band n92	832 – 862 MHz	-96 dBm	100 kHz	
WA NR Band n94	880 – 915 MHz	-96 dBm	100 kHz	
WA NR Band n95	2010 - 2025 MHz	-96 dBm	100 kHz	

The power of any spurious emission shall not exceed the limits of Table 6.6.4.5.5-2 for a Local Area BS where requirements for co-location with a BS type listed in the first column apply. For BS capable of multi-band operation, the exclusions and conditions in the Note column of Table 6.6.4.5.5-2 apply for each supported operating band. For BS capable of multi-band operation where multiple bands are mapped on separate antenna connectors, the exclusions and conditions in the Note column of Table 6.6.4.5.5-2 apply for the operating band supported at that antenna connector.

Table 6.6.4.5.5-2: BS Spurious emissions limits for Local Area BS co-located with another BS

Type of co-located BS	Frequency range for co-location requirement	Maximum Level	Measurement Bandwidth	Note
Pico GSM900	876-915 MHz	-70 dBm	100 kHz	
Pico DCS1800	1710 - 1785 MHz	-80 dBm	100 kHz	
Pico PCS1900	1850 - 1910 MHz	-80 dBm	100 kHz	
Pico GSM850	824 - 849 MHz	-70 dBm	100 kHz	
LA UTRA FDD Band I or E-UTRA Band 1 or NR band n1	1920 - 1980 MHz	-88 dBm	100 kHz	
LA UTRA FDD Band II or E-UTRA Band 2 or NR band n2	1850 - 1910 MHz	-88 dBm	100 kHz	
LA UTRA FDD Band III or E-UTRA Band 3 or NR band n3	1710 - 1785 MHz	-88 dBm	100 kHz	
LA UTRA FDD Band IV or E-UTRA Band 4	1710 - 1755 MHz	-88 dBm	100 kHz	
LA UTRA FDD Band V or E-UTRA Band 5 or NR band n5	824 - 849 MHz	-88 dBm	100 kHz	
LA UTRA FDD Band VI, XIX or E-UTRA Band 6, 19	830 - 845 MHz	-88 dBm	100 kHz	
LA UTRA FDD Band VII or E-UTRA Band 7 or NR band n7	2500 - 2570 MHz	-88 dBm	100 kHz	
LA UTRA FDD Band VIII or E-UTRA Band 8 or NR band n8	880 - 915 MHz	-88 dBm	100 kHz	
LA UTRA FDD Band IX or E-UTRA Band 9	1749.9 - 1784.9 MHz	-88 dBm	100 kHz	
LA UTRA FDD Band X or E-UTRA Band 10	1710 - 1770 MHz	-88 dBm	100 kHz	
LA UTRA FDD Band XI or E-UTRA Band 11	1427.9 - 1447.9 MHz	-88 dBm	100 kHz	This is not applicable to E-UTRA BS operating in Band 50, 51, 75 or 76
LA UTRA FDD Band XII or E-UTRA Band 12 or NR band n12	699 - 716 MHz	-88 dBm	100 kHz	
LA UTRA FDD Band XIII or E-UTRA Band 13	777 - 787 MHz	-88 dBm	100 kHz	
LA UTRA FDD Band XIV or E-UTRA Band 14 or NR Band n14	788 - 798 MHz	-88 dBm	100 kHz	
LA E-UTRA Band 17	704 - 716 MHz	-88 dBm	100 kHz	
LA E-UTRA Band 18 or NR Band n18	815 - 830 MHz	-88 dBm	100 kHz	
LA UTRA FDD Band XX or E-UTRA Band 20 or NR band n20	832 - 862 MHz	-88 dBm	100 kHz	
LA UTRA FDD Band XXI or E-UTRA Band 21	1447.9 – 1462.9 MHz	-88 dBm	100 kHz	This is not applicable to E-UTRA BS operating in Band 32, 50 or 75
LA UTRA FDD Band XXII or E-UTRA Band 22	3410 – 3490 MHz	-88 dBm	100 kHz	This is not applicable to E-UTRA BS operating in Band 42
LA E-UTRA Band 24	1626.5 – 1660.5 MHz	-88 dBm	100 kHz	
LA UTRA FDD Band XXV or E-UTRA Band 25 or NR band n25	1850 – 1915 MHz	-88 dBm	100 kHz	
LA UTRA FDD Band XXVI or E-UTRA Band 26 or NR Band n26	814 – 849 MHz	-88 dBm	100 kHz	

LA E-UTRA Band 27	807 - 824 MHz	-88 dBm	100 kHz	
LA E-UTRA Band 28 or NR band n28	703 – 748 MHz	-88 dBm	100 KHz	This is not applicable to E-UTRA BS operating in Band 44
LA E-UTRA Band 30 or NR Band n30	2305 – 2315 MHz	-88 dBm	100 kHz	This is not applicable to E-UTRA BS operating in Band 40
LA E-UTRA Band 31	452.5 – 457.5 MHz	-88 dBm	100 kHz	
LA UTRA TDD Band a) or E-UTRA Band 33	1900 - 1920 MHz	-88 dBm	100 kHz	This is not applicable to E-UTRA BS operating in Band 33
LA UTRA TDD Band a) or E-UTRA Band 34 or NR band n34	2010 - 2025 MHz	-88 dBm	100 kHz	This is not applicable to E-UTRA BS operating in Band 34
LA UTRA TDD Band b) or E-UTRA Band 35	1850 – 1910 MHz	-88 dBm	100 kHz	This is not applicable to E-UTRA BS operating in Band 35
LA UTRA TDD Band b) or E-UTRA Band 36	1930 - 1990 MHz	-88 dBm	100 kHz	This is not applicable to E-UTRA BS operating in Band 2 and 36
LA UTRA TDD Band c) or E-UTRA Band 37	1910 - 1930 MHz	-88 dBm	100 kHz	This is not applicable to E-UTRA BS operating in Band 37. This unpaired band is defined in ITU-R M.1036, but is pending any future deployment.
LA UTRA TDD Band d) or E-UTRA Band 38 or NR band n38	2570 – 2620 MHz	-88 dBm	100 kHz	This is not applicable to E-UTRA BS operating in Band 38.
LA UTRA TDD Band f) or E-UTRA Band 39 or NR band n39	1880 – 1920MHz	-88 dBm	100 kHz	This is not applicable to E-UTRA BS operating in Band 33 and 39
LA UTRA TDD Band e) or E-UTRA Band 40 or NR band n40	2300 – 2400MHz	-88 dBm	100 kHz	This is not applicable to E-UTRA BS operating in Band 30 or 40
LA E-UTRA Band 41 or NR band n41	2496 – 2690 MHz	-88 dBm	100 kHz	This is not applicable to E-UTRA BS operating in Band 41 or 53
LA E-UTRA Band 42	3400 – 3600 MHz	-88 dBm	100 kHz	This is not applicable to E-UTRA BS operating in Band 22, 42, 43, 48, 49 or 52
LA E-UTRA Band 43	3600 – 3800 MHz	-88 dBm	100 kHz	This is not applicable to E-UTRA BS operating in Band 42, 43, 48 or 49
LA E-UTRA Band 44	703 – 803 MHz	-88 dBm	100 kHz	This is not applicable to E-UTRA BS operating in Band 28 or 44

LA E-UTRA Band 45	1447 – 1467 MHz	-88 dBm	100 kHz	This is not applicable to E-UTRA BS operating in Band 45
LA E-UTRA Band 46 or NR Band n46	5150 – 5925 MHz	-88 dBm	100 kHz	This is not applicable to E-UTRA BS operating in Band 46
LA E-UTRA Band 48 or NR band n48	3550 – 3700 MHz	-88 dBm	100 kHz	This is not applicable to E-UTRA BS operating in Band 42, 43, 48 or 49
LA E-UTRA Band 49	3550 – 3700 MHz	-88 dBm	100 kHz	This is not applicable to E-UTRA BS operating in Band 42, 43, 48 or 49
LA E-UTRA Band 50 or NR band n50	1432 – 1517 MHz	-88 dBm	100 kHz	This is not applicable to E-UTRA BS operating in Band 11, 21, 32, 51, 74, 75 or 76
LA E-UTRA Band 51 or NR band n51	1427 – 1432 MHz	-88 dBm	100 kHz	This is not applicable to E-UTRA BS operating in Band 50, 75 or 76
LA E-UTRA Band 52	3300 – 3400 MHz	-88 dBm	100 kHz	This is not applicable to E-UTRA BS operating in Band 42 or 52
LA E-UTRA Band 53 or NR Band n53	2483.5 – 2495 MHz	-88 dBm	100 kHz	This is not applicable to E-UTRA BS operating in Band 41 or 53
LA E-UTRA Band 65 or NR band n65	1920 - 2010 MHz	-88 dBm	100 kHz	
LA E-UTRA Band 66 or NR band n66	1710 - 1780 MHz	-88 dBm	100 kHz	
LA E-UTRA Band 68	698 - 728 MHz	-88 dBm	100 kHz	
LA E-UTRA Band 70 or NR band n70	1695 - 1710 MHz	-88 dBm	100 kHz	
LA E-UTRA Band 71 or NR band n71	663 - 698 MHz	-88 dBm	100 kHz	
LA E-UTRA Band 72	451 - 456 MHz	-88 dBm	100 kHz	
LA E-UTRA Band 73	450 - 455 MHz	-88 dBm	100 kHz	
LA E-UTRA Band 74 or NR band n74	1427 – 1470 MHz	-88 dBm	100 kHz	This is not applicable to E-UTRA BS operating in Band 50 or 51
LA NR band n77	3300 – 4200 MHz	-88 dBm	100 kHz	This is not applicable to E-UTRA BS operating in Band 22, 42, 43, 48, 49 or 52
LA NR band n78	3300 – 3800 MHz	-88 dBm	100 kHz	This is not applicable to E-UTRA BS operating in Band 22, 42, 43, 48, 49 or 52
LA NR Band n79	4.4 – 5.0 GHz	-88 dBm	100 kHz	
LA NR Band n80	1710 – 1785 MHz	-88 dBm	100 kHz	
LA NR Band n81	880 – 915 MHz	-88 dBm	100 kHz	
LA NR Band n82	832 – 862 MHz	-88 dBm	100 kHz	
LA NR Band n83	703 – 748 MHz	-88 dBm	100 kHz	
LA NR Band n84	1920 – 1980 MHz	-88 dBm	100 kHz	
LA E-UTRA Band 85	698 - 716 MHz	-88 dBm	100 kHz	

LA NR Band n86	1920 – 1980 MHz	-88 dBm	100 kHz	
LA E-UTRA Band 87	410 - 415 MHz	-88 dBm	100 kHz	
LA E-UTRA Band 88	412 - 417 MHz	-88 dBm	100 kHz	
LA NR Band n89	824 – 849 MHz	-88 dBm	100 kHz	
LA NR Band n91	832 – 862 MHz	-88 dBm	100 kHz	
LA NR Band n92	832 – 862 MHz	-88 dBm	100 kHz	
LA NR Band n93	880 – 915 MHz	-88 dBm	100 kHz	
LA NR Band n94	880 – 915 MHz	-88 dBm	100 kHz	
LA NR Band n95	2010 - 2025 MHz	-88 dBm	100 kHz	
LA NR Band n96	5925 - 7125 MHz	-87 dBm	100 kHz	This is not applicable to E-UTRA BS operating in Band 46

The power of any spurious emission shall not exceed the limits of Table 6.6.4.5.5-3 for a Medium Range BS where requirements for co-location with a BS type listed in the first column apply. For BS capable of multi-band operation, the exclusions and conditions in the Note column of Table 6.6.4.5.5-3 apply for each supported operating band. For BS

capable of multi-band operation where multiple bands are mapped on separate antenna connectors, the exclusions and conditions in the Note column of Table 6.6.4.5.5-3 apply for the operating band supported at that antenna connector.

Table 6.6.4.5.5-3: BS Spurious emissions limits for Medium range BS co-located with another BS

Type of co-located BS	Frequency range for co-location requirement	Maximum Level	Measurement Bandwidth	Note
Micro/MR GSM900	876-915 MHz	-91 dBm	100 kHz	
Micro/MR DCS1800	1710 - 1785 MHz	-91 dBm	100 kHz	
Micro/MR PCS1900	1850 - 1910 MHz	-91 dBm	100 kHz	
Micro/MR GSM850	824 - 849 MHz	-91 dBm	100 kHz	
MR UTRA FDD Band I or E-UTRA Band 1 or NR band n1	1920 - 1980 MHz	-91 dBm	100 kHz	
MR UTRA FDD Band II or E-UTRA Band 2 or NR band n2	1850 - 1910 MHz	-91 dBm	100 kHz	
MR UTRA FDD Band III or E-UTRA Band 3 or NR band n3	1710 - 1785 MHz	-91 dBm	100 kHz	
MR UTRA FDD Band IV or E-UTRA Band 4	1710 - 1755 MHz	-91 dBm	100 kHz	
MR UTRA FDD Band V or E-UTRA Band 5 or NR band n5	824 - 849 MHz	-91 dBm	100 kHz	
MR UTRA FDD Band VI, XIX or E-UTRA Band 6, 19	830 - 850 MHz	-91 dBm	100 kHz	
MR UTRA FDD Band VII or E-UTRA Band 7 or NR band n7	2500 - 2570 MHz	-91 dBm	100 KHz	
MR UTRA FDD Band VIII or E-UTRA Band 8 or NR band n8	880 - 915 MHz	-91 dBm	100 KHz	
MR UTRA FDD Band IX or E-UTRA Band 9	1749.9 - 1784.9 MHz	-91 dBm	100 KHz	
MR UTRA FDD Band X or E-UTRA Band 10	1710 - 1770 MHz	-91 dBm	100 kHz	
MR UTRA FDD Band XI or E-UTRA Band 11	1427.9 - 1447.9 MHz	-91 dBm	100 kHz	This is not applicable to E-UTRA BS operating in Band 50 or 75
MR UTRA FDD Band XII or E-UTRA Band 12 or NR band n12	699 - 716 MHz	-91 dBm	100 kHz	
MR UTRA FDD Band XIII or E-UTRA Band 13	777 - 787 MHz	-91 dBm	100 kHz	
MR UTRA FDD Band XIV or E-UTRA Band 14 or NR Band n14	788 - 798 MHz	-91 dBm	100 kHz	
MR E-UTRA Band 17	704 - 716 MHz	-91 dBm	100 kHz	
MR E-UTRA Band 18 or NR Band n18	815 - 830 MHz	-91 dBm	100 KHz	
MR UTRA FDD Band XX or E-UTRA Band 20 or NR band n20	832 - 862 MHz	-91 dBm	100 KHz	
MR UTRA FDD Band XXI or E-UTRA Band 21	1447.9 - 1462.9 MHz	-91 dBm	100 KHz	This is not applicable to E-UTRA BS operating in Band 32, 50 or 75
MR UTRA FDD Band XXII or E-UTRA Band 22	3410 – 3490 MHz	-91 dBm	100 kHz	This is not applicable to E-UTRA BS operating in Band 42
MR E-UTRA Band 24	1626.5 – 1660.5 MHz	-91 dBm	100 KHz	
MR UTRA FDD Band XXV or E-UTRA Band 25 or NR band n25 or NR Band n26	1850 – 1915 MHz	-91 dBm	100 kHz	
MR UTRA FDD Band XXVI or E-UTRA Band 26	814 – 849 MHz	-91 dBm	100 kHz	

MR E-UTRA Band 27	807 - 824 MHz	-91 dBm	100 kHz	
MR E-UTRA Band 28 or NR band n28	703 – 748 MHz	-91 dBm	100 KHz	This is not applicable to E-UTRA BS operating in Band 44
MR E-UTRA Band 30 or NR Band n30	2305 – 2315 MHz	-91 dBm	100 kHz	This is not applicable to E-UTRA BS operating in Band 40
MR E-UTRA Band 31	452.5 – 457.5 MHz	-91 dBm	100 kHz	
MR E-UTRA Band 33	1900 - 1920 MHz	-91 dBm	100 kHz	This is not applicable to E-UTRA BS operating in Band 33
MR E-UTRA Band 34 or NR band n34	2010 - 2025 MHz	-91 dBm	100 kHz	This is not applicable to E-UTRA BS operating in Band 34
MR E-UTRA Band 35	1850 – 1910 MHz	-91 dBm	100 kHz	This is not applicable to E-UTRA BS operating in Band 35
MR E-UTRA Band 36	1930 - 1990 MHz	-91 dBm	100 kHz	This is not applicable to E-UTRA BS operating in Band 2 and 36
MR E-UTRA Band 37	1910 - 1930 MHz	-91 dBm	100 kHz	This is not applicable to E-UTRA BS operating in Band 37. This unpaired band is defined in ITU-R M.1036, but is pending any future deployment.
MR E-UTRA Band 38 or NR band n38	2570 – 2620 MHz	-91 dBm	100 kHz	This is not applicable to E-UTRA BS operating in Band 38.
MR E-UTRA Band 39 or NR band n39	1880 – 1920MHz	-91 dBm	100 kHz	This is not applicable to E-UTRA BS operating in Band 33 and 39
MR E-UTRA Band 40 or NR band n40	2300 – 2400MHz	-91 dBm	100 kHz	This is not applicable to E-UTRA BS operating in Band 30 or 40
MR E-UTRA Band 41 or NR band n41	2496 – 2690 MHz	-91 dBm	100 kHz	This is not applicable to E-UTRA BS operating in Band 41 or 53
MR E-UTRA Band 42	3400 – 3600 MHz	-91 dBm	100 kHz	This is not applicable to E-UTRA BS operating in Band 22, 42, 43, 48 or 52
MR E-UTRA Band 43	3600 – 3800 MHz	-91 dBm	100 kHz	This is not applicable to E-UTRA BS operating in Band 42, 43 or 48
MR E-UTRA Band 44	703 – 803 MHz	-91 dBm	100 kHz	This is not applicable to E-UTRA BS operating in Band 28 or 44

MR E-UTRA Band 45	1447 – 1467 MHz	-91 dBm	100 kHz	This is not applicable to E-UTRA BS operating in Band 45
MR E-UTRA Band 46 or NR Band n46	5150 – 5925 MHz	-91 dBm	100 kHz	This is not applicable to E-UTRA BS operating in Band 46
MR E-UTRA Band 48 or NR band n48	3550 – 3700 MHz	-91 dBm	100 kHz	This is not applicable to E-UTRA BS operating in Band 42, 43 or 48
MR E-UTRA Band 50 or NR band n50	1432 – 1517 MHz	-91 dBm	100 kHz	This is not applicable to E-UTRA BS operating in Band 11, 21, 32, 51, 74, 75 or 76
MR E-UTRA Band 52	3300 – 3400 MHz	-91 dBm	100 kHz	This is not applicable to E-UTRA BS operating in Band 42 or 52
MR E-UTRA Band 53 or NR Band n53	2483.5 – 2495 MHz	-91 dBm	100 kHz	This is not applicable to E-UTRA BS operating in Band 41 or 53
MR E-UTRA Band 65 or NR band n65	1920 - 2010 MHz	-91 dBm	100 kHz	
MR E-UTRA Band 66 or NR band n66	1710 - 1780 MHz	-91 dBm	100 kHz	
MR E-UTRA Band 68	698 - 728 MHz	-91 dBm	100 kHz	
MR E-UTRA Band 70 or NR band n70	1695 - 1710 MHz	-91 dBm	100 kHz	
MR E-UTRA Band 71	663 - 698 MHz	-91 dBm	100 kHz	
MR E-UTRA Band 72	451 - 456 MHz	-91 dBm	100 kHz	
MR E-UTRA Band 73	450 - 455 MHz	-91 dBm	100 kHz	
MR E-UTRA Band 74 or NR band n74	1427 – 1470 MHz	-91 dBm	100 kHz	This is not applicable to E-UTRA BS operating in Band 50
MR NR band n77	3300 – 4200 MHz	-91 dBm	100 kHz	This is not applicable to E-UTRA BS operating in Band 22, 42, 43, 48 or 52
MR NR band n78	3300 – 3800 MHz	-91 dBm	100 kHz	This is not applicable to E-UTRA BS operating in Band 22, 42, 43, 48 or 52
MR NR Band n79	4.4 – 5.0 GHz	-91 dBm	100 kHz	
MR NR Band n80	1710 – 1785 MHz	-91 dBm	100 kHz	
MR NR Band n81	880 – 915 MHz	-91 dBm	100 kHz	
MR NR Band n82	832 – 862 MHz	-91 dBm	100 kHz	
MR NR Band n83	703 – 748 MHz	-91 dBm	100 kHz	
MR NR Band n84	1920 – 1980 MHz	-91 dBm	100 kHz	
MR E-UTRA Band 85	698 - 716 MHz	-91 dBm	100 kHz	
MR NR Band n86	1710 – 1780 MHz	-91 dBm	100 kHz	
MR E-UTRA Band 87	410 - 415 MHz	-91 dBm	100 kHz	
MR E-UTRA Band 88	412 - 417 MHz	-91 dBm	100 kHz	
MR NR Band n89	824 – 849 MHz	-91 dBm	100 kHz	
MR NR Band n92	832 – 862 MHz	-91 dBm	100 kHz	
MR NR Band n94	880 – 915 MHz	-91 dBm	100 kHz	
MR NR Band n95	2010 - 2025 MHz	-91 dBm	100 kHz	
MR NR Band n96	5925 - 7125 MHz	-90 dBm	100 kHz	This is not applicable to E-UTRA BS operating in Band 46

NOTE 1: As defined in the scope for spurious emissions in this clause, the co-location requirements in Table 6.6.4.5.5-1 to Table 6.6.4.5.5-3 do not apply for the 10 MHz frequency range immediately outside the BS transmit frequency range of a downlink operating band (see Table 5.5-1). The current state-of-the-art technology does not allow a single generic solution for co-location with other system on adjacent frequencies for 30dB BS-BS minimum coupling loss. However, there are certain site-engineering solutions that can be used. These techniques are addressed in TR 25.942 [11].

NOTE 2: Tables 6.6.4.5.5-1 to 6.6.4.5.5-3 assume that two operating bands, where the corresponding eNode B transmit and receive frequency ranges in Table 5.3-1 would be overlapping, are not deployed in the same geographical area. For such a case of operation with overlapping frequency arrangements in the same geographical area, special co-location requirements may apply that are not covered by the 3GPP specifications.

NOTE 3: Co-located TDD base stations that are synchronized and using the same or adjacent operating band can transmit without special co-locations requirements. For unsynchronized base stations, special co-location requirements may apply that are not covered by the 3GPP specifications.

6.7 Transmitter intermodulation

6.7.1 Definition and applicability

The transmitter intermodulation requirement is a measure of the capability of the transmitter to inhibit the generation of signals in its non-linear elements caused by presence of the wanted signal and an interfering signal reaching the transmitter via the antenna. The requirement applies during the transmitter ON period and the transmitter transient period.

For BS capable of multi-band operation where multiple bands are mapped on separate antenna connectors, the single-band requirements apply regardless of the interfering signals position relative to the Inter RF Bandwidth gap.

The transmit intermodulation level is the power of the intermodulation products when an E-UTRA signal of channel bandwidth 5 MHz as an interfering signal is injected into an antenna connector at a power level of 30 dB lower than that of the rated total output power in the operating band.

The wanted signal is E-UTRA single carrier or multi-carrier, or multiple contiguously aggregated carriers, for both contiguous and non-contiguous spectrum operation.

The interfering signal centre frequency offset shall be as in Table 6.7.1-1.

Table 6.7.1-1: Interfering signal centre frequency offset

Parameter	Value
Interfering signal centre frequency offset from the lower/upper edge of the wanted signal or edge of sub-block inside a sub-block gap	± 2.5 MHz ± 7.5 MHz ± 12.5 MHz
NOTE 1: Interfering signal positions that are partially or completely outside of the downlink operating band of the base station are excluded from the requirement, unless the interfering signal positions fall within the frequency range of adjacent downlink operating bands in the same geographical area.	
NOTE 2: In certain regions, NOTE 1 is not applied in Band 1, 3, 8, 9, 11, 18, 19, 21, 28, 32 operating within 1475.9-1495.9MHz, 34, 74.	

The wanted signal channel bandwidth BW_{Channel} shall be the maximum channel bandwidth supported by the base station.

The requirements shall apply whatever the type of transmitter considered (single carrier, multi-carrier and/or CA) and for all transmission modes foreseen by the manufacturer's specification.

In case that none of the interfering signal positions according to the conditions of Table 6.7.1-1 is applicable, a wanted signal channel bandwidth BW_{Channel} less than the maximum channel bandwidth supported by the base station shall be selected so that at least one applicable interfering signal position according to Table 6.7.1-1 is obtained.

6.7.2 Minimum Requirement

The minimum requirement is in TS 36.104 [2] subclause 6.7.1.

6.7.2A Additional requirement for Band 41

The additional requirement for Band 41 in certain regions is in TS 36.104 [2] subclause 6.7.2.

6.7.3 Test purpose

The test purpose is to verify the ability of the BS transmitter to restrict the generation of intermodulation products in its non-linear elements caused by presence of the wanted signal and an interfering signal reaching the transmitter via the antenna to below specified levels.

6.7.4 Method of test

6.7.4.1 Initial conditions

Test environment: normal; see Annex D.2.

RF channels to be tested for single carrier: B, M and T; see subclause 4.7.

Base Station RF Bandwidth positions to be tested for multi-carrier and/or CA: B_{RFBW} , M_{RFBW} and T_{RFBW} ; see subclause 4.7.1.

Connect the signal analyzer to the base station antenna connector as shown in Annex I.1.2.

6.7.4.2 Procedures

- 1) For a n E-UTRABS declared to be capable of single carrier operation only, generate the wanted signal according to E-TM1.1 at manufacturer's declared rated output power.

For a n E-UTRABS declared to be capable of multi-carrier and/or CA operation, set the base station to transmit according to E-TM1.1 on all carriers configured using the applicable test configuration and corresponding power setting specified in clause 4.10 and 4.11.

For an E-UTRA BS declared to be capable of NB-IoT in-band operation, start transmission according to E-TM1.1 with the NB-IoT PRB constructed according to N-TM at manufacturer's declared rated output power using the applicable test configuration and corresponding power setting specified in clause 4.10 and 4.11.

For an E-UTRA BS declared to be capable of NB-IoT guard-band operation, start transmission according to E-TM1.1 with the NB-IoT PRB constructed according to N-TM at manufacturer's declared rated output power using the applicable test configuration and corresponding power setting specified in clause 4.10 and 4.11.

For a NB-IoT BS declared to be capable of single carrier operation, start transmission according to N-TM at manufacturer's declared rated output power.

For a NB-IoT BS declared to be capable of multi-carrier operation, set the base station to transmit according to N-TM on all carriers configured using in the applicable test configuration and corresponding power setting specified in clause 4.10 and 4.11.

For an E-UTRA and NB-IoT standalone BS declared to be capable of multi-carrier operation, start transmission according to E-TM1.1 on all E-UTRA carriers and N-TM on all NB-IoT carriers configured using in the applicable test configuration and corresponding power setting specified in clause 4.10 and 4.11.

- 2) Generate the interfering signal according to E-TM1.1, with 5 MHz channel bandwidth and a centre frequency offset according to the conditions of Table 6.7.1-1 but exclude interfering frequencies that are outside of the allocated downlink operating band or interfering frequencies that are not completely within the sub-block gap or within the Inter RF Bandwidth gap.
- 3) Adjust ATT1 so that level of the E-UTRA interfering signal is as defined in subclause 6.7.5.

- 4) Perform the Out-of-band emission tests as specified in subclauses 6.6.2 and 6.6.3, for all third and fifth order intermodulation products which appear in the frequency ranges defined in subclauses 6.6.2 and 6.6.3. The width of the intermodulation products shall be taken into account.
- 5) Perform the Transmitter spurious emissions test as specified in subclause 6.6.4, for all third and fifth order intermodulation products which appear in the frequency ranges defined in subclause 6.6.4. The width of the intermodulation products shall be taken into account.
- 6) Verify that the emission level does not exceed the required level with the exception of interfering signal frequencies.
- 7) Repeat the test for the remaining interfering signal centre frequency offsets according to the conditions of Table 6.7.1-1.

In addition, for a multi-band capable BS, the following step shall apply:

- 8) For multi-band capable BS and single band tests, repeat the steps above per involved band where single band test configurations and test models shall apply with no carrier activated in the other band. For multi-band capable BS with separate antenna connector, the antenna connector not being under test shall be terminated.

NOTE: The third order intermodulation products are centred at $2F1 \pm F2$ and $2F2 \pm F1$. The fifth order intermodulation products are centred at $3F1 \pm 2F2$, $3F2 \pm 2F1$, $4F1 \pm F2$, and $4F2 \pm F1$ where $F1$ represents the wanted signal centre frequency or centre frequency of each sub-block and $F2$ represents the interfering signal centre frequency.

The width of intermodulation products are:

- $(n \cdot BW_{F1} + m \cdot 5\text{MHz})$ for the $nF1 \pm mF2$ products
- $(n \cdot 5\text{MHz} + m \cdot BW_{F1})$ for the $nF2 \pm mF1$ products

where BW_{F1} represents the wanted signal RF bandwidth, or channel bandwidth in case of single carrier, or sub-block bandwidth.

6.7.5 Test Requirements

In the frequency range relevant for this test, the transmit intermodulation level shall not exceed the out-of-band emission requirements of subclauses 6.6.2 and 6.6.3 and transmitter spurious emissions requirements of subclause 6.6.4 in the presence of a E-UTRA interfering signal with a power level 30 dB below the rated total output power in the operating band.

The requirement is applicable outside the Base Station RF Bandwidth or Maximum Radio Bandwidth. The interfering signal offset is defined relative to the Base Station RF Bandwidth edges or Maximum Radio Bandwidth edges.

For a BS operating in non-contiguous spectrum, the requirement is also applicable inside a sub-block gap for interfering signal offsets where the interfering signal falls completely within the sub-block gap. The interfering signal offset is defined relative to the sub-block edges.

For a BS capable of multi-band operation, the requirement applies relative to the Base Station RF Bandwidth edge of each supported operating band. In case the Inter RF Bandwidth gap is less than 15 MHz, the requirement in the gap applies only for interfering signal offsets where the interfering signal falls completely within the Inter RF Bandwidth gap.

The measurements for out-of-band emissions and spurious emission requirements due to intermodulation can be limited to the frequency ranges of all third and fifth order intermodulation products, considering the width of these products and excluding the bandwidths of the wanted and interfering signals.

NOTE: If the above Test Requirement differs from the Minimum Requirement then the Test Tolerance applied for this test is non-zero. The Test Tolerance for this test is defined in Annex G. The explanation of how the Minimum Requirement has been relaxed by the Test Tolerance is given in Annex G.

6.7.6 Additional test requirements for Band 41

In the frequency range relevant for this test, the transmitter intermodulation level shall not exceed the maximum levels according to Table 6.6.2-2 with a square filter in the first adjacent channel, and Table 6.6.4.5.4-6 in the presence of a wanted signal and an interfering signal according to Table 6.7.2-1 in TS 36.104 [2] for a BS operating in Band 41. The measurement may be limited to frequencies on which third and fifth order intermodulation products appear, considering the width of these products and excluding the bandwidths of the wanted and interfering signals.

7 Receiver characteristics

7.1 General

General test conditions for receiver tests are given in Clause 4, including interpretation of measurement results and configurations for testing. BS configurations for the tests are defined in Clause 4.5, while Annex H provides an informative description of E-UTRAN test cases.

Unless otherwise stated the requirements in clause 7 apply during the base station receive period.

The throughput requirements defined for the receiver characteristics in this clause do not assume HARQ transmissions.

When the BS is configured to receive multiple carriers, all the throughput requirements are applicable for each received carrier. For ACS, blocking and intermodulation characteristics, the negative offsets of the interfering signal apply relative to the lower Base Station RF Bandwidth edge and positive offsets of the interfering signal apply relative to the upper Base Station RF Bandwidth edge.

Unless otherwise stated, a BS declared to be capable of E-UTRA with NB-IoT in-band or guard band operations is only required to pass the receiver tests for E-UTRA with NB-IoT in-band or guard band; it is not required to perform the receiver tests again for E-UTRA only.

For a BS declared to be capable of E-UTRA with NB-IoT in-band operations, it is not required to perform the receiver test for subPRB allocation.

7.2 Reference sensitivity level

7.2.1 Definition and applicability

The reference sensitivity power level P_{REFSENS} is the minimum mean power received at the antenna connector at which a throughput requirement shall be met for a specified reference measurement channel.

The test is set up according to Annex I.2.1 and performed without interfering signal power applied to the BS antenna connector. For duplex operation, the measurement configuration principle is indicated for one duplex branch in Annex I.2.1. The reference point for signal power is at the input of the receiver (antenna connector).

7.2.2 Minimum Requirement

The minimum requirement is in TS 36.104 [2] subclause 7.2.1.

7.2.3 Test purpose

To verify that at the BS Reference sensitivity level the throughput requirement shall be met for a specified reference measurement channel.

7.2.4 Method of testing

7.2.4.1 Initial conditions

Test environment: normal; see subclause D.2

RF channels to be tested for single carrier: B, M and T; see subclause 4.7.

The following additional tests shall be performed:

- a) On each of B, M and T, the test shall be performed under extreme power supply as defined in subclause D.5

NOTE: Tests under extreme power supply also test extreme temperature.

- 1) Connect the test equipment as shown in Annex I.2.1.

7.2.4.2 Procedure

- 1) a) For FDD BS start BS transmission according to E-TM 1.1 at manufacturer's declared rated output power.
b) For NB-IoT BS start BS transmission according to N-TM at manufacturer's declared rated output power.
- 2) Set the test signal mean power as specified in table 7.2-1 for E-UTRA Wide Area BS, in Table 7.2-2 for E-UTRA Local Area BS, in Table 7.2-3 for E-UTRA Home BS, in Table 7.2-4 for E-UTRA Medium Range BS, in Table 7.2-5 for NB-IoT Wide Area BS, in Table 7.2-6 for NB-IoT Local Area BS, in Table 7.2-7 for NB-IoT Home BS and in Table 7.2-8 for NB-IoT Medium Range BS, in Table 7.2-9 for subPRB allocation for Wide Area BS, in Table 7.2-10 for subPRB allocation for Local Area BS, in Table 7.2-11 for subPRB allocation for Home BS and in Table 7.2-12 for subPRB allocation for Medium Range BS.
- 3) Measure the throughput according to Annex E.
- 4) Repeat the measurement for the other RX port(s).

In addition, for a multi-band capable BS, the following step shall apply:

- 5) For multi-band capable BS and single band tests, repeat the steps above per involved band where single carrier test models shall apply with no carrier activated in the other band. For multi-band capable BS with separate antenna connector, the antenna connector not being under test shall be terminated.

7.2.5 Test requirement

For each measured E-UTRA carrier, the throughput shall be $\geq 95\%$ of the maximum throughput of the reference measurement channel as specified in Annex A.1 with parameters specified in Table 7.2.5-1 for Wide Area BS, in Table 7.2.5-2 for Local Area BS, in Table 7.2.5-3 for Home BS and in Table 7.2.5-4 for Medium Range BS.

Table 7.2-1: E-UTRA Wide Area BS reference sensitivity levels

E-UTRA channel bandwidth [MHz]	Reference measurement channel	Reference sensitivity power level, P _{REFSENS} [dBm]	
		f ≤ 3.0GHz	3.0GHz < f ≤ 4.2GHz
1.4	FRC A1-1 in Annex A.1	-106.1	-105.8
3	FRC A1-2 in Annex A.1	-102.3	-102.0
3	FRC A1-6 in Annex A.1 for E-UTRA with NB-IoT in-band operation ^{Note 3}	-102.3 ^{Note 2}	N/A
5	FRC A1-3 in Annex A.1	-100.8	-100.5
5	FRC A1-7 in Annex A.1 for E-UTRA with NB-IoT in-band operation	-100.8 ^{Note 2}	N/A
10	FRC A1-3 in Annex A.1 ^{Note 1}	-100.8	-100.5
10	FRC A1-7 in Annex A.1 for E-UTRA with NB-IoT in-band operation ^{Note 4}	-100.8 ^{Note 2}	N/A
15	FRC A1-3 in Annex A.1 ^{Note 1}	-100.8	-100.5
15	FRC A1-7 in Annex A.1 for E-UTRA with NB-IoT in-band operation ^{Note 4}	-100.8 ^{Note 2}	N/A
20	FRC A1-3 in Annex A.1 ^{Note 1}	-100.8	-100.5
20	FRC A1-7 in Annex A.1 for E-UTRA with NB-IoT in-band operation ^{Note 4}	-100.8 ^{Note 2}	N/A
Note 1:	P _{REFSENS} is the power level of a single instance of the reference measurement channel. This requirement shall be met for each consecutive application of a single instance of FRC A1-3 mapped to disjoint frequency ranges with a width of 25 resource blocks each.		
Note 2:	The requirements apply to BS that supports E-UTRA with NB-IoT in-band operation.		
Note 3:	P _{REFSENS} is the power level of a single instance of the reference measurement channel. This requirement shall be met for a single instance of FRC A1-6 mapped to the 12 E-UTRA resource blocks adjacent to the NB-IoT PRB.		
Note 4:	P _{REFSENS} is the power level of a single instance of the reference measurement channel. This requirement shall be met for a single instance of FRC A1-7 mapped to the 24 E-UTRA resource blocks adjacent to the NB-IoT PRB (location of which is specified in clause 4.7.3), and for each consecutive application of a single instance of FRC A1-3 mapped to disjoint frequency ranges with a width of 25 resource blocks each		

Table 7.2-2: E-UTRA Local Area BS reference sensitivity levels

E-UTRA channel bandwidth [MHz]	Reference measurement channel	Reference sensitivity power level, PREFSENS [dBm]		
		$f \leq 3.0\text{GHz}$	$3.0\text{GHz} < f \leq 4.2\text{GHz}$	$4.2\text{GHz} < f \leq 6.0\text{GHz}$
1.4	FRC A1-1 in Annex A.1	-98.1	-97.8	
3	FRC A1-2 in Annex A.1	-94.3	-94.0	
3	FRC A1-6 in Annex A.1 for E-UTRA with NB-IoT in-band operation (Note 4)	-94.3 (Note 3)		
5	FRC A1-3 in Annex A.1	-92.8	-92.5	
5	FRC A1-7 in Annex A.1 for E-UTRA with NB-IoT in-band operation	-92.8 (Note 3)		
10	FRC A1-3 in Annex A.1 (Note 1) FRC A1-8 in Annex A.1 (Note 2)	-92.8	-92.5	-94.7
10	FRC A1-7 in Annex A.1 for E-UTRA with NB-IoT in-band operation (Note 5)	-92.8 (Note 3)		
15	FRC A1-3 in Annex A.1 (Note 1)	-92.8	-92.5	
15	FRC A1-7 in Annex A.1 for E-UTRA with NB-IoT in-band operation (Note 5)	-92.8 (Note 3)		
20	FRC A1-3 in Annex A.1 (Note 1) FRC A1-9 in Annex A.1 (Note 2)	-92.8	-92.5	-94.7
20	FRC A1-7 in Annex A.1 for E-UTRA with NB-IoT in-band operation (Note 5)	-92.8 (Note 3)		
<p>Note 1: PREFSENS is the power level of a single instance of the reference measurement channel. This requirement shall be met for each consecutive application of a single instance of FRC A1-3 mapped to disjoint frequency ranges with a width of 25 resource blocks each. This reference measurement channel is not applied for Band 46 and Band 49.</p> <p>Note 2: PREFSENS is the power level of a single instance of the reference measurement channel. This requirement shall be tested for at least one interlace of FRC A1-8 (if supported) and A1-9. This reference measurement channel is only applied for Band 46 and Band 49.</p> <p>Note 3: The requirements apply to BS that supports E-UTRA with NB-IoT in-band operation.</p> <p>Note 4: PREFSENS is the power level of a single instance of the reference measurement channel. This requirement shall be met for a single instance of FRC A1-6 mapped to the 12 E-UTRA resource blocks adjacent to the NB-IoT PRB.</p> <p>Note 5: PREFSENS is the power level of a single instance of the reference measurement channel. This requirement shall be met for a single instance of FRC A1-7 mapped to the 24 E-UTRA resource blocks adjacent to the NB-IoT PRB (location of which is specified in clause 4.7.3), and for each consecutive application of a single instance of FRC A1-3 mapped to disjoint frequency ranges with a width of 25 resource blocks each.</p>				

Table 7.2-3: E-UTRA Home BS reference sensitivity levels

E-UTRA channel bandwidth [MHz]	Reference measurement channel	Reference sensitivity power level, P _{REFSENS} [dBm]	
		$f \leq 3.0\text{GHz}$	$3.0\text{GHz} < f \leq 4.2\text{GHz}$
1.4	FRC A1-1 in Annex A.1	-98.1	-97.8
3	FRC A1-2 in Annex A.1	-94.3	-94.0
3	FRC A1-6 in Annex A.1 for E-UTRA with NB-IoT in-band operation (Note 3)	-94.3 (Note 2)	
5	FRC A1-3 in Annex A.1	-92.8	-92.5
5	FRC A1-7 in Annex A.1 for E-UTRA with NB-IoT in-band operation	-92.8 (Note 2)	
10	FRC A1-3 in Annex A.1 (Note 1)	-92.8	-92.5
10	FRC A1-7 in Annex A.1 for E-UTRA with NB-IoT in-band operation (Note 4)	-92.8 (Note 2)	
15	FRC A1-3 in Annex A.1 (Note 1)	-92.8	-92.5
15	FRC A1-7 in Annex A.1 for E-UTRA with NB-IoT in-band operation (Note 4)	-92.8 (Note 2)	
20	FRC A1-3 in Annex A.1 (Note 1)	-92.8	-92.5
20	FRC A1-7 in Annex A.1 for E-UTRA with NB-IoT in-band operation (Note 4)	-92.8 (Note 2)	
<p>Note 1: P_{REFSENS} is the power level of a single instance of the reference measurement channel. This requirement shall be met for each consecutive application of a single instance of FRC A1-3 mapped to disjoint frequency ranges with a width of 25 resource blocks each</p> <p>Note 2: The requirements apply to BS that supports E-UTRA with NB-IoT in-band operation.</p> <p>Note 3: P_{REFSENS} is the power level of a single instance of the reference measurement channel. This requirement shall be met for a single instance of FRC A1-6 mapped to the 12 E-UTRA resource blocks adjacent to the NB-IoT PRB.</p> <p>Note 4: P_{REFSENS} is the power level of a single instance of the reference measurement channel. This requirement shall be met for a single instance of FRC A1-7 mapped to the 24 E-UTRA resource blocks adjacent to the NB-IoT PRB (location of which is specified in clause 4.7.3), and for each consecutive application of a single instance of FRC A1-3 mapped to disjoint frequency ranges with a width of 25 resource blocks each.</p>			

Table 7.2-4: E-UTRA Medium Range BS reference sensitivity levels

E-UTRA channel bandwidth [MHz]	Reference measurement channel	Reference sensitivity power level, PREFSENS [dBm]		
		$f \leq 3.0\text{GHz}$	$3.0\text{GHz} < f \leq 4.2\text{GHz}$	$4.2\text{GHz} < f \leq 6.0\text{GHz}$
1.4	FRC A1-1 in Annex A.1	-101.1	-97.8	
3	FRC A1-2 in Annex A.1	-97.3	-94.0	
3	FRC A1-6 in Annex A.1 for E-UTRA with NB-IoT in-band operation (Note 4)	-97.3 (Note 3)		
5	FRC A1-3 in Annex A.1	-95.8	-92.5	
5	FRC A1-7 in Annex A.1 for E-UTRA with NB-IoT in-band operation	-95.8 (Note 3)		
10	FRC A1-3 in Annex A.1 (Note 1) FRC A1-8 in Annex A.1 (Note 2)	-95.8	-92.5	-97.7
10	FRC A1-7 in Annex A.1 for E-UTRA with NB-IoT in-band operation (Note 5)	-95.8 (Note 3)		
15	FRC A1-3 in Annex A.1 (Note 1)	-95.8	-92.5	
15	FRC A1-7 in Annex A.1 for E-UTRA with NB-IoT in-band operation (Note 5)	-95.8 (Note 3)		
20	FRC A1-3 in Annex A.1 (Note 1) FRC A1-9 in Annex A.1 (Note 2)	-95.8	-92.5	-97.7
20	FRC A1-7 in Annex A.1 for E-UTRA with NB-IoT in-band operation (Note 5)	-95.8 (Note 3)		
<p>Note 1: PREFSENS is the power level of a single instance of the reference measurement channel. This requirement shall be met for each consecutive application of a single instance of FRC A1-3 mapped to disjoint frequency ranges with a width of 25 resource blocks each. This reference measurement channel is not applied for Band 46.</p> <p>Note 2: PREFSENS is the power level of a single instance of the reference measurement channel. This requirement shall be tested for at least one interlace of FRC A1-8 (if supported) and A1-9. This reference measurement channel is only applied for Band 46.</p> <p>Note 3: The requirements apply to BS that supports E-UTRA with NB-IoT in-band operation.</p> <p>Note 4: PREFSENS is the power level of a single instance of the reference measurement channel. This requirement shall be met for a single instance of FRC A1-6 mapped to the 12 E-UTRA resource blocks adjacent to the NB-IoT PRB.</p> <p>Note 5: PREFSENS is the power level of a single instance of the reference measurement channel. This requirement shall be met for a single instance of FRC A1-7 mapped to the 24 E-UTRA resource blocks adjacent to the NB-IoT PRB (location of which is specified in clause 4.7.3), and for each consecutive application of a single instance of FRC A1-3 mapped to disjoint frequency ranges with a width of 25 resource blocks each.</p>				

For NB-IoT standalone BS or E-UTRA BS with NB-IoT (in-band and/or guard band), NB-IoT throughput shall be $\geq 95\%$ of the maximum throughput of the reference measurement channel as specified in Annex A with parameters specified in Table 7.2-5 for Wide Area BS, Table 7.2-6 for Local Area BS, Table 7.2-7 for Home BS and Table 7.2-8 for Medium Range BS.

Table 7.2-5: NB-IoT Wide Area BS reference sensitivity levels

NB-IoT channel bandwidth [kHz]	NB-IoT Sub-carrier spacing [kHz]	Reference measurement channel	Reference sensitivity power level, PREFSENS [dBm] ($f \leq 3.0\text{ GHz}$)
200	15	FRC A14-1 in Annex A.14	-126.6
200	3.75	FRC A14-2 in Annex A.14	-132.6

Table 7.2-6: NB-IoT Local Area BS reference sensitivity levels

NB-IoT channel bandwidth [kHz]	NB-IoT Sub-carrier spacing [kHz]	Reference measurement channel	Reference sensitivity power level, PREFSENS [dBm] ($f \leq 3.0\text{ GHz}$)
200	15	FRC A14-1 in Annex A.14	-118.6
200	3.75	FRC A14-2 in Annex A.14	-124.6

Table 7.2-7: NB-IoT Home BS reference sensitivity levels

NB-IoT channel bandwidth [kHz]	NB-IoT Sub-carrier spacing [kHz]	Reference measurement channel	Reference sensitivity power level, PREFSENS [dBm]	
			$f \leq 3.0$ GHz	3.0 GHz $< f \leq 4.2$ GHz
200	15	FRC A14-1 in Annex A.14	-118.6	-118.3
200	3.75	FRC A14-2 in Annex A.14	-124.6	-124.3

Table 7.2-8: NB-IoT Medium Range BS reference sensitivity levels

NB-IoT channel bandwidth [kHz]	NB-IoT Sub-carrier spacing [kHz]	Reference measurement channel	Reference sensitivity power level, PREFSENS [dBm] ($f \leq 3.0$ GHz)
200	15	FRC A14-1 in Annex A.14	-121.6
200	3.75	FRC A14-2 in Annex A.14	-127.6

For E-UTRA BS with subPRB allocation, subPRB allocation throughput shall be $\geq 95\%$ of the maximum throughput of the reference measurement channel as specified in Annex A with parameters specified in Table 7.2-9 for Wide Area BS, in Table 7.2-10 for Local Area BS, in Table 7.2-11 for Home BS and in Table 7.2-12 for Medium Range BS.

Table 7.2-9: SubPRB allocation for Wide Area BS reference sensitivity levels

SubPRB transmission bandwidth [kHz]	subPRB Sub-carrier spacing [kHz]	Reference measurement channel	Reference sensitivity power level, PREFSENS [dBm]
30	15	FRC A23-1 in Annex A.	-124

Table 7.2-10: subPRB allocation for Local Area BS reference sensitivity levels

SubPRB transmission bandwidth [kHz]	subPRB Sub-carrier spacing [kHz]	Reference measurement channel	Reference sensitivity power level, PREFSENS [dBm]
30	15	FRC A23-1 in Annex A.	-116

Table 7.2-11: subPRB allocation for Home BS reference sensitivity levels

SubPRB transmission bandwidth [kHz]	subPRB Sub-carrier spacing [kHz]	Reference measurement channel	Reference sensitivity power level, PREFSENS [dBm]
30	15	FRC A23-1 in Annex A.	-116

Table 7.2-12: subPRB allocation for Medium Range BS reference sensitivity levels

SubPRB transmission bandwidth [kHz]	subPRB Sub-carrier spacing [kHz]	Reference measurement channel	Reference sensitivity power level, PREFSENS [dBm]
30	15	FRC A23-1 in Annex A.	-119

NOTE: If the above Test Requirement differs from the Minimum Requirement then the Test Tolerance applied for this test is non-zero. The relationship between Minimum Requirements and Test Requirements is defined in subclause 4.1 and the explanation of how the Minimum Requirement has been relaxed by the Test Tolerance is given in Annex G.

7.3 Dynamic range

7.3.1 Definition and applicability

The dynamic range is specified as a measure of the capability of the receiver to receive a wanted signal in the presence of an interfering signal inside the received channel bandwidth. In this condition a throughput requirement shall be met for a specified reference measurement channel. The interfering signal for the dynamic range requirement is an AWGN signal.

7.3.2 Minimum Requirement

The minimum requirement is in TS 36.104 [2] subclause 7.3.1.

7.3.3 Test purpose

To verify that at the BS receiver dynamic range, the relative throughput shall fulfil the specified limit.

7.3.4 Method of testing

7.3.4.1 Initial conditions

Test environment: normal; see subclause D.2

RF channels to be tested for single carrier: B, M and T; see subclause 4.7

- 1) Connect the test equipment as shown in Annex I.2.2.

7.3.4.2 Procedure

For E-UTRA and E-UTRA with NB-IoT in-band or guard band operation:

For each supported E-UTRA channel BW:

- 1) Adjust the signal generator for the wanted signal as specified in Table 7.3-1 for E-UTRA Wide Area BS, in Table 7.3-2 for E-UTRA Local Area BS, in Table 7.3-3 for E-UTRA Home BS and in table 7.3-4 for E-UTRA Medium Range BS.

For a BS declared to be capable of NB-IoT in-band or guard band operation for the tested E-UTRA channel BW, adjust the signal generator for the wanted signal in Table 7.3-6 for Wide Area BS.

- 2) Adjust the AWGN generator level as specified in Table 7.3-1 for E-UTRA Wide Area BS, in Table 7.3-2 for E-UTRA Local Area BS, in Table 7.3-3 for E-UTRA Home BS, in table 7.3-4 for E-UTRA Medium Range BS, in tables 7.3-5 and 7.3-6 for NB-IoT Wide Area BS, in tables 7.3-7 and 7.3-8 for NB-IoT Local Area BS, in tables 7.3-9 and 7.3-10 for NB-IoT Home BS, in tables 7.3-11 and 7.3-12 for NB-IoT Medium Range BS and set the frequency to the same frequency as the tested channel.
- 3) Measure the E-UTRA throughput according to Annex E and verify that it is within the specified level.
- 4) Repeat the measurement for the other RX port(s).

For a BS declared to be capable of NB-IoT in-band or guard band operation for the tested E-UTRA channel BW, measure the NB-IoT throughput according to Annex E and verify that it is within the specified level.

In addition, for a multi-band capable BS, the following step shall apply:

- 5) For multi-band capable BS and single band tests, repeat the steps above per involved band with no carrier activated in the other band. For multi-band capable BS with separate antenna connector, the antenna connector not being under test shall be terminated.

For NB-IoT standalone BS:

- 1) Adjust the signal generator for the wanted signal as specified in Table 7.3-5.
- 2) Adjust the AWGN generator level as specified in Table 7.3-5 and set the frequency to the same frequency as the tested channel.
- 3) Measure the NB-IoT throughput according to Annex E and verify that it is within the specified level.
- 4) Repeat the measurement for the other RX port(s).

7.3.5 Test Requirements

For each measured E-UTRA carrier, the throughput shall be $\geq 95\%$ of the maximum throughput of the reference measurement channel as specified in Annex A with parameters specified in Table 7.3-1 for Wide Area BS, in Table 7.3-2 for Local Area BS, in Table 7.3-3 for Home BS and in Table 7.3-4 for Medium Range BS.

Table 7.3-1: Wide Area BS dynamic range for E-UTRA carrier

E-UTRA channel bandwidth [MHz]	Reference measurement channel	Wanted signal mean power [dBm]	Interfering signal mean power [dBm] / BW_{Config}	Type of interfering signal
1.4	FRC A2-1 in Annex A.2	-76.0	-88.7	AWGN
3	FRC A2-2 in Annex A.2	-72.1	-84.7	AWGN
5	FRC A2-3 in Annex A.2	-69.9	-82.5	AWGN
10	FRC A2-3 in Annex A.2*	-69.9	-79.5	AWGN
15	FRC A2-3 in Annex A.2*	-69.9	-77.7	AWGN
20	FRC A2-3 in Annex A.2*	-69.9	-76.4	AWGN
Note*:	The wanted signal mean power is the power level of a single instance of the reference measurement channel. This requirement shall be met for each consecutive application of a single instance of FRC A2-3 mapped to disjoint frequency ranges with a width of 25 resource blocks each			

Table 7.3-2: Local Area BS dynamic range for E-UTRA carrier

E-UTRA channel bandwidth [MHz]	Reference measurement channel	Wanted signal mean power [dBm]	Interfering signal mean power [dBm] / BW _{Config}	Type of interfering signal
1.4	FRC A2-1 in Annex A.2	-68.0	-80.7	AWGN
3	FRC A2-2 in Annex A.2	-64.1	-76.7	AWGN
5	FRC A2-3 in Annex A.2	-61.9	-74.5	AWGN
10	FRC A2-3 in Annex A.2 (Note 1) FRC A2-4 in Annex A.2 (Note 2)	-61.9 -65.0	-71.5	AWGN
15	FRC A2-3 in Annex A.2 (Note 1)	-61.9	-69.7	AWGN
20	FRC A2-3 in Annex A.2 (Note 1) FRC A2-5 in Annex A.2 (Note 1)	-61.9 -65.0	-68.4	AWGN
Note 1:	The wanted signal mean power is the power level of a single instance of the reference measurement channel. This requirement shall be met for each consecutive application of a single instance of FRC A2-3 mapped to disjoint frequency ranges with a width of 25 resource blocks each. This reference measurement channel is not applied for Band 46 and Band 49.			
Note 2:	The wanted signal mean power is the power level of a single instance of the reference measurement channel. This requirement shall be tested for at least one interlace of FRC A2-4 (if supported) and A2-5. This reference measurement channel is only applied for Band 46 and Band 49.			

Table 7.3-3: Home BS dynamic range for E-UTRA carrier

E-UTRA channel bandwidth [MHz]	Reference measurement channel	Wanted signal mean power [dBm]	Interfering signal mean power [dBm] / BW _{Config}	Type of interfering signal
1.4	FRC A2-1 in Annex A.2	-31.5	-44.2	AWGN
3	FRC A2-2 in Annex A.2	-27.6	-40.2	AWGN
5	FRC A2-3 in Annex A.2	-25.4	-38	AWGN
10	FRC A2-3 in Annex A.2*	-25.4	-35	AWGN
15	FRC A2-3 in Annex A.2*	-25.4	-33.2	AWGN
20	FRC A2-3 in Annex A.2*	-25.4	-31.9	AWGN
Note*:	The wanted signal mean power is the power level of a single instance of the reference measurement channel. This requirement shall be met for each consecutive application of a single instance of FRC A2-3 mapped to disjoint frequency ranges with a width of 25 resource blocks each			

Table 7.3-4: Medium Range BS dynamic range for E-UTRA carrier

E-UTRA channel bandwidth [MHz]	Reference measurement channel	Wanted signal mean power [dBm]	Interfering signal mean power [dBm] / BWConfig	Type of interfering signal
1.4	FRC A2-1 in Annex A.2	-71.0	-83.7	AWGN
3	FRC A2-2 in Annex A.2	-67.1	-79.7	AWGN
5	FRC A2-3 in Annex A.2	-64.9	-77.5	AWGN
10	FRC A2-3 in Annex A.2 (Note 1) FRC A2-4 in Annex A.2 (Note 2)	-64.9 -68.0	-74.5	AWGN
15	FRC A2-3 in Annex A.2 (Note 1)	-64.9	-72.7	AWGN
20	FRC A2-3 in Annex A.2 (Note 1) FRC A2-5 in Annex A.2 (Note 2)	-64.9 -68.0	-71.4	AWGN
<p>Note 1: The wanted signal mean power is the power level of a single instance of the reference measurement channel. This requirement shall be met for each consecutive application of a single instance of FRC A2-3 mapped to disjoint frequency ranges with a width of 25 resource blocks each. This reference measurement channel is not applied for Band 46.</p> <p>Note 2: The wanted signal mean power is the power level of a single instance of the reference measurement channel. This requirement shall be tested for at least one interlace of FRC A2-4 (if supported) and A2-5. This reference measurement channel is only applied for Band 46.</p>				

For NB-IoT standalone operation, the throughput shall be $\geq 95\%$ of the maximum throughput of the reference measurement channel as specified in Annex A with parameters specified in Table 7.3-5 for Wide Area BS.

Table 7.3-5: Wide Area BS dynamic range for NB-IoT standalone operation

NB-IoT channel bandwidth [kHz]	Reference measurement channel	Wanted signal mean power [dBm]	Interfering signal mean power [dBm] / BW _{Channel}	Type of interfering signal
200	FRC A15-1 in Annex A.15	-99.4	-96	AWGN
200	FRC A15-2 in Annex A.15	-105.3	-96	AWGN

For NB-IoT in-band or guard band operation, the throughput shall be $\geq 95\%$ of the maximum throughput of the reference measurement channel as specified in Annex A with parameters specified in Table 7.3-6 for Wide Area BS.

Table 7.3-6: Wide Area BS dynamic range for NB-IoT in-band or guard band operation

NB-IoT channel bandwidth [MHz]	Reference measurement channel	Wanted signal mean power [dBm]	Interfering signal mean power [dBm] / BW_{Channel}	Type of interfering signal
3 (Note 1)	FRC A15-1 in Annex A.15	-99.4	-84.2	AWGN
	FRC A15-2 in Annex A.15	-105.3		
5	FRC A15-1 in Annex A.15	-99.4	-82.0	AWGN
	FRC A15-2 in Annex A.15	-105.3		
10	FRC A15-1 in Annex A.15	-99.4	-79.0	AWGN
	FRC A15-2 in Annex A.15	-105.3		
15	FRC A15-1 in Annex A.15	-99.4	-77.2	AWGN
	FRC A15-2 in Annex A.15	-105.3		
20	FRC A15-1 in Annex A.15	-99.4	-76.0	AWGN
	FRC A15-2 in Annex A.15	-105.3		
Note 1: 1.4 MHz and 3 MHz channel bandwidth is not applicable to guard band operation.				

For NB-IoT standalone operation, the throughput shall be $\geq 95\%$ of the maximum throughput of the reference measurement channel as specified in Annex A with parameters specified in Table 7.3-7 for Local Area BS.

Table 7.3-7: Local Area BS dynamic range for NB-IoT standalone operation

NB-IoT channel bandwidth [kHz]	Reference measurement channel	Wanted signal mean power [dBm]	Interfering signal mean power [dBm] / BW_{Channel}	Type of interfering signal
200	FRC A15-1 in Annex A.15	-91.4	-88	AWGN
200	FRC A15-2 in Annex A.15	-97.3	-88	AWGN

For NB-IoT in-band or guard band operation, the throughput shall be $\geq 95\%$ of the maximum throughput of the reference measurement channel as specified in Annex A with parameters specified in Table 7.3-8 for Local Area BS.

Table 7.3-8: Local Area BS dynamic range for NB-IoT in-band or guard band operation

NB-IoT channel bandwidth [MHz]	Reference measurement channel	Wanted signal mean power [dBm]	Interfering signal mean power [dBm] / BW_{Channel}	Type of interfering signal
3 (Note 1)	FRC A15-1 in Annex A.15	-91.4	-76.2	AWGN
	FRC A15-2 in Annex A.15	-97.3		
5	FRC A15-1 in Annex A.15	-91.4	-74.0	AWGN
	FRC A15-2 in Annex A.15	-97.3		
10	FRC A15-1 in Annex A.15	-91.4	-71.0	AWGN
	FRC A15-2 in Annex A.15	-97.3		
15	FRC A15-1 in Annex A.15	-91.4	-69.2	AWGN
	FRC A15-2 in Annex A.15	-97.3		
20	FRC A15-1 in Annex A.15	-91.4	-68.0	AWGN
	FRC A15-2 in Annex A.15	-97.3		
Note 1: 1.4 MHz and 3 MHz channel bandwidth is not applicable to guard band operation.				

For NB-IoT standalone operation, the throughput shall be $\geq 95\%$ of the maximum throughput of the reference measurement channel as specified in Annex A with parameters specified in Table 7.3-9 for Home BS.

Table 7.3-9: Home BS dynamic range for NB-IoT standalone operation

NB-IoT channel bandwidth [kHz]	Reference measurement channel	Wanted signal mean power [dBm]	Interfering signal mean power [dBm] / BW_{Channel}	Type of interfering signal
200	FRC A15-1 in Annex A.15	-54.9	-51.5	AWGN
200	FRC A15-2 in Annex A.15	-60.8	-51.5	AWGN

For NB-IoT in-band or guard band operation, the throughput shall be $\geq 95\%$ of the maximum throughput of the reference measurement channel as specified in Annex A with parameters specified in Table 7.3-10 for Home BS.

Table 7.3-10: Home BS dynamic range for NB-IoT in-band or guard band operation

NB-IoT channel bandwidth [MHz]	Reference measurement channel	Wanted signal mean power [dBm]	Interfering signal mean power [dBm] / BW_{Channel}	Type of interfering signal
3 (Note 1)	FRC A15-1 in Annex A.15	-54.9	-39.7	AWGN
	FRC A15-2 in Annex A.15	-60.8		
5	FRC A15-1 in Annex A.15	-54.9	-37.5	AWGN
	FRC A15-2 in Annex A.15	-60.8		
10	FRC A15-1 in Annex A.15	-54.9	-34.5	AWGN
	FRC A15-2 in Annex A.15	-60.8		
15	FRC A15-1 in Annex A.15	-54.9	-32.7	AWGN
	FRC A15-2 in Annex A.15	-60.8		
20	FRC A15-1 in Annex A.15	-54.9	-31.5	AWGN
	FRC A15-2 in Annex A.15	-60.8		
Note 1: 1.4 MHz and 3 MHz channel bandwidth is not applicable to guard band operation.				

For NB-IoT standalone operation, the throughput shall be $\geq 95\%$ of the maximum throughput of the reference measurement channel as specified in Annex A with parameters specified in Table 7.3-11 for Medium Range BS.

Table 7.3-11: Medium Range BS dynamic range for NB-IoT standalone operation

NB-IoT channel bandwidth [kHz]	Reference measurement channel	Wanted signal mean power [dBm]	Interfering signal mean power [dBm] / BW_{Channel}	Type of interfering signal
200	FRC A15-1 in Annex A.15	-94.4	-91	AWGN
200	FRC A15-2 in Annex A.15	-100.3	-91	AWGN

For NB-IoT in-band or guard band operation, the throughput shall be $\geq 95\%$ of the maximum throughput of the reference measurement channel as specified in Annex A with parameters specified in Table 7.3-12 for Medium Range BS.

Table 7.3-12: Medium Range BS dynamic range for NB-IoT in-band or guard band operation

NB-IoT channel bandwidth [MHz]	Reference measurement channel	Wanted signal mean power [dBm]	Interfering signal mean power [dBm] / BW_{Channel}	Type of interfering signal
3 (Note 1)	FRC A15-1 in Annex A.15	-94.4	-79.2	AWGN
	FRC A15-2 in Annex A.15	-100.3		
5	FRC A15-1 in Annex A.15	-94.4	-77.0	AWGN
	FRC A15-2 in Annex A.15	-100.3		
10	FRC A15-1 in Annex A.15	-94.4	-74.0	AWGN
	FRC A15-2 in Annex A.15	-100.3		
15	FRC A15-1 in Annex A.15	-94.4	-72.2	AWGN
	FRC A15-2 in Annex A.15	-100.3		
20	FRC A15-1 in Annex A.15	-94.4	-71.0	AWGN
	FRC A15-2 in Annex A.15	-100.3		
Note 1: 1.4 MHz and 3 MHz channel bandwidth is not applicable to guard band operation.				

NOTE: If the above Test Requirement differs from the Minimum Requirement then the Test Tolerance applied for this test is non-zero. The relationship between Minimum Requirements and Test Requirements is defined in subclause 4.1 and the explanation of how the Minimum Requirement has been relaxed by the Test Tolerance is given in Annex G.

7.4 In-channel selectivity

7.4.1 Definition and applicability

In-channel selectivity (ICS) is a measure of the receiver ability to receive a wanted signal at its assigned resource block locations in the presence of an interfering signal received at a larger power spectral density. In this condition a throughput requirement shall be met for a specified reference measurement channel. The interfering signal shall be an E-UTRA signal as specified in Annex C and shall be time aligned with the wanted signal.

7.4.2 Minimum Requirement

The minimum requirement is in TS 36.104 [2] subclause 7.4.1.

7.4.3 Test purpose

The purpose of this test is to verify the BS receiver ability to suppress the IQ leakage.

7.4.4 Method of testing

7.4.4.1 Initial conditions

Test environment: normal; see subclause D.2.

RF channels to be tested for single carrier: B, M and T; see subclause 4.7

- 1) Connect the test equipment as shown in Annex I.2.3.

7.4.4.2 Procedure

For each supported E-UTRA channel BW:

- 1) Adjust the signal generator for the wanted E-UTRA signal as specified in Table 7.4-1 for Wide Area BS, in Table 7.4-2 for Local Area BS, in Table 7.4-3 for Home BS and in Table 7.4-4 for Medium Range BS on one side of the F_C .
- 2) Adjust the signal generator for the interfering signal as specified in Table 7.4-1 for Wide Area BS, in Table 7.4-2 for Local Area BS, in Table 7.4-3 for Home BS and in Table 7.4-4 for Medium Range BS at opposite side of the F_C and adjacent to the wanted signal.
- 3) Measure the throughput according to Annex E.
- 4) Repeat the measurement with the wanted signal on the other side of the F_C , and the interfering signal at opposite side of the F_C and adjacent to the wanted signal.
- 5) Repeat the measurement for the other RX port(s).

In addition, for a multi-band capable BS, the following step shall apply:

- 6) For multi-band capable BS and single band tests, repeat the steps above per involved band with no carrier activated in the other band. For multi-band capable BS with separate antenna connector, the antenna connector not being under test shall be terminated.

For each supported E-UTRA channel BW with NB-IoT in-band operation:

- 1) Adjust the signal generator for the wanted NB-IoT signal as specified in Table 7.4-5 for Wide Area BS, in Table 7.4-7 for Local Area BS, in Table 7.4-9 for Home BS, in Table 7.4-11 for Medium Range BS with 15 kHz channel spacing and in Table 7.4-6 for Wide Area BS, in Table 7.4-8 for Local Area BS, in Table 7.4-10 for Home BS, in Table 7.4-12 for Medium Range BS with 3.75 kHz channel spacing on one side of the F_C .
- 2) Adjust the signal generator for the interfering signal as specified in Table 7.4-5 for Wide Area BS, in Table 7.4-7 for Local Area BS, in Table 7.4-9 for Home BS, in Table 7.4-11 for Medium Range BS with 15 kHz channel spacing and in Table 7.4-6 for Wide Area BS, in Table 7.4-8 for Local Area BS, in Table 7.4-10 for Home BS, in Table 7.4-12 for Medium Range BS with 3.75 kHz spacing at opposite side of the F_C .
- 3) Measure the throughput according to Annex E.
- 4) Repeat the measurement with the wanted signal on the other side of the F_C , and the interfering signal at opposite side of the F_C .
- 5) Repeat the measurement for the other RX port(s).

7.4.5 Test Requirements

For each measured E-UTRA carrier, the throughput shall be $\geq 95\%$ of the maximum throughput of the reference measurement channel as specified in Annex A with parameters specified in Table 7.4-1 for Wide Area BS, in Table 7.4-2 for Local Area BS, in Table 7.4-3 for Home BS and in Table 7.4-4 for Medium Range BS.

Table 7.4-1: Wide Area BS in-channel selectivity for E-UTRA

E-UTRA channel bandwidth (MHz)	Reference measurement channel	Wanted signal mean power [dBm]		Interfering signal mean power [dBm]	Type of interfering signal
		$f \leq 3.0\text{GHz}$	$3.0\text{GHz} < f \leq 4.2\text{GHz}$		
1.4	A1-4 in Annex A.1	-105.5	-105.1	-87	1.4 MHz E-UTRA signal, 3 RBs
3	A1-5 in Annex A.1	-100.7	-100.3	-84	3 MHz E-UTRA signal, 6 RBs
5	A1-2 in Annex A.1	-98.6	-98.2	-81	5 MHz E-UTRA signal, 10 RBs
10	A1-3 in Annex A.1	-97.1	-96.7	-77	10 MHz E-UTRA signal, 25 RBs
15	A1-3 in Annex A.1*	-97.1	-96.7	-77	15 MHz E-UTRA signal, 25 RBs*
20	A1-3 in Annex A.1*	-97.1	-96.7	-77	20 MHz E-UTRA signal, 25 RBs*

Note*: Wanted and interfering signal are placed adjacently around F_c

Table 7.4-2: Local Area BS in-channel selectivity for E-UTRA

E-UTRA channel bandwidth (MHz)	Reference measurement channel	Wanted signal mean power [dBm]			Interfering signal mean power [dBm]	Type of interfering signal
		$f \leq 3.0\text{GHz}$	$3.0\text{GHz} < f \leq 4.2\text{GHz}$	$4.2\text{GHz} < f \leq 6.0\text{GHz}$		
1.4	A1-4 in Annex A.1	-97.5	-97.1		-79	1.4 MHz E-UTRA signal, 3 RBs
3	A1-5 in Annex A.1	-92.7	-92.3		-76	3 MHz E-UTRA signal, 6 RBs
5	A1-2 in Annex A.1	-90.6	-90.2		-73	5 MHz E-UTRA signal, 10 RBs
10	A1-3 in Annex A.1 (Note 3) A1-8 in Annex A.1 (Note 2)	-89.1	-88.7	-90.7	-69 -71.8	10 MHz E-UTRA signal, 25 RBs (Note 3) 10 MHz E-UTRA interlace signal, 10 RBs (Note 2)
15	A1-3 in Annex A.1 (Note 1)	-89.1	-88.7		-69	15 MHz E-UTRA signal, 25 RBs (Note 1)
20	A1-3 in Annex A.1 (Note 1) A1-9 in Annex A.1 (Note 2)	-89.1	-88.7	-90.7	-69 -71.8	20 MHz E-UTRA signal, 25 RBs (Note 1) 20 MHz E-UTRA interlace signal, 10 RBs (Note 2)

Note 1: Wanted and interfering signal are placed adjacently around F_c , this reference measurement channel and interfering signal are not applied for Band 46 and Band 49.

Note 2: Wanted and interfering signal interlaces are mirrored around F_c , this reference measurement channel and interfering signal are only applied for Band 46 and Band 49.

Note 3: This reference measurement channel and interfering signal are not applied for Band 46 and Band 49.

Table 7.4-3: Home BS in-channel selectivity for E-UTRA

E-UTRA channel bandwidth (MHz)	Reference measurement channel	Wanted signal mean power [dBm]		Interfering signal mean power [dBm]	Type of interfering signal
		$f \leq 3.0\text{GHz}$	$3.0\text{GHz} < f \leq 4.2\text{GHz}$		
1.4	A1-4 in Annex A.1	-97.5	-97.1	-79	1.4 MHz E-UTRA signal, 3 RBs
3	A1-5 in Annex A.1	-92.7	-92.3	-76	3 MHz E-UTRA signal, 6 RBs
5	A1-2 in Annex A.1	-90.6	-90.2	-73	5 MHz E-UTRA signal, 10 RBs
10	A1-3 in Annex A.1	-89.1	-88.7	-69	10 MHz E-UTRA signal, 25 RBs
15	A1-3 in Annex A.1*	-89.1	-88.7	-69	15 MHz E-UTRA signal, 25 RBs*
20	A1-3 in Annex A.1*	-89.1	-88.7	-69	20 MHz E-UTRA signal, 25 RBs*

Note*: Wanted and interfering signal are placed adjacently around F_c

Table 7.4-4: Medium Range BS in-channel selectivity for E-UTRA

E-UTRA channel bandwidth (MHz)	Reference measurement channel	Wanted signal mean power [dBm]			Interfering signal mean power [dBm]	Type of interfering signal
		$f \leq 3.0\text{GHz}$	$3.0\text{GHz} < f \leq 4.2\text{GHz}$	$4.2\text{GHz} < f \leq 6.0\text{GHz}$		
1.4	A1-4 in Annex A.1	-100.5	-100.1		-82	1.4 MHz E-UTRA signal, 3 RBs
3	A1-5 in Annex A.1	-95.7	-95.3		-79	3 MHz E-UTRA signal, 6 RBs
5	A1-2 in Annex A.1	-93.6	-93.2		-76	5 MHz E-UTRA signal, 10 RBs
10	A1-3 in Annex A.1 (Note 3) A1-8 in Annex A.1 (Note 2)	-92.1	-91.7	-93.7	-72 -74.8	10 MHz E-UTRA signal, 25 RBs (Note 3) 10 MHz E-UTRA interlace signal, 10 RBs (Note 2)
15	A1-3 in Annex A.1 (Note 1)	-92.1	-91.7		-72	15 MHz E-UTRA signal, 25 RBs (Note 1)
20	A1-3 in Annex A.1 (Note 1) A1-9 in Annex A.1 (Note 2)	-92.1	-91.7	-93.7	-72 -74.8	20 MHz E-UTRA signal, 25 RBs (Note 1) 20 MHz E-UTRA interlace signal, 10 RBs (Note 2)

Note 1: Wanted and interfering signal are placed adjacently around F_c , this reference measurement channel and interfering signal are not applied for Band 46.

Note 2: Wanted and interfering signal interlaces are mirrored around F_c , this reference measurement channel and interfering signal are only applied for Band 46.

Note 3: This reference measurement channel and interfering signal are not applied for Band 46.

NOTE: If the above Test Requirement differs from the Minimum Requirement then the Test Tolerance applied for this test is non-zero. The relationship between Minimum Requirements and Test Requirements is defined in subclause 4.1 and the explanation of how the Minimum Requirement has been relaxed by the Test Tolerance is given in Annex G.

For NB-IoT in-band operation carrier, the throughput shall be $\geq 95\%$ of the maximum throughput of the reference measurement channel as specified in Annex A with parameters specified in Table 7.4-5 for Wide Area BS with 15 kHz channel spacing and in Table 7.4-6 for Wide Area BS with 3.75 kHz channel spacing.

Table 7.4-5: Wide Area BS in-channel selectivity for NB-IoT in-band operation with 15kHz channel spacing

E-UTRA channel bandwidth (MHz)	Reference measurement channel	Wanted signal mean power [dBm] ($f \leq 3.0$ GHz)	Interfering signal mean power [dBm]	Type of interfering signal
3	FRC A14-1 in Annex A.14	-122.9	-84	3 MHz E-UTRA signal, 6 RBs (Note 2)
5	FRC A14-1 in Annex A.14	-122.9	-81	5 MHz E-UTRA signal, 10 RBs (Note 1)
10	FRC A14-1 in Annex A.14	-122.9	-77	10 MHz E-UTRA signal, 25 RBs (Note 1)
15	FRC A14-1 in Annex A.14	-122.9	-77	15 MHz E-UTRA signal, 25 RBs (Note 1)
20	FRC A14-1 in Annex A.14	-122.9	-77	20 MHz E-UTRA signal, 25 RBs (Note 1)
Note 1: Interfering signal is placed in one side of the F_c , while the NB-IoT PRB is placed on the other side. Both interfering signal and NB-IoT PRB are placed at the middle of the available PRB locations. The wanted NB-IoT tone is placed at the centre of this NB-IoT PRB. Note 2: Interfering signal is placed from the edge of BW_{config} , while the NB-IoT PRB is placed at the middle of the remaining PRB locations. The wanted NB-IoT tone is placed at the centre of this NB-IoT PRB.				

Table 7.4-6: Wide Area BS in-channel selectivity for NB-IoT in-band operation with 3.75kHz channel spacing

E-UTRA channel bandwidth (MHz)	Reference measurement channel	Wanted signal mean power [dBm] ($f \leq 3.0$ GHz)	Interfering signal mean power [dBm]	Type of interfering signal
3	FRC A14-2 in Annex A.14	-128.8	-84	3 MHz E-UTRA signal, 6 RBs (Note 2)
5	FRC A14-2 in Annex A.14	-128.8	-81	5 MHz E-UTRA signal, 10 RBs (Note 1)
10	FRC A14-2 in Annex A.14	-128.8	-77	10 MHz E-UTRA signal, 25 RBs (Note 1)
15	FRC A14-2 in Annex A.14	-128.8	-77	15 MHz E-UTRA signal, 25 RBs (Note 1)
20	FRC A14-2 in Annex A.14	-128.8	-77	20 MHz E-UTRA signal, 25 RBs (Note 1)
Note 1: Interfering signal is placed in one side of the F_c , while the NB-IoT PRB is placed on the other side. Both interfering signal and NB-IoT PRB are placed at the middle of the available PRB locations. The wanted NB-IoT tone is placed at the centre of this NB-IoT PRB. Note 2: Interfering signal is placed from the edge of BW_{config} , while the NB-IoT PRB is placed at the middle of the remaining PRB locations. The wanted NB-IoT tone is placed at the centre of this NB-IoT PRB.				

For NB-IoT in-band operation carrier, the throughput shall be $\geq 95\%$ of the maximum throughput of the reference measurement channel as specified in Annex A with parameters specified in Table 7.4-7 for Local Area BS with 15 kHz channel spacing and in Table 7.4-8 for Local Area BS with 3.75 kHz channel spacing.

Table 7.4-7: Local Area BS in-channel selectivity for NB-IoT in-band operation with 15kHz channel spacing

E-UTRA channel bandwidth (MHz)	Reference measurement channel	Wanted signal mean power [dBm] ($f \leq 3.0$ GHz)	Interfering signal mean power [dBm]	Type of interfering signal
3	FRC A14-1 in Annex A.14	-114.9	-76	3 MHz E-UTRA signal, 6 RBs (Note 2)
5	FRC A14-1 in Annex A.14	-114.9	-73	5 MHz E-UTRA signal, 10 RBs (Note 1)
10	FRC A14-1 in Annex A.14	-114.9	-69	10 MHz E-UTRA signal, 25 RBs (Note 1)
15	FRC A14-1 in Annex A.14	-114.9	-69	15 MHz E-UTRA signal, 25 RBs (Note 1)
20	FRC A14-1 in Annex A.14	-114.9	-69	20 MHz E-UTRA signal, 25 RBs (Note 1)
Note 1: Interfering signal is placed in one side of the F_c , while the NB-IoT PRB is placed on the other side. Both interfering signal and NB-IoT PRB are placed at the middle of the available PRB locations. The wanted NB-IoT tone is placed at the centre of this NB-IoT PRB. Note 2: Interfering signal is placed from the edge of BW_{config} , while the NB-IoT PRB is placed at the middle of the remaining PRB locations. The wanted NB-IoT tone is placed at the centre of this NB-IoT PRB.				

Table 7.4-8: Local Area BS in-channel selectivity for NB-IoT in-band operation with 3.75kHz channel spacing

E-UTRA channel bandwidth (MHz)	Reference measurement channel	Wanted signal mean power [dBm] ($f \leq 3.0$ GHz)	Interfering signal mean power [dBm]	Type of interfering signal
3	FRC A14-2 in Annex A.14	-120.8	-76	3 MHz E-UTRA signal, 6 RBs (Note 2)
5	FRC A14-2 in Annex A.14	-120.8	-73	5 MHz E-UTRA signal, 10 RBs (Note 1)
10	FRC A14-2 in Annex A.14	-120.8	-69	10 MHz E-UTRA signal, 25 RBs (Note 1)
15	FRC A14-2 in Annex A.14	-120.8	-69	15 MHz E-UTRA signal, 25 RBs (Note 1)
20	FRC A14-2 in Annex A.14	-120.8	-69	20 MHz E-UTRA signal, 25 RBs (Note 1)
Note 1: Interfering signal is placed in one side of the F_c , while the NB-IoT PRB is placed on the other side. Both interfering signal and NB-IoT PRB are placed at the middle of the available PRB locations. The wanted NB-IoT tone is placed at the centre of this NB-IoT PRB. Note 2: Interfering signal is placed from the edge of BW_{config} , while the NB-IoT PRB is placed at the middle of the remaining PRB locations. The wanted NB-IoT tone is placed at the centre of this NB-IoT PRB.				

For NB-IoT in-band operation carrier, the throughput shall be $\geq 95\%$ of the maximum throughput of the reference measurement channel as specified in Annex A with parameters specified in Table 7.4-9 for Home BS with 15 kHz channel spacing and in Table 7.4-10 for Home BS with 3.75 kHz channel spacing.

Table 7.4-9: Home BS in-channel selectivity for NB-IoT in-band operation with 15kHz channel spacing

E-UTRA channel bandwidth (MHz)	Reference measurement channel	Wanted signal mean power [dBm] ($f \leq 3.0$ GHz)	Interfering signal mean power [dBm]	Type of interfering signal
3	FRC A14-1 in Annex A.14	-114.9	-76	3 MHz E-UTRA signal, 6 RBs (Note 2)
5	FRC A14-1 in Annex A.14	-114.9	-73	5 MHz E-UTRA signal, 10 RBs (Note 1)
10	FRC A14-1 in Annex A.14	-114.9	-69	10 MHz E-UTRA signal, 25 RBs (Note 1)
15	FRC A14-1 in Annex A.14	-114.9	-69	15 MHz E-UTRA signal, 25 RBs (Note 1)
20	FRC A14-1 in Annex A.14	-114.9	-69	20 MHz E-UTRA signal, 25 RBs (Note 1)

Note 1: Interfering signal is placed in one side of the F_c , while the NB-IoT PRB is placed on the other side. Both interfering signal and NB-IoT PRB are placed at the middle of the available PRB locations. The wanted NB-IoT tone is placed at the centre of this NB-IoT PRB.

Note 2: Interfering signal is placed from the edge of BW_{config} , while the NB-IoT PRB is placed at the middle of the remaining PRB locations. The wanted NB-IoT tone is placed at the centre of this NB-IoT PRB.

Table 7.4-10: Home BS in-channel selectivity for NB-IoT in-band operation with 3.75kHz channel spacing

E-UTRA channel bandwidth (MHz)	Reference measurement channel	Wanted signal mean power [dBm] ($f \leq 3.0$ GHz)	Interfering signal mean power [dBm]	Type of interfering signal
3	FRC A14-2 in Annex A.14	-120.8	-76	3 MHz E-UTRA signal, 6 RBs (Note 2)
5	FRC A14-2 in Annex A.14	-120.8	-73	5 MHz E-UTRA signal, 10 RBs (Note 1)
10	FRC A14-2 in Annex A.14	-120.8	-69	10 MHz E-UTRA signal, 25 RBs (Note 1)
15	FRC A14-2 in Annex A.14	-120.8	-69	15 MHz E-UTRA signal, 25 RBs (Note 1)
20	FRC A14-2 in Annex A.14	-120.8	-69	20 MHz E-UTRA signal, 25 RBs (Note 1)

Note 1: Interfering signal is placed in one side of the F_c , while the NB-IoT PRB is placed on the other side. Both interfering signal and NB-IoT PRB are placed at the middle of the available PRB locations. The wanted NB-IoT tone is placed at the centre of this NB-IoT PRB.

Note 2: Interfering signal is placed from the edge of BW_{config} , while the NB-IoT PRB is placed at the middle of the remaining PRB locations. The wanted NB-IoT tone is placed at the centre of this NB-IoT PRB.

For NB-IoT in-band operation carrier, the throughput shall be $\geq 95\%$ of the maximum throughput of the reference measurement channel as specified in Annex A with parameters specified in Table 7.4-11 for Medium Range BS with 15 kHz channel spacing and in Table 7.4-12 for Medium Range BS with 3.75 kHz channel spacing.

Table 7.4-11: Medium Range BS in-channel selectivity for NB-IoT in-band operation with 15kHz channel spacing

E-UTRA channel bandwidth (MHz)	Reference measurement channel	Wanted signal mean power [dBm] ($f \leq 3.0$ GHz)	Interfering signal mean power [dBm]	Type of interfering signal
3	FRC A14-1 in Annex A.14	-117.9	-79	3 MHz E-UTRA signal, 6 RBs (Note 2)
5	FRC A14-1 in Annex A.14	-117.9	-76	5 MHz E-UTRA signal, 10 RBs (Note 1)
10	FRC A14-1 in Annex A.14	-117.9	-72	10 MHz E-UTRA signal, 25 RBs (Note 1)
15	FRC A14-1 in Annex A.14	-117.9	-72	15 MHz E-UTRA signal, 25 RBs (Note 1)
20	FRC A14-1 in Annex A.14	-117.9	-72	20 MHz E-UTRA signal, 25 RBs (Note 1)
Note 1: Interfering signal is placed in one side of the F_c , while the NB-IoT PRB is placed on the other side. Both interfering signal and NB-IoT PRB are placed at the middle of the available PRB locations. The wanted NB-IoT tone is placed at the centre of this NB-IoT PRB. Note 2: Interfering signal is placed from the edge of BW_{config} , while the NB-IoT PRB is placed at the middle of the remaining PRB locations. The wanted NB-IoT tone is placed at the centre of this NB-IoT PRB.				

Table 7.4-12: Medium Range BS in-channel selectivity for NB-IoT in-band operation with 3.75kHz channel spacing

E-UTRA channel bandwidth (MHz)	Reference measurement channel	Wanted signal mean power [dBm] ($f \leq 3.0$ GHz)	Interfering signal mean power [dBm]	Type of interfering signal
3	FRC A14-2 in Annex A.14	-123.8	-79	3 MHz E-UTRA signal, 6 RBs (Note 2)
5	FRC A14-2 in Annex A.14	-123.8	-76	5 MHz E-UTRA signal, 10 RBs (Note 1)
10	FRC A14-2 in Annex A.14	-123.8	-72	10 MHz E-UTRA signal, 25 RBs (Note 1)
15	FRC A14-2 in Annex A.14	-123.8	-72	15 MHz E-UTRA signal, 25 RBs (Note 1)
20	FRC A14-2 in Annex A.14	-123.8	-72	20 MHz E-UTRA signal, 25 RBs (Note 1)
Note 1: Interfering signal is placed in one side of the F_c , while the NB-IoT PRB is placed on the other side. Both interfering signal and NB-IoT PRB are placed at the middle of the available PRB locations. The wanted NB-IoT tone is placed at the centre of this NB-IoT PRB. Note 2: Interfering signal is placed from the edge of BW_{config} , while the NB-IoT PRB is placed at the middle of the remaining PRB locations. The wanted NB-IoT tone is placed at the centre of this NB-IoT PRB.				

7.5 Adjacent Channel Selectivity (ACS) and narrow-band blocking

7.5.1 Definition and applicability

Adjacent channel selectivity (ACS) is a measure of the receiver's ability to receive a wanted signal at its assigned channel frequency in the presence of an adjacent channel signal with a specified centre frequency offset of the interfering signal to the band edge of a victim system.

The interfering signal shall be an E-UTRA signal as specified in Annex C.

Unless otherwise stated, a BS declared to be capable of E-UTRA with NB-IoT in-band and guard band operations is only required to pass the ACS and narrow-band blocking receiver tests for E-UTRA with guard band operation; it is not required to perform the ACS and narrow-band blocking receiver tests again for E-UTRA with in-band operation.

7.5.2 Minimum Requirement

The minimum requirement is in TS 36.104 [2] subclause 7.5.

7.5.3 Test purpose

The test purpose is to verify the ability of the BS receiver filter to suppress interfering signals in the channels adjacent to the wanted channel.

7.5.4 Method of test

7.5.4.1 Initial conditions

Test environment: normal; see subclause D.2.

RF channels to be tested for single carrier: B, M and T; see subclause 4.7.

Base Station RF Bandwidth edge position to be tested for multi-carrier and/or CA: M_{RFBW} in single-band operation, see subclause 4.7.1; $B'_{\text{RFBW}}T'_{\text{RFBW}}$ and $B'_{\text{RFBW}}T_{\text{RFBW}}$ in multi-band operation, see subclause 4.7.1.

- 1) Set-up the measurement system as shown in Annex I.2.4.

7.5.4.2 Procedure for Adjacent Channel Selectivity

For E-UTRA and E-UTRA with NB-IoT in-band or guard band operation:

- 1) Generate the E-UTRA wanted signal using the applicable test configuration specified in subclause 4.10 and 4.11 and adjust the input level to the base station under test to the level specified in Table 7.5-3 for E-UTRA Wide Area BS, in Table 7.5-4 for E-UTRA Local Area BS, in Table 7.5-5 for E-UTRA Home BS and in Table 7.5-6 for E-UTRA Medium Range BS.

For a BS declared to be capable of NB-IoT in-band or guard band operation, generate the NB-IoT wanted signal using the applicable test configuration specified in subclause 4.10 and 4.11 and adjust the input level to the base station under test to the level specified in Table 7.5-3a for NB-IoT in-band operation Wide Area BS and Table 7.5-3b for NB-IoT in guard band operation Wide Area BS, in Table 7.5-4a for NB-IoT in-band operation Local Area BS and Table 7.5-4b for NB-IoT in guard band operation Local Area BS, in Table 7.5-5a for NB-IoT in-band operation Home BS and Table 7.5-5b for NB-IoT in guard band operation Home BS, in Table 7.5-6a for NB-IoT in-band operation Medium Range BS and Table 7.5-6b for NB-IoT in guard band operation Medium Range BS.

- 2) Set-up the interfering signal at the adjacent channel frequency and adjust the interfering signal level at the base station input to the level defined in Table 7.5-3 for E-UTRA Wide Area BS, in Table 7.5-4 for E-UTRA Local Area BS, in Table 7.5-5 for E-UTRA Home BS, in Table 7.5-6 for E-UTRA Medium Range BS, in Table 7.5-3a for NB-IoT in-band operation Wide Area BS and Table 7.5-3b for NB-IoT in guard band operation Wide Area

BS, in Table 7.5-4a for NB-IoT in-band operation Local Area BS and Table 7.5-4b for NB-IoT in guard band operation Local Area BS, in Table 7.5-5a for NB-IoT in-band operation Home BS and Table 7.5-5b for NB-IoT in guard band operation Home BS, in Table 7.5-6a for NB-IoT in-band operation Medium Range BS and Table 7.5-6b for NB-IoT in guard band operation Medium Range BS.

- 3) Measure the E-UTRA throughput according to Annex E, for multi-carrier and/or CA operation the throughput shall be measured for relevant carriers specified by the test configuration specified in subclause 4.10 and 4.11.

For a BS declared to be capable of NB-IoT in-band or guard band operation, measure the NB-IoT throughput according to Annex E, for multi-carrier the throughput shall be measured for relevant carriers specified by the test configuration specified in subclause 4.10 and 4.11.

- 4) Repeat the test for the port(s), which was (were) terminated.

In addition, for a multi-band capable BS with separate antenna connectors, the following steps shall apply:

- 5) For single band tests, repeat the steps above per involved band where single band test configurations shall apply with no carrier activated in the other band.

Interfering signal shall first be applied on the same port as the wanted signal. The test shall be repeated with the interfering signal applied on the other port (if any) mapped to the same receiver as the wanted signal. Any antenna connector with no signal applied in case of single-band or multi-band test shall be terminated.

- 6) Repeat step 5) with the wanted signal for the other band(s) applied on the respective port(s).

For NB-IoT standalone operation:

- 1) Generate the NB-IoT wanted signal using the applicable test configuration specified in subclause 4.10 and 4.11 and adjust the input level to the base station under test to the level specified in Table 7.5-3c for NB-IoT standalone Wide Area BS, in Table 7.5-4c for NB-IoT standalone Local Area BS, in Table 7.5-5c for NB-IoT standalone Home BS and in Table 7.5-6c for NB-IoT standalone Medium Range BS.
- 2) Set-up the interfering signal at the adjacent channel frequency and adjust the interfering signal level at the base station input to the level defined in Table 7.5-3c for NB-IoT standalone Wide Area BS, in Table 7.5-4c for NB-IoT standalone Local Area BS, in Table 7.5-5c for NB-IoT standalone Home BS and in Table 7.5-6c for NB-IoT standalone Medium Range BS.
- 3) Measure NB-IoT throughput according to Annex E.
- 4) Repeat the test for the port(s), which was (were) terminated.

7.5.4.3 Procedure for narrow-band blocking

For E-UTRA and E-UTRA with NB-IoT in-band or guard band BS:

- 1) For FDD BS declared to be capable of single carrier operation only, start BS transmission according to E-TM 1.1 at manufacturer's declared rated output power.

For a FDD BS declared to be capable of multi-carrier and/or CA operation, set the BS to transmit according to E-TM 1.1 on all carriers configured using the applicable test configuration and corresponding power setting specified in clause 4.10 and 4.11.

For BS declared to be capable of NB-IoT in-band or guard band operation single carrier only, start BS transmission according to N-TM at manufacturer's declared rated output power.

For a BS declared to be capable of NB-IoT multi-carrier, set the BS to transmit according to N-TM on all carriers configured using the applicable test configuration and corresponding power setting specified in clause 4.10 and 4.11.

- 2) Generate the E-UTRA wanted signal using the applicable test configuration specified in subclause 4.10 and 4.11 and adjust the input level to the base station under test to the level specified in Table 7.5-1.

For a BS declared to be capable of NB-IoT in-band or guard band operation, generate the NB-IoT wanted signal using the applicable test configuration specified in subclause 4.10 and 4.11 and adjust the input level to the base

station under test to the level specified in Table 7.5-1a for NB-IoT in-band operation and Table 7.5-1b for NB-IoT guard band operation.

- 3) Adjust the interfering signal level at the base station input to the level defined in Table 7.5-1 for E-UTRA, in Table 7.5-1a for NB-IoT in-band operation and Table 7.5-1b for NB-IoT guard band operation. Set-up and sweep the interfering RB centre frequency offset to the channel edge of the wanted signal according to Table 7.5-2.
- 4) Measure the E-UTRA throughput according to Annex E, for multi-carrier and/or CA operation the throughput shall be measured for relevant carriers specified by the test configuration specified in subclause 4.10 and 4.11.

For a BS declared to be capable of NB-IoT in-band or guard band operation, measure the NB-IoT throughput according to Annex E, for multi-carrier the throughput shall be measured for relevant carriers specified by the test configuration specified in subclause 4.10 and 4.11.

- 5) Repeat the test for the port(s), which was (were) terminated.

In addition, for a multi-band capable BS with separate antenna connectors, the following steps shall apply:

- 6) For single band tests, repeat the steps above per involved band where single band test configurations and test models shall apply with no carrier activated in the other band.
- 7) Interfering signal shall first be applied on the same port as the wanted signal. The test shall be repeated with the interfering signal applied on the other port (if any) mapped to the same receiver as the wanted signal. Any antenna connector with no signal applied in case of single-band or multi-band test shall be terminated.
- 8) Repeat step 7) with the wanted signal for the other band(s) applied on the respective port(s).

For NB-IoT standalone BS:

- 1) For BS declared to be capable of NB-IoT standalone single carrier only, start BS transmission according to N-TM at manufacturer's declared rated output power.

For a BS declared to be capable of NB-IoT multi-carrier, set the BS to transmit according to N-TM on all carriers configured using the applicable test configuration and corresponding power setting specified in clause 4.10 and 4.11.

- 2) Generate the NB-IoT wanted signal using the applicable test configuration specified in subclause 4.10 and 4.11 and adjust the input level to the base station under test to the level specified in Table 7.5-1c.
- 3) Adjust the interfering signal level at the base station input to the level defined in Table 7.5-1c. Set-up and sweep the interfering RB centre frequency offset to the channel edge of the wanted signal according to Table 7.5-2a.
- 4) Measure the NB-IoT throughput according to Annex E, for multi-carrier the throughput shall be measured for relevant carriers specified by the test configuration specified in subclause 4.10 and 4.11.
- 5) Repeat the test for the port(s), which was (were) terminated.

For E-UTRA and NB-IoT standalone BS:

- 1) Set the BS to transmit according to E-TM 1.1 on all E-UTRA carriers and according to N-TM on all NB-IoT carriers configured using the applicable test configuration and corresponding power setting specified in clause 4.10 and 4.11.
- 2) Generate the E-UTRA wanted signal using the applicable test configuration specified in subclause 4.10 and 4.11 and adjust the input level to the base station under test to the level specified in Table 7.5-1.

Generate the NB-IoT wanted signal using the applicable test configuration specified in subclause 4.10 and 4.11 and adjust the input level to the base station under test to the level specified in Table 7.5-1c.

- 3) a) On the side where E-UTRA signal is positioned:

Adjust the interfering signal level at the base station input to the level defined in Table 7.5-1 for E-UTRA. Set-up and sweep the interfering RB centre frequency offset to the channel edge of the wanted signal according to Table 7.5-2.

b) On the side where NB-IoT signal is positioned:

Adjust the interfering signal level at the base station input to the level defined in Table 7.5-1c. Set-up and sweep the interfering RB centre frequency offset to the channel edge of the wanted signal according to Table 7.5-2a.

- 4) Measure the E-UTRA throughput and the NB-IoT throughput according to Annex E, for multi-carrier the throughput shall be measured for relevant carriers specified by the test configuration specified in subclause 4.10 and 4.11.
- 5) Repeat the test for the port(s), which was (were) terminated.

7.5.5 Test Requirements

For each measured E-UTRA carrier, the throughput shall be $\geq 95\%$ of the maximum throughput of the reference measurement channel.

For each measured NB-IoT carrier, the throughput shall be $\geq 95\%$ of the maximum throughput of the reference measurement channel.

For E-UTRA Wide Area BS, the wanted and the interfering signal coupled to the BS antenna input are specified in Table 7.5-1 and 7.5-2 for narrowband blocking and 7.5-3 for ACS. The reference measurement channel for the wanted signal is specified in Table 7.2-1 for each channel bandwidth and further specified in Annex A.

For E-UTRA Medium Range BS, the wanted and the interfering signal coupled to the BS antenna input are specified in Tables 7.5-1 and 7.5-2 for narrowband blocking and in Table 7.5-6 for ACS. Narrowband blocking requirements are not applied for Band 46. The reference measurement channel for the wanted signal is specified in Table 7.2-4 for each channel bandwidth and further specified in Annex A.

For E-UTRA Local Area BS, the wanted and the interfering signal coupled to the BS antenna input are specified in Tables 7.5-1 and 7.5-2 for narrowband blocking and 7.5-4 for ACS. Narrowband blocking requirements are not applied for Band 46. The reference measurement channel for the wanted signal is specified in Table 7.2-2 for each channel bandwidth and further specified in Annex A.

For E-UTRA Home BS, the wanted and the interfering signal coupled to the BS antenna input are specified in Table 7.5-1 and 7.5-2 for narrowband blocking and 7.5-5 for ACS. The reference measurement channel for the wanted signal is specified in Table 7.2-3 for each channel bandwidth and further specified in Annex A.

For E-UTRA Wide Area BS declared to be capable of NB-IoT in-band, the E-UTRA wanted, the NB-IoT wanted and the interfering signal coupled to the BS antenna input are specified in Table 7.5-1, 7.5-1a and 7.5-2 for narrowband blocking and 7.5-3 and 7.5-3a for ACS. The reference measurement channel for the E-UTRA wanted signal is specified in Table 7.2-1 for each channel bandwidth and further specified in Annex A. The reference measurement channel for the NB-IoT wanted signal is specified in Table 7.2-5 for each sub-carrier spacing and further specified in Annex A.

For E-UTRA Wide Area BS declared to be capable of NB-IoT guard band, the E-UTRA wanted, the NB-IoT wanted and the interfering signal coupled to the BS antenna input are specified in Table 7.5-1, 7.5-1b and 7.5-2 for narrowband blocking and 7.5-3 and 7.5-3b for ACS. The reference measurement channel for the E-UTRA wanted signal is specified in Table 7.2-1 for each channel bandwidth and further specified in Annex A. The reference measurement channel for the NB-IoT wanted signal is specified in Table 7.2-5 for each sub-carrier spacing and further specified in Annex A.

For NB-IoT standalone Wide Area BS, the NB-IoT wanted and the interfering signal coupled to the BS antenna input are specified in Table 7.5-1c and 7.5-2a for narrowband blocking and 7.5-3c for ACS. The reference measurement channel for the NB-IoT wanted signal is specified in Table 7.2-5 for each sub-carrier spacing and further specified in Annex A.

For E-UTRA Local Area BS declared to be capable of NB-IoT in-band, the E-UTRA wanted, the NB-IoT wanted and the interfering signal coupled to the BS antenna input are specified in Table 7.5-1, 7.5-1a and 7.5-2 for narrowband blocking and 7.5-4 and 7.5-4a for ACS. The reference measurement channel for the E-UTRA wanted signal is specified in Table 7.2-1 for each channel bandwidth and further specified in Annex A. The reference measurement channel for the NB-IoT wanted signal is specified in Table 7.2-5 for each sub-carrier spacing and further specified in Annex A.

For E-UTRA Local Area BS declared to be capable of NB-IoT guard band, the E-UTRA wanted, the NB-IoT wanted and the interfering signal coupled to the BS antenna input are specified in Table 7.5-1, 7.5-1b and 7.5-2 for narrowband blocking and 7.5-4 and 7.5-4b for ACS. The reference measurement channel for the E-UTRA wanted signal is specified

in Table 7.2-1 for each channel bandwidth and further specified in Annex A. The reference measurement channel for the NB-IoT wanted signal is specified in Table 7.2-5 for each sub-carrier spacing and further specified in Annex A.

For NB-IoT standalone Local Area BS, the NB-IoT wanted and the interfering signal coupled to the BS antenna input are specified in Table 7.5-1c and 7.5-2a for narrowband blocking and 7.5-4c for ACS. The reference measurement channel for the NB-IoT wanted signal is specified in Table 7.2-5 for each sub-carrier spacing and further specified in Annex A.

For E-UTRA Home BS declared to be capable of NB-IoT in-band, the E-UTRA wanted, the NB-IoT wanted and the interfering signal coupled to the BS antenna input are specified in Table 7.5-1, 7.5-1a and 7.5-2 for narrowband blocking and 7.5-5 and 7.5-5a for ACS. The reference measurement channel for the E-UTRA wanted signal is specified in Table 7.2-1 for each channel bandwidth and further specified in Annex A. The reference measurement channel for the NB-IoT wanted signal is specified in Table 7.2-5 for each sub-carrier spacing and further specified in Annex A.

For E-UTRA Home BS declared to be capable of NB-IoT guard band, the E-UTRA wanted, the NB-IoT wanted and the interfering signal coupled to the BS antenna input are specified in Table 7.5-1, 7.5-1b and 7.5-2 for narrowband blocking and 7.5-5 and 7.5-5b for ACS. The reference measurement channel for the E-UTRA wanted signal is specified in Table 7.2-1 for each channel bandwidth and further specified in Annex A. The reference measurement channel for the NB-IoT wanted signal is specified in Table 7.2-5 for each sub-carrier spacing and further specified in Annex A.

For NB-IoT standalone Home BS, the NB-IoT wanted and the interfering signal coupled to the BS antenna input are specified in Table 7.5-1c and 7.5-2a for narrowband blocking and 7.5-5c for ACS. The reference measurement channel for the NB-IoT wanted signal is specified in Table 7.2-5 for each sub-carrier spacing and further specified in Annex A.

For E-UTRA Medium Range BS declared to be capable of NB-IoT in-band, the E-UTRA wanted, the NB-IoT wanted and the interfering signal coupled to the BS antenna input are specified in Table 7.5-1, 7.5-1a and 7.5-2 for narrowband blocking and 7.5-6 and 7.5-6a for ACS. The reference measurement channel for the E-UTRA wanted signal is specified in Table 7.2-1 for each channel bandwidth and further specified in Annex A. The reference measurement channel for the NB-IoT wanted signal is specified in Table 7.2-5 for each sub-carrier spacing and further specified in Annex A.

For E-UTRA Medium Range BS declared to be capable of NB-IoT guard band, the E-UTRA wanted, the NB-IoT wanted and the interfering signal coupled to the BS antenna input are specified in Table 7.5-1, 7.5-1b and 7.5-2 for narrowband blocking and 7.5-6 and 7.5-6b for ACS. The reference measurement channel for the E-UTRA wanted signal is specified in Table 7.2-1 for each channel bandwidth and further specified in Annex A. The reference measurement channel for the NB-IoT wanted signal is specified in Table 7.2-5 for each sub-carrier spacing and further specified in Annex A.

For NB-IoT standalone Medium Range BS, the NB-IoT wanted and the interfering signal coupled to the BS antenna input are specified in Table 7.5-1c and 7.5-2a for narrowband blocking and 7.5-6c for ACS. The reference measurement channel for the NB-IoT wanted signal is specified in Table 7.2-5 for each sub-carrier spacing and further specified in Annex A.

The ACS and narrowband blocking requirement is always applicable outside the Base Station RF Bandwidth or Maximum Radio Bandwidth. The interfering signal offset is defined relative to the Base station RF Bandwidth edges or Maximum Radio Bandwidth edges.

For a BS operating in non-contiguous spectrum within any operating band, the ACS requirement applies in addition inside any sub-block gap, in case the sub-block gap size is at least as wide as the E-UTRA interfering signal in Tables 7.5-3, 7.5-4 and 7.5-6. The interfering signal offset is defined relative to the sub-block edges inside the sub-block gap.

For a BS capable of multi-band operation, the ACS requirement applies in addition inside any Inter RF Bandwidth gap, in case the Inter RF Bandwidth gap size is at least as wide as the E-UTRA interfering signal in Tables 7.5-3, 7.5-4 and 7.5-6. The interfering signal offset is defined relative to the Base Station RF Bandwidth edges inside the Inter RF Bandwidth gap.

For a BS operating in non-contiguous spectrum within any operating band, the narrowband blocking requirement applies in addition inside any sub-block gap, in case the sub-block gap size is at least as wide as the channel bandwidth of the E-UTRA interfering signal in Table 7.5-2. The interfering signal offset is defined relative to the sub-block edges inside the sub-block gap.

For a BS capable of multi-band operation, the narrowband blocking requirement applies in addition inside any Inter RF Bandwidth gap, in case the Inter RF Bandwidth gap size is at least as wide as the E-UTRA interfering signal in Table 7.5-2. The interfering signal offset is defined relative to the Base Station RF Bandwidth edges inside the Inter RF Bandwidth gap.

Table 7.5-1: Narrowband blocking requirement

	Wanted signal mean power [dBm]	Interfering signal mean power [dBm]	Type of interfering signal
Wide Area BS	$P_{\text{REFSENS}} + 6\text{dB}^*$	-49	See Table 7.5-2
Medium Range BS	$P_{\text{REFSENS}} + 6\text{dB}^*$	-44	See Table 7.5-2
Local Area BS	$P_{\text{REFSENS}} + 6\text{dB}^*$	-41	See Table 7.5-2
Home BS	$P_{\text{REFSENS}} + 14\text{dB}^*$	-33	See Table 7.5-2
Note*: P_{REFSENS} depends on the channel bandwidth as specified in TS 36.104 [2] subclause 7.2.1.			

Table 7.5-1a: Narrowband blocking requirement for NB-IoT in-band operation BS

	E-UTRA channel BW of the lowest/highest carrier received [MHz]	NB-IoT Wanted signal mean power [dBm]	Interfering signal mean power [dBm]	Type of interfering signal
Wide Area BS	3	$P_{\text{REFSENS}} + 11\text{ dB}^*$	-49	See Table 7.5.2
	5	$P_{\text{REFSENS}} + 8\text{ dB}^*$	-49	See Table 7.5.2
	10	$P_{\text{REFSENS}} + 6\text{ dB}^*$	-49	See Table 7.5.2
	15	$P_{\text{REFSENS}} + 6\text{ dB}^*$	-49	See Table 7.5.2
	20	$P_{\text{REFSENS}} + 6\text{ dB}^*$	-49	See Table 7.5.2
Local Area BS	3	$P_{\text{REFSENS}} + 11\text{ dB}^*$	-41	See Table 7.5.2
	5	$P_{\text{REFSENS}} + 8\text{ dB}^*$	-41	See Table 7.5.2
	10	$P_{\text{REFSENS}} + 6\text{ dB}^*$	-41	See Table 7.5.2
	15	$P_{\text{REFSENS}} + 6\text{ dB}^*$	-41	See Table 7.5.2
	20	$P_{\text{REFSENS}} + 6\text{ dB}^*$	-41	See Table 7.5.2
Home BS	3	$P_{\text{REFSENS}} + 19\text{ dB}^*$	-33	See Table 7.5.2
	5	$P_{\text{REFSENS}} + 16\text{ dB}^*$	-33	See Table 7.5.2
	10	$P_{\text{REFSENS}} + 14\text{ dB}^*$	-33	See Table 7.5.2
	15	$P_{\text{REFSENS}} + 14\text{ dB}^*$	-33	See Table 7.5.2
	20	$P_{\text{REFSENS}} + 14\text{ dB}^*$	-33	See Table 7.5.2
Medium Range BS	3	$P_{\text{REFSENS}} + 11\text{ dB}^*$	-44	See Table 7.5.2
	5	$P_{\text{REFSENS}} + 8\text{ dB}^*$	-44	See Table 7.5.2
	10	$P_{\text{REFSENS}} + 6\text{ dB}^*$	-44	See Table 7.5.2
	15	$P_{\text{REFSENS}} + 6\text{ dB}^*$	-44	See Table 7.5.2
	20	$P_{\text{REFSENS}} + 6\text{ dB}^*$	-44	See Table 7.5.2
Note*: P_{REFSENS} depends on the sub-carrier spacing as specified in TS 36.104 [2] subclause 7.2.1..				

Table 7.5-1b: Narrowband blocking requirement for NB-IoT guard band operation BS

	E-UTRA channel BW of the lowest/highest carrier received [MHz]	NB-IoT Wanted signal mean power [dBm]	Interfering signal mean power [dBm]	Type of interfering signal
Wide Area BS	5	$P_{\text{REFSENS}} + 11 \text{ dB}^*$	-49	See Table 7.5.2
	10	$P_{\text{REFSENS}} + 6 \text{ dB}^*$	-49	See Table 7.5.2
	15	$P_{\text{REFSENS}} + 6 \text{ dB}^*$	-49	See Table 7.5.2
	20	$P_{\text{REFSENS}} + 6 \text{ dB}^*$	-49	See Table 7.5.2
Local Area BS	5	$P_{\text{REFSENS}} + 11 \text{ dB}^*$	-41	See Table 7.5.2
	10	$P_{\text{REFSENS}} + 6 \text{ dB}^*$	-41	See Table 7.5.2
	15	$P_{\text{REFSENS}} + 6 \text{ dB}^*$	-41	See Table 7.5.2
	20	$P_{\text{REFSENS}} + 6 \text{ dB}^*$	-41	See Table 7.5.2
Home BS	5	$P_{\text{REFSENS}} + 19 \text{ dB}^*$	-33	See Table 7.5.2
	10	$P_{\text{REFSENS}} + 14 \text{ dB}^*$	-33	See Table 7.5.2
	15	$P_{\text{REFSENS}} + 14 \text{ dB}^*$	-33	See Table 7.5.2
	20	$P_{\text{REFSENS}} + 14 \text{ dB}^*$	-33	See Table 7.5.2
Medium Range BS	5	$P_{\text{REFSENS}} + 11 \text{ dB}^*$	-41	See Table 7.5.2
	10	$P_{\text{REFSENS}} + 6 \text{ dB}^*$	-44	See Table 7.5.2
	15	$P_{\text{REFSENS}} + 6 \text{ dB}^*$	-44	See Table 7.5.2
	20	$P_{\text{REFSENS}} + 6 \text{ dB}^*$	-44	See Table 7.5.2
Note:	The mentioned desens values consider only one NB-IoT PRB in the guard band, which is placed adjacent to the E-UTRA PRB edge as close as possible (i.e., away from edge of channel bandwidth).			
Note*:	P_{REFSENS} depends on the sub-carrier spacing as specified in TS 36.104 [2] subclause 7.2.1.			

Table 7.5-1c: Narrowband blocking requirement for NB-IoT standalone

	NB-IoT channel bandwidth of the lowest/highest carrier received [kHz]	Wanted signal mean power [dBm]	Interfering signal mean power [dBm]	Type of interfering signal
Wide Area BS	200	$P_{\text{REFSENS}} + 12 \text{ dB}^*$	-49	See Table 7.5.2a
Local Area BS	200	$P_{\text{REFSENS}} + 12 \text{ dB}^*$	-41	See Table 7.5.2a
Home BS	200	$P_{\text{REFSENS}} + 20 \text{ dB}^*$	-33	See Table 7.5.2a
Medium Range BS	200	$P_{\text{REFSENS}} + 12 \text{ dB}^*$	-44	See Table 7.5.2a
Note*:	P_{REFSENS} depends on the sub-carrier spacing as specified in TS 36.104 [2] subclause 7.2.1.			

Table 7.5-2: Interfering signal for Narrowband blocking requirement for E-UTRA BS

E-UTRA channel BW of the lowest/highest carrier received [MHz]	Interfering RB centre frequency offset to the lower/upper Base Station RF Bandwidth edge or sub-block edge inside a sub-block gap [kHz]	Type of interfering signal
1.4	$\pm(252.5+m*180)$, m=0, 1, 2, 3, 4, 5	1.4 MHz E-UTRA signal, 1 RB*
3	$\pm(247.5+m*180)$, m=0, 1, 2, 3, 4, 7, 10, 13	3 MHz E-UTRA signal, 1 RB*
5	$\pm(342.5+m*180)$, m=0, 1, 2, 3, 4, 9, 14, 19, 24	5 MHz E-UTRA signal, 1 RB*
10	$\pm(347.5+m*180)$, m=0, 1, 2, 3, 4, 9, 14, 19, 24	5 MHz E-UTRA signal, 1 RB*
15	$\pm(352.5+m*180)$, m=0, 1, 2, 3, 4, 9, 14, 19, 24	5 MHz E-UTRA signal, 1 RB*
20	$\pm(342.5+m*180)$, m=0, 1, 2, 3, 4, 9, 14, 19, 24	5 MHz E-UTRA signal, 1 RB*
Note*: Interfering signal consisting of one resource block is positioned at the stated offset, the channel bandwidth of the interfering signal is located adjacently to the lower/upper Base Station RF Bandwidth edge.		

Table 7.5-2a: Interfering signal for Narrowband blocking requirement for NB-IoT standalone operation BS

NB-IoT channel bandwidth of the lowest/highest carrier received [kHz]	Interfering RB centre frequency offset to the lower/upper Base Station RF Bandwidth edge or sub-block edge inside a sub-block gap [kHz]	Type of interfering signal
200	$\pm(240 +m*180)$, m=0, 1, 2, 3, 4, 9, 14	3 MHz E-UTRA signal, 1 RB*
Note*: Interfering signal consisting of one resource block is positioned at the stated offset, the channel bandwidth of the interfering signal is located adjacently to the lower/upper Base Station RF Bandwidth edge.		

Table 7.5-3: Adjacent channel selectivity for E-UTRA Wide Area BS

E-UTRA channel bandwidth of the lowest/highest carrier received [MHz]	Wanted signal mean power [dBm]	Interfering signal mean power [dBm]	Interfering signal centre frequency offset from the lower/upper Base Station RF Bandwidth edge or sub-block edge inside a sub-block gap [MHz]	Type of interfering signal
1.4	$P_{\text{REFSENS}} + 11\text{dB}^*$	-52	± 0.7025	1.4MHz E-UTRA signal
3	$P_{\text{REFSENS}} + 8\text{dB}^*$	-52	± 1.5075	3MHz E-UTRA signal
5	$P_{\text{REFSENS}} + 6\text{dB}^*$	-52	± 2.5025	5MHz E-UTRA signal
10	$P_{\text{REFSENS}} + 6\text{dB}^*$	-52	± 2.5075	5MHz E-UTRA signal
15	$P_{\text{REFSENS}} + 6\text{dB}^*$	-52	± 2.5125	5MHz E-UTRA signal
20	$P_{\text{REFSENS}} + 6\text{dB}^*$	-52	± 2.5025	5MHz E-UTRA signal

Note*: P_{REFSENS} depends on the channel bandwidth as specified in TS 36.104 [2] subclause 7.2.1.

Table 7.5-3a: Adjacent channel selectivity for NB-IoT in-band operation Wide Area BS

E-UTRA channel bandwidth of the lowest/highest carrier received [MHz]	NB-IoT wanted signal mean power [dBm]	Interfering signal mean power [dBm]	Interfering signal centre frequency offset from the lower/upper Base Station RF Bandwidth edge or sub-block edge inside a sub-block gap [MHz]	Type of interfering signal
3	$P_{\text{REFSENS}} + 8\text{dB}^*$	-52	± 1.5075	3MHz E-UTRA signal
5	$P_{\text{REFSENS}} + 6\text{dB}^*$	-52	± 2.5025	5MHz E-UTRA signal
10	$P_{\text{REFSENS}} + 6\text{dB}^*$	-52	± 2.5075	5MHz E-UTRA signal
15	$P_{\text{REFSENS}} + 6\text{dB}^*$	-52	± 2.5125	5MHz E-UTRA signal
20	$P_{\text{REFSENS}} + 6\text{dB}^*$	-52	± 2.5025	5MHz E-UTRA signal

Note*: P_{REFSENS} depends on the sub-carrier spacing as specified in TS 36.104 [2] subclause 7.2.1.

Table 7.5-3b: Adjacent channel selectivity NB-IoT guard band operation Wide Area BS

E-UTRA channel bandwidth of the lowest/highest carrier received [MHz]	NB-IoT wanted signal mean power [dBm]	Interfering signal mean power [dBm]	Interfering signal centre frequency offset from the lower/upper Base Station RF Bandwidth edge or sub-block edge inside a sub-block gap [MHz]	Type of interfering signal
5	$P_{\text{REFSENS}} + 10\text{ dB}^*$	-52	± 2.5025	5MHz E-UTRA signal
10	$P_{\text{REFSENS}} + 8\text{ dB}^*$	-52	± 2.5075	5MHz E-UTRA signal
15	$P_{\text{REFSENS}} + 6\text{ dB}^*$	-52	± 2.5125	5MHz E-UTRA signal
20	$P_{\text{REFSENS}} + 6\text{ dB}^*$	-52	± 2.5025	5MHz E-UTRA signal

Note*: P_{REFSENS} depends on the sub-carrier spacing as specified in TS 36.104 [2] subclause 7.2.1.

Table 7.5-3c: Adjacent channel selectivity for NB-IoT standalone Wide Area BS

NB-IoT channel bandwidth of the lowest/highest carrier received [kHz]	Wanted signal mean power [dBm]	Interfering signal mean power [dBm]	Interfering signal centre frequency offset to the lower/upper Base Station RF Bandwidth edge or sub-block edge inside a sub-block gap [kHz]	Type of interfering signal
200	$P_{\text{REFSENS}} + 19.5\text{dB}^*$	-52	± 100	180 kHz NB-IoT signal
Note*: P_{REFSENS} depends on the sub-carrier spacing as specified in TS 36.104 [2] subclause 7.2.1.				

Table 7.5-4: Adjacent channel selectivity for E-UTRA Local Area BS

E-UTRA channel bandwidth of the lowest/highest carrier received [MHz]	Wanted signal mean power [dBm]	Interfering signal mean power [dBm]	Interfering signal centre frequency offset from the lower/upper Base Station RF Bandwidth edge or sub-block edge inside a sub-block gap [MHz]	Type of interfering signal
1.4	$P_{\text{REFSENS}} + 11\text{dB}^*$	-44	± 0.7025	1.4MHz E-UTRA signal
3	$P_{\text{REFSENS}} + 8\text{dB}^*$	-44	± 1.5075	3MHz E-UTRA signal
5	$P_{\text{REFSENS}} + 6\text{dB}^*$	-44	± 2.5025	5MHz E-UTRA signal
10	$P_{\text{REFSENS}} + 6\text{dB}^*$	-44	± 2.5075 ± 10.0175	5MHz E-UTRA signal** 20 MHz E-UTRA signal***
15	$P_{\text{REFSENS}} + 6\text{dB}^*$	-44	± 2.5125	5MHz E-UTRA signal
20	$P_{\text{REFSENS}} + 6\text{dB}^*$	-44	± 2.5025 ± 10.0175	5MHz E-UTRA signal** 20 MHz E-UTRA signal***
Note*: P_{REFSENS} depends on the channel bandwidth as specified in TS 36.104 [2] subclause 7.2.1.				
Note**: This type of interfering signal is not applied for Band 46.				
Note***: This type of interfering signal is only applied for Band 46.				

Table 7.5-4a: Adjacent channel selectivity for NB-IoT in-band operation Local Area BS

E-UTRA channel bandwidth of the lowest/highest carrier received [MHz]	NB-IoT wanted signal mean power [dBm]	Interfering signal mean power [dBm]	Interfering signal centre frequency offset from the lower/upper Base Station RF Bandwidth edge or sub-block edge inside a sub-block gap [MHz]	Type of interfering signal
3	$P_{\text{REFSENS}} + 8\text{dB}^*$	-44	± 1.5075	3MHz E-UTRA signal
5	$P_{\text{REFSENS}} + 6\text{dB}^*$	-44	± 2.5025	5MHz E-UTRA signal
10	$P_{\text{REFSENS}} + 6\text{dB}^*$	-44	± 2.5075	5MHz E-UTRA signal
15	$P_{\text{REFSENS}} + 6\text{dB}^*$	-44	± 2.5125	5MHz E-UTRA signal
20	$P_{\text{REFSENS}} + 6\text{dB}^*$	-44	± 2.5025	5MHz E-UTRA signal
Note*: P_{REFSENS} depends on the sub-carrier spacing as specified in TS 36.104 [2] subclause 7.2.1.				

Table 7.5-4b: Adjacent channel selectivity NB-IoT guard band operation Local Area BS

E-UTRA channel bandwidth of the lowest/highest carrier received [MHz]	NB-IoT wanted signal mean power [dBm]	Interfering signal mean power [dBm]	Interfering signal centre frequency offset from the lower/upper Base Station RF Bandwidth edge or sub-block edge inside a sub-block gap [MHz]	Type of interfering signal
5	$P_{\text{REFSENS}} + 10 \text{ dB}^*$	-44	± 2.5025	5MHz E-UTRA signal
10	$P_{\text{REFSENS}} + 8 \text{ dB}^*$	-44	± 2.5075	5MHz E-UTRA signal
15	$P_{\text{REFSENS}} + 6 \text{ dB}^*$	-44	± 2.5125	5MHz E-UTRA signal
20	$P_{\text{REFSENS}} + 6 \text{ dB}^*$	-44	± 2.5025	5MHz E-UTRA signal
Note*: P_{REFSENS} depends on the sub-carrier spacing as specified in TS 36.104 [2] subclause 7.2.1.				

Table 7.5-4c: Adjacent channel selectivity for NB-IoT standalone Local Area BS

NB-IoT channel bandwidth of the lowest/highest carrier received [kHz]	Wanted signal mean power [dBm]	Interfering signal mean power [dBm]	Interfering signal centre frequency offset to the lower/upper Base Station RF Bandwidth edge or sub-block edge inside a sub-block gap [kHz]	Type of interfering signal
200	$P_{\text{REFSENS}} + 19.5 \text{ dB}^*$	-44	± 100	180 kHz NB-IoT signal
Note*: P_{REFSENS} depends on the sub-carrier spacing as specified in TS 36.104 [2] subclause 7.2.1.				

Table 7.5-5: Adjacent channel selectivity for E-UTRA Home BS

E-UTRA channel bandwidth [MHz]	Wanted signal mean power [dBm]	Interfering signal mean power [dBm]	Interfering signal centre frequency offset from the channel edge of the wanted signal [MHz]	Type of interfering signal
1.4	$P_{\text{REFSENS}} + 27 \text{ dB}^*$	-28	0.7025	1.4MHz E-UTRA signal
3	$P_{\text{REFSENS}} + 24 \text{ dB}^*$	-28	1.5075	3MHz E-UTRA signal
5	$P_{\text{REFSENS}} + 22 \text{ dB}^*$	-28	2.5025	5MHz E-UTRA signal
10	$P_{\text{REFSENS}} + 22 \text{ dB}^*$	-28	2.5075	5MHz E-UTRA signal
15	$P_{\text{REFSENS}} + 22 \text{ dB}^*$	-28	2.5125	5MHz E-UTRA signal
20	$P_{\text{REFSENS}} + 22 \text{ dB}^*$	-28	2.5025	5MHz E-UTRA signal
Note*: P_{REFSENS} depends on the channel bandwidth as specified in TS 36.104 [2] subclause 7.2.1.				

Table 7.5-5a: Adjacent channel selectivity for NB-IoT in-band operation Home BS

E-UTRA channel bandwidth of the lowest/highest carrier received [MHz]	NB-IoT wanted signal mean power [dBm]	Interfering signal mean power [dBm]	Interfering signal centre frequency offset from the lower/upper Base Station RF Bandwidth edge or sub-block edge inside a sub-block gap [MHz]	Type of interfering signal
3	$P_{\text{REFSENS}} + 24 \text{ dB}^*$	-28	± 1.5075	3MHz E-UTRA signal
5	$P_{\text{REFSENS}} + 22 \text{ dB}^*$	-28	± 2.5025	5MHz E-UTRA signal
10	$P_{\text{REFSENS}} + 22 \text{ dB}^*$	-28	± 2.5075	5MHz E-UTRA signal
15	$P_{\text{REFSENS}} + 22 \text{ dB}^*$	-28	± 2.5125	5MHz E-UTRA signal
20	$P_{\text{REFSENS}} + 22 \text{ dB}^*$	-28	± 2.5025	5MHz E-UTRA signal
Note*: P_{REFSENS} depends on the sub-carrier spacing as specified in TS 36.104 [2] subclause 7.2.1.				

Table 7.5-5b: Adjacent channel selectivity NB-IoT guard band operation Home BS

E-UTRA channel bandwidth of the lowest/highest carrier received [MHz]	NB-IoT wanted signal mean power [dBm]	Interfering signal mean power [dBm]	Interfering signal centre frequency offset from the lower/upper Base Station RF Bandwidth edge or sub-block edge inside a sub-block gap [MHz]	Type of interfering signal
5	$P_{\text{REFSENS}} + 26 \text{ dB}^*$	-28	± 2.5025	5MHz E-UTRA signal
10	$P_{\text{REFSENS}} + 24 \text{ dB}^*$	-28	± 2.5075	5MHz E-UTRA signal
15	$P_{\text{REFSENS}} + 22 \text{ dB}^*$	-28	± 2.5125	5MHz E-UTRA signal
20	$P_{\text{REFSENS}} + 22 \text{ dB}^*$	-28	± 2.5025	5MHz E-UTRA signal
Note*: P_{REFSENS} depends on the sub-carrier spacing as specified in TS 36.104 [2] subclause 7.2.1.				

Table 7.5-5c: Adjacent channel selectivity for NB-IoT standalone Home BS

NB-IoT channel bandwidth of the lowest/highest carrier received [kHz]	Wanted signal mean power [dBm]	Interfering signal mean power [dBm]	Interfering signal centre frequency offset to the lower/upper Base Station RF Bandwidth edge or sub-block edge inside a sub-block gap [kHz]	Type of interfering signal
200	$P_{\text{REFSENS}} + 35.5 \text{ dB}^*$	-28	± 100	180 kHz NB-IoT signal
Note*: P_{REFSENS} depends on the sub-carrier spacing as specified in TS 36.104 [2] subclause 7.2.1.				

Table 7.5-6: Adjacent channel selectivity for E-UTRA Medium Range BS

E-UTRA channel bandwidth of the lowest/highest carrier received [MHz]	Wanted signal mean power [dBm]	Interfering signal mean power [dBm]	Interfering signal centre frequency offset from the lower/upper Base Station RF Bandwidth edge or sub-block edge inside a sub-block gap [MHz]	Type of interfering signal
1.4	$P_{\text{REFSENS}} + 11 \text{ dB}^*$	-47	± 0.7025	1.4MHz E-UTRA signal
3	$P_{\text{REFSENS}} + 8 \text{ dB}^*$	-47	± 1.5075	3MHz E-UTRA signal
5	$P_{\text{REFSENS}} + 6 \text{ dB}^*$	-47	± 2.5025	5MHz E-UTRA signal
10	$P_{\text{REFSENS}} + 6 \text{ dB}^*$	-47	± 2.5075 ± 10.0175	5MHz E-UTRA signal** 20 MHz E-UTRA signal***
15	$P_{\text{REFSENS}} + 6 \text{ dB}^*$	-47	± 2.5125	5MHz E-UTRA signal
20	$P_{\text{REFSENS}} + 6 \text{ dB}^*$	-47	± 2.5025 ± 10.0175	5MHz E-UTRA signal** 20 MHz E-UTRA signal***
Note*: P_{REFSENS} depends on the channel bandwidth as specified in TS 36.104 [2] subclause 7.2.1.				
Note**: This type of interfering signal is not applied for Band 46.				
Note***: This type of interfering signal is only applied for Band 46.				

Table 7.5-6a: Adjacent channel selectivity for NB-IoT in-band operation Medium Range BS

E-UTRA channel bandwidth of the lowest/highest carrier received [MHz]	NB-IoT wanted signal mean power [dBm]	Interfering signal mean power [dBm]	Interfering signal centre frequency offset from the lower/upper Base Station RF Bandwidth edge or sub-block edge inside a sub-block gap [MHz]	Type of interfering signal
3	$P_{\text{REFSENS}} + 8\text{dB}^*$	-47	± 1.5075	3MHz E-UTRA signal
5	$P_{\text{REFSENS}} + 6\text{dB}^*$	-47	± 2.5025	5MHz E-UTRA signal
10	$P_{\text{REFSENS}} + 6\text{dB}^*$	-47	± 2.5075	5MHz E-UTRA signal
15	$P_{\text{REFSENS}} + 6\text{dB}^*$	-47	± 2.5125	5MHz E-UTRA signal
20	$P_{\text{REFSENS}} + 6\text{dB}^*$	-47	± 2.5025	5MHz E-UTRA signal
Note*: P_{REFSENS} depends on the sub-carrier spacing as specified in TS 36.104 [2] subclause 7.2.1.				

Table 7.5-6b: Adjacent channel selectivity NB-IoT guard band operation Medium Range BS

E-UTRA channel bandwidth of the lowest/highest carrier received [MHz]	NB-IoT wanted signal mean power [dBm]	Interfering signal mean power [dBm]	Interfering signal centre frequency offset from the lower/upper Base Station RF Bandwidth edge or sub-block edge inside a sub-block gap [MHz]	Type of interfering signal
5	$P_{\text{REFSENS}} + 10\text{dB}^*$	-47	± 2.5025	5MHz E-UTRA signal
10	$P_{\text{REFSENS}} + 8\text{dB}^*$	-47	± 2.5075	5MHz E-UTRA signal
15	$P_{\text{REFSENS}} + 6\text{dB}^*$	-47	± 2.5125	5MHz E-UTRA signal
20	$P_{\text{REFSENS}} + 6\text{dB}^*$	-47	± 2.5025	5MHz E-UTRA signal
Note*: P_{REFSENS} depends on the sub-carrier spacing as specified in TS 36.104 [2] subclause 7.2.1.				

Table 7.5-6c: Adjacent channel selectivity for NB-IoT standalone Medium Range BS

NB-IoT channel bandwidth of the lowest/highest carrier received [kHz]	Wanted signal mean power [dBm]	Interfering signal mean power [dBm]	Interfering signal centre frequency offset to the lower/upper Base Station RF Bandwidth edge or sub-block edge inside a sub-block gap [kHz]	Type of interfering signal
200	$P_{\text{REFSENS}} + 19.5\text{dB}^*$	-47	± 100	180 kHz NB-IoT signal
Note*: P_{REFSENS} depends on the sub-carrier spacing as specified in TS 36.104 [2] subclause 7.2.1.				

NOTE: If the above Test Requirement differs from the Minimum Requirement then the Test Tolerance applied for this test is non-zero. The relationship between Minimum Requirements and Test Requirements is defined in subclause 4.1 and the explanation of how the Minimum Requirement has been relaxed by the Test Tolerance is given in Annex G.

7.6 Blocking

7.6.1 Definition and applicability

The blocking characteristics is a measure of the receiver ability to receive a wanted signal at its assigned channel in the presence of an unwanted interferer, which are either a 1.4MHz, 3MHz or 5MHz E-UTRA signal for in-band blocking or a CW signal for out-of-band blocking. The interfering E-UTRA signal shall be as specified in Annex C.

The blocking performance requirement applies as specified in the Tables 7.6-1, 7.6-1a, 7.6-1b, 7.6-1c, 7.6-1d, 7.6-1e, 7.6-2 and 7.6-2a in clause 7.6.5.

Unless otherwise stated, a BS declared to be capable of E-UTRA with NB-IoT in-band and guard band operations is only required to pass the blocking receiver tests for E-UTRA with guard band operation; it is not required to perform the blocking receiver tests again for E-UTRA with in-band operation.

7.6.2 Minimum Requirements

The minimum requirement is in TS 36.104 [2] subclause 7.6.1.

7.6.3 Test purpose

The test stresses the ability of the BS receiver to withstand high-level interference from unwanted signals at specified frequency offsets without undue degradation of its sensitivity.

7.6.4 Method of test

7.6.4.1 Initial conditions

Test environment: normal; see subclause D.2.

RF channels to be tested for single carrier: M see subclause 4.7. The BS shall be configured to operate as close to the centre of the operating band (see Table 5.5-1) as possible.

Base Station RF Bandwidth positions to be tested for multi-carrier and/or CA: M_{RFBW} in single-band operation, see subclause 4.7.1; $B_{\text{RFBW_T_RFBW}}$ and $B'_{\text{RFBW_T_RFBW}}$ in multi-band operation, see subclause 4.7.1.

In addition, in multi-band operation:

- For $B_{\text{RFBW_T_RFBW}}$, out-of-band blocking testing above the highest operating band may be omitted
- For $B'_{\text{RFBW_T_RFBW}}$, out-of-band blocking testing below the lowest operating band may be omitted

Channel bandwidths to be tested:

- a) In the interferer frequency range $(F_{\text{UL_low}} - 20)$ MHz to $(F_{\text{UL_high}} + 20)$ MHz the requirement shall be tested with the lowest and the highest bandwidth supported by the BS.
 - b) In the interferer frequency ranges 1 MHz to $(F_{\text{UL_low}} - 20)$ MHz and $(F_{\text{UL_high}} + 20)$ MHz to 12750 MHz the requirement shall be tested only with the lowest bandwidth supported by the BS.
- 1) Connect the signal generator for the wanted signal and the signal generator for the interfering signal to the antenna connector of one Rx port as shown in Annex I.2.5.
 - 2) Terminate any other Rx port(s) not under test.
 - 3) Generate the wanted signal according to reference measurement channel in annex A.1 to the BS under test. The level of the wanted signal measured at the BS antenna connector shall be set to the level specified in subclause 7.6.5.

7.6.4.2 Procedure

For E-UTRA and E-UTRA with NB-IoT in-band or guard band BS:

- 1) For FDD BS declared to be capable of single carrier operation only, start BS transmission according to E-TM 1.1 at manufacturer's declared rated output power.

For a FDD BS declared to be capable of multi-carrier and/or CA operation, set the BS to transmit according to E-TM 1.1 on all carriers configured using the applicable test configuration and corresponding power setting specified in clause 4.10 and 4.11.

For BS declared to be capable of NB-IoT in-band or guard band operation single carrier operation only, start BS transmission according to E-TM 1.1 and N-TM at manufacturer's declared rated output power.

For a BS declared to be capable of NB-IoT in-band or guard band operation multi-carrier, set the BS to transmit according to E-TM 1.1 on all E-UTRA carriers and to N-TM on all NB-IoT carriers configured using the applicable test configuration and corresponding power setting specified in clause 4.10 and 4.11.

The transmitter may be turned off for the out-of-band blocker tests when the frequency of the blocker is such that no IM2 or IM3 products fall inside the bandwidth of the wanted signal.

- 2) Adjust the signal generators to the type of interfering signals, levels and the frequency offsets as specified in Tables 7.6-1, 7.6-2 and 7.6-3 for E-UTRA Wide Area BS, in Tables 7.6-1a, 7.6-2 and 7.6-4 for E-UTRA Local Area BS, in Table 7.6-1b and 7.6-2 for E-UTRA Home BS, in Table 7.6-1c, 7.6.2 and 7.6-5 for E-UTRA Medium Range BS, in Tables 7.6-1e, 7.6-2b and 7.6-3 for NB-IoT in-band/guard band operation Wide Area BS, in Tables 7.6-1g, 7.6-2b and 7.6-3 for NB-IoT in-band/guard band operation Local Area BS, in Tables 7.6-1i, 7.6-2b and 7.6-3 for NB-IoT in-band/guard band operation Home BS, in Tables 7.6-1k, 7.6-2b and 7.6-3 for NB-IoT in-band/guard band operation Medium Range BS. The E-UTRA interfering signal shall be swept with a step size of 1 MHz starting from the minimum offset to the channel edges of the wanted signal as specified in Table 7.6-2. The CW interfering signal shall be swept with a step size of 1 MHz within the range specified in Tables 7.6-1 and 7.6-3 for E-UTRA Wide Area BS, in Tables 7.6-1a and 7.6-4 for E-UTRA Local Area BS, in Tables 7.6-1b for E-UTRA Home BS, in Tables 7.6-1c and 7.6-5 for E-UTRA Medium Range and in Tables 7.6-1e and 7.6-3 for NB-IoT in-band/guard band operation Wide Area BS, in Tables 7.6-1g and 7.6-3 for NB-IoT in-band/guard band operation Local Area BS, in Tables 7.6-1i and 7.6-3 for NB-IoT in-band/guard band operation Home BS, in Tables 7.6-1k and 7.6-3 for NB-IoT in-band/guard band operation Medium Range BS.
- 3) Measure the E-UTRA throughput of the wanted signal at the BS receiver according to Annex E, for multi-carrier and/or CA operation the throughput shall be measured for relevant carriers specified by the test configuration specified in subclause 4.10 and 4.11.

For BS declared to be capable of NB-IoT in-band or guard band operation, measure the NB-IoT throughput of the wanted signal at the BS receiver according to Annex E, for multi-carrier the throughput shall be measured for relevant carriers specified by the test configuration specified in subclause 4.10 and 4.11.

- 4) Interchange the connections of the BS Rx ports and repeat the measurements according to steps (1) to (3).

In addition, for a multi-band capable BS with separate antenna connectors, the following steps shall apply:

- 5) For single band tests, repeat the steps above per involved band where single band test configurations and test models shall apply with no carrier activated in the other band.

Interfering signal shall first be applied on the same port as the wanted signal. The test shall be repeated with the interfering signal applied on the other port (if any) mapped to the same receiver as the wanted signal. Any antenna connector with no signal applied in case of single-band or multi-band test shall be terminated.

- 6) Repeat step 5) with the wanted signal for the other band(s) applied on the respective port(s).

For NB-IoT standalone BS:

- 1) For BS declared to be capable of NB-IoT standalone single carrier only, start BS transmission according to N-TM at manufacturer's declared rated output power.

For a BS declared to be capable of NB-IoT multi-carrier, set the BS to transmit according to N-TM on all carriers configured using the applicable test configuration and corresponding power setting specified in clause 4.10 and 4.11.

The transmitter may be turned off for the out-of-band blocker tests when the frequency of the blocker is such that no IM2 or IM3 products fall inside the bandwidth of the wanted signal.

- 2) Adjust the signal generators to the type of interfering signals, levels and the frequency offsets as specified in Tables 7.6-1d, 7.6-2a and 7.6-3 for Wide Area BS, in Tables 7.6-1f, 7.6-2a and 7.6-3 for Local Area BS, in Tables 7.6-1h, 7.6-2a and 7.6-3 for Home BS, in Tables 7.6-1j, 7.6-2a and 7.6-3 for Medium Range BS. The E-UTRA interfering signal shall be swept with a step size of 1 MHz starting from the minimum offset to the channel edges of the wanted signal as specified in Table 7.6-2a. The CW interfering signal shall be swept with a step size of 1 MHz within the range specified in Table 7.6-1d and 7.6-3.
- 3) Measure the NB-IoT throughput of the wanted signal at the BS receiver according to Annex E, for multi-carrier the throughput shall be measured for relevant carriers specified by the test configuration specified in subclause 4.10 and 4.11.

- 4) Interchange the connections of the BS Rx ports and repeat the measurements according to steps (1) to (3).

For E-UTRA and NB-IoT standalone BS:

- 1) Set the BS to transmit according to E-TM 1.1 on all E-UTRA carriers and according to N-TM on all NB-IoT carriers configured using the applicable test configuration and corresponding power setting specified in clause 4.10 and 4.11.

The transmitter may be turned off for the out-of-band blocker tests when the frequency of the blocker is such that no IM2 or IM3 products fall inside the bandwidth of the wanted signal.

- 2) a) On the side where E-UTRA signal is positioned:

Adjust the signal generators to the type of interfering signals, levels and the frequency offsets as specified in Tables 7.6-1, 7.6-2 and 7.6-3. The E-UTRA interfering signal shall be swept with a step size of 1 MHz starting from the minimum offset to the channel edges of the wanted signal as specified in Table 7.6-2. The CW interfering signal shall be swept with a step size of 1 MHz within the range specified in Table 7.6-1 and 7.6-3.

- b) On the side where NB-IoT signal is positioned:

Adjust the signal generators to the type of interfering signals, levels and the frequency offsets as specified in Tables 7.6-1d, 7.6-2a and 7.6-3 for Wide Area BS, in Tables 7.6-1f, 7.6-2a and 7.6-3 for Local Area BS, in Tables 7.6-1h, 7.6-2a and 7.6-3 for Home BS, in Tables 7.6-1j, 7.6-2a and 7.6-3 for Medium Range BS. The E-UTRA interfering signal shall be swept with a step size of 1 MHz starting from the minimum offset to the channel edges of the wanted signal as specified in Table 7.6-2a. The CW interfering signal shall be swept with a step size of 1 MHz within the range specified in Table 7.6-1d and 7.6-3

- 3) Measure the E-UTRA throughput of the E-UTRA wanted signal and the NB-IoT throughput of the NB-IoT wanted signal at the BS receiver according to Annex E, for multi-carrier operation the throughput shall be measured for relevant carriers specified by the test configuration specified in subclause 4.10 and 4.11.
- 4) Interchange the connections of the BS Rx ports and repeat the measurements according to steps (1) to (3).

NOTE 1: For the Public Safety LTE BS in Korea from 718 to 728 MHz in band 28, adjust the input level to the base station under test to the level specified in Table G-2.2 for Wide Area BS, in Table G-2.3 for Local Area BS, in Table G-2.4 for Home BS and in Table G-2.5 for Medium Range BS in annex G.2 of [2].

NOTE 2: For the Public Safety LTE BS in Korea from 718 to 728 MHz in band 28, adjust the interfering signal level to the base station under test to the level specified in Table G-2.2 for Wide Area BS, in Table G-2.3 for Local Area BS, in Table G-2.4 for Home BS and in Table G-2.5 for Medium Range BS in annex G.2 of [2].

7.6.5 Test Requirements

7.6.5.1 General requirement

For each measured E-UTRA carrier, the throughput shall be $\geq 95\%$ of the maximum throughput of the reference measurement channel, with a wanted and an interfering signal coupled to BS antenna input using the parameters in Tables 7.6-1, 7.6-1a, 7.6-1b, 7.6-1c and 7.6-2. The reference measurement channel for the wanted signal is specified in Tables 7.2-1, 7.2-2, 7.2-3 and 7.2-4 for each channel bandwidth and further specified in Annex A.

For each measured NB-IoT carrier, the throughput shall be $\geq 95\%$ of the maximum throughput of the reference measurement channel, with a wanted and an interfering signal coupled to BS antenna input using the parameters in Tables 7.6-1d, 7.6-1e, 7.6-1f, 7.6-1g, 7.6-1h, 7.6-1i, 7.6-1j, 7.6-1k, 7.6-2a and 7.6-2b. The reference measurement

channel for the wanted signal is specified in Table 7.2-5 for each subcarrier spacing option and further specified in Annex A.

The blocking requirement is always applicable outside the Base Station RF Bandwidth or Maximum Radio Bandwidth. The interfering signal offset is defined relative to the Base Station RF Bandwidth edges or Maximum Radio Bandwidth edges.

For a BS operating in non-contiguous spectrum within any operating band, the blocking requirement applies in addition inside any sub-block gap, in case the sub-block gap size is at least as wide as twice the interfering signal minimum offset in Table 7.6-2. The interfering signal offset is defined relative to the sub-block edges inside the sub-block gap.

For a BS capable of multi-band operation, the requirement in the in-band blocking frequency ranges applies for each supported operating band. The requirement applies in addition inside any Inter RF Bandwidth gap, in case the Inter RF Bandwidth gap size is at least as wide as twice the interfering signal minimum offset in Table 7.6-2.

For a BS capable of multi-band operation, the requirement in the out-of-band blocking frequency ranges apply for each operating band, with the exception that the in-band blocking frequency ranges of all supported operating bands according to Tables 7.6-1, 7.6-1a and 7.6-1c shall be excluded from the out-of-band blocking requirement.

For the Public Safety LTE BS in Korea from 718 to 728 MHz in band 28, the wanted and the interfering signal coupled to the BS antenna input are specified in Tables G-2.2, G-2.3, G-2.4 and G-2.5 for the band blocking requirements in

annex G.2 of [2]. The reference measurement channel for the wanted signal is A.1-3 for 10 MHz channel bandwidth and further specified in Annex A.

Table 7.6-1: Blocking performance requirement for Wide Area BS for E-UTRA

Operating Band	Centre Frequency of Interfering Signal [MHz]	Interfering Signal mean power [dBm]	Wanted Signal mean power [dBm] *	Interfering signal centre frequency minimum frequency offset from the lower/upper Base Station RF Bandwidth edge or sub-block edge inside a sub-block gap [MHz]	Type of Interfering Signal
1-7, 9-11, 13, 14, 18, 19, 21-23, 24, 27, 30, 33-45, 48, 50, 52, 65, 66, 68, 70	(F _{UL_low} -20) to (F _{UL_high} +20)	-43	P _{REFSENS} +6dB**	See table 7.6-2	See table 7.6-2
	1 to (F _{UL_low} -20) (F _{UL_high} +20) to 12750	-15	P _{REFSENS} +6dB	—	CW carrier
8, 26, 28	(F _{UL_low} -20) to (F _{UL_high} +10)	-43	P _{REFSENS} +6dB**	See table 7.6-2	See table 7.6-2
	1 to (F _{UL_low} -20) (F _{UL_high} +10) to 12750	-15	P _{REFSENS} +6dB	—	CW carrier
12	(F _{UL_low} -20) to (F _{UL_high} +13)	-43	P _{REFSENS} +6dB**	See table 7.6-2	See table 7.6-2
	1 to (F _{UL_low} -20) (F _{UL_high} +13) to 12750	-15	P _{REFSENS} +6dB	—	CW carrier
17	(F _{UL_low} -20) to (F _{UL_high} +18)	-43	P _{REFSENS} +6dB**	See table 7.6-2	See table 7.6-2
	1 to (F _{UL_low} -20) (F _{UL_high} +18) to 12750	-15	P _{REFSENS} +6dB	—	CW carrier
20, 71	(F _{UL_low} -11) to (F _{UL_high} +20)	-43	P _{REFSENS} +6dB**	See table 7.6-2	See table 7.6-2
	1 to (F _{UL_low} -11) (F _{UL_high} +20) to 12750	-15	P _{REFSENS} +6dB	—	CW carrier
25	(F _{UL_low} -20) to (F _{UL_high} +15)	-43	P _{REFSENS} +6dB**	See table 7.6-2	See table 7.6-2
	1 to (F _{UL_low} -20) (F _{UL_high} +15) to 12750	-15	P _{REFSENS} +6dB	—	CW carrier
31, 72, 73, 74, 87, 88	(F _{UL_low} -20) to (F _{UL_high} +5)	-43	P _{REFSENS} +6dB**	See table 7.6-2	See table 7.6-2
	1 to (F _{UL_low} -20) (F _{UL_high} +5) to 12750	-15	P _{REFSENS} +6dB	—	CW carrier
85	(F _{UL_low} -20) to (F _{UL_high} +12)	-43	P _{REFSENS} +6dB**	See table 7.6-2	See table 7.6-2
	1 to (F _{UL_low} -20) (F _{UL_high} +12) to 12750	-15	P _{REFSENS} +6dB	—	CW carrier
Note*:	P _{REFSENS} depends on the channel bandwidth as specified in TS 36.104 [2] subclause 7.2.1.				
Note**:	For a BS capable of multiband operation, in case of interfering signal that is not in the in-band blocking frequency range of the operating band where the wanted signal is present, and not in the in-band blocking frequency range of an adjacent or overlapping operating band, the wanted signal mean power is equal to P _{REFSENS} + 1.4 dB.				

NOTE: Table 7.6-1 assumes that two operating bands, where the downlink operating band (see Table 5.5-1) of one band would be within the in-band blocking region of the other band, are not deployed in the same geographical area.

Table 7.6-1a: Blocking performance requirement for Local Area BS for E-UTRA

Operating Band	Centre Frequency of Interfering Signal [MHz]	Interfering Signal mean power [dBm]	Wanted Signal mean power [dBm] *	Interfering signal centre frequency minimum frequency offset from the lower(upper) edge or sub-block edge inside a sub-block gap [MHz]	Type of Interfering Signal
1-7, 9-11, 13-14, 18,19,21-23, 24, 27, 30, 33-45, 48-53, 65, 66, 68, 70	(F _{UL_low} -20) to (F _{UL_high} +20)	-35	P _{REFSENS} +6dB**	See table 7.6-2	See table 7.6-2
	1 to (F _{UL_low} -20) (F _{UL_high} +20) to 12750	-15	P _{REFSENS} +6dB	—	CW carrier
8, 26, 28	(F _{UL_low} -20) to (F _{UL_high} +10)	-35	P _{REFSENS} +6dB**	See table 7.6-2	See table 7.6-2
	1 to (F _{UL_low} -20) (F _{UL_high} +10) to 12750	-15	P _{REFSENS} +6dB	—	CW carrier
12	(F _{UL_low} -20) to (F _{UL_high} +13)	-35	P _{REFSENS} +6dB**	See table 7.6-2	See table 7.6-2
	1 to (F _{UL_low} -20) (F _{UL_high} +13) to 12750	-15	P _{REFSENS} +6dB	—	CW carrier
17	(F _{UL_low} -20) to (F _{UL_high} +18)	-35	P _{REFSENS} +6dB**	See table 7.6-2	See table 7.6-2
	1 to (F _{UL_low} -20) (F _{UL_high} +18) to 12750	-15	P _{REFSENS} +6dB	—	CW carrier
20, 71	(F _{UL_low} -11) to (F _{UL_high} +20)	-35	P _{REFSENS} +6dB**	See table 7.6-2	See table 7.6-2
	1 to (F _{UL_low} -11) (F _{UL_high} +20) to 12750	-15	P _{REFSENS} +6dB	—	CW carrier
25	(F _{UL_low} -20) to (F _{UL_high} +15)	-35	P _{REFSENS} +6dB**	See table 7.6-2	See table 7.6-2
	1 to (F _{UL_low} -20) (F _{UL_high} +15) to 12750	-15	P _{REFSENS} +6dB	—	CW carrier
31, 72, 73, 74, 87, 88	(F _{UL_low} -20) to (F _{UL_high} +5)	-35	P _{REFSENS} +6dB**	See table 7.6-2	See table 7.6-2
	1 to (F _{UL_low} -20) (F _{UL_high} +5) to 12750	-15	P _{REFSENS} +6dB	—	CW carrier
46	(F _{UL_low} -20) to (F _{UL_high} +20)	-35	P _{REFSENS} +6dB*	See table 7.6-2	See table 7.6-2
	(F _{UL_low} -500) to (F _{UL_high} +500)	-35	P _{REFSENS} +6dB*	—	CW carrier
	1 to (F _{UL_low} -500) (F _{UL_high} +500) to 12750	-15	P _{REFSENS} +6dB*	—	CW carrier
85	(F _{UL_low} -20) to (F _{UL_high} +12)	-35	P _{REFSENS} +6dB**	See table 7.6-2	See table 7.6-2
	1 to (F _{UL_low} -20) (F _{UL_high} +12) to 12750	-15	P _{REFSENS} +6dB	—	CW carrier
Note*:	P _{REFSENS} depends on the channel bandwidth as specified in TS 36.104 [2] subclause 7.2.1.				
Note**:	For a BS capable of multiband operation, in case of interfering signal that is not in the in-band blocking frequency range of the operating band where the wanted signal is present, and not in the in-band blocking frequency range of an adjacent or overlapping operating band, the wanted signal mean power is equal to P _{REFSENS} + 1.4 dB.				

NOTE: Table 7.6-1a assumes that two operating bands, where the downlink operating band (see Table 5.5-1) of one band would be within the in-band blocking region of the other band, are not deployed in the same geographical area.

Table 7.6-1b: Blocking performance requirement for Home BS for E-UTRA

Operating Band	Centre Frequency of Interfering Signal [MHz]	Interfering Signal mean power [dBm]	Wanted Signal mean power [dBm] *	Interfering signal centre frequency minimum frequency offset from the channel edge of the wanted signal [MHz]	Type of Interfering Signal
1-7, 9-11, 13, 14, 18,19, 21-23, 24, 27, 30, 33-44, 48, 50-52, 65, 66, 68, 70	(F _{UL_low} -20) to (F _{UL_high} +20)	-27	P _{REFSENS} +14dB	See table 7.6-2	See table 7.6-2
	1 to (F _{UL_low} -20) (F _{UL_high} +20) to 12750	-15	P _{REFSENS} +14dB	—	CW carrier
8, 26, 28	(F _{UL_low} -20) to (F _{UL_high} +10)	-27	P _{REFSENS} +14dB	See table 7.6-2	See table 7.6-2
	1 to (F _{UL_low} -20) (F _{UL_high} +10) to 12750	-15	P _{REFSENS} +14dB	—	CW carrier
12	(F _{UL_low} -20) to (F _{UL_high} +13)	-27	P _{REFSENS} +14dB	See table 7.6-2	See table 7.6-2
	1 to (F _{UL_low} -20) (F _{UL_high} +13) to 12750	-15	P _{REFSENS} +14dB	—	CW carrier
17	(F _{UL_low} -20) to (F _{UL_high} +18)	-27	P _{REFSENS} +14dB	See table 7.6-2	See table 7.6-2
	1 to (F _{UL_low} -20) (F _{UL_high} +18) to 12750	-15	P _{REFSENS} +14dB	—	CW carrier
20, 71	(F _{UL_low} -11) to (F _{UL_high} +20)	-27	P _{REFSENS} +14dB	See table 7.6-2	See table 7.6-2
	1 to (F _{UL_low} -11) (F _{UL_high} +20) to 12750	-15	P _{REFSENS} +14dB	—	CW carrier
25	(F _{UL_low} -20) to (F _{UL_high} +15)	-27	P _{REFSENS} +14dB	See table 7.6-2	See table 7.6-2
	1 to (F _{UL_low} -20) (F _{UL_high} +15) to 12750	-15	P _{REFSENS} +14dB	—	CW carrier
74	(F _{UL_low} -20) to (F _{UL_high} +5)	-27	P _{REFSENS} +14dB	See table 7.6-2	See table 7.6-2
	1 to (F _{UL_low} -20) (F _{UL_high} +5) to 12750	-15	P _{REFSENS} +14dB	—	CW carrier
85	(F _{UL_low} -20) to (F _{UL_high} +12)	-27	P _{REFSENS} +14dB	See table 7.6-2	See table 7.6-2
	1 to (F _{UL_low} -20) (F _{UL_high} +12) to 12750	-15	P _{REFSENS} +14dB	—	CW carrier

Note*: P_{REFSENS} depends on the channel bandwidth as specified in TS 36.104 [2] subclause 7.2.1.

NOTE: Table 7.6-1b assumes that two operating bands, where the downlink operating band (see Table 5.5-1) of one band would be within the in-band blocking region of the other band, are not deployed in the same geographical area.

Table 7.6-1c: Blocking performance requirement for Medium Range BS for E-UTRA

Operating Band	Centre Frequency of Interfering Signal [MHz]	Interfering Signal mean power [dBm]	Wanted Signal mean power [dBm] *	Interfering signal centre frequency minimum frequency offset to the lower (higher) edge or sub-block edge inside a sub-block gap [MHz]	Type of Interfering Signal
1-7, 9-11, 13, 14, 18,19, 21-23, 24, 27, 30, 33-45, 48, 50, 52-53, 65, 66, 68, 70	(F _{UL_low} -20) to (F _{UL_high} +20)	-38	P _{PREFSENS} +6dB**	See table 7.6-2	See table 7.6-2
	1 to (F _{UL_low} -20) (F _{UL_high} +20) to 12750	-15	P _{PREFSENS} +6dB	—	CW carrier
8, 26, 28	(F _{UL_low} -20) to (F _{UL_high} +10)	-38	P _{PREFSENS} +6dB**	See table 7.6-2	See table 7.6-2
	1 to (F _{UL_low} -20) (F _{UL_high} +10) to 12750	-15	P _{PREFSENS} +6dB	—	CW carrier
12	(F _{UL_low} -20) to (F _{UL_high} +13)	-38	P _{PREFSENS} +6dB**	See table 7.6-2	See table 7.6-2
	1 to (F _{UL_low} -20) (F _{UL_high} +13) to 12750	-15	P _{PREFSENS} +6dB	—	CW carrier
17	(F _{UL_low} -20) to (F _{UL_high} +18)	-38	P _{PREFSENS} +6dB**	See table 7.6-2	See table 7.6-2
	1 to (F _{UL_low} -20) (F _{UL_high} +18) to 12750	-15	P _{PREFSENS} +6dB	—	CW carrier
20, 71	(F _{UL_low} -11) to (F _{UL_high} +20)	-38	P _{PREFSENS} +6dB**	See table 7.6-2	See table 7.6-2
	1 to (F _{UL_low} -11) (F _{UL_high} +20) to 12750	-15	P _{PREFSENS} +6dB	—	CW carrier
25	(F _{UL_low} -20) to (F _{UL_high} +15)	-38	P _{PREFSENS} +6dB**	See table 7.6-2	See table 7.6-2
	1 to (F _{UL_low} -20) (F _{UL_high} +15) to 12750	-15	P _{PREFSENS} +6dB	—	CW carrier
31, 72, 73, 74, 87, 88	(F _{UL_low} -20) to (F _{UL_high} +5)	-38	P _{PREFSENS} +6dB**	See table 7.6-2	See table 7.6-2
	1 to (F _{UL_low} -20) (F _{UL_high} +5) to 12750	-15	P _{PREFSENS} +6dB	—	CW carrier
46	(F _{UL_low} -20) to (F _{UL_high} +20)	-38	P _{PREFSENS} +6dB*	See table 7.6-2	See table 7.6-2
	(F _{UL_low} -500) to (F _{UL_high} +20) (F _{UL_high} +20) to (F _{UL_high} +500)	-35	P _{PREFSENS} +6dB*	—	CW carrier
	1 to (F _{UL_low} -500) (F _{UL_high} +500) to 12750	-15	P _{PREFSENS} +6dB*	—	CW carrier
85	(F _{UL_low} -20) to (F _{UL_high} +12)	-38	P _{PREFSENS} +6dB**	See table 7.6-2	See table 7.6-2
	1 to (F _{UL_low} -20) (F _{UL_high} +12) to 12750	-15	P _{PREFSENS} +6dB	—	CW carrier
Note*:	P _{PREFSENS} depends on the channel bandwidth as specified in TS 36.104 [2] subclause 7.2.1.				
Note**:	For a BS capable of multiband operation, in case of interfering signal that is not in the in-band blocking frequency range of the operating band where the wanted signal is present, and not in the in-band blocking frequency range of an adjacent or overlapping operating band, the wanted signal mean power is equal to P _{PREFSENS} + 1.4 dB.				

NOTE: Table 7.6-1c assumes that two operating bands, where the downlink operating band (see Table 5.5-1) of one band would be within the in-band blocking region of the other band, are not deployed in the same geographical area.

Table 7.6.1d: Blocking performance requirement for Wide Area BS for NB-IoT standalone operation

Operating Band	Centre Frequency of Interfering Signal [MHz]	Interfering Signal mean power [dBm]	Wanted Signal mean power [dBm]	Interfering signal centre frequency minimum frequency offset from the lower/upper Base Station RF Bandwidth edge or sub-block edge inside a sub-block gap [MHz]	Type of Interfering Signal
1-5, 7, 11, 13-14, 18, 19, 21, 26, 42, 43, 65, 66, 70	(F _{UL_low} -20) to (F _{UL_high} +20)	-43	P _{REFSENS} +6dB*	See table 7.6.2a	See table 7.6. 2a
	1 to (F _{UL_low} -20) (F _{UL_high} +20) to 12750	-15**	P _{REFSENS} +6dB*	—	CW carrier
8, 26, 28	(F _{UL_low} -20) to (F _{UL_high} +10)	-43	P _{REFSENS} +6dB*	See table 7.6.2a	See table 7.6. 2a
	1 to (F _{UL_low} -20) (F _{UL_high} +10) to 12750	-15**	P _{REFSENS} +6dB*	—	CW carrier
12	(F _{UL_low} -20) to (F _{UL_high} +13)	-43	P _{REFSENS} +6dB*	See table 7.6. 2a	See table 7.6. 2a
	1 to (F _{UL_low} -20) (F _{UL_high} +13) to 12750	-15**	P _{REFSENS} +6dB*	—	CW carrier
17	(F _{UL_low} -20) to (F _{UL_high} +18)	-43	P _{REFSENS} +6dB*	See table 7.6. 2a	See table 7.6. 2a
	1 to (F _{UL_low} -20) (F _{UL_high} +18) to 12750	-15**	P _{REFSENS} +6dB*	—	CW carrier
20, 71	(F _{UL_low} -11) to (F _{UL_high} +20)	-43	P _{REFSENS} +6dB*	See table 7.6. 2a	See table 7.6. 2a
	1 to (F _{UL_low} -11) (F _{UL_high} +20) to 12750	-15**	P _{REFSENS} +6dB*	—	CW carrier
25	(F _{UL_low} -20) to (F _{UL_high} +15)	-43	P _{REFSENS} +6dB*	See table 7.6-2a	See table 7.6-2a
	1 to (F _{UL_low} -20) (F _{UL_high} +15) to 12750	-15**	P _{REFSENS} +6dB*	—	CW carrier
31, 72, 73, 74, 87, 88	(F _{UL_low} -20) to (F _{UL_high} +5)	-43	P _{REFSENS} +6dB*	See table 7.6-2a	See table 7.6-2a
	1 to (F _{UL_low} -20) (F _{UL_high} +5) to 12750	-15**	P _{REFSENS} +6dB*	—	CW carrier
85	(F _{UL_low} -20) to (F _{UL_high} +12)	-43	P _{REFSENS} +6dB*	See table 7.6. 2a	See table 7.6. 2a
	1 to (F _{UL_low} -20) (F _{UL_high} +12) to 12750	-15**	P _{REFSENS} +6dB*	—	CW carrier
Note*:	P _{REFSENS} is specified in TS 36.104 [2] subclause 7.2.1				
Note**:	Up to 24 exceptions are allowed for spurious response frequencies in each wanted signal frequency when measured using a 1MHz step size. For these exceptions the above throughput requirement shall be met when the blocking signal is set to a level of -40 dBm for 15 kHz subcarrier spacing and -46 dBm for 3.75 kHz subcarrier spacing. In addition, each group of exceptions shall not exceed three contiguous measurements using a 1MHz step size.				

NOTE: Table 7.6.1d assumes that two operating bands, where the downlink operating band (see Table 5.5-1) of one band would be within the in-band blocking region of the other band, are not deployed in the same geographical area.

Table 7.6.1e: Blocking performance requirement for Wide Area BS for E-UTRA with NB-IoT in-band/guard band operation

Operating Band	Centre Frequency of Interfering Signal [MHz]	Interfering Signal mean power [dBm]	Wanted Signal mean power [dBm]	Interfering signal centre frequency minimum frequency offset from the lower/upper Base Station RF Bandwidth edge or sub-block edge inside a sub-block gap [MHz]	Type of Interfering Signal
1-5, 7, 11, 13-14, 18, 19, 21, 26, 42, 43, 65, 66, 70	(F _{UL_low} -20) to (F _{UL_high} +20)	-43	P _{REFSENS} +6dB*	See table 7.6.2b	See table 7.6.2b
	1 to (F _{UL_low} -20) (F _{UL_high} +20) to 12750	-15***	P _{REFSENS} +6dB*	—	CW carrier
8, 26, 28	(F _{UL_low} -20) to (F _{UL_high} +10)	-43	P _{REFSENS} +6dB*	See table 7.6.2b	See table 7.6.2b
	1 to (F _{UL_low} -20) (F _{UL_high} +10) to 12750	-15***	P _{REFSENS} +6dB*	—	CW carrier
12	(F _{UL_low} -20) to (F _{UL_high} +13)	-43	P _{REFSENS} +6dB*	See table 7.6.2b	See table 7.6.2b
	1 to (F _{UL_low} -20) (F _{UL_high} +13) to 12750	-15***	P _{REFSENS} +6dB*	—	CW carrier
17	(F _{UL_low} -20) to (F _{UL_high} +18)	-43	P _{REFSENS} +6dB*	See table 7.6.2b	See table 7.6.2b
	1 to (F _{UL_low} -20) (F _{UL_high} +18) to 12750	-15***	P _{REFSENS} +6dB*	—	CW carrier
20, 71	(F _{UL_low} -11) to (F _{UL_high} +20)	-43	P _{REFSENS} +6dB*	See table 7.6.2b	See table 7.6.2b
	1 to (F _{UL_low} -11) (F _{UL_high} +20) to 12750	-15***	P _{REFSENS} +6dB*	—	CW carrier
25	(F _{UL_low} -20) to (F _{UL_high} +15)	-43	P _{REFSENS} +6dB*	See table 7.6-2b	See table 7.6-2b
	1 to (F _{UL_low} -20) (F _{UL_high} +15) to 12750	-15***	P _{REFSENS} +6dB*	—	CW carrier
31, 72, 73, 74, 87, 88	(F _{UL_low} -20) to (F _{UL_high} +5)	-43	P _{REFSENS} +6dB*	See table 7.6-2b	See table 7.6-2b
	1 to (F _{UL_low} -20) (F _{UL_high} +5) to 12750	-15***	P _{REFSENS} +6dB*	—	CW carrier
85	(F _{UL_low} -20) to (F _{UL_high} +12)	-43	P _{REFSENS} +6dB*	See table 7.6.2b	See table 7.6.2b
	1 to (F _{UL_low} -20) (F _{UL_high} +12) to 12750	-15***	P _{REFSENS} +6dB*	—	CW carrier
Note*:	P _{REFSENS} depends on the channel bandwidth or supported subcarrier spacing as specified in TS 36.104 [2] subclause 7.2.1.				
Note**:	For a BS capable of multiband operation, in case of interfering signal that is not in the in-band blocking frequency range of the operating band where the wanted signal is present, and not in the in-band blocking frequency range of an adjacent or overlapping operating band, the wanted signal mean power is equal to P _{REFSENS} + 1.4 dB.				
Note***:	For NB-IoT, up to 24 exceptions are allowed for spurious response frequencies in each wanted signal frequency when measured using a 1MHz step size. For these exceptions the above throughput requirement shall be met when the blocking signal is set to a level of -40 dBm for 15 kHz subcarrier spacing and -46 dBm for 3.75 kHz subcarrier spacing. In addition, each group of exceptions shall not exceed three contiguous measurements using a 1MHz step size.				

NOTE: Table 7.6.1e assumes that two operating bands, where the downlink operating band (see Table 5.5-1) of one band would be within the in-band blocking region of the other band, are not deployed in the same geographical area.

Table 7.6.1f: Blocking performance requirement for Local Area BS for NB-IoT standalone operation

Operating Band	Centre Frequency of Interfering Signal [MHz]	Interfering Signal mean power [dBm]	Wanted Signal mean power [dBm]	Interfering signal centre frequency minimum frequency offset from the lower/upper Base Station RF Bandwidth edge or sub-block edge inside a sub-block gap [MHz]	Type of Interfering Signal
1-5, 7, 11, 13-14, 18, 19, 21, 26, 42, 43, 65, 66, 70	(F _{UL_low} -20) to (F _{UL_high} +20)	-35	P _{REFSENS} +6dB*	See table 7.6.2a	See table 7.6. 2a
	1 to (F _{UL_low} -20) (F _{UL_high} +20) to 12750	-15**	P _{REFSENS} +6dB*	—	CW carrier
8, 26, 28	(F _{UL_low} -20) to (F _{UL_high} +10)	-35	P _{REFSENS} +6dB*	See table 7.6.2a	See table 7.6. 2a
	1 to (F _{UL_low} -20) (F _{UL_high} +10) to 12750	-15**	P _{REFSENS} +6dB*	—	CW carrier
12	(F _{UL_low} -20) to (F _{UL_high} +13)	-35	P _{REFSENS} +6dB*	See table 7.6. 2a	See table 7.6. 2a
	1 to (F _{UL_low} -20) (F _{UL_high} +13) to 12750	-15**	P _{REFSENS} +6dB*	—	CW carrier
17	(F _{UL_low} -20) to (F _{UL_high} +18)	-35	P _{REFSENS} +6dB*	See table 7.6. 2a	See table 7.6. 2a
	1 to (F _{UL_low} -20) (F _{UL_high} +18) to 12750	-15**	P _{REFSENS} +6dB*	—	CW carrier
20, 71	(F _{UL_low} -11) to (F _{UL_high} +20)	-35	P _{REFSENS} +6dB*	See table 7.6. 2a	See table 7.6. 2a
	1 to (F _{UL_low} -11) (F _{UL_high} +20) to 12750	-15**	P _{REFSENS} +6dB*	—	CW carrier
25	(F _{UL_low} -20) to (F _{UL_high} +15)	-35	P _{REFSENS} +6dB*	See table 7.6-2a	See table 7.6-2a
	1 to (F _{UL_low} -20) (F _{UL_high} +15) to 12750	-15**	P _{REFSENS} +6dB*	—	CW carrier
31, 72, 74, 87, 88	(F _{UL_low} -20) to (F _{UL_high} +5)	-35	P _{REFSENS} +6dB*	See table 7.6-2a	See table 7.6-2a
	1 to (F _{UL_low} -20) (F _{UL_high} +5) to 12750	-15**	P _{REFSENS} +6dB*	—	CW carrier
85	(F _{UL_low} -20) to (F _{UL_high} +12)	-35	P _{REFSENS} +6dB*	See table 7.6. 2a	See table 7.6. 2a
	1 to (F _{UL_low} -20) (F _{UL_high} +12) to 12750	-15**	P _{REFSENS} +6dB*	—	CW carrier
Note*:	P _{REFSENS} is specified in TS 36.104 [2] subclause 7.2.1				
Note**:	Up to 24 exceptions are allowed for spurious response frequencies in each wanted signal frequency when measured using a 1MHz step size. For these exceptions the above throughput requirement shall be met when the blocking signal is set to a level of -40 dBm for 15 kHz subcarrier spacing and -46 dBm for 3.75 kHz subcarrier spacing. In addition, each group of exceptions shall not exceed three contiguous measurements using a 1MHz step size.				

NOTE: Table 7.6.1f assumes that two operating bands, where the downlink operating band (see Table 5.5-1) of one band would be within the in-band blocking region of the other band, are not deployed in the same geographical area.

Table 7.6.1g: Blocking performance requirement for Local Area BS for E-UTRA with NB-IoT in-band/guard band operation

Operating Band	Centre Frequency of Interfering Signal [MHz]	Interfering Signal mean power [dBm]	Wanted Signal mean power [dBm]	Interfering signal centre frequency minimum frequency offset from the lower/upper Base Station RF Bandwidth edge or sub-block edge inside a sub-block gap [MHz]	Type of Interfering Signal
1-5, 7, 11, 13-14, 18, 19, 21, 26, 42, 43, 65, 66, 70	(F _{UL_low} -20) to (F _{UL_high} +20)	-35	P _{REFSENS} +6dB*	See table 7.6.2b	See table 7.6.2b
	1 to (F _{UL_low} -20) (F _{UL_high} +20) to 12750	-15***	P _{REFSENS} +6dB*	—	CW carrier
8, 26, 28	(F _{UL_low} -20) to (F _{UL_high} +10)	-35	P _{REFSENS} +6dB*	See table 7.6.2b	See table 7.6.2b
	1 to (F _{UL_low} -20) (F _{UL_high} +10) to 12750	-15***	P _{REFSENS} +6dB*	—	CW carrier
12	(F _{UL_low} -20) to (F _{UL_high} +13)	-35	P _{REFSENS} +6dB*	See table 7.6.2b	See table 7.6.2b
	1 to (F _{UL_low} -20) (F _{UL_high} +13) to 12750	-15***	P _{REFSENS} +6dB*	—	CW carrier
17	(F _{UL_low} -20) to (F _{UL_high} +18)	-35	P _{REFSENS} +6dB*	See table 7.6.2b	See table 7.6.2b
	1 to (F _{UL_low} -20) (F _{UL_high} +18) to 12750	-15***	P _{REFSENS} +6dB*	—	CW carrier
20, 71	(F _{UL_low} -11) to (F _{UL_high} +20)	-35	P _{REFSENS} +6dB*	See table 7.6.2b	See table 7.6.2b
	1 to (F _{UL_low} -11) (F _{UL_high} +20) to 12750	-15***	P _{REFSENS} +6dB*	—	CW carrier
25	(F _{UL_low} -20) to (F _{UL_high} +15)	-35	P _{REFSENS} +6dB*	See table 7.6-2b	See table 7.6-2b
	1 to (F _{UL_low} -20) (F _{UL_high} +15) to 12750	-15***	P _{REFSENS} +6dB*	—	CW carrier
31, 72, 74, 87, 88	(F _{UL_low} -20) to (F _{UL_high} +5)	-35	P _{REFSENS} +6dB*	See table 7.6-2b	See table 7.6-2b
	1 to (F _{UL_low} -20) (F _{UL_high} +5) to 12750	-15***	P _{REFSENS} +6dB*	—	CW carrier
85	(F _{UL_low} -20) to (F _{UL_high} +12)	-35	P _{REFSENS} +6dB*	See table 7.6.2b	See table 7.6.2b
	1 to (F _{UL_low} -20) (F _{UL_high} +12) to 12750	-15***	P _{REFSENS} +6dB*	—	CW carrier
Note*:	P _{REFSENS} depends on the channel bandwidth or supported subcarrier spacing as specified in TS 36.104 [2] subclause 7.2.1.				
Note**:	For a BS capable of multiband operation, in case of interfering signal that is not in the in-band blocking frequency range of the operating band where the wanted signal is present, and not in the in-band blocking frequency range of an adjacent or overlapping operating band, the wanted signal mean power is equal to P _{REFSENS} + 1.4 dB.				
Note***:	For NB-IoT, up to 24 exceptions are allowed for spurious response frequencies in each wanted signal frequency when measured using a 1MHz step size. For these exceptions the above throughput requirement shall be met when the blocking signal is set to a level of -40 dBm for 15 kHz subcarrier spacing and -46 dBm for 3.75 kHz subcarrier spacing. In addition, each group of exceptions shall not exceed three contiguous measurements using a 1MHz step size.				

NOTE: Table 7.6.1g assumes that two operating bands, where the downlink operating band (see Table 5.5-1) of one band would be within the in-band blocking region of the other band, are not deployed in the same geographical area.

Table 7.6.1h: Blocking performance requirement for Home BS for NB-IoT standalone operation

Operating Band	Centre Frequency of Interfering Signal [MHz]	Interfering Signal mean power [dBm]	Wanted Signal mean power [dBm]	Interfering signal centre frequency minimum frequency offset from the lower/upper Base Station RF Bandwidth edge or sub-block edge inside a sub-block gap [MHz]	Type of Interfering Signal
1-5, 7,11, 13-14,18,19, 21, 26, 42, 43, 65, 66, 70	(F _{UL_low} -20) to (F _{UL_high} +20)	-27	P _{REFSENS} +14dB*	See table 7.6.2a	See table 7.6. 2a
	1 to (F _{UL_low} -20) (F _{UL_high} +20) to 12750	-15**	P _{REFSENS} +14dB*	—	CW carrier
8, 26, 28	(F _{UL_low} -20) to (F _{UL_high} +10)	-27	P _{REFSENS} +14dB*	See table 7.6.2a	See table 7.6. 2a
	1 to (F _{UL_low} -20) (F _{UL_high} +10) to 12750	-15**	P _{REFSENS} +14dB*	—	CW carrier
12	(F _{UL_low} -20) to (F _{UL_high} +13)	-27	P _{REFSENS} +14dB*	See table 7.6. 2a	See table 7.6. 2a
	1 to (F _{UL_low} -20) (F _{UL_high} +13) to 12750	-15**	P _{REFSENS} +14dB*	—	CW carrier
17	(F _{UL_low} -20) to (F _{UL_high} +18)	-27	P _{REFSENS} +14dB*	See table 7.6. 2a	See table 7.6. 2a
	1 to (F _{UL_low} -20) (F _{UL_high} +18) to 12750	-15**	P _{REFSENS} +14dB*	—	CW carrier
20, 71	(F _{UL_low} -11) to (F _{UL_high} +20)	-27	P _{REFSENS} +14dB*	See table 7.6. 2a	See table 7.6. 2a
	1 to (F _{UL_low} -11) (F _{UL_high} +20) to 12750	-15**	P _{REFSENS} +14dB*	—	CW carrier
25	(F _{UL_low} -20) to (F _{UL_high} +15)	-27	P _{REFSENS} +14dB*	See table 7.6-2a	See table 7.6-2a
	1 to (F _{UL_low} -20) (F _{UL_high} +15) to 12750	-15**	P _{REFSENS} +14dB*	—	CW carrier
74	(F _{UL_low} -20) to (F _{UL_high} +5)	-27	P _{REFSENS} +14dB*	See table 7.6-2a	See table 7.6-2a
	1 to (F _{UL_low} -20) (F _{UL_high} +5) to 12750	-15**	P _{REFSENS} +14dB*	—	CW carrier
85	(F _{UL_low} -20) to (F _{UL_high} +12)	-27	P _{REFSENS} +14dB*	See table 7.6. 2a	See table 7.6. 2a
	1 to (F _{UL_low} -20) (F _{UL_high} +12) to 12750	-15**	P _{REFSENS} +14dB*	—	CW carrier
Note*:	P _{REFSENS} is specified in TS 36.104 [2] subclause 7.2.1				
Note**:	Up to 24 exceptions are allowed for spurious response frequencies in each wanted signal frequency when measured using a 1MHz step size. For these exceptions the above throughput requirement shall be met when the blocking signal is set to a level of -40 dBm for 15 kHz subcarrier spacing and -46 dBm for 3.75 kHz subcarrier spacing. In addition, each group of exceptions shall not exceed three contiguous measurements using a 1MHz step size.				

NOTE: Table 7.6.1h assumes that two operating bands, where the downlink operating band (see Table 5.5-1) of one band would be within the in-band blocking region of the other band, are not deployed in the same geographical area.

Table 7.6.1i: Blocking performance requirement for Home BS for E-UTRA with NB-IoT in-band/guard band operation

Operating Band	Centre Frequency of Interfering Signal [MHz]	Interfering Signal mean power [dBm]	Wanted Signal mean power [dBm]	Interfering signal centre frequency minimum frequency offset from the lower/upper Base Station RF Bandwidth edge or sub-block edge inside a sub-block gap [MHz]	Type of Interfering Signal
1-5, 7, 11, 13-14, 18, 19, 21, 26, 42, 43, 65, 66, 70	(F _{UL_low} -20) to (F _{UL_high} +20)	-27	P _{REFSENS} +14dB*	See table 7.6.2b	See table 7.6.2b
	1 to (F _{UL_low} -20) (F _{UL_high} +20) to 12750	-15**	P _{REFSENS} +14dB*	—	CW carrier
8, 26, 28	(F _{UL_low} -20) to (F _{UL_high} +10)	-27	P _{REFSENS} +14dB*	See table 7.6.2b	See table 7.6.2b
	1 to (F _{UL_low} -20) (F _{UL_high} +10) to 12750	-15**	P _{REFSENS} +14dB*	—	CW carrier
12	(F _{UL_low} -20) to (F _{UL_high} +13)	-27	P _{REFSENS} +14dB*	See table 7.6.2b	See table 7.6.2b
	1 to (F _{UL_low} -20) (F _{UL_high} +13) to 12750	-15**	P _{REFSENS} +14dB*	—	CW carrier
17	(F _{UL_low} -20) to (F _{UL_high} +18)	-27	P _{REFSENS} +14dB*	See table 7.6.2b	See table 7.6.2b
	1 to (F _{UL_low} -20) (F _{UL_high} +18) to 12750	-15**	P _{REFSENS} +14dB*	—	CW carrier
20, 71	(F _{UL_low} -11) to (F _{UL_high} +20)	-27	P _{REFSENS} +14dB*	See table 7.6.2b	See table 7.6.2b
	1 to (F _{UL_low} -11) (F _{UL_high} +20) to 12750	-15**	P _{REFSENS} +14dB*	—	CW carrier
25	(F _{UL_low} -20) to (F _{UL_high} +15)	-27	P _{REFSENS} +14dB*	See table 7.6-2b	See table 7.6-2b
	1 to (F _{UL_low} -20) (F _{UL_high} +15) to 12750	-15**	P _{REFSENS} +14dB*	—	CW carrier
74	(F _{UL_low} -20) to (F _{UL_high} +5)	-27	P _{REFSENS} +14dB*	See table 7.6-2b	See table 7.6-2b
	1 to (F _{UL_low} -20) (F _{UL_high} +5) to 12750	-15**	P _{REFSENS} +14dB*	—	CW carrier
85	(F _{UL_low} -20) to (F _{UL_high} +12)	-27	P _{REFSENS} +14dB*	See table 7.6.2b	See table 7.6.2b
	1 to (F _{UL_low} -20) (F _{UL_high} +12) to 12750	-15**	P _{REFSENS} +14dB*	—	CW carrier
Note*:	P _{REFSENS} depends on the channel bandwidth or supported subcarrier spacing as specified in TS 36.104 [2] subclause 7.2.1.				
Note**:	For NB-IoT, up to 24 exceptions are allowed for spurious response frequencies in each wanted signal frequency when measured using a 1MHz step size. For these exceptions the above throughput requirement shall be met when the blocking signal is set to a level of -40 dBm for 15 kHz subcarrier spacing and -46 dBm for 3.75 kHz subcarrier spacing. In addition, each group of exceptions shall not exceed three contiguous measurements using a 1MHz step size.				

NOTE: Table 7.6.1i assumes that two operating bands, where the downlink operating band (see Table 5.5-1) of one band would be within the in-band blocking region of the other band, are not deployed in the same geographical area.

Table 7.6.1j: Blocking performance requirement for Medium Range BS for NB-IoT standalone operation

Operating Band	Centre Frequency of Interfering Signal [MHz]	Interfering Signal mean power [dBm]	Wanted Signal mean power [dBm]	Interfering signal centre frequency minimum frequency offset from the lower/upper Base Station RF Bandwidth edge or sub-block edge inside a sub-block gap [MHz]	Type of Interfering Signal
1-5, 7, 11, 13-14, 18, 19, 21, 26, 42, 43, 65, 66, 70	(F _{UL_low} -20) to (F _{UL_high} +20)	-38	P _{REFSENS} +6dB*	See table 7.6.2a	See table 7.6. 2a
	1 to (F _{UL_low} -20) (F _{UL_high} +20) to 12750	-15**	P _{REFSENS} +6dB*	—	CW carrier
8, 26, 28	(F _{UL_low} -20) to (F _{UL_high} +10)	-38	P _{REFSENS} +6dB*	See table 7.6.2a	See table 7.6. 2a
	1 to (F _{UL_low} -20) (F _{UL_high} +10) to 12750	-15**	P _{REFSENS} +6dB*	—	CW carrier
12	(F _{UL_low} -20) to (F _{UL_high} +13)	-38	P _{REFSENS} +6dB*	See table 7.6. 2a	See table 7.6. 2a
	1 to (F _{UL_low} -20) (F _{UL_high} +13) to 12750	-15**	P _{REFSENS} +6dB*	—	CW carrier
17	(F _{UL_low} -20) to (F _{UL_high} +18)	-38	P _{REFSENS} +6dB*	See table 7.6. 2a	See table 7.6. 2a
	1 to (F _{UL_low} -20) (F _{UL_high} +18) to 12750	-15**	P _{REFSENS} +6dB*	—	CW carrier
20, 71	(F _{UL_low} -11) to (F _{UL_high} +20)	-38	P _{REFSENS} +6dB*	See table 7.6. 2a	See table 7.6. 2a
	1 to (F _{UL_low} -11) (F _{UL_high} +20) to 12750	-15**	P _{REFSENS} +6dB*	—	CW carrier
25	(F _{UL_low} -20) to (F _{UL_high} +15)	-38	P _{REFSENS} +6dB*	See table 7.6-2a	See table 7.6-2a
	1 to (F _{UL_low} -20) (F _{UL_high} +15) to 12750	-15**	P _{REFSENS} +6dB*	—	CW carrier
31, 72, 74, 87, 88	(F _{UL_low} -20) to (F _{UL_high} +5)	-38	P _{REFSENS} +6dB*	See table 7.6-2a	See table 7.6-2a
	1 to (F _{UL_low} -20) (F _{UL_high} +5) to 12750	-15**	P _{REFSENS} +6dB*	—	CW carrier
85	(F _{UL_low} -20) to (F _{UL_high} +12)	-38	P _{REFSENS} +6dB*	See table 7.6. 2a	See table 7.6. 2a
	1 to (F _{UL_low} -20) (F _{UL_high} +12) to 12750	-15**	P _{REFSENS} +6dB*	—	CW carrier
Note*:	P _{REFSENS} is specified in TS 36.104 [2] subclause 7.2.1				
Note**:	Up to 24 exceptions are allowed for spurious response frequencies in each wanted signal frequency when measured using a 1MHz step size. For these exceptions the above throughput requirement shall be met when the blocking signal is set to a level of -40 dBm for 15 kHz subcarrier spacing and -46 dBm for 3.75 kHz subcarrier spacing. In addition, each group of exceptions shall not exceed three contiguous measurements using a 1MHz step size.				

NOTE: Table 7.6.1j assumes that two operating bands, where the downlink operating band (see Table 5.5-1) of one band would be within the in-band blocking region of the other band, are not deployed in the same geographical area.

Table 7.6.1k: Blocking performance requirement for Medium Range BS for E-UTRA with NB-IoT in-band/guard band operation

Operating Band	Centre Frequency of Interfering Signal [MHz]	Interfering Signal mean power [dBm]	Wanted Signal mean power [dBm]	Interfering signal centre frequency minimum frequency offset from the lower/upper Base Station RF Bandwidth edge or sub-block edge inside a sub-block gap [MHz]	Type of Interfering Signal
1-5, 7, 11, 13-14, 18, 19, 21, 26, 42, 43, 65, 66, 70	(F _{UL_low} -20) to (F _{UL_high} +20)	-38	P _{REFSENS} +6dB*	See table 7.6.2b	See table 7.6.2b
	1 to (F _{UL_low} -20) (F _{UL_high} +20) to 12750	-15***	P _{REFSENS} +6dB*	—	CW carrier
8, 26, 28	(F _{UL_low} -20) to (F _{UL_high} +10)	-38	P _{REFSENS} +6dB*	See table 7.6.2b	See table 7.6.2b
	1 to (F _{UL_low} -20) (F _{UL_high} +10) to 12750	-15***	P _{REFSENS} +6dB*	—	CW carrier
12	(F _{UL_low} -20) to (F _{UL_high} +13)	-38	P _{REFSENS} +6dB*	See table 7.6.2b	See table 7.6.2b
	1 to (F _{UL_low} -20) (F _{UL_high} +13) to 12750	-15***	P _{REFSENS} +6dB*	—	CW carrier
17	(F _{UL_low} -20) to (F _{UL_high} +18)	-38	P _{REFSENS} +6dB*	See table 7.6.2b	See table 7.6.2b
	1 to (F _{UL_low} -20) (F _{UL_high} +18) to 12750	-15***	P _{REFSENS} +6dB*	—	CW carrier
20, 71	(F _{UL_low} -11) to (F _{UL_high} +20)	-38	P _{REFSENS} +6dB*	See table 7.6.2b	See table 7.6.2b
	1 to (F _{UL_low} -11) (F _{UL_high} +20) to 12750	-15***	P _{REFSENS} +6dB*	—	CW carrier
25	(F _{UL_low} -20) to (F _{UL_high} +15)	-38	P _{REFSENS} +6dB*	See table 7.6-2b	See table 7.6-2b
	1 to (F _{UL_low} -20) (F _{UL_high} +15) to 12750	-15***	P _{REFSENS} +6dB*	—	CW carrier
31, 72, 74, 87, 88	(F _{UL_low} -20) to (F _{UL_high} +5)	-38	P _{REFSENS} +6dB*	See table 7.6-2b	See table 7.6-2b
	1 to (F _{UL_low} -20) (F _{UL_high} +5) to 12750	-15***	P _{REFSENS} +6dB*	—	CW carrier
85	(F _{UL_low} -20) to (F _{UL_high} +12)	-38	P _{REFSENS} +6dB*	See table 7.6.2b	See table 7.6.2b
	1 to (F _{UL_low} -20) (F _{UL_high} +12) to 12750	-15***	P _{REFSENS} +6dB*	—	CW carrier
Note*:	P _{REFSENS} depends on the channel bandwidth or supported subcarrier spacing as specified in TS 36.104 [2] subclause 7.2.1.				
Note**:	For a BS capable of multiband operation, in case of interfering signal that is not in the in-band blocking frequency range of the operating band where the wanted signal is present, and not in the in-band blocking frequency range of an adjacent or overlapping operating band, the wanted signal mean power is equal to P _{REFSENS} + 1.4 dB.				
Note***:	For NB-IoT, up to 24 exceptions are allowed for spurious response frequencies in each wanted signal frequency when measured using a 1MHz step size. For these exceptions the above throughput requirement shall be met when the blocking signal is set to a level of -40 dBm for 15 kHz subcarrier spacing and -46 dBm for 3.75 kHz subcarrier spacing. In addition, each group of exceptions shall not exceed three contiguous measurements using a 1MHz step size.				

NOTE: Table 7.6.1k assumes that two operating bands, where the downlink operating band (see Table 5.5-1) of one band would be within the in-band blocking region of the other band, are not deployed in the same geographical area.

Table 7.6-2: Interfering signals for blocking performance requirement

E-UTRA channel BW of the lowest/highest carrier received [MHz]	Interfering signal centre frequency minimum offset to the lower/upper Base Station RF Bandwidth edge or sub-block edge inside a sub-block gap [MHz]	Type of interfering signal
1.4	± 2.1	1.4MHz E-UTRA signal
3	± 4.5	3MHz E-UTRA signal
5	± 7.5	5MHz E-UTRA signal
10	± 7.5	5MHz E-UTRA signal
15	± 7.5	5MHz E-UTRA signal
20	± 7.5	5MHz E-UTRA signal (Note 1)
20	± 30	20 MHz E-UTRA signal (Note 2)
Note 1: This type of interfering signal is not applied for Band 46.		
Note 2: This type of interfering signal is only applied for Band 46.		

Table 7.6.2a: Interfering signals for blocking performance requirement for NB-IoT standalone operation

NB-IoT channel BW of the lowest/highest carrier received [MHz]	Interfering signal centre frequency minimum offset to the lower/upper Base Station RF Bandwidth edge or sub-block edge inside a sub-block gap [MHz]	Type of interfering signal
0.2	± 7.5	5MHz E-UTRA signal

Table 7.6-2b: Interfering signals for blocking performance requirement for E-UTRA with NB-IoT in-band/guard band operation

E-UTRA channel BW of the lowest/highest carrier received [MHz]	Interfering signal centre frequency minimum offset to the lower/upper Base Station RF Bandwidth edge or sub-block edge inside a sub-block gap [MHz]	Type of interfering signal
3	± 4.5	3MHz E-UTRA signal
5	± 7.5	5MHz E-UTRA signal
10	± 7.5	5MHz E-UTRA signal
15	± 7.5	5MHz E-UTRA signal
20	± 7.5	5MHz E-UTRA signal

NOTE: If the above Test Requirement differs from the Minimum Requirement then the Test Tolerance applied for this test is non-zero. The relationship between Minimum Requirements and Test Requirements is defined in subclause 4.1 and the explanation of how the Minimum Requirement has been relaxed by the Test Tolerance is given in Annex G.

7.6.5.2 Co-location with other base stations

This additional blocking requirement may be applied for the protection of E-UTRA BS or NB-IoT receivers when GSM, CMDA, UTRA, NR or E-UTRA BS operating in a different frequency band are co-located with an E-UTRA or NB-IoT BS. The requirement is applicable to all channel bandwidths supported by the E-UTRA BS.

The requirements in this clause assume a 30 dB coupling loss between interfering transmitter and E-UTRA or NB-IoT BS receiver and are based on co-location with base stations of the same class.

For each measured E-UTRA carrier, the throughput shall be $\geq 95\%$ of the maximum throughput of the reference measurement channel, with a wanted and an interfering signal coupled to BS antenna input using the parameters in Table 7.6-3 for Wide Area BS, in Table 7.6-4 for Local Area BS and in Table 7.6-5 for Medium Range BS. The reference measurement channel for the wanted signal is specified in Tables 7.2-1, 7.2-2 and 7.2-4 for each channel bandwidth and further specified in Annex A.

For each measured NB-IoT carrier, the throughput shall be $\geq 95\%$ of the maximum throughput of the reference measurement channel, with a wanted and an interfering signal coupled to BS antenna input using the parameters in Table 7.6-3 for Wide Area BS. The reference measurement channel for the wanted signal is specified in Tables 7.2-5 for each channel sub-carrier spacing option and further specified in Annex A.

Table 7.6-3: Blocking performance requirement for E-UTRA and NB-IoT Wide Area BS when co-located with BS in other frequency bands.

Co-located BS type	Centre Frequency of Interfering Signal (MHz)	Interfering Signal mean power (dBm)	Wanted Signal mean power (dBm)	Type of Interfering Signal
Macro GSM850 or CDMA850	869 – 894	+16**	$P_{\text{REFSENS}} + 6\text{dB}^*$	CW carrier
Macro GSM900	921 – 960	+16**	$P_{\text{REFSENS}} + 6\text{dB}^*$	CW carrier
Macro DCS1800	1805 – 1880	+16**	$P_{\text{REFSENS}} + 6\text{dB}^*$	CW carrier
Macro PCS1900	1930 – 1990	+16**	$P_{\text{REFSENS}} + 6\text{dB}^*$	CW carrier
WA UTRA FDD Band I or E-UTRA Band 1 or NR band n1	2110 – 2170	+16**	$P_{\text{REFSENS}} + 6\text{dB}^*$	CW carrier
WA UTRA FDD Band II or E-UTRA Band 2 or NR band n2	1930 – 1990	+16**	$P_{\text{REFSENS}} + 6\text{dB}^*$	CW carrier
WA UTRA FDD Band III or E-UTRA Band 3 or NR band n3	1805 – 1880	+16**	$P_{\text{REFSENS}} + 6\text{dB}^*$	CW carrier
WA UTRA FDD Band IV or E-UTRA Band 4	2110 – 2155	+16**	$P_{\text{REFSENS}} + 6\text{dB}^*$	CW carrier
WA UTRA FDD Band V or E-UTRA Band 5 or NR band n5	869 – 894	+16**	$P_{\text{REFSENS}} + 6\text{dB}^*$	CW carrier
WA UTRA FDD Band VI or E-UTRA Band 6	875 – 885	+16**	$P_{\text{REFSENS}} + 6\text{dB}^*$	CW carrier
WA UTRA FDD Band VII or E-UTRA Band 7 or NR band n7	2620 – 2690	+16**	$P_{\text{REFSENS}} + 6\text{dB}^*$	CW carrier
WA UTRA FDD Band VIII or E-UTRA Band 8 or NR band n8	925 – 960	+16**	$P_{\text{REFSENS}} + 6\text{dB}^*$	CW carrier
WA UTRA FDD Band IX or E-UTRA Band 9	1844.9 – 1879.9	+16**	$P_{\text{REFSENS}} + 6\text{dB}^*$	CW carrier
WA UTRA FDD Band X or E-UTRA Band 10	2110 – 2170	+16**	$P_{\text{REFSENS}} + 6\text{dB}^*$	CW carrier
WA UTRA FDD Band XI or E-UTRA Band 11	1475.9 – 1495.9	+16**	$P_{\text{REFSENS}} + 6\text{dB}^*$	CW carrier
WA UTRA FDD Band XII or E-UTRA Band 12 or NR band n12	729 - 746	+16**	$P_{\text{REFSENS}} + 6\text{dB}^*$	CW carrier
WA UTRA FDD Band XIII or E-UTRA Band 13	746 - 756	+16**	$P_{\text{REFSENS}} + 6\text{dB}^*$	CW carrier
WA UTRA FDD Band XIV or E-UTRA Band 14 or NR Band n14	758 - 768	+16**	$P_{\text{REFSENS}} + 6\text{dB}^*$	CW carrier
WA E-UTRA Band 17	734 - 746	+16**	$P_{\text{REFSENS}} + 6\text{dB}^*$	CW carrier
WA E-UTRA Band 18	860 - 875	+16**	$P_{\text{REFSENS}} + 6\text{dB}^*$	CW carrier
WA UTRA FDD Band XIX or E-UTRA Band 19	875 - 890	+16**	$P_{\text{REFSENS}} + 6\text{dB}^*$	CW carrier
WA UTRA FDD Band XX or E-UTRA Band 20 or NR band n20	791 - 821	+16**	$P_{\text{REFSENS}} + 6\text{dB}^*$	CW carrier
WA UTRA FDD Band XXI or E-UTRA Band 21	1495.9 – 1510.9	+16**	$P_{\text{REFSENS}} + 6\text{dB}^*$	CW carrier
WA UTRA FDD Band XXII or E-UTRA Band 22	3510 – 3590	+16**	$P_{\text{REFSENS}} + 6\text{dB}^*$	CW carrier
WA E-UTRA Band 24	1525 – 1559	+16**	$P_{\text{REFSENS}} + 6\text{dB}^*$	CW carrier
WA UTRA FDD Band XXV or E-UTRA Band 25 or NR band n25	1930 – 1995	+16**	$P_{\text{REFSENS}} + 6\text{dB}^*$	CW carrier
WA UTRA FDD Band XXVI or E-UTRA Band 26 or NR Band n26	859 – 894	+16**	$P_{\text{REFSENS}} + 6\text{dB}^*$	CW carrier
WA E-UTRA Band 27	852 - 869	+16**	$P_{\text{REFSENS}} + 6\text{dB}^*$	CW carrier
WA E-UTRA Band 28 or NR band n28	758 – 803	+16**	$P_{\text{REFSENS}} + 6\text{dB}^*$	CW carrier

WA E-UTRA Band 29 or NR Band n29	717 – 728	+16**	P _{REFSENS} + 6dB*	CW carrier
WA E-UTRA Band 30 or NR Band n30	2350 – 2360	+16**	P _{REFSENS} + 6dB*	CW carrier
WA E-UTRA Band 31	462.5 – 467.5	+16**	P _{REFSENS} + 6dB*	CW carrier
WA UTRA FDD Band XXXII or E-UTRA Band 32	1452-1496 (NOTE 3)	+16**	P _{REFSENS} + 6dB*	CW carrier
WA UTRA TDD Band a) or E-UTRA in Band 33	1900-1920	+16**	P _{REFSENS} + 6dB*	CW carrier
WA UTRA TDD Band a) or E-UTRA in Band 34 or NR band n34	2010-2025	+16**	P _{REFSENS} + 6dB*	CW carrier
WA UTRA TDD Band b) or E-UTRA in Band 35	1850-1910	+16**	P _{REFSENS} + 6dB*	CW carrier
WA UTRA TDD Band b) or E-UTRA in Band 36	1930-1990	+16**	P _{REFSENS} + 6dB*	CW carrier
WA UTRA TDD Band c) or E-UTRA Band 37	1910-1930	+16**	P _{REFSENS} + 6dB*	CW carrier
WA UTRA TDD Band d) or E-UTRA Band 38 or NR band n38	2570-2620	+16**	P _{REFSENS} + 6dB*	CW carrier
WA UTRA TDD Band f) or E-UTRA Band 39 or NR band n39	1880-1920	+16**	P _{REFSENS} + 6dB*	CW carrier
WA UTRA TDD Band e) or E-UTRA Band 40 or NR band n40	2300-2400	+16**	P _{REFSENS} + 6dB*	CW carrier
WA E-UTRA Band 41 or NR band n41	2496-2690	+16**	P _{REFSENS} + 6dB*	CW carrier
WA E-UTRA Band 42	3400 - 3600	+16**	P _{REFSENS} + 6dB*	CW carrier
WA E-UTRA Band 43	3600 - 3800	+16**	P _{REFSENS} + 6dB*	CW carrier
WA E-UTRA Band 44	703-803	+16**	P _{REFSENS} + 6dB*	CW carrier
WA E-UTRA Band 45	1447-1467	+16**	P _{REFSENS} + 6dB*	CW carrier
WA E-UTRA Band 48 or NR band n48	3550-3700	+16**	P _{REFSENS} + 6dB*	CW carrier
WA E-UTRA Band 50 or NR band n50	1432 – 1517	+16**	P _{REFSENS} + 6dB*	CW carrier
WA E-UTRA Band 52	3300 - 3400	+16**	P _{REFSENS} + 6dB*	CW carrier
WA E-UTRA Band 65 or NR band n65	2110 – 2200	+16**	P _{REFSENS} + 6dB*	CW carrier
WA E-UTRA Band 66 or NR band n66	2110 – 2200	+16**	P _{REFSENS} + 6dB*	CW carrier
WA E-UTRA Band 67	738-758	+16**	P _{REFSENS} + 6dB*	CW carrier
WA E-UTRA Band 68	753-783	+16**	P _{REFSENS} + 6dB*	CW carrier
WA E-UTRA Band 69	2570-2620	+16**	P _{REFSENS} + 6dB*	CW carrier
WA E-UTRA Band 70 or NR band n70	1995-2020	+16**	P _{REFSENS} + 6dB*	CW carrier
WA E-UTRA Band 71 or NR band n71	617 – 652	+16**	P _{REFSENS} + 6dB*	CW carrier
WA E-UTRA Band 72	461 – 466	+16**	P _{REFSENS} + 6dB*	CW carrier
WA E-UTRA Band 73	460 – 465	+16**	P _{REFSENS} + 6dB*	CW carrier
WA E-UTRA Band 74 or NR band n74	1475 - 1518	+16**	P _{REFSENS} + 6dB*	CW carrier
WA E-UTRA Band 75 or NR band n75	1432 – 1517	+16**	P _{REFSENS} + 6dB*	CW carrier
WA NR Band n77	3300 – 4200 MHz	+16**	P _{REFSENS} + 6dB*	CW carrier
WA NR Band n78	3300 – 3800 MHz	+16**	P _{REFSENS} + 6dB*	CW carrier
WA NR band n79	4400-5000	+16**	P _{REFSENS} + 6dB*	CW carrier
WA E-UTRA Band 85	728 - 746	+16**	P _{REFSENS} + 6dB*	CW carrier
WA E-UTRA Band 87	420 – 425	+16**	P _{REFSENS} + 6dB*	CW carrier
WA E-UTRA Band 88	422 – 427	+16**	P _{REFSENS} + 6dB*	CW carrier
WA NR band n92	1432 – 1517	+16**	P _{REFSENS} + 6dB*	CW carrier
WA NR band n94	1432 – 1517	+16**	P _{REFSENS} + 6dB*	CW carrier

Note*:	P _{REFSENS} is related to the channel bandwidth and specified in TS 36.104 [2] subclause 7.2.1.
Note**:	For NB-IoT, up to 24 exceptions are allowed for spurious response frequencies in each wanted signal frequency when measured using a 1MHz step size. For these exceptions the above throughput requirement shall be met when the blocking signal is set to a level of -40 dBm for 15 kHz subcarrier spacing and -46 dBm for 3.75 kHz subcarrier spacing. In addition, each group of exceptions shall not exceed three contiguous measurements using a 1MHz step size.
NOTE 1:	Except for a BS operating in Band 13, these requirements do not apply when the interfering signal falls within any of the supported uplink operating band or in the 10 MHz immediately outside any of the supported uplink operating band. For a BS operating in band 13 the requirements do not apply when the interfering signal falls within the frequency range 768-797 MHz.
NOTE 2:	Some combinations of bands may not be possible to co-site based on the requirements above. The current state-of-the-art technology does not allow a single generic solution for co-location of UTRA TDD or E-UTRA TDD with E-UTRA FDD on adjacent frequencies for 30dB BS-BS minimum coupling loss. However, there are certain site-engineering solutions that can be used. These techniques are addressed in TR 25.942 [11].
NOTE 3:	For a BS operating in band 11, 21 or 74, the requirement for co-location with Band 32 applies for interfering signal within the frequency range 1475.9-1495.9 MHz.
NOTE 4:	Co-located TDD base stations that are synchronized and using the same or adjacent operating band can receive without special co-location requirements. For unsynchronized base stations, special co-location requirements may apply that are not covered by the 3GPP specifications.

Table 7.6-4: Blocking performance requirement for E-UTRA and NB-IoT Local Area BS when co-located with BS in other frequency bands.

Co-located BS type	Centre Frequency of Interfering Signal (MHz)	Interfering Signal mean power (dBm)	Wanted Signal mean power (dBm)	Type of Interfering Signal
Pico GSM850	869 – 894	-7**	P _{REFSENS} + 6dB*	CW carrier
Pico GSM900	921 – 960	-7**	P _{REFSENS} + 6dB*	CW carrier
Pico DCS1800	1805 – 1880	-4**	P _{REFSENS} + 6dB*	CW carrier
Pico PCS1900	1930 – 1990	-4**	P _{REFSENS} + 6dB*	CW carrier
LA UTRA FDD Band I or E-UTRA Band 1 or NR band n1	2110 – 2170	-6**	P _{REFSENS} + 6dB*	CW carrier
LA UTRA FDD Band II or E-UTRA Band 2 or NR band n2	1930 – 1990	-6**	P _{REFSENS} + 6dB*	CW carrier
LA UTRA FDD Band III or E-UTRA Band 3 or NR band n3	1805 – 1880	-6**	P _{REFSENS} + 6dB*	CW carrier
LA UTRA FDD Band IV or E-UTRA Band 4	2110 – 2155	-6**	P _{REFSENS} + 6dB*	CW carrier
LA UTRA FDD Band V or E-UTRA Band 5 or NR band n5	869 – 894	-6**	P _{REFSENS} + 6dB*	CW carrier
LA UTRA FDD Band VI or E-UTRA Band 6	875 – 885	-6**	P _{REFSENS} + 6dB*	CW carrier
LA UTRA FDD Band VII or E-UTRA Band 7 or NR band n7	2620 – 2690	-6**	P _{REFSENS} + 6dB*	CW carrier
LA UTRA FDD Band VIII or E-UTRA Band 8 or NR band n8	925 – 960	-6**	P _{REFSENS} + 6dB*	CW carrier
LA UTRA FDD Band IX or E-UTRA Band 9	1844.9 – 1879.9	-6**	P _{REFSENS} + 6dB*	CW carrier
LA UTRA FDD Band X or E-UTRA Band 10	2110 – 2170	-6**	P _{REFSENS} + 6dB*	CW carrier
LA UTRA FDD Band XI or E-UTRA Band 11	1475.9 - 1495.9	-6**	P _{REFSENS} + 6dB*	CW carrier
LA UTRA FDD Band XII or E-UTRA Band 12 or NR band n12	729 - 746	-6**	P _{REFSENS} + 6dB*	CW carrier
LA UTRA FDD Band XIII or E-UTRA Band 13	746 - 756	-6**	P _{REFSENS} + 6dB*	CW carrier
LA UTRA FDD Band XIV or E-UTRA Band 14 or NR Band n14	758 - 768	-6**	P _{REFSENS} + 6dB*	CW carrier
LA E-UTRA Band 17	734 - 746	-6**	P _{REFSENS} + 6dB*	CW carrier
LA E-UTRA Band 18	860 - 875	-6**	P _{REFSENS} + 6dB*	CW carrier
LA UTRA FDD Band XIX or E-UTRA Band 19	875 - 890	-6**	P _{REFSENS} + 6dB*	CW carrier
LA UTRA FDD Band XX or E-UTRA Band 20 or NR band n20	791 - 821	-6**	P _{REFSENS} + 6dB*	CW carrier
LA UTRA FDD Band XXI or E-UTRA Band 21	1495.9 – 1510.9	-6**	P _{REFSENS} + 6dB*	CW carrier
LA UTRA FDD Band XXII or E-UTRA Band 22	3510 – 3590	-6**	P _{REFSENS} + 6dB*	CW carrier
LA E-UTRA Band 24	1525 – 1559	-6**	P _{REFSENS} + 6dB*	CW carrier
LA UTRA FDD Band XXV or E-UTRA Band 25 or NR band n25	1930 – 1995	-6**	P _{REFSENS} + 6dB*	CW carrier
LA UTRA FDD Band XXVI or E-UTRA Band 26 or NR Band n26	859 – 894	-6**	P _{REFSENS} + 6dB*	CW carrier
LA E-UTRA Band 27	852 - 869	-6**	P _{REFSENS} + 6dB*	CW carrier
LA E-UTRA Band 28 or NR band n28	758 – 803	-6**	P _{REFSENS} + 6dB*	CW carrier
LA E-UTRA Band 29 or NR Band n29	717 – 728	-6**	P _{REFSENS} + 6dB*	CW carrier

LA E-UTRA Band 30 or NR Band n30	2350 – 2360	-6**	P _{REFSENS} + 6dB*	CW carrier
LA E-UTRA Band 31	462.5 – 467.5	-6**	P _{REFSENS} + 6dB*	CW carrier
LA UTRA FDD Band XXXII or E-UTRA Band 32	1452-1496 (NOTE 3)	-6**	P _{REFSENS} + 6dB*	CW carrier
LA UTRA TDD Band a) or E-UTRA Band 33	1900-1920	-6**	P _{REFSENS} + 6dB*	CW carrier
LA UTRA TDD Band a) or E-UTRA Band 34 or NR band n34	2010-2025	-6**	P _{REFSENS} + 6dB*	CW carrier
LA UTRA TDD Band b) or E-UTRA Band 35	1850-1910	-6**	P _{REFSENS} + 6dB*	CW carrier
LA UTRA TDD Band b) or E-UTRA Band 36	1930-1990	-6**	P _{REFSENS} + 6dB*	CW carrier
LA UTRA TDD Band c) or E-UTRA Band 37	1910-1930	-6**	P _{REFSENS} + 6dB*	CW carrier
LA UTRA TDD in Band d) or E-UTRA Band 38 or NR band n38	2570-2620	-6**	P _{REFSENS} + 6dB*	CW carrier
LA UTRA TDD in Band f) or E-UTRA Band 39 or NR band n39	1880-1920	-6**	P _{REFSENS} + 6dB*	CW carrier
LA UTRA TDD in Band e) or E-UTRA Band 40 or NR band n40	2300-2400	-6**	P _{REFSENS} + 6dB*	CW carrier
LA E-UTRA Band 41 or NR band n41	2496-2690	-6**	P _{REFSENS} + 6dB*	CW carrier
LA E-UTRA Band 42	3400 - 3600	-6**	P _{REFSENS} + 6dB*	CW carrier
LA E-UTRA Band 43	3600 - 3800	-6**	P _{REFSENS} + 6dB*	CW carrier
LA E-UTRA Band 44	703-803	-6**	P _{REFSENS} + 6dB*	CW carrier
LA E-UTRA Band 45	1447-1467	-6**	P _{REFSENS} + 6dB*	CW carrier
LA E-UTRA Band 46 or NR Band n46	5150-5925	-6**	P _{REFSENS} + 6dB*	CW carrier
LA E-UTRA Band 48 or NR band n48	3550-3700	-6**	P _{REFSENS} + 6dB*	CW carrier
LA E-UTRA Band 49	3550-3700	-6**	P _{REFSENS} + 6dB*	CW carrier
LA E-UTRA Band 50 or NR band n50	1432 - 1517	-6**	P _{REFSENS} + 6dB*	CW carrier
LA E-UTRA Band 51 or NR band n51	1427 - 1432	-6**	P _{REFSENS} + 6dB*	CW carrier
LA E-UTRA Band 52	3300 - 3400	-6	P _{REFSENS} + 6dB*	CW carrier
LA E-UTRA Band 53 or NR Band n53	2483.5 - 2495	-6**	P _{REFSENS} + 6dB*	CW carrier
LA E-UTRA Band 65 or NR band n65	2110 – 2200	-6**	P _{REFSENS} + 6dB*	CW carrier
LA E-UTRA Band 66 or NR band n66	2110 – 2200	-6**	P _{REFSENS} + 6dB*	CW carrier
LA E-UTRA Band 67	738-758	-6**	P _{REFSENS} + 6dB*	CW carrier
LA E-UTRA Band 68	753-783	-6**	P _{REFSENS} + 6dB*	CW carrier
LA E-UTRA Band 69	2570-2620	-6**	P _{REFSENS} + 6dB*	CW carrier
LA E-UTRA Band 70 or NR band n70	1995-2020	-6**	P _{REFSENS} + 6dB*	CW carrier
LA E-UTRA Band 71 or NR band n71	617 – 652	-6**	P _{REFSENS} + 6dB*	CW carrier
LA E-UTRA Band 72	461 – 466	-6**	P _{REFSENS} + 6dB*	CW carrier
LA E-UTRA Band 73	460 – 465	-6**	P _{REFSENS} + 6dB*	CW carrier
LA E-UTRA Band 74 or NR band n74	1475 - 1518	-6**	P _{REFSENS} + 6dB*	CW carrier
LA E-UTRA Band 75 or NR band n75	1432 - 1517	-6**	P _{REFSENS} + 6dB*	CW carrier
LA E-UTRA Band 76 or NR band n76	1427 - 1432	-6**	P _{REFSENS} + 6dB*	CW carrier
LA NR band n77	3300 – 4200	-6**	P _{REFSENS} + 6dB*	CW carrier
LA NR band n78	3300 - 3800	-6**	P _{REFSENS} + 6dB*	CW carrier
LA NR band n79	4400-5000	-6**	P _{REFSENS} + 6dB*	CW carrier
LA E-UTRA Band 85	728 - 746	-6**	P _{REFSENS} + 6dB*	CW carrier

LA E-UTRA Band 87	420 – 425	-6**	$P_{\text{REFSENS}} + 6\text{dB}^*$	CW carrier
LA E-UTRA Band 88	422 – 427	-6**	$P_{\text{REFSENS}} + 6\text{dB}^*$	CW carrier
LA NR band n91	1427 – 1432	-6**	$P_{\text{REFSENS}} + 6\text{dB}^*$	CW carrier
LA NR band n92	1432 – 1517	-6**	$P_{\text{REFSENS}} + 6\text{dB}^*$	CW carrier
LA NR band n93	1427 – 1432	-6**	$P_{\text{REFSENS}} + 6\text{dB}^*$	CW carrier
LA NR band n94	1432 – 1517	-6**	$P_{\text{REFSENS}} + 6\text{dB}^*$	CW carrier
LA NR band n96	5925 – 7125	-6	$P_{\text{REFSENS}} + 6\text{dB}^*$	CW carrier
Note*:	P_{REFSENS} is related to the channel bandwidth and specified in TS 36.104 [2] subclause 7.2.1.			
Note**:	For NB-IoT, up to 24 exceptions are allowed for spurious response frequencies in each wanted signal frequency when measured using a 1MHz step size. For these exceptions the above throughput requirement shall be met when the blocking signal is set to a level of -40 dBm for 15 kHz subcarrier spacing and -46 dBm for 3.75 kHz subcarrier spacing. In addition, each group of exceptions shall not exceed three contiguous measurements using a 1MHz step size.			
NOTE 1:	Except for a BS operating in Band 13, these requirements do not apply when the interfering signal falls within any of the supported uplink operating band or in the 10 MHz immediately outside any of the supported uplink operating band. For a BS operating in band 13 the requirements do not apply when the interfering signal falls within the frequency range 768-797 MHz.			
NOTE 2:	Some combinations of bands may not be possible to co-site based on the requirements above. The current state-of-the-art technology does not allow a single generic solution for co-location of UTRA TDD or E-UTRA TDD with E-UTRA FDD on adjacent frequencies for 30dB BS-BS minimum coupling loss. However, there are certain site-engineering solutions that can be used. These techniques are addressed in TR 25.942 [11].			
NOTE 3:	For a BS operating in band 11, 21 or 74, the requirement for co-location with Band 32 applies for interfering signal within the frequency range 1475.9-1495.9 MHz.			
NOTE 4:	Co-located TDD base stations that are synchronized and using the same or adjacent operating band can receive without special co-location requirements. For unsynchronized base stations, special co-location requirements may apply that are not covered by the 3GPP specifications.			

Table 7.6-5: Blocking performance requirement for E-UTRA and NB-IoT Medium Range BS when co-located with BS in other frequency bands.

Co-located BS type	Centre Frequency of Interfering Signal (MHz)	Interfering Signal mean power (dBm)	Wanted Signal mean power (dBm)	Type of Interfering Signal
Micro/MR GSM850	869 – 894	+8**	$P_{\text{REFSENS}} + 6\text{dB}^*$	CW carrier
Micro/MR GSM900	921 – 960	+8**	$P_{\text{REFSENS}} + 6\text{dB}^*$	CW carrier
Micro/MR DCS1800	1805 – 1880	+8**	$P_{\text{REFSENS}} + 6\text{dB}^*$	CW carrier
Micro/MR PCS1900	1930 – 1990	+8**	$P_{\text{REFSENS}} + 6\text{dB}^*$	CW carrier
MR UTRA FDD Band I or E-UTRA Band 1 or NR band n1	2110 – 2170	+8**	$P_{\text{REFSENS}} + 6\text{dB}^*$	CW carrier
MR UTRA FDD Band II or E-UTRA Band 2 or NR band n2	1930 – 1990	+8**	$P_{\text{REFSENS}} + 6\text{dB}^*$	CW carrier
MR UTRA FDD Band III or E-UTRA Band 3 or NR band n3	1805 – 1880	+8**	$P_{\text{REFSENS}} + 6\text{dB}^*$	CW carrier
MR UTRA FDD Band IV or E-UTRA Band 4	2110 – 2155	+8**	$P_{\text{REFSENS}} + 6\text{dB}^*$	CW carrier
MR UTRA FDD Band V or E-UTRA Band 5 or NR band n5	869 – 894	+8**	$P_{\text{REFSENS}} + 6\text{dB}^*$	CW carrier
MR UTRA FDD Band VI or E-UTRA Band 6	875 – 885	+8**	$P_{\text{REFSENS}} + 6\text{dB}^*$	CW carrier
MR UTRA FDD Band VII or E-UTRA Band 7 or NR band n7	2620 – 2690	+8**	$P_{\text{REFSENS}} + 6\text{dB}^*$	CW carrier
MR UTRA FDD Band VIII or E-UTRA Band 8 or NR band n8	925 – 960	+8**	$P_{\text{REFSENS}} + 6\text{dB}^*$	CW carrier
MR UTRA FDD Band IX or E-UTRA Band 9	1844.9 – 1879.9	+8**	$P_{\text{REFSENS}} + 6\text{dB}^*$	CW carrier
MR UTRA FDD Band X or E-UTRA Band 10	2110 – 2170	+8**	$P_{\text{REFSENS}} + 6\text{dB}^*$	CW carrier
MR UTRA FDD Band XI or E-UTRA Band 11	1475.9 – 1495.9	+8**	$P_{\text{REFSENS}} + 6\text{dB}^*$	CW carrier
MR UTRA FDD Band XII or E-UTRA Band 12 or NR band n12	729 - 746	+8**	$P_{\text{REFSENS}} + 6\text{dB}^*$	CW carrier
MR UTRA FDD Band XIII or E-UTRA Band 13	746 - 756	+8**	$P_{\text{REFSENS}} + 6\text{dB}^*$	CW carrier
MR UTRA FDD Band XIV or E-UTRA Band 14 or NR Band n14	758 - 768	+8**	$P_{\text{REFSENS}} + 6\text{dB}^*$	CW carrier
MR E-UTRA Band 17	734 - 746	+8**	$P_{\text{REFSENS}} + 6\text{dB}^*$	CW carrier
MR E-UTRA Band 18	860 - 875	+8**	$P_{\text{REFSENS}} + 6\text{dB}^*$	CW carrier
MR UTRA FDD Band XIX or E-UTRA Band 19	875 - 890	+8**	$P_{\text{REFSENS}} + 6\text{dB}^*$	CW carrier
MR UTRA FDD Band XX or E-UTRA Band 20 or Nr band n20	791 - 821	+8**	$P_{\text{REFSENS}} + 6\text{dB}^*$	CW carrier
MR UTRA FDD Band XXI or E-UTRA Band 21	1495.9 – 1510.9	+8**	$P_{\text{REFSENS}} + 6\text{dB}^*$	CW carrier
MR UTRA FDD Band XXII or E-UTRA Band 22	3510 – 3590	+8**	$P_{\text{REFSENS}} + 6\text{dB}^*$	CW carrier
MR E-UTRA Band 24	1525 – 1559	+8**	$P_{\text{REFSENS}} + 6\text{dB}^*$	CW carrier
MR UTRA FDD Band XXV or E-UTRA Band 25 or NR band n25	1930 – 1995	+8**	$P_{\text{REFSENS}} + 6\text{dB}^*$	CW carrier
MR UTRA FDD Band XXVI or E-UTRA Band 26 or NR Band n26	859 – 894	+8**	$P_{\text{REFSENS}} + 6\text{dB}^*$	CW carrier
MR E-UTRA Band 27	852 - 869	+8**	$P_{\text{REFSENS}} + 6\text{dB}^*$	CW carrier
MR E-UTRA Band 28 or NR band n28	758 – 803	+8**	$P_{\text{REFSENS}} + 6\text{dB}^*$	CW carrier
MR E-UTRA Band 29 or NR Band n29	717 – 728	+8**	$P_{\text{REFSENS}} + 6\text{dB}^*$	CW carrier

MR E-UTRA Band 30 or NR Band n30	2350 – 2360	+8**	P _{REFSENS} + 6dB*	CW carrier
MR E-UTRA Band 31	462.5 – 467.5	+8**	P _{REFSENS} + 6dB*	CW carrier
MR UTRA FDD Band XXXII or E-UTRA Band 32	1452-1496 (NOTE 3)	+8**	P _{REFSENS} + 6dB*	CW carrier
MR E-UTRA Band 33	1900-1920	+8**	P _{REFSENS} + 6dB*	CW carrier
MR E-UTRA Band 34 or NR band n34	2010-2025	+8**	P _{REFSENS} + 6dB*	CW carrier
MR E-UTRA Band 35	1850-1910	+8**	P _{REFSENS} + 6dB*	CW carrier
MR E-UTRA Band 36	1930-1990	+8**	P _{REFSENS} + 6dB*	CW carrier
MR E-UTRA Band 37	1910-1930	+8**	P _{REFSENS} + 6dB*	CW carrier
MR E-UTRA Band 38 or NR band n38	2570-2620	+8**	P _{REFSENS} + 6dB*	CW carrier
MR E-UTRA Band 39 or NR band n39	1880-1920	+8**	P _{REFSENS} + 6dB*	CW carrier
MR E-UTRA Band 40 or NR band n40	2300-2400	+8**	P _{REFSENS} + 6dB*	CW carrier
MR E-UTRA Band 41 or NR band n41	2496 - 2690	+8**	P _{REFSENS} + 6dB*	CW carrier
MR E-UTRA Band 42	3400-3600	+8**	P _{REFSENS} + 6dB*	CW carrier
MR E-UTRA Band 43	3600-3800	+8**	P _{REFSENS} + 6dB*	CW carrier
MR E-UTRA Band 44	703-803	+8**	P _{REFSENS} + 6dB*	CW carrier
MR E-UTRA Band 45	1447-1467	+8**	P _{REFSENS} + 6dB*	CW carrier
MR E-UTRA Band 46 or NR Band n46	5150-5925	+8	P _{REFSENS} + 6dB*	CW carrier
MR E-UTRA Band 48 or NR band n48	3550-3700	+8**	P _{REFSENS} + 6dB*	CW carrier
MR E-UTRA Band 50 or NR band n50	1432 - 1517	+8**	P _{REFSENS} + 6dB*	CW carrier
MR E-UTRA Band 52	3300-3400	+8**	P _{REFSENS} + 6dB*	CW carrier
MR E-UTRA Band 53 or NR Band n53	2483.5 - 2495	+8**	P _{REFSENS} + 6dB*	CW carrier
MR E-UTRA Band 65 or NR band n65	2110 – 2200	+8**	P _{REFSENS} + 6dB*	CW carrier
MR E-UTRA Band 66 or NR band n66	2110 – 2200	+8**	P _{REFSENS} + 6dB*	CW carrier
MR E-UTRA Band 67	738-758	+8**	P _{REFSENS} + 6dB*	CW carrier
MR E-UTRA Band 69	2570-2620	+8**	P _{REFSENS} + 6dB*	CW carrier
MR E-UTRA Band 70 or NR band n70	1695-1710	+8**	P _{REFSENS} + 6dB*	CW carrier
MR E-UTRA Band 68	753-783	+8**	P _{REFSENS} + 6dB*	CW carrier
MR E-UTRA Band 71 or NR band n71	617 – 652	+8**	P _{REFSENS} + 6dB*	CW carrier
MR E-UTRA Band 72	461 – 466	+8**	P _{REFSENS} + 6dB*	CW carrier
MR E-UTRA Band 73	460 – 465	+8**	P _{REFSENS} + 6dB*	CW carrier
MR E-UTRA Band 74 or NR band n74	1475 - 1518	+8**	P _{REFSENS} + 6dB*	CW carrier
MR E-UTRA Band 75 or NR band n75	1432 - 1517	+8**	P _{REFSENS} + 6dB*	CW carrier
MR NR Band n77	3300 – 4200	+8**	P _{REFSENS} + 6dB*	CW carrier
MR NR Band n78	3300 - 3800	+8**	P _{REFSENS} + 6dB*	CW carrier
MR NR band n79	4400-5000	+8**	P _{REFSENS} + 6dB*	CW carrier
MR E-UTRA Band 85	728 - 746	+8**	P _{REFSENS} + 6dB*	CW carrier
MR E-UTRA Band 87	420 – 425	+8**	P _{REFSENS} + 6dB*	CW carrier
MR E-UTRA Band 88	422 – 427	+8**	P _{REFSENS} + 6dB*	CW carrier
MR NR band n92	1432 – 1517	+8**	P _{REFSENS} + 6dB*	CW carrier
MR NR band n94	1432 – 1517	+8**	P _{REFSENS} + 6dB*	CW carrier
MR NR band n96	5925 – 7125	+8	P _{REFSENS} + 6dB*	CW carrier

Note*:	PREFSENS is related to the channel bandwidth and specified in TS 36.104 [2] subclause 7.2.1.
Note**:	For NB-IoT, up to 24 exceptions are allowed for spurious response frequencies in each wanted signal frequency when measured using a 1MHz step size. For these exceptions the above throughput requirement shall be met when the blocking signal is set to a level of -40 dBm for 15 kHz subcarrier spacing and -46 dBm for 3.75 kHz subcarrier spacing. In addition, each group of exceptions shall not exceed three contiguous measurements using a 1MHz step size.
NOTE 1:	Except for a BS operating in Band 13, these requirements do not apply when the interfering signal falls within any of the supported uplink operating band or in the 10 MHz immediately outside any of the supported uplink operating band. For a BS operating in band 13 the requirements do not apply when the interfering signal falls within the frequency range 768-797 MHz.
NOTE 2:	Some combinations of bands may not be possible to co-site based on the requirements above. The current state-of-the-art technology does not allow a single generic solution for co-location of UTRA TDD or E-UTRA TDD with E-UTRA FDD on adjacent frequencies for 30dB BS-BS minimum coupling loss. However, there are certain site-engineering solutions that can be used. These techniques are addressed in TR 25.942 [11].
NOTE 3:	For a BS operating in band 11, 21 or 74, the requirement for co-location with Band 32 applies for interfering signal within the frequency range 1475.9-1495.9 MHz.
NOTE 4:	Co-located TDD base stations that are synchronized and using the same or adjacent operating band can receive without special co-location requirements. For unsynchronized base stations, special co-location requirements may apply that are not covered by the 3GPP specifications.

7.7 Receiver spurious emissions

7.7.1 Definition and applicability

The spurious emissions power is the power of emissions generated or amplified in a receiver that appear at the BS receiver antenna connector. The requirements apply to all BS with separate RX and TX antenna ports. The test shall be performed when both TX and RX are on, with the TX port terminated.

For TDD BS with common RX and TX antenna port the requirement applies during the Transmitter OFF period. For FDD BS with common RX and TX antenna port the transmitter spurious emission as specified in clause 6.6.4 is valid.

For BS capable of multi-band operation where multiple bands are mapped on separate antenna connectors, the single-band requirements apply and the excluded frequency range is only applicable for the operating band supported on each antenna connector.

Unless otherwise stated, a BS declared to be capable of E-UTRA with NB-IoT in-band and guard band operations is only required to pass the receiver spurious emissions tests for E-UTRA with guard band operation; it is not required to perform the receiver spurious emissions tests again for E-UTRA with in-band operation.

7.7.2 Minimum Requirements

The minimum requirement is in TS 36.104 [2] subclause 7.7.1.

7.7.3 Test purpose

The test purpose is to verify the ability of the BS to limit the interference caused by receiver spurious emissions to other systems.

7.7.4 Method of test

7.7.4.1 Initial conditions

Test environment: normal; see subclause D.2.

RF channels to be tested for single carrier: M, see subclause 4.7.

Base Station RF Bandwidth edge positions to be tested for multi-carrier and/or CA: M_{RFBW} in single-band operation, see subclause 4.7.1; $B_{\text{RFBW_T_RFBW}}$ and $B'_{\text{RFBW_T_RFBW}}$ in multi-band operation, see subclause 4.7.1.

- 1) Connect a measurement receiver to the BS antenna connector as shown in Annex I.2.6.
- 2) Enable the BS receiver.
- 3) Terminate the BS Tx antenna connector as shown in Annex I.2.6.
- 4) Detection mode: True RMS.

The emission power should be averaged over an appropriate time duration to ensure the measurement is within the measurement uncertainty in Table 4.1.2-2.

7.7.4.2 Procedure

- 1) For a E-UTRA BS declared to be capable of single carrier operation only, start BS transmission according to E-TM 1.1 at manufacturer's declared rated output power.

For a E-UTRA BS declared to be capable of multi-carrier and/or CA operation, set the BS to transmit according to E-TM 1.1 on all carriers configured using the applicable test configuration and corresponding power setting specified in clause 4.10 and 4.11

For E-UTRA BS declared to be capable of NB-IoT in-band or guard band operation single carrier operation only, start BS transmission according to E-TM 1.1. and N-TM at manufacturer's declared rated output power.

For a E-UTRA BS declared to be capable of NB-IoT in-band or guard band operation multi-carrier, set the BS to transmit according to E-TM 1.1 on all E-UTRA carriers and to N-TM on all NB-IoT carriers configured using the applicable test configuration and corresponding power setting specified in clause 4.10 and 4.11.

For a BS declared to be capable of NB-IoT standalone single carrier operation only, start BS transmission according to N-TM at manufacturer's declared rated output power.

For a BS declared to be capable of NB-IoT standalone multi-carrier operation, set the BS to transmit according to N-TM on all carriers configured using the applicable test configuration and corresponding power setting specified in clause 4.10 and 4.11

For a E-UTRA and NB-IoT standalone BS, set the BS to transmit according to E-TM 1.1 on all E-UTRA carriers and according to N-TM on all NB-IoT carriers configured using the applicable test configuration and corresponding power setting specified in clause 4.10 and 4.11

For TDD connectors capable of transmit and receive ensure the transmitter is OFF.

- 2) Set measurement equipment parameters as specified in table 7.7-1.
- 3) Measure the spurious emissions over each frequency range described in subclause 7.7.5.
- 4) Repeat the test for the Rx port(s), which was (were) terminated.

In addition, for a multi-band capable BS, the following step shall apply:

- 5) For multi-band capable BS and single band tests, repeat the steps above per involved band where single band test configurations and test models shall apply with no carrier activated in the other band. For multi-band capable BS with separate antenna connector, the antenna connector not being under test in case of single-band or multi-band test shall be terminated.

7.7.5 Test requirements

The power of any spurious emission shall not exceed the levels in Table 7.7-1.

In addition to the requirements in Table 7.7-1, the power of any spurious emission shall not exceed the levels specified for Protection of the E-UTRA FDD BS receiver of own or different BS in Clause 6.6.4.5.3 and for Co-existence with

other systems in the same geographical area in Clause 6.6.4.5.4. In addition, the co-existence requirements for co-located base stations specified in subclause 6.6.4.5.5 may also be applied.

Table 7.7-1: General spurious emission test requirement

Frequency range	Maximum level	Measurement Bandwidth	Note
30MHz - 1 GHz	-57 dBm	100 kHz	
1 GHz - 12.75 GHz	-47 dBm	1 MHz	
12.75 GHz - 5 th harmonic of the upper frequency edge of the UL operating band in GHz	-47 dBm	1 MHz	Applies only for Bands 22, 42, 43, 48 or 49.
12.75 GHz - 26 GHz	-47 dBm	1 MHz	Applies only for Band 46
<p>NOTE: The frequency range between $2.5 * BW_{\text{Channel}}$ below the first carrier frequency and $2.5 * BW_{\text{Channel}}$ above the last carrier frequency transmitted by the BS, where BW_{Channel} is the channel bandwidth according to Table 5.6-1, may be excluded from the requirement. However, frequencies that are more than 10 MHz below the lowest frequency of any of the BS supported downlink operating band or more than 10 MHz above the highest frequency of any of the BS supported downlink operating band (see Table 5.5-1) shall not be excluded from the requirement.</p> <p>For BS capable of multi-band operation, the excluded frequency range applies for all supported operating bands. For BS capable of multi-band operation where multiple bands are mapped on separate antenna connectors, the single-band requirements apply and the excluded frequency range is only applicable for the operating band supported on each antenna connector.</p>			

NOTE: If the above Test Requirement differs from the Minimum Requirement then the Test Tolerance applied for this test is non-zero. The relationship between Minimum Requirements and Test Requirements is defined in subclause 4.1 and the explanation of how the Minimum Requirement has been relaxed by the Test Tolerance is given in Annex G.

7.8 Receiver intermodulation

7.8.1 Definition and applicability

Third and higher order mixing of the two interfering RF signals can produce an interfering signal in the band of the desired channel. Intermodulation response rejection is a measure of the capability of the receiver to receive a wanted signal on its assigned channel frequency in the presence of two interfering signals which have a specific frequency relationship to the wanted signal. Interfering signals shall be a CW signal and an E-UTRA signal as specified in Annex C.

Unless otherwise stated, a BS declared to be capable of E-UTRA with NB-IoT in-band and guard band operations is only required to pass the receiver intermodulation tests for E-UTRA with guard band operation; it is not required to perform the receiver intermodulation tests again for E-UTRA with in-band operation.

7.8.2 Minimum Requirement

The minimum requirement is in TS 36.104 [2] subclause 7.8.1.

7.8.3 Test purpose

The test purpose is to verify the ability of the BS receiver to inhibit the generation of intermodulation products in its non-linear elements caused by the presence of two high-level interfering signals at frequencies with a specific relationship to the frequency of the wanted signal.

7.8.4 Method of test

7.8.4.1 Initial conditions

Test environment: normal; see subclause D.2.

RF channels to be tested for single carrier: B, M and T; see subclause 4.7.

Base Station RF Bandwidth edge positions to be tested for multi-carrier and/or CA: B_{RFBW} and T_{RFBW} in single-band operation, see subclause 4.7.1; $B_{\text{RFBW_T}}^{\text{RFBW}}$ and $B_{\text{RFBW_T}}^{\text{RFBW}}$ in multi-band operation, see subclause 4.7.1.

- 1) Set-up the measurement system as shown in Annex I.2.7.

7.8.4.2 Procedures

For E-UTRA and E-UTRA with NB-IoT in-band or guard band operation:

- 1) Generate the E-UTRA wanted signal using the applicable test configuration specified in subclause 4.10 and 4.11 and adjust the signal level to the BS under test to the level specified in Table 7.8-1.

For BS declared to be capable of NB-IoT in-band or guard band operation, generate the NB-IoT wanted signal using the applicable test configuration specified in subclause 4.10 and 4.11 and adjust the signal level to the BS under test to the level specified in Table 7.8-1a or Table 7.8-1b.

- 2) Adjust the signal generators to the type of interfering signals, levels and the frequency offsets as specified in Table 7.8-2 for intermodulation requirement and Table 7.8-3, Table 7.8-3a, Table 7.8-3b, Table 7.8-4, Table 7.8-4a, Table 7.8-4b, Table 7.8-5, Table 7.8-5a and Table 7.8-5b, Table 7.8-6, Table 7.8-6a and Table 7.8-6b for narrowband intermodulation requirement.
- 3) Adjust the signal generators to obtain the specified level of interfering signal at the BS input.
- 4) Measure the E-UTRA throughput according to Annex E, for multi-carrier and/or CA operation the throughput shall be measured for relevant carriers specified by the test configuration specified in subclause 4.10 and 4.11.

For BS declared to be capable of NB-IoT in-band or guard band operation, measure the NB-IoT throughput according to Annex E, for multi-carrier the throughput shall be measured for relevant carriers specified by the test configuration specified in subclause 4.10 and 4.11.

- 5) Repeat the test for the port(s) which was (were) terminated.

In addition, for a multi-band capable BS with separate antenna connectors, the following steps shall apply:

- 6) For single band tests, repeat the steps above per involved band where single band test configurations shall apply with no carrier activated in the other band.

Interfering signal shall first be applied on the same port as the wanted signal. The test shall be repeated with the interfering signal applied on the other port (if any) mapped to the same receiver as the wanted signal. Any antenna connector with no signal applied in case of single-band or multi-band test shall be terminated.

- 7) Repeat step 6) with the wanted signal for the other band(s) applied on the respective port(s).

For NB-IoT standalone operation:

- 1) Generate the NB-IoT wanted signal using the applicable test configuration specified in subclause 4.10 and 4.11 and adjust the signal level to the BS under test to the level specified in Table 7.8-1c.
- 2) Adjust the signal generators to the type of interfering signals, levels and the frequency offsets as specified in Table 7.8-2a for intermodulation requirement and Tables 7.8-3c, 7.8-4c, 7.8-5c, 7.8-6c for narrowband intermodulation requirement.
- 3) Adjust the signal generators to obtain the specified level of interfering signal at the BS input.
- 4) Measure the NB-IoT throughput according to Annex E, for multi-carrier the throughput shall be measured for relevant carriers specified by the test configuration specified in subclause 4.10 and 4.11.

- 5) Repeat the test for the port(s) which was (were) terminated.

For E-UTRA and NB-IoT standalone BS:

- 1) Generate the E-UTRA wanted signal using the applicable test configuration specified in subclause 4.10 and 4.11 and adjust the signal level to the BS under test to the level specified in Table 7.8-1.

Generate the NB-IoT wanted signal using the applicable test configuration specified in subclause 4.10 and 4.11 and adjust the signal level to the BS under test to the level specified in Table 7.8-1c.

- 2) a) On the side where E-UTRA signal is positioned:

Adjust the signal generators to the type of interfering signals, levels and the frequency offsets as specified in Table 7.8-2 for intermodulation requirement and Table 7.8-3, Table 7.8-4, Table 7.8-5 and Table 7.8-6 for narrowband intermodulation requirement.

- b) On the side where NB-IoT signal is positioned:

Adjust the signal generators to the type of interfering signals, levels and the frequency offsets as specified in Table 7.8-2a for intermodulation requirement and Tables 7.8-3c, 7.8-4c, 7.8-5c, 7.8-6c for narrowband intermodulation requirement.

- 3) Adjust the signal generators to obtain the specified level of interfering signal at the BS input.
- 4) Measure the E-UTRA throughput according to Annex E, for multi-carrier and/or CA operation the throughput shall be measured for relevant carriers specified by the test configuration specified in subclause 4.10 and 4.11.

Measure the NB-IoT throughput according to Annex E, for multi-carrier the throughput shall be measured for relevant carriers specified by the test configuration specified in subclause 4.10 and 4.11.

- 5) Repeat the test for the port(s) which was (were) terminated.

7.8.5 Test requirements

For each measured E-UTRA carrier, the throughput shall be $\geq 95\%$ of the maximum throughput of the reference measurement channel, with a wanted signal at the assigned channel frequency and two interfering signals with the conditions specified in Table 7.8-1 and Table 7.8-2 for intermodulation performance and in Table 7.8-3, Table 7.8-4, Table 7.8-5 and Table 7.8-6 for narrowband intermodulation performance. Narrowband intermodulation requirements are not applied for Band 46. The reference measurement channel for the wanted signal is specified in Table 7.2-1, Table 7.2-2, Table 7.2-3 and Table 7.2-4 for each channel bandwidth and further specified in Annex A.

For each measured NB-IoT carrier, the throughput shall be $\geq 95\%$ of the maximum throughput of the reference measurement channel, with a wanted signal at the assigned channel frequency and two interfering signals with the conditions specified in Table 7.8-1a, 7.8-1b, Table 7.8-1c, Table 7.8-2 and Table 7.8-2a for intermodulation performance and in Table 7.8-3a, Table 7.8-3b, Table 7.8-3c, Table 7.8-4a, Table 7.8-4b, Table 7.8-4c, Table 7.8-5a, Table 7.8-5b, Table 7.8-5c, Table 7.8-6a, Table 7.8-6b, Table 7.8-6c for narrowband intermodulation performance. The reference measurement channel for the wanted signal is specified in Table 7.2-5 for each channel sub-carrier spacing option and further specified in Annex A.

The receiver intermodulation requirement is always applicable outside the Base Station RF Bandwidth or Maximum Radio Bandwidth. The interfering signal offset is defined relative to the Base Station RF Bandwidth edges or Maximum Radio Bandwidth edges.

For a BS operating in non-contiguous spectrum within any operating band, the narrowband intermodulation requirement applies in addition inside any sub-block gap in case the sub-block gap is at least as wide as the channel bandwidth of the E-UTRA interfering signal in Table 7.8-3. The interfering signal offset is defined relative to the sub-block edges inside the sub-block gap. The requirement applies separately for both sub-blocks.

For a BS capable of multi-band operation, the intermodulation requirement applies in addition inside any Inter RF Bandwidth gap, in case the gap size is at least twice as wide as the E-UTRA interfering signal centre frequency offset from the Base Station RF Bandwidth edge.

For a BS capable of multi-band operation, the narrowband intermodulation requirement applies in addition inside any Inter RF Bandwidth gap in case the gap size is at least as wide as the E-UTRA interfering signal in Tables 7.8-3, 7.8-4

and 7.8-6. The interfering signal offset is defined relative to the Base Station RF Bandwidth edges inside the Inter RF Bandwidth gap.

Table 7.8-1: Intermodulation performance requirement for E-UTRA

BS type	Wanted signal mean power [dBm]	Interfering signal mean power [dBm]	Type of interfering signal
Wide Area BS	$P_{\text{REFSENS}} + 6\text{dB}^*$	-52	See Table 7.8-2
Medium Range BS	$P_{\text{REFSENS}} + 6\text{dB}^*$	-47	
Local Area BS	$P_{\text{REFSENS}} + 6\text{dB}^*$	-44	
Home BS	$P_{\text{REFSENS}} + 14\text{dB}^*$	-36	
Note*: P_{REFSENS} depends on the channel bandwidth as specified in TS 36.104 [2] subclause 7.2.1. For E-UTRA channel bandwidths 10, 15 and 20 MHz this requirement shall apply only for a FRC A1-3 mapped to the frequency range at the channel edge adjacent to the interfering signals.			

Table 7.8-1a: Intermodulation performance requirement for E-UTRA with NB-IoT in-band operation BS

BS type	Wanted signal mean power [dBm]	Interfering signal mean power [dBm]	Type of interfering signal
Wide Area BS	$P_{\text{REFSENS}} + 6\text{dB}^*$	-52	See Table 7.8-2
Medium Range BS	$P_{\text{REFSENS}} + 6\text{dB}^*$	-47	
Local Area BS	$P_{\text{REFSENS}} + 6\text{dB}^*$	-44	
Home BS	$P_{\text{REFSENS}} + 14\text{dB}^*$	-36	
Note*: P_{REFSENS} depends on the sub-carrier spacing as specified in TS 36.104 [2] subclause 7.2.1.			

Table 7.8-1b: Intermodulation performance requirement for E-UTRA with NB-IoT guard band operation BS

BS type	Wanted signal mean power [dBm]	Interfering signal mean power [dBm]	Type of interfering signal
Wide Area BS	$P_{\text{REFSENS}} + 6\text{dB}^*$	-52	See Table 7.8-2
Medium Range BS	$P_{\text{REFSENS}} + 6\text{dB}^*$	-47	
Local Area BS	$P_{\text{REFSENS}} + 6\text{dB}^*$	-44	
Home BS	$P_{\text{REFSENS}} + 14\text{dB}^*$	-36	
Note*: P_{REFSENS} depends on the sub-carrier spacing as specified in TS 36.104 [2] subclause 7.2.1.			

Table 7.8-1c: Intermodulation performance requirement for NB-IoT standalone

	NB-IoT channel bandwidth of the lowest/highest carrier received [kHz]	Wanted signal mean power [dBm]	Interfering signal mean power [dBm]	Type of interfering signal
Wide Area BS	200	$P_{\text{REFSENS}} + 6\text{ dB}^*$	-52	See Table 7.8-2a
Medium Range BS	200	$P_{\text{REFSENS}} + 6\text{ dB}^*$	-47	
Local Area BS	200	$P_{\text{REFSENS}} + 6\text{ dB}^*$	-44	
Home BS	200	$P_{\text{REFSENS}} + 14\text{ dB}^*$	-36	
Note*: P_{REFSENS} depends on the sub-carrier spacing as specified in TS 36.104 [2] subclause 7.2.1.				

Table 7.8-2: Interfering signal for Intermodulation performance requirement for E-UTRA or E-UTRA with NB-IoT in-band/guard band operation BS

E-UTRA channel bandwidth of the lowest/highest carrier received [MHz]	Interfering signal centre frequency offset from the lower/upper Base Station RF Bandwidth edge [MHz]	Type of interfering signal
3 ^{Note 1}	±4.5	CW
	±10.5	3MHz E-UTRA signal
5	±7.5	CW
	±17.5	5MHz E-UTRA signal
10	±7.375	CW
	±17.5	5MHz E-UTRA signal
15	±7.25	CW
	±17.5	5MHz E-UTRA signal
20	±7.125	CW
	±17.5	5MHz E-UTRA signal ^{Note 2}
20	±7.125	CW
	±24	20 MHz E-UTRA signal ^{Note 3}
Note 1: 3 MHz channel bandwidth is not applicable to guard band operation.		
Note 2: This type of interfering signal is not applied for Band 46.		
Note 3: This type of interfering signal is only applied for Band 46.		

Table 7.8-2a: Interfering signal for Intermodulation performance requirement for NB-IoT standalone operation BS

Channel bandwidth of the lowest/highest carrier received [MHz]	Interfering signal centre frequency offset from the lower/upper Base Station RF Bandwidth edge [MHz]	Type of interfering signal
0.2	±7.575	CW
	±17.5	5 MHz E-UTRA signal

Table 7.8-3: Narrowband intermodulation performance requirement for Wide Area BS for E-UTRA

E-UTRA channel bandwidth of the lowest/highest carrier received [MHz]	Wanted signal mean power [dBm]	Interfering signal mean power [dBm]	Interfering RB centre frequency offset from the lower/upper Base Station RF Bandwidth edge or sub-block edge inside a sub-block gap [kHz]	Type of interfering signal
1.4	$P_{\text{REFSENS}} + 6\text{dB}^*$	-52	± 270	CW
		-52	± 790	1.4 MHz E-UTRA signal, 1 RB**
3	$P_{\text{REFSENS}} + 6\text{dB}^*$	-52	± 270	CW
		-52	± 780	3.0 MHz E-UTRA signal, 1 RB**
5	$P_{\text{REFSENS}} + 6\text{dB}^*$	-52	± 360	CW
		-52	± 1060	5 MHz E-UTRA signal, 1 RB**
10	$P_{\text{REFSENS}} + 6\text{dB}^*$ (***)	-52	± 325	CW
		-52	± 1240	5 MHz E-UTRA signal, 1 RB**
15	$P_{\text{REFSENS}} + 6\text{dB}^*$ (***)	-52	± 380	CW
		-52	± 1600	5MHz E-UTRA signal, 1 RB**
20	$P_{\text{REFSENS}} + 6\text{dB}^*$ (***)	-52	± 345	CW
		-52	± 1780	5MHz E-UTRA signal, 1 RB**
Note*:	P_{REFSENS} is related to the channel bandwidth as specified in TS 36.104 [2] subclause 7.2.1.			
Note**:	Interfering signal consisting of one resource block positioned at the stated offset, the channel bandwidth of the interfering signal is located adjacently to the lower/upper Base Station RF Bandwidth edge.			
Note***:	This requirement shall apply only for a FRC A1-3 mapped to the frequency range at the channel edge adjacent to the interfering signals			

Table 7.8-3a: Narrowband intermodulation performance requirement for Wide Area BS for E-UTRA with NB-IoT in-band operation BS

E-UTRA channel bandwidth of the lowest/highest carrier received [MHz]	Wanted signal mean power [dBm]	Interfering signal mean power [dBm]	Interfering RB centre frequency offset from the lower/upper Base Station RF Bandwidth edge or sub-block edge inside a sub-block gap [kHz]	Type of interfering signal
3	$P_{\text{REFSENS}} + 6\text{dB}^*$	-52	± 270	CW
		-52	± 780	3.0 MHz E-UTRA signal, 1 RB**
5	$P_{\text{REFSENS}} + 6\text{dB}^*$	-52	$\pm 360^{\text{****}}$	CW
		-52	± 1060	5 MHz E-UTRA signal, 1 RB**
10	$P_{\text{REFSENS}} + 6\text{dB}^*$ (***)	-52	$\pm 325^{\text{****}}$	CW
		-52	± 1240	5 MHz E-UTRA signal, 1 RB**
15	$P_{\text{REFSENS}} + 6\text{dB}^*$ (***)	-52	$\pm 380^{\text{****}}$	CW
		-52	± 1600	5MHz E-UTRA signal, 1 RB**
20	$P_{\text{REFSENS}} + 6\text{dB}^*$ (***)	-52	$\pm 345^{\text{****}}$	CW
		-52	± 1780	5MHz E-UTRA signal, 1 RB**
<p>Note*: P_{REFSENS} depends on the sub-carrier spacing as specified in TS 36.104 [2] subclause 7.2.1.</p> <p>Note**: Interfering signal consisting of one resource block positioned at the stated offset, the channel bandwidth of the interfering signal is located adjacently to the lower/upper Base Station RF Bandwidth edge.</p> <p>Note***: This requirement shall apply only for a FRC A1-3 mapped to the frequency range at the channel edge adjacent to the interfering signals.</p> <p>Note****: The frequency offset shall be adjusted to accommodate the IMD product to fall in the NB-IoT RB for NB-IoT in-band operation.</p> <p>Note*****: If a BS RF receiver fails the test of the requirement, the test shall be performed with the CW interfering signal frequency shifted away from the wanted signal by 180 kHz and the E-UTRA interfering signal frequency shifted away from the wanted signal by 360 kHz. If the BS RF receiver still fails the test after the frequency shift, then the BS RF receiver shall be deemed to fail the requirement</p>				

Table 7.8-3b: Narrowband intermodulation performance requirement for Wide Area BS for E-UTRA with NB-IoT guard band operation BS

E-UTRA channel bandwidth of the lowest/highest carrier received [MHz]	Wanted signal mean power [dBm]	Interfering signal mean power [dBm]	Interfering RB centre frequency offset from the lower/upper Base Station RF Bandwidth edge or sub-block edge inside a sub-block gap [kHz]	Type of interfering signal
5	$P_{\text{REFSENS}} + 6\text{dB}^*$	-52	$\pm 360^{****}$	CW
		-52	± 1060	5 MHz E-UTRA signal, 1 RB**
10	$P_{\text{REFSENS}} + 6\text{dB}^*$ (***)	-52	$\pm 325^{****}$	CW
		-52	± 1240	5 MHz E-UTRA signal, 1 RB**
15	$P_{\text{REFSENS}} + 6\text{dB}^*$ (***)	-52	$\pm 380^{****}$	CW
		-52	± 1600	5MHz E-UTRA signal, 1 RB**
20	$P_{\text{REFSENS}} + 6\text{dB}^*$ (***)	-52	$\pm 345^{****}$	CW
		-52	± 1780	5MHz E-UTRA signal, 1 RB**
<p>Note*: P_{REFSENS} depends on the sub-carrier spacing as specified in TS 36.104 [2] subclause 7.2.1.</p> <p>Note**: Interfering signal consisting of one resource block positioned at the stated offset, the channel bandwidth of the interfering signal is located adjacently to the lower/upper Base Station RF Bandwidth edge.</p> <p>Note***: This requirement shall apply only for a FRC A1-3 mapped to the frequency range at the channel edge adjacent to the interfering signals.</p> <p>Note****: The frequency offset shall be adjusted to accommodate the IMD product to fall in the NB-IoT RB for NB-IoT guard band operation.</p> <p>Note*****: If a BS RF receiver fails the test of the requirement, the test shall be performed with the CW interfering signal frequency shifted away from the wanted signal by 180 kHz and the E-UTRA interfering signal frequency shifted away from the wanted signal by 360 kHz. If the BS RF receiver still fails the test after the frequency shift, then the BS RF receiver shall be deemed to fail the requirement.</p>				

Table 7.8-3c: Narrowband intermodulation performance requirement for Wide Area BS for NB-IoT standalone

Channel bandwidth of the lowest/highest carrier received [MHz]	Wanted signal mean power [dBm]	Interfering signal mean power [dBm]	Interfering RB centre frequency offset from the lower/upper Base Station RF Bandwidth edge or sub-block edge inside a sub-block gap [kHz]	Type of interfering signal
0.2	$P_{\text{REFSENS}} + 6\text{dB}^*$	-52	± 340	CW
		-52	± 880	5MHz E-UTRA signal, 1 RB**
<p>Note*: P_{REFSENS} depends on the sub-carrier spacing as specified in TS 36.104 [2] subclause 7.2.1.</p> <p>Note**: Interfering signal consisting of one resource block positioned at the stated offset, the channel bandwidth of the interfering signal is located adjacently to the lower/upper Base Station RF Bandwidth edge.</p> <p>Note***: If a BS RF receiver fails the test of the requirement, the test shall be performed with the CW interfering signal frequency shifted away from the wanted signal by 180 kHz and the E-UTRA interfering signal frequency shifted away from the wanted signal by 360 kHz. If the BS RF receiver still fails the test after the frequency shift, then the BS RF receiver shall be deemed to fail the requirement.</p>				

Table 7.8-4: Narrowband intermodulation performance requirement for Local Area BS for E-UTRA

E-UTRA channel bandwidth of the lowest/highest carrier received [MHz]	Wanted signal mean power [dBm]	Interfering signal mean power [dBm]	Interfering RB centre frequency offset from the lower/upper Base Station RF Bandwidth edge or sub-block edge inside a sub-block [kHz]	Type of interfering signal
1.4	$P_{\text{REFSENS}} + 6\text{dB}^*$	-44	± 270	CW
		-44	± 790	1.4 MHz E-UTRA signal, 1 RB**
3	$P_{\text{REFSENS}} + 6\text{dB}^*$	-44	± 275	CW
		-44	± 790	3.0 MHz E-UTRA signal, 1 RB**
5	$P_{\text{REFSENS}} + 6\text{dB}^*$	-44	± 360	CW
		-44	± 1060	5 MHz E-UTRA signal, 1 RB**
10	$P_{\text{REFSENS}} + 6\text{dB}^*$ (***)	-44	± 415	CW
		-44	± 1420	5 MHz E-UTRA signal, 1 RB**
15	$P_{\text{REFSENS}} + 6\text{dB}^*$ (***)	-44	± 380	CW
		-44	± 1600	5MHz E-UTRA signal, 1 RB**
20	$P_{\text{REFSENS}} + 6\text{dB}^*$ (***)	-44	± 345	CW
		-44	± 1780	5MHz E-UTRA signal, 1 RB**
Note*:	P_{REFSENS} is related to the channel bandwidth as specified in TS 36.104 [2] subclause 7.2.1.			
Note**:	Interfering signal consisting of one resource block positioned at the stated offset, the channel bandwidth of the interfering signal is located adjacently to the lower/upper Base Station RF Bandwidth edge.			
Note***:	This requirement shall apply only for a FRC A1-3 mapped to the frequency range at the channel edge adjacent to the interfering signals			

Table 7.8-4a: Narrowband intermodulation performance requirement for Local Area BS for E-UTRA with NB-IoT in-band operation BS

E-UTRA channel bandwidth of the lowest/highest carrier received [MHz]	Wanted signal mean power [dBm]	Interfering signal mean power [dBm]	Interfering RB centre frequency offset from the lower/upper Base Station RF Bandwidth edge or sub-block edge inside a sub-block gap [kHz]	Type of interfering signal
3	$P_{\text{REFSENS}} + 6\text{dB}^*$	-44	± 270	CW
		-44	± 780	3.0 MHz E-UTRA signal, 1 RB**
5	$P_{\text{REFSENS}} + 6\text{dB}^*$	-44	$\pm 360^{\text{****}}$	CW
		-44	± 1060	5 MHz E-UTRA signal, 1 RB**
10	$P_{\text{REFSENS}} + 6\text{dB}^*$ (***)	-44	$\pm 325^{\text{****}}$	CW
		-44	± 1240	5 MHz E-UTRA signal, 1 RB**
15	$P_{\text{REFSENS}} + 6\text{dB}^*$ (***)	-44	$\pm 380^{\text{****}}$	CW
		-44	± 1600	5MHz E-UTRA signal, 1 RB**
20	$P_{\text{REFSENS}} + 6\text{dB}^*$ (***)	-44	$\pm 345^{\text{****}}$	CW
		-44	± 1780	5MHz E-UTRA signal, 1 RB**
<p>Note*: P_{REFSENS} depends on the sub-carrier spacing as specified in TS 36.104 [2] subclause 7.2.1.</p> <p>Note**: Interfering signal consisting of one resource block positioned at the stated offset, the channel bandwidth of the interfering signal is located adjacently to the lower/upper Base Station RF Bandwidth edge.</p> <p>Note***: This requirement shall apply only for a FRC A1-3 mapped to the frequency range at the channel edge adjacent to the interfering signals.</p> <p>Note****: The frequency offset shall be adjusted to accommodate the IMD product to fall in the NB-IoT RB for NB-IoT in-band operation.</p> <p>Note*****: If a BS RF receiver fails the test of the requirement, the test shall be performed with the CW interfering signal frequency shifted away from the wanted signal by 180 kHz and the E-UTRA interfering signal frequency shifted away from the wanted signal by 360 kHz. If the BS RF receiver still fails the test after the frequency shift, then the BS RF receiver shall be deemed to fail the requirement</p>				

Table 7.8-4b: Narrowband intermodulation performance requirement for Local Area BS for E-UTRA with NB-IoT guard band operation BS

E-UTRA channel bandwidth of the lowest/highest carrier received [MHz]	Wanted signal mean power [dBm]	Interfering signal mean power [dBm]	Interfering RB centre frequency offset from the lower/upper Base Station RF Bandwidth edge or sub-block edge inside a sub-block gap [kHz]	Type of interfering signal
5	$P_{\text{REFSENS}} + 6\text{dB}^*$	-44	$\pm 360^{****}$	CW
		-44	± 1060	5 MHz E-UTRA signal, 1 RB**
10	$P_{\text{REFSENS}} + 6\text{dB}^*$ (***)	-44	$\pm 325^{****}$	CW
		-44	± 1240	5 MHz E-UTRA signal, 1 RB**
15	$P_{\text{REFSENS}} + 6\text{dB}^*$ (***)	-44	$\pm 380^{****}$	CW
		-44	± 1600	5MHz E-UTRA signal, 1 RB**
20	$P_{\text{REFSENS}} + 6\text{dB}^*$ (***)	-44	$\pm 345^{****}$	CW
		-44	± 1780	5MHz E-UTRA signal, 1 RB**
<p>Note*: P_{REFSENS} depends on the sub-carrier spacing as specified in TS 36.104 [2] subclause 7.2.1.</p> <p>Note**: Interfering signal consisting of one resource block positioned at the stated offset, the channel bandwidth of the interfering signal is located adjacently to the lower/upper Base Station RF Bandwidth edge.</p> <p>Note***: This requirement shall apply only for a FRC A1-3 mapped to the frequency range at the channel edge adjacent to the interfering signals.</p> <p>Note****: The frequency offset shall be adjusted to accommodate the IMD product to fall in the NB-IoT RB for NB-IoT guard band operation.</p> <p>Note*****: If a BS RF receiver fails the test of the requirement, the test shall be performed with the CW interfering signal frequency shifted away from the wanted signal by 180 kHz and the E-UTRA interfering signal frequency shifted away from the wanted signal by 360 kHz. If the BS RF receiver still fails the test after the frequency shift, then the BS RF receiver shall be deemed to fail the requirement.</p>				

Table 7.8-4c: Narrowband intermodulation performance requirement for Local Area BS for NB-IoT standalone

Channel bandwidth of the lowest/highest carrier received [MHz]	Wanted signal mean power [dBm]	Interfering signal mean power [dBm]	Interfering RB centre frequency offset from the lower/upper Base Station RF Bandwidth edge or sub-block edge inside a sub-block gap [kHz]	Type of interfering signal
0.2	$P_{\text{REFSENS}} + 6\text{dB}^*$	-44	± 340	CW
		-44	± 880	5MHz E-UTRA signal, 1 RB**
<p>Note*: P_{REFSENS} depends on the sub-carrier spacing as specified in TS 36.104 [2] subclause 7.2.1.</p> <p>Note**: Interfering signal consisting of one resource block positioned at the stated offset, the channel bandwidth of the interfering signal is located adjacently to the lower/upper Base Station RF Bandwidth edge.</p> <p>Note***: If a BS RF receiver fails the test of the requirement, the test shall be performed with the CW interfering signal frequency shifted away from the wanted signal by 180 kHz and the E-UTRA interfering signal frequency shifted away from the wanted signal by 360 kHz. If the BS RF receiver still fails the test after the frequency shift, then the BS RF receiver shall be deemed to fail the requirement.</p>				

Table 7.8-5: Narrowband intermodulation performance requirement for Home BS for E-UTRA

E-UTRA channel bandwidth [MHz]	Wanted signal mean power [dBm]	Interfering signal mean power [dBm]	Interfering RB centre frequency offset from the channel edge of the wanted signal [kHz]	Type of interfering signal
1.4	$P_{\text{REFSENS}} + 14\text{dB}^*$	-36	270	CW
		-36	790	1.4 MHz E-UTRA signal, 1 RB**
3	$P_{\text{REFSENS}} + 14\text{dB}^*$	-36	270	CW
		-36	780	3.0 MHz E-UTRA signal, 1 RB**
5	$P_{\text{REFSENS}} + 14\text{dB}^*$	-36	360	CW
		-36	1060	5 MHz E-UTRA signal, 1 RB**
10	$P_{\text{REFSENS}} + 14\text{dB}^*$ (***)	-36	325	CW
		-36	1240	5 MHz E-UTRA signal, 1 RB**
15	$P_{\text{REFSENS}} + 14\text{dB}^*$ (***)	-36	380	CW
		-36	1600	5MHz E-UTRA signal, 1 RB**
20	$P_{\text{REFSENS}} + 14\text{dB}^*$ (***)	-36	345	CW
		-36	1780	5MHz E-UTRA signal, 1 RB**
<p>Note*: P_{REFSENS} is related to the channel bandwidth as specified in TS 36.104 [2] subclause 7.2.1.</p> <p>Note**: Interfering signal consisting of one resource block positioned at the stated offset, the channel bandwidth of the interfering signal is located adjacently to the channel edge of the wanted signal.</p> <p>Note***: This requirement shall apply only for a FRC A1-3 mapped to the frequency range at the channel edge adjacent to the interfering signals</p>				

Table 7.8-5a: Narrowband intermodulation performance requirement for Home BS for E-UTRA with NB-IoT in-band operation BS

E-UTRA channel bandwidth of the lowest/highest carrier received [MHz]	Wanted signal mean power [dBm]	Interfering signal mean power [dBm]	Interfering RB centre frequency offset from the lower/upper Base Station RF Bandwidth edge or sub-block edge inside a sub-block gap [kHz]	Type of interfering signal
3	$P_{\text{REFSENS}} + 14\text{dB}^*$	-36	± 270	CW
		-36	± 780	3.0 MHz E-UTRA signal, 1 RB**
5	$P_{\text{REFSENS}} + 14\text{dB}^*$	-36	$\pm 360^{\text{****}}$	CW
		-36	± 1060	5 MHz E-UTRA signal, 1 RB**
10	$P_{\text{REFSENS}} + 14\text{dB}^*$ (***)	-36	$\pm 325^{\text{****}}$	CW
		-36	± 1240	5 MHz E-UTRA signal, 1 RB**
15	$P_{\text{REFSENS}} + 14\text{dB}^*$ (***)	-36	$\pm 380^{\text{****}}$	CW
		-36	± 1600	5MHz E-UTRA signal, 1 RB**
20	$P_{\text{REFSENS}} + 14\text{dB}^*$ (***)	-36	$\pm 345^{\text{****}}$	CW
		-36	± 1780	5MHz E-UTRA signal, 1 RB**
<p>Note*: P_{REFSENS} depends on the sub-carrier spacing as specified in TS 36.104 [2] subclause 7.2.1.</p> <p>Note**: Interfering signal consisting of one resource block positioned at the stated offset, the channel bandwidth of the interfering signal is located adjacently to the lower/upper Base Station RF Bandwidth edge.</p> <p>Note***: This requirement shall apply only for a FRC A1-3 mapped to the frequency range at the channel edge adjacent to the interfering signals.</p> <p>Note****: The frequency offset shall be adjusted to accommodate the IMD product to fall in the NB-IoT RB for NB-IoT in-band operation.</p> <p>Note*****: If a BS RF receiver fails the test of the requirement, the test shall be performed with the CW interfering signal frequency shifted away from the wanted signal by 180 kHz and the E-UTRA interfering signal frequency shifted away from the wanted signal by 360 kHz. If the BS RF receiver still fails the test after the frequency shift, then the BS RF receiver shall be deemed to fail the requirement</p>				

Table 7.8-5b: Narrowband intermodulation performance requirement for Home BS for E-UTRA with NB-IoT guard band operation BS

E-UTRA channel bandwidth of the lowest/highest carrier received [MHz]	Wanted signal mean power [dBm]	Interfering signal mean power [dBm]	Interfering RB centre frequency offset from the lower/upper Base Station RF Bandwidth edge or sub-block edge inside a sub-block gap [kHz]	Type of interfering signal
5	$P_{\text{REFSENS}} + 14\text{dB}^*$	-36	$\pm 360^{****}$	CW
		-36	± 1060	5 MHz E-UTRA signal, 1 RB**
10	$P_{\text{REFSENS}} + 14\text{dB}^*$ (***)	-36	$\pm 325^{****}$	CW
		-36	± 1240	5 MHz E-UTRA signal, 1 RB**
15	$P_{\text{REFSENS}} + 14\text{dB}^*$ (***)	-36	$\pm 380^{****}$	CW
		-36	± 1600	5MHz E-UTRA signal, 1 RB**
20	$P_{\text{REFSENS}} + 14\text{dB}^*$ (***)	-36	$\pm 345^{****}$	CW
		-36	± 1780	5MHz E-UTRA signal, 1 RB**
<p>Note*: P_{REFSENS} depends on the sub-carrier spacing as specified in TS 36.104 [2] subclause 7.2.1.</p> <p>Note**: Interfering signal consisting of one resource block positioned at the stated offset, the channel bandwidth of the interfering signal is located adjacently to the lower/upper Base Station RF Bandwidth edge.</p> <p>Note***: This requirement shall apply only for a FRC A1-3 mapped to the frequency range at the channel edge adjacent to the interfering signals.</p> <p>Note****: The frequency offset shall be adjusted to accommodate the IMD product to fall in the NB-IoT RB for NB-IoT guard band operation.</p> <p>Note*****: If a BS RF receiver fails the test of the requirement, the test shall be performed with the CW interfering signal frequency shifted away from the wanted signal by 180 kHz and the E-UTRA interfering signal frequency shifted away from the wanted signal by 360 kHz. If the BS RF receiver still fails the test after the frequency shift, then the BS RF receiver shall be deemed to fail the requirement.</p>				

Table 7.8-5c: Narrowband intermodulation performance requirement for Home BS for NB-IoT standalone

Channel bandwidth of the lowest/highest carrier received [MHz]	Wanted signal mean power [dBm]	Interfering signal mean power [dBm]	Interfering RB centre frequency offset from the lower/upper Base Station RF Bandwidth edge or sub-block edge inside a sub-block gap [kHz]	Type of interfering signal
0.2	$P_{\text{REFSENS}} + 14\text{dB}^*$	-36	± 340	CW
		-36	± 880	5MHz E-UTRA signal, 1 RB**
<p>Note*: P_{REFSENS} depends on the sub-carrier spacing as specified in TS 36.104 [2] subclause 7.2.1.</p> <p>Note**: Interfering signal consisting of one resource block positioned at the stated offset, the channel bandwidth of the interfering signal is located adjacently to the lower/upper Base Station RF Bandwidth edge.</p> <p>Note***: If a BS RF receiver fails the test of the requirement, the test shall be performed with the CW interfering signal frequency shifted away from the wanted signal by 180 kHz and the E-UTRA interfering signal frequency shifted away from the wanted signal by 360 kHz. If the BS RF receiver still fails the test after the frequency shift, then the BS RF receiver shall be deemed to fail the requirement.</p>				

Table 7.8-6: Narrowband intermodulation performance requirement for Medium Range BS for E-UTRA

E-UTRA channel bandwidth of the lowest/highest carrier received [MHz]	Wanted signal mean power [dBm]	Interfering signal mean power [dBm]	Interfering RB centre frequency offset to the lower (higher) edge or sub-block edge inside a sub-block gap [kHz]	Type of interfering signal
1.4	$P_{\text{REFSENS}} + 6\text{dB}^*$	-47	± 270	CW
		-47	± 790	1.4 MHz E-UTRA signal, 1 RB**
3	$P_{\text{REFSENS}} + 6\text{dB}^*$	-47	± 270	CW
		-47	± 780	3.0 MHz E-UTRA signal, 1 RB**
5	$P_{\text{REFSENS}} + 6\text{dB}^*$	-47	± 360	CW
		-47	± 1060	5 MHz E-UTRA signal, 1 RB**
10	$P_{\text{REFSENS}} + 6\text{dB}^*$ (***)	-47	± 325	CW
		-47	± 1240	5 MHz E-UTRA signal, 1 RB**
15	$P_{\text{REFSENS}} + 6\text{dB}^*$ (***)	-47	± 380	CW
		-47	± 1600	5MHz E-UTRA signal, 1 RB**
20	$P_{\text{REFSENS}} + 6\text{dB}^*$ (***)	-47	± 345	CW
		-47	± 1780	5MHz E-UTRA signal, 1 RB**
<p>Note*: P_{REFSENS} is related to the channel bandwidth as specified in TS 36.104 [2] subclause 7.2.1.</p> <p>Note**: Interfering signal consisting of one resource block positioned at the stated offset, the channel bandwidth of the interfering signal is located adjacently to the lower (higher) edge.</p> <p>Note***: This requirement shall apply only for a FRC A1-3 mapped to the frequency range at the channel edge adjacent to the interfering signals</p>				

Table 7.8-6a: Narrowband intermodulation performance requirement for Medium Range BS for E-UTRA with NB-IoT in-band operation BS

E-UTRA channel bandwidth of the lowest/highest carrier received [MHz]	Wanted signal mean power [dBm]	Interfering signal mean power [dBm]	Interfering RB centre frequency offset from the lower/upper Base Station RF Bandwidth edge or sub-block edge inside a sub-block gap [kHz]	Type of interfering signal
3	$P_{\text{REFSENS}} + 6\text{dB}^*$	-47	± 270	CW
		-47	± 780	3.0 MHz E-UTRA signal, 1 RB**
5	$P_{\text{REFSENS}} + 6\text{dB}^*$	-47	$\pm 360^{\text{****}}$	CW
		-47	± 1060	5 MHz E-UTRA signal, 1 RB**
10	$P_{\text{REFSENS}} + 6\text{dB}^*$ (***)	-47	$\pm 325^{\text{****}}$	CW
		-47	± 1240	5 MHz E-UTRA signal, 1 RB**
15	$P_{\text{REFSENS}} + 6\text{dB}^*$ (***)	-47	$\pm 380^{\text{****}}$	CW
		-47	± 1600	5MHz E-UTRA signal, 1 RB**
20	$P_{\text{REFSENS}} + 6\text{dB}^*$ (***)	-47	$\pm 345^{\text{****}}$	CW
		-47	± 1780	5MHz E-UTRA signal, 1 RB**
<p>Note*: P_{REFSENS} depends on the sub-carrier spacing as specified in TS 36.104 [2] subclause 7.2.1.</p> <p>Note**: Interfering signal consisting of one resource block positioned at the stated offset, the channel bandwidth of the interfering signal is located adjacently to the lower/upper Base Station RF Bandwidth edge.</p> <p>Note***: This requirement shall apply only for a FRC A1-3 mapped to the frequency range at the channel edge adjacent to the interfering signals.</p> <p>Note****: The frequency offset shall be adjusted to accommodate the IMD product to fall in the NB-IoT RB for NB-IoT in-band operation.</p> <p>Note*****: If a BS RF receiver fails the test of the requirement, the test shall be performed with the CW interfering signal frequency shifted away from the wanted signal by 180 kHz and the E-UTRA interfering signal frequency shifted away from the wanted signal by 360 kHz. If the BS RF receiver still fails the test after the frequency shift, then the BS RF receiver shall be deemed to fail the requirement</p>				

Table 7.8-6b: Narrowband intermodulation performance requirement for Medium Range BS for E-UTRA with NB-IoT guard band operation BS

E-UTRA channel bandwidth of the lowest/highest carrier received [MHz]	Wanted signal mean power [dBm]	Interfering signal mean power [dBm]	Interfering RB centre frequency offset from the lower/upper Base Station RF Bandwidth edge or sub-block edge inside a sub-block gap [kHz]	Type of interfering signal
5	$P_{\text{REFSENS}} + 6\text{dB}^*$	-47	$\pm 360^{****}$	CW
		-47	± 1060	5 MHz E-UTRA signal, 1 RB**
10	$P_{\text{REFSENS}} + 6\text{dB}^*$ (***)	-47	$\pm 325^{****}$	CW
		-47	± 1240	5 MHz E-UTRA signal, 1 RB**
15	$P_{\text{REFSENS}} + 6\text{dB}^*$ (***)	-47	$\pm 380^{****}$	CW
		-47	± 1600	5MHz E-UTRA signal, 1 RB**
20	$P_{\text{REFSENS}} + 6\text{dB}^*$ (***)	-47	$\pm 345^{****}$	CW
		-47	± 1780	5MHz E-UTRA signal, 1 RB**
<p>Note*: P_{REFSENS} depends on the sub-carrier spacing as specified in TS 36.104 [2] subclause 7.2.1.</p> <p>Note**: Interfering signal consisting of one resource block positioned at the stated offset, the channel bandwidth of the interfering signal is located adjacently to the lower/upper Base Station RF Bandwidth edge.</p> <p>Note***: This requirement shall apply only for a FRC A1-3 mapped to the frequency range at the channel edge adjacent to the interfering signals.</p> <p>Note****: The frequency offset shall be adjusted to accommodate the IMD product to fall in the NB-IoT RB for NB-IoT guard band operation.</p> <p>Note*****: If a BS RF receiver fails the test of the requirement, the test shall be performed with the CW interfering signal frequency shifted away from the wanted signal by 180 kHz and the E-UTRA interfering signal frequency shifted away from the wanted signal by 360 kHz. If the BS RF receiver still fails the test after the frequency shift, then the BS RF receiver shall be deemed to fail the requirement.</p>				

Table 7.8-6c: Narrowband intermodulation performance requirement for Medium Range BS for NB-IoT standalone

Channel bandwidth of the lowest/highest carrier received [MHz]	Wanted signal mean power [dBm]	Interfering signal mean power [dBm]	Interfering RB centre frequency offset from the lower/upper Base Station RF Bandwidth edge or sub-block edge inside a sub-block gap [kHz]	Type of interfering signal
0.2	$P_{\text{REFSENS}} + 6\text{dB}^*$	-47	± 340	CW
		-47	± 880	5MHz E-UTRA signal, 1 RB**
<p>Note*: P_{REFSENS} depends on the sub-carrier spacing as specified in TS 36.104 [2] subclause 7.2.1.</p> <p>Note**: Interfering signal consisting of one resource block positioned at the stated offset, the channel bandwidth of the interfering signal is located adjacently to the lower/upper Base Station RF Bandwidth edge.</p> <p>Note***: If a BS RF receiver fails the test of the requirement, the test shall be performed with the CW interfering signal frequency shifted away from the wanted signal by 180 kHz and the E-UTRA interfering signal frequency shifted away from the wanted signal by 360 kHz. If the BS RF receiver still fails the test after the frequency shift, then the BS RF receiver shall be deemed to fail the requirement.</p>				

NOTE: If the above Test Requirement differs from the Minimum Requirement then the Test Tolerance applied for this test is non-zero. The relationship between Minimum Requirements and Test Requirements is defined in subclause 4.1 and the explanation of how the Minimum Requirement has been relaxed by the Test Tolerance is given in Annex G.

8 Performance requirement

8.1 General

Performance requirements are specified for a number of test environments and multipath channel classes.

Unless stated otherwise, performance requirements apply for a single carrier only. Performance requirements for a BS supporting carrier aggregation are defined in terms of single carrier requirements. The requirements only apply to those measurement channels that are supported by the base station.

The performance requirements for High Speed Train conditions defined in Annex B.3 are optional.

The performance requirements for UL timing adjustment scenario 2 defined in Annex B.4 are optional.

For BS with receiver antenna diversity the required SNR shall be applied separately at each antenna port.

In tests performed with signal generators a synchronization signal may be provided, from the base station to the signal generator, to enable correct timing of the wanted signal.

For tests in clause 8 the transmitter may be off.

8.2 Performance requirements for PUSCH

8.2.1 Performance requirements of PUSCH in multipath fading propagation conditions transmission on single antenna port

8.2.1.1 Definition and applicability

The performance requirement of PUSCH is determined by a minimum required throughput for a given SNR. The required throughput is expressed as a fraction of maximum throughput for the FRCs listed in Annex A. The performance requirements assume HARQ re-transmissions.

A test for a specific channel bandwidth is only applicable if the BS supports it.

For a BS supporting FDD multiple channel bandwidths but not supporting FDD UL carrier aggregation, only the tests for the lowest and the highest FDD channel bandwidths supported by the BS are applicable. For a BS supporting TDD multiple channel bandwidths but not supporting TDD UL carrier aggregation, only the tests for the lowest and the highest TDD channel bandwidths supported by the BS are applicable. For a BS supporting FDD UL carrier aggregation, only the FDD CC combination with largest aggregated bandwidth is used for the test. If there is more than one combination the FDD CC combination with the largest number of component carriers is used for the test. For this CC combination the tests using full PRB allocation FRC are conducted on per CC basis and measured by the required SNR levels corresponding to the bandwidths used on the different CCs.

For a BS supporting TDD UL carrier aggregation, only the TDD CC combination with largest aggregated bandwidth is used for the test. If there is more than one combination the TDD CC combination with the largest number of component carriers is used for the test. For this CC combination the tests using full PRB allocation FRC are conducted on per CC basis and measured by the required SNR levels corresponding to the bandwidths used on the different CCs.

For a BS supporting carrier aggregation the tests with single PRB FRC are conducted on any single component carrier only.

The requirements defined based on FRC in Annex A.17 apply to the BS supporting PUSCH with 256QAM.

The requirements defined based on FRC in Annex A.18 apply to the BS supporting PUSCH transmission in UpPTS. The requirements defined based on FRC in Annex A.19 apply to the BS supporting both PUSCH transmission in UpPTS and PUSCH with 256QAM.

8.2.1.2 Minimum Requirement

The minimum requirement is in TS 36.104 [2] subclause 8.2.1.1.

8.2.1.3 Test Purpose

The test shall verify the receiver's ability to achieve throughput under multipath fading propagation conditions for a given SNR.

8.2.1.4 Method of test

8.2.1.4.1 Initial Conditions

Test environment: Normal, see subclause D.2.

RF channels to be tested: M; see subclause 4.7.

- 1) Connect the BS tester generating the wanted signal, multipath fading simulators and AWGN generators to all BS antenna connectors for diversity reception via a combining network as shown in Annex I.3.2.

8.2.1.4.2 Procedure

- 1) Adjust the AWGN generator, according to the channel bandwidth, defined in Table 8.2.1.4.2-1.

Table 8.2.1.4.2-1: AWGN power level at the BS input

Channel bandwidth [MHz]	AWGN power level
1.4	-92.7dBm / 1.08MHz
3	-88.7dBm / 2.7MHz
5	-86.5dBm / 4.5MHz
10	-83.5dBm / 9MHz
15	-81.7dBm / 13.5MHz
20	-80.4dBm / 18MHz

- 2) The characteristics of the wanted signal shall be configured according to the corresponding UL reference measurement channel defined in annex A and the test parameters in Table 8.2.1.4.2-2. For reference channels using 1 resource block the resource block in the middle of the channel bandwidth shall be used. In case the number of resource blocks in the channel bandwidth are even the one in the middle with lower number is to be used for testing. For PUSCH transmission in UpPTS, the special subframe configuration is 10 as specified in 36.211 [12] Table 4.2-1, and during the test only special subframe is scheduled.

Table 8.2.1.4.2-2: Test parameters for testing PUSCH

Parameter	Value
Maximum number of HARQ transmissions	4
RV sequence	0, 2, 3, 1, 0, 2, 3, 1
Uplink-downlink allocation for TDD	Configuration 1 (2:2)

- 3) The multipath fading emulators shall be configured according to the corresponding channel model defined in annex B.
- 4) Adjust the equipment so that required SNR specified in Table 8.2.1.5-1 to 8.2.1.5-6 is achieved at the BS input.
- 5) For each of the reference channels in Table 8.2.1.5-1 to 8.2.1.5-6 applicable for the base station, measure the throughput, according to annex E.

8.2.1.5 Test Requirement

The throughput measured according to subclause 8.2.1.4.2 shall not be below the limits for the SNR levels specified in Table 8.2.1.5-1 to 8.2.1.5-6.

Table 8.2.1.5-1: Test requirements for PUSCH, 1.4 MHz Channel Bandwidth

Number of TX antennas	Number of RX antennas	Cyclic prefix	Propagation conditions and correlation matrix (Annex B)	FRC (Annex A)	Fraction of maximum throughput	SNR [dB]
1	2	Normal	EPA 5Hz Low	A3-2	30%	-3.5
					70%	0.7
				A4-3	70%	11.2
					A5-2	70%
				A17-1	70%	22.0
				A18-1	70%	8.0
			A19-1	70%	18.7	
			EVA 5Hz Low	A3-1	30%	-2.1
					70%	2.4
				A4-1	30%	5.0
					70%	11.9
				A5-1	70%	19.2
				EVA 70Hz Low	A3-2	30%
			70%			1.3
			A4-3	30%	4.6	
				70%	12.5	
			ETU 70Hz* Low	A3-1	30%	-1.8
					70%	3.0
	ETU 300Hz* Low	A3-1	30%	-1.6		
			70%	3.5		
	Extended	ETU 70Hz* Low	A4-2	30%	5.4	
			70%	14.1		
	4	Normal	EPA 5Hz Low	A3-2	30%	-6.0
					70%	-2.5
				A4-3	70%	7.7
					A5-2	70%
				A17-1	70%	18.8
				A18-1	70%	4.7
			A19-1	70%	15.3	
			EVA 5Hz Low	A3-1	30%	-4.4
					70%	-0.7
				A4-1	30%	1.9
					70%	8.4
				A5-1	70%	16.0
				EVA 70Hz Low	A3-2	30%
			70%			-2.1
			A4-3	30%	1.4	
				70%	8.9	
			ETU 70Hz* Low	A3-1	30%	-4.2
					70%	-0.4
			ETU 300Hz* Low	A3-1	30%	-4.0
					70%	0.0
ETU 600Hz** Low			A13-1	30%	-0.3	
				70%	6.7	
Extended			ETU 70Hz* Low	A4-2	30%	2.2
				70%	10.5	
8	Normal	EPA 5Hz Low	A3-2	30%	-8.8	
				70%	-5.8	
			A4-3	70%	4.6	
				A5-2	70%	11.5
			A17-1	70%	15.7	
			A18-1	70%	1.7	
		A19-1	70%	12.2		
		EVA 5Hz Low	A3-1	30%	-6.6	
				70%	-3.2	
			A4-1	30%	-1.1	
				70%	5.2	
			A5-1	70%	12.3	
			EVA 70Hz Low	A3-2	30%	-8.4
		70%			-5.2	

				A4-3	30%	-1.9
					70%	5.4
			ETU 70Hz* Low	A3-1	30%	-6.2
					70%	-3.0
			ETU 300Hz* Low	A3-1	30%	-6.1
					70%	-2.7
		Extended	ETU 70Hz* Low	A4-2	30%	-0.5
					70%	7.0
Note*: Not applicable for Local Area BS and Home BS.						
Note**: Not applicable for Local Area BS and Home BS, and only applicable for BS supporting ETU600.						

Table 8.2.1.5-2: Test requirements for PUSCH, 3 MHz Channel Bandwidth

Number of TX antennas	Number of RX antennas	Cyclic prefix	Propagation conditions and correlation matrix (Annex B)	FRC (Annex A)	Fraction of maximum throughput	SNR [dB]
1	2	Normal	EPA 5Hz Low	A3-3	30%	-3.5
					70%	0.7
				A4-4	70%	11.5
					A5-3	70%
				A17-2	70%	22.6
				A18-2	70%	8.0
			A19-2	70%	18.5	
			EVA 5Hz Low	A3-1	30%	-2.2
					70%	2.4
				A4-1	30%	4.9
			70%		12.1	
			A5-1	70%	19.4	
			EVA 70Hz Low	A3-3	30%	-3.4
					70%	1.2
				A4-4	30%	5.3
			70%		13.1	
			ETU 70Hz* Low	A3-1	30%	-1.9
			ETU 300Hz* Low	A3-1	70%	3.0
					30%	-1.6
			70%	A3-1	70%	3.5
					30%	5.3
	Extended	ETU 70Hz* Low	70%	14.1		
			30%	5.3		
	4	Normal	EPA 5Hz Low	A3-3	30%	-6.2
					70%	-2.8
				A4-4	70%	8.3
					A5-3	70%
				A17-2	70%	19.3
				A18-2	70%	4.6
			A19-2	70%	14.6	
			EVA 5Hz Low	A3-1	30%	-4.4
					70%	-0.7
				A4-1	30%	1.8
			70%		8.4	
			A5-1	70%	16.0	
			EVA 70Hz Low	A3-3	30%	-5.9
					70%	-2.3
				A4-4	30%	2.2
			70%		9.3	
			ETU 70Hz* Low	A3-1	30%	-4.2
			ETU 300Hz* Low	A3-1	70%	-0.3
					30%	-4.0
70%			A3-1	70%	0.0	
				30%	-0.5	
ETU 600Hz** Low	A13-2	70%	6.4			
		30%	2.1			
Extended	ETU 70Hz* Low	70%	10.5			
		30%	2.1			
8	Normal	EPA 5Hz Low	A3-3	30%	-9.0	
				70%	-6.0	
			A4-4	70%	4.7	
				A5-3	70%	11.7
			A17-2	70%	16.2	
			A18-2	70%	1.9	
		A19-2	70%	11.6		
		EVA 5Hz Low	A3-1	30%	-6.5	
				70%	-3.4	
			A4-1	30%	-1.0	
		70%		5.0		
		A5-1	70%	12.3		
		EVA 70Hz Low	A3-3	30%	-8.7	
				70%	-5.3	
			30%	-5.3		

				A4-4	30%	-2.2
					70%	5.4
			ETU 70Hz* Low	A3-1	30%	-6.4
					70%	-3.1
			ETU 300Hz* Low	A3-1	30%	-6.2
					70%	-2.7
		Extended	ETU 70Hz* Low	A4-2	30%	-0.6
					70%	7.1
Note*: Not applicable for Local Area BS and Home BS.						
Note**: Not applicable for Local Area BS and Home BS, and only applicable for BS supporting ETU600.						

Table 8.2.1.5-3: Test requirements for PUSCH, 5 MHz Channel Bandwidth

Number of TX antennas	Number of RX antennas	Cyclic prefix	Propagation conditions and correlation matrix (Annex B)	FRC (Annex A)	Fraction of maximum throughput	SNR [dB]		
1	2	Normal	EPA 5Hz Low	A3-4	30%	-4.1		
					70%	-0.1		
				A4-5	70%	11.0		
					A5-4	70%	18.6	
				A17-3	70%	22.5		
				A18-3	70%	8.9		
			A19-3	70%	20.0			
			EVA 5Hz Low	A3-1	30%	-2.1		
					70%	2.4		
				A4-1	30%	4.9		
					70%	12.1		
				A5-1	70%	19.2		
				EVA 70Hz Low	A3-4	30%	-3.9	
			70%			0.5		
			A4-5	30%	4.9			
				70%	12.9			
			ETU 70Hz* Low	A3-1	30%	-1.9		
					70%	3.0		
			ETU 300Hz* Low	A3-1	30%	-1.6		
					70%	3.5		
			Extended	ETU 70Hz* Low	A4-2	30%	5.4	
					70%	14.1		
			4	Normal	EPA 5Hz Low	A3-4	30%	-6.5
							70%	-3.2
	A4-5	70%				8.2		
		A5-4				70%	15.0	
	A17-3	70%				19.1		
	A18-3	70%				5.7		
	A19-3	70%			16.4			
	EVA 5Hz Low	A3-1			30%	-4.5		
					70%	-0.8		
		A4-1			30%	1.8		
					70%	8.5		
		A5-1			70%	16.1		
		EVA 70Hz Low			A3-4	30%	-6.3	
	70%					-2.7		
	A4-5	30%			1.8			
		70%			8.9			
	ETU 70Hz* Low	A3-1			30%	-4.2		
					70%	-0.3		
	ETU 300Hz* Low	A3-1			30%	-4.0		
					70%	0.0		
	ETU 600Hz** Low	A13-3			30%	-0.3		
					70%	6.7		
	Extended	ETU 70Hz* Low			A4-2	30%	2.2	
					70%	10.5		
	8	Normal	EPA 5Hz Low	A3-4	30%	-9.5		
					70%	-6.6		
A4-5				70%	4.6			
				A5-4	70%	11.9		
A17-3				70%	15.9			
A18-3				70%	2.6			
A19-3			70%	13.1				
EVA 5Hz Low			A3-1	30%	-6.5			
				70%	-3.3			
			A4-1	30%	-1.3			
				70%	5.0			
			A5-1	70%	12.3			
			EVA 70Hz Low	A3-4	30%	-9.3		
70%					-6.1			

				A4-5	30%	-1.9
					70%	5.2
			ETU 70Hz* Low	A3-1	30%	-6.3
					70%	-2.8
			ETU 300Hz* Low	A3-1	30%	-6.3
					70%	-2.7
		Extended	ETU 70Hz* Low	A4-2	30%	-0.6
					70%	7.0
Note*: Not applicable for Local Area BS and Home BS.						
Note**: Not applicable for Local Area BS and Home BS, and only applicable for BS supporting ETU600.						

Table 8.2.1.5-4: Test requirements for PUSCH, 10 MHz Channel Bandwidth

Number of TX antennas	Number of RX antennas	Cyclic prefix	Propagation conditions and correlation matrix (Annex B)	FRC (Annex A)	Fraction of maximum throughput	SNR [dB]	
1	2	Normal	EPA 5Hz Low	A3-5	30%	-3.6	
					70%	0.2	
				A4-6	70%	11.4	
					A5-5	70%	18.9
				A17-4	70%	23.2	
				A18-4	70%	9.1	
			A19-4	70%	20.1		
			EVA 5Hz Low	A3-1	30%	-2.1	
					70%	2.5	
				A4-1	30%	4.9	
			70%		12.0		
			A5-1	70%	19.4		
			EVA 70Hz Low	A3-5	30%	-3.5	
					70%	0.7	
				A4-6	30%	5.1	
			70%		13.2		
			ETU 70Hz* Low	A3-1	30%	-1.9	
			ETU 300Hz* Low	A3-1	30%	-1.6	
					70%	3.5	
			Extended	ETU 70Hz* Low	A4-2	30%	5.4
					70%	14.2	
	4	Normal	EPA 5Hz Low	A3-5	30%	-6.2	
					70%	-2.9	
				A4-6	70%	8.1	
					A5-5	70%	15.3
				A17-4	70%	19.8	
				A18-4	70%	5.9	
			A19-4	70%	16.4		
			EVA 5Hz Low	A3-1	30%	-4.4	
					70%	-0.6	
				A4-1	30%	1.8	
			70%		8.5		
			A5-1	70%	16.1		
			EVA 70Hz Low	A3-5	30%	-6.1	
					70%	-2.3	
				A4-6	30%	1.3	
			70%		8.6		
			ETU 70Hz* Low	A3-1	30%	-4.2	
			ETU 300Hz* Low	A3-1	30%	-0.3	
					70%	0.0	
			ETU 600Hz** Low	A13-4	30%	-4.0	
			Extended	ETU 70Hz* Low	30%	-0.4	
70%					6.8		
ETU 70Hz* Low			A4-2	30%	2.3		
				70%	10.9		
8			Normal	EPA 5Hz Low	A3-5	30%	-9.2
						70%	-6.1
					A4-6	70%	4.8
	A5-5	70%				12.1	
	A17-4	70%			16.5		
	A18-4	70%			2.7		
	A19-4	70%		13.1			
	EVA 5Hz Low	A3-1		30%	-6.3		
				70%	-3.2		
		A4-1		30%	-1.1		
	70%			5.1			
	A5-1	70%		12.5			
	EVA 70Hz Low	A3-5		30%	-9.1		
				70%	-5.6		

				A4-6	30%	-2.0
					70%	5.3
			ETU 70Hz* Low	A3-1	30%	-6.2
					70%	-3.0
			ETU 300Hz* Low	A3-1	30%	-6.2
					70%	-2.7
		Extended	ETU 70Hz* Low	A4-2	30%	-0.5
					70%	7.1
Note*: Not applicable for Local Area BS and Home BS.						
Note**: Not applicable for Local Area BS and Home BS, and only applicable for BS supporting ETU600.						

Table 8.2.1.5-5: Test requirements for PUSCH, 15 MHz Channel Bandwidth

Number of TX antennas	Number of RX antennas	Cyclic prefix	Propagation conditions and correlation matrix (Annex B)	FRC (Annex A)	Fraction of maximum throughput	SNR [dB]
1	2	Normal	EPA 5Hz Low	A3-6	30%	-3.9
					70%	-0.2
				A4-7	70%	11.9
				A5-6	70%	19.4
				A17-5	70%	23.4
				A18-5	70%	10.0
			A19-5	70%	22.0	
			EVA 5Hz Low	A3-1	30%	-2.2
					70%	2.4
				A4-1	30%	4.8
					70%	12.0
			A5-1	70%	19.3	
			EVA 70Hz Low	A3-6	30%	-3.9
					70%	0.3
				A4-7	30%	4.8
					70%	13.5
			ETU 70Hz* Low	A3-1	30%	-1.9
					70%	3.0
			ETU 300Hz* Low	A3-1	30%	-1.6
					70%	3.5
			Extended	ETU 70Hz* Low	A4-2	30%
		70%			14.2	
	4	Normal	EPA 5Hz Low	A3-6	30%	-6.6
					70%	-3.2
				A4-7	70%	8.2
				A5-6	70%	15.6
				A17-5	70%	19.5
				A18-5	70%	6.5
			A19-5	70%	17.7	
			EVA 5Hz Low	A3-1	30%	-4.4
					70%	-0.6
				A4-1	30%	1.8
					70%	8.5
			A5-1	70%	16.3	
			EVA 70Hz Low	A3-6	30%	-6.4
					70%	-2.7
				A4-7	30%	1.3
					70%	9.1
			ETU 70Hz* Low	A3-1	30%	-4.2
					70%	-0.4
			ETU 300Hz* Low	A3-1	30%	-4.0
					70%	0.0
ETU 600Hz** Low			A13-5	30%	-0.3	
		70%	7.0			
Extended	ETU 70Hz*	A4-2	30%	2.2		
			70%	10.7		
8	Normal	EPA 5Hz Low	A3-6	30%	-9.8	
				70%	-6.7	
			A4-7	70%	5.0	
			A5-6	70%	12.4	
			A17-5	70%	16.1	
			A18-5	70%	3.4	
		A19-5	70%	14.4		
		EVA 5Hz Low	A3-1	30%	-6.5	
				70%	-3.4	
			A4-1	30%	-1.1	
				70%	5.0	
		A5-1	70%	12.3		
		EVA 70Hz Low	A3-6	30%	-9.5	
				70%	-6.2	

				A4-7	30%	-1.9
					70%	5.6
			ETU 70Hz* Low	A3-1	30%	-6.4
					70%	-3.0
			ETU 300Hz* Low	A3-1	30%	-6.3
					70%	-2.7
		Extended	ETU 70Hz* Low	A4-2	30%	-0.5
					70%	7.3

Note*: Not applicable for Local Area BS and Home BS.
 Note**: Not applicable for Local Area BS and Home BS, and only applicable for BS supporting ETU600.

Table 8.2.1.5-6: Test requirements for PUSCH, 20 MHz Channel Bandwidth

Number of TX antennas	Number of RX antennas	Cyclic prefix	Propagation conditions and correlation matrix (Annex B)	FRC (Annex A)	Fraction of maximum throughput	SNR [dB]
1	2	Normal	EPA 5Hz Low	A3-7	30%	-3.6
					70%	0.2
				A4-8	70%	12.1
					A5-7	70%
				A17-6	70%	24.3
				A18-6	70%	9.9
			A19-6	70%	21.6	
			EVA 5Hz Low	A3-1	30%	-2.1
					70%	2.4
				A4-1	30%	4.9
			70%		12.1	
			A5-1	70%	19.3	
			EVA 70Hz Low	A3-7	30%	-3.5
					70%	0.8
				A4-8	30%	4.8
			70%		13.6	
			ETU 70Hz* Low	A3-1	30%	-1.8
			ETU 300Hz* Low	A3-1	30%	3.0
					70%	-1.5
			ETU 300Hz* Low	A3-1	30%	3.5
					70%	3.5
	Extended	ETU 70Hz* Low	A4-2	30%	5.3	
			70%	14.2		
	4	Normal	EPA 5Hz Low	A3-7	30%	-6.2
					70%	-2.9
				A4-8	70%	8.1
					A5-7	70%
				A17-6	70%	20.4
				A18-6	70%	6.3
			A19-6	70%	17.3	
			EVA 5Hz Low	A3-1	30%	-4.5
					70%	-0.7
				A4-1	30%	1.8
			70%		8.5	
			A5-1	70%	16.2	
			EVA 70Hz Low	A3-7	30%	-6.1
					70%	-2.3
				A4-8	30%	1.3
			70%		9.2	
			ETU 70Hz* Low	A3-1	30%	-3.8
			ETU 300Hz* Low	A3-1	30%	-0.3
					70%	-4.0
ETU 300Hz* Low			A3-1	30%	-0.1	
				70%	-0.1	
ETU 600Hz** Low	A13-6	30%	-0.3			
		70%	7.0			
Extended	ETU 70Hz* Low	A4-2	30%	2.2		
		70%	10.6			
8	Normal	EPA 5Hz Low	A3-7	30%	-9.1	
				70%	-6.1	
			A4-8	70%	4.9	
				A5-7	70%	13.1
			A17-6	70%	16.9	
			A18-6	70%	3.2	
		A19-6	70%	13.8		
		EVA 5Hz Low	A3-1	30%	-6.4	
				70%	-3.3	
			A4-1	30%	-1.1	
		70%		5.2		
		A5-1	70%	12.6		
		EVA 70Hz Low	A3-7	30%	-9.1	
				70%	-5.5	

				A4-8	30%	-1.6
					70%	5.5
			ETU 70Hz* Low	A3-1	30%	-6.3
					70%	-2.9
			ETU 300Hz* Low	A3-1	30%	-6.2
					70%	-2.7
		Extended	ETU 70Hz* Low	A4-2	30%	-0.6
					70%	7.1
Note	Not applicable for Local Area BS and Home BS.					
Note**:	Not applicable for Local Area BS and Home BS, and only applicable for BS supporting ETU600.					

NOTE: If the above Test Requirement differs from the Minimum Requirement then the Test Tolerance applied for this test is non-zero. The Test Tolerance for this test and the explanation of how the Minimum Requirement has been relaxed by the Test Tolerance is given in Annex G.

8.2.1A Performance requirements of PUSCH in multipath fading propagation conditions transmission on two antenna ports

8.2.1A.1 Definition and applicability

The performance requirement of PUSCH is determined by a minimum required throughput for a given SNR. The required throughput is expressed as a fraction of maximum throughput for the FRCs listed in Annex A. The performance requirements assume HARQ re-transmissions.

A test for a specific channel bandwidth is only applicable if the BS supports it.

For a BS supporting multiple channel bandwidths only the tests for the lowest and the highest channel bandwidths supported by the BS are applicable.

For the tests on two antenna ports the HARQ retransmissions for multiple codewords are independent.

8.2.1A.2 Minimum Requirement

The minimum requirement is in TS 36.104 [2] subclause 8.2.1.1.

8.2.1A.3 Test Purpose

The test shall verify the receiver's ability to achieve throughput of two layer spatial multiplexing transmission under multipath fading propagation conditions for a given SNR.

8.2.1A.4 Method of test

8.2.1A.4.1 Initial Conditions

Test environment: Normal, see subclause D.2.

RF channels to be tested: M; see subclause 4.7.

- 1) Connect the BS tester generating the wanted signal, multipath fading simulators and AWGN generators to all BS antenna connectors for diversity reception via a combining network as shown in Annex I.3.6.

8.2.1A.4.2 Procedure

- 1) Adjust the AWGN generator, according to the channel bandwidth, defined in Table 8.2.1A.4.2-1.

Table 8.2.1A.4.2-1: AWGN power level at the BS input

Channel bandwidth [MHz]	AWGN power level
1.4	-92.7dBm / 1.08MHz
3	-88.7dBm / 2.7MHz
5	-86.5dBm / 4.5MHz
10	-83.5dBm / 9MHz
15	-81.7dBm / 13.5MHz
20	-80.4dBm / 18MHz

- 2) The characteristics of the wanted signal shall be configured according to the corresponding UL reference measurement channel defined in annex A and the test parameters in Table 8.2.1A.4.2-2. For reference channels using 1 resource block the resource block in the middle of the channel bandwidth shall be used. In case the number of resource blocks in the channel bandwidth are even the one in the middle with lower number is to be used for testing.

Table 8.2.1A.4.2-2 Test parameters for testing PUSCH

Parameter	Value
Maximum number of HARQ transmissions	4
RV sequence	0, 2, 3, 1, 0, 2, 3, 1
Uplink-downlink allocation for TDD	Configuration 1 (2:2)

- 3) The multipath fading emulators shall be configured according to the corresponding channel model defined in annex B.
- 4) Adjust the equipment so that required SNR specified in Table 8.2.1A.5-1 to 8.2.1A.5-6 is achieved at the BS input.
- 5) For each of the reference channels in Table 8.2.1A.5-1 to 8.2.1A.5-6 applicable for the base station, measure the throughput, according to annex E.

8.2.1A.5 Test Requirement

The throughput measured according to subclause 8.2.1A.4.2 shall not be below the limits for the SNR levels specified in Table 8.2.1A.5-1 to 8.2.1A.5-6.

Table 8.2.1A.5-1 Test requirements for PUSCH, 1.4 MHz Channel Bandwidth

Number of TX antennas	Number of RX antennas	Cyclic prefix	Propagation conditions and correlation matrix (Annex B)	FRC (Annex A)	Fraction of maximum throughput	SNR [dB]
2	2	Normal	EPA 5Hz Low	A3-2	70%	[5.4]
				A4-3	70%	18.5
	4	Normal	EPA 5Hz Low	A3-2	70%	0.7
				A4-3	70%	12.7
	8	Normal	EPA 5Hz Low	A3-2	70%	-2.2
				A4-3	70%	8.3

Table 8.2.1A.5-2 Test requirements for PUSCH, 3 MHz Channel Bandwidth

Number of TX antennas	Number of RX antennas	Cyclic prefix	Propagation conditions and correlation matrix (Annex B)	FRC (Annex A)	Fraction of maximum throughput	SNR [dB]
2	2	Normal	EPA 5Hz Low	A3-3	70%	5.2
				A4-4	70%	18.4
	4	Normal	EPA 5Hz Low	A3-3	70%	1.1
				A4-4	70%	12.6
	8	Normal	EPA 5Hz Low	A3-3	70%	-2.3
				A4-4	70%	8.4

Table 8.2.1A.5-3 Test requirements for PUSCH, 5 MHz Channel Bandwidth

Number of TX antennas	Number of RX antennas	Cyclic prefix	Propagation conditions and correlation matrix (Annex B)	FRC (Annex A)	Fraction of maximum throughput	SNR [dB]
2	2	Normal	EPA 5Hz Low	A3-4	70%	4.5
				A4-5	70%	19.0
	4	Normal	EPA 5Hz Low	A3-4	70%	0.3
				A4-5	70%	12.7
	8	Normal	EPA 5Hz Low	A3-4	70%	-3.1
				A4-5	70%	8.4

Table 8.2.1A.5-4 Test requirements for PUSCH, 10 MHz Channel Bandwidth

Number of TX antennas	Number of RX antennas	Cyclic prefix	Propagation conditions and correlation matrix (Annex B)	FRC (Annex A)	Fraction of maximum throughput	SNR [dB]
2	2	Normal	EPA 5Hz Low	A3-5	70%	5.0
				A4-6	70%	19.4
	4	Normal	EPA 5Hz Low	A3-5	70%	1.0
				A4-6	70%	12.8
	8	Normal	EPA 5Hz Low	A3-5	70%	-2.5
				A4-6	70%	8.7

Table 8.2.1A.5-5 Test requirements for PUSCH, 15 MHz Channel Bandwidth

Number of TX antennas	Number of RX antennas	Cyclic prefix	Propagation conditions and correlation matrix (Annex B)	FRC (Annex A)	Fraction of maximum throughput	SNR [dB]
2	2	Normal	EPA 5Hz Low	A3-6	70%	4.5
				A4-7	70%	20.2
	4	Normal	EPA 5Hz Low	A3-6	70%	0.6
				A4-7	70%	13.5
	8	Normal	EPA 5Hz Low	A3-6	70%	-3.0
				A4-7	70%	9.1

Table 8.2.1A.5-6 Test requirements for PUSCH, 20 MHz Channel Bandwidth

Number of TX antennas	Number of RX antennas	Cyclic prefix	Propagation conditions and correlation matrix (Annex B)	FRC (Annex A)	Fraction of maximum throughput	SNR [dB]
2	2	Normal	EPA 5Hz Low	A3-7	70%	5.2
				A4-8	70%	20.5
	4	Normal	EPA 5Hz Low	A3-7	70%	1.3
				A4-8	70%	13.5
	8	Normal	EPA 5Hz Low	A3-7	70%	-2.6
				A4-8	70%	9.1

8.2.2 Performance requirements for UL timing adjustment

8.2.2.1 Definition and applicability

The performance requirement of PUSCH is determined by a minimum required throughput measured for the moving UE at given SNR. The required throughput is expressed as 70% of maximum throughput for the FRCs listed in Annex A. The performance requirements assume HARQ re-transmissions.

In the tests for UL timing adjustment, two signals are configured, one being transmitted by moving UE and the other being transmitted by stationary UE. The transmission of SRS from UE is optional. FRC parameters in Table A.7-1 and Table A.8-1 are applied for both UEs. The received power for both UEs is the same. The resource blocks allocated for both UEs are consecutive. In Scenario 2, Doppler shift is not taken into account.

A test for a specific channel bandwidth is only applicable if the BS supports it.

For a BS supporting multiple channel bandwidths only the tests for the lowest and the highest channel bandwidths supported by the BS are applicable.

This requirement shall not be applied to Local Area BS and Home BS.

8.2.2.2 Minimum Requirement

The minimum requirement is in TS 36.104 [2] subclause 8.2.2.1.

8.2.2.3 Test Purpose

The test shall verify the receiver's ability to achieve throughput measured for the moving UE at given SNR under moving propagation conditions.

8.2.2.4 Method of test

8.2.2.4.1 Initial Conditions

Test environment: Normal, see subclause D.2.

RF channels to be tested: M; see subclause 4.7.

- 1) Connect the BS tester generating the wanted signal, multipath fading simulators and AWGN generators to all BS antenna connectors for diversity reception via a combining network as shown in Annex I.3.4.

8.2.2.4.2 Procedure

- 1) Adjust the AWGN generator, according to the channel bandwidth, defined in Table 8.2.2.4.2-1.

Table 8.2.2.4.2-1: AWGN power level at the BS input

Channel bandwidth [MHz]	AWGN power level
1.4	-92.7 dBm / 1.08MHz
3	-88.7 dBm / 2.7MHz
5	-86.5 dBm / 4.5MHz
10	-83.5 dBm / 9MHz
15	-81.7 dBm / 13.5MHz
20	-80.4 dBm / 18MHz

- 2) The characteristics of the wanted signals (transmitted by moving UE) shall be configured according to the corresponding UL reference measurement channel defined in Annex A and the test parameters in Table 8.2.2.4.2-2.

Table 8.2.2.4.2-2 Test parameters for testing UL timing adjustment

Parameter	Value
Maximum number of HARQ transmissions	4
RV sequence	0, 2, 3, 1, 0, 2, 3, 1
Uplink-downlink allocation for TDD	Configuration 1 (2:2)
Subframes in which PUSCH is transmitted	For FDD: subframe #0, #2, #4, #6, and #8 in radio frames For TDD: Subframe #2, #3, #7, #8 in each radio frame
Subframes in which sounding RS is transmitted (Note 1)	For FDD: subframe #1 in radio frames For TDD: UpPTS in subframe #1 in radio frames
Note 1: The transmission of SRS is optional.	

- 3) The multipath fading emulators shall be configured according to the corresponding channel model defined in Annex B.
- 4) Adjust the equipment so that required SNR specified in Table 8.2.2.5-1 is achieved at the BS input.
- 5) For each of the reference channels in Table 8.2.2.5-1 applicable for the base station, measure the throughput, according to Annex E.

8.2.2.5 Test Requirement

The throughput measured for the moving UE according to subclause 8.2.2.4.2 shall not be below the limits for the SNR levels specified in Table 8.2.2.5-1.

Table 8.2.2.5-1: Test requirements for UL timing adjustment

Number of TX antennas	Number of RX antennas	Cyclic prefix	Channel Bandwidth [MHz]	Moving propagation conditions and correlation matrix (Annex B)	FRC (Annex A)	SNR [dB]
1	2	Normal	1.4	Scenario 1 Low	A7-1	13.7
				Scenario 2 Low	A8-1	-1.6
			3	Scenario 1 Low	A7-2	14.0
				Scenario 2 Low	A8-2	-1.2
			5	Scenario 1 Low	A7-3	13.8
				Scenario 2 Low	A8-3	-1.3
			10	Scenario 1 Low	A7-4	14.4
				Scenario 2 Low	A8-4	-1.5
			15	Scenario 1 Low	A7-5	14.6
				Scenario 2 Low	A8-5	-1.5
			20	Scenario 1 Low	A7-6	14.5
				Scenario 2 Low	A8-6	-1.5

NOTE: If the above Test Requirement differs from the Minimum Requirement then the Test Tolerance applied for this test is non-zero. The Test Tolerance for this test is defined in subclause 4.1 and the explanation of how the Minimum Requirement has been relaxed by the Test Tolerance is given in Annex G.

8.2.3 Performance requirements for HARQ-ACK multiplexed on PUSCH

8.2.3.1 Definition and applicability

The performance requirement of HARQ-ACK multiplexed on PUSCH is determined by the two parameters: probability of false detection of the ACK and the probability of detection of ACK. The performance is measured by the required SNR at probability of detection equal to 0.99. The probability of false detection of the ACK shall be 0.01 or less at PUSCH power settings presented in table 8.2.3.5-1.

The probability of detection of ACK on PUSCH is defined as conditional probability of detection of the ACK when the ACK is transmitted on PUSCH allocated RE.

The probability of false detection of the ACK on PUSCH is defined as a conditional probability of erroneous detection of the ACK when data only is sent on PUSCH allocated RE, where HARQ-ACK can be allocated (i.e. by puncturing data). Pseudo-random data shall be used as an input for PUSCH coding and modulation purposes.

These tests shall be performed on one of RE's, where HARQ-ACK information was multiplexed on PUSCH.

In the test for HARQ-ACK multiplexed on PUSCH data is punctured by HARQ-ACK information in both slots within a subframe on symbols as specified in 36.212 [13] subclause 5.2.2.8. Amount of resources for HARQ-ACK information is calculated according to 36.212 [13] subclause 5.2.2.6. None of CQI, RI nor SRS is to be transmitted in these tests. Tests are performed for one bit HARQ-ACK information ($O = 1$).

This test is applied for QPSK 1/3 and 16QAM 3/4 modulation and coding schemes, with appropriate fixed reference channels for performance requirement applied as presented in table 8.2.3.5-1. Normal CP, 2 Rx antennas and ETU70 propagation conditions shall be used for this test.

A test for a specific channel bandwidth is only applicable if the BS supports it.

For a BS supporting multiple channel bandwidths only the tests for the lowest and the highest channel bandwidths supported by the BS are applicable.

8.2.3.2 Minimum Requirement

The minimum requirement is in TS 36.104 [2] subclause 8.2.4.1.

8.2.3.3 Test Purpose

The test shall verify the receiver’s ability to detect HARQ-ACK information multiplexed on PUSCH under multipath fading propagation conditions for a given SNR.

8.2.3.4 Method of test

8.2.3.4.1 Initial Conditions

Test environment: Normal, see subclause D.2.

RF channels to be tested: M; see subclause 4.7.

- 1) Connect the BS tester generating the wanted signal, multipath fading simulators and AWGN generators to all BS antenna connectors for diversity reception via a combining network as shown in Annex I.3.2.

8.2.3.4.2 Procedure

- 1) Adjust the AWGN generator, according to the channel bandwidth, defined in Table 8.2.3.4.2-1.

Table 8.2.3.4.2-1: AWGN power level at the BS input

Channel bandwidth [MHz]	AWGN power level
1.4	-92.7 dBm / 1.08MHz
3	-88.7 dBm / 2.7MHz
5	-86.5 dBm / 4.5MHz
10	-83.5 dBm / 9MHz
15	-81.7 dBm / 13.5MHz
20	-80.4 dBm / 18MHz

- 2) The characteristics of the wanted signal shall be configured according to the corresponding UL reference measurement channel defined in Annex A and details presented in chapter 8.2.3.1. For reference channels using 1 resource block the RB in the middle of the channel bandwidth should be used. In case the number of resource blocks in the channel bandwidth are even the one in the middle with lower number is to be used for testing.
- 3) The multipath fading emulators shall be configured according to ETU70 channel model defined in Annex B.2.
- 4) Adjust the equipment so that required SNR specified in Table 8.2.3.5-1 is achieved at the BS input during the ACK transmissions.
- 5) The signal generator sends a test pattern on one of RE’s where HARQ-ACK information can be multiplexed on PUSCH with the pattern outlined in figure 8.2.3.4.2-1. The following statistics are kept: the number of ACKs detected during data only transmissions and the number of missed ACKs during PUSCH with ACK transmission.

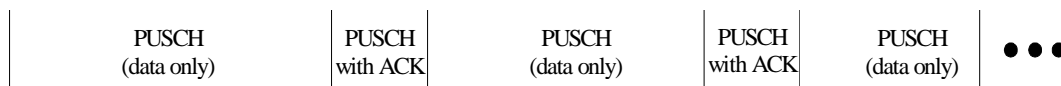

Figure 8.2.3.4.2-1: Test signal pattern for HARQ-ACK multiplexed on PUSCH demodulation tests

8.2.3.5 Test Requirement

The fraction of falsely detected ACKs measured according to subclause 8.2.3.4.2 shall be less than 1% and the fraction of correctly detected ACKs shall be larger than 99% for the SNR listed in table 8.2.3.5-1.

Table 8.2.3.5-1: Test requirements for HARQ-ACK multiplexed on PUSCH

Number of TX antennas	Number of RX antennas	Cyclic Prefix	Propagation conditions and correlation matrix (Annex B)	Channel Bandwidth [MHz]	FRC (Annex A)	$I_{offset}^{HARQ-ACK}$	SNR [dB]
1	2	Normal	EVA 5* Low	1.4	A.3-1	8	7.4
					A.4-3	5	14.2
				3	A.3-1	8	7.4
					A.4-4	5	13.7
				5	A.3-1	8	7.5
					A.4-5	5	13
				10	A.3-1	8	7.4
					A.4-6	5	13
				15	A.3-1	8	7.4
					A.4-7	5	12.6
			20	A.3-1	8	7.4	
				A.4-8	5	12.5	
			ETU70** Low	1.4	A.3-1	8	7.2
					A.4-3	5	14.4
				3	A.3-1	8	7.2
					A.4-4	5	13.5
				5	A.3-1	8	7.1
					A.4-5	5	13.1
				10	A.3-1	8	7.2
					A.4-6	5	12.9
15	A.3-1	8		7.3			
	A.4-7	5		12.7			
20	A.3-1	8	7.1				
	A.4-8	5	12.6				
Note*: Not applicable for Wide Area BS and Medium Range BS.							
Note**: Not applicable for Local Area BS and Home BS.							

NOTE: If the above Test Requirement differs from the Minimum Requirement then the Test Tolerance applied for this test is non-zero. The Test Tolerance for this test and the explanation of how the Minimum Requirement has been relaxed by the Test Tolerance is given in Annex G.

8.2.4 Performance requirements for High Speed Train conditions

8.2.4.1 Definition and applicability

The performance requirement of PUSCH for High Speed Train conditions is determined by a minimum throughput for a given SNR. The required throughput is expressed as 30% and 70% of maximum throughput for the FRCs listed in Annex A. The performance requirements assume HARQ retransmissions and are applied for normal CP.

A test for a specific channel bandwidth is only applicable if the BS supports it.

For a BS supporting multiple channel bandwidths only the tests for the lowest and the highest channel bandwidths supported by the BS are applicable.

The performance requirements for High Speed Train conditions are optional.

This requirement shall not be applied to Local Area BS and Home BS.

8.2.4.2 Minimum Requirement

The minimum requirement is in TS 36.104 [2] subclause 8.2.3.1

8.2.4.3 Test Purpose

The test shall verify the receiver's ability to achieve throughput under High Speed Train conditions for a given SNR.

8.2.4.4 Method of test

8.2.4.4.1 Initial Conditions

Test environment: Normal, see subclause D.2.

RF channels to be tested: M; see subclause 4.7.

- 1) Connect the BS tester generating the wanted signal, channel simulators and AWGN generators to all BS antenna connectors (depending on HST scenario) via a combining network as shown in Annex I.3.2.

8.2.4.4.2 Procedure

- 1) Adjust the AWGN generator, according to the channel bandwidth, defined in Table 8.2.4.4.2-1.

Table 8.2.4.4.2-1: AWGN power level at the BS input

Channel bandwidth [MHz]	AWGN power level
1.4	-92.7 dBm / 1.08MHz
3	-88.7 dBm / 2.7MHz
5	-86.5 dBm / 4.5MHz
10	-83.5 dBm / 9MHz
15	-81.7 dBm / 13.5MHz
20	-80.4 dBm / 18MHz

- 2) The characteristics of the wanted signal shall be configured according to the corresponding UL reference measurement channel defined in Annex A and the test parameters in Table 8.2.4.4.2-2.

Table 8.2.4.4.2-2: Test parameters for High Speed Train conditions

Parameter	Value
Maximum number of HARQ transmissions	4
RV sequence	0, 2, 3, 1, 0, 2, 3, 1
Uplink-downlink allocation for TDD	Configuration 1 (2:2)
Subframes in which PUSCH is transmitted	For FDD: subframe #0 and #8 in radio frames for which SFN mod 4 = 0 subframe #6 in radio frames for which SFN mod 4 = 1 subframe #4 in radio frames for which SFN mod 4 = 2 subframe #2 in radio frames for which SFN mod 4 = 3 For TDD: Subframe #2 in each radio frames
Subframes in which PUCCH is transmitted (Note 1, Note 2)	For FDD: subframe #5 in radio frames For TDD: Subframe #3 in each radio frame
NOTE 1: The configuration of PUCCH (format 2) is optional.	
NOTE 2: The SNR values per antenna shall be set to -4.5 dB and -1.5 dB for Scenario 1 and 3, respectively.	

- 3) The channel simulators shall be configured according to the corresponding channel model defined in Annex B.3.
- 4) Adjust the equipment so that required SNR specified in Table 8.2.4.5-1 is achieved at the BS input.
- 5) For each of the reference channels in Table 8.2.4.5-1 applicable for the base station, measure the throughput, according to Annex E.

8.2.4.5 Test Requirement

The throughput measured according to subclause 8.2.4.4.2 shall not be below the limits for the SNR levels specified in Table 8.2.4.5-1.

Table 8.2.4.5-1: Test requirements for High Speed Train conditions

Channel Bandwidth [MHz]	FRC (Annex A)	Number of TX antennas	Number of RX antennas	Propagation conditions and correlation matrix (Annex B)	Fraction of maximum throughput	SNR [dB]
1.4	A3-2	1	1	HST Scenario 3	30%	-1.2
					70%	2.2
				Scenario 3-LTE500a ^(Note 1)	30%	-1.2
					70%	2.2
				Scenario 3-LTE500b ^(Note 2)	30%	-1.2
					70%	2.2
			2	HST Scenario 1 Low	30%	-3.6
					70%	-0.3
				Scenario 1-LTE500a Low ^(Note 1)	30%	-3.6
					70%	-0.3
				Scenario 1-LTE500b Low ^(Note 2)	30%	-3.6
					70%	-0.3
3	A3-3		1	HST Scenario 3	30%	-1.8
					70%	1.9
				Scenario 3-LTE500a ^(Note 1)	30%	-1.8
					70%	2.1
				Scenario 3-LTE500b ^(Note 2)	30%	-1.8
					70%	2.0
			2	HST Scenario 1 Low	30%	-4.2
					70%	-0.7
				Scenario 1-LTE500a Low ^(Note 1)	30%	-4.2
					70%	-0.7
				Scenario 1-LTE500b Low ^(Note 2)	30%	-4.2
					70%	-0.7
5	A3-4	1	HST Scenario 3	30%	-2.3	
				70%	1.6	
			Scenario 3-LTE500a ^(Note 1)	30%	-2.3	
				70%	1.6	
			Scenario 3-LTE500b ^(Note 2)	30%	-2.3	
				70%	1.6	
		2	HST Scenario 1 Low	30%	-4.8	
				70%	-1.1	
			Scenario 1-LTE500a Low ^(Note 1)	30%	-4.8	
				70%	-1.1	
			Scenario 1-LTE500b Low ^(Note 2)	30%	-4.8	
				70%	-1.1	
10	A3-5	1	HST Scenario 3	30%	-2.4	
				70%	1.5	
			Scenario 3-LTE500a ^(Note 1)	30%	-2.4	
				70%	2.0	
			Scenario 3-LTE500b ^(Note 2)	30%	-2.4	
				70%	2.0	
		2	HST Scenario 1 Low	30%	-5.1	
				70%	-1.2	
			Scenario 1-LTE500a Low ^(Note 1)	30%	-5.1	
				70%	-1.2	
			Scenario 1-LTE500b Low ^(Note 2)	30%	-5.1	
				70%	-0.9	
15	A3-6	1	HST Scenario 3	30%	-2.4	
				70%	1.5	
			Scenario 3-LTE500a ^(Note 1)	30%	-2.4	
				70%	1.5	
				30%	-2.4	
				30%	-2.4	

20	A3-7	2	Scenario 3-LTE500b ^(Note 2)	70%	1.5
			HST Scenario 1 Low	30%	-4.9
				70%	-1.1
			Scenario 1-LTE500a Low ^(Note 1)	30%	-4.9
				70%	-1.1
			Scenario 1-LTE500b Low ^(Note 2)	30%	-4.9
				70%	-1.1
			1	HST Scenario 3	30%
		70%			1.5
		Scenario 3-LTE500a ^(Note 1)		30%	-2.4
				70%	1.8
		Scenario 3-LTE500b ^(Note 2)		30%	-2.4
70%	2.1				
2	HST Scenario 1 Low	30%	-5.0		
		70%	-1.1		
	Scenario 1-LTE500a Low ^(Note 1)	30%	-5.0		
		70%	-1.1		
	Scenario 1-LTE500b Low ^(Note 2)	30%	-5.0		
		70%	-1.1		
NOTE 1: Not applicable if the BS manufacturer declares supported maximum Doppler frequency is 1750 Hz					
NOTE 2: Not applicable if the BS manufacturer declares supported maximum Doppler frequency is 1944 Hz					

NOTE: If the above Test Requirement differs from the Minimum Requirement then the Test Tolerance applied for this test is non-zero. The Test Tolerance for this test and the explanation of how the Minimum Requirement has been relaxed by the Test Tolerance is given in Annex G.

8.2.5 Performance requirements for PUSCH with TTI bundling and enhanced HARQ pattern

8.2.5.1 Definition and applicability

The performance requirement of PUSCH configured with TTI bundling and enhanced HARQ pattern, as specified in 36.213 [16] clause 8 and 8.0, is determined by residual block error probability (BLER) after HARQ retransmission. The performance is measured by the required SNR at residual BLER of 2% for the FRCs listed in Annex A.11. The residual BLER is defined as follows:

$$BLER_{residual} = \frac{A}{B}$$

where:

- *A* is the number of incorrectly decoded transport blocks after HARQ retransmission.
- *B* is the number of transmitted transport blocks (retransmitted transport blocks are not counted repetitively).

The test is applicable for FDD. TTI bundling and enhanced HARQ pattern are enabled in the tests.

A test for a specific channel bandwidth is only applicable if the BS supports it.

For a BS supporting multiple channel bandwidths only the tests for the highest channel bandwidth supported by the BS are applicable.

8.2.5.2 Minimum Requirement

The minimum requirement is in TS 36.104 [2] subclause 8.2.5.1.

8.2.5.3 Test Purpose

The test shall verify the receiver's ability to decode PUSCH configured with TTI bundling and enhanced HARQ pattern, under multipath fading propagation conditions for a given SNR.

8.2.5.4 Method of test

8.2.5.4.1 Initial Conditions

Test environment: Normal, see subclause D.2.

RF channels to be tested: M; see subclause 4.7.

- 1) Connect the BS tester generating the wanted signal, multipath fading simulators and AWGN generators to all BS antenna connectors for diversity reception via a combining network as shown in Annex I.3.2.

8.2.5.4.2 Procedure

- 1) Adjust the AWGN generator, according to the channel bandwidth, defined in Table 8.2.5.4.2-1.

Table 8.2.5.4.2-1: AWGN power level at the BS input

Channel bandwidth [MHz]	AWGN power level
1.4	-92.7dBm / 1.08MHz
3	-88.7dBm / 2.7MHz
5	-86.5dBm / 4.5MHz
10	-83.5dBm / 9MHz
15	-81.7dBm / 13.5MHz
20	-80.4dBm / 18MHz

- 2) The characteristics of the wanted signal shall be configured according to the corresponding UL reference measurement channel defined in annex A.11 and the test parameters in Table 8.2.5.4.2-2. The 3 contiguous resource blocks in the middle of the channel bandwidth shall be used for testing. In case the number of resource blocks in the channel bandwidth is even, the 3 contiguous resource blocks in the middle with lower numbers are to be used.

Table 8.2.5.4.2-2: Test parameters for PUSCH with TTI bundling and enhanced HARQ pattern

Parameter	Value
Number of TTIs for a TTI bundle	4
RV sequence for 4 TTIs within a TTI bundle	0, 2, 3, 1
HARQ round trip time	12 ms
Maximum number of HARQ transmissions for a TTI bundle	5

- 3) The multipath fading emulators shall be configured according to the corresponding channel model defined in annex B.
- 4) Adjust the equipment so that required SNR specified in Table 8.2.5.5-1 is achieved at the BS input during the PUSCH transmissions.
- 5) The signal generator sends a test pattern in which a new transmission is generated at every 20 ms as illustrated in figure 8.2.5.4.2-1. The residual BLER after HARQ retransmission is measured.

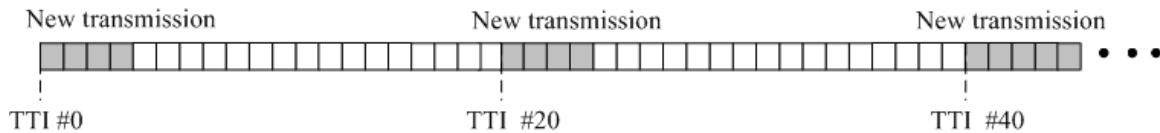

Figure 8.2.5.4.2-1: Test signal pattern for PUSCH with TTI bundling and enhanced HARQ pattern (retransmissions of TTI bundles are not shown)

8.2.5.5 Test Requirement

The residual BLER measured according to subclause 8.2.5.4.2 shall be lower than 2% at the given SNR in Table 8.2.5.5-1.

Table 8.2.5.5-1: Test requirements for PUSCH with TTI bundling and enhanced HARQ pattern

Number of TX antennas	Number of RX antennas	Cyclic Prefix	Propagation conditions and correlation matrix (Annex B)	Channel Bandwidth / SNR [dB]					
				1.4 MHz	3 MHz	5 MHz	10 MHz	15 MHz	20 MHz
1	2	Normal	EVA 5 Low	-4.1	-4.1	-4.1	-4.1	-4	-4
			ETU 300* Low	-7.3	-7.3	-7.4	-7.3	-7.4	-7.3
	4		EVA 5 Low	-7.8	-7.7	-7.7	-7.7	-7.8	-7.8
			ETU 300* Low	-9.7	-9.7	-9.7	-9.8	-9.7	-9.7
	8		EVA 5 Low	-10.8	-10.7	-10.8	-10.8	-10.7	-10.8
			ETU 300* Low	-11.9	-11.8	-11.9	-11.8	-11.8	-11.9
Note*: Not applicable for Local Area BS and Home BS.									

NOTE: If the above Test Requirement differs from the Minimum Requirement then the Test Tolerance applied for this test is non-zero. The Test Tolerance for this test and the explanation of how the Minimum Requirement has been relaxed by the Test Tolerance is given in Annex G.

8.2.6 Enhanced performance requirements type A of PUSCH in multipath fading propagation conditions with synchronous interference

8.2.6.1 Definition and applicability

The enhanced performance requirement type A of PUSCH is determined by a minimum required throughput for a given SINR. The required throughput is expressed as a fraction of maximum throughput for the FRCs listed in Annex A. The performance requirements assume HARQ retransmissions.

The purpose is to verify the demodulation performance when the wanted PUSCH signal in the serving cell is interfered by PUSCH of one or two dominant interferer(s) applying the interference model defined in clause B.6.2.

The requirements apply to the BS supporting the enhanced performance requirements type A.

The requirements apply to the BS receiving the synchronous interference i.e. the interference is time-synchronous with the tested signal.

A test for a specific channel bandwidth is only applicable if the BS supports it.

For a BS supporting FDD multiple channel bandwidths but not supporting FDD UL carrier aggregation, only the tests for the lowest and the highest FDD channel bandwidths supported by the BS are applicable. For a BS supporting TDD multiple channel bandwidths but not supporting TDD UL carrier aggregation, only the tests for the lowest and the highest TDD channel bandwidths supported by the BS are applicable.

For a BS supporting FDD UL carrier aggregation, only the FDD CC combination with largest aggregated bandwidth is used for the test. If there is more than one combination with the largest aggregated bandwidth, the FDD CC combination with the largest number of component carriers is used for the test. For this CC combination the tests using full PRB allocation FRC are conducted on per CC basis and measured by the required SINR levels corresponding to the bandwidths used on the different CCs.

For a BS supporting TDD UL carrier aggregation, only the TDD CC combination with largest aggregated bandwidth is used for the test. If there is more than one combination with the largest aggregated bandwidth, the TDD CC combination with the largest number of component carriers is used for the test. For this CC combination the tests using full PRB allocation FRC are conducted on per CC basis and measured by the required SINR levels corresponding to the bandwidths used on the different CCs.

8.2.6.2 Minimum Requirement

The minimum requirement is in TS 36.104 [2] subclause 8.2.6.1.

8.2.6.3 Test Purpose

The test shall verify the receiver's ability to achieve throughput on the wanted signal at the presence of one or two dominant interferer(s) as specified in clause 8.2.6.4.2, under multipath fading propagation conditions for a given SINR.

8.2.6.4 Method of test

8.2.6.4.1 Initial Conditions

Test environment: Normal, see subclause D.2.

RF channels to be tested: M; see subclause 4.7.

- 1) Connect the BS tester generating the wanted signal, interference signal(s), multipath fading simulators and AWGN generators to all BS antenna connectors for diversity reception via a combining network as shown in Annex I.3.7.
- 2) Interconnect attenuators for relative power setting purposes for all transmitting branches (wanted signal and all interferers, separately).

8.2.6.4.2 Procedure

- 1) Adjust the AWGN generator, according to the channel bandwidth, defined in Table 8.2.6.4.2-1.

Table 8.2.6.4.2-1: AWGN power level at the BS input

Channel bandwidth [MHz]	AWGN power level
1.4	-92.7dBm / 1.08MHz
3	-88.7dBm / 2.7MHz
5	-86.5dBm / 4.5MHz
10	-83.5dBm / 9MHz
15	-81.7dBm / 13.5MHz
20	-80.4dBm / 18MHz

- 2) The characteristics of the wanted signal and the interferer(s) shall be configured according to the corresponding UL reference measurement channel defined in annex A and the test parameters in Table 8.2.6.4.2-2.

Table 8.2.6.4.2-2: Test parameters for enhanced performance requirement type A

Parameter		Unit	Tested signal	Interferer 1 (Note 1)	Interferer 2 (Note 1)
Maximum number of HARQ transmissions			4	N/A	N/A
RV sequence			0, 2, 3, 1, 0, 2, 3, 1	N/A	N/A
DIP (Note 2)	Set 1	dB	N/A	-1.11	-10.91
	Set 2	dB	N/A	-0.43	-13.78
Cell Id			0	1	2
Interference model			N/A	As specified in clause B.6.2	As specified in clause B.6.2
Cyclic Prefix			Normal		
Uplink-downlink allocation for TDD			Configuration 1 (2:2)		
Demodulation reference signal for PUSCH			$\Delta_{ss} = 0, n_{DMRS}^{(1)} = 0, n_{DMRS,0}^{(2)} = 0$ Group hopping and sequence hopping are disabled.		
Note 1: One explicit interferer, i.e., interferer 1, is modelled for tests with 2 RX antennas. Two explicit interferers are modelled for tests with 4 or 8 RX antennas. Note 2: The respective received energy of each interferer relative to N_r is defined by its associated DIP value as specified in clause B.6.1. DIP set 1 and set 2 are derived respectively in homogeneous and heterogeneous network scenarios. Note 3: All cells are time-synchronous.					

- 3) The multipath fading emulators shall be configured according to the corresponding channel model defined in annex B.
- 4) Adjust the equipment so that required SINR specified in Table 8.2.6.5-1 to 8.2.6.5-6 is achieved at the BS input.
- 5) For each of the reference channels in Table 8.2.6.5-1 to 8.2.6.5-6 applicable for the base station, measure the throughput, according to annex E.

8.2.6.5 Test Requirement

The throughput measured according to subclause 8.2.6.4.2 shall not be below the limits for the SINR levels specified in Table 8.2.6.5-1 to Table 8.2.6.5-6.

Table 8.2.6.5-1: Enhanced performance requirement type A for PUSCH, 1.4MHz Channel Bandwidth

Number of TX antennas (Note 1)	Number of RX antennas (Note 1)	Propagation conditions and correlation matrix (Annex B) (Note 2)			DIP set	FRC (Annex A)	Fraction of maximum throughput	SINR [dB] (Note 3)
		Tested signal	Interferer 1	Interferer 2				
1	2	EPA 5 Low	ETU 5 Low	N/A	Set 2	A12-1	70%	-4.2
		EVA 70 Low	ETU 70 Low	N/A	Set 1*	A12-1	70%	-1.4
	4	EPA 5 Low	ETU 5 Low	ETU 5 Low	Set 2	A13-1	70%	-3.5
		EVA 70 Low	ETU 70 Low	ETU 70 Low	Set 1*	A13-1	70%	0.5
	8	EPA 5 Low	ETU 5 Low	ETU 5 Low	Set 2	A4-3	70%	-4.1
		EVA 70 Low	ETU 70 Low	ETU 70 Low	Set 1*	A4-3	70%	0.6
Note*: Not applicable for Local Area BS and Home BS.								
Note 1: Antenna configuration applies for each of the tested signal, interferer 1 and interferer 2.								
Note 2: The propagation conditions for the tested signal, interferer 1 and interferer 2 are statistically independent.								

Table 8.2.6.5-2: Enhanced performance requirement type A for PUSCH, 3 MHz Channel Bandwidth

Number of TX antennas (Note 1)	Number of RX antennas (Note 1)	Propagation conditions and correlation matrix (Annex B) (Note 2)			DIP set	FRC (Annex A)	Fraction of maximum throughput	SINR [dB] (Note 3)
		Tested signal	Interferer 1	Interferer 2				
1	2	EPA 5 Low	ETU 5 Low	N/A	Set 2	A12-2	70%	-4.4
		EVA 70 Low	ETU 70 Low	N/A	Set 1*	A12-2	70%	-1.7
	4	EPA 5 Low	ETU 5 Low	ETU 5 Low	Set 2	A13-2	70%	-3.8
		EVA 70 Low	ETU 70 Low	ETU 70 Low	Set 1*	A13-2	70%	0.5
	8	EPA 5 Low	ETU 5 Low	ETU 5 Low	Set 2	A4-4	70%	-4.0
		EVA 70 Low	ETU 70 Low	ETU 70 Low	Set 1*	A4-4	70%	0.5

Note*: Not applicable for Local Area BS and Home BS.

Note 1: Antenna configuration applies for each of the tested signal, interferer 1 and interferer 2.

Note 2: The propagation conditions for the tested signal, interferer 1 and interferer 2 are statistically independent.

Table 8.2.6.5-3: Enhanced performance requirement type A for PUSCH, 5 MHz Channel Bandwidth

Number of TX antennas (Note 1)	Number of RX antennas (Note 1)	Propagation conditions and correlation matrix (Annex B) (Note 2)			DIP set	FRC (Annex A)	Fraction of maximum throughput	SINR [dB] (Note 3)
		Tested signal	Interferer 1	Interferer 2				
1	2	EPA 5 Low	ETU 5 Low	N/A	Set 2	A12-3	70%	-4.5
		EVA 70 Low	ETU 70 Low	N/A	Set 1*	A12-3	70%	-1.9
	4	EPA 5 Low	ETU 5 Low	ETU 5 Low	Set 2	A13-3	70%	-3.5
		EVA 70 Low	ETU 70 Low	ETU 70 Low	Set 1*	A13-3	70%	0.7
	8	EPA 5 Low	ETU 5 Low	ETU 5 Low	Set 2	A4-5	70%	-4.1
		EVA 70 Low	ETU 70 Low	ETU 70 Low	Set 1*	A4-5	70%	0.1

Note*: Not applicable for Local Area BS and Home BS.

Note 1: Antenna configuration applies for each of the tested signal, interferer 1 and interferer 2.

Note 2: The propagation conditions for the tested signal, interferer 1 and interferer 2 are statistically independent.

Table 8.2.6.5-4: Enhanced performance requirement type A for PUSCH, 10 MHz Channel Bandwidth

Number of TX antennas (Note 1)	Number of RX antennas (Note 1)	Propagation conditions and correlation matrix (Annex B) (Note 2)			DIP set	FRC (Annex A)	Fraction of maximum throughput	SINR [dB] (Note 3)
		Tested signal	Interferer 1	Interferer 2				
1	2	EPA 5 Low	ETU 5 Low	N/A	Set 2	A12-4	70%	-4.8
		EVA 70 Low	ETU 70 Low	N/A	Set 1*	A12-4	70%	-2.1
	4	EPA 5 Low	ETU 5 Low	ETU 5 Low	Set 2	A13-4	70%	-3.6
		EVA 70 Low	ETU 70 Low	ETU 70 Low	Set 1*	A13-4	70%	0.5
	8	EPA 5 Low	ETU 5 Low	ETU 5 Low	Set 2	A4-6	70%	-3.9
		EVA 70 Low	ETU 70 Low	ETU 70 Low	Set 1*	A4-6	70%	0.4

Note*: Not applicable for Local Area BS and Home BS.

Note 1: Antenna configuration applies for each of the tested signal, interferer 1 and interferer 2.

Note 2: The propagation conditions for the tested signal, interferer 1 and interferer 2 are statistically independent.

Table 8.2.6.5-5 Enhanced performance requirement type A for PUSCH, 15 MHz Channel Bandwidth

Number of TX antennas (Note 1)	Number of RX antennas (Note 1)	Propagation conditions and correlation matrix (Annex B) (Note 2)			DIP set	FRC (Annex A)	Fraction of maximum throughput	SINR [dB] (Note 3)
		Tested signal	Interferer 1	Interferer 2				
1	2	EPA 5 Low	ETU 5 Low	N/A	Set 2	A12-5	70%	-4.9
		EVA 70 Low	ETU 70 Low	N/A	Set 1*	A12-5	70%	-2.1
	4	EPA 5 Low	ETU 5 Low	ETU 5 Low	Set 2	A13-5	70%	-3.4
		EVA 70 Low	ETU 70 Low	ETU 70 Low	Set 1*	A13-5	70%	0.6
	8	EPA 5 Low	ETU 5 Low	ETU 5 Low	Set 2	A4-7	70%	-3.9
		EVA 70 Low	ETU 70 Low	ETU 70 Low	Set 1*	A4-7	70%	0.3

Note*: Not applicable for Local Area BS and Home BS.

Note 1: Antenna configuration applies for each of the tested signal, interferer 1 and interferer 2.

Note 2: The propagation conditions for the tested signal, interferer 1 and interferer 2 are statistically independent.

Table 8.2.6.5-6 Enhanced performance requirement type A for PUSCH, 20 MHz Channel Bandwidth

Number of TX antennas (Note 1)	Number of RX antennas (Note 1)	Propagation conditions and correlation matrix (Annex B) (Note 2)			DIP set	FRC (Annex A)	Fraction of maximum throughput	SINR [dB] (Note 3)
		Tested signal	Interferer 1	Interferer 2				
1	2	EPA 5 Low	ETU 5 Low	N/A	Set 2	A12-6	70%	-5.1
		EVA 70 Low	ETU 70 Low	N/A	Set 1*	A12-6	70%	-2.4
	4	EPA 5 Low	ETU 5 Low	ETU 5 Low	Set 2	A13-6	70%	-3.9
		EVA 70 Low	ETU 70 Low	ETU 70 Low	Set 1*	A13-6	70%	0.2
	8	EPA 5 Low	ETU 5 Low	ETU 5 Low	Set 2	A4-8	70%	-4.0
		EVA 70 Low	ETU 70 Low	ETU 70 Low	Set 1*	A4-8	70%	0.5

Note*: Not applicable for Local Area BS and Home BS.

Note 1: Antenna configuration applies for each of the tested signal, interferer 1 and interferer 2.

Note 2: The propagation conditions for the tested signal, interferer 1 and interferer 2 are statistically independent.

NOTE: If the above Test Requirement differs from the Minimum Requirement then the Test Tolerance applied for this test is non-zero. The Test Tolerance for this test and the explanation of how the Minimum Requirement has been relaxed by the Test Tolerance is given in Annex G.

8.2.6A Enhanced performance requirements type A of PUSCH in multipath fading propagation conditions with asynchronous interference

8.2.6A.1 Definition and applicability

The enhanced performance requirement type A of PUSCH is determined by a minimum required throughput for a given SINR. The required throughput is expressed as a fraction of maximum throughput for the FRCs listed in Annex A. The performance requirements assume HARQ retransmissions.

The purpose is to verify the demodulation performance when the wanted PUSCH signal in the serving cell is interfered by PUSCH of two interferers from the same interfering cell, applying the interference model defined in clause B.6.3.

The requirements apply to the BS supporting the enhanced performance requirements type A.

The requirements apply to the BS receiving the asynchronous interference i.e. the interference is time-asynchronous with the tested signal.

A test for a specific channel bandwidth is only applicable if the BS supports it.

For a BS supporting FDD multiple channel bandwidths but not supporting FDD UL carrier aggregation, only the tests for the lowest and the highest FDD channel bandwidths supported by the BS are applicable. For a BS supporting TDD multiple channel bandwidths but not supporting TDD UL carrier aggregation, only the tests for the lowest and the highest TDD channel bandwidths supported by the BS are applicable.

For a BS supporting FDD UL carrier aggregation, only the FDD CC combination with largest aggregated bandwidth is used for the test. If there is more than one combination with the largest aggregated bandwidth, the FDD CC

combination with the largest number of component carriers is used for the test. For this CC combination the tests using full PRB allocation FRC are conducted on per CC basis and measured by the required SINR levels corresponding to the bandwidths used on the different CCs.

For a BS supporting TDD UL carrier aggregation, only the TDD CC combination with largest aggregated bandwidth is used for the test. If there is more than one combination with the largest aggregated bandwidth, the TDD CC combination with the largest number of component carriers is used for the test. For this CC combination the tests using full PRB allocation FRC are conducted on per CC basis and measured by the required SINR levels corresponding to the bandwidths used on the different CCs.

8.2.6A.2 Minimum Requirement

The minimum requirement is in TS 36.104 [2] subclause 8.2.6A.1.

8.2.6A.3 Test Purpose

The test shall verify the receiver's ability to achieve throughput on the wanted signal at the presence of two dominant interferers as specified in clause 8.2.6A.4.2, under multipath fading propagation conditions for a given SINR.

8.2.6A.4 Method of test

8.2.6A.4.1 Initial Conditions

Test environment: Normal, see subclause D.2.

RF channels to be tested: M; see subclause 4.7.

- 1) Connect the BS tester generating the wanted signal, interference signals, multipath fading simulators and AWGN generators to all BS antenna connectors for diversity reception via a combining network as shown in Annex I.3.7.
- 2) Interconnect attenuators for relative power setting purposes for all transmitting branches (wanted signal and all interferers, separately).

8.2.6A.4.2 Procedure

- 1) Adjust the AWGN generator, according to the channel bandwidth, defined in Table 8.2.6A.4.2-1.

Table 8.2.6A.4.2-1: AWGN power level at the BS input

Channel bandwidth [MHz]	AWGN power level
1.4	-92.7dBm / 1.08MHz
3	-88.7dBm / 2.7MHz
5	-86.5dBm / 4.5MHz
10	-83.5dBm / 9MHz
15	-81.7dBm / 13.5MHz
20	-80.4dBm / 18MHz

- 2) The characteristics of the wanted signal and the interferers shall be configured according to the corresponding UL reference measurement channel defined in annex A and the test parameters in Table 8.2.6A.4.2-2.

Table 8.2.6A.4.2-2: Test parameters for enhanced performance requirement type A

Parameter	Unit	Tested signal	Interferer 1-1 (Note 1)	Interferer 1-2 (Note 1)
Maximum number of HARQ transmissions		4	N/A	N/A
RV sequence		0, 2, 3, 1, 0, 2, 3, 1	N/A	N/A
DIP (Note 2)	dB	N/A	-0.43	-0.43
Cell Id		0	1	1
Interference model		N/A	As specified in clause B.6.3	As specified in clause B.6.3
Cyclic Prefix		Normal		
Demodulation reference signal for PUSCH		$\Delta_{ss} = 0, n_{DMRS}^{(1)} = 0, n_{DMRS,0}^{(2)} = 0$ Group hopping and sequence hopping are disabled.		
Note 1: Interferer 1-1 and interferer 1-2 are connected to the same cell and configured to transmit respectively in the even subframes and odd subframes.				
Note 2: The respective received energy of each interferer relative to N_r is defined by its associated DIP value as specified in clause B.6.1.				
Note 3: The transmissions of both interferer 1-1 and interferer 1-2 are delayed with respect to the tested signal by 0.33 ms.				

- 3) The multipath fading emulators shall be configured according to the corresponding channel model defined in annex B.
- 4) Adjust the equipment so that required SINR specified in Table 8.2.6A.5-1 to 8.2.6A.5-6 is achieved at the BS input.
- 5) For each of the reference channels in Table 8.2.6A.5-1 to 8.2.6A.5-6 applicable for the base station, measure the throughput, according to annex E.

8.2.6A.5 Test Requirement

The throughput measured according to subclause 8.2.6A.4.2 shall not be below the limits for the SINR levels specified in Table 8.2.6A.5-1 to Table 8.2.6A.5-6.

Table 8.2.6A.5-1 Enhanced performance requirement type A for PUSCH, 1.4MHz Channel Bandwidth

Number of TX antennas (Note 1)	Number of RX antennas (Note 1)	Propagation conditions and correlation matrix (Annex B) (Note 2)			FRC (Annex A)	Fraction of maximum throughput	SINR [dB]
		Tested signal	Interferer 1-1	Interferer 1-2			
1	2	EPA 5 Low	ETU 5 Low	ETU 5 Low	A12-1	70%	-1.7
	4	EPA 5 Low	ETU 5 Low	ETU 5 Low	A13-1	70%	-0.8
	8	EPA 5 Low	ETU 5 Low	ETU 5 Low	A4-3	70%	-1.6
Note 1: Antenna configuration applies for each of the tested signal, interferer 1-1 and interferer 1-2.							
Note 2: The propagation conditions for the tested signal, interferer 1-1 and interferer 1-2 are statistically independent.							

Table 8.2.6A.5-2 Enhanced performance requirement type A for PUSCH, 3 MHz Channel Bandwidth

Number of TX antennas (Note 1)	Number of RX antennas (Note 1)	Propagation conditions and correlation matrix (Annex B) (Note 2)			FRC (Annex A)	Fraction of maximum throughput	SINR [dB]
		Tested signal	Interferer 1-1	Interferer 1-2			
1	2	EPA 5 Low	ETU 5 Low	ETU 5 Low	A12-2	70%	-1.9
	4	EPA 5 Low	ETU 5 Low	ETU 5 Low	A13-2	70%	-1.0
	8	EPA 5 Low	ETU 5 Low	ETU 5 Low	A4-4	70%	-1.6
Note 1: Antenna configuration applies for each of the tested signal, interferer 1-1 and interferer 1-2.							
Note 2: The propagation conditions for the tested signal, interferer 1-1 and interferer 1-2 are statistically independent.							

Table 8.2.6A.5-3 Enhanced performance requirement type A for PUSCH, 5 MHz Channel Bandwidth

Number of TX antennas (Note 1)	Number of RX antennas (Note 1)	Propagation conditions and correlation matrix (Annex B) (Note 2)			FRC (Annex A)	Fraction of maximum throughput	SINR [dB]
		Tested signal	Interferer 1-1	Interferer 1-2			
1	2	EPA 5 Low	ETU 5 Low	ETU 5 Low	A12-3	70%	-2.0
	4	EPA 5 Low	ETU 5 Low	ETU 5 Low	A13-3	70%	-0.7
	8	EPA 5 Low	ETU 5 Low	ETU 5 Low	A4-5	70%	-1.5
Note 1: Antenna configuration applies for each of the tested signal, interferer 1-1 and interferer 1-2.							
Note 2: The propagation conditions for the tested signal, interferer 1-1 and interferer 1-2 are statistically independent.							

Table 8.2.6A.5-4 Enhanced performance requirement type A for PUSCH, 10 MHz Channel Bandwidth

Number of TX antennas (Note 1)	Number of RX antennas (Note 1)	Propagation conditions and correlation matrix (Annex B) (Note 2)			FRC (Annex A)	Fraction of maximum throughput	SINR [dB]
		Tested signal	Interferer 1-1	Interferer 1-2			
1	2	EPA 5 Low	ETU 5 Low	ETU 5 Low	A12-4	70%	-2.2
	4	EPA 5 Low	ETU 5 Low	ETU 5 Low	A13-4	70%	-0.7
	8	EPA 5 Low	ETU 5 Low	ETU 5 Low	A4-6	70%	-1.3
Note 1: Antenna configuration applies for each of the tested signal, interferer 1-1 and interferer 1-2.							
Note 2: The propagation conditions for the tested signal, interferer 1-1 and interferer 1-2 are statistically independent.							

Table 8.2.6A.5-5 Enhanced performance requirement type A for PUSCH, 15 MHz Channel Bandwidth

Number of TX antennas (Note 1)	Number of RX antennas (Note 1)	Propagation conditions and correlation matrix (Annex B) (Note 2)			FRC (Annex A)	Fraction of maximum throughput	SINR [dB]
		Tested signal	Interferer 1-1	Interferer 1-2			
1	2	EPA 5 Low	ETU 5 Low	ETU 5 Low	A12-5	70%	-2.1
	4	EPA 5 Low	ETU 5 Low	ETU 5 Low	A13-5	70%	-0.5
	8	EPA 5 Low	ETU 5 Low	ETU 5 Low	A4-7	70%	-0.8
Note 1: Antenna configuration applies for each of the tested signal, interferer 1-1 and interferer 1-2.							
Note 2: The propagation conditions for the tested signal, interferer 1-1 and interferer 1-2 are statistically independent.							

Table 8.2.6A.5-6 Enhanced performance requirement type A for PUSCH, 20 MHz Channel Bandwidth

Number of TX antennas (Note 1)	Number of RX antennas (Note 1)	Propagation conditions and correlation matrix (Annex B) (Note 2)			FRC (Annex A)	Fraction of maximum throughput	SINR [dB]
		Tested signal	Interferer 1-1	Interferer 1-2			
1	2	EPA 5 Low	ETU 5 Low	ETU 5 Low	A12-6	70%	-2.3
	4	EPA 5 Low	ETU 5 Low	ETU 5 Low	A13-6	70%	-0.5
	8	EPA 5 Low	ETU 5 Low	ETU 5 Low	A4-8	70%	-0.7
Note 1: Antenna configuration applies for each of the tested signal, interferer 1-1 and interferer 1-2.							
Note 2: The propagation conditions for the tested signal, interferer 1-1 and interferer 1-2 are statistically independent.							

NOTE: If the above Test Requirement differs from the Minimum Requirement then the Test Tolerance applied for this test is non-zero. The Test Tolerance for this test and the explanation of how the Minimum Requirement has been relaxed by the Test Tolerance is given in Annex G.

8.2.7 Performance requirements of PUSCH in multipath fading propagation conditions transmission on single antenna port for coverage enhancement

8.2.7.1 Definition and applicability

The performance requirement of PUSCH is determined by a minimum required throughput for a given SNR. The required throughput is expressed as a fraction of maximum throughput for the FRCs listed in Annex A. The performance requirements assume HARQ re-transmissions.

The tests for CEModeA defined in Clause 8.2.7 are applicable only to the base stations supporting coverage enhancement configured with CEModeA. The tests for CEModeB defined in Clause 8.2.7 are applicable only to the base stations supporting coverage enhancement configured with CEModeB.

A test for a specific channel bandwidth is only applicable if the BS supports it. For a BS supporting FDD multiple channel bandwidths, only the tests for the lowest and the highest FDD channel bandwidths supported by the BS are applicable. For a BS supporting TDD multiple channel bandwidths, only the tests for the lowest and the highest TDD channel bandwidths supported by the BS are applicable.

8.2.7.2 Minimum Requirement

The minimum requirement is in TS 36.104 [2] subclause 8.2.7.

8.2.7.3 Test Purpose

The test shall verify the receiver's ability to achieve throughput under multipath fading propagation conditions for a given SNR.

8.2.7.4 Method of test

8.2.7.4.1 Initial Conditions

Test environment: Normal, see subclause D.2.

RF channels to be tested: M; see subclause 4.7.

- 1) Connect the BS tester generating the wanted signal, multipath fading simulators and AWGN generators to all BS antenna connectors for diversity reception via a combining network as shown in Annex I.3.2.

8.2.7.4.2 Procedure

- 1) Adjust the AWGN generator, according to the channel bandwidth, defined in Table 8.2.7.4.2-1.

Table 8.2.7.4.2-1: AWGN power level at the BS input

Channel bandwidth [MHz]	AWGN power level
1.4	-92.7dBm / 1.08MHz
3	-88.7dBm / 2.7MHz
5	-86.5dBm / 4.5MHz
10	-83.5dBm / 9MHz
15	-81.7dBm / 13.5MHz
20	-80.4dBm / 18MHz

- 2) The characteristics of the wanted signal shall be configured according to the corresponding UL reference measurement channel defined in annex A and the test parameters in Table 8.2.7.4.2-2. The index of the narrowband is set to 0. For reference channels using resource blocks less than 6, the resource blocks shall be allocated from the lowest number within the indicated narrowband.

Table 8.2.7.4.2-2: Test parameters for testing PUSCH

Parameter	unit	CEMode A	CEMode B
Maximum number of HARQ transmissions		4	2
RV sequences		0, 2, 3, 1, 0, 2, 3, 1	FDD: 0, 0, 0, 0, 2, 2, 2, 2, 3, 3, 3, 3, 1, 1, 1, 1 TDD: 0, 0, 0, 0, 0, 2, 2, 2, 2, 3, 3, 3, 3, 1, 1, 1, 1, 1, 1
Number of PUSCH repetitions		8	256
Frequency hopping		ON	ON
Frequency hopping interval	subframes	4: FDD 5: TDD	4: FDD 5: TDD
Frequency hopping offset		$N_{NB}^{UL} - 1$ (Note 2)	$N_{NB}^{UL} - 1$ (Note 2)
Note 1: Guard period shall be created according to TS36.211, 5.2.5 [12]			
Note 2: N_{NB}^{UL} is the total number of uplink narrowbands specified in TS36.211, 5.2.4 [12]			

- 3) The multipath fading emulators shall be configured according to the corresponding channel model defined in annex B.
- 4) Adjust the equipment so that required SNR specified in Table 8.2.7.5-1 to 8.2.7.5-2 is achieved at the BS input.
- 5) For each of the reference channels in Table 8.2.7.5-1 to 8.2.7.5-2 applicable for the base station, measure the throughput, according to annex E.

8.2.7.5 Test Requirement

The throughput measured according to subclause 8.2.7.4.2 shall not be below the limits for the SNR levels specified in Table 8.2.7.5-1 for CEMode A tests and not be below the limits for the SNR levels specified in Table 8.2.7.5-2 for CEMode B tests.

Table 8.2.7.5-1 Minimum requirements for PUSCH for CEMode A

Number of TX antennas	Number of RX antennas	Channel Bandwidth (MHz)	Propagation conditions and correlation matrix (Annex B)	FRC (Annex A)	Fraction of maximum throughput	SNR [dB]
1	2	3	EPA 5Hz Low	A3-2	70%	-5.6
1	2	5	EPA 5Hz Low	A3-2	70%	-6.0
1	2	10	EPA 5Hz Low	A3-2	70%	-6.3
1	2	15	EPA 5Hz Low	A3-2	70%	-6.3
1	2	20	EPA 5Hz Low	A3-2	70%	-6.4
1	2	3	ETU 200Hz Low	A3-2	70%	-6.5
1	2	5	ETU 200Hz Low	A3-2	70%	-6.5
1	2	10	ETU 200Hz Low	A3-2	70%	-6.5
1	2	15	ETU 200Hz Low	A3-2	70%	-6.5
1	2	20	ETU 200Hz Low	A3-2	70%	-6.5

Table 8.2.7.5-2 Minimum requirements for PUSCH for CEMode B

Number of TX antennas	Number of RX antennas	Channel Bandwidth (MHz)	Propagation conditions and correlation matrix (Annex B)	FRC (Annex A)	Fraction of maximum throughput	SNR [dB]
1	2	3	ETU 1Hz Low	A3-1	70%	-14.4
1	2	5	ETU 1Hz Low	A3-1	70%	-14.6
1	2	10	ETU 1Hz Low	A3-1	70%	-14.7
1	2	15	ETU 1Hz Low	A3-1	70%	-14.5
1	2	20	ETU 1Hz Low	A3-1	70%	-14.6

NOTE: If the above Test Requirement differs from the Minimum Requirement then the Test Tolerance applied for this test is non-zero. The Test Tolerance for this test and the explanation of how the Minimum Requirement has been relaxed by the Test Tolerance is given in Annex G.

8.2.8 Performance requirements of PUSCH with Frame structure type 3

8.2.8.1 Definition and applicability

The performance requirement of PUSCH is determined by a minimum required throughput for a given SNR. The required throughput is expressed as a fraction of maximum throughput for the FRCs listed in Annex A. The performance requirements assume HARQ re-transmissions.

A test for a specific number of receive antenna is only applicable if the BS supports it.

8.2.8.2 Minimum Requirement

The minimum requirement is in TS 36.104 [2] subclause 8.2.8.

8.2.8.3 Test Purpose

The test shall verify the receiver's ability to achieve throughput under multipath fading propagation conditions with uplink resource allocation type 3 for a given SNR.

8.2.8.4 Method of test

8.2.8.4.1 Initial Conditions

Test environment: Normal, see subclause D.2.

RF channels to be tested: M; see subclause 4.7.

- 1) Connect the BS tester generating the wanted signal, multipath fading simulators and AWGN generators to all BS antenna connectors for diversity reception via a combining network as shown in Annex I.3.2.

8.2.8.4.2 Procedure

- 1) Adjust the AWGN generator, according to the channel bandwidth, defined in Table 8.2.8.4.2-1.

Table 8.2.8.4.2-1: AWGN power level at the BS input

Channel bandwidth [MHz]	AWGN power level
20	-80.4dBm / 18MHz

- 2) The characteristics of the wanted signal shall be configured according to the corresponding UL reference measurement channel defined in annex A and the test parameters in Table 8.2.8.4.2-2.

Table 8.2.8.4.2-2: Test parameters for testing PUSCH

Parameter	Value
Maximum number of HARQ transmissions	4
RV sequence	0, 2, 0, 2
PUSCH starting position(Note 2)	'01'
PUSCH ending symbol(Note 3)	'0'
Note 1:	PUSCH scheduling pattern is defined as the bitmap {1111000000} with the periodicity of 10ms. Value 1 in the bitmap indicates there is PUSCH data transmission on the corresponding subframes; Value 0 indicates that there is no PUSCH data transmission on the corresponding subframes.
Note 2:	The PUSCH starting position is applicable to only the first PUSCH transmission subframe indicated in the bitmap. For other transmission subframes indicated in the bitmap, PUSCH starting position is at symbol 0.
Note 3:	The PUSCH ending symbol value 0 indicates the last symbol of the last PUSCH transmission subframe indicated in the bitmap.

- 3) The multipath fading emulators shall be configured according to the corresponding channel model defined in annex B.
- 4) Adjust the equipment so that required SNR specified in Table 8.2.8.5-1 is achieved at the BS input.
- 5) For each of the reference channels in Table 8.2.8.5-1 applicable for the base station, measure the throughput, according to annex E.

8.2.8.5 Test Requirement

The throughput measured according to subclause 8.2.8.4.2 shall not be below the limits for the SNR levels specified in Table 8.2.8.5-1.

Table 8.2.8.5-1: Test requirements for eLAA PUSCH, 20MHz Channel Bandwidth

Number of TX antennas	Number of RX antennas	Cyclic prefix	Propagation conditions and correlation matrix (Annex B)	FRC (Annex A)	Fraction of nominal maximum throughput (Note 1)	SNR [dB]
1	2	Normal	EPA 5Hz Low	A20-1	70%	0.4
				A20-2	70%	12.7
	4	Normal	EPA 5Hz Low	A20-1	70%	-2.6
				A20-2	70%	8.9
Note1: Fraction of nominal maximum throughput is calculated based on the actual transmitted PUSCH.						

NOTE: If the above Test Requirement differs from the Minimum Requirement then the Test Tolerance applied for this test is non-zero. The Test Tolerance for this test and the explanation of how the Minimum Requirement has been relaxed by the Test Tolerance is given in Annex G.

8.2.9 Enhanced performance requirements type B of PUSCH in multipath fading propagation conditions

8.2.9.1 Definition and applicability

The enhanced performance requirement type B of PUSCH is determined by a minimum required throughput for a given SINR. The required throughput is expressed as a fraction of maximum sum throughput of all the co-scheduled intra-cell UEs for the FRCs listed in Annex A. The performance requirements assume HARQ retransmissions.

The purpose is to verify the demodulation performance when there are multiple co-scheduled intra-cell UEs in the serving cell and one inter-cell interfering UE in the neighboring cell. The PUSCH of all the intra-cell UEs are wanted signal for the BS.

The requirements apply to the BS supporting the enhanced performance requirements type B.

A test for a specific channel bandwidth is only applicable if the BS supports it.

For a BS supporting FDD multiple channel bandwidths but not supporting FDD UL carrier aggregation, only the tests for the lowest and the highest FDD channel bandwidths supported by the BS are applicable. For a BS supporting TDD multiple channel bandwidths but not supporting TDD UL carrier aggregation, only the tests for the lowest and the highest TDD channel bandwidths supported by the BS are applicable.

For a BS supporting FDD UL carrier aggregation, only the FDD CC combination with largest aggregated bandwidth is used for the test. If there is more than one combination with the largest aggregated bandwidth, the FDD CC combination with the largest number of component carriers is used for the test. For this CC combination the tests using the PRB allocation in FRC are conducted on per CC basis and measured by the required SINR levels corresponding to the bandwidths used on the different CCs.

For a BS supporting TDD UL carrier aggregation, only the TDD CC combination with largest aggregated bandwidth is used for the test. If there is more than one combination with the largest aggregated bandwidth, the TDD CC combination with the largest number of component carriers is used for the test. For this CC combination the tests using the PRB allocation in FRC are conducted on per CC basis and measured by the required SINR levels corresponding to the bandwidths used on the different CCs.

8.2.9.2 Minimum Requirement

The minimum requirement is in TS 36.104 [2] subclause 8.2.9.

8.2.9.3 Test Purpose

The test shall verify the receiver's ability to achieve throughput on the wanted signal at the presence of one inter-cell interferer as specified in clause 8.2.9.4.2, under multipath fading propagation conditions for a given SINR.

8.2.9.4 Method of test

8.2.9.4.1 Initial Conditions

Test environment: Normal, see subclause D.2.

RF channels to be tested: M; see subclause 4.7.

- 1) Connect the BS tester generating the wanted signal, interference signal, multipath fading simulators and AWGN generators to all BS antenna connectors for diversity reception via a combining network as shown in Annex I.3.8.
- 2) Interconnect attenuators for relative power setting purposes for all transmitting branches (wanted signal and interferer, separately).

8.2.9.4.2 Procedure

- 1) Adjust the AWGN generator, according to the channel bandwidth, defined in Table 8.2.9.4.2-1.

Table 8.2.9.4.2-1: AWGN power level at the BS input

Channel bandwidth [MHz]	AWGN power level
1.4	-92.7dBm / 1.08MHz
3	-88.7dBm / 2.7MHz
5	-86.5dBm / 4.5MHz
10	-83.5dBm / 9MHz
15	-81.7dBm / 13.5MHz
20	-80.4dBm / 18MHz

- 2) The characteristics of the wanted signal and the interferer shall be configured according to the corresponding UL reference measurement channel defined in annex A and the test parameters in Table 8.2.9.4.2-2 and Table 8.2.9.4.2-3.

Table 8.2.9.4.2-2: Test parameters for enhanced performance requirement type B, 2Rx antennas

Parameter		Unit	Wanted intra-cell UEs (Note 1)		Inter-cell interfering UE
			UE1	UE2	
Cyclic Prefix			Normal		
Uplink-downlink allocation for TDD			Configuration 1 (2:2)		
Maximum number of HARQ transmissions			4		N/A
RV sequence			0, 2, 3, 1, 0, 2, 3, 1		N/A
Cell Id			0		1
Inter-cell interference model			N/A		As specified in clause B.6.2
DIP (Note 2)	Set 1	dB	N/A		-5.45
	Set 2	dB	N/A		-0.43
Relative power of intra-cell UEs (Note 3)	Set 1	dB	0	0	N/A
	Set 2	dB	0	3	N/A
Time offset		us	-1	1	0
Frequency offset		Hz	-200	200	0
Demodulation reference signal for PUSCH	$n_{\text{DMRS}}^{(1)}$		0	6	0
	$\Delta_{\text{ss}}, n_{\text{DMRS},0}^{(2)}$		$\Delta_{\text{ss}} = 0, n_{\text{DMRS},0}^{(2)} = 0$ Group hopping and sequence hopping are disabled.		
<p>Note 1: Two intra-cell UEs, i.e., UE1 and UE2, are configured for tests with 2 RX antennas.</p> <p>Note 2: The respective received energy of each inter-cell interferer relative to N is defined by its associated DIP value as specified in clause B.6.1. DIP set 1 and set 2 are derived respectively in homogeneous and heterogeneous network scenarios.</p> <p>Note 3: For set 1, equal average received signal energy is configured for the intra-cell UEs, while short-term variation remains. For set 2, the average received signal energy of UE2 is 3 dB higher than that of UE1.</p>					

Table 8.2.9.4.2-3: Test parameters for enhanced performance requirement type B, 4Rx antennas

Parameter		Unit	Wanted intra-cell UEs (Note 1)				Inter-cell interfering UE
			UE1	UE2	UE3	UE4	
Cyclic Prefix			Normal				
Uplink-downlink allocation for TDD			Configuration 1 (2:2)				
Maximum number of HARQ transmissions			4				N/A
RV sequence			0, 2, 3, 1, 0, 2, 3, 1				N/A
Cell Id			0				1
Inter-cell interference model			N/A				As specified in clause B.6.2
DIP (Note 2)	Set 1	dB	N/A				-5.45
	Set 2	dB	N/A				-0.43
Relative power of intra-cell UEs (Note 3)	Set 1	dB	0	0	0	0	N/A
	Set 2	dB	0	3	0	3	N/A
Time offset		us	-1	-0.5	0.5	1	0
Frequency offset		Hz	-200	-100	100	200	0
Demodulation reference signal for PUSCH	$n_{\text{DMRS}}^{(1)}$		0	3	6	9	0
	$\Delta_{\text{ss}}, n_{\text{DMRS},0}^{(2)}$		$\Delta_{\text{ss}} = 0, n_{\text{DMRS},0}^{(2)} = 0$				Group hopping and sequence hopping are disabled.
<p>Note 1: Four intra-cell UEs, i.e., UE1, UE2, UE3 and UE4, are configured for tests with 4 RX antennas.</p> <p>Note 2: The respective received energy of each inter-cell interferer relative to N_r is defined by its associated DIP value as specified in clause B.6.1. DIP set 1 and set 2 are derived respectively in homogeneous and heterogeneous network scenarios.</p> <p>Note 3: For set 1, equal average received signal energy is configured for the intra-cell UEs, while short-term variation remains. For set 2, the average received signal energy of UE1 and UE3 is the same, the average received signal energy of UE2 and UE4 is the same, and the average received signal energy of UE2 and UE4 is 3 dB higher than that of UE1 and UE3.</p>							

- 3) The multipath fading emulators shall be configured according to the corresponding channel model defined in annex B.
- 4) Adjust the equipment so that required SINR specified in Table 8.2.9.5-1 to 8.2.9.5-6 is achieved at the BS input.
- 5) For each of the reference channels in Table 8.2.9.5-1 to 8.2.9.5-6 applicable for the base station, measure the throughput, according to annex E.

8.2.9.5 Test Requirement

The throughput measured according to subclause 8.2.9.4.2 shall not be below the limits for the SINR levels specified in Table 8.2.9.5-1 to Table 8.2.9.5-6.

Table 8.2.9.5-1: Enhanced performance requirement type B for PUSCH, 1.4 MHz Channel Bandwidth

Number of TX antennas (Note 1)	Number of RX antennas (Note 1)	Propagation conditions and correlation matrix (Annex B) (Note 2)		DIP set	Relative power of intra-cell UEs	FRC (Annex A)		Fraction of maximum sum throughput of all the intra-cell UEs	UE1's SINR [dB]
		Wanted intra-cell UEs	Inter-cell interfering UE			UE1, UE3	UE2, UE4		
1	2	EPA 5 Low	ETU 5 Low	Set 2	Set 1	A22-1	A22-1	80%	16.0
		EVA 70 Low	ETU 70 Low	Set 1*	Set 2	A13-1	A13-1	80%	11.9
	4	EVA 70 Low	ETU 70 Low	Set 1*	Set 1	A13-1	A13-1	80%	10.9
		EPA 5 Low	ETU 5 Low	Set 2	Set 2	A21-1	A13-1	80%	1.2
Note*: Not applicable for Local Area BS and Home BS.									
Note 1: Antenna configuration applies for each of the intra-cell and inter-cell UEs.									
Note 2: The propagation conditions for the intra-cell and inter-cell UEs are statistically independent.									

Table 8.2.9.5-2: Enhanced performance requirement type B for PUSCH, 3 MHz Channel Bandwidth

Number of TX antennas (Note 1)	Number of RX antennas (Note 1)	Propagation conditions and correlation matrix (Annex B) (Note 2)		DIP set	Relative power of intra-cell UEs	FRC (Annex A)		Fraction of maximum sum throughput of all the intra-cell UEs	UE1's SINR [dB]
		Wanted intra-cell UEs	Inter-cell interfering UE			UE1, UE3	UE2, UE4		
1	2	EPA 5 Low	ETU 5 Low	Set 2	Set 1	A22-2	A22-2	80%	16.1
		EVA 70 Low	ETU 70 Low	Set 1*	Set 2	A13-2	A13-2	80%	11.3
	4	EVA 70 Low	ETU 70 Low	Set 1*	Set 1	A13-2	A13-2	80%	10.5
		EPA 5 Low	ETU 5 Low	Set 2	Set 2	A21-2	A13-2	80%	0.7
Note*: Not applicable for Local Area BS and Home BS.									
Note 1: Antenna configuration applies for each of the intra-cell and inter-cell UEs.									
Note 2: The propagation conditions for the intra-cell and inter-cell UEs are statistically independent.									

Table 8.2.9.5-3: Enhanced performance requirement type B for PUSCH, 5 MHz Channel Bandwidth

Number of TX antennas (Note 1)	Number of RX antennas (Note 1)	Propagation conditions and correlation matrix (Annex B) (Note 2)		DIP set	Relative power of intra-cell UEs	FRC (Annex A)		Fraction of maximum sum throughput of all the intra-cell UEs	UE1's SINR [dB]
		Wanted intra-cell UEs	Inter-cell interfering UE			UE1, UE3	UE2, UE4		
1	2	EPA 5 Low	ETU 5 Low	Set 2	Set 1	A22-3	A22-3	80%	16.7
		EVA 70 Low	ETU 70 Low	Set 1*	Set 2	A13-3	A13-3	80%	11.6
	4	EVA 70 Low	ETU 70 Low	Set 1*	Set 1	A13-3	A13-3	80%	11.0
		EPA 5 Low	ETU 5 Low	Set 2	Set 2	A21-3	A13-3	80%	1.0
Note*: Not applicable for Local Area BS and Home BS.									
Note 1: Antenna configuration applies for each of the intra-cell and inter-cell UEs.									
Note 2: The propagation conditions for the intra-cell and inter-cell UEs are statistically independent.									

Table 8.2.9.5-4: Enhanced performance requirement type B for PUSCH, 10 MHz Channel Bandwidth

Number of TX antennas (Note 1)	Number of RX antennas (Note 1)	Propagation conditions and correlation matrix (Annex B) (Note 2)		DIP set	Relative power of intra-cell UEs	FRC (Annex A)		Fraction of maximum sum throughput of all the intra-cell UEs	UE1's SINR [dB]
		Wanted intra-cell UEs	Inter-cell interfering UE			UE1, UE3	UE2, UE4		
1	2	EPA 5 Low	ETU 5 Low	Set 2	Set 1	A22-4	A22-4	80%	16.8
		EVA 70 Low	ETU 70 Low	Set 1*	Set 2	A13-4	A13-4	80%	11.1
	4	EVA 70 Low	ETU 70 Low	Set 1*	Set 1	A13-4	A13-4	80%	10.6
		EPA 5 Low	ETU 5 Low	Set 2	Set 2	A21-4	A13-4	80%	0.8
Note*: Not applicable for Local Area BS and Home BS.									
Note 1: Antenna configuration applies for each of the intra-cell and inter-cell UEs.									
Note 2: The propagation conditions for the intra-cell and inter-cell UEs are statistically independent.									

Table 8.2.9.5-5: Enhanced performance requirement type B for PUSCH, 15 MHz Channel Bandwidth

Number of TX antennas (Note 1)	Number of RX antennas (Note 1)	Propagation conditions and correlation matrix (Annex B) (Note 2)		DIP set	Relative power of intra-cell UEs	FRC (Annex A)		Fraction of maximum sum throughput of all the intra-cell UEs	UE1's SINR [dB]
		Wanted intra-cell UEs	Inter-cell interfering UE			UE1, UE3	UE2, UE4		
1	2	EPA 5 Low	ETU 5 Low	Set 2	Set 1	A22-4	A22-4	80%	16.8
		EVA 70 Low	ETU 70 Low	Set 1*	Set 2	A13-5	A13-5	80%	11.2
	4	EVA 70 Low	ETU 70 Low	Set 1*	Set 1	A13-5	A13-5	80%	10.9
		EPA 5 Low	ETU 5 Low	Set 2	Set 2	A21-5	A13-5	80%	1.1
Note*: Not applicable for Local Area BS and Home BS.									
Note 1: Antenna configuration applies for each of the intra-cell and inter-cell UEs.									
Note 2: The propagation conditions for the intra-cell and inter-cell UEs are statistically independent.									

Table 8.2.9.5-6: Enhanced performance requirement type B for PUSCH, 20 MHz Channel Bandwidth

Number of TX antennas (Note 1)	Number of RX antennas (Note 1)	Propagation conditions and correlation matrix (Annex B) (Note 2)		DIP set	Relative power of intra-cell UEs	FRC (Annex A)		Fraction of maximum sum throughput of all the intra-cell UEs	UE1's SINR [dB]
		Wanted intra-cell UEs	Inter-cell interfering UE			UE1, UE3	UE2, UE4		
1	2	EPA 5 Low	ETU 5 Low	Set 2	Set 1	A22-4	A22-4	80%	16.9
		EVA 70 Low	ETU 70 Low	Set 1*	Set 2	A13-6	A13-6	80%	11.2
	4	EVA 70 Low	ETU 70 Low	Set 1*	Set 1	A13-6	A13-6	80%	10.9
		EPA 5 Low	ETU 5 Low	Set 2	Set 2	A21-6	A13-6	80%	1.2
Note*: Not applicable for Local Area BS and Home BS.									
Note 1: Antenna configuration applies for each of the intra-cell and inter-cell UEs.									
Note 2: The propagation conditions for the intra-cell and inter-cell UEs are statistically independent.									

NOTE: If the above Test Requirement differs from the Minimum Requirement then the Test Tolerance applied for this test is non-zero. The Test Tolerance for this test and the explanation of how the Minimum Requirement has been relaxed by the Test Tolerance is given in Annex G.

8.2.10 Performance requirements of PUSCH in multipath fading propagation conditions transmission on single antenna port for subPRB transmission

8.2.10.1 Definition and applicability

The performance requirement of PUSCH is determined by a minimum required throughput for a given SNR. The required throughput is expressed as a fraction of maximum throughput for the FRCs listed in Annex A. The performance requirements assume HARQ re-transmissions.

The tests for CEModeA defined in clause 8.2.10 are applicable only to the base stations supporting subPRB transmission under coverage enhancement configured with CEModeA. The tests for CEModeB defined in clause 8.2.10 are applicable only to the base stations supporting subPRB transmission under coverage enhancement configured with CEModeB.

A test for a specific channel bandwidth is only applicable if the BS supports it. For a BS supporting FDD multiple channel bandwidths, only the tests for the lowest and the highest FDD channel bandwidths supported by the BS are applicable. For a BS supporting TDD multiple channel bandwidths, only the tests for the lowest and the highest TDD channel bandwidths supported by the BS are applicable.

8.2.10.2 Minimum Requirement

The minimum requirement is in TS 36.104 [2] subclause 8.2.10.

8.2.10.3 Test Purpose

The test shall verify the receiver's ability to achieve throughput under multipath fading propagation conditions for a given SNR.

8.2.10.4 Method of test

8.2.10.4.1 Initial Conditions

Test environment: Normal, see subclause D.2.

RF channels to be tested: M; see subclause 4.7.

- 1) Connect the BS tester generating the wanted signal, multipath fading simulators and AWGN generators to all BS antenna connectors for diversity reception via a combining network as shown in Annex I.3.2.

8.2.10.4.2 Procedure

- 1) Adjust the AWGN generator, according to the channel bandwidth, defined in Table 8.2.10.4.2-1.

Table 8.2.10.4.2-1: AWGN power level at the BS input

Channel bandwidth [MHz]	AWGN power level
3	-88.7 dBm / 2.7 MHz
5	-86.5 dBm / 4.5 MHz
10	-83.5 dBm / 9 MHz
15	-81.7 dBm / 13.5 MHz
20	-80.4 dBm / 18 MHz

- 2) The characteristics of the wanted signal shall be configured according to the corresponding UL reference measurement channel defined in annex A and the test parameters in Table 8.2.10.4.2-2. The index of the narrowband is set to 0. For reference channels using resource blocks less than 6, the resource blocks shall be allocated from the lowest number within the indicated narrowband.

Table 8.2.10.4.2-2: Test parameters for testing PUSCH

Parameter	unit	CEMode A	CEMode B
Maximum number of HARQ transmissions		4	2
RV sequences (Note 3)		0, 2, 3, 1, 0, 2, 3, 1	0, 2, 3, 1, 0, 2, 3, 1
Number of PUSCH repetitions		1	16
Frequency hopping		ON	ON
Frequency hopping interval	subframes	4: FDD 5: TDD	4: FDD 5: TDD
Frequency hopping offset		$N_{NB}^{UL} - 1$ (Note 2)	$N_{NB}^{UL} - 1$ (Note 2)
Note 1: Guard period shall be created according to TS 36.211, 5.2.5 [12]			
Note 2: N_{NB}^{UL} is the total number of uplink narrowbands specified in TS 36.211, 5.2.4 [12]			
Note 3: RV changes per repetition every (RU size x number of RUs) transmission subframes.			

- 3) The multipath fading emulators shall be configured according to the corresponding channel model defined in annex B.
- 4) Adjust the equipment so that required SNR specified in Table 8.2.10.5-1 to 8.2.10.5-2 is achieved at the BS input.
- 5) For each of the reference channels in Table 8.2.10.5-1 to 8.2.10.5-2 applicable for the base station, measure the throughput, according to annex E.

8.2.10.5 Test Requirement

The throughput measured according to subclause 8.2.10.4.2 shall not be below the limits for the SNR levels specified in Table 8.2.10.5-1 for CEMode A tests and not be below the limits for the SNR levels specified in Table 8.2.10.5-2 for CEMode B tests.

Table 8.2.10.5-1: Minimum requirements for PUSCH for CEMode A

Number of TX antennas	Number of RX antennas	Channel Bandwidth (MHz)	Propagation conditions and correlation matrix (Annex B)	FRC (Annex A)	Fraction of maximum throughput	SNR [dB]
1	2	3	EPA 5Hz Low	A24-1	70%	0.0
1	2	5	EPA 5Hz Low	A24-1	70%	-0.2
1	2	10	EPA 5Hz Low	A24-1	70%	-0.2
1	2	15	EPA 5Hz Low	A24-1	70%	-0.4
1	2	20	EPA 5Hz Low	A24-1	70%	-0.4

Table 8.2.10.5-2: Minimum requirements for PUSCH for CEMode B

Number of TX antennas	Number of RX antennas	Channel Bandwidth (MHz)	Propagation conditions and correlation matrix (Annex B)	FRC (Annex A)	Fraction of maximum throughput	SNR [dB]
1	2	3	EPA 5Hz Low	A24-2	70%	-8.7
1	2	5	EPA 5Hz Low	A24-2	70%	-8.9
1	2	10	EPA 5Hz Low	A24-2	70%	-8.9
1	2	15	EPA 5Hz Low	A24-2	70%	-8.9
1	2	20	EPA 5Hz Low	A24-2	70%	-8.9

NOTE: If the above Test Requirement differs from the Minimum Requirement then the Test Tolerance applied for this test is non-zero. The Test Tolerance for this test and the explanation of how the Minimum Requirement has been relaxed by the Test Tolerance is given in Annex G.

8.3 Performance requirements for PUCCH

8.3.1 ACK missed detection for single user PUCCH format 1a transmission on single antenna port

8.3.1.1 Definition and applicability

The performance requirement of single user PUCCH for ACK missed detection is determined by the two parameters: probability of false detection of the ACK and the probability of detection of ACK. The performance is measured by the required SNR at probability of detection equal to 0.99. The probability of false detection of the ACK shall be 0.01 or less.

The probability of false detection of the ACK is defined as a conditional probability of erroneous detection of the ACK when input is only noise.

The probability of detection of ACK is defined as conditional probability of detection of the ACK when the signal is present.

The test is applicable to all BS. A test for a specific channel bandwidth is only applicable if the BS supports it.

For a BS supporting multiple channel bandwidths only the tests for the lowest and the highest channel bandwidth supported by the BS are applicable.

ACK/NACK repetitions are disabled for PUCCH transmission.

8.3.1.2 Minimum Requirement

The minimum requirement is in TS 36.104 [2] subclause 8.3.1.1 and 8.3.2.1.

8.3.1.3 Test purpose

The test shall verify the receiver's ability to detect ACK under multipath fading propagation conditions for a given SNR.

8.3.1.4 Method of test

8.3.1.4.1 Initial Conditions

Test environment: Normal, see subclause D.2.

RF channels to be tested: M; see subclause 4.7

- 1) Connect the BS tester generating the wanted signal, multipath fading simulators and AWGN generators to all BS antenna connectors for diversity reception via a combining network as shown in Annex I.3.2.

8.3.1.4.2 Procedure

- 1) Adjust the AWGN generator, according to the channel bandwidth defined in Table 8.3.1.4.2-1.

Table 8.3.1.4.2-1: AWGN power level at the BS input

Channel bandwidth [MHz]	AWGN power level
1.4	-89.7 dBm / 1.08MHz
3	-85.7 dBm / 2.7MHz
5	-83.5 dBm / 4.5MHz
10	-80.5 dBm / 9MHz
15	-78.7 dBm / 13.5MHz
20	-77.4 dBm / 18MHz

- 2) The characteristics of the wanted signal shall be configured according to TS 36.211 [12].
- 3) The multipath fading emulators shall be configured according to the corresponding channel model defined in Annex B.
- 4) Adjust the equipment so that the SNR specified in Table 8.3.1.5-1 is achieved at the BS input during the ACK transmissions.
- 5) The signal generator sends a test pattern with the pattern outlined in figure 8.3.1.4.2-1. The following statistics are kept: the number of ACKs detected in the idle periods and the number of missed ACKs.



Figure 8.3.1.4.2-1: Test signal pattern for single user PUCCH format 1a demodulation tests

8.3.1.5 Test Requirement

The fraction of falsely detected ACKs shall be less than 1% and the fraction of correctly detected ACKs shall be larger than 99% for the SNR listed in Table 8.3.1.5-1.

Table 8.3.1.5-1: Required SNR for single user PUCCH format 1a demodulation tests

Number of TX antennas	Number of RX antennas	Cyclic Prefix	Propagation conditions and correlation matrix (Annex B)	Channel Bandwidth / SNR [dB]					
				1.4 MHz	3 MHz	5 MHz	10 MHz	15 MHz	20 MHz
1	2	Normal	EPA 5 Low	-1.9	-3.3	-4.2	-4.8	-4.7	-4.5
			EVA 5 Low	-3.9	-4.5	-4.5	-4.4	-4.5	-4.5
			EVA 70 Low	-4.3	-4.6	-4.6	-4.5	-4.6	-4.5
			ETU 300* Low	-4.4	-4.5	-4.3	-4.4	-4.6	-4.6
		Extended	ETU 70* Low	-3.6	-3.7	-3.5	-3.7	-3.6	-3.7
	4	Normal	EPA 5 Low	-7.3	-7.8	-8.1	-8.3	-8.3	-8.4
			EVA 5 Low	-8.2	-8.5	-8.5	-8.2	-8.3	-8.3
			EVA 70 Low	-8.3	-8.4	-8.4	-8.2	-8.4	-8.2
			ETU 300* Low	-8.1	-8.3	-8.1	-8.1	-8.3	-8.2
		Extended	ETU 70* Low	-7.3	-7.5	-7.3	-7.5	-7.4	-7.4
	8	Normal	EPA 5 Low	-10.6	-10.9	-11.6	-11.7	-11.7	-11.7
			EVA 5 Low	-11.4	-11.4	-11.5	-11.5	-11.7	-11.6
			EVA 70 Low	-11.4	-11.5	-11.6	-11.5	-11.7	-11.5
			ETU 300* Low	-11	-11	-11	-11.2	-11	-11.2
		Extended	ETU 70* Low	-9.9	-10.1	-10	-10.1	-10	-10
	Note*: Not applicable for Local Area BS and Home BS.								

NOTE: If the above Test Requirement differs from the Minimum Requirement then the Test Tolerance applied for this test is non-zero. The Test Tolerance for this test and the explanation of how the Minimum Requirement has been relaxed by the Test Tolerance is given in Annex G.

8.3.2 CQI performance requirements for PUCCH format 2 transmission on single antenna port

8.3.2.1 Definition and applicability

The performance requirement of PUCCH format 2 for CQI is determined by the block error probability (BLER) of CQI. The performance is measured by the required SNR at BLER of 1%.

The CQI block error probability is defined as the conditional probability of incorrectly decoding the CQI information when the CQI information is sent. All CQI information shall be decoded (no exclusion due to DTX).

The test is applicable to all BS. A test for a specific channel bandwidth is only applicable if the BS supports it.

For a BS supporting multiple channel bandwidths only the tests for the lowest and the highest channel bandwidths supported by the BS are applicable.

8.3.2.2 Minimum Requirement

The minimum requirement is in TS 36.104 [2] subclause 8.3.3.1.

8.3.2.3 Test purpose

The test shall verify the receiver's ability to detect CQI under multipath fading propagation conditions for a given SNR.

8.3.2.4 Method of test

8.3.2.4.1 Initial Conditions

Test environment: Normal, see subclause D.2.

RF channels to be tested: M; see subclause 4.7

- 1) Connect the BS tester generating the wanted signal, multipath fading simulators and AWGN generators to all BS antenna connectors for diversity reception via a combining network as shown in Annex I.3.2.

8.3.2.4.2 Procedure

- 1) Adjust the AWGN generator, according to the channel bandwidth defined in Table 8.3.2.4.2-1.

Table 8.3.2.4.2-1: AWGN power level at the BS input

Channel bandwidth [MHz]	AWGN power level
1.4	-89.7 dBm / 1.08MHz
3	-85.7 dBm / 2.7MHz
5	-83.5 dBm / 4.5MHz
10	-80.5 dBm / 9MHz
15	-78.7 dBm / 13.5MHz
20	-77.4 dBm / 18MHz

- 2) The characteristics of the wanted signal shall be configured according to TS 36.211. The CQI information bit payload per sub-frame is equal to 4 bits.
- 3) The multipath fading emulators shall be configured according to the corresponding channel model defined in Annex B.
- 4) Adjust the equipment so that the SNR specified in Table 8.3.2.5-1 is achieved at the BS input during the CQI transmissions.
- 5) The signal generator sends a test pattern with the pattern outlined in figure 8.3.2.4.2-1. The following statistics are kept: the number of incorrectly decoded CQI.



Figure 8.3.2.4.2-1: Test signal pattern for PUCCH format 2 demodulation tests

8.3.2.5 Test Requirement

The fraction of incorrectly decoded CQIs shall be less than 1% for the SNR listed in Table 8.3.2.5-1.

Table 8.3.2.5-1: Required SNR for PUCCH format 2 demodulation tests

Number of TX antennas	Number of RX antennas	Cyclic Prefix	Propagation conditions and correlation matrix (Annex B)	Channel Bandwidth / SNR [dB]					
				1.4 MHz	3 MHz	5 MHz	10 MHz	15 MHz	20 MHz
1	2	Normal	EVA 5* Low	-3.1	-3.5	-3.8	-3.4	-3.6	-3.6
			ETU 70** Low	-3.3	-3.8	-3.6	-3.8	-3.8	-3.8
Note*: Not applicable for Wide Area BS and Medium Range BS.									
Note**: Not applicable for Local Area BS and Home BS.									

NOTE: If the above Test Requirement differs from the Minimum Requirement then the Test Tolerance applied for this test is non-zero. The Test Tolerance for this test and the explanation of how the Minimum Requirement has been relaxed by the Test Tolerance is given in Annex G.

8.3.3 ACK missed detection for multi user PUCCH format 1a

8.3.3.1 Definition and applicability

The performance requirement of multi user PUCCH for ACK missed detection is determined by the two parameters: probability of false detection of the ACK and the probability of detection of ACK on the wanted signal. The performance is measured by the required SNR at probability of detection equal to 0.99. The probability of false detection of the ACK shall be 0.01 or less. These probabilities are measured on the wanted signal at presence of three interfering signals as specified in clause 8.3.3.4.2.

The probability of false detection of the ACK is defined as a conditional probability of erroneous detection of the ACK when input is only noise and the interfering signals are present.

The probability of detection of ACK is defined as conditional probability of detection of the ACK when the signal is present.

The test is applicable to all BS. A test for a specific channel bandwidth is only applicable if the BS supports it.

For a BS supporting multiple channel bandwidths only the tests for the lowest and the highest channel bandwidths supported by the BS **are** applicable.

Multi user PUCCH test is performed only for 2 Rx antennas, Normal CP and for ETU70 propagation conditions.

ACK/NACK repetitions are disabled for PUCCH transmission.

8.3.3.2 Minimum Requirement

The minimum requirements are in TS 36.104 [2] subclause 8.3.1.1 and 8.3.4.1.

8.3.3.3 Test purpose

The test shall verify the receiver's ability to detect ACK on the wanted signal at presence of three interfering signals as specified in clause 8.3.3.4.2, under multipath fading propagation conditions for a given SNR.

8.3.3.4 Method of test

8.3.3.4.1 Initial Conditions

Test environment: Normal, see subclause D.2.

RF channels to be tested: M; see subclause 4.7.

- 1) Connect the BS tester generating the wanted and all interfering signals, multipath fading simulators and AWGN generators to both BS antenna connectors for 2Rx diversity reception via a combining network as shown in Annex I.3.3.
- 2) Interconnect attenuators for relative power setting purposes for all transmitting branches (wanted signal and all interferers, separately).

8.3.3.4.2 Procedure

- 1) Adjust the AWGN generator, according to the channel bandwidth defined in Table 8.3.3.4.2-1.

Table 8.3.3.4.2-1: AWGN power level at the BS input

Channel bandwidth [MHz]	AWGN power level
1.4	-89.7 dBm / 1.08MHz
3	-85.7 dBm / 2.7MHz
5	-83.5 dBm / 4.5MHz
10	-80.5 dBm / 9MHz
15	-78.7 dBm / 13.5MHz
20	-77.4 dBm / 18MHz

- 2) In multi user PUCCH test, four signals are configured: one wanted signal and three interferers, which are transmitted via separate fading paths using relative power settings presented in Annex A.9.

All signals are transmitted on the same PUCCH resources, with different PUCCH channel indices, as presented in Annex A.9.

The characteristics of the all signals (i.e. wanted and all interferers) shall be configured according to 36.211 [12].

- 3) The multipath fading emulators shall be configured according to ETU70 propagation conditions defined in Annex B.
- 4) Adjust the equipment so that the SNR specified in Table 8.3.3.5-1 is achieved at the BS input during the ACK transmissions on the wanted signal.
- 5) The signal generator sends a test pattern with the pattern outlined in figure 8.3.3.4.2-1. This statement is valid for the wanted PUCCH signal. All interferers are present for all subframes. The following statistics are kept: the number of ACKs detected in the idle periods and the number of missed ACKs on the wanted PUCCH signal.



Figure 8.3.3.4.2-1: Test signal pattern for multi user PUCCH demodulation tests

8.3.3.5 Test Requirement

The fraction of falsely detected ACKs on the wanted signal shall be less than 1% and the fraction of correctly detected ACKs shall be larger than 99% for the SNR listed in Table 8.3.3.5-1.

Table 8.3.3.5-1: Required SNR for multi user PUCCH demodulation tests

Number of TX antennas	Number of RX antennas	Cyclic Prefix	Propagation conditions and correlation matrix (Annex B)	Channel Bandwidth / SNR [dB]					
				1.4 MHz	3 MHz	5 MHz	10 MHz	15 MHz	20 MHz
1	2	Normal	ETU 70* Low	-3.5	-3.8	-3.8	-4.0	-4.0	-3.8

Note*: Not applicable for Local Area BS and Home BS.

NOTE: If the above Test Requirement differs from the Minimum Requirement then the Test Tolerance applied for this test is non-zero. The Test Tolerance for this test and the explanation of how the Minimum Requirement has been relaxed by the Test Tolerance is given in Annex G.

8.3.4 ACK missed detection for PUCCH format 1b with Channel Selection

8.3.4.1 Definition and applicability

The performance requirement of PUCCH format 1b with Channel Selection for ACK missed detection is determined by the two parameters: probability of false detection of the ACK and the probability of detection of ACK. The performance is measured by the required SNR at probability of detection equal to 0.99. The probability of false detection of the ACK shall be 0.01 or less.

The probability of false detection of the ACK is defined as a conditional probability of erroneous detection of the ACK at particular channel when input is only noise.

The probability of detection of ACK is defined as conditional probability of detection of the ACK when the ACK was sent at particular channel.

The test is applicable to all BS. A test for a specific channel bandwidth is only applicable if the BS supports it.

For a BS supporting multiple channel bandwidths only the tests for the lowest and the highest channel bandwidth supported by the BS are applicable.

The number of encoded ACK/NACK bits per sub-frame is equal to 4 bits (AAAA),

ACK/NACK repetitions are disabled for PUCCH transmission.

8.3.4.2 Minimum Requirement

The minimum requirement is in TS 36.104 [2] subclause 8.3.1.1 and 8.3.5.1.

8.3.4.3 Test purpose

The test shall verify the receiver's ability to detect ACK bits under multipath fading propagation conditions for a given SNR.

8.3.4.4 Method of test

8.3.4.4.1 Initial Conditions

Test environment: Normal, see subclause D.2.

RF channels to be tested: M; see subclause 4.7

- 1) Connect the BS tester generating the wanted signal, multipath fading simulators and AWGN generators to all BS antenna connectors for diversity reception via a combining network as shown in Annex I.3.2.

8.3.4.4.2 Procedure

- 1) Adjust the AWGN generator, according to the channel bandwidth defined in Table 8.3.4.4.2-1.

Table 8.3.4.4.2-1: AWGN power level at the BS input

Channel bandwidth [MHz]	AWGN power level
10	-80.5 dBm / 9MHz
15	-78.7 dBm / 13.5MHz
20	-77.4 dBm / 18MHz

- 2) The characteristics of the wanted signal shall be configured according to TS 36.211 [12].
- 3) The multipath fading emulators shall be configured according to the corresponding channel model defined in Annex B.
- 4) Adjust the equipment so that the SNR specified in Table 8.3.4.5-1 is achieved at the BS input during the AAAA codeword transmissions.
- 5) The signal generator sends AAAA codeword in regular time periods. The following statistics are kept: the number of ACK bits falsely detected in the idle periods and the number of missed ACK bits. Each falsely detected ACK bit in the idle periods is accounted as one error for the statistics of false ACK detection, and each missed ACK bit is accounted as one error for the statistics of missed ACK detection.

8.3.4.5 Test Requirement

The fraction of falsely detected ACK bits shall be less than 1% and the fraction of correctly detected ACK bits shall be larger than 99% for the SNR listed in Table 8.3.4.5-1.

Table 8.3.4.5-1: Required SNR for PUCCH format 1b with Channel Selection demodulation tests

Number of TX antennas	Number of RX antennas	Cyclic Prefix	Propagation conditions and correlation matrix (Annex B)	Channel Bandwidth / SNR [dB]					
				1.4MHz	3MHz	5MHz	10 MHz	15MHz	20MHz
1	2	Normal	EPA 5 Low	-	-	-	-3.9	-4.0	-4.0
			EVA70 Low	-	-	-	-3.7	-3.9	-3.9
	4	Normal	EPA 5 Low	-	-	-	-7.8	-7.9	-8.0
			EVA70 Low	-	-	-	-7.7	-7.9	-7.9
	8	Normal	EPA 5 Low	-	-	-	-11.1	-11.2	-11.2
			EVA70 Low	-	-	-	-10.9	-11.1	-11.0

NOTE: If the above Test Requirement differs from the Minimum Requirement then the Test Tolerance applied for this test is non-zero. The Test Tolerance for this test and the explanation of how the Minimum Requirement has been relaxed by the Test Tolerance is given in Annex G.

8.3.5 ACK missed detection for PUCCH format 3

8.3.5.1 Definition and applicability

The performance requirement of PUCCH format 3 for ACK missed detection is determined by the two parameters: probability of false detection of the ACK and the probability of detection of ACK. The performance is measured by the required SNR at probability of detection equal to 0.99. The probability of false detection of the ACK shall be 0.01 or less.

The probability of false detection of the ACK is defined as a conditional probability of erroneous detection of the ACK at particular bit position when input is only noise.

The probability of detection of ACK is defined as conditional probability of detection of the ACK when the ACK was sent at particular bit position. Each missed ACK bit is counted as one error.

The test is applicable to all BS. A test for a specific channel bandwidth is only applicable if the BS supports it.

For a BS supporting multiple channel bandwidths only the tests for the lowest and the highest channel bandwidth supported by the BS are applicable.

The number of encoded ACK/NACK bits per sub-frame is defined for two cases as presented below:

- 4AN bits: applicable for FDD and TDD
- 16AN bits : applicable for TDD

ACK/NACK repetitions are disabled for PUCCH transmission. Random codeword selection is assumed.

8.3.5.2 Minimum Requirement

The minimum requirement is in TS 36.104 [2] subclause 8.3.1.1 and 8.3.6.1.

8.3.5.3 Test purpose

The test shall verify the receiver's ability to detect ACK bits in codeword's from applicable codebook being randomly selected, under multipath fading propagation conditions for a given SNR.

8.3.5.4 Method of test

8.3.5.4.1 Initial Conditions

Test environment: Normal, see subclause D.2.

RF channels to be tested: M; see subclause 4.7

- 1) Connect the BS tester generating the wanted signal, multipath fading simulators and AWGN generators to all BS antenna connectors for diversity reception via a combining network as shown in Annex I.3.2.

8.3.5.4.2 Procedure

- 1) Adjust the AWGN generator, according to the channel bandwidth defined in Table 8.3.5.4.2-1.

Table 8.3.5.4.2-1: AWGN power level at the BS input

Channel bandwidth [MHz]	AWGN power level
10	-80.5 dBm / 9MHz
15	-78.7 dBm / 13.5MHz
20	-77.4 dBm / 18MHz

- 2) The characteristics of the wanted signal shall be configured according to TS 36.211 [12].
- 3) The multipath fading emulators shall be configured according to the corresponding channel model defined in Annex B.
- 4) Adjust the equipment so that the SNR specified in Table 8.3.5.5-1 or 8.3.5.5-2 is achieved at the BS input during the codeword's transmissions.
- 5) The signal generator sends random codewords from applicable codebook, in regular time periods. The following statistics are kept: the number of ACK bits falsely detected in the idle periods and the number of missed ACK bits. Each falsely detected ACK bit in the idle periods is accounted as one error for the statistics of false ACK detection, and each missed ACK bit is accounted as one error for the statistics of missed ACK detection.

8.3.5.5 Test Requirement

The fraction of falsely detected ACK bits shall be less than 1% and the fraction of correctly detected ACK bits shall be larger than 99% for the SNR listed in Tables 8.3.5.5-1 and 8.3.5.5-2.

Table 8.3.5.5-1: Required SNR for PUCCH format 3 demodulation tests, 4AN bits

Number of TX antennas	Number of RX antennas	Cyclic Prefix	Propagation conditions and correlation matrix (Annex B)	Channel Bandwidth / SNR [dB]					
				1.4MHz	3MHz	5MHz	10 MHz	15MHz	20MHz
1	2	Normal	EPA 5 Low	-	-	-	-3.1	-3.2	-3.2
			EVA70 Low	-	-	-	-2.9	-3.0	-3.1
	4	Normal	EPA 5 Low	-	-	-	-6.7	-6.8	-6.9
			EVA70 Low	-	-	-	-6.6	-6.7	-6.7
	8	Normal	EPA 5 Low	-	-	-	-10.5	-10.3	-10.5
			EVA70 Low	-	-	-	-10.3	-10.4	-10.4

Table 8.3.5.5-2: Required SNR for PUCCH format 3 demodulation tests, 16AN bits

Number of TX antennas	Number of RX antennas	Cyclic Prefix	Propagation conditions and correlation matrix (Annex B)	Channel Bandwidth / SNR [dB]					
				1.4MHz	3MHz	5MHz	10 MHz	15MHz	20MHz
1	2	Normal	EPA 5 Low	-	-	-	-0.7	-0.6	-0.6
			EVA70 Low	-	-	-	-0.2	-0.3	-0.3
	4	Normal	EPA 5 Low	-	-	-	-4.7	-4.7	-4.8
			EVA70 Low	-	-	-	-4.4	-4.5	-4.5
	8	Normal	EPA 5 Low	-	-	-	-8.2	-8.2	-8.3
			EVA70 Low	-	-	-	-8.1	-8.2	-8.1

NOTE: If the above Test Requirement differs from the Minimum Requirement then the Test Tolerance applied for this test is non-zero. The Test Tolerance for this test and the explanation of how the Minimum Requirement has been relaxed by the Test Tolerance is given in Annex G.

8.3.6 NACK to ACK detection for PUCCH format 3

8.3.6.1 Definition and applicability

The performance requirement of PUCCH format 3 for NACK to ACK detection is determined by the two parameters: probability of false detection of the ACK and the NACK to ACK detection probability. The performance is measured by the required SNR at probability of the NACK to ACK detection equal to 0.001 or less. The probability of false detection of the ACK shall be 0.01 or less.

The probability of false detection of the ACK is defined as a conditional probability of erroneous detection of the ACK at particular bit position when input is only noise. Each false bit detection is counted as one error.

The NACK to ACK detection probability is the probability of detecting an ACK bit when an NACK bit was sent on particular bit position. Each NACK bit erroneously detected as ACK bit is counted as one error. Erroneously detected NACK bits in the definition do not contain the NACK bits which are mapped from DTX, i.e. NACK bits received when DTX is sent should not be considered.

The test is applicable to all BS. A test for a specific channel bandwidth is only applicable if the BS supports it.

For a BS supporting multiple channel bandwidths only the tests for the lowest and the highest channel bandwidth supported by the BS are applicable.

The number of encoded ACK/NACK bits per sub-frame is defined as presented below, with random codeword selection assumed:

- 16AN bits: applicable for TDD

ACK/NACK repetitions are disabled for PUCCH transmission. Random codeword selection is assumed.

8.3.6.2 Minimum Requirement

The minimum requirement is in TS 36.104 [2] subclause 8.3.1.1 and 8.3.6.1.

8.3.6.3 Test purpose

The test shall verify the receiver's ability not to falsely detect NACK bits, transmitted in codeword randomly selected from applicable codebook, as ACK bits under multipath fading propagation conditions for a given SNR.

8.3.6.4 Method of test

8.3.6.4.1 Initial Conditions

Test environment: Normal, see subclause D.2.

RF channels to be tested: M; see subclause 4.7

- 1) Connect the BS tester generating the wanted signal, multipath fading simulators and AWGN generators to all BS antenna connectors for diversity reception via a combining network as shown in Annex I.3.2.

8.3.6.4.2 Procedure

- 1) Adjust the AWGN generator, according to the channel bandwidth defined in Table 8.3.6.4.2-1.

Table 8.3.6.4.2-1: AWGN power level at the BS input

Channel bandwidth [MHz]	AWGN power level
10	-80.5 dBm / 9MHz
15	-78.7 dBm / 13.5MHz
20	-77.4 dBm / 18MHz

- 2) The characteristics of the wanted signal shall be configured according to TS 36.211 [12].
- 3) The multipath fading emulators shall be configured according to the corresponding channel model defined in Annex B.
- 4) Adjust the equipment so that the SNR specified in Table 8.3.6.5-1 is achieved at the BS input during the codeword's transmissions.
- 5) The signal generator sends random codeword from applicable codebook, in regular time periods. The following statistics are kept: the number of ACK bits detected in the idle periods and the number of NACK bits detected as ACK.

8.3.6.5 Test Requirement

The fraction of falsely detected ACK bits shall be less than 1% and the fraction of NACK bits falsely detected as ACK shall be less than 0,1% for the SNR listed in Tables 8.3.6.5-1.

Table 8.3.6.5-1: Required SNR for PUCCH format 3 demodulation tests, 16AN bits

Number of TX antennas	Number of RX antennas	Cyclic Prefix	Propagation conditions and correlation matrix (Annex B)	Channel Bandwidth / SNR [dB]					
				1.4MHz	3MHz	5MHz	10 MHz	15MHz	20MHz
1	2	Normal	EPA 5 Low	-	-	-	2.0	2.2	2.1
			EVA70 Low	-	-	-	2.7	2.5	2.5
	4	Normal	EPA 5 Low	-	-	-	-2.5	-2.7	-2.9
			EVA70 Low	-	-	-	-2.3	-2.5	-2.6
	8	Normal	EPA 5 Low	-	-	-	-6.7	-6.7	-6.7
			EVA70 Low	-	-	-	-6.4	-6.5	-6.6

NOTE: If the above Test Requirement differs from the Minimum Requirement then the Test Tolerance applied for this test is non-zero. The Test Tolerance for this test and the explanation of how the Minimum Requirement has been relaxed by the Test Tolerance is given in Annex G.

8.3.7 ACK missed detection for PUCCH format 1a transmission on two antenna ports

8.3.7.1 Definition and applicability

The performance requirement of PUCCH for ACK missed detection is determined by the two parameters: probability of false detection of the ACK and the probability of detection of ACK. The performance is measured by the required SNR at probability of detection equal to 0.99. The probability of false detection of the ACK shall be 0.01 or less.

The probability of false detection of the ACK is defined as a conditional probability of erroneous detection of the ACK when input is only noise.

The probability of detection of ACK is defined as conditional probability of detection of the ACK when the signal is present.

The test is applicable to all BS. A test for a specific channel bandwidth is only applicable if the BS supports it.

For a BS supporting multiple channel bandwidths only the tests for the lowest and the highest channel bandwidth supported by the BS are applicable.

ACK/NACK repetitions are disabled for PUCCH transmission.

8.3.7.2 Minimum Requirement

The minimum requirement is in TS 36.104 [2] subclause 8.3.1.1 and 8.3.2.1.

8.3.7.3 Test purpose

The test shall verify the receiver's ability to detect ACK under multipath fading propagation conditions for a given SNR.

8.3.7.4 Method of test

8.3.7.4.1 Initial Conditions

Test environment: Normal, see subclause D.2.

RF channels to be tested: M; see subclause 4.7

- 1) Connect the BS tester generating the wanted signal, multipath fading simulators and AWGN generators to all BS antenna connectors for diversity reception via a combining network as shown in Annex I.3.5.

8.3.7.4.2 Procedure

- 1) Adjust the AWGN generator, according to the channel bandwidth defined in Table 8.3.7.4.2-1.

Table 8.3.7.4.2-1: AWGN power level at the BS input

Channel bandwidth [MHz]	AWGN power level
1.4	-89.7 dBm / 1.08MHz
3	-85.7 dBm / 2.7MHz
5	-83.5 dBm / 4.5MHz
10	-80.5 dBm / 9MHz
15	-78.7 dBm / 13.5MHz
20	-77.4 dBm / 18MHz

- 2) Signals transmitted on two antenna ports are on the same PUCCH resource block with different channel indices as presented in Annex A.10. The characteristics of the wanted signal shall be configured according to TS 36.211 [12].
- 3) The multipath fading emulators shall be configured according to the corresponding channel model defined in Annex B.
- 4) Adjust the equipment so that the SNR specified in Table 8.3.7.5-1 is achieved at the BS input during the ACK transmissions.
- 5) The signal generator sends a test pattern with the pattern outlined in figure 8.3.7.4.2-1. The following statistics are kept: the number of ACKs detected in the idle periods and the number of missed ACKs.



Figure 8.3.7.4.2-1: Test signal pattern for PUCCH format 1a demodulation tests

8.3.7.5 Test Requirement

The fraction of falsely detected ACKs shall be less than 1% and the fraction of correctly detected ACKs shall be larger than 99% for the SNR listed in Table 8.3.7.5-1.

Table 8.3.7.5-1: Required SNR for single user PUCCH format 1a demodulation tests

Number of TX antennas	Number of RX antennas	Cyclic Prefix	Propagation conditions and correlation matrix (Annex B)	Channel Bandwidth / SNR [dB]					
				1.4 MHz	3 MHz	5 MHz	10 MHz	15 MHz	20 MHz
2	2	Normal	EPA 5 Low	-3.8	-4.1	-5.6	-5.7	-5.7	-5.9
			EVA 70 Low	-5.0	-5.1	-5.6	-5.1	-5.6	-5.6
	4	Normal	EPA 5 Low	-7.7	-7.7	-8.5	-8.7	-8.7	-8.7
			EVA 70 Low	-8.2	-8.4	-8.5	-8.5	-8.6	-8.7
	8	Normal	EPA 5 Low	-10.6	-10.7	-11.1	-11.2	-11.1	-11.2
			EVA 70 Low	-10.9	-11.0	-11.0	-11.0	-11.0	-11.0

NOTE: If the above Test Requirement differs from the Minimum Requirement then the Test Tolerance applied for this test is non-zero. The Test Tolerance for this test and the explanation of how the Minimum Requirement has been relaxed by the Test Tolerance is given in Annex G.

8.3.8 CQI performance requirements for PUCCH format 2 transmission on two antenna ports

8.3.8.1 Definition and applicability

The performance requirement of PUCCH format 2 for CQI is determined by the block error probability (BLER) of CQI. The performance is measured by the required SNR at BLER of 1%.

The CQI block error probability is defined as the conditional probability of incorrectly decoding the CQI information when the CQI information is sent. All CQI information shall be decoded (no exclusion due to DTX).

The test is applicable to all BS. A test for a specific channel bandwidth is only applicable if the BS supports it.

For a BS supporting multiple channel bandwidths only the tests for the lowest and the highest channel bandwidths supported by the BS are applicable.

8.3.8.2 Minimum Requirement

The minimum requirement is in TS 36.104 [2] subclause 8.3.2.1.

8.3.8.3 Test purpose

The test shall verify the receiver's ability to detect CQI under multipath fading propagation conditions for a given SNR.

8.3.8.4 Method of test

8.3.8.4.1 Initial Conditions

Test environment: Normal, see subclause D.2.

RF channels to be tested: M; see subclause 4.7

- 1) Connect the BS tester generating the wanted signal, multipath fading simulators and AWGN generators to all BS antenna connectors for diversity reception via a combining network as shown in Annex I.3.5.

8.3.8.4.2 Procedure

- 1) Adjust the AWGN generator, according to the channel bandwidth defined in Table 8.3.8.4.2-1.

Table 8.3.8.4.2-1: AWGN power level at the BS input

Channel bandwidth [MHz]	AWGN power level
1.4	-89.7 dBm / 1.08MHz
3	-85.7 dBm / 2.7MHz
5	-83.5 dBm / 4.5MHz
10	-80.5 dBm / 9MHz
15	-78.7 dBm / 13.5MHz
20	-77.4 dBm / 18MHz

- 2) Signals transmitted on two antenna ports are on the same PUCCH resource block with different channel indices as presented in Annex A.10. The characteristics of the wanted signal shall be configured according to TS 36.211. The CQI information bit payload per sub-frame is equal to 4 bits.
- 3) The multipath fading emulators shall be configured according to the corresponding channel model defined in Annex B.
- 4) Adjust the equipment so that the SNR specified in Table 8.3.8.5-1 is achieved at the BS input during the CQI transmissions.
- 5) The signal generator sends a test pattern with the pattern outlined in figure 8.3.8.4.2-1. The following statistics are kept: the number of incorrectly decoded CQI.



Figure 8.3.8.4.2-1: Test signal pattern for PUCCH format 2 demodulation tests

8.3.8.5 Test Requirement

The fraction of incorrectly decoded CQIs shall be less than 1% for the SNR listed in Table 8.3.8.5-1.

Table 8.3.8.5-1: Required SNR for PUCCH format 2 demodulation tests

Number of TX antennas	Number of RX antennas	Cyclic Prefix	Propagation conditions and correlation matrix (Annex B)	Channel Bandwidth / SNR [dB]					
				1.4 MHz	3 MHz	5 MHz	10 MHz	15 MHz	20 MHz
2	2	Normal	EVA 5 Low	-4.9	-4.8	-5.1	-5.0	-5.1	-5.1

NOTE: If the above Test Requirement differs from the Minimum Requirement then the Test Tolerance applied for this test is non-zero. The Test Tolerance for this test and the explanation of how the Minimum Requirement has been relaxed by the Test Tolerance is given in Annex G.

8.3.9 CQI performance requirements for PUCCH format 2 with DTX detection

8.3.9.1 Definition and applicability

The requirements in this subclause apply to a BS supporting PUCCH format 2 with DTX. It is optional for a BS to support PUCCH format 2 with DTX.

A BS may meet the PUCCH format 2 requirements specified in Clause 8.3.9 instead of requirements specified in Clause 8.3.2 and Clause 8.3.8 for single antenna port and two antenna ports, respectively.

The performance requirement of PUCCH format 2 for CQI is determined by the block error probability (BLER) of CQI. The CQI block error probability (BLER) is defined as the sum of the:

- conditional probability of incorrectly decoding the CQI information when the CQI information is sent and
- conditional probability of detecting UE transmission as DTX, when the CQI information is sent.

The CQI false alarm probability is defined as the conditional probability of false detecting the CQI information transmitted from UE when no CQI information is sent.

The performance is measured by the required SNR at CQI BLER of 1% and CQI false alarm rate of 10%.

A test for a specific channel bandwidth is only applicable if the BS supports it.

For a BS supporting multiple channel bandwidths only the tests for the lowest and the highest channel bandwidths supported by the BS are applicable.

8.3.9.2 Minimum Requirement

The minimum requirement is in TS 36.104 [2] subclause 8.3.8.1.

8.3.9.3 Test purpose

The test shall verify the receiver's ability to detect CQI under multipath fading propagation conditions for a given SNR.

8.3.9.4 Method of test

8.3.9.4.1 Initial Conditions

Test environment: Normal, see subclause D.2.

RF channels to be tested: M; see subclause 4.7

- 1) Connect the BS tester generating the wanted signal, multipath fading simulators and AWGN generators to all BS antenna connectors for diversity reception via a combining network as shown in Annex I.3.2 for single transmit antenna port, and in Annex I.3.5 for two antenna ports.

8.3.9.4.2 Procedure

- 1) Adjust the AWGN generator, according to the channel bandwidth defined in Table 8.3.9.4.2-1.

Table 8.3.9.4.2-1: AWGN power level at the BS input

Channel bandwidth [MHz]	AWGN power level
1.4	-89.7 dBm / 1.08MHz
3	-85.7 dBm / 2.7MHz
5	-83.5 dBm / 4.5MHz
10	-80.5 dBm / 9MHz
15	-78.7 dBm / 13.5MHz
20	-77.4 dBm / 18MHz

- 2) For two antenna ports, transmitted signals are on the same PUCCH resource block with different channel indices as presented in Annex A.10. The characteristics of the wanted signal shall be configured according to TS 36.211. The CQI information bit payload per sub-frame is equal to 4 bits.
- 3) The multipath fading emulators shall be configured according to the corresponding channel model defined in Annex B.
- 4) Adjust the equipment so that the SNR specified in Table 8.3.9.5-1 is achieved at the BS input during the CQI transmissions.
- 5) The signal generator sends a test pattern with the pattern outlined in figure 8.3.9.4.2-1. The following statistics are kept: the number of incorrectly decoded CQI, and the number of incorrectly detected DTX.



Figure 8.3.9.4.2-1: Test signal pattern for PUCCH format 2 demodulation tests

8.3.9.5 Test Requirement

The CQI false alarm probability and the CQI block error probability shall not exceed 10% and 1%, respectively, at the SNR given in table 8.3.9.5-1.

Table 8.3.9.5-1: Required SNR for PUCCH format 2 demodulation tests with DTX detection

Number of TX antennas	Number of RX antennas	Cyclic Prefix	Propagation conditions and correlation matrix (Annex B)	Channel Bandwidth / SNR [dB]					
				1.4 MHz	3 MHz	5 MHz	10 MHz	15 MHz	20 MHz
1	2	Normal	EVA 5* Low	-3.1	-3.4	-3.8	-3.4	-3.6	-3.6
			ETU 70** Low	-3.1	-3.4	-3.1	-3.5	-3.3	-3.5
2	2	Normal	EVA 5 Low	-4.5	-4.4	-4.7	-4.6	-4.5	-4.7

Note*: Not applicable for Wide Area BS and Medium Range BS.
 Note**: Not applicable for Local Area BS and Home BS.

NOTE: If the above Test Requirement differs from the Minimum Requirement then the Test Tolerance applied for this test is non-zero. The Test Tolerance for this test and the explanation of how the Minimum Requirement has been relaxed by the Test Tolerance is given in Annex G.

8.3.10 ACK missed detection for PUCCH format 1a transmission on single antenna port for coverage enhancement

8.3.10.1 Definition and applicability

The performance requirement of PUCCH for ACK missed detection is determined by the two parameters: probability of false detection of the ACK and the probability of detection of ACK. The performance is measured by the required SNR at probability of detection equal to 0.99. The probability of false detection of the ACK shall be 0.01 or less.

The probability of false detection of the ACK is defined as a conditional probability of erroneous detection of the ACK for the configured PUCCH transmission repetitions when input is only noise.

The probability of detection of ACK is defined as conditional probability of detection of the ACK for the configured PUCCH transmission repetitions when the signal is present.

The test is applicable only to base stations supporting coverage enhancement. A test for a specific channel bandwidth is only applicable if the BS supports it.

For a BS supporting multiple channel bandwidths only the tests for the lowest and the highest channel bandwidth supported by the BS are applicable.

8.3.10.2 Minimum Requirement

The minimum requirement is in TS 36.104 [2] subclause 8.3.9.1 and 8.3.9.2.

8.3.10.3 Test purpose

The test shall verify the receiver’s ability to detect ACK under multipath fading propagation conditions for a given SNR.

8.3.10.4 Method of test

8.3.10.4.1 Initial Conditions

Test environment: Normal, see subclause D.2.

RF channels to be tested: M; see subclause 4.7

- 1) Connect the BS tester generating the wanted signal, multipath fading simulators and AWGN generators to all BS antenna connectors for diversity reception via a combining network as shown in Annex I.3.2.

8.3.10.4.2 Procedure

- 1) Adjust the AWGN generator, according to the channel bandwidth defined in Table 8.3.10.4.2-1.

Table 8.3.10.4.2-1: AWGN power level at the BS input

Channel bandwidth [MHz]	AWGN power level
1.4	-89.7 dBm / 1.08MHz
3	-85.7 dBm / 2.7MHz
5	-83.5 dBm / 4.5MHz
10	-80.5 dBm / 9MHz
15	-78.7 dBm / 13.5MHz
20	-77.4 dBm / 18MHz

- 2) The characteristics of the wanted signal shall be configured according to TS 36.211 [12].
- 3) The multipath fading emulators shall be configured according to the corresponding channel model defined in Annex B.
- 4) Adjust the equipment so that the SNR specified in Table 8.3.10.5-1 is achieved at the BS input during the ACK transmissions.
- 5) The signal generator sends a test pattern with the pattern outlined in figure 8.3.10.4.2-1. The following statistics are kept: the number of ACKs detected in the idle periods and the number of missed ACKs.

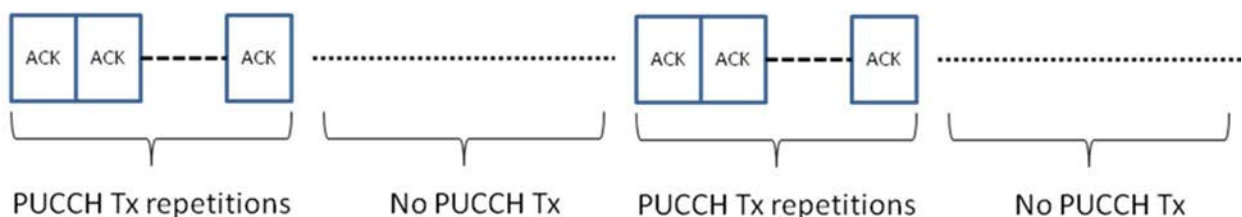

Figure 8.3.10.4.2-1: Test signal pattern for PUCCH format 1a demodulation tests

8.3.10.5 Test Requirement

The fraction of falsely detected ACKs shall be less than 1% and the fraction of correctly detected ACKs shall be larger than 99% for the SNR listed in Table 8.3.10.5-1.

Table 8.3.10.5-1: Required SNR for PUCCH format 1a demodulation tests

Number of TX antennas	Number of RX antennas	Cyclic Prefix	Propagation conditions and correlation matrix (Annex B)	Repetitions	Channel Bandwidth / SNR [dB]				
					3 MHz	5 MHz	10 MHz	15 MHz	20 MHz
1	2	normal	EPA5 Low	4	-4.6	-4.9	-4.9	-5.0	-4.9
				8	-8.6	-10.4	-10.3	-10.5	-10.7
				32	-13.1	-14.2	-14.5	-14.5	-14.5
Note 1: Frequency Hopping Intervals: 4 (FDD); 10 (TDD)									
Note 2: Guard period shall be created according to TS36.211, 5.2.5 [12]									

NOTE: If the above Test Requirement differs from the Minimum Requirement then the Test Tolerance applied for this test is non-zero. The Test Tolerance for this test and the explanation of how the Minimum Requirement has been relaxed by the Test Tolerance is given in Annex G.

8.3.11 CQI performance requirements for PUCCH format 2 transmission on single antenna port for coverage enhancement

8.3.11.1 Definition and applicability

The performance requirement of PUCCH format 2 for CQI is determined by the block error probability (BLER) of CQI. The performance is measured by the required SNR at BLER of 1%.

The CQI block error probability is defined as the conditional probability of incorrectly decoding the CQI information for the configured PUCCH transmission repetitions when the CQI information is sent. All CQI information shall be decoded (no exclusion due to DTX).

The test is applicable to all BS. A test for a specific channel bandwidth is only applicable if the BS supports it.

For a BS supporting multiple channel bandwidths only the tests for the lowest and the highest channel bandwidths supported by the BS are applicable.

8.3.11.2 Minimum Requirement

The minimum requirement is in TS 36.104 [2] subclause 8.3.9.3.

8.3.11.3 Test purpose

The test shall verify the receiver's ability to detect CQI under multipath fading propagation conditions for a given SNR.

8.3.11.4 Method of test

8.3.11.4.1 Initial Conditions

Test environment: Normal, see subclause D.2.

RF channels to be tested: M; see subclause 4.7

- 1) Connect the BS tester generating the wanted signal, multipath fading simulators and AWGN generators to all BS antenna connectors for diversity reception via a combining network as shown in Annex I.3.2.

8.3.11.4.2 Procedure

- 1) Adjust the AWGN generator, according to the channel bandwidth defined in Table 8.3.11.4.2-1.

Table 8.3.11.4.2-1: AWGN power level at the BS input

Channel bandwidth [MHz]	AWGN power level
1.4	-89.7 dBm / 1.08MHz
3	-85.7 dBm / 2.7MHz
5	-83.5 dBm / 4.5MHz
10	-80.5 dBm / 9MHz
15	-78.7 dBm / 13.5MHz
20	-77.4 dBm / 18MHz

- 2) The characteristics of the wanted signal shall be configured according to TS 36.211. The CQI information bit payload per sub-frame is equal to 4 bits.
- 3) The multipath fading emulators shall be configured according to the corresponding channel model defined in Annex B.
- 4) Adjust the equipment so that the SNR specified in Table 8.3.11.5-1 is achieved at the BS input during the CQI transmissions.
- 5) The signal generator sends a test pattern with the pattern outlined in figure 8.3.11.4.2-1. The following statistics are kept: the number of incorrectly decoded CQI.

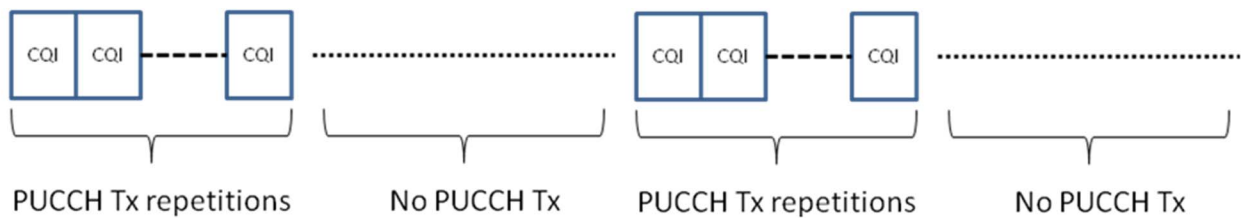

Figure 8.3.11.4.2-1: Test signal pattern for PUCCH format 2 demodulation tests

8.3.11.5 Test Requirement

The fraction of incorrectly decoded CQIs shall be less than 1% for the SNR listed in Table 8.3.11.5-1.

Table 8.3.11.5-1: Required SNR for PUCCH format 2 demodulation tests

Number of TX antennas	Number of RX antennas	Cyclic Prefix	Propagation conditions and correlation matrix (Annex B)	Repetitions	Channel Bandwidth / SNR [dB]				
					3 MHz	5 MHz	10 MHz	15 MHz	20 MHz
1	2	normal	EVA5 Low	4	-3.5	-4.4	-4.5	-4.3	-4.1
				8	-9.2	-9.7	-9.4	-9.5	-9.4
				32	-13.1	-13.5	-13.2	-13.4	-13.3
Note 1: Frequency Hopping Intervals: 4 (FDD); 10 (TDD)									
Note 2: Guard period shall be created according to TS36.211, 5.2.5 [12]									

NOTE: If the above Test Requirement differs from the Minimum Requirement then the Test Tolerance applied for this test is non-zero. The Test Tolerance for this test and the explanation of how the Minimum Requirement has been relaxed by the Test Tolerance is given in Annex G.

8.3.12 ACK missed detection for PUCCH format 4

8.3.12.1 Definition and applicability

The performance requirement of PUCCH format 4 for ACK missed detection is determined by the two parameters: probability of false detection of the ACK and the probability of detection of ACK. The performance is measured by the

required SNR at probability of detection equal to 0.99. The probability of false detection of the ACK shall be 0.01 or less.

The probability of false detection of the ACK is defined as a conditional probability of erroneous detection of the ACK at particular bit position when input is only noise.

The probability of detection of ACK is defined as conditional probability of detection of the ACK when the ACK was sent at particular bit position. Each missed ACK bit is counted as one error.

The test is applicable to all BS. A test for a specific channel bandwidth is only applicable if the BS supports it.

For a BS supporting multiple channel bandwidths only the tests for the lowest and the highest channel bandwidth supported by the BS are applicable.

The number of encoded ACK/NACK bits per sub-frame is defined for two cases as presented below:

- 24AN bits with 1PRB allocated: applicable for FDD and TDD
- 64AN bits with 2PRB allocated: applicable for FDD and TDD

In this test PUCCH is transmitted only on PCell.

ACK/NACK repetitions are disabled for PUCCH transmission. DAI based codebook size determination is disabled. Random codeword selection is assumed.

8.3.12.2 Minimum Requirement

The minimum requirement is in TS 36.104 [2] subclause 8.3.1.1 and 8.3.9.1.

8.3.12.3 Test purpose

The test shall verify the receiver's ability to detect ACK bits in codeword's from applicable codebook being randomly selected, under multipath fading propagation conditions for a given SNR.

8.3.12.4 Method of test

8.3.12.4.1 Initial Conditions

Test environment: Normal, see subclause D.2.

RF channels to be tested: M; see subclause 4.7

- 1) Connect the BS tester generating the wanted signal, multipath fading simulators and AWGN generators to all BS antenna connectors for diversity reception via a combining network as shown in Annex I.3.2.

8.3.12.4.2 Procedure

- 1) Adjust the AWGN generator, according to the channel bandwidth defined in Table 8.3.12.4.2-1.

Table 8.3.12.4.2-1: AWGN power level at the BS input

Channel bandwidth [MHz]	AWGN power level
10	-80.5 dBm / 9MHz
15	-78.7 dBm / 13.5MHz
20	-77.4 dBm / 18MHz

- 2) The characteristics of the wanted signal shall be configured according to TS 36.211 [12].
- 3) The multipath fading emulators shall be configured according to the corresponding channel model defined in Annex B.
- 4) Adjust the equipment so that the SNR specified in Table 8.3.12.5-1 or 8.3.12.5-2 is achieved at the BS input during the codeword's transmissions.

- 5) The signal generator sends random codewords from applicable codebook, in regular time periods. The following statistics are kept: the number of ACK bits falsely detected in the idle periods and the number of missed ACK bits. Each falsely detected ACK bit in the idle periods is accounted as one error for the statistics of false ACK detection, and each missed ACK bit is accounted as one error for the statistics of missed ACK detection.

8.3.12.5 Test Requirement

The fraction of falsely detected ACK bits shall be less than 1% and the fraction of correctly detected ACK bits shall be larger than 99% for the SNR listed in Tables 8.3.12.5-1 and 8.3.12.5-2.

Table 8.3.12.5-1: Required SNR for PUCCH format 4 demodulation tests, 24AN bits with 1 PRB allocated

Number of TX antennas	Number of RX antennas	Cyclic Prefix	Propagation conditions and correlation matrix (Annex B)	Channel Bandwidth / SNR [dB]					
				1.4 MHz	3 MHz	5 MHz	10 MHz	15 MHz	20 MHz
1	2	Normal	EPA 5 Low	-	-	-	1.8	1.7	1.6
			EVA 70 Low	-	-	-	2.0	1.8	1.8
	4	Normal	EPA 5 Low	-	-	-	-2.4	-2.2	-2.3
			EVA 70 Low	-	-	-	2.0	-2.4	-2.4
	8	Normal	EPA 5 Low	-	-	-	-5.5	-5.5	-5.5
			EVA 70 Low	-	-	-	-5.4	-5.4	-5.5

Table 8.3.12.5-2: Required SNR for PUCCH format 4 demodulation tests, 64AN bits with 2 PRB allocated

Number of TX antennas	Number of RX antennas	Cyclic Prefix	Propagation conditions and correlation matrix (Annex B)	Channel Bandwidth / SNR [dB]					
				1.4 MHz	3 MHz	5 MHz	10 MHz	15 MHz	20 MHz
1	2	Normal	EPA 5 Low	-	-	-	2.3	2.1	2.1
			EVA 70 Low	-	-	-	2.7	2.6	2.5
	4	Normal	EPA 5 Low	-	-	-	-2.4	-2.3	-2.3
			EVA 70 Low	-	-	-	-1.9	-2.1	-2.1
	8	Normal	EPA 5 Low	-	-	-	-5.7	-5.7	-5.8
			EVA 70 Low	-	-	-	-5.4	-5.6	-5.6

NOTE: If the above Test Requirement differs from the Minimum Requirement then the Test Tolerance applied for this test is non-zero. The Test Tolerance for this test and the explanation of how the Minimum Requirement has been relaxed by the Test Tolerance is given in Annex G.

8.3.13 ACK missed detection for PUCCH format 5

8.3.13.1 Definition and applicability

The performance requirement of PUCCH format 5 for ACK missed detection is determined by the two parameters: probability of false detection of the ACK and the probability of detection of ACK. The performance is measured by the required SNR at probability of detection equal to 0.99. The probability of false detection of the ACK shall be 0.01 or less.

The probability of false detection of the ACK is defined as a conditional probability of erroneous detection of the ACK at particular bit position when input is only noise.

The probability of detection of ACK is defined as conditional probability of detection of the ACK when the ACK was sent at particular bit position. Each missed ACK bit is counted as one error.

The test is applicable if BS supports PUCCH format 5. A test for a specific channel bandwidth is only applicable if the BS supports it.

For a BS supporting multiple channel bandwidths only the tests for the lowest and the highest channel bandwidth supported by the BS are applicable.

The number of encoded ACK/NACK bits per sub-frame is equal to 24 bits.

ACK/NACK repetitions are disabled for PUCCH transmission. DAI based codebook size determination is disabled. Random codeword selection is assumed.

In this test PUCCH is transmitted only on PCell.

8.3.13.2 Minimum Requirement

The minimum requirement is in TS 36.104 [2] subclause 8.3.1.1 and 8.3.12.1.

8.3.13.3 Test purpose

The test shall verify the receiver's ability to detect ACK bits in codeword's from applicable codebook being randomly selected, under multipath fading propagation conditions for a given SNR.

8.3.13.4 Method of test

8.3.13.4.1 Initial Conditions

Test environment: Normal, see subclause D.2.

RF channels to be tested: M; see subclause 4.7

- 1) Connect the BS tester generating the wanted signal, multipath fading simulators and AWGN generators to all BS antenna connectors for diversity reception via a combining network as shown in Annex I.3.2.

8.3.13.4.2 Procedure

- 1) Adjust the AWGN generator, according to the channel bandwidth defined in Table 8.3.13.4.2-1.

Table 8.3.5.11.2-1: AWGN power level at the BS input

Channel bandwidth [MHz]	AWGN power level
10	-80.5 dBm / 9MHz
15	-78.7 dBm / 13.5MHz
20	-77.4 dBm / 18MHz

- 2) The characteristics of the wanted signal shall be configured according to TS 36.211 [12].
- 3) The multipath fading emulators shall be configured according to the corresponding channel model defined in Annex B.
- 4) Adjust the equipment so that the SNR specified in Table 8.3.13.5-1 is achieved at the BS input during the codeword's transmissions.
- 5) The signal generator sends random codewords from applicable codebook, in regular time periods. The following statistics are kept: the number of ACK bits falsely detected in the idle periods and the number of missed ACK bits. Each falsely detected ACK bit in the idle periods is accounted as one error for the statistics of false ACK detection, and each missed ACK bit is accounted as one error for the statistics of missed ACK detection.

8.3.13.5 Test Requirement

The fraction of falsely detected ACK bits shall be less than 1% and the fraction of correctly detected ACK bits shall be larger than 99% for the SNR listed in Tables 8.3.13.5-1.

Table 8.3.13.5-1: Required SNR for PUCCH format 5 demodulation tests

Number of TX antennas	Number of RX antennas	Cyclic Prefix	Propagation conditions and correlation matrix (Annex B)	Channel Bandwidth / SNR [dB]					
				1.4MHz	3MHz	5MHz	10 MHz	15MHz	20MHz
1	2	Normal	EPA 5 Low	-	-	-	2.2	1.9	1.9
			EVA70 Low	-	-	-	2.2	2.1	2.1
	4	Normal	EPA 5 Low	-	-	-	-2.3	-2.2	-2.2
			EVA70 Low	-	-	-	-1.9	-2.2	-2.1
	8	Normal	EPA 5 Low	-	-	-	-5.4	-5.3	-5.4
			EVA70 Low	-	-	-	-5.2	-5.3	-5.4

NOTE: If the above Test Requirement differs from the Minimum Requirement then the Test Tolerance applied for this test is non-zero. The Test Tolerance for this test and the explanation of how the Minimum Requirement has been relaxed by the Test Tolerance is given in Annex G.

8.4 Performance requirements for PRACH

8.4.1 PRACH false alarm probability and missed detection

8.4.1.1 Definition and applicability

The performance requirement of PRACH for preamble detection is determined by the two parameters: total probability of false detection of the preamble (P_{fa}) and the probability of detection of preamble (P_d). The performance is measured by the required SNR at probability of detection, P_d of 99%. P_{fa} shall be 0.1% or less.

P_{fa} is defined as a conditional total probability of erroneous detection of the preamble (i.e. erroneous detection from any detector) when input is only noise.

P_d is defined as conditional probability of detection of the preamble when the signal is present. The erroneous detection consists of several error cases – detecting different preamble than the one that was sent, not detecting a preamble at all or correct preamble detection but with the wrong timing estimation. For AWGN, a timing estimation error occurs if the estimation error of the timing of the strongest path is larger than 1.04 μ s. For ETU70, and EPA1 a timing estimation error occurs if the estimation error of the timing of the strongest path is larger than 2.08 μ s. The strongest path for the timing estimation error refers to the strongest path (i.e. average of the delay of all paths having the same highest gain = 310ns for ETU) in the power delay profile.

The test preambles for normal mode are listed in table A.6-1 and the test preambles for high speed mode restricted set type A are listed in A.6-2. The test preambles for coverage enhancement are listed in table A.6-3. The test preambles for high speed mode restricted set type B are listed in A.6-4.

The normal mode test (Table 8.4.1.5-1) is applicable to all BS. The high speed mode test restricted set type A (Table 8.4.1.5-2) and high speed mode restricted set type B (table 8.4.2.1-5) are applicable to high speed BS supporting high speed mode restricted set A and restricted set type B respectively. The coverage enhancement tests (Table 8.4.1.5-3 and Table 8.4.1.5-4) are applicable to the base stations supporting coverage enhancement.

8.4.1.2 Minimum Requirement

The minimum requirement is in TS 36.104 [2] subclause 8.4.1.1 and 8.4.2.1.

8.4.1.3 Test purpose

The test shall verify the receiver’s ability to detect PRACH preamble under multipath fading propagation conditions for a given SNR.

8.4.1.4 Method of test

8.4.1.4.1 Initial Conditions

Test environment: Normal, see subclause D.2.

RF channels to be tested: M; see subclause 4.7

- 1) Connect the BS tester generating the wanted signal, multipath fading simulators and AWGN generators to all BS antenna connectors for diversity reception via a combining network as shown in Annex I.3.1 or Annex I.3.2 as applicable.

8.4.1.4.2 Procedure

- 1) Adjust the AWGN generator, according to the channel bandwidth.

Table 8.4.1.4.2-1: AWGN power level at the BS input

Channel bandwidth [MHz]	AWGN power level
1.4	-89.7 dBm / 1.08MHz
3	-85.7 dBm / 2.7MHz
5	-83.5 dBm / 4.5MHz
10	-80.5 dBm / 9MHz
15	-78.7 dBm / 13.5MHz
20	-77.4 dBm / 18MHz

- 2) The characteristics of the wanted signal shall be configured according to the corresponding UL reference measurement channel defined in Annex A.
- 3) The multipath fading emulators shall be configured according to the corresponding channel model defined in Annex B.
- 4) Adjust the frequency offset of the test signal according to Table 8.4.1.5-1 or 8.4.1.5-2 or 8.4.1.5-3 or 8.4.1.5-4 or 8.4.1.5-5.
- 5) Adjust the equipment so that the SNR specified in Table 8.4.1.5-1 or 8.4.1.5-2 or 8.4.1.5-3 or 8.4.1.5-4 or 8.4.1.5-5 is achieved at the BS input during the PRACH preambles.
- 6) The test signal generator sends a preamble and the receiver tries to detect the preamble. This pattern is repeated as illustrated in figure 8.4.1.4.2-1. The preambles are sent with certain timing offsets as described below. The following statistics are kept: the number of preambles detected in the idle period and the number of missed preambles.



Figure 8.4.1.4.2-1: PRACH preamble test pattern

The timing offset base value is set to 50% of Ncs. This offset is increased within the loop, by adding in each step a value of 0.1us, until the end of the tested range, which is 0.9us. Then the loop is being reset and the timing offset is set again to 50% of Ncs. The timing offset scheme is presented in Figure 8.4.1.4.2-2.

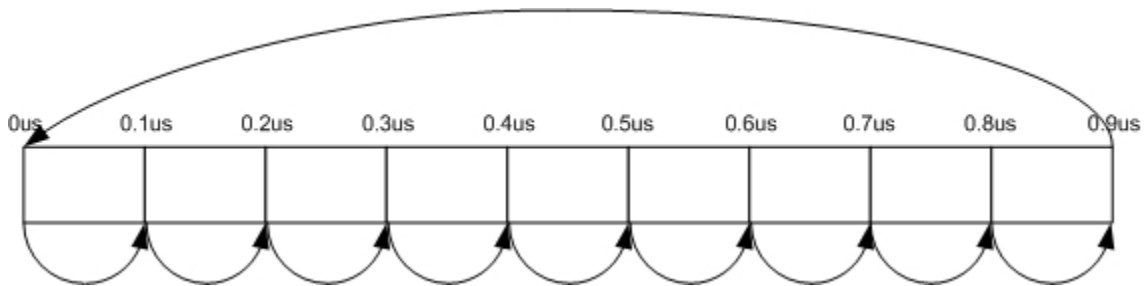

Figure 8.4.1.4.2-2: Timing offset scheme

8.4.1.5 Test Requirement

Pfa shall not exceed 0.1%. Pd shall not be below 99% for the SNRs in Tables 8.4.1.5-1 to 8.4.1.5-5.

Table 8.4.1.5-1: PRACH missed detection test requirements for Normal Mode

Number of TX antennas	Number of RX antennas	Propagation conditions and correlation matrix (Annex B)	Frequency offset	SNR [dB]				
				Burst format 0	Burst format 1	Burst format 2	Burst format 3	Burst format 4
1	2	AWGN	0	-13.9	-13.9	-16.1	-16.2	-6.9
		ETU 70 Low*	270 Hz	-7.4	-7.2	-9.4	-9.5	0.5
	4	AWGN	0	-16.6	-16.4	-18.7	-18.5	-9.5
		ETU 70 Low*	270 Hz	-11.5	-11.1	-13.5	-13.3	-4.5
8	AWGN	0	-19.5	-19.1	-21.2	-21	-11.5	
	ETU 70 Low*	270 Hz	-15.7	-15.3	-17.2	-16.9	-8.0	

Note*: Not applicable for Local Area BS and Home BS.

The requirements in Table 8.4.1.5-2 shall not be applied to Local Area BS and Home BS

Table 8.4.1.5-2: PRACH missed detection test requirements for High speed Mode restricted set type A

Number of TX antennas	Number of RX antennas	Propagation conditions and correlation matrix (Annex B)	Frequency offset	SNR [dB]			
				Burst format 0	Burst format 1	Burst format 2	Burst format 3
1	2	AWGN	0	-13.8	-13.9	-16.0	-16.3
		ETU 70 Low	270 Hz	-6.8	-6.7	-8.7	-8.9
		AWGN	625 Hz	-12.1	-12.0	-14.1	-14.1
		AWGN	1340 Hz	-13.1	-13.2	-15.2	-15.4
	4	AWGN	0	-16.6	-16.3	-18.6	-18.5
		ETU 70 Low	270 Hz	-11.2	-10.8	-13.1	-13.1
		AWGN	625 Hz	-14.6	-14.3	-16.5	-16.5
		AWGN	1340 Hz	-15.6	-15.2	-17.5	-17.5
	8	AWGN	0	-19.0	-18.8	-20.6	-20.7
		ETU 70 Low	270 Hz	-15.0	-14.5	-16.4	-16.4
		AWGN	625 Hz	-17.4	-17.1	-19.0	-19.1
		AWGN	1340 Hz	-18.4	-18.1	-20.2	-20.2

Table 8.4.1.5-3: PRACH missed detection requirements for coverage enhancement (PRACH frequency hopping OFF)

Number of TX antennas	Number of RX antennas	Propagation conditions and correlation matrix (Annex B)	Frequency offset	Number of Repetitions	SNR [dB]			
					Burst format 0	Burst format 1	Burst format 2	Burst format 3
1	2	AWGN	0	4	-	-	-21.0	-20.8
				8	-21.4	-21.0	-	-
				16	-	-	-24.8	-24.7
				32	-25.3	-25.0	-	-
		EPA1 Low	270 Hz	4	-	-	-11.5	-11.1
				8	-12.4	-11.7	-	-
				16	-	-	-16.6	-16.6
				32	-18.4	-18.0	-	-

Note 1: Under fading channels, the PRACH detection performance may be significantly different with different PRACH Configuration Indexes. The requirements in this table are defined based on the simulation results with PRACH Configuration Indexes (3, 19, 35, 51) for Format 0, Format 1, Format 2, and Format 3 respectively.

Table 8.4.1.5-4: PRACH missed detection requirements for coverage enhancement (PRACH frequency hopping ON)

Number of TX antennas	Number of RX antennas	Propagation conditions and correlation matrix (Annex B)	Frequency offset	Number of Repetitions	SNR [dB]			
					Burst format 0	Burst format 1	Burst format 2	Burst format 3
1	2	EPA1 Low	270 Hz	4	-	-	-14.9	-14.7
				8	-15.6	-15.2	-	-
				16	-	-	-19.5	-19.6
				32	-20.7	-20.5	-	-

Note 1: Under fading channels, the PRACH detection performance may be significantly different with different PRACH Configuration Indexes. The requirements in this table are defined based on the simulation results with PRACH Configuration Indexes (3, 19, 35, 51) for Format 0, Format 1, Format 2, and Format 3 respectively.

Note 2: The requirements in this table are defined under the assumption that UE RF tuning during PRACH frequency hopping has no impact on the symbols in PRACH subframes and thus all symbols in PRACH subframes are available for the transmission of PRACH preambles.

Note 3: The requirements in this table are defined under the assumption that the PRACH frequency offset (prach-FreqOffset-r13) is 0 and frequency hopping offset is $N_{RB}^{UL} - 6$, where N_{RB}^{UL} is defined in TS36.211 [12].

Note 4: The requirements in this table apply for channel bandwidth of 5MHz, 10MHz, 15MHz or 20MHz. For channel bandwidth of 3MHz, the requirements in Table 8.4.1.5-3 apply.

Table 8.4.2.1-5 PRACH missed detection requirements for High speed Mode restricted set type B

Number of TX antennas	Number of RX antennas	Propagation conditions and correlation matrix (Annex B)	Frequency offset	SNR [dB]			
				Burst format 0	Burst format 1	Burst format 2	Burst format 3
1	2	AWGN	0	-14.2	-13.8	-16.4	-16.5
		AWGN	625 Hz	-11.7	-11.4	-13.6	-13.6
		ETU 70 Low	270 Hz	-6.7	-6.3	-8.5	-8.6
		AWGN	1875 Hz	-11.5	-11.1	-13.5	-13.7
		AWGN	1944 Hz	-11.4	-11.1	-13.5	-13.7
	4	AWGN	0	-16.8	-16.3	-18.8	-18.8
		AWGN	625 Hz	-14.1	-13.8	-15.8	-15.9
		ETU 70 Low	270 Hz	-11.2	-10.7	-12.9	-12.8
		AWGN	1875 Hz	-13.9	-13.5	-15.6	-16.0
	8	AWGN	1944 Hz	-13.9	-13.5	-15.6	-16.0
		AWGN	0	-19.3	-18.8	-20.9	-20.9
		AWGN	625 Hz	-16.1	-16.0	-17.8	-17.9
		ETU 70 Low	270 Hz	-14.7	-14.5	-16.5	-16.9
		AWGN	1875 Hz	-16.0	-15.7	-17.7	-18.1
		AWGN	1944 Hz	-16.0	-15.7	-17.7	-18.1
		AWGN	1944 Hz	-16.0	-15.7	-17.7	-18.1

NOTE: If the above Test Requirement differs from the Minimum Requirement then the Test Tolerance applied for this test is non-zero. The Test Tolerance for this test and the explanation of how the Minimum Requirement has been relaxed by the Test Tolerance is given in Annex G.

8.5 Performance requirements for Narrowband IoT

8.5.1 Performance requirements for NPUSCH format 1

8.5.1.1 Definition and applicability

The performance requirement of NPUSCH format 1 is determined by a minimum required throughput for a given SNR. The required throughput is expressed as a fraction of maximum throughput for the FRCs listed in Annex A. The performance requirements assume HARQ re-transmissions.

The tests for 3.75KHz subcarrier spacing are applicable to the base stations supporting 3.75 kHz subcarrier spacing requirements. The tests for single-subcarrier/multi-subcarrier of 15KHz subcarrier spacing are applicable to the base stations supporting the number of subcarriers of 15 kHz subcarrier spacing requirements.

The tests defined in Table 8.5.1.5-4 are applicable to the base stations supporting two HARQ processes, multiple TBs scheduling with interleaved transmission when multiple TBs are scheduled.

8.5.1.2 Minimum Requirement

The minimum requirement is in TS 36.104 [2] subclause 8.5.1.

8.5.1.3 Test Purpose

The test shall verify the receiver's ability to achieve the throughput under multipath fading propagation conditions for a given SNR.

8.5.1.4 Method of test

8.5.1.4.1 Initial Conditions

Test environment: Normal, see subclause D.2.

RF channels to be tested: M; see subclause 4.7.

- 1) Connect the BS tester generating the wanted signal, multipath fading simulators and AWGN generators to all BS antenna connectors for diversity reception via a combining network as shown in Annex I.3.2.

8.5.1.4.2 Procedure

- 1) Adjust the AWGN generator, according to the channel bandwidth, defined in Table 8.5.1.4.2-1.

Table 8.5.1.4.2-1: AWGN power level at the BS input

Channel bandwidth [KHz]	AWGN power level
200	-100.5dBm /180KHz

- 2) The characteristics of the wanted signal shall be configured according to the corresponding UL reference measurement channel defined in annex A and the test parameters in Table 8.5.1.4.2-2.

Table 8.5.1.4.2-2: Test parameters for testing NPUSCH format 1

Parameter	unit	Value
Maximum number of HARQ transmissions		4
RV sequences		RV0, RV2

- 3) The multipath fading emulators shall be configured according to the corresponding channel model defined in annex B.
- 4) Adjust the equipment so that required SNR specified in tables 8.5.1.5-1 to 8.5.1.5-3 is achieved at the BS input.
- 5) The signal generator sends a test pattern with the pattern outlined in Figure 8.5.1.4.2-1. For each of the reference channels in Table 8.5.1.5-1 to 8.5.1.5-3 applicable for the base station, measure the throughput, according to annex E.

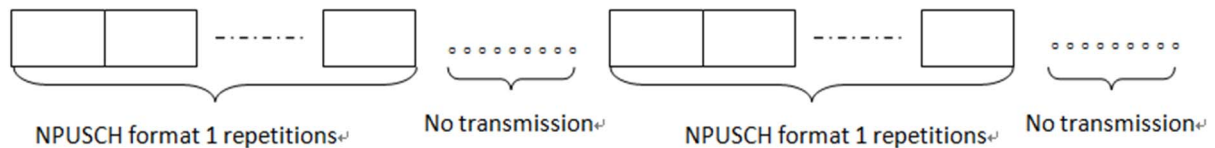

Figure 8.5.1.4.2-1: Test signal pattern for NPUSCH format 1 demodulation tests

8.5.1.5 Test Requirement

The throughput measured according to subclause 8.5.1.4.2 shall not be below the limits for the SNR levels specified in Table 8.5.1.5-1 for 3.75KHz subcarrier spacing tests, not be below the limits for the SNR levels specified in Table 8.5.1.5-2 for 15KHz subcarrier spacing with single subcarrier tests and not be below the limits for the SNR levels specified in Table 8.5.1.5-3 for 15KHz subcarrier spacing with the supported number of subcarrier tests.

Table 8.5.1.5-1 Required SNR for NPUSCH format 1 test, 200KHz Channel Bandwidth, 3.75KHz subcarrier spacing, 1Tx

Number of TX antennas	Number of RX antennas	Subcarrier spacing	Number of allocated subcarriers	Propagation conditions and correlation matrix (Annex B)	FRC (Annex A)	Repetition number	Fraction of maximum throughput	SNR [dB]
1	2	3.75KHz	1	ETU 1Hz Low	A16-1	1	70%	-1.3
						16	70%	-8.6
						64	70%	-11.6

Table 8.5.1.5-2 Required SNR for NPUSCH format 1 test, 200KHz Channel Bandwidth, 15KHz subcarrier spacing, single subcarrier, 1Tx

Number of TX antennas	Number of RX antennas	Subcarrier spacing	Number of allocated subcarriers	Propagation conditions and correlation matrix (Annex B)	FRC (Annex A)	Repetition number	Fraction of maximum throughput	SNR [dB]
1	2	15KHz	1	ETU 1Hz Low	A16-2	1	70%	-1.5
						16	70%	-8.2
						64	70%	-12

Table 8.5.1.5-3 Required SNR for NPUSCH format 1 test, 200KHz Channel Bandwidth, 15KHz subcarrier spacing, multiple subcarriers, 1Tx

Number of TX antennas	Number of RX antennas	Subcarrier spacing	Number of allocated subcarriers	Propagation conditions and correlation matrix (Annex B)	FRC (Annex A)	Repetition number	Fraction of maximum throughput	SNR [dB]
1	2	15KHz	3	ETU 1Hz Low	A16-3	2	70%	-2.4
						16	70%	-7.5
						64	70%	-10.8
			6	ETU 1Hz Low	A16-4	2	70%	0
						16	70%	-6.2
						64	70%	-9.9
			12	ETU 1Hz Low	A16-5	2	70%	-0.1
						16	70%	-5.8
						64	70%	-9.5

Table 8.5.1.5-4: Required SNR for NPUSCH format 1 with two HARQ processes and multiple TBs with interleaved transmission

Number of TX antennas	Number of RX antennas	Subcarrier spacing	Number of allocated subcarriers	Propagation conditions and correlation matrix (Annex B)	FRC (Annex A)	Repetition number	Fraction of maximum throughput	SNR [dB]
1	2	15KHz	12	ETU 1Hz Low	A16-6	64	70%	-13.3

NOTE: If the above Test Requirement differs from the Minimum Requirement then the Test Tolerance applied for this test is non-zero. The Test Tolerance for this test and the explanation of how the Minimum Requirement has been relaxed by the Test Tolerance is given in Annex G.

8.5.2 ACK missed detection for NPUSCH format 2

8.5.2.1 Definition and applicability

The performance requirement of NPUSCH format 2 for ACK missed detection is determined by the two parameters: probability of false detection of the ACK and the probability of detection of ACK. The performance is measured by the required SNR at probability of detection equal to 0.99. The probability of false detection of the ACK shall be 0.01 or less.

The probability of false detection of the ACK is defined as a conditional probability of erroneous detection of the ACK when input is only noise.

The probability of detection of ACK is defined as conditional probability of detection of the ACK when the ACK was sent per NPUSCH format 2 transmission when the signal is present.

The tests for 3.75KHz subcarrier spacing are applicable to the base stations supporting 3.75 KHz subcarrier spacing requirements. The tests for 15KHz subcarrier spacing are applicable to the base stations supporting 15KHz subcarrier spacing requirements.

8.5.2.2 Minimum Requirement

The minimum requirement is in TS 36.104 [2] subclause 8.5.2.1 and 8.5.2.2.

8.5.2.3 Test purpose

The test shall verify the receiver’s ability to detect ACK under multipath fading propagation conditions for a given SNR.

8.5.2.4 Method of test

8.5.2.4.1 Initial Conditions

Test environment: Normal, see subclause D.2.

RF channels to be tested: M; see subclause 4.7

- 1) Connect the BS tester generating the wanted signal, multipath fading simulators and AWGN generators to all BS antenna connectors for diversity reception via a combining network as shown in Annex I.3.2.

8.5.2.4.2 Procedure

- 1) Adjust the AWGN generator, according to the channel bandwidth defined in Table 8.5.2.4.2-1.

Table 8.5.2.4.2-1: AWGN power level at the BS input

Channel bandwidth [KHz]	AWGN power level
200	-100.5dBm /180KHz

- 2) The characteristics of the wanted signal shall be configured according to TS 36.211 [12].
- 3) The multipath fading emulators shall be configured according to the corresponding channel model defined in Annex B.
- 4) Adjust the equipment so that the SNR specified in tables 8.5.2.5-1 to 8.5.2.5-2 is achieved at the BS input during the ACK transmissions.
- 5) The signal generator sends a test pattern with the pattern outlined in figure 8.5.2.4.2-1. The following statistics are kept: the number of ACKs falsely detected in the idle periods and the number of missed ACKs. Each falsely detected ACK transmission in the idle periods is accounted as one error for the statistics of false ACK detection, and each missed ACK transmission per NPUSCH format 2 transmission is accounted as one error for the statistics of missed ACK detection.

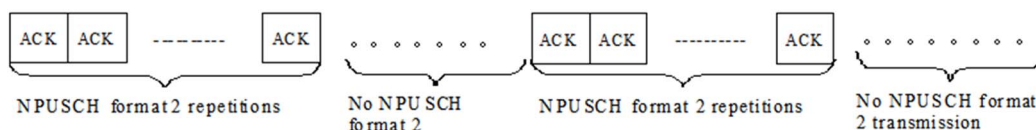

Figure 8.5.2.4.2-1: Test signal pattern for NPUSCH format 2 demodulation tests

8.5.2.5 Test Requirement

The fraction of falsely detected ACKs shall be less than 1% and the fraction of correctly detected ACKs shall be larger than 99% for the SNR listed in Table 8.5.2.5-1 and Table 8.5.2.5-2.

Table 8.5.2.5-1 Required SNR for NPUSCH format 2 test, 200KHz Channel Bandwidth, 3.75KHz subcarrier spacing, 1Tx

Number of TX antennas	Number of RX antennas	Propagation conditions and correlation matrix (Annex B)	Number of allocated subcarriers	Subcarrier spacing	Repetition number	SNR [dB]
1	2	EPA 5 Low	1	3.75KHz	1	7.6
					16	-4.7
					64	-10.3

Table 8.5.2.5-2 Required SNR for NPUSCH format 2 test, 200KHz Channel Bandwidth, 15KHz subcarrier spacing, 1Tx

Number of TX antennas	Number of RX antennas	Propagation conditions and correlation matrix (Annex B)	Number of allocated subcarriers	Subcarrier spacing	Repetition number	SNR [dB]
1	2	EPA 5 Low	1	15KHz	1	6.9
					16	-3.3
					64	-8.9

NOTE: If the above Test Requirement differs from the Minimum Requirement then the Test Tolerance applied for this test is non-zero. The Test Tolerance for this test and the explanation of how the Minimum Requirement has been relaxed by the Test Tolerance is given in Annex G.

8.5.3 Performance requirements for NPRACH

8.5.3.1 Definition and applicability

The performance requirement of NPRACH for preamble detection is determined by two parameters: the total probability of false detection of the preamble (P_{fa}) and the probability of detection of the preamble (P_d). The performance is measured for the required SNR

- at probability of P_d which shall not be smaller than 99% and
- at probability of P_{fa} which shall not be larger than 0.1%.

P_{fa} is defined as a conditional total probability of erroneous detection of the preamble (i.e. erroneous detection from any detector) when input is only noise.

P_d is defined as conditional probability of detection of the preamble when the signal is present. The erroneous detection consists of several error cases – detecting different preamble than the one that was sent, not detecting a preamble at all or correct preamble detection but with the wrong timing estimation. A timing estimation error occurs if the estimation error of the timing of the strongest path is larger than 3.646 μ s. The strongest path for the timing estimation error refers to the strongest path in the power delay profile.

The performance requirements for TDD are optional and only valid for base stations supporting TDD.

The parameters of NPRACH test preambles are listed in Table 8.5.3.1-1.

Table 8.5.3.1-1 NPRACH Test Parameters

Parameter	Value	Value
Narrowband physical layer cell identity	0	0
Initial subcarrier index	0	0
nprach-Periodicity (ms)	160 for preamble format 2, otherwise 80	[1280] for preamble format 2, otherwise 320
nprach-SubcarrierOffset	0	0
numRepetitionsPerPreambleAttempt	8	32
nprach-NumSubcarriers	36 for FDD preamble format 2, otherwise 12	
Uplink-downlink configuration for TDD	1	
Special subframe configuration for TDD	7	

8.5.3.2 Minimum Requirement

The minimum requirement is in TS 36104 [2] subclause 8.5.3.1.1 and 8.5.3.2.1.

8.5.3.3 Test purpose

The test shall verify the receiver's ability to detect NPRACH preamble under multipath fading propagation conditions for a given SNR.

8.5.3.4 Method of test

8.5.3.4.1 Initial Conditions

Test environment: Normal, see subclause D.2.

RF channels to be tested: M; see subclause 4.7.

- 1) Connect the BS tester generating the wanted signal, multipath fading simulators and AWGN generators to all BS antenna connectors for diversity reception via a combining network as shown in Annex I.3.2.

8.5.3.4.2 Procedure

- 1) Adjust the AWGN generator, according to the channel bandwidth.

Table 8.5.3.4.2-1: AWGN power level at the BS input

Channel bandwidth [KHz]	AWGN power level
200	-100.5dBm /180KHz

- 2) The characteristics of the wanted signal shall be configured according to the corresponding UL reference measurement channel defined in Annex A.
- 3) The multipath fading emulators shall be configured according to the corresponding channel model defined in Annex B.
- 4) Adjust the frequency offset of the test signal according to Table 8.5.3.5-1.
- 5) Adjust the equipment so that the SNR specified in Table 8.5.3.5-1 is achieved at the BS input during the NPRACH preambles.

6) The test signal generator sends a preamble with repetitions and the receiver tries to detect the preamble. This pattern is repeated as illustrated in figure 8.5.3.4.2-1. The preambles are sent with a fixed timing offset of $0.5T_{CP}$ during the test, where T_{CP} is NPRACH cyclic prefix of length as defined in TS36.211 [12]. The following statistics are kept: the number of preambles detected in the idle period and the number of missed preambles.



Figure 8.5.3.4.2-1: NPRACH preamble test pattern

8.5.3.5 Test Requirement

Pfa shall not exceed 0.1% and Pmd shall not exceed 1% for the SNRs in Table 8.5.3.5-1.

Table 8.5.3.5-1: NPRACH missed detection test requirements for FDD

Number of TX antennas	Number of RX antennas	Repetition number	Propagation conditions and correlation matrix (Annex B)	Frequency offset	SNR[dB]		
					Preamble format 0	Preamble format 1	Preamble format 2
1	2	8	AWGN	0	-1.8	-1.8	-0.7
			EPA1 Low	200 Hz	6.7	6.7	9.6
		32	AWGN	0	-6.5	-6.5	-4.8
			EPA1 Low	200 Hz	1.1	1.1	2.8

Table 8.5.3.5-2: NPRACH missed detection requirements for TDD

Number of TX antennas	Number of RX antennas	Repetition number	Propagation conditions and correlation matrix (Annex B)	Frequency offset	SNR[dB]			
					Preamble format 0	Preamble format 1	Preamble format 0-a	Preamble format 1-a
1	2	8	AWGN	0	5.9	2.8	4.3	1.3
			EPA1 Low	200 Hz	15.3	10.7	14.3	9.6
		32	AWGN	0	1.2	-1.9	-0.4	-3.3
			EPA1 Low	200 Hz	10.4	4.9	10.6	3.1

NOTE: If the above Test Requirement differs from the Minimum Requirement then the Test Tolerance applied for this test is non-zero. The Test Tolerance for this test and the explanation of how the Minimum Requirement has been relaxed by the Test Tolerance is given in Annex G.

8.6 Performance requirements for subslot-PUSCH

8.6.1 Definition and applicability

The performance requirement of subslot-PUSCH is determined by a minimum required throughput for a given SNR. The required throughput is expressed as a fraction of maximum throughput for the FRCs listed in Annex A. The performance requirements assume HARQ re-transmissions.

8.6.2 Minimum Requirement

The minimum requirement is in TS 36.104 [2] subclause 8.6.

8.6.3 Test Purpose

The test shall verify the receiver's ability to achieve throughput under multipath fading propagation conditions for a given SNR.

8.6.4 Method of test

8.6.4.1 Initial Conditions

Test environment: Normal, see subclause D.2.

RF channels to be tested: M; see subclause 4.7.

- 1) Connect the BS tester generating the wanted signal, multipath fading simulators and AWGN generators to all BS antenna connectors for diversity reception via a combining network as shown in Annex I.3.2.

8.6.4.2 Procedure

- 1) Adjust the AWGN generator, according to the channel bandwidth, defined in Table 8.6.4.2-1.

Table 8.6.4.2-1: AWGN power level at the BS input

Channel bandwidth [MHz]	AWGN power level
1.4	-92.7dBm / 1.08MHz
3	-88.7dBm / 2.7MHz
5	-86.5dBm / 4.5MHz
10	-83.5dBm / 9MHz
15	-81.7dBm / 13.5MHz
20	-80.4dBm / 18MHz

- 2) The characteristics of the wanted signal shall be configured according to the corresponding UL reference measurement channel defined in Annex A.23 and the test parameters in Table 8.6.4.2-2.

Table 8.6.4.2-2: Test parameters for testing subslot-PUSCH

Parameter	Value
Maximum number of HARQ transmissions	4
RV sequence	0, 2, 3, 1, 0, 2, 3, 1
Number of HARQ processes	16
With DMRS sharing pattern	RDD DD DD RD DD RDD

- 3) The multipath fading emulators shall be configured according to the corresponding channel model defined in Annex B.
- 4) Adjust the equipment so that required SNR specified in Table 8.6.5-1 to 8.6.5-4 is achieved at the BS input.
- 5) For each of the reference channels in Table 8.6.5-1 to 8.6.5-4 applicable for the base station, measure the throughput, according to Annex E.

8.6.5 Test Requirement

The throughput shall be equal to or larger than the fraction of maximum throughput stated in the Tables 8.6.5-1 to 8.6.5-4 at the given SNR for 1Tx

Table 8.6.5-1: Minimum requirements for subslot-PUSCH, 5 MHz Channel Bandwidth, 1Tx

Number of TX antennas	Number of RX antennas	Cyclic prefix	Propagation conditions and correlation matrix (Annex B)	FRC (Annex A)	Fraction of maximum throughput	SNR [dB]
1	2	Normal	EPA 5Hz Low	A23-1	70%	12.8
	4	Normal	EPA 5Hz Low	A23-1	70%	9.5

Table 8.6.5-2: Minimum requirements for subslot-PUSCH, 10 MHz Channel Bandwidth, 1Tx

Number of TX antennas	Number of RX antennas	Cyclic prefix	Propagation conditions and correlation matrix (Annex B)	FRC (Annex A)	Fraction of maximum throughput	SNR [dB]
1	2	Normal	EPA 5Hz Low	A23-2	70%	12.8
	4	Normal	EPA 5Hz Low	A23-2	70%	9.5

Table 8.6.5-3: Minimum requirements for subslot-PUSCH, 15 MHz Channel Bandwidth, 1Tx

Number of TX antennas	Number of RX antennas	Cyclic prefix	Propagation conditions and correlation matrix (Annex B)	FRC (Annex A)	Fraction of maximum throughput	SNR [dB]
1	2	Normal	EPA 5Hz Low	A23-3	70%	12.8
	4	Normal	EPA 5Hz Low	A23-3	70%	9.4

Table 8.6.5-4: Minimum requirements for subslot-PUSCH, 20 MHz Channel Bandwidth, 1Tx

Number of TX antennas	Number of RX antennas	Cyclic prefix	Propagation conditions and correlation matrix (Annex B)	FRC (Annex A)	Fraction of maximum throughput	SNR [dB]
1	2	Normal	EPA 5Hz Low	A23-4	70%	13.0
	4	Normal	EPA 5Hz Low	A23-4	70%	9.7

8.7 Performance requirements for SPUCCH

8.7.1 ACK missed detection for single user SPUCCH format 1a

8.7.1.1 Definition and applicability

The performance requirement of single user SPUCCH for ACK missed detection is determined by the two parameters: probability of false detection of the ACK and the probability of detection of ACK. The performance is measured by the required SNR at probability of detection equal to 0.99. The probability of false detection of the ACK shall be 0.01 or less.

The probability of false detection of the ACK is defined as a conditional probability of erroneous detection of the ACK when input is only noise.

The probability of detection of ACK is defined as conditional probability of detection of the ACK when the signal is present.

The test is applicable to all BS. A test for a specific channel bandwidth is only applicable if the BS supports it.

For a BS supporting multiple channel bandwidths only the tests for the lowest and the highest channel bandwidth supported by the BS are applicable.

ACK/NACK repetitions are disabled for SPUCCH transmission.

8.7.1.2 Minimum Requirement

The minimum requirement is in TS 36.104 [2] subclause 8.7.

8.7.1.3 Test Purpose

The test shall verify the receiver’s ability to detect ACK in SPUCCH under multipath fading propagation conditions for a given SNR.

8.7.1.4 Method of test

8.7.1.4.1 Initial Conditions

Test environment: Normal, see subclause D.2.

RF channels to be tested: M; see subclause 4.7.

- 1) Connect the BS tester generating the wanted signal, multipath fading simulators and AWGN generators to all BS antenna connectors for diversity reception via a combining network as shown in Annex I.3.2.

8.7.1.4.2 Procedure

- 1) Adjust the AWGN generator, according to the channel bandwidth, defined in Table 8.7.1.4.2-1.

Table 8.7.1.4.2-1: AWGN power level at the BS input

Channel bandwidth [MHz]	AWGN power level
5	-86.5dBm / 4.5MHz
10	-83.5dBm / 9MHz
15	-81.7dBm / 13.5MHz
20	-80.4dBm / 18MHz

- 2) The characteristics of the wanted signal shall be configured according to TS 36.211 [12].
- 3) The multipath fading emulators shall be configured according to the corresponding channel model defined in Annex B
- 4) Adjust the equipment so that the SNR specified in Table 8.7.1.5-1 is achieved at the BS input during the ACK transmissions.
- 5) The signal generator sends a test pattern with the pattern outlined in figure 8.7.1.4.2-1. The following statistics are kept: the number of ACKs detected in the idle periods and the number of missed ACKs transmitted on SPUCCH.



Figure 8.7.1.4.2-1: Test signal pattern for single user PUCCH format 1a demodulation tests

8.7.1.5 Test Requirement

The ACK missed detection probability shall not exceed 1% at the SNR given in Table 8.7.1.5-1.

Table 8.7.1.5-1: Minimum requirements for single user SPUCCH format 1a, 1Tx

Number of TX antennas	Number of RX antennas	Cyclic Prefix	Propagation conditions and correlation matrix (Annex B)	Channel Bandwidth / SNR [dB]			
				5 MHz	10 MHz	15 MHz	20 MHz
1	2	Normal	EPA 5 Low	4.3	4.2	4.4	4.4
	4	Normal	EPA 5 Low	0.5	0.4	0.5	0.5

8.7.2 ACK missed detection requirements for SPUCCH format 4

8.7.2.1 Definition and applicability

The performance requirement of PUCCH format 4 for ACK missed detection is determined by the two parameters: probability of false detection of the ACK and the probability of detection of ACK. The performance is measured by the required SNR at probability of detection equal to 0.99. The probability of false detection of the ACK shall be 0.01 or less.

The probability of false detection of the ACK is defined as a conditional probability of erroneous detection of the ACK at particular bit position when input is only noise.

The probability of detection of ACK is defined as conditional probability of detection of the ACK when the ACK was sent at particular bit position. Each missed ACK bit is counted as one error.

The test is applicable to all BS. A test for a specific channel bandwidth is only applicable if the BS supports it.

For a BS supporting multiple channel bandwidths only the tests for the lowest and the highest channel bandwidth supported by the BS are applicable.

The number of encoded ACK/NACK bits per sub-slot is defined as presented below:

- 3AN bits (AAA): applicable for FDD and TDD

The transmitted sub-slots include both subslot with $N_{\text{subslot}}^{\text{SPUCCH}} = 2$ and subslot with $N_{\text{subslot}}^{\text{SPUCCH}} = 3$. ACK/NACK repetitions are disabled for SPUCCH transmission.

8.7.2.2 Minimum Requirement

The minimum requirement is in TS 36.104 [2] subclause 8.7.

8.7.2.3 Test Purpose

The test shall verify the receiver's ability to detect ACK bits under multipath fading propagation conditions for a given SNR.

8.7.2.4 Method of test

8.7.2.4.1 Initial Conditions

Test environment: Normal, see subclause D.2.

RF channels to be tested: M; see subclause 4.7.

- 1) Connect the BS tester generating the wanted signal, multipath fading simulators and AWGN generators to all BS antenna connectors for diversity reception via a combining network as shown in Annex I.3.2.

8.7.2.4.2 Procedure

- 1) Adjust the AWGN generator, according to the channel bandwidth, defined in Table 8.7.2.4.2-1.

Table 8.7.2.4.2-1: AWGN power level at the BS input

Channel bandwidth [MHz]	AWGN power level
5	-86.5dBm / 4.5MHz
10	-83.5dBm / 9MHz
15	-81.7dBm / 13.5MHz
20	-80.4dBm / 18MHz

- 2) The characteristics of the wanted signal shall be configured according to TS 36.211 [12].
- 3) The multipath fading emulators shall be configured according to the corresponding channel model defined in Annex B
- 4) Adjust the equipment so that the SNR specified in Table 8.7.2.5-1 is achieved at the BS input during the ACK transmissions.
- 5) The signal generator sends AAA codeword in regular time periods. The following statistics are kept: the number of ACK bits falsely detected in the idle periods and the number of missed ACK bits. Each falsely detected ACK bit in the idle periods is accounted as one error for the statistics of false ACK detection, and each missed ACK bit is accounted as one error for the statistics of missed ACK detection.

8.7.2.5 Test Requirement

The ACK missed detection probability shall not exceed 1% at the SNR given in Table 8.7.2.5-1 for 3 AN bits per subslot.

Table 8.7.2.5-1: Minimum requirements for SPUCCH format 4, 3AN bits

Number of Tx antennas	Number of RX antennas	Cyclic Prefix	Propagation Conditions and correlation matrix (Annex B)	Channel Bandwidth / SNR [dB]			
				5MHz	10 MHz	15MHz	20MHz
1	2	Normal	EPA 5 Low	6.8	6.9	6.8	6.8
	4	Normal	EPA 5 Low	1.1	1.1	1.3	1.4

NOTE: If the above Test Requirement differs from the Minimum Requirement then the Test Tolerance applied for this test is non-zero. The Test Tolerance for this test and the explanation of how the Minimum Requirement has been relaxed by the Test Tolerance is given in Annex G.

9 (Void)

Annex A (normative): Reference Measurement channels

A.0 General

The parameters for the reference measurement channels are specified in clause A.1 for E-UTRA reference sensitivity and in-channel selectivity and in clause A.2 for dynamic range.

A schematic overview of the encoding process for the E-UTRA reference measurement channels is provided in Figure A0-1.

E-UTRA receiver requirements in the present document are defined with a throughput stated relative to the Maximum throughput of the FRC. The Maximum throughput for an FRC equals the Payload size * the Number of uplink subframes per second. For FDD, 1000 uplink sub-frames per second are used.

The parameters for the reference measurement channels are specified in clause A.14 for NB-IoT reference sensitivity and in-channel selectivity and in clause A.15 for dynamic range.

A schematic overview of the encoding process for the NB-IoT reference measurement channels is provided in Figure A0-2.

NB-IoT receiver requirements in the present document are defined with a throughput stated relative to the Maximum throughput of the FRC. The Maximum throughput for an FRC equals the Payload size/ (Number of Resource Unit * time to send one Resource Unit).

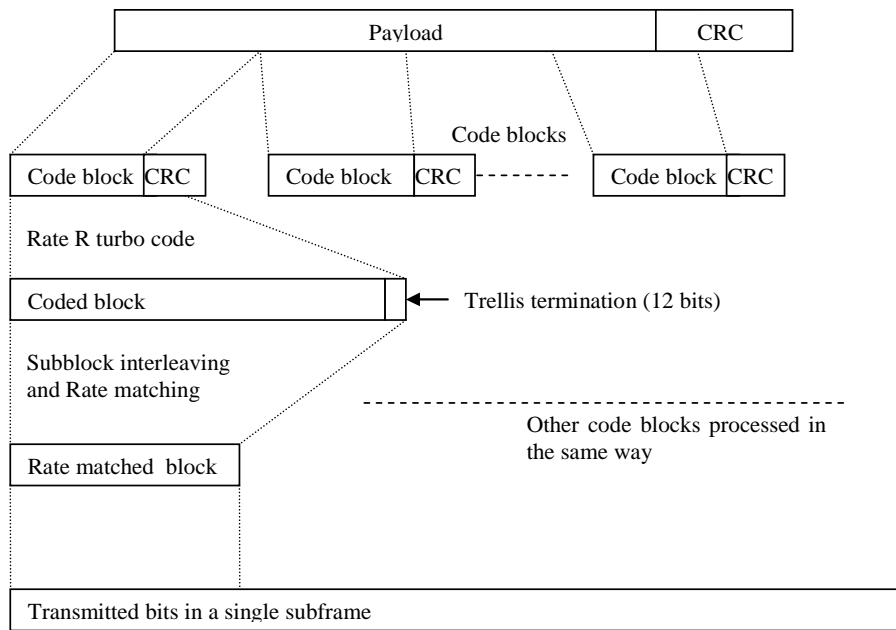

Figure A0-1: Schematic overview of the encoding process

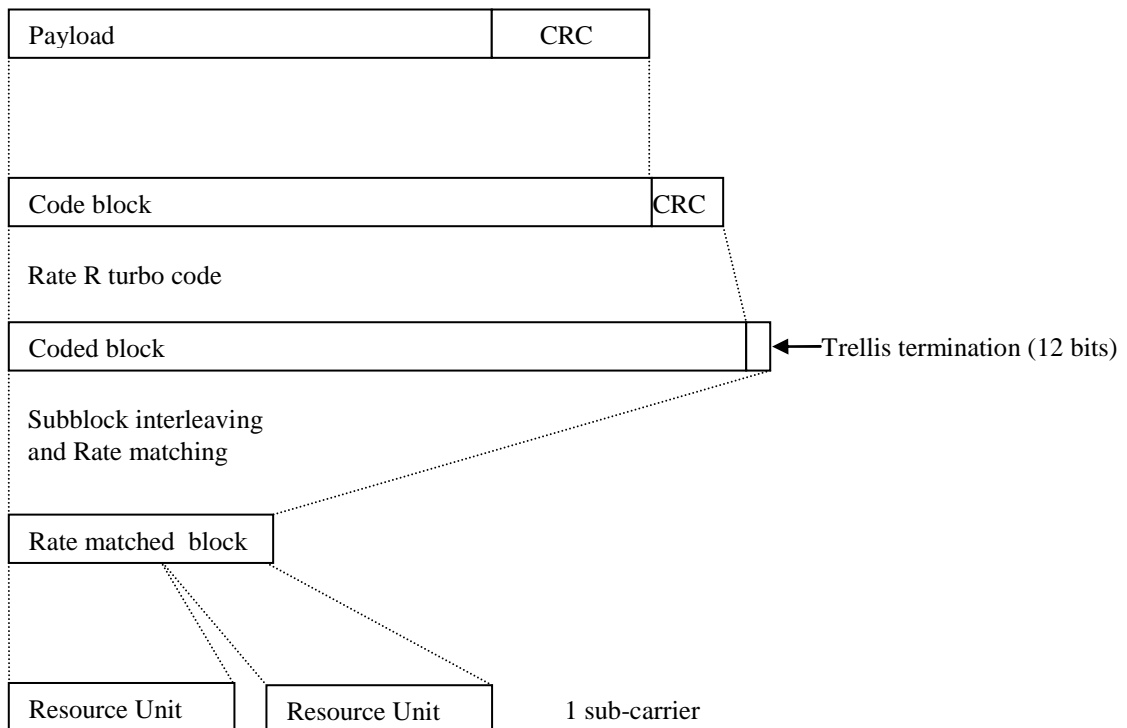

Figure A0-2. Schematic overview of the encoding process for NB-LoT

A.1 Fixed Reference Channels for reference sensitivity and in-channel selectivity (QPSK, R=1/3)

The parameters for the reference measurement channels are specified in Table A.1-1 for reference sensitivity and in-channel selectivity

Table A.1-1: FRC parameters for reference sensitivity and in-channel selectivity

Reference channel	A1-1	A1-2	A1-3	A1-4	A1-5	A1-6	A1-7	A1-8	A1-9
Allocated resource blocks	6	15	25	3	9	12	24	10 ¹	10 ²
DFT-OFDM Symbols per subframe	12	12	12	12	12	12	12	12	12
Modulation	QPSK	QPSK	QPSK	QPSK	QPSK	QPSK	QPSK	QPSK	QPSK
Code rate	1/3	1/3	1/3	1/3	1/3	1/3	1/3	1/3	1/3
Payload size (bits)	600	1544	2216	256	936	1224	2088	1032	1032
Transport block CRC (bits)	24	24	24	24	24	24	24	24	24
Code block CRC size (bits)	0	0	0	0	0	0	0	0	0
Number of code blocks - C	1	1	1	1	1	1	1	1	1
Coded block size including 12bits trellis termination (bits)	1884	4716	6732	852	2892	3756	6348	3180	3180
Total number of bits per sub-frame	1728	4320	7200	864	2592	3456	6912	2880	2880
Total symbols per sub-frame	864	2160	3600	432	1296	1728	3456	1440	1440
NOTE 1: For reference channel A1-8, the allocated RB's are uniformly spaced over the channel bandwidth at RB index N, N+5, N+10, ..., N+45 where N = {0, 1, 2, 3, 4}.									
NOTE 2: For reference channel A1-9, the allocated RB's are uniformly spaced over the channel bandwidth at RB index N, N+10, N+20, ..., N+90 where N = {0, 1, 2, ... 9}.									

A.2 Fixed Reference Channels for dynamic range (16QAM, R=2/3)

The parameters for the reference measurement channels are specified in Table A.2-1 for dynamic range.

Table A.2-1: FRC parameters for dynamic range

Reference channel	A2-1	A2-2	A2-3	A2-4	A2-5
Allocated resource blocks	6	15	25	10 ¹	10 ²
DFT-OFDM Symbols per subframe	12	12	12	12	12
Modulation	16QAM	16QAM	16QAM	16QAM	16QAM
Code rate	2/3	2/3	2/3	2/3	2/3
Payload size (bits)	2344	5992	9912	4008	4008
Transport block CRC (bits)	24	24	24	24	24
Code block CRC size (bits)	0	0	24	0	0
Number of code blocks - C	1	1	2	1	1
Coded block size including 12bits trellis termination (bits)	7116	18060	14988	12108	12108
Total number of bits per sub-frame	3456	8640	14400	5760	5760
Total symbols per sub-frame	864	2160	3600	1440	1440
NOTE 1: For reference channel A2-4, the allocated RB's are uniformly spaced over the channel bandwidth at RB index N, N+5, N+10, ..., N+45 where N = {0, 1, 2, 3, 4}.					
NOTE 2: For reference channel A2-5, the allocated RB's are uniformly spaced over the channel bandwidth at RB index N, N+10, N+20, ..., N+90 where N = {0, 1, 2, ... 9}.					

A.3 Fixed Reference Channels for performance requirements (QPSK 1/3)

Table A.3-1: FRC parameters for performance requirements (QPSK 1/3)

Reference channel	A3-1	A3-2	A3-3	A3-4	A3-5	A3-6	A3-7
Allocated resource blocks	1	6	15	25	50	75	100
DFT-OFDM Symbols per subframe	12	12	12	12	12	12	12
Modulation	QPSK	QPSK	QPSK	QPSK	QPSK	QPSK	QPSK
Code rate	1/3	1/3	1/3	1/3	1/3	1/3	1/3
Payload size (bits)	104	600	1544	2216	5160	6712	10296
Transport block CRC (bits)	24	24	24	24	24	24	24
Code block CRC size (bits)	0	0	0	0	0	24	24
Number of code blocks - C	1	1	1	1	1	2	2
Coded block size including 12bits trellis termination (bits)	396	1884	4716	6732	15564	10188	15564
Total number of bits per sub-frame	288	1728	4320	7200	14400	21600	28800
Total symbols per sub-frame	144	864	2160	3600	7200	10800	14400

A.4 Fixed Reference Channels for performance requirements (16QAM 3/4)

Table A.4-1: FRC parameters for performance requirements (16QAM 3/4)

Reference channel	A4-1	A4-2	A4-3	A4-4	A4-5	A4-6	A4-7	A4-8
Allocated resource blocks	1	1	6	15	25	50	75	100
DFT-OFDM Symbols per subframe	12	10	12	12	12	12	12	12
Modulation	16QAM	16QAM	16QAM	16QAM	16QAM	16QAM	16QAM	16QAM
Code rate	3/4	3/4	3/4	3/4	3/4	3/4	3/4	3/4
Payload size (bits)	408	376	2600	6456	10680	21384	32856	43816
Transport block CRC (bits)	24	24	24	24	24	24	24	24
Code block CRC size (bits)	0	0	0	24	24	24	24	24
Number of code blocks - C	1	1	1	2	2	4	6	8
Coded block size including 12bits trellis termination (bits)	1308	1212	7884	9804	16140	16140	16524	16524
Total number of bits per sub-frame	576	480	3456	8640	14400	28800	43200	57600
Total symbols per sub-frame	144	120	864	2160	3600	7200	10800	14400

A.5 Fixed Reference Channels for performance requirements (64QAM 5/6)

Table A.5-1: FRC parameters for performance requirements (64QAM 5/6)

Reference channel	A5-1	A5-2	A5-3	A5-4	A5-5	A5-6	A5-7
Allocated resource blocks	1	6	15	25	50	75	100
DFT-OFDM Symbols per subframe	12	12	12	12	12	12	12
Modulation	64QAM	64QAM	64QAM	64QAM	64QAM	64QAM	64QAM
Code rate	5/6	5/6	5/6	5/6	5/6	5/6	5/6
Payload size (bits)	712	4392	11064	18336	36696	55056	75376
Transport block CRC (bits)	24	24	24	24	24	24	24
Code block CRC size (bits)	0	0	24	24	24	24	24
Number of code blocks - C	1	1	2	3	6	9	13
Coded block size including 12bits trellis termination (bits)	2220	13260	16716	18444	18444	18444	17484
Total number of bits per sub-frame	864	5184	12960	21600	43200	64800	86400
Total symbols per sub-frame	144	864	2160	3600	7200	10800	14400

A.6 PRACH Test preambles

Table A.6-1: Test preambles for Normal Mode

Burst format	Ncs	Logical sequence index	v
0	13	22	32
1	167	22	2
2	167	22	0
3	0	22	0
4	10	0	0

Table A.6-2: Test preambles for High speed Mode restricted set type A

Burst format	Ncs	Logical sequence index	v
0	15	384	0
1	202	384	0
2	202	384	0
3	237	384	0

Table A.6-3 Test preambles for coverage enhancement

Burst format	Ncs	Logical sequence index	v
0	13	22	32
1	167	22	2
2	167	22	0
3	0	22	0

Table A.6-4 Test preambles for High speed Mode restricted set type B

Burst format	Ncs	Logical sequence index	v
0	15	30	30
1	100	168	20
2	118	204	10
3	137	264	0

A.7 Fixed Reference Channels for UL timing adjustment (Scenario 1)

Table A.7-1: FRC parameters for UL timing adjustment (Scenario 1)

Reference channel	A7-1	A7-2	A7-3	A7-4	A7-5	A7-6
Allocated resource blocks	3	6	12	25	25	25
DFT-OFDM Symbols per subframe	12	12	12	12	12	12
Modulation	16QAM	16QAM	16QAM	16QAM	16QAM	16QAM
Code rate	3/4	3/4	3/4	3/4	3/4	3/4
Payload size (bits)	1288	2600	5160	10680	10680	10680
Transport block CRC (bits)	24	24	24	24	24	24
Code block CRC size (bits)	0	0	0	24	24	24
Number of code blocks - C	1	1	1	2	2	2
Coded block size including 12bits trellis termination (bits)	3948	7884	15564	16140	16140	16140
Total number of bits per sub-frame	1728	3456	6912	14400	14400	14400
Total symbols per sub-frame	432	864	1728	3600	3600	3600
SRS bandwidth configuration (See TS 36.211, 5.5.3) (Note 1)	7	5	3	2	5	2
SRS-Bandwidth b (See TS 36.211, 5.5.3) (Note 1, 2)	0	0	0	0	0	1
Note 1. The transmission of SRS is optional						
Note 2. PUSCH resource blocks shall be included in SRS resource blocks						

A.8 Fixed Reference Channels for UL timing adjustment (Scenario 2)

Table A.8-1: FRC parameters for UL timing adjustment (Scenario 2)

Reference channel	A8-1	A8-2	A8-3	A8-4	A8-5	A8-6
Allocated resource blocks	3	6	12	25	25	25
DFT-OFDM Symbols per subframe	12	12	12	12	12	12
Modulation	QPSK	QPSK	QPSK	QPSK	QPSK	QPSK
Code rate	1/3	1/3	1/3	1/3	1/3	1/3
Payload size (bits)	256	600	1224	2216	2216	2216
Transport block CRC (bits)	24	24	24	24	24	24
Code block CRC size (bits)	0	0	0	0	0	0
Number of code blocks - C	1	1	1	1	1	1
Coded block size including 12bits trellis termination (bits)	852	1884	3756	6732	6732	6732
Total number of bits per sub-frame	864	1728	3456	7200	7200	7200
Total symbols per sub-frame	432	864	1728	3600	3600	3600
SRS bandwidth configuration (See TS 36.211, 5.5.3) (Note 1)	7	5	3	2	5	2
SRS-Bandwidth b (See TS 36.211, 5.5.3) (Note 1, 2)	0	0	0	0	0	1
Note 1. The transmission of SRS is optional						
Note 2. PUSCH resource blocks shall be included in SRS resource blocks						

A.9 Multi user PUCCH test

Table A.9-1: Test parameters for multi user PUCCH case

	Resource index for PUCCH formats 1/1a/1b $n_{\text{PUCCH}}^{(1)}$	Relative power [dB]	Relative timing [ns]
Tested signal	2	-	-
Interferer 1	1	0	0
Interferer 2	7	-3	
Interferer 3	14	3	

NOTE1: The following parameters shall be used $N_{\text{ID}}^{\text{cell}} = 150$, $N_{\text{cs}}^{(1)} = 0$ and $\Delta_{\text{shift}}^{\text{PUCCH}} = 2$.

NOTE2: All above listed signals are transmitted on the same PUCCH resource block, with different PUCCH resource indices as presented above.

A.10 PUCCH transmission on two antenna ports test

Table A.10-1: Test parameters for PUCCH transmission on two antenna ports case

PUCCH format	Resource indices for two antenna ports
Format 1a	$n_{\text{PUCCH}}^{(1,p=p_0)} = 1$, $n_{\text{PUCCH}}^{(1,p=p_1)} = 2$
Format 2	$n_{\text{PUCCH}}^{(2,p=p_0)} = 1$, $n_{\text{PUCCH}}^{(2,p=p_1)} = 2$

NOTE1: The following parameters shall be used $N_{\text{ID}}^{\text{cell}} = 150$, $N_{\text{cs}}^{(1)} = 0$. For PUCCH format 1a, $\Delta_{\text{shift}}^{\text{PUCCH}} = 2$ is assumed.

NOTE2: The signals transmitted on two antenna ports are in the same PUCCH resource block with different resource indices as presented above.

A.11 Fixed Reference Channel for PUSCH with TTI bundling and enhanced HARQ pattern

Table A.11-1: FRC parameters for PUSCH with TTI bundling and enhanced HARQ pattern

Reference channel	A11-1
Allocated resource blocks	3
DFT-OFDM Symbols per subframe	12
Modulation	QPSK
Code rate	11/27*
Payload size (bits)	328
Transport block CRC (bits)	24
Code block CRC size (bits)	0
Number of code blocks - C	1
Coded block size including 12bits trellis termination (bits)	1068
Total number of bits per sub-frame	864
Total symbols per sub-frame	432
Note *: code rate per TTI	

A.12 Fixed Reference Channels for performance requirements (QPSK 0.36)

Table A.12-1 FRC parameters for performance requirements (QPSK 0.36)

Reference channel	A12-1	A12-2	A12-3	A12-4	A12-5	A12-6
Allocated resource blocks	6	15	25	50	75	100
DFT-OFDM Symbols per subframe	12	12	12	12	12	12
Modulation	QPSK	QPSK	QPSK	QPSK	QPSK	QPSK
Code rate	0.36	0.36	0.36	0.36	0.36	0.36
MCS index	6	6	6	6	6	6
Payload size (bits)	600	1544	2600	5160	7736	10296
Transport block CRC (bits)	24	24	24	24	24	24
Code block CRC size (bits)	0	0	0	0	24	24
Number of code blocks - C	1	1	1	1	2	2
Coded block size including 12bits trellis termination (bits)	1884	4716	7884	15564	11724	15564
Total number of bits per sub-frame	1728	4320	7200	14400	21600	28800
Total symbols per sub-frame	864	2160	3600	7200	10800	14400
NOTE 1: FRC A12-1, A12-2, A12-4, A12-6 are identical to FRC A3-2, A3-3, A3-5, A3-7, respectively.						

A.13 Fixed Reference Channels for performance requirements (16QAM 1/2)

Table A.13-1: FRC parameters for performance requirements (16QAM 1/2)

Reference channel	A13-1	A13-2	A13-3	A13-4	A13-5	A13-6
Allocated resource blocks	6	15	25	50	75	100
DFT-OFDM Symbols per subframe	12	12	12	12	12	12
Modulation	16QAM	16QAM	16QAM	16QAM	16QAM	16QAM
Code rate	0.51	0.50	0.50	0.49	0.50	0.49
MCS index	15	15	15	15	15	15
Payload size (bits)	1736	4264	7224	14112	21384	28336
Transport block CRC (bits)	24	24	24	24	24	24
Code block CRC size (bits)	0	0	24	24	24	24
Number of code blocks - C	1	1	2	3	4	5
Coded block size including 12bits trellis termination (bits)	5292	12876	10956	14220	16140	17100
Total number of bits per sub-frame	3456	8640	14400	28800	43200	57600
Total symbols per sub-frame	864	2160	3600	7200	10800	14400

A.14 Fixed Reference Channels for NB-IOT reference sensitivity ($\pi/2$ BPSK, R=1/3)

The parameters for the reference measurement channels are specified in Table A.14-1 for reference sensitivity.

Table A.14-1 FRC parameters for reference sensitivity and in-channel selectivity

Reference channel	A14-1	A14-2
Sub-carrier spacing (kHz)	15	3.75
Number of tone	1	1
Diversity	No	No
Modulation	$\pi/2$ BPSK	$\pi/2$ BPSK
Frequency offset	0	0
Channel estimation length (ms) ^{Note1}	4	16
Number of NPUSCH repetition	1	1
IMCS / TBS	0 / 0	0 / 0
Payload size (bits)	32	32
Allocated resource unit	2	2
Code rate (target)	1/3	1/3
Code rate (effective)	0.29	0.29
Transport block CRC (bits)	24	24
Code block CRC size (bits)	0	0
Number of code blocks - C	1	1
Total number of bits per resource unit	96	96
Total symbols per resource unit	96	96
Tx time (ms)	16	64
Note 1: Channel estimation lengths are included in the table for information only.		

A.14.1 Void

A.15 Fixed Reference Channels for NB-IoT dynamic range ($\pi/4$ QPSK, R=2/3)

The parameters for the reference measurement channels are specified in Table A.15-1 for NB-IoT dynamic range.

Table A.15-1 FRC parameters for NB-IoT dynamic range

Reference channel	A15-1	A15-2
Sub carrier spacing (kHz)	15	3.75
Number of tone	1	1
Modulation	$\pi/4$ QPSK	$\pi/4$ QPSK
Diversity	No	No
Frequency offset	0	0
IMCS / ITBS	7 / 7	7 / 7
Payload size (bits)	104	104
Allocated resource units	1	1
Transport block CRC (bits)	24	24
Coding rate (target)	2/3	2/3
Coding Rate	0.67	0.67
Code block CRC size (bits)	0	0
Number of code blocks - C	1	1
Total symbols per resource unit	96	96
Total number of bits per resource unit	192	192
Tx time (ms)	8	32
Frequency offset	0	0
Channel estimation length (ms) ^{Note1}	4	16
Note 1: Channel estimation lengths are included in the table for information only.		

A.16 Fixed Reference Channels for NB-IoT NPUSCH format 1

A.16.1 One PRB

Table A.16.1-1: FRC parameters for NB-IoT NPUSCH format 1

Reference channel	A16-1	A16-2	A16-3	A16-4	A16-5	A16-6
Subcarrier spacing (kHz)	3.75	15	15	15	15	15
Number of allocated subcarriers	1	1	3	6	12	12
Diversity	No	No	No	No	No	No
Modulation	BPSK	BPSK	QPSK	QPSK	QPSK	QPSK
I_{TBS} / I_{RU}	0 / 1	0 / 1	3 / 0	7 / 0	9 / 0	5 / 4
Payload size (bits)	32	32	40	104	136	424
Allocated resource unit	2	2	1	1	1	5
Code rate (target)	1/3	1/3	1/3	1/3	2/3	1/3
Code rate (effective)	0.29	0.29	0.22	0.44	0.56	0.34
Transport block CRC (bits)	24	24	24	24	24	24
Code block CRC size (bits)	0	0	0	0	0	0
Number of code blocks - C	1	1	1	1	1	1
Total number of bits per resource unit	96	96	288	288	288	1440
Total symbols per resource unit	96	96	144	144	144	720
Channel estimation length (ms) ^{Note 1}	16	4	4	4		4

Note 1: Channel estimation lengths are included in the table for information only.

A.17 Fixed Reference Channels for performance requirements (256QAM 5/6)

Table A.17-1 FRC parameters for performance requirements (64QAM 5/6)

Reference channel	A17-1	A17-2	A17-3	A17-4	A17-5	A17-6
Allocated resource blocks	6	15	25	50	75	100
DFT-OFDM Symbols per subframe	12	12	12	12	12	12
Modulation	256QAM	256QAM	256QAM	256QAM	256QAM	256QAM
Code rate	5/6	5/6	5/6	5/6	5/6	5/6
Payload size (bits)	5544	14112	22920	46888	68808	93800
Transport block CRC (bits)	24	24	24	24	24	24
Code block CRC size (bits)	0	24	24	24	24	24
Number of code blocks - C	1	3	4	8	12	16
Coded block size including 12bits trellis termination (bits)	16716	14220	17292	17676	17292	17676
Total number of bits per sub-frame	6912	17280	28800	57600	86400	115200
Total symbols per sub-frame	864	2160	3600	7200	10800	14400

A.18 Fixed Reference Channels for PUSCH transmission in UpPTS (16QAM 0.65)

Table A18-1: FRC parameters for PUSCH transmission in UpPTS (16QAM 0.65)

Reference channel	A18-1	A18-2	A18-3	A18-4	A18-5	A18-6
Allocated resource blocks	6	15	25	50	75	100
DFT-OFDM Symbols in UpPTS	5	5	5	5	5	5
Modulation	16QAM	16QAM	16QAM	16QAM	16QAM	16QAM
Code rate	0.65	0.65	0.65	0.65	0.65	0.65
Payload size (bits) (Note 1)	840	2152	3880	7736	12216	15840
Transport block CRC (bits)	24	24	24	24	24	24
Code block CRC size (bits)	0	0	24	24	24	24
Number of code blocks - C	1	1	1	2	2	3
Coded block size including 12bits trellis termination (bits)	2604	6540	17724	11724	18516	15948
Total number of bits in UpPTS	1440	3600	6000	12000	18000	24000
Total symbols in UpPTS	360	900	1500	3000	4500	6000
Note 1:	For special subframe configuration with more than 3 UpPTS SC-FDMA data symbols, the UE shall determine the TBS using $\max\{\lfloor N_{PRB} \times 0.375 \rfloor, 1\}$.					

A.19 Fixed Reference Channels for PUSCH transmission in UpPTS (256QAM 0.69)

Table A19-1: FRC parameters for PUSCH transmission in UpPTS (256QAM 0.69)

Reference channel	A19-1	A19-2	A19-3	A19-4	A19-5	A19-6
Allocated resource blocks	6	15	25	50	75	100
DFT-OFDM Symbols in UpPTS	5	5	5	5	5	5
Modulation	256QAM	256QAM	256QAM	256QAM	256QAM	256QAM
Code rate	0.69	0.69	0.69	0.69	0.69	0.69
Payload size (bits)	1864	4584	8248	16416	26416	34008
Transport block CRC (bits)	24	24	24	24	24	24
Code block CRC size (bits)	0	0	24	24	24	24
Number of code blocks - C	1	1	2	3	5	6
Coded block size including 12bits trellis termination (bits)	5767	13836	12492	16524	15948	17100
Total number of bits in UpPTS	2880	7200	12000	24000	36000	48000
Total symbols in UpPTS	360	900	1500	3000	4500	6000
Note 1:	For special subframe configuration with more than 3 UpPTS SC-FDMA data symbols, the UE shall determine the TBS using $\max\{\lfloor N_{PRB} \times 0.375 \rfloor, 1\}$.					

A.20 Fixed Reference Channels for PUSCH with Frame structure type 3

Table A.20-1: FRC parameters for performance requirements

Reference channel	A20-1	A20-2
Allocated resource blocks	50	50
DFT-OFDM Symbols per subframe	11	11
Modulation	QPSK	16QAM
Code rate	1/3	3/4
MCS index	5	19
Payload size (bits)	4392	19848
Transport block CRC (bits)	24	24
Code block CRC size (bits)	0	24
Number of code blocks - C	1	4
Coded block size including 12bits trellis termination (bits)	13260	14988
Total number of bits per sub-frame with the PUSCH starting position at 25us in symbol 0	13200	26400
Total number of bits per sub-frame with the PUSCH starting position at symbol 0	14400	28800
Total RE per sub-frame with the PUSCH starting position at 25us in symbol 0	6600	6600
Total RE per sub-frame with the PUSCH starting position at symbol 0	7200	7200
Note 1: The PUSCH ending symbol for all scheduled subframes is the last symbol.		

A.21 Fixed Reference Channels for performance requirements (QPSK 3/5)

Table A.21-1: FRC parameters for performance requirements (QPSK 3/5)

Reference channel	A21-1	A21-2	A21-3	A21-4	A21-5	A21-6
Allocated resource blocks	6	15	25	50	75	100
DFT-OFDM Symbols per subframe	12	12	12	12	12	12
Modulation	QPSK	QPSK	QPSK	QPSK	QPSK	QPSK
Code rate	0.61	0.62	0.61	0.61	0.60	0.61
MCS index	10	10	10	10	10	10
Payload size (bits)	1032	2664	4392	8760	12960	17568
Transport block CRC (bits)	24	24	24	24	24	24
Code block CRC size (bits)	0	0	0	24	24	24
Number of code blocks - C	1	1	1	2	3	3
Coded block size including 12bits trellis termination (bits)	3180	8076	13260	13260	13068	17676
Total number of bits per sub-frame	1728	4320	7200	14400	21600	28800
Total symbols per sub-frame	864	2160	3600	7200	10800	14400

A.22 Fixed Reference Channels for performance requirements (64QAM 1/2)

Table A.22-1: FRC parameters for performance requirements (64QAM 1/2)

Reference channel	A22-1	A22-2	A22-3	A22-4
Allocated resource blocks	6	15	25	50
DFT-OFDM Symbols per subframe	12	12	12	12
Modulation	64QAM	64QAM	64QAM	64QAM
Code rate	0.51	0.50	0.50	0.50
MCS index	21	21	21	21
Payload size (bits)	2600	6456	10680	21384
Transport block CRC (bits)	24	24	24	24
Code block CRC size (bits)	0	24	24	24
Number of code blocks - C	1	2	2	4
Coded block size including 12bits trellis termination (bits)	7884	9804	16140	16140
Total number of bits per sub-frame	5184	12960	21600	43200
Total symbols per sub-frame	864	2160	3600	7200

A.23 Fixed Reference Channel for subslot-PUSCH

Table A.23-1: FRC parameters for performance requirements (16QAM 3/4)

Reference channel	A23-1		A23-2		A23-3		A23-4	
Allocated resource blocks	24		48		72		100	
DFT-OFDM Symbols per subframe	1	2	1	2	1	2	1	2
Modulation	16QAM		16QAM		16QAM		16QAM	
Code rate	3/4		3/4		3/4		3/4	
Payload size (bits)	872	1736	1736	3496	2536	5160	3624	7224
Transport block CRC (bits)	24	24	24	24	24	24	24	24
Code block CRC size (bits)	24	24	24	24	24	24	24	24
Number of code blocks - C	1	1	1	1	1	1	1	2
Coded block size including 12bits trellis termination (bits)	2700	5292	5292	10572	7692	15564	10956	10956
Total number of bits per sub-frame	1152	2304	2304	4608	3456	6912	4800	9600
Total symbols per sub-frame	288	576	576	1152	864	1728	1200	2400

A.24 Fixed Reference Channels for PUSCH with SubPRB transmission

Table A.24-1: FRC parameters for performance requirements (subPRB transmission)

Reference channel	A24-1	A24-2
Diversity	No	No
Allocated resource blocks	1	1
Number of subcarriers	2 out of 3	2 out of 3
DFT-OFDM Symbols per subframe	12	12
Modulation	$\pi/2$ BPSK	$\pi/2$ BPSK
Code rate	1/3	1/3
MCS index	0	0
Payload size (bits)	32	88
Transport block CRC (bits)	24	24
Code block CRC size (bits)	0	0
Number of code blocks - C	1	1
Total number of bits per resource unit	96*2	96*2
Total symbols per resource unit	96*2	96*2
Frequency offset	0	0
Number of RUs	1	2
Tx time (ms)	8	16

Annex B (normative): Propagation conditions

B.1 Static propagation condition

The propagation for the static performance measurement is an Additive White Gaussian Noise (AWGN) environment. No fading or multi-paths exist for this propagation model.

B.2 Multi-path fading propagation conditions

Tables B.2-1 - B.2-3 show multi-path delay profiles that are used for the performance measurements in multi-path fading environment. All taps have classical Doppler spectrum, defined as:

$$(CLASS) \quad S(f) \propto 1/(1 - (f / f_D)^2)^{0.5} \quad \text{for } f \in -f_D, f_D.$$

Table B.2-1: Extended Pedestrian A model (EPA)

Excess tap delay [ns]	Relative power [dB]
0	0.0
30	-1.0
70	-2.0
90	-3.0
110	-8.0
190	-17.2
410	-20.8

Table B.2-2: Extended Vehicular A model (EVA)

Excess tap delay [ns]	Relative power [dB]
0	0.0
30	-1.5
150	-1.4
310	-3.6
370	-0.6
710	-9.1
1090	-7.0
1730	-12.0
2510	-16.9

Table B.2-3 Extended Typical Urban model (ETU)

Excess tap delay [ns]	Relative power [dB]
0	-1.0
50	-1.0
120	-1.0
200	0.0
230	0.0
500	0.0
1600	-3.0
2300	-5.0
5000	-7.0

A multipath fading propagation condition is defined by a combination of a multi-path delay profile and a maximum Doppler frequency f_D which is either 5, 70 or 300 Hz. In addition, 200 Hz Doppler frequency is specified for UL timing adjustment performance requirement.

B.3 High speed train condition

High speed train conditions are as follows:

Scenario 1 / Scenario 1-LTE500a / Scenario 1-LTE500b: Open space

Scenario 3 / Scenario 3-LTE500a / Scenario 3-LTE500b: Tunnel for multi-antennas

The high speed train conditions for the test of the baseband performance are two non-fading propagation channels in both scenarios. For BS with Rx diversity defined in scenario 1 / Scenario 1-LTE500a / Scenario 1-LTE500b, the Doppler shift variation is the same between antennas.

Doppler shift for both scenarios is given by:

$$f_s(t) = f_d \cos \theta(t) \quad (\text{B.3.1})$$

where $f_s(t)$ is the Doppler shift and f_d is the maximum Doppler frequency. The cosine of angle $\theta(t)$ is given by:

$$\cos \theta(t) = \frac{D_s/2 - vt}{\sqrt{D_{\min}^2 + (D_s/2 - vt)^2}}, \quad 0 \leq t \leq D_s/v \quad (\text{B.3.2})$$

$$\cos \theta(t) = \frac{-1.5D_s + vt}{\sqrt{D_{\min}^2 + (-1.5D_s + vt)^2}}, \quad D_s/v < t \leq 2D_s/v$$

(B.3.3)

$$\cos \theta(t) = \cos \theta(t \bmod (2D_s/v)), \quad t > 2D_s/v \quad (\text{B.3.4})$$

where $D_s/2$ is the initial distance of the train from BS, and D_{\min} is BS-Railway track distance, both in meters; V is the velocity of the train in m/s, t is time in seconds.

Doppler shift and cosine angle is given by equations B.3.1 and B.3.2-B.3.4 respectively, where the required input parameters listed in Table B.3-1 and B.3-2, and the resulting Doppler shift is shown in Figure B.3-1, B.3-2, B.3-3, B.3-4, B.3-5 and B.3-6 are applied for all frequency bands.

Table B.3-1: Parameters for high speed train conditions for UE velocity up to 350 km/h

Parameter	Value	
	Scenario 1	Scenario 3
D_s	1000 m	300 m
D_{\min}	50 m	2 m
V	350 km/h	300 km/h
f_d	1340 Hz	1150 Hz

Table B.3-2: Parameters for high speed train conditions for UE velocity up to 500 km/h

Parameter	Value			
	Scenario 1-LTE500a	Scenario 3-LTE500a	Scenario 1-LTE500b	Scenario 3-LTE500b
D_s	1000 m	300 m	1000 m	300 m
D_{min}	50 m	2 m	50 m	2 m
v	500 km/h	500 km/h	500 km/h	500 km/h
f_d	1944 Hz	1944 Hz	1750 Hz	1750 Hz

NOTE 1: Parameters for HST conditions in table B.3-1 including f_d and Doppler shift trajectories presented on figures B.3-1 and B.3-2 were derived from Band 1 and are applied for performance verification in all frequency bands.

NOTE 2: Parameters for scenario 1-LTE500a and scenario 3-LTE500a in table B.3-2 including f_d and Doppler shift trajectories presented on figures B.3-3 and B.3-4 were derived from Band1 and are applied for performance verification in all frequency bands.

NOTE 3: Parameters for scenario 1-LTE500b and scenario 3-LTE500b in table B.3-2 including f_d and Doppler shift trajectories presented on figures B.3-5 and B.3-6 were derived from Band3 and are applied for performance verification in all frequency bands.

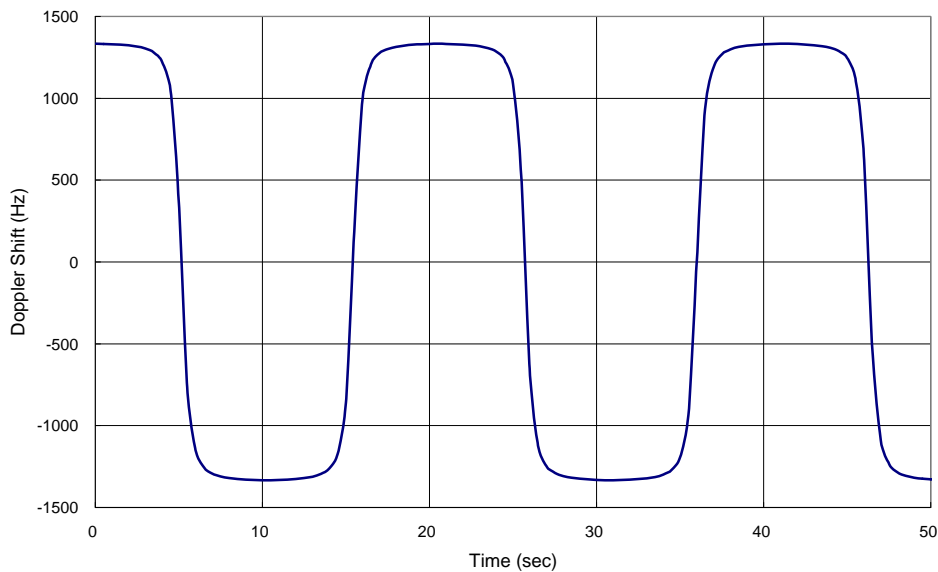
**Figure B.3-1: Doppler shift trajectory for scenario 1**

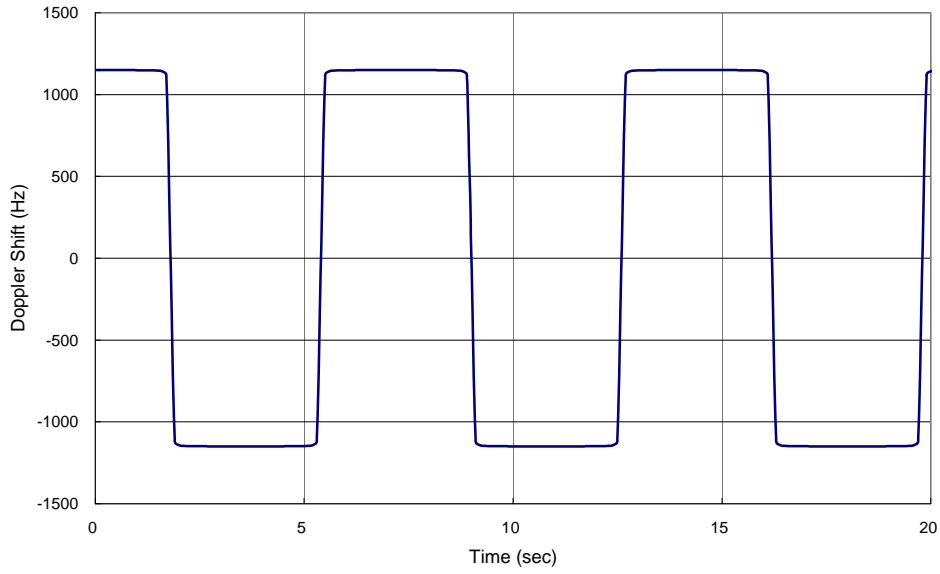

Figure B.3-2: Doppler shift trajectory for scenario 3

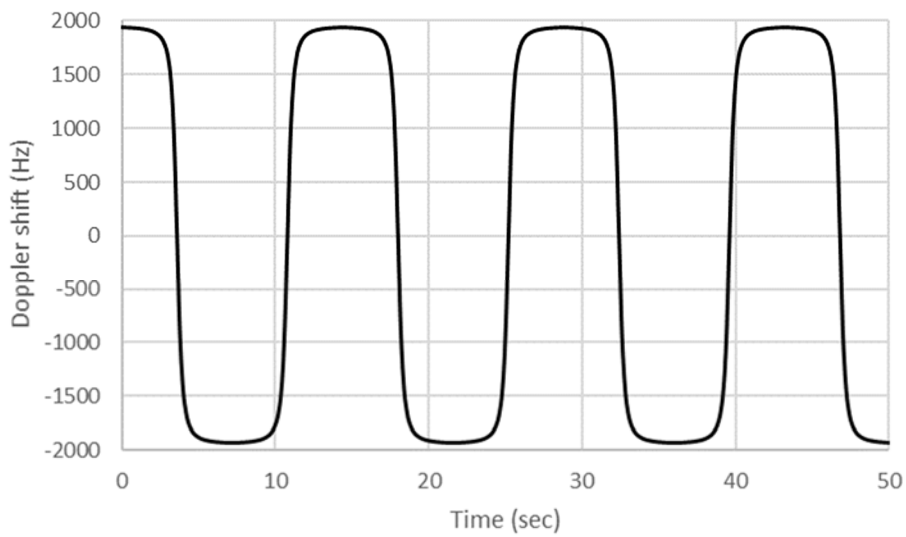

Figure B.3-3: Doppler shift trajectory for scenario 1-LTE500a

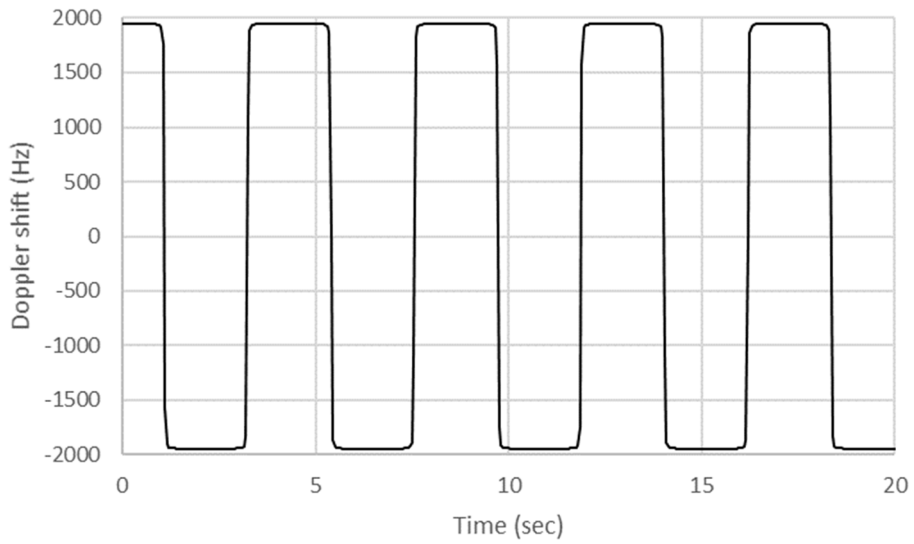

Figure B.3-4: Doppler shift trajectory for scenario 3-LTE500a

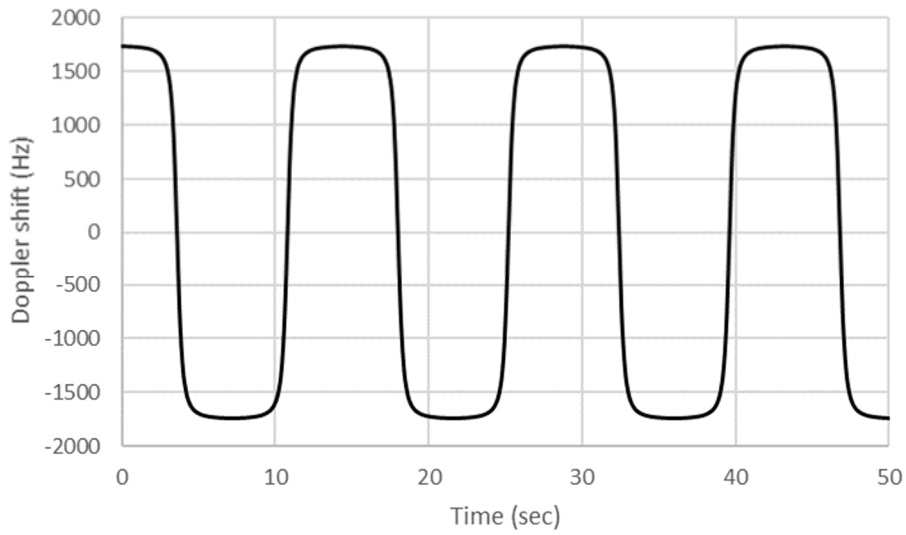

Figure B.3-5: Doppler shift trajectory for scenario 1-LTE500b

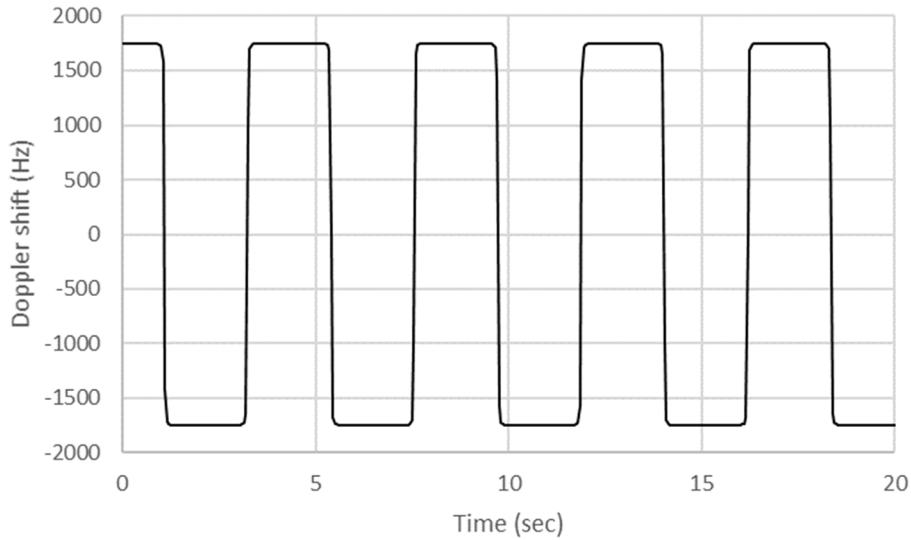

Figure B.3-6: Doppler shift trajectory for scenario 3-LTE500b

B.4 Moving propagation conditions

Figure B.4-1 illustrates the moving propagation conditions for the test of the UL timing adjustment performance. The time difference between the reference timing and the first tap is according Equation (B.4-1). The timing difference between moving UE and stationary UE is equal to $\Delta\tau - (T_A - 31) \times 16T_s$. The relative timing among all taps is fixed. The parameters for the moving propagation conditions are shown in Table B.4-1.

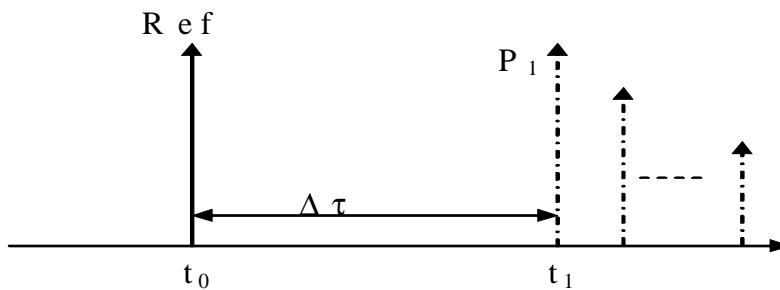

Figure B.4-1: Moving propagation conditions

$$\Delta\tau = \frac{A}{2} \cdot \sin(\Delta\omega \cdot t) \tag{B.4-1}$$

Table B.4-1: Parameters for UL timing adjustment

Parameter	Scenario 1	Scenario 2
Channel model	Stationary UE: AWGN Moving UE: ETU200	AWGN
UE speed	120 km/h	350 km/h
CP length	Normal	Normal
A	10 μ s	10 μ s
$\Delta\omega$	0.04 s ⁻¹	0.13 s ⁻¹

NOTE 1: Multipath fading propagation conditions for Scenario 1 were derived for Band 1 with additional rounding applied to the Doppler frequency calculated for the specified UE speed.

NOTE 2: In Scenario 2, the UE speed is only used to calculate $\Delta\omega$ and the Doppler shift is not applied to the channel.

B.5 Multi-Antenna channel models

The MIMO channel correlation matrices defined in B.5 apply for the antenna configuration using uniform linear arrays at both UE and eNodeB.

B.5.1 Definition of MIMO Correlation Matrices

Table B.5.1-1 defines the correlation matrix for the eNodeB:

Table B.5.1-1: eNodeB correlation matrix

	One antenna	Two antennas	Four antennas
eNode B Correlation	$R_{eNB} = 1$	$R_{eNB} = \begin{pmatrix} 1 & \alpha \\ \alpha^* & 1 \end{pmatrix}$	$R_{eNB} = \begin{pmatrix} 1 & \alpha^{1/9} & \alpha^{4/9} & \alpha \\ \alpha^{1/9*} & 1 & \alpha^{1/9} & \alpha^{4/9} \\ \alpha^{4/9*} & \alpha^{1/9*} & 1 & \alpha^{1/9} \\ \alpha^* & \alpha^{4/9*} & \alpha^{1/9*} & 1 \end{pmatrix}$

Table B.5.1-2 defines the correlation matrix for the UE:

Table B.5.1-2: UE correlation matrix

	One antenna	Two antennas	Four antennas
UE Correlation	$R_{UE} = 1$	$R_{UE} = \begin{pmatrix} 1 & \beta \\ \beta^* & 1 \end{pmatrix}$	$R_{UE} = \begin{pmatrix} 1 & \beta^{1/9} & \beta^{4/9} & \beta \\ \beta^{1/9*} & 1 & \beta^{1/9} & \beta^{4/9} \\ \beta^{4/9*} & \beta^{1/9*} & 1 & \beta^{1/9} \\ \beta^* & \beta^{4/9*} & \beta^{1/9*} & 1 \end{pmatrix}$

Table B.5.1-3 defines the channel spatial correlation matrix R_{spat} . The parameters α and β in Table B.5.1-3 defines the spatial correlation between the antennas at the eNodeB and UE.

Table B.5.1-3: R_{spat} correlation matrices

1x2 case	$R_{spat} = R_{eNB} = \begin{pmatrix} 1 & \alpha \\ \alpha^* & 1 \end{pmatrix}$
2x2 case	$R_{spat} = R_{UE} \otimes R_{eNB} = \begin{bmatrix} 1 & \beta \\ \beta^* & 1 \end{bmatrix} \otimes \begin{bmatrix} 1 & \alpha \\ \alpha^* & 1 \end{bmatrix} = \begin{bmatrix} 1 & \alpha & \beta & \beta\alpha \\ \alpha^* & 1 & \beta\alpha^* & \beta \\ \beta^* & \beta^*\alpha & 1 & \alpha \\ \beta^*\alpha^* & \beta^* & \alpha^* & 1 \end{bmatrix}$
2x4 case	$R_{spat} = R_{UE} \otimes R_{eNB} = \begin{bmatrix} 1 & \beta \\ \beta^* & 1 \end{bmatrix} \otimes \begin{bmatrix} 1 & \alpha^{1/9} & \alpha^{4/9} & \alpha \\ \alpha^{1/9*} & 1 & \alpha^{1/9} & \alpha^{4/9} \\ \alpha^{4/9*} & \alpha^{1/9*} & 1 & \alpha^{1/9} \\ \alpha^* & \alpha^{4/9*} & \alpha^{1/9*} & 1 \end{bmatrix}$
4x4 case	$R_{spat} = R_{UE} \otimes R_{eNB} = \begin{pmatrix} 1 & \beta^{1/9} & \beta^{4/9} & \beta \\ \beta^{1/9*} & 1 & \beta^{1/9} & \beta^{4/9} \\ \beta^{4/9*} & \beta^{1/9*} & 1 & \beta^{1/9} \\ \beta^* & \beta^{4/9*} & \beta^{1/9*} & 1 \end{pmatrix} \otimes \begin{bmatrix} 1 & \alpha^{1/9} & \alpha^{4/9} & \alpha \\ \alpha^{1/9*} & 1 & \alpha^{1/9} & \alpha^{4/9} \\ \alpha^{4/9*} & \alpha^{1/9*} & 1 & \alpha^{1/9} \\ \alpha^* & \alpha^{4/9*} & \alpha^{1/9*} & 1 \end{bmatrix}$

For cases with more antennas at either eNodeB or UE or both, the channel spatial correlation matrix can still be expressed as the Kronecker product of R_{UE} and R_{eNB} according to $R_{spat} = R_{UE} \otimes R_{eNB}$.

B.5.2 MIMO Correlation Matrices at High, Medium and Low Level

The α and β for different correlation types are given in Table B.5.2-1.

Table B.5.2-1: Correlation for High Medium and Low Level

Low correlation		Medium Correlation		High Correlation	
α	β	α	β	α	β
0	0	0.9	0.3	0.9	0.9

The correlation matrices for high, medium and low correlation are defined in Table B.5.2-2, B.5.2-3 and B.5.2-4 as below.

The values in Table B.5.2-2 have been adjusted for the 2x4 and 4x4 high correlation cases to insure the correlation matrix is positive semi-definite after round-off to 4 digit precision. This is done using the equation:

$$\mathbf{R}_{high} = [\mathbf{R}_{spatial} + a\mathbf{I}_n] / (1 + a)$$

Where the value “a” is a scaling factor such that the smallest value is used to obtain a positive semi-definite result. For the 2x4 high correlation case, a=0.00010. For the 4x4 high correlation case, a=0.00012.

The same method is used to adjust the 4x4 medium correlation matrix in Table B.5.2-3 to insure the correlation matrix is positive semi-definite after round-off to 4 digit precision with a =0.00012.

Table B.5.2-2: MIMO correlation matrices for high correlation

1x2 case	$R_{high} = \begin{pmatrix} 1 & 0.9 \\ 0.9 & 1 \end{pmatrix}$
2x2 case	$R_{high} = \begin{pmatrix} 1 & 0.9 & 0.9 & 0.81 \\ 0.9 & 1 & 0.81 & 0.9 \\ 0.9 & 0.81 & 1 & 0.9 \\ 0.81 & 0.9 & 0.9 & 1 \end{pmatrix}$
2x4 case	$R_{high} = \begin{bmatrix} 1.0000 & 0.9883 & 0.9542 & 0.8999 & 0.8999 & 0.8894 & 0.8587 & 0.8099 \\ 0.9883 & 1.0000 & 0.9883 & 0.9542 & 0.8894 & 0.8999 & 0.8894 & 0.8587 \\ 0.9542 & 0.9883 & 1.0000 & 0.9883 & 0.8587 & 0.8894 & 0.8999 & 0.8894 \\ 0.8999 & 0.9542 & 0.9883 & 1.0000 & 0.8099 & 0.8587 & 0.8894 & 0.8999 \\ 0.8999 & 0.8894 & 0.8587 & 0.8099 & 1.0000 & 0.9883 & 0.9542 & 0.8999 \\ 0.8894 & 0.8999 & 0.8894 & 0.8587 & 0.9883 & 1.0000 & 0.9883 & 0.9542 \\ 0.8587 & 0.8894 & 0.8999 & 0.8894 & 0.9542 & 0.9883 & 1.0000 & 0.9883 \\ 0.8099 & 0.8587 & 0.8894 & 0.8999 & 0.8999 & 0.9542 & 0.9883 & 1.0000 \end{bmatrix}$
4x4 case	$R_{high} = \begin{bmatrix} 1.0000 & 0.9882 & 0.9541 & 0.8999 & 0.9882 & 0.9767 & 0.9430 & 0.8894 & 0.9541 & 0.9430 & 0.9105 & 0.8587 & 0.8999 & 0.8894 & 0.8587 & 0.8099 \\ 0.9882 & 1.0000 & 0.9882 & 0.9541 & 0.9767 & 0.9882 & 0.9767 & 0.9430 & 0.9430 & 0.9541 & 0.9430 & 0.9105 & 0.8894 & 0.8999 & 0.8894 & 0.8587 \\ 0.9541 & 0.9882 & 1.0000 & 0.9882 & 0.9430 & 0.9767 & 0.9882 & 0.9767 & 0.9105 & 0.9430 & 0.9541 & 0.9430 & 0.8587 & 0.8894 & 0.8999 & 0.8894 \\ 0.8999 & 0.9541 & 0.9882 & 1.0000 & 0.8894 & 0.9430 & 0.9767 & 0.9882 & 0.8587 & 0.9105 & 0.9430 & 0.9541 & 0.8099 & 0.8587 & 0.8894 & 0.8999 \\ 0.9882 & 0.9767 & 0.9430 & 0.8894 & 1.0000 & 0.9882 & 0.9541 & 0.8999 & 0.9882 & 0.9767 & 0.9430 & 0.8894 & 0.9541 & 0.9430 & 0.9105 & 0.8587 \\ 0.9767 & 0.9882 & 0.9767 & 0.9430 & 0.9882 & 1.0000 & 0.9882 & 0.9541 & 0.9767 & 0.9882 & 0.9767 & 0.9430 & 0.9430 & 0.9541 & 0.9430 & 0.9105 \\ 0.9430 & 0.9767 & 0.9882 & 0.9767 & 0.9541 & 0.9882 & 1.0000 & 0.9882 & 0.9430 & 0.9767 & 0.9882 & 0.9767 & 0.9105 & 0.9430 & 0.9541 & 0.9430 \\ 0.8894 & 0.9430 & 0.9767 & 0.9882 & 0.8999 & 0.9541 & 0.9882 & 1.0000 & 0.8894 & 0.9430 & 0.9767 & 0.9882 & 0.8587 & 0.9105 & 0.9430 & 0.9541 \\ 0.9541 & 0.9430 & 0.9105 & 0.8587 & 0.9882 & 0.9767 & 0.9430 & 0.8894 & 1.0000 & 0.9882 & 0.9541 & 0.8999 & 0.9882 & 0.9767 & 0.9430 & 0.8894 \\ 0.9430 & 0.9541 & 0.9430 & 0.9105 & 0.9767 & 0.9882 & 0.9767 & 0.9430 & 0.9882 & 1.0000 & 0.9882 & 0.9541 & 0.9767 & 0.9882 & 0.9767 & 0.9430 \\ 0.9105 & 0.9430 & 0.9541 & 0.9430 & 0.9430 & 0.9767 & 0.9882 & 0.9767 & 0.9541 & 0.9882 & 1.0000 & 0.9882 & 0.9430 & 0.9767 & 0.9882 & 0.9767 \\ 0.8587 & 0.9105 & 0.9430 & 0.9541 & 0.8894 & 0.9430 & 0.9767 & 0.9882 & 0.8999 & 0.9541 & 0.9882 & 1.0000 & 0.8894 & 0.9430 & 0.9767 & 0.9882 \\ 0.8999 & 0.8894 & 0.8587 & 0.8099 & 0.9541 & 0.9430 & 0.9105 & 0.8587 & 0.9882 & 0.9767 & 0.9430 & 0.8894 & 1.0000 & 0.9882 & 0.9541 & 0.8999 \\ 0.8894 & 0.8999 & 0.8894 & 0.8587 & 0.9430 & 0.9541 & 0.9430 & 0.9105 & 0.9767 & 0.9882 & 0.9767 & 0.9430 & 0.9882 & 1.0000 & 0.9882 & 0.9541 \\ 0.8587 & 0.8894 & 0.8999 & 0.8894 & 0.9105 & 0.9430 & 0.9541 & 0.9430 & 0.9430 & 0.9767 & 0.9882 & 0.9767 & 0.9541 & 0.9882 & 1.0000 & 0.9882 \\ 0.8099 & 0.8587 & 0.8894 & 0.8999 & 0.8587 & 0.9105 & 0.9430 & 0.9541 & 0.8894 & 0.9430 & 0.9767 & 0.9882 & 0.8999 & 0.9541 & 0.9882 & 1.0000 \end{bmatrix}$

Table B.5.2-3: MIMO correlation matrices for medium correlation

1x2 case	N/A
2x2 case	$R_{medium} = \begin{pmatrix} 1.0000 & 0.9000 & 0.3000 & 0.2700 \\ 0.9000 & 1.0000 & 0.2700 & 0.3000 \\ 0.3000 & 0.2700 & 1.0000 & 0.9000 \\ 0.2700 & 0.3000 & 0.9000 & 1.0000 \end{pmatrix}$
2x4 case	$R_{medium} = \begin{pmatrix} 1.0000 & 0.9884 & 0.9543 & 0.9000 & 0.3000 & 0.2965 & 0.2863 & 0.2700 \\ 0.9884 & 1.0000 & 0.9884 & 0.9543 & 0.2965 & 0.3000 & 0.2965 & 0.2863 \\ 0.9543 & 0.9884 & 1.0000 & 0.9884 & 0.2863 & 0.2965 & 0.3000 & 0.2965 \\ 0.9000 & 0.9543 & 0.9884 & 1.0000 & 0.2700 & 0.2863 & 0.2965 & 0.3000 \\ 0.3000 & 0.2965 & 0.2863 & 0.2700 & 1.0000 & 0.9884 & 0.9543 & 0.9000 \\ 0.2965 & 0.3000 & 0.2965 & 0.2863 & 0.9884 & 1.0000 & 0.9884 & 0.9543 \\ 0.2863 & 0.2965 & 0.3000 & 0.2965 & 0.9543 & 0.9884 & 1.0000 & 0.9884 \\ 0.2700 & 0.2863 & 0.2965 & 0.3000 & 0.9000 & 0.9543 & 0.9884 & 1.0000 \end{pmatrix}$
4x4 case	$R_{medium} = \begin{pmatrix} 1.0000 & 0.9882 & 0.9541 & 0.8999 & 0.8747 & 0.8645 & 0.8347 & 0.7872 & 0.5855 & 0.5787 & 0.5588 & 0.5270 & 0.3000 & 0.2965 & 0.2862 & 0.2700 \\ 0.9882 & 1.0000 & 0.9882 & 0.9541 & 0.8645 & 0.8747 & 0.8645 & 0.8347 & 0.5787 & 0.5855 & 0.5787 & 0.5588 & 0.2965 & 0.3000 & 0.2965 & 0.2862 \\ 0.9541 & 0.9882 & 1.0000 & 0.9882 & 0.8347 & 0.8645 & 0.8747 & 0.8645 & 0.5588 & 0.5787 & 0.5855 & 0.5787 & 0.2862 & 0.2965 & 0.3000 & 0.2965 \\ 0.8999 & 0.9541 & 0.9882 & 1.0000 & 0.7872 & 0.8347 & 0.8645 & 0.8747 & 0.5270 & 0.5588 & 0.5787 & 0.5855 & 0.2700 & 0.2862 & 0.2965 & 0.3000 \\ 0.8747 & 0.8645 & 0.8347 & 0.7872 & 1.0000 & 0.9882 & 0.9541 & 0.8999 & 0.8747 & 0.8645 & 0.8347 & 0.7872 & 0.5855 & 0.5787 & 0.5588 & 0.5270 \\ 0.8645 & 0.8747 & 0.8645 & 0.8347 & 0.9882 & 1.0000 & 0.9882 & 0.9541 & 0.8645 & 0.8747 & 0.8645 & 0.8347 & 0.5787 & 0.5855 & 0.5787 & 0.5588 \\ 0.8347 & 0.8645 & 0.8747 & 0.8645 & 0.9541 & 0.9882 & 1.0000 & 0.9882 & 0.8347 & 0.8645 & 0.8747 & 0.8645 & 0.5588 & 0.5787 & 0.5855 & 0.5787 \\ 0.7872 & 0.8347 & 0.8645 & 0.8747 & 0.8999 & 0.9541 & 0.9882 & 1.0000 & 0.7872 & 0.8347 & 0.8645 & 0.8747 & 0.5270 & 0.5588 & 0.5787 & 0.5855 \\ 0.5855 & 0.5787 & 0.5588 & 0.5270 & 0.8747 & 0.8645 & 0.8347 & 0.7872 & 1.0000 & 0.9882 & 0.9541 & 0.8999 & 0.8747 & 0.8645 & 0.8347 & 0.7872 \\ 0.5787 & 0.5855 & 0.5787 & 0.5588 & 0.8645 & 0.8747 & 0.8645 & 0.8347 & 0.9882 & 1.0000 & 0.9882 & 0.9541 & 0.8645 & 0.8747 & 0.8645 & 0.8347 \\ 0.5588 & 0.5787 & 0.5855 & 0.5787 & 0.8347 & 0.8645 & 0.8747 & 0.8645 & 0.9541 & 0.9882 & 1.0000 & 0.9882 & 0.8347 & 0.8645 & 0.8747 & 0.8645 \\ 0.5270 & 0.5588 & 0.5787 & 0.5855 & 0.7872 & 0.8347 & 0.8645 & 0.8747 & 0.8999 & 0.9541 & 0.9882 & 1.0000 & 0.7872 & 0.8347 & 0.8645 & 0.8747 \\ 0.3000 & 0.2965 & 0.2862 & 0.2700 & 0.5855 & 0.5787 & 0.5588 & 0.5270 & 0.8747 & 0.8645 & 0.8347 & 0.7872 & 1.0000 & 0.9882 & 0.9541 & 0.8999 \\ 0.2965 & 0.3000 & 0.2965 & 0.2862 & 0.5787 & 0.5855 & 0.5787 & 0.5588 & 0.8645 & 0.8747 & 0.8645 & 0.8347 & 0.9882 & 1.0000 & 0.9882 & 0.9541 \\ 0.2862 & 0.2965 & 0.3000 & 0.2965 & 0.5588 & 0.5787 & 0.5855 & 0.5787 & 0.8347 & 0.8645 & 0.8747 & 0.8645 & 0.9541 & 0.9882 & 1.0000 & 0.9882 \\ 0.2700 & 0.2862 & 0.2965 & 0.3000 & 0.5270 & 0.5588 & 0.5787 & 0.5855 & 0.7872 & 0.8347 & 0.8645 & 0.8747 & 0.8999 & 0.9541 & 0.9882 & 1.0000 \end{pmatrix}$

Table B.5.2-4: MIMO correlation matrices for low correlation

1x2 case	$R_{low} = \mathbf{I}_2$
1x4 case	$R_{low} = \mathbf{I}_4$
2x2 case	$R_{low} = \mathbf{I}_4$
2x4 case	$R_{low} = \mathbf{I}_8$
4x4 case	$R_{low} = \mathbf{I}_{16}$

In Table B.5.2-4, \mathbf{I}_d is a $d \times d$ identity matrix.

NOTE: For completeness, the 1x2 cases were defined for high, medium and low correlation but for Rel-8 onwards for 1Tx, performance requirements exist only for low correlation.

B.5A Multi-Antenna channel models using cross polarized antennas

The MIMO channel correlation matrices defined in B.5A apply to two cases as presented below:

- One TX antenna and multiple RX antennas case, with cross polarized antennas used at eNodeB;
- Multiple TX antennas and multiple RX antennas case, with cross polarized antennas used at both UE and eNodeB.

The cross-polarized antenna elements with +/-45 degrees polarization slant angles are deployed at eNB. For one TX antenna case, antenna element with +90 degree polarization slant angle is deployed at UE. For multiple TX antennas case, cross-polarized antenna elements with +90/0 degrees polarization slant angles are deployed at UE.

For the cross-polarized antennas, the N antennas are labelled such that antennas for one polarization are listed from 1 to N/2 and antennas for the other polarization are listed from N/2+1 to N, where N is the number of TX or RX antennas.

B.5A.1 Definition of MIMO Correlation Matrices using cross polarized antennas

For the channel spatial correlation matrix, the following is used:

$$R_{Spat} = P_{UL} (R_{UE} \otimes \Gamma_{UL} \otimes R_{eNB}) P_{UL}^T$$

Where

- R_{UE} is the spatial correlation matrix at the UE with same polarization,
- R_{eNB} is the spatial correlation matrix at the eNB with same polarization,
- Γ_{UL} is a polarization correlation matrix,
- P_{UL} is a permutation matrix, and
- $(\bullet)^T$ denotes transpose.

Table B.5A.1-1 defines the polarization correlation matrix.

Table B.5A.1-1: Polarization correlation matrix

	One TX antenna	Multiple TX antennas
Polarization correlation matrix	$\Gamma_{UL} = \begin{bmatrix} 1 & -\gamma \\ -\gamma & 1 \end{bmatrix}$	$\Gamma_{UL} = \begin{bmatrix} 1 & -\gamma & 0 & 0 \\ -\gamma & 1 & 0 & 0 \\ 0 & 0 & 1 & \gamma \\ 0 & 0 & \gamma & 1 \end{bmatrix}$

The matrix P_{UL} is defined as

$$P_{UL}(a,b) = \begin{cases} 1 & \text{for } a = (j-1)Nr + i \text{ and } b = 2(j-1)Nr + i, & i = 1, \dots, Nr, j = 1, \dots, \lceil Nt/2 \rceil \\ 1 & \text{for } a = (j-1)Nr + i \text{ and } b = 2(j - Nt/2)Nr - Nr + i, & i = 1, \dots, Nr, j = \lceil Nt/2 \rceil + 1, \dots, Nt \\ 0 & \text{otherwise} \end{cases}$$

where Nt and Nr is the number of TX and RX antennas respectively, and $\lceil \bullet \rceil$ is the ceiling operator.

The matrix P_{UL} is used to map the spatial correlation coefficients in accordance with the antenna element labelling system described in B.5A.

B.5A.2 Spatial Correlation Matrices at UE and eNB sides

B.5A.2.1 Spatial Correlation Matrices at UE side

For 1-antenna transmitter, $R_{UE} = 1$.

For 2-antenna transmitter using one pair of cross-polarized antenna elements, $R_{UE} = 1$.

For 4-antenna transmitter using two pairs of cross-polarized antenna elements, $R_{UE} = \begin{pmatrix} 1 & \beta \\ \beta^* & 1 \end{pmatrix}$.

B.5A.2.2 Spatial Correlation Matrices at eNB side

For 2-antenna receiver using one pair of cross-polarized antenna elements, $R_{eNB} = 1$.

For 4-antenna receiver using two pairs of cross-polarized antenna elements, $R_{eNB} = \begin{pmatrix} 1 & \alpha \\ \alpha^* & 1 \end{pmatrix}$.

For 8-antenna receiver using four pairs of cross-polarized antenna elements, $R_{eNB} = \begin{pmatrix} 1 & \alpha^{1/9} & \alpha^{4/9} & \alpha \\ \alpha^{1/9*} & 1 & \alpha^{1/9} & \alpha^{4/9} \\ \alpha^{4/9*} & \alpha^{1/9*} & 1 & \alpha^{1/9} \\ \alpha^* & \alpha^{4/9*} & \alpha^{1/9*} & 1 \end{pmatrix}$.

B.5A.3 MIMO Correlation Matrices using cross polarized antennas

The values for parameters α , β and γ for low spatial correlation are given in Table B.5A.3-1.

Table B.5A.3-1: Values for parameters α , β and γ

Low spatial correlation		
α	β	γ
0	0	0
Note 1: Value of α applies when more than one pair of cross-polarized antenna elements at eNB side.		
Note 2: Value of β applies when more than one pair of cross-polarized antenna elements at UE side.		

The correlation matrices for low spatial correlation are defined in Table B.5A.3-2 as below.

Table B.5A.3-2: MIMO correlation matrices for low spatial correlation

1x8 case	$R_{low} = \mathbf{I}_8$
2x8 case	$R_{low} = \mathbf{I}_{16}$

In Table B.5A.3-2, \mathbf{I}_d is a $d \times d$ identity matrix.

B.6 Interference model for enhanced performance requirements type A and type B

This clause provides a description for the modelling of inter-cell interfering UE transmissions for enhanced performance requirements type A and type B including: definition of dominant interferer proportion, interference model for synchronous scenario and interference model for asynchronous scenario.

B.6.1 Dominant interferer proportion

Each inter-cell interferer involved in enhanced performance requirements type A and type B is characterized by its associated dominant interferer proportion (DIP) value:

$$DIP_i = \frac{\hat{I}_{or(i)}}{N'} \quad (i = 1, \dots, M)$$

where $\hat{I}_{or(i)}$ is the received energy from the i -th strongest inter-cell interferer involved in the requirement scenario and

$N' = \sum_{j=1}^M \hat{I}_{or(j)} + N$ where N is the energy of the white noise source consistent with the definition provided in

subclause 8.1 of TS 36.104 [2] and M is the total number of simultaneously transmitted inter-cell interferers involved in a given requirement scenario.

B.6.2 Interference model for synchronous scenario

This subclause provides interference modelling for each explicitly modelled inter-cell interferer in the requirement scenario where the inter-cell interferer(s) are time-synchronous with the tested signal.

In each subframe, each interferer shall transmit 16QAM randomly modulated data over the entire PUSCH region and the same resource blocks as the tested signal. Demodulation reference signal, configured according to Table 8.2.6.4.2-2 for enhanced performance requirements type A, and Table 8.2.9.4.2-2 to Table 8.2.9.4.2-3 for enhanced performance requirements type B, is transmitted associated with the transmission of PUSCH.

B.6.3 Interference model for asynchronous scenario

This subclause provides interference modelling for each explicitly modelled inter-cell interferer in the requirement scenario where the inter-cell interferer(s) are time-asynchronous with the tested signal.

Two interfering UEs from the same interfering cell, named interferer 1-1 and interferer 1-2, are modelled. Interferer 1-1 and interferer 1-2 shall transmit 16QAM randomly modulated data over the entire PUSCH region and the same resource blocks as the tested signal, respectively in the even subframes and odd subframes, as illustrated in Figure B.6.3-1. Demodulation reference signal, configured according to Table 8.2.6A.4.2-2, is transmitted associated with the transmission of PUSCH. The transmissions of both interferer 1-1 and interferer 1-2 are delayed with respect to the tested signal by 0.33 ms.

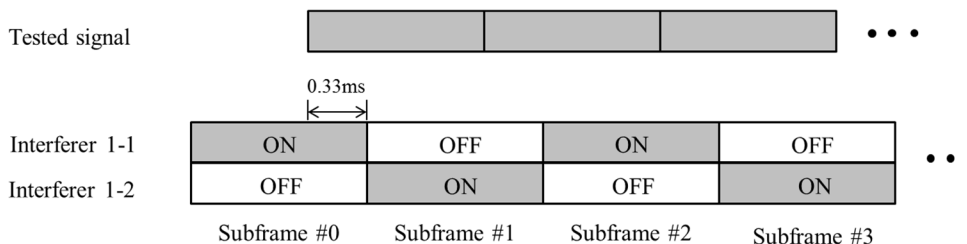

Figure B.6.3-1: Configuration of asynchronous interferers

Annex C (normative): Characteristics of the interfering signals

<Text will be added.>

The interfering signal shall be a PUSCH containing data and reference symbols. Normal cyclic prefix is used. The data content shall be uncorrelated to the wanted signal and modulated according to clause 5 of TS36.211. Mapping of PUSCH modulation to receiver requirement are specified in Table C.1.

Table C.1: Modulation of the interfering signal

Receiver requirement	Modulation
In-channel selectivity	16QAM
Adjacent channel selectivity and narrow-band blocking	QPSK
Blocking	QPSK
Receiver intermodulation	QPSK

Annex D (normative): Environmental requirements for the BS equipment

D.1 General

For each test in the present document, the environmental conditions under which the BS is to be tested are defined.

D.2 Normal test environment

When a normal test environment is specified for a test, the test should be performed within the minimum and maximum limits of the conditions stated in Table D.1.

Table D.1: Limits of conditions for Normal Test Environment

Condition	Minimum	Maximum
Barometric pressure	86 kPa	106 kPa
Temperature	15°C	30°C
Relative Humidity	20 %	85 %
Power supply	Nominal, as declared by the manufacturer	
Vibration	Negligible	

The ranges of barometric pressure, temperature and humidity represent the maximum variation expected in the uncontrolled environment of a test laboratory. If it is not possible to maintain these parameters within the specified limits, the actual values shall be recorded in the test report.

NOTE: This may, for instance, be the case for measurements of radiated emissions performed on an open field test site.

D.3 Extreme test environment

The manufacturer shall declare one of the following:

- 1) the equipment class for the equipment under test, as defined in the IEC 60 721-3-3 [6];
- 2) the equipment class for the equipment under test, as defined in the IEC 60 721-3-4 [7];
- 3) the equipment that does not comply to the mentioned classes, the relevant classes from IEC 60 721 documentation for Temperature, Humidity and Vibration shall be declared.

NOTE: Reduced functionality for conditions that fall outside of the standard operational conditions is not tested in the present document. These may be stated and tested separately.

D.3.1 Extreme temperature

When an extreme temperature test environment is specified for a test, the test shall be performed at the standard minimum and maximum operating temperatures defined by the manufacturer's declaration for the equipment under test.

Minimum temperature:

The test shall be performed with the environment test equipment and methods including the required environmental phenomena into the equipment, conforming to the test procedure of IEC 60 068-2-1 [8].

Maximum temperature:

The test shall be performed with the environmental test equipment and methods including the required environmental phenomena into the equipment, conforming to the test procedure of IEC 60 068-2-2 [9].

NOTE: It is recommended that the equipment is made fully operational prior to the equipment being taken to its lower operating temperature.

D.4 Vibration

When vibration conditions are specified for a test, the test shall be performed while the equipment is subjected to a vibration sequence as defined by the manufacturer's declaration for the equipment under test. This shall use the environmental test equipment and methods of inducing the required environmental phenomena in to the equipment, conforming to the test procedure of IEC 60 068-2-6 [10]. Other environmental conditions shall be within the ranges specified in clause D.2.

NOTE: The higher levels of vibration may induce undue physical stress in to equipment after a prolonged series of tests. The testing body should only vibrate the equipment during the RF measurement process.

D.5 Power supply

When extreme power supply conditions are specified for a test, the test shall be performed at the standard upper and lower limits of operating voltage defined by manufacturer's declaration for the equipment under test.

Upper voltage limit:

The equipment shall be supplied with a voltage equal to the upper limit declared by the manufacturer (as measured at the input terminals to the equipment). The tests shall be carried out at the steady state minimum and maximum temperature limits declared by the manufacturer for the equipment, to the methods described in IEC 60 068-2-1 [8] Test Ab/Ad and IEC 60 068-2-2 [9] Test Bb/Bd: Dry Heat.

Lower voltage limit:

The equipment shall be supplied with a voltage equal to the lower limit declared by the manufacturer (as measured at the input terminals to the equipment). The tests shall be carried out at the steady state minimum and maximum temperature limits declared by the manufacturer for the equipment, to the methods described in IEC 60 068-2-1 [8] Test Ab/Ad and IEC 60 068-2-2 [9] Test Bb/Bd: Dry Heat.

D.6 Measurement of test environments

The measurement accuracy of the BS test environments defined in Annex D, Test environments shall be.

Pressure:	±5 kPa.
Temperature:	±2 degrees.
Relative Humidity:	±5 %.
DC Voltage:	±1,0 %.
AC Voltage:	±1,5 %.
Vibration:	10 %.
Vibration frequency:	0,1 Hz.

The above values shall apply unless the test environment is otherwise controlled and the specification for the control of the test environment specifies the uncertainty for the parameter.

Annex E (normative): General rules for statistical testing

<Text will be added.>

Annex F (normative): Global In-Channel TX-Test

F.1 General

The global in-channel Tx test enables the measurement of all relevant parameters that describe the in-channel quality of the output signal of the TX under test in a single measurement process.

The parameters describing the in-channel quality of a transmitter, however, are not necessarily independent. The algorithm chosen for description inside this annex places particular emphasis on the exclusion of all interdependencies among the parameters.

F.2.1 Basic principle

The process is based on the comparison of the actual **output signal of the TX under test**, received by an ideal receiver, with a **reference signal**, that is generated by the measuring equipment and represents an ideal error free received signal. All signals are represented as equivalent (generally complex) baseband signals.

The description below uses numbers and illustrations as examples. These numbers are taken from frame structure 1 with normal CP length and a transmission bandwidth configuration of $N_{RB} = 100$. The application of the text below, however, is not restricted to this parameterset.

F.2.2 Output signal of the TX under test

The output signal of the TX under test is acquired by the measuring equipment and stored for further processing. It is sampled at a sampling rate of 30.72 Msps and it is named $z(v)$. In the time domain it comprises at least 1 frame:: $z(v)$. It is modelled as a signal with the following parameters: demodulated data content, carrier frequency, amplitude and phase for each subcarrier.

F.2.3 Reference signal

Two types of reference signal are defined:

The reference signal $i_1(v)$ is constructed by the measuring equipment according to the relevant TX specifications, using the following parameters: demodulated data content, nominal carrier frequency, nominal amplitude and phase for each subcarrier. It is represented as a sequence of samples at a sampling rate of 30.72 Msps in the time domain. The structure of the signal is described in the testmodels.

The reference signal $i_2(v)$ is constructed by the measuring equipment according to the relevant TX specifications, using the following parameters: restricted data content: nominal Reference Symbols and the Primary Synchronisation Channel, (all other modulation symbols are set to 0 V), nominal carrier frequency, nominal amplitude and phase for each applicable subcarrier, nominal timing. It is represented as a sequence of samples at a sampling rate of 30.72 Msps in the time domain.

F.2.4 Measurement results

The measurement results, achieved by the global in channel TX test are the following:

- Carrier Frequency error
- EVM (Error Vector Magnitude)
- Resource Element TX power
 - RS TX power (RSTP)

- OFDM Symbol TX power (OSTP)

Other side results are: residual amplitude- and phase response of the TX chain after equalisation.

F.2.5 Measurement points

Resource element TX power is measured after the FFT as described below. EVM is calculated after the Equalizer (Ampl./ Phase correction). The result of the frequency synchronisation is the frequency offset. It is performed in the pre- and/or post-FFT domain. The FFT window of 2048 samples out of 2194 samples (data +CP) in the time domain is selected in the box CP removal.

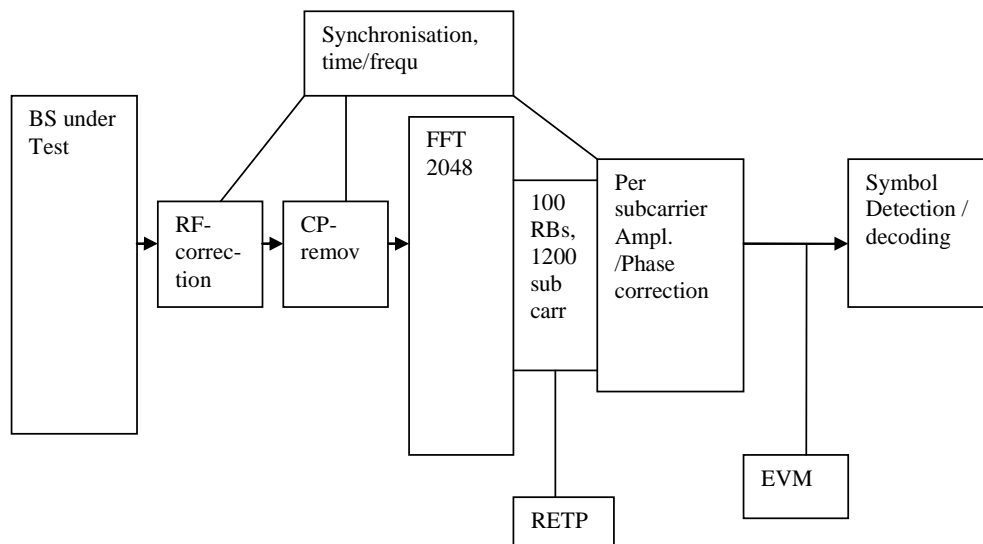

Figure E.2.5-1: Measurement points

F.3.1 Pre FFT minimization process

Sample Timing, Carrier Frequency in $z(v)$ are varied in order to minimise the difference between $z(v)$ and $i_1(v)$, after the amplitude ratio of $z(v)$ and $i_1(v)$ has been scaled. Best fit (minimum difference) is achieved when the RMS difference value between $z(v)$ and $i(v)$ is an absolute minimum.

The carrier frequency variation is the measurement result: Carrier Frequency Error.

From the acquired samples one carrier frequency error can be derived.

- Note 1: The minimisation process, to derive the RF error can be supported by Post FFT operations. However the minimisation process defined in the pre FFT domain comprises all acquired samples (i.e. it does not exclude the samples inbetween the FFT widths and it does not exclude the bandwidth outside the transmission bandwidth configuration).
- Note 2: The algorithm would allow to derive Carrier Frequency error and Sample Frequency error of the TX under test separately. However there are no requirements for Sample Frequency error. Hence the algorithm models the RF and the sample frequency commonly (not independently). It returns one error and does not distinguish between both.

After this process the samples $z(v)$ are called $z^0(v)$.

F.3.2 Timing of the FFT window

The FFT window length is 2048 samples per OFDM symbol. 140 FFTs (286720 samples) cover less than the acquired number of samples (307200 samples in 10 subframes) The position in time for FFT must be determined.

In an ideal signal, the FFT may start at any instant within the cyclic prefix without causing an error. The TX filter, however, reduces the window. The EVM requirements shall be met within a window $W < CP$. There are three different instants for FFT:

Centre of the reduced window, called $\Delta\tilde{c}$, $\Delta C - W/2$ and $\Delta C + W/2$,

The BS shall transmit a signal according to the Test models, intended for EVM. The primary synchronisation signal and the reference signal shall be used to find the centre of the FFT window.

The timing of the measured signal is determined in the pre FFT domain as follows, using $z^0(v)$ and $i_2(v)$:

1. The measured signal is delay spread by the TX filter. Hence the distinct borders between the OFDM symbols and between Data and CP are also spread and the timing is not obvious.
2. In the Reference Signal $i_2(v)$ the timing is known.

Correlation between (1.) and (2.) will result in a correlation peak. The meaning of the correlation peak is approx. the “impulse response” of the TX filter.

3. The meaning of “impulse response” assumes that the autocorrelation of the reference signal $i_2(v)$ is a Dirac peak and that the correlation between the reference signal $i_2(v)$ and the data in the measured signal is 0. The correlation peak, (the highest, or in case of more than one highest, the earliest) indicates the timing in the measured signal.

The number of samples, used for FFT is reduced compared to $z^0(v)$. This subset of samples is called $z'(v)$.

From the acquired samples one timing can be derived.

The timing of the centre $\Delta\tilde{c}$ with respect to the different CP length in a slot is as follows: (Frame structure 1, normal CP length)

$\Delta\tilde{c}$ is on $T_f=72$ within the CP of length 144 (in OFDM symbol 1 to 6)

$\Delta\tilde{c}$ is on $T_f=88$ (=160-72) within the CP of length 160 (in OFDM symbol 0)

F.3.3 Resource Element TX power

Perform FFT ($z'(v)$) with the FFT window timing $\Delta\tilde{c}$

The result is called $Z'(t,f)$. The RE TX power is then defined as:

$$RETP = |Z'(t, f)|^2 \cdot 15 \text{ KHz}$$

From this the Reference Signal Transmit power (RSTP) is derived as follows:

$$RSTP = \frac{1}{n_{RSRElocations \text{ within subframe}}} \sum RETP,$$

It is an average power and accumulates the powers of the reference symbols within a sub frame divided by n , the number of reference symbols within a sub frame.

From RETP the OFDM Symbol TX power (OSTP) is derived as follows:

$$OSTP = \sum_{\substack{\text{all } N_{RB}^{DL} N_{sc}^{RB} \\ \text{RE locations} \\ \text{of 4th symbol within subframe}}} RETP$$

It accumulates all sub carrier powers of the 4th OFDM symbol. The 4th (out of 14 OFDM symbols within a subframe (in case of frame type 1, normal CP length)) contains exclusively PDSCH.

From the acquired samples 10 values for each RSTP and OSTP can be derived.

F.3.4 Post FFT equalisation

Perform 140 FFTs on $z'(v)$, one for each OFDM symbol comprising the full frame with the FFT window timing $\Delta\tilde{C}$. (in case of frame type 1, normal CP length) The result is an array of samples, 140 in the time axis t times 2048 in the frequency axis f .

The equalizer coefficients $\tilde{a}(f)$ and $\tilde{\varphi}(f)$ are determined as follows:

1. Calculate the complex ratios (amplitude and phase) of the post-FFT acquired signal $Z'(t, f)$ and the post-FFT Ideal signal $I_2(t, f)$, for each reference symbol, over 10 subframes. This process creates a set of complex ratios:

$$a(t, f).e^{j\varphi(t, f)} = \frac{Z'(t, f)}{I_2(t, f)}$$

2. Perform time averaging at each reference signal subcarrier of the complex ratios, the time-averaging length is 10 subframes. Prior to the averaging of the phases $\varphi(t_i, f)$ an unwrap operation must be performed according to the following definition: The unwrap operation corrects the radian phase angles of $\varphi(t_i, f)$ by adding multiples of $2*\text{PI}$ when absolute phase jumps between consecutive time instances t_i are greater then or equal to the jump tolerance of PI radians. This process creates an average amplitude and phase for each reference signal subcarrier (i.e. every third subcarrier with the exception of the reference subcarrier spacing across the DC subcarrier).

$$a(f) = \frac{\sum_{i=1}^N a(t_i, f)}{N}$$

$$\varphi(f) = \frac{\sum_{i=1}^N \varphi(t_i, f)}{N}$$

Where N is the number of reference symbol time-domain locations t_i from $Z'(f, t)$ for each reference signal subcarrier f .

3. The equalizer coefficients for amplitude and phase $\hat{a}(f)$ and $\hat{\varphi}(f)$ at the reference signal subcarriers are obtained by computing the moving average in the frequency domain of the time-averaged reference signal subcarriers, i.e. every third subcarrier. The moving average window size is 19. For reference subcarriers at or near the edge of the channel the window size is reduced accordingly as per figure F. 3.4.
4. Perform linear interpolation from the equalizer coefficients $\hat{a}(f)$ and $\hat{\varphi}(f)$ to compute coefficients $\tilde{a}(f)$, $\tilde{\varphi}(f)$ for each subcarrier.

The equalized samples are called $Z'_{\text{eq}}(f, t)$.

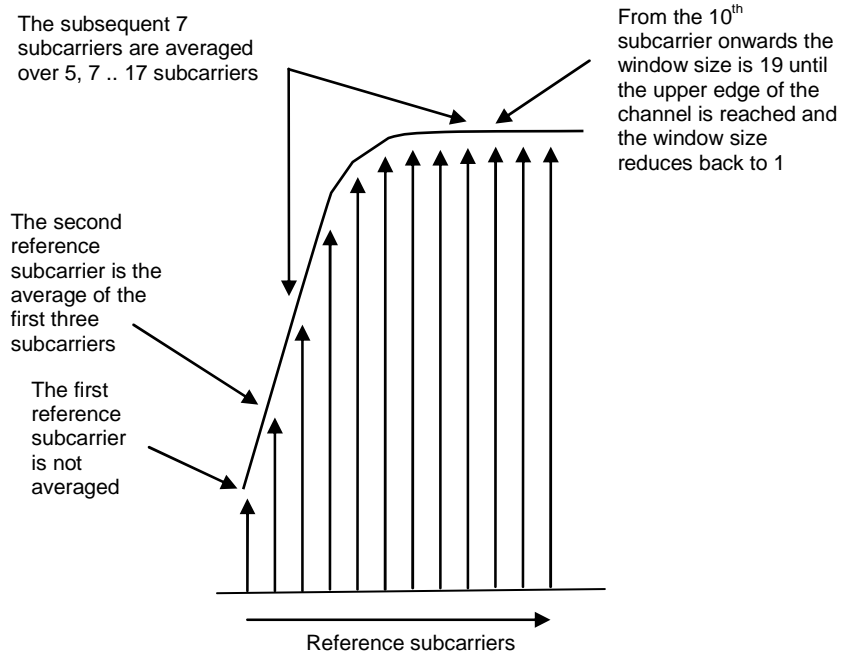

Figure F.3.4-1: Reference subcarrier smoothing in the frequency domain

F.4.1 EVM

For EVM create two sets of $Z'_{eq}(f,t)$, according to the timing " $\Delta C - W/2$ and $\Delta C + W/2$ ", using the equalizer coefficients from F.3.4.

The equivalent ideal samples are calculated from $i_1(v)$ (clause F.2.3) and are called $I(f,t)$.

The EVM is the difference between the ideal waveform and the measured and equalized waveform.

$$EVM = \sqrt{\frac{\sum_{t \in T} \sum_{f \in F(t)} |Z'_{eq}(f, t) - I(f, t)|^2}{\sum_{t \in T} \sum_{f \in F(t)} |I(f, t)|^2}}$$

where

T is the set of symbols with the considered modulation scheme being active within the subframe or within the sTTI,

$F(t)$ is the set of subcarriers within the N_{SC}^{RB} resource blocks with the considered modulation scheme being active in symbol t ,

$I(t, f)$ is the ideal signal reconstructed by the measurement equipment in accordance with relevant Test models,

$Z'_{eq}(t, f)$ is the equalized signal under test.

Note1: Although the basic unit of measurement is one subframe or one sTTI, the equalizer is calculated over the entire 10 subframes measurement period to reduce the impact of noise in the reference symbols.

Note 2: Applicability of EVM calculation:

One EVM value is associated to 12 subcarriers times 1 subframe = pair of 2 RBs = 168 resource elements. For sTTI, one EVM value is associated to 12 subcarriers times 1 slot or 84 resource elements (slot TTI) or times 1 subslot or 24/36 resource elements (subslot TTI).

But only a reduced number of REs in this pair of 2 RBs contribute to EVM. Those are the PDSCH or sPDSCH REs, containing the considered modulation scheme. Only those pairs of 2 RBs are evaluated with respect to EVM, which contain the maximum number of PDSCH or sPDSCH REs. (EVM-relevant location in the time/frequency grid) The others are not evaluated.

In specific:

- For bandwidth 1.4 MHz:
 - Only the pairs of 2 RBs containing 138 PDSCH REs are used for EVM. Only those 138 REs contribute to EVM
 - All pairs of 2 RBs, which contain less than 138 PDSCH REs, are not evaluated with respect to EVM.
- For all other Bandwidths:
 - Only the pairs of 2 RBs containing 150 PDSCH REs are used for EVM. Only those 150 REs contribute to EVM
 - All pairs of 2 RBs, which contain less than 150 PDSCH REs, are not evaluated with respect to EVM.
- For sTTI and all Bandwidths:
 - Only when EVM value could be evaluated over [84] sPDSCH REs for slot TTI or [24 or 36] sPDSCH REs for subslot TTI, value is considered for EVM.
 - When there are less than [84] REs for slot TTI or [24 or 36] REs for subslot TTI value is not considered with respect to EVM.

This restriction serves to avoid weighted averaging in F.4.2.

F.4.2 Averaged EVM

EVM is averaged over all allocated EVM relevant locations in the frequency domain, and 10 consecutive downlink subframes (10 ms):

(The locations in the time-frequency grid are occupied irregularly, see Fig F.4.2-1)

\overline{EVM} is derived by: square the EVM results in F.4.1, sum the squares over all EVM relevant locations in the time/frequency grid, divide the sum by the number of EVM relevant locations, square-root the quotient.

The EVM requirements should be tested against the maximum of the average EVM at the window W extremities of the EVM measurements:

Thus \overline{EVM}_l is calculated using $\Delta\tilde{f} = \Delta\tilde{f}_l$ in the expressions above and \overline{EVM}_h is calculated using $\Delta\tilde{f} = \Delta\tilde{f}_h$. (l and h, low and high. Where l is the timing $\Delta C - W/2$ and high is the timing $\Delta C + W/2$)

Thus we get:

$$EVM_{final} = \max(\overline{EVM}_l, \overline{EVM}_h)$$

For TDD special fields (DwPTS and GP) are not included in the averaging.

15 RBs

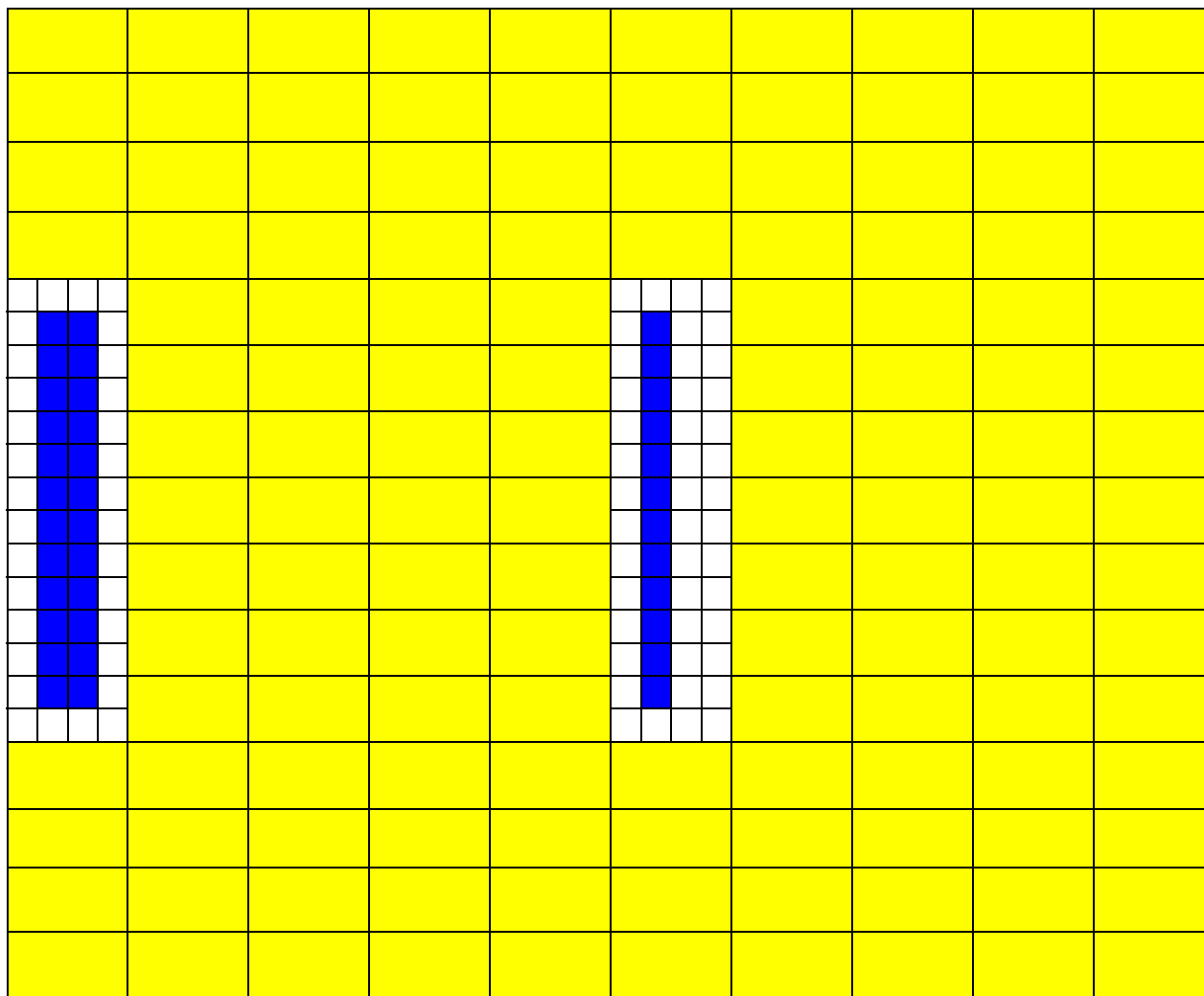

10 subframes →

Yellow: 136 EVM-relevant locations in the time/frequency grid

Blue: non PDSCH REs

White: RBs with non-maximum number of PDSCH REs

Figure F.4.2-1: Applicability of EVM calculation Example: E-TM1.x, E-TM3.x, 3MHz

F.4.2.1 Averaged EVM (TDD)

For TDD the averaging in the time domain can be calculated from subframes or slots (for slot TTI) of different frames and should have a minimum of 10 subframes averaging length. TDD special fields (DwPTS and GP) are not included in the averaging.

\overline{EVM}_{frame} is derived by: Square the EVM results in a frame. Relevant for EVM are subframes or slots (for slot TTI) in a frame, which are active in the DL, *Ndl*. Within these subframes or slots, those RBs are relevant, that carry the maximum number of PDSCH REs (same as FDD) or sPDSCH REs (slot TTI). Sum the squares, divide the sum by the number of EVM relevant locations, square-root the quotient. (RMS)

The EVM_{frame} is calculated, using the maximum of \overline{EVM}_{frame} at the window W extremities. Thus $\overline{EVM}_{frame,l}$ is calculated using $\Delta\tilde{f} = \Delta\tilde{f}_l$ and $\overline{EVM}_{frame,h}$ is calculated using $\Delta\tilde{f} = \Delta\tilde{f}_h$. (l and h , low and high. Where l is the timing $\Delta C - W/2$ and h is the timing $\Delta C + W/2$)

$$EVM_{frame} = \max(\overline{EVM}_{frame,l}, \overline{EVM}_{frame,h})$$

In order to unite at least 10 subframes, consider the minimum integer number of radio frames, containing at least 10 EVM relevant subframes or 20 l . Unite by RMS.

$$\overline{EVM} = \sqrt{\frac{1}{N_{frame}} \sum_{k=1}^{N_{frame}} EVM_{frame,k}^2}, \quad N_{frame} = \left\lceil \frac{10}{N_{dl}} \right\rceil$$

The result, \overline{EVM} , is compared against the limit.

Annex G (informative): Test Tolerances and Derivation of Test Requirements

The Test Requirements in this specification have been calculated by relaxing the Minimum Requirements of the core specification using the Test Tolerances defined here. When the Test Tolerance is zero, the Test Requirement will be the same as the Minimum Requirement. When the Test Tolerance is non-zero, the Test Requirements will differ from the Minimum Requirements, and the formula used for this relaxation is given in the following tables.

The Test Tolerances are derived from Test System uncertainties, regulatory requirements and criticality to system performance. As a result, the Test Tolerances may sometimes be set to zero.

The test tolerances should not be modified for any reason e.g. to take account of commonly known test system errors (such as mismatch, cable loss, etc.).

Note that a formula for applying Test Tolerances is provided for all tests, even those with a test tolerance of zero. This is necessary in the case where the Test System uncertainty is greater than that allowed in clause 4.1.2. In this event, the excess error shall be subtracted from the defined test tolerance in order to generate the correct tightened Test Requirements as defined in this Annex.

For example, a Test System having 0.9 dB uncertainty for test 6.2 Base Station maximum output power (which is 0.2 dB above the limit specified in clause 4.1.2) would subtract 0.2 dB from the Test Tolerance of 0.7 dB defined in this Annex. This new test tolerance of 0.5 dB would then be applied to the Minimum Requirement using the formula defined in Table G.2-1 to give a new range of ± 2.5 dB of the manufacturer's rated output power.

Using this same approach for the case where a test had a test tolerance of 0 dB, an excess error of 0.2 dB would result in a modified test tolerance of -0.2 dB.

Unless otherwise stated, the Test Tolerances in this annex apply to the Test System for testing BS that supports E-UTRA or E-UTRA with NB-IoT in-band/guard band operation or NB-IoT standalone operation.

G.1 Measurement of transmitter

Table G.1-1: Derivation of Test Requirements (Transmitter tests)

Test	Minimum Requirement in TS 36.104	Test Tolerance (TT)	Test Requirement in TS 36.141
6.2 Base station maximum output power	<p>In normal conditions: within ± 2 dB of manufacturer's rated output power</p> <p>In extreme conditions: within ± 2.5 dB of manufacturer's rated output power</p> <p>Standalone NB-IoT</p> <p>In normal conditions: within ± 2 dB of manufacturer's rated output power</p> <p>In extreme conditions: within ± 2.5 dB of manufacturer's rated output power</p>	<p>Normal and extreme conditions: 0.7 dB, $f \leq 3.0$GHz</p> <p>1.0 dB, 3.0GHz < $f \leq 4.2$GHz</p> <p>1.0 dB</p> <p>1.0 dB</p>	<p>Formula: Upper limit + TT, Lower limit - TT</p> <p>In normal conditions: within +2.7 dB and -2.7 dB of the manufacturer's rated output power, $f \leq 3.0$GHz within +3.0 dB and -3.0 dB of the manufacturer's rated output power, 3.0GHz < $f \leq 4.2$GHz</p> <p>In extreme conditions: within +3.2 dB and -3.2 dB of the manufacturer's rated output power, $f \leq 3.0$GHz within +3.5 dB and -3.5 dB of the manufacturer's rated output power, 3.0GHz < $f \leq 4.2$GHz</p> <p>In normal conditions: within +3.0 dB and -3.0 dB of the manufacturer's rated output power</p> <p>In extreme conditions: within +3.5 dB and -3.5 dB of the manufacturer's rated output power</p>
6.3.2 Total power dynamic range	<p>Total power dynamic range (dB):</p> <p>1.4 MHz E-UTRA: 7.7</p> <p>3 MHz E-UTRA: 11.7</p> <p>5 MHz E-UTRA: 13.9</p> <p>10 MHz E-UTRA: 16.9</p> <p>15 MHz E-UTRA: 18.7</p> <p>20 MHz E-UTRA: 20</p>	0.4 dB	<p>Formula: Total power dynamic range – TT (dB)</p> <p>1.4 MHz E-UTRA: 7.3</p> <p>3 MHz E-UTRA: 11.3</p> <p>5 MHz E-UTRA: 13.5</p> <p>10 MHz E-UTRA: 16.5</p> <p>15 MHz E-UTRA: 18.3</p> <p>20 MHz E-UTRA: 19.6</p>
6.3.3 NB-IoT RB power dynamic range for in-band or guard band operation	6 dB	0.4 dB	<p>Formula: Minimum Requirement + TT</p>

6.4.1 Transmitter OFF power	-85dBm/MHz.	2 dB, $f \leq 3.0\text{GHz}$ 2.5 dB, $3.0\text{GHz} < f \leq 4.2\text{GHz}$	Formula: Minimum Requirement + TT
6.4.2 Transmitter transient period	Transmitter transient period : off to on: 17 us on to off: 17 us	N/A	Minimum Requirement
6.5.1 Frequency error	Frequency error limit ± 0.05 ppm	12 Hz	Formula: Frequency Error limit + TT 0.05 ppm + 12 Hz
6.5.2 EVM	EVM limit: QPSK: 17.5 % 16QAM: 12.5 % 64QAM: 8 % 256QAM: 3.5% 1024QAM: 2.5%	1 %	Formula: EVM limit + TT QPSK: 18.5 % 16QAM: 13.5 % 64QAM: 9 % 256QAM: 4.5% 1024QAM: 3.5%
6.5.3 Time alignment error	Time alignment error within 65 ns	25 ns	Formula: Time alignment error limit + TT 90 ns
6.5.4 DL RS power	DL RS power shall be within ± 2.1 dB	0.8 dB, $f \leq 3.0\text{GHz}$ 1.1 dB, $3.0\text{GHz} < f \leq 4.2\text{GHz}$	Formula: Upper limit + TT Lower limit - TT DL RS power shall be within ± 2.9 dB, $f \leq 3.0\text{GHz}$ DL RS power shall be within ± 3.2 dB, $3.0\text{GHz} < f \leq 4.2\text{GHz}$
6.6.1 Occupied bandwidth	1.4 MHz 3 MHz 5 MHz 10 MHz 15 MHz 20 MHz Standalone NB-IoT: 200 kHz	0 kHz	Formula: Minimum Requirement + TT

<p>6.6.2 Adjacent Channel Leakage power Ratio (ACLR)</p>	<p>Paired spectrum ACLR: 45 dB for E-UTRA 45 dB for UTRA</p> <p>Standalone NB-IoT: 40 dB (ACLR1) 50 dB (ACLR2)</p> <p>Unpaired spectrum ACLR: 45 dB for E-UTRA 45 dB for 1.28 Mcps UTRA 45 dB for 3.84 Mcps UTRA 45 dB for 7.82 Mcps UTRA</p> <p>CACLR: 45 dB</p> <p>CACLR in Band 46: 35 dB or 40 dB</p> <p>Absolute limit -13dBm / MHz Absolute limit -15dBm / MHz</p>	<p>0.8 dB 0.8 dB</p> <p>0.8 dB 0.8 dB</p> <p>0.8 dB 0.8 dB 0.8 dB 0.8 dB</p> <p>0.8 dB</p> <p>0.8 dB</p> <p>0 dB</p> <p>0 dB</p>	<p>Formula: ACLR Minimum Requirement - TT Absolute limit +TT Paired spectrum ACLR: 44.2 dB 44.2 dB</p> <p>Standalone NB-IoT: 39.2 dB (ACLR1) 49.2 dB (ACLR2)</p> <p>Unpaired spectrum ACLR: 44.2 dB 44.2 dB 44.2 dB 44.2 dB</p> <p>CACLR: 44.2 dB</p> <p>CACLR in Band 46: 34.2 dB or 39.2 dB</p> <p>Absolute limit -13dBm / MHz</p> <p>Absolute limit -15dBm / MHz</p>
--	--	--	---

<p>6.6.3 Operating band unwanted emissions</p>	<p><u>For Wide Area BS:</u></p> <p><u>Category A, bands < 1GHz</u> For 1.4MHz BW: Offsets < 2.8MHz -1dBm to -11dBm / 100kHz Offsets ≥ 2.8MHz -13dBm / 100kHz</p> <p>For 3MHz BW: Offsets < 3MHz -4.5dBm to -14.5dBm / 100kHz Offsets ≥ 3MHz -13dBm / 100kHz</p> <p>For 5, 10, 15, 20MHz BW: Offsets < 10MHz -7dBm to -14dBm / 100kHz Offsets ≥ 10MHz -13dBm / 100kHz</p> <p><u>Category A, bands > 1GHz</u> For 1.4MHz BW: Offsets < 2.8MHz -1dBm to -11dBm / 100kHz Offsets ≥ 2.8MHz -13dBm / 1MHz</p> <p>For 3MHz BW: Offsets < 6MHz -5dBm to -15dBm / 100kHz Offsets ≥ 6MHz -13dBm / 1MHz</p> <p>For 5, 10, 15, 20MHz BW: Offsets < 10MHz -7dBm to -14dBm / 100kHz Offsets ≥ 10MHz -13dBm / 1MHz</p> <p><u>Category B, bands < 1GHz</u> For 1.4MHz BW: Offsets < 2.8MHz -1dBm to -11dBm / 100kHz Offsets ≥ 2.8MHz -16dBm / 100kHz</p> <p>For 3MHz BW: Offsets < 6MHz -5dBm to -15dBm / 100kHz Offsets ≥ 6MHz -16dBm / 100kHz</p>	<p>1.5dB</p> <p>0dB</p> <p>1.5dB</p> <p>0dB</p> <p>1.5dB</p> <p>0dB</p> <p>1.5dB, f ≤ 3.0GHz</p> <p>1.8dB, 3.0GHz < f ≤ 4.2GHz</p> <p>0dB</p> <p>1.5dB, f ≤ 3.0GHz</p> <p>1.8dB, 3.0GHz < f ≤ 4.2GHz</p> <p>0dB</p> <p>1.5dB, f ≤ 3.0GHz</p> <p>1.8dB, 3.0GHz < f ≤ 4.2GHz</p> <p>0dB</p> <p>1.5dB</p> <p>0dB</p> <p>1.5dB</p> <p>0dB</p>	<p>Formula:</p> <p>Minimum Requirement + TT</p>
--	---	--	---

	<p>For 5, 10, 15, 20MHz BW: Offsets < 10MHz -7dBm to -14dBm / 100kHz Offsets ≥ 10MHz -16dBm / 100kHz</p> <p><u>Category B, bands > 1GHz</u> For 1.4MHz BW: Offsets < 2.8MHz -1dBm to -11dBm / 100kHz Offsets ≥ 2.8MHz -15dBm / 1MHz</p> <p>For 3MHz BW: Offsets < 6MHz -5dBm to -15dBm / 100kHz</p> <p>Offsets ≥ 6MHz -15dBm / 1MHz</p> <p>For 5, 10, 15, 20MHz BW: Offsets < 10MHz -7dBm to -14dBm / 100kHz Offsets ≥ 10MHz -15dBm / 1MHz</p> <p>For Home BS:</p> <p><u>Category A and B:</u> For 1.4MHz BW: Offsets < 2.8MHz -30dBm to -36dBm / 100kHz Offsets ≥ 2.8MHz -50 dBm to -32dBm / 1MHz</p> <p>For 3MHz BW: Offsets < 6MHz -34dBm to -40dBm / 100kHz</p> <p>Offsets ≥ 6MHz -50dBm to -32dBm / 1MHz</p> <p>For 5, 10, 15, 20MHz BW: Offsets < 10MHz -36dBm to -42dBm / 100kHz Offsets ≥ 10MHz -50dBm to -32dBm / 1MHz</p> <p><u>Standalone NB-IoT</u></p>	<p>1.5dB</p> <p>0dB</p> <p>1.5dB, f ≤ 3.0GHz 1.8dB, 3.0GHz < f ≤ 4.2GHz</p> <p>0dB</p> <p>1.5dB, f ≤ 3.0GHz 1.8dB, 3.0GHz < f ≤ 4.2GHz</p> <p>0dB</p> <p>1.5dB, f ≤ 3.0GHz 1.8dB, 3.0GHz < f ≤ 4.2GHz</p> <p>0dB</p> <p>1.5dB, f ≤ 3.0GHz 1.8dB, 3.0GHz < f ≤ 4.2GHz</p> <p>0dB</p> <p>1.5dB, f ≤ 3.0GHz 1.8dB, 3.0GHz < f ≤ 4.2GHz</p> <p>0dB</p> <p>1.5dB, f ≤ 3.0GHz 1.8dB, 3.0GHz < f ≤ 4.2GHz</p> <p>0dB</p> <p>1.5dB, f ≤ 3.0GHz</p>	
--	---	--	--

	<p>Offset < 0.05 MHz 2 dBm/30kHz to 5 dBm/30 kHz</p> <p>0.05 MHz ≤ Offset -14 dBm/30kHz to 2 dBm/30 kHz</p> <p>For Band 46 for 10 MHz BW:</p> <p><u>Additional Reqts. bands < 1GHz</u> All BWs:</p> <p><u>Additional Reqts. bands > 1GHz</u> All BWs:</p> <p><u>Additional Reqts bands 12,13,14</u> All BWs:</p> <p><u>Additional Reqts bands 20</u> All BWs:</p>	<p>1.8dB, 3.0GHz < f ≤ 4.2GHz</p> <p>1.5dB, f ≤ 3.0GHz</p> <p>1.8dB, 3.0GHz < f ≤ 4.2GHz</p> <p>2.2 dB, 4.2GHz < f ≤ 6.0GHz</p> <p>0dB</p> <p>0dB</p> <p>0dB</p> <p>0dB</p>	
6.6.4.5.1 Transmitter spurious emissions, Mandatory Requirements	<p><u>Category A</u></p> <p>9 kHz ≤ f < 150 kHz: -13dBm / 1kHz</p> <p>150 kHz ≤ f < 30 MHz: -13dBm / 10 kHz</p> <p>30 MHz ≤ f < 1 GHz: -13dBm / 100 kHz</p> <p>1 GHz ≤ f < 12.75 GHz: -13dBm / 1 MHz</p>	0dB	Formula: Minimum Requirement + TT
6.6.4.5.2 Transmitter spurious emissions, Mandatory Requirements	<p><u>Category B</u></p> <p>9 kHz ≤ f < 150 kHz: -36dBm / 1 kHz</p> <p>150 kHz ≤ f < 30 MHz: -36dBm / 10 kHz</p> <p>30 MHz ≤ f < 1 GHz: -36dBm / 100 kHz</p> <p>1 GHz ≤ f < 12.75 GHz: -36dBm / 1 MHz</p>	0dB	Formula: Minimum Requirement + TT
6.6.4.5.3 Transmitter spurious emissions, Protection of BS receiver	-96dBm / 100 kHz	0dB	Formula: Minimum Requirement + TT

6.6.4.5.4 Transmitter spurious emissions, Additional spurious emissions requirements	Levels from -61dBm to -41dBm Bandwidths from 6.25 kHz to 1MHz See TS 36.104 [2] for details	0dB	Formula: Minimum Requirement + TT
6.6.4.5.5 Transmitter spurious emissions, Co-location	Levels from -98dBm to -96dBm Bandwidth 100 kHz See TS 36.104 [2] for details	0dB	Formula: Minimum Requirement + TT
6.7 Transmitter intermodulation (interferer requirements) This tolerance applies to the stimulus and not the measurements defined in 6.6.2, 6.6.3 and 6.6.4.	Wanted signal level - interferer level = 30dB	0dB	Formula: Ratio + TT Wanted signal level - interferer level = 30 + 0dB

G.2 Measurement of receiver

Table G.2-1: Derivation of Test Requirements (Receiver tests)

Test	Minimum Requirement in TS 36.104	Test Tolerance (TT)	Test Requirement in TS 36.141
------	----------------------------------	---------------------	-------------------------------

<p>7.2 Reference sensitivity level</p>	<p>Reference sensitivity power level:</p> <p>For E-UTRA:</p> <p>-106.8 dBm for 1.4 MHz BW -103.0 dBm for 3 MHz BW -101.5 dBm for 5 MHz BW -101.5 dBm for 10 MHz BW -101.5 dBm for 15 MHz BW -101.5 dBm for 20 MHz BW</p> <p>For NB-IoT:</p> <p>-127.3 dBm for 15 kHz sub-carrier spacing -133.3 dBm for 3.75 kHz sub-carrier spacing</p> <p>For eLAA:</p> <p>-96.2 dBm for Local Area BS -99.2 dBm for Medium Range BS</p> <p>T-put limit = 95% of maximum for the Ref Meas channel</p>	<p>$f \leq 3.0\text{GHz}$ 0.7 dB</p> <p>$3.0\text{GHz} < f \leq 4.2\text{GHz}$ 1.0 dB</p> <p>$4.2\text{GHz} < f \leq 6.0\text{GHz}$ 1.5 dB</p>	<p>Formula: Reference sensitivity power level + TT</p> <p>$f \leq 3.0\text{GHz}$ For E-UTRA:</p> <p>-106.1 dBm for 1.4 MHz BW -102.3 dBm for 3 MHz BW -100.8 dBm for 5 MHz BW -100.8 dBm for 10 MHz BW -100.8 dBm for 15 MHz BW -100.8 dBm for 20 MHz BW</p> <p>For NB-IoT:</p> <p>-126.3 dBm for 15 kHz sub-carrier spacing -132.3 dBm for 3.75 kHz sub-carrier spacing</p> <p>$3.0\text{GHz} < f \leq 4.2\text{GHz}$</p> <p>-105.8 dBm for 1.4 MHz BW -102.0 dBm for 3 MHz BW -100.5 dBm for 5 MHz BW -100.5 dBm for 10 MHz BW -100.5 dBm for 15 MHz BW -100.5 dBm for 20 MHz BW</p> <p>$4.2\text{GHz} < f \leq 6.0\text{GHz}$</p> <p>For eLAA:</p> <p>-94.7 dBm for Local Area BS -97.7 dBm for Medium Range BS</p> <p>T-put limit unchanged</p>
--	--	---	--

<p>7.3 Dynamic range</p>	<p>Wanted signal power for Wide Area BS:</p> <p>For E-UTRA:</p> <ul style="list-style-type: none"> -76.3 dBm for 1.4 MHz BW -72.4 dBm for 3 MHz BW -70.2 dBm for 5 MHz BW -70.2 dBm for 10 MHz BW -70.2 dBm for 15 MHz BW -70.2 dBm for 20 MHz BW <p>For NB-IoT:</p> <ul style="list-style-type: none"> -99.7 dBm for 15 kHz sub-carrier spacing -105.6 dBm for 3.75 kHz sub-carrier spacing <p>Wanted signal power for Home BS:</p> <ul style="list-style-type: none"> -31.8 dBm for 1.4 MHz BW -27.9 dBm for 3 MHz BW -25.7 dBm for 5 MHz BW -25.7 dBm for 10 MHz BW -25.7 dBm for 15 MHz BW -25.7 dBm for 20 MHz BW <p>Wanted signal power for eLAA BS:</p> <ul style="list-style-type: none"> -65.3 dBm for Local Area BS -68.3 dBm for Medium Range BS <p>T-put limit = 95% of maximum for the Ref Meas channel</p>	<p>0.3 dB</p>	<p>Formula: Wanted signal power + TT</p> <p>For E-UTRA</p> <ul style="list-style-type: none"> -76.0 dBm for 1.4 MHz BW -72.1 dBm for 3 MHz BW -69.9 dBm for 5 MHz BW -69.9 dBm for 10 MHz BW -69.9 dBm for 15 MHz BW -69.9 dBm for 20 MHz BW <p>For NB-IoT:</p> <ul style="list-style-type: none"> -99.4 dBm for 15 kHz sub-carrier spacing -105.3 dBm for 3.75 kHz sub-carrier spacing <p>For eLAA BS:</p> <ul style="list-style-type: none"> -65.0 dBm for Local Area BS -68.0 dBm for Medium Range BS <p>Interferer signal power unchanged T-put limit unchanged</p>
--------------------------	--	---------------	---

<p>7.4 In-channel selectivity</p>	<p>Wanted signal power:</p> <p>For E-UTRA:</p> <ul style="list-style-type: none"> -106.9 dBm for 1.4 MHz BW -102.1 dBm for 3 MHz BW -100.0 dBm for 5 MHz BW -98.5 dBm for 10 MHz BW -98.5 dBm for 15 MHz BW -98.5 dBm for 20 MHz BW <p>For in-band NB-IoT:</p> <ul style="list-style-type: none"> -124.3 dBm for 15 kHz sub-carrier spacing -130.2 dBm for 3.75 kHz sub-carrier spacing <p>For eLAA BS:</p> <ul style="list-style-type: none"> -93.2 dBm for Local Area BS -96.2 dBm for Medium Range BS <p>T-put limit = 95% of maximum for the Ref Meas channel</p>	<p>$f \leq 3.0\text{GHz}$ 1.4 dB</p> <p>$3.0\text{GHz} < f \leq 4.2\text{GHz}$ 1.8 dB</p> <p>$4.2\text{GHz} < f \leq 6.0\text{GHz}$ 2.5 dB</p>	<p>Formula: Wanted signal power + TT</p> <p>$f \leq 3.0\text{GHz}$ For E-UTRA:</p> <ul style="list-style-type: none"> -105.5 dBm for 1.4 MHz BW -100.7 dBm for 3 MHz BW -98.6 dBm for 5 MHz BW -97.1 dBm for 10 MHz BW -97.1 dBm for 15 MHz BW -97.1 dBm for 20 MHz BW <p>For in-band NB-IoT:</p> <ul style="list-style-type: none"> -122.9 dBm for 15 kHz sub-carrier spacing -128.8 dBm for 3.75 kHz sub-carrier spacing <p>$3.0\text{GHz} < f \leq 4.2\text{GHz}$</p> <ul style="list-style-type: none"> -105.1 dBm for 1.4 MHz BW -100.3 dBm for 3 MHz BW -98.2 dBm for 5 MHz BW -96.7 dBm for 10 MHz BW -96.7 dBm for 15 MHz BW -96.7 dBm for 20 MHz BW <p>$4.2\text{GHz} < f \leq 6.0\text{GHz}$</p> <p>For eLAA BS:</p> <ul style="list-style-type: none"> -90.7 dBm for Local Area BS -93.7dBm for Medium Range BS <p>Interferer signal power unchanged T-put limit unchanged</p>
-----------------------------------	---	---	--

<p>7.5 Adjacent Channel Selectivity (ACS) and narrow-band blocking</p>	<p><u>Narrowband blocking:</u> Wanted signal power For E-UTRA, all BWs: ($P_{\text{REFSENS}} + 6 \text{ dB}$)</p> <p>For in-band NB-IoT, 1.4 MHz and 3 MHz BW: $(P_{\text{REFSENS}} + 11 \text{ dB})$</p> <p>For in-band NB-IoT, 5 MHz BW: $(P_{\text{REFSENS}} + 8 \text{ dB})$</p> <p>For in-band NB-IoT, 10MHz, 15MHz and 20MHz BW: $(P_{\text{REFSENS}} + 6 \text{ dB})$</p> <p>For guard-band NB-IoT, 5 MHz BW: $(P_{\text{REFSENS}} + 11 \text{ dB})$</p> <p>For guard-band NB-IoT, 10MHz, 15MHz and 20MHz BW: $(P_{\text{REFSENS}} + 6 \text{ dB})$</p> <p>For standalone NB-IoT: $(P_{\text{REFSENS}} + 12 \text{ dB})$</p> <p>Interferer signal power, all BWs: -49dBm</p> <p><u>Adjacent channel selectivity:</u> Wanted signal power For E-UTRA, 1.4 MHz BW: $(P_{\text{REFSENS}} + 11 \text{ dB})$ For E-UTRA, 3 MHz BW: $(P_{\text{REFSENS}} + 8 \text{ dB})$ For E-UTRA, 5 MHz, 10MHz, 15MHz and 20MHz BW: $(P_{\text{REFSENS}} + 6 \text{ dB})$</p> <p>For in-band NB-IoT, 1.4 MHz BW: $(P_{\text{REFSENS}} + 11 \text{ dB})$</p> <p>For in-band NB-IoT, 3 MHz BW: $(P_{\text{REFSENS}} + 8 \text{ dB})$</p> <p>For in-band NB-IoT, 5 MHz, 10MHz, 15MHz and 20MHz BW: $(P_{\text{REFSENS}} + 6 \text{ dB})$</p> <p>For guard-band NB-IoT, 5 MHz BW: $(P_{\text{REFSENS}} + 10 \text{ dB})$</p> <p>For guard-band NB-IoT, 10 MHz BW: $(P_{\text{REFSENS}} + 8 \text{ dB})$</p>	<p>0 dB</p>	<p>Formula: Wanted signal power + TT</p> <p><u>Narrowband blocking:</u> For E-UTRA, all BWs: ($P_{\text{REFSENS}} + 6 \text{ dB}$) For in-band NB-IoT, 1.4 MHz and 3 MHz BW: $(P_{\text{REFSENS}} + 11 \text{ dB})$</p> <p>For in-band NB-IoT, 5 MHz BW: $(P_{\text{REFSENS}} + 8 \text{ dB})$</p> <p>For in-band NB-IoT, 10MHz, 15MHz and 20MHz BW: $(P_{\text{REFSENS}} + 6 \text{ dB})$</p> <p>For guard-band NB-IoT, 5 MHz BW: $(P_{\text{REFSENS}} + 11 \text{ dB})$</p> <p>For guard-band NB-IoT, 10MHz, 15MHz and 20MHz BW: $(P_{\text{REFSENS}} + 6 \text{ dB})$</p> <p>For standalone NB-IoT: $(P_{\text{REFSENS}} + 12 \text{ dB})$</p> <p>Interferer signal power unchanged</p> <p><u>Adjacent channel selectivity:</u> Wanted signal power For E-UTRA, 1.4 MHz BW: $(P_{\text{REFSENS}} + 11 \text{ dB})$ For E-UTRA, 3 MHz BW: $(P_{\text{REFSENS}} + 8 \text{ dB})$ For E-UTRA, 5 MHz, 10MHz, 15MHz and 20MHz BW: $(P_{\text{REFSENS}} + 6 \text{ dB})$</p> <p>For in-band NB-IoT, 1.4 MHz BW: $(P_{\text{REFSENS}} + 11 \text{ dB})$</p> <p>For in-band NB-IoT, 3 MHz BW: $(P_{\text{REFSENS}} + 8 \text{ dB})$</p> <p>For in-band NB-IoT, 5 MHz, 10MHz, 15MHz and 20MHz BW: $(P_{\text{REFSENS}} + 6 \text{ dB})$</p> <p>For guard-band NB-IoT, 5 MHz BW: $(P_{\text{REFSENS}} + 10 \text{ dB})$</p> <p>For guard-band NB-IoT, 10 MHz BW: $(P_{\text{REFSENS}} + 8 \text{ dB})$</p> <p>For guard-band NB-IoT, 15MHz and 20MHz BW: $(P_{\text{REFSENS}} + 6 \text{ dB})$</p>
--	---	-------------	---

	<p>For guard-band NB-IoT, 15MHz and 20MHz BW: ($P_{REFSENS} + 6dB$)</p> <p>For standalone NB-IoT: ($P_{REFSENS} + 19.5dB$)</p> <p>Interferer signal power, all BWs: -52 dBm</p> <p>T-put limit = 95% of maximum for the Ref Meas channel</p>		<p>For standalone NB-IoT: ($P_{REFSENS} + 19.5dB$)</p> <p>Interferer signal power unchanged</p> <p>T-put limit unchanged</p>
7.6.5.1 Blocking (General requirements)	<p><u>In-band blocking</u></p> <p>Wanted signal power, all BWs: ($P_{REFSENS} + 6 dB$)</p> <p>Interferer signal power, all BWs: -43dBm</p> <p><u>Out of band blocking</u></p> <p>Wanted signal power, all BWs: ($P_{REFSENS} + 6 dB$)</p> <p>Interferer signal power, all BWs: -15dBm CW</p> <p>T-put limit = 95% of maximum for the Ref Meas channel</p>	0 dB	<p>Formula: Wanted signal power + TT, all BWs: ($P_{REFSENS} + 6 dB$)</p> <p>Interferer signal power unchanged</p> <p>T-put limit unchanged</p>
7.6.5.2 Blocking (Co-location with other base stations)	<p><u>Co-located blocking</u></p> <p>Wanted signal power, all BWs: ($P_{REFSENS} + 6 dB$)</p> <p>Interferer signal power, all BWs: +16dBm</p> <p>T-put limit = 95% of maximum for the Ref Meas channel</p>	0 dB	<p>Formula: Wanted signal power + TT, all BWs: ($P_{REFSENS} + 6 dB$)</p> <p>Interferer signal power unchanged</p> <p>T-put limit unchanged</p>
7.7 Receiver spurious emissions	<p>-57dBm / 100 kHz -47dBm / 1 MHz</p>	0dB	<p>Formula: Minimum Requirement + TT</p> <p>Emission requirements unchanged</p>
7.8 Receiver intermodulation	<p>Wanted signal power, all BWs: ($P_{REFSENS} + 6dB$)</p> <p>CW Interferer power, all BWs: -52 dBm</p> <p>Modulated_Interferer power:, all BWs: -52 dBm</p> <p>T-put limit = 95% of maximum for the Ref Meas channel</p>	0 dB	<p>Formula: Wanted signal power + TT, all BWs: ($P_{REFSENS} + 6dB$)</p> <p>CW Interferer signal power unchanged</p> <p>Modulated Interferer signal power unchanged</p> <p>T-put limit unchanged</p>

G.3 Measurement of Performance Requirements

Table G.3-1: Derivation of Test Requirements (Performance tests)

Test	Minimum Requirement in TS 36.104	Test Tolerance (TT)	Test Requirement in TS 36.141
8.2.1 Performance requirements of PUSCH in multipath fading propagation conditions transmission on single antenna port	SNRs as specified	0.6dB	Formula: SNR + TT T-put limit unchanged
8.2.1A Performance requirements of PUSCH in multipath fading propagation conditions transmission on two antenna ports	SNRs as specified	0.8dB	Formula: SNR + TT T-put limit unchanged
8.2.2 Performance requirements for UL timing adjustment	SNRs as specified	0.6dB for fading cases 0.3dB for AWGN cases	Formula: SNR + TT T-put limit unchanged
8.2.3 Performance requirements for HARQ-ACK multiplexed on PUSCH	SNRs as specified	0.6dB	Formula: SNR + TT False ACK limit unchanged Correct ACK limit unchanged
8.2.4 Performance requirements for High Speed Train conditions	SNRs as specified	0.3dB	Formula: SNR + TT T-put limit unchanged
8.2.5 Performance requirements for PUSCH with TTI bundling and enhanced HARQ pattern	SNRs as specified	0.6dB	Formula: SNR + TT Residual BLER limit unchanged
8.2.6 Enhanced performance requirements type A of PUSCH in multipath fading propagation conditions with synchronous interference	SINRs as specified	0.6dB	Formula: SINR + TT T-put limit unchanged
8.2.6A Enhanced performance requirements type A of PUSCH in multipath fading propagation conditions with asynchronous interference	SINRs as specified	0.6dB	Formula: SINR + TT T-put limit unchanged
8.2.7 Performance requirements of PUSCH in multipath fading propagation conditions transmission on single antenna port for supporting Cat-M1 UEs	SINRs as specified	0.6dB	Formula: SINR + TT T-put limit unchanged
8.2.9 Enhanced performance requirements type B of PUSCH in multipath fading propagation conditions	SINRs as specified	0.6dB	Formula: SINR + TT T-put limit unchanged
8.3.1 ACK missed detection for single user PUCCH format 1a transmission on single antenna port	SNRs as specified	0.6dB	Formula: SNR + TT False ACK limit unchanged Correct ACK limit unchanged
8.3.2 CQI missed detection for PUCCH format 2 transmission on single antenna port	SNRs as specified	0.6dB	Formula: SNR + TT False CQI limit unchanged Correct CQI limit unchanged
8.3.3 ACK missed detection for multi user PUCCH format 1a	SNRs as specified	0.6dB	Formula: SNR + TT False ACK limit unchanged Correct ACK limit unchanged

8.3.4 ACK missed detection for PUCCH format 1b with Channel Selection	SNRs as specified	0.6 dB	Formula: SNR + TT False ACK limit unchanged Correct ACK limit unchanged
8.3.5 ACK missed detection for PUCCH format 3	SNRs as specified	0.6 dB	Formula: SNR + TT False ACK limit unchanged Correct ACK limit unchanged
8.3.6 NACK to ACK detection for PUCCH format 3	SNRs as specified	0.6 dB	Formula: SNR + TT False ACK limit unchanged Correct NACK limit unchanged
8.3.7 ACK missed detection for PUCCH format 1a transmission on two antenna ports	SNRs as specified	0.8dB	Formula: SNR + TT False ACK limit unchanged Correct ACK limit unchanged
8.3.8 CQI performance requirements for PUCCH format 2 transmission on two antenna ports	SNRs as specified	0.8dB	Formula: SNR + TT False ACK limit unchanged Correct ACK limit unchanged
8.3.9 CQI missed detection for PUCCH format 2 with DTX detection	SNRs as specified	0.6 dB for one antenna port 0.8 dB for two antenna ports	Formula: SNR + TT False CQI limit unchanged Correct CQI limit unchanged
8.3.10 ACK missed detection for PUCCH format 1a transmission on single antenna port for supporting Cat-M1 UEs	SNRs as specified	0.6 dB	Formula: SNR + TT False ACK limit unchanged Correct ACK limit unchanged
8.3.11 CQI performance requirements for PUCCH format 2 transmission on single antenna port for supporting Cat-M1 UEs	SNRs as specified	0.6 dB	Formula: SNR + TT False CQI limit unchanged Correct CQI limit unchanged
8.3.12 ACK missed detection for PUCCH format 4	SNRs as specified	0.6 dB	Formula: SNR + TT False ACK limit unchanged Correct ACK limit unchanged
8.4.1 PRACH false alarm probability and missed detection	SNRs as specified	0.6dB for fading cases 0.3dB for AWGN cases	Formula: SNR + TT PRACH False detection limit unchanged PRACH detection limit unchanged
8.5.1 Performance requirements for NPUSCH format 1	SINRs as specified	0.6dB	Formula: SINR + TT T-put limit unchanged
8.5.2 ACK missed detection for NPUSCH format 2	SINRs as specified	0.6dB	Formula: SNR + TT False ACK limit unchanged Correct ACK limit unchanged
8.5.3 Performance requirements for NPRACH	SNRs as specified	0.6dB for fading cases 0.3dB for AWGN cases	Formula: SNR + TT NPRACH False detection limit unchanged NPRACH detection limit unchanged
8.6 Performance requirements for subslot-PUSCH	SINRs as specified	0.6dB	Formula: SNR + TT T-put limit unchanged
8.7.1 ACK missed detection for single user SPUCCH format 1a	SNRs as specified	0.6dB	Formula: SNR + TT T-put limit unchanged
8.7.2 ACK missed detection requirements for SPUCCH format 4	SNRs as specified	0.6dB	Formula: SNR + TT T-put limit unchanged

Annex H (Informative): E-UTRAN Measurement Test Cases

<Text will be added.>

Annex I (Informative): Measurement system set-up

Example of measurement system set-ups are attached below as an informative annex.

I.1 Transmitter

I.1.1 Base station output power, output power dynamics, transmitted signal quality, Frequency error, EVM, DL RS power, Unwanted emissions

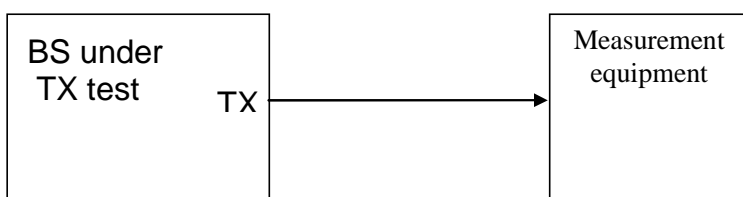

Figure I.1-1: Measuring system Set-up for base station output power, output power dynamics, transmitted signal quality, Frequency error, EVM, DL RS power, Unwanted emissions

I.1.2 Transmitter intermodulation

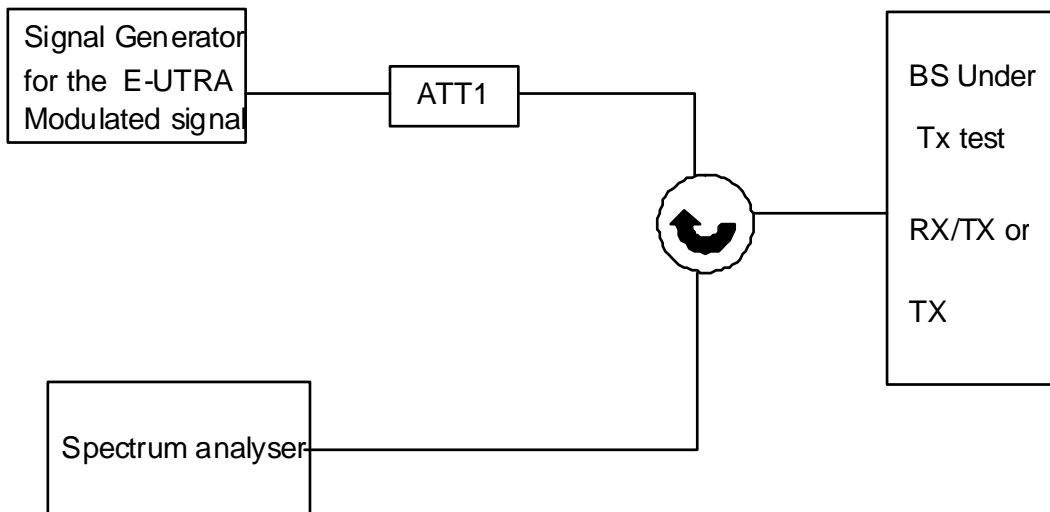

Figure I.1-2: Measuring system Set-up for Transmitter intermodulation

I.1.3 Time alignment error

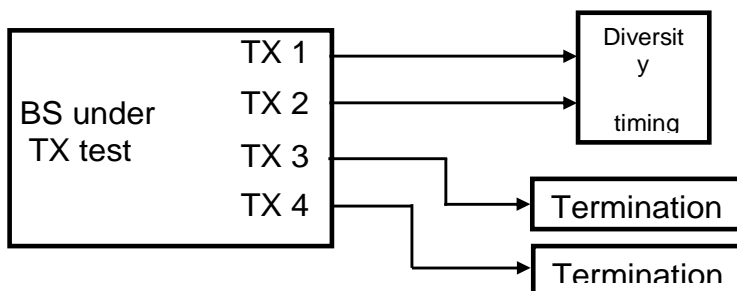

Figure I.1-3: Measuring system Set-up for Test of Time alignment error

I.1.4 Home BS output power for adjacent channel protection

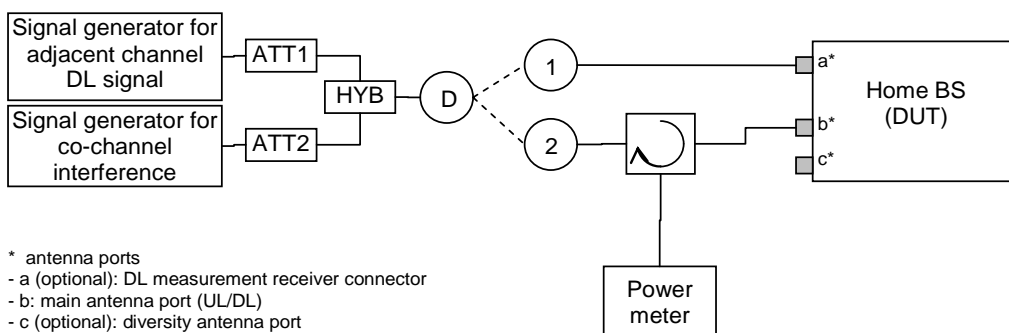

Figure I.1-4: Measuring system set-up for Home BS output power for adjacent channel protection

I.1.5 Home BS output power for co-channel E-UTRA protection

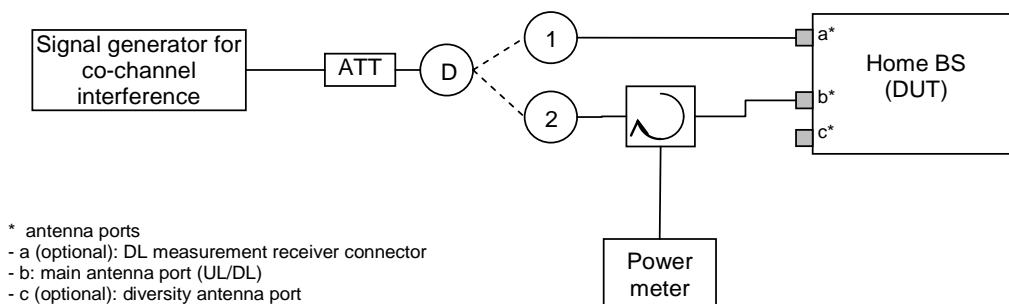

Figure I.1-5: (Option 1) Measuring system set-up for Home BS output power for co-channel E-UTRA protection

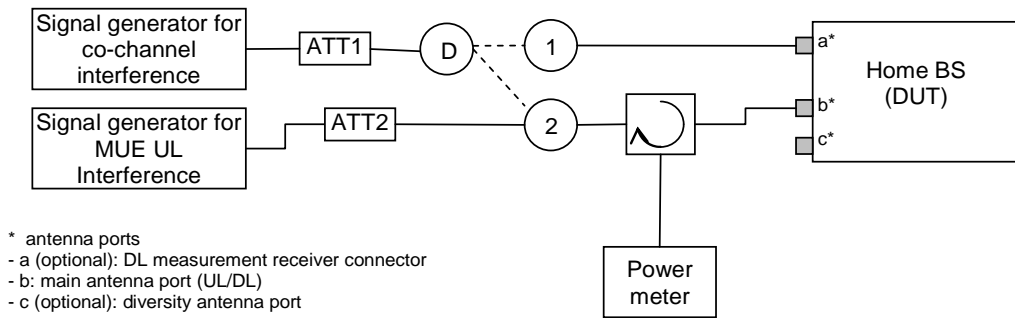

Figure I.1-6: (Option 2) Measuring system set-up for Home BS output power for co-channel E-UTRA protection

I.2 Receiver

NOTE: No HARQ feedback is done for any receiver test in Annex I.2.

I.2.1 Reference sensitivity level

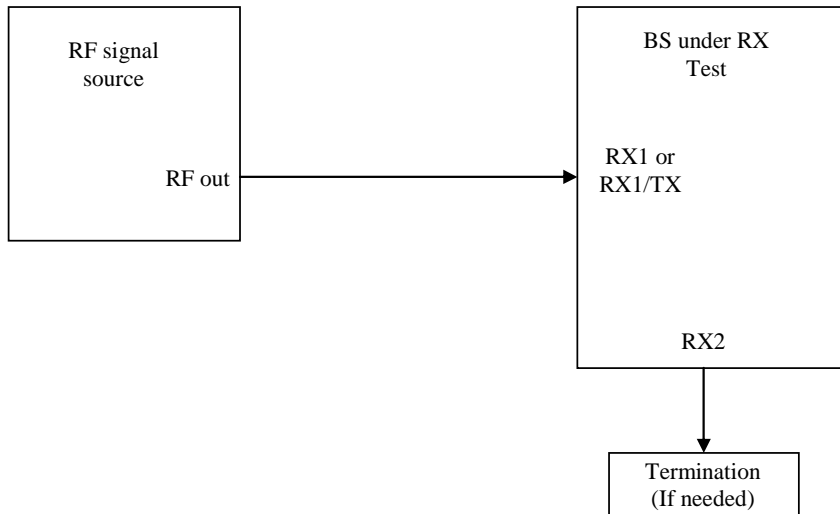

Figure I.2-1: Measuring system Set-up for Base Station Reference sensitivity level Test

1.2.2 Dynamic range

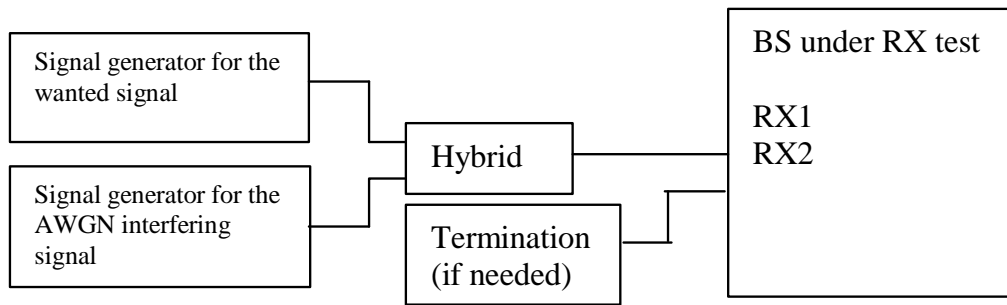

Figure I.2-2: Measuring system Set-up for Dynamic range

1.2.3 In-channel selectivity

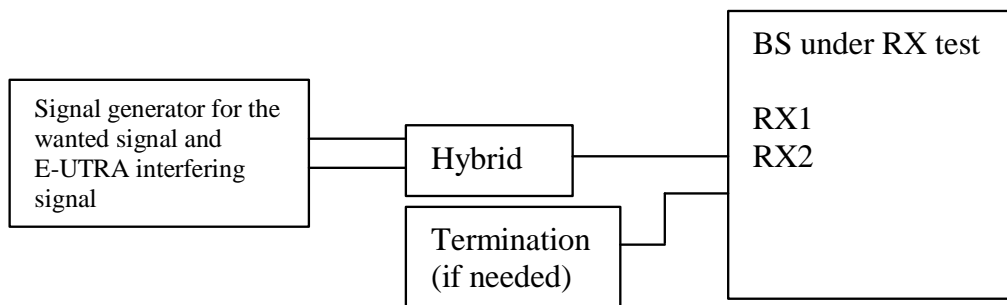

Figure I.2-3: Measuring system Set-up for In-channel selectivity

1.2.4 Adjacent Channel Selectivity (ACS) and narrowband blocking

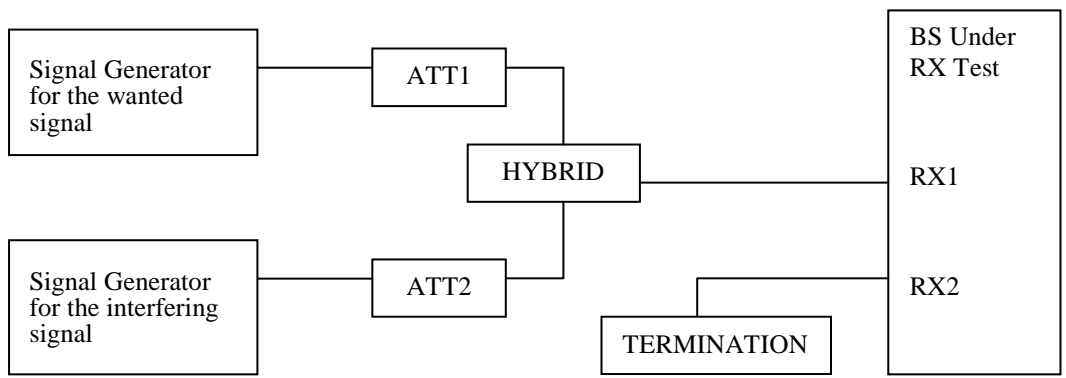

Figure I.2-4: Measuring system Set-up for Adjacent channel selectivity and narrowband blocking

1.2.5 Blocking characteristics

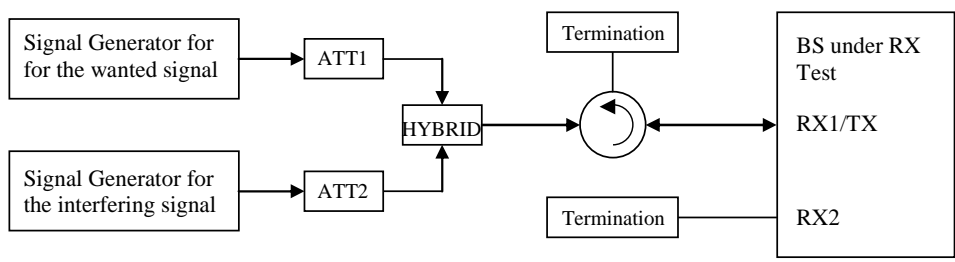

Figure I.2-5: Measuring system Set-up for Blocking characteristics

I.2.6 Receiver spurious emission

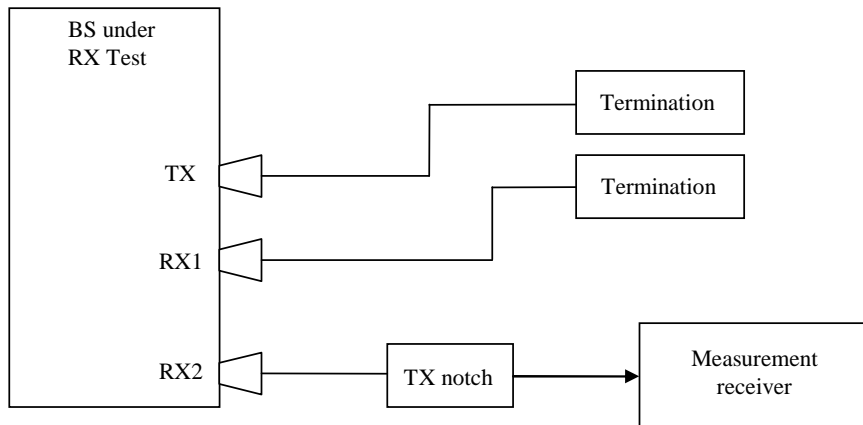

Figure I.2-6: Measuring system Set-up for Receiver spurious emission

I.2.7 Intermodulation characteristics

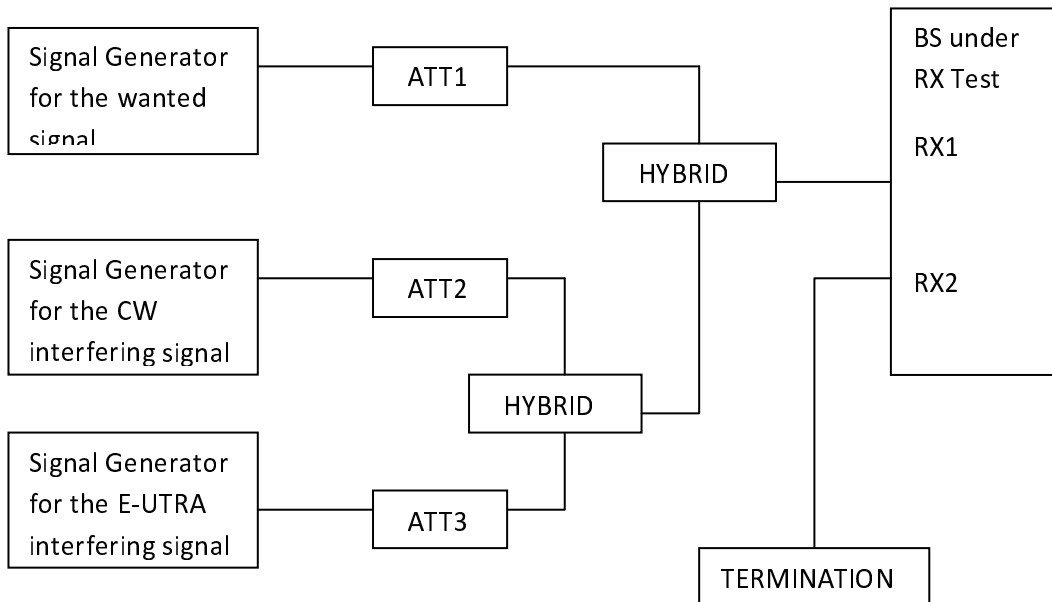

Figure I.2-7: Measuring system Set-up for intermodulation characteristics

I.3 Performance requirement

I.3.1 Performance requirements for PRACH in static conditions

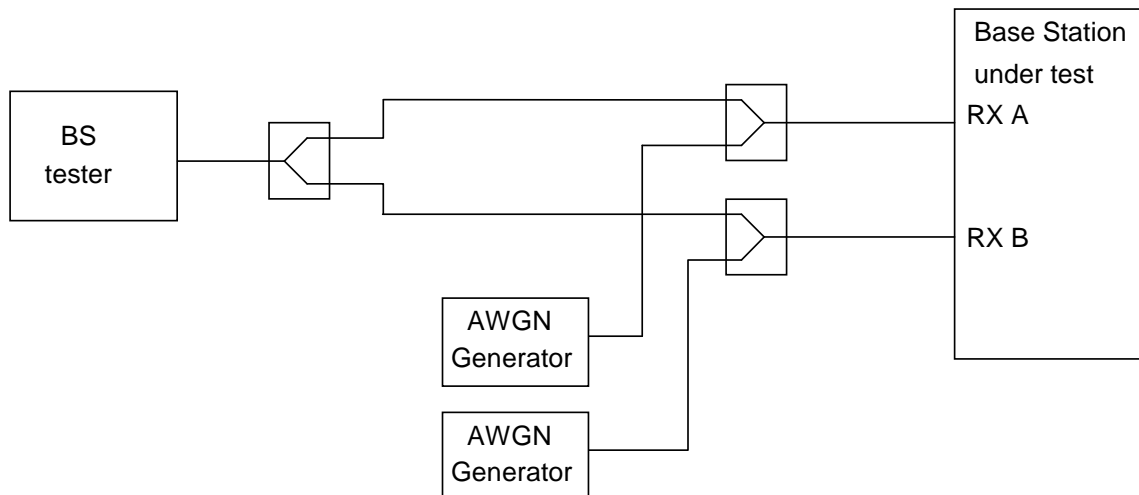

Figure I.3-1: Functional set-up for performance requirements for PRACH in static conditions for BS with Rx diversity (2 Rx case shown)

I.3.2 Performance requirements for PUSCH, PRACH, single user PUCCH in multipath fading conditions and for High Speed Train conditions

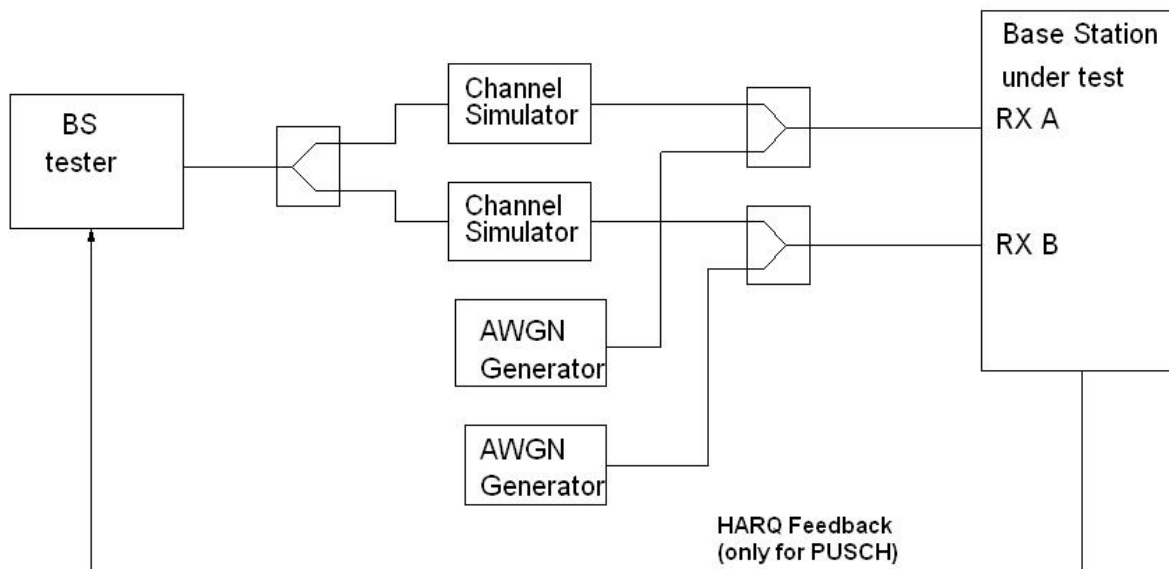

Figure I.3-2: Functional set-up for performance requirements for PUSCH, PRACH, single user PUCCH in multipath fading conditions and for High Speed Train conditions for BS with Rx diversity (2 Rx case shown)

NOTE 1: For HST tests which are specified in static conditions, the Channel Simulators are assumed to simulate the Doppler shift.

NOTE 2: The HARQ Feedback could be done as an RF feedback or as a digital feedback. The HARQ Feedback should be error free.

1.3.3 Performance requirements for multi user PUCCH in multipath fading conditions

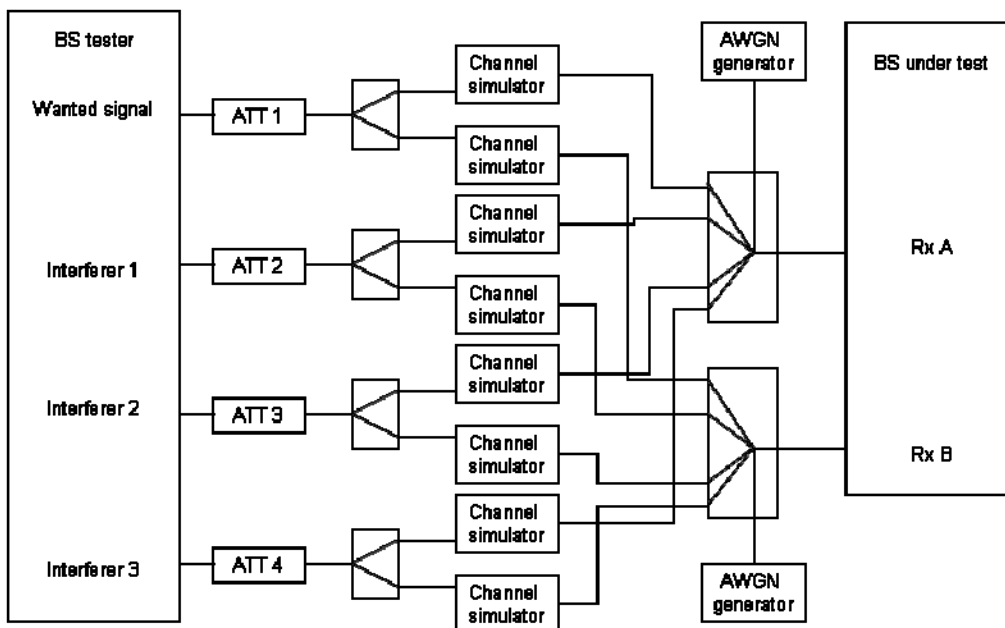

Figure I.3-3: Functional set-up for performance requirements for multi user PUCCH in multipath fading conditions

1.3.4 Performance requirement for UL timing adjustment

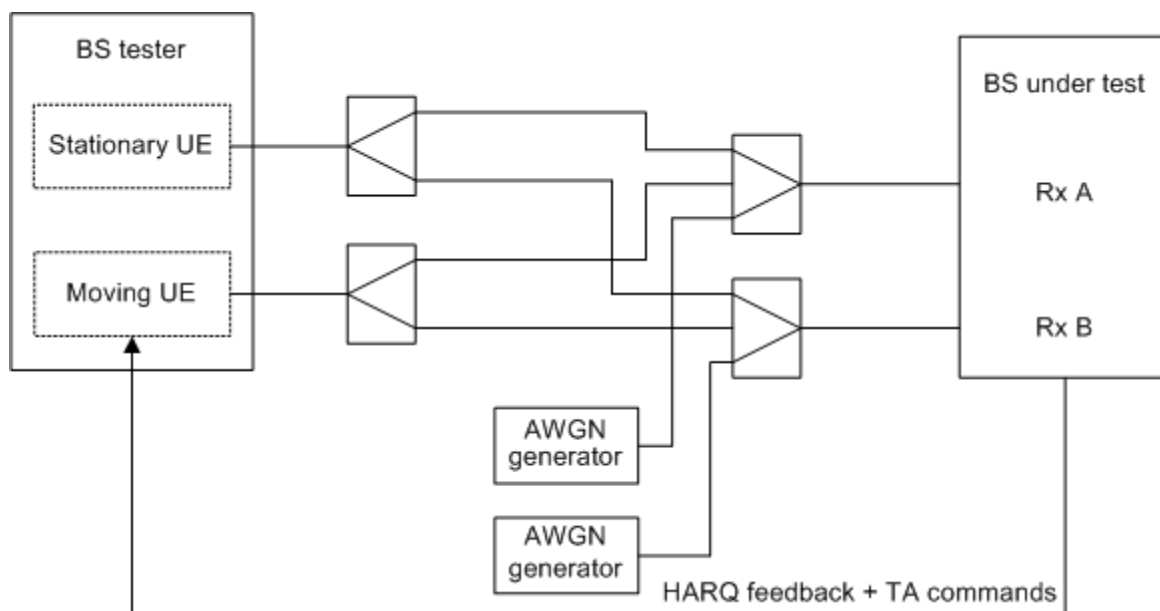

Figure I.3-4: Functional set-up for performance requirement for UL timing adjustment (Scenario 2 case shown)

NOTE 1: In case of UL timing adjustment Scenario 1, channel simulators needs to be used for fading and Doppler shift emulation.

NOTE 2: The HARQ feedback and TA commands could be done as an RF feedback or as a digital feedback. The HARQ feedback and TA commands should be error free.

1.3.5 Performance requirements for PUCCH transmission on two antenna ports in multipath fading conditions

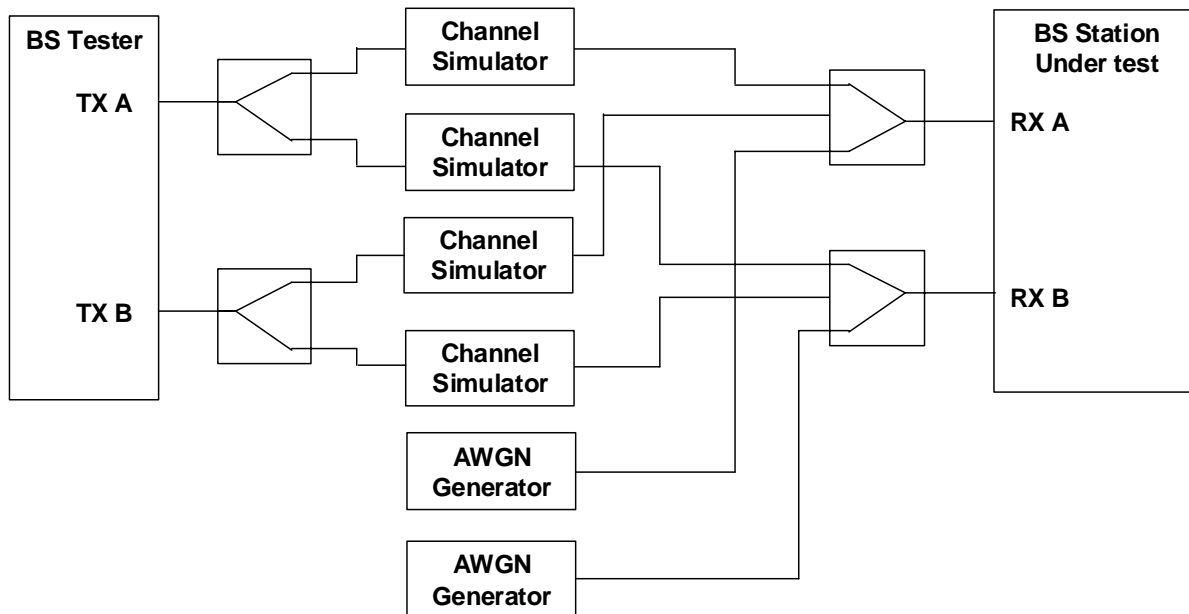

Figure I.3-5: Functional set-up for performance requirements for PUCCH transmission on two antenna ports in multipath fading conditions (2 Rx case shown)

1.3.6 Performance requirements for PUSCH transmission on two antenna ports in multipath fading conditions

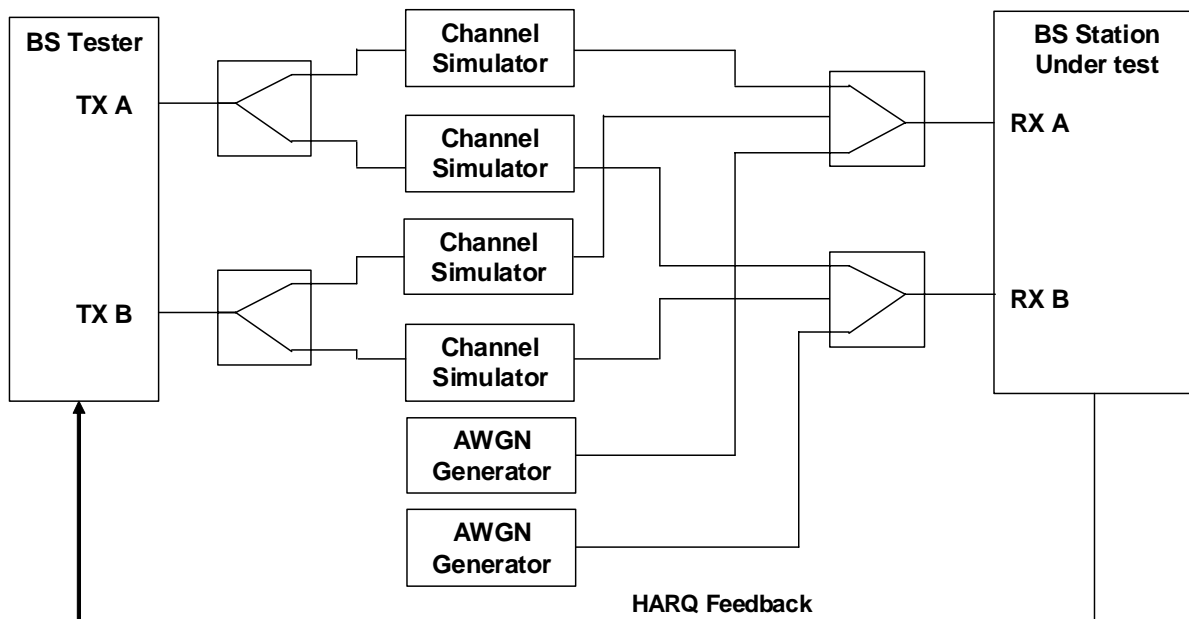

Figure I.3-6: Functional set-up for performance requirements for PUSCH transmission on two antenna ports in multipath fading conditions (2 Rx case shown)

I.3.7 Enhanced performance requirements type A of PUSCH in multipath fading propagation conditions with synchronous or asynchronous interference

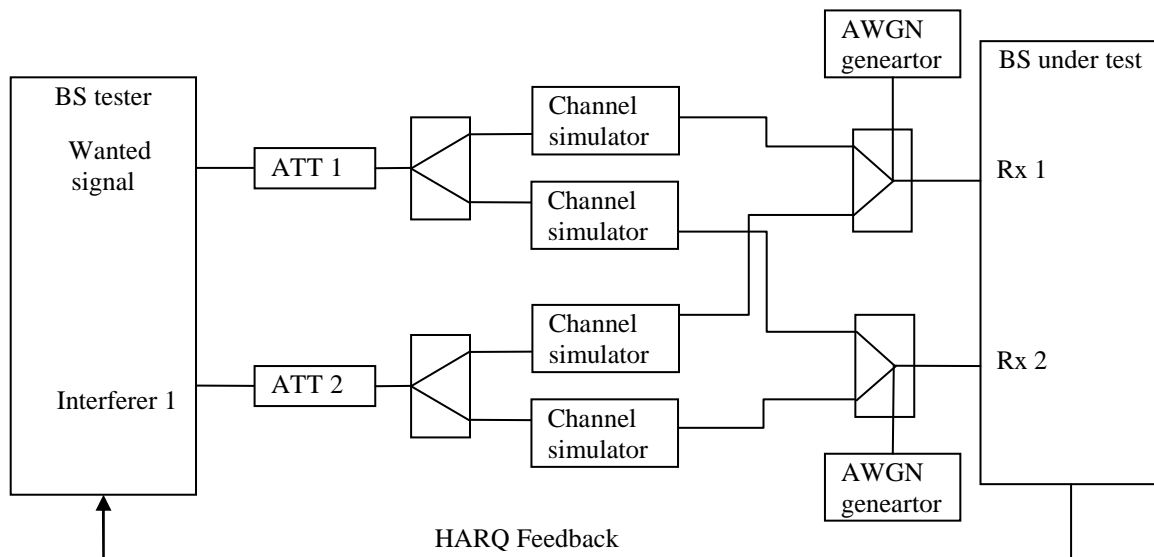

Figure I.3-7a: Functional set-up for enhanced performance requirements type A of 2Rx PUSCH in multipath fading conditions with synchronous interference (1 interferer and 2 Rx case shown)

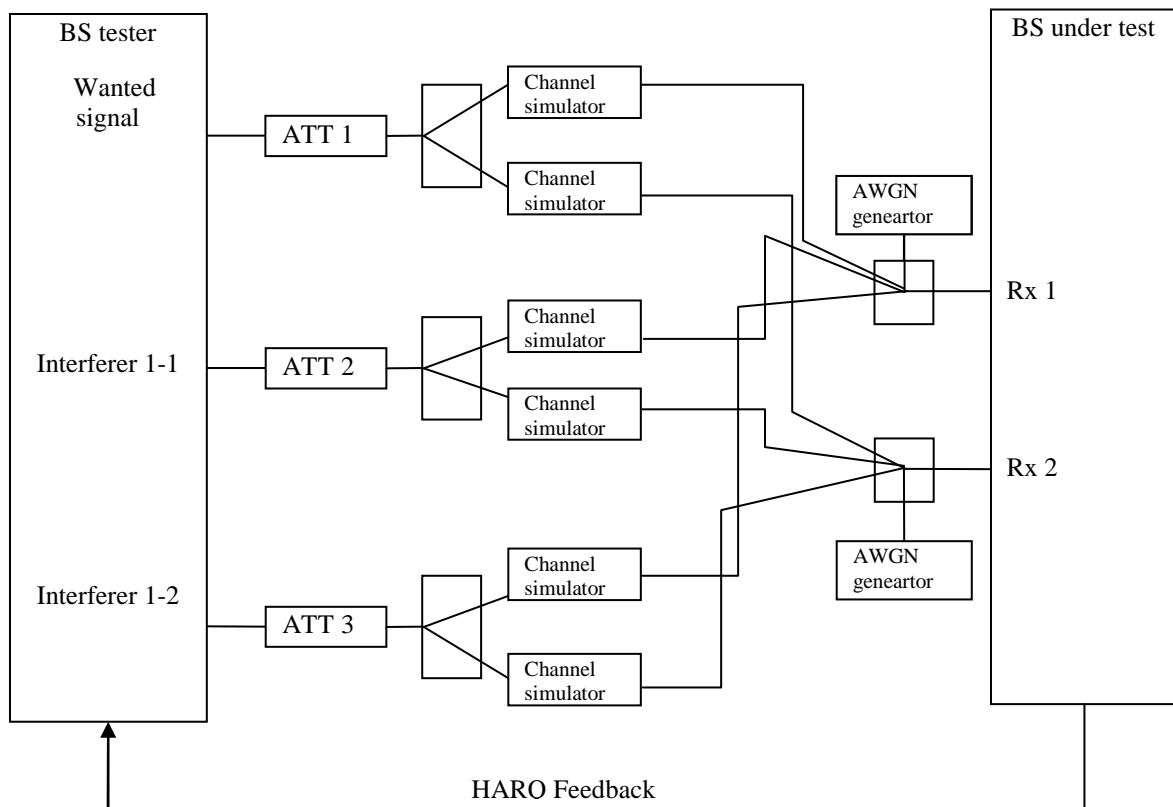

Figure I.3-7b: Functional set-up for enhanced performance requirements type A of PUSCH with 2Rx in multipath fading conditions with asynchronous interference (2 interferers and 2 Rx case shown)

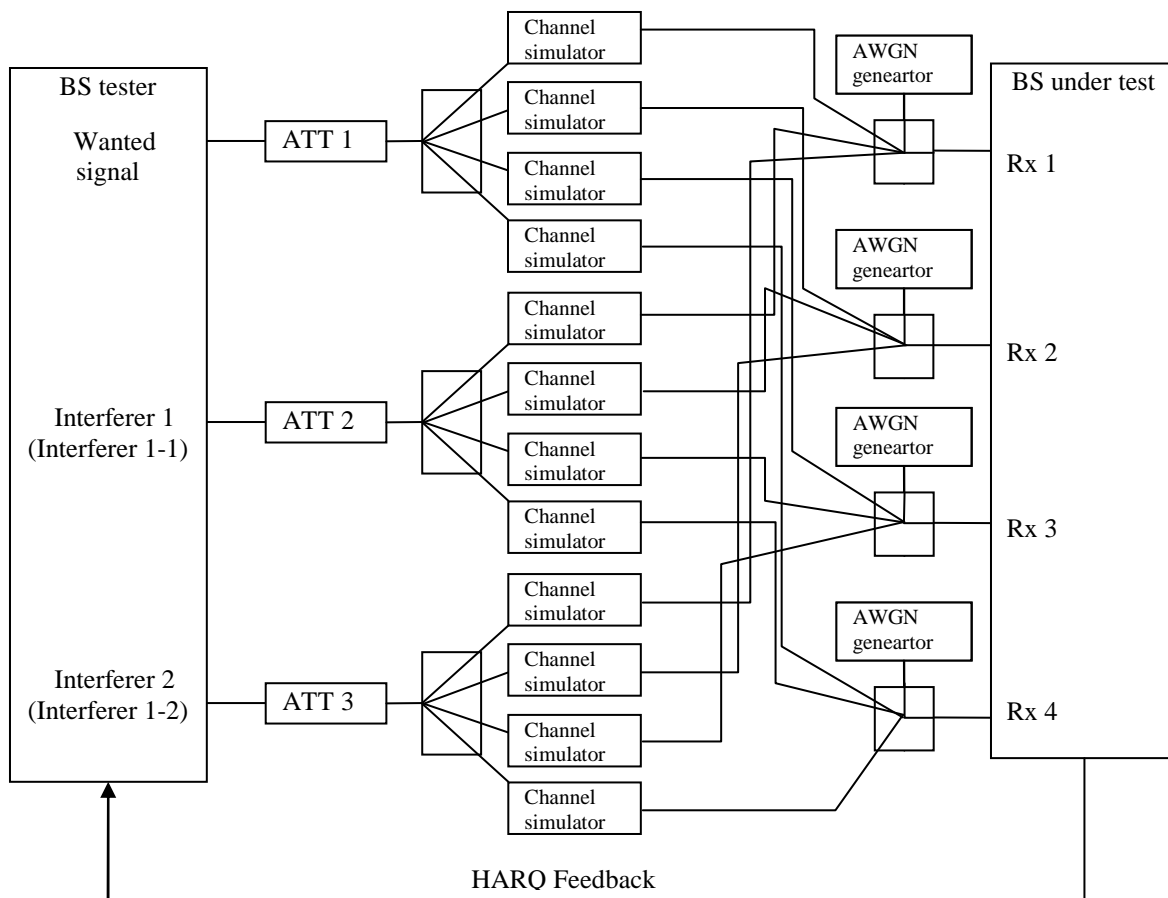

Figure I.3-7c: Functional set-up for enhanced performance requirements type A of 4Rx PUSCH in multipath fading conditions with synchronous or asynchronous interference (2 interferers and 4 Rx case shown)

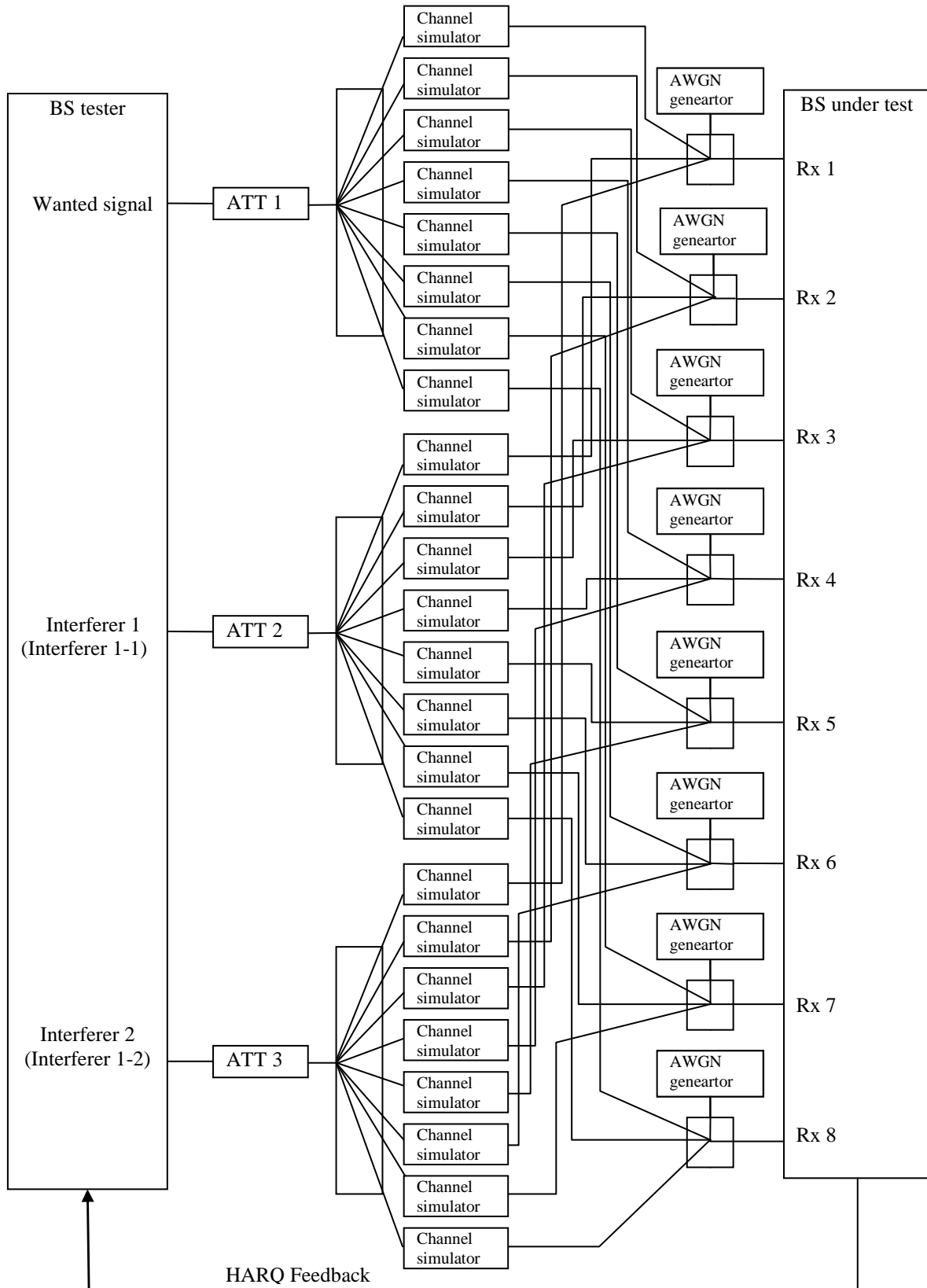

Figure I.3-7d: Functional set-up for enhanced performance requirements type A of 8Rx PUSCH in multipath fading conditions with synchronous or asynchronous interference (2 interferers and 8 Rx case shown)

I.3.8 Enhanced performance requirement type B of PUSCH in multipath fading propagation conditions

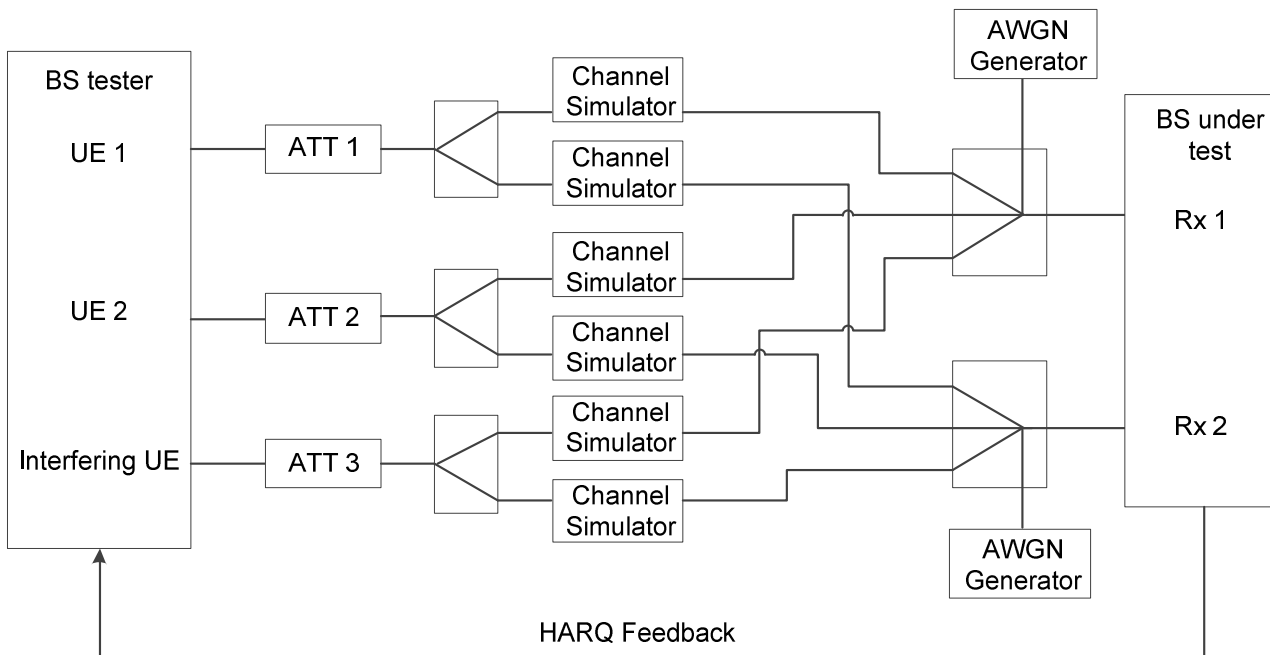

Figure I.3-8: Functional set-up for enhanced performance requirement type B of PUSCH in multipath fading conditions (2 Rx case shown)

I.4 Channel access procedures

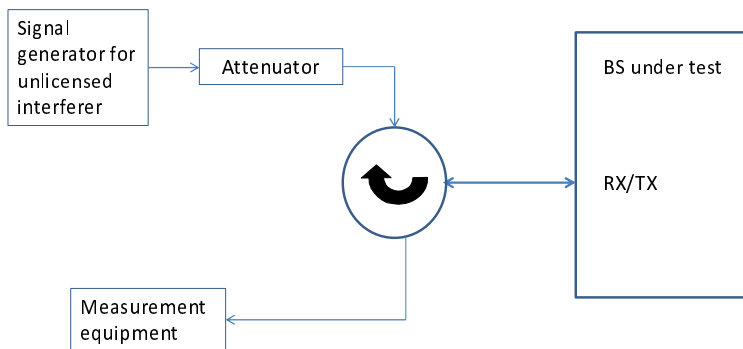

Figure I.4: Measuring system Set-up for Channel access procedures

Annex J (Informative): Unwanted emission requirements for multi-carrier BS

J.1 General

In clause 6.6, unwanted emission requirements for single carrier or multi-carrier BS are specified. This multi-carrier BS corresponds to a multi-carrier BS for E-UTRA, or a BS supporting intra-band contiguous CA. The following two pragmatic scenarios are considered in this annex:

- multi-carrier BS of different E-UTRA channel bandwidths, covering all scenarios except the channel bandwidth of the outermost carrier less than 5 MHz
- multi-carrier BS of E-UTRA and UTRA, covering all scenarios except the channel bandwidth of the outermost carrier less than 5 MHz.

All scenarios for channel bandwidths of the outermost carrier less than 5 MHz are for further study. Only multi-carrier BS with contiguous carriers are considered. The guidelines below assumes that the power spectral density of the multiple carriers is the same. All other combinations of multiple carriers are ffs.

Note 1: Further information and analysis for these scenarios can be found in TR 36.942 [14].

J.2 Multi-carrier BS of different E-UTRA channel bandwidths

For a multi-carrier E-UTRA BS transmitting a group of carriers of different channel bandwidths, the channel bandwidth of the outermost carriers (≥ 5 MHz) should be considered for ACLR and Operating band unwanted emission requirements. That is, the corresponding requirements for the channel bandwidth of each of the outermost carriers should be applied at the respective side of the group of transmitted carriers.

J.3 Multi-carrier BS of E-UTRA and UTRA

For a multi-carrier BS transmitting a group of carriers of E-UTRA and UTRA, the RAT being used on the outermost carriers (≥ 5 MHz) should be considered for ACLR and Operating band unwanted emission requirements. That is, the corresponding requirements for the RAT being used on each of the outermost carriers should be applied at the respective side of the group of transmitted carriers.

Annex K (informative): Change history

Change history							
Date	Meeting	TDoc	CR	Rev	Cat	Subject/Comment	New version
2007-08	RAN4#44	R4-071503				TS skeleton created from 3GPP TS template.	0.0.1
2008-02	RAN4#46	R4-080004				Text proposals for section 2 to 4 (R4-072237) and Annex A (R4-072048), which were agreed at RAN4#45, are incorporated.	0.1.0
2008-02	RAN4#46	R4-080446				Section for In-channel selectivity (new 7.4) is inserted and following sections are re-numbered. Editorial corrections are made in section 1, 3.2, 4.3, Table 4.3-1, 4.5.2.1, 4.6, 4.6.3, 4.6.4, 4.6.5 and A.2.	0.1.1
2008-02	RAN4#46	R4-080508				Text proposals in R4-080447, R4-080058, R4-080453, R4-080047, R4-080048, R4-080049, R4-080050, R4-080051, R4-080444, R4-080501, R4-080044, R4-080045 and R4-080046 are incorporated with modifications agreed in the first round discussion in RAN4#46 meeting. Overlapped parts in R4-080058 and R4-080044 for Annex A, R4-080444 and R4-080501 for section 8 are merged by the editor.	0.2.0
2008-03	RAN4#46 bis	R4-080659				Editorial correction on section 8 is made: Text proposals for section 8 in R4-080444 are removed and the text proposal in R4-080501 is applied. Some editorial corrections are applied.	0.2.1
2008-04	RAN4#46 bis	R4-080828				Text proposals agreed in R4-080583,R4-080617,R4-080663,R4-080664,R4-080606,R4-080584,,R4-080660,R4-080792,R4-080586,R4-080587,R4-080564,R4-080566 and R4-0806007 are incorporated with some editorial modifications.	0.3.0
2008-05	RAN4#47	R4-080844				Text proposals agreed in R4-080803,R4-0799,R4-0800,R4-080801 and R4-080826 are incorporated with editorial modifications.	0.4.0
2008-05	RAN4#47	R4-081198				Text proposals agreed in R4-081055, R4-081007, R4-081070, R4-081170, R4-080924, R4-080888, R4-081176, R4-080853, R4-080854, R4-080855, R4-081056, R4-080889 and R4-081178 are incorporated.	0.5.0
2008-05	RAN#40	RP-080381				Presented for information as V1.0.0.	1.0.0
2008-05	RAN#40	RP-080456				Editorial corrections on the formats in order to comply with the drafting rule of 3GPP.	1.0.1
2008-06	RAN4#47 bis	R4-081255				Correction in section 6.5.1.5, which was incorrectly proposed in R4-081226, is made. Editorial corrections on 6.5.3.4.1 and 8.4.1.4.2 are made.	1.0.2
2008-06	RAN4#47 bis	R4-081256				Text proposals agreed in R4-081184 and R4-081187 are incorporated.	1.1.0
2008-06	RAN4#47 bis	R4-081329				Editorial corrections in Table 8.4.1.5-2.	1.1.1
2008-08	RAN4#48	R4-081832				Text proposals agreed in the following documents are incorporated: R4-081377, R4-081547, R4-081282, R4-081284,R4-081652, R4-081502, R4-081283, R4-081650, R4-081268, R4-081269, R4-081270, R4-081653, R4-081272, R4-081645, R4-081481, R4-081281, R4-081322.	1.2.0
2008-08	RAN4#48	R4-082185				Text proposals agreed in the following documents are incorporated: R4-081832, R4-082087, R4-082093, R4-081847, R4-081965, R4-081967, R4-081944, R4-081709 , 4-082109, R4-081711, R4-081712, R4-082090, R4-081714, R4-081715, R4-081834, R4-082135, R4-082173, R4-082160, R4-082171	1.3.0
2008-09	RAN#41	RP-080715				Typo in Table 8.4.1.5-1 (section 8.4.1.5) , which was brought in at V1.1.0 when implementing R4-081187 is corrected.	2.0.0
2008-09	RAN#41	RP-080715				Presented for approval as V2.0.0	8.0.0
2008-12	RAN #42	RP-080915	10			Correction to the figure with the Transmission Bandwidth configuration	8.1.0
2008-12	RAN #42	RP-080916	14			Modification to EARFCN	8.1.0
2008-12	RAN #42	RP-080919	3			Introduction of Band 17	8.1.0
2008-12	RAN #42	RP-080920	27			Update of total dynamic range limits	8.1.0
2008-12	RAN #42	RP-080921	28			Update of TDD-FDD coexistence requirements	8.1.0
2008-12	RAN #42	RP-080922	30			PRACH demodulation requirements update	8.1.0
2008-12	RAN #42	RP-090923	4			General corrections in section 7-Annexes	8.1.0
2008-12	RAN #42	RP-080923	12			General corrections in sections 4-6	8.1.0

2008-12	RAN #42	RP-080923	19	1		Corrections to references, definitions symbols and abbreviations	8.1.0
2008-12	RAN #42	RP-080923	20	1		Corrections to clause 4 and 5	8.1.0
2008-12	RAN #42	RP-080923	21	2		Correction to clause 6	8.1.0
2008-12	RAN #42	RP-080923	22	1		Correction to clause 7	8.1.0
2008-12	RAN #42	RP-080923	23			Correction to clause 8	8.1.0
2008-12	RAN #42	RP-080923	24			Correction to Annex G	8.1.0
2008-12	RAN #42	RP-080924	5			Correction of EVM test condition related to total power dynamic range	8.1.0
2008-12	RAN #42	RP-080924	8			Addition of BS transmit ON/OFF power tests	8.1.0
2008-12	RAN #42	RP-080924	11			Clarificatiopn on emission requirements	8.1.0
2008-12	RAN #42	RP-080924	32			E-UTRA TDD test models	8.1.0
2008-12	RAN #42	RP-080924	17			Correction to transmitter intermodulation test	8.1.0
2008-12	RAN #42	RP-080924	26			Correction to E-UTRA test models	8.1.0
2008-12	RAN #42	RP-080925	25			EVM averaging for TDD in the global in channel TX test	8.1.0
2008-12	RAN #42	RP-080926	1	1		eNB performance test requirement for UL timing adjustment	8.1.0
2008-12	RAN #42	RP-080926	2	1		eNB performance test requirement for PUCCH format 2	8.1.0
2008-12	RAN #42	RP-080926	13	1		eNB performance test requirements for Multi User PUCCH	8.1.0
2008-12	RAN #42	RP-080926	31			eNB performance requirements for HARQ ACK multiplexed on PUSCH	8.1.0
2008-12	RAN #42	RP-080927	9			eNB performance test requirements for High Speed Train conditions	8.1.0
2008-12	RAN #42	RP-080927	15	1		Clarification of eNB HST propagation conditions (36.141, rel-8)	8.1.0
2008-12	RAN #42	RP-080927	7	1		Correction of Doppler shift trajectories equations for HST conditions	8.1.0
2009-03	RAN #43	RP-090173	54			Clarification of EARFCN for 36.141	8.2.0
2009-03	RAN #43	RP-090175	55	1		Regional requirement on maximum rated power for Band 34	8.2.0
2009-03	RAN #43	RP-090177	43			Clarification of the BS performance test w.r.t PUCCH ACK/NACK Repetition configuration	8.2.0
2009-03	RAN #43	RP-090177	48			PUSCH ACK/NAK simulation assumptions finalization for simulations with implementation margins	8.2.0
2009-03	RAN #43	RP-090177	53			HARQ-ACK multiplexed on PUSCH performance requirement results	8.2.0
2009-03	RAN #43	RP-090178	36			Correction of clause 4.	8.2.0
2009-03	RAN #43	RP-090178	39			Correction and update of Annex G.	8.2.0
2009-03	RAN #43	RP-090179	34			Corrections related to E-UTRA test models	8.2.0
2009-03	RAN #43	RP-090179	35			Correction of E-UTRAN TDD eNodeB test models	8.2.0
2009-03	RAN #43	RP-090179	37			Correction and update of clause 6.	8.2.0
2009-03	RAN #43	RP-090179	40			Clarification of PHS band including the future plan	8.2.0
2009-03	RAN #43	RP-090179	45			Correction to transmitter intermodulation test	8.2.0
2009-03	RAN #43	RP-090179	49			Unsynchronized TDD coexistence requirements	8.2.0
2009-03	RAN #43	RP-090179	51			Correction to unwanted emission limit for 3MHz(E-UTRA bands < 1GHz) for Category A	8.2.0
2009-03	RAN #43	RP-090180	42	1		Correction to BS reciever test requirements	8.2.0
2009-03	RAN #43	RP-090180	56			eNB ACS frequency offset	8.2.0
2009-03	RAN #43	RP-090181	38			Correction of clause 8.	8.2.0
2009-03	RAN #43	RP-090181	41			Modifications on parameter settings for some demodulation test cases.	8.2.0
2009-03	RAN #43	RP-090181	44			AWGN level for UL demodulation performance tests	8.2.0
2009-05	RAN #44	RP-090544	61			Clarification of requirements for multicarrier BS. (Technically Endorsed CR in R4-50bis - R4-091445)	8.3.0
2009-05	RAN #44	RP-090545	62			Correction of test models for E-UTRAN. (Technically Endorsed CR in R4-50bis - R4-091461)	8.3.0
2009-05	RAN #44	RP-090545	66			Test system uncertainty for Transmitter intermodulation	8.3.0
2009-05	RAN #44	RP-090545	67			Adding test model for transmit ON/OFF test	8.3.0
2009-05	RAN #44	RP-090545	68			Correction to DL RS power	8.3.0
2009-05	RAN #44	RP-090545	64r1			Addition of missing Test Tolerances for transmitter tests	8.3.0
2009-05	RAN #44	RP-090545	70			Test system uncertainty for Receiver dynamic range	8.3.0
2009-05	RAN #44	RP-090545	58			CR 36.141 ACS frequency offset. (Technically Endorsed CR in R4-50bis - R4-091330)	8.3.0
2009-05	RAN #44	RP-090545	63r2			Test Tolerances for Performance test cases	8.3.0
2009-05	RAN #44	RP-090545	59			UL timing adjustment measurement system set-up. (Technically Endorsed CR in R4-50bis - R4-091414)	8.3.0

2009-05	RAN #44	RP-090545	60			UL timing adjustment performance requirement clarifications. (Technically Endorsed CR in R4-50bis - R4-091438)	8.3.0
2009-05	RAN #44	RP-090559	57			Introduction of Extended LTE800 requirements. (Technically Endorsed CR in R4-50bis - R4-091064)	9.0.0
2009-09	RAN #45	RP-090833				Clarification of the multi user PUCCH performance determination (R43-51Cat F Endorsed CR in: R4-092227)	9.1.0
2009-09	RAN #45	RP-090833	072				
2009-09	RAN #45	RP-090833	074			Clarification of the UL timing adjustment performance determination (R43-51Cat F Endorsed CR in: R4-092229)	9.1.0
2009-09	RAN #45	RP-090833	076			Receiver intermodulation clarification	9.1.0
2009-09	RAN #45	RP-090833	078			Corrections to E-UTRA Rx requirements	9.1.0
2009-09	RAN #45	RP-090826				Correction of spurious emission requirements for LTE800	9.1.0
2009-09	RAN #45	RP-090833	079				
2009-09	RAN #45	RP-090833	081			Clarifications on testing UL timing adjustment requirements	9.1.0
2009-09	RAN #45	RP-090833	083			Correction on reference of extreme power supply	9.1.0
2009-09	RAN #45	RP-090833	092			LTE operating band unwanted emissions revision	9.1.0
2009-12							
	RP-46	RP-091286	095			Introduction of Extended LTE1500 requirements for TS36.141 (Technically endorsed at RAN 4 52bis in R4-093637)	9.2.0
2009-12	RP-46	RP-091267	098			Clarification of the test method for blocking (Technically endorsed at RAN 4 52bis in R4-093769)	9.2.0
2009-12	RP-46	RP-091267	100			Adding missing EARFCN for band 33 and 34 (Technically endorsed at RAN 4 52bis in R4-093770)	9.2.0
2009-12	RP-46	RP-091267	102			Incorrect FRC A3-2 Coded block size (Technically endorsed at RAN 4 52bis in R4-093771)	9.2.0
2009-12	RP-46	RP-091266	104			LTE operating band unwanted emissions correction (Technically endorsed at RAN 4 52bis in R4-093802)	9.2.0
2009-12	RP-46	RP-091267	106			HARQ feedback clarification addition (Annex B) (Technically endorsed at RAN 4 52bis in R4-093997)	9.2.0
2009-12							
	RP-46	RP-091266	108			Clarification on Spurious emissions limits for BS co-existed with another BS (Technically endorsed at RAN 4 52bis in R4-094012)	9.2.0
2009-12	RP-46	RP-091265	109			Corrections to ICS requirement (Technically endorsed at RAN 4 52bis in R4-093640)	9.2.0
2009-12	RP-46	RP-091270	111	1		Clarification on PRACH False alarm probability	9.2.0
2009-12	RP-46	RP-091295	112	1		E-UTRA BS classification	9.2.0
2009-12	RP-46	RP-091295	113	1		Home eNode B maximum output power	9.2.0
2009-12	RP-46	RP-091295	114	1		Home eNode B in-channel selectivity requirement	9.2.0
2009-12	RP-46	RP-091295	115	1		Home eNode B receiver intermodulation requirement	9.2.0
2009-12	RP-46	RP-091269	117	1		UL Timing Adjustment test clarifications	9.2.0
2009-12							
	RP-46	RP-091266	119			Multi-path fading propagation conditions reference correction	9.2.0
2009-12	RP-46	RP-091265	121			Corrections on frequency range of unwanted emissions requirements	9.2.0
2009-12	RP-46	RP-091266	122	1		Correction to the transmitter intermodulation	9.2.0
2009-12							
	RP-46	RP-091276	124			Testing in case of Rx diversity, Tx diversity and MIMO	9.2.0
2009-12	RP-46	RP-091295	130	1		Home eNode B ACLR requirement	9.2.0
2009-12							
	RP-46	RP-091295	131	1		Home eNode B ACS and narrow band blocking requirement	9.2.0
2009-12	RP-46	RP-091295	132	1		Home eNode B Blocking requirement	9.2.0
2009-12	RP-46	RP-091294	133	1		Home eNode B dynamic range requirement	9.2.0
2009-12	RP-46	RP-091294	134	1		Home eNode B frequency error requirement	9.2.0
2009-12	RP-46	RP-091294	135	2		Home eNode B performance requirement	9.2.0
2009-12							
	RP-46	RP-091294	136	1		Home eNode B operating band unwanted emissions requirement	9.2.0
2009-12	RP-46	RP-091294	137	1		Home eNode B reference sensitivity level requirement	9.2.0
2009-12	RP-46	RP-091294	138	2		Home eNode B spurious emission requirement	9.2.0
2009-12	RP-46	RP-091284	140	2		Inclusion of Band 20 BS Test parameters	9.2.0
2009-12							
	RP-46	RP-091267	144	1		Applicability of uncertainty for transmitter transient period	9.2.0
2010-03	RP-47	RP-100252	174			Correction of the frequency range for unwanted emissions limits (cat-B/option 2/BW 3MHz)	9.3.0
2010-03	RP-47	RP-100252	171			Correction of Band 4 and 10 co-existence requirement	9.3.0
2010-03	RP-47	RP-100275	148			Dynamic range requirement for Local Area BS	9.3.0
2010-03	RP-47	RP-100275	149			In-channel selectivity for Local Area BS	9.3.0
2010-03	RP-47	RP-100275	150			ACS and narrow band blocking for Local Area BS	9.3.0

2010-03	RP-47	RP-100275	151		Receiver intermodulation for Local Area BS	9.3.0
2010-03	RP-47	RP-100275	152		Performance requirement for Local Area BS	9.3.0
2010-03	RP-47	RP-100275	153		E-UTRA BS classification	9.3.0
2010-03	RP-47	RP-100275	154		Maximum output power for Pico NodeB	9.3.0
2010-03	RP-47	RP-100275	155		Frequency error requirement for Pico NodeB	9.3.0
2010-03	RP-47	RP-100275	156		Reference sensitivity level requirement for Pico NodeB	9.3.0
2010-03	RP-47	RP-100275	158		ACLR requirement for Pico NodeB	9.3.0
2010-03	RP-47	RP-100275	159		Operating band unwanted emissions requirement for Pico NodeB	9.3.0
2010-03	RP-47	RP-100275	147	1	Spurious emissions requirement for Local Area BS	9.3.0
2010-03	RP-47	RP-100275	157	2	Blocking requirement for Pico NodeB	9.3.0
2010-03	RP-47	RP-100263	172		Correction of DTT protection requirement	9.3.0
2010-03	RP-47	RP-100266	161		Operating band unwanted emissions requirement for Home eNodeB	9.3.0
2010-03	RP-47	RP-100266	160	1	Dynamic range requirement for Home eNodeB	9.3.0
2010-03	RP-47	RP-100266	162		Corrections of additional spurious emissions and blocking requirements for HeNB	9.3.0
2010-03	RP-47	RP-100266	166		Home BS Output Power Conformance Testing for Adjacent Channel Protection	9.3.0
2010-03	RP-47	RP-100274	175		Requirements for HARQ-ACK multiplexed on PUSCH for E-UTRA LA and Home BS	9.3.0
2010-03	RP-47	RP-100274	176		CQI missed detection requirements for PUCCH format 2 for E-UTRA LA and Home BS	9.3.0
2010-03	RP-47	RP-100274	165	1	Corrections to the receiver intermodulation requirements	9.3.0
2010-06	RP-48	RP-100621	180		Clarification on narrowband blocking requirements	9.4.0
2010-06	RP-48	RP-100621	178		Spurious emissions limits and blocking requirements for coexistence with CDMA850	9.4.0
2010-06	RP-48	RP-100621	183	1	Correction to the FRC for PUSCH 1.4M requirements	9.4.0
2010-06	RP-48	RP-100625	191	1	Clarification of applicability of requirements for multi-carrier BS	9.4.0
2010-06	RP-48	RP-100631	186		Co-existence with services in adjacent frequency bands	9.4.0
2010-09	RP-49	RP-100916	193		Clarifications on Base Station transmit and receive configurations	9.5.0
2010-09	RP-49	RP-100920	196		UL Timing Adjustment: Stationary UE propagation channel clarification	9.5.0
2010-09	RP-49	RP-100917	198	1	Modification on testing of time mask of E-UTRA TDD base station in R9	9.5.0
2010-09	RP-49	RP-100916	207		Adding operating unwanted emissions test to tests applicable to Ancillary RF Amplifiers	9.5.0
2010-09	RP-49	RP-100928	194		CR LTE_TDD_2600_US spectrum band definition additions to TS 36.141	10.0.0
2010-12	RP-50	RP-101327	224		Band 12 channel arrangement correction on 36.141	10.1.0
2010-12	RP-50	RP-101328	217		PUCCH format 2 performance requirements definition clarification	10.1.0
2010-12	RP-50	RP-101328	236		Correction on multi user PUCCH test	10.1.0
2010-12	RP-50	RP-101342	213		Equaliser coefficient derivation for Global In-Channel TX-Test	10.1.0
2010-12	RP-50	RP-101342	221		Correction of applicability of requirements	10.1.0
2010-12	RP-50	RP-101356	211	3	CR UMTS/LTE-3500 TDD spectrum band definition additions for BS to TS 36.141	10.1.0
2010-12	RP-50	RP-101362	209	3	Introduction of L-band in TS36.141	10.1.0
2011-04	RP-51	RP-110336	241	-	Receiver spurious emissions reference correction	10.2.0
2011-04	RP-51	RP-110337	247	2	Power off test tolerance	10.2.0
2011-04	RP-51	RP-110352	248	1	TS 36.141 subclause 6.5.4: DL RS Power	10.2.0
2011-04	RP-51	RP-110352	251	1	Correction of the test port description for TS 36.141 Rel-10	10.2.0
2011-04	RP-51	RP-110357	253	2	Band 42 and 43 co-existence for UMTS/LTE 3500 (TDD) for TS 36.141	10.2.0
2011-04	RP-51	RP-110344	255	-	Operating band unwanted emissions for Band 1, 33 and 34 (TS 36.141)	10.2.0
2011-06	RP-52	RP-110794	261		Modifications to Band 3 to allow LTE Band 3 operation in Japan (Rel-10 TS36.141 CR)	10.3.0
2011-06	RP-52	RP-110807	262		Carrier Aggregation for LTE in TS 36.141 / general requirements	10.3.0
2011-06	RP-52	RP-110807	264		Carrier Aggregation for LTE in TS 36.141 / receiver requirements	10.3.0
2011-06	RP-52	RP-110802	266		Co-existence/co-location between Band 42 and 43 in TS 36.141	10.3.0

2011-06	RP-52	RP-110796	267			Harmonization of co-existence between Home BS and WA BS in 36.141	10.3.0
2011-06	RP-52	RP-110804	258	1		Expanded 1900 MHz addition to 36.141	10.3.0
2011-06	RP-52	RP-110807	263	1		Carrier Aggregation for LTE in TS 36.141 / transmitter requirements	10.3.0
2011-06	RP-52	RP-110813	265	1		Add 2GHz S-Band (Band 23) in 36.141	10.3.0
2011-06	RP-52	RP-110795	273	1		Fixing the misalignment of Band 24 GPS Coexistence specifications between 36.104 and 36.141	10.3.0
2011-09	RP-53	RP-111252	290			Band 3/III operation in Japan	10.4.0
2011-09	RP-53	RP-111255	287			Uncertainties and Test Tolerances for 3000MHz to 4200MHz	10.4.0
2011-09	RP-53	RP-111255	292	1		Band 42 and 43 for LTE 3500 (TDD) correction to TS 36.141	10.4.0
2011-09	RP-53	RP-111255	293	1		Add Band 22/XXII for LTE/UMTS 3500 (FDD) to TS 36.141	10.4.0
2011-09	RP-53	RP-111260	277	1		Test tolerance for UL-MIMO performance test cases	10.4.0
2011-09	RP-53	RP-111260	278	2		Performance requirements for UL-MIMO	10.4.0
2011-09	RP-53	RP-111262	282			Specifying acceptable uncertainty of OBW test in CA	10.4.0
2011-09	RP-53	RP-111262	285	1		CR to TS 36.141 Test requirements of Operating Band Unwanted Emissions	10.4.0
2011-09	RP-53	RP-111262	286	2		Correction for TS 36.141	10.4.0
2011-09	RP-53	RP-111262	291			Co-existence and co-location corrections in 36.141	10.4.0
2011-09	RP-53	RP-111266	268	3		TS36.141 CR: on PUSCH tests	10.4.0
2011-09	RP-53	RP-111266	283			CA PUCCH performance requirements for 36.141	10.4.0
2011-12	RP-54	RP-111684	295			Corrections of CA uplink performance test cases in TS36.141	10.5.0
2011-12	RP-54	RP-111691	296			CA PUCCH performance requirements with test tolerance updates for 36.141	10.5.0
2011-12	RP-54	RP-111734	297			Clarification of general blocking requirements for co-existence in TS 36.141	10.5.0
2011-12	RP-54	RP-111693	298			Home BS Output Power for co-channel E-UTRA protection for 36.141	10.5.0
2011-12	RP-54	RP-111693	300			Update on Home BS Output Power for co-channel E-UTRA protection for 36.141	10.5.0
2011-12	RP-54	RP-111735	301			Corrections to 3500 MHz	10.5.0
2011-12	RP-54	RP-111686	302	1		TS36.141 CR: on Multi-Antenna channel models	10.5.0
2011-12	RP-54	RP-111690	303			Test procedure clarification for ACK false detection of multi-user PUCCH format 1a	10.5.0
2011-12	RP-54	RP-111687	304	3		TX ON or OFF CR 36.141	10.5.0
2011-12	RP-54	RP-111733	305			Correction of frequency range for spurious emission requirements	10.5.0
2012-03	RP-55	RP-120303	309	1		Clarification on test procedure for BS In-channel selectivity test	10.6.0
2012-03	RP-55	RP-120304	311	1		Definition of synchronized operation	10.6.0
2012-03	RP-55	RP-120295	312	1		Finalizing Home BS Output Power parameters for co-channel E-UTRA protection in 36.141	10.6.0
2012-03	RP-55	RP-120298	314	1		Addition of Band 23 HeNB specifications in 36.141	10.6.0
2012-03	RP-55	RP-120310	306			TS36.141 change for B41 CA	11.0.0
2012-03	RP-55	RP-120305	316			Introduction of Band 26/XXVI to TS 36.141	11.0.0
2012-06	RP-56	RP-120788	319	2		Introduction of intra-band non-contiguous operation in TS 36.141	11.1.0
2012-06	RP-56	RP-120773	320			Introduction of CA band combination Band1 + Band19 to TS 36.104	11.1.0
2012-06	RP-56	RP-120770	323			Editorial corrections in Home BS output power tests	11.1.0
2012-06	RP-56	RP-120780	325	1		Editorial corrections in TS 36.141	11.1.0
2012-06	RP-56	RP-120788	330			Introduction of time alignment error test requirement for intra-band non-contiguous carrier aggregation	11.1.0
2012-06	RP-56	RP-120793	331			Introduction of APAC700(FDD) into TS 36.141	11.1.0
2012-06	RP-56	RP-120795	335			Editorial correction of the TDD eNB test model configuration in TS 36.141	11.1.0
2012-06	RP-56	RP-120793	336			Introduction of Band 44	11.1.0
2012-06	RP-56	RP-120782	337			Time alignment error headline	11.1.0
2012-06	RP-56	RP-120783	338	1		Time alignment procedure in TS 36.141	11.1.0
2012-06	RP-56	RP-120773	341			Introduction of CA band combination Band4 + Band13 to TS 36.141	11.1.0
2012-06	RP-56	RP-120773	342			Introduction of CA band combination Band4 + Band17 to TS 36.141	11.1.0
2012-06	RP-56	RP-120792	343	3		Introduction of E850_LB (Band 27) to TS 36.141	11.1.0
2012-06	RP-56	RP-120764	348			Correction of PHS protection requirements for TS 36.141	11.1.0
2012-09	RP-57	RP-121305	350			Clarification of inter-band CA test configuration generation	11.2.0

2012-09	RP-57	RP-121328	351			Introduction of CA band combination Band2 + Band17 to TS 36.141	11.2.0
2012-09	RP-57	RP-121321	352			Correction to intra-band non-contiguous carrier aggregation bands acronym	11.2.0
2012-09	RP-57	RP-121336	353			Introduction of CA band combination Band1 + Band21 to TS 36.141	11.2.0
2012-09	RP-57	RP-121327	354			Introduction of CA_B7_B20 in 36.141	11.2.0
2012-09	RP-57	RP-121301	357			Introduction of Japanese regulatory requirements for LTE band 8 in 36.141 R11	11.2.0
2012-09	RP-57	RP-121334	359	1		Add requirements for inter-band CA of B_1-18 in TS36.141	11.2.0
2012-09	RP-57	RP-121339	360	1		TS 36.141 CR for CA_7	11.2.0
2012-09	RP-57	RP-121308	361	2		Reusing band 41 requirements for the Japan 2.5G TDD band	11.2.0
2012-09	RP-57	RP-121330	362	1		Introduction of CA band combination Band3 + Band5 to TS 36.141	11.2.0
2012-09	RP-57	RP-121322	363	1		Intra-band non-contiguous CA BS receiver requirement	11.2.0
2012-09	RP-57	RP-121300	369			Modifications of frequency ranges on spurious emission requirements for Band 6, 18, 19	11.2.0
2012-09	RP-57	RP-121332	370			Introduction of CA band combination Band3 + Band20 to TS 36.141	11.2.0
2012-09	RP-57	RP-121332	372			Introduction of CA band combination Band8 + Band20 to TS 36.104	11.2.0
2012-09	RP-57	RP-121324	373			Introduction of CA_B3_B7 in 36.141	11.2.0
2012-12	RP-58	RP-121885	374			Introduction of CA band combination Band3 + Band8 to TS 36.141	11.3.0
2012-12	RP-58	RP-121891	375			Introduction of CA band combination Band4 + Band5 to TS 36.141	11.3.0
2012-12	RP-58	RP-121897	376			Introduction of CA band combination Band5 + Band17 to TS 36.141	11.3.0
2012-12	RP-58	RP-121855	381			Modification of output power requirement for LA E-UTRA BS	11.3.0
2012-12	RP-58	RP-121911	384	1		Modification on E-UTRA BS transmitter requirements	11.3.0
2012-12	RP-58	RP-121867	385			Clean up of specification R11	11.3.0
2012-12	RP-58	RP-121867	388			Cleanup of 36.141 performance	11.3.0
2012-12	RP-58	RP-121900	389			Implementing NC CA in all LTE Power Classes	11.3.0
2012-12	RP-58	RP-121895	390			Introduction of CA_B5_B12 in 36.141	11.3.0
2012-12	RP-58	RP-121911	391			Correcting missing figure and subclause numbering in TS 36.141	11.3.0
2012-12	RP-58	RP-121900	393			Correction to intra-band non-contiguous carrier aggregation bands acronym	11.3.0
2012-12	RP-58	RP-121853	395			CR to add the rated output power for 8 Tx antennas	11.3.0
2012-12	RP-58	RP-121867	398			Correction to test requirements of operating band unwanted emissions	11.3.0
2012-12	RP-58	RP-121900	400			Further corrections for NC CA in LTE LA BS	11.3.0
2012-12	RP-58	RP-121907	401	1		CR for TS 36.141 transmitter characteristics (Clause 6) due to introduction of Medium Range BS	11.3.0
2012-12	RP-58	RP-121888	402			Introduction of inter-band CA_4-12 into TS 36.141	11.3.0
2012-12	RP-58	RP-121883	403			Introduction of inter-band CA_11-18 into TS 36.141	11.3.0
2012-12	RP-58	RP-121907	404			Introduction of new BS classes to E-UTRA test specification (performance part)	11.3.0
2012-12	RP-58	RP-121907	405	1		E-UTRA MR BS receiver requirement	11.3.0
2012-12	RP-58	RP-121907	407			Introduction of medium range BS class to TS 36.141 (clause 1-5)	11.3.0
2012-12	RP-58	RP-121911	408			Allowing two antenna ports configuration in TAE test procedure for MIMO and Tx diversity	11.3.0
2012-12	RP-58	RP-121911	410			Replace TBD with final requirements for PUCCH format 2 with DTX detection	11.3.0
2012-12	RP-58	RP-121863	412			Removal of brackets around medium correlation in table B.5.2-1	11.3.0
2012-12	RP-58	RP-121911	413			Clarification of Doppler shift for moving propagation conditions test	11.3.0
2012-12	RP-58	RP-121867	415			Clarification of BS RF channels to be tested for ACLR	11.3.0

2012-12	RP-58	RP-121911	416	1		Correction of BS test configuration table	11.3.0
2012-12	RP-58	RP-121893	417			Introduction of inter-band CA_4-7 into TS 36.141	11.3.0
2012-12	RP-58	RP-121902	418			Introduction of Band 29	11.3.0
2013-03	RP-59	RP-130306	0334	1		TS 36.141 CR for CA_38	11.4.0
2013-03	RP-59	RP-130366	0388	2		Cleanup of 36.141 performance.	11.4.0
2013-03	RP-59	RP-130266	421			Correction of BS performance conformance tests	11.4.0
2013-03	RP-59	RP-130274	424	1		Correction of UEM requirements in TS 36.141	11.4.0
2013-03	RP-59	RP-130274	425			Correction to MSR BS classes conformance test requirements	11.4.0
2013-03	RP-59	RP-130274	426			Correction to LTE BS classes performance requirements	11.4.0
2013-03	RP-59	RP-130284	428	1		Alignment of terminology for intra-band non-contiguous CA requirement	11.4.0
2013-03	RP-59	RP-130268	430			Correction to test requirements for PUSCH with 20 MHz channel bandwidth	11.4.0
2013-03	RP-59	RP-130287	431			Band 41 requirements for operation in Japan	11.4.0
2013-03	RP-59	RP-130284	432	1		Further corrections for non-contiguous spectrum operation in TS36.141	11.4.0
2013-06	RP-60	RP-130769	433			Add the receiver requirements test procedure for Medium Range BS in TS36.141	11.5.0
2013-06	RP-60	RP-130770	434			Clarifications on transmitter spurious emission test in TS36.141	11.5.0
2013-06	RP-60	RP-130770	435			Further correct some mistakes for non-contiguous spectrum operation in TS36.141	11.5.0
2013-06	RP-60	RP-130766	441			CR on TAE for inter-band CA	11.5.0
2013-06	RP-60	RP-130767	442	1		Editorial correction of inter band CA table to TS 36.141	11.5.0
2013-06	RP-60	RP-130770	443			Addition of Bands for intra-band non-contiguous CA for 36.141	11.5.0
2013-06	RP-60	RP-130770	444			Clarification on non-contiguous spectrum operation test configuration	11.5.0
2013-06	RP-60	RP-130769	446			Modification on co-location spurious emission requirement for Medium Range BS	11.5.0
2013-06	RP-60	RP-130769	447	1		Modification on co-location blocking requirement for E-UTRA Medium Range BS	11.5.0
2013-06	RP-60	RP-130765	454			CR for UL-MIMO conformance test	11.5.0
2013-06	RP-60	RP-130772	419	1		Introduction of CA 1+8 into TS36.141(Rel-12)	12.0.0
2013-06	RP-60	RP-130782	427	1		Introduction of LTE Advanced inter-band Carrier Aggregation of Band 3 and Band 28 to TS 36.141	12.0.0
2013-06	RP-60	RP-130786	436			Introduction of LTE Advanced inter-band Carrier Aggregation of Band 23 and Band 29 to TS 36.141	12.0.0
2013-06	RP-60	RP-130780	437			Introduction of LTE Advanced inter-band carrier aggregation of Band 3 and Band 26 into TS36.141 (Rel-12)	12.0.0
2013-06	RP-60	RP-130778	438			Introduction of CA band combination Band3 + Band19 to TS 36.141	12.0.0
2013-06	RP-60	RP-130784	439			Introduction of CA band combination Band19 + Band21 to TS 36.141	12.0.0
2013-06	RP-60	RP-130789	445			CR for 36.141 : Adding B25 non-contiguous intraband CA	12.0.0
2013-06	RP-60	RP-130774	448			Introduction of inter-band CA combination for Band 2 and Band 4	12.0.0
2013-06	RP-60	RP-130788	449			Introduction of intra-band non-contiguous CA combination for Band 4	12.0.0
2013-06	RP-60	RP-130792	450	1		Introduction of US WCS Band (Band 30) to TS 36.141	12.0.0
2013-06	RP-60	RP-130790	451			Introduction of LTE 450 in Brazil into TS 36.141	12.0.0
2013-06	RP-60	RP-130776	452	1		Introduction of LTE Advanced Inter-Band Carrier Aggregation of Band 2 and Band 13 to TS36.141	12.0.0
09-2013	RP-61	RP-131301	455			36.141 CR for LTE_CA_C_B3	12.1.0
09-2013	RP-61	RP-131296	458			Add requirements for inter-band CA_1-26 into TS36.141	12.1.0
09-2013	RP-61	RP-131299	461			Introduction of inter-band CA Band 2+5	12.1.0
09-2013	RP-61	RP-131280	465			Add the Receiver Blocking test procedure for Home BS to TS36.141	12.1.0
12-2013	RP-62	RP-131960	466			Introduction of intra-band contiguous CA for Band 27	12.2.0
12-2013	RP-62	RP-131966	467			Introduction of LTE-Advanced intra-band non-contiguous Carrier Aggregation in Band 23 to TS 36.141	12.2.0
12-2013	RP-62	RP-131947	472			Introduction of CA band combination Band2 + Band12 to TS 36.141	12.2.0

12-2013	RP-62	RP-131955	473			Introduction of CA band combination Band12 + Band25 to TS 36.141	12.2.0
12-2013	RP-62	RP-131945	475	2		CR 36.141: 1Tx 8Rx PUSCH conformance testing requirements	12.2.0
12-2013	RP-62	RP-131945	476	1		CR 36.141: 2Tx 8Rx PUCCH format 1a conformance testing requirements	12.2.0
12-2013	RP-62	RP-131945	477	2		CR on 1x8 PUCCH f1b, f3 conformance test	12.2.0
12-2013	RP-62	RP-131945	480	2		Introduction of 2x8 PUSCH test requirements for LTE 8Rx UL	12.2.0
12-2013	RP-62	RP-131945	481	3		CR 36.141: 1Tx 8Rx PRACH conformance testing requirements	12.2.0
12-2013	RP-62	RP-131926	482			Editorial correction for the UL-MIMO channel model	12.2.0
12-2013	RP-62	RP-131945	483	1		CR for conformance test of PUCCH format 1a with 1Tx8Rx	12.2.0
12-2013	RP-62	RP-131945	485			Introduction of UL 8Rx channel correlation matrices	12.2.0
12-2013	RP-62	RP-131939	487			Correction to PUSCH test requirement	12.2.0
12-2013	RP-62	RP-131958	488			Introduction of LTE-Advanced intra-band contiguous Carrier Aggregation in Band 23 to TS 36.141	12.2.0
12-2013	RP-62	RP-131962	489			Introduction of Intra-band non-contiguous CA in band 3 to TS 36.141	12.2.0
12-2013	RP-62	RP-131951	495			Introduction of CA band combination Band5 + Band25 to TS 36.141	12.2.0
12-2013	RP-62	RP-131949	498			Introduction of CA band combination B5 + B7 to TS 36.141	12.2.0
12-2013	RP-62	RP-131953	500			Introduction of CA band combination B7 + B28 to TS 36.141	12.2.0
12-2013	RP-62	RP-131931	502			Consideration on CA OBW requirement	12.2.0
12-2013	RP-62	RP-131964	505			Introduction of Intra-band non-contiguous CA in band 7 to TS 36.141	12.2.0
12-2013	RP-62	RP-131930	508			Clarification for CA CLR in TS36.141	12.2.0
12-2013	RP-62	RP-131967	509			Band 41 deployment in Japan	12.2.0
03-2014	RP-63	RP-140388	506	1		TS36.141 change for B39 CA	12.3.0
03-2014	RP-63	RP-140386	510			Introduction of CA band combination Band 3 and Band 27 to TS 36.141	12.3.0
03-2014	RP-63	RP-140389	513	1		Corrections in TS 36.141	12.3.0
03-2014	RP-63	RP-140372	518			Introduction of multi-band BS testing to TS 36.141 (Clauses 1 - 5)	12.3.0
03-2014	RP-63	RP-140372	520			Introduction of test requirements for multi-band operation with conformance test improvement for multi-carrier testing (36.141, section 6 and 7)	12.3.0
03-2014	RP-63	RP-140375	523			Correction of abbreviations for negative acknowledgement	12.3.0
03-2014	RP-63	RP-140387	490	1		Introduction of CA band combination Band 39+Band 41 into BS specification	12.3.0
06-2014	RP-64	RP-140913	527			Multi-band corrections in 36.141 chapter 7	12.4.0
06-2014	RP-64	RP-140913	536			Corrections of multi-band BS testing to TS 36.141 (Clauses 1 - 5)	12.4.0
06-2014	RP-64	RP-140913	525			Multi-band corrections in 36.141 chapter 6	12.4.0
06-2014	RP-64	RP-140913	598			Correction on manufacturer's declaration in TS36.141	12.4.0
06-2014	RP-64	RP-140913	567			Clarification on definitions and ACLR requirement in TS36.141	12.4.0
06-2014	RP-64	RP-140914	538			Band 29 correction	12.4.0
06-2014	RP-64	RP-140926	573	1		Introduction of operating band 32 and CA band 20+32 in TS36.141	12.4.0
06-2014	RP-64	RP-140930	571			Introduction of LTE-Advanced CA of Band 8 and Band 40 into TS 36.141	12.4.0
06-2014	RP-64	RP-140931	564			Introduction of CA 1+11 to 36.141 (Rel-12)	12.4.0
06-2014	RP-64	RP-140933	569			Introduction of CA band combination Band 4 and Band 27 to TS 36.141	12.4.0
06-2014	RP-64	RP-140938	546			Introduction of intra-band non-contiguous Carrier Aggregation in Band 2 to TS 36.141	12.4.0
06-2014	RP-64	RP-140940	588			Introduction of LTE_CA_NC_B42 into 36.141	12.4.0
06-2014	RP-64	RP-140942	531			Introduction of CA band combination Band 1 and Band 20 to TS 36.141	12.4.0
06-2014	RP-64	RP-140942	595			Introduction of CA band combination Band 1 and Band 20 to TS 36.141	12.4.0
06-2014	RP-64	RP-140944	541			Introduction of intra-band non-contiguous Carrier Aggregation in Band 41 for 3DL to TS 36.141	12.4.0
06-2014	RP-64	RP-140946	596			Introduction of intra-band CA_Band 42C to TS 36.141	12.4.0
09-2014	RP-65	RP-141538	596	1		Introduction of intra-band CA_Band 42C to TS 36.141	12.5.0

09-2014	RP-65	RP-141556	621		Introduction of 3 Band Carrier Aggregation (3DL/1UL) of Band 1, Band 3 and Band 8 to TS 36.141	12.5.0
09-2014	RP-65	RP-141532	623		Clarification of high speed train conditions in 36.141	12.5.0
09-2014	RP-65	RP-141551	624		Introduction of CA 8+11 to 36.141 (Rel-12)	12.5.0
09-2014	RP-65	RP-141548	626		Introduction of CA band combination Band1 + Band3 to TS 36.141	12.5.0
09-2014	RP-65	RP-141202	627	1	Introduction of CA band combination Band1 + Band3 + Band19 to TS 36.104	12.5.0
09-2014	RP-65	RP-141557	628		Introduction of CA band combination Band19 + Band42 + Band42 to TS 36.141	12.5.0
09-2014	RP-65	RP-141559	629		Introduction of CA band combination Band1 + Band42 + Band42 to TS 36.141	12.5.0
09-2014	RP-65	RP-141525	633		CR for clarification on Transmitter off power	12.5.0
09-2014	RP-65	RP-141447	635	1	Introduction of CA band combination B1+B7 and B1+B5+B 7 to TS 36.141	12.5.0
09-2014	RP-65	RP-141707	636	1	Introduction of 3 Band Carrier Aggregation of Band 1, Band 3 and Band 5 to TS 36.141	12.5.0
09-2014	RP-65	RP-141109	638	1	Introduction of inter-band CA_18-28 into TS36.141	12.5.0
09-2014	RP-65	RP-141558	644		Introduction of CA band combination Band 1, Band 3 and Band 20 to TS 36.141	12.5.0
09-2014	RP-65	RP-141528	654		Correction on UEM related to multi-band operation in TS36.141	12.5.0
09-2014	RP-65	RP-141528	656		Correction of applicability of test configuration table for a BS capable of multi-carrier and/or CA operation in both contiguous and non-contiguous spectrum in single band	12.5.0
09-2014	RP-65	RP-141554	657	1	Introduction of CA combinations	12.5.0
09-2014	RP-65	RP-141533	658		Update of definitions to support supplemental DL in TS36.141	12.5.0
09-2014	RP-65	RP-141464	661		Introduction of CA band combination Band 1, Band 7 and Band 20 to TS 36.141	12.5.0
12-2014	RP-66	RP-142175	665	2	CR on reference channel and test tolerance for coverage enhancement performance test	12.6.0
12-2014	RP-66	RP-142146	678		Multi-band test configurations corrections	12.6.0
12-2014	RP-66	RP-142182	682		Introduction of inter-band CA_1-28 into TS36.141	12.6.0
12-2014	RP-66	RP-142149	687		Correction on transmitter intermodulation requirement	12.6.0
12-2014	RP-66	RP-142189	693		CR for TR 36.141: LTE_CA_B5_B13	12.6.0
12-2014	RP-66	RP-142175	683	1	Test requirements for PUSCH with TTI bundling and enhanced HARQ pattern	12.6.0
12-2014	RP-66	RP-142177	689	1	Scope for BS performance test requirements for TDD-FDD CA	12.6.0
12-2014	RP-66	RP-142179	675	1	Introduction of 256QAM	12.6.0
12-2014	RP-66	RP-142190	676	2	Introduction of 3DL CA combinations	12.6.0
03-2015	RP-67	RP-150382	696		Co-location between Band 42 and Band 43 in TS 36.141	12.7.0
03-2015	RP-67	RP-150391	698		Introduction of CA_3A-42A and CA_3A-42C into 36.141	12.7.0
03-2015	RP-67	RP-150388	707		MB and TDD+FDD	12.7.0
07-2015	RP-68	RP-150955	721		Clarification of parameter P for emission requirements	12.8.0
07-2015	RP-68	RP-150955	734		Some corrections related to single carrier requirements	12.8.0
07-2015	RP-68	RP-150968	701	4	Introduction of 2DL CA combinations	13.0.0
07-2015	RP-68	RP-150972	702	4	Introduction of 3DL CA combinations	13.0.0
07-2015	RP-68	RP-150974	729	1	Introduction of 4DL CA combinations	13.0.0
07-2015	RP-68	RP-150670	744		Introduction of CA_3A-40A to TS 36.141	13.0.0
09-2015	RP-69	RP-151476	747		BS Spec improvements: TS 36.141 Corrections	13.1.0
09-2015	RP-69	RP-151506	761		CR on conformance test for support of 256QAM in wide area BS	13.1.0
09-2015	RP-69	RP-151476	764		Multi-band high PSD test configuration clarification	13.1.0
09-2015	RP-69	RP-151499	766		Introduction of 3DL CA combinations	13.1.0
09-2015	RP-69	RP-151501	767		Introduction of 4DL CA combinations	13.1.0
09-2015	RP-69	RP-151203	768		Introduction of CA_7A-40A and CA_7A-40C to TS 36.141	13.1.0
09-2015	RP-70	RP-152168	772		Introduction of intra-band CA_8B to TS 36.141	13.2.0
09-2015	RP-70	RP-152171	782		Introduction of Band 65 to TS 36.141	13.2.0
09-2015	RP-70	RP-152157	783	1	Introduction of Band 67 and CA_20-67 to 36.141	13.2.0
09-2015	RP-70	RP-152167	789		Introduction of intra-band CA_5B to TS 36.141	13.2.0
09-2015	RP-70	RP-152169	790		Introduction of intra-band NC CA_5A-5A to TS 36.141	13.2.0
09-2015	RP-70	RP-152173	792		Introduction of 1447-1467MHz Band into 36.141	13.2.0

09-2015	RP-70	RP-152132	795			Correction on UEM requirement for Multi-band base station	13.2.0
09-2015	RP-70	RP-152132	798			BS Spec improvements: TS 36.141 Corrections	13.2.0
09-2015	RP-70	RP-152132	806			Corrections on definition of $f_{offsetmax}$ for BS operating in multiple bands or non-contiguous spectrum	13.2.0
09-2015	RP-70	RP-152156	811			Introduction of 2DL CA combinations	13.2.0
09-2015	RP-70	RP-152161	812			Introduction of 3DL CA combinations	13.2.0
09-2015	RP-70	RP-152162	813			Introduction of 4DL CA combinations	13.2.0
09-2015	RP-70	RP-152132	816			Clarification on the transmitter intermodulation requirement in TS 36.141	13.2.0
09-2015	RP-70	RP-152172	818			Introduction of Band 66 to 36.141	13.2.0
03/2016	RP-71	RP-160480	0829		B	Introduction of 3DL CA combinations	13.3.0
03/2016	RP-71	RP-160481	0830		B	Introduction of 4DL CA combinations	13.3.0
03/2016	RP-71	RP-160482	0828		B	Introduction of 5DL CA combinations	13.3.0
03/2016	RP-71	RP-160483	0819	2	B	Introduction of Band 68 into 36.141	13.3.0
03/2016	RP-71	RP-160488	0825		A	Band 20 and Band 28 BS co-existence	13.3.0
03/2016	RP-71	RP-160489	0821		A	Corrections to BS spurious emissions requirements for band 22 and 42 in TS36.141 (Rel-13)	13.3.0
06/2016	RP-72	RP-161131	833	2	B	CR on BS-IRC conformance test	13.4.0
06/2016	RP-72	RP-161131	836		B	CR on definition for BS IRC performance requirements in 36.141	13.4.0
06/2016	RP-72	RP-161134	838		B	Introduction of Band 46 in TS 36.141 Rel-13	13.4.0
06/2016	RP-72	RP-161141	846	-	F	Corrections to sub-clause number of BS spurious emissions limits in TS36.141 (Rel-13)	13.4.0
06/2016	RP-72	RP-161129	847	1	B	CR: Conformance test for eCA new PUCCH format 4 (Rel-13)	13.4.0
06/2016	RP-72	RP-161131	848	-	B	Connection diagrams for BS MMSE-IRC receiver	13.4.0
06/2016	RP-72	RP-161131	849	-	B	36.141 CR for interference model for synchronous and asynchronous scenarios	13.4.0
06/2016	RP-72	RP-161129	850	1	B	CR for PUCCH format 5 performance requirements for 36.141	13.4.0
06/2016	RP-72	RP-161142	851	1	F	Correction related to band 65	13.4.0
06/2016	RP-72	RP-161140	858	1	F	Corrections on definition of multi-band definition and blocking	13.4.0
06/2016	RP-72	RP-161131	859	1	B	36.141 CR for BS MMSE-IRC receiver - Demodulation conformance tests in asynchronous interference scenario.	13.4.0
06/2016	RP-72	RP-161128	861	1	B	CR: Cat-M1 PRACH Performance Requirements for 36.141	13.4.0
06/2016	RP-72	RP-161128	862	1	B	CR: Cat-M1 PUCCH Performance Requirements for 36.141	13.4.0
06/2016	RP-72	RP-161128	863	1	B	CR: Cat-M1 PUSCH Performance Requirements for 36.141	13.4.0
06/2016	RP-72	RP-161131	864	-	B	36.141 CR: Introduction of new FRC tables for MMSE-IRC	13.4.0
06/2016	RP-72	RP-161134	867	-	B	Introduction of LBT performance test for LAA	13.4.0
06/2016	RP-72	RP-161125	844	-	B	Introduction of Band 70 to 36.141	14.0.0
06/2016	RP-72	RP-161119	852	-	B	Introduction of 4DL CA combinations	14.0.0
06/2016	RP-72	RP-161117	855	-	B	Introduction of completed R14 2DL band combinations to TS 36.141	14.0.0
06/2016	RP-72	RP-161118	857	1	B	Introduction of completed R14 3DL band combination to TS 36.141	14.0.0
06/2016	RP-72	RP-161124	866	-	B	Introduction of Band 69 and CA_3-69 to 36.141	14.0.0
09/2016	RP-73	RP-161623	868		B	Introduction of completed R14 3DL band combination to TS 36.141	14.1.0
09/2016	RP-73	RP-161622	869		B	Introduction of completed R14 2DL band combinations to TS 36.141	14.1.0
09/2016	RP-73	RP-161786	873		A	36.141 CR on bracket removal for BS IRC receiver	14.1.0
09/2016	RP-73	RP-161782	875		A	CR for eMTC PUCCH conformance test (Rel-13)	14.1.0
09/2016	RP-73	RP-161780	879		A	CR: NPUSCH format 1 and FRC demodulation conformance test (Rel-13)	14.1.0
09/2016	RP-73	RP-161780	881		A	CR: NPUSCH format 2 demodulation conformance test (Rel-14)	14.1.0
09/2016	RP-73	RP-161782	884		A	CR: Add Test tolerances for eMTC BS demodulation performance requirements	14.1.0
09/2016	RP-73	RP-161780	886		A	CR: Add Test tolerances for NB-IoT BS demodulation performance requirements	14.1.0
09/2016	RP-73	RP-161624	887		B	Introduction of 4DL CA combinations	14.1.0
09/2016	RP-73	RP-161629	889		F	Corrections of CA operating band tables	14.1.0
09/2016	RP-73	RP-161638	895		A	Correction on LBT test procedure	14.1.0
09/2016	RP-73	RP-161625	896		B	Introduction of 5DL CA combinations	14.1.0
09/2016	RP-73	RP-161618	882	1	B	CR on ETU600 PUSCH test for 36.141	14.1.0

09/2016	RP-73	RP-161617	905		B	Introduction of V2V bands	14.1.0
09/2016	RP-73	RP-161783	902	2	A	Correction of CA CLR for Band 46	14.1.0
09/2016	RP-73	RP-161635	891	1	A	Introduction of Korea regulatory requirements for PS-LTE BS, band 28, 36.141	14.1.0
09/2016	RP-73	RP-161614	906		A	LAA BS unwanted emission mask requirements in 36.141	14.1.0
12/2016	RP-74	RP-162384	0910	-	A	CR for Rel-14 eMTC PRACH conformance test	14.2.0
12/2016	RP-74	RP-162388	0911	1	F	Maintenance for PUSCH ETU600 conformance tests	14.2.0
12/2016	RP-74	RP-162457	0918	-	B	Introduction of 4DL CA combinations	14.2.0
12/2016	RP-74	RP-162398	0919	-	B	Introduction of additional band combinations for Intra-band CA	14.2.0
12/2016	RP-74	RP-162379	0921	-	A	CR: Correction of Fixed Reference Channels for NPUSCH format 1 (Rel-14,36.141)	14.2.0
12/2016	RP-74	RP-162395	0922	1	B	CR for 36.141: Multi-band testing with 3 or more bands	14.2.0
12/2016	RP-74	RP-162379	0924	-	A	Introduction of NB-IoT into 36.141	14.2.0
12/2016	RP-74	RP-162379	0926	-	A	CR: Updates to NPUSCH format 1 demodulation conformance test (Rel-14)	14.2.0
12/2016	RP-74	RP-162379	0928	-	A	CR: Updates to NPUSCH format 2 demodulation conformance test (Rel-14)	14.2.0
12/2016	RP-74	RP-162382	0930	-	A	CR on cleaning up Rel-14 eMTC PUSCH conformance test	14.2.0
12/2016	RP-74	RP-162387	0931	-	B	LAA BS unwanted emission mask for 10 MHz carrier in 36.141	14.2.0
12/2016	RP-74	RP-162387	0932	-	B	ACL R for Band 46 for 10 MHz carrier in 36.141	14.2.0
12/2016	RP-74	RP-162399	0933	-	B	Introduction of completed R14 2DL band combinations to TS 36.141	14.2.0
12/2016	RP-74	RP-162400	0934	-	B	Introduction of completed R14 3DL band combinations to TS 36.141	14.2.0
12/2016	RP-74	RP-162402	0937	-	B	Introduction of 5DL CA combinations	14.2.0
12/2016	RP-74	RP-162405	0938	-	B	Introduction of Band 48	14.2.0
03/2017	RP-75	RP-170568	0939	-	B	Introduction of 4DL CA combinations	14.3.0
03/2017	RP-75	RP-170565	0940	2	B	Introduction of additional band combinations for Intra-band CA	14.3.0
03/2017	RP-75	RP-170577	0941	-	F	Editorial error correction of CA_1-8	14.3.0
03/2017	RP-75	RP-170569	0942	-	B	Introduction of 5DL CA combinations	14.3.0
03/2017	RP-75	RP-170593	0946	-	A	CR to 36.141 for correction of test requirements for BS MMSE-IRC receiver	14.3.0
03/2017	RP-75	RP-170573	0948	1	A	CR to 36.141: Addition of 1.4 and 3 MHz channel bandwidths for Band 65	14.3.0
03/2017	RP-75	RP-170601	0950	-	A	CR:Cleanup for the NB-IoT NPUSCH conformance test(R14)	14.3.0
03/2017	RP-75	RP-170596	0954	-	A	CR for PRACH conformance test (Rel-14)	14.3.0
03/2017	RP-75	RP-170600	0959	-	A	Correction on FRC for NB-IoT in TS 36.141	14.3.0
03/2017	RP-75	RP-170567	0960	-	B	Introduction of completed R14 3DL band combinations to TS 36.141	14.3.0
03/2017	RP-75	RP-170595	0962	-	A	Correction CR on PUSCH and PUCCH supporting Cat-M1 considering guard period in 36.141	14.3.0
03/2017	RP-75	RP-170600	0965	-	F	Corrections on NB-IoT narrowband intermodulation performance requirement	14.3.0
03/2017	RP-75	RP-170600	0967	-	A	Corrections on NB-IoT Test Configuration	14.3.0
03/2017	RP-75	RP-170577	0968	-	F	B70 Carrier Frequency and EARFCN Correction	14.3.0
03/2017	RP-75	RP-170572	0969	-	B	Introduction of new bands for NB-IoT in 36.141	14.3.0
03/2017	RP-75	RP-170566	0970	-	B	Introduction of completed R14 2DL band combinations to TS 36.141	14.3.0
03/2017	RP-75	RP-170600	0972	1	A	CR: NPRACH performance requirements (Rel-13, TS36.141)	14.3.0
06-2017	RP-76	RP-171279	975	1	B	Introduction of new bands for NB-IoT in 36.141	14.4.0
06-2017	RP-76	RP-171255	990	1	B	CR on eLAA BS for TS 36.141	14.4.0
06-2017	RP-76	RP-171282	991	1	F	CR on BS for protection of V2X UE in TS 36.141	14.4.0
06-2017	RP-76	RP-171309	1005		A	CR on 1-PRB FRC in eMTC PUSCH conformance R14	14.4.0
06-2017	RP-76	RP-171302	1008		A	Updates to NPUSCH format 1 conformance test(R14)	14.4.0
06-2017	RP-76	RP-171310	1010		A	clean up eMTC PUCCH conformance test (Rel-14)	14.4.0
06-2017	RP-76	RP-171257	1011	3	B	CR for new PRACH conformance test	14.4.0
06-2017	RP-76	RP-171294	1023	1	A	Correction of maximum test system uncertainty for out of band blocking	14.4.0
06-2017	RP-76	RP-171276	1024	1	B	Introduction of 5DL CA combinations to 36.141	14.4.0
06-2017	RP-76	RP-171310	1026		A	Clarification of PRB allocation for PUSCH test for eMTC (Rel-14)	14.4.0
06-2017	RP-76	RP-171302	1030		A	NB-IoT Cell-ID value in Test Model N-TM and some editorials	14.4.0

06-2017	RP-76	RP-171302	1032		A	Wrong tolerance for NPUSCH format 1	14.4.0
06-2017	RP-76	RP-171272	1033	1	B	Introduction of additional band combinations for Intra-band CA	14.4.0
06-2017	RP-76	RP-171275	1034	3	B	Introduction of Rel-14 4DL/1UL combinations in 36.141	14.4.0
06-2017	RP-76	RP-171273	1035	1	B	Introduction of completed R14 2DL band combinations to TS 36.141	14.4.0
06-2017	RP-76	RP-171274	1036		B	Introduction of completed R14 3DL band combinations to TS 36.141	14.4.0
06-2017	RP-76	RP-171260	1038	1	B	Introduction of BS performance requirements for 256QAM in 36.141	14.4.0
06-2017	RP-76	RP-171303	1040		F	Channel Raster For Multiple Standalone NB-IoT Carriers (TS 36.141)	14.4.0
06-2017	RP-76	RP-171300	1042		A	Narrowband blocking requirement for NB-IoT guard band operation (TS 36.141)	14.4.0
06-2017	RP-76	RP-171303	1044		A	Intermodulation performance requirement for NB-IoT operation (TS 36.141)	14.4.0
06-2017	RP-76	RP-171303	1046		A	Clarification on small BW support for in-band and guard band operation (TS 36.141)	14.4.0
06-2017	RP-76	RP-171300	1051		A	Note on BS in-channel selectivity for NB-IoT	14.4.0
09-2017	RP-77	RP-171972	1056		A	NB-IoT PRB position in Refsens for >5 MHz E-UTRA in-band operation (TS 36.141)	14.5.0
09-2017	RP-77	RP-171970	1061		A	CR on eMTC BS PRACH conformance tests R14	14.5.0
09-2017	RP-77	RP-171934	1067	1	B	Introduction of BS performance requirements for 256QAM in 36.141	14.5.0
09-2017	RP-77	RP-171934	1069		B	Introduction of performance requirements for PUSCH transmission in UpPTS	14.5.0
09-2017	RP-77	RP-171973	1072	1	A	CR to 36.141: Correction of typo error in FFT sample	14.5.0
09-2017	RP-77	RP-171942	1078		F	Maintenance CR for HST PRACH enhancement conformance test	14.5.0
09-2017	RP-77	RP-171933	1079	1	B	Addition of PUSCH conformance test for eLAA	14.5.0
09-2017	RP-77	RP-171945	1057		B	36.141 CR for BS IC receiver - Connection diagram	15.0.0
09-2017	RP-77	RP-171955	1058	4	B	Introduction of Rel-15 LTE Intra-band combinations in 36.141	15.0.0
09-2017	RP-77	RP-171958	1059	1	B	Introduction of Rel-15 LTE 4DL/1UL combinations in 36.141	15.0.0
09-2017	RP-77	RP-171945	1062		B	Introduction of FRC for BS IC in 36.141	15.0.0
09-2017	RP-77	RP-171948	1063	2	B	Introduction of the FDD L-band (Band 74) into TS 36.141	15.0.0
09-2017	RP-77	RP-171959	1064	1	B	Introduction of 5DL CA combinations	15.0.0
09-2017	RP-77	RP-171952	1065		B	CR to 36.141: Introduction of Band 71	15.0.0
09-2017	RP-77	RP-171946	1066		B	CR to 36.141: Introduction of Band 72	15.0.0
09-2017	RP-77	RP-171957	1068		B	Introduction of completed R15 3DL band combinations to TS 36.141	15.0.0
09-2017	RP-77	RP-171956	1074	4	B	Introduction of completed combination to 36.141	15.0.0
09-2017	RP-77	RP-171945	1075	1	B	CR to 36.141 on definition of BS IC receiver	15.0.0
09-2017	RP-77	RP-171950	1076	1	B	Introduction of SDL L-band into TS 36.141	15.0.0
09-2017	RP-77	RP-171949	1077	1	B	Introduction of TDD L-band into TS 36.141	15.0.0
09-2017	RP-77	RP-171945	1080		B	CR for PUSCH conformance test in TS 36.141 for BS IC	15.0.0
09-2017	RP-77	RP-172049	1081		B	CR to 36.141: Support of NB-IoT for Bands 4, 14 and 71	15.0.0
2017-12	RAN#78	RP-172609	1086		A	Correction on NB-IoT RB power dynamic range for in-band band operation	15.1.0
2017-12	RAN#78	RP-172586	1088		A	Updates to eLAA PUSCH conformance requirements	15.1.0
2017-12	RAN#78	RP-172600	1089		F	Cleanup for BS IC conformance requirements	15.1.0
2017-12	RAN#78	RP-172613	1093		A	CR to 36.141: BS Spurious emissions limits for protection of the BS receiver for B28 in Europe	15.1.0
2017-12	RAN#78	RP-172593	1097	1	B	CR to 36.141: Introduction of Band 73	15.1.0
2017-12	RAN#78	RP-172596	1099		B	CR for 36.141	15.1.0
2017-12	RAN#78	RP-172595	1100		B	Introduction of additional band combinations for Intra-band CA	15.1.0
2017-12	RAN#78	RP-172704	1101		B	Introduction of additional band combinations for 4DL CA	15.1.0
2017-12	RAN#78	RP-172584	1103		A	CR to 36.141: Corrections to co-location tables for B48	15.1.0
2017-12	RAN#78	RP-172594	1104	1	B	CR to 36.141: Introduction of Band 49	15.1.0
2017-12	RAN#78	RP-172588	1107		B	CR on addition of NB-IoT small cell support (36.141)	15.1.0
2017-12	RAN#78	RP-172611	1110		A	Removal of BS repetition sensitivity	15.1.0
2017-12	RAN#78	RP-172597	1111		B	Introduction of completed R15 3DL band combinations to TS 36.141	15.1.0
2017-12	RAN#78	RP-172598	1112		B	Introduction of 5DL CA combinations to 36.141	15.1.0

2017-12	RAN#78	RP-172551	1113		B	Introduction of missing 3DL fallbacks to 4DL combinations	15.1.0
2018-03	RAN#79	RP-180267	1127		F	CR on corrections of tables for NB-IoT small cell support (TS 36.141)	15.2.0
2018-03	RAN#79	RP-180271	1128		B	CR for 36.141	15.2.0
2018-03	RAN#79	RP-180272	1114		B	Introduction of completed R15 3DL/1UL band combinations to TS 36.141	15.2.0
2018-03	RAN#79	RP-180273	1116		B	Introduction of Rel-15 LTE 4DL/1UL combinations in 36.141	15.2.0
2018-03	RAN#79	RP-180274	1117		B	Introduction of 5DL CA combinations to 36.141	15.2.0
2018-03	RAN#79	RP-180278	1129		B	Introduction of TDD 3.3-3.4GHz band (band 52)	15.2.0
2018-03	RAN#79	RP-180279	1120		B	CR to 36.141: Introduction of Band 85 (B12-extended)	15.2.0
2018-03	RAN#79	RP-180281	1118	1	B	CR to 36.141: Introduction of new additional unwanted emission limit for L-Band	15.2.0
2018-03	RAN#79	RP-180293	1123		A	CR on clarifications of NB-IoT RB power dynamic range for in-band or guard band operation (TS 36.141)	15.2.0
2018-03	RAN#79	RP-180293	1126		A	CR on corrections of table for NB-IoT stand-alone test configurations	15.2.0
2018-06	RAN#80	RP-181080	1130	1	B	CR on BS requirements for DL 1024QAM in TS 36.141	15.3.0
2018-06	RAN#80	RP-181112	1133		A	Clarification on Base Station RF Bandwidth for stand-alone NB-IoT operation (36.141)	15.3.0
2018-06	RAN#80	RP-181112	1136		A	Correction on Cell ID for in-band/guard-band NB-IoT operation	15.3.0
2018-06	RAN#80	RP-181091	1141		B	Introduction of Rel-15 LTE 4DL/1UL combinations in 36.141 (This CR was superseded by CR#1151)	15.3.0
2018-06	RAN#80	RP-181089	1143		B	CR to add new 2DL1UL CA combos to 36141	15.3.0
2018-06	RAN#80	RP-181090	1144		B	Introduction of Rel-15 LTE 3DL/1UL combinations in 36.141 (This CR was superseded by CR#1152)	15.3.0
2018-06	RAN#80	RP-181089	1145	1	B	CR for 36.141 to update 2DL1UL basket items	15.3.0
2018-06	RAN#80	RP-181102	1146		F	Correction on FRC indices for enhanced performance requirement type B	15.3.0
2018-06	RAN#80	RP-181084	1147	2	B	NB-IoT: Adding TDD support in TS 36.141	15.3.0
2018-06	RAN#80	RP-181100	1148		F	CR to TS 36.141: Correct P _{max,c} to Prated,c for UEM requirements	15.3.0
2018-06	RAN#80	RP-181088	1150		B	Introduction of Rel-15 LTE Intra-band combinations in 36.141	15.3.0
2018-06	RAN#80	RP-181091	1151		B	Introduction of Rel-15 LTE 4DL/1UL combinations in 36.141	15.3.0
2018-06	RAN#80	RP-181090	1152		B	Introduction of completed R15 3DL/1UL band combinations to TS 36.141	15.3.0
2018-06	RAN#80	RP-181092	1156		B	Introduction of 5DL CA combinations to 36.141	15.3.0
2018-09	RAN#81	RP-181898	1157	3	B	CR: SPUSCH conformance test for 36.141	15.4.0
2018-09	RAN#81	RP-181898	1158	3	B	CR: SPUCCH conformance test for 36.141	15.4.0
2018-09	RAN#81	RP-181900	1167	1	F	CR to TS 36.141: Finalization of NB-IoT TDD test model and correction on NB-IoT operating band unwanted emission requirement (5.5, 6.1.1, 6.1.3, 6.6.3.5.3)	15.4.0
2018-09	RAN#81	RP-181900	1168	2	B	Introduction of NB-IoT TDD – TM updates	15.4.0
2018-09	RAN#81	RP-181898	1169	2	B	Introduction of sTTI	15.4.0
2018-09	RAN#81	RP-181899	1171	1	B	CR of test on BS REFSSENS for subPRB feature	15.4.0
2018-09	RAN#81	RP-181901	1174		F	Removing Section 9 from 36.141	15.4.0
2018-12	RAN#82	RP-182366	1183		F	CR to TS 36.141: Correction on NB-IoT TDD test model (6.1.3)	15.5.0
2018-12	RAN#82	RP-182362	1184	1	B	Addition of NR co-location and co-existence test requirements	15.5.0
2018-12	RAN#82	RP-182365	1186	2	B	Introduction of BS demodulation requirements for eFeMTC (TS36.141)	15.5.0
2018-12	RAN#82	RP-182367	1189	1	B	CR to TS 36.141: Implementation of UL PRB to DL PRB center offset for TDD NB-IoT	15.5.0
2018-12	RAN#82	RP-182377	1187	1	B	CR of adding B65 for NB1	16.0.0
2018-12	RAN#82	RP-182375	1188		F	Removal of CA bands list for E-UTRA	16.0.0
2018-12	RAN#82	RP-182376	1190		B	CR to 36.141: Introduction of Band 53	16.0.0
2019-03	RAN#83	RP-190420	1194		A	CR to 36.141: frequency offset between anchor and non-anchor carrier for TDD NB-IoT standalone operation	16.1.0
2019-03	RAN#83	RP-190420	1194		A	Correction to 256QAM and 1024QAM test models and declarations	16.1.0
2019-03	RAN#83	RP-190406	1198		A	CR: Addition of conformance testing for new NPRACH formats in 36.141(Rel-16)	16.1.0

2019-03	RAN#83	RP-190405	1200		A	CR: Update to conformance tests for sTTI	16.1.0
2019-03	RAN#83	RP-190417	1203		A	Correction of PUSCH 256QAM 8Rx conformance test requirements	16.1.0
2019-06	RAN#84	RP-191264	1211	1	A	Correction of PUSCH demodulation requirements for eFeMTC (36.141)	16.2.0
2019-06	RAN#84	RP-191248	1215		B	CR to 36.141: Introduction of co-existence requirements with Band n48	16.2.0
2019-06	RAN#84	RP-191265	1217		A	CR to 36.141: Corrections to blocking performance requirements for Home BS	16.2.0
2019-06	RAN#84	RP-191267	1220		A	CR to 36.141: category B option 2 unwanted emissions for 2500-2690 MHz band	16.2.0
2019-06	RAN#84	RP-191242	1221		B	CR to TS 36.141: Introduction of band n14	16.2.0
2019-06	RAN#84	RP-191246	1222		B	CR to TS 36.141: Introduction of band n30	16.2.0
2019-06	RAN#84	RP-191250	1223	1	B	n65 introduction to 36.141	16.2.0
2019-06	RAN#84	RP-191265	1225		A	Corrections to demodulation performance for NPRACH FDD preamble format 2	16.2.0
2019-06	RAN#84	RP-191256	1229		B	CR to 36.141: Introduction of Band 87 and 88	16.2.0
2019-09	RAN#85	RP-192055	1233		A	CR to TS 36.141: Removal of square brackets in receiver narrowband intermodulation performance requirement for all BS classes for NB-IoT standalone	16.3.0
2019-09	RAN#85	RP-192029	1234		B	CR on Protection of SUL band n89 to TS 36.141	16.3.0
2019-09	RAN#85	RP-192055	1236		A	Clean up of PUSCH demodulation requirements for eFeMTC (36.141)	16.3.0
2019-09	RAN#85	RP-192034	1237		B	n29 introduction to 36.141	16.3.0
2019-09	RAN#85	RP-192043	1238	1	B	CR of adding LTE B42/B43 for UE category NB1 in R16	16.3.0
2019-09	RAN#85	RP-192043	1239	1	B	CR of adding LTE B7 for UE category NB1 in R16	16.3.0
2019-12	RAN#86	RP-193013	1240		B	Introduction of 2010-2025MHz SUL band into Rel-16 TS 36.141	16.4.0
2019-12	RAN#86	RP-193026	1241	1	B	CR to TS 36.141: Introduction of PUSCH performance requirements for enhanced HST scenario	16.4.0
2019-12	RAN#86	RP-193026	1242	1	B	CR to TS 36.141: Introduction of PRACH performance requirements for enhanced HST scenario	16.4.0
2019-12	RAN#86	RP-192846	1246		B	CR to 36.141 on variable duplex FDD bands	16.4.0
2020-03	RAN#87	RP-200381	1247		B	Introduction of n26	16.5.0
2020-03	RAN#87	RP-200382	1248		B	Introduction of n53	16.5.0
2020-03	RAN#87	RP-200412	1249		F	CR to TS 36.141 Updates of PUSCH performance requirements for enhanced HST scenario	16.5.0
2020-03	RAN#87	RP-200412	1250		F	CR to TS 36.141 Updates of PRACH performance requirements for enhanced HST scenario	16.5.0
2020-06	RAN#88	RP-200989	1253		A	CR to TS 36.141: Corrections on table note index for test models	16.6.0
2020-06	RAN#88	RP-200964	1254		F	CR to TS 36.141 Finalization on PUSCH performance requirements for enhanced HST scenario	16.6.0
2020-06	RAN#88	RP-200964	1255		F	CR to TS 36.141 Finalization on PRACH performance requirements for enhanced HST scenario	16.6.0
2020-06	RAN#88	RP-200988	1257		A	CR: Updates to FeNB-IoT NPRACH TDD conformance testing in TS 36.141 (Rel-16)	16.6.0
2020-06	RAN#88	RP-200992	1266		A	CR: Correction on LTE SRS configuration for UL timing adjustment conformance testing (Rel-15)	16.6.0
2020-09	RAN#89	RP-201509	1271	1	B	CR: Introduce NPUSCH format 1 test requirements for multi-TB interleaved transmission for TS 36.141	16.7.0
2020-09	RAN#89	RP-201512	1273		A	CR to TS 36.141: Corrections of table note for shortened TTI test models	16.7.0
2020-12	RAN#90	RP-202500	1279		A	CR to TS 36.141: Clarification on manufacturer	16.8.0
2020-12	RAN#90	RP-202496	1282		A	Correction of eLAA FRC table	16.8.0
2020-12	RAN#90	RP-202474	1284		F	CR: Cleanup for NPUSCH format 1 conformance testing for multi-TB interleaved transmission in TS 36.141	16.8.0
2020-12	RAN#90	RP-202510	1287		A	CR to 36.141 on Removal of additional limit for Band 1	16.8.0
2021-03	RAN#91e	RP-210121	1291		A	CR to TS 36.141: Additions of regional requirements for band 41 in Japan, Rel-16	16.9.0
2021-03	RAN#91e	RP-210111	1302		A	CR to 36.141: Correction to Band 24 requirements (Rel-16)	16.9.0
2021-06	RAN#92	RP-211093	1305		A	CR to TS 36.141: ETC2 correction	16.10.0
2021-06	RAN#92	RP-211094	1309		B	CR to TS 36.141: introduction of NR-U BS	16.10.0
2021-06	RAN#92	RP-211090	1312		A	CR to 36.141: In-band blocking for multi-band Base Stations	16.10.0
2021-06	RAN#92	RP-211093	1305		A	CR to TS 36.141: ETC2 correction	16.10.0

2021-09	RAN#93	RP-211925	1318		A	Big CR for TS 36.141 Maintenance (Rel-16, CAT A)	16.11.0
2021-12	RAN#94	RP-212856	1322		A	Big CR for TS 36.141 Maintenance (Rel-16, CAT A)	16.12.0
2022-03	RAN#95	RP-220331	1329		A	Big CR for TS 36.141 Maintenance (Rel-16, CAT A)	16.13.0
2022-06	RAN#96	RP-221660	1333		A	CR for TS 36.141 On sweep time for unwanted emission testing (Rel-16)	16.14.0
2022-12	RAN#98-e	RP-223294	1342		A	CR to TS 36.141: FFS/TBD removal for band 23 co-ex for HomeNB, TT derivation, and multi-band requirements, Rel-16 Note: Partically implemented as E-UTRA Band 23 does not exist	16.15.0
2023-03	RAN#99	RP-230500	1348		A	CR to TS36.141[R16] E-UTRA slot TTI Test Model 2-1	16.16.0
2023-06	RAN#100	RP-231354	1359	1	F	CR to 36.141: Receiver spurious emissions	16.17.0
2023-06	RAN#100	RP-231352	1362	1	F	Draft CR for 36.141 Operating band unwanted emissions for Single RAT multi-band BS	16.17.0
2023-12	RAN#102	RP-233339	1367		F	[NR_n18-Perf] CR to TS 36.141 on correction of transmitter spurious emissions for protection of Band n18	16.18.0
2023-12	RAN#102	RP-233336	1377		A	[LTE_LAA-Perf] CR to TS 36.141 on correction of transmitter OFF power for Band 46	16.18.0

History

Document history		
V16.6.0	July 2020	Publication
V16.7.0	November 2020	Publication
V16.8.0	January 2021	Publication
V16.9.0	April 2021	Publication
V16.10.0	September 2021	Publication
V16.11.0	October 2021	Publication
V16.12.0	March 2022	Publication
V16.13.0	April 2022	Publication
V16.14.0	July 2022	Publication
V16.15.0	January 2023	Publication
V16.16.0	April 2023	Publication
V16.17.0	July 2023	Publication
V16.18.0	January 2024	Publication